

JVC

SERVICE MANUAL

AUDIO/VIDEO CONTROL RECEIVER

RX-7022RSL RX-7020RBK

RX-7022RSL	
Area suffix	
B	U.K.
E	Continental Europe
EN	Northern Europe
EV	Eastern Europe
RX-7020RBK	
Area suffix	
E	Continental Europe

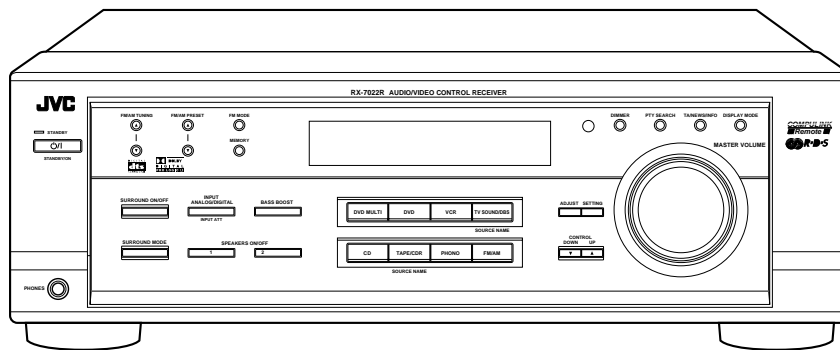
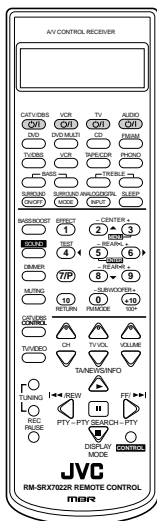

COMPU LINK
Remote

DIGITAL
dts
SURROUND

DOLBY
DIGITAL
PRO LOGIC II

R-D-S

Model	panel color	top cover
RX-7022RSL	silver	silver
RX-7020RBK	black	black

Contents

Safety precautions1-2

Disassembly method1-3

Adjustment method1-8

Description of major ICs1-9~24

Safety Precautions

1. This design of this product contains special hardware and many circuits and components specially for safety purposes. For continued protection, no changes should be made to the original design unless authorized in writing by the manufacturer. Replacement parts must be identical to those used in the original circuits. Services should be performed by qualified personnel only.
2. Alterations of the design or circuitry of the product should not be made. Any design alterations of the product should not be made. Any design alterations or additions will void the manufacturer's warranty and will further relieve the manufacture of responsibility for personal injury or property damage resulting therefrom.
3. Many electrical and mechanical parts in the products have special safety-related characteristics. These characteristics are often not evident from visual inspection nor can the protection afforded by them necessarily be obtained by using replacement components rated for higher voltage, wattage, etc. Replacement parts which have these special safety characteristics are identified in the Parts List of Service Manual. Electrical components having such features are identified by shading on the schematics and by (\triangle) on the Parts List in the Service Manual. The use of a substitute replacement which does not have the same safety characteristics as the recommended replacement parts shown in the Parts List of Service Manual may create shock, fire, or other hazards.
4. The leads in the products are routed and dressed with ties, clamps, tubings, barriers and the like to be separated from live parts, high temperature parts, moving parts and/or sharp edges for the prevention of electric shock and fire hazard. When service is required, the original lead routing and dress should be observed, and it should be confirmed that they have been returned to normal, after re-assembling.
5. Leakage current check (Electrical shock hazard testing)
After re-assembling the product, always perform an isolation check on the exposed metal parts of the product (antenna terminals, knobs, metal cabinet, screw heads, headphone jack, control shafts, etc.) to be sure the product is safe to operate without danger of electrical shock.
Do not use a line isolation transformer during this check.

- Plug the AC line cord directly into the AC outlet. Using a "Leakage Current Tester", measure the leakage current from each exposed metal parts of the cabinet, particularly any exposed metal part having a return path to the chassis, to a known good earth ground. Any leakage current must not exceed 0.5mA AC (r.m.s.).

- Alternate check method

Plug the AC line cord directly into the AC outlet. Use an AC voltmeter having, 1,000 ohms per volt or more sensitivity in the following manner. Connect a $1,500\ \Omega$ 10W resistor paralleled by a $0.15\ \mu\text{F}$ AC-type capacitor between an exposed metal part and a known good earth ground. Measure the AC voltage across the resistor with the AC voltmeter.

Move the resistor connection to each exposed metal part, particularly any exposed metal part having a return path to the chassis, and measure the AC voltage across the resistor. Now, reverse the plug in the AC outlet and repeat each measurement. Voltage measured any must not exceed 0.75 V AC (r.m.s.). This corresponds to 0.5 mA AC (r.m.s.).

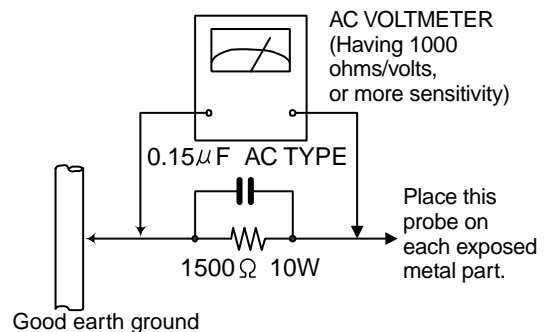

Warning

1. This equipment has been designed and manufactured to meet international safety standards.
2. It is the legal responsibility of the repairer to ensure that these safety standards are maintained.
3. Repairs must be made in accordance with the relevant safety standards.
4. It is essential that safety critical components are replaced by approved parts.
5. If mains voltage selector is provided, check setting for local voltage.

CAUTION

Burrs formed during molding may be left over on some parts of the chassis. Therefore, pay attention to such burrs in the case of performing repair of this system.

In regard with component parts appearing on the silk-screen printed side (parts side) of the PWB diagrams, the parts that are printed over with black such as the resistor (\blacksquare), diode (\blacksquare) and ICP (\bullet) or identified by the " \triangle " mark nearby are critical for safety.

(This regulation does not correspond to J and C version.)

Disassembly method

■ Removing the top cover (See Fig.1)

1. Remove the four screws **A** attaching the top cover on both sides of the body.
2. Remove the three screws **B** on the back of the body.
3. Remove the top cover from behind in the direction of the arrow while pulling both sides outward.

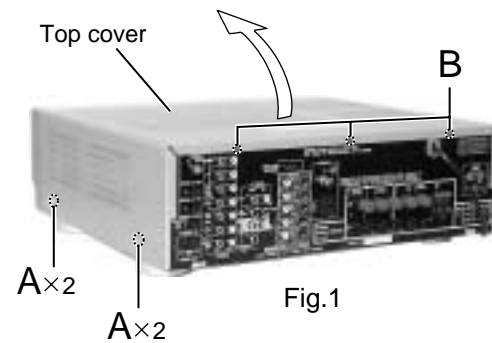

■ Removing the front panel assembly (See Fig.2, 3)

- Prior to performing the following procedure, remove the top cover.
1. Disconnect the card wire from connector CN402, CN403 on the audio board and CN201 on the power supply board in the front panel assembly.
 2. Cut off the tie band fixing the harness.
 3. Remove the three screws **C** attaching the front panel assembly.
 4. Remove the four screws **D** attaching the front panel assembly on the bottom of the body. Detach the front panel assembly toward the front.

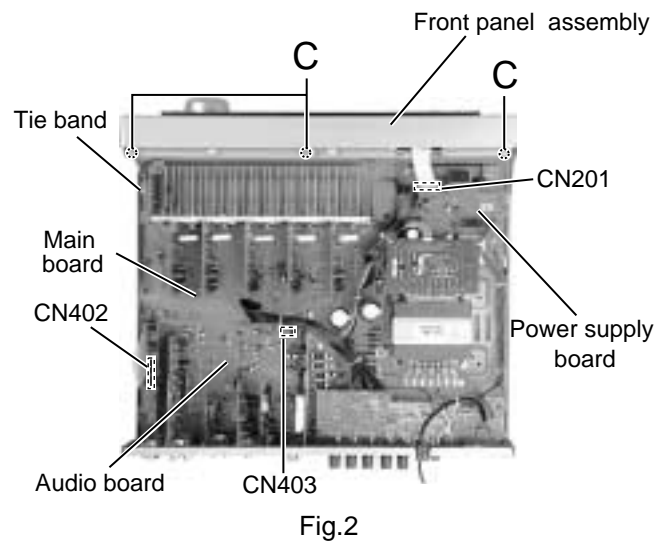

Fig.2

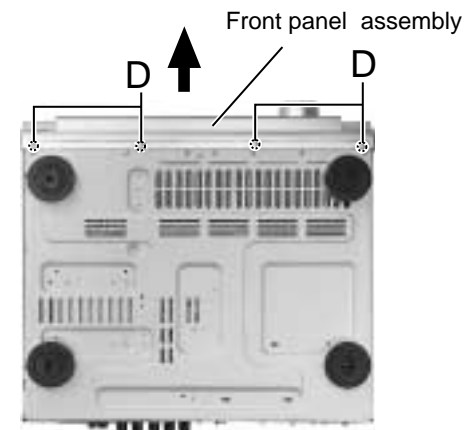

Fig.3

■ Removing the rear panel (See Fig.4)

- Prior to performing the following procedure, remove the top cover.
1. Remove the power cord stopper from the rear panel by moving it in the direction of the arrow.
 2. Remove the twenty-seven screws **E** attaching the each boards to the rear panel on the back of the body.
 3. Remove the four screws **F** attaching the rear panel on the back of the body.

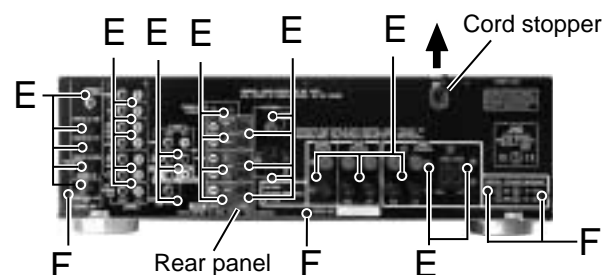

Fig.4

■ Removing each board connected to the rear side of the audio board

(See Fig.5 to 9)

• Prior to performing the following procedure, remove the top cover and the rear panel.

1. Cut off the tie band fixing the harness.
2. Disconnect the DSP board from connector CN481 on the audio board.
3. Disconnect the audio input board, DVD board Video board and the S video board from connector CN421, CN431, CN441 and CN461 on the audio board.
4. Disconnect the tuner board from connector CN411 on the audio board.

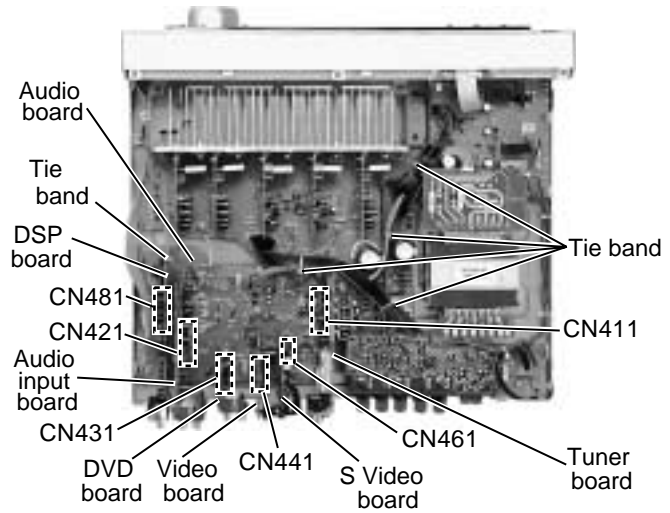

Fig.5

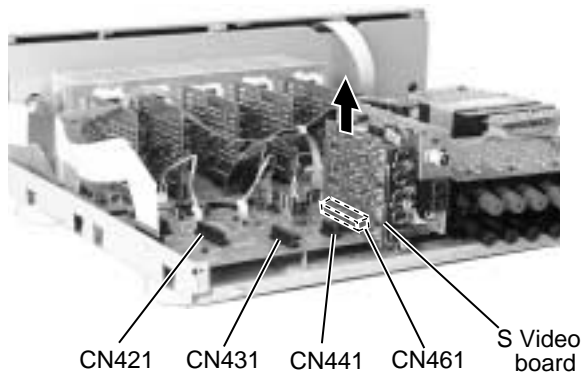

Fig.8

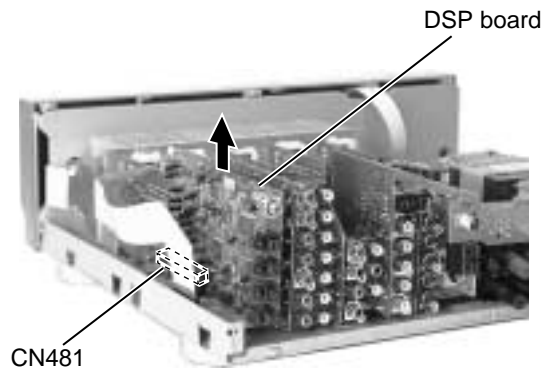

Fig.6

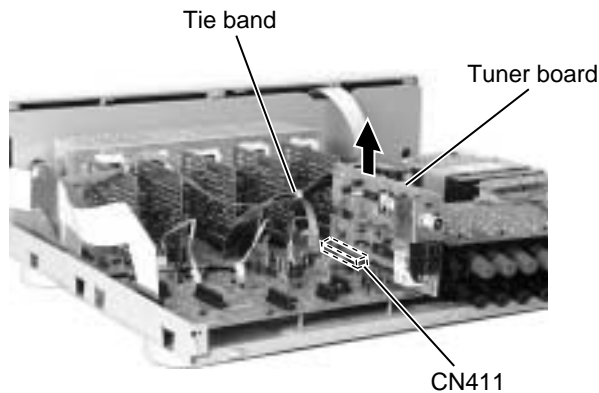

Fig.9

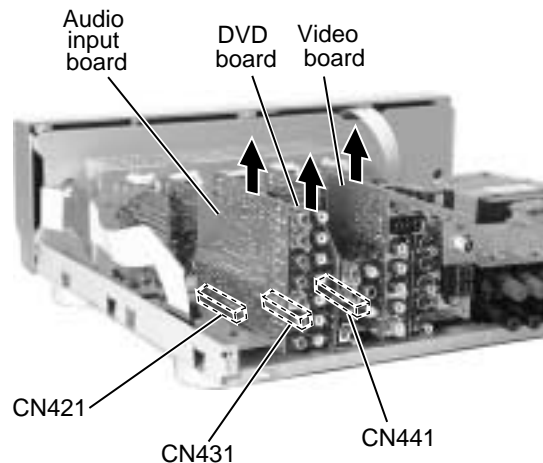
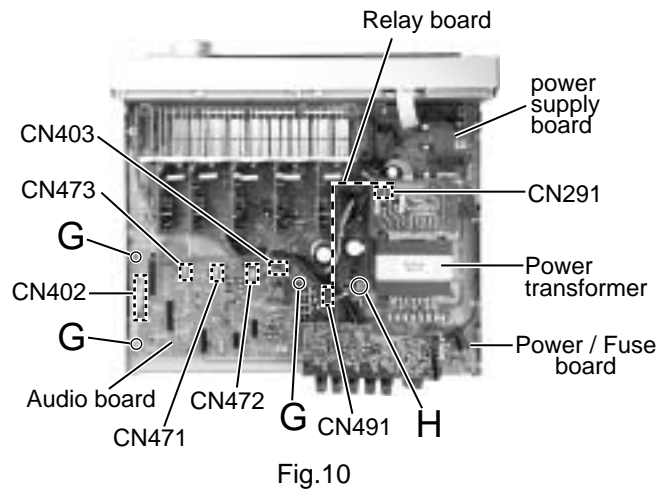

Fig.7

■ Removing the audio board (See Fig.10)

- Prior to performing the following procedure, remove the top cover and the rear panel.
1. Disconnect the card wire from connector CN402 CN403 on the audio board.
 2. Disconnect the relay board from the audio board and the power supply board. (CN291, CN491)
 3. Disconnect the harness from connector CN471, CN472, CN473.
 4. Remove the three screws **G** attaching the audio board assembly.
 5. Remove the screw **H** attaching the audio board assembly.



■ Removing the main board (See Fig.11)

- Prior to performing the following procedure, remove the top cover, the rear panel and audio board.
1. Disconnect the harness from connector CN241 and CN203 on the power supply board respectively.
 2. Disconnect the harness from connector CN251 on the power transformer board .
 3. Remove the four screws **I** and the two screws **J** attaching the main board.

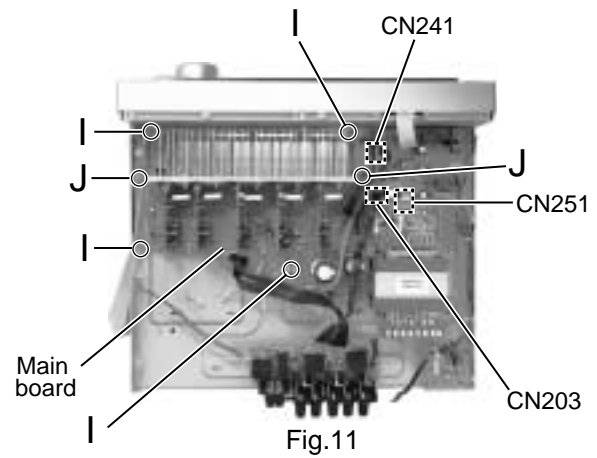

■ Removing the heat sink (See Fig.12 to 14)

- Prior to performing the following procedure, remove the top cover and main board.
1. Remove the two screws **K** attaching the heat sink to the reverse side of main board.
 2. Disconnect the for connectors with each amp. board, and remove the main board.
 3. Remove the four screws **M** and ten screws **L** attaching the heat sink.

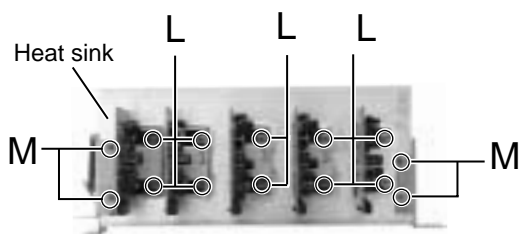
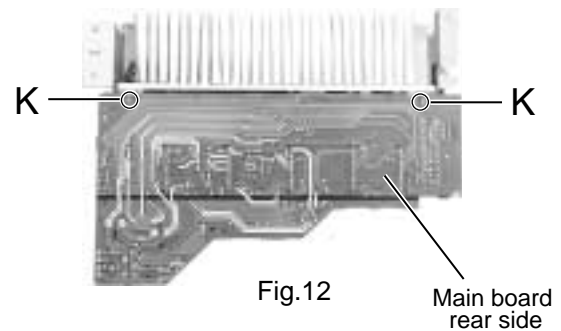

Fig.14

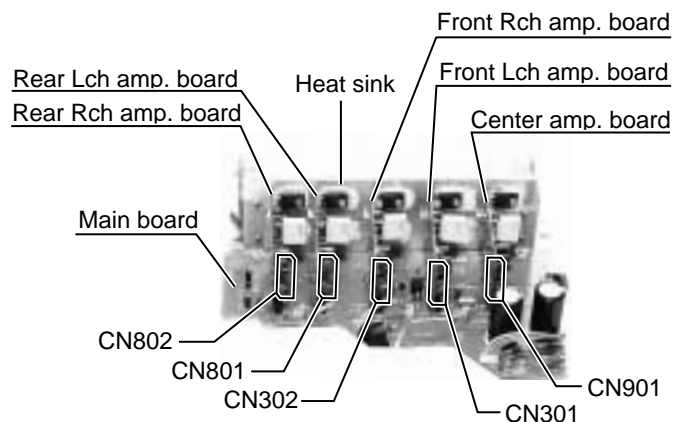
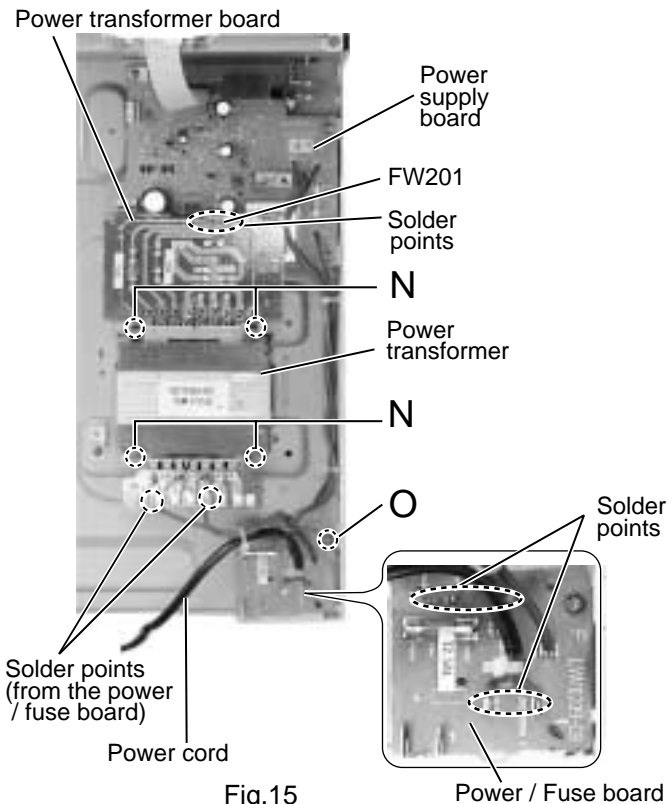

Fig.13

■ Removing the power transformer
(See Fig.15)

- Prior to performing the following procedures, remove the top cover.
1. Cut off the tie band fixing the harness.
 2. Unsolder the solder points the two harnesses connected to the power transformer.
 3. Unsolder the solder points the harness connected to the FW201 on the power transformer board.
 4. Remove the four screws **N** attaching the power transformer.



■ Removing the power / fuse board
(See Fig.15)

- Prior to performing the following procedure, remove the top cover and the rear panel.
1. Remove the screw **O** attaching the power / fuse board.
 2. Unsolder the solder points the power cord and other harnesses connected to the power / fuse board.

■ Removing the power supply board
(See Fig.16, 17)

- Prior to performing the following procedure, remove the top cover and the front panel.
1. Remove the one nut attaching the headphone jack of the power supply board on the front side of the body.
 2. Disconnect the harness connected to connector CN241, CN201, CN203, and CN291 on the power supply board (If necessary, cut off the band fixing the harness on the side of the base chassis).
 3. Remove the three screws **P** attaching the power supply board and pull out the power supply board from the front bracket backward.
 4. Unsolder the solder points the three harnesses connected to the power supply board.

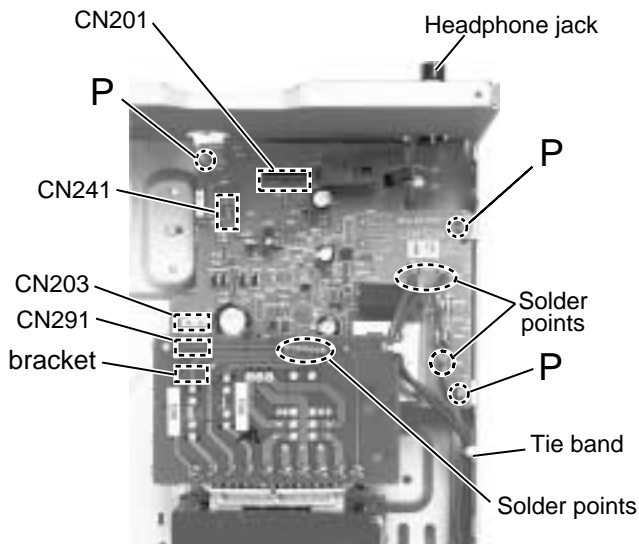
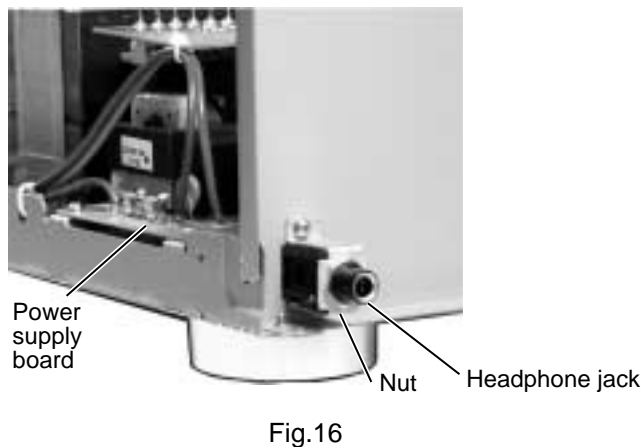

■ Removing the system control board / power switch board (See Fig.18 to 20)

- Prior to performing the following procedure, remove the top cover and the front panel assembly.
1. Pull out the volume knob on the front side of the front panel and remove the nut attaching the system control board.
 2. Remove the two screws **Q** attaching the power switch board.
 3. Disconnect the harness from connector CN714 on the power switch board.
 4. Remove the six screws **R** attaching the system control board on the back of the front panel.
 5. On the back of the front panel, release the six joints by pushing the joint tabs inward. Remove the operation switch panel toward the front.
 6. Release the two hook attaching the system control board.

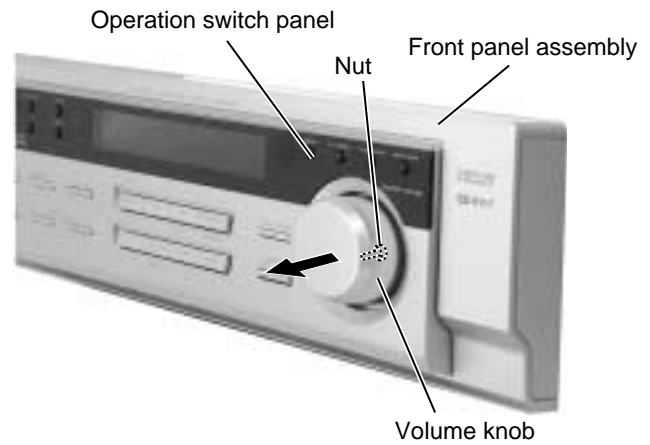

Fig.18

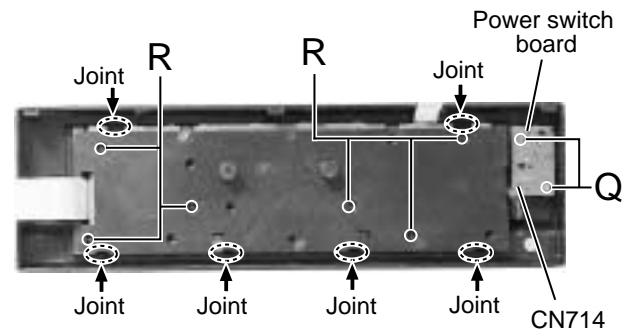

Fig.19

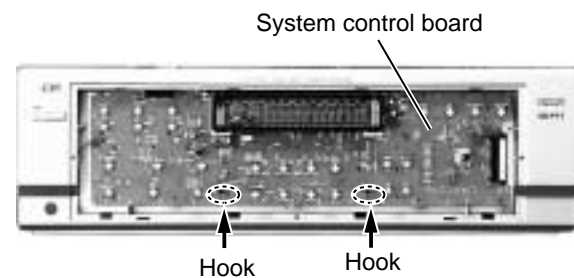

Fig.20

Adjustment method

■ Tuner section

1. Tuner range

FM	87.5MHz~108.0MHz
AM (MW)	522kHz~1629kHz
(LW)	144kHz~ 288kHz

■ Power amplifier section

Adjustment of idling current

Measurement location	TP301(Lch) , TP302(Rch)
Adjustment part	VR301(Lch) , VR302(Rch)

Attention

This adjustment does not obtain a correct adjustment value immediately after the amplifier is used (state that an internal temperature has risen).

Please adjust immediately after using the amplifier after turning off the power supply of the amplifier and falling an internal temperature.

<Adjustment method>

1. Set the volume control to minimum during this adjustment. (No signal & No load)
2. Set the surround mode OFF.
3. Turn VR301 and VR302 fully counterclockwise to warm up before adjustment.
If the heat sink is already warm from previous use the correct adjustment can not be made.
4. For L-ch, connect a DC voltmeter between TP301's B216 and B217 (Lch) and, connect it between TP302's B218 and B219 (Rch).
5. 30 seconds later after power on, adjust VR301 for L-ch, or VR302 for R-ch so that the DC voltmeter value has 2.0mV.

* It is not abnormal though the idling current might not become 0mA even if it is finished to turn variable resistance (VR301,VR302) in the direction of counterclockwise.

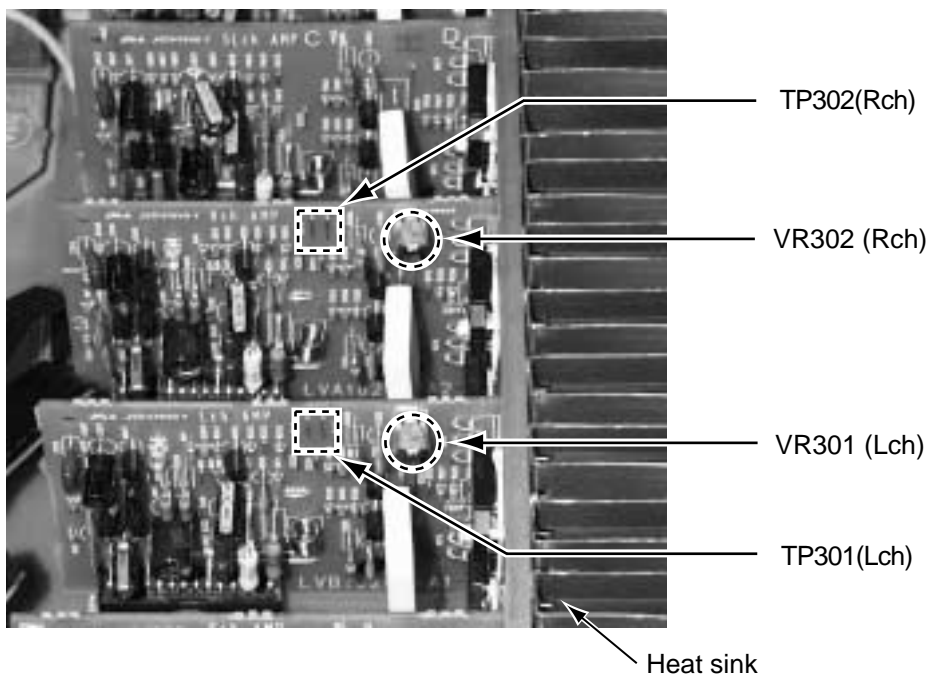

Description of major ICs

■ TC9162AF (IC423) : Analog switch

1. Pin layout

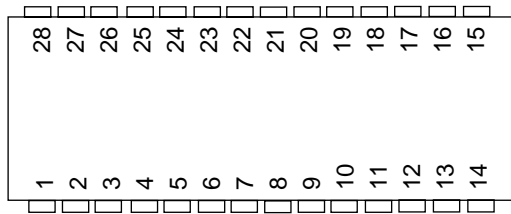

2. Block diagram

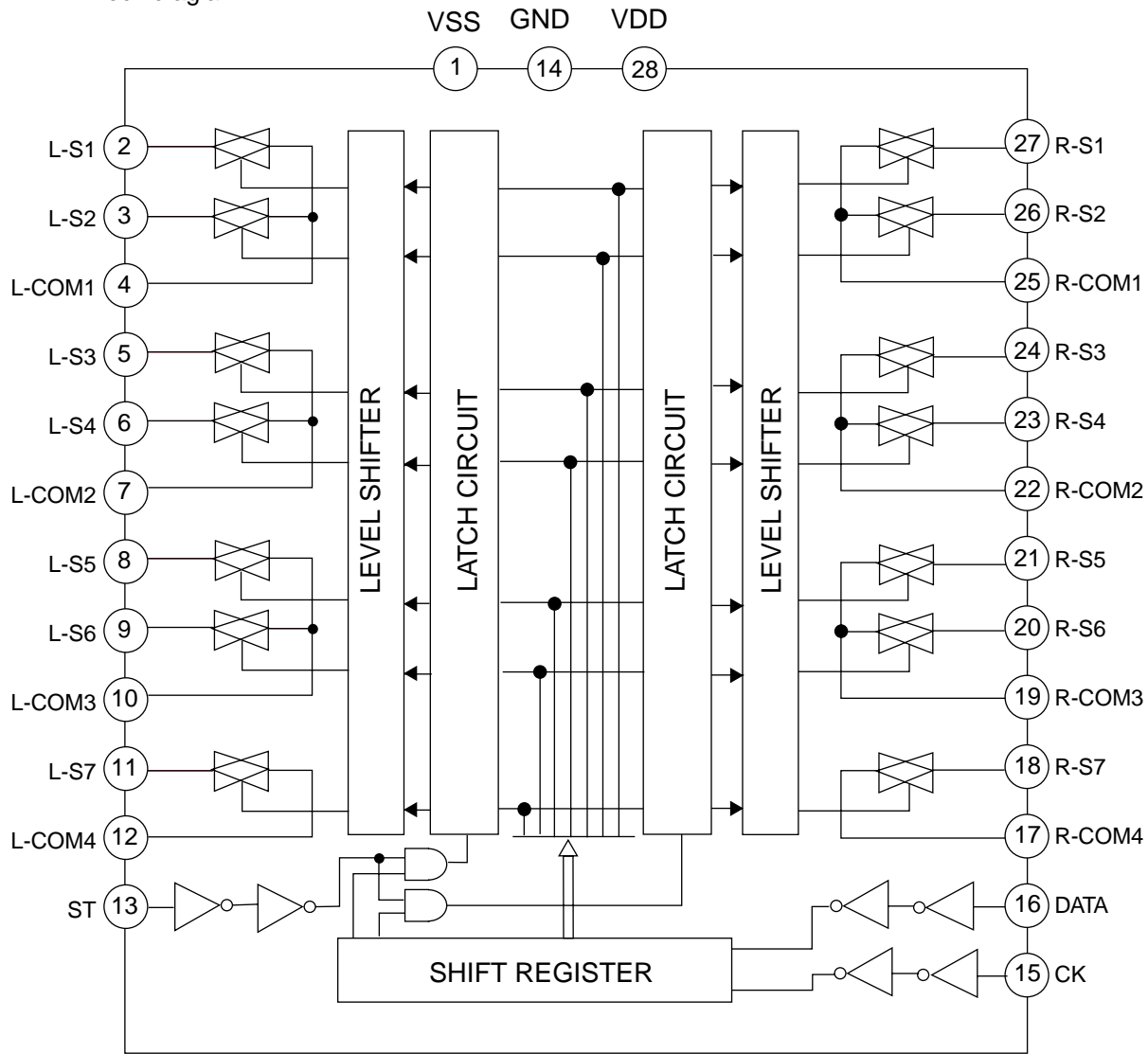

■ BA15218 (IC451) : Ope. amp.

1. Pin layout / Block diagram

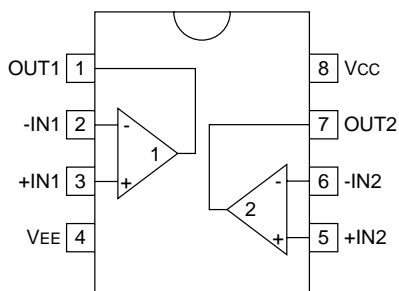

■ BA15218N (IC403) : Dual ope. amp.

1. Pin layout / Block diagram

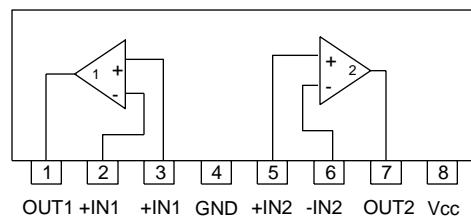

■ AK4527BVQP (IC601) : A/D,D/A converter

1.Pin layout

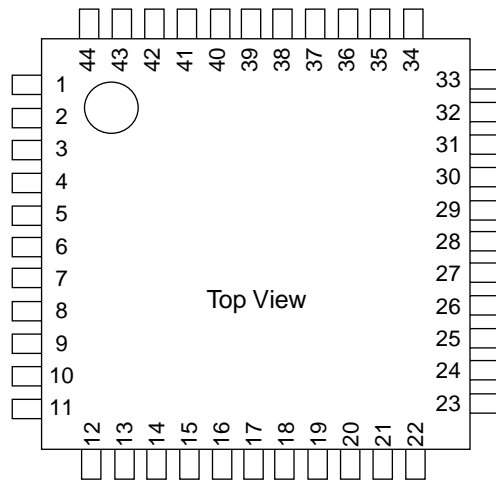

2. Pin function (1/2)

No.	Symbol	I/O	Function
1	SDOS	I	SDTO Source Select Pin (Note 1) "L" : Internal ADC output, "H" : DAUX input
2	OSKS	I	Control Mode Select Pin "L" : 3-wire Serial, "H" : I2C Bus
3	MIS	-	Soft Mute Pin (Note 1), Connect to GND When this pin goes to "H", soft mute cycle is initialized. When returning to "L", the output mute releases.
4	BICK	I	Audio Serial Data Clock Pin
5	LRCK	I/O	Input Channel Clock Pin
6	SDTI1	I	DAC1 Audio Serial Data Input Pin
7	SDTI2	I	DAC2 Audio Serial Data Input Pin
8	SDTI3	I	DAC3 Audio Serial Data Input Pin
9	SDTO	O	Audio Serial Data Output Pin
10	D,AUX	-	Sub Audio Serial Data Input Pin, Connect to GND
11	DFS	-	Double Speed Sampling Mode Pin (Note 1) "L" : Normal Speed, "H" : Double Speed
12	DEMI	-	Connect to GND No internal bonding.
13	DEMO	-	Zero Input Detect Enable Pin, Connect to GND "L" : mode 7 (disable) at parallel mode, zero detect mode is selectable by DZFM2-0 bits at serial mode. "H" : mode 0 (DZF is AND of all six channels)
14	MCKO	-	Output Buffer Power supply Pin, 2.7V~5.5V
15	DVDD	I	Digital Power Supply Pin, 4.5V~5.5V
16	DVSS	-	De-emphasis Pin, 0V
17	PD	I	Power-Down & Reset Pin When "L", the AK4527B is powered-down and the control registers are reset to default state. If the state of P/S or CAD0-1 changes, then the AK4527B must be reset by PDN.
18	XTS	-	Test Pin, Connect to GND This pin should be connected to DVSS.

Pin function (2/2)

AK4527

No.	Symbol	I/O	Function
19	ICKS	-	Connect to GND No internal bonding.
20	ADIF	-	Analog Input Format Select Pin, Digital Power Supply "H" : Full-differential input, "L" : Single-ended input
21	CAD1	-	Chip Address 1 Pin, Connect to GND
22	CAD0	-	Chip Address 0 Pin, Connect to GND
23	LOUT3	O	DAC3 Lch Analog Output Pin
24	ROUT3	O	DAC3 Rch Analog Output Pin
25	LOUT2	O	DAC2 Lch Analog Output Pin
26	ROUT2	O	DAC2 Rch Analog Output Pin
27	LOUT1	O	DAC1 Lch Analog Output Pin
28	ROUT1	O	DAC1 Rch Analog Output Pin
29	LIN-	I	Lch Analog Negative Input Pin
30	LIN+	I	Lch Analog Positive Input Pin
31	RIN-	I	Rch Analog Negative Input Pin
32	RIN+	I	Rch Analog Positive Input Pin
33	VREFL	-	Zero Input Detect 2 Pin (Note 2), Non Connect When the input data of the group 1 follow total 8192LRCK cycles with "0" input data, this pin goes to "H".
	OVF	O	Analog Input Overflow Detect Pin (Note 3) This pin goes to "H" if the analog input of Lch or Rch is overflows.
34	VCOM	O	Common Voltage Output Pin, AVDD/2 Large external capacitor around 2.2uF is used to reduce power-supply noise.
35	VREFH	-	Positive Voltage Reference Input Pin, AVDD
36	AVDD	-	Analog Power Supply Pin, 4.5V~5.5V
37	AVSS	-	Analog Ground Pin, 0V
38	XTI	-	Zero Input Detect 1 Pin (Note 2), Non connect When the input data of the group 1 follow total 8192 LRCK cycles with "0" input data, this pin goes to "H".
39	XTO	I	Master Clock Input Pin
40	P1S	-	Parallel / Serial Select Pin "L" : Serial control mode, "H" : Parallel control mode
41	\overline{CS}	I	Audio Data Interface Format 0 Pin in parallel mode
	CSN	I	Chip select pin in 3-wire serial control mode This pin should be connected to DVDD at I2C bus control mode
42	DIF1	I	Audio Data Interface Format 1 Pin in parallel mode
	SCL/CCLK	I	Control Data Clock Pin in serial control mode I2C = "L" : CCLK(3-wire Serial), I2C = "H" : SCL(I2C Bus)
43	LOOP0	I	Loopback Mode 0 Pin in parallel control mode Enables digital loop-back from ADC to 3 DACs.
	SAD/CDTI	I/O	Control Data Input Pin in serial control mode I2C = "L" : CDTI(3-wire Serial), I2C = "H" : SDA(I2C Bus)
44	CTD	I	Loopback Mode 1 Pin (Note 1) Enable all 3 DAC channels to be input from SDTII.

- Notes :
1. SDOS, SMUTE, DFS, and LOOP1 pins are ORed with register data if P/S = "L".
 2. The group 1 and 2 can be selected by DZFM2-0 bit if P/S = "L" and DZFM2 = "L".
 3. This pin becomes OVF pin if OVFE bit is set to "1" at serial control mode.
 4. All input pins should not be left floating.

■ M62446FP (IC428) : 6ch master volume

1. Block Diagram

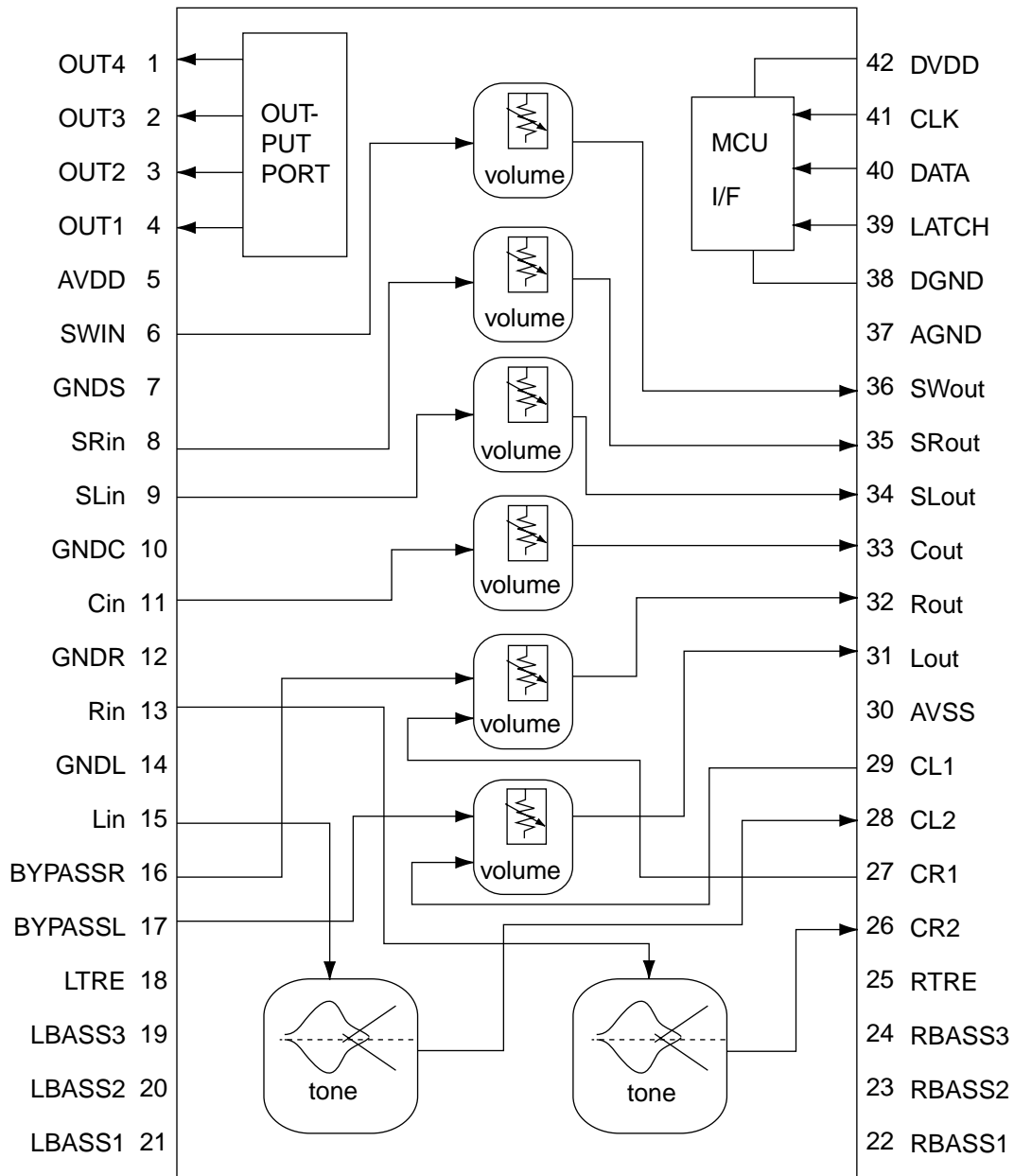

2.Pin Function

M62446FP

Pin No.	Symbol	I/O	Function
1	OUT4	O	BASS BOOST control terminal
2	OUT3	O	SURROUND control terminal
3	OUT2	O	VIDEO 2 control terminal
4	OUT1	O	VIDEO 1 control terminal
5	AVDD	-	Analog positive power supply terminal
6	SW IN	I	SUB Woofer volume signal input terminal
7	A.GND	-	Analog ground terminal
8	RR IN	I	R ch volume signal input terminal for rear speaker
9	RL IN	I	L ch volume signal input terminal for rear speaker
10	A.GND	-	Analog ground terminal
11	C IN	I	Center volume signal input terminal
12	A.GND	-	Analog ground terminal
13	R IN	I	R ch volume signal input terminal
14	A.GND	-	Analog ground terminal
15	L IN	I	L ch volume signal input terminal
16		-	Non connect
17		-	Non connect
18	LTRE	-	Frequency adjustment terminal tone/treble
19	LBASS3	-	Frequency adjustment terminal tone/bass
20	LBASS2	-	Frequency adjustment terminal tone/bass
21	KBASS1	-	Frequency adjustment terminal tone/bass
22	CR2	O	Tone output terminal
23	RBASS2	-	Frequency adjustment terminal tone/bass
24	RBASS3	-	Frequency adjustment terminal tone/bass
25	RTRE	-	Frequency adjustment terminal tone/treble
26	RBASS1	-	Frequency adjustment terminal tone/bass
27	CR1	I	L/R volume input terminal
28	LL2	O	Tone output terminal
29	CL1	I	L/R volume input terminal
30	AVSS	-	Analog negative power supply terminal
31	L OUT	O	L ch output
32	R OUT	O	R ch output
33	C OUT	O	Center volume signal output terminal
34	RL OUT	O	L ch volume signal output terminal for rear speaker
35	RR OUT	O	R ch volume signal output terminal for rear speaker
36	SW OUT	O	SUB Woofer volume signal output terminal
37	A.GND	-	Analog ground terminal
38	D.GND	-	Digital ground terminal
39	VOL LACH	I	Latch input terminal
40	VOL DATA	I	Volume data input terminal
41	VOL CLK	I	Clock input terminal for data transfer
42	DVDD	-	Digital power supply terminal

■ MN101C35DJW (IC701) : System controller

1. Pin layout

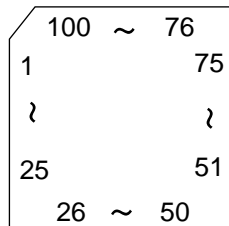

2. Pin function (1/2)

Pin No.	Symbol	I/O	Function
1	VOL.JOG IN_1	I	VOL.JOG IN_1
2	VOL.JOG IN_2	I	VOL.JOG IN_2
3	DATA (PLL)	I/O	DATA (PLL)
4	CLK (PLL)	O	CLK (PLL)
5	DE (PLL)	O	DE (PLL)
6	VIDEO S/C DVD	I	VIDEO S/C DVD
7	VIDEO S/C VCR	I	VIDEO S/C VCR
8	VDD	-	Power supply +5V
9	OSC2	I/O	Connecting the crystal oscillator for system clock (8MHz)
10	OSC1	I/O	Connecting the crystal oscillator for system clock (8MHz)
11	VSS	-	Connect to GND
12		-	Connect to GND
13	NC	-	Non connect
14		-	Connect to GND
15		-	Connect to GND
16	KEY IN 1	I	KEY INPUT 1
17	KEY IN 2	I	KEY INPUT 2
18	KEY IN 3	I	KEY INPUT 3
19	KEY IN 4	I	KEY INPUT 4
20	KEY IN 5	I	KEY INPUT 5
21	INH IN	I	INH IN
22	CS 1	I	CHIP SELECT 1
23	CS 2	I	CHIP SELECT 2
24	VREF+	-	Power supply +5V
25	VIDEO S/C DBS	I	VIDEO S/C DBS
26	RESET	I	RESET INPUT
27	CLK (RDS)	O	RDS CLK OUT (RDS)
28	DCS IN	I	DCS INPUT
29	DCS OUT	O	DCS OUTPUT
30	VCR IN	I	AVLINK VCR IN
31	VCR OUT	O	AVLINK VCR OUT
32	DATA (RDS)	I/O	RDS DATA (RDS)
33	PROTECTOR IN	I	PROTECTOR IN
34	RM IN	I	REMOCON INPUT
35	TUNED IN	I	TUNED IN (TUNER)
36	STEREO IN	I	STEREO IN (TUNER)
37	DAVN (RDS)	I	RDS DAVN (RDS)
38	SELF DET	I	SELF DET INPUT
39	COMMAND (DSP)	O	COMMAND (DSP)
40	STATUS (DSP)	I	STATUS (DSP)

Pin function (2/2)

MN101C35DJW

Pin No.	Symbol	I/O	Function
41	CLK DSP	O	CLK (DSP)
42	READY	O	READY (DSP)
43	RESET	O	RESET (DSP)
44	RY S	O	RELAY SURROUND
45	RY C	O	RELAY CENTER
46	RY L/R1	O	RELAY FRONT 1
47	RY L/R2	O	RELAY FRONT 2
48	RY HP	O	RELAY HEADPHONE
49 ~ 64	GRID16~GRID1	O	FL GRID SIGNAL CONTROL OUT
65 ~ 80	SEG1~SEG16	O	FL SEGMENT SIGNAL CONTROL OUT
81	NC	-	Non connect
82	NC	-	Non connect
83	NC	-	Non connect
84	NC	-	Non connect
85	NC	-	Non connect
86	NC	-	Non connect
87	NC	-	Non connect
88	POWER	-	POWER ON Relay Control
89	S MUTE	O	SOUSE MUTE
90	SW MUTE	O	SUBWOOFER MUTE
91	TU MUTE	O	TUNER MUTE
92	STB LED	O	STANDBY LED
93	SURROUND	O	SURROUND
94	DATA	O	AUDIO SW DATA
95	CLK	O	CLK (AUDIO SW)
96	STB	O	STB (AUDIO SW)
97	LATCH	O	LATCH (VOLUME)
98	DATA	O	VOLUME DATA
99	CLK	O	CLK (VOLUME)
100	VPP	-	VPP

■ UPD784215AGC167 (IC671) : Dital signal controller

1.Pin layout

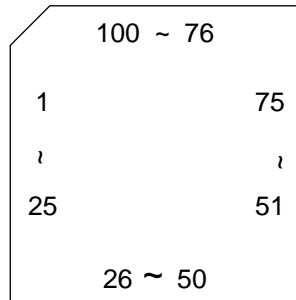

2.Pin function (1/2)

Pin No.	Symbol	I/O	Function
1~8		-	Non connect
9	VDD	-	Power supply terminal
10	X2	O	Connecting the crystal oscillator for system main clock
11	X1	I	Connecting the crystal oscillator for system main clock
12	VSS	-	Connect to GND
13	XT2	O	Connecting the crystal oscillator for system sub clock
14	XT1	I	Connecting the crystal oscillator for system sub clock
15	$\overline{\text{RESET}}$	I	System reset signal input
16	$\overline{\text{AUTODATA}}$	I	Output of DSP to general-purpose port
17	LOCK	I	Output of DSP to general-purpose port
18	DIGITAL0	I	Output of DSP to general-purpose port
19	FORMAT	I	Output of DSP to general-purpose port
20	CHANNEL	I	Output of DSP to general-purpose port
21	ERR	I	Output of DSP to general-purpose port
22	$\overline{\text{REST IN}}$	I	Reset signal input
23	AVDD	-	Power supply terminal
24	AVREF0	-	Connect to GND
25		-	Connect to GND
26		-	Connect to GND
27		-	Connect to GND
28		-	Connect to GND
29		-	Connect to GND
30		-	Connect to GND
31		-	Connect to GND
32		-	Connect to GND
33	AVSS	-	Connect to GND
34,35		-	Non connect
36	AV REF1	-	Power supply terminal
37	RX	-	Not use
38	TX	-	Not use
39		-	Non connect
40	$\overline{\text{DSPCOM}}$	I	Communication port from IC701
41	DSPSTS	O	Status communication port to IC701
42	DSPCLK	I	Clock input from IC701
43	DSPRDY	I	Ready signal input from IC701
44		-	Non connect
45	MIDIO IN	I/O	Interface I/O terminal with microcomputer
46	MIDIO OUT	I/O	Interface I/O terminal with microcomputer
47	$\overline{\text{MICK}}$	O	Interface I/O terminal with microcomputer of clock signal
48	$\overline{\text{MICS}}$	O	Interface I/O terminal with microcomputer of chip select

Pin function (2/2)

UPD784215AGC167

Pin No.	Symbol	I/O	Function
49	$\overline{\text{MILP}}$	O	Interface I/O terminal with microcomputer
50	$\overline{\text{MIACK}}$	O	Interface I/O terminal with microcomputer
51		-	Non connect
52		-	Non connect
53	$\overline{\text{DSPRST}}$	O	Reset signal output of DSP
54~63		-	Non connect
64	CODEC OUT	I/O	Interface I/O terminal with microcomputer
65	CODEC IN	I/O	Interface I/O terminal with microcomputer
66	CODEC CLK	O	Interface I/O terminal with microcomputer of clock signal
67	$\overline{\text{CODEC CS}}$	O	Interface I/O terminal with microcomputer of chip select
68	CODEC XTS	-	Non connect
69		-	Non connect
70		-	Non connect
71	$\overline{\text{PD}}$	O	Reset signal output
72	GND	-	Connect to GND
73		-	Non connect
74		-	Non connect
75		-	Non connect
76		-	Non connect
77		-	Non connect
78		-	Non connect
79		-	Non connect
80		-	Non connect
81	VDD	-	Power supply
82		-	Non connect
83		-	Non connect
84	ANA/T-TONE	O	Test tone control
85	LEF-MIX	O	Control at output destination of LFE channel
86		-	Non connect
87	$\overline{\text{D.MUTE}}$	O	Mute of the digital out terminal is controlled
88	$\overline{\text{S.MUTE}}$	O	Mute of the audio signal is controlled
89		-	Non connect
90	ASW1	O	Selection of digital input selector
91	ASW2	O	Selection of digital input selector
92	ASW3	O	Selection of digital input selector
93	ASW4	O	Selection of digital input selector
94	TEST	-	Test terminal
95		-	Non connect
96		-	Non connect
97		-	Non connect
98		-	Non connect
99		-	Non connect
100		-	Non connect

■ LA1838 (IC102) : FM AM IF amp. & Detector, FM MPX decoder

1. Block Diagram

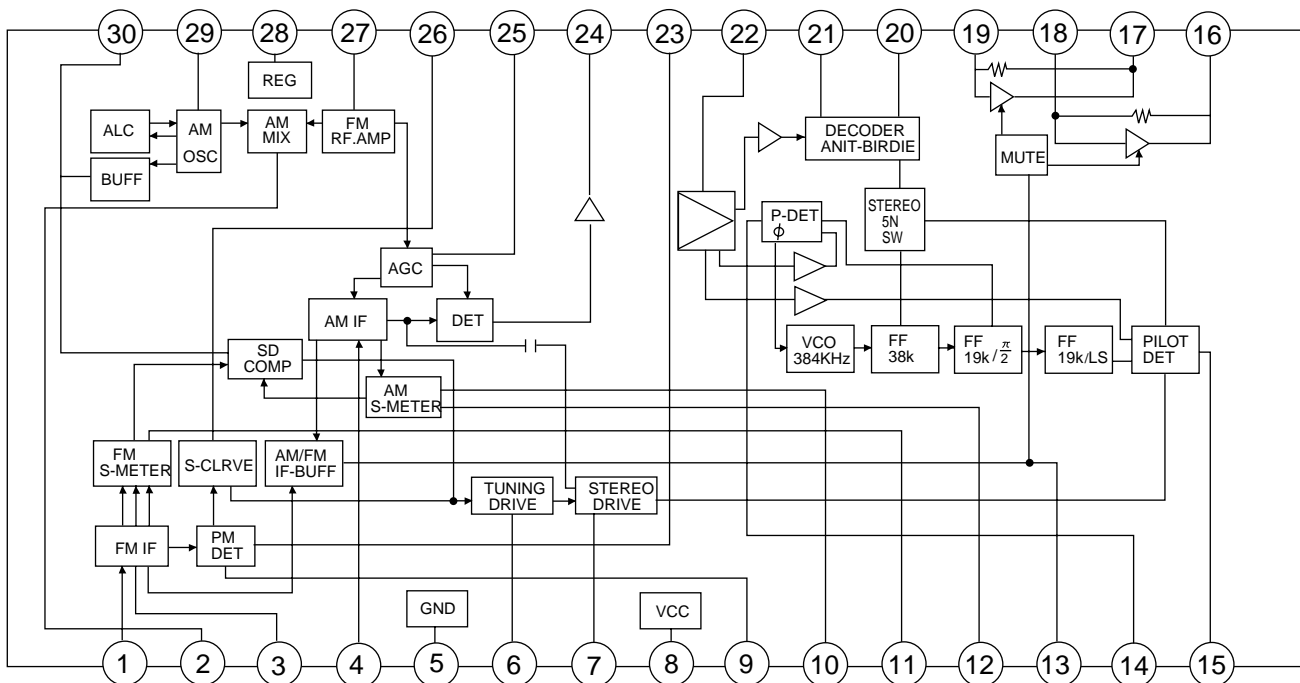

2. Pin Function

Pin No.	Symbol	I/O	Function	Pin No.	Symbol	I/O	Function
1	FM IN	I	This is an input terminal of FM IF signal.	16	L OUT	O	Left channel signal output.
2	AM MIX	O	This is an out put terminal for AM mixer.	17	R OUT	O	Right channel signal output.
3	FM IF	I	Bypass of FM IF	18	L IN	I	Input terminal of the Left channel post AMP.
4	AM IF	I	Input of AM IF Signal.	19	R IN	I	Input terminal of the Right channel post AMP.
5	GND	-	This is the device ground terminal.	20	RO	O	Mpx Right channel signal output.
6	TUNED	O	When the set is tuning,this terminal becomes "L".	21	LO	O	Mpx Left channel signal output.
7	STEREO	O	Stereo indicator output. Stereo "L", Mono: "H"	22	MPX IN	I	Mpx input terminal
8	VCC	-	This is the power supply terminal.	23	FM OUT	O	FM detection output.
9	FM DET	-	FM detect transformer.	24	AM DET	O	AM detection output.
10	AM SD	-	This is a terminal of AM ceramic filter.	25	AM AGC	I	This is an AGC voltage input terminal for AM
11	FM VSM	O	Adjust FM SD sensitivity.	26	AFC	-	This is an output terminal of voltage for FM-AFC.
12	AM VSM	O	Adjust AM SD sensitivity.	27	AM RF	I	AM RF signal input.
13	MUTE	I/O	When the signal of IF REQ of IC121(LC72131) appear, the signal of FM/AM IF output. //Muting control input.	28	REG	O	Register value between pin 26 and pin28 besides the frequency width of the input signal.
14	FM/AM	I	Change over the FM/AM input. "H" :FM, "L" : AM	29	AM OSC	-	This is a terminal of AM Local oscillation circuit.
15	MONO/ST	O	Stereo : "H", Mono: "L"	30	OSC BUFFER	O	AM Local oscillation Signal output.

■ LC72136N (IC121) : PLL frequency synthesizer

1. Pin layout

XT	1	22	XT
FM/AM	2	21	GND
CE	3	20	LPFOUT
DI	4	19	LPFIN
CLOCK	5	18	PD
DO	6	17	VCC
FM/ST/VCO	7	16	FMIN
AM/FM	8	15	AMIN
	9	14	
	10	13	IFCONT
SDIN	11	12	IFIN

2. Block diagram

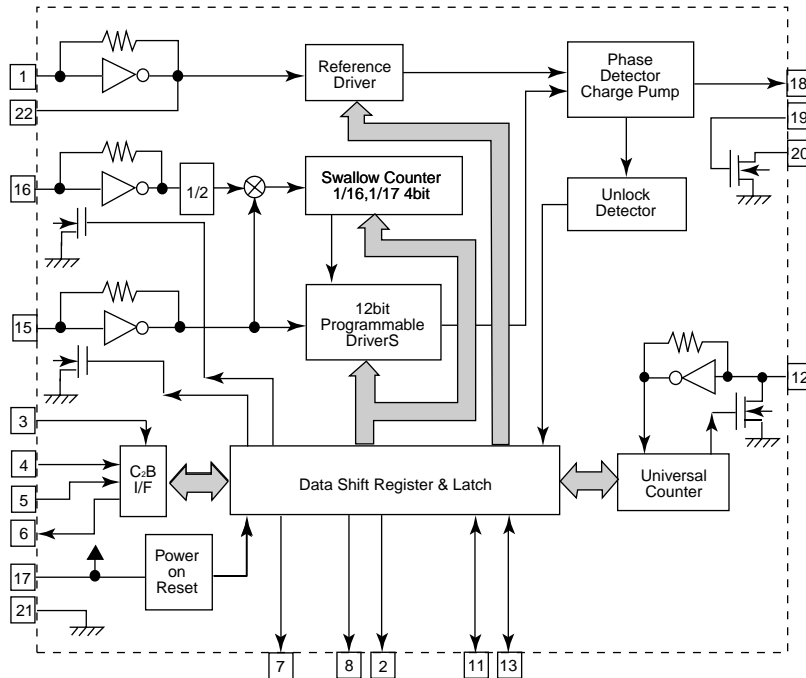

3. Pin function

Pin No.	Symbol	I/O	Function	Pin No.	Symbol	I/O	Function
1	XT	I	X'tal oscillator connect (75kHz)	12	IFIN	I	IF counter signal input
2	FM/AM	O	LOW:FM mode	13	IFCONT	O	IF signal output
3	CE	I	When data output/input for 4pin(input) and 6pin(output): H	14		-	Not use
4	DI	I	Input for receive the serial data from controller	15	AMIN	I	AM Local OSC signal output
5	CLOCK	I	Sync signal input use	16	FMIN	I	FM Local OSC signal input
6	DO	O	Data output for Controller Output port	17	VCC	-	Power suply(VDD=4.5-5.5V) When power ON:Reset circuit move
7	FM/ST/VCO	O	"Low": MW mode	18	PD	O	PLL charge pump output(H: Local OSC frequency Height than Reference frequency. L: Low Agreement: Height impedance)
8	AM/FM	O	Open state after the power on reset	19	LPFIN	I	Input for active lowpassfilter of PLL
9	LW	I/O	Input/output port	20	LPFOUT	O	Output for active lowpassfilter of PLL
10	MW	I/O	Input/output port	21	GND	-	Connected to GND
11	SDIN	I/O	Data input/output	22	XT	I	X'tal oscillator(75KHz)

**■ TC9446F-025 (IC631) : Digital signal processor for dolby digital (AC-3)
/ DTS audio decode**

Pin No.	Symbol	I/O	Function
1	RST	I	Reset signal input terminal (L:reset H: normal operation)
2	MIMD	I	Microcomputer interface mode selection input terminal (L:serial H:IC bus)
3	MICS	I	Microcomputer interface chip select input terminal
4	MILP	I	Microcomputer interface latch pulse input
5	MIDIO	I/O	Microcomputer interface data I/O terminal
6	MICK	I	Microcomputer interface clock input terminal
7	MIACK	O	Microcomputer interface acknowledge output terminal
8~11	FI0~3	I	Flag input terminal 0~3
12	IRQ	I	Interrupt input terminal
13	VSS	-	Digital ground terminal
14	LRCKA	I	Audio interface LR clock input terminal A
15	BCKA	I	Audio interface bit clock input terminal A
16~18	SDO0~2	O	Audio interface data output terminal 0
19	SD03	-	Non connect
20	LRCKB	I	Audio interface LR clock input terminal B
21	BCKB	I	Audio interface bit clock input terminal B
22	SDT0	I	Audio interface data input terminal 0
23	SDT1	I	Audio interface data input terminal 1
24	VDD	-	Power supply for digital circuit
25	LRCKOA	O	Audio interface LR clock output terminal A
26	BCKOA	O	Audio interface bit clock output terminal A
27,28	TEST0,1	I	Test input terminal 0/1 (L:test H: normal operation)
29~30	LRCKOB,BCKOB	-	Non connect
31	TXO	O	SPDIF Output
32,33	TEST2,3	I	Test input terminal (L:test H: normal operation)
34	RX	I	SPDIF input terminal
35	VSS	-	Ground terminal for digital circuit
36	TSTSUB0	I	Test sub input terminal 0 (L:test H: normal operation)
37	FCONT	O	VCO Frequency control output terminal
38,39	TSTSUB1,TSTSUB2	I	Test sub input terminal 1,2 (L:test H: normal operation)
40	PDO	O	Phase detect signal output terminal
41	VDDA	-	Power supply for analog circuit
42	PLON	I	Clock selection input terminal (L:external clock H:VCO clock)
43	AMPI	I	amplifier input terminal for LPF
44	AMPO	O	amplifier output terminal for LPF
45	CKI	I	External clock input terminal
46	VSSA	-	Ground terminal for analog circuit
47	CKO	O	DIR Clock output terminal
48	LOCK	O	VCO Lock output terminal
49	VSS	-	Ground terminal for digital circuit
50	WR	O	External SRAM writing signal output terminal
51	OE	O	External SRAM output enable signal output terminal
52	CE	O	External SRAM chip enable signal output terminal
53	VDD	-	Power supply terminal for digital circuit
54~61	IO7~0	I/O	External SRAM data I/O terminal 7~0
62	VSS	-	Ground terminal for digital circuit
63~70	AD0~7	O	External SRAM address output terminal 0~7
71	VDD	-	Power supply terminal for digital circuit
72~80	AD8~16	O	External SRAM address output terminal 8~16
81	VSS	-	Ground terminal for digital circuit
82~89	PO0~7	O	General purpose output terminal 0~7
90	VDDDL	-	Power supply terminal for DLL
91	LPFO	O	LPF output terminal for DLL
92,93	DLON,DLCKS	I	Refer to the undermentioned table
94	SCKO	-	Non connect
95	VSSDL	-	Ground terminal for DLL
96	SCKI	I	External system clock input terminal
97	VSSX	-	Ground terminal for oscillation circuit
98,99	XO,XI	I/O	Oscillation I/O terminal
100	VDDX	-	Power supply terminal for oscillation circuit

DLCKS terminal	DLONterminal	DLL clock setting
L	L	SCKI input (DLL circuit OFF)
L	H	Four times XI clock
H	L	Three times XI clock
H	H	Six times XI clock

■ **NJM2246D (IC501, 551, 552) : Video switch**

1. Pin layout / Block diagram

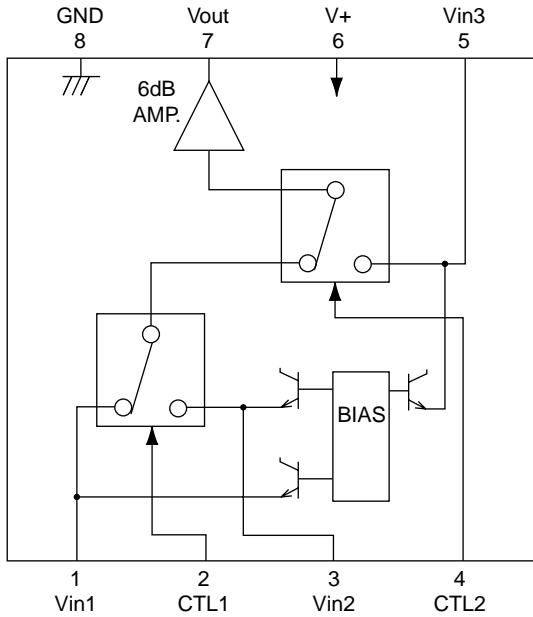

Control input - output signal

CTL 1	CTL 2	Output
L	L	VIN 1
H	L	VIN 2
L/H	H	VIN 3

■ **TC74HCU04AF (IC621) : Inverter**

1. Pin layout

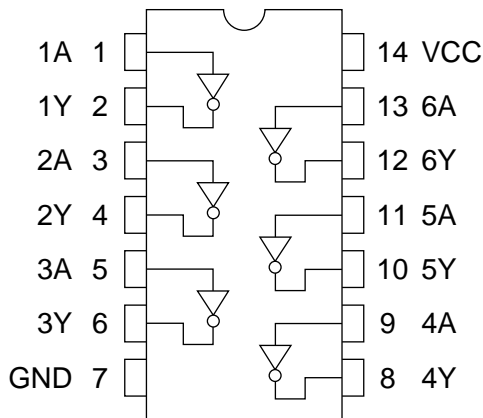

2. Truth value

A	Y
L	H
H	L

■ **IMX9-W (IC652, IC662, IC682) : Driver**

1. Pin layout / Block diagram

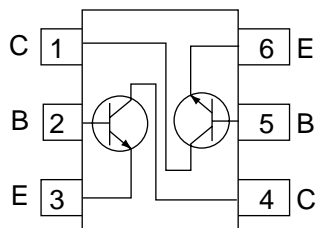

■ **TC7SET32FU (IC672) : Z-Input or gate**

1. Pin layout / Block diagram

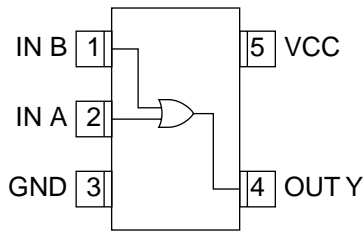

■ **TC74HCU08AF (IC611) : Inverter**

1. Pin layout / Block diagram

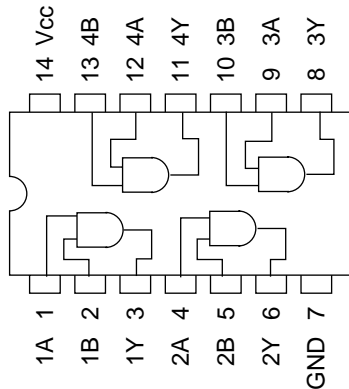

2. The truth value table

A	B	Y
L	L	L
L	H	L
H	L	L
H	H	H

■ **TC74HC4072AF (IC612) : 4-Input gate**

1. Pin layout & block diagram

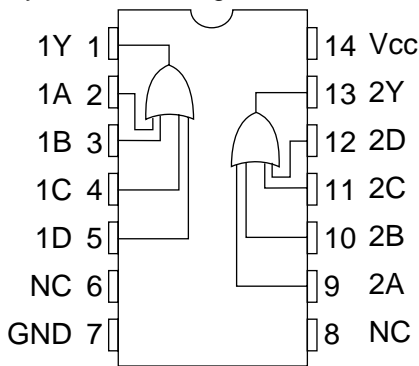

2. Truth table

A	B	C	D	Y
H	X	X	X	H
X	H	X	X	H
X	X	H	X	H
X	X	X	H	H
L	L	L	L	L

■ **BA15218F (IC421, 422, 427, 609, 610, 650, 651, 661, 690, 691) : Op amp.**

1. Pin layout / Block diagram

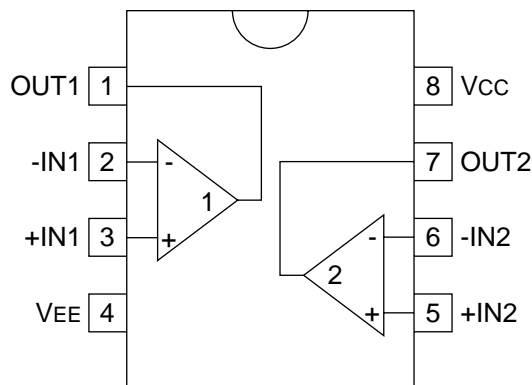

■ W24L010AJ-12 (IC641) : SRAM

1. Pin layout

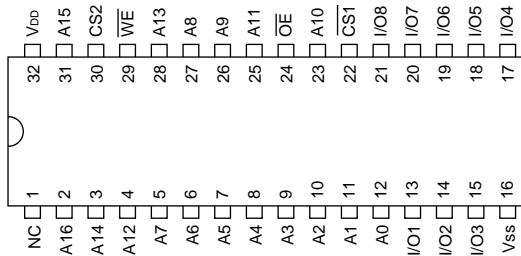

2. Block diagram

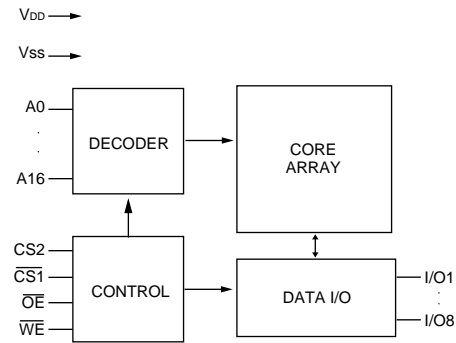

3. Pin function

Pin No.	Symbol	Function	Pin No.	Symbol	Function
1	NC	No Connection	17	I/O4	Data Input/Output
2	A16	Address Input	18	I/O5	Data Input/Output
3	A14	Address Input	19	I/O6	Data Input/Output
4	A12	Address Input	20	I/O7	Data Input/Output
5	A7	Address Input	21	I/O8	Data Input/Output
6	A6	Address Input	22	$\overline{CS1}$	Chip Select Inputs
7	A5	Address Input	23	A10	Address Input
8	A4	Address Input	24	\overline{OE}	Output Enable Input
9	A3	Address Input	25	A11	Address Input
10	A2	Address Input	26	A9	Address Input
11	A1	Address Input	27	A8	Address Input
12	A0	Address Input	28	A13	Address Input
13	I/O1	Data Input/Output	29	\overline{WE}	Write Enable Input
14	I/O2	Data Input/Output	30	CS2	Chip Select Inputs
15	I/O3	Data Input/Output	31	A15	Address Input
16	Vss	Ground	32	VDD	Power Supply

■ TC9164AN (IC402) : Analog switch

1. Function

Switch to On/Off of S1 to S8 by control of LSI.

2. Pin layout & Block Diagram

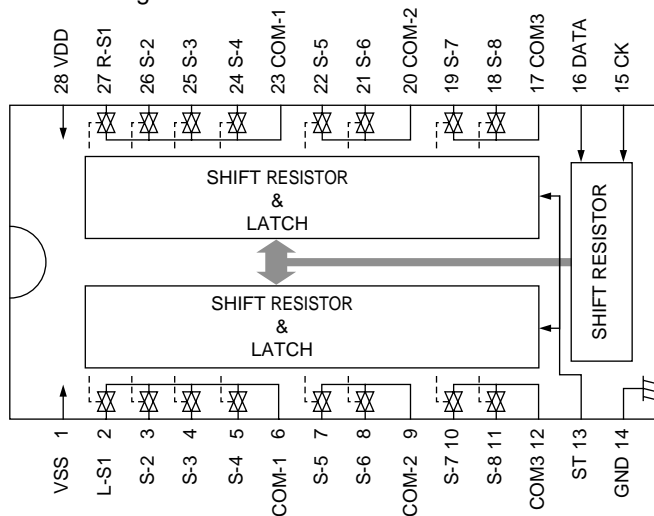

■ SAA6588 (IC191) : RDS detector

1. Terminal Layout



2. Pin Function

Pin No.	Symbol	I/O	Function
1	MRO	O	Multi-path rectifier output
2	NC	-	Non connect
3	GND	I	Test control input pin
4	OSCO	O	Oscillator output
5	OSCI	I	Oscillator input
6	VSSD	-	Digital ground (0V)
7	VDDD	-	Digital power supply (5V)
8	DAVN	O	Data available output (active LOW)
9	SDA	I/O	IC-bus serial data I/O
10	SCL	I	IC-bus serial clock input
11	NC	-	Non connect
12	GND	-	Connect to ground
13	NC	-	Non connect
14	VDDA	-	Analog power supply (5V)
15	VSSA	-	Connect to ground
16	MPX	I	Multiplex input signal
17	Vref	O	Reference voltage output
18	SCOUT	O	Band-pass filter output
19	CIN	O	Comparator output
20	NC	I	Level input

3. Block Diagram

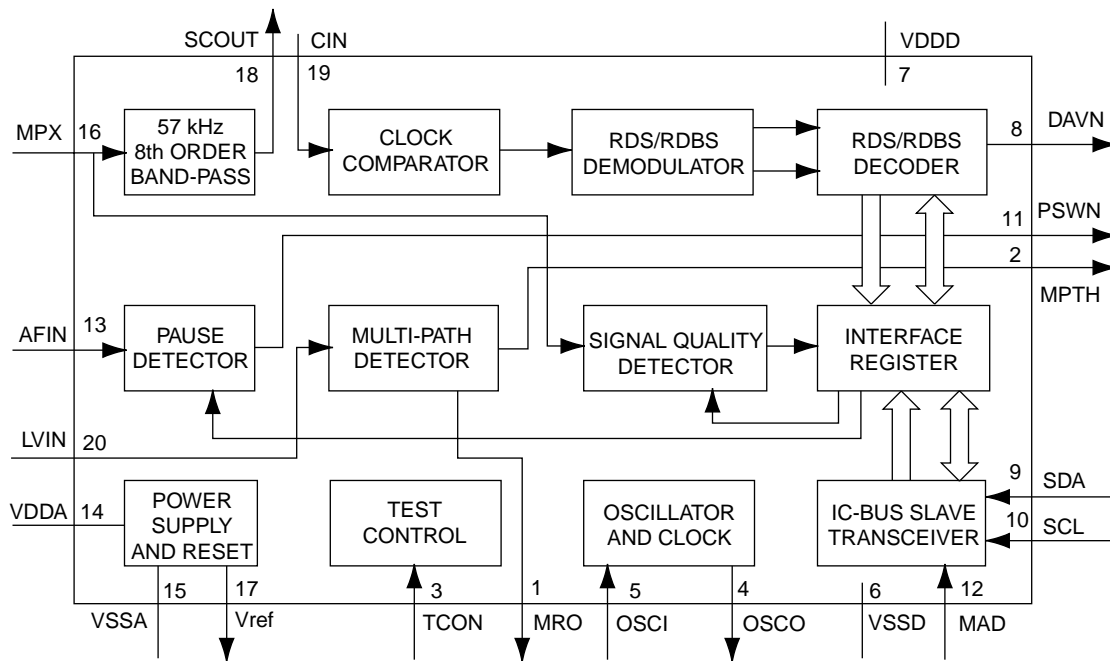

< MEMO >



VICTOR COMPANY OF JAPAN, LIMITED

AUDIO & COMMUNICATION BUSINESS DIVISION

PERSONAL & MOBILE NETWORK BUSINESS UNIT. 10-1,1chome,Ohwatari-machi,Maebashi-city,371-8543,Japan

JVC

SCHEMATIC DIAGRAMS

AUDIO/VIDEO CONTROL RECEIVER

RX-7022RSL RX-7020RBK

CD-ROM No.SML200205

RX-7022RSL

Area suffix

B ----- U.K.
E ----- Continental Europe
EN ----- Northern Europe
EV ----- Eastern Europe

RX-7020RBK

Area suffix

E ----- Continental Europe

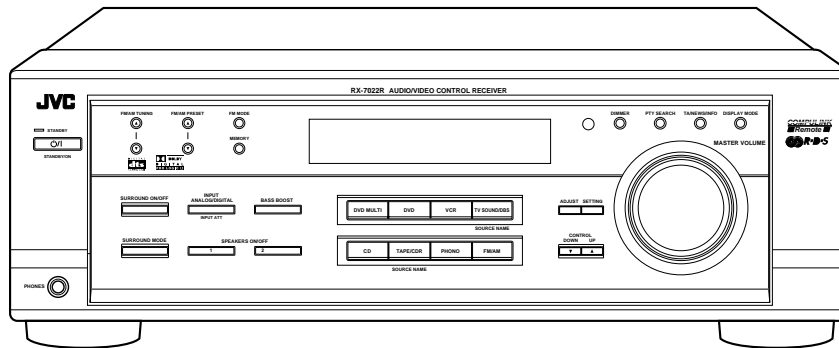
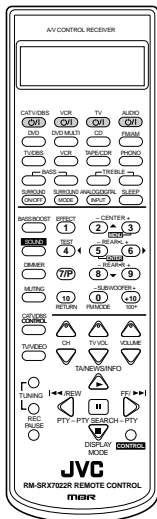

Model	panel color	top cover
RX-7022RSL	silver	silver
RX-7020RBK	black	black

Contents

Block diagram ----- 2-1
 Standard schematic diagrams ----- 2-2
 Printed circuit boards ----- 2-10~14

In regard with component parts appearing on the silk-screen printed side (parts side) of the PWB diagrams, the parts that are printed over with black such as the resistor (■), diode (⬤) and ICP (●) or identified by the "▲" mark nearby are critical for safety.

(This regulation does not correspond to J and C version.)

Block diagram

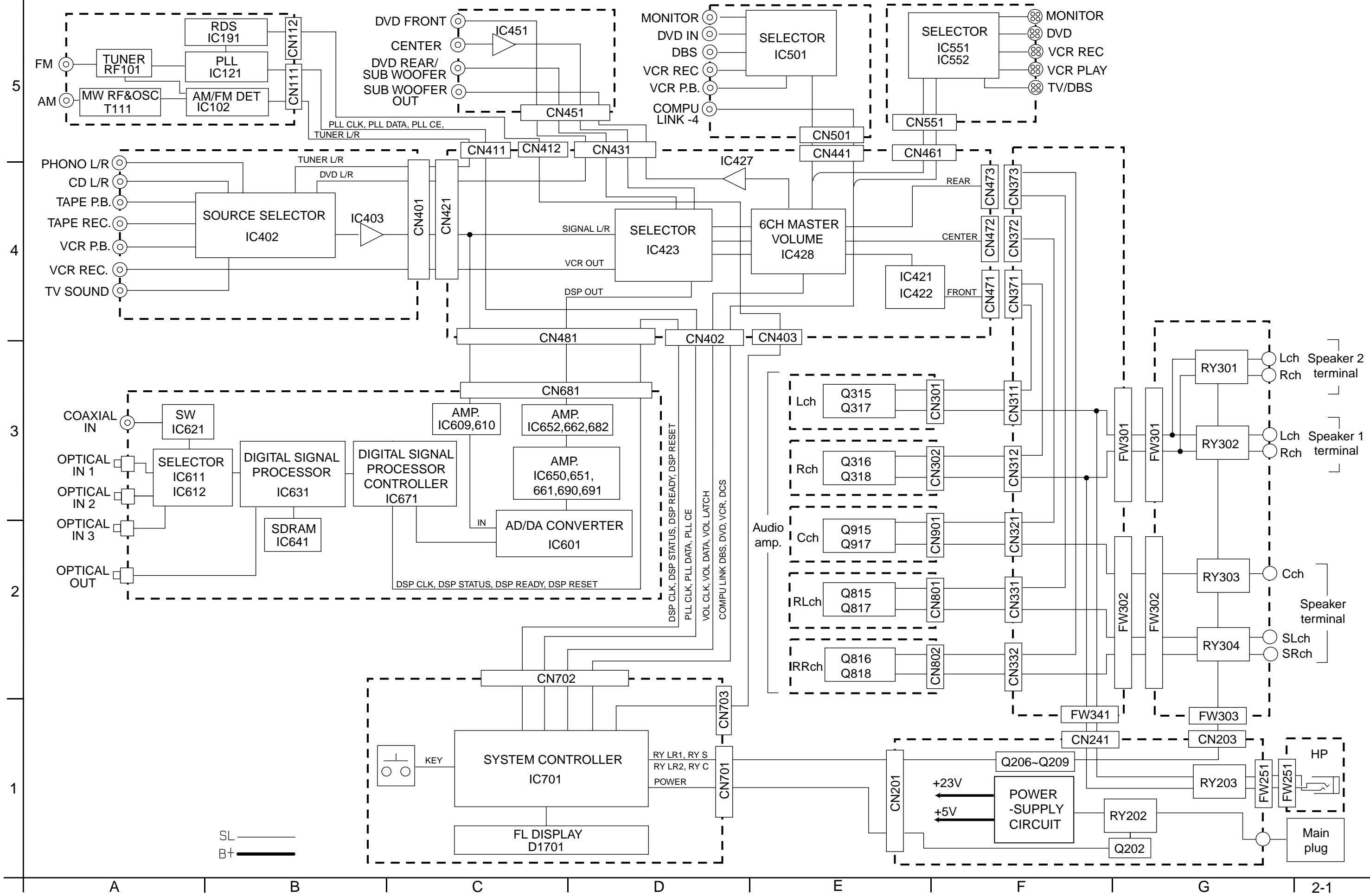

SL ———
 B+ ———

Standard schematic diagrams

Power supply section

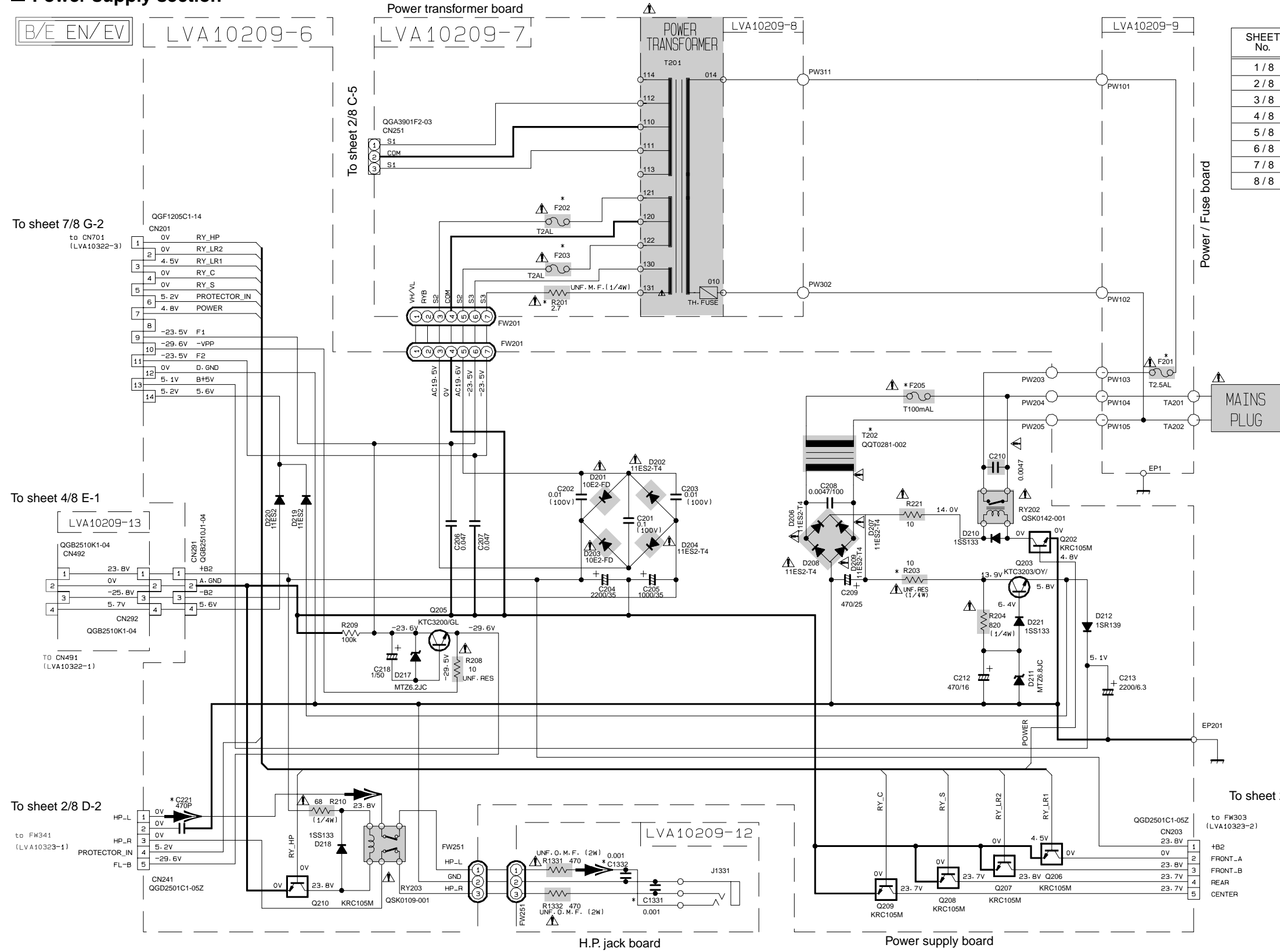

SHEET No.	CIRCUIT DESCRIPTION
1 / 8	POWER SUPPLY
2 / 8	SPEAKER TERMINAL
3 / 8	AUDIO AMP
4 / 8	VOLUME / REGULATOR / SOURCE SELECT IC
5 / 8	AUDIO VIDEO SIGNAL INPUT TERMINAL / SOURCE SELECT IC
6 / 8	SURROUND IC / DIGITAL SIGNAL INPUT TERMINAL
7 / 8	USER CONTROL KEYS / SYSTEMCONTROL LSI / FL DISPLAY
8 / 8	TUNER

VERSION CODES	
J	: U. S. A.
C	: CANADA
B	: U. K.
E	: CONTINENTAL EUROPE
EN	: NORDIC COUNTRIES
EV	: EASTERN EUROPE
US	: SINGAPORE
UT	: TAIWAN
UJ	: MLLITARY MARKET
A	: AUSTRARIA

MARK LIST				
F201	J/C	B/E/EN/EV/A	US/UT/UJ	
F201	USE	USE	USE	USE
F202-F203	NONE	NONE	NONE	NONE
F204	USE	USE	USE	USE
F205	NONE	NONE	NONE	NONE
B170	USE	NONE	NONE	NONE
V1001	USE	NONE	NONE	USE

MARK LIST				
R1-EP1	J/C	B/E/EN/EV/A	US/UT/UJ	A
R1-EP1	USE	NONE	NONE	NONE
R211-R212	NONE	NONE	NONE	USE
R213-R214	USE	USE	USE	USE
R215-R216	USE	USE	USE	NONE
R217	10	10	3.9	3.9
R218	470/25	470/25	470/25	470/25
R219	2.7	4.7	330P	330P
C1301	330P	1000P	330P	330P
C1302	330P	1000P	330P	330P
C21	NONE	USE	NONE	NONE

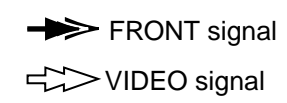

Parts are safety assurance parts. When replacing those parts make sure to use the specified.

■ Audio & Speaker terminal section

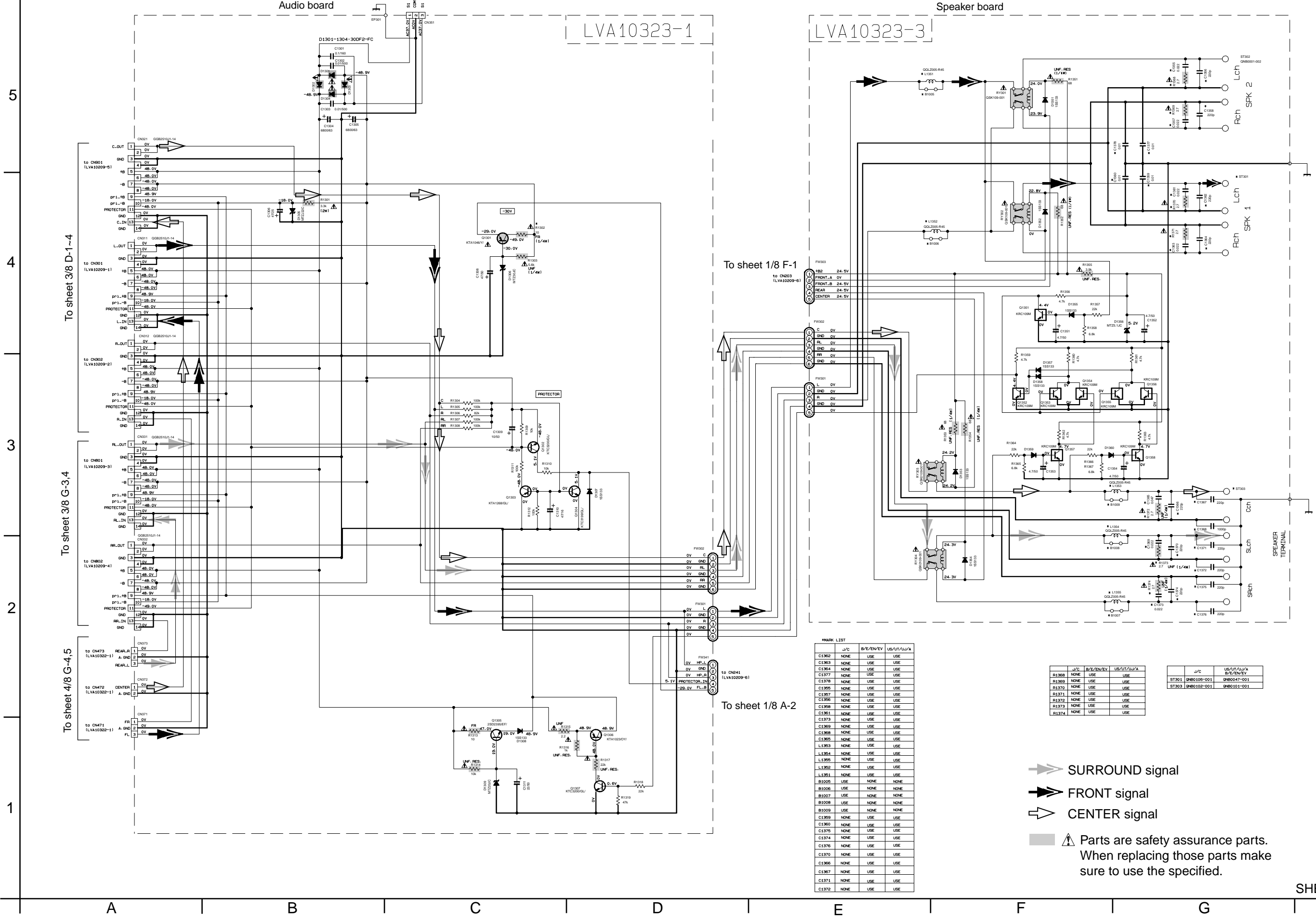

MARK LIST

J/C	B/E/EN/VE	US/UT/UA/A
C1362	NONE	USE
C1363	NONE	USE
C1364	NONE	USE
C1377	NONE	USE
C1378	NONE	USE
C1395	NONE	USE
C1397	NONE	USE
C1396	NONE	USE
C1398	NONE	USE
C1361	NONE	USE
C1373	NONE	USE
C1369	NONE	USE
C1368	NONE	USE
C1365	NONE	USE
L1353	NONE	USE
L1354	NONE	USE
L1355	NONE	USE
L1352	NONE	USE
L1351	NONE	USE
B1006	USE	NONE
B1008	USE	NONE
B1007	USE	NONE
B1008	USE	NONE
B1009	USE	NONE
C1399	NONE	USE
C1360	NONE	USE
C1375	NONE	USE
C1374	NONE	USE
C1376	NONE	USE
C1366	NONE	USE
C1367	NONE	USE
C1371	NONE	USE
C1372	NONE	USE

J/C	US/UT/UA/A	B/E/EN/VE
B1369	USE	USE
B1369	USE	USE
B1370	USE	USE
B1371	USE	USE
B1372	USE	USE
B1373	USE	USE
B1374	USE	USE

J/C	US/UT/UA/A	B/E/EN/VE
ST301	QNB0100-001	QNB0047-001
ST303	QNB0102-001	QNB0101-001

- ➡ SURROUND signal
- ➡ FRONT signal
- ➡ CENTER signal

⚠ Parts are safety assurance parts. When replacing those parts make sure to use the specified.

Audio amplifier section

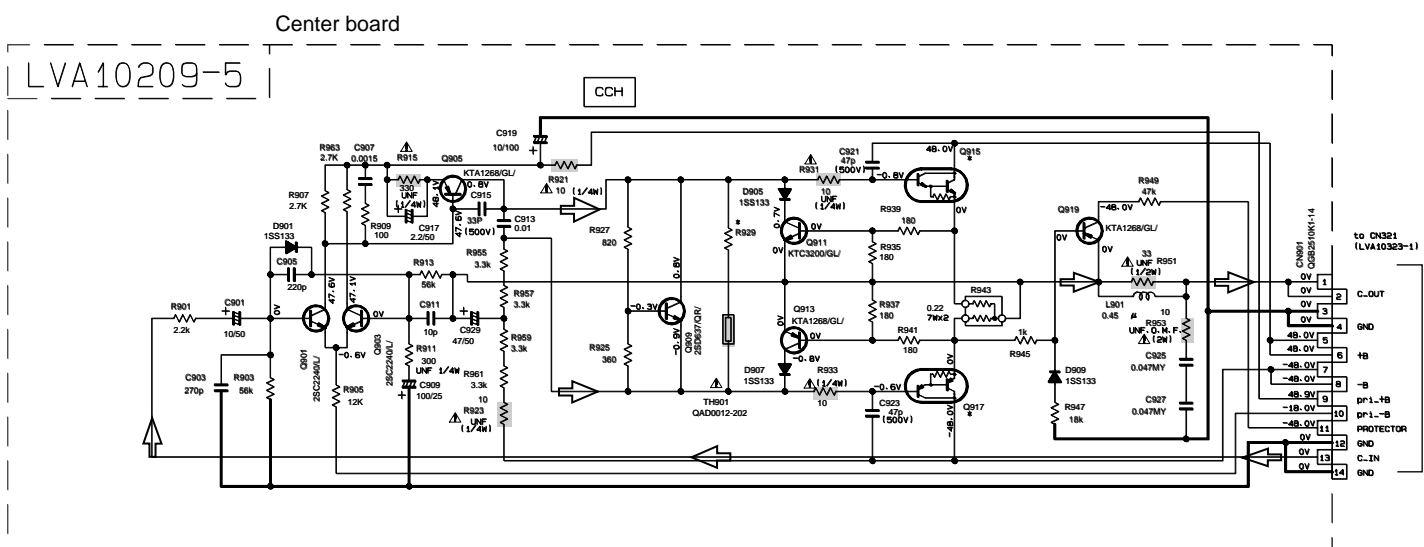
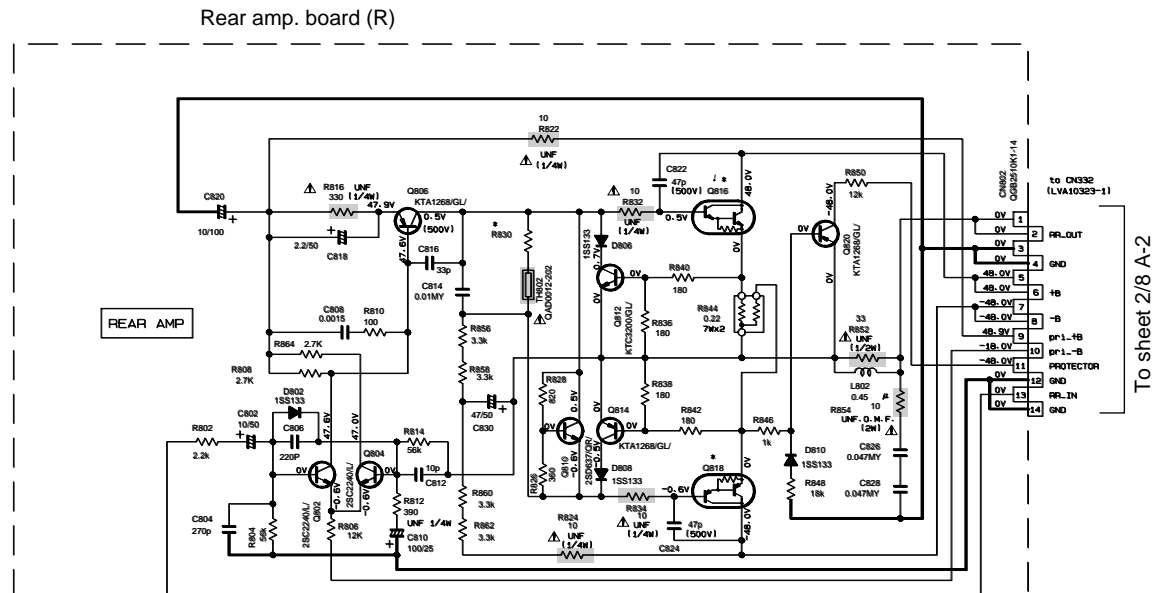
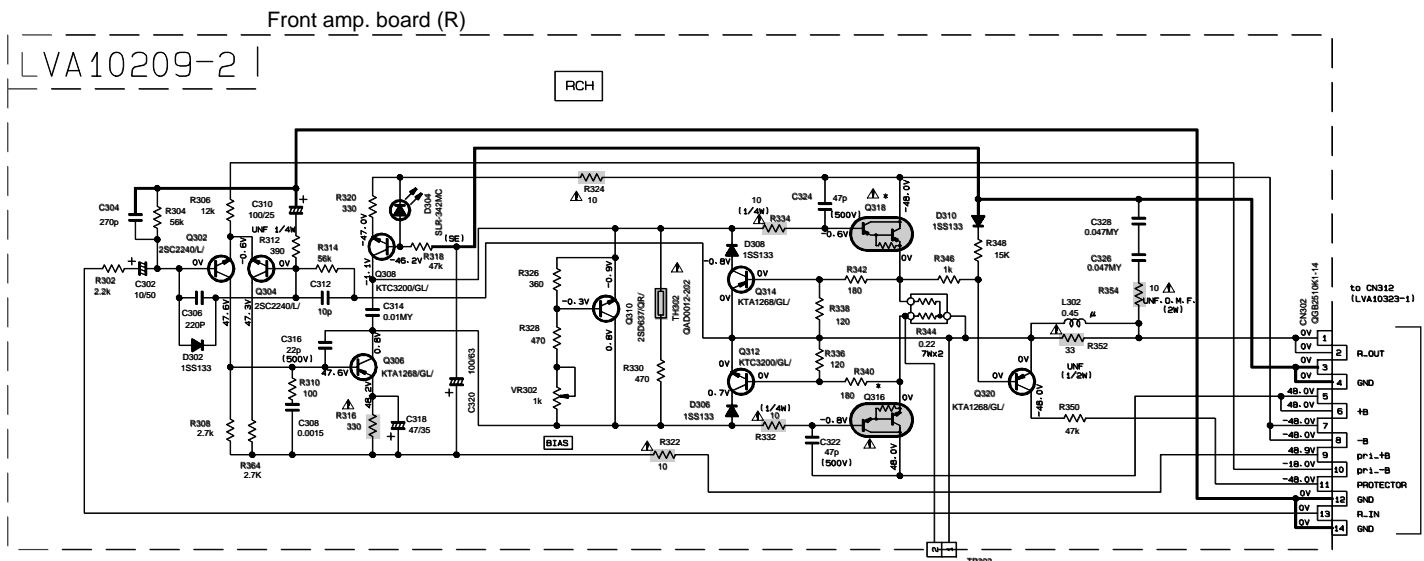
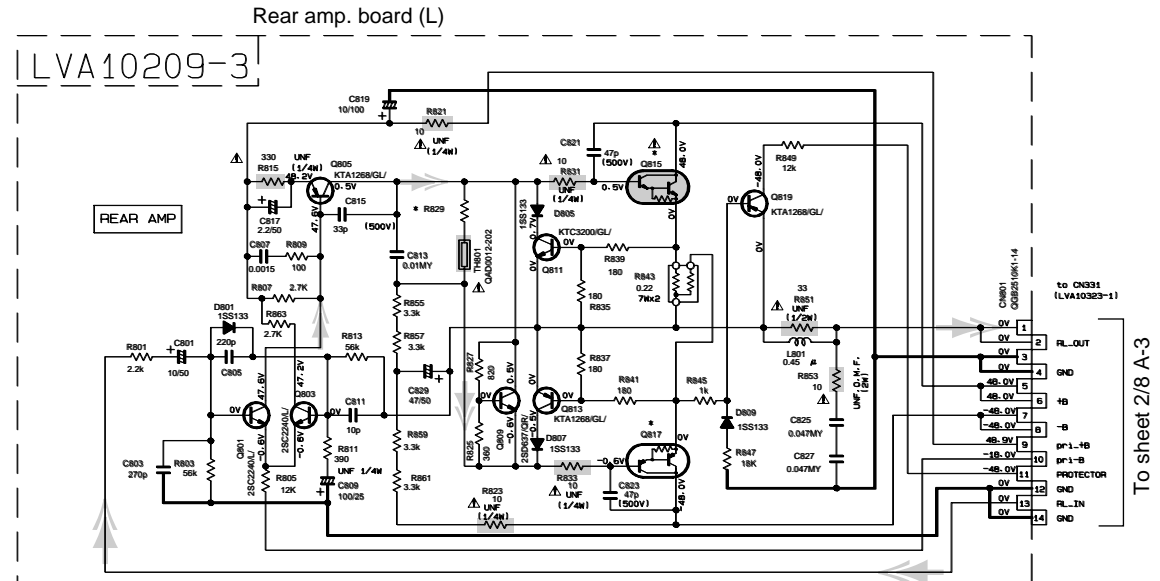
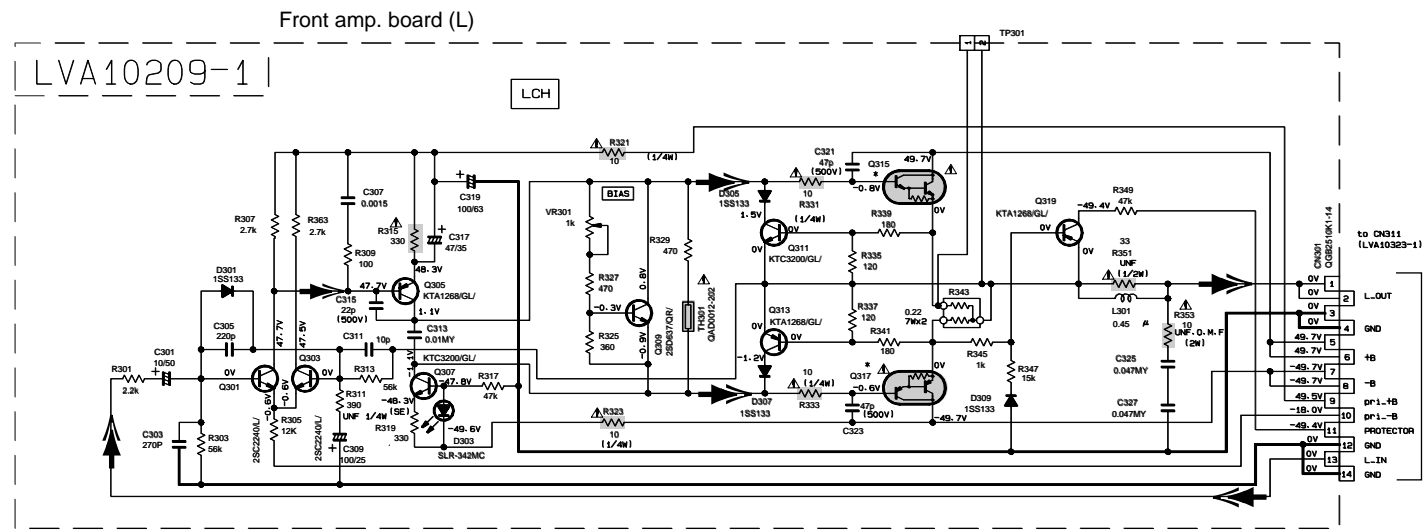

MARK LIST

	J/C	B/E/EN/VE	US/UT/U/A
Q315, Q316 Q815, Q816 Q915	2SD2389/OPY/-F6	2SD2390/OPY/-F6	2SD2390/OPY/-F6
Q317, Q318 Q817, Q818 Q917	2SB1559/OPY/-F6	2SB1560/OPY/-F6	2SB1560/OPY/-F6
R829, R830 R929	470	470	220

- SURROUND signal
- FRONT signal
- CENTER signal

⚠ Parts are safety assurance parts. When replacing those parts make sure to use the specified.

Main section
(Volume / Regulator / Source select)

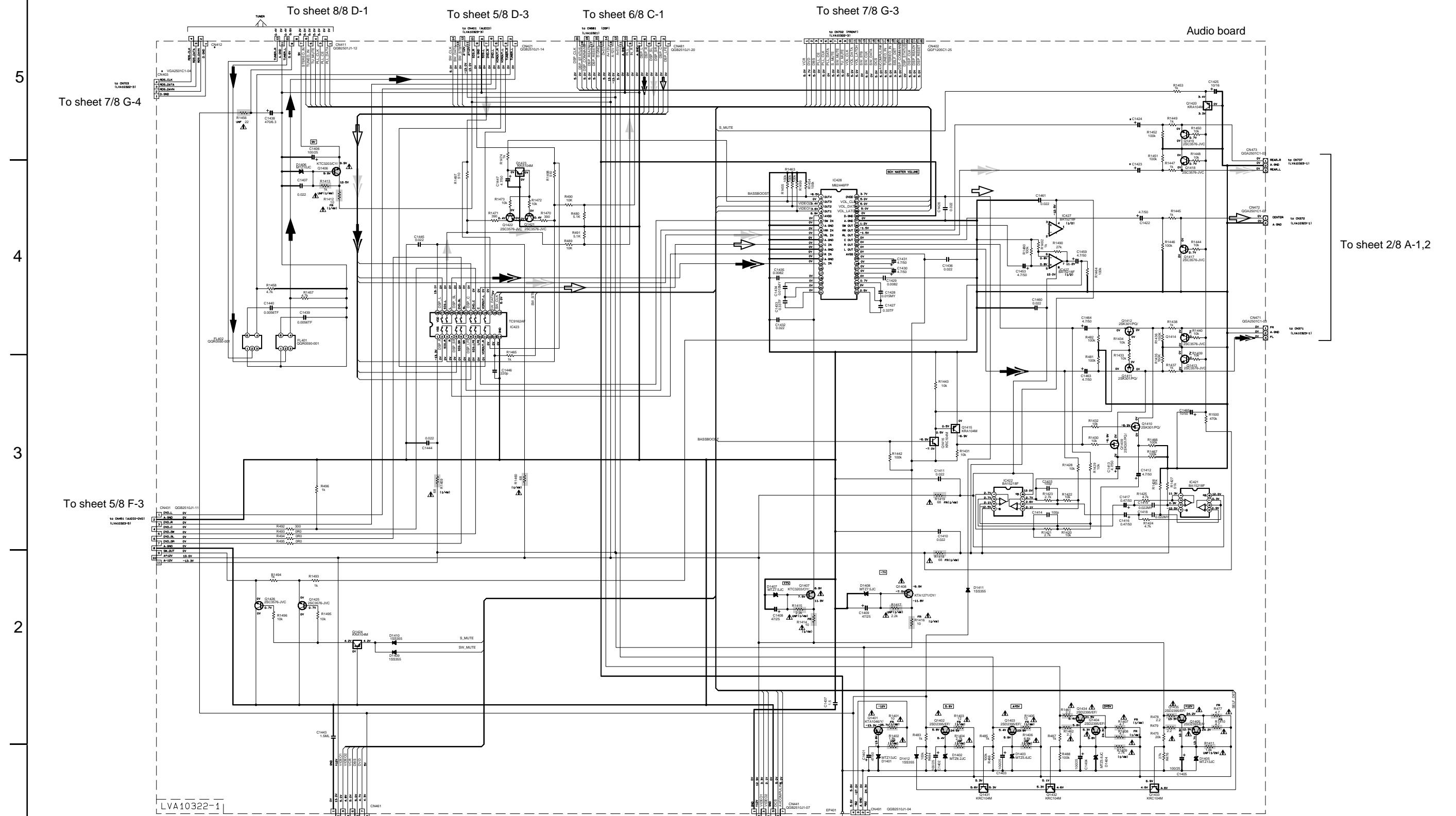

- AUDIO signal
- TUNER signal
- SURROUND signal
- FRONT signal
- CENTER signal

MAIN LIST	J/C	B/E/EN/VEY	US/AT/LA/TA
CN412- CN403	NONE	USE	NONE
C1463- C1464	4. 7/50	10/25	10/25

Parts are safety assurance parts. When replacing those parts make sure to use the specified.

Audio / Video signal input terminal section

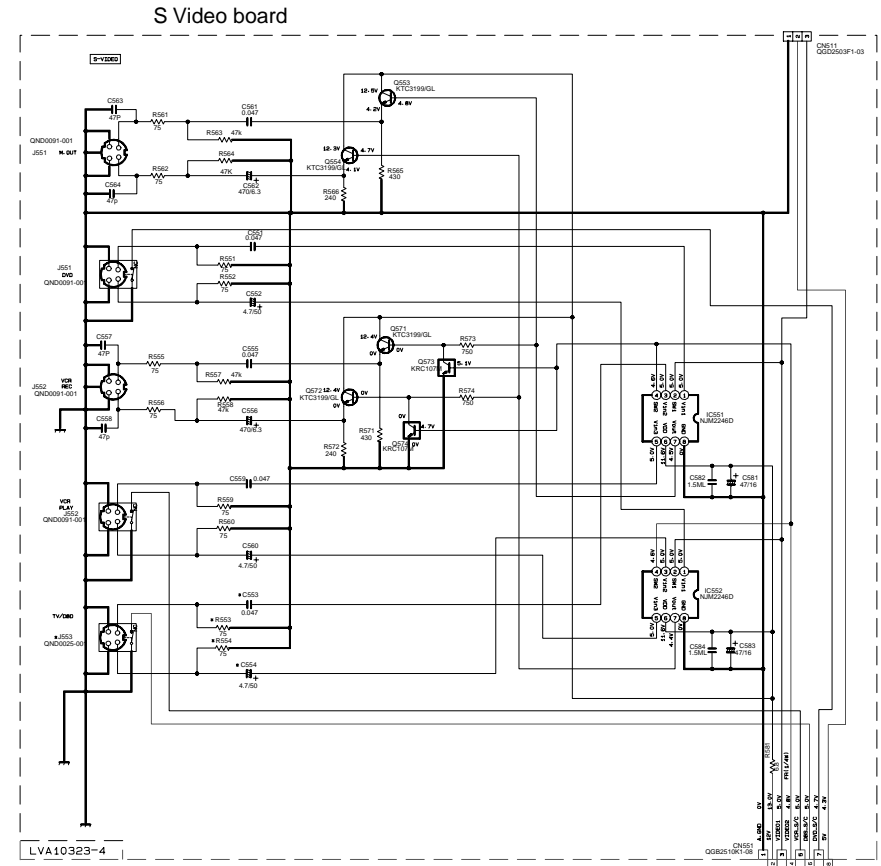
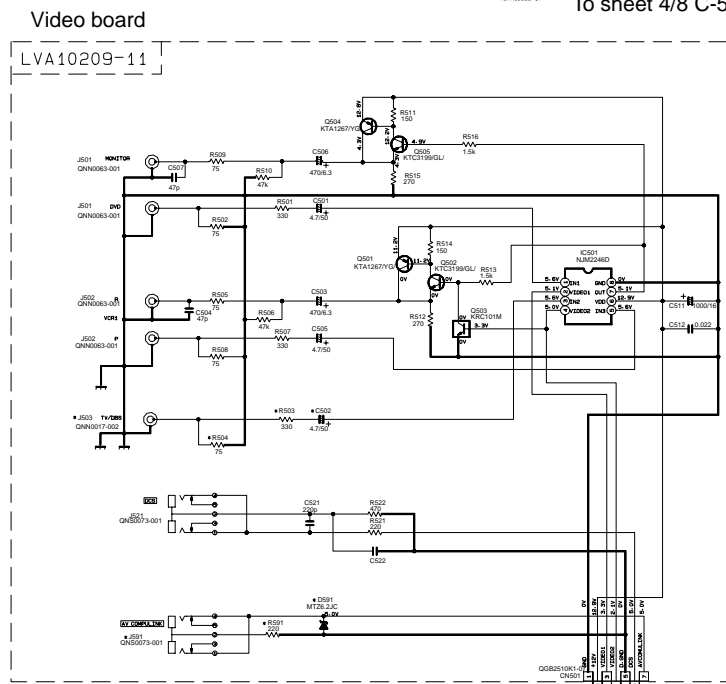
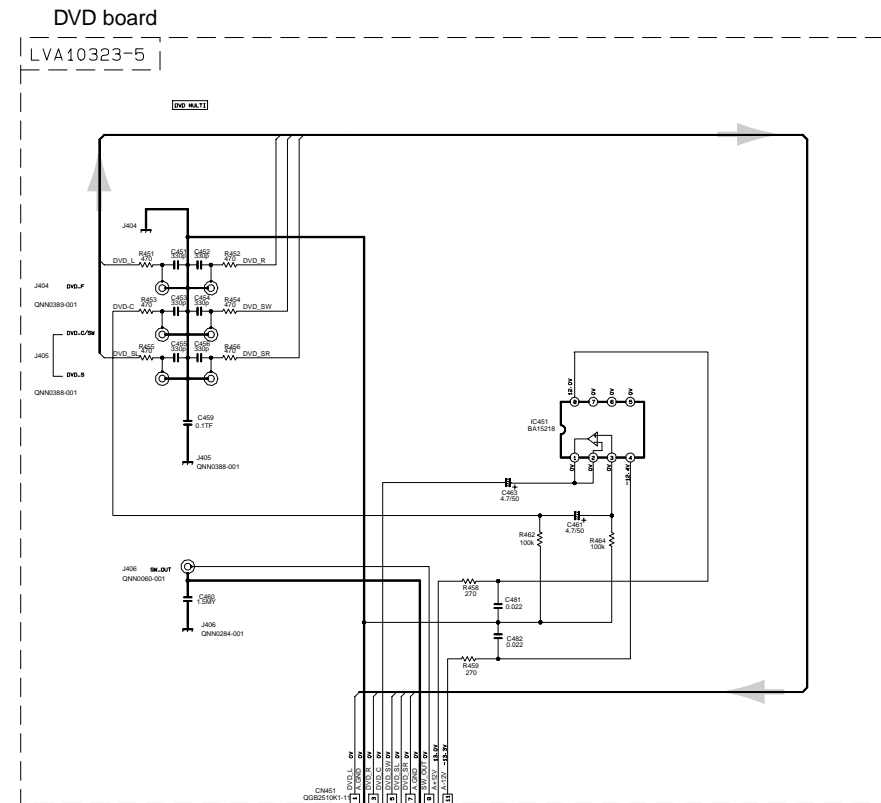
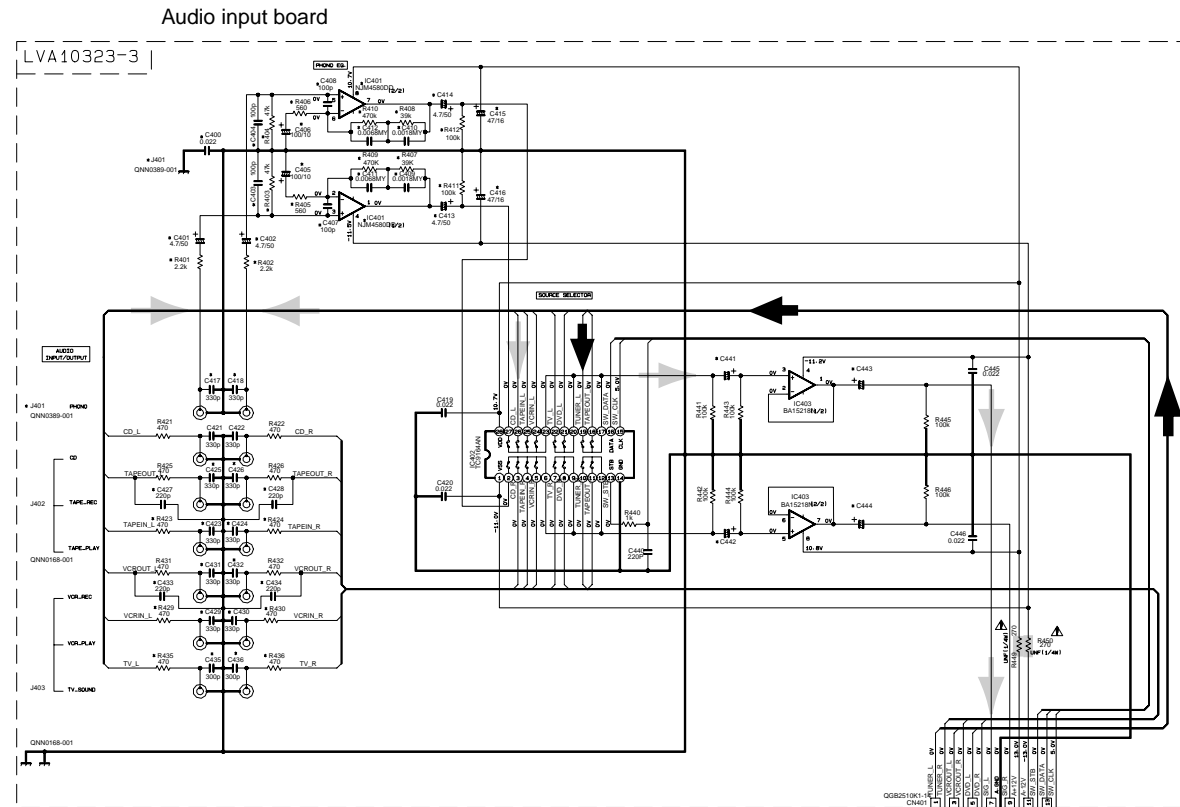

Part No.	Qty	Remarks
IC501	1	IC501
IC502	1	IC502
IC503	1	IC503
IC504	1	IC504
IC505	1	IC505
IC506	1	IC506
IC507	1	IC507
IC508	1	IC508
IC509	1	IC509
IC510	1	IC510
IC511	1	IC511
IC512	1	IC512
IC513	1	IC513
IC514	1	IC514
IC515	1	IC515
IC516	1	IC516
IC517	1	IC517
IC518	1	IC518
IC519	1	IC519
IC520	1	IC520
IC521	1	IC521
IC522	1	IC522
IC523	1	IC523
IC524	1	IC524
IC525	1	IC525
IC526	1	IC526
IC527	1	IC527
IC528	1	IC528
IC529	1	IC529
IC530	1	IC530
IC531	1	IC531
IC532	1	IC532
IC533	1	IC533
IC534	1	IC534
IC535	1	IC535
IC536	1	IC536
IC537	1	IC537
IC538	1	IC538
IC539	1	IC539
IC540	1	IC540
IC541	1	IC541
IC542	1	IC542
IC543	1	IC543
IC544	1	IC544
IC545	1	IC545
IC546	1	IC546
IC547	1	IC547
IC548	1	IC548
IC549	1	IC549
IC550	1	IC550
IC551	1	IC551
IC552	1	IC552
IC553	1	IC553
IC554	1	IC554
IC555	1	IC555
IC556	1	IC556
IC557	1	IC557
IC558	1	IC558
IC559	1	IC559
IC560	1	IC560
IC561	1	IC561
IC562	1	IC562
IC563	1	IC563
IC564	1	IC564
IC565	1	IC565
IC566	1	IC566
IC567	1	IC567
IC568	1	IC568
IC569	1	IC569
IC570	1	IC570
IC571	1	IC571
IC572	1	IC572
IC573	1	IC573
IC574	1	IC574
IC575	1	IC575
IC576	1	IC576
IC577	1	IC577
IC578	1	IC578
IC579	1	IC579
IC580	1	IC580
IC581	1	IC581
IC582	1	IC582
IC583	1	IC583
IC584	1	IC584
IC585	1	IC585
IC586	1	IC586
IC587	1	IC587
IC588	1	IC588
IC589	1	IC589
IC590	1	IC590
IC591	1	IC591
IC592	1	IC592
IC593	1	IC593
IC594	1	IC594
IC595	1	IC595
IC596	1	IC596
IC597	1	IC597
IC598	1	IC598
IC599	1	IC599
IC600	1	IC600
IC601	1	IC601
IC602	1	IC602
IC603	1	IC603
IC604	1	IC604
IC605	1	IC605
IC606	1	IC606
IC607	1	IC607
IC608	1	IC608
IC609	1	IC609
IC610	1	IC610
IC611	1	IC611
IC612	1	IC612
IC613	1	IC613
IC614	1	IC614
IC615	1	IC615
IC616	1	IC616
IC617	1	IC617
IC618	1	IC618
IC619	1	IC619
IC620	1	IC620
IC621	1	IC621
IC622	1	IC622
IC623	1	IC623
IC624	1	IC624
IC625	1	IC625
IC626	1	IC626
IC627	1	IC627
IC628	1	IC628
IC629	1	IC629
IC630	1	IC630
IC631	1	IC631
IC632	1	IC632
IC633	1	IC633
IC634	1	IC634
IC635	1	IC635
IC636	1	IC636
IC637	1	IC637
IC638	1	IC638
IC639	1	IC639
IC640	1	IC640
IC641	1	IC641
IC642	1	IC642
IC643	1	IC643
IC644	1	IC644
IC645	1	IC645
IC646	1	IC646
IC647	1	IC647
IC648	1	IC648
IC649	1	IC649
IC650	1	IC650
IC651	1	IC651
IC652	1	IC652
IC653	1	IC653
IC654	1	IC654
IC655	1	IC655
IC656	1	IC656
IC657	1	IC657
IC658	1	IC658
IC659	1	IC659
IC660	1	IC660
IC661	1	IC661
IC662	1	IC662
IC663	1	IC663
IC664	1	IC664
IC665	1	IC665
IC666	1	IC666
IC667	1	IC667
IC668	1	IC668
IC669	1	IC669
IC670	1	IC670
IC671	1	IC671
IC672	1	IC672
IC673	1	IC673
IC674	1	IC674
IC675	1	IC675
IC676	1	IC676
IC677	1	IC677
IC678	1	IC678
IC679	1	IC679
IC680	1	IC680
IC681	1	IC681
IC682	1	IC682
IC683	1	IC683
IC684	1	IC684
IC685	1	IC685
IC686	1	IC686
IC687	1	IC687
IC688	1	IC688
IC689	1	IC689
IC690	1	IC690
IC691	1	IC691
IC692	1	IC692
IC693	1	IC693
IC694	1	IC694
IC695	1	IC695
IC696	1	IC696
IC697	1	IC697
IC698	1	IC698
IC699	1	IC699
IC700	1	IC700

Part No.	Qty	Remarks
IC501	1	IC501
IC502	1	IC502
IC503	1	IC503
IC504	1	IC504
IC505	1	IC505
IC506	1	IC506
IC507	1	IC507
IC508	1	IC508
IC509	1	IC509
IC510	1	IC510
IC511	1	IC511
IC512	1	IC512
IC513	1	IC513
IC514	1	IC514
IC515	1	IC515
IC516	1	IC516
IC517	1	IC517
IC518	1	IC518
IC519	1	IC519
IC520	1	IC520
IC521	1	IC521
IC522	1	IC522
IC523	1	IC523
IC524	1	IC524
IC525	1	IC525
IC526	1	IC526
IC527	1	IC527
IC528	1	IC528
IC529	1	IC529
IC530	1	IC530
IC531	1	IC531
IC532	1	IC532
IC533	1	IC533
IC534	1	IC534
IC535	1	IC535
IC536	1	IC536
IC537	1	IC537
IC538	1	IC538
IC539	1	IC539
IC540	1	IC540
IC541	1	IC541
IC542	1	IC542
IC543	1	IC543
IC544	1	IC544
IC545	1	IC545
IC546	1	IC546
IC547	1	IC547
IC548	1	IC548
IC549	1	IC549
IC550	1	IC550
IC551	1	IC551
IC552	1	IC552
IC553	1	IC553
IC554	1	IC554
IC555	1	IC555
IC556	1	IC556
IC557	1	IC557
IC558	1	IC558
IC559	1	IC559
IC560	1	IC560
IC561	1	IC561
IC562	1	IC562
IC563	1	IC563
IC564	1	IC564
IC565	1	IC565
IC566	1	IC566
IC567	1	IC567
IC568	1	IC568
IC569	1	IC569
IC570	1	IC570
IC571	1	IC571
IC572	1	IC572
IC573	1	IC573
IC574	1	IC574
IC575	1	IC575
IC576	1	IC576
IC577	1	IC577
IC578	1	IC578
IC579	1	IC579
IC580	1	IC580
IC581	1	IC581
IC582	1	IC582
IC583	1	IC583
IC584	1	IC584
IC585	1	IC585
IC586	1	IC586
IC587	1	IC587
IC588	1	IC588
IC589	1	IC589
IC590	1	IC590
IC591	1	IC591
IC592	1	IC592
IC593	1	IC593
IC594	1	IC594
IC595	1	IC595
IC596	1	IC596
IC597	1	IC597
IC598	1	IC598
IC599	1	IC599
IC600	1	IC600

AUDIO signal
 TUNER signal

To sheet 4/8 B-1

5
4
3
2
1

■ Digital signal input terminal / Surround section

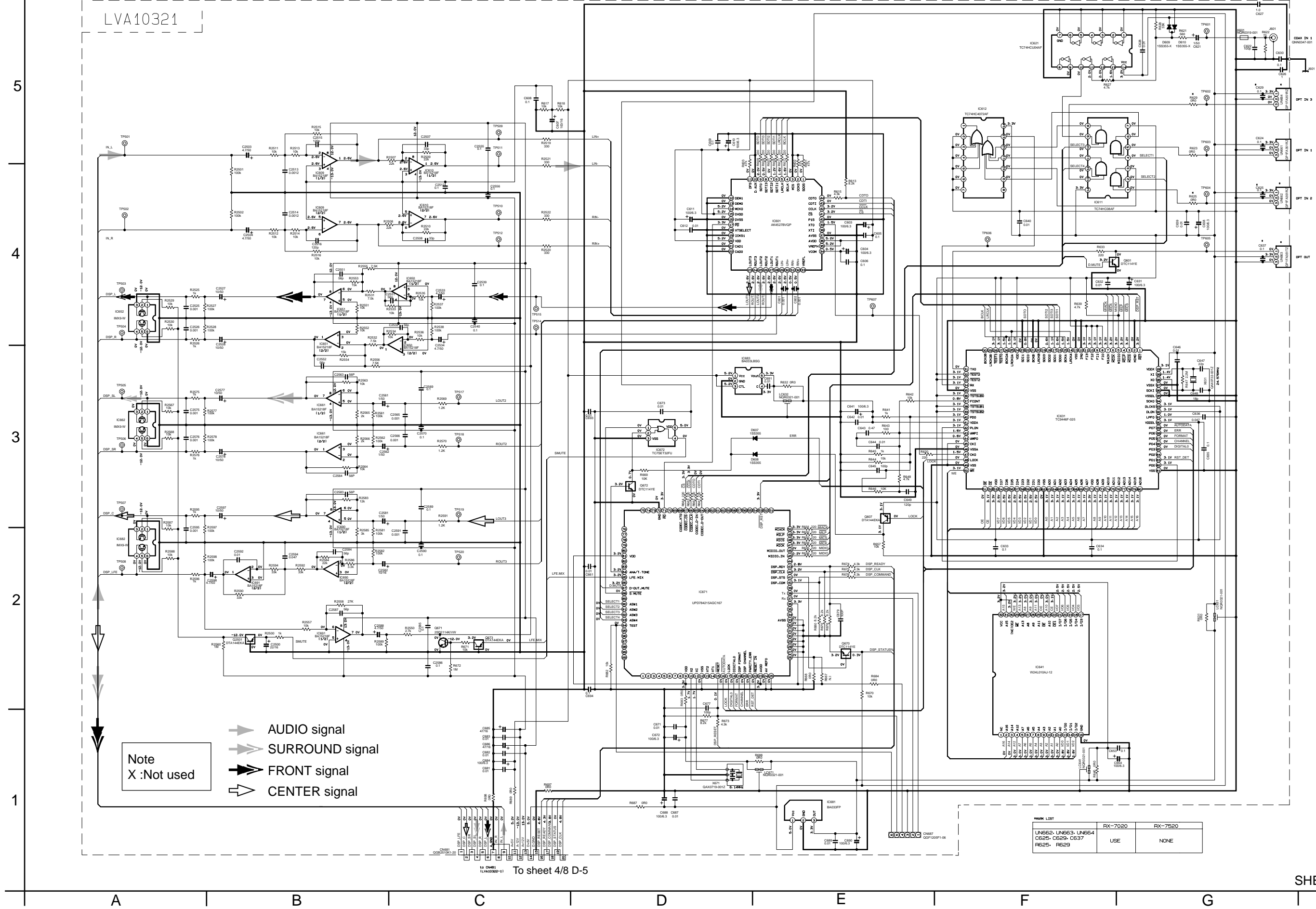

Note
X :Not used

- ➔ AUDIO signal
- ➔ SURROUND signal
- ➔ FRONT signal
- ➔ CENTER signal

MARK LIST	RX-7020	RX-7520
UN563, UN563-3, UN564	USE	NONE
C625, C629, C637	USE	NONE
R625, R629	USE	NONE

To sheet 4/8 D-5

User control / System control / FL displaying section

System control board

LVA10322-3

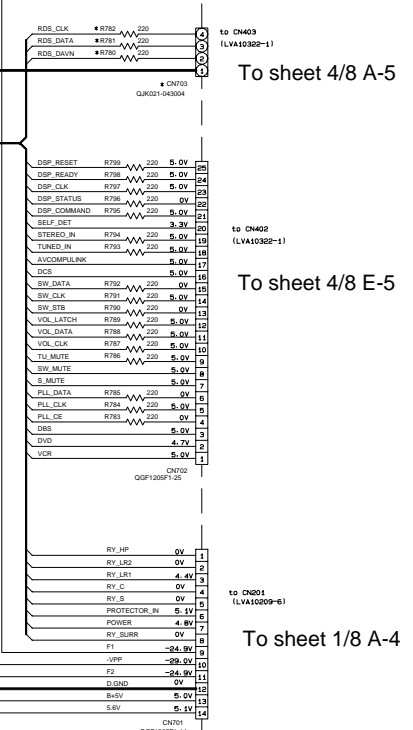
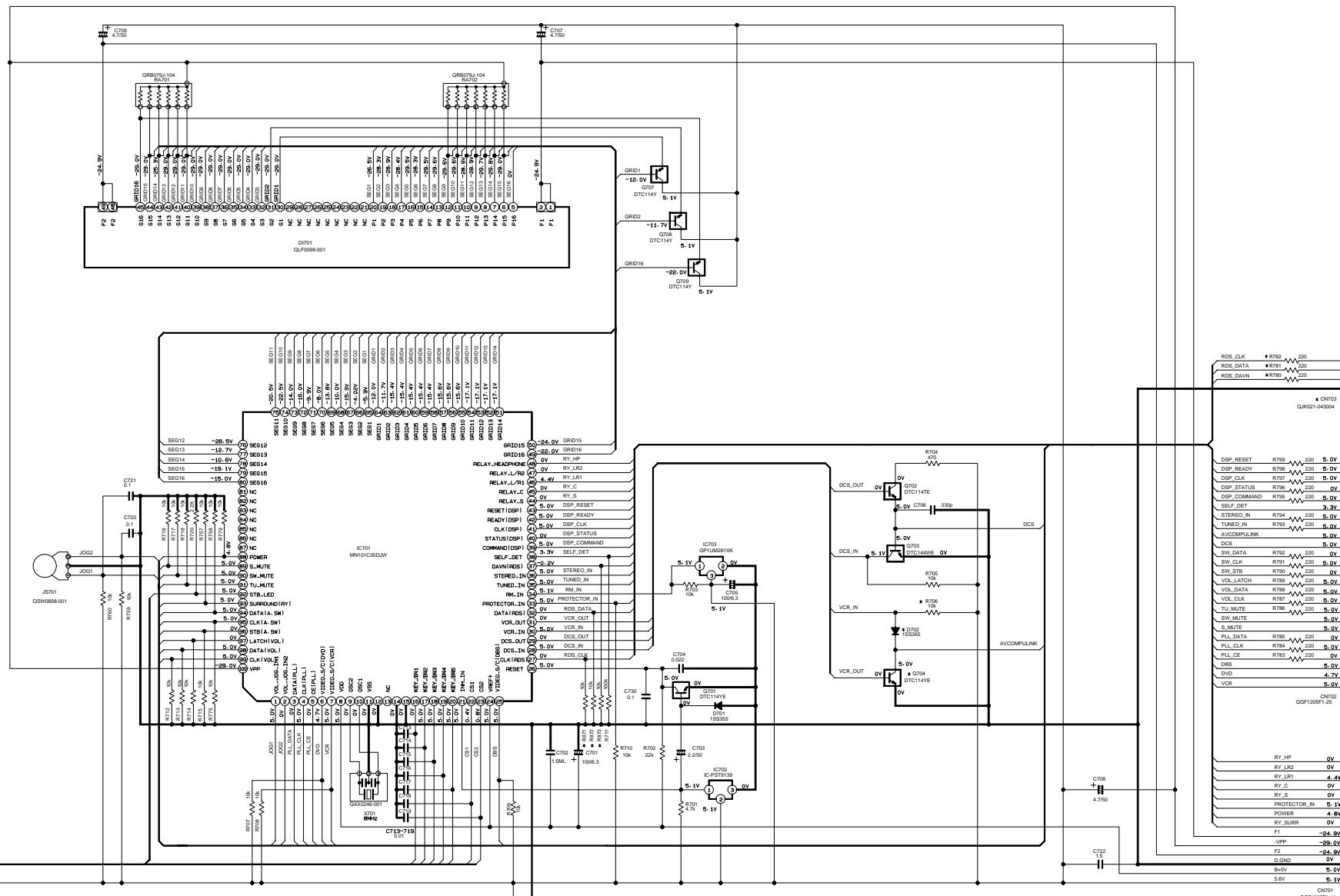

To sheet 4/8 A-5

To sheet 4/8 E-5

To sheet 1/8 A-4

MARK LIST

J/C	B/E/EN/VEY	LSA/UT/ALI	A	RX-7020	RX-7520
R701	USE	NONE	NONE		
R702	NONE	USE	NONE		
R704	NONE	NONE	USE		
R705	NONE	NONE	NONE		
R706	NONE	NONE	NONE	USE	
R708	NONE	NONE	NONE	USE	USE
R710	NONE	USE	NONE		
R711	NONE	USE	NONE		
R712	NONE	USE	NONE		
R713	NONE	USE	NONE		
R714	NONE	USE	NONE		
R715	NONE	USE	NONE		
R716	NONE	USE	NONE		
R717	NONE	USE	NONE		
R718	NONE	USE	NONE		
R719	NONE	USE	NONE		
R720	NONE	USE	NONE		
R721	NONE	USE	NONE		
R722	NONE	USE	NONE		
R723	NONE	USE	NONE		
R724	NONE	USE	NONE		
R725	NONE	USE	NONE		
R726	NONE	USE	NONE		
R727	NONE	USE	NONE		
R728	NONE	USE	NONE		
R729	NONE	USE	NONE		
R730	NONE	USE	NONE		
R731	NONE	USE	NONE		
R732	NONE	USE	NONE		
R733	NONE	USE	NONE		
R734	NONE	USE	NONE		
R735	NONE	USE	NONE		
R736	NONE	USE	NONE		
R737	NONE	USE	NONE		
R738	NONE	USE	NONE		
R739	NONE	USE	NONE		
R740	NONE	USE	NONE		
R741	NONE	USE	NONE		
R742	NONE	USE	NONE		
R743	NONE	USE	NONE		
R744	NONE	USE	NONE		
R745	NONE	USE	NONE		
R746	NONE	USE	NONE		
R747	NONE	USE	NONE		
R748	NONE	USE	NONE		
R749	NONE	USE	NONE		
R750	NONE	USE	NONE		
R751	NONE	USE	NONE		
R752	NONE	USE	NONE		
R753	NONE	USE	NONE		
R754	NONE	USE	NONE		
R755	NONE	USE	NONE		
R756	NONE	USE	NONE		
R757	NONE	USE	NONE		
R758	NONE	USE	NONE		
R759	NONE	USE	NONE		
R760	NONE	USE	NONE		
R761	NONE	USE	NONE		
R762	NONE	USE	NONE		
R763	NONE	USE	NONE		
R764	NONE	USE	NONE		
R765	NONE	USE	NONE		
R766	NONE	USE	NONE		
R767	NONE	USE	NONE		
R768	NONE	USE	NONE		
R769	NONE	USE	NONE		
R770	NONE	USE	NONE		
R771	NONE	USE	NONE		
R772	NONE	USE	NONE		
R773	NONE	USE	NONE		
R774	NONE	USE	NONE		
R775	NONE	USE	NONE		
R776	NONE	USE	NONE		
R777	NONE	USE	NONE		
R778	NONE	USE	NONE		
R779	NONE	USE	NONE		
R780	NONE	USE	NONE		
R781	NONE	USE	NONE		
R782	NONE	USE	NONE		
R783	NONE	USE	NONE		
R784	NONE	USE	NONE		
R785	NONE	USE	NONE		
R786	NONE	USE	NONE		
R787	NONE	USE	NONE		
R788	NONE	USE	NONE		
R789	NONE	USE	NONE		
R790	NONE	USE	NONE		
R791	NONE	USE	NONE		
R792	NONE	USE	NONE		
R793	NONE	USE	NONE		
R794	NONE	USE	NONE		
R795	NONE	USE	NONE		
R796	NONE	USE	NONE		
R797	NONE	USE	NONE		
R798	NONE	USE	NONE		
R799	NONE	USE	NONE		
R800	NONE	USE	NONE		

Power switch board

LVA10322-4

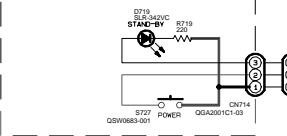

■ Tuner section

FOR E/EN/B (WITH RDS)
LVA10009

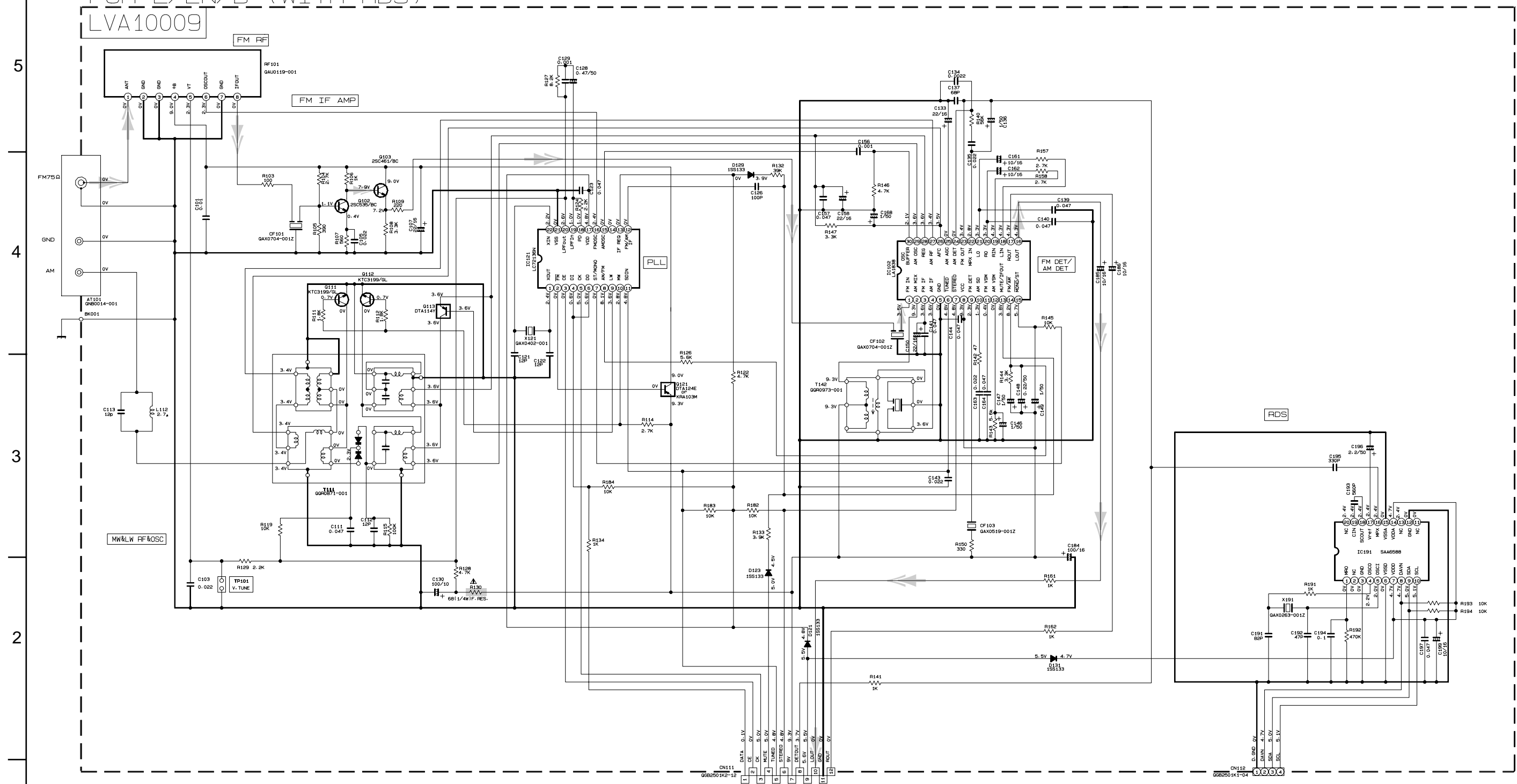

To sheet 4/8 B-5

To sheet 4/8 A-5

▲ Parts are safety assurance parts.
When replacing those parts make
sure to use the specified one.

➡ FM / Tuner signal

Printed circuit boards

■ Main board

Wire protection board

Audio input board

Speaker board

DVD board

S Video board

Main board

T2B

5
4
3
2
1

A B C D E F G H

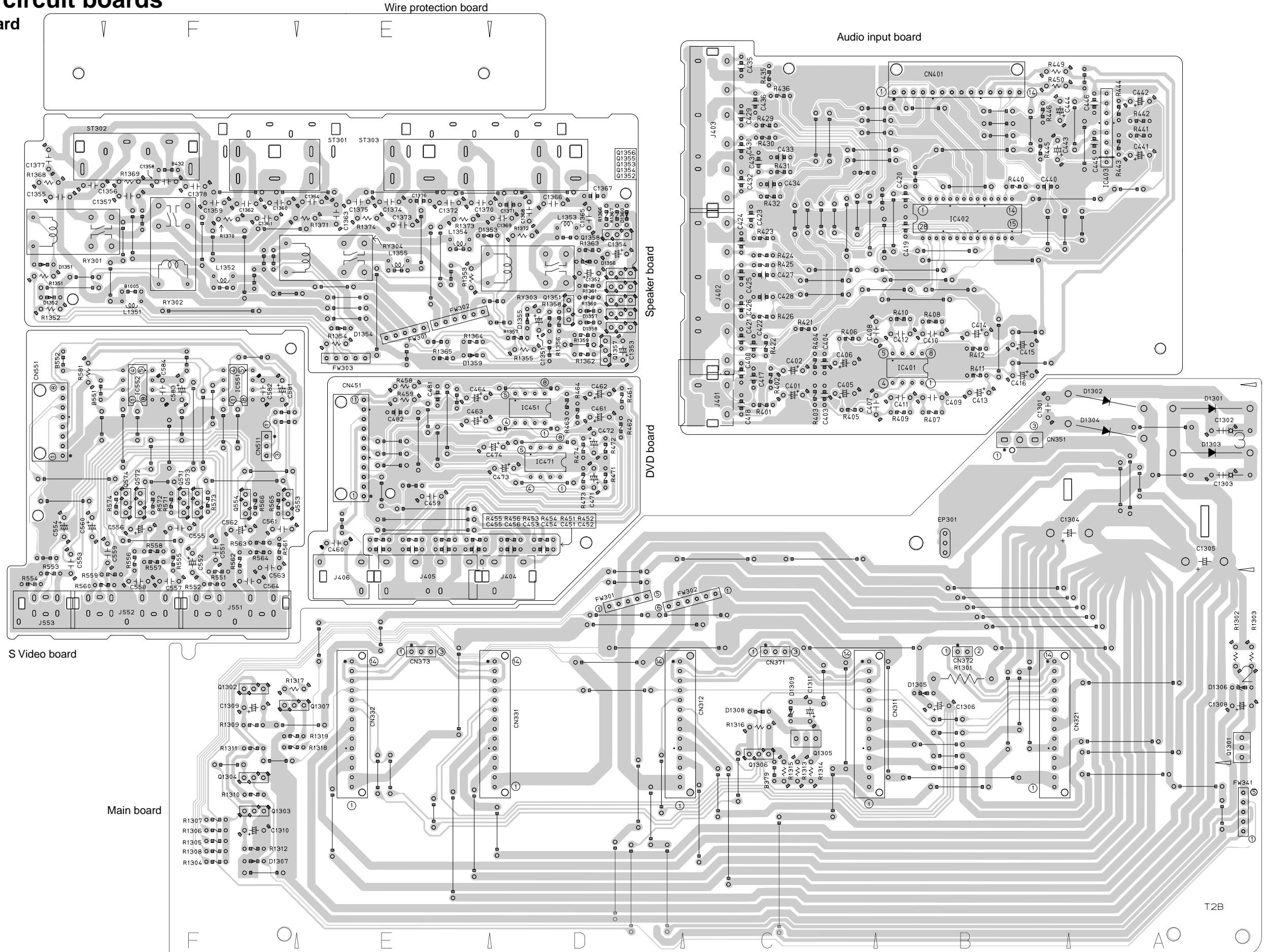

System control & Audio board

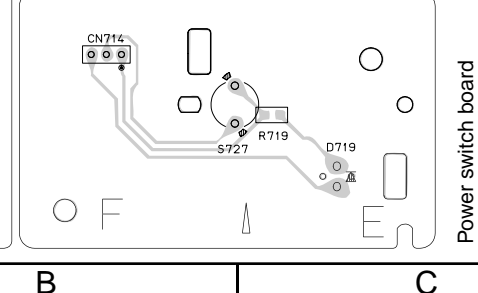
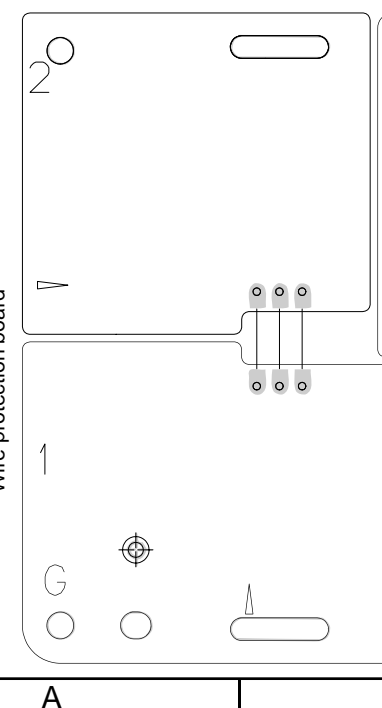
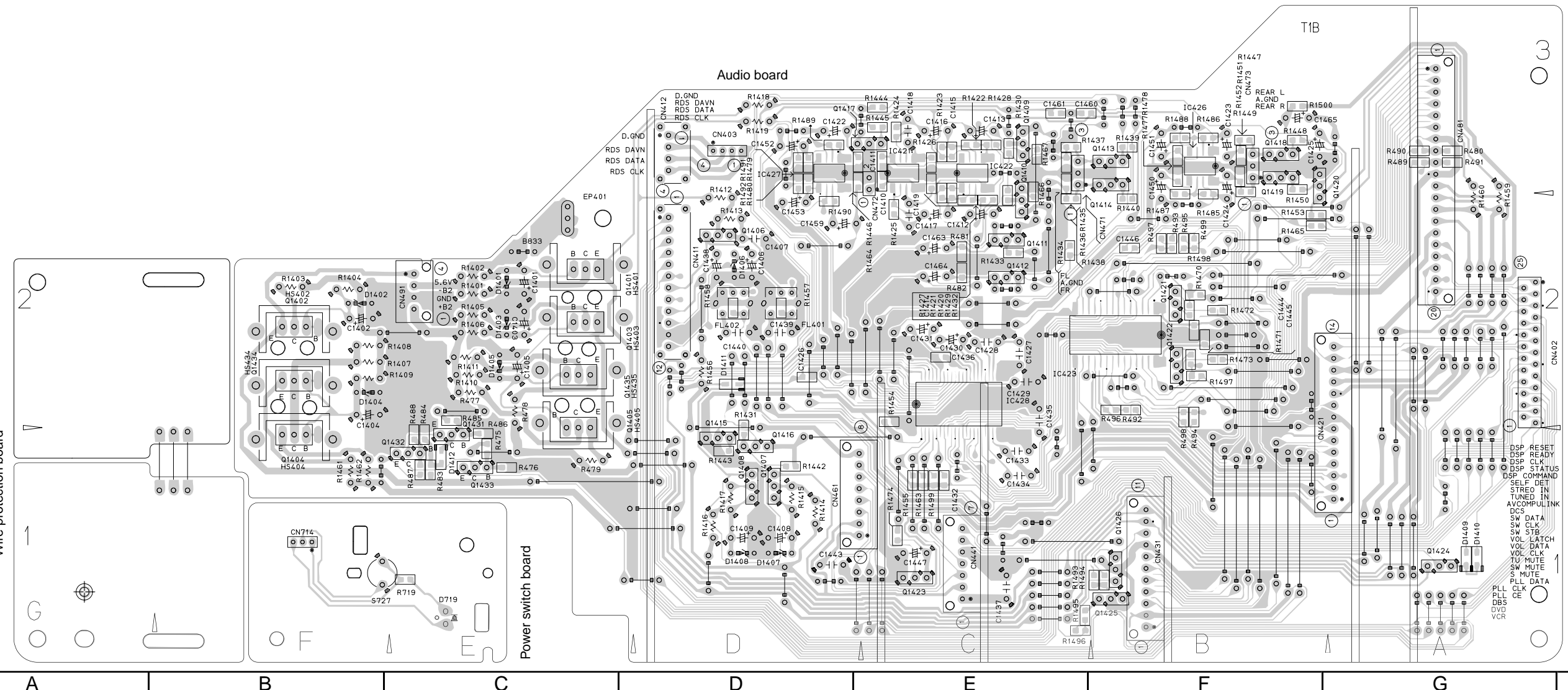
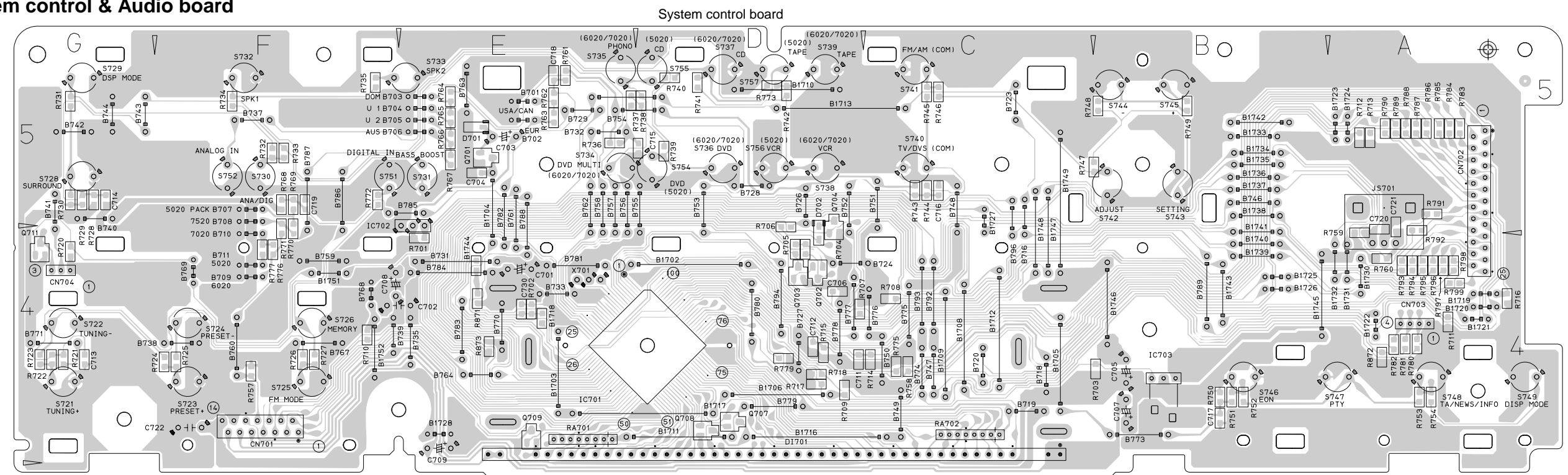

5
4
3
2
1

A B C D E F G

■ Digital signal input terminal board

Forward side

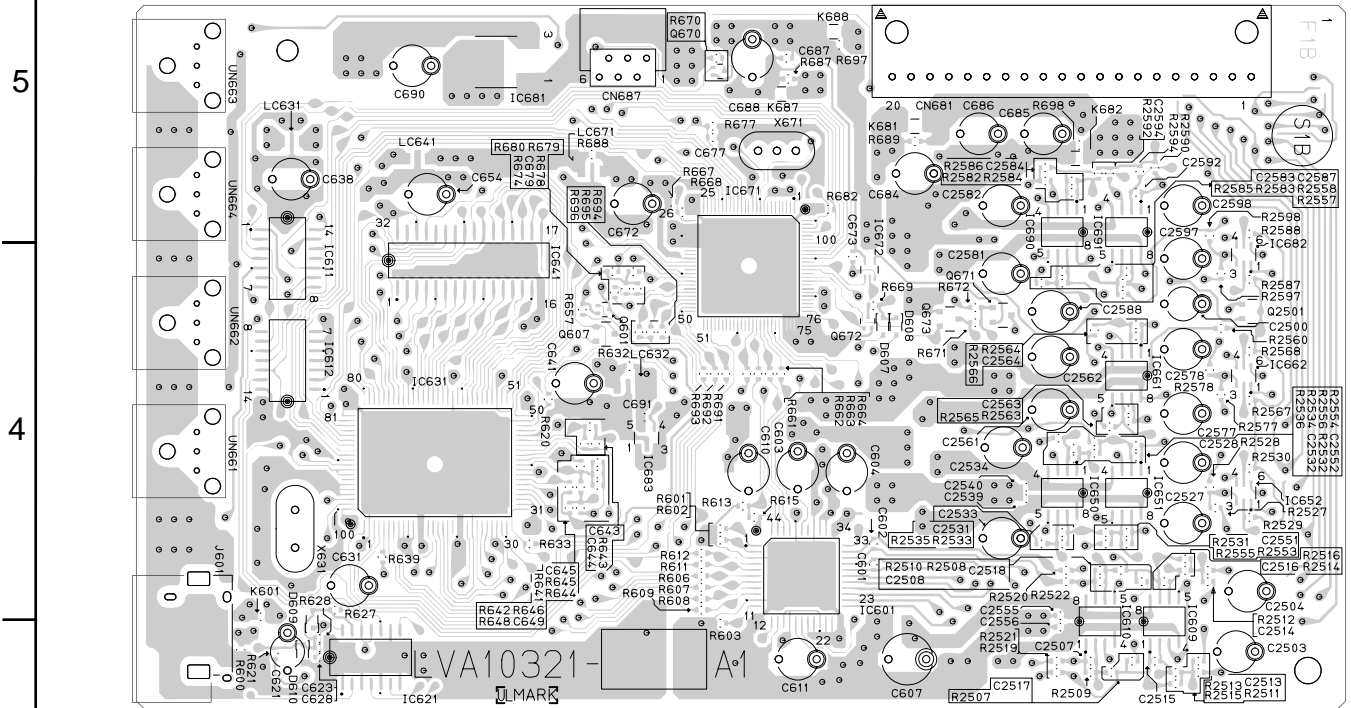

3

Reverse side

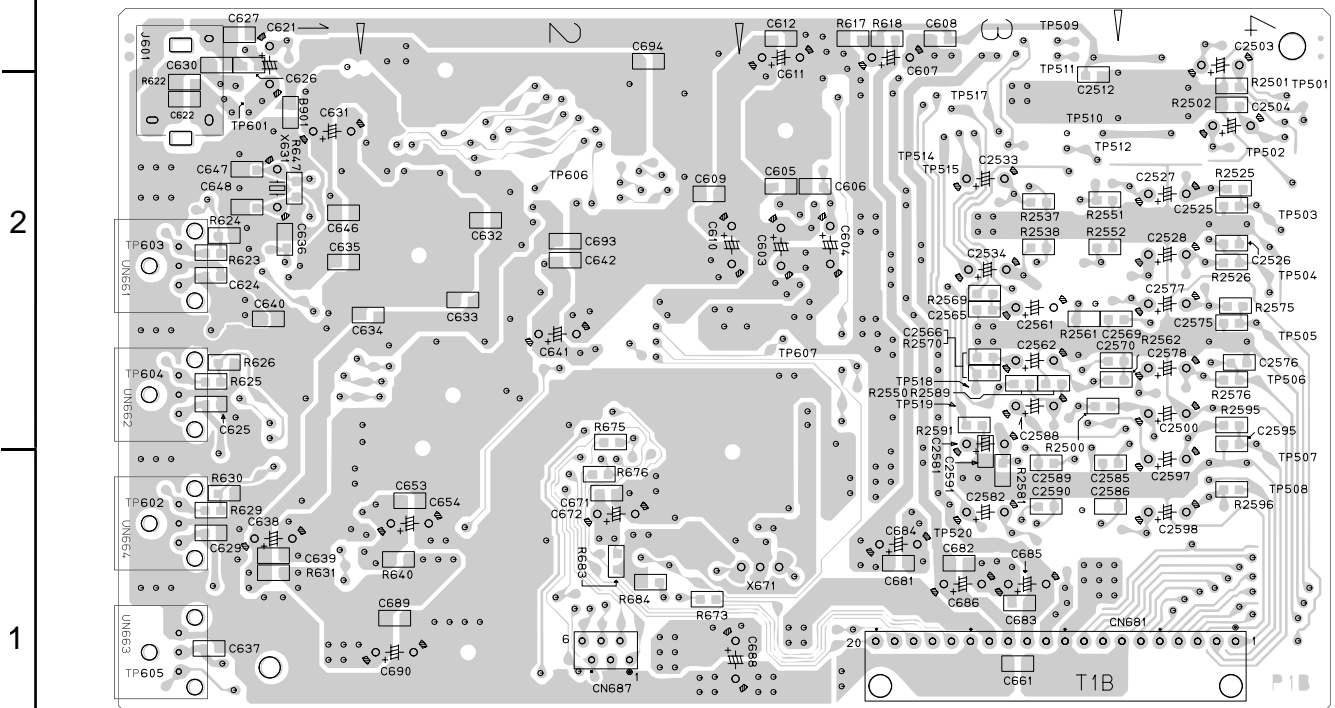

2

1

A

B

C

■ Tuner board

5

4

3

2

1

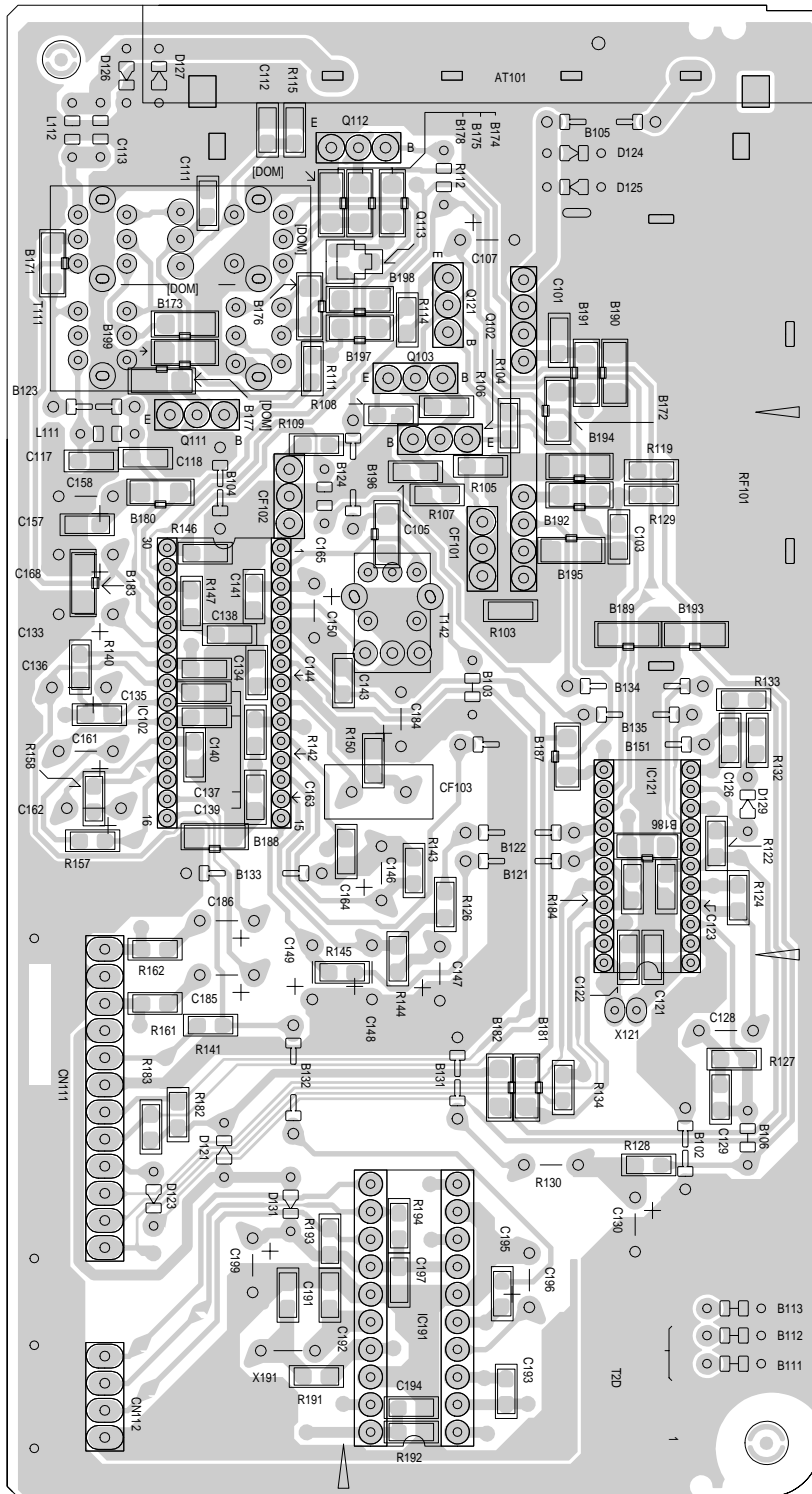

< M E M O >



VICTOR COMPANY OF JAPAN, LIMITED

AUDIO & COMMUNICATION BUSINESS DIVISION

PERSONAL & MOBILE NETWORK BUSINESS UNIT. 10-1,1chome,Ohwatari-machi,Maebashi-city,371-8543,Japan

PARTS LIST

[RX-7022RSL]

[RX-7020RBK]

* All printed circuit boards and its assemblies are not available as service parts.

RX-7022RSL	RX-7020RBK
Area suffix	Area suffix
B ----- U.K. E ----- Continental Europe EN ----- Northern Europe EV ----- Eastern Europe	E ----- Continental Europe

- Contents -

Exploded view of general assembly and parts list (Block No.M1)	3- 3
Electrical parts list (Block No.01~05)	3- 5
Packing materials and accessories parts list (Block No.M3,M5)	3-20

< M E M O >

Exploded view of general assembly and parts list

Block No. **M 1 M M**

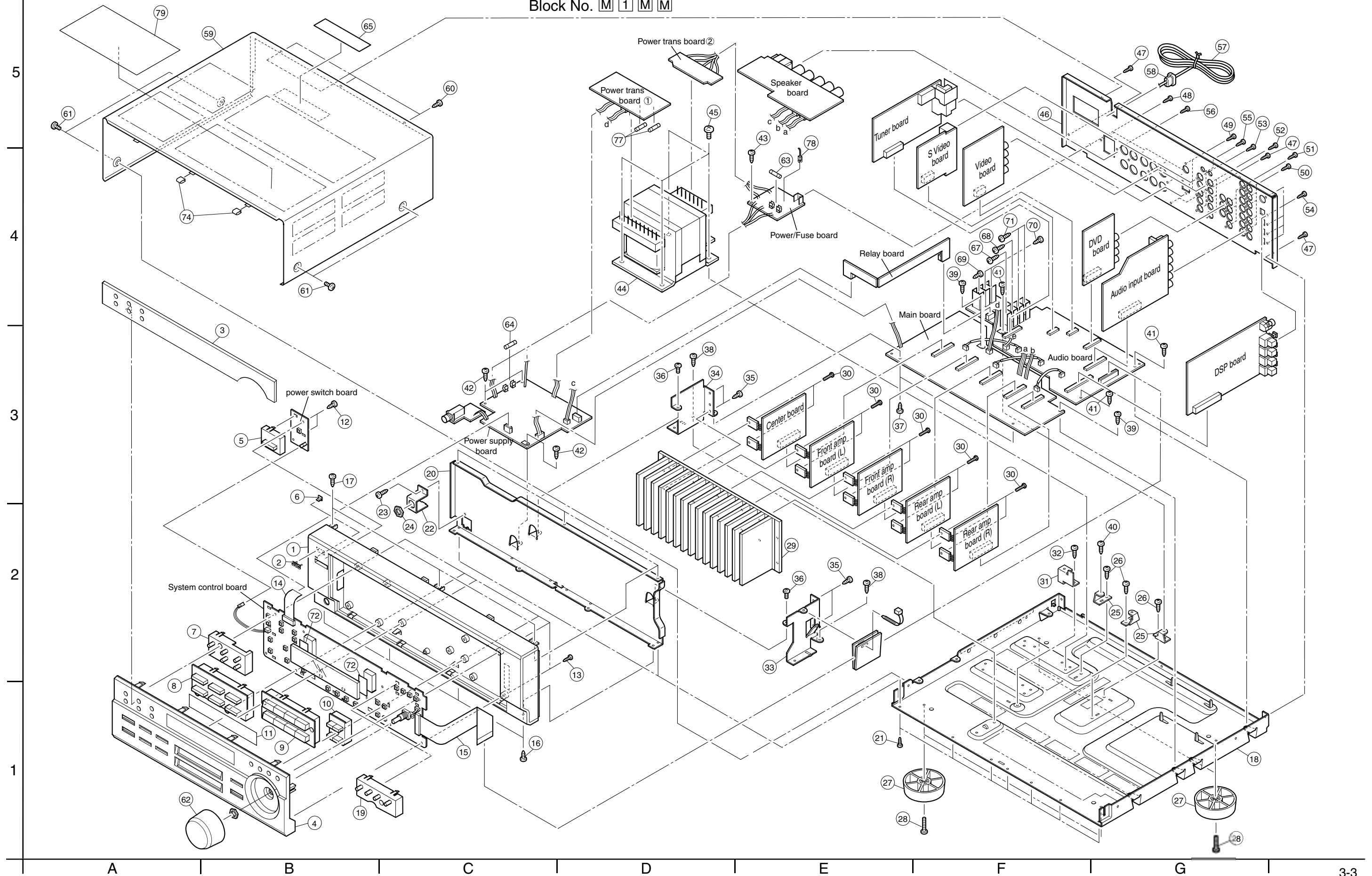

■ Parts list (General assembly)

Block No. M1MM

△	Item	Parts number	Parts name	Q'ty	Description	Area
	1	LV10457-015A	FRONT PANEL	1	RX-7020RBK	
		LV10457-016A	FRONT PANEL	1	RX-7022RSL	
	2	VJD5429-002SS	JVC MARK	1	RX-7022RSL	
		VJD5429-001SS	JVC MARK	1	RX-7020RBK	
	3	LV20950-010A	LENS	1		
	4	LV10459-018A	SUB PANEL	1	RX-7022RSL	
		LV10459-017A	SUB PANEL	1	RX-7020RBK	
	5	LV32431-004A	POWER BUTTON	1	RX-7020RBK	
		LV32431-002A	POWER BUTTON	1	RX-7022RSL	
	6	LV42096-001A	INDICATOR	1	POWER	
	7	LV20951-001A	PUSH BUTTON	1	TUNER	
	8	LV20919-002A	PUSH BUTTON(C)	1	RX-7022RSL	
		LV20919-001A	PUSH BUTTON(C)	1	RX-7020RBK	
	9	LV20917-004A	PUSH BUTTON(D)	1	RX-7022RSL	
		LV20917-003A	PUSH BUTTON(D)	1	RX-7020RBK	
	10	LV32430-001A	PUSH BUTTON(F)	1	RX-7020RBK	
		LV32430-002A	PUSH BUTTON(F)	1	RX-7022RSL	
	11	LV42095-001A	FL SCREEN	1		
	12	QYSBSF2610Z	SCREW	2	FRONT C.B	
	13	QYSBSF2610Z	SCREW	6	FRONT C.B FL	
	14	QUQ412-1415CJ	FFC WIRE	1		
	15	QUQ412-2538CJ	FFC WIRE	1		
	16	QYSDSG3006Z	SCREW	4	FRONT D	
	17	QYSBSG3006Z	T.SCREW	3	FRONT U	
	18	LV10019-003A	CHASSIS BASE	1		
	19	LV20952-001A	PUSH BUTTON	1	RDS	
	20	LV10458-002A	FRONT BRACKET	1		
	21	QYSDSG3006Z	SCREW	7	C.B-F.B	
	22	LV42094-003A	H.P BKT	1		
	23	QYSBSG3006Z	T.SCREW	1	H.P BKT-F.B	
	24	VKZ4150-001	SPECIAL NUT	1	H,P	
	25	E68587-223SM	CB BKT	3		
	26	QYSBST3006Z	T.SCREW	3	C.B-BKT	
	27	QZF6018-003	FOOT	4	RX-7022RSL	
		QZF6018-001	FOOT	4	RX-7020RBK	
	28	QYSBST3010Z	T.SCREW	4	FOOT	
	29	LV20916-002A	HEAT SINK	1	NEW TYPE	
	30	QYSBSG3012E	SCREW	10	TR	
	31	LV42098-001A	C.B BKT	1	PRI/SEC C.B	
	32	QYSBST3006Z	T.SCREW	1	C.B BKT	
	33	LV32433-001A	H.S BRACKET(R)	1		
	34	LV32434-001A	H.S BRACKET(L)	1		
	35	QYSBSG3008Z	T.SCREW	4	H.S-BKT	
	36	QYSBST3006Z	T.SCREW	2	H.S BKT-F.BKT	
	37	QYSBSG3006Z	T.SCREW	2	H.S BKT	
	38	QYSBST3006Z	T.SCREW	2	H.S BKT-CHASSIS	
	39	QYSBSG3006Z	T.SCREW	2	M.C.B	
	40	E65923-003	TAPPING SCREW	1	M.C.B	

■ Parts list (General assembly)

Block No. M1MM

△	Item	Parts number	Parts name	Q'ty	Description	Area
	41	QYSBSG3006Z	T.SCREW	3	H.S-C.B	
	42	QYSBSG3006Z	T.SCREW	3	P.C.B-CHASSIS	
	43	QYSBSG3006Z	T.SCREW	1	C.B-CHASSIS	
△	44	QQT0365-001	POWER TRANSF	1		
	45	QYSDSTL4008Z	SPECIAL SCREW	4	P.TRANS	
	46	LV20915-029A	REAR PANEL	1	RX-7022RSL	B,E,EN
		LV20915-030A	REAR PANEL	1	RX-7022RSL	EV
		LV20915-028A	REAR PANEL	1	RX-7020RBK	
	47	QYSBSGY3008M	SPECIAL SCREW	3	R.P-C.BASE	
	48	QYSBSGY3008M	SPECIAL SCREW	1	R.P	
	49	QYSBSGY3008M	SPECIAL SCREW	2	TUNER	
	50	QYSBSGY3008M	SPECIAL SCREW	5	INPUT	
	51	QYSBSGY3008M	SPECIAL SCREW	3	V AUDIO	
	52	QYSBSGY3008M	SPECIAL SCREW	3	VIDEO	
	53	QYSBSGY3008M	SPECIAL SCREW	3	S VIDEO	
	54	QYSBSGY3008M	SPECIAL SCREW	5	DIGITAL	
	55	QYSBSGY3008M	SPECIAL SCREW	1	COMP C.B	
	56	QYSBSGY3008M	SPECIAL SCREW	5	SPK C.B	
△	57	QMPK250-205-JV	POWER CORD	1	RX-7022RSL	E,EN,EV
△		QMPK250-205-JV	POWER CORD	1	RX-7020RBK	
△		QMPN100-200-JD	POWER CORD	1	RX-7022RSL	B
△	58	QZW0033-001	STRAIN RELIEF	1		
	59	LE20131-008A/S/	METAL COVER	1	RX-7020RBK	
		LE20131-009A/S/	METAL COVER	1	RX-7022RSL	
	60	QYSBSGY3008M	SPECIAL SCREW	3		
	61	E406308-004	SPECIAL SCREW	4	RX-7022RSL	
		E406308-003	SPECIAL SCREW	4	RX-7020RBK	
	62	LV32435-005A	VOLUME KNOB	1	RX-7022RSL	
		LV32435-003A	VOLUME KNOB	1	RX-7020RBK	
△	63	QMF51W2-2R5-J8	FUSE	1	F 201	
△	64	QMF51E2-R10-J1	FUSE	1	F 205	
	65	E409396-003	CAUTION LABEL	1		
	67	QYSBSG3008E	T.SCREW	1		
	68	QYSBSG3008E	T.SCREW	1		
	69	QYSBSG3008E	T.SCREW	1		
	70	QYSBSG3008E	T.SCREW	2		
	71	QYSBSG3008E	T.SCREW	2		
	74	LV30225-0E5A	SPACER	2	FOR METAL COVER	
△	77	QMF51W2-2R0-J8	FUSE	2	F 202 F 203	
	78	E307572-001	FASTENER	1		
	79	LV30077-004A	PROTECT SHEET	1	RX-7020RBK	
		LV30077-006A	PROTECT SHEET	1	RX-7022RSL	

■ Electrical parts list (Power amp board)

Block No. 01

△	Item	Parts number	Parts name	Remarks	Area
	C 201	QFLC2AJ-104Z	M CAPACITOR	.10MF 5% 100V	
	C 202	QFLC2AJ-104Z	M CAPACITOR	.10MF 5% 100V	
	C 203	QFLC2AJ-104Z	M CAPACITOR	.10MF 5% 100V	
	C 204	QETM1VM-228	E.CAPACITOR	2200MF 20% 35V	
	C 205	QETM1VM-108	E.CAPACITOR	1000MF 20% 35V	
	C 206	QFLC1HJ-473Z	M CAPACITOR	.047MF 5% 50V	
	C 207	QFLC1HJ-473Z	M CAPACITOR	.047MF 5% 50V	
	C 208	QFLC2AJ-472Z	M CAPACITOR	4700PF 5% 100V	
	C 209	QETN1EM-477Z	E CAPACITOR	470MF 20% 25V	
△	C 210	QCZ9104-472	C CAPACITOR	4700PF	
	C 212	QETN1CM-477Z	E CAPACITOR	470MF 20% 16V	
	C 213	QETM0JM-228	E CAPACITOR	2200MF 20% 6.3V	
	C 218	QETN1HM-105Z	E CAPACITOR	1.0MF 20% 50V	
	C 221	QCB1HK-471Y	C CAPACITOR	B169	
	C 301	QEHR1HM-106Z	E CAPACITOR	10MF 20% 50V	
	C 302	QEHR1HM-106Z	E CAPACITOR	10MF 20% 50V	
	C 303	QCS31HJ-271Z	C CAPACITOR	270PF 5% 50V	
	C 304	QCS31HJ-271Z	C CAPACITOR	270PF 5% 50V	
	C 305	QCS31HJ-221Z	C CAPACITOR	220PF 5% 50V	
	C 306	QCS31HJ-221Z	C CAPACITOR	220PF 5% 50V	
	C 307	QCB31HK-152Z	C CAPACITOR	1500PF 10% 50V	
	C 308	QCB31HK-152Z	C CAPACITOR	1500PF 10% 50V	
	C 309	QETN1EM-107Z	E CAPACITOR	100MF 20% 25V	
	C 310	QETN1EM-107Z	E CAPACITOR	100MF 20% 25V	
	C 311	QCS31HJ-100Z	C CAPACITOR	10PF 5% 50V	
	C 312	QCS31HJ-100Z	C CAPACITOR	10PF 5% 50V	
	C 313	QFLC1HJ-103Z	M CAPACITOR	.010MF 5% 50V	
	C 314	QFLC1HJ-103Z	M CAPACITOR	.010MF 5% 50V	
	C 315	QCS32HJ-220Z	C CAPACITOR	22PF 5% 500V	
	C 316	QCS32HJ-220Z	C CAPACITOR	22PF 5% 500V	
	C 317	QEHR1VM-476Z	E CAPACITOR	47MF 20% 35V	
	C 318	QEHR1VM-476Z	E CAPACITOR	47MF 20% 35V	
	C 319	QETN1JM-107Z	E CAPACITOR	100MF 20% 63V	
	C 320	QETN1JM-107Z	E CAPACITOR	100MF 20% 63V	
	C 321	QCS32HJ-470Z	C CAPACITOR	47PF 5% 500V	
	C 322	QCS32HJ-470Z	C CAPACITOR	47PF 5% 500V	
	C 323	QCS32HJ-470Z	C CAPACITOR	47PF 5% 500V	
	C 324	QCS32HJ-470Z	C CAPACITOR	47PF 5% 500V	
	C 325	QFLC1HJ-473Z	M CAPACITOR	.047MF 5% 50V	
	C 326	QFLC1HJ-473Z	M CAPACITOR	.047MF 5% 50V	
	C 327	QFLC1HJ-473Z	M CAPACITOR	.047MF 5% 50V	
	C 328	QFLC1HJ-473Z	M CAPACITOR	.047MF 5% 50V	
	C 501	QEKC1HM-475Z	E CAPACITOR	4.7MF 20% 50V	
	C 502	QEKC1HM-475Z	E CAPACITOR	4.7MF 20% 50V	
	C 503	QETN0JM-477Z	E CAPACITOR	470MF 20% 6.3V	
	C 504	QCS31HJ-470Z	C CAPACITOR	47PF 5% 50V	
	C 505	QEKC1HM-475Z	E CAPACITOR	4.7MF 20% 50V	
	C 506	QETN0JM-477Z	E CAPACITOR	470MF 20% 6.3V	
	C 507	QCS31HJ-470Z	C CAPACITOR	47PF 5% 50V	
	C 511	QETN1CM-108Z	E CAPACITOR	1000MF 20% 16V	
	C 512	QCB1HK-223Y	C CAPACITOR	.022MF 10% 50V	
	C 521	QCB1HK-221Y	C CAPACITOR	220PF 10% 50V	
	C 522	QCZ0202-155Z	ML C CAPA I/M	1.5MF	
	C 801	QEHR1HM-106Z	E CAPACITOR	10MF 20% 50V	
	C 802	QEHR1HM-106Z	E CAPACITOR	10MF 20% 50V	
	C 803	QCS31HJ-271Z	C CAPACITOR	270PF 5% 50V	
	C 804	QCS31HJ-271Z	C CAPACITOR	270PF 5% 50V	
	C 805	QCS31HJ-221Z	C CAPACITOR	220PF 5% 50V	
	C 806	QCS31HJ-221Z	C CAPACITOR	220PF 5% 50V	
	C 807	QCB31HK-152Z	C CAPACITOR	1500PF 10% 50V	
	C 808	QCB31HK-152Z	C CAPACITOR	1500PF 10% 50V	
	C 809	QETN1EM-107Z	E CAPACITOR	100MF 20% 25V	
	C 810	QETN1EM-107Z	E CAPACITOR	100MF 20% 25V	

△	Item	Parts number	Parts name	Remarks	Area
	C 811	QCS31HJ-100Z	C CAPACITOR	10PF 5% 50V	
	C 812	QCS31HJ-100Z	C CAPACITOR	10PF 5% 50V	
	C 813	QFLC1HJ-103Z	M CAPACITOR	.010MF 5% 50V	
	C 814	QFLC1HJ-103Z	M CAPACITOR	.010MF 5% 50V	
	C 815	QCS32HJ-330Z	C CAPACITOR	33PF 5% 500V	
	C 816	QCS32HJ-330Z	C CAPACITOR	33PF 5% 500V	
	C 817	QEHR1HM-225Z	E CAPACITOR	2.2MF 20% 50V	
	C 818	QEHR1HM-225Z	E CAPACITOR	2.2MF 20% 50V	
	C 819	QEHR2AM-106Z	E CAPACITOR	10MF 20% 100V	
	C 820	QEHR2AM-106Z	E CAPACITOR	10MF 20% 100V	
	C 821	QCS32HJ-470Z	C CAPACITOR	47PF 5% 500V	
	C 822	QCS32HJ-470Z	C CAPACITOR	47PF 5% 500V	
	C 823	QCS32HJ-470Z	C CAPACITOR	47PF 5% 500V	
	C 824	QCS32HJ-470Z	C CAPACITOR	47PF 5% 500V	
	C 825	QFLC1HJ-473Z	M CAPACITOR	.047MF 5% 50V	
	C 826	QFLC1HJ-473Z	M CAPACITOR	.047MF 5% 50V	
	C 827	QFLC1HJ-473Z	M CAPACITOR	.047MF 5% 50V	
	C 828	QFLC1HJ-473Z	M CAPACITOR	.047MF 5% 50V	
	C 829	QETN1HM-476Z	E CAPACITOR	47MF 20% 50V	
	C 830	QETN1HM-476Z	E CAPACITOR	47MF 20% 50V	
	C 901	QEHR1HM-106Z	E CAPACITOR	10MF 20% 50V	
	C 903	QCS31HJ-271Z	C CAPACITOR	270PF 5% 50V	
	C 905	QCS31HJ-221Z	C CAPACITOR	220PF 5% 50V	
	C 907	QCB31HK-152Z	C CAPACITOR	1500PF 10% 50V	
	C 909	QETN1EM-107Z	E CAPACITOR	100MF 20% 25V	
	C 911	QCS31HJ-100Z	C CAPACITOR	10PF 5% 50V	
	C 913	QFLC1HJ-103Z	M CAPACITOR	.010MF 5% 50V	
	C 915	QCS32HJ-330Z	C CAPACITOR	33PF 5% 500V	
	C 917	QEHR1HM-225Z	E CAPACITOR	2.2MF 20% 50V	
	C 919	QEHR2AM-106Z	E CAPACITOR	10MF 20% 100V	
	C 921	QCS32HJ-470Z	C CAPACITOR	47PF 5% 500V	
	C 923	QCS32HJ-470Z	C CAPACITOR	47PF 5% 500V	
	C 925	QFLC1HJ-473Z	M CAPACITOR	.047MF 5% 50V	
	C 927	QFLC1HJ-473Z	M CAPACITOR	.047MF 5% 50V	
	C 929	QETN1HM-476Z	E CAPACITOR	47MF 20% 50V	
	CN201	QGF1205C1-14	CONNECTOR		
	CN203	QGD2501C1-05Z	SOCKET I.M		
	CN241	QGD2501C1-05Z	SOCKET I.M		
	CN251	QGA3901F2-03	CONNECTOR		
	CN291	QGB2510J1-04	CONNECTOR		
	CN292	QGB2510K1-04	CONNECTOR		
	CN301	QGB2510K1-14	CONNECTOR		
	CN302	QGB2510K1-14	CONNECTOR		
	CN492	QGB2510K1-04	CONNECTOR		
	CN501	QGB2510K1-07	CONNECTOR		
	CN801	QGB2510K1-14	CONNECTOR		
	CN802	QGB2510K1-14	CONNECTOR		
	CN901	QGB2510K1-14	CONNECTOR		
	C1331	QDGB1HK-102Y	C CAPACITOR		
	C1332	QDGB1HK-102Y	C CAPACITOR		
△	D 201	10E2-FD	DIODE		
△	D 202	11ES2-T4	DIODE I.M		
△	D 203	10E2-FD	DIODE		
△	D 204	11ES2-T4	DIODE I.M		
△	D 206	11ES2-T4	DIODE I.M		
△	D 207	11ES2-T4	DIODE I.M		
△	D 208	11ES2-T4	DIODE I.M		
△	D 209	11ES2-T4	DIODE I.M		
	D 210	1SS133-T2	SI DIODE IM		
	D 211	MTZJ6.8C-T2	Z DIODE I/M		
	D 212	11ES2-T4	DIODE I.M		
	D 217	MTZJ6.2C-T2	Z DIODE I/M		
	D 218	1SS133-T2	SI DIODE IM		

■ Electrical parts list (Power amp board)

Block No. 01

△	Item	Parts number	Parts name	Remarks	Area	△	Item	Parts number	Parts name	Remarks	Area
	D 219	11ES2-T4	DIODE I.M				Q 308	KTC3200/GL-T	TRANSISTOR		
	D 220	11ES2-T4	DIODE I.M				Q 309	2SD637/QR/	TRANSISTOR		
	D 221	1SS133-T2	SI DIODE IM				Q 310	2SD637/QR/	TRANSISTOR		
	D 301	1SS133-T2	SI DIODE IM				Q 311	KTC3200/GL-T	TRANSISTOR		
	D 302	1SS133-T2	SI DIODE IM				Q 312	KTC3200/GL-T	TRANSISTOR		
	D 303	SLR-342MC-T	LED				Q 313	KTA1268/GL-T	TRANSISTOR		
	D 304	SLR-342MC-T	LED				Q 314	KTA1268/GL-T	TRANSISTOR		
	D 305	1SS133-T2	SI DIODE IM			△	Q 315	2SD2390/OPY/-F6	TRANSISTOR		
	D 306	1SS133-T2	SI DIODE IM			△	Q 316	2SD2390/OPY/-F6	TRANSISTOR		
	D 307	1SS133-T2	SI DIODE IM			△	Q 317	2SB1560/OPY/-F6	TRANSISTOR		
	D 308	1SS133-T2	SI DIODE IM			△	Q 318	2SB1560/OPY/-F6	TRANSISTOR		
	D 309	1SS133-T2	SI DIODE IM				Q 319	KTA1268/GL-T	TRANSISTOR		
	D 310	1SS133-T2	SI DIODE IM				Q 320	KTA1268/GL-T	TRANSISTOR		
	D 801	1SS133-T2	SI DIODE IM				Q 501	KTA1267/YG-T	TRANSISTOR		
	D 802	1SS133-T2	SI DIODE IM				Q 502	KTC3199/GL-T	TRANSISTOR		
	D 805	1SS133-T2	SI DIODE IM				Q 503	KRC101M-T	TR I/M		
	D 806	1SS133-T2	SI DIODE IM				Q 504	KTA1267/YG-T	TRANSISTOR		
	D 807	1SS133-T2	SI DIODE IM				Q 505	KTC3199/GL-T	TRANSISTOR		
	D 808	1SS133-T2	SI DIODE IM				Q 801	2SC2240/L-T	TR.I/M		
	D 809	1SS133-T2	SI DIODE IM				Q 802	2SC2240/L-T	TR.I/M		
	D 810	1SS133-T2	SI DIODE IM				Q 803	2SC2240/L-T	TR.I/M		
	D 901	1SS133-T2	SI DIODE IM				Q 804	2SC2240/L-T	TR.I/M		
	D 905	1SS133-T2	SI DIODE IM				Q 805	KTA1268/GL-T	TRANSISTOR		
	D 907	1SS133-T2	SI DIODE IM				Q 806	KTA1268/GL-T	TRANSISTOR		
	D 909	1SS133-T2	SI DIODE IM				Q 809	2SD637/QR/	TRANSISTOR		
	EP 1	E409182-001SM	GRAND TERMINAL				Q 810	2SD637/QR/	TRANSISTOR		
	EP201	QNZ0136-001Z	EARTH PLATE				Q 811	KTC3200/GL-T	TRANSISTOR		
	FC211	QNG0020-001Z	FUSE CLIP	F201			Q 812	KTC3200/GL-T	TRANSISTOR		
	FC212	QNG0020-001Z	FUSE CLIP	F201			Q 813	KTA1268/GL-T	TRANSISTOR		
	FC221	QNG0020-001Z	FUSE CLIP	F202			Q 814	KTA1268/GL-T	TRANSISTOR		
	FC222	QNG0020-001Z	FUSE CLIP	F202		△	Q 815	2SD2390/OPY/-F6	TRANSISTOR		
	FC231	QNG0020-001Z	FUSE CLIP	F203			Q 816	2SD2390/OPY/-F6	TRANSISTOR		
	FC232	QNG0020-001Z	FUSE CLIP	F203			Q 817	2SB1560/OPY/-F6	TRANSISTOR		
	FC251	QNG0020-001Z	FUSE CLIP	F205			Q 818	2SB1560/OPY/-F6	TRANSISTOR		
	FC252	QNG0020-001Z	FUSE CLIP	F205			Q 819	KTA1268/GL-T	TRANSISTOR		
	FW201	QUM137-14Z4Z4	PARA RIBON WIRE				Q 820	KTA1268/GL-T	TRANSISTOR		
	FW251	QUM133-08Z4Z4	PARA RIBON WIRE				Q 901	2SC2240/L-T	TR.I/M		
	IC501	NJM2246D	IC				Q 903	2SC2240/L-T	TR.I/M		
	J 501	QNN0063-001	PIN JACK				Q 905	KTA1268/GL-T	TRANSISTOR		
	J 502	QNN0063-001	PIN JACK	VCR(R/P)			Q 909	2SD637/QR/	TRANSISTOR		
	J 503	QNN0017-002	PIN JACK	DBS			Q 911	KTC3200/GL-T	TRANSISTOR		
	J 521	QNS0073-001	JACK				Q 913	KTA1268/GL-T	TRANSISTOR		
	J1331	QNS0022-001	JACK				Q 915	2SD2390/OPY/-F6	TRANSISTOR		
	L 301	QQLZ005-R45	INDUCTOR				Q 917	2SB1560/OPY/-F6	TRANSISTOR		
	L 302	QQLZ005-R45	INDUCTOR				Q 919	KTA1268/GL-T	TRANSISTOR		
	L 801	QQLZ005-R45	INDUCTOR			△	R 201	QRJ146J-2R7X	UNF C RESISTOR	2.7 5% 1/4W	
	L 802	QQLZ005-R45	INDUCTOR			△	R 203	QRJ146J-100X	UNF C RESISTOR	10 5% 1/4W	
	L 901	QQLZ005-R45	INDUCTOR			△	R 204	QRJ146J-821X	UNF C RESISTOR	820 5% 1/4W	
	Q 202	KRC105M-T	D.TR.I.M.			△	R 208	QRJ146J-100X	UNF C RESISTOR	10 5% 1/4W	
	Q 203	KTC3203/OY-T	TRANSISTOR				R 209	QRE141J-104Y	C RESISTOR	100K 5% 1/4W	
	Q 205	KTC3200/GL-T	TRANSISTOR			△	R 210	QRJ146J-680X	UNF C RESISTOR	68 5% 1/4W	
	Q 206	KRC105M-T	D.TR.I.M.			△	R 221	QRJ146J-100X	UNF C RESISTOR	10 5% 1/4W	
	Q 207	KRC105M-T	D.TR.I.M.				R 301	QRE141J-222Y	C RESISTOR	2.2K 5% 1/4W	
	Q 208	KRC105M-T	D.TR.I.M.				R 302	QRE141J-222Y	C RESISTOR	2.2K 5% 1/4W	
	Q 209	KRC105M-T	D.TR.I.M.				R 303	QRE141J-563Y	C RESISTOR	56K 5% 1/4W	
	Q 210	KRC105M-T	D.TR.I.M.				R 304	QRE141J-563Y	C RESISTOR	56K 5% 1/4W	
	Q 301	2SC2240/L-T	TR.I/M				R 305	QRE141J-123Y	C RESISTOR	12K 5% 1/4W	
	Q 302	2SC2240/L-T	TR.I/M				R 306	QRE141J-123Y	C RESISTOR	12K 5% 1/4W	
	Q 303	2SC2240/L-T	TR.I/M				R 307	QRE141J-272Y	C RESISTOR	2.7K 5% 1/4W	
	Q 304	2SC2240/L-T	TR.I/M				R 308	QRE141J-272Y	C RESISTOR	2.7K 5% 1/4W	
	Q 305	KTA1268/GL-T	TRANSISTOR				R 309	QRE141J-101Y	C RESISTOR	100 5% 1/4W	
	Q 306	KTA1268/GL-T	TRANSISTOR				R 310	QRE141J-101Y	C RESISTOR	100 5% 1/4W	
	Q 307	KTC3200/GL-T	TRANSISTOR				R 311	QRJ146J-391X	UNF C RESISTOR	390 5% 1/4W	

■ Electrical parts list (Power amp board)

Block No. 01

△	Item	Parts number	Parts name	Remarks	Area
	R 312	QRJ146J-391X	UNF C RESISTOR	390 5% 1/4W	
	R 313	QRE141J-563Y	C RESISTOR	56K 5% 1/4W	
	R 314	QRE141J-563Y	C RESISTOR	56K 5% 1/4W	
△	R 315	QRJ146J-331X	UNF C RESISTOR	330 5% 1/4W	
△	R 316	QRJ146J-331X	UNF C RESISTOR	330 5% 1/4W	
	R 317	QRE141J-473Y	C RESISTOR	47K 5% 1/4W	
	R 318	QRE141J-473Y	C RESISTOR	47K 5% 1/4W	
	R 319	QRJ146J-331X	UNF C RESISTOR	330 5% 1/4W	
	R 320	QRJ146J-331X	UNF C RESISTOR	330 5% 1/4W	
△	R 321	QRJ146J-100X	UNF C RESISTOR	10 5% 1/4W	
△	R 322	QRJ146J-100X	UNF C RESISTOR	10 5% 1/4W	
△	R 323	QRJ146J-100X	UNF C RESISTOR	10 5% 1/4W	
△	R 324	QRJ146J-100X	UNF C RESISTOR	10 5% 1/4W	
	R 325	QRE141J-361Y	C RESISTOR	360 5% 1/4W	
	R 326	QRE141J-361Y	C RESISTOR	360 5% 1/4W	
	R 327	QRE141J-471Y	C RESISTOR	470 5% 1/4W	
	R 328	QRE141J-471Y	C RESISTOR	470 5% 1/4W	
	R 329	QRE141J-471Y	C RESISTOR	470 5% 1/4W	
	R 330	QRE141J-471Y	C RESISTOR	470 5% 1/4W	
△	R 331	QRJ146J-100X	UNF C RESISTOR	10 5% 1/4W	
△	R 332	QRJ146J-100X	UNF C RESISTOR	10 5% 1/4W	
△	R 333	QRJ146J-100X	UNF C RESISTOR	10 5% 1/4W	
△	R 334	QRJ146J-100X	UNF C RESISTOR	10 5% 1/4W	
	R 335	QRE141J-121Y	C RESISTOR	120 5% 1/4W	
	R 336	QRE141J-121Y	C RESISTOR	120 5% 1/4W	
	R 337	QRE141J-121Y	C RESISTOR	120 5% 1/4W	
	R 338	QRE141J-121Y	C RESISTOR	120 5% 1/4W	
	R 339	QRE141J-181Y	C RESISTOR	180 5% 1/4W	
	R 340	QRE141J-181Y	C RESISTOR	180 5% 1/4W	
	R 341	QRE141J-181Y	C RESISTOR	180 5% 1/4W	
	R 342	QRE141J-181Y	C RESISTOR	180 5% 1/4W	
	R 343	QRZ0218-R22	C RESISTOR	1/2W	
	R 344	QRZ0218-R22	C RESISTOR	1/2W	
	R 345	QRE141J-102Y	C RESISTOR	1.0K 5% 1/4W	
	R 346	QRE141J-102Y	C RESISTOR	1.0K 5% 1/4W	
	R 347	QRE141J-153Y	C RESISTOR	15K 5% 1/4W	
	R 348	QRE141J-153Y	C RESISTOR	15K 5% 1/4W	
	R 349	QRE141J-473Y	C RESISTOR	47K 5% 1/4W	
	R 350	QRE141J-473Y	C RESISTOR	47K 5% 1/4W	
△	R 351	QRJ125J-330	UNF OMF RESISTO	33 5% 1/2W	
△	R 352	QRJ125J-330	UNF OMF RESISTO	33 5% 1/2W	
△	R 353	QRL027J-100	UNF.OMF.RES.	10 5% 1/2W	
△	R 354	QRL027J-100	UNF.OMF.RES.	10 5% 1/2W	
	R 363	QRE141J-272Y	C RESISTOR	2.7K 5% 1/4W	
	R 364	QRE141J-272Y	C RESISTOR	2.7K 5% 1/4W	
	R 501	QRE141J-331Y	C RESISTOR	330 5% 1/4W	
	R 502	QRE141J-750Y	C RESISTOR	75 5% 1/4W	
	R 503	QRE141J-331Y	C RESISTOR	330 5% 1/4W	
	R 504	QRE141J-750Y	C RESISTOR	75 5% 1/4W	
	R 505	QRE141J-750Y	C RESISTOR	75 5% 1/4W	
	R 506	QRE141J-473Y	C RESISTOR	47K 5% 1/4W	
	R 507	QRE141J-331Y	C RESISTOR	330 5% 1/4W	
	R 508	QRE141J-750Y	C RESISTOR	75 5% 1/4W	
	R 509	QRE141J-750Y	C RESISTOR	75 5% 1/4W	
	R 510	QRE141J-473Y	C RESISTOR	47K 5% 1/4W	
	R 511	QRE141J-151Y	C RESISTOR	150 5% 1/4W	
	R 512	QRE141J-271Y	C RESISTOR	270 5% 1/4W	
	R 513	QRE141J-152Y	C RESISTOR	1.5K 5% 1/4W	
	R 514	QRE141J-151Y	C RESISTOR	150 5% 1/4W	
	R 515	QRE141J-271Y	C RESISTOR	270 5% 1/4W	
	R 516	QRE141J-152Y	C RESISTOR	1.5K 5% 1/4W	
	R 521	QRE141J-221Y	C RESISTOR	220 5% 1/4W	
	R 522	QRE141J-471Y	C RESISTOR	470 5% 1/4W	

△	Item	Parts number	Parts name	Remarks	Area
	R 801	QRE141J-222Y	C RESISTOR	2.2K 5% 1/4W	
	R 802	QRE141J-222Y	C RESISTOR	2.2K 5% 1/4W	
	R 803	QRE141J-563Y	C RESISTOR	56K 5% 1/4W	
	R 804	QRE141J-563Y	C RESISTOR	56K 5% 1/4W	
	R 805	QRE141J-123Y	C RESISTOR	12K 5% 1/4W	
	R 806	QRE141J-123Y	C RESISTOR	12K 5% 1/4W	
	R 807	QRE141J-272Y	C RESISTOR	2.7K 5% 1/4W	
	R 808	QRE141J-272Y	C RESISTOR	2.7K 5% 1/4W	
	R 809	QRE141J-101Y	C RESISTOR	100 5% 1/4W	
	R 810	QRE141J-101Y	C RESISTOR	100 5% 1/4W	
	R 811	QRJ146J-391X	UNF C RESISTOR	390 5% 1/4W	
	R 812	QRJ146J-391X	UNF C RESISTOR	390 5% 1/4W	
	R 813	QRE141J-563Y	C RESISTOR	56K 5% 1/4W	
	R 814	QRE141J-563Y	C RESISTOR	56K 5% 1/4W	
△	R 815	QRJ146J-331X	UNF C RESISTOR	330 5% 1/4W	
△	R 816	QRJ146J-331X	UNF C RESISTOR	330 5% 1/4W	
△	R 821	QRJ146J-100X	UNF C RESISTOR	10 5% 1/4W	
△	R 822	QRJ146J-100X	UNF C RESISTOR	10 5% 1/4W	
△	R 823	QRJ146J-100X	UNF C RESISTOR	10 5% 1/4W	
△	R 824	QRJ146J-100X	UNF C RESISTOR	10 5% 1/4W	
	R 825	QRE141J-361Y	C RESISTOR	360 5% 1/4W	
	R 826	QRE141J-361Y	C RESISTOR	360 5% 1/4W	
	R 827	QRE141J-821Y	C RESISTOR	820 5% 1/4W	
	R 828	QRE141J-821Y	C RESISTOR	820 5% 1/4W	
	R 829	QRE141J-471Y	C RESISTOR	470 5% 1/4W	
	R 830	QRE141J-471Y	C RESISTOR	470 5% 1/4W	
△	R 831	QRJ146J-100X	UNF C RESISTOR	10 5% 1/4W	
△	R 832	QRJ146J-100X	UNF C RESISTOR	10 5% 1/4W	
△	R 833	QRJ146J-100X	UNF C RESISTOR	10 5% 1/4W	
△	R 834	QRJ146J-100X	UNF C RESISTOR	10 5% 1/4W	
	R 835	QRE141J-181Y	C RESISTOR	180 5% 1/4W	
	R 836	QRE141J-181Y	C RESISTOR	180 5% 1/4W	
	R 837	QRE141J-181Y	C RESISTOR	180 5% 1/4W	
	R 838	QRE141J-181Y	C RESISTOR	180 5% 1/4W	
	R 839	QRE141J-181Y	C RESISTOR	180 5% 1/4W	
	R 840	QRE141J-181Y	C RESISTOR	180 5% 1/4W	
	R 841	QRE141J-181Y	C RESISTOR	180 5% 1/4W	
	R 842	QRE141J-181Y	C RESISTOR	180 5% 1/4W	
	R 843	QRZ0218-R22	C RESISTOR	1/2W	
	R 844	QRZ0218-R22	C RESISTOR	1/2W	
	R 845	QRE141J-102Y	C RESISTOR	1.0K 5% 1/4W	
	R 846	QRE141J-102Y	C RESISTOR	1.0K 5% 1/4W	
	R 847	QRE141J-183Y	C RESISTOR	18K 5% 1/4W	
	R 848	QRE141J-183Y	C RESISTOR	18K 5% 1/4W	
	R 849	QRE141J-123Y	C RESISTOR	12K 5% 1/4W	
	R 850	QRE141J-123Y	C RESISTOR	12K 5% 1/4W	
△	R 851	QRJ125J-330	UNF OMF RESISTO	33 5% 1/2W	
△	R 852	QRJ125J-330	UNF OMF RESISTO	33 5% 1/2W	
△	R 853	QRL027J-100	UNF.OMF.RES.	10 5% 1/2W	
△	R 854	QRL027J-100	UNF.OMF.RES.	10 5% 1/2W	
	R 855	QRE141J-332Y	C RESISTOR	3.3K 5% 1/4W	
	R 856	QRE141J-332Y	C RESISTOR	3.3K 5% 1/4W	
	R 857	QRE141J-332Y	C RESISTOR	3.3K 5% 1/4W	
	R 858	QRE141J-332Y	C RESISTOR	3.3K 5% 1/4W	
	R 859	QRE141J-332Y	C RESISTOR	3.3K 5% 1/4W	
	R 860	QRE141J-332Y	C RESISTOR	3.3K 5% 1/4W	
	R 861	QRE141J-332Y	C RESISTOR	3.3K 5% 1/4W	
	R 862	QRE141J-332Y	C RESISTOR	3.3K 5% 1/4W	
	R 863	QRE141J-272Y	C RESISTOR	2.7K 5% 1/4W	
	R 864	QRE141J-272Y	C RESISTOR	2.7K 5% 1/4W	
	R 901	QRE141J-222Y	C RESISTOR	2.2K 5% 1/4W	
	R 903	QRE141J-563Y	C RESISTOR	56K 5% 1/4W	
	R 905	QRE141J-123Y	C RESISTOR	12K 5% 1/4W	

■ Electrical parts list (Power amp board)

Block No. 01

△	Item	Parts number	Parts name	Remarks	Area
	R 907	QRE141J-272Y	C RESISTOR	2.7K 5% 1/4W	
	R 909	QRE141J-101Y	C RESISTOR	100 5% 1/4W	
	R 911	QRJ146J-301X	UNF C RESISTOR	300 5% 1/4W	
	R 913	QRE141J-563Y	C RESISTOR	56K 5% 1/4W	
△	R 915	QRJ146J-331X	UNF C RESISTOR	330 5% 1/4W	
△	R 921	QRJ146J-100X	UNF C RESISTOR	10 5% 1/4W	
△	R 923	QRJ146J-100X	UNF C RESISTOR	10 5% 1/4W	
	R 925	QRE141J-361Y	C RESISTOR	360 5% 1/4W	
	R 927	QRE141J-821Y	C RESISTOR	820 5% 1/4W	
	R 929	QRE141J-471Y	C RESISTOR	470 5% 1/4W	
△	R 931	QRJ146J-100X	UNF C RESISTOR	10 5% 1/4W	
△	R 933	QRJ146J-100X	UNF C RESISTOR	10 5% 1/4W	
	R 935	QRE141J-181Y	C RESISTOR	180 5% 1/4W	
	R 937	QRE141J-181Y	C RESISTOR	180 5% 1/4W	
	R 939	QRE141J-181Y	C RESISTOR	180 5% 1/4W	
	R 941	QRE141J-181Y	C RESISTOR	180 5% 1/4W	
	R 943	QRZ0218-R22	C RESISTOR	1/2W	
	R 945	QRE141J-102Y	C RESISTOR	1.0K 5% 1/4W	
	R 947	QRE141J-183Y	C RESISTOR	18K 5% 1/4W	
	R 949	QRE141J-473Y	C RESISTOR	47K 5% 1/4W	
△	R 951	QRJ125J-330	UNF OMF RESISTO	33 5% 1/2W	
△	R 953	QRL027J-100	UNF.OMF.RES.	10 5% 1/2W	
	R 955	QRE141J-332Y	C RESISTOR	3.3K 5% 1/4W	
	R 957	QRE141J-332Y	C RESISTOR	3.3K 5% 1/4W	
	R 959	QRE141J-332Y	C RESISTOR	3.3K 5% 1/4W	
	R 961	QRE141J-332Y	C RESISTOR	3.3K 5% 1/4W	
	R 963	QRE141J-272Y	C RESISTOR	2.7K 5% 1/4W	
△	RY202	QSK0142-001	RELAY		
△	RY203	QSK0109-001	RELAY		
△	R1331	QRL027J-471	UNF OMF.RES.	470 5% 1/2W	
△	R1332	QRL027J-471	UNF OMF.RES.	470 5% 1/2W	
△	T 202	QQT0281-002	POWER TRANSF		
	TA201	QNZ0079-001Z	TAB IM		
	TA202	QNZ0079-001Z	TAB IM		
△	TH301	QAD0012-202	BATTERY PACK		
△	TH302	QAD0012-202	BATTERY PACK		
△	TH801	QAD0012-202	BATTERY PACK		
△	TH802	QAD0012-202	BATTERY PACK		
△	TH901	QAD0012-202	BATTERY PACK		
	VR301	QVP0008-102Z	SEMI V RESISTOR		
	VR302	QVP0008-102Z	SEMI V RESISTOR		

■ Electrical parts list (Main board)

Block No. 02

△	Item	Parts number	Parts name	Remarks	Area	△	Item	Parts number	Parts name	Remarks	Area	
	C 400	QCBB1HK-103Y	C CAPACITOR	.010MF 10% 50V			C 584	QCZ0202-155Z	ML C CAPA I/M	1.5MF		
	C 401	QETN1HM-475Z	E CAPACITOR	4.7MF 20% 50V			CN311	QGB2510J1-14	CONNECTOR			
	C 402	QETN1HM-475Z	E CAPACITOR	4.7MF 20% 50V			CN312	QGB2510J1-14	CONNECTOR			
	C 403	QCBB1HK-101Y	C CAPACITOR	100PF 10% 50V			CN321	QGB2510J1-14	CONNECTOR			
	C 404	QCBB1HK-101Y	C CAPACITOR	100PF 10% 50V			CN331	QGB2510J1-14	CONNECTOR			
	C 405	QETN1AM-107Z	E CAPACITOR	100MF 20% 10V			CN332	QGB2510J1-14	CONNECTOR			
	C 406	QETN1AM-107Z	E CAPACITOR	100MF 20% 10V			CN351	QJK012-032403	SKT WIRE ASSY			
	C 407	QCS31HJ-101Z	C CAPACITOR	100PF 5% 50V			CN371	QJP001-031201	SHI CR C-B WIRE			
	C 408	QCS31HJ-101Z	C CAPACITOR	100PF 5% 50V			CN372	QJP002-021201	SHI CR C-B WIRE			
	C 409	QFLC1HJ-182Z	M CAPACITOR	1800PF 5% 50V			CN373	QJP001-031201	SHI CR C-B WIRE			
	C 410	QFLC1HJ-182Z	M CAPACITOR	1800PF 5% 50V			CN401	QGB2510K1-14	CONNECTOR			
	C 411	QFLC1HJ-682Z	M CAPACITOR	6800PF 5% 50V			CN451	QGB2510K1-11	CONNECTOR			
	C 412	QFLC1HJ-682Z	M CAPACITOR	6800PF 5% 50V			CN551	QGB2510K1-08	CONNECTOR			
	C 413	QETN1HM-475Z	E CAPACITOR	4.7MF 20% 50V			C1301	QFZ9076-104Z	MM CAPACITOR	.10MF		
	C 414	QETN1HM-475Z	E CAPACITOR	4.7MF 20% 50V			C1302	QCE22HP-103	C CAPACITOR	.010MF +100:-0%		
	C 415	QETN1CM-476Z	E CAPACITOR	47MF 20% 16V			C1303	QCE22HP-103	C CAPACITOR	.010MF +100:-0%		
	C 416	QETN1CM-476Z	E CAPACITOR	47MF 20% 16V			C1304	QEZ0341-688	E CAPACITER	6800MF		
	C 417	QCBB1HK-331Y	C CAPACITOR	330PF 10% 50V			C1305	QEZ0341-688	E CAPACITER	6800MF		
	C 418	QCBB1HK-331Y	C CAPACITOR	330PF 10% 50V			C1306	QETN1EM-476Z	E CAPACITOR	47MF 20% 25V		
	C 419	QCBB1HK-223Y	C CAPACITOR	.022MF 10% 50V			C1308	QETN1HM-476Z	E CAPACITOR	47MF 20% 50V		
	C 420	QCBB1HK-223Y	C CAPACITOR	.022MF 10% 50V			C1309	QEKC1HM-106Z	E CAPACITOR	10MF 20% 50V		
	C 421	QCBB1HK-331Y	C CAPACITOR	330PF 10% 50V			C1310	QEKC1CM-476Z	E CAPACITOR	47MF 20% 16V		
	C 422	QCBB1HK-331Y	C CAPACITOR	330PF 10% 50V			C1311	QEKC1HM-226Z	E CAPACITOR	22MF 20% 50V		
	C 427	QCBB1HK-681Y	C CAPACITOR	680PF 10% 50V			C1351	QETN1HM-475Z	E CAPACITOR	4.7MF 20% 50V		
	C 428	QCBB1HK-681Y	C CAPACITOR	680PF 10% 50V			C1352	QEKC1HM-475Z	E CAPACITOR	4.7MF 20% 50V		
	C 433	QCBB1HK-681Y	C CAPACITOR	680PF 10% 50V			C1353	QEKC1HM-475Z	E CAPACITOR	4.7MF 20% 50V		
	C 434	QCBB1HK-681Y	C CAPACITOR	680PF 10% 50V			C1354	QEKC1HM-475Z	E CAPACITOR	4.7MF 20% 50V		
	C 440	QCBB1HK-221Y	C CAPACITOR	220PF 10% 50V			C1355	QFLC1HJ-223Z	M CAPACITOR	.022MF 5% 50V		
	C 441	QETN1EM-106Z	E CAPACITOR	10MF 20% 25V			C1356	QCS31HJ-221Z	C CAPACITOR	220PF 5% 50V		
	C 442	QETN1EM-106Z	E CAPACITOR	10MF 20% 25V			C1357	QFLC1HJ-223Z	M CAPACITOR	.022MF 5% 50V		
	C 443	QETN1EM-226Z	E CAPACITOR	22MF 20% 25V			C1358	QCS31HJ-221Z	C CAPACITOR	.202PF 5% 50V		
	C 444	QETN1EM-226Z	E CAPACITOR	22MF 20% 25V			C1359	QFLC1HJ-223Z	M CAPACITOR	.022MF 5% 50V		
	C 445	QCBB1HK-223Y	C CAPACITOR	.022MF 10% 50V			C1360	QFLC1HJ-223Z	M CAPACITOR	.022MF 5% 50V		
	C 446	QCBB1HK-223Y	C CAPACITOR	.022MF 10% 50V			C1361	QFLC1HJ-223Z	M CAPACITOR	.022MF 5% 50V		
	C 451	QCBB1HK-331Y	C CAPACITOR	330PF 10% 50V			C1362	QCS31HJ-221Z	C CAPACITOR	220PF 5% 50V		
	C 452	QCBB1HK-331Y	C CAPACITOR	330PF 10% 50V			C1363	QFLC1HJ-223Z	M CAPACITOR	.022MF 5% 50V		
	C 453	QCBB1HK-561Y	C CAPACITOR	560PF 10% 50V			C1364	QCS31HJ-221Z	C CAPACITOR	220PF 5% 50V		
	C 454	QCBB1HK-331Y	C CAPACITOR	330PF 10% 50V			C1365	QFLC1HJ-473Z	M CAPACITOR	.047MF 5% 50V		
	C 455	QCBB1HK-331Y	C CAPACITOR	330PF 10% 50V			C1366	QCS31HJ-221Z	C CAPACITOR	220PF 5% 50V		
	C 456	QCBB1HK-331Y	C CAPACITOR	330PF 10% 50V			C1367	QCBB1HK-221Y	C CAPACITOR	220PF 10% 50V		
	C 459	QFLC1HJ-104Z	M CAPACITOR	.10MF 5% 50V			C1368	QFLC1HJ-102Z	M CAPACITOR	1000PF 5% 50V		
	C 460	QCZ0202-155Z	ML C CAPA I/M	1.5MF			C1369	QFLC1HJ-223Z	M CAPACITOR	.022MF 5% 50V		
	C 461	QETN1HM-475Z	E CAPACITOR	4.7MF 20% 50V			C1370	QCS31HJ-221Z	C CAPACITOR	220PF 5% 50V		
	C 463	QETN1HM-475Z	E CAPACITOR	4.7MF 20% 50V			C1371	QCBB1HK-221Y	C CAPACITOR	220PF 10% 50V		
	C 481	QCBB1HK-223Y	C CAPACITOR	.022MF 10% 50V			C1372	QFLC1HJ-102Z	M CAPACITOR	1000PF 5% 50V		
	C 482	QCBB1HK-223Y	C CAPACITOR	.022MF 10% 50V			C1373	QFLC1HJ-223Z	M CAPACITOR	.022MF 5% 50V		
	C 551	QDX31EM-473Z	C CAPACITOR				C1374	QCS31HJ-221Z	C CAPACITOR	220PF 5% 50V		
	C 552	QEKC1HM-475Z	E CAPACITOR	4.7MF 20% 50V			C1375	QFLC1HJ-102Z	M CAPACITOR	1000PF 5% 50V		
	C 553	QDX31EM-473Z	C CAPACITOR				C1376	QCBB1HK-221Y	C CAPACITOR	220PF 10% 50V		
	C 554	QEKC1HM-475Z	E CAPACITOR	4.7MF 20% 50V			C1377	QFLC1HJ-103Z	M CAPACITOR	.010MF 5% 50V		
	C 555	QDX31EM-473Z	C CAPACITOR				C1378	QFLC1HJ-103Z	M CAPACITOR	.010MF 5% 50V		
	C 556	QETN0JM-477Z	E CAPACITOR	470MF 20% 6.3V			△	D1301	30DF2-FC	DIODE		
	C 557	QCS31HJ-470Z	C CAPACITOR	47PF 5% 50V			△	D1302	30DF2-FC	DIODE		
	C 558	QCS31HJ-470Z	C CAPACITOR	47PF 5% 50V			△	D1303	30DF2-FC	DIODE		
	C 559	QDX31EM-473Z	C CAPACITOR				△	D1304	30DF2-FC	DIODE		
	C 560	QEKC1HM-475Z	E CAPACITOR	4.7MF 20% 50V				D1305	MTZJ22C-T2	ZENER DIODE		
	C 561	QDX31EM-473Z	C CAPACITOR					D1306	MTZJ30C-T2	ZENER DIODE		
	C 562	QETN0JM-477Z	E CAPACITOR	470MF 20% 6.3V				D1307	1SS133-T2	SI DIODE IM		
	C 563	QCS31HJ-470Z	C CAPACITOR	47PF 5% 50V				D1308	1SS133-T2	SI DIODE IM		
	C 564	QCS31HJ-470Z	C CAPACITOR	47PF 5% 50V				D1309	MTZJ20C-T2	Z.DIODE I.M		
	C 581	QEKC1CM-476Z	E CAPACITOR	47MF 20% 16V				D1351	1SS133-T2	SI DIODE IM		
	C 582	QCZ0202-155Z	ML C CAPA I/M	1.5MF				D1352	1SS133-T2	SI DIODE IM		
	C 583	QEKC1CM-476Z	E CAPACITOR	47MF 20% 16V				D1353	1SS133-T2	SI DIODE IM		

■ Electrical parts list (Main board)

Block No. 02

Item	Parts number	Parts name	Remarks	Area
D1354	1SS133-T2	SI DIODE IM		
D1355	1SS133-T2	SI DIODE IM		
D1356	MTZJ5.1C-T2	ZENER DIODE		
D1357	1SS133-T2	SI DIODE IM		
D1358	1SS133-T2	SI DIODE IM		
D1359	1SS133-T2	SI DIODE IM		
D1360	1SS133-T2	SI DIODE IM		
EP301	QNZ0136-001Z	EARTH PLATE		
FW301	QUM135-25Z4Z4	PARA RIBON WIRE		
FW302	QUM136-25Z4Z4	PARA RIBON WIRE		
FW303	QUM135-28DGZ4	PARA RIBON WIRE		
FW341	QUM135-20DGZ4	PARA RIBON WIRE		
IC401	NJM4580DD	IC		
IC402	TC9164AN	IC		
IC403	BA15218N	IC		
IC451	BA15218	IC		
IC551	NJM2246D	IC		
IC552	NJM2246D	IC		
J 401	QNN0389-001	PIN JACK	PHONO	
J 402	QNN0168-001	PIN JACK		
J 403	QNN0168-001	PIN JACK		
J 404	QNN0389-001	PIN JACK	DVD FL/FR	
J 405	QNN0388-001	PIN JACK	DVD C/SW/RL/RR	
J 406	QNN0060-001	PIN JACK		
J 551	QND0091-001	S JACK		
J 552	QND0091-001	S JACK	VCR(R/P)	
J 553	QND0092-001	S JACK	DBS	
L1351	QQLZ005-R45	INDUCTOR		
L1352	QQLZ005-R45	INDUCTOR		
L1353	QQLZ005-R45	INDUCTOR		
L1354	QQLZ005-R45	INDUCTOR		
L1355	QQLZ005-R45	INDUCTOR		
Q 553	KTC3199/GL-T	TRANSISTOR		
Q 554	KTC3199/GL-T	TRANSISTOR		
Q 571	KTC3199/GL-T	TRANSISTOR		
Q 572	KTC3199/GL-T	TRANSISTOR		
Q 573	KRC107M-T	D.TR.I.M		
Q 574	KRC107M-T	D.TR.I.M		
Q1301	KTA1046/Y/	TRANSISTOR		
Q1302	KTC3200/GL-T	TRANSISTOR		
Q1303	KTA1268/GL-T	TRANSISTOR		
Q1304	KTC3199/GL-T	TRANSISTOR		
Q1305	2SD2395/EF/	TRANSISTOR		
Q1306	KTA1023/OY-T	TRANSISTOR		
Q1307	KTC3200/GL-T	TRANSISTOR		
Q1351	KRC109M-T	D.TR.I.M.		
Q1352	KRC109M-T	D.TR.I.M.		
Q1353	KRC109M-T	D.TR.I.M.		
Q1354	KRC109M-T	D.TR.I.M.		
Q1355	KRC109M-T	D.TR.I.M.		
Q1356	KRC109M-T	D.TR.I.M.		
Q1357	KRC109M-T	D.TR.I.M.		
Q1358	KRC109M-T	D.TR.I.M.		
R 401	QRE141J-222Y	C RESISTOR	2.2K 5% 1/4W	
R 402	QRE141J-222Y	C RESISTOR	2.2K 5% 1/4W	
R 403	QRE141J-473Y	C RESISTOR	47K 5% 1/4W	
R 404	QRE141J-473Y	C RESISTOR	47K 5% 1/4W	
R 405	QRE141J-561Y	C RESISTOR	560 5% 1/4W	
R 406	QRE141J-561Y	C RESISTOR	560 5% 1/4W	
R 407	QRE141J-393Y	C RESISTOR	39K 5% 1/4W	
R 408	QRE141J-393Y	C RESISTOR	39K 5% 1/4W	
R 409	QRE141J-474Y	C RESISTOR	470K 5% 1/4W	
R 410	QRE141J-474Y	C RESISTOR	470K 5% 1/4W	

Item	Parts number	Parts name	Remarks	Area
R 411	QRE141J-104Y	C RESISTOR	100K 5% 1/4W	
R 412	QRE141J-104Y	C RESISTOR	100K 5% 1/4W	
R 421	QRE141J-471Y	C RESISTOR	470 5% 1/4W	
R 422	QRE141J-471Y	C RESISTOR	470 5% 1/4W	
R 423	QRE141J-272Y	C RESISTOR	2.7K 5% 1/4W	
R 424	QRE141J-272Y	C RESISTOR	2.7K 5% 1/4W	
R 425	QRE141J-471Y	C RESISTOR	470 5% 1/4W	
R 426	QRE141J-471Y	C RESISTOR	470 5% 1/4W	
R 429	QRE141J-102Y	C RESISTOR	1.0K 5% 1/4W	
R 430	QRE141J-102Y	C RESISTOR	1.0K 5% 1/4W	
R 431	QRE141J-471Y	C RESISTOR	470 5% 1/4W	
R 432	QRE141J-471Y	C RESISTOR	470 5% 1/4W	
R 435	QRE141J-102Y	C RESISTOR	1.0K 5% 1/4W	
R 436	QRE141J-102Y	C RESISTOR	1.0K 5% 1/4W	
R 440	QRE141J-102Y	C RESISTOR	1.0K 5% 1/4W	
R 441	QRE141J-104Y	C RESISTOR	100K 5% 1/4W	
R 442	QRE141J-104Y	C RESISTOR	100K 5% 1/4W	
R 443	QRE141J-104Y	C RESISTOR	100K 5% 1/4W	
R 444	QRE141J-104Y	C RESISTOR	100K 5% 1/4W	
R 445	QRE141J-104Y	C RESISTOR	100K 5% 1/4W	
R 446	QRE141J-104Y	C RESISTOR	100K 5% 1/4W	
R 449	QRJ146J-271X	UNF C RESISTOR	270 5% 1/4W	
R 450	QRJ146J-271X	UNF C RESISTOR	270 5% 1/4W	
R 451	QRE141J-471Y	C RESISTOR	470 5% 1/4W	
R 452	QRE141J-471Y	C RESISTOR	470 5% 1/4W	
R 453	QRE141J-102Y	C RESISTOR	1.0K 5% 1/4W	
R 454	QRE141J-471Y	C RESISTOR	470 5% 1/4W	
R 455	QRE141J-471Y	C RESISTOR	470 5% 1/4W	
R 456	QRE141J-471Y	C RESISTOR	470 5% 1/4W	
R 458	QRJ146J-271X	UNF C RESISTOR	270 5% 1/4W	
R 459	QRJ146J-271X	UNF C RESISTOR	270 5% 1/4W	
R 462	QRE141J-104Y	C RESISTOR	100K 5% 1/4W	
R 464	QRE141J-104Y	C RESISTOR	100K 5% 1/4W	
R 551	QRE141J-750Y	C RESISTOR	75 5% 1/4W	
R 552	QRE141J-750Y	C RESISTOR	75 5% 1/4W	
R 553	QRE141J-750Y	C RESISTOR	75 5% 1/4W	
R 554	QRE141J-750Y	C RESISTOR	75 5% 1/4W	
R 555	QRE141J-750Y	C RESISTOR	75 5% 1/4W	
R 556	QRE141J-750Y	C RESISTOR	75 5% 1/4W	
R 557	QRE141J-473Y	C RESISTOR	47K 5% 1/4W	
R 558	QRE141J-473Y	C RESISTOR	47K 5% 1/4W	
R 559	QRE141J-750Y	C RESISTOR	75 5% 1/4W	
R 560	QRE141J-750Y	C RESISTOR	75 5% 1/4W	
R 561	QRE141J-750Y	C RESISTOR	75 5% 1/4W	
R 562	QRE141J-750Y	C RESISTOR	75 5% 1/4W	
R 563	QRE141J-473Y	C RESISTOR	47K 5% 1/4W	
R 564	QRE141J-473Y	C RESISTOR	47K 5% 1/4W	
R 565	QRE141J-431Y	C RESISTOR	430 5% 1/4W	
R 566	QRE141J-241Y	C RESISTOR	240 5% 1/4W	
R 571	QRE141J-431Y	C RESISTOR	430 5% 1/4W	
R 572	QRE141J-241Y	C RESISTOR	240 5% 1/4W	
R 573	QRE141J-751Y	C RESISTOR	750 5% 1/4W	
R 574	QRE141J-751Y	C RESISTOR	750 5% 1/4W	
R 581	QRJ146J-6R8X	UNF C RESISTOR	6.8 5% 1/4W	
RY301	QSK0109-001	RELAY		
RY302	QSK0109-001	RELAY		
RY303	QSK0109-001	RELAY		
RY304	QSK0109-001	RELAY		
R1301	QRL027J-332	UNF.OMF.RES.	3.3K 5% 1/2W	
R1302	QRZ9005-100X	F RESISTOR	10 1/4W	
R1303	QRJ146J-562X	UNF C RESISTOR	5.6K 5% 1/4W	
R1304	QRE141J-104Y	C RESISTOR	100K 5% 1/4W	
R1305	QRE141J-104Y	C RESISTOR	100K 5% 1/4W	

■ Electrical parts list (Main board)

Block No. 02

△	Item	Parts number	Parts name	Remarks	Area
	R1306	QRE141J-823Y	C RESISTOR	82K 5% 1/4W	
	R1307	QRE141J-104Y	C RESISTOR	100K 5% 1/4W	
	R1308	QRE141J-104Y	C RESISTOR	100K 5% 1/4W	
	R1309	QRE141J-103Y	C RESISTOR	10K 5% 1/4W	
	R1310	QRE141J-103Y	C RESISTOR	10K 5% 1/4W	
	R1311	QRE141J-104Y	C RESISTOR	100K 5% 1/4W	
	R1312	QRE141J-104Y	C RESISTOR	100K 5% 1/4W	
△	R1313	QRZ9005-100X	F RESISTOR	10 1/4W	
△	R1314	QRJ146J-103X	UNF C RESISTOR	10K 5% 1/4W	
△	R1315	QRJ146J-2R2X	UNF C RESISTOR	2.2 5% 1/4W	
△	R1316	QRJ146J-102X	UNF C RESISTOR	1.0K 5% 1/4W	
△	R1317	QRJ146J-223X	UNF C RESISTOR	22K 5% 1/4W	
	R1318	QRE141J-223Y	C RESISTOR	22K 5% 1/4W	
	R1319	QRE141J-473Y	C RESISTOR	47K 5% 1/4W	
△	R1351	QRJ146J-680X	UNF C RESISTOR	68 5% 1/4W	
△	R1352	QRJ146J-680X	UNF C RESISTOR	68 5% 1/4W	
△	R1353	QRJ146J-680X	UNF C RESISTOR	68 5% 1/4W	
△	R1354	QRJ146J-680X	UNF C RESISTOR	68 5% 1/4W	
△	R1355	QRJ146J-392X	UNF C RESISTOR	3.9K 5% 1/4W	
	R1356	QRE141J-472Y	C RESISTOR	4.7K 5% 1/4W	
	R1357	QRE141J-223Y	C RESISTOR	22K 5% 1/4W	
	R1358	QRE141J-682Y	C RESISTOR	6.8K 5% 1/4W	
	R1359	QRE141J-472Y	C RESISTOR	4.7K 5% 1/4W	
	R1360	QRE141J-472Y	C RESISTOR	4.7K 5% 1/4W	
	R1361	QRE141J-472Y	C RESISTOR	4.7K 5% 1/4W	
	R1362	QRE141J-472Y	C RESISTOR	4.7K 5% 1/4W	
	R1363	QRE141J-472Y	C RESISTOR	4.7K 5% 1/4W	
	R1364	QRE141J-223Y	C RESISTOR	22K 5% 1/4W	
	R1365	QRE141J-682Y	C RESISTOR	6.8K 5% 1/4W	
	R1366	QRE141J-223Y	C RESISTOR	22K 5% 1/4W	
	R1367	QRE141J-682Y	C RESISTOR	6.8K 5% 1/4W	
△	R1368	QRJ146J-2R7X	UNF C RESISTOR	2.7 5% 1/4W	
△	R1369	QRJ146J-2R7X	UNF C RESISTOR	2.7 5% 1/4W	
△	R1370	QRJ146J-2R7X	UNF C RESISTOR	2.7 5% 1/4W	
△	R1371	QRJ146J-2R7X	UNF C RESISTOR	2.7 5% 1/4W	
△	R1372	QRJ146J-2R7X	UNF C RESISTOR	2.7 5% 1/4W	
△	R1373	QRJ146J-2R7X	UNF C RESISTOR	2.7 5% 1/4W	
△	R1374	QRJ146J-2R7X	UNF C RESISTOR	2.7 5% 1/4W	
	ST301	QNB0047-001	SPK TERMINAL	SPK1	
	ST302	QNB0001-002	SPK TERMINAL	SPK2	
	ST303	QNB0101-001	SPK TERMINAL		

■ Electrical parts list (System control & Audio board) Block No. 03

△	Item	Parts number	Parts name	Remarks	Area
	BK701	LV42093-001A	FL HOLDER(L)		
	BK702	LV42092-001A	FL HOLDER(R)		
	C 701	QEKC0JM-107Z	E CAPACITOR	100MF 20% 6.3V	
	C 702	QCZ0202-155Z	ML C CAPA I/M	1.5MF	
	C 703	QEKC1HM-225Z	E CAPACITOR	2.2MF 20% 50V	
	C 704	NCB31CK-223X	C CAPACITOR		
	C 705	QEKC0JM-107Z	E CAPACITOR	100MF 20% 6.3V	
	C 706	NCB21HK-331X	C.CAPA. C.M		
	C 707	QEKC1HM-475Z	E CAPACITOR	4.7MF 20% 50V	
	C 708	QEKC1HM-475Z	E CAPACITOR	4.7MF 20% 50V	
	C 709	QEKC1HM-475Z	E CAPACITOR	4.7MF 20% 50V	
	C 713	NCB21HK-103X	C CAPACITOR		
	C 714	NCB21HK-103X	C CAPACITOR		
	C 715	NCB21HK-103X	C CAPACITOR		
	C 716	NCB21HK-103X	C CAPACITOR		
	C 717	NCB21HK-103X	C CAPACITOR		
	C 718	NCB21HK-103X	C CAPACITOR		
	C 719	NCB21HK-103X	C CAPACITOR		
	C 720	NCB31CK-104X	C CAPACITOR		
	C 721	NCB31CK-104X	C CAPACITOR		
	C 722	QCZ0202-155Z	ML C CAPA I/M	1.5MF	
	C 730	NCB31CK-104X	C CAPACITOR		
	CN402	QGF1205C1-25	CONNECTOR		
	CN403	QGA2001C1-04	4P PLUG ASSY		
	CN411	QGB2501J1-12	CONNECTOR		
	CN412	QGB2501J1-04	CONNECTOR		
	CN421	QGB2510J1-14	CONNECTOR		
	CN431	QGB2510J1-11	CONNECTOR		
	CN441	QGB2510J1-07	CONNECTOR		
	CN461	QGB2510J1-08	CONNECTOR		
	CN471	QGA2501C1-03	3P CONNECTOR		
	CN472	QGA2501C1-02	2P CONNECTOR		
	CN473	QGA2501C1-03	3P CONNECTOR		
	CN481	QGB2510J1-20	CONNECTOR		
	CN491	QGB2510J1-04	CONNECTOR		
	CN701	QGF1205F1-14	CONNECTOR		
	CN702	QGF1205F1-25	CONNECTOR		
	CN703	WJS0021-001A	SIN CR C-B WIRE	RDS	
	CN704	WJS0020-001A	SKT.WIRE ASS'Y		
	CN714	QGA2001C1-03	3P PLUG ASSY		
	C1401	QETN1HM-476Z	E CAPACITOR	47MF 20% 50V	
	C1402	QETN1EM-107Z	E CAPACITOR	100MF 20% 25V	
	C1403	QETN1EM-107Z	E CAPACITOR	100MF 20% 25V	
	C1404	QETN1EM-107Z	E CAPACITOR	100MF 20% 25V	
	C1405	QETN1EM-107Z	E CAPACITOR	100MF 20% 25V	
	C1406	QETN1EM-107Z	E CAPACITOR	100MF 20% 25V	
	C1407	QCF31HZ-223Z	C CAPACITOR	.022MF +80-20%	
	C1408	QETN1EM-476Z	E CAPACITOR	47MF 20% 25V	
	C1409	QETN1EM-476Z	E CAPACITOR	47MF 20% 25V	
	C1410	NCB31CK-223X	C CAPACITOR		
	C1411	NCB31CK-223X	C CAPACITOR		
	C1412	QETN1HM-475Z	E CAPACITOR	4.7MF 20% 50V	
	C1413	QETN1HM-475Z	E CAPACITOR	4.7MF 20% 50V	
	C1414	NCS31HJ-101X	C.CAPA. C.M		
	C1415	NCS31HJ-101X	C.CAPA. C.M		
	C1416	QETN1HM-474Z	E CAPACITOR	.47MF 20% 50V	
	C1417	QETN1HM-474Z	E CAPACITOR	.47MF 20% 50V	
	C1418	QFLC1HJ-223Z	M CAPACITOR	.022MF 5% 50V	
	C1419	QFLC1HJ-223Z	M CAPACITOR	.022MF 5% 50V	
	C1422	QETN1HM-475Z	E CAPACITOR	4.7MF 20% 50V	
	C1423	QEKC1HM-475Z	E CAPACITOR	4.7MF 20% 50V	
	C1424	QEKC1HM-475Z	E CAPACITOR	4.7MF 20% 50V	
	C1425	QEKC1CM-106Z	E CAPACITOR	10MF 20% 16V	

△	Item	Parts number	Parts name	Remarks	Area
	C1426	NCB31CK-223X	C CAPACITOR		
	C1427	QFVF1HJ-334Z	MF CAPACITOR	.33MF 5% 50V	
	C1428	QFLC1HJ-153Z	M CAPACITOR	.015MF 5% 50V	
	C1429	QCB31HK-822Z	C CAPACITOR	8200PF 10% 50V	
	C1430	QETN1HM-475Z	E CAPACITOR	4.7MF 20% 50V	
	C1431	QETN1HM-475Z	E CAPACITOR	4.7MF 20% 50V	
	C1432	NCB31CK-223X	C CAPACITOR		
	C1433	QFVF1HJ-334Z	MF CAPACITOR	.33MF 5% 50V	
	C1434	QFLC1HJ-153Z	M CAPACITOR	.015MF 5% 50V	
	C1435	QCB31HK-822Z	C CAPACITOR	8200PF 10% 50V	
	C1436	NCB31CK-223X	C CAPACITOR		
	C1437	QCZ0202-155Z	ML C CAPA I/M	1.5MF	
	C1438	QETN0JM-477Z	E CAPACITOR	470MF 20% 6.3V	
	C1439	QFLC1HJ-562Z	M CAPACITOR	5600PF 5% 50V	
	C1440	QFLC1HJ-562Z	M CAPACITOR	5600PF 5% 50V	
	C1443	QCZ0202-155Z	ML C CAPA I/M	1.5MF	
	C1444	NCB31CK-223X	C CAPACITOR		
	C1445	NCB31CK-223X	C CAPACITOR		
	C1446	NCB31HK-221X	C CAPACITOR		
	C1447	QEKC1HM-475Z	E CAPACITOR	4.7MF 20% 50V	
	C1453	QETN1HM-475Z	E CAPACITOR	4.7MF 20% 50V	
	C1459	QETN1HM-475Z	E CAPACITOR	4.7MF 20% 50V	
	C1460	NCB31CK-223X	C CAPACITOR		
	C1461	NCB31CK-223X	C CAPACITOR		
	C1463	QETN1EM-106Z	E CAPACITOR	10MF 20% 25V	
	C1464	QETN1EM-106Z	E CAPACITOR	10MF 20% 25V	
	C1465	QETN1HM-106Z	E CAPACITOR	10MF 20% 50V	
	D 701	1SS355-X	DIODE C.M		
	D 702	1SS355-X	DIODE C.M		
	D 719	SLR-342VC-T	LED		
	DI701	QLF0098-001	FL TUBE		
	D1401	MTZJ13C-T2	ZENER DIODE		
	D1402	MTZJ6.2C-T2	Z DIODE I/M		
	D1403	MTZJ5.6C-T2	ZENER DIODE		
	D1404	MTZJ5.6C-T2	ZENER DIODE		
	D1405	MTZJ13C-T2	ZENER DIODE		
	D1406	MTZJ10C-T2	Z.DIODE I.M		
	D1407	MTZJ7.5C-T2	ZENER DIODE		
	D1408	MTZJ7.5C-T2	ZENER DIODE		
	D1409	1SS355-X	DIODE C.M		
	D1410	1SS355-X	DIODE C.M		
	D1411	1SS355-X	DIODE C.M		
	D1412	1SS355-X	DIODE C.M		
	EP401	QNZ0136-001Z	EARTH PLATE		
	FL401	QQR0590-001	FILTER		
	FL402	QQR0590-001	FILTER		
	HS401	E70306-001	HEAT SINK		
	HS402	E70306-001	HEAT SINK		
	HS403	E70306-001	HEAT SINK		
	HS404	E70306-001	HEAT SINK		
	HS405	E70306-001	HEAT SINK		
	HS434	E70306-001	HEAT SINK		
	HS435	E70306-001	HEAT SINK		
	IC421	BA15218F-XE	IC		
	IC422	BA15218F-XE	IC		
	IC423	TC9162AF-X	IC		
	IC427	BA15218F-XE	IC		
	IC428	M62446FP-X	IC		
	IC701	MN101C35DJW	IC		
	IC702	IC-PT9139-T	IC I.M		
	IC703	GP1UM281XK	IR DETECT UNIT		
	JS701	QSW0898-001	JOG VOLUME		
	Q 701	DTC114YKA-X	CHIP D.TRANSIST		

■ Electrical parts list (System control & Audio board) Block No. 03

△	Item	Parts number	Parts name	Remarks	Area	△	Item	Parts number	Parts name	Remarks	Area
	Q 702	DTC114TKA-X	TRANSISTOR				R 704	NRSA63J-471X	MG RESISTOR		
	Q 703	DTC144WKA-X	TRANSISTOR				R 705	NRSA63J-103X	MG RESISTOR		
	Q 704	DTC114YKA-X	CHIP D.TRANSIST				R 706	NRSA63J-103X	MG RESISTOR		
	Q 707	DTC114YKA-X	CHIP D.TRANSIST				R 707	NRSA63J-103X	MG RESISTOR		
	Q 708	DTC114YKA-X	CHIP D.TRANSIST				R 708	NRSA63J-103X	MG RESISTOR		
	Q 709	DTC114YKA-X	CHIP D.TRANSIST				R 709	NRSA63J-103X	MG RESISTOR		
	Q 711	DTA144EKA-X	TRANSISTOR				R 710	NRSA63J-103X	MG RESISTOR		
△	Q1401	KTA1046/Y/	TRANSISTOR				R 711	NRSA63J-104X	MG RESISTOR		
△	Q1402	2SD2395/EF/	TRANSISTOR				R 712	NRSA63J-103X	MG RESISTOR		
△	Q1403	2SD2395/EF/	TRANSISTOR				R 713	NRSA63J-103X	MG RESISTOR		
△	Q1404	2SD2395/EF/	TRANSISTOR				R 714	NRSA63J-103X	MG RESISTOR		
△	Q1405	2SD2395/EF/	TRANSISTOR				R 715	NRSA63J-103X	MG RESISTOR		
△	Q1406	KTC3203/OY/-T	TRANSISTOR				R 716	NRSA63J-103X	MG RESISTOR		
△	Q1407	KTC3203/OY/-T	TRANSISTOR				R 717	NRSA63J-103X	MG RESISTOR		
△	Q1408	KTA1271/OY/-T	TRANSISTOR				R 718	NRSA63J-103X	MG RESISTOR		
	Q1409	2SK301/PQ/-T	FET I/M				R 719	NRSA63J-221X	MG RESISTOR		
	Q1410	2SK301/PQ/-T	FET I/M				R 720	NRSA63J-222X	MG RESISTOR		
	Q1411	2SK301/PQ/-T	FET I/M				R 721	NRSA63J-103X	MG RESISTOR		
	Q1412	2SK301/PQ/-T	FET I/M				R 722	NRSA63J-102X	MG RESISTOR		
	Q1413	2SC3576-JVC-T	TRANSISTOR I/M				R 723	NRSA63J-102X	MG RESISTOR		
	Q1414	2SC3576-JVC-T	TRANSISTOR I/M				R 724	NRSA63J-122X	MG RESISTOR		
	Q1415	KRA104M-T	D.TR.I.M				R 725	NRSA63J-152X	MG RESISTOR		
	Q1416	KRC104M-T	D.TR.I.M				R 726	NRSA63J-222X	MG RESISTOR		
	Q1417	2SC3576-JVC-T	TRANSISTOR I/M				R 727	NRSA63J-272X	MG RESISTOR		
	Q1418	2SC3576-JVC-T	TRANSISTOR I/M				R 728	NRSA63J-103X	MG RESISTOR		
	Q1419	2SC3576-JVC-T	TRANSISTOR I/M				R 729	NRSA63J-102X	MG RESISTOR		
	Q1420	KRA104M-T	D.TR.I.M				R 730	NRSA63J-102X	MG RESISTOR		
	Q1421	2SC3576-JVC-T	TRANSISTOR I/M				R 731	NRSA63J-122X	MG RESISTOR		
	Q1422	2SC3576-JVC-T	TRANSISTOR I/M				R 732	NRSA63J-152X	MG RESISTOR		
	Q1423	KRA104M-T	D.TR.I.M				R 733	NRSA63J-222X	MG RESISTOR		
	Q1424	KRA104M-T	D.TR.I.M				R 734	NRSA63J-272X	MG RESISTOR		
	Q1425	2SC3576-JVC-T	TRANSISTOR I/M				R 735	NRSA63J-392X	MG RESISTOR		
	Q1426	2SC3576-JVC-T	TRANSISTOR I/M				R 736	NRSA63J-103X	MG RESISTOR		
	Q1431	KRC104M-T	D.TR.I.M				R 737	NRSA63J-102X	MG RESISTOR		
	Q1432	KRC104M-T	D.TR.I.M				R 738	NRSA63J-102X	MG RESISTOR		
	Q1433	KRC104M-T	D.TR.I.M				R 739	NRSA63J-122X	MG RESISTOR		
△	Q1434	2SD2395/EF/	TRANSISTOR				R 740	NRSA63J-152X	MG RESISTOR		
△	Q1435	2SD2395/EF/	TRANSISTOR				R 741	NRSA63J-222X	MG RESISTOR		
	R 475	NRSA63J-203X	MG RESISTOR				R 742	NRSA63J-272X	MG RESISTOR		
	R 476	NRSA63J-273X	MG RESISTOR				R 743	NRSA63J-103X	MG RESISTOR		
	R 477	QRZ9006-4R7X	F RESISTOR	4.7 1/4W			R 744	NRSA63J-102X	MG RESISTOR		
	R 478	QRJ146J-2R2X	UNF C RESISTOR	2.2 5% 1/4W			R 745	NRSA63J-102X	MG RESISTOR		
	R 479	QRJ146J-2R2X	UNF C RESISTOR	2.2 5% 1/4W			R 746	NRSA63J-122X	MG RESISTOR		
	R 480	NRSA63J-512X	MG RESISTOR				R 747	NRSA63J-152X	MG RESISTOR		
	R 481	NRSA63J-104X	MG RESISTOR				R 748	NRSA63J-222X	MG RESISTOR		
	R 482	NRSA63J-104X	MG RESISTOR				R 749	NRSA63J-272X	MG RESISTOR		
	R 483	NRSA63J-102X	MG RESISTOR				R 750	NRSA63J-103X	MG RESISTOR		
	R 484	NRSA63J-104X	MG RESISTOR				R 751	NRSA63J-102X	MG RESISTOR		
	R 485	NRSA63J-102X	MG RESISTOR				R 752	NRSA63J-102X	MG RESISTOR		
	R 486	NRSA63J-104X	MG RESISTOR				R 753	NRSA63J-122X	MG RESISTOR		
	R 487	NRSA63J-102X	MG RESISTOR				R 754	NRSA63J-152X	MG RESISTOR		
	R 488	NRSA63J-104X	MG RESISTOR				R 757	NRSA63J-103X	MG RESISTOR		
	R 489	NRSA63J-103X	MG RESISTOR				R 758	NRSA63J-103X	MG RESISTOR		
	R 490	NRSA63J-103X	MG RESISTOR				R 759	NRSA63J-103X	MG RESISTOR		
	R 491	NRSA63J-512X	MG RESISTOR				R 760	NRSA63J-103X	MG RESISTOR		
	R 492	NRSA63J-301X	MG RESISTOR				R 761	NRSA63J-103X	MG RESISTOR		
	R 493	NRSA63J-0R0X	MG RESISTOR				R 762	NRSA63J-102X	MG RESISTOR		
	R 494	NRSA63J-0R0X	MG RESISTOR				R 763	NRSA63J-102X	MG RESISTOR		
	R 495	NRSA63J-0R0X	MG RESISTOR				R 768	NRSA63J-103X	MG RESISTOR		
	R 496	NRSA63J-102X	MG RESISTOR				R 769	NRSA63J-102X	MG RESISTOR		
	R 701	NRSA63J-472X	MG RESISTOR				R 770	NRSA63J-102X	MG RESISTOR		
	R 702	NRSA63J-223X	MG RESISTOR				R 771	NRSA63J-122X	MG RESISTOR		
	R 703	NRSA63J-103X	MG RESISTOR				R 775	NRSA63J-103X	MG RESISTOR		

■ Electrical parts list (System control & Audio board) Block No. 03

△	Item	Parts number	Parts name	Remarks	Area
	R 776	NRSA63J-152X	MG RESISTOR		
	R 779	NRSA63J-103X	MG RESISTOR		
	R 780	NRSA63J-221X	MG RESISTOR		
	R 781	NRSA63J-221X	MG RESISTOR		
	R 782	NRSA63J-221X	MG RESISTOR		
	R 783	NRSA63J-221X	MG RESISTOR		
	R 784	NRSA63J-221X	MG RESISTOR		
	R 785	NRSA63J-221X	MG RESISTOR		
	R 786	NRSA63J-221X	MG RESISTOR		
	R 787	NRSA63J-221X	MG RESISTOR		
	R 788	NRSA63J-221X	MG RESISTOR		
	R 789	NRSA63J-221X	MG RESISTOR		
	R 790	NRSA63J-221X	MG RESISTOR		
	R 791	NRSA63J-221X	MG RESISTOR		
	R 792	NRSA63J-221X	MG RESISTOR		
	R 793	NRSA63J-221X	MG RESISTOR		
	R 794	NRSA63J-221X	MG RESISTOR		
	R 795	NRSA63J-221X	MG RESISTOR		
	R 796	NRSA63J-221X	MG RESISTOR		
	R 797	NRSA63J-221X	MG RESISTOR		
	R 798	NRSA63J-221X	MG RESISTOR		
	R 799	NRSA63J-221X	MG RESISTOR		
△	R1401	QRZ9005-100X	F RESISTOR	10 1/4W	
△	R1402	QRJ146J-182X	UNF C RESISTOR	1.8K 5% 1/4W	
△	R1403	QRZ9005-120X	F RESISTOR	12 1/4W	
△	R1404	QRJ146J-272X	UNF C RESISTOR	2.7K 5% 1/4W	
△	R1405	QRZ9005-120X	F RESISTOR	12 1/4W	
△	R1406	QRK126J-682X	C RESISTOR	6.8K 5% 1/2W	
△	R1407	QRZ9006-4R7X	F RESISTOR	4.7 1/4W	
△	R1408	QRZ9006-4R7X	F RESISTOR	4.7 1/4W	
△	R1409	QRJ146J-272X	UNF C RESISTOR	2.7K 5% 1/4W	
△	R1410	QRZ9006-4R7X	F RESISTOR	4.7 1/4W	
△	R1411	QRJ146J-182X	UNF C RESISTOR	1.8K 5% 1/4W	
△	R1412	QRZ9005-100X	F RESISTOR	10 1/4W	
△	R1413	QRJ146J-102X	UNF C RESISTOR	1.0K 5% 1/4W	
△	R1414	QRZ9005-100X	F RESISTOR	10 1/4W	
△	R1415	QRJ146J-222X	UNF C RESISTOR	2.2K 5% 1/4W	
△	R1416	QRZ9005-100X	F RESISTOR	10 1/4W	
△	R1417	QRJ146J-222X	UNF C RESISTOR	2.2K 5% 1/4W	
△	R1418	QRZ9005-680X	F RESISTOR	68 1/4W	
△	R1419	QRZ9005-680X	F RESISTOR	68 1/4W	
	R1420	NRSA63J-103X	MG RESISTOR		
	R1421	NRSA63J-272X	MG RESISTOR		
	R1422	NRSA63J-103X	MG RESISTOR		
	R1423	NRSA63J-272X	MG RESISTOR		
	R1424	NRSA63J-472X	MG RESISTOR		
	R1425	NRSA63J-472X	MG RESISTOR		
	R1426	NRSA63J-513X	MG RESISTOR		
	R1427	NRSA63J-513X	MG RESISTOR		
	R1428	NRSA63J-103X	MG RESISTOR		
	R1429	NRSA63J-103X	MG RESISTOR		
	R1430	NRSA63J-103X	MG RESISTOR		
	R1431	NRSA63J-103X	MG RESISTOR		
	R1432	NRSA63J-103X	MG RESISTOR		
	R1433	NRSA63J-103X	MG RESISTOR		
	R1434	NRSA63J-103X	MG RESISTOR		
	R1435	NRSA63J-154X	MG RESISTOR		
	R1436	NRSA63J-154X	MG RESISTOR		
	R1437	NRSA63J-102X	MG RESISTOR		
	R1438	NRSA63J-102X	MG RESISTOR		
	R1439	NRSA63J-103X	MG RESISTOR		
	R1440	NRSA63J-103X	MG RESISTOR		
	R1442	NRSA63J-104X	MG RESISTOR		
	R1443	NRSA63J-103X	MG RESISTOR		
	R1444	NRSA63J-103X	MG RESISTOR		
	R1445	NRSA63J-102X	MG RESISTOR		
	R1446	NRSA63J-104X	MG RESISTOR		

△	Item	Parts number	Parts name	Remarks	Area
	R1447	NRSA63J-102X	MG RESISTOR		
	R1448	NRSA63J-103X	MG RESISTOR		
	R1449	NRSA63J-102X	MG RESISTOR		
	R1450	NRSA63J-103X	MG RESISTOR		
	R1451	NRSA63J-104X	MG RESISTOR		
	R1452	NRSA63J-104X	MG RESISTOR		
	R1453	NRSA63J-102X	MG RESISTOR		
	R1455	NRSA63J-104X	MG RESISTOR		
△	R1456	QRJ146J-220X	UNF C RESISTOR	22 5% 1/4W	
	R1457	NRSA63J-472X	MG RESISTOR		
	R1458	NRSA63J-472X	MG RESISTOR		
△	R1459	QRZ9005-680X	F RESISTOR	68 1/4W	
△	R1460	QRZ9005-680X	F RESISTOR	68 1/4W	
	R1461	QRJ146J-2R2X	UNF C RESISTOR	2.2 5% 1/4W	
	R1462	QRJ146J-2R2X	UNF C RESISTOR	2.2 5% 1/4W	
	R1463	NRSA63J-104X	MG RESISTOR		
	R1464	NRSA63J-104X	MG RESISTOR		
	R1465	NRSA63J-102X	MG RESISTOR		
	R1466	NRSA63J-104X	MG RESISTOR		
	R1467	NRSA63J-104X	MG RESISTOR		
	R1470	NRSA63J-391X	MG RESISTOR		
	R1471	NRSA63J-391X	MG RESISTOR		
	R1472	NRSA63J-103X	MG RESISTOR		
	R1473	NRSA63J-103X	MG RESISTOR		
	R1474	NRSA63J-102X	MG RESISTOR		
	R1480	NRSA63J-104X	MG RESISTOR		
	R1490	NRSA63J-273X	MG RESISTOR		
	R1492	NRSA63J-102X	MG RESISTOR		
	R1493	NRSA63J-102X	MG RESISTOR		
	R1494	NRSA63J-102X	MG RESISTOR		
	R1495	NRSA63J-103X	MG RESISTOR		
	R1496	NRSA63J-103X	MG RESISTOR		
	R1497	NRSA63J-511X	MG RESISTOR		
	R1498	NRSA63J-511X	MG RESISTOR		
	R1499	NRSA63J-104X	MG RESISTOR		
	R1500	NRSA63J-474X	MG RESISTOR		
	S 721	QSW0683-001Z	PUSH SWITCH	TUNING+	
	S 722	QSW0683-001Z	PUSH SWITCH	TUNING-	
	S 723	QSW0683-001Z	PUSH SWITCH	PRESET+	
	S 724	QSW0683-001Z	PUSH SWITCH	PRESET-	
	S 725	QSW0683-001Z	PUSH SWITCH	FM MODE	
	S 726	QSW0683-001Z	PUSH SWITCH	MEMORY	
	S 727	QSW0683-001Z	PUSH SWITCH	POWER	
	S 728	QSW0683-001Z	PUSH SWITCH	SURROUND	
	S 729	QSW0683-001Z	PUSH SWITCH	SURR MODE	
	S 730	QSW0683-001Z	PUSH SWITCH	ANA/DIG	
	S 731	QSW0683-001Z	PUSH SWITCH	BASS BOOST	
	S 732	QSW0683-001Z	PUSH SWITCH	SPK1	
	S 733	QSW0683-001Z	PUSH SWITCH	SPK2	
	S 734	QSW0683-001Z	PUSH SWITCH	DVD MULTI	
	S 735	QSW0683-001Z	PUSH SWITCH	CD	
	S 736	QSW0683-001Z	PUSH SWITCH	DVD	
	S 737	QSW0683-001Z	PUSH SWITCH	CD	
	S 738	QSW0683-001Z	PUSH SWITCH	VCR	
	S 739	QSW0683-001Z	PUSH SWITCH	PHONO/FM	
	S 740	QSW0683-001Z	PUSH SWITCH	TV/DBS(COM)	
	S 741	QSW0683-001Z	PUSH SWITCH	FM/AM(COM)	
	S 742	QSW0683-001Z	PUSH SWITCH	ADJUST	
	S 743	QSW0683-001Z	PUSH SWITCH	SETTING	
	S 744	QSW0683-001Z	PUSH SWITCH	+	
	S 745	QSW0683-001Z	PUSH SWITCH	-	
	S 746	QSW0683-001Z	PUSH SWITCH	DIMMER	
	S 747	QSW0683-001Z	PUSH SWITCH	PTY	
	S 748	QSW0683-001Z	PUSH SWITCH	TA/NEWS/INFO	
	S 749	QSW0683-001Z	PUSH SWITCH	DISPLAY	
	X 701	QAX0246-001Z	C RESONATOR		

■ Electrical parts list (DSP board)

Block No. 04

△	Item	Parts number	Parts name	Remarks	Area	△	Item	Parts number	Parts name	Remarks	Area
	C 601	NCB31HK-102X	C CAPACITOR				C2504	QETN1HM-475Z	E CAPACITOR	4.7MF 20% 50V	
	C 602	NCB31HK-102X	C CAPACITOR				C2507	NCS31HJ-330X	C CAPACITOR		
	C 603	QEK0JM-107Z	E CAPACITOR	100MF 20% 6.3V			C2508	NCS31HJ-330X	C CAPACITOR		
	C 604	QEK0JM-107Z	E CAPACITOR	100MF 20% 6.3V			C2512	NCF31CZ-104X	C CAPACITOR		
	C 605	NCF31CZ-104X	C CAPACITOR				C2513	NCB31HK-122X	C CAPACITOR		
	C 606	NCF31CZ-104X	C CAPACITOR				C2514	NCB31HK-122X	C CAPACITOR		
	C 607	QEK0JM-107Z	E CAPACITOR	100MF 20% 16V			C2515	NCS31HJ-121X	C CAPACITOR		
	C 608	NCF31CZ-104X	C CAPACITOR				C2516	NCS31HJ-121X	C CAPACITOR		
	C 609	NCF31CZ-104X	C CAPACITOR				C2525	NCB31HK-102X	C CAPACITOR		
	C 610	QEK0JM-107Z	E CAPACITOR	100MF 20% 6.3V			C2526	NCB31HK-102X	C CAPACITOR		
	C 611	QEK0JM-107Z	E CAPACITOR	100MF 20% 6.3V			C2527	QETN1HM-106Z	E CAPACITOR	10MF 20% 50V	
	C 612	NCB31CK-103X	C CAPACITOR				C2528	QETN1HM-106Z	E CAPACITOR	10MF 20% 50V	
	C 621	QEK0JM-105Z	E CAPACITOR	1.0MF 20% 50V			C2531	NCS31HJ-560X	C CAPACITOR		
	C 622	NCS31HJ-101X	C.CAPA. C.M				C2532	NCS31HJ-560X	C CAPACITOR		
	C 624	NCF31CZ-104X	C CAPACITOR				C2533	QETN1HM-475Z	E CAPACITOR	4.7MF 20% 50V	
	C 625	NCB31CK-104X	C CAPACITOR				C2534	QETN1HM-475Z	E CAPACITOR	4.7MF 20% 50V	
	C 626	NCF31AZ-105X	C CAPACITOR				C2539	NCF31CZ-104X	C CAPACITOR		
	C 627	NCF31AZ-105X	C CAPACITOR				C2540	NCF31CZ-104X	C CAPACITOR		
	C 628	NCB31CK-103X	C CAPACITOR				C2551	NCS31HJ-560X	C CAPACITOR		
	C 629	NCB31CK-104X	C CAPACITOR				C2552	NCS31HJ-560X	C CAPACITOR		
	C 631	QEK0JM-107Z	E CAPACITOR	100MF 20% 6.3V			C2555	NCF31CZ-104X	C CAPACITOR		
	C 632	NCB31CK-103X	C CAPACITOR				C2556	NCF31CZ-104X	C CAPACITOR		
	C 633	NCF31CZ-104X	C CAPACITOR				C2561	QETN1HM-105Z	E CAPACITOR	1.0MF 20% 50V	
	C 634	NCF31CZ-104X	C CAPACITOR				C2562	QETN1HM-105Z	E CAPACITOR	1.0MF 20% 50V	
	C 635	NCF31CZ-104X	C CAPACITOR				C2563	NCS31HJ-560X	C CAPACITOR		
	C 636	NCB31CK-473X	C CAPACITOR				C2564	NCS31HJ-560X	C CAPACITOR		
	C 637	NCB31CK-104X	C CAPACITOR				C2565	NCB31HK-102X	C CAPACITOR		
	C 638	QEK0JM-107Z	E CAPACITOR	100MF 20% 6.3V			C2566	NCB31HK-102X	C CAPACITOR		
	C 639	NCB31CK-103X	C CAPACITOR				C2569	NCF31CZ-104X	C CAPACITOR		
	C 640	NCB31CK-103X	C CAPACITOR				C2570	NCF31CZ-104X	C CAPACITOR		
	C 641	QEK0JM-107Z	E CAPACITOR	100MF 20% 6.3V			C2575	NCB31HK-102X	C CAPACITOR		
	C 642	NCB31CK-103X	C CAPACITOR				C2576	NCB31HK-102X	C CAPACITOR		
	C 643	NCB31AK-474X	C CAPACITOR				C2577	QETN1HM-106Z	E CAPACITOR	10MF 20% 50V	
	C 644	NCB31CK-103X	C CAPACITOR				C2578	QETN1HM-106Z	E CAPACITOR	10MF 20% 50V	
	C 645	NCS31HJ-101X	C.CAPA. C.M				C2581	QETN1HM-105Z	E CAPACITOR	1.0MF 20% 50V	
	C 646	NCB31CK-103X	C CAPACITOR				C2582	QETN1CM-106Z	E CAPACITOR	10MF 20% 16V	
	C 647	NCS31HJ-220X	C CAPACITOR				C2583	NCS31HJ-560X	C CAPACITOR		
	C 648	NCS31HJ-180X	C CAPACITOR				C2584	NCS31HJ-560X	C CAPACITOR		
	C 649	NCS31HJ-121X	C CAPACITOR				C2585	NCF31CZ-104X	C CAPACITOR		
	C 653	NCB31CK-104X	C CAPACITOR				C2586	NCF31CZ-104X	C CAPACITOR		
	C 654	QEK0JM-107Z	E CAPACITOR	100MF 20% 6.3V			C2587	NCS31HJ-560X	C CAPACITOR		
	C 661	NCB31CK-103X	C CAPACITOR				C2588	QETN1HM-475Z	E CAPACITOR	4.7MF 20% 50V	
	C 671	NCB31CK-103X	C CAPACITOR				C2589	NCF31CZ-104X	C CAPACITOR		
	C 672	QEK0JM-107Z	E CAPACITOR	100MF 20% 6.3V			C2590	NCF31CZ-104X	C CAPACITOR		
	C 673	NCB31CK-103X	C CAPACITOR				C2591	NCB31HK-102X	C CAPACITOR		
	C 677	NCS31HJ-101X	C.CAPA. C.M				C2592	NCB31HK-103X	C CAPACITOR		
	C 679	NCS31HJ-101X	C.CAPA. C.M				C2594	NCB31CK-473X	C CAPACITOR		
	C 681	NCB31CK-103X	C CAPACITOR				C2595	NCB31HK-102X	C CAPACITOR		
	C 682	NCB31CK-103X	C CAPACITOR				C2597	QETN1HM-106Z	E CAPACITOR	10MF 20% 50V	
	C 683	NCB31CK-103X	C CAPACITOR				C2598	QETN1HM-475Z	E CAPACITOR	4.7MF 20% 50V	
	C 684	QEK0JM-107Z	E CAPACITOR	100MF 20% 6.3V			D 607	1SS355-X	DIODE C.M		
	C 685	QEK0JM-476Z	E CAPACITOR	47MF 20% 16V			D 608	1SS355-X	DIODE C.M		
	C 686	QEK0JM-476Z	E CAPACITOR	47MF 20% 16V			D 609	1SS355-X	DIODE C.M		
	C 687	NCB31CK-103X	C CAPACITOR				D 610	1SS355-X	DIODE C.M		
	C 688	QEK0JM-107Z	E CAPACITOR	100MF 20% 6.3V			IC601	AK4527BVQP	IC		
	C 689	NCB31CK-103X	C CAPACITOR				IC609	BA15218F-XE	IC		
	C 690	QEK0JM-107Z	E CAPACITOR	100MF 20% 6.3V			IC610	BA15218F-XE	IC		
	C 691	NCB31HK-103X	C CAPACITOR				IC611	TC74HC08AF-X	IC		
	C 693	NCB31CK-103X	C CAPACITOR				IC612	TC74HC4072AF-X	IC		
	C 694	NCF31CZ-104X	C CAPACITOR				IC621	TC74HCU04AF-W	IC		
	CN681	QGB2510K1-20	B TO B CONNE				IC631	TC9446F-025	IC		
	C2500	QEK0JM-226Z	E CAPACITOR	22MF 20% 16V			IC641	W24L010AJ-12-X	IC		
	C2503	QETN1HM-475Z	E CAPACITOR	4.7MF 20% 50V			IC650	BA15218F-XE	IC		

■ Electrical parts list (DSP board)

Block No. 04

△	Item	Parts number	Parts name	Remarks	Area
	IC651	BA15218F-XE	IC		
	IC652	IMX9-W	IC		
	IC661	BA15218F-XE	IC		
	IC662	IMX9-W	IC		
	IC671	UPD784215AGC167	IC(MICRO C ROM)		
	IC672	TC7SET32FU-X	IC		
	IC681	BA033FP-X	I.C.		
	IC682	IMX9-W	IC		
	IC683	BA033LBSG-W	IC		
	IC690	BA15218F-XE	IC		
	IC691	BA15218F-XE	IC		
	J 601	QNN0347-001	PIN JACK		
	K 601	NQR0269-004X	FERRITE BEADS		
	Q 601	DTC114YE-X	TRANSISTOR		
	Q 607	DTA144EKA-X	TRANSISTOR		
	Q 670	DTC114YE-X	TRANSISTOR		
	Q 671	2SD2114K/VW-X	CHIP TRANSISTOR		
	Q 672	DTC114YE-X	TRANSISTOR		
	Q 673	DTA144EKA-X	TRANSISTOR		
	Q2501	DTA144EKA-X	TRANSISTOR		
	R 600	NRSA63J-0R0X	MG RESISTOR		
	R 601	NRSA63J-473X	MG RESISTOR		
	R 602	NRSA63J-473X	MG RESISTOR		
	R 603	NRSA63J-473X	MG RESISTOR		
	R 606	NRSA63J-221X	MG RESISTOR		
	R 607	NRSA63J-221X	MG RESISTOR		
	R 608	NRSA63J-221X	MG RESISTOR		
	R 609	NRSA63J-221X	MG RESISTOR		
	R 611	NRSA63J-221X	MG RESISTOR		
	R 612	NRSA63J-221X	MG RESISTOR		
	R 613	NRSA63J-822X	MG RESISTOR		
	R 615	NRSA63J-432X	MG RESISTOR		
	R 617	NRSA63J-103X	MG RESISTOR		
	R 618	NRSA63J-103X	MG RESISTOR		
	R 620	NRSA63J-221X	MG RESISTOR		
	R 621	NRSA63J-561X	MG RESISTOR		
	R 622	NRSA63J-750X	MG RESISTOR		
	R 623	NRSA63J-0R0X	MG RESISTOR		
	R 625	NRSA63J-0R0X	MG RESISTOR		
	R 627	NRSA63J-472X	MG RESISTOR		
	R 628	NRSA63J-333X	MG RESISTOR		
	R 629	NRSA63J-0R0X	MG RESISTOR		
	R 631	NRSA63J-0R0X	MG RESISTOR		
	R 632	NRSA63J-0R0X	MG RESISTOR		
	R 633	NRSA63J-221X	MG RESISTOR		
	R 639	NRSA63J-472X	MG RESISTOR		
	R 640	NRSA63J-0R0X	MG RESISTOR		
	R 641	NRSA63F-102X	MG RESISTOR		
	R 642	NRSA63J-103X	MG RESISTOR		
	R 643	NRSA63J-101X	MG RESISTOR		
	R 644	NRSA63J-153X	MG RESISTOR		
	R 645	NRSA63F-102X	MG RESISTOR		
	R 646	NRSA63J-103X	MG RESISTOR		
	R 647	NRSA63J-225X	MG RESISTOR		
	R 648	NRSA63J-472X	MG RESISTOR		
	R 657	NRSA63J-103X	MG RESISTOR		
	R 661	NRSA63J-221X	MG RESISTOR		
	R 662	NRSA63J-221X	MG RESISTOR		
	R 663	NRSA63J-221X	MG RESISTOR		
	R 664	NRSA63J-221X	MG RESISTOR		
	R 668	NRSA63J-0R0X	MG RESISTOR		
	R 669	NRSA63J-103X	MG RESISTOR		
	R 670	NRSA63J-103X	MG RESISTOR		

△	Item	Parts number	Parts name	Remarks	Area
	R 671	NRSA63J-103X	MG RESISTOR		
	R 672	NRSA63J-105X	MG RESISTOR		
	R 673	NRSA63J-432X	MG RESISTOR		
	R 674	NRSA63J-432X	MG RESISTOR		
	R 675	NRSA63J-432X	MG RESISTOR		
	R 676	NRSA63J-432X	MG RESISTOR		
	R 677	NRSA63J-822X	MG RESISTOR		
	R 678	NRSA63J-822X	MG RESISTOR		
	R 679	NRSA63J-822X	MG RESISTOR		
	R 680	NRSA63J-822X	MG RESISTOR		
	R 682	NRSA63J-103X	MG RESISTOR		
	R 683	NRSA63J-0R0X	MG RESISTOR		
	R 684	NRSA63J-0R0X	MG RESISTOR		
	R 687	NRSA63J-0R0X	MG RESISTOR		
	R 688	NRSA63J-0R0X	MG RESISTOR		
	R 689	NRSA63J-0R0X	MG RESISTOR		
	R 691	NRSA63J-221X	MG RESISTOR		
	R 692	NRSA63J-221X	MG RESISTOR		
	R 693	NRSA63J-221X	MG RESISTOR		
	R 694	NRSA63J-221X	MG RESISTOR		
	R 695	NRSA63J-221X	MG RESISTOR		
	R 696	NRSA63J-221X	MG RESISTOR		
	R 697	NRSA63J-0R0X	MG RESISTOR		
	R 698	NRSA63J-0R0X	MG RESISTOR		
	R2500	NRSA63J-102X	MG RESISTOR		
	R2501	NRSA63J-104X	MG RESISTOR		
	R2502	NRSA63J-104X	MG RESISTOR		
	R2507	NRSA63J-223X	MG RESISTOR		
	R2508	NRSA63J-223X	MG RESISTOR		
	R2509	NRSA63J-223X	MG RESISTOR		
	R2510	NRSA63J-223X	MG RESISTOR		
	R2511	NRSA63J-103X	MG RESISTOR		
	R2512	NRSA63J-103X	MG RESISTOR		
	R2513	NRSA63J-103X	MG RESISTOR		
	R2514	NRSA63J-103X	MG RESISTOR		
	R2515	NRSA63J-103X	MG RESISTOR		
	R2516	NRSA63J-103X	MG RESISTOR		
	R2519	NRSA63J-331X	MG RESISTOR		
	R2520	NRSA63J-331X	MG RESISTOR		
	R2521	NRSA63J-331X	MG RESISTOR		
	R2522	NRSA63J-331X	MG RESISTOR		
	R2525	NRSA63J-102X	MG RESISTOR		
	R2526	NRSA63J-102X	MG RESISTOR		
	R2527	NRSA63J-104X	MG RESISTOR		
	R2528	NRSA63J-104X	MG RESISTOR		
	R2529	NRSA63J-103X	MG RESISTOR		
	R2530	NRSA63J-103X	MG RESISTOR		
	R2531	NRSA63J-752X	MG RESISTOR		
	R2532	NRSA63J-752X	MG RESISTOR		
	R2533	NRSA63J-103X	MG RESISTOR		
	R2534	NRSA63J-103X	MG RESISTOR		
	R2535	NRSA63J-103X	MG RESISTOR		
	R2536	NRSA63J-103X	MG RESISTOR		
	R2537	NRSA63J-104X	MG RESISTOR		
	R2538	NRSA63J-104X	MG RESISTOR		
	R2550	NRSA63J-272X	MG RESISTOR		
	R2551	NRSA63J-103X	MG RESISTOR		
	R2552	NRSA63J-103X	MG RESISTOR		
	R2553	NRSA63J-153X	MG RESISTOR		
	R2554	NRSA63J-153X	MG RESISTOR		
	R2555	NRSA63J-752X	MG RESISTOR		
	R2556	NRSA63J-752X	MG RESISTOR		
	R2557	NRSA63J-103X	MG RESISTOR		

■ Electrical parts list (DSP board)

Block No. 04

△	Item	Parts number	Parts name	Remarks	Area
	R2558	NRSA63J-273X	MG RESISTOR		
	R2560	NRSA63J-105X	MG RESISTOR		
	R2561	NRSA63J-104X	MG RESISTOR		
	R2562	NRSA63J-104X	MG RESISTOR		
	R2563	NRSA63J-103X	MG RESISTOR		
	R2564	NRSA63J-103X	MG RESISTOR		
	R2565	NRSA63J-202X	MG RESISTOR		
	R2566	NRSA63J-202X	MG RESISTOR		
	R2567	NRSA63J-103X	MG RESISTOR		
	R2568	NRSA63J-103X	MG RESISTOR		
	R2569	NRSA63J-122X	MG RESISTOR		
	R2570	NRSA63J-122X	MG RESISTOR		
	R2575	NRSA63J-102X	MG RESISTOR		
	R2576	NRSA63J-102X	MG RESISTOR		
	R2577	NRSA63J-104X	MG RESISTOR		
	R2578	NRSA63J-104X	MG RESISTOR		
	R2581	NRSA63J-104X	MG RESISTOR		
	R2582	NRSA63J-104X	MG RESISTOR		
	R2583	NRSA63J-123X	MG RESISTOR		
	R2584	NRSA63J-223X	MG RESISTOR		
	R2585	NRSA63J-302X	MG RESISTOR		
	R2586	NRSA63J-332X	MG RESISTOR		
	R2587	NRSA63J-103X	MG RESISTOR		
	R2588	NRSA63J-103X	MG RESISTOR		
	R2589	NRSA63J-104X	MG RESISTOR		
	R2590	NRSA63J-333X	MG RESISTOR		
	R2591	NRSA63J-122X	MG RESISTOR		
	R2592	NRSA63J-333X	MG RESISTOR		
	R2594	NRSA63J-333X	MG RESISTOR		
	R2595	NRSA63J-102X	MG RESISTOR		
	R2596	NRSA63J-102X	MG RESISTOR		
	R2597	NRSA63J-104X	MG RESISTOR		
	R2598	NRSA63J-104X	MG RESISTOR		
	UN661	GP1FA351RZ	OPT RECEIVER		
	UN662	GP1FA351RZ	OPT RECEIVER		
	UN663	GP1FA351TZ	OPT TRANSMITTER		
	UN664	GP1FA351RZ	OPT RECEIVER		
	X 631	QAX0722-001Z	CRYSTAL		
	X 671	QAX0719-001Z	1COSCELLATOR		

■ Electrical parts list (Tuner board)

Block No. 05

△	Item	Parts number	Parts name	Remarks	Area
	AT101	QNB0014-001	ANT TERMINAL		
	BK 1	LV31618-001A	SHIELD BKT		
	C 101	NCB21HK-103X	C CAPACITOR		
	C 103	NCB21HK-223X	C CAPACITOR		
	C 105	NCB21HK-223X	C CAPACITOR		
	C 107	QEKC1CM-226Z	E CAPACITOR	22MF 20% 16V	
	C 111	NCB21HK-473X	C CAPACITOR		
	C 112	NDC21HJ-120X	C CAPACITOR		
	C 113	QCSB1HJ-120Y	C CAPACITOR	12PF 5% 50V	
	C 121	NDC21HJ-120X	C CAPACITOR		
	C 122	NDC21HJ-120X	C CAPACITOR		
	C 123	NCB21HK-473X	C CAPACITOR		
	C 126	NCS21HJ-101X	C CAPACITOR		
	C 128	QENC1HM-474Z	NP E CAPACITOR	.47MF 20% 50V	
	C 129	NCB21HK-102X	C CAPACITOR		
	C 130	QEKC1AM-107Z	E CAPACITOR	100MF 20% 10V	
	C 133	QEKC1CM-226Z	E CAPACITOR	22MF 20% 16V	
	C 134	NCB21HK-222X	C CAPACITOR		
	C 135	NCB21HK-223X	C CAPACITOR		
	C 136	QEKC1HM-105Z	E CAPACITOR	1.0MF 20% 50V	
	C 137	NCS21HJ-680X	C CAPACITOR		
	C 139	NCB21HK-473X	C CAPACITOR		
	C 140	NCB21HK-473X	C CAPACITOR		
	C 141	NCB21HK-473X	C CAPACITOR		
	C 143	NCB21HK-223X	C CAPACITOR		
	C 144	NCB21HK-473X	C CAPACITOR		
	C 146	QEKC1HM-105Z	E CAPACITOR	1.0MF 20% 50V	
	C 147	QEKC1HM-105Z	E CAPACITOR	1.0MF 20% 50V	
	C 148	QEKC1HM-224Z	E CAPACITOR	.22MF 20% 50V	
	C 149	QEKC1HM-105Z	E CAPACITOR	1.0MF 20% 50V	
	C 150	QEKC1CM-226Z	E CAPACITOR	22MF 20% 16V	
	C 156	QDGB1HK-102Y	C CAPACITOR		
	C 157	NCB21HK-473X	C CAPACITOR		
	C 158	QEKC1CM-226Z	E CAPACITOR	22MF 20% 16V	
	C 161	QEKC1CM-106Z	E CAPACITOR	10MF 20% 16V	
	C 162	QEKC1CM-106Z	E CAPACITOR	10MF 20% 16V	
	C 163	NCB21HK-223X	C CAPACITOR		
	C 164	NCB21HK-473X	C CAPACITOR		
	C 168	QEKC1HM-105Z	E CAPACITOR	1.0MF 20% 50V	
	C 184	QEKC1CM-107Z	E CAPACITOR	100MF 20% 16V	
	C 185	QEKC1CM-106Z	E CAPACITOR	10MF 20% 16V	
	C 186	QEKC1CM-106Z	E CAPACITOR	10MF 20% 16V	
	C 191	NCS21HJ-820X	C CAPACITOR		
	C 192	NCS21HJ-470X	C CAPACITOR		
	C 193	NCB21HK-561X	C CAPACITOR		
	C 194	NCB21HK-104X	C CAPACITOR		
	C 195	NCB21HK-331X	C.CAPA. C.M		
	C 196	QEKC1HM-225Z	E CAPACITOR	2.2MF 20% 50V	
	C 197	NCB21HK-473X	C CAPACITOR		
	C 199	QEKC1CM-106Z	E CAPACITOR	10MF 20% 16V	
	CF101	QAX0704-001Z	C.FILTER		
	CF102	QAX0704-001Z	C.FILTER		
	CF103	QAX0519-001Z	C FILTER		
	CN111	QGB2501K2-12	CONNECTOR		
	CN112	QGB2501K1-04	CONNECTOR		
	D 121	1SS133-T2	SI DIODE IM		
	D 123	1SS133-T2	SI DIODE IM		
	D 129	1SS133-T2	SI DIODE IM		
	D 131	1SS133-T2	SI DIODE IM		
	IC102	LA1838	IC		
	IC121	LC72136N	IC		
	IC191	SAA6588	IC(RDS)		
	L 112	QQL231K-2R7Y	INDUCTOR		

△	Item	Parts number	Parts name	Remarks	Area
	Q 102	2SC535/BC/-T	TRANSISTOR		
	Q 103	2SC461/BC/-T	TRANSISTOR		
	Q 111	KTC3199/GL/-T	TRANSISTOR		
	Q 112	KTC3199/GL/-T	TRANSISTOR		
	Q 113	DTA114YKA-X	TRANSISTOR		
	Q 121	KRA103M-T	TRANSISTOR		
	R 103	NRSA02J-101X	MG RESISTOR		
	R 104	NRSA02J-272X	MG RESISTOR		
	R 105	NRSA02J-391X	MG RESISTOR		
	R 106	NRSA02J-102X	MG RESISTOR		
	R 107	NRSA02J-561X	MG RESISTOR		
	R 108	NRSA02J-332X	MG RESISTOR		
	R 109	NRSA02J-221X	MG RESISTOR		
	R 111	NRSA02J-182X	MG RESISTOR		
	R 112	QRE141J-182Y	C RESISTOR	1.8K 5% 1/4W	
	R 114	NRSA02J-272X	MG RESISTOR		
	R 115	NRSA02J-104X	MG RESISTOR		
	R 119	NRSA02J-103X	MG RESISTOR		
	R 122	NRSA02J-472X	MG RESISTOR		
	R 124	NRSA02J-222X	MG RESISTOR		
	R 126	NRSA02J-562X	MG RESISTOR		
	R 127	NRSA02J-822X	MG RESISTOR		
	R 128	NRSA02J-472X	MG RESISTOR		
	R 129	NRSA02J-222X	MG RESISTOR		
	R 130	QRZ9005-680X	F RESISTOR	68 1/4W	
	R 132	NRSA02J-393X	MG RESISTOR		
	R 133	NRSA02J-392X	MG RESISTOR		
	R 134	NRSA02J-102X	MG RESISTOR		
	R 140	NRSA02J-563X	MG RESISTOR		
	R 141	NRSA02J-102X	MG RESISTOR		
	R 142	NRSA02J-470X	MG RESISTOR		
	R 143	NRSA02J-562X	MG RESISTOR		
	R 144	NRSA02J-332X	MG RESISTOR		
	R 145	NRSA02J-103X	MG RESISTOR		
	R 146	NRSA02J-472X	MG RESISTOR		
	R 147	NRSA02J-332X	MG RESISTOR		
	R 150	NRSA02J-331X	MG RESISTOR		
	R 157	NRSA02J-272X	MG RESISTOR		
	R 158	NRSA02J-272X	MG RESISTOR		
	R 161	NRSA02J-102X	MG RESISTOR		
	R 162	NRSA02J-102X	MG RESISTOR		
	R 182	NRSA02J-103X	MG RESISTOR		
	R 183	NRSA02J-103X	MG RESISTOR		
	R 184	NRSA02J-103X	MG RESISTOR		
	R 191	NRSA02J-102X	MG RESISTOR		
	R 192	NRSA02J-474X	MG RESISTOR		
	R 193	NRSA02J-103X	MG RESISTOR		
	R 194	NRSA02J-103X	MG RESISTOR		
	RF101	QAU0119-001	FRONT END	FOR FTZ	
	T 111	QQR0871-001	COIL BLOCK		
	T 142	QQR0973-001	IFT		
	X 121	QAX0402-001	CRYSTAL		
	X 191	QAX0263-001Z	CRYSTAL		

< MEMO >

Packing materials and accessories parts list

Block No.

M	3	M	M
---	---	---	---

Block No.

M	5	M	M
---	---	---	---

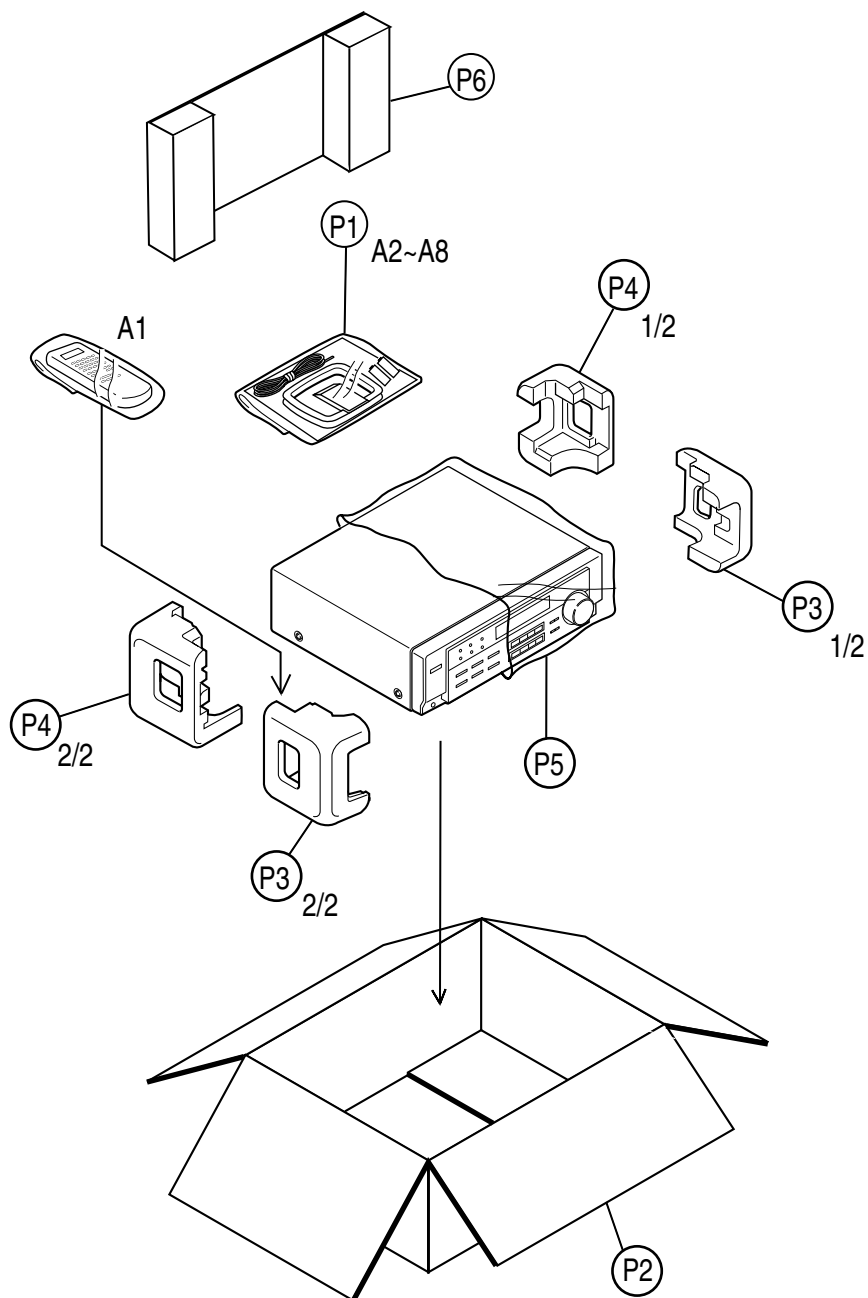

■ Parts list (Packing)

Block No. M3MM

△	Item	Parts number	Parts name	Q'ty	Description	Area
	P 1	QPA02503505P	POLY BAG	1		
	P 2	LV20983-022A	PACKING CASE	1	RX-7020RBK	
		LV20983-023A	PACKING CASE	1	RX-7022RSL	E,EN
		LV20983-024A	PACKING CASE	1	RX-7022RSL	B
		LV20983-025A	PACKING CASE	1	RX-7022RSL	EV
	P 3	LV20925-001A	PACKING PAD	1		
	P 4	LV20926-001A	PACKING PAD	1		
	P 5	QPC06507015P	POLY BAG	1		
	P 6	LV30385-004A	SHEET	1	RX-7022RSL	B

■ Parts list (Accessories)

Block No. M5MM

△	Item	Parts number	Parts name	Q'ty	Description	Area
	A 1	RM-SRX7020R	REMOCON	1	RX-7020RBK	
		RM-SRX7022R	REMOCON	1	RX-7022RSL	
	A 2	-----	BATTERY	2		
	A 3	LVT0852-007A	INST.BOOK(7022RSL)	1	ENG	B
		LVT0852-008A	INST.BOOK(7022RSL)	1	GER,FRE,DUT	E
			INST.BOOK(7020RBK)	1	GER,FRE,DUT	E
		LVT0852-009A	INST.BOOK(7022RSL)	1	SWE,FIN,DAN,GER	EN
			INST.BOOK(7022RSL)	1	FRE,SPA,ITA	EN
		LVT0852-010A	INST.BOOK(7022RSL)	1	HUN,POL,CZE,RUS	EV
	A 4	EWP503-001C	ANT.WIRE	1		
	A 5	QAL0204-001	AM LOOP ANT	1		
	A 6	BT-54013-2	W.CARD	1		
	A 7	E43486-340B	SAFETY INST	1	RX-7022RSL	B
	A 8	VNA3000-204	REGIST.CARD	1	RX-7022RSL	B