

# JVC

## SERVICE MANUAL

### AUDIO/VIDEO CONTROL RECEIVER

# RX-718PBK

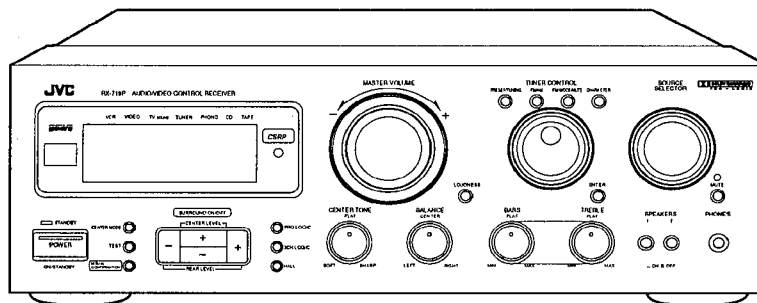
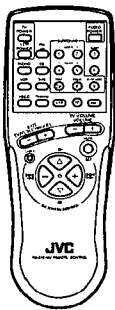

#### Area Suffix

UB .... Hong Kong  
 US .... Singapore  
 U ..... Other Area

**COMPU LINK**  
 Remote Control Component

## Contents

<i>Safety Precautions</i> .....	1-2	<i>Adjustment Procedures</i> .....	1-36
<i>Instruction Book</i> .....	1-3	<i>Block Diagrams</i> .....	1-39
<i>Description of Major ICs</i> .....	1-20	<i>Schematic Diagrams</i> .....	1-40
<i>Internal Connection of FL Display</i> .....	1-32	<i>Printed Circuit Boards</i> .....	1-45
<i>Disassembly Procedures</i> .....	1-34	<i>Parts List</i> .....	2-1

## Safety Precautions

1. The design of this product contains special hardware and many circuits and components specially for safety purposes. For continued protection, no changes should be made to the original design unless authorized in writing by the manufacturer. Replacement parts must be identical to those used in the original circuits. Services should be performed by qualified personnel only.
2. Alterations of the design or circuitry of the product should not be made. Any design alterations of the product should not be made. Any design alterations or additions will void the manufacturer's warranty and will further relieve the manufacture of responsibility for personal injury or property damage resulting therefrom.
3. Many electrical and mechanical parts in the products have special safety-related characteristics. These characteristics are often not evident from visual inspection nor can the protection afforded by them necessarily be obtained by using replacement components rated for higher voltage, wattage, etc. Replacement parts which have these special safety characteristics are identified in the Parts List of Service Manual. Electrical components having such features are identified by shading on the schematics and by ( $\Delta$ ) on the Parts List in the Service Manual. The use of a substitute replacement which does not have the same safety characteristics as the recommended replacement parts shown in the Parts List of Service Manual may create shock, fire, or other hazards.
4. The leads in the products are routed and dressed with ties, clamps, tubings, barriers and the like to be separated from live parts, high temperature parts, moving parts and/or sharp edges for the prevention of electric shock and fire hazard. When service is required, the original lead routing and dress should be observed, and it should be confirmed that they have been returned to normal, after re-assembling.

### 5. Leakage current check (Electrical shock hazard testing)

After re-assembling the product, always perform an isolation check on the exposed metal parts of the product (antenna terminals, knobs, metal cabinet, screw heads, headphone jack, control shafts, etc.) to be sure the product is safe to operate without danger of electrical shock.

Do not use a line isolation transformer during this check.

- Plug the AC line cord directly into the AC outlet. Using a "Leakage Current Tester", measure the leakage current from each exposed metal parts of the cabinet, particularly any exposed metal part having a return path to the chassis, to a known good earth ground. Any leakage current must not exceed 0.5mA AC (r.m.s.).

#### ● Alternate check method

Plug the AC line cord directly into the AC outlet. Use an AC voltmeter having, 1,000 ohms per volt or more sensitivity in the following manner. Connect a 1,500 $\Omega$  10 W resistor paralleled by a 0.15  $\mu$ F AC-type capacitor between an exposed metal part and a known good earth ground.

Measure the AC voltage across the resistor with the AC voltmeter.

Move the resistor connection to each exposed metal part, particularly any exposed metal part having a return path to the chassis, and measure the AC voltage across the resistor.

Now, reverse the plug in the AC outlet and repeat each measurement. Any voltage measured must not exceed 0.75 V AC (r.m.s.). This corresponds to 0.5 mA AC (r.m.s.).

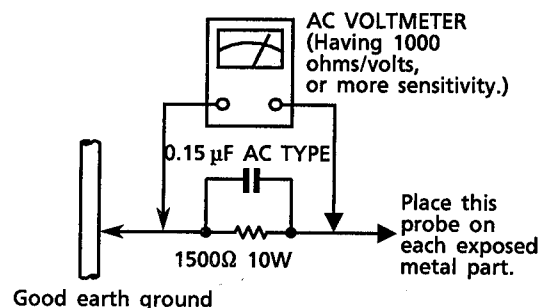

## Warning

1. This equipment has been designed and manufactured to meet international safety standards.
2. It is the legal responsibility of the repairer to ensure that these safety standards are maintained.
3. Repairs must be made in accordance with the relevant safety standards.
4. It is essential that safety critical components are replaced by approved parts.
5. If mains voltage selector is provided, check setting for local voltage.

# Instruction Book

**Table of Contents**

<b>Getting Started</b> .....	<b>2</b>
Before Installation .....	2
Checking the Supplied Accessories .....	2
Setting the Voltage Selector Switch.....	2
Connecting the FM and AM Antennas.....	3
Connecting the Speakers.....	4
Connecting Audio/Video Components .....	6
Connecting Audio Components for the COMPU LINK-3 Remote Control System.....	7
Power Supply through the Receiver to the Connected Components (Except for Singapore and Hong Kong).....	7
Connecting the Power Cord .....	8
Putting Batteries in the Remote Control .....	8
<b>Parts Identification</b> .....	<b>9</b>
<b>Basic Operations</b> .....	<b>10</b>
Turning the Power On and Off .....	10
Selecting the Source to Play .....	10
Selecting the Front Speakers .....	11
Adjusting the Volume .....	11
Adjusting the Front Speaker Output Balance .....	11
Adjusting the Tone.....	11
Listening at Low Volume (Loudness) .....	12
Muting the Sound .....	12
Listening with Headphones .....	12
Recording a Source .....	12
<b>Receiving Radio Broadcasts</b> .....	<b>13</b>
Setting the AM Tuner Interval Spacing .....	13
Tuning in Stations Manually .....	13
Using the Preset Tuning.....	14
Selecting the FM Reception Mode.....	15
Assigning Names to Preset Stations.....	16
<b>Using the Surround Modes</b> .....	<b>17</b>
Using JVC's Hall Surround.....	18
Arranging the Speakers for Dolby Surround .....	19
Preparing for Dolby Surround.....	20
<b>Other Features</b> .....	<b>23</b>
Using the CSRP Function .....	23
Using the Sleep Timer .....	23
Using the Visual Confirmation .....	24
<b>Using the On-Screen Display to Control the Receiver</b> .....	<b>25</b>
Basic Procedures .....	25
<b>Using the Remote Control</b> .....	<b>30</b>
<b>COMPU LINK Remote Control System</b> .....	<b>31</b>
<b>Troubleshooting</b> .....	<b>32</b>
<b>Specifications</b> .....	<b>33</b>

**Getting Started**

This section explains how to connect stereo components and speakers to the receiver, and how to connect the power supply.

**Before Installation**

- General**
- Be sure your hands are dry.
  - Turn the power off to all components.
  - Read the manuals supplied with the components you are going to connect.

**Locations**

- Install the receiver in a location that is level and protected from moisture.
- The temperature around the receiver must be between 23° and 104° F (-5° and 40° C).
- Make sure there is good ventilation around the receiver. Poor ventilation could cause overheating and damage the receiver.

**Handling the receiver**

- Do not insert any metal object into the receiver.
- Do not disassemble the receiver or remove screws, covers, or cabinet.
- Do not expose the receiver to rain or moisture.

**Checking the Supplied Accessories**

Check to be sure you have all of the following items, which are supplied with the receiver. The number in the parenthesis indicates the quantity of the pieces supplied.

- Remote Control (1)
  - Batteries (2)
  - AM Loop Antenna (1)
  - FM Wire Antenna (1)
  - AC Plug Adaptor (1) (Except for Hong Kong)
- If anything is missing, contact your dealer immediately.

**Setting the Voltage Selector Switch**

Before connections, always do the following first if necessary.

**How to set the voltage selector**

Set the correct voltage for your area with the voltage selector switch on the rear panel. Use a screw driver to rotate the switch so the number the arrow is pointing at is the same as the voltage where you are plugging in the receiver.

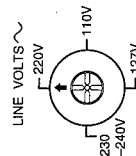

This mark indicates that you can also use the Menus to do the same operations. Actual operations using the Menus are explained on pages indicated next to the marks.

- The following functions are available only using the Menus.
- Selecting the BACK GROUND COLOR on the TV screen (see page 29)
  - Using the AUTO DEMO START to see the demonstration of the Menu operations (see page 29)

**Connecting the Speakers**

You can connect the following speakers:

- Two sets of front speakers to produce normal stereo sound.
- One set of rear speakers to enjoy the surround effect.
- One center speaker to produce more effective surround effect (to make human voices outstanding).
- One subwoofer speaker to enhance the bass.

For each speaker, connect one end of the speaker signal cable (not supplied) to the speaker terminal on the rear panel and the other end to the speaker. For connecting a subwoofer, see page 5.

1. Open each terminal.



2. Insert the end of the speaker signal cable as shown (be sure to remove the insulation at the end of each wire first).



3. Close the terminals to clamp the speaker signal cables firmly in place.
4. Connect the black (-) and red (+) terminals on the rear panel to the black (-) and red (+) terminals marked on the speakers.

**CAUTION:**  
Use speakers with the same **SPEAKER IMPEDANCE** indicated by the speaker terminals.

**Connecting the front speakers**

Connect the front speakers to the **FRONT SPEAKERS** terminals.

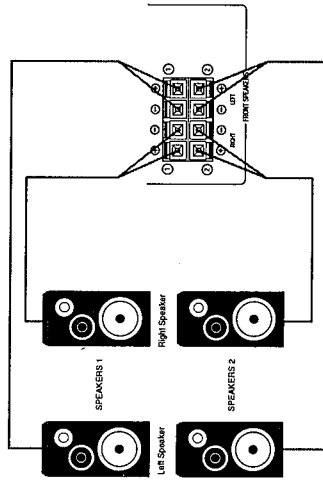

**Connecting the FM and AM Antennas**

**FM Antenna Connections**

Extend the FM wire antenna horizontally.

If reception is poor, connect an outside antenna. Before attaching a 75-ohm coaxial cable (the kind with a round wire going to an outside antenna), disconnect the supplied FM wire antenna.

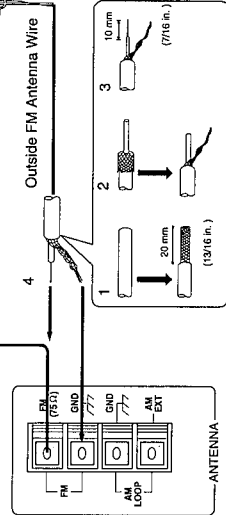

**How to strip the 75-ohm coaxial cable and connect it to the FM terminals**

1. Strip back the outside covering of the 75-ohm coaxial cable to expose the braided metallic mesh.
2. Pull the mesh back and twist it into a single connector, as shown in the illustration above.
3. Strip the insulation about 10 mm (7/16 inches) back from the central wire.
4. Insert the twisted mesh and the central wire to the FM terminals, as shown in the illustration above.

**AM Antenna Connections**

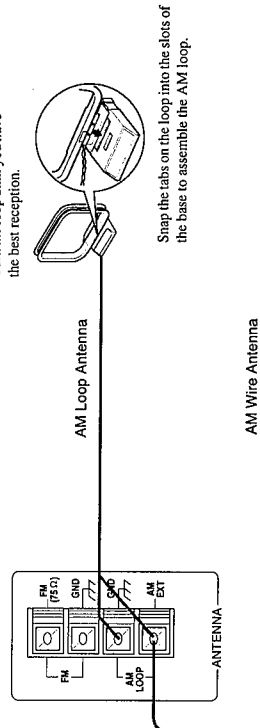

If reception is poor, connect an outdoor single vinyl-covered wire to the AM EXT terminal. (Keep the AM loop antenna connected.)

**Note:**  
Make sure the antenna conductors do not touch any other terminals, connecting cords and power cord. This could cause poor reception.

**Connecting the rear and center speakers**

Connect rear speakers to the REAR SPEAKERS terminals and a center speaker to the CENTER SPEAKER terminals.

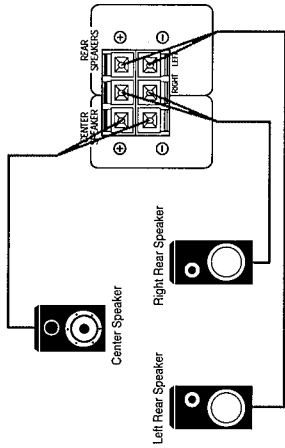

**Note:**  
When you connect rear speakers, make sure that both left and right speakers are connected; otherwise, no sound will come out of the rear speakers.

**Enhancing the bass**

You can enhance the bass by connecting a subwoofer using a cable with RCA pin plugs. To connect a subwoofer, you also need a separate power amplifier.

- 1 Connect the input jack of the power amplifier to the SUB WOOFER OUT jack on the rear panel.
- 2 Connect a subwoofer speaker to the speaker terminal of the power amplifier.

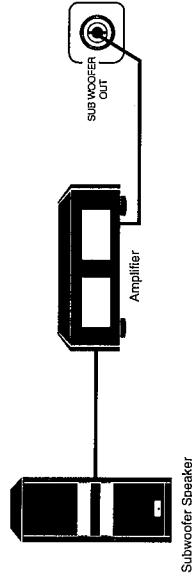

**Connecting Audio/Video Components**

You can connect the other audio/video components to the receiver using cables with RCA pin plugs.

- Notes:**
- Both plugs and jacks are color-coded; the red ones are for right audio signals, the white ones for left audio signals, and yellow ones for video signals.
  - Any turntables incorporating a small-output cartridge such as an MC (moving-coil type) must be connected to this receiver through a commercial head amplifier or step-up transformer. Direct connection may result in insufficient volume.
  - If a ground cable is provided for your turntable, connect the cable to the screw marked GND on the rear panel.

**Audio component connections**

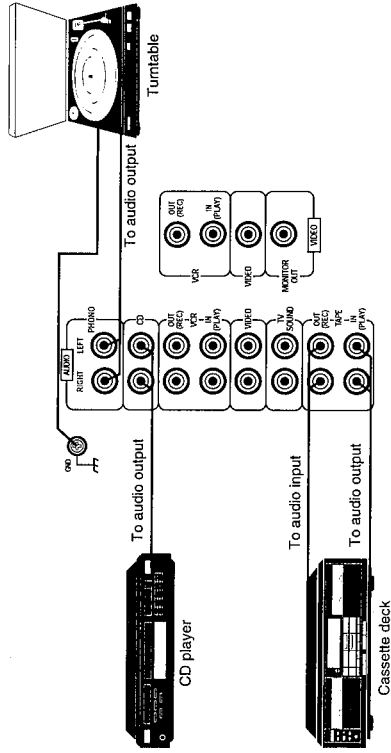

**Video component connections**

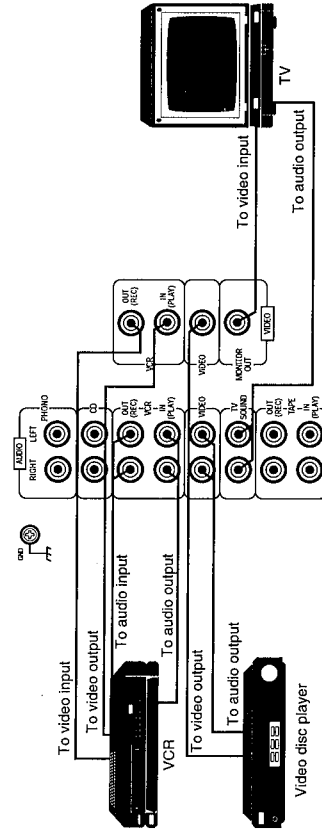

**Connecting the Power Cord**

Before plugging the receiver into an AC outlet, make sure that all connections have been made. When the power cord is connected, the STANDBY indicator above the POWER button lights up.

Keep the power cord away from the connecting cables for the TV, VCR, and antenna. The power cord may cause noise or screen interference. We recommend that you use a coaxial cable to connect the antenna, since it is well-shielded against interference.

**Notes:**

- A small amount of power is always consumed even in standby mode. To switch off the power completely, unplug the power cord from the AC outlet.
- If the power cord is unplugged or a power failure occurs, preset settings will be erased in a few days.
- Except for Hong Kong: If the wall outlet does not match the AC plug, use the supplied AC plug adaptor.

**CAUTIONS:**

- Do not touch the power cord with wet hands.
- Do not pull on the power cord to unplug the unit. When unplugging the unit, always grasp the plug itself so as not to damage the cord.

**Putting Batteries in the Remote Control**

Before using the remote control, put two supplied batteries first. When using the remote control, aim the remote control directly at the remote sensor on the receiver.

1. On the back of the remote control, press down on the battery cover and slide it out.
2. Insert batteries. Make sure to observe the proper polarity: (+) to (+) and (-) to (-).
3. Slide the cover in.

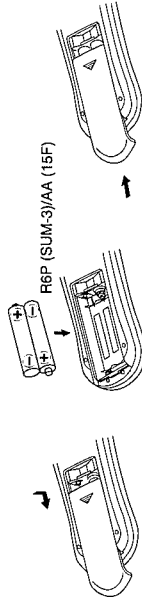

If the range or effectiveness of the remote control decreases, replace the batteries. Use two R6P (SUM-3)/AA (15F) type dry-cell batteries.

**CAUTIONS:**

Follow these precautions to avoid leaking or cracking cells:

- Place batteries in the remote control so they match the polarity indicated: (+) to (+) and (-) to (-).
- Use the correct type of batteries. Batteries that look similar may differ in voltage.
- Always replace both batteries at the same time.
- Do not expose batteries to heat or flame.

**Connecting Audio Components for the COMPU LINK-3 Remote Control System**

The COMPU LINK-3 remote control system allows you to control either JVC audio components from the receiver or vice versa. To use this system, connect your JVC audio components and the receiver with the cable (monaural mini-plug) supplied with those components.

If your audio component has two COMPU LINK-3 SYNCHRO jacks, you can use either one. If it has only one COMPU LINK-3 SYNCHRO jack, connect it so that it is the last item in the series of components. (For example, the turntable or CD player in the diagram below)

**Notes:**

- The COMPU LINK-3 remote control system is the upgraded version of the COMPU LINK-1 and COMPU LINK-2. Even if your component has the COMPU LINK-1 or COMPU LINK-2 jacks, you can still connect it in the COMPU LINK-3 remote control system, but some functions may not work correctly.
- For more information about the COMPU LINK-3 (-1 and -2) remote control system, see page 31.

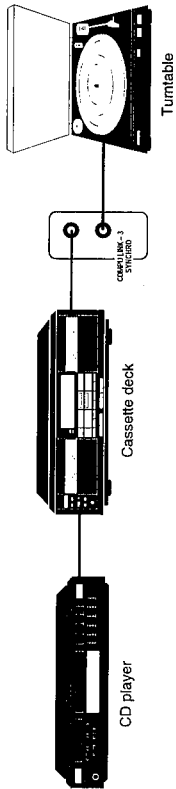

**Power Supply through the Receiver to the Connected Components**

If the AC plug of your receiver is of the parallel flat blade type, AC outlets (illustrated to the left) are equipped on the rear of the receiver.

You can use the AC outlets on the rear of the receiver to supply power to audio components. These AC outlets are "switched" outlets. So when the receiver is off (that is, in standby mode), power is not supplied through these outlets. By turning the receiver on and off, you can turn the connected components on and off at the same time.

**Note:**

Do not use the AC outlets on the rear of the receiver to supply power to the components in the COMPU LINK remote control system; otherwise, the COMPU LINK remote control system may not work correctly.

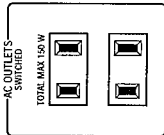

**CAUTION:**

Do not plug the components to the AC outlets on the rear if their total power consumption is greater than indicated by the AC outlets.

**Parts Identification**

Become familiar with the buttons and controls on your receiver before use.

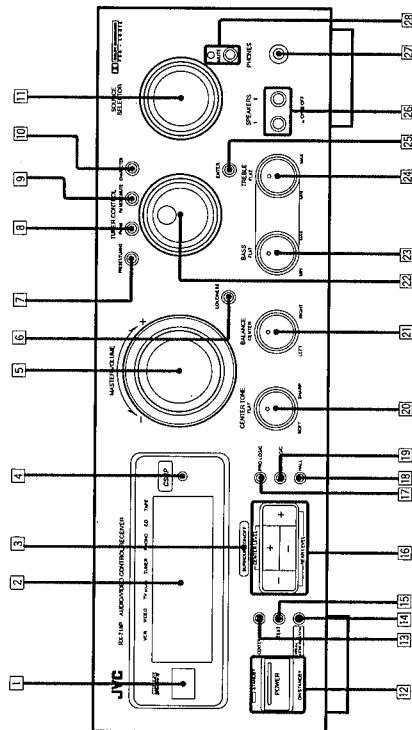

Refer to the pages in parentheses for details.

**Front Panel**

- 1 Remote sensor
- 2 Display (10)
- 3 SURROUND ON/OFF button
- 4 CSRP button (23)
- 5 MASTER VOLUME control (11)
- 6 LOUDNESS button (12)
- 7 PRESET/TUNING button (13, 15)
- 8 FM/AM button (13)
- 9 FM MODE/MUTE button (15)
- 10 CHARACTER button (16)
- 11 SOURCE SELECTOR (10)
- 12 POWER button and STANDBY indicator (10)
- 13 CENTER MODE button (20)
- 14 VISUAL CONFIRMATION button (24)
- 15 TEST button (21)
- 16 Cursor buttons (+/-) for surround adjustment (21)
- 17 PRO LOGIC button (20)
- 18 HALL button (18)
- 19 3CH LOGIC button (20)
- 20 CENTER TONE control (22)
- 21 BALANCE control (11)
- 22 TUNER CONTROL (13, 16)
- 23 BASS control (11)
- 24 TREBLE control (11)
- 25 ENTER button (14, 16)
- 26 SPEAKERS 1/2 buttons (11)
- 27 PHONES jack (12)
- 28 MUTE button and indicator (12)

**Remote Control**

- 1 TV POWER and VCR POWER buttons (30)
  - 2 Source selecting buttons (10)
  - 3 TV/VCR CHANNEL buttons (+/-) (30)
  - 4 EXIT button (25)
  - 5 SHIFT button (18, 20, 23, 25, 30)
  - 6 AUDIO POWER button (10)
  - 7 SLEEP button (23)
  - 8 Surround adjustment buttons (18, 20)
  - 9 DISC button (30)
  - 10 VOLUME buttons (+/-) (11)
  - 11 TV VOLUME buttons (30)
  - 12 MUTE button (12)
  - 13 SET button (25)
  - 14 Operating buttons for IVC audio/video components (30)
  - 15 Cursor buttons for menu operation (25)
- \* Some buttons on the remote control have been assigned more than one function. To have the buttons function as marked in green, press the SHIFT button at the same time.*

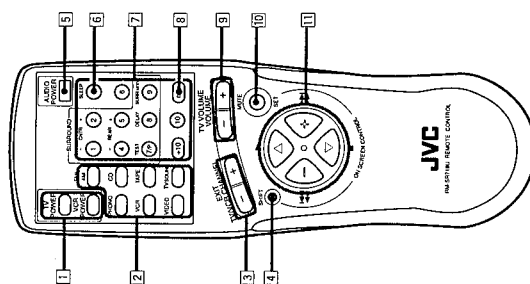

**Basic Operations**

The following operations are commonly used when you play any sound source.

**Turning the Power On and Off**

To turn on the power, press the POWER button on the front panel or the AUDIO POWER button on the remote control. The STANDBY indicator turns off. The name of the current source appears on the display.

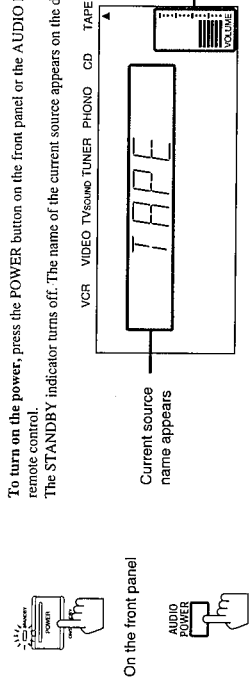

On the front panel

From the remote control



**Selecting the Source to Play**

You need to select the source to listen before you start playing any source.

On the front panel:

Turn the SOURCE SELECTOR so that the desired source name appears on the display (at the same time the arrow (▲) on the display points the source).

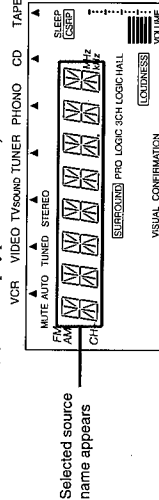

Selected source name appears

On the front panel

- VCR View the video component connected to the VCR jacks.
- VIDEO View the video component connected to the VIDEO jacks.
- TV sound Listen to TV broadcasts.
- TUNER Listen to FM or AM broadcasts.
- PHONO Listen to records.
- CD Listen to CDs.
- TAPE Listen to cassette tapes.

From the remote control:

Press the desired source selecting buttons.

- VCR View the video component connected to the VCR jacks.
- VIDEO View the video component connected to the VIDEO jacks.
- TV sound Listen to TV broadcasts.
- PHONO\* Listen to FM or AM broadcasts.
- CD\* Listen to records.
- TAPE\* Listen to cassette tapes.

From the remote control

Note:  
When you press one of the source selecting buttons marked above with an asterisk (\*), the receiver automatically turns on.

**Selecting the Front Speakers**

When you have connected two sets of the front speakers, you can select which to use. Pressing in the SPEAKERS 1 or SPEAKERS 2 button on the front panel activates the respective set of the speakers.



To use the speakers connected to the FRONT SPEAKERS ① terminals, press in the SPEAKERS 1 button (ON), and press out the SPEAKERS 2 button (OFF).  
 To use the speakers connected to the FRONT SPEAKERS ② terminals, press in the SPEAKERS 2 button (ON), and press out the SPEAKERS 1 button (OFF).  
 To use both sets of the speakers, press in both the SPEAKERS 1 and 2 buttons (ON).  
 To use neither set of the speakers, press out both the SPEAKERS 1 and 2 buttons (OFF).

**Note:**  
 When only one set of the speakers is connected to either the FRONT SPEAKERS ① or ② terminals, do not press in both SPEAKERS 1 and 2 buttons (ON). If you do, no sound comes out of the front speakers.



See also page 25.

**Adjusting the Volume**

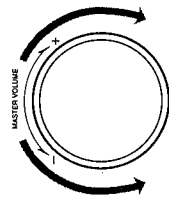

When you turn on the power or change the volume level, the volume level is shown on the display.

**On the front panel:**

To increase the volume, turn the MASTER VOLUME control clockwise.  
 To decrease the volume, turn it counterclockwise.

**From the remote control:**

To increase the volume, press the VOLUME + button.  
 To decrease the volume, press the VOLUME - button.

On the front panel

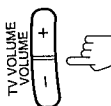

From the remote control

**CAUTION:**  
 Always set the volume level to the minimum before starting any source. If the volume level is left turned up, the sudden blast of sound energy can permanently damage your hearing and/or ruin your speakers.

**Adjusting the Front Speaker Output Balance**

If the sounds you hear from the right and left front speakers are unequal, you can adjust the speaker output balance with the BALANCE control on the front panel.

To decrease the left channel sound, turn the BALANCE control clockwise.  
 To decrease the right channel sound, turn the BALANCE control counterclockwise.



**Adjusting the Tone**

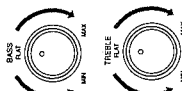

You can increase or decrease the amount of the bass and the treble reinforcement using the BASS and TREBLE controls on the front panel.  
 Usually set these controls at the FLAT position.

To increase the bass reinforcement, turn the BASS control clockwise.  
 To decrease the bass reinforcement, turn the BASS control counterclockwise.  
 To increase the treble reinforcement, turn the TREBLE control clockwise.  
 To decrease the treble reinforcement, turn the TREBLE control counterclockwise.

**Listening at Low Volume (Loudness)**

Human ears are not sensitive to bass at low volume. To compensate for this, the loudness function automatically boosts the bass level as you lower the volume.



To use the loudness function, press the LOUDNESS button on the front panel.  
 The LOUDNESS indicator lights up on the display.

To turn the function off, press the LOUDNESS button again.  
 The LOUDNESS indicator goes off.

**Muting the Sound**



You can easily turn off the volume by pressing the MUTE button.

To mute the sound through all speakers and headphones connected  
 Press the MUTE button so that the indicator on the front panel turns on. ("MUTE" also appears on the display.)

To cancel the mute, press the MUTE button again so that the indicator turns off.

When you turn the MASTER VOLUME control or press the VOLUME +/- button, mute is also cancelled.

**Listening with Headphones**

A standard pair of headphones can be connected to the PHONES jack on the front panel. Be sure to turn down the volume before connecting or putting on headphones, as high volume can damage both the headphones and your hearing.

To listen with only headphones  
 Press out both the SPEAKERS 1 and 2 buttons (OFF).

**Recording a Source**

You can record any source playing through the receiver to the cassette deck connected to the TAPE jacks, and the YCR connected to the YCR jacks at the same time.  
 While recording, you can listen to the selected sound source at whatever sound level you like, without affecting the sound levels of the recording.

**Note:**  
 The output volume level, tone adjustments, and surround modes will not affect the recording.



See also page 26.



### Using the Preset Tuning

Once a station is assigned to a channel number, the station can be quickly tuned. You can preset up to 40 stations, either AM, FM, or a mixture of both, at random.

You can preset the stations you want into memory by following the presetting method below.

1. Tune in the station you want to preset (see above).
2. Press the **ENTER** button on the front panel. "CH. ---" appears on the display for 5 seconds.
3. Select a channel number within the 5 seconds.
  - On the front panel: Turn the **TUNER CONTROL**.
  - From the remote control: Press the 10 keys to select a channel number.
    - Examples: For channel number 5, press 5. For channel number 15, press +10 then 5. For channel number 20, press +10 then 10.

**Note:**  
When you use the remote control, be sure that the remote control is activated for tuner, not for the CD and others. (See page 30.)

4. Press the **ENTER** button again while the selected channel number is flashing on the display. The selected channel number stops flashing, and the station is assigned to the selected channel number.

To erase a stored station  
Storing a new station on a used number erases the previously stored one.

**CAUTION:**  
Preset stations may be erased when power is cut off to the receiver, as when it is unplugged from the AC outlet or a power failure occurs. If the preset stations are lost, simply store the stations again using the above procedure.



NEW CONTROL



On the front panel



From the remote control

### Receiving Radio Broadcasts

You can browse through all the stations or use the preset function to go immediately to a particular station.

### Setting the AM Tuner Interval Spacing

Some countries space AM stations 9 kHz apart, and other countries use 10 kHz spacing.

When shipped, the spacing is set to 9 kHz.



To select the 10 kHz interval, be sure the receiver is turned off, but is plugged into an AC outlet. Hold down the upper cursor button (+) and press the **POWER** button (both buttons on the front panel). "10K STEP" appears on the display for about three seconds. Now the 10 kHz interval is selected.

To change back to the 9 kHz interval, be sure the receiver is turned off, but is plugged into an AC outlet. Hold down the lower cursor button (-) and press the **POWER** button (both buttons on the front panel). "9K STEP" appears on the display for about three seconds. Now the 9 kHz interval is selected.

See also page 26.



### Tuning in Stations Manually

1. Select **TUNER** as the source to play and choose the band.
  - On the front panel:
    - 1 Turn the **SOURCE SELECTOR** to select **TUNER**. The last received station is tuned in.
    - 2 Press the **FM/AM** button. Each time you press the button, the band (FM and AM) alternates.
  - From the remote control: Press the **FM/AM** button. The last received station is tuned in. Each time you press the button, the band (FM and AM) alternates.

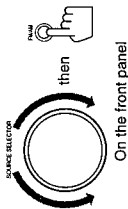

On the front panel

FM/AM

From the remote control

**Note:**  
If you do not see a preset channel number on the display, the receiver is already in the manual tuning mode, so skip Step 2 below.

2. Press the **PRESET/TUNING** button on the front panel to set the tuning mode to the manual tuning. When the manual tuning is selected, the preset channel number disappears from the display. Each time you press the button, the manual tuning and preset tuning modes alternate.

3. Turn the **TUNER CONTROL** on the front panel clockwise or counterclockwise. Turning it clockwise increases the frequency. Turning it counterclockwise decreases the frequency.

**Notes:**

- When you turn the **TUNER CONTROL** fast, the frequency keeps changing until you turn the **TUNER CONTROL** again or a station is tuned in.
- When a station of sufficient signal strength is tuned in, the **TUNED** indicator lights up on the display.
- When an FM stereo program is received, the **STEREO** indicator also lights up.



NEW CONTROL



See also page 27.



**Assigning Names to Preset Stations**

You can assign a name of up to five characters to each preset station (from channel number 1 to 20). When a preset station is tuned in, its assigned name will appear on the display.

**On the front panel only:**

1. **Tune in a preset station (channel number 1 to 20).**  
See page 15 for details.
2. **Press the CHARACTER button on the front panel.**  
The first character position starts flashing.

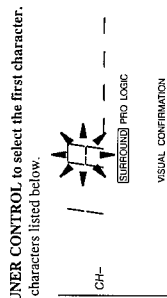
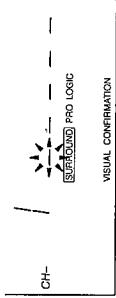

3. **Turn the TUNER CONTROL to select the first character.**  
You can use characters listed below.

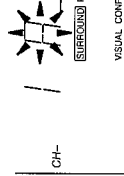

4. **When the character you want appears, press the CHARACTER button.**  
The next character position starts flashing.

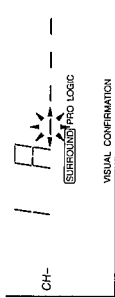

5. **Repeat Steps 3 and 4 to enter up to five characters.**
6. **Press the ENTER button after you have assigned a name.**

To erase the input characters insert blanks using the same procedure described above. When using the Menus, you can erase them more easily. (See page 27.)

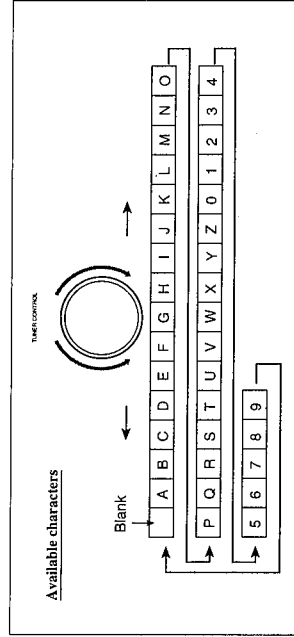

**Tuning in a preset station**

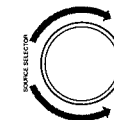

1. **Turn the SOURCE SELECTOR to select TUNER.**  
The last received station is tuned in.

**Note:**

If you see a preset channel number on the display, the receiver is already in the preset tuning mode, so skip Step 2 below.



2. **Press the PRESET/TUNING button to set the tuning mode to the preset tuning.**  
When the preset tuning is selected, a preset channel number appears on the display. Each time you press the button, the manual tuning and preset tuning modes alternate.

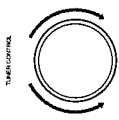

3. **Turn the TUNER CONTROL to select a preset channel number.**  
Turning it clockwise changes preset channels in increasing order.  
Turning it counterclockwise changes preset channels in decreasing order.



**From the remote control:**

1. **Press the FM/AM button.**  
The last received station is tuned in.
2. **Press the 10 keys to select a preset channel number.**  
Examples: For channel number 5, press 5. For channel number 15, press +10 then 5.  
For channel number 20, press +10 then 10.

**Note:**

When you use the remote control, be sure that the remote control is activated for tuner, not for the CD and others. (See page 30.)



**Selecting the FM Reception Mode**



You can change the FM reception mode so that reception will be improved.

**When an FM stereo broadcast is hard to receive or noisy**  
Press the FM MODE/MUTE button on the front panel. The MUTE AUTO indicator goes off on the display. Reception will be improved although you will lose the stereo effect. In this mode, you will hear noise while tuning into the stations.

**To restore stereo effect**

Press the FM MODE/MUTE button again so that the MUTE AUTO indicator lights up on the display. In this mode, when a program is broadcast in stereo, you will hear stereo sound; when in monaural, you will hear monaural sounds. This mode is also useful to suppress static noise between stations.

See also pages 27 to 28.



Using JVC's Hall Surround

You need to connect one set of rear speakers to obtain the full effect.

1. Set the surround mode on, then select the Hall Surround.

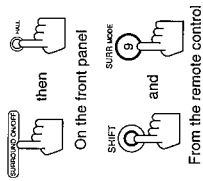

- On the front panel: Press SURROUND ON/OFF button... Press the HALL button.

From the remote control: Press the SURR MODE button repeatedly... The HALL indicator also lights up.



2. Set the output levels of the rear speakers.

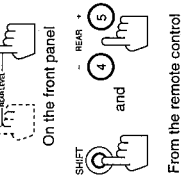

- On the front panel: Press the left or right cursor button (REAR LEVEL +/-) repeatedly.

From the remote control: Press the REAR +/- button repeatedly... Press the DELAY button while pressing the SHIFT button.



- From the remote control: Press the DELAY button while pressing the SHIFT button. Each time you press the button, the delay time changes among 4 levels.

Notes: You can adjust the sound level in 1 dB step within the range of +/- 10 dB. The sound levels of the left and right rear speakers will be the same. The sound level of the rear speakers can be only stored for the Hall Surround.

To cancel the Hall Surround, press the SURROUND ON/OFF button again. When using the remote control, press the SURR MODE button repeatedly, while pressing the SHIFT button, until the 'SURR OFF' appears on the display.

Using the Surround Modes

The built-in surround processor provides three types of surround modes — Dolby Pro Logic and Dolby 3-Channel Logic and JVC's Hall Surround.

- Notes: The surround processor has no effect on monaural sources. The surround processor cannot be used for recording.

What can the surround processor do?

The sound heard in a concert hall or a movie theater consists of direct sound and indirect sound: early reflections and reflections from behind. The reflected sounds are always delayed by the distances of the ceiling and walls from the listener. The early reflections are some of the most important elements of the acoustic surround. So, what the surround processor does is to reproduce these elements in your listening room.

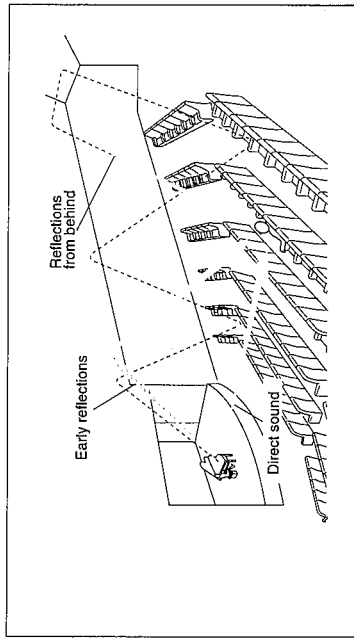

On Dolby Surround

The Dolby Surround has been developed to reproduce the important elements of the acoustic surround at home. To watch the soundtracks of video software bearing the mark DOLBY SURROUND, which includes the same encoded surround information as found in Dolby Stereo films, the receiver can provide you with 2 Dolby Surround modes (Dolby Pro Logic and Dolby 3ch Logic).

Dolby Pro Logic: Select this mode when optional rear speakers are connected. Dolby 3ch Logic: Select this mode when a center speaker is connected without rear speakers.

On JVC's Hall Surround

In order to reproduce a more realistic sound field in your listening room while playing an ordinary stereo source, JVC's Hall Surround has been designed to give you clearer vocals and to create the feeling of a concert hall. The sound is reproduced through the front speakers and rear speakers.

\* Manufactured under license from Dolby Laboratories Licensing Corporation. DOLBY, the double-D symbol and "PRO LOGIC" are trademarks of Dolby Laboratories Licensing Corporation.



Preparing for Dolby Surround

The receiver memorizes Dolby Surround adjustments.

1. Set the surround mode on, then select either PRO LOGIC or 3CH LOGIC.

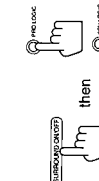

On the front panel:

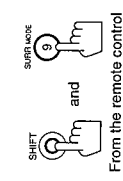

From the remote control:

1. Press the SURROUND ON/OFF button so that the SURROUND indicator and one of the surround mode indicators (PRO LOGIC, 3CH LOGIC, or HALL) light up on the display.
2. Press either the PRO LOGIC or 3CH LOGIC button.

"PRO LOGIC" or "3ch LOGIC" appears on the display. The corresponding indicator also lights up.

From the remote control:

Press the SURR MODE button repeatedly, while pressing the SHIFT button, until "PRO LOGIC" or "3ch LOGIC" appears on the display.

The corresponding indicator also lights up.



**PRO LOGIC:** Use this mode to watch a video tape with Dolby Surround when you have connected the rear speakers.

**3CH LOGIC:** Use this mode to watch a video tape with Dolby Surround when you have connected a center speaker and no rear speakers.

**HALL:** This is JVC's original surround program, and different from Dolby Surround. To use this, see page 18.

2. Set the center mode.

On the front panel:

Press the CENTER MODE button.

Each time you press the CENTER MODE button, the mode changes as follows.

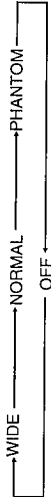

**WIDE:** Select this mode when the size of the center speaker is the same as that of the front speakers.

**NORMAL:** Select this mode when the size of the center speaker is smaller than that of the front speakers.

**PHANTOM:** Select this mode when you have not connected a center speaker.

**OFF:** Select this mode to shut off the output of the center channel signal.

*Note:* When you have selected 3CH LOGIC in Step 1 above, you cannot select PHANTOM.



From the remote control:

3. Set the delay time of the delayed sound.

From the remote control:

Press the DELAY button.

Each time you press the button, the delay time changes among 4 levels.

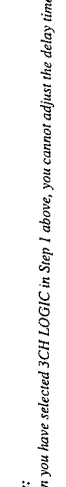

**DELAY-1:** When your distance to your rear speakers is greater than that to the front speakers.

**DELAY-2:** When your distance to your rear speakers is almost equal to that to the front speakers.

**DELAY-3:** When your distance to your rear speakers is a little less than that to the front speakers.

**DELAY-4:** When your distance to your rear speakers is much less than that to the front speakers.

*Note:* When you have selected 3CH LOGIC in Step 1 above, you cannot adjust the delay time.

Arranging the Speakers for Dolby Surround

The following illustrations show how to obtain the optimum sound environment for various Dolby Surround settings. Try to find the speaker direction and location to create the optimum sound field.

When you have added a center speaker and rear speakers

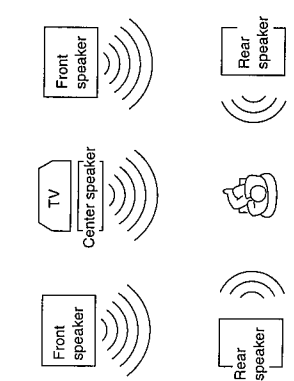

In this case:

1. Select PRO LOGIC.
2. Select NORMAL or WIDE for center mode.

See pages 20 to 22 for more details.

When you have added rear speakers

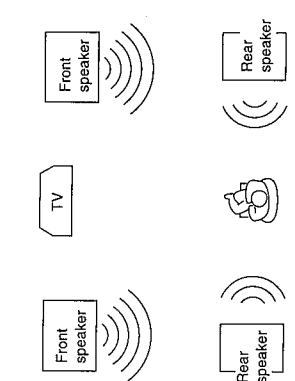

In this case:

1. Select PRO LOGIC.
2. Select PHANTOM for center mode.

See pages 20 to 22 for more details.

When you have added a center speaker (without rear speakers)

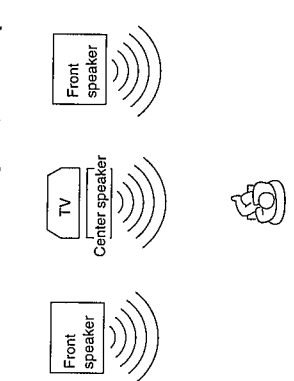

In this case:

1. Select 3CH LOGIC.
2. Select NORMAL or WIDE for center mode.

See pages 20 to 22 for more details.

**Enjoying Dolby Surround**

Once you have set Dolby Surround adjustments, you can use the same adjustments every time you want to enjoy Dolby Surround.

1. Set the surround mode on, then select either **PRO LOGIC** or **3CH LOGIC**.

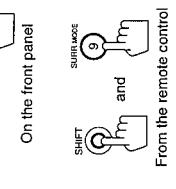
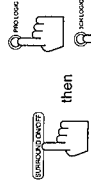

**On the front panel:**  
 1 Press the **SURROUND ON/OFF** button so that the **SURROUND** indicator and one of the surround mode indicators (**PRO LOGIC**, **3CH LOGIC**, or **HALL**) light up on the display.  
 2 Press either the **PRO LOGIC** or **3CH LOGIC** button.  
 "PRO LOGIC" or "3ch LOGIC" appears on the display. The corresponding indicator also lights up.

**From the remote control:**  
 Press the **SURR MODE** button repeatedly, while pressing the **SHIFT** button, until "PRO LOGIC" or "3ch LOGIC" appears on the display.  
 The corresponding indicator also lights up.



2. Play a sound source which was processed with Dolby Surround and is labeled with **DOLBY SURROUND** mark.

**To cancel Dolby Surround, press the SURROUND ON/OFF button again.**  
 When using the remote control, press the **SURR MODE** button repeatedly, while pressing the **SHIFT** button, until the "SURR OFF" appears on the display.

**Making dialogues in movies softer or clearer**

By using the **CENTER TONE** control, you can adjust the level of mid-frequency range, which the human voice is mostly made up of.



**To make dialogues clearer,** turn the control toward **SHARP**.  
**To make them softer,** turn the control toward **SOFT**.  
 When set to the **FLAT** position, no adjustment is applied.

**Note:**  
 The **CENTER TONE** control cannot be used when sounds do not come out of the center speaker.

4. Start checking speaker output balance.

**On the front panel:**  
 Press the **TEST** button.  
**From the remote control:**  
 Press the **TEST** button while pressing the **SHIFT** button.  
 When you press the button, "TEST" starts flashing on the display and a test tone comes out of speakers in the following order:



**Notes:**

- No test tone comes out of the rear speakers when you have selected **3CH LOGIC**.
- No test tone comes out of the center speaker when you select **PHANTOM** or **OFF** for the center mode.

5. Set the output levels of the center and the rear speakers.

**On the front panel:**  
 Press the upper or lower cursor button (**CENTER LEVEL +/-**) repeatedly to set the sound level of the center speaker.  
 Press the left or right cursor button (**REAR LEVEL +/-**) repeatedly to set the sound level of the rear speakers.

**From the remote control:**  
 Press the **CNTR +/-** button, while pressing the **SHIFT** button, to set the sound level of the center speaker.  
 Press the **REAR +/-** button, while pressing the **SHIFT** button, to set the sound level of the rear speakers.

**Notes:**

- You can adjust these levels in 1 dB step within the range of  $\pm 10$  dB. The sound levels of the left and right rear speakers will be the same.
- You cannot set the sound level of the rear speakers when you have selected **3CH LOGIC**.
- You cannot set the sound level of the center speaker when you select **PHANTOM** or **OFF** for the center mode.

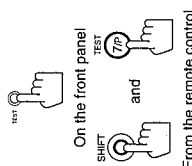
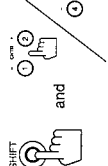
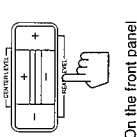
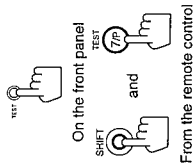

6. Finish checking speaker output balance.
- On the front panel:**  
 Press the **TEST** button again.  
**From the remote control:**  
 Press the **TEST** button again while pressing the **SHIFT** button.  
 The test tone stops.

**Other Features**

The receiver has some other features like the CSRSP function, the Sleep Timer and the Visual Confirmation. By using these useful features your audio/video life will be much improved.

**Using the CSRSP Function**

The optimum sound settings differ for each playing source. So, you have to change settings each time you select a different source.  
 The JVC's CSRSP (COMPLINK Source-Related Preset) function is used to assign and store different sound settings for each different playing source. By using this function, you don't have to change the settings every time you change the source. The stored settings for the newly selected source are automatically recalled.



The following can be stored for each source:

- Volume level (see page 11)
- Loudness (see page 12)
- Surround settings (see pages 17 to 22)

**Note:**

*If the source is FM or AM, the CSRSP function works only when one of the preset channels from 1 — 20 is tuned in. You can assign a different setting for each preset channel.*

To store the sound settings by using the CSRSP function

1. Press the CSRSP button on the front panel.  
 The CSRSP indicator lights up on the display.
2. Select the sound effects listed above while the CSRSP indicator is lit on the display.

To recall the sound settings

Whenever the CSRSP indicator is lit on the display, the settings for the currently selected source is always recalled.

To cancel the CSRSP function, press the CSRSP button so that the CSRSP indicator goes off from the display. (Even though the CSRSP function is canceled, recalled sound effects remains active.)

**Using the Sleep Timer**

Using the Sleep Timer, you can fall asleep to music and know the receiver will turn off by itself rather than play all night.

To set the Sleep Timer

Press the SLEEP button on the remote control repeatedly while pressing the SHIFT button. The SLEEP indicator lights up and the shut-off time appears on the display.

Each time you press the button, the shut-off time on the display changes as shown below:

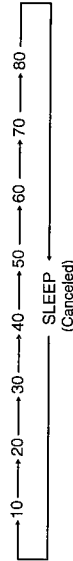

The receiver will turn off after the time you have set.

To check or change the time remaining until the shut-off time

Press the SLEEP button once while pressing the SHIFT button. The remaining time is displayed in minutes. If you press the button repeatedly, you can change the shut-off time.

To cancel the Sleep Timer

Press the SLEEP button repeatedly, while pressing the SHIFT button until the SLEEP indicator goes off.

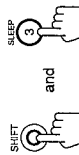

**Using the Visual Confirmation**



See also page 28.

When you press a certain button or turn a control knob on the front panel, you can see what you are doing on the TV screen.

To use this function, you need to connect the TV to the MONITOR OUT jack on the rear panel (see page 6), and set the TV's input mode to the proper position to which the receiver is connected. When the TV's input mode is for TV, you cannot see the on-screen display.

To activate the Visual Confirmation

Press the VISUAL CONFIRMATION button on the front panel so that the VISUAL CONFIRMATION indicator lights up on the display.

**EXAMPLES:**

When you turn the SOURCE SELECTOR:

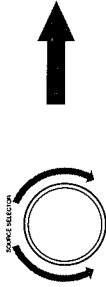

The SOURCE SELECT Menu appears for a while.

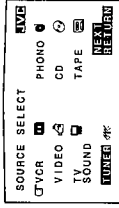

When you press the FM/AM button:



If the tuning mode is "manual"; The TUNER BAND/TUNING Menu appears for a while.

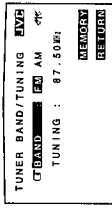

If the tuning mode is "preset";

The TUNER PRESET CH. Menu appears for a while.

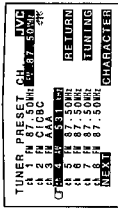

To cancel the Visual Confirmation

Press the VISUAL CONFIRMATION button again so that the VISUAL CONFIRMATION indicator goes off.

### Using the On-Screen Display to Control the Receiver

You can use the Menus on the TV screen to control the Unit. Before using the Menus, be sure that you have connected the TV correctly (page 6). This is possible only using the remote control.

#### Basic Procedures

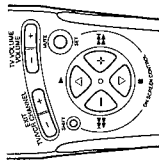

1. Press and hold the **SHIFT** button until you finish the following procedures.

2. Press the **SET** button or the cursor buttons ( $\Delta$ ,  $\nabla$ ,  $\rightarrow$ ,  $\leftarrow$ ). The **MAIN MENU** appears on the TV screen.

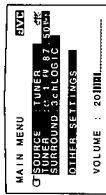

3. Press the cursor buttons ( $\Delta$ ,  $\nabla$ ) to move  $\square$  to the Sub-Menu you want to set, then press the **SET** button. The Sub-Menu you want appears.

4. Press the cursor buttons ( $\Delta$ ,  $\nabla$ ,  $\rightarrow$ ,  $\leftarrow$ ) to move  $\square$  to the item you want to set.  $\Delta$ ,  $\nabla$ : Move  $\square$  up and down.  $\rightarrow$ ,  $\leftarrow$ : Move  $\square$  to the left and right.

5. Press the cursor buttons ( $\rightarrow$ ,  $\leftarrow$ ) to change the setting for the selected item.

6. When you finish, press the **EXIT** button. The Menu disappears from the TV screen.

To go back to the **MAIN MENU** (or previous Menus) any time while using the Menus Press the cursor buttons ( $\Delta$ ,  $\nabla$ ,  $\rightarrow$ ,  $\leftarrow$ ) to move  $\square$  to **RETURN**, then press the **SET** button.

To go to the next screens Press the cursor buttons ( $\Delta$ ,  $\nabla$ ,  $\rightarrow$ ,  $\leftarrow$ ) to move  $\square$  to **NEXT**, then press the **SET** button.

#### Adjusting the volume (see also page 11)

1. Press and hold the **SHIFT** button until you finish the following procedures.

2. Press the **SET** button or the cursor buttons ( $\Delta$ ,  $\nabla$ ,  $\rightarrow$ ,  $\leftarrow$ ). The **MAIN MENU** appears on the TV screen.

3. Press the cursor buttons ( $\Delta$ ,  $\nabla$ ) to move  $\square$  to "VOLUME". See On-Screen 1.

4. Press the cursor buttons ( $\rightarrow$ ,  $\leftarrow$ ) to adjust the volume.

5. When you finish, press the **EXIT** button. The Menu disappears from the TV screen.

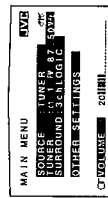

On-Screen 1

#### Selecting the source (see also page 10)

1. Press and hold the **SHIFT** button until you finish the following procedures.

2. Press the **SET** button or the cursor buttons ( $\Delta$ ,  $\nabla$ ,  $\rightarrow$ ,  $\leftarrow$ ). The **MAIN MENU** appears on the TV screen.

3. Press the **SET** button. The **SOURCE SELECT** Menu (see On-Screen 2) appears.

4. Press the cursor buttons ( $\Delta$ ,  $\nabla$ ,  $\rightarrow$ ,  $\leftarrow$ ) to move  $\square$  to the source you want to play, then press the **SET** button.

5. When you finish, press the **EXIT** button. The Menu disappears from the TV screen.

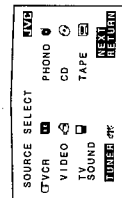

On-Screen 2

#### Tuning into stations and storing into memory (see also pages 13 and 14)

1. Press and hold the **SHIFT** button until you finish the following procedures.

2. Press the **SET** button or the cursor buttons ( $\Delta$ ,  $\nabla$ ,  $\rightarrow$ ,  $\leftarrow$ ). The **MAIN MENU** appears on the TV screen.

3. Press the cursor buttons ( $\Delta$ ,  $\nabla$ ) to move  $\square$  to "TUNER", then press the **SET** button. The **TUNER PRESET CH. Menu** (see On-Screen 3) appears.

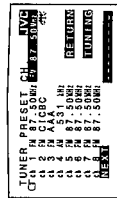

On-Screen 3

4. Press the cursor buttons ( $\Delta$ ,  $\nabla$ ,  $\rightarrow$ ,  $\leftarrow$ ) to move  $\square$  to "TUNING", then press the **SET** button. The **TUNER BAND/TUNING Menu** (see On-Screen 4) appears.

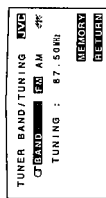

On-Screen 4

5. Press the cursor buttons ( $\rightarrow$ ,  $\leftarrow$ ) to select either "FM" or "AM".

6. Press the cursor buttons ( $\Delta$ ,  $\nabla$ ) to move  $\square$  to "TUNING".

7. Press the cursor buttons ( $\rightarrow$ ,  $\leftarrow$ ) to tune in the stations.

8. Press the cursor buttons ( $\Delta$ ,  $\nabla$ ) to move  $\square$  to "MEMORY", then press the **SET** button. The **PRESET CH. MEMORY Menu** (see On-Screen 5) appears.

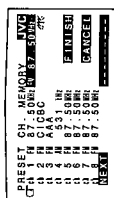

On-Screen 5

9. Press the cursor buttons ( $\Delta$ ,  $\nabla$ ) to move  $\square$  to select a preset channel number, then press the **SET** button. See On-Screen 6.

To go to the next screens, move  $\square$  to "NEXT", then press the **SET** button.

10. Press the cursor buttons ( $\Delta$ ,  $\nabla$ ,  $\rightarrow$ ,  $\leftarrow$ ) to move  $\square$  to "FINISH", then press the **SET** button. The **TUNER BAND/TUNING Menu** appears again.

To cancel presetting the station, move  $\square$  to "CANCEL", then press the **SET** button.

11. Repeat steps 5 to 10 until you preset all stations you want.

12. When you finish, press the **EXIT** button. The Menu disappears from the TV screen.

#### Tuning in a preset station (see also page 15)

1. Press and hold the **SHIFT** button until you finish the following procedures.

2. Press the **SET** button or the cursor buttons ( $\Delta$ ,  $\nabla$ ,  $\rightarrow$ ,  $\leftarrow$ ). The **MAIN MENU** appears on the TV screen.

3. Press the cursor buttons ( $\Delta$ ,  $\nabla$ ) to move  $\square$  to "TUNER", then press the **SET** button. The **TUNER PRESET CH. Menu** (see On-Screen 7) appears.

4. Press the cursor buttons ( $\Delta$ ,  $\nabla$ ) to move  $\square$  to the preset station you want, then press the **SET** button. To go to the next screens, move  $\square$  to "NEXT", then press the **SET** button.

5. When you finish, press the **EXIT** button. The Menu disappears from the TV screen.

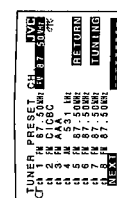

On-Screen 7

**Assigning names to the preset stations (see also page 16)**

1. Press and hold the **SHIFT** button until you finish the following procedures.
2. Press the **SET** button or the cursor buttons ( $\Delta$ ,  $\nabla$ ,  $\rightarrow$ ,  $\leftarrow$ ). The **MAIN MENU** appears on the TV screen.
3. Press the cursor buttons ( $\Delta$ ,  $\nabla$ ) to move **CT** to "TUNER", then press the **SET** button. The **TUNER PRESET CH. MENU** (see On-Screen 8) appears.
4. Press the cursor buttons ( $\Delta$ ,  $\nabla$ ) to move **CT** to a preset station you want, then press the **SET** button.

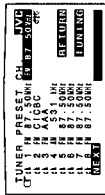



### Using the Remote Control

You can operate JVC's audio and video components with this receiver's remote control, since control signals for JVC components are preset in the remote control. To operate these components with the remote control, first select a source with the source selecting buttons on the remote control. Then, operate that source using the remote control. To have the buttons function as marked in green, press the SHIFT button at the same time.

**Note:** If you use the buttons on the front panel or the Menu to choose a source, the remote control will not operate that source. To operate a source with the remote control, the source must be selected using buttons on the remote control.

**Tuner**  
After pressing the FM/AM button, you can perform the following operations:  
FM/AM Alternates between FM and AM.  
1 — 10, +10 Selects a preset channel number directly  
To select channel number 5, press 5. For channel number 15, press +10, then 5. For channel number 20, press +10, then 10.

**CD player**  
After pressing the CD button, you can perform the following operations on a CD player:  
Starts playing  
Returns to the beginning of the current (or previous) track  
Skips to the beginning of the next track  
Stops Playing  
Selects a track number directly  
1 — 10, +10 To select track number 5, press 5. For track number 15, press +10, then 5. For track number 20, press +10, then 10.

**CD player-changer**  
After pressing the DISC button, you can perform the following operations on a CD player-changer:  
1 — 6, 7P Select the number of a disc installed in a CD player-changer. Then continue to operate the CD player as described above.

**Note:** If you have the CD player-changer XL-MC100C and XL-MC100M, 1 — 6 buttons function as the DISC SKIP button.  
• Press 2, 4, or 6 to skip to the next disc.  
• Press 1, 3, or 5 to skip back to the previous disc.

**Cassette deck**  
After pressing the TAPE button, you can perform the following operations on a cassette deck:  
Starts playback  
Fast winds the tape from right to left  
Fast winds the tape from left to right  
Stops operation

**VCR**  
After pressing the VCR button, you can perform the following operations on a VCR:  
Starts playback  
Rewinds a tape  
Fast winds a tape  
Stops operation  
TV/VCR CHANNEL +/- Changes the TV channels on the VCR.

**TV**  
After pressing the TV SOUND button, you can perform the following operations on a TV:  
TV/VCR CHANNEL +/- Changes the TV channels.  
You can always perform the following operation on a TV:  
TV VOLUME +/- Adjust the TV volume (always press the SHIFT button at the same time)

**Note:** You can also turn the VCR and the TV on and off by pressing the VCR POWER button and TV POWER button on the remote control.

**CAUTION:** If you press the cursor buttons (Δ, ∇, +, -) or the SET button while pressing the SHIFT at the same time, the Menu setting, for example volume level or surround setting, will change though you have not connected a TV to the receiver. When you use the Menus, make sure that you have connected a TV and operate the Menus while watching the on-screen displays on the TV.

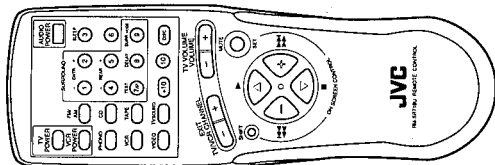

### Setting the background color on the TV screen

You can change the back ground color of the TV screen. This is possible only using the Menus.  
1. Press and hold the SHIFT button until you finish the following procedures.  
2. Press the SET button or the cursor buttons (Δ, ∇, +, -). The MAIN MENU appears on the TV screen.

- Press the cursor buttons (Δ, ∇) to move **CF** to "OTHER SETTINGS", then press the SET button. The OTHER SETTINGS Menu appears.
- Press the cursor buttons (Δ, ∇) to move **CF** to "BACK GROUND COLOR". See On-Screen 13.
- Press the cursor buttons (+, -) to select the background color.
- When you finish, press the EXIT button. The Menu disappears from the TV screen.

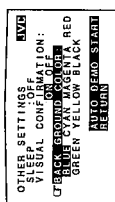

On-Screen 13

### Using the demonstration

You can see the demonstration of Menu operation. This is possible only using the Menus.

- Press and hold the SHIFT button until you finish the following procedures.
- Press the SET button or the cursor buttons (Δ, ∇, +, -). The MAIN MENU appears on the TV screen.
- Press the cursor buttons (Δ, ∇) to move **CF** to "OTHER SETTINGS", then press the SET button. The OTHER SETTINGS Menu appears.
- Press the cursor buttons (Δ, ∇) to move **CF** to "AUTO DEMO START", then press the SET button. See On-Screen 14.
- When you finish, press the EXIT button. The Menu disappears from the TV screen, and the demonstration stops.

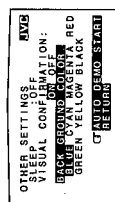

On-Screen 14

COMPU LINK Remote Control System



The COMPU LINK remote control system allows you to operate JVC audio components through the remote sensor on the receiver.  
To use this remote control system, you need to connect JVC audio components through the COMPU LINK-3 SYNCHRO jacks (see page 7) in addition to the connections using cables with RCA pin plugs (see page 6). This remote control system allows you to use four functions listed below.

■ Remote Control through the Remote Sensor on the Receiver

You can control all components through the remote sensor on the receiver using this remote control. For details, see page 30.

Note:

Aim the remote control directly at the remote sensor on the receiver.

■ Automatic Source Selection

When you press the play (▶) button on a connected component or on its own remote control, the receiver automatically turns on and changes the source to the component. On the other hand, if you select a new source on the receiver or the remote control, the selected component begins playing immediately. In both cases, the previously selected source continues playing without sound for a few seconds.

■ Automatic Power On/Off (only possible with the COMPU LINK-3 connection)

Both the CD player and cassette deck turns on and off along with the receiver. When you turn on the receiver, the CD player or cassette deck will turn on automatically, depending on which component has been previously selected. When you turn off the receiver, both the CD player and cassette deck will turn off.

■ Synchronized Recording

Synchronized recording means the cassette deck starts recording as soon as a CD or a record begins playing.

To use synchronized recording, follow these steps:

- 1 Put a tape in the cassette deck, and a disc in the CD player (or a record on the turntable).
- 2 Press the record (●) button and the pause (II) button on the cassette deck at the same time. This puts the cassette deck into recording pause.

Note:

If you do not press the record (●) button and pause (II) button at the same time, the synchronized recording feature will not operate.

- 3 Press the play (▶) button on the CD player or on the turntable.

The source changes on the receiver, and as soon as play starts, the cassette deck starts recording. When the play ends, the cassette deck enters recording pause, and stops about 4 seconds later.

Notes:

- During synchronized recording, the selected source cannot be changed.
- If your CD player is playing in program mode, a 4-second blank is recorded between tracks so that the music scan feature of your cassette deck can be used on the recorded tape.
- If the power of any component is shut off during synchronized recording, the COMPU LINK remote control system may not operate properly. In this case, you must start again from the beginning.
- Refer also to the manuals supplied with your audio components.

Troubleshooting

Use this chart to help you solve daily operational problems. If there is any problem you cannot solve, contact your JVC service center.

PROBLEM	POSSIBLE CAUSE	SOLUTION
The display does not light up.	The power cord is not plugged in.	Plug the power cord into an AC outlet.
No sound from speakers.	Speaker signal cables are not connected.	Check speaker wiring and reconnect if necessary.
	The SPEAKERS 1 and 2 buttons are not set correctly.	Press the SPEAKERS 1 and 2 buttons in or out correctly.
	An incorrect source is selected.	Select the correct source.
	Mute is activated.	Press the MUTE button so that the indicator goes off.
Sound from one speaker only.	Speaker signal cables are not connected properly.	Check speaker wiring and reconnect if necessary.
	The BALANCE control is set to one extreme.	Adjust the BALANCE control properly.
Continuous hiss or buzzing during FM reception.	Incoming signal is too weak.	Connect an outside FM antenna or contact your dealer.
	The station is too far away.	Select a new station.
	An incorrect antenna is used.	Check with your dealer to be sure you have a correct antenna.
	Antennas are not connected properly.	Check connections.
Occasional crackling noise during FM reception.	Ignition noise from automobiles.	Move the antenna farther from automobile traffic.
	The color system of the connected TV is not PAL.	Connect a PAL TV.
Howling during record playing.	Your turntable is too close to speakers.	Move speakers away from the turntable.
Remote control does not work.	There is an obstruction in front of the remote sensor on the receiver.	Remove the obstruction.
	Batteries are weak.	Replace batteries.

**Specifications**

**Amplifier**

Output Power	At Stereo operation	100 watts per channel, min. RMS, both channels driven into 8 ohms at 1 kHz with no more than 0.9% total harmonic distortion. (IEC268-3/DIN)
	At Surround operation	95 watts per channel, min. RMS, both channels driven into 8 ohms, 20 Hz to 20 kHz, with no more than 0.06% total harmonic distortion.
	Front Channels	70 watts per channel, min. RMS, driven into 8 ohms at 1 kHz with no more than 0.8% total harmonic distortion.
	Center channel	70 watts, min. RMS, driven into 8 ohms at 1 kHz, with no more than 0.8% total harmonic distortion.
	Rear channels	17 watts per channel, min. RMS, driven into 8 ohms at 1 kHz, with no more than 0.8% total harmonic distortion.
Total Harmonic Distortion (8 ohms, 1 kHz)		0.06 %* at 100 watts output (* Measured by JVC Audio Analysis System)
Audio Input Sensitivity/Impedance (1 kHz)	PHONO (MM) CD, TAPE, TV SOUND, VCR, VIDEO	2.5 mV/47 k ohms 230 mV/47 k ohms
Audio Output Level	TAPE, VCR	230 mV
Signal-to-Noise Ratio ('66 IHF/DIN)	PHONO CD, TAPE, TV SOUND, VCR, VIDEO	70 dB/78 dB (at REC OUT) 87 dB/80 dB
Frequency Response (8 ohms)	PHONO CD, TAPE, TV SOUND, VCR, VIDEO	20 Hz to 20 kHz (±1 dB) 20 Hz to 20 kHz (±1 dB)
RIAA Phono Equalization		±0.5 dB (20 Hz to 20 kHz)
LOUDNESS Control (Volume Control at -40 dB)		+6 ±1 dB at 100 Hz +4 ±1 dB at 10 kHz
Tone Control	BASS	+8 ±2 dB -8 ±2 dB at 100 Hz
	TREBLE	+8 ±2 dB -8 ±2 dB at 10 kHz

**Video**

Video Input Sensitivity/Impedance	VCR, VIDEO	1 Vp-p/75 ohms
Video Output Level	VCR, MONITOR OUT	1 Vp-p (at 1 Vp-p input)
Synchronization		Negative
Signal-to-Noise Ratio		45 dB
On-Screen Color System		PAL

**FM tuner (IHF)**

Tuning Range	87.5 MHz to 108.0 MHz
Usable Sensitivity	10.8 dBf (0.95 µV/75 ohms)
50 dB Quieting Sensitivity	16.3 dBf (1.8 µV/75 ohms) 38.3 dBf (22.5 µV/75 ohms)
Signal-to-Noise Ratio (IHF-A weighted)	80 dB at 85 dBf 73 dB at 85 dBf
Total Harmonic Distortion	0.15 % at 1 kHz 0.2 % at 1 kHz
Stereo Separation at REC OUT	40 dB at 1 kHz
Capture Ratio	1.5 dB at 85 dBf
Alternate Channel Selectivity	60 dB; (±400 kHz)
Frequency Response	30 Hz to 15 kHz; (+0.5 dB, -3 dB)

**AM tuner**

Tuning Range	531 kHz to 1,602 kHz (at 9 kHz interval) 530 kHz to 1,600 kHz (at 10 kHz interval)
Usable Sensitivity	300 µV/m 30µV
Signal-to-Noise Ratio	50 dB (100mV/m)

**General**

Power Requirements	AC 110/127/220/230-240V <sup>~</sup> , 50/60 Hz
Power Consumption	380 watts 5 watts (in standby mode)
Dimensions (W x H x D)	435 x 156 x 396 mm (17 3/16 x 6 1/16 x 15 5/16 inches)
Mass	12.5 kg (27.6 lbs)

Designs & specifications are subject to change without notice.

# Description of Major LSIs

## ■ MN171601 (IC401) : SYSTEM CONTROLLER 1

### 1. Terminal Layout

VDD	1	64	OSC1
DAP ON/OFF	2	63	OSC2
CLK	3	62	VSS
STB	4	61	X2
DATA	5	60	X1
STB	6	59	RST
SCL	7	58	SUR CLK
SDA	8	57	SUR DATA
LED STANDBY	9	56	SUR STB
REMOCON	10	55	TV CONT
INH	11	54	TV OUT
VR ENC.A	12	53	VCR OUT
VR ENC.B	13	52	VCR IN
S.SEL ENC.A	14	51	TUN.ENC.B
S.SEL ENC.B	15	50	TUN.ENC.A
VCR S/C	16	49	DCS IN
LED SEA	17	48	DCS OUT
LED SUR	18	47	VIDEO ON
LED MUTE	19	46	V.SEL
POWER	20	45	V.SEL2
S.MUTE	21	44	SEA DI
	22	43	SEA CLK
COM STB	23	42	SUR ON/OFF
COM CLK	24	41	KO4
DI0	25	40	KO3
DI1	26	39	KO2
DI2	27	38	KO1
DI3	28	37	KO0
DI4	29	36	KI3
REQ	30	35	KI2
BUSY	31	34	KI1
SEA CS	32	33	KI0

### 2.Key Matrix

	KI0 (PIN33)	KI1 (PIN34)	KI2 (PIN35)	KI3 (PIN36)
KO0 (PIN37)	POWER (S400)	CENTER MODE (S401)	TEST (S402)	VISUAL CONFIRMATION (S403)
KO1 (PIN38)	CENTER LEVEL + (S404)	REAR LEVEL + (S405)	SURROUND ON/OFF (S406)	PRO LOGIC (S407)
KO2 (PIN39)	CENTER LEVEL- (S408)	REAR LEVEL- (S409)	3CH LOGIC (S410)	HALL (S411)
KO3 (PIN40)	PRESET /TUNING (S412)	CHARACTER (S491)	FM MODE /MUTE (S414)	FM/AM (S415)
KO4 (PIN41)	LOUDNESS (S416)	ENTER (S492)	MUTE (S490)	CSRP (S418)

### 3. Description

Pin No.	Symbol	I/O	Description	Pin NO.	Symbol	I/O	Description
1	VDD	--	Power supply	33	KI0	I	Key matrix Input
2	DAP ON/OFF	--	Nut used	34	KI1	I	Key matrix Input
3	CLK	O	Clock to IC305,IC307	35	KI2	I	Key matrix Input
4	STB	O	Strbe signal to IC305	36	KI3	I	Key matrix Input
5	DATA	O	Data to IC305,IC307	37	KO0	O	Key matrix output
6	STB	O	Strbe signal to IC307	38	KO1	O	Key matrix output
7	SCL	--	Not used(GND)	39	KO2	O	Key matrix output
8	SDA	--	Not used(GND)	40	KO3	O	Key matrix output
9	LED STANDBY	O	STANDBY LED control signal	41	KO4	O	Key matrix output
10	REMOCON	I	Remote signal input	42	SUR ON/OFF	O	SURROUND ON/OFF control
11	INH	I	Inhibit signal input	43	SEA CLK	O	Clock to IC551(RX-770VBK)
12	VR ENC.A	I	R. Encoder control signal input (VOL)	44	SEA DI	O	Data to IC551(RX-770VBK)
13	VR ENC. B	I	R. Encoder control signal input (VOL)	45	V.SEL 2	O	Not used
14	S.SEL ENC.A	I	R. Encoder control signal input(SOURCE)	46	V.SEL	O	VIDEO SELCT signal output
15	S.SEL ENC.B	I	R. Encoder control signal input(SOURCE)	47	VIDEO ON	O	VIDEO ON/OFF control signal
16	VCR S/C	I	VCR S/C signal	48	DCS OUT	O	Compulink signal output
17	LED SEA	O	SEA indication control	49	DCS IN	I	Compulink signal input
18	LED SUR	O	SURROUND indication control	50	TUN.ENC.A	I	R. Encoder control signal input (TUNER)
19	LED MUTE	O	MUTE indication control	51	TUN.ENC.B	I	R. Encoder control signal input (TUNER)
20	POWER	O	POWER ON/OFF control	52	VCR IN	I	AV COMPULINK
21	S.MUTE	O	SOUECE MUTE control	53	VCR OUT	O	AV COMPULINK
22		--		54	TV OUT	O	AV COMPULINK
23	COM STB	O	Strobe signal to IC400	55	TV CONT	O	AV COMPULINK
24	COM CLK	O	Clock to IC400	56	SUR STB	O	Strobe signal for IC601,IC641
25	DI0	I/O	Data signal to IC400	57	SUR DATA	O	Data signal for IC601.IC641
26	DI1	I/O	Data signal to IC400	58	SUR CLK	O	Clock output for IC601.IC641
27	DI2	I/O	Data signal to IC400	59	RST	I	Reset signal input
28	DI3	I/O	Data signal to IC400	60	X1	--	GND
29	DI4	I/O	Data signal to IC400	61	X2	--	Not used
30	REQ	I	Request signal for IC400	62	VSS	--	GND
31	BUSY	I	Busy signal from IC400	63	OSC2	--	Oscillation terminal
32	SEA CS	I	Chip select RX-718/RX-770	64	OSC1	--	Oscillation terminal

■ MN172412 (IC400)  
: SYSTEM CONTROLLER 2

1. Terminal Layout

21 ~ 1	
22	84
}	}
42	64
43 ~ 63	

3. Description

Pin No.	Symbol	I/O	Description	Pin No.	Symbol	I/O	Description
1		--	GND	43	OSD SIN	I	Data for IC222
2		--	GND	44	OSD ON	O	ON SCREEN on/off
3		--	GND	45	T.CLK	I	Clock input for IC191
4		--	GND	46	IFDATA	I	Data signal for IC191
5		--	GND	47	T.DATA	I	Datasignal for IC191
6	17G	O	Grid control signal	48	COMSTB	I	Strobe signal for IC401
7	16G	O	Grid control signal	49	COMCLK	I	Clock to IC401
8	15G	O	Grid control signal	50	TUNED	I	TUNED signal to IC104
9	14G	O	Grid control signal	51	STEREO	I	STEREO signal to IC105
10	13G	O	Grid control signal	52	T.MUTE	O	TUNER MUTE signal output
11	12G	O	Grid control signal	53	T.CS	I	TUNER chip select
12	11G	O	Grid control signal	54	CE	I	Fix the chip enable
13	10G	O	Grid control signal	55		--	GND
14	9G	O	Grid control signal	56		--	GND
15	8G	O	Grid control signal	57		--	GND
16	7G	O	Grid control signal	58		--	GND
17	6G	O	Grid control signal	59		--	GND
18	5G	O	Grid control signal	60	DI0	I/O	Data signal to IC401
19	4G	O	Grid control signal	61	DI1	I/O	Data signal to IC401
20	3G	O	Grid control signal	62	DI2	I/O	Data signal to IC401
21	2G	O	Grid control signal	63	DI3	I/O	Data signal to IC401
22	1G	O	Grid control signal	64	DI4	I/O	Data signal to IC401
23	VPP	--	Power supply	65	REQ	O	Request signal for IC401
24	S1	O	Segment control signal	66	BUSY	O	Busy signal from IC401
25	S2	O	Segment control signal	67	INH	I	Inhibit signal input
26	S3	O	Segment control signal	68	RST	I	Reset signal input
27	S4	O	Segment control signal	69	X1	--	GND
28	S5	O	Segment control signal	70	X2	--	Not used
29	S6	O	Segment control signal	71	VSS	--	GND
30	S7	O	Segment control signal	72	OSC2	--	Oscillation terminal
31	S8	O	Segment control signal	73	OSC1	--	Oscillation terminal
32	S9	O	Segment control signal	74	VDD	--	Power supply
33	S10	O	Segment control signal	75	VL/VH	O	R800,R801 control
34	S11	O	Segment control signal	76	4/8Ω SEL	I	4/8Ω select
35	S12	O	Segment control signal	77	4/8Ω DETECT	I	
36	S13	O	Segment control signal	78	MODEL CS	I	J,C/U select
37	S14	O	Segment control signal	79		--	GND
38	S15	O	Segment control signal	80		--	GND
39	S16	O	Segment control signal	81		--	GND
40	OSD CS	O	Chip select signal for IC222	82		--	GND
41	SCK	O	Clock output for IC222	83		--	GND
42	OSC	--	GND	84		--	GND

■ LC72131M (IC121) : PLL Synthesizer

1. Terminal Layout

XIN	1	20	XOUT
CE	2	19	V <sub>SS</sub>
TDATA	3	18	LPF OUT
CK	4	17	LPF IN
IFDATA	5	16	PD
FM	6	15	V <sub>DD</sub>
MW	7	14	FM OSC
LW	8	13	AM OSC
AUTO/MONO	9	12	IF REQ
POWER	10	11	FM/AM IF

2. Block Diagram

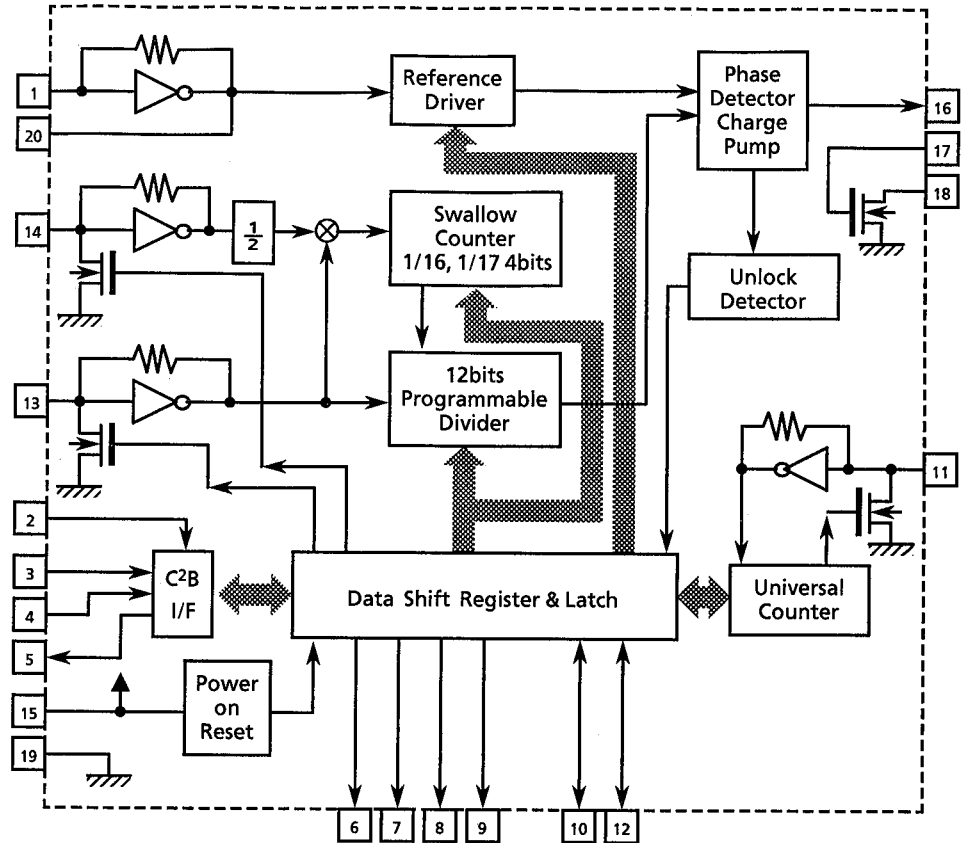

3. Pin Functions

Pin No.	Symbol	I/O	Functions	Pin No.	Symbol	I/O	Functions
1	Xin	I	Crystal oscillator (7.2MHz).	11	FM/AM IF	I	Universal counter input
2	CE	I	Fix the chip enable to "H" when inputting (DI) and outputting (DO) the serial data.	12	IF REQ	O	Output the "IF-signal request" to IC102
3	TDATA	I	Receive the control data from the controller (IC201).	13	AM IN	I	Input the local oscillator signal of AM.
4	CK	I	This clock is used to synchronize data when transmitting the data of DI and DO.	14	FM IN	I	Input the local oscillator signal of FM.
5	IFDATA	O	Transmit the data from LC72131M to the controller which is synchronized with CK.	15	V <sub>DD</sub>	--	This is a terminal of power supply.
6	FM	O	It is "L" on FM mode.	16	PD	O	PLL charge pump output : When the local oscillator signal frequency is higher than the reference frequency high level signals will output. When it is lower than the reference frequency, low level signals will output. When it is same as reference frequency signals, it will be floating.
7	MW	O	It is "L" on MW mode.	17	LPF IN	I	Transistor used for the PLL active low-pass filter
8	LW	O	It is "L" on LW mode.	18	LPF OUT	O	Transistor used for the PLL active low-pass filter
9	AUTO/MONO	O	It is "L" on monaural, "H" on auto.	19	V <sub>SS</sub>	--	Connected to GND
10	POWER	O	Regulator control signal PON "H", STANDBY "L"	20	X out	O	Crystal oscillator (7.2MHz).

■ LA1266A (IC104) : FM AM IF AMP & detector

1. The main function descriptions

- (1) Amplify and detect of FM intermodulation frequencies.
- (2) It has local oscillator and mixer for AM, and amplify the AM-IF signal.

2. Top View

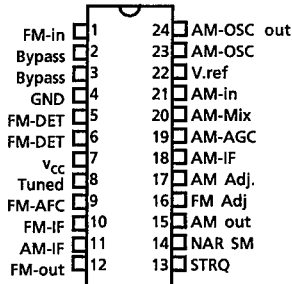

3. Block Diagram

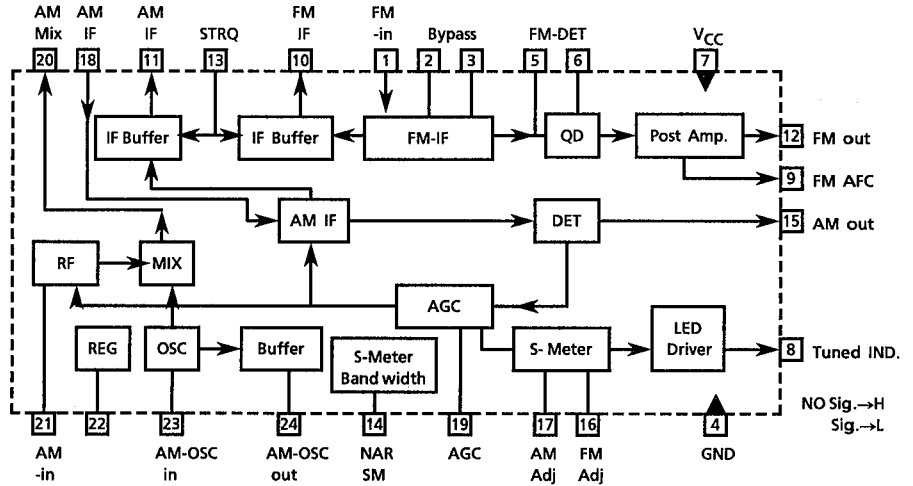

4. Pin Function Description

Pin No.	Symbol	I/O	Functions and Operations
1	FM in	I	This is an input terminal of FM IF Signal.
2, 3	Bypass	--	Bypass of FM IF Amp.
4	GND	--	This is the device ground terminal.
5, 6	FM DET	--	FM detect transformer.
7	V <sub>CC</sub>	--	This is the power supply terminal.
8	Tuned	O	When the set is tuning, this terminal become "L".
9	FM AFC	O	This is an output terminal of voltage for FM - AFC.
10	FM IF out	O	When the IF REQ signal of IC251(LC7218) applies to pin13, the signal of FM IF outputs.
11	AM IF out	O	When the IF REQ signal of IC251(LC7218) applies to pin13, the signal of AM IF outputs.
12	FM out	O	FM detection output.
13	STRQ	I	The IF-signals come out from pin10 (FM-IF) or pin11 (AM-IF) while this terminal goes to "High".
14	NAR SM	--	Control the Band-width of AM signal meter.
15	AM out	O	AM detection output.
16	FM Adj	--	For adjust the stop level (or mute level) of FM.
17	AM Adj	--	For adjust the stop level (or mute level) of AM.
18	AM-IF	I	Input of AM IF Signal.
19	AM-AGC	I	This is an AGC voltage Input terminal for AM.
20	AM-MIX	O	This is an output terminal for AM mixer.
21	AM-IN	I	This is an input terminal for AM RF Signal.
22	V.REF	--	Control the Band-width of FM signal meter.
23	AM-OSC	--	This is a terminal of AM Local oscillation circuit.
24	AM-OSC out	O	AM Local Oscillation Signal output.

■ LA3401 (IC105) : FM MPX Detector

1. The main function descriptions

- (1) Detect the FM Multiplex Signal (Stereo signal).
- (2) When receiving FM Stereo Signal, it outputs the signal for indicator.
- (3) AM / FM Audio Amplifier.

2. Terminal Layout

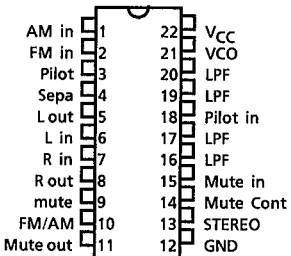

3. Block Diagram

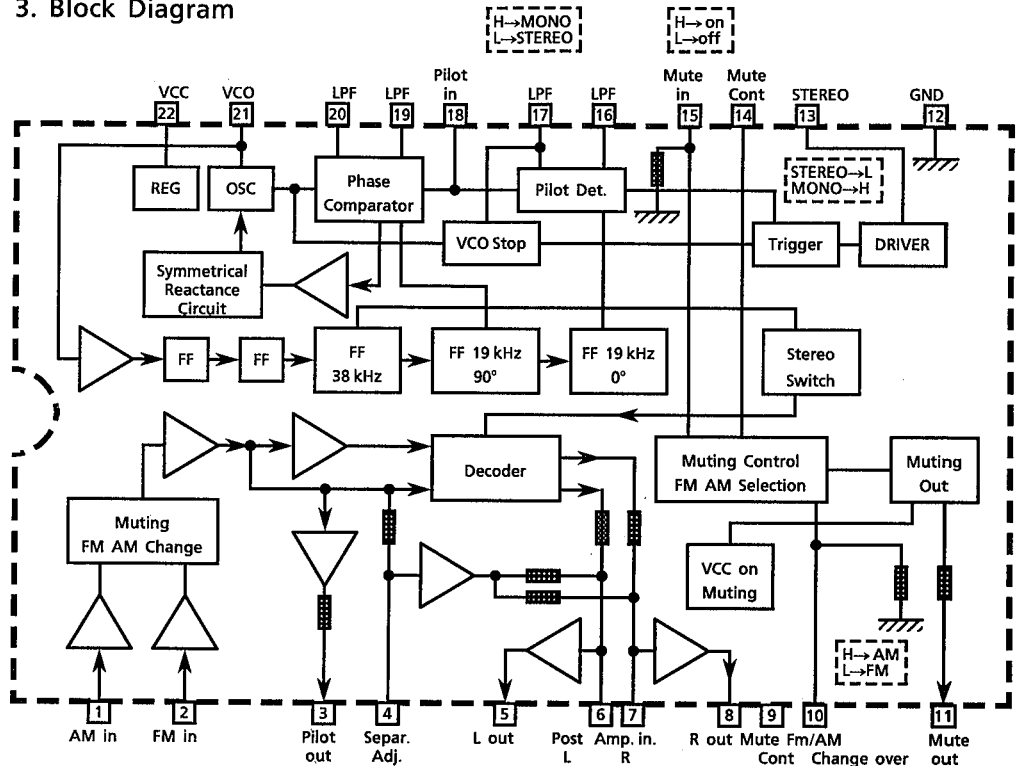

4. Pin Function Description

Pin No.	Symbol	I/O	Functions and Operations
1	AM in	I	This is an input terminal for AM detection signal.
2	FM in	I	This is an input terminal for FM detection signal.
3	Pilot out	O	Output of MPX pilot signal (Connect to Pin18).
4	Sepa. Adj.	--	Separation adjustment.
5	L. out	O	Left channel signal output.
6	L	O	Reversal output of Pin5.
7	R	O	Reversal output of Pin8.
8	R out	O	Right channel signal output
9	Mute Cont	--	The mute time is controlled by the connected capacitor when turning the power switch on.
10	FM / AM	I	Change over the FM / AM input. "H" : AM, "L" : FM
11	Mute out	--	Not use
12	GND	--	Ground terminal.
13	Stereo	O	Stereo indicator output. Stereo : "L", Mono : "H"
14	Mute Cont	--	The mute time is controlled by the connected capacitor when changing over the FM / AM .
15	Mute in	I	Mute signal input. "H" : Mute on, "L" : Mute off.
16	LPF	--	Low pass filter of pilot detector.
17	LPF	--	While this terminal goes to "H", the VCO stop.
18	Pilot in	I	Pilot input.
19	LPF	--	Low-pass filter of PLL.
20	LPF	--	Low-pass filter of PLL.
21	VCO	I	Voltage controlled oscillator terminal.
22	V <sub>CC</sub>	--	Power supply.



## ■ LA2785 (IC601) : Dolby Pro Logic Surround Signal Processor

### 1. Terminal Layout

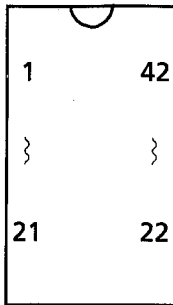

### 2. Pin Functions

Pin No	Symbol	I/O	Functions	Pin No	Symbol	I/O	Functions
1	NS-BPF1	--	Capacitor for spectrum filter in noise sequencer	22	VCS-1	--	Capacitor for time constant (in log differential area)
2	NS-BPF2	--	Capacitor for spectrum filter in noise sequencer	23	VCS-2	--	Capacitor for time constant (in log differential area)
3	VREF	--	Analog reference voltage	24	VCS-TH	--	Capacitor for time constant (in log differential area)
4	S-DC-OUT	--	Capacitor for DC-cut Sch	25	L+R RECT	--	Capacitor for Center channel detection
5	C-DC-OUT	--	Capacitor for DC-cut Cch	26	DC-CUT	--	Capacitor for DC-cut at detection circuit
6	L-DC-OUT	--	Capacitor for DC-cut Lch	27	L-R RECT	--	Capacitor for Surround channel detection
7	R-DC-OUT	--	Capacitor for DC-cut Rch	28	DC-CUT	--	Capacitor for DC-cut at detection circuit
8	VREF-BUFFER	--	VREF low impedance	29	R-BPF3	--	LPF,HPF for Right channel control circuit
9	L-IN	I	Left channel signal input	30	R-BPF2	--	LPF,HPF for Right channel control circuit
10	R-IN	I	Right channel signal input	31	R-BPF1	--	LPF,HPF for Right channel control circuit
11	GND	--	Ground	32	C-TRIM DC-CUT	--	Capacitor for DC-cut Center channel
12	L-BPF1	--	LPF,HPF for Lch control circuit	33	C-MODE- CAP	--	Capacitor for Center channel output low-pass filter
13	L-BPF2	--	LPF,HPF Left channel control circuit	34	C-OUT	O	Center signal output
14	L-BPF3	--	LPF,HPF Left channel control circuit	35	S-OUT	O	Surround signal output
15	DC-CUT	--	Capacitor for DC-cut at detection circuit	36	R-OUT	O	Right channel signal output
16	R RECT	--	Capacitor for Right channel detection	37	L-OUT	O	Left channel signal output
17	DC-CUT	--	Capacitor for DC-cut at detection circuit	38	VCC	--	power supply
18	L RECT	--	Capacitor for Left channel detection	39	OSC	--	Oscillation for noise sequencer and auto balance
19	VLR-TH	--	Capacitor for time constant (in log differential area)	40	STB	I	Strobe signal input
20	VLR-2	--	Capacitor for time constant (in log differential area)	41	DATA	I	Serial interface data input
21	VLR-1	--	Capacitor for time constant (in log differential area)	42	CLK	I	Serial interface clock

3. Block Diagram

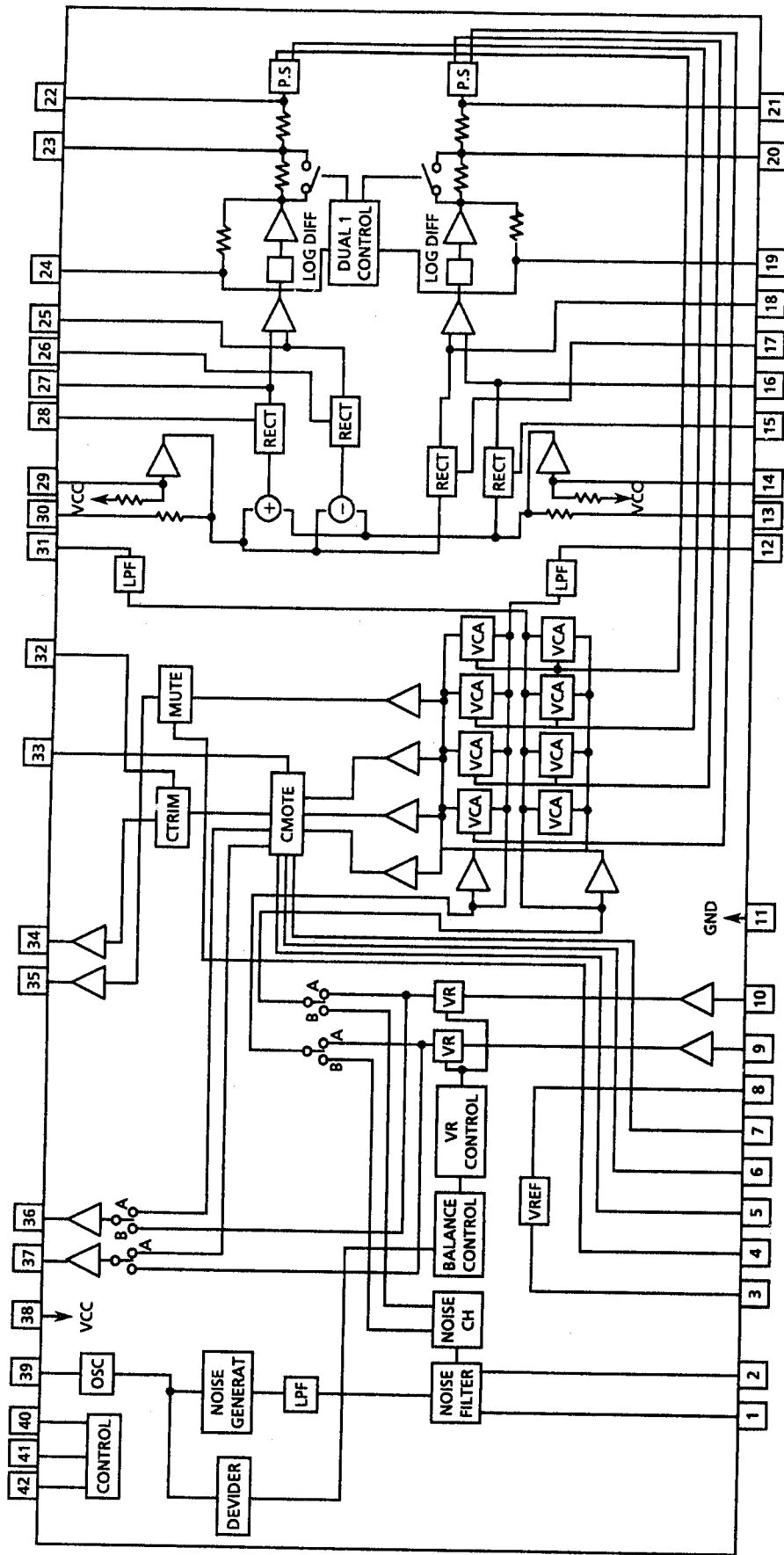

■ LV1011 (IC641) : Dolby Surround Passive Decoder

1. Terminal Layout

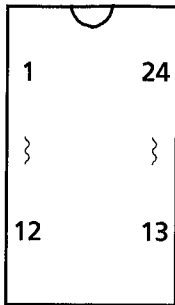

2. Block Diagram

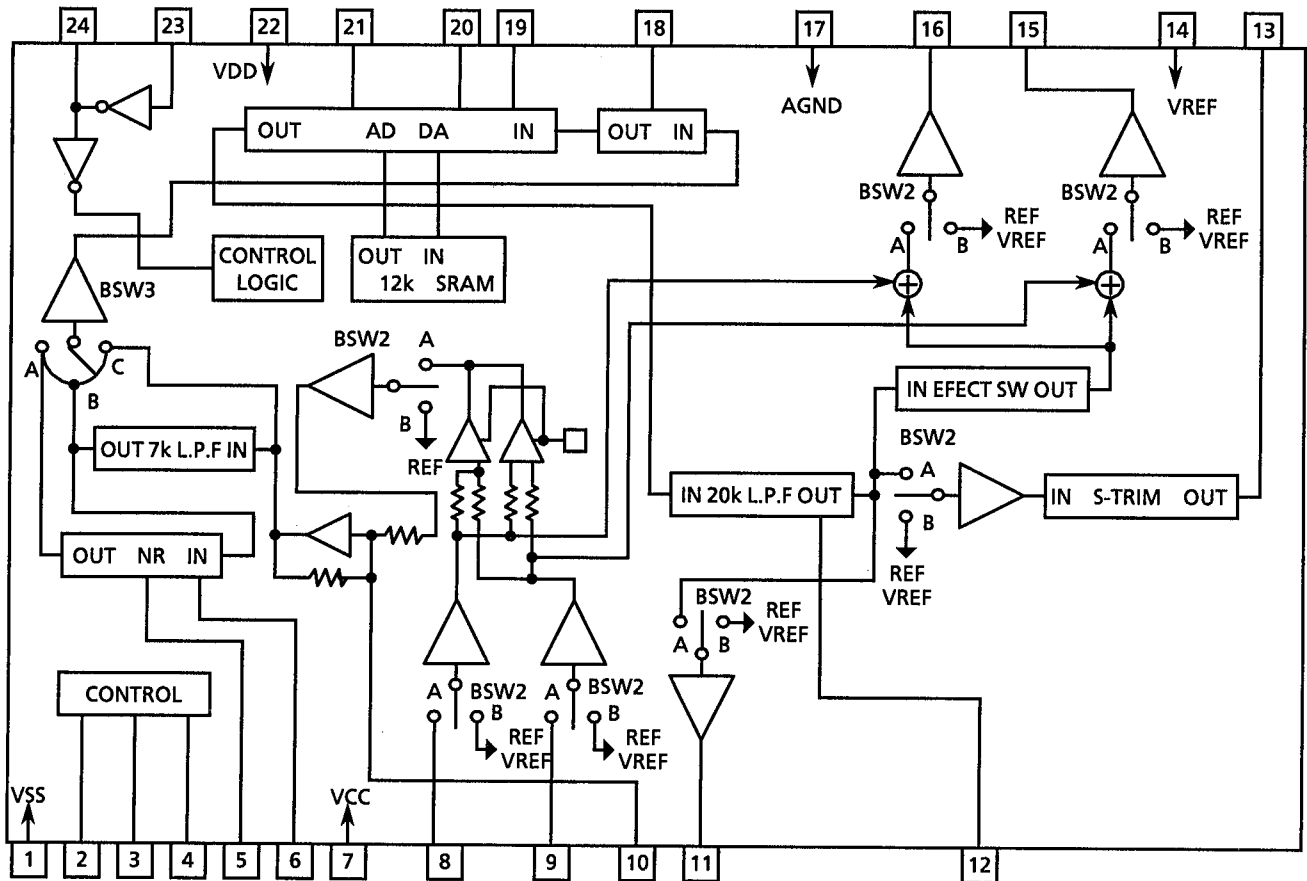

■ IC551 : LC7522 (Variable Resistor for SEA Control)

- (1) Terminal Layout (2) Block Diagram

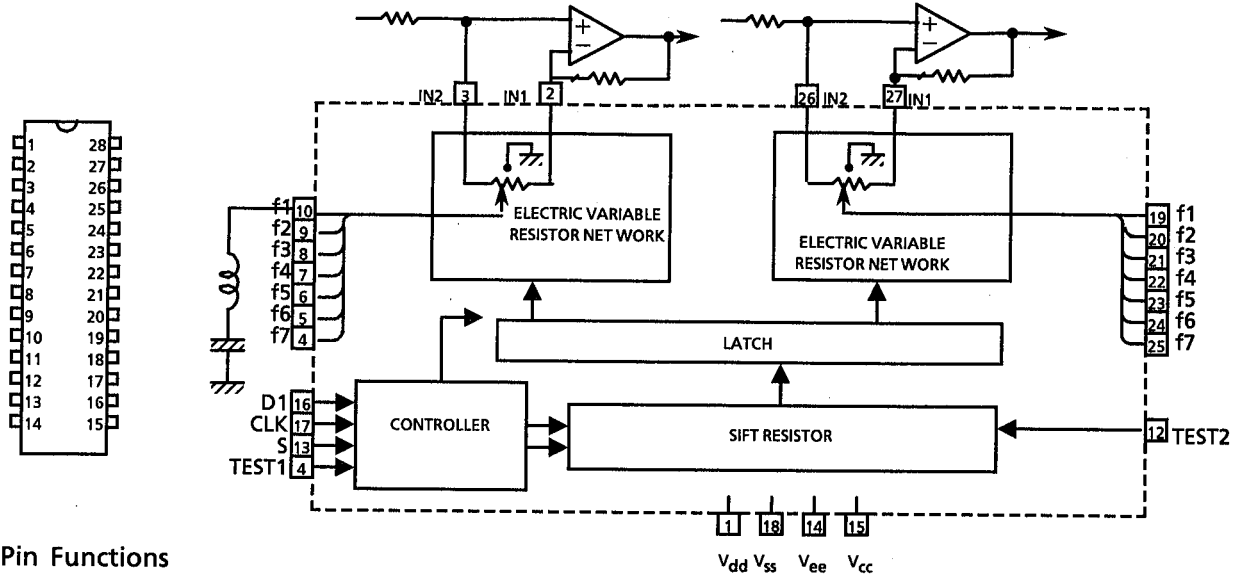

(3) Pin Functions

Pin No.	Pin Name	Functions
1	V <sub>DD</sub>	Power supply +7V for audio signal
18	V <sub>SS</sub>	Ground.
14	V <sub>EE</sub>	Power supply -7V for audio signal.
15	V <sub>CC</sub>	Power supply +5V
2,27	IN 1	Audio signal input
3, 26	IN 2	The inversion signal of the operational amplifier inputs to IN 1 normally. The non-inversion signal of the operational amplifier inputs to IN 2 normally.
16	DI	Data input from the CPU. Schmitt inverter type
17	CLK	Clock signal input from the CPU. Schmitt inverter type
4~10 19~25	f1~f7	For connect to band-pass filter. f1~f7x2 (Left and Right)
11	TEST 1	Not use
12	TEST 2	Not use
13	S	Chip Select
28	NC	Not use

■ M5243P (IC552) : S.E.A. Graphic Equalizer

- Functions  
It makes inductive characteristic instead of coil.
- Block Diagram

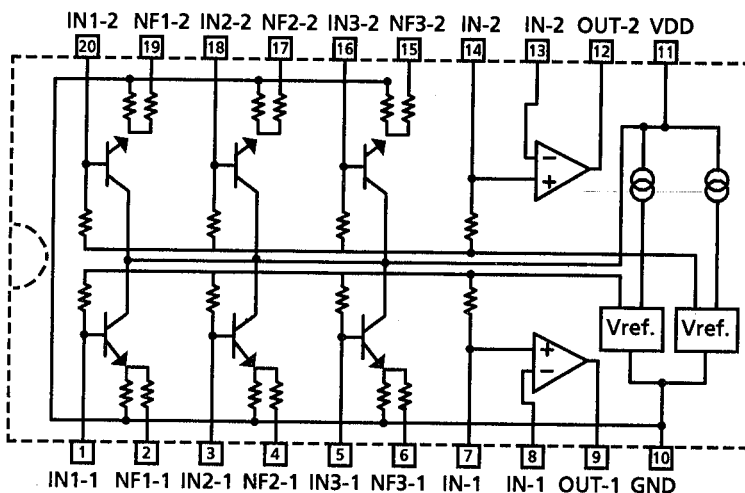

■ IC221 : NJM2279D (Video Switch)

(1) Terminal Layout

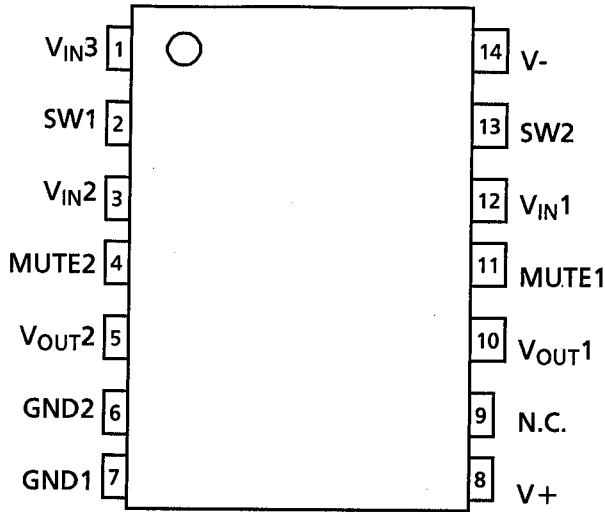

(2) Block Diagram

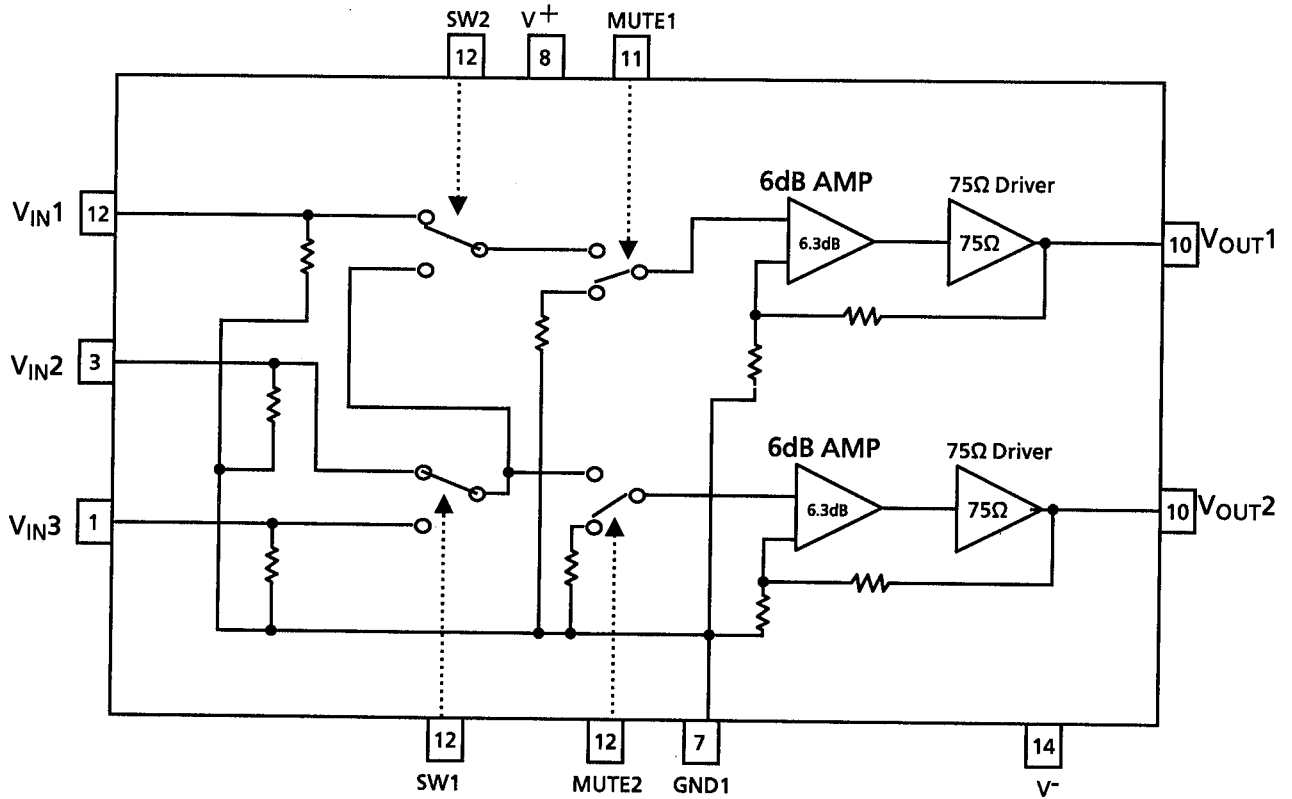

■ IC222 : M35012-120SP (ON SCREEN IC)

(2) Block Diagram

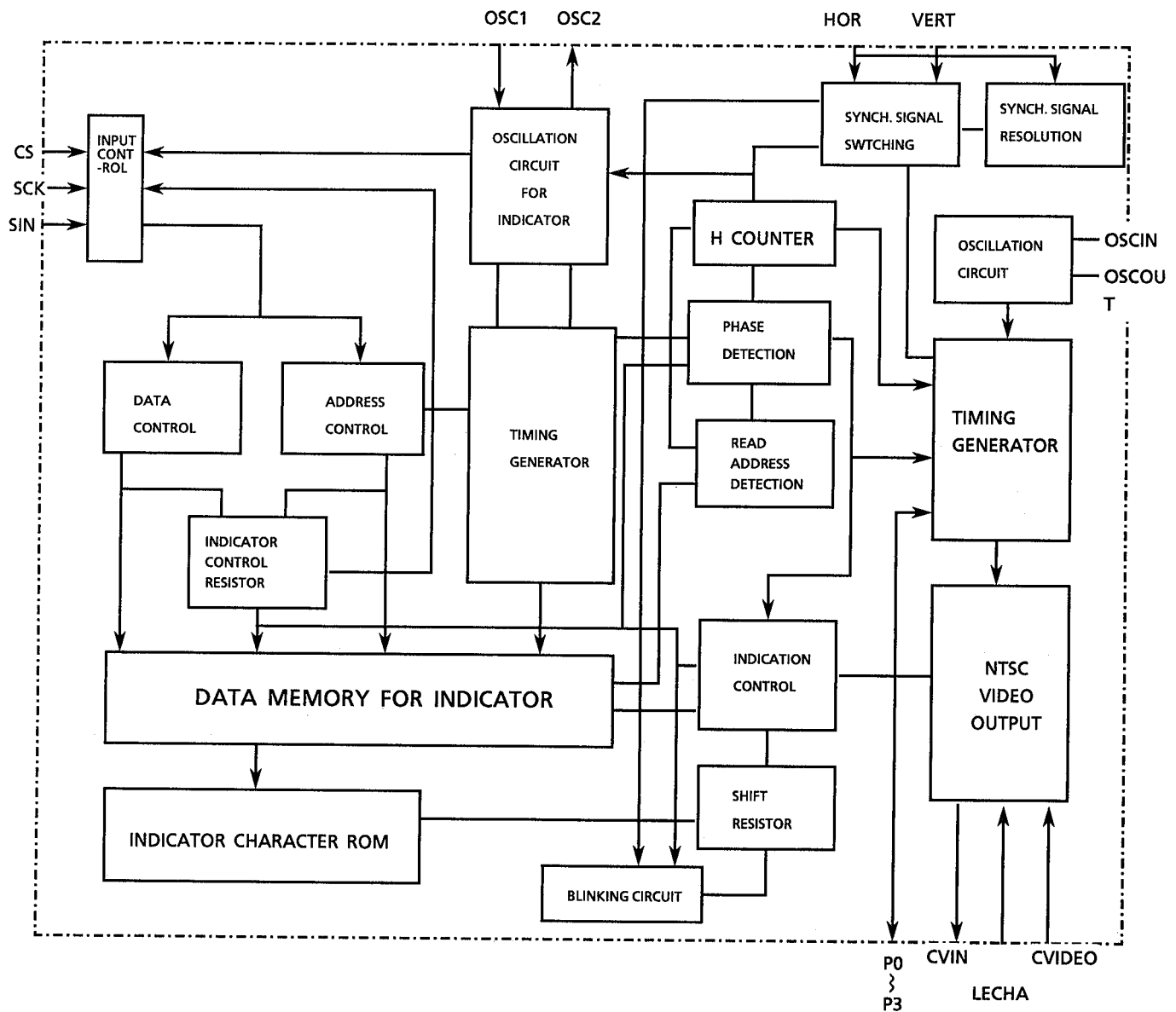

## (3) Pin Functions

Pin No.	Pin Name	Functions
1	OSC1	Oscillation terminal
2	OSC2	Oscillation terminal
3	CS	Chip Select
4	SCK	Serial clock signal
5	SIN	Serial data input
6	AC	Auto clear input
7	VDD2	Power supply
8	OSC OUT	Composite video signal input
9		NC
10		NC
11	VSS	GND
12		NC
13		NC
14		NC
15		NC
16	OSCOUT	Oscillation terminal
17	OSCIN	Oscillation terminal
18	GND	
19	GND	
20	VDD1	Power supply

# Internal Connections of the FL Display

■ELU0001-215 : DI400

## Grid Separation

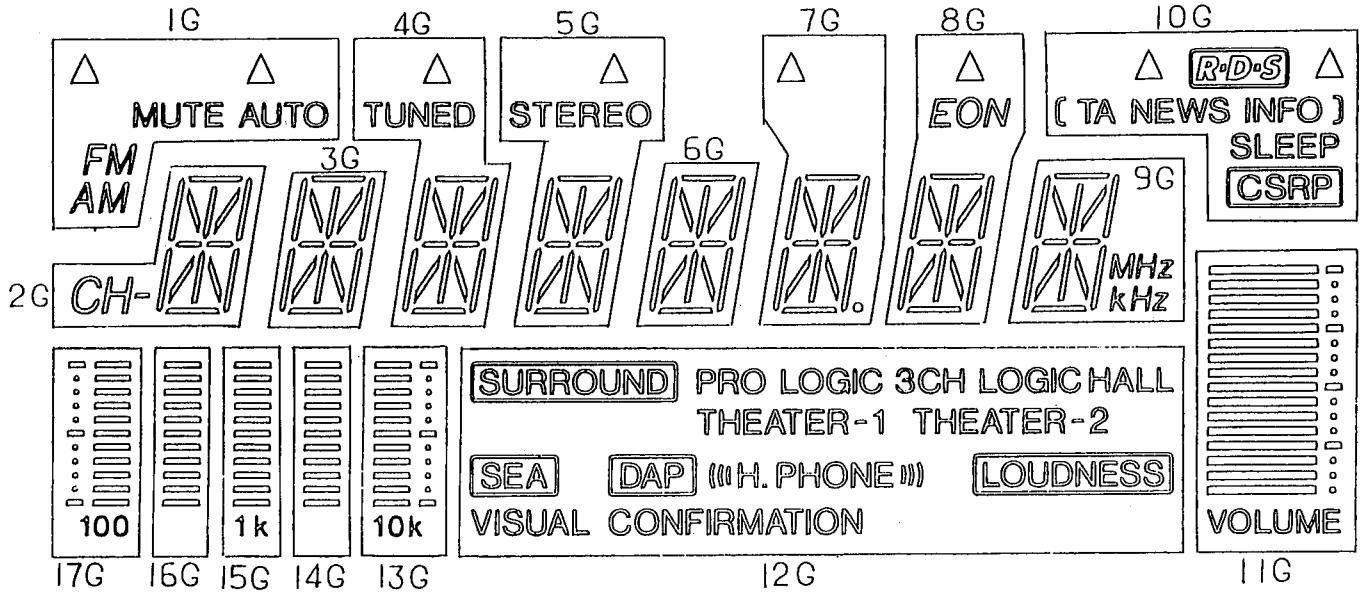

## Pin Connection

TERMINAL NO.	1	2	3	4	5	6	7	8	9	10	11	12	13	14							
ELECTRODE	F1	F1	F1	NP	17G	16G	15G	14G	13G	12G	11G	10G	9G	8G							
TERMINAL NO.	15	16	17	18	19	20	21	22	23	24	25	26	27	28	29	30	31	32	33	34	
ELECTRODE	7G	6G	5G	4G	3G	2G	1G	NP	NP	NP	NP	NP	NP	P <sub>51</sub>	P <sub>52</sub>	P <sub>53</sub>	P <sub>54</sub>	P <sub>55</sub>	P <sub>56</sub>	P <sub>57</sub>	
TERMINAL NO.									35	36	37	38	39	40	41	42	43	44	45	46	47
ELECTRODE									P <sub>58</sub>	P <sub>59</sub>	P <sub>510</sub>	P <sub>511</sub>	P <sub>512</sub>	P <sub>513</sub>	P <sub>514</sub>	P <sub>515</sub>	P <sub>516</sub>	NP	F2	F2	F2

Notes F: Filament NP: No Pin  
G: Grid  
P: Anode



# Internal Connection • Anode Designation

	1G	2G	3G	4G	5G	6G	7G	8G	9G	10G
S1		a	a	a	a	a	a	a	a	CSRP
S2		b	b	b	b	b	b	b	b	SLEEP
S3		i	i	i	i	i	i	i	i	TA
S4		j	j	j	j	j	j	j	j	NEWS
S5		h	h	h	h	h	h	h	h	INFO
S6		f	f	f	f	f	f	f	f	[ ]
S7		k	k	k	k	k	k	k	k	Δ(Right)
S8		g	g	g	g	g	g	g	g	R.D.S
S9		c	c	c	c	c	c	c	c	Δ(Left)
S10		l	l	l	l	l	l	l	l	
S11	FM	n	n	n	n	n	n	n	n	
S12	AM	m	m	m	m	m	m	m	m	
S13	MUTE AUTO	-	e	e	e	e	e	e	e	
S14		d	d	d	d	d	d	d	d	
S15	Δ(Left)	CH-		TUNED	STEREO		(DPT)	EON		MHz
S16	Δ(Right)			Δ	Δ		Δ	Δ		KHz

	11G	12G	13G	14G	15G	16G	17G
S1	A1						
S2	A2	LOUDNESS					Scale(Left)
S3	A3	VISUAL CON- FIRMATION	10k		1k		100
S4	A4						
S5	A5		B1	B1	B1	B1	B1
S6	A6		B2	B2	B2	B2	B2
S7	A7		B3	B3	B3	B3	B3
S8	A8	THEATER-2	B4	B4	B4	B4	B4
S9	A9	HALL	B5	B5	B5	B5	B5
S10	A10	3CH LOGIC	B6	B6	B6	B6	B6
S11	A11	H. PHONE	B7	B7	B7	B7	B7
S12	A12	THEATER-1	B8	B8	B8	B8	B8
S13	A13	PRO LOGIC	B9	B9	B9	B9	B9
S14	A14	DAP	B10	B10	B10	B10	B10
S15	A15	SEA	B11	B11	B11	B11	B11
S16	A16	SURROUND	Scale(Right)				

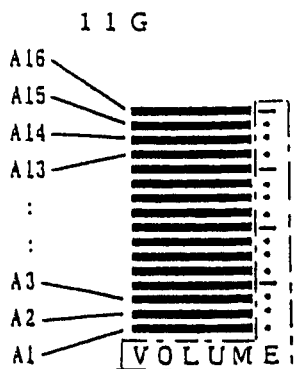
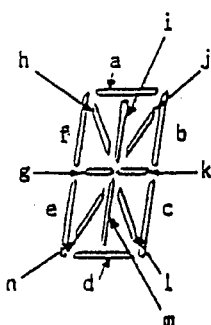

These segments pattern are connected to 11G.

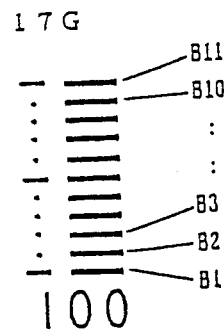

The segment pattern of 13G to 16G is same as above.

## Disassembly Procedures

### (1) Removing the top cover

1. Remove 4 screws **A** fastening both sides of top cover, and 3 screws **B** fastening the rear side.
2. Remove the top cover.

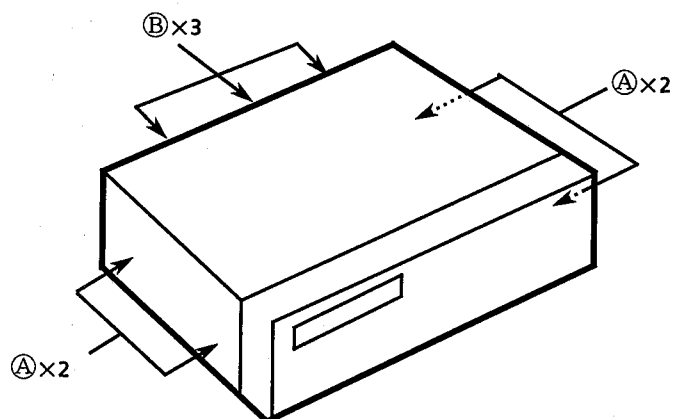

### (2) Removing the Bottom Cover

1. Remove 14 screws **C** and **C''**.
2. Remove the bottom cover.

※ The screw **C''** which secures the bottom cover is also used for ground.  
It is necessary to ground before checking after the bottom cover is removed.

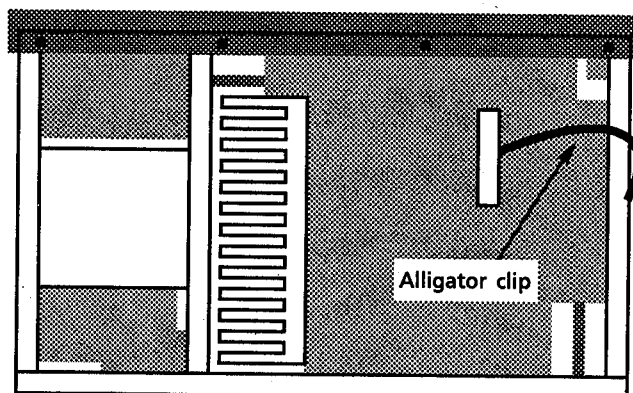
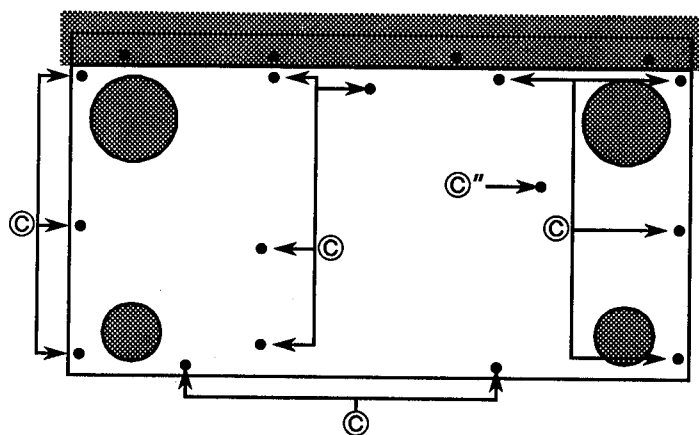

**A** .. E61660-004

**B** ... E73273-006

**C, C''** .... SBSG3008CC

**(3) Removing the Front Panel Assembly**

1. Removing the top cover.
2. Remove 3 screws ③ fastening top of the front panel, and 4 screws ④ fastening bottom of it.
3. Remove the Center tone knob, bass knob, treble knob and Balance knob.
4. Remove the front panel disconnecting some wires. (CN401,CN413)

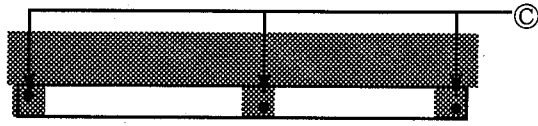

TOP SIDE

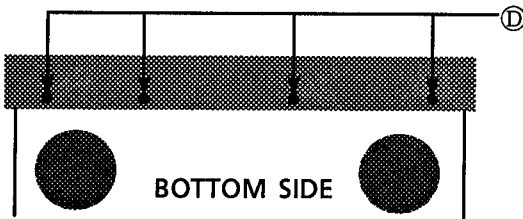

BOTTOM SIDE

**(4) Removing the Front P.C. Board**

1. Removing the top cover.
2. Removing the front panel assembly.
3. Remove 9 screws ⑤.
4. Remove the Master volume knob, tuner control knob and source selector knob.
5. Remove 2 nut fastening the rotary encoder.
6. Remove a nut fastening the Master volume.
7. Remove the front P.C. Board.

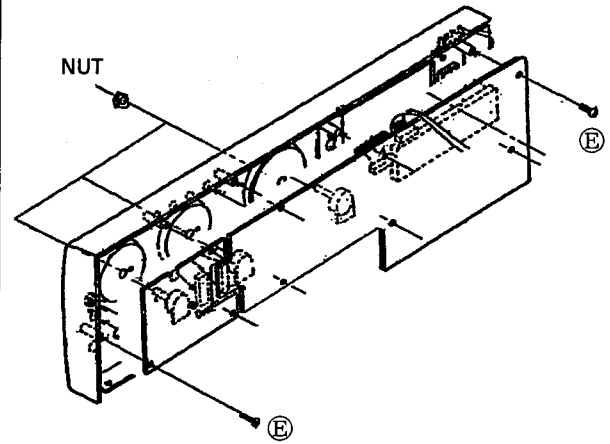

**(5) Removing the Rear Panel**

1. Removing the top cover.
2. Remove 21 screws ⑥, ⑥" and 2 screws ④.
3. Remove 2 screws ③ fastening bottom sides of rear panel.
4. Take it out.

※ 4pcs. of screw ⑥" which secure the rear panel are also used for ground. Installing of those screws is required before checking.

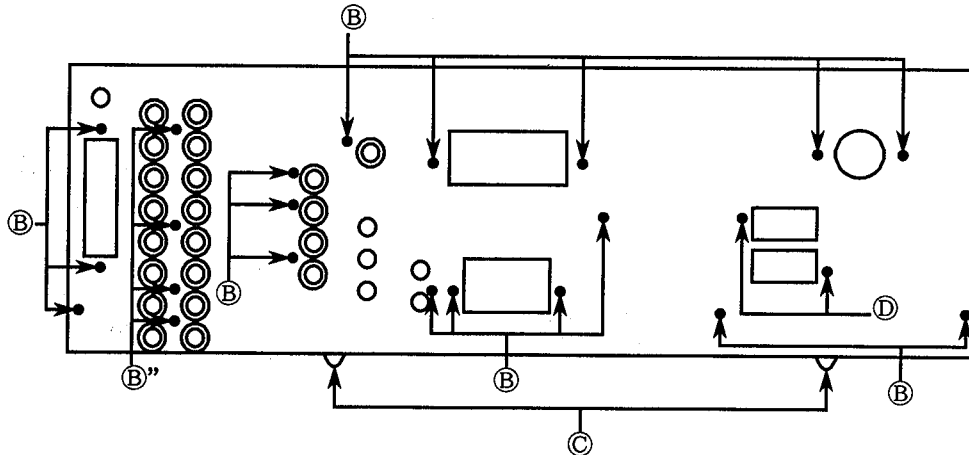

⑥, ⑥" E73273-006

③ SBSG3008CC

④ SD SG3008M

⑤ SDSF2608Z

- (6) Removing the Power Transistor
1. Remove the top cover and bottom cover.
  2. Unsolder the broken transistor.
  3. Remove the some screws  $\text{\textcircled{P}}$  fastening it.
  4. Remove it.

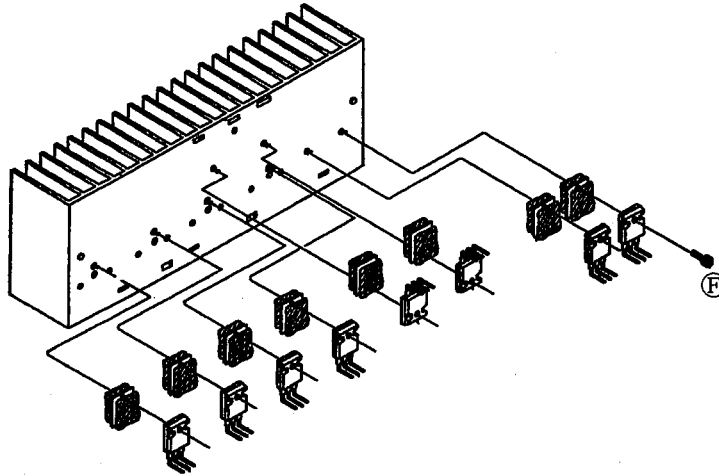

$\text{\textcircled{P}}$  .. E73525-003

## ADJUSTMENT PROCEDURES

### ■ Tuner section

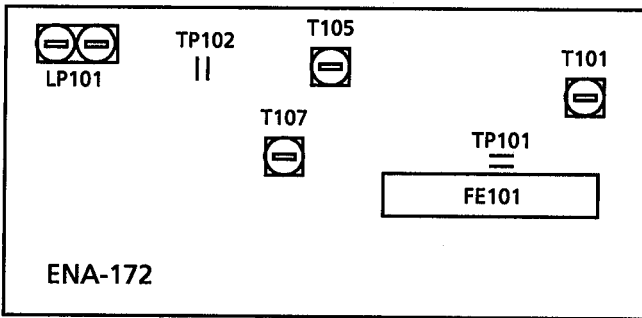

### Tuning range

Area	Range	
	MW (kHz)	FM (MHz)
Universal type (AM Channel space 9kHz)	531~1602	87.5MHz~ 108MHz
Universal type (AM Channel space 10kHz)	530~1600	

#### (1) Tuning Voltage

Confirm the voltages in the table at TP101.

#### FM Tuning voltage (Unit : V)

Area	Frequency	
	87.5MHz	108MHz
Universal	$1.6 \pm 1.0$	$8.0 \pm 2.0$

#### AM Tuning voltage (Unit : V)

Area	Frequency (MW)						
	522KHz	530KHz	531KHz	1600KHz	1602KHz	1629KHz	1710KHz
Universal (Chanel space 9kHz)	—	—	$1.0 > 0.5$	—	$7.2 \pm 0.7$	—	—
Universal (Chanel space 10kHz)	—	$1.0 > 0.5$	—	$7.2 \pm 0.7$	—	—	—

#### (2) FM Center meter

Receive a broadcast by using the function of 'AUTO STOP'.

Adjust T105 (Detector coil) so taht the voltage at TP102 becomes  $0 \pm 1.5\text{mV}$ .

## ■ Power Amplifier section

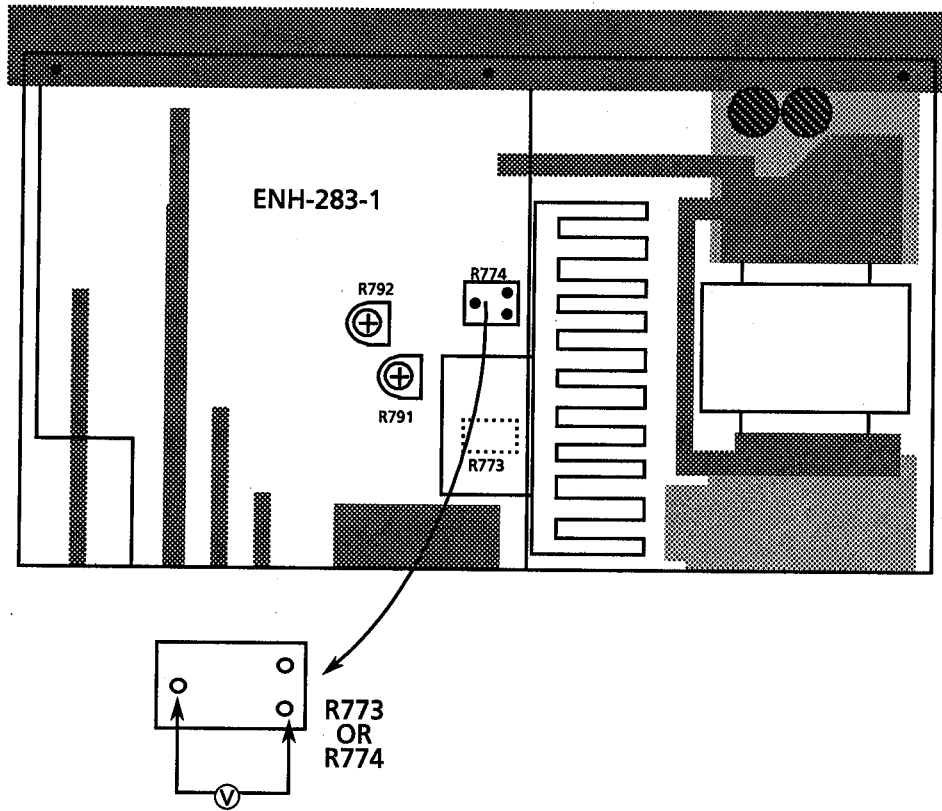

### ■ Idling current

- (1) Set the volume control to minimum during this adjustment.
- (2) Turn R791 and R792 fully counterclockwise to warm up before adjustment.  
If the heatsink is already warm from previous use the correct adjustment can not be made.
- (3) Connect a DC voltmeter to R773 resistor's leads for left channel, or to R774 for right channel.
- (4) Adjust R773 for left channel, or R774 for right channel, so that the DC voltmeter becomes 1mV~10mV.

- MEMO -



# Block Diagrams

## ■ Tuner Section

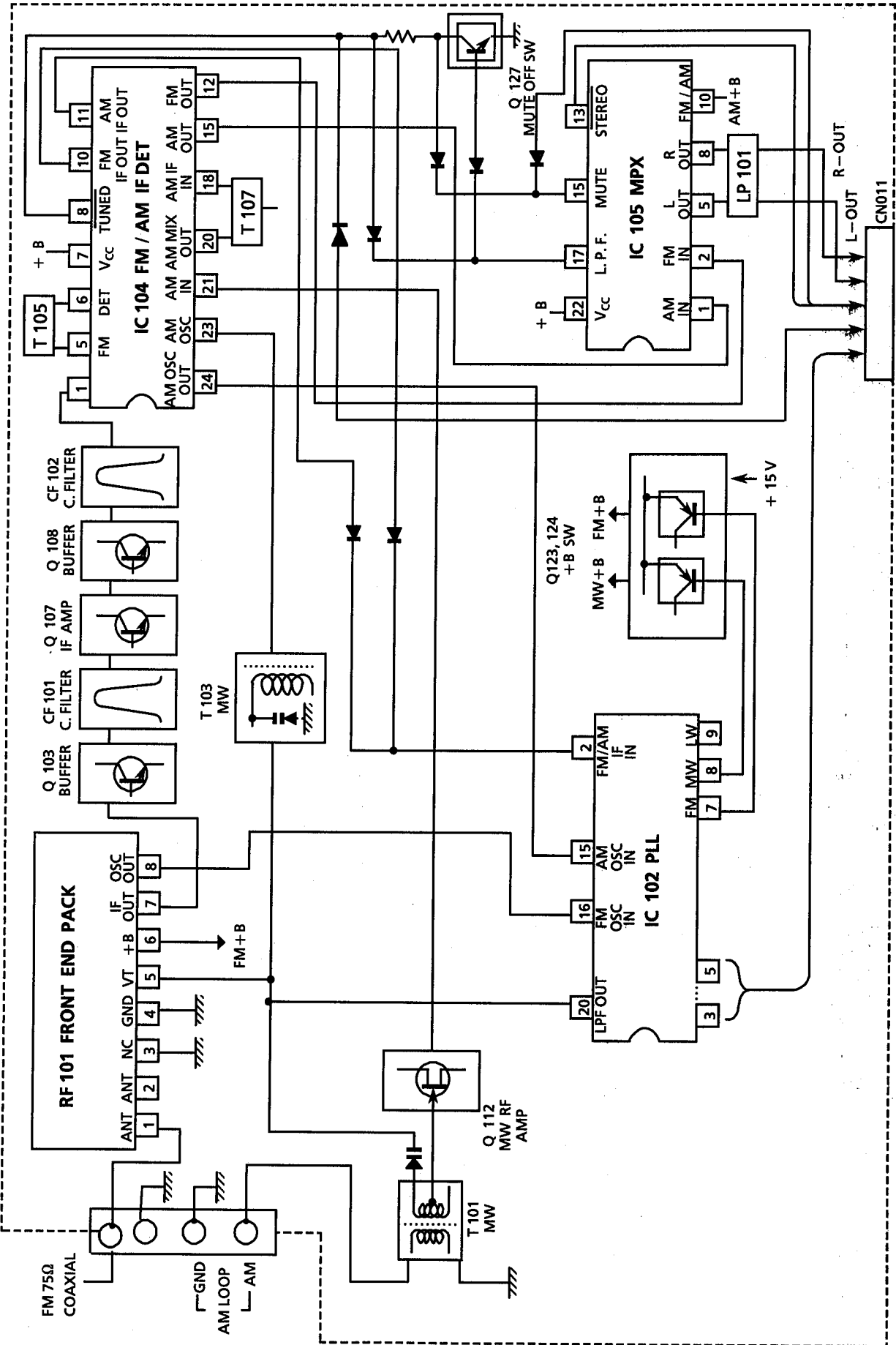



**SignalFlow**

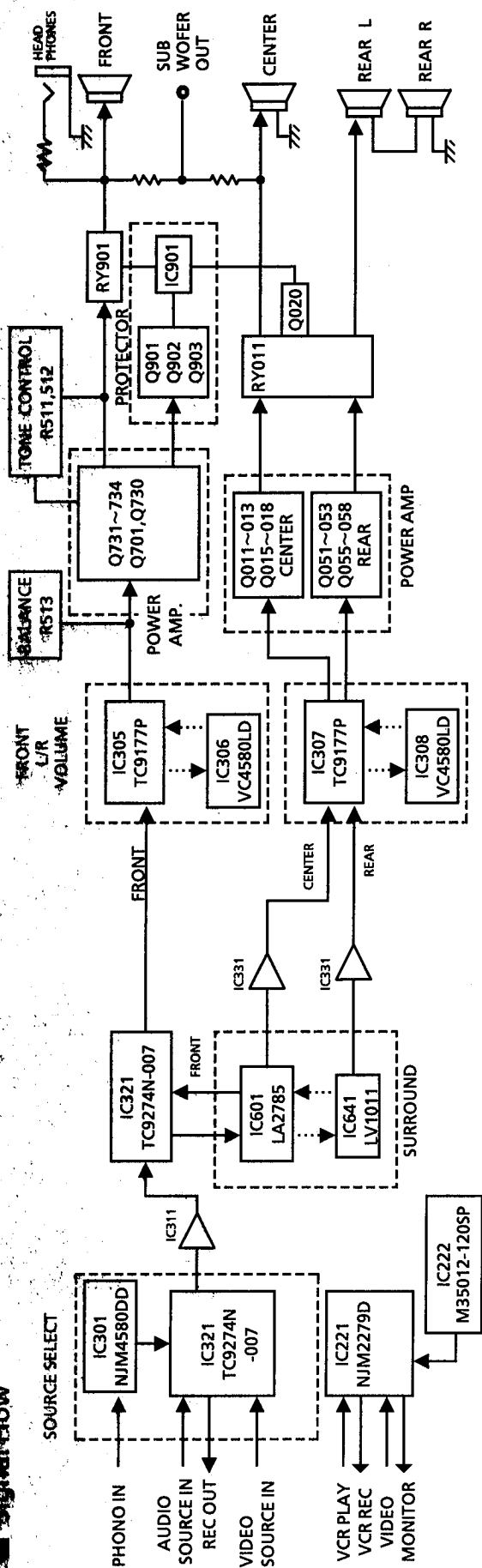

**Control Section**

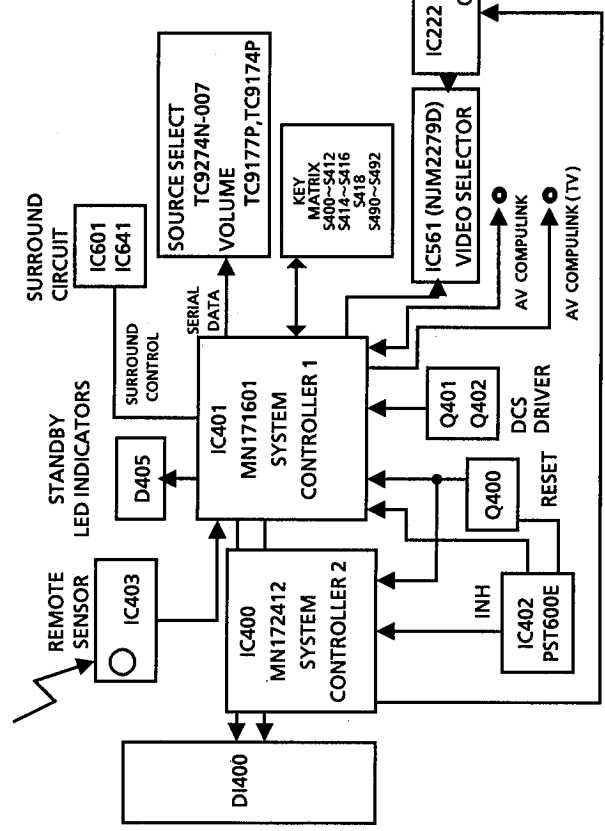

**Power Supply Section**

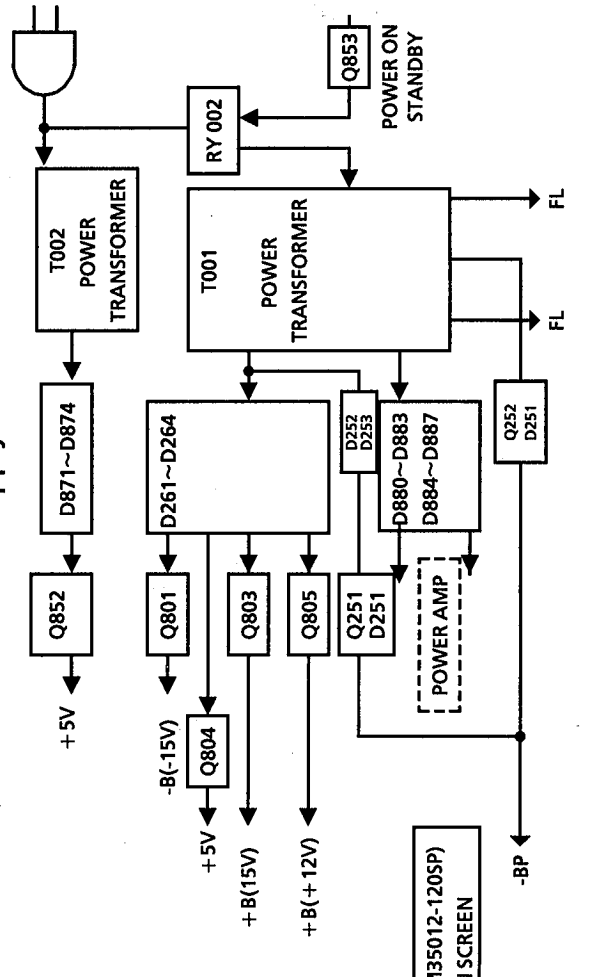

# Schematic Diagrams

## Power Supply Section

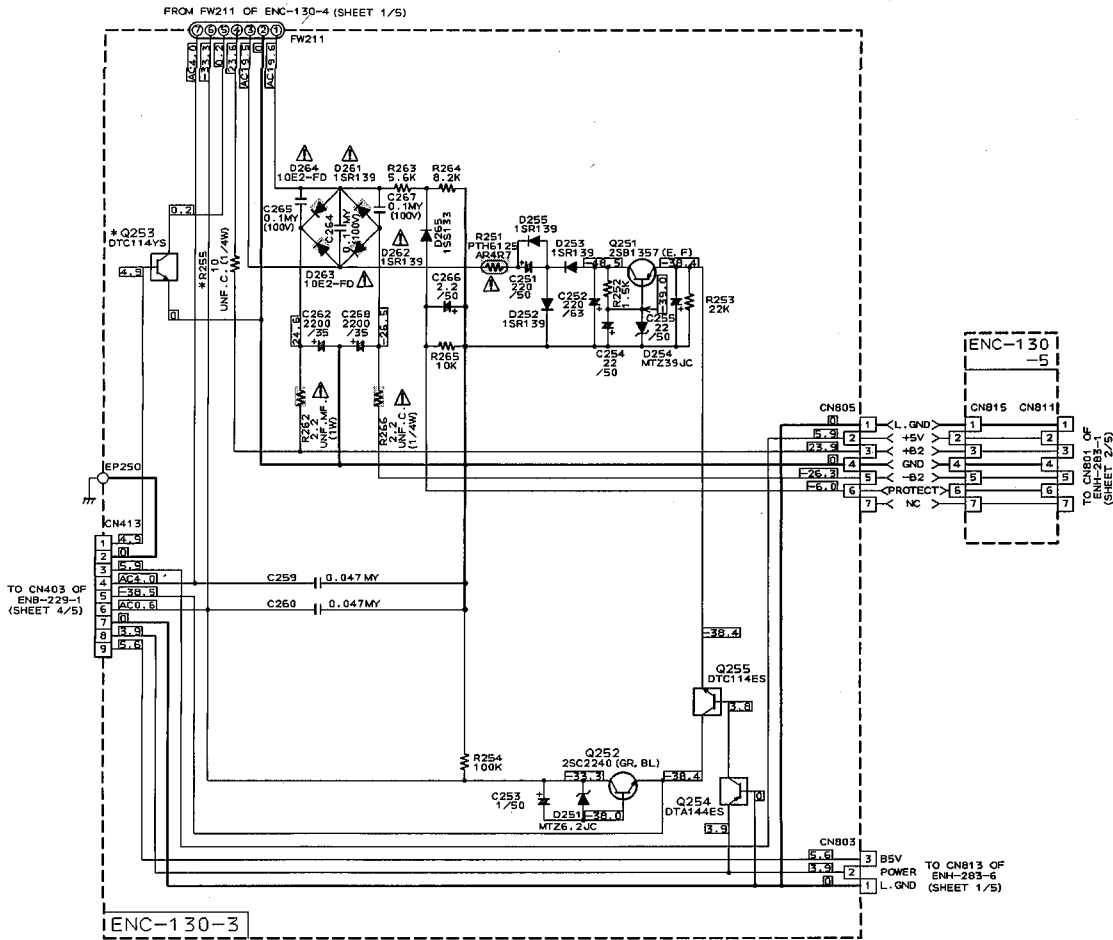

**MARK	J.C	U.UB_US
Q253	USED	NONE
R255	USED	NONE

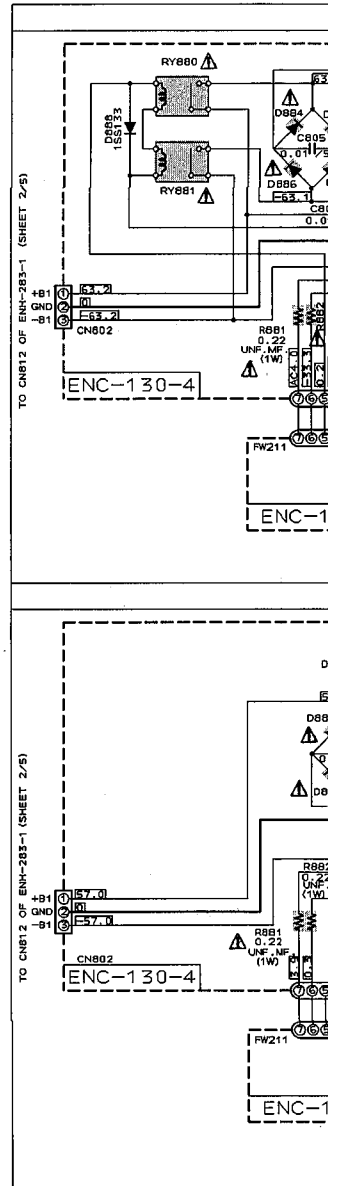





P1-41-a

P1-41-b

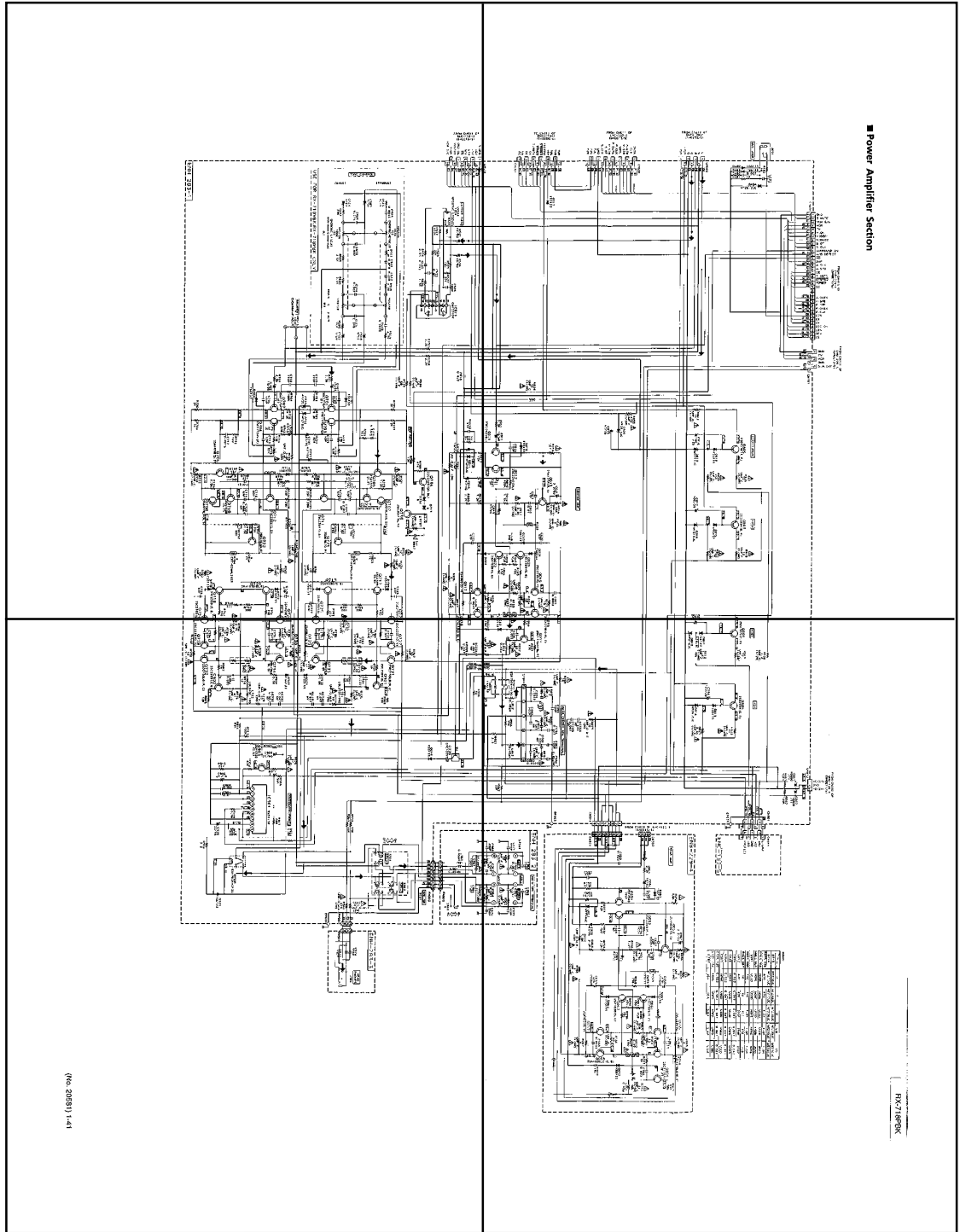

(No. 2028) 1-41

ENCLOSURE

P1-41-c

P1-41-d





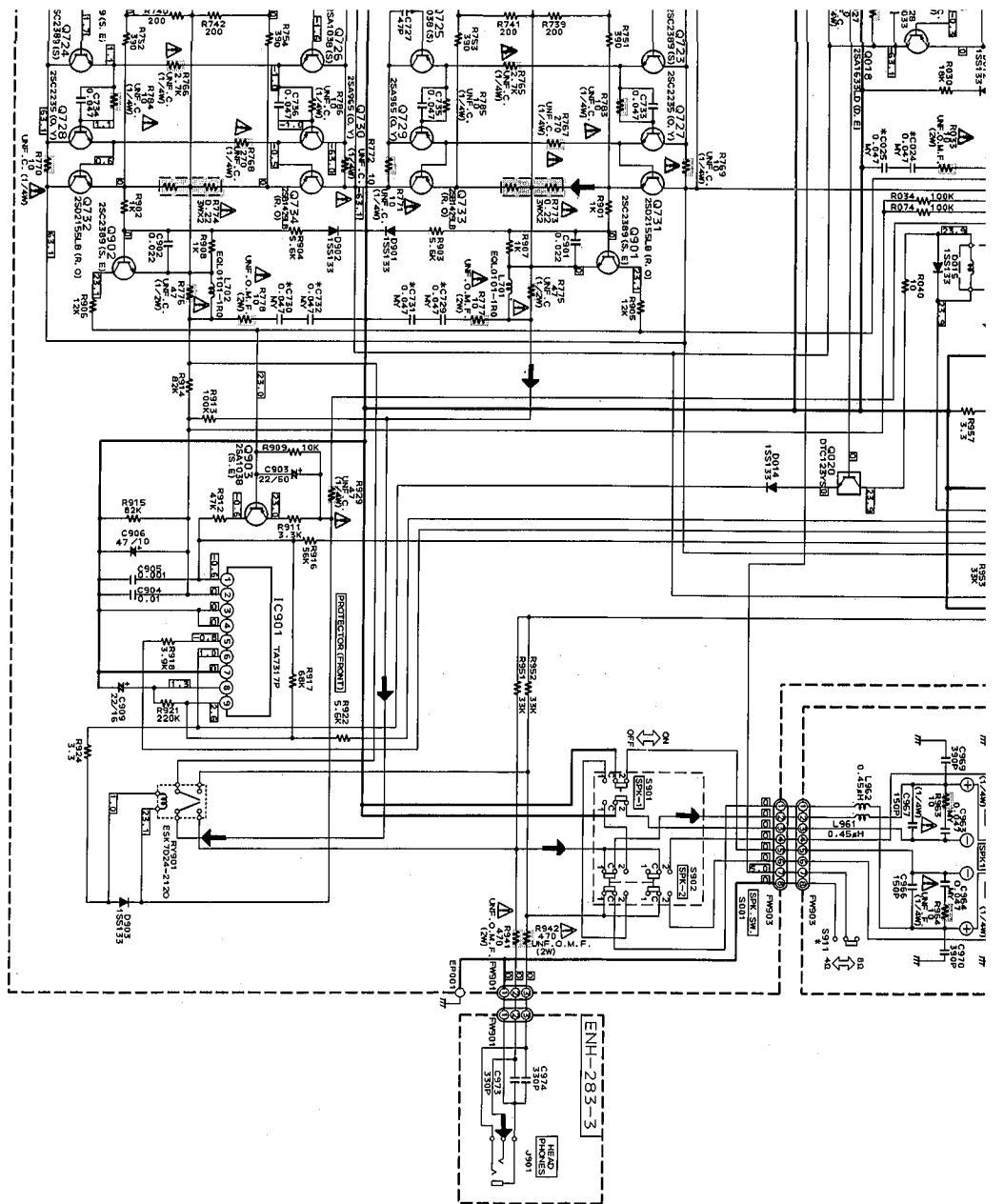

(No. 20581) 1-41



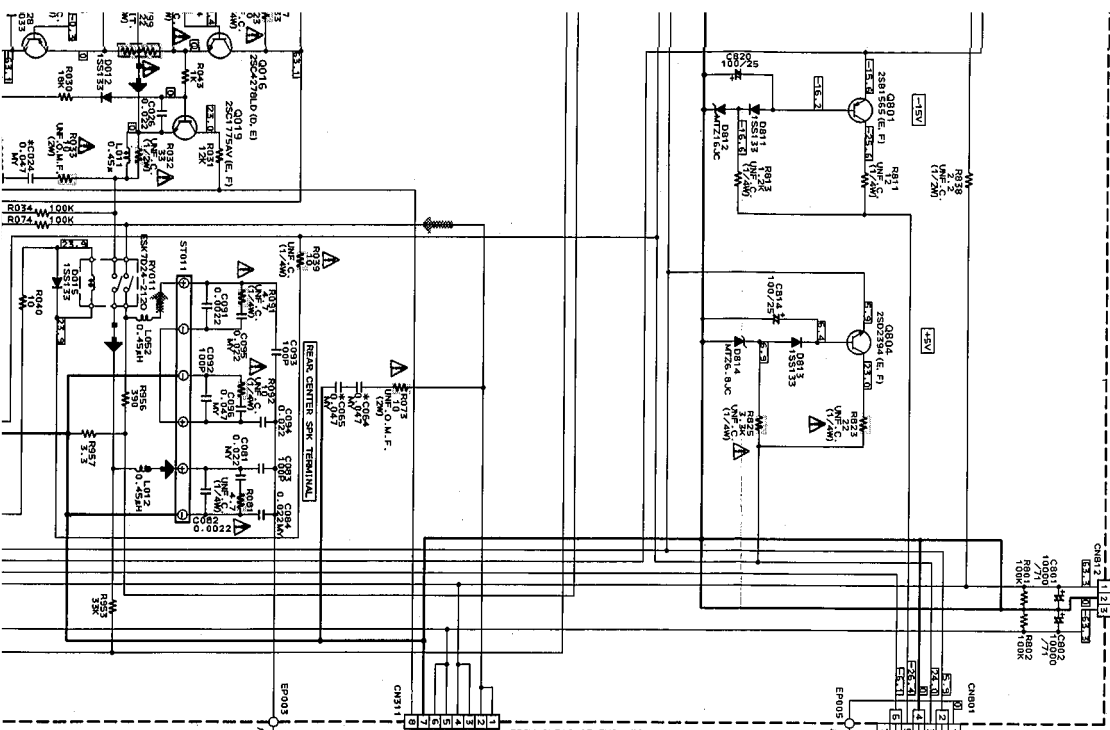

FROM CH02 OF  
ENC-130-4  
(S&C-130-5)  
12.0V  
4.5V  
15.0V

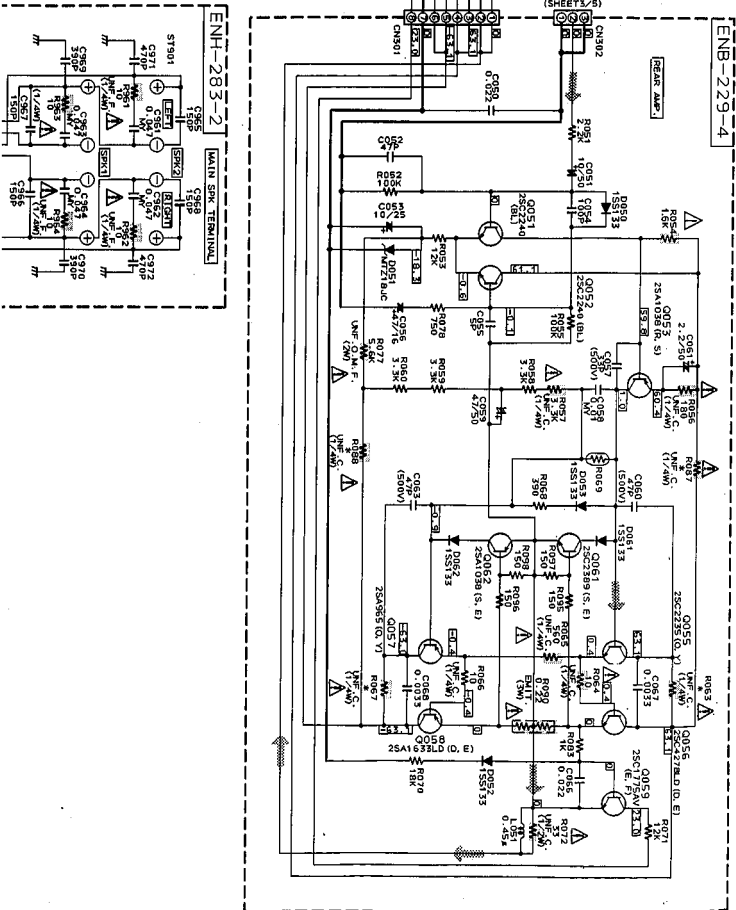

MARK	J	C	U	U/S	U/S	U/S
0715	MFT200C	MFT200C	MFT200C	MFT200C	MFT200C	MFT200C
0714	MFT200C	MFT200C	MFT200C	MFT200C	MFT200C	MFT200C
R055 036	470	470	1.5K	USED	USED	1.5K
R053 764	NONE	NONE	USED	USED	USED	USED
R053 864	NONE	NONE	USED	USED	USED	USED
R051 188	USED	USED	NONE	NONE	NONE	NONE
R051 188	10	10	1.5K	1.5K	1.5K	1.5K
R051 188	10	10	1.5K	1.5K	1.5K	1.5K
R051 188	10	10	1.5K	1.5K	1.5K	1.5K
C004	0.022	0.047	0.047	0.047	0.047	0.047
C005	NONE	USED	USED	USED	USED	USED
C006	NONE	USED	USED	USED	USED	USED
C007	100	100	0.047	0.047	0.047	0.047
C008	100	100	10K	5.6K	5.6K	5.6K
R727	10K	10K	5.6K	5.6K	5.6K	5.6K

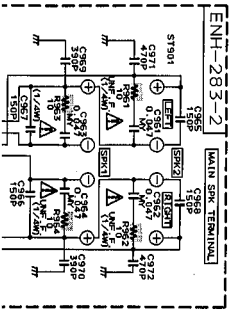



P1-42-a

P1-42-b

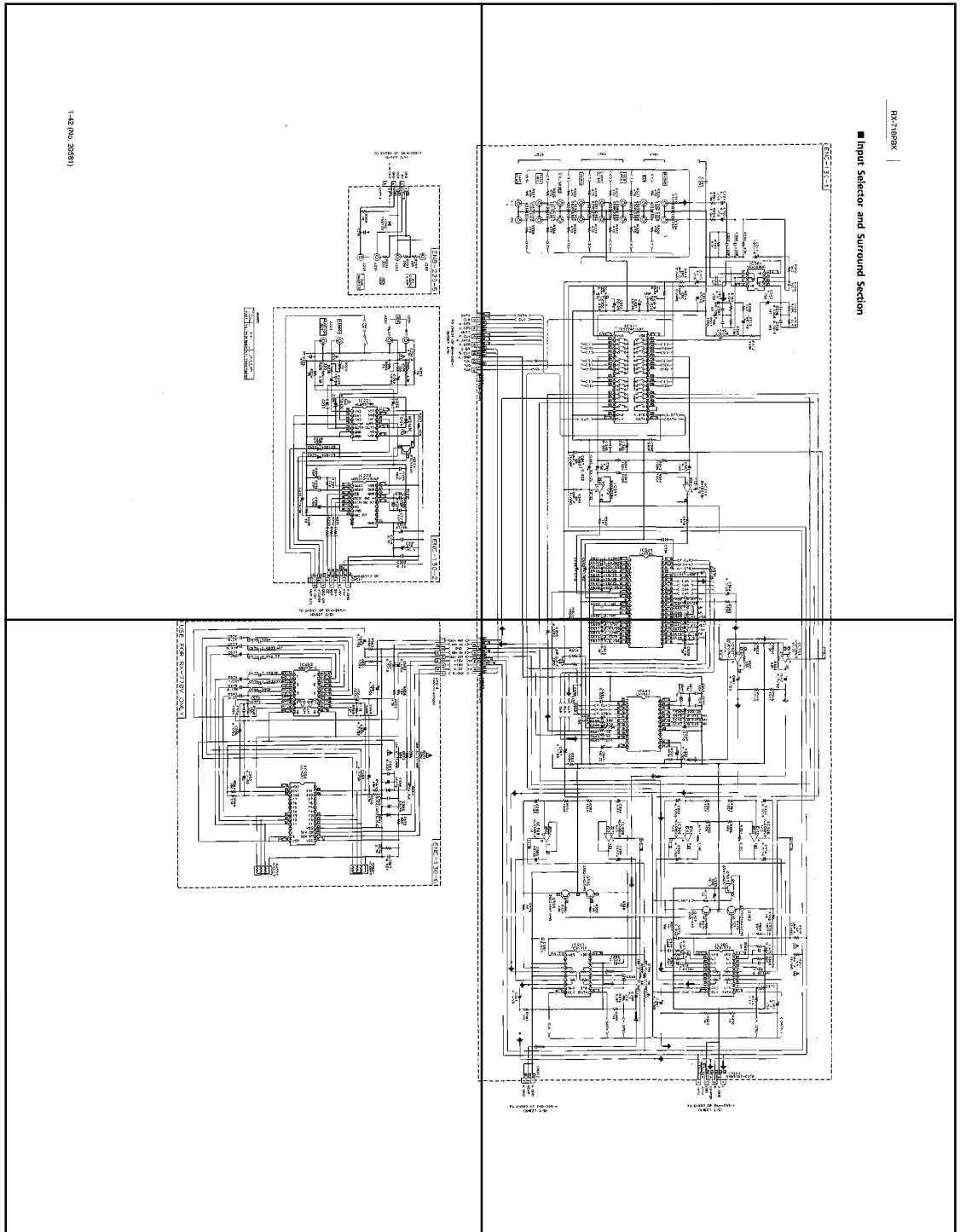





V.GND  
 +5V  
 -5V  
 SIN  
 SIN  
 RES  
 RES  
 OSD ON  
 VIDEO1  
 V.ON  
 VCR S/C

TO C5501 OF ENH-285-1  
 (SHEET 2/5)

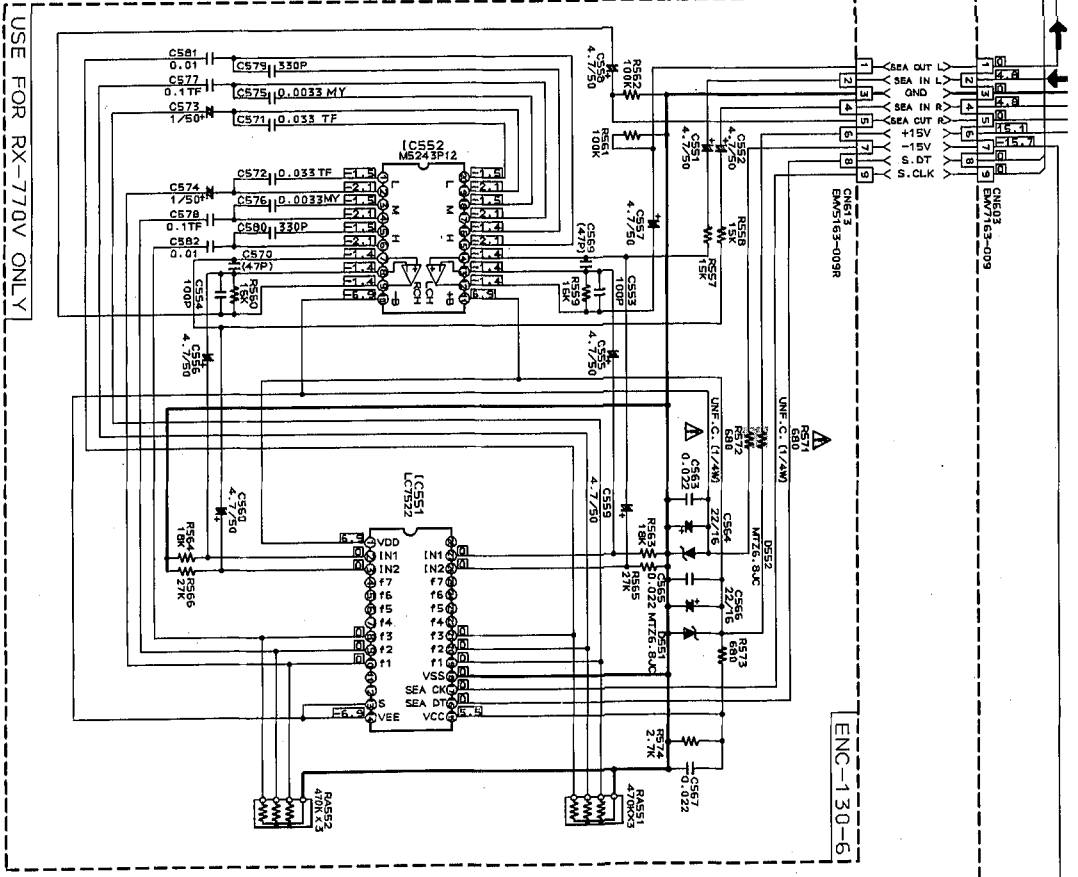







P1-43-a

P1-43-b

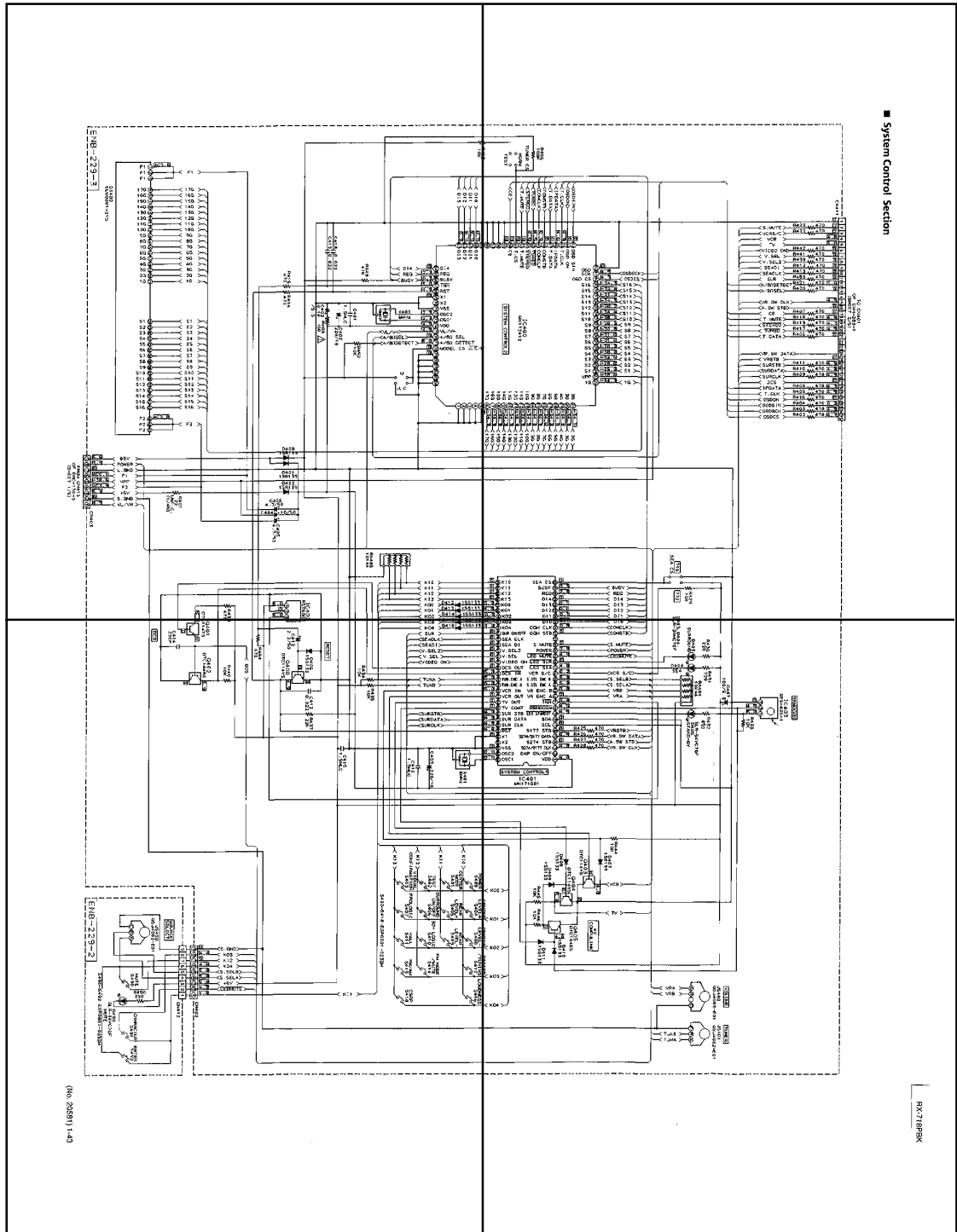

P1-43-c

P1-43-d

ENB-229-3

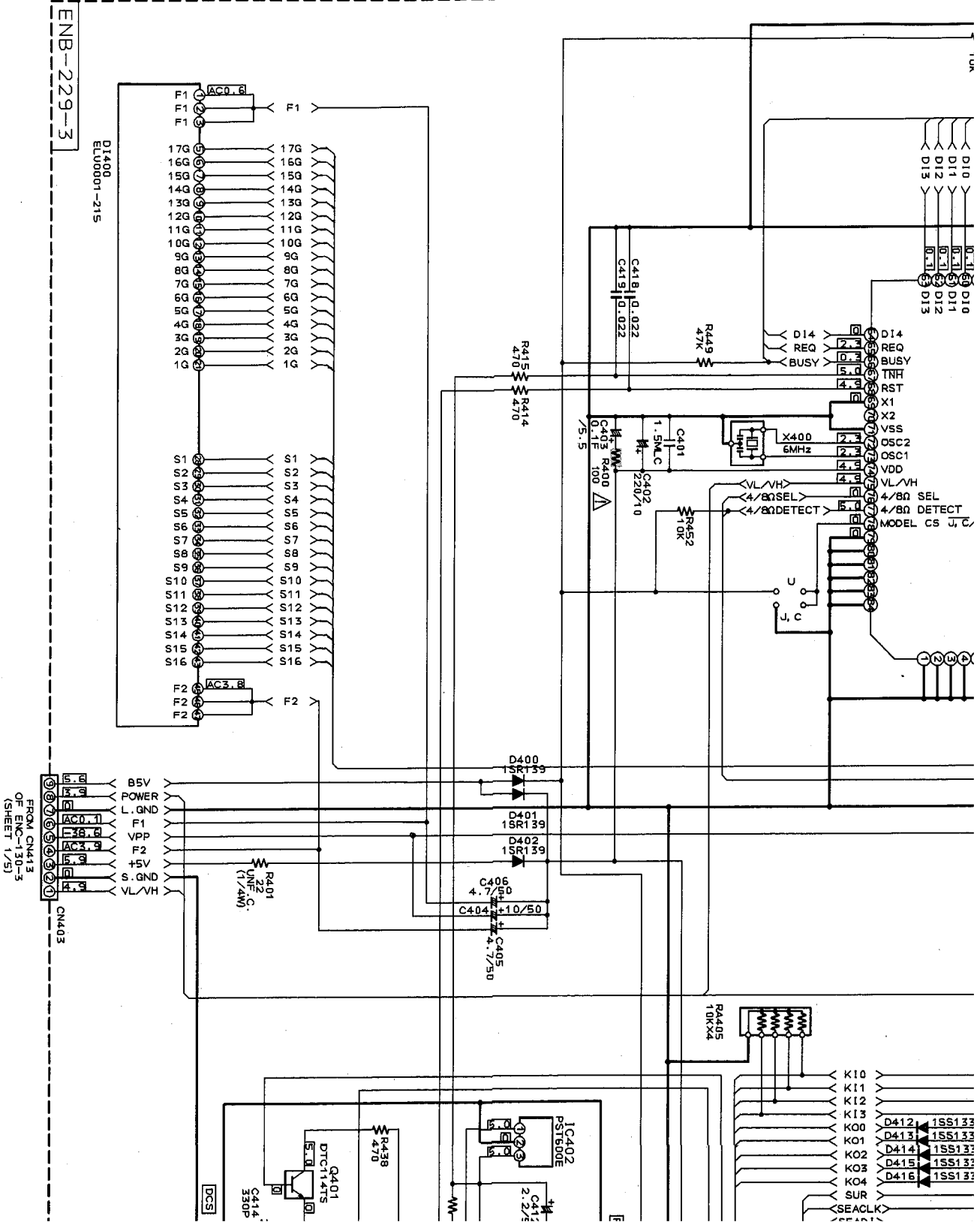

FROM CN413  
OF ENC-130-3  
(SHEET 1/5)

CN403

D1400  
ELU0001-215





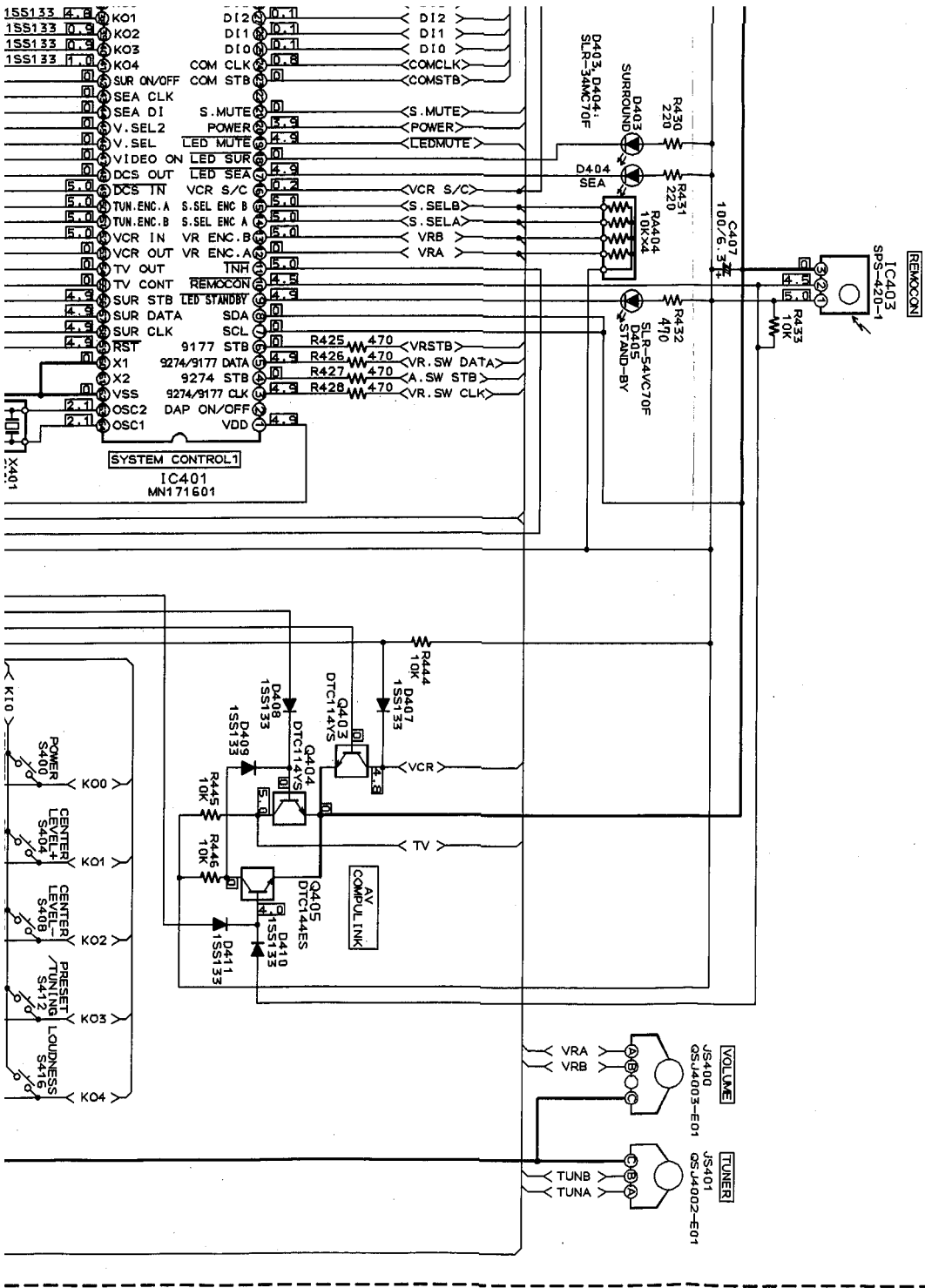





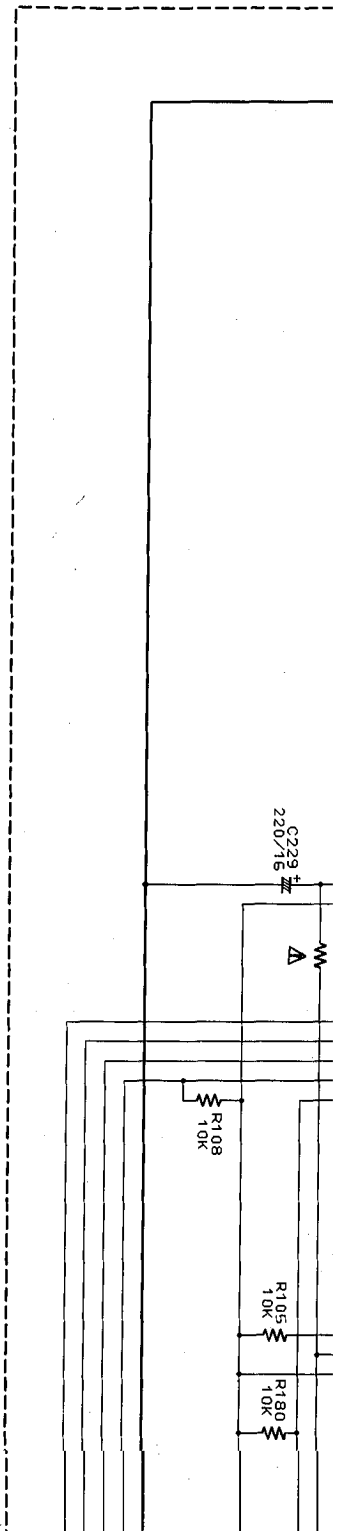

RF101  
EAF2203-004

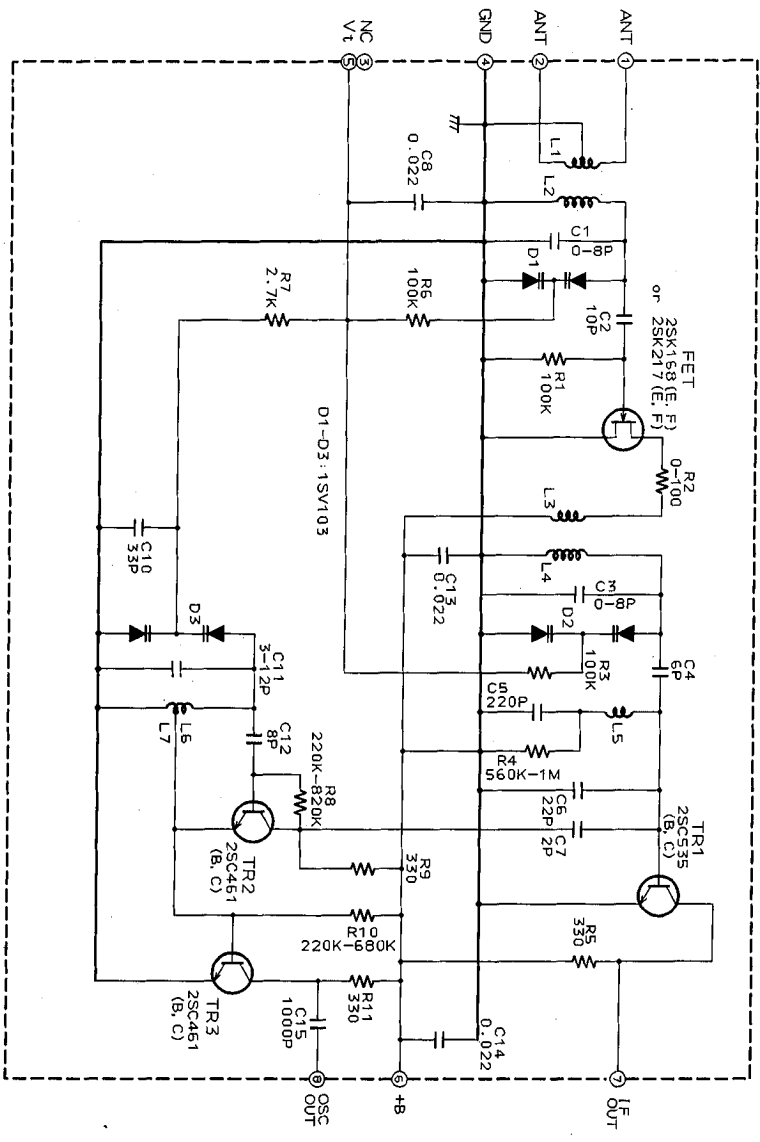





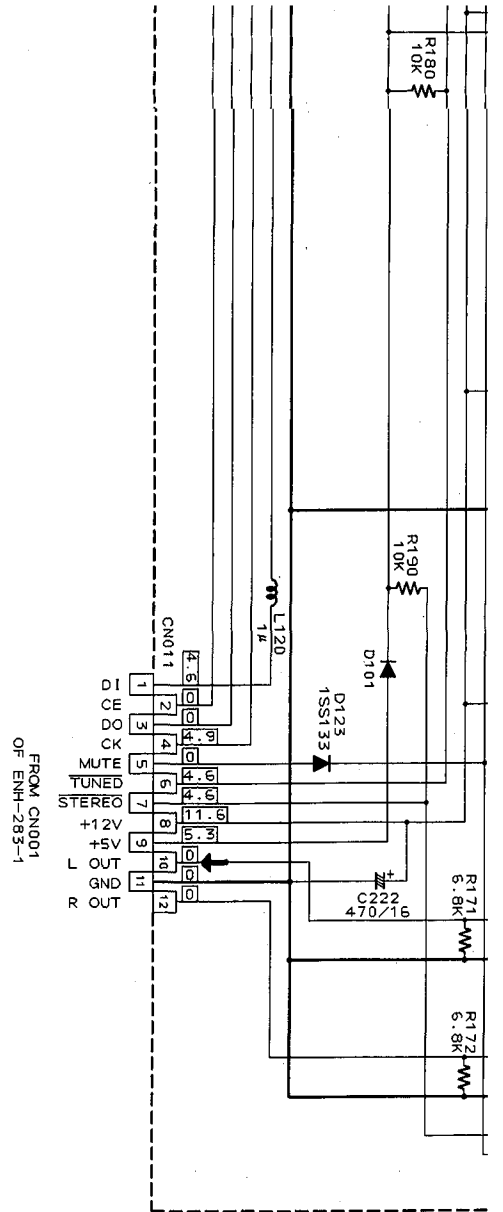

FROM CN001  
OF ENH-283-1

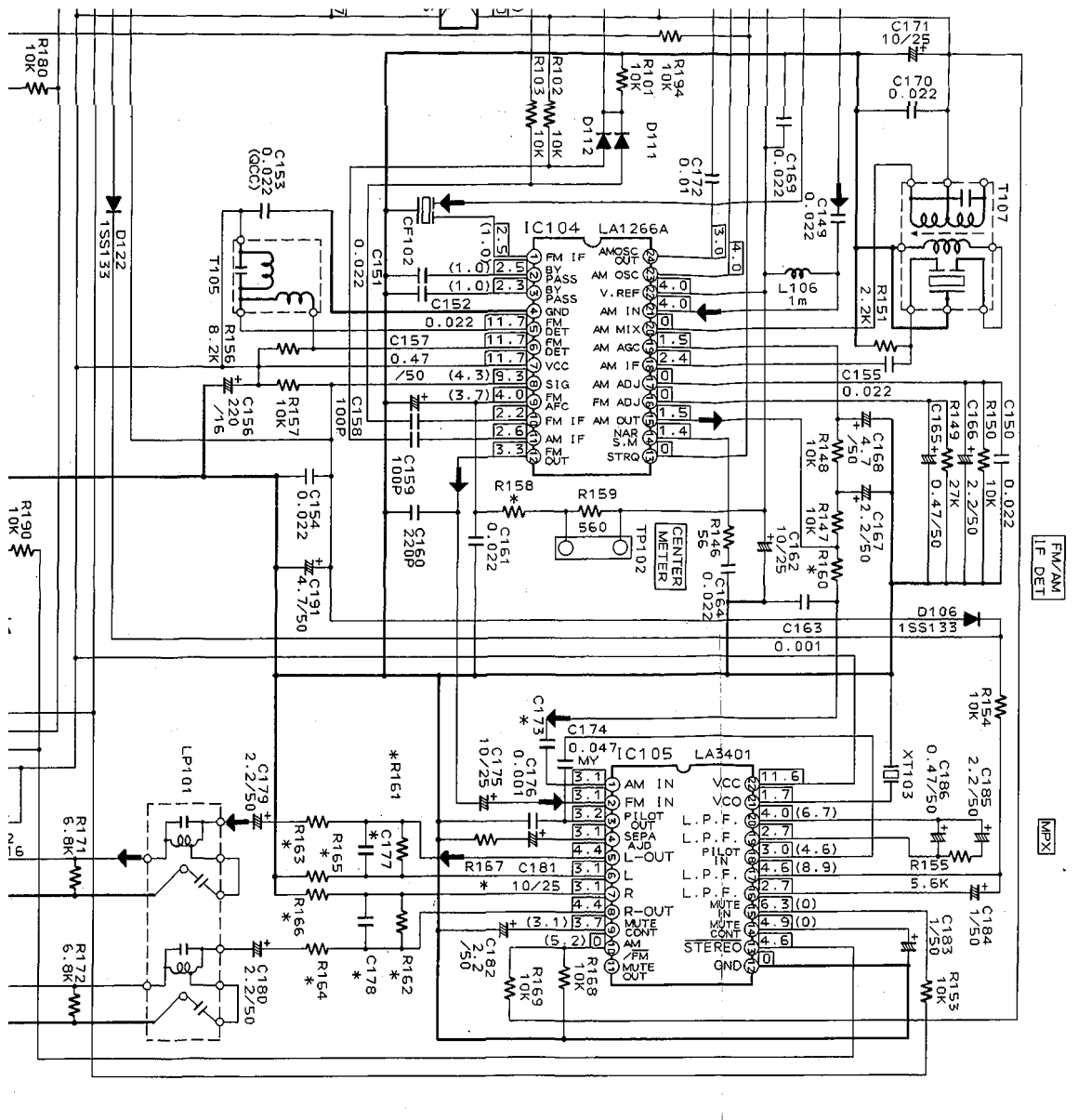

FM/AM  
LP/DET

MPX

	V/US/UB/UT	A	J/C
R109	58 UNF-F (1/4W)	47K	39K
R157	39K		
R150	5.6K	10K	5.6K
R151	82K	100K	82K
R153	4.7K	3.3K	4.7K
R155	180K	270K	180K
R156	180K	560K	180K
R158	27K	27K	18K
R173	0.059	0.022	0.059

\* MARK

□ FM AUTO NO SIGNAL  
( ) LM NO SIGNAL  
[ ] LW NO SIGNAL





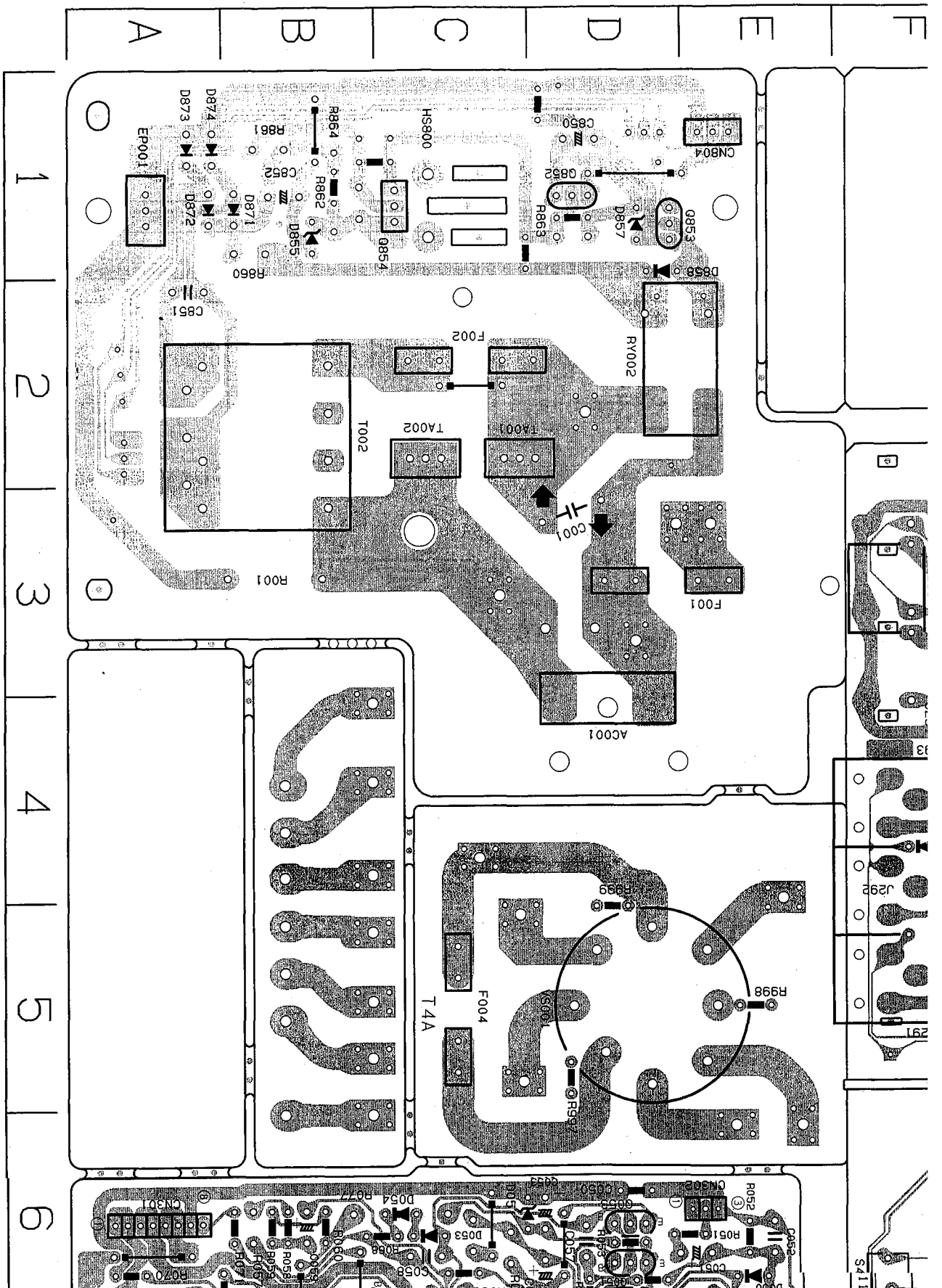

# Printed Circuit Boards

■ System Control & Rear Power Amplifier P.C. Board (ENB-229)

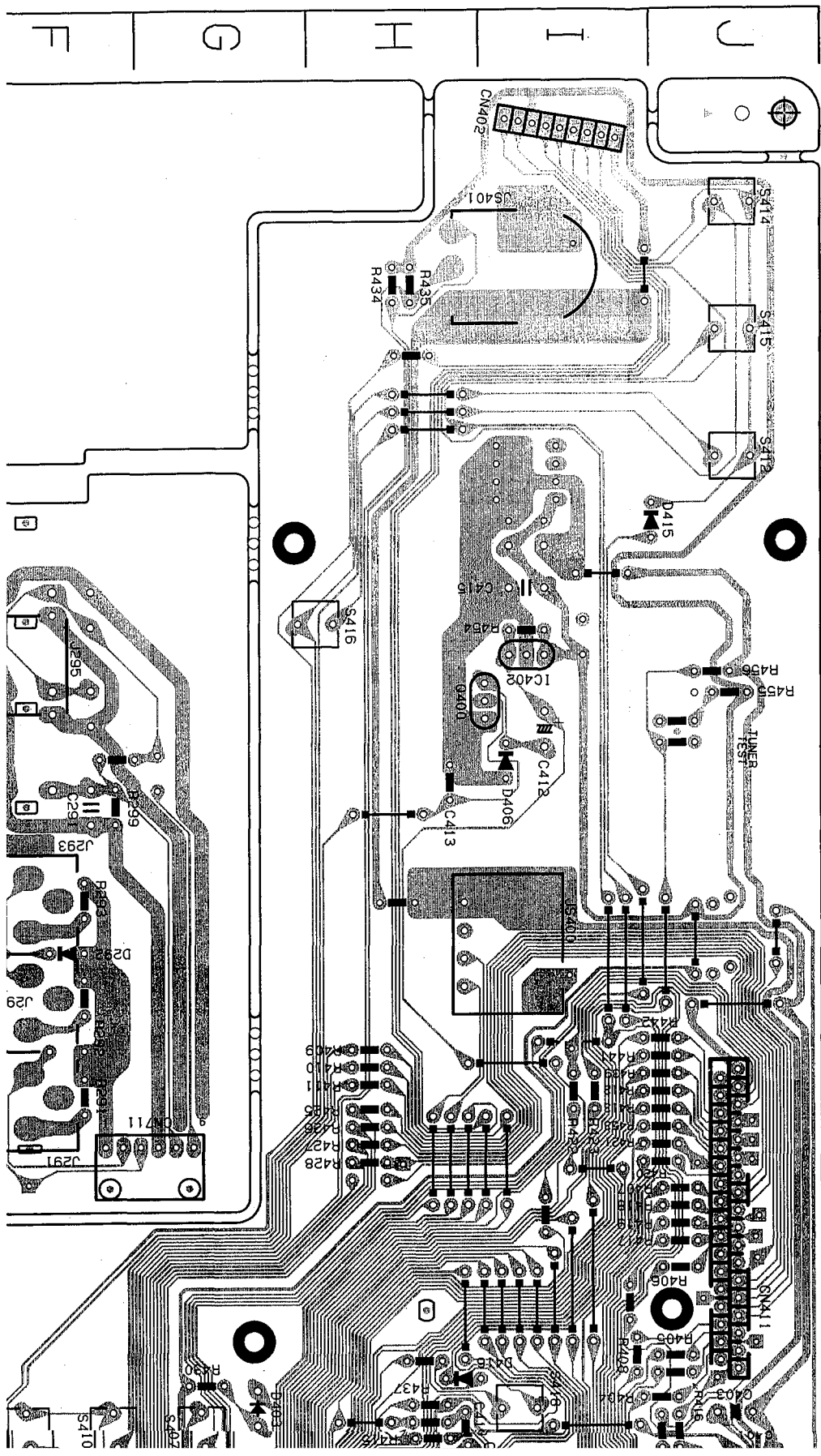

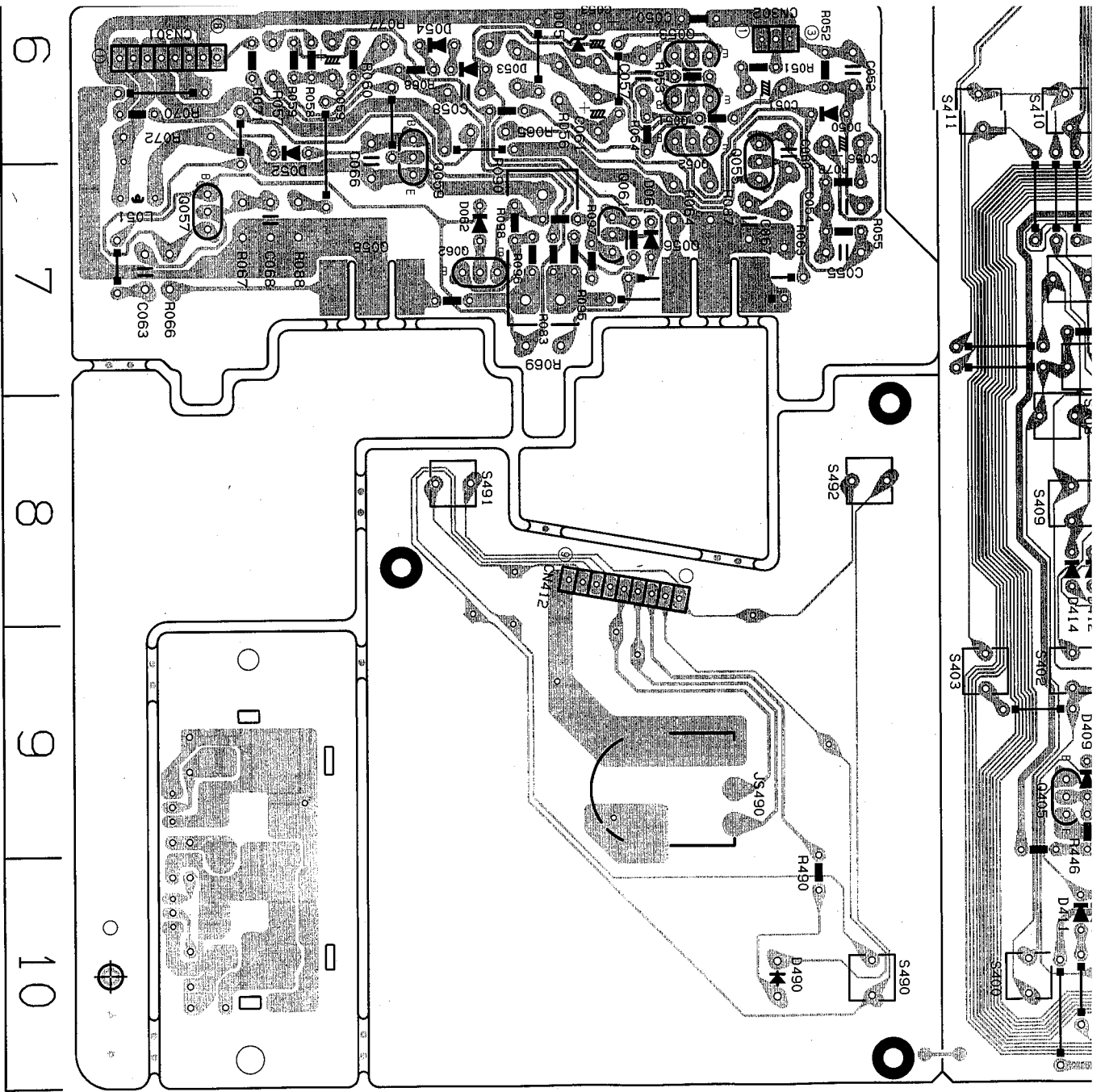

R067	6B
R068	6B
R069	6B

D416	6I
D490	10E
D555	1B

R057	6B
R058	6B
R059	6B

R060	6B	R429	9G	S412	2J
R063	7E	R430	9G	S414	1J
R064	7D	R431	9G	S415	2J
R065	6C	R432	10G	S416	3H
R066	7A	R433	10H	S418	6I
R067	7B	R434	1H	S490	10E
R068	6B	R435	1H	S491	8G
R069	7C	R436	10I	S492	8E
R070	6A	R437	6H	T002	2B
R071	6B	R438	10J	TA001	2C
R072	6A	R439	5I	TA002	2C
R077	6B	R440	10I	X400	7H
R078	7E	R441	5I	X401	10H
R083	7C	R442	5I		
R087	7D	R443	3I		
R088	7B	R444	9G		
R090	7C	R445	9G		
R095	7C	R446	9F		
R096	7C	R447	10J		
R097	7D	R448	9J		
R098	7C	R449	8I		
R206	1C	R452	7H		
R291	5F	R453	5I		
R292	5F	R454	3I		
R293	4F	R455	3J		
R299	4F	R456	3J		
R400	7J	R460	10E		
R401	8J	R591	9A		
R402	6J	R592	10A		
R403	6J	R860	1B		
R404	6I	R861	1B		
R405	6J	R862	1B		
R406	6J	R863	1D		
R407	5J	R864	1B		
R408	6I	R997	5D		
R409	5H	R998	5E		
R410	5H	R999	5D		
R411	5H	RA402	8I		
R412	5I	RA403	8I		
R413	5I	RA404	9H		
R414	6H	RA405	8I		
R415	6H	PV001	2E		
R416	6J	RV002	2D		
R417	5J	SA01	9G		
R418	5J	SA00	10F		
R419	5J	SA02	9F		
R420	5I	SA03	9F		
R421	5I	SA04	7F		
R422	5I	SA05	7F		
R423	5I	SA06	8G		
R424	5H	SA07	6G		
R425	5H	SA08	8F		
R426	5H	SA09	8F		
R427	5H	SA10	6F		
R428	5H	SA11	6F		

(No. 20581) 1-45



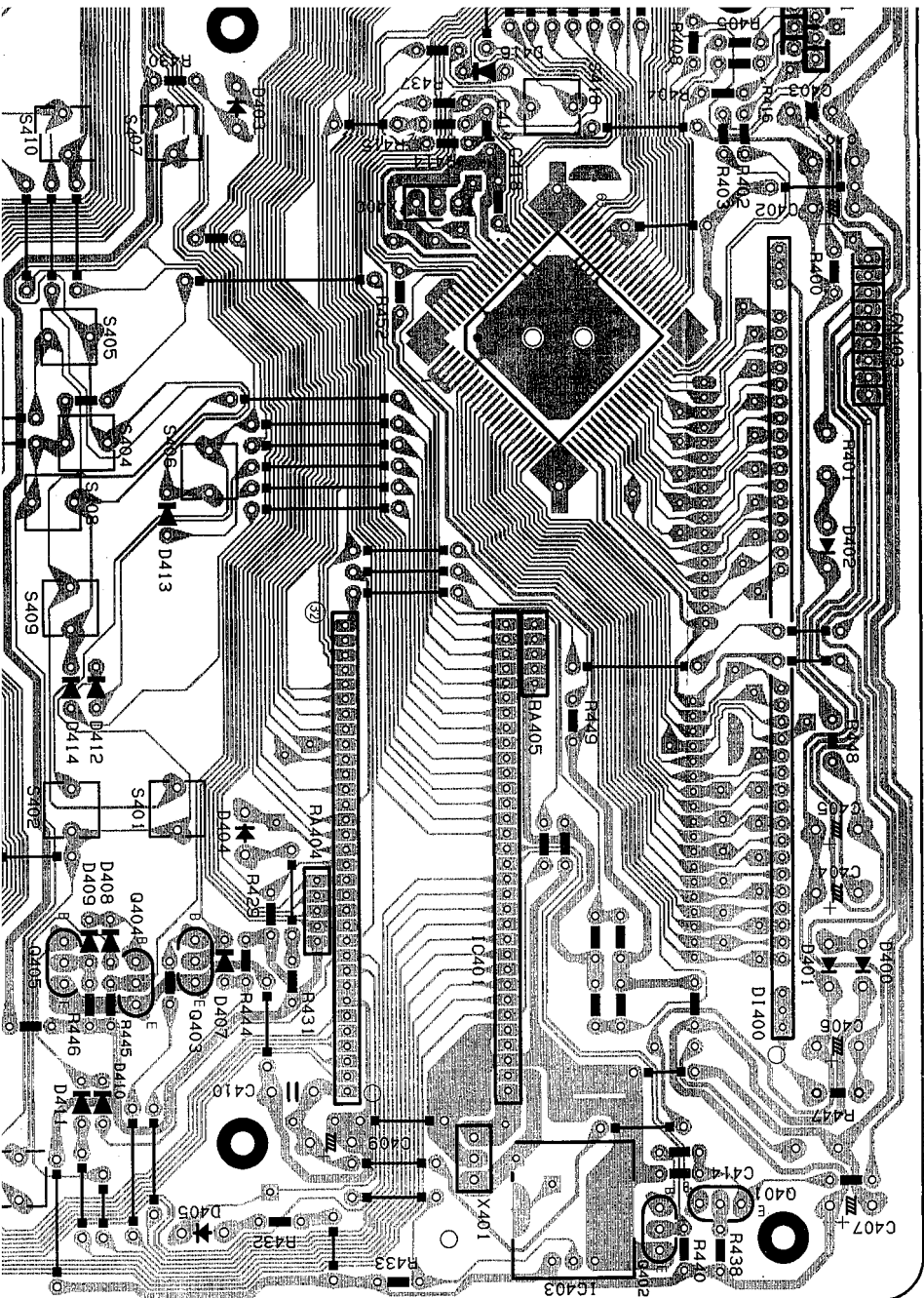

Location List (ENB-229 )

Symbol	X	Y	Symbol	X	Y	Symbol	X	Y
0001	3 D	IC407	6 J	0857	1 D			
0050	6 D	IC408	6 J	0858	1 D			
0051	6 D	IC409	6 J	0859	1 B			
0052	6 E	IC410	5 J	0872	1 A			
0053	6 D	IC411	5 J	0873	1 A			
0054	7 E	IC412	5 J	0874	1 A			
0055	7 E	IC413	5 J	0875	1 A			
0056	6 E	IC414	5 J	0876	1 A			
0057	6 D	IC415	5 J	0877	1 A			
0058	6 C	IC416	5 J	0878	1 A			
0059	6 B	IC417	5 I	0879	1 A			
0060	6 E	IC418	4 I	0880	1 A			
0061	6 D	IC419	5 H	0881	1 A			
0062	7 A	IC420	1 I	0882	1 A			
0063	7 A	IC421	7 J	0883	1 A			
0064	7 B	IC422	7 H	0884	1 A			
0065	7 B	IC423	6 H	0885	1 A			
0066	7 B	IC424	6 A	0886	1 A			
0067	7 D	IC425	6 E	0887	1 A			
0068	7 B	IC426	6 E	0888	1 A			
0069	7 B	IC427	6 E	0889	1 A			
0070	7 B	IC428	6 E	0890	1 A			
0071	7 B	IC429	6 E	0891	1 A			
0072	7 B	IC430	6 E	0892	1 A			
0073	7 B	IC431	6 E	0893	1 A			
0074	7 B	IC432	6 E	0894	1 A			
0075	7 B	IC433	6 E	0895	1 A			
0076	7 B	IC434	6 E	0896	1 A			
0077	7 B	IC435	6 E	0897	1 A			
0078	7 B	IC436	6 E	0898	1 A			
0079	7 B	IC437	6 E	0899	1 A			
0080	7 B	IC438	6 E	0900	1 A			
0081	7 B	IC439	6 E	0901	1 A			
0082	7 B	IC440	6 E	0902	1 A			
0083	7 B	IC441	6 E	0903	1 A			
0084	7 B	IC442	6 E	0904	1 A			
0085	7 B	IC443	6 E	0905	1 A			
0086	7 B	IC444	6 E	0906	1 A			
0087	7 B	IC445	6 E	0907	1 A			
0088	7 B	IC446	6 E	0908	1 A			
0089	7 B	IC447	6 E	0909	1 A			
0090	7 B	IC448	6 E	0910	1 A			
0091	7 B	IC449	6 E	0911	1 A			
0092	7 B	IC450	6 E	0912	1 A			
0093	7 B	IC451	6 E	0913	1 A			
0094	7 B	IC452	6 E	0914	1 A			
0095	7 B	IC453	6 E	0915	1 A			
0096	7 B	IC454	6 E	0916	1 A			
0097	7 B	IC455	6 E	0917	1 A			
0098	7 B	IC456	6 E	0918	1 A			
0099	7 B	IC457	6 E	0919	1 A			
0100	7 B	IC458	6 E	0920	1 A			
0101	7 B	IC459	6 E	0921	1 A			
0102	7 B	IC460	6 E	0922	1 A			
0103	7 B	IC461	6 E	0923	1 A			
0104	7 B	IC462	6 E	0924	1 A			
0105	7 B	IC463	6 E	0925	1 A			
0106	7 B	IC464	6 E	0926	1 A			
0107	7 B	IC465	6 E	0927	1 A			
0108	7 B	IC466	6 E	0928	1 A			
0109	7 B	IC467	6 E	0929	1 A			
0110	7 B	IC468	6 E	0930	1 A			
0111	7 B	IC469	6 E	0931	1 A			
0112	7 B	IC470	6 E	0932	1 A			
0113	7 B	IC471	6 E	0933	1 A			
0114	7 B	IC472	6 E	0934	1 A			
0115	7 B	IC473	6 E	0935	1 A			
0116	7 B	IC474	6 E	0936	1 A			
0117	7 B	IC475	6 E	0937	1 A			
0118	7 B	IC476	6 E	0938	1 A			
0119	7 B	IC477	6 E	0939	1 A			
0120	7 B	IC478	6 E	0940	1 A			
0121	7 B	IC479	6 E	0941	1 A			
0122	7 B	IC480	6 E	0942	1 A			
0123	7 B	IC481	6 E	0943	1 A			
0124	7 B	IC482	6 E	0944	1 A			
0125	7 B	IC483	6 E	0945	1 A			
0126	7 B	IC484	6 E	0946	1 A			
0127	7 B	IC485	6 E	0947	1 A			
0128	7 B	IC486	6 E	0948	1 A			
0129	7 B	IC487	6 E	0949	1 A			
0130	7 B	IC488	6 E	0950	1 A			
0131	7 B	IC489	6 E	0951	1 A			
0132	7 B	IC490	6 E	0952	1 A			
0133	7 B	IC491	6 E	0953	1 A			
0134	7 B	IC492	6 E	0954	1 A			
0135	7 B	IC493	6 E	0955	1 A			
0136	7 B	IC494	6 E	0956	1 A			
0137	7 B	IC495	6 E	0957	1 A			
0138	7 B	IC496	6 E	0958	1 A			
0139	7 B	IC497	6 E	0959	1 A			
0140	7 B	IC498	6 E	0960	1 A			
0141	7 B	IC499	6 E	0961	1 A			
0142	7 B	IC500	6 E	0962	1 A			

RX-718PBK



P1-46-a

P1-46-b

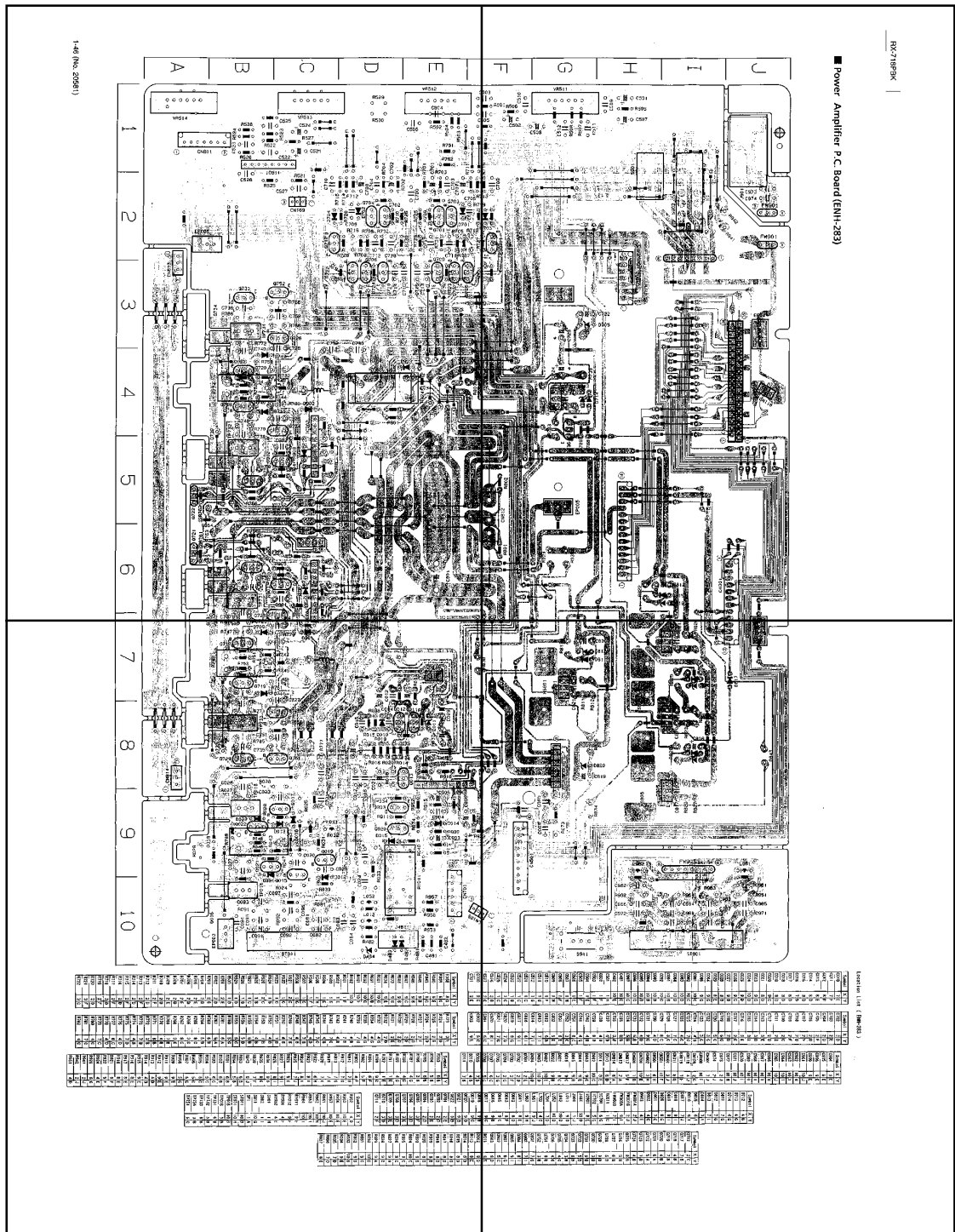

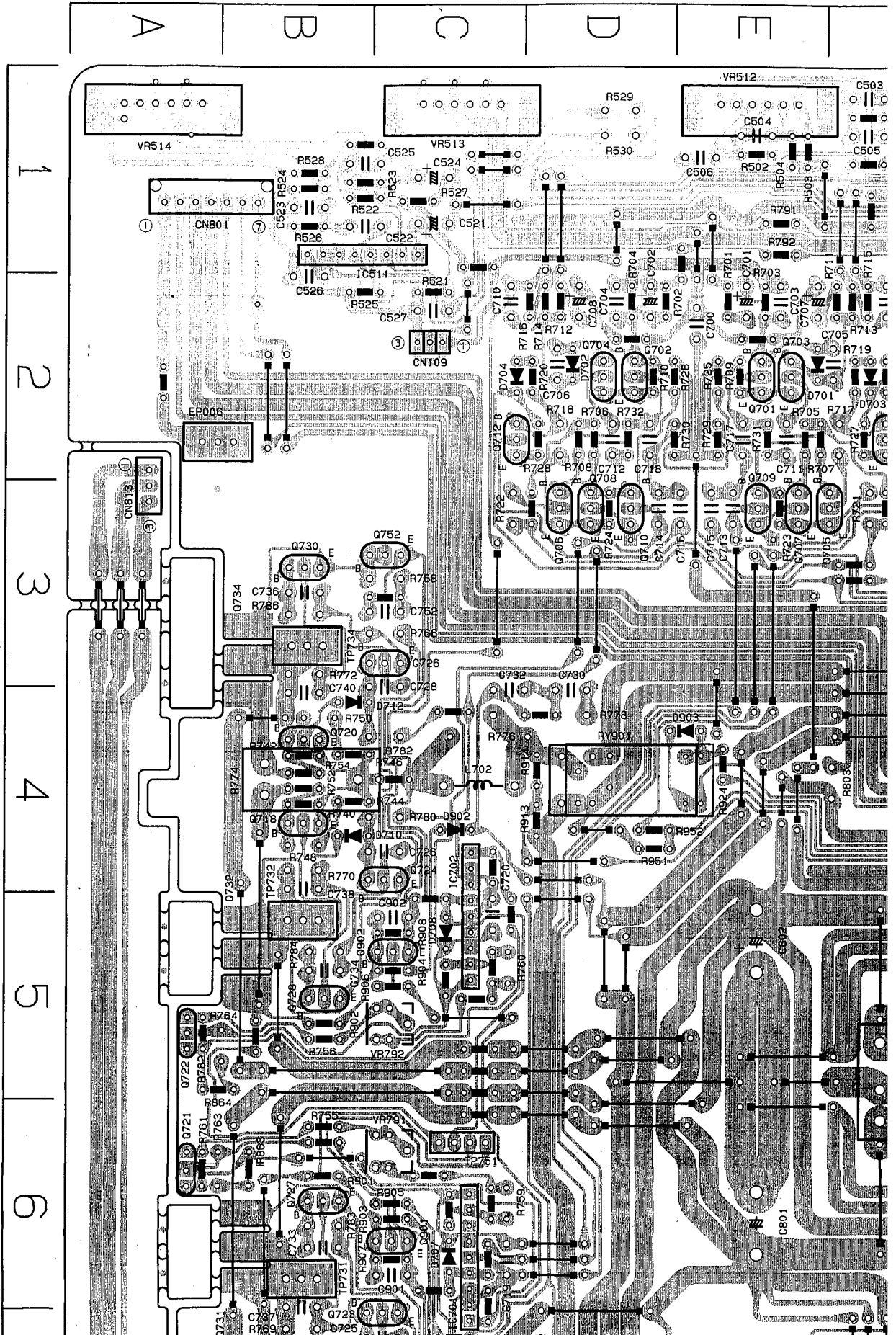

Power Amplifier P.C. Board (ENH-283)

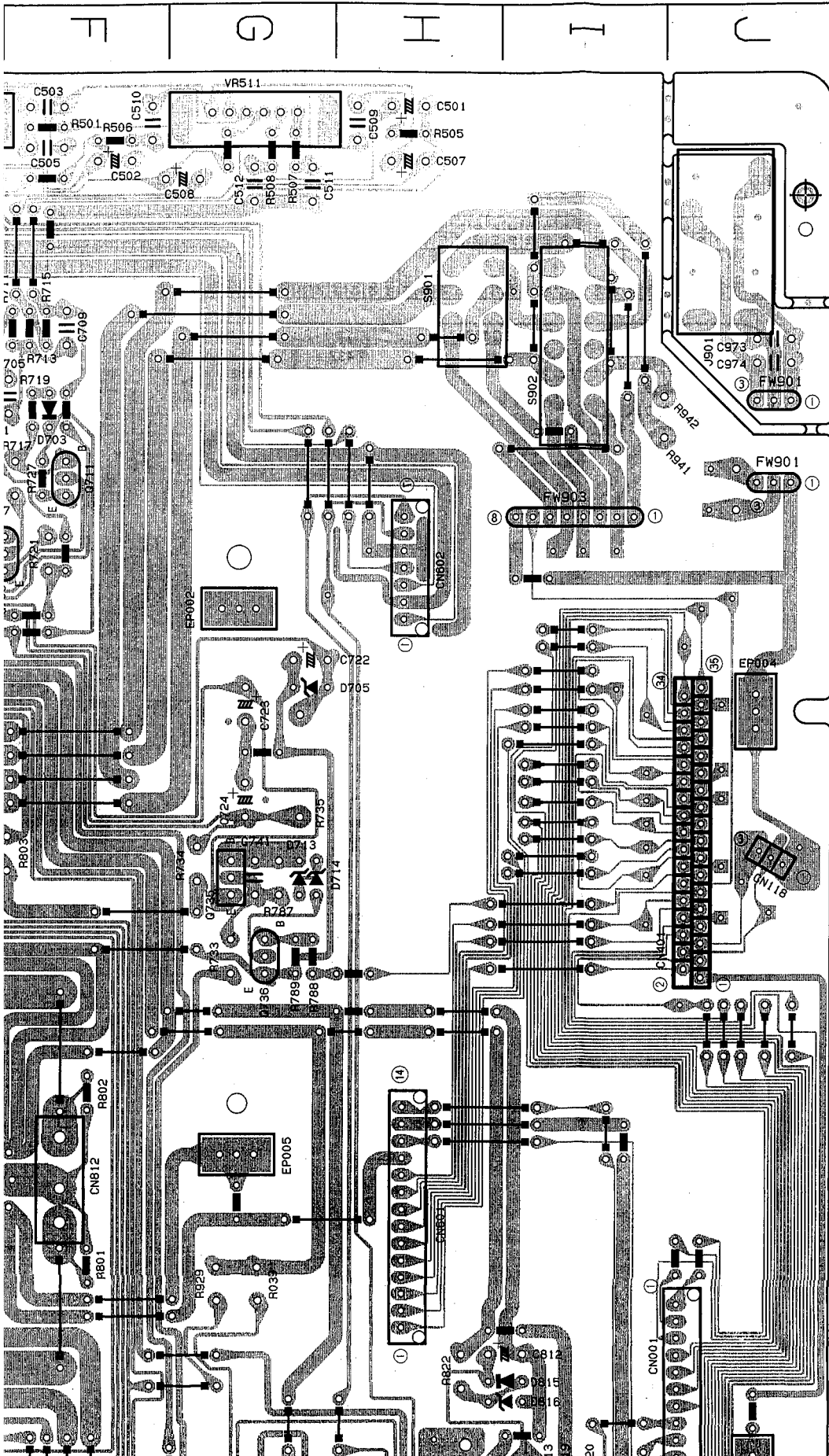

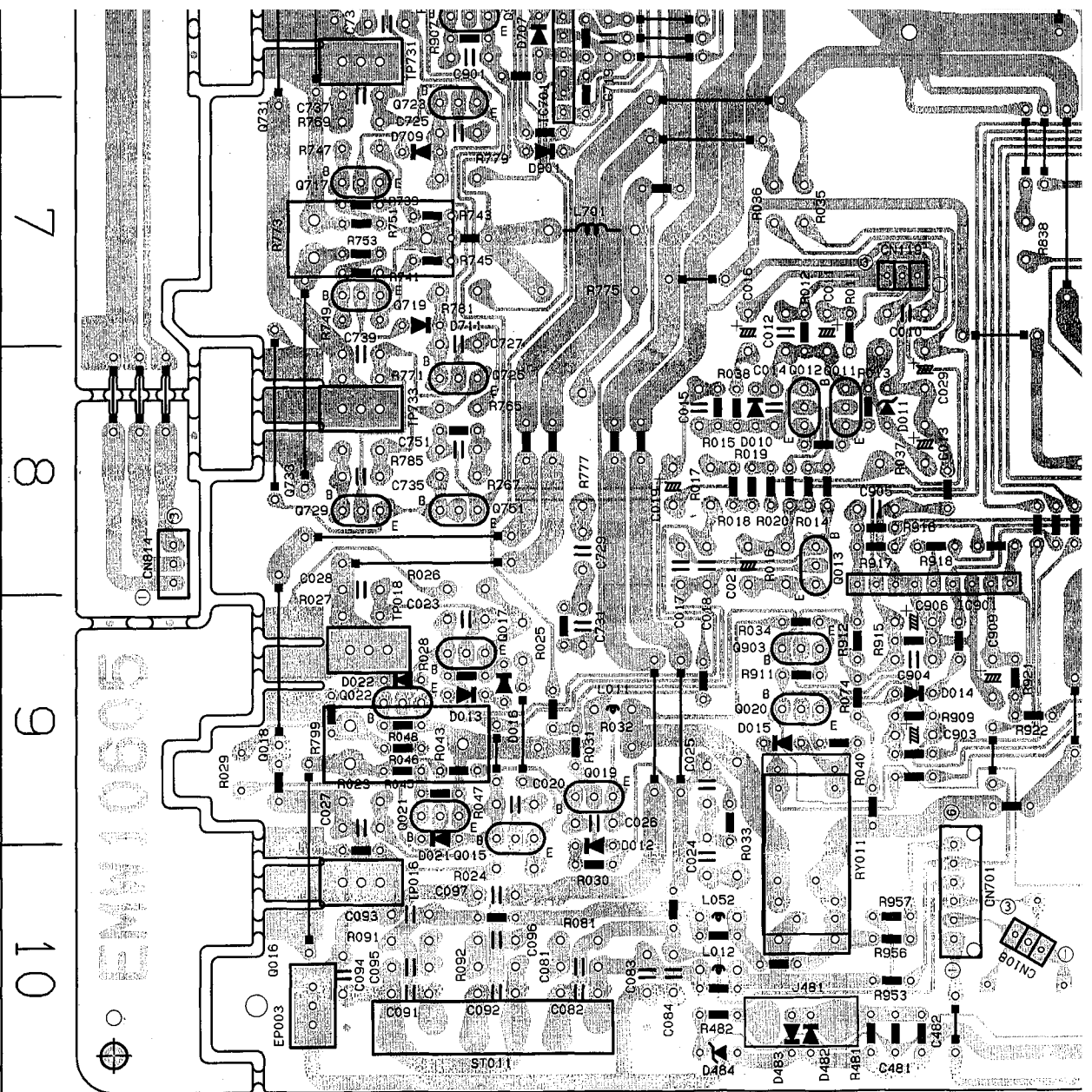

R526	2/B	R620	8/I	D707	6/G	R016	9/B	R903	9/D
C527	2/C	C901	6/C	D708	5/C	D017	9/C	R011	8/E
C700	2/E	C902	5/C	D709	7/B	D710	7/B	R012	8/D
C701	2/E	C903	9/E	D711	4/B	D711	4/B	R013	8/E
								R014	8/D
								R015	8/D
								R016	8/D
								R017	8/D
								R018	8/D
								R019	8/D
								R020	8/D
								R021	8/D
								R022	9/A
								R023	9/A
								R024	9/A
								R025	9/A
								R026	9/C
								R027	9/B
								R028	9/C
								R029	9/A
								R030	10/C
								R031	9/C
								R032	9/D
								R033	10/D
								R034	9/E
								R035	7/D
								R036	7/D
								R037	8/E

R038	8/D	R723	3/E	R783	6/B	R701	2/E	R030	10/C
R039	6/G	R724	3/D	R783	6/B	R702	2/E	R031	9/C
R040	9/E	R725	2/E	R784	5/B	R703	2/E	R032	9/D
R043	9/C	R726	2/U	R785	5/B	R704	2/D	R033	10/D
R045	9/B	R727	2/F	R786	3/B	R705	3/F	R034	9/E
R046	9/B	R728	2/D	R787	4/G	R706	3/D	R035	7/D
R047	9/C	R729	2/E	R788	4/G	R707	3/E	R036	7/D
R048	9/B	R730	2/D	R789	4/G	R708	3/D	R037	8/E
R073	9/G	R731	2/E	R791	1/E	R709	3/E		
R074	9/E	R732	2/D	R792	1/E	R710	2/F		
R081	10/C	R733	4/G	R799	9/C	R711	2/F		
R091	10/B	R734	4/G	R801	6/F				
R092	10/C	R735	4/G	R802	5/F				
R481	10/E	R739	7/B	R803	4/F				
R482	10/D	R740	4/B	R811	7/G				
R801	1/F	R741	7/B	R812	7/G				
R802	1/E	R742	4/B	R813	7/G				
R803	1/E	R743	7/C	R819	7/I				
R804	1/E	R744	4/B	R820	7/I				
H805	1/H	R745	7/C	R822	6/H				
R806	1/F	R746	4/B	R823	8/I				
R807	1/G	R747	7/B	R824	8/I				
R808	1/G	R748	4/B	R825	7/I				
R821	2/C	R749	7/B	R826	9/I				
R822	1/G	R750	4/B	R827	9/I				
R823	1/C	R751	7/B	R828	8/I				
R824	1/B	R752	4/B	R834	9/G				
R825	2/C	R753	7/B	R835	8/G				
R826	1/B	R754	4/B	R838	7/F				
R827	1/C	R755	6/B	R843	8/J				
R828	1/B	R756	5/B	R863	6/B				
R829	1/D	R759	6/C	R884	5/B				
R530	1/D	R760	5/C	R901	6/B				
R701	2/E	R761	6/A	R902	5/B				
R702	2/D	R762	5/A	R903	6/C				
R703	2/E	R763	6/B	R904	5/C				
R704	2/D	R764	5/B	R905	6/C				
R705	2/E	R765	8/C	R906	5/C				
R706	2/D	R766	3/C	R907	6/C				
R707	2/E	R767	8/C	R908	5/C				
R708	2/D	R768	3/C	R909	9/E				
R709	2/E	R769	7/B	R911	9/E				
R710	2/D	R770	4/B	R912	9/E				
R711	2/F	R771	8/B	R913	4/D				
R712	2/D	R772	3/B	R914	4/D				
R713	2/F	R773	7/B	R915	9/E				
R714	2/D	R774	4/B	R916	8/E				
R715	2/F	R775	7/D	R917	8/E				
R716	2/D	R776	4/D	R918	8/E				
R717	2/F	R777	8/C	R921	9/F				
R718	2/D	R778	4/D	R922	9/F				
R719	2/E	R779	7/C	R924	4/E				
R720	2/D	R780	4/C	R929	6/G				
R721	3/F	R781	7/C	R941	2/J				
R722	3/C	R782	4/C	R942	2/J				

R801	1/F	R741	7/B	R811	7/G	R952	4/D	R032	9/D
R802	1/E	R742	4/B	R812	7/G	R953	10/E	R033	10/D
R803	1/E	R743	7/C	R813	7/G	R956	10/E	R034	9/E
R804	1/E	R744	4/B	R819	7/I	R957	10/E	R035	7/D
H805	1/H	R745	7/C	R820	7/I	R961	10/J	R036	7/D
R806	1/F	R746	4/B	R822	6/H	R962	10/H	R037	8/E
R807	1/G	R747	7/B	R823	8/I	R963	10/I		
R808	1/G	R748	4/B	R824	8/I	R964	10/I		
R821	2/C	R749	7/B	R825	7/I	R9011	9/E		
R822	1/G	R750	4/B	R826	9/I	R9012	9/E		
R823	1/C	R751	7/B	R827	9/I	R9014	4/E		
R824	1/B	R752	4/B	R828	8/I	R902	1/H		
R825	2/C	R753	7/B	R834	9/G	R901	4/E		
R826	1/B	R754	4/B	R835	8/G	R902	1/H		
R827	1/C	R755	6/B	R843	8/J	S901	1/A		
R828	1/B	R756	5/B	R863	6/B	S911	10/G		
R829	1/D	R759	6/C	R884	5/B	SP	1/A		
R530	1/D	R760	5/C	R901	6/B	ST011	10/B		
R701	2/E	R761	6/A	R902	5/B	TP910	10/H		
R702	2/D	R762	5/A	R903	6/C	TP918	9/B		
R703	2/E	R763	6/B	R904	5/C	TP916	10/B		
R704	2/D	R764	5/B	R905	6/C	TP731	6/B		
R705	2/E	R765	8/C	R906	5/C	TP732	5/B		
R706	2/D	R766	3/C	R907	6/C	TP733	8/B		
R707	2/E	R767	8/C	R908	5/C	TP734	3/B		
R708	2/D	R768	3/C	R909	9/E	TP751	6/C		
R709	2/E	R769	7/B	R911	9/E				
R710	2/D	R770	4/B	R912	9/E				
R711	2/F	R771	8/B	R913	4/D				
R712	2/D	R772	3/B	R914	4/D				
R713	2/F	R773	7/B	R915	9/E				
R714	2/D	R774	4/B	R916	8/E				
R715	2/F	R775	7/D	R917	8/E				
R716	2/D	R776	4/D	R918	8/E				
R717	2/F	R777	8/C	R921	9/F				
R718	2/D	R778	4/D	R922	9/F				
R719	2/E	R779	7/C	R924	4/E				
R720	2/D	R780	4/C	R929	6/G				
R721	3/F	R781	7/C	R941	2/J				
R722	3/C	R782	4/C	R942	2/J				

Location List ( ENH-283 )

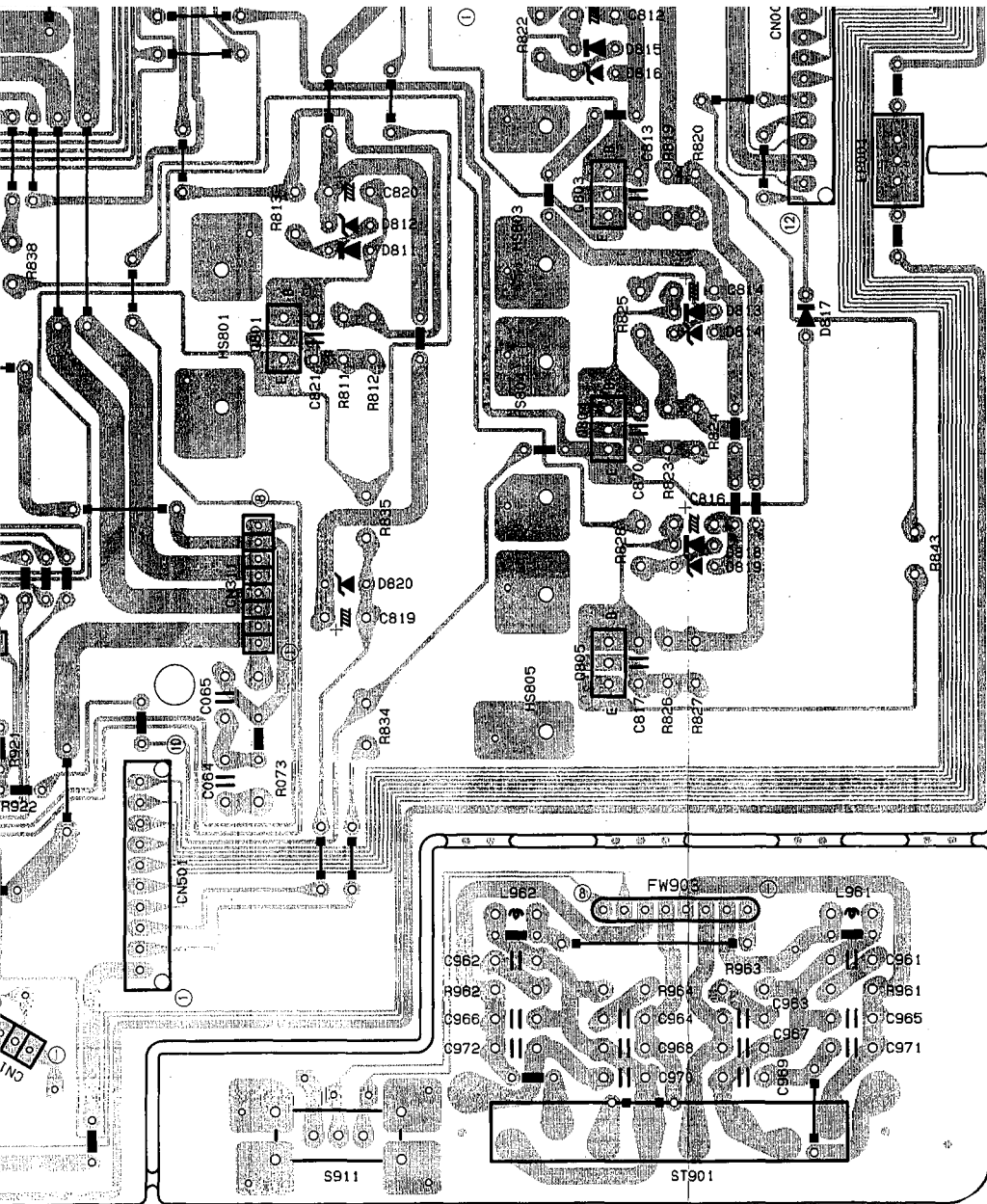

Symbol	X	Y	Symbol	X	Y	Symbol	X	Y	Symbol	X	Y	Symbol	X	Y
G010	7E	7E	G702	2D	2D	G904	9E	9E	D015	9D	9D	G712	2C	2C
G011	7E	7E	G703	2E	2E	G905	8E	8E	D016	9D	9D	G717	7B	7B
G012	8D	8D	G704	2D	2D	G906	8E	8E	D017	7D	7D	G718	4B	4B
G013	8E	8E	G705	2F	2F	G906	9E	9E	D018	8I	8I	G719	7B	7B
G014	8D	8D	G706	2D	2D	G909	9E	9E	D019	8I	8I	G720	4B	4B
G015	8D	8D	G707	2E	2E	G961	10J	10J	D020	8I	8I	G721	6A	6A
G016	7D	7D	G708	2F	2F	G962	10H	10H	D021	7C	7C	G722	5A	5A
G017	8D	8D	G709	2F	2F	G963	10I	10I	D022	4C	4C	G723	7B	7B
G018	8D	8D	G710	2C	2C	G964	10I	10I	D023	4E	4E	G724	4B	4B
G019	8D	8D	G711	2E	2E	G965	10J	10J	D024	2J	2J	G725	4B	4B
G020	9C	9C	G712	2D	2D	G966	10H	10H	D025	2J	2J	G726	8B	8B
G021	8D	8D	G713	3E	3E	G967	10I	10I	D026	8I	8I	G727	8B	8B
G022	9C	9C	G714	3D	3D	G968	10I	10I	D027	8I	8I	G728	8B	8B
G023	9C	9C	G715	3E	3E	G969	10J	10J	D028	8I	8I	G729	8B	8B
G024	10D	10D	G716	3E	3E	G970	10J	10J	D029	8I	8I	G730	8B	8B
G025	9D	9D	G717	2E	2E	G971	10J	10J	D030	8I	8I	G731	8B	8B
G026	9C	9C	G718	2D	2D	G972	10H	10H	D031	8I	8I	G732	8B	8B
G027	9B	9B	G719	6C	6C	G973	2J	2J	D032	8I	8I	G733	8B	8B
G028	8B	8B	G720	5C	5C	G974	2J	2J	D033	7I	7I	G734	8B	8B
G029	8E	8E	G721	3G	3G	G975	2J	2J	D034	7I	7I	G735	4G	4G
G030	9G	9G	G722	3G	3G	G976	10I	10I	D035	7I	7I	G736	4G	4G
G031	9G	9G	G723	3G	3G	G977	10I	10I	D036	7I	7I	G737	4G	4G
G032	8E	8E	G724	4G	4G	G978	10I	10I	D037	7I	7I	G738	4G	4G
G033	9G	9G	G725	3E	3E	G979	10I	10I	D038	7I	7I	G739	4G	4G
G034	9G	9G	G726	4C	4C	G980	10I	10I	D039	7I	7I	G740	4B	4B
G035	9D	9D	G727	7C	7C	G981	10E	10E	D040	8D	8D	G741	4G	4G
G036	9C	9C	G728	3C	3C	G982	3H	3H	D041	10E	10E	G742	4G	4G
G037	10B	10B	G729	8C	8C	G983	3H	3H	D042	10C	10C	G743	4G	4G
G038	10B	10B	G730	4D	4D	G984	8H	8H	D043	9G	9G	G744	4B	4B
G039	10B	10B	G731	9C	9C	G985	8H	8H	D044	9D	9D	G745	4B	4B
G040	10B	10B	G732	4D	4D	G986	8H	8H	D045	9D	9D	G746	4B	4B
G041	10C	10C	G733	6B	6B	G987	8H	8H	D046	9D	9D	G747	4B	4B
G042	10C	10C	G734	5B	5B	G988	8H	8H	D047	9D	9D	G748	4B	4B
G043	10E	10E	G735	8B	8B	G989	8H	8H	D048	9D	9D	G749	4B	4B
G044	10E	10E	G736	8B	8B	G990	8H	8H	D049	9D	9D	G750	4B	4B
G045	10B	10B	G737	6B	6B	G991	8H	8H	D050	9D	9D	G751	4B	4B
G046	10B	10B	G738	4B	4B	G992	8H	8H	D051	9D	9D	G752	3B	3B
G047	10C	10C	G739	8B	8B	G993	8H	8H	D052	9D	9D	G753	3B	3B
G048	10E	10E	G740	4B	4B	G994	8H	8H	D053	9D	9D	G754	3B	3B
G049	10E	10E	G741	4G	4G	G995	8H	8H	D054	9D	9D	G755	4G	4G
G050	1F	1F	G742	4B	4B	G996	8H	8H	D055	9D	9D	G756	4G	4G
G051	1F	1F	G743	6B	6B	G997	8H	8H	D056	9D	9D	G757	4G	4G
G052	1F	1F	G744	4B	4B	G998	8H	8H	D057	9D	9D	G758	4G	4G
G053	1F	1F	G745	8B	8B	G999	8H	8H	D058	9D	9D	G759	4G	4G
G054	1E	1E	G746	4B	4B	G1000	8H	8H	D059	9D	9D	G760	4G	4G
G055	1F	1F	G747	4G	4G	G1001	8H	8H	D060	9D	9D	G761	4G	4G
G056	1E	1E	G748	4B	4B	G1002	8H	8H	D061	9D	9D	G762	4G	4G
G057	1H	1H	G749	8C	8C	G1003	8H	8H	D062	9D	9D	G763	4G	4G
G058	1F	1F	G750	8C	8C	G1004	8H	8H	D063	9D	9D	G764	4G	4G
G059	1H	1H	G751	8C	8C	G1005	8H	8H	D064	9D	9D	G765	4G	4G
G060	1F	1F	G752	3C	3C	G1006	8H	8H	D065	9D	9D	G766	4G	4G
G061	1F	1F	G753	3C	3C	G1007	8H	8H	D066	9D	9D	G767	4G	4G
G062	1F	1F	G754	8B	8B	G1008	8H	8H	D067	9D	9D	G768	4G	4G
G063	1F	1F	G755	8B	8B	G1009	8H	8H	D068	9D	9D	G769	4G	4G
G064	1F	1F	G756	8B	8B	G1010	8H	8H	D069	9D	9D	G770	4G	4G
G065	1F	1F	G757	8B	8B	G1011	8H	8H	D070	9D	9D	G771	4G	4G
G066	1F	1F	G758	8B	8B	G1012	8H	8H	D071	9D	9D	G772	4G	4G
G067	1F	1F	G759	8B	8B	G1013	8H	8H	D072	9D	9D	G773	4G	4G
G068	1F	1F	G760	4B	4B	G1014	8H	8H	D073	9D	9D	G774	4G	4G
G069	1F	1F	G761	4G	4G	G1015	8H	8H	D074	9D	9D	G775	4G	4G
G070	1G	1G	G762	7I	7I	G1016	8H	8H	D075	9D	9D	G776	4G	4G
G700	2E	2E	G902	5C	5C	G1017	8H	8H	D076	9D	9D	G777	4G	4G
						G1018	8H	8H	D077	9D	9D	G778	4G	4G
						G1019	8H	8H	D078	9D	9D	G779	4G	4G
						G1020	8H	8H	D079	9D	9D	G780	4G	4G





P1-47-a

P1-47-b

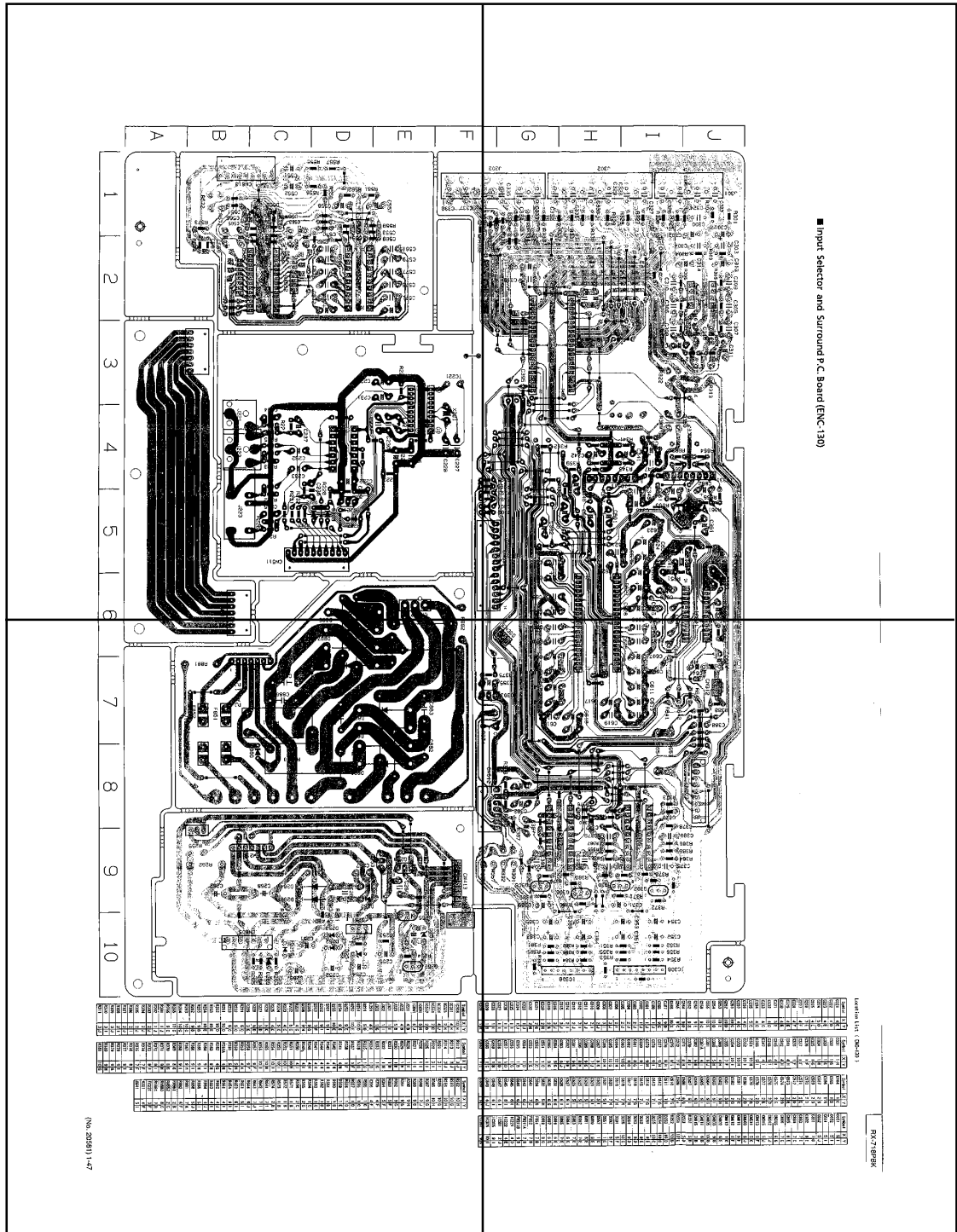

P1-47-c

P1-47-d

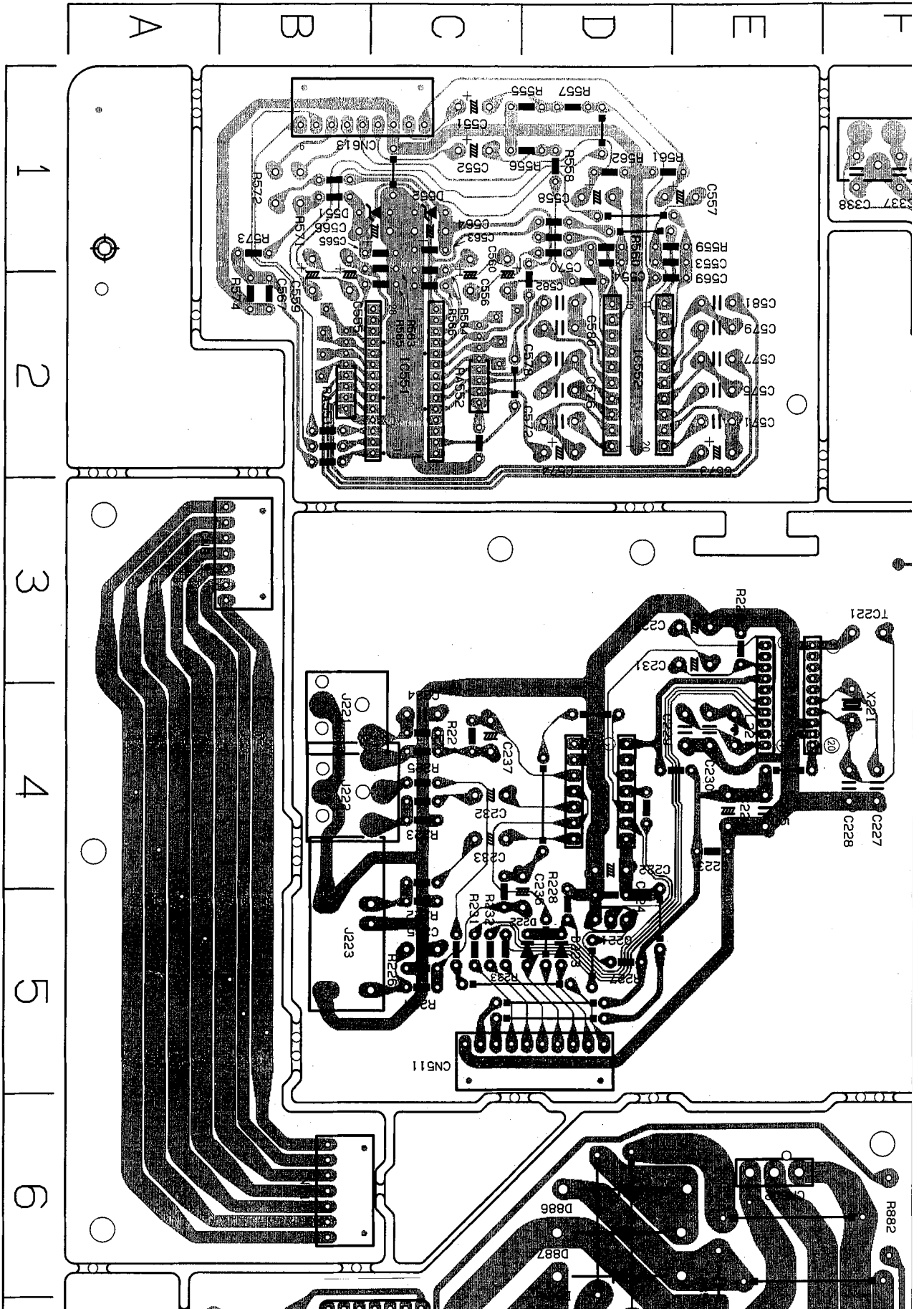

Input Selector and Surround P.C. Board (ENC-130)

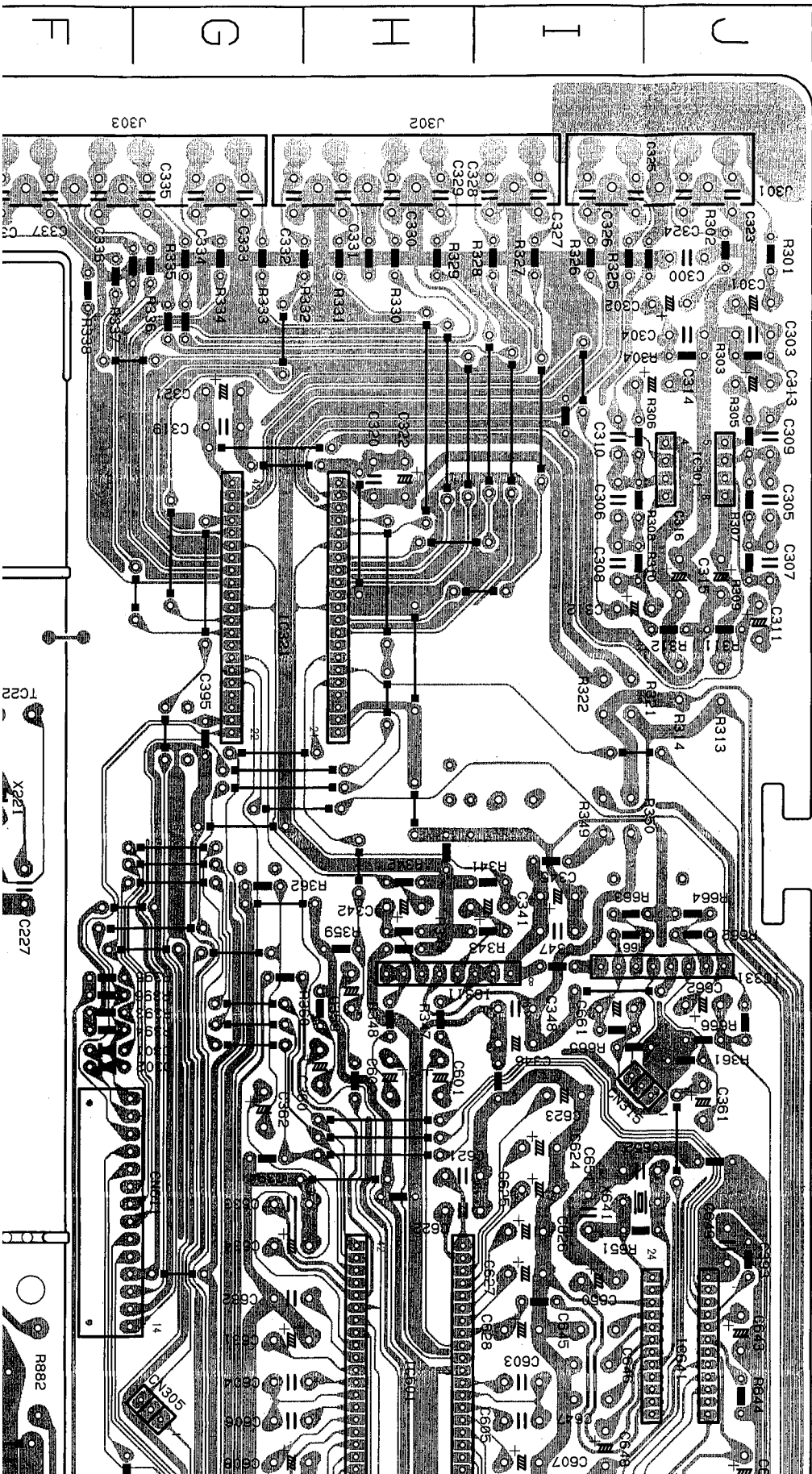

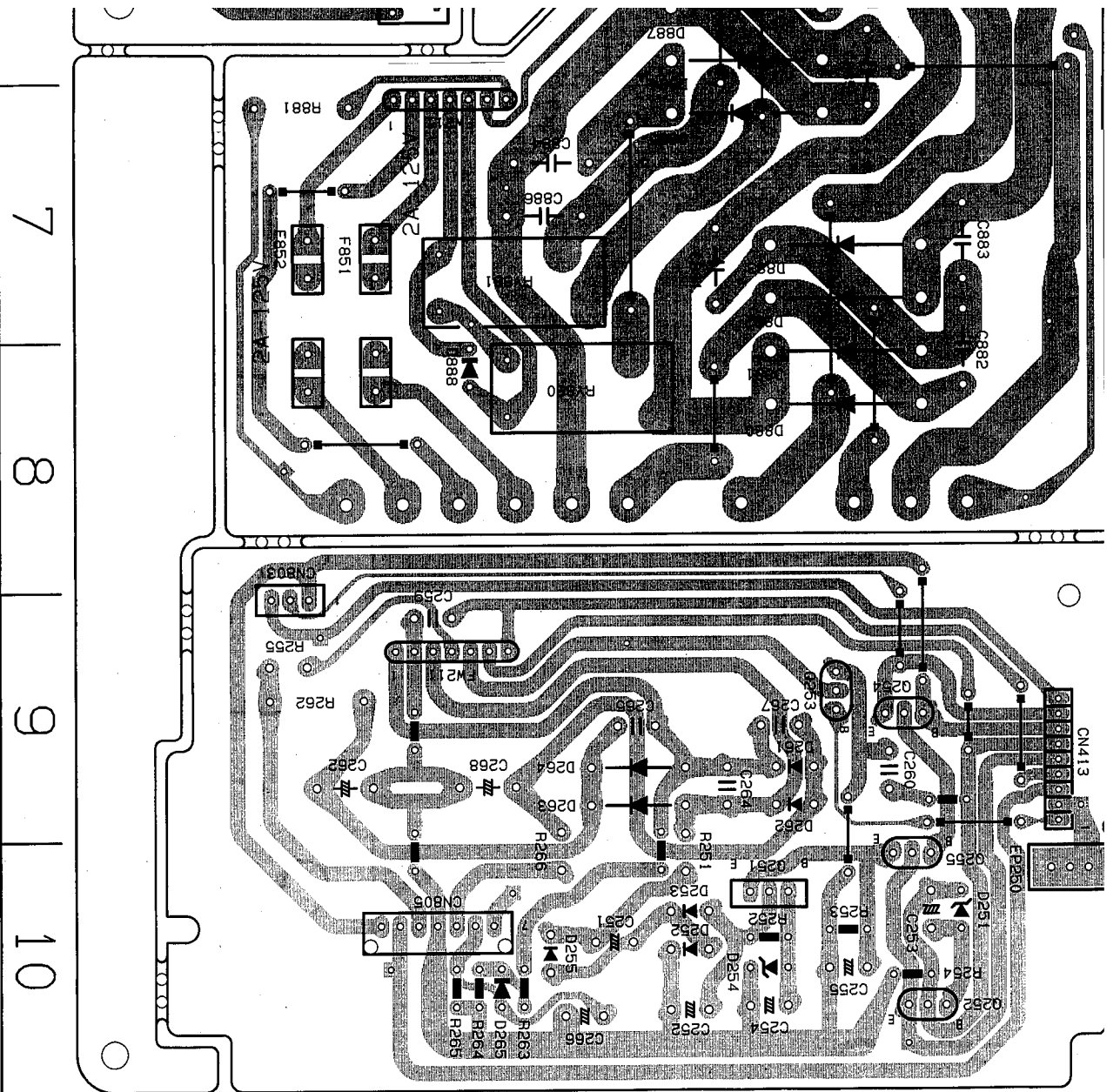

Symbol	X	Y	Symbol	X	Y	Symbol	X	Y
IC308	10H	10H	R312	3J	3J	R382	10H	10H
IC311	4H	4H	R313	3J	3J	R383	10G	10G
IC321	2H	2H	R314	3U	3U	R384	10H	10H
IC331	4J	4J	R321	3I	3I	R385	10G	10G
IC551	2C	2C	R322	3I	3I	R386	10H	10H
IC652	2D	2D	R325	1I	1I	R387	9G	9G
IC681	6H	6H	R326	1I	1I	R388	7J	7J
IC641	6J	6J	R327	1I	1I	R389	9G	9G
J222	4B	4B	R328	1I	1I	R390	9H	9H
J223	5B	5B	R329	1H	1H	R391	9G	9G
J302	1I	1I	R330	1H	1H	R392	9G	9G
J303	1G	1G	R331	1H	1H	R393	5F	5F
J221	4E	4E	R332	1H	1H	R394	5F	5F
Q251	5D	5D	R333	1G	1G	R395	4F	4F
Q251	10D	10D	R336	1G	1G	R396	1C	1C
Q252	10E	10E	R337	1F	1F	R395	1C	1C
Q253	9E	9E	R338	1F	1F	R358	1D	1D
Q254	9E	9E	R341	4H	4H	R559	1E	1E
Q255	10E	10E	R342	4H	4H	R560	1D	1D
Q301	9I	9I	R343	4H	4H	R561	1D	1D
Q302	9I	9I	R344	4H	4H	R562	1D	1D
Q303	7F	7F	R347	4H	4H	R563	1C	1C
Q305	9G	9G	R348	4H	4H	R564	1C	1C
Q306	9H	9H	R349	4I	4I	R565	2C	2C
R221	4C	4C	R350	4I	4I	R566	2C	2C
R222	5C	5C	R351	10H	10H	R571	1B	1B
R223	4C	4C	R352	10I	10I	R572	1B	1B
R224	5C	5C	R353	10I	10I	R73	1B	1B
R225	4C	4C	R354	10I	10I	R574	2B	2B
R226	5C	5C	R355	10H	10H	R641	7I	7I
R227	5D	5D	R356	10I	10I	R642	7I	7I
R228	5D	5D	R357	9F	9F	R643	7J	7J
R229	3E	3E	R358	9F	9F	R644	6J	6J
R231	5C	5C	R359	4H	4H	R651	5I	5I
R232	5C	5C	R360	5H	5H	R652	8I	8I
R233	5C	5C	R361	5J	5J	R654	8I	8I
R251	10D	10D	R361A	4H	4H	R661	4I	4I
R252	10D	10D	R362	4G	4G	R662	4J	4J
R253	10E	10E	R363	9H	9H	R663	4I	4I
R254	10E	10E	R364	9I	9I	R664	4J	4J
R255	9B	9B	R365	9H	9H	R665	5I	5I
R256	9B	9B	R366	9I	9I	R666	5J	5J
R263	10C	10C	R367	9H	9H	R681	7A	7A
R264	10C	10C	R368	9I	9I	R682	6F	6F
R265	10C	10C	R369	8G	8G	RA551	2B	2B
R266	9C	9C	R370	8G	8G	RA552	2C	2C
R301	1J	1J	R371	9H	9H	R7880	8C	8C
R302	1J	1J	R372	9I	9I	RV881	7B	7B
R303	2J	2J	R373	8I	8I	TC221	3F	3F
R304	2J	2J	R374	7F	7F	V221	4F	4F
R305	2J	2J	R375	7F	7F	V641	5I	5I
R306	2I	2I	R376	8H	8H			
R307	2J	2J	R377	9I	9I			
R308	2I	2I	R378	9I	9I			
R309	3J	3J	R379	9G	9G		</	

Location List (EMC-130)

Symbol	X	Y	Symbol	X	Y	Symbol	X	Y	Symbol	X	Y
G221	4E	1H	C331	1H	1C	G564	5I	1I	G651	5I	1I
G222	4D	1G	C332	1G	1B	G565	1B	1B	G652	5I	1I
G223	4E	1G	C333	1G	1B	G566	1B	1B	G651	5I	1I
G224	5D	1G	C334	1G	2B	G567	2B	2B	G652	5J	1J
G225	4E	1G	C335	1G	1G	G568	1G	1G	G681	7D	1D
G226	3E	1F	C336	1F	2D	G570	2D	2D	G682	8E	1E
G227	4F	1F	C337	1F	2E	G571	2E	2E	G683	7E	1E
G228	4F	1F	C338	1F	2D	G572	2D	2D	G684	7C	1C
G229	4E	1F	C341	4H	2E	G573	2E	2E	G685	6E	1E
G230	4E	1F	C342	4H	2D	G574	2D	2D	G686	7C	1C
G231	3E	1F	C345	4I	2E	G575	2E	2E	G6803	6E	1E
G232	4C	1F	C346	5I	2D	G576	2D	2D	G612	8F	1F
G233	4C	1F	C347	4I	2E	G577	2E	2E	G613	1C	1C
G234	4C	1F	C348	5I	2D	G578	2D	2D	G612	8F	1F
G235	5C	1C	C351	10H	2E	G579	2E	2E	G611	5F	1F
G236	4D	1C	C352	10I	2D	G580	2D	2D	G612	8F	1F
G251	10C	4C	C353	10H	2E	G581	2E	2E	G613	1C	1C
G252	10D	4C	C355	7F	5H	G601	5H	5H	G612	8F	1F
G253	10E	4H	C359	4H	5H	G602	5H	5H	G613	1C	1C
G254	10D	5H	C361	5J	6I	G603	6I	6I	G613	1C	1C
G255	10E	5J	C361A	4I	6I	G604	6I	6I	G613	1C	1C
G259	9C	4I	C362	5I	6I	G605	6I	6I	G613	1C	1C
G260	9E	5I	C372	7F	6I	G606	6I	6I	G613	1C	1C
G262	9B	8I	C370	8I	6I	G607	6I	6I	G613	1C	1C
G264	9D	8I	C371	9H	6I	G608	6I	6I	G613	1C	1C
G265	9C	9I	C372	7F	6I	G609	6I	6I	G613	1C	1C
G266	10C	9I	C375	9I	7I	G610	7I	7I	G613	1C	1C
G267	9D	9I	C376	9H	7I	G611	7I	7I	G613	1C	1C
G268	9C	9H	C377	9H	7I	G612	7I	7I	G613	1C	1C
G269	1J	9I	C378	9I	7I	G613	7I	7I	G613	1C	1C
G270	1J	9H	C379	9H	7I	G614	7I	7I	G613	1C	1C
G271	1J	9I	C380	9I	7I	G615	7I	7I	G613	1C	1C
G272	2J	8I	C381	8I	7I	G616	7I	7I	G613	1C	1C
G273	2J	8I	C382	8I	7H	G617	7H	7H	G613	1C	1C
G274	2J	8I	C383	10G	7H	G618	7H	7H	G613	1C	1C
G275	2J	8I	C384	10H	7H	G619	7H	7H	G613	1C	1C
G276	3J	8I	C385	10G	7H	G620	7H	7H	G613	1C	1C
G277	3J	8I	C386	10H	7H	G621	7H	7H	G613	1C	1C
G278	3J	8I	C387	8I	6I	G622	6I	6I	G613	1C	1C
G279	2J	8I	C388	7J	6I	G623	6I	6I	G613	1C	1C
G280	2J	8I	C389	8I	6I	G624	6I	6I	G613	1C	1C
G281	3J	8I	C390	8H	6I	G625	6I	6I	G613	1C	1C
G282	3J	8I	C391	9I	6I	G626	6I	6I	G613	1C	1C
G283	3J	8I	C392	9H	6I	G627	6I	6I	G613	1C	1C
G284	3J	8I	C393	6J	6I	G628	6I	6I	G613	1C	1C
G285	3J	8I	C394	5I	6I	G629	6I	6I	G613	1C	1C
G286	2I	6I	C395	3I	6I	G630	6I	6I	G613	1C	1C
G287	2I	6I	C396	2I	6I	G631	6I	6I	G613	1C	1C
G288	2I	6I	C397	2I	6I	G632	6I	6I	G613	1C	1C
G289	2I	6I	C398	2I	6I	G633	6I	6I	G613	1C	1C
G290	2I	6I	C399	2I	6I	G634	6I	6I	G613	1C	1C
G291	2I	6I	C400	2I	6I	G635	6I	6I	G613	1C	1C
G292	2I	6I	C401	2I	6I	G636	6I	6I	G613	1C	1C
G293	2I	6I	C402	2I	6I	G637	6I	6I	G613	1C	1C
G294	2I	6I	C403	2I	6I	G638	6I	6I	G613	1C	1C
G295	2I	6I	C404	2I	6I	G639	6I	6I	G613	1C	1C
G296	2I	6I	C405	2I	6I	G640	6I	6I	G613	1C	1C
G297	2I	6I	C406	2I	6I	G641	6I	6I	G613	1C	1C
G298	2I	6I	C407	2I	6I	G642	6I	6I	G613	1C	1C
G299	2I	6I	C408	2I	6I	G643	6I	6I	G613	1C	1C
G300	2I	6I	C409	2I	6I	G644	6I	6I	G613	1C	1C
G301	2I	6I	C410	2I	6I	G645	6I	6I	G613	1C	1C
G302	2I	6I	C411	2I	6I	G646	6I	6I	G613	1C	1C
G303	2I	6I	C412	2I	6I	G647	6I	6I	G613	1C	1C
G304	2I	6I	C413	2I	6I	G648	6I	6I	G613	1C	1C
G305	2I	6I	C414	2I	6I	G649	6I	6I	G613	1C	1C
G306	2I	6I	C415	2I	6I	G650	6I	6I	G613	1C	1C
G307	2I	6I	C416	2I	6I	G651	6I	6I	G613	1C	1C
G308	2I	6I	C417	2I	6I	G652	6I	6I	G613	1C	1C
G309	2I	6I	C418	2I	6I	G653	6I	6I	G613	1C	1C
G310	2I	6I	C419	2I	6I	G654	6I	6I	G613	1C	1C
G311	2I	6I	C420	2I	6I	G655	6I	6I	G613	1C	1C
G312	2I	6I	C421	2I	6I	G656	6I	6I	G613	1C	1C
G313	2I	6I	C422	2I	6I	G657	6I	6I	G613	1C	1C
G314	2I	6I	C423	2I	6I	G658	6I	6I	G613	1C	1C
G315	2I	6I	C424	2I	6I	G659	6I	6I	G613	1C	1C
G316	2I	6I	C425	2I	6I	G660	6I	6I	G613	1C	1C
G317	2I	6I	C426	2I	6I	G661	6I	6I	G613	1C	1C
G318	2I	6I	C427	2I	6I	G662	6I	6I	G613	1C	1C
G319	2I	6I	C428	2I	6I	G663	6I	6I	G613	1C	1C
G320	2I	6I	C429	2I	6I	G664	6I	6I	G613	1C	1C
G321	2I	6I	C430	2I	6I	G665	6I	6I	G613	1C	1C
G322	2I	6I	C431	2I	6I	G666	6I	6I	G613	1C	1C
G323	2I	6I	C432	2I	6I	G667	6I	6I	G613	1C	1C
G324	2I	6I	C433	2I	6I	G668	6I	6I	G613	1C	1C
G325	2I	6I	C434	2I	6I	G669	6I	6I	G613	1C	1C
G326	2I	6I	C435	2I	6I	G670	6I	6I	G613	1C	1C
G327	2I	6I	C436	2I	6I	G671	6I	6I	G613	1C	1C
G328	2I	6I	C437	2I	6I	G672	6I	6I	G613	1C	1C
G329	2I	6I	C438	2I	6I	G673	6I	6I	G613	1C	1C
G330	2I	6I	C439	2I	6I	G674	6I	6I	G613	1C	1C

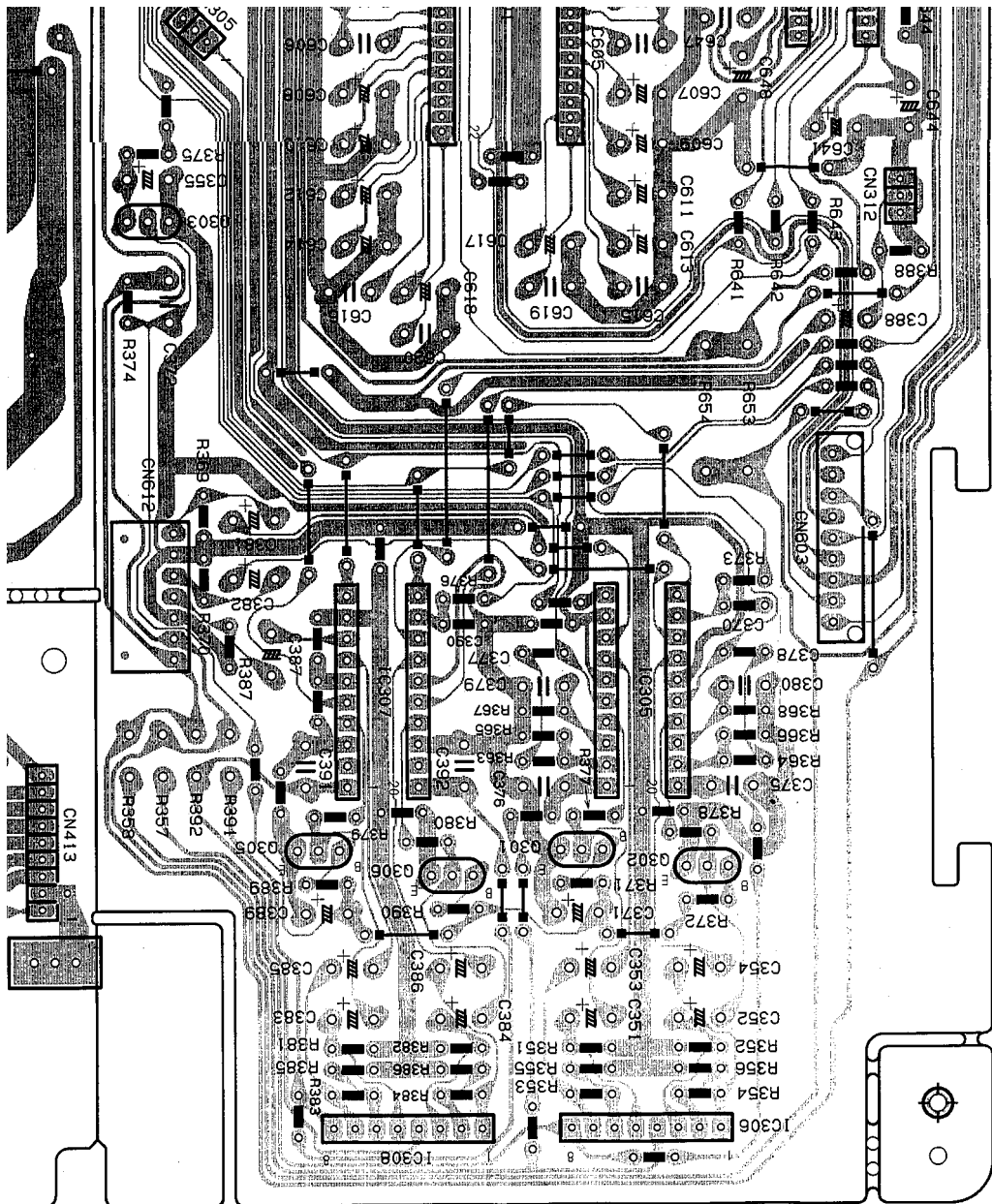



P1-48-a

P1-48-b

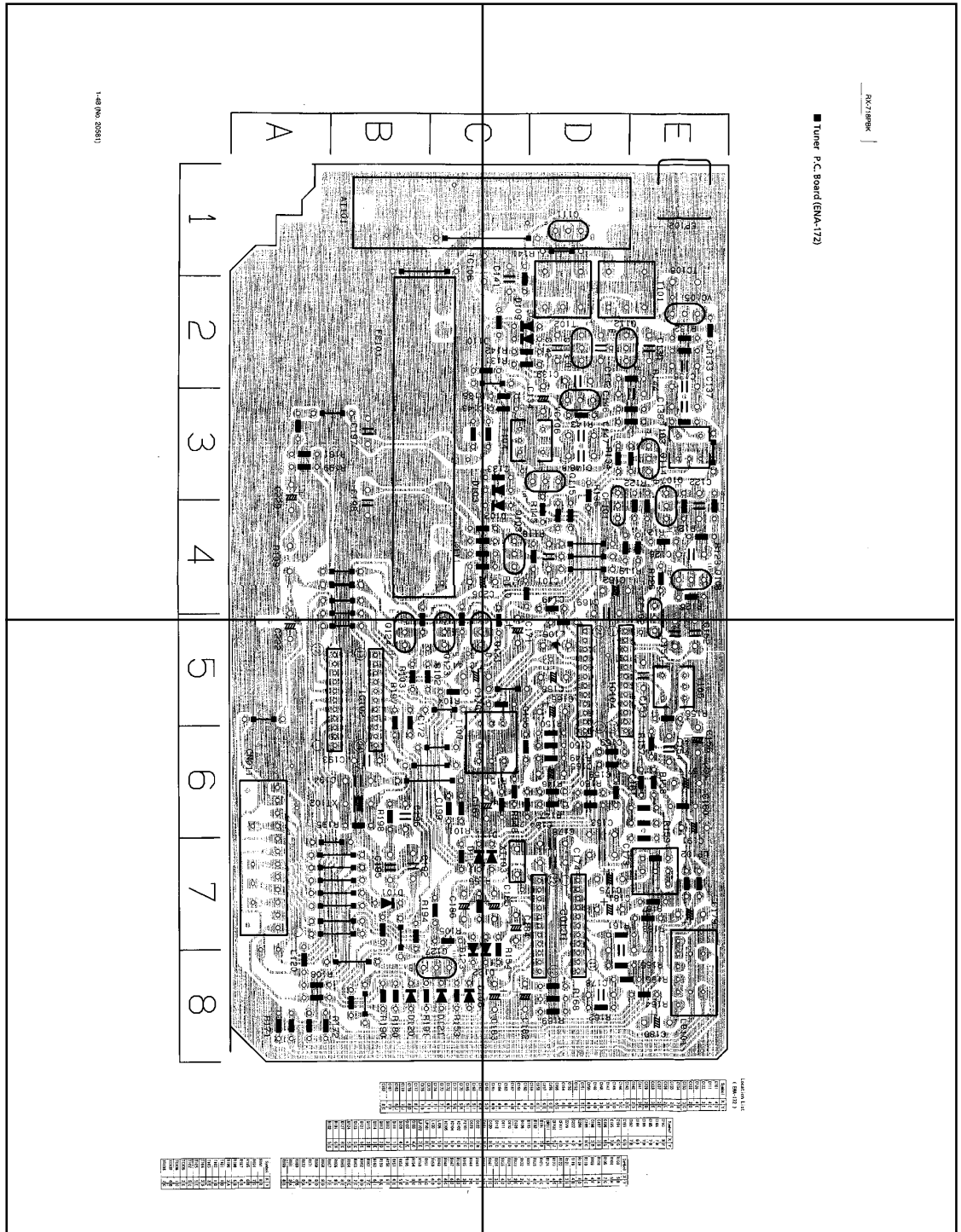

P1-48-c

P1-48-d

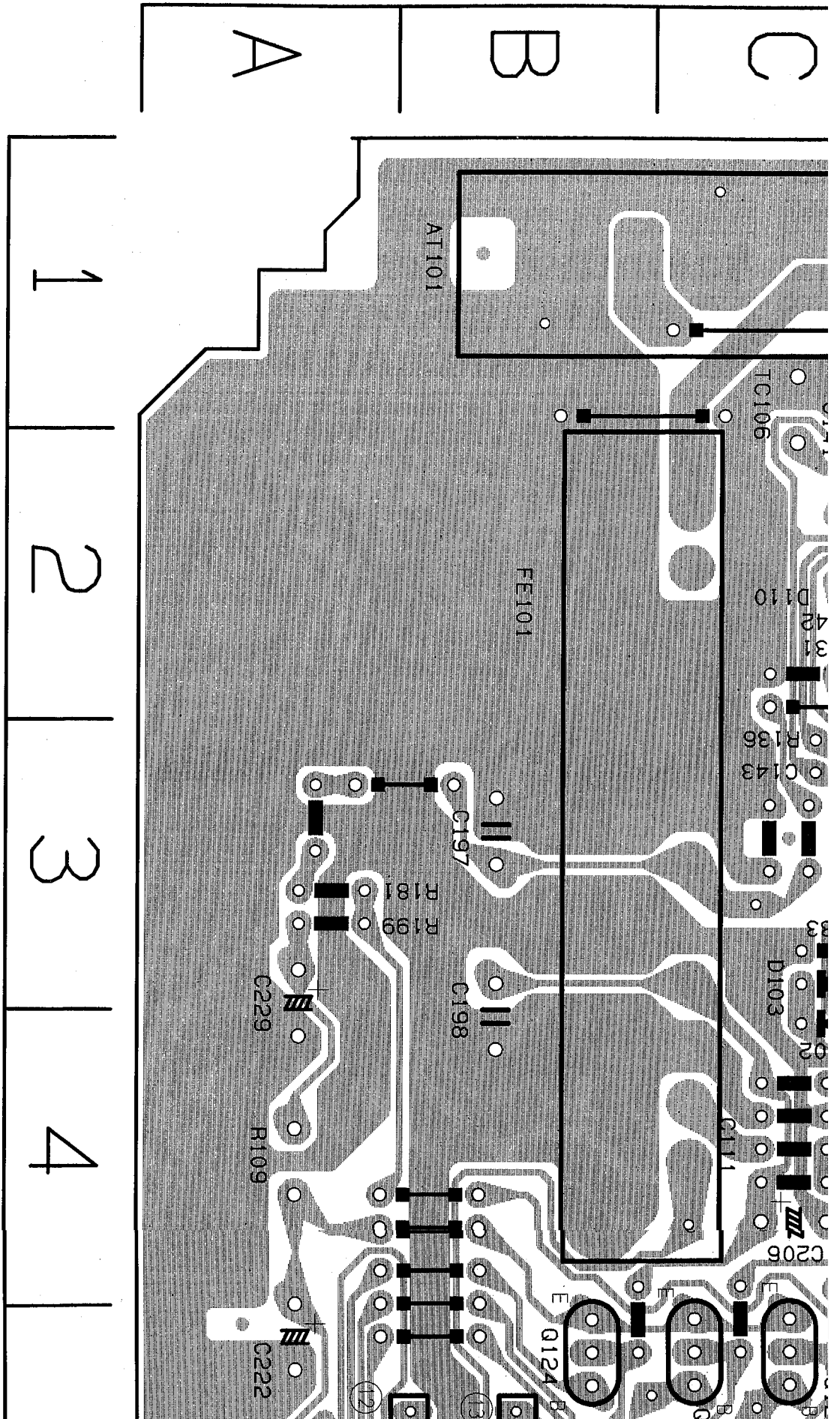



■ Tuner P.C. Board (ENA-172)

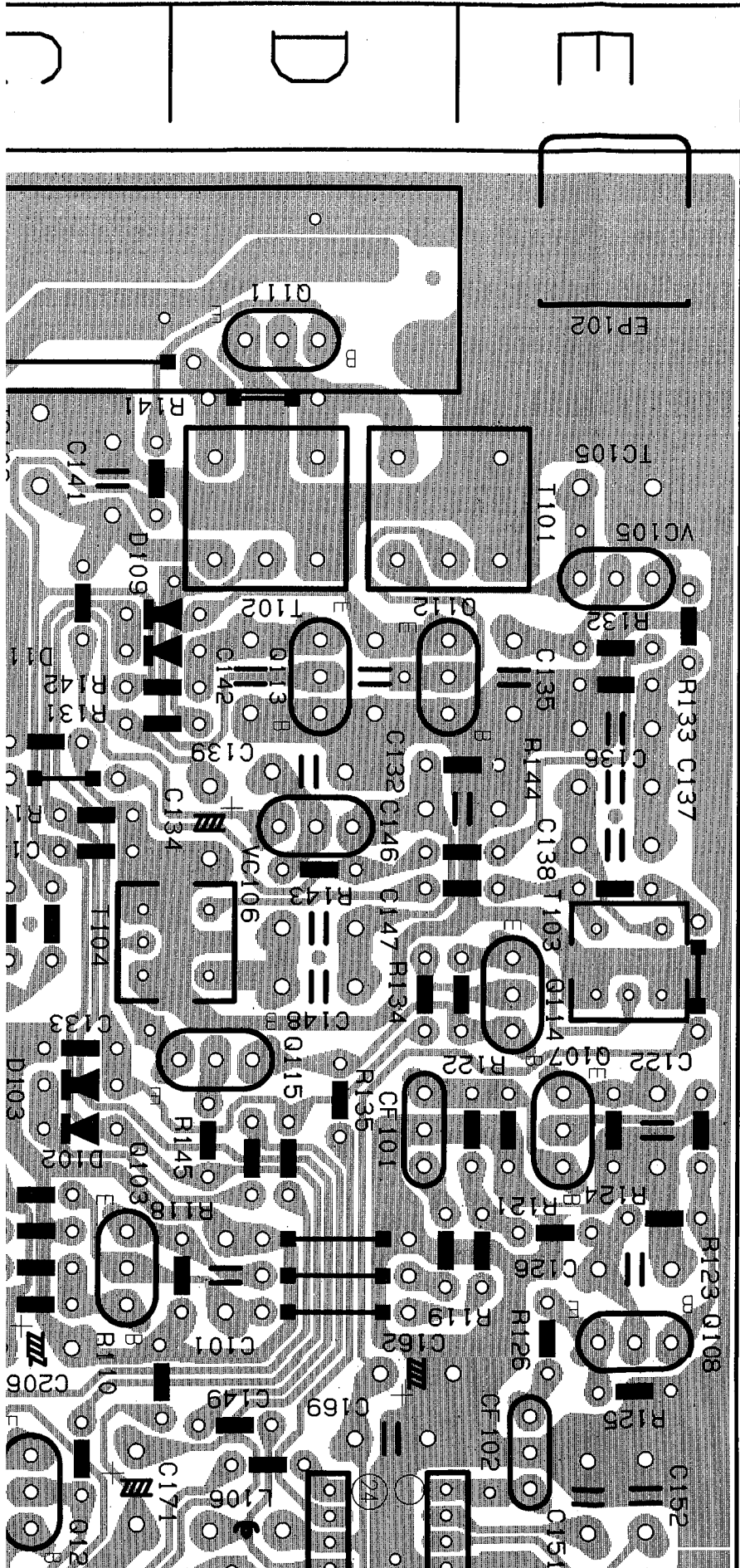

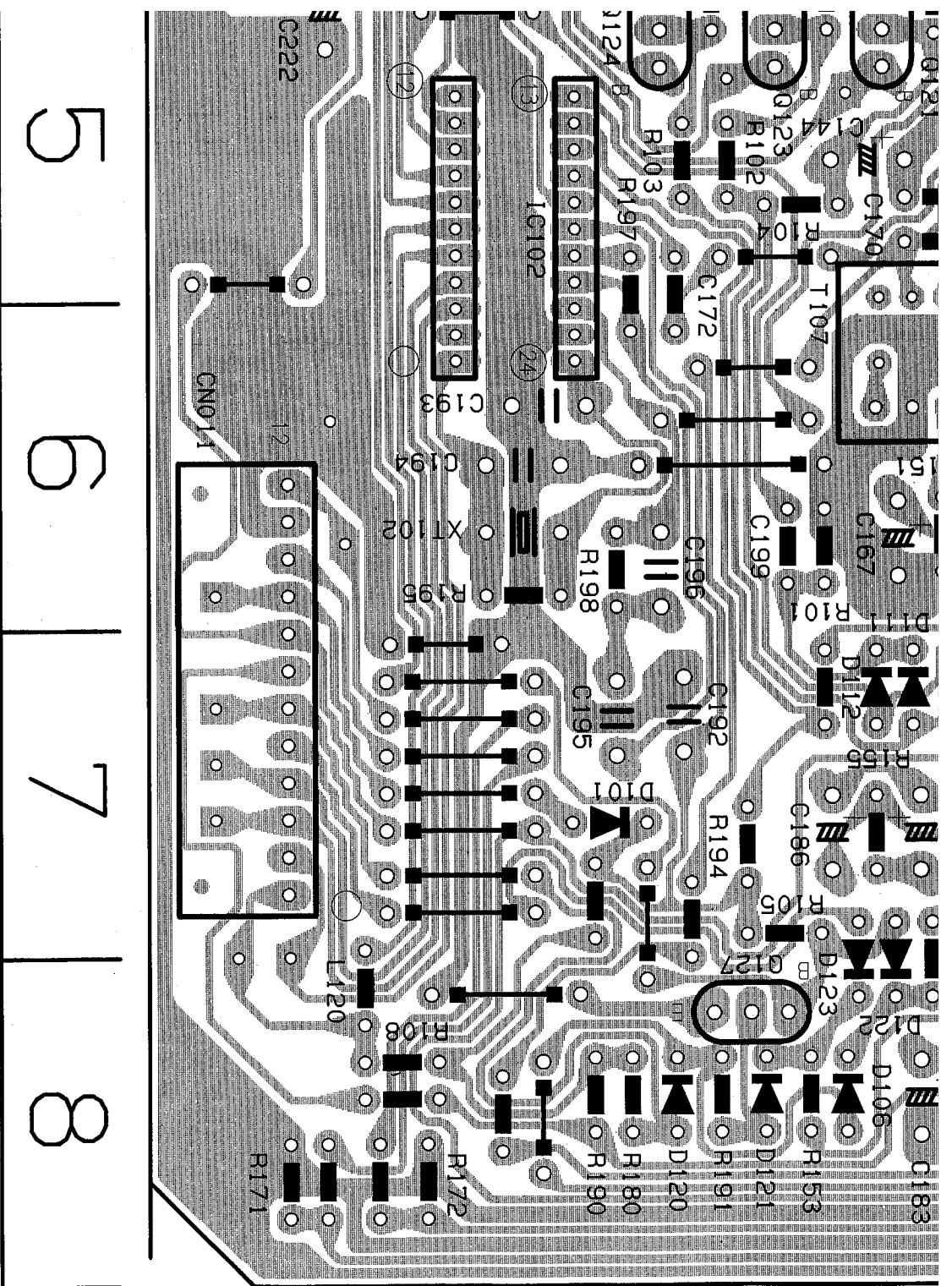

U104	9H
G185	6D
G186	5D
G167	6H
G168	5I
G169	5I
G170	5H
G171	5C
G172	6G
G173	7I
G174	7I
G175	7I
G176	7D
G177	8J
G178	8D
G180	8J
G181	7I
G182	8C

D112	7C
D120	8G
D121	8C
D122	7H
D123	7C
FE101	2C
FE102	6B
IC104	5D
IC105	7D
L106	5D
L120	8A
LP101	8E
LP102	7E
Q103	4C
Q107	4E
Q108	4J
Q111	1D
Q112	2I
Q113	2D
Q114	3E
Q115	3D
Q121	5C
Q123	5C
Q124	5B
Q127	8C
R101	6H
R102	5G
R136	3C
R141	2C
R142	2D
R143	3D
R144	2E
R145	3D
R146	6D
R147	6D
R148	6C
R149	6D
R150	6D
R151	6C
R153	8C
R154	8C
R155	7C
R156	5E
R157	6E
R158	6E
R159	6E
R160	6I
R161	7E
R162	8D
R163	7E
R164	8E
R165	8E
R166	8E
R167	7E
R168	8D
R169	8D
R171	8A
R172	8A
R180	8B
R181	3A
R190	8B

Symbol	X	Y
R191	8B	7C
R194	7C	6B
R195	6B	6B
R197	6B	6B
R198	6B	6B
R199	3A	3A
T101	1D	1D
T102	1D	1D
T103	3E	3E
T104	3D	3D
T105	5E	5E
T107	5C	5C
TC105	2E	2E
TC106	1C	1C
XT102	6B	7C
XT103	7C	7C

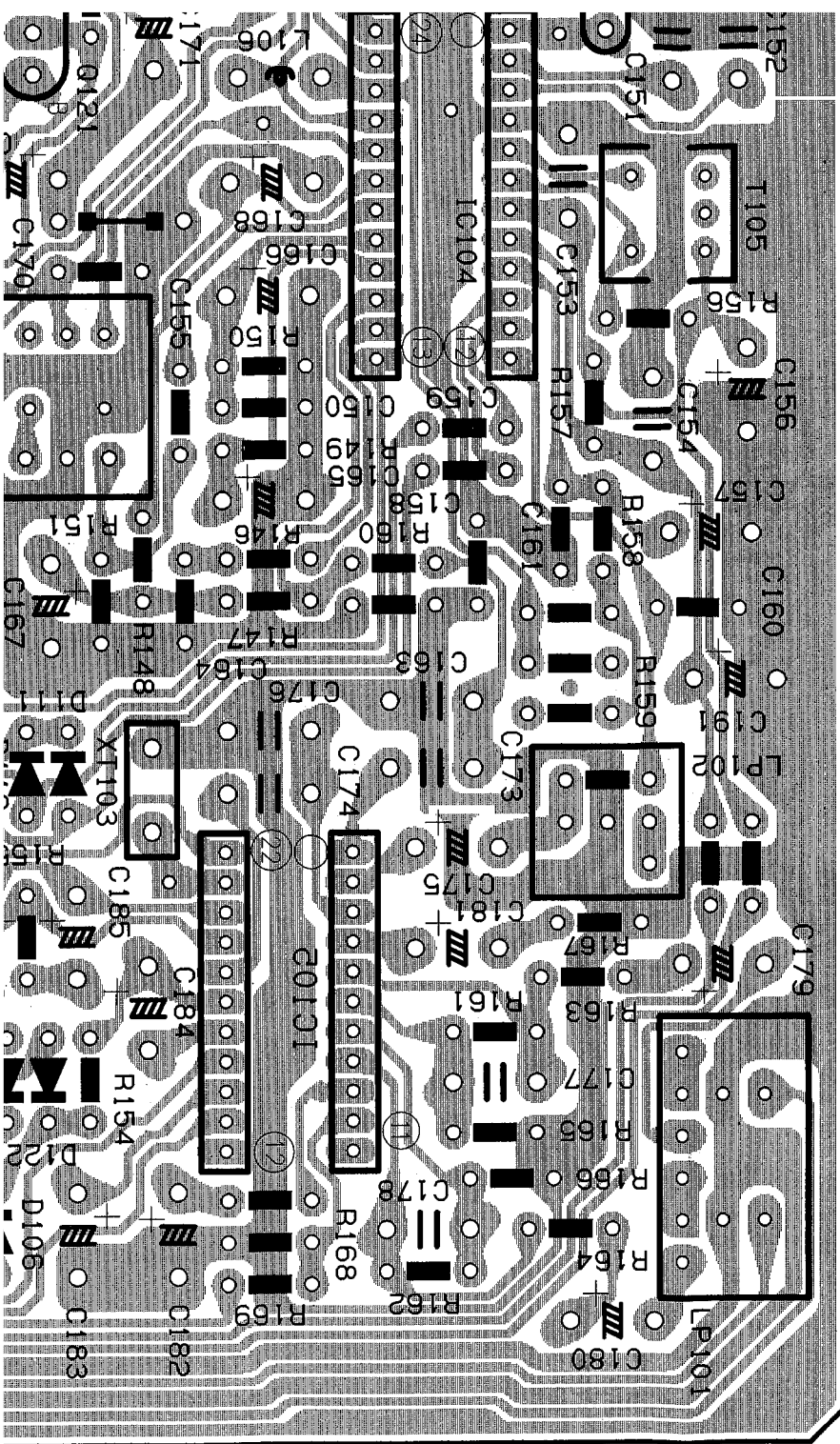

Location List  
( ENA-172 )

Symbol	X	Y	Symbol	X	Y	Symbol	X	Y
C101	4	D	C183	8	H	R103	5	B
C111	4	C	C184	7	H	R104	5	H
C122	3	E	C185	7	H	R105	7	C
C126	4	E	C186	7	H	R108	8	A
C132	2	D	C187	7	H	R109	4	F
C133	3	C	C188	7	H	R110	4	C
C134	2	D	C189	7	B	R118	4	D
C135	2	E	C190	6	E	R119	4	D
C136	2	E	C191	6	E	R121	3	E
C137	2	E	C192	7	B	R122	4	E
C138	3	E	C193	6	G	R123	4	E
C139	2	D	C194	6	G	R124	3	E
C141	2	C	C195	7	B	R125	4	E
C142	2	D	C196	6	G	R126	4	E
C143	3	C	C197	3	G	R128	2	E
C144	5	C	C198	3	B	R131	2	D
C146	3	D	C199	6	C	R132	2	E
C147	3	D	C200	4	H	R133	2	E
C148	3	D	C222	4	F	R134	3	D
C149	4	D	C229	3	A	R135	4	D
C150	6	D	C229	3	A	R136	3	C
C151	5	E	C229	3	A	R141	2	D
C152	5	E	C229	3	A	R142	2	D
C153	5	E	C229	3	A	R143	3	D
C154	6	E	C229	3	A			
C155	6	C	C229	3	A			
C156	6	E	C229	3	A			
C157	6	E	C229	3	A			
C158	6	I	C229	3	A			
C159	6	D	C229	3	A			
C160	6	J	C229	3	A			
C161	6	J	C229	3	A			
C162	6	J	C229	3	A			
C163	6	J	C229	3	A			
C164	6	J	C229	3	A			
C165	6	J	C229	3	A			
C166	5	D	C229	3	A			
C167	6	H	C229	3	A			
C168	5	I	C229	3	A			



# < PARTS LIST >

**Note : All printed circuit boards and its assemblies are not available as service parts.**

Area Suffix	
UB ....	Hong Kong
US ....	Singapore
U .....	Universal Except All of Above

## Contents

General Exploded View and Parts List .....	2 - 2
Printed Circuit Board Ass'y and Parts List .....	2 - 5
■ ENB-172 .....	2 - 5
■ ENB-229 .....	2 - 7
■ ENC-130 .....	2 - 11
■ ENH-283 .....	2 - 14
Accessories List .....	2 - 18
Packing Materials and Parts List .....	2 - 19

# General Exploded View and Parts List

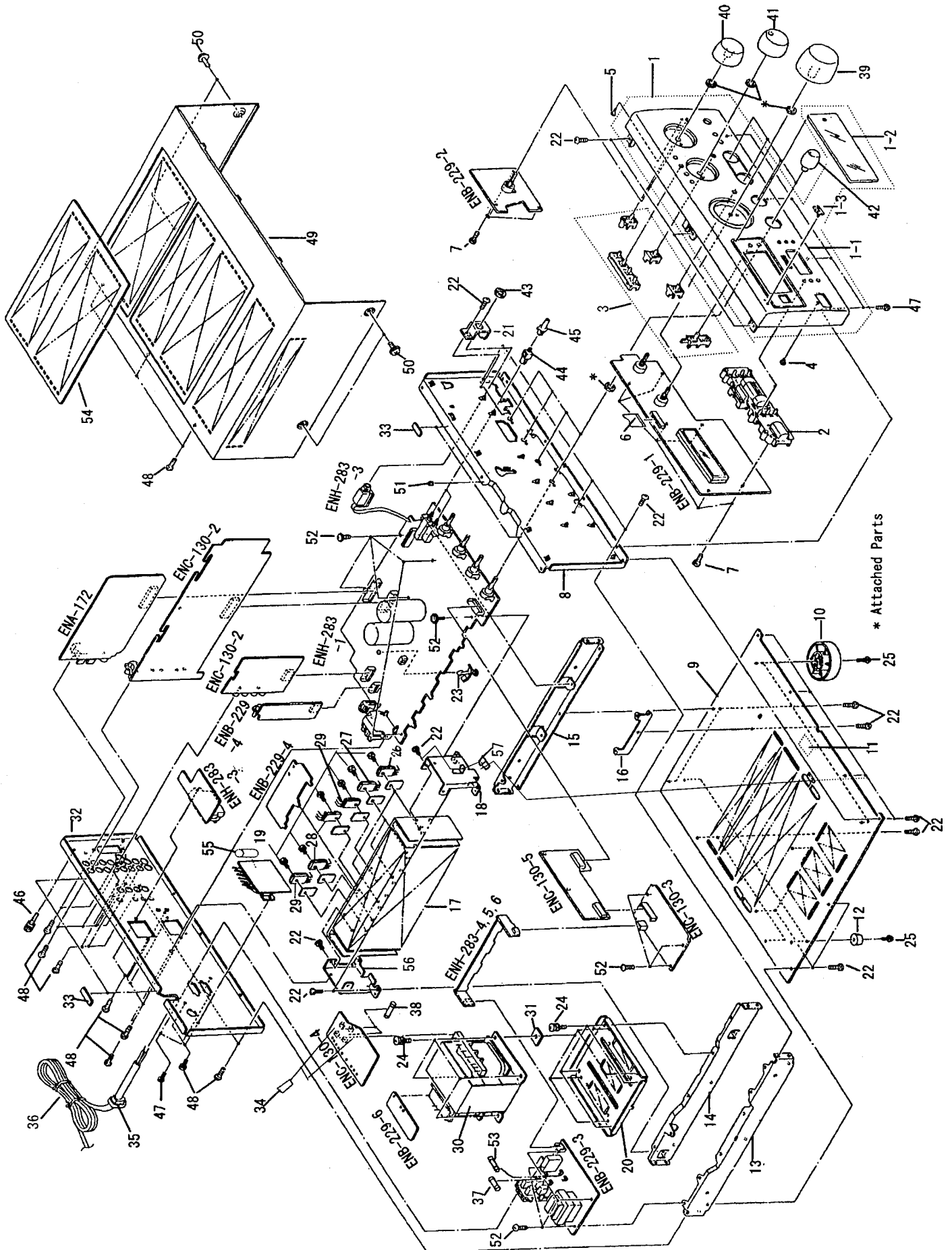

# Parts List

△	No.	Parts Number	Parts Name	Q'ty	Description	Area
	1	EFP-RX718PBK(U)	FRONT PANEL ASS	1		
	1-1	E102909-028SM	FRONT PANEL	1		
	1-2	E309112-019SM	WINDOW SCREEN	1		
	1-3	VJD5429-001	JVC MARK	1		
	2	E208276-001SM	PUSH BUTTON	1	POWER/SURROUND	
	3	E309105-004SM	PUSH BUTTON	1	TUNER/ETC	
	4	FSJD4001-002	INDICATOR LENS	1	POWER	
	5	E408326-001SM	INDICATOR LENS	1	TAPE2 MON	
	6	VWF1235-45PPB	FFC CABLE	1		
	7	SDSF2608Z	SCREW	9		
	8	E102911-003SM	FRONT BRACKET	1		
	9	E102820-002SM	BOTTOM PLATE	1		
	10	VJF4039-00PSM	FOOT ASSY	2	FRONT	
	11	E70115-002	CAUTION LABEL	1		
	12	E47227-036	FOOT	2	REAR	
	13	E208548-001SM	SIDE BRACKET	1	LEFT	
	14	E208549-001SM	CENTER BRACKET	1		
	15	E208081-003SM	SIDE BRACKET	1	RIGHT	
	16	E407984-001SM	P. W. BOARD HOLDER	1		
	17	E309170-004SM	HEAT SINK	1		
	18	E308836-004SM	HEAT SINK BRACKET	1	FRONT	
	19	E73525-003	SCREW	8		
	20	E309459-002SM	TRANSFORMER BRACKET	1		
	21	E407323-002SM	HEADPHONE BRACKET	1		
	22	SBSG3008CC	TAPPING SCREW	26		
	23	E406084-002	FASTENER	1		
	24	E65389-006	SPECIAL SCREW	8		
	25	SBST3010Z	TAPPING SCREW	4		
	26	2SB1429LB(R, O)	SI. TRANSISTOR	2	Q733/Q734	
	27	2SD2155LB(R, O)	SI. TRANSISTOR	2	Q731/Q732	
	28	2SA1633LD(D, E)	SI. TRANSISTOR	1	Q018/Q058	
	29	2SC4278LD(D, E)	SI. TRANSISTOR	1	Q016/Q056	
△	30	ETP1200-70FAJ	POWER TRANSFORMER	1		
	31	E406309-002	SPACER	4		
	32	E103041-015SM	REAR PANEL	1		U
	32	E103041-016SM	REAR PANEL	1		UB, US
	33	E306805-146	SPACER	4		
	34	E67132-T2R0	FUSE LABEL	2		
△	35	QHS3771-108	CORD STOPPER	1		
△	36	QMP39E0-200	POWER CORD	1		US
△	36	QMP5530-0085BS	POWER CORD	1		UB
△	36	QMP7520-200	POWER CORD	1		U
△	37	QMF51A2-8R0	FUSE	1	F001	
△	38	QMF51E2-2R0	FUSE	2	F851	
	39	E309823-001SM	VOLUME KNOB	1		
	40	E309110-001SM	SELECT KNOB	1	SOURCE	
	41	E309110-003SM	SELECT KNOB	1	JOG	
	42	E309111-003SM	BALANCE KNOB	4	TONE/BLNCE	
	43	VKZ4150-001	NUT	1		
	44	E407983-001SM	PUSH SHAFT	2		
	45	E407321-002SM	PUSH BUTTON	2		
	46	E409257-001	GND TERMINAL	1		
	47	SDSG3008M	TAPPING SCREW	4		

■ Parts List

△	No.	Parts Number	Parts Name	Q'ty	Description	Area
	47	SDSG3008M	TAPPING SCREW	2	AC OUTLET	U
	48	E73273-003	SPECIAL SCREW	24		
	49	E207378-025SM	METAL COVER	1		
	50	E61660-004	SPECIAL SCREW	4		
	51	E306805-028	SPACER	1		
	52	GBSG3008CC	TAPPING SCREW	13		
△	53	QMF51A2-R10S	FUSE	1	F002	
	54	E208294-001	PROTECTOR COVER	1		
△	55	QMF51E2-4R0	FUSE	1	F004	
	56	E308836-003SM	HEAT SINK BRACKET	1	REAR	
	57	E68587-010	BRACKET	1		
	-	E75139-003	Z LABEL	1		U



### ■ Electrical Parts List (ENB-172)

△	No.	Parts Number	Description	Area	△	No.	Parts Number	Description	Area
		I. C. S				C169	QCF21HP-223A	0.022MF 50V CER. CAP.	
	IC102	LC72131	I. C (M)			C170	QCHB1EZ-223	0.022MF 25V CER. CAP.	
	IC104	LA1266A	I. C (MONO-ANALOG)			C171	QEK51EM-106	10MF 25V AL E. CAP.	
	IC105	LA3401	I. C (MONO-ANALOG)			C172	QCVB1CM-103Y	0.01MF 16V CER. CAP.	
		DIODES				C173	QFLB1HJ-393	0.039MF 50V MYLAR CAP.	
	D101	1SS133	SI. DIODE			C174	QFLB1HJ-473	0.047MF 50V MYLAR CAP.	
	D106	1SS133	SI. DIODE			C175	QETB1EM-106	10MF 25V AL E. CAP.	
	D111	1SS133	SI. DIODE			C176	QCY31HK-102Z	1000PF 50V CER. CAP.	
	D112	1SS133	SI. DIODE			C177	QCS31HJ-821Z	820PF 50V CER. CAP.	
	D120	1SS133	SI. DIODE			C178	QCS31HJ-821Z	820PF 50V CER. CAP.	
	D121	1SS133	SI. DIODE			C179	QETB1HM-225	2.2MF 50V AL E. CAP.	
	D122	1SS133	SI. DIODE			C180	QETB1HM-225	2.2MF 50V AL E. CAP.	
	D123	1SS133	SI. DIODE			C181	QETB1EM-106	10MF 25V AL E. CAP.	
	VC105	SVC342 (L)	VAR I-CAPA DIODE			C182	QETB1HM-225	2.2MF 50V AL E. CAP.	
		TRANSISTORS				C183	QETB1HM-105	1MF 50V AL E. CAP.	
	Q103	2SC461	SI. TRANSISTOR			C184	QETB1HM-105	1MF 50V AL E. CAP.	
	Q107	2SC535	SI. TRANSISTOR			C185	QEK51HM-225G	2.2MF 50V AL E. CAP.	
	Q108	2SC461	SI. TRANSISTOR			C186	QETB1HM-474	0.47MF 50V E. CAP.	
	Q112	2SK301 (P, Q)	F. E. T.			C191	QETB1HM-475E	4.7MF 50V E. CAP.	
	Q123	DTA144ES	DIGITAL TRANSISTOR			C192	QCC21EM-473	0.047MF 25V CER. CAP.	
	Q124	DTA144ES	DIGITAL TRANSISTOR			C193	QCS21HJ-180A	18PF 50V CER. CAP.	
	Q127	DTC144ES	DIGITAL TRANSISTOR			C194	QCS21HJ-180A	18PF 50V CER. CAP.	
		CAPACITORS				C195	QFV71HJ-474ZM	0.47MF 50V THIN FILM	
	C101	QCF21HP-223A	0.022MF 50V CER. CAP.			C196	QCY31HK-102Z	1000PF 50V CER. CAP.	
	C122	QCF21HP-223A	0.022MF 50V CER. CAP.			C197	QCF21HP-223A	0.022MF 50V CER. CAP.	
	C126	QCF21HP-223A	0.022MF 50V CER. CAP.			C198	QCF21HP-103A	0.01MF 50V CER. CAP.	
	C132	QCS31HJ-561Z	560PF 50V CER. CAP.			C199	QCVB1CM-103Y	0.01MF 16V CER. CAP.	
	C133	QCHB1EZ-223	0.022MF 25V CER. CAP.			C222	QETB1CM-477M	470MF 16V E. CAP.	
	C134	QETB1EM-106	10MF 25V AL E. CAP.			C229	QETB1CM-227	220MF 16V AL E. CAP.	
	C135	QCC21EM-223	0.022MF 25V CER. CAP.			TC105	ENZ1003-006	00MF TRIMMER CA	
	C136	QCT25CH-180Z	18PF 50V CER. CAP.				RESISTORS		
	C137	QCT26CH-221	220PF 50V CER. CAP.			R101	QRD161J-103	10K 1/6W CARBON RE	
	C138	QCT26CH-241	240PF 50V CER. CAP.			R102	QRD161J-103	10K 1/6W CARBON RE	
	C149	QCHB1EZ-223	0.022MF 25V CER. CAP.			R103	QRD161J-103	10K 1/6W CARBON RE	
	C150	QCHB1EZ-223	0.022MF 25V CER. CAP.			R105	QRD161J-103	10K 1/6W CARBON RE	
	C151	QCF21HP-223A	0.022MF 50V CER. CAP.			R108	QRD161J-103	10K 1/6W CARBON RE	
	C152	QCF21HP-223A	0.022MF 50V CER. CAP.			△ R109	QRD14CJ-680SX	68 1/4W UNF. CARBON	
	C153	QCC21EM-223	0.022MF 25V CER. CAP.			R118	QRD167J-332	3.3K 1/6W CARBON RE	
	C154	QCF21HP-223A	0.022MF 50V CER. CAP.			R119	QRD161J-221	220 1/6W CARBON RE	
	C155	QCHB1EZ-223	0.022MF 25V CER. CAP.			R121	QRD161J-391	390 1/6W CARBON RE	
	C156	QETB1CM-227	220MF 16V AL E. CAP.			R122	QRD167J-272	2.7K 1/6W CARBON RE	
	C157	QETB1HM-474	0.47MF 50V E. CAP.			R123	QRD161J-102	1K 1/6W CARBON RE	
	C158	QCBB1HK-101Y	100PF 50V CER. CAP.			R124	QRD161J-681	680 1/6W CARBON RE	
	C159	QCBB1HK-101Y	100PF 50V CER. CAP.			R125	QRD167J-332	3.3K 1/6W CARBON RE	
	C160	QCBB1HK-221Y	220PF 50V CER. CAP.			R126	QRD161J-221	220 1/6W CARBON RE	
	C161	QCHB1EZ-223	0.022MF 25V CER. CAP.			R131	QRD161J-331	330 1/6W CARBON RE	
	C162	QETB1EM-106	10MF 25V AL E. CAP.			R132	QRD161J-103	10K 1/6W CARBON RE	
	C163	QFLB1HJ-102	1000PF 50V MYLAR CAP.			R133	QRD161J-473	47K 1/6W CARBON RE	
	C164	QCHB1EZ-223	0.022MF 25V CER. CAP.			R135	QRD161J-470	47 1/6W CARBON RE	
	C165	QETB1HM-474	0.47MF 50V E. CAP.			R136	QRD161J-103	10K 1/6W CARBON RE	
	C166	QETB1HM-225	2.2MF 50V AL E. CAP.			R146	QRD167J-560	56 1/6W CARBON RE	
	C167	QETB1HM-225	2.2MF 50V AL E. CAP.			R147	QRD161J-103	10K 1/6W CARBON RE	
	C168	QEK51HM-475	4.7MF 50V AL E. CAP.			R148	QRD161J-103	10K 1/6W CARBON RE	

### ■ Electrical Parts List (ENB-172)

△	No.	Parts Number	Description	Area
	R149	QRD161J-273	27K 1/6W CARBON RE	
	R150	QRD161J-103	10K 1/6W CARBON RE	
	R151	QRD161J-222	2.2K 1/6W CARBON RE	
	R153	QRD161J-103	10K 1/6W CARBON RE	
	R154	QRD161J-103	10K 1/6W CARBON RE	
	R155	QRD167J-562	5.6K 1/6W CARBON RE	
	R156	QRD167J-822	8.2K 1/6W CARBON RE	
	R157	QRD161J-103	10K 1/6W CARBON RE	
	R158	QRD161J-273	27K 1/6W CARBON RE	
	R159	QRD161J-561	560 1/6W CARBON RE	
	R160	QRD167J-562	5.6K 1/6W CARBON RE	
	R161	QRD161J-823	82K 1/6W CARBON RE	
	R162	QRD161J-823	82K 1/6W CARBON RE	
	R163	QRD161J-472	4.7K 1/6W CARBON RE	
	R164	QRD161J-472	4.7K 1/6W CARBON RE	
	R165	QRD161J-184	180K 1/6W CARBON RE	
	R166	QRD161J-184	180K 1/6W CARBON RE	
	R167	QRD161J-393	39K 1/6W CARBON RE	
	R168	QRD161J-103	10K 1/6W CARBON RE	
	R169	QRD161J-103	10K 1/6W CARBON RE	
	R171	QRD167J-682	6.8K 1/6W CARBON RE	
	R172	QRD167J-682	6.8K 1/6W CARBON RE	
	R180	QRD161J-103	10K 1/6W CARBON RE	
	R181	QRD161J-222	2.2K 1/6W CARBON RE	
	R190	QRD161J-103	10K 1/6W CARBON RE	
	R191	QRD167J-562	5.6K 1/6W CARBON RE	
	R194	QRD161J-103	10K 1/6W CARBON RE	
	R195	QRD161J-473	47K 1/6W CARBON RE	
	R197	QRD161J-222	2.2K 1/6W CARBON RE	
	R198	QRD167J-822	8.2K 1/6W CARBON RE	
	R199	QRD161J-472	4.7K 1/6W CARBON RE	
		OTHERS		
		EMW10604-003	PRINTED BOARD	
	L106	EQL3001-102K	INDUCTOR	
	L120	EQL4007-1R0	INDUCTOR	
	T101	EQR1111-014	RF COIL	
	T103	EQR1207-017	RF COIL	
	T105	EQT2140-017	I. F. TRANSFORMER	
	T107	ECB1560-010	CERAMIC FILTER	
	AT101	FMMB10YV-401K	ANTENNA TERMINAL	
	CF101	ECB2123-006R	CERAMIC FILTER	
	CF102	ECB2123-006R	CERAMIC FILTER	
	CN011	EMV5163-012R	CONNECT TERMINAL	
	FE101	EAF2203-004	FRONT END	
	LP101	EQF0101-002	LOWPASS FILTER	
	XT102	ECX0007-200KWJ1	CRYSTAL	
	XT103	ECX0000-456KR	CERAMIC RESONATOR	

### ■ Electrical Parts List (ENB-229)

△	No.	Parts Number	Description	Area	△	No.	Parts Number	Description	Area
		I. C. S							
	IC511	BA15218N	I. C (MONO-ANALOG)			Q705	2SA1038 (R, S)	SI. TRANSISTOR	
	IC901	TA7317P	I. C (MONO-ANALOG)			Q706	2SA1038 (R, S)	SI. TRANSISTOR	
		DIODES				Q707	2SA933LN (R, S)	SI. TRANSISTOR	
	D010	1SS133	SI. DIODE			Q708	2SA933LN (R, S)	SI. TRANSISTOR	
	D011	MTZ18JC	ZENER DIODE			Q709	2SA1038 (R, S)	SI. TRANSISTOR	
	D012	1SS133	SI. DIODE			Q710	2SA1038 (R, S)	SI. TRANSISTOR	
	D013	1SS133	SI. DIODE			Q711	2SC2389 (S, E)	SI. TRANSISTOR	
	D014	1SS133	SI. DIODE			Q712	2SC2389 (S, E)	SI. TRANSISTOR	
	D015	1SS133	SI. DIODE			Q717	2SC2389 (S, E)	SI. TRANSISTOR	
	D021	1SS133	SI. DIODE			Q718	2SC2389 (S, E)	SI. TRANSISTOR	
	D022	1SS133	SI. DIODE			Q719	2SA1038 (R, S)	SI. TRANSISTOR	
	D482	1SS133	SI. DIODE			Q720	2SA1038 (R, S)	SI. TRANSISTOR	
	D483	1SS133	SI. DIODE			Q721	2SD636	SI. TRANSISTOR	
	D484	MTZ6. 2JC	ZENER DIODE			Q722	2SD636	SI. TRANSISTOR	
	D701	1SS133	SI. DIODE			Q723	2SC2389 (S, E)	SI. TRANSISTOR	
	D702	1SS133	SI. DIODE			Q724	2SC2389 (S, E)	SI. TRANSISTOR	
	D703	1SS133	SI. DIODE			Q725	2SA1038 (R, S)	SI. TRANSISTOR	
	D704	1SS133	SI. DIODE			Q726	2SA1038 (R, S)	SI. TRANSISTOR	
	D705	MTZ18JC	ZENER DIODE			Q727	2SC2235 (O, Y)	SI. TRANSISTOR	
	D709	1SS133	SI. DIODE			Q728	2SC2235 (O, Y)	SI. TRANSISTOR	
	D710	1SS133	SI. DIODE			Q729	2SA965 (Y)	SI. TRANSISTOR	
	D711	1SS133	SI. DIODE			Q730	2SA965 (Y)	SI. TRANSISTOR	
	D712	1SS133	SI. DIODE			Q735	2SD2061 (F, G)	SI. TRANSISTOR	
	D713	MTZ20JC	ZENER DIODE			Q736	2SC2240 (GR, BL)	SI. TRANSISTOR	
	D714	MTZ20JC	ZENER DIODE			Q801	2SB1187 (F, G)	SI. TRANSISTOR	
	D811	1SS133	SI. DIODE			Q803	2SD2061 (F, G)	SI. TRANSISTOR	
	D812	MTZ16JC	ZENER DIODE			Q804	2SD2061 (F, G)	SI. TRANSISTOR	
	D813	1SS133	SI. DIODE			Q805	2SD2061 (F, G)	SI. TRANSISTOR	
	D814	MTZ6. 8JC	ZENER DIODE			Q901	2SC2389 (S, E)	SI. TRANSISTOR	
	D815	1SS133	SI. DIODE			Q902	2SC2389 (S, E)	SI. TRANSISTOR	
	D816	MTZ16JC	ZENER DIODE			Q903	2SA1038 (R, S)	SI. TRANSISTOR	
	D817	1SS133	SI. DIODE				CAPACITORS		
	D818	1SS133	SI. DIODE			C010	QCF21HP-223A	0. 022MF 50V CER. CAP.	
	D819	MTZ13JC	ZENER DIODE			C011	QETB1HM-106	10MF 50V E. CAP.	
	D820	MTZ5. 1JC	ZENER DIODE			C012	QCS21HJ-271A	270PF 50V CER. CAP.	
	D901	1SS133	SI. DIODE			C013	QETB1EM-106	10MF 25V AL E. CAP.	
	D902	1SS133	SI. DIODE			C014	QCS21HJ-101A	100PF 50V CER. CAP.	
	D903	1SS133	SI. DIODE			C015	QCS21HJ-5R0	5PF 50V CER. CAP.	
		TRANSISTORS				C016	QETB1CM-476	47MF 16V AL E. CAP.	
	Q011	2SC2240 (BL)	SI. TRANSISTOR			C017	QCS22HJ-330	33PF 500V CER. CAP.	
	Q012	2SC2240 (BL)	SI. TRANSISTOR			C018	QFLB1HJ-103	0. 01MF 50V MYLAR CAP.	
	Q013	2SA1038 (R, S)	SI. TRANSISTOR			C019	QETB1HM-476	47MF 50V E. CAP.	
	Q015	2SC2235 (O, Y)	SI. TRANSISTOR			C020	QCS22HJ-470A	47PF 500V CER. CAP.	
	Q017	2SA965 (Y)	SI. TRANSISTOR			C021	QETB1HM-225	2. 2MF 50V AL E. CAP.	
	Q019	2SC1775AV (F1)	SI. TRANSISTOR			C023	QCS22HJ-470A	47PF 500V CER. CAP.	
	Q020	DTC123YS	SI. TRANSISTOR			C024	QFLB1HJ-473	0. 047MF 50V MYLAR CAP.	
	Q021	2SC2389 (S, E)	SI. TRANSISTOR			C025	QFLB1HJ-473	0. 047MF 50V MYLAR CAP.	
	Q022	2SA1038 (R, S)	SI. TRANSISTOR			C026	QCF21HP-223A	0. 022MF 50V CER. CAP.	
	Q701	2SC1775AV (F1)	SI. TRANSISTOR			C027	QCY31HK-332Z	3300PF 50V CER. CAP.	
	Q702	2SC1775AV (F1)	SI. TRANSISTOR			C028	QCY31HK-332Z	3300PF 50V CER. CAP.	
	Q703	2SC1775AV (F1)	SI. TRANSISTOR			C064	QFLB1HJ-473	0. 047MF 50V MYLAR CAP.	
	Q704	2SC1775AV (F1)	SI. TRANSISTOR			C065	QFLB1HJ-473	0. 047MF 50V MYLAR CAP.	
						C481	QCB1HK-331Y	330PF 50V CER. CAP.	

### ■ Electrical Parts List (ENB-229)

△	No.	Parts Number	Description	Area	△	No.	Parts Number	Description	Area
	C482	QCHB1EZ-223	0.022MF 25V CER. CAP.			C741	QCF21HP-472	4700PF 50V CER. CAP.	
	C501	QETB1HM-105	1MF 50V AL E. CAP.			C801	EEW7103-109T	10000MF AL E. CAP.	
	C502	QETB1HM-105	1MF 50V AL E. CAP.			C802	EEW7103-109T	10000MF AL E. CAP.	
	C503	QFLB1HJ-823	0.082MF 50V MYLAR CAP.			C812	QETB1EM-107	100MF 25V AL E. CAP.	
	C504	QFLB1HJ-823	0.082MF 50V MYLAR CAP.			C814	QETB1EM-107	100MF 25V AL E. CAP.	
	C505	QFLB1HJ-153	0.015MF 50V MYLAR CAP.			C816	QETB1EM-107	100MF 25V AL E. CAP.	
	C506	QFLB1HJ-153	0.015MF 50V MYLAR CAP.			C819	QETB1EM-107	100MF 25V AL E. CAP.	
	C507	QETB1HM-105	1MF 50V AL E. CAP.			C820	QETB1EM-107	100MF 25V AL E. CAP.	
	C508	QETB1HM-105	1MF 50V AL E. CAP.			C901	QCF21HP-223A	0.022MF 50V CER. CAP.	
	C509	QFLB1HJ-332	3300PF 50V MYLAR CAP.			C902	QCF21HP-223A	0.022MF 50V CER. CAP.	
	C510	QFLB1HJ-332	3300PF 50V MYLAR CAP.			C903	QETB1HM-226E	22MF 50V E. CAP.	
	C511	QFLB1HJ-183	0.018MF 50V MYLAR CAP.			C904	QCF21HP-103A	0.01MF 50V CER. CAP.	
	C512	QFLB1HJ-183	0.018MF 50V MYLAR CAP.			C905	QCY31HK-102Z	1000PF 50V CER. CAP.	
	C521	QETB1HM-106	10MF 50V E. CAP.			C906	QETB1AM-476	47MF 10V E. CAP.	
	C522	QCY31HK-103Z	0.01MF 50V CER. CAP.			C909	QETB1CM-226	22MF 16V E. CAP.	
	C523	QFLB1HJ-123	0.012MF 50V MYLAR CAP.				RESISTORS		
	C524	QETB1HM-106	10MF 50V E. CAP.			R011	QRD161J-222	2.2K 1/6W CARBON RE	
	C525	QCS21HJ-101A	100PF 50V CER. CAP.			R012	QRD161J-104	100K 1/6W CARBON RE	
	C701	QETB1HM-106	10MF 50V E. CAP.			R013	QRD161J-123	12K 1/6W CARBON RE	
	C702	QETB1HM-106	10MF 50V E. CAP.			R014	QRD161J-162	1.6K 1/6W CARBON RE	
	C703	QCS21HJ-271A	270PF 50V CER. CAP.			R015	QRD161J-104	100K 1/6W CARBON RE	
	C704	QCS21HJ-271A	270PF 50V CER. CAP.		△	R016	QRD14CJ-181S	180 1/4W UNF. CARBON	
	C705	QCS21HJ-101A	100PF 50V CER. CAP.		△	R017	QRD14CJ-332SX	3.3K 1/4W UNF. CARBON	
	C706	QCS21HJ-101A	100PF 50V CER. CAP.			R018	QRD167J-332	3.3K 1/6W CARBON RE	
	C707	QETB1CM-476	47MF 16V AL E. CAP.			R019	QRD167J-332	3.3K 1/6W CARBON RE	
	C708	QETB1CM-476	47MF 16V AL E. CAP.			R020	QRD167J-332	3.3K 1/6W CARBON RE	
	C709	QCS21HJ-100	10PF 50V CER. CAP.		△	R023	QRD14CJ-100SX	10 1/4W UNF. CARBON	
	C710	QCS21HJ-100	10PF 50V CER. CAP.		△	R024	QRD14CJ-100SX	10 1/4W UNF. CARBON	
	C711	QCY31HK-152Z	1500PF 50V CER. CAP.		△	R025	QRD14CJ-561SX	560 1/4W UNF. CARBON	
	C712	QCY31HK-152Z	1500PF 50V CER. CAP.		△	R026	QRD14CJ-100SX	10 1/4W UNF. CARBON	
	C713	QCS21HJ-680A	68PF 50V CER. CAP.		△	R027	QRD14CJ-100SX	10 1/4W UNF. CARBON	
	C714	QCS21HJ-680A	68PF 50V CER. CAP.			R028	QRD161J-391	390 1/6W CARBON RE	
	C715	QCS21HJ-680A	68PF 50V CER. CAP.			R029	ERT-D2WHL202S	2K 1/4W NEGATIVE T	
	C716	QCS21HJ-680A	68PF 50V CER. CAP.			R030	QRD161J-183	18K 1/6W CARBON RE	
	C717	QCS22HJ-220	22PF 500V CER. CAP.			R031	QRD161J-123	12K 1/6W CARBON RE	
	C718	QCS22HJ-220	22PF 500V CER. CAP.		△	R032	QRD125J-330	33 1/2W UNF. CARBON	
	C719	QFLB1HJ-472	4700PF 50V MYLAR CAP.		△	R033	QRG022J-100A	10 2W OXIDE META	
	C720	QFLB1HJ-472	4700PF 50V MYLAR CAP.			R034	QRD161J-104	100K 1/6W CARBON RE	
	C722	QETB1EM-476	47MF 25V AL E. CAP.		△	R035	QRD14CJ-182SX	1.8K 1/4W UNF. CARBON	
	C723	QETB2AM-476	47MF 100V AL E. CAP.		△	R036	QRD14CJ-182SX	1.8K 1/4W UNF. CARBON	
	C724	QETB2AM-476	47MF 100V AL E. CAP.		△	R037	QRG022J-562A	5.6K 2W OXIDE META	
	C725	QCS22HJ-470A	47PF 500V CER. CAP.			R038	QRD167J-751	750 1/6W CARBON RE	
	C726	QCS22HJ-470A	47PF 500V CER. CAP.		△	R039	QRD14CJ-100SX	10 1/4W UNF. CARBON	
	C727	QCS22HJ-470A	47PF 500V CER. CAP.			R040	QRD161J-3R3	3.3 1/6W CARBON RE	
	C728	QCS22HJ-470A	47PF 500V CER. CAP.			R043	QRD161J-102	1K 1/6W CARBON RE	
	C729	QFLB1HJ-473	0.047MF 50V MYLAR CAP.			R045	QRD167J-151	150 1/6W CARBON RE	
	C730	QFLB1HJ-473	0.047MF 50V MYLAR CAP.			R046	QRD167J-151	150 1/6W CARBON RE	
	C731	QFLB1HJ-473	0.047MF 50V MYLAR CAP.			R047	QRD167J-151	150 1/6W CARBON RE	
	C732	QFLB1HJ-473	0.047MF 50V MYLAR CAP.			R048	QRD167J-151	150 1/6W CARBON RE	
	C733	QCF21HP-472	4700PF 50V CER. CAP.		△	R073	QRG022J-100A	10 2W OXIDE META	
	C734	QCF21HP-472	4700PF 50V CER. CAP.			R074	QRD161J-104	100K 1/6W CARBON RE	
	C735	QCF21HP-472	4700PF 50V CER. CAP.			R481	QRD161J-100	10 1/6W CARBON RE	
	C736	QCF21HP-472	4700PF 50V CER. CAP.			R482	QRD161J-102	1K 1/6W CARBON RE	

### ■ Electrical Parts List (ENB-229)

△	No.	Parts Number	Description	Area	△	No.	Parts Number	Description	Area
	R501	QRD161J-203	20K 1/6W CARBON RE			R740	QRD161J-201	200 1/6W CARBON RE	
	R502	QRD161J-203	20K 1/6W CARBON RE			R741	QRD161J-201	200 1/6W CARBON RE	
	R503	QRD161J-362	3.6K 1/6W CARBON RE			R742	QRD161J-201	200 1/6W CARBON RE	
	R504	QRD161J-362	3.6K 1/6W CARBON RE			R751	QRD161J-391	390 1/6W CARBON RE	
	R505	QRD161J-472	4.7K 1/6W CARBON RE			R752	QRD161J-391	390 1/6W CARBON RE	
	R506	QRD161J-472	4.7K 1/6W CARBON RE			R753	QRD161J-391	390 1/6W CARBON RE	
	R507	QRD161J-122	1.2K 1/6W CARBON RE			R754	QRD161J-391	390 1/6W CARBON RE	
	R508	QRD161J-122	1.2K 1/6W CARBON RE			R755	QRD167J-152	1.5K 1/6W CARBON RE	
	R521	QRD161J-104	100K 1/6W CARBON RE			R756	QRD167J-152	1.5K 1/6W CARBON RE	
	R522	QRD161J-203	20K 1/6W CARBON RE			R761	QRD161J-391	390 1/6W CARBON RE	
	R523	QRD161J-183	18K 1/6W CARBON RE			R762	QRD161J-391	390 1/6W CARBON RE	
	R524	QRD161J-202	2K 1/6W CARBON RE			R763	ERT-D2WHL202S	2K 1/4W NEGATIVE T	
	R525	QRD167J-223	22K 1/6W CARBON RE			R764	ERT-D2WHL202S	2K 1/4W NEGATIVE T	
	R526	QRD161J-132	1.3K 1/6W CARBON RE		△	R765	QRD14CJ-272S	2.7K 1/4W UNF. CARBON	
	R528	QRD161J-203	20K 1/6W CARBON RE		△	R766	QRD14CJ-272S	2.7K 1/4W UNF. CARBON	
△	R529	QRZ0077-680	68 1/4W FUSIBLE RE		△	R767	QRD14CJ-271S	270 1/4W UNF. CARBON	
△	R530	QRZ0077-680	68 1/4W FUSIBLE RE		△	R768	QRD14CJ-271S	270 1/4W UNF. CARBON	
	R701	QRD161J-222	2.2K 1/6W CARBON RE		△	R769	QRD14CJ-100SX	10 1/4W UNF. CARBON	
	R702	QRD161J-222	2.2K 1/6W CARBON RE		△	R770	QRD14CJ-100SX	10 1/4W UNF. CARBON	
	R703	QRD161J-104	100K 1/6W CARBON RE		△	R771	QRD14CJ-100SX	10 1/4W UNF. CARBON	
	R704	QRD161J-104	100K 1/6W CARBON RE		△	R772	QRD14CJ-100SX	10 1/4W UNF. CARBON	
	R705	QRD161J-202	2K 1/6W CARBON RE		△	R773	ERF032K-R22	0.22 3W CEM. RES.	
	R706	QRD161J-202	2K 1/6W CARBON RE		△	R774	ERF032K-R22	0.22 3W CEM. RES.	
	R707	QRD161J-202	2K 1/6W CARBON RE		△	R775	QRD129J-470	47 1/2W UNF. CARBON	
	R708	QRD161J-202	2K 1/6W CARBON RE		△	R776	QRD129J-470	47 1/2W UNF. CARBON	
	R709	QRD167J-822	8.2K 1/6W CARBON RE		△	R777	QRG022J-100A	10 2W OXIDE META	
	R710	QRD167J-822	8.2K 1/6W CARBON RE		△	R778	QRG022J-100A	10 2W OXIDE META	
	R711	QRD161J-821	820 1/6W CARBON RE		△	R779	QRD14CJ-100SX	10 1/4W UNF. CARBON	
	R712	QRD161J-821	820 1/6W CARBON RE		△	R780	QRD14CJ-100SX	10 1/4W UNF. CARBON	
	R713	QRD161J-133Y	13K 1/6W CARBON RE		△	R781	QRD14CJ-100SX	10 1/4W UNF. CARBON	
	R714	QRD161J-133Y	13K 1/6W CARBON RE		△	R782	QRD14CJ-100SX	10 1/4W UNF. CARBON	
	R715	QRD161J-823	82K 1/6W CARBON RE		△	R783	QRD14CJ-100SX	10 1/4W UNF. CARBON	
	R716	QRD161J-823	82K 1/6W CARBON RE		△	R784	QRD14CJ-100SX	10 1/4W UNF. CARBON	
	R717	QRD12CJ-153SX	15K 1/2W UNF. CARBON		△	R785	QRD14CJ-100SX	10 1/4W UNF. CARBON	
	R718	QRD12CJ-153SX	15K 1/2W UNF. CARBON		△	R786	QRD14CJ-100SX	10 1/4W UNF. CARBON	
	R719	QRD161J-391	390 1/6W CARBON RE		△	R787	QRD14CJ-562SX	5.6K 1/4W UNF. CARBON	
	R720	QRD161J-391	390 1/6W CARBON RE			R788	QRD161J-103	10K 1/6W CARBON RE	
	R721	QRD14CJ-151SX	150 1/4W UNF. CARBON			R789	QRD161J-473	47K 1/6W CARBON RE	
	R722	QRD14CJ-151SX	150 1/4W UNF. CARBON			R791	QRD161J-222	2.2K 1/6W CARBON RE	
	R723	QRD167J-152	1.5K 1/6W CARBON RE			R792	QRD161J-222	2.2K 1/6W CARBON RE	
	R724	QRD167J-152	1.5K 1/6W CARBON RE		△	R799	ERF032K-R22	0.22 3W CEM. RES.	
	R725	QRD161J-333	33K 1/6W CARBON RE			R801	QRD161J-104	100K 1/6W CARBON RE	
	R726	QRD161J-333	33K 1/6W CARBON RE			R802	QRD161J-104	100K 1/6W CARBON RE	
	R727	QRD161J-391	390 1/6W CARBON RE		△	R811	QRD14CJ-120SX	12 1/4W UNF. CARBON	
	R728	QRD161J-391	390 1/6W CARBON RE		△	R813	QRD14CJ-122SX	1.2K 1/4W UNF. CARBON	
	R729	QRD161J-391	390 1/6W CARBON RE		△	R819	QRD14CJ-100SX	10 1/4W UNF. CARBON	
	R730	QRD161J-391	390 1/6W CARBON RE		△	R822	QRD14CJ-272S	2.7K 1/4W UNF. CARBON	
	R731	QRD161J-101	100 1/6W CARBON RE		△	R823	QRD14CJ-220S	22 1/4W UNF. CARBON	
	R732	QRD161J-101	100 1/6W CARBON RE		△	R825	QRD14CJ-332SX	3.3K 1/4W UNF. CARBON	
△	R733	QRD14CJ-100SX	10 1/4W UNF. CARBON		△	R826	QRD14CJ-120SX	12 1/4W UNF. CARBON	
△	R734	QRD14CJ-100SX	10 1/4W UNF. CARBON			R828	QRD12CJ-153SX	15K 1/2W UNF. CARBON	
△	R735	QRG022J-562A	5.6K 2W OXIDE META		△	R834	QRD14CJ-100SX	10 1/4W UNF. CARBON	
	R739	QRD161J-201	200 1/6W CARBON RE			R835	QRD12CJ-471SX	470 1/2W UNF. CARBON	

## ■ Electrical Parts List (ENB-229)

△	No.	Parts Number	Description	Area	△	No.	Parts Number	Description	Area
△	R838	QRD12CJ-2R2SX	2.2 1/2W CARBON RE			CN401	EMV7123-035	CONNECT TERMINAL	
△	R843	QRD14CJ-100SX	10 1/4W UNF. CARBON			CN501	EMV7163-010	CONNECT TERMINAL	
	R863	QRD161J-102	1K 1/6W CARBON RE			CN601	EMV7163-014	CONNECT TERMINAL	
	R864	QRD161J-102	1K 1/6W CARBON RE			CN602	EMV7163-007	CONNECT TERMINAL	
	R901	QRD161J-102	1K 1/6W CARBON RE			CN701	EMV7163-006	CONNECT TERMINAL	
	R902	QRD161J-102	1K 1/6W CARBON RE			CN801	EMV7163-007	CONNECT TERMINAL	
	R903	QRD167J-562	5.6K 1/6W CARBON RE			CN812	EMV5129-003	CONNECTOR	
	R904	QRD167J-562	5.6K 1/6W CARBON RE			CN813	VMC0178-003	CONNECT TERMINAL	
	R905	QRD161J-123	12K 1/6W CARBON RE			CN814	VMC0178-003	CONNECT TERMINAL	
	R906	QRD161J-123	12K 1/6W CARBON RE			EP001	EMZ4002-001Z	EARTH PLATE	
	R907	QRD161J-102	1K 1/6W CARBON RE			EP003	EMZ4002-001Z	EARTH PLATE	
	R908	QRD161J-102	1K 1/6W CARBON RE			EP004	EMZ4002-001Z	EARTH PLATE	
	R909	QRD161J-103	10K 1/6W CARBON RE			EP005	EMZ4002-001Z	EARTH PLATE	
	R911	QRD167J-332	3.3K 1/6W CARBON RE			EP006	EMZ4002-001Z	EARTH PLATE	
	R912	QRD161J-473	47K 1/6W CARBON RE			FW901	EWR33D-08SS	FLAT WIRE ASSY	
	R913	QRD161J-104	100K 1/6W CARBON RE			FW903	EWR38D-45SS	FLAT WIRE ASSY	
	R914	QRD161J-823	82K 1/6W CARBON RE			HS801	E70306-001	HEAT SINK	
	R915	QRD161J-823	82K 1/6W CARBON RE			HS803	E70306-001	HEAT SINK	
	R916	QRD161J-563	56K 1/6W CARBON RE			HS804	E70306-001	HEAT SINK	
	R917	QRD161J-683	68K 1/6W CARBON RE			HS805	E70306-001	HEAT SINK	
	R918	QRD161J-392	3.9K 1/6W CARBON RE			RY011	ESK7D24-213R	RELAY	
	R921	QRD161J-224	220K 1/6W CARBON RE			RY901	ESK7D24-213R	RELAY	
	R922	QRD167J-562	5.6K 1/6W CARBON RE			ST011	EMB90TV-601G	SPEAKER TERMINAL	
	R924	QRD161J-3R3	3.3 1/6W CARBON RE			ST901	EMB90TV-806A	SPEAKER TERMINAL	
△	R929	QRD14CJ-470SX	47 1/4W UNF. CARBON			TP751	QMV5005-004K	PLUG ASSY	
△	R941	QRG022J-471A	470 2W OXIDE META						
△	R942	QRG022J-471A	470 2W OXIDE META						
	R951	QRD161J-333	33K 1/6W CARBON RE						
	R952	QRD161J-333	33K 1/6W CARBON RE						
	R953	QRD161J-333	33K 1/6W CARBON RE						
	R956	QRD161J-391	390 1/6W CARBON RE						
	R957	QRD167J-223	22K 1/6W CARBON RE						
	VR511	QVDB96C-E15CJ3	100K VARIABLE R						
	VR512	QVDB96C-E15CJ3	100K VARIABLE R						
	VR513	QVDA96W-E15DJ3	100K VARIABLE R						
	VR514	QVDB96C-E15DJ3	100K VARIABLE R						
	VR791	QVPA601-501A	500 TRIMMER RE						
	VR792	QVPA601-501A	500 TRIMMER RE						
		OTHERS							
		EMW10605-002	PRINTED BOARD						
		SBSG3008CC	TAPPING SCREW						
	J481	QMS3501-021	PIN JACK						
	J901	QMS6022-V01	MICROPHONE JACK						
	L011	EQL0011-R45J1	INDUCTOR						
	L701	EQL0001-1R0	INDUCTOR						
	L702	EQL0001-1R0	INDUCTOR						
	S001	QSP6002-E02J2	PUSH SWITCH						
	CN001	EMV7163-012	CONNECT TERMINAL						
	CN108	EWS293-0145	SOCKET WIRE						
	CN109	EWS293-0130	SOCKET WIRE						
	CN118	VMC0075-003	CONNECTOR						
	CN119	VMC0075-003	CONNECTOR						
	CN311	VMC0075-008N	CONNECT TERMINAL						

### ■ Electrical Parts List (ENC-130)

△	No.	Parts Number	Description	Area	△	No.	Parts Number	Description	Area
		I. C. S				Q854	2SD1266	SI. TRANSISTOR	
	IC400	MN172412K8C	I. C (MICRO-COMPUTER)				CAPACITORS		
	IC401	MN171601K8B	I. C (MICRO-COMPUTER)		△	C001	QCZ9019-472	4700PF C. CAP.	
	IC402	PST600E-T	I. C (MONO-ANALOG)			C050	QCHB1EZ-223	0.022MF 25V CER. CAP.	
	IC403	SPS-420-1	INFRARED DETECT UNIT			C051	QETB1HM-106	10MF 50V E. CAP.	
		DIODES				C052	QCS21HJ-271A	270PF 50V CER. CAP.	
	D050	1SS133	SI. DIODE			C053	QETB1EM-106	10MF 25V AL E. CAP.	
	D051	MTZ18JC	ZENER DIODE			C054	QCS21HJ-101A	100PF 50V CER. CAP.	
	D052	1SS133	SI. DIODE			C055	QCS21HJ-5R0	5PF 50V CER. CAP.	
	D053	1SS133	SI. DIODE			C056	QETB1CM-476	47MF 16V AL E. CAP.	
	D061	1SS133	SI. DIODE			C057	QCS22HJ-330	33PF 500V CER. CAP.	
	D062	1SS133	SI. DIODE			C058	QFLB1HJ-103	0.01MF 50V MYLAR CAP.	
	D292	1SS133	SI. DIODE			C059	QETB1HM-476	47MF 50V E. CAP.	
	D400	1SR139-200	SI. DIODE			C060	QCS22HJ-470A	47PF 500V CER. CAP.	
	D401	1SR139-200	SI. DIODE			C061	QETB1HM-225	2.2MF 50V AL E. CAP.	
	D402	1SR139-200	SI. DIODE			C063	QCS22HJ-470A	47PF 500V CER. CAP.	
	D405	SLR-54VC50F124	L. E. D.			C066	QCF21HP-223A	0.022MF 50V CER. CAP.	
	D406	1SS133	SI. DIODE			C067	QCY31HK-332Z	3300PF 50V CER. CAP.	
	D407	1SS133	SI. DIODE			C068	QCY31HK-332Z	3300PF 50V CER. CAP.	
	D408	1SS133	SI. DIODE			C291	QCS31HJ-471Z	470PF 50V CER. CAP.	
	D409	1SS133	SI. DIODE			C401	QCZ0202-155	1.5MF 25V CER. RES.	
	D410	1SS133	SI. DIODE			C402	QEK61AM-227ZM	220MF 10V AL E. CAP.	
	D411	1SS133	SI. DIODE			C403	QEADOHZ-10AZM	AL E. CAP.	
	D412	1SS133	SI. DIODE			C404	QETB1HM-106	10MF 50V E. CAP.	
	D413	1SS133	SI. DIODE			C405	QETB1HM-475E	4.7MF 50V E. CAP.	
	D414	1SS133	SI. DIODE			C406	QETB1HM-475E	4.7MF 50V E. CAP.	
	D415	1SS133	SI. DIODE			C407	QETBOJM-107	100MF 6.3V AL E. CAP.	
	D416	1SS133	SI. DIODE			C409	QETB1AM-227	220MF 10V E. CAP.	
	D490	SLR-34VC3F	L. E. D.			C410	QCZ0202-155	1.5MF 25V CER. RES.	
	D855	MTZ12JC	ZENER DIODE			C412	QEK51HM-225G	2.2MF 50V AL E. CAP.	
	D857	MTZ6.2JC	ZENER DIODE			C413	QCHB1EZ-223	0.022MF 25V CER. CAP.	
	D858	1SS133	SI. DIODE			C414	QCB1HK-331Y	330PF 50V CER. CAP.	
	D871	1SR139-200	SI. DIODE			C415	QCZ0202-155	1.5MF 25V CER. RES.	
	D872	1SR139-200	SI. DIODE			C418	QCHB1EZ-223	0.022MF 25V CER. CAP.	
	D873	1SR139-200	SI. DIODE			C419	QCHB1EZ-223	0.022MF 25V CER. CAP.	
	D874	1SR139-200	SI. DIODE			C850	QETB1CM-476	47MF 16V AL E. CAP.	
		TRANSISTORS				C851	QFN82AK-472	4700PF 100V METAL. MYLA	
	Q051	2SC2240 (BL)	SI. TRANSISTOR			C852	QETB1JM-227	220MF 63V AL E. CAP.	
	Q052	2SC2240 (BL)	SI. TRANSISTOR				RESISTORS		
	Q053	2SA1038 (R, S)	SI. TRANSISTOR			R051	QRD161J-222	2.2K 1/6W CARBON RE	
	Q055	2SC2235 (O, Y)	SI. TRANSISTOR			R052	QRD161J-104	100K 1/6W CARBON RE	
	Q057	2SA965 (Y)	SI. TRANSISTOR			R053	QRD161J-123	12K 1/6W CARBON RE	
	Q059	2SC1775AV (F1)	SI. TRANSISTOR			R054	QRD161J-162	1.6K 1/6W CARBON RE	
	Q061	2SC2389 (S, E)	SI. TRANSISTOR			R055	QRD161J-104	100K 1/6W CARBON RE	
	Q062	2SA1038 (R, S)	SI. TRANSISTOR		△	R056	QRD14CJ-181S	180 1/4W UNF. CARBON	
	Q400	DTC114YS	DIGITAL TRANSISTOR		△	R057	QRD14CJ-332SX	3.3K 1/4W UNF. CARBON	
	Q401	DTC114TN	DIGITAL TRANSISTOR			R058	QRD167J-332	3.3K 1/6W CARBON RE	
	Q402	DTC144WS	DIGITAL TRANSISTOR			R059	QRD167J-332	3.3K 1/6W CARBON RE	
	Q403	DTC114YS	DIGITAL TRANSISTOR			R060	QRD167J-332	3.3K 1/6W CARBON RE	
	Q404	DTC114YS	DIGITAL TRANSISTOR			R063	QRD14CJ-151SX	150 1/4W UNF. CARBON	
	Q405	DTC144ES	DIGITAL TRANSISTOR		△	R064	QRD14CJ-100SX	10 1/4W UNF. CARBON	
	Q852	2SC2235 (O, Y)	SI. TRANSISTOR		△	R065	QRD14CJ-561SX	560 1/4W UNF. CARBON	
	Q853	DTC114YS	DIGITAL TRANSISTOR		△	R066	QRD14CJ-100SX	10 1/4W UNF. CARBON	

### ■ Electrical Parts List (ENC-130)

△	No.	Parts Number	Description	Area	△	No.	Parts Number	Description	Area
	R067	QRD14CJ-151SX	150 1/4W UNF. CARBON			R434	QRD161J-103	10K 1/6W CARBON RE	
	R068	QRD161J-391	390 1/6W CARBON RE			R435	QRD161J-103	10K 1/6W CARBON RE	
	R069	ERT-D2WHL202S	2K 1/4W NEGATIVE T			R437	QRD167J-223	22K 1/6W CARBON RE	
	R070	QRD161J-183	18K 1/6W CARBON RE			R438	QRD161J-471	470 1/6W CARBON RE	
	R071	QRD161J-123	12K 1/6W CARBON RE			R439	QRD161J-471	470 1/6W CARBON RE	
△	R072	QRD125J-330	33 1/2W UNF. CARBON			R440	QRD161J-103	10K 1/6W CARBON RE	
△	R077	QRG022J-562A	5.6K 2W OXIDE META			R441	QRD161J-471	470 1/6W CARBON RE	
	R078	QRD167J-751	750 1/6W CARBON RE			R442	QRD161J-471	470 1/6W CARBON RE	
	R083	QRD161J-102	1K 1/6W CARBON RE			R444	QRD161J-103	10K 1/6W CARBON RE	
	R087	QRD14CJ-152SX	1.5K 1/4W UNF. CARBON			R445	QRD161J-103	10K 1/6W CARBON RE	
	R088	QRD14CJ-152SX	1.5K 1/4W UNF. CARBON			R446	QRD161J-103	10K 1/6W CARBON RE	
△	R090	ERF032K-R22	0.22 3W CEM. RES.			R449	QRD161J-473	47K 1/6W CARBON RE	
	R095	QRD167J-151	150 1/6W CARBON RE			R452	QRD161J-103	10K 1/6W CARBON RE	
	R096	QRD167J-151	150 1/6W CARBON RE			R453	QRD161J-471	470 1/6W CARBON RE	
	R097	QRD167J-151	150 1/6W CARBON RE			R454	QRD161J-471	470 1/6W CARBON RE	
	R098	QRD167J-151	150 1/6W CARBON RE			R455	QRD161J-103	10K 1/6W CARBON RE	
	R291	QRD161J-221	220 1/6W CARBON RE			R456	QRD161J-104	100K 1/6W CARBON RE	
	R292	QRD161J-221	220 1/6W CARBON RE			R490	QRD161J-221	220 1/6W CARBON RE	
	R293	QRD161J-221	220 1/6W CARBON RE		△	R861	QRZ0076-3R3	3.3 1/4W FUSIBLE RE	
	R299	QRD161J-102	1K 1/6W CARBON RE		△	R862	QRV144F-1502	15K 1/4W CONST. META	
	R400	QRD161J-101	100 1/6W CARBON RE			R863	QRD161J-821	820 1/6W CARBON RE	
△	R401	QRD14CJ-220S	22 1/4W UNF. CARBON		△	R864	QRG012J-332A	3.3K 1W OXIDE META	
	R402	QRD161J-471	470 1/6W CARBON RE			R997	QRD161J-103	10K 1/6W CARBON RE	
	R403	QRD161J-471	470 1/6W CARBON RE			R998	QRD161J-103	10K 1/6W CARBON RE	
	R404	QRD161J-471	470 1/6W CARBON RE			R999	QRD161J-103	10K 1/6W CARBON RE	
	R405	QRD161J-471	470 1/6W CARBON RE			RA404	QRB049J-103	10K 1/10WRES.	
	R406	QRD161J-471	470 1/6W CARBON RE			RA405	QRB049J-103	10K 1/10WRES.	
	R407	QRD161J-471	470 1/6W CARBON RE				OTHERS		
	R408	QRD161J-471	470 1/6W CARBON RE				EMW10606-002	PRINTED BOARD	
	R409	QRD161J-471	470 1/6W CARBON RE				E67132-T8R0	FUSE LABEL	
	R410	QRD161J-471	470 1/6W CARBON RE				QWE880-14RR	VINYL WIRE	
	R411	QRD161J-471	470 1/6W CARBON RE				QWE881-13RR	VINYL WIRE	
	R412	QRD161J-471	470 1/6W CARBON RE				QWE882-18RR	VINYL WIRE	
	R413	QRD161J-471	470 1/6W CARBON RE				QWE883-16RR	VINYL WIRE	
	R414	QRD161J-471	470 1/6W CARBON RE				QWE884-18RR	VINYL WIRE	
	R415	QRD161J-471	470 1/6W CARBON RE				QWE886-16RR	PIN WIRE	
	R416	QRD161J-471	470 1/6W CARBON RE				QWE886-20RR	VINYL WIRE	
	R417	QRD161J-471	470 1/6W CARBON RE				QWE888-16RR	VINYL WIRE	
	R418	QRD161J-471	470 1/6W CARBON RE				SBST3008CC	TAPPING SCREW	
	R419	QRD161J-471	470 1/6W CARBON RE			J291	QMS3L10-0AO	MICROPHONE JACK	
	R420	QRD161J-471	470 1/6W CARBON RE			J292	QMS3L10-0AO	MICROPHONE JACK	
	R421	QRD161J-471	470 1/6W CARBON RE			J293	QMS3L10-0AO	MICROPHONE JACK	
	R422	QRD161J-471	470 1/6W CARBON RE			J295	EMN00TV-118A	PIN JACK	
	R423	QRD161J-471	470 1/6W CARBON RE			L051	EGL0011-R45J1	INDUCTOR	
	R425	QRD161J-471	470 1/6W CARBON RE			S400	ESP0001-023M	TACT SWITCH	
	R426	QRD161J-471	470 1/6W CARBON RE			S401	ESP0001-023M	TACT SWITCH	
	R427	QRD161J-471	470 1/6W CARBON RE			S402	ESP0001-023M	TACT SWITCH	
	R428	QRD161J-471	470 1/6W CARBON RE			S403	ESP0001-023M	TACT SWITCH	
	R429	QRD161J-103	10K 1/6W CARBON RE			S404	ESP0001-023M	TACT SWITCH	
	R430	QRD161J-221	220 1/6W CARBON RE			S405	ESP0001-023M	TACT SWITCH	
	R431	QRD161J-221	220 1/6W CARBON RE			S406	ESP0001-023M	TACT SWITCH	
	R432	QRD161J-471	470 1/6W CARBON RE			S407	ESP0001-023M	TACT SWITCH	
	R433	QRD161J-103	10K 1/6W CARBON RE			S408	ESP0001-023M	TACT SWITCH	



### ■ Electrical Parts List (ENC-130)

△	No.	Parts Number	Description	Area
	S409	ESP0001-023M	TACT SWITCH	
	S410	ESP0001-023M	TACT SWITCH	
	S411	ESP0001-023M	TACT SWITCH	
	S412	ESP0001-023M	TACT SWITCH	
	S414	ESP0001-023M	TACT SWITCH	
	S415	ESP0001-023M	TACT SWITCH	
	S416	ESP0001-023M	TACT SWITCH	
	S418	ESP0001-023M	TACT SWITCH	
	S490	ESP0001-023M	TACT SWITCH	
	S491	ESP0001-023M	TACT SWITCH	
	S492	ESP0001-023M	TACT SWITCH	
△	T002	ETP1000-41ZB	POWER TRASNFORMER	
	X400	ECXP6R0-001ZA	CRYSTAL	
	X401	ECXP6R0-001ZA	CRYSTAL	
△	AC001	QMACA002-E02S	AC OUTLET	U
	BK400	E309106-001SM	FL HOLDER	
	CN301	EWS268-A920J	SOCKET WIRE ASSY	
	CN302	EWS293-0118	SOCKET WIRE	
	CN402	EWS269-A210	SOCKET WIRE ASSY	
	CN403	EWS269-A422J	SOCKET WIRE ASSY	
	CN411	VMC0161-R35	CONNECT TERMINAL	
	CN412	EMV5109-009A	PIN PLUG	
	CN711	EMV5163-006R	CONNECT TERMINAL	
	CN804	VMC0177-003	CONNECT TERMINAL	
	DI400	ELU0001-215	FLUORESCENT DISPLAY TUB	
	EP001	EMZ4002-001Z	EARTH PLATE	
	FC001	EMG7331-003Z	FUSE CLIP	
	FC002	EMG7331-003Z	FUSE CLIP	
	FC003	EMG7331-003Z	FUSE CLIP	
	FC004	EMG7331-003Z	FUSE CLIP	
	FC007	EMG7331-003Z	FUSE CLIP	
	FC008	EMG7331-003Z	FUSE CLIP	
	FS001	E3400-444	FELT SPACER	
	FS002	E3400-444	FELT SPACER	
	HS800	E70945-H40B	HEAT SINK	
	JS400	QSJ4003-E01	PUSH SWITCH	
	JS401	QSJ4002-E01	PUSH SWITCH	
	JS490	QSJ4002-E01	PUSH SWITCH	
	RY002	ESK1D12-119J3	RELAY	
	SP400	VYH7653-001	SPRING	
	TA001	EMZ4001-001	TAB	
	TA002	EMZ4001-001	TAB	
	VS001	QSR8001-E01U	ROTARY SWITCH	

## ■ Electrical Parts List (ENH-283)

△	No.	Parts Number	Description	Area	△	No.	Parts Number	Description	Area
		I. C. S				C224	QCVB1CM-103Y	0.01MF 16V CER. CAP.	
	IC221	NJM2279D	I. C (MONO-ANALOG)			C225	QCZO205-155	1.5MF 25V C. CAP.	
	IC222	M35012-120SP	I. C (M)			C226	QETB1HM-105	1MF 50V AL E. CAP.	
	IC301	VC4580DD	I. C (MONO-ANALOG)			C227	QCS21HJ-100	10PF 50V CER. CAP.	
	IC305	TC9177P	I. C (DIGI-MOS)			C228	QCS21HJ-100	10PF 50V CER. CAP.	
	IC306	VC4580LD	I. C (MONO-ANALOG)			C229	QCS21HJ-150	15PF 50V CER. CAP.	
	IC307	TC9177P	I. C (DIGI-MOS)			C230	QCS21HJ-270	27PF 50V CER. CAP.	
	IC308	VC4580LD	I. C (MONO-ANALOG)			C231	QETB1HM-106	10MF 50V E. CAP.	
	IC311	BA15218N	I. C (MONO-ANALOG)			C232	QETB1HM-106	10MF 50V E. CAP.	
	IC321	TC9274N-007	I. C (M)			C233	QETB1HM-106	10MF 50V E. CAP.	
	IC331	VC4580LD	I. C (MONO-ANALOG)			C234	QCS21HJ-470	47PF 50V CER. CAP.	
	IC601	LA2785	I. C (M)			C235	QCS21HJ-470	47PF 50V CER. CAP.	
	IC641	LV1011	I. C (M)			C251	QETB1HM-227	220MF 50V E. CAP.	
		DIODES				C252	QETB1JM-227	220MF 63V AL E. CAP.	
	D222	1SS133	SI. DIODE			C253	QETB1HM-105	1MF 50V AL E. CAP.	
	D223	1SS133	SI. DIODE			C254	QETB1HM-226E	22MF 50V E. CAP.	
	D225	MTZ12JC	ZENER DIODE			C255	QETB1HM-226E	22MF 50V E. CAP.	
	D226	MTZ12JC	ZENER DIODE			C259	QFLB1HJ-473	0.047MF 50V MYLAR CAP.	
	D251	MTZ6.2JC	ZENER DIODE			C260	QFLB1HJ-473	0.047MF 50V MYLAR CAP.	
	D252	1SR139-200	SI. DIODE			C262	QETB1VM-228N	2200MF 35V E. CAP.	
	D253	1SR139-200	SI. DIODE			C264	QFN82AJ-104	0.1MF 100V MYLAR CAP.	
	D254	MTZ39JCT-77	ZENER DIODE			C265	QFN82AJ-104	0.1MF 100V MYLAR CAP.	
	D255	1SR139-200	SI. DIODE			C266	QETB1HM-225	2.2MF 50V AL E. CAP.	
	D261	1SR139-200	SI. DIODE			C267	QFN82AJ-104	0.1MF 100V MYLAR CAP.	
	D262	1SR139-200	SI. DIODE			C268	QETB1VM-228N	2200MF 35V E. CAP.	
△	D263	10E2-FD	DIODE			C300	QCF21HP-223A	0.022MF 50V CER. CAP.	
△	D264	10E2-FD	DIODE			C301	QETB1HM-475E	4.7MF 50V E. CAP.	
	D265	1SS133	SI. DIODE			C302	QETB1HM-475E	4.7MF 50V E. CAP.	
	D880	30D2FC	GE. DIODE			C303	QCS21HJ-101A	100PF 50V CER. CAP.	
	D881	30D2FC	GE. DIODE			C304	QCS21HJ-101A	100PF 50V CER. CAP.	
	D882	30D2FC	GE. DIODE			C305	QFLB1HJ-182	1800PF 50V MYLAR CAP.	
	D883	30D2FC	GE. DIODE			C306	QFLB1HJ-182	1800PF 50V MYLAR CAP.	
	D884	30D2FC	GE. DIODE			C307	QFLB1HJ-682	6800PF 50V MYLAR CAP.	
	D885	30D2FC	GE. DIODE			C308	QFLB1HJ-682	6800PF 50V MYLAR CAP.	
	D886	30D2FC	GE. DIODE			C309	QCS21HJ-101A	100PF 50V CER. CAP.	
	D887	30D2FC	GE. DIODE			C310	QCS21HJ-101A	100PF 50V CER. CAP.	
	D888	1SS133	SI. DIODE			C311	QETB1HM-475E	4.7MF 50V E. CAP.	
		TRANSISTORS				C312	QETB1HM-475E	4.7MF 50V E. CAP.	
	Q221	DTC114YS	DIGITAL TRANSISTOR			C313	QETB1AM-107	100MF 10V AL E. CAP.	
	Q251	2SB1357 (E, F)	SI. TRANSISTOR			C314	QETB1AM-107	100MF 10V AL E. CAP.	
	Q252	2SC2240 (GR, BL)	SI. TRANSISTOR			C315	QETB1CM-476	47MF 16V AL E. CAP.	
	Q253	DTC114YS	DIGITAL TRANSISTOR			C316	QETB1CM-476	47MF 16V AL E. CAP.	
	Q254	DTA144ES	DIGITAL TRANSISTOR			C319	QCF21HP-223A	0.022MF 50V CER. CAP.	
	Q255	DTC114ES	DIGITAL TRANSISTOR			C320	QCF21HP-223A	0.022MF 50V CER. CAP.	
	Q301	2SD2144S (VW)	SI. TRANSISTOR			C321	QETB1EM-226N	22MF 25V E. CAP.	
	Q302	2SD2144S (VW)	SI. TRANSISTOR			C322	QETB1EM-226N	22MF 25V E. CAP.	
	Q303	DTA144ES	DIGITAL TRANSISTOR			C341	QETB1HM-475E	4.7MF 50V E. CAP.	
	Q305	2SD2144S (VW)	SI. TRANSISTOR			C342	QETB1HM-475E	4.7MF 50V E. CAP.	
	Q306	2SD2144S (VW)	SI. TRANSISTOR			C345	QETB1EM-226N	22MF 25V E. CAP.	
		CAPACITORS				C346	QETB1EM-226N	22MF 25V E. CAP.	
	C221	QETB0JM-477	470MF 6.3V AL E. CAP.			C347	QCF21HP-223A	0.022MF 50V CER. CAP.	
	C222	QETB1CM-476	47MF 16V AL E. CAP.			C348	QCF21HP-223A	0.022MF 50V CER. CAP.	
	C223	QCVB1CM-103Y	0.01MF 16V CER. CAP.			C351	QETB1HM-475E	4.7MF 50V E. CAP.	

### ■ Electrical Parts List (ENH-283)

△	No.	Parts Number	Description	Area	△	No.	Parts Number	Description	Area
	C352	QETB1HM-475E	4. 7MF 50V E. CAP.			C631	QETB1EM-476	47MF 25V AL E. CAP.	
	C353	QETB1HM-475E	4. 7MF 50V E. CAP.			C632	QFV71HJ-474ZM	0. 47MF 50V THIN FILM	
	C354	QETB1HM-475E	4. 7MF 50V E. CAP.			C633	QCS31HJ-681Z	680PF 50V CER. CAP.	
	C355	QETB0JM-107	100MF 6. 3V AL E. CAP.			C634	QETB1EM-227	220MF 25V AL E. CAP.	
	C359	QETB1HM-475E	4. 7MF 50V E. CAP.			C641	QETB1EM-106	10MF 25V AL E. CAP.	
	C360	QETB1HM-475E	4. 7MF 50V E. CAP.			C643	QETB1HM-225	2. 2MF 50V AL E. CAP.	
	C361	QETB1HM-475E	4. 7MF 50V E. CAP.			C644	QETB1EM-227	220MF 25V AL E. CAP.	
	C362	QETB1HM-475E	4. 7MF 50V E. CAP.			C645	QFN81HJ-333	0. 033MF 50V MYLAR CAP.	
	C375	QCF21HP-223A	0. 022MF 50V CER. CAP.			C646	QFN81HJ-152	1500PF 50V METAL. MYLA	
	C376	QCF21HP-223A	0. 022MF 50V CER. CAP.			C647	QFN81HJ-333	0. 033MF 50V MYLAR CAP.	
	C377	QCBB1HK-181Y	180PF 50V CER. CAP.			C648	QETB1HM-105	1MF 50V AL E. CAP.	
	C378	QCBB1HK-181Y	180PF 50V CER. CAP.			C649	QCF21HP-223A	0. 022MF 50V CER. CAP.	
	C379	QFLB1HJ-333	0. 033MF 50V MYLAR CAP.			C650	QETB1EM-227	220MF 25V AL E. CAP.	
	C380	QFLB1HJ-333	0. 033MF 50V MYLAR CAP.			C651	QCS21HJ-300	30PF 50V CER. CAP.	
	C381	QETB1HM-475E	4. 7MF 50V E. CAP.			C652	QCS21HJ-300	30PF 50V CER. CAP.	
	C382	QETB1HM-475E	4. 7MF 50V E. CAP.			C661	QETB1HM-475E	4. 7MF 50V E. CAP.	
	C383	QETB1HM-105	1MF 50V AL E. CAP.			C662	QETB1HM-475E	4. 7MF 50V E. CAP.	
	C384	QETB1HM-105	1MF 50V AL E. CAP.			C881	QCE22HP-103A	0. 01MF 500V CER. CAP.	
	C385	QETB1EM-106	10MF 25V AL E. CAP.			C882	QCE22HP-103A	0. 01MF 500V CER. CAP.	
	C386	QETB1EM-106	10MF 25V AL E. CAP.			C883	QCE22HP-103A	0. 01MF 500V CER. CAP.	
	C387	QETB1HM-475E	4. 7MF 50V E. CAP.			C884	QCE22HP-103A	0. 01MF 500V CER. CAP.	
	C388	QETB1HM-475E	4. 7MF 50V E. CAP.			C885	QCE22HP-103A	0. 01MF 500V CER. CAP.	
	C391	QCF21HP-223A	0. 022MF 50V CER. CAP.			C886	QCE22HP-103A	0. 01MF 500V CER. CAP.	
	C392	QCF21HP-223A	0. 022MF 50V CER. CAP.				RESISTORS		
	C395	QCBB1HK-561Y	560PF 50V CER. CAP.			R221	QRD161J-750	75 1/6W CARBON RE	
	C601	QETB1HM-105	1MF 50V AL E. CAP.			R222	QRD161J-750	75 1/6W CARBON RE	
	C602	QETB1HM-105	1MF 50V AL E. CAP.			R223	QRD161J-750	75 1/6W CARBON RE	
	C603	QFLB1HJ-104	0. 1MF 50V MYLAR CAP.			R224	QRD161J-750	75 1/6W CARBON RE	
	C604	QFLB1HJ-104	0. 1MF 50V MYLAR CAP.			R225	QRD167J-332	3. 3K 1/6W CARBON RE	
	C605	QFLB1HJ-104	0. 1MF 50V MYLAR CAP.			R226	QRD167J-332	3. 3K 1/6W CARBON RE	
	C606	QFLB1HJ-104	0. 1MF 50V MYLAR CAP.			R227	QRD161J-103	10K 1/6W CARBON RE	
	C607	QETB1HM-474	0. 47MF 50V E. CAP.			R228	QRD161J-104	100K 1/6W CARBON RE	
	C608	QETB1HM-474	0. 47MF 50V E. CAP.			R229	QRD161J-102	1K 1/6W CARBON RE	
	C609	QETB1HM-475E	4. 7MF 50V E. CAP.			R235	QRD161J-331	330 1/6W CARBON RE	
	C610	QETB1HM-475E	4. 7MF 50V E. CAP.			R236	QRD161J-331	330 1/6W CARBON RE	
	C611	QETB1HM-474	0. 47MF 50V E. CAP.		△	R251	PTH61G25AR4R7M	POSITIVE T	
	C612	QETB1HM-474	0. 47MF 50V E. CAP.			R252	QRD167J-152	1. 5K 1/6W CARBON RE	
	C613	QETB1HM-475E	4. 7MF 50V E. CAP.			R253	QRD167J-223	22K 1/6W CARBON RE	
	C614	QETB1HM-475E	4. 7MF 50V E. CAP.			R254	QRD161J-104	100K 1/6W CARBON RE	
	C615	QFV81HJ-154	0. 15MF 50V THIN FILM		△	R255	QRD14CJ-100SX	10 1/4W UNF. CARBON	
	C616	QFV81HJ-154	0. 15MF 50V THIN FILM		△	R262	QRX012J-2R2AF	2. 2 1W METAL FILM	
	C617	QETB1HM-335	3. 3MF 50V AL E. CAP.			R263	QRD167J-562	5. 6K 1/6W CARBON RE	
	C618	QETB1HM-335	3. 3MF 50V AL E. CAP.			R264	QRD167J-822	8. 2K 1/6W CARBON RE	
	C619	QFV81HJ-154	0. 15MF 50V THIN FILM			R265	QRD161J-103	10K 1/6W CARBON RE	
	C620	QFV81HJ-154	0. 15MF 50V THIN FILM		△	R266	QRD14CJ-2R2SX	2. 2 1/4W UNF. CARBON	
	C621	QFN81HJ-223	0. 022MF 50V METAL. MYLA			R301	QRD161J-222	2. 2K 1/6W CARBON RE	
	C622	QFN81HJ-473	0. 047MF 50V METAL. MYLA			R302	QRD161J-222	2. 2K 1/6W CARBON RE	
	C623	QETB1EM-227	220MF 25V AL E. CAP.			R303	QRD161J-473	47K 1/6W CARBON RE	
	C624	QETB1EM-106	10MF 25V AL E. CAP.			R304	QRD161J-473	47K 1/6W CARBON RE	
	C625	QETB1EM-106	10MF 25V AL E. CAP.			R305	QRD161J-561	560 1/6W CARBON RE	
	C626	QETB1EM-106	10MF 25V AL E. CAP.			R306	QRD161J-561	560 1/6W CARBON RE	
	C627	QETB1EM-106	10MF 25V AL E. CAP.			R307	QRD161J-393	39K 1/6W CARBON RE	
	C628	QETB1EM-227	220MF 25V AL E. CAP.			R308	QRD161J-393	39K 1/6W CARBON RE	

### ■ Electrical Parts List (ENH-283)

△	No.	Parts Number	Description	Area	△	No.	Parts Number	Description	Area
	R309	QRD161J-474	470K 1/6W CARBON RE			R375	QRD161J-102	1K 1/6W CARBON RE	
	R310	QRD161J-474	470K 1/6W CARBON RE			R376	QRD167J-562	5.6K 1/6W CARBON RE	
	R311	QRD161J-104	100K 1/6W CARBON RE			R377	QRD161J-102	1K 1/6W CARBON RE	
	R312	QRD161J-104	100K 1/6W CARBON RE			R378	QRD161J-102	1K 1/6W CARBON RE	
△	R313	QRD14CJ-391SX	390 1/4W UNF. CARBON			R379	QRD161J-102	1K 1/6W CARBON RE	
△	R314	QRD14CJ-391SX	390 1/4W UNF. CARBON			R380	QRD161J-102	1K 1/6W CARBON RE	
△	R321	QRZ0077-680	68 1/4W FUSIBLE RE			R381	QRD161J-104	100K 1/6W CARBON RE	
△	R322	QRZ0077-680	68 1/4W FUSIBLE RE			R382	QRD161J-104	100K 1/6W CARBON RE	
	R325	QRD161J-471	470 1/6W CARBON RE			R387	QRD161J-105	1M 1/6W CARBON RE	
	R326	QRD161J-471	470 1/6W CARBON RE			R388	QRD161J-105	1M 1/6W CARBON RE	
	R327	QRD161J-471	470 1/6W CARBON RE			R389	QRD161J-103	10K 1/6W CARBON RE	
	R328	QRD161J-471	470 1/6W CARBON RE			R390	QRD161J-103	10K 1/6W CARBON RE	
	R329	QRD161J-471	470 1/6W CARBON RE		△	R391	QRZ0077-680	68 1/4W FUSIBLE RE	
	R330	QRD161J-471	470 1/6W CARBON RE		△	R392	QRZ0077-680	68 1/4W FUSIBLE RE	
	R331	QRD161J-471	470 1/6W CARBON RE			R641	QRD161J-102	1K 1/6W CARBON RE	
	R332	QRD161J-471	470 1/6W CARBON RE			R642	QRD161J-102	1K 1/6W CARBON RE	
	R333	QRD161J-471	470 1/6W CARBON RE			R643	QRD161J-203	20K 1/6W CARBON RE	
	R334	QRD161J-471	470 1/6W CARBON RE			R644	QRD161J-393	39K 1/6W CARBON RE	
	R335	QRD161J-471	470 1/6W CARBON RE			R651	QRD161J-105	1M 1/6W CARBON RE	
	R336	QRD161J-471	470 1/6W CARBON RE		△	R653	QRG022J-680AM	68 2W OXIDE META	
	R337	QRD161J-471	470 1/6W CARBON RE			R661	QRD161J-333	33K 1/6W CARBON RE	
	R338	QRD161J-471	470 1/6W CARBON RE			R662	QRD161J-333	33K 1/6W CARBON RE	
	R341	QRD161J-104	100K 1/6W CARBON RE			R663	QRD161J-103	10K 1/6W CARBON RE	
	R342	QRD161J-104	100K 1/6W CARBON RE			R664	QRD161J-103	10K 1/6W CARBON RE	
	R343	QRD161J-104	100K 1/6W CARBON RE			R665	QRD161J-104	100K 1/6W CARBON RE	
	R344	QRD161J-104	100K 1/6W CARBON RE			R666	QRD161J-104	100K 1/6W CARBON RE	
	R347	QRD161J-102	1K 1/6W CARBON RE		△	R881	QRX012J-R22A	0.22 1W METAL FILM	
	R348	QRD161J-102	1K 1/6W CARBON RE		△	R882	QRX012J-R22A	0.22 1W METAL FILM	
△	R349	QRZ0077-680	68 1/4W FUSIBLE RE				OTHERS		
△	R350	QRZ0077-680	68 1/4W FUSIBLE RE				EMW10607-002	PRINTED BOARD	
	R351	QRD161J-104	100K 1/6W CARBON RE			J221	EMN00TV-116A	PIN JACK	
	R352	QRD161J-104	100K 1/6W CARBON RE			J222	EMN01TV-102A	PIN JACK	
	R353	QRD161J-392	3.9K 1/6W CARBON RE			J223	EMN00YV-217A	PIN JACK	
	R354	QRD161J-392	3.9K 1/6W CARBON RE			J301	EMN00TV-422AJ2	PIN JACK	
	R355	QRD161J-103	10K 1/6W CARBON RE			J302	EMN00TV-622AJ2	PIN JACK	
	R356	QRD161J-103	10K 1/6W CARBON RE			J303	EMN00TV-622AJ2	PIN JACK	
△	R357	QRZ0077-680	68 1/4W FUSIBLE RE			L221	EQL4007-220	INDUCTOR	
△	R358	QRZ0077-680	68 1/4W FUSIBLE RE			X221	ECX0177-344EWT	CRYSTAL	
	R359	QRD161J-104	100K 1/6W CARBON RE			X641	ECXP8R0-001Z	CRYSTAL	
	R360	QRD161J-104	100K 1/6W CARBON RE			CN305	EWS293-0113	SOCKET WIRE ASSY	
	R361	QRD161J-104	100K 1/6W CARBON RE			CN312	VMC0075-003	CONNECTOR	
	R362	QRD161J-104	100K 1/6W CARBON RE			CN315	VMC0075-003	CONNECTOR	
	R363	QRD161J-563	56K 1/6W CARBON RE			CN413	EMV5109-009A	PIN PLUG	
	R364	QRD161J-563	56K 1/6W CARBON RE			CN511	EMV5163-010R	CONNECT TERMINAL	
	R365	QRD161J-105	1M 1/6W CARBON RE			CN611	EMV5163-014R	CONNECT TERMINAL	
	R366	QRD161J-105	1M 1/6W CARBON RE			CN612	EMV5163-007R	CONNECT TERMINAL	
	R367	QRD161J-563	56K 1/6W CARBON RE			CN802	EWS273-005	SOCKET WIRE ASSY	
	R368	QRD161J-563	56K 1/6W CARBON RE			CN803	VMC0177-003	CONNECT TERMINAL	
	R369	QRD161J-105	1M 1/6W CARBON RE			CN805	EMV7163-007	CONNECT TERMINAL	
	R370	QRD161J-105	1M 1/6W CARBON RE			CN811	EMV5163-007R	CONNECT TERMINAL	
	R371	QRD161J-103	10K 1/6W CARBON RE			CN815	EMV5163-007R	CONNECT TERMINAL	
	R372	QRD161J-103	10K 1/6W CARBON RE			EP250	EMZ4002-001Z	EARTH PLATE	
	R373	QRD167J-562	5.6K 1/6W CARBON RE			FC881	EMG7331-003Z	FUSE CLIP	

## ■ Electrical Parts List (ENH-283)

△	No.	Parts Number	Description	Area
	FC882	EMG7331-003Z	FUSE CLIP	
	FC883	EMG7331-003Z	FUSE CLIP	
	FC884	EMG7331-003Z	FUSE CLIP	
	FS225	E3400-431	FELT SPACER	
	FW211	EWR37D-13SS	CORD	
	LA851	E67132-T2R0	FUSE LABEL	
	LA852	E67132-T2R0	FUSE LABEL	
	RY880	ESK1D12-119J3	RELAY	
	RY881	ESK1D12-119J3	RELAY	

■ Accessories List

△	No.	Parts Number	Parts Name	Q'ty	Description	Area
	1	E30580-2413A	INSTRUCTION BOOK	1		
	2	RM-SR718U	WIRE-LESS REMOTE CONTROL	1		
	3	R6PRPA-2STSA	DRY CELL	1		
	4	EQB4001-015	LOOP ANTENNA	1		
	5	EWP201-011	ANTENNA WIRE	1		
	6	E309758-001	POLY BAG	1		
△	-	ENZ2202-001	SIEMENS PLUG	1		US
△	-	ENZ2203-001	ADAPTOR PLUG	1		U

# Packing Materials and Parts List

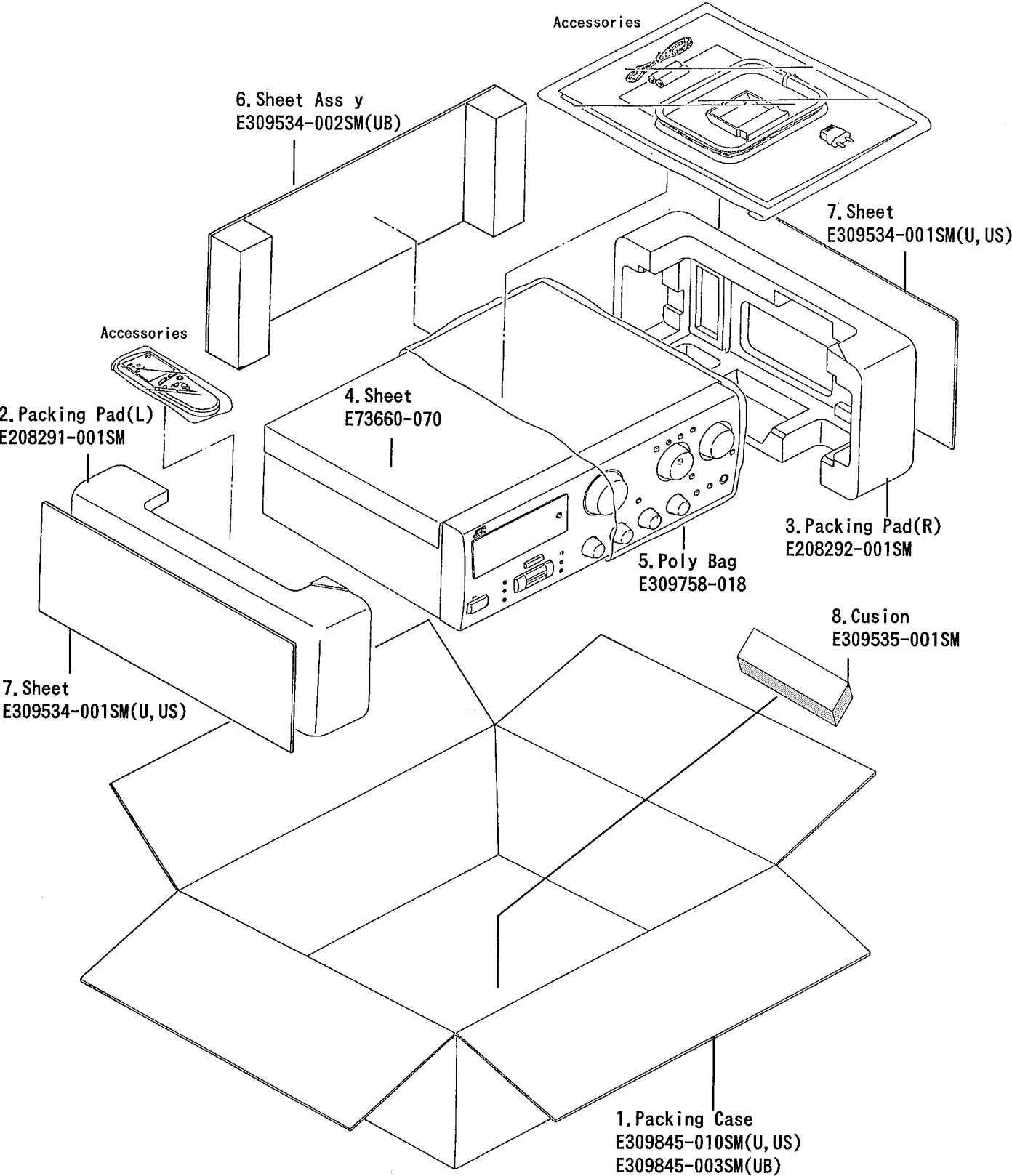







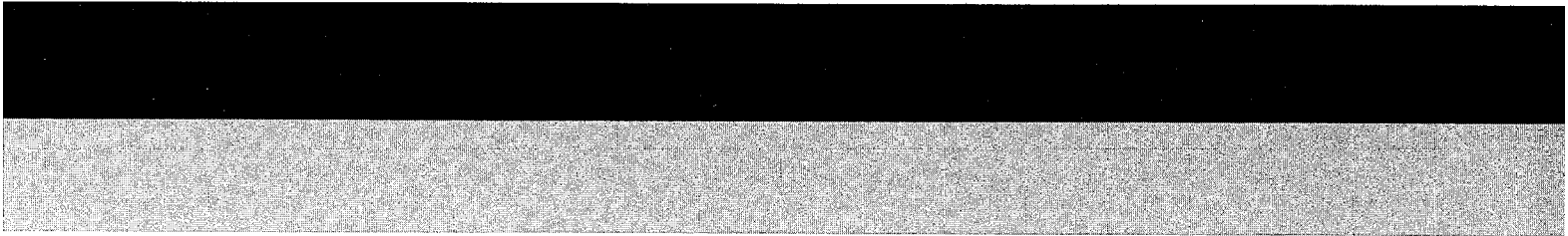

**JVC**

VICTOR COMPANY OF JAPAN, LIMITED  
AUDIO PRODUCT DIVISION, , 1644, SHIMOTSURUMA, YAMATO - SHI, KANAGAWA - KEN, 242, JAPAN