

JVC

SERVICE MANUAL

AUDIO/VIDEO CONTROL RECEIVER

RX-8012VSL RX-8010VBK

Area Suffix
RX-8012VSL UW---Brazil, Mexico, Peru
RX-8010VBK UJ----- U.S.Military

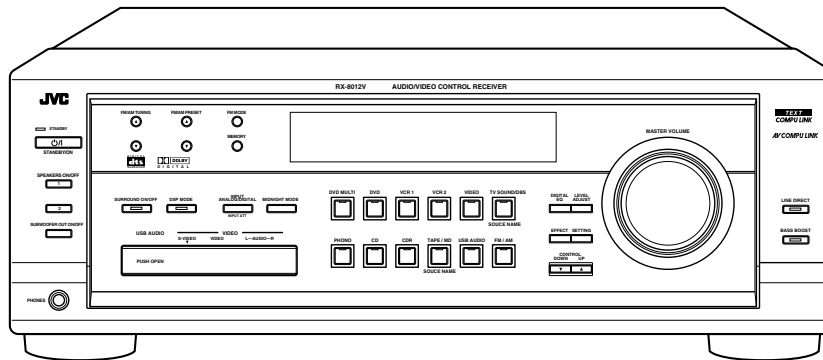
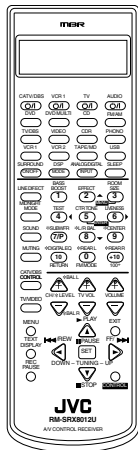

AV COMPULINK

**TEXT
COMPU LINK**

DIGITAL
dts
SURROUND

DOLBY
DIGITAL

Model	Color
RX-8012VSL	Silver
RX-8010VBK	Black

Contents

Safety precautions	1-2
Disassembly method	1-3
Adjustment method	1-9
Self-diagnose function	1-10
Description of major ICs	1-12~28



Safety Precautions

1. This design of this product contains special hardware and many circuits and components specially for safety purposes. For continued protection, no changes should be made to the original design unless authorized in writing by the manufacturer. Replacement parts must be identical to those used in the original circuits. Services should be performed by qualified personnel only.
2. Alterations of the design or circuitry of the product should not be made. Any design alterations of the product should not be made. Any design alterations or additions will void the manufacturer's warranty and will further relieve the manufacture of responsibility for personal injury or property damage resulting therefrom.
3. Many electrical and mechanical parts in the products have special safety-related characteristics. These characteristics are often not evident from visual inspection nor can the protection afforded by them necessarily be obtained by using replacement components rated for higher voltage, wattage, etc. Replacement parts which have these special safety characteristics are identified in the Parts List of Service Manual. Electrical components having such features are identified by shading on the schematics and by (\triangle) on the Parts List in the Service Manual. The use of a substitute replacement which does not have the same safety characteristics as the recommended replacement parts shown in the Parts List of Service Manual may create shock, fire, or other hazards.
4. The leads in the products are routed and dressed with ties, clamps, tubings, barriers and the like to be separated from live parts, high temperature parts, moving parts and/or sharp edges for the prevention of electric shock and fire hazard. When service is required, the original lead routing and dress should be observed, and it should be confirmed that they have been returned to normal, after re-assembling.

5. Leakage current check (Electrical shock hazard testing)

After re-assembling the product, always perform an isolation check on the exposed metal parts of the product (antenna terminals, knobs, metal cabinet, screw heads, headphone jack, control shafts, etc.) to be sure the product is safe to operate without danger of electrical shock.

Do not use a line isolation transformer during this check.

- Plug the AC line cord directly into the AC outlet. Using a "Leakage Current Tester", measure the leakage current from each exposed metal parts of the cabinet, particularly any exposed metal part having a return path to the chassis, to a known good earth ground. Any leakage current must not exceed 0.5mA AC (r.m.s.).

● Alternate check method

Plug the AC line cord directly into the AC outlet. Use an AC voltmeter having, 1,000 ohms per volt or more sensitivity in the following manner. Connect a 1,500 Ω 10W resistor paralleled by a 0.15 μ F AC-type capacitor between an exposed metal part and a known good earth ground. Measure the AC voltage across the resistor with the AC voltmeter.

Move the resistor connection to each exposed metal part, particularly any exposed metal part having a return path to the chassis, and measure the AC voltage across the resistor. Now, reverse the plug in the AC outlet and repeat each measurement. Voltage measured any must not exceed 0.75 V AC (r.m.s.). This corresponds to 0.5 mA AC (r.m.s.).

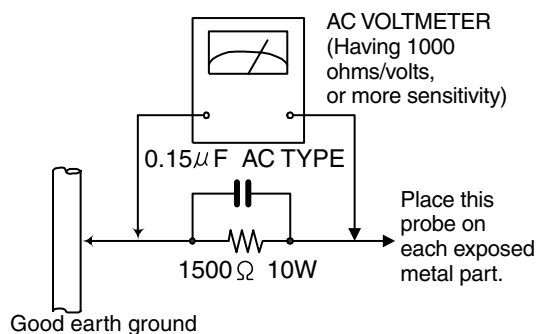

Warning

1. This equipment has been designed and manufactured to meet international safety standards.
2. It is the legal responsibility of the repairer to ensure that these safety standards are maintained.
3. Repairs must be made in accordance with the relevant safety standards.
4. It is essential that safety critical components are replaced by approved parts.
5. If mains voltage selector is provided, check setting for local voltage.

CAUTION

Burrs formed during molding may be left over on some parts of the chassis. Therefore, pay attention to such burrs in the case of preforming repair of this system.

In regard with component parts appearing on the silk-screen printed side (parts side) of the PWB diagrams, the parts that are printed over with black such as the resistor (■), diode (▣) and ICP (●) or identified by the " \triangle " mark nearby are critical for safety.

When replacing them, be sure to use the parts of the same type and rating as specified by the manufacturer. (Except the J&C version)

Disassembly method

■ Removing the top cover (See Fig.1)

1. Remove the four screws **A** attaching the top cover on both sides of the body.
2. Remove the three screws **B** on the back of the body.
3. Remove the top cover from behind in the direction of the arrow while pulling both sides outward.

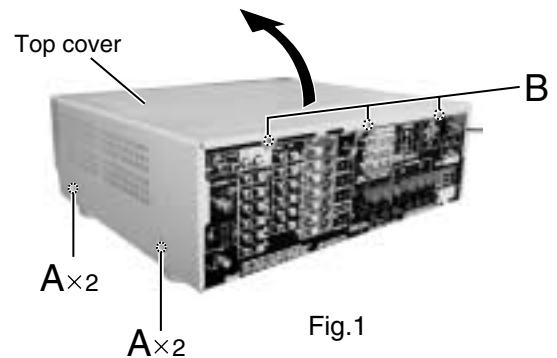

■ Removing the front panel assembly (See Fig.2 to 3)

- Prior to performing the following procedure, remove the top cover.
1. Disconnect the card wire from connector CN400 on the audio board and CN402 on the power supply board in the front panel assembly.
 2. Cut off the tie band fixing the harness.
 3. Remove the three screws **C** attaching the front panel assembly.
 4. Remove the four screws **D** attaching the front panel assembly on the bottom of the body. Detach the front panel assembly toward the front.

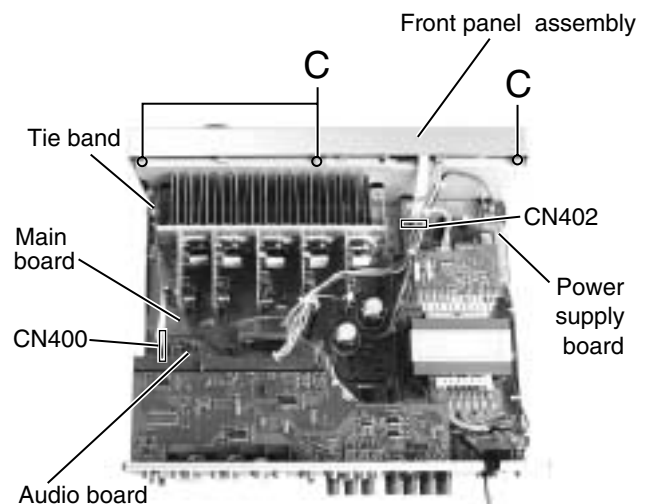

Fig.2

■ Removing the voltage selector (See Fig.4)

- Prior to performing the following procedure, remove the top cover.
1. Remove the power cord stopper from the rear panel by moving it in the direction of the arrow.
 2. Remove the two screws **F'** attaching the rear panel on the back of the body.

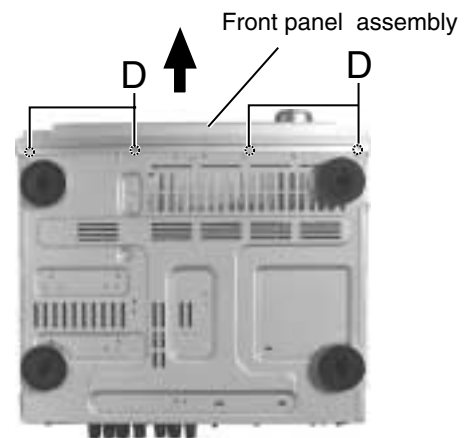

Fig.3

■ Removing the rear panel (See Fig.4)

- Prior to performing the following procedure, remove the top cover.
1. Remove the power cord stopper from the rear panel by moving it in the direction of the arrow.
 2. Remove the thirty four screws **E** attaching the each boards to the rear panel on the back of the body.
 3. Remove the three screws **F** attaching the rear panel on the back of the body.

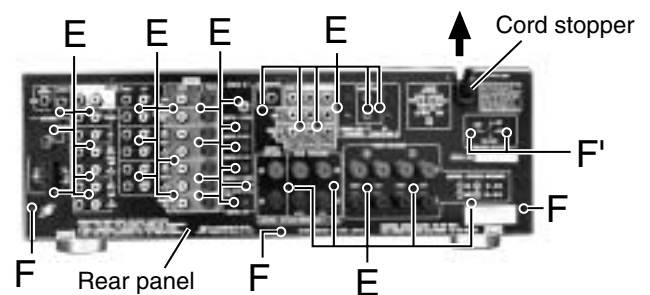
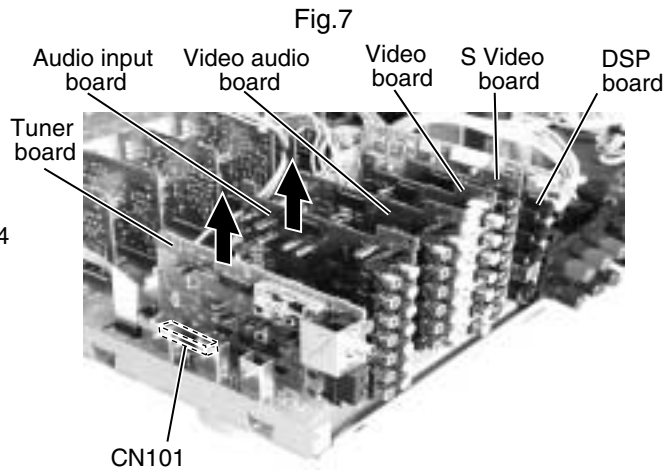
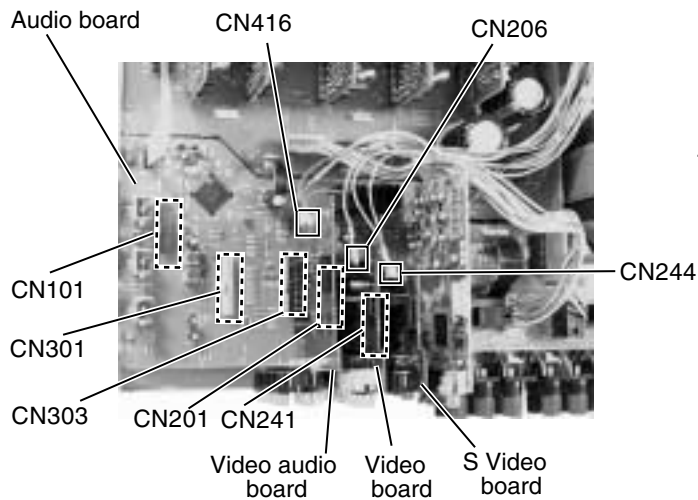
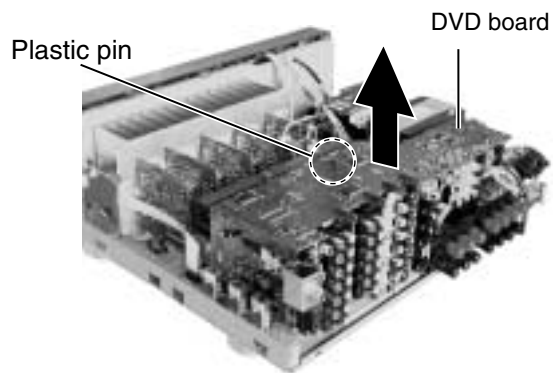
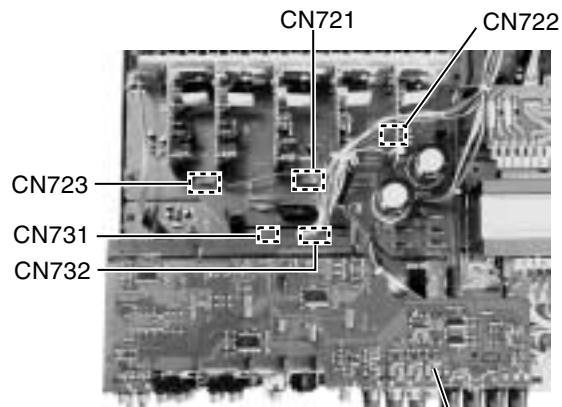
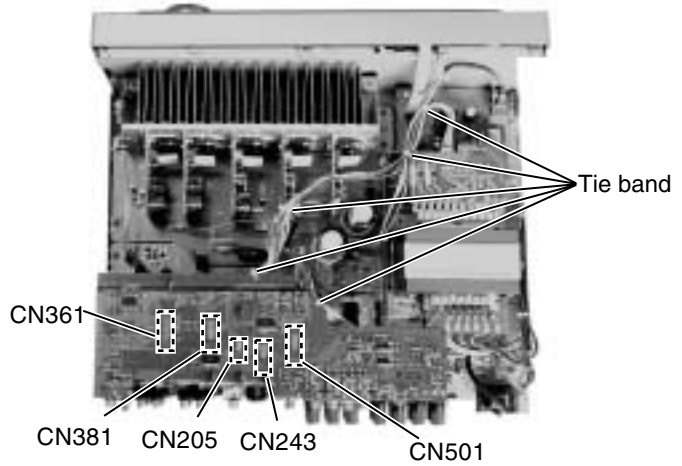

Fig.4

■ Removing each board connected to the rear side of the audio board
(See Fig.5 to 11)

• Prior to performing the following procedure, remove the top cover and the rear panel.

1. Cut off the tie band fixing the harness.
2. Disconnect the connect CN501, CN243, CN205, CN381, CN361 on the DVD board.
3. Disconnect the harness from connector CN721, CN722 and CN723.
4. Disconnect the tuner board and audio input board from connector CN101 and CN301 on the audio board.
5. Disconnect the video audio board and video board from connector CN303 and CN201 on the audio board.
6. Disconnect the S video board from connector CN241 on the audio board.
7. Disconnect the DSP board from connector CN601 on the audio board.
8. Pull out the plastic pin which prevents from coming out.



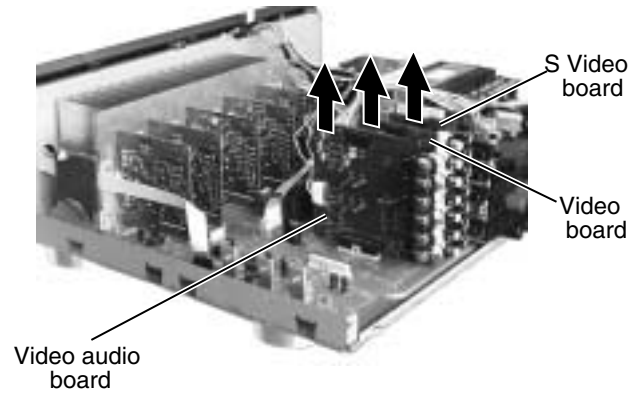

Fig.10

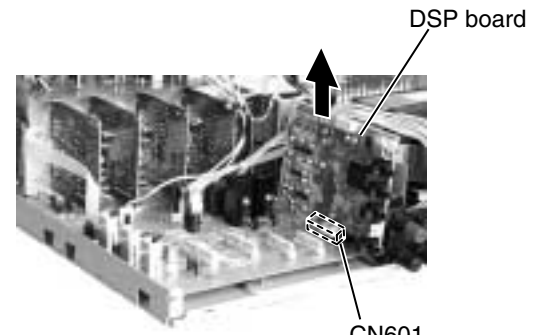

Fig.11

■ Removing the audio board
(See Fig.12 to 13)

• Prior to performing the following procedure, remove the top cover and the tuner board, audio input board, video audio board, video board, S-video board, DVD board and the rear panel.

1. Disconnect the harness from connector CN813 and CN814 on the main board.
2. Disconnect the card wire from connector CN931 and CN932 on the audio board.
3. Cut off the tie band fixing the harness.
4. Disconnect the relay board from the audio board and the power supply board. (CN71, CN81)
5. Disconnect the card wire from connector CN831 on the main board.
6. Remove the three screws **G** attaching the audio board.
7. Remove the screw **H** attaching the audio board .

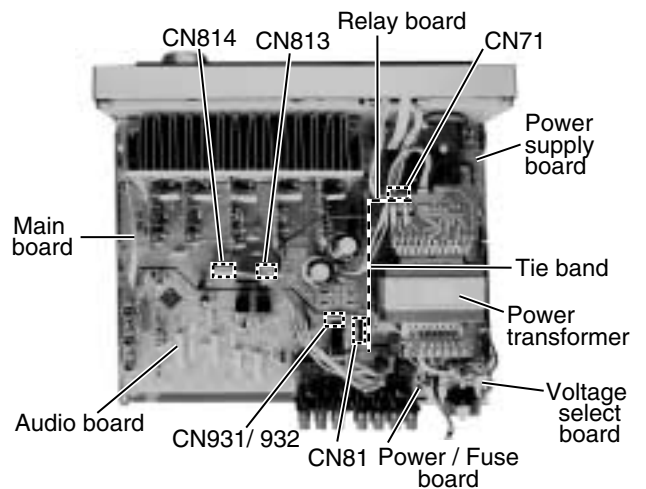

Fig.12

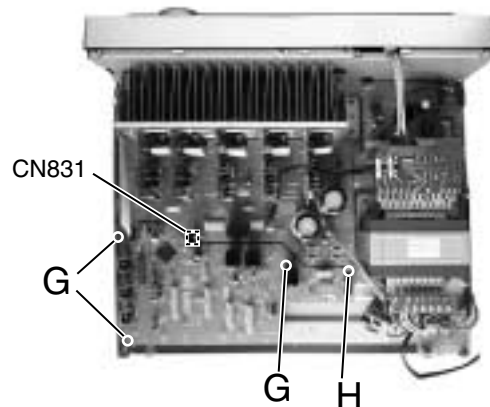

Fig.13

■ Removing the main board (See Fig.14)

• Prior to performing the following procedure, remove the top cover, the rear panel and audio board.

1. Cut off the tie band fixing the harness.
2. Disconnect the harness from connector CN811 on the power supply board respectively.
3. Disconnect the harness from connector CN881 on the main board.
4. Remove the four screws **I** and the four screws **J** attaching the main board.

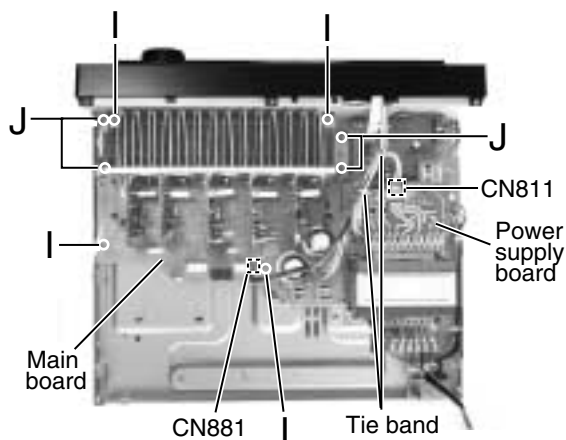

Fig.14

■ Removing the heat sink (See Fig.15 to 16)

1. Remove the ten screws **K** and four screws **L** attaching the heat sink.
2. Remove the two screws **L'** attaching the heat sink from the rear side of main board.

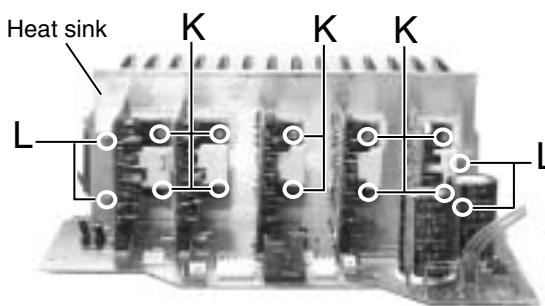

Fig.15

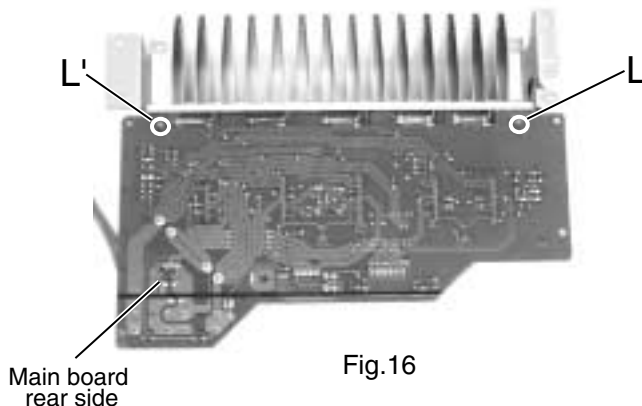

Fig.16

■ Removing the voltage select board (See Fig.17)

• Prior to performing the following procedures, remove the top cover and the rear panel.

1. Cut off the tie band fixing the harness.
2. Unsolder the six harnesses connected to the power transformer.

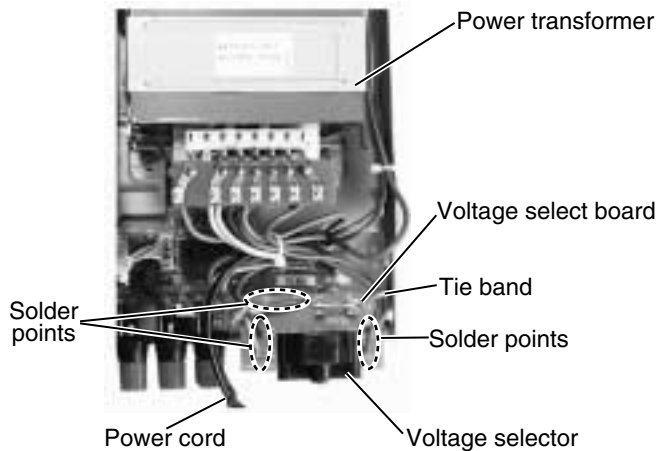
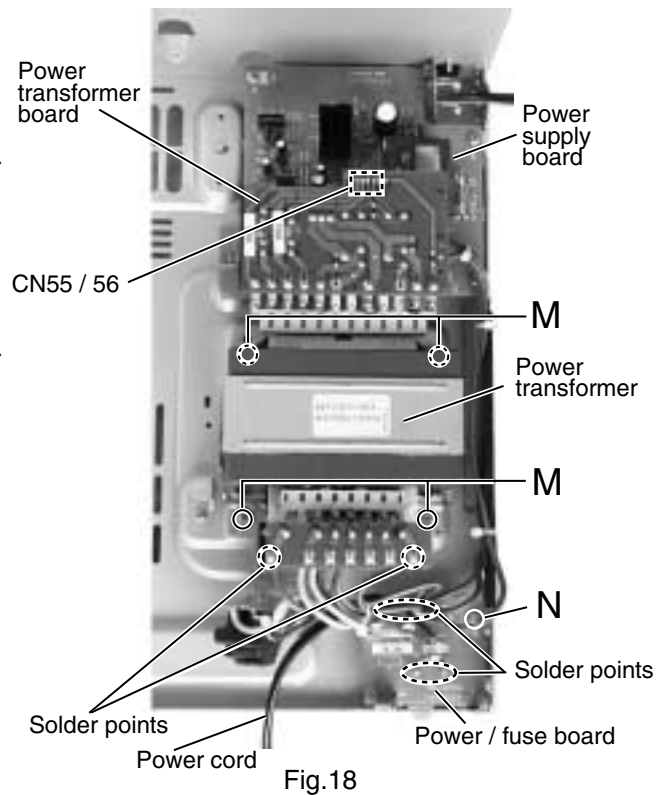

Fig.17

■ Removing the power transformer

(See Fig.18)

- Prior to performing the following procedures, remove the top cover.
1. Unsolder the two harnesses connected to the power transformer.
 2. Disconnect the harness from connector CN55 and CN56 on the power transformer board.
 3. Remove the four screws **M** attaching the power transformer.



■ Removing the power / fuse board

(See Fig.18)

- Prior to performing the following procedure, remove the top cover and the rear panel.
1. Remove the screw **N** attaching the power / fuse board.
 2. Unsolder the power cord and other harnesses connected to the power / fuse board.

■ Removing the power supply board

(See Fig.19 to 21)

- Prior to performing the following procedure, remove the top cover and the front panel.
1. Remove the screw **O** fixing a bonding ground.
 2. Remove the one nut attaching the headphone jack of the power supply board on the front side of the body.
 3. Remove the front panel assembly, and the screw a ground.
 4. Disconnect the card wire from connector CN402 on the power supply board.
 5. Remove the three screws **P** attaching the power supply board and pull out the power supply board from the front bracket backward.
 6. Unsolder the three harnesses connected to the power supply board.

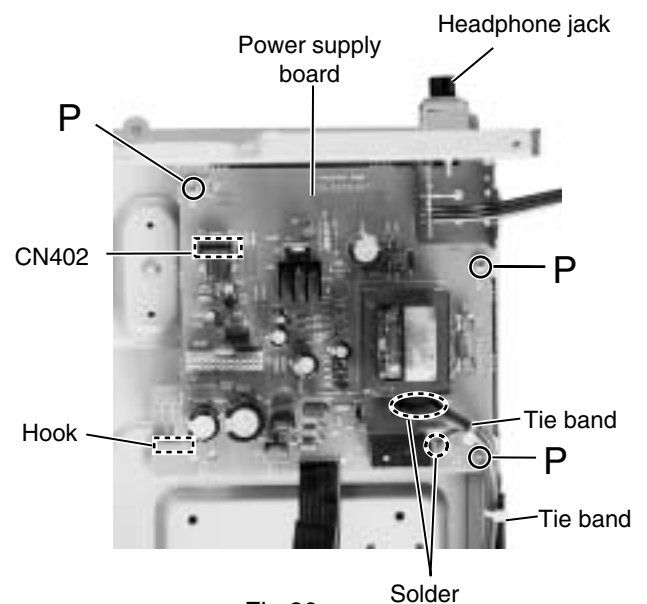
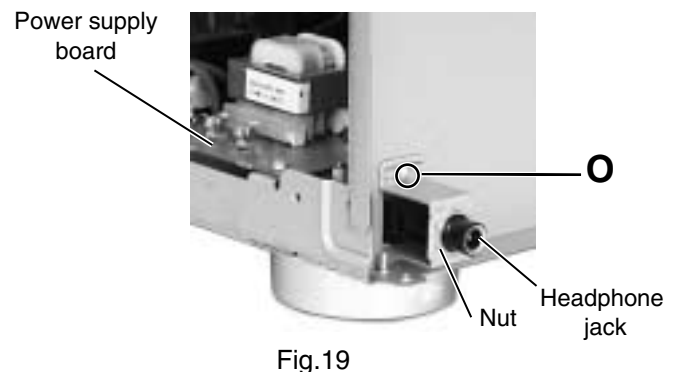

■ Removing the system control board / power switch board (See Fig.21 to 23)

- Prior to performing the following procedure, remove the top cover and the front panel assembly.
- 1. Pull out the volume knob on the front side of the front panel and remove the nut attaching the system control board.
- 2. Remove the two screws **Q** attaching the power switch board.
- 3. Remove the two screws **R** attaching the switch board.
- 4. Remove the cords from the three hooks **a**.
- 5. Remove the eight screws **S** attaching the system control board on the back of the front panel.
- 6. On the back of the front panel, release the four joints by pushing the joint tabs inward. Remove the operation switch panel toward the front.
- 7. Disconnect the harness from connector CN420 and CN422 on the system control board.
- 8. Release the two hooks **b** attaching the system control board.

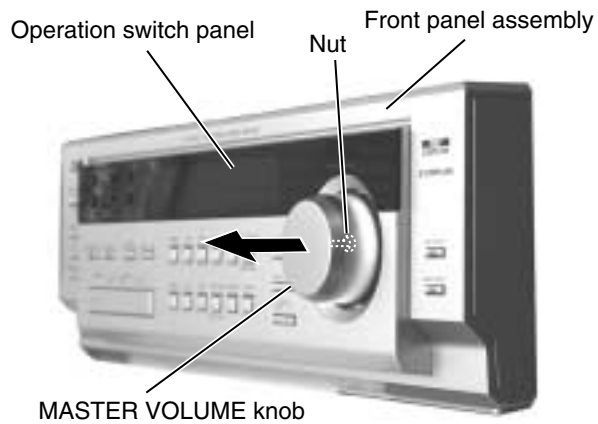

Fig.21

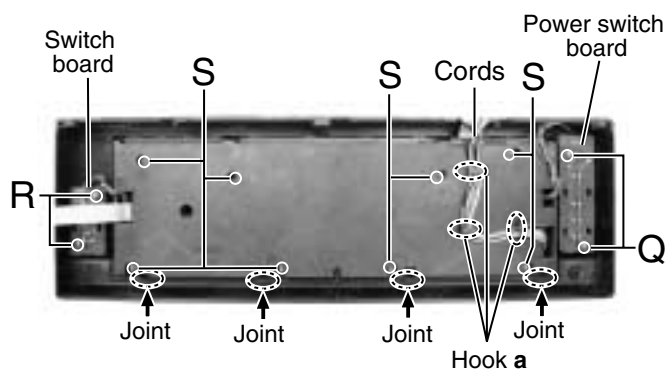

Fig.22

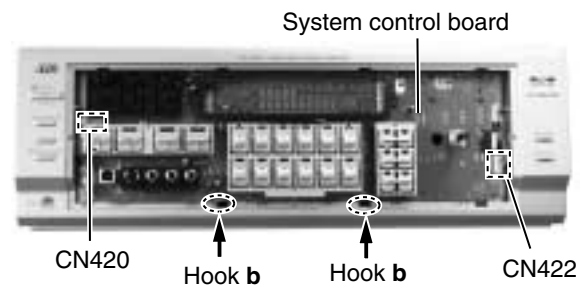
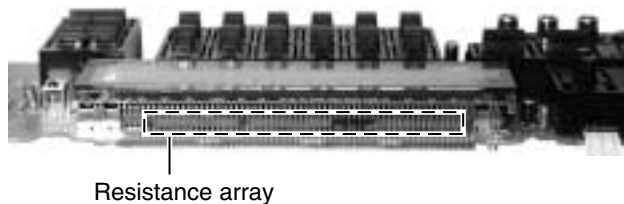

Fig.23

■ Matters that require attention during replacement of IC400

- In case where there is a resistance array:
Both onetime IC and mask IC can be used
- In case where there is no resistance array:
Only mask IC can be used



Adjustment method

■ Tuner section

1. Tuner range

FM	87.5MHz~108.0MHz
AM(MW)	531kHz~1710kHz

■ Power amplifier section

Adjustment of idling current

Measurement location	B2204-B2205(Lch) , B2213-2214(Rch)
Adjustment part	VR787(Lch) , VR788(Rch)

Attention

This adjustment does not obtain a correct adjustment value immediately after the amplifier is used (state that an internal temperature has risen).

Please adjust immediately after using the amplifier after turning off the power supply of the amplifier and falling an internal temperature.

<Adjustment method>

1. Set the volume control to minimum during this adjustment. (No signal & No load)
2. Set the surround mode OFF.
2. Turn VR787 and VR788 fully counterclockwise to warm up before adjustment.
If the heat sink is already warm from previous use the correct adjustment can not be made.
3. For L-ch, connect a DC voltmeter between B2204 and B2205 (Lch)
And, connect it between B2213 and B2214 (Rch).
4. 30 minutes later after power on, adjust VR787 for L-ch, or VR788 for R-ch so that the DC voltmeter value has 1mV~10mV.

* It is not abnormal though the idling current might not become 0mA even if it is finished to turn variable resistance (VR787, VR788) in the direction of counterclockwise.

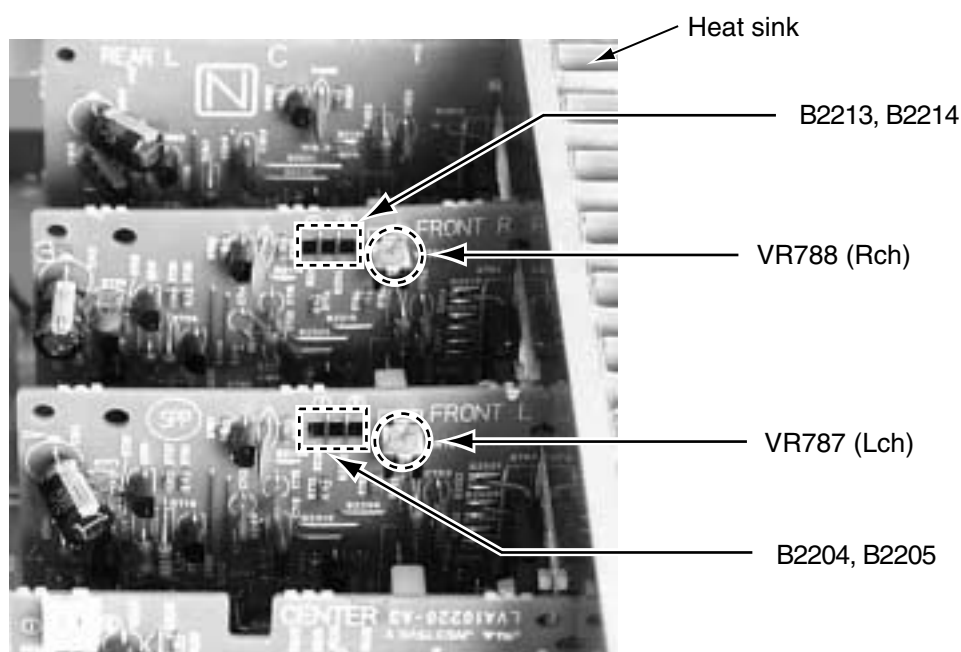

Self-diagnose function

1. Detection of abnormal power supply and voltage

- When the power is turned ON, if an abnormality is detected during the signal input at the A/D port (IC901, pin 2-5, 7) for one second continuously, the status will become STANDBY mode immediately.
- When the power is turned ON again, detection of abnormal power supply and voltage will not be carried out during the first 4 seconds.
- Given below is a list of threshold values at the detection of abnormalities.

	At abnormal state (Low voltage)	At normal state	At abnormal state (High voltage)
Pin 2 Micro-computer+5V	Analog value 0 - 2.2V	Analog value 2.2 - 2.8V	Analog value 2.8 - 5.0V
Pin 3 Digital+5V	Analog value 0 - 2.2V	Analog value 2.2 - 2.8V	Analog value 2.8 - 5.0V
Pin 4 Analog+5V	Analog value 0 - 2.2V	Analog value 2.2 - 2.8V	Analog value 2.8 - 5.0V
Pin 5 +12V	Analog value 0 - 2.2V	Analog value 2.2 - 2.8V	Analog value 2.8 - 5.0V
Pin 7 Tuner+9V	Analog value 0 - 2.2V	Analog value 2.2 - 2.8V	Analog value 2.8 - 5.0V

2. Initial setting on ship

- To gain the initial setting on ship, put the power plug in the socket while pressing DOWN key and UP key together simultaneously, then turn the power ON.

3. Test mode

- To enter the test mode, put the power plug in the socket while pressing EFFECT key and UP key together simultaneously, then turn the power ON.
- Workings of test mode:
 - ① All FLs are turned ON for 3 seconds. (the FLs, which are divided in two groups, are turned ON alternatively)
 - ② A Faster volume UP/DOWN operation can be achieved with the remote controller.
- When the power is turned OFF, the test mode will be released.
- The FL display returns to normal after the three seconds. Then the STANDBY LED is turned ON (flashing ON and OFF for each one second) to show the present status being a test mode.

4. Self-diagnose

- To enter the self-diagnose mode, put the power plug in the socket while pressing SETTING key and UP key together simultaneously, then turn the power ON. With the UP/DOWN key operation, DSP microcomputer, ROM No.of system microcomputer as well as working status of DSP can be displayed for five seconds. While the working status is being displayed, the followings items can be switched with the UP/DOWN key operation.

VERSION of system microcomputer → Local microcomputer CH0 →
 Local microcomputer CH01 → Local microcomputer CH2 →
 Local microcomputer CH3 → Local microcomputer CH4

- When the power is turned OFF, the self-diagnose mode will be released.
- During the self-diagnose mode, the STANDBY LED is turned ON .
 (flashing ON for one second then OFF for three seconds)
- FL transient display will be carried out as follows. When the transient display is not carried out, normal display/workings are carried out.

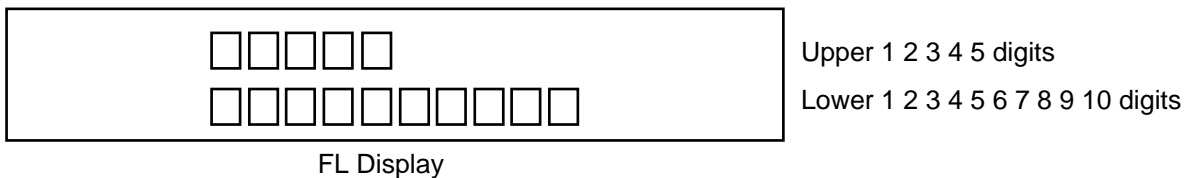

S 0 0 **1 1**
2 0 0 0 1 2 0 9 0 0

- Information on VERSION of system microcomputer (IC901)
 Example : VER1.1 2000/12/9

↓

D 0 0

- Display of communication information on DSP microcomputer (IC581)

↓

D 0 1

- Display of communication information on DIR AK4112A (IC551)

↓

D 0 2

- Display of communication information on DSP XCA56367 (IC501)

↓

D 0 3

- Display of communication information on CODEC AK4527 (IC571)

↓

D 0 4 **1 1**
2 0 0 0 1 2 0 9 0 0

- Information on VERSION of DSP microcomputer (IC581)
 Example :VER1.1 2000/12/9

Description of major ICs

■ AK4112A (IC551) : 96kHz 24bit DIR

1. Pin Layout

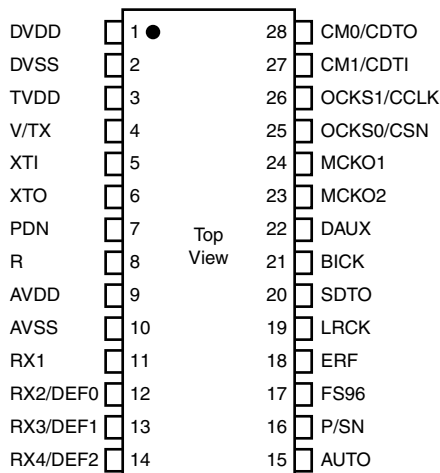

2. Block diagram

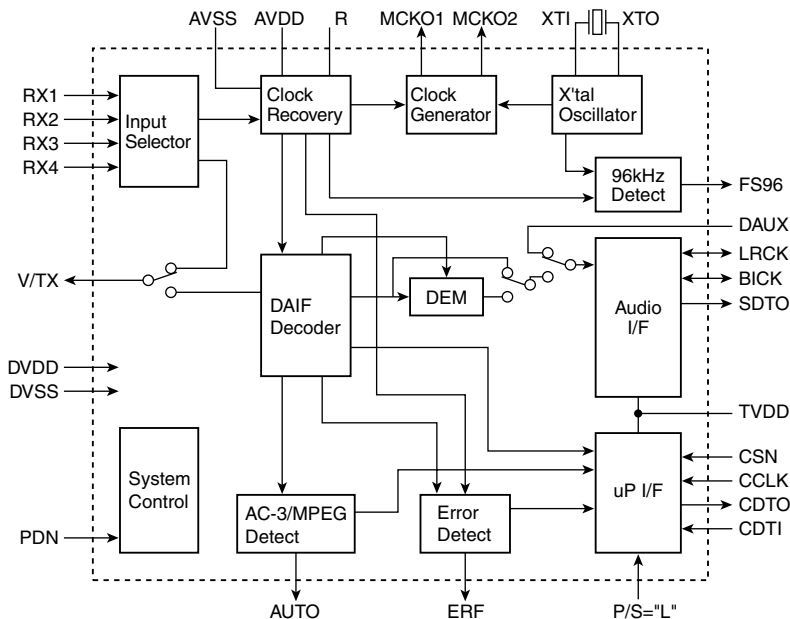

3. Pin Function

No.	Pin Name	I/O	Function
1	DVDD	-	Digital Power Supply Pin, 3.3V
2	DVSS	-	Digital Ground Pin
3	TVDD	-	Input Buffer Power Supply Pin, 3.3V or 5V
4	V	O	Validity Flag Output Pin in parallel mode
	TX	O	Transmit channel (through data) Output Pin in serial mode
5	XTI	I	X'tal Input Pin
6	XTO	O	X'tal Output Pin
7	PDN	I	Power-down mode Pin When "L", the AK4112A is powerd-down and reset.
8	R	-	External resister pin 18Kohm +/-1% resistor to AVSS externally.
9	AVDD	-	Analog Power Supply Pin
10	AVSS	-	Analog Ground pin
11	RX1	I	Receiver Channel 1 This channel is selected in parallel mode or default of serial mode.
12	DIF0	I	Audio Data Interface format 0 Pin in parallel mode
	RX2	I	Receiver Channel 2 in serial mode
13	DIF1	I	Audio Data Interface format 1 Pin in parallel mode
	RX3	I	Receiver Channel 3 in serial mode
14	DIF2	I	Audio Data Interface format 2 Pin in parallel mode
	RX4	I	Receiver Channel 4 in serial mode
15	AUTO	O	Non-PCM Detect Pin "L": No detect, "H": Detect

No.	Pin Name	I/O	Function
16	P/S	I	Parallel/Serial Select Pin "L": Serial mode, "H": Parallel mode
17	FS96	O	96kHz sampling detect pin (RX mode) "H": fs=88.2kHz or more, "L" fs=54kHz or less. (X'tal mode) "L" : XFS96=1, "L" : XFS96=0.
18	ERF	O	Unlock & Parity Error Output Pin "L": No error, "H": Error
19	LRCK	I/O	Output Channel Clock Pin
20	SDTO	O	Audio Serial Data Output Pin
21	BICK	I/O	Audio Serial Data Clock Pin
22	DAUX	I	Auxiliary audio data input pin
23	MCKO2	O	Master Clock #2 Output Pin
24	MCKO1	O	Master Clock #1 Output Pin
25	OCKS0	I	Output Clock Select 0 Pin in parallel mode
	CSN	I	Chip Select Pin in serial mode
26	OCKS1	I	Output Clock Select 1 Pin in parallel mode
	CCLK	I	Control Data Clock Pin in serial mode
27	CM1	I	Master Clock Operation Mode Pin in parallel mode
	CDTI	I	Control Date Input Pin in serial mode
28	CM0	I	Master Clock Source select Pin in parallel mode
	CDTO	O	Control Date Output Pin in serial mode

Note: All input pins except internal pull-down pins should not be left floating.

■ AK4527B (IC571) : A/D,D/A converter

1.Pin layout

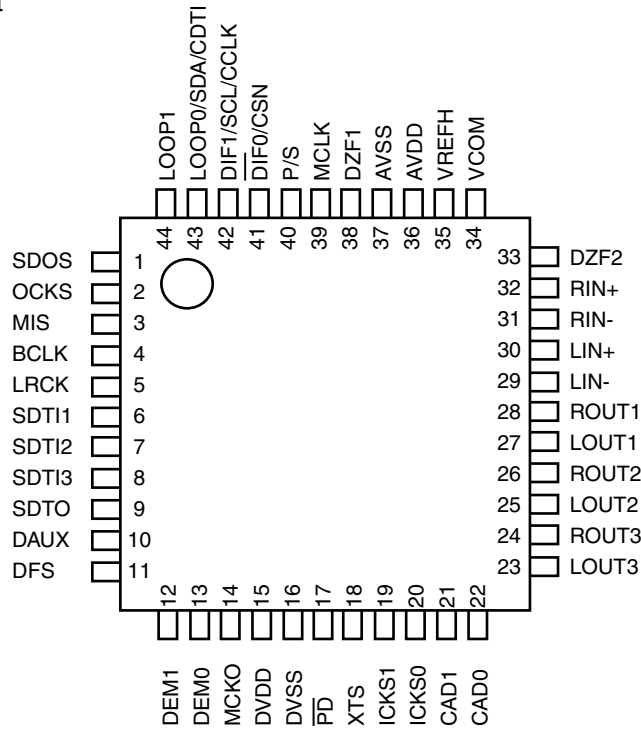

2.Block diagram

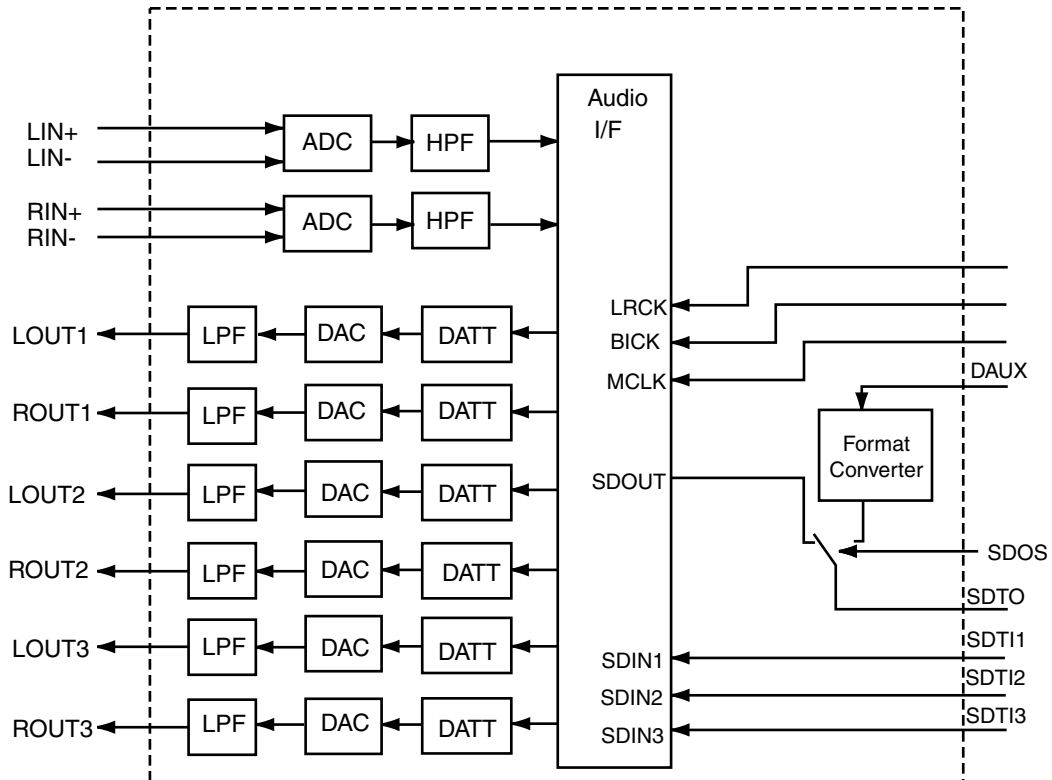

Block Diagram (DIR and AC-3) DSP are external parts)

3. Pin function (1/2)

AK4527(1/2)

No.	Pin name	I/O	Function
1	SDOS	I	SDTO Source select pin "L" : Internal ADC output, "H" : DAUX input ORed with serial control register if P/S="L".
2	OCKS	I	MCKO Clock frequency select pin "L" : MCLK, "H" : MCLK/2. ORed with serial control register if P/S= "L".
3	MIS	I	Connect to GND
4	BICK	I	Audio serial data clock pin
5	LRCK	I/O	Input/Output channel clock pin
6	SDTI1	I	DAC1 Audio serial data input pin
7	SDTI2	I	DAC2 Audio serial data input pin
8	SDTI3	I	DAC3 Audio serial data input pin
9	SDTO	O	Audio serial data output pin
10	DAUX	I	AUX Audio serial data input pin
11	DFS	I	Double speed sampling mode pin "L" : Normal speed, "H" : Double speed, the ADC is powered down. ORed with serial control register if P/S="L".
12	DEM1	I	De-emphasis pin ORed with serial control register if P/S="L"
13	DEM0	I	De-emphasis Pin ORed with serial control register if P/S="L"
14	MCKO	O	Master clock output pin
15	DVDD	-	Digital power supply pin
16	DVSS	-	Digital ground pin
17	PD	I	Power-down & Reset pin When "L", the AK4527 is powered-down and the control registers are reset to default state. If the state of CAD0-1 changes, then the AK4527 must be reset by PDN.
18	XTS	I	X'tal oscillator Select/Test mode pin "H" : X'tal Oscillator selected "L" : External clock source selected
19	ICKS1	I	Input clock select 1 pin
20	ICKS0	I	Input clock select 0 pin
21	CAD1	I	Chip address pin Used during the serial control mode.
22	CAD0	I	Chip address pin Used during the serial control mode.
23	LOUT3	O	Lch #3 analog output pin
24	ROUT3	O	Rch #3 analog output pin
25	LOUT2	O	Lch #2 analog output pin
26	ROUT2	O	Rch #2 analog output pin
27	LOUT1	O	Lch #1 analog output pin
28	ROUT1	O	Rch #1 analog output pin
29	LIN-	I	Lch analog negative Input Pin
30	LIN+	I	Lch analog positive Input Pin
31	RIN-	I	Rch analog negative Input Pin
32	RIN+	I	Rch analog positive Input Pin

3.Pin function (2/2)

AK4527(2/2)

No.	Pin Name	I/O	Function
33	DZF2	O	Zero Input detection pin, 2PIN
34	VCOM	O	Common voltage output pin,AVDD/2 Large external capacitor around 2.2uF is used to reduce power-supply noise
35	VREFH	I	Positive voltage reference input pin,AVDD
36	AVDD	-	Analog power supply pin
37	AVSS	-	Analog ground pin
38	XTI	I	X'tal input pin
39	XTO	O	X'tal output pin if XTS="H"
	MCKI	I	External master clock input pin if XTS="L"
40	P/S	I	Parallel/Serial select pin "L" : Serial control mode, "H" : Parallel control mode
41	DIF0	I	Audio data interface format pin in parallel mode
	CS	I	Chip select pin in serial mode
42	DIF1	I	Audio data interface format pin in parallel mode
	CCLK	I	Control data clock pin in serial mode
43	LOOP0	I	Loop back mode pin in parallel mode Enables digital loop-back from ADC to 3 DACs.
	CDTI	I	Control data input pin in serial mode
44	LOOP1	I	Loop back mode pin in parallel mode Enable all 3 DAC channels to be input from SDTII.
	CDTO	O	Control data output pin in serial mode

■ **BA15218F (IC303, IC304, IC372, IC385, IC386, IC521, IC522, IC523, IC524, IC525, IC526, IC527, IC528, IC529) : Op amp.**

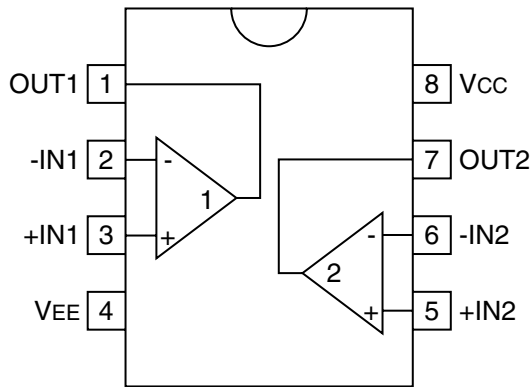

■ **BA7625 (IC201, IC242) : Video selector**

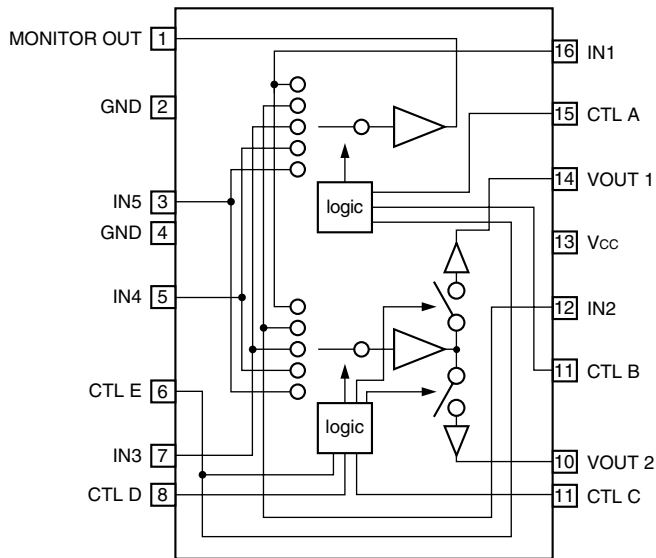

A	B	E	MONITOR OUT
L	L	*	IN1
H	L	*	IN2
L	H	*	IN3
H	H	L	IN4
H	H	H	IN5

C	D	E	VOUT1
L	L	*	--
H	L	*	IN2
L	H	*	IN3
H	H	L	IN4
H	H	H	IN5

C	D	E	VOUT2
L	L	*	IN1
H	L	*	--
L	H	*	IN3
H	H	L	IN4
H	H	H	IN5

■ **BA7626 (IC241) : Video selector**

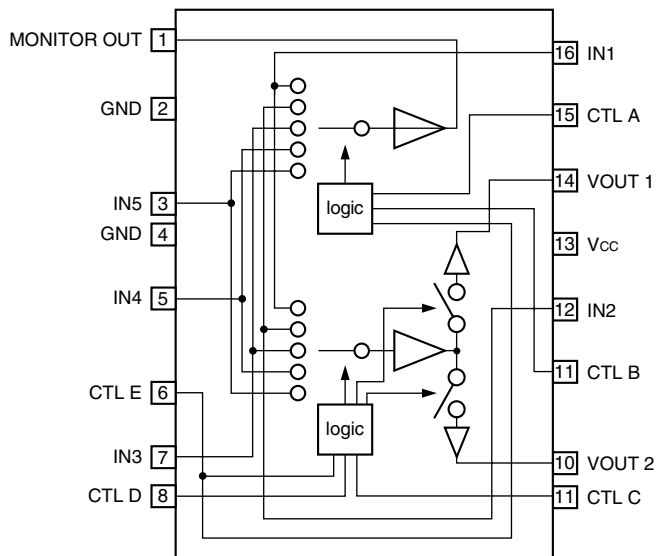

A	B	E	MONITOR OUT
L	L	*	IN1
H	L	*	IN2
L	H	*	IN3
H	H	L	IN4
H	H	H	IN5

C	D	E	VOUT1
L	L	*	--
H	L	*	IN2
L	H	*	IN3
H	H	L	IN4
H	H	H	IN5

C	D	E	VOUT2
L	L	*	IN1
H	L	*	--
L	H	*	IN3
H	H	L	IN4
H	H	H	IN5

BU2092(IC402) : Port expander

1. Terminal Layout

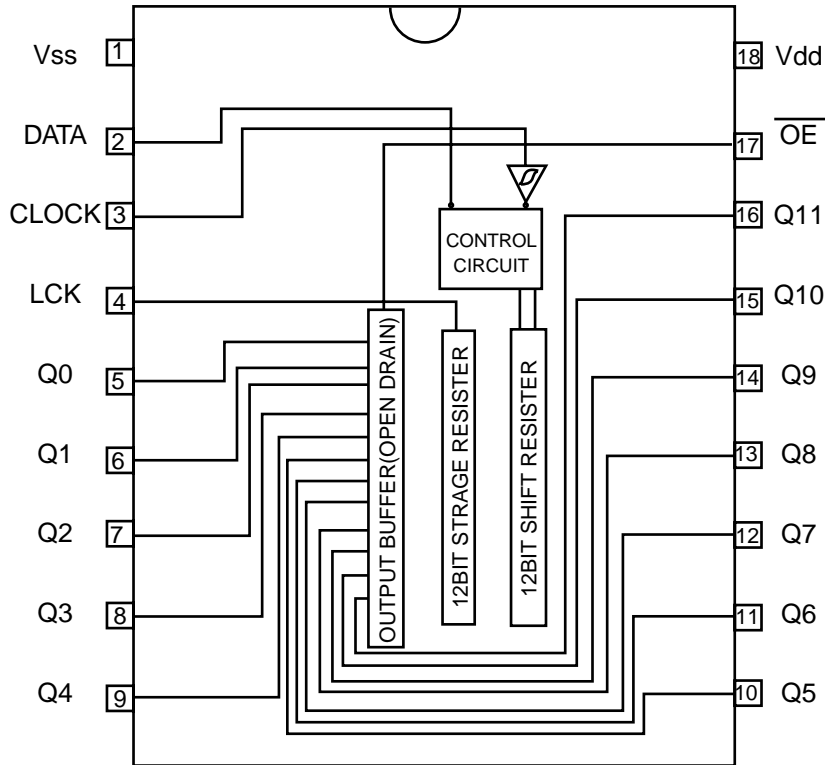

2.Pin Function

Pin No.	Symbol	I/O	Function						
1	Vss	-	Connect to GND						
2	DATA	I	Serial Data input						
3	CLOCK	I	Shift Clock of Data						
4	LCK	I	Latch Clock of Data						
5~16	Q0~Q11	O	Parallel Data Output <table border="1" style="margin-left: 20px;"> <tr> <td>Latch Data</td> <td>L</td> <td>H</td> </tr> <tr> <td>OUTPUT</td> <td>ON</td> <td>OFF</td> </tr> </table>	Latch Data	L	H	OUTPUT	ON	OFF
Latch Data	L	H							
OUTPUT	ON	OFF							
17	$\overline{\text{OE}}$	I	Output Enable						
18	Vdd	-	Power Supply						

■ **MB90088 (IC203) : On screen display controller**

1. Terminal Layout

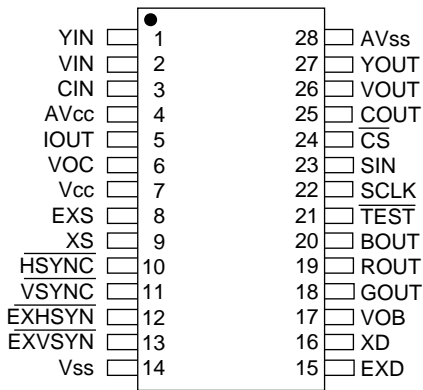

2. Block Diagram

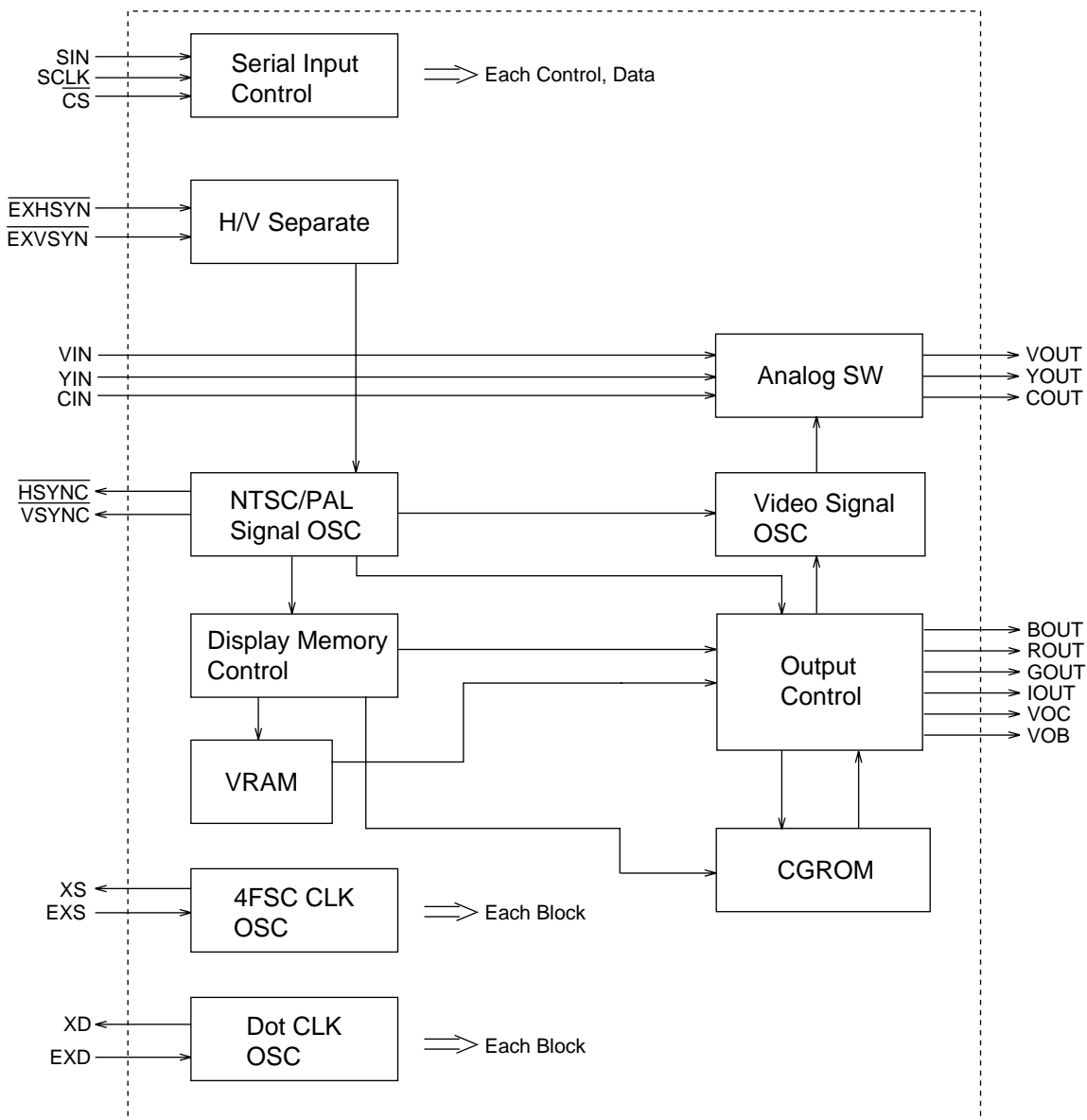

3.Functions

pin no	Symbol	I/O	Function
1	YIN	I	Lux signal Input terminal for Superinpause indication
2	VIN	I	Composite video signal input terminal for Superinpause indication
3	CIN	I	Contrast signal input terminal for Superinpause indication
4	AVcc	-	Analog power supply terminal
5	IOUT	O	Color (Lux) signal output terminal
6	VOC	O	Character output terminal
7	Vcc	-	Power supply terminal
8	EXS	I	Clock generater outside circuit terminal for color burst
9	XS	O	
10	$\overline{\text{HSYNC}}$	O	Horizontal signal output terminal
11	$\overline{\text{VSYNC}}$	O	Vertical signal output terminal
12	$\overline{\text{EXHSYN}}$	I	EXT horizontal signal input terminal
13	$\overline{\text{EXVSYN}}$	I	EXT vertical signal input terminal
14	Vss	-	GND
15	EXD	I	Dot clock generater outside circuit signal terminal for indication
16	XD	O	
17	VOB	O	Character & background signal output terminal
18	GOUT	O	Color signal (Green, Red, Blue)
19	ROUT		
20	BOUT		
21	$\overline{\text{TEST}}$	I	Test signal input terminal
22	SCLK	I	Shift clock input terminal for serial transmission
23	SIN	I	Serial data input terminal
24	$\overline{\text{CS}}$	I	Chip select terminal
25	COUT	O	Contrast signal output terminal
26	VOUT	O	Composite video signal output terminal
27	YOUT	O	Lux signal output terminal
28	AVss	-	Analog GND terminal

■ NJM4580D (IC301) : LPF, Mic and h.phone amp.

1.Terminal layout

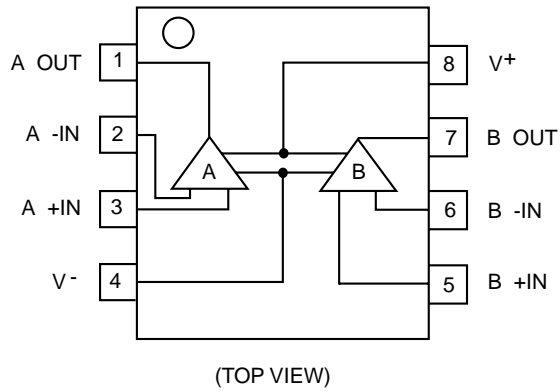

2.Block diagram

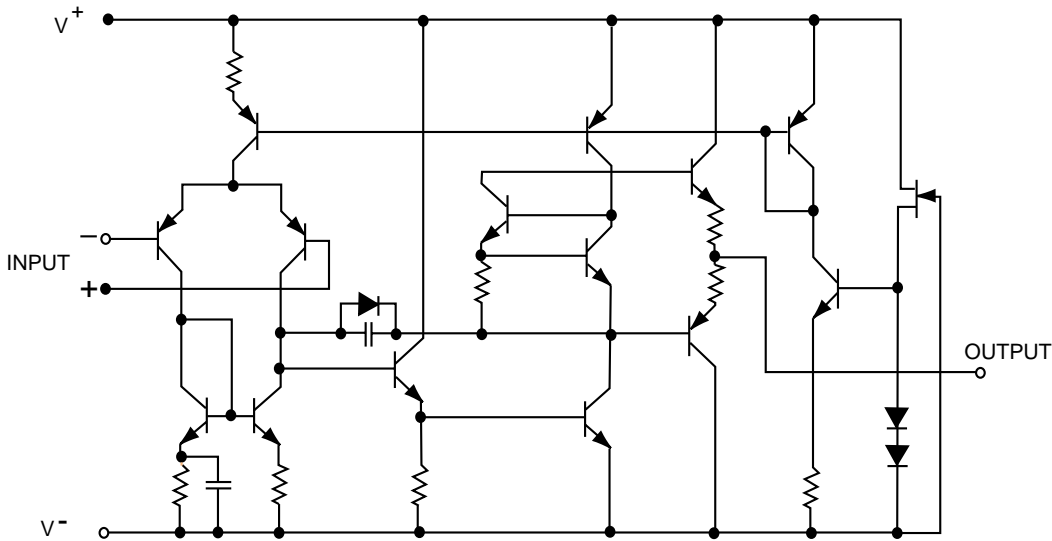

■ NJU7241F33(IC411) : Voltage regulator

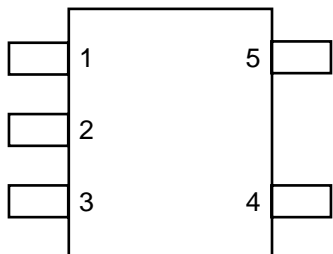

- PIN FUNCTION
- 1. GND
 - 2. V_{IN}
 - 3. V_{OUT}
 - 4. +NC
 - 5. STB

■ PCM2702E-X (IC410) : Digital/ Analog converter

1.Pin layout

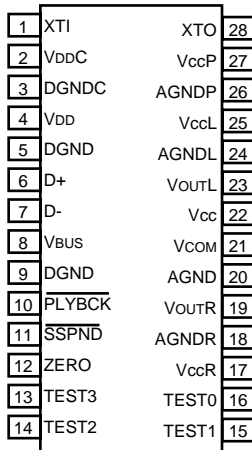

2. Block diagram

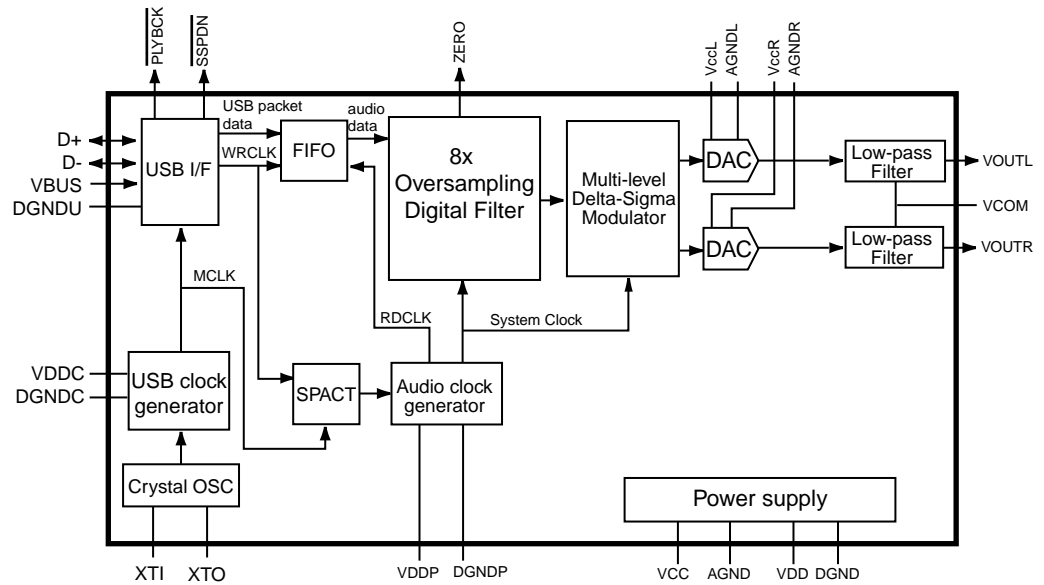

3.Pin function

PIN	Symbol	I/O	Function
1	XTI	IN	Crystal Oscillator Input. (1)
2	VDDC	-	Digital Power Supply for Clock Generator, +3.3V.
3	DGND	-	Digital Ground for Clock Generator.
4	VDD	-	Digital Power Supply, +3.3V.
5	DGND	-	Digital Ground.
6	D+	I/O	USB Differential Input/Output Plus.
7	D-	I/O	USB Differential Input/Output Minus.
8	VBUS	IN	USB Bus Power (This pin NEVER consumes the USB bus power). (2)
9	DGNDU	-	Digital Ground for USB Transceiver.
10	PLYBCK	OUT	Playback flag, active LOW. (LOW: playback, HIGH: idle).
11	SSPND	OUT	Suspend flag, active LOW. (LOW: suspend, HIGH: operational).
12	ZERO	OUT	Zero flag, (LOW: Normal, HIGH: ZERO).
13	TEST3	IN	Test pin 3. Connect to digital ground. (2)
14	TEST2	IN	Test pin 2. Connect to digital ground. (2)
15	TEST1	IN	Test pin 1. Connect to digital ground. (2)
16	TEST0	IN	Test pin 0. Connect to digital ground. (2)
17	VccR	-	Analog Supply for R-channel, +5V.
18	AGNDR	-	Analog Ground for R-channel.
19	Vou _{TR}	OUT	Analog Output for R-channel.
20	AGND	-	Analog Ground.
21	VCOM	-	Common for DAC.
22	Vcc	-	Analog Supply, +5V.
23	VoutL	OUT	Analog output for L-channel.
24	AGNDL	-	Analog Ground for L-channel.
25	VccL	-	Analog Supply for L-channel, +5V.
26	AGNDP	-	Analog Ground for PLL.
27	VccP	-	Analog Supply for PLL, +5V.
28	XTO	OUT	Crystal Oscillator Output.

Note:

(1) 3.3V tolerant.

(2) Schmitt trigger input with internal pull-down, 5V tolerant.

■ TC9162AN (IC380) : Analog switch

VSS	1	28	VDD
L-S1	2	27	R-S1
L-S2	3	26	R-S2
L-COM1	4	25	R-COM1
L-S3	5	24	R-S3
L-S4	6	23	R-S4
L-COM2	7	22	R-COM2
L-S5	8	21	R-S5
L-S6	9	20	R-S6
L-COM3	10	19	R-COM3
L-S7	11	18	R-S7
L-COM4	12	17	R-COM4
ST	13	16	DATA
GND	14	15	CK

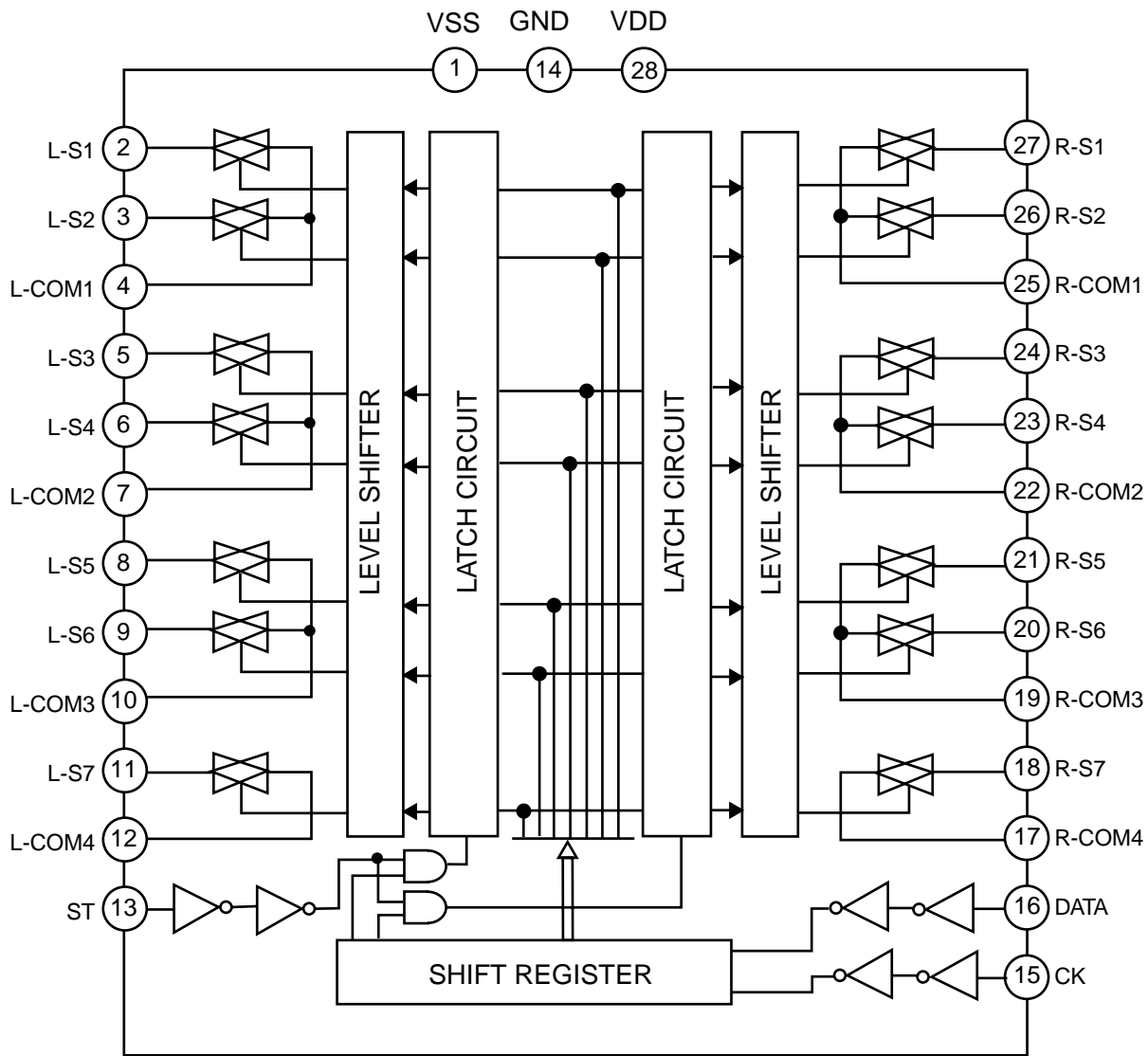

■ TC9163AF-X (IC371) : Analog switch

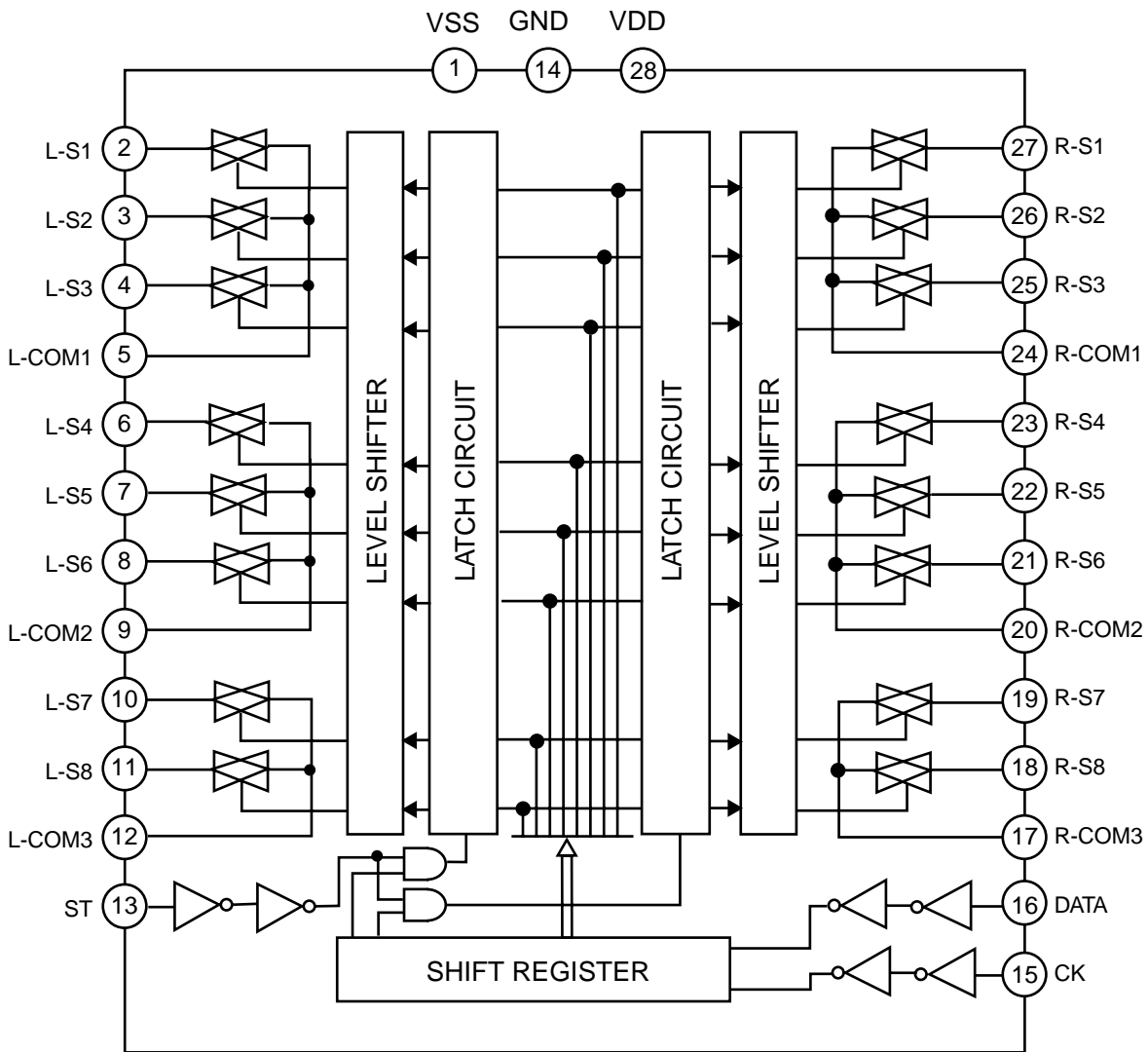
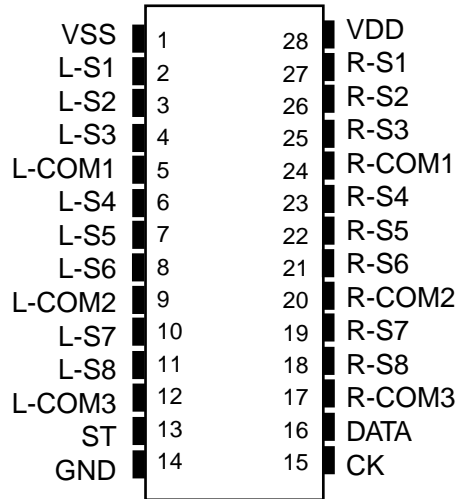

■ TC9164AF-X (IC302) : Analog switch

VSS	1	28	VDD
L-S1	2	27	R-S1
L-S2	3	26	R-S2
L-S3	4	25	R-S3
L-S4	5	24	R-S4
L-COM1	6	23	R-COM1
L-S5	7	22	R-S5
L-S6	8	21	R-S6
L-COM2	9	20	R-COM2
L-S7	10	19	R-S7
L-S8	11	18	R-S8
L-COM3	12	17	R-COM3
ST	13	16	DATA
GND	14	15	CK

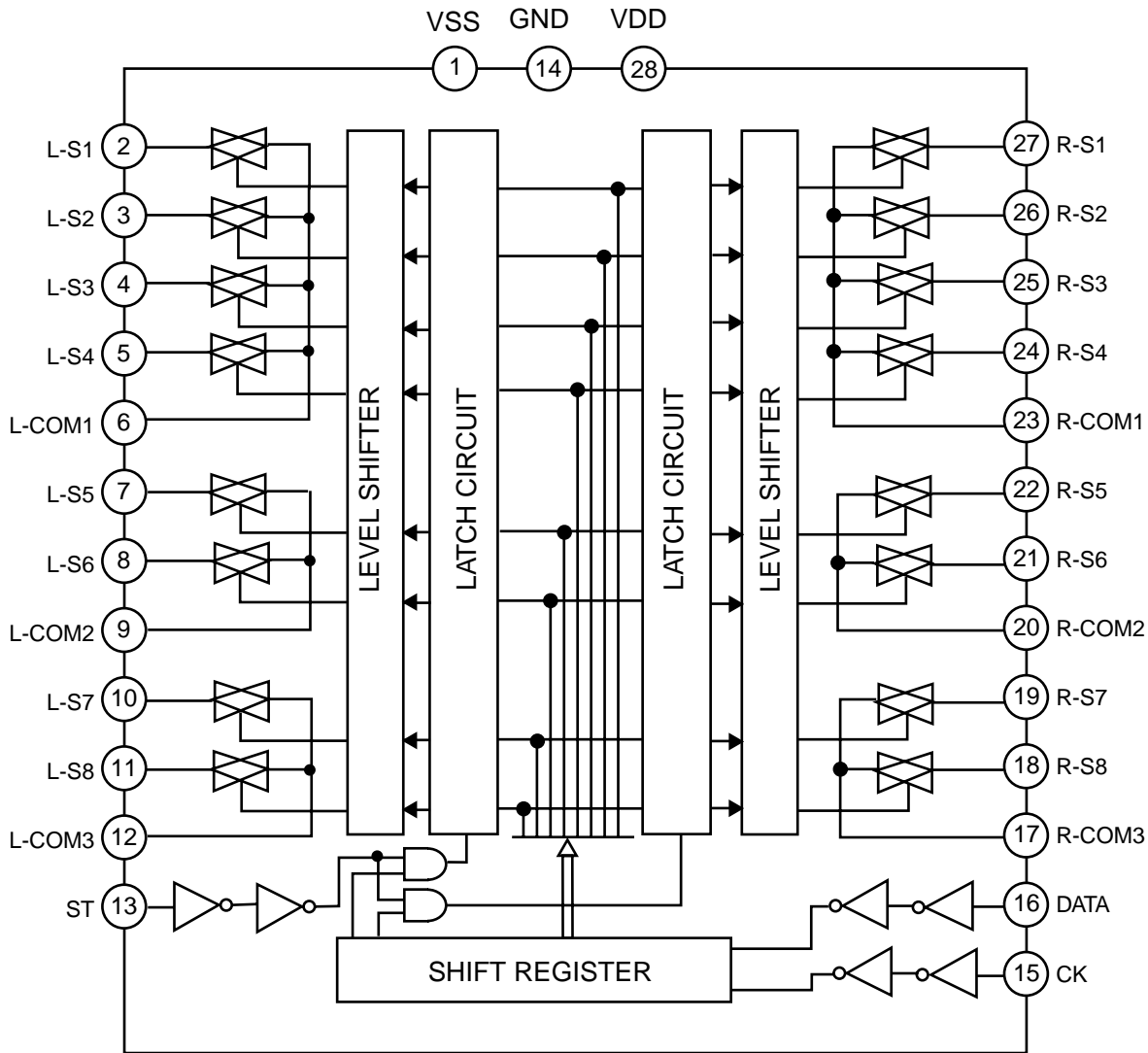

■ TC9459F (IC381, IC382, IC383) : Electronic volume control

1. Terminal layout

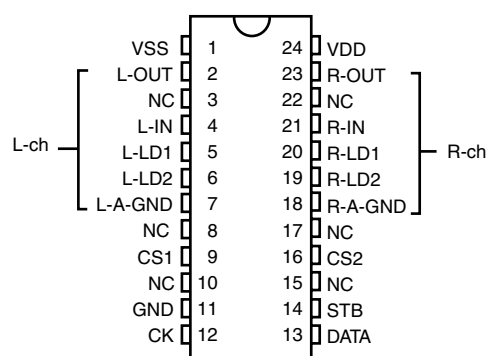

2. Block diagram

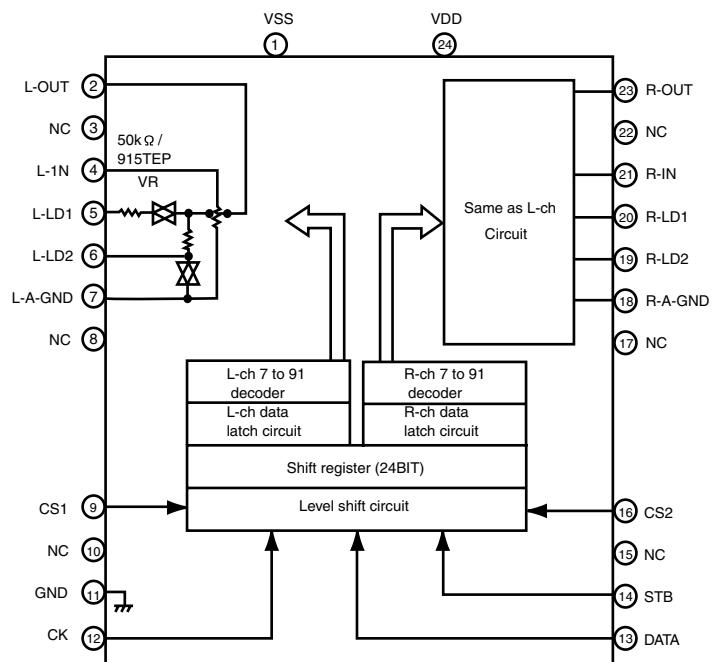

3. Pin function

Pin No.	Symbol	Function	Pin No.	Symbol	Function
1	VSS	Negative power supply pin	13	DATA	Data input pin
2	L-OUT	Volume output pin	14	STB	Strobe input pin
3	NC	No connection	15	NC	No connection
4	NC	No connection	16	CS2	Chip select input pin
5	L-LD1	Loudness tap output pin	17	NC	No connection
6	L-LD2	Loudness tap output pin	18	R-A-GND	Analog GND pin
7	L-A-GND	Analog GND pin	19	R-LD2	Loudness tap output pin
8	NC	No connection	20	R-LD1	Loudness tap output pin
9	CS1	Chip select input pin	21	R-IN	Volume input pin
10	NC	No connection	22	NC	No connection
11	NC	No connection	23	R-OUT	Volume output pin
12	CK	Clock input pin	24	VDD	Positive power supply pin

■ MAX4018ESD (IC390) : Op amp.

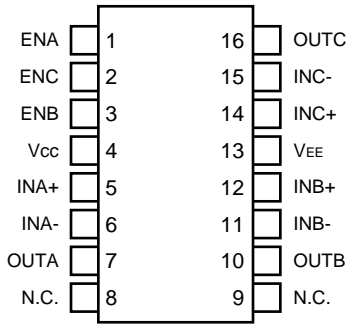

■ NJM2285V-W (IC202) : 2-input 3-channel video switch

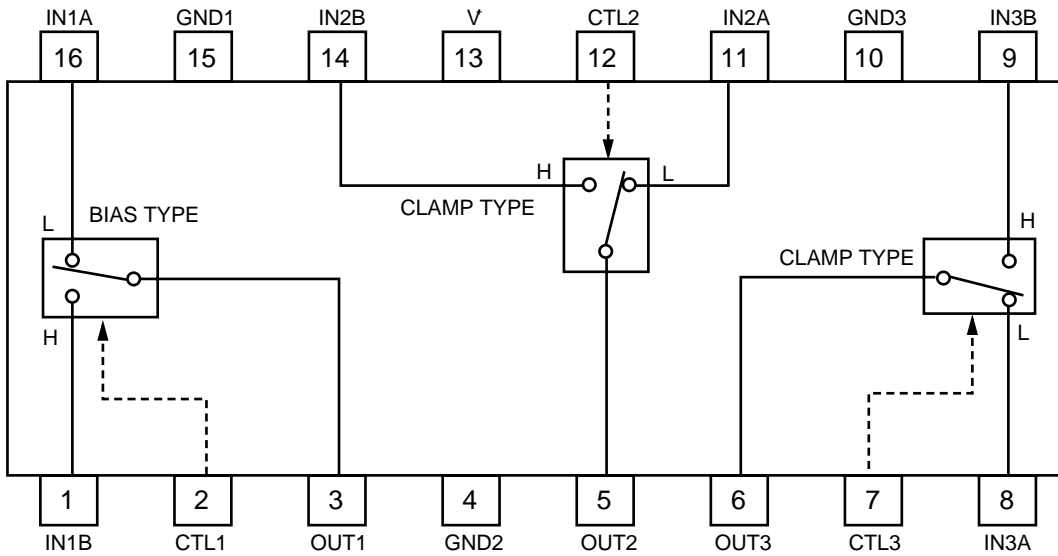

■ PQ3DZ53 (IC583) : Regulator IC

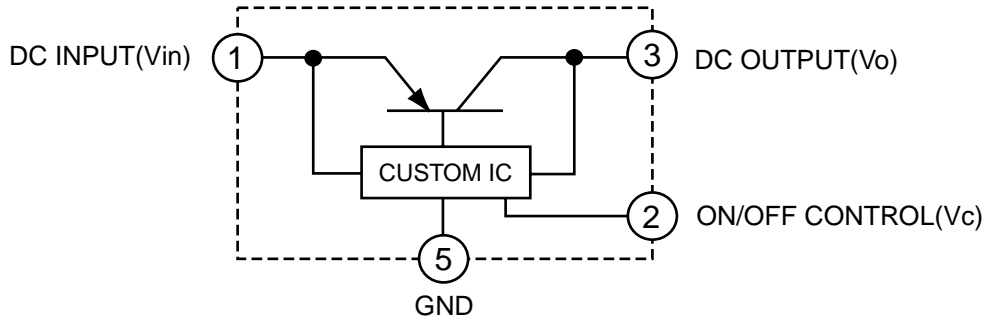

■ TC74HC4053AF (IC388, IC389) : Multiplexe

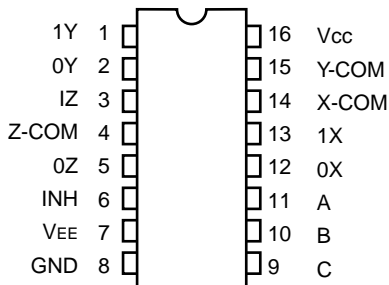

CONTROL INPUTS			
INHIBIT	C	B	A
L	L	L	K
L	L	L	H
L	L	H	K
L	L	H	H
L	H	L	K
L	H	L	H
L	H	H	K
L	H	H	H
H	X	X	X

X: Don't Care.

■ W24L010AJ-12 (IC511) : CMOS static RAM

1. Pin layout

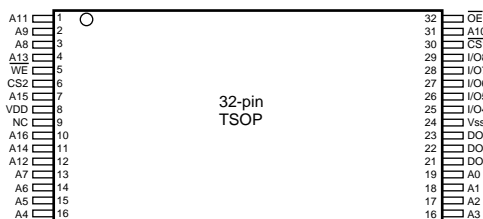
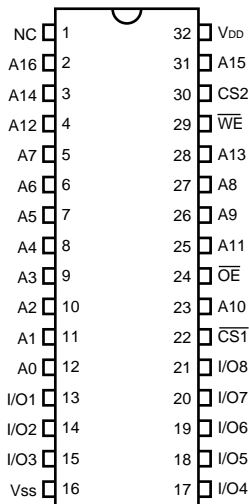

2. Block diagram

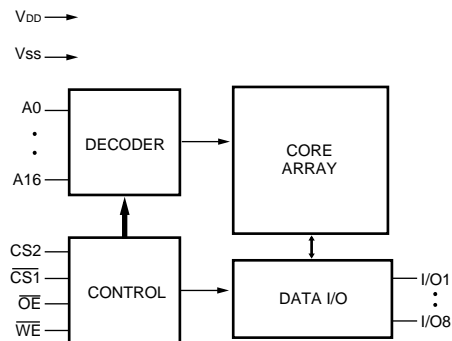

3. Pin function

SYMBOL	DESCRIPTION
A0 - A16	Address Input
I/O1 - I/O8	Data Input/Output
CS1, CS2	Chip Select Inputs
WE	Write Enable Input
OE	Output Enable Input
VDD	Power Supply
Vss	Ground
NC	No Connection

■ UPD784215AGC152 (IC581) : Unit CPU

1.Pin layout

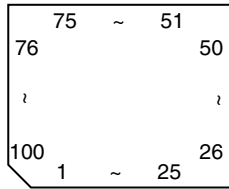

2.Pin function

Pin No.	Symbol	I/O	Function
1~8		-	Non connect
9	VDD	-	Power supply terminal
10	X2	-	Connecting the crystal oscillator for system main clock
11	X1		Connecting the crystal oscillator for system main clock
12	VSS	-	Connect to GND
13	XT2	-	Connecting the crystal oscillator for system sub clock
14	XT1		Connect VSS
15	RESET		System reset signal input
16	AUTO		Output of DSP to general-purpose port
17	ERR		Output of DSP to general-purpose port
18	Fz96k		Output of DSP to general-purpose port
19~22	P03~P06		Output of DSP to general-purpose port
23	AVDD	-	Power supply terminal
24	AV REF0	-	Connect to GND
25~32	P10~P17	-	Connect to GND
33	AVSS	-	Connect to GND
34,35	P130, P131	O	Non connect
36	AV REF1	-	Power supply terminal
37,38	RX, TX	O	Not use
39		O	Non connect
40	DSPCOM		Communication port from IC901
41	DSPSTS	O	Status communication port to IC901
42	DSPCLK		Clock input from IC901
43	DSPRDY		Ready signal input from IC901
44		O	Non connect
45,46	MIDIO_IN/OUT	I/O	Interface I/O terminal with microcomputer
47	MICK	O	Interface I/O terminal with microcomputer of clock signal
48	HREQ		HREQ
49	SS	O	System slave select
50,51		-	Non connect
52	DSP_RST	O	Reset signal output of DSP
53		-	Non connect
54	D_CS	O	Chip setselct output
55		-	Non connect
56	PD/ DIR	O	Reset signal output
57~63		-	Non connect
64,65	CDTI/CDTO	O/I	Interface I/O terminal with microcomputer
66	CCLK	O	Interface I/O terminal with microcomputer of clock signal
67	CS	O	CS
68~70		-	Non connect
71	PD	O	Reset signal output
72	GND	-	Connect to GND
73~75		-	Non connect
76	EQ	O	EQ
77	CTR TONE	O	CENTER TONE
78	3D	O	3D-Phonic
79,80		-	Non connect
81	VDD	-	Power supply
82,83		-	Non connect
84	ANA_TT	O	Analog./T.TONE
85	LEF_MIX	O	Select 1
86	LEF_OUT	O	Select 2
87	MIX_OUT	O	Select 3
88	S_MUTE	O	S.MUTE
89~93		-	Non connect
94	TEST	-	Test terminal
95~100		-	Non connect

< MEMO >

Block diagrams

■ Signal I/O block section

■ Main section

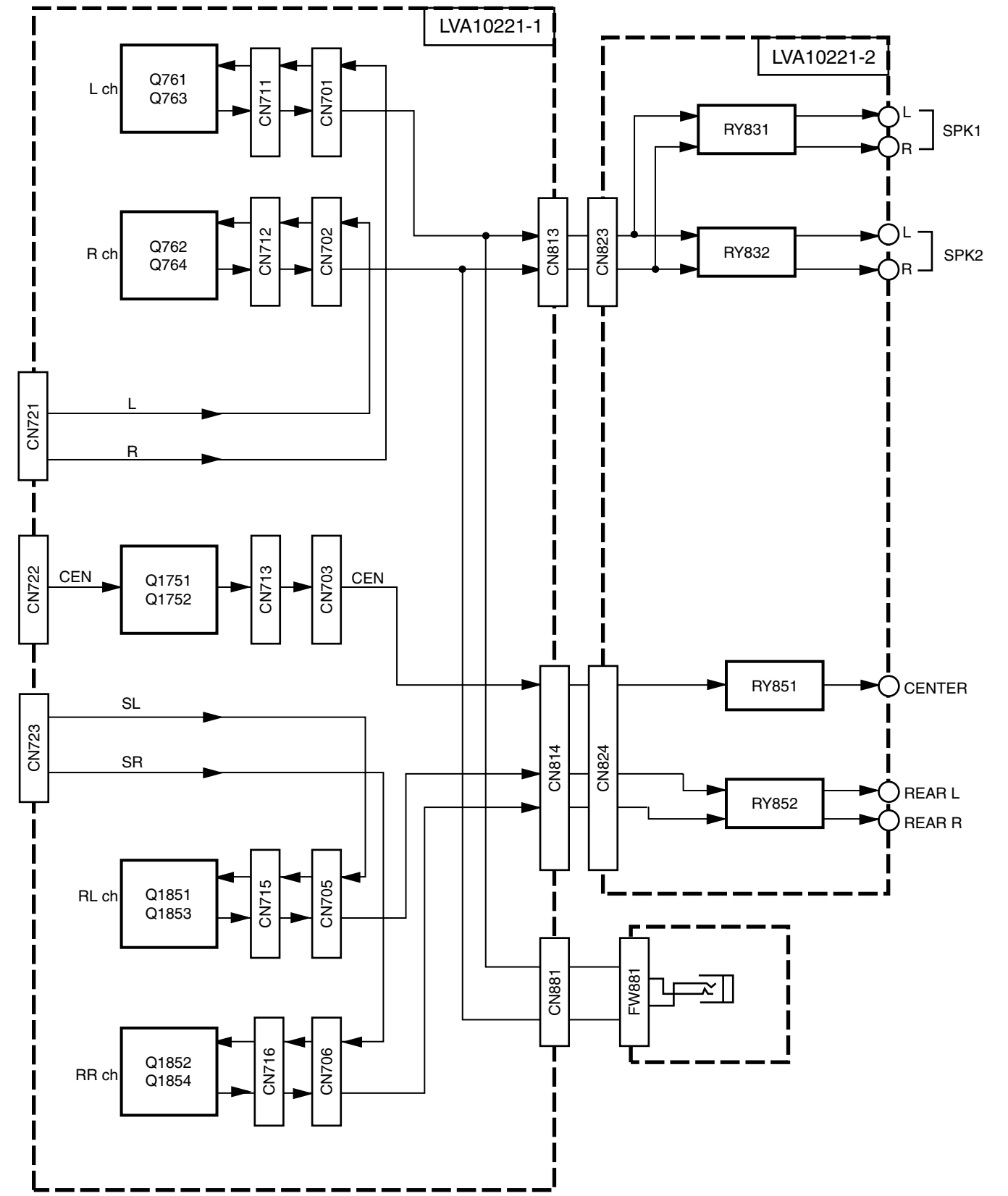
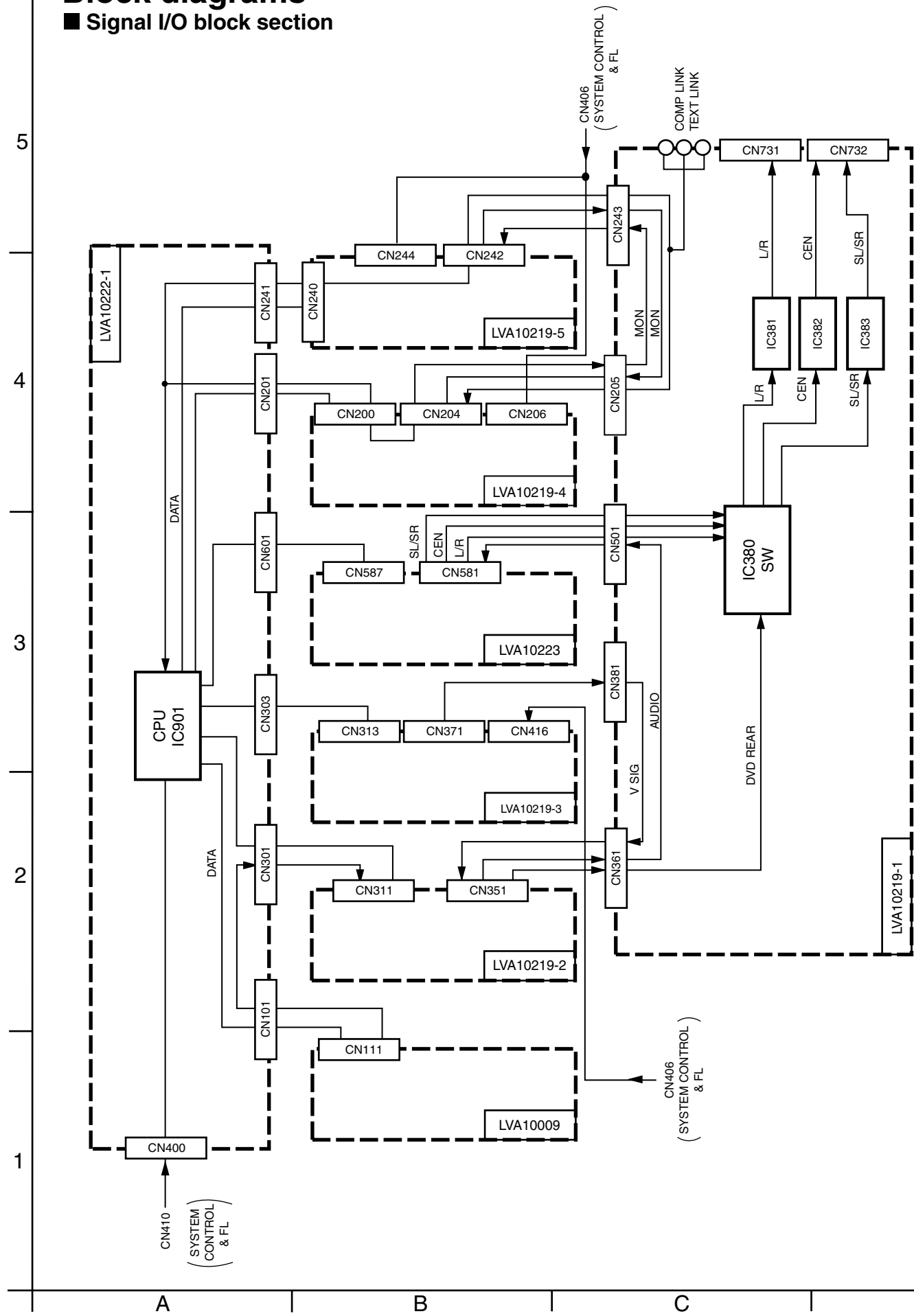

■ Video section

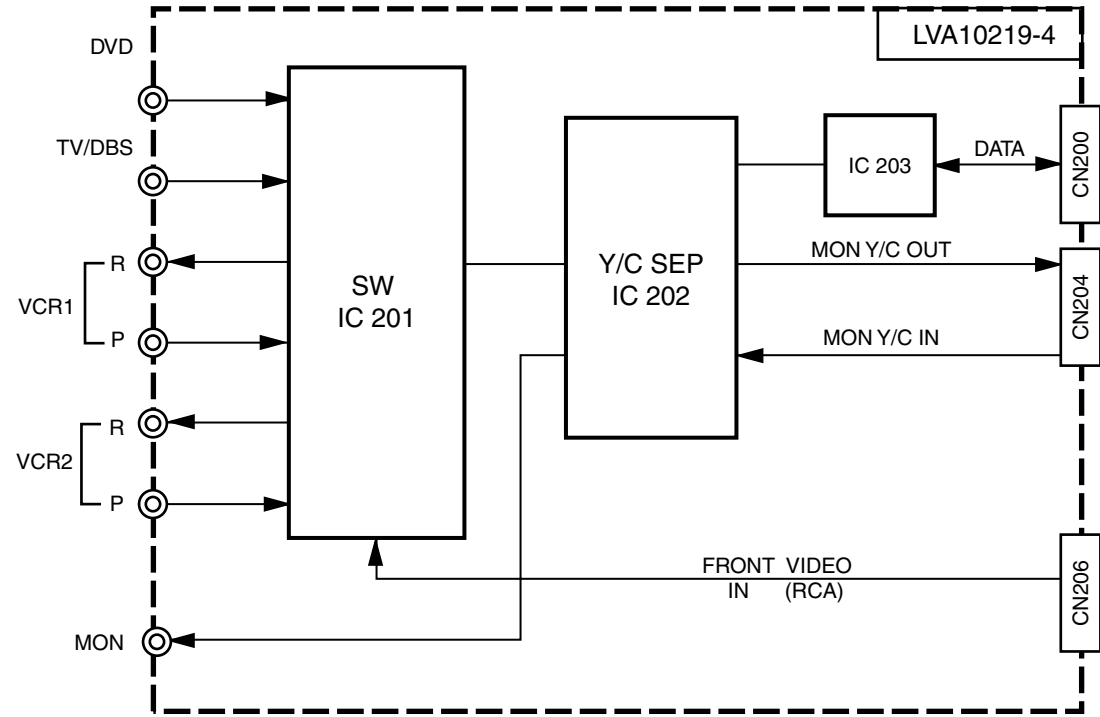

■ Video input section

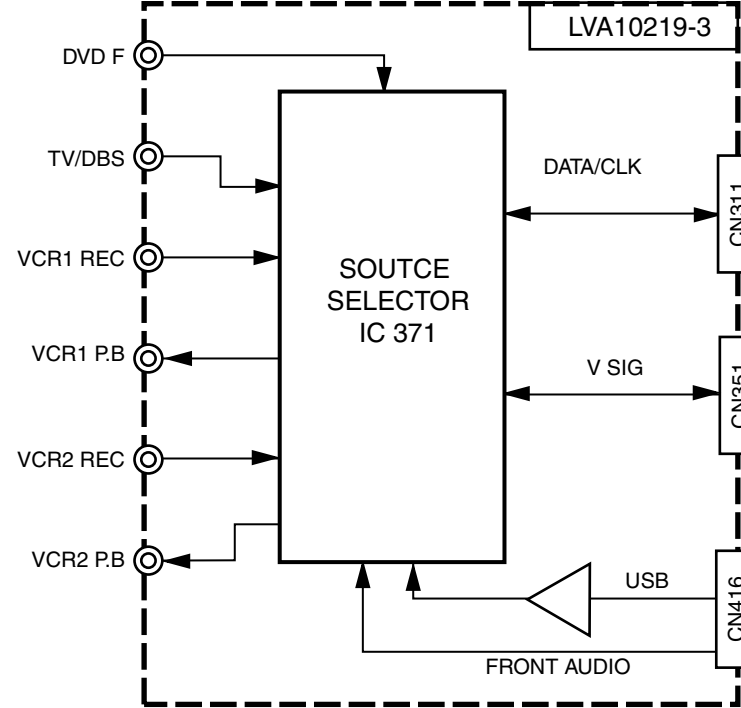

■ S Video section

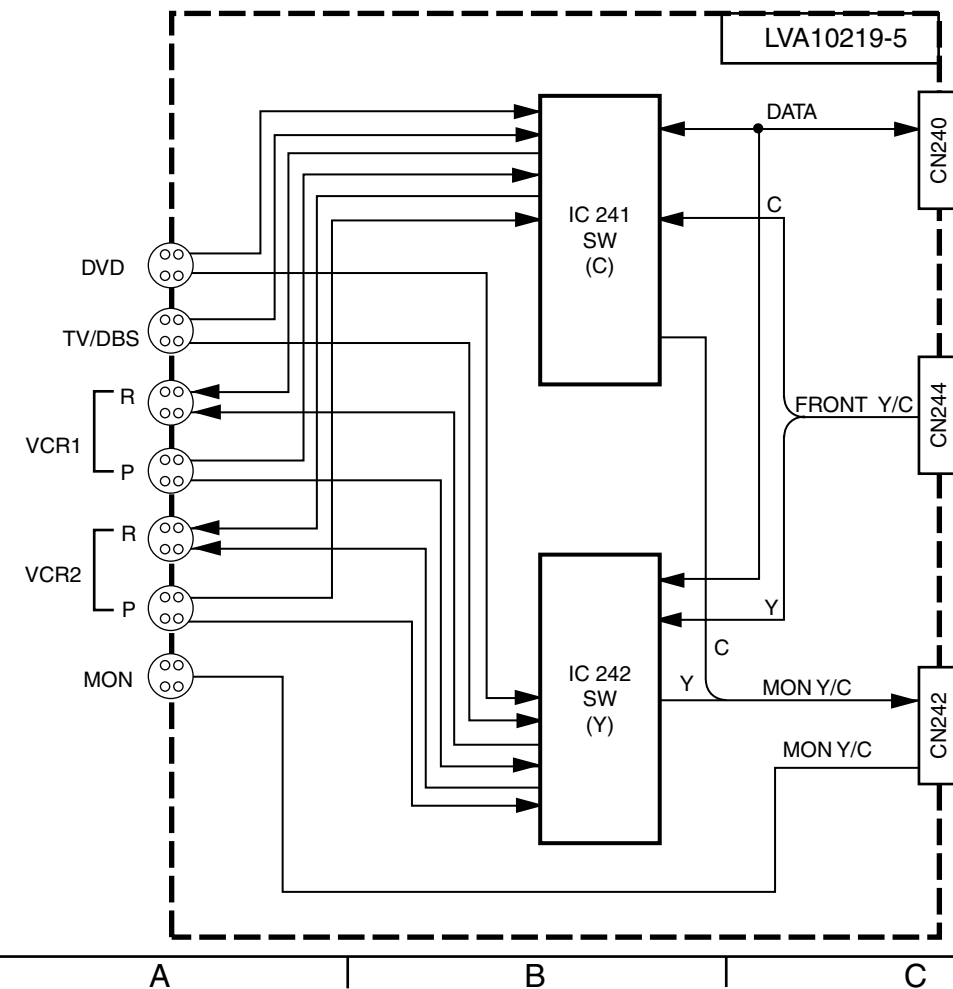

■ DSP section

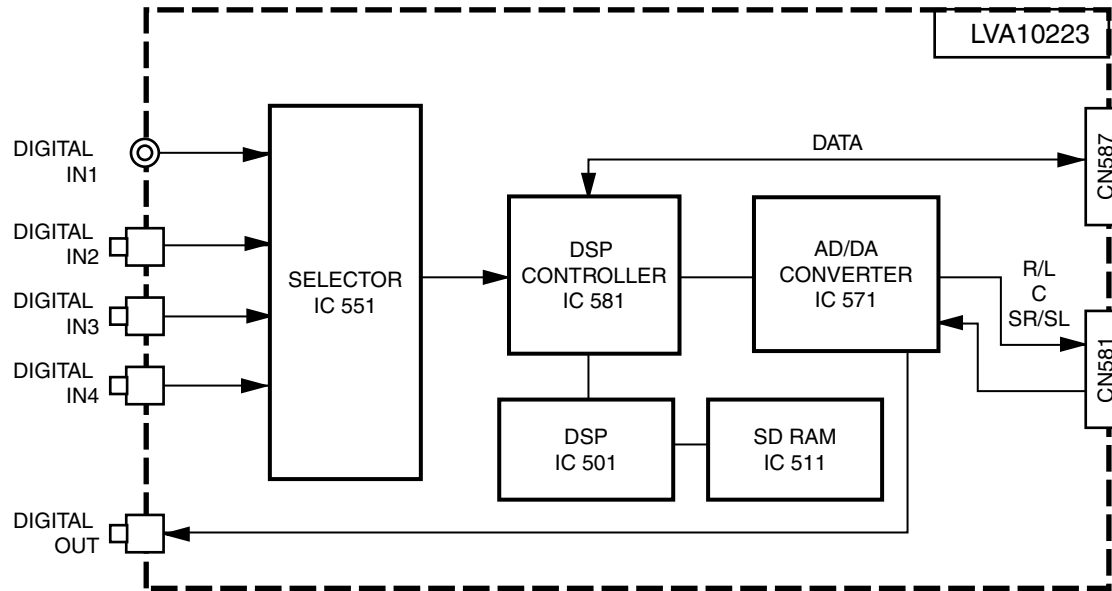

5

4

3

2

1

A

B

C

2-2

D

E

F

G

H

■ Tuner section

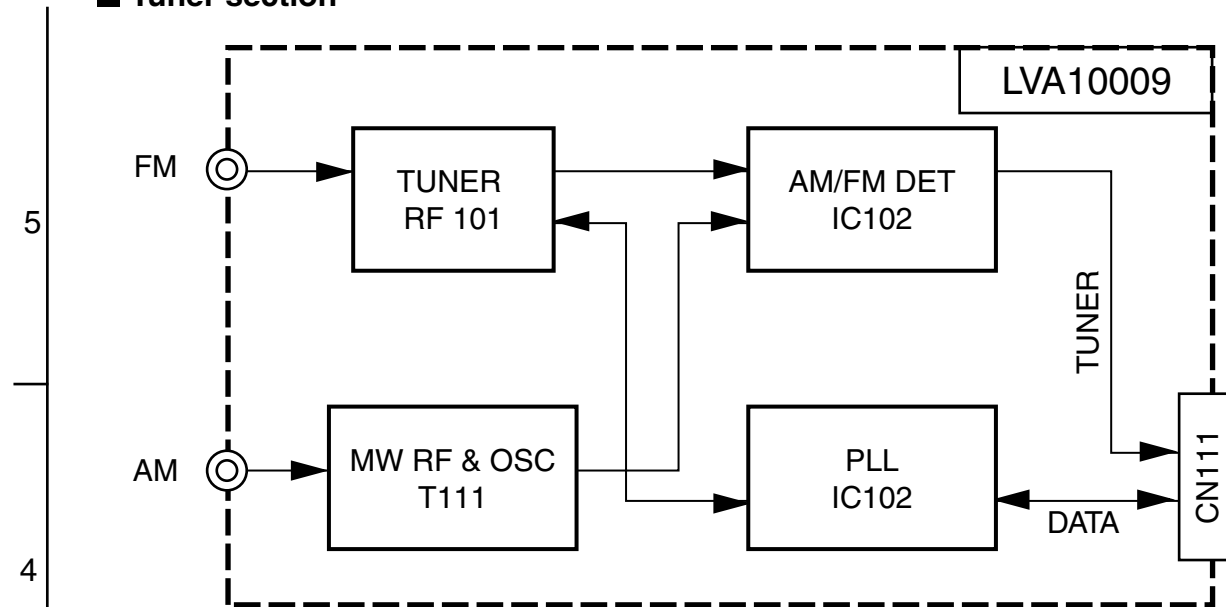

■ Audio input section

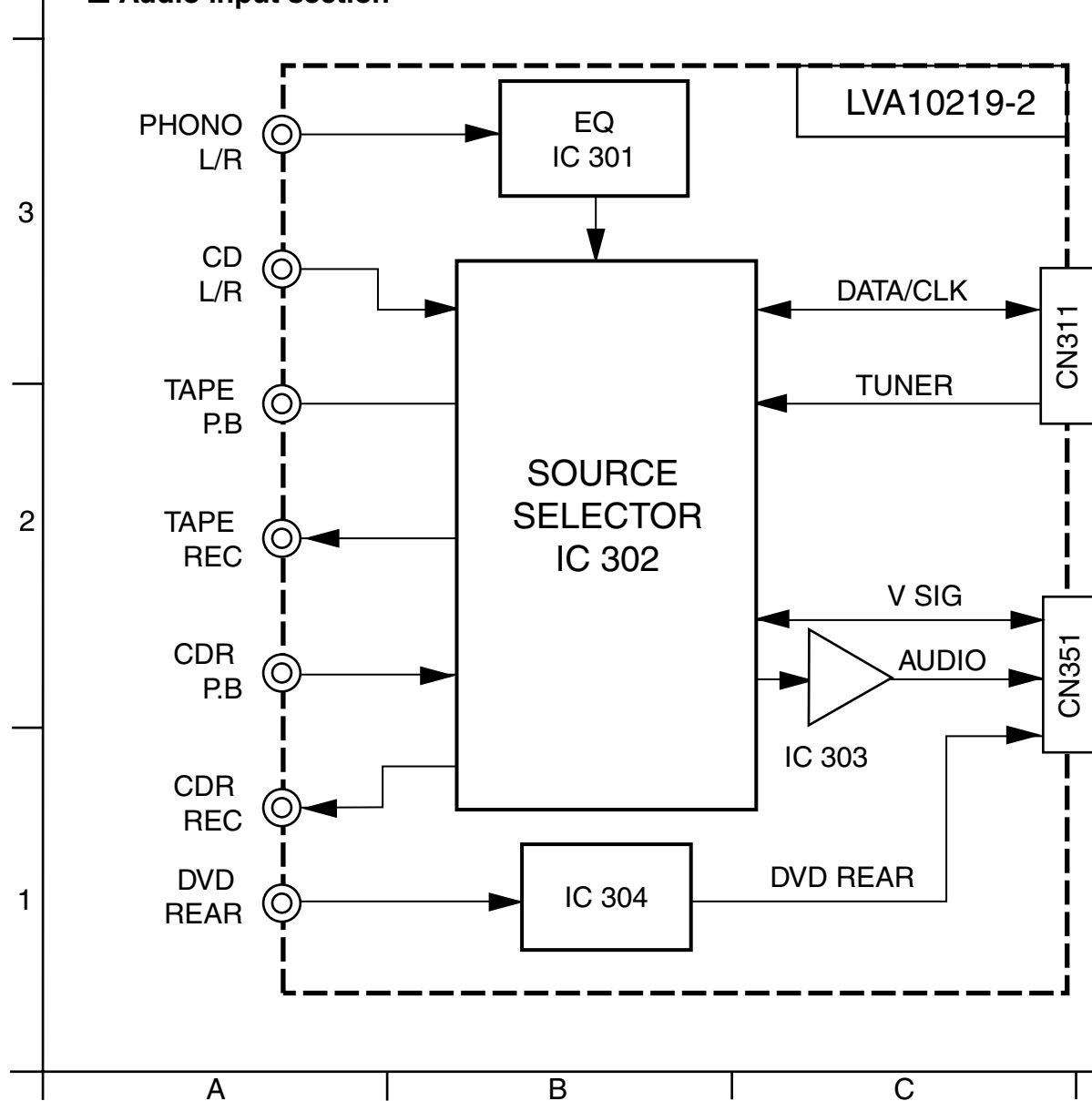

■ System control & FL section

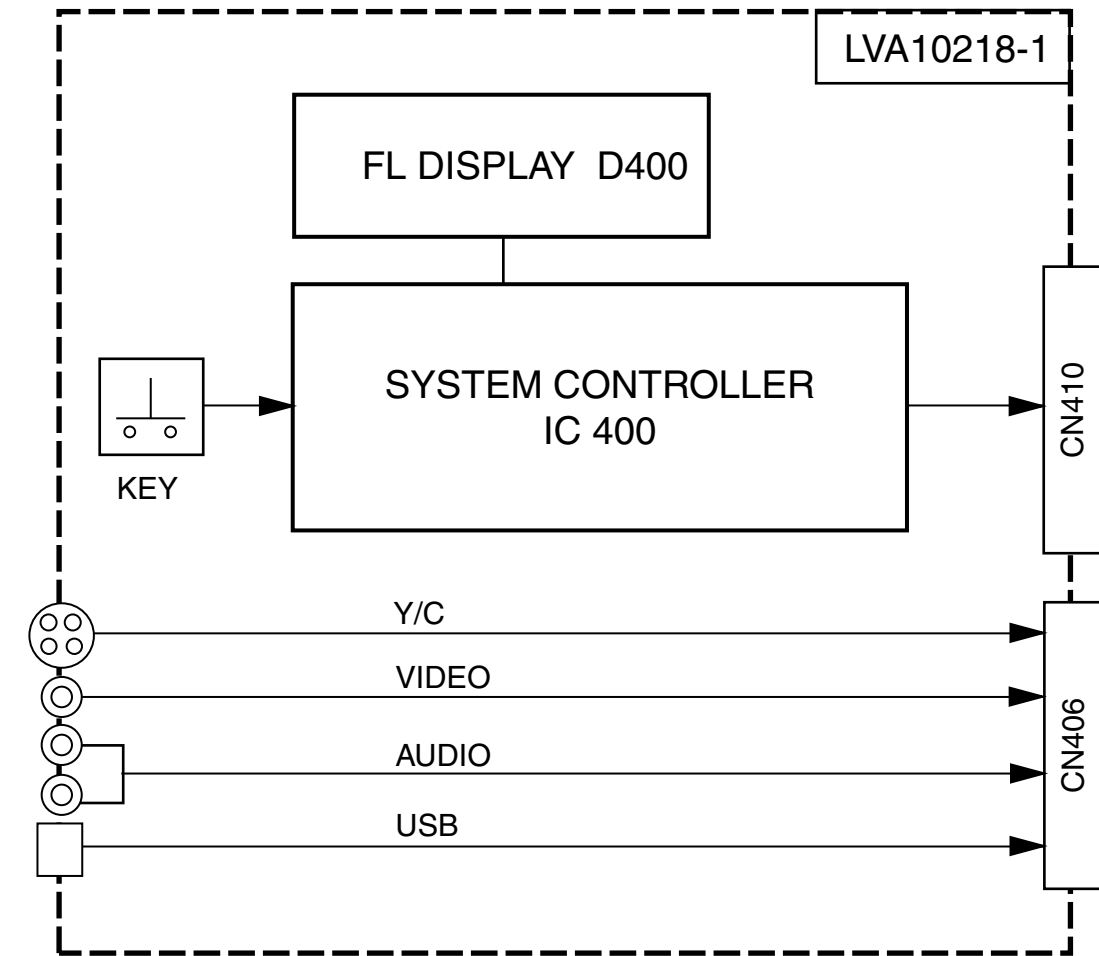

Standard schematic diagrams

Power supply section

5
4
3
2
1

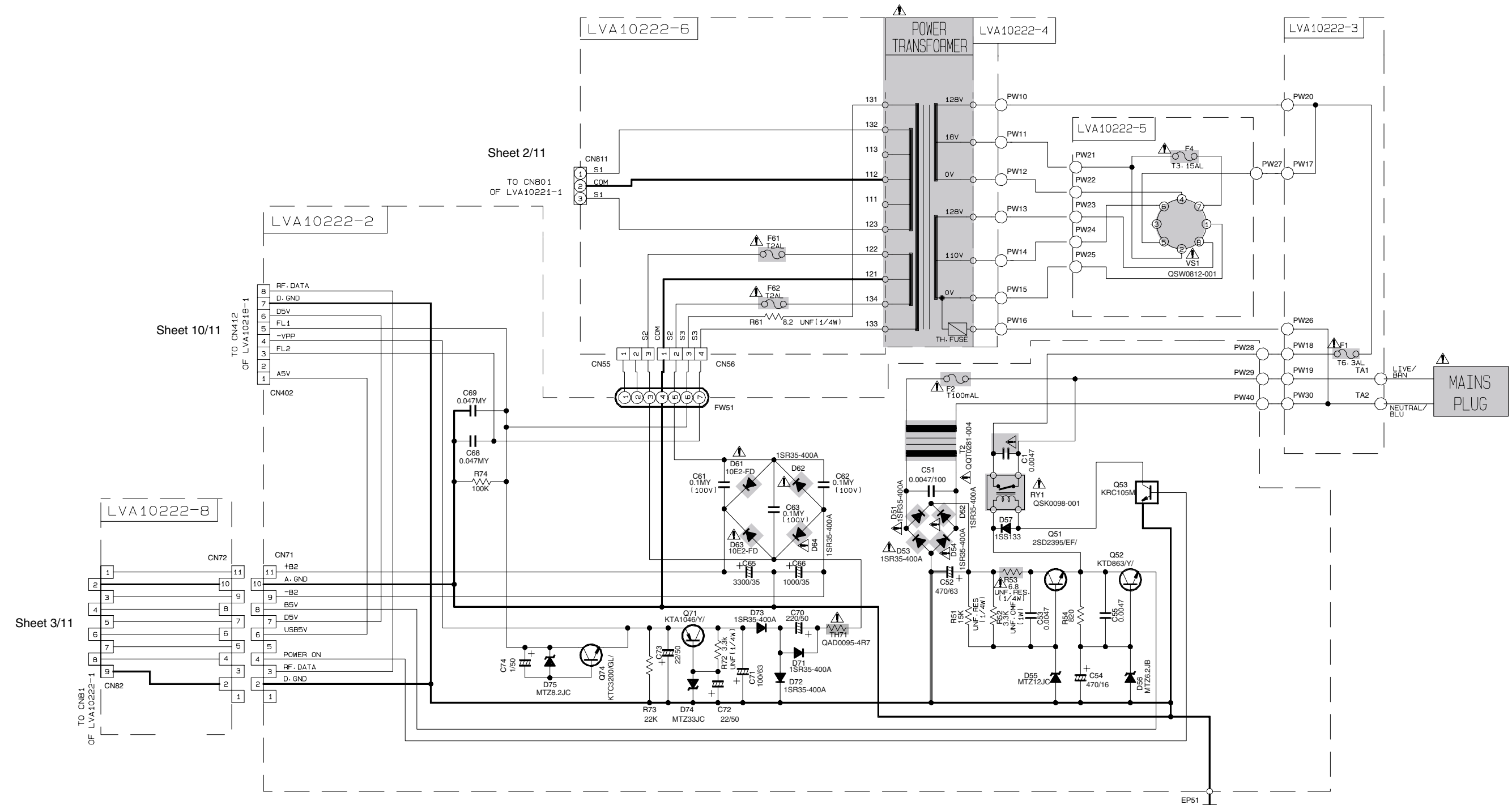

SHEET NUMBER	CIRCUIT DESCRIPTION
1/11	POWER SUPPLY
2/11	MAIN
3/11	AUDIO
4/11	AUDIO SIGNAL INPUT
5/11	VIDEO SIGNAL INPUT
6/11	AUDIO AMP (FRONT CHANNEL)
7/11	AUDIO AMP (CENTER, REAR CHANNEL)
8/11	DSP
9/11	DVD
10/11	SYSTEM CONTROL
11/11	TUNER

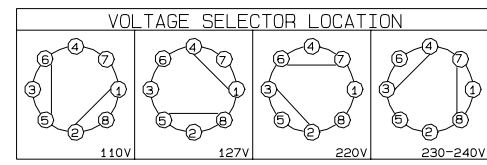

▲ Parts are safety assurance parts. When replacing those parts make sure to use the specified one.

A | B | C | 2-4 | D | E | F | G | H

■ Main & Speaker terminal section

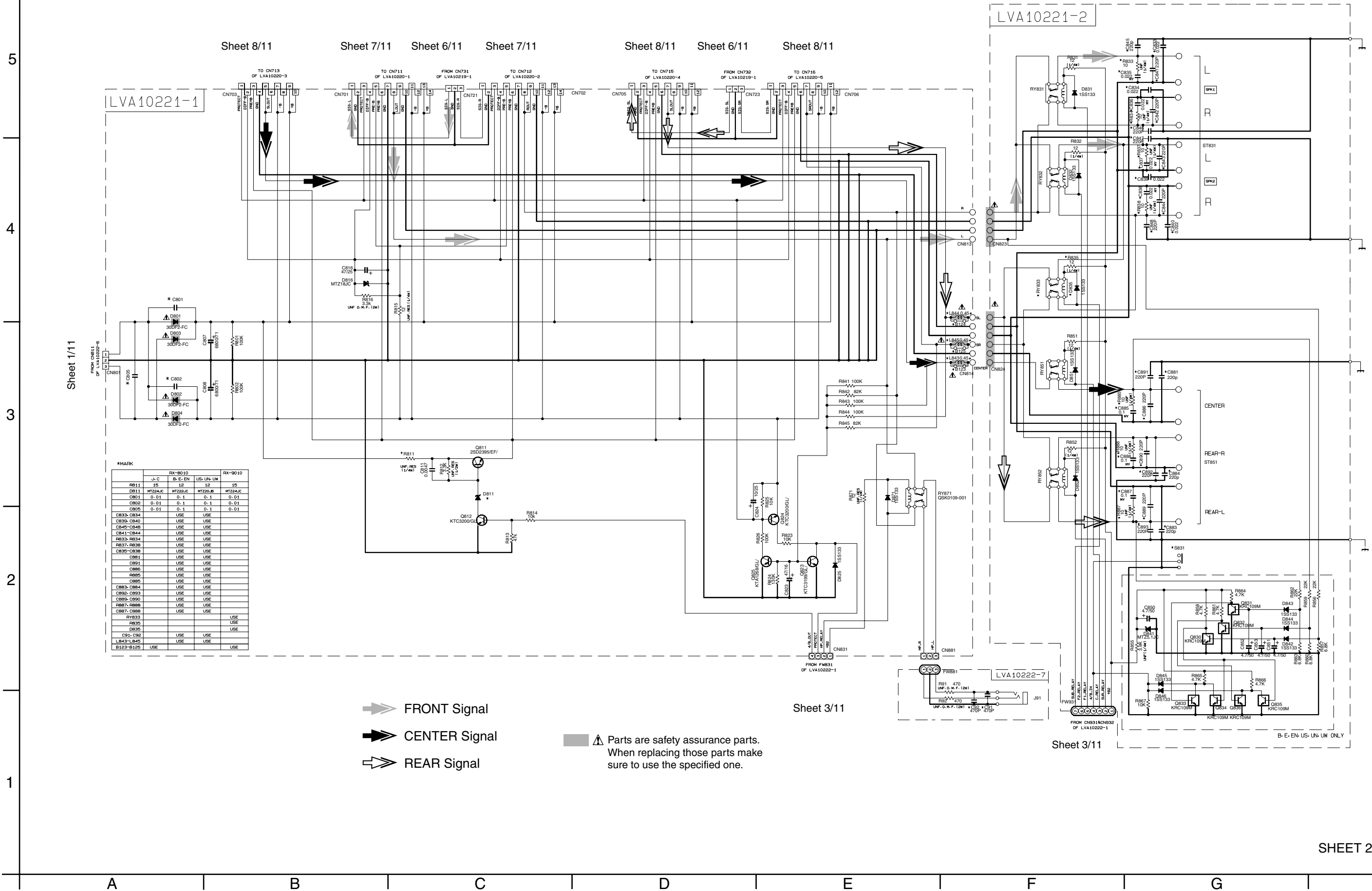

*MARK

	J-C	B-E-EN	US-LIN	LN	RX-8010	RX-9010
RB11	15	12	12	15		
DB11	MT24J-C	MT22J-C	MT20J-B	MT24J-C		
CB01	0.01	0.1	0.1	0.01		
CB02	0.01	0.1	0.1	0.01		
CB05	0.01	0.1	0.1	0.01		
CB33-CB34	USE	USE				
CB36-CB40	USE	USE				
CB42-CB48	USE	USE				
CB41-CB44	USE	USE				
CB33-CB34	USE	USE				
CB37-CB38	USE	USE				
CB35-CB38	USE	USE				
CB81	USE	USE				
CB91	USE	USE				
CB90	USE	USE				
CB85	USE	USE				
CB85	USE	USE				
CB83-CB84	USE	USE				
CB92-CB93	USE	USE				
CB89-CB90	USE	USE				
CB87-CB88	USE	USE				
RY83				USE		
RY85				USE		
DB35				USE		
CB1-CB2	USE	USE				
LB43-LB45	USE	USE				
B123-B125	USE	USE				

- ➡ FRONT Signal
- ➡ CENTER Signal
- ➡ REAR Signal
- ⚠ Parts are safety assurance parts. When replacing those parts make sure to use the specified one.

■ Audio section

5

4

3

2

1

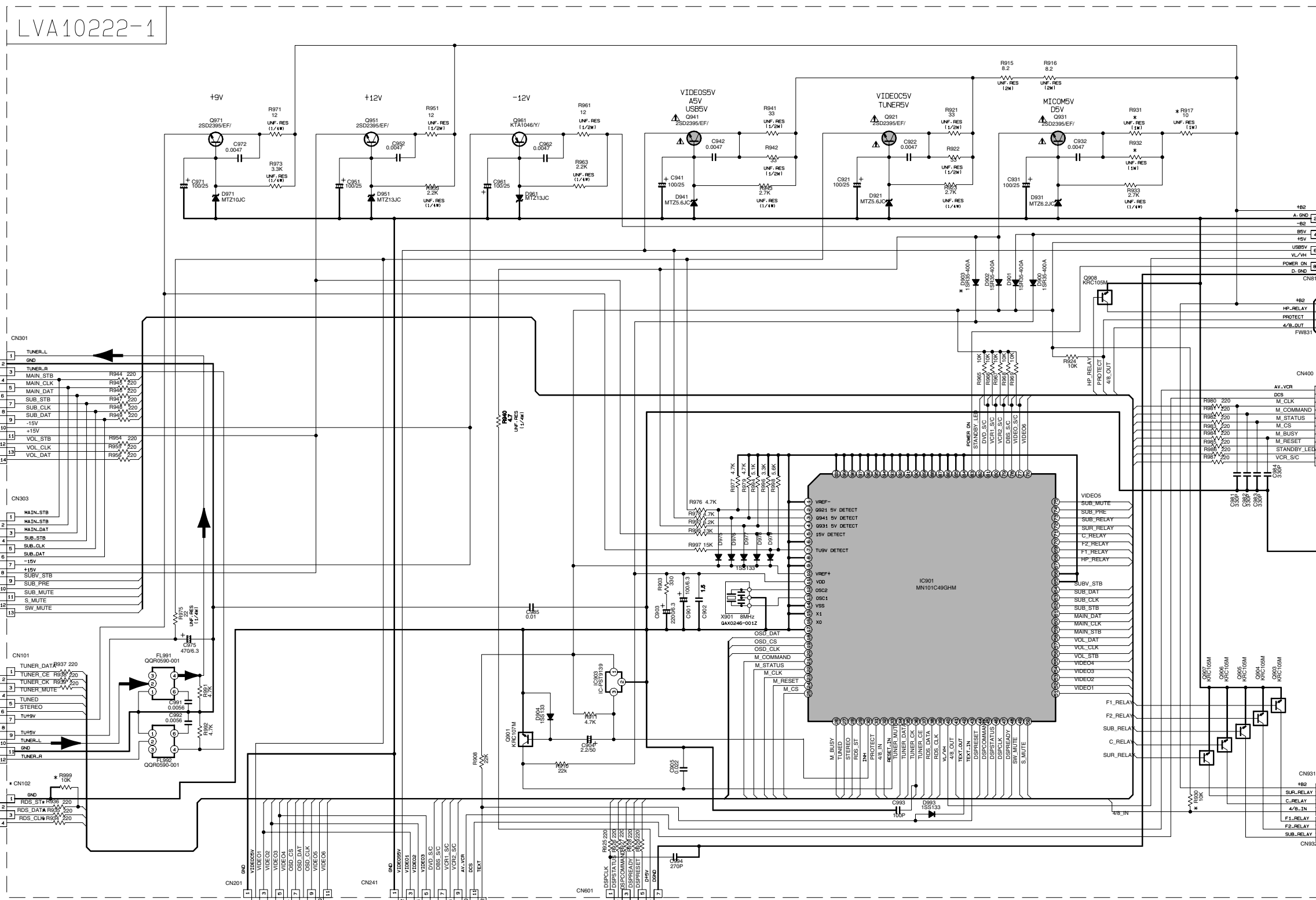

Sheet 4/11

Sheet 4/11

Sheet 11/11

Sheet 5/11

Sheet 5/11

Sheet 9/11

Sheet 1/11

Sheet 2/11

Sheet 10/11

Sheet 2/11

*MARK

	U-C	B-E-EN	US-UN-UW	RX-9010
R930	USE			USE
R939	USE			USE
R934	USE		USE	USE
R935	USE			USE
R936	USE			USE
CN102	USE			SHORT
R917	SHORT	SHORT	USE	SHORT
R931	43	43	43	39
R932	43	43	43	39
D903				USE

➔ TUNER Signal

⚠ Parts are safety assurance parts. When replacing those parts make sure to use the specified one.

■ Audio / V Audio signal input section

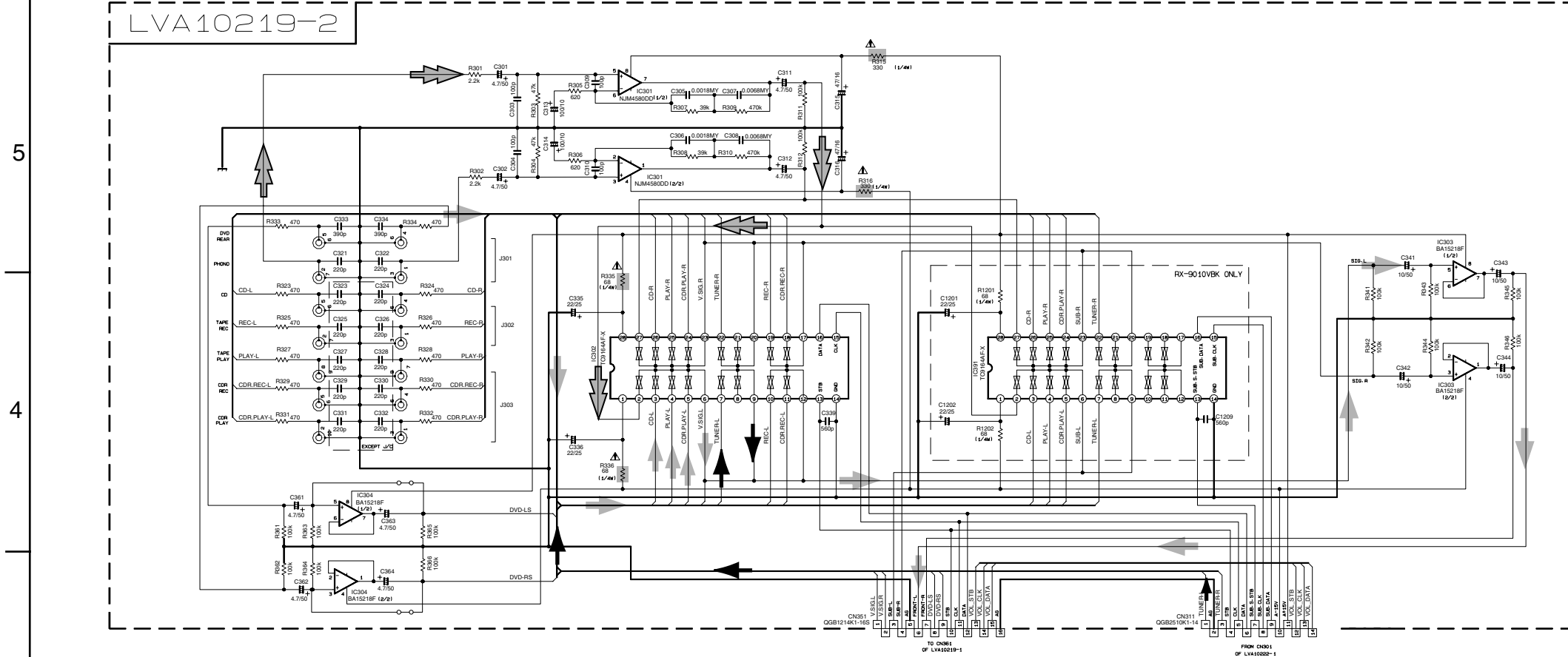

Sheet 6/11

Sheet 3/11

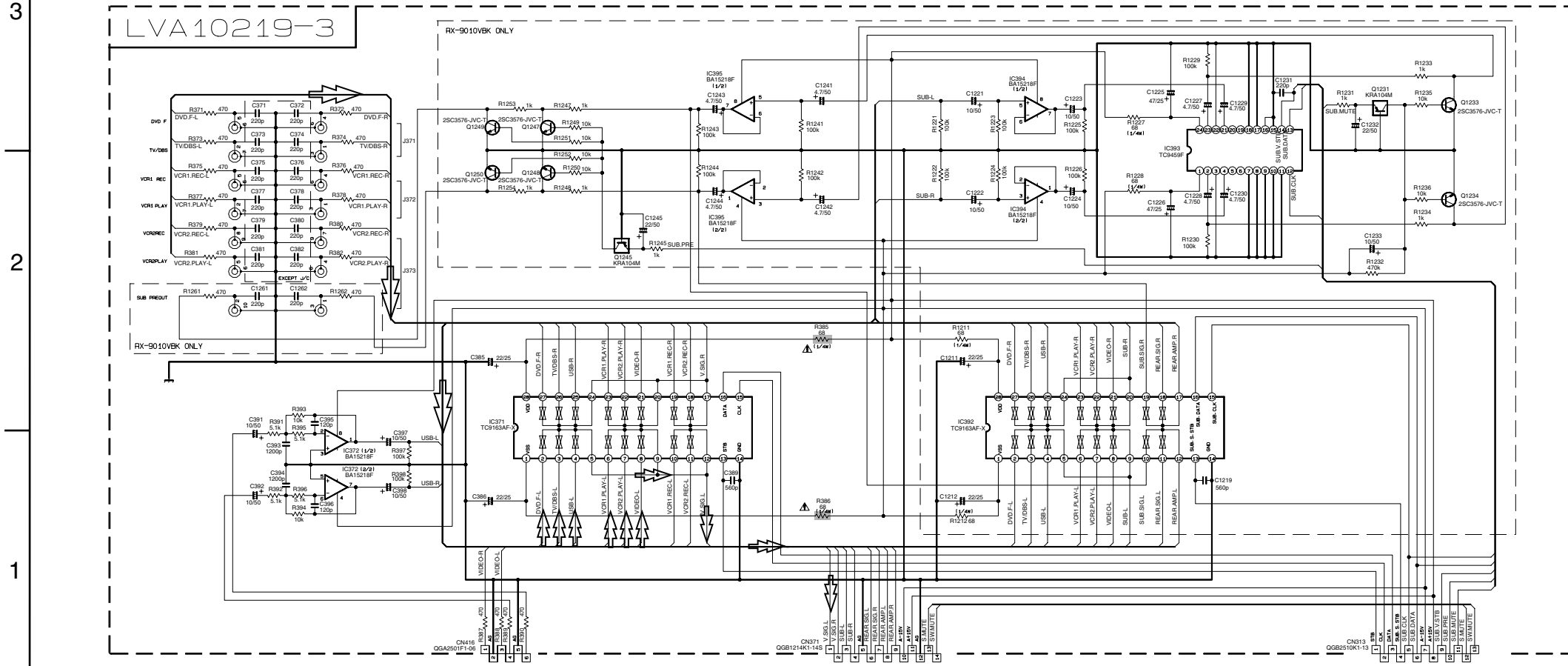

Sheet 10/11

Sheet 6/11

Sheet 2/11

- AUDIO Signal
- TUNER Signal
- PHONO Signal
- VIDEO AUDIO Signal

▲ Parts are safety assurance parts.
When replacing those parts make
sure to use the specified one.

Video / S video signal input section

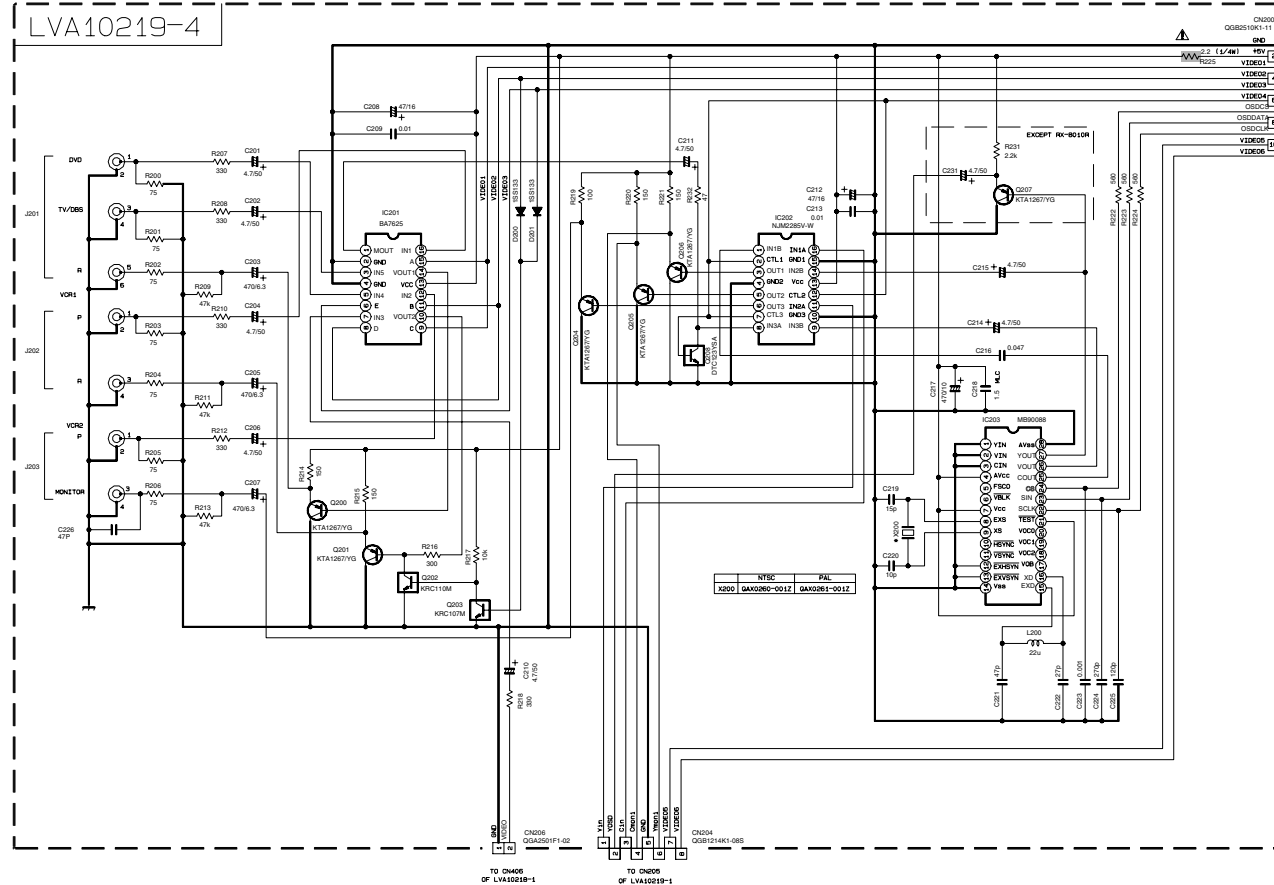

Sheet 3/11

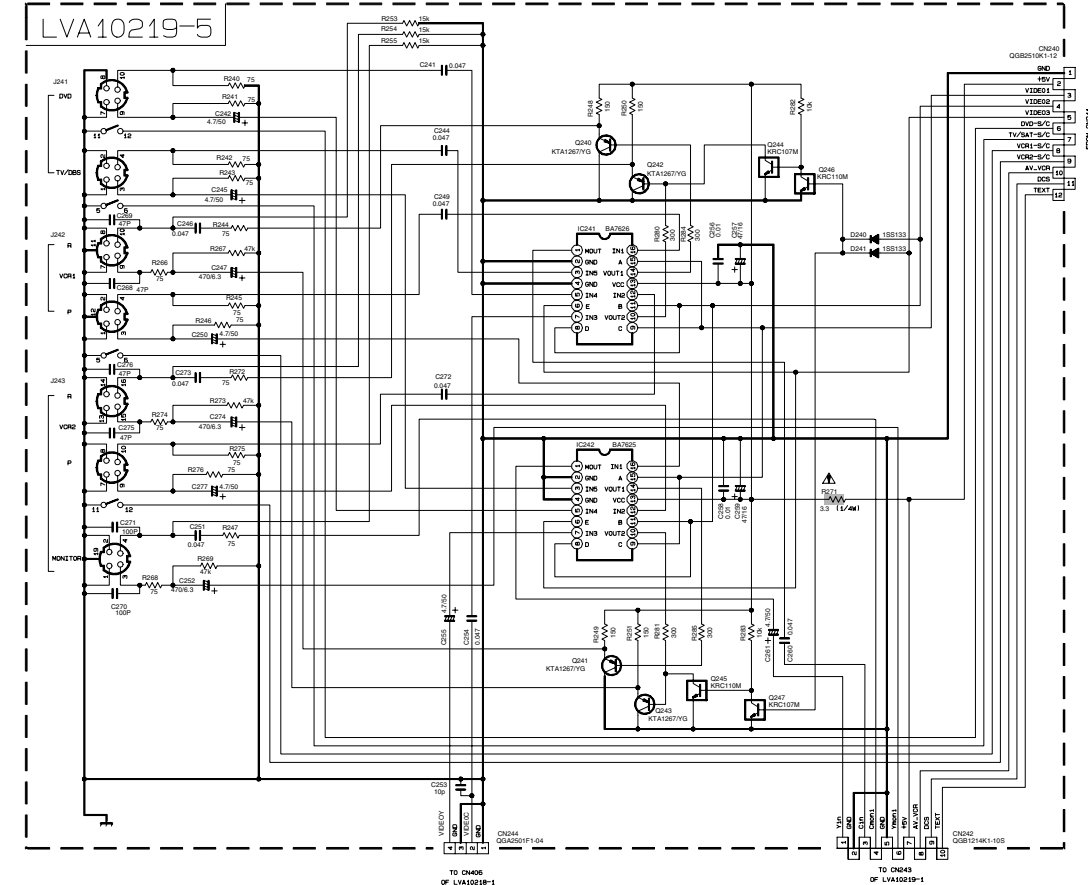

Sheet 3/11

⚠ Parts are safety assurance parts. When replacing those parts make sure to use the specified one.

DVD section

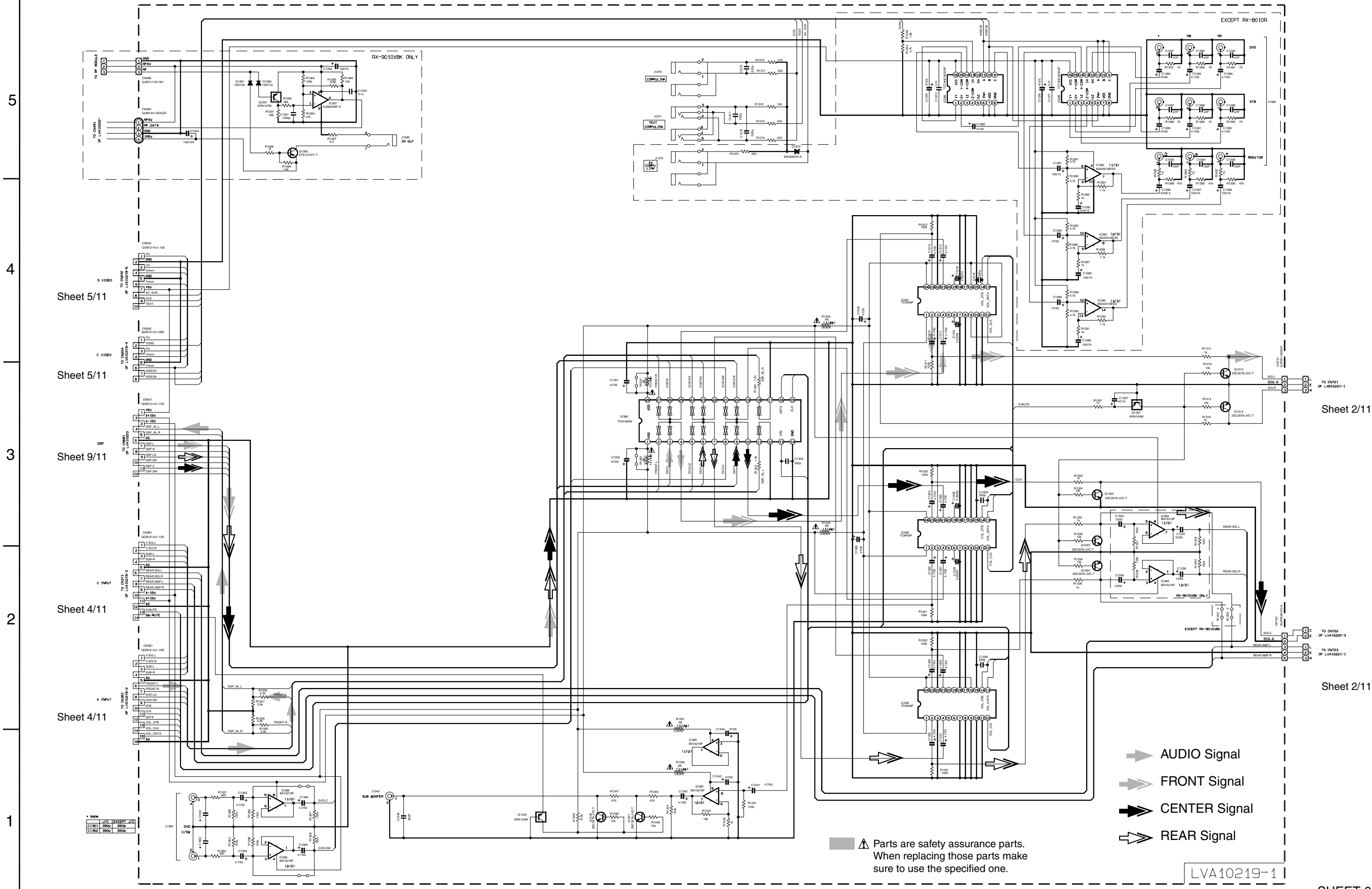

Sheet 2/11

Sheet 2/11

SHEET 6/11

RX-8012VSL/RX-8010VBK

■ Audio amplifier section (1/2)

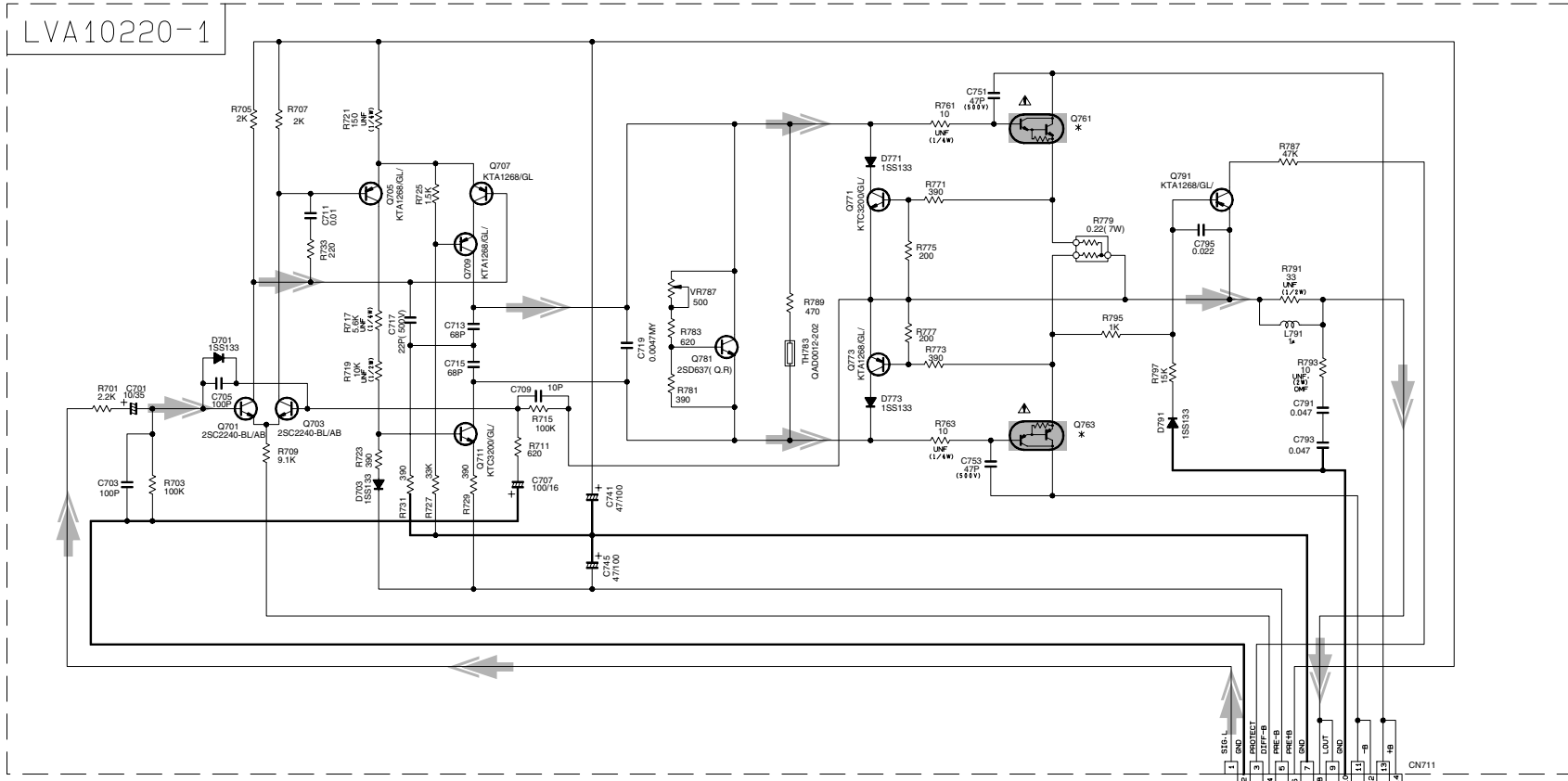

Sheet 2/11

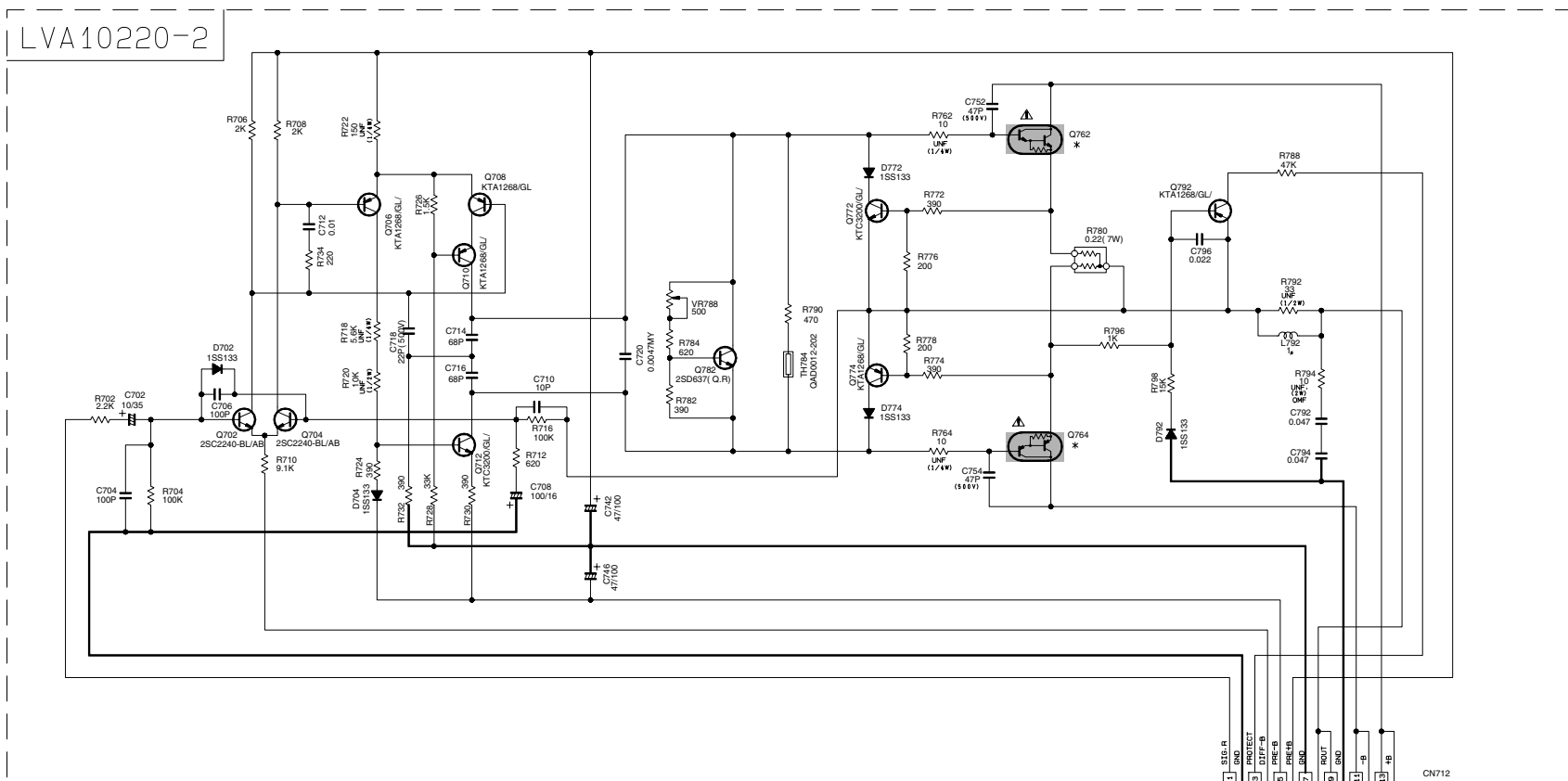

Sheet 2/11

*MARK

	RX-8010		RX-9010
	B-E-EN-US-LN-LW	J-C	
Q761-Q762	2SD2390/OPV/-F6	2SD2560/OPV/-F6	2SD2560/OPV/-F6
Q763-Q764	2SB1560/OPV/-F6	2SB1647/OPV/-F6	2SB1647/OPV/-F6

➡ FRONT Signal

▲ Parts are safety assurance parts. When replacing those parts make sure to use the specified one.

5
4
3
2
1

A B C 2-10 D E F G H

■ Audio amplifier section (2/2)

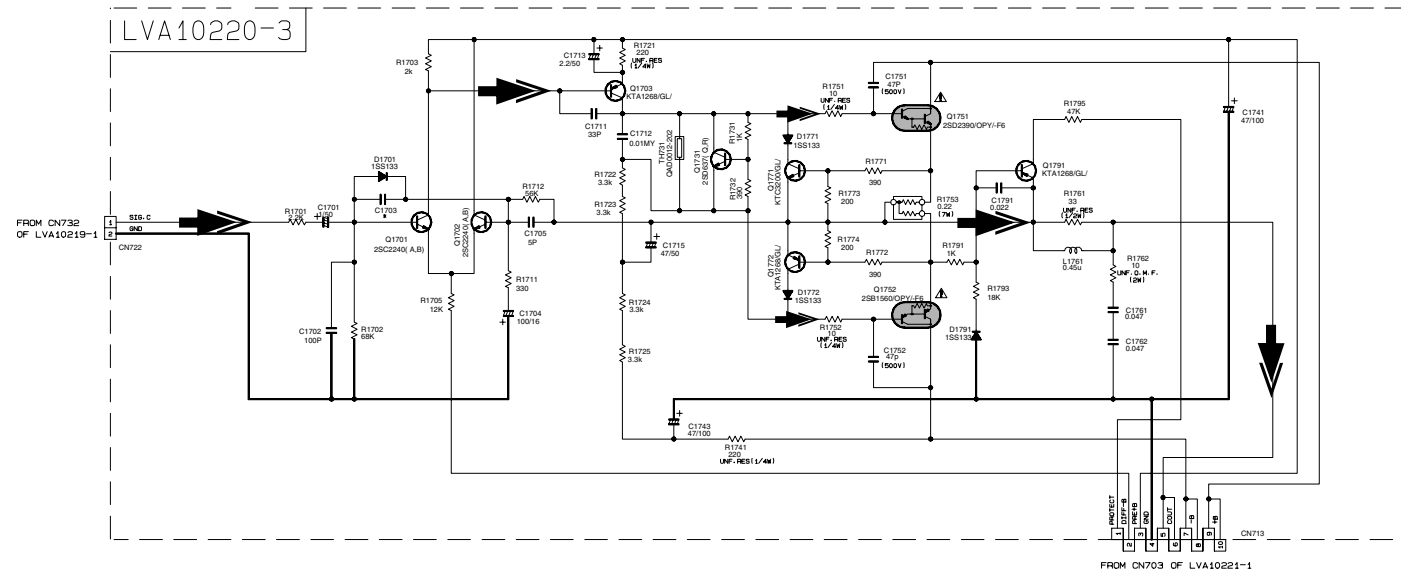

*MARK	RX-8010	RX-9010
C1803, C1804	100P	180P
C1703-C1805, C1806	J/C	EXCEPT J/C
	100P	220P

➡ CENTER Signal

➡ REAR Signal

⚠ Parts are safety assurance parts. When replacing those parts make sure to use the specified one.

Sheet 2/11

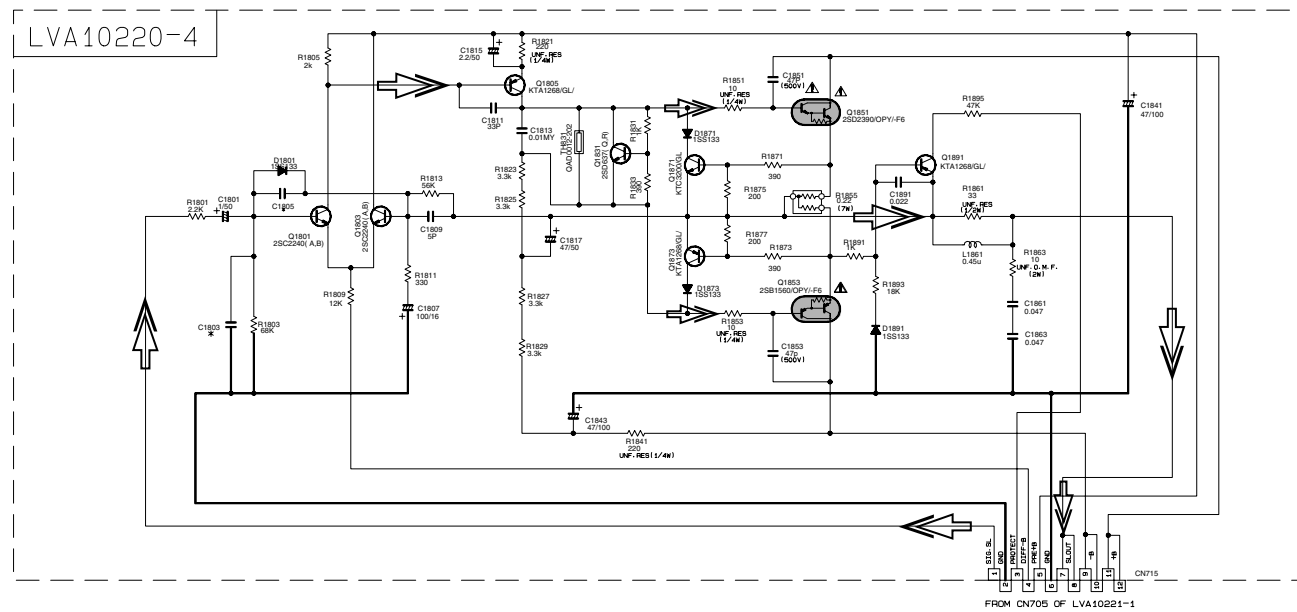

Sheet 2/11

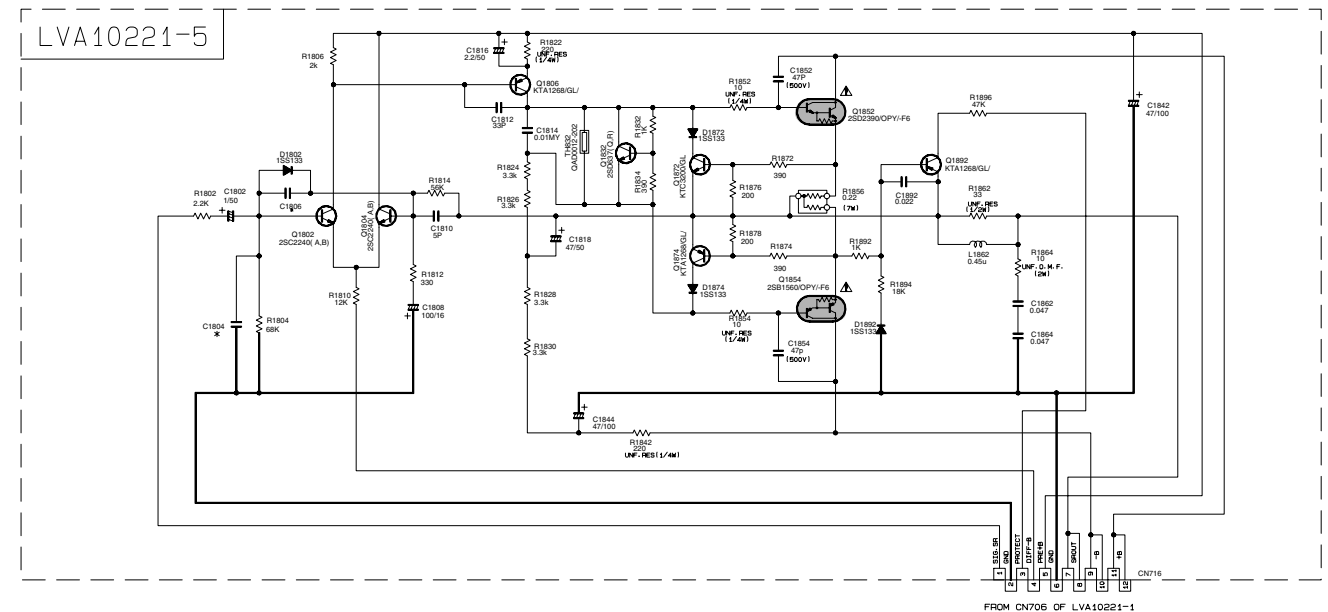

Sheet 2/11

DSP section

5
4
3
2
1

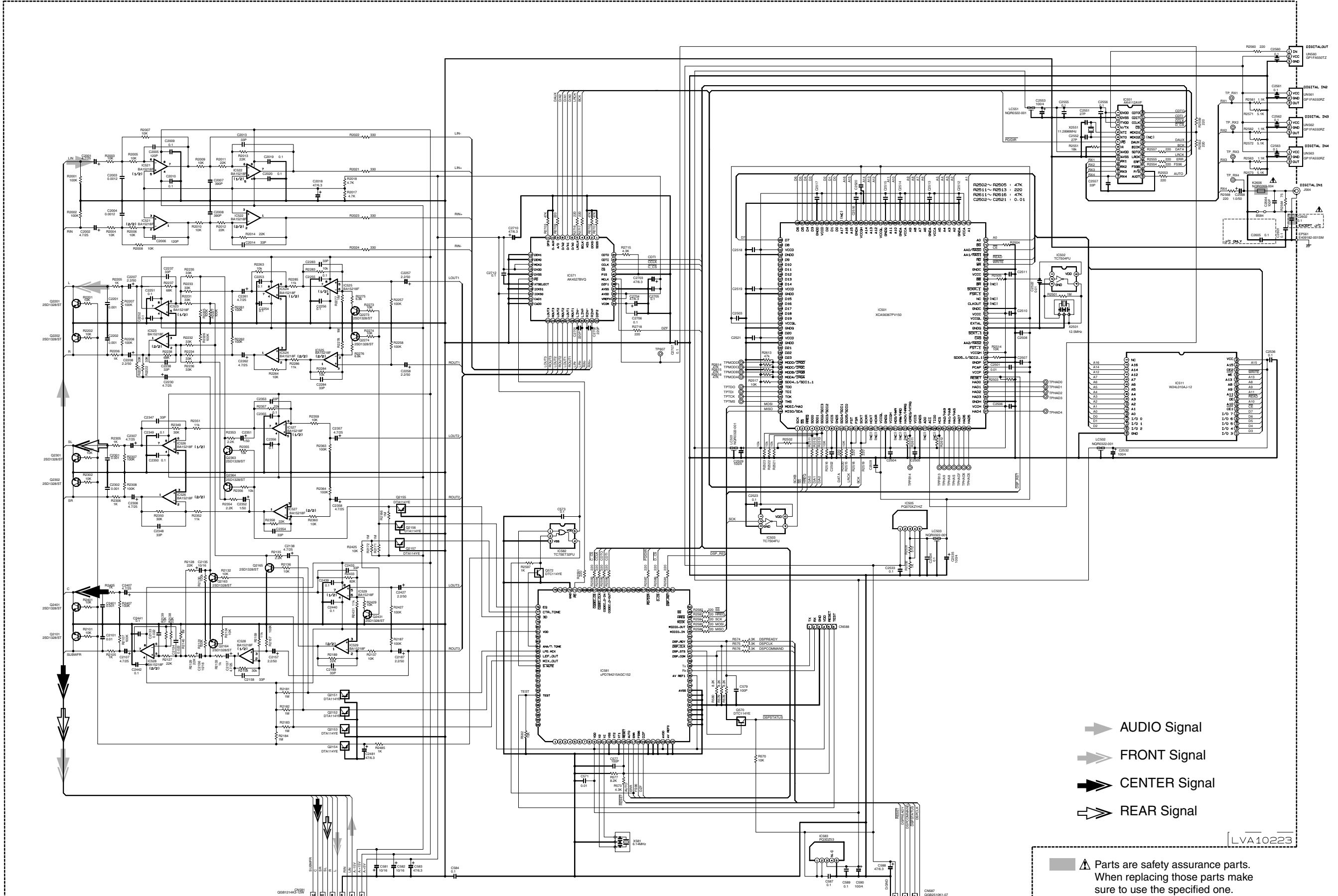

- ➔ AUDIO Signal
- ➔ FRONT Signal
- ➔ CENTER Signal
- ➔ REAR Signal

▲ Parts are safety assurance parts.
When replacing those parts make
sure to use the specified one.

A B C 2-12 D E F G H

System control & FL display section

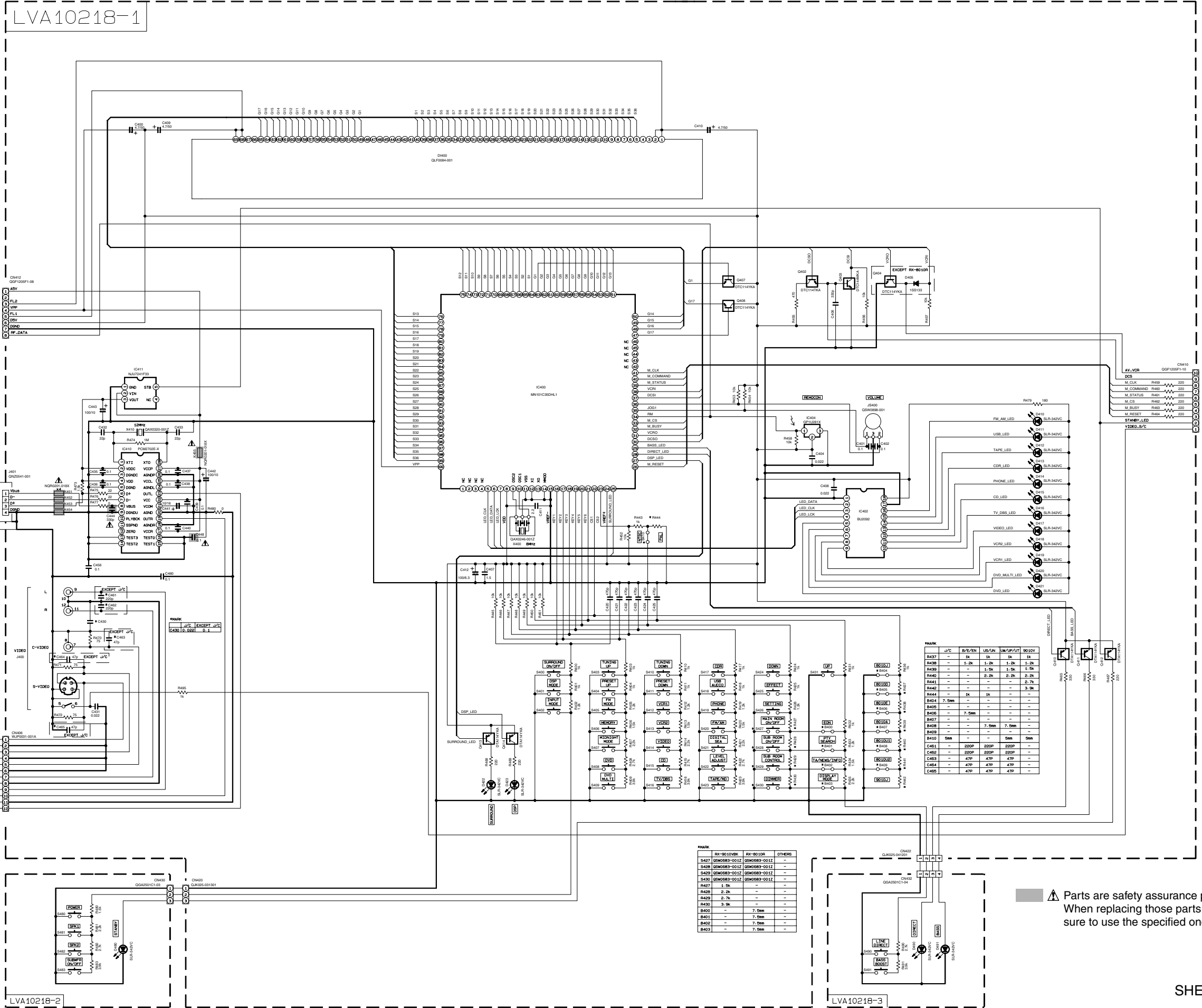

Sheet 1/11

Sheet 5/11
Sheet 5/11
Sheet 4/11

Sheet 3/11

MARK	RX-8010VBK	RX-8010R	OTHERS
S427	DEM0983-0012	DEM0983-0012	-
S428	DEM0983-0012	DEM0983-0012	-
S429	DEM0983-0012	DEM0983-0012	-
S430	DEM0983-0012	DEM0983-0012	-
R427	1.5k	-	-
R428	2.2k	-	-
R429	2.7k	-	-
R430	3.9k	-	-
R431	-	7.5m	-
R432	-	7.5m	-
R433	-	7.5m	-

Parts are safety assurance parts. When replacing those parts make sure to use the specified one.

■ Tuner section

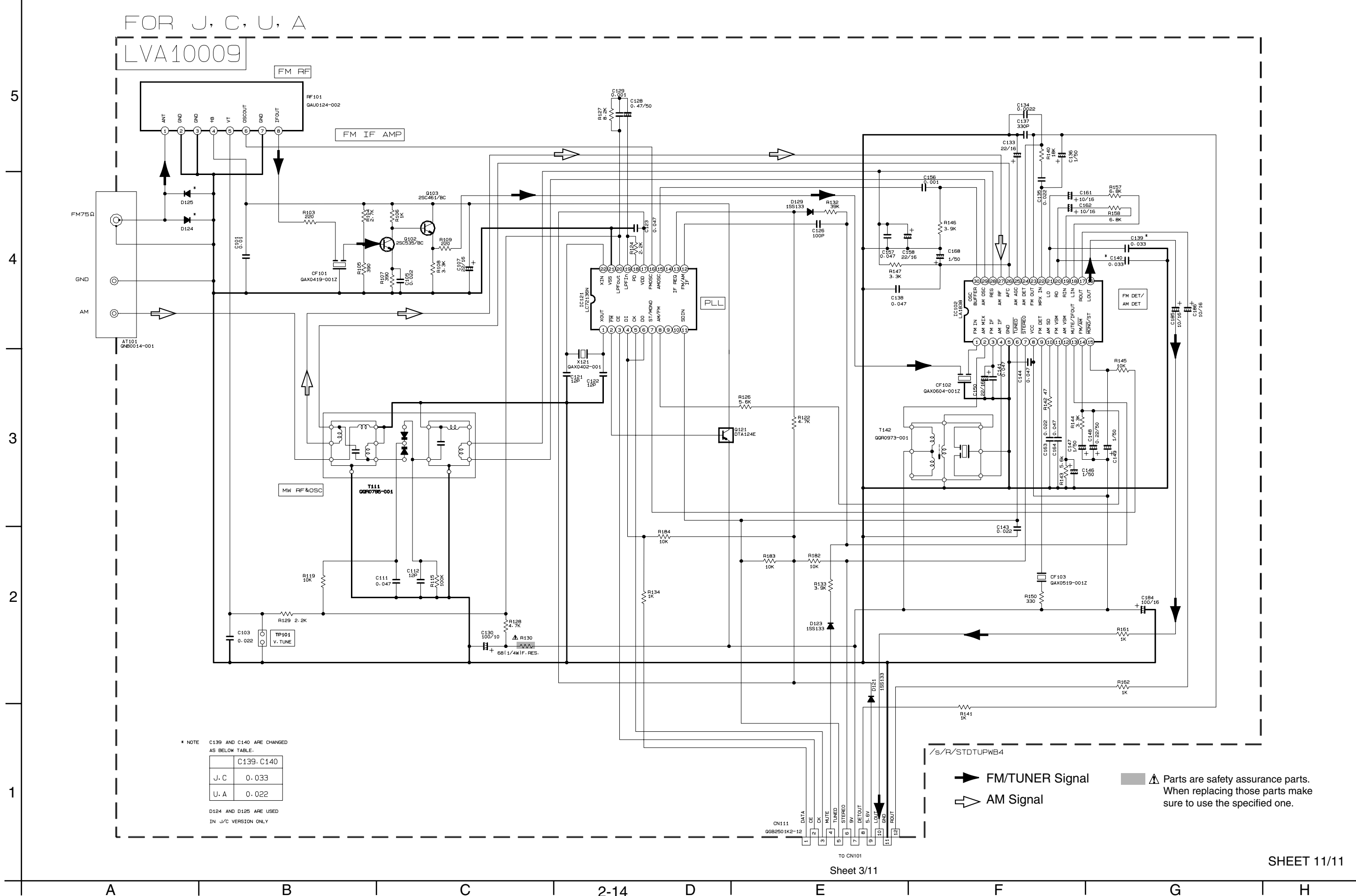

* NOTE C139 AND C140 ARE CHANGED AS BELOW TABLE.

	C139, C140
J. C	0.033
U. A	0.022

D124 AND D125 ARE USED IN J/C VERSION ONLY

/s/R/STDUPWB4

➔ FM/TUNER Signal

➤ AM Signal

⚠ Parts are safety assurance parts. When replacing those parts make sure to use the specified one.

Printed circuit boards

■ Main board

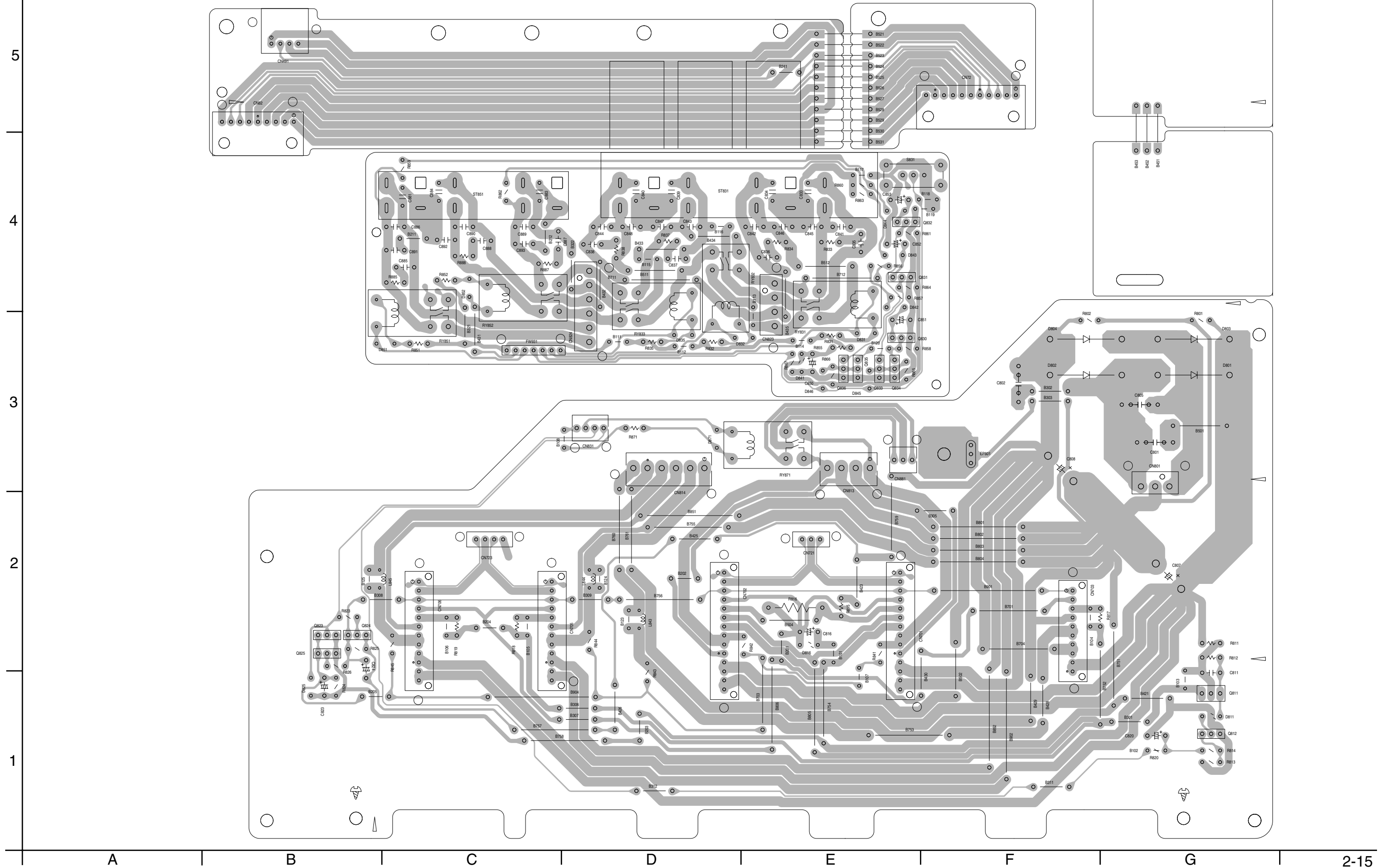

RX-8012VSL/RX-8010VBK

■ Micon board

5

4

3

2

1

A

B

C

2-16

D

E

F

G

H

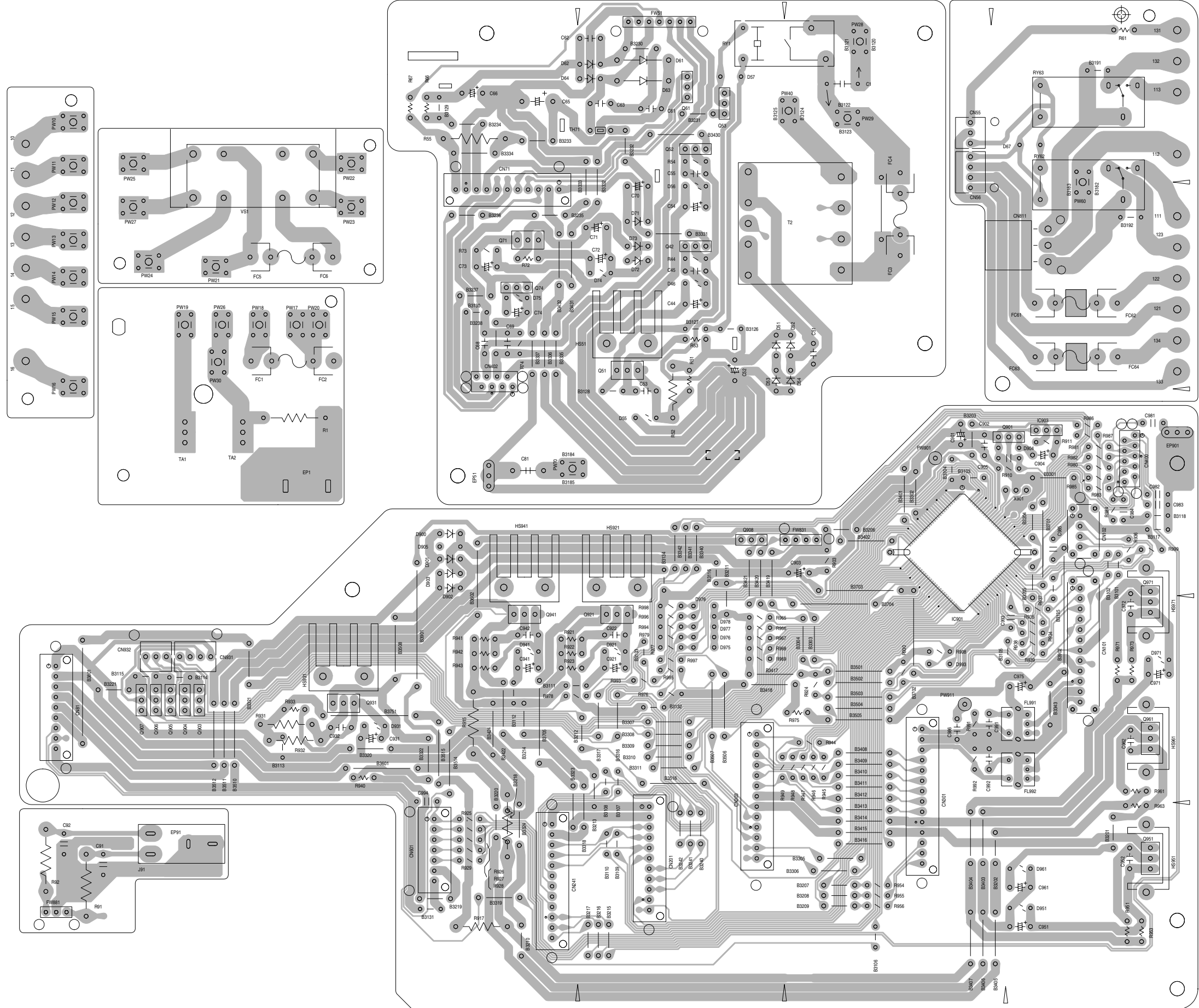

■ Front board

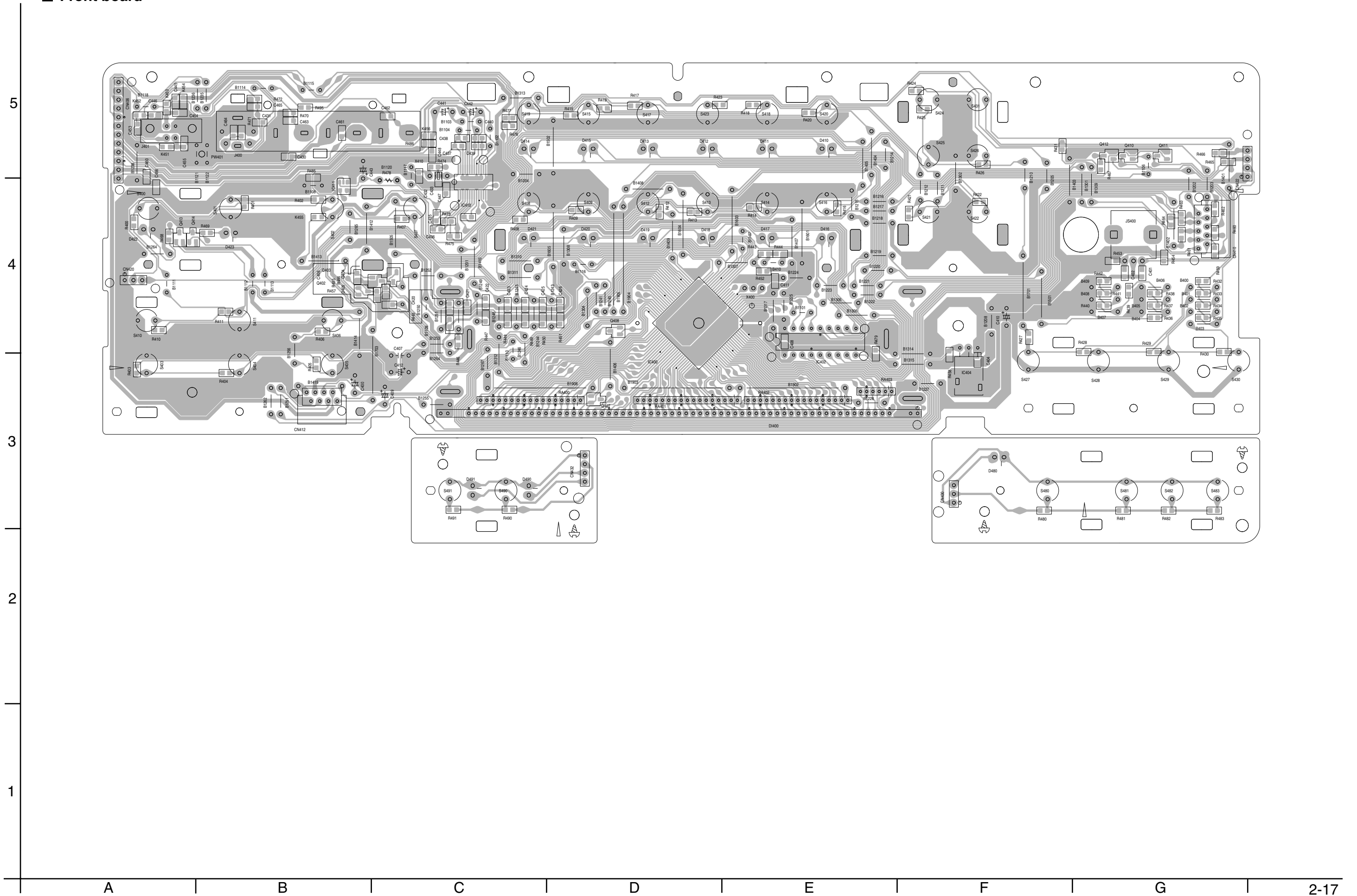

■ Input board (Forward side)

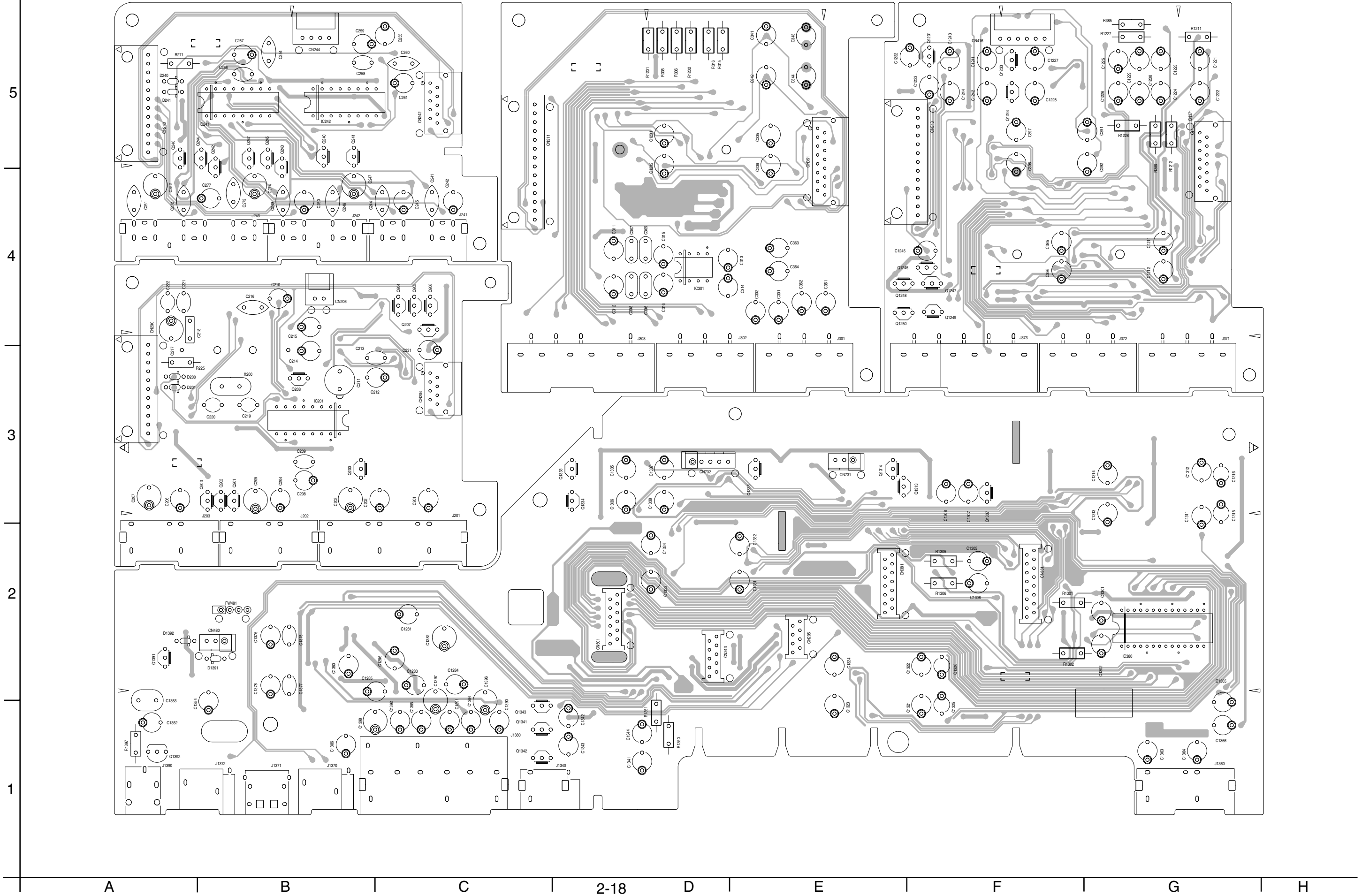

■ Input board (Reverse side)

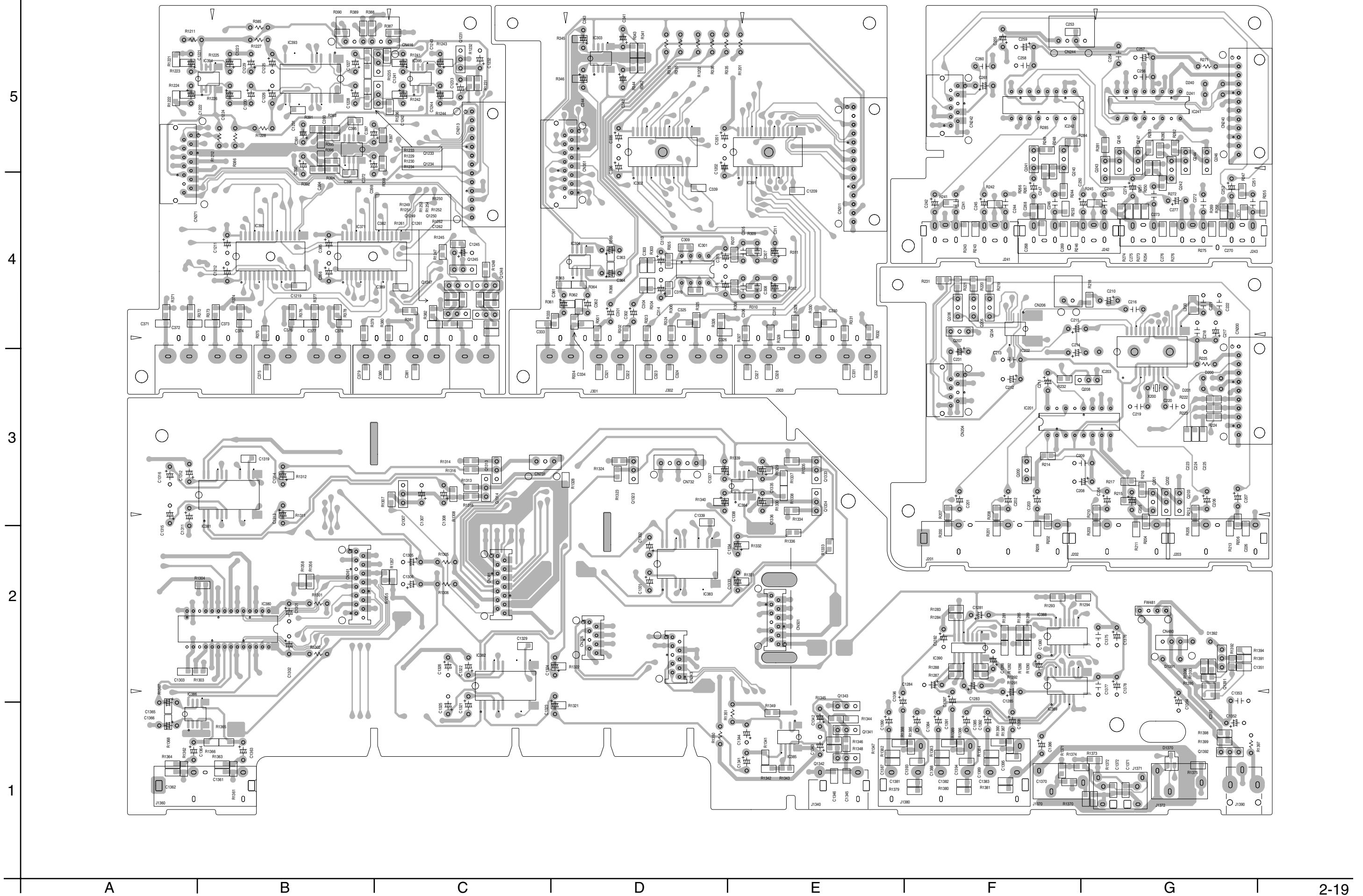

■ Power board

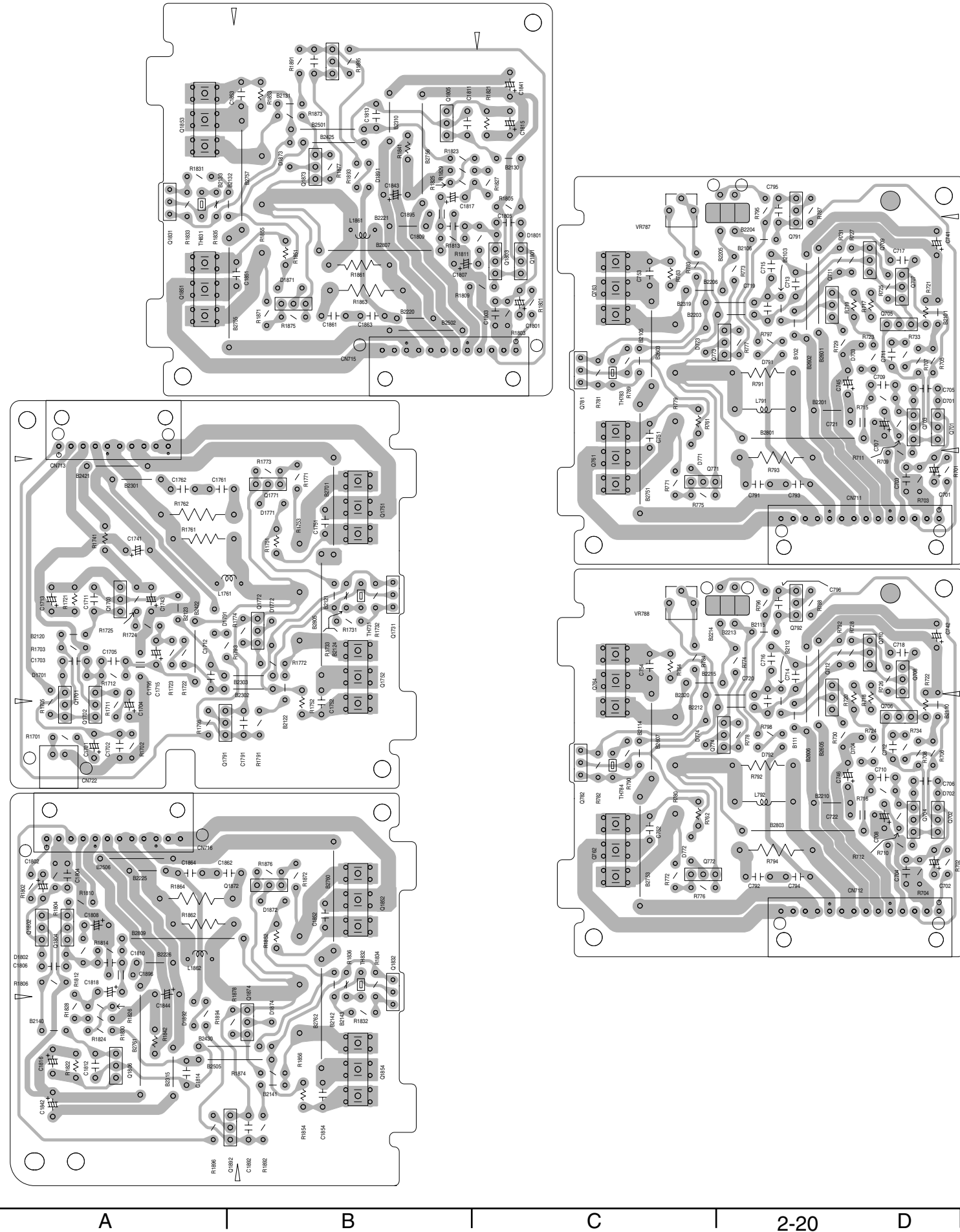

■ DSP board

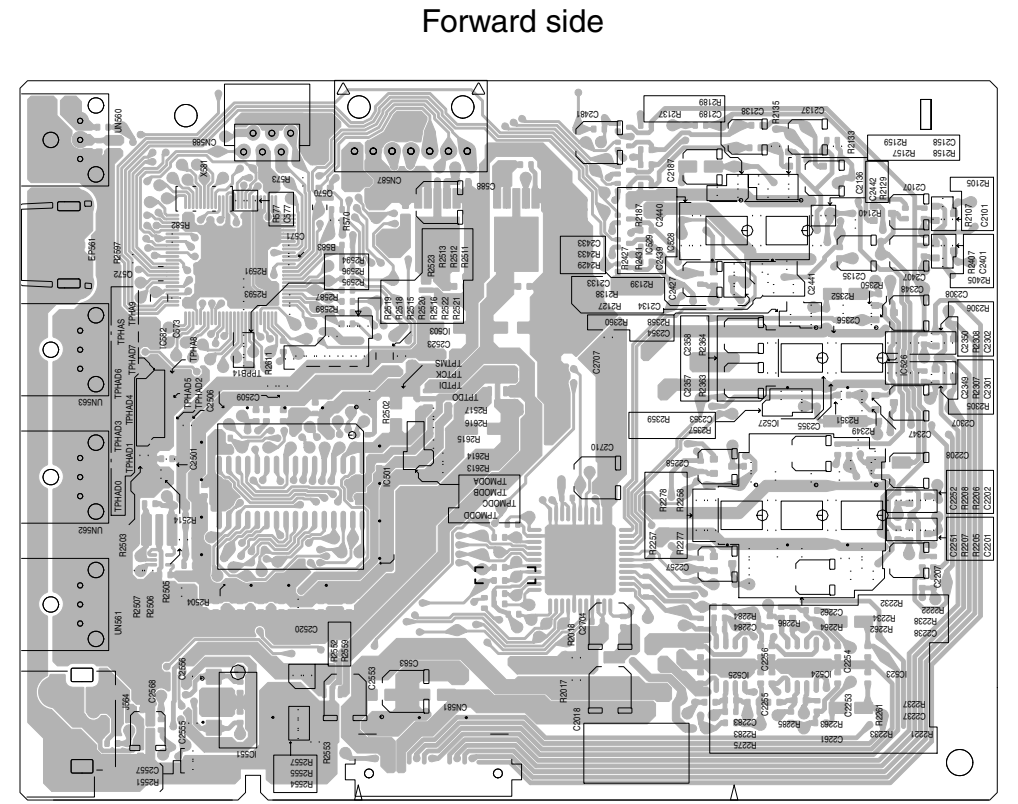

Forward side

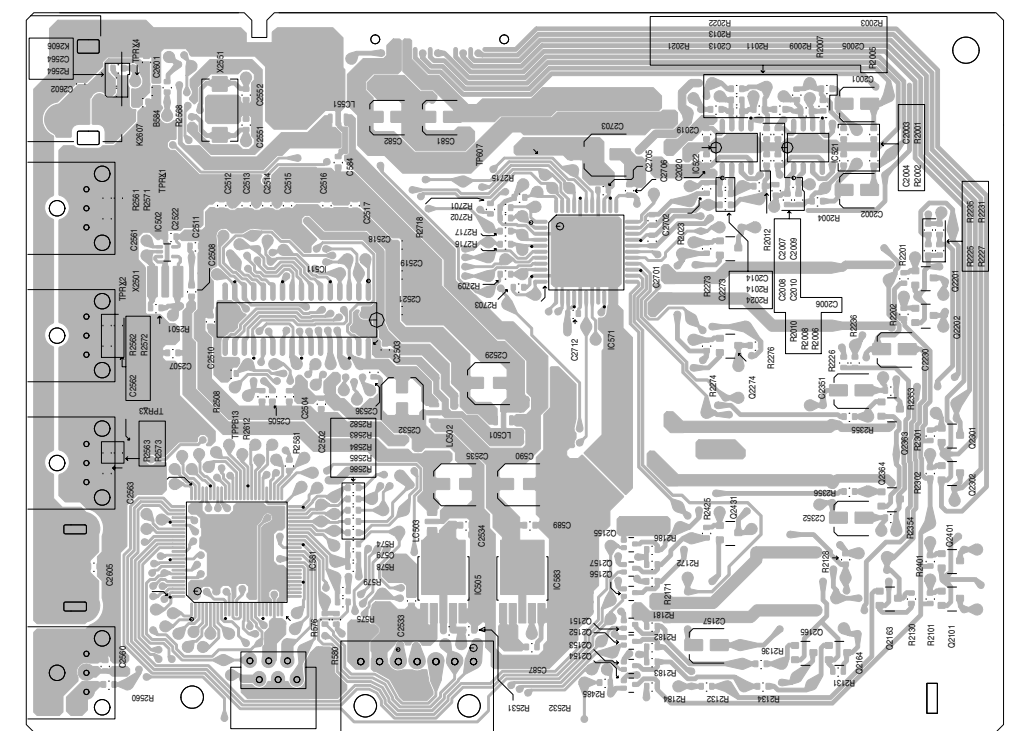

Reverse side

■ Tuner board

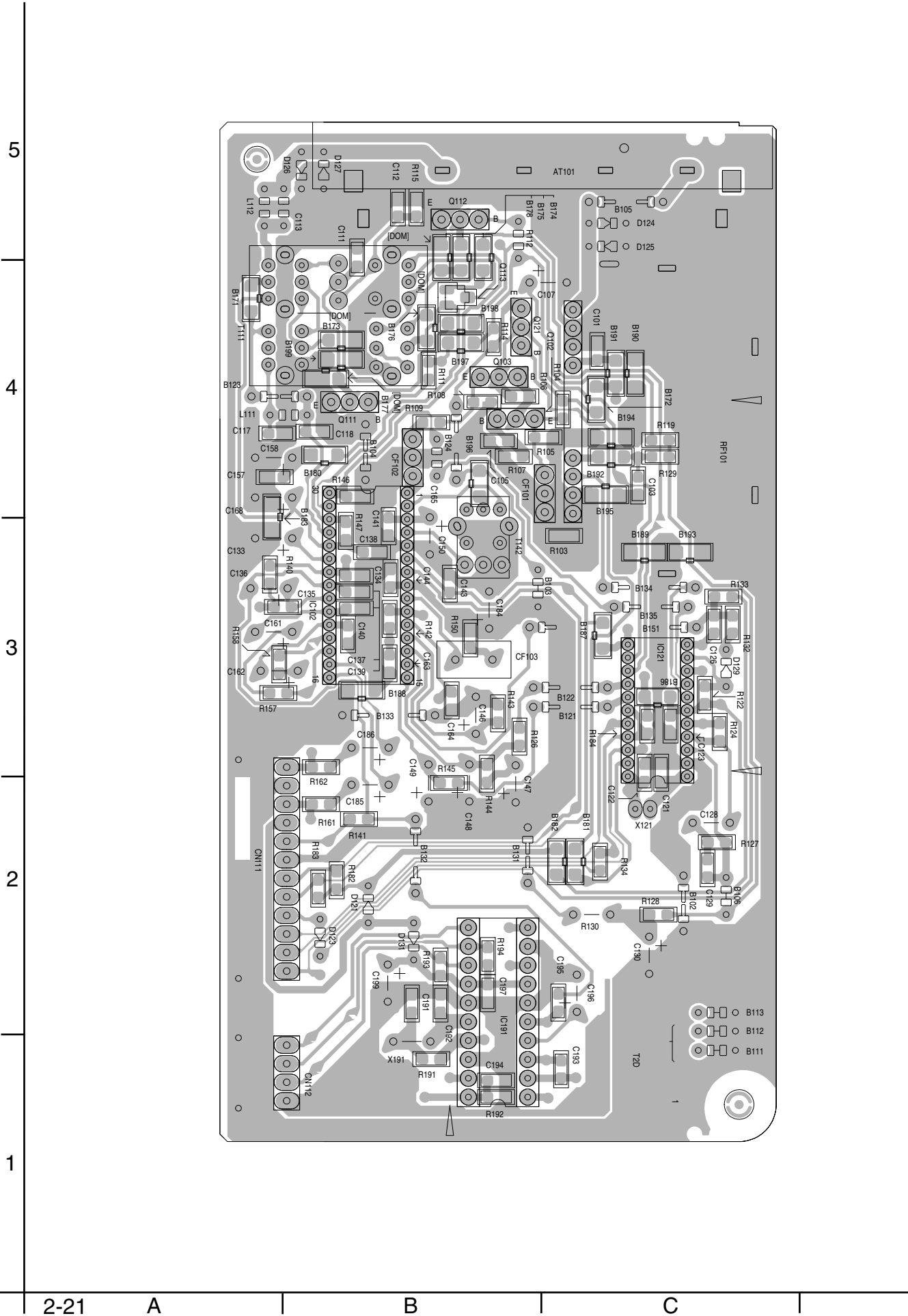

PARTS LIST

[RX-8010VBK]
[RX-8012VSL]

* All printed circuit boards and its assemblies are not available as service parts.

RX-8010VBK	RX-8012VSL
Area suffix	Area suffix
UJ ----- U.S.Military	UW ----- Brazil,Mexico,Peru

- Contents -

Exploded view of general assembly and parts list	3- 3
Electrical parts list	3- 5
Packing materials and accessories parts list	3-22

< M E M O >

Exploded view of general assembly and parts list

Block No. **M** **1** **M** **M**

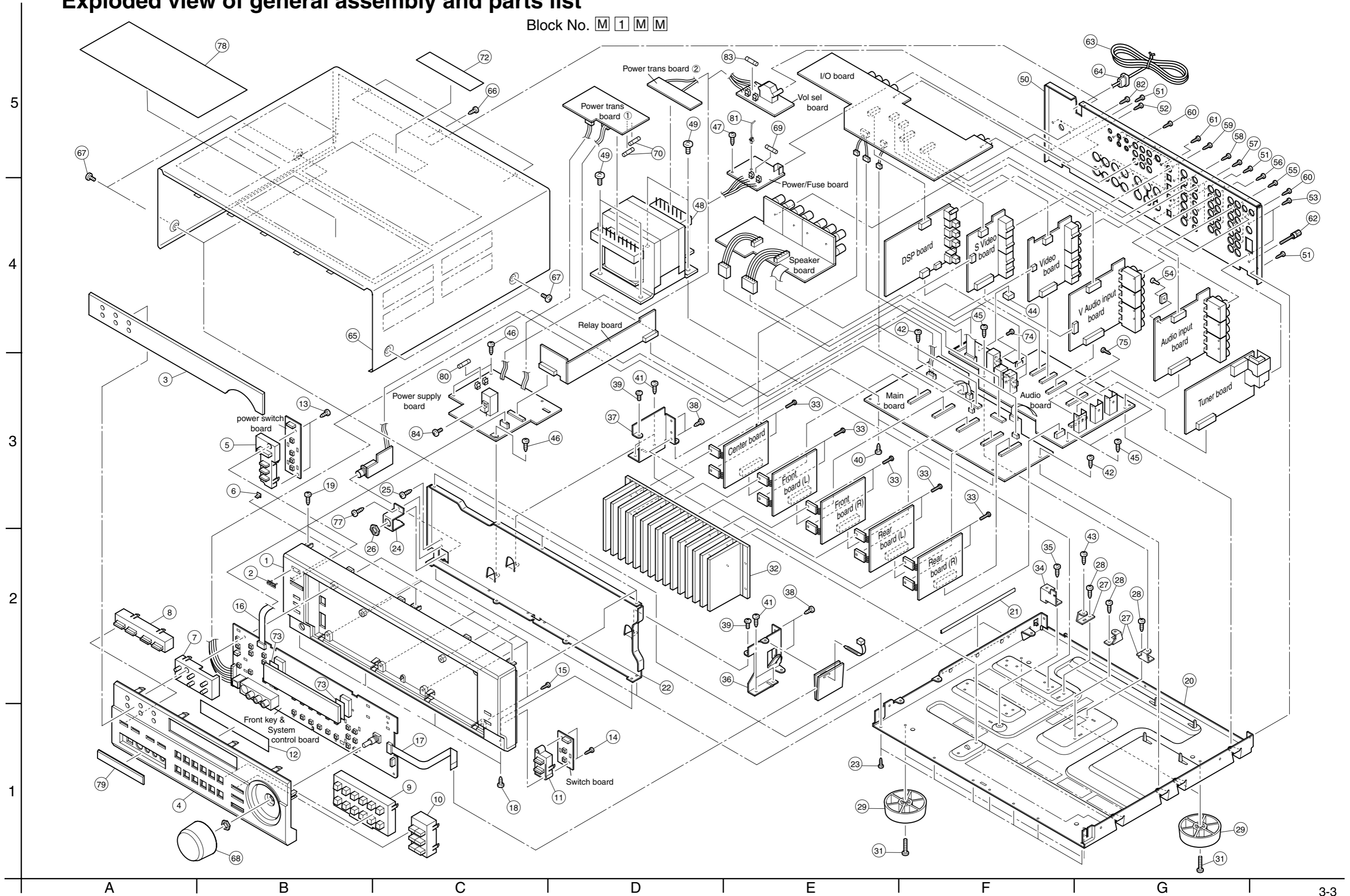

■ Parts list (General assembly)

Block No. M1MM

△	Item	Parts number	Parts name	Q'ty	Description	Area
	1	LV10469-005A	FRONT PANEL	1	RX-8012VSL	
		LV10469-009A	FRONT PANEL	1	RX-8010VBK	
	2	VJD5429-001SS	JVC MARK	1	RX-8010VBK	
		VJD5429-002SS	JVC MARK	1	RX-8012VSL	
	3	LV20949-004A	LENS	1		
	4	LV10470-001A	SUB PANEL	1	RX-8010VBK	
		LV10470-002A	SUB PANEL	1	RX-8012VSL	
	5	LV20939-002A	PUSH BUTTON	1	RX-8012VSL	
		LV20939-003A	PUSH BUTTON	1	RX-8010VBK	
	6	LV42096-001A	INDICATOR	1	POWER	
	7	LV20951-001A	PUSH BUTTON	1	TUNER	
	8	LV20940-001A	P.BUTTON ASSY	1	RX-8010VBK	
		LV20940-002A	P.BUTTON ASSY	1	RX-8012VSL	
	9	LV20944-001A	P.BUTTON ASSY	1	RX-8010VBK	
		LV20944-002A	P.BUTTON ASSY	1	RX-8012VSL	
	10	LV20942-002A	PUSH BUTTON	1	RX-8012VSL	
		LV20942-001A	PUSH BUTTON	1	RX-8010VBK	
	11	LV32486-001A	P.BUTTON ASSY	1	RX-8010VBK	
		LV32486-002A	P.BUTTON ASSY	1	RX-8012VSL	
	12	LV42095-002A	FL SCREEN	1		
	13	QYSBSF2610Z	SCREW	2	FRONT C.B	
	14	QYSBSF2610Z	SCREW	2		
	15	QYSBSF2610Z	SCREW	8	FRONT C.B FL	
	16	QUQ412-0815CJ	FFC WIRE	1		
	17	QUQ412-1030CJ	FFC WIRE	1		
	18	QYSDSG3006Z	SCREW	4	FRONT D	
	19	QYSBSG3006Z	T.SCREW	3	FRONT U	
	20	LV10019-003A	CHASSIS BASE	1		
	21	EXO150010H09S11	FELT SPACER	1	FOR C.BASE	
	22	LV10471-002A	FRONT BRACKET	1		
	23	QYSDSG3006Z	SCREW	7	C.B-F.B	
	24	LV42094-002A	H.P. BKT	1		
	25	QYSBSG3006Z	T.SCREW	1	H.P BKT-F.B	
	26	VKZ4150-001	SPECIAL NUT	1		
	27	E68587-223SM	CB BKT	3		
	28	QYSBST3006Z	T.SCREW	3	C.B-BKT	
	29	QZF6018-003	FOOT	4	RX-8012VSL	
		QZF6018-001	FOOT	4	RX-8010VBK	
	31	QYSBST3010Z	T.SCREW	4	FOOT	
	32	LV20984-002A	HEAT SINK	1		
	33	E73525-003SS	SCREW	10	TR	
	34	LV42098-001A	C.B BKT	1	PRI/SEC C.B	
	35	QYSBST3006Z	T.SCREW	1	C.B BKT	
	36	LV32433-001A	H.S BRACKET(R)	1		
	37	LV32434-001A	H.S BRACKET(L)	1		
	38	QYSBSG3008Z	T.SCREW	4	H.S-BKT	
	39	QYSBSG3006Z	T.SCREW	2	H.S BKT-F.BKT	
	40	QYSBSG3006Z	T.SCREW	2	H.S BKT	

■ Parts list (General assembly)

Block No. M1MM

△	Item	Parts number	Parts name	Q'ty	Description	Area
	41	QYSBST3006Z	T.SCREW	4	H.S BKT-CHASSIS	
	42	QYSBSG3006Z	T.SCREW	2	M.C.B	
	43	E65923-003	TAPPING SCREW	1	M.C.B	
	44	LV30225-0B2A	SPACER	1		
	45	QYSBSG3006Z	T.SCREW	3	H.S-C.B	
	46	QYSBSG3006Z	T.SCREW	3	P.C.B-CHASSIS	
	47	QYSBSG3006Z	T.SCREW	1	C.B-CHASSIS	
△	48	QQT0325-003	TRANSFORMER	1		
	49	QYSDSTL4008Z	SPECIAL SCREW	4	P.TRANS	
	50	LV10472-015A	REAR PANEL	1	RX-8010VBK	
		LV10472-010A	REAR PANEL	1	RX-8012VSL	
	51	QYSBSGY3008M	SPECIAL SCREW	3	R.P-C.BASE	
	52	QYSBSGY3008M	SPECIAL SCREW	1	R.P-ud---	
	53	QYSBSGY3008M	SPECIAL SCREW	2	TUNER	
	54	FMYH4004-001	PLASTIC RIVET	1	A.INPUT	
	55	QYSBSGY3008M	SPECIAL SCREW	4	A.INPUT	
	56	QYSBSGY3008M	SPECIAL SCREW	3	V.INPUT	
	57	QYSBSGY3008M	SPECIAL SCREW	3	VIDEO	
	58	QYSBSGY3008M	SPECIAL SCREW	4	S VIDEO	
	59	QYSBSGY3008M	SPECIAL SCREW	6	DIGITAL	
	60	QYSBSGY3008M	SPECIAL SCREW	7	COMP C.B	
	61	QYSBSGY3008M	SPECIAL SCREW	4	SPK C.B	
	62	E409257-001	GND TERMINAL	1		
△	63	QMPK150-200-JD	POWER CORD	1		
△	64	QZW0033-001	STRAIN RELIEF	1		
	65	LV20038-009A/S/	TOP COVER	1	RX-8010VBK	
		LV20038-010A/S/	TOP COVER	1	RX-8012VSL	
	66	QYSBSGY3008M	SPECIAL SCREW	3		
	67	E406308-004	SPECIAL SCREW	4	RX-8012VSL	
		E406308-003	SPECIAL SCREW	4	RX-8010VBK	
	68	LV32435-003A	VOL KNOB	1	RX-8010VBK	
		LV32435-004A	VOL KNOB	1	RX-8012VSL	
△	69	QMF51E2-6R3-J1	FUSE	1	F1	
△	70	QMF51E2-2R0-J1	FUSE	2	F61 F62	
	72	E409396-002	CAUTION LABEL	1		
	73	E3400-444	FELT SPACER	2	FS400 FS401	
	74	QYSBSG3008E	T.SCREW	3		
	75	QYSBSG3008E	T.SCREW	3		
	77	QYSBSG3006Z	T.SCREW	1		
	78	LV30077-006A	PROTECT SHEET	1	RX-8012VSL	
		LV30077-004A	PROTECT SHEET	1	RX-8010VBK	
	79	LV32488-003A	COVER	1	RX-8010VBK	
		LV32488-004A	COVER	1	RX-8012VSL	
△	80	QMF51E2-R10-J1	FUSE	1	F2	
	81	E307572-001	FASTENER	1		
	82	QYSBSGY3008M	SPECIAL SCREW	2	VOL SEL	
△	83	QMF51E2-3R15-J1	FUSE	1	F4	
	84	QYSBSG3008E	T.SCREW	1		

■ Electrical parts list (Main board)

Block No. 01

△	Item	Parts number	Parts name	Remarks	Area	△	Item	Parts number	Parts name	Remarks	Area
	C 801	QFN82CK-104	M CAPACITOR	.10MF 10% 160V			D 825	1SS133-T2	SI DIODE		
	C 802	QFN82CK-104	M CAPACITOR	.10MF 10% 160V			D 831	1SS133-T2	SI DIODE		
	C 805	QFN82CK-104	M CAPACITOR	.10MF 10% 160V			D 832	1SS133-T2	SI DIODE		
	C 807	QEZO462-688	E CAPACITOR	6800MF			D 841	MTZJ5.1C-T2	Z DIODE		
	C 808	QEZO462-688	E CAPACITOR	6800MF			D 842	1SS133-T2	SI DIODE		
	C 811	QCF31HZ-472Z	C CAPACITOR	4700PF +80:-20%			D 843	1SS133-T2	SI DIODE		
	C 816	QETN1EM-476Z	E CAPACITOR	47MF 20% 25V			D 844	1SS133-T2	SI DIODE		
	C 823	QETN1CM-476Z	E CAPACITOR	47MF 20% 16V			D 845	1SS133-T2	SI DIODE		
	C 824	QETN1EM-106Z	E CAPACITOR	10MF 20% 25V			D 846	1SS133-T2	SI DIODE		
	C 833	QDVB1EZ-223Y	C CAPACITOR				D 851	1SS133-T2	SI DIODE		
	C 834	QDVB1EZ-223Y	C CAPACITOR				D 852	1SS133-T2	SI DIODE		
	C 835	QFLC1HJ-223Z	M CAPACITOR	.022MF 5% 50V			D 871	1SS133-T2	SI DIODE		
	C 836	QFLC1HJ-223Z	M CAPACITOR	.022MF 5% 50V			EP801	QNZ0136-001Z	EARTH PLATE		
	C 837	QFLC1HJ-223Z	M CAPACITOR	.022MF 5% 50V			FW931	QUM137-08DGZ4	PARA RIBON WIRE		
	C 838	QFLC1HJ-223Z	M CAPACITOR	.022MF 5% 50V		△	L 843	QQLZ005-R45	INDUCTOR		
	C 839	QDVB1EZ-223Y	C CAPACITOR			△	L 844	QQLZ005-R45	INDUCTOR		
	C 840	QDVB1EZ-223Y	C CAPACITOR			△	L 845	QQLZ005-R45	INDUCTOR		
	C 841	QCS31HJ-221Z	C CAPACITOR	220PF 5% 50V			Q 811	2SD2395/EF/	TRANSISTOR		
	C 842	QCS31HJ-221Z	C CAPACITOR	220PF 5% 50V			Q 812	KTC3200/GL-T	TRANSISTOR		
	C 843	QCS31HJ-221Z	C CAPACITOR	220PF 5% 50V			Q 823	KTC3199/GL-T	TRANSISTOR		
	C 844	QCS31HJ-221Z	C CAPACITOR	220PF 5% 50V			Q 824	KTC3200/GL-T	TRANSISTOR		
	C 845	QCS31HJ-221Z	C CAPACITOR	220PF 5% 50V			Q 825	KTA1268/GL-T	TRANSISTOR		
	C 846	QCS31HJ-221Z	C CAPACITOR	220PF 5% 50V			Q 830	KRC109M-T	D TRANSISTOR		
	C 847	QCS31HJ-221Z	C CAPACITOR	220PF 5% 50V			Q 831	KRC109M-T	D TRANSISTOR		
	C 848	QCS31HJ-221Z	C CAPACITOR	220PF 5% 50V			Q 832	KRC109M-T	D TRANSISTOR		
	C 850	QETN1HM-475Z	E CAPACITOR	4.7MF 20% 50V			Q 833	KRC109M-T	D TRANSISTOR		
	C 851	QETN1HM-475Z	E CAPACITOR	4.7MF 20% 50V			Q 834	KRC109M-T	D TRANSISTOR		
	C 852	QETN1HM-475Z	E CAPACITOR	4.7MF 20% 50V			Q 835	KRC109M-T	D TRANSISTOR		
	C 853	QETN1HM-475Z	E CAPACITOR	4.7MF 20% 50V			Q 836	KRC109M-T	D TRANSISTOR		
	C 881	QCBB1HK-221Y	C CAPACITOR	220PF 10% 50V			R 801	QRE141J-104Y	C RESISTOR	100K 5% 1/4W	
	C 883	QCBB1HK-221Y	C CAPACITOR	220PF 10% 50V			R 802	QRE141J-104Y	C RESISTOR	100K 5% 1/4W	
	C 884	QCBB1HK-221Y	C CAPACITOR	220PF 10% 50V			R 811	QRJ146J-120X	UNF C RESISTOR	12 5% 1/4W	
	C 885	QFVJ1HJ-104Z	MF CAPACITOR	.10MF 5% 50V			R 812	QRK126J-332X	UNF C RESISTOR	3.3K 5% 1/2W	
	C 886	QCS31HJ-221Z	C CAPACITOR	220PF 5% 50V			R 813	QRE141J-473Y	C RESISTOR	47K 5% 1/4W	
	C 887	QFVJ1HJ-104Z	MF CAPACITOR	.10MF 5% 50V			R 814	QRE141J-103Y	C RESISTOR	10K 5% 1/4W	
	C 888	QFVJ1HJ-104Z	MF CAPACITOR	.10MF 5% 50V			R 815	QRJ146J-120X	UNF C RESISTOR	12 5% 1/4W	
	C 889	QCS31HJ-221Z	C CAPACITOR	220PF 5% 50V			R 816	QRL022J-332	UNF OMF RESISTOR	3.3K 5% 1/2W	
	C 890	QCS31HJ-221Z	C CAPACITOR	220PF 5% 50V			R 823	QRE141J-103Y	C RESISTOR	10K 5% 1/4W	
	C 891	QCS31HJ-221Z	C CAPACITOR	220PF 5% 50V			R 824	QRE141J-134Y	C RESISTOR	130K 5% 1/4W	
	C 892	QCS31HJ-221Z	C CAPACITOR	220PF 5% 50V			R 825	QRE141J-103Y	C RESISTOR	10K 5% 1/4W	
	C 893	QCS31HJ-221Z	C CAPACITOR	220PF 5% 50V			R 826	QRE141J-104Y	C RESISTOR	100K 5% 1/4W	
	CN 72	QGB2510K1-11	CONNECTOR				R 831	QRJ146J-120X	UNF C RESISTOR	12 5% 1/4W	
	CN 82	QGB2510K1-09	CONNECTOR				R 832	QRJ146J-120X	UNF C RESISTOR	12 5% 1/4W	
	CN701	QGB2510J1-14	CONNECTOR				R 833	QRJ146J-100X	UNF C RESISTOR	10 5% 1/4W	
	CN702	QGB2510J1-14	CONNECTOR				R 834	QRJ146J-100X	UNF C RESISTOR	10 5% 1/4W	
	CN703	QGB2510J1-10	CONNECTOR				R 837	QRJ146J-100X	UNF C RESISTOR	10 5% 1/4W	
	CN705	QGB2510J1-12	CONNECTOR				R 838	QRJ146J-100X	UNF C RESISTOR	10 5% 1/4W	
	CN706	QGB2510J1-12	CONNECTOR				R 841	QRE141J-104Y	C RESISTOR	100K 5% 1/4W	
	CN721	QGA2501C1-03	3P CONNECTOR				R 842	QRE141J-823Y	C RESISTOR	82K 5% 1/4W	
	CN723	QGA2501C1-04	4P CONNECTOR				R 843	QRE141J-104Y	C RESISTOR	100K 5% 1/4W	
	CN801	QJK012-032403	SKT WIRE ASSY				R 844	QRE141J-104Y	C RESISTOR	100K 5% 1/4W	
	CN813	QGA3901C1-04	4P CONNECTOR				R 845	QRE141J-823Y	C RESISTOR	82K 5% 1/4W	
	CN814	QGA3901C1-06	6P PLUG ASSY				R 851	QRJ146J-120X	UNF C RESISTOR	12 5% 1/4W	
△	CN823	QJK015-043004	SKT WIRE ASSY				R 852	QRJ146J-120X	UNF C RESISTOR	12 5% 1/4W	
△	CN824	QJK015-063504	SKT WIRE ASSY				R 855	QRJ146J-392X	UNF C RESISTOR	3.9K 5% 1/4W	
	CN831	QGD2501C1-04Z	SOCKET				R 856	QRE141J-223Y	C RESISTOR	22K 5% 1/4W	
	CN881	QGD2501C1-03Z	SOCKET				R 857	QRE141J-682Y	C RESISTOR	6.8K 5% 1/4W	
△	D 801	30DF2-FC	DIODE				R 858	QRE141J-472Y	C RESISTOR	4.7K 5% 1/4W	
△	D 802	30DF2-FC	DIODE				R 859	QRE141J-223Y	C RESISTOR	22K 5% 1/4W	
△	D 803	30DF2-FC	DIODE				R 860	QRE141J-682Y	C RESISTOR	6.8K 5% 1/4W	
△	D 804	30DF2-FC	DIODE				R 861	QRE141J-472Y	C RESISTOR	4.7K 5% 1/4W	
	D 811	MTZJ20B-T2	Z DIODE				R 862	QRE141J-223Y	C RESISTOR	22K 5% 1/4W	
	D 816	MTZJ18C-T2	Z DIODE				R 863	QRE141J-682Y	C RESISTOR	6.8K 5% 1/4W	

■ Electrical parts list (Main board)

Block No. 01

△	Item	Parts number	Parts name	Remarks	Area
	R 864	QRE141J-472Y	C RESISTOR	4.7K 5% 1/4W	
	R 865	QRE141J-472Y	C RESISTOR	4.7K 5% 1/4W	
	R 866	QRE141J-472Y	C RESISTOR	4.7K 5% 1/4W	
	R 867	QRE141J-103Y	C RESISTOR	10K 5% 1/4W	
	R 871	QRJ146J-120X	UNF C RESISTOR	12 5% 1/4W	
	R 885	QRJ146J-100X	UNF C RESISTOR	10 5% 1/4W	
	R 887	QRJ146J-100X	UNF C RESISTOR	10 5% 1/4W	
	R 888	QRJ146J-100X	UNF C RESISTOR	10 5% 1/4W	
	RY831	QSK0109-001	RELAY		
	RY832	QSK0109-001	RELAY		
	RY851	QSK0109-001	RELAY		
	RY852	QSK0109-001	RELAY		
	RY871	QSK0109-001	RELAY		
	ST831	QNB0111-001	SPK TERMINAL		
	ST851	QNB0079-001	SPK TERMINAL		

■ Electrical parts list (Front board)

Block No. 02

△	Item	Parts number	Parts name	Remarks	Area	△	Item	Parts number	Parts name	Remarks	Area
	BK400	LV42092-001A	FL HOLDER(R)				D 480	SLR-342VC-T	LED	(STANDBY)	
	BK401	LV42093-001A	FL HOLDER(L)				D 490	SLR-342VC-T	LED	(DIRECT)	
	C 400	QEK1HM-475Z	E CAPACITOR	4.7MF 20% 50V			D 491	SLR-342VC-T	LED	(BASS)	
	C 401	NCB31CK-104X	C CAPACITOR				DI400	QLF0084-001	FL TUBE		
	C 402	NCB31CK-104X	C CAPACITOR				IC400	MN101C35DHL1	IC		
	C 404	NCB31EK-223X	C CAPACITOR				IC402	BU2092	IC		
	C 406	NCB31HK-331X	C CAPACITOR				IC404	GP1U281X	IC		
	C 407	QCZ0205-155Z	ML C CAPACITOR	1.5MF			IC410	PCM2702E-X	IC		
	C 408	NCB31EK-223X	C CAPACITOR				IC411	NJU7241F33-X	IC		
	C 409	QEK1HM-475Z	E CAPACITOR	4.7MF 20% 50V			J 400	QND0026-001	S JACK		
	C 410	QEK1HM-475Z	E CAPACITOR	4.7MF 20% 50V			J 401	QNZ0541-001	USB JACK		
	C 411	NCB21AK-225X	C CAPACITOR				JS400	QSW0898-001	JOG VOLUME		
	C 412	QEK0JM-107Z	E CAPACITOR	100MF 20% 6.3V		△	K 451	NQR0201-018X	INDUCTOR		
	C 420	NCB31HK-471X	C CAPACITOR			△	K 452	NQR0201-018X	INDUCTOR		
	C 421	NCB31HK-471X	C CAPACITOR			△	K 453	NQR0201-018X	INDUCTOR		
	C 422	NCB31HK-471X	C CAPACITOR			△	K 454	NQR0201-018X	INDUCTOR		
	C 423	NCB31HK-471X	C CAPACITOR			△	K 455	NQR0201-018X	INDUCTOR		
	C 424	NCB31HK-471X	C CAPACITOR				Q 402	DTC114TKA-X	TRANSISTOR		
	C 425	NCB31HK-471X	C CAPACITOR				Q 403	DTC144WKA-X	TRANSISTOR		
	C 430	NCB31CK-104X	C CAPACITOR				Q 404	DTC114YKA-X	CHIP D TRANSIST		
	C 431	NCB31EK-223X	C CAPACITOR				Q 407	DTC114YKA-X	CHIP D TRANSIST		
	C 432	NCS31HJ-220X	C CAPACITOR				Q 408	DTC114YKA-X	CHIP D TRANSIST		
	C 433	NCS31HJ-220X	C CAPACITOR				Q 410	DTA114YKA-X	TRANSISTOR	(DIRECT)	
	C 435	NCB31CK-104X	C CAPACITOR				Q 411	DTA114YKA-X	TRANSISTOR	(BASS)	
	C 436	NCB31CK-104X	C CAPACITOR				Q 412	DTA114YKA-X	TRANSISTOR	(STANBY)	
	C 437	NCB31CK-104X	C CAPACITOR				Q 413	DTA114YKA-X	TRANSISTOR	(SURROUND)	
	C 438	NCB31CK-104X	C CAPACITOR				Q 414	DTA114YKA-X	TRANSISTOR	(DSP)	
	C 439	NCB31CK-104X	C CAPACITOR				R 400	NRSA63J-102X	MG RESISTOR		
	C 440	NCB31CK-104X	C CAPACITOR				R 401	NRSA63J-102X	MG RESISTOR		
	C 441	QEK1CM-106Z	E CAPACITOR	10MF 20% 16V			R 402	NRSA63J-122X	MG RESISTOR		
	C 442	QETN1AM-107Z	E CAPACITOR	100MF 20% 10V			R 403	NRSA63J-102X	MG RESISTOR		
	C 443	QETN1AM-107Z	E CAPACITOR	100MF 20% 10V			R 404	NRSA63J-102X	MG RESISTOR		
△	C 444	NCS31HJ-331X	C CAPACITOR				R 405	NRSA63J-122X	MG RESISTOR		
△	C 448	NCB31CK-104X	C CAPACITOR				R 406	NRSA63J-152X	MG RESISTOR		
	C 456	NCB31CK-104X	C CAPACITOR				R 407	NRSA63J-222X	MG RESISTOR		
	C 460	NCB31CK-104X	C CAPACITOR				R 408	NRSA63J-272X	MG RESISTOR		
	C 461	NCB31HK-221X	C CAPACITOR	(FTZ)			R 409	NRSA63J-332X	MG RESISTOR		
	C 462	NCB31HK-221X	C CAPACITOR	(FTZ)			R 410	NRSA63J-102X	MG RESISTOR		
	C 463	NCS31HJ-470X	C CAPACITOR				R 411	NRSA63J-102X	MG RESISTOR		
	C 464	NCS31HJ-470X	C CAPACITOR				R 412	NRSA63J-122X	MG RESISTOR		
	C 465	NCS31HJ-470X	C CAPACITOR				R 413	NRSA63J-152X	MG RESISTOR		
	CN406	WJP0031-001A	C-B WIRE ASSY				R 414	NRSA63J-222X	MG RESISTOR		
	CN410	QGF1205F1-10	CONNECTOR				R 415	NRSA63J-272X	MG RESISTOR		
	CN412	QGF1205F1-08	CONNECTOR				R 416	NRSA63J-332X	MG RESISTOR		
	CN420	QJK025-031301	C-B WIRE ASSY	(LEFT)			R 417	NRSA63J-102X	MG RESISTOR		
	CN422	QJK025-041201	SIN ID C-B WIRE	(RIGHT)			R 418	NRSA63J-102X	MG RESISTOR		
	CN430	QGA2501C1-03	3P CONNECTOR				R 419	NRSA63J-122X	MG RESISTOR		
	CN432	QGA2501C1-04	4P CONNECTOR				R 420	NRSA63J-152X	MG RESISTOR		
	D 405	1SS133-T2	SI DIODE				R 421	NRSA63J-222X	MG RESISTOR		
	D 410	SLR-342VC-T	LED	(FM/AM)			R 422	NRSA63J-272X	MG RESISTOR		
	D 411	SLR-342VC-T	LED	(USB)			R 423	NRSA63J-332X	MG RESISTOR		
	D 412	SLR-342VC-T	LED	(TAPE)			R 424	NRSA63J-102X	MG RESISTOR		
	D 413	SLR-342VC-T	LED	(CDR)			R 425	NRSA63J-102X	MG RESISTOR		
	D 414	SLR-342VC-T	LED	(PHONE)			R 426	NRSA63J-122X	MG RESISTOR		
	D 415	SLR-342VC-T	LED	(CD)			R 431	NRSA63J-102X	MG RESISTOR		
	D 416	SLR-342VC-T	LED	(TV/DBS)			R 432	NRSA63J-102X	MG RESISTOR		
	D 417	SLR-342VC-T	LED	(VIDEO)			R 433	NRSA63J-122X	MG RESISTOR		
	D 418	SLR-342VC-T	LED	(VCR2)			R 434	NRSA63J-152X	MG RESISTOR		
	D 419	SLR-342VC-T	LED	(VCR1)			R 435	NRSA63J-222X	MG RESISTOR		
	D 420	SLR-342VC-T	LED	(DVD MULTI)			R 436	NRSA63J-102X	MG RESISTOR		
	D 421	SLR-342VC-T	LED	(DVD)			R 437	NRSA63J-102X	MG RESISTOR		
	D 422	SLR-342VC-T	LED	(SURROUND)			R 438	NRSA63J-122X	MG RESISTOR		
	D 423	SLR-342VC-T	LED	(DSP)			R 439	NRSA63J-152X	MG RESISTOR		

■ Electrical parts list (Front board)

Block No. 02

△	Item	Parts number	Parts name	Remarks	Area
	R 440	NRSA63J-222X	MG RESISTOR		
	R 443	NRSA63J-102X	MG RESISTOR		
	R 445	NRSA63J-103X	MG RESISTOR		
	R 446	NRSA63J-103X	MG RESISTOR		
	R 447	NRSA63J-103X	MG RESISTOR		
	R 448	NRSA63J-103X	MG RESISTOR		
	R 449	NRSA63J-103X	MG RESISTOR		
	R 450	NRSA63J-103X	MG RESISTOR		
	R 451	NRSA63J-103X	MG RESISTOR		
	R 452	NRSA63J-103X	MG RESISTOR		
	R 453	NRSA63J-103X	MG RESISTOR		
	R 454	NRSA63J-103X	MG RESISTOR		
	R 455	NRSA63J-471X	MG RESISTOR		
	R 456	NRSA63J-103X	MG RESISTOR		
	R 457	NRSA63J-103X	MG RESISTOR		
	R 458	NRSA63J-103X	MG RESISTOR		
	R 459	NRSA63J-221X	MG RESISTOR		
	R 460	NRSA63J-221X	MG RESISTOR		
	R 461	NRSA63J-221X	MG RESISTOR		
	R 462	NRSA63J-221X	MG RESISTOR		
	R 463	NRSA63J-221X	MG RESISTOR		
	R 464	NRSA63J-221X	MG RESISTOR		
	R 465	NRSA63J-331X	MG RESISTOR		
	R 466	NRSA63J-331X	MG RESISTOR		
	R 467	NRSA63J-221X	MG RESISTOR		
	R 468	NRSA63J-221X	MG RESISTOR		
	R 469	NRSA63J-221X	MG RESISTOR		
	R 470	NRSA63J-750X	MG RESISTOR		
	R 471	NRSA63J-750X	MG RESISTOR		
	R 472	NRSA63J-750X	MG RESISTOR		
	R 473	NRSA63J-152X	MG RESISTOR		
	R 474	NRSA63J-105X	MG RESISTOR		
	R 475	NRSA63J-220X	MG RESISTOR		
	R 476	NRSA63J-220X	MG RESISTOR		
	R 477	NRSA63J-0R0X	MG RESISTOR		
	R 479	NRSA63J-181X	MG RESISTOR		
	R 480	NRSA63J-152X	MG RESISTOR		
	R 481	NRSA63J-222X	MG RESISTOR		
	R 482	NRSA63J-272X	MG RESISTOR		
	R 483	NRSA63J-392X	MG RESISTOR		
	R 486	NRSA63J-0R0X	MG RESISTOR		
	R 490	NRSA63J-272X	MG RESISTOR		
	R 491	NRSA63J-392X	MG RESISTOR		
	R 495	NRSA63J-102X	MG RESISTOR		
	S 400	QSW0683-001Z	PUSH SWITCH	(SURROUND)	
	S 401	QSW0683-001Z	PUSH SWITCH	(DSP MODE)	
	S 402	QSW0683-001Z	PUSH SWITCH	(INPUT MODE)	
	S 403	QSW0683-001Z	PUSH SWITCH	(TUNING UP)	
	S 404	QSW0683-001Z	PUSH SWITCH	(PRESET UP)	
	S 405	QSW0683-001Z	PUSH SWITCH	(FM MODE)	
	S 406	QSW0683-001Z	PUSH SWITCH	(MEMORY)	
	S 407	QSW0683-001Z	PUSH SWITCH	(MIDNIGHT MODE)	
	S 408	QSW0683-001Z	PUSH SWITCH	(DVD)	
	S 409	QSW0683-001Z	PUSH SWITCH	(DVD MULTI)	
	S 410	QSW0683-001Z	PUSH SWITCH	(TUNING DOWN)	
	S 411	QSW0683-001Z	PUSH SWITCH	(PRESET DOWN)	
	S 412	QSW0683-001Z	PUSH SWITCH	(VCR1)	
	S 413	QSW0683-001Z	PUSH SWITCH	(VCR2)	
	S 414	QSW0683-001Z	PUSH SWITCH	(VIDEO)	
	S 415	QSW0683-001Z	PUSH SWITCH	(CD)	
	S 416	QSW0683-001Z	PUSH SWITCH	(TV/DBS)	
	S 417	QSW0683-001Z	PUSH SWITCH	(CDR)	
	S 418	QSW0683-001Z	PUSH SWITCH	(USB AUDIO)	

△	Item	Parts number	Parts name	Remarks	Area
	S 419	QSW0683-001Z	PUSH SWITCH	(PHONE)	
	S 420	QSW0683-001Z	PUSH SWITCH	(FM/AM)	
	S 421	QSW0683-001Z	PUSH SWITCH	(DIGITAL SEA)	
	S 422	QSW0683-001Z	PUSH SWITCH	(LEVEL ADJUST)	
	S 423	QSW0683-001Z	PUSH SWITCH	(TAPE/MD)	
	S 424	QSW0683-001Z	PUSH SWITCH	(DOWN)	
	S 425	QSW0683-001Z	PUSH SWITCH	(EFFECT)	
	S 426	QSW0683-001Z	PUSH SWITCH	(SETTING)	
	S 431	QSW0683-001Z	PUSH SWITCH	(UP)	
	S 480	QSW0683-001Z	PUSH SWITCH	(POWER)	
	S 481	QSW0683-001Z	PUSH SWITCH	(SPK1)	
	S 482	QSW0683-001Z	PUSH SWITCH	(SPK2)	
	S 483	QSW0683-001Z	PUSH SWITCH	(SUBWFR)	
	S 490	QSW0683-001Z	PUSH SWITCH	(DIRECT)	
	S 491	QSW0683-001Z	PUSH SWITCH	(BASS)	
	X 400	QAX0246-001Z	RESONATOR		
	X 410	QAX0320-001Z	CRYSTAL		

■ Electrical parts list (Power board)

Block No. 03

△	Item	Parts number	Parts name	Remarks	Area	△	Item	Parts number	Parts name	Remarks	Area
	C 701	QTE1V06-106Z	E CAPACITOR				C1808	QETN1CM-107Z	E CAPACITOR	100MF 20% 16V	
	C 702	QTE1V06-106Z	E CAPACITOR				C1809	QCS31HJ-5R0Z	C CAPACITOR	5.0PF 5% 50V	
	C 703	QCS31HJ-101Z	C CAPACITOR	100PF 5% 50V			C1810	QCS31HJ-5R0Z	C CAPACITOR	5.0PF 5% 50V	
	C 704	QCS31HJ-101Z	C CAPACITOR	100PF 5% 50V			C1811	QCS32HJ-330Z	C CAPACITOR	33PF 5% 500V	
	C 705	QCS31HJ-101Z	C CAPACITOR	100PF 5% 50V			C1812	QCS32HJ-330Z	C CAPACITOR	33PF 5% 500V	
	C 706	QCS31HJ-101Z	C CAPACITOR	100PF 5% 50V			C1813	QFLC1HJ-103Z	M CAPACITOR	.010MF 5% 50V	
	C 707	QETN1CM-107Z	E CAPACITOR	100MF 20% 16V			C1814	QFLC1HJ-103Z	M CAPACITOR	.010MF 5% 50V	
	C 708	QETN1CM-107Z	E CAPACITOR	100MF 20% 16V			C1815	QETN1CM-107Z	E CAPACITOR	100MF 20% 16V	
	C 709	QCS31HJ-100Z	C CAPACITOR	10PF 5% 50V			C1816	QETN1CM-107Z	E CAPACITOR	100MF 20% 16V	
	C 710	QCS31HJ-100Z	C CAPACITOR	10PF 5% 50V			C1817	QETN1HM-476Z	E CAPACITOR	47MF 20% 50V	
	C 711	QFLC1HJ-103Z	M CAPACITOR	.010MF 5% 50V			C1818	QETN1HM-476Z	E CAPACITOR	47MF 20% 50V	
	C 712	QFLC1HJ-103Z	M CAPACITOR	.010MF 5% 50V			C1841	QETN2AM-476Z	E CAPACITOR	47MF 20% 100V	
	C 713	QCS31HJ-680Z	C CAPACITOR	68PF 5% 50V			C1842	QETN2AM-476Z	E CAPACITOR	47MF 20% 100V	
	C 714	QCS31HJ-680Z	C CAPACITOR	68PF 5% 50V			C1843	QETN2AM-476Z	E CAPACITOR	47MF 20% 100V	
	C 715	QCS31HJ-680Z	C CAPACITOR	68PF 5% 50V			C1844	QETN2AM-476Z	E CAPACITOR	47MF 20% 100V	
	C 716	QCS31HJ-680Z	C CAPACITOR	68PF 5% 50V			C1851	QCS32HJ-470Z	C CAPACITOR	47PF 5% 500V	
	C 717	QCS32HJ-220Z	C CAPACITOR	22PF 5% 500V			C1852	QCS32HJ-470Z	C CAPACITOR	47PF 5% 500V	
	C 718	QCS32HJ-220Z	C CAPACITOR	22PF 5% 500V			C1853	QCS32HJ-470Z	C CAPACITOR	47PF 5% 500V	
	C 719	QFLC1HJ-472Z	M CAPACITOR	4700PF 5% 50V			C1854	QCS32HJ-470Z	C CAPACITOR	47PF 5% 500V	
	C 720	QFLC1HJ-472Z	M CAPACITOR	4700PF 5% 50V			C1861	QFLC1HJ-473Z	M CAPACITOR	.047MF 5% 50V	
	C 741	QETN2AM-476Z	E CAPACITOR	47MF 20% 100V			C1862	QFLC1HJ-473Z	M CAPACITOR	.047MF 5% 50V	
	C 742	QETN2AM-476Z	E CAPACITOR	47MF 20% 100V			C1863	QFLC1HJ-473Z	M CAPACITOR	.047MF 5% 50V	
	C 745	QETN2AM-476Z	E CAPACITOR	47MF 20% 100V			C1864	QFLC1HJ-473Z	M CAPACITOR	.047MF 5% 50V	
	C 746	QETN2AM-476Z	E CAPACITOR	47MF 20% 100V			C1891	QCF31HZ-223Z	C CAPACITOR	.022MF +80:-20%	
	C 751	QCS32HJ-470Z	C CAPACITOR	47PF 5% 500V			C1892	QCF31HZ-223Z	C CAPACITOR	.022MF +80:-20%	
	C 752	QCS32HJ-470Z	C CAPACITOR	47PF 5% 500V			D 701	1SS133-T2	SI DIODE		
	C 753	QCS32HJ-470Z	C CAPACITOR	47PF 5% 500V			D 702	1SS133-T2	SI DIODE		
	C 754	QCS32HJ-470Z	C CAPACITOR	47PF 5% 500V			D 703	1SS133-T2	SI DIODE		
	C 791	QFLC1HJ-473Z	M CAPACITOR	.047MF 5% 50V			D 704	1SS133-T2	SI DIODE		
	C 792	QFLC1HJ-473Z	M CAPACITOR	.047MF 5% 50V			D 771	1SS133-T2	SI DIODE		
	C 793	QFLC1HJ-473Z	M CAPACITOR	.047MF 5% 50V			D 772	1SS133-T2	SI DIODE		
	C 794	QFLC1HJ-473Z	M CAPACITOR	.047MF 5% 50V			D 773	1SS133-T2	SI DIODE		
	C 795	QCF31HZ-223Z	C CAPACITOR	.022MF +80:-20%			D 774	1SS133-T2	SI DIODE		
	C 796	QCF31HZ-223Z	C CAPACITOR	.022MF +80:-20%			D 791	1SS133-T2	SI DIODE		
	CN711	QGB2510K1-14	CONNECTOR				D 792	1SS133-T2	SI DIODE		
	CN712	QGB2510K1-14	CONNECTOR				D1701	1SS133-T2	SI DIODE		
	CN713	QGB2510K1-10	CONNECTOR				D1771	1SS133-T2	SI DIODE		
	CN715	QGB2510K1-12	CONNECTOR				D1772	1SS133-T2	SI DIODE		
	CN716	QGB2510K1-12	CONNECTOR				D1791	1SS133-T2	SI DIODE		
	CN722	QGA2501F1-02	CONNECTOR				D1801	1SS133-T2	SI DIODE		
	C1701	QETN1HM-105Z	E CAPACITOR	1.0MF 20% 50V			D1802	1SS133-T2	SI DIODE		
	C1702	QCS31HJ-101Z	C CAPACITOR	100PF 5% 50V			D1871	1SS133-T2	SI DIODE		
	C1703	QCS31HJ-221Z	C CAPACITOR	220PF 5% 50V			D1872	1SS133-T2	SI DIODE		
	C1704	QETN1CM-107Z	E CAPACITOR	100MF 20% 16V			D1873	1SS133-T2	SI DIODE		
	C1705	QCS31HJ-5R0Z	C CAPACITOR	5.0PF 5% 50V			D1874	1SS133-T2	SI DIODE		
	C1711	QCS32HJ-330Z	C CAPACITOR	33PF 5% 500V			D1891	1SS133-T2	SI DIODE		
	C1712	QFLC1HJ-103Z	M CAPACITOR	.010MF 5% 50V			D1892	1SS133-T2	SI DIODE		
	C1713	QETN1CM-107Z	E CAPACITOR	100MF 20% 16V			L 791	QQLZ003-1R0	INDUCTOR		
	C1715	QETN1HM-476Z	E CAPACITOR	47MF 20% 50V			L 792	QQLZ003-1R0	INDUCTOR		
	C1741	QETN2AM-476Z	E CAPACITOR	47MF 20% 100V			L1761	QQLZ005-R45	INDUCTOR		
	C1743	QETN2AM-476Z	E CAPACITOR	47MF 20% 100V			L1861	QQLZ005-R45	INDUCTOR		
	C1751	QCS32HJ-470Z	C CAPACITOR	47PF 5% 500V			L1862	QQLZ005-R45	INDUCTOR		
	C1752	QCS32HJ-470Z	C CAPACITOR	47PF 5% 500V			Q 701	2SC2240-BL/AB/T	TRANSISTOR		
	C1761	QFLC1HJ-473Z	M CAPACITOR	.047MF 5% 50V			Q 702	2SC2240-BL/AB/T	TRANSISTOR		
	C1762	QFLC1HJ-473Z	M CAPACITOR	.047MF 5% 50V			Q 703	2SC2240-BL/AB/T	TRANSISTOR		
	C1791	QCF31HZ-223Z	C CAPACITOR	.022MF +80:-20%			Q 704	2SC2240-BL/AB/T	TRANSISTOR		
	C1801	QETN1HM-105Z	E CAPACITOR	1.0MF 20% 50V			Q 705	KTA1268/GL-T	TRANSISTOR		
	C1802	QETN1HM-105Z	E CAPACITOR	1.0MF 20% 50V			Q 706	KTA1268/GL-T	TRANSISTOR		
	C1803	QCS31HJ-101Z	C CAPACITOR	100PF 5% 50V			Q 707	KTA1268/GL-T	TRANSISTOR		
	C1804	QCS31HJ-101Z	C CAPACITOR	100PF 5% 50V			Q 708	KTA1268/GL-T	TRANSISTOR		
	C1805	QCS31HJ-221Z	C CAPACITOR	220PF 5% 50V			Q 709	KTA1268/GL-T	TRANSISTOR		
	C1806	QCS31HJ-221Z	C CAPACITOR	220PF 5% 50V			Q 710	KTA1268/GL-T	TRANSISTOR		
	C1807	QETN1CM-107Z	E CAPACITOR	100MF 20% 16V			Q 711	KTC3200/GL-T	TRANSISTOR		

■ Electrical parts list (Power board)

Block No. 03

△	Item	Parts number	Parts name	Remarks	Area
	Q 712	KTC3200/GL/-T	TRANSISTOR		
△	Q 761	2SD2390/OPY/-F6	TRANSISTOR		
	Q 762	2SD2390/OPY/-F6	TRANSISTOR		
△	Q 763	2SB1560/OPY/-F6	TRANSISTOR		
△	Q 764	2SB1560/OPY/-F6	TRANSISTOR		
	Q 771	KTC3200/GL/-T	TRANSISTOR		
	Q 772	KTC3200/GL/-T	TRANSISTOR		
	Q 773	KTA1268/GL/-T	TRANSISTOR		
	Q 774	KTA1268/GL/-T	TRANSISTOR		
	Q 781	2SD637/QR/	TRANSISTOR		
	Q 782	2SD637/QR/	TRANSISTOR		
	Q 791	KTA1268/GL/-T	TRANSISTOR		
	Q 792	KTA1268/GL/-T	TRANSISTOR		
	Q1701	2SC2240-BL/AB/T	TRANSISTOR		
	Q1702	2SC2240-BL/AB/T	TRANSISTOR		
	Q1703	KTA1268/GL/-T	TRANSISTOR		
	Q1731	2SD637/QR/	TRANSISTOR		
△	Q1751	2SD2390/OPY/-F6	TRANSISTOR		
△	Q1752	2SB1560/OPY/-F6	TRANSISTOR		
	Q1771	KTC3200/GL/-T	TRANSISTOR		
	Q1772	KTA1268/GL/-T	TRANSISTOR		
	Q1791	KTA1268/GL/-T	TRANSISTOR		
	Q1801	2SC2240-BL/AB/T	TRANSISTOR		
	Q1802	2SC2240-BL/AB/T	TRANSISTOR		
	Q1803	2SC2240-BL/AB/T	TRANSISTOR		
	Q1804	2SC2240-BL/AB/T	TRANSISTOR		
	Q1805	KTA1268/GL/-T	TRANSISTOR		
	Q1806	KTA1268/GL/-T	TRANSISTOR		
	Q1831	2SD637/QR/	TRANSISTOR		
	Q1832	2SD637/QR/	TRANSISTOR		
△	Q1851	2SD2390/OPY/-F6	TRANSISTOR		
△	Q1852	2SD2390/OPY/-F6	TRANSISTOR		
△	Q1853	2SB1560/OPY/-F6	TRANSISTOR		
△	Q1854	2SB1560/OPY/-F6	TRANSISTOR		
	Q1871	KTC3200/GL/-T	TRANSISTOR		
	Q1872	KTC3200/GL/-T	TRANSISTOR		
	Q1873	KTA1268/GL/-T	TRANSISTOR		
	Q1874	KTA1268/GL/-T	TRANSISTOR		
	Q1891	KTA1268/GL/-T	TRANSISTOR		
	Q1892	KTA1268/GL/-T	TRANSISTOR		
	R 701	QRE141J-222Y	C RESISTOR	2.2K 5% 1/4W	
	R 702	QRE141J-222Y	C RESISTOR	2.2K 5% 1/4W	
	R 703	QRE141J-104Y	C RESISTOR	100K 5% 1/4W	
	R 704	QRE141J-104Y	C RESISTOR	100K 5% 1/4W	
	R 705	QRE141J-202Y	C RESISTOR	2.0K 5% 1/4W	
	R 706	QRE141J-202Y	C RESISTOR	2.0K 5% 1/4W	
	R 707	QRE141J-202Y	C RESISTOR	2.0K 5% 1/4W	
	R 708	QRE141J-202Y	C RESISTOR	2.0K 5% 1/4W	
	R 709	QRE141J-912Y	C RESISTOR	9.1K 5% 1/4W	
	R 710	QRE141J-912Y	C RESISTOR	9.1K 5% 1/4W	
	R 711	QRE141J-621Y	C RESISTOR	620 5% 1/4W	
	R 712	QRE141J-621Y	C RESISTOR	620 5% 1/4W	
	R 715	QRE141J-104Y	C RESISTOR	100K 5% 1/4W	
	R 716	QRE141J-104Y	C RESISTOR	100K 5% 1/4W	
	R 717	QRJ146J-562X	UNF C RESISTOR	5.6K 5% 1/4W	
	R 718	QRJ146J-562X	UNF C RESISTOR	5.6K 5% 1/4W	
	R 719	QRK126J-103X	UNF C RESISTOR	10K 5% 1/2W	
	R 720	QRK126J-103X	UNF C RESISTOR	10K 5% 1/2W	
	R 721	QRJ146J-151X	UNF C RESISTOR	150 5% 1/4W	
	R 722	QRJ146J-151X	UNF C RESISTOR	150 5% 1/4W	
	R 723	QRE141J-391Y	C RESISTOR	390 5% 1/4W	
	R 724	QRE141J-391Y	C RESISTOR	390 5% 1/4W	
	R 725	QRE141J-152Y	C RESISTOR	1.5K 5% 1/4W	

△	Item	Parts number	Parts name	Remarks	Area
	R 726	QRE141J-152Y	C RESISTOR	1.5K 5% 1/4W	
	R 727	QRE141J-333Y	C RESISTOR	33K 5% 1/4W	
	R 728	QRE141J-333Y	C RESISTOR	33K 5% 1/4W	
	R 729	QRE141J-391Y	C RESISTOR	390 5% 1/4W	
	R 730	QRE141J-391Y	C RESISTOR	390 5% 1/4W	
	R 731	QRE141J-391Y	C RESISTOR	390 5% 1/4W	
	R 732	QRE141J-391Y	C RESISTOR	390 5% 1/4W	
	R 733	QRE141J-221Y	C RESISTOR	220 5% 1/4W	
	R 734	QRE141J-221Y	C RESISTOR	220 5% 1/4W	
	R 761	QRJ146J-100X	UNF C RESISTOR	10 5% 1/4W	
	R 762	QRJ146J-100X	UNF C RESISTOR	10 5% 1/4W	
	R 763	QRJ146J-100X	UNF C RESISTOR	10 5% 1/4W	
	R 764	QRJ146J-100X	UNF C RESISTOR	10 5% 1/4W	
	R 771	QRE141J-391Y	C RESISTOR	390 5% 1/4W	
	R 772	QRE141J-391Y	C RESISTOR	390 5% 1/4W	
	R 773	QRE141J-391Y	C RESISTOR	390 5% 1/4W	
	R 774	QRE141J-391Y	C RESISTOR	390 5% 1/4W	
	R 775	QRE141J-201Y	C RESISTOR	200 5% 1/4W	
	R 776	QRE141J-201Y	C RESISTOR	200 5% 1/4W	
	R 777	QRE141J-201Y	C RESISTOR	200 5% 1/4W	
	R 778	QRE141J-201Y	C RESISTOR	200 5% 1/4W	
	R 779	QRZ0218-R22	EMIT RESISTOR	1/2W	
	R 780	QRZ0218-R22	EMIT RESISTOR	1/2W	
	R 781	QRE141J-391Y	C RESISTOR	390 5% 1/4W	
	R 782	QRE141J-391Y	C RESISTOR	390 5% 1/4W	
	R 783	QRE141J-621Y	C RESISTOR	620 5% 1/4W	
	R 784	QRE141J-621Y	C RESISTOR	620 5% 1/4W	
	R 787	QRE141J-473Y	C RESISTOR	47K 5% 1/4W	
	R 788	QRE141J-473Y	C RESISTOR	47K 5% 1/4W	
	R 789	QRE141J-471Y	C RESISTOR	470 5% 1/4W	
	R 790	QRE141J-471Y	C RESISTOR	470 5% 1/4W	
	R 791	QRJ125J-330	UNF C RESISTOR	33 5% 1/2W	
	R 792	QRJ125J-330	UNF C RESISTOR	33 5% 1/2W	
	R 793	QRL022J-100	UNF OMF RESISTOR	10 5% 1/2W	
	R 794	QRL022J-100	UNF OMF RESISTOR	10 5% 1/2W	
	R 795	QRE141J-102Y	C RESISTOR	1.0K 5% 1/4W	
	R 796	QRE141J-102Y	C RESISTOR	1.0K 5% 1/4W	
	R 797	QRE141J-153Y	C RESISTOR	15K 5% 1/4W	
	R 798	QRE141J-153Y	C RESISTOR	15K 5% 1/4W	
	R1701	QRE141J-222Y	C RESISTOR	2.2K 5% 1/4W	
	R1702	QRE141J-683Y	C RESISTOR	68K 5% 1/4W	
	R1703	QRE141J-202Y	C RESISTOR	2.0K 5% 1/4W	
	R1705	QRE141J-123Y	C RESISTOR	12K 5% 1/4W	
	R1711	QRE141J-331Y	C RESISTOR	330 5% 1/4W	
	R1712	QRE141J-563Y	C RESISTOR	56K 5% 1/4W	
	R1721	QRJ146J-221X	UNF C RESISTOR	220 5% 1/4W	
	R1722	QRE141J-332Y	C RESISTOR	3.3K 5% 1/4W	
	R1723	QRE141J-332Y	C RESISTOR	3.3K 5% 1/4W	
	R1724	QRE141J-332Y	C RESISTOR	3.3K 5% 1/4W	
	R1725	QRE141J-332Y	C RESISTOR	3.3K 5% 1/4W	
	R1731	QRE141J-102Y	C RESISTOR	1.0K 5% 1/4W	
	R1732	QRE141J-391Y	C RESISTOR	390 5% 1/4W	
	R1741	QRJ146J-221X	UNF C RESISTOR	220 5% 1/4W	
	R1751	QRJ146J-100X	UNF C RESISTOR	10 5% 1/4W	
	R1752	QRJ146J-100X	UNF C RESISTOR	10 5% 1/4W	
	R1753	QRZ0218-R22	EMIT RESISTOR	1/2W	
	R1761	QRJ125J-330	UNF C RESISTOR	33 5% 1/2W	
	R1762	QRL022J-100	UNF OMF RESISTOR	10 5% 1/2W	
	R1771	QRE141J-391Y	C RESISTOR	390 5% 1/4W	
	R1772	QRE141J-391Y	C RESISTOR	390 5% 1/4W	
	R1773	QRE141J-201Y	C RESISTOR	200 5% 1/4W	
	R1774	QRE141J-201Y	C RESISTOR	200 5% 1/4W	
	R1791	QRE141J-102Y	C RESISTOR	1.0K 5% 1/4W	

■ Electrical parts list (Power board)

Block No. 03

△	Item	Parts number	Parts name	Remarks	Area
	R1793	QRE141J-183Y	C RESISTOR	18K 5% 1/4W	
	R1795	QRE141J-473Y	C RESISTOR	47K 5% 1/4W	
	R1801	QRE141J-222Y	C RESISTOR	2.2K 5% 1/4W	
	R1802	QRE141J-222Y	C RESISTOR	2.2K 5% 1/4W	
	R1803	QRE141J-683Y	C RESISTOR	68K 5% 1/4W	
	R1804	QRE141J-683Y	C RESISTOR	68K 5% 1/4W	
	R1805	QRE141J-202Y	C RESISTOR	2.0K 5% 1/4W	
	R1806	QRE141J-202Y	C RESISTOR	2.0K 5% 1/4W	
	R1809	QRE141J-123Y	C RESISTOR	12K 5% 1/4W	
	R1810	QRE141J-123Y	C RESISTOR	12K 5% 1/4W	
	R1811	QRE141J-331Y	C RESISTOR	330 5% 1/4W	
	R1812	QRE141J-331Y	C RESISTOR	330 5% 1/4W	
	R1813	QRE141J-563Y	C RESISTOR	56K 5% 1/4W	
	R1814	QRE141J-563Y	C RESISTOR	56K 5% 1/4W	
	R1821	QRJ146J-221X	UNF C RESISTOR	220 5% 1/4W	
	R1822	QRJ146J-221X	UNF C RESISTOR	220 5% 1/4W	
	R1823	QRE141J-332Y	C RESISTOR	3.3K 5% 1/4W	
	R1824	QRE141J-332Y	C RESISTOR	3.3K 5% 1/4W	
	R1825	QRE141J-332Y	C RESISTOR	3.3K 5% 1/4W	
	R1826	QRE141J-332Y	C RESISTOR	3.3K 5% 1/4W	
	R1827	QRE141J-332Y	C RESISTOR	3.3K 5% 1/4W	
	R1828	QRE141J-332Y	C RESISTOR	3.3K 5% 1/4W	
	R1829	QRE141J-332Y	C RESISTOR	3.3K 5% 1/4W	
	R1830	QRE141J-332Y	C RESISTOR	3.3K 5% 1/4W	
	R1831	QRE141J-102Y	C RESISTOR	1.0K 5% 1/4W	
	R1832	QRE141J-102Y	C RESISTOR	1.0K 5% 1/4W	
	R1833	QRE141J-391Y	C RESISTOR	390 5% 1/4W	
	R1834	QRE141J-391Y	C RESISTOR	390 5% 1/4W	
	R1841	QRJ146J-221X	UNF C RESISTOR	220 5% 1/4W	
	R1842	QRJ146J-221X	UNF C RESISTOR	220 5% 1/4W	
	R1851	QRJ146J-100X	UNF C RESISTOR	10 5% 1/4W	
	R1852	QRJ146J-100X	UNF C RESISTOR	10 5% 1/4W	
	R1853	QRJ146J-100X	UNF C RESISTOR	10 5% 1/4W	
	R1854	QRJ146J-100X	UNF C RESISTOR	10 5% 1/4W	
	R1855	QRZ0218-R22	EMIT RESISTOR	1/2W	
	R1856	QRZ0218-R22	EMIT RESISTOR	1/2W	
	R1861	QRJ125J-330	UNF C RESISTOR	33 5% 1/2W	
	R1862	QRJ125J-330	UNF C RESISTOR	33 5% 1/2W	
	R1863	QRL022J-100	UNF OMF RESISTOR	10 5% 1/2W	
	R1864	QRL022J-100	UNF OMF RESISTOR	10 5% 1/2W	
	R1871	QRE141J-391Y	C RESISTOR	390 5% 1/4W	
	R1872	QRE141J-391Y	C RESISTOR	390 5% 1/4W	
	R1873	QRE141J-391Y	C RESISTOR	390 5% 1/4W	
	R1874	QRE141J-391Y	C RESISTOR	390 5% 1/4W	
	R1875	QRE141J-201Y	C RESISTOR	200 5% 1/4W	
	R1876	QRE141J-201Y	C RESISTOR	200 5% 1/4W	
	R1877	QRE141J-201Y	C RESISTOR	200 5% 1/4W	
	R1878	QRE141J-201Y	C RESISTOR	200 5% 1/4W	
	R1891	QRE141J-102Y	C RESISTOR	1.0K 5% 1/4W	
	R1892	QRE141J-102Y	C RESISTOR	1.0K 5% 1/4W	
	R1893	QRE141J-183Y	C RESISTOR	18K 5% 1/4W	
	R1894	QRE141J-183Y	C RESISTOR	18K 5% 1/4W	
	R1895	QRE141J-473Y	C RESISTOR	47K 5% 1/4W	
	R1896	QRE141J-473Y	C RESISTOR	47K 5% 1/4W	
	TH731	QAD0012-202	THERMISTOR		
	TH783	QAD0012-202	THERMISTOR		
	TH784	QAD0012-202	THERMISTOR		
	TH831	QAD0012-202	THERMISTOR		
	TH832	QAD0012-202	THERMISTOR		
	VR787	QVP0008-501Z	SEMI V RESISTOR		
	VR788	QVP0008-501Z	SEMI V RESISTOR		

■ Electrical parts list (Input board)

Block No. 04

△	Item	Parts number	Parts name	Remarks	Area	△	Item	Parts number	Parts name	Remarks	Area
	C 201	QETN1HM-475Z	E CAPACITOR	4.7MF 20% 50V			C 308	QFLC1HJ-682Z	M CAPACITOR	6800PF 5% 50V	
	C 202	QETN1HM-475Z	E CAPACITOR	4.7MF 20% 50V			C 309	NCS31HJ-101X	C CAPACITOR		
	C 203	QETN0JM-477Z	E CAPACITOR	470MF 20% 6.3V			C 310	NCS31HJ-101X	C CAPACITOR		
	C 204	QETN1HM-475Z	E CAPACITOR	4.7MF 20% 50V			C 311	QETN1HM-475Z	E CAPACITOR	4.7MF 20% 50V	
	C 205	QETN0JM-477Z	E CAPACITOR	470MF 20% 6.3V			C 312	QETN1HM-475Z	E CAPACITOR	4.7MF 20% 50V	
	C 206	QETN1HM-475Z	E CAPACITOR	4.7MF 20% 50V			C 313	QETN1AM-107Z	E CAPACITOR	100MF 20% 10V	
	C 207	QETN0JM-477Z	E CAPACITOR	470MF 20% 6.3V			C 314	QETN1AM-107Z	E CAPACITOR	100MF 20% 10V	
	C 208	QETN1CM-476Z	E CAPACITOR	47MF 20% 16V			C 315	QETN1CM-476Z	E CAPACITOR	47MF 20% 16V	
	C 209	QCF31HZ-103Z	C CAPACITOR	.010MF +80:-20%			C 316	QETN1CM-476Z	E CAPACITOR	47MF 20% 16V	
	C 210	QETN1HM-475Z	E CAPACITOR	4.7MF 20% 50V			C 321	NCB31HK-221X	C CAPACITOR		
	C 211	QETN1HM-475Z	E CAPACITOR	4.7MF 20% 50V			C 322	NCB31HK-221X	C CAPACITOR		
	C 212	QETN1CM-476Z	E CAPACITOR	47MF 20% 16V			C 323	NCB31HK-221X	C CAPACITOR		
	C 213	QCF31HZ-103Z	C CAPACITOR	.010MF +80:-20%			C 324	NCB31HK-221X	C CAPACITOR		
	C 214	QETN1HM-475Z	E CAPACITOR	4.7MF 20% 50V			C 325	NCB31HK-221X	C CAPACITOR		
	C 215	QETN1HM-475Z	E CAPACITOR	4.7MF 20% 50V			C 326	NCB31HK-221X	C CAPACITOR		
	C 216	QDX31EM-473Z	C CAPACITOR				C 327	NCB31HK-221X	C CAPACITOR		
	C 217	QETN1AM-477Z	E CAPACITOR	470MF 20% 10V			C 328	NCB31HK-221X	C CAPACITOR		
	C 218	QCZ0202-155Z	ML C CAPACITOR	1.5MF			C 329	NCB31HK-221X	C CAPACITOR		
	C 219	QDC31HJ-150Z	C CAPACITOR				C 330	NCB31HK-221X	C CAPACITOR		
	C 220	QDC31HJ-100Z	C CAPACITOR				C 331	NCB31HK-221X	C CAPACITOR		
	C 221	QDC31HJ-470Z	C CAPACITOR				C 332	NCB31HK-221X	C CAPACITOR		
	C 222	QDC31HJ-270Z	C CAPACITOR				C 333	NCS31HJ-391X	C CAPACITOR		
	C 223	NCB31HK-102X	C CAPACITOR				C 334	NCS31HJ-391X	C CAPACITOR		
	C 224	NCS31HJ-271X	C CAPACITOR				C 335	QETN1EM-226Z	E CAPACITOR	22MF 20% 25V	
	C 225	NCS31HJ-121X	C CAPACITOR				C 336	QETN1EM-226Z	E CAPACITOR	22MF 20% 25V	
	C 226	NCS31HJ-470X	C CAPACITOR				C 339	NCB31HK-561X	C CAPACITOR		
	C 231	QETN1HM-475Z	E CAPACITOR	4.7MF 20% 50V			C 341	QETN1HM-106Z	E CAPACITOR	10MF 20% 50V	
	C 241	QDX31EM-473Z	C CAPACITOR				C 342	QETN1HM-106Z	E CAPACITOR	10MF 20% 50V	
	C 242	QETN1HM-475Z	E CAPACITOR	4.7MF 20% 50V			C 343	QETN1HM-106Z	E CAPACITOR	10MF 20% 50V	
	C 244	QDX31EM-473Z	C CAPACITOR				C 344	QETN1HM-106Z	E CAPACITOR	10MF 20% 50V	
	C 245	QETN1HM-475Z	E CAPACITOR	4.7MF 20% 50V			C 361	QETN1HM-475Z	E CAPACITOR	4.7MF 20% 50V	
	C 246	QDX31EM-473Z	C CAPACITOR				C 362	QETN1HM-475Z	E CAPACITOR	4.7MF 20% 50V	
	C 247	QETN0JM-477Z	E CAPACITOR	470MF 20% 6.3V			C 363	QETN1HM-475Z	E CAPACITOR	4.7MF 20% 50V	
	C 249	QDX31EM-473Z	C CAPACITOR				C 364	QETN1HM-475Z	E CAPACITOR	4.7MF 20% 50V	
	C 250	QETN1HM-475Z	E CAPACITOR	4.7MF 20% 50V			C 371	NCB31HK-221X	C CAPACITOR		
	C 251	QDX31EM-473Z	C CAPACITOR				C 372	NCB31HK-221X	C CAPACITOR		
	C 252	QETN0JM-477Z	E CAPACITOR	470MF 20% 6.3V			C 373	NCB31HK-221X	C CAPACITOR		
	C 253	NCS31HJ-100X	C CAPACITOR				C 374	NCB31HK-221X	C CAPACITOR		
	C 254	QDX31EM-473Z	C CAPACITOR				C 375	NCB31HK-221X	C CAPACITOR		
	C 255	QETN1HM-475Z	E CAPACITOR	4.7MF 20% 50V			C 376	NCB31HK-221X	C CAPACITOR		
	C 256	QCF31HZ-103Z	C CAPACITOR	.010MF +80:-20%			C 377	NCB31HK-221X	C CAPACITOR		
	C 257	QETN1CM-476Z	E CAPACITOR	47MF 20% 16V			C 378	NCB31HK-221X	C CAPACITOR		
	C 258	QCF31HZ-103Z	C CAPACITOR	.010MF +80:-20%			C 379	NCB31HK-221X	C CAPACITOR		
	C 259	QETN1CM-476Z	E CAPACITOR	47MF 20% 16V			C 380	NCB31HK-221X	C CAPACITOR		
	C 260	QDX31EM-473Z	C CAPACITOR				C 381	NCB31HK-221X	C CAPACITOR		
	C 261	QETN1HM-475Z	E CAPACITOR	4.7MF 20% 50V			C 382	NCB31HK-221X	C CAPACITOR		
	C 268	NCS31HJ-470X	C CAPACITOR				C 385	QETN1EM-226Z	E CAPACITOR	22MF 20% 25V	
	C 269	NCS31HJ-470X	C CAPACITOR				C 386	QETN1EM-226Z	E CAPACITOR	22MF 20% 25V	
	C 270	NCS31HJ-101X	C CAPACITOR				C 389	NCB31HK-561X	C CAPACITOR		
	C 271	NCS31HJ-101X	C CAPACITOR				C 391	QETN1HM-106Z	E CAPACITOR	10MF 20% 50V	
	C 272	QDX31EM-473Z	C CAPACITOR				C 392	QETN1HM-106Z	E CAPACITOR	10MF 20% 50V	
	C 273	QDX31EM-473Z	C CAPACITOR				C 393	NCB31HK-122X	C CAPACITOR		
	C 274	QETN0JM-477Z	E CAPACITOR	470MF 20% 6.3V			C 394	NCB31HK-122X	C CAPACITOR		
	C 275	NCS31HJ-470X	C CAPACITOR				C 395	NCS31HJ-121X	C CAPACITOR		
	C 276	NCS31HJ-470X	C CAPACITOR				C 396	NCS31HJ-121X	C CAPACITOR		
	C 277	QETN1HM-475Z	E CAPACITOR	4.7MF 20% 50V			C 397	QETN1HM-106Z	E CAPACITOR	10MF 20% 50V	
	C 301	QETN1HM-475Z	E CAPACITOR	4.7MF 20% 50V			C 398	QETN1HM-106Z	E CAPACITOR	10MF 20% 50V	
	C 302	QETN1HM-475Z	E CAPACITOR	4.7MF 20% 50V			CN200	QGB2510K1-11	CONNECTOR		
	C 303	NCS31HJ-101X	C CAPACITOR				CN204	QGB1214K1-08S	CONNECTOR		
	C 304	NCS31HJ-101X	C CAPACITOR				CN205	QGB1214J1-08S	CONNECTOR		
	C 305	QFLC1HJ-182Z	M CAPACITOR	1800PF 5% 50V			CN206	QGA2501F1-02	CONNECTOR		
	C 306	QFLC1HJ-182Z	M CAPACITOR	1800PF 5% 50V			CN240	QGB2510K1-12	CONNECTOR		
	C 307	QFLC1HJ-682Z	M CAPACITOR	6800PF 5% 50V			CN242	QGB1214K1-10S	CONNECTOR		

■ Electrical parts list (Input board)

Block No. 04

△	Item	Parts number	Parts name	Remarks	Area	△	Item	Parts number	Parts name	Remarks	Area
	CN243	QGB1214J1-10S	CONNECTOR				C1381	NCS31HJ-470X	C CAPACITOR		
	CN244	QGA2501F1-04	CONNECTOR				C1382	NCS31HJ-470X	C CAPACITOR		
	CN311	QGB2510K1-14	CONNECTOR				C1383	NCS31HJ-470X	C CAPACITOR		
	CN313	QGB2510K1-13	CONNECTOR				C1384	QETN1EM-476Z	E CAPACITOR	47MF 20% 25V	
	CN351	QGB1214K1-16S	CONNECTOR				C1385	QETN1HM-475Z	E CAPACITOR	4.7MF 20% 50V	
	CN361	QGB1214J1-16S	CONNECTOR				C1386	QETN1HM-475Z	E CAPACITOR	4.7MF 20% 50V	
	CN371	QGB1214K1-14S	CONNECTOR				C1387	NCS31HJ-470X	C CAPACITOR		
	CN381	QGB1214J1-14S	CONNECTOR				C1388	NCS31HJ-470X	C CAPACITOR		
	CN416	QGA2501F1-06	CONNECTOR				C1389	NCS31HJ-470X	C CAPACITOR		
	CN501	QGB1214J1-12S	CONNECTOR				C1390	QETN1EM-476Z	E CAPACITOR	47MF 20% 25V	
	CN731	QJP001-032301	SHI CR C-B WIRE				C1391	QETN1HM-475Z	E CAPACITOR	4.7MF 20% 50V	
	CN732	WJP0026-001A	CONNECTOR				C1392	QETN1HM-475Z	E CAPACITOR	4.7MF 20% 50V	
	C1281	QETN1AM-107Z	E CAPACITOR	100MF 20% 10V			C1393	NCS31HJ-101X	C CAPACITOR		
	C1282	QETN1AM-477Z	E CAPACITOR	470MF 20% 10V			C1394	NCS31HJ-101X	C CAPACITOR		
	C1283	QETN1EM-476Z	E CAPACITOR	47MF 20% 25V			C1395	NCS31HJ-101X	C CAPACITOR		
	C1284	QETN1AM-107Z	E CAPACITOR	100MF 20% 10V			C1396	QETN0JM-477Z	E CAPACITOR	470MF 20% 6.3V	
	C1285	QETN1EM-476Z	E CAPACITOR	47MF 20% 25V			C1397	QETN1AM-107Z	E CAPACITOR	100MF 20% 10V	
	C1286	QETN1AM-107Z	E CAPACITOR	100MF 20% 10V			C1398	QETN1AM-107Z	E CAPACITOR	100MF 20% 10V	
	C1301	QETN1EM-476Z	E CAPACITOR	47MF 20% 25V			D 200	1SS133-T1	SI DIODE		
	C1302	QETN1EM-476Z	E CAPACITOR	47MF 20% 25V			D 201	1SS133-T1	SI DIODE		
	C1303	NCB31HK-221X	C CAPACITOR				D 240	1SS133-T1	SI DIODE		
	C1305	QETN1EM-476Z	E CAPACITOR	47MF 20% 25V			D 241	1SS133-T1	SI DIODE		
	C1306	QETN1EM-476Z	E CAPACITOR	47MF 20% 25V			D1370	MA3062/H/-X	Z DIODE		
	C1307	QETN1CM-476Z	E CAPACITOR	47MF 20% 16V			HL203	VYH7653-005	IC HOLDER		
	C1311	QETN1HM-475Z	E CAPACITOR	4.7MF 20% 50V			IC201	BA7625	IC		
	C1312	QETN1HM-475Z	E CAPACITOR	4.7MF 20% 50V			IC202	NJM2285V-W	IC		
	C1313	QETN1HM-475Z	E CAPACITOR	4.7MF 20% 50V			IC203	MB90088PF-131	IC		
	C1314	QETN1HM-475Z	E CAPACITOR	4.7MF 20% 50V			IC241	BA7626	IC		
	C1315	QER61HM-224Z	E CAPACITOR	.22MF 20% 50V			IC242	BA7625	IC		
	C1316	QER61HM-224Z	E CAPACITOR	.22MF 20% 50V			IC301	NJM4580D-D	IC		
	C1319	NCB31HK-221X	C CAPACITOR				IC302	TC9164AF-X	IC		
	C1321	QETN1HM-475Z	E CAPACITOR	4.7MF 20% 50V			IC303	BA15218F-XE	IC		
	C1322	QETN1HM-475Z	E CAPACITOR	4.7MF 20% 50V			IC304	BA15218F-XE	IC		
	C1323	QETN1HM-475Z	E CAPACITOR	4.7MF 20% 50V			IC371	TC9163AF-X	IC		
	C1324	QETN1HM-475Z	E CAPACITOR	4.7MF 20% 50V			IC372	BA15218F-XE	IC		
	C1325	QER61HM-224Z	E CAPACITOR	.22MF 20% 50V			IC380	TC9162AN	IC		
	C1326	QER61HM-224Z	E CAPACITOR	.22MF 20% 50V			IC381	TC9459F-X	IC		
	C1329	NCB31HK-221X	C CAPACITOR				IC382	TC9459F-X	IC		
	C1331	QETN1HM-475Z	E CAPACITOR	4.7MF 20% 50V			IC383	TC9459F-X	IC		
	C1332	QETN1HM-475Z	E CAPACITOR	4.7MF 20% 50V			IC385	BA15218F-XE	IC		
	C1333	QETN1HM-475Z	E CAPACITOR	4.7MF 20% 50V			IC386	BA15218F-XE	IC		
	C1334	QETN1HM-475Z	E CAPACITOR	4.7MF 20% 50V			IC388	TC74HC4053AF-X	IC		
	C1339	NCB31HK-221X	C CAPACITOR				IC389	TC74HC4053AF-X	IC		
	C1341	QETN1HM-475Z	E CAPACITOR	4.7MF 20% 50V			IC390	MAX4018ESD-X	IC		
	C1342	QETN1HM-475Z	E CAPACITOR	4.7MF 20% 50V			J 201	QNN0078-001	PIN JACK		
	C1343	QETN1EM-476Z	E CAPACITOR	47MF 20% 25V			J 202	QNN0011-001	PIN JACK		
	C1344	QETN1EM-476Z	E CAPACITOR	47MF 20% 25V			J 203	QNN0011-001	PIN JACK		
	C1345	NCS31HJ-391X	C CAPACITOR				J 241	QND0002-001	S-CONNECTOR		
	C1346	NCB31EK-223X	C CAPACITOR				J 242	QND0028-001	DIN CONNECTOR		
	C1361	NCB31HK-391X	C CAPACITOR				J 243	QND0088-001	S JACK		
	C1362	NCB31HK-391X	C CAPACITOR				J 301	QNN0056-001	PIN JACK		
	C1363	QETN1HM-475Z	E CAPACITOR	4.7MF 20% 50V			J 302	QNN0056-001	PIN JACK		
	C1364	QETN1HM-475Z	E CAPACITOR	4.7MF 20% 50V			J 303	QNN0058-001	PIN JACK		
	C1365	QETN1HM-475Z	E CAPACITOR	4.7MF 20% 50V			J 371	QNN0056-001	PIN JACK		
	C1366	QETN1HM-475Z	E CAPACITOR	4.7MF 20% 50V			J 372	QNN0056-001	PIN JACK		
	C1370	NCB31HK-221X	C CAPACITOR				J 373	QNN0056-001	PIN JACK		
	C1371	NCB31HK-221X	C CAPACITOR				J1340	QNN0060-001	PIN JACK		
	C1372	NCB31HK-221X	C CAPACITOR				J1360	QNN0390-001	PIN JACK		
	C1375	QCF31HZ-103Z	C CAPACITOR	.010MF +80:-20%			J1370	QNS0083-001	3.5 JACK		
	C1376	QETN1EM-476Z	E CAPACITOR	47MF 20% 25V			J1371	QNS0077-001	3.5 JACK		
	C1377	QCF31HZ-103Z	C CAPACITOR	.010MF +80:-20%			J1372	QNS0083-001	3.5 JACK		
	C1378	QETN1EM-476Z	E CAPACITOR	47MF 20% 25V			J1380	QNN0391-001	PIN JACK		
	C1380	QETN1EM-476Z	E CAPACITOR	47MF 20% 25V			L 200	NQL085J-220X	INDUCTOR		

■ Electrical parts list (Input board)

Block No. 04

△	Item	Parts number	Parts name	Remarks	Area	△	Item	Parts number	Parts name	Remarks	Area
	Q 200	KTA1267/YG/-T	TRANSISTOR				R 249	NRSA63J-151X	MG RESISTOR		
	Q 201	KTA1267/YG/-T	TRANSISTOR				R 250	NRSA63J-151X	MG RESISTOR		
	Q 202	KRC110M-T	TRANSISTOR				R 251	NRSA63J-151X	MG RESISTOR		
	Q 203	KRC107M-T	D TRANSISTOR				R 253	NRSA63J-153X	MG RESISTOR		
	Q 204	KTA1267/YG/-T	TRANSISTOR				R 254	NRSA63J-153X	MG RESISTOR		
	Q 205	KTA1267/YG/-T	TRANSISTOR				R 255	NRSA63J-153X	MG RESISTOR		
	Q 206	KTA1267/YG/-T	TRANSISTOR				R 266	NRSA63J-750X	MG RESISTOR		
	Q 207	KTA1267/YG/-T	TRANSISTOR				R 267	NRSA63J-473X	MG RESISTOR		
	Q 208	DTC123YSA-T	D TRANSISTOR				R 268	NRSA63J-750X	MG RESISTOR		
	Q 240	KTA1267/YG/-T	TRANSISTOR				R 269	NRSA63J-473X	MG RESISTOR		
	Q 241	KTA1267/YG/-T	TRANSISTOR			△	R 271	QRJ146J-3R3X	UNF C RESISTOR	3.3 5% 1/4W	
	Q 242	KTA1267/YG/-T	TRANSISTOR				R 272	NRSA63J-750X	MG RESISTOR		
	Q 243	KTA1267/YG/-T	TRANSISTOR				R 273	NRSA63J-473X	MG RESISTOR		
	Q 244	KRC110M-T	TRANSISTOR				R 274	NRSA63J-750X	MG RESISTOR		
	Q 245	KRC110M-T	TRANSISTOR				R 275	NRSA63J-750X	MG RESISTOR		
	Q 246	KRC107M-T	D TRANSISTOR				R 276	NRSA63J-750X	MG RESISTOR		
	Q 247	KRC107M-T	D TRANSISTOR				R 280	NRSA63J-301X	MG RESISTOR		
	Q1307	KRA104M-T	D TRANSISTOR				R 281	NRSA63J-301X	MG RESISTOR		
	Q1313	2SC3576-JVC-T	TRANSISTOR				R 282	NRSA63J-103X	MG RESISTOR		
	Q1314	2SC3576-JVC-T	TRANSISTOR				R 283	NRSA63J-103X	MG RESISTOR		
	Q1323	2SC3576-JVC-T	TRANSISTOR				R 284	NRSA63J-301X	MG RESISTOR		
	Q1333	2SC3576-JVC-T	TRANSISTOR				R 285	NRSA63J-301X	MG RESISTOR		
	Q1334	2SC3576-JVC-T	TRANSISTOR				R 301	NRSA63J-222X	MG RESISTOR		
	Q1341	2SC3576-JVC-T	TRANSISTOR				R 302	NRSA63J-222X	MG RESISTOR		
	Q1342	2SC3576-JVC-T	TRANSISTOR				R 303	NRSA63J-473X	MG RESISTOR		
	Q1343	KRA104M-T	D TRANSISTOR				R 304	NRSA63J-473X	MG RESISTOR		
	R 200	NRSA63J-750X	MG RESISTOR				R 305	NRSA63J-621X	MG RESISTOR		
	R 201	NRSA63J-750X	MG RESISTOR				R 306	NRSA63J-621X	MG RESISTOR		
	R 202	NRSA63J-750X	MG RESISTOR				R 307	NRSA63J-393X	MG RESISTOR		
	R 203	NRSA63J-750X	MG RESISTOR				R 308	NRSA63J-393X	MG RESISTOR		
	R 204	NRSA63J-750X	MG RESISTOR				R 309	NRSA63J-474X	MG RESISTOR		
	R 205	NRSA63J-750X	MG RESISTOR				R 310	NRSA63J-474X	MG RESISTOR		
	R 206	NRSA63J-750X	MG RESISTOR				R 311	NRSA63J-104X	MG RESISTOR		
	R 207	NRSA63J-331X	MG RESISTOR				R 312	NRSA63J-104X	MG RESISTOR		
	R 208	NRSA63J-331X	MG RESISTOR			△	R 315	QRJ146J-331X	UNF C RESISTOR	330 5% 1/4W	
	R 209	NRSA63J-473X	MG RESISTOR			△	R 316	QRJ146J-331X	UNF C RESISTOR	330 5% 1/4W	
	R 210	NRSA63J-331X	MG RESISTOR				R 323	NRSA63J-471X	MG RESISTOR		
	R 211	NRSA63J-473X	MG RESISTOR				R 324	NRSA63J-471X	MG RESISTOR		
	R 212	NRSA63J-331X	MG RESISTOR				R 325	NRSA63J-471X	MG RESISTOR		
	R 213	NRSA63J-473X	MG RESISTOR				R 326	NRSA63J-471X	MG RESISTOR		
	R 214	NRSA63J-151X	MG RESISTOR				R 327	NRSA63J-471X	MG RESISTOR		
	R 215	NRSA63J-151X	MG RESISTOR				R 328	NRSA63J-471X	MG RESISTOR		
	R 216	NRSA63J-301X	MG RESISTOR				R 329	NRSA63J-471X	MG RESISTOR		
	R 217	NRSA63J-103X	MG RESISTOR				R 330	NRSA63J-471X	MG RESISTOR		
	R 218	NRSA63J-331X	MG RESISTOR				R 331	NRSA63J-471X	MG RESISTOR		
	R 219	NRSA63J-101X	MG RESISTOR				R 332	NRSA63J-471X	MG RESISTOR		
	R 220	NRSA63J-151X	MG RESISTOR				R 333	NRSA63J-471X	MG RESISTOR		
	R 221	NRSA63J-151X	MG RESISTOR				R 334	NRSA63J-471X	MG RESISTOR		
	R 222	NRSA63J-561X	MG RESISTOR			△	R 335	QRZ9005-680X	F RESISTOR	68 1/4W	
	R 223	NRSA63J-561X	MG RESISTOR			△	R 336	QRZ9005-680X	F RESISTOR	68 1/4W	
	R 224	NRSA63J-561X	MG RESISTOR				R 341	NRSA63J-104X	MG RESISTOR		
△	R 225	QRJ146J-2R2X	UNF C RESISTOR	2.2 5% 1/4W			R 342	NRSA63J-104X	MG RESISTOR		
	R 231	NRSA63J-222X	MG RESISTOR				R 343	NRSA63J-104X	MG RESISTOR		
	R 232	NRSA63J-470X	MG RESISTOR				R 344	NRSA63J-104X	MG RESISTOR		
	R 240	NRSA63J-750X	MG RESISTOR				R 345	NRSA63J-104X	MG RESISTOR		
	R 241	NRSA63J-750X	MG RESISTOR				R 346	NRSA63J-104X	MG RESISTOR		
	R 242	NRSA63J-750X	MG RESISTOR				R 361	NRSA63J-104X	MG RESISTOR		
	R 243	NRSA63J-750X	MG RESISTOR				R 362	NRSA63J-104X	MG RESISTOR		
	R 244	NRSA63J-750X	MG RESISTOR				R 363	NRSA63J-104X	MG RESISTOR		
	R 245	NRSA63J-750X	MG RESISTOR				R 364	NRSA63J-104X	MG RESISTOR		
	R 246	NRSA63J-750X	MG RESISTOR				R 365	NRSA63J-104X	MG RESISTOR		
	R 247	NRSA63J-750X	MG RESISTOR				R 366	NRSA63J-104X	MG RESISTOR		
	R 248	NRSA63J-151X	MG RESISTOR				R 371	NRSA63J-471X	MG RESISTOR		

■ Electrical parts list (Input board)

Block No. 04

△	Item	Parts number	Parts name	Remarks	Area	△	Item	Parts number	Parts name	Remarks	Area
	R 372	NRSA63J-471X	MG RESISTOR				R1336	NRSA63J-102X	MG RESISTOR		
	R 373	NRSA63J-471X	MG RESISTOR				R1341	NRSA63J-104X	MG RESISTOR		
	R 374	NRSA63J-471X	MG RESISTOR				R1342	NRSA63J-102X	MG RESISTOR		
	R 375	NRSA63J-471X	MG RESISTOR				R1343	NRSA63J-183X	MG RESISTOR		
	R 376	NRSA63J-471X	MG RESISTOR				R1344	NRSA63J-104X	MG RESISTOR		
	R 377	NRSA63J-471X	MG RESISTOR				R1345	NRSA63J-471X	MG RESISTOR		
	R 378	NRSA63J-471X	MG RESISTOR				R1346	NRSA63J-103X	MG RESISTOR		
	R 379	NRSA63J-471X	MG RESISTOR				R1347	NRSA63J-471X	MG RESISTOR		
	R 380	NRSA63J-471X	MG RESISTOR				R1348	NRSA63J-103X	MG RESISTOR		
	R 381	NRSA63J-471X	MG RESISTOR				R1349	NRSA63J-474X	MG RESISTOR		
	R 382	NRSA63J-471X	MG RESISTOR			△	R1350	QRZ9005-680X	F RESISTOR	68 1/4W	
△	R 385	QRZ9005-680X	F RESISTOR	68 1/4W		△	R1351	QRZ9005-680X	F RESISTOR	68 1/4W	
△	R 386	QRZ9005-680X	F RESISTOR	68 1/4W			R1355	NRSA63J-222X	MG RESISTOR		
	R 387	NRSA63J-471X	MG RESISTOR				R1356	NRSA63J-222X	MG RESISTOR		
	R 388	NRSA63J-471X	MG RESISTOR				R1357	NRSA63J-392X	MG RESISTOR		
	R 389	NRSA63J-471X	MG RESISTOR				R1358	NRSA63J-392X	MG RESISTOR		
	R 390	NRSA63J-471X	MG RESISTOR				R1361	NRSA63J-561X	MG RESISTOR		
	R 391	NRSA63J-512X	MG RESISTOR				R1362	NRSA63J-561X	MG RESISTOR		
	R 392	NRSA63J-512X	MG RESISTOR				R1363	NRSA63J-104X	MG RESISTOR		
	R 393	NRSA63J-103X	MG RESISTOR				R1364	NRSA63J-104X	MG RESISTOR		
	R 394	NRSA63J-103X	MG RESISTOR				R1365	NRSA63J-104X	MG RESISTOR		
	R 395	NRSA63J-512X	MG RESISTOR				R1366	NRSA63J-104X	MG RESISTOR		
	R 396	NRSA63J-512X	MG RESISTOR				R1367	NRSA63J-104X	MG RESISTOR		
	R 397	NRSA63J-104X	MG RESISTOR				R1368	NRSA63J-104X	MG RESISTOR		
	R 398	NRSA63J-104X	MG RESISTOR				R1370	NRSA63J-471X	MG RESISTOR		
	R1281	NRSA63J-472X	MG RESISTOR				R1371	NRSA63J-221X	MG RESISTOR		
	R1282	NRSA63J-472X	MG RESISTOR				R1372	NRSA63J-101X	MG RESISTOR		
	R1283	NRSA63J-102X	MG RESISTOR				R1373	NRSA63J-221X	MG RESISTOR		
	R1284	NRSA63J-112X	MG RESISTOR				R1374	NRSA63J-221X	MG RESISTOR		
	R1285	NRSA63J-472X	MG RESISTOR				R1375	NRSA63J-221X	MG RESISTOR		
	R1286	NRSA63J-472X	MG RESISTOR				R1379	NRSA63J-750X	MG RESISTOR		
	R1287	NRSA63J-102X	MG RESISTOR				R1380	NRSA63J-750X	MG RESISTOR		
	R1288	NRSA63J-112X	MG RESISTOR				R1381	NRSA63J-750X	MG RESISTOR		
	R1289	NRSA63J-472X	MG RESISTOR				R1382	NRSA63J-750X	MG RESISTOR		
	R1290	NRSA63J-472X	MG RESISTOR				R1383	NRSA63J-750X	MG RESISTOR		
	R1291	NRSA63J-102X	MG RESISTOR				R1384	NRSA63J-750X	MG RESISTOR		
	R1292	NRSA63J-112X	MG RESISTOR				R1385	NRSA63J-750X	MG RESISTOR		
	R1293	NRSA63J-162X	MG RESISTOR				R1386	NRSA63J-750X	MG RESISTOR		
	R1294	NRSA63J-472X	MG RESISTOR				R1387	NRSA63J-750X	MG RESISTOR		
△	R1301	QRZ9005-680X	F RESISTOR	68 1/4W			R1388	NRSA63J-473X	MG RESISTOR		
△	R1302	QRZ9005-680X	F RESISTOR	68 1/4W			R1389	NRSA63J-473X	MG RESISTOR		
	R1303	NRSA63J-122X	MG RESISTOR				R1390	NRSA63J-473X	MG RESISTOR		
	R1304	NRSA63J-122X	MG RESISTOR				X 200	QAX0260-001Z	CRYSTAL	NTSC ONLY	
△	R1305	QRZ9005-680X	F RESISTOR	68 1/4W							
△	R1306	QRZ9005-680X	F RESISTOR	68 1/4W							
	R1307	NRSA63J-102X	MG RESISTOR								
	R1311	NRSA63J-104X	MG RESISTOR								
	R1312	NRSA63J-104X	MG RESISTOR								
	R1313	NRSA63J-102X	MG RESISTOR								
	R1314	NRSA63J-103X	MG RESISTOR								
	R1315	NRSA63J-103X	MG RESISTOR								
	R1316	NRSA63J-102X	MG RESISTOR								
	R1321	NRSA63J-104X	MG RESISTOR								
	R1322	NRSA63J-104X	MG RESISTOR								
	R1323	NRSA63J-102X	MG RESISTOR								
	R1324	NRSA63J-103X	MG RESISTOR								
	R1329	NRSA63J-0R0X	MG RESISTOR								
	R1330	NRSA63J-0R0X	MG RESISTOR								
	R1331	NRSA63J-104X	MG RESISTOR								
	R1332	NRSA63J-104X	MG RESISTOR								
	R1333	NRSA63J-102X	MG RESISTOR								
	R1334	NRSA63J-103X	MG RESISTOR								
	R1335	NRSA63J-103X	MG RESISTOR								

■ Electrical parts list (DSP board)

Block No. 05

△	Item	Parts number	Parts name	Remarks	Area	△	Item	Parts number	Parts name	Remarks	Area
	C 571	NCB31HK-103X	C CAPACITOR				C2308	NEA71EM-475X	E CAPACITOR		
	C 573	NCF31CZ-104X	C CAPACITOR				C2347	NCS31HJ-330X	C CAPACITOR		
	C 577	NCS31HJ-101X	C CAPACITOR				C2348	NCS31HJ-330X	C CAPACITOR		
	C 579	NCS31HJ-101X	C CAPACITOR				C2349	NCF31CZ-104X	C CAPACITOR		
	C 581	NEA71CM-106X	E CAPACITOR				C2350	NCF31CZ-104X	C CAPACITOR		
	C 582	NEA71CM-106X	E CAPACITOR				C2351	NEA71HM-105X	E CAPACITOR		
	C 583	NEA70JM-476X	E CAPACITOR				C2352	NEA71HM-105X	E CAPACITOR		
	C 584	NCB31CK-104X	C CAPACITOR				C2353	NCS31HJ-330X	C CAPACITOR		
	C 587	NCF31CZ-104X	C CAPACITOR				C2354	NCS31HJ-330X	C CAPACITOR		
	C 588	NEA70JM-476X	E CAPACITOR				C2355	NCF31CZ-104X	C CAPACITOR		
	C 589	NCF31CZ-104X	C CAPACITOR				C2356	NCF31CZ-104X	C CAPACITOR		
	C 590	NEA70GM-107X	E CAPACITOR				C2357	NEA71EM-475X	E CAPACITOR		
	CN581	QGB1214K3-12W	CONNECTOR				C2358	NEA71EM-475X	E CAPACITOR		
	CN587	QGB2510K1-07	CONNECTOR				C2401	NCB31HK-102X	C CAPACITOR		
	C2001	NEA71EM-475X	E CAPACITOR				C2407	NEA71EM-475X	E CAPACITOR		
	C2002	NEA71EM-475X	E CAPACITOR				C2427	NEA71HM-225X	E CAPACITOR		
	C2003	NCB31HK-122X	C CAPACITOR				C2433	NCS31HJ-330X	C CAPACITOR		
	C2004	NCB31HK-122X	C CAPACITOR				C2439	NCF31CZ-104X	C CAPACITOR		
	C2005	NCS31HJ-121X	C CAPACITOR				C2440	NCF31CZ-104X	C CAPACITOR		
	C2006	NCS31HJ-121X	C CAPACITOR				C2441	NCF31CZ-104X	C CAPACITOR		
	C2007	NCS31HJ-391X	C CAPACITOR				C2442	NCF31CZ-104X	C CAPACITOR		
	C2008	NCS31HJ-391X	C CAPACITOR				C2481	NEA70JM-476X	E CAPACITOR		
	C2009	NCF31CZ-104X	C CAPACITOR				C2501	NCB31HK-103X	C CAPACITOR		
	C2010	NCF31CZ-104X	C CAPACITOR				C2502	NCB31HK-103X	C CAPACITOR		
	C2013	NCS31HJ-330X	C CAPACITOR				C2503	NCB31HK-103X	C CAPACITOR		
	C2014	NCS31HJ-330X	C CAPACITOR				C2504	NCB31HK-103X	C CAPACITOR		
	C2018	NEA70JM-476X	E CAPACITOR				C2505	NCB31HK-103X	C CAPACITOR		
	C2019	NCF31CZ-104X	C CAPACITOR				C2506	NCB31HK-103X	C CAPACITOR		
	C2020	NCF31CZ-104X	C CAPACITOR				C2507	NCB31HK-103X	C CAPACITOR		
	C2101	NCB31HK-103X	C CAPACITOR				C2508	NCB31HK-103X	C CAPACITOR		
	C2107	NEA71EM-475X	E CAPACITOR				C2509	NCB31HK-103X	C CAPACITOR		
	C2133	NCB31EK-223X	C CAPACITOR				C2510	NCB31HK-103X	C CAPACITOR		
	C2134	NCB31EK-223X	C CAPACITOR				C2511	NCB31HK-103X	C CAPACITOR		
	C2135	NEA71CM-106X	E CAPACITOR				C2512	NCB31HK-103X	C CAPACITOR		
	C2136	NEA71CM-106X	E CAPACITOR				C2513	NCB31HK-103X	C CAPACITOR		
	C2137	NEA71EM-475X	E CAPACITOR				C2514	NCB31HK-103X	C CAPACITOR		
	C2138	NEA71EM-475X	E CAPACITOR				C2515	NCB31HK-103X	C CAPACITOR		
	C2157	NEA71HM-225X	E CAPACITOR				C2516	NCB31HK-103X	C CAPACITOR		
	C2158	NCS31HJ-330X	C CAPACITOR				C2517	NCB31HK-103X	C CAPACITOR		
	C2187	NEA71HM-225X	E CAPACITOR				C2518	NCB31HK-103X	C CAPACITOR		
	C2189	NCS31HJ-330X	C CAPACITOR				C2519	NCB31HK-103X	C CAPACITOR		
	C2201	NCB31HK-102X	C CAPACITOR				C2520	NCB31HK-103X	C CAPACITOR		
	C2202	NCB31HK-102X	C CAPACITOR				C2521	NCB31HK-103X	C CAPACITOR		
	C2207	NEA71HM-225X	E CAPACITOR				C2522	NCB31HK-103X	C CAPACITOR		
	C2208	NEA71HM-225X	E CAPACITOR				C2523	NCF31CZ-104X	C CAPACITOR		
	C2230	NEA71EM-475X	E CAPACITOR				C2529	NEA70GM-107X	E CAPACITOR		
	C2237	NCS31HJ-330X	C CAPACITOR				C2532	NEA70GM-107X	E CAPACITOR		
	C2238	NCS31HJ-330X	C CAPACITOR				C2533	NCF31CZ-104X	C CAPACITOR		
	C2251	NCF31CZ-104X	C CAPACITOR				C2534	NCF31CZ-104X	C CAPACITOR		
	C2252	NCF31CZ-104X	C CAPACITOR				C2535	NEA70GM-107X	E CAPACITOR		
	C2253	NCF31CZ-104X	C CAPACITOR				C2536	NCF31CZ-104X	C CAPACITOR		
	C2254	NCF31CZ-104X	C CAPACITOR				C2551	NCS31HJ-270X	C CAPACITOR		
	C2255	NCF31CZ-104X	C CAPACITOR				C2552	NCS31HJ-270X	C CAPACITOR		
	C2256	NCF31CZ-104X	C CAPACITOR				C2553	NEA70GM-107X	E CAPACITOR		
	C2257	NEA71HM-225X	E CAPACITOR				C2555	NCF31CZ-104X	C CAPACITOR		
	C2258	NEA71HM-225X	E CAPACITOR				C2556	NCF31CZ-104X	C CAPACITOR		
	C2261	NEA71EM-475X	E CAPACITOR				C2557	NCS31HJ-330X	C CAPACITOR		
	C2262	NEA71EM-475X	E CAPACITOR				C2560	NCF31CZ-104X	C CAPACITOR		
	C2283	NCS31HJ-330X	C CAPACITOR				C2561	NCF31CZ-104X	C CAPACITOR		
	C2284	NCS31HJ-330X	C CAPACITOR				C2562	NCF31CZ-104X	C CAPACITOR		
	C2301	NCB31HK-102X	C CAPACITOR				C2563	NCF31CZ-104X	C CAPACITOR		
	C2302	NCB31HK-102X	C CAPACITOR				C2564	NCS31HJ-101X	C CAPACITOR		
	C2307	NEA71EM-475X	E CAPACITOR				C2568	NEA71HM-105X	E CAPACITOR		

■ Electrical parts list (DSP board)

Block No. 05

△	Item	Parts number	Parts name	Remarks	Area	△	Item	Parts number	Parts name	Remarks	Area
	C2601	NCB31CK-104X	C CAPACITOR				R 575	NRSA63J-432X	MG RESISTOR		
△	C2602	NCB31CK-104X	C CAPACITOR				R 576	NRSA63J-432X	MG RESISTOR		
	C2701	NCB31HK-221X	C CAPACITOR				R 577	NRSA63J-822X	MG RESISTOR		
	C2702	NCB31HK-221X	C CAPACITOR				R 578	NRSA63J-822X	MG RESISTOR		
	C2703	NEA70JM-476X	E CAPACITOR				R 579	NRSA63J-822X	MG RESISTOR		
	C2704	NEA70JM-476X	E CAPACITOR				R 580	NRSA63J-822X	MG RESISTOR		
	C2705	NCF31CZ-104X	C CAPACITOR				R 582	NRSA63J-103X	MG RESISTOR		
	C2706	NCF31CZ-104X	C CAPACITOR				R2001	NRSA63J-104X	MG RESISTOR		
	C2707	NCB31CK-104X	C CAPACITOR				R2002	NRSA63J-104X	MG RESISTOR		
	C2710	NEA70JM-476X	E CAPACITOR				R2003	NRSA63J-103X	MG RESISTOR		
	C2712	NCF31CZ-104X	C CAPACITOR				R2004	NRSA63J-103X	MG RESISTOR		
	EP561	E409182-001SM	GRAND TERMINAL				R2005	NRSA63J-103X	MG RESISTOR		
	IC501	XCA56367PV150	IC				R2006	NRSA63J-103X	MG RESISTOR		
	IC502	TC7S04FU-X	IC				R2007	NRSA63J-103X	MG RESISTOR		
	IC503	TC7S04FU-X	IC				R2008	NRSA63J-103X	MG RESISTOR		
	IC505	PQ070XZ1HZ-X	IC				R2009	NRSA63J-103X	MG RESISTOR		
	IC511	W24L010AJ-12-X	IC				R2010	NRSA63J-103X	MG RESISTOR		
	IC521	BA15218F-XE	IC				R2011	NRSA63J-223X	MG RESISTOR		
	IC522	BA15218F-XE	IC				R2012	NRSA63J-223X	MG RESISTOR		
	IC523	BA15218F-XE	IC				R2013	NRSA63J-223X	MG RESISTOR		
	IC524	BA15218F-XE	IC				R2014	NRSA63J-223X	MG RESISTOR		
	IC525	BA15218F-XE	IC				R2017	NRSA63J-472X	MG RESISTOR		
	IC526	BA15218F-XE	IC				R2018	NRSA63J-472X	MG RESISTOR		
	IC527	BA15218F-XE	IC				R2021	NRSA63J-331X	MG RESISTOR		
	IC528	BA15218F-XE	IC				R2022	NRSA63J-331X	MG RESISTOR		
	IC529	BA15218F-XE	IC				R2023	NRSA63J-331X	MG RESISTOR		
	IC551	AK4112AVF-X	IC				R2024	NRSA63J-331X	MG RESISTOR		
	IC571	AK4527BVQ	IC				R2101	NRSA63J-103X	MG RESISTOR		
	IC581	UPD784215AGC152	IC				R2105	NRSA63J-102X	MG RESISTOR		
	IC582	TC7SET32FU-X	IC				R2107	NRSA63J-104X	MG RESISTOR		
	IC583	PQ3DZ53-X	IC				R2127	NRSA63J-223X	MG RESISTOR		
	J 564	QNN0347-001	PIN JACK				R2128	NRSA63J-223X	MG RESISTOR		
△	K2606	NQR0269-004X	FERRITE BEADS				R2129	NRSA63J-223X	MG RESISTOR		
	LC501	NQR0322-001X	EMI FILTER				R2130	NRSA63J-104X	MG RESISTOR		
	LC502	NQR0322-001X	EMI FILTER				R2131	NRSA63J-104X	MG RESISTOR		
	LC503	NQR0322-001X	EMI FILTER				R2132	NRSA63J-103X	MG RESISTOR		
	LC551	NQR0322-001X	EMI FILTER				R2133	NRSA63J-102X	MG RESISTOR		
	Q 570	DTC114YE-X	TRANSISTOR				R2134	NRSA63J-103X	MG RESISTOR		
	Q 572	DTC114YE-X	TRANSISTOR				R2135	NRSA63J-222X	MG RESISTOR		
	Q2101	2SD1328/ST/-X	TRANSISTOR				R2136	NRSA63J-103X	MG RESISTOR		
	Q2151	DTA114YE-X	TRANSISTOR				R2137	NRSA63J-103X	MG RESISTOR		
	Q2152	DTA114YE-X	TRANSISTOR				R2138	NRSA63J-223X	MG RESISTOR		
	Q2153	DTA114YE-X	TRANSISTOR				R2139	NRSA63J-103X	MG RESISTOR		
	Q2154	DTA114YE-X	TRANSISTOR				R2140	NRSA63J-105X	MG RESISTOR		
	Q2155	DTA114YE-X	TRANSISTOR				R2157	NRSA63J-104X	MG RESISTOR		
	Q2156	DTA114YE-X	TRANSISTOR				R2158	NRSA63J-303X	MG RESISTOR		
	Q2157	DTA114YE-X	TRANSISTOR				R2159	NRSA63J-113X	MG RESISTOR		
	Q2163	2SD1328/ST/-X	TRANSISTOR				R2171	NRSA63J-105X	MG RESISTOR		
	Q2164	2SD1328/ST/-X	TRANSISTOR				R2172	NRSA63J-105X	MG RESISTOR		
	Q2165	2SD1328/ST/-X	TRANSISTOR				R2181	NRSA63J-105X	MG RESISTOR		
	Q2201	2SD1328/ST/-X	TRANSISTOR				R2182	NRSA63J-105X	MG RESISTOR		
	Q2202	2SD1328/ST/-X	TRANSISTOR				R2183	NRSA63J-105X	MG RESISTOR		
	Q2273	2SD1328/ST/-X	TRANSISTOR				R2184	NRSA63J-105X	MG RESISTOR		
	Q2274	2SD1328/ST/-X	TRANSISTOR				R2186	NRSA63J-105X	MG RESISTOR		
	Q2301	2SD1328/ST/-X	TRANSISTOR				R2187	NRSA63J-104X	MG RESISTOR		
	Q2302	2SD1328/ST/-X	TRANSISTOR				R2189	NRSA63J-223X	MG RESISTOR		
	Q2363	2SD1328/ST/-X	TRANSISTOR				R2201	NRSA63J-103X	MG RESISTOR		
	Q2364	2SD1328/ST/-X	TRANSISTOR				R2202	NRSA63J-103X	MG RESISTOR		
	Q2401	2SD1328/ST/-X	TRANSISTOR				R2205	NRSA63J-102X	MG RESISTOR		
	Q2431	2SD1328/ST/-X	TRANSISTOR				R2206	NRSA63J-102X	MG RESISTOR		
	R 570	NRSA63J-103X	MG RESISTOR				R2207	NRSA63J-104X	MG RESISTOR		
	R 573	NRSA63J-432X	MG RESISTOR				R2208	NRSA63J-104X	MG RESISTOR		
	R 574	NRSA63J-432X	MG RESISTOR				R2221	NRSA63J-333X	MG RESISTOR		

■ Electrical parts list (DSP board)

Block No. 05

△	Item	Parts number	Parts name	Remarks	Area
	R2222	NRSA63J-333X	MG RESISTOR		
	R2225	NRSA63J-104X	MG RESISTOR		
	R2226	NRSA63J-104X	MG RESISTOR		
	R2227	NRSA63J-104X	MG RESISTOR		
	R2231	NRSA63J-333X	MG RESISTOR		
	R2232	NRSA63J-333X	MG RESISTOR		
	R2233	NRSA63J-333X	MG RESISTOR		
	R2234	NRSA63J-333X	MG RESISTOR		
	R2235	NRSA63J-333X	MG RESISTOR		
	R2236	NRSA63J-333X	MG RESISTOR		
	R2237	NRSA63J-683X	MG RESISTOR		
	R2238	NRSA63J-683X	MG RESISTOR		
	R2257	NRSA63J-104X	MG RESISTOR		
	R2258	NRSA63J-104X	MG RESISTOR		
	R2261	NRSA63J-104X	MG RESISTOR		
	R2262	NRSA63J-104X	MG RESISTOR		
	R2263	NRSA63J-103X	MG RESISTOR		
	R2264	NRSA63J-103X	MG RESISTOR		
	R2273	NRSA63J-103X	MG RESISTOR		
	R2274	NRSA63J-103X	MG RESISTOR		
	R2275	NRSA63J-682X	MG RESISTOR		
	R2276	NRSA63J-682X	MG RESISTOR		
	R2277	NRSA63J-105X	MG RESISTOR		
	R2278	NRSA63J-105X	MG RESISTOR		
	R2283	NRSA63J-103X	MG RESISTOR		
	R2284	NRSA63J-103X	MG RESISTOR		
	R2285	NRSA63J-113X	MG RESISTOR		
	R2286	NRSA63J-113X	MG RESISTOR		
	R2301	NRSA63J-103X	MG RESISTOR		
	R2302	NRSA63J-103X	MG RESISTOR		
	R2305	NRSA63J-102X	MG RESISTOR		
	R2306	NRSA63J-102X	MG RESISTOR		
	R2307	NRSA63J-104X	MG RESISTOR		
	R2308	NRSA63J-104X	MG RESISTOR		
	R2349	NRSA63J-303X	MG RESISTOR		
	R2350	NRSA63J-303X	MG RESISTOR		
	R2351	NRSA63J-113X	MG RESISTOR		
	R2352	NRSA63J-113X	MG RESISTOR		
	R2353	NRSA63J-222X	MG RESISTOR		
	R2354	NRSA63J-222X	MG RESISTOR		
	R2355	NRSA63J-103X	MG RESISTOR		
	R2356	NRSA63J-103X	MG RESISTOR		
	R2357	NRSA63J-223X	MG RESISTOR		
	R2358	NRSA63J-223X	MG RESISTOR		
	R2359	NRSA63J-103X	MG RESISTOR		
	R2360	NRSA63J-103X	MG RESISTOR		
	R2363	NRSA63J-104X	MG RESISTOR		
	R2364	NRSA63J-104X	MG RESISTOR		
	R2401	NRSA63J-103X	MG RESISTOR		
	R2405	NRSA63J-102X	MG RESISTOR		
	R2407	NRSA63J-104X	MG RESISTOR		
	R2425	NRSA63J-103X	MG RESISTOR		
	R2427	NRSA63J-104X	MG RESISTOR		
	R2429	NRSA63J-103X	MG RESISTOR		
	R2431	NRSA63J-113X	MG RESISTOR		
	R2433	NRSA63J-823X	MG RESISTOR		
	R2485	NRSA63J-102X	MG RESISTOR		
	R2501	NRSA63J-105X	MG RESISTOR		
	R2502	NRSA63J-473X	MG RESISTOR		
	R2503	NRSA63J-473X	MG RESISTOR		
	R2504	NRSA63J-473X	MG RESISTOR		
	R2505	NRSA63J-473X	MG RESISTOR		
	R2506	NRSA63J-473X	MG RESISTOR		

△	Item	Parts number	Parts name	Remarks	Area
	R2507	NRSA63J-473X	MG RESISTOR		
	R2508	NRSA63J-473X	MG RESISTOR		
	R2511	NRSA63J-221X	MG RESISTOR		
	R2512	NRSA63J-221X	MG RESISTOR		
	R2513	NRSA63J-221X	MG RESISTOR		
	R2514	NRSA63J-103X	MG RESISTOR		
	R2515	NRSA63J-103X	MG RESISTOR		
	R2516	NRSA63J-103X	MG RESISTOR		
	R2517	NRSA63J-103X	MG RESISTOR		
	R2518	NRSA63J-221X	MG RESISTOR		
	R2519	NRSA63J-221X	MG RESISTOR		
	R2520	NRSA63J-221X	MG RESISTOR		
	R2521	NRSA63J-103X	MG RESISTOR		
	R2522	NRSA63J-103X	MG RESISTOR		
	R2523	NRSA63J-103X	MG RESISTOR		
	R2531	NRSA63F-511X	MG RESISTOR		
	R2532	NRSA63F-102X	MG RESISTOR		
	R2551	NRSA63J-183X	MG RESISTOR		
	R2552	NRSA63J-221X	MG RESISTOR		
	R2553	NRSA63J-221X	MG RESISTOR		
	R2554	NRSA63J-221X	MG RESISTOR		
	R2555	NRSA63J-221X	MG RESISTOR		
	R2557	NRSA63J-221X	MG RESISTOR		
	R2559	NRSA63J-221X	MG RESISTOR		
	R2560	NRSA63J-221X	MG RESISTOR		
	R2561	NRSA63J-112X	MG RESISTOR		
	R2562	NRSA63J-112X	MG RESISTOR		
	R2563	NRSA63J-112X	MG RESISTOR		
	R2564	NRSA63J-750X	MG RESISTOR		
	R2568	NRSA63J-221X	MG RESISTOR		
	R2571	NRSA63J-512X	MG RESISTOR		
	R2572	NRSA63J-512X	MG RESISTOR		
	R2573	NRSA63J-512X	MG RESISTOR		
	R2581	NRSA63J-221X	MG RESISTOR		
	R2582	NRSA63J-221X	MG RESISTOR		
	R2583	NRSA63J-221X	MG RESISTOR		
	R2584	NRSA63J-221X	MG RESISTOR		
	R2585	NRSA63J-221X	MG RESISTOR		
	R2586	NRSA63J-221X	MG RESISTOR		
	R2587	NRSA63J-221X	MG RESISTOR		
	R2589	NRSA63J-221X	MG RESISTOR		
	R2591	NRSA63J-221X	MG RESISTOR		
	R2593	NRSA63J-221X	MG RESISTOR		
	R2594	NRSA63J-221X	MG RESISTOR		
	R2595	NRSA63J-221X	MG RESISTOR		
	R2596	NRSA63J-221X	MG RESISTOR		
	R2597	NRSA63J-102X	MG RESISTOR		
	R2611	NRSA63J-473X	MG RESISTOR		
	R2612	NRSA63J-473X	MG RESISTOR		
	R2613	NRSA63J-473X	MG RESISTOR		
	R2614	NRSA63J-473X	MG RESISTOR		
	R2615	NRSA63J-473X	MG RESISTOR		
	R2616	NRSA63J-473X	MG RESISTOR		
	R2701	NRSA63J-473X	MG RESISTOR		
	R2702	NRSA63J-473X	MG RESISTOR		
	R2703	NRSA63J-473X	MG RESISTOR		
	R2709	NRSA63J-221X	MG RESISTOR		
	R2715	NRSA63J-432X	MG RESISTOR		
	R2716	NRSA63J-221X	MG RESISTOR		
	R2717	NRSA63J-221X	MG RESISTOR		
	R2718	NRSA63J-221X	MG RESISTOR		
	UN560	GP1FA550TZ	OPT TRANSMITTER		
	UN561	GP1FA550RZ	OPT RECEIVER		
	UN562	GP1FA550RZ	OPT RECEIVER		
	UN563	GP1FA550RZ	OPT RECEIVER		
	X 581	NAX0275-001X	1COSCIALLATOR		
	X2501	NAX0308-001X	RESONATOR		
	X2551	NAX0213-001X	CRYSTAL		

■ Electrical parts list (Micon board)

Block No. 06

△	Item	Parts number	Parts name	Remarks	Area	△	Item	Parts number	Parts name	Remarks	Area
△	C 1	QCZ9104-472	C CAPACITOR	4700PF		△	D 52	1SR35-400A-T5	DIODE		
	C 51	QFLC2AJ-472Z	M CAPACITOR	4700PF 5% 100V			D 53	1SR35-400A-T5	DIODE		
	C 52	QETM1JM-477	E CAPACITOR	470MF 20% 63V		△	D 54	1SR35-400A-T5	DIODE		
	C 53	QCF31HZ-472Z	C CAPACITOR	4700PF +80:-20%			D 55	MTZJ12C-T2	Z DIODE		
	C 54	QETN1CM-477Z	E CAPACITOR	470MF 20% 16V			D 56	MTZJ6.2B-T2	Z DIODE		
	C 55	QCF31HZ-472Z	C CAPACITOR	4700PF +80:-20%			D 57	1SS133-T2	SI DIODE		
	C 61	QFLC2AJ-104Z	M CAPACITOR	.10MF 5% 100V		△	D 61	10E2-FD	DIODE		
	C 62	QFLC2AJ-104Z	M CAPACITOR	.10MF 5% 100V		△	D 62	1SR35-400A-T5	DIODE		
	C 63	QFLC2AJ-104Z	M CAPACITOR	.10MF 5% 100V		△	D 63	10E2-FD	DIODE		
	C 65	QETM1VM-338	E CAPACITOR	3300MF 20% 35V		△	D 64	1SR35-400A-T5	DIODE		
	C 66	QETM1VM-108	E CAPACITOR	1000MF 20% 35V			D 71	1SR35-400A-T5	DIODE		
	C 68	QFLC1HJ-473Z	M CAPACITOR	.047MF 5% 50V			D 72	1SR35-400A-T5	DIODE		
	C 69	QFLC1HJ-473Z	M CAPACITOR	.047MF 5% 50V			D 73	1SR35-400A-T5	DIODE		
	C 70	QETN1HM-227Z	E CAPACITOR	220MF 20% 50V			D 74	MTZJ33C-T2	Z DIODE		
	C 71	QETN1JM-107Z	E CAPACITOR	100MF 20% 63V			D 75	MTZJ8.2C-T2	Z DIODE		
	C 72	QETN1HM-226Z	E CAPACITOR	22MF 20% 50V			D 900	1SR35-400A-T5	DIODE		
	C 73	QETN1HM-226Z	E CAPACITOR	22MF 20% 50V			D 901	1SR35-400A-T5	DIODE		
	C 74	QETN1HM-105Z	E CAPACITOR	1.0MF 20% 50V			D 902	1SR35-400A-T5	DIODE		
	C 91	QCBB1HK-471Y	C CAPACITOR	470PF 10% 50V			D 904	1SS133-T2	SI DIODE		
	C 92	QCBB1HK-471Y	C CAPACITOR	470PF 10% 50V			D 921	MTZJ5.6C-T2	Z DIODE		
	C 901	QETN0JM-107Z	E CAPACITOR	100MF 20% 6.3V			D 931	MTZJ6.2C-T2	Z DIODE		
	C 902	QCZ0205-155Z	ML C CAPACITOR	1.5MF			D 941	MTZJ5.6C-T2	Z DIODE		
	C 903	QETN0JM-228Z	E CAPACITOR	2200MF 20% 6.3V			D 951	MTZJ13C-T2	Z DIODE		
	C 904	QETN1HM-225Z	E CAPACITOR	2.2MF 20% 50V			D 961	MTZJ13C-T2	Z DIODE		
	C 905	QDVB1EZ-223Y	C CAPACITOR				D 971	MTZJ10C-T2	Z DIODE		
	C 921	QETN1EM-107Z	E CAPACITOR	100MF 20% 25V			D 975	1SS133-T2	SI DIODE		
	C 922	QCF31HZ-472Z	C CAPACITOR	4700PF +80:-20%			D 976	1SS133-T2	SI DIODE		
	C 931	QETN1EM-107Z	E CAPACITOR	100MF 20% 25V			D 977	1SS133-T2	SI DIODE		
	C 932	QCF31HZ-472Z	C CAPACITOR	4700PF +80:-20%			D 978	1SS133-T2	SI DIODE		
	C 941	QETN1EM-107Z	E CAPACITOR	100MF 20% 25V			D 979	1SS133-T2	SI DIODE		
	C 942	QCF31HZ-472Z	C CAPACITOR	4700PF +80:-20%			D 993	1SS133-T2	SI DIODE		
	C 951	QETN1EM-107Z	E CAPACITOR	100MF 20% 25V			EP 1	E409182-001SM	GRAND TERMINAL		
	C 952	QCF31HZ-472Z	C CAPACITOR	4700PF +80:-20%			EP 51	QNZ0136-001Z	EARTH PLATE		
	C 961	QETN1EM-107Z	E CAPACITOR	100MF 20% 25V			EP 91	E406523-001SM	GND BKT		
	C 962	QCF31HZ-472Z	C CAPACITOR	4700PF +80:-20%			EP901	QNZ0136-001Z	EARTH PLATE		
	C 971	QETN1EM-107Z	E CAPACITOR	100MF 20% 25V			FC 1	QNG0020-001Z	FUSE CLIP	F001	
	C 972	QCF31HZ-472Z	C CAPACITOR	4700PF +80:-20%			FC 2	QNG0020-001Z	FUSE CLIP	F001	
	C 975	QETN0JM-477Z	E CAPACITOR	470MF 20% 6.3V			FC 3	QNG0020-001Z	FUSE CLIP	F002	
	C 981	QCBB1HK-331Y	C CAPACITOR	330PF 10% 50V			FC 4	QNG0020-001Z	FUSE CLIP	F002	
	C 982	QCBB1HK-331Y	C CAPACITOR	330PF 10% 50V			FC 5	QNG0020-001Z	FUSE CLIP	F004	
	C 983	QCBB1HK-331Y	C CAPACITOR	330PF 10% 50V			FC 6	QNG0020-001Z	FUSE CLIP	F004	
	C 984	QCBB1HK-331Y	C CAPACITOR	330PF 10% 50V			FC 61	QNG0020-001Z	FUSE CLIP	F061	
	C 985	QCBB1HK-103Y	C CAPACITOR	.010MF 10% 50V			FC 62	QNG0020-001Z	FUSE CLIP	F061	
	C 991	QFLC1HJ-562Z	M CAPACITOR	5600PF 5% 50V			FC 63	QNG0020-001Z	FUSE CLIP	F062	
	C 992	QFLC1HJ-562Z	M CAPACITOR	5600PF 5% 50V			FC 64	QNG0020-001Z	FUSE CLIP	F062	
	C 993	QCBB1HK-101Y	C CAPACITOR	100PF 10% 50V			FL991	QQR0590-001	FILTER		
	C 994	QCBB1HK-271Y	C CAPACITOR	270PF 10% 50V			FL992	QQR0590-001	FILTER		
	CN 55	QGD2501C1-03Z	SOCKET				FW 51	QUM137-10DGZ4	PARA RIBON WIRE		
	CN 56	QGD2501C1-04Z	SOCKET				FW831	QUM134-08DGZ4	PARA RIBON WIRE		
	CN 71	QGB2510J1-11	CONNECTOR				FW881	QUM133-44DGZ4	PARA RIBON WIRE		
	CN 81	QGB2510J1-09	CONNECTOR				HL901	VYH7237-002	IC HOLDER		
	CN101	QGB2501J1-12	CONNECTOR				HS 51	E70945-H40B	HEAT SINK		
	CN201	QGB2510J1-11	CONNECTOR			△	HS921	E70945-H40B	HEAT SINK		
	CN241	QGB2510J1-12	CONNECTOR			△	HS931	E70945-H40B	HEAT SINK		
	CN301	QGB2510J1-14	CONNECTOR			△	HS941	E70945-H40B	HEAT SINK		
	CN303	QGB2510J1-13	CONNECTOR				HS951	E70306-001	HEAT SINK		
	CN400	QGF1205C1-10	CONNECTOR				HS961	E70306-001	HEAT SINK		
	CN402	QGF1205C1-08	CONNECTOR				HS971	E70306-001	HEAT SINK		
	CN601	QGB2510J1-07	CONNECTOR			△	IC901	MN101C49GHM	IC		
	CN811	QGA3901F2-03	CONNECTOR				IC903	IC-PST9139-T	IC		
	CN931	QGD2501C1-04Z	SOCKET				J 91	QNS0022-001	JACK		
	CN932	QGD2501C1-03Z	SOCKET				Q 51	2SD2395/EF/	TRANSISTOR		
△	D 51	1SR35-400A-T5	DIODE				Q 52	KTD863/Y/-T	TRANSISTOR		

■ Electrical parts list (Micon board)

Block No. 06

△	Item	Parts number	Parts name	Remarks	Area
	Q 53	KRC105M-T	D TRANSISTOR		
	Q 71	KTA1046/Y/	TRANSISTOR		
	Q 74	KTC3200/GL-T	TRANSISTOR		
	Q 901	KRC107M-T	D TRANSISTOR		
	Q 903	KRC105M-T	D TRANSISTOR		
	Q 904	KRC105M-T	D TRANSISTOR		
	Q 905	KRC105M-T	D TRANSISTOR		
	Q 906	KRC105M-T	D TRANSISTOR		
	Q 907	KRC105M-T	D TRANSISTOR		
	Q 908	KRC105M-T	D TRANSISTOR		
△	Q 921	2SD2395/EF/	TRANSISTOR		
△	Q 931	2SD2395/EF/	TRANSISTOR		
△	Q 941	2SD2395/EF/	TRANSISTOR		
	Q 951	2SD2395/EF/	TRANSISTOR		
	Q 961	KTA1046/Y/	TRANSISTOR		
	Q 971	2SD2395/EF/	TRANSISTOR		
	R 51	QRJ146J-153X	UNF C RESISTOR	15K 5% 1/4W	
	R 52	QRL012J-332	UNF OMF RESISTOR	3.3K 5% 1/1W	
△	R 53	QRJ146J-6R8X	UNF C RESISTOR	6.8 5% 1/4W	
	R 54	QRE141J-821Y	C RESISTOR	820 5% 1/4W	
	R 61	QRJ146J-8R2X	UNF C RESISTOR	8.2 5% 1/4W	
	R 72	QRJ146J-332X	UNF C RESISTOR	3.3K 5% 1/4W	
	R 73	QRE141J-223Y	C RESISTOR	22K 5% 1/4W	
	R 74	QRE141J-104Y	C RESISTOR	100K 5% 1/4W	
	R 91	QRL022J-471	UNF OMF RESISTOR	470 5% 1/2W	
	R 92	QRL022J-471	UNF OMF RESISTOR	470 5% 1/2W	
	R 903	QRE141J-331Y	C RESISTOR	330 5% 1/4W	
	R 908	QRE141J-223Y	C RESISTOR	22K 5% 1/4W	
	R 910	QRE141J-223Y	C RESISTOR	22K 5% 1/4W	
	R 911	QRE141J-472Y	C RESISTOR	4.7K 5% 1/4W	
	R 915	QRT022J-8R2	UNF MF RESISTOR	8.2 5% 1/2W	
	R 916	QRT022J-8R2	UNF MF RESISTOR	8.2 5% 1/2W	
	R 917	QRL017J-100	UNF OMF RESISTOR	10 5% 1/1W	
	R 921	QRK126J-330X	UNF C RESISTOR	33 5% 1/2W	
	R 922	QRK126J-330X	UNF C RESISTOR	33 5% 1/2W	
	R 923	QRJ146J-272X	UNF C RESISTOR	2.7K 5% 1/4W	
	R 924	QRE141J-103Y	C RESISTOR	10K 5% 1/4W	
	R 925	QRE141J-221Y	C RESISTOR	220 5% 1/4W	
	R 926	QRE141J-221Y	C RESISTOR	220 5% 1/4W	
	R 927	QRE141J-221Y	C RESISTOR	220 5% 1/4W	
	R 928	QRE141J-221Y	C RESISTOR	220 5% 1/4W	
	R 929	QRE141J-221Y	C RESISTOR	220 5% 1/4W	
	R 931	QRL017J-430	UNF OMF RESISTOR	43 5% 1/1W	
	R 932	QRL017J-430	UNF OMF RESISTOR	43 5% 1/1W	
	R 933	QRJ146J-272X	UNF C RESISTOR	2.7K 5% 1/4W	
	R 937	QRE141J-221Y	C RESISTOR	220 5% 1/4W	
	R 938	QRE141J-221Y	C RESISTOR	220 5% 1/4W	
	R 939	QRE141J-221Y	C RESISTOR	220 5% 1/4W	
	R 940	QRJ146J-4R7X	UNF C RESISTOR	4.7 5% 1/4W	
	R 941	QRK126J-330X	UNF C RESISTOR	33 5% 1/2W	
	R 942	QRK126J-330X	UNF C RESISTOR	33 5% 1/2W	
	R 943	QRJ146J-272X	UNF C RESISTOR	2.7K 5% 1/4W	
	R 944	QRE141J-221Y	C RESISTOR	220 5% 1/4W	
	R 945	QRE141J-221Y	C RESISTOR	220 5% 1/4W	
	R 946	QRE141J-221Y	C RESISTOR	220 5% 1/4W	
	R 947	QRE141J-221Y	C RESISTOR	220 5% 1/4W	
	R 948	QRE141J-221Y	C RESISTOR	220 5% 1/4W	
	R 949	QRE141J-221Y	C RESISTOR	220 5% 1/4W	
	R 951	QRK126J-120X	UNF C RESISTOR	12 5% 1/2W	
	R 953	QRJ146J-222X	UNF C RESISTOR	2.2K 5% 1/4W	
	R 954	QRE141J-221Y	C RESISTOR	220 5% 1/4W	
	R 955	QRE141J-221Y	C RESISTOR	220 5% 1/4W	
	R 956	QRE141J-221Y	C RESISTOR	220 5% 1/4W	

△	Item	Parts number	Parts name	Remarks	Area
	R 961	QRK126J-120X	UNF C RESISTOR	12 5% 1/2W	
	R 963	QRJ146J-222X	UNF C RESISTOR	2.2K 5% 1/4W	
	R 965	QRE141J-103Y	C RESISTOR	10K 5% 1/4W	
	R 966	QRE141J-103Y	C RESISTOR	10K 5% 1/4W	
	R 967	QRE141J-103Y	C RESISTOR	10K 5% 1/4W	
	R 968	QRE141J-103Y	C RESISTOR	10K 5% 1/4W	
	R 969	QRE141J-103Y	C RESISTOR	10K 5% 1/4W	
	R 971	QRJ146J-120X	UNF C RESISTOR	12 5% 1/4W	
	R 973	QRJ146J-332X	UNF C RESISTOR	3.3K 5% 1/4W	
	R 975	QRJ146J-220X	UNF C RESISTOR	22 5% 1/4W	
	R 976	QRE141J-472Y	C RESISTOR	4.7K 5% 1/4W	
	R 977	QRE141J-472Y	C RESISTOR	4.7K 5% 1/4W	
	R 978	QRE141J-472Y	C RESISTOR	4.7K 5% 1/4W	
	R 979	QRE141J-472Y	C RESISTOR	4.7K 5% 1/4W	
	R 980	QRE141J-221Y	C RESISTOR	220 5% 1/4W	
	R 981	QRE141J-221Y	C RESISTOR	220 5% 1/4W	
	R 982	QRE141J-221Y	C RESISTOR	220 5% 1/4W	
	R 983	QRE141J-221Y	C RESISTOR	220 5% 1/4W	
	R 984	QRE141J-221Y	C RESISTOR	220 5% 1/4W	
	R 985	QRE141J-221Y	C RESISTOR	220 5% 1/4W	
	R 986	QRE141J-221Y	C RESISTOR	220 5% 1/4W	
	R 987	QRE141J-221Y	C RESISTOR	220 5% 1/4W	
	R 991	QRE141J-472Y	C RESISTOR	4.7K 5% 1/4W	
	R 992	QRE141J-472Y	C RESISTOR	4.7K 5% 1/4W	
	R 993	QRE141J-622Y	C RESISTOR	6.2K 5% 1/4W	
	R 994	QRE141J-512Y	C RESISTOR	5.1K 5% 1/4W	
	R 995	QRE141J-133Y	C RESISTOR	13K 5% 1/4W	
	R 996	QRE141J-332Y	C RESISTOR	3.3K 5% 1/4W	
	R 997	QRE141J-153Y	C RESISTOR	15K 5% 1/4W	
	R 998	QRE141J-562Y	C RESISTOR	5.6K 5% 1/4W	
	R 999	QRE141J-103Y	C RESISTOR	10K 5% 1/4W	
△	RY 1	QSK0098-001	RELAY		
△	T 2	QQT0281-004	POWER TRANSF		
	TA 1	QNZ0079-001Z	TAB		
	TA 2	QNZ0079-001Z	TAB		
△	TH 71	QAD0095-4R7Z	POSISTOR		
△	VS 1	QSW0812-001	VOLTAGE SWITCH		
	X 901	QAX0246-001Z	RESONATOR		

■ Electrical parts list (Tuner board)

Block No. 07

△	Item	Parts number	Parts name	Remarks	Area
	AT101	QNB0014-001	ANT TERMINAL		
	BK 1	LV31618-001A	SHIELD BKT		
	C 101	NCB21HK-103X	C CAPACITOR		
	C 103	NCB21HK-223X	C CAPACITOR		
	C 105	NCB21HK-223X	C CAPACITOR		
	C 107	QEK1CM-226Z	E CAPACITOR	22MF 20% 16V	
	C 111	NCB21HK-473X	C CAPACITOR		
	C 112	NDC21HJ-120X	C CAPACITOR		
	C 121	NDC21HJ-120X	C CAPACITOR		
	C 122	NDC21HJ-120X	C CAPACITOR		
	C 123	NCB21HK-473X	C CAPACITOR		
	C 126	NCS21HJ-101X	C CAPACITOR		
	C 128	QENC1HM-474Z	NP E CAPACITOR	.47MF 20% 50V	
	C 129	NCB21HK-102X	C CAPACITOR		
	C 130	QEK1AM-107Z	E CAPACITOR	100MF 20% 10V	
	C 133	QEK1CM-226Z	E CAPACITOR	22MF 20% 16V	
	C 134	NCB21HK-222X	C CAPACITOR		
	C 135	NCB21HK-223X	C CAPACITOR		
	C 136	QEK1HM-105Z	E CAPACITOR	1.0MF 20% 50V	
	C 137	NCB21HK-331X	C CAPACITOR		
	C 138	NCB21HK-473X	C CAPACITOR		
	C 139	NCB21HK-223X	C CAPACITOR		
	C 140	NCB21HK-223X	C CAPACITOR		
	C 141	NCB21HK-473X	C CAPACITOR		
	C 143	NCB21HK-223X	C CAPACITOR		
	C 144	NCB21HK-473X	C CAPACITOR		
	C 146	QEK1HM-105Z	E CAPACITOR	1.0MF 20% 50V	
	C 147	QEK1HM-105Z	E CAPACITOR	1.0MF 20% 50V	
	C 148	QEK1HM-224Z	E CAPACITOR	.22MF 20% 50V	
	C 149	QEK1HM-105Z	E CAPACITOR	1.0MF 20% 50V	
	C 150	QEK1CM-226Z	E CAPACITOR	22MF 20% 16V	
	C 156	QDGB1HK-102Y	C CAPACITOR		
	C 157	NCB21HK-473X	C CAPACITOR		
	C 158	QEK1CM-226Z	E CAPACITOR	22MF 20% 16V	
	C 161	QEK1CM-106Z	E CAPACITOR	10MF 20% 16V	
	C 162	QEK1CM-106Z	E CAPACITOR	10MF 20% 16V	
	C 163	NCB21HK-223X	C CAPACITOR		
	C 164	NCB21HK-473X	C CAPACITOR		
	C 168	QEK1HM-105Z	E CAPACITOR	1.0MF 20% 50V	
	C 184	QEK1CM-107Z	E CAPACITOR	100MF 20% 16V	
	C 185	QEK1CM-106Z	E CAPACITOR	10MF 20% 16V	
	C 186	QEK1CM-106Z	E CAPACITOR	10MF 20% 16V	
	CF101	QAX0419-001Z	C FILTER		
	CF102	QAX0604-001Z	C FILTER		
	CF103	QAX0519-001Z	C FILTER		
	CN111	QGB2501K2-12	CONNECTOR		
	D 121	1SS133-T2	SI DIODE		
	D 123	1SS133-T2	SI DIODE		
	D 129	1SS133-T2	SI DIODE		
	IC102	LA1838	IC		
	IC121	LC72136N	IC		
	Q 102	2SC535/BC/-T	TRANSISTOR		
	Q 103	2SC461/BC/-T	TRANSISTOR		
	Q 121	KRA103M-T	TRANSISTOR	FM+B	
	R 103	NRSA02J-221X	MG RESISTOR		
	R 104	NRSA02J-272X	MG RESISTOR		
	R 105	NRSA02J-391X	MG RESISTOR		
	R 106	NRSA02J-102X	MG RESISTOR		
	R 107	NRSA02J-391X	MG RESISTOR		
	R 108	NRSA02J-332X	MG RESISTOR		
	R 109	NRSA02J-221X	MG RESISTOR		
	R 115	NRSA02J-104X	MG RESISTOR		
	R 119	NRSA02J-103X	MG RESISTOR		

△	Item	Parts number	Parts name	Remarks	Area
	R 122	NRSA02J-472X	MG RESISTOR		
	R 124	NRSA02J-222X	MG RESISTOR		
	R 126	NRSA02J-562X	MG RESISTOR		
	R 127	NRSA02J-822X	MG RESISTOR		
	R 128	NRSA02J-472X	MG RESISTOR		
	R 129	NRSA02J-222X	MG RESISTOR		
△	R 130	QRZ9005-680X	F RESISTOR	68 1/4W	
	R 132	NRSA02J-393X	MG RESISTOR		
	R 133	NRSA02J-392X	MG RESISTOR		
	R 134	NRSA02J-102X	MG RESISTOR		
	R 140	NRSA02J-183X	MG RESISTOR		
	R 141	NRSA02J-102X	MG RESISTOR		
	R 142	NRSA02J-470X	MG RESISTOR		
	R 143	NRSA02J-562X	MG RESISTOR		
	R 144	NRSA02J-332X	MG RESISTOR		
	R 145	NRSA02J-103X	MG RESISTOR		
	R 146	NRSA02J-392X	MG RESISTOR		
	R 147	NRSA02J-332X	MG RESISTOR		
	R 150	NRSA02J-331X	MG RESISTOR		
	R 157	NRSA02J-682X	MG RESISTOR		
	R 158	NRSA02J-682X	MG RESISTOR		
	R 161	NRSA02J-102X	MG RESISTOR		
	R 162	NRSA02J-102X	MG RESISTOR		
	R 182	NRSA02J-103X	MG RESISTOR		
	R 183	NRSA02J-103X	MG RESISTOR		
	R 184	NRSA02J-103X	MG RESISTOR		
	RF101	QAU0124-002	FRONT END		
	T 111	QQR0796-001	COIL BLOCK		
	T 142	QQR0973-001	IFT		
	X 121	QAX0402-001	CRYSTAL		

Packing materials and accessories parts list

Block No.

M	2	M	M
---	---	---	---

Block No.

M	3	M	M
---	---	---	---

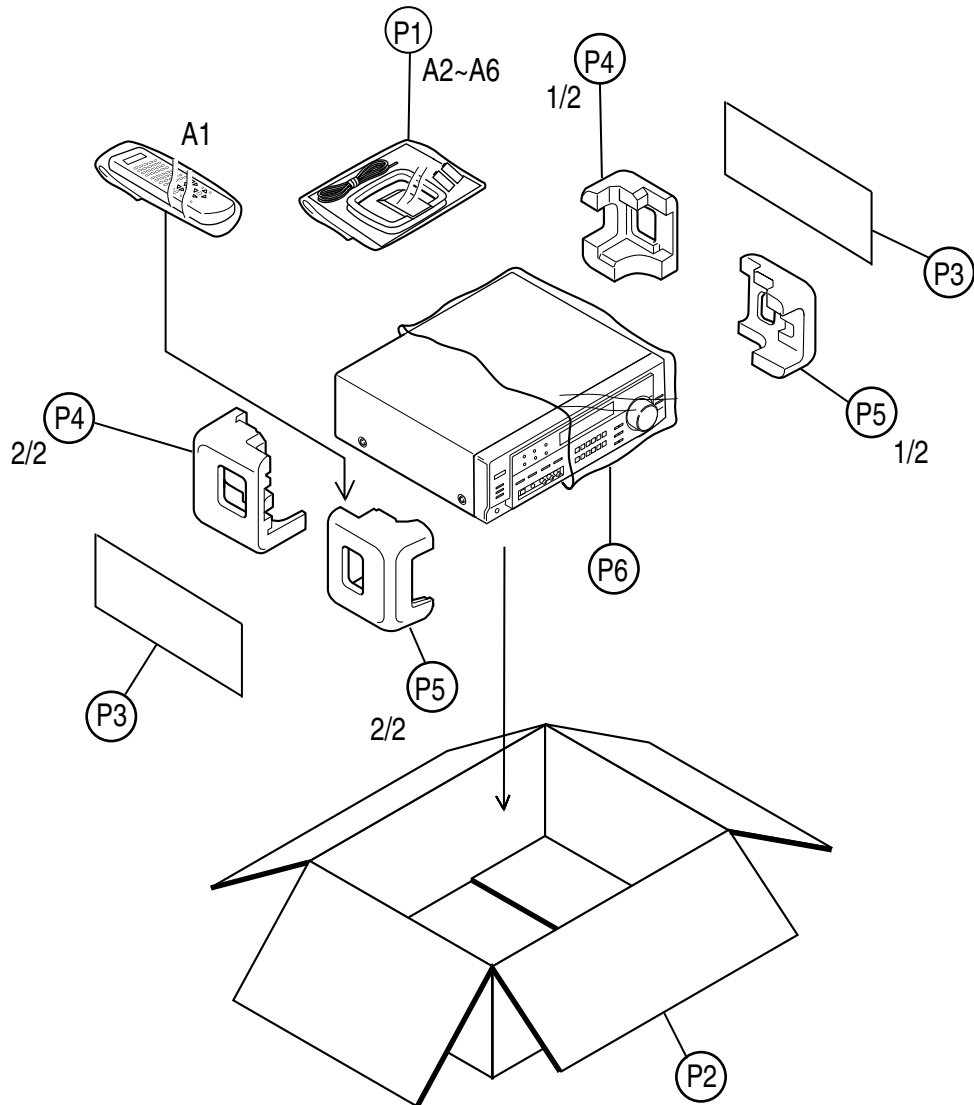

Parts list (Packing)

Block No. M2MM

△	Item	Parts number	Parts name	Q'ty	Description	Area
	P 1	QPA02503505P	POLY BAG	1	FOR INST	
	P 2	LV20989-017A	PACKING CASE	1	RX-8012VSL	
		LV20989-019A	PACKING CASE	1	RX-8010VBK	
	P 3	LV32034-003A	SHEET	2		
	P 4	LV20947-001A	PACKING PAD	1		
	P 5	LV20948-001A	PACKING PAD	1		
	P 6	QPC06507015P	POLY BAG	1	FOR SET	

Parts list (Accessories)

Block No. M3MM

△	Item	Parts number	Parts name	Q'ty	Description	Area
	A 1	RM-SRX8010U	REMOCON	1	RX-8010VBK	
		RM-SRX8012U	W.LESS REMOCON	1	RX-8012VSL	
	A 2	-----	BATTERY	2		
	A 3	LVT0618-003A	I.BOOK(RX-8010)	1	ENG, CHI	
		LVT0618-007A	I.BOOK(RX-8012)	1	ENG, SPA, POR	
	A 4	EWP503-001C	ANT.WIRE	1		
	A 5	QAL0204-001	AM LOOP ANT	1		
△	A 6	QAM0112-001	AC PLUG ADAPTER	1		



VICTOR COMPANY OF JAPAN, LIMITED

AUDIO & COMMUNICATION BUSINESS DIVISION

PERSONAL & MOBILE NETWORK BUSINESS UNIT. 10-1,1chome,Ohwatari-machi,Maebashi-city,371-8543,Japan



AUDIO/VIDEO CONTROL RECEIVER

RECEPTOR DE CONTROL DE AUDIO/VÍDEO
RECEPTOR DE COMANDO AUDIO/VÍDEO

RX-8012VSL

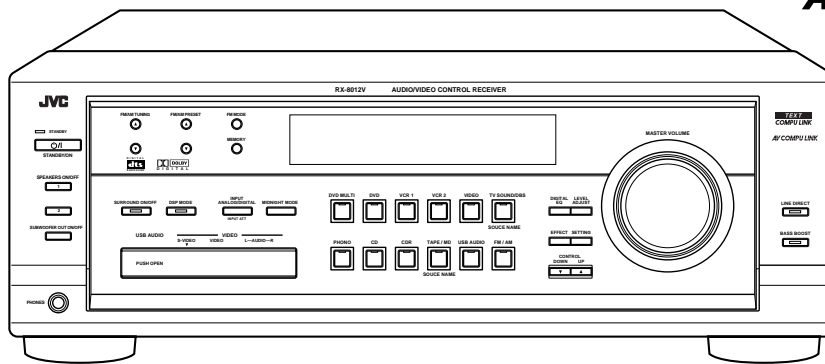
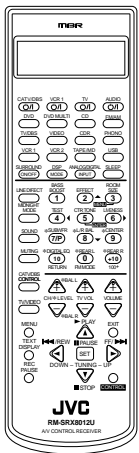

AV COMPU LINK

**TEXT
COMPU LINK**

DIGITAL
dts
SURROUND

DOLBY
DIGITAL

INSTRUCTIONS

MANUAL DE INSTRUCCIONES
INSTRUÇÕES

For Customer Use:

Enter below the Model No. and Serial No. which are located either on the rear, bottom or side of the cabinet. Retain this information for future reference.

Model No. _____

Serial No. _____

Warnings, Cautions and Others / Avisos, precauciones y otras notas / Advertências, precauções e outras notas

Caution — switch!

Disconnect the mains plug to shut the power off completely. The  switch in any position does not disconnect the mains line. The power can be remote controlled.

Precaución — Interruptor /!

Desconectar el cable de alimentación para desactivar la alimentación totalmente. Cualquiera que sea la posición de ajuste del interruptor /!, la alimentación no es cortada completamente. La alimentación puede ser controlada remotamente.

Precaução — Interruptor /!

Desconectar o cabo de alimentação para desligar a alimentação por completo. Qualquer que seja a posição de ajuste do interruptor /!, a alimentação não é completamente cortada. A alimentação pode ser controlada remotamente.

CAUTION

To reduce the risk of electrical shocks, fire, etc.:

1. Do not remove screws, covers or cabinet.
2. Do not expose this appliance to rain or moisture.

ATENÇÃO

Para reduzir riscos de choques eléctricos, incêndio, etc.:

1. Não retire parafusos nem desmonte as tampas ou o gabinete.
2. Não exponha este aparelho à chuva nem à umidade.

CAUTION

- Do not block the ventilation openings or holes. (If the ventilation openings or holes are blocked by a newspaper or cloth, etc., the heat may not be able to get out.)
- Do not place any naked flame sources, such as lighted candles, on the apparatus.
- When discarding batteries, environmental problems must be considered and local rules or laws governing the disposal of these batteries must be followed strictly.
- Do not use this apparatus in a bathroom or places with water. Also do not place any containers filled with water or liquids (such as cosmetics or medicines, flower vases, potted plants, cups, etc.) on top of this apparatus.

AVISO

- Não obstrua as aberturas e orifícios de ventilação. (Se os orifícios ou aberturas de ventilação estiverem obstruídos por qualquer papel ou tecido, não haverá circulação do ar quente.)
- Não coloque nenhum objeto com chamas, como velas acesas, sobre o aparelho.
- Ao descartar as baterias, leve em consideração os problemas que possam ser causados ao meio ambiente e os regulamentos e leis locais e governamentais sobre recolhimento dessas baterias devem ser rigorosamente seguidos.
- Não utilize este aparelho em banheiros ou em locais com água. Além disso, não coloque nenhum recipiente com água ou qualquer tipo de líquido (como cosméticos ou remédios, vasos com flores, plantas, xícaras, etc.) sobre o aparelho.

PRECAUCIÓN

Para reducir riesgos de choques eléctricos, incendio, etc.:

1. No extraiga los tornillos, los cubiertas ni la caja.
2. No exponga este aparato a la lluvia o a la humedad.

PRECAUCION

- No obstruya las rendijas o los orificios de ventilación. (Si las rendijas o los orificios de ventilación quedan tapados con un periódico, un trozo de tela, etc., no se podrá disipar el calor).
- No ponga sobre el aparato ninguna llama al descubierto, como velas encendidas.
- Cuando tenga que descartar las pilas, tenga en cuenta los problemas ambientales y observe estrictamente los reglamentos o las leyes locales sobre disposición de las pilas.
- No utilice este aparato en el cuarto de baño o en lugares donde hay agua. Tampoco coloque ningún recipiente que contenga agua u otros líquidos (frascos de cosméticos o medicinas, floreros, macetas, vasos, etc.) encima de este aparato.

Caution: Proper Ventilation

To avoid risk of electric shock and fire and to protect from damage.

Locate the apparatus as follows:

- Front: No obstructions open spacing.
 - Sides: No obstructions in 10 cm from the sides.
 - Top: No obstructions in 10 cm from the top.
 - Back: No obstructions in 15 cm from the back.
 - Bottom: No obstructions, place on the level surface.
- In addition, maintain the best possible air circulation as illustrated.

Precaución: Ventilación Adecuada

Para evitar el riesgo de choque eléctrico e incendio y para proteger el aparato contra daños.

Ubique el aparato de la siguiente manera:

- Frente: Espacio abierto sin obstrucciones
- Lados: 10 cm sin obstrucciones a los lados
- Parte superior: 10 cm sin obstrucciones en la parte superior
- Parte trasera: 15 cm sin obstrucciones en la parte trasera
- Fondo: Sin obstrucciones, colóquelo sobre una superficie nivelada

Además, mantenga la mejor circulación de aire posible como se ilustra.

Precaução: ventilação apropriada

Para prevenir o risco de choque elétrico ou incêndio e para proteger o aparelho contra danos.

Localize-o da seguinte maneira:

- Frente: Espaço aberto, sem obstruções
- Lados: Espaço de 10 cm sem obstruções nos lados
- Topo: Espaço de 10 cm sem obstruções acima
- Atrás: Espaço de 15 cm sem obstruções atrás
- Parte inferior: Sem obstruções. Coloque o aparelho em superfície nivelada.

Mantenha, além disso, a maior circulação de ar possível, como indica a ilustração.

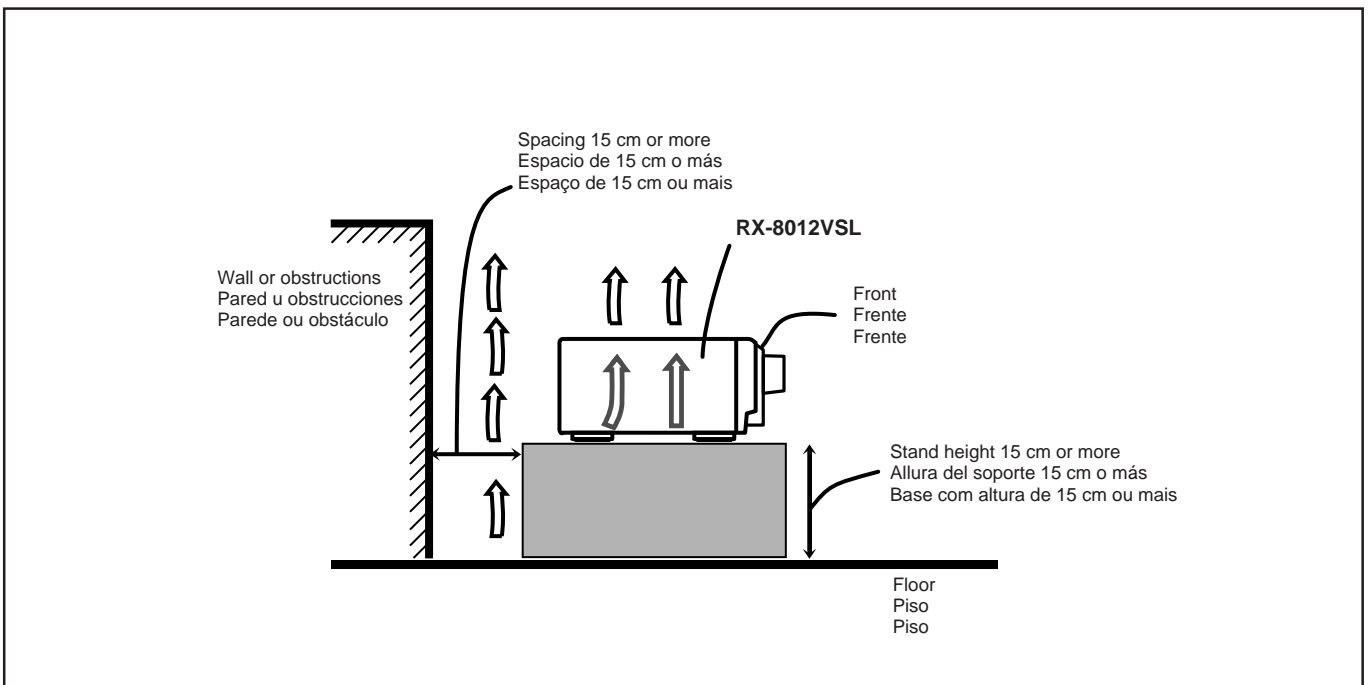
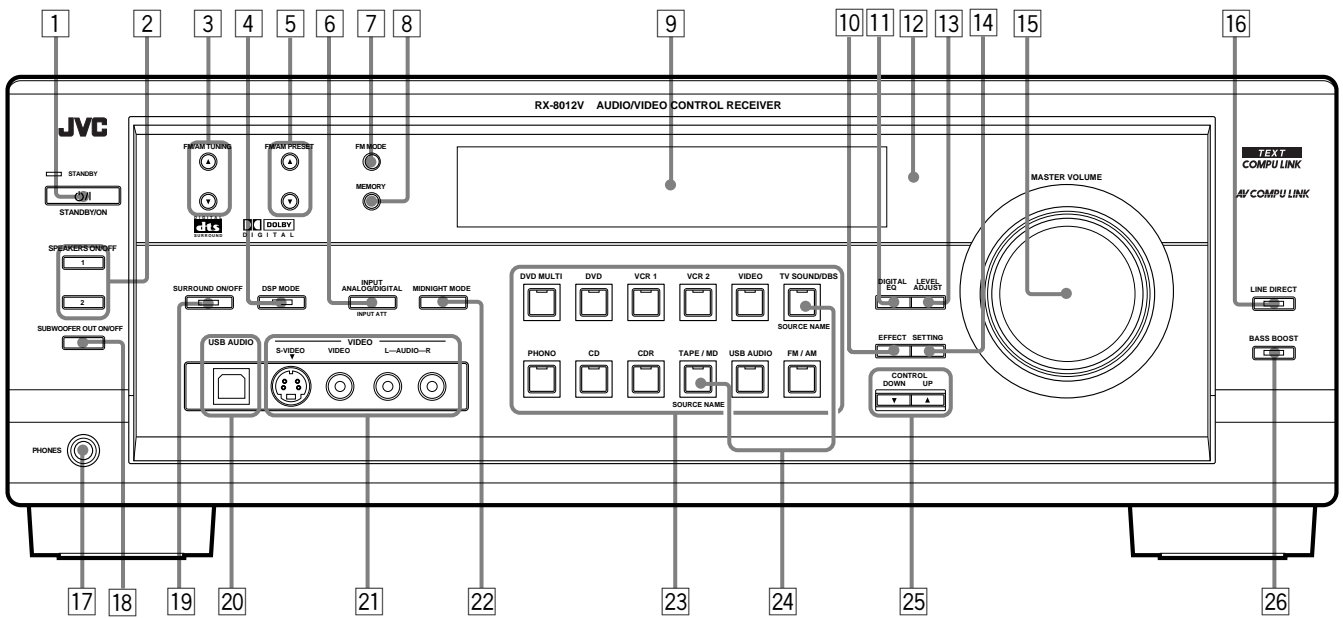

Table of Contents

Parts Identification	2	Creating a Surround Field in Your Room	24
Getting Started	3	■ Surround modes	24
Before Installation	3	■ DSP modes	24
Checking the Supplied Accessories	3	Reproducing the Sound Field	25
Setting the Voltage Selector Switch	3	Available DSP Modes According to the Speaker Arrangement ..	26
Connecting the FM and AM Antennas	3	Adjusting the Surround Modes	27
Connecting the Speakers	4	Adjusting the DAP Modes	28
Connecting Audio/Video Components	5	Adjusting the Surround Modes with the DAP Modes	30
■ Analog Connections	5	Adjusting the 5 CH/4 CH Stereo Mode	32
■ Digital Connections	8	Adjusting the 3D-PHONIC Modes	33
■ USB Connection	9	Using the DVD MULTI Playback Mode	35
Connecting the Power Cord	10	Activating the DVD MULTI Playback Mode	35
Putting Batteries in the Remote Control	10	Using the On-Screen Menus	36
Basic Operations	11	■ Showing the MENU on the TV Screen	36
Turning the Power On and Off (Standby)	11	■ Activating the Surround Modes	36
Selecting the Source to Play	11	■ Activating the DSP Modes	36
Adjusting the Volume	12	■ Selecting the Analog or Digital Input Mode	36
Selecting the Front Speakers	13	■ Adjusting the Equalization Pattern	37
Muting the Sound	13	■ Adjusting the Surround and DSP Modes	37
Listening at Night — Midnight Mode	13	■ Adjusting the DVD MULTI Playback Mode	38
Activating the Subwoofer Sound	14	■ Listening at Night — Midnight Mode	38
Reinforcing the Bass	14	■ Attenuating the Input Signal	38
Attenuating the Input Signal	14	■ Selecting the Line Direct Function	39
Selecting the Line Direct Function	14	■ Selecting the Bass Boost Function	39
Adjusting the Equalization Patterns	15	■ Activating the Subwoofer Sound	39
Using the Sleep Timer	15	■ Operating the Tuner	39
Recording a Source	15	■ Storing the Preset Stations	39
Basic Settings	16	■ Setting the Basic Setting Items	40
Adjusting the Front Speaker Output Balance	16	COMPU LINK Remote Control System	41
Changing the Source Name	16	TEXT COMPU LINK Remote Control System ..	42
Selecting the Video Input Terminal	16	■ Showing the Disc Information on the TV Screen	43
Setting the Subwoofer Information	17	■ Searching for a Disc (Only for the CD player)	44
Adjusting the Subwoofer Output Level	17	■ Entering the Disc Information	45
Setting the Speakers for a Surround Field	17	AV COMPU LINK Remote Control System	47
Digital Input (DIGITAL IN) Terminal Setting	19	Operating JVC's Audio/Video Components ...	49
Selecting the Analog or Digital Input Mode	20	Operating Audio Components	49
Showing the Text Information on the Display	21	Operating Video Components	51
Basic Setting and Adjustment — Auto Memory	21	Operating Other Manufacturers' Video	
Receiving Radio Broadcasts	22	Equipment	52
Setting the AM Tuner Interval Spacing	22	Troubleshooting	55
Tuning in Stations Manually	22	Specifications	57
Using Preset Tuning	22		
Selecting the FM Reception Mode	23		

Parts Identification

Become familiar with the buttons and controls on the receiver before use.
Refer to the pages in parentheses for details.



Remote Control

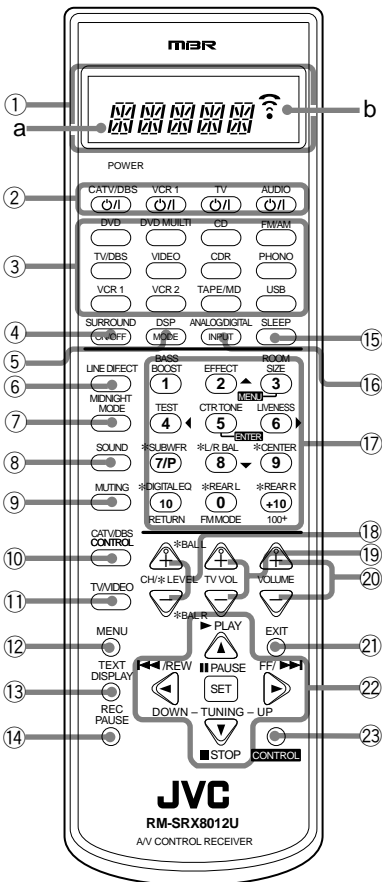

- ① Display window (11)
 - a. Remote control operation mode indicator
 - b. Signal transmission indicator
- ② **⏻** buttons (11, 51 – 54)
CATV/DBS, VCR 1, TV, AUDIO
- ③ Source selecting buttons (11)
DVD, DVD MULTI, CD, FM/AM, TV/DBS, VIDEO, CDR, PHONO, VCR 1, VCR 2, TAPE/MD, USB
- ④ SURROUND ON/OFF button (26, 27, 30)
- ⑤ DSP MODE button (26, 29 – 33)
- ⑥ LINE DIRECT button (14)
- ⑦ MIDNIGHT MODE button (13)
- ⑧ SOUND button (14 – 17, 27 – 35, 49)
- ⑨ MUTING button (13)
- ⑩ CATV/DBS CONTROL button (53)
- ⑪ TV/VIDEO button (51, 52)
- ⑫ MENU button (36 – 40)
- ⑬ TEXT DISPLAY button (43 – 46)
- ⑭ REC PAUSE button (50, 51, 53)
- ⑮ SLEEP button (15)
- ⑯ ANALOG/DIGITAL INPUT button (20)
- ⑰ • 10 keys for selecting preset channels (23)
• 10 keys for adjusting sound (14 – 17, 27 – 35, 49)
• 10 keys for operating audio/video components (49 – 54)
- ⑱ • LEVEL +/- buttons* (15, 17, 27 – 35)
• BAL L and BAL R buttons* (16)
• CH +/- buttons (51 – 53)
- ⑲ TV VOL +/- buttons (51, 52)
- ⑳ VOLUME +/- buttons (12)
- ㉑ EXIT button (36 – 40, 43 – 45)
- ㉒ • TUNING UP **▶**/DOWN **◀** buttons (22, 49)
• On screen operation buttons (36 – 40, 43 – 46)
• Operating buttons for audio/video components (49 – 54)
- ㉓ CONTROL button (50, 51)

Front Panel

- ① STANDBY/ON **⏻** button and STANDBY lamp (11, 22)
- ② • SPEAKERS ON/OFF 1 button (13)
• SPEAKERS ON/OFF 2 button (13)
- ③ FM/AM TUNING **▲**/**▼** buttons (22)
- ④ DSP MODE button and lamp (26, 28 – 33)
- ⑤ FM/AM PRESET **▲**/**▼** buttons (22, 23)
- ⑥ • INPUT ANALOG/DIGITAL button (20)
• INPUT ATT button (14)
- ⑦ FM MODE button (23)
- ⑧ MEMORY button (22)
- ⑨ Display (11)
- ⑩ EFFECT button (28 – 33)
- ⑪ DIGITAL EQ button (15)
- ⑫ Remote sensor (10)
- ⑬ LEVEL ADJUST button (16, 17, 28 – 35)
- ⑭ SETTING button (16 – 19, 21)
- ⑮ MASTER VOLUME control (12)
- ⑯ LINE DIRECT button and lamp (14)
- ⑰ PHONES jack (13)
- ⑱ SUBWOOFER OUT ON/OFF button (14)
- ⑲ SURROUND ON/OFF button and lamp (26, 28, 31)
- ⑳ USB AUDIO terminal (9)
- ㉑ VIDEO input terminals (7)
- ㉒ MIDNIGHT MODE button (13)
- ㉓ Source selecting buttons and lamps (11)
DVD MULTI, DVD, VCR 1, VCR 2, VIDEO, TV SOUND/DBS, PHONO, CD, CDR, TAPE/MD, USB AUDIO, FM/AM
- ㉔ SOURCE NAME buttons (16)
- ㉕ CONTROL UP **▲**/DOWN **▼** buttons
- ㉖ BASS BOOST button and lamp (14)

* These buttons function only after pressing 10 keys on the remote control which are marked with an asterisk (*).

Getting Started

This section explains how to connect audio/video components and speakers to the receiver, and how to connect the power supply.

Before Installation

General

- Be sure your hands are dry.
- Turn the power off to all components.
- Read the manuals supplied with the components you are going to connect.

Locations

- Install the receiver in a location that is level and protected from moisture.
- The temperature around the receiver must be between -5°C and 35°C (23°F and 95°F).
- Make sure there is good ventilation around the receiver. Poor ventilation could cause overheating and damage the receiver.

Handling the receiver

- Do not insert any metal object into the receiver.
- Do not disassemble the receiver or remove screws, covers, or cabinet.
- Do not expose the receiver to rain or moisture.

Checking the Supplied Accessories

Check to be sure you have all of the following items, which are supplied with the receiver.

The number in the parentheses indicates quantity of the pieces supplied.

- Remote Control (1)
- Batteries (2)
- AM Loop Antenna (1)
- FM Antenna (1)
- AC Plug Adaptor (1)

If anything is missing, contact your dealer immediately.

Setting the Voltage Selector Switch

Before connections, always do the following first if necessary.

Set the correct voltage for your area with the voltage selector switch on the rear panel. Rotate the voltage selector using a screw driver, so the voltage number the voltage mark is set at is the same as the voltage where you are plugging in the receiver.

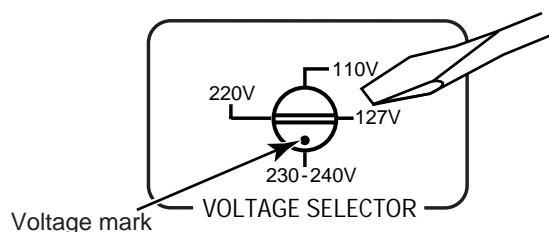

Connecting the FM and AM Antennas

FM Antenna Connections

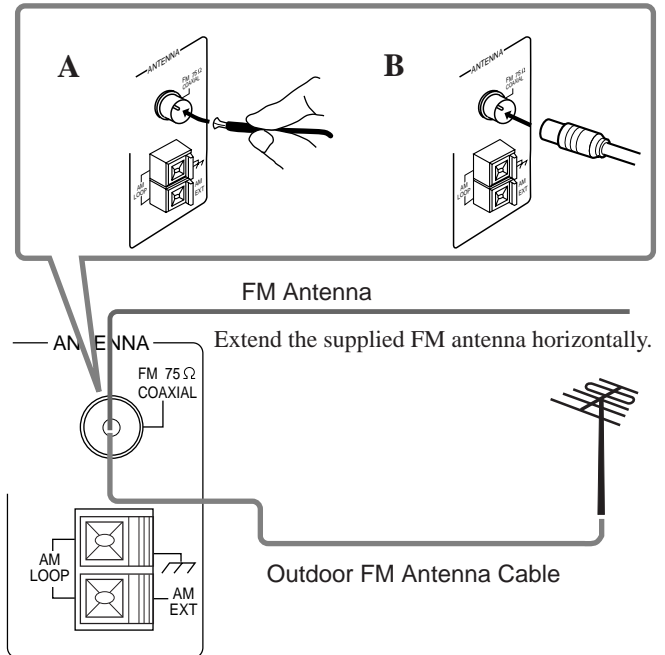

A. Using the Supplied FM Antenna

The FM antenna provided can be connected to the FM 75 Ω COAXIAL terminal as temporary measure.

B. Using the Standard Type Connector (Not Supplied)

A standard type connector should be connected to the FM 75 Ω COAXIAL terminal.

Note:

If reception is poor, connect the outdoor antenna. Before attaching a 75 Ω coaxial cable (the kind with a round wire going to an outdoor antenna), disconnect the supplied FM antenna.

AM Antenna Connections

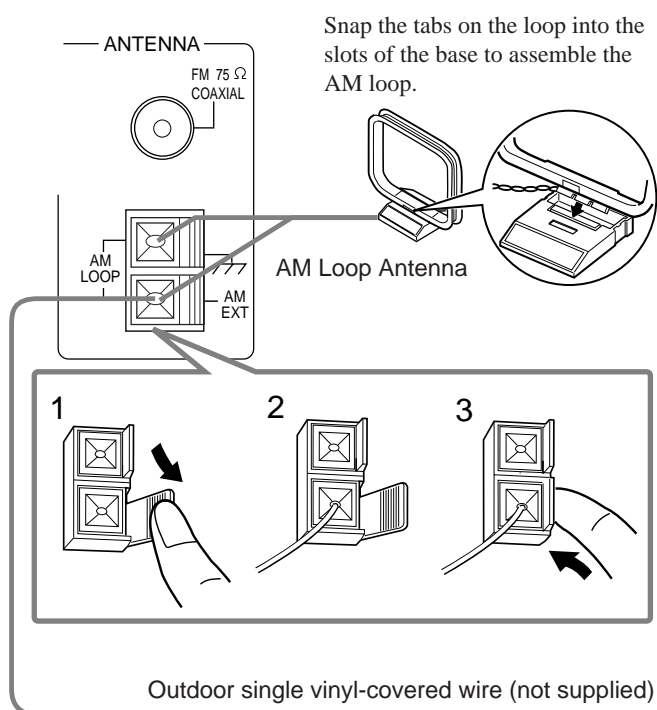

Turn the loop until you have the best reception.

Notes:

- If the AM loop antenna wire is covered with vinyl, remove the vinyl by twisting it as shown in the diagram.
- Make sure the antenna conductors do not touch any other terminals, connecting cords and power cord. This could cause poor reception.
- If reception is poor, connect an outdoor single vinyl-covered wire to the AM EXT terminal. (Keep the AM loop antenna connected.)



Connecting the Speakers

You can connect the following speakers:

- Two pairs of front speakers to produce normal stereo sound.
- One pair of rear speakers to enjoy the surround effect.
- One center speaker to produce more effective surround effect (to emphasize human voices).
- One subwoofer to enhance the bass.

IMPORTANT:

After connecting the speakers listed above, set the speaker setting information properly to obtain the best possible Surround and DSP effect. For details, see page 17.

For each speaker (except for a subwoofer), connect the (+) and (-) terminals on the rear panel to the (+) and (-) terminals marked on the speakers. For connecting a subwoofer, see page 5.

CAUTION:

Use speakers with the SPEAKER IMPEDANCE indicated by the speaker terminals.

Basic connecting procedure

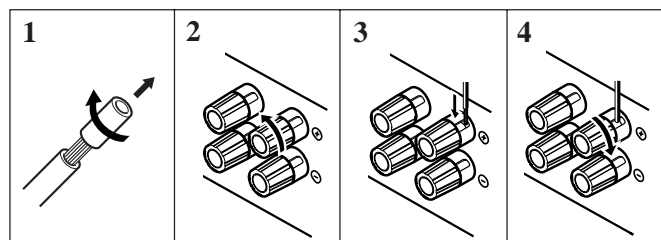

1 Cut, twist and remove the insulation at the end of each speaker signal cable (not supplied).

2 Turn the knob counterclockwise.

3 Insert the speaker signal cable.

4 Turn the knob clockwise.

Connecting the front speakers

You can connect two pairs of front speakers (one pair to the FRONT SPEAKERS ① terminals, and another pair to the FRONT SPEAKERS ② terminals).

Right speaker — FRONT SPEAKERS ① — Left speaker

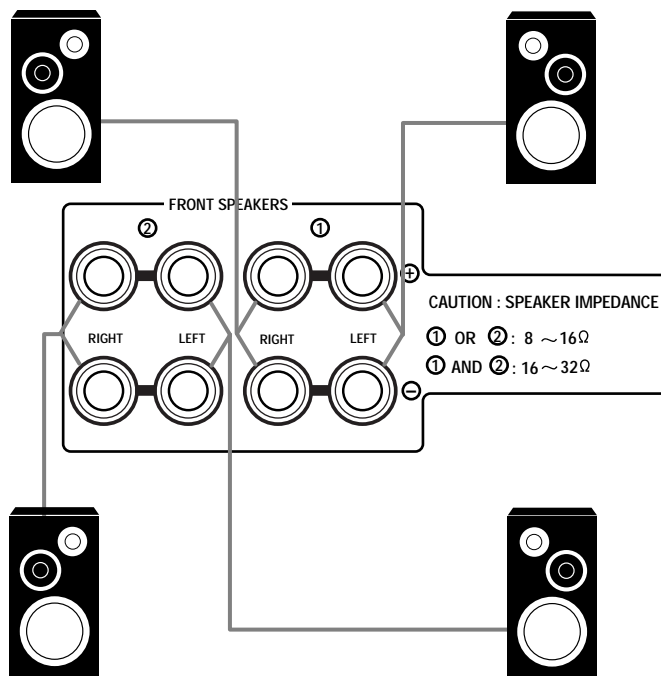

Right speaker — FRONT SPEAKERS ② — Left speaker

About the speaker impedance

The required speaker impedance of the front speakers does differ depending on whether both the FRONT SPEAKERS ① and FRONT SPEAKERS ② terminals are used or only one of them is used.

CASE 1 When you connect only one pair of front speakers

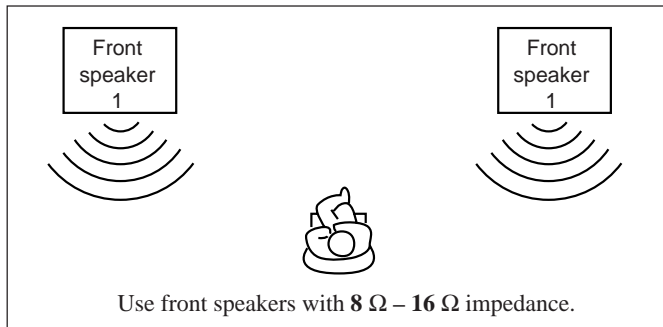

CASE 2 When you connect two pairs of front speakers

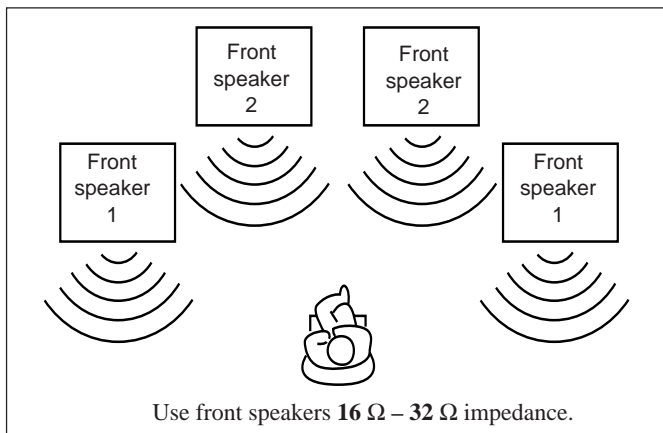

Connecting the rear and center speakers

Connect rear speakers to the REAR SPEAKERS terminals and a center speaker to the CENTER SPEAKER terminals.

Center speaker

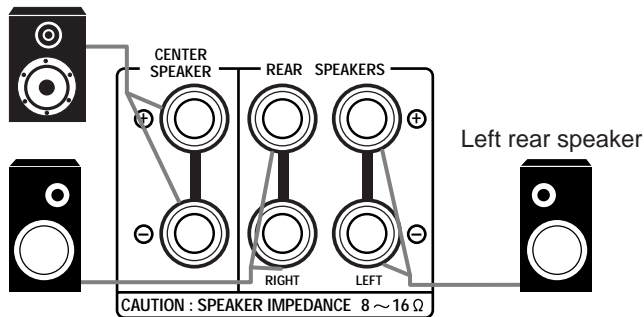

Right rear speaker

Connecting the subwoofer speaker

You can enhance the bass by connecting a subwoofer. Connect the input jack of a powered subwoofer to the SUBWOOFER OUT jack on the rear panel, using a cable with RCA pin plugs (not supplied).



Powered subwoofer

Connecting Audio/Video Components

You can connect the following audio/video components to this receiver. Refer also to the manuals supplied with your components.

Audio Components	Video Components
• Turntable	• DVD player*
• CD player*	• TV*
• Cassette deck or MD recorder*	• DBS tuner*
• CD recorder*	• VCR(s)
• Personal computer (PC)	• Video camera

* You can connect these components using the methods described in "Analog connections" (below), or in "Digital connections" (see page 8).

Analog Connections

Audio component connections

Use the cables with RCA pin plugs (not supplied). Connect the white plug to the audio left jack, and the red plug to the audio right jack.

CAUTION:

If you connect a sound-enhancing device such as a graphic equalizer between the source components and this receiver, the sound output through this receiver may be distorted.

Turntable

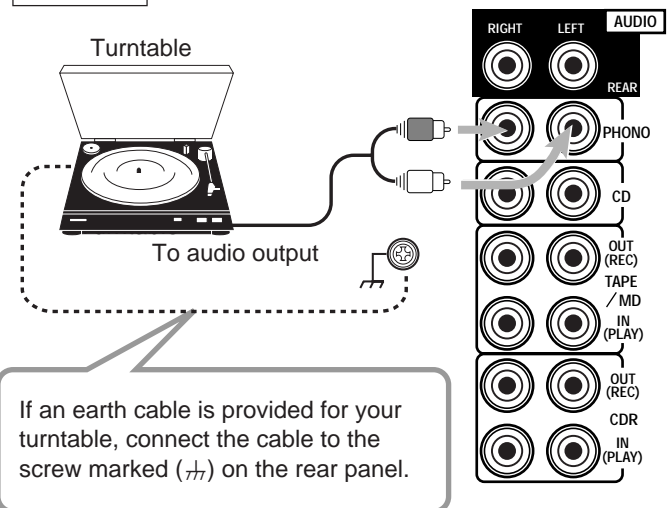

Ex.: This connection is for the turntable with an MM (moving-magnet) type cartridge.

Note:

Any turntables incorporating a small-output cartridge such as an MC (moving-coil) type must be connected to this receiver through a commercial head amplifier or step-up transformer. Direct connection may result in insufficient volume.

CD player

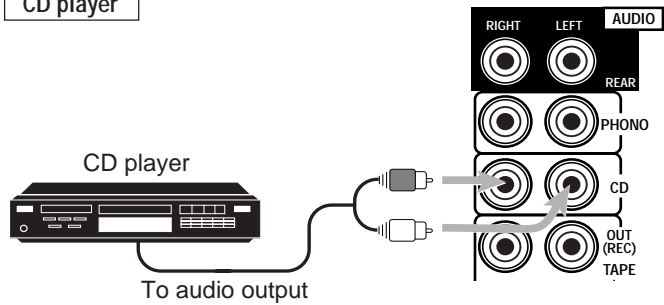

Cassette deck or MD recorder

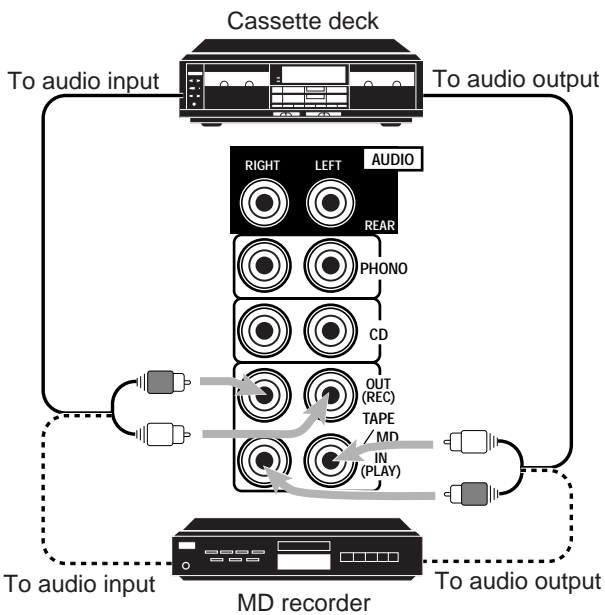

Note:

You can connect either a cassette deck or an MD recorder to the TAPE/MD jacks. When connecting an MD recorder to the TAPE/MD jacks, change the source name, which will be shown on the display when selected as the source, to "MD." See page 16 for details.

CD recorder

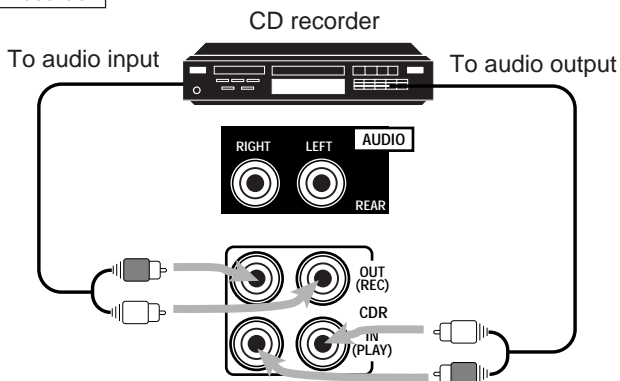

If your audio components have a COMPU LINK or TEXT COMPU LINK jack

- See also page 41 for detailed information about the connection and the COMPU LINK remote control system.
- See also page 42 for detailed information about the connection and the TEXT COMPU LINK remote control system.

Video component connections

Use the cables with RCA pin plugs (not supplied). Connect the white plug to the audio left jack, the red plug to the audio right jack, and the yellow plug to the video jack.

- If your video components have S-video (Y/C-separation) and/or component video (Y, P_B/C_B, P_R/C_R) terminals, connect them using an S-video cable (not supplied) and/or component video cable (not supplied). By using these terminals, you can get a better picture quality in the order — Component video > S-video > Composite video.

IMPORTANT:

This receiver is equipped with the following video terminals — composite video, S-video and component video terminals. You can use any of the three to connect a video component. However, **remember that the video signals from one type of these input terminals are output only through the video output terminals of the same type.** Therefore, if a recording video component and a playing video component are connected to the receiver through the different video terminals, you cannot record the picture from the playing component on the recording component. In addition, if the TV and a playing video component are connected to the receiver through the different video terminals, you cannot view the playback picture from the playing component on the TV.

VCR(s)

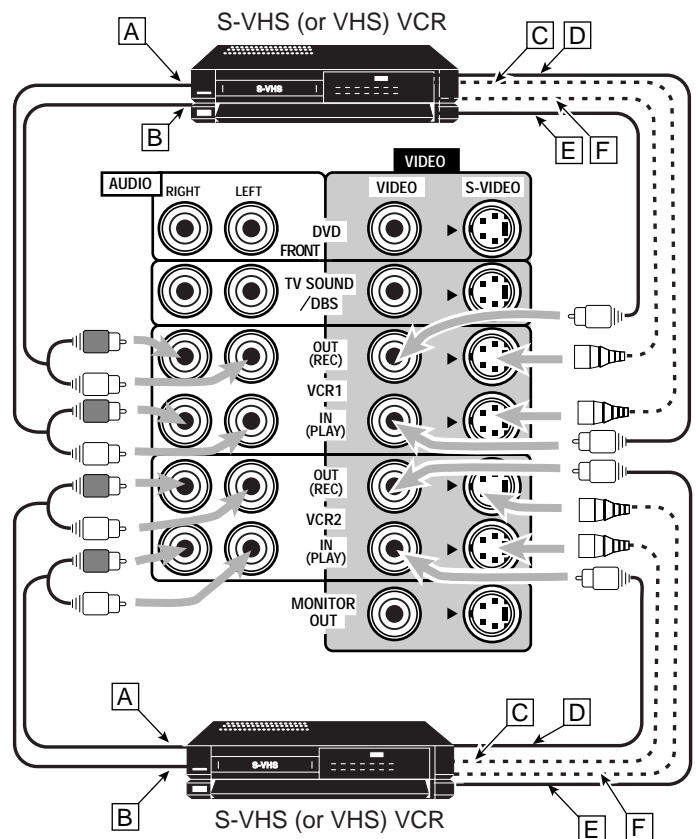

- A To left/right channel audio output
- B To left/right channel audio input
- C To S-video output
- D To composite video output
- E To composite video input
- F To S-video input

TV and/or DBS tuner

When connecting the TV to the AUDIO jacks (TV SOUND/DBS), DO NOT connect the TV's video output to these video input terminals.

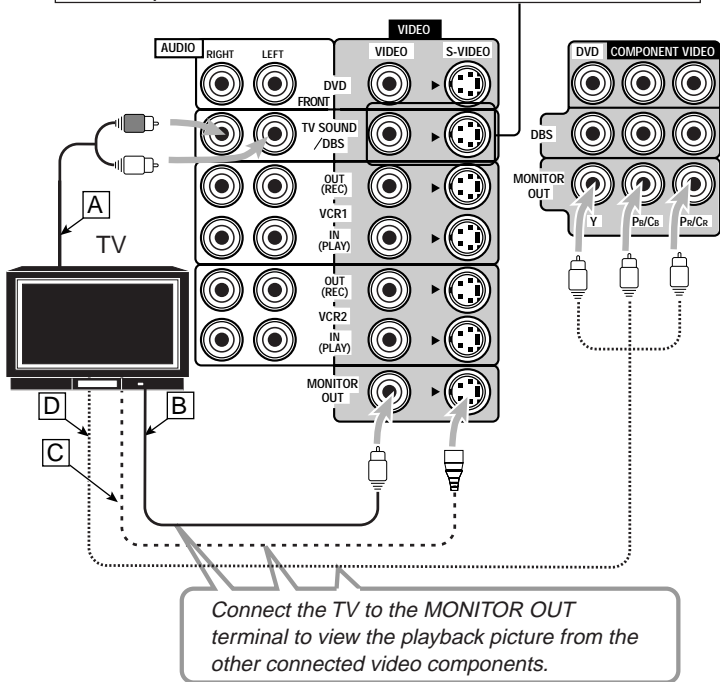

- A To audio output
- B To composite video input
- C To S-video input
- D To component video input

Video camera

The VIDEO input terminals on the front panel are convenient when connecting and disconnecting the equipment frequently.

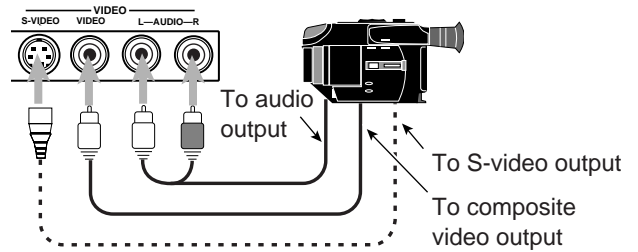

DVD player

When you connect the DVD player with stereo output jacks:

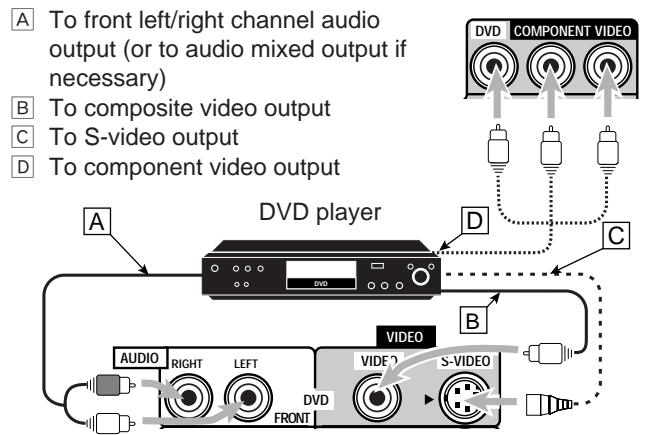

When you connect the DVD player with its analog discrete output (5.1 CH reproduction) jacks:

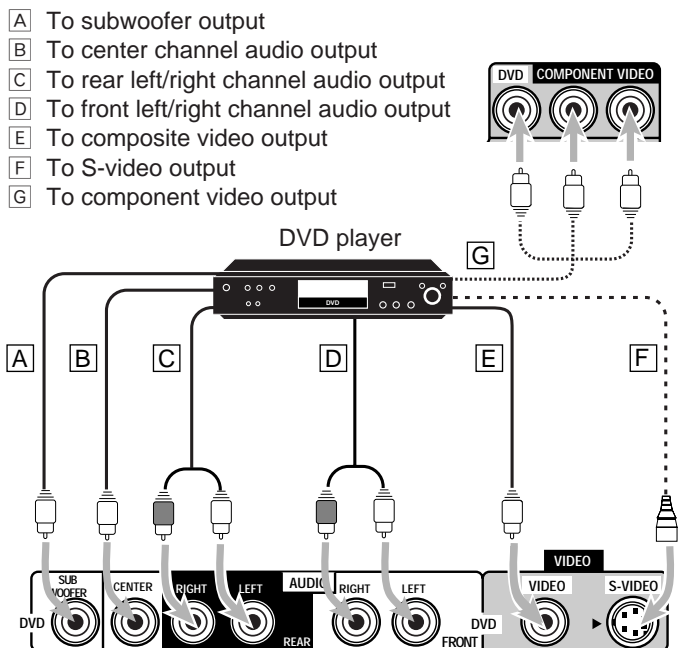

Note:

When operating the DVD player by using the AV COMPU LINK remote control system, change the video input terminal setting correctly. See pages 16 and 47 for details.

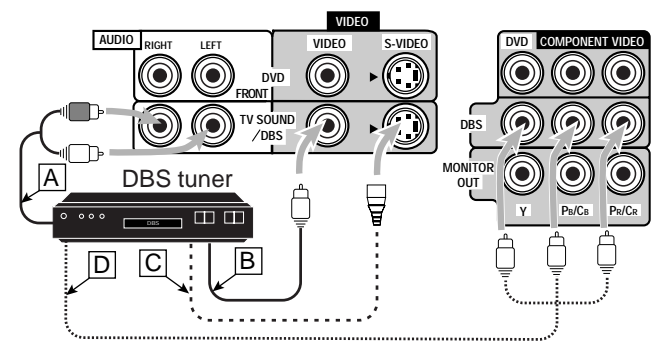

- A To audio output
- B To composite video output
- C To S-video output
- D To component video output

Notes:

- When connecting the DBS tuner to the TV SOUND/DBS jacks, change the source name, which will be shown on the display when selected as the source, to "DBS." See page 16 for details.
- When operating the DBS tuner by using the AV COMPU LINK remote control system, change the video input terminal setting correctly. See pages 16 and 47 for details.

Digital Connections

This receiver is equipped with four DIGITAL IN terminals — one digital coaxial terminal and three digital optical terminals, and one DIGITAL OUT terminal.

IMPORTANT:

- When connecting the DVD player, digital TV broadcast tuner or DBS tuner using the digital terminals, you also need to connect it to the video terminal on the rear. Without connecting it to the video terminal, you can view no playback picture.
- After connecting the components using the DIGITAL IN terminals, set the following correctly if necessary.
 - Set the digital input (DIGITAL IN) terminal setting correctly. For details, see “Digital Input (DIGITAL IN) Terminal Setting” on page 19.
 - Select the digital input mode correctly. For details, see “Selecting the Analog or Digital Input Mode” on page 20.

Notes:

- When shipped from the factory, the DIGITAL IN terminals have been set for use with the following components.
 - DIGITAL 1 (coaxial): For DVD player
 - DIGITAL 2 (optical): For CD player
 - DIGITAL 3 (optical): For digital TV broadcast tuner
 - DIGITAL 4 (optical): For CD recorder
- When you want to operate the CD player, CD recorder, or MD recorder using the COMPU LINK remote control system, connect the target component also as described in “Analog Connections” (see pages 5 and 6).
- When you want to operate the DVD player using the AV COMPU LINK remote control system, connect the DVD player also as described in “Analog Connections” (see page 7).

Digital input terminals

You can connect any digital equipment as follow.

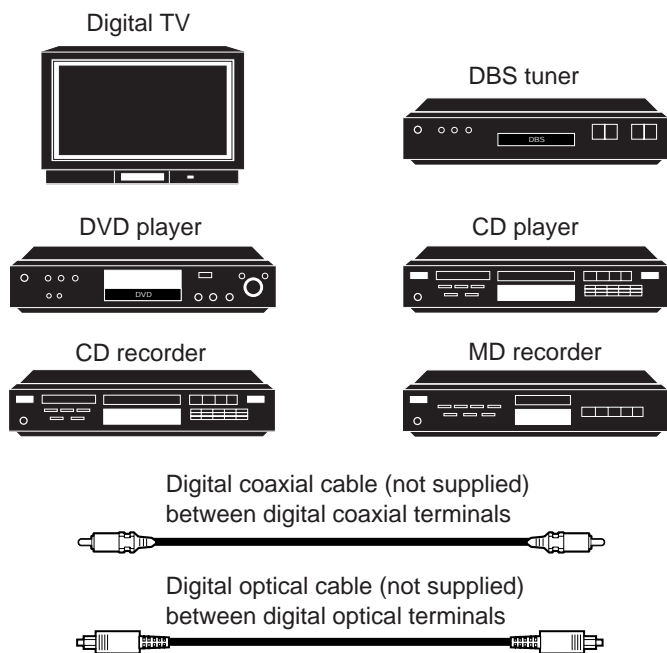

Digital output terminal

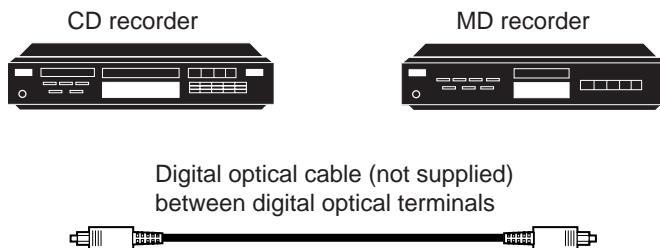

When the digital recording equipment such as an MD recorder and CD recorder has a digital optical input terminal, connecting it to the DIGITAL OUT terminal enables you to perform digital-to-digital recording.

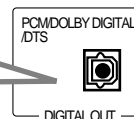

When the component has a digital coaxial output terminal, connect it to the DIGITAL 1 (DVD) terminal, using the digital coaxial cable (not supplied).

When the component has a digital optical output terminal, connect it to the DIGITAL 2 (CD), DIGITAL 3 (TV) or DIGITAL 4 (CDR) terminal, using the digital optical cable (not supplied).

Before connecting a digital optical cable, unplug the protective plug.

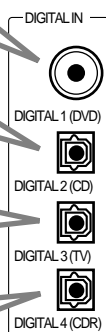
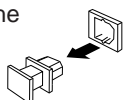

Note:

The digital signal format output through the DIGITAL OUT terminal is the same as that of the input signal. This means that when the DTS Digital Surround signals are input, the DTS Digital Surround signals are output.

USB Connection

This receiver is equipped with a USB terminal on the front panel. You can connect your PC to this terminal and enjoy sound reproduced through your PC.

When you connect your PC for the first time, follow the procedure below.

- Remember you cannot send any signal or data to your PC from this receiver.

IMPORTANT

- Check if your PC equipped with the CD-ROM drive is running on Windows® 98*, Windows® Me*, or Windows® 2000* and prepare its CD-ROM.
- Check your PC's BIOS setting — whether USB is available, and whether USB IRQ is set to "AUTO" or to available IRQ number.

How to install the USB drivers

The following procedure is described using the English version of Windows® 98. If your PC is running on a different version of Windows, the screens shown on your PC's monitor will differ from the ones used in the following procedure.

1. Turn on your PC and start running Windows® 98, Windows® Me or Windows® 2000.

If the PC has been turned on, quit all the applications now running.

2. Turn on the receiver, and press USB AUDIO on the front panel or USB on the remote control.

The lamp on the USB AUDIO button lights up.

3. Connect the receiver to the PC using a USB cable (not supplied).

Your PC automatically recognizes this connection, and shows the following screen on the monitor.

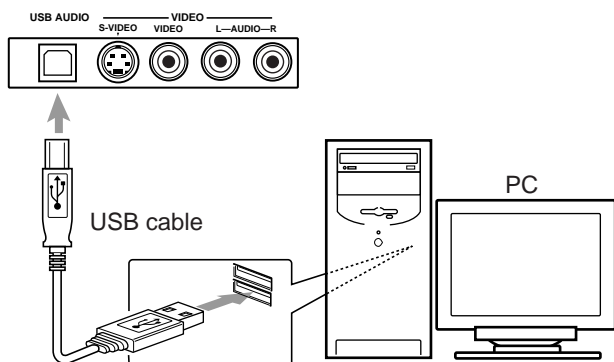

4. Install the USB drivers following the instructions on the PC's monitor.

5. Check if the drivers are correctly installed.

1. Open the Control Panel on your PC: Select [Start] → [Settings] → [Control Panel]
2. Select [System], then [Device Manager] and click [Sound, video and game controllers] and [Universal Serial Bus controllers.]

The following window appears, and you can check whether the drivers are installed.

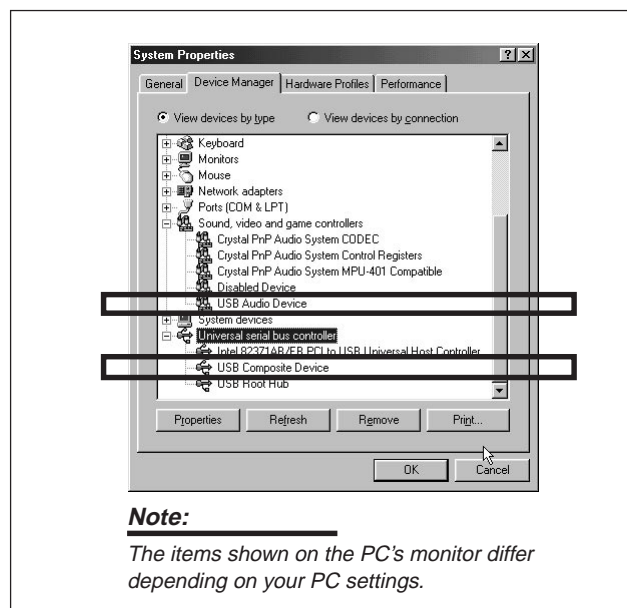

6. Change the PC audio setting.

1. If you have closed Control Panel, open it again: Select [Start] → [Settings] → [Control Panel]
2. Click [Multimedia], then select "USB Audio Device [1]" for "Playback" of "Audio," and close the window.

To play back a CD from CD-ROM drive on PC, click [Multimedia], [CD Music] then check [Enable digital CD audio for this CD-ROM device].

Now PC is ready for playback through the USB connection.

After installation is completed, you can use your PC as the playback source. The PC automatically recognizes the receiver whenever a USB cable is connected between the PC and the receiver while the receiver is turned on.

- When not using the PC as the playback source, disconnect the USB cable.

To play back sounds on the PC, refer to the manuals supplied with the sound reproduction application installed in the PC.

Notes:

- DO NOT turn off the receiver or disconnect the USB cable while installing the drivers and for a several seconds each time your PC is recognizing the receiver.
- Use a full speed USB cable (revision 1.0).
- If your PC does not recognize the receiver, disconnect the USB cable and connect it again. If this does not work, restart Windows.
- The drivers installed can be recognized only when the USB cable is connected between the receiver and your PC.
- The sound may not be played back correctly — interrupted or degraded — due to your PC settings and PC specifications.

* Microsoft®, Windows® 98, Windows® Me and Windows® 2000 are registered trademarks of Microsoft Corporation.

Connecting the Power Cord

Before plugging the receiver into an AC outlet, make sure that all connections have been made.

Plug the power cord into an AC outlet.

Keep the power cord away from the connecting cables and the antenna. The power cord may cause noise or screen interference. We recommend that you use a coaxial cable to connect the antenna, since it is well-shielded against interference.

Notes:

- The preset settings such as preset channels and sound adjustment may be erased in a few days in the following cases:
 - When you unplug the power cord.
 - When a power failure occurs.
- If the wall outlet does not match the AC plug, use the supplied AC plug adaptor.

CAUTIONS:

- Do not plug in before setting the voltage selector switch on the rear of the unit and all connection procedures are complete.
- Do not touch the power cord with wet hands.
- Do not pull on the power cord to unplug the cord. When unplugging the cord, always grasp the plug so as not to damage the cord.

Putting Batteries in the Remote Control

Before using the remote control, put two supplied batteries first. When using the remote control, aim the remote control directly at the remote sensor on the receiver.

1. On the back of the remote control, remove the battery cover.

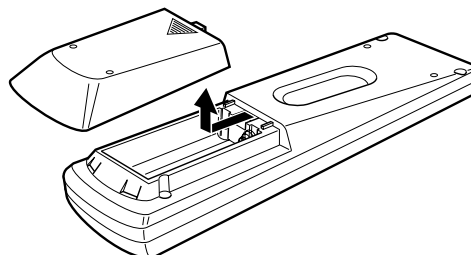

2. Insert batteries. Make sure to match the polarity: (+) to (+) and (-) to (-).

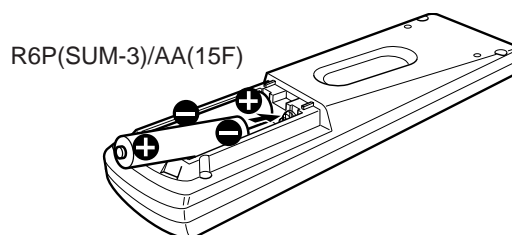

3. Replace the cover.

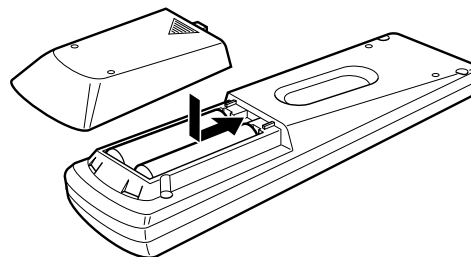

If the range or effectiveness of the remote control decreases, replace the batteries. Use two R6P(SUM-3)/AA(15F) type dry-cell batteries.

Note:

After replacing the batteries, set the manufacturers' codes again (see page 52).

CAUTION:

Follow these precautions to avoid leaking or cracking cells:

- Place batteries in the remote control so they match the polarity: (+) to (+) and (-) to (-).
- Use the correct type of batteries. Batteries that look similar may differ in voltage.
- Always replace both batteries at the same time.
- Do not expose batteries to heat or flame.

Basic Operations

The following operations are commonly used when you play any sound source.

Before using the remote control

How to confirm the remote control operation mode

The display window on the remote control shows following information for about 10 seconds when you press certain buttons on the remote control, so that you can confirm which operation you do.

Pressing one of the source selecting buttons, the source name selected appears on the display.

Buttons	Indications
FM/AM	TUNER
CD	CD
PHONO	PHONO
TAPE/MD	TAPE
DVD or DVD MULTI	DVD
CDR	CDR
USB	USB
TV/DBS	TV
VCR 1	VCR 1
VCR 2	VCR 2
VIDEO	VIDEO

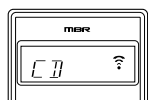

Ex.: When you press CD.

Pressing SOUND before you adjust the sound effect, "SOUND" appears on the display.



Pressing TEXT DISPLAY or MENU before you use on-screen menu or TEXT COMPUTE LINK, "MENU" appears on the display (see pages 36 and 43).



Pressing CONTROL or CATV/DBS CONTROL before you operate an audio or video equipment connected to the receiver, the remote control operation mode selected appears on the display (see pages 49 and 52).

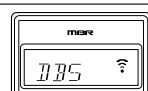

Ex.: When you press CATV/DBS CONTROL.

Turning the Power On and Off (Standby)

On the front panel:

To turn on the power, press STANDBY/ON .

The STANDBY lamp goes off. The name of the current source and Surround/DSP mode appear on the display.

Current source name and Surround/DSP mode appear

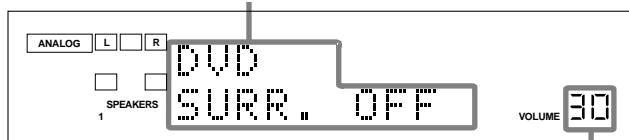

Current volume level appears

To turn off the power (into standby mode), press STANDBY/ON again.

The STANDBY lamp lights up. A small amount of power is consumed in standby mode. To turn the power off completely, unplug the AC power cord.

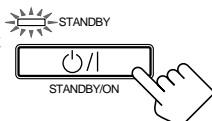

From the remote control:

To turn on the power, press AUDIO .

The STANDBY lamp on the front panel goes off.

The name of the current source and Surround/DSP mode appear on the display.



To turn off the power (into standby mode), press AUDIO again.

The STANDBY lamp on the front panel lights up.

Selecting the Source to Play

Press one of the source selecting buttons.

The lamp on the front panel button for selected source lights up.

- The selected source name and Surround/DSP mode also appear on the display.

On the front panel:

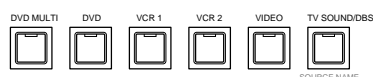

From the remote control:

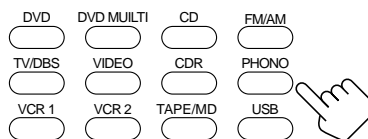

Selected source name and current Surround/DSP mode appear

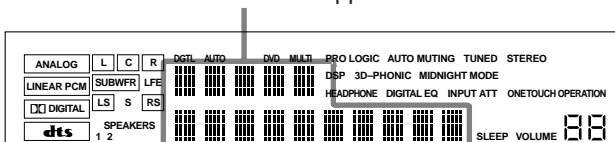

DVD MULTI

Select the DVD player for viewing the digital video disc using the analog discrete output mode (5.1CH reproduction).

To enjoy the DVD MULTI playback, see page 35.

DVD

Select the DVD player.

VCR 1

Select the video component connected to the VCR 1 terminals.

VCR 2

Select the video component connected to the VCR 2 terminals.

VIDEO

Select video component connected to the VIDEO terminals.

TV (SOUND)/DBS

Select TV sounds (or the DBS tuner).

PHONO *

Select the turntable.

CD *

Select the CD player.

CDR *

Select the CD recorder.

TAPE/MD *

Select the cassette deck (or the MD recorder).

USB (AUDIO) *

Select the personal computer (PC) connected to the USB terminal.

FM/AM *

Select an FM or AM broadcast.

- Each time you press the button, the band alternates between FM and AM.

Notes:

- When connecting an MD recorder (to the TAPE/MD jacks), and a DBS tuner (to the TV SOUND/DBS jacks), change the source names shown on the display. For details, see page 16.
- When you press one of the source selecting buttons on the remote control marked with an asterisk (*), the receiver automatically turns on.

Signal and speaker indicators on the display**The signal indicators light up in the following cases:**

- Only the indicators for the incoming signals light up.
- When analog input is selected, “L” and “R” always light up.
- When “DVD MULTI” is selected as the source, “L,” “C,” “R,” “LFE,” “LS” and “RS” light up.

The speaker indicators light up only —:

The frames of “C,” “LS,” and “RS” light up, when the corresponding speaker is set to “LARGE” or “SMALL”.

Signal indicators light up in red:	Speaker indicators light up in white:

- L: • **When digital input is selected:** Lights up when the left channel signal comes in.
 • **When analog input is selected:** Always lights up.
- R: • **When digital input is selected:** Lights up when the right channel signal comes in.
 • **When analog input is selected:** Always lights up.
- C: Lights up when the center channel signal comes in.
- LS: Lights up when the left rear channel signal comes in.
- RS: Lights up when the right rear channel signal comes in.
- S: Lights up when the monaural rear channel signal comes in.
- LFE: Lights up when the LFE channel signal comes in.

Note:

When “SUBWOOFER” is set to “YES,” lights up (see page 17).

Selecting different sources for picture and sound

You can watch picture from a video component while listening to sound from another component.

Press one of the audio source selecting buttons — PHONO, CD, CDR, TAPE/MD, USB(AUDIO), FM/AM — while viewing the picture from a video component such as the VCR or DVD player, etc.

The lamp on the front panel button for selected source lights up.

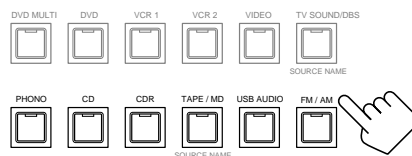
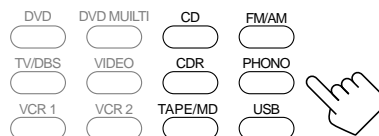
On the front panel:**From the remote control:****Note:**

Once you have selected a video source, pictures of the selected source are sent to the TV until you select another video source.

Adjusting the Volume**On the front panel:**

To increase the volume, turn MASTER VOLUME clockwise.

To decrease the volume, turn it counterclockwise.

- When you turn MASTER VOLUME rapidly, the volume level also changes rapidly.
- When you turn MASTER VOLUME slowly, the volume level also changes slowly.

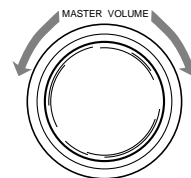
**From the remote control:**

To increase the volume, press VOLUME +.

To decrease the volume, press VOLUME -.

**CAUTION:**

Always set the volume to the minimum before starting any source. If the volume is set at its high level, the sudden blast of sound energy can permanently damage your hearing and/or ruin your speakers.

Notes:

- The volume level can be adjusted within the range of “0” (minimum) to “90” (maximum).
- If you set One Touch Operation to “ON” (see page 21), you do not have to adjust the volume level each time you change the source. It is automatically set to the stored level.

Selecting the Front Speakers

On the front panel ONLY:

When you have connected two pairs of the front speakers, you can select which to use.

To use the speakers connected to the FRONT SPEAKERS ① terminals, press SPEAKERS ON/OFF 1 so that SPEAKERS 1 indicator lights up on the display. Make sure that the SPEAKERS 2 is not lit on the display.

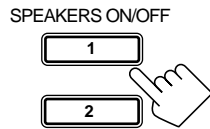

To use the speakers connected to the FRONT SPEAKERS ② terminals, press SPEAKERS ON/OFF 2 so that SPEAKERS 2 indicator lights up on the display. Make sure that the SPEAKERS 1 is not lit on the display.

To use both sets of the speakers, press SPEAKERS ON/OFF 1 and 2 so that the SPEAKERS 1 and SPEAKERS 2 indicators light up on the display.

To use neither sets of the speakers, press SPEAKERS ON/OFF 1 and 2 so that the SPEAKERS 1 and SPEAKERS 2 indicators disappear from the display.

The HEADPHONE indicator lights up and "HEADPHONE" appears on the display.

- Activating the speaker turns on the Surround and DSP modes previously selected.
- **Listening only with headphones:** You can listen with the headphones without deactivating both pairs of speakers by connecting a pair of headphones to the PHONES jack on the front panel. If you want to use a pair of headphones without outputting sounds from the front speakers, you must turn off both pairs of the front speakers as mentioned above.

Notes:

- If you use any of the Surround and DSP modes using the center or rear speakers with both front speakers activated, the speakers connected to the FRONT SPEAKERS ② terminals are deactivated.
- When you use HEADPHONE DSP mode, you can enjoy spacious stereo effect (see page 25).

CAUTION:

Be sure to turn down the volume before connecting or putting on headphones, as high volume can damage both the headphones and your hearing.

Muting the Sound

From the remote control ONLY:

Press MUTING to mute the sound through all speakers and headphones connected.

"MUTING" appears on the display and the volume turns off (the volume level indicator goes off).



To restore the sound, press MUTING again so that "MUTING OFF" appears on the display.

- Turning MASTER VOLUME on the front panel or pressing VOLUME +/- on the remote control also restores the sound.

Listening at Night — Midnight Mode

Using the midnight mode, you can enjoy a powerful sound at night even at a low volume level.

- You can do this setting for each source.

Press MIDNIGHT MODE to select the midnight mode.



On the front panel



From the remote control

- Each time you press the button, the midnight mode changes as follow.

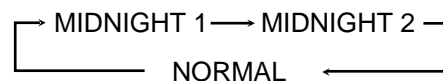

MIDNIGHT 1: Select this when you want to compress the dynamic range a little. The MIDNIGHT MODE indicator lights up on the display.

MIDNIGHT 2: Select this when you want to compress the dynamic range fully. (Useful at midnight). The MIDNIGHT MODE indicator lights up on the display.

NORMAL: Select this when you want to enjoy sound with its full dynamic range. (No effect applied.) The MIDNIGHT MODE indicator goes off from the display.

Notes:

- When the line direct function is turned on, the midnight mode is canceled temporarily.
- The midnight mode is not valid for the DVD MULTI playback mode.

Activating the Subwoofer Sound

You can cancel the subwoofer sound even though you have connected a subwoofer and have set “SUBWOOFER” to “YES” (see page 17). This is useful when enjoying surround sound at night.

On the front panel ONLY:

Press **SUBWOOFER OUT ON/OFF** to cancel the subwoofer sound output.

Each time you press the button, the subwoofer sound output is deactivated (“SUBWFR OFF”) or activated (“SUBWFR ON”).

- Select “SUBWFR OFF” to deactivate the subwoofer sound output.
- Select “SUBWFR ON” to activate it.



Note:

You cannot select “SUBWFR OFF” even though “SUBWOOFER” is set to “YES,” when “SMALL” is selected for the front speakers (see page 17.)

Reinforcing the Bass

You can boost the bass level.

- You can do this setting for each source.

On the front panel:

Press **BASS BOOST** to select the bass boost function.

The BASS BOOST lamp on the front panel button lights up.

- Each time you press the button, the bass boost function turns on (“BOOST ON”) and off (“BOOST OFF”).
 - Select “BOOST ON” to activate the bass boost function. The BASS BOOST lamp on the front panel button lights up.
 - Select “BOOST OFF” to cancel it. The BASS BOOST lamp on the front panel button goes off.

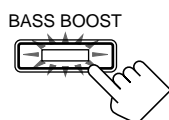

From the remote control:

1. Press SOUND.

The 10 keys are activated for sound adjustments.

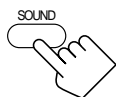

2. Press BASS BOOST to select the bass boost function.

The BASS BOOST lamp on the front panel button lights up.

- Each time you press the button, the bass boost function turns on (“BOOST ON”) and off (“BOOST OFF”).
 - Select “BOOST ON” to activate the bass boost function. The BASS BOOST lamp on the front panel button lights up.
 - Select “BOOST OFF” to cancel it. The BASS BOOST lamp on the front panel button goes off.



Note:

This function does not affect the sounds outputting from the rear speakers.

Attenuating the Input Signal

When the input level of the playing source is too high, the sounds will be distorted. If this happens, you need to attenuate the input signal level to prevent the sound distortion.

- You can do this setting for each source.

On the front panel ONLY:

Press and hold **INPUT ATT (INPUT ANALOG/DIGITAL)** so that the **INPUT ATT** indicator lights up on the display.

- Each time you press and hold the button, the input attenuator mode turns on (“ATT ON”) or off (“NORMAL”).

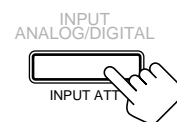

Notes:

- This function is available only for the sources connected using the analog terminals.
- When selecting “DVD MULTI” as the source, this effect does not work.

Selecting the Line Direct Function

You can enjoy the sound closer to original source by skipping the sound adjustments such as digital equalization and midnight mode. Only the volume level and bass boost function are adjustable when the line direct function is turned on.

- You can do this setting for each source.

Press LINE DIRECT.

The LINE DIRECT lamp on the front panel button lights up.

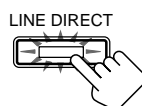

On the front panel



From the remote control

- Each time you press the button, the line direct function turns on (“DIRECT ON”) and off (“DIRECT OFF”).
 - Select “DIRECT ON” to activate the line direct function. The LINE DIRECT lamp on the front panel button lights up.
 - Select “DIRECT OFF” to cancel it. The LINE DIRECT lamp on the front panel button goes off.

Notes:

- If you turn on the line direct function while using the Surround and DSP modes, the effect changes as follows:

Input \ Mode	Surround	DSP
Analog	Not valid	Not valid
Digital	Valid	Not valid

- Turning off the line direct function activates the sound adjustments previously selected such as the digital equalization and midnight mode.

Adjusting the Equalization Patterns

You can adjust equalization to your preference.

- You can do this setting for each source.

Before you start, remember....

- There is a time limit in doing the following steps. If the setting is canceled before you finish, start from step 1 again.

On the front panel:

- Press **DIGITAL EQ (Equalization)** repeatedly to select the frequency.

- Each time you press the button, the frequency with its current level changes as follows:

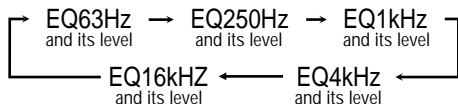

- Press **CONTROL UP ▲/DOWN ▼** repeatedly to adjust the frequency level.

The frequency level changes by 2 dB from -8 dB to +8 dB. The DIGITAL EQ indicator lights up on the display.

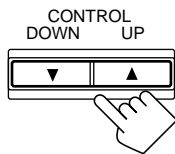

- Repeat Steps 1 and 2 to adjust the other frequency level.

To flat the equalization pattern,

Set all the frequency levels to "0" in step 2. The DIGITAL EQ indicator goes off from the display.

From the remote control:

- Press **SOUND**.

The 10 keys are activated for sound adjustments.

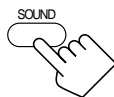

- Press **DIGITAL EQ (Equalization)** repeatedly to select the frequency you want.

"EQ" appears on the remote control display window.

- Each time you press the button, the frequency with its level changes as follows:

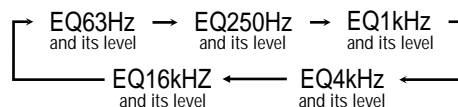

- Press **LEVEL + or -** repeatedly to adjust the frequency level.

The frequency level changes by 2 dB from -8 dB to +8 dB. The DIGITAL EQ indicator lights up on the display.



- Repeat steps 2 and 3 to adjust the other frequency level.

To flat the equalization pattern,

Set all the frequency levels to "0" in step 3. The DIGITAL EQ indicator goes off from the display.

Notes:

- When the line direct function is turned on, the digital equalization cannot be adjusted.
- The digital equalization affects the front speaker sounds only.

Using the Sleep Timer

Using the Sleep Timer, you can fall asleep to music and know the receiver will turn off by itself rather than play all night.

From the remote control ONLY:

Press **SLEEP** repeatedly.

The SLEEP indicator lights up on the display, and the shut-off time changes as follows (in minutes):

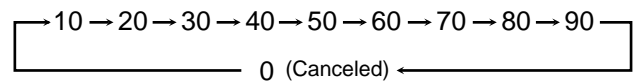

When the shut-off time comes

The receiver turns off automatically.

To check or change the time remaining until the shut-off time

Press **SLEEP** once.

The remaining time until the shut-off time appears in minutes.

- To change the shut-off time, press **SLEEP** repeatedly.

To cancel the Sleep Timer

Press **SLEEP** repeatedly until "SLEEP 0min" appears on the display. (The SLEEP indicator goes off.)

- Turning off the power also cancels the Sleep Timer.

Recording a Source

For analog-to-analog recording

You can record any analog source through the receiver to —

- the cassette deck (or MD recorder) connected to the TAPE/MD jacks,
 - the VCRs connected to the VCR 1 and VCR 2 jacks, and
 - the CD recorder connected to the CDR jacks
- at the same time.

For digital-to-digital recording

You can record the currently selected digital input source through the receiver to a digital recording device connected to the DIGITAL OUT terminal.

Notes:

- Analog-to-digital and digital-to-analog recordings are not possible.
- The output volume level, midnight mode (see page 13), bass boost (see page 14), digital equalization (see the left), Surround modes and DSP modes (see page 24) cannot affect the recording.
- The test tone signal (see page 27) does not come out through the DIGITAL OUT terminal.

Basic Settings

Some of the following settings are required after connecting and positioning your speakers in your listening room, while others will make operations easier.

Adjusting the Front Speaker Output Balance

If the sounds you hear from the front right and left speakers are unequal, you can adjust the speaker output balance.

- You can do this setting for each source.

Before you start, remember....

- There is a time limit in doing the following steps. If the setting is canceled before you finish, start from step 1 again.

On the front panel:

1. Press **LEVEL ADJUST** repeatedly until **"BAL-** (with current setting)" appears on the display.



2. Press **CONTROL UP ▲/DOWN ▼** to adjust the balance.

- Pressing **CONTROL UP ▲** decreases the left channel output (from CENTER to L-21).
- Pressing **CONTROL DOWN ▼** decreases the right channel output (from CENTER to R-21).

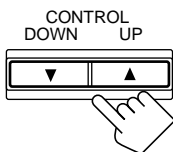

From the remote control:

1. Press **SOUND**.

The 10 keys are activated for sound adjustments.

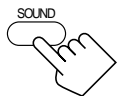

2. Press **L/R BAL**.

"L/R" appears on the remote control display window.



3. Press **BAL L** or **BAL R** to adjust the balance.

- Pressing **BAL L** decreases the right channel output (from CENTER to R-21).
- Pressing **BAL R** decreases the left channel output (from CENTER to L-21).



Changing the Source Name

When you have connected an MD recorder to the TAPE/MD jacks or the DBS tuner to the TV SOUND/DBS jacks on the rear panel, change the source name which will be shown on the display when you select the MD recorder or DBS tuner as the source.

On the front panel ONLY:

When changing the source name from **"TAPE"** to **"MD"**:

- Press and hold **SOURCE NAME** (TAPE/MD) until **"ASSGN. MD"** appears on the display.

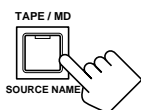

When changing the source name from **"TV"** to **"DBS"**:

- Press and hold **SOURCE NAME** (TV SOUND/DBS) until **"ASSGN. DBS"** appears on the display.

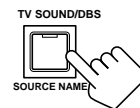

To change the source name to **"TAPE"** or **"TV,"** repeat the same procedure above — press and hold **SOURCE NAME** (TAPE/MD) to select **"TAPE,"** or press and hold **SOURCE NAME** (TV SOUND/DBS) to select **"TV."**

Note:

Without changing the source name, you can still use the connected components. However, there may be some inconvenience.

- "TAPE" or "TV" will appear on the display when you select the MD recorder or DBS tuner.
- You cannot use the digital input (see page 19) for the MD recorder.
- You cannot use the COMPU LINK remote control system (see page 41) to operate the MD recorder.

Selecting the Video Input Terminal

This receiver is equipped with the component video input terminals for the DVD player and DBS tuner, which give you higher picture quality. When you use the component video input terminals for the DVD player and/or DBS tuner, change the video input terminal setting.

Before you start, remember....

- There is a time limit in doing the following steps. If the setting is canceled before you finish, start from step 1 again.

On the front panel ONLY:

1. Press **SETTING** repeatedly until **"VIDEO DVD"** or **"VIDEO DBS"** appears on the display.

The display changes to show the current setting.

- Select **"VIDEO DVD"** to select the video input terminal for the DVD player and **"VIDEO DBS"** for the DBS tuner.

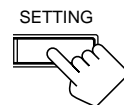

2. Press **CONTROL UP ▲/DOWN ▼** to select the appropriate video input terminal.

- Each time you press the button, the display changes to show the following:

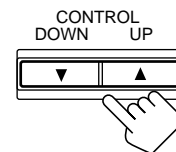

COMPNT (Component) ← S/C (S-video/Composite)

COMPNT: Select this when you connect the DVD player or DBS tuner to the component video input terminals.

S/C: Select this when you connect the DVD player or DBS tuner to the composite video or S-video input terminal.

Note:

Without changing the video input terminal setting, you can see the picture through the video input terminals, but cannot use the AV COMPU LINK remote control system correctly (see page 47).

Setting the Subwoofer Information

Register whether you have connected a subwoofer or not.

Before you start, remember....

- There is a time limit in doing the following steps. If the setting is canceled before you finish, start from step 1 again.

On the front panel ONLY:

1. Press **SETTING** repeatedly until “SUBWOOFER” appears on the display.

The display changes to show the current setting.

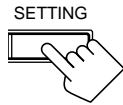

2. Press **CONTROL UP ▲/DOWN ▼** to select “YES” or “NO.”

- Each time you press the button, the display alternates between “YES” and “NO.”

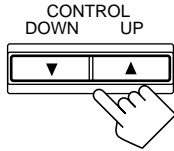

YES: Select this when a subwoofer is connected.

NO: Select this when no subwoofer is used.

Note:

You cannot use **SUBWOOFER OUT ON/OFF** on the front panel (see page 14) and adjust the subwoofer output level (see below) when “SUBWOOFER” is set to “NO.”

Adjusting the Subwoofer Output Level

You can adjust the subwoofer output level if you have selected “YES” for the “SUBWOOFER” (see above).

Once it has been adjusted, the receiver memorizes the adjustment.

- You can do this setting for each source.

Before you start, remember....

- There is a time limit in doing the following steps. If the setting is canceled before you finish, start from step 1 again.
- When the front speakers are all deactivated, the subwoofer level cannot be adjusted.

On the front panel:

1. Press **LEVEL ADJUST** repeatedly until “SUBWFR” appears on the display.

The display changes to show the current setting.



2. Press **CONTROL UP ▲/DOWN ▼** to adjust the subwoofer output level (from -20 dB to +10 dB).

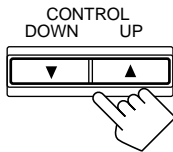

From the remote control:

1. Press **SOUND**.

The 10 keys are activated for sound adjustments.

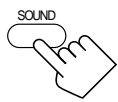

2. Press **SUBWFR**.

“S-WFR” appears on the remote control display window.



3. Press **LEVEL +/-** to adjust the subwoofer output level (from -20 dB to +10 dB).



Setting the Speakers for a Surround Field

To obtain the best possible surround sound of the Surround and DSP modes, you have to register the information about the speakers arrangement after all connections are completed.

Before you start, remember....

- There is a time limit in doing the following steps. If the setting is canceled before you finish, start from step 1 again.

Front, Center, and Rear Speaker Setting

Register the sizes of all the connected speakers.

- When you change your speakers, you need to register the information about the speakers again.

On the front panel ONLY:

1. Press **SETTING** repeatedly until “FRONT SPK” (Front Speaker), “CTR SPK” (Center Speaker) or “REAR SPK” (Rear Speaker) appears on the display.

The display changes to show the current setting.

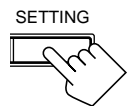

2. Press **CONTROL UP ▲/DOWN ▼** to select the appropriate item about the speaker selected in the above step.

- Each time you press the button, the display changes to show the following:

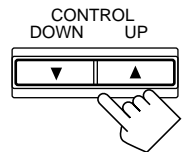

→ LARGE ↔ SMALL ↔ NONE ←

LARGE: Select this when the speaker size is relatively large.

SMALL: Select this when the speaker size is relatively small.

NONE: Select this when you have not connected a speaker. (Not selectable for the front speakers)

3. Repeat steps 1 and 2 to select the appropriate items for the other speakers.

Notes:

- Keep the following comment in mind as reference when adjusting.
 - If the size of the cone speaker unit built in your speaker is greater than 12 cm, select “LARGE,” and if it is smaller than 12 cm, select “SMALL.”
- If you have selected “NO” for the subwoofer setting, you can only select “LARGE” for the front speaker setting.
- If you have selected “SMALL” for the front speaker setting, you cannot select “LARGE” for the center and rear speaker settings.

Center Delay Time Setting

Register the delay time of the sound from the center speaker, comparing to that of the sound from the front speakers.

If the distance from your listening point to the center speaker is equal to that to the front speakers, select 0 ms. As the distance to the center speaker becomes shorter, increase the delay time.

- 1 msec increase (or decrease) in delay time corresponds to 30 cm decrease (or increase) in distance.
- When shipped from the factory, the delay time is set to 0 ms.

On the front panel ONLY:

1. Press **SETTING** repeatedly until “**CTR DELAY**” (Center Delay) appears on the display.

The display changes to show the current setting.

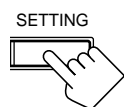

2. Press **CONTROL UP ▲/DOWN ▼** to select the delay time of the center speaker output (from 0 ms to 5 ms).

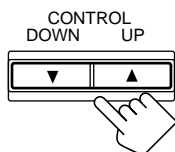

Notes:

- Center delay time is not valid for the DVD MULTI playback mode.
- You cannot adjust the center delay time when you have set “CTR SPK” to “NONE.”

Rear Delay Time Setting

Register the delay time of the sound from the rear speakers, comparing to that of the sound from the front speakers.

If the distance from your listening point to the rear speakers is equal to that to the front speakers, select 0 ms. As the distance to the rear speakers becomes shorter, increase the delay time.

- 1 msec increase (or decrease) in delay time corresponds to 30 cm decrease (or increase) in distance.
- When shipped from the factory, the delay time is set to 5 ms.

On the front panel ONLY:

1. Press **SETTING** repeatedly until “**REAR DELAY**” appears on the display.

The display changes to show the current setting.

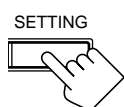

2. Press **CONTROL UP ▲/DOWN ▼** to select the delay time of the rear speaker output (from 0 ms to 15 ms).

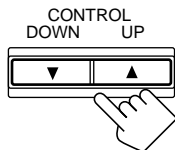

Notes:

- Rear delay time is not valid for the DVD MULTI playback mode.
- You cannot adjust the rear delay time when you have set “REAR SPK” to “NONE.”

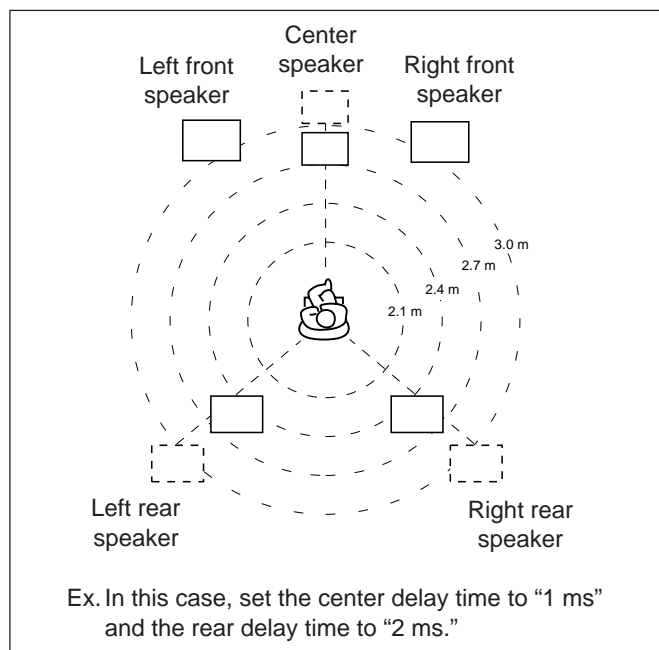

Crossover Frequency Setting

Small speakers cannot reproduce the bass sound very well. So, if you have used a small speaker for any of the front, center, and rear channels, this receiver automatically reallocates the bass elements, originally assigned to the channel for which you have connected the small speaker, to another channel (for which you have connected the large speaker).

To use this function properly, you need to set the crossover frequency level according to the size of the small speaker connected.

- If you have selected “LARGE” for all speakers (see page 17), this function cannot be adjusted.

On the front panel ONLY:

1. Press **SETTING** repeatedly until “**CROSS OVER**” appears on the display.

The display changes to show the current setting.

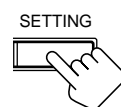

2. Press **CONTROL UP ▲/DOWN ▼** to select the crossover frequency level according to the size of the small speaker connected.

- Each time you press the button, the display changes to show the following:

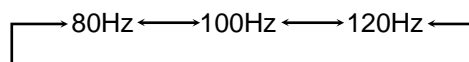

- Use the following comments as reference when adjusting.

80Hz: Select this when the cone speaker unit built in the speaker is about 12 cm.

100Hz: Select this when the cone speaker unit built in the speaker is about 10 cm.

120Hz: Select this when the cone speaker unit built in the speaker is about 8 cm.

Note:

Crossover frequency is not valid for the DVD MULTI playback, 5 CH / 4 CH Stereo, 3D-PHONIC, and HEADPHONE DSP modes.

Low Frequency Effect Attenuator Setting

If the bass sound is distorted while playing back a source using Dolby Digital or DTS Digital Surround, follow the procedure below.

On the front panel ONLY:

1. Press **SETTING** repeatedly until **“LFE ATT” (Low Frequency Effect Attenuator)** appears on the display.

The display changes to show the current setting.

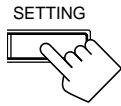

2. Press **CONTROL UP ▲/DOWN ▼** to select the low frequency effect attenuator level.

- Each time you press the button, the display changes to show the following:

0dB ←→ 10dB

0dB:	Normally select this.
10dB:	Select this when the bass sound is distorted.

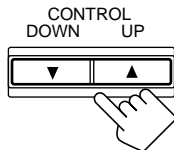

Notes:

- Low frequency effect attenuator is not valid for the DVD MULTI playback mode.
- This function takes effect only when the Dolby Digital or DTS Digital Surround sounds with LFE signal comes in (with “SUBWOOFER” set to “YES”).

Digital Input (DIGITAL IN) Terminal Setting

When you use the digital input terminals, you have to register what components are connected to which terminals (DIGITAL IN 1/2/3/4).

Before you start, remember...

- There is a time limit in doing the following steps. If the setting is canceled before you finish, start from step 1 again.

On the front panel ONLY:

To set the DIGITAL 1 terminal:

1. Press **SETTING** repeatedly until **“DGTL COAX” (Digital Coaxial)** appears on the display.

The display changes to show the current setting for DIGITAL 1 terminal.

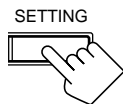

2. Press **CONTROL UP ▲/DOWN ▼** to select the appropriate digital terminal setting.

- Each time you press the button, the display changes to show the following:

1: DVD ⇄ 1: MD** ⇄ 1: CDR ⇄ 1: TV (or DBS*) ⇄
1: CD ⇄ (back to the beginning)

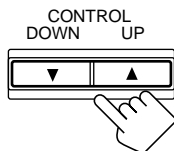

* If you have changed the source name from “TV” to “DBS,” “DBS” appears (see page 16).

** Change the source name to “MD” for TAPE/MD jacks when you use an MD recorder (see page 16).

To set the DIGITAL 2/3/4 terminals:

1. Press **SETTING** again until **DIGITAL 2/3/4 terminals' setting** appears on the display.

The display changes to show the current settings.

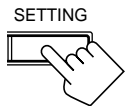

DIGITAL 2 terminal setting

2: CD
3: TV 4: CDR

DIGITAL 3 terminal setting DIGITAL 4 terminal setting

2. Press **CONTROL UP ▲/DOWN ▼** to select the appropriate digital terminal settings.

- Each time you press the buttons, the display changes to show the following:

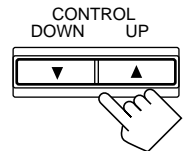

When the DGTL COAX (DIGITAL 1) is set to “DVD”

2: CD 3: TV (or DBS*) 4: CDR ⇄
2: CD 3: TV (or DBS*) 4: MD** ⇄
2: CD 3: MD** 4: CDR ⇄
2: MD** 3: TV (or DBS*) 4: CDR ⇄
(back to the beginning)

When the DGTL COAX (DIGITAL 1) is set to “MD”**

2: CD 3: TV (or DBS*) 4: DVD ⇄
2: CD 3: DVD 4: CDR ⇄
2: DVD 3: TV (or DBS*) 4: CDR ⇄
2: CD 3: TV (or DBS*) 4: CDR ⇄
(back to the beginning)

When the DGTL COAX (DIGITAL 1) is set to “CDR”

2: MD** 3: TV (or DBS*) 4: DVD ⇄
2: CD 3: TV (or DBS*) 4: DVD ⇄
2: CD 3: TV (or DBS*) 4: MD** ⇄
2: CD 3: MD** 4: DVD ⇄
(back to the beginning)

When the DGTL COAX (DIGITAL 1) is set to “TV” or “DBS”

2: CD 3: MD** 4: CDR ⇄ 2: MD** 3: DVD 4: CDR ⇄
2: CD 3: DVD 4: CDR ⇄ 2: CD 3: DVD 4: MD** ⇄
(back to the beginning)

When the DGTL COAX (DIGITAL 1) is set to “CD”

2: DVD 3: TV (or DBS*) 4: MD** ⇄
2: DVD 3: MD** 4: CDR ⇄
2: MD** 3: TV (or DBS*) 4: CDR ⇄
2: DVD 3: TV (or DBS*) 4: CDR ⇄
(back to the beginning)

* If you have changed the source name from “TV” to “DBS,” “DBS” appears (see page 16).

** Change the source name to “MD” for TAPE/MD jacks when you use an MD recorder (see page 16).

Note:

When shipped from the factory, the DIGITAL IN terminals have been set for use with the following components.

- DIGITAL 1 (coaxial): For DVD player
- DIGITAL 2 (optical): For CD player
- DIGITAL 3 (optical): For digital TV broadcast tuner
- DIGITAL 4 (optical): For CD recorder

Selecting the Analog or Digital Input Mode

When you have connected digital source components using the digital terminals (see page 8), you need to change the input mode for these components to the appropriate digital input mode correctly — DGTL AUTO, DGTL DTS, or DGTL D.D.

Before you start, remember...

- The digital input (DIGITAL IN) terminal setting should be correctly done for the sources you want to select the digital input mode for. Without setting this digital input terminal correctly, you cannot change the input mode from analog input to digital input even if you follow the procedure below.

On the front panel:

1. Press one of the source selecting button (DVD, TV SOUND/DBS, CD, CDR, or TAPE/MD)* for which you want to change the input mode.

The lamp on the front panel button for selected source lights up.

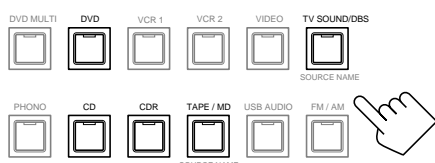

Note:

* Among the source listed above, you can select the digital input only for the sources which you have selected the digital input terminals for. (See "Digital Input (DIGITAL IN) Terminal Setting" on page 19.)

2. Press INPUT ANALOG/DIGITAL (INPUT ATT) briefly to change the input mode.

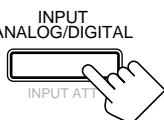

- Each time you press the button, the input mode changes as follows.

DGTL AUTO (Digital) ↔ ANALOG

DGTL AUTO: Select this for the digital input mode. The receiver automatically detects the incoming signal.

ANALOG: Select this for the analog input mode.

ANALOG always lights up.

When selecting "DGTL AUTO," following indicators showing detected signals light up on the display.

DGTL AUTO	: Always lights up.
LINEAR PCM	: • Lights up when Linear PCM signals come in. • The frame flashes when detecting signals. • LINEAR PCM without frame flashes when PCM signals are not recognized.
DIGITAL	: Lights up when Dolby Digital signals come in.
dts	: Lights up when DTS Digital Surround signals come in.

When playing a software encoded with the Dolby Digital or DTS Digital Surround, "DGTL AUTO" may not work properly and the following symptoms may occur:

- Sound does not come out at the beginning of playback.
- Noise comes out while using the searching or skipping chapters or tracks.

In this case press CONTROL UP ▲/DOWN ▼ to select "DGTL D.D" or "DGTL DTS" while "DGTL AUTO" still remains on the display.

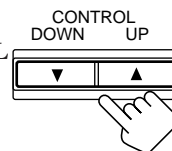

- Each time you press the button, the input mode changes as follows.



When selecting "DGTL D.D" or "DGTL DTS," following indicators showing detected signals light up on the display.

DGTL : Always lights up.

When selecting "DGTL D.D"

DIGITAL : • Lights up when Dolby Digital signals come in.
• The frame flashes when Dolby Digital signals are not recognized.

When selecting "DGTL DTS"

dts : • Lights up when DTS Digital Surround signals come in.
• The frame flashes when DTS Digital Surround signals are not recognized.

Note:

When you turn off the power or select another source, "DGTL D.D" and "DGTL DTS" settings are canceled and the digital input mode is automatically reset to "DGTL AUTO."

To change the input mode back to analog input, select "ANALOG" in step 2.

From the remote control:

1. Press the source selecting button (DVD, CD, TV/DBS, CDR, or TAPE/MD)* for which you want to change the input mode.

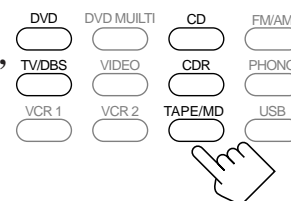

Note:

* Among the source listed above, you can select the digital input only for the sources which you have selected the digital input terminals for. (See "Digital Input (DIGITAL IN) Terminal Setting" on page 19.)

2. Press ANALOG/DIGITAL INPUT to change the input mode.



- Each time you press the button, the input mode changes as follows:

DGTL AUTO (Digital) ↔ ANALOG

When playing a software encoded with the Dolby Digital or DTS Digital Surround, "DGTL AUTO" may not happen to work well. In this case press CONTROL UP ▲/DOWN ▼ on the front panel to select "DGTL D.D" or "DGTL DTS" (while "DGTL AUTO" remains on the display).

Note:

You can select "DGTL D.D" or "DGTL DTS" from the remote control by using the On-Screen Menus (see page 36).

Showing the Text Information on the Display

When you have connected an MD recorder or CD player equipped with TEXT COMPU LINK remote control system (see page 42), you can show the text information, such as disc title or track title, on the display of this receiver. To show it on the display, follow the procedure below.

Before you start, remember....

- There is a time limit in doing the following steps. If the setting is canceled before you finish, start from step 1 again.

On the front panel ONLY:

1. Press **SETTING** repeatedly until “**FL DISP**” (Display) appears on the display.

The display changes to show the current setting.

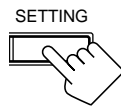

2. Press **CONTROL UP ▲/DOWN ▼** to select either the source name or the text information to be shown on the display.

- Each time you press the button, the display changes to show the following:

NORM (Normal) ←→ TEXT

NORM:	Source name and Surround/DSP mode appear during play.
TEXT:	Text information appears during play.

Note:

Though you have selected “TEXT,” the source name and Surround / DSP mode appear if a playing disc has no text information.

Basic Setting and Adjustment — Auto Memory

Without any setting required, this receiver stores different sound settings for each different playing source automatically whenever you do the following:

- Turning on the power (see page 11)
- Changing the source to play (see page 11)
- Changing the source name (see page 16)

So, you do not have to change the sound settings next time you select the same source. The stored settings for the selected source are automatically recalled.

The following settings are automatically stored for each source:

- Front speaker output balance (see page 16)
- Subwoofer setting and its output level (see page 17)
- Input attenuator mode (see page 14)
- Midnight mode (see page 13)
- Bass boost (see page 14)
- Digital equalization adjustment (see page 15)
- Line direct (see page 14)
- Surround mode on/off (see page 26)
- Surround/DSP mode setting (see pages 27 – 34)
- DVD MULTI playback mode setting (see page 35)
- Analog/digital input mode (see page 20)

You can assign and store the volume level for each source. See below.

Notes:

- If the source is FM or AM, you can assign different settings for each band.
- You cannot assign and store different settings for each digital input mode.
- The Surround modes and DSP modes cannot be used with DVD MULTI playback mode at the same time.

To store the volume level

Before you start, remember....

- There is a time limit in doing the following steps. If the setting is canceled before you finish, start from step 1 again.

On the front panel ONLY:

1. Press **SETTING** repeatedly until “**ONE TOUCH**” appears on the display.

The display changes to show the current setting.

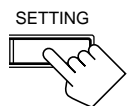

2. Press **CONTROL UP ▲/DOWN ▼** to turn on the One Touch Operation.

The ONE TOUCH OPERATION indicator lights up on the display.

- Each time you press the button, the one touch operation function turns on (“ON”) and off (“OFF”).

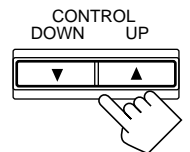

To recall the volume level

With the ONE TOUCH OPERATION indicator lit, the volume level for the currently selected source is recalled when the source is selected.

To cancel the One Touch Operation

Select “OFF” in step 2 above so that the ONE TOUCH OPERATION indicator goes off. (Even though the One Touch Operation is canceled, the recalled volume remains active.)

Receiving Radio Broadcasts

You can browse through all the stations or use the preset function to go immediately to a particular station.

Setting the AM Tuner Interval Spacing

Some countries space AM stations 9 kHz apart, and other countries use 10 kHz spacing.

On the front panel ONLY:

To select the 10 kHz interval:

Be sure the receiver is turned off, but is plugged into an AC outlet. Hold down FM/AM TUNING ▲ and press STANDBY/ON ⏻. Now the 10 kHz interval is selected.

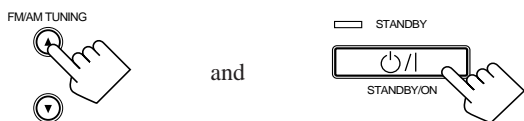

To change back to the 9 kHz interval:

Be sure the receiver is turned off, but is plugged into an AC outlet. Hold down FM/AM TUNING ▼ and press STANDBY/ON ⏻. Now the 9 kHz interval is selected.

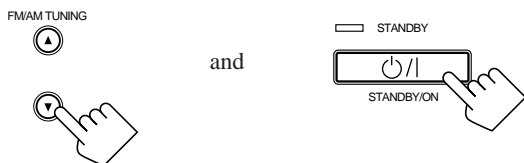

Tuning in Stations Manually

On the front panel:

1. Press FM/AM to select the band (FM or AM).

The FM/AM lamp on the front panel button lights up. The last received station of the selected band is tuned in.

- Each time you press the button, the band alternates between FM and AM.

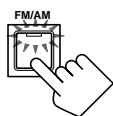
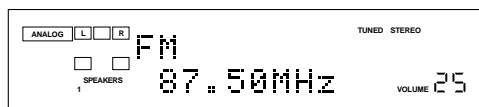

2. Press FM/AM TUNING ▲/▼ until you find the frequency you want.

- Pressing FM/AM TUNING ▲ increases the frequency.
- Pressing FM/AM TUNING ▼ decreases the frequency.



From the remote control:

1. Press FM/AM to select the band (FM or AM).

The FM/AM lamp on the front panel button lights up. The last received station of the selected band is tuned in.

- Each time you press the button, the band alternates between FM and AM.



2. Press TUNING UP ► or TUNING DOWN ◀ until you find the frequency you want.

- Pressing TUNING UP ► increases the frequency.
- Pressing TUNING DOWN ◀ decreases the frequency.



Notes:

- When a station of sufficient signal strength is tuned in, the TUNED indicator lights up on the display.
- When an FM stereo program is received, the STEREO indicator also lights up.
- When you hold the button (and release it) in step 2, the frequency keeps changing until a station is tuned in.

Using Preset Tuning

Once a station is assigned to a channel number, the station can be quickly tuned. You can preset up to 30 FM and 15 AM stations.

To store the preset stations

Before you start, remember..

- There is a time limit in doing the following steps. If the setting is canceled before you finish, start from step 1 again.

On the front panel ONLY:

1. Tune in the station you want to preset (see “Tuning in Stations Manually” on the left).

- If you want to store the FM reception mode for this station, select the FM reception mode you want. See “Selecting the FM Reception Mode” on page 23.

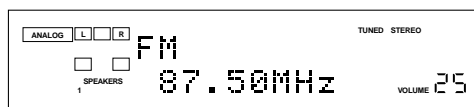

2. Press MEMORY.

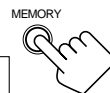

The channel number position starts flashing on the display for about 10 seconds.

3. Press FM/AM PRESET ▲/▼ to select a channel number while the channel number position is flashing.



4. Press MEMORY again while the selected channel number is flashing on the display.

The selected channel number stops flashing. The station is assigned to the selected channel number.

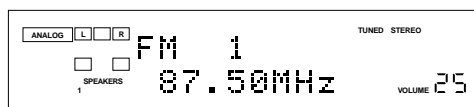
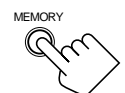

5. Repeat steps 1 to 4 until you store all the stations you want.

To erase a stored preset station

Storing a new station on a used number erases the previously stored one.

To tune in a preset station

On the front panel:

1. Press FM/AM to select the band (FM or AM).

The FM/AM lamp on the front panel button lights up. The last received station of the selected band is tuned in.

- Each time you press the button, the band alternates between FM and AM.

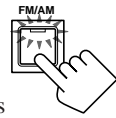

2. Press FM/AM PRESET ▲/▼ until you find the channel you want.

- Pressing FM/AM PRESET ▲ increases the number.
- Pressing FM/AM PRESET ▼ decreases the number.



From the remote control:

1. Press FM/AM.

The last received station of the selected band is tuned in.

- Each time you press the button, the band alternates between FM and AM.

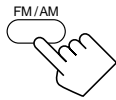

2. Press the 10 keys to select a preset channel number.

- For channel number 5, press 5.
- For channel number 15, press +10 then 5.
- For channel number 20, press +10 then 10.
- For channel number 30, press +10, +10, then 10.

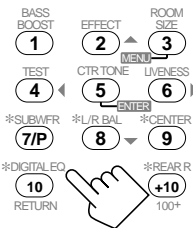

Note:

When you use the 10 keys on the remote control, be sure that they are activated for the tuner, not for the CD and others. (See page 11.)

Selecting the FM Reception Mode

When an FM stereo broadcast is hard to receive or noisy

You can change the FM reception mode while receiving an FM broadcast.

- You can store the FM reception mode for each preset station.

Press FM MODE.

- Each time you press the button, the FM reception mode alternates between "AUTOMUTING" and "MONO."



On the front panel



From the remote control

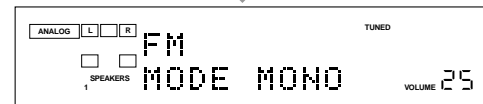
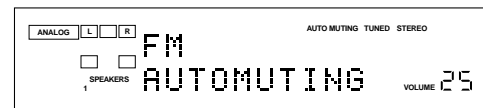

AUTOMUTING: When a program is broadcasted in stereo, you will hear stereo sound; when in monaural, you will hear monaural sounds. This mode is also useful to suppress static noise between stations. The AUTO MUTING indicator lights up on the display.

MONO: Reception will be improved although you will lose the stereo effect. In this mode, you will hear noise while tuning into the stations. The AUTO MUTING indicator goes off from the display.

Note:

When using the FM MODE on the remote control, be sure that the 10 keys are activated for the tuner, not for the CD and others. (See page 11.)

Creating a Surround Field in Your Room

The built-in Surround Processor provides Surround mode and four types of the DSP (Digital Signal Processor) mode — DAP (Digital Acoustic Processor) mode, 5 CH/4 CH Stereo mode, 3D-PHONIC mode, and HEADPHONE DSP mode. With this receiver, you can use a Surround mode and a DSP mode at the same time. Once you have adjusted Surround and/or DSP modes, the adjustments done for each source are memorized.

Surround modes

With this receiver, you can use two types of the Surround mode. **Following modes cannot be used when only the front speakers are connected to this receiver (without the rear speakers or center speaker).**

Dolby Surround (Dolby Digital and Dolby Pro Logic)*

Used to watch the soundtracks of software encoded with Dolby Digital (bearing the mark ) or with Dolby Surround (bearing the mark .

Dolby Surround encoding format records the left front channel, right front channel, center channel, and rear channel (total 4 channels) signals into 2 channels. The Dolby Pro Logic decoder built in this receiver decodes these 2 channel signals into original 4 channel signals — matrix-based multichannel reproduction, and allows you to enjoy the realistic sound field in your listening room.

On the other hand, Dolby Digital encoding method (so called a discrete 5.1 channel digital audio format) records and compresses the left front channel, right front channel, center channel, left rear channel, right rear channel, and LFE channel (total 6 channels, but LFE channel is counted as 0.1 channel, therefore called 5.1 channels) signals digitally. Each channel is completely independent from other channel signals to avoid interference, therefore, you can obtain much better sound quality with much stereo and surround effects.

The Dolby Digital decoder built in this receiver can create much more realistic sound field in your listening room. You may feel as if you were in a real theater.

In addition, Dolby Digital enables stereo rear sounds, and sets the cutoff frequency of the rear treble at 20 kHz, comparing to 7 kHz for Dolby Pro Logic. These facts enhance the sound movement and being-there feelings much more than Dolby Pro Logic.

- To enjoy the software encoded with Dolby Digital, you must connect the source component using the digital terminal on the rear of this receiver. (See page 8.)

DTS Digital Surround**

DTS Digital Surround is another discrete 5.1 channel digital audio format available on CD, LD, and DVD software encoded with DTS Digital Surround (bearing the mark .

Comparing to Dolby Digital, audio compression rate is relatively low. This fact allows DTS Digital Surround format to add breadth and depth to the reproduced sounds. As a result, DTS Digital Surround features natural, solid and clear sound.

- To enjoy the software encoded with DTS Digital Surround, you must connect the source component using the digital terminal on the rear of this receiver. (See page 8.)

DSP modes

With this receiver, you can use four types of the DSP mode.

DAP modes

In order to reproduce a more acoustic sound field in your listening room while playing music sources, you can use DAP modes. **This mode can be used when the front speakers are connected to this receiver (without respect to the rear/center speaker connection).**

THEATER 1:	Reproduces the sound field of a large theater (where the seating capacity about 1,000).
THEATER 2:	Reproduces the sound field of a small theater (where the seating capacity about 300).
HALL 1:	Gives clear vocal and the feeling of a large concert hall (where the seating capacity about 1,000).
HALL 2:	Gives clear vocal and the feeling of a small concert hall (where the seating capacity about 300).
LIVE CLUB:	Gives the feeling of a live music club with a low ceiling.
DANCE CLUB:	Gives a throbbing bass beat.
PAVILION:	Gives the spacious feeling of a pavilion with a high ceiling.

5 CH/4 CH Stereo mode

You can create more powerful sound field for both of the digital and analog stereo sounds source. The 4 CH Stereo mode reproduces a sound field through the front left and right speakers and rear left and right speakers. The 5 CH Stereo mode adds the center channel element to the 4 CH Stereo sound field by outputting mixed left and right signals through the center speaker. **This mode cannot be used when only the front speakers are connected to this receiver without the rear speakers.**

Note:

"5CH STEREO" is selected when setting the center speaker to "LARGE" or "SMALL," and "4CH STEREO" is selected when setting the center speaker to "NONE" (see page 17).

* Manufactured under license from Dolby Laboratories. "Dolby," "Pro Logic," and the double-D symbol are trademarks of Dolby Laboratories. Confidential Unpublished Works. ©1992–1997 Dolby Laboratories, Inc. All rights reserved.

** Manufactured under license from Digital Theater Systems, Inc. US Pat. No. 5,451,942 and other world-wide patents issues and pending. "DTS" and "DTS Digital Surround" are trademarks of Digital Theater Systems, Inc. ©1996 Digital Theater Systems, Inc. All rights reserved.

3D-PHONIC modes

The 3D-PHONIC mode gives you such a nearly surround effect as is reproduced through the Dolby Surround decoder, which is widely used to reproduce sounds with a feeling of movement like those experienced in movie theaters. The 3D-PHONIC mode is the result of research on sound localization technology carried out at JVC for many years. **This mode can be used when the front speakers are connected to this receiver (without respect to the rear/center speaker connection).** When the 3D-PHONIC mode is reproduced with the center speaker connected, you can feel as if actors on the screen actually speak in your room.

- You can select “3D ACTION” only when playing an analog or linear PCM (digital) source.
- You can select “3D DIGITAL” only when playing a source encoded with Dolby Digital or DTS Digital Surround.

3D ACTION: Best for action and war movies — where the action is fast and explosive.

3D DIGITAL: Reproduces multichannel source encoded with Dolby Digital or with DTS Digital Surround.

HEADPHONE DSP mode

The HEADPHONE DSP mode can create the stereo sound as if you listen through the speakers while listening to a source using headphones. So you can feel as if you were in a music room. **This mode can be used only when both of the front speakers are deactivated (see page 13.)**

Notes:

- When you select “DVD MULTI” as the source to play, you cannot select or adjust the Surround and DSP modes.
- The PRO LOGIC indicator lights up when the Dolby Pro Logic decoder built in this receiver is activated.
- When the line direct function is turned on, the Surround and DSP modes are canceled temporarily (see page 14).
- No adjustment can be made for the HEADPHONE DSP mode.

Reproducing the Sound Field

The sound heard in a concert hall or club consists of direct sound and indirect sound — early reflections and reflections from behind. Direct sounds reach the listener directly without any reflection. On the other hand, indirect sounds are delayed by the distances of the ceiling and walls. These direct sounds and indirect sounds are the most important elements of the acoustic surround effects. The Surround and DSP modes can create these important elements, and give you a real “being there” feeling.

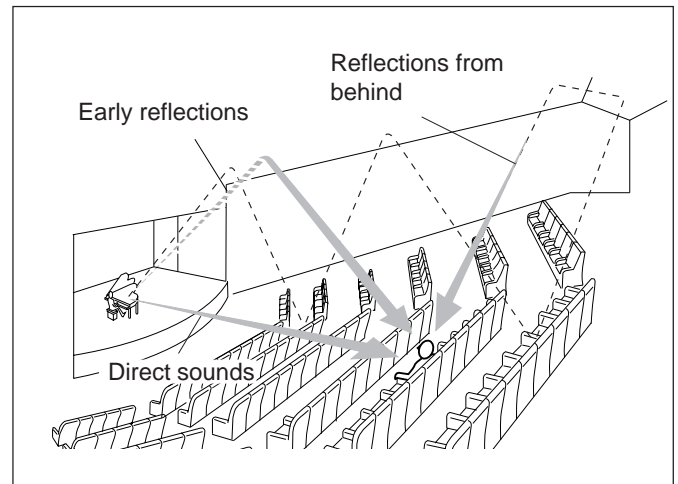

DVD MULTI Playback Mode

This receiver provides the DVD MULTI playback mode for reproducing the analog discrete 5.1 channel output mode of the DVD player or other equipment.

You can adjust the DVD MULTI playback mode while playing back a video software such as a DVD using the analog discrete 5.1 channel output mode.

- For the DVD MULTI playback mode connection, see page 7.
- For details on the DVD MULTI playback mode, see page 35.

DSP Modes Available to Input Mode

○: Possible / ×: Impossible

MODE INPUT SIGNAL	SURROUND	D S P			SURROUND with DAP	SURRE. OFF DSP OFF	HEADPHOHE	
		DAP MODE	3D ACTION (DIGITAL)	5 CH/4 CH Stereo			HEADPHONE DSP	HEADPHONE
ANALOG (2 CH)	○ (DOLBY PRO LOGIC)	○	○ (3D ACTION)	○	○	○	○	○
DVD MULTI (5.1 CH)	×	×	×	×	×	×	×	○
LINEAR PCM	○ (DOLBY PRO LOGIC)	○	○ (3D ACTION)	○	○	○	○	○
DOLBY DIGITAL	○ ¹ (DOLBY DIGITAL)	○	○ (3D DIGITAL)	○	○	○	○	○
DTS	○ ² (DTS SURROUND)	○	○ (3D DIGITAL)	○	○	○	○	○

¹ When 2 channel signal comes in, DOLBY PRO LOGIC is selected. When other signals come in, DOLBY DIGITAL is selected.

² When 2 channel signal comes in, DOLBY PRO LOGIC is selected. When other signals come in, DTS SURROUND is selected.

Available DSP Modes According to the Speaker Arrangement

Available DSP modes will vary depending on how many speakers are used with this receiver.

Make sure that you have set the speaker information correctly (see page 17).

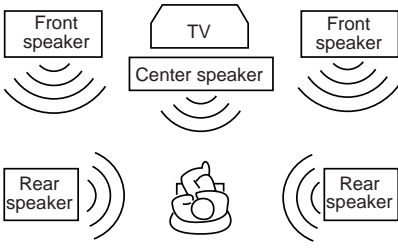
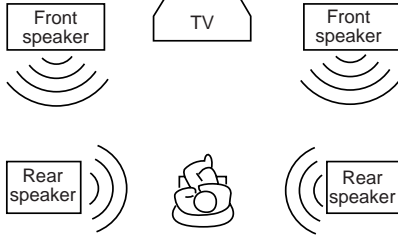
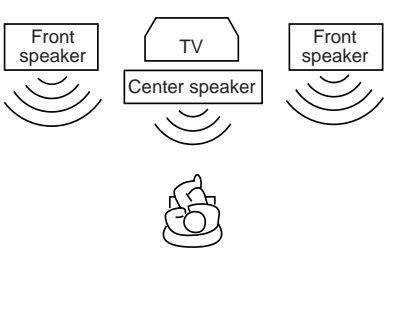
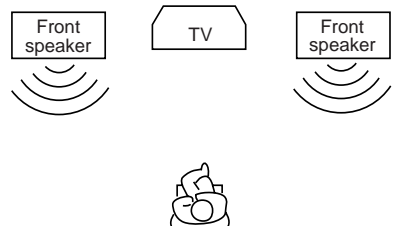
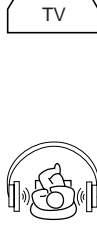
Speaker arrangements	Available DSP modes
	<p>Each time you press DSP MODE, the DSP modes change as follows:</p> <p>THEATER 1 → THEATER 2 → HALL 1 → HALL 2 → LIVE CLUB → DANCE CLUB → PAVILION → 5CH STEREO (when using 5 speakers) or 4CH STEREO (when using 4 speakers)* → 3D ACTION or 3D DIGITAL → SURR. OFF (DSP OFF) → (Back to the beginning)</p> <div style="border: 1px solid black; padding: 5px; margin-top: 10px;"> <p>To activate the Surround mode, press SURROUND ON/OFF button so that the SURROUND ON/OFF lamp on the front panel button lights up.</p> </div> <p>Notes:</p> <ul style="list-style-type: none"> If the settings for the center and the rear speakers are changed to "NONE" (see page 17), the Surround mode will be canceled. When both of the Surround mode and DSP mode are deactivated, "SURR. OFF" appears on the display. <p>* "5CH STEREO" is selected when setting the center speaker to "LARGE" or "SMALL," and "4CH STEREO" is selected when setting the center speaker to "NONE" (see page 17).</p>
	<p>THEATER 1 → THEATER 2 → HALL 1 → HALL 2 → LIVE CLUB → DANCE CLUB → PAVILION → 3D ACTION or 3D DIGITAL → SURR. OFF (DSP OFF) → (Back to the beginning)</p> <div style="border: 1px solid black; padding: 5px; margin-top: 10px;"> <p>To activate the Surround mode, press SURROUND ON/OFF button so that the SURROUND ON/OFF lamp on the front panel button lights up.</p> </div> <p>Notes:</p> <ul style="list-style-type: none"> If the setting for the center speaker is changed to "NONE" (see page 17), the Surround mode will be canceled. When both of the Surround mode and DSP mode are deactivated, "SURR. OFF" appears on the display.
	<p>THEATER 1 → THEATER 2 → HALL 1 → HALL 2 → LIVE CLUB → DANCE CLUB → PAVILION → 3D ACTION or 3D DIGITAL → SURR. OFF (DSP OFF) → (Back to the beginning)</p> <p>Note:</p> <p>Surround mode cannot be used when only the front speakers are connected.</p>
	<p>THEATER 1 → THEATER 2 → HALL 1 → HALL 2 → LIVE CLUB → DANCE CLUB → PAVILION → 3D ACTION or 3D DIGITAL → SURR. OFF (DSP OFF) → (Back to the beginning)</p> <p>Note:</p> <p>Surround mode cannot be used when only the front speakers are connected.</p>
	<p>HEADPHONE ↔ HEADPHONE DSP</p> <p>Note:</p> <p>To use the HEADPHONE or HEADPHONE DSP mode, deactivate both of the front speakers (see page 13).</p>

Adjusting the Surround Modes



You can also use a Surround mode with a DAP mode (see page 30).

Before you start, remember...

- Make sure that you have set the speaker information correctly (see page 17).
- There is a time limit in doing the following steps. If the setting is canceled before you finish, start from step 3 again.
- You cannot adjust the rear speaker output levels when you have set "REAR SPK" to "NONE." See page 17.
- You cannot adjust the center speaker output level and center tone when you have set "CTR SPK" to "NONE." See page 17.
- To adjust the front speaker output balance and subwoofer output level, see pages 16 and 17.

From the remote control:

1. Select and play a sound source.

- To enjoy Dolby Pro Logic, play back a software encoded with Dolby Surround and labeled with  mark.
- To enjoy Dolby Digital, play back a software encoded with Dolby Digital and labeled with  mark.
- To enjoy DTS Digital Surround, play back a software encoded with DTS Digital Surround and labeled with  mark.

2. Press SURROUND ON/OFF to activate an appropriate Surround mode — PRO LOGIC, DOLBY DIGITAL or DTS SURROUND.



The SURROUND ON/OFF lamp on the front panel button lights up.

- Each time you press the button, the Surround mode turns on and off alternately.
- When "PRO LOGIC" is selected, the PRO LOGIC indicator lights up on the display.

3. Press SOUND.

The 10 keys are activated for sound adjustments.

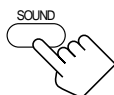

4. Press TEST to check the speaker output balance.

"TEST TONE L" starts flashing on the display, and a test tone comes out of the speakers in the following order:

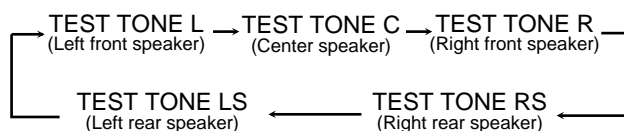
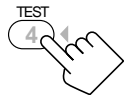

Notes:

- You can adjust the speaker output levels without outputting the test tone.
- No test tone comes out of the center speaker when "CTR SPK" is set to "NONE" (see page 17).
- No test tone comes out of the rear speakers when "REAR SPK" is set to "NONE" (see page 17).
- If the TV is turned on and the proper video input is selected on the TV, the test tone screen will appear on the TV.

5. Select the speaker you want to adjust.

- To select the center speaker level, press CENTER. "CTR" appears on the remote control display window.
- To select the left rear speaker level, press REAR L. "REARL" appears on the remote control display window.
- To select the right rear speaker level, press REAR R. "REARR" appears on the remote control display window.



6. Press LEVEL +/- to adjust the speaker output levels (-10 dB to +10 dB).

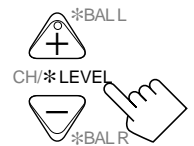

7. Press SOUND.

- To adjust other speaker output levels, repeat steps 5 and 6.

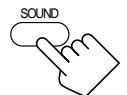

8. Press TEST again to stop the test tone.



9. Press CTR TONE to select the center tone level you want.



The center tone adjustment affects the mid-frequency range, which the human voice is mostly made up of.

- Each time you press the button, the display changes to show the following:

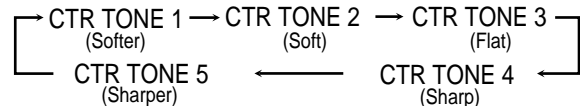

To make the dialogue softer, select "CTR TONE 1" or "CTR TONE 2."



To make the dialogue clearer, select "CTR TONE 4" or "CTR TONE 5."

When "CTR TONE 3" is selected, no adjustment is applied.

On the front panel:

You can also use the buttons on the front panel to adjust the Surround modes. However, no test tone is available when using the buttons on the front panel. So, make adjustments while listening to the sound of the source played back.

1. Select and play a sound source.

- To enjoy Dolby Pro Logic, play back a software encoded with Dolby Surround and labeled with  mark.
- To enjoy Dolby Digital, play back a software encoded with Dolby Digital and labeled with  mark.
- To enjoy DTS Digital Surround, play back a software encoded with DTS Digital Surround and labeled with  mark.

2. Press SURROUND ON/OFF to activate an appropriate Surround mode — PRO LOGIC, DOLBY DIGITAL or DTS SURROUND.

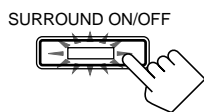

The SURROUND ON/OFF lamp on the front panel button lights up.

- Each time you press the button, the Surround mode turns on and off alternately.
- When “PRO LOGIC” is selected, the PRO LOGIC indicator lights up on the display.

3. Adjust the speaker output levels.

1) Press LEVEL ADJUST repeatedly until one of the following indications appears on the display.

“CENTER”:

To adjust the center speaker level.

“REAR L”:

To adjust the left rear speaker level.

“REAR R”:

To adjust the right rear speaker level.

2) Press CONTROL UP ▲/DOWN ▼ to adjust the selected speaker output level (from -10 dB to +10 dB).

3) Repeat 1) and 2) to adjust the other speaker output levels.

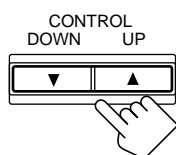

4. Adjust the center tone.

1) Press EFFECT repeatedly until “CTR TONE” appears on the display.

The display shows the current setting.

2) Press CONTROL UP ▲/DOWN ▼ to select the center tone level you want.

- Each time you press the button, the display changes to show the following:

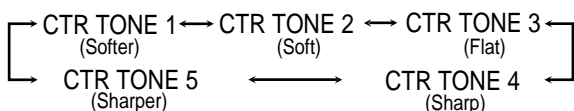

To make the dialogue softer, select “CTR TONE 1” or “CTR TONE 2.”

To make the dialogue clearer, select “CTR TONE 4” or “CTR TONE 5.”

When “CTR TONE 3” is selected, no adjustment is applied.

On the front panel:

1. Press DSP MODE repeatedly until the DAP mode you want to adjust — THEATER 1, THEATER 2, HALL 1, HALL 2, LIVE CLUB, DANCE CLUB, or PAVILION — appears on the display.

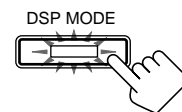

The DSP MODE lamp on the front panel button lights up, and the DSP indicator also lights up on the display.

- When you have set “REAR SPK” to “NONE,” the 3D-PHONIC indicator also lights up.

2. Adjust the speaker output levels.

1) Press LEVEL ADJUST repeatedly until one of the following indications appears on the display.

“CENTER”:

To adjust the center speaker level.

“REAR L”:

To adjust the left rear speaker level.

“REAR R”:

To adjust the right rear speaker level.

2) Press CONTROL UP ▲/DOWN ▼ to adjust the selected speaker output level (from -10 dB to +10 dB).

3) Repeat 1) and 2) to adjust the other speaker output levels.

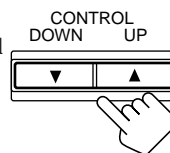

3. Adjust the center tone.

1) Press EFFECT repeatedly until “CTR TONE” appears on the display.

The display shows the current setting.

2) Press CONTROL UP ▲/DOWN ▼ to select the center tone level you want.

The center tone adjustment affects the mid-frequency range, which the human voice is mostly made up of.

- Each time you press the button, the display changes to show the following:

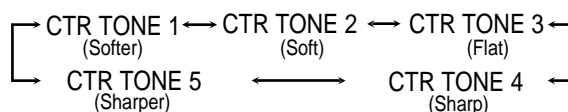

To make the dialogue softer, select “CTR TONE 1” or “CTR TONE 2.”

To make the dialogue clearer, select “CTR TONE 4” or “CTR TONE 5.”

When “CTR TONE 3” is selected, no adjustment is applied.

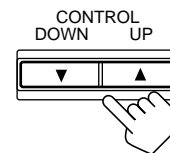

Adjusting the DAP Modes

You can also use a DAP mode with a Surround mode (see page 30).

Before you start, remember...

- Make sure that you have set the speaker information correctly (see page 17).
- There is a time limit in doing the following steps. If the setting is canceled before you finish, start from step 2 again.
- You cannot adjust the rear speaker output level when you have set “REAR SPK” to “NONE.” See page 17.
- You cannot adjust the center speaker output level when you have set “CTR SPK” to “NONE.” See page 17.
- To adjust the front speaker output balance and subwoofer output level, see pages 16 and 17.

Continued to the next page.

4. Adjust the overall levels of the effect.

- 1) Press **EFFECT** repeatedly until **"EFFECT"** appears on the display. The display shows the current setting.
- 2) Press **CONTROL UP ▲/DOWN ▼** to select the effect level you want.

• Each time you press the button, the display changes to show the following:

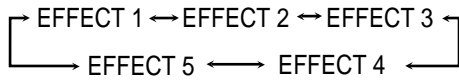

As the number increases, the selected DAP effect becomes stronger. (Normally set it to "EFFECT 3.")

5. Adjust the room size (sense of spaciousness).

- 1) Press **EFFECT** repeatedly until **"ROOMSIZE"** appears on the display. The display shows the current setting.
- 2) Press **CONTROL UP ▲/DOWN ▼** to select the room size you want.

• Each time you press the button, the display changes to show the following:

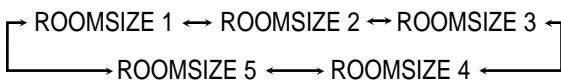

As the number increases, the interval between reflections increases so that you will feel as if you were in a larger room. (Normally set it to "ROOMSIZE 3.")

6. Adjust the liveness.

- 1) Press **EFFECT** repeatedly until **"LIVENESS"** appears on the display. The display shows the current setting.
- 2) Press **CONTROL UP ▲/DOWN ▼** to select the liveness level you want.

• Each time you press the button, the display changes to show the following:

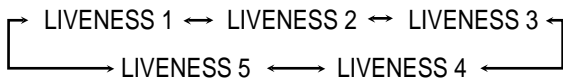

As the number increases, the attenuation level of reflections over time decreases so that acoustics change from "Dead" to "Live." (Normally set it to "LIVENESS 3.")

From the remote control:

1. Press **DSP MODE** repeatedly until the **DAP mode you want to adjust — THEATER 1, THEATER 2, HALL 1, HALL 2, LIVE CLUB, DANCE CLUB, or PAVILION —** appears on the display.

The DSP MODE lamp on the front panel button lights up, and the DSP indicator also lights up on the display.

• When you have set "REAR SPK" to "NONE," the 3D-PHONIC indicator also lights up.

2. Press **SOUND**.

The 10 keys are activated for sound adjustments.

3. Select the speaker you want to adjust.

- To select the center speaker level, press **CENTER**. "CTR" appears on the remote control display window.
- To select the left rear speaker level, press **REAR L**. "REARL" appears on the remote control display window.
- To select the right rear speaker level, press **REAR R**. "REARR" appears on the remote control display window.



4. Press **LEVEL +/-** to adjust the speaker output levels (-10 dB to +10 dB).

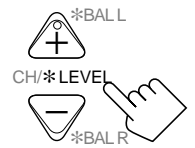

5. Press **SOUND**.

• To adjust other speaker output levels, repeat steps 3 and 4.

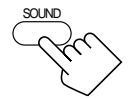

6. Press **CTR TONE** to select the center tone level you want.

• Each time you press the button, the display changes to show the following:

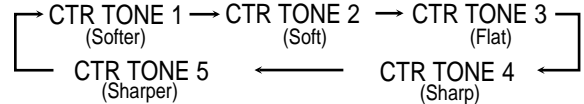

To make the dialogue softer, select "CTR TONE 1" or "CTR TONE 2."

To make the dialogue clearer, select "CTR TONE 4" or "CTR TONE 5."

When "CTR TONE 3" is selected, no adjustment is applied.

7. Press **EFFECT** to adjust the overall level of the effect.

• Each time you press the button, the effect level changes as follows:

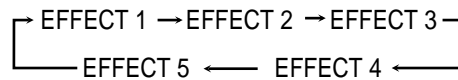

As the number increases, the selected DAP effect becomes stronger. (Normally set it to "EFFECT 3.")

8. Press **ROOM SIZE** to adjust the room size (sense of spaciousness).

• Each time you press the button, the room size changes as follows:

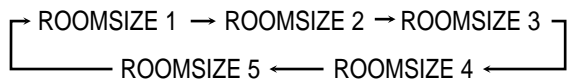

As the number increases, the interval between reflections increases so that you will feel as if you were in a larger room. (Normally set it to "ROOMSIZE 3.")

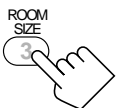

9. Press LIVENESS to adjust the liveness.

- Each time you press the button, the liveness changes as follows:

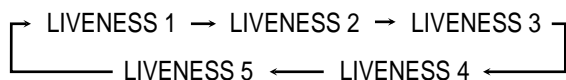

As the number increases, the attenuation level of reflections over time decreases so that acoustics change from “Dead” to “Live.” (Normally set it to “LIVENESS 3.”)

Adjusting the Surround Modes with the DAP Modes

Before you start, remember...

- Make sure that you have set the speaker information correctly (see page 17).
- There is a time limit in doing the following steps. If the setting is canceled before you finish, start from step 4 again.
- You cannot adjust the rear speaker output levels when you have set “REAR SPK” to “NONE.” See page 17.
- You cannot adjust the center speaker output level and center tone when you have set “CTR SPK” to “NONE.” See page 17.
- To adjust the front speaker output balance and subwoofer output level, see pages 16 and 17.

From the remote control:

1. Select and play a sound source.

- To enjoy Dolby Pro Logic, play back a software encoded with Dolby Surround and labeled with mark.
- To enjoy Dolby Digital, play back a software encoded with Dolby Digital and labeled with mark.
- To enjoy DTS Digital Surround, play back a software encoded with DTS Digital Surround and labeled with mark.

2. Press SURROUND ON/OFF to activate an appropriate Surround mode — PRO LOGIC, DOLBY DIGITAL or DTS SURROUND.



The SURROUND ON/OFF lamp on the front panel button lights up.

- Each time you press the button, the Surround mode turns on and off alternately.
- When “PRO LOGIC” is selected, the PRO LOGIC indicator lights up on the display.

3. Press DSP MODE repeatedly until the DAP mode you want to adjust — THEATER 1, THEATER 2, HALL 1, HALL 2, LIVE CLUB, DANCE CLUB, or PAVILION — appears on the display.

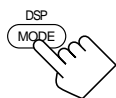

The DSP MODE lamp on the front panel button lights up, and the DSP indicator also lights up on the display.

4. Press SOUND.

The 10 keys are activated for sound adjustments.

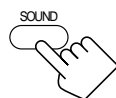

5. Press TEST to check the speaker output balance.



“TEST TONE L” starts flashing on the display, and a test tone comes out of the speakers in the following order:

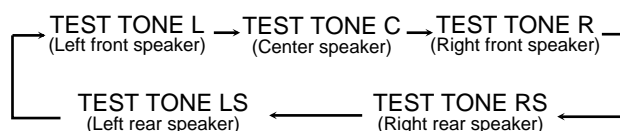

Notes:

- You can adjust the speaker output levels without outputting the test tone.
- No test tone comes out of the center speaker when “CTR SPK” is set to “NONE” (see page 17).
- No test tone comes out of the rear speakers when “REAR SPK” is set to “NONE” (see page 17).
- If the TV is turned on and the proper video input is selected on the TV, the test tone screen will appear on the TV.

6. Select the speaker you want to adjust.

- To select the center speaker level, press CENTER. “CTR” appears on the remote control display window.
- To select the left rear speaker level, press REAR L. “REARL” appears on the remote control display window.
- To select the right rear speaker level, press REAR R. “REARR” appears on the remote control display window.



7. Press LEVEL +/- to adjust the speaker output levels (–10 dB to +10 dB).

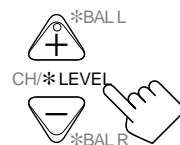

8. Press SOUND.

- To adjust other speaker output levels repeat steps 6 and 7.

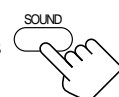

9. Press TEST again to stop the test tone.



10. Press CTR TONE to select the center tone level you want.

The center tone adjustment affects the mid-frequency range, which the human voice is mostly made up of.

- Each time you press the button, the display changes to show the following:

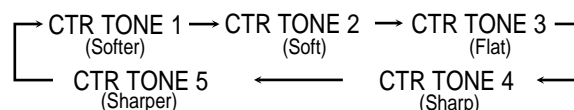

To make the dialogue softer, select “CTR TONE 1” or “CTR TONE 2.”

To make the dialogue clearer, select “CTR TONE 4” or “CTR TONE 5.”

When “CTR TONE 3” is selected, no adjustment is applied.

Continued to the next page.

11. Press EFFECT to adjust the overall level of the effect.

- Each time you press the button, the effect level changes as follows:

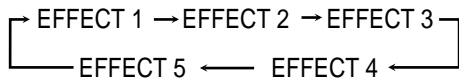

As the number increases, DAP effect becomes stronger.
(Normally set it to "EFFECT 3.")



12. Press ROOM SIZE to adjust the room size (sense of spaciousness).

- Each time you press the button, the room size changes as follows:

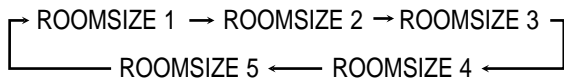

As the number increases, the interval between reflections increases so that you will feel as if you were in a larger room.
(Normally set it to "ROOMSIZE 3.")



13. Press LIVENESS to adjust the liveness.

- Each time you press the button, the liveness changes as follows:

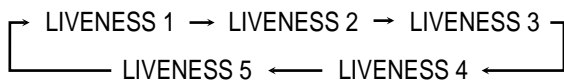

As the number increases, the attenuation level of reflections over time decreases so that acoustics change from "Dead" to "Live."
(Normally set it to "LIVENESS 3.")



On the front panel:

You can also use the buttons on the front panel to adjust the sound with a Surround mode and a DAP mode. However, no test tone is available when using the buttons on the front panel. So, make adjustments while listening to the sound of the source played back.

1. Select and play a sound source.

- To enjoy Dolby Pro Logic, play back a software encoded with Dolby Surround and labeled with mark.
- To enjoy Dolby Digital, play back a software encoded with Dolby Digital and labeled with mark.
- To enjoy DTS Digital Surround, play back a software encoded with DTS Digital Surround and labeled with mark.

2. Press SURROUND ON/OFF to activate an appropriate Surround mode — PRO LOGIC, DOLBY DIGITAL or DTS SURROUND.

SURROUND ON/OFF

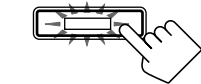

The SURROUND ON/OFF lamp on the front panel button lights up.

- Each time you press the button, the Surround mode turns on and off alternately.
- When "PRO LOGIC" is selected, the PRO LOGIC indicator lights up on the display.

3. Press DSP MODE repeatedly until the DAP mode you want to adjust — THEATER 1, THEATER 2, HALL 1, HALL 2, LIVE CLUB, DANCE CLUB, or PAVILION — appears on the display.

The DSP MODE lamp on the front panel button lights up, and the DSP indicator also lights up on the display.

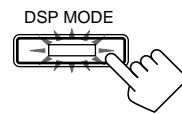

4. Adjust the speaker output levels.

- Press LEVEL ADJUST repeatedly until one of the following indications appears on the display.

"CENTER":

To adjust the center speaker level.

"REAR L":

To adjust the left rear speaker level.

"REAR R":

To adjust the right rear speaker level.



- Press CONTROL UP ▲/DOWN ▼ to adjust the selected speaker output level (from -10 dB to +10 dB).

- Repeat 1) and 2) to adjust the other speaker output levels.

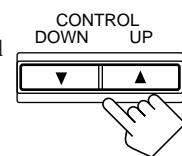

5. Adjust the center tone.

- Press EFFECT repeatedly until "CTR TONE" appears on the display.

The display shows the current setting.

- Press CONTROL UP ▲/DOWN ▼ to select the center tone level you want.

- Each time you press the button, the display changes to show the following:

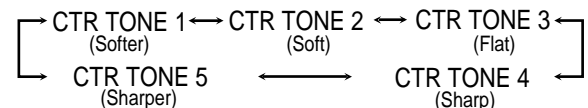

To make the dialogue softer, select "CTR TONE 1" or "CTR TONE 2."

To make the dialogue clearer, select "CTR TONE 4" or "CTR TONE 5."

When "CTR TONE 3" is selected, no adjustment is applied.

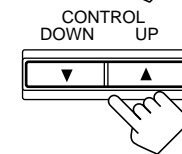
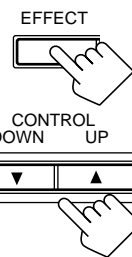

6. Adjust the overall levels of the effect.

- Press EFFECT repeatedly until "EFFECT" appears on the display.

The display shows the current setting.

- Press CONTROL UP ▲/DOWN ▼ to select the effect level you want.

- Each time you press the button, the display changes to show the following:

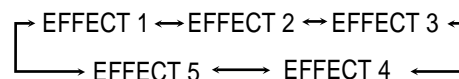

As the number increases, DAP effect becomes stronger.
(Normally set it to "EFFECT 3.")

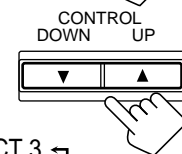
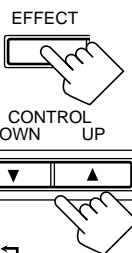

7. Adjust the room size (sense of spaciousness).

- 1) Press **EFFECT** repeatedly until **"ROOMSIZE"** appears on the display.

The display shows the current setting.

- 2) Press **CONTROL UP ▲/DOWN ▼** to select the room size you want.

- Each time you press the button, the display changes to show the following:

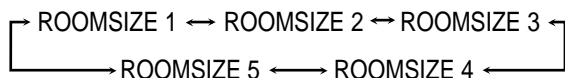

As the number increases, the interval between reflections increases so that you will feel as if you were in a larger room. (Normally set it to "ROOMSIZE 3.")

8. Adjust the liveness.

- 1) Press **EFFECT** repeatedly until **"LIVENESS"** appears on the display.

The display shows the current setting.

- 2) Press **CONTROL UP ▲/DOWN ▼** to select the liveness level you want.

- Each time you press the button, the display changes to show the following:

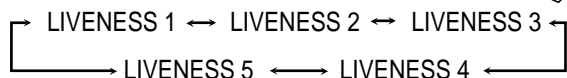

As the number increases, the attenuation level of reflections over time decreases so that acoustics change from "Dead" to "Live." (Normally set it to "LIVENESS 3.")

Adjusting the 5 CH/4 CH Stereo Mode

Before you start, remember...

- Make sure that you have set the speaker information correctly (see page 17).
- There is a time limit in doing the following steps. If the setting is canceled before you finish, start from step 2 again.
- You cannot adjust the center speaker output level and select the center tone level for 4 CH Stereo mode.
- To adjust the front speaker output balance and subwoofer output level, see pages 16 and 17.

On the front panel:

1. Press **DSP MODE** repeatedly until **"5CH STEREO"** or **"4CH STEREO"** appears on the display.

The DSP MODE lamp on the front panel button lights up, and the DSP indicator also lights up on the display.

- "4CH STEREO" appears on the display when you have set "CTR SPK" to "NONE" (see page 17).

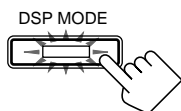

2. Adjust the speaker output levels.

- 1) Press **LEVEL ADJUST** repeatedly until one of the following indications appears on the display.

"CENTER" — for 5 CH Stereo mode only:

To adjust the center speaker level.

"REAR L":

To adjust the left rear speaker level.

"REAR R":

To adjust the right rear speaker level.

- 2) Press **CONTROL UP ▲/DOWN ▼** to adjust the selected speaker output level (from -10 dB to +10 dB).

- 3) Repeat 1) and 2) to adjust the other speaker output levels.

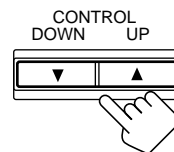

3. Adjust the center tone — for 5 CH Stereo mode only.

- 1) Press **EFFECT** repeatedly until **"CTR TONE"** appears on the display.

The display shows the current setting.

- 2) Press **CONTROL UP ▲/DOWN ▼** to select the center tone level you want.

The center tone adjustment affects the mid-frequency range, which the human voice is mostly made up of.

- Each time you press the button, the display changes to show the following:

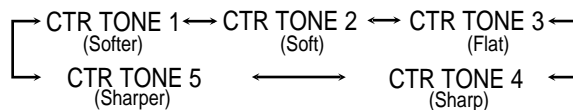

To make the dialogue softer, select "CTR TONE 1" or "CTR TONE 2."

To make the dialogue clearer, select "CTR TONE 4" or "CTR TONE 5."

When "CTR TONE 3" is selected, no adjustment is applied.

From the remote control:

1. Press **DSP MODE** repeatedly until **"5CH STEREO"** or **"4CH STEREO"** appears on the display.

The DSP MODE lamp on the front panel button lights up, and the DSP indicator also lights up on the display.

- "4CH STEREO" appears on the display when you have set "CTR SPK" to "NONE" (see page 17).

2. Press **SOUND**.

The 10 keys are activated for sound adjustments.

3. Select the speaker you want to adjust.

- To select the center speaker level, press **CENTER**— for 5 CH Stereo mode only.

"CTR" appears on the remote control display window.

- To select the left rear speaker level, press **REAR L**.

"REAR L" appears on the remote control display window.

- To select the right rear speaker level, press **REAR R**.

"REARR" appears on the remote control display window.



Continued to the next page.

4. Press **LEVEL +/-** to adjust the speaker output levels (-10 dB to +10 dB).



5. Press **SOUND**.

- To adjust other speaker output levels, repeat steps 3 and 4.

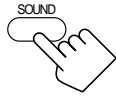

6. Press **CTR TONE** to select the center tone level you want — for 5 CH Stereo mode only.

- Each time you press the button, the display changes to show the following:

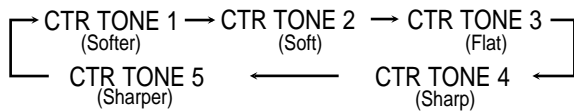

To make the dialogue softer, select “CTR TONE 1” or “CTR TONE 2.”

To make the dialogue clearer, select “CTR TONE 4” or “CTR TONE 5.”

When “CTR TONE 3” is selected, no adjustment is applied.

3. Adjust the center tone.

- Press **EFFECT** repeatedly until “CTR TONE” appears on the display. The display shows the current setting.
- Press **CONTROL UP ▲/DOWN ▼** to select the center tone level you want.

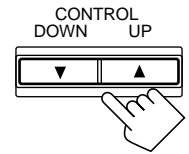
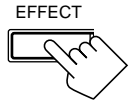

The center tone adjustment affects the mid-frequency range, which the human voice is mostly made up of.

- Each time you press the button, the display changes to show the following:

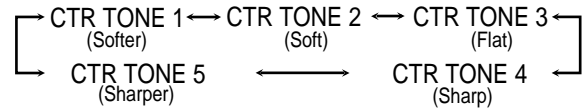

To make the dialogue softer, select “CTR TONE 1” or “CTR TONE 2.”

To make the dialogue clearer, select “CTR TONE 4” or “CTR TONE 5.”

When “CTR TONE 3” is selected, no adjustment is applied.

4. Adjust the overall levels of the effect.

- Press **EFFECT** repeatedly until “EFFECT” appears on the display. The display shows the current setting.
- Press **CONTROL UP ▲/DOWN ▼** to select the effect level you want.

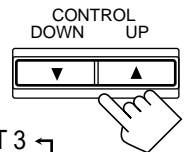
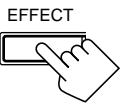

- Each time you press the button, the display changes to show the following:

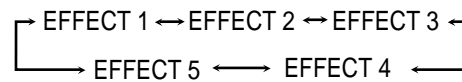

As the number increases, the selected 3D effect mode becomes stronger. (Normally set it to “EFFECT 3.”)

Adjusting the 3D-PHONIC Modes

Before you start, remember...

- Make sure that you have set the speaker information correctly (see page 17).
- There is a time limit in doing the following steps. If the setting is canceled before you finish, start from step 2 again.
- You cannot adjust the center speaker output level when you have set “CTR SPK” to “NONE.” See page 17.
- To adjust the front speaker output balance and subwoofer output level, see pages 16 and 17.

On the front panel:

1. Press **DSP MODE** repeatedly until “3D ACTION” or “3D DIGITAL” appears on the display.

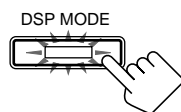

The DSP MODE lamp on the front panel button lights up, and the 3D-PHONIC and DSP indicators also light up on the display.

2. Adjust the center speaker output level.

- Press **LEVEL ADJUST** repeatedly until “CENTER” appears on the display.
- Press **CONTROL UP ▲/DOWN ▼** to adjust the center speaker output level (from -10 dB to +10 dB).

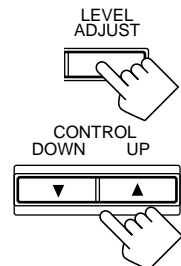

From the remote control:

1. Press **DSP MODE** repeatedly until “3D ACTION” or “3D DIGITAL” appears on the display.

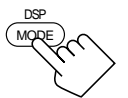

The DSP MODE lamp on the front panel button lights up, and the 3D-PHONIC and DSP indicators also light up on the display.

2. Press **SOUND**.

The 10 keys are activated for sound adjustments.

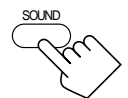

3. Press **CENTER** to select the center speaker.

- “CTR” appears on the remote control display window.



4. Press **LEVEL +/-** to adjust the center speaker output levels (from -10 dB to +10 dB).



5. Press **SOUND**.

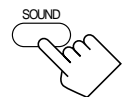

Using the DVD MULTI Playback Mode

This receiver provides the DVD MULTI playback mode for reproducing the analog discrete output mode of the DVD player. Before playing back a DVD, refer also to the manual supplied with the DVD player.

Activating the DVD MULTI Playback Mode

You can adjust the DVD MULTI playback mode while playing back a DVD using the analog discrete output mode on the DVD player. Once you have made adjustments, the receiver memorizes the adjustments until you change them. You also need to set the DVD player to the analog discrete output mode.

Before you start, remember...

- There is a time limit in doing the following steps. If the setting is canceled before you finish, start from step 3 again.
- To adjust the front speaker output balance and subwoofer output level, see pages 16 and 17.

On the front panel:

1. Press DVD MULTI so that “DVD MULTI” appears on the display.

The DVD MULTI lamp on the front panel button lights up.



Note:

When you select “DVD MULTI” as the source to play, the Surround and DSP modes are canceled, and the SURROUND ON/OFF and DSP MODE buttons do not work.

2. Select the analog discrete output mode on the DVD player, and start playing a DVD.

- Refer to the manual supplied with the DVD player.

If you need to make any adjustment, go to the following steps.

3. Adjust the speaker output levels.

- 1) Press LEVEL ADJUST repeatedly until one of the following indications appears on the display.

“CENTER”:

To adjust the center speaker level.

“REAR L”:

To adjust the left rear speaker level.

“REAR R”:

To adjust the right rear speaker level.

- 2) Press CONTROL UP ▲/DOWN ▼ to adjust the selected speaker output level (from -10 dB to +10 dB).

- 3) Repeat 1) and 2) to adjust the other speaker output levels.

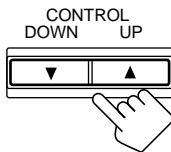

Notes:

- You cannot adjust the center tone level.
- You cannot use the midnight mode for DVD MULTI playback mode (see page 13).
- When using a pair of headphones, the sounds of front left and right are output from the headphones.

From the remote control:

1. Press DVD MULTI so that “DVD MULTI” appears on the display.

The DVD MULTI lamp on the front panel button lights up.



Note:

When you select “DVD MULTI” as the source to play, the Surround and DSP modes are canceled, and the SURROUND ON/OFF and DSP MODE buttons do not work.

2. Select the analog discrete output mode on the DVD player, and start playing a DVD.

- Refer to the manual supplied with the DVD player.

If you need to make any adjustment, go to the following steps.

3. Press SOUND.

The 10 keys are activated for adjusting the sound.

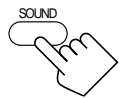

4. Select the speaker you want to adjust.

- To select the center speaker level, press CENTER. “CTR” appears on the remote control display window.
- To select the left rear speaker level, press REAR L. “REAR L” appears on the remote control display window.
- To select the right rear speaker level, press REAR R. “REARR” appears on the remote control display window.



5. Press LEVEL +/- to adjust the speaker output levels (from -10 dB to +10 dB).



6. Press SOUND.

- To adjust other speaker output levels, then repeat steps 4 and 5.

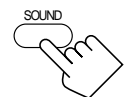

Using the On-Screen Menus

You can use the Menus on the TV screen to control the receiver.

To use this function, you need to connect the TV to the MONITOR OUT jack on the rear panel (see page 7), and set the TV's input mode to the proper position to which the receiver is connected.

- When the TV's input mode is incorrect; for example, if a different video input or TV tuner mode is selected, you cannot show the Menus on the TV screen.

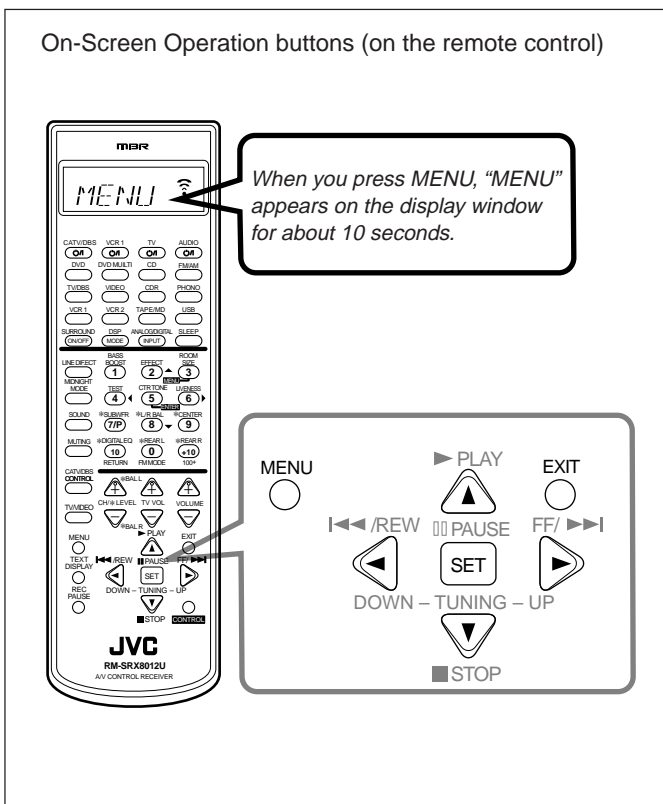

Activating the Surround Modes (Also see page 27)

1. Press MENU.

The MENU appears on the TV.

- Pressing one of the ▲ / ▼ / ◀ / ▶ buttons also displays the MENU.

2. Press ▲ / ▼ to move to "SURROUND."

3. Press ◀ / ▶ to select the Surround mode you want to use.

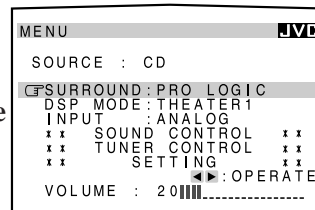

4. When you finish, press EXIT.

The menu disappears from the TV.

Activating the DSP Modes (Also see pages 28 – 34)

1. Press MENU.

The MENU appears on the TV.

- Pressing one of the ▲ / ▼ / ◀ / ▶ buttons also displays the MENU.

2. Press ▲ / ▼ to move to "DSP MODE."

3. Press ◀ / ▶ to select the DSP mode you want to use.

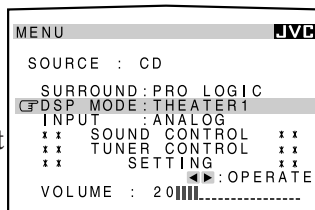

4. When you finish, press EXIT.

The menu disappears from the TV.

Showing the MENU on the TV Screen

Press MENU.

The MENU appears on the TV.

- Pressing one of the ▲ / ▼ / ◀ / ▶ buttons also displays the MENU.

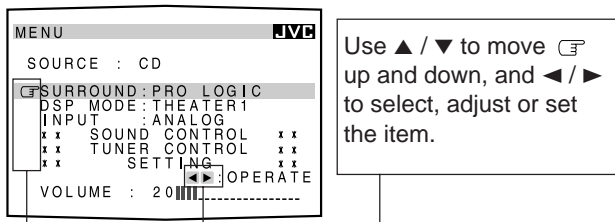

Notes:

- "INPUT" appears only when the digital input (DIGITAL IN) terminal setting has been correctly done for the digital source currently selected. (See page 19.)
- The on-screen display will disappear if no operation is done for about 1 minute.
- The on-screen display is shown in black and white.

Note

If "DVD MULTI" is selected as a playing source, the "SURROUND MODE" and "DSP MODE" do not appear on the display.

Selecting the Analog or Digital Input Mode (Also see page 20)

This selection is only possible when the digital input (DIGITAL IN) terminal setting has been correctly done for the digital source currently selected (see page 19).

1. Press MENU.

The MENU appears on the TV.

- Pressing one of the ▲ / ▼ / ◀ / ▶ buttons also displays the MENU.

2. Press ▲ / ▼ to move to "INPUT."

3. Press ◀ / ▶ to select the analog or digital input mode you want.

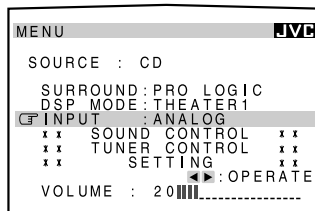

4. When you finish, press EXIT.

The menu disappears from the TV.

Adjusting the Equalization Pattern

(Also see page 15)

1. Press MENU.

The MENU appears on the TV.

- Pressing one of the ▲ / ▼ / ◀ / ▶ buttons also displays the MENU.

2. Press ▲ / ▼ to move to "SOUND CONTROL," then press ◀ / ▶.

The SOUND CONTROL menu appears.

3. Press ▲ / ▼ to move to "DIGITAL EQ," then press ◀ / ▶.

The DIGITAL EQ menu appears.

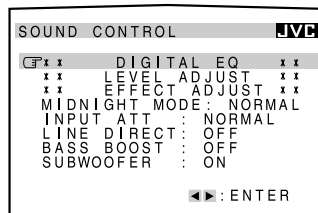

4. Press ▲ / ▼ to move to the frequency you want to adjust.

5. Press ◀ / ▶ to adjust the frequency level you want.

The frequency level changes by 2 dB from -8 dB to +8 dB.

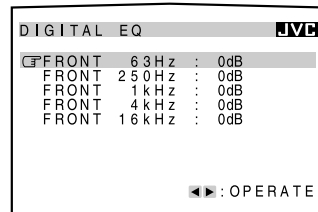

6. When you finish, press EXIT repeatedly until the menu disappears from the TV.

Adjusting the Surround and DSP Modes

(Also see pages 27 – 34)

You can use a Surround mode with a DAP mode, but not with the 5 CH/4 CH Stereo mode and 3D-PHONIC mode.

1. Press MENU.

The MENU appears on the TV.

- Pressing one of the ▲ / ▼ / ◀ / ▶ buttons also displays the MENU.

2. Select Surround mode and/or DSP mode you like to adjust (see page 36).

3. Press ▲ / ▼ to move to "SOUND CONTROL," then press ◀ / ▶.

The SOUND CONTROL menu appears.

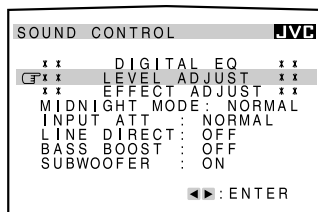

4. Press ▲ / ▼ to move to "LEVEL ADJUST," then press ◀ / ▶.

The LEVEL ADJUST menu appears.

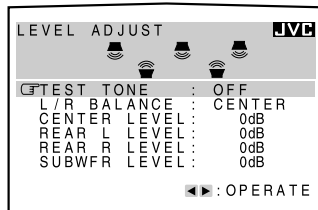

5. Press ▲ / ▼ to move to the item you want to set or adjust, then press ◀ / ▶.

On these adjustment menus, you can do the followings:

For Surround mode, Surround mode with DAP mode:

- "TEST TONE": Output a test tone.
- "L/R BALANCE": Adjust the right and left balance of the front speakers.
- "CENTER LEVEL": Adjust the center speaker output level. *
- "REAR L LEVEL": Adjust the left rear speaker output level. **
- "REAR R LEVEL": Adjust the right rear speaker output level. **
- "SUBWFR LEVEL": Adjust the subwoofer output level. ***

For DAP mode:

- "L/R BALANCE": Adjust the right and left balance of the front speakers.
- "CENTER LEVEL": Adjust the center speaker output level. *
- "REAR L LEVEL": Adjust the left rear speaker output level. **
- "REAR R LEVEL": Adjust the right rear speaker output level. **
- "SUBWFR LEVEL": Adjust the subwoofer output level. ***

For 5 CH/4 CH Stereo mode:

- "L/R BALANCE": Adjust the right and left balance of the front speakers.
- "CENTER LEVEL": Adjust the center speaker output level. ****
- "REAR L LEVEL": Adjust the left rear speaker output level. **
- "REAR R LEVEL": Adjust the right rear speaker output level. **
- "SUBWFR LEVEL": Adjust the subwoofer output level. ***

For 3D-PHONIC mode:

- "L/R BALANCE": Adjust the right and left balance of the front speakers.
- "CENTER LEVEL": Adjust the center speaker output level. *
- "SUBWFR LEVEL": Adjust the subwoofer output level. ***

For Surround off and DSP OFF:

- "L/R BALANCE": Adjust the right and left balance of the front speakers.
- "SUBWFR LEVEL": Adjust the subwoofer output level. ***

Notes:

- * You cannot select "CENTER LEVEL" when "CTR SPK" is set to "NONE" (see page 17).
- ** You cannot select "REAR L LEVEL" and "REAR R LEVEL" when "REAR SPK" is set to "NONE" (see page 17).
- *** You cannot select "SUBWFR LEVEL" when "SUBWOOFER" is set to "NO" (see page 17).
- **** You cannot select "CENTER LEVEL" when 4 CH Stereo mode is selected.

6. Press EXIT once.

7. Press ▲ / ▼ to move  to “EFFECT ADJUST,” then press ◀ / ▶.

The EFFECT ADJUST menu appears.

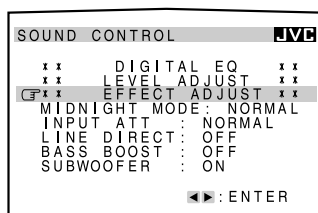

8. Press ▲ / ▼ to move  to the item you want to set or adjust, then press ◀ / ▶.

On these adjustment menus, you can do the followings.

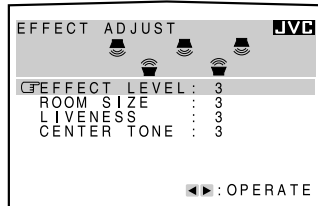

For Surround mode:

“CENTER TONE”: Select the center tone level. *

For DAP mode, Surround mode with DAP:

“EFFECT LEVEL”: Adjust the surround effect level.

“ROOM SIZE”: Adjust the room size effect.

“LIVENESS”: Adjust the liveness level.

“CENTER TONE”: Select the center tone level. *

For 5 CH Stereo mode:

“CENTER TONE”: Select the center tone level.

For 3D-PHONIC mode:

“EFFECT LEVEL”: Adjust the surround effect level.

“CENTER TONE”: Select the center tone level. *

Notes:

- You cannot select “EFFECT ADJUST” in step 7, when both of the Surround and DSP modes are deactivated.
- * You cannot select “CENTER TONE” when “CTR SPK” is set to “NONE” (see page 17).

9. When you finish, press EXIT repeatedly until the menu disappears from the TV.

■ Adjusting the DVD MULTI Playback Mode
(Also see page 35)

1. Select DVD MULTI as the playing source.

Press DVD MULTI.

2. Press MENU.

The MENU appears on the TV.

- Pressing one of the ▲ / ▼ / ◀ / ▶ buttons also displays the MENU.

3. Press ▲ / ▼ to move  to “SOUND CONTROL,” then press ◀ / ▶.

The SOUND CONTROL menu appears.

4. Press ▲ / ▼ to move  to “LEVEL ADJUST,” then press ◀ / ▶.

The LEVEL ADJUST menu appears.

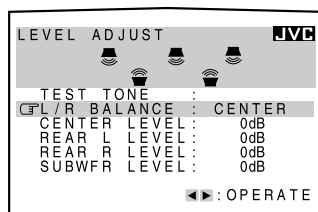

5. Press ▲ / ▼ to move  to the item you want to set or adjust, then press ◀ / ▶.

On this adjustment menu, you can do the following:

“L/R BALANCE”: Adjust the right and left balance of the front speakers.

“CENTER LEVEL”: Adjust the center speaker output level.

“REAR L LEVEL”: Adjust the left rear speaker output level.

“REAR R LEVEL”: Adjust the right rear speaker output level.

“SUBWFR LEVEL”: Adjust the subwoofer output level.

6. When you finish, press EXIT repeatedly until the menu disappears from the TV.

■ Listening at Night — Midnight Mode
(Also see page 13)

1. Press MENU.

The MENU appears on the TV.

- Pressing one of the ▲ / ▼ / ◀ / ▶ buttons also displays the MENU.

2. Press ▲ / ▼ to move  to “SOUND CONTROL,” then press ◀ / ▶.

The SOUND CONTROL menu appears.

3. Press ▲ / ▼ to move  to “MIDNIGHT MODE.”

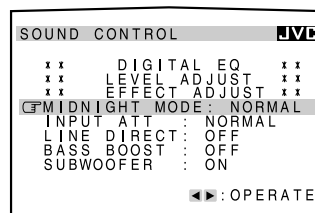

4. Press ◀ / ▶ to select the mode you want to use.

5. When you finish, press EXIT repeatedly until the menu disappears from the TV.

■ Attenuating the Input Signal
(Also see page 14)

1. Press MENU.

The MENU appears on the TV.

- Pressing one of the ▲ / ▼ / ◀ / ▶ buttons also displays the MENU.

2. Press ▲ / ▼ to move  to “SOUND CONTROL,” then press ◀ / ▶.

The SOUND CONTROL menu appears.

3. Press ▲ / ▼ to move  to “INPUT ATT.”

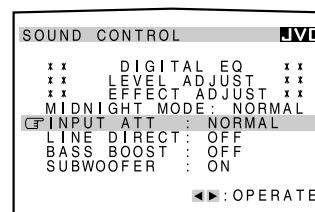

4. Press ◀ / ▶ to select the Input Attenuator mode “ATT ON” or “NORMAL.”

5. When you finish, press EXIT repeatedly until the menu disappears from the TV.

■ Selecting the Line Direct Function

(Also see page 14)

1. Press MENU.

The MENU appears on the TV.

- Pressing one of the ▲ / ▼ / ◀ / ▶ buttons also displays the MENU.

2. Press ▲ / ▼ to move to "SOUND CONTROL," then press ◀ / ▶.

The SOUND CONTROL menu appears.

3. Press ▲ / ▼ to move to "LINE DIRECT."

4. Press ◀ / ▶ to turn the line direct function "ON" or "OFF."

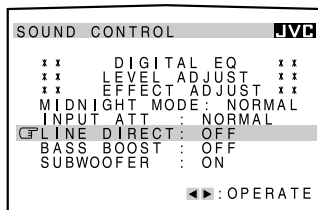

5. When you finish, press EXIT repeatedly until the menu disappears from the TV.

■ Selecting the Bass Boost Function

(Also see page 14)

1. Press MENU.

The MENU appears on the TV.

- Pressing one of the ▲ / ▼ / ◀ / ▶ buttons also displays the MENU.

2. Press ▲ / ▼ to move to "SOUND CONTROL," then press ◀ / ▶.

The SOUND CONTROL menu appears.

3. Press ▲ / ▼ to move to "BASS BOOST."

4. Press ◀ / ▶ to turn the bass boost function "ON" or "OFF."

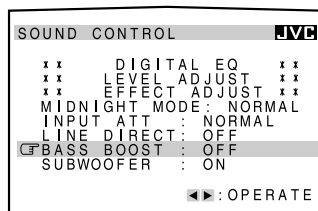

5. When you finish, press EXIT repeatedly until the menu disappears from the TV.

■ Activating the Subwoofer Sound

(Also see page 14)

1. Press MENU.

The MENU appears on the TV.

- Pressing one of the ▲ / ▼ / ◀ / ▶ buttons also displays the MENU.

2. Press ▲ / ▼ to move to "SOUND CONTROL," then press ◀ / ▶.

The SOUND CONTROL menu appears.

3. Press ▲ / ▼ to move to "SUBWOOFER."

4. Press ◀ / ▶ to turn the subwoofer output "ON" or "OFF."

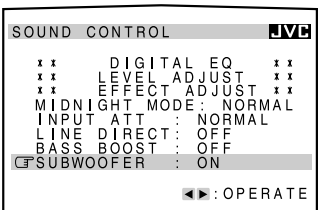

5. When you finish, press EXIT repeatedly until the menu disappears from the TV.

■ Operating the Tuner (Also see pages 22 and 23)

1. Select FM or AM as the playing source.

Press FM/AM.

2. Press MENU.

The MENU appears on the TV.

- Pressing one of the ▲ / ▼ / ◀ / ▶ buttons also displays the MENU.

3. Press ▲ / ▼ to move to "TUNER CONTROL," then press ◀ / ▶.

The TUNER CONTROL menu appears.

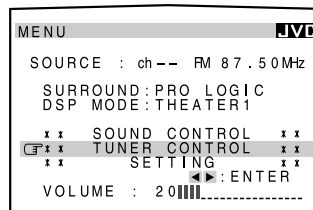

4. Press ▲ / ▼ to move to the item you want to set or adjust, then press ◀ / ▶.

On the TUNER CONTROL

menu, you can do the

following:

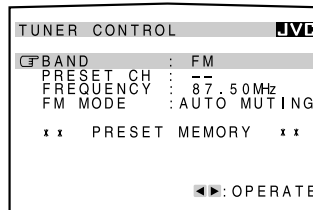

"BAND":	Select the band.
"PRESET CH":	Select a preset channel station.
"FREQUENCY":	Tune in a station manually.
"FM MODE":	Select the FM reception mode.*
"PRESET MEMORY":	See "Storing the Preset Stations."

Note:

* Not displayed when an AM station is selected.

5. When you finish, press EXIT repeatedly until the menu disappears from the TV.

■ Storing the Preset Stations (Also see page 22)

1. Press MENU.

The MENU appears on the TV.

- Pressing one of the ▲ / ▼ / ◀ / ▶ buttons also displays the MENU.

2. Press ▲ / ▼ to move to "TUNER CONTROL," then press ◀ / ▶.

The TUNER CONTROL menu appears.

3. Tune into a station on the TUNER CONTROL menu, referring to "Operating the Tuner".

4. Press ▲ / ▼ to move to "PRESET MEMORY," then press ◀ / ▶.

 moves to "PRESET CH" and the channel number starts flashing.

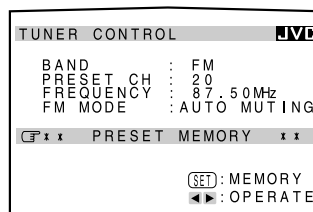

5. Press ◀ / ▶ to select a preset station number you want.

6. Press SET to store the setting.

The selected channel number stops flashing.

7. When you finish, press EXIT repeatedly until the menu disappears from the TV.

Setting the Basic Setting Items

(Also see pages 16 – 21)

1. Press MENU.

The MENU appears on the TV.

- Pressing one of the ▲ / ▼ / ◀ / ▶ buttons also displays the MENU.

2. Press ▲ / ▼ to move

☞ to “SETTING,” then press ◀ / ▶.

The SETTING 1 appears.

3. Press ▲ / ▼ to move

☞ to the item you want to set or adjust, then press ◀ / ▶.

- To go to the SETTING 2 menu, move ☞ to “NEXT PAGE,” then press ◀ / ▶.
- To go back to the SETTING 1 menu, move ☞ to “PREVIOUS PAGE,” then press ◀ / ▶.

On the SETTING 1 and 2 menus, you can do the following:

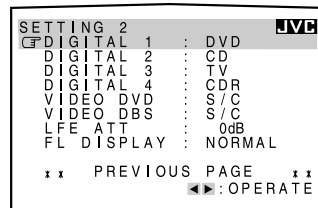
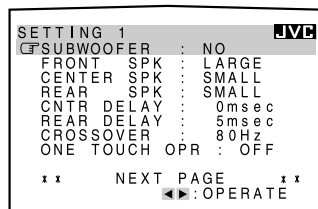
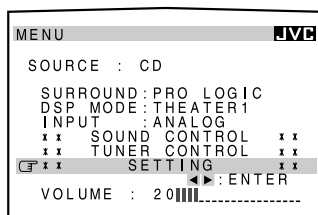

SETTING 1 menu

- “SUBWOOFER”: Set the subwoofer information (see page 17).
- “FRONT SPK”: Set the front speaker information (see page 17).
- “CENTER SPK”: Set the center speaker information (see page 17).
- “REAR SPK”: Set the rear speaker information (see page 17).
- “CNTR DELAY”: Adjust the delay time of the center speaker output (see page 18). *
- “REAR DELAY”: Adjust the delay time of the rear speaker output (see page 18). **
- “CROSSOVER”: Set the crossover frequency (see page 18).
- “ONE TOUCH OPR”: Set the one touch operation (see page 21).

SETTING 2 menu

- “DIGITAL 1/2/3/4”: Set the digital input terminal 1/2/3/4 (see page 19).
- “VIDEO DVD”: Set the video input terminal for the DVD player (see page 16).
- “VIDEO DBS”: Set the video input terminal for the DBS tuner (see page 16).
- “LFE ATT”: Set the low frequency effect attenuator level (see page 19).
- “FL DISPLAY”: Shows the disc text information on the display (see page 21).

Notes:

- * You cannot select “CNTR DELAY” when “CTR SPK” is set to “NONE” (see page 17).
- ** You cannot select “REAR DELAY” when “REAR SPK” is set to “NONE” (see page 17).

4. When you finish, press EXIT repeatedly until the menu disappears from the TV.

COMPU LINK Remote Control System

The COMPU LINK remote control system allows you to operate JVC audio components through the remote sensor on the receiver.

To use this remote control system, you need to connect JVC audio components through the COMPU LINK (SYNCHRO) jacks (see below) in addition to the connections using cables with RCA pin plugs (see pages 5 and 6).

- Make sure that the AC power cords of these components are unplugged before connection. Plug the AC power cords only after all connections are complete.

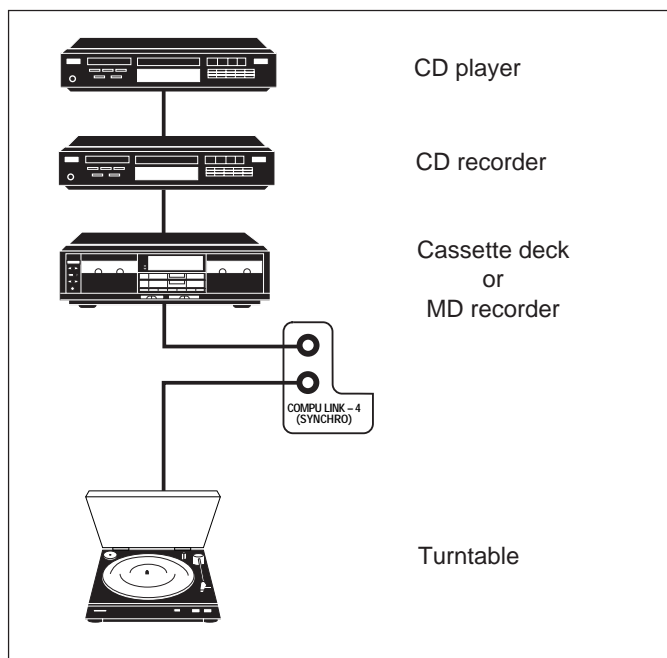

Notes:

- There are four versions of COMPU LINK remote control system. This receiver is equipped with the fourth version — COMPU LINK-4. This version is added systematic operations with the CD recorder to the previous version — COMPU LINK-3.
- If your audio component has two COMPU LINK jacks, you can use either one. If it has only one COMPU LINK jack, connect it so that it is the last item in the series of components. (For example, the turntable or CD player in the diagram above.)
- To operate the cassette deck or MD recorder using the COMPU LINK remote control system, set the source name correctly. (See page 16.)
- Refer also to the manuals supplied with your audio components.

This remote control system allows you to use four functions listed below.

Remote Control through the Remote Sensor on the Receiver

You can control the connected audio components through the remote sensor on the receiver using this remote control. Aim the remote control directly at the remote sensor on the receiver. For details, see pages 49 and 50.

Automatic Source Selection

When you press the play (▶) button on a connected component or on its own remote control, the receiver automatically turns on and changes the source to the component. On the other hand, if you select a new source on the receiver or on the remote control, the selected component begins playing immediately.

In both cases, the previously selected source continues playing without sound for a few seconds.

Automatic Power On/Off (Standby): only possible with the COMPU LINK-3 and COMPU LINK-4 connection

The connected components turn on and off (standby) along with the receiver.

When you turn on the receiver, one of the connected components will turn on automatically, depending on which component has been previously selected.

When you turn off the receiver, the connected components will turn off (standby).

Synchronized Recording

Synchronized recording means the cassette deck (or MD recorder) starts recording as soon as a CD begins playing.

To use synchronized recording, follow these steps:

1. Put a tape in the cassette deck (or an MD in the MD recorder), and a disc in the CD player.
2. Press the record (●) button and the pause (II) button on the cassette deck (or MD recorder) at the same time.

This puts the cassette deck (or MD recorder) into recording pause.

If you do not press the record (●) button and pause (II) button at the same time, the synchronized recording feature will not operate.

3. Press the play (▶) button on the CD player.

The source changes on the receiver, and as soon as play starts, the cassette deck (or MD recorder) starts recording. When the play ends, the cassette deck (or MD recorder) enters recording pause, and stops about 4 seconds later.

Notes:

- During synchronized recording, the selected source cannot be changed.
- If the power of any component is shut off during synchronized recording, the COMPU LINK remote control system may not operate properly. In this case, you must start again from the beginning.

TEXT COMPU LINK Remote Control System

The TEXT COMPU LINK remote control system has been developed to deal with the disc information recorded in the CD Text* and MDs. Using these information in the discs, you can operate the CD player or MD recorder equipped with the TEXT COMPU LINK remote control system through the receiver.

CONNECTIONS:

To use this remote control system, you need to connect the CD player and/or MD recorder you want to operate, following the procedures below.

1. If you have already plugged your CD player, MD recorder, and this receiver into the AC outlets, unplug their AC power cords first.
2. Connect your CD player, MD recorder, and this receiver as follows, through the COMPU LINK jacks and TEXT COMPU LINK jacks.

- 1) **COMPU LINK jacks:** Use the cables with the monaural mini-plugs (not supplied with this receiver).

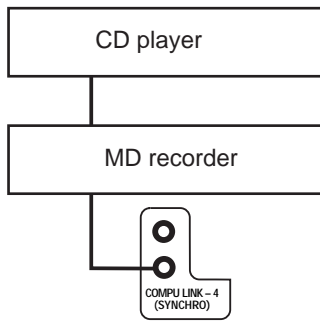

- 2) **TEXT COMPU LINK jacks:** Use the cables with the stereo mini-plugs (not supplied with this receiver).

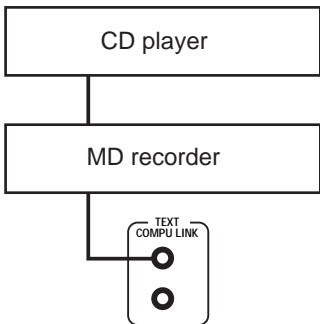

3. Connect your CD player, MD recorder and this receiver, using the cables with RCA pin plugs (see pages 5 and 6).
4. Plug the AC power cords of these components above into the AC outlets.
5. When turning on these components for the first time, turn on the connected components first, then turn on this receiver.

FUNCTIONS:

This remote control system allows you to use the functions listed below.

Displaying the Disc Information on the TV screen

Disc information such as its performer and disc title (and track titles only when a CD Text is selected) is shown on the TV screen.

Disc Search: Only for CD Player

This remote control system can allow you to search for discs by the performer, disc title, and music genre.

With this disc search, you can easily find the disc you want to play.

Disc Title Input:

If your CD player or MD recorder has the disc memory function, you can input the following information about the normal audio CDs or MDs on the TV screen.

- For CDs: Performer, disc title, and music genre
- For MDs: Disc title and song titles

*What is a CD Text?

In a CD Text, some information about the disc (its disc title, performer, composer, arranger, etc.) is recorded.

Notes:

- If your audio component has two COMPU LINK jacks, you can use either one. If it has only one COMPU LINK jack, connect it so that it is the last item in the series of components. (For example, the CD player in the diagram in the left column.)
- If your audio component has two TEXT COMPU LINK jacks, you can use either one. If it has only one TEXT COMPU LINK jack, connect it so that it is the last item in the series of components. (For example, the CD player in the diagram in the left column.)
- "TEXT COMPULINK SOURCE NOT CONNECTED" appears on the display in the following cases:
 - When the connections explained in the left column are not correctly done.
 - When you try to use the TEXT COMPU LINK function a few seconds after you turn on the connected equipment. This is not a malfunction of the units.
- Refer also to the manuals supplied with your CD player or MD recorder.

IMPORTANT:

If you turn on the receiver before turning on the other components after connecting the components, the TEXT COMPU LINK remote control system does not work correctly.

If this happens:

1. Turn off all the components including this receiver.
2. Turn on the connected components.
3. Turn on this receiver.

OPERATIONS:

To use this remote control system, you need to connect the TV to the MONITOR OUT jack on the rear panel (see page 7), and set the TV's input mode to the proper position to which the receiver is connected. **Make sure you have connected the CD player or MD recorder equipped with the TEXT COMPU LINK remote control system. If not, you cannot use the following functions.**

On-Screen Operation buttons (on the remote control)

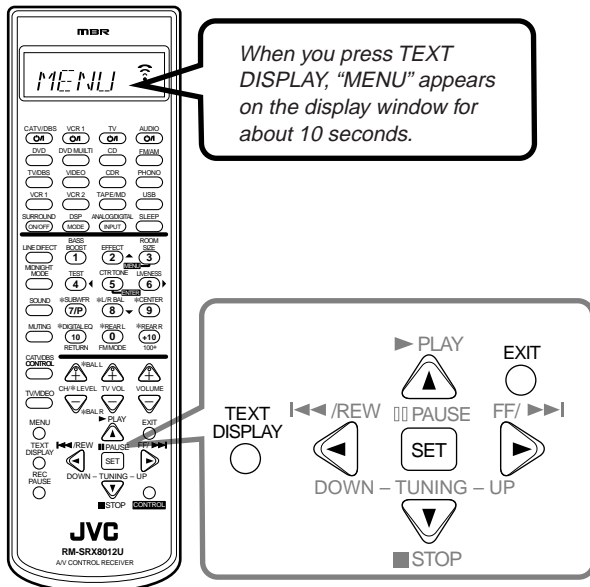

- ① Source name: CD or MD
- ② Select or , then press SET to change the disc.
- ③ Track numbers and track titles.
 - When you move to a track number, you can change the track information by pressing / . Each time you press the button, track information alternates between its track title and its performer. (You can also start playing the track by pressing SET.)
- ④ Select this (move in front), then press SET to go to the DISC SEARCH screen (see page 44).
- ⑤ Select this (move in front), then press SET to go to the TITLE INPUT screen (see page 45).
- ⑥ This appears only when a CD Text is selected.
- ⑦ Disc information such as the disc title, performer, and music genre.

When this is selected (in front), you can change the disc information by pressing / . Each time you press the button, disc information (see "Note on ⑦") changes.
- ⑧ Select or , then press SET to change the track.
- ⑨ Usable buttons and their functions for the current selection.

Indication here will be changed according to what is currently selected (in front) on the screen. See "Note on ⑨."

Note on ⑦:

The following information will appear on the display:

- For CD Texts — Disc title, Performer, Genre, Song writer, Composer, Arranger, Message
Only recorded information will be shown. If there is no data, "NO DATA" will appear.
- For MDs — Disc title
If there is no data, "NO DATA" will appear.

Note on ⑨:

For example, the SET button will be used to start play (PLAY), to go to the next screen (ENTER), and to determine the selection (ENTER).

To exit from the Disc information screen:

Press EXIT.

Notes:

- The on-screen display will disappear in the following cases:
 - if no operation is done for about 10 minutes.
 - if you do any operation other than explained in this section.
- To control the MD recorder using the TEXT COMPU LINK remote control system, you have to change the source name shown on the display from "TAPE" to "MD." (See page 16.)
- Some special characters and marks cannot be displayed correctly.
- The on-screen display is shown in black and white.

Showing the Disc Information on the TV Screen

Press TEXT DISPLAY while "CD" or "MD" is selected as the source.

The Disc Information screen appears on the TV.

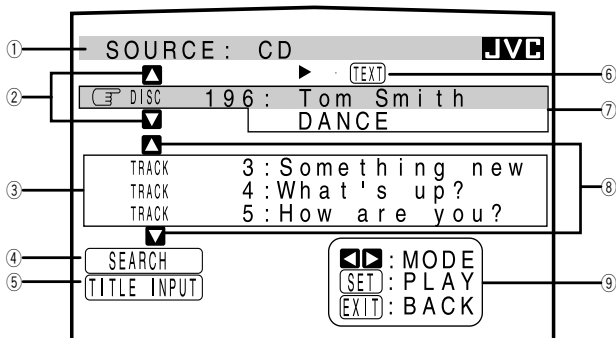

■ Searching for a Disc (Only for the CD player)

Search for a disc by its performer:

1. Press **TEXT DISPLAY** while “CD” is selected as the source.

The Disc Information screen appears on the TV.

2. Press **▲ / ▼** to move **☞** to “SEARCH,” then press **SET**.

The DISC SEARCH screen appears.

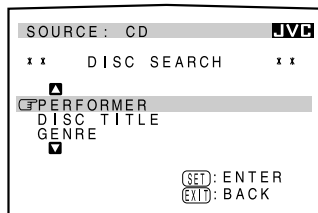

3. Press **▲ / ▼** to move **☞** to “PERFORMER,” then press **SET**.

The PERFORMER SEARCH screen appears.

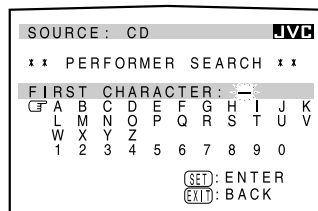

4. Press **▲ / ▼ / ◀ / ▶** to move **☞** in front of the first character of the performer you want to search for, then press **SET**.

To correct the incorrect entry, press **▲ / ▼ / ◀ / ▶** to move **☞** in front of the correct character, then press **SET**.

Note:

Symbols such as @, # or \$ cannot be available for search.

5. Press **SET** again.

Disc search starts, then the SEARCH RESULT screen, showing the performers, appears.

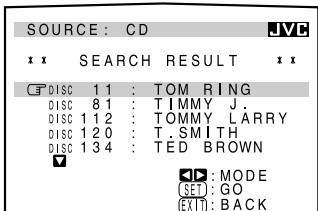

6. On the SEARCH RESULT screen, you can do the following:

- **Changing the indication of the disc information:** Press **▲ / ▼** to move **☞** to a searched disc, then press **◀ / ▶**. Each time you press **◀ / ▶**, the disc information alternates between its performer and its disc title.
- **Starting a disc play and going to the Disc Information screen (see page 43):** Press **▲ / ▼** to move **☞** to a searched disc, then press **SET**.
- **Showing unseen disc information (if more than 5 discs are listed as a result of the search):** Press **▲ / ▼** until they appear.
- **Going back to the PERFORMER SEARCH screen:** Press **EXIT**.

Search for a disc by its disc title:

1. Press **TEXT DISPLAY** while “CD” is selected as the source.

The Disc Information screen appears on the TV.

2. Press **▲ / ▼** to move **☞** to “SEARCH,” then press **SET**.

The DISC SEARCH screen appears.

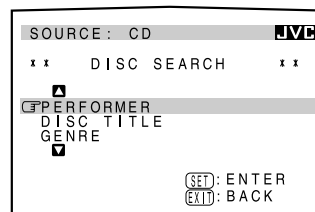

3. Press **▲ / ▼** to move **☞** to “DISC TITLE,” then press **SET**.

The DISC TITLE SEARCH screen appears.

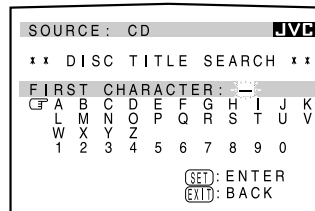

4. Press **▲ / ▼ / ◀ / ▶** to move **☞** in front of the first character of the disc title you want to search for, then press **SET**.

To correct the incorrect entry, press **▲ / ▼ / ◀ / ▶** to move **☞** in front of the correct character, then press **SET**.

Note:

Symbols such as @, # or \$ cannot be available for search.

5. Press **SET** again.

Disc search starts, then the SEARCH RESULT screen, showing the disc titles, appears.

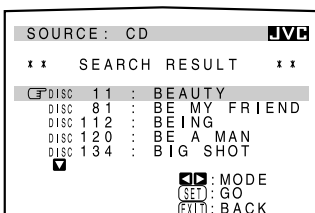

6. On the SEARCH RESULT screen, you can do the following:

- **Changing the indication of the disc information:** Press **▲ / ▼** to move **☞** to a searched disc, then press **◀ / ▶**. Each time you press **◀ / ▶**, the disc information alternates between its disc title and its performer.
- **Starting a disc play and going to the Disc Information screen (see page 43):** Press **▲ / ▼** to move **☞** to a searched disc, then press **SET**.
- **Showing unseen disc information (if more than 5 discs are listed as a result of the search):** Press **▲ / ▼** until they appear.
- **Going back to the DISC TITLE SEARCH screen:** Press **EXIT**.

Search for a disc by its genre:

1. Press **TEXT DISPLAY** while “CD” is selected as the source.

The Disc Information screen appears on the TV.

2. Press **▲ / ▼** to move **⇐** to “SEARCH,” then press **SET**.

The DISC SEARCH screen appears.

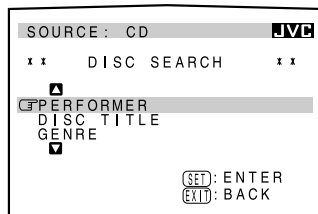

3. Press **▲ / ▼** to move **⇐** to “GENRE,” then press **SET**.

The GENRE SEARCH screen appears.

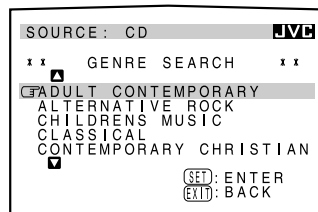

4. Press **▲ / ▼** to move **⇐** to the genre you want to search for, then press **SET**.

To show the unseen genres, press **▲ / ▼** until they appear.

Disc search starts, then the SEARCH RESULT screen, showing the disc titles, appears.

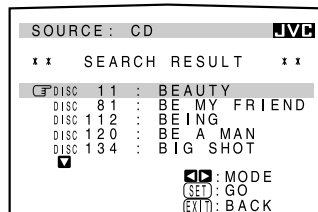

5. On the SEARCH RESULT screen, you can do the following:

- **Changing the indication of the disc information:** Press **▲ / ▼** to move **⇐** to a searched disc, then press **◀ / ▶**. Each time you press **◀ / ▶**, the disc information alternates between its disc title and its performer.
- **Starting a disc play and going to the Disc Information screen (see page 43):** Press **▲ / ▼** to move **⇐** to a searched disc, then press **SET**.
- **Showing unseen disc information (if more than 5 discs are listed as a result of the search):** Press **▲ / ▼** until they appear.
- **Going back to the GENRE SEARCH screen:** Press **EXIT**.

Entering the Disc Information**For the CD Player with the disc memory function:**

You can use the disc memory function through this receiver.

The disc information (its performer, disc title, and music genre) of normal audio CDs will be stored into the memory built in the CD player.

For the disc memory function, refer to the manual supplied with your CD player.

- The performer, disc title, and music genre information are usually recorded in a CD Text. However, if a CD Text has no genre information recorded in the disc itself, you can input its music genre by yourself.

Note:

You can enter the TITLE INPUT screens for a CD Text and input its titles. However, you cannot store the titles you have input for a CD Text.

Example: Entering the following information for Disc 1
Performer: “MICHAEL”
Disc title: “MY FAVORITE”

1. Press **TEXT DISPLAY** while “CD” is selected as the source.

The Disc Information screen appears on the TV.

2. Press **▲ / ▼** to move **⇐** to “TITLE INPUT,” then press **SET**.

The TITLE INPUT/PERFORMER screen appears.

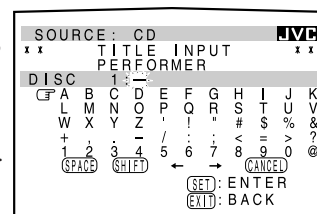

3. Press **▲ / ▼ / ◀ / ▶** to move **⇐** in front of a character you want, then press **SET** to enter the character.

- If the current CD is a CD Text, go to step 5 without entering the performer.

To use the lower case letters, press **▲ / ▼ / ◀ / ▶** to move **⇐** to **(SHIFT)**, then press **SET**.

To use the upper case letters again, press **▲ / ▼ / ◀ / ▶** to move **⇐** to **(SHIFT)**, then press **SET**.

4. Repeat step 3 until you finish putting a performer name (up to 32 characters).

To insert a space, press ▲/▼ / ◀/▶ to move **CF** to **SPACE**, then press SET.

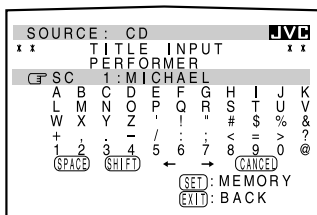

To correct an incorrect character:

- 1) Press ▲/▼/◀/▶ to move **CF** to ← or →, then press SET until the incorrect character is selected.
- 2) Press ▲/▼/◀/▶ to move **CF** to **CANCEL**, then press SET to erase the character.
- 3) Press ▲/▼/◀/▶ to move **CF** in front of the correct character, then press SET to enter the correct character.

5. Press ▲/▼/◀/▶ to move **CF** to “DISC 1: MICHAEL (in this example),” then press SET.

The TITLE INPUT: DISC TITLE screen appears.

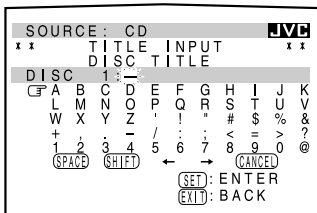

6. Enter the disc title, referring to steps 3 and 4.

- If the current CD is a CD Text, go to the next step without entering the disc title.

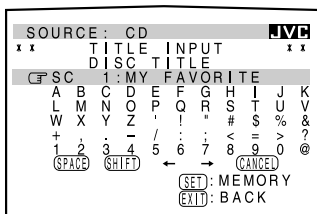

7. Press ▲/▼/◀/▶ to move **CF** to “DISC 1: MY FAVORITE (in this example),” then press SET.

The TITLE INPUT: DISC 1 GENRE screen appears.

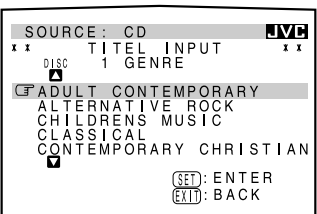

8. Press ▲/▼ to move **CF** to the genre you want, then press SET.

The Disc Information screen appears again.

To show the unseen genres, press ▲/▼ until they appear.

For the MD recorder:

You can write the disc information (disc title and song titles) into the disc. You can only write the song title for the song currently selected.

- If you have the CD-MD combination deck, you can also enter the disc information (its performer, disc title, and its music genre) of normal audio CDs into the memory built in the CD-MD combination deck. (To do this, follow the procedure of “For the CD Player with the disc memory function.”)
- If you change the disc or song title with more than 32 characters, the characters following 32nd will be erased from the title.

1. Press **TEXT DISPLAY** while “MD” is selected as the source.

The Disc Information screen appears on the TV.

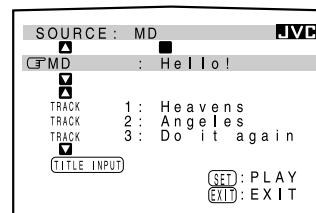

2. Press ▲/▼ to move **CF** to “TITLE INPUT,” then press SET.

The DISC TITLE INPUT screen appears.

3. Enter the title, referring to steps 3 and 4 of “For the CD Player with the disc memory function.”

- You can enter up to 32 characters for the disc title.

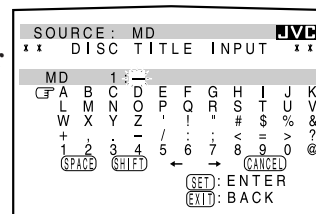

4. Press ▲/▼/◀/▶ to move **CF** to the disc title you have just entered, then press SET.

The disc title is stored into the memory, and the SONG TITLE INPUT screen for the currently selected song appears.

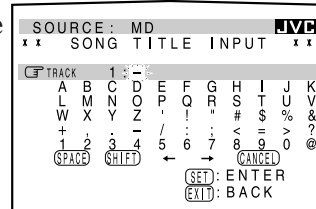

- You can enter a song title for the song currently selected.

5. Enter the song title, referring to steps 3 and 4 of “For the CD Player with the disc memory function.”

- You can enter up to 32 characters for the song title.

6. Press ▲/▼/◀/▶ to move **CF** to the song title you have just entered, then press SET.

The song title is stored into the memory, and the Disc Information screen appears again.

AV COMPU LINK Remote Control System

The AV COMPU LINK remote control system allows you to operate JVC video components (TV, VCR, and DVD player) through the receiver.

This receiver is equipped with the AV COMPU LINK-III, which added a function to operate JVC video components through the video components terminals. To use this remote control system, you need to connect the video components you want to operate, following the diagrams below and the procedure on the next page.

CONNECTIONS 1: AV COMPU LINK Connection

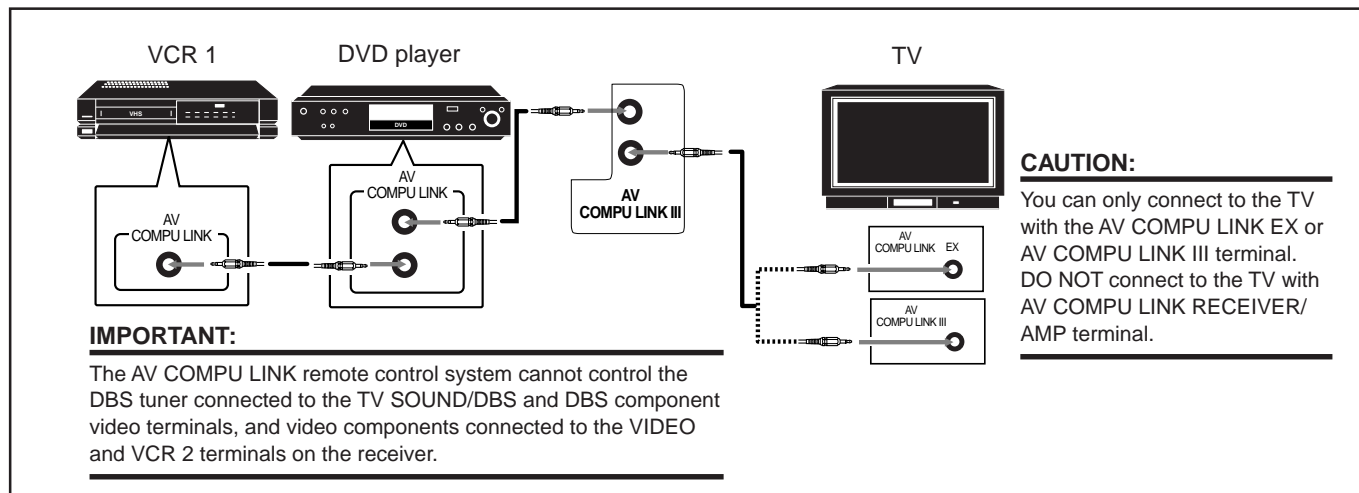



Notes:

- When connecting the receiver and a TV with the AV COMPU LINK EX terminal by using a component video cable, you cannot use Automatic Selection of TV's Input Mode (see page 48).
- When connecting only the VCR 1 or DVD player to this receiver, connect it directly to the receiver using cables with the monaural mini-plugs.
- Refer also to the manuals supplied with your video components.

CONNECTIONS 2: Video Cable Connection

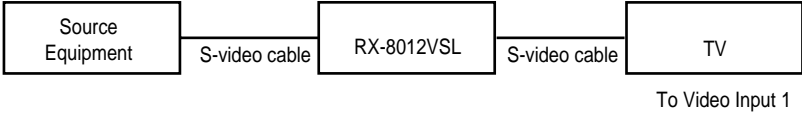
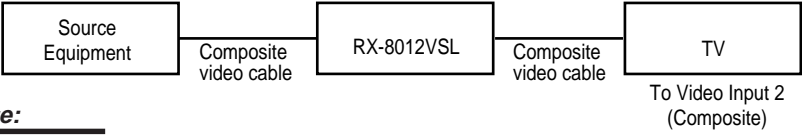
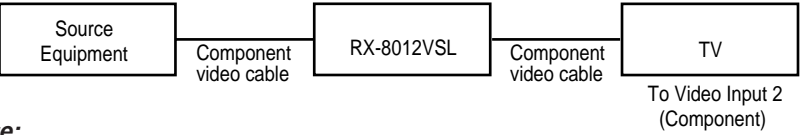
This receiver is equipped with three types of the video terminals — S-video, composite video, or component video, and the signals coming into this receiver through one type of video terminals can output only through the same type of the terminal. So you need to connect the VCR and/or DVD player to the TV using one of the following three ways:

<p>CASE 1</p>	<p>When connecting the source equipment to the receiver using the S-video terminals, connect also this receiver to the TV's Video Input 1 terminal using S-video cables.</p>  <p>Note: If you connect the DVD player and the DBS tuner to this receiver using the S-video terminals, change the video input terminal setting to "S/C" (see page 16).</p>
<p>CASE 2</p>	<p>When connecting the source equipment to the receiver using the composite video terminals, connect also this receiver to the TV's Video Input 2 terminal (composite video input) using composite video cables.</p>  <p>Note: If you connect the DVD player and the DBS tuner to this receiver using the composite video terminals, change the video input terminal setting to "S/C" (see page 16).</p>
<p>CASE 3</p>	<p>When connecting the source equipment to the receiver using the component video terminals, connect also this receiver to the TV's Video Input 2 terminals (component video input) using component video cables.</p>  <p>Note: If you connect the DVD player and the DBS tuner to this receiver using the video component terminals, change the video input terminal setting to "COMPNT" (see page 16).</p>

1. **If you have already plugged your VCR 1 (VCR connected to the VCR 1 jacks), DVD player, TV and this receiver into the AC outlets, unplug their AC power cords first.**
2. **Connect your VCR 1, DVD player, TV and this receiver as follows, using the cables with the monaural mini-plugs (not supplied).**
 - See “CONNECTIONS 1” on the previous page.
3. **Connect the audio input/output jacks on VCR 1, DVD player, TV and this receiver using the cables with RCA pin plug.**
 - See pages 6 and 7.
4. **Connect the video input/output jacks on VCR 1, DVD player, TV and this receiver, using the cables with RCA pin plug, with S-video plug or with component video plugs.**
 - See “CONNECTIONS 2” on the previous page.
5. **Plug the AC power cords of the components into the AC outlets.**
6. **When turning on the TV for the first time after the AV COMPU LINK connection, turn the TV volume to the minimum using the TV volume control on the TV.**
7. **Turn on the other connected components first, then turn on this receiver.**
 - When turning on the VCR 1, use the remote control supplied with this receiver (press VCR 1 .

The AV COMPU LINK remote control system allows you to use the five basic functions listed below.

Remote Control of the TV, DVD player, and VCR Using This Remote Control

See page 51 for details.

- Aim the remote control directly at **the remote sensor on each target component.**

One-Touch Video Play

Simply by inserting a video cassette without its safety tab into the VCR 1 (the VCR connected to the VCR 1 jacks), you can enjoy the video playback without setting other switches manually. The receiver automatically turns on and changes the source to “VCR 1.” The TV automatically turns on and changes the input mode to the position so that you can view the playback picture. When you insert a video cassette with its safety tab, press the play () button on the VCR 1 or on the remote control. So, you can get the same result.

One-Touch DVD Play

Simply by starting playback on the DVD player, you can enjoy the DVD playback without setting other switches manually.

- When the DVD player is connected through the analog input jacks on this receiver (and analog input is selected), the receiver automatically turns on and changes the source to “DVD” or “DVD MULTI.”
- When the DVD player is connected through the digital input terminal on this receiver (and digital input is selected), the receiver automatically turns on and changes the source to “DVD DGTL.”

The TV automatically turns on and changes the input mode to the appropriate position so that you can view the playback picture.

Automatic Selection of TV's Input Mode

- When you select “TV” as the source to play on the receiver, the TV automatically changes the input mode to the TV tuner so that you can watch TV.
- When you select “DVD,” “DVD MULTI,” “VCR 1,” “VCR 2,” “VIDEO” or “DBS” as the source to play on the receiver, the TV automatically changes the input mode to the appropriate position (either Video Input 1 or Video Input 2) so that you can view the playback picture.

Notes:

- When connecting a TV with the AV COMPU LINK EX terminal to this receiver, you cannot use a component video cable (as case 3 on page 47). Connect the TV using a S-video or composite video cable (as cases 1 and 2).
- When you select “TV” as the source on the receiver, you cannot see the menu on the TV screen since the AV COMPU LINK remote control system automatically changes the TV's input mode to the TV tuner.
If you do not mind stopping listening to the TV sounds, you can then show the on-screen displays after changing the TV's input mode to the appropriate position the receiver is connected to.

Automatic Power On/Off

The TV, VCR 1 (the VCR connected to the VCR 1 jacks), and DVD player turn on and off along with the receiver.

When you turn on the receiver;

- If the previously selected source is “VCR 1,” the TV and VCR 1 will turn on automatically.
- If the previously selected source is “VIDEO,” “VCR 2,” “TV” or “DBS,” only the TV will turn on automatically.
- If the previously selected source is “DVD” or “DVD MULTI,” the TV and DVD player will turn on automatically.

When you turn off the receiver, the TV, VCR 1 and the DVD player will turn off.

Note:

If you turn off the receiver while recording on the VCR 1, the VCR 1 will not turn off, but continue recording.

Operating JVC's Audio/Video Components

You can operate JVC's audio and video components with this receiver's remote control, since control signals for JVC components are preset in the remote control.

Operating Audio Components

IMPORTANT:

To operate JVC's audio components using this remote control:

- You need to connect JVC audio components through the COMPU LINK (SYNCHRO) jacks (see page 41) in addition to the connections using cables with RCA pin plugs (see pages 5 and 6).
- Aim the remote control directly at the remote sensor on the receiver.
- If you use the buttons on the front panel or the menu function to choose a source, the remote control will not operate that source. To operate a source with the remote control, the source must be selected using source selecting buttons on the remote control.
- To operate the cassette deck or MD recorder using the COMPU LINK remote control system, set the source name correctly. (See page 16.)
- Refer also to the manuals supplied with your components.

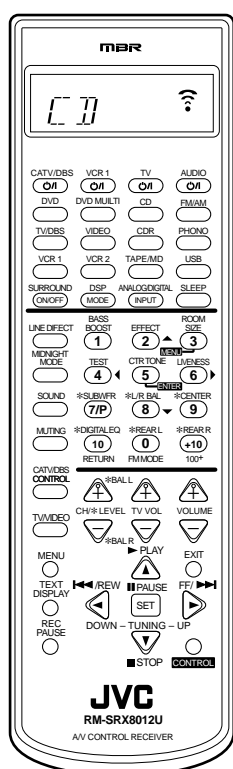

Note:

When you press one of the following buttons mentioned in this section, the operation mode appears on the display window for about 10 seconds. For example, the above illustration shows that you have pressed CD.

Buttons	Indications						
FM/AM	TUNER						
CD	CD						
CDR	CDR						
PHONO	PHONO						
TAPE/MD	TAPE						
CONTROL (repeatedly)	<table border="0"> <tr> <td>VCR 1</td> <td>→</td> <td>TAPE</td> </tr> <tr> <td>CDDSC</td> <td>←</td> <td>CDR</td> </tr> </table>	VCR 1	→	TAPE	CDDSC	←	CDR
VCR 1	→	TAPE					
CDDSC	←	CDR					
SOUND	SOUND						

Tuner

You can always perform the following operations:

FM/AM: Alternates between FM and AM.

After pressing FM/AM, you can perform the following operations:

1 – 10, +10: Selects a preset channel number directly.
 For channel number 5, press 5.
 For channel number 15, press +10, then 5.
 For channel number 20, press +10, then 10.

TUNING UP ►/DOWN ◀: Tunes into stations.
 FM MODE: Changes the FM reception mode.

Sound control section (Amplifier)

You can always perform the following operations:

SURROUND ON/OFF: Turns on or off the Surround modes — Dolby Pro Logic, Dolby Digital, and DTS Digital Surround.

DSP MODE: Selects the DSP modes.

After pressing SOUND, you can perform the following operations:

SUBWFR then LEVEL +/-: Adjusts the subwoofer output level.
 L/R BAL then BAL L/BAL R: Adjusts the front speaker output balance.
 CENTER then LEVEL +/-: Adjusts the center speaker output level.
 REAR L then LEVEL +/-: Adjusts the left rear speaker output level.
 REAR R then LEVEL +/-: Adjusts the right rear speaker output level.
 DIGITAL EQ then LEVEL +/-: Selects the audio band and adjusts its frequency level.

EFFECT: Selects the effect level.

TEST: Turns on or off the test tone output.

CTR TONE: Selects the center tone.

ROOM SIZE: Selects the room size.

LIVENESS: Selects the liveness.

Note:

After adjusting sounds, press the corresponding source selecting button to operate your target source by using the 10 keys; otherwise, the 10 keys cannot be used for operating your target source.

CD player

After pressing CD, you can perform the following operations on the CD player:

► PLAY: Starts playing.
 ◀◀: Returns to the beginning of the current (or previous) track.

▶▶: Skips to the beginning of the next track.
 ■ STOP: Stops playing.

■ PAUSE: Pauses playing. To release it, press ► PLAY.

1 – 10, +10: Selects a track number directly.
 For track number 5, press 5.
 For track number 15, press +10, then 5.
 For track number 20, press +10, then 10.
 For track number 30, press +10, +10, then 10.

CD changer

After selecting “CDDSC” by pressing CONTROL repeatedly, you can perform the following operations on a CD changer:

- ▶ PLAY: Starts playing.
- ◀◀: Returns to the beginning of the current (or previous) track.
- ▶▶: Skips to the beginning of the next track.
- STOP: Stops playing.
- ▬ PAUSE: Pauses playing. To release it, press ▶ PLAY.
- 1 – 6, 7/P: Selects the number of a disc installed in a CD changer.

After pressing CD, you can perform the following operations on the CD changer:

- 1 – 10, +10: Selects a track number directly.
For track number 5, press 5.
For track number 15, press +10, then 5.
For track number 20, press +10, then 10.
For track number 30, press +10, +10, then 10.

EXAMPLE:

- Selecting disc number 4, track number 12, and starting playback.
 1. Press CONTROL repeatedly until “CDDSC” appears on the display window, then press 4.
 2. Press CD, then press +10, 2.

Turntable

After pressing PHONO, you can perform the following operations on a turntable:

- ▶ PLAY: Starts playing.
- STOP: Stops operations.

CD recorder

After pressing CDR (or selecting “CDR” by pressing CONTROL repeatedly), you can perform the following operations on a CD recorder:

- ▶ PLAY: Starts playing.
- ◀◀: Returns to the beginning of the current (or previous) track.
- ▶▶: Skips to the beginning of the next track.
- STOP: Stops playing.
- ▬ PAUSE: Pauses playing. To release it, press ▶ PLAY.
- 1 – 10, +10: Selects a track number directly.
For track number 5, press 5.
For track number 15, press +10, then 5.
For track number 20, press +10, then 10.
For track number 30, press +10, +10, then 10.

Notes:

- When you start recording on the CD recorder, use the buttons on the CD recorder itself or on the remote control supplied with it.
- You can use either CDR or CONTROL to activate the buttons listed above. If you press CDR, the playing source also changes. On the other hand, if you press CONTROL repeatedly to select “CDR,” the playing source does not change.

Cassette deck

After pressing TAPE/MD (or selecting “TAPE” by pressing CONTROL repeatedly), you can perform the following operations on a cassette deck:

- ▶ PLAY: Starts playing.
- REW: Fast winds the tape from right to left.
- FF: Fast winds the tape from left to right.
- STOP: Stops operations.
- ▬ PAUSE: Pauses playing. To release it, press ▶ PLAY.
- REC PAUSE: Enters recording pause.

Notes:

- You can use either TAPE/MD or CONTROL to activate the buttons listed above. If you press TAPE/MD, the playing source also changes. On the other hand, if you press CONTROL repeatedly to select “TAPE,” the playing source does not change.
- When you use a cassette deck, change the source name connected to TAPE/MD jacks correctly (see page 16).

MD recorder

After pressing TAPE/MD, you can perform the following operations on the MD recorder:

- ▶ PLAY: Starts playing.
- ◀◀: Returns to the beginning of the current (or previous) track.
- ▶▶: Skips to the beginning of the next track.
- STOP: Stops playing.
- ▬ PAUSE: Pauses playing. To release it, press ▶ PLAY.
- REC PAUSE: Enters recording pause.

Note:

When you use an MD recorder, change the source name connected to TAPE/MD jacks correctly (see page 16).

Operating Video Components

IMPORTANT:

To operate JVC's video components using this remote control:

- You need to connect JVC video components through the AV COMPU LINK jacks (see page 47) in addition to the connections using cables with RCA pin plugs (see pages 6 and 7).
- Some JVC VCRs can accept two types of the control signals — remote code "A" and "B." Before using this remote control, make sure that the remote control code of the VCR connected to the VCR 1 jacks is set to code "A."
 - When another JVC VCR is connected to the VCR 2 or VIDEO terminals, set its remote control code to code "B." (This remote control cannot emit the control signals of code "B.")
- When using the remote control:
 - For the DVD player and VCR 1 operations, aim the remote control directly at the remote sensor on each component, not on the receiver.
 - For the TV having the AV COMPU LINK EX or AV COMPU LINK III terminal, aim the remote control directly at the remote sensor on the TV.

VCR 1 (VCR connected to the VCR 1 jacks)

You can always perform the following operations:

VCR 1 $\odot/|$: Turns on or off the VCR 1.

After pressing VCR 1 (or selecting "VCR 1" by pressing CONTROL repeatedly), you can perform the following operations on the VCR 1:

- 1 – 9, 0: Selects the TV channels on the VCR.
- ▶ PLAY: Starts playing.
- REW: Rewinds a tape.
- FF: Fast winds a tape.
- STOP: Stops operations.
- || PAUSE: Pauses playing. To release it, press ▶ PLAY.
- REC PAUSE: Enters recording pause.
- CH +/-: Changes the TV channels on the VCR.

Note:

You can use either VCR 1 or CONTROL to activate the buttons listed above. If you press VCR 1, the playing source also changes. On the other hand, if you press CONTROL repeatedly to select "VCR 1," the playing source does not change.

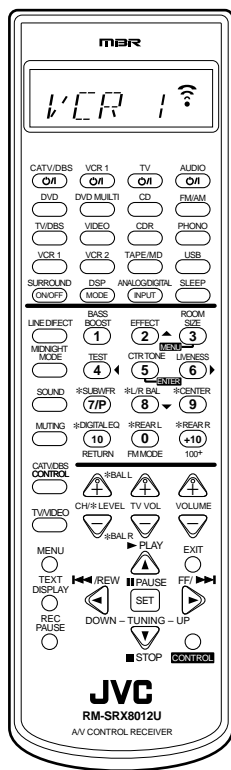

Note:

When you press one of the following buttons mentioned in this section, the operation mode appears on the display window for about 10 seconds. For example, above illustration shows that you have pressed VCR 1.

Buttons	Indications								
VCR 1	VCR 1								
DVD or DVD MULTI	DVD								
TV/DBS	TV								
CONTROL (repeatedly)	<table border="0"> <tr> <td>→</td> <td>VCR 1</td> <td>→</td> <td>TAPE</td> </tr> <tr> <td>←</td> <td>CDDSC</td> <td>←</td> <td>CDR</td> </tr> </table>	→	VCR 1	→	TAPE	←	CDDSC	←	CDR
→	VCR 1	→	TAPE						
←	CDDSC	←	CDR						

DVD player

After pressing DVD or DVD MULTI, you can perform the following operations on a DVD player:

- ▶ PLAY: Starts playing.
- ◀◀: Returns to the beginning of the current (or previous) track.
- ▶▶: Skips to the beginning of the next track.
- STOP: Stops playing.
- || PAUSE: Stops playing temporarily. To release it, press ▶ PLAY.

After pressing DVD or DVD MULTI, these buttons can be used for the DVD menu operations.

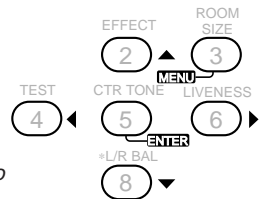

Note:

For detailed menu operations, refer to the instructions supplied with the discs or the DVD player.

TV

You can always perform the following operations:

- TV $\odot/|$: Turns on or off the TV.
- TV VOL +/-: Adjusts the volume.
- TV/VIDEO: Sets the input mode (either TV or VIDEO).

After pressing TV/DBS, you can perform the following operations on a TV:

- CH +/-: Changes the channels.
- 1 – 9, 0, 100+: Selects the channels.
- RETURN: Alternates between the previously selected channel and the current channel.

Operating Other Manufacturers' Video Equipment

This remote control supplied with the receiver can transmit control signals for other manufacturers' VCRs, TVs, CATV converters, DBS tuners and DVD players. By changing the transmittable signals from preset ones to the other manufacturers', you can operate the other manufacturer's components using this remote control.

When operating the other manufacturers' components, refer also to the manuals supplied with them. To operate these components with the remote control, first you need to set the manufacturer's code each for VCR, TV, CATV converters, DBS tuners and DVD players.

After replacing batteries for the remote control, you need to set the manufactures' codes again.

To change the transmittable signals for operating another manufacturer's TV

1. Press and hold TV $\odot/|$.
2. Press TV/DBS.
3. Enter manufacturer's code using buttons 1-9, and 0.

See the list below to find the code.

4. Release TV $\odot/|$.

The following buttons can be used for operating the TV:

TV $\odot/|$: Turns on and off the TV.
 TV VOL +/-: Adjusts the volume.
 TV/VIDEO: Sets the input mode (either TV or VIDEO).

After pressing TV/DBS, you can perform the following operations on a TV:

CH +/-: Changes the channels.
 1 - 10, 0, 100+ (+10): Selects the channels.
 The 10 button will function as the ENTER button if your TV requires pressing ENTER after selecting a channel number.

Note:

Refer to the manual supplied with your TV.

5. Try to operate your TV by pressing TV $\odot/|$.

When your TV turns on or off, you have entered the correct code.

If there are more than one code listed for your brand of TV, try each one until the correct one is entered.

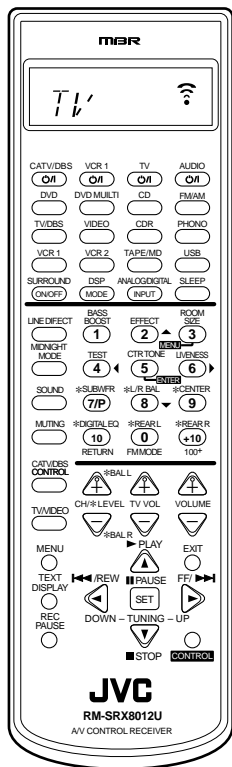

Note:

When you press one of the following buttons mentioned in this section, the operation mode appears on the display window for about 10 seconds. For example, the above illustration shows that you have pressed TV/DBS.

Buttons	Indications
TV/DBS	TV
CATV/DBS CONTROL	DBS
VCR 1	VCR 1
DVD or DVD MULTI	DVD

Manufacturer	Codes	Manufacturer	Codes
JVC	00, 02, 13, 14, 47, 74	QUELLE	52, 53, 54, 55, 56, 57, 58, 59, 60, 61, 62, 63, 64, 65, 66, 67
AKAI	01, 02	RCA/ PROSCAN	08, 24, 29, 30, 31, 48
BLAUPUNKT	03, 04,		SABA
FISHER	01, 05	SAMSUNG	06, 08, 16, 34, 35, 49
GRUNDIG	03, 06, 07		SANYO
HITACHI	08, 09, 10, 49	SCHNEIDER	02, 15, 36
IRADDIO	02	SHARP	37, 38, 77
ITT/NOKIA	11, 12	SONY	39
LOEWE	06, 15, 16	TELEFUNKEN	40, 41, 42, 69
MAGNAVOX	08, 17, 49	THOMSON	71, 72
METS	50, 51, 52, 53	TOSHIBA	37, 43, 44
MITSUBISHI	08, 18, 19, 20		ZENITH
MIVAR	21		
NORDMENDE	22, 23		
OKANO	15		
PANASONIC	24, 25, 26, 27, 76		
PHILIPS	15, 17, 28, 75		

Manufacturers' codes are subject to change without notice. If they are changed, this remote control cannot operate the equipment.

To change the transmittable signals for operating a CATV converter or DBS tuner

1. Press and hold CATV/DBS $\odot/|$.
2. Press CATV/DBS CONTROL.
3. Enter manufacturer's code using buttons 1–9, and 0.

See the following lists to find the code.

4. Release CATV/DBS $\odot/|$.

The following buttons can be used for the CATV converter and DBS tuner:

CATV/DBS $\odot/ $:	Turns on and off the CATV converter or DBS tuner.
CH +/-:	Changes the channels.
1 – 10, 0, 100+ (+10):	Selects the channels. The 10 button will function as the ENTER button if your equipment requires pressing ENTER after selecting a channel number.

Note:

Refer to the manual supplied with your CATV converter or DBS tuner.

5. Try to operate your CATV converter or DBS tuner by pressing CATV/DBS $\odot/|$.

When your CATV converter or DBS tuner turns on or off, you have entered the correct code.

If there are more than one code listed for your brand of CATV converter or DBS tuner, try each one until the correct one is entered.

Note:

You cannot use both of the CATV converter and DBS tuner at the same time.

For DBS tuner

Manufacturer	Codes
JVC	56, 57, 67
AMSTRAD	43, 44, 45, 46, 47, 48, 49
BLAUPUNKT	30
ECHOSTAR	50, 51, 67
GOLDSTAR	31
GRUNDIG	32, 33
HIRSHMANN	48, 52, 53, 54, 55
INSTRUMENT	68
ITT/NOKIA	34
KATHREIN	52, 58, 59, 60, 61, 62, 63
NEC	35, 36
ORBITECH	48
PHILIPS	37, 38
RCA	65
SAMSUNG	39, 40
SCHWAIGER	61, 64
SIEMENS	41, 42
SONY	66
TECHNISAT	48

Manufacturers' codes are subject to change without notice. If they are changed, this remote control cannot operate the equipment.

For CATV converter

Manufacturer	Codes
GENERAL INSTRUMENT	06, 07, 08, 09, 10, 11, 12, 13, 14, 29
HAMLIN/REGAL	01, 02, 03, 04, 05
JERROLD	06, 07, 08, 09, 10, 11, 12, 13, 14
OAK	15, 16, 17
PANASONIC	18, 19, 20
PIONEER	21, 22
SCIENTIFIC ATLANTA	23, 24, 25
TOCOM	26
ZENITH	27, 28

Manufacturers' codes are subject to change without notice. If they are changed, this remote control cannot operate the equipment.

To change the transmittable signals for operating another manufacturer's VCR

1. Press and hold VCR 1 $\odot/|$.
2. Press VCR 1.
3. Enter manufacturer's code using buttons 1–9, and 0.

See the list on the next page to find the code.

4. Release VCR 1 $\odot/|$.

The following button can be used for operating the VCR:

VCR 1 $\odot/ $:	Turns on and off the VCR.
-------------------	---------------------------

After pressing VCR 1, you can perform the following operations on the VCR:

CH +/-:	Changes the TV channels on the VCR.
1 – 10, 0, 100+ (+10):	Selects the TV channels. The 10 button will function as the ENTER button if your VCR requires pressing ENTER after selecting a channel number.
▶ PLAY:	Starts playback.
REW:	Rewinds a video tape.
FF:	Fast winds a video tape.
■ STOP:	Stops operation.
PAUSE:	Pauses.
REC PAUSE:	Enters recording pause.

Note:

Refer to the manual supplied with your VCR.

5. Try to operate your VCR by pressing VCR 1 $\odot/|$.

When your VCR turns on or off, you have entered the correct code.

If there are more than one code listed for your brand of VCR, try each one until the correct one is entered.

Manufacturer	Codes
JVC	00, 26, 27, 28, 29, 58
AIWA	01, 02
BELL & HOWELL	03
BLAUPUNKT	04, 05
CGM	06, 07
EMERSON	08, 10, 11, 12, 64, 65
FISHER	03, 14, 15, 16, 17
FUNAI	01
GE	18, 19, 20
GOLDSTAR	07
GOODMANS	13, 21
GRUNDIG	06, 22
HITACHI	18, 23, 24, 25, 66
LOEWE	07, 21
MAGNAVOX	04, 19, 24
MITSUBISHI	30, 31, 32, 33, 34, 35
NEC	26, 27
NOKIA	03, 36
NORDMENDE	38
ORION	09
PANASONIC	19, 24, 39, 40
PHILIPS	04, 19, 21, 24, 41, 42
PHONOLA	21
RCA/PROSCAN	04, 18, 19, 23, 24, 43, 44, 45
SABA	38, 46
SAMSUNG	45, 47, 59, 61, 62, 63
SANYO	03, 48, 49
SHARP	37, 50
SIEMENS	03, 51
SONY	52, 53, 54
TELEFUNKEN	55, 60
TOSHIBA	43, 44
ZENITH	56, 57

Manufacturers' codes are subject to change without notice. If they are changed, this remote control cannot operate the equipment.

To change the transmittable signals for operating a DVD player

1. Press and hold **AUDIO** .
2. Press **DVD**.
3. Enter manufacturer's code using buttons 1–9, and 0.

See the following list to find the code.

4. Release **AUDIO** .

After pressing DVD or DVD MULTI, you can perform the following operations on a DVD player:

- ▶ **PLAY:** Starts playing.
- ◀◀: Returns to the beginning of the current (or previous) track.
- ▶▶: Skips to the beginning of the next track.
- **STOP:** Stops playing.
- || **PAUSE:** Stops playing temporarily. To release it, press ▶ **PLAY**.

After pressing DVD, these buttons can be used for the DVD menu operations.



Note:

For detailed menu operations, refer to the instructions supplied with the discs or the DVD player.

Note:

Refer to the manual supplied with your DVD player.

5. Try to operate your DVD player by pressing one of the above buttons.

- DO NOT forget to turn on the DVD player before pressing one of the above buttons.

If there are more than one code listed for your brand of DVD, try each one until the correct one is entered.



Manufacturer	Codes
JVC	00, 02
DENON	01
PANASONIC	03
PHILIPS	13
PIONEER	04, 05, 06
RCA	07
SAMSUNG	08
SONY	09
TOSHIBA	10
YAMAHA	11, 12

Manufacturers' codes are subject to change without notice. If they are changed, this remote control cannot operate the equipment.

Troubleshooting

Use this chart to help you solve daily operational problems. If there is any problem you cannot solve, contact your JVC service center.

PROBLEM	POSSIBLE CAUSE	SOLUTION
The display does not light up.	The power cord is not plugged in.	Plug the power cord into an AC outlet. (See page 10.)
No sound from speakers.	Speaker signal cables are not connected.	Check speaker wiring and reconnect if necessary. (See pages 4 and 5.)
	The SPEAKERS ON/OFF 1 and SPEAKERS ON/OFF 2 buttons are not set correctly.	Press SPEAKERS ON/OFF 1 and SPEAKERS ON/OFF 2 correctly. (See page 13.)
	An incorrect source is selected.	Select the correct source.
	Muting is activated.	Press MUTING to cancel the mute. (See page 13.)
	An incorrect input mode (analog or digital) is selected.	Select the correct input mode (analog or digital). (See page 20.)
Sound from one speaker only.	Connections are incorrect.	Check connections. For analog connections, see page 5. For digital connections, see page 8. For USB connection, see page 9.
	Speaker signal cables are not connected properly.	Check speaker wiring and reconnect if necessary. (See pages 4 and 5.)
No sound from PC connected with a USB cable.	The balance is set to one extreme.	Adjust the balance properly. (See page 16).
	An electrical shock is applied to the receiver, PC, or USB cable.	Turn off and on the receiver once, then restart the application installed in the PC.
Noise while reproducing PC sound connected with a USB cable.	USB device is not selected on the computer.	Select "USB Audio Device [1]" for "Playback" of "Audio" (see page 9). Refer to the manuals supplied with your PC.
	"Mute" is selected on the PC.	Check if the volume is set at low level. Refer to the manuals supplied with your PC.
Sound from PC connected with a USB cable is intermittent.	Strong electromagnetic wave is emitted from such as television.	Move the PC away from the device such as TV emitting strong electromagnetic wave.
Continuous hiss or buzzing during FM reception.	PC is subjected to excessive load due to using other applications.	Close the applications you do not use.
Occasional cracking noise during FM reception.	Incoming signal is too weak.	Connect an outdoor FM antenna or contact your dealer. (See page 3.)
	The station is too far away.	Select a new station.
	An incorrect antenna is used.	Check with your dealer to be sure you have the correct antenna.
	Antennas are not connected properly.	Check connections. (See page 3.)
Noise is heard.	Ignition noise from automobiles.	Move the antenna farther from automobile traffic.
No sound effect such as DSP mode and digital equalization.	An earth (⏏) cable is not connected to the AM (⏏) terminal on the rear panel.	Connect the cable to the AM (⏏) terminal on the rear panel.
Howling during record playing.	The line direct function is turned on.	Turn off the line direct function. (See page 14.)
	Your turntable is too close to the speakers.	Move the speakers away from the turntable.

PROBLEM	POSSIBLE CAUSE	SOLUTION
“OVERLOAD” starts flashing on the display.	Speakers are overloaded because of high volume.	<ol style="list-style-type: none"> 1. Press STANDBY/ON  on the front panel to turn off the receiver. 2. Stop the playback source. 3. Turn on the receiver again, and adjust the volume.
	Speakers are overloaded because of short circuit of speaker terminals.	<p>Press STANDBY/ON  on the front panel, then check the speaker wiring.</p> <p>If “OVERLOAD” does not disappear, unplug the AC power cord, then plug it back again.</p> <p>If speaker wiring is not short-circuited, contact your dealer.</p>
The STANDBY lamp lights up after turning on the power, but soon the receiver turns off again (into standby mode).	The receiver is overloaded because of a high voltage.	Press STANDBY/ON  on the front panel to turn off the receiver. After unplugging the AC power cord, consult your dealer.
Remote control does not work.	There is an obstruction in front of the remote sensor on the receiver.	Remove the obstruction.
	Batteries are weak.	Replace batteries. (See page 10.)
Remote control does not work intendedly.	An incorrect remote control operation mode is selected.	Select the correct remote control operation mode. (See page 49 – 54.)

Specifications

Amplifier

Output Power:

At Stereo operation:

Front channels: 100 W* per channel, min. RMS, driven into 8 Ω at 1 kHz with no more than 0.8% total harmonic distortion. (IEC268-3/DIN)

At Surround operation:

Front channels: 100 W* per channel, min. RMS, driven into 8 Ω at 1 kHz with no more than 0.8% total harmonic distortion.

Center channel: 100 W*, min. RMS, driven into 8 Ω at 1 kHz, with no more than 0.8% total harmonic distortion.

Rear channels: 100 W* per channel, min. RMS, driven into 8 Ω at 1 kHz, with no more than 0.8% total harmonic distortion.

(*Measured on AC 110 V, 127 V, 220 V and 240 V)

Audio

Audio Input Sensitivity/Impedance (1 kHz): PHONO (MM): 2.5 mV/47 kΩ
 DVD, VCR 1, VCR 2, VIDEO, TV SOUND/DBS, CD, CDR, TAPE/MD: 200 mV/47 kΩ

Audio Input (DIGITAL IN)* : Coaxial: DIGITAL 1 (DVD): 0.5 V(p-p)/75 Ω
 Optical: DIGITAL 2 (CD), DIGITAL 3 (TV), DIGITAL 4 (CDR): -21 dBm to -15 dBm (660 nm ±30 nm)

*Corresponding to Linear PCM, Dolby Digital, and DTS Digital Surround (with sampling frequency — 32 kHz, 44.1 kHz, 48 kHz).

USB: Revision 1.0, full-speed (with sampling frequency — 32 kHz, 44.1 kHz, 48 kHz)

Audio Output Level: VCR 1, VCR 2, CDR, TAPE/MD: 200 mV

Digital output: Optical: DIGITAL OUTPUT: Signal wave length: 660 nm
 Output level: -21 dBm to -15 dBm

Signal-to-Noise Ratio (‘66 IHF/DIN): PHONO (MM): 70 dB/66 dB
 DVD, VCR 1, VCR 2, VIDEO, TV SOUND/DBS, CD, CDR, TAPE/MD: 87 dB/67 dB

Frequency Response (8 Ω): PHONO: 20 Hz to 20 kHz (±1 dB)
 DVD, VCR 1, VCR 2, VIDEO, TV SOUND/DBS, CD, CDR, TAPE/MD: 20 Hz to 100 kHz (+1 dB, -3 dB)
 USB: 20 Hz to 20 kHz (+1 dB, -3 dB)

RIAA Phono Equalization: ±1.0 dB (20 Hz to 20 kHz)

Bass boost: +6 dB ±1.0 dB at 100 Hz

Video

Video Input Sensitivity/Impedance:
 Composite video: DVD, VCR 1, VCR 2, VIDEO, TV SOUND/DBS: 1 V(p-p)/75 Ω
 S-video: DVD, VCR 1, VCR 2, VIDEO, TV SOUND/DBS:
 (Y: luminance): 1 V(p-p)/75 Ω
 (C: chrominance, burst): 0.286 V(p-p)/75 Ω
 Component video: DVD, DBS:
 (Y: luminance): 1 V(p-p)/75 Ω
 (PB, PR): 0.7 V(p-p)/75 Ω

Video Output Level:
 Composite video: VCR 1, VCR 2, MONITOR OUT: 1 V(p-p)/75 Ω
 S-video: VCR 1, VCR 2, MONITOR OUT: (Y: luminance): 1 V(p-p)/75 Ω
 (C: chrominance, burst): 0.286 V(p-p)/75 Ω
 Component video: MONITOR OUT: (Y: luminance): 1 V(p-p)/75 Ω
 (PB, PR): 0.7 V(p-p)/75 Ω

Synchronization: Negative

Signal-to-Noise Ratio: 45 dB

On-Screen Color System: NTSC

FM tuner (IHF)

Tuning Range:	87.50 MHz to 108.00 MHz	
Usable Sensitivity:	Monaural:	12.8 dBf (1.2 μ V/75 Ω)
50 dB Quieting Sensitivity:	Monaural:	21.3 dBf (3.2 μ V/75 Ω)
	Stereo:	41.3 dBf (31.5 μ V/75 Ω)
Signal-to-Noise Ratio (IHF-A weighted):	Monaural:	78 dB at 85 dBf
	Stereo:	73 dB at 85 dBf
Total Harmonic Distortion:	Monaural:	0.4% at 1 kHz
	Stereo:	0.6% at 1 kHz
Stereo Separation at REC OUT:	35 dB at 1 kHz	
Alternate Channel Selectivity:	45 dB: (\pm 400 kHz)	
Frequency Response:	30 Hz to 15 kHz: (+0.5 dB, -3 dB)	

AM tuner

Tuning Range:	531 kHz to 1 602 kHz (at 9 kHz intervals) 530 kHz to 1 600 kHz (at 10 kHz intervals)	
Usable Sensitivity:	Loop antenna	400 μ V/m
Signal-to-Noise Ratio:	50 dB (100 mV/m)	

General

Power Requirements:	AC 110 V/127 V/220 V/230 V – 240V \sim , adjustable with the voltage selector, 50 Hz/60 Hz	
Power Consumption:	210 W (at operation) 2 W (in standby mode)	
Dimensions (W x H x D):	435 mm x 156.5 mm x 425 mm (17 ³ / ₁₆ in. x 6 ³ / ₁₆ in. x 16 ³ / ₄ in.)	
Mass:	11.5 kg (25.4 lbs)	

Designs & specifications are subject to change without notice.

Mains (AC) Line Instruction (not applicable for Europe, U.S.A., Canada, Australia and U.K.)

Instrucción sobre la línea de la red (CA) (no aplicable para Europa, EE.UU., Canadá, Australia, ni el Reino Unido)

Instrução sobre a tensão da rede eléctrica (CA) (não aplicável para a Europa, os E.U.A., o Canadá, a Austrália e o Reino Unido)

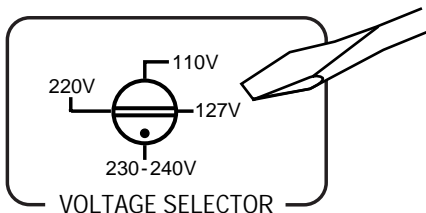
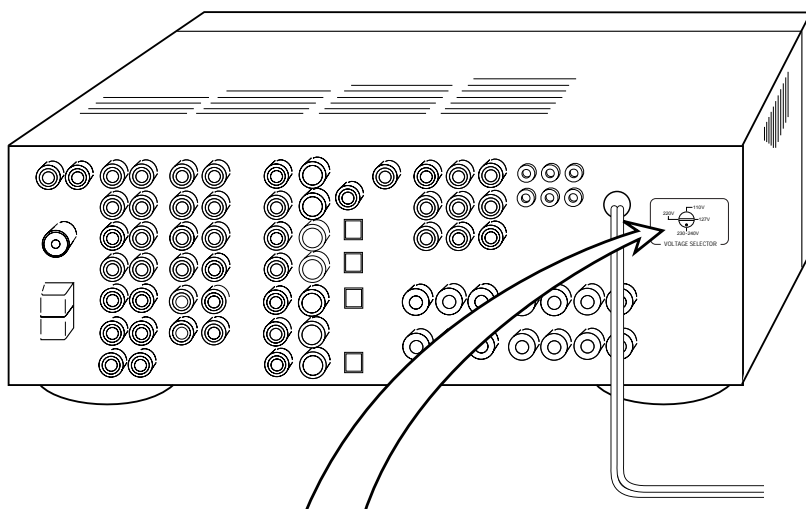

CAUTION for mains (AC) line

BEFORE PLUGGING IN, do check that your mains (AC) line voltage corresponds with the position of the voltage selector switch provided on the outside of this equipment and, if different, reset the voltage selector switch, to prevent from a damage or risk of fire/electric shock.

PRECAUCIÓN para la línea de la red (CA)

ANTES DE ENCHUFAR EL EQUIPO, compruebe si la tensión de la línea de la red (CA) corresponde con la posición del selector de tensión situado en la parte exterior del equipo, y si es diferente, reajuste el selector de tensión para evitar el riesgo de incendios/ descargas eléctricas.

PRECAUÇÃO para a ligação à tensão da rede (CA)

ANTES DE LIGAR O APARELHO A UMA TOMADA DA REDE, verifique se a tensão da rede CA corresponde à posição do selector de tensão localizado na parte externa deste equipamento. Caso não corresponda, reajuste o selector de tensão a fim de evitar avarias ou riscos de incêndio e choque eléctrico.

JVC

VICTOR COMPANY OF JAPAN, LIMITED