

JVC

SERVICE MANUAL

AUDIO/VIDEO CONTROL RECEIVER

RX-816RBK

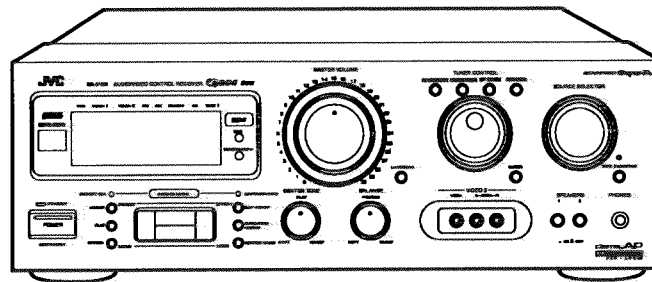
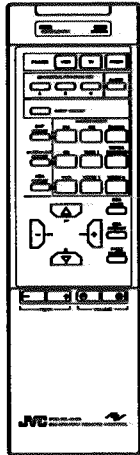

Area Suffix

BS	the U.K.
EF	Continental Europe
EN	Scandinavia
G	Germany
GI	Italy

COMPU LINK
 Remote Control Component

Contents

<i>Safety Precautions</i>	1-2	<i>Adjustment Procedures</i>	1-47
<i>Instruction Book</i>	1-3	<i>Block Diagrams</i>	1-49
<i>Description of Major ICs</i>	1-24	<i>Schematic Diagrams</i>	1-53
<i>Internal Connection of Display</i>	1-43	<i>Printed Circuit Boards</i>	1-59
<i>Disassembly Procedures</i>	1-45	<i>Parts List</i>	2-1

RX-816RBK

Safety Precautions

1. The design of this product contains special hardware and many circuits and components specially for safety purposes. For continued protection, no changes should be made to the original design unless authorized in writing by the manufacturer. Replacement parts must be identical to those used in the original circuits. Services should be performed by qualified personnel only.
2. Alterations of the design or circuitry of the product should not be made. Any design alterations of the product should not be made. Any design alterations or additions will void the manufacturer's warranty and will further relieve the manufacture of responsibility for personal injury or property damage resulting therefrom.
3. Many electrical and mechanical parts in the products have special safety-related characteristics. These characteristics are often not evident from visual inspection nor can the protection afforded by them necessarily be obtained by using replacement components rated for higher voltage, wattage, etc. Replacement parts which have these special safety characteristics are identified in the Parts List of Service Manual. Electrical components having such features are identified by shading on the schematics and by (Δ) on the Parts List in the Service Manual. The use of a substitute replacement which does not have the same safety characteristics as the recommended replacement parts shown in the Parts List of Service Manual may create shock, fire, or other hazards.
4. The leads in the products are routed and dressed with ties, clamps, tubings, barriers and the like to be separated from live parts, high temperature parts, moving parts and/or sharp edges for the prevention of electric shock and fire hazard. When service is required, the original lead routing and dress should be observed, and it should be confirmed that they have been returned to normal, after re-assembling.
5. Leakage current check (Electrical shock hazard testing)
After re-assembling the product, always perform an isolation check on the exposed metal parts of the product (antenna terminals, knobs, metal cabinet, screw heads, headphone jack, control shafts, etc.) to be sure the product is safe to operate without danger of electrical shock.

Do not use a line isolation transformer during this check.

- Plug the AC line cord directly into the AC outlet. Using a "Leakage Current Tester", measure the leakage current from each exposed metal parts of the cabinet, particularly any exposed metal part having a return path to the chassis, to a known good earth ground. Any leakage current must not exceed 0.5mA AC (r.m.s.).
- Alternate check method
Plug the AC line cord directly into the AC outlet. Use an AC voltmeter having, 1,000 ohms per volt or more sensitivity in the following manner. Connect a 1,500 Ω 10 W resistor paralleled by a 0.15 μ F AC-type capacitor between an exposed metal part and a known good earth ground.

Measure the AC voltage across the resistor with the AC voltmeter.

Move the resistor connection to each exposed metal part, particularly any exposed metal part having a return path to the chassis, and measure the AC voltage across the resistor.

Now, reverse the plug in the AC outlet and repeat each measurement. Any voltage measured must not exceed 0.75 V AC (r.m.s.). This corresponds to 0.5 mA AC (r.m.s.).

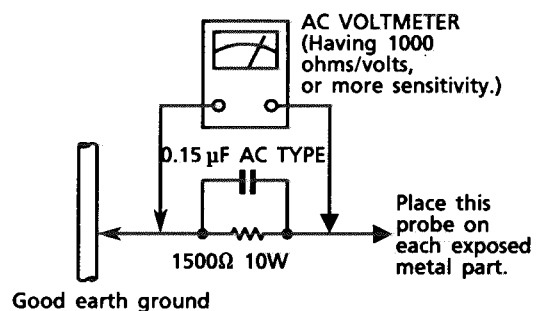

Warning

1. This equipment has been designed and manufactured to meet international safety standards.
2. It is the legal responsibility of the repairer to ensure that these safety standards are maintained.
3. Repairs must be made in accordance with the relevant safety standards.
4. It is essential that safety critical components are replaced by approved parts.
5. If mains voltage selector is provided, check setting for local voltage.

Table of Contents

Introduction 2

Switches, Buttons and Controls 2

Getting Started 4

Before Installation 4

Checking the Supplied Accessories 4

Connecting the FM and AM (MW/LW) Antennas 5

Connecting the Speakers 6

Connecting Audio/Video Components 9

Connecting Audio Components for the COMPU LINK-3 Remote Control System 10

Power Supply through the RX-816RBK to a Connected Component 11

Connecting the Power Cord 12

Putting Batteries in the Remote 12

Basic Operations 13

Turning the Power On and Off 13

Selecting the Source to Play 13

Selecting the Front Speakers 14

Adjusting the Volume 14

Adjusting the Front Speaker Output Balance 15

Listening at Low Volume (Loudness) 15

Recording a Source 15

Listening with Headphones 15

Muting the Sound 15

Receiving Radio Broadcasts 16

Tuning in Stations Manually 16

Using the Preset Tuning 16

Selecting the FM Reception Mode 17

Using the RDS (Radio Data System) to Receive FM Stations 17

Assigning Names to Preset Stations 21

Using the Preset SEA Modes 22

Using the Digital Surround Processor 23

Using the DAP Modes 23

Using the Surround Modes 25

Other Features 29

Recording Monitor 29

Using the CSR Function 29

Using the Sleep Timer 30

Using the Remote for Operating JVC's Audio/Video Components 30

Simplifying the Operations Using the Remote 33

Operating Other Manufacturers' Audio/Video Components 35

COMPU LINK Remote Control System 38

Troubleshooting 40

Specifications 41

Introduction

Become familiar with the buttons and controls on your RX-816RBK before use.

Switches, Buttons and Controls

Front Panel of the Main Unit

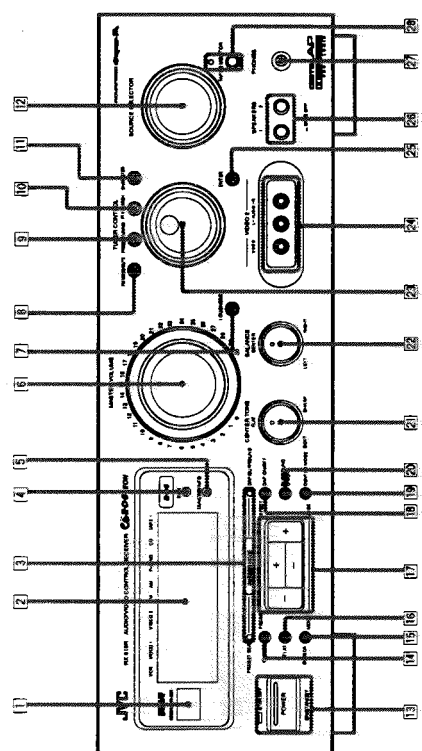

Refer to the pages in parentheses for details.

- Front Panel**
- 1 Remote sensor
 - 2 Display (13)
 - 3 CURSOR MODE button and indicators (22, 24, 27, 28)
 - 4 EON button (20)
 - 5 TA/NEWS/INFO button (20)
 - 6 MASTER VOLUME control (14)
 - 7 LOUDNESS button (15)
 - 8 FM MODE/MUTE button (17)
 - 9 PRESET/TUNING button (16)
 - 10 PTY SEARCH button (19)
 - 11 CHARACTER button (21)
 - 12 SOURCE SELECTOR (13)
 - 13 POWER button and STANDBY indicator (13)
 - 14 Preset SEA ON/OFF button (22)
 - 15 SPI/SEA (Spectrum Peak Indicator/Sound Effect Amplifier) button (22)
 - 16 ELAT button (22)
 - 17 Cursor buttons (+/-) (22, 24, 26, 28)
 - 18 DAP ON/OFF button (23)
 - 19 CENTER MODE button (26)
 - 20 SURROUND ON/OFF button (26, 28)
 - 21 CENTER TONE control (28)
 - 22 BALANCE control (14)
 - 23 TUNER CONTROL (16, 21)
 - 24 VIDEO 2 input jacks (10)
 - 25 ENTER button (16, 21)
 - 26 SPEAKERS 1/2 buttons (14)
 - 27 PHONES jack (15)
 - 28 TAPE 2 MONITOR button and indicator (13, 29)

Remote Control Unit (called "Remote" hereafter)

Outside panel

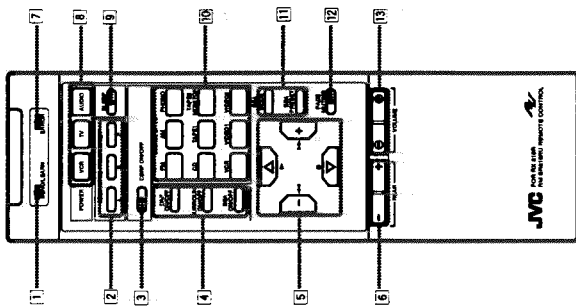

Inside panel

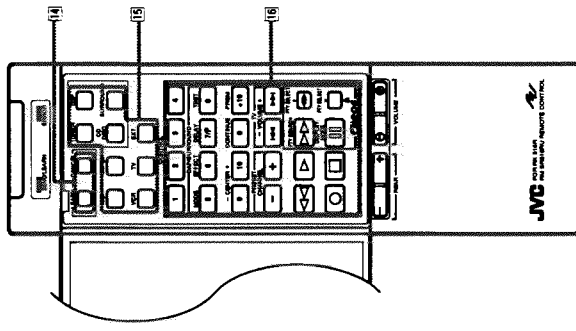

Remote Control Unit

- Outside panel**
- 1 SEND/LEARN indicator (33, 35)
 - 2 SEQUENTIAL PROGRAM KEYS (33)
 - 3 CSRP ON/OFF button (29)
 - 4 Sound mode on/off buttons (22, 23, 26, 28)
 - 5 Cursor buttons (17, 30)
 - 6 REAR (+/-) buttons (24, 27)
 - 7 ERROR indicator (33, 35)
 - 8 POWER section (13, 32)
 - 9 SLEEP button (30)
 - 10 SOURCE SELECT section (13, 30)
 - 11 SEA buttons (22)
 - 12 FADE MUTING button (15)
 - 13 VOLUME +/- buttons (14)
- Inside panel**
- 14 Learning function buttons (33, 35)
 - 15 CONTROL section (30)
 - 16 Sound Adjustment buttons (24, 26, 28)
 - Component operating buttons (30, 35)
 - RDS operating buttons (18, 19, 20)

How to open the outside panel

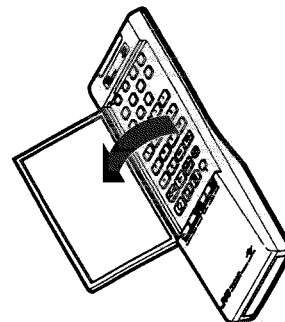

Getting Started

This section explains how to connect stereo components and speakers to the RX-816RBK, and how to connect the power supply.

Before Installation

General

- Be sure your hands are dry.
- Turn the power off to all components.
- Read the manuals supplied with the components you are going to connect.

Locations

- Install the unit in a location that is level and protected from moisture.
- The temperature around the unit must be between 23° and 104° F (-5° and 40° C).
- Make sure there is good ventilation around the unit. Poor ventilation could cause overheating and damage the unit.

Handling the unit

- Do not insert any metal object into the unit.
- Do not disassemble the unit or remove screws, covers, or cabinet.
- Do not expose the unit to rain or moisture.

Checking the Supplied Accessories

Check to be sure you have all of the following items, which are supplied with the RX-816RBK. The number in the parenthesis indicates the quantity of the pieces supplied.

- Remote (1)
- Batteries (2)
- AM (MW/LW) Loop Antenna (1)
- FM Wire Antenna (only for Germany) (1)
- FM Feeder Antenna (except for Germany) (1)
- Antenna Adaptor (except for Germany) (1)
- Mains Plug (only for the U.K.) (1)

If anything is missing, contact your dealer immediately.



Except for the U.K., Germany, and Italy
When shipped from the factory, the fuse appropriate for the voltage of AC 230 V_~ is installed in the fuse holder.

Connecting the Speakers

You can connect the following speakers:

- Two sets of front speakers to produce normal stereo sound.
- One set of rear speakers to enjoy the surround effect.
- One center speaker to produce more effective surround effect (to make human voices outstanding).
- One subwoofer speaker to enhance the bass. For connecting a subwoofer, see page 9.

For each speaker, connect the black (-) and red (+) terminals on the rear panel to the black (-) and red (+) terminals marked on the speakers.

CAUTION:
Use speakers with the same SPEAKER IMPEDANCE indicated by the speaker terminals.

Connecting the Front Speakers

Twist and remove the insulation at the end of each speaker signal cable first, and then, connect the front speakers to the FRONT SPEAKERS terminals by using the cables.

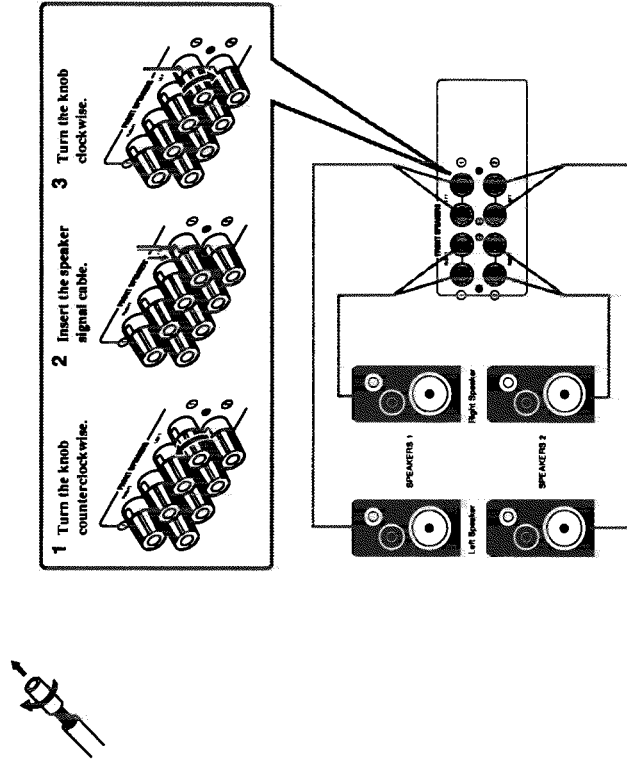

Connecting the FM and AM (MW/LW) Antennas

FM Antenna Connections

For Germany
 (A) Using the supplied wire antenna
 The FM wire antenna supplied can be connected to the FM 75Ω COAXIAL, as a temporary measure.
 (B) Using the coaxial type connector (not supplied)
 A 75-ohm antenna with coaxial type connector (DIN 45332) should be connected to the FM 75Ω COAXIAL terminal.

For Other European Countries
 (C) Using the supplied feeder antenna
 (1) Attach the feeder antenna to the supplied antenna adaptor as shown in the figure.
 (2) Connect the antenna adaptor to the FM 75Ω COAXIAL terminal.
 (D) Using FM 75-ohm antenna cable (not supplied)
 (1) Open the claws at both sides and remove the cover.
 (2) Move the conductor wire from ① to ② using tweezers or similar tool (only when using coaxial cable).
 (3) Fix the coaxial cable and its core.
 (4) Put on the cover.
 (5) Connect the supplied antenna adaptor to the FM 75Ω COAXIAL terminal.

Note:
 Make sure the antenna conductors do not touch any other terminals, connecting cords and power cord. This could cause poor reception.

For Other Countries
 Unfold the loops of the supplied FM feeder antenna and extend them as shown. Fasten them up in the position which gives you the best FM reception.

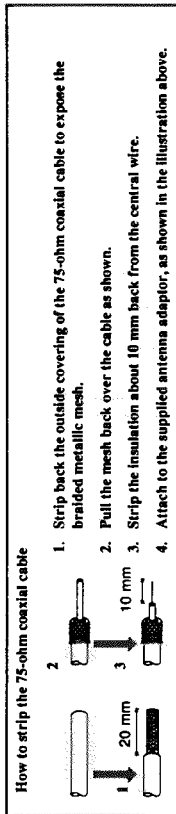
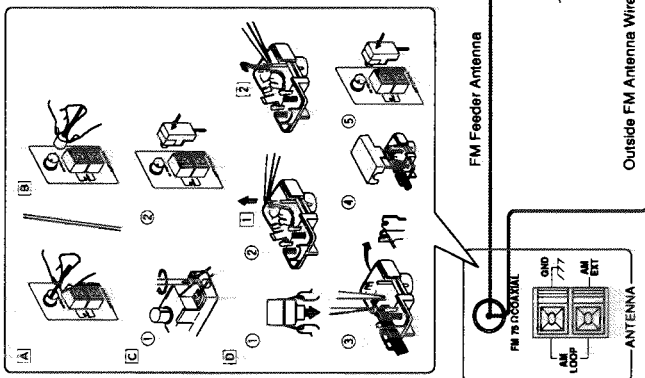

AM (MW/LW) Antenna Connections

AM (MW/LW) Wire Antenna
 If reception is poor, connect an outdoor single vinyl-covered antenna to the terminal marked AM EXT.

Turn the loop until you have the best reception.

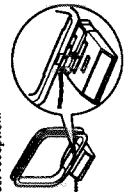

Snap the tabs on the loop into the slots of the base to assemble the AM (MW/LW) loop.

Note:
 Even when connecting an outside AM (MW/LW) antenna, keep the indoor AM (MW/LW) loop antenna connected.

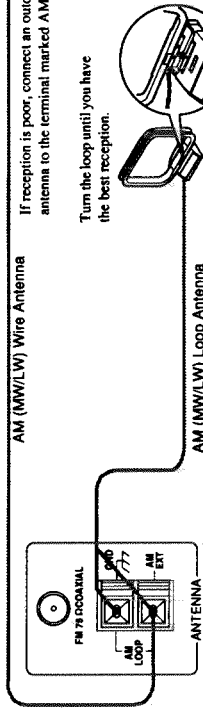

About the speaker impedance of the speakers

CAUTION:

Use speakers with the same **SPEAKER IMPEDANCE** indicated by the speaker terminals.

Notes:

- The required speaker impedance of the front speakers differs depending on whether both the **FRONT SPEAKERS** (Ⓛ) and **FRONT SPEAKERS** (Ⓜ) terminals are used or only one of them is used.
- The required speaker impedance of the front speakers differs depending on whether or not a center and/or rear speakers are connected at the same time. Check which one fits your case and use the speaker with the impedance described below.

CASE 1 When you connect only one set of front speakers



Use front speakers with 4 — 16 ohm impedance.

CASE 2 When you connect two set of front speakers

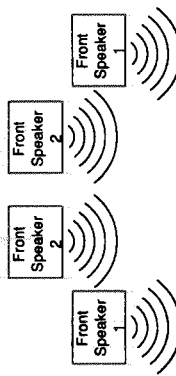

Use front speakers with 8 — 16 ohm impedance.

CASE 3 When you connect front speakers and a center speaker

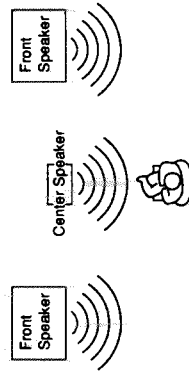

Use the following speakers:

- Front speakers: 8 — 16 ohm impedance
- Center speaker: 8 — 16 ohm impedance

CASE 4 When you connect front and rear speakers

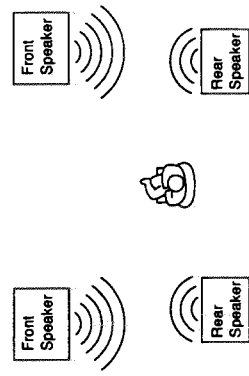

Use the following speakers:

- Front speakers: 8 — 16 ohm impedance
- Rear speakers: 8 — 16 ohm impedance

CASE 5 When you connect fronts, rear speakers and a center speaker

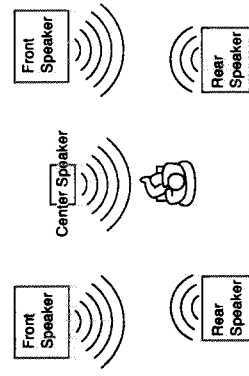

Use the following speakers:

- Front speakers: 8 — 16 ohm impedance
- Rear speakers: 8 — 16 ohm impedance
- Center speaker: 8 — 16 ohm impedance

Connecting the rear and center speakers

Twist and remove the insulation at the end of each speaker signal cable first, and then, connect rear speakers to the **REAR SPEAKERS** terminals and a center speaker to the **CENTER SPEAKER** terminals by using the cables.

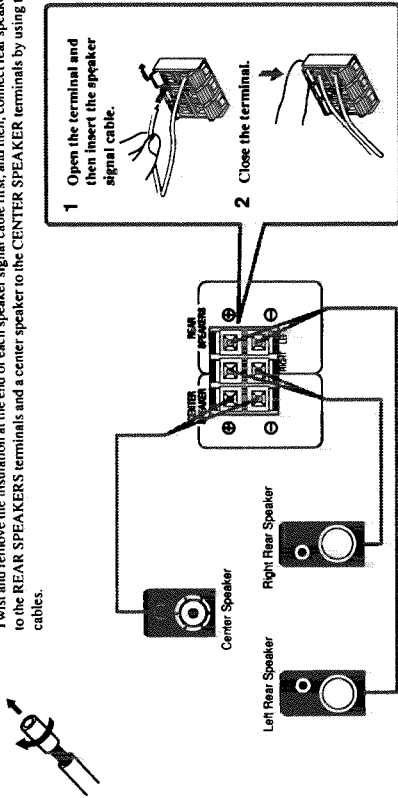

1 Open the terminal and then insert the speaker signal cable.

2 Close the terminal.

Note:
When you connect rear speakers, make sure that both left and right speakers are connected, otherwise, no sound will come out of the rear speakers.

Increasing the power for the rear speakers

You can use a separate power amplifier to reinforce sounds through the rear speakers.

- 1 Connect the input jacks of the power amplifier to the **REAR OUT** jacks on the rear panel.
- 2 Connect the rear speakers to the speaker terminals of the power amplifier.

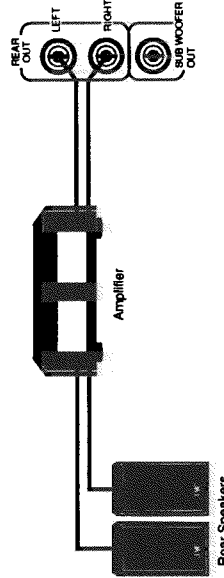

Enhancing the bass

You can enhance the bass by connecting a subwoofer. To connect a subwoofer, you also need a separate power amplifier.

- 1 Connect the input jack of the power amplifier to the SUB WOOFER OUT jack on the rear panel.
- 2 Connect a subwoofer speaker to the speaker terminal of the power amplifier.

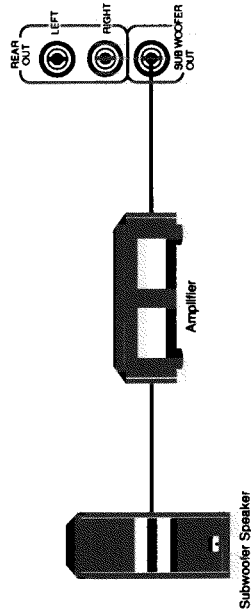

Connecting Audio/Video Components

You can connect the following components to the RX-816RBK using cables with RCA pin plugs.

- Notes:**
- Both plugs and jacks are color-coded; the red ones are for right audio signals, the white ones for left audio signals, and yellow ones for video signals.
 - Any turntables incorporating a small-output cartridge such as an MC (moving-coil type) must be connected to this unit through a commercial head amplifier or step-up transformer. Direct connection may result in insufficient volume.
 - If an earth cable is provided for your turntable, connect the cable to the screw marked GND on the rear panel.

Audio component connections

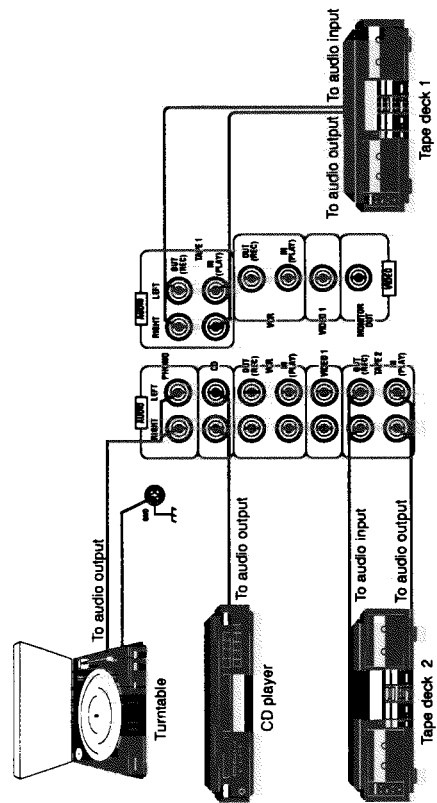

Video component connections

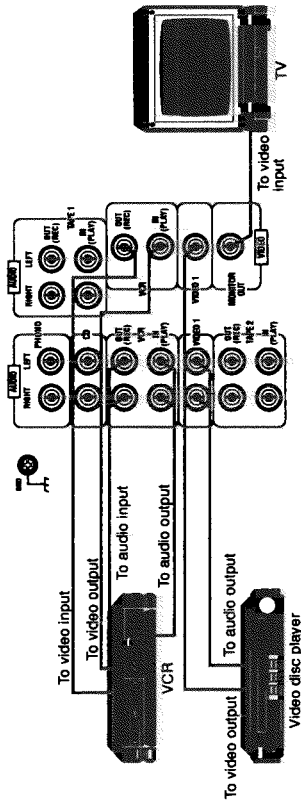

For connecting a video camera

You can use the VIDEO 2 jacks on the front panel, since this jacks are convenient for connecting and disconnecting the component frequently.

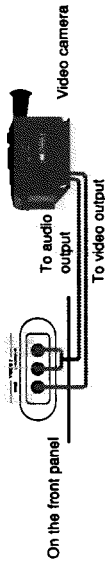

Connecting Audio Components for the COMPU LINK-3 Remote Control System

The COMPU LINK-3 remote control system allows you to control other JVC audio components from the RX-816RBK or vice versa. To use this system, connect your JVC audio components and the RX-816RBK with the cable (monaural mini-plug) supplied with those components.

If your audio component has two COMPU LINK-3 SYNCHRO jacks, you can use either one. If it has only one COMPU LINK-3 SYNCHRO jack, connect it so that it is the last item in the series of components. (For example, the turntable in the diagram below)

Notes:

- The COMPU LINK-3 remote control system is the upgraded version of the COMPU LINK-1 and COMPU LINK-2. Even if your component has the COMPU LINK-1 or COMPU LINK-2 jacks, you can still connect it in the COMPU LINK-3 remote control system, but some functions may not work correctly.
- For more information about the COMPU LINK-3 (-1 and -2) remote control system, see page 38.

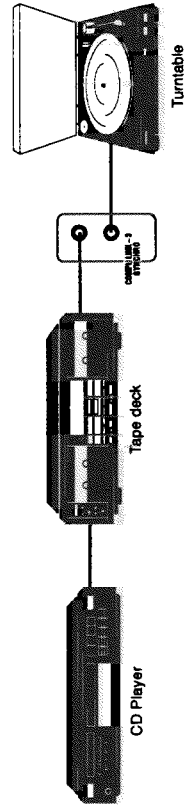

CAUTION:
The COMPU LINK-3 remote control system cannot control the cassette deck connected to the TAPE 2 jacks. Use only the cassette deck connected to the TAPE 1 jacks.

Power Supply through the RX-816RBK to a Connected Component

You can use the AC outlet on the rear of the RX-816RBK to supply power to an audio component. This AC outlet is "switched" outlet. So when the RX-816RBK is off (that is, in standby mode), power is not supplied through this outlet. By turning the RX-816RBK on and off, you can turn the connected component on and off at the same time.

Note:
Do not use the AC outlet on the rear of the RX-816RBK to supply power to the component in the COMPU LINK remote control system; otherwise, the COMPU LINK remote control system may not work correctly.

CAUTION:
Do not plug the component to the AC outlet on the rear if the maximum power consumption is greater than indicated by the AC outlet.

For the U.K. model

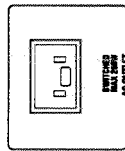

For the model for the other countries

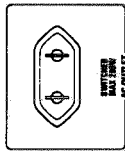

Connecting the Power Cord

Before plugging the RX-816RBK into an AC outlet, make sure that all connections have been made. When the power cord is connected, the STANDBY indicator above the POWER button lights up.

Keep the power cord away from the connecting cables for the TV, VCR, and antenna. The power cord may cause noise or screen interference. We recommend that you use a coaxial cable to connect the antenna, since it is well-shielded against interference.

Notes:

- A small amount of power is always consumed even in standby mode. To switch off the power completely, unplug the power cord from the AC outlet.
- If the power cord is unplugged or a power failure occurs, preset settings will be erased in a few days.

CAUTIONS:

- Do not touch the power cord with wet hands.
- Do not pull on the power cord to unplug the unit. When unplugging the unit, always grasp the plug itself so as not to damage the cord.

Putting Batteries in the Remote

Before using the Remote, put two supplied batteries first. When using the Remote, aim the Remote directly at the remote sensor on the RX-816RBK.

- On the back of the Remote, press down on the battery cover and slide it out.
- Insert batteries. Make sure to observe the proper polarity: (+) to (+) and (-) to (-).
- Slide the cover in.

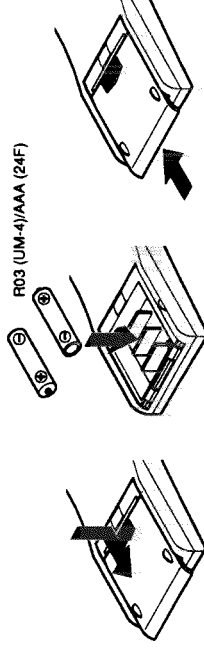

If the range or effectiveness of the Remote decreases, replace the batteries. Use two R03 (UM-4)/AAA (24F) type dry-cell batteries.

CAUTION:
When replacing the batteries, finish it without delay; otherwise, the stored signals are all erased. (See pages 33-37.)

CAUTIONS:
Follow these precautions to avoid leaking or cracking cells:

- Place batteries in the Remote so they match the polarity indicated: (+) to (+) and (-) to (-).
- Use the correct type of batteries. Batteries that look similar may differ in voltage.
- Always replace both batteries at the same time.
- Do not expose batteries to heat or flame.

Basic Operations

The following operations are commonly used when you play any sound source.

Turning the Power On and Off

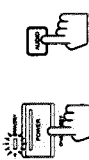

To turn on the power, press the POWER button on the front panel or the AUDIO button on the POWER section of the Remote.
The STANDBY indicator goes off.

To turn off the power, press the POWER button or the AUDIO button on the POWER section of the Remote again.
The STANDBY indicator lights up.

Selecting the Source to Play

You need to select the source to listen before you start playing any source.

On the front panel:
Turn the SOURCE SELECTOR so that the desired source name appears on the display (at the same time the arrow (▲) on the display points the source).

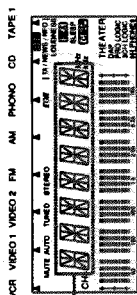

Front panel

- VCR View the video component connected to the VCR jacks.
- VIDEO 1 View the video component connected to the VIDEO 1 jacks.
- VIDEO 2 View the video component connected to the VIDEO 2 jacks.
- FM Listen to an FM broadcast.
- AM Listen to an AM (MW/LW) broadcast.
- PHONO Listen to a record.
- CD Listen to the CD player.
- TAPE 1 Listen to the cassette deck connected to the TAPE 1 jacks.
- TAPE 2 Listen to the cassette deck connected to the TAPE 2 jacks.

To listen to the cassette deck connected to the TAPE 2 jacks, press the TAPE 2 MONITOR button so that the TAPE 2 MONITOR indicator lights up on the front panel ("ON" appears on the display). However, do not press the TAPE 2 MONITOR button if no component is connected to the TAPE 2 jacks; otherwise, no sound comes out of the speakers.

From the Remote:

Press the desired source selecting buttons on the SOURCE SELECT section.

- VCR View the video component connected to the VCR jacks.
- VIDEO 1 View the video component connected to the VIDEO 1 jacks.
- VIDEO 2 View the video component connected to the VIDEO 2 jacks.
- FM* Listen to an FM broadcast.
- AM* Listen to an AM (MW/LW) broadcast.
- PHONO* Listen to a record.
- CD* Listen to the CD player.
- TAPE 1* Listen to the cassette deck connected to the TAPE 1 jacks.
- TAPE 2 MONITOR Listen to the cassette deck connected to the TAPE 2 jacks.



Remote: Outside

- Notes:**
- The TAPE 2 MONITOR button has a different function from other source selecting buttons since this button allows you to monitor the recording. For more details, see "Recording Monitor" on page 29.
 - When you press one of the source selecting buttons marked above with an asterisk (*), the RX-816RBK automatically turns on.

Selecting the Front Speakers



When you have connected two sets of front speakers, you can select which to use. Pressing in the SPEAKERS 1 or SPEAKERS 2 button activates the respective set of speakers.

To use the set of speakers connected to the FRONT SPEAKERS ① terminals, press in the SPEAKERS 1 button (=ON), and press out the SPEAKERS 2 button (=OFF).

To use the set of speakers connected to the FRONT SPEAKERS ② terminals, press in the SPEAKERS 2 button (=ON), and press out the SPEAKERS 1 button (=OFF).

To use both sets of speakers, press in both the SPEAKERS 1 and 2 buttons (=ON).
To use neither set of speakers, press out both the SPEAKERS 1 and 2 buttons (=OFF).

Front panel

Adjusting the Volume

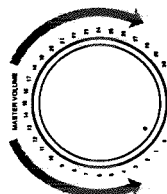

On the front panel:

To increase the volume, turn the MASTER VOLUME control clockwise.
To decrease the volume, turn it counterclockwise.

From the Remote:

To increase the volume, press the VOLUME + button.
To decrease the volume, press the VOLUME - button.

Front panel



Remote: Outside

CAUTION:
Always set the MASTER VOLUME control to the minimum before starting any source. If the MASTER VOLUME control is left turned up, the sudden blast of sound energy can permanently damage your hearing and/or ruin your speakers.

Adjusting the Front Speaker Output Balance



Front panel

If the sounds you hear from the right and left front speakers are unequal, you can adjust the speaker output balance with the BALANCE control.

To decrease the left channel sound, turn the BALANCE control clockwise.
To decrease the right channel sound, turn it counterclockwise.

Listening at Low Volume (Loudness)

Human ears are not sensitive to bass at low volume. To compensate for this, the loudness function automatically boosts the bass level as you lower the volume.

To use the loudness function, press the LOUDNESS button on the front panel. The LOUDNESS indicator lights up on the display.

To turn the function off, press the LOUDNESS button again. The LOUDNESS indicator goes off.



Front panel

Recording a Source

You can record any source playing through the RX-816RBK to the cassette decks connected to the TAPE 1 and TAPE 2 jacks, and the VCR connected to the VCR jacks at the same time. While recording, you can listen to the selected sound source at whatever sound level you like, without affecting the sound levels of the recording.

Notes:

- When recording from the cassette deck connected to the TAPE 2 jacks to the one connected to TAPE 1, press TAPE 2 MONITOR button and select a source other than TAPE 1.
- The output volume level, preset SEA modes and surround effects will not affect the recording.
- See also "Recording Monitor" on page 29.

Listening with Headphones

A standard pair of headphones can be connected to the PHONES jack on the front panel. Be sure to turn down the volume before connecting or putting on headphones, as high volume can damage both the headphones and your hearing.

To listen with only headphones

Press on both the SPEAKERS 1 and 2 buttons (OFF).

Muting the Sound

You can easily turn off the volume by pressing the FADE MUTING button on the Remote.

To mute the sound through all speakers and headphones connected

Press the FADE MUTING button so that "MUTING" appears on the display and the MASTER VOLUME control turns down.

To cancel the mute, press the VOLUME + button (or the VOLUME - button) on the Remote.



Remote: Outside

Receiving Radio Broadcasts

You can browse through all the stations or use the preset function to go immediately to a particular station.

Tuning in Stations Manually

1. Select the band.

On the front panel:

Turn the SOURCE SELECTOR.

From the Remote:

Press the FM button or the AM button so that the last received station is tuned in.

Note:

If you do not see a preset channel number on the display, the RX-816RBK is already in the manual tuning mode, so skip Step 2 below.

2. Press the PRESET/TUNING button to set the tuning mode to the manual mode.

3. Turn the TUNER CONTROL clockwise or counterclockwise.

Turning it clockwise increases the frequency.

Turning it counterclockwise decreases the frequency.

Notes:

- When you turn the TUNER CONTROL fast, the frequency keeps changing until you turn the TUNER CONTROL again or a station is tuned in.
- When a station of sufficient signal strength is tuned in, the TUNED indicator lights up on the display.
- When an FM stereo program is received, the STEREO indicator also lights up.

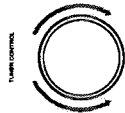

Using the Preset Tuning

Once a station is assigned to a channel number, the station can be quickly tuned. You can preset up to 40 stations, either AM (MW/LW), FM, or a mixture of both, at random.

On the front panel:

1. Tune in the station you want to preset (see above).

Press the ENTER button.

"CH ——" appears on the display for 5 seconds.

3. Turn the TUNER CONTROL to select a channel number within the 5 seconds.

You can also use the Remote to select a channel number. To use the Remote, see page 30.

4. Press the ENTER button again while the selected channel number is flashing on the display.

The selected channel number stops flashing, and the station is assigned to the selected channel number.

To cancel a stored preset station

Storing a new station on a used number erases the previously stored one.

CAUTION:

Preset stations may be erased when power is cut off to the RX-816RBK, as when it is unplugged from the AC outlet or a power failure occurs. If the preset stations are lost, simply set the stations again using the above procedure.

Storing the preset stations



TUNER CONTROL



Tuning in a Preset Station



On the front panel:

1. Turn the **SOURCE SELECTOR** to select either FM or AM. The last received station of the selected band is tuned in.

Note:

If you see a **preset channel number** on the display, the RX-816RBK is already in the preset tuning mode, so skip Step 2 below.



2. Press the **PRESET/TUNING** button to set the tuning mode to the preset mode.

3. Turn the **TUNER CONTROL** to select a preset channel number.

Turning it clockwise changes preset channels in increasing order. Turning it counterclockwise changes preset channels in decreasing order.



From the Remote:

1. Press the **FM** button on the AM button. The last received station of the selected band is tuned in.
2. Press the **upper or lower cursor** button on the outside panel to select a preset channel number (see page 30). You can also use the **PRESET CHANNEL +/-** buttons on the inside panel.

To select a preset channel number directly, press the 10 keys on the inside panel.

Examples: For channel number 5, press 5. For channel number 15, press +10 then 5. For channel number 20, press +10 then 10.

Note:

When you use the Remote, be sure that the Remote are activated for tuner, not for the CD and others. (See page 30.)

Selecting the FM Reception Mode



You can change the FM reception mode so that reception will be improved.

When an FM stereo broadcast is hard to receive or noisy

Press the **FM MODE/MUTE** button on the front panel. The **MUTE AUTO** indicator goes off on the display. Reception will be improved although you will lose the stereo effect. In this mode, you will hear noise while tuning into the stations.

To restore stereo effect

Press the **FM MODE/MUTE** button again so that the **MUTE AUTO** indicator lights up on the display. In this mode, when a program is broadcast in stereo, you will hear stereo sound, when in monaural, you will hear monaural sounds. This mode is also useful to suppress static noise between stations.

Using the RDS (Radio Data System) to Receive FM Stations



RDS allows FM stations to send additional signals along with their regular program signals. For example, the stations send their station names, and information about what type of program they broadcast, such as sports or music, etc.

When tuned to an FM station which provides the RDS service, the RDS indicator lights up.

- PS (Program Service): shows station names commonly known
- PTY (Program Type): shows types of broadcast programs
- RT (Radio Text): shows text messages the station sends
- TA (Traffic Announcement): shows traffic announcement is being broadcast

What information can RDS signals provide?

You can see the RDS signals the station sends on the display.

To show the RDS signals on the display:

1. Open the outside panel of the Remote and press the **TUNER** button on the **CONTROL** section.
2. Press the **DISPLAY MODE** button while listening to an FM station. Each time you press the button, the display changes to show you the following information:

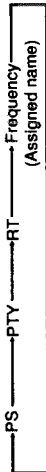

PS (Program Service):

While searching, "PS" appears and then the station names will be displayed. "NO PS" appears if no signal is sent.

PTY (Program Type):

While searching, "PTY" appears and then the type of the broadcast program will be displayed. "NO PTY" appears if no signal is sent.

RT (Radio Text):

While searching, "RT" appears and then text messages the station sends will be displayed. "NO RT" appears if no signal is sent.

Station Frequency or assigned name (non-RDS service):

Station frequency or assigned name (see page 21)

Notes:

- If searching finishes at once, "PS", "PTY", and "RT" will not appear on the display.
- RDS is not available in AM (MW/LW) broadcasts.

On characters displayed

When the display shows PS, PTY, or RT signals, the following characters are used.

- The display cannot differentiate upper case and lower case letters and always uses upper case letters.
- The display cannot show accented letters; therefore, "A", for instance, may stand for accented "A" like "À, Á, Â, Ã, Ä, and Å."

A	A.A.A.	K	U	0	/	<
B	B	L	V	1	/	>
C	C.C.C	M	W	2	-	-
D	D.D	N	X	3	/	/
E	E.E.E.	O	Y	4	/	/
F	F	P	Z	5	/	//
G	G	Q		6	-	-
H	H	R	R	7	-	-
I	I.I.I.I.I	S	S	8	-	-
J	J	T	T	9	/	/

To search the program by PTY codes

One of the advantages of the RDS service is that you can locate a particular kind of program by specifying the PTY codes.

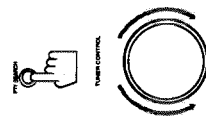

1. Press the PTY SEARCH button while listening to an FM station. The display alternates between "PTY" and "SELECT."
2. Turn the TUNER CONTROL clockwise or counterclockwise to select a PTY code. The display gives you the PTY codes described below.
3. Press the PTY SEARCH button again. While searching, the display alternates between "SEARCH" and the selected PTY code. The RX-816RBK searches 40 preset channels, stops when it finds the one you have selected, and tunes in that station.

On the Remote:

1. Open the outside panel of the Remote and press the TUNER button on the CONTROL section.
2. Press the PTY SEARCH button while listening to an FM station. The display alternates between "PTY" and "SELECT."
3. Turn the PTY SELECT + button or the PTY SELECT - button to select a PTY code. The display gives you the PTY codes described below.
4. Press the PTY SEARCH button again. While searching, the display alternates between "SEARCH" and the selected PTY code. The RX-816RBK searches 40 preset channels, stops when it finds the one you have selected, and tunes in that station.

Remote: Inside



Remote: Inside



Remote: Inside

- Descriptions of the PTY codes**
- NEWS: News
 - AFFAIRS: Topical program expanding on the current news or affairs
 - INFO: Programs on medical service, weather forecast, etc.
 - SPORT: Sports events
 - EDUCATE: Educational programs
 - DRAMA: Radio plays
 - CULTURE: Programs on national or regional culture
 - SCIENCE: Programs on natural sciences and technology
 - VARIED: Other programs like comedies or ceremonies
 - POP M: Pop music
 - ROCK M: Rock music
 - M.O.R. M: Middle-of-the-road music (usually called "easy listening")
 - LIGHT M: Light music
 - CLASSICS: Classics
 - OTHER M: Other music
 - NONE: Undefined (this cannot be searched.)

When an emergency broadcast (ALARM signal) is sent from an FM station

The RX-816RBK automatically switches the source to FM and tunes in the station except in the following cases:

- When you are listening to non-RDS stations (all AM (MW/LW) and some FM stations).
- When the power to the RX-816RBK is turned off.

While receiving an emergency broadcast, "ALARM" appears on the display.

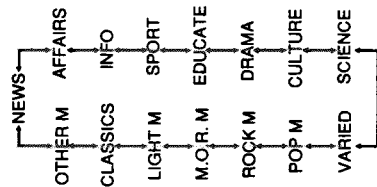

To switch to a broadcast program of your choice temporarily

Another convenient RDS service is called "EON (Enhanced Other Network)." This allows the RX-816RBK to switch temporarily to a broadcast program of your choice from other sources *except the following cases:*

- When you are listening to a non-RDS station (all AM (MW/LW) stations and some FM stations)
- When the last received FM station is a non-RDS station.



To select the program type

Press the TA/NEWS/INFO button on the front panel. Each time you press the button, the display changes to show the following:

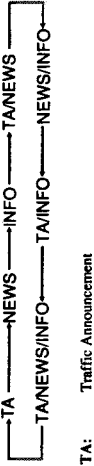

TA: Traffic Announcement
 NEWS: News
 INFO: Programs on medical service, weather forecast, etc.

To use the EON function

Press the EON button on the front panel. The EON indicator lights up on the display, and the RX-816RBK enters EON standby mode.



CASE 1 If there is no station broadcasting the program of the type you have selected

The RX-816RBK continues playing the current source.



When a station starts broadcasting the program of the type you have selected, the RX-816RBK automatically switches to the station. The EON indicator starts flashing.



When the program is over, the RX-816RBK goes back to the currently selected source, but still remains in EON standby mode.

CASE 2 If there is a station broadcasting the program of the type you have selected

The RX-816RBK changes the source, and tunes in the program. The EON indicator starts flashing.



When the program is over, the RX-816RBK goes back to the currently selected source, but still remains in EON standby mode.

To stop listening to the program selected by EON

Press the EON button again so that the EON indicator goes off on the display. The RX-816RBK enters EON off mode and goes back to the currently selected source. Each time you press the button, the EON mode alternates between standby mode and off mode.

Notes:

- In EON standby mode, if you change the source to AM or if you carry out synchronized recording (see page 38), EON standby mode is canceled temporarily. The RX-816RBK goes back to EON standby mode again when you have finished that operation.
- While listening to a program tuned in by the EON function, you can only use the POWER, EON, and DISPLAY MODE buttons.
- When the RX-816RBK is turned off, the EON function is also turned off.

CAUTION:

When the source alternates intermittently between the station tuned in by the EON function and the currently selected source, press the EON button to cancel the EON function (the EON indicator goes off on the display). This is not the malfunction of the RX-816RBK.

Using the Preset SEA Modes

The RX-816RBK has five preset SEA (Sound Effect Amplifier) modes (COUNTRY, JAZZ, ROCK, MUSICAL, and MOVIE) which give you control of the way your music sounds, so you can create it for your room and for the quality of the source.

On the front panel:
 1. Press the ON/OFF button under the PRESET SEA indicator so that the SEA indicator lights up on the display.
 Now the previously selected preset SEA mode comes into effect.

2. Press the left or right cursor button (+/-) to select a preset SEA mode.
 Pressing the button changes the preset SEA modes in the following sequence:

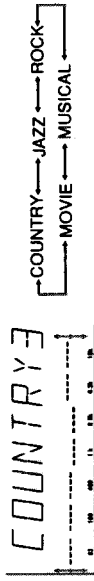

- COUNTRY:** Enhances the high-frequency range so that instruments such as a violin and banjo sound outstanding.
- JAZZ:** Gives a feeling of a live atmosphere. Good for acoustic music.
- ROCK:** Gives a heavy sound. Both high and low frequencies are boosted.
- MUSICAL:** Enhance the mid-frequency range which human voice is mostly made up of.
- MOVIE:** Adds breath to sounds so you feel like you are in a movie theater.

Note:
 When using the cursor buttons on the front panel, make sure that the PRESET SEA indicator on the front panel is turned on. If not, press the CURSOR MODE button once so that the cursor buttons can be used for selecting a preset SEA mode and its level.

3. Press the upper or lower cursor button (+/-) to select the level (from 1 to 5) of the preset SEA mode selected in above step.
 Pressing the upper cursor button (+) increases the SEA preset level.
 Pressing the lower cursor button (-) decreases the SEA preset level.

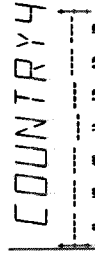

From the Remote:

1. Press the SEA ON/OFF button so that the SEA indicator lights up on the display.
 Now the previously selected preset SEA mode comes into effect.
2. Press the SEA MODE button repeatedly.
 Each time you press the button, the preset SEA modes changes.
3. Press the SEA PRESET button repeatedly.
 Each time you press the button, the SEA preset level changes.

To flatten the equalizing curve while using the preset SEA modes
 Press the FLAT button on the front panel so that "SEA FLAT" appears on the display.

To compare the original sound and the sound processed by using the preset SEA modes
 Press the ON/OFF button on the front panel for the preset SEA modes repeatedly. (When using the Remote, press the SEA ON/OFF button.)

- While the SEA indicator is turned on, you can listen to the processed sound.
- While the SEA indicator is turned off, you can listen to the original sound.

To see the actual sound output level on the display (Spectrum Peak Indicator mode)
 Press the SPT/SEA button on the front panel so that the actual sound output level can be shown in 7 frequency ranges on the display.
 To cancel it, press the button again.

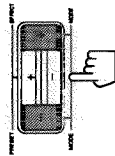
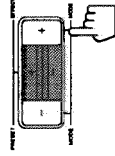

Remote: Outside



Remote: Outside



Remote: Outside

Assigning Names to Preset Stations

You can assign a name of up to four characters to each preset station (from channel number 1 to 20). When a preset station is tuned in, its assigned name will appear on the display.

On the front panel only:
 1. Tune in a preset station (channel number 1 to 20).
 See page 17 for details.

2. Press the CHARACTER button.
 The cursor appears at the first character position.



3. Turn the TUNER CONTROL to select the first character.
 You can use characters listed below



4. When the character you want appears, press the CHARACTER button.
 The cursor moves to the next character position.



5. Repeat Steps 3 and 4 to enter up to four characters.
 6. Press the ENTER button after you have assigned a name.

To erase the input characters
 Insert blanks using the same procedure described above.

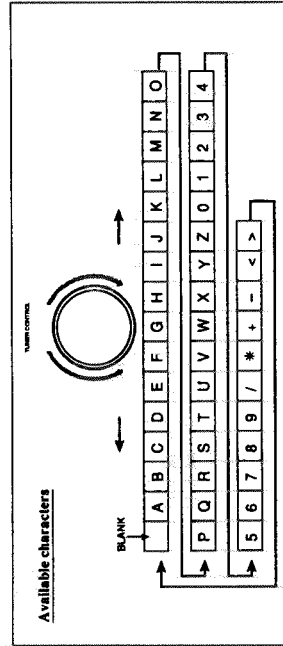

Using the Digital Surround Processor

The built-in digital surround processor provides two groups of programs — DAP (Digital Acoustic Processor) modes and surround modes (Dolby Surround* and JVC Theater Surround). You cannot use these DAP modes and surround modes at the same time.

Notes:

- The digital surround processor has no effect on monaural sources.
- The digital surround processor cannot be used for recording.
- Manufactured under license from Dolby Laboratories Licensing Corporation. DOLBY and the double-D symbol are trademarks of Dolby Laboratories Licensing Corporation.

What can the digital surround processor do?

The sound heard in a concert hall or a movie theater consists of direct sound and indirect sound: early reflections and reflection from behind. The reflected sounds are always delayed by the distances of the ceiling and walls from the listener. These reflections are some of the most important elements of the acoustic surround. So, what the digital surround processor does is to reproduce these elements in your listening room.

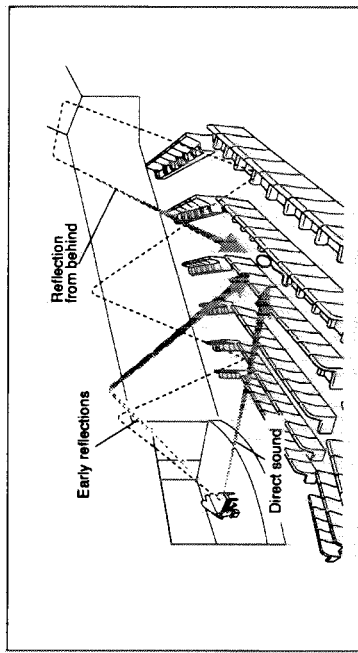

Using the DAP Modes

You need to connect the front and rear speakers to enjoy the DAP modes — HALL, L(live) CLUB, PAVILION, D(dance) CLUB. By using these modes, the sound field can be enlarged to give a more realistic sound. The DAP modes do not require the center speaker. When you use these four modes, you can adjust the output level of the rear speaker and the effect depth. Once you have adjusted these, the RX-816RBK memorizes the setting for each mode.

Among the DAP modes, H PHONES (headphones) is very special and newly developed by JVC. It can create the same stereo sound as you can listen from the speakers in air. So, when you listen to a source using headphones, you can feel as if you were not using headphones.

1. Set the DAP mode on.

Press the DAP ON/OFF button so that the DAP indicator lights up on the display. When you have selected H PHONES (headphones) previously, the H-PHONE indicator also lights up on the display.



Front panel



Remote: Outside

2. Select the mode you want.

- On the front panel:**
Press the left or right cursor button (+/-) repeatedly until the mode you want appears on the display.
- From the Remote:**
2-1 Open the outside panel and press the DAP button on the CONTROL section.
2-2 Press the MODE button until the mode you want appears on the display.
Each time you press the button, the DAP modes change as follows (when using the button on the Remote, it changes only rightward):

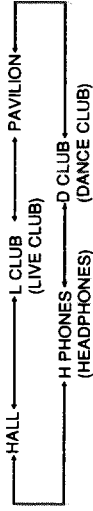

- HALL:** Gives clear vocal and the feeling of a concert hall.
L CLUB: Gives the feeling of a live music club with the low ceiling.
PAVILION: Gives the spacious feeling of a pavilion with the high ceiling.
D CLUB: Gives a throbbing bass beat.
H PHONES: Gives a spacious stereo effect when listening with headphones.

Note:
When using the cursor buttons on the front panel, make sure that the DAP/SURROUND indicator is turned on. If not, press the CURSOR MODE button once so that the cursor buttons can be used for selecting the DAP modes.

3. Set the output levels of the rear speakers.

- From the Remote only:**
Press the REAR + button or REAR - button to set the sound level of the rear speakers.



Remote: At bottom

Note:
When you have selected H PHONES (headphones) in Step 2 above, you cannot set the output levels of the rear speakers.

4. Select the effect depth among 5 preset levels.

- On the front panel:**
Press the upper or lower cursor button (+/-) repeatedly.
To increase the effect depth, press the upper cursor button (+), and to decrease it press the lower cursor button (-).
- From the Remote:**
Press the EFFECT button repeatedly. Selecting the higher number makes the effect deeper. Each time you press the button, the effect depth changes as follows (when using the button on the Remote, it changes only rightward):



Note:
When you have selected H PHONES (headphones) in Step 2 above, you cannot select the effect depth.

Using the Surround Modes

You can enjoy two types of surround modes — Dolby Surround and JVC's Theater Surround.

On Dolby Surround

The Dolby Surround has been also developed to reproduce the important elements of the acoustic surround at home.

To watch the soundtracks of video software bearing the mark  which includes the same encoded surround information as found in Dolby Stereo films, the RX-816RBK can provide you with 2Dolby Surround modes (Dolby Pro Logic and Dolby 3ch Logic).

Dolby Pro Logic: Select this mode when optional rear speakers are connected.

Dolby 3ch Logic: Select this mode when a center speaker is connected without rear speakers.

On JVC's Theater (1 and 2) Surround

In order to reproduce a more realistic sound field in your listening room while playing soundtracks of video software bearing the mark , JVC's Theater Surround has been designed to give you clearer vocals and to create the feeling of being there. The sound is reproduced through the front speakers, rear speakers, and center speaker.

Speaker arrangements for surround modes

The following illustrations show how to obtain the optimum sound environment for various surround settings. Try to find the speaker direction and location to create the optimum sound field.

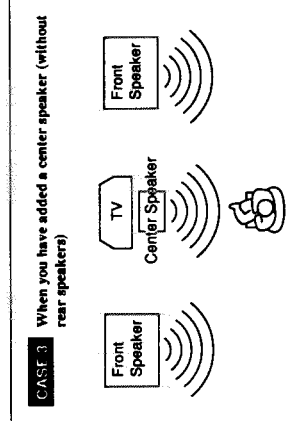
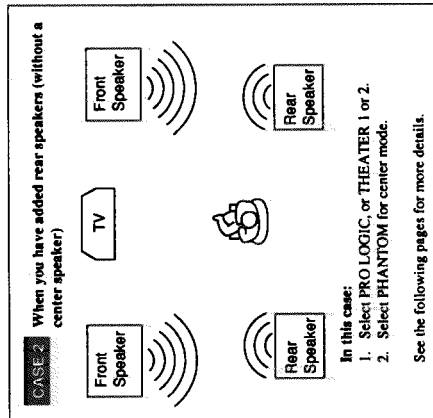
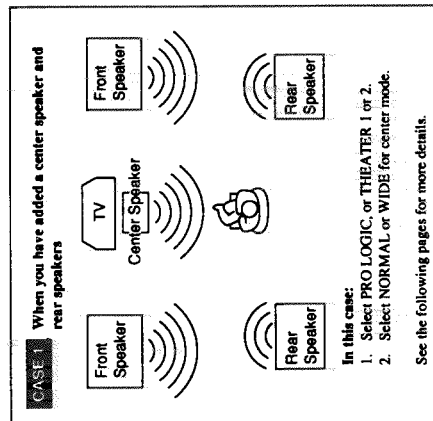

Preparing for the surround modes

The RX-816RBK memorizes surround adjustments for each mode.

1. Set the surround mode on.
Press the SURROUND ON/OFF button so that one of the surround mode indicators (THEATER, PRO LOGIC, or 3CH LOGIC) lights up on the display.

2. Select the mode you want.
On the front panel:
Press the left or right cursor button (+/-) repeatedly until the mode you want appears on the display.
From the Remote:
2-1 Open the outside panel and press the SURROUND button on the CONTROL section.
2-2 Press the MODE button repeatedly until the mode you want appears on the display.
Each time you press the button, the surround modes change as follows (when using the button on the Remote, it changes only rightward):

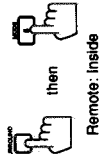
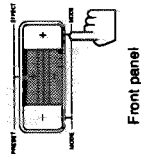

- PRO LOGIC:** Use this mode to watch a video tape with Dolby Surround when you have connected the rear speakers.
- 3CH LOGIC:** Use this mode to watch a video tape with Dolby Surround when you have connected a center speaker and no rear speakers.
- THEATER 1:** Use this mode to watch a video tape with Dolby Surround when you have connected the rear speakers.
- THEATER 2:** Use this mode to watch a video tape with Dolby Surround when you have connected the rear speakers.
- This mode gives you the feeling of a small movie theater with a seating capacity of 100.
- PHANTOM:** Use this mode to watch a video tape with Dolby Surround when you have connected the rear speakers.
- This mode gives you the feeling of a large movie theater with a seating capacity of 1000.

Note: When using the cursor buttons on the front panel, make sure that the DAP/SURROUND indicator is turned on. If not, press the CURSOR MODE button once so that the cursor buttons can be used for selecting the surround modes.

3. Set the center mode.
On the front panel only:
Press the CENTER MODE button.
Each time you press the CENTER MODE button, the mode changes as follows.
→PHANTOM →NORMAL →OFF →WIDE

- PHANTOM:** Select this mode when you have not connected a center speaker.
- NORMAL:** Select this mode when the size of the center speaker is smaller than that of the front speakers.
- WIDE:** Select this mode when the size of the center speaker is the same as that of the front speakers.
- OFF:** Select this mode to shut off the output of the center channel signal.

Note: When you have selected 3CH LOGIC in Step 2 above, you cannot select PHANTOM.

Enjoying the surround modes

Once you have set the surround adjustments you can use the same adjustments every time you want to enjoy the surround you want.

On the front panel:
1. Press the **SURROUND ON/OFF** button so that one of the surround mode indicators lights up on the display.

2. Press the left or right cursor button (+/-) repeatedly until the surround mode indicator you want lights up. Each time you press the button, the display changes to show the following:



Note: When using the cursor buttons on the front panel, make sure that the DAP/SURROUND indicator is turned on. If not, press the CURSOR MODE button once so that the cursor buttons can be used for selecting the surround modes.

3. Play a sound source which was processed with Dolby Surround and is labeled with **DOLBY SURROUND** mark.

To cancel the surround, press the **SURROUND ON/OFF** button again.

From the Remote:

1. Press the **SURROUND ON/OFF** button so that one of the surround mode indicator lights up on the display.

2. Open the outside panel and press the **SURROUND** button on the **CONTROL** section. Now you can use the Remote for selecting the surround modes.

3. Press the **MODE** button repeatedly until the surround mode indicators you want lights up. Each time you press the button, the display changes to show the following:



4. Play a sound source which was processed with Dolby Surround and is labeled with **DOLBY SURROUND** mark.

To cancel the surround, press the **SURROUND ON/OFF** button again.

To make dialogues in movies softer or clearer

By using the **CENTER TONE** control you can adjust the level of mid-frequency range, which the human voice is mostly made up of.

To make dialogues clearer, turn the control toward **SHARP**.
To make them softer, turn the control toward **SOFT**.

When set to the **FLAT** position, no adjustment is applied.

Note: The **CENTER TONE** control cannot be used when sounds do not come out of the center speaker.

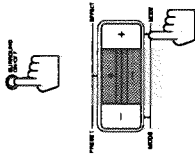

Remote: Outside



Remote: Inside



Remote: Inside



To make dialogues in movies softer or clearer

4. Set the delay time of the delayed sound.

From the Remote only:

Press the **DELAY** button. Each time you press the button, the delay time changes among 4 levels.



Remote: Inside

DELAY-1: When your distance to your rear speakers is greater than that to the front speakers.
DELAY-2: When your distance to your rear speakers is almost equal to that to the front speakers.
DELAY-3: When your distance to your rear speakers is a little less than that to the front speakers.
DELAY-4: When your distance to your rear speakers is much less than that to the front speakers.

Note: When you have selected **3CH LOGIC** in Step 2 above, you cannot adjust the delay time.

5. Start checking speaker output balance.

From the Remote only:

Press the **TEST** button.

When you press the button, "TEST" starts flashing and a test tone comes out of speakers in the following order:

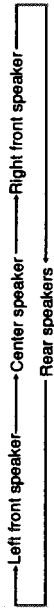

Remote: Inside

6. Set the output levels of the center and the rear speakers.

From the Remote only:

Press the **CENTER +** button or the **CENTER -** button to set the sound level of the center speaker. Press the **REAR +** button or the **REAR -** button to set the sound level of the rear speakers.

Notes:

- You can adjust these levels in 1 dB step within the range of ± 10 dB. The sound levels of the left and right rear speakers will be the same.
- You cannot set the sound level of the rear speakers when you have selected **3CH LOGIC**.
- You cannot set the sound level of the center speaker when you select **PHANTOM** or **OFF** for center mode.

7. Finish checking speaker output balance.

From the Remote only:

Press the **TEST** button again. The test tone stops.

Note:

When you use the **SOURCE SELECTOR**, the test tone also stops.

8. Select the effect depth among 5 preset levels only for JVC's Theater Surround.

On the front panel:

Press the upper or lower cursor button (+/-) repeatedly. To increase the effect depth, press the upper cursor button (+), and to decrease it press the lower cursor button (-).

From the Remote:

Press the **EFFECT** button repeatedly. Selecting the higher number makes the effect deeper. Each time you press the button, the effect depth changes as follows (when using the button on the Remote, it changes only rightward):



Remote: Inside

Note: When you have selected Dolby Surround modes in Step 2 above, you cannot select the effect depth.



Remote: Inside



Remote: Inside



Remote: Inside



Remote: At bottom



Remote: Inside



Front panel



Remote: Inside

Using the Sleep Timer

Using the sleep timer, you can fall asleep to music and know the RX-816RBK will turn off by itself rather than play all night.

To set the sleep timer

Press the SLEEP button on the Remote repeatedly while playing a source. The SLEEP indicator lights up on the display.

Each time you press the button, the shut-off time shown on the display changes as shown below:

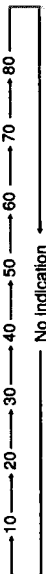

Remote: Outside

The RX-816RBK will turn off after the time you have set.

To check or change the time remaining until the shut-off time

Press the SLEEP button once. The remaining time is displayed in minutes. If you press the button repeatedly, you can change the shut-off time.

To cancel the sleep timer

Press the SLEEP button repeatedly until the SLEEP indicator goes off.

Using the Remote for Operating JVC's Audio/Video Components

You can operate JVC's audio and video components with this Remote, since control signals for JVC components are preset in the Remote. (You can also use this Remote to operate the other manufacturers' components; see page 35 for more details.)

To operate JVC's components with the Remote, make sure the following, before operating that source using the Remote:

- Select a source with the buttons on the SOURCE SELECT section (outside panel) of the Remote.
- Or press the buttons on the CONTROL section (inside panel) of the Remote.

Note:

If you choose a source on the front panel directly, the Remote will not operate that source.

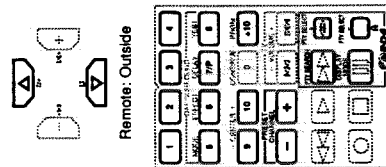

Tuner

Remote: Outside

Remote: Inside

After pressing the AM or FM button (on the SOURCE SELECT section) or the TUNER button (on the CONTROL section), you can perform the following operations on the built-in tuner:

- ▲ / ▼ Changes the preset channels.
- 1 - 10, +10 Selects the preset channels directly.
- To select preset channel number 5, press 5.
- For preset channel number 15, press +10, then 5.
- For preset channel number 20, press +10, then 10.

- PRESET CHANNEL +/- Changes the preset channels.
- RDS operating buttons Starts and ends searching a broadcast using the RDS.
- PTY SEARCH Selects a program type.
- PTY SELECT +/-
- DISPLAY MODE Change the RDS display mode.

Note:

To activate the Remote for tuner operations, you can use the AM button or the FM button on the SOURCE SELECT section (of the outside panel) or the TUNER button on the CONTROL section (of the inside panel). If you press the button on the CONTROL section, you can operate the tuner using the Remote, but the playing source will not be changed to the tuner.

Other Features

The RX-816RBK has some other features like the recording monitor function, the CSRP function and the sleep timer. By using these useful features your audio life will be much improved. The remote control system is more precisely described in this section.

Recording Monitor

If the cassette deck connected to the TAPE 2 jacks is of the three-head type, you can compare the sound quality of the playing source and of the recording being made on the cassette deck.

To use the recording monitor function

Press the TAPE 2 MONITOR button. The TAPE 2 MONITOR indicator lights up on the front panel and "ON" appears on the display. You can hear the sound just recorded on the tape.

To cancel recording monitor function

Press the TAPE 2 MONITOR button again. The TAPE 2 MONITOR indicator goes off and "OFF" appears on the display, and you hear the sound from the source playing.

Remote: Outside

Notes:

- Refer also to the manual supplied with your cassette deck.
- Do not press the TAPE 2 MONITOR button if no component is connected to the TAPE 2 jacks; otherwise, no sound comes out of the speakers.

Using the CSRP Function

The optimum sound settings differ for each playing source. So, you have to change settings each time you select a different source.

The JVC's CSRP (COMPU LINK Source-Related Preset) function is used to assign and store different sound settings for each different playing source. By using this function, you don't have to change the settings every time you change the source. The stored settings for the newly selected source are automatically recalled.

The following can be stored for each source:

- Loudness (see page 15)
- Preset SEA modes (see page 22)
- DAP or surround settings (see pages 23 and 26)

Notes:

- For the cassette deck connected to the TAPE 2 jacks, the CSRP function does not work.
- If the source is FM or AM (MW/LW), the CSRP function works only when one of the preset channels from 1 - 20 is tuned in. You can assign a different setting for each preset channel.

To store the sound settings by using the CSRP function

1. Press the CSRP ON/OFF button on the Remote. The CSRP indicator starts flashing and remains lit on the display.
2. Select the sound effects listed above while the CSRP indicator is lit on the display.

To recall the sound settings

Whenever the CSRP indicator is lit on the display, the settings for the currently selected source is always recalled. When you change the source, it takes several seconds to activate the CSRP function (the CSRP indicator flashes).

To cancel the CSRP function, press the CSRP ON/OFF button so that the CSRP indicator goes off from the display. (Even though the CSRP function is canceled, recalled sound effects remains active.)



Remote: Outside

Turntable

After pressing the PHONO button (on the SOURCE SELECT section), you can perform the following operations on a turntable:

- ▲ Starts playing.
- Stops playing.

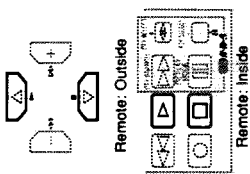

CD player

After pressing the CD button (either on the SOURCE SELECT section or on the CONTROL section), you can perform the following operations on a CD player:

- ▲ Starts playing.
- ▲ Fast reverses the CD.
- ▲ Fast forwards the CD.
- ▲ Returns to the beginning of the current track.
- ▲ Skips to the beginning of the next track.
- ▲ Stops playing.
- Stops playing temporarily. To release it, press ▲.
- Opens or closes the tray.
- 1 — 10, +10 Selects a track number directly
- To select track number 5, press 5.
- For track number 15, press +10, then 5.
- For track number 20, press +10, then 10.

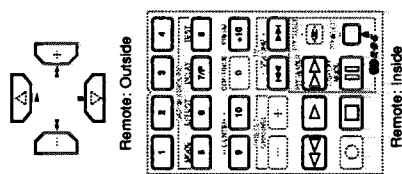

CD player-changer

After pressing the CD DISC button (on the CONTROL section), you can perform the following operations on a CD player-changer:

- ▲ Starts playing.
- ▲ Fast reverses the CD.
- ▲ Fast forwards the CD.
- ▲ Returns to the beginning of the current track.
- ▲ Skips to the beginning of the next track.
- ▲ Stops playing.
- Stops playing temporarily. To release it, press ▲.
- Opens or closes the tray.
- 1 — 6, 7/P Select the number of a disc installed in a CD player-changer.
- CONTINUE Sets the playing mode to the CONTINUE mode.
- PRGM Sets the playing mode to the PROGRAM mode.

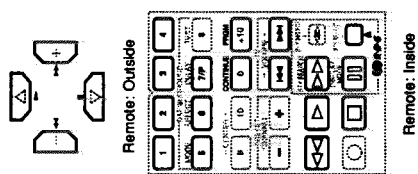

Cassette deck

After pressing the TAPE I button (either on the SOURCE SELECT section or on the CONTROL section), you can perform the following operations on a cassette deck:

- ▲ Starts playback.
- ▲ Fast winds the tape from right to left.
- ▲ Fast winds the tape from left to right.
- ▲ Returns to the beginning of the current recording.
- ▲ Skips to the beginning of the next recording.
- ▲ Changes the direction of tape running.
- ▲ Stops operation.
- Stops playing or recording temporarily. To release it, press ▲.
- Press this button with ▲ to start recording.
- Press this button with ■ to enter the recording standby mode.

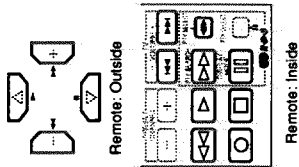

Note:

To activate the Remote for deck operations, you can use either one of the TAPE I buttons — one as the source selecting button on the SOURCE SELECT section (of the outside panel); the other on the CONTROL section (of the inside panel). If you press the one on the CONTROL section, you can operate the cassette deck using the Remote, but the playing source will not be changed to TAPE I.

VCR

After pressing the VCR button (either on the SOURCE SELECT section or on the CONTROL section), you can perform the following operations on a VCR:

- ▲ Starts playback.
- ▲ Rewinds a tape.
- ▲ Fast winds a tape.
- ▲ Stops operation.
- Stops playing or recording temporarily. To release it, press ▲.
- Press this button with ■ to start recording.
- Press this button with ■ to enter the recording standby mode.
- PRESET CHANNEL +/- Changes the TV channels on the VCR.
- 1 — 9, 0 Selects the TV channels on the VCR.

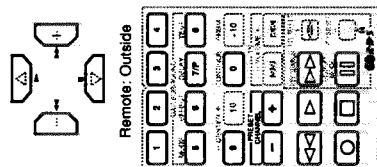

Notes:

- To activate the Remote for VCR operations, you can use either one of the VCR buttons — one as the source selecting button on the SOURCE SELECT section (of the outside panel); the other on the CONTROL section (of the inside panel). If you press the one on the CONTROL section, you can operate the VCR using the Remote, but the playing source will not be changed to VCR.
- You can always turn the VCR on and off by pressing the VCR button of the POWER section (outside panel) on the Remote.

TV

You can always perform the following operations on a TV.

- TV (of the POWER section) Turns on or off TV.
- TV (of the CONTROL section) Changes the input mode to TV.

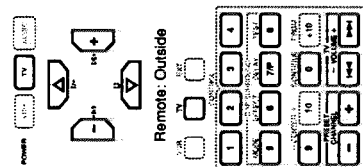

After pressing the TV button on the CONTROL section, you can also perform the following operations on the TV:

- ▲/▼ Changes the TV volume.
- +/- Changes the TV channels.
- 1 — 9, 0 Selects the TV channels.
- PRESET CHANNEL +/- Changes the TV channels.
- TV VOLUME +/- Changes the TV volume.

Simplifying the Operations Using the Remote

You can program a series of operations in a specific order you want. After making a program, you can perform these programmed operations at a press of the SEQUENTIAL PROGRAM KEY.

To program a series of operations

You can make 3 different programs, each containing up to 16 steps.

- 1 Open the outside panel of the Remote.
- 2 Press the LEARN button so that the SEND/LEARN indicator lights up (green).
- 3 Close the outside panel.
- 4 Press one of the SEQUENTIAL PROGRAM KEYS (A, B, and C) to which you want to assign a program you are making from now. The SEND/LEARN indicator starts flashing.



Remote: Inside

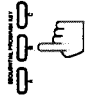

Remote: Outside



Remote: Inside



- 7 Press the LEARN button again to finish the programming procedure. Both the SEND/LEARN and ERROR indicators go off.

CAUTION:
When replacing the batteries, finish it without delay; otherwise, the stored signals are all erased.

- 6 Repeat Steps 5 until you program up to 16 steps.
- Notes:**
- If the ERROR indicator flashes 3 times, you cannot program this step.
 - 16 steps are already programmed or this particular step is not programmable.
 - You cannot program an operation performed by pressing two buttons at the same time — like pressing ● and ► at the same time to start recording.
 - Do not program a TV operation step immediately after the step of turning on the TV. The TV operation may be ignored since the TV is not yet ready to accept the signal.

To erase a program

- 1 Open the outside panel of the Remote.
- 2 Press the LEARN button so that the SEND/LEARN indicator lights up (green).
- 3 Press the CANCEL button. Both the SEND/LEARN and ERROR indicators light up.
- 4 Close the outside panel, and press and hold the SEQUENTIAL PROGRAM KEY (A, B, or C) to which the program you want to erase has been assigned to, until both the SEND/LEARN and ERROR indicators start flashing.



Remote: Inside



Remote: Inside



Remote: Outside

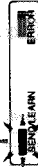
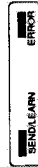
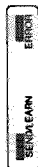

Note:
If the ERROR indicator remains lit, no program is assigned to the SEQUENTIAL PROGRAM KEY. In this case, press the CANCEL button to turn off the ERROR indicator.

- 5 Press the LEARN button again to finish the erase. The SEND/LEARN indicator goes off.



Remote: Inside



Note:
If the ERROR indicator lights up (red) while the SEND/LEARN indicator is flashing, you have already assigned a program to that SEQUENTIAL PROGRAM KEY. To add steps to the program, continue to Step 5. If you do not want to change it, press another SEQUENTIAL PROGRAM KEY after the SEND/LEARN indicator stops flashing.

- 5 While the SEND/LEARN indicator is flashing, press the button you want to store as the first step of the program. Both the SEND/LEARN and ERROR indicators light up, and then only the ERROR indicator goes off.

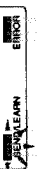
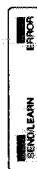

When the SEND/LEARN indicator goes off and starts flashing again, the first step is stored. The ERROR indicator lights up while the SEND/LEARN indicator is flashing.

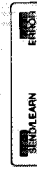

Note:
If the SEND/LEARN indicator stops flashing before you press the button, repeat from Step 4 again.

Operating the Other Manufacturers' Audio/Video Components

The Remote supplied with the RX-816RBK can learn and memorize the signals used for the other manufacturers' remote control unit. By storing these signals, you can operate the other manufacturers' audio/video components.

To store the signals

Before storing another manufacturer's signals, make sure that manufacturer's remote control unit (hereafter called "target Remote") actually works.

- Place the two Remotes on a level surface with signal transmitting windows facing each other. Leave a space of 5 cm to 10 cm (2 inches to 4 inches) between the two Remotes; otherwise, storing may be failed.

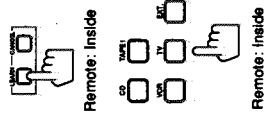
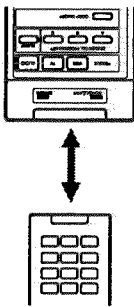

- Open the outside panel of this Remote.

- Press the LEARN button so that the SEND/LEARN indicator lights up (green).



- Press one of the buttons on the CONTROL section. If possible, select the source corresponding to the target Remote's usage.

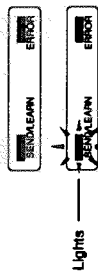

Note: Since no signal have been press for the EXT. mode, you can store signals from the target Remote without losing any prezer signals.

- Press one of the buttons (illustrated to the left), to which you want to assign a signal from the target Remote. The SEND/LEARN indicator starts flashing.

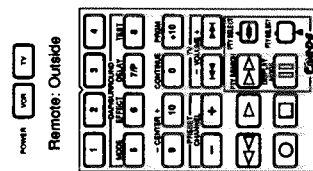

Notes:

- If the ERROR indicator lights red, you have already stored a signal. To change the stored signal, go to the next step. If you do not want to change it, press another button.
- Some buttons such as the PRESET CHANNEL +/-, TV VOLUME +/- (when used for inner TV), and buttons on the outside panel, so if you change the signals for these buttons, the signals the cursor buttons transmit will also change.

- While the SEND/LEARN indicator is flashing, press the button on the target Remote, the signal of which you want to assign to the button of this Remote you have pressed in Step 5. The SEND/LEARN indicator stops flashing and remains lit, and the ERROR indicator also lights red but soon goes off.

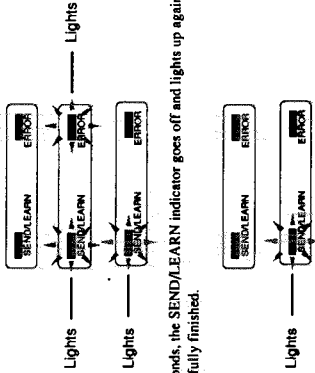

After several seconds, the SEND/LEARN indicator goes off and lights up again. This means that the storing is successfully finished.

- Notes:**
- If the SEND/LEARN indicator stops flashing before you press the button on the target Remote, repeat from Step 5 again.
 - If the ERROR indicator lights red and does not go off, you have failed in storing the signal.
 - If the ERROR indicator flashes, you have failed in storing the signal. Try again. However some signals do not match to this Remote even though this Remote can learn most infrared signals.

- Repeat Steps 4 — 6 to store more signals from the target Remote.

- Press the LEARN button to finish the storing procedure.

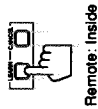

Note: The signals stored into this Remote from the target Remote deviates slightly from the original signals. Since some components will not accept these deviating signals, you may not be able to operate those components using this Remote even though the storing procedure has been successfully finished.

CAUTION: When replacing the batteries, finish it without delay; otherwise, the stored signals are all erased.

To erase stored signals

After erasing stored signals, preset signals are resumed and you can operate JVC's components again.

- 1 Open the outside panel of the Remote.
- 2 Press the LEARN button so that the SEND/LEARN indicator lights up (green).



Remote: Inside



Remote: Inside

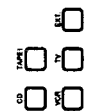

Remote: Inside



Remote: Inside

COMPU LINK Remote Control System

**COMPU LINK
III Remote III
Control System**

The COMPU LINK remote control system allows you to operate JVC audio components through the remote sensor on the RX-816RBK.
To use this remote control system, you need to connect JVC audio components through the COMPU LINK-3 SYNCHRO jacks (see page 10) in addition to the connections using cables with RCA pin plugs (see page 9). This remote control system allows you to use four functions listed below.

■ **Remote Control through the Remote Sensor on the RX-816RBK**

You can control all audio components through the remote sensor on the RX-816RBK using this Remote. For details, see page 30.

Note:

Aim the Remote directly at the remote sensor on the RX-816RBK.

■ **Automatic Source Selection**

When you press the play (▶) button on a connected component or on its own Remote, the RX-816RBK automatically turns on and changes the source to the component. On the other hand, if you select a new source on the RX-816RBK or the Remote, the selected component begins playing immediately.
In both cases, the previously selected source continues playing without sound for a few seconds.

■ **Automatic Power On/Off (only possible with the COMPU LINK-3 connection)**

Both the CD player and cassette deck turns on and off along with the RX-816RBK.
When you turn on the RX-816RBK, the CD player or cassette deck will turn on automatically, depending on which component has been previously selected.
When you turn off the RX-816RBK, both the CD player and cassette deck will turn off.

■ **Synchronized Recording**

Synchronized recording means the cassette deck starts recording as soon as a CD or a record begins playing.

To use synchronized recording, follow these steps:

- 1 Put a tape in the cassette deck, and a disc in the CD player (or a record on the turntable).
- 2 Press the record (●) button and the pause (||) button on the cassette deck at the same time.
This puts the cassette deck into recording pause.

Note:

If you do not press the record (●) button and pause (||) button at the same time, the synchronized recording feature will not operate.

- 3 Press the play (▶) button on the CD player or on the turntable.

The source changes on the RX-816RBK, and as soon as play starts, the cassette deck starts recording.
When the play ends, the cassette deck enters recording pause, and stops about 4 seconds later.

Notes:

- During synchronized recording, the selected source cannot be changed.
- If your CD player is playing in program mode, a 4-second blank is recorded between tracks so that the music scan feature of your cassette deck can be used on the recorded tape.
- If the power of any component is shut off during synchronized recording, the COMPU LINK remote control system may not operate properly. In this case, you must start again from the beginning.
- Refer also to the manuals supplied with your audio components.

- 4 Press and hold the one of the buttons on the CONTROL section until both the SEND/LEARN and ERROR indicators start flashing.
All the signals assigned under the selected CONTROL section are erased at the same time.
You cannot erase a signal assigned to a particular button only.

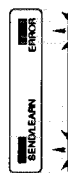

Flashes

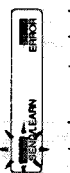

Lights

Note:
If the ERROR indicator remains lit, no signals are assigned to the buttons under the selected CONTROL section. In this case, press the CANCEL button to turn off the ERROR indicator.

- 5 Press the LEARN button again to finish the erase.

The SEND/LEARN indicator goes off.

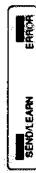

Troubleshooting

Use this chart to help you solve daily operational problems. If there is any problem you cannot solve, contact your JVC service center.

PROBLEM	POSSIBLE CAUSE	SOLUTION
The display does not light up.	The power cord is not plugged in.	Plug the power cord into an AC outlet.
No sound from speakers.	Speaker wires are not connected properly.	Check speaker wiring and reconnect if necessary.
	The SPEAKERS buttons are not set correctly.	Press the SPEAKERS buttons in or out correctly.
	An incorrect source is selected.	Select the correct source.
	The TAPE 2 MONITOR indicator lights up when no component is connected to the TAPE 2 jacks.	Press the TAPE 2 MONITOR button so that the indicator goes off.
Sound from one speaker only.	Speaker wires are not connected properly.	Check speaker wiring and reconnect if necessary.
	The BALANCE control is set to one extreme.	Adjust the BALANCE control properly.
Continuous hiss or buzzing during FM reception.	Incoming signal is too weak.	Adjust the antenna.
	The station is too far away.	Select a new station.
	An incorrect antenna is used.	Check with your dealer to be sure you have a correct antenna.
	Antennas are not connected properly.	Check connections.
The source alternates between an FM station and the currently selected source.	An incorrect EON signal are being sent.	Press the EON button so that the EON function is off, and that the EON indicator goes off.
Occasional crackling noise during FM reception.	Ignition noise from automobiles.	Move the antenna farther from automobile traffic.
Howling during record playing.	Your turntable is too close to speakers.	Move speakers away from the turntable.
Remote does not work.	There is an obstruction in front of the remote sensor on the RX-816RBK.	Remove the obstruction.
	Batteries are weak.	Replace batteries.

Specifications

Amplifier

Output Power	At Stereo operation
100 watts per channel, min. RMS, both channels driven into 4 ohms at 1 kHz with no more than 0.9% total harmonic distortion (IEC268-3/DIN).	
70 watts per channel, min. RMS, both channels driven into 8 ohms at 1 kHz with no more than 0.9% total harmonic distortion (IEC268-3/DIN).	
65 watts per channel, min. RMS, both channels driven into 8 ohms, 20 Hz to 20 kHz with no more than 0.007% total harmonic distortion.	
80 watts per channel, min. RMS, driven into 8 ohms at 1 kHz with no more than 0.7% total harmonic distortion.	At Surround operation Front Channels
80 watts, min. RMS, driven into 8 ohms at 1 kHz, with no more than 0.7% total harmonic distortion.	Center Channel
20 watts per channel, min. RMS, driven into 8 ohms at 1 kHz, with no more than 0.7% total harmonic distortion.	Rear Channels
0.007%* at 65 watts output (* Measured by JVC Audio Analysis System)	
20 Hz to 20 kHz (±0.5 dB) 10 Hz to 30 kHz (±1 dB)	PHONO CD, TAPE 1, TAPE 2, VCR, VIDEO 1, VIDEO 2
70 dB/66 dB 91 dB/67 dB	PHONO CD, TAPE 1, TAPE 2, VCR, VIDEO 1, VIDEO 2
±0.5 dB (20 Hz to 20 kHz)	RIAA Phono Equalization
2.7 mV/47 k ohms 230 mV/47 k ohms	Audio Input Sensitivity/ Impedance (1 kHz)
230 mV	Audio Output Level
1 V _{p-p} /75 ohms	Video Input Sensitivity/ Impedance
1 V _{p-p} (at 1 V _{p-p} input)	Video Output Level
Negative	Synchronization
45 dB	Signal-to-Noise Ratio

FM tuner (IHF)

Tuning Range	87.5 MHz to 108.0 MHz
Usable Sensitivity	12.7 dBf (1.2 μ V/75 ohms)
50 dB Quieting Sensitivity	16.3 dBf (1.8 μ V/75 ohms) 38.3 dBf (22.5 μ V/75 ohms)
Signal-to-Noise Ratio (IHF-A weighted)	80 dB at 85 dBf 73 dB at 85 dBf
Total Harmonic Distortion	0.15 % at 1 kHz 0.2 % at 1 kHz
Stereo Separation at REC OUT	40 dB at 1 kHz
Capture Ratio	1.5 dB
Alternate Channel Selectivity	60 dB: (\pm 400 kHz)
Frequency Response	30 Hz to 15 kHz: (+0.5 dB, -3 dB)

AM (MW/LW) tuner

Tuning Range	MW: 522 kHz to 1,629 kHz LW: 144 kHz to 288 kHz
Usable Sensitivity	MW: Loop antenna 300 μ V/m External antenna 30 μ V LW: Loop antenna 600 μ V/m
Signal-to-Noise Ratio	50 dB (100mV/m)

General

Power Requirements	AC 230V [~] , 50 Hz
Power Consumption	320 watts 5 watts (in standby mode)
Dimensions (W x H x D)	435 x 156 x 406 mm (17 7/16 x 6 1/4 x 16 inches)
Mass	13.5 kg (29.8 lbs) 13.6 kg (30 lbs)

Continental Europe:
U.K.:

Designs & specifications subject to change without notice

Description of Major LSIs

■ MN172412J5X (IC401) : SYSTEM CONTROLLER

1. Terminal Layout

21 ~ 1	
22	84
}	}
42	64
43 ~ 63	

2. Key Matrix

	KEY IN 0	KEY IN 1	KEY IN2	KEY IN3
KEY OUT 0	POWER S401	SEA ON/OFF S402	SEA FLAT S403	SPI/SEA S404
KEY OUT 1	EFFECT + S405	SEA/SURR. MODE + S406	CURSOR. MODE S407	DAP ON/OFF S408
KEY OUT 2	EFFECT - S409	SEA/SURR. MODE - S410	SURR. ON/OFF S411	CENTER MODE S412
KEY OUT 3	FM MODE S414	CHARACTER S415	PTY SEARCH S416	TUN ↔ PRE S417
KEY OUT 4	LOUDNESS S413	ENTER S418	TAPE 2 S419	EON S420
KEY OUT 5	TA/NEWS/INFO S421	—	—	—

3. Description

Pin No.	Symbol	I/O	Description	Pin No.	Symbol	I/O	Description
1	FAN OFF	I	FAN check signal. L:FAN is stopped	43	DATA	O	Data for IC411,321,552 and IC096
2		--	GND	44	INH IN	I	Inhibit signal input
3	AC POWER	O	RY201 control signal	45	RDS CLK	I	Clock input for IC191
4	FAN ON	O	FAN control signal. L:FAN ON	46	RDS DATA	I	Data signal for IC191
5	STAND-BY LED	O	STAND-BY indication control	47	RDS RESET	I	Reset signal for IC191
6	KO6	O	Key matrix out	48	RM IN	I	Detection for protector
7	KI0	I	Key matrix in	49	RDS D-START	I	D.Start signal for IC191
8	KI1	I	Key matrix in	50	STEREO IN	I	STEREO indication control
9	KI2	I	Key matrix in	51	TUNED IN	I	TUNED indication control
10	KI3	I	Key matrix in	52	CE (PLL)	O	Chip select signal for IC121
11	D9/KO0	O	Grid control signal (Key matrix out)	53	CLK (PLL)	O	Clock output for IC121
12	D8/KO1	O	Grid control signal (Key matrix out)	54	DI (PLL)	I	Data to IC121
13	D7/KO2	O	Grid control signal (Key matrix out)	55	DO (PLL)	O	Data for IC121
14	D6/KO3	O	Grid control signal (Key matrix out)	56	DCS IN	I	Compulink signal input
15	D5/KO4	O	Grid control signal (Key matrix out)	57	DCS OUT	O	Compulink signal output
16	D4/KO5	O	Grid control signal (Key matrix out)	58	SOURCE E.IN1	I	R. Encoder control signal input (SOURCE)
17	D3	O	Grid control signal	59	SOURCE E.IN2	I	R. Encoder control signal input (SOURCE)
18	D2	O	Grid control signal	60	DAP RESET	O	Reset signal for IC096
19	D1	O	Grid control signal	61	DAP REQ	O	Request signal for IC096
20	SEA LED	O	SEA indication control	62	SCL(AT24C)	I	Clock for IC412
21	SUR.LED	O	SURROUND indication control	63	SDA(AT24C)	I/O	Data signal for IC412
22	TAPE2 LED	O	TAPE2 MONITOR indication control	64	TV CONT.	O	AV COMPULINK
23	VPP	--	Power supply	65	TV OUT	O	AV COMPULINK
24	S1	O	Segment control signal	66	VCR OUT	O	AV COMPULINK
25	S2	O	Segment control signal	67	VCR IN	I	AV COMPULINK
26	S3	O	Segment control signal	68	RST	I	Reset signal input
27	S4	O	Segment control signal	69	X1	--	GND
28	S5	O	Segment control signal	70	X2	--	Not used
29	S6	O	Segment control signal	71	VSS	--	GND
30	S7	O	Segment control signal	72	OSC2	--	Oscillation terminal
31	S8	O	Segment control signal	73	OSC1	--	Oscillation terminal
32	S9	O	Segment control signal	74	VDD	--	Power supply
33	S10	O	Segment control signal	75	CHIP SELECT	--	+ 5V
34	S11	O	Segment control signal	76	TUNER E.IN1	I	R. Encoder control signal input (TUNER)
35	S12	O	Segment control signal	77	TUNER E.IN2	I	R. Encoder control signal input (TUNER)
36	S13	O	Segment control signal	78	DAP BUSY	I	Busy signal from IC096
37	S14	O	Segment control signal	79	CS(XR)	O	Chip select signal for IC404
38	S15	O	Segment control signal	80	SP CLK(XR)	O	Clock output for IC404
39	S16	O	Segment control signal	81	SP DATA(XR)	O	Data signal for IC404
40	STB2	O	Strobe signal for IC411	82	STB3	O	Strobe signal for IC552
41	CLK	O	Clock output for IC411,321,552 and IC096	83	VIDEO OFF	O	VIDEO OFF control signal
42	STB1	O	Strobe signal for IC321	84	VCR S/C	I	VCR S/C signal

■ TMP87C847U-4195 (IC096) : CMOS 8-bit Microcontroller

1. Terminal Layout

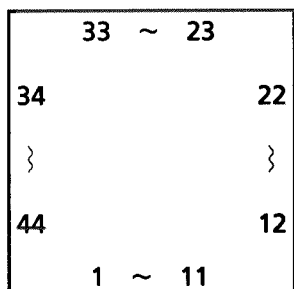

2. Block Diagram

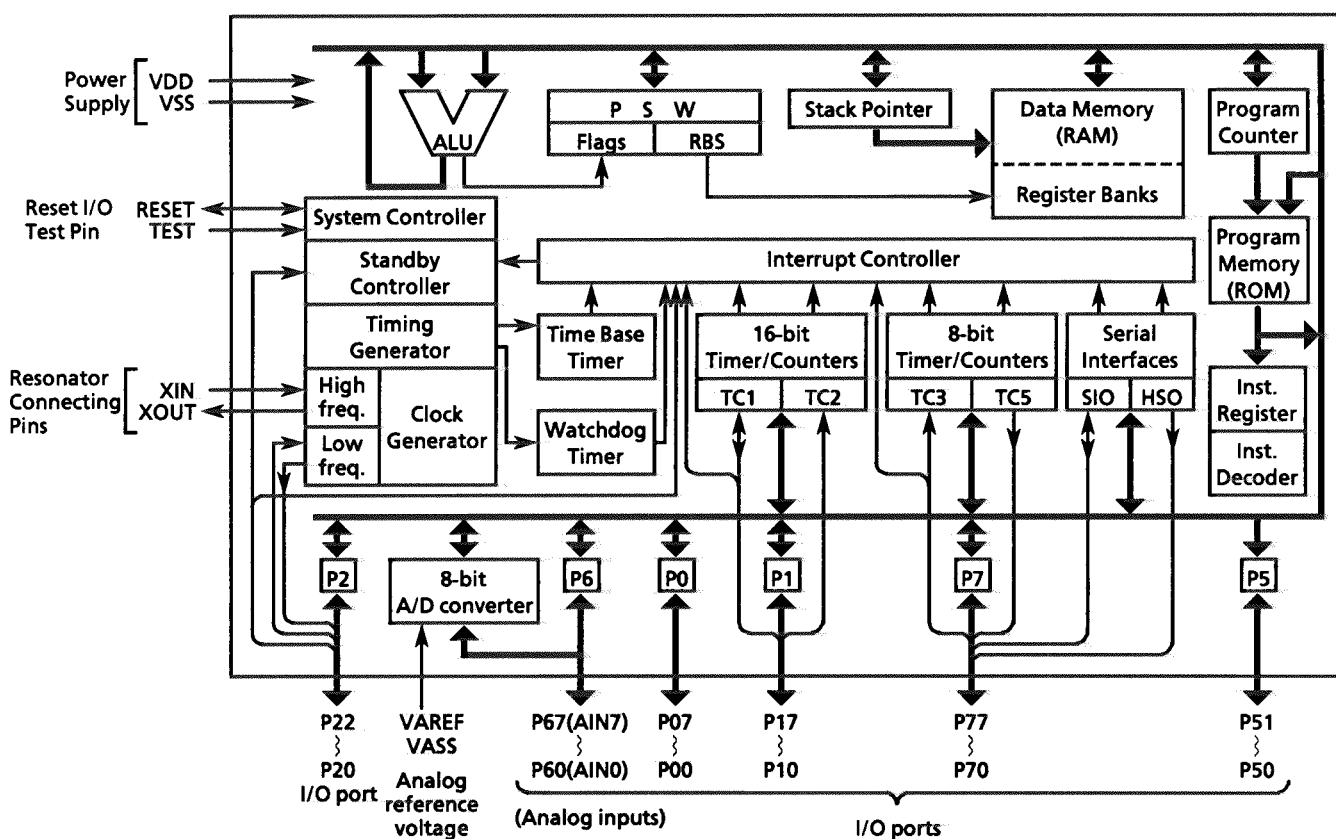

3. Pin Functions

Pin No.	Symbol	I/O	Functions
1	P73 (SCK)	I	Serial clock input from IC401
2	P72 (PWM/PDO)	I/O	Not used
3	P71 (INT4)	I/O	Not used
4	P70 (INT3/TC3)	I/O	Not used
5	P07 (ACK)	I	Acknowledge signal input from IC081
6	P06 (IFCD)	O	Command/data switching signal to IC081

RX-816RBK

Pin No.	Symbol	I/O	Functions
7	P05 (CS)	O	Chip select signal output to IC081
8	P04 (RST)	O	Reset signal output to IC081
9	P03 (TEST0)	I	Test terminal, generally it is used as "L"
10	P02 (TB2)	I	Test terminal, generally it is used as "L"
11	P01 (TB1)	I	Test terminal, generally it is used as "L"
12	P00 (TB0)	I	Test terminal, generally it is used as "L"
13	TEST	I	Test pin for out-going test. Be tied to low
14	RESET	I	Reset signal input or watchdog timer output/address-trap-reset output/system-clock-reset output
15	XIN	I	Resonator connecting pins for high-frequency clock. For inputting external clock, XIN is used and XOUT is opened
16	XOUT	O	Not used
17	VSS	--	GND
18	VAREF	--	Analog reference voltage
19~26	P60 (AIN0)~ P67 (AIN7)	I/O	Not used
27	P50	O	Not used
28	P51 (MUTE)	O	Mute signal output
29	P10 (INT0)	I/O	Not used
30	P11 (REQ)	I	External interrupt request signal from IC401
31	P12 (BUSY)	O	Busy output to IC401
32	P13 (DVO)	I/O	Not used
33	P14 (PPG)	I/O	Not used
34	P15 (VOL STB)	O	Volume strobe signal output for write data to IC341
35	P16 (VOL SI)	O	Volume serial data signal output to IC341
36	P17 (VOL CK)	O	Volume clock output for data transfer to IC341
37	P20 (INT5/STOP)	I/O	Not used
38	P21 (XTIN)	I/O	Not used
39	P22 (XTOUT)	I/O	Not used
40	VDD	--	Power supply (5V)
41	P77 (IFDI)	O	Serial data output to IC081
42	P76 (IFCK)	O	Shift clock output to IC081
43	P75 (SO)	I/O	Not used
44	P74 (SI)	I	Serial data input from IC401

■ TC9332F-010 (IC081) : Audio digital signal processor

1. Terminal Layout

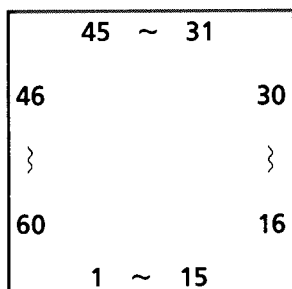

2. Block Diagram

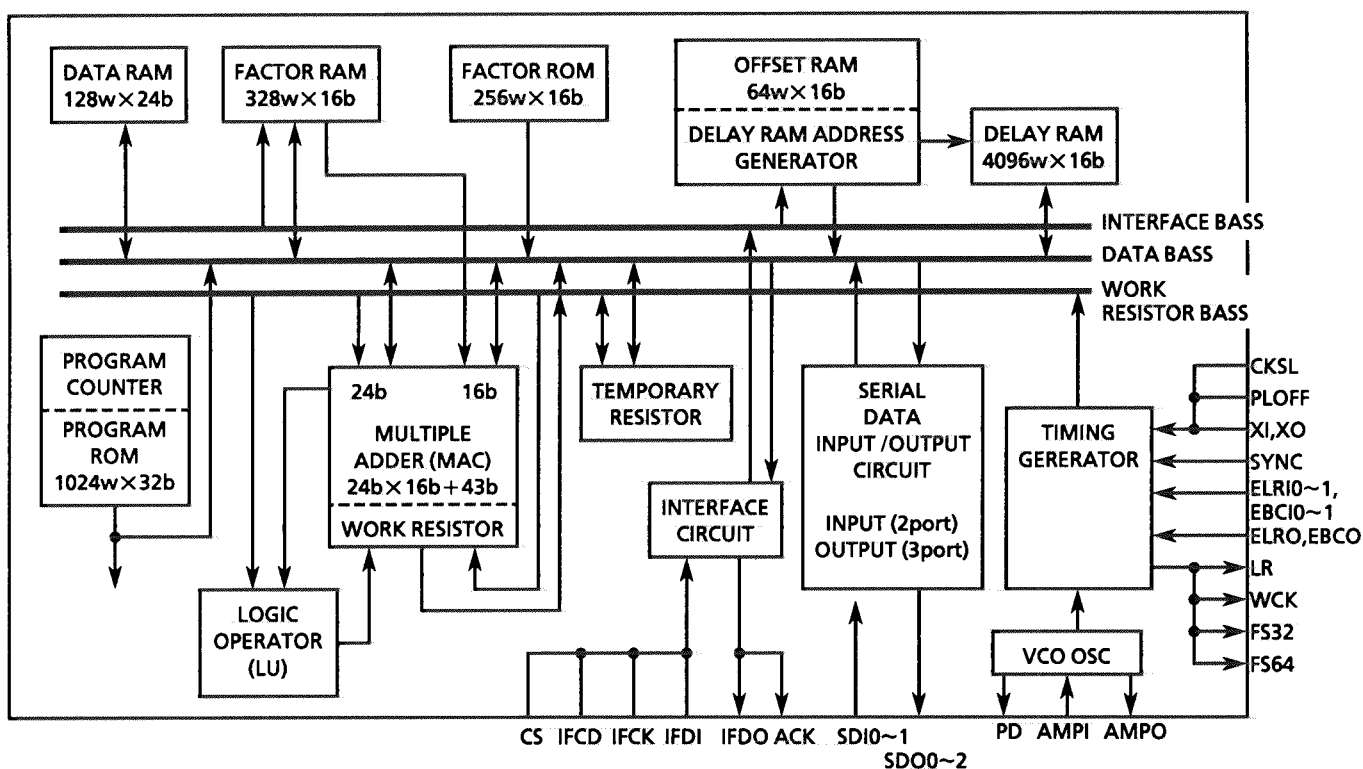

3. Pin Functions

Pin No.	Symbol	I/O	Functions
1~3	TP8~TP6	O	Test data output, Generally it is used as open
4	VDD	-	Power supply
5	VSS	-	GND
6~11	TP5~TP0	O	Test data output. Generally it is used as open
12	VSSR	-	GND for inner delay RAM (DLRAM)
13	VDDR	-	Power supply for inner delay RAM (DLRAM) (5V)
14	VSS	-	GND
15	SDO2	O	Not used
16	SDO1	O	Serial data output to IC061

RX-816RBK

Pin No.	Symbol	I/O	Functions
17	SDO0	O	Serial data output to IC041
18	SDI1	I	Not used
19	SDI0	I	Serial data input from IC021
20	LR	O	LR clock output (1fs)
21	WCK	O	Word clock output (2fs)
22	FS32	O	Bit clock output (32fs)
23	FS64	O	Bit clock output (64fs)
24	EBC0	I	Bit clock input. Shift clock input for SDO 0/1/2 data output
25	EBC11	I	Bit clock input. Shift clock input for SDI 0/1 data input
26	EBC10	I	Bit clock input. Shift clock input for SDI 0/1 data input
27	ELRO	I	LR clock input for SDO 0/1/2 data output
28	ELR11	I	LR clock input for SDI 0/1 data input
29	ELR10	I	LR clock input for SDI 0/1 data input
30	SYNC	I	Synchronizing signal input. SYNC signal edge sets program counter "0" forcefully. The microprocessor controls the polarity
31	VDD	--	Power supply (5V)
32	XI	I	X'tal oscillation terminal
33	XO	O	X'tal oscillation terminal
34	VSS	--	GND
35	CKSL	I	Oscillation clock switching terminal L:384fs, H:512fs
36	PLOFF	I	Oscillation mode switching terminal for 'Xtal and VCO. Built-in VCO oscillation mode in "L" and 'Xtal oscillation mode in "H"
37	PD	O	Phase comparison data output
38	VSSA	--	Analog GND
39	AMPO	O	Amplifier output for L.P.F
40	AMPI	I	Amplifier input for L.P.F
41	VDDA	--	Analog Power supply (5V)
42~44	TES0~TES2	I	Test terminal, Generally it is transmitted from μ -com when cs is lactive
45	$\overline{\text{RST}}$	I	Reset signal input from IC096
46	$\overline{\text{CS}}$	I	Chip select signal input from IC096
47	IFCD	I	It selects command or data input mode from IC096. It recognizes the command in "H" and the data in "L"
48	IFDI	I	μ -com data input. Firstly, LSB of data and command are received from IC096.
49	IFDO	O	Data output of data bass. LSB of data bus data is transmitted to μ -com
50	IFCK	I	Shift clock input form IC096
51	$\overline{\text{ACK}}$	O	Acknowledge signal output for IC096. Acknowledge signal is output when command and data's parity are OK
52	VSS	--	GND
53~60	TP16~TP9	O	Test data output. Generally, it is used as open

■ TDA1386T (IC041,061) : Noise shaping filter-DAC

1. Terminal Layout

VDDA	1	24	VDDO
VSSA	2	23	VSSO
TEST1	3	22	VREF
BCK	4	21	VOR
WS	5	20	FILTCR
DATA	6	19	FILTCL
CKSL1	7	18	VOL
CKSL2	8	17	APP0
VSSD	9	16	APP1
VDDD	10	15	APP2
TEST2	11	14	APPL
SYSCLK	12	13	APP3

2. Block Diagram

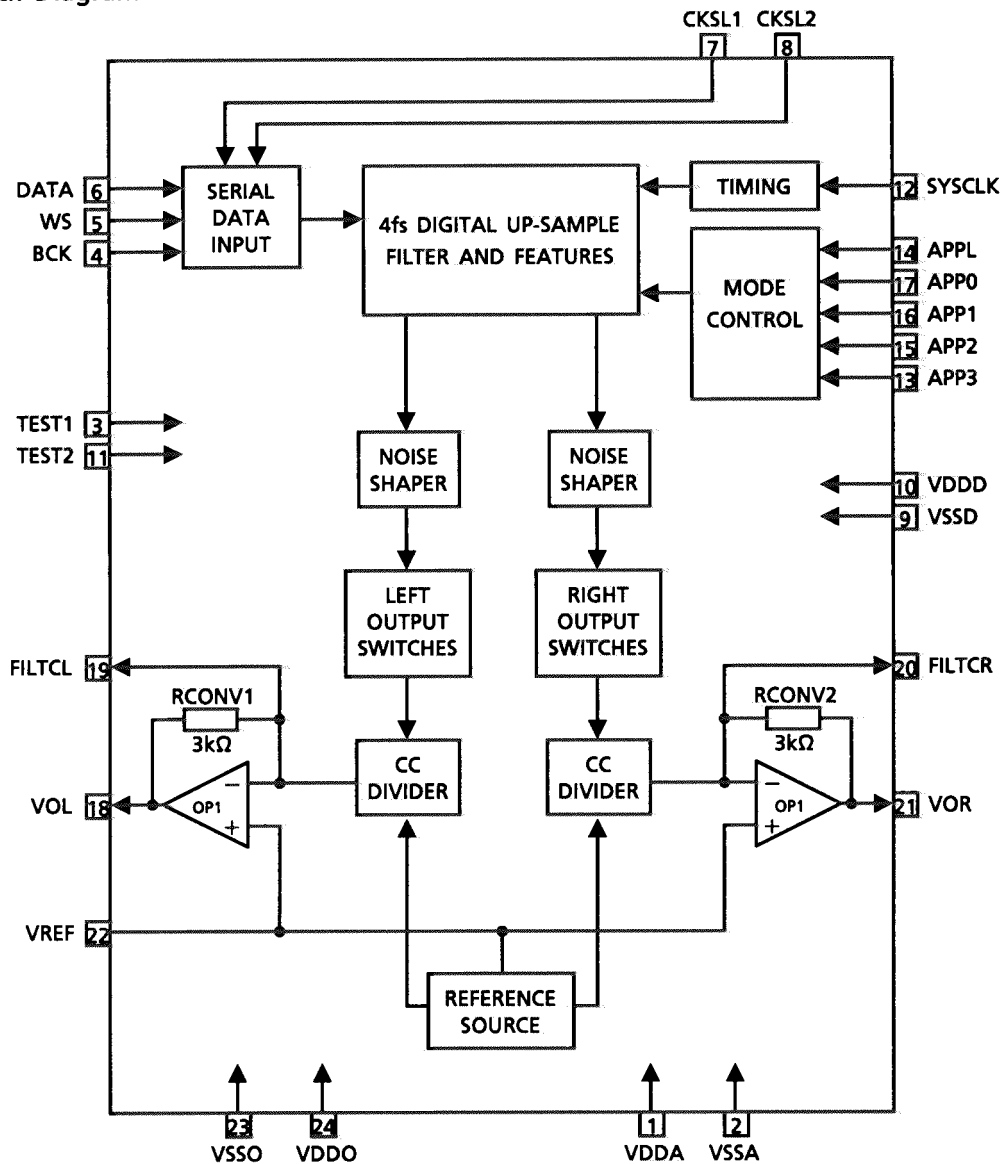

3. Pin Functions

Pin No.	Symbol	I/O	Functions
1	VDDA	--	Analog supply voltage (5V)
2	VSSA	--	Analog ground
3	TEST1	--	Test input 1 ; pin should be connected to ground
4	BCK	I	Bit clock input from IC081
5	WS	I	Word select input from IC081
6	DATA	I	Data input from IC081
7	CKSL1	I	Format selection 1
8	CKSL2	I	Format selection 2
9	VSSD	--	Digital ground
10	VDDD	--	Digital supply voltage (5V)
11	TEST2	--	Test input 2 ; pin should be connected to ground
12	SYCLK	I	System clock 256fs input from IC093
13	APP3	I	Application mode 3 input
14	APPL	I	Application mode selection input
15	APP2	I	Application mode 2 input
16	APP1	I	Application mode 1 input
17	APP0	I	Application mode 0 input
18	VOL	O	Left channel output
19	FILTCL	O	Capacitor for left channel first-order filter function, should be connected between pins 19 and 18
20	FILTCL	O	Capacitor for right channel first-order filter function, should be connected between pins 20 and 21
21	VOR	O	Right channel output
22	VREF	--	Internal reference voltage for output channels (0.5 VDDO typ.)
23	VSSO	--	Operational amplifier ground
24	VDDO	--	Operational amplifier supply voltage (5V)

■ SAA7366T (IC021) : A/D Converter

1. Terminal Layout

SFOR	1	24	SLAVE
STDB	2	23	VDDA
OVLD	3	22	VREFL
CKIN	4	21	BIL
VDD	5	20	BOL
VSS	6	19	VDACP
SDO	7	18	VDACN
SWS	8	17	BOR
SCK	9	16	BIR
TEST 1	10	15	VREFR
HPEN	11	14	IREF
TEST B	12	13	VSSA

2. Block Diagram

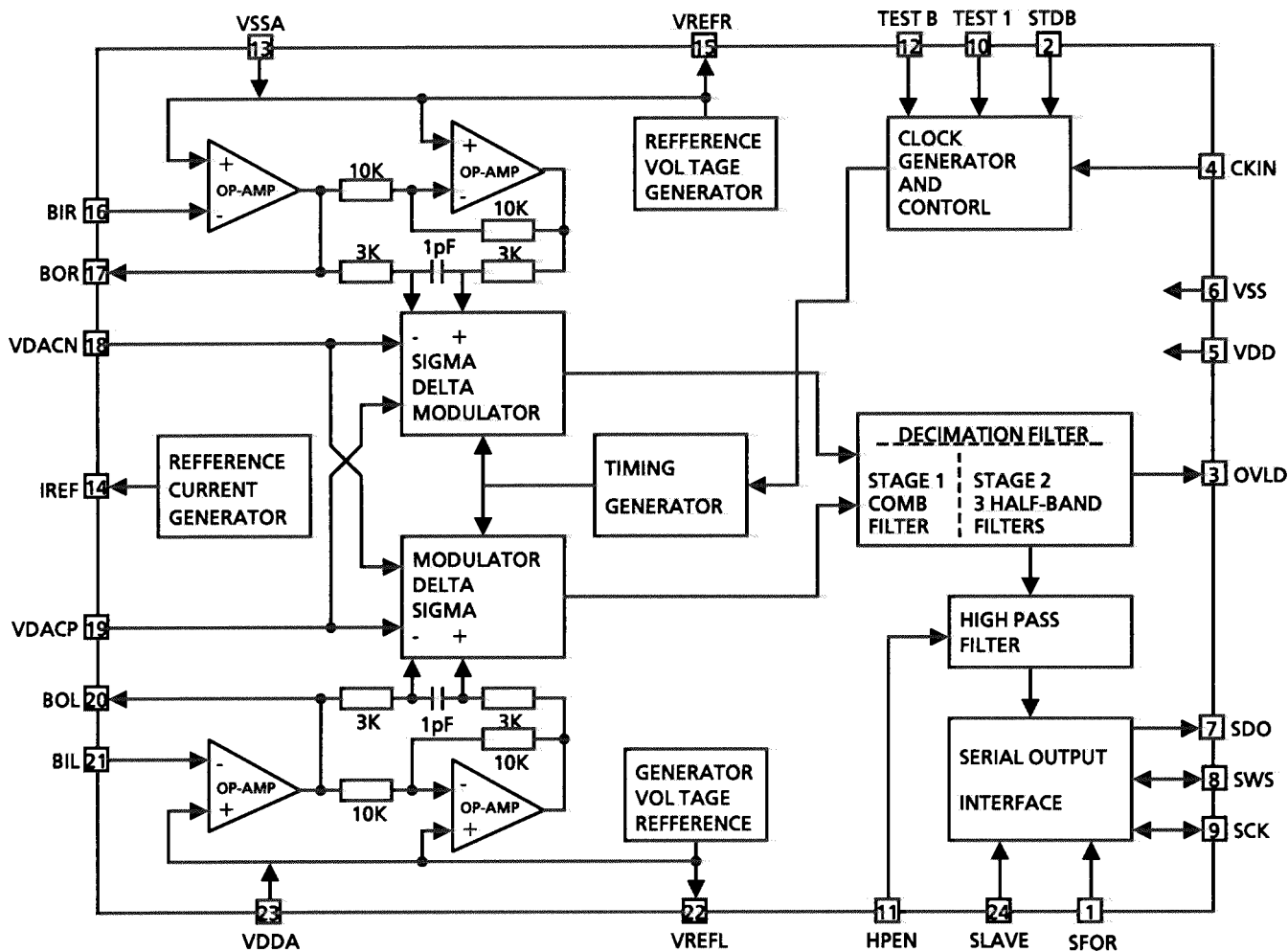

3. Pin Functions

Pin No.	Symbol	I/O	Functions
1	SFOR	I	Input for selectiing serial interface output format. HIGH=Format 1 LOW=Format 2
2	STDB	I	Input for selectiing STANDBY mode HIGH=Normal operation LOW=STANDBY (Low power consumption)
3	OVL D	O	Overload indication output. This pin indicates whether the internal digital signal is within 1dB of maximum. In STANDBY mode this output is in high impedance
4	CKIN	I	System clock input from IC093
5	VDD	--	Supply for the digital section (5V)
6	VSS	--	Ground supply for the digital section
7	SDO	O	Serial interface data output to IC081. In STANDBY mode this output is in high impedance
8	SWS	I/O	Serial interface word select signal. This pin is the word select input to the serial interface.
9	SCK	I/O	Serial interface clock. This pin is the input for the external bit clock.
10	TEST1	I	Test input 1. This pin should be left open circuit
11	HPEN	I	High pass filter enable input. (HPEN HIGH=enabled). If unconnected this pin defaults HIGH
12	TESETB	I	Test input 2. This pin should be left open circuit
13	VSSA	--	Ground supply for the analogue section
14	IREF	--	Current reference mode
15	VREFR	--	VDDA/2 reference generator for the right channel analog section
16	BIR	I	Buffer op-amp inverting input for right channel
17	BOR	O	Buffer op-amp output for right channel
18	VDACN	I	Negative 1 bit DAC reference voltage input, normally connected to 0V
19	VDACP	I	Positive 1 bit DAC reference voltage input, normally connected to 5V
20	BOL	O	Buffer op-amp output for left channel
21	BIL	I	Buffer op-amp inverting input for left channel
22	VREFL	--	VDDA/2 reference generator for the left channel analog section
23	VDDA	--	Supply for the analog section (5V)
24	SLAVE	I	Input for selectiing serial interface operating mode MASTER/SLAVE HIGH=SLAVE, LOW=MASTER If unconnected the pin will default LOW

TC9299P (IC341) : Electronic volume

1. Terminal Layout

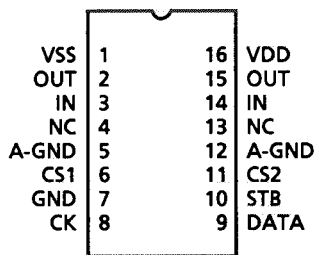

2. Block Diagram

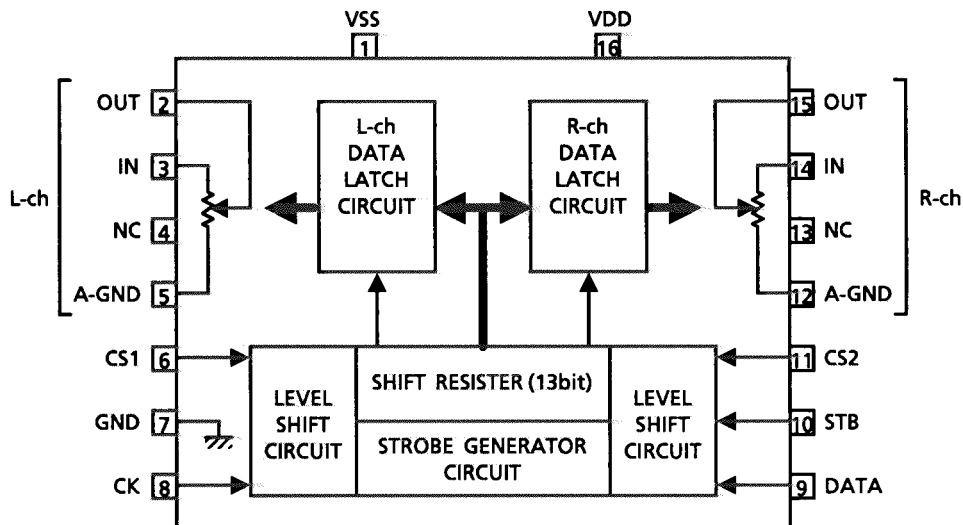

3. Pin Functions

Pin No.	Symbol	I/O	Functions	Pin No.	Symbol	I/O	Functions
1	VSS	-	Power supply voltage (-)	9	DATA	I	Serial data input to set fader.
2	L-OUT	O	Volume output	10	STB	I	Strobe signal input for write data

RX-816RBK

■ XR1095CP (IC404): Graphic Equalizer Filter & Display driver

1. Terminal Layout

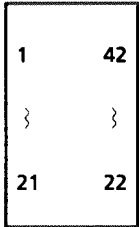

2. Pin function

Pin No.	Symbol	Function
1~5,9~16	A1~A13	Anode terminal
30~38	G1~G9	Grid terminal
25	RIN	Right channel input
26	LIN	Left channel input
22	DIM	Brightness control varies width of G outputs.
27	GPH	Filter amplitude display duration control. A resistor and timing capacitor from this pin to VSS adjust Peak Hold Decay Time.
28	TPH	Total output display on / off control.
40	CLKR	Oscillator timing resistor between this pin and CLKC pin.
41	CLKC	Oscillator timing capacitor between this pin and VSS.
20	S1	Chip select 1 pin.
21	S1	Chip select 2 pin.
19	DI	Serial port data.
18	SPCLK	Serial port clock.
17	CS	Chip Select.
42	VDD	Plus supply, nominally 5VDC.
23	VSS	Minus supply, nominally -5VDC.
24	GND	Analog input reference.

3. Block Diagram

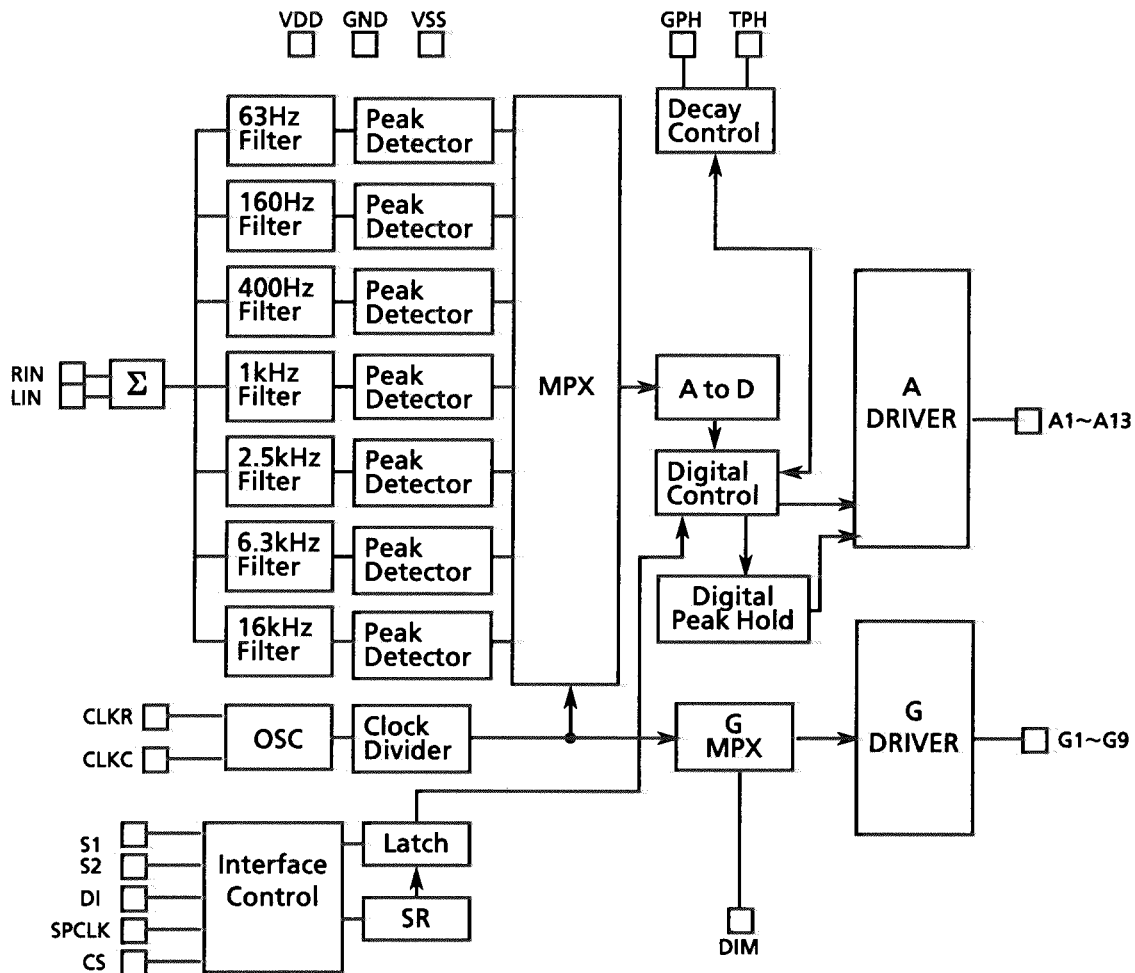

■ LC7218JM (IC121) : PLL Synthesizer

1. The main function descriptions

- (1) It makes the local oscillation frequency by the control data from IC401.
- (2) Decode the control signal and transmit the signal for receiving conditions.
- (3) For the best tuning, count the internal-frequency and transmit the data to IC201.

2. Terminal Layout

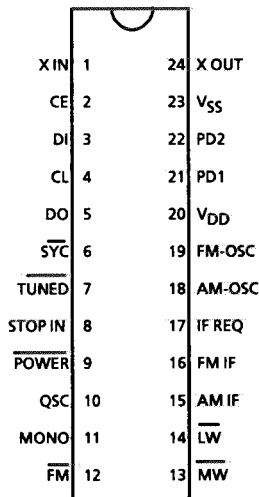

3. Block Diagram

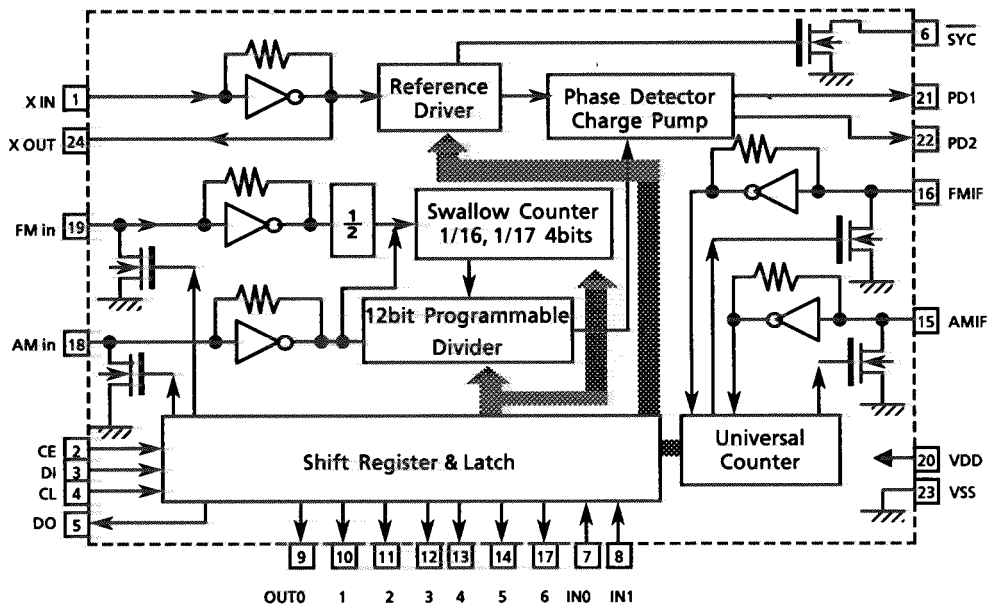

4. Pin Functions

Pin No.	Symbol	I/O	Functions
1,24	X in, X out	I/O	Crystal oscillator (7.2MHz).
2	CE	I	Fix the chip enable to "H" when inputting (DI) and outputting (DO) the serial data.
3	DI	I	Receive the control data from the controller (IC401).
4	CL	I	This clock is used to synchronize data when transmitting the data of DI and DO.
5	DO	O	Transmit the data from LC7218JM to the controller which is synchronized with CL.
6	SYC	—	Not used.
7	TUNED	I	Receive the tuned signal from IC102 (LA1836M).
8	STOP IN	—	Connected to GND
9	POWER	—	Not used.
10	QSC	—	Not used.
11	MONO	O	It is "H" on FM-monaural, "L" on FM-Stereo.
12	FM	O	It is "L" on FM mode.
13	MW	O	It is "L" on MW mode.
14	LW	O	It is "L" on LW mode.
15	AM-IF	I	Universal counter input for AM-IF from IC102 (LA1836M).
16	FM-IF	I	Universal counter input for FM-IF from IC102 (LA1836M).
17	IF REQ	O	Output the "IF-signal request" to IC102 when the pin-7 (tuned in) goes to "H".
18	AM OSC	I	Input the local oscillator signal of AM.
19	FM OSC	I	Input the local oscillator signal of FM.
20	V _{DD}	—	This is a terminal of power supply.
21	PD1	O	PLL charge pump output : When the local oscillator signal frequency is higher than the reference frequency high level signals will output. When it is lower than the reference frequency, low level signals will output. When it is same as reference frequency signals, it will be floating.
22	PD2	—	Not used.
23	V _{SS}	—	Connected to GND

LA1836M (IC102) : FM AM IF AMP & detector, FM MPX DECODER

1. Terminal Layout

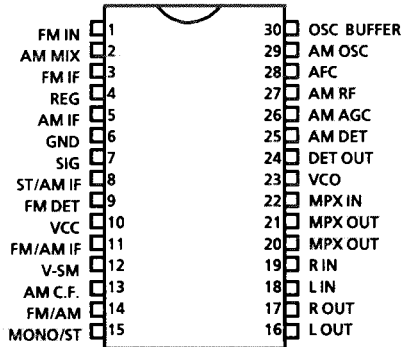

3. Pin Function

Pin No.	Symbol	I/O	Function
1	FM IN	I	This is an input terminal of FM IF Signal.
2	AM MIX	O	This is an output terminal for AM mixer.
3	FM IF	I	Bypass of FM IF
4	REG	-	Register value between pin4 and pin28 desides the frequency width of the input signal.
5	AM IF	I	Input of AM IF Signal.
6	GND	-	This is the device ground terminal.
7	SIG	O	When the set is tuning , this terminal becomes "L".
8	ST/AM IF	O	Stereo indicator output. Stereo : "L", Mono : "H"
9	FM DET	-	FM detect transformer.
10	VCC	-	This is the power supply terminal.
11	FM/AM IF //MUTE	O/I	When the signal of IF REQ of IC121(LC7218JM) appear, the signal of FM/AM IF output. //Muting control input.
12	VSM	O	S Meter output and adjust AM SD sensitivity.
13	AM C.F.	O	This is a terminal of AM ceramic filter.
14	FM/AM	I	Change over the FM / AM input. "H" : FM, "L" : AM
15	MONO/ST	O	Stereo : "H", Mono : "L"
16	L OUT	O	Left channel signal output.
17	R OUT	O	Right channel signal output
18	L IN	I	Input terminal of the Left channel post AMP.
19	R IN	I	Input terminal of the Right channel post AMP.
20	MPX L OUT	O	Mpx Left channel signal output.
21	MPX R OUT	O	Mpx Right channel signal output.
22	MPX IN	I	Mpx input terminal.
23	VCO	I	Voltage controlled oscillator terminal.
24	DET OUT	O	AM/FM detection output.
25	AM DET	-	AM low cut adjustment.
26	AM AGC	I	This is an AGC voltage input terminal for AM.
27	AM RF	I	This is an input terminal for AM RF signal.
28	AFC	-	This is an output terminal of voltage for FM-AFC.
29	AM OSC	-	This is a terminal of AM Local oscillation circuit.
30	OSC BUFFER	O	AM Local oscillation Signal output.

2. Block Diagram

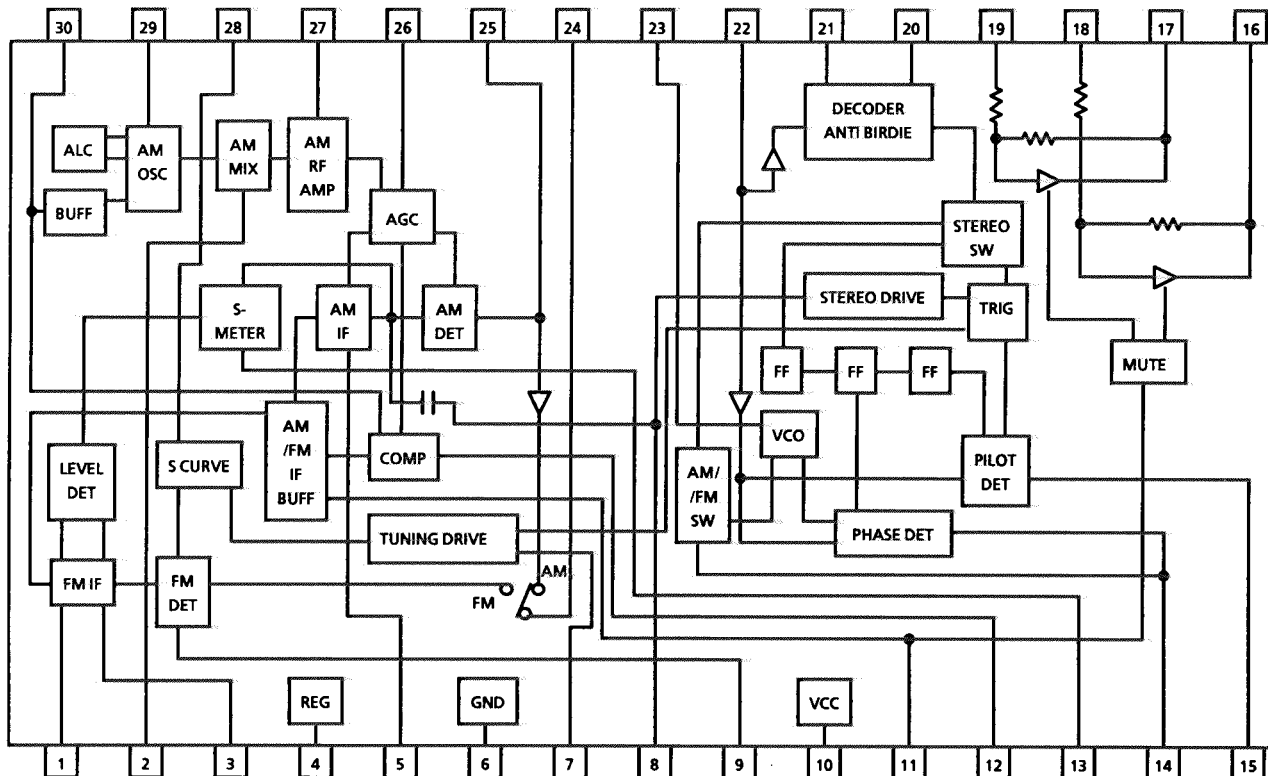

■ LC7073M (IC191) : Radio Data System

1. Terminal Layout

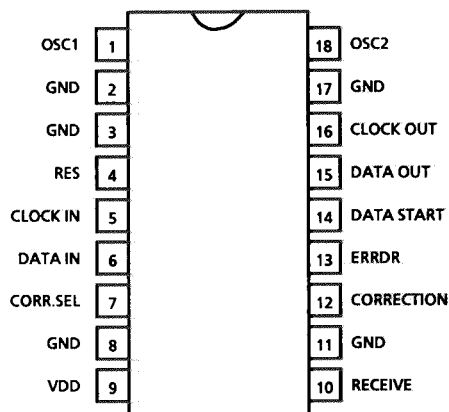

2. Block Diagram

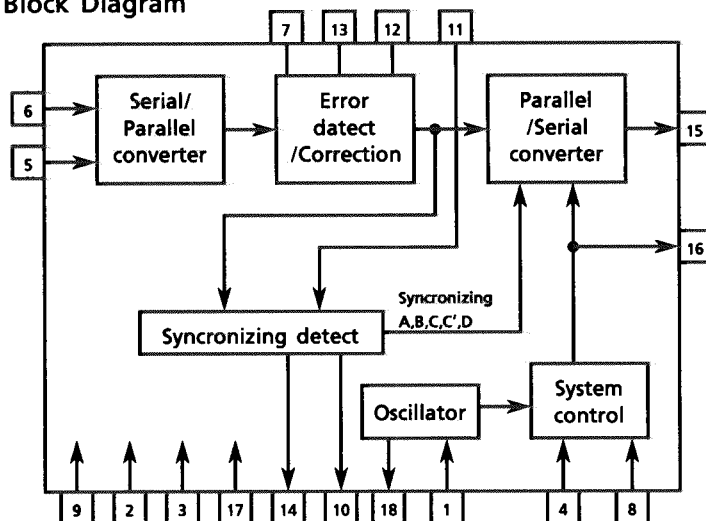

3. Pin Functions

Pin No.	Symbol	I/O	Function
1	OSC1,OSC2	I/O	Oscillation terminal
2	GND	—	GND
3	GND	—	GND
4	RES	I	Reset input
5	CLOCK IN	I	RDS clock input
6	DATA IN	I	RDS data input
7	CORR.SEL	I	Non connection
8	GND	—	GND
9	VDD	—	Power supply
10	RECEIVE	—	Non connection
11	GND	—	GND
12	CORRECTION	—	Non connection
13	ERRDR	—	Non connection
14	DATA START	O	Data start signal for block data to output serial data.
15	DATA OUT	O	Serial data output
16	CLOCK OUT	O	Data output of serial data output
17	GND	—	GND
18	OSC2	I/O	Oscillation terminal

RX-816RBK

■ SAA6579T (IC192) : Radio data system demodulator

1. Terminal Layout

QUAL	1	16	RDCL
RDDA	2	15	T57
Vref	3	14	OSCO
MUX	4	13	OSCI
VDDA	5	12	VDD
GND	6	11	GND
CIN	7	10	GND
SCOUT	8	9	GND

2. Pin Function

Pin No.	Symbol	I/O	Function
1	QUAL	—	Non connection
2	RDDA	O	RDS data output
3	Vref	O	Reference voltage output
4	MUX	I	Multiplex signal input
5	VDDA	—	+5V supply voltage for analog part
6	GND	—	Ground for analog part (0V)
7	CIN	I	Subcarrier input to comparator
8	SCOUT	O	Subcarrier output of reconstruction filter
9	GND	—	Ground for digital part (0V)
10	GND	—	Ground for digital part (0V)
11	GND	—	Ground for digital part (0V)
12	VDD	—	+5V supply voltage for digital part
13	OSCI	I	Oscillator input
14	OSCO	O	Oscillator output
15	T57	—	Non connection
16	RDCL	O	RDS clock output

3. Block Diagram

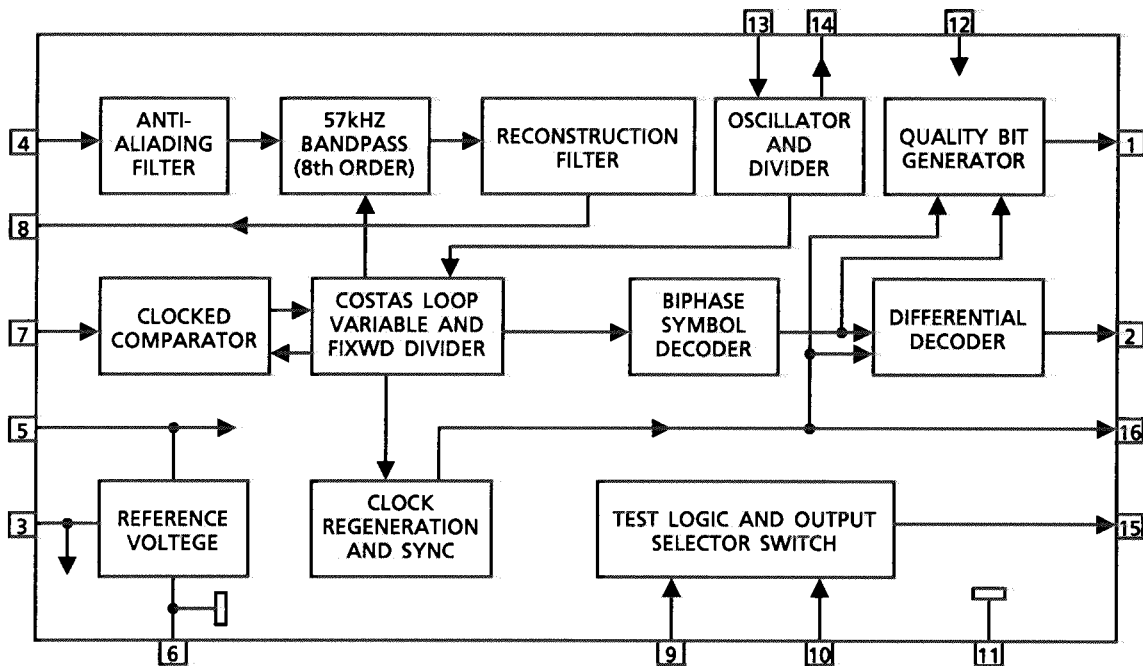

■ TA7317P (IC901) : Protector

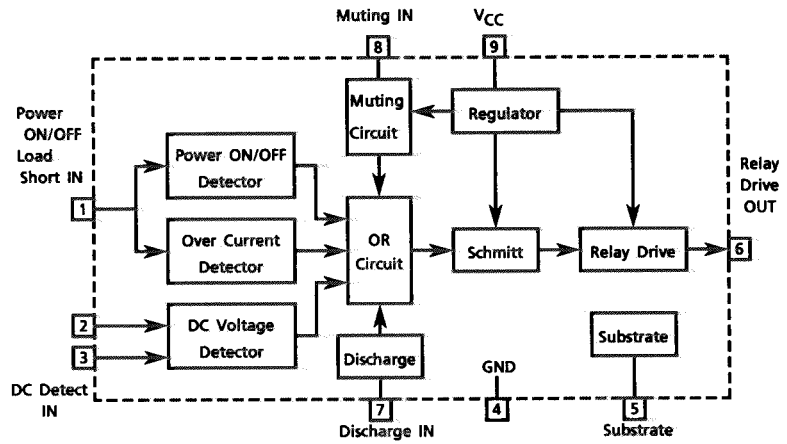
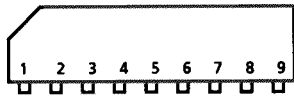

■ MN1281(P,Q) (IC403) : Reset IC

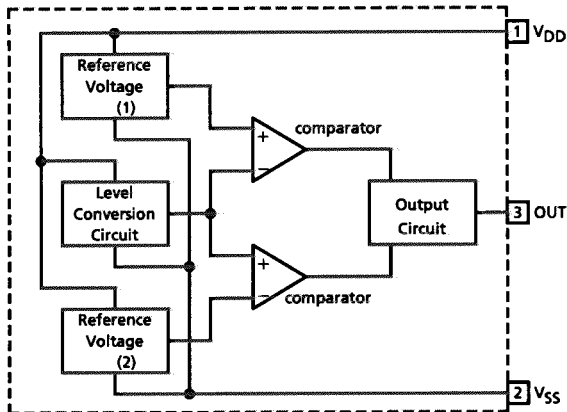

Pin No.	Pin Name	Functions
1	V _{DD}	Power supply
2	V _{SS}	Ground
3	OUT	Reset signal output : Low level is output when resetting : High level is output when cancelling the reset.

■ LB1639-CV (IC361) : Motor Driver

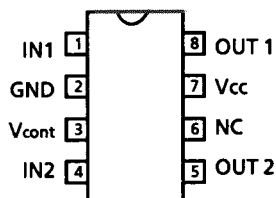

IN 1	IN 2	OUT 1	OUT 2	MOTOR
H	L	H	L	CLOCKWISE
L	H	L	H	COUNTER-CLOCKWISE
H	H	OFF	OFF	WAITING
L	L	OFF	OFF	WAITING

RX-816BK

■ SPS-420-1 (IC402) : Remote Control Module IC

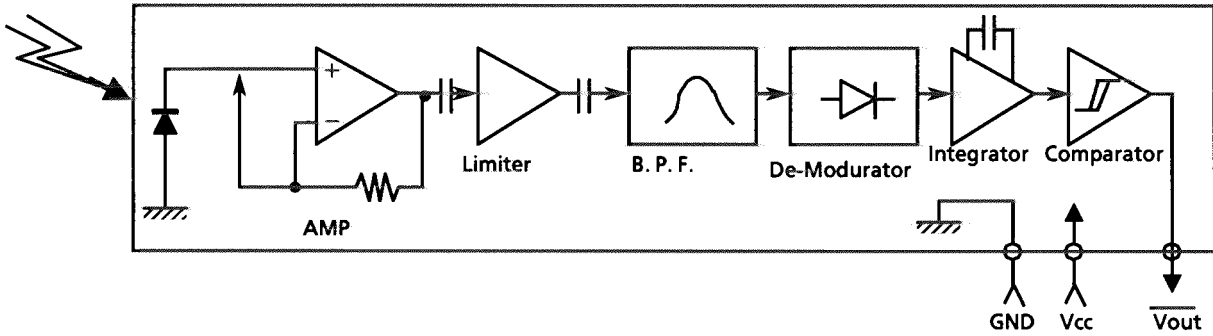

■ NJM2246D (IC221) : Video Switch

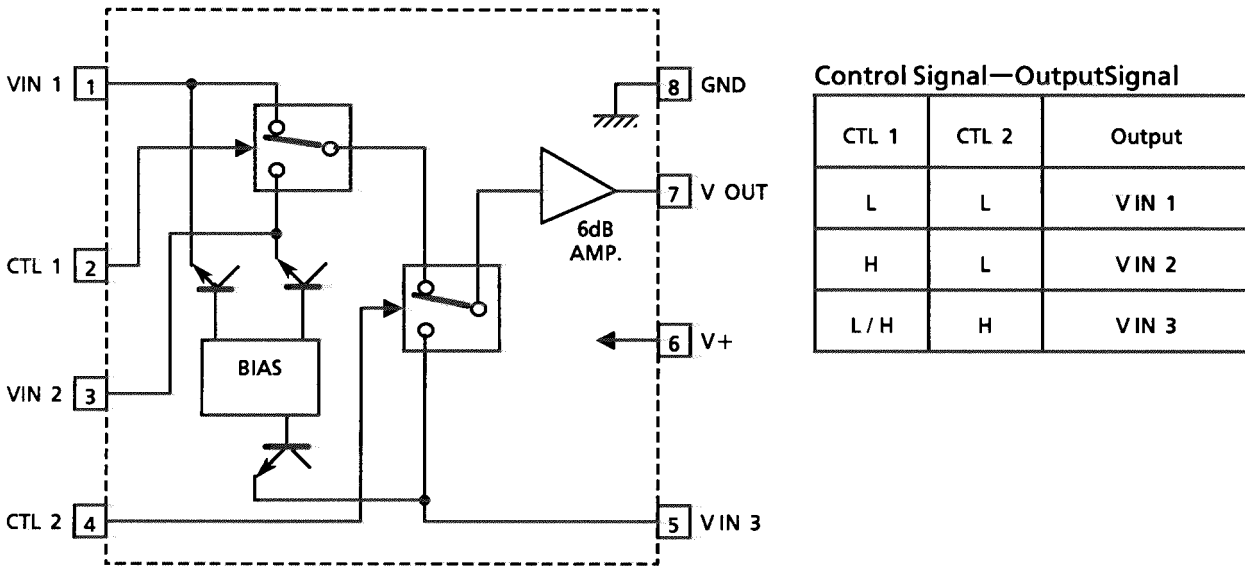

■ VC5022-2 (IC701,702) : SUPER A

(1) Terminal Layout

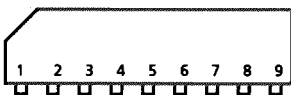

(2) Block Diagram

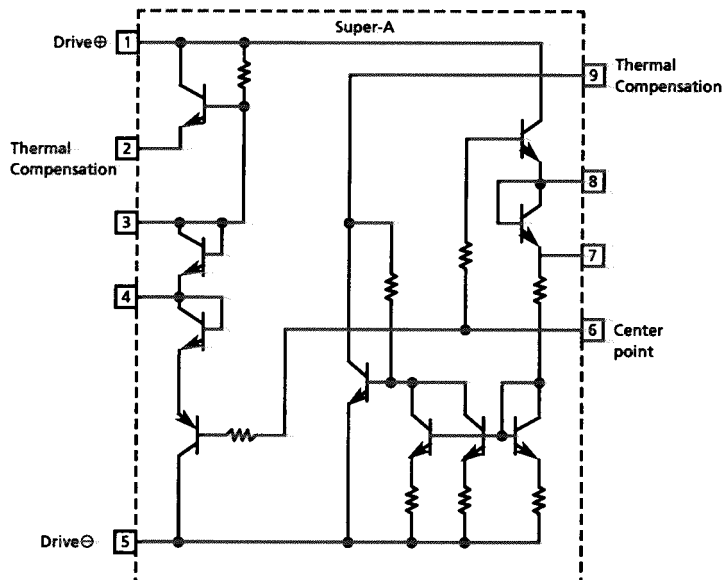

■ NJU3715L (IC411) : 16-BIT Serial-parallel converter

1. Terminal layout

VIDEO2	1	22	VDD
	2	21	VIDEO1
VOL+	3	20	
VOL-	4	19	LOUDNESS
VOL LED	5	18	TU.MUTE
VSS	6	17	S.MUTE
	7	16	SEA ON
SUR.RELAY	8	15	CLR
C.RELAY	9	14	STB2
	10	13	CLK
	11	12	DATA

2. Internal Block Diagram

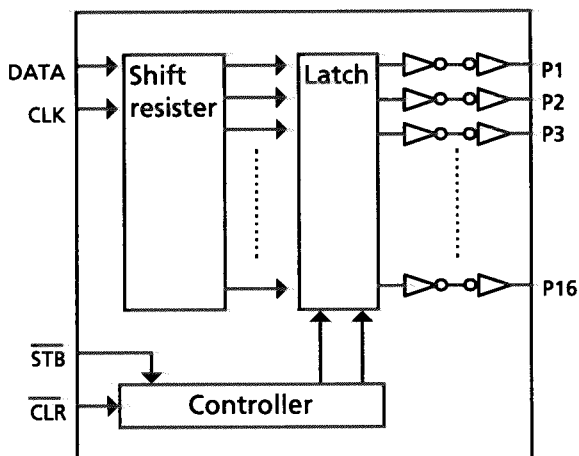

- P1 C. ON/OFF
- P2 NORMAL
- P3 WIDE
- P4 SURR. ON/OFF
- P5 HALL
- P6 VIDEO1
- P7 VIDEO2
- P8 SOURCE MUTE
- P9 3CH. LOGIC
- P10 NOISE ON/OFF
- P11 NOISE1
- P12 NOISE2
- P13 DELAY1
- P14 DELAY2
- P15 DELAY3
- P16 —

3. Terminal Description

Pin No.	I/O	Function
1~5, 7~11, 16~21	O	Parallel data output
12	I	Serial data input
13	I	Clock input (When this terminal is set low level, all of the output become low.)
14	I	Strobe signal input
15	I	Clear signal input

4. Function

CLK	STB	CLR	Function
X	X	L	All the data stored in the latch circuit are eliminated. (The data in the shift register are not eliminated.)
	H	H	Data are inputted synchronizing the rising edge of the clock.
L	L	H	The data in the shift register are transmitted to the latch circuit. The data outputted from parallel outputs.
	L	H	The data in the shift register are shifted synchronizing the rising edge of the clock. (The data outputted from the latch circuit are changed.)

5. Function Table

SURROUND RELAY CONTROL			VOLUME CONTROL				VIDEO CONTROL		
MODE	Port of IC411		MODE	Port of IC411			MODE	Port of IC411	
	SUR. RELAY	C. RELAY		VOLUME UP	VOLUME DOWN	VOLUME LED		VIDEO 1	VIDEO 2
DAP OFF	L	L	UP	H	L	L	VCR	H	H
SUR. OFF	L	L	DOWN	L	H	L	VIDEO1	L	H
PRO LOGIC	H	H	STOP	L	L	L	EXCEPT VCR, VIDEO1	L	L
3CH LOGIC	L	H	MUTE	L	H	BLINKLING	STAND BY	L	L
THEATER	H	H							
DAP (Except H.Phone)	H	L							
H. Phone	L	L							

SEA CONTROL		LOUDNESS	
MODE	Port of IC411	MODE	Port of IC411
	SEA ON		LOUDNESS
SEA ON	H	ON	L
SEA OFF	L	OFF	H

RX-816RBK

■ AT24C02 (IC412) : Serial Eeprom

1. Terminal Layout

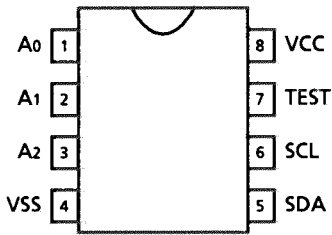

2. Terminal Functions

Pin No.	Symbol	Functions
1~3	A0~A2	ADDRESS INPUT (NOT USED)
4	VSS	GND
5	SDA	SERIAL DATA
6	SCL	SERIAL CLOCK
7	TEST	TEST PIN (CONNECTED TO GND)
8	VCC	POWER SUPPLY

3. Block Diagram

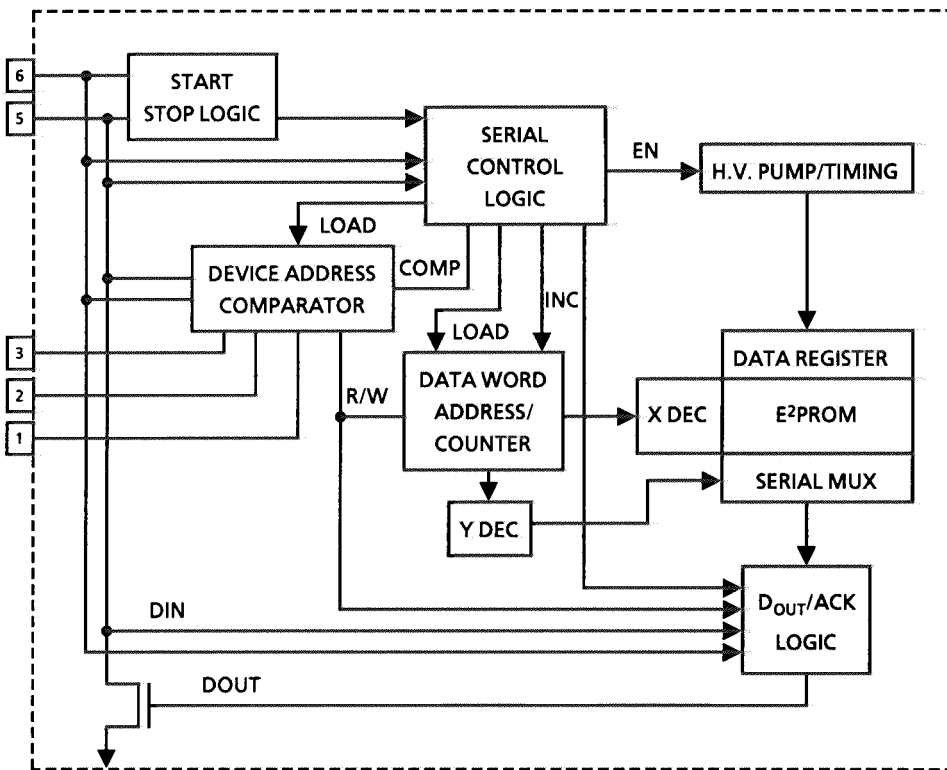

■ TC74HC74AF (IC093) : DUAL D FLIP FLOP WITH PRESET AND CLEAR

1. Terminal Layout

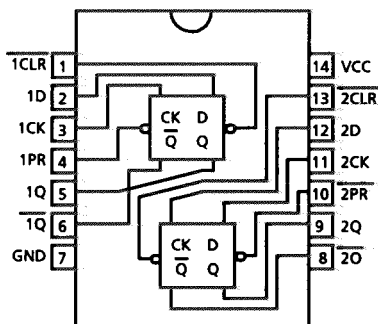

2. Pin function

INPUTS				OUTPUTS		FUNCTION
CLR	PR	D	CK	Q	Q	
L	H	X	X	L	H	CLEAR
H	L	X	X	H	L	PRESET
L	L	X	X	H	H	—
H	H	L	↑	L	H	—
H	H	H	↑	H	L	—
H	H	X	↓	Q _n	Q _n	NO CHANGE

X : Don't care

Internal Connections of the FL Display

■ELU0001-202 : FL401

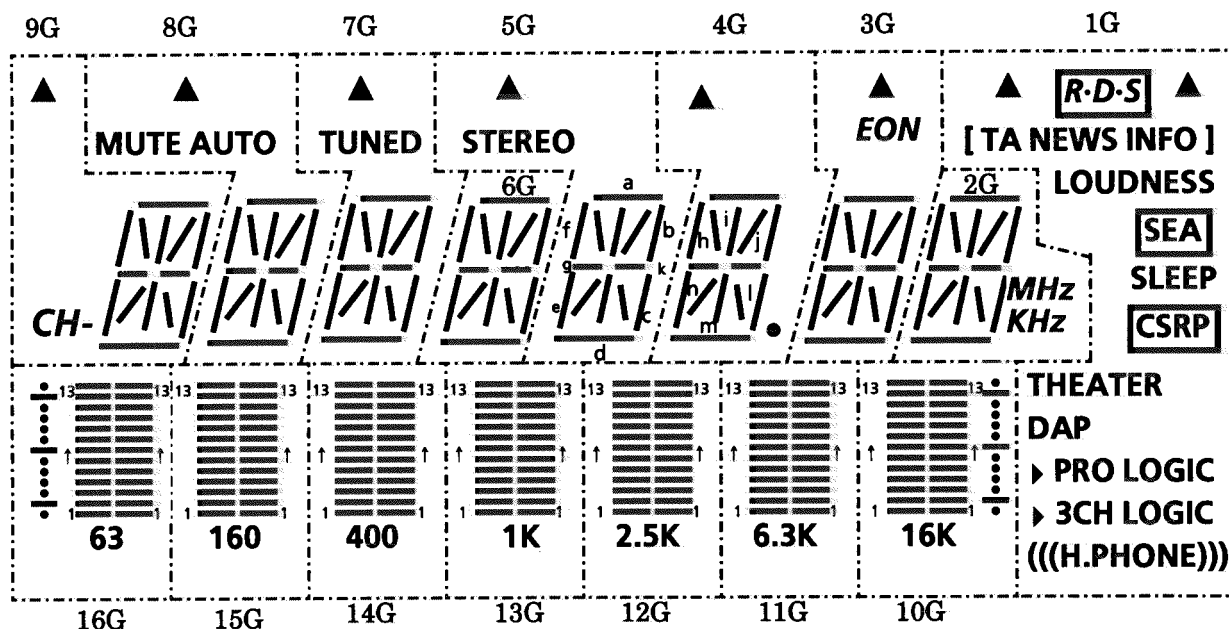

Pin Connection

Upper

PIN NUMBER	39	40	41	42	43	44	45	46	47	48	49	50	51	52	53	54	55	56	57
ELECTRODE	F2	F2	F2	NP	NP	NP	NP	NP	NP	NP	P16 (S16)	P15 (S15)	P14 (S14)	P13 (S13)	P12 (S12)	P11 (S11)	P10 (S10)	P9 (S9)	P8 (S8)
PIN NUMBER	58	59	60	61	62	63	64	65	66	67	68	69	70	71	72	73	74	75	76
ELECTRODE	P7 (S7)	P6 (S6)	P5 (S5)	P4 (S4)	P3 (S3)	P2 (S2)	P1 (S1)	1G (D1)	2G (D2)	3G (D3)	4G (D4)	5G (D5)	6G (D6)	7G (D7)	8G (D8)	NP	F1	F1	F1

Lower

PIN NUMBER	1	2	3	4	5	6	7	8	9	10	11	12	13	14	15	16	17	18	19
ELECTRODE	F1	F1	F1	NP	P17 (T1)	P18 (T2)	P19 (T3)	P20 (T4)	P21 (T5)	P22 (T6)	P23 (T7)	P24 (T8)	P25 (T9)	P26 (T10)	P27 (T11)	P28 (T12)	P29 (T13)	16G (1G)	15G (2G)
PIN NUMBER	20	21	22	23	24	25	26	27	28	29	30	31	32	33	34	35	36	37	38
ELECTRODE	14G (3G)	13G (4G)	12G (5G)	11G (6G)	10G (7G)	9G (8G)	NP	NP	NP	NP	NP	NP	NP	NP	NP	NP	F2	F2	F2

Note F : Filament, G : Grid, P : Anode, NP : No Pin

Grid - Anode Assignment (1G~9G)

	9G	8G	7G	6G	5G	4G	3G	2G	1G
S1	a	a	a	a	a	a	a	a	▲ (LEFT)
S2	b	b	b	b	b	b	b	b	R·D·S
S3	i	i	i	i	i	i	i	i	▲ (RIGHT)
S4	j	j	j	j	j	j	j	j	()
S5	h	h	h	h	h	h	h	h	TA
S6	f	f	f	f	f	f	f	f	NEWS
S7	k	k	k	k	k	k	k	k	INFO
S8	g	g	g	g	g	g	g	g	LOUDNESS
S9	c	c	c	c	c	c	c	c	SEA
S10	l	l	l	l	l	l	l	l	SLEEP
S11	n	n	n	n	n	n	n	n	CSRP
S12	m	m	m	m	m	m	m	m	THEATER
S13	e	e	e	e	e	e	e	e	DAP
S14	d	d	d	d	d	d	d	d	PRO LOGIC
S15	CH-	MUTE AUTO	TUNED	--	STEREO	● (DOT)	EON	MHz	3CH LOGIC
S16	▲	▲	▲	--	▲	▲	▲	KHZ	((H,PHONE))

Grid - Anode Assignment (10G~16G)

	16G	15G	14G	13G	12G	11G	10G
S17	(1)	(1)	(1)	(1)	(1)	(1)	(1)
S18	(2)	(2)	(2)	(2)	(2)	(2)	(2)
S19	(3)	(3)	(3)	(3)	(3)	(3)	(3)
S20	(4)	(4)	(4)	(4)	(4)	(4)	(4)
S21	(5)	(5)	(5)	(5)	(5)	(5)	(5)
S22	(6)	(6)	(6)	(6)	(6)	(6)	(6)
S23	(7)	(7)	(7)	(7)	(7)	(7)	(7)
S24	(8)	(8)	(8)	(8)	(8)	(8)	(8)
S25	(9)	(9)	(9)	(9)	(9)	(9)	(9)
S26	(10)	(10)	(10)	(10)	(10)	(10)	(10)
S27	(11)	(11)	1(1)	(11)	(11)	(11)	(11)
S28	(12)	(12)	(12)	1(2)	(12)	(12)	(12)
S29	(13)	(13)	(13)	(13)	(13)	(13)	(13)

(NOTE) Dots(*) on both side of 63,160,400,1K,2.5K,6.3K and 16K are connceted with their each grids. (*)



Disassembly Procedures

(1) Removing the top cover

1. Remove 4 screws **A** fastening both sides of top cover, and 3 screws **B** fastening the rear side.
2. Remove the top cover.

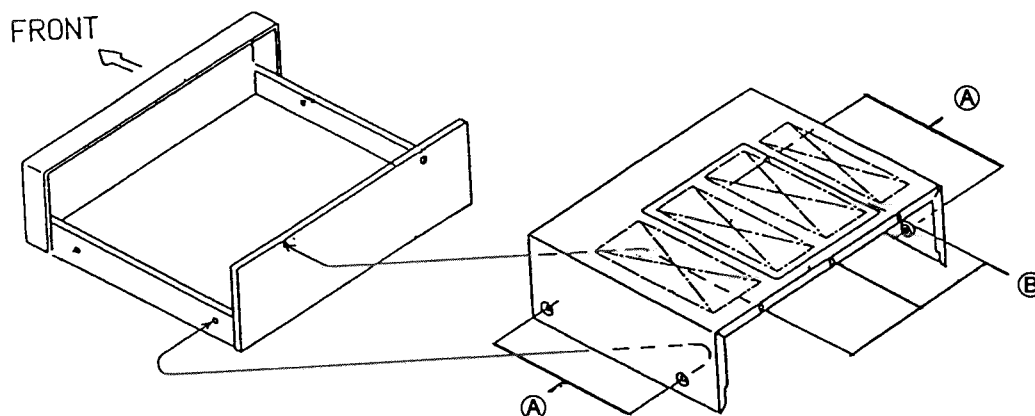

(2) Removing the Bottom Cover

1. Remove 13 screws **C** and **C''**.
2. Remove the bottom cover.

※ The screw **C''** which secures the bottom cover is also used for ground.
It is necessary to ground before checking after the bottom cover is removed.

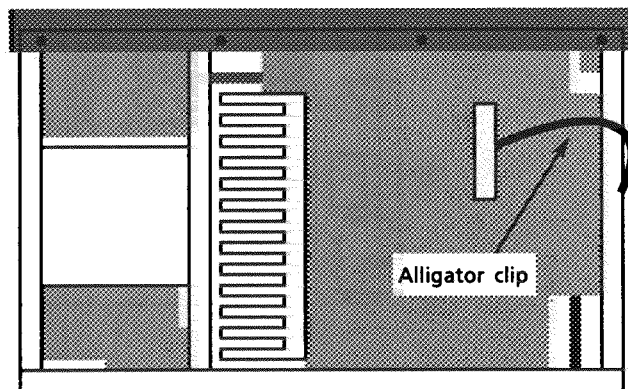
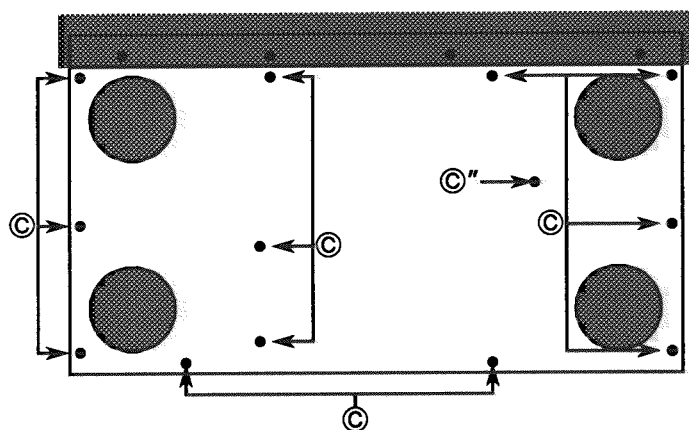

A .. E61660-004

B ... E73273-006

C, C'' SBSG3008CC

(3) Removing the Front Panel Assembly

1. Remove 3 screws ③ fastening top of the front panel, and 4 screws ④ fastening bottom of it.
2. Remove the Master volume knob, Center tone knob and Balance knob.
3. Remove the nut fastening the Master volume.
4. Remove the front panel disconnecting some wires. (JB441,P704,P311,P222,P271)

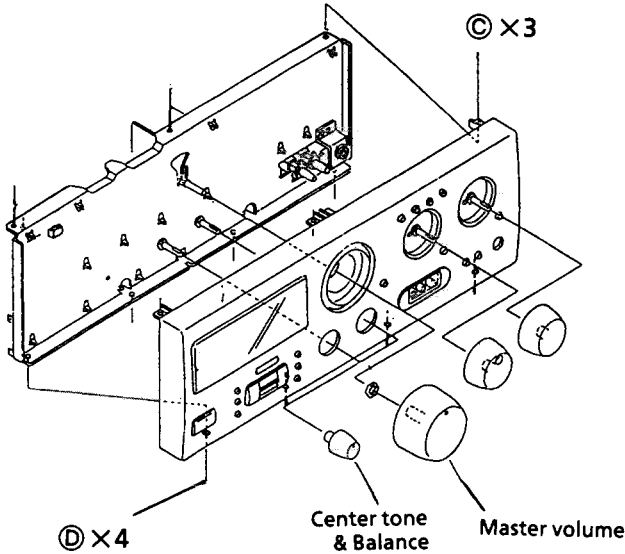

(4) Removing the Front P.C. Board

1. Removing the front panel assembly.
2. Remove 9 screws ⑤.
3. Remove 2 nut fastening the rotary encoder.
4. Remove the front P.C. Board.

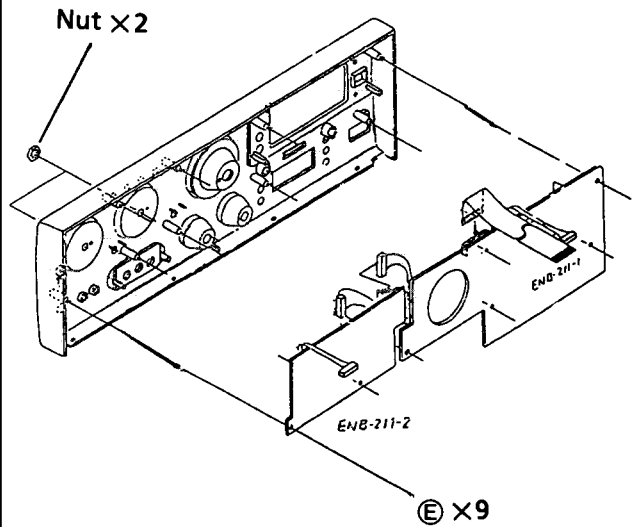

(5) Removing the Rear Panel

1. Remove 20 screws ⑥, ⑥" and ⑦.
2. Remove 2 screws ③ fastening bottom sides of rear panel.
3. Take it out.

※ 3pcs. of screw ⑥" which secure the rear panel are also used for ground. Installing of those screws is required before checking.

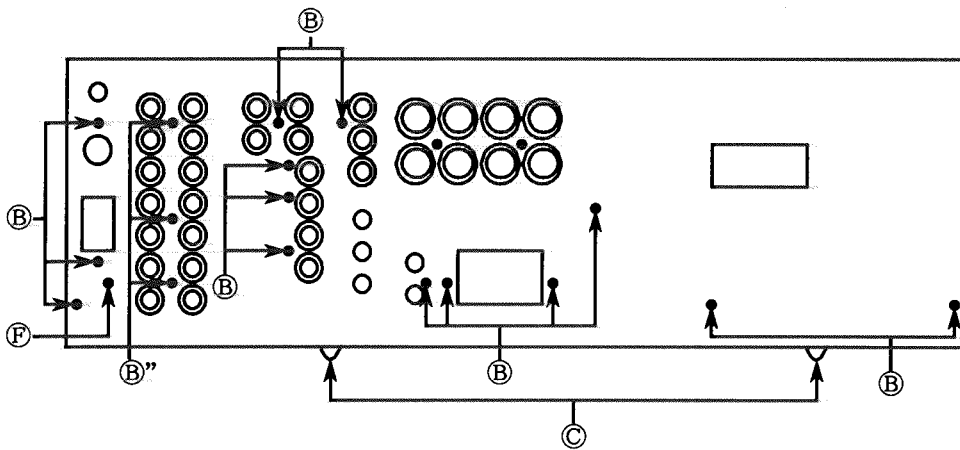

⑥, ⑥" E73273-006

③ SBSG3008CC

④ SDSG3008M

⑤ SDSF2608Z

⑦ SBST3006M

- (6) Removing the Power Transistor
1. Remove the top cover and bottom cover.
 2. Unsolder the broken transistor.
 3. Remove the some screws © fastening it.
 4. Remove it.

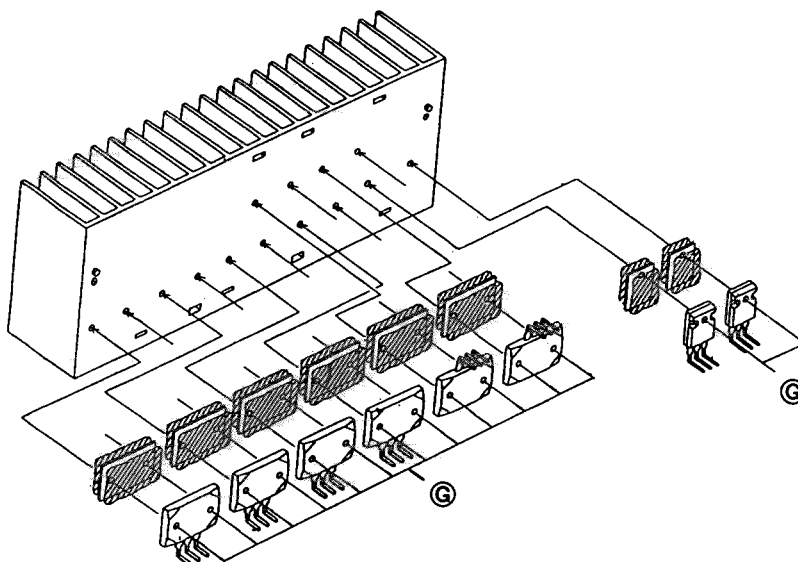

© ... E73525-003

ADJUSTMENT PROCEDURES

■ Tuner section

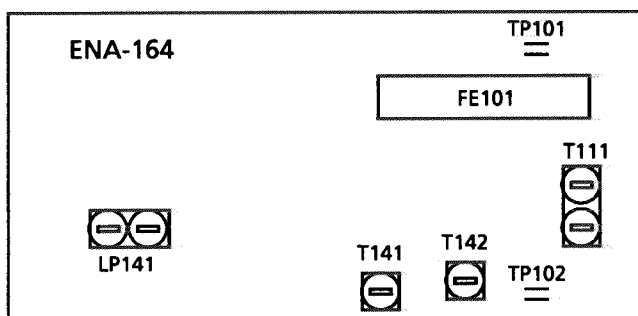

Tuning range

Area	Range		
	LW (kHz)	MW (kHz)	FM (MHz)
Continental Europe, the U.K	144~288	522~1629	87.5~108

(1) Tuning Voltage

Confirm the voltages in the table at TP101.

FM Tuning voltage (Unit : V)

Area	Frequency	
	87.5MHz	108MHz
the U.K., Continental Europe	1.6±1.0	8.0±2.0

AM Tuning voltage (Unit : V)

Area	Frequency(MW)		Frequency(LW)	
	522KHz	1629KHz	144kHz	288kHz
the U.K., Continental Europe	0.5 < 1.0	7.5 < 8.5	0.5 < 1.0	5.0 < 7.5

(2) FM Center meter

Receive a broadcast by using the function of 'AUTO STOP'.

Adjust T141 (Detector coil) so taht the voltage at TP102 becomes 0±1.5mV.

■ Power Amplifier section

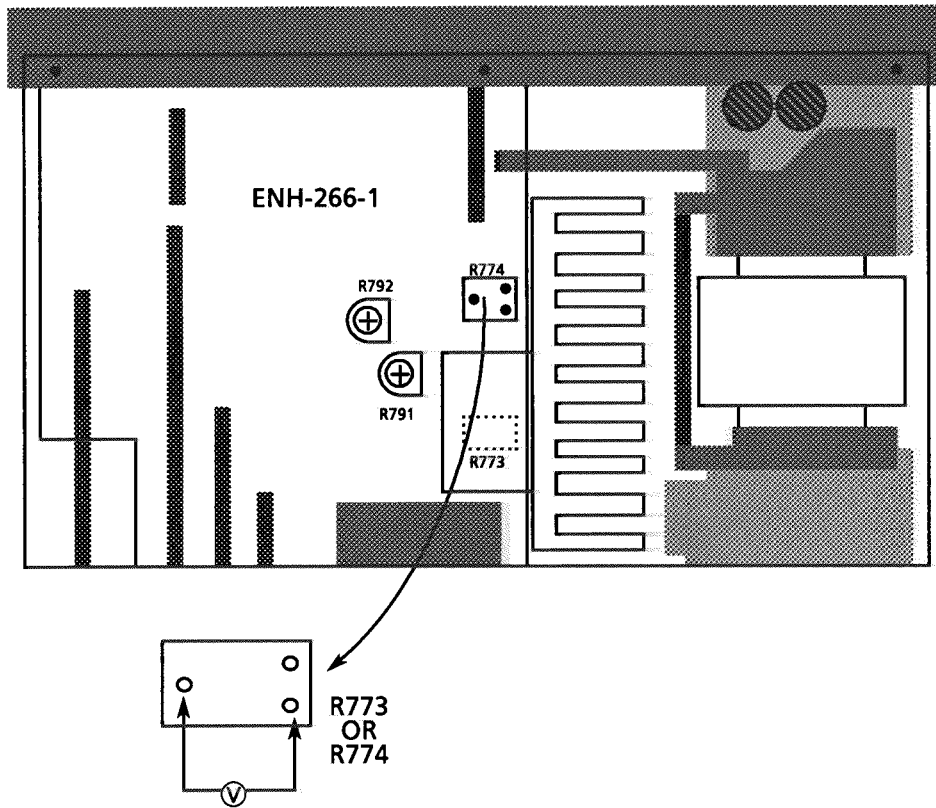

■ Idling current

- (1) Set the volume control to minimum during this adjustment.
- (2) Turn R791 and R792 fully counterclockwise to warm up before adjustment.
If the heatsink is already warm from previous use the correct adjustment can not be made.
- (3) Connect a DC voltmeter to R773 resistor's leads for left channel, or to R774 for right channel.
- (4) Adjust R773 for left channel, or R774 for right channel, so that the DC voltmeter becomes 1mV~10mV.

Block Diagrams

Control Section

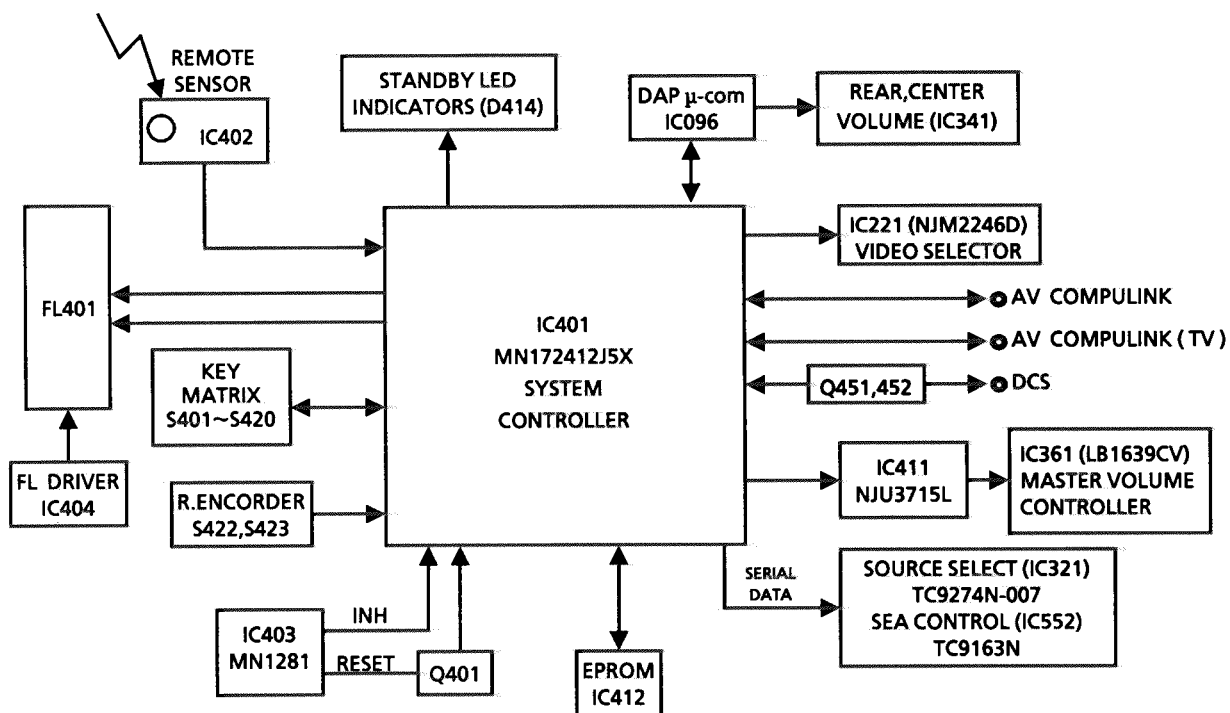

Power Supply Section

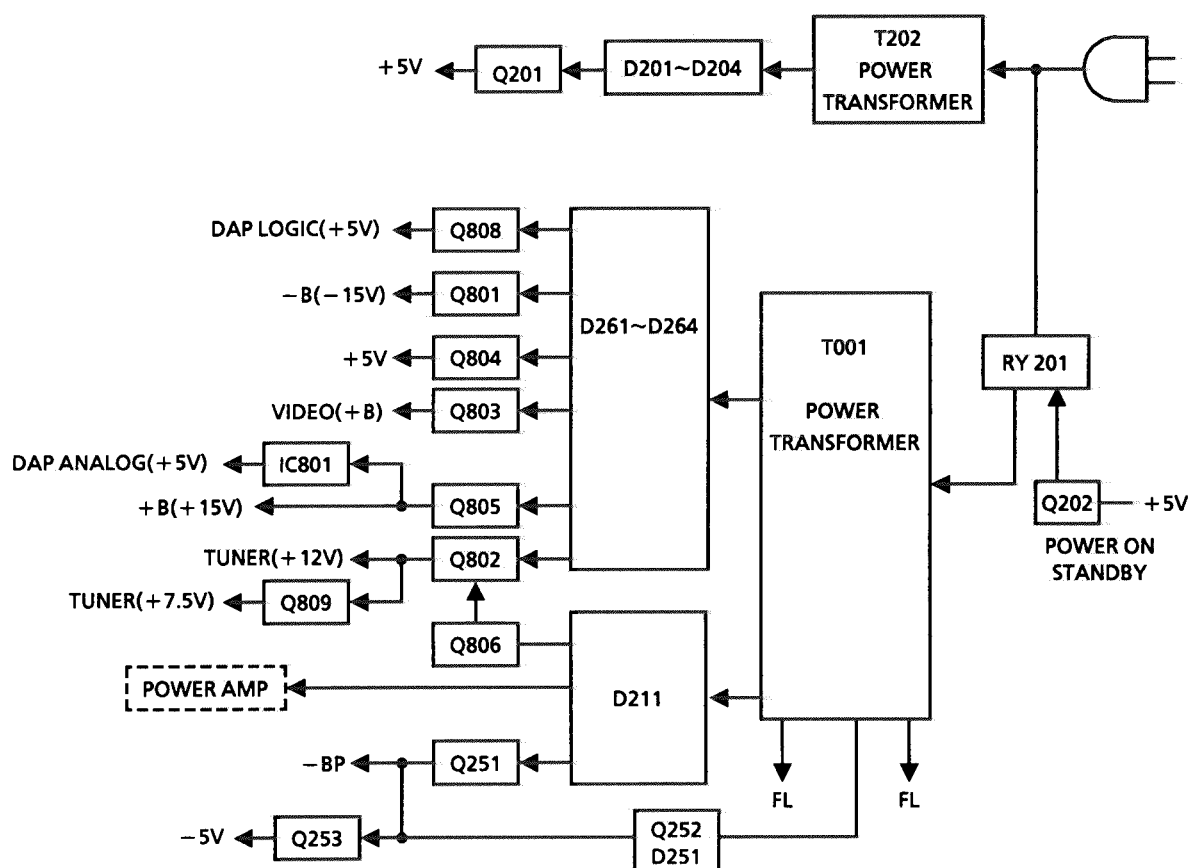

■ Signal Flow Section

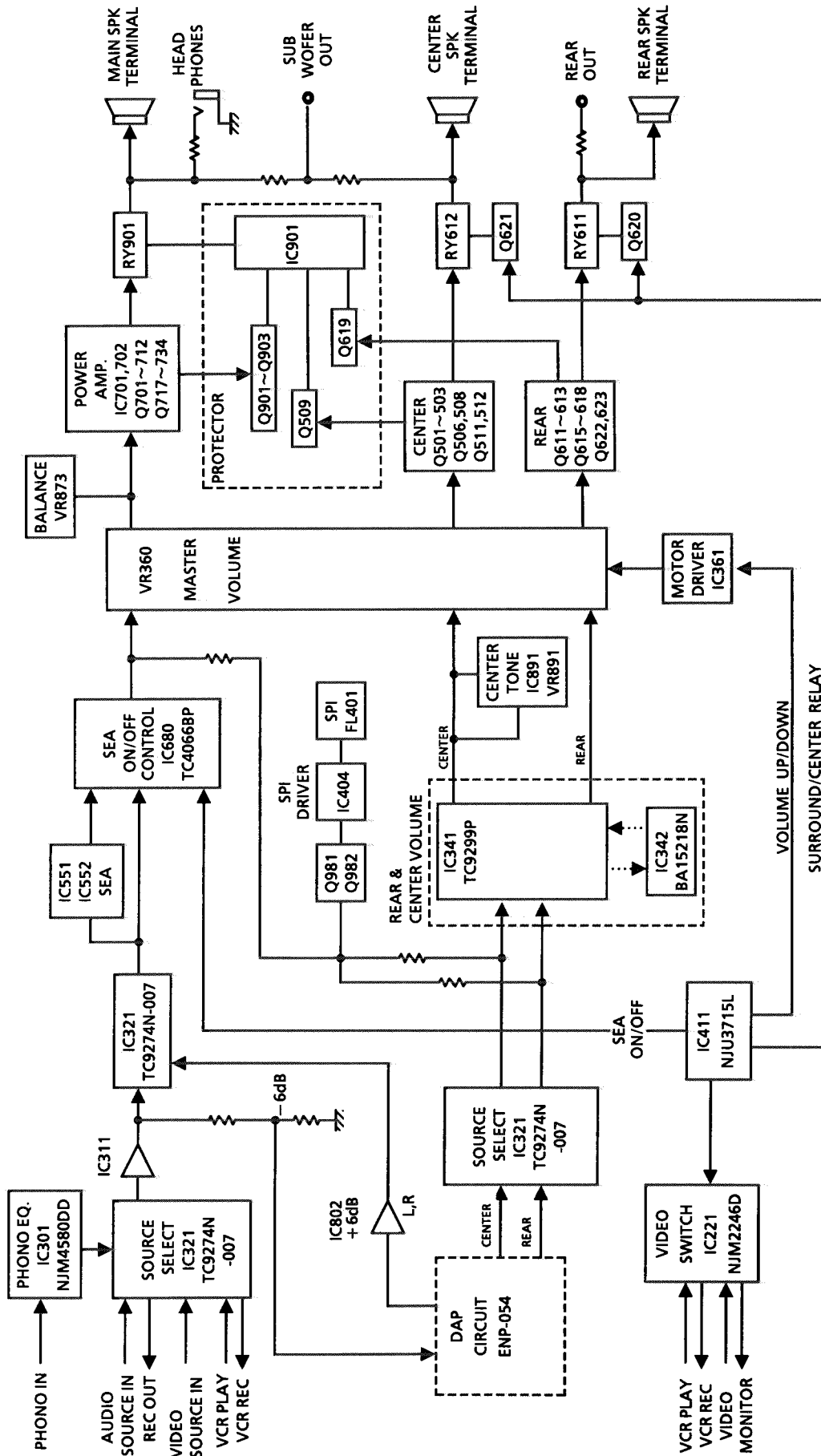

■ Digital Signal Processor Section

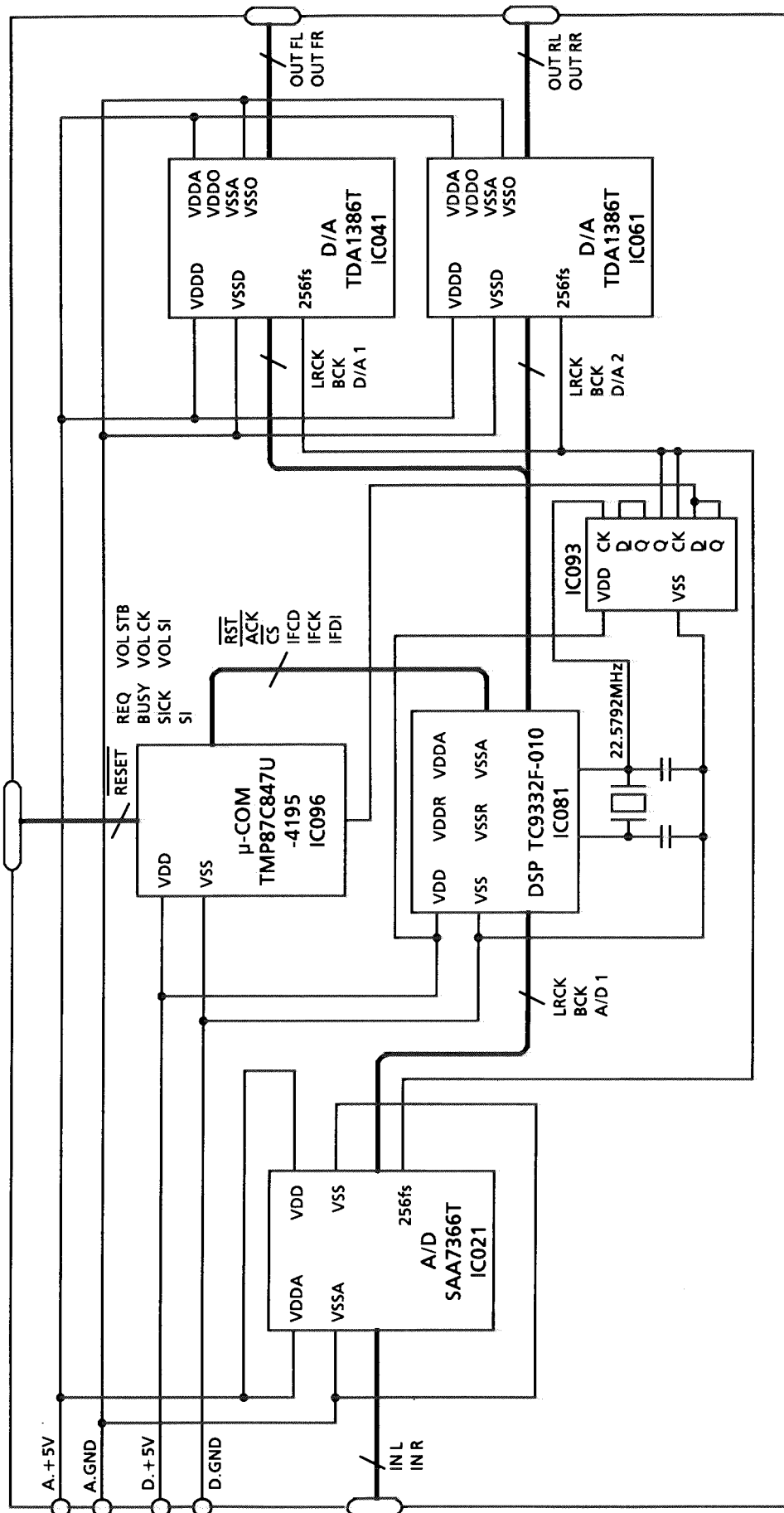

■ Tuner Section

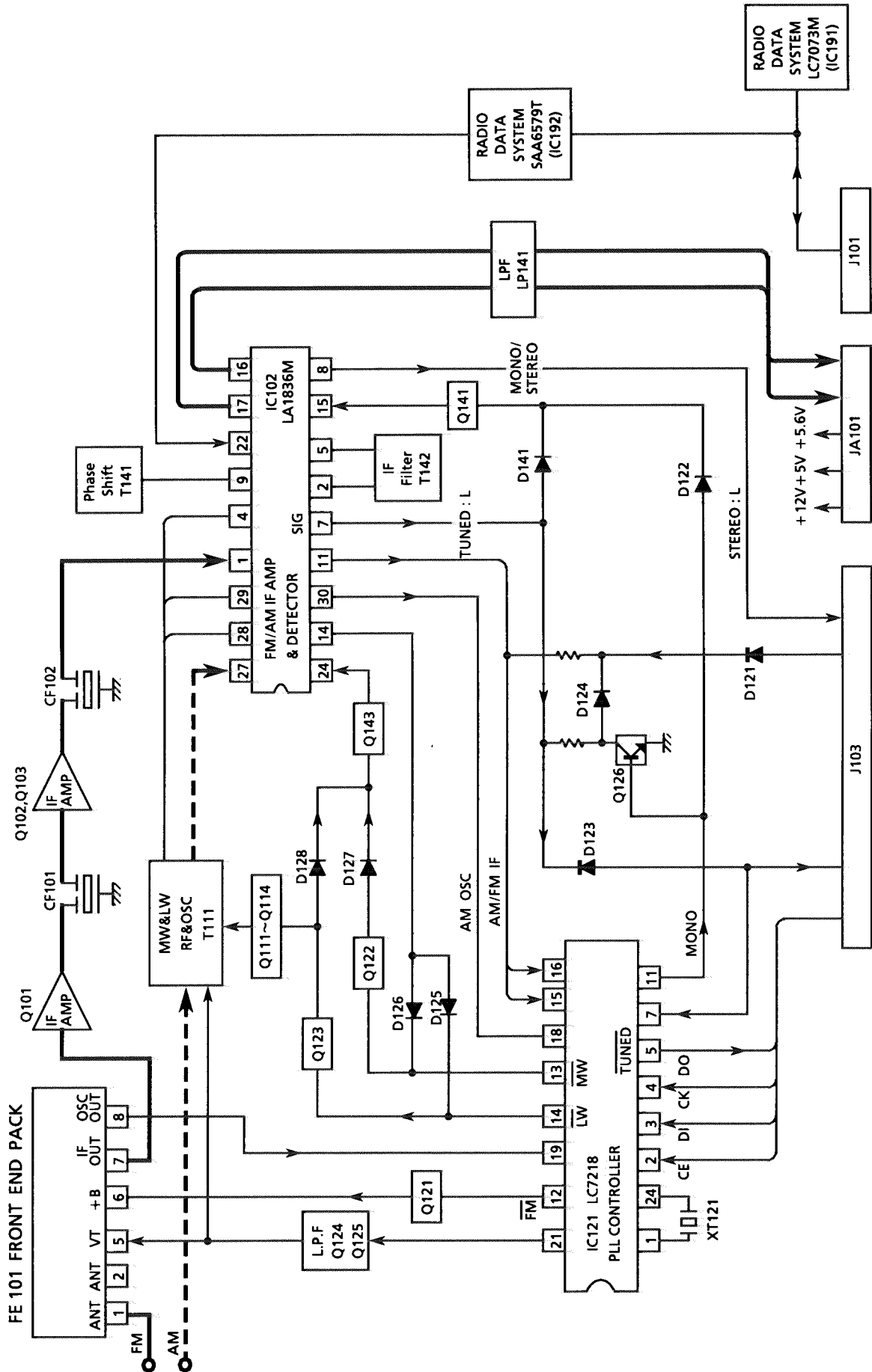

J K L M N O P Q R S

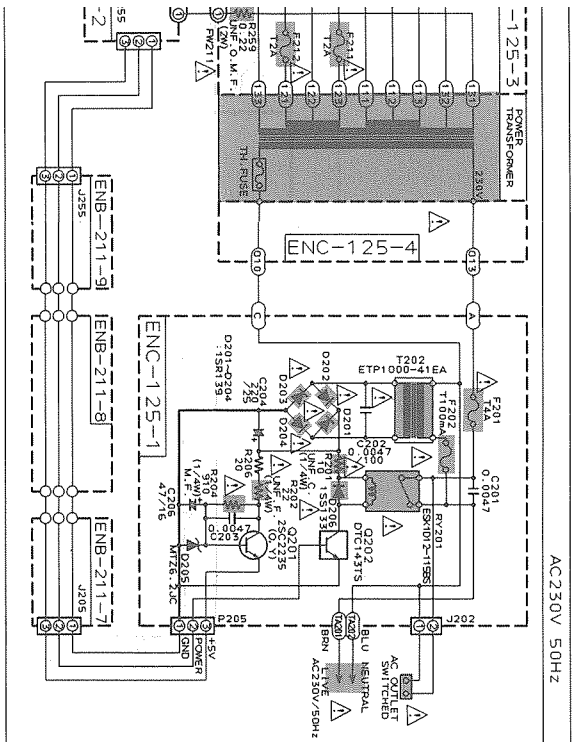

VERSION CODES
 EN: NORDIC COUNTRIES
 BS: U.K.
 EF: CONTINENTAL EUROPE EXCEPT
 G: GERMANY AND ITALY
 GI: ITALY

NOTE: DEVIATIONS FROM OTHERS ARE SHOWN WITH (*)

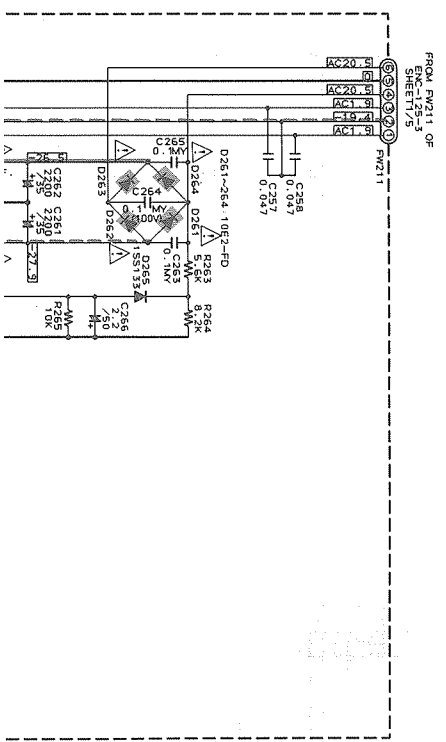
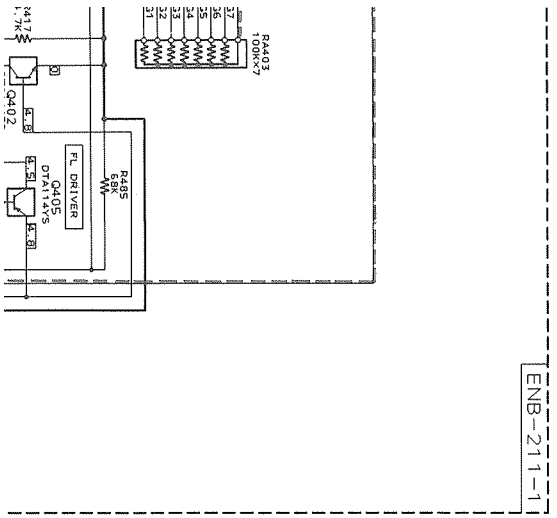

ENB-211-6

P1-54-a

P1-54-b

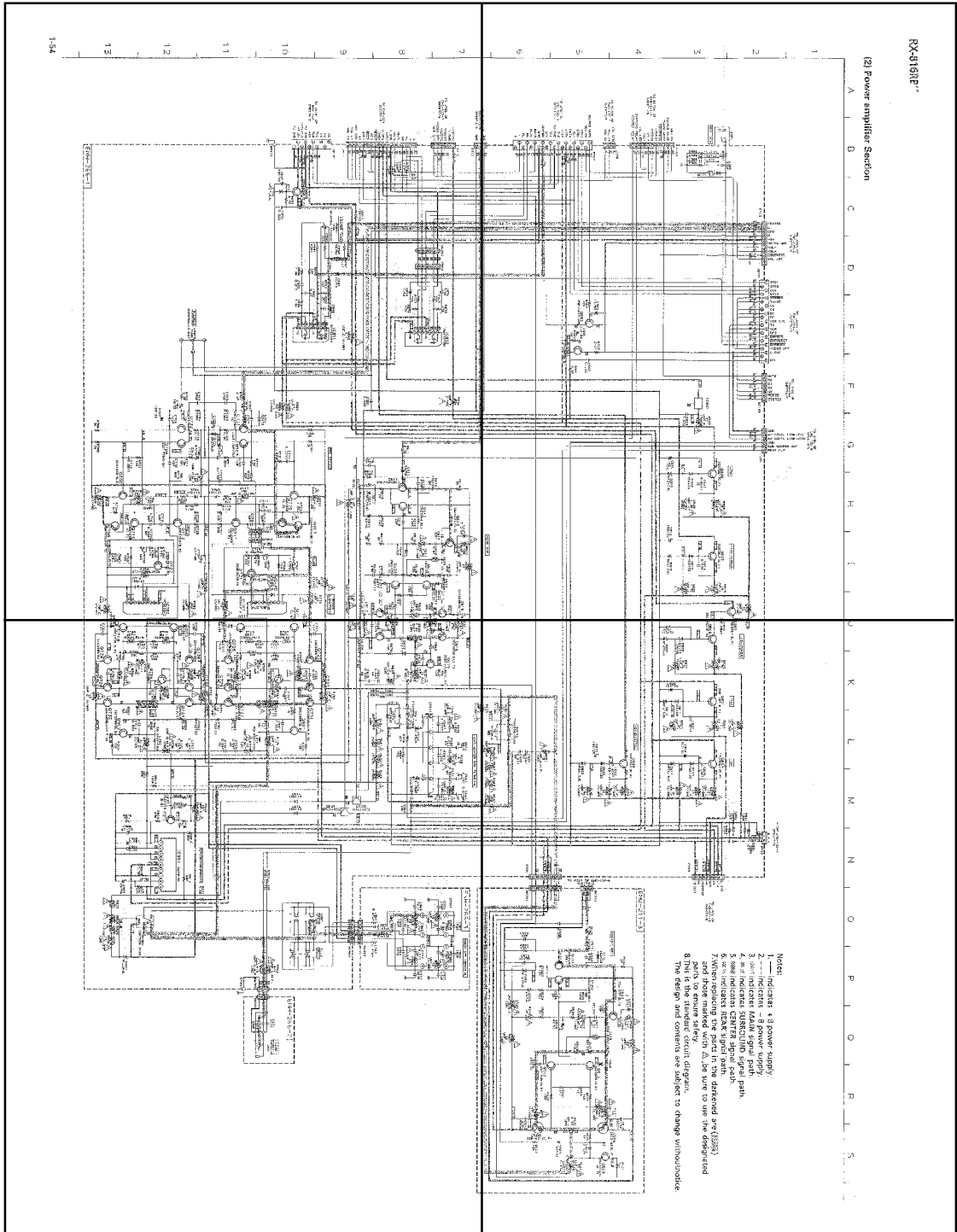

P1-54-c

P1-54-d

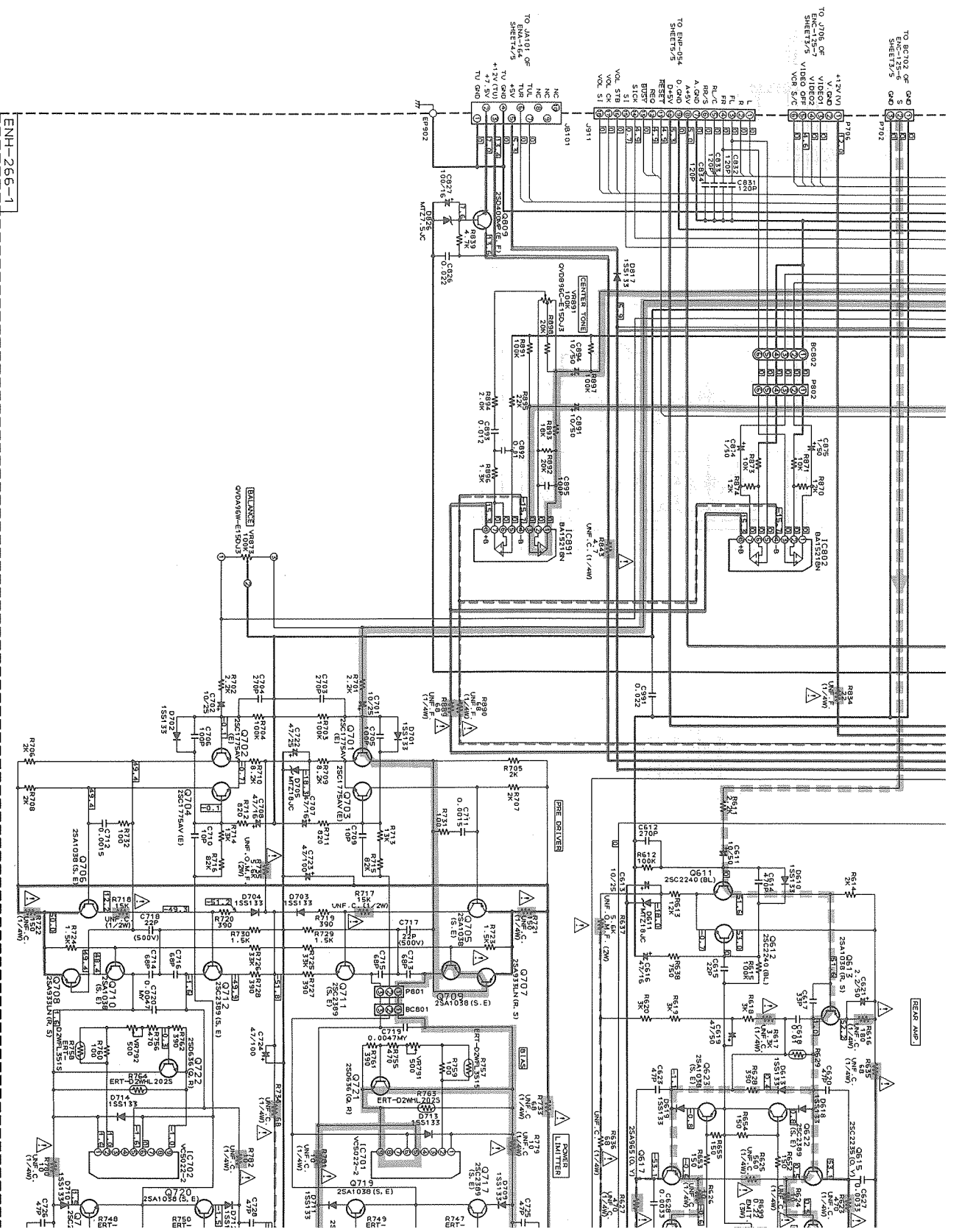

ENH-266-1

7

8

9

10

11

12

13

1-54

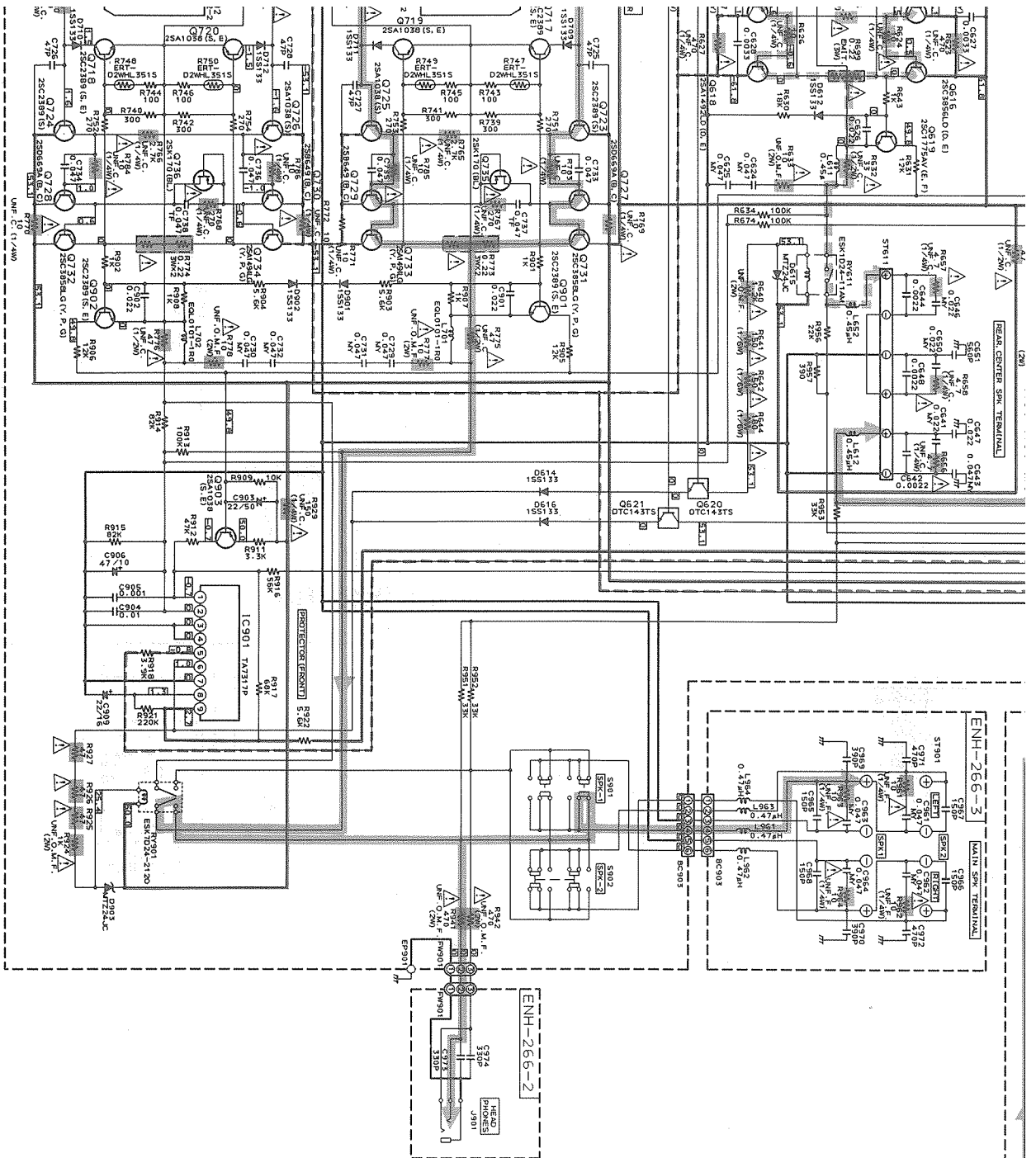

J K L M N O P Q R S

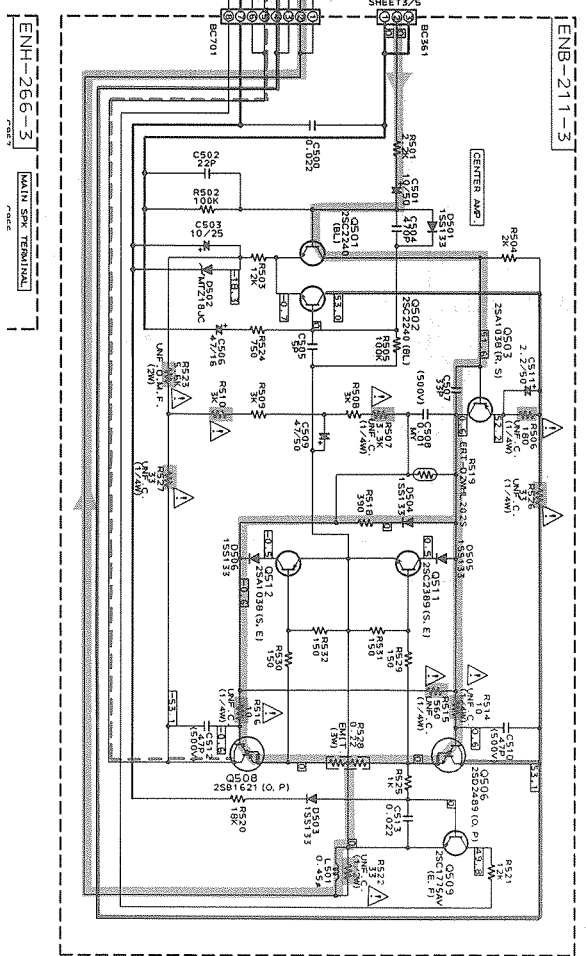
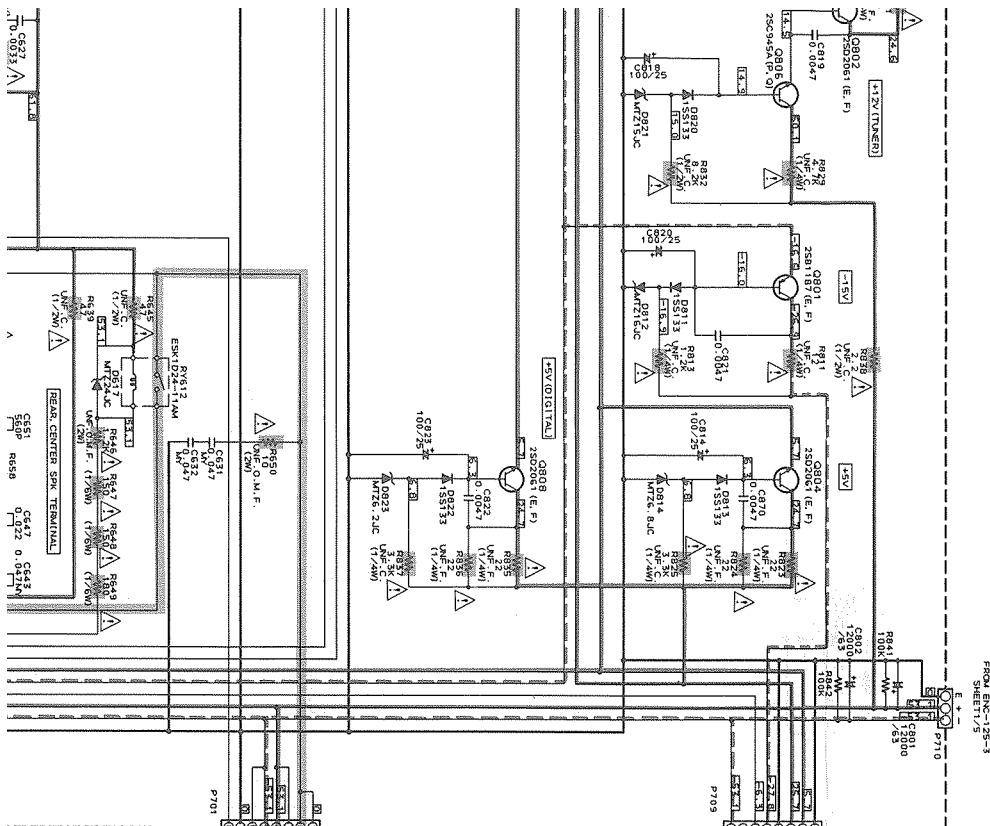

- Notes:
1. — indicates + B power supply.
 2. - - - indicates - B power supply.
 3. ■ indicates MAIN signal path.
 4. ■ indicates SURROUND signal path.
 5. ■ indicates CENTER signal path.
 6. ■ indicates REAR signal path.
 7. When replacing the parts in the darkened area (■) and those marked with △, be sure to use the designated parts to ensure safety.
 8. This is the standard circuit diagram.
- The design and contents are subject to change without notice.

P1-55-a

P1-55-b

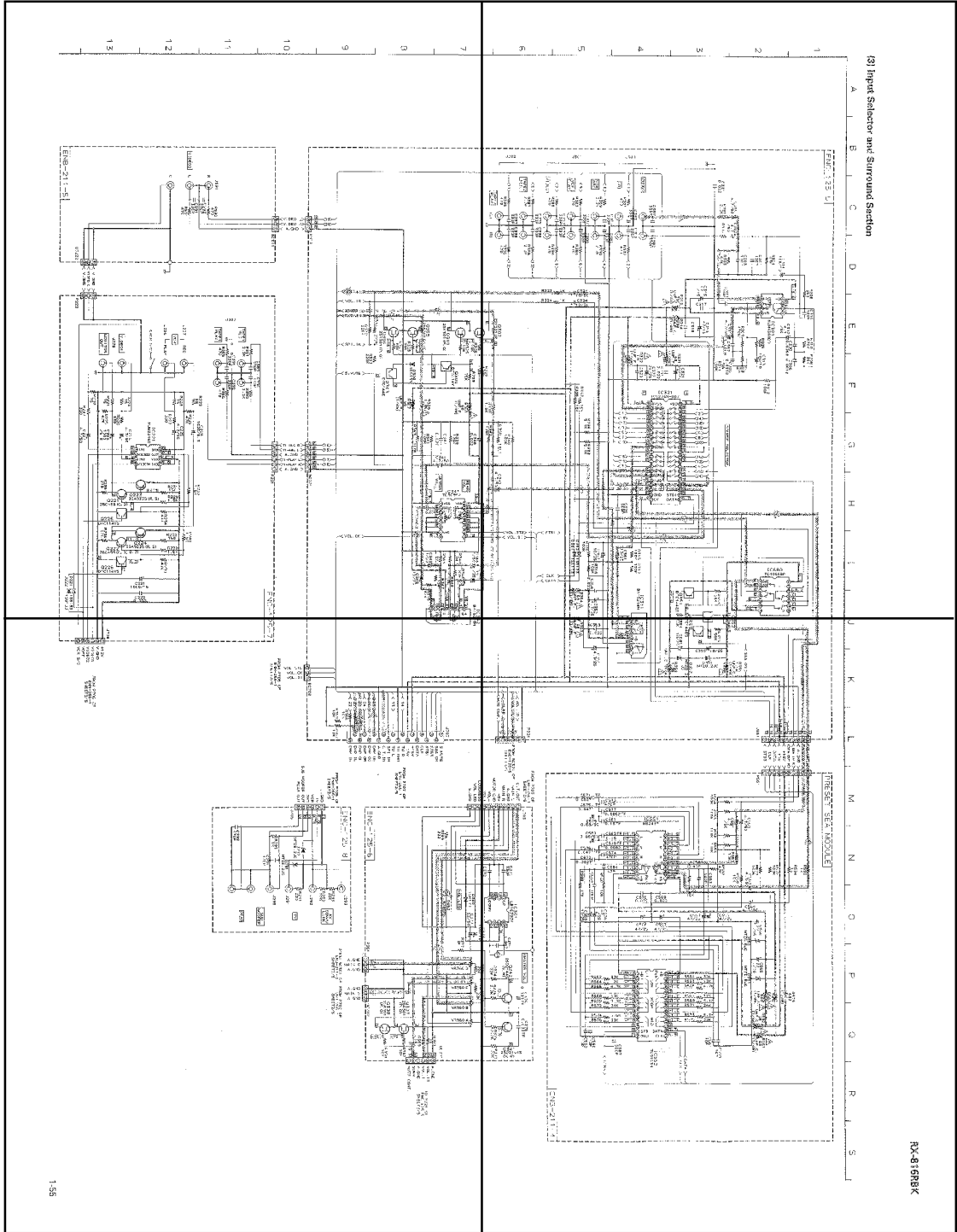

P1-55-c

P1-55-d

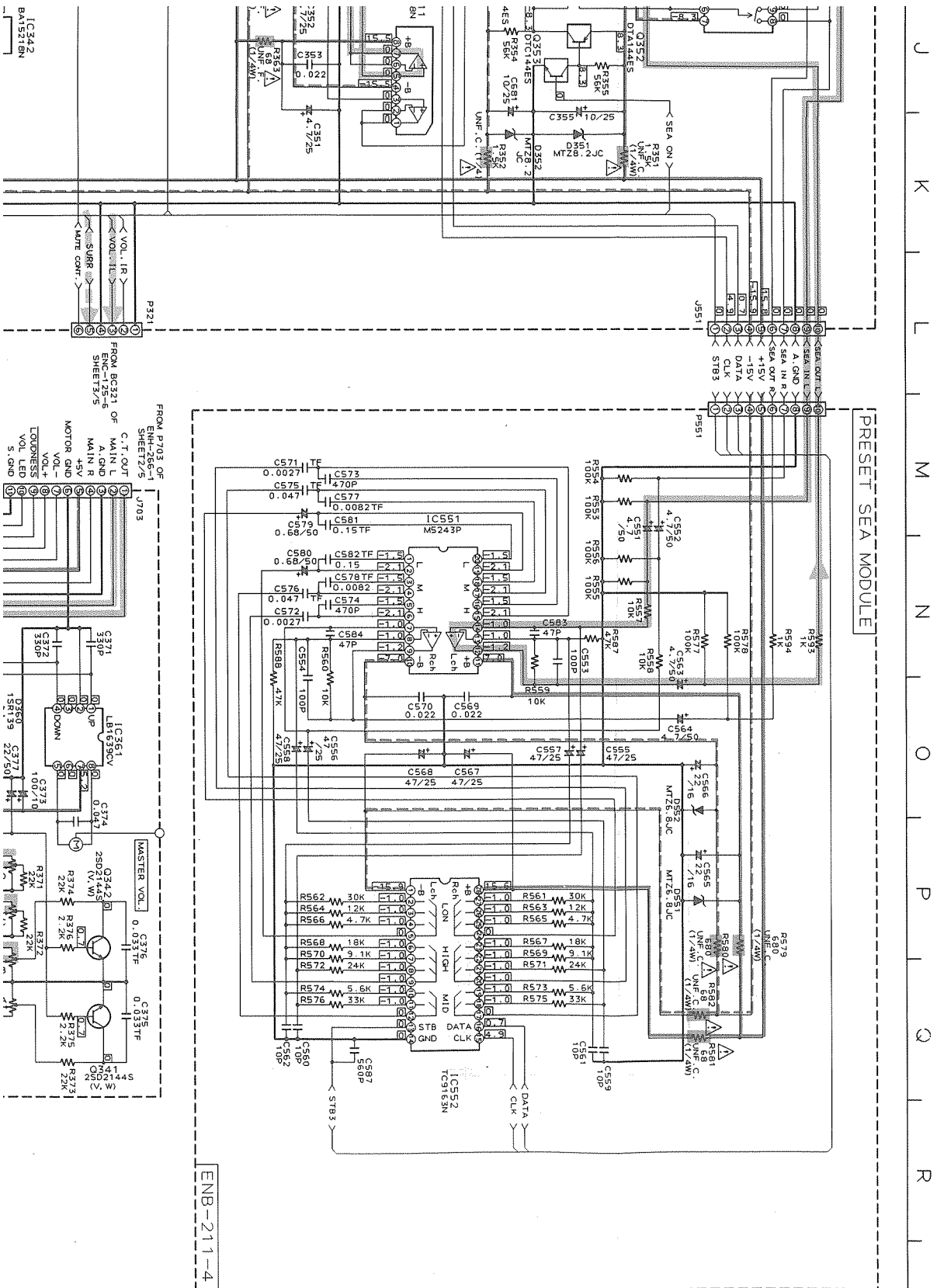

PRESET SEA MODULE

ENB-211-4

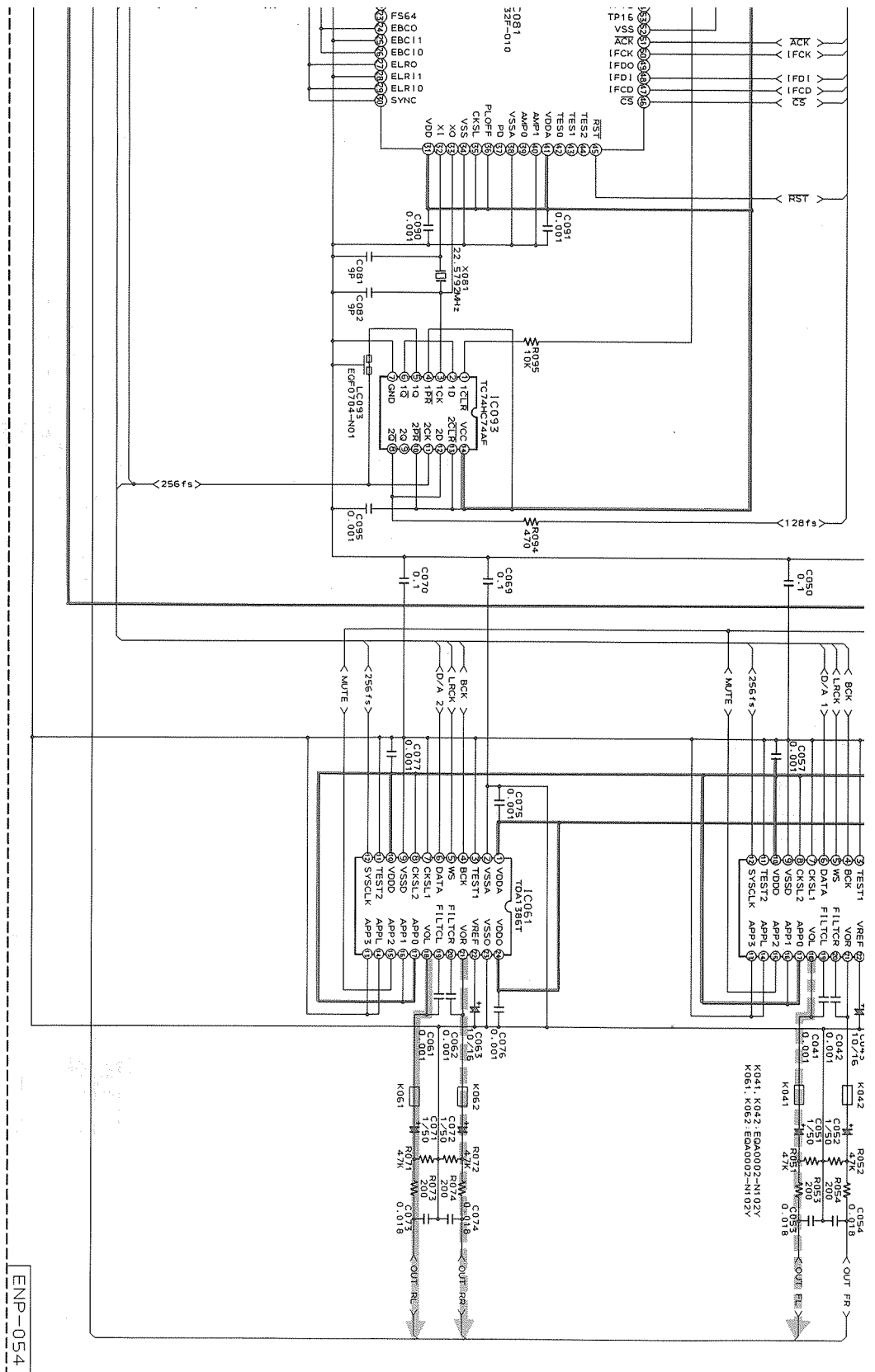

ENP-054

J K L M N O P Q R S

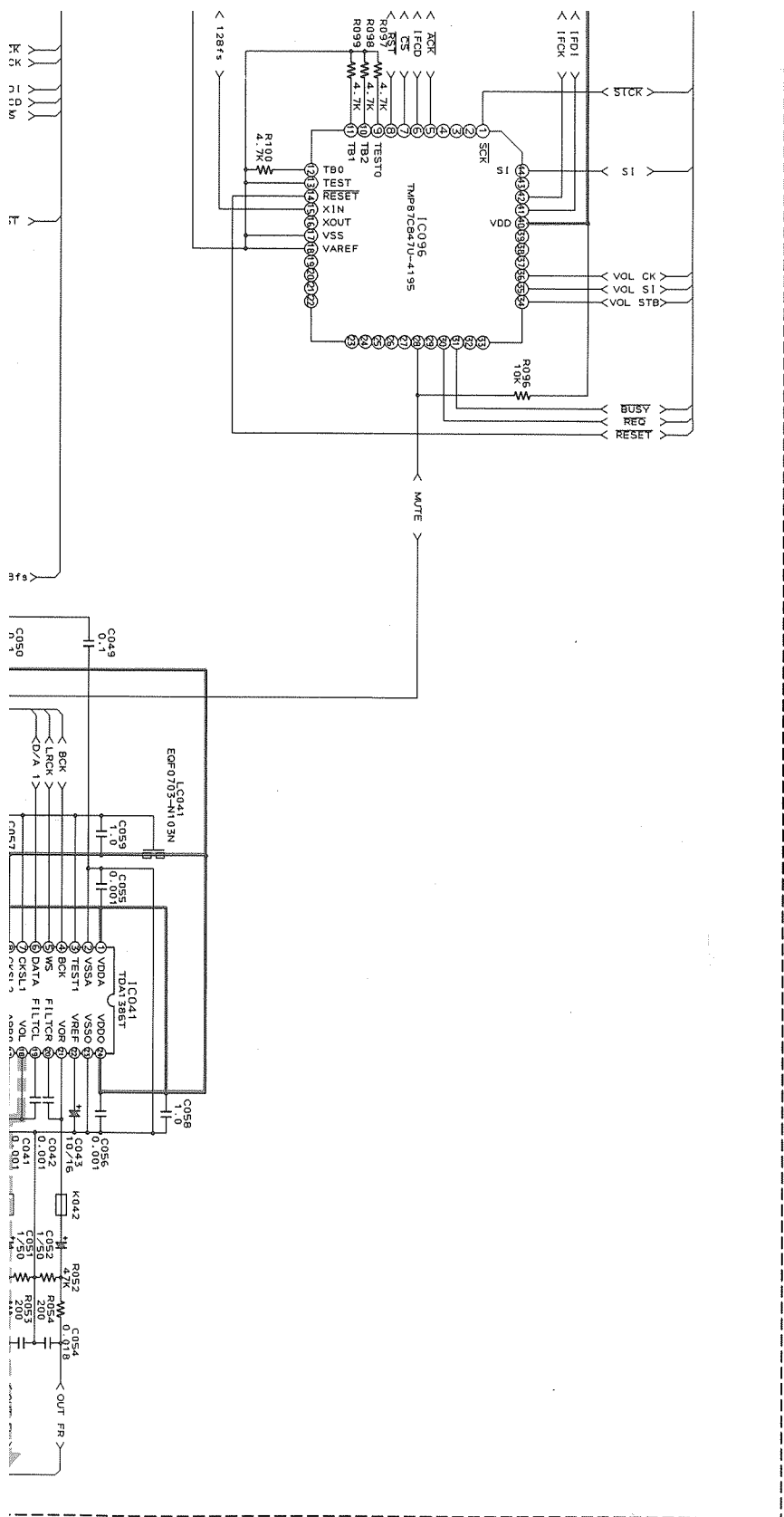

J K L M N O P Q R S

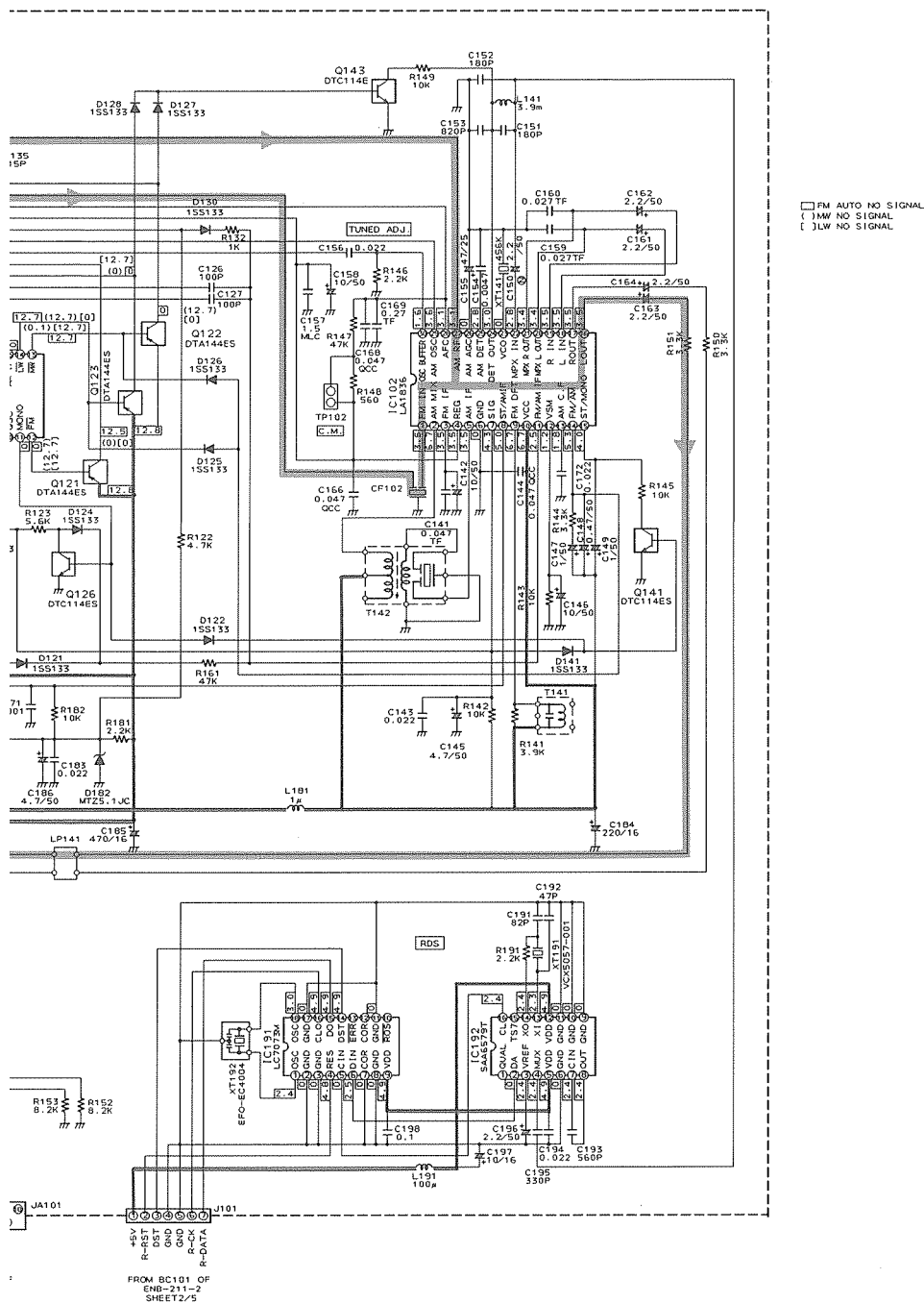

Printed Circuit Boards

■ Input Selector and Power Supply P.C. Board (ENC-125)

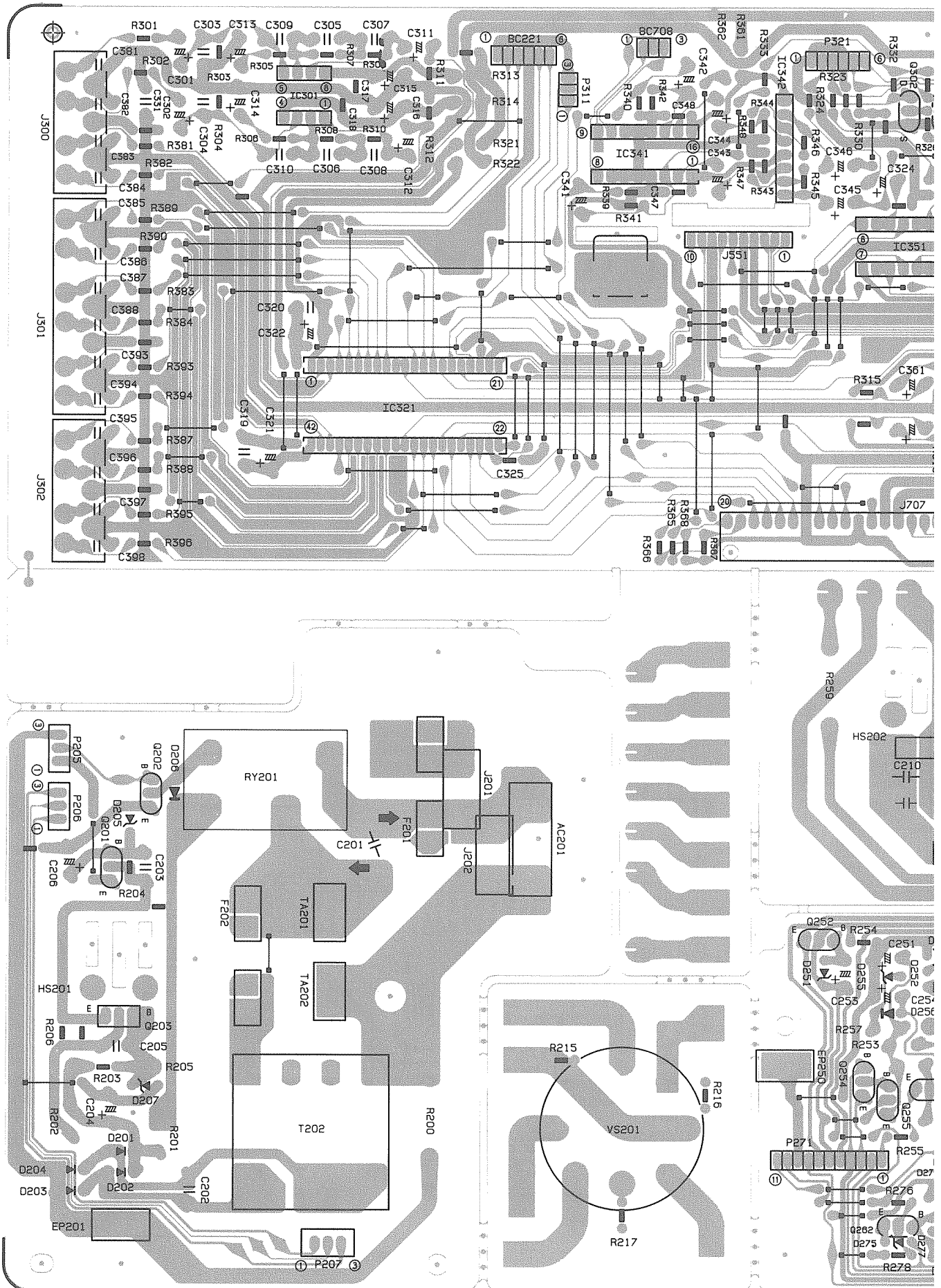

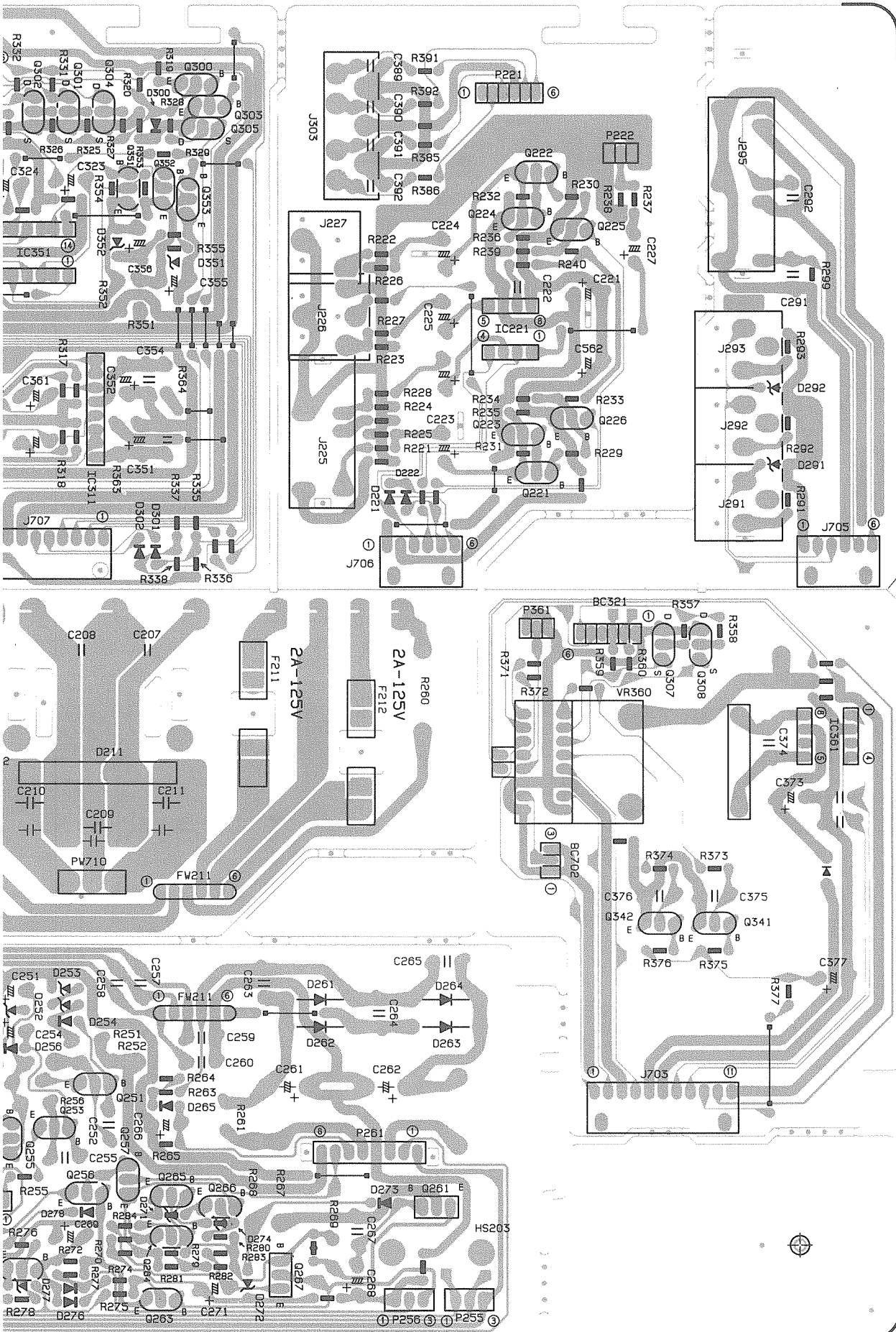

■ Amplifier P.C. Board (ENH-266)

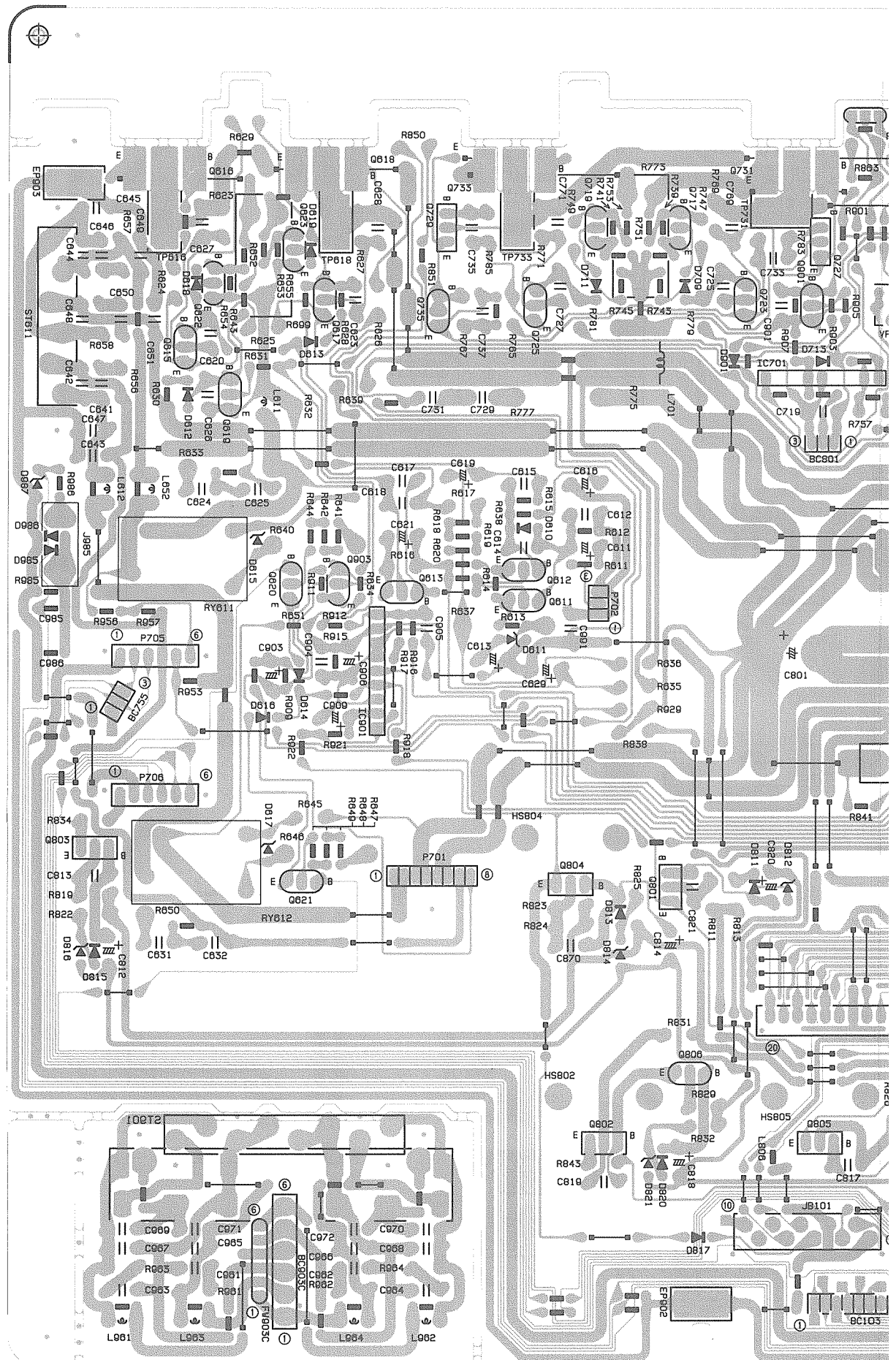

EMW10518

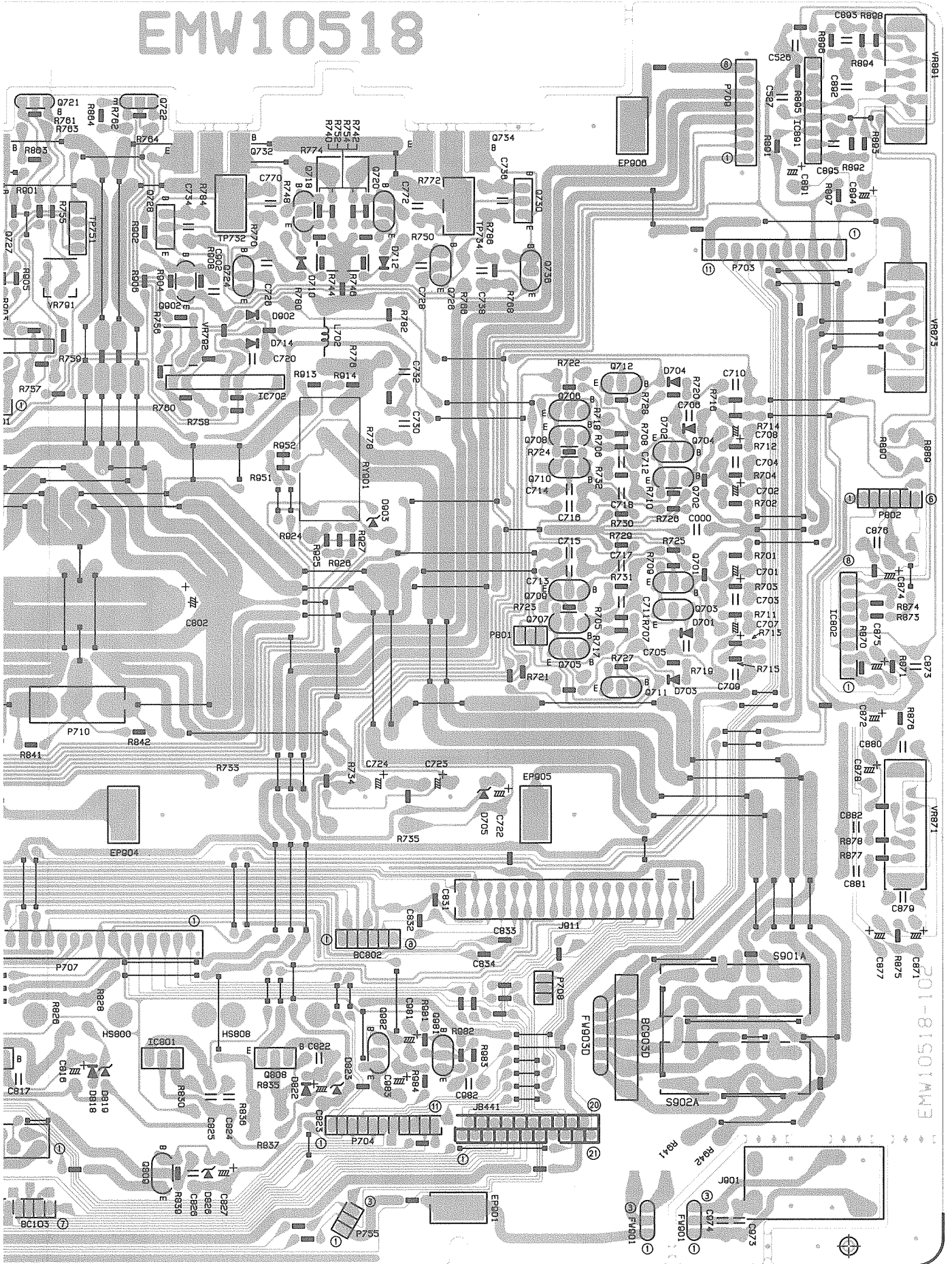

System Control & FL Display P.C. Board (ENB-211)

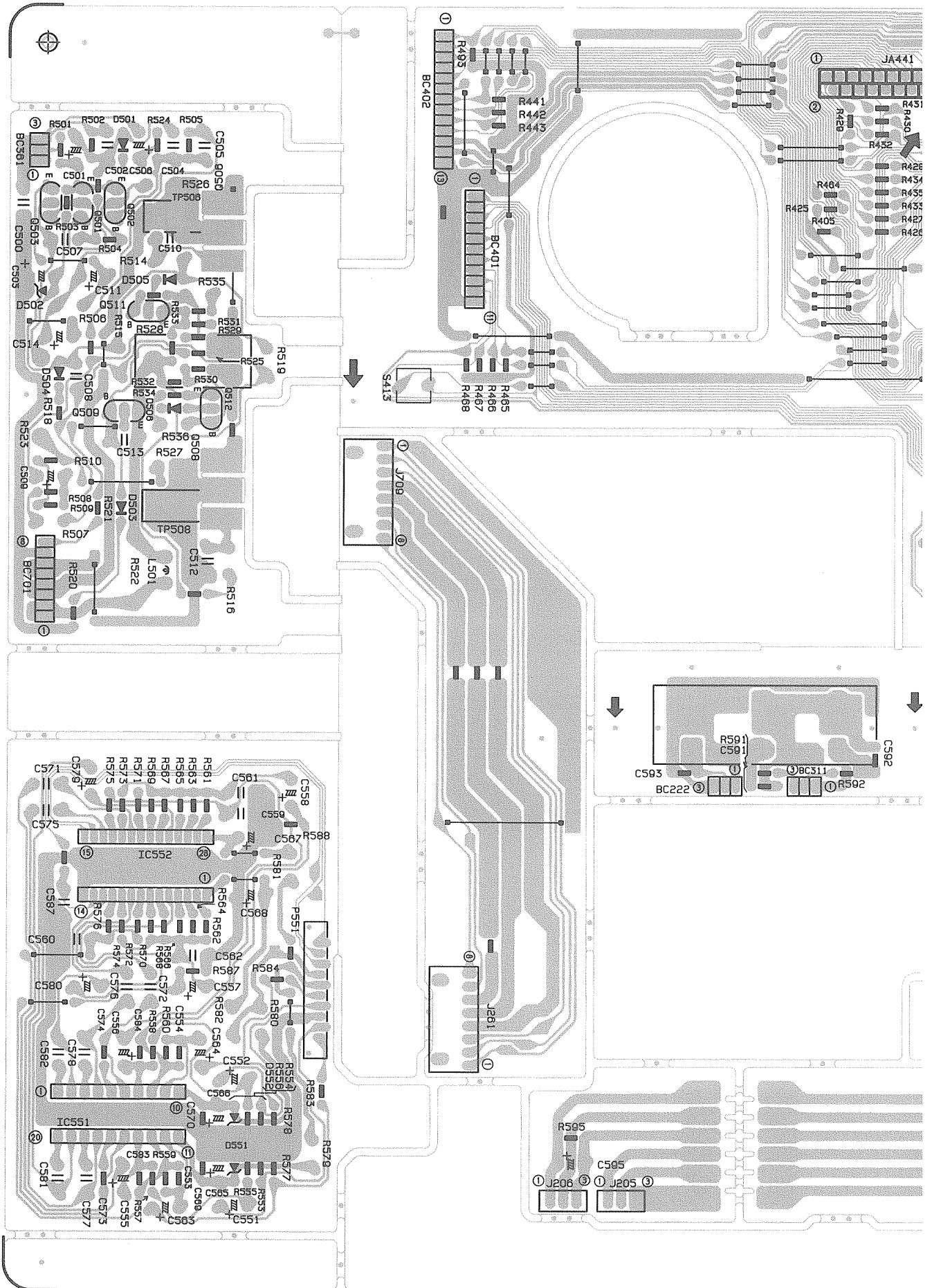

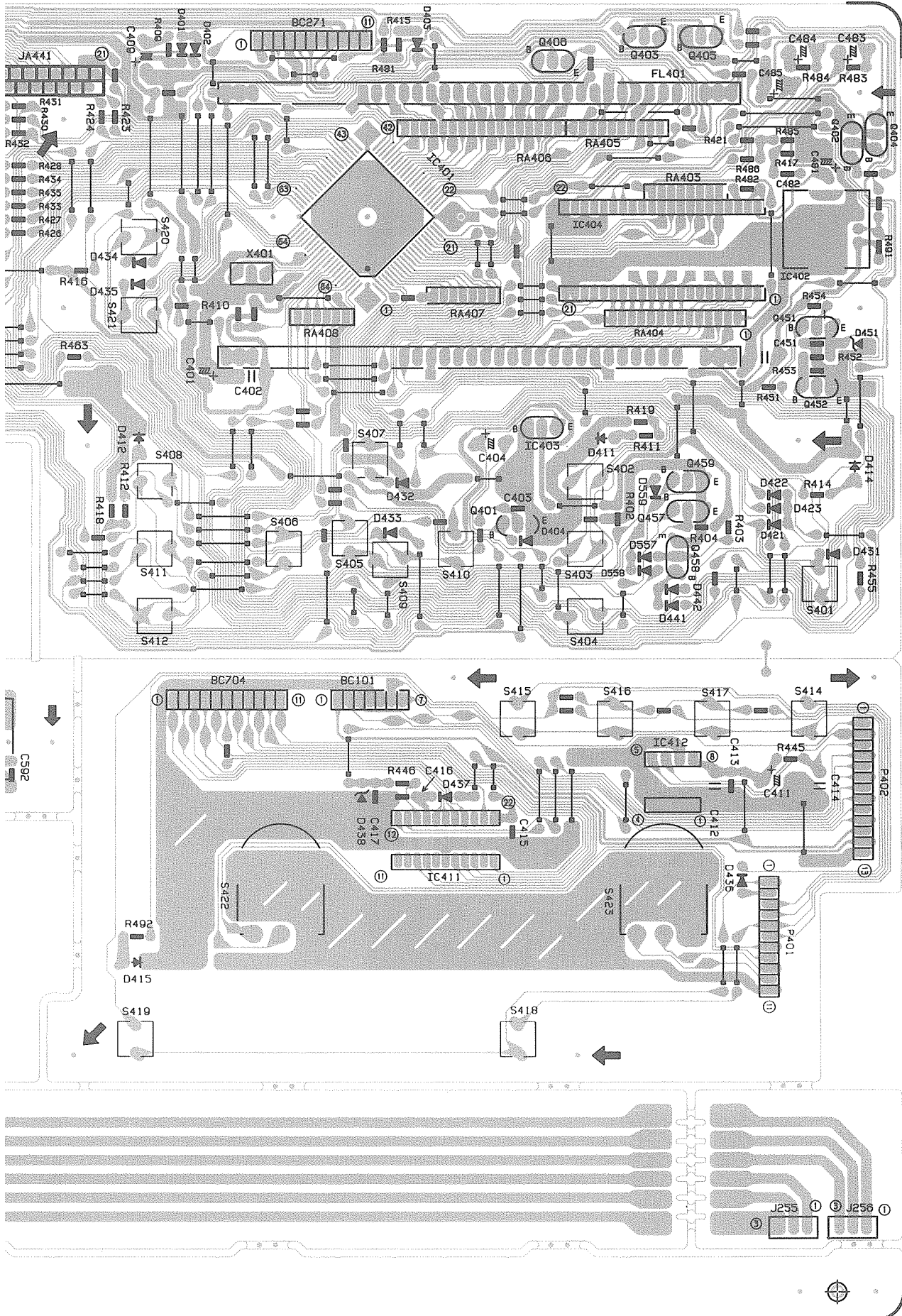

PARTS LIST

Note : All printed circuit boards assemblies are not available as service parts.

Contents

General Exploded View and Parts List	2-2
Printed Circuit Board Ass'y and Parts List	2-5
■ ENH-266 <input checked="" type="checkbox"/> Amplifier PC Board Ass'y	2-5
■ ENC-125 <input type="checkbox"/> Input Selector PC Board Ass'y	2-9
■ ENB-211 <input type="checkbox"/> FL Display PC Board Ass'y	2-13
■ ENA-164 <input checked="" type="checkbox"/> Tuner PC Board Ass'y	2-16
■ ENP-054 <input checked="" type="checkbox"/> DSP PC Board Ass'y	2-17
Accessories List	2-19
Packing Materials and Part Numbers	2-20

General Exploded View and Parts List

Symbol No.

M	1	M	M
---	---	---	---

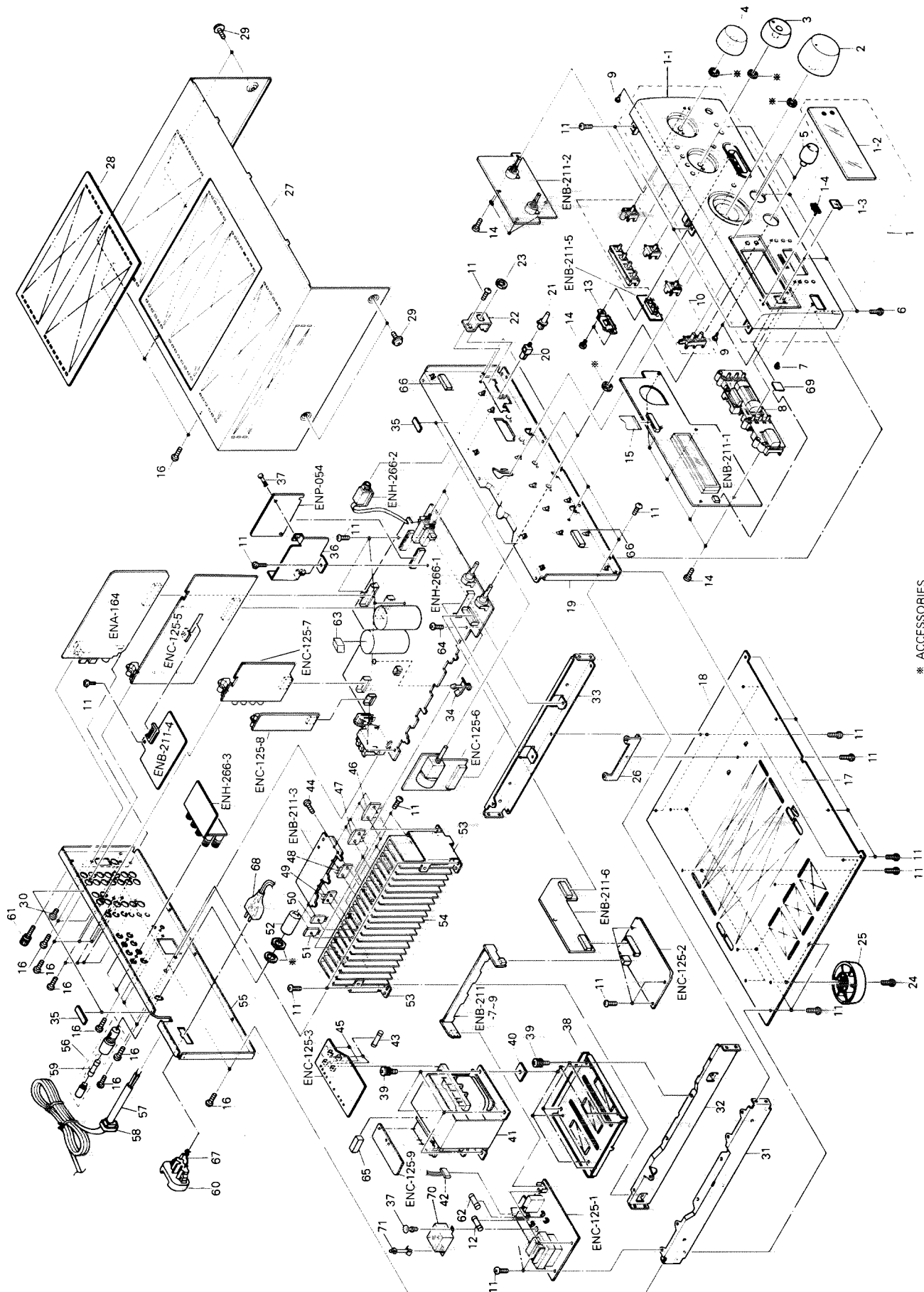

■ PARTS LIST

△	Item	Part Number	Part Name	Q'ty	Description	Area
	1	EFP-RX816RBKE(S)	FRONT PANEL ASS	1		
	1-1	E102909-019SM	FRONT PANEL	1		
	1-2	E309112-015SM	WINDOW SCREEN	1		
	1-3	E72436-006	REMORT SCREEN	1		
	1-4	VJD5429-001	JVC MARK	1		
	2	E309465-001SM	VOLUME KNOB	1		
	3	E309110-003SM	SELECT KNOB	1	TUNER/JOG	
	4	E309110-001SM	SELECT KNOB	1	SOURCE/JOG	
	5	E309111-003SM	BALANCE KNOB	2	TONE	
	6	SDSG3008M	TAPPING SCREW	4		
	7	FSJD4001-002	INDICATOR	1	POWER	
	8	E208276-005SM	PUSH BUTTON	1	SURROUND/POWER	
	9	E408326-001SM	INDICATOR	3	TAPE 2 MONITOR/ETC	
	10	E309105-001SM	PUSH BUTTON	1	TUNER/ETC	
	11	SBSG3008CC	TAPPING SCREW	37		
△	12	QMF51E2-4R0	FUSE	1	F201	EF,EN,G,GI
△		QMF51E2-4R0J1BS	FUSE	1	F201	BS
	13	E408713-001SM	P.W.BOARD HOLDER	1		
	14	SDSF2608Z	SCREW	11		
	15	EWR621K-40TTJ2	FFC CABLE	1	FW441	
	16	E73273-006	SPECIAL SCREW	22		
	17	E70115-002	CAUTION LABEL	1	BOTTOM PLATE	
	18	E102820-002SM	BOTTOM PLATE	1		
	19	E102911-002SM	FRONT BRACKET	1		
	20	E407983-001SM	PUSH SHAFT	2		
	21	E407321-002SM	PUSH BUTTON	2	SPEAKER	
	22	E407323-002SM	HEADPHONE BRACKET	1		
	23	VKZ4150-001	NUT	1	HEADPHONE	
	24	SBST3010Z	TAPPING SCREW	4		
	25	E406379-008SS	FOOT	4		
	26	E407984-001SM	P.W.BOARD HOLDER	1		
	27	E207378-014	METAL COVER	1		
	28	E208294-001	PROTECTOR COVER	1		
	29	E61660-004	SPECIAL SCREW	4		
	30	SBST3006M	TAPPING SCREW	1		
	31	E208548-001SM	SIDE BRACKET	1	LEFT	
	32	E208549-001SM	CENTER BRACKET	1		
	33	E208081-003SM	SIDE BRACKET	1	RIGHT	
	34	E406084-002	FASTENER	1		
	35	E306805-146	SPACER	4		
	36	E309458-001SM	SHIELD BRACKET	1		
	37	E48729-008	PLASTIC RIVET	2		
	38	E309459-001SM	TRANSFORMER BRACKET	1		
	39	E65389-006	SPECIAL SCREW	8		
	40	E406309-002	SPACER	4		
△	41	ETP1200-67EAJ	POWER TRANSFORMER	1		EF,EN,G,GI,BS
	42	EWS282-003	SOCKET WIRE	1		EF,EN,G,GI
		EWS282-004BS	SOCKET WIRE	1		BS
△	43	QMF51E2-2R0	FUSE	2	F211,F212	
	44	E73525-003SS	SCREW	14		
	45	E67132-T2R0	FUSE LABEL	2		
	46	2SA1494LG(Y,P,G)	SI.TRANSISTOR	2	Q733,Q734	
	47	2SC3858LG(Y,P,G)	SI.TRANSISTOR	2	Q731,Q732	

RX-816RBK

⚠	Item	Part Number	Part Name	Q'ty	Description	Area
	48	2SD2489LG(OPY)	SI.TRANSISTOR	1	Q506	
	49	2SB1621LG(OPY)	SI.TRANSISTOR	1	Q508	
	50	2SA1492LD(O,Y)	SI.TRANSISTOR	1	Q618	
	51	2SC3856LD(O,Y)	SI.TRANSISTOR	1	Q616	
	52	E69291-001	FUSE COVER	1		EF,EN
	53	E308836-002SM	HEAT SINK BRACKET	2		
	54	E309170-002SM	HEAT SINK	1		
	55	E103041-004SM	REAR PANEL	1		EF,EN
		E103041-005SM	REAR PANEL	1		BS,G,GI
⚠	56	QMG0301-003	FUSE HOLDER	1		EF,EN
⚠	57	QMP3900-200	POWER CORD	1		EF,EN,G,GI
⚠		QMP5530-0085BS	POWER CORD	1		BS
⚠	58	QHS3771-108	CORD STOPPER	1		EF,EN,G,GI
⚠		QHS3771-108BS	CORD STOPPER	1		BS
⚠	59	QMF51E2-1R25	FUSE	1	F003	EF,EN
⚠	60	EMC0236-001	AC OUTLET	1		EF,EN,G,GI
⚠		EMC0237-001BS	AC OUTLET	1		BS
	61	E408091-001	GND TERMINAL	1		
⚠	62	QMF51A2-R10S	FUSE	1	F202	EF,EN,G,GI
⚠		QMF51E2-R10SBS	FUSE	1	F202	BS
	63	E306805-167	SPACER	1		
	64	E73265-001	SPECIAL SCREW	1		
	65	E408834-001	SPACER ASSY	1		
	66	E306805-127	SPACER	2		
	67	QWE882-16FF	SHIELD WIRE	1		EF,EN
	68	E406079-001	AC OUTLET COVER	1		BS
	69	E72437-013	SHEET	1		
	70	E406528-003	PRIMARY COVER	1		
	71	E306232-001	FASTNER	1		
	-	E407619-041	RX-816R FTZ LAB	1		G
	-	E408450-001	CE LABEL	1		
	-	E70028-001	APPROVAL LABEL	1		EN
	-	E75040-055	RX-816RBK GI LA	1		GI
	-	QZL1007-001	BEAB LABEL	1		BS
	-	QZL1031-101	LABEL	1		EF

The Marks for Designated Areas

EF Continental Europe EN Scandinavia G Germany GI Italy

BS the U.K.

No mark indicates all area.

Printed Circuit Board Ass'y and Parts List

■ ENH-266 A Amplifier PC Board Assy

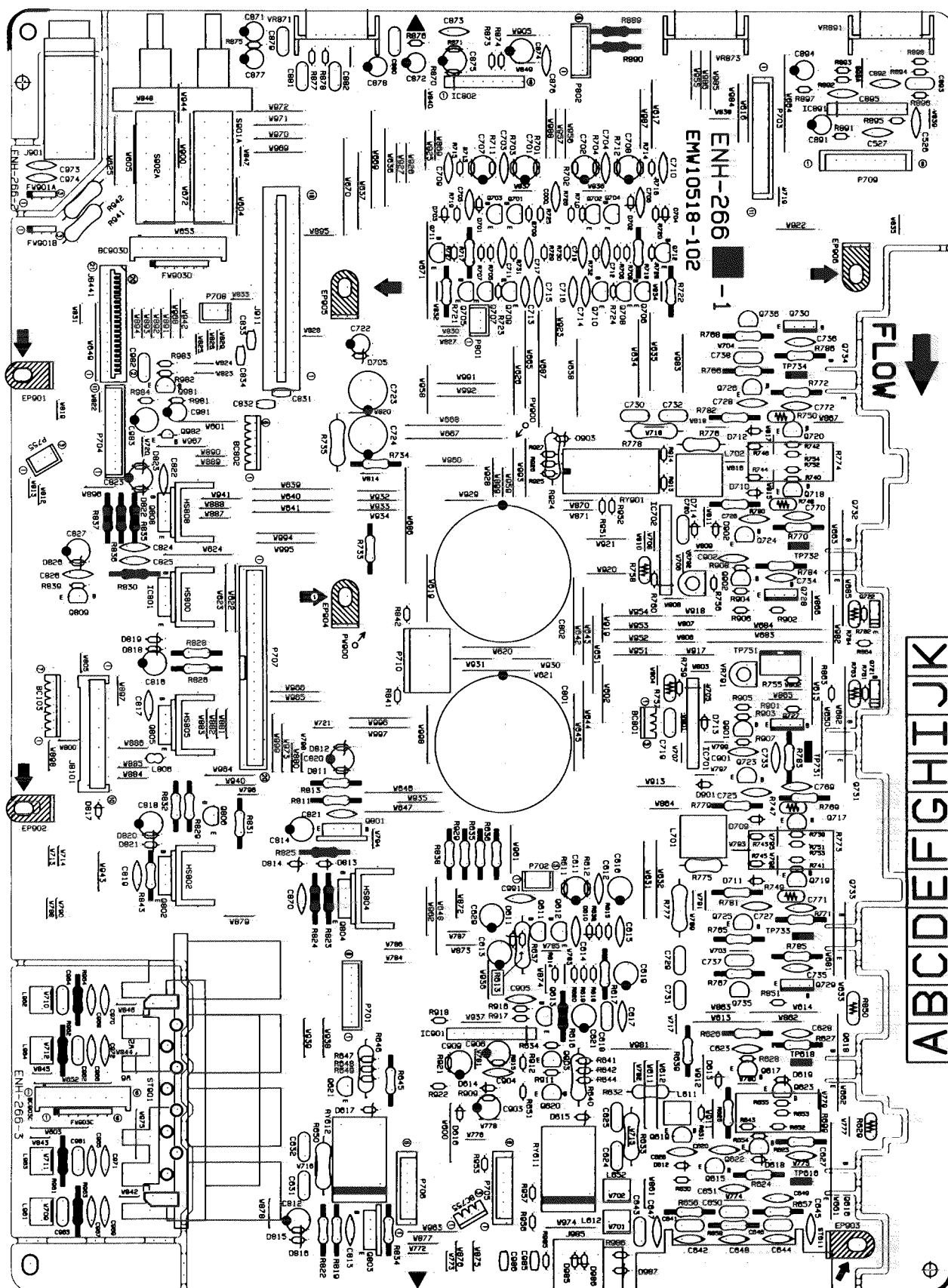

Transistors

Δ ITEM	PART NUMBER	DESCRIPTION	AREA
Q611	2SC2240(BL)	SI. TRANSIST	
Q612	2SC2240(BL)	SI. TRANSIST	
Q613	2SA1038(R,S)	SI. TRANSIST ROHM	
Q615	2SC2235(O,Y)	SI. TRANSIST TOSHIBA	
Q617	2SA965(Y)	SI. TRANSIST TOSHIBA	
Q619	2SC1775AV(F1)	SI. TRANSIST HITACHI	
Q620	DTC143TS	DIGITAL TRA ROHM	
Q621	DTC143TS	DIGITAL TRA ROHM	
Q622	2SC2389(S,E)	SI. TRANSIST ROHM	
Q623	2SA1038(R,S)	SI. TRANSIST ROHM	
Q701	2SC1775AV(F1)	SI. TRANSIST HITACHI	
Q702	2SC1775AV(F1)	SI. TRANSIST HITACHI	
Q703	2SC1775AV(F1)	SI. TRANSIST HITACHI	
Q704	2SC1775AV(F1)	SI. TRANSIST HITACHI	
Q705	2SA1038(R,S)	SI. TRANSIST ROHM	
Q706	2SA1038(R,S)	SI. TRANSIST ROHM	
Q707	2SA933LN(R,S)	SI. TRANSIST ROHM	
Q708	2SA933LN(R,S)	SI. TRANSIST ROHM	
Q709	2SA1038(R,S)	SI. TRANSIST ROHM	
Q710	2SA1038(R,S)	SI. TRANSIST ROHM	
Q711	2SC2389(S,E)	SI. TRANSIST ROHM	
Q712	2SC2389(S,E)	SI. TRANSIST ROHM	
Q717	2SC2389(S,E)	SI. TRANSIST ROHM	
Q718	2SC2389(S,E)	SI. TRANSIST ROHM	
Q719	2SA1038(R,S)	SI. TRANSIST ROHM	
Q720	2SA1038(R,S)	SI. TRANSIST ROHM	
Q721	2SD636	SI. TRANSIST MATSUSHITA	
Q722	2SD636	SI. TRANSIST MATSUSHITA	
Q723	2SC2389(S,E)	SI. TRANSIST ROHM	
Q724	2SC2389(S,E)	SI. TRANSIST ROHM	
Q725	2SA1038(R,S)	SI. TRANSIST ROHM	
Q726	2SA1038(R,S)	SI. TRANSIST ROHM	
Q727	2SD669A(B,C)	SI. TRANSIST HITACHI	
Q728	2SD669A(B,C)	SI. TRANSIST HITACHI	
Q729	2SB649A(B,C)	SI. TRANSIST HITACHI	
Q730	2SB649A(B,C)	SI. TRANSIST HITACHI	
Q735	2SK170(BL)	F.E.T. TOSHIBA	
Q736	2SK170(BL)	F.E.T. TOSHIBA	
Q801	2SB1187(F,G)	SI. TRANSIST ROHM	
Q802	2SD2061(F,G)	SI. TRANSIST ROHM	
Q803	2SD2061(F,G)	SI. TRANSIST ROHM	
Q804	2SD2061(F,G)	SI. TRANSIST ROHM	
Q805	2SD2061(F,G)	SI. TRANSIST ROHM	
Q806	2SC945A	SI. TRANSIST NEC	
Q808	2SD2061(F,G)	SI. TRANSIST ROHM	
Q809	2SD400MP(E,F)	SI. TRANSIST SANYO	
Q901	2SC2389(S,E)	SI. TRANSIST ROHM	
Q902	2SC2389(S,E)	SI. TRANSIST ROHM	
Q903	2SA1038(R,S)	SI. TRANSIST ROHM	
Q981	2SC1685	SI. TRANSIST ROHM	
Q982	2SD2144S(VW)	SI. TRANSIST ROHM	

Δ : SAFETY PARTS

I.C.s

Δ ITEM	PART NUMBER	DESCRIPTION	AREA
IC701	VC5022-2	I.C(MONO-AN SANYO	
IC702	VC5022-2	I.C(MONO-AN SANYO	
IC801	NJM78M05FA	I.C(MONO-AN DAINICHI	
IC802	BA15218N	I.C(MONO-AN ROHM	
IC891	BA15218N	I.C(MONO-AN ROHM	
IC901	TA7317P	I.C(MONO-AN TOSHIBA	

Δ : SAFETY PARTS

Diodes

Δ ITEM	PART NUMBER	DESCRIPTION	AREA
D610	1SS133	SI. DIODE ROHM	
D611	MTZ18JC	ZENER DIODE ROHM	
D612	1SS133	SI. DIODE ROHM	
D613	1SS133	SI. DIODE ROHM	
D614	1SS133	SI. DIODE ROHM	
D615	MTZ24JC	ZENER DIODE ROHM	
D616	1SS133	SI. DIODE ROHM	
D617	MTZ24JC	ZENER DIODE ROHM	
D618	1SS133	SI. DIODE ROHM	
D619	1SS133	SI. DIODE ROHM	
D701	1SS133	SI. DIODE ROHM	
D702	1SS133	SI. DIODE ROHM	
D703	1SS133	SI. DIODE ROHM	
D704	1SS133	SI. DIODE ROHM	
D705	MTZ18JC	ZENER DIODE ROHM	
D709	1SS133	SI. DIODE ROHM	
D710	1SS133	SI. DIODE ROHM	
D711	1SS133	SI. DIODE ROHM	
D712	1SS133	SI. DIODE ROHM	
D713	1SS133	SI. DIODE ROHM	

Δ : SAFETY PARTS

Diodes

Δ ITEM	PART NUMBER	DESCRIPTION	AREA
D714	1SS133	SI. DIODE ROHM	
D811	1SS133	SI. DIODE ROHM	
D812	MTZ16JC	ZENER DIODE ROHM	
D813	1SS133	SI. DIODE ROHM	
D814	MTZ6.8JC	ZENER DIODE ROHM	
D815	1SS133	SI. DIODE ROHM	
D816	MTZ13JC	ZENER DIODE ROHM	
D817	1SS133	SI. DIODE ROHM	
D818	1SS133	SI. DIODE ROHM	
D819	MTZ16JC	ZENER DIODE ROHM	
D820	1SS133	SI. DIODE ROHM	
D821	MTZ15JC	ZENER DIODE ROHM	
D822	1SS133	SI. DIODE ROHM	
D823	MTZ6.2JC	ZENER DIODE ROHM	
D826	MTZ7.5JC	ZENER DIODE ROHM	
D901	1SS133	SI. DIODE ROHM	
D902	1SS133	SI. DIODE ROHM	
D903	MTZ24JC	ZENER DIODE ROHM	
D985	1SS133	SI. DIODE ROHM	
D986	1SS133	SI. DIODE ROHM	
D987	MTZ6.2JC	ZENER DIODE ROHM	

Δ : SAFETY PARTS

Capacitors

Δ ITEM	PART NUMBER	DESCRIPTION	AREA
C611	QETB1HM-106	10MF 50V E.CAPACITO	
C612	QCS21HJ-271A	270PF 50V CER.CAPACI	
C613	QETB1EM-106	10MF 25V AL E.CAPAC	
C614	QCS31HJ-471Z	470PF 50V CER.CAPACI	
C615	QCS21HJ-220A	22PF 50V CER.CAPACI	
C616	QETB1CM-476	47MF 16V AL E.CAPAC	
C617	QCS22HJ-330	33PF 500V CER.CAPACI	
C618	QFLB1HJ-103	0.01MF 50V MYLAR CAPA	
C619	QETB1HM-476	47MF 50V E.CAPACITO	
C620	QCS22HJ-470A	47PF 500V CER.CAPACI	
C621	QETB1HM-225	2.2MF 50V AL E.CAPAC	
C623	QCS22HJ-470A	47PF 500V CER.CAPACI	
C624	QFLB1HJ-473	0.047MF 50V MYLAR CAPA	
C625	QFLB1HJ-473	0.047MF 50V MYLAR CAPA	
C626	QCF21HP-223A	0.022MF 50V CER.CAPACI	
C627	QCY31HK-332Z	3300PF 50V CER.CAPACI	
C628	QCY31HK-332Z	3300PF 50V CER.CAPACI	
C631	QFLB1HJ-473	0.047MF 50V MYLAR CAPA	
C632	QFLB1HJ-473	0.047MF 50V MYLAR CAPA	
C641	QFLB1HJ-223	0.022MF 50V MYLAR CAPA	
C642	QCF21HP-222	2200PF 50V CER.CAPACI	
C643	QFLB1HJ-473	0.047MF 50V MYLAR CAPA	
C644	QCF21HP-222	2200PF 50V CER.CAPACI	
C646	QFLB1HJ-223	0.022MF 50V MYLAR CAPA	
C647	QCF21HP-223A	0.022MF 50V CER.CAPACI	
C648	QCF21HP-222	2200PF 50V CER.CAPACI	
C650	QFLB1HJ-223	0.022MF 50V MYLAR CAPA	
C651	QCS31HJ-561Z	560PF 50V CER.CAPACI	
C701	QETB1HM-106	10MF 50V E.CAPACITO	
C702	QETB1HM-106	10MF 50V E.CAPACITO	
C703	QCS21HJ-271A	270PF 50V CER.CAPACI	
C704	QCS21HJ-271A	270PF 50V CER.CAPACI	
C705	QCS21HJ-101A	100PF 50V CER.CAPACI	
C706	QCS21HJ-101A	100PF 50V CER.CAPACI	
C707	QETB1CM-476	47MF 16V AL E.CAPAC	
C708	QETB1CM-476	47MF 16V AL E.CAPAC	
C709	QCS21HJ-5R0	5PF 50V CER.CAPACI	
C710	QCS21HJ-5R0	5PF 50V CER.CAPACI	
C711	QCY31HK-152Z	1500PF 50V CER.CAPACI	
C712	QCY31HK-152Z	1500PF 50V CER.CAPACI	
C713	QCS21HJ-680A	68PF 50V CER.CAPACI	
C714	QCS21HJ-680A	68PF 50V CER.CAPACI	
C715	QCS21HJ-680A	68PF 50V CER.CAPACI	
C716	QCS21HJ-680A	68PF 50V CER.CAPACI	
C717	QCS22HJ-220	22PF 500V CER.CAPACI	
C718	QCS22HJ-220	22PF 500V CER.CAPACI	
C719	QFLB1HJ-472	4700PF 50V MYLAR CAPA	
C720	QFLB1HJ-472	4700PF 50V MYLAR CAPA	
C722	QETB1EM-476	47MF 25V AL E.CAPAC	
C723	QETB2AM-476	47MF 100V AL E.CAPAC	
C724	QETB2AM-476	47MF 100V AL E.CAPAC	
C725	QCS22HJ-470A	47PF 500V CER.CAPACI	
C726	QCS22HJ-470A	47PF 500V CER.CAPACI	
C727	QCS22HJ-470A	47PF 500V CER.CAPACI	
C728	QCS22HJ-470A	47PF 500V CER.CAPACI	
C729	QFLB1HJ-473	0.047MF 50V MYLAR CAPA	
C730	QFLB1HJ-473	0.047MF 50V MYLAR CAPA	
C731	QFLB1HJ-473	0.047MF 50V MYLAR CAPA	
C732	QFLB1HJ-473	0.047MF 50V MYLAR CAPA	
C733	QCF21HP-472	4700PF 50V CER.CAPACI	
C734	QCF21HP-472	4700PF 50V CER.CAPACI	
C735	QCF21HP-472	4700PF 50V CER.CAPACI	
C736	QCF21HP-472	4700PF 50V CER.CAPACI	
C737	QFLB1HJ-473	0.047MF 50V MYLAR CAPA	
C738	QFLB1HJ-473	0.047MF 50V MYLAR CAPA	

Δ : SAFETY PARTS

Capacitors

Δ	ITEM	PART NUMBER	DESCRIPTION		AREA
	C801	EEW6321-129T	12000MF	E. CAPACITO	
	C802	EEW6321-129T	12000MF	E. CAPACITO	
	C812	QETB1EM-107	100MF 25V	AL E. CAPAC	
	C813	QCF21HP-472	4700PF 50V	CER. CAPACI	
	C814	QETB1EM-107	100MF 25V	AL E. CAPAC	
	C816	QETB1EM-107	100MF 25V	AL E. CAPAC	
	C817	QCF21HP-472	4700PF 50V	CER. CAPACI	
	C818	QETB1EM-107	100MF 25V	AL E. CAPAC	
	C819	QCF21HP-472	4700PF 50V	CER. CAPACI	
	C820	QETB1EM-107	100MF 25V	AL E. CAPAC	
	C821	QCF21HP-472	4700PF 50V	CER. CAPACI	
	C822	QCF21HP-472	4700PF 50V	CER. CAPACI	
	C823	QETB1EM-107	100MF 25V	AL E. CAPAC	
	C824	QCF21HP-223A	0.022MF 50V	CER. CAPACI	
	C826	QCF21HP-223A	0.022MF 50V	CER. CAPACI	
	C827	QETB1EM-107	100MF 25V	AL E. CAPAC	
	C831	QCBB1HK-121Y	120PF 50V	CER. CAPACI	
	C832	QCBB1HK-121Y	120PF 50V	CER. CAPACI	
	C833	QCBB1HK-121Y	120PF 50V	CER. CAPACI	
	C834	QCBB1HK-121Y	120PF 50V	CER. CAPACI	
	C870	QCF21HP-472	4700PF 50V	CER. CAPACI	
	C874	QETB1HM-105	1MF 50V	AL E. CAPAC	
	C875	QETB1HM-105	1MF 50V	AL E. CAPAC	
	C891	QETB1HM-106	10MF 50V	E. CAPACITO	
	C892	QCY31HK-103Z	0.01MF 50V	CER. CAPACI	
	C893	QFLB1HJ-123	0.012MF 50V	MYLAR CAPA	
	C894	QETB1HM-106	10MF 50V	E. CAPACITO	
	C895	QCS21HJ-101A	100PF 50V	CER. CAPACI	
	C901	QCF21HP-223A	0.022MF 50V	CER. CAPACI	
	C902	QCF21HP-223A	0.022MF 50V	CER. CAPACI	
	C903	QETB1HM-226E	22MF 50V	E. CAPACITO	
	C904	QCF21HP-103A	0.01MF 50V	CER. CAPACI	
	C905	QCY31HK-102Z	1000PF 50V	CER. CAPACI	
	C906	QETB1AM-476	47MF 10V	E. CAPACITO	
	C909	QETB1CM-226	22MF 16V	E. CAPACITO	
	C961	QFLB1HJ-473	0.047MF 50V	MYLAR CAPA	
	C962	QFLB1HJ-473	0.047MF 50V	MYLAR CAPA	
	C963	QFLB1HJ-473	0.047MF 50V	MYLAR CAPA	
	C964	QFLB1HJ-473	0.047MF 50V	MYLAR CAPA	
	C965	QCS31HJ-151Z	150PF 50V	CER. CAPACI	
	C966	QCS31HJ-151Z	150PF 50V	CER. CAPACI	
	C967	QCS31HJ-151Z	150PF 50V	CER. CAPACI	
	C968	QCS31HJ-151Z	150PF 50V	CER. CAPACI	
	C969	QCS31HJ-391Z	390PF 50V	CER. CAPACI	
	C970	QCS31HJ-391Z	390PF 50V	CER. CAPACI	
	C971	QCS31HJ-471Z	470PF 50V	CER. CAPACI	
	C972	QCS31HJ-471Z	470PF 50V	CER. CAPACI	
	C973	QCS31HJ-331Z	330PF 50V	CER. CAPACI	
	C974	QCS31HJ-331Z	330PF 50V	CER. CAPACI	
	C981	QETB1HM-225	2.2MF 50V	AL E. CAPAC	
	C982	QFLB1HJ-223	0.022MF 50V	MYLAR CAPA	
	C983	QETB1HM-106	10MF 50V	E. CAPACITO	
	C985	QCBB1HK-331Y	330PF 50V	CER. CAPACI	
	C986	QCHB1EZ-223	0.022MF 25V	CER. CAPACI	
	C991	QCF21HP-223A	0.022MF 50V	CER. CAPACI	

Δ : SAFETY PARTS

Resistors

Δ	ITEM	PART NUMBER	DESCRIPTION		AREA
	R611	QRD161J-222	2.2K	1/6W CARBON RES	
	R612	QRD161J-104	100K	1/6W CARBON RES	
	R613	QRD161J-123	12K	1/6W CARBON RES	
	R614	QRD161J-202	2K	1/6W CARBON RES	
	R615	QRD161J-104	100K	1/6W CARBON RES	
	R616	QRD14CJ-181S	180	1/4W UNF. CARBON	
	R617	QRD14CJ-332SX	3.3K	1/4W UNF. CARBON	
	R618	QRD161J-302	3K	1/6W CARBON RES	
	R619	QRD161J-302	3K	1/6W CARBON RES	
	R620	QRD161J-302	3K	1/6W CARBON RES	
	R623	QRD14CJ-471SX	470	1/4W UNF. CARBON	
	R624	QRD14CJ-100SX	10	1/4W UNF. CARBON	
	R625	QRD14CJ-561SX	560	1/4W UNF. CARBON	
	R626	QRD14CJ-100SX	10	1/4W UNF. CARBON	
	R627	QRD14CJ-471SX	470	1/4W UNF. CARBON	
	R628	QRD161J-391	390	1/6W CARBON RES	
	R629	ERT-D2WHL202S	2K	1/4W NEGATIVE T	
	R630	QRD161J-183	18K	1/6W CARBON RES	
	R631	QRD161J-123	12K	1/6W CARBON RES	
	R632	QRD125J-330	33	1/2W UNF. CARBON	
	R633	QRG022J-100A	10	2W OXIDE META	
	R634	QRD161J-104	100K	1/6W CARBON RES	
	R635	QRD14CJ-330SX	33	1/4W UNF. CARBON	
	R636	QRD14CJ-330SX	33	1/4W UNF. CARBON	
	R637	QRG022J-562A	5.6K	2W OXIDE META	
	R638	QRD167J-751	750	1/6W CARBON RES	
	R639	QRD12CJ-470SX	47	1/2W CARBON RES	
	R640	QRG022J-122AM	1.2K	2W OXIDE META	
	R641	QRD167J-151	150	1/6W CARBON RES	
	R642	QRD167J-151	150	1/6W CARBON RES	

Δ : SAFETY PARTS

Resistors

Δ	ITEM	PART NUMBER	DESCRIPTION		AREA
	R643	QRD161J-102	1K	1/6W CARBON RES	
	R644	QRD161J-181	180	1/6W CARBON RES	
	R645	QRD12CJ-470SX	47	1/2W CARBON RES	
	R646	QRG022J-122AM	1.2K	2W OXIDE META	
	R647	QRD167J-151	150	1/6W CARBON RES	
	R648	QRD167J-151	150	1/6W CARBON RES	
	R649	QRD161J-181	180	1/6W CARBON RES	
	R649	QRD167J-151	150	1/6W CARBON RES	
	R650	QRG022J-100A	10	2W OXIDE META	
	R651	QRD161J-104	100K	1/6W CARBON RES	
	R652	QRD167J-151	150	1/6W CARBON RES	
	R653	QRD167J-151	150	1/6W CARBON RES	
	R654	QRD167J-151	150	1/6W CARBON RES	
	R655	QRD167J-151	150	1/6W CARBON RES	
	R656	QRD14CJ-4R7S	4.7	1/4W UNF. CARBON	
	R657	QRD14CJ-4R7S	4.7	1/4W UNF. CARBON	
	R658	QRD14CJ-4R7S	4.7	1/4W UNF. CARBON	
	R699	ERF032K-R22	0.22	3W CEM. RESIST	
	R701	QRD161J-222	2.2K	1/6W CARBON RES	
	R702	QRD161J-222	2.2K	1/6W CARBON RES	
	R703	QRD161J-104	100K	1/6W CARBON RES	
	R704	QRD161J-104	100K	1/6W CARBON RES	
	R705	QRD161J-202	2K	1/6W CARBON RES	
	R706	QRD161J-202	2K	1/6W CARBON RES	
	R707	QRD161J-202	2K	1/6W CARBON RES	
	R708	QRD161J-202	2K	1/6W CARBON RES	
	R709	QRD167J-822	8.2K	1/6W CARBON RES	
	R710	QRD167J-822	8.2K	1/6W CARBON RES	
	R711	QRD161J-821	820	1/6W CARBON RES	
	R712	QRD161J-821	820	1/6W CARBON RES	
	R715	QRV144F-1003	100K	1/4W M. FILM	
	R716	QRV144F-1003	100K	1/4W M. FILM	
	R717	QRD12CJ-153SX	15K	1/2W UNF. CARBON	
	R718	QRD12CJ-153SX	15K	1/2W UNF. CARBON	
	R719	QRD161J-391	390	1/6W CARBON RES	
	R720	QRD161J-391	390	1/6W CARBON RES	
	R721	QRD14CJ-151SX	150	1/4W UNF. CARBON	
	R722	QRD14CJ-151SX	150	1/4W UNF. CARBON	
	R723	QRD167J-152	1.5K	1/6W CARBON RES	
	R724	QRD167J-152	1.5K	1/6W CARBON RES	
	R725	QRD161J-333	33K	1/6W CARBON RES	
	R726	QRD161J-333	33K	1/6W CARBON RES	
	R727	QRD161J-391	390	1/6W CARBON RES	
	R728	QRD161J-391	390	1/6W CARBON RES	
	R729	QRD167J-152	1.5K	1/6W CARBON RES	
	R730	QRD167J-152	1.5K	1/6W CARBON RES	
	R731	QRD161J-101	100	1/6W CARBON RES	
	R732	QRD161J-101	100	1/6W CARBON RES	
	R733	QRD14CJ-680SX	68	1/4W UNF. CARBON	
	R734	QRD14CJ-680SX	68	1/4W UNF. CARBON	
	R735	QRG022J-562A	5.6K	2W OXIDE META	
	R739	QRD161J-301	300	1/6W CARBON RES	
	R740	QRD161J-301	300	1/6W CARBON RES	
	R741	QRD161J-301	300	1/6W CARBON RES	
	R742	QRD161J-301	300	1/6W CARBON RES	
	R743	QRD161J-101	100	1/6W CARBON RES	
	R744	QRD161J-101	100	1/6W CARBON RES	
	R745	QRD161J-101	100	1/6W CARBON RES	
	R746	QRD161J-101	100	1/6W CARBON RES	
	R747	ERT-D2WFL351S	350	1/4W NEGATIVE T	
	R748	ERT-D2WFL351S	350	1/4W NEGATIVE T	
	R749	ERT-D2WFL351S	350	1/4W NEGATIVE T	
	R750	ERT-D2WFL351S	350	1/4W NEGATIVE T	
	R751	QRD161J-271	270	1/6W CARBON RES	
	R752	QRD161J-271	270	1/6W CARBON RES	
	R753	QRD161J-271	270	1/6W CARBON RES	
	R754	QRD161J-271	270	1/6W CARBON RES	
	R755	QRD161J-471	470	1/6W CARBON RES	
	R756	QRD161J-471	470	1/6W CARBON RES	
	R757	ERT-D2WFL351S	350	1/4W NEGATIVE T	
	R758	ERT-D2WFL351S	350	1/4W NEGATIVE T	
	R759	QRD161J-101	100	1/6W CARBON RES	
	R760	QRD161J-101	100	1/6W CARBON RES	
	R761	QRD161J-391	390	1/6W CARBON RES	
	R762	QRD161J-391	390	1/6W CARBON RES	
	R763	ERT-D2WHL202S	2K	1/4W NEGATIVE T	
	R764	ERT-D2WHL202S	2K	1/4W NEGATIVE T	
	R765	QRD14CJ-272S	2.7K	1/4W UNF. CARBON	
	R766	QRD14CJ-272S	2.7K	1/4W UNF. CARBON	
	R767	QRD14CJ-271S	270	1/4W UNF. CARBON	
	R768	QRD14CJ-271S	270	1/4W UNF. CARBON	
	R769	QRD14CJ-100SX	10	1/4W UNF. CARBON	
	R770	QRD14CJ-100SX	10	1/4W UNF. CARBON	
	R771	QRD14CJ-100SX	10	1/4W UNF. CARBON	
	R772	QRD14CJ-100SX	10	1/4W UNF. CARBON	
	R773	ERF032K-R22	0.22	3W CEM. RESIST	
	R774	ERF032K-R22	0.22	3W CEM. RESIST	
	R775	QRD125J-470	47	1/2W UNF. CARBON	
	R776	QRD125J-470	47	1/2W UNF. CARBON	
	R777	QRG022J-100A	10	2W OXIDE META	
	R778	QRG022J-100A	10	2W OXIDE META	
	R779	QRD14CJ-100SX	10	1/4W UNF. CARBON	
	R780	QRD14CJ-100SX	10	1/4W UNF. CARBON	
	R781	QRD14CJ-100SX	10	1/4W UNF. CARBON	
	R782	QRD14CJ-100SX	10	1/4W UNF. CARBON	

Δ : SAFETY PARTS

Resistors

Δ	ITEM	PART NUMBER	DESCRIPTION	AREA
Δ	R783	QRD14CJ-100SX	10 1/4W UNF. CARBON	
Δ	R784	QRD14CJ-100SX	10 1/4W UNF. CARBON	
Δ	R785	QRD14CJ-100SX	10 1/4W UNF. CARBON	
Δ	R786	QRD14CJ-100SX	10 1/4W UNF. CARBON	
Δ	R811	QRD14CJ-120SX	12 1/4W UNF. CARBON	
Δ	R813	QRD14CJ-102SX	1K 1/4W UNF. CARBON	
Δ	R819	QRD14CJ-100SX	10 1/4W UNF. CARBON	
Δ	R822	QRD14CJ-272S	2.7K 1/4W UNF. CARBON	
Δ	R823	QRZ0077-220X	22 1/4W FUSIBLE RE	
Δ	R824	QRZ0077-220X	22 1/4W FUSIBLE RE	
Δ	R825	QRD14CJ-332SX	5.3K 1/4W UNF. CARBON	
Δ	R826	QRZ0077-100	10 1/4W FUSIBLE RE	
Δ	R828	QRD14CJ-102SX	1K 1/4W UNF. CARBON	
Δ	R829	QRD143J-472S	4.7K 1/4W CARBON RES	
Δ	R830	QRZ0077-100	10 1/4W FUSIBLE RE	
Δ	R831	QRZ0077-150	15 1/4W FUSIBLE RE	
Δ	R832	QRD12CJ-822S	8.2K 1/2W NETWORK RE	
Δ	R834	QRZ0077-220X	22 1/4W FUSIBLE RE	
Δ	R835	QRZ0077-220X	22 1/4W FUSIBLE RE	
Δ	R836	QRZ0077-220X	22 1/4W FUSIBLE RE	
Δ	R837	QRD14CJ-822S	8.2K 1/4W UNF. CARBON	
Δ	R838	QRD12CJ-2R2SX	2.2 1/2W CARBON RES	
Δ	R839	QRD161J-472	4.7K 1/6W CARBON RES	
Δ	R841	QRD161J-104	100K 1/6W CARBON RES	
Δ	R842	QRD161J-104	100K 1/6W CARBON RES	
Δ	R843	QRD14CJ-4R7S	4.7 1/4W UNF. CARBON	
Δ	R870	QRD161J-123	12K 1/6W CARBON RES	
Δ	R871	QRD161J-103	10K 1/6W CARBON RES	
Δ	R873	QRD161J-103	10K 1/6W CARBON RES	
Δ	R874	QRD161J-123	12K 1/6W CARBON RES	
Δ	R889	QRZ0077-680	68 1/4W FUSIBLE RE	
Δ	R890	QRZ0077-680	68 1/4W FUSIBLE RE	
Δ	R891	QRD161J-104	100K 1/6W CARBON RES	
Δ	R892	QRD161J-203	20K 1/6W CARBON RES	
Δ	R893	QRD161J-183	18K 1/6W CARBON RES	
Δ	R894	QRD161J-202	2K 1/6W CARBON RES	
Δ	R895	QRD167J-223	22K 1/6W CARBON RES	
Δ	R896	QRD161J-132	1.3K 1/6W CARBON RES	
Δ	R897	QRD161J-104	100K 1/6W CARBON RES	
Δ	R898	QRD161J-203	20K 1/6W CARBON RES	
Δ	R901	QRD161J-102	1K 1/6W CARBON RES	
Δ	R902	QRD161J-102	1K 1/6W CARBON RES	
Δ	R903	QRD167J-562	5.6K 1/6W CARBON RES	
Δ	R904	QRD167J-562	5.6K 1/6W CARBON RES	
Δ	R905	QRD161J-123	12K 1/6W CARBON RES	
Δ	R906	QRD161J-123	12K 1/6W CARBON RES	
Δ	R907	QRD161J-102	1K 1/6W CARBON RES	
Δ	R908	QRD161J-102	1K 1/6W CARBON RES	
Δ	R909	QRD161J-103	10K 1/6W CARBON RES	
Δ	R911	QRD167J-332	3.3K 1/6W CARBON RES	
Δ	R912	QRD161J-473	47K 1/6W CARBON RES	
Δ	R913	QRD161J-104	100K 1/6W CARBON RES	
Δ	R914	QRD161J-823	82K 1/6W CARBON RES	
Δ	R915	QRD161J-823	82K 1/6W CARBON RES	
Δ	R916	QRD161J-563	56K 1/6W CARBON RES	
Δ	R917	QRD161J-683	68K 1/6W CARBON RES	
Δ	R918	QRD161J-392	3.9K 1/6W CARBON RES	
Δ	R921	QRD161J-224	220K 1/6W CARBON RES	
Δ	R922	QRD167J-562	5.6K 1/6W CARBON RES	
Δ	R924	QRG022J-102AF	1K 2W OXIDE META	
Δ	R925	QRD161J-470	47 1/6W CARBON RES	
Δ	R926	QRD161J-470	47 1/6W CARBON RES	
Δ	R927	QRD161J-470	47 1/6W CARBON RES	
Δ	R929	QRD14CJ-151SX	150 1/4W UNF. CARBON	
Δ	R941	QRG022J-471A	470 2W OXIDE META	
Δ	R942	QRG022J-471A	470 2W OXIDE META	
Δ	R951	QRD161J-333	33K 1/6W CARBON RES	
Δ	R952	QRD161J-333	33K 1/6W CARBON RES	
Δ	R953	QRD161J-333	33K 1/6W CARBON RES	
Δ	R956	QRD167J-223	22K 1/6W CARBON RES	
Δ	R957	QRD161J-391	390 1/6W CARBON RES	
Δ	R961	QRZ0077-100	10 1/4W FUSIBLE RE	
Δ	R962	QRZ0077-100	10 1/4W FUSIBLE RE	
Δ	R963	QRZ0077-100	10 1/4W FUSIBLE RE	
Δ	R964	QRZ0077-100	10 1/4W FUSIBLE RE	
Δ	R981	QRD161J-222	2.2K 1/6W CARBON RES	
Δ	R982	QRD161J-222	2.2K 1/6W CARBON RES	
Δ	R983	QRD161J-105	1M 1/6W CARBON RES	
Δ	R984	QRD161J-103	10K 1/6W CARBON RES	
Δ	R985	QRD161J-100	10 1/6W CARBON RES	
Δ	R986	QRD161J-102	1K 1/6W CARBON RES	
Δ	VR791	QVPA601-501A	500 TRIMMER RE	
Δ	VR792	QVPA601-501A	500 TRIMMER RE	
Δ	VR873	QVDA96W-E15DJ3	100K VARIABLE R	
Δ	VR891	QVDB96C-E15DJ3	100K VARIABLE R	

Δ : SAFETY PARTS

Others

Δ	ITEM	PART NUMBER	DESCRIPTION	AREA
		EMW10518-102	PRINTED BOA	
		SBSG3008CC	TAPPING SCR	
	J901	QNS6022-V01	MICROPHONE	
	J911	EMV7164-036	CONNECT TER	
	J985	QMS3501-021	PIN JACK	
	L611	EQL0011-R45J1	INDUCTOR	
	L612	EQL0011-R45J1	INDUCTOR	
	L652	EQL0011-R45J1	INDUCTOR	
	L701	EQL0001-1R0	INDUCTOR	
	L702	EQL0001-1R0	INDUCTOR	
	L961	EQL0011-R45J1	INDUCTOR	
	L962	EQL0011-R45J1	INDUCTOR	
	L963	EQL0011-R45J1	INDUCTOR	
	L964	EQL0011-R45J1	INDUCTOR	
	P701	VMC0075-008N	CONNECT TER	
	P702	EMV5109-003A	MALE CONNec	
	P703	EMV5125-011	MALE CONNec	
	P704	EMV5109-011A	MALE CONNec	
	P705	EMV5125-006	CONNECT TER	
	P706	EMV5125-006	CONNECT TER	
	P707	EMV7163-020	CONNECT TER	
	P708	EMV5109-003A	MALE CONNec	
	P709	EMV5125-008	MALE CONNec	
	P710	EMV5129-003	CONNECTOR	
	P755	EMV5109-003A	MALE CONNec	
	P801	EMV5109-003A	MALE CONNec	
	P802	EMV5109-006A	CONNECT TER	
	S911	GSP6002-E04J2	PUSH SWITCH	
	BC103	EWS267-A408	SOCKET WIRE	
	BC755	EWS293-0145	SOCKET WIRE	
	BC801	EWS263-A422	SOCKET WIRE	
	BC802	EWS296-0120	SOCKET WIRE	
	BC903	EWS356-001	SOCKET WIRE	
	EP901	EMZ4002-001Z	EARTH PLATE	
	EP902	EMZ4002-001Z	EARTH PLATE	
	EP903	EMZ4002-001Z	EARTH PLATE	
	EP904	EMZ4002-001Z	EARTH PLATE	
	EP905	EMZ4002-001Z	EARTH PLATE	
	FW901	EWR33D-08SS	FLAT WIRE A	
	HS800	E70306-001	HEAT SINK	
	HS802	E70306-001	HEAT SINK	
	HS804	E70306-001	HEAT SINK	
	HS805	E70306-001	HEAT SINK	
	HS808	E70306-001	HEAT SINK	
	JB101	EMV5140-010	VOLUME SOCK	
	JB441	EMV7123-021	CONNECT TER	
	RY611	ESK1D24-11AM	RELAY	
	RY612	ESK1D24-11AM	RELAY	
	RY901	ESK7D24-2120	RELAY	
	ST611	EMB90TV-601G	SPEAKER TER	
	ST901	EMB00TV-801B	TERMINAL	
	TP751	QMV5005-004K	PLUG-ASSY	

Δ : SAFETY PARTS

Note (1)

PC Board Ass'y	Version	Designated Areas
ENC-125 B	BS	the U.K.
ENC-125 A	G GI	Germany Italy
ENC-125 J	EN EF	Scandinavia Continental Europe

Transistors

ITEM	PART NUMBER	DESCRIPTION	AREA
Q201	2SC2235(O,Y)	SI.TRANSIST TOSHIBA	
Q202	DTC143TS	DIGITAL TRA ROHM	
Q221	2SC458(C,D)	SI.TRANSIST HITACHI	
Q222	2SC458(C,D)	SI.TRANSIST HITACHI	
Q223	2SA933S(RS)	SI.TRANSIST	
Q224	2SA933S(RS)	SI.TRANSIST	
Q225	DTC114YS	DIGITAL TRA ROHM	
Q226	DTC114YS	DIGITAL TRA ROHM	
Q251	2SA965(Y)	SI.TRANSIST TOSHIBA	
Q252	2SC2240(GR,BL)	SI.TRANSIST TOSHIBA	
Q253	2SA965(Y)	SI.TRANSIST TOSHIBA	
Q254	DTA144ES	DIGITAL TRA ROHM	
Q255	DTC144ES	DIGITAL TRA ROHM	
Q300	DTA114YS	DIGITAL TRA ROHM	
Q301	2SK301(P,Q)	F.E.T.	
Q302	2SK301(P,Q)	F.E.T.	
Q303	DTC144ES	DIGITAL TRA ROHM	
Q304	2SK301(P,Q)	F.E.T.	
Q305	2SK301(P,Q)	F.E.T.	
Q307	2SK301(P,Q)	F.E.T.	
Q308	2SK301(P,Q)	F.E.T.	
Q341	2SD2144S(VW)	SI.TRANSIST ROHM	
Q342	2SD2144S(VW)	SI.TRANSIST ROHM	
Q351	DTC144ES	DIGITAL TRA ROHM	
Q352	DTA144ES	DIGITAL TRA ROHM	
Q353	DTC144ES	DIGITAL TRA ROHM	

Δ : SAFETY PARTS

I.C.s

ITEM	PART NUMBER	DESCRIPTION	AREA
IC221	NJM2246D	I.C.(MONO-AN DAINICHI	
IC301	VC4580DD	I.C.(MONO-AN DAINICHI	
IC311	BA15218N	I.C.(MONO-AN ROHM	
IC321	TC9274N-007	I.C.(M) TOSHIBA	
IC341	TC9299P	I.C.(DIGI-MO TOSHIBA	
IC342	BA15218N	I.C.(MONO-AN ROHM	
IC351	UPD40668C	I.C.(DIGI-MO NEC	
IC361	LB1639-CV	I.C.(DIGI-OT SANYO	

Δ : SAFETY PARTS

Diodes

ITEM	PART NUMBER	DESCRIPTION	AREA
D201	1SR139-200	SI.DIODE ROHM	
D202	1SR139-200	SI.DIODE ROHM	
D203	1SR139-200	SI.DIODE ROHM	
D204	1SR139-200	SI.DIODE ROHM	
D205	MTZ6.2JC	ZENER DIODE ROHM	
D206	1SS133	SI.DIODE ROHM	
D211	U6SBA20	DIODE	
D221	1SS133	SI.DIODE ROHM	
D222	1SS133	SI.DIODE ROHM	
D251	MTZ5.6JC	ZENER DIODE ROHM	
D252	MTZ10JC	ZENER DIODE ROHM	
D253	MTZ16JC	ZENER DIODE ROHM	
D254	1SS133	SI.DIODE ROHM	
D255	MTZ6.8JC	ZENER DIODE ROHM	
D256	1SS133	SI.DIODE ROHM	
D257	MTZ7.5JC	ZENER DIODE ROHM	
D258	MTZ7.5JC	ZENER DIODE ROHM	
D259	MTZ7.5JC	ZENER DIODE ROHM	
D261	10E2-FD	DIODE NIHONINTER	
D262	10E2-FD	DIODE NIHONINTER	
D263	10E2-FD	DIODE NIHONINTER	
D264	10E2-FD	DIODE NIHONINTER	
D265	1SS133	SI.DIODE ROHM	
D291	MTZ6.2JC	ZENER DIODE ROHM	
D292	MTZ6.2JC	ZENER DIODE ROHM	
D300	1SS133	SI.DIODE ROHM	
D301	1SS133	SI.DIODE ROHM	
D302	1SS133	SI.DIODE ROHM	
D351	MTZ8.2JC	ZENER DIODE ROHM	
D352	MTZ8.2JC	ZENER DIODE ROHM	
D360	1SR139-200	SI.DIODE ROHM	

Δ : SAFETY PARTS

Capacitors

ITEM	PART NUMBER	DESCRIPTION	AREA
C201	QCZ9019-472	4700PF C.CAPACITO	EF
C201	QCZ9019-472	4700PF C.CAPACITO	EN
C201	QCZ9019-472	4700PF C.CAPACITO	G
C201	QCZ9019-472	4700PF C.CAPACITO	GI
C201	QCZ9019-472BS	4700PF CERAMIC	BS
C202	QFN82AK-472	4700PF 100V METAL.MYLA	
C203	QCF21HP-472	4700PF 50V CER.CAPACI	
C204	QETB1EM-227	220MF 25V AL E.CAPAC	
C206	QETB1CM-476	47MF 16V AL E.CAPAC	
C207	QFN82AJ-104	0.1MF 100V MYLAR CAPA	
C208	QFN82AJ-104	0.1MF 100V MYLAR CAPA	
C209	QFN82CK-104	0.1MF 160V METAL.MYLA	
C210	QFN82CK-104	0.1MF 160V METAL.MYLA	
C211	QFN82CK-104	0.1MF 160V METAL.MYLA	
C221	QETB1CM-108	1000MF 16V AL E.CAPAC	
C222	QCF21HP-223A	0.022MF 50V CER.CAPACI	
C223	QETB0JM-108N	1000MF 6.3V E.CAPACITO	
C224	QETB0JM-108N	1000MF 6.3V E.CAPACITO	
C225	QETB1HM-475E	4.7MF 50V E.CAPACITO	
C226	QETB1HM-475E	4.7MF 50V E.CAPACITO	
C227	QETB1HM-475E	4.7MF 50V E.CAPACITO	
C251	QETB1HM-476	47MF 50V E.CAPACITO	
C252	QCF21HP-472	4700PF 50V CER.CAPACI	
C253	QETB1EM-107	100MF 25V AL E.CAPAC	
C254	QETB1EM-107	100MF 25V AL E.CAPAC	
C255	QCF21HP-472	4700PF 50V CER.CAPACI	
C257	QFLB1HJ-473	0.047MF 50V MYLAR CAPA	
C258	QFLB1HJ-473	0.047MF 50V MYLAR CAPA	
C259	QFLB1HJ-473	0.047MF 50V MYLAR CAPA	
C260	QFLB1HJ-473	0.047MF 50V MYLAR CAPA	
C261	QETB1VM-228N	2200MF 35V E.CAPACITO	
C262	QETB1VM-228N	2200MF 35V E.CAPACITO	
C263	QFN82AJ-104	0.1MF 100V MYLAR CAPA	
C264	QFN82AJ-104	0.1MF 100V MYLAR CAPA	
C265	QFN82AJ-104	0.1MF 100V MYLAR CAPA	
C266	QETB1HM-225	2.2MF 50V AL E.CAPAC	
C271	QETB1HM-476	47MF 50V E.CAPACITO	
C291	QCS31HJ-471Z	470PF 50V CER.CAPACI	EN
C292	QCS31HJ-471Z	470PF 50V CER.CAPACI	
C301	QETB1HM-475E	4.7MF 50V E.CAPACITO	
C302	QETB1HM-475E	4.7MF 50V E.CAPACITO	
C303	QCS21HJ-101A	100PF 50V CER.CAPACI	
C304	QCS21HJ-101A	100PF 50V CER.CAPACI	
C305	QFLB1HJ-182	1800PF 50V MYLAR CAPA	
C306	QFLB1HJ-182	1800PF 50V MYLAR CAPA	
C307	QFLB1HJ-682	6800PF 50V MYLAR CAPA	
C308	QFLB1HJ-682	6800PF 50V MYLAR CAPA	
C309	QCS21HJ-101A	100PF 50V CER.CAPACI	
C310	QCS21HJ-101A	100PF 50V CER.CAPACI	
C311	QETB1HM-475E	4.7MF 50V E.CAPACITO	
C312	QETB1HM-475E	4.7MF 50V E.CAPACITO	
C313	QETB1AM-107	100MF 10V AL E.CAPAC	
C314	QETB1AM-107	100MF 10V AL E.CAPAC	
C315	QETB1CM-476	47MF 16V AL E.CAPAC	
C316	QETB1CM-476	47MF 16V AL E.CAPAC	
C319	QCF21HP-223A	0.022MF 50V CER.CAPACI	
C320	QCF21HP-223A	0.022MF 50V CER.CAPACI	
C321	QETB1EM-226N	22MF 25V E.CAPACITO	
C322	QETB1EM-226N	22MF 25V E.CAPACITO	
C323	QETB1HM-106	10MF 50V E.CAPACITO	
C324	QETB1HM-106	10MF 50V E.CAPACITO	
C325	QGBB1HK-561Y	560PF 50V CER.CAPACI	
C331	QCF21HP-223A	0.022MF 50V CER.CAPACI	
C341	QETB1HM-475E	4.7MF 50V E.CAPACITO	
C342	QETB1HM-475E	4.7MF 50V E.CAPACITO	
C343	QETB1HM-105	1MF 50V AL E.CAPAC	
C344	QETB1HM-105	1MF 50V AL E.CAPAC	
C345	QETB1EM-106	10MF 25V AL E.CAPAC	
C346	QETB1EM-106	10MF 25V AL E.CAPAC	
C347	QCHB1EZ-223	0.022MF 25V CER.CAPACI	
C348	QCHB1EZ-223	0.022MF 25V CER.CAPACI	
C351	QEK51EM-475G	4.7MF 25V AL E.CAPAC	
C352	QEK51EM-475G	4.7MF 25V AL E.CAPAC	
C353	QCF21HP-223A	0.022MF 50V CER.CAPACI	
C354	QCF21HP-223A	0.022MF 50V CER.CAPACI	
C355	QETB1EM-106	10MF 25V AL E.CAPAC	
C356	QETB1EM-106	10MF 25V AL E.CAPAC	
C361	QER51EM-106	10MF 25V E.CAPACITO	
C362	QER51EM-106	10MF 25V E.CAPACITO	
C371	QCY21HK-331	330PF 50V CER.CAPACI	
C372	QCY21HK-331	330PF 50V CER.CAPACI	
C373	QETB1AM-107	100MF 10V AL E.CAPAC	
C374	QCF21HP-473A	0.047MF 50V CER.CAPACI	
C375	QFLB1HJ-333	0.033MF 50V MYLAR CAPA	
C376	QFLB1HJ-333	0.033MF 50V MYLAR CAPA	
C377	QETB1HM-226E	22MF 50V E.CAPACITO	
C381	QCS31HJ-331Z	330PF 50V CER.CAPACI	
C382	QCS31HJ-331Z	330PF 50V CER.CAPACI	
C383	QCS31HJ-331Z	330PF 50V CER.CAPACI	
C384	QCS31HJ-331Z	330PF 50V CER.CAPACI	
C385	QCS31HJ-331Z	330PF 50V CER.CAPACI	
C386	QCS31HJ-331Z	330PF 50V CER.CAPACI	
C387	QCS31HJ-331Z	330PF 50V CER.CAPACI	
C388	QCS31HJ-331Z	330PF 50V CER.CAPACI	
C389	QCS31HJ-331Z	330PF 50V CER.CAPACI	

Δ : SAFETY PARTS

Capacitors

Δ	ITEM	PART NUMBER	DESCRIPTION			AREA
	C390	QCS31HJ-331Z	330PF	50V	CER.CAPACI	
	C391	QCS31HJ-331Z	330PF	50V	CER.CAPACI	
	C392	QCS31HJ-331Z	330PF	50V	CER.CAPACI	
	C393	QCS31HJ-331Z	330PF	50V	CER.CAPACI	
	C394	QCS31HJ-331Z	330PF	50V	CER.CAPACI	
	C395	QCS31HJ-331Z	330PF	50V	CER.CAPACI	
	C396	QCS31HJ-331Z	330PF	50V	CER.CAPACI	
	C397	QCS31HJ-331Z	330PF	50V	CER.CAPACI	
	C398	QCS31HJ-331Z	330PF	50V	CER.CAPACI	

Δ : SAFETY PARTS

Resistors

Δ	ITEM	PART NUMBER	DESCRIPTION			AREA
Δ	R201	QRD14CJ-100SX	10	1/4W	UNF.CARBON	
	R202	QRZ0077-220X	22	1/4W	FUSIBLE RE	
Δ	R204	QRV144F-8200		1/4W	CONST.META	EF
Δ	R204	QRV144F-8200		1/4W	CONST.META	EN
Δ	R204	QRV144F-8200		1/4W	CONST.META	G
Δ	R204	QRV144F-8200		1/4W	CONST.META	GI
Δ	R204	QRV144F-9100		1/4W	M.F.RESIST	BS
	R206	QRD167J-200	20	1/6W	CARBON RES	BS
	R221	QRD161J-750	75	1/6W	CARBON RES	
	R222	QRD167J-680	68	1/6W	CARBON RES	
	R223	QRD161J-750	75	1/6W	CARBON RES	
	R224	QRD161J-750	75	1/6W	CARBON RES	
	R225	QRD161J-473	47K	1/6W	CARBON RES	
	R226	QRD161J-473	47K	1/6W	CARBON RES	
	R227	QRD161J-331	330	1/6W	CARBON RES	
	R228	QRD161J-331	330	1/6W	CARBON RES	
	R229	QRD167J-152	1.5K	1/6W	CARBON RES	
	R230	QRD167J-152	1.5K	1/6W	CARBON RES	
	R231	QRD167J-151	150	1/6W	CARBON RES	
	R232	QRD167J-151	150	1/6W	CARBON RES	
	R233	QRD167J-152	1.5K	1/6W	CARBON RES	
	R234	QRD161J-473	47K	1/6W	CARBON RES	
	R235	QRD161J-271	270	1/6W	CARBON RES	
	R236	QRD161J-271	270	1/6W	CARBON RES	
	R237	QRD161J-331	330	1/6W	CARBON RES	
	R238	QRD161J-750	75	1/6W	CARBON RES	
	R239	QRD161J-473	47K	1/6W	CARBON RES	
	R240	QRD167J-152	1.5K	1/6W	CARBON RES	
	R251	QRD14CJ-123SX	12K	1/4W	UNF.CARBON	
Δ	R252	QRG022J-391A	390	2W	OXIDE META	
Δ	R253	QRZ0077-220X	22	1/4W	FUSIBLE RE	
	R254	QRD161J-104	100K	1/6W	CARBON RES	
	R255	QRD161J-270	27	1/6W	CARBON RES	
Δ	R256	QRD14CJ-330SX	33	1/4W	UNF.CARBON	
Δ	R257	QRD14CJ-332SX	3.3K	1/4W	UNF.CARBON	
Δ	R259	QRX022J-R22A	0.22	2W	METAL FILM	
Δ	R260	QRX022J-R22A	0.22	2W	METAL FILM	
Δ	R261	QRD12CJ-2R25X	2.2	1/2W	CARBON RES	
Δ	R262	QRX012J-3R2AM	2.2	1W	METAL FILM	
	R263	QRD167J-562	5.6K	1/6W	CARBON RES	
	R264	QRD167J-822	8.2K	1/6W	CARBON RES	
	R265	QRD161J-103	10K	1/6W	CARBON RES	
	R276	QRD161J-102	1K	1/6W	CARBON RES	
	R278	QRD161J-103	10K	1/6W	CARBON RES	
	R291	QRD161J-221	220	1/6W	CARBON RES	
	R292	QRD161J-221	220	1/6W	CARBON RES	
	R293	QRD161J-221	220	1/6W	CARBON RES	
	R299	QRD161J-102	1K	1/6W	CARBON RES	
	R301	QRD161J-222	2.2K	1/6W	CARBON RES	
	R302	QRD161J-222	2.2K	1/6W	CARBON RES	
	R303	QRD161J-473	47K	1/6W	CARBON RES	
	R304	QRD161J-473	47K	1/6W	CARBON RES	
	R305	QRD161J-561	560	1/6W	CARBON RES	
	R306	QRD161J-561	560	1/6W	CARBON RES	
	R307	QRD161J-393	39K	1/6W	CARBON RES	
	R308	QRD161J-393	39K	1/6W	CARBON RES	
	R309	QRD161J-474	470K	1/6W	CARBON RES	
	R310	QRD161J-474	470K	1/6W	CARBON RES	
	R311	QRD161J-104	100K	1/6W	CARBON RES	
	R312	QRD161J-104	100K	1/6W	CARBON RES	
Δ	R313	QRD14CJ-391SX	390	1/4W	UNF.CARBON	
Δ	R314	QRD14CJ-391SX	390	1/4W	UNF.CARBON	
	R315	QRD161J-104	100K	1/6W	CARBON RES	
	R316	QRD161J-104	100K	1/6W	CARBON RES	
	R317	QRD161J-104	100K	1/6W	CARBON RES	
	R318	QRD161J-104	100K	1/6W	CARBON RES	
	R319	QRD161J-753	75K	1/6W	CARBON RES	
	R320	QRD161J-104	100K	1/6W	CARBON RES	
Δ	R321	QRZ0077-680	68	1/4W	FUSIBLE RE	
Δ	R322	QRZ0077-680	68	1/4W	FUSIBLE RE	
	R323	QRD161J-102	1K	1/6W	CARBON RES	
	R324	QRD161J-102	1K	1/6W	CARBON RES	
	R325	QRD161J-103	10K	1/6W	CARBON RES	
	R326	QRD161J-103	10K	1/6W	CARBON RES	
	R327	QRD161J-103	10K	1/6W	CARBON RES	

Δ : SAFETY PARTS

Resistors

Δ	ITEM	PART NUMBER	DESCRIPTION			AREA
	R333	QRD161J-224	220K	1/6W	CARBON RES	
	R335	QRD161J-103	10K	1/6W	CARBON RES	
	R336	QRD161J-512	5.1K	1/6W	CARBON RES	
	R337	QRD161J-103	10K	1/6W	CARBON RES	
	R338	QRD161J-512	5.1K	1/6W	CARBON RES	
	R339	QRD161J-104	100K	1/6W	CARBON RES	
	R340	QRD161J-104	100K	1/6W	CARBON RES	
	R341	QRD161J-104	100K	1/6W	CARBON RES	
	R342	QRD161J-104	100K	1/6W	CARBON RES	
	R343	QRD161J-105	1M	1/6W	CARBON RES	
	R344	QRD161J-105	1M	1/6W	CARBON RES	
	R345	QRD161J-823	82K	1/6W	CARBON RES	
	R346	QRD161J-823	82K	1/6W	CARBON RES	
	R347	QRD161J-103	10K	1/6W	CARBON RES	
	R348	QRD161J-103	10K	1/6W	CARBON RES	
	R349	QRD161J-104	100K	1/6W	CARBON RES	
	R350	QRD161J-104	100K	1/6W	CARBON RES	
	R351	QRD14CJ-152SX	1.5K	1/4W	UNF.CARBON	
	R352	QRD14CJ-152SX	1.5K	1/4W	UNF.CARBON	
	R353	QRD161J-563	56K	1/6W	CARBON RES	
	R354	QRD161J-563	56K	1/6W	CARBON RES	
	R355	QRD161J-563	56K	1/6W	CARBON RES	
	R357	QRD161J-103	10K	1/6W	CARBON RES	
	R358	QRD161J-103	10K	1/6W	CARBON RES	
	R359	QRD161J-102	1K	1/6W	CARBON RES	
	R360	QRD161J-102	1K	1/6W	CARBON RES	
Δ	R361	QRZ0077-680	68	1/4W	FUSIBLE RE	
Δ	R362	QRZ0077-680	68	1/4W	FUSIBLE RE	
Δ	R363	QRZ0077-680	68	1/4W	FUSIBLE RE	
Δ	R364	QRZ0077-680	68	1/4W	FUSIBLE RE	
	R328	QRD161J-103	10K	1/6W	CARBON RES	
	R329	QRD167J-152	1.5K	1/6W	CARBON RES	
	R330	QRD167J-152	1.5K	1/6W	CARBON RES	
	R331	QRD161J-224	220K	1/6W	CARBON RES	
	R332	QRD161J-224	220K	1/6W	CARBON RES	
	R365	QRD167J-152	1.5K	1/6W	CARBON RES	
	R366	QRD167J-152	1.5K	1/6W	CARBON RES	
	R367	QRD167J-152	1.5K	1/6W	CARBON RES	
	R368	QRD167J-152	1.5K	1/6W	CARBON RES	
	R369	QRD161J-221	220	1/6W	CARBON RES	
	R371	QRD167J-223	22K	1/6W	CARBON RES	
	R372	QRD167J-223	22K	1/6W	CARBON RES	
	R373	QRD167J-223	22K	1/6W	CARBON RES	
	R374	QRD167J-223	22K	1/6W	CARBON RES	
	R375	QRD161J-222	2.2K	1/6W	CARBON RES	
	R376	QRD161J-222	2.2K	1/6W	CARBON RES	
	R377	QRD161J-202	2K	1/6W	CARBON RES	
	R381	QRD161J-471	470	1/6W	CARBON RES	
	R382	QRD161J-471	470	1/6W	CARBON RES	
	R383	QRD161J-471	470	1/6W	CARBON RES	
	R384	QRD161J-471	470	1/6W	CARBON RES	
	R385	QRD161J-471	470	1/6W	CARBON RES	
	R386	QRD161J-471	470	1/6W	CARBON RES	
	R387	QRD161J-222	2.2K	1/6W	CARBON RES	
	R388	QRD161J-222	2.2K	1/6W	CARBON RES	
	R389	QRD161J-222	2.2K	1/6W	CARBON RES	
	R390	QRD161J-222	2.2K	1/6W	CARBON RES	
	R391	QRD161J-222	2.2K	1/6W	CARBON RES	
	R392	QRD161J-222	2.2K	1/6W	CARBON RES	
	R393	QRD161J-471	470	1/6W	CARBON RES	
	R394	QRD161J-471	470	1/6W	CARBON RES	
	R395	QRD161J-471	470	1/6W	CARBON RES	
	R396	QRD161J-471	470	1/6W	CARBON RES	
	VR360	QVDC94Z-E15EJ5	100K		VARIABLE R	

Δ : SAFETY PARTS

Others

Δ	ITEM	PART NUMBER	DESCRIPTION		AREA
		EMW10519-004	PRINTED BOA		
		QWE881-16RR	VINYL WIRE		EF
		QWE881-16RR	VINYL WIRE		EN
		QWE881-16RR	VINYL WIRE		G
		QWE881-16RR	VINYL WIRE		GI
		QWE881-16RRBS	VINYL WIRE		BS
		QWE886-16RR	PIN WIRE		EF
		QWE886-16RR	PIN WIRE		EN
		QWE886-16RR	PIN WIRE		G
		QWE886-16RR	PIN WIRE		GI
		QWE886-16RRBS	VINYL WIRE		BS
		SBSG3008CC	TAPPING SCR		
	J202	EMV5137-002	CONNECT TER		
	J225	EMN00YV-217A	PIN JACK		
	J226	EMN01TV-102A	PIN JACK		
	J227	EMN00TV-116A	PIN JACK		
	J291	QMS3L10-0A0	MICROPHONE		
	J292	QMS3L10-0A0	MICROPHONE		
	J293	QMS3L10-0A0	MICROPHONE		
	J295	EMN00YV-319AJ1	PIN JACK		

Δ : SAFETY PARTS

RX-816RBK

Others

Δ	ITEM	PART NUMBER	DESCRIPTION	AREA
	J300	EMN00TV-422AJ2	PIN JACK	
	J301	EMN00TV-615AJ2	PIN JACK	
	J302	EMN00TV-422AJ2	PIN JACK	
	J303	EMN00TV-422AJ2	PIN JACK	
	J551	EMV7159-010	PIN PLUG	
	J703	EMV7125-011R	MALE CONNec	
	J705	EMV7125-006R	CONNECT TER	
	J706	EMV7125-006R	CONNECT TER	
	J707	EMV5163-020R	CONNECT TER	
	P205	VMC0177-003	CONNECT TER	
	P221	EMV5109-006A	CONNECT TER	
	P222	EMV5142-903	CONNECT TER	
	P255	VMC0177-003	CONNECT TER	
	P261	EMV5125-008	MALE CONNec	
	P271	EMV5109-011A	MALE CONNec	
	P311	EMV5109-003A	MALE CONNec	
	P321	EMV5109-006B	CONNECT TER	
	P361	EMV5109-003A	MALE CONNec	
	T202	ETP1000-41EA	POWER TRASN	EF
Δ	T202	ETP1000-41EA	POWER TRASN	EN
Δ	T202	ETP1000-41EA	POWER TRASN	G
Δ	T202	ETP1000-41EABS	POWER TRASN	GI
	BC221	EWS296-0113	CONNECTOR W	BS
	BC321	EWS296-0130	SOCKET WIRE	
	BC702	EWS293-0130	SOCKET WIRE	
	BC708	EWS263-A418	SOCKET WIRE	
	EP201	EMZ4002-001Z	EARTH PLATE	
	EP250	EMZ4002-001Z	EARTH PLATE	
	EP350	E70225-001	EARTH PLATE	
	FC201	VMZ0087-001Z	FUSE HOLDER	
	FC202	VMZ0087-001Z	FUSE HOLDER	
	FC203	VMZ0087-001Z	FUSE HOLDER	
	FC204	VMZ0087-001Z	FUSE HOLDER	
	FC211	VMZ0087-001Z	FUSE HOLDER	
	FC212	VMZ0087-001Z	FUSE HOLDER	
	FC213	VMZ0087-001Z	FUSE HOLDER	
	FC214	VMZ0087-001Z	FUSE HOLDER	
	FW211	EWR36D-08SST	FLAT WIRE	
	HS202	E408032-002SS	HEAT SINK	
	LA201	E67132-T4R0	FUSE LABEL	
	LA211	E67132-T2R0	FUSE LABEL	
	LA212	E67132-T2R0	FUSE LABEL	
	PW710	RWS273-005	SOCKET WIRE	
	RY201	ESK1D12-113	RELAY	EF
	RY201	ESK1D12-113	RELAY	EN
Δ	RY201	ESK1D12-115	RELAY	G
Δ	RY201	ESK1D12-115	RELAY	GI
	RY201	ESK1D12-115BS	RELAY	BS
	SH201	E308132-001	SHIELD COVE	
	TA201	EMZ4001-001	TAB	
	TA202	EMZ4001-001	TAB	

Δ : SAFETY PARTS

Note (2)

PC Board Ass'y	Version	Designated Areas
ENB-211 [E]	BS	the U.K.
ENB-211 [A]	G	Germany
	GI	Italy
	EN	Scandinavia
	EF	Continental Europe

Transistors

ITEM	PART NUMBER	DESCRIPTION	AREA
Q401	DTC114YS	DIGITAL TRA ROHM	
Q402	DTC144ES	DIGITAL TRA ROHM	
Q403	DTC144ES	DIGITAL TRA ROHM	
Q404	DTA114YS	DIGITAL TRA ROHM	
Q405	DTA114YS	DIGITAL TRA ROHM	
Q406	DTC114YS	DIGITAL TRA ROHM	
Q451	2SC1740S(R,S)	SI.TRANSIST ROHM	
Q452	2SC1740S(R,S)	SI.TRANSIST ROHM	
Q457	DTC114YS	DIGITAL TRA ROHM	
Q458	DTC144ES	DIGITAL TRA ROHM	
Q459	DTC114YS	DIGITAL TRA ROHM	
Q501	2SC2240(BL)	SI.TRANSIST	
Q502	2SC2240(BL)	SI.TRANSIST	
Q503	2SA1038(R,S)	SI.TRANSIST ROHM	
Q509	2SC1775AV(F,2)	SI.TRANSIST HITACHI	
Q511	2SC2389(S,E)	SI.TRANSIST ROHM	
Q512	2SA1038(R,S)	SI.TRANSIST ROHM	

△ : SAFETY PARTS

I.C.s

ITEM	PART NUMBER	DESCRIPTION	AREA
IC401	MN172412J5X	I.C(MICRO-C MATSUSHITA	
IC402	SPS-420-1	INFRARED DE SANYO	
IC403	MN1281(P,Q)	I.C(DIGI-MO MATSUSHITA	
IC404	XR1095CP	I.C(MONO-AN EXAR JAPAN	
IC411	NJU3715L	I.C(MONO-AN DAINICHI	
IC412	AT24C02-10PC	I.C(EP-ROM) MITSUBISHI	
IC551	M5243P12	I.C(MONO-AN MITSUBISHI	
IC552	TC9163N	I.C(DIGI-MO TOSHIBA	

△ : SAFETY PARTS

Diodes

ITEM	PART NUMBER	DESCRIPTION	AREA
D401	1SS133	SI.DIODE ROHM	
D402	1SS133	SI.DIODE ROHM	
D403	1SS133	SI.DIODE ROHM	
D404	1SS133	SI.DIODE ROHM	
D411	SLR-34MC70F124	L.E.D. ROHM	
D412	SLR-34MC70F124	L.E.D. ROHM	
D414	SLA-580L770F124	L.E.D. ROHM	BS
D414	SLR-54VC50F124	L.E.D. ROHM	EF
D414	SLR-54VC50F124	L.E.D. ROHM	EN
D414	SLR-54VC50F124	L.E.D. ROHM	G
D414	SLR-54VC50F124	L.E.D. ROHM	GI
D415	SLR-34VC3F	L.E.D. ROHM	
D422	1SS133	SI.DIODE ROHM	
D431	1SS133	SI.DIODE ROHM	
D432	1SS133	SI.DIODE ROHM	
D433	1SS133	SI.DIODE ROHM	
D434	1SS133	SI.DIODE ROHM	
D435	1SS133	SI.DIODE ROHM	
D436	1SS133	SI.DIODE ROHM	
D437	1SS133	SI.DIODE ROHM	
D438	MTZ6.2JC	ZENER DIODE ROHM	
D441	1SS133	SI.DIODE ROHM	
D442	1SS133	SI.DIODE ROHM	
D451	MTZ7.5JC	ZENER DIODE ROHM	
D501	1SS133	SI.DIODE ROHM	
D502	MTZ18JC	ZENER DIODE ROHM	
D503	1SS133	SI.DIODE ROHM	
D504	1SS133	SI.DIODE ROHM	
D505	1SS133	SI.DIODE ROHM	
D506	1SS133	SI.DIODE ROHM	
D551	MTZ6.8JC	ZENER DIODE ROHM	
D552	MTZ6.8JC	ZENER DIODE ROHM	
D557	1SS133	SI.DIODE ROHM	
D558	1SS133	SI.DIODE ROHM	
D559	1SS133	SI.DIODE ROHM	

△ : SAFETY PARTS

Capacitors

ITEM	PART NUMBER	DESCRIPTION	AREA
C401	QETB1AM-227	220MF 10V E.CAPACITO	
C402	QCZ0202-155	1.5MF 25V CER.RESIST	
C403	QCHB1EZ-223	0.022MF 25V CER.CAPACI	
C404	QEK51HM-225G	2.2MF 50V AL E.CAPAC	
C409	QEAD0HZ-479ZB	47000MF E.CAPACITO	
C411	QETB1HM-225	2.2MF 50V AL E.CAPAC	
C412	QCZ0202-155	1.5MF 25V CER.RESIST	
C413	QCHB1EZ-223	0.022MF 25V CER.CAPACI	
C415	QCHB1EZ-223	0.022MF 25V CER.CAPACI	
C416	QCHB1EZ-223	0.022MF 25V CER.CAPACI	
C417	QCBB1HK-561Y	560PF 50V CER.CAPACI	
C451	QCBB1HK-331Y	330PF 50V CER.CAPACI	
C481	QETB1HM-106	10MF 50V E.CAPACITO	
C482	QCBB1HK-102Y	1000PF 50V CER.CAPACI	
C483	QETB1HM-225	2.2MF 50V AL E.CAPAC	
C484	QETB1HM-225	2.2MF 50V AL E.CAPAC	
C485	QETB1HM-106	10MF 50V E.CAPACITO	
C500	QCF21HP-223A	0.022MF 50V CER.CAPACI	
C501	QEMB1HM-106	10MF 50V AL E.CAPAC	
C502	QCS21HJ-220Z	22PF 50V CERAMIC	
C503	QEMB1HM-106	10MF 50V AL E.CAPAC	
C504	QCS31HJ-471Z	470PF 50V CER.CAPACI	
C505	QCS21HJ-5R0	5PF 50V CER.CAPACI	
C506	QEMB1HM-476	47MF 50V AL E.CAPAC	
C507	QCS22HJ-330	33PF 500V CER.CAPACI	
C508	QFLB1HJ-103	0.01MF 50V MYLAR CAPA	
C509	QEMB1HM-476	47MF 50V AL E.CAPAC	
C510	QCS22HJ-470A	47PF 500V CER.CAPACI	
C511	EETB1HM-225E	2.2MF 50V E.CAPACITO	
C512	QCS22HJ-470A	47PF 500V CER.CAPACI	
C513	QCF21HP-223A	0.022MF 50V CER.CAPACI	
C551	QETB1HM-475E	4.7MF 50V E.CAPACITO	
C552	QETB1HM-475E	4.7MF 50V E.CAPACITO	
C553	QCBB1HK-101Y	100PF 50V CER.CAPACI	
C554	QCBB1HK-101Y	100PF 50V CER.CAPACI	
C555	QETB1EM-476	47MF 25V AL E.CAPAC	
C556	QETB1EM-476	47MF 25V AL E.CAPAC	
C557	QETB1EM-476	47MF 25V AL E.CAPAC	
C558	QETB1EM-476	47MF 25V AL E.CAPAC	
C559	QCS21HJ-100	10PF 50V CER.CAPACI	
C560	QCS21HJ-100	10PF 50V CER.CAPACI	
C561	QCS21HJ-100	10PF 50V CER.CAPACI	
C562	QCS21HJ-100	10PF 50V CER.CAPACI	
C563	QETB1HM-475E	4.7MF 50V E.CAPACITO	
C564	QETB1HM-475E	4.7MF 50V E.CAPACITO	
C565	QETB1EM-226N	22MF 25V E.CAPACITO	
C566	QETB1EM-226N	22MF 25V E.CAPACITO	
C567	QETB1EM-476	47MF 25V AL E.CAPAC	
C568	QETB1EM-476	47MF 25V AL E.CAPAC	
C569	QCHB1EZ-223	0.022MF 25V CER.CAPACI	
C570	QCHB1EZ-223	0.022MF 25V CER.CAPACI	
C571	QFLB1HJ-272	2700PF 50V MYLAR CAPA	
C572	QFLB1HJ-272	2700PF 50V MYLAR CAPA	
C573	QCBB1HK-471Y	470PF 50V CER.CAPACI	
C574	QCBB1HK-471Y	470PF 50V CER.CAPACI	
C575	QFV81HJ-473	0.047MF 50V THIN FILM	
C576	QFV81HJ-473	0.047MF 50V THIN FILM	
C577	QFLB1HJ-822	8200PF 50V MYLAR CAPA	
C578	QFLB1HJ-822	8200PF 50V MYLAR CAPA	
C579	QER51HM-684	0.68MF 50V AL E.CAPAC	
C580	QER51HM-684	0.68MF 50V AL E.CAPAC	
C581	QFV81HJ-104	0.1MF 50V THIN FILM	
C582	QFV81HJ-104	0.1MF 50V THIN FILM	
C583	QCSB1HJ-470	47PF 50V CER.CAPACI	
C584	QCSB1HJ-470	47PF 50V CER.CAPACI	
C587	QCS31HJ-561Z	560PF 50V CER.CAPACI	
C591	QCBB1HK-331Y	330PF 50V CER.CAPACI	
C592	QCBB1HK-331Y	330PF 50V CER.CAPACI	

△ : SAFETY PARTS

Resistors

ITEM	PART NUMBER	DESCRIPTION	AREA
R402	QRD161J-103	10K 1/6W CARBON RES	
R403	QRD161J-103	10K 1/6W CARBON RES	
R404	QRD161J-103	10K 1/6W CARBON RES	
R405	QRD161J-104	100K 1/6W CARBON RES	
R409	QRD161J-331	330 1/6W CARBON RES	
R410	QRD167J-223	22K 1/6W CARBON RES	
R411	QRD161J-221	220 1/6W CARBON RES	
R412	QRD161J-221	220 1/6W CARBON RES	
R414	QRD161J-221	220 1/6W CARBON RES	
R415	QRD161J-100	10 1/6W CARBON RES	
R416	QRD161J-472	4.7K 1/6W CARBON RES	
R417	QRD161J-472	4.7K 1/6W CARBON RES	
R418	QRD161J-104	100K 1/6W CARBON RES	
R419	QRD161J-104	100K 1/6W CARBON RES	
R421	QRD161J-471	470 1/6W CARBON RES	
R423	QRD161J-221	220 1/6W CARBON RES	
R424	QRD161J-471	470 1/6W CARBON RES	
R425	QRD161J-471	470 1/6W CARBON RES	
R426	QRD161J-471	470 1/6W CARBON RES	
R427	QRD161J-471	470 1/6W CARBON RES	

△ : SAFETY PARTS

Resistors

Δ	ITEM	PART NUMBER	DESCRIPTION		AREA
	R428	QRD161J-471	470	1/6W CARBON RES	
	R429	QRD161J-471	470	1/6W CARBON RES	
	R430	QRD161J-471	470	1/6W CARBON RES	
	R431	QRD161J-471	470	1/6W CARBON RES	
	R432	QRD161J-471	470	1/6W CARBON RES	
	R433	QRD161J-471	470	1/6W CARBON RES	
	R434	QRD161J-471	470	1/6W CARBON RES	
	R435	QRD161J-471	470	1/6W CARBON RES	
	R445	QRD161J-103	10K	1/6W CARBON RES	
	R446	QRD161J-471	470	1/6W CARBON RES	
	R451	QRD161J-103	10K	1/6W CARBON RES	
	R452	QRD161J-473	47K	1/6W CARBON RES	
	R453	QRD167J-223	22K	1/6W CARBON RES	
	R454	QRD161J-471	470	1/6W CARBON RES	
	R455	QRD161J-103	10K	1/6W CARBON RES	
	R463	QRD161J-471	470	1/6W CARBON RES	
	R464	QRD161J-471	470	1/6W CARBON RES	
	R465	QRD161J-103	10K	1/6W CARBON RES	
	R466	QRD161J-103	10K	1/6W CARBON RES	
	R467	QRD161J-103	10K	1/6W CARBON RES	
	R468	QRD161J-103	10K	1/6W CARBON RES	
	R481	QRD161J-220	22	1/6W CARBON RES	
	R482	QRD161J-102	1K	1/6W CARBON RES	
	R483	QRD161J-105	1M	1/6W CARBON RES	
	R484	QRD161J-105	1M	1/6W CARBON RES	
	R485	QRD161J-683	68K	1/6W CARBON RES	
	R486	QRD161J-222	2.2K	1/6W CARBON RES	
	R491	QRD161J-103	10K	1/6W CARBON RES	
	R492	QRD161J-221	220	1/6W CARBON RES	
	R493	QRD161J-103	10K	1/6W CARBON RES	
	R501	QRD161J-222	2.2K	1/6W CARBON RES	
	R502	QRD161J-104	100K	1/6W CARBON RES	
	R503	QRD161J-123	12K	1/6W CARBON RES	
	R504	QRD161J-202	2K	1/6W CARBON RES	
	R505	QRD161J-104	100K	1/6W CARBON RES	
Δ	R506	QRD14CJ-181S	180	1/4W UNF. CARBON	
Δ	R507	QRD14CJ-332SX	3.3K	1/4W UNF. CARBON	
	R508	QRD161J-302	3K	1/6W CARBON RES	
	R509	QRD161J-302	3K	1/6W CARBON RES	
	R510	QRD161J-302	3K	1/6W CARBON RES	
Δ	R514	QRD14CJ-100SX	10	1/4W UNF. CARBON	
Δ	R515	QRD14CJ-561SX	560	1/4W UNF. CARBON	
Δ	R516	QRD14CJ-100SX	10	1/4W UNF. CARBON	
	R518	QRD161J-391	390	1/6W CARBON RES	
	R519	ERT-D2WHL202S	2K	1/4W NEGATIVE T	
	R520	QRD161J-183	18K	1/6W CARBON RES	
	R521	QRD161J-123	12K	1/6W CARBON RES	
	R522	QRD125J-330	33	1/2W UNF. CARBON	
Δ	R523	QRG022J-562A	5.6K	2W OXIDE META	
Δ	R524	QRD167J-751	750	1/6W CARBON RES	
	R525	QRD161J-102	1K	1/6W CARBON RES	
Δ	R526	QRD14CJ-330SX	33	1/4W UNF. CARBON	
Δ	R527	QRD14CJ-330SX	33	1/4W UNF. CARBON	
Δ	R528	ERF032K-R22	0.22	3W CEM. RESIST	
	R529	QRD167J-151	150	1/6W CARBON RES	
	R530	QRD167J-151	150	1/6W CARBON RES	
	R531	QRD167J-151	150	1/6W CARBON RES	
	R532	QRD167J-151	150	1/6W CARBON RES	
	R553	QRD161J-104	100K	1/6W CARBON RES	
	R554	QRD161J-104	100K	1/6W CARBON RES	
	R555	QRD161J-104	100K	1/6W CARBON RES	
	R556	QRD161J-104	100K	1/6W CARBON RES	
	R557	QRD161J-103	10K	1/6W CARBON RES	
	R558	QRD161J-103	10K	1/6W CARBON RES	
	R559	QRD161J-103	10K	1/6W CARBON RES	
	R560	QRD161J-103	10K	1/6W CARBON RES	
	R561	QRD161J-303Y	30K	1/6W CARBON RES	
	R562	QRD161J-303Y	30K	1/6W CARBON RES	
	R563	QRD161J-123	12K	1/6W CARBON RES	
	R564	QRD161J-123	12K	1/6W CARBON RES	
	R565	QRD161J-472	4.7K	1/6W CARBON RES	
	R566	QRD161J-472	4.7K	1/6W CARBON RES	
	R567	QRD161J-183	18K	1/6W CARBON RES	
	R568	QRD161J-183	18K	1/6W CARBON RES	
	R569	QRD161J-912	9.1K	1/6W CARBON RES	
	R570	QRD161J-912	9.1K	1/6W CARBON RES	
	R571	QRD161J-243	24K	1/6W CARBON RES	
	R572	QRD161J-243	24K	1/6W CARBON RES	
	R573	QRD161J-103	10K	1/6W CARBON RES	
	R574	QRD161J-103	10K	1/6W CARBON RES	
	R575	QRD161J-333	33K	1/6W CARBON RES	
	R576	QRD161J-333	33K	1/6W CARBON RES	
	R577	QRD161J-104	100K	1/6W CARBON RES	
	R578	QRD161J-104	100K	1/6W CARBON RES	
Δ	R579	QRD14CJ-681SX	680	1/4W UNF. CARBON	
Δ	R580	QRD14CJ-681SX	680	1/4W UNF. CARBON	
Δ	R581	QRD14CJ-680SX	68	1/4W UNF. CARBON	
Δ	R582	QRD14CJ-680SX	68	1/4W UNF. CARBON	
	R583	QRD161J-102	1K	1/6W CARBON RES	
	R584	QRD161J-102	1K	1/6W CARBON RES	

Δ : SAFETY PARTS

Resistors

Δ	ITEM	PART NUMBER	DESCRIPTION		AREA
	R587	QRD161J-473	47K	1/6W CARBON RES	
	R588	QRD161J-473	47K	1/6W CARBON RES	
	R591	QRD161J-471	470	1/6W CARBON RES	
	R592	QRD161J-471	470	1/6W CARBON RES	
	RA403	QRB079J-104	100K	1/10W NETWORK RE	
	RA404	QRB139J-104	100K	1/10W RESISTOR	
	RA407	QRS069J-104	100K	1/10W NETWORK RE	
	RA408	QRS059J-103	10K	1/10W NETWORK RE	

Δ : SAFETY PARTS

Others

Δ	ITEM	PART NUMBER	DESCRIPTION		AREA
		EMW10520-004	PRINTED BOA		
		EWTO11-174	TERMINAL WI		
	J205	VMC0178-003	CONNECT TER		
	J255	VMC0178-003	CONNECT TER		
	J261	EMV7125-008R	MALE CONNec		
	J591	EMN00YP-308A	PIN JACK		
	J709	EMV7125-008R	MALE CONNec		
	L501	EGL0011-R45J1	INDUCTOR		
	P401	EMV5109-011B	CONNECT TER		
	P402	EMV5109-013A	CONNECT TER		
	P551	EMV5159-010R	CONNECT TER		
	S401	ESPO001-023M	TACT SWITCH POWER		
	S402	ESPO001-023M	TACT SWITCH SEA ON/OFF		
	S403	ESPO001-023M	TACT SWITCH SEA FLAT		
	S404	ESPO001-023M	TACT SWITCH SPU/SEA		
	S405	ESPO001-023M	TACT SWITCH EFFECT +		
	S406	ESPO001-023M	TACT SWITCH MODE +		
	S407	ESPO001-023M	TACT SWITCH CURSOL MODE		
	S408	ESPO001-023M	TACT SWITCH DAP ON/OFF		
	S409	ESPO001-023M	TACT SWITCH EFFECT -		
	S410	ESPO001-023M	TACT SWITCH MODE -		
	S411	ESPO001-023M	TACT SWITCH SURROUND ON/OFF		
	S412	ESPO001-023M	TACT SWITCH CENTER MODE		
	S413	ESPO001-023M	TACT SWITCH LOUDNESS		
	S414	ESPO001-023M	TACT SWITCH FM MODE		
	S415	ESPO001-023M	TACT SWITCH CHARACTER		
	S416	ESPO001-023M	TACT SWITCH TUNING/PTY SEARCH		
	S417	ESPO001-023M	TACT SWITCH PRESET/PRESET/TUNING		
	S418	ESPO001-023M	TACT SWITCH ENTER		
	S419	ESPO001-023M	TACT SWITCH TAPEZ MONITOR		
	S420	ESPO001-023M	TACT SWITCH CSR/PEON		
	S421	ESPO001-023M	TACT SWITCH TA/NWS/INFO		
	S422	QSJ4002-E01	PUSH SWITCH SOURCE SELECT		
	S423	QSJ4002-E01	PUSH SWITCH TUNER CONTROL		
	X401	ECXP6R0-001ZA	CRYSTAL		
	BC101	EWS267-A425	SOCKET WIRE		
	BC222	EWS323-A940	CONNECTING		
	BC271	EWS268-A426J	SOCKET WIRE		
	BC311	EWS293-0140	SOCKET WIRE		
	BC361	EWS293-0125	SOCKET WIRE		
	BC401	EWS268-A408J	SOCKET WIRE		
	BC402	EWS26D-A408J	SOCKET WIRE		
	BC701	EWS268-A416J2	SOCKET WIRE		
	BC704	EWS268-A422J	SOCKET WIRE		
	FL401	ELJ0001-202	FLUORESCENT		
	JA442	EMV7123-021R	CONNECTOR		

Δ : SAFETY PARTS

■ ENA-164 A Tuner PC Board Assy

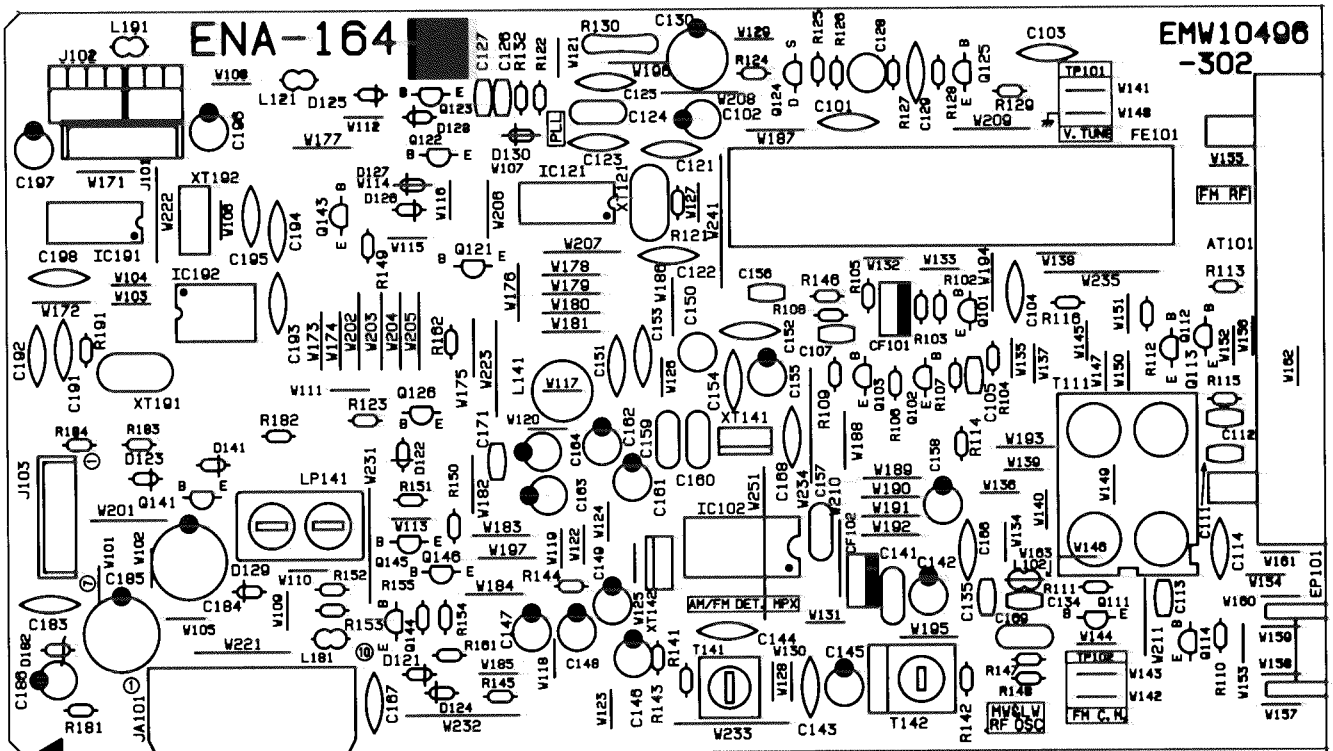

Transistors

ITEM	PART NUMBER	DESCRIPTION	AREA
Q101	2SC461	SI. TRANSIST	
Q102	2SC535	SI. TRANSIST HITACHI	
Q103	2SC461	SI. TRANSIST	
Q111	2SD2144S(VW)	SI. TRANSIST ROHM	
Q112	2SD2144S(VW)	SI. TRANSIST ROHM	
Q113	2SC1740S(R,S)	SI. TRANSIST ROHM	
Q114	2SD2144S(VW)	SI. TRANSIST ROHM	
Q121	DTA144ES	DIGITAL TRA ROHM	
Q122	DTA144ES	DIGITAL TRA ROHM	
Q123	DTA144ES	DIGITAL TRA ROHM	
Q124	2SK301(P,Q)	F.E.T.	
Q125	2SC458(C,D)	SI. TRANSIST HITACHI	
Q126	DTC114ES	DIGITAL TRA ROHM	
Q141	DTC114ES	DIGITAL TRA ROHM	
Q143	DTC114ES	DIGITAL TRA ROHM	

△ : SAFETY PARTS

I.C.s

ITEM	PART NUMBER	DESCRIPTION	AREA
IC102	LA1836M	I.C.(MONO-AN SANYO	
IC121	LC7218JMX	I.C.(DIGI-MO SANYO	
IC191	LC7073M	I.C.(DIGI-MO SANYO	
IC192	SAA6579T	I.C.(M)	

△ : SAFETY PARTS

Diodes

ITEM	PART NUMBER	DESCRIPTION	AREA
D121	1SS133	SI. DIODE ROHM	
D122	1SS133	SI. DIODE ROHM	
D123	1SS133	SI. DIODE ROHM	
D124	1SS133	SI. DIODE ROHM	
D125	1SS133	SI. DIODE ROHM	
D126	1SS133	SI. DIODE ROHM	
D127	1SS133	SI. DIODE ROHM	
D128	1SS133	SI. DIODE ROHM	
D129	1SS133	SI. DIODE ROHM	
D130	1SS133	SI. DIODE ROHM	
D141	1SS133	SI. DIODE ROHM	
D182	MTZ5.1JC	ZENER DIODE ROHM	

△ : SAFETY PARTS

Capacitors

ITEM	PART NUMBER	DESCRIPTION	AREA
C101	QC21HP-103A	0.01MF 50V CER. CAPACI	
C102	QETB1EM-476	47MF 25V AL E. CAPAC	
C103	QC21HP-223A	0.022MF 50V CER. CAPACI	
C104	QC21HP-223A	0.022MF 50V CER. CAPACI	
C105	QCHB1EZ-223	0.022MF 25V CER. CAPACI	
C107	QCHB1EZ-223	0.022MF 25V CER. CAPACI	
C111	QCHB1EZ-223	0.022MF 25V CER. CAPACI	
C112	QCT30CH-120Y	12PF 50V CER. CAPACI	
C113	QCHB1EZ-223	0.022MF 25V CER. CAPACI	
C114	QCC21EM-473	0.047MF 25V CER. CAPACI	
C121	QCS21HJ-180A	18PF 50V CER. CAPACI	
C122	QCS21HJ-180A	18PF 50V CER. CAPACI	
C123	QCC21EM-473	0.047MF 25V CER. CAPACI	
C124	QCZ0202-155	1.5MF 25V CER. RESIST	
C125	QC21HP-223A	0.022MF 50V CER. CAPACI	
C126	QCB1HK-101Y	100PF 50V CER. CAPACI	
C127	QCB1HK-101Y	100PF 50V CER. CAPACI	
C128	QENB1HM-474	0.47MF 50V NP E. CAPAC	
C129	QCY31HK-102Z	1000PF 50V CER. CAPACI	
C130	QETB1CM-227	220MF 16V AL E. CAPAC	
C134	QCSB1HK-5R6Y	5.6PF 50V CER. CAPACI	
C135	QCSB1HJ-150Y	15PF 50V CER. CAPACI	
C141	QFLB1HJ-473	0.047MF 50V MYLAR CAPA	
C142	QETB1HM-106	10MF 50V E. CAPACITO	
C143	QC21HP-223A	0.022MF 50V CER. CAPACI	
C144	QCC21EM-473	0.047MF 25V CER. CAPACI	
C145	QETB1HM-475E	4.7MF 50V E. CAPACITO	
C146	QETB1HM-106	10MF 50V E. CAPACITO	
C147	QETB1HM-105	1MF 50V AL E. CAPAC	
C148	QETB1HM-474	0.47MF 50V ELECTRO	
C149	QETB1HM-105	1MF 50V AL E. CAPAC	
C150	QETC1HM-225ZM	2.2MF 50V AL E. CAPAC	
C151	QCS21HJ-181A	180PF 50V CER. CAPACI	
C152	QCS21HJ-181A	180PF 50V CER. CAPACI	
C153	QCY31HK-821Z	820PF 50V CER. CAPACI	
C154	QCY31HK-472Z	4700PF 50V CER. CAPACI	
C155	QETB1EM-476	47MF 25V AL E. CAPAC	
C156	QCHB1EZ-223	0.022MF 25V CER. CAPACI	
C157	QCZ0202-155	1.5MF 25V CER. RESIST	
C158	QETB1HM-106	10MF 50V E. CAPACITO	
C159	QFLB1HJ-273	0.027MF 50V MYLAR CAPA	
C160	QFLB1HJ-273	0.027MF 50V MYLAR CAPA	
C161	QETB1HM-225	2.2MF 50V AL E. CAPAC	
C162	QETB1HM-225	2.2MF 50V AL E. CAPAC	
C163	QETB1HM-225	2.2MF 50V AL E. CAPAC	

△ : SAFETY PARTS

Capacitors

ITEM	PART NUMBER	DESCRIPTION	AREA
C164	QETB1HM-225	2.2MF 50V AL E.CAPAC	
C166	QCC21EM-473	0.047MF 25V CER.CAPACI	
C168	QCC21EM-473	0.047MF 25V CER.CAPACI	
C169	QFV81HJ-274	0.27MF 50V T.FILM CAP	
C171	QCBB1HK-102Y	1000PF 50V CER.CAPACI	
C172	QCHB1EZ-223	0.022MF 25V CER.CAPACI	
C183	QCF21HP-223A	0.022MF 50V CER.CAPACI	
C184	QETB1CM-227	220MF 16V AL E.CAPAC	
C185	QETB1CM-477M	470MF 16V E.CAPACITO	
C186	QETB1HM-475E	4.7MF 50V E.CAPACITO	
C191	QCS21HJ-820	82PF 50V CER.CAPACI	
C192	QCS21HJ-470	47PF 50V CER.CAPACI	
C193	QCS31HJ-561Z	560PF 50V CER.CAPACI	
C194	QCF21HP-223A	0.022MF 50V CER.CAPACI	
C195	QCS31HJ-331Z	330PF 50V CER.CAPACI	
C196	QETB1HM-225	2.2MF 50V AL E.CAPAC	
C197	QETB1HM-106	10MF 50V E.CAPACITO	
C198	QCC21EM-104	0.1MF 25V CER.CAPACI	

△ : SAFETY PARTS

Resistors

ITEM	PART NUMBER	DESCRIPTION	AREA
R150	QRD167J-332	3.3K 1/6W CARBON RES	
R151	QRD167J-332	3.3K 1/6W CARBON RES	
R152	QRD167J-822	8.2K 1/6W CARBON RES	
R153	QRD167J-822	8.2K 1/6W CARBON RES	
R161	QRD161J-473	47K 1/6W CARBON RES	
R162	QRD161J-222	2.2K 1/6W CARBON RES	
R181	QRD161J-222	2.2K 1/6W CARBON RES	
R182	QRD161J-103	10K 1/6W CARBON RES	
R183	QRD161J-103	10K 1/6W CARBON RES	
R184	QRD161J-473	47K 1/6W CARBON RES	
R191	QRD161J-222	2.2K 1/6W CARBON RES	

△ : SAFETY PARTS

Resistors

ITEM	PART NUMBER	DESCRIPTION	AREA
R102	QRD167J-332	3.3K 1/6W CARBON RES	
R103	QRD161J-221	220 1/6W CARBON RES	
R104	QRD167J-272	2.7K 1/6W CARBON RES	
R105	QRD161J-391	390 1/6W CARBON RES	
R106	QRD161J-102	1K 1/6W CARBON RES	
R107	QRD161J-681	680 1/6W CARBON RES	
R108	QRD167J-332	3.3K 1/6W CARBON RES	
R109	QRD161J-221	220 1/6W CARBON RES	
R110	QRD161J-472	4.7K 1/6W CARBON RES	
R111	QRD161J-472	4.7K 1/6W CARBON RES	
R112	QRD161J-472	4.7K 1/6W CARBON RES	
R113	QRD161J-103	10K 1/6W CARBON RES	
R114	QRD161J-103	10K 1/6W CARBON RES	
R115	QRD161J-104	100K 1/6W CARBON RES	
R116	QRD161J-222	2.2K 1/6W CARBON RES	
R121	QRD161J-473	47K 1/6W CARBON RES	
R122	QRD161J-472	4.7K 1/6W CARBON RES	
R123	QRD167J-562	5.6K 1/6W CARBON RES	
R124	QRD161J-222	2.2K 1/6W CARBON RES	
R125	QRD161J-222	2.2K 1/6W CARBON RES	
R126	QRD161J-101	180 1/6W CARBON RES	
R127	QRD167J-822	8.2K 1/6W CARBON RES	
R128	QRD161J-472	4.7K 1/6W CARBON RES	
R129	QRD161J-222	2.2K 1/6W CARBON RES	
R130	QRZ0077-680	68 1/4W FUSIBLE RE	
R132	QRD161J-102	1K 1/6W CARBON RES	
R141	QRD161J-392	3.9K 1/6W CARBON RES	
R142	QRD161J-103	10K 1/6W CARBON RES	
R143	QRD161J-103	10K 1/6W CARBON RES	
R144	QRD167J-332	3.3K 1/6W CARBON RES	
R145	QRD161J-103	10K 1/6W CARBON RES	
R146	QRD161J-222	2.2K 1/6W CARBON RES	
R147	QRD161J-473	47K 1/6W CARBON RES	
R148	QRD161J-561	560 1/6W CARBON RES	
R149	QRD161J-103	10K 1/6W CARBON RES	

△ : SAFETY PARTS

Others

ITEM	PART NUMBER	DESCRIPTION	AREA
	EMW10496-303A	CIR. BOARD	
	E308963-001	SHIELD BRAC	
	E3400-431	FELT SPACER	
	QWE351-10BB	VINYL WIRE	
J101	EMV5109-007A	MALE CONNCT	
J103	EMV5109-007A	MALE CONNCT	
L102	EQL4007-150T	INDUCTOR	
L121	EQL4007-1R0	INDUCTOR	
L141	EQL2108-392	INDUCTOR	
L181	EQL4007-1R0	INDUCTOR	
L191	EQL4007-101	INDUCTOR	
T111	EQR7121-006	RF COIL	
T141	EQT2140-021	I.F.TRANSFO	
T142	ECB1560-010	CERAMIC FIL	
AT101	EMB41YV-302K	ANTENNA TER	
CF101	ECB2118-007R	CERAMIC FIL	
CF102	ECB2118-007R	CERAMIC FIL	
EP101	E70225-001	EARTH PLATE	
FE101	EAF2203-005	FRONT END	
JA101	EMV7140-L10R	PIN CONNECT	
LP141	EQF0101-002	LOWPASS FIL	
XT121	ECX0007-200KWJ1	CRYSTAL	
XT141	ECXPR46-001A	CRYSTAL	
XT191	VCX5057-001	CRYSTAL	
XT192	EFO-EC4004T4	CERAMIC RES	

△ : SAFETY PARTS

■ ENP-054 [A] DSP/PC Board Assy

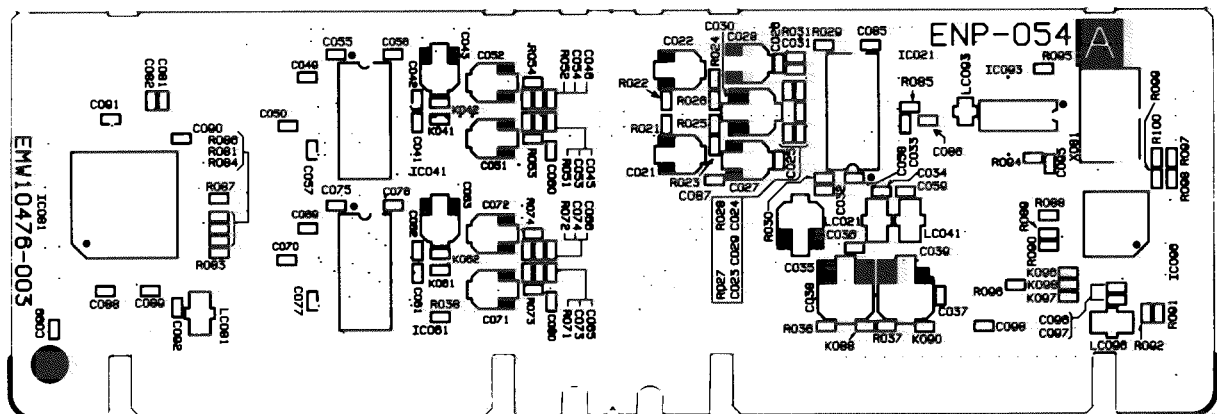

I.C.s

ITEM	PART NUMBER	DESCRIPTION	AREA
IC021	SAA7366TX	I.C(DIGI-MO	
IC041	TDA1386TX	I.C(MONO-AN	
IC061	TDA1386TX	I.C(MONO-AN	
IC081	TC9332F-010	I.C(M) TOSHIBA	
IC093	TC74HC74AFT1	I.C(DIGI-MO TOSHIBA	
IC096	TMP87C847U-4195	I.C(M) TOSHIBA	

△ : SAFETY PARTS

Capacitors

ITEM	PART NUMBER	DESCRIPTION	AREA
C021	NEA71EM-475NZ	4.7MF 25V E.CAPACITO	
C022	NEA71EM-475NZ	4.7MF 25V E.CAPACITO	
C023	NCS31HJ-680AY	68PF 50V CER.CAPACI	
C024	NCS31HJ-680AY	68PF 50V CER.CAPACI	
C025	NCB31CK-473AYU	0.047MF 16V C.CAPA. C.	
C026	NCB31CK-473AYU	0.047MF 16V C.CAPA. C.	
C027	NEA70GM-476NZ	47MF E.CAPACITO	
C028	NEA70GM-476NZ	47MF E.CAPACITO	
C029	NCB31CK-473AYU	0.047MF 16V C.CAPA. C.	
C030	NEA70JM-476NZ	47MF 6.3V E.CAPACITO	
C031	NCB31CK-223A	0.022MF 16V CER.CAPACI	
C032	NCB31HK-102AY	1000PF 50V CER.CAPACI	
C033	NCF31AZ-105AYUU	1MF 10V CER.CAPACI	
C035	NEA70JM-476NZ	47MF 6.3V E.CAPACITO	
C036	NCF31AZ-105AYUU	1MF 10V CER.CAPACI	
C037	NCF31AZ-105AYUU	1MF 10V CER.CAPACI	
C038	NEA70JM-107NP	100MF 6.3V E.CAPACITO	
C039	NEA70JM-107NP	100MF 6.3V E.CAPACITO	
C041	NCS31HJ-102AYM	1000PF 50V CER.CAPACI	
C042	NCS31HJ-102AYM	1000PF 50V CER.CAPACI	
C043	NEA71CM-106NZ	10MF 16V E.CAPACITO	
C049	NCB31CK-104AYM	0.1MF 16V C.CAPA. C	
C050	NCB31CK-104AYM	0.1MF 16V C.CAPA. C	
C051	NEA71HM-105NZ	1MF 50V E.CAPACITO	
C052	NEA71HM-105NZ	1MF 50V E.CAPACITO	
C053	NCB31CK-183AY	0.018MF 16V CER.CAPACI	
C054	NCB31CK-183AY	0.018MF 16V CER.CAPACI	
C055	NCB31HK-102AY	1000PF 50V CER.CAPACI	
C056	NCB31HK-102AY	1000PF 50V CER.CAPACI	
C057	NCB31HK-102AY	1000PF 50V CER.CAPACI	
C058	NCF31AZ-105AYUU	1MF 10V CER.CAPACI	
C059	NCF31AZ-105AYUU	1MF 10V CER.CAPACI	
C061	NCS31HJ-102AYM	1000PF 50V CER.CAPACI	
C062	NCS31HJ-102AYM	1000PF 50V CER.CAPACI	
C063	NEA71CM-106NZ	10MF 16V E.CAPACITO	
C069	NCB31CK-104AYM	0.1MF 16V C.CAPA. C	
C070	NCB31CK-104AYM	0.1MF 16V C.CAPA. C	
C071	NEA71HM-105NZ	1MF 50V E.CAPACITO	
C072	NEA71HM-105NZ	1MF 50V E.CAPACITO	
C073	NCB31CK-183AY	0.018MF 16V CER.CAPACI	
C074	NCB31CK-183AY	0.018MF 16V CER.CAPACI	
C075	NCB31HK-102AY	1000PF 50V CER.CAPACI	
C076	NCB31HK-102AY	1000PF 50V CER.CAPACI	
C077	NCB31HK-102AY	1000PF 50V CER.CAPACI	
C081	NCS31HD-9ROAYM	9PF 50V CER.CAPACI	
C082	NCS31HD-9ROAYM	9PF 50V CER.CAPACI	
C085	NCB31CK-104AYM	0.1MF 16V C.CAPA. C	
C086	NCB31CK-104AYM	0.1MF 16V C.CAPA. C	
C088	NCB31HK-102AY	1000PF 50V CER.CAPACI	
C089	NCB31HK-102AY	1000PF 50V CER.CAPACI	
C090	NCB31HK-102AY	1000PF 50V CER.CAPACI	
C091	NCB31HK-102AY	1000PF 50V CER.CAPACI	
C092	NCF31AZ-105AYUU	1MF 10V CER.CAPACI	
C095	NCB31HK-102AY	1000PF 50V CER.CAPACI	
C096	NCB31HK-102AY	1000PF 50V CER.CAPACI	
C097	NCF31AZ-105AYUU	1MF 10V CER.CAPACI	
C098	NCB31HK-102AY	1000PF 50V CER.CAPACI	
C099	NCS31HJ-101AY	100PF 50V CER.CAPACI	

△ : SAFETY PARTS

Resistors

ITEM	PART NUMBER	DESCRIPTION	AREA
R021	NRSA63J-104NY	METAL GLAZ	
R022	NRSA63J-104NY	METAL GLAZ	
R023	NRSA63J-103N	METAL GLAZ	
R024	NRSA63J-103N	METAL GLAZ	
R025	NRSA63J-624NY	METAL GLAZ	
R026	NRSA63J-334NY	METAL GLAZ	
R027	NRSA63F-103NY	METAL GLAZ	
R028	NRSA63F-103NY	METAL GLAZ	
R029	NRSA63J-271NY	METAL GLAZ	
R030	NRSA63J-271NY	METAL GLAZ	
R031	NRSA63J-333NY	METAL GLAZ	
R036	NRSA63J-0ROAY	METAL GLAZ	
R037	NRSA63J-0ROAY	METAL GLAZ	
R038	NRSA63J-0ROAY	METAL GLAZ	
R051	NRSA63J-473NY	METAL GLAZ	
R052	NRSA63J-473NY	METAL GLAZ	
R053	NRSA63J-201NY	METAL GLAZ	
R054	NRSA63J-201NY	METAL GLAZ	
R071	NRSA63J-473NY	METAL GLAZ	
R072	NRSA63J-473NY	METAL GLAZ	
R073	NRSA63J-201NY	METAL GLAZ	
R074	NRSA63J-201NY	METAL GLAZ	
R081	NRSA63J-0ROAY	METAL GLAZ	
R083	NRSA63J-112NY	METAL GLAZ	
R084	NRSA63J-112NY	METAL GLAZ	
R085	NRSA63J-112NY	METAL GLAZ	
R086	NRSA63J-182NY	METAL GLAZ	
R087	NRSA63J-112NY	METAL GLAZ	
R088	NRSA63J-0ROAY	METAL GLAZ	
R089	NRSA63J-0ROAY	METAL GLAZ	
R090	NRSA63J-0ROAY	METAL GLAZ	
R091	NRSA63J-0ROAY	METAL GLAZ	
R092	NRSA63J-0ROAY	METAL GLAZ	
R094	NRSA63J-471N	METAL GLAZ	
R095	NRSA63J-103N	METAL GLAZ	
R096	NRSA63J-103N	METAL GLAZ	
R097	NRSA63J-472NY	METAL GLAZ	
R098	NRSA63J-472NY	METAL GLAZ	
R099	NRSA63J-472NY	METAL GLAZ	
R100	NRSA63J-472NY	METAL GLAZ	

△ : SAFETY PARTS

Others

ITEM	PART NUMBER	DESCRIPTION	AREA
	EMW10476-003A	CIR. BOARD	
K041	EQA0002-N102Y	FERRITE BEA	
K042	EQA0002-N102Y	FERRITE BEA	
K061	EQA0002-N102Y	FERRITE BEA	
K062	EQA0002-N102Y	FERRITE BEA	
K088	EQA0001-N01Y	FERRITE BEA	
K090	EQA0001-N01Y	FERRITE BEA	
K096	EQA0002-N102Y	FERRITE BEA	
K097	EQA0002-N102Y	FERRITE BEA	
K028	EQA0002-N102Y	FERRITE BEA	
LC021	ECX0225-792EN9Y	CRYSTAL	
LC041	EQF0703-N103NZ	INDUCTOR	
LC081	EQF0703-N103NZ	INDUCTOR	
LC093	EQF0704-N01YU	INDUCTOR	
LC096	EQF0703-N103NZ	INDUCTOR	

△ : SAFETY PARTS

Accessories List

Symbol No.

M	2	M	M
---	---	---	---

Item	Part Number	Part Name	Q'ty	Description	Area	
1	E30580-2253A	INSTRUCTION BOOK	1		EF,BS,G,GI	
	E30580-2254A	INSTRUCTION BOOK	1		EN	
	2	RM-SR816RU	REMOCON	1		
	3	UM-4NJ-2PSA	DRY CELL	1		
4	E03614-004	FM FEEDER ANTENNA	1		BS,EF,EN,GI	
5	E67007-001	ANTENNA WIRE	1		G	
	EQB4001-015	LOOP ANTENNA	1			
	6	EMZ2001-014	ADAPTOR PLUG	1		Except G
	7	QPGA025-03505B	POLY BAG	1		
	-	BT-20066A	WARRANTY CARD	1		BS
-	BT-20134	WARRANTY CARD	1		G	
	BT20060	WARRANTY CARD	1		BS	
	EMC0202-001BS	AC PLUG	1		BS	
	E43486-340A	SAFETY SHEET	1		BS	

The Marks for Designated Areas

EF Continental Europe

EN Scandinavia

G Germany

GI Italy

BS the U.K.

No mark indicates all area.

Packing Materials and Part Numbers

Symbol No.

M	3	M	M
---	---	---	---

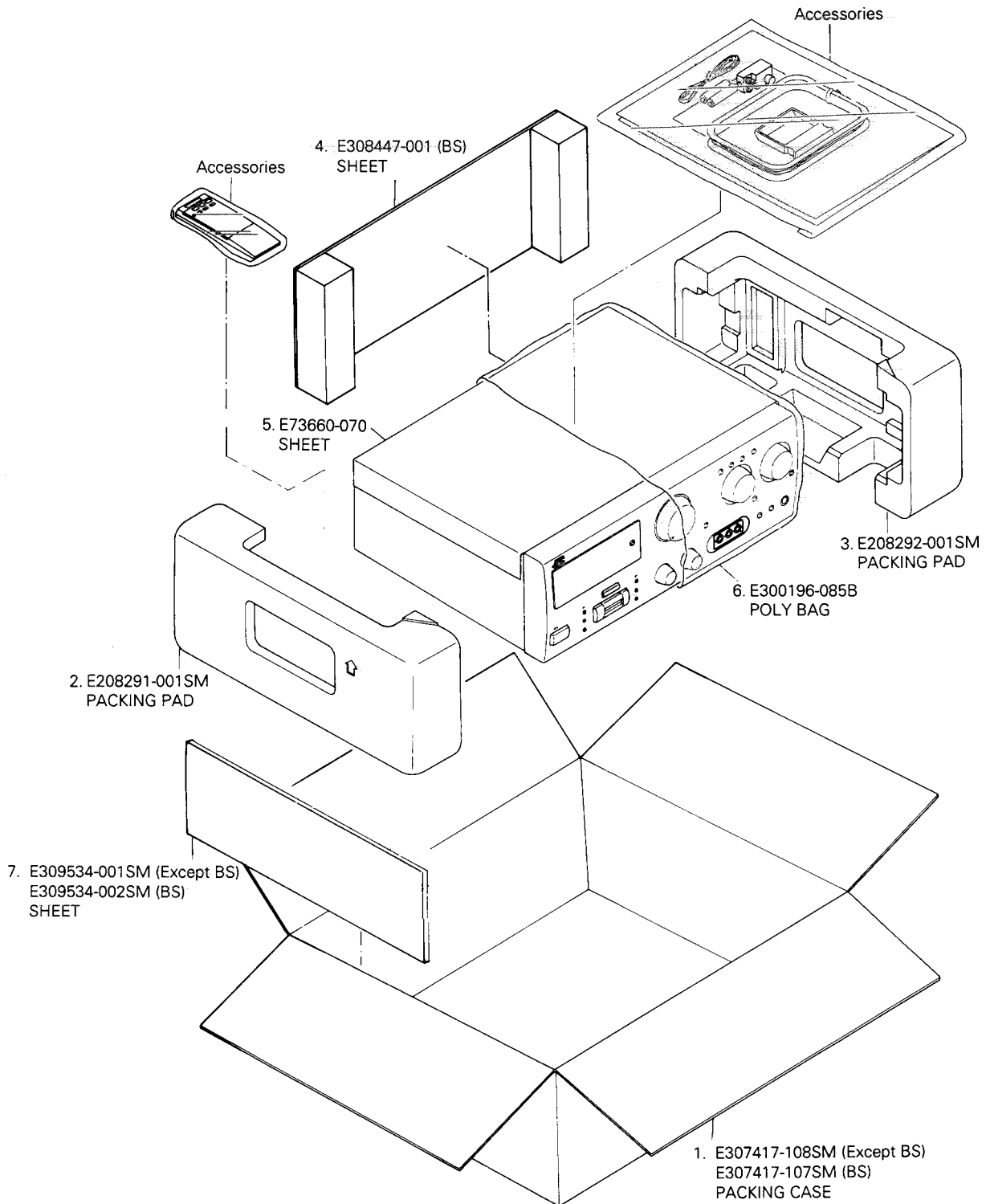

The Marks for Designated Areas

BS	the U.K.	G	Germany	GI	Italy	EN	Scandinavia
EF	Continental Europe									
No mark indicates all area.											

RX-816RBK

JVC

VICTOR COMPANY OF JAPAN, LIMITED

AUDIO DIVISION, YAMATO PLANT, 1644, SHIMOTSURUMA, YAMATO-SHI, KANAGAWA-KEN, 242, JAPAN

(No. 20535)



Printed in Japan
9506 (S)