

# JVC

## SERVICE MANUAL

### AUDIO/VIDEO CONTROL RECEIVER

# RX-816VBK RX-817VTN

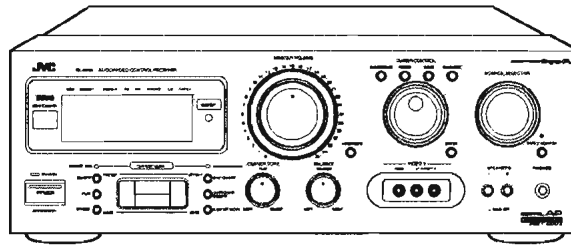
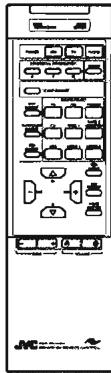

(RX-816VBK)

#### Area Suffix

A	.....	Australia
C	.....	Canada
J	.....	the U.S.A.
UT	.....	Taiwan
U	.....	Other Area

**COMPU LINK**  
 Remote  
 Control Component

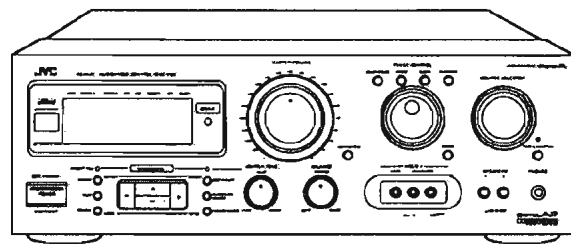
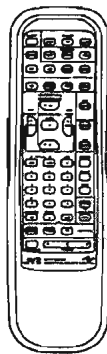

(RX-817VTN)

**AV COMPU LINK**

**COMPU LINK**  
 Remote  
 Control Component

## Contents

<i>Safety Precautions</i> .....	1-2	<i>Adjustment Procedures</i> .....	1-42
<i>Instruction Book</i> .....	1-3	<i>Block Diagrams</i> .....	1-44
<i>Description of Major ICs</i> .....	1-21	<i>Schematic Diagrams</i> .....	Insertion
<i>Internal Connection of FL Display</i> .....	1-38	<i>Printed Circuit Boards</i> .....	Insertion
<i>Disassembly Procedures</i> .....	1-40	<i>Parts List</i> .....	Separate-volume Insertion

RX-816VBK  
RX-817VTN

## Safety Precautions

1. The design of this product contains special hardware and many circuits and components specially for safety purposes. For continued protection, no changes should be made to the original design unless authorized in writing by the manufacturer. Replacement parts must be identical to those used in the original circuits. Services should be performed by qualified personnel only.
2. Alterations of the design or circuitry of the product should not be made. Any design alterations of the product should not be made. Any design alterations or additions will void the manufacturer's warranty and will further relieve the manufacture of responsibility for personal injury or property damage resulting therefrom.
3. Many electrical and mechanical parts in the products have special safety-related characteristics. These characteristics are often not evident from visual inspection nor can the protection afforded by them necessarily be obtained by using replacement components rated for higher voltage, wattage, etc. Replacement parts which have these special safety characteristics are identified in the Parts List of Service Manual. Electrical components having such features are identified by shading on the schematics and by ( $\Delta$ ) on the Parts List in the Service Manual. The use of a substitute replacement which does not have the same safety characteristics as the recommended replacement parts shown in the Parts List of Service Manual may create shock, fire, or other hazards.
4. The leads in the products are routed and dressed with ties, clamps, tubings, barriers and the like to be separated from live parts, high temperature parts, moving parts and/or sharp edges for the prevention of electric shock and fire hazard. When service is required, the original lead routing and dress should be observed, and it should be confirmed that they have been returned to normal, after re-assembling.
5. Leakage current check (Electrical shock hazard testing)  
After re-assembling the product, always perform an isolation check on the exposed metal parts of the product (antenna terminals, knobs, metal cabinet, screw heads, headphone jack, control shafts, etc.) to be sure the product is safe to operate without danger of electrical shock.  
Do not use a line isolation transformer during this check.

- Plug the AC line cord directly into the AC outlet. Using a "Leakage Current Tester", measure the leakage current from each exposed metal parts of the cabinet, particularly any exposed metal part having a return path to the chassis, to a known good earth ground. Any leakage current must not exceed 0.5mA AC (r.m.s.).

- Alternate check method  
Plug the AC line cord directly into the AC outlet. Use an AC voltmeter having, 1,000 ohms per volt or more sensitivity in the following manner. Connect a 1,500 $\Omega$  10 W resistor paralleled by a 0.15  $\mu$ F AC-type capacitor between an exposed metal part and a known good earth ground.

Measure the AC voltage across the resistor with the AC voltmeter.

Move the resistor connection to each exposed metal part, particularly any exposed metal part having a return path to the chassis, and measure the AC voltage across the resistor.

Now, reverse the plug in the AC outlet and repeat each measurement. Any voltage measured must not exceed 0.75 V AC (r.m.s.). This corresponds to 0.5 mA AC (r.m.s.).

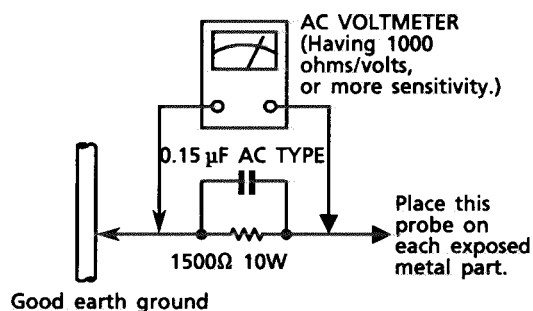

## Warning

1. This equipment has been designed and manufactured to meet international safety standards.
2. It is the legal responsibility of the repairer to ensure that these safety standards are maintained.
3. Repairs must be made in accordance with the relevant safety standards.
4. It is essential that safety critical components are replaced by approved parts.
5. If mains voltage selector is provided, check setting for local voltage.

**Table of Contents**

**Introduction** ..... 2

**Switches, Buttons and Controls** ..... 2

**Getting Started**..... 3

Before Installation ..... 3

Checking the Supplied Accessories ..... 3

Connecting the FM and AM Antennas ..... 4

Connecting the Speakers ..... 4

Connecting Audio/Video Components ..... 7

Connecting Audio/Video Components for the COMPULINK-3 Remote Control System ..... 8

Connecting Video Components for the AV COMPULINK Remote Control System ..... 8

Power Supply through the RX-817VTN to the Connected Components ..... 9

Connecting the Power Cord ..... 9

Putting Batteries in the Remote Control ..... 9

**Basic Operations** ..... 10

Turning the Power On and Off ..... 10

Selecting the Source to Play ..... 10

Selecting the Front Speakers ..... 11

Adjusting the Volume ..... 11

Adjusting the Front Speaker Output Balance ..... 11

Listening at Low Volume (Loudness) ..... 12

Recording a Source ..... 12

Listening with Headphones ..... 12

Muting the Sound ..... 12

**Receiving Radio Broadcasts** ..... 13

Tuning in Stations Manually ..... 13

Using the Preset Tuning ..... 13

Selecting the FM Reception Mode ..... 14

Assigning Names to Preset Stations ..... 15

Using the Preset SEA Modes ..... 16

Using the Digital Surround Processor ..... 17

Using the DAP Modes ..... 17

Using the Surround Modes ..... 19

**Other Features** ..... 23

Recording Monitor ..... 23

Using the CSRSP Function ..... 23

Using the Sleep Timer ..... 24

Using the Remote Control ..... 24

Operating Other Manufacturers' Components ..... 26

COMPULINK Remote Control System ..... 30

AV COMPULINK Remote Control System ..... 31

**Troubleshooting** ..... 32

**Specifications** ..... 33

**Introduction**

Become familiar with the main switches and controls on your RX-817VTN before use.

**Switches, Buttons and Controls**

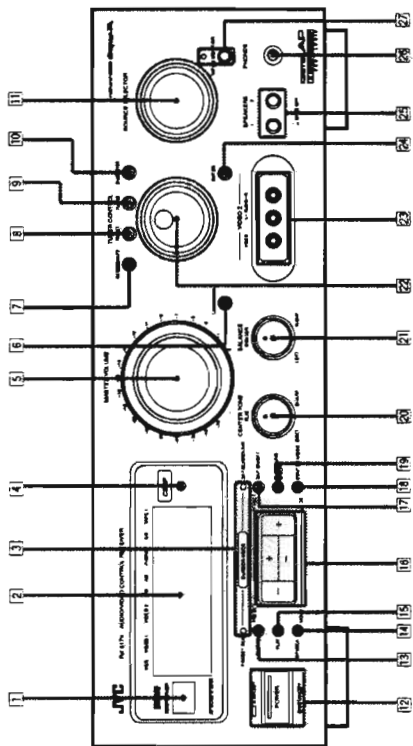

Refer to the pages in parentheses for details.

**Front Panel**

- 1 Remote sensor
- 2 Display (10)
- 3 CURSOR MODE button and indicators (16, 18, 20, 22)
- 4 CSRSP button (23)
- 5 MASTER VOLUME control (11)
- 6 LOUDNESS button (12)
- 7 FM MODE/MUTE button (14)
- 8 PRESET button (14)
- 9 TUNING button (13)
- 10 CHARACTER button (15)
- 11 SOURCE SELECTOR (10) indicator (10)
- 12 POWER button and STANDBY indicator (10)
- 13 Preset SEA ON/OFF button (16)
- 14 SPI/SEA (Spectrum Peak Indicator/Sound Equalizing Amplifier) button (16)
- 15 FLAT button (16)
- 16 CURSOR buttons (+/-) (16, 18, 20, 22)
- 17 DAP ON/OFF button (17)
- 18 CENTER MODE button (20)
- 19 SURROUND ON/OFF button (20, 22)
- 20 CENTER TONE control (22)
- 21 BALANCE control (11)
- 22 TUNER CONTROL (13, 15)
- 23 VIDEO 2-input jacks (7)
- 24 ENTER button (13, 15)
- 25 SPEAKERS 1/2 buttons (11)
- 26 PHONES jack (12)
- 27 TAPE 2 MONITOR button and indicator (10, 23)

**Remote Control**

- 1 SLEEP button (24)
- 2 Source selecting buttons (10)
- 3 Sound adjustment buttons (16, 18, 20, 22)
- 4 LIGHTING button (24)
- 5 CONTROL section (TAPE 1, VCR, and TV buttons) (25, 26, 28)
- 6 FADE MUTING (12)
- 7 POWER section (VCR, TV, and AUDIO buttons) (10, 25, 26, 28)
- 8 CONTROL section (DAP, SURR., and SEA buttons) (16, 17, 20, 22)
- 9 Sound mode on/off buttons (16, 17, 20, 22)
- 10 Surround adjustment buttons (18, 21)
- 11 CD CHANGER buttons (25) (TRACK and DISC buttons)
- 12 VOLUME buttons (+/-) (11)

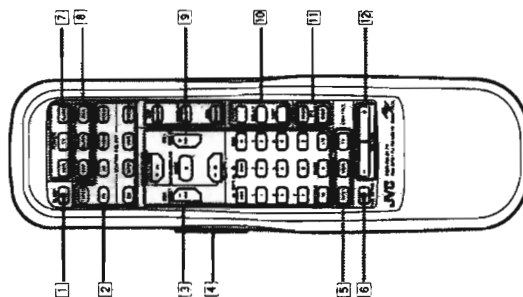

## Getting Started

This section explains how to connect stereo components and speakers to the RX-817VTN, and how to connect the power supply.

### Before Installation

#### General

- Be sure your hands are dry.
- Turn the power off to all components.
- Read the manuals supplied with the components you are going to connect.

#### Locations

- Install the unit in a location that is level and protected from moisture.
- The temperature around the unit must be between 23° and 104° F (-5° and 40° C).
- Make sure there is good ventilation around the unit. Poor ventilation could cause overheating and damage the unit.

#### Handling the unit

- Do not insert any metal object into the unit.
- Do not disassemble the unit or remove screws, covers, or cabinet.
- Do not expose the unit to rain or moisture.

### Checking the Supplied Accessories

Check to be sure you have all of the following items, which are supplied with the RX-817VTN.

- Remote Control (1)
- Batteries (2)
- AM Loop Antenna (1)
- FM Feeder Antenna (1)
- Antenna Adaptor (1)

If anything is missing, contact your dealer immediately.

## Connecting the FM and AM Antennas

### FM Antenna Connections

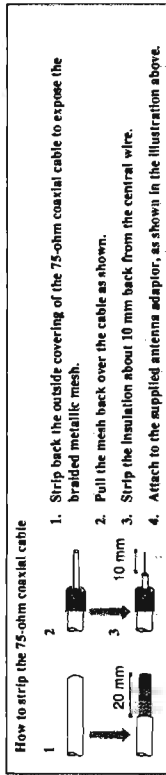
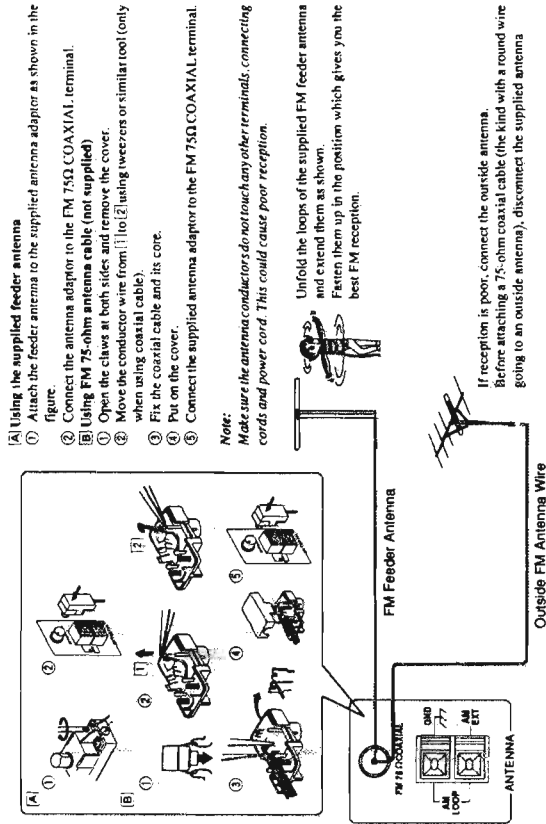

### AM Antenna Connections

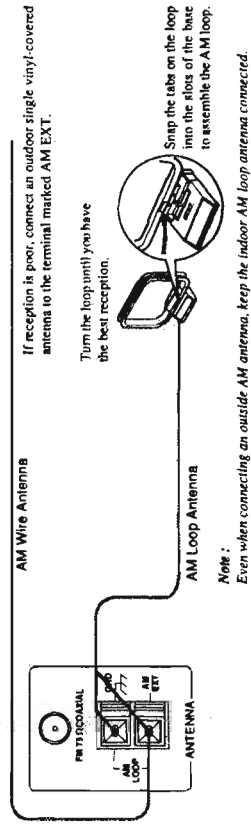

**Connecting the Speakers**

You can connect the following speakers:

- Two sets of front speakers to produce normal stereo sound.
- One set of rear speakers to enjoy the surround effect.
- One center speaker to produce more effective surround effect (to make human voices outstanding).
- One subwoofer speaker to enhance the bass. For connecting a subwoofer, see page 6.

For each speaker, connect one end of the speaker signal cable (not supplied) to the speaker terminal on the rear panel and the other end to the speaker.

1. Open each terminal.
2. Insert the end of the speaker signal cable as shown (be sure to remove the insulation at the end of each wire first).
3. Close the terminals to clamp the speaker signal cables firmly in place.
4. Connect the black (-) and red (+) terminals on the rear panel to the black (-) and red (+) terminals marked on the speakers.



**CAUTION:**  
Use speakers with the same SPEAKER IMPEDANCE indicated by the speaker terminals.

**Connecting the front speakers**

Connect the front speakers to the FRONT SPEAKERS terminals.

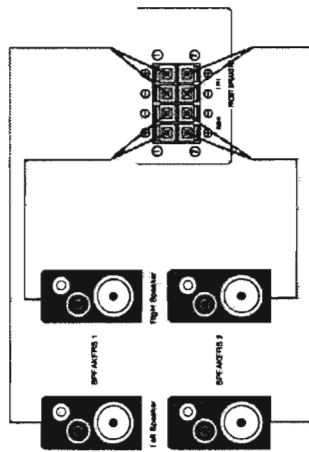

**Connecting the rear and center speakers**

Connect rear speakers to the REAR SPEAKERS terminals and a center speaker to the CENTER SPEAKER terminals.

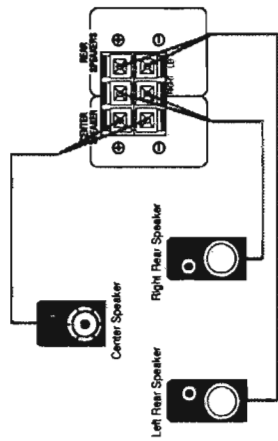

**Note:**  
When you connect rear speakers, make sure that both left and right speakers are connected, otherwise, no sound will come out of the rear speakers.

**Increasing the power for the rear speakers**

You can use a separate power amplifier to reinforce sounds through the rear speakers.

1. Connect the input jacks of the power amplifier to the REAR OUT jacks on the rear panel.
2. Connect the rear speakers to the speaker terminals of the power amplifier.

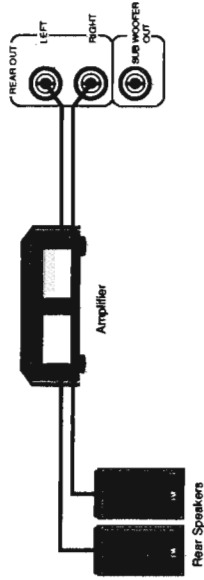

**Enhancing the bass**

You can enhance the bass by connecting a subwoofer. To connect a subwoofer, you also need a separate power amplifier.

1. Connect the input jack of the power amplifier to the SUB WOOFER OUT jack on the rear panel.
2. Connect a subwoofer speaker to the speaker terminal of the power amplifier.

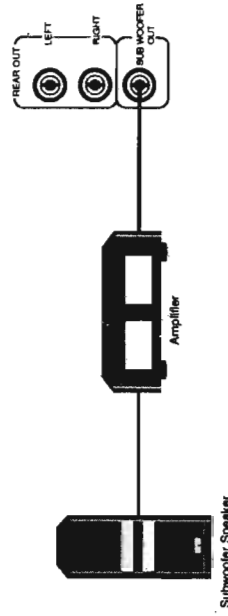



## Basic Operations

The following operations are commonly used when you play any sound source.

### Turning the Power On and Off

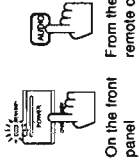

To turn on the power, press the POWER button on the front panel or the AUDIO button of the POWER section on the remote control.  
The STANDBY indicator goes off.

To turn off the power, press the POWER button or the AUDIO button of the POWER section on the remote control again.  
The STANDBY indicator lights up.

### Selecting the Source to Play

You need to select the source to listen before you start playing any source.

On the front panel:

Turn the SOURCE SELECTOR so that the desired source name appears on the display (at the same time the arrow (▲) on the display points the source).

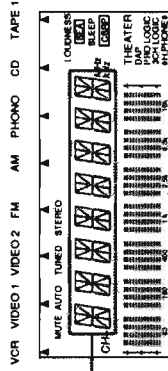

Selected source name appears

- VCR View the video component connected to the VCR jacks.
- VIDEO 1 View the video component connected to the VIDEO 1 jacks.
- VIDEO 2 View the video component connected to the VIDEO 2 jacks.
- FM Listen to an FM broadcast.
- AM Listen to an AM broadcast.
- PHONO Listen to a record.
- CD Listen to the CD player.
- TAPE 1 Listen to the cassette deck connected to the TAPE 1 jacks.

To listen to the cassette deck connected to the TAPE 2 jacks, press the TAPE 2 MONITOR button (or the TAPE 2 button on the remote control) so that the TAPE 2 MONITOR indicator lights up on the front panel ("ON" appears on the display). However, do not press the TAPE 2 MONITOR (or TAPE 2) button if no component is connected to the TAPE 2 jacks; otherwise, no sound comes out of the speakers.

From the remote control:

Press the desired source selecting buttons.

- VCR View the video component connected to the VCR jacks.
- VIDEO 1 View the video component connected to the VIDEO 1 jacks.
- VIDEO 2 View the video component connected to the VIDEO 2 jacks.
- FM\* Listen to an FM broadcast.
- AM\* Listen to an AM broadcast.
- PHONO\* Listen to a record.
- CD\* Listen to the CD player.
- TAPE 1\* Listen to the cassette deck connected to the TAPE 1 jacks.
- TAPE 2 Listen to the cassette deck connected to the TAPE 2 jacks.

Notes:

- \* The TAPE 2 MONITOR button on the front panel and the TAPE 2 button on the remote control have a different function from other source selecting buttons, since this button allows you to monitor the recording. For more details, see "Recording Monitor" on page 23.
- \* When you press one of the source selecting buttons marked above with an asterisk (\*), the RX-817VTN automatically turns on.

## Power Supply through the RX-817VTN to the Connected Components

You can use the AC outlets on the rear of the RX-817VTN to supply power to audio components. These AC outlets are "switched" outlets. So when the RX-817VTN is off (that is, in standby mode), power is not supplied through these outlets. By turning the RX-817VTN on and off, you can turn the connected components on and off at the same time.

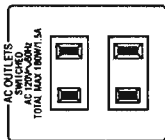

Note:  
Do not use the AC outlets on the rear of the RX-817VTN to supply power to the components in the COMPU LINK remote control system; otherwise, the COMPU LINK remote control system may not work correctly.

**CAUTION:**  
Do not plug the components to the AC outlets on the rear if their total power consumption is greater than indicated by the AC outlets.

## Connecting the Power Cord

Before plugging the RX-817VTN into an AC outlet, make sure that all connections have been made. When the power cord is connected, the STANDBY indicator above the POWER button lights up.

Keep the power cord away from the connecting cables for the TV, VCR, and antenna. The power cord may cause noise or screen interference. We recommend that you use a coaxial cable to connect the antenna, since it is well-shielded against interference.

Notes:

- \* A small amount of power is always consumed even in standby mode. To switch off the power completely, unplug the power cord from the AC outlet.
- \* If the power cord is unplugged or a power failure occurs, preset settings will be erased in a few days.

**CAUTIONS:**

- Do not touch the power cord with wet hands.
- Do not pull on the power cord to unplug the unit. When unplugging the unit, always grasp the plug itself so as not to damage the cord.

## Putting Batteries in the Remote Control

Before using the remote control, put two supplied batteries first. When using the remote control, aim the remote control directly at the remote sensor on the RX-817VTN.

1. On the back of the remote control, press down on the battery cover and slide it out.
2. Insert batteries. Make sure to observe the proper polarity: (+) to (+) and (-) to (-).
3. Slide the cover in.

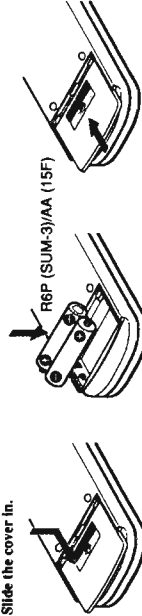

If the range or effectiveness of the remote control decreases, replace the batteries. Use two R6P (SUM-3) AA (15F) type dry-cell batteries.

**CAUTIONS:**

- Follow these precautions to avoid leaking or cracking cells.
- Place batteries in the remote control so they match the polarity indicated: (+) to (+) and (-) to (-).
- Use the correct type of batteries. Batteries that look similar may differ in voltage.
- Always replace both batteries at the same time.
- Do not expose batteries to heat or flame.

### Selecting the Front Speakers

When you have connected two sets of front speakers, you can select which to use. Pressing in the SPEAKERS 1 or SPEAKERS 2 button activates the respective set of speakers.



To use the set of speakers connected to the FRONT SPEAKERS ① terminals, press in the SPEAKERS 1 button (=ON), and press out the SPEAKERS 2 button (=OFF).  
To use the set of speakers connected to the FRONT SPEAKERS ② terminals, press in the SPEAKERS 2 button (=ON), and press out the SPEAKERS 1 button (=OFF).  
To use both sets of speakers, press in both the SPEAKERS 1 and 2 buttons (=ON).  
To use neither set of speakers, press out both the SPEAKERS 1 and 2 buttons (=OFF).

**Note:**  
When only one set of the front speakers is connected to either the FRONT SPEAKERS ① or ② terminals, do not press in both SPEAKERS 1 and 2 buttons (=ON). If you do, no sound comes out of the front speakers.

### Adjusting the Volume

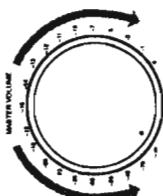

**On the front panel:**  
To increase the volume, turn the MASTER VOLUME control clockwise.  
To decrease the volume, turn it counterclockwise.

**From the remote control:**  
To increase the volume, press the VOLUME + button.  
To decrease the volume, press the VOLUME - button.

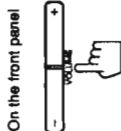

From the remote control

**CAUTION:**  
Always set the MASTER VOLUME control to the minimum before starting any source. If the MASTER VOLUME control is left turned up, the sudden blast of sound energy can permanently damage your hearing and/or ruin your speakers.

### Adjusting the Front Speaker Output Balance

If the sounds you hear from the right and left front speakers are unequal, you can adjust the speaker output balance with the BALANCE control.

To decrease the left channel sound, turn the BALANCE control clockwise.  
To decrease the right channel sound, turn it counterclockwise.

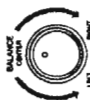

### Listening at Low Volume (Loudness)

Human ears are not sensitive to bass at low volume. To compensate for this, the loudness function automatically boosts the bass level as you lower the volume.



To use the loudness function, press the LOUDNESS button on the front panel.  
The LOUDNESS indicator lights up on the display.

To turn the function off, press the LOUDNESS button again.  
The LOUDNESS indicator goes off.

### Recording a Source

You can record any source playing through the RX-817VTN to the cassette decks connected to the TAPE 1 and TAPE 2 jacks, and the VCR connected to the VCR jacks at the same time.  
While recording, you can listen to the selected sound source at whatever sound level you like, without affecting the sound levels of the recording.

**Notes:**

- When recording from the cassette deck connected to the TAPE 2 jacks to the one connected to TAPE 1, press TAPE 2 MONITOR button and select a source other than TAPE 1.
- The output volume level, preset SEA modes and surround effects will not affect the recording.
- See also "Recording Monitor" on page 23.

### Listening with Headphones

A standard pair of headphones can be connected to the PHONES jack on the front panel. Be sure to turn down the volume before connecting or putting on headphones, as high volume can damage both the headphones and your hearing.

To listen with only headphones  
Press out both the SPEAKERS 1 and 2 buttons (=OFF).

### Muting the Sound

You can easily turn off the volume by pressing the FADE MUTING button on the remote control.



To mute the sound through all speakers and headphones connected  
Press the FADE MUTING button so that "MUTING" appears on the display and the VOLUME control turns down.

To cancel the mute, turn the VOLUME control clockwise on the front panel or press the VOLUME + button (or the VOLUME - button) on the remote control.



## Receiving Radio Broadcasts

You can browse through all the stations or use the preset function to go immediately to a particular station.

### Tuning in Stations Manually

- 1. Select the band.**  
**On the front panel:**  
 Turn the SOURCE SELECTOR.  
**From the remote control:**  
 Press the FM button or the AM button so that the last received station is tuned in.  
*Note:*  
 If you do not see a preset channel number on the display, the RX-817VTN is already in the manual tuning mode, so skip Step 2 below.
- 2. Press the TUNING button to set the tuning mode to the manual mode.**
- 3. Turn the TUNER CONTROL, clockwise or counterclockwise.**  
 Turning it clockwise increases the frequency.  
 Turning it counterclockwise decreases the frequency.



#### Notes:

- When you turn the TUNER CONTROL fast, the frequency keeps changing until you turn the TUNER CONTROL again or a station is tuned in.
- When a station of sufficient signal strength is tuned in, the TUNED indicator lights up on the display.  
 When an FM stereo program is received, the STEREO indicator also lights up.

### Using the Preset Tuning

Once a station is assigned to a channel number, the station can be quickly tuned. You can preset up to 40 stations, either AM, FM, or a mixture of both, at random.

### Storing the preset stations

- 1. Tune in the station you want to preset (see above).**
- 2. Press the ENTER button.**  
 "CH: ----" appears on the display for 5 seconds.
- 3. Select a channel number within the 5 seconds.**  
**On the front panel:**  
 Turn the TUNER CONTROL.  
**From the remote control:**  
 Press the TUNER PRESET + button or TUNER PRESET - button to select a channel number, or:  
 Press the 10 keys to directly select a channel number.  
 Examples: For channel number 5, press 5. For channel number 15, press +10 then 5.  
 For channel number 20, press +10 then 10.



*Note:*  
 When you use the remote control, be sure that the remote control are activated for tuner, not for the CD and others. (See page 24.)

- 4. Press the ENTER button again while the selected channel number is flashing on the display.**  
 The selected channel number stops flashing, and the station is assigned to the selected channel number.

To cancel a stored preset station  
 Storing a new station on a used number erases the previously stored one.

**CAUTION:**  
 Preset stations may be erased when power is cut off to the RX-817VTN, as when it is unplugged from the AC outlet or a power failure occurs. If the preset stations are lost, simply set the stations again using the above procedure.

### Tuning in a Preset Station



- On the front panel:**
- 1. Turn the SOURCE SELECTOR to select either FM or AM.**  
 The last received station of the selected band is tuned in.

*Note:*  
 If you see a preset channel number on the display, the RX-817VTN is already in the preset tuning mode, so skip Step 2 below.



- 2. Press the PRESET button to set the tuning mode to the preset mode.**
- 3. Turn the TUNER CONTROL to select a preset channel number.**  
 Turning it clockwise changes preset channels in increasing order.  
 Turning it counterclockwise changes preset channels in decreasing order.



#### On the remote control:

- 1. Press the FM button or the AM button.**  
 The last received station of the selected band is tuned in.
- 2. Press the TUNER PRESET + or TUNER PRESET - to select a preset channel number, or:**  
 Press the 10 keys to directly select a preset channel number.  
 Examples: For channel number 5, press 5. For channel number 15, press +10 then 5.  
 For channel number 20, press +10 then 10.

#### Note:

When you use the remote control, be sure that the remote control are activated for tuner, not for the CD and others. (See page 24.)

### Selecting the FM Reception Mode

You can change the FM reception mode so that reception will be improved.



**When an FM stereo broadcast is hard to receive or noisy**  
 Press the FM MODE/MUTE button on the front panel. The MUTE AUTO indicator goes off on the display. Reception will be improved although you will lose the stereo effect. In this mode, you will hear noise while tuning into the stations.

**To restore stereo effect**  
 Press the FM MODE/MUTE button again so that the MUTE AUTO indicator lights up on the display. In this mode, when a program is broadcast in stereo, you will hear stereo sound; when in monaural, you will hear monaural sounds. This mode is also useful to suppress static noise between stations.

### Using the Preset SEA Modes

The RX-817VTN has five preset SEA (Sound Effect Amplifier) modes (COUNTRY, JAZZ, ROCK, MUSICAL, and MOVIE) which give you control of the way your music sounds, so you can create it for your room and for the quality of the source.

On the front panel:

1. Press the ON/OFF button under the PRESET SEA indicator so that the SEA indicator lights up on the display.  
Now the previously selected preset SEA mode comes into effect.
2. Press the left or right cursor button (+/-) to select a preset SEA mode.  
Pressing the button changes the preset SEA modes in the following sequence:

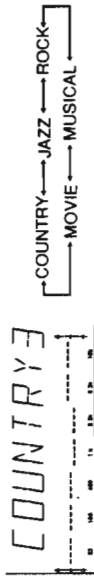

**COUNTRY:** Enhances the high-frequency range so that instruments such as a violin and banjo sound outstanding.

**JAZZ:** Gives a feeling of a live atmosphere. Good for acoustic music.

**ROCK:** Gives a heavy sound. Both high and low frequencies are boosted.

**MUSICAL:** Enhance the mid-frequency range which human voice is mostly made up of.

**MOVIE:** Add breath to sounds so you feel like you are in a movie theater.

**Note:**

When using the cursor buttons, make sure that the PRESET SEA indicator on the front panel is turned on. If not, press the CURSOR MODE button once so that the cursor buttons can be used for selecting a preset SEA mode and its level.

3. Press the upper or lower cursor button (+/-) to select the level (from 1 to 5) of the preset SEA mode selected in a above step.  
Pressing the upper cursor button (+) increases the SEA preset level.  
Pressing the lower cursor button (-) decreases the SEA preset level.

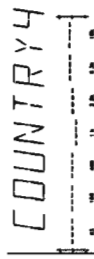

From the remote control:

1. Press the SEA button of the CONTROL section.  
Now you can use the remote control for selecting the SEA modes.
2. Press the SEA ON/OFF button so that the SEA indicator lights up on the display.  
Now the previously selected preset SEA mode comes into effect.
3. Press the SEA MODE button.  
Each time you press the button, the preset SEA modes changes.
4. Press the SEA PRESET button repeatedly.  
Each time you press the button, the SEA preset level changes.

To flatten the equalizing curve while using the preset SEA modes  
Press the FLAT button on the front panel so that "SEA FLAT" appears on the display.

To compare the original sound and the sound processed by using the preset SEA modes  
Press the ON/OFF button on the front panel for the preset SEA modes repeatedly. (When using the remote control, press the SEA ON/OFF button.)

- While the SEA indicator is turned on, you can listen to the processed sound.
- While the SEA indicator is turned off, you can listen to the original sound.

To see the actual sound output level on the display (Spectrum Peak Indicator mode)  
Press the SP/SEA button on the front panel so that the actual sound output level can be shown in 7 frequency ranges on the display.  
To cancel it, press the button again.

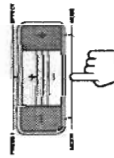
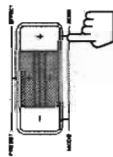

### Assigning Names to Preset Stations

You can assign a name of up to four characters to each preset station (from channel number 1 to 20). When a preset station is tuned in, its assigned name will appear on the display.

On the front panel only:

1. Tune in a preset station (channel number 1 to 20).  
See page 14 for details.
2. Press the CHARACTER button.  
The cursor appears at the first character position.



3. Turn the TUNER CONTROL to select the first character.  
You can use characters listed below

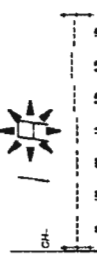

4. When the character you want appears, press the CHARACTER button.  
The cursor moves to the next character position.

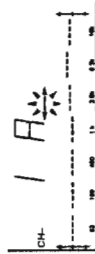

5. Repeat Steps 3 and 4 to enter up to four characters.

6. Press the ENTER button after you have assigned a name.



To erase the input characters  
Insert blanks using the same procedure described above.

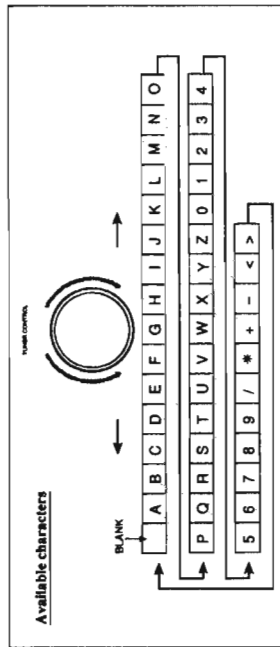

## Using the Digital Surround Processor

The built-in digital surround processor provides two groups of programs — DAP (Digital Acoustic Processor) modes and surround modes (Dolby Surround\* and JVC Theater Surround). You cannot use these DAP modes and surround modes at the same time.

**Notes:**

- The digital surround processor has no effect on monaural sources.
- The digital surround processor cannot be used for recording.
- Manufactured under license from Dolby Laboratories Licensing Corporation. Additionally licensed under one or more of the following patents: U.S. number 3,959,590; Canadian number 1,004,603 and 1,037,877. "Dolby", "Pro Logic", and the double-D symbol are trademarks of Dolby Laboratories Licensing Corporation.

### What can the digital surround processor do?

The sound heard in a concert hall or a movie theater consists of direct sound and indirect sound: early reflections and reflections from behind. The reflected sounds are always delayed by the distances of the ceiling and walls from the listener. The early reflections are some of the most important elements of the acoustic surround. So, what the digital surround processor does is to reproduce these elements in your listening room.

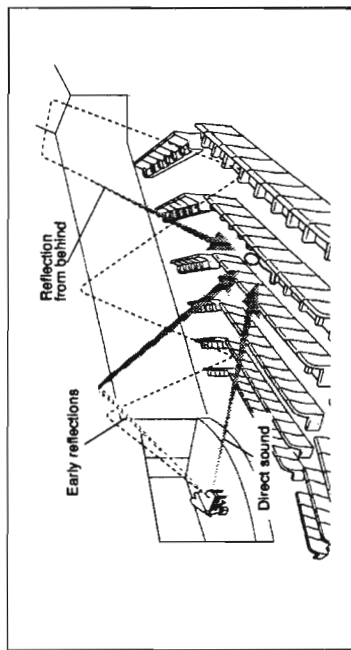

## Using the DAP Modes

You need to connect the front and rear speakers to enjoy the DAP modes — HALL, L(live) CLUB, PAVILION, D(ance) CLUB. By using these modes, the sound field can be enlarged to give a more realistic sound. The DAP modes do not require the center speaker.

When you use these four modes, you can adjust the output level of the rear speaker output and the effect depth. Once you have adjusted these, the RX-817VTN memorizes the setting for each mode.

Among the DAP modes, H PHONES (headphones) is very special and newly developed by JVC. It can create the same stereo sound as you can listen from the speakers in air. So, when you listen to a source using headphones, you can feel as if you were not using headphones.

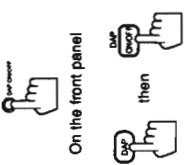

**1. Set the DAP mode on.**

- On the front panel: Press the DAP ON/OFF button so that the DAP indicator lights up on the display. When you have selected H PHONES (headphones) previously, the H-PHONE indicator also lights up on the display.
- From the remote control: I-1 Press the DAP button of the CONTROL section. I-2 Press the DAP ON/OFF button so that the DAP indicator lights up on the display. When you have selected H PHONES (headphones) previously, the H-PHONE indicator also lights up on the display.

**2. Select the mode you want.**

On the front panel: Press the left or right cursor button (+/-) repeatedly until the mode you want appears on the display. From the remote control: Press the DAP/SURROUND MODE button repeatedly until the mode you want appears on the display. Each time you press the button, the DAP modes change as follows (when using the button on the remote control, it changes only rightward):

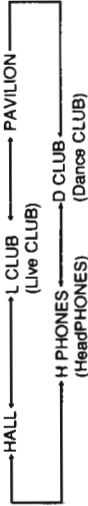

- HALL:** Gives clear vocal and the feeling of a concert hall.
- L CLUB:** Gives the feeling of a live music club with the low ceiling.
- PAVILION:** Gives the spacious feeling of a pavilion with the high ceiling.
- D CLUB:** Gives a throbbing bass beat.
- H PHONES:** Gives a spacious stereo effect when listening with headphones.

**Note:** When using the cursor buttons on the front panel, make sure that the DAP/SURROUND indicator is turned on. If not, press the CURSOR MODE button once so that the cursor levels of the selecting the DAP modes.

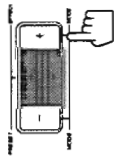

On the front panel



From the remote control

**3. Set the output levels of the rear speakers.**

From the remote control only: Press the REAR + button or the REAR - button to set the sound level of the rear speakers.

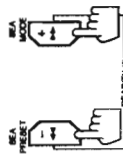

From the remote control

**4. Select the effect depth among 5 preset levels.**

On the front panel: Press the upper or lower cursor button (+/-) repeatedly. To increase the effect depth, press the upper cursor button (+), and to decrease it press the lower cursor button (-).

From the remote control: Press the EFFECT button repeatedly. Selecting the higher number makes the effect deeper.

Each time you press the button, the effect depth changes as follows (when using the button on the remote control, it changes only rightward):



**Note:**

When you have selected H PHONES (headphones) in Step 2 above, you cannot select the effect depth.

**Preparing for the surround modes**

The RX-817VTN memorizes surround adjustments for each mode.

1. Set the surround mode on.  
On the front panel:  
Press the SURROUND ON/OFF button so that one of the surround mode indicators (THEATER, PRO LOGIC, or 3CH LOGIC) lights up on the display.  
From the remote control:  
I-1 Press the SURR. button of the CONTROL section.  
I-2 Press the SURROUND ON/OFF button so that one of the surround mode indicators lights up on the display.

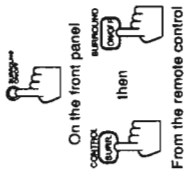

2. Select the mode you want.  
On the front panel:  
Press the left or right cursor button (+/-) repeatedly until the mode you want appears on the display.  
From the remote control:  
Press the DAPSURROUND MODE button repeatedly until the mode you want appears on the display.  
Each time you press the button, the surround modes change as follows (when using the button on the remote control, it changes only rightward):



- PRO LOGIC:** Use this mode to watch a video tape with Dolby Surround when you have connected the rear speakers.
- 3CH LOGIC:** Use this mode to watch a video tape with Dolby Surround when you have connected a center speaker and no rear speakers.
- THEATER 1:** Use this mode to watch a video tape with Dolby Surround when you have connected the rear speakers.
- This mode gives you the feeling of a small movie theater with a seating capacity of 100.
- THEATER 2:** Use this mode to watch a video tape with Dolby Surround when you have connected the rear speakers.
- This mode gives you the feeling of a large movie theater with a seating capacity of 1000.

**Note:** When using the cursor buttons on the front panel, make sure that the DAPSURROUND indicator is turned on. If not, press the CURSOR MODE button once so that the cursor buttons can be used for selecting the surround modes.

3. Set the center mode.  
On the front panel only:  
Press the CENTER MODE button.  
Each time you press the CENTER MODE button, the mode changes as follows.



- PHANTOM:** Select this mode when you have not connected a center speaker.
- NORMAL:** Select this mode when the size of the center speaker is smaller than that of the front speakers.
- WIDE:** Select this mode when the size of the center speaker is the same as that of the front speakers.
- OFF:** Select this mode to shut off the output of the center channel signal.

**Note:** When you have selected 3CH LOGIC in Step 2 above, you cannot select PHANTOM.

**Using the Surround Modes**

You can enjoy two types of surround modes — Dolby Surround and JVC's Theater Surround.

**On Dolby Surround**  
The Dolby Surround has been also developed to reproduce the important elements of the acoustic surround at home.  
To watch the soundtracks of video software bearing the mark which includes the same encoded surround information as found in Dolby Stereo films, the RX-817VTN can provide you with 2 Dolby Surround modes (Dolby Pro Logic and Dolby 3ch Logic).  
**Dolby Pro Logic:** Select this mode when optional rear speakers are connected.  
**Dolby 3ch Logic:** Select this mode when a center speaker is connected without rear speakers.

**On JVC's Theater (1 and 2) Surround**  
In order to reproduce a more realistic sound field in your listening room while playing soundtracks of video software bearing the mark JVC's Theater Surround has been designed to give you clearer vocals and to create the feeling of being there. The sound is reproduced through the front speakers, rear speakers, and center speaker.

**Speaker arrangements for surround modes**

The following illustrations show how to obtain the optimum sound environment for various surround settings. Try to find the speaker direction and location to create the optimum sound field.

**CASE 1** When you have added a center speaker and rear speakers

**In this case:**  
1. Select PRO LOGIC or THEATER 1 or 2.  
2. Select NORMAL or WIDE for center mode.

See page the following pages for more details.

**CASE 2** When you have added rear speakers (without a center speaker)

**In this case:**  
1. Select PRO LOGIC or THEATER 1 or 2.  
2. Select PHANTOM for center mode.

See the following pages for more details.

**CASE 3** When you have added a center speaker (without rear speakers)

**In this case:**  
1. Select 3CH LOGIC.  
2. Select NORMAL or WIDE for center mode.

See the following pages for more details.

**Enjoying the surround modes**

Once you have set the surround adjustments you can use the same adjustments every time you want to enjoy the surround you want.

**On the front panel:**  
1. Press the **SURROUND ON/OFF** button so that one of the surround mode indicators lights up on the display.

2. Press the left or right cursor button (+/-) repeatedly until the surround mode indicator you want lights up. Each time you press the button, the display changes to show the following:



**Note:**  
When using the cursor buttons on the front panel, make sure that the DAP/SURROUND indicator is turned on. If not, press the **CURSOR MODE** button once so that the cursor buttons can be used for selecting the surround modes.

3. Play a sound source which was processed with Dolby Surround and is labeled with **DOLBY SURROUND** mark.

To cancel the surround, press the **SURROUND ON/OFF** button again.

**From the remote control:**

- Press the **SURR.** button of the **CONTROL** section. Now you can use the remote control for selecting the surround modes.
- Press the **SURROUND ON/OFF** button so that one of the surround mode indicator lights up on the display.
- Press the **DAP/SURROUND MODE** button repeatedly until the surround mode indicators you want lights up. Each time you press the button, the display changes to show the following:

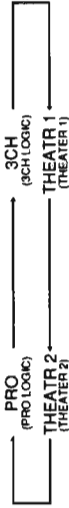

4. Play a sound source which was processed with Dolby Surround and is labeled with **DOLBY SURROUND** mark.

To cancel the surround, press the **SURROUND ON/OFF** button again.

**To make dialogues in movies softer or clearer**

By using the **CENTER TONE** control you can adjust the level of mid-frequency range, which the human voice is mostly made up of.

To make dialogues clearer, turn the control toward **SHARP**.

To make them softer, turn the control toward **SOFT**.

When set to the **FLAT** position, no adjustment is applied.

**Note:**  
The **CENTER TONE** control cannot be used when sounds do not come out of the center speaker.

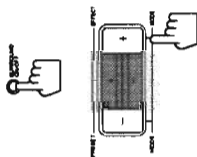

**4. Set the delay time of the delayed sound.**

**From the remote control only:**

Press the **DELAY** button. Each time you press the button, the delay time changes among 4 levels.



**DELAY-1:** When your distance to your rear speakers is greater than that to the front speakers.  
**DELAY-2:** When your distance to your rear speakers is almost equal to that to the front speakers.  
**DELAY-3:** When your distance to your rear speakers is a little less than that to the front speakers.  
**DELAY-4:** When your distance to your rear speakers is much less than that to the front speakers.

**Note:**

When you have selected **3CH LOGIC** in Step 2 above, you cannot adjust the delay time.

**5. Start checking speaker output balance.**

**From the remote control only:**

Press the **TEST** button. When you press the button, "TEST" starts flashing and a test tone comes out of speakers in the following order:

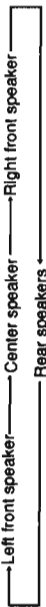

**6. Set the output level of the center and the rear speakers.**

**From the remote control only:**

Press the **CENTER +** button or the **CENTER -** button to set the sound level of the center speaker. Press the **REAR +** button or the **REAR -** button to set the sound level of the rear speakers.

**Notes:**

- You can adjust these levels in 1 dB step within the range of  $\pm 10$  dB. The sound levels of the left and right rear speakers will be the same.
- You cannot set the sound level of the rear speakers when you have selected **3CH LOGIC**.
- You cannot set the sound level of the center speaker when you select **PHANTOM** or **OFF** for center mode.

**7. Finish checking speaker output balance.**

**From the remote control only:**

Press the **TEST** button again. The test tone stops.

**Note:**

When you use the **SOURCE SELECTOR**, the test tone also stops.

**8. Select the effect depth among 5 preset levels only for JVC's Theater Surround.**

**On the front panel:**

Press the upper or lower cursor button (+/-) repeatedly. To increase the effect depth, press the upper cursor button (+), and to decrease it press the lower cursor button (-).

**From the remote control:**

Press the **EFFECT** button repeatedly. Selecting the higher number makes the effect deeper. Each time you press the button, the effect depth changes as follows (when using the button on the remote control, it changes only rightward):



**Note:**

When you have selected Dolby Surround modes in Step 2 above, you cannot select the effect depth.

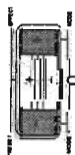
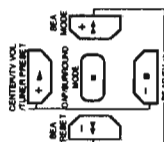

On the front panel



From the remote control

**Other Features**

The RX-817VTN has some other features like the recording monitor function, the CSRSP function and the sleep timer. By using these useful features your audio life will be much improved. The remote control system is more precisely described in this section.

**Recording Monitor**



On the front panel



From the remote control

If the cassette deck connected to the TAPE 2 jacks is of the three-head type, you can compare the sound quality of the playing source and of the recording being made on the cassette deck.

**To use the recording monitor function**

Press the TAPE 2 MONITOR button on the front panel or the TAPE 2 button on the remote control. The TAPE 2 MONITOR indicator lights up on the front panel. You can hear the sound just recorded on the tape.

**To cancel recording monitor function**

Press the TAPE 2 MONITOR button or the TAPE 2 button again. The TAPE 2 MONITOR indicator goes off, and you hear the sound from the source playing.

**Notes:**

- Refer also to the manual supplied with your cassette deck.
- Do not press the TAPE 2 MONITOR (or TAPE 2) button if no component is connected to the TAPE 2 jacks; otherwise, no sound comes out of the speakers.

**Using the CSRSP Function**

The optimum sound settings differ for each playing source. So, you have to change settings each time you select a different source. The JVC's CSRSP (COMPULINK Source-Related Preset) function is used to assign and store different sound settings for each different playing source. By using this function, you don't have to change the settings every time you change the source. The stored settings for the newly selected source are automatically recalled.

The following can be stored for each source:

- Loudness (see page 12)
- Preset SEA modes (see page 16)
- DAP or Surround settings (see pages 17 and 20)

**Notes:**

- For the cassette deck connected to the TAPE 2 jacks, the CSRSP function does not work.
- If the source is FM or AM, the CSRSP function works only when one of the preset channels from 1—20 is tuned in. You can assign a different setting for each preset channel.

**To store the sound settings by using the CSRSP function**

1. Press the CSRSP button on the front panel. The CSRSP indicator starts flashing and remains lit on the display.

2. Select the sound effects listed above while the CSRSP indicator is lit on the display.

**To recall the sound settings**

Whenever the CSRSP indicator is lit on the display, the settings for the currently selected source is always recalled. When you change the source, it takes several seconds to activate the CSRSP function (the CSRSP indicator blinks and the stored settings are shown on the display).

To cancel the CSRSP function, press the CSRSP button so that the CSRSP indicator goes off from the display. (Even though the CSRSP function is canceled, recalled sound effects remains active.)



**Using the Sleep Timer**

Using the sleep timer, you can fall asleep to music and know the RX-817VTN will turn off by itself rather than play all night.

**To set the sleep timer**

Press the SLEEP button on the remote control repeatedly while playing a source. The SLEEP indicator lights up on the display. Each time you press the button, the shut-off time shown on the display changes as shown below:



The RX-817VTN will turn off after the time you have set.

**To check or change the (time remaining until the shut-off time**

Press the SLEEP button once. The remaining time is displayed in minutes. If you press the button repeatedly, you can change the shut-off time.

**To cancel the sleep timer**

Press the SLEEP button repeatedly until the SLEEP indicator goes off.

**Using the Remote Control**

You can operate JVC's audio and video components with this receiver's remote control, since control signals for JVC components are preset in the remote control.

To operate these components with the remote control, first select a source with the source selecting buttons on the remote control. Then, operate that source using the remote control.

**Note:**

If you choose a source on the front panel directly, the remote control will not operate that source. To operate a source with the remote control, the source must be selected using buttons on the remote control.

**To check which source the remote control is activated for**

Press the LIGHTING button on the left side of the remote control.

One of the source selecting buttons is backlit for a while to inform you that the remote control is activated for the backlit source. (Some other buttons are also backlit to show these buttons can be used for the backlit source.)

- If the remote control is activated for either FM or AM, both the FM and AM buttons are backlit.
- If the remote control is activated for TV, no source selecting buttons are backlit.

**Turntable**



After pressing the PHONO button, you can perform the following operations on a turntable:

- ▶ Starts playing.
- Stops playing.

**CD player**

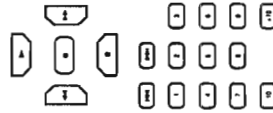

After pressing the CD button, you can perform the following operations on a CD player:

- ▶ Starts playing.
  - ◀ Fast reverses the CD.
  - ▶ Fast forwards the CD.
  - ◀ Returns to the beginning of the current track.
  - ▶ Skips to the beginning of the next track.
  - Stops playing.
  - Stops playing temporarily. To release it, press ▶.
  - 1—10, +10 Selects a track number directly.
- To select track number 5, press 5. For track number 15, press +10, then 5. For track number 20, press +10, then 10.

**Operating Other Manufacturers' Components**

The remote control supplied with the RX-817VTN can transmit control signals for other manufacturers' TVs and VCRs. By changing the transmittable signals from preset ones to the other manufacturers', you can operate the other manufacturer's components using this remote control.

When operating the other manufacturers' components, refer also the manuals supplied with them.

**To change the transmittable signals for operating another manufacturer's TV**

1. Press and hold the TV button of the POWER section on the remote control until the all procedures are completed.
2. Press the TV button of the CONTROL section once.
3. Enter the manufacturer's code (three digits) using buttons 1 - 9, and 0. See the lists on page 27 to find the code.
4. Release the TV button of the POWER section.

The following buttons can be used for operating the TV:

TV (of the POWER section)  
Turns on and off TV.

After pressing the TV button of the CONTROL section, you can perform the following operations on the TV:

- TV VOL. +/- Adjust the TV volume.
- TV ch +/- Changes the TV channels.
- 1 - 10, 0, +10 Selects the TV channels.

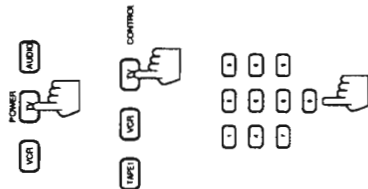
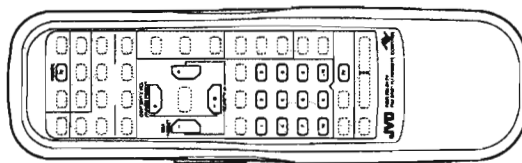

**CD player-changer**

By using the buttons of the CD CHANGER section, you can perform the following operations on a CD player-changer:

After pressing the DISC button, you can select the discs loaded in the CD player-changer and the playing mode:

- 1 - 6, 7/P Select the number of a disc installed in a CD player-changer. Then continue to operate the CD player as described above.
  - CONTINUE Sets the playing mode to the CONTINUE mode.
  - PRGM Sets the playing mode to the PROGRAM mode.
- After pressing the TRACK button, you can select one of the track in the CD using the 10 keys.

**Note:**  
If you have the CD player-changer XL-MC100C and XL-MC100M, 1 - 6 buttons function as the DISC SKIP button.

- Press 2, 4, or 6 to skip to the next disc.
- Press 1, 3, or 5 to skip back to the previous disc.

**Cassette deck**

After pressing the TAPE 1 button, you can perform the following operations on a cassette deck:

- Starts playback.
- Fast winds the tape from right to left.
- Fast winds the tape from left to right.
- Returns to the beginning of the current recording.
- Skips to the beginning of the next recording.
- Stops operation.
- Stops playing or recording temporarily. To release it, press ▶.
- Press this button with ▶ to start recording.
- Press this button with ⏏ to enter the recording standby mode.

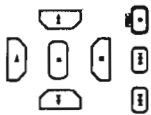

**Note:**  
You can use either one of the TAPE 1 buttons (one as the source selecting button on the SOURCE SELECT section; the other on the CONTROL section). If you press the one on the CONTROL section, you can operate the cassette deck using the remote control, but the playing source will not be changed to TAPE 1.

**VCR**

After pressing the VCR button, you can perform the following operations on a VCR:

- Starts playback.
- Rewinds a tape.
- Fast winds a tape.
- Stops operation.
- Stops playing or recording temporarily. To release it, press ▶.
- Press this button with ▶ to start recording.
- Press this button with ⏏ to enter the recording standby mode.
- VCR ch +/- Changes the TV channels on the VCR.
- 1 - 9, 0 Selects the TV channels.



**Note:**  
You can use either one of the VCR buttons (one as the source selecting button on the SOURCE SELECT section; the other on the CONTROL section). If you press the one on the CONTROL section, you can operate the VCR using the remote control, but the playing source will not be changed to VCR.

**TV**

You can also perform the following operations on a TV (of the CONTROL section):

- Changes the input mode to TV.
- TV VOL. +/- Adjust the TV volume.
- TV ch +/- Changes the TV channels.
- 1 - 9, 0 Selects the TV channels.

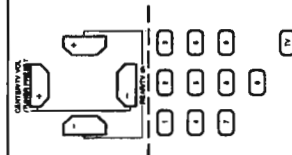

**Note:**  
You can also turn the VCR and the TV on and off by pressing the VCR button and TV button of the POWER section on the remote control.

**Manufacturers' codes for TV**

Anam	180	Sampo	030, 052
Anam National	055	Samsung	019, 030, 039, 056, 060
AOC	019, 030, 052	Sanyo	146, 154, 159
Candle	030, 046, 056, 186	Scott	039, 179, 180, 236
Capchart	052	Sears	047, 056, 146, 149, 154, 156, 159, 171, 178, 179
Citizen	030, 039, 046, 056, 060, 092, 186	Sharp	039, 093, 153, 165
Concord	086	Signature	016
Contec	180	Sony Unified	000
Craig	180	Sony	000, 011, 080, 273
Crown	039	Soundesign	178, 180, 186
Curtis Mathes	030, 039, 060	SSS	019, 180
CXC	180	Supra-Macy	046
Daewoo	019, 039, 092, 451	Sylvania	020, 024, 028, 030, 054, 065, 186, 187
Daytron	039	Symphonic	171
Electrohome	039	Tandy	093
Emerson	039, 177, 178, 179, 180, 181, 236, 270, 280, 282, 463	Taung	055
Envision	030	Technics	051, 250
Fisher	154, 159	Techwood	056
Formosa	093	Teknika	180, 186, 312
Fujitsu	179	Tera	031
Funai	179, 180	THK	056, 178
Futuretech	180	Tohiba	060, 149, 154, 156
GE	021, 027, 029, 047, 051, 055, 178, 282	Television	039
Goldstar	019, 039, 056, 178	Universal	021, 027
Hallmark	178	Vector Research	030
Harman Kardon TV Projector	078	Victor	053, 250
Hitachi	038, 039, 056, 095, 097, 145, 151	Vidtech	019, 178
Infinity	054	Viking	046
JBL	054	Wards	016, 019, 020, 021, 027, 028, 029, 030, 054, 165, 178, 179, 187
JVC	053, 069, 160, 169	Yamaha	019, 030
Kenwood	030	Zenith	016
Kloss	046, 078	Zenith Unified	017
KTV	039, 180, 280		
Logik	016		
Luxman	056		
LXI	047, 054, 154, 156		
Magnavox	020, 024, 028, 050, 054, 186, 187		
Marantz	030, 054		
Marushita	250		
Memorex	016, 154		
MGA	019, 030, 150, 178		
Mitsubishi	019, 178		
Mitsubishi Unified	150		
MTC	019, 030, 056, 060		
Multitech	217		
NAD	156, 166		
NEC	019, 056, 170		
NEC Unified	030		
Novabeam	078		
Onwa	180		
Optonica	093, 165		
Panasonic	051, 054, 055, 250		
Panney	018, 019, 021, 030, 039, 047, 060, 135, 149		
Philco	019, 020, 024, 028, 030, 054, 186, 187		
Philips	000, 054		
Pioneer	038, 166, 172		
Portland	019, 039		
ProScan	047		
Proton	031, 039, 052, 178		
Pulsar	017		
Quasar	051, 055, 250		
Radio Shack	039, 165, 180		
RCA	018, 019, 029, 038, 090, 135		
RCA Unified	047		
Realistic	154		

To change the transmittable signals for operating another manufacturer's VCR

1. Press and hold the VCR button of the POWER section on the remote control until the all procedures are completed.
2. Press the VCR button of the CONTROL section once.
3. Enter the manufacturer's code (three digits) using buttons 1 - 9, and 0. See the lists on page 29 to find the code.
4. Release the VCR button of the POWER section. The following buttons can be used for operating the VCR:  
VCR (of the POWER section)  
Turns on and off VCR.

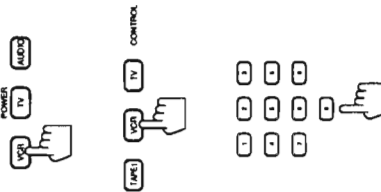

- After pressing the VCR button of the CONTROL section, you can perform the following operations on the VCR:
- ▶ Starts playback
  - ◀◀ Rewinds a tape
  - ▶▶ Fast winds a tape
  - Stops operation.
  - Stops playing or recording temporarily. To release it, press ▶
  - Press this button with ▶ to start recording.
  - Press this button with ■ to enter the recording standby mode.
  - VCR ch +/- Changes the TV channels on the VCR.
  - 1 - 10, 0, +10 Selects the TV channels on the VCR.

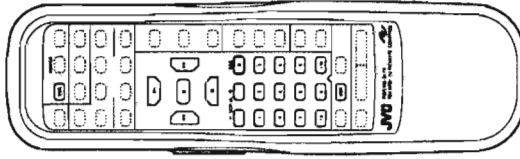



**COMPU LINK Remote Control System**



The COMPU LINK remote control system allows you to operate JVC audio components through the remote sensor on the RX-817VTN.

To use this remote control system, you need to connect JVC audio components through the COMPU LINK-3 SYNCHRO jacks (see page 8) in addition to the connections using cables with RCA pin plugs (see page 7). This remote control system allows you to use four functions listed below.

■ **Remote Control through the Remote Sensor on the RX-817VTN**

You can control all components through the remote sensor on the RX-817VTN using this remote control. For details, see page 24.

Note:

Aim the remote control directly at the remote sensor on the RX-817VTN.

■ **Automatic Source Selection**

When you press the play (▶) button on a connected component or on its own remote control, the RX-817VTN automatically turns on and changes the source to the component. On the other hand, if you select a new source on the RX-817VTN or the remote control, the selected component begins playing immediately. In both cases, the previously selected source continues playing without sound for a few seconds.

■ **Automatic Power On/Off (only possible with the COMPU LINK-3 connection)**

Both the CD player and cassette deck turns on and off along with the RX-817VTN. When you turn on the RX-817VTN, the CD player or cassette deck will turn on automatically, depending on which component has been previously selected. When you turn off the RX-817VTN, both the CD player and cassette deck will turn off.

■ **Synchronized Recording**

Synchronized recording means the cassette deck starts recording as soon as a CD or a record begins playing.

To use synchronized recording, follow these steps:

- 1 Put a tape in the cassette deck, and a disc in the CD player (or a record on the turntable).
- 2 Press the record (●) button and the pause (H) button on the cassette deck at the same time. This puts the cassette deck into recording pause.

Note:

If you do not press the record (●) button and pause (H) button at the same time, the synchronized recording feature will not operate.

- 3 Press the play (▶) button on the CD player or on the turntable.

The source changes on the RX-817VTN, and as soon as play starts, the cassette deck starts recording. When the play ends, the cassette deck enters recording pause, and stops about 4 seconds later.

Notes:

- During synchronized recording, the selected source cannot be changed.
- If your CD player is playing in program mode, a 4-second blank is recorded between tracks so that the music scan feature of your cassette deck can be used on the recorded tape.
- If the power of any component is shut off during synchronized recording, the COMPU LINK remote control system may not operate properly. In this case, you must start again from the beginning.
- Refer also to the manuals supplied with your audio components.

**Manufacturers' codes for VCR**

Aiwa	000	Tandy	000
Akal	041, 053, 061, 106, 242	Taung	041
Broksonic	184, 211	Teic	000, 041
Canon	035, 167	Technics	035
Capehart	020	Teknika	000, 035, 037
Chig	047, 240	Toshiba	043, 045, 066, 212
Curtis Mathes	035	Television	037, 240
Dacwco	020, 045, 278	Unitech	240
Daytron	020	Vector Research	038
Dynatech	000	Victor	008, 067
Emerson	000, 002, 037, 061, 121, 184, 211, 212, 294, 295	Video Concepts	038, 061
Fisher	047, 054, 066, 104	Videoscopic	240
Funai	000	Wards	000, 035, 042, 047, 048, 062, 072, 149, 212, 240
GJE	035, 060, 065	Yamaha	038, 041
Goldstar	018, 037, 038	Zenith	033, 034
Harman Kardon	038, 075	Zenith Unified	039
Hitachi	000, 041, 042, 065, 105, 166		
JCL	035		
Jensen	041		
JVC	008, 041, 067		
Kenwood	041, 046, 067		
Lloyd	000		
Logik	072		
LXI	037		
Magnavox	035, 081, 149		
Mirantz	035, 038, 081		
Miana	037		
MEI	035		
Memorex	000, 035, 037, 039, 047, 048, 104		
MGA	043, 061		
Minolta	042, 105		
Mitsubishi	061, 075, 214, 242		
Mitsubishi Unified	043		
MTC	000, 240		
Multitech	000, 072		
NAD	058		
NEC	038, 041, 067		
Optonica	048, 062		
Panasonic	035, 077, 162, 225		
Pennay	035, 038, 042, 240		
Peniux	042, 065, 105		
Philco	035		
Philips	035, 062, 081		
Pilot	037		
Pioneer	058, 168		
Pioneer Unified	058, 067		
Pontland	020		
Pulsar	039		
Quartz	046		
Quasar	035, 162		
RCA	035, 042, 065, 077, 105, 149, 202		
RCA Unified	060		
Realistic	000, 035, 037, 046, 047, 048, 062, 066, 104, 240		
Ricoh	034		
Samsung	045, 053, 240		
Sansui	041, 067		
Sanyo	046, 047, 104		
Scott	045, 121, 184, 212		
Sears	037, 042, 046, 047, 054, 066, 104, 105		
Sharp	048, 062		
Shinrom	072		
Sony	011, 032, 033, 034		
STS	042		
Sylvania	035, 043		
Symphonic	000		

**Troubleshooting**

Use this chart to help you solve daily operational problems. If there is any problem you cannot solve, contact your JVC service center.

PROBLEM	POSSIBLE CAUSE	SOLUTION
The display does not light up.	The power cord is not plugged in.	Plug the power cord into an AC outlet.
No sound from speakers.	Speaker wires are not connected.	Check speaker wiring and reconnect if necessary.
	The SPEAKERS buttons are not set correctly.	Press the SPEAKERS buttons in or out correctly.
	An incorrect source is selected.	Select the correct source.
	The TAPE 2 MONITOR indicator lights up when no component is connected to the TAPE 2 jacks.	Press the TAPE 2 MONITOR button so that the indicator goes off.
Sound from one speaker only.	Speaker wires are not connected properly.	Check speaker wiring and reconnect if necessary.
	The BALANCE control is set to one extreme.	Adjust the BALANCE control properly.
	Incoming signal is too weak.	Adjust the antenna.
	The station is too far away.	Select a new station.
	An incorrect antenna is used.	Check with your dealer to be sure you have a correct antenna.
	Antennas are not connected properly.	Check connections.
Occasional crackling noise during FM reception.	Ignition noise from automobiles.	Move the antenna farther from automobile traffic.
Howling during record playing.	Your turntable is too close to speakers.	Move speakers away from the turntable.
Remote control does not work.	There is an obstruction in front of the remote sensor on the RX-817VTN.	Remove the obstruction.
	Batteries are weak.	Replace batteries.

**AV COMPU LINK Remote Control System**

The AV COMPU LINK remote control system allows you to operate JVC video components through the RX-817VTN. To use this remote control system, you need to connect JVC video components through the AV COMPU LINK jacks (see page 8) in addition to the connections using cables with RCA pin plugs (see page 7). However, this remote control system cannot control video components connected to the VIDEO 1 and VIDEO 2 jacks. So, when you connect the VCR you want to operate using the AV COMPU LINK remote control system, connect it to the VCR jacks.

**AV COMPU LINK**

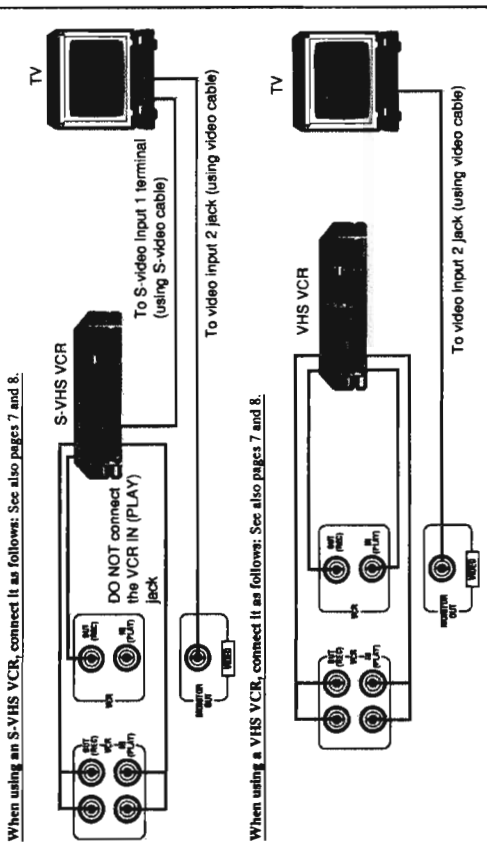

When using an S-VHS VCR, connect it as follows: See also pages 7 and 8.

When using a VHS VCR, connect it as follows: See also pages 7 and 8.

This remote control system allows you to use three functions listed below.

- **Remote Control of the TV through the Remote Sensor on the RX-817VTN**  
You can control the TV through the remote sensor on the RX-817VTN using this remote control. For details, see page 25.
- Note:*  
Aim the remote control directly at the remote sensor on the RX-817VTN when operating the TV. (However, to operate the VCR, always aim the remote control directly at the remote sensor on the VCR.)
- **One-Touch Video Play**  
Simply by inserting a video cassette without its safety tab into the VCR, you can enjoy the video playback without setting other switches manually.  
The RX-817VTN automatically turns on and changes the source to the VCR.  
The TV automatically turns on and changes the input mode to the position you can view the VCR playback. When you insert a video cassette with its safety tab, press the play (▶) button on VCR or on the remote control. So, you can get the same result.
- **Automatic Power On/Off**  
Both the TV and the VCR turn on and off along with the RX-817VTN.  
When you turn on the RX-817VTN:
  - If the previously selected source is VCR, the TV and VCR will turn on automatically.
  - If the previously selected source is VIDEO 1 and VIDEO 2, only the TV will turn on automatically.
 When you turn off the RX-817VTN, both the TV and VCR will turn off.

- Notes:*
- If you turn off the RX-817VTN while recording on the VCR, the VCR will not turn off, but continue recording.
  - Refer also to the manuals supplied with your video components.

Specifications (RX-817VTN)

**Specifications**

**Amplifier**

Output Power	At Stereo operation	<b>105 watts per channel, min. RMS, both channels driven into 8 ohms, 20 Hz to 20 kHz with no more than 0.007% total harmonic distortion.</b>
	At Surround operation Front Channels	105 watts per channel, min. RMS, driven into 8 ohms at 1 kHz with no more than 0.7% total harmonic distortion.
	Center channel	105 watts, min. RMS, driven into 8 ohms at 1 kHz, with no more than 0.7% total harmonic distortion.
	Rear channels	25 watts per channel, min. RMS, driven into 8 ohms at 1 kHz, with no more than 0.7% total harmonic distortion.
Total Harmonic Distortion (8 ohms, 1 kHz)		0.007%* at 105 watts output
Frequency Response (8 ohms)	PHONO CD, TAPE 1, TAPE 2, VCR, VIDEO 1, VIDEO 2	(* Measured by JVC Audio Analysis System) 20 Hz to 20 kHz (±0.5 dB) 10 Hz to 30 kHz (±1 dB)
Signal-to-Noise Ratio ('66 IHF/78 IHF)	PHONO CD, TAPE 1, TAPE 2, VCR, VIDEO 1, VIDEO 2	70 dB/78 dB (at REC OUT) 91 dB/80 dB
R/AA Phono Equalization		±0.5 dB (20 Hz to 20 kHz)
Audio Input Sensitivity/Impedance (1 kHz)	PHONO CD, TAPE 1, TAPE 2, VCR, VIDEO 1, VIDEO 2	2.7 mV/47 k ohms 230 mV/47 k ohms
Audio Output Level	TAPE 1, TAPE 2, VCR	230 mV
Video Input Sensitivity/Impedance	VCR, VIDEO 1, VIDEO 2	1 Vp-p/75 ohms
Video Output Level	VCR, MONITOR OUT	1 Vp-p (at 1 Vp-p input)
Synchronization		Negative
Signal-to-Noise Ratio		45 dB

**FM tuner (IHF)**

Tuning Range		87.5 MHz to 108.0 MHz
Usable Sensitivity		10.8 dBf (0.95 µV/75 ohms)
50 dB Quieting Sensitivity	Monaural Stereo	16.3 dBf (1.8 µV/75 ohms) 38.3 dBf (22.5 µV/75 ohms)
Signal-to-Noise Ratio (IHF-A weighted)	Monaural Stereo	80 dB at 85 dBf 73 dB at 85 dBf
Total Harmonic Distortion	Monaural Stereo	0.15% at 1 kHz 0.2% at 1 kHz
Stereo Separation at REC OUT		40 dB at 1 kHz
Capture Ratio		1.5 dB
Alternate Channel Selectivity		60 dB (±400 kHz)
Frequency Response		30 Hz to 15 kHz: (+0.5 dB, -3 dB)

**AM tuner**

Tuning Range		530 kHz to 1,710 kHz
Usable Sensitivity	Loop antenna External antenna	300 µV/m 30 µV
Signal-to-Noise Ratio		50 dB (100mV/m)

**General**

Power Requirements		AC 120V <sup>~</sup> , 60 Hz
Power Consumption		370 watts/510 VA 5 watts (in standby mode)
Dimensions (W x H x D)		435 x 136 x 399 mm (17 1/16 x 6 7/16 x 15 3/4 inches)
Weight		13.5 kg (29.8 lbs)

Designs & specifications are subject to change without notice.

Specifications (RX-816VBK)

Specifications

Amplifier

Output Power At Stereo operation  
100 watts per channel, min. RMS, both channels driven into 8 ohms at 1 kHz with no more than 0.9% total harmonic distortion (IEC268-5/DIN).  
80 watts per channel, min. RMS, both channels driven into 8 ohms, 20 Hz to 20 kHz with no more than 0.007% total harmonic distortion.  
100 watts per channel, min. RMS, driven into 8 ohms at 1 kHz with no more than 0.7% total harmonic distortion.  
100 watts, min. RMS, driven into 8 ohms at 1 kHz, with no more than 0.7% total harmonic distortion.  
20 watts per channel, min. RMS, driven into 8 ohms at 1 kHz, with no more than 0.007% total harmonic distortion  
(\* Measured by JVC Audio Analysis System)

Total Harmonic Distortion (8 ohms, 1 kHz)

Frequency Response (8 ohms)  
PHONO  
CD, TAPE 1, TAPE 2,  
VCR, VIDEO 1, VIDEO 2

Signal-to-Noise Ratio ('66 IHF/DIN)  
PHONO  
CD, TAPE 1, TAPE 2,  
VCR, VIDEO 1, VIDEO 2

RIAA Phono Equalization

Audio Input Sensitivity/Impedance (1 kHz)  
PHONO  
CD, TAPE 1, TAPE 2,  
VCR, VIDEO 1, VIDEO 2

Audio Output Level  
TAPE 1, TAPE 2, VCR  
VCR, VIDEO 1, VIDEO 2

Video Input Sensitivity/Impedance  
VCR, MONITOR OUT

Synchronization

Signal-to-Noise Ratio

FM tuner (IHF)

Tuning Range 87.5 MHz to 108.0 MHz  
Usable Sensitivity 10.8 dBf (0.95 µV/75 ohms)  
16.3 dBf (1.8 µV/75 ohms)  
38.3 dBf (22.5 µV/75 ohms)  
30 dB Quieting Sensitivity Monaural Stereo  
Signal-to-Noise Ratio (IHF-A weighted) Monaural Stereo  
73 dB at 85 dBf  
Total Harmonic Distortion Monaural Stereo  
0.15 % at 1 kHz  
0.2 % at 1 kHz  
Stereo Separation at REC OUT 40 dB at 1 kHz  
Capture Ratio 1.5 dB  
Alternate Channel Selectivity 60 dB (±400 kHz)  
Frequency Response 30 Hz to 15 kHz: (+0.5 dB, -3 dB)

AM tuner

Tuning Range Australia: 522 kHz to 1,629 kHz  
Other countries: 531 kHz to 1,602 kHz (at 9 kHz interval)  
530 kHz to 1,600 kHz (at 10 kHz interval)  
Usable Sensitivity Loop antenna 300 µV/m  
External antenna 30 µV  
Signal-to-Noise Ratio 50 dB (100mV/m)

General

Power Requirements AC 240V~, 50 Hz  
AC 110/127/220/240 V~, adjustable with the voltage selector.  
50/60 Hz  
Power Consumption 360 watts  
5 watts (in standby mode)  
Dimensions (W x H x D) 435 x 156 x 406 mm  
(17 1/4 x 6 1/4 x 16 inches)  
Mass 13.5 kg (29.8 lbs)

Design & specifications subject to change without notice

## Description of Major LSIs

### ■ MN172412J5X (IC401) : SYSTEM CONTROLLER

#### 1. Terminal Layout

21 ~ 1	
22	84
}	}
42	64
43 ~ 63	

#### 2. Key Matrix

	KEY IN 0	KEY IN 1	KEY IN 2	KEY IN 3
KEY OUT 0	POWER S401	SEA ON/OFF S402	SEA FLAT S403	SPI/SEA S404
KEY OUT 1	EFFECT + S405	SEA/SURROUND MODE + S406	CURSOR MODE S407	DAP ON/OFF S408
KEY OUT 2	EFFECT - S409	SEA/SURROUND MODE - S410	SURROUND ON/OFF S411	CENTER MODE S412
KEY OUT 3	FM MODE S414	CHARACTER S415	TUNING S416	PRESET S417
KEY OUT 4	LOUDNESS S413	ENTER S418	TAPE 2 S419	CSRP S420

#### 3. Description

Pin No.	Symbol	I/O	Description	Pin No.	Symbol	I/O	Description
1	FAN OFF	I	FAN check signal. L:FAN is stopped	43	DATA	O	Data for IC411,321,552 and IC096
2		--	GND	44	INH IN	I	Inhibit signal input
3	AC POWER	O	RY201 control signal	45	RDS CLK	I	Clock input for IC191
4	FAN ON	O	FAN control signal. L:FAN ON	46	RDS DATA	I	Data signal for IC191
5	STAND-BY LED	O	STAND-BY indication control	47	RDS RESET	I	Reset signal for IC191
6	KO6	O	Key matrix out	48	RM IN	I	Detection for protector
7	KI0	I	Key matrix in	49	RDS D-START	I	D.Start signal for IC191
8	KI1	I	Key matrix in	50	STEREO IN	I	STEREO indication control
9	KI2	I	Key matrix in	51	TUNED IN	I	TUNED indication control
10	KI3	I	Key matrix in	52	CE (PLL)	O	Chip select signal for IC121
11	D9/KO0	O	Grid control signal (Key matrix out)	53	CLK (PLL)	O	Clock output for IC121
12	D8/KO1	O	Grid control signal (Key matrix out)	54	DI (PLL)	I	Data to IC121
13	D7/KO2	O	Grid control signal (Key matrix out)	55	DO (PLL)	O	Data for IC121
14	D6/KO3	O	Grid control signal (Key matrix out)	56	DCS IN	I	Compulink signal input
15	D5/KO4	O	Grid control signal (Key matrix out)	57	DCS OUT	O	Compulink signal output
16	D4/KO5	O	Grid control signal (Key matrix out)	58	SOURCE E.IN1	I	R. Encoder control signal input (SOURCE)
17	D3	O	Grid control signal	59	SOURCE E.IN2	I	R. Encoder control signal input (SOURCE)
18	D2	O	Grid control signal	60	DAP RESET	O	Reset signal for IC096
19	D1	O	Grid control signal	61	DAP REQ	O	Request signal for IC096
20	SEA LED	O	SEA indication control	62	SCL(AT24C)	I	Clock for IC412
21	SUR.LED	O	SURROUND indication control	63	SDA(AT24C)	I/O	Data signal for IC412
22	TAPE2 LED	O	TAPE2 MONITOR indication control	64	TV CONT.	O	AV COMPULINK
23	VPP	--	Power supply	65	TV OUT	O	AV COMPULINK
24	S1	O	Segment control signal	66	VCR OUT	O	AV COMPULINK
25	S2	O	Segment control signal	67	VCR IN	I	AV COMPULINK
26	S3	O	Segment control signal	68	RST	I	Reset signal input
27	S4	O	Segment control signal	69	X1	--	GND
28	S5	O	Segment control signal	70	X2	--	Not used
29	S6	O	Segment control signal	71	VSS	--	GND
30	S7	O	Segment control signal	72	OSC2	--	Oscillation terminal
31	S8	O	Segment control signal	73	OSC1	--	Oscillation terminal
32	S9	O	Segment control signal	74	VDD	--	Power supply
33	S10	O	Segment control signal	75	CHIP SELECT	--	GND
34	S11	O	Segment control signal	76	TUNER E.IN1	I	R. Encoder control signal input (TUNER)
35	S12	O	Segment control signal	77	TUNER E.IN2	I	R. Encoder control signal input (TUNER)
36	S13	O	Segment control signal	78	DAP BUSY	I	Busy signal from IC096
37	S14	O	Segment control signal	79	CS(XR)	O	Chip select signal for IC404
38	S15	O	Segment control signal	80	SP CLK(XR)	O	Clock output for IC404
39	S16	O	Segment control signal	81	SP DATA(XR)	O	Data signal for IC404
40	STB2	O	Strobe signal for IC411	82	STB3	O	Strobe signal for IC552
41	CLK	O	Clock output for IC411,321,552 and IC096	83	VIDEO OFF	O	VIDEO OFF control signal
42	STB1	O	Strobe signal for IC321	84	VCR S/C	I	VCR S/C signal

■ TMP87C847U-4195 (IC096) : CMOS 8-bit Microcontroller

1. Terminal Layout

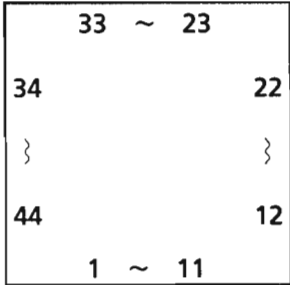

2. Block Diagram

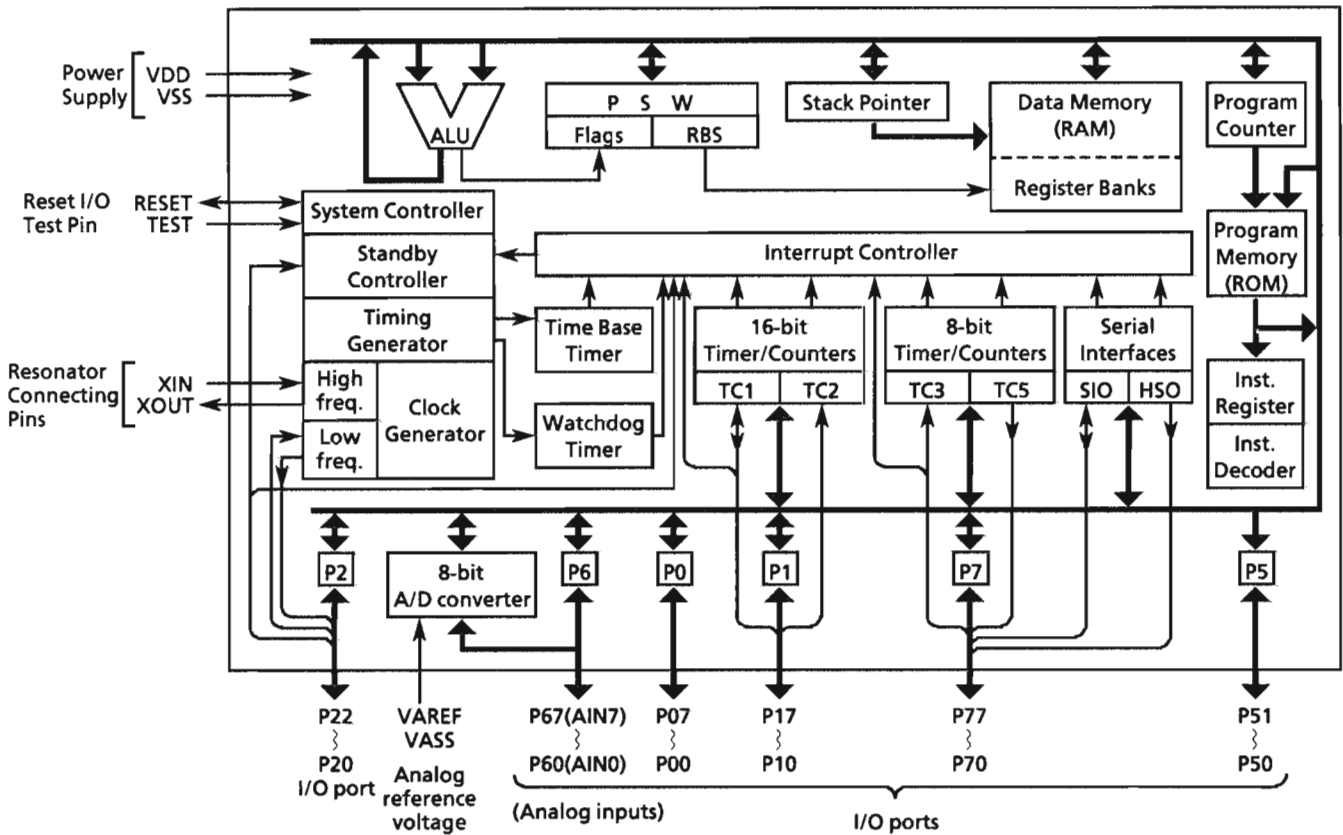

3. Pin Functions

Pin No.	Symbol	I/O	Functions
1	P73 (SCK)	I	Serial clock input from IC401
2	P72 (PWM/PDO)	I/O	Not used
3	P71 (INT4)	I/O	Not used
4	P70 (INT3/TC3)	I/O	Not used
5	P07 (ACK)	I	Acknowledge signal input from IC081
6	P06 (IFCD)	O	Command/data switching signal to IC081

Pin No.	Symbol	I/O	Functions
7	P05 ( $\overline{\text{CS}}$ )	O	Chip select signal output to IC081
8	P04 ( $\overline{\text{RST}}$ )	O	Reset signal output to IC081
9	P03 (TEST0)	I	Test terminal, generally it is used as "L"
10	P02 (TB2)	I	Test terminal, generally it is used as "L"
11	P01 (TB1)	I	Test terminal, generally it is used as "L"
12	P00 (TB0)	I	Test terminal, generally it is used as "L"
13	TEST	I	Test pin for out-going test. Be tied to low
14	$\overline{\text{RESET}}$	I	Reset signal input or watchdog timer output/address-trap-reset output/system-clock-reset output
15	XIN	I	Resonator connecting pins for high-frequency clock. For inputting external clock, XIN is used and XOUT is opened
16	XOUT	O	Not used
17	VSS	--	GND
18	VAREF	--	Analog reference voltage
19~26	P60 (AIN0)~ P67 (AIN7)	I/O	Not used
27	P50	O	Not used
28	P51 (MUTE)	O	Mute signal output
29	P10 (INT0)	I/O	Not used
30	P11 ( $\overline{\text{REQ}}$ )	I	External interrupt request signal from IC401
31	P12 ( $\overline{\text{BUSY}}$ )	O	Busy output to IC401
32	P13 (DVO)	I/O	Not used
33	P14 (PPG)	I/O	Not used
34	P15 (VOL STB)	O	Volume strobe signal output for write data to IC341
35	P16 (VOL SI)	O	Volume serial data signal output to IC341
36	P17 (VOL CK)	O	Volume clock output for data transfer to IC341
37	P20 (INT5/STOP)	I/O	Not used
38	P21 (XTIN)	I/O	Not used
39	P22 (XTOUT)	I/O	Not used
40	VDD	--	Power supply (5V)
41	P77 (IFDI)	O	Serial data output to IC081
42	P76 (IFCK)	O	Shift clock output to IC081
43	P75 (SO)	I/O	Not used
44	P74 (SI)	I	Serial data input from IC401

■ TC9332F-010 (IC081) : Audio digital signal processor

1. Terminal Layout

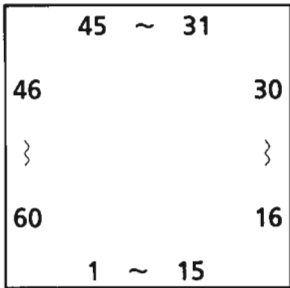

2. Block Diagram

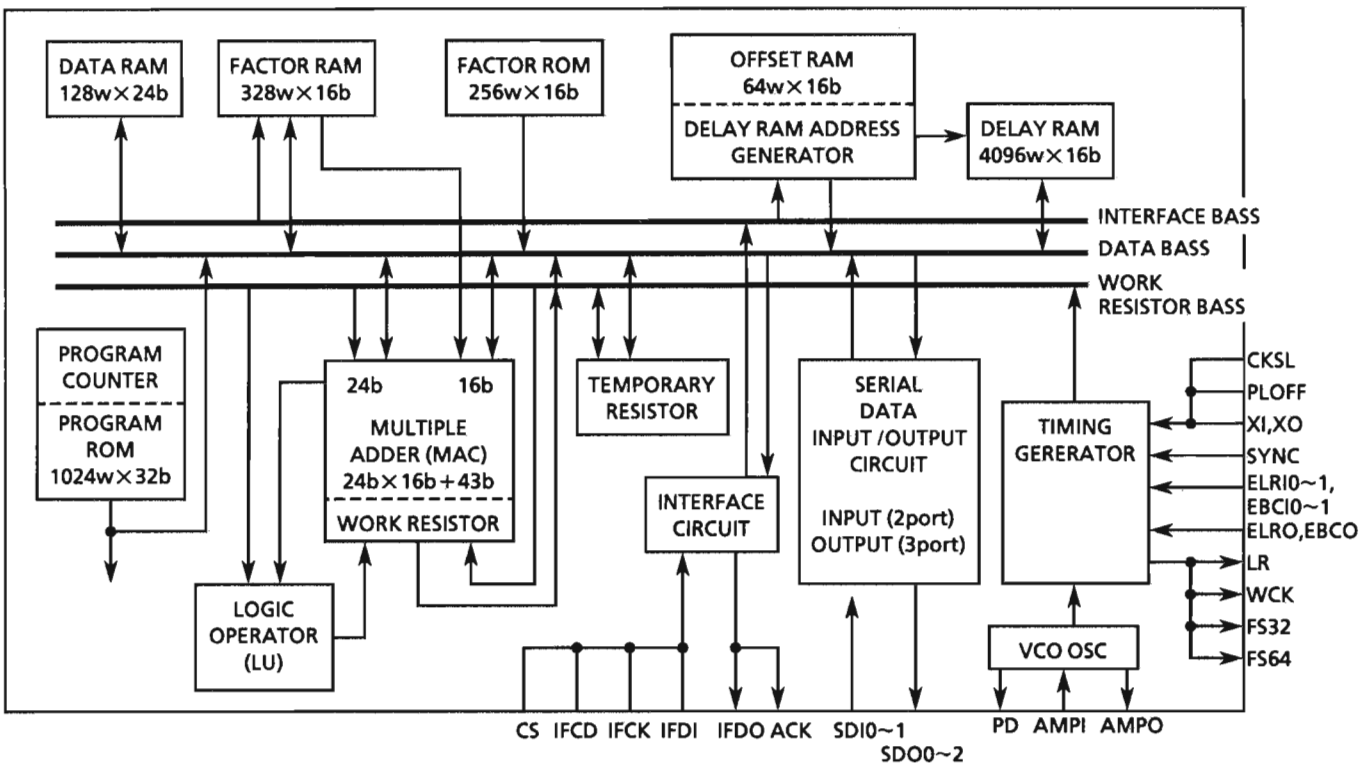

3. Pin Functions

Pin No.	Symbol	I/O	Functions
1~3	TP8~TP6	O	Test data output, Generally it is used as open
4	VDD	--	Power supply
5	VSS	--	GND
6~11	TP5~TP0	O	Test data output. Generally it is used as open
12	VSSR	--	GND for inner delay RAM (DLRAM)
13	VDDR	--	Power supply for inner delay RAM (DLRAM) (5V)
14	VSS	--	GND
15	SDO2	O	Not used
16	SDO1	O	Serial data output to IC061



Pin No.	Symbol	I/O	Functions
17	SDO0	O	Serial data output to IC041
18	SDI1	I	Not used
19	SDI0	I	Serial data input from IC021
20	LR	O	LR clock output (1fs)
21	WCK	O	Word clock output (2fs)
22	F532	O	Bit clock output (32fs)
23	F564	O	Bit clock output (64fs)
24	EBC0	I	Bit clock input. Shift clock input for SDO 0/1/2 data output
25	EBC11	I	Bit clock input. Shift clock input for SDI 0/1 data input
26	EBC10	I	Bit clock input. Shift clock input for SDI 0/1 data input
27	ELRO	I	LR clock input for SDO 0/1/2 data output
28	ELRI1	I	LR clock input for SDI 0/1 data input
29	ELRI0	I	LR clock input for SDI 0/1 data input
30	SYNC	I	Synchronizing signal input. SYNC signal edge sets program counter "0" forcefully. The microprocessor controls the polarity
31	VDD	--	Power supply (5V)
32	XI	I	X'tal oscillation terminal
33	XO	O	X'tal oscillation terminal
34	VSS	--	GND
35	CKSL	I	Oscillation clock switching terminal L:384fs, H:512fs
36	PLOFF	I	Oscillation mode switching terminal for 'Xtal and VCO. Built-in VCO oscillation mode in "L" and 'Xtal oscillation mode in "H"
37	PD	I	Phase comparison data output
38	VSSA	--	Analog GND
39	AMPO	O	Amplifier output for L.P.F
40	AMPI	I	Amplifier input for L.P.F
41	VDDA	--	Analog Power supply (5V)
42~44	TES0~TES2	I	Test terminal, Generally it is transmitted from $\mu$ -com when cs is lactive
45	$\overline{\text{RST}}$	I	Reset signal input from IC096
46	$\overline{\text{CS}}$	I	Chip select signal input from IC096
47	IFCD	I	It selects command or data input mode from IC096. It recognizes the command in "H" and the data in "L"
48	IFDI	I	$\mu$ -com data input. Firstly, LSB of data and command are received.
49	IFDO	O	Data output of data bass. LSB of data bus data is transmitted to $\mu$ -com
50	IFCK	I	Shift clock input form IC096
51	$\overline{\text{ACK}}$	O	Acknowledge signal output for IC096. Acknowledge signal is output when command and data's parity are OK
52	VSS	--	GND
53~60	TP16~TP9	O	Test data output. Generally, it is used as open

■ TDA1386T (IC041,061) : Noise shaping filter-DAC

1. Terminal Layout

VDDA	1	24	VDDO
VSSA	2	23	VSSO
TEST1	3	22	VREF
BCK	4	21	VOR
WS	5	20	FILTCR
DATA	6	19	FILTCL
CKSL1	7	18	VOL
CKSL2	8	17	APP0
VSSD	9	16	APP1
VDDD	10	15	APP2
TEST2	11	14	APPL
SYSCLK	12	13	APP3

2. Block Diagram

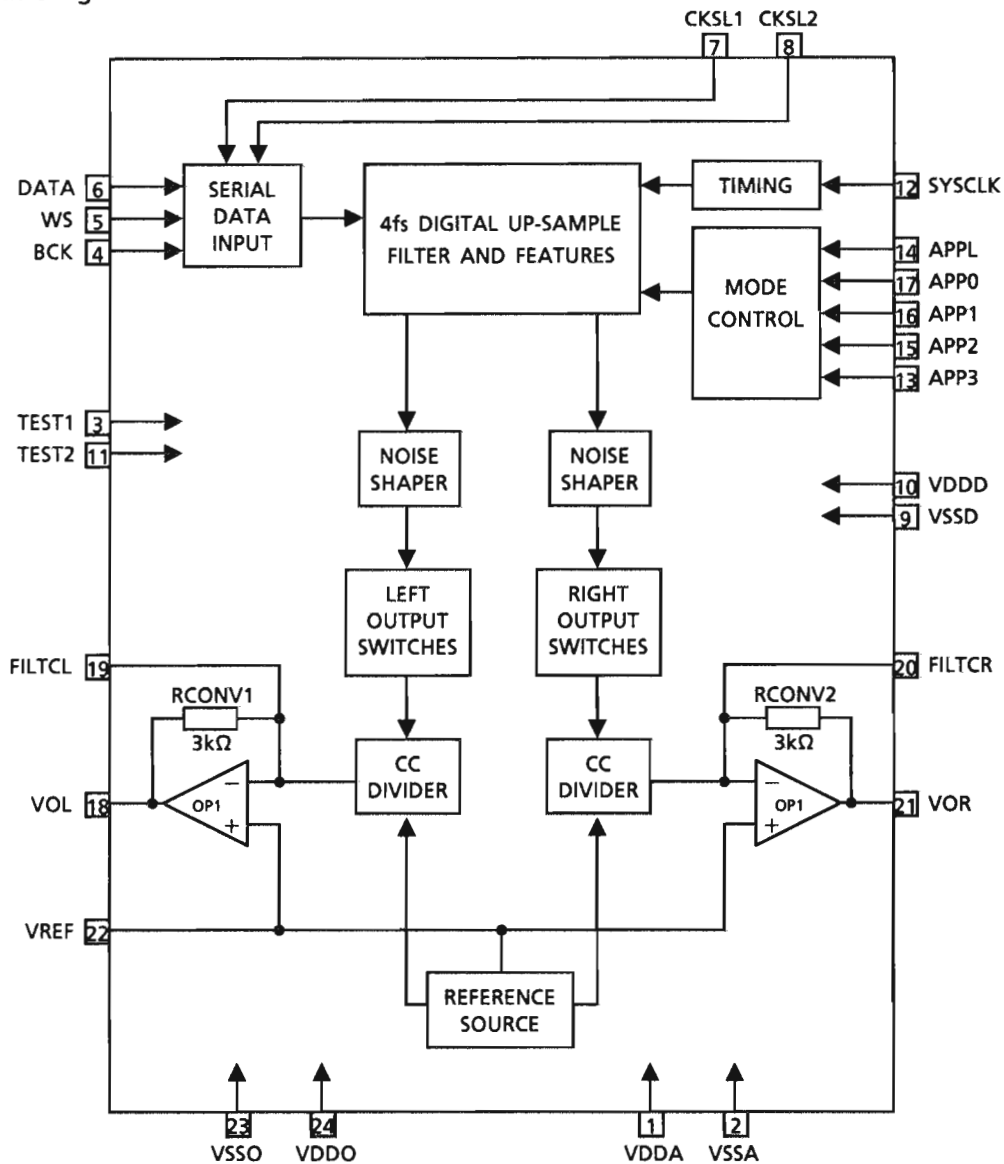

### 3. Pin Functions

Pin No.	Symbol	I/O	Functions
1	VDDA	--	Analog supply voltage (5V)
2	VSSA	--	Analog ground
3	TEST1	--	Test input 1 ; pin should be connected to ground
4	BCK	I	Bit clock input from IC081
5	WS	I	Word select input from IC081
6	DATA	I	Data input from IC081
7	CKSL1	I	Format selection 1
8	CKSL2	I	Format selection 2
9	VSSD	--	Digital ground
10	VDDD	--	Digital supply voltage (5V)
11	TEST2	--	Test input 2 ; pin should be connected to ground
12	SYSCLK	I	System clock 256fs input from IC093
13	APP3	I	Application mode 3 input
14	APPL	I	Application mode selection input
15	APP2	I	Application mode 2 input
16	APP1	I	Application mode 1 input
17	APP0	I	Application mode 0 input
18	VOL	O	Left channel output
19	FILTCL	O	Capacitor for left channel first-order filter function, should be connected between pins 19 and 18
20	FILTCL	O	Capacitor for right channel first-order filter function, should be connected between pins 20 and 21
21	VOR	O	Right channel output
22	VREF	--	Internal reference voltage for output channels (0.5 VDDO typ.)
23	VSSO	--	Operational amplifier ground
24	VDDO	--	Operational amplifier supply voltage (5V)

■ SAA7366T (IC021) :

1. Terminal Layout

SFOR	1	24	SLAVE
STDB	2	23	VDDA
OVLD	3	22	VREFL
CKIN	4	21	BIL
VDD	5	20	BOL
VSS	6	19	VDACP
SDO	7	18	VDACN
SWS	8	17	BOR
SCK	9	16	BIR
TEST 1	10	15	VREFR
HPEN	11	14	IREFR
TEST B	12	13	VSSA

2. Block Diagram

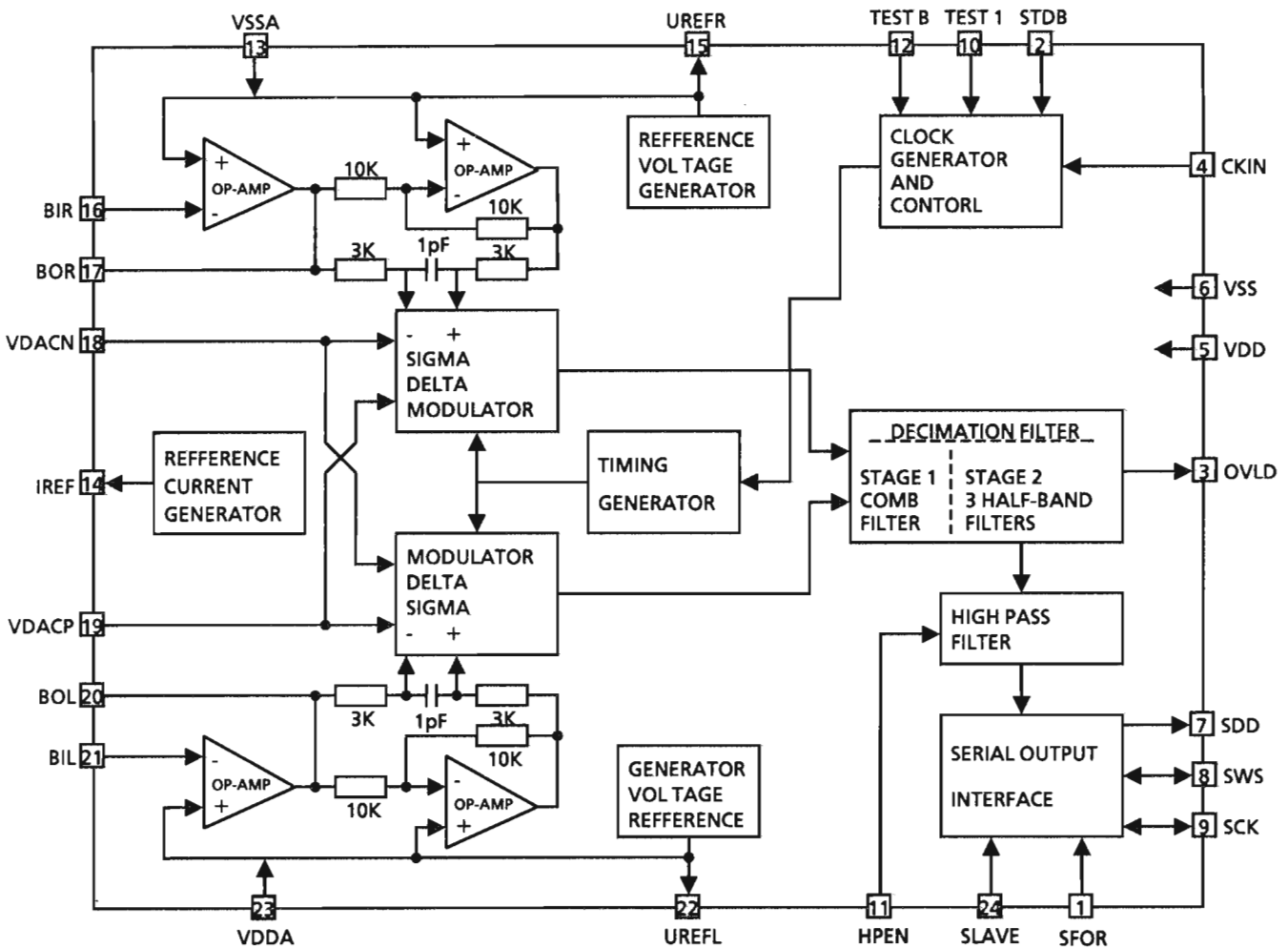

### 3. Pin Functions

Pin No.	Symbol	I/O	Functions
1	SFOR	I	Input for selectiing serial interface output format. HIGH=Format 1 LOW=Format 2
2	STD	I	Input for selectiing STANDBY mode HIGH=Normal operation LOW=STANDBY (Low power consumption)
3	OVL	O	Overload indication output. This pin indicates whether the internal digital signal is within 1dB of maximum. In STANDBY mode this output is in high impedance
4	CKIN	I	System clock input from !C093
5	VDD	--	Supply for the digital section (5V)
6	VSS	--	Ground supply for the digital section
7	SDO	O	Serial interface data output to IC081. In STANDBY mode this output is in high impedance
8	SWS	I	Serial interface word select signal. This pin is the word select input to the serial interface.
9	SCK	I	Serial interface clock. This pin is the input for the external bit clock.
10	TEST1	I	Test input 1. This pin should be left open circuit
11	HPEN	I	High pass filter enable input. (HPEN HIGH = enabled). If unconnected this pin defaults HIGH
12	TESET2	I	Test input 2. This pin should be left open circuit
13	VSSA	--	Ground supply for the analogue section
14	IREF	--	Current reference node
15	VREFR	--	VDDA/2 reference generator for the right channel analog section
16	BIR	I	Buffer op-amp inverting input for right channel
17	BOR	O	Buffer op-amp output for right channel
18	VDACN	I	Negative 1 bit DAC reference voltage input, normally connected to 0V
19	VDACP	I	Positive 1 bit DAC reference voltage input, normally connected to 5V
20	BOL	O	Buffer op-amp output for left channel
21	BIL	I	Buffer op-amp inverting input for left channel
22	VREFL	--	VDDA/2 reference generator for the left channel analog section
23	VDDA	--	Supply for the analog section (5V)
24	SLAVE	I	Input for selectiing serial interface operating mode MASTER/SLAVE HIGH=SLAVE, LOW=MASTER If unconnected the pin will default LOW

■ TC9299P (IC341) : Electronic volume

1. Terminal Layout

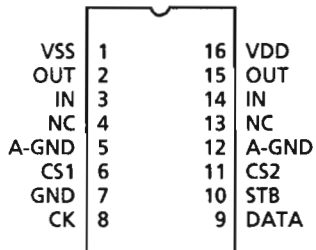

2. Block Diagram

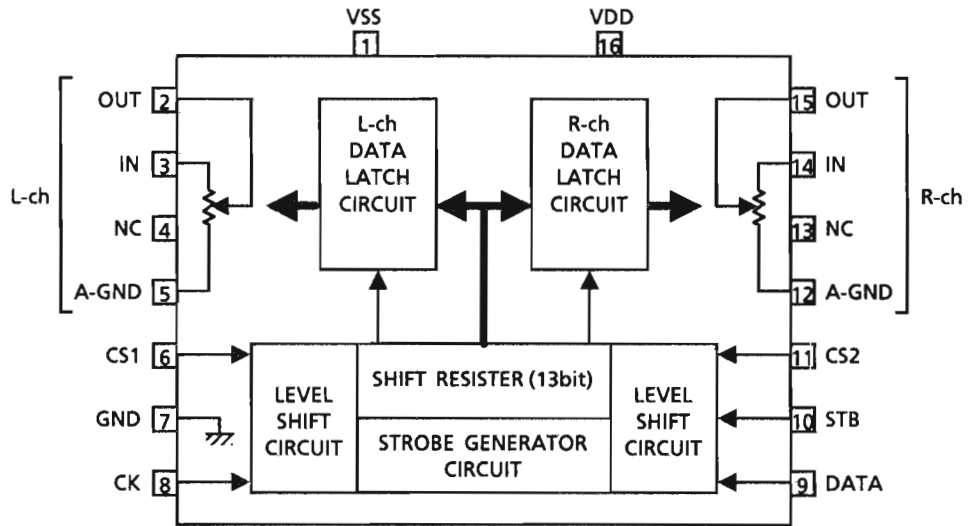

3. Pin Functions

Pin No.	Symbol	I/O	Functions	Pin No.	Symbol	I/O	Functions
1	VSS	--	Power supply voltage (-)	9	DATA	I	Serial data input to set fader.
2	L-OUT	O	Volume output	10	STB	I	Strobe signal input for write data
3	L-IN	I	Volume input	11	CS2	I	Chip select input
4	NC	--	Not used	12	R-A-GND	--	Analog ground
5	L-A-GND	--	Analog ground	13	NC	--	Not used
6	CS1	I	Chip select input	14	R-IN	I	Volume input
7	GND	--	Ground	15	R-OUT	O	Volume output
8	CK	I	Input data transfer clock	16	VDD	--	Power supply voltage (+)

■ M5243P (IC551) : S.E.A. Graphic Equalizer

1. Functions

It makes inductive characteristic instead of coil.

2. Block Diagram

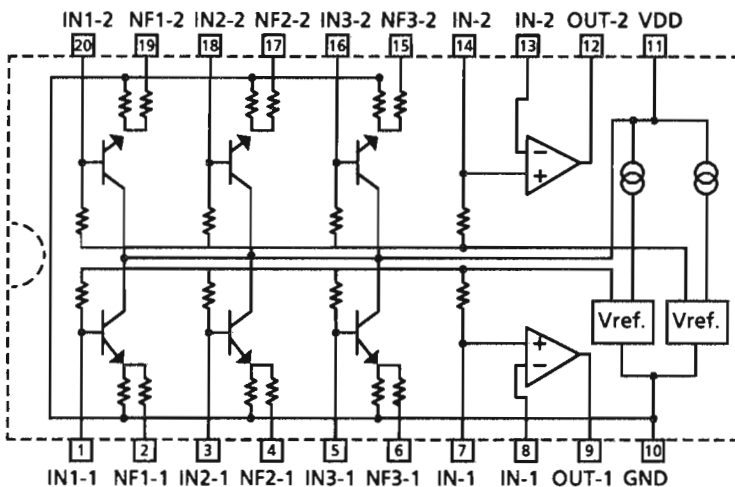

■ XR1095CP (IC404): Graphic Equalizer Filter & Display driver

1. Terminal Layout

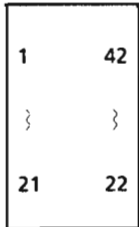

2. Pin function

Pin No.	Symbol	Function
1~5,9~16	A1~A13	Anode terminal
30~38	G1~G9	Grid terminal
25	RIN	Right channel input
26	LIN	Left channel input
22	DIM	Brightness control varies width of G outputs.
27	GPH	Filter amplitude display duration control. A resistor and timing capacitor from this pin to VSS adjust Peak Hold Decay Time.
28	TPH	Total output display on / off control.
40	CLKR	Oscillator timing resistor between this pin and CLKC pin.
41	CLKC	Oscillator timing capacitor between this pin and VSS.
20	S1	Chip select 1 pin.
21	S2	Chip select 2 pin.
19	DI	Serial port data.
18	SPCLK	Serial port clock.
17	CS	Chip Select.
42	VDD	Plus supply, nominally 5VDC.
23	VSS	Minus supply, nominally -5VDC.
24	GND	Analog input reference.

3. Block Diagram

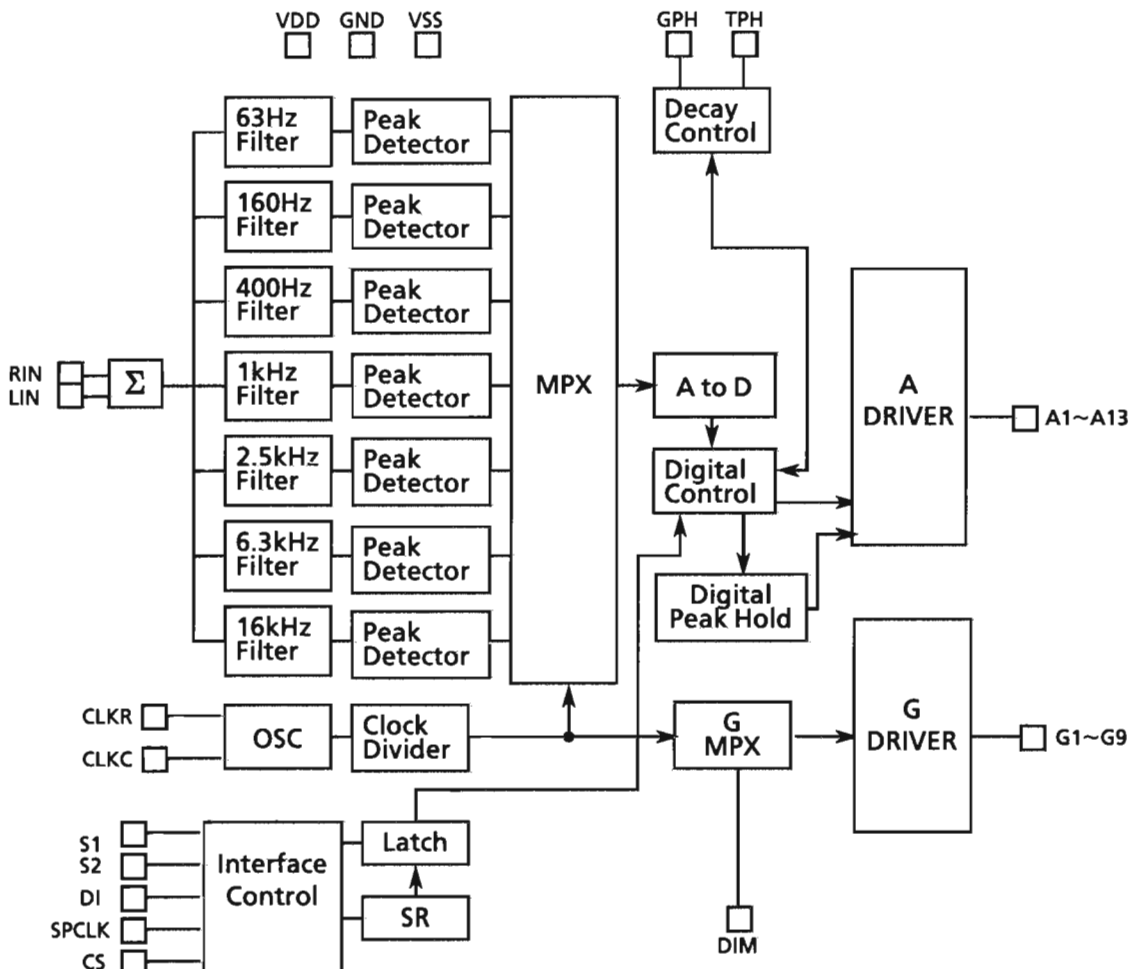

■ LC7218M (IC121) : PLL Synthesizer

1. The main function descriptions

- (1) It makes the local oscillation frequency by the control data from IC401.
- (2) Decode the control signal and transmit the signal for receiving conditions.
- (3) For the best tuning, count the internal-frequency and transmit the data to IC201.

2. Terminal Layout

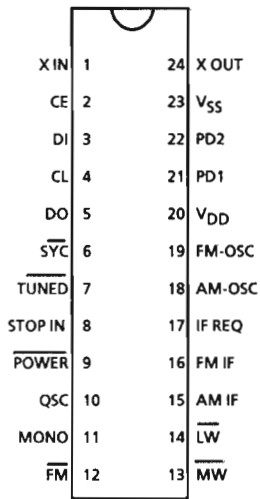

3. Block Diagram

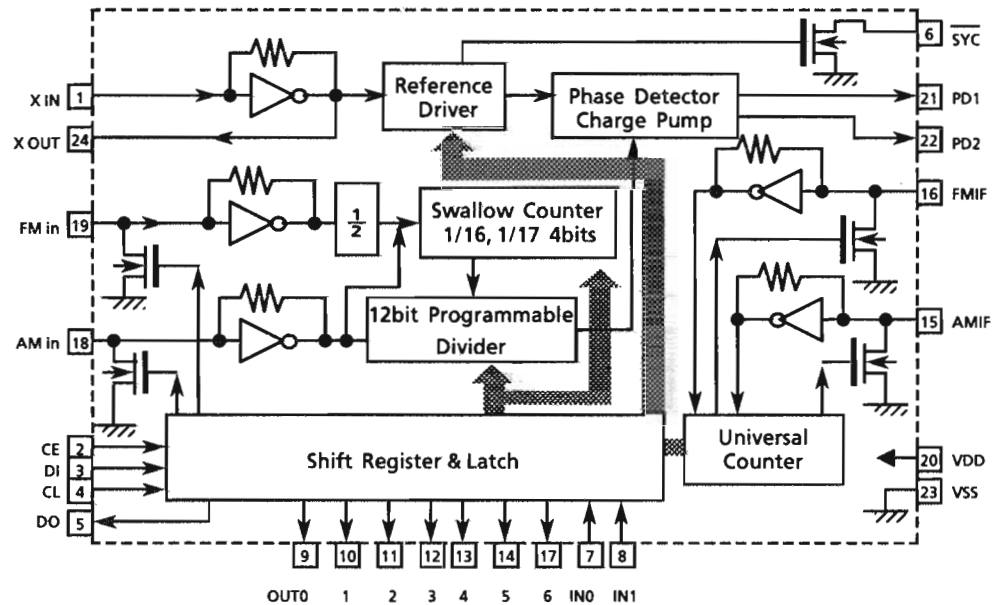

4. Pin Functions

Pin No.	Symbol	I/O	Functions
1,24	X in , X out	I/O	Crystal oscillator (7.2MHz).
2	CE	I	Fix the chip enable to "H" when inputting (DI) and outputting (DO) the serial data.
3	DI	I	Receive the control data from the controller (IC401).
4	CL	I	This clock is used to synchronize data when transmitting the data of DI and DO.
5	DO	O	Transmit the data from LC7218JM to the controller which is synchronized with CL.
6	SYNC	—	Not used.
7	TUNED	I	Receive the tuned signal from IC102 (LA1836M).
8	STOP IN	—	Connected to GND
9	POWER	—	Not used.
10	QSC	—	Not used.
11	MONO	O	It is "H" on FM-monaural, "L" on FM-Stereo.
12	FM	O	It is "L" on FM mode.
13	MW	O	It is "L" on MW mode.
14	LW	O	It is "L" on LW mode.
15	AM-IF	I	Universal counter input for AM-IF from IC102 (LA1836M).
16	FM-IF	I	Universal counter input for FM-IF from IC102 (LA1836M).
17	IF REQ	O	Output the "IF-signal request" to IC102 when the pin-7 (tuned in) goes to "H".
18	AM OSC	I	Input the local oscillator signal of AM.
19	FM OSC	I	Input the local oscillator signal of FM.
20	V <sub>DD</sub>	—	This is a terminal of power supply.
21	PD1	O	PLL charge pump output : When the local oscillator signal frequency is higher than the reference frequency high level signals will output. When it is lower than the reference frequency, low level signals will output. When it is same as reference frequency signals, it will be floating.
22	PD2	—	Not used.
23	V <sub>SS</sub>	—	Connected to GND



■ LA1836M (IC102) : FM AM IF AMP & detector, FM MPX DECODER

1. Terminal Layout

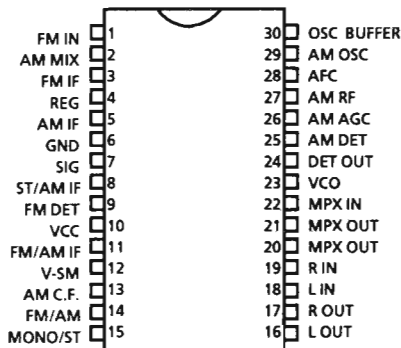

3. Pin Function

Pin No.	Symbol	I/O	Function
1	FM IN	I	This is an input terminal of FM IF Signal.
2	AM MIX	O	This is an output terminal for AM mixer.
3	FM IF	I	Bypass of FM IF
4	REG	—	Register value between pin4 and pin28 desides the frequency width of the input signal.
5	AM IF	I	Input of AM IF Signal.
6	GND	—	This is the device ground terminal.
7	SIG	O	When the set is tuning, this terminal becomes "L".
8	ST/AM IF	O	Stereo indicator output. Stereo : "L", Mono : "H"
9	FM DET	—	FM detect transformer.
10	VCC	—	This is the power supply terminal.
11	FM/AM IF	O/I	When the signal of IF REQ of IC121(LC7218JM) appear, the signal of FM/AM IF output. //Muting control input.
12	VSM	O	S Meter output and adjust AM SD sensitivity.
13	AM C.F.	O	This is a terminal of AM ceramic filter.
14	FM/AM	I	Change over the FM / AM input. "H" : FM, "L" : AM
15	MONO/ST	O	Stereo : "H", Mono : "L"
16	L OUT	O	Left channel signal output.
17	R OUT	O	Right channel signal output
18	L IN	I	Input terminal of the Left channel post AMP.
19	R IN	I	Input terminal of the Right channel post AMP.
20	MPX L OUT	O	Mpx Left channel signal output.
21	MPX R OUT	O	Mpx Right channel signal output.
22	MPX IN	I	Mpx input terminal.
23	VCO	I	Voltage controlled oscillator terminal.
24	DET OUT	O	AM/FM detection output.
25	AM DET	—	AM low cut adjustment.
26	AM AGC	I	This is an AGC voltage input terminal for AM.
27	AM RF	I	This is an input terminal for AM RF signal.
28	AFC	—	This is an output terminal of voltage for FM-AFC.
29	AM OSC	—	This is a terminal of AM Local oscillation circuit.
30	OSC BUFFER	O	AM Local oscillation Signal output.

2. Block Diagram

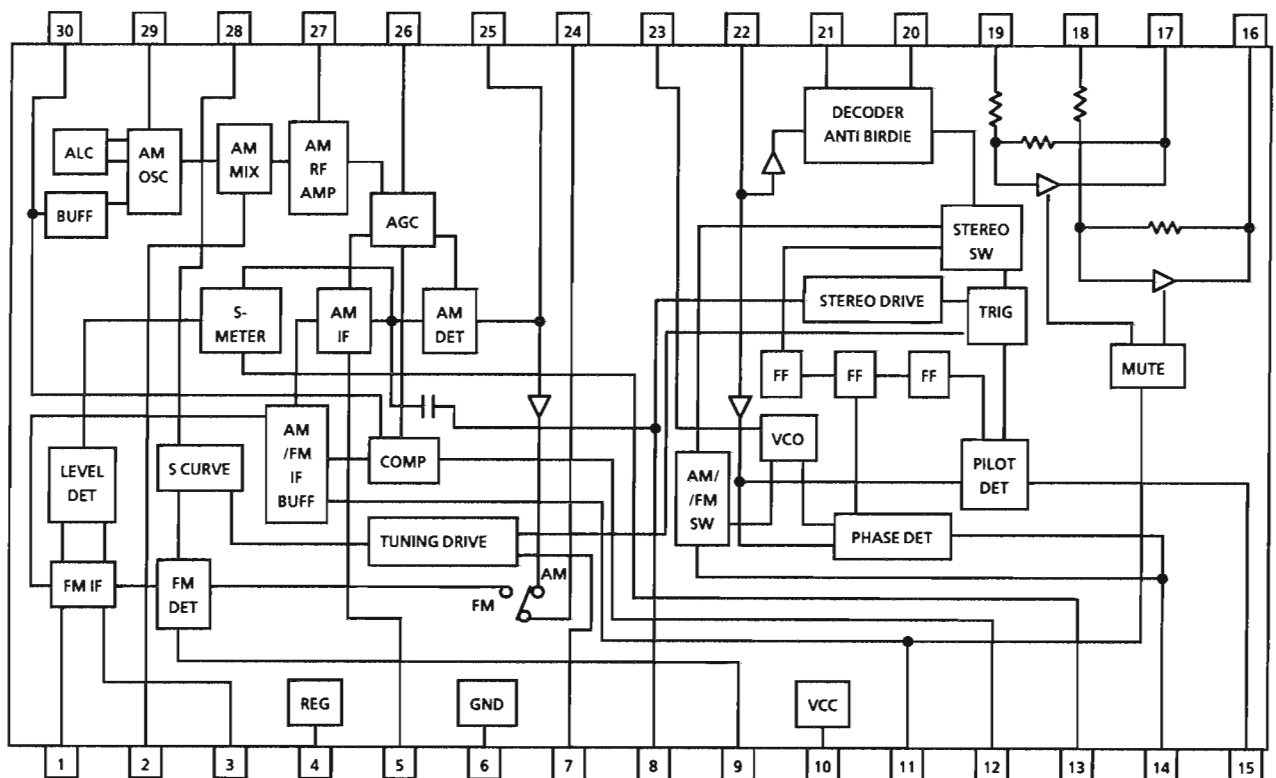

RX-816VBK  
RX-817VTN

■ TA7317P (IC901) : Protector

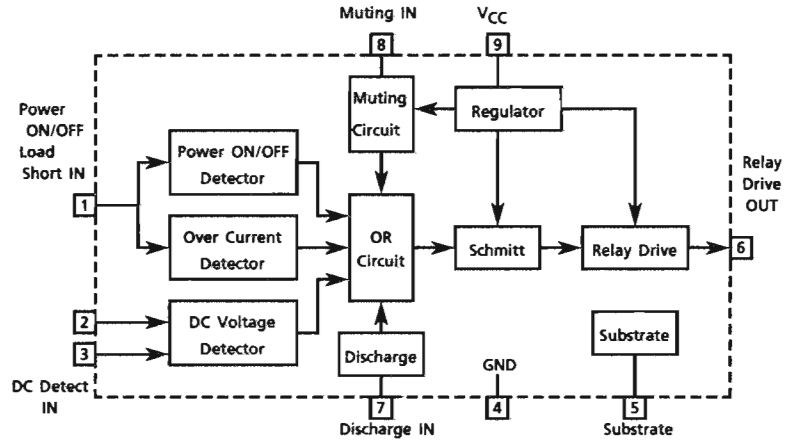
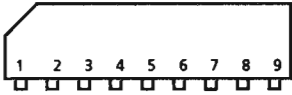

■ MN1281(P,Q) (IC403) : Reset IC

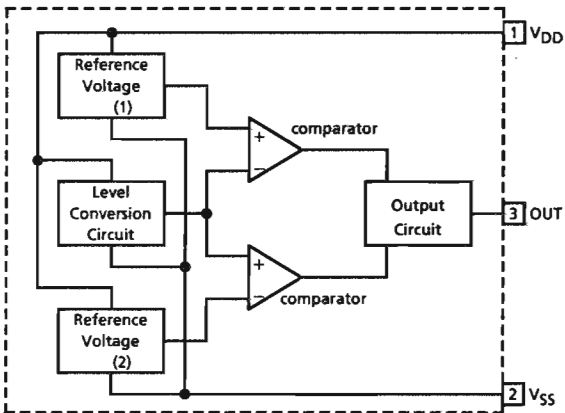

Pin No.	Pin Name	Functions
1	V <sub>DD</sub>	Power supply
2	V <sub>SS</sub>	Ground
3	OUT	Reset signal output : Low level is output when resetting : High level is output when cancelling the reset.

■ LB1639-CV (IC361) : Motor Driver

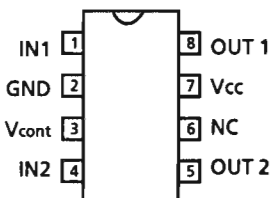

IN 1	IN 2	OUT 1	OUT 2	MOTOR
H	L	H	L	CLOCKWISE
L	H	L	H	COUNTER-CLOCKWISE
H	H	OFF	OFF	WAITING
L	L	OFF	OFF	WAITING

■ SPS-420-1 (IC402) : Remote Control Module IC

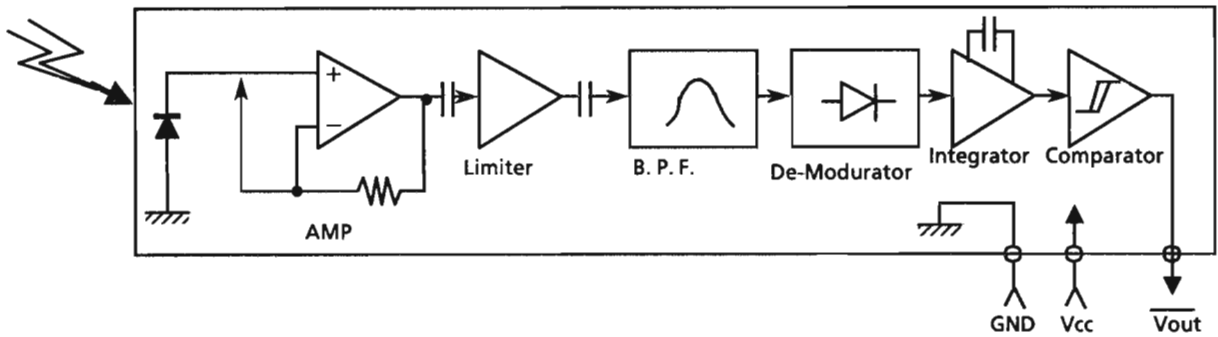

■ NJM2246D (IC221) : Video Switch

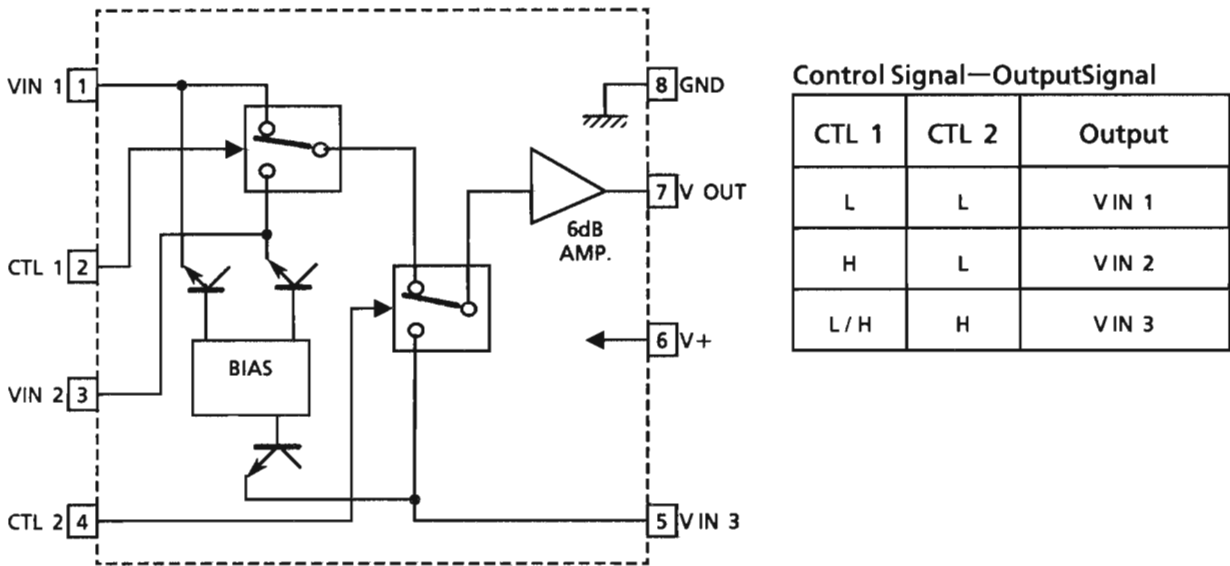

■ VC5022-2 (IC701,702) : SUPER A

(1) Terminal Layout

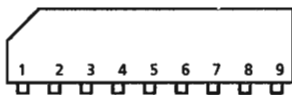

(2) Block Diagram

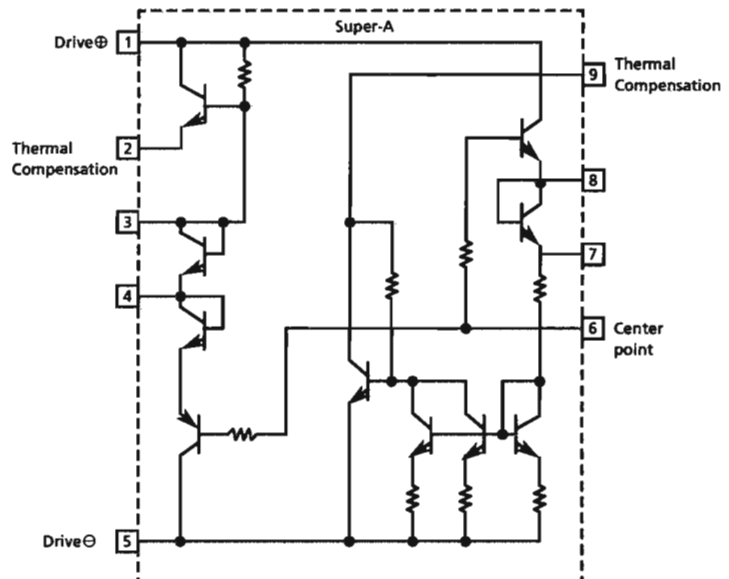

■ NJU3715L (IC411) : 16-BIT Serial-parallel converter

1. Terminal layout

VIDEO2	1	22	VDD
	2	21	VIDEO1
VOL+	3	20	
VOL-	4	19	LOUDNESS
VOL LED	5	18	TU.MUTE
VSS	6	17	S.MUTE
	7	16	SEA ON
SUR.RELAY	8	15	CLR
C.RELAY	9	14	STB2
	10	13	CLK
	11	12	DATA

2. Internal Block Diagram

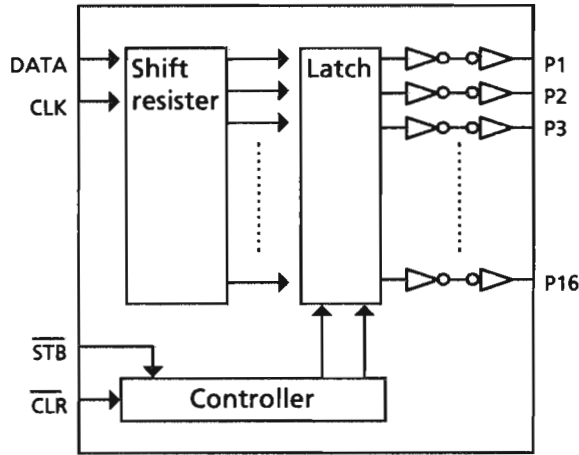

- P1 C. ON/OFF
- P2 NORMAL
- P3 WIDE
- P4 SURR. ON/OFF
- P5 HALL
- P6 VIDEO1
- P7 VIDEO2
- P8 SOURCE MUTE
- P9 3CH. LOGIC
- P10 NOISE ON/OFF
- P11 NOISE1
- P12 NOISE2
- P13 DELAY1
- P14 DELAY2
- P15 DELAY3
- P16 —

3. Terminal Description

Pin No.	I/O	Function
1~5, 7~11, 16~21	O	Parallel data output
12	I	Serial data input
13	I	Clock input (When this terminal is set low level, all of the output become low.)
14	I	Strobe signal input
15	I	Clear signal input

4. Function

CLK	STB	CLR	Function
X	X	L	All the data stored in the latch circuit are eliminated. (The data in the shift register are not eliminated.)
	H	H	Data are inputted synchronizing the rising edge of the clock.
L	L	H	The data in the shift register are transmitted to the latch circuit. The data outputted from parallel outputs.
	L	H	The data in the shift register are shifted synchronizing the rising edge of the clock. (The data outputted from the latch circuit are changed.)

5. Function Table

SURROUND RELAY CONTROL

MODE	Port of IC411	
	SUR. RELAY	C. RELAY
DAP OFF	L	L
SUR. OFF	L	L
PROLOGIC	H	H
3CH PROLOGIC	L	H
THEATER	H	H
DAP (Except H.Phone)	H	L
H. Phone	L	L

VOLUME CONTROL

MODE	Port of IC411		
	VOLUME UP	VOLUME DOWN	VOLUME LED
UP	H	L	L
DOWN	L	H	L
STOP	L	L	L
MUTE	L	H	BLINKLING

VIDEO CONTROL

MODE	Port of IC411	
	VIDEO 1	VIDEO 2
VCR	H	H
VIDEO1	L	H
EXCEPT VCR, VIDEO1	L	L
STAND BY	L	L

SEA CONTROL

MODE	Port of IC411
	SEA ON
SEA ON	H
SEA OFF	L

LOUDNESS

MODE	Port of IC411
	LOUDNESS
ON	L
OFF	H

■ AT24C02 (IC412) : Serial Eeprom

1. Terminal Layout

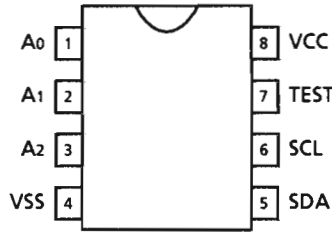

2. Terminal Functions

Pin No.	Symbol	Functions
1~3	A0~A2	ADDRESS INPUT (NOT USED)
4	VSS	GND
5	SDA	SERIAL DATA
6	SCL	SERIAL CLOCK
7	TEST	TEST PIN (CONNECTED TO GND)
8	VCC	POWER SUPPLY

3. Block Diagram

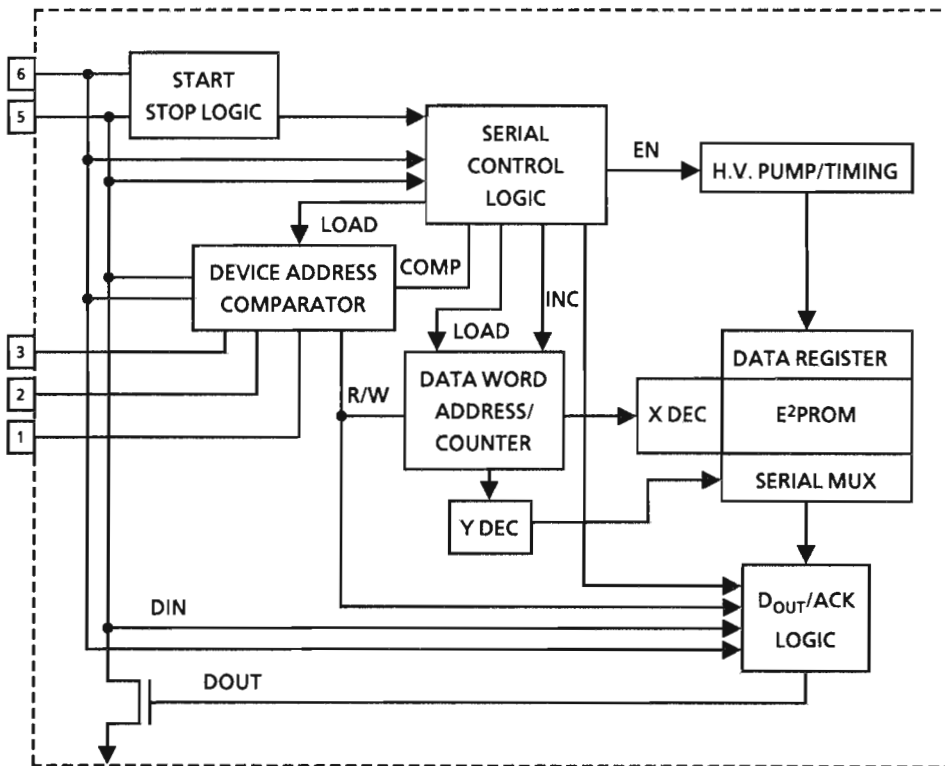

■ TC74HC74AF (IC093) : DUAL D FLIP FLOP WITH PRESET AND CLEAR

1. Terminal Layout

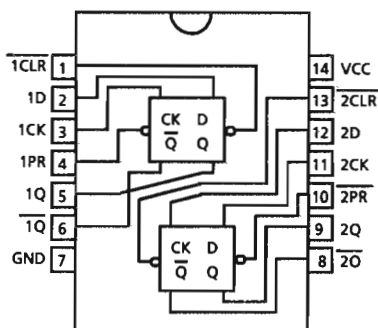

2. Pin function

INPUTS				OUTPUTS		FUNCTION
CLR	PR	D	CK	Q	Q̄	
L	H	X	X	L	H	CLEAR
H	L	X	X	H	L	PRESET
L	L	X	X	H	H	—
H	H	L	↑	L	H	—
H	H	H	↑	H	L	—
H	H	X	↓	Q <sub>n</sub>	Q̄ <sub>n</sub>	NO CHANGE

X: Don't care

## Internal Connections of the FL Display

■ ELU0001-202 : FL401

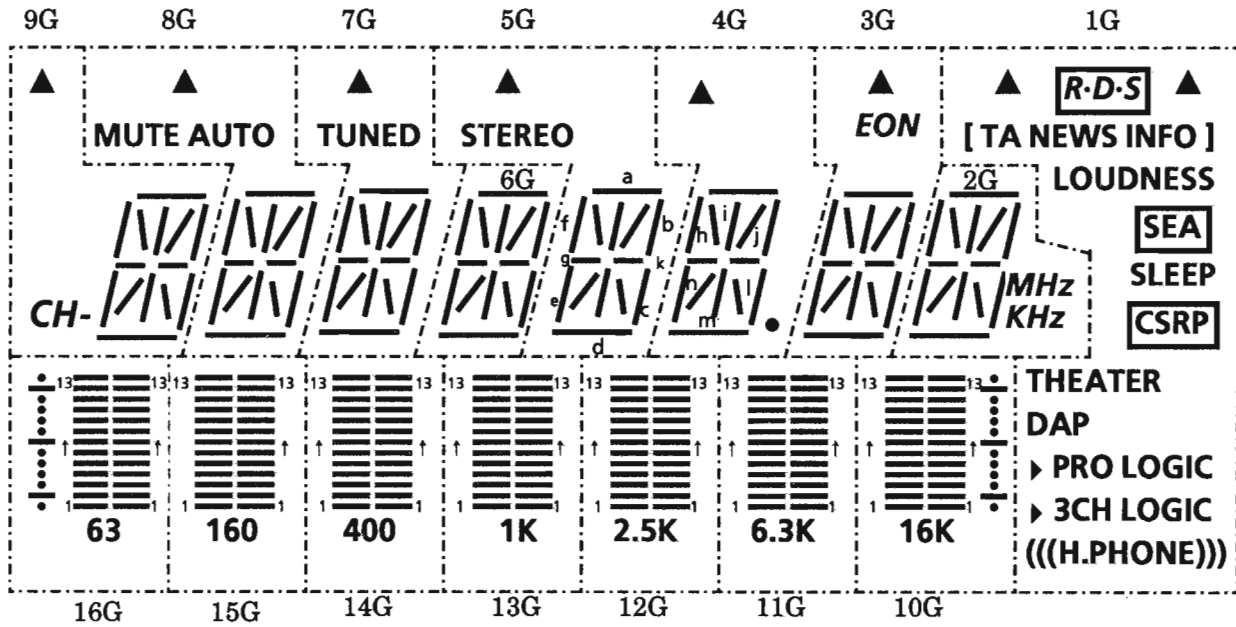

### Pin Connection

#### Upper

PIN NUMBER	39	40	41	42	43	44	45	46	47	48	49	50	51	52	53	54	55	56	57
ELECTRODE	F2	F2	F2	NP	NP	NP	NP	NP	NP	NP	P16 (S16)	P15 (S15)	P14 (S14)	P13 (S13)	P12 (S12)	P11 (S11)	P10 (S10)	P9 (S9)	P8 (S8)
PIN NUMBER	58	59	60	61	62	63	64	65	66	67	68	69	70	71	72	73	74	75	76
ELECTRODE	P7 (S7)	P6 (S6)	P5 (S5)	P4 (S4)	P3 (S3)	P2 (S2)	P1 (S1)	1G (D1)	2G (D2)	3G (D3)	4G (D4)	5G (D5)	6G (D6)	7G (D7)	8G (D8)	NP	F1	F1	F1

#### Lower

PIN NUMBER	1	2	3	4	5	6	7	8	9	10	11	12	13	14	15	16	17	18	19
ELECTRODE	F1	F1	F1	NP	P17 (T1)	P18 (T2)	P19 (T3)	P20 (T4)	P21 (T5)	P22 (T6)	P23 (T7)	P24 (T8)	P25 (T9)	P26 (T10)	P27 (T11)	P28 (T12)	P29 (T13)	16G (1G)	15G (2G)
PIN NUMBER	20	21	22	23	24	25	26	27	28	29	30	31	32	33	34	35	36	37	38
ELECTRODE	14G (3G)	13G (4G)	12G (5G)	11G (6G)	10G (7G)	9G (8G)	NP	NP	NP	NP	NP	NP	NP	NP	NP	NP	F2	F2	F2

Note F : Filament, G : Grid, P : Anode, NP : No Pin

Grid - Anode Assignment ( 1G~9G )

	9G	8G	7G	6G	5G	4G	3G	2G	1G
S1	a	a	a	a	a	a	a	a	▲ (LEFT)
S2	b	b	b	b	b	b	b	b	R·D·S
S3	i	i	i	i	i	i	i	i	▲ (RIGHT)
S4	j	j	j	j	j	j	j	j	( )
S5	h	h	h	h	h	h	h	h	TA
S6	f	f	f	f	f	f	f	f	NEWS
S7	k	k	k	k	k	k	k	k	INFO
S8	g	g	g	g	g	g	g	g	LOUDNESS
S9	c	c	c	c	c	c	c	c	SEA
S10	l	l	l	l	l	l	l	l	SLEEP
S11	n	n	n	n	n	n	n	n	CSRP
S12	m	m	m	m	m	m	m	m	THEATER
S13	e	e	e	e	e	e	e	e	DAP
S14	d	d	d	d	d	d	d	d	PRO LOGIC
S15	CH-	MUTE AUTO	TUNED	--	STEREO	● (DOT)	EON	MHz	3CH LOGIC
S16	▲	▲	▲	--	▲	▲	▲	KHZ	((((H,PHONE)))

Grid - Anode Assignment ( 10G~16G )

	16G	15G	14G	13G	12G	11G	10G
S17	(1)	(1)	(1)	(1)	(1)	(1)	(1)
S18	(2)	(2)	(2)	(2)	(2)	(2)	(2)
S19	(3)	(3)	(3)	(3)	(3)	(3)	(3)
S20	(4)	(4)	(4)	(4)	(4)	(4)	(4)
S21	(5)	(5)	(5)	(5)	(5)	(5)	(5)
S22	(6)	(6)	(6)	(6)	(6)	(6)	(6)
S23	(7)	(7)	(7)	(7)	(7)	(7)	(7)
S24	(8)	(8)	(8)	(8)	(8)	(8)	(8)
S25	(9)	(9)	(9)	(9)	(9)	(9)	(9)
S26	(10)	(10)	(10)	(10)	(10)	(10)	(10)
S27	(11)	(11)	1(1)	(11)	(11)	(11)	(11)
S28	(12)	(12)	(12)	1(2)	(12)	(12)	(12)
S29	(13)	(13)	(13)	(13)	(13)	(13)	(13)

(NOTE) Dots(\*) on both side of 63,160,400,1K,2.5K,6.3K and 16K are connccted with their each grids. (\*)



## Disassembly Procedures

### (1) Removing the top cover

1. Remove 4 screws (A) fastening both sides of top cover, and 3 screws (B) fastening the rear side.
2. Remove the top cover.

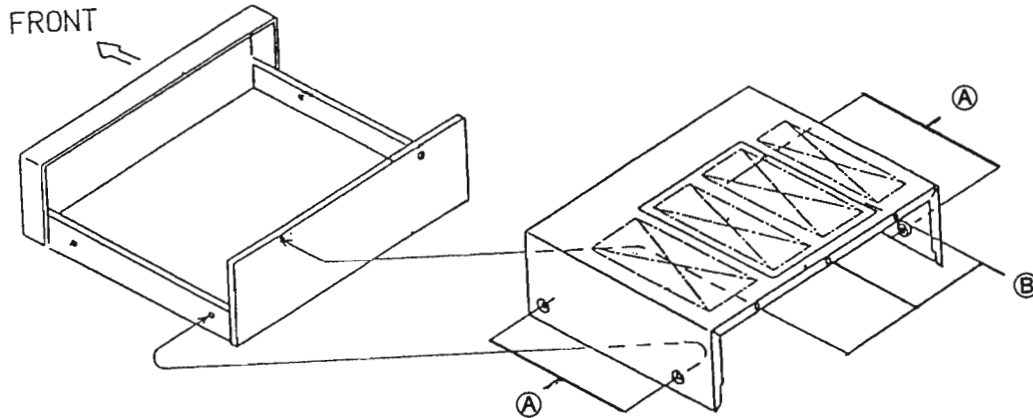

### (2) Removing the Bottom Cover

1. Remove 13 screws (C) and (C').
2. Remove the bottom cover.

※ The screw (C') which secures the bottom cover is also used for ground.  
It is necessary to ground before checking after the bottom cover is removed.

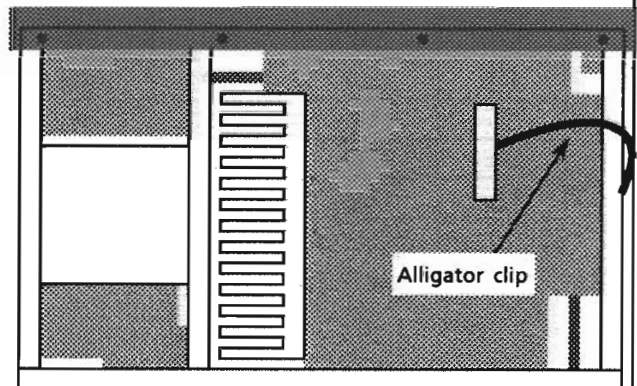
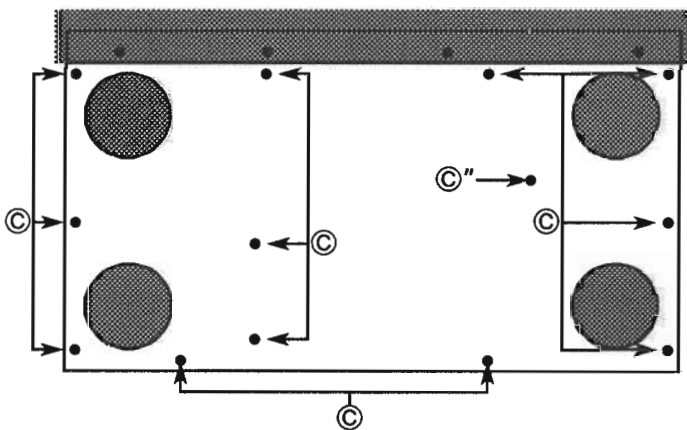

(A) .. E61660-004

(B) ... E73273-006

(C),(C') .... SBSG3008CC



(3) Removing the Front Panel Assembly

1. Remove 3 screws ③ fastening top of the front panel, and 4 screws ④ fastening bottom of it.
2. Remove the Master volume knob, Center tone knob and Balance knob.
3. Remove the nut fastening the Master volume.
4. Remove the front panel disconnecting some wires. (JB441,P704,P311,P222,P271)

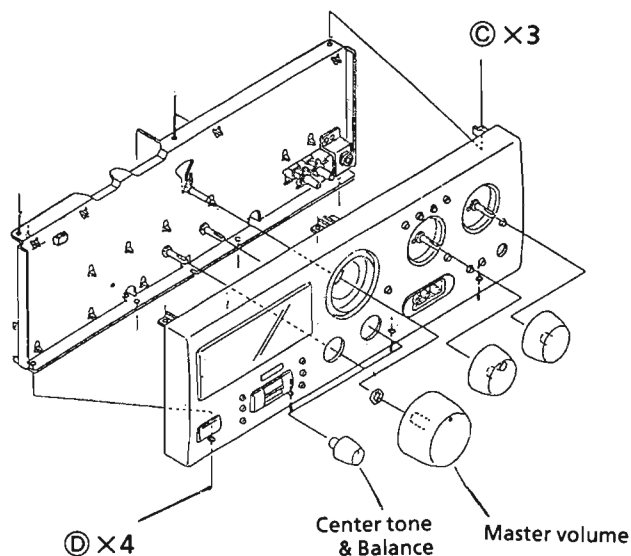

(4) Removing the Front P.C. Board

1. Removing the front panel assembly.
2. Remove 9 screws ⑤.
3. Remove 2 nut fastening the rotary encoder.
4. Remove the front P.C. Board.

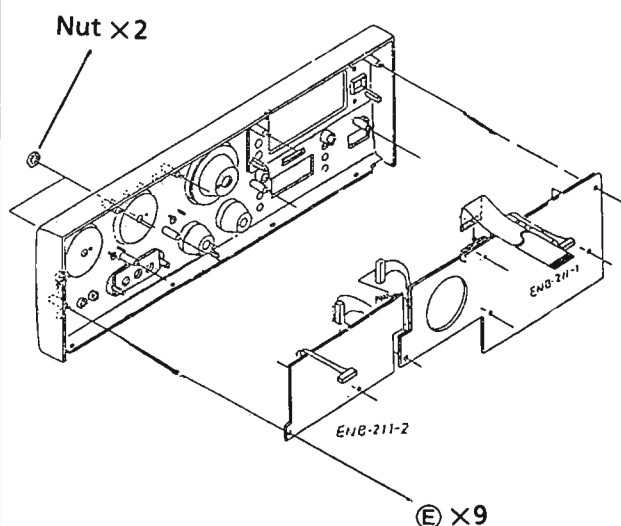

(5) Removing the Rear Panel

1. Remove 20 screws ⑥, ⑥'' and ⑦.
2. Remove 2 screws ③ fastening bottom sides of rear panel.
3. Take it out.

※ 3pcs. of screw ⑥'' which secure the rear panel are also used for ground.  
Installing of those screws is required before checking.

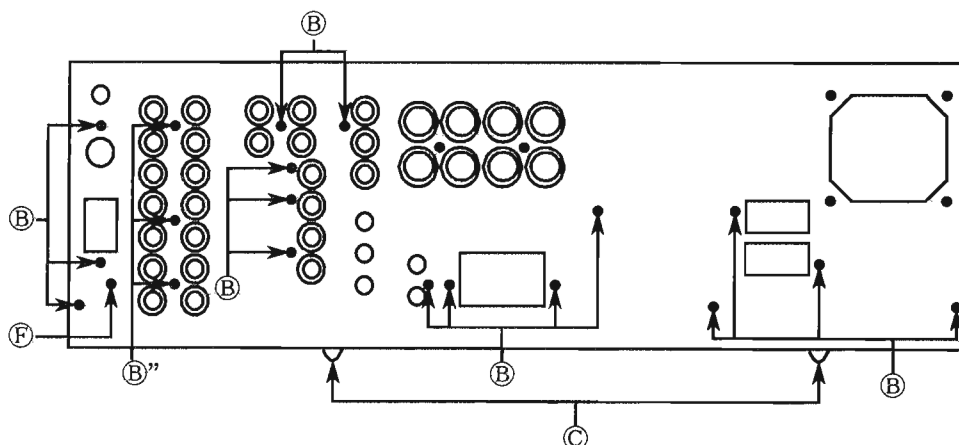

⑥, ⑥'' E73273-006

③ SBSG3008CC

④ SDSG3008M

⑤ SDSF2608Z

⑦ SBST3006M

- (6) Removing the Power Transistor
1. Remove the top cover and bottom cover.
  2. Unsolder the broken transistor.
  3. Remove the some screws (C) fastening it.
  4. Remove it.

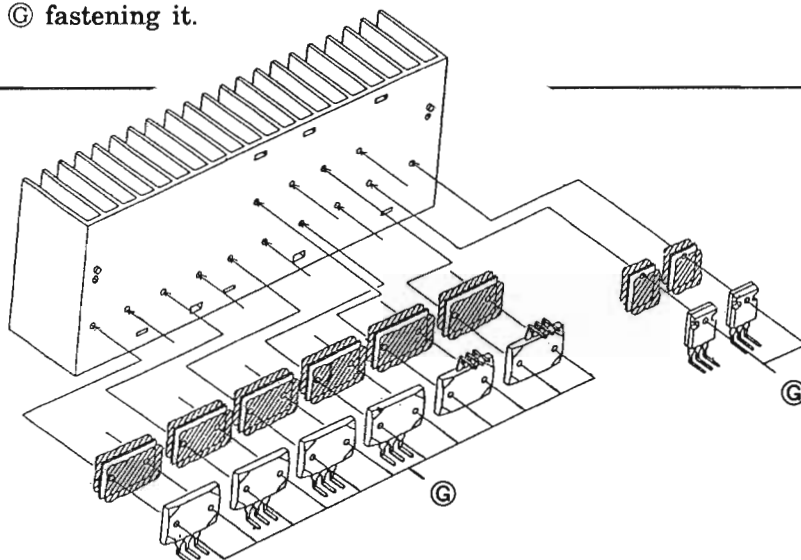

© .. E73525-003

## ADJUSTMENT PROCEDURES

### ■ Tuner section

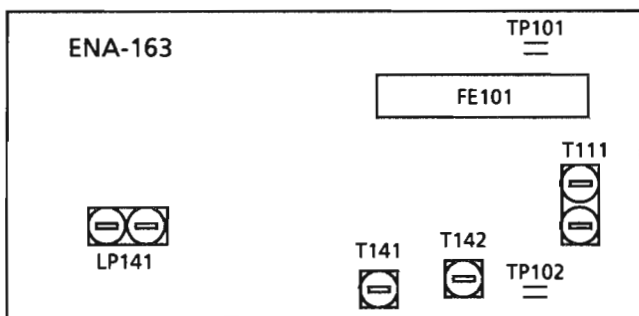

### Tuning range

Area	Range	
	MW (kHz)	FM (MHz)
the U.S.A., Canada	530~1710	87.5MHz~ 108MHz
Australia	522~1629	
Universal type (AM Channel space 9kHz)	531~1602	
Universal type (AM Channel space 10kHz)	530~1600	

#### (1) Tuning Voltage

Confirm the voltages in the table at TP101.

#### FM Tuning voltage (Unit : V)

Area	Frequency	
	87.5MHz	108MHz
the U.S.A., Canada, Australia, Universal	1.6±1.0	8.0±2.0

#### AM Tuning voltage (Unit : V)

Area	Frequency (MW)						
	522KHz	530KHz	531KHz	1600KHz	1602KHz	1629KHz	1710KHz
the U.S.A., Canada	—	1.0 > 0.5	—	—	—	—	8.0±0.8
Australia	1.0 > 0.5	—	—	—	—	7.5±0.8	—
Universal (Chanel space 9kHz)	—	—	1.0 > 0.5	—	7.2±0.7	—	—
Universal (Chanel space 10kHz)	—	1.0 > 0.5	—	7.2±0.7	—	—	—

#### (2) FM Center meter

Receive a broadcast by using the function of 'AUTO STOP'.

Adjust T141 (Detector coil) so taht the voltage at TP102 becomes 0±1.5mV.

■ Power Amplifier section

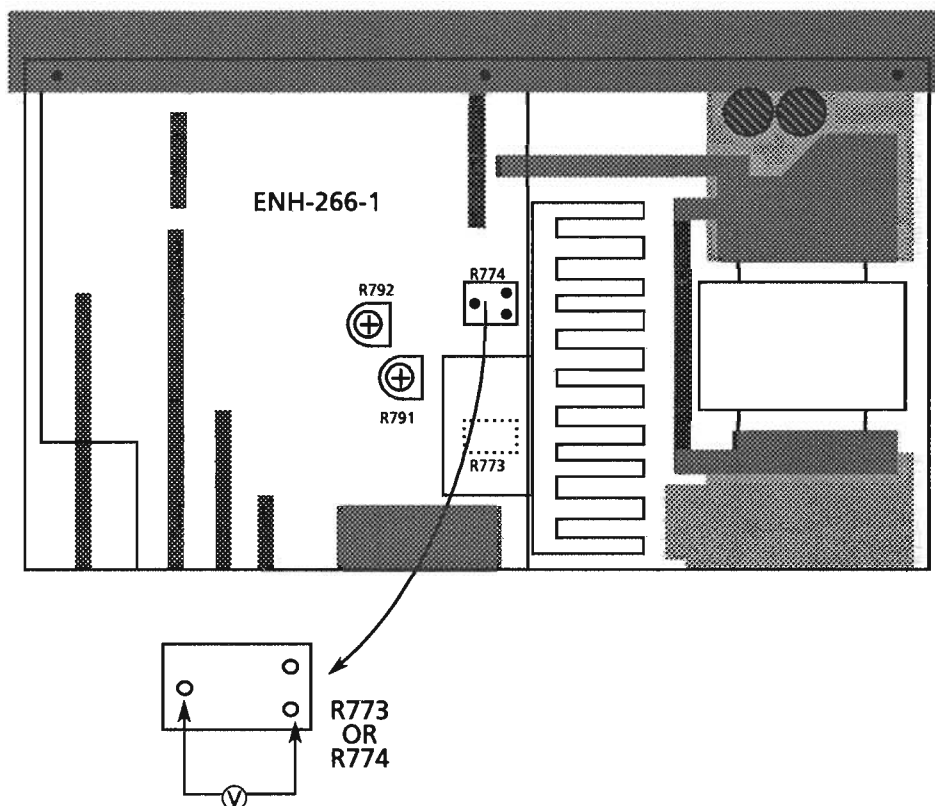

■ Idling current

- (1) Set the volume control to minimum during this adjustment.
- (2) Turn R791 and R792 fully counterclockwise to warm up before adjustment.  
If the heatsink is already warm from previous use the correct adjustment can not be made.
- (3) Connect a DC voltmeter to R773 resistor's leads for left channel, or to R774 for right channel.
- (4) Adjust R773 for left channel, or R774 for right channel, so that the DC voltmeter becomes 1mV~10mV.

# Block Diagrams

## Control Section

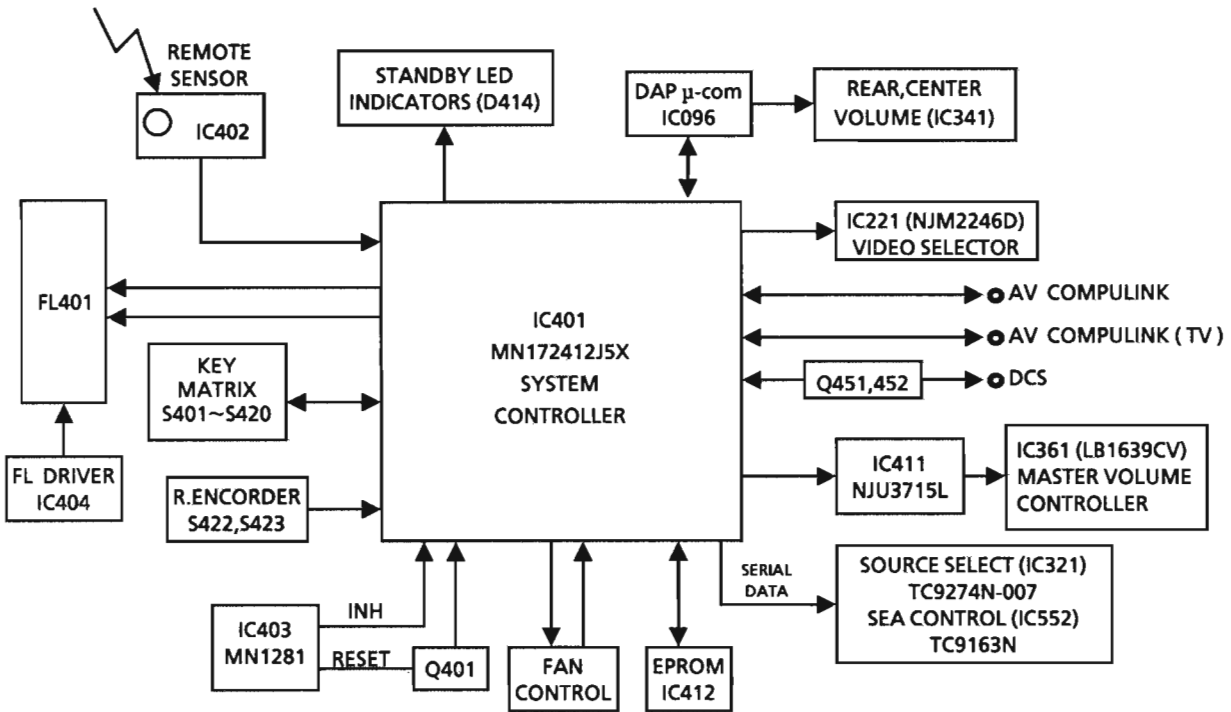

## Power Supply Section

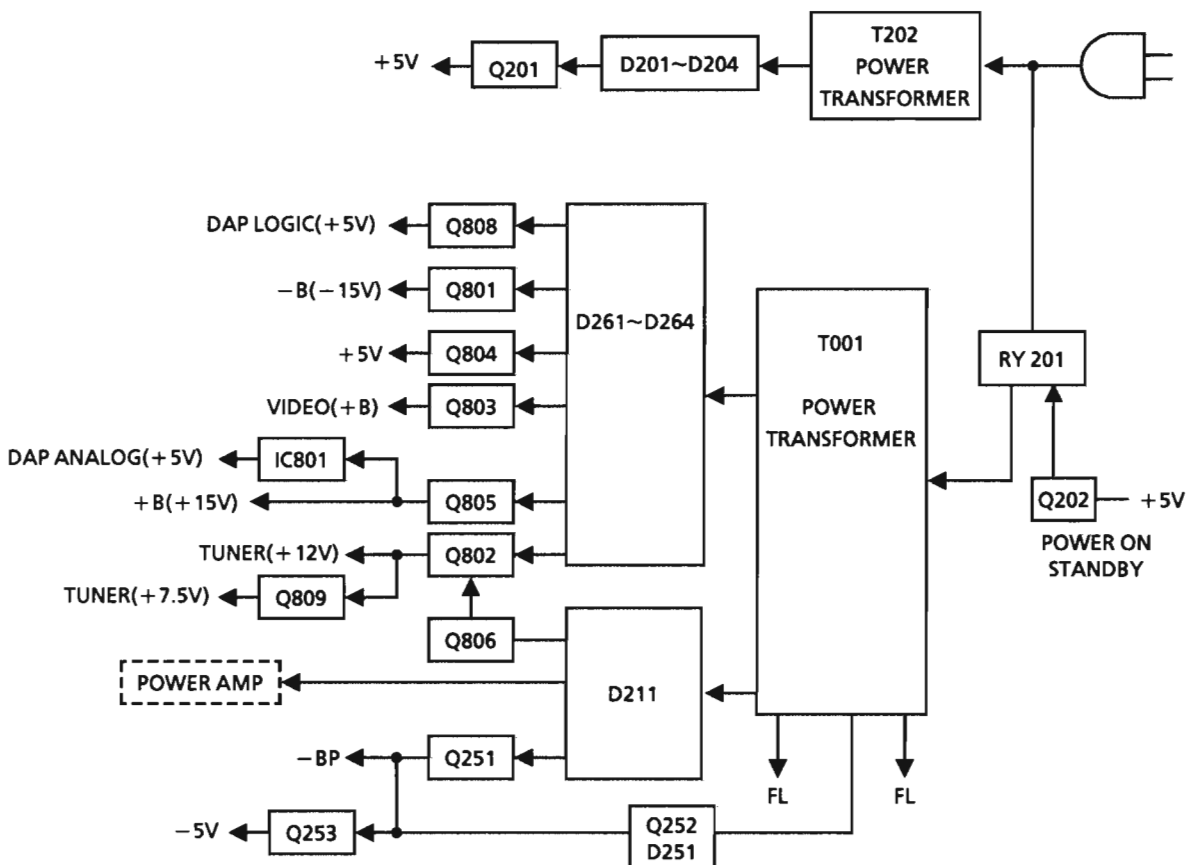

■ Signal Flow

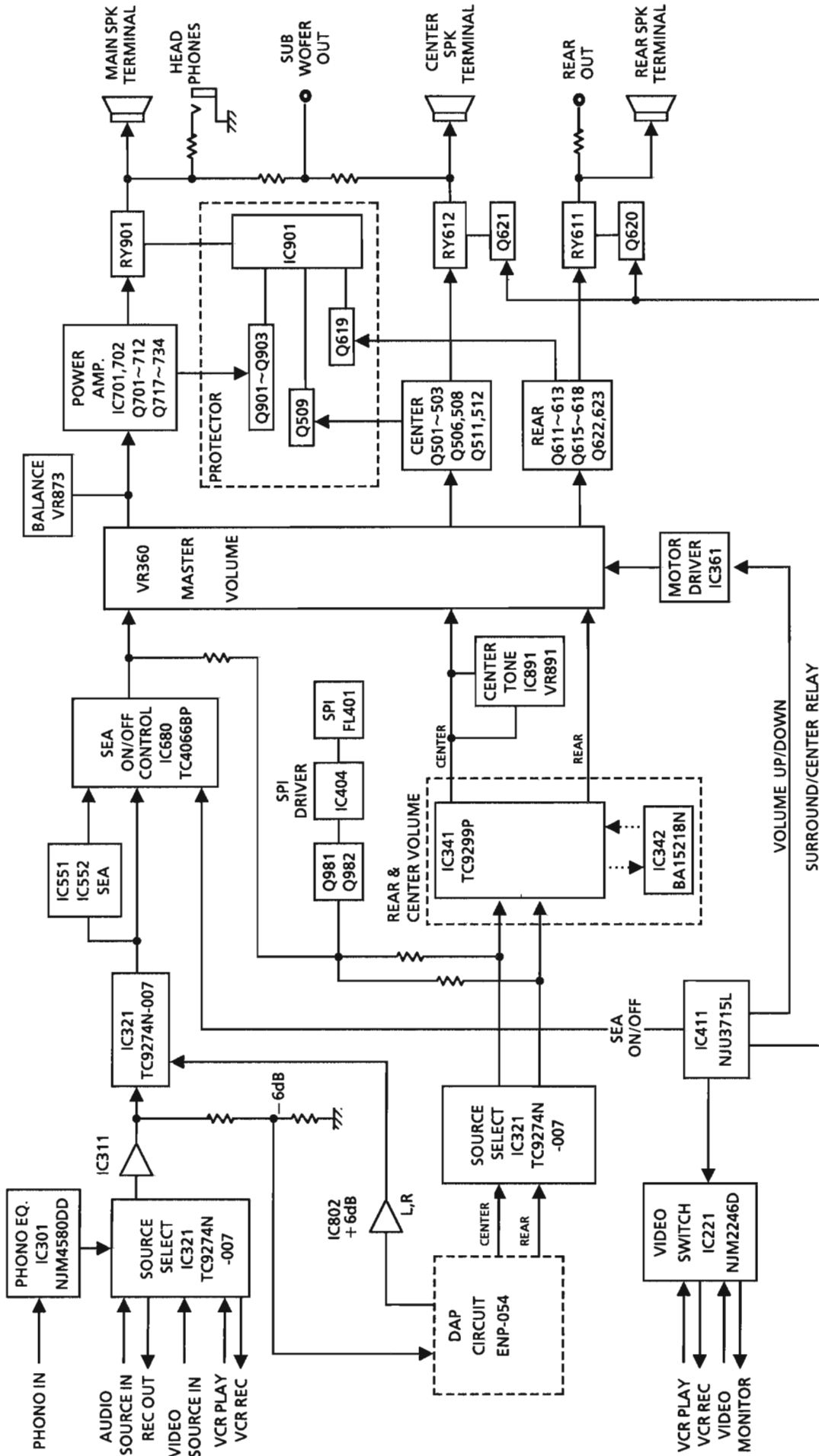

■ DAP Section

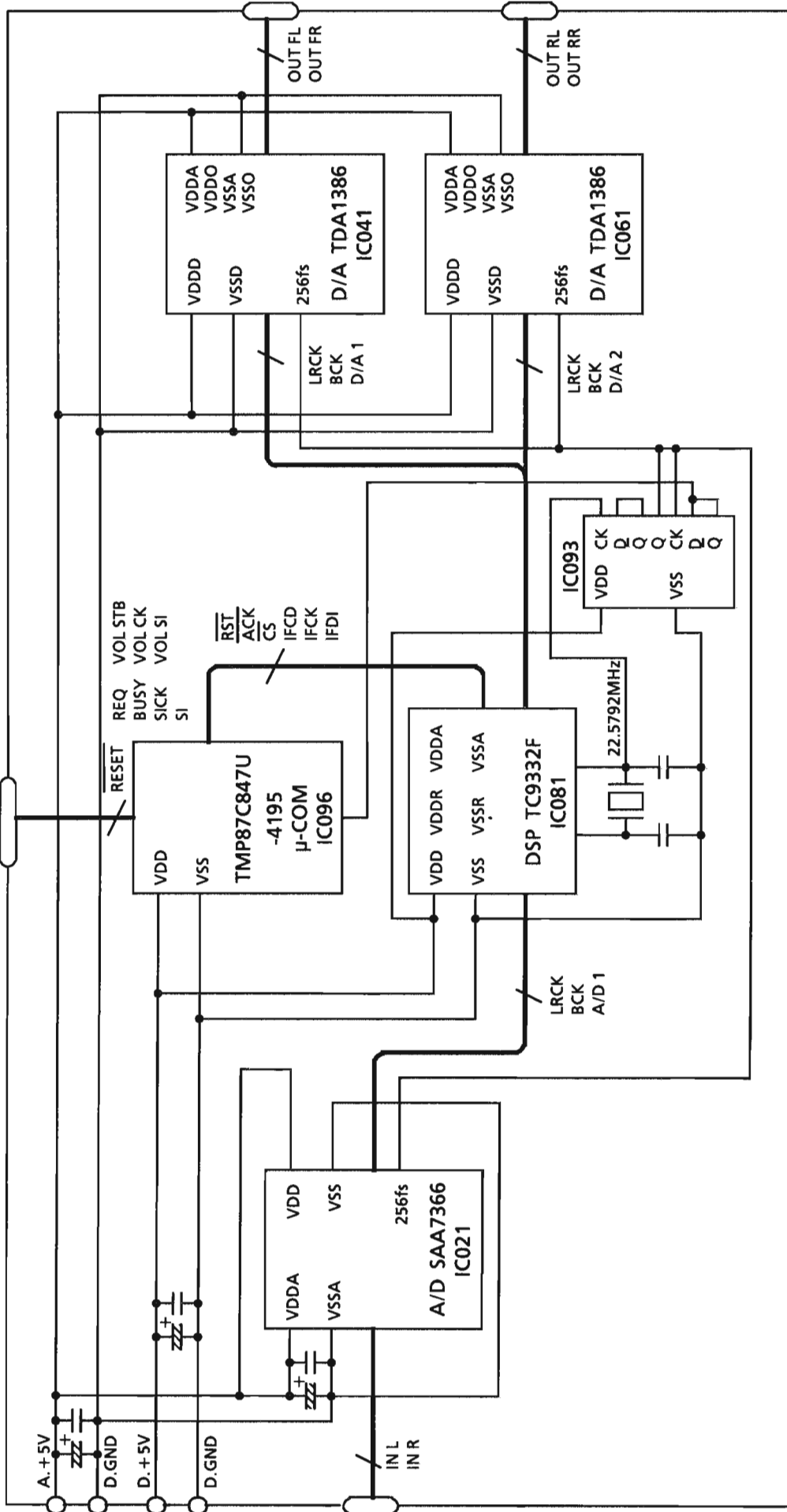







S.D-(1)-a

S.D-(1)-b

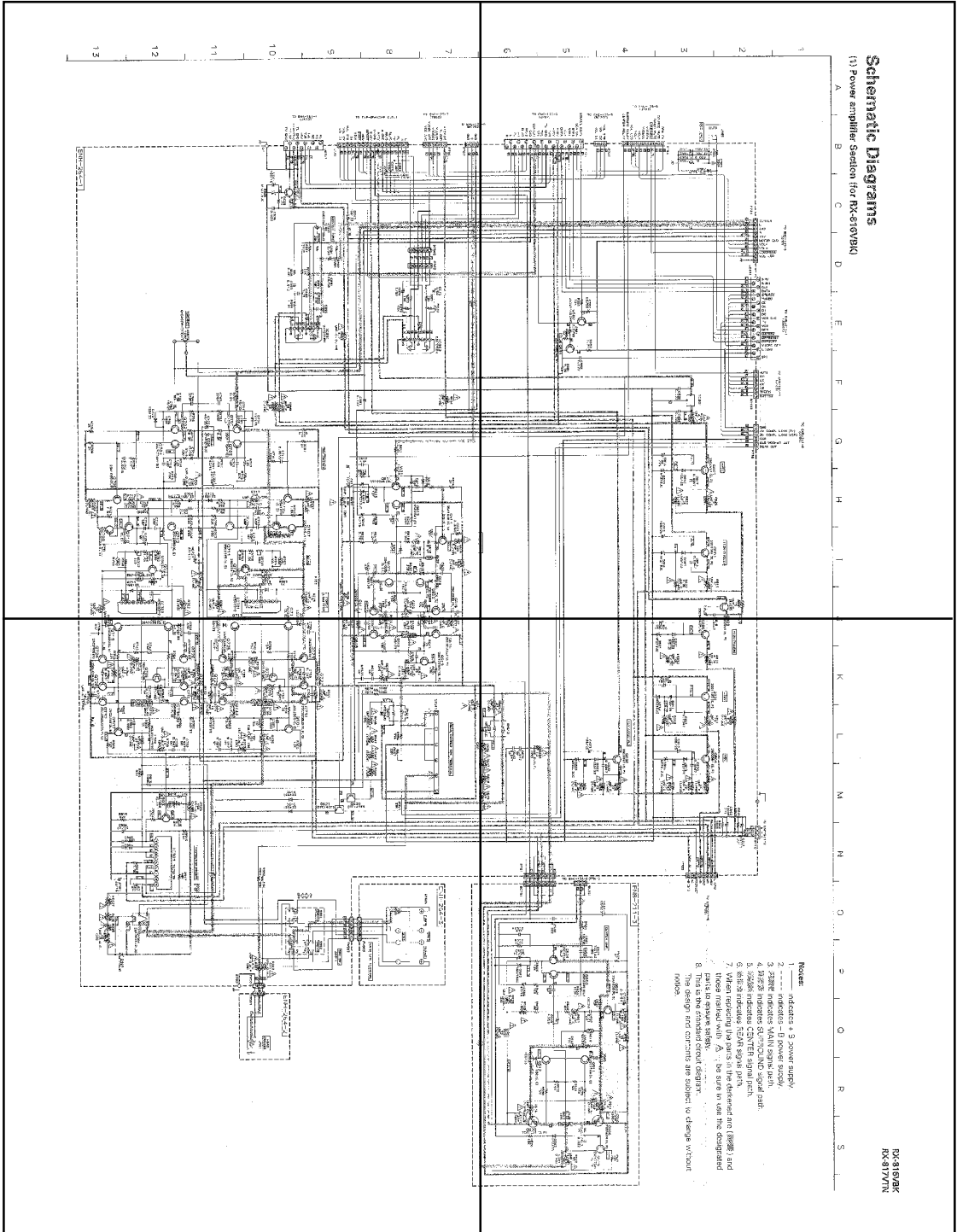

S.D-(1)-c

S.D-(1)-d

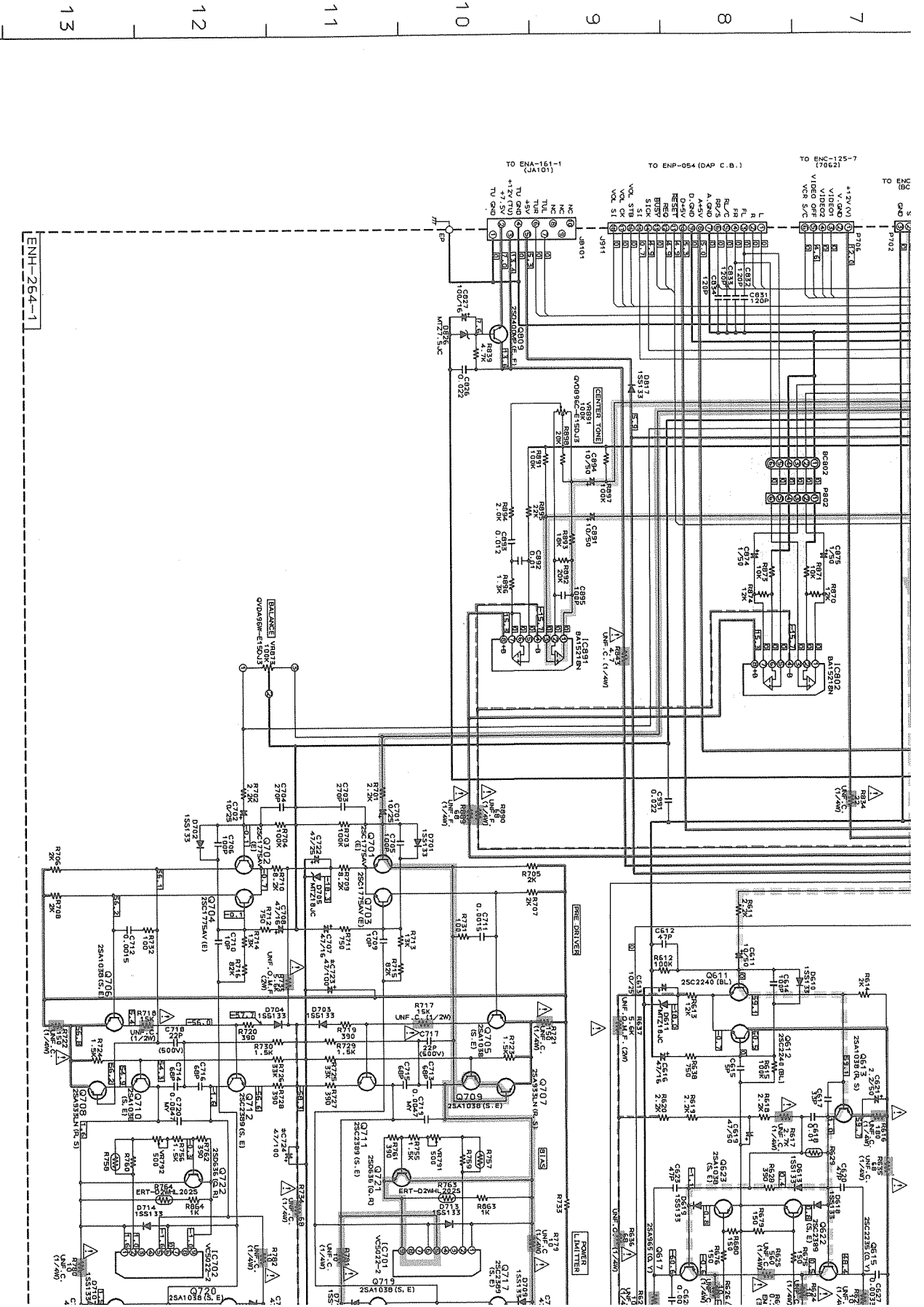

# Schematic Diagrams

## (1) Power amplifier Section (for RX-816VBK)

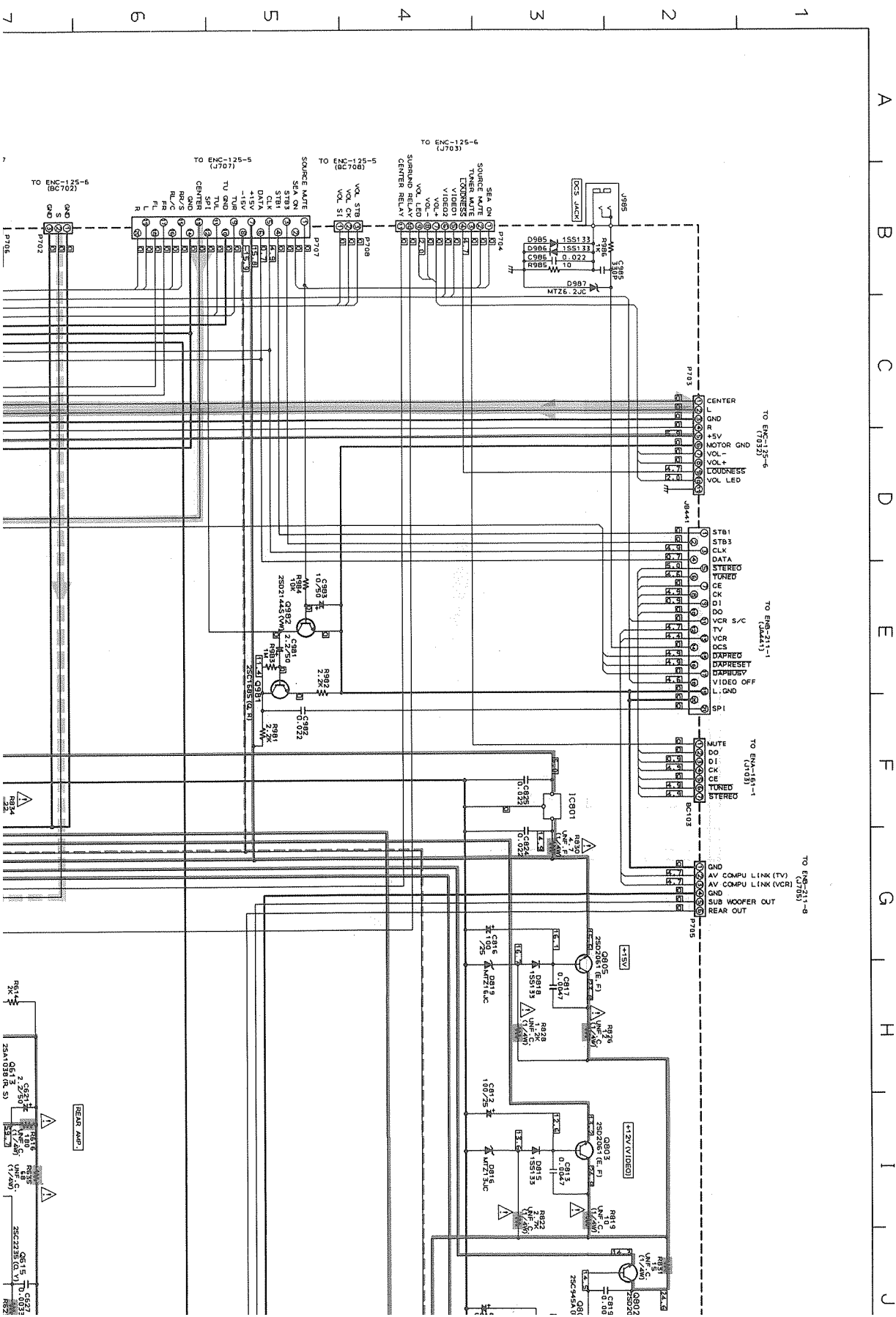

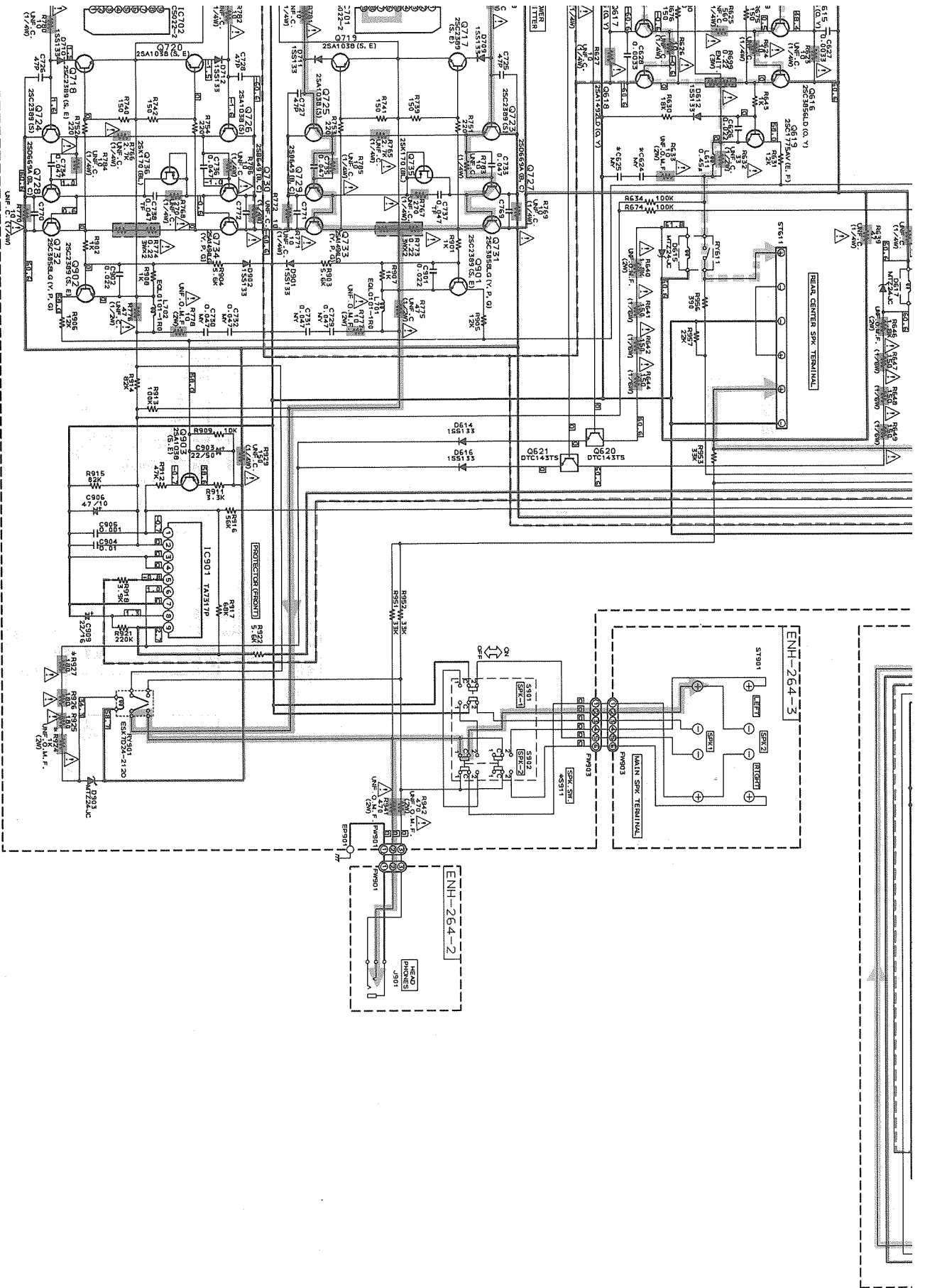

J K L M N O P Q R S

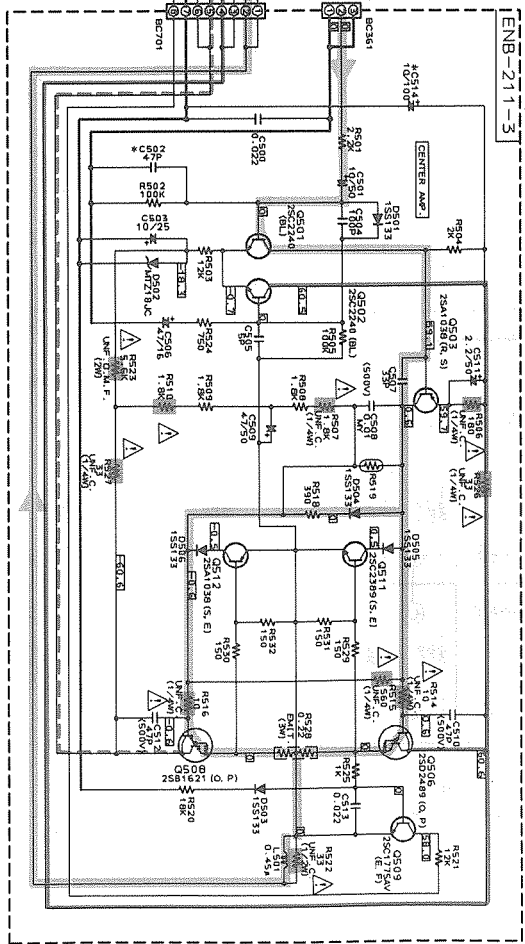
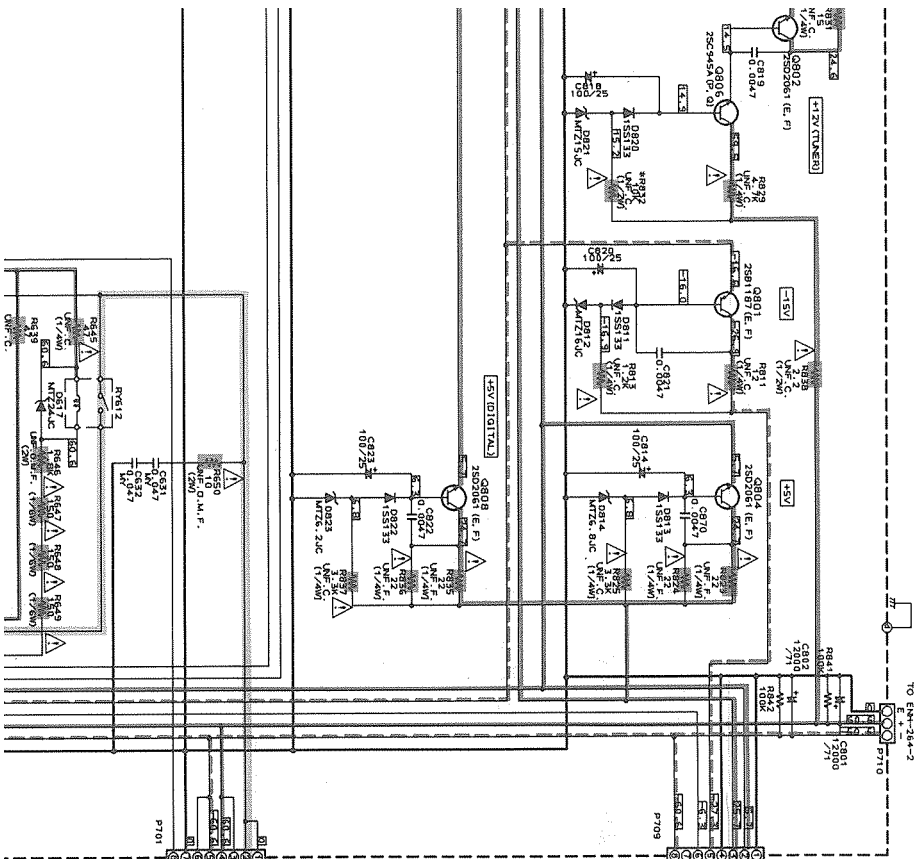

- Notes:**
1. \_\_\_\_\_ indicates + B power supply.
  2. - - - - - indicates - B power supply.
  3. [diagonal lines] indicates MAIN signal path.
  4. [cross-hatch] indicates SURROUND signal path.
  5. [horizontal lines] indicates CENTER signal path.
  6. [vertical lines] indicates REAR signal path.
  7. When replacing the parts in the darkened are ( [diagonal lines] ) and those marked with  $\Delta$ , be sure to use the designated parts to ensure safety.
  8. This is the standard circuit diagram. The design and contents are subject to change without notice.



S.D-(2)-a

S.D-(2)-b

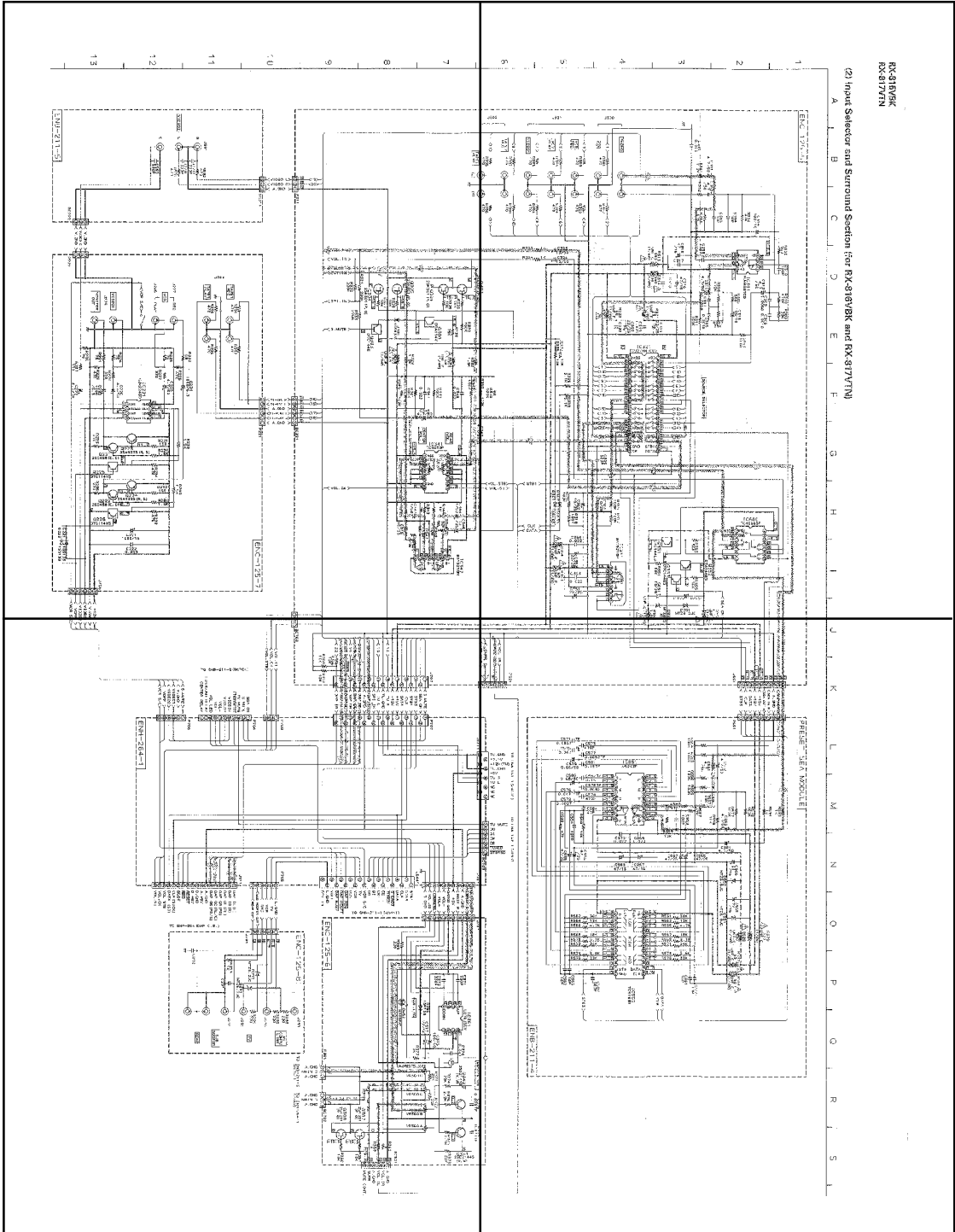

S.D-(2)-c

S.D-(2)-d

5  
6  
7  
8  
9  
10  
11  
12  
13

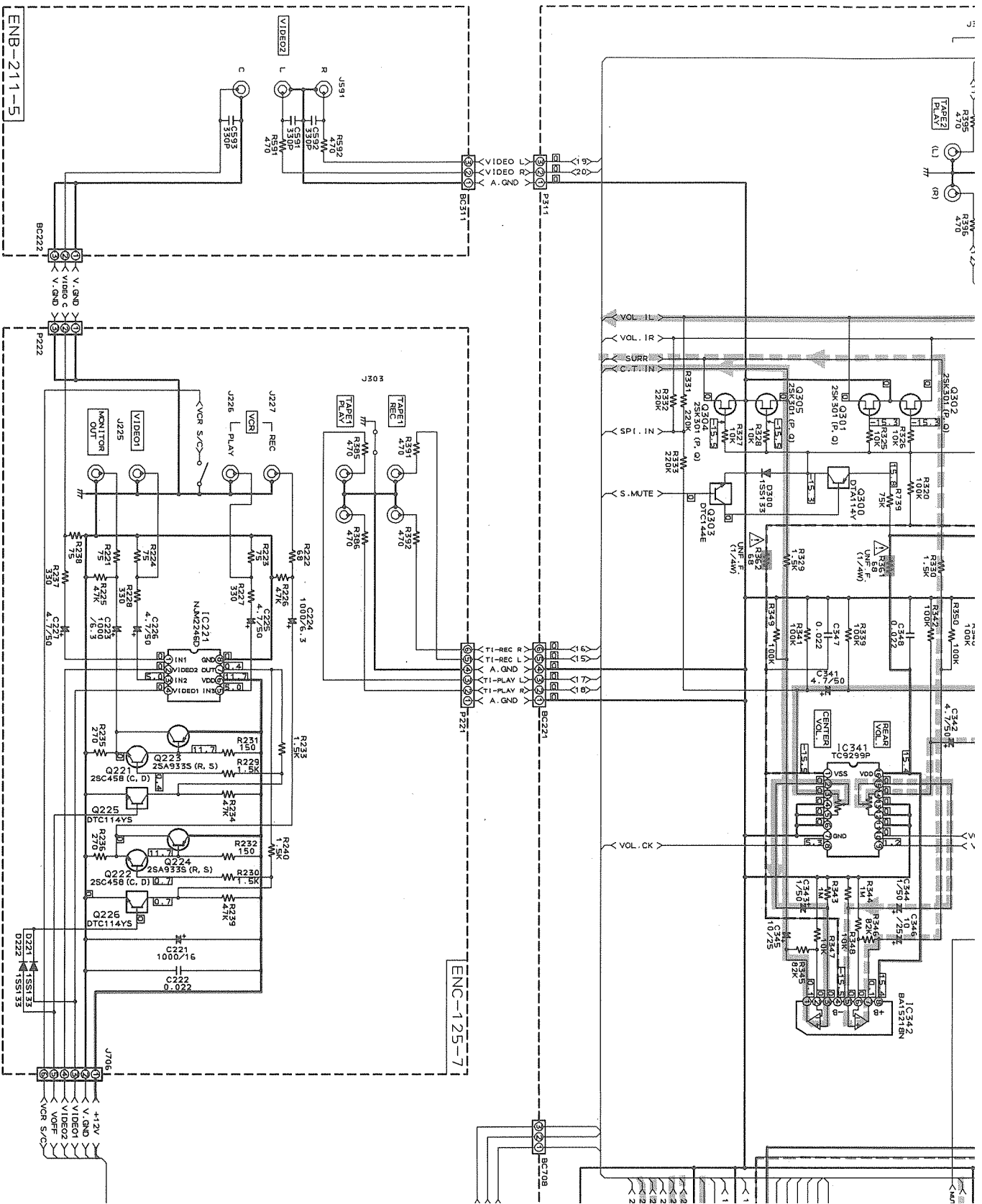



RX-816VBK  
RX-817VTN

(2) Input Selector and Surround Section (for RX-816VBK and RX-817VTN)

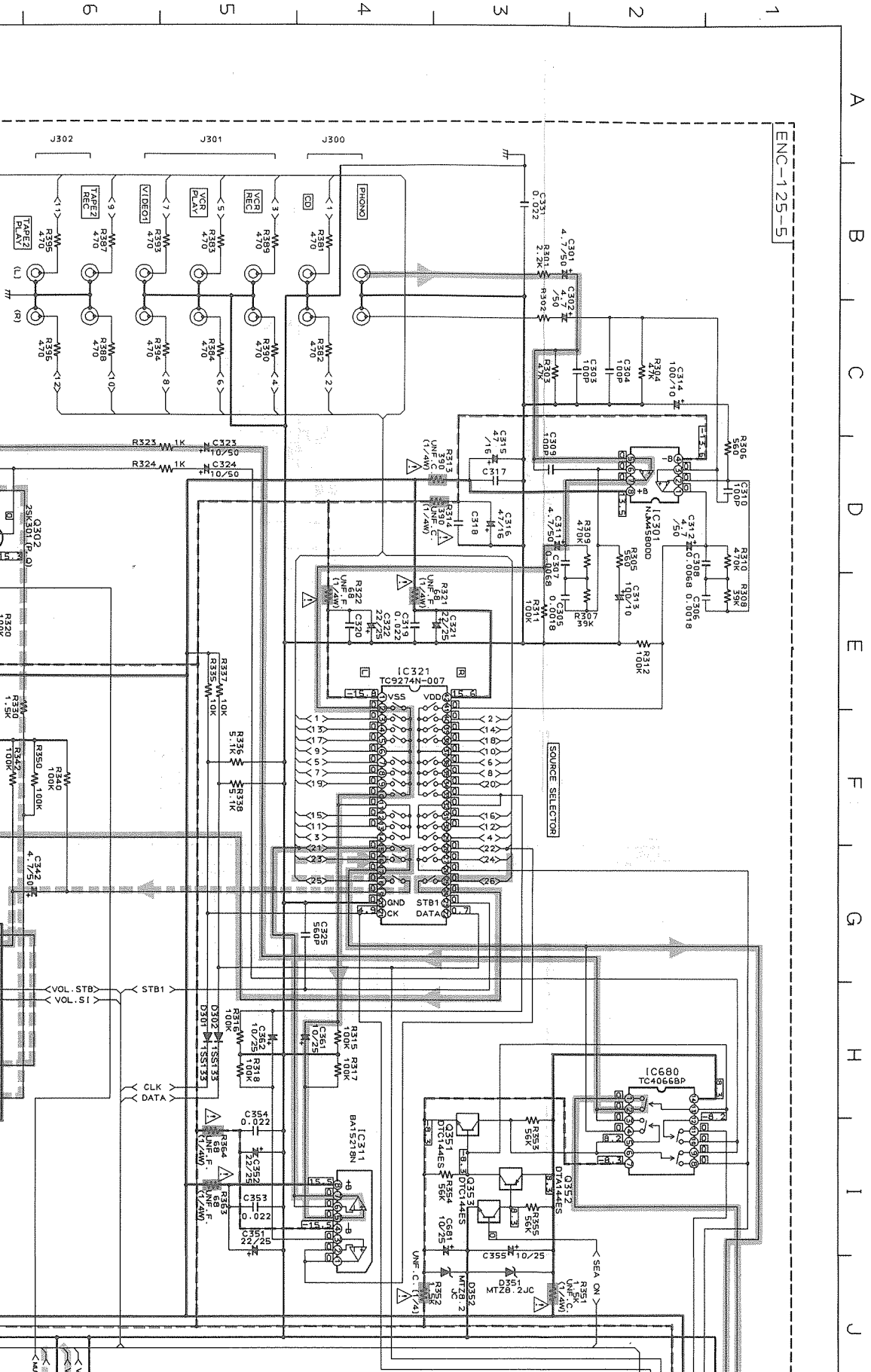

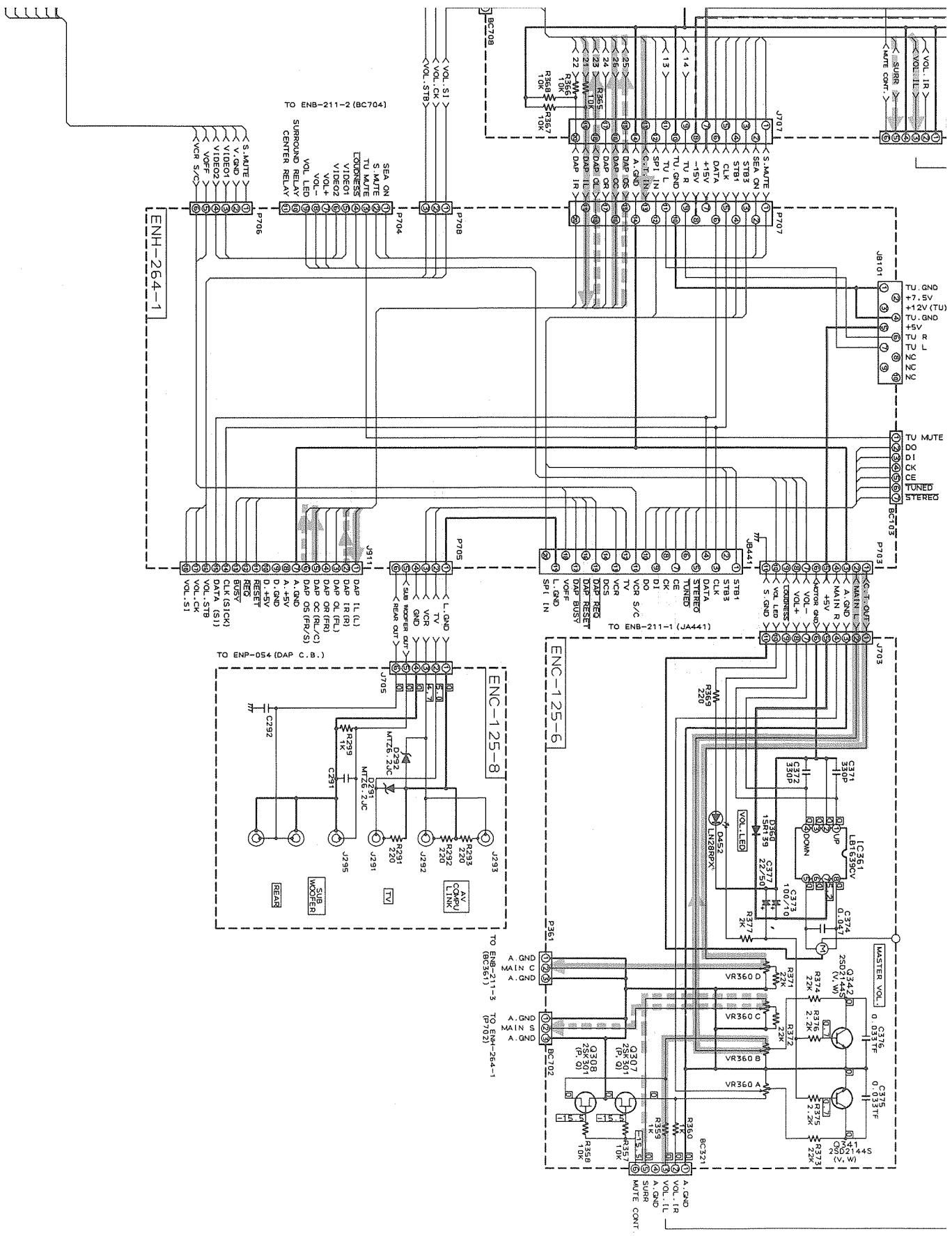











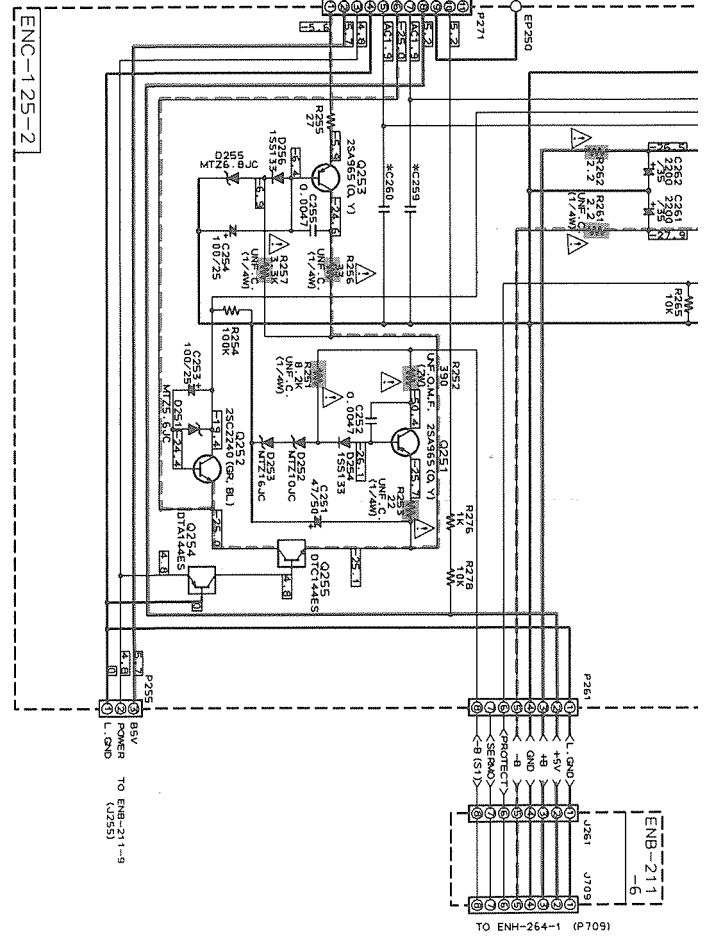
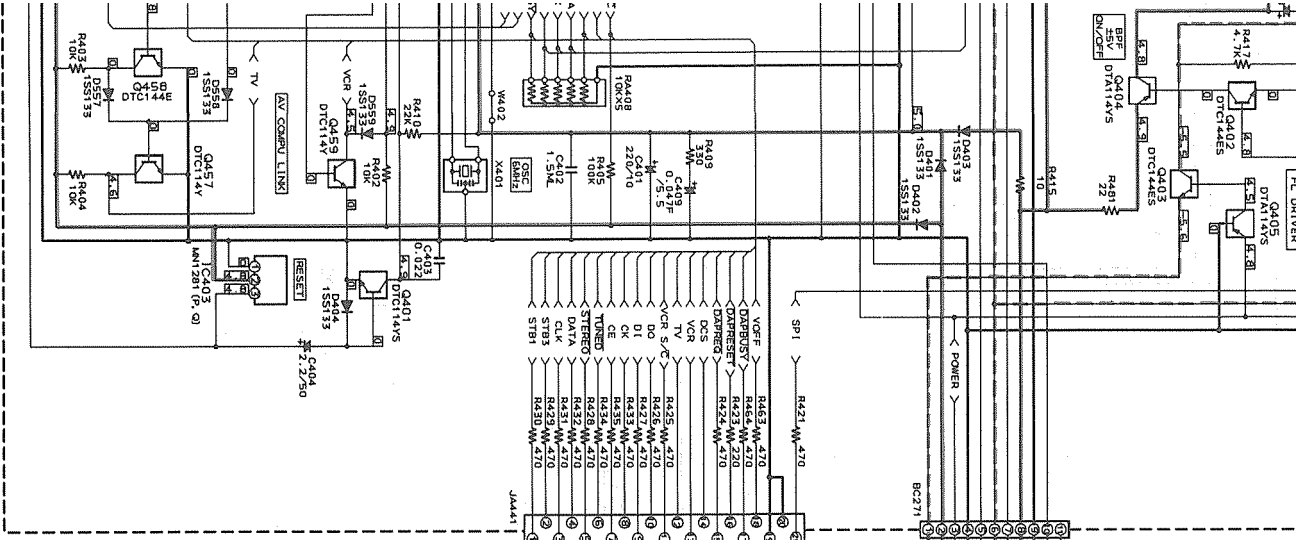



J K L M N O P Q R S

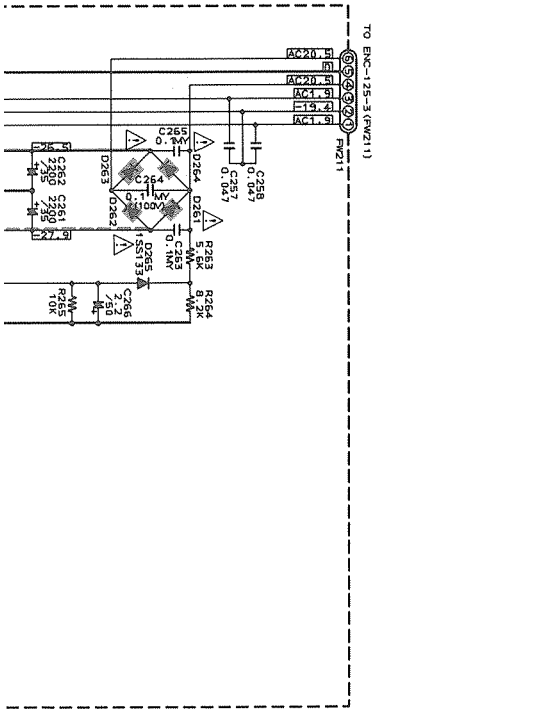
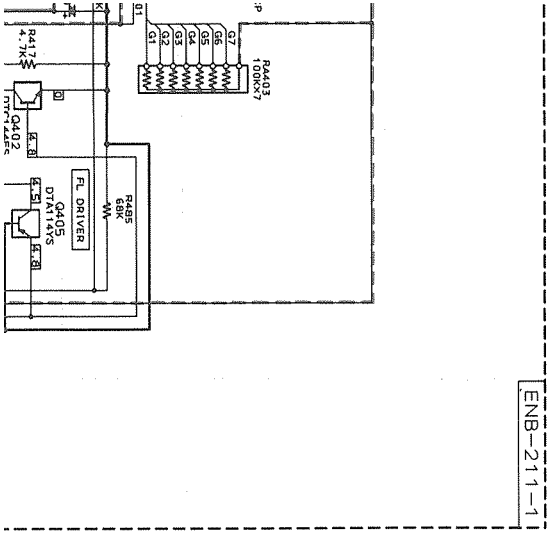
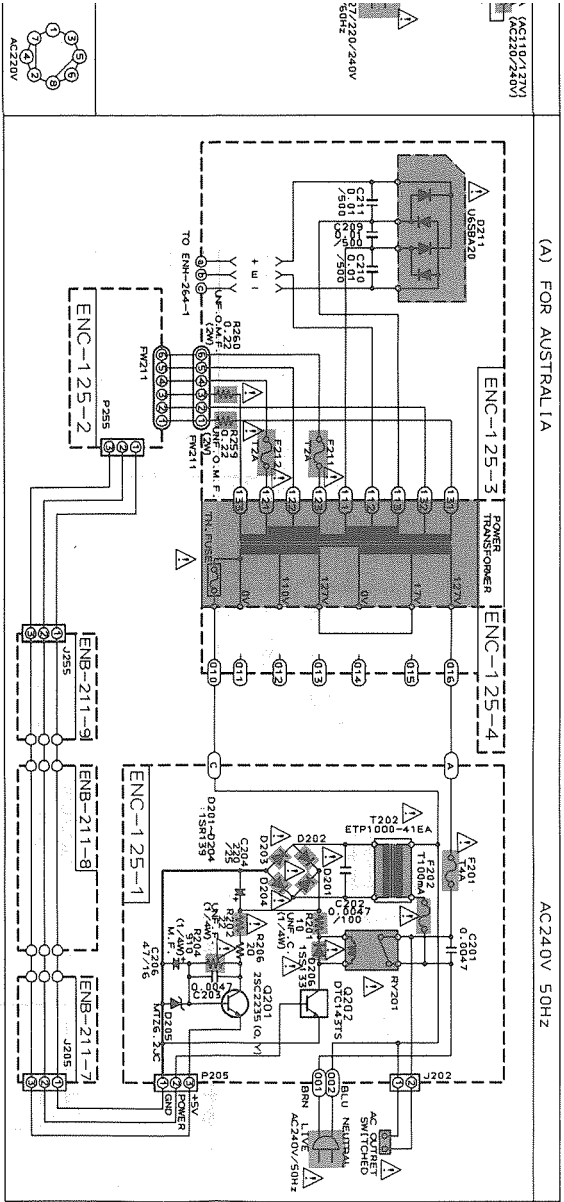

ENC-211-6



S.D-(4)-a

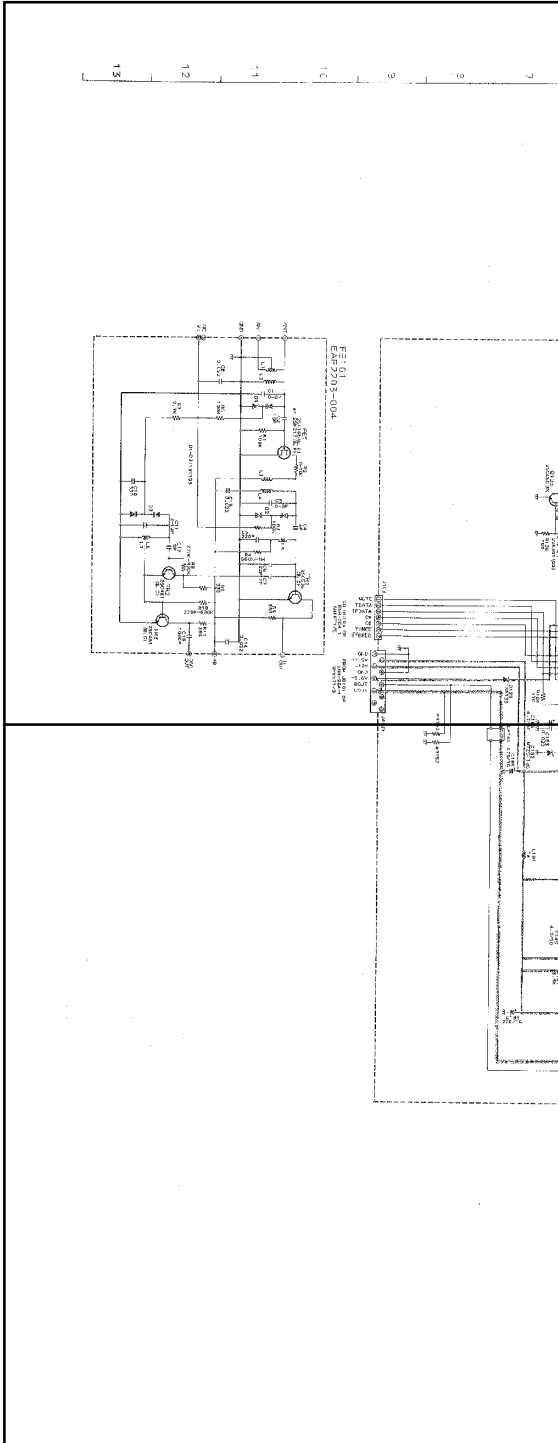

S.D-(4)-c

S.D-(4)-b

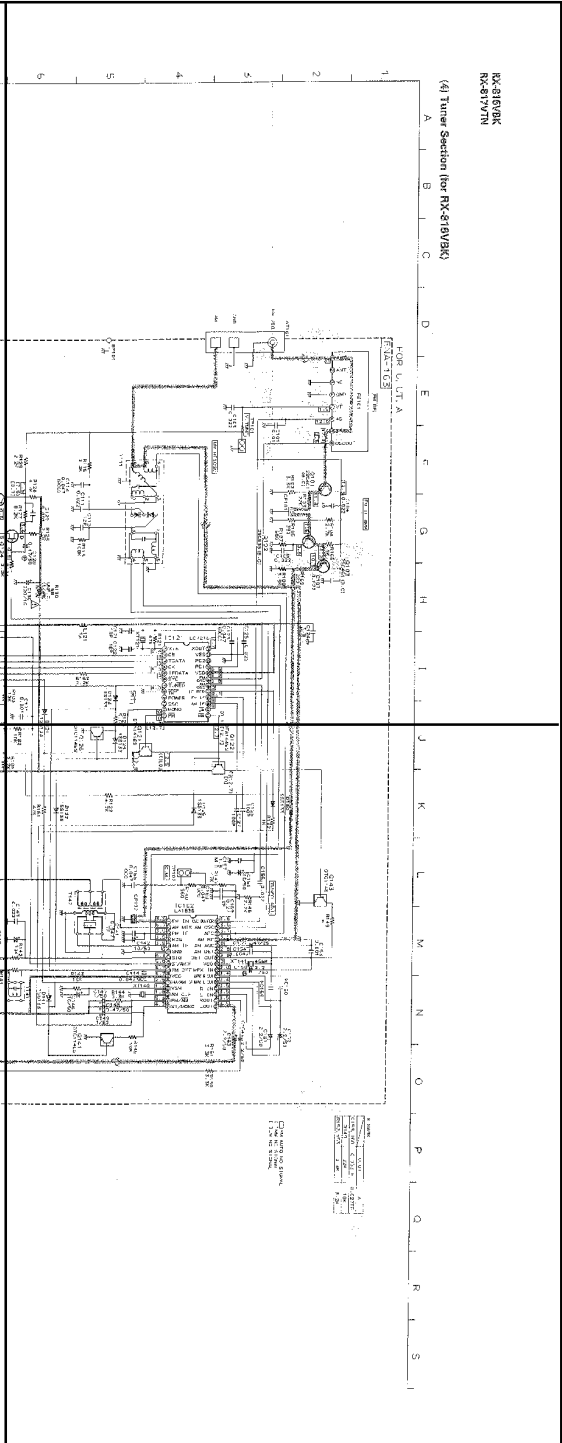

S.D-(4)-d

7  
8  
9  
10  
11  
12  
13

FE101  
EAF2203-004

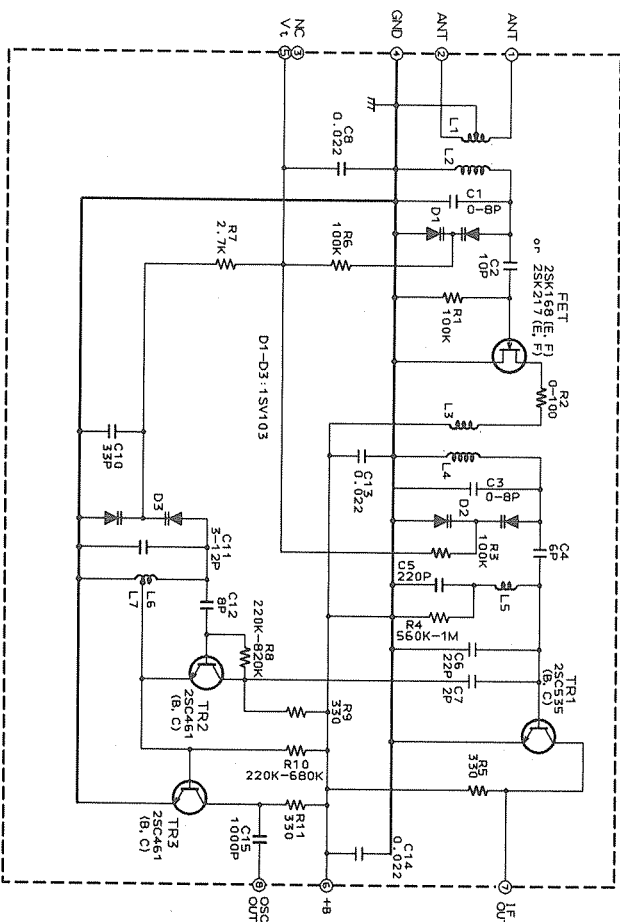

TO BR103 OF  
ENH-254-1  
SHEET 1/5

FROM 151-01 OF  
ENH-254-1  
SHEET 1/5

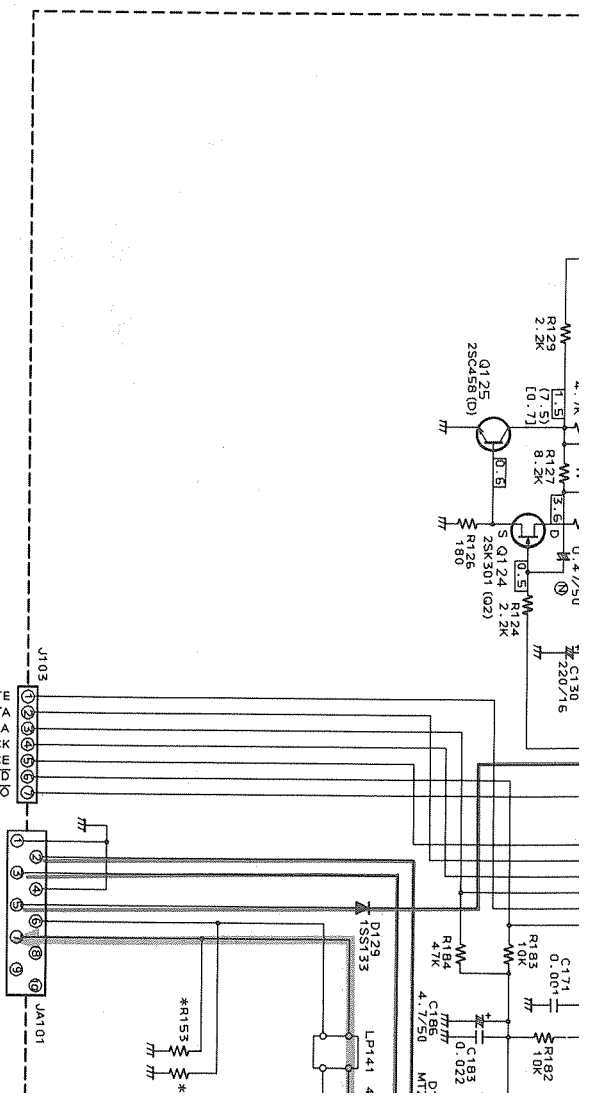

(4) Tuner Section (for RX-816VBK)

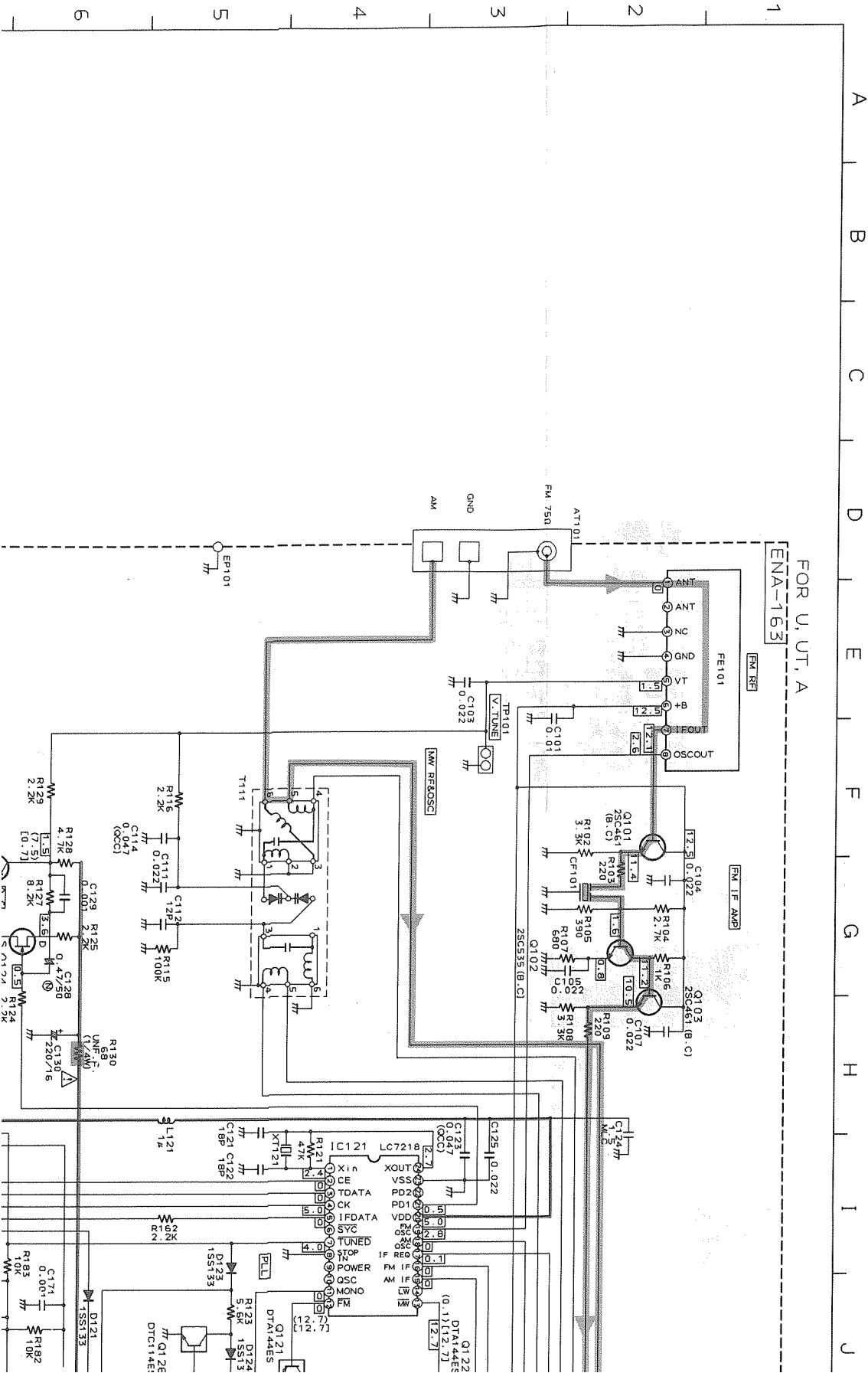

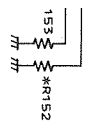
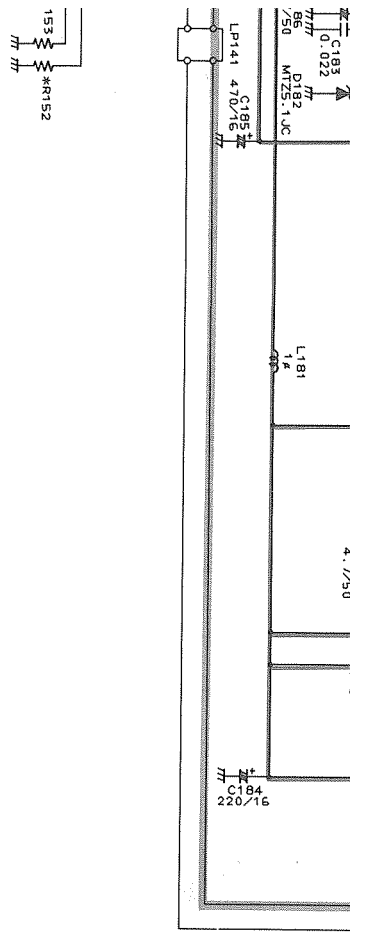

1101

J K L M N O P Q R S

\* MARK

MARK	U, UT	A
C153, 150	0.033TF	0.027TF
R149	22K	10K
R152, 153	3.3K	8.2K

□ FM AUTO. NO. SIGNAL  
 ( ) FM NO. SIGNAL  
 [ ] LW NO. SIGNAL

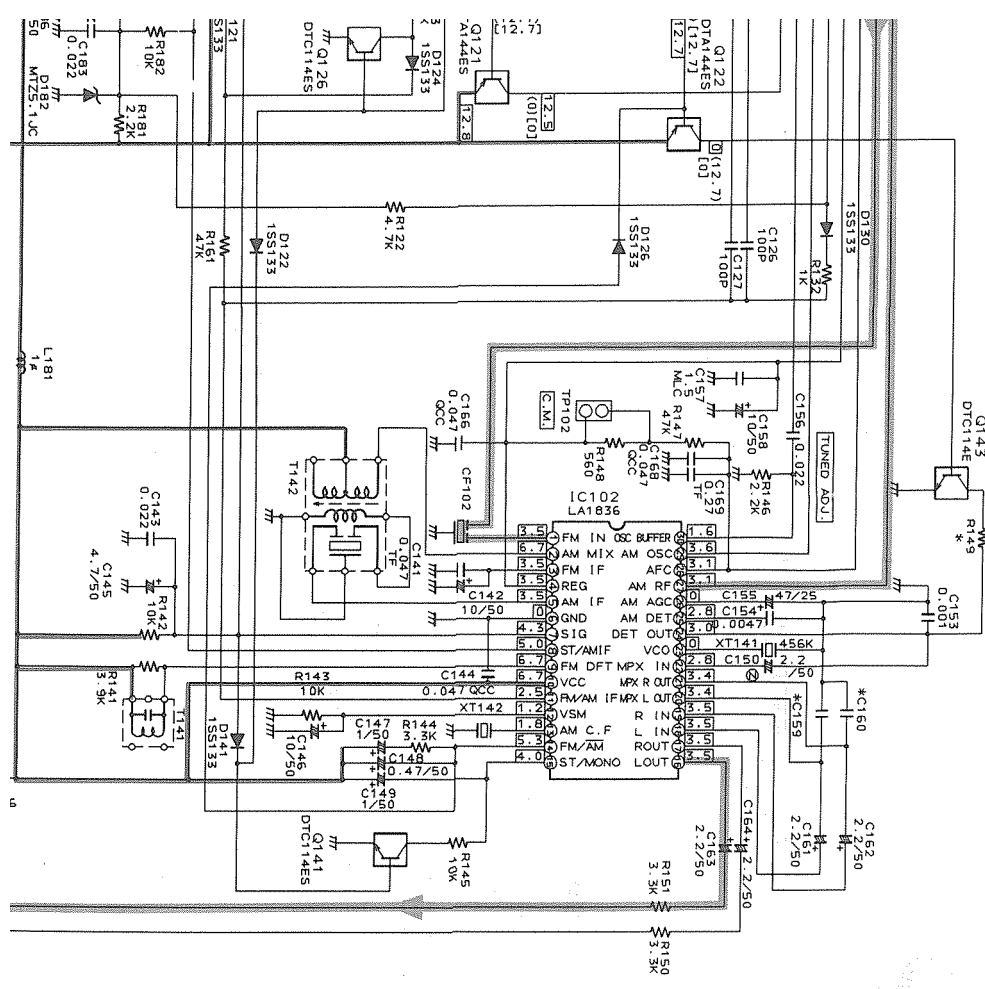













RX-816VBK  
RX-817VTN

J K L M N O P Q R S

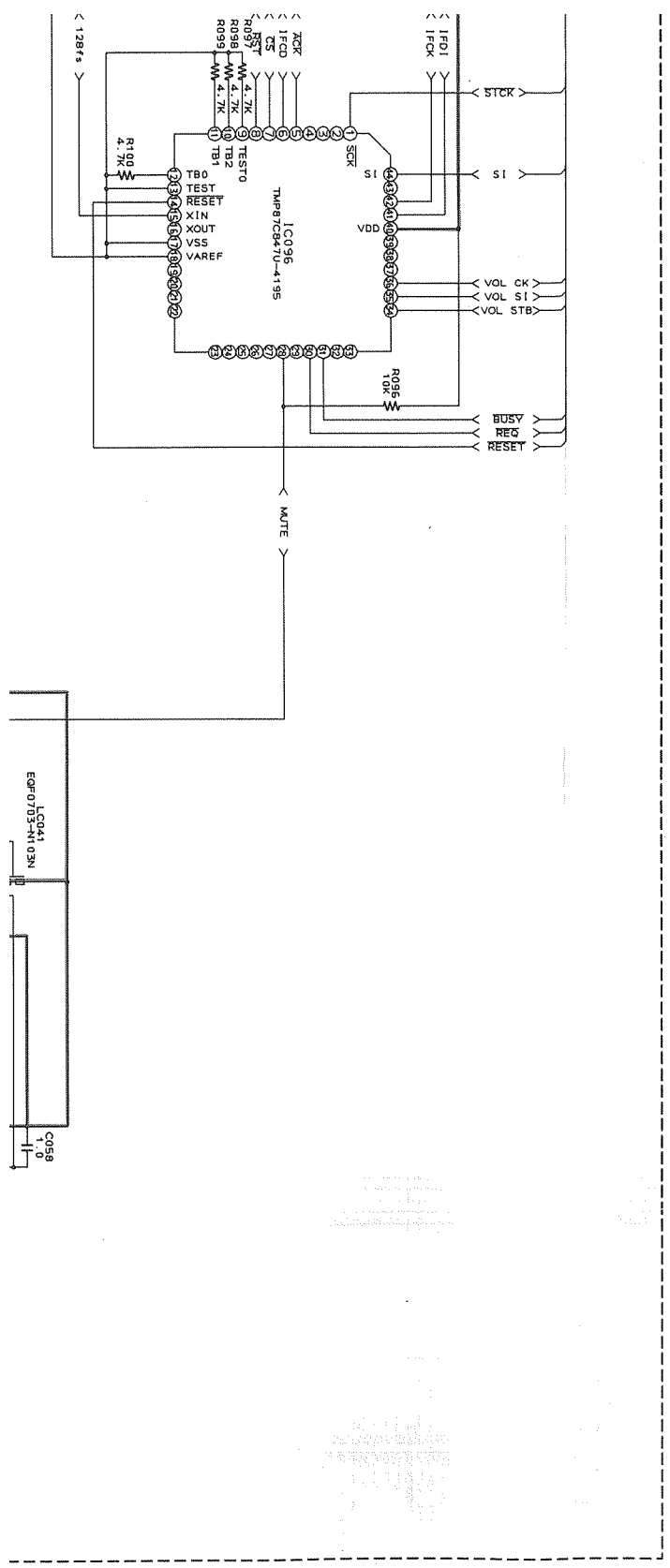





7  
8  
9  
10  
11  
12  
13

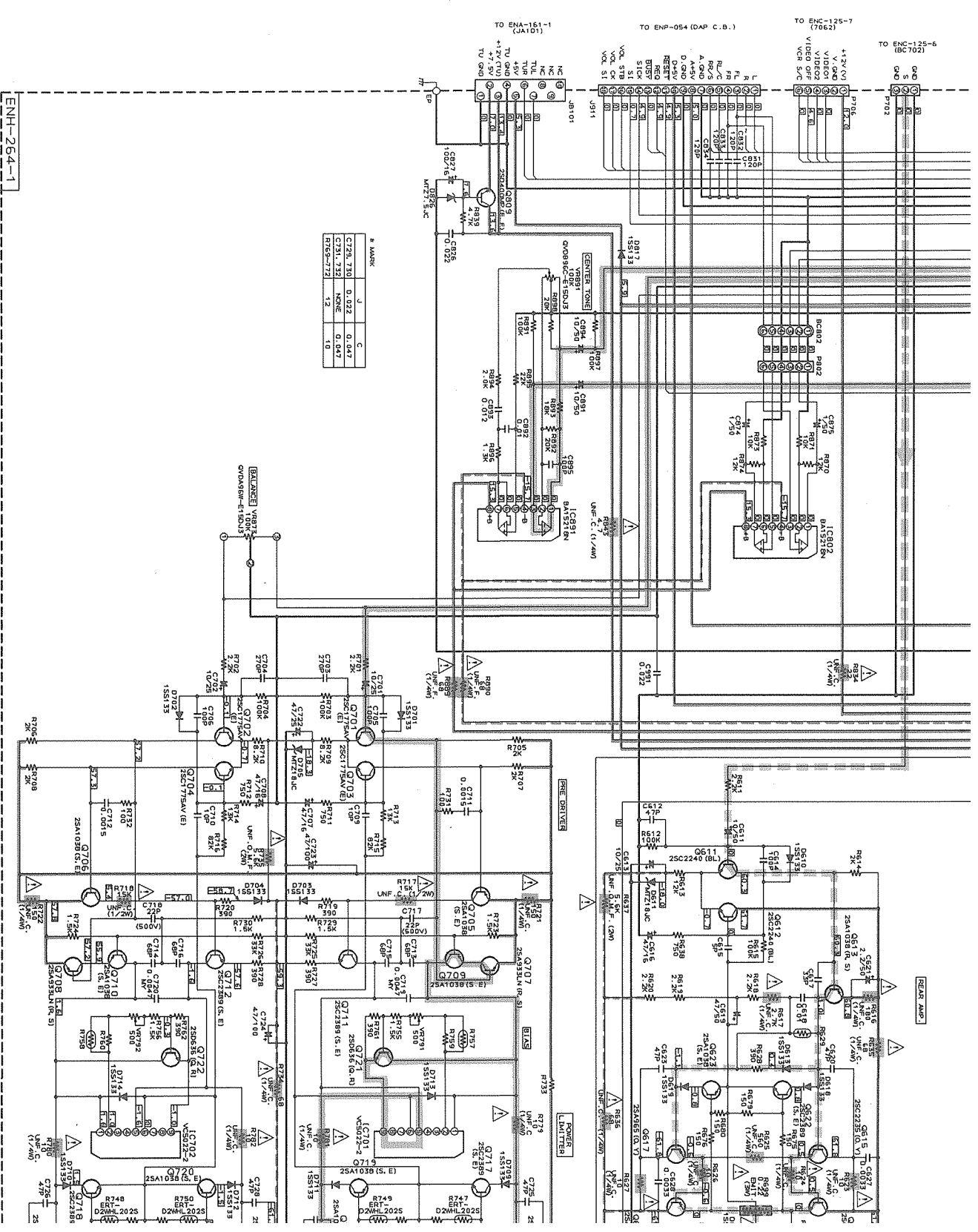





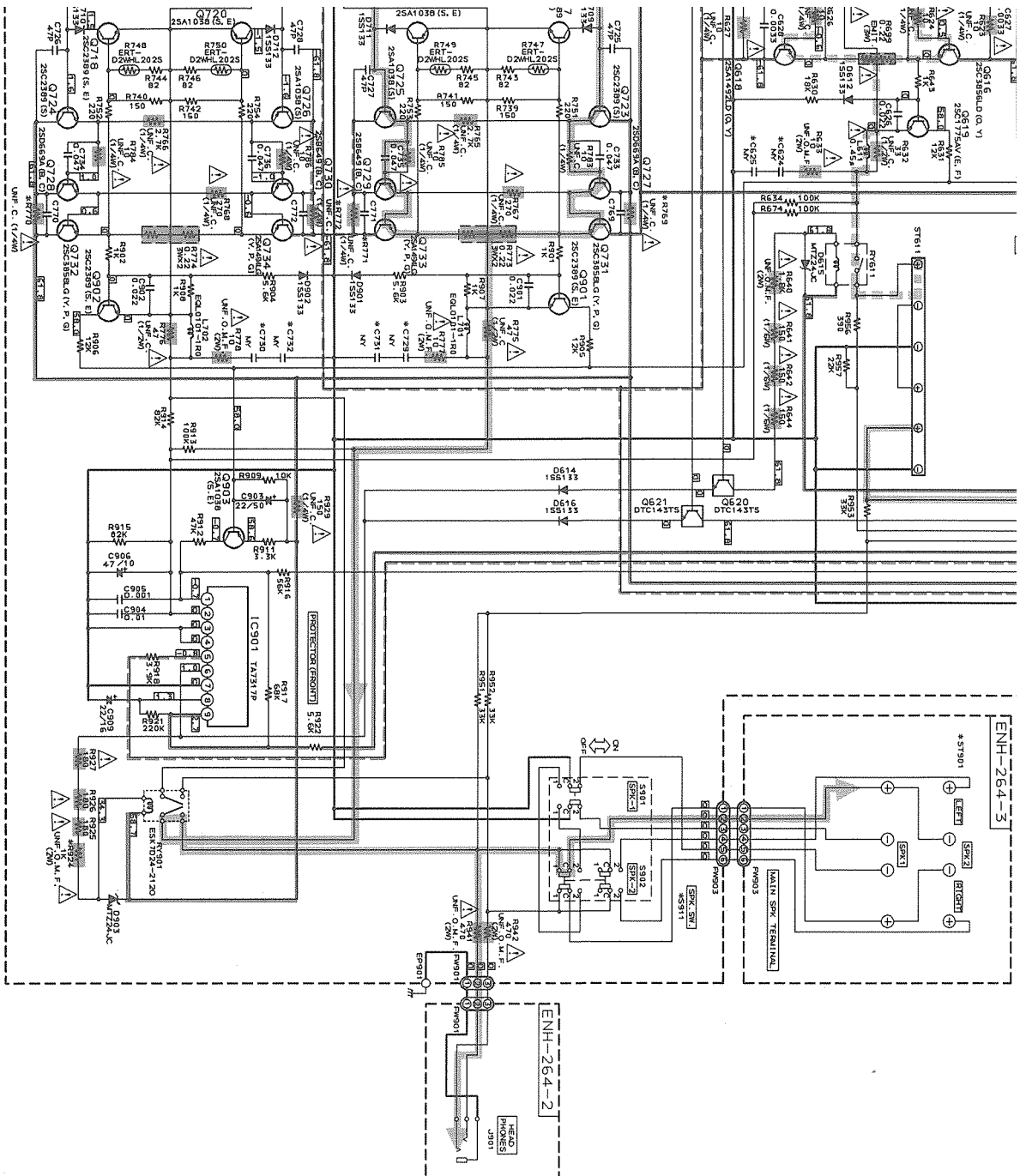

J K L M N O P Q R S

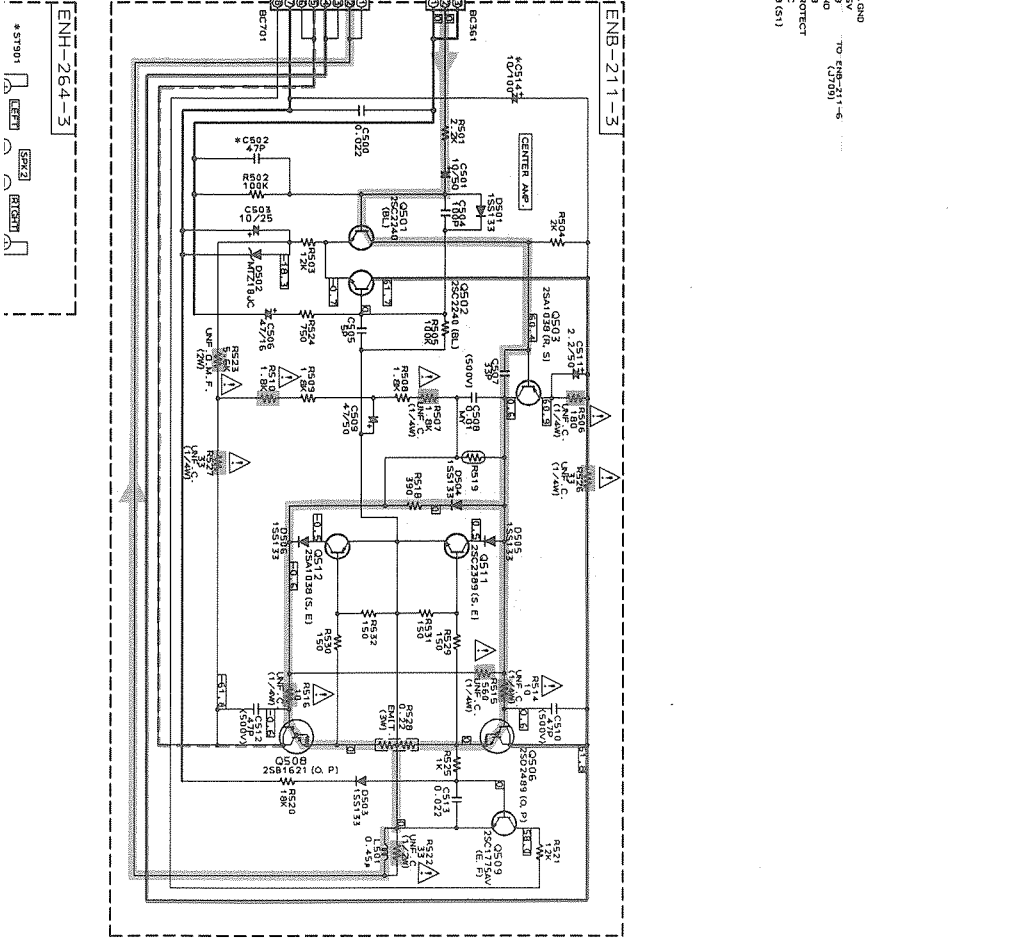
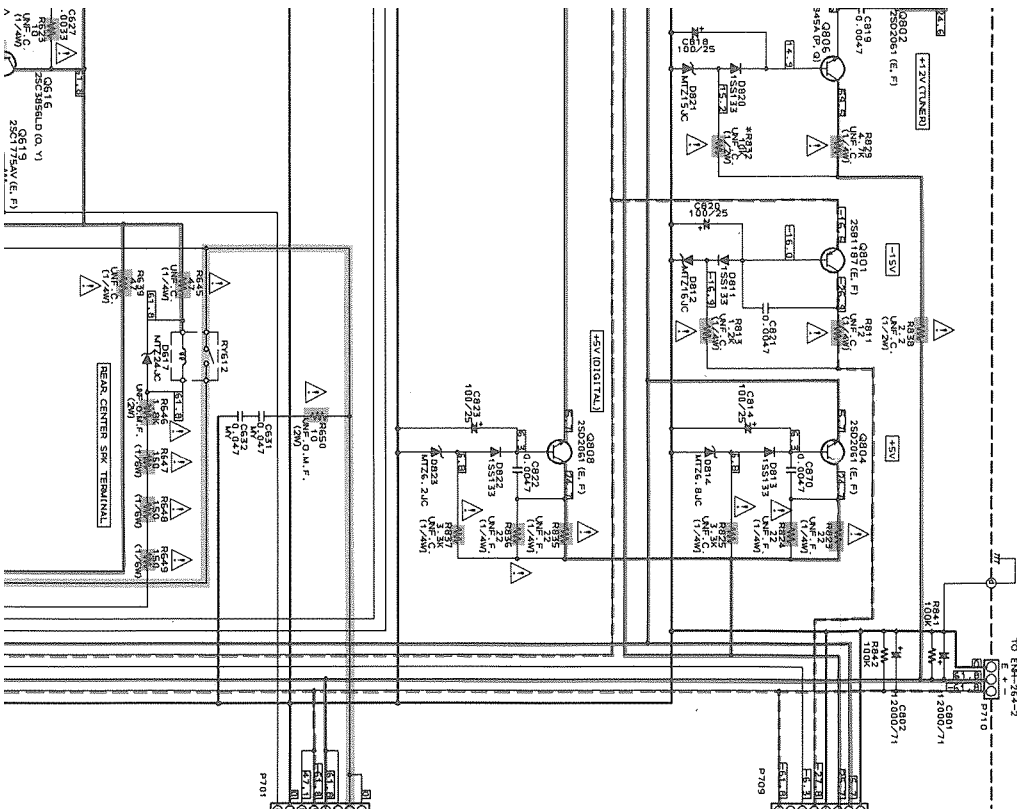



S.D-(7)-a

S.D-(7)-b

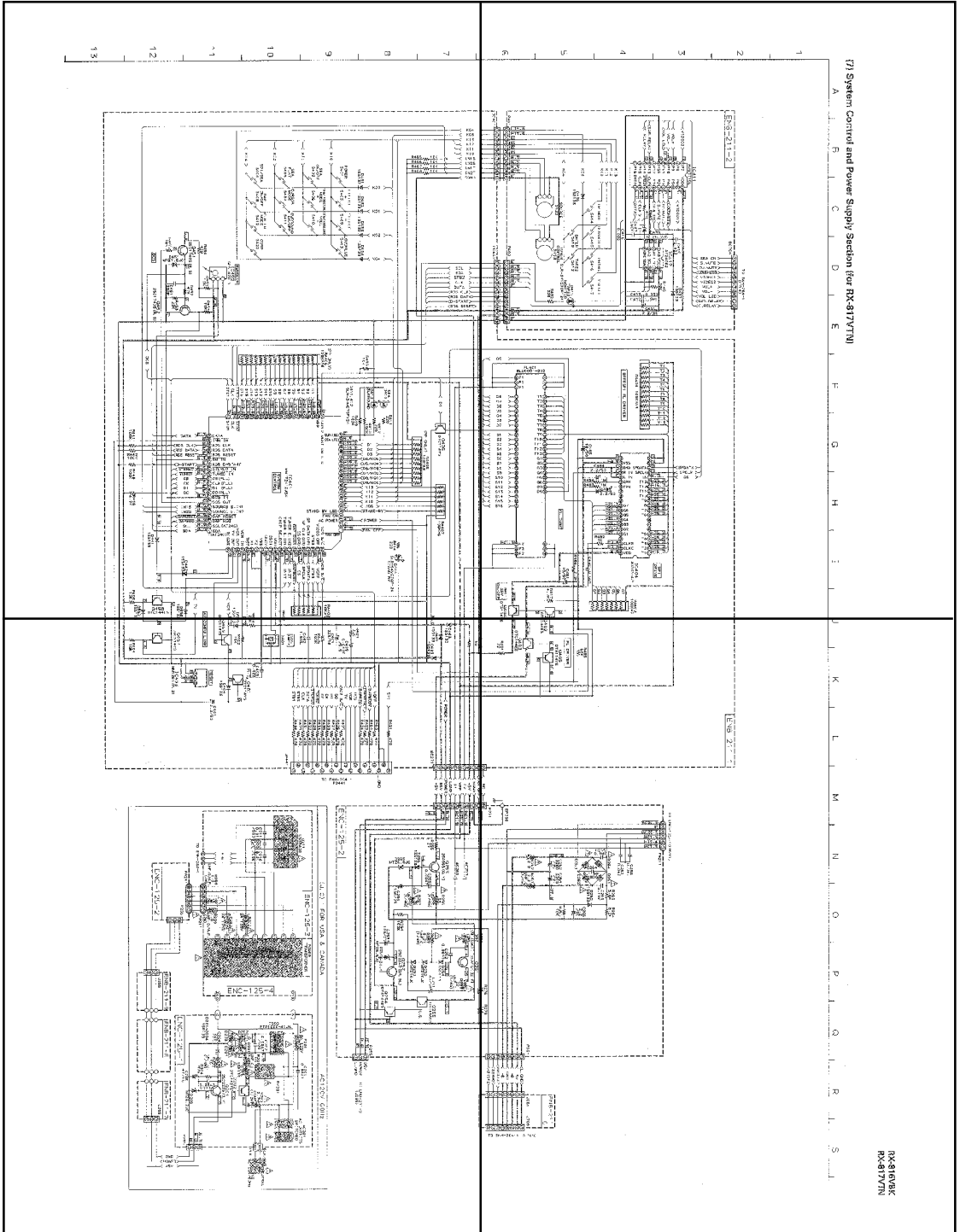

S.D-(7)-c

S.D-(7)-d













S.D-(8)-a

S.D-(8)-b

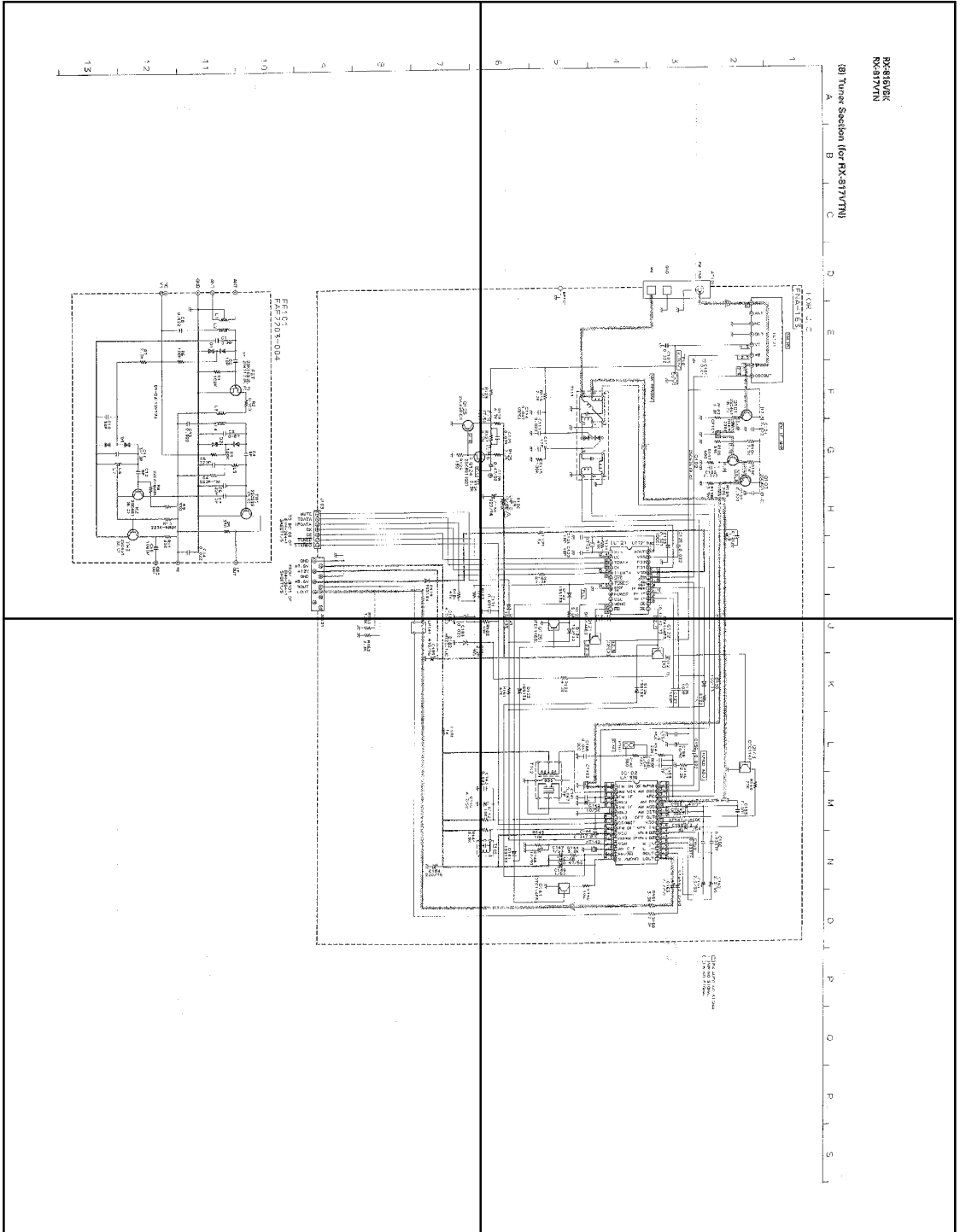

S.D-(8)-c

S.D-(8)-d

7  
8  
9  
10  
11  
12  
13

FE101  
EAF2203-004

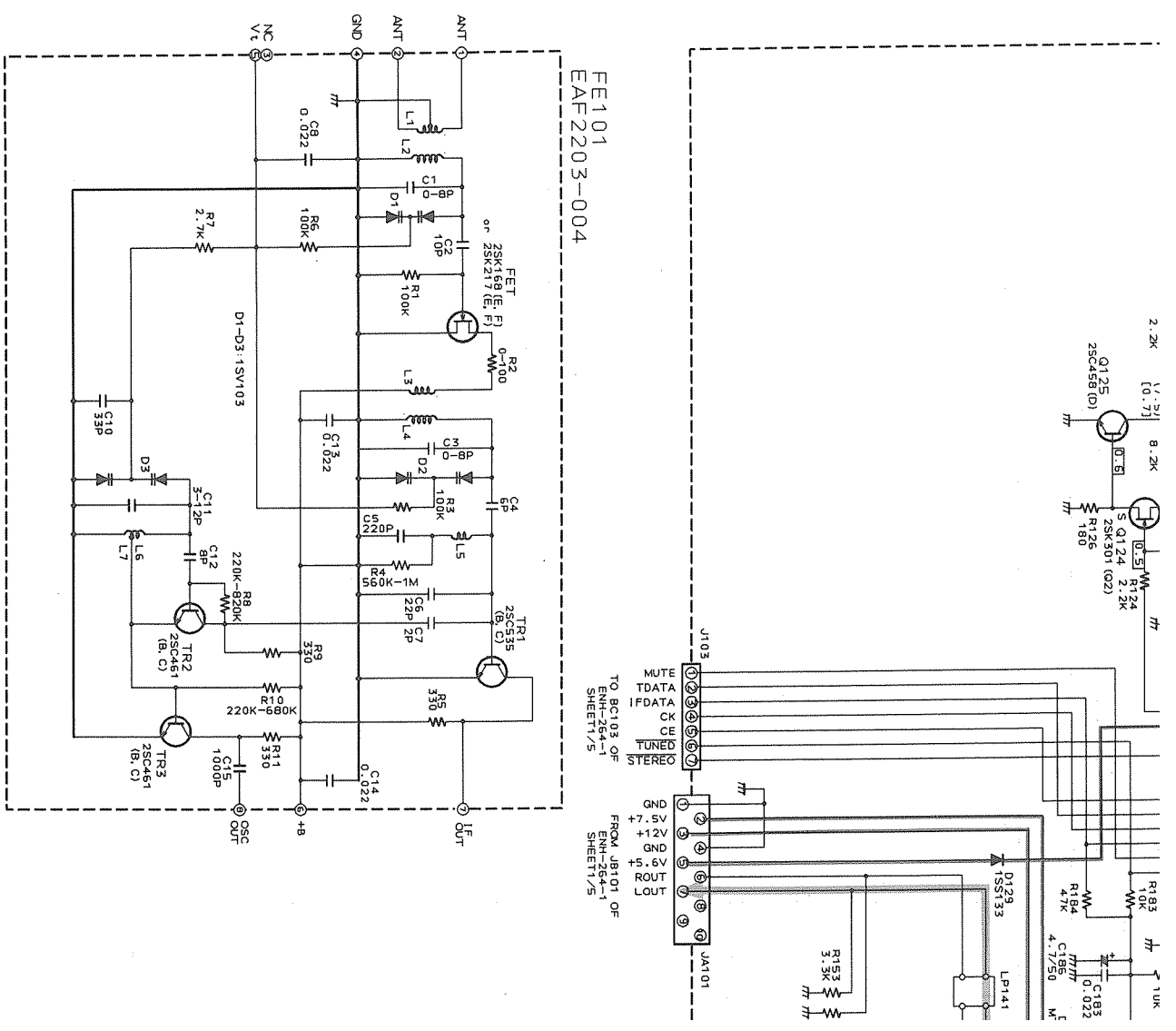

RX-816VBK  
RX-817VTN

(8) Tuner Section (for RX-817VTN)

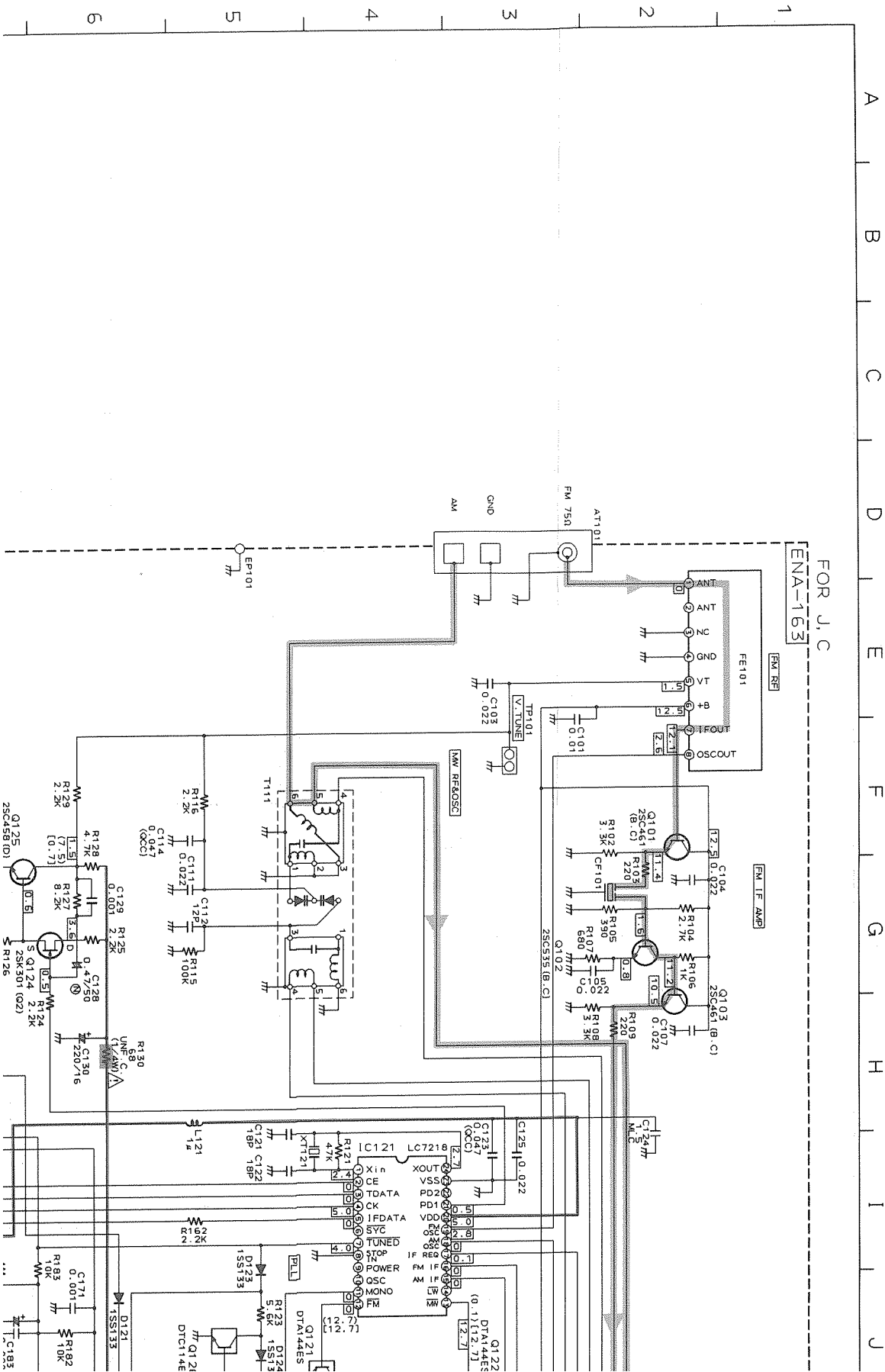

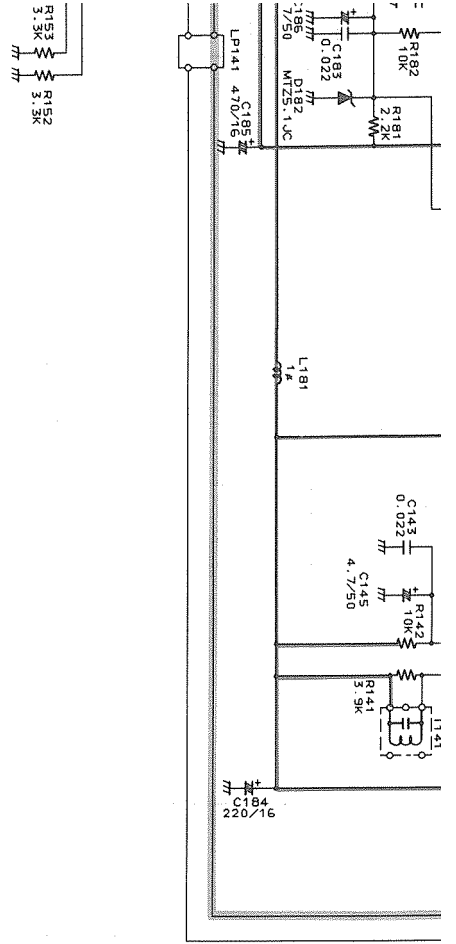

JAN 01

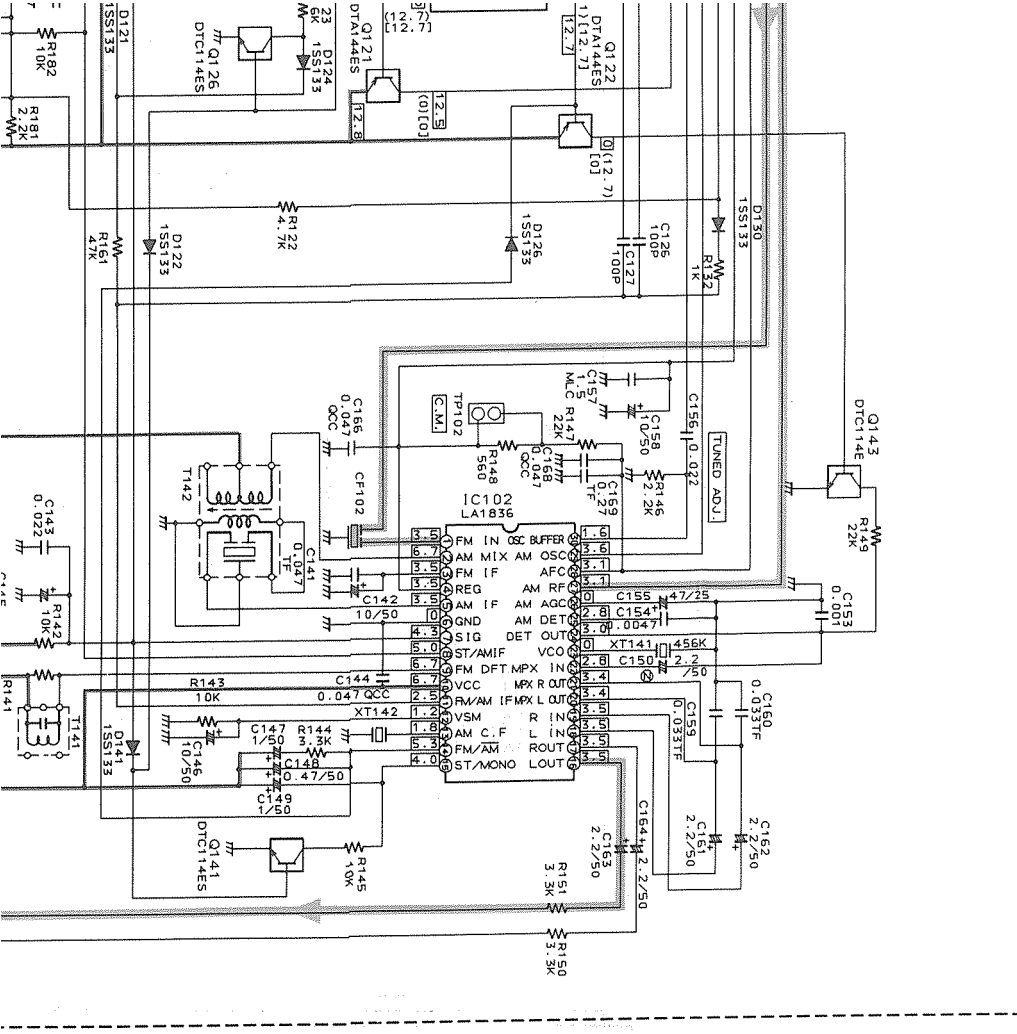

J K L M N O P Q R S

7 8 9 10 11 12 13 14 15

□ FM AUTO NO SIGNAL  
 ( ) FM NO SIGNAL  
 [ ] LW NO SIGNAL

# Printed Circuit Boards

## ■ Input Selector and Power Supply P.C. Board (ENC-125)

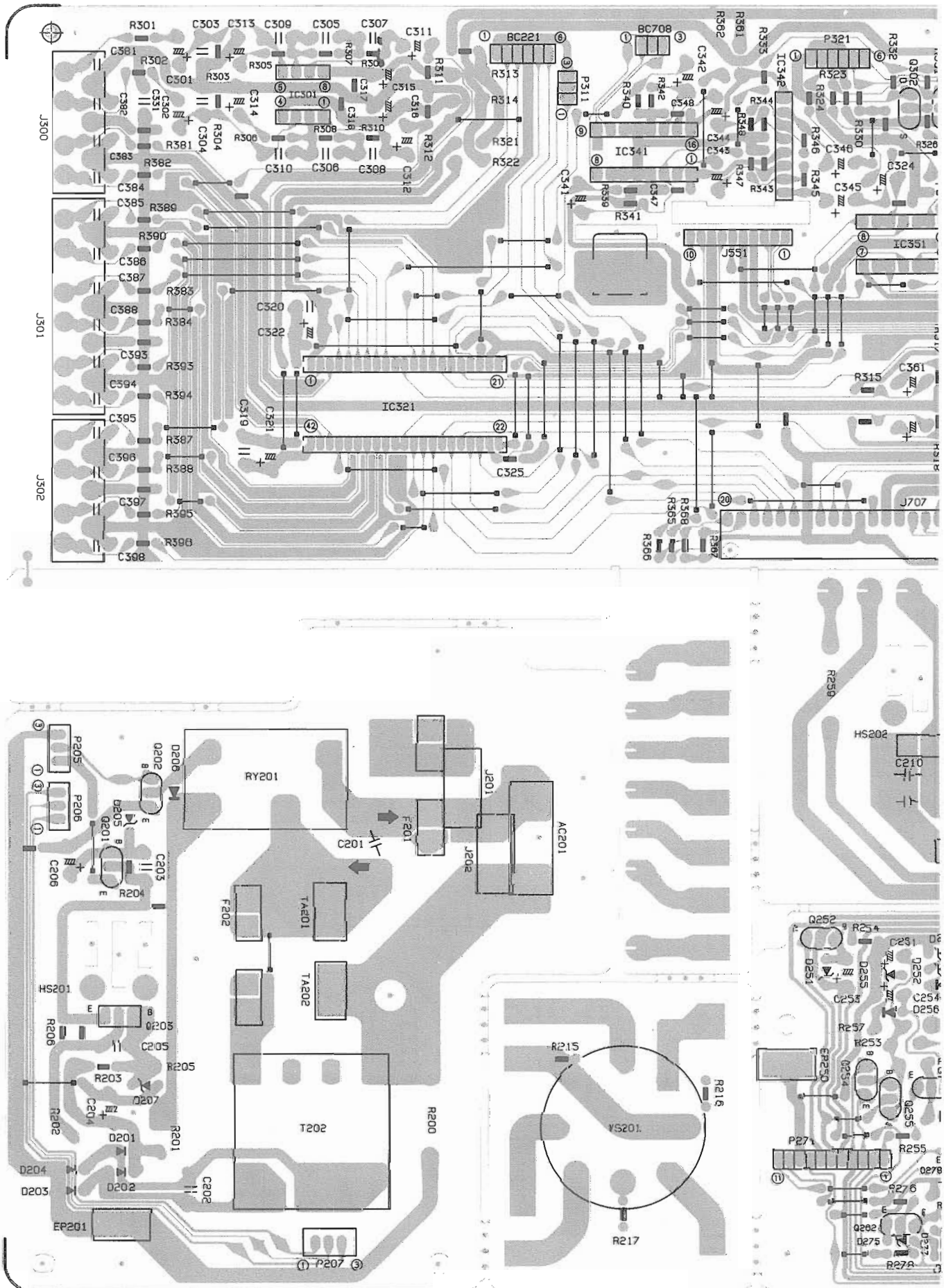









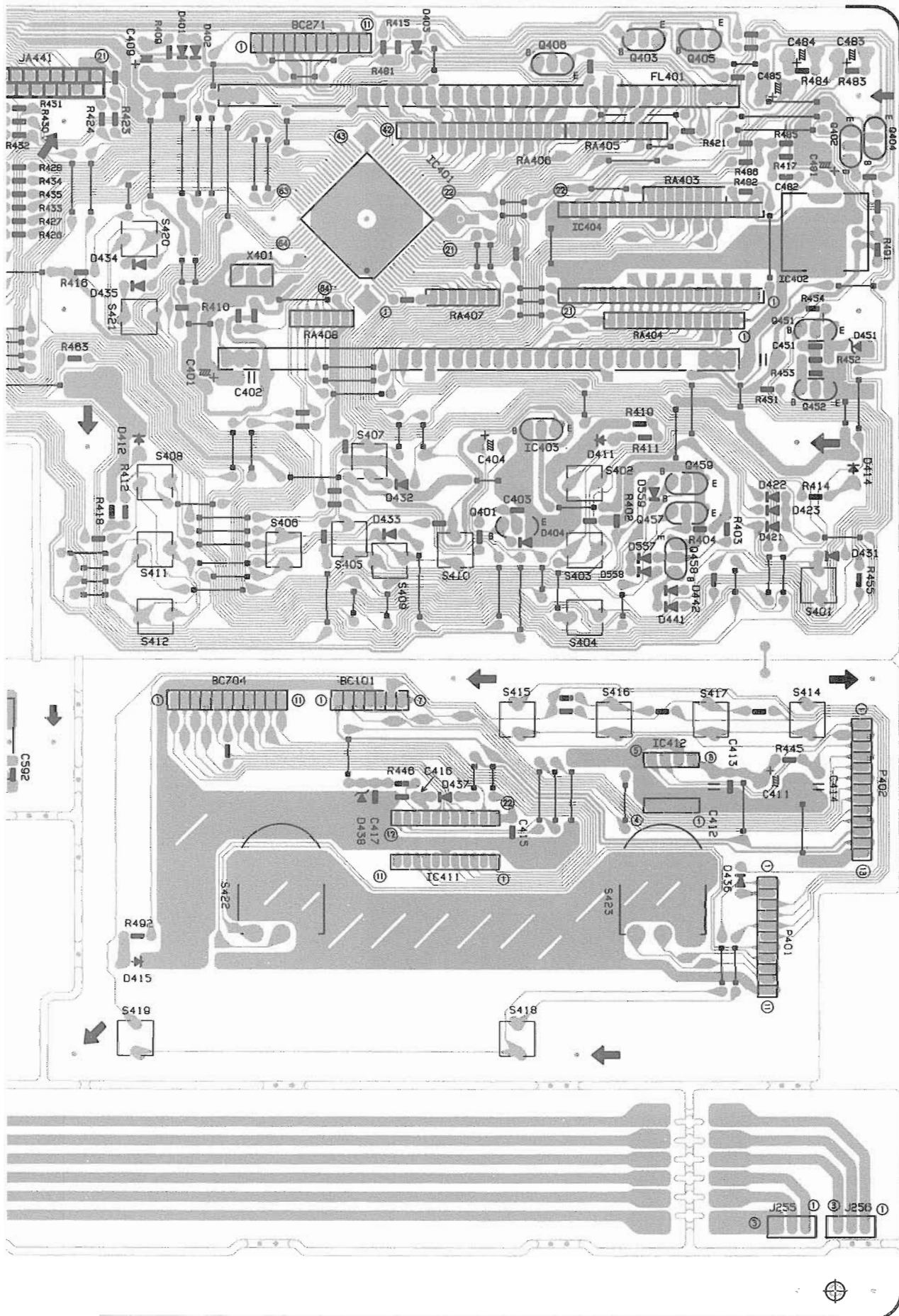

RX-816VBK  
RX-817VTN

■ Tuner P.C. Board (ENA-163)

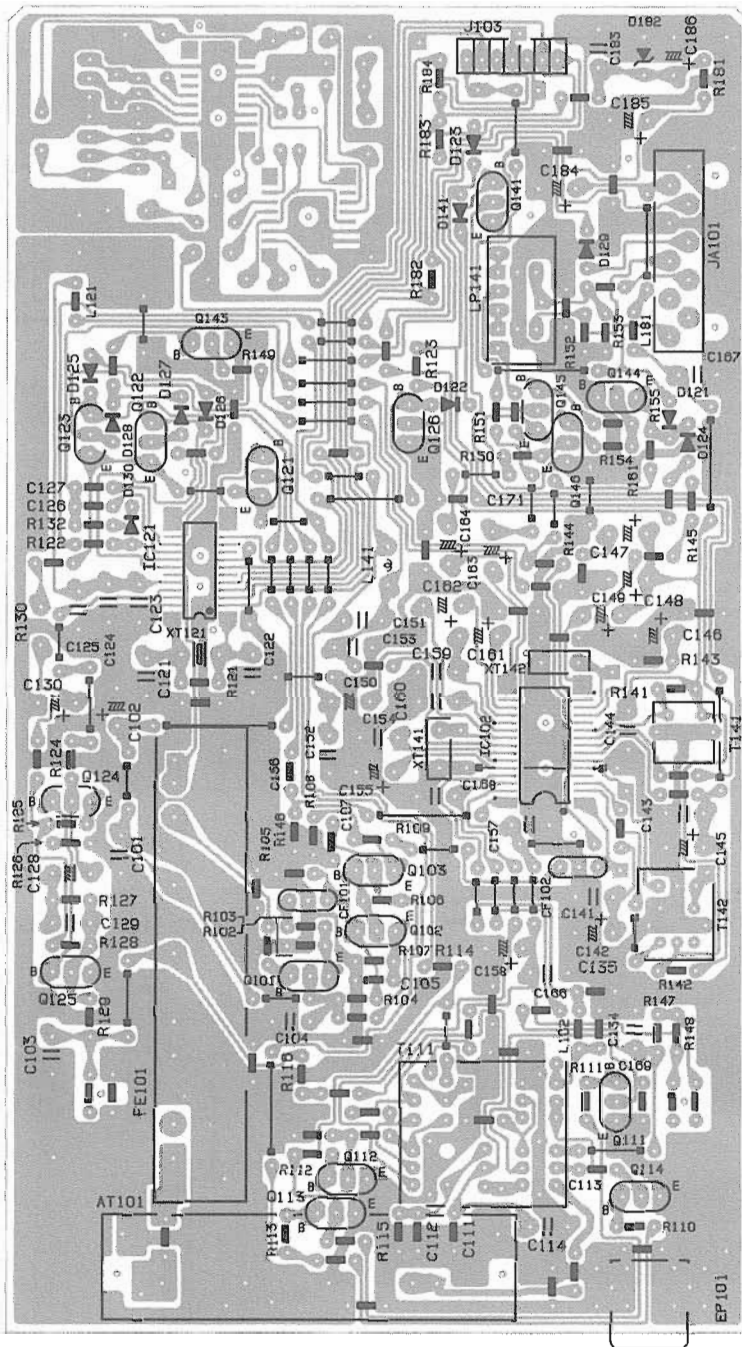

■ Digital Signal Processor P.C. Board (ENP-054)

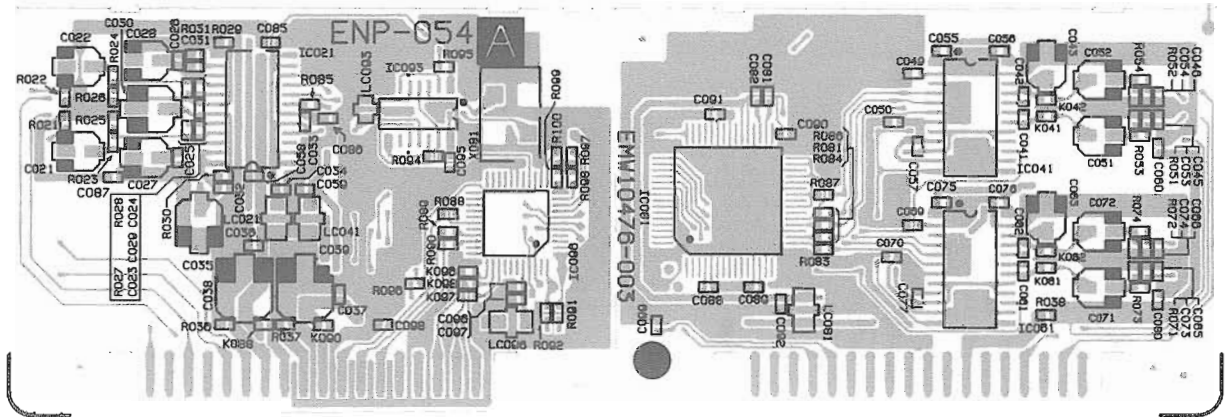



# PARTS LIST

**Note : All printed circuit boards assemblies are not available as service parts.**

## Contents

General Exploded View and Parts List .....	2 - 2
Printed Circuit Board Ass'y and Parts List .....	2 - 5
■ ENH-264 <input type="checkbox"/> Amplifier PC Board Ass'y .....	2 - 5
■ ENC-125 <input type="checkbox"/> Input Selector PC Board Ass'y .....	2 - 9
■ ENB-211 <input type="checkbox"/> FL Display PC Board Ass'y .....	2 - 13
■ ENA-163 <input type="checkbox"/> Tuner PC Board Ass'y .....	2 - 16
■ ENP-054 <input checked="" type="checkbox"/> DSP PC Board Ass'y .....	2 - 17
Accessories List .....	2 - 19
Packing Materials and Part Numbers .....	2 - 20



# General Exploded View and Parts List

Symbol No. 

M	1	M	M
---	---	---	---

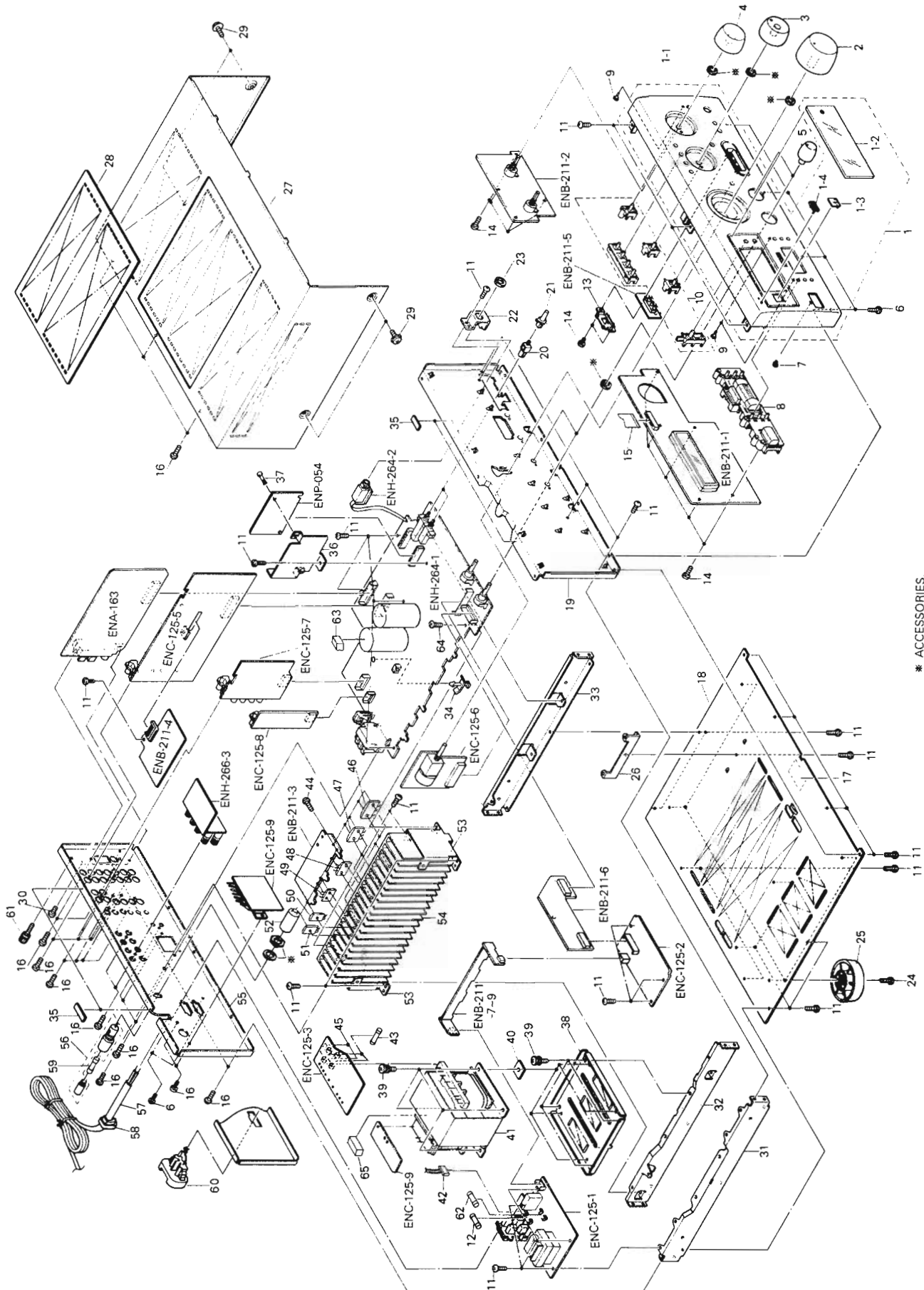

\* ACCESSORIES.

## ■ PARTS LIST

Symbol No.

M 1 M M

△	Item	Part Number	Part Name	Q'ty	Description	Area
	1	EFP-RX816VBKU(S	FRONT PANEL ASSY	1		
	1-1	E102909-0185M	FRONT PANEL	1		
	1-2	E309112-0145M	WINDOW SCREEN	1		
	1-3	E72436-006	REMORT SCREEN	1		
	1-4	VJD5429-001	JVC MARK	1		
	2	E309465-0015M	VOLUME KNOB	1		
	3	E309110-0035M	SELECT KNOB	1	TUNER/JOG	
	4	E309110-0015M	SELECT KNOB	1	SOURCE/JOG	
	5	E309111-0035M	BALANCE KNOB	2	TOEN,BALANCE	
	6	SDSG3008M	TAPPING SCREW	4		
	7	SDSG3008M	TAPPING SCREW	2	AC OUTLET	U,UT
	8	FSJD4001-002	INDICATOR LENS	1	POWER	
	9	E208276-0055M	PUSH BUTTON	1	SURROUND/POWER	
	10	E408326-0015M	INDICATOR LENS	3	TAPE 2 MONITOR/ETC	
	10	E309105-0045M	PUSH BUTTON	1	TUNER/ETC	
△	11	SBSG3008CC	TAPPING SCREW	37		
	12	QMF51E2-4R0	FUSE	1	F201	A
	13	E408713-0015M	P.W.BOARD HOLDER	1		
	14	SDSF2608Z	SCREW	11		
	15	EWR621K-40TTJ2	FFC CABLE	1	FW441	
	16	E73273-006	SPECIAL SCREW	22		
	17	E73273-006	SPECIAL SCREW	2	VOL.SEL.	U,UT
	18	E70115-002	CAUTION LABEL	1	BOTTOM PLATE	
	19	E102820-0025M	BOTTOM PLATE	1		
	19	E102911-0025M	FRONT BRACKET	1		
	20	E407983-0015M	PUSH SHAFT	2		
	21	E407321-0025M	PUSH BUTTON	2	SPEAKER	
	22	E407323-0025M	HEADPHONE BRACKET	1		
	23	VKZ4150-001	NUT	1		
	24	SBST3010Z	TAPPING SCREW	4		
	25	VJF4039-00F	FOOT	4		
	26	E407984-0015M	P.W.BOARD HOLDER	1		
	27	E207378-018	METAL COVER	1		
	28	E208294-001	PROTECTOR COVER	1		
	29	E61660-004	SPECIAL SCREW	4		
	30	SBST3006M	TAPPING SCREW	1		
	31	E208548-0015M	SIDE BRACKET	1	LEFT	
	32	E208549-0015M	CENTER BRACKET	1		
	33	E208081-0035M	SIDE BRACKET	1	RIGHT	
	34	E406084-002	FASTENER	1		
	35	E306805-146	SPACER	4		
	36	E309458-0015M	SHIELD BRACKET	1		
	37	E48729-008	PLASTIC RIVET	1		
	38	E309459-0015M	TRANSFORMER BRACKET	1		
	39	E65389-006	SPECIAL SCREW	8		
△	40	E406309-002	SPACER	4		
	41	ETP1200-67FAJ	POWER TRANSFORMER	1		
	42	EWS282-003	SOCKET WIRE	1		A
	42	EWS282-008	SOCKET WIRE ASSY	1		U,UT
△	43	QMF51E2-2R0	FUSE	2	F211,F212	
	44	E73525-003	SCREW	14		

⚠	Item	Part Number	Part Name	Q'ty	Description	Area
	45	E67132-T2R0	FUSE LABEL	2		
	46	2SA1494LG(Y,P,G	SI.TRANSISTOR	2	Q733,Q734	
	47	2SC3858LG(Y,P,G	SI.TRANSISTOR	2	Q731,Q732	
	48	2SD2489LG(OPY)	SI.TRANSISTOR	1	Q618	
	49	2SB1621LG(OPY)	SI.TRANSISTOR	1	Q616	
	50	2SA1492LD(O,Y)	SI.TRANSISTOR	1	Q506	
	51	2SC3856LD(O,Y)	SI.TRANSISTOR	1	Q508	
	52	E69291-001	FUSE COVER	1		U,UT
	53	E308836-002SM	HEAT SINK BRACKET	2		
	54	E309170-002SM	HEAT SINK	1		
	55	E103041-002SM	REAR PANEL	1		U,UT
		E103041-003SM	REAR PANEL	1		A
⚠	56	QMG0301-003	FUSE HOLDER	1		U,UT
⚠	57	QMP25F0-244	POWER CORD	1		A
⚠		QMP7520-200	POWER CORD	1		U,UT
⚠	58	QHS3771-108	CORD STOPPER	1		
⚠	59	QMF51E2-4R0	FUSE	1	F004	U,UT
⚠	60	EMC0238-001	AC SOCKET	1		A
	61	E408091-001	GND TERMINAL	1		
⚠	62	QMF51A2-R10S	FUSE	1	F202	
	63	E306805-167	SPACER	1		
	64	E73265-001	SPECIAL SCREW	1		
	65	E408834-001	SPACER ASS'Y	1		
	-	E309384-011	RX-816VBK R.LAB	1		UT
	-	E75139-003	Z LABEL	1		U,UT

**The Marks for Designated Areas**

A ..... Australia

U ..... Universal Type

UT ..... Taiwan

No mark indicates all area.

# Printed Circuit Board Ass'y and Parts List

■ ENH-264 □ Amplifier PC Board Assy

Note : ENH-264 □ varies according to the areas employed. See note (1) when placing an order.

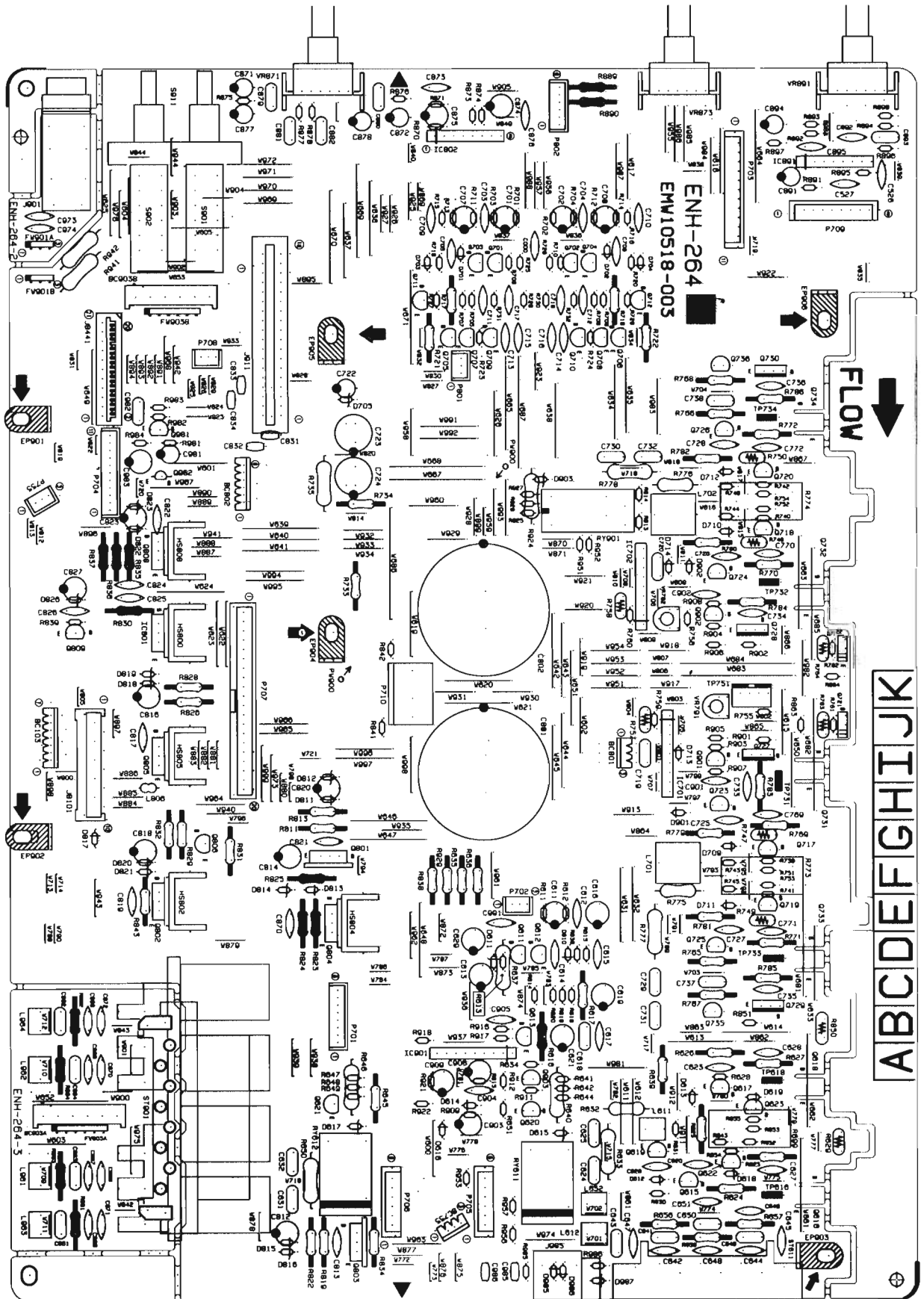

Note (1)

PC Board Ass'y	Version	Designated Areas
ENH-264 <b>A</b>	A	Australia
ENH-264 <b>B</b>	U UT	Universal Type Taiwan

Transistors

ITEM	PART NUMBER	DESCRIPTION	AREA
Q611	2SC2240(BL)	SI. TRANSIST	
Q612	2SC2240(BL)	SI. TRANSIST	
Q613	2SA1038(R,S)	SI. TRANSIST ROHM	
Q615	2SC2235(O,Y)	SI. TRANSIST TOSHIBA	
Q617	2SA965(Y)	SI. TRANSIST TOSHIBA	
Q619	2SC1775AV(F1)	SI. TRANSIST HITACHI	
Q620	DTC143TS	DIGITAL TRA ROHM	
Q621	DTC143TS	DIGITAL TRA ROHM	
Q622	2SC2389(S,E)	SI. TRANSIST ROHM	
Q623	2SA1038(R,S)	SI. TRANSIST ROHM	
Q701	2SC1775AV(F1)	SI. TRANSIST HITACHI	
Q702	2SC1775AV(F1)	SI. TRANSIST HITACHI	
Q703	2SC1775AV(F1)	SI. TRANSIST HITACHI	
Q704	2SC1775AV(F1)	SI. TRANSIST HITACHI	
Q705	2SA1038(R,S)	SI. TRANSIST ROHM	
Q706	2SA1038(R,S)	SI. TRANSIST ROHM	
Q707	2SA933LN(R,S)	SI. TRANSIST ROHM	
Q708	2SA933LN(R,S)	SI. TRANSIST ROHM	
Q709	2SA1038(R,S)	SI. TRANSIST ROHM	
Q710	2SA1038(R,S)	SI. TRANSIST ROHM	
Q711	2SC2389(S,E)	SI. TRANSIST ROHM	
Q712	2SC2389(S,E)	SI. TRANSIST ROHM	
Q717	2SC2389(S,E)	SI. TRANSIST ROHM	
Q718	2SC2389(S,E)	SI. TRANSIST ROHM	
Q719	2SA1038(R,S)	SI. TRANSIST ROHM	
Q720	2SA1038(R,S)	SI. TRANSIST ROHM	
Q721	2SD636	SI. TRANSIST MATSUSHITA	
Q722	2SD636	SI. TRANSIST MATSUSHITA	
Q723	2SC2389(S,E)	SI. TRANSIST ROHM	
Q724	2SC2389(S,E)	SI. TRANSIST ROHM	
Q725	2SA1038(R,S)	SI. TRANSIST ROHM	
Q726	2SA1038(R,S)	SI. TRANSIST ROHM	
Q727	2SD669A(B,C)	SI. TRANSIST HITACHI	
Q728	2SD669A(B,C)	SI. TRANSIST HITACHI	
Q729	2SB649A(B,C)	SI. TRANSIST HITACHI	
Q730	2SB649A(B,C)	SI. TRANSIST HITACHI	
Q735	2SK170(BL)	F.E.T. TOSHIBA	
Q736	2SK170(BL)	F.E.T. TOSHIBA	
Q801	2SB1187(F,G)	SI. TRANSIST ROHM	
Q802	2SD2061(F,G)	SI. TRANSIST ROHM	
Q803	2SD2061(F,G)	SI. TRANSIST ROHM	
Q804	2SD2061(F,G)	SI. TRANSIST ROHM	
Q805	2SD2061(F,G)	SI. TRANSIST ROHM	
Q806	2SC945A	SI. TRANSIST NEC	
Q808	2SD2061(F,G)	SI. TRANSIST ROHM	
Q809	2SD400MP(E,F)	SI. TRANSIST SANYO	
Q901	2SC2389(S,E)	SI. TRANSIST ROHM	
Q902	2SC2389(S,E)	SI. TRANSIST ROHM	
Q903	2SA1038(R,S)	SI. TRANSIST ROHM	
Q981	2SC1685	SI. TRANSIST ROHM	
Q982	2SD2144S(VW)	SI. TRANSIST ROHM	

△ : SAFETY PARTS

I.C.s

ITEM	PART NUMBER	DESCRIPTION	AREA
IC701	VC5022-2	I.C(MONO-AN SANYO	
IC702	VC5022-2	I.C(MONO-AN SANYO	
IC801	NJM78M05FA	I.C(MONO-AN DAINICHI	
IC802	BA15218N	I.C(MONO-AN ROHM	
IC891	BA15218N	I.C(MONO-AN ROHM	
IC901	TA7317P	I.C(MONO-AN TOSHIBA	

△ : SAFETY PARTS

Diodes

ITEM	PART NUMBER	DESCRIPTION	AREA
D610	1SS133	SI. DIODE ROHM	
D611	MTZ18JC	ZENER DIODE ROHM	
D612	1SS133	SI. DIODE ROHM	
D613	1SS133	SI. DIODE ROHM	
D614	1SS133	SI. DIODE ROHM	

△ : SAFETY PARTS

Diodes

ITEM	PART NUMBER	DESCRIPTION	AREA
D615	MTZ24JC	ZENER DIODE ROHM	
D616	1SS133	SI. DIODE ROHM	
D617	MTZ24JC	ZENER DIODE ROHM	
D618	1SS133	SI. DIODE ROHM	
D619	1SS133	SI. DIODE ROHM	
D701	1SS133	SI. DIODE ROHM	
D702	1SS133	SI. DIODE ROHM	
D703	1SS133	SI. DIODE ROHM	
D704	1SS133	SI. DIODE ROHM	
D705	MTZ18JC	ZENER DIODE ROHM	
D709	1SS133	SI. DIODE ROHM	
D710	1SS133	SI. DIODE ROHM	
D711	1SS133	SI. DIODE ROHM	
D712	1SS133	SI. DIODE ROHM	
D713	1SS133	SI. DIODE ROHM	
D714	1SS133	SI. DIODE ROHM	
D811	1SS133	SI. DIODE ROHM	
D812	MTZ16JC	ZENER DIODE ROHM	
D813	1SS133	SI. DIODE ROHM	
D814	MTZ6.8JC	ZENER DIODE ROHM	
D815	1SS133	SI. DIODE ROHM	
D816	MTZ13JC	ZENER DIODE ROHM	
D817	1SS133	SI. DIODE ROHM	
D818	1SS133	SI. DIODE ROHM	
D819	MTZ16JC	ZENER DIODE ROHM	
D820	1SS133	SI. DIODE ROHM	
D821	MTZ15JC	ZENER DIODE ROHM	
D822	1SS133	SI. DIODE ROHM	
D823	MTZ6.2JC	ZENER DIODE ROHM	
D826	MTZ7.5JC	ZENER DIODE ROHM	
D901	1SS133	SI. DIODE ROHM	
D902	1SS133	SI. DIODE ROHM	
D903	MTZ24JC	ZENER DIODE ROHM	
D985	1SS133	SI. DIODE ROHM	
D986	1SS133	SI. DIODE ROHM	
D987	MTZ6.2JC	ZENER DIODE ROHM	

△ : SAFETY PARTS

Capacitors

ITEM	PART NUMBER	DESCRIPTION	AREA
C611	QETB1HM-106	10MF 50V E.CAPACITO	
C612	QCS21HJ-271A	270PF 50V CER. CAPACI	
C613	QETB1EM-106	10MF 25V AL E. CAPAC	
C614	QCS21HJ-101A	100PF 50V CER. CAPACI	
C615	QCS21HJ-5R0	5PF 50V CER. CAPACI	
C616	QETB1CM-476	47MF 16V AL E. CAPAC	
C617	QCS22HJ-330	33PF 500V CER. CAPACI	
C618	QFLB1HJ-103	0.01MF 50V MYLAR CAPA	
C619	QETB1HM-476	47MF 50V E. CAPACITO	
C620	QCS22HJ-470A	47PF 500V CER. CAPACI	
C621	QETB1HM-225	2.2MF 50V AL E. CAPAC	
C623	QCS22HJ-470A	47PF 500V CER. CAPACI	
C624	QFLB1HJ-473	0.047MF 50V MYLAR CAPA	
C625	QFLB1HJ-473	0.047MF 50V MYLAR CAPA	
C626	QCF21HP-223A	0.022MF 50V CER. CAPACI	
C627	QCY31HK-332Z	3300PF 50V CER. CAPACI	
C628	QCY31HK-332Z	3300PF 50V CER. CAPACI	
C631	QFLB1HJ-473	0.047MF 50V MYLAR CAPA	
C632	QFLB1HJ-473	0.047MF 50V MYLAR CAPA	
C701	QETB1HM-106	10MF 50V E. CAPACITO	
C702	QETB1HM-106	10MF 50V E. CAPACITO	
C703	QCS21HJ-271A	270PF 50V CER. CAPACI	
C704	QCS21HJ-271A	270PF 50V CER. CAPACI	
C705	QCS21HJ-101A	100PF 50V CER. CAPACI	
C706	QCS21HJ-101A	100PF 50V CER. CAPACI	
C707	QETB1CM-476	47MF 16V AL E. CAPAC	
C708	QETB1CM-476	47MF 16V AL E. CAPAC	
C709	QCS21HJ-5R0	5PF 50V CER. CAPACI	
C710	QCS21HJ-5R0	5PF 50V CER. CAPACI	
C711	QCY31HK-152Z	1500PF 50V CER. CAPACI	
C712	QCY31HK-152Z	1500PF 50V CER. CAPACI	
C713	QCS21HJ-680A	68PF 50V CER. CAPACI	
C714	QCS21HJ-680A	68PF 50V CER. CAPACI	
C715	QCS21HJ-680A	68PF 50V CER. CAPACI	
C716	QCS21HJ-680A	68PF 50V CER. CAPACI	
C717	QCS22HJ-220	22PF 500V CER. CAPACI	
C718	QCS22HJ-220	22PF 500V CER. CAPACI	
C719	QFLB1HJ-472	4700PF 50V MYLAR CAPA	
C720	QFLB1HJ-472	4700PF 50V MYLAR CAPA	
C722	QETB1EM-476	47MF 25V AL E. CAPAC	
C723	QETB2AM-476	47MF 100V AL E. CAPAC	A
C724	QETB2AM-476	47MF 100V AL E. CAPAC	A
C725	QCS22HJ-470A	47PF 500V CER. CAPACI	
C726	QCS22HJ-470A	47PF 500V CER. CAPACI	
C727	QCS22HJ-470A	47PF 500V CER. CAPACI	
C728	QCS22HJ-470A	47PF 500V CER. CAPACI	
C729	QFLB1HJ-473	0.047MF 50V MYLAR CAPA	
C730	QFLB1HJ-473	0.047MF 50V MYLAR CAPA	
C731	QFLB1HJ-473	0.047MF 50V MYLAR CAPA	
C732	QFLB1HJ-473	0.047MF 50V MYLAR CAPA	

△ : SAFETY PARTS

Capacitors

Δ	ITEM	PART NUMBER	DESCRIPTION	AREA
	C733	QCF21HP-472	4700PF 50V CER.CAPACI	
	C734	QCF21HP-472	4700PF 50V CER.CAPACI	
	C735	QCF21HP-472	4700PF 50V CER.CAPACI	
	C736	QCF21HP-472	4700PF 50V CER.CAPACI	
	C737	QFLB1HJ-473	0.047MF 50V MYLAR CAPA	
	C738	QFLB1HJ-473	0.047MF 50V MYLAR CAPA	
	C801	EEW7108-129E	12000MF E.CAPACITO	
	C802	EEW7108-129E	12000MF E.CAPACITO	
	C812	QETB1EM-107	100MF 25V AL E.CAPAC	
	C813	QCF21HP-472	4700PF 50V CER.CAPACI	
	C814	QETB1EM-107	100MF 25V AL E.CAPAC	
	C816	QETB1EM-107	100MF 25V AL E.CAPAC	
	C817	QCF21HP-472	4700PF 50V CER.CAPACI	
	C818	QETB1EM-107	100MF 25V AL E.CAPAC	
	C819	QCF21HP-472	4700PF 50V CER.CAPACI	
	C820	QETB1EM-107	100MF 25V AL E.CAPAC	
	C821	QCF21HP-472	4700PF 50V CER.CAPACI	
	C822	QCF21HP-472	4700PF 50V CER.CAPACI	
	C823	QETB1EM-107	100MF 25V AL E.CAPAC	
	C824	QCF21HP-223A	0.022MF 50V CER.CAPACI	
	C825	QCF21HP-223A	0.022MF 50V CER.CAPACI	
	C826	QCF21HP-223A	0.022MF 50V CER.CAPACI	
	C827	QETB1EM-107	100MF 25V AL E.CAPAC	
	C831	QCBB1HK-121Y	120PF 50V CER.CAPACI	
	C832	QCBB1HK-121Y	120PF 50V CER.CAPACI	
	C833	QCBB1HK-121Y	120PF 50V CER.CAPACI	
	C834	QCBB1HK-121Y	120PF 50V CER.CAPACI	
	C870	QCF21HP-472	4700PF 50V CER.CAPACI	
	C874	QETB1HM-105	1MF 50V AL E.CAPAC	
	C875	QETB1HM-105	1MF 50V AL E.CAPAC	
	C891	QETB1HM-106	10MF 50V E.CAPACITO	
	C892	QCY31HK-103Z	0.01MF 50V CER.CAPACI	
	C893	QFLB1HJ-123	0.012MF 50V MYLAR CAPA	
	C894	QETB1HM-106	10MF 50V E.CAPACITO	
	C895	QCS21HJ-101A	100PF 50V CER.CAPACI	
	C901	QCF21HP-223A	0.022MF 50V CER.CAPACI	
	C902	QCF21HP-223A	0.022MF 50V CER.CAPACI	
	C903	QETB1HM-226E	22MF 50V E.CAPACITO	
	C904	QCF21HP-103A	0.01MF 50V CER.CAPACI	
	C905	QCY31HK-102Z	1000PF 50V CER.CAPACI	
	C906	QETB1AM-476	47MF 10V E.CAPACITO	
	C909	QETB1CM-226	22MF 16V E.CAPACITO	
	C981	QETB1HM-225	2.2MF 50V AL E.CAPAC	
	C982	QFLB1HJ-223	0.022MF 50V MYLAR CAPA	
	C983	QETB1HM-106	10MF 50V E.CAPACITO	
	C985	QCBB1HK-331Y	330PF 50V CER.CAPACI	
	C986	QCHB1EZ-223	0.022MF 25V CER.CAPACI	
	C991	QCF21HP-223A	0.022MF 50V CER.CAPACI	

Δ USAFETY PARTS

Resistors

Δ	ITEM	PART NUMBER	DESCRIPTION	AREA
	R611	QRD161J-222	2.2K 1/6W CARBON RES	
	R612	QRD161J-104	100K 1/6W CARBON RES	
	R613	QRD161J-123	12K 1/6W CARBON RES	
	R614	QRD161J-202	2K 1/6W CARBON RES	
	R615	QRD161J-104	100K 1/6W CARBON RES	
	R616	QRD14CJ-181S	180 1/4W UNF.CARBON	
	R617	QRD14CJ-332SX	3.3K 1/4W UNF.CARBON	
	R618	QRD161J-302	3K 1/6W CARBON RES	
	R619	QRD161J-302	3K 1/6W CARBON RES	
	R620	QRD161J-302	3K 1/6W CARBON RES	
	R623	QRD14CJ-471SX	470 1/4W UNF.CARBON	
	R624	QRD14CJ-100SX	10 1/4W UNF.CARBON	
	R625	QRD14CJ-561SX	560 1/4W UNF.CARBON	
	R626	QRD14CJ-100SX	10 1/4W UNF.CARBON	
	R627	QRD14CJ-471SX	470 1/4W UNF.CARBON	
	R628	QRD161J-391	390 1/6W CARBON RES	
	R629	ERT-D2WHL202S	2K 1/4W NEGATIVE T	
	R630	QRD161J-183	18K 1/6W CARBON RES	
	R631	QRD161J-123	12K 1/6W CARBON RES	
	R632	QRD125J-330	33 1/2W UNF.CARBON	
	R633	QRG022J-100A	10 2W OXIDE META	
	R634	QRD161J-104	100K 1/6W CARBON RES	
	R635	QRD14CJ-330SX	33 1/4W UNF.CARBON	
	R636	QRD14CJ-330SX	33 1/4W UNF.CARBON	
	R637	QRG022J-562A	5.6K 2W OXIDE META	
	R638	QRD167J-751	750 1/6W CARBON RES	
	R639	QRD12CJ-470SX	47 1/2W CARBON RES	
	R640	QRG022J-182A	1.8K 2W OXIDE META	
	R641	QRD167J-151	150 1/6W CARBON RES	
	R642	QRD167J-151	150 1/6W CARBON RES	
	R643	QRD161J-102	1K 1/6W CARBON RES	
	R644	QRD167J-151	150 1/6W CARBON RES	
	R645	QRD12CJ-470SX	47 1/2W CARBON RES	
	R646	QRG022J-182A	1.8K 2W OXIDE META	
	R647	QRD167J-151	150 1/6W CARBON RES	
	R648	QRD167J-151	150 1/6W CARBON RES	
	R649	QRD167J-151	150 1/6W CARBON RES	
	R650	QRG022J-100A	10 2W OXIDE META	
	R651	QRD161J-104	100K 1/6W CARBON RES	
	R652	QRD167J-151	150 1/6W CARBON RES	

Δ USAFETY PARTS

Resistors

Δ	ITEM	PART NUMBER	DESCRIPTION	AREA
	R653	QRD167J-151	150 1/6W CARBON RES	
	R654	QRD167J-151	150 1/6W CARBON RES	
	R655	QRD167J-151	150 1/6W CARBON RES	
	R699	ERF032K-R22	0.22 3W CEM.RESIST	
	R701	QRD161J-222	2.2K 1/6W CARBON RES	
	R702	QRD161J-222	2.2K 1/6W CARBON RES	
	R703	QRD161J-104	100K 1/6W CARBON RES	
	R704	QRD161J-104	100K 1/6W CARBON RES	
	R705	QRD161J-202	2K 1/6W CARBON RES	
	R706	QRD161J-202	2K 1/6W CARBON RES	
	R707	QRD161J-202	2K 1/6W CARBON RES	
	R708	QRD161J-202	2K 1/6W CARBON RES	
	R709	QRD167J-822	8.2K 1/6W CARBON RES	
	R710	QRD167J-822	8.2K 1/6W CARBON RES	
	R711	QRD161J-681	680 1/6W CARBON RES	
	R712	QRD161J-681	680 1/6W CARBON RES	
	R713	QRD161J-333	33K 1/6W CARBON RES	
	R714	QRD161J-333	33K 1/6W CARBON RES	
	R715	QRD161J-683	68K 1/6W CARBON RES	
	R716	QRD161J-683	68K 1/6W CARBON RES	
	R717	QRD12CJ-153SX	15K 1/2W UNF.CARBON	
	R718	QRD12CJ-153SX	15K 1/2W UNF.CARBON	
	R719	QRD161J-391	390 1/6W CARBON RES	
	R720	QRD161J-391	390 1/6W CARBON RES	
	R721	QRD14CJ-151SX	150 1/4W UNF.CARBON	
	R722	QRD14CJ-151SX	150 1/4W UNF.CARBON	
	R723	QRD167J-152	1.5K 1/6W CARBON RES	
	R724	QRD167J-152	1.5K 1/6W CARBON RES	
	R725	QRD161J-333	33K 1/6W CARBON RES	
	R726	QRD161J-333	33K 1/6W CARBON RES	
	R727	QRD161J-391	390 1/6W CARBON RES	
	R728	QRD161J-391	390 1/6W CARBON RES	
	R729	QRD167J-152	1.5K 1/6W CARBON RES	
	R730	QRD167J-152	1.5K 1/6W CARBON RES	
	R731	QRD161J-101	100 1/6W CARBON RES	
	R732	QRD161J-101	100 1/6W CARBON RES	
	R733	QRD14CJ-101S	100 1/4W UNF.CARBON	
	R734	QRD14CJ-101S	100 1/4W UNF.CARBON	
	R735	QRG022J-562A	5.6K 2W OXIDE META	
	R739	QRD167J-151	150 1/6W CARBON RES	
	R740	QRD167J-151	150 1/6W CARBON RES	
	R741	QRD167J-151	150 1/6W CARBON RES	
	R742	QRD167J-151	150 1/6W CARBON RES	
	R751	QRD161J-221	220 1/6W CARBON RES	
	R752	QRD161J-221	220 1/6W CARBON RES	
	R753	QRD161J-221	220 1/6W CARBON RES	
	R754	QRD161J-221	220 1/6W CARBON RES	
	R755	QRD161J-471	470 1/6W CARBON RES	
	R756	QRD161J-471	470 1/6W CARBON RES	
	R757	ERT-D2WFL351S	350 1/4W NEGATIVE T	
	R758	ERT-D2WFL351S	350 1/4W NEGATIVE T	
	R759	QRD161J-101	100 1/6W CARBON RES	
	R760	QRD161J-101	100 1/6W CARBON RES	
	R761	QRD161J-391	390 1/6W CARBON RES	
	R762	QRD161J-391	390 1/6W CARBON RES	
	R763	ERT-D2WHL202S	2K 1/4W NEGATIVE T	
	R764	ERT-D2WHL202S	2K 1/4W NEGATIVE T	
	R765	QRD14CJ-272S	2.7K 1/4W UNF.CARBON	
	R766	QRD14CJ-272S	2.7K 1/4W UNF.CARBON	
	R767	QRD14CJ-271S	270 1/4W UNF.CARBON	
	R768	QRD14CJ-271S	270 1/4W UNF.CARBON	
	R769	QRD14CJ-100SX	10 1/4W UNF.CARBON	
	R770	QRD14CJ-100SX	10 1/4W UNF.CARBON	
	R771	QRD14CJ-100SX	10 1/4W UNF.CARBON	
	R772	QRD14CJ-100SX	10 1/4W UNF.CARBON	
	R773	ERF032K-R22	0.22 3W CEM.RESIST	
	R774	ERF032K-R22	0.22 3W CEM.RESIST	
	R775	QRD125J-470	47 1/2W UNF.CARBON	
	R776	QRD125J-470	47 1/2W UNF.CARBON	
	R777	QRG022J-100A	10 2W OXIDE META	
	R778	QRG022J-100A	10 2W OXIDE META	
	R779	QRD14CJ-100SX	10 1/4W UNF.CARBON	
	R780	QRD14CJ-100SX	10 1/4W UNF.CARBON	
	R781	QRD14CJ-100SX	10 1/4W UNF.CARBON	
	R782	QRD14CJ-100SX	10 1/4W UNF.CARBON	
	R783	QRD14CJ-100SX	10 1/4W UNF.CARBON	
	R784	QRD14CJ-100SX	10 1/4W UNF.CARBON	
	R785	QRD14CJ-100SX	10 1/4W UNF.CARBON	
	R786	QRD14CJ-100SX	10 1/4W UNF.CARBON	
	R811	QRD14CJ-120SX	12 1/4W UNF.CARBON	
	R813	QRD14CJ-102SX	1K 1/4W UNF.CARBON	
	R819	QRD14CJ-100SX	10 1/4W UNF.CARBON	
	R822	QRD14CJ-272S	2.7K 1/4W UNF.CARBON	
	R823	QRD14CJ-220S	22 1/4W UNF.CARBON	
	R824	QRD14CJ-220S	22 1/4W UNF.CARBON	
	R825	QRD14CJ-332SX	3.3K 1/4W UNF.CARBON	
	R826	QRD14CJ-100SX	10 1/4W UNF.CARBON	
	R828	QRD14CJ-102SX	1K 1/4W UNF.CARBON	
	R829	QRD143J-472S	4.7K 1/4W CARBON RES	
	R830	QRD14CJ-100SX	10 1/4W UNF.CARBON	
	R831	QRD145J-150S	15 1/4W UNF.CARBON	
	R832	QRD12CJ-103S	10K 1/2W UNF.CARBON	
	R834	QRD14CJ-220S	22 1/4W UNF.CARBON	
	R835	QRD14CJ-220S	22 1/4W UNF.CARBON	
	R836	QRD14CJ-220S	22 1/4W UNF.CARBON	

Δ USAFETY PARTS

Resistors

Δ	ITEM	PART NUMBER	DESCRIPTION		AREA
Δ	R837	QRD14CJ-822S	8.2K	1/4W UNF. CARBON	
	R838	QRD12CJ-2R2SX	2.2	1/2W CARBON RES	
	R839	QRD161J-472	4.7K	1/6W CARBON RES	
	R841	QRD161J-104	100K	1/6W CARBON RES	
	R842	QRD161J-104	100K	1/6W CARBON RES	
Δ	R843	QRD14CJ-4R7S	4.7	1/4W UNF. CARBON	
	R863	QRD161J-102	1K	1/6W CARBON RES	
	R864	QRD161J-102	1K	1/6W CARBON RES	
	R870	QRD161J-123	12K	1/6W CARBON RES	
	R871	QRD161J-103	10K	1/6W CARBON RES	
	R873	QRD161J-103	10K	1/6W CARBON RES	
	R874	QRD161J-123	12K	1/6W CARBON RES	
Δ	R889	QRZ0077-680	68	1/4W FUSIBLE RE	
Δ	R890	QRZ0077-680	68	1/4W FUSIBLE RE	
	R891	QRD161J-104	100K	1/6W CARBON RES	
	R892	QRD161J-203	20K	1/6W CARBON RES	
	R893	QRD161J-183	18K	1/6W CARBON RES	
	R894	QRD161J-202	2K	1/6W CARBON RES	
	R895	QRD167J-223	22K	1/6W CARBON RES	
	R896	QRD161J-132	1.3K	1/6W CARBON RES	
	R897	QRD161J-104	100K	1/6W CARBON RES	
	R898	QRD161J-203	20K	1/6W CARBON RES	
	R901	QRD161J-102	1K	1/6W CARBON RES	
	R902	QRD161J-102	1K	1/6W CARBON RES	
	R903	QRD167J-562	5.6K	1/6W CARBON RES	
	R904	QRD167J-562	5.6K	1/6W CARBON RES	
	R905	QRD161J-123	12K	1/6W CARBON RES	
	R906	QRD161J-123	12K	1/6W CARBON RES	
	R907	QRD161J-102	1K	1/6W CARBON RES	
	R908	QRD161J-102	1K	1/6W CARBON RES	
	R909	QRD161J-103	10K	1/6W CARBON RES	
	R911	QRD167J-332	3.3K	1/6W CARBON RES	
	R912	QRD161J-473	47K	1/6W CARBON RES	
	R913	QRD161J-104	100K	1/6W CARBON RES	
	R914	QRD161J-823	82K	1/6W CARBON RES	
	R915	QRD161J-823	82K	1/6W CARBON RES	
	R916	QRD161J-563	56K	1/6W CARBON RES	
	R917	QRD161J-683	68K	1/6W CARBON RES	
	R918	QRD161J-392	3.9K	1/6W CARBON RES	
	R921	QRD161J-224	220K	1/6W CARBON RES	
	R922	QRD167J-562	5.6K	1/6W CARBON RES	
Δ	R924	QRG022J-102AM	1K	2W OXIDE META	
	R925	QRD161J-181	180	1/6W CARBON RES	
	R926	QRD161J-181	180	1/6W CARBON RES	
	R927	QRD161J-181	180	1/6W CARBON RES	
	R929	QRD14CJ-151SX	150	1/4W UNF. CARBON	
Δ	R941	QRG022J-471A	470	2W OXIDE META	
Δ	R942	QRG022J-471A	470	2W OXIDE META	
	R951	QRD161J-333	33K	1/6W CARBON RES	
	R952	QRD161J-333	33K	1/6W CARBON RES	
	R953	QRD161J-333	33K	1/6W CARBON RES	
	R956	QRD167J-223	22K	1/6W CARBON RES	
	R957	QRD161J-391	390	1/6W CARBON RES	
	R981	QRD161J-222	2.2K	1/6W CARBON RES	
	R982	QRD161J-222	2.2K	1/6W CARBON RES	
	R983	QRD161J-105	1M	1/6W CARBON RES	
	R984	QRD161J-103	10K	1/6W CARBON RES	
	R985	QRD161J-100	10	1/6W CARBON RES	
	R986	QRD161J-102	1K	1/6W CARBON RES	
	VR791	QVPA601-501A	500	TRIMMER RE	
	VR792	QVPA601-501A	500	TRIMMER RE	
	VR873	QVDA96W-E15DJ3	100K	VARIABLE R	
	VR891	QVDB96C-E15DJ3	100K	VARIABLE R	

Δ : SAFETY PARTS.

Others

Δ	ITEM	PART NUMBER	DESCRIPTION		AREA
		EMW10518-003		PRINTED BOA	
		SBSG3008CC		TAPPING SCR	
	J901	QMS6022-V01		MICROPHONE	
	J911	EMV7164-036		CONNECT TER	
	J985	QMS3501-021		PIN JACK	
	L611	EQL0011-R45J1		INDUCTOR	
	L701	EQL0001-1R0		INDUCTOR	
	L702	EQL0001-1R0		INDUCTOR	
	P701	VMC0075-008N		CONNECT TER	
	P702	EMV5109-003A		MALE CONNec	
	P703	EMV5125-011		MALE CONNec	
	P704	EMV5109-011A		MALE CONNec	
	P705	EMV5125-006		CONNECT TER	
	P706	EMV5125-006		CONNECT TER	
	P707	EMV7163-020		CONNECT TER	
	P708	EMV5109-003A		MALE CONNec	
	P709	EMV5125-008		MALE CONNec	
	P710	EMV5129-003		CONNECTOR	
	P755	EMV5109-003A		MALE CONNec	
	P801	EMV5109-003A		MALE CONNec	
	P802	EMV5109-006A		CONNECT TER	
	S911	QSP6002-E02J2		PUSH SWITCH	
	8C103	EWS267-A408J		SOCKET WIRE	
	8C755	EWS293-0145		SOCKET WIRE	
	8C801	EWS263-A413J		SOCKET WIRE	
	8C802	EWS296-0120J6		SOCKET WIRE	
	EP901	EMZ4002-001Z		EARTH PLATE	
	EP902	EMZ4002-001Z		EARTH PLATE	
	EP903	EMZ4002-001Z		EARTH PLATE	
	EP904	EMZ4002-001Z		EARTH PLATE	
	EP905	EMZ4002-001Z		EARTH PLATE	
	FW901	EW333D-08SS		FLAT WIRE A	
	FW903	EW336D-45SS		FLAT WIRE A	
	HS800	E70306-001		HEAT SINK	
	HS802	E70306-001		HEAT SINK	
	HS804	E70306-001		HEAT SINK	
	HS805	E70306-001		HEAT SINK	
	HS808	E70306-001		HEAT SINK	
	JB101	EMV5140-010		VOLUME SOCK	
	JB441	EMV7123-021		CONNECT TER	
	RY611	ESK1D24-11AM		RELAY	
	RY612	ESK1D24-11AM		RELAY	
	RY901	ESK7D24-2120		RELAY	
	ST611	EMB90TV-601G		SPEAKER TER	
	ST901	EMB00TV-801B		TERMINAL	
	TP751	QMV5005-004K		PLUG ASSY	

Δ : SAFETY PARTS.

■ ENC-125 □ Input Selector PC Board Assy

Note : ENC-125 □ varies according to the areas employed. See note (2) when placing an order.

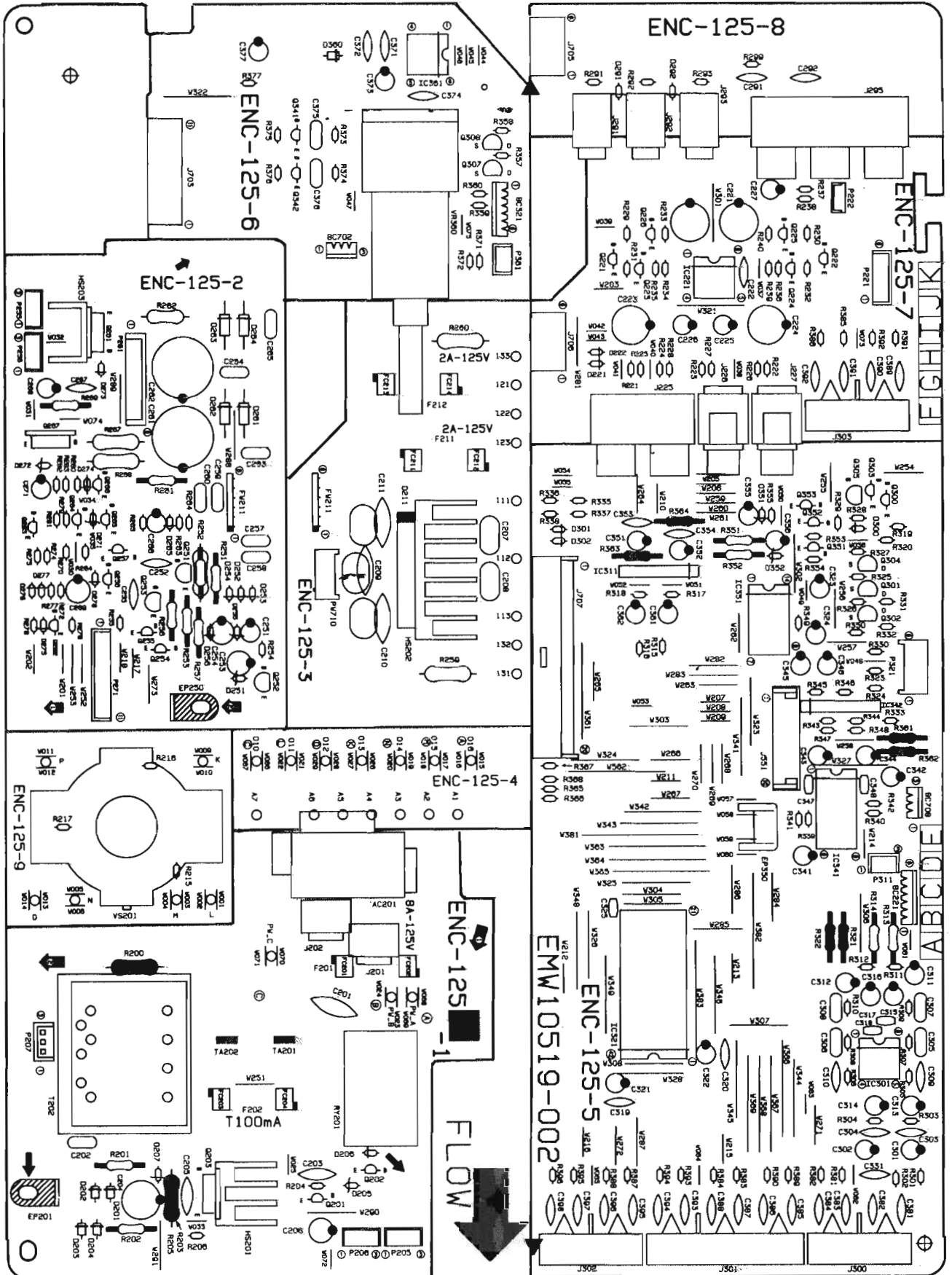



Note (2)

PC Board Ass'y	Version	Designated Areas
ENC-125 <b>D</b>	A	Australia
ENC-125 <b>C</b>	U UT	Universal Type Taiwan

Transistors

ITEM	PART NUMBER	DESCRIPTION	AREA
Q201	2SC2235(O,Y)	SI.TRANSIST TOSHIBA	
Q202	DTC143TS	DIGITAL TRA ROHM	
Q203	2SD1266	SI.TRANSIST MATSUSHITA	U
Q203	2SD1266	SI.TRANSIST MATSUSHITA	UT
Q221	2SC458(C,D)	SI.TRANSIST HITACHI	
Q222	2SC458(C,D)	SI.TRANSIST HITACHI	
Q223	2SA933S(RS)	SI.TRANSIST	
Q224	2SA933S(RS)	SI.TRANSIST	
Q225	DTC114YS	DIGITAL TRA ROHM	
Q226	DTC114YS	DIGITAL TRA ROHM	
Q251	2SA965(Y)	SI.TRANSIST TOSHIBA	
Q252	2SC2240(GR,BL)	SI.TRANSIST TOSHIBA	
Q253	2SA965(Y)	SI.TRANSIST TOSHIBA	
Q254	DTA144ES	DIGITAL TRA ROHM	
Q255	DTC144ES	DIGITAL TRA ROHM	
Q300	DTA114YS	DIGITAL TRA ROHM	
Q301	2SK301(P,Q)	F.E.T.	
Q302	2SK301(P,Q)	F.E.T.	
Q303	DTC144ES	DIGITAL TRA ROHM	
Q304	2SK301(P,Q)	F.E.T.	
Q305	2SK301(P,Q)	F.E.T.	
Q307	2SK301(P,Q)	F.E.T.	
Q308	2SK301(P,Q)	F.E.T.	
Q341	2SD2144S(VW)	SI.TRANSIST ROHM	
Q342	2SD2144S(VW)	SI.TRANSIST ROHM	
Q351	DTC144ES	DIGITAL TRA ROHM	
Q352	DTA144ES	DIGITAL TRA ROHM	
Q353	DTC144ES	DIGITAL TRA ROHM	

△ SAFETY PARTS

I.C.s

ITEM	PART NUMBER	DESCRIPTION	AREA
IC221	NJM2246D	I.C(MONO-AN DAINICHI	
IC301	VC4580DD	I.C(MONO-AN DAINICHI	
IC311	BA15218N	I.C(MONO-AN ROHM	
IC321	TC9274N-007	I.C(M) TOSHIBA	
IC341	TC9299P	I.C(DIGI-MO TOSHIBA	
IC342	BA15218N	I.C(MONO-AN ROHM	
IC351	UPD4066BC	I.C(DIGI-MO NEC	
IC361	LB1639-CV	I.C(DIGI-OT SANYO	

△ SAFETY PARTS

Diodes

ITEM	PART NUMBER	DESCRIPTION	AREA
D201	1SR139-200	SI.DIODE ROHM	
D202	1SR139-200	SI.DIODE ROHM	
D203	1SR139-200	SI.DIODE ROHM	
D204	1SR139-200	SI.DIODE ROHM	
D205	MT26.2JC	ZENER DIODE ROHM	
D206	1SS133	SI.DIODE ROHM	
D207	MT212JC	ZENER DIODE ROHM	U
D207	MT212JC	ZENER DIODE ROHM	UT
D211	U6SBA20	DIODE SINDENGEN	
D221	1SS133	SI.DIODE ROHM	
D222	1SS133	SI.DIODE ROHM	
D251	MT25.6JC	ZENER DIODE ROHM	
D252	MT210JC	ZENER DIODE ROHM	
D253	MT216JC	ZENER DIODE ROHM	
D254	1SS133	SI.DIODE ROHM	
D255	MT26.8JC	ZENER DIODE ROHM	
D256	1SS133	SI.DIODE ROHM	
D261	10E2-FD	DIODE NIHONINTER	
D262	10E2-FD	DIODE NIHONINTER	
D263	10E2-FD	DIODE NIHONINTER	
D264	10E2-FD	DIODE NIHONINTER	
D265	1SS133	SI.DIODE ROHM	
D291	MT26.2JC	ZENER DIODE ROHM	
D292	MT26.2JC	ZENER DIODE ROHM	
D300	1SS133	SI.DIODE ROHM	
D301	1SS133	SI.DIODE ROHM	
D302	1SS133	SI.DIODE ROHM	
D351	MT28.2JC	ZENER DIODE ROHM	
D352	MT28.2JC	ZENER DIODE ROHM	
D360	1SR139-200	SI.DIODE ROHM	

△ SAFETY PARTS

Capacitors

ITEM	PART NUMBER	DESCRIPTION	AREA
C201	QCZ9019-472	4700PF C.CAPACITO	
C202	QFN82AK-472	4700PF 100V METAL.MYLA	
C203	QCF21HP-472	4700PF 50V CER.CAPACI	
C204	QETB1EM-227	220MF 25V AL E.CAPAC	A
C204	QETB1JM-227	220MF 63V AL E.CAPAC	U
C204	QETB1JM-227	220MF 63V AL E.CAPAC	UT
C205	QCF21HP-472	4700PF 50V CER.CAPACI	U
C205	QCF21HP-472	4700PF 50V CER.CAPACI	UT
C206	QETB1CM-476	47MF 16V AL E.CAPAC	
C209	QCE22HP-103A	0.01MF 500V CER.CAPACI	
C210	QCE22HP-103A	0.01MF 500V CER.CAPACI	
C211	QCE22HP-103A	0.01MF 500V CER.CAPACI	
C221	QETB1CM-108	1000MF 16V AL E.CAPAC	
C222	QCF21HP-223A	0.022MF 50V CER.CAPACI	
C223	QETB0JM-108N	1000MF 6.3V E.CAPACITO	
C224	QETB0JM-108N	1000MF 6.3V E.CAPACITO	
C225	QETB1HM-475E	4.7MF 50V E.CAPACITO	
C226	QETB1HM-475E	4.7MF 50V E.CAPACITO	
C227	QETB1HM-475E	4.7MF 50V E.CAPACITO	
C251	QETB1HM-476	47MF 50V E.CAPACITO	
C252	QCF21HP-472	4700PF 50V CER.CAPACI	
C253	QETB1EM-107	100MF 25V AL E.CAPAC	
C254	QETB1EM-107	100MF 25V AL E.CAPAC	
C255	QCF21HP-472	4700PF 50V CER.CAPACI	
C257	QFLB1HJ-473	0.047MF 50V MYLAR CAPA	
C258	QFLB1HJ-473	0.047MF 50V MYLAR CAPA	
C261	QETB1VM-228N	2200MF 35V E.CAPACITO	
C262	QETB1VM-228N	2200MF 35V E.CAPACITO	
C263	QFN82AJ-104	0.1MF 100V MYLAR CAPA	
C264	QFN82AJ-104	0.1MF 100V MYLAR CAPA	
C265	QFN82AJ-104	0.1MF 100V MYLAR CAPA	
C266	QETB1HM-225	2.2MF 50V AL E.CAPAC	
C291	QCS31HJ-471Z	470PF 50V CER.CAPACI	
C292	QCS31HJ-471Z	470PF 50V CER.CAPACI	
C301	QETB1HM-475E	4.7MF 50V E.CAPACITO	
C302	QETB1HM-475E	4.7MF 50V E.CAPACITO	
C303	QCS21HJ-101A	100PF 50V CER.CAPACI	
C304	QCS21HJ-101A	100PF 50V CER.CAPACI	
C305	QFLB1HJ-182	1800PF 50V MYLAR CAPA	
C306	QFLB1HJ-182	1800PF 50V MYLAR CAPA	
C307	QFLB1HJ-682	6800PF 50V MYLAR CAPA	
C308	QFLB1HJ-682	6800PF 50V MYLAR CAPA	
C309	QCS21HJ-101A	100PF 50V CER.CAPACI	
C310	QCS21HJ-101A	100PF 50V CER.CAPACI	
C311	QETB1HM-475E	4.7MF 50V E.CAPACITO	
C312	QETB1HM-475E	4.7MF 50V E.CAPACITO	
C313	QETB1AM-107	100MF 10V AL E.CAPAC	
C314	QETB1AM-107	100MF 10V AL E.CAPAC	
C315	QETB1CM-476	47MF 16V AL E.CAPAC	
C316	QETB1CM-476	47MF 16V AL E.CAPAC	
C319	QCF21HP-223A	0.022MF 50V CER.CAPACI	
C320	QCF21HP-223A	0.022MF 50V CER.CAPACI	
C321	QETB1EM-226N	22MF 25V E.CAPACITO	
C322	QETB1EM-226N	22MF 25V E.CAPACITO	
C323	QETB1HM-106	10MF 50V E.CAPACITO	
C324	QETB1HM-106	10MF 50V E.CAPACITO	
C325	QCB11K-561Y	560PF 50V CER.CAPACI	
C331	QCF21HP-223A	0.022MF 50V CER.CAPACI	
C341	QETB1HM-475E	4.7MF 50V E.CAPACITO	
C342	QETB1HM-475E	4.7MF 50V E.CAPACITO	
C343	QETB1HM-105	1MF 50V AL E.CAPAC	
C344	QETB1HM-105	1MF 50V AL E.CAPAC	
C345	QETB1EM-106	10MF 25V AL E.CAPAC	
C346	QETB1EM-106	10MF 25V AL E.CAPAC	
C347	QCHB1EZ-223	0.022MF 25V CER.CAPACI	
C348	QCHB1EZ-223	0.022MF 25V CER.CAPACI	
C351	QEK51EM-475G	4.7MF 25V AL E.CAPAC	
C352	QEK51EM-475G	4.7MF 25V AL E.CAPAC	
C353	QCF21HP-223A	0.022MF 50V CER.CAPACI	
C354	QCF21HP-223A	0.022MF 50V CER.CAPACI	
C355	QETB1EM-106	10MF 25V AL E.CAPAC	
C356	QETB1EM-106	10MF 25V AL E.CAPAC	
C361	QER51EM-106	10MF 25V E.CAPACITO	
C362	QER51EM-106	10MF 25V E.CAPACITO	
C371	QCY21HK-331	330PF 50V CER.CAPACI	
C372	QCY21HK-331	330PF 50V CER.CAPACI	
C373	QETB1AM-107	100MF 10V AL E.CAPAC	
C374	QCF21HP-473A	0.047MF 50V CER.CAPACI	
C375	QFLB1HJ-333	0.033MF 50V MYLAR CAPA	
C376	QFLB1HJ-333	0.033MF 50V MYLAR CAPA	
C377	QETB1HM-226E	22MF 50V E.CAPACITO	

△ SAFETY PARTS

**Resistors**

Δ	ITEM	PART NUMBER	DESCRIPTION		AREA
Δ	R201	QRD14CJ-100SX	10	1/4W UNF. CARBON	A
Δ	R202	QRZ0076-3R3	3.3	1/4W FUSIBLE RE	U
Δ	R202	QRZ0076-3R3	3.3	1/4W FUSIBLE RE	UT
Δ	R202	QRZ0077-220X	22	1/4W FUSIBLE RE	A
Δ	R203	QRV144F-1502	15K	1/4W CONST. META	U
Δ	R203	QRV144F-1502	15K	1/4W CONST. META	UT
Δ	R204	QRD161J-821	820	1/6W CARBON RES	U
Δ	R204	QRD161J-821	820	1/6W CARBON RES	UT
Δ	R204	QRV144F-9100		1/4W M.F. RESIST	A
Δ	R205	QRG012J-332A	3.3K	1W OXIDE META	U
Δ	R205	QRG012J-332A	3.3K	1W OXIDE META	UT
Δ	R206	QRD167J-200	20	1/6W CARBON RES	A
Δ	R215	QRD161J-103	10K	1/6W CARBON RES	U
Δ	R215	QRD161J-103	10K	1/6W CARBON RES	UT
Δ	R216	QRD161J-103	10K	1/6W CARBON RES	U
Δ	R216	QRD161J-103	10K	1/6W CARBON RES	UT
Δ	R217	QRD161J-103	10K	1/6W CARBON RES	U
Δ	R217	QRD161J-103	10K	1/6W CARBON RES	UT
Δ	R221	QRD161J-750	75	1/6W CARBON RES	U
Δ	R221	QRD161J-750	75	1/6W CARBON RES	UT
Δ	R222	QRD167J-680	68	1/6W CARBON RES	U
Δ	R222	QRD167J-680	68	1/6W CARBON RES	UT
Δ	R223	QRD161J-750	75	1/6W CARBON RES	U
Δ	R223	QRD161J-750	75	1/6W CARBON RES	UT
Δ	R224	QRD161J-750	75	1/6W CARBON RES	U
Δ	R224	QRD161J-750	75	1/6W CARBON RES	UT
Δ	R225	QRD161J-473	47K	1/6W CARBON RES	U
Δ	R225	QRD161J-473	47K	1/6W CARBON RES	UT
Δ	R226	QRD161J-473	47K	1/6W CARBON RES	U
Δ	R226	QRD161J-473	47K	1/6W CARBON RES	UT
Δ	R227	QRD161J-331	330	1/6W CARBON RES	U
Δ	R227	QRD161J-331	330	1/6W CARBON RES	UT
Δ	R228	QRD161J-331	330	1/6W CARBON RES	U
Δ	R228	QRD161J-331	330	1/6W CARBON RES	UT
Δ	R229	QRD167J-152	1.5K	1/6W CARBON RES	U
Δ	R229	QRD167J-152	1.5K	1/6W CARBON RES	UT
Δ	R230	QRD167J-152	1.5K	1/6W CARBON RES	U
Δ	R230	QRD167J-152	1.5K	1/6W CARBON RES	UT
Δ	R231	QRD167J-151	150	1/6W CARBON RES	U
Δ	R231	QRD167J-151	150	1/6W CARBON RES	UT
Δ	R232	QRD167J-151	150	1/6W CARBON RES	U
Δ	R232	QRD167J-151	150	1/6W CARBON RES	UT
Δ	R233	QRD167J-152	1.5K	1/6W CARBON RES	U
Δ	R233	QRD167J-152	1.5K	1/6W CARBON RES	UT
Δ	R234	QRD161J-473	47K	1/6W CARBON RES	U
Δ	R234	QRD161J-473	47K	1/6W CARBON RES	UT
Δ	R235	QRD161J-271	270	1/6W CARBON RES	U
Δ	R235	QRD161J-271	270	1/6W CARBON RES	UT
Δ	R236	QRD161J-271	270	1/6W CARBON RES	U
Δ	R236	QRD161J-271	270	1/6W CARBON RES	UT
Δ	R237	QRD161J-331	330	1/6W CARBON RES	U
Δ	R237	QRD161J-331	330	1/6W CARBON RES	UT
Δ	R238	QRD161J-750	75	1/6W CARBON RES	U
Δ	R238	QRD161J-750	75	1/6W CARBON RES	UT
Δ	R239	QRD161J-473	47K	1/6W CARBON RES	U
Δ	R239	QRD161J-473	47K	1/6W CARBON RES	UT
Δ	R240	QRD167J-152	1.5K	1/6W CARBON RES	U
Δ	R240	QRD167J-152	1.5K	1/6W CARBON RES	UT
Δ	R251	QRD14CJ-123SX	12K	1/4W UNF. CARBON	A
Δ	R252	QRG022J-391AM	390	2W OXIDE META	A
Δ	R253	QRD14CJ-220S	22	1/4W UNF. CARBON	A
Δ	R254	QRD161J-104	100K	1/6W CARBON RES	A
Δ	R255	QRD161J-270	27	1/6W CARBON RES	A
Δ	R256	QRD14CJ-330SX	33	1/4W UNF. CARBON	A
Δ	R257	QRD14CJ-332SX	3.3K	1/4W UNF. CARBON	A
Δ	R259	QRX022J-R22AM	0.22	2W METAL FILM	A
Δ	R260	QRX022J-R22AM	0.22	2W METAL FILM	A
Δ	R261	QRD12CJ-2R2SX	2.2	1/2W CARBON RES	A
Δ	R262	QRD12CJ-2R2SX	2.2	1/2W CARBON RES	A
Δ	R263	QRD167J-562	5.6K	1/6W CARBON RES	A
Δ	R264	QRD167J-822	8.2K	1/6W CARBON RES	A
Δ	R265	QRD161J-103	10K	1/6W CARBON RES	A
Δ	R276	QRD161J-102	1K	1/6W CARBON RES	A
Δ	R278	QRD161J-103	10K	1/6W CARBON RES	A
Δ	R291	QRD161J-221	220	1/6W CARBON RES	A
Δ	R292	QRD161J-221	220	1/6W CARBON RES	A
Δ	R293	QRD161J-221	220	1/6W CARBON RES	A
Δ	R299	QRD161J-102	1K	1/6W CARBON RES	A
Δ	R301	QRD161J-222	2.2K	1/6W CARBON RES	A
Δ	R302	QRD161J-222	2.2K	1/6W CARBON RES	A
Δ	R303	QRD161J-473	47K	1/6W CARBON RES	A
Δ	R304	QRD161J-473	47K	1/6W CARBON RES	A
Δ	R305	QRD161J-561	560	1/6W CARBON RES	A
Δ	R306	QRD161J-561	560	1/6W CARBON RES	A
Δ	R307	QRD161J-393	39K	1/6W CARBON RES	A
Δ	R308	QRD161J-393	39K	1/6W CARBON RES	A
Δ	R309	QRD161J-474	470K	1/6W CARBON RES	A
Δ	R310	QRD161J-474	470K	1/6W CARBON RES	A
Δ	R311	QRD161J-104	100K	1/6W CARBON RES	A
Δ	R312	QRD161J-104	100K	1/6W CARBON RES	A
Δ	R313	QRD14CJ-391SX	390	1/4W UNF. CARBON	A
Δ	R314	QRD14CJ-391SX	390	1/4W UNF. CARBON	A
Δ	R315	QRD161J-104	100K	1/6W CARBON RES	A
Δ	R316	QRD161J-104	100K	1/6W CARBON RES	A
Δ	R317	QRD161J-104	100K	1/6W CARBON RES	A
Δ	R318	QRD161J-104	100K	1/6W CARBON RES	A
Δ	R319	QRD161J-753	75K	1/6W CARBON RES	A
Δ	R320	QRD161J-104	100K	1/6W CARBON RES	A
Δ	R321	QRZ0077-680	68	1/4W FUSIBLE RE	A
Δ	R322	QRZ0077-680	68	1/4W FUSIBLE RE	A
Δ	R323	QRD161J-102	1K	1/6W CARBON RES	A
Δ	R324	QRD161J-102	1K	1/6W CARBON RES	A
Δ	R325	QRD161J-103	10K	1/6W CARBON RES	A
Δ	R326	QRD161J-103	10K	1/6W CARBON RES	A
Δ	R327	QRD161J-103	10K	1/6W CARBON RES	A
Δ	R328	QRD161J-103	10K	1/6W CARBON RES	A
Δ	R329	QRD167J-152	1.5K	1/6W CARBON RES	A
Δ	R330	QRD167J-152	1.5K	1/6W CARBON RES	A
Δ	R331	QRD161J-224	220K	1/6W CARBON RES	A
Δ	R332	QRD161J-224	220K	1/6W CARBON RES	A
Δ	R333	QRD161J-224	220K	1/6W CARBON RES	A
Δ	R335	QRD161J-103	10K	1/6W CARBON RES	A
Δ	R336	QRD161J-512	5.1K	1/6W CARBON RES	A
Δ	R337	QRD161J-103	10K	1/6W CARBON RES	A
Δ	R338	QRD161J-512	5.1K	1/6W CARBON RES	A

Δ : SAFETY PARTS

**Resistors**

Δ	ITEM	PART NUMBER	DESCRIPTION		AREA
Δ	R339	QRD161J-104	100K	1/6W CARBON RES	A
Δ	R340	QRD161J-104	100K	1/6W CARBON RES	A
Δ	R341	QRD161J-104	100K	1/6W CARBON RES	A
Δ	R342	QRD161J-104	100K	1/6W CARBON RES	A
Δ	R343	QRD161J-105	1M	1/6W CARBON RES	A
Δ	R344	QRD161J-105	1M	1/6W CARBON RES	A
Δ	R345	QRD161J-823	82K	1/6W CARBON RES	A
Δ	R346	QRD161J-823	82K	1/6W CARBON RES	A
Δ	R347	QRD161J-103	10K	1/6W CARBON RES	A
Δ	R348	QRD161J-103	10K	1/6W CARBON RES	A
Δ	R349	QRD161J-104	100K	1/6W CARBON RES	A
Δ	R350	QRD161J-104	100K	1/6W CARBON RES	A
Δ	R351	QRD14CJ-152SX	1.5K	1/4W UNF. CARBON	A
Δ	R352	QRD14CJ-152SX	1.5K	1/4W UNF. CARBON	A
Δ	R353	QRD161J-563	56K	1/6W CARBON RES	A
Δ	R354	QRD161J-563	56K	1/6W CARBON RES	A
Δ	R355	QRD161J-563	56K	1/6W CARBON RES	A
Δ	R357	QRD161J-103	10K	1/6W CARBON RES	A
Δ	R358	QRD161J-103	10K	1/6W CARBON RES	A
Δ	R359	QRD161J-102	1K	1/6W CARBON RES	A
Δ	R360	QRD161J-102	1K	1/6W CARBON RES	A
Δ	R361	QRZ0077-680	68	1/4W FUSIBLE RE	A
Δ	R362	QRZ0077-680	68	1/4W FUSIBLE RE	A
Δ	R363	QRZ0077-680	68	1/4W FUSIBLE RE	A
Δ	R364	QRZ0077-680	68	1/4W FUSIBLE RE	A
Δ	R365	QRD167J-152	1.5K	1/6W CARBON RES	A
Δ	R366	QRD167J-152	1.5K	1/6W CARBON RES	A
Δ	R367	QRD167J-152	1.5K	1/6W CARBON RES	A
Δ	R368	QRD167J-152	1.5K	1/6W CARBON RES	A
Δ	R369	QRD161J-221	220	1/6W CARBON RES	A
Δ	R371	QRD167J-223	22K	1/6W CARBON RES	A
Δ	R372	QRD167J-223	22K	1/6W CARBON RES	A
Δ	R373	QRD167J-223	22K	1/6W CARBON RES	A
Δ	R374	QRD167J-223	22K	1/6W CARBON RES	A
Δ	R375	QRD161J-222	2.2K	1/6W CARBON RES	A
Δ	R376	QRD161J-222	2.2K	1/6W CARBON RES	A
Δ	R377	QRD161J-202	2K	1/6W CARBON RES	A
Δ	R381	QRD161J-471	470	1/6W CARBON RES	A
Δ	R382	QRD161J-471	470	1/6W CARBON RES	A
Δ	R383	QRD161J-471	470	1/6W CARBON RES	A
Δ	R384	QRD161J-471	470	1/6W CARBON RES	A
Δ	R385	QRD161J-471	470	1/6W CARBON RES	A
Δ	R386	QRD161J-471	470	1/6W CARBON RES	A
Δ	R387	QRD161J-471	470	1/6W CARBON RES	A
Δ	R388	QRD161J-471	470	1/6W CARBON RES	A
Δ	R389	QRD161J-471	470	1/6W CARBON RES	A
Δ	R390	QRD161J-471	470	1/6W CARBON RES	A
Δ	R391	QRD161J-471	470	1/6W CARBON RES	A
Δ	R392	QRD161J-471	470	1/6W CARBON RES	A
Δ	R393	QRD161J-471	470	1/6W CARBON RES	A
Δ	R394	QRD161J-471	470	1/6W CARBON RES	A
Δ	R395	QRD161J-471	470	1/6W CARBON RES	A
Δ	R396	QRD161J-471	470	1/6W CARBON RES	A
Δ	VR360	QVDC94Z-E15EJ5	100K	VARIABLE R	A

Δ : SAFETY PARTS

**Others**

Δ	ITEM	PART NUMBER	DESCRIPTION		AREA
Δ		EMW10519-003	PRINTED BOA		
Δ		QWE880-14RR	VINYL WIRE		U
Δ		QWE880-14RR	VINYL WIRE		UT
Δ		QWE881-16RR	VINYL WIRE		U
Δ		QWE882-18RR	VINYL WIRE		U
Δ		QWE882-18RR	VINYL WIRE		UT
Δ		QWE883-08RR	VINYL WIRE		A
Δ		QWE883-16RR	VINYL WIRE		U
Δ		QWE883-16RR	VINYL WIRE		UT
Δ		QWE884-18RR	VINYL WIRE		U
Δ		QWE884-18RR	VINYL WIRE		UT
Δ		QWE886-16RR	PIN WIRE		U
Δ		QWE886-16RR	PIN WIRE		UT
Δ		QWE886-20RR	VINYL WIRE		U
Δ		QWE888-16RR	VINYL WIRE		UT
Δ		SBST3008CC	TAPPING SCR		U
Δ		SBST3008CC	TAPPING SCR		UT
Δ		SBST3008CC	TAPPING SCR		U
Δ	J201	EMV5137-002	CONNECT TER		U
Δ	J201	EMV5137-002	CONNECT TER		UT
Δ	J202	EMV5137-002	CONNECT TER		A
Δ	J225	EMN00YV-217A	PIN JACK		U
Δ	J226	EMN01TV-102A	PIN JACK		U
Δ	J227	EMN00TV-116A	PIN JACK		U
Δ	J291	QMS3L10-0A0	MICROPHONE		U
Δ	J292	QMS3L10-0A0	MICROPHONE		U
Δ	J293	QMS3L10-0A0	MICROPHONE		U
Δ	J295	EMN00YV-319AJ1	PIN JACK		U
Δ	J300	EMN00TV-422AJ2	PIN JACK		U
Δ	J301	EMN00TV-615AJ2	PIN JACK		U
Δ	J302	EMN00TV-422AJ2	PIN JACK		U
Δ	J303	EMN00TV-422AJ2	PIN JACK		U
Δ	J551	EMV7159-010	PIN PLUG		U

Others

Δ	ITEM	PART NUMBER	DESCRIPTION	AREA
	J705	EMV7125-006R	CONNECT TER	
	J706	EMV7125-006R	CONNECT TER	
	J707	EMV5163-020R	CONNECT TER	
	P205	VMC0177-003	CONNECT TER	
	P221	EMV5109-006A	CONNECT TER	
	P222	EMV5142-903	CONNECT TER	
	P255	VMC0177-003	CONNECT TER	
	P261	EMV5125-008	MALE CONNEC	
	P271	EMV5109-011A	MALE CONNEC	
	P311	EMV5109-003A	MALE CONNEC	
	P321	EMV5109-006B	CONNECT TER	
	P361	EMV5109-003A	MALE CONNEC	
Δ	T202	ETP1000-41EA	POWER TRASN	A
Δ	T202	ETP1000-41ZB	POWER TRASN	U
Δ	T202	ETP1000-41ZB	POWER TRASN	UT
Δ	AC201	QMCA002-E02S	AC OUTLET	U
Δ	AC201	QMCA002-E02S	AC OUTLET	UT
	BC221	EWS296-0113	SOCKET WIRE	
	BC321	EWS296-0130	SOCKET WIRE	
	BC702	EWS293-0130	SOCKET WIRE	
	BC708	EWS263-A41B	SOCKET WIRE	
	EP201	EMZ4002-001Z	EARTH PLATE	
	EP250	EMZ4002-001Z	EARTH PLATE	
	EP350	E70225-001	EARTH PLATE	
	FC201	VMZ0087-001Z	FUSE HOLDER	A
	FC202	VMZ0087-001Z	FUSE HOLDER	A
	FC203	VMZ0087-001Z	FUSE HOLDER	
	FC204	VMZ0087-001Z	FUSE HOLDER	
	FC211	VMZ0087-001Z	FUSE HOLDER	
	FC212	VMZ0087-001Z	FUSE HOLDER	
	FC213	VMZ0087-001Z	FUSE HOLDER	
	FC214	VMZ0087-001Z	FUSE HOLDER	
	FW211	EWR36D-10SS	FLAT WIRE	
	HS201	E70945-H40B	HEAT SINK	U
	HS201	E70945-H40B	HEAT SINK	UT
	HS202	E408032-002SS	HEAT SINK	
	LA201	E67132-T4R0	FUSE LABEL	A
	LA211	E67132-T2R0	FUSE LABEL	
	LA212	E67132-T2R0	FUSE LABEL	
	PW710	EWS273-005	SOCKET WIRE	
Δ	RY201	ESK1D12-115	RELAY	
	SH201	ES08132-001	SHIELD COVE	
	TA201	EMZ4001-001	TAB	
	TA202	EMZ4001-001	TAB	
Δ	VS201	QSR0085-01B	SELECT SWIT	U
Δ	VS201	QSR0085-01B	SELECT SWIT	UT

Δ : SAFETY PARTS

■ ENB-211 □ FL Display PC Board Assy

Note : ENB-211 □ varies according to the areas employed. See note (3) when placing an order.

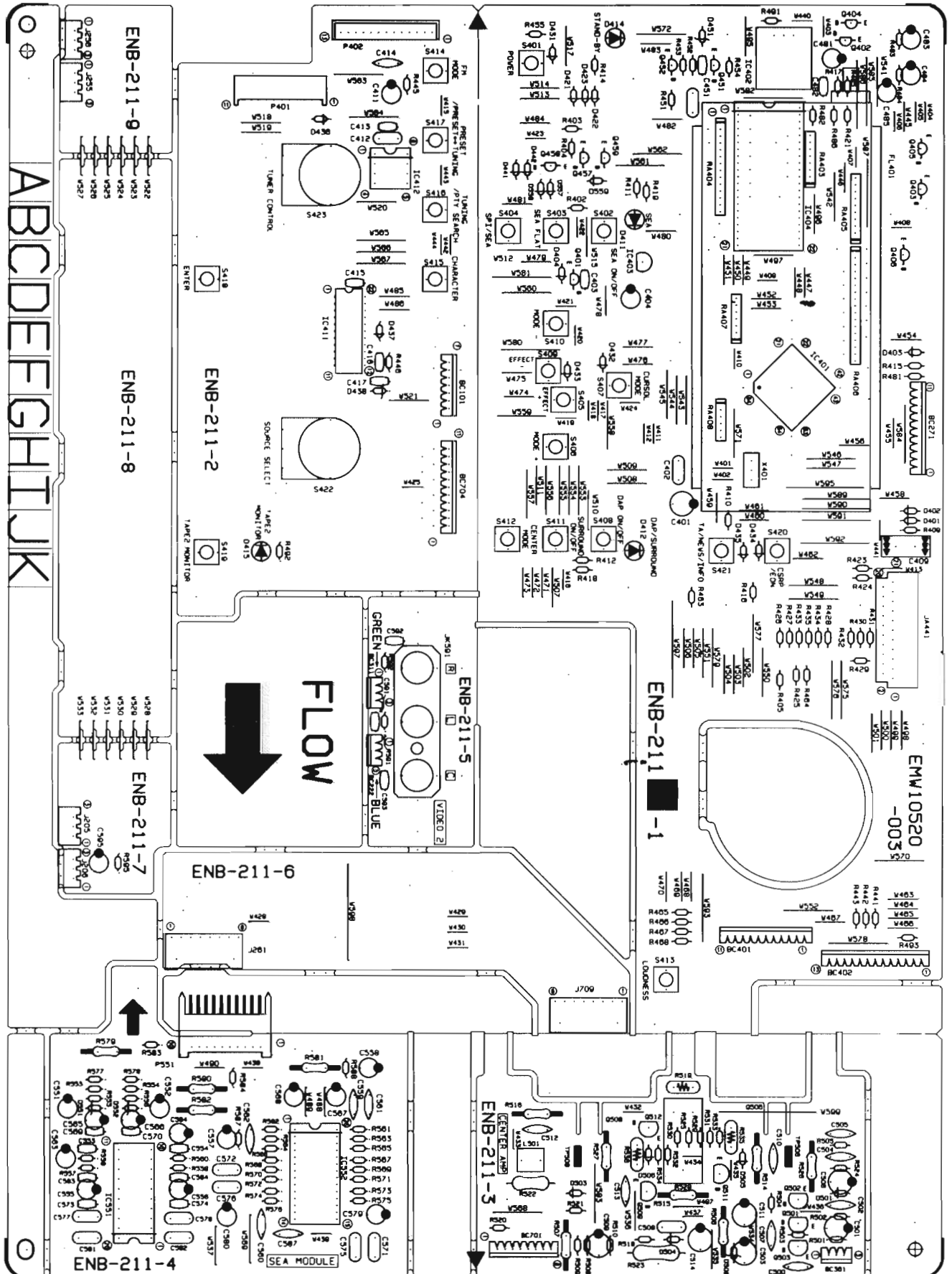

Note (3)

PC Board Ass'y	Version	Designated Areas
ENB-211 <b>B</b>	A	Australia
ENB-211 <b>C</b>	U UT	Universal Type Taiwan

Transistors

ITEM	PART NUMBER	DESCRIPTION	AREA
Q401	DTC114YS	DIGITAL TRA ROHM	
Q402	DTC144ES	DIGITAL TRA ROHM	
Q403	DTC144ES	DIGITAL TRA ROHM	
Q404	DTA114YS	DIGITAL TRA ROHM	
Q405	DTA114YS	DIGITAL TRA ROHM	
Q406	DTC114YS	DIGITAL TRA ROHM	
Q451	2SC1740S(R,S)	SI.TRANSIST ROHM	
Q452	2SC1740S(R,S)	SI.TRANSIST ROHM	
Q457	DTC114YS	DIGITAL TRA ROHM	
Q458	DTC144ES	DIGITAL TRA ROHM	
Q459	DTC114YS	DIGITAL TRA ROHM	
Q501	2SC2240(BL)	SI.TRANSIST	
Q502	2SC2240(BL)	SI.TRANSIST	
Q503	2SA1038(R,S)	SI.TRANSIST ROHM	
Q509	2SC1775AV(F1)	SI.TRANSIST HITACHI	
Q511	2SC2389(S,E)	SI.TRANSIST ROHM	
Q512	2SA1038(R,S)	SI.TRANSIST ROHM	

△ : SAFETY PARTS

I.C.s

ITEM	PART NUMBER	DESCRIPTION	AREA
IC401	MN172412J5X	I.C(MICRO-C MATSUSHITA	
IC402	SPS-420-1	INFRARED DE SANYO	
IC403	MN1281(P,Q)	I.C(DIGI-MO MATSUSHITA	
IC404	XR1095CP	I.C(MONO-AN EXAR JAPAN	
IC411	NJU3715L	I.C(MONO-AN DAINICHI	
IC412	AT24C02-10PC	I.C(EEP-ROM) MITSUBISHI	
IC551	MS243P12	I.C(MONO-AN MITSUBISHI	
IC552	TC9163N	I.C(DIGI-MO TOSHIBA	

△ : SAFETY PARTS

Diodes

ITEM	PART NUMBER	DESCRIPTION	AREA
D401	1SS133	SI.DIODE ROHM	
D402	1SS133	SI.DIODE ROHM	
D403	1SS133	SI.DIODE ROHM	
D404	1SS133	SI.DIODE ROHM	
D411	SLR-34MC70F124	L.E.D. ROHM	
D412	SLR-34MC70F124	L.E.D. ROHM	
D414	SLR-34VC50F124	L.E.D. ROHM	
D415	SLR-34VC3F	L.E.D. ROHM	
D421	1SS133	SI.DIODE ROHM	U
D421	1SS133	SI.DIODE ROHM	UT
D422	1SS133	SI.DIODE ROHM	A
D423	1SS133	SI.DIODE ROHM	
D431	1SS133	SI.DIODE ROHM	
D432	1SS133	SI.DIODE ROHM	
D433	1SS133	SI.DIODE ROHM	
D434	1SS133	SI.DIODE ROHM	
D436	1SS133	SI.DIODE ROHM	
D437	1SS133	SI.DIODE ROHM	
D438	MTZ6.2JC	ZENER DIODE ROHM	
D441	1SS133	SI.DIODE ROHM	
D442	1SS133	SI.DIODE ROHM	
D451	MTZ7.5JC	ZENER DIODE ROHM	
D501	1SS133	SI.DIODE ROHM	
D502	MTZ18JC	ZENER DIODE ROHM	
D503	1SS133	SI.DIODE ROHM	
D504	1SS133	SI.DIODE ROHM	
D505	1SS133	SI.DIODE ROHM	
D506	1SS133	SI.DIODE ROHM	
D551	MTZ6.8JC	ZENER DIODE ROHM	
D552	MTZ6.8JC	ZENER DIODE ROHM	
D557	1SS133	SI.DIODE ROHM	
D558	1SS133	SI.DIODE ROHM	
D559	1SS133	SI.DIODE ROHM	

△ : SAFETY PARTS

Capacitors

ITEM	PART NUMBER	DESCRIPTION	AREA
C401	QETB1AM-227	220MF 10V E.CAPACITO	
C402	QCZ0202-155	1.5MF 25V CER.RESIST	
C403	QCHB1EZ-223	0.022MF 25V CER.CAPACI	
C404	QEK51HM-225G	2.2MF 50V AL E.CAPAC	
C409	QEAD0HZ-479ZB	47000MF E.CAPACITO	
C411	QETB1HM-225	2.2MF 50V AL E.CAPAC	
C412	QCZ0202-155	1.5MF 25V CER.RESIST	
C413	QCHB1EZ-223	0.022MF 25V CER.CAPACI	
C415	QCHB1EZ-223	0.022MF 25V CER.CAPACI	
C416	QCHB1EZ-223	0.022MF 25V CER.CAPACI	
C417	QCB1HK-561Y	560PF 50V CER.CAPACI	
C451	QCB1HK-331Y	330PF 50V CER.CAPACI	
C481	QETB1HM-106	10MF 50V E.CAPACITO	
C482	QCB1HK-102Y	1000PF 50V CER.CAPACI	
C483	QETB1HM-225	2.2MF 50V AL E.CAPAC	
C484	QETB1HM-225	2.2MF 50V AL E.CAPAC	
C485	QETB1HM-106	10MF 50V E.CAPACITO	
C500	QCF21HP-223A	0.022MF 50V CER.CAPACI	
C501	QETB1HM-106	10MF 50V E.CAPACITO	
C502	QCS21HJ-271A	270PF 50V CER.CAPACI	
C503	QETB1HM-106	10MF 50V E.CAPACITO	
C504	QCS21HJ-101A	100PF 50V CER.CAPACI	
C505	QCS21HJ-SR0	5PF 50V CER.CAPACI	
C506	QETB1CM-476	47MF 16V AL E.CAPAC	
C507	QCS22HJ-330	33PF 500V CER.CAPACI	
C508	QFLB1HJ-103	0.01MF 50V MYLAR CAPA	
C509	QETB1HM-476	47MF 50V E.CAPACITO	
C510	QCS22HJ-470A	47PF 500V CER.CAPACI	
C511	QETB1HM-225	2.2MF 50V AL E.CAPAC	
C512	QCS22HJ-470A	47PF 500V CER.CAPACI	
C513	QCF21HP-223A	0.022MF 50V CER.CAPACI	
C551	QETB1HM-475E	4.7MF 50V E.CAPACITO	
C552	QETB1HM-475E	4.7MF 50V E.CAPACITO	
C553	QCB1HK-101Y	100PF 50V CER.CAPACI	
C554	QCB1HK-101Y	100PF 50V CER.CAPACI	
C555	QETB1EM-476	47MF 25V AL E.CAPAC	
C556	QETB1EM-476	47MF 25V AL E.CAPAC	
C557	QETB1EM-476	47MF 25V AL E.CAPAC	
C558	QETB1EM-476	47MF 25V AL E.CAPAC	
C559	QCS21HJ-100	10PF 50V CER.CAPACI	
C560	QCS21HJ-100	10PF 50V CER.CAPACI	
C561	QCS21HJ-100	10PF 50V CER.CAPACI	
C562	QCS21HJ-100	10PF 50V CER.CAPACI	
C563	QETB1HM-475E	4.7MF 50V E.CAPACITO	
C564	QETB1HM-475E	4.7MF 50V E.CAPACITO	
C565	QETB1EM-226N	22MF 25V E.CAPACITO	
C566	QETB1EM-226N	22MF 25V E.CAPACITO	
C567	QETB1EM-476	47MF 25V AL E.CAPAC	
C568	QETB1EM-476	47MF 25V AL E.CAPAC	
C569	QCHB1EZ-223	0.022MF 25V CER.CAPACI	
C570	QCHB1EZ-223	0.022MF 25V CER.CAPACI	
C571	QFLB1HJ-272	2700PF 50V MYLAR CAPA	
C572	QFLB1HJ-272	2700PF 50V MYLAR CAPA	
C573	QCB1HK-471Y	470PF 50V CER.CAPACI	
C574	QCB1HK-471Y	470PF 50V CER.CAPACI	
C575	QFV81HJ-473	0.047MF 50V THIN FILM	
C576	QFV81HJ-473	0.047MF 50V THIN FILM	
C577	QFLB1HJ-822	8200PF 50V MYLAR CAPA	
C578	QFLB1HJ-822	8200PF 50V MYLAR CAPA	
C579	QER51HM-684	0.68MF 50V AL E.CAPAC	
C580	QER51HM-684	0.68MF 50V AL E.CAPAC	
C581	QFV81HJ-104	0.1MF 50V THIN FILM	
C582	QFV81HJ-104	0.1MF 50V THIN FILM	
C583	QCSB1HJ-470	47PF 50V CER.CAPACI	
C584	QCSB1HJ-470	47PF 50V CER.CAPACI	
C587	QCS31HJ-561Z	560PF 50V CER.CAPACI	
C591	QCB1HK-331Y	330PF 50V CER.CAPACI	
C592	QCB1HK-331Y	330PF 50V CER.CAPACI	
C593	QCSB1HK-331Y	330PF 50V CER.CAPACI	

△ : SAFETY PARTS

Resistors

ITEM	PART NUMBER	DESCRIPTION	AREA
R402	QRD161J-103	10K 1/6W CARBON RES	
R403	QRD161J-103	10K 1/6W CARBON RES	
R404	QRD161J-103	10K 1/6W CARBON RES	
R405	QRD161J-104	100K 1/6W CARBON RES	
R409	QRD161J-331	330 1/6W CARBON RES	
R410	QRD167J-223	22K 1/6W CARBON RES	
R411	QRD161J-221	220 1/6W CARBON RES	
R412	QRD161J-221	220 1/6W CARBON RES	
R414	QRD161J-221	220 1/6W CARBON RES	
R415	QRD161J-100	10 1/6W CARBON RES	
R416	QRD161J-472	4.7K 1/6W CARBON RES	
R417	QRD161J-472	4.7K 1/6W CARBON RES	
R418	QRD161J-104	100K 1/6W CARBON RES	
R419	QRD161J-104	100K 1/6W CARBON RES	
R421	QRD161J-471	470 1/6W CARBON RES	

△ : SAFETY PARTS

**Resistors**

Δ	ITEM	PART NUMBER	DESCRIPTION			AREA
	R423	QRD161J-221	220	1/6W	CARBON RES	
	R424	QRD161J-471	470	1/6W	CARBON RES	
	R425	QRD161J-471	470	1/6W	CARBON RES	
	R426	QRD161J-471	470	1/6W	CARBON RES	
	R427	QRD161J-471	470	1/6W	CARBON RES	
	R428	QRD161J-471	470	1/6W	CARBON RES	
	R429	QRD161J-471	470	1/6W	CARBON RES	
	R430	QRD161J-471	470	1/6W	CARBON RES	
	R431	QRD161J-471	470	1/6W	CARBON RES	
	R432	QRD161J-471	470	1/6W	CARBON RES	
	R433	QRD161J-471	470	1/6W	CARBON RES	
	R434	QRD161J-471	470	1/6W	CARBON RES	
	R435	QRD161J-471	470	1/6W	CARBON RES	
	R441	QRD161J-104	100K	1/6W	CARBON RES	
	R442	QRD161J-104	100K	1/6W	CARBON RES	
	R443	QRD161J-104	100K	1/6W	CARBON RES	
	R445	QRD161J-103	10K	1/6W	CARBON RES	
	R446	QRD161J-471	470	1/6W	CARBON RES	
	R451	QRD161J-103	10K	1/6W	CARBON RES	
	R452	QRD161J-473	47K	1/6W	CARBON RES	
	R453	QRD167J-223	22K	1/6W	CARBON RES	
	R454	QRD161J-471	470	1/6W	CARBON RES	
	R455	QRD161J-103	10K	1/6W	CARBON RES	
	R463	QRD161J-471	470	1/6W	CARBON RES	
	R464	QRD161J-471	470	1/6W	CARBON RES	
	R465	QRD161J-103	10K	1/6W	CARBON RES	
	R466	QRD161J-103	10K	1/6W	CARBON RES	
	R467	QRD161J-103	10K	1/6W	CARBON RES	
	R468	QRD161J-103	10K	1/6W	CARBON RES	
	R481	QRD161J-220	22	1/6W	CARBON RES	
	R482	QRD161J-102	1K	1/6W	CARBON RES	
	R483	QRD161J-105	1M	1/6W	CARBON RES	
	R484	QRD161J-105	1M	1/6W	CARBON RES	
	R485	QRD161J-683	68K	1/6W	CARBON RES	
	R486	QRD161J-222	2.2K	1/6W	CARBON RES	
	R491	QRD161J-103	10K	1/6W	CARBON RES	
	R492	QRD161J-221	220	1/6W	CARBON RES	
	R493	QRD161J-103	10K	1/6W	CARBON RES	
	R501	QRD161J-222	2.2K	1/6W	CARBON RES	
	R502	QRD161J-104	100K	1/6W	CARBON RES	
	R503	QRD161J-123	12K	1/6W	CARBON RES	
	R504	QRD161J-202	2K	1/6W	CARBON RES	
	R505	QRD161J-104	100K	1/6W	CARBON RES	
Δ	R506	QRD14CJ-181S	180	1/4W	UNF. CARBON	
Δ	R507	QRD14CJ-332SX	3.3K	1/4W	UNF. CARBON	
	R508	QRD161J-302	3K	1/6W	CARBON RES	
	R509	QRD161J-302	3K	1/6W	CARBON RES	
	R510	QRD161J-302	3K	1/6W	CARBON RES	
Δ	R514	QRD14CJ-100SX	10	1/4W	UNF. CARBON	
Δ	R515	QRD14CJ-561SX	560	1/4W	UNF. CARBON	
Δ	R516	QRD14CJ-100SX	10	1/4W	UNF. CARBON	
	R518	QRD161J-391	390	1/6W	CARBON RES	
	R519	ERT-D2WHL202S	2K	1/4W	NEGATIVE T	
	R520	QRD161J-183	18K	1/6W	CARBON RES	
	R521	QRD161J-123	12K	1/6W	CARBON RES	
Δ	R522	QRD125J-330	33	1/2W	UNF. CARBON	
Δ	R523	QRG022J-562A	5.6K	2W	OXIDE META	
	R524	QRD167J-751	750	1/6W	CARBON RES	
	R525	QRD161J-102	1K	1/6W	CARBON RES	
Δ	R526	QRD14CJ-330SX	33	1/4W	UNF. CARBON	
Δ	R527	QRD14CJ-330SX	33	1/4W	UNF. CARBON	
Δ	R528	ERF032K-R22	0.22	3W	CEM. RESIST	
	R529	QRD167J-151	150	1/6W	CARBON RES	
	R530	QRD167J-151	150	1/6W	CARBON RES	
	R531	QRD167J-151	150	1/6W	CARBON RES	
	R532	QRD167J-151	150	1/6W	CARBON RES	
	R553	QRD161J-104	100K	1/6W	CARBON RES	
	R554	QRD161J-104	100K	1/6W	CARBON RES	
	R555	QRD161J-104	100K	1/6W	CARBON RES	
	R556	QRD161J-104	100K	1/6W	CARBON RES	
	R557	QRD161J-103	10K	1/6W	CARBON RES	
	R558	QRD161J-103	10K	1/6W	CARBON RES	
	R559	QRD161J-103	10K	1/6W	CARBON RES	
	R560	QRD161J-103	10K	1/6W	CARBON RES	
	R561	QRD161J-303Y	30K	1/6W	CARBON RES	
	R562	QRD161J-303Y	30K	1/6W	CARBON RES	
	R563	QRD161J-123	12K	1/6W	CARBON RES	
	R564	QRD161J-123	12K	1/6W	CARBON RES	
	R565	QRD161J-472	4.7K	1/6W	CARBON RES	
	R566	QRD161J-472	4.7K	1/6W	CARBON RES	
	R567	QRD161J-183	18K	1/6W	CARBON RES	
	R568	QRD161J-183	18K	1/6W	CARBON RES	
	R569	QRD161J-912	9.1K	1/6W	CARBON RES	
	R570	QRD161J-912	9.1K	1/6W	CARBON RES	
	R571	QRD161J-243	24K	1/6W	CARBON RES	
	R572	QRD161J-243	24K	1/6W	CARBON RES	
	R573	QRD161J-103	10K	1/6W	CARBON RES	
	R574	QRD161J-103	10K	1/6W	CARBON RES	
	R575	QRD161J-333	33K	1/6W	CARBON RES	
	R576	QRD161J-333	33K	1/6W	CARBON RES	
	R577	QRD161J-104	100K	1/6W	CARBON RES	
	R578	QRD161J-104	100K	1/6W	CARBON RES	
Δ	R579	QRD14CJ-681SX	680	1/4W	UNF. CARBON	
Δ	R580	QRD14CJ-681SX	680	1/4W	UNF. CARBON	
Δ	R581	QRD14CJ-680SX	68	1/4W	UNF. CARBON	

Δ : SAFETY PARTS

**Resistors**

Δ	ITEM	PART NUMBER	DESCRIPTION			AREA
Δ	R582	QRD14CJ-680SX	68	1/4W	UNF. CARBON	
	R583	QRD161J-102	1K	1/6W	CARBON RES	
	R584	QRD161J-102	1K	1/6W	CARBON RES	
	R587	QRD161J-473	47K	1/6W	CARBON RES	
	R588	QRD161J-473	47K	1/6W	CARBON RES	
	R591	QRD161J-471	470	1/6W	CARBON RES	
	R592	QRD161J-471	470	1/6W	CARBON RES	
	RA403	QRB079J-104	100K	1/10W	NETWORK RE	
	RA404	QRB139J-104	100K	1/10W	RESISTOR	
	RA407	QRB069J-104	100K	1/10W	NETWORK RE	
	RA408	QRB059J-103	10K	1/10W	NETWORK RE	

Δ : SAFETY PARTS

**Others**

Δ	ITEM	PART NUMBER	DESCRIPTION			AREA
	J205	EMW10520-003	PRINTED BOA			
	J255	VMC0178-003	CONNECT TER			
	J261	EMV7125-008R	CONNECT TER			
	J591	EMN00YP-308A	MALE CONNEC			
	J709	EMV7125-008R	PIN JACK			
	L501	EGL0011-R45J1	MALE CONNEC			
	P401	EMV5109-011B	INDUCTOR			
	P402	EMV5109-013A	CONNECT TER			
	P551	EMV5159-010R	CONNECT TER			
	S401	ESP0001-023M	TACT SWITCH POWER			
	S402	ESP0001-023M	TACT SWITCH SEA ON/OFF			
	S403	ESP0001-023M	TACT SWITCH SEA FLAT			
	S404	ESP0001-023M	TACT SWITCH SPI/SEA			
	S405	ESP0001-023M	TACT SWITCH EFFECT +			
	S406	ESP0001-023M	TACT SWITCH MODE +			
	S407	ESP0001-023M	TACT SWITCH CURSOL MODE			
	S408	ESP0001-023M	TACT SWITCH DAP ON/OFF			
	S409	ESP0001-023M	TACT SWITCH EFFECT -			
	S410	ESP0001-023M	TACT SWITCH MODE -			
	S411	ESP0001-023M	TACT SWITCH SURROUND ON/OFF			
	S412	ESP0001-023M	TACT SWITCH CENTER MODE			
	S413	ESP0001-023M	TACT SWITCH LOUDNESS			
	S414	ESP0001-023M	TACT SWITCH FM MODE			
	S415	ESP0001-023M	TACT SWITCH CHARACTER			
	S416	ESP0001-023M	TACT SWITCH TUNING/PTY SEARCH			
	S417	ESP0001-023M	TACT SWITCH PRESET/PRESET TUNING			
	S418	ESP0001-023M	TACT SWITCH ENTER			
	S419	ESP0001-023M	TACT SWITCH TAPEZ MONITOR			
	S420	ESP0001-023M	TACT SWITCH CSR/PEON			
	S422	QJSJ4002-E01	PUSH SWITCH SOURCE SELECT			
	S423	QJSJ4002-E01	PUSH SWITCH TUNER CONTROL			
	X401	EXCP6R0-001ZA	CRYSTAL			
	BC222	EWS323-A940J	SOCKET WIRE			
	BC271	EWS26B-A426J	SOCKET WIRE			
	BC311	EWS293-0140J	SOCKET WIRE			
	BC361	EWS293-0125	SOCKET WIRE			
	BC401	EWS26B-A408J	SOCKET WIRE			
	BC402	EWS26D-A408J	SOCKET WIRE			
	BC701	EWS26B-A416J	SOCKET WIRE			
	BC704	EWS26B-A422J	SOCKET WIRE			
	FL401	ELU0001-202	FLUORESCENT			
	JA441	EMV7123-021R	CONNECTOR			

Δ : SAFETY PARTS

■ ENA-163 □ Tuner PC Board Assy

Note : ENA-163 □ varies according to the areas employed. See note (4) when placing an order.

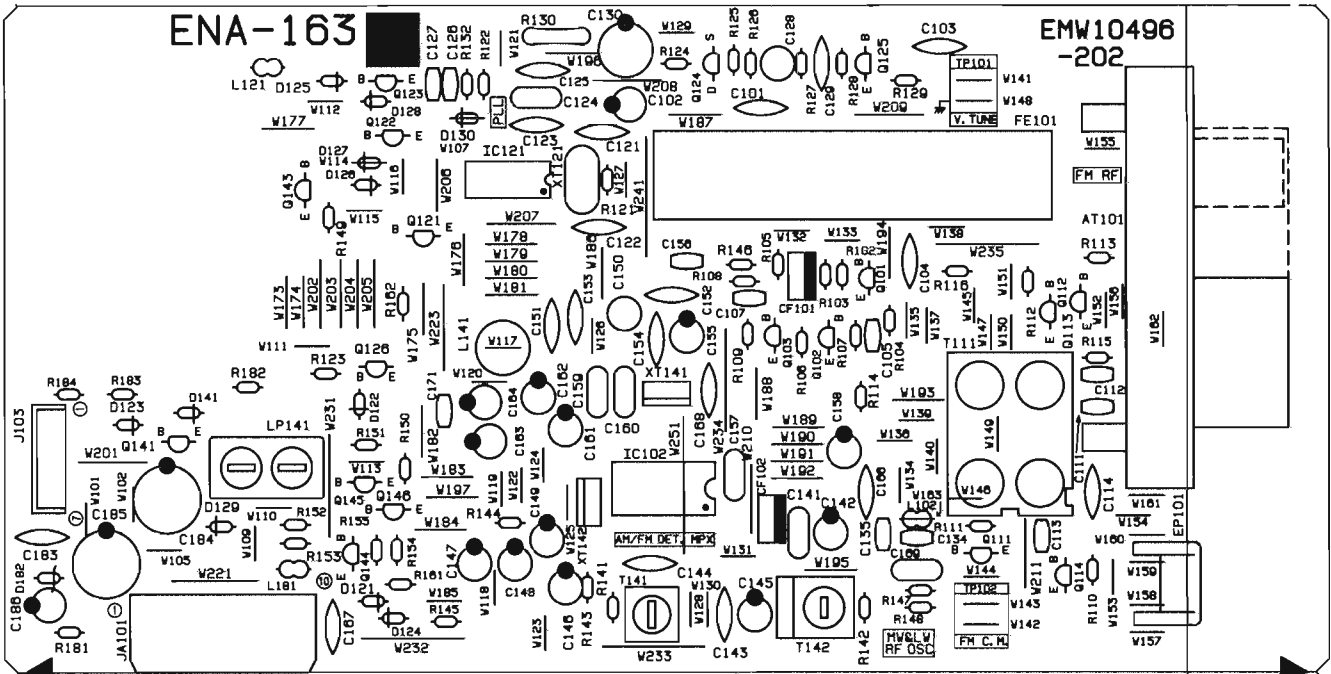

Note (4)

PC Board Ass'y	Version	Designated Areas
ENA-163 <b>F</b>	A	Australia
ENA-163 <b>E</b>	U UT	Universal Type Taiwan

Transistors

ITEM	PART NUMBER	DESCRIPTION	AREA
Q101	2SC461	SI. TRANSIST	
Q102	2SC535	SI. TRANSIST HITACHI	
Q103	2SC461	SI. TRANSIST	
Q121	DTA144ES	DIGITAL TRA ROHM	
Q122	DTA144ES	DIGITAL TRA ROHM	
Q124	2SK301(P,Q)	F.E.T.	
Q125	2SC458(C,D)	SI. TRANSIST HITACHI	
Q126	DTC114ES	DIGITAL TRA ROHM	
Q141	DTC114ES	DIGITAL TRA ROHM	
Q143	DTC114ES	DIGITAL TRA ROHM	

△ SAFETY PARTS

I.C.s

ITEM	PART NUMBER	DESCRIPTION	AREA
IC102	LA1836M	I.C(MONO-AN SANYO	
IC121	LC7218JMX	I.C(DIGI-MO SANYO	

△ SAFETY PARTS

Diodes

ITEM	PART NUMBER	DESCRIPTION	AREA
D121	1SS133	SI. DIODE ROHM	
D122	1SS133	SI. DIODE ROHM	
D123	1SS133	SI. DIODE ROHM	
D124	1SS133	SI. DIODE ROHM	
D126	1SS133	SI. DIODE ROHM	
D129	1SS133	SI. DIODE ROHM	
D130	1SS133	SI. DIODE ROHM	
D141	1SS133	SI. DIODE ROHM	
D182	MTZ5.1JC	ZENER DIODE ROHM	

△ SAFETY PARTS

Capacitors

ITEM	PART NUMBER	DESCRIPTION	AREA
C101	QCF21HP-103A	0.01MF 50V CER.CAPACI	
C103	QCF21HP-223A	0.022MF 50V CER.CAPACI	
C104	QCF21HP-223A	0.022MF 50V CER.CAPACI	
C105	QCHB1EZ-223	0.022MF 25V CER.CAPACI	
C107	QCHB1EZ-223	0.022MF 25V CER.CAPACI	
C111	QCHB1EZ-223	0.022MF 25V CER.CAPACI	
C112	QCT30CH-120Y	12PF 50V CER.CAPACI	
C114	QCC21EM-473	0.047MF 25V CER.CAPACI	
C121	QCS21HJ-180A	18PF 50V CER.CAPACI	
C122	QCS21HJ-180A	18PF 50V CER.CAPACI	
C123	QCC21EM-473	0.047MF 25V CER.CAPACI	
C124	QCZ0202-155	1.5MF 25V CER.RESIST	
C125	QCF21HP-223A	0.022MF 50V CER.CAPACI	
C126	QCB81HK-101Y	100PF 50V CER.CAPACI	
C127	QCB81HK-101Y	100PF 50V CER.CAPACI	
C128	QENB1HM-474	0.47MF 50V NP E.CAPAC	
C129	QCY31HK-102Z	1000PF 50V CER.CAPACI	
C130	QETB1CM-227	220MF 16V AL E.CAPAC	
C141	QFLB1HJ-473	0.047MF 50V MYLAR CAPA	
C142	QETB1HM-106	10MF 50V E.CAPACITO	
C143	QCF21HP-223A	0.022MF 50V CER.CAPACI	
C144	QCC21EM-473	0.047MF 25V CER.CAPACI	
C145	QETB1HM-475E	4.7MF 50V E.CAPACITO	
C146	QETB1HM-106	10MF 50V E.CAPACITO	
C147	QETB1HM-105	1MF 50V AL E.CAPAC	
C148	QETB1HM-474	0.47MF 50V ELECTRO	
C149	QETB1HM-105	1MF 50V AL E.CAPAC	
C150	QETC1HM-225ZM	2.2MF 50V AL E.CAPAC	
C153	QCY31HK-102Z	1000PF 50V CER.CAPACI	
C154	QCY31HK-472Z	4700PF 50V CER.CAPACI	
C155	QETB1EM-476	47MF 25V AL E.CAPAC	
C156	QCHB1EZ-223	0.022MF 25V CER.CAPACI	
C157	QCZ0202-155	1.5MF 25V CER.RESIST	
C158	QETB1HM-106	10MF 50V E.CAPACITO	
C159	QFLB1HJ-273	0.027MF 50V MYLAR CAPA	A
C159	QFLB1HJ-333	0.033MF 50V MYLAR CAPA	U
C159	QFLB1HJ-333	0.033MF 50V MYLAR CAPA	UT
C160	QFLB1HJ-273	0.027MF 50V MYLAR CAPA	A
C160	QFLB1HJ-333	0.033MF 50V MYLAR CAPA	U
C160	QFLB1HJ-333	0.033MF 50V MYLAR CAPA	UT
C161	QETB1HM-225	2.2MF 50V AL E.CAPAC	
C162	QETB1HM-225	2.2MF 50V AL E.CAPAC	
C163	QETB1HM-225	2.2MF 50V AL E.CAPAC	
C164	QETB1HM-225	2.2MF 50V AL E.CAPAC	
C166	QCC21EM-473	0.047MF 25V CER.CAPACI	
C168	QCC21EM-473	0.047MF 25V CER.CAPACI	
C169	QFV81HJ-274	0.27MF 50V T.FILM CAP	
C171	QCB81HK-102Y	1000PF 50V CER.CAPACI	
C183	QCF21HP-223A	0.022MF 50V CER.CAPACI	
C184	QETB1CM-227	220MF 16V AL E.CAPAC	
C185	QETB1CM-477M	470MF 16V E.CAPACITO	
C186	QETB1HM-475E	4.7MF 50V E.CAPACITO	

△ SAFETY PARTS

**Resistors**

Δ	ITEM	PART NUMBER	DESCRIPTION	AREA
	R102	QRD167J-332	3.3K 1/6W CARBON RES	
	R103	QRD161J-221	220 1/6W CARBON RES	
	R104	QRD167J-272	2.7K 1/6W CARBON RES	
	R105	QRD161J-391	390 1/6W CARBON RES	
	R106	QRD161J-102	1K 1/6W CARBON RES	
	R107	QRD161J-681	680 1/6W CARBON RES	
	R108	QRD167J-332	3.3K 1/6W CARBON RES	
	R109	QRD161J-221	220 1/6W CARBON RES	
	R115	QRD161J-104	100K 1/6W CARBON RES	
	R116	QRD161J-222	2.2K 1/6W CARBON RES	
	R121	QRD161J-473	47K 1/6W CARBON RES	
	R122	QRD161J-472	4.7K 1/6W CARBON RES	
	R123	QRD167J-562	5.6K 1/6W CARBON RES	
	R124	QRD161J-222	2.2K 1/6W CARBON RES	
	R125	QRD161J-222	2.2K 1/6W CARBON RES	
	R126	QRD161J-181	180 1/6W CARBON RES	
	R127	QRD167J-822	8.2K 1/6W CARBON RES	
	R128	QRD161J-472	4.7K 1/6W CARBON RES	
	R129	QRD161J-222	2.2K 1/6W CARBON RES	
Δ	R130	QRZ0077-680	68 1/4W FUSIBLE RE	
	R132	QRD161J-102	1K 1/6W CARBON RES	
	R141	QRD161J-392	3.9K 1/6W CARBON RES	
	R142	QRD161J-103	10K 1/6W CARBON RES	
	R143	QRD161J-103	10K 1/6W CARBON RES	
	R144	QRD167J-332	3.3K 1/6W CARBON RES	
	R145	QRD161J-103	10K 1/6W CARBON RES	
	R146	QRD161J-222	2.2K 1/6W CARBON RES	
	R147	QRD161J-473	47K 1/6W CARBON RES	
	R148	QRD161J-561	560 1/6W CARBON RES	
	R149	QRD161J-103	10K 1/6W CARBON RES	A
	R149	QRD167J-223	22K 1/6W CARBON RES	U
	R149	QRD167J-223	22K 1/6W CARBON RES	UT
	R150	QRD167J-332	3.3K 1/6W CARBON RES	
	R151	QRD167J-332	3.3K 1/6W CARBON RES	
	R152	QRD167J-332	3.3K 1/6W CARBON RES	U
	R152	QRD167J-332	3.3K 1/6W CARBON RES	UT
	R152	QRD167J-822	8.2K 1/6W CARBON RES	A
	R153	QRD167J-332	3.3K 1/6W CARBON RES	U
	R153	QRD167J-332	3.3K 1/6W CARBON RES	UT
	R153	QRD167J-822	8.2K 1/6W CARBON RES	A
	R161	QRD161J-473	47K 1/6W CARBON RES	
	R162	QRD161J-222	2.2K 1/6W CARBON RES	
	R181	QRD161J-222	2.2K 1/6W CARBON RES	
	R182	QRD161J-103	10K 1/6W CARBON RES	
	R183	QRD161J-103	10K 1/6W CARBON RES	
	R184	QRD161J-473	47K 1/6W CARBON RES	

Δ : SAFETY PARTS

**Others**

Δ	ITEM	PART NUMBER	DESCRIPTION	AREA
		EMW10496-202A	CIR. BOARD	
		E308963-001	SHIELD BRAC	
	J103	EMV5109-007A	MALE CONNEC	
	L121	EQL4007-1R0	INDUCTOR	
	L181	EQL4007-1R0	INDUCTOR	
	T111	EQR7121-004	RF COIL	
	T141	EQT2140-021	I.F.TRANSFO	
	T142	ECB1560-010	CERAMIC FIL	
	AT101	EMB41YV-302K	ANTENNA TER	
	CF101	ECB2123-006R	CERAMIC FIL	
	CF102	ECB2123-006R	CERAMIC FIL	
	EP101	E70225-001	EARTH PLATE	
	FE101	SAF2203-004	FRONT END	
	UA101	EMV7140-L10R	PIN CONNECT	
	LP141	EQF0101-002	LOWPASS FIL	
	XT121	ECX0007-200KJW1	CRYSTAL	
	XT141	ECXPR46-001A	CRYSTAL	
	XT142	ECB1001-002	CERAMIC FIL	

Δ : SAFETY PARTS

■ ENP-054 A DSP PC Board Assy

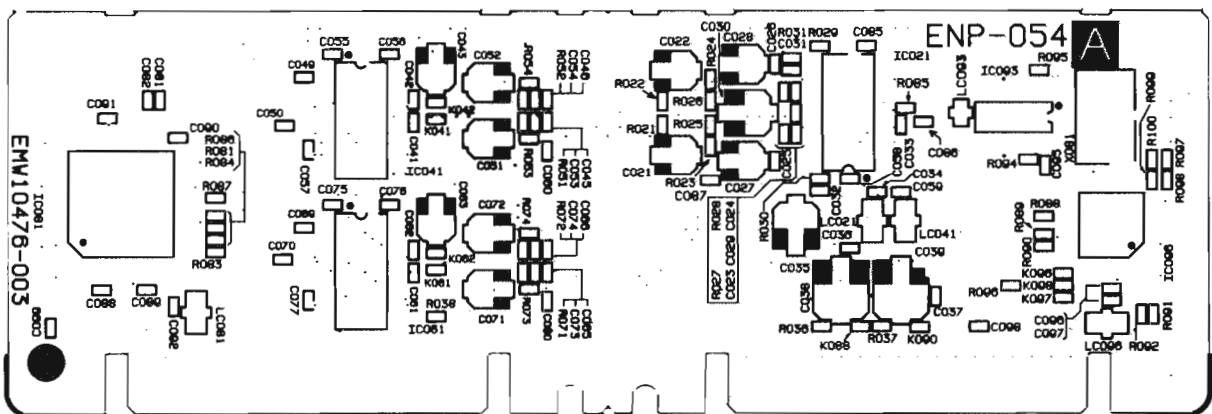

**I.C.s**

Δ	ITEM	PART NUMBER	DESCRIPTION	AREA
	IC021	SAA7366TX	I.C(DIGI-MO	
	IC041	TDA1386TX	I.C(MONO-AN	
	IC061	TDA1386TX	I.C(MONO-AN	
	IC081	TC9332F-010	I.C(M) TOSHIBA	
	IC093	TC74HC74AFT1	I.C(DIGI-MO TOSHIBA	
	IC096	TMP87C847U-4195	I.C(M) TOSHIBA	

Δ : SAFETY PARTS

**Capacitors**

Δ	ITEM	PART NUMBER	DESCRIPTION	AREA
	C021	NEA71EM-475N2	4.7MF 25V E.CAPACITO	
	C022	NEA71EM-475N2	4.7MF 25V E.CAPACITO	
	C023	NCS31HJ-680AY	68PF 50V CER.CAPACI	
	C024	NCS31HJ-680AY	68PF 50V CER.CAPACI	
	C025	NCB21CK-473AYU	0.047MF 16V CER.CAPACI	

Δ : SAFETY PARTS



**Capacitors**

ITEM	PART NUMBER	DESCRIPTION	AREA
C026	NCB21CK-473AYU	0.047MF 16V CER.CAPACI	
C027	NEA70GM-476NZ	47MF E.CAPACITO	
C028	NEA70GM-476NZ	47MF E.CAPACITO	
C029	NCB21CK-473AYU	0.047MF 16V CER.CAPACI	
C030	NEA70JM-476NZ	47MF 6.3V E.CAPACITO	
C031	NCB31CK-223A	0.022MF 16V CER.CAPACI	
C032	NCB31HK-102AY	1000PF 50V CER.CAPACI	
C033	NCF31AZ-105AYUU	1MF 10V CER.CAPACI	
C035	NEA70JM-476NZ	47MF 6.3V E.CAPACITO	
C036	NCF31AZ-105AYUU	1MF 10V CER.CAPACI	
C037	NCF31AZ-105AYUU	1MF 10V CER.CAPACI	
C038	NEA70JM-107NP	100MF 6.3V E.CAPACITO	
C039	NEA70JM-107NP	100MF 6.3V E.CAPACITO	
C041	NCS21HJ-102	1000PF 50V CER.CAPACI	
C042	NCS21HJ-102	1000PF 50V CER.CAPACI	
C043	NEA71CM-106NZ	10MF 16V E.CAPACITO	
C049	NCB21CK-104AYU	0.1MF 16V CER.CAPACI	
C050	NCB21CK-104AYU	0.1MF 16V CER.CAPACI	
C051	NEA71HM-105NZ	1MF 50V E.CAPACITO	
C052	NEA71HM-105NZ	1MF 50V E.CAPACITO	
C053	NCB31CK-183AY	0.018MF 16V CER.CAPACI	
C054	NCB31CK-183AY	0.018MF 16V CER.CAPACI	
C055	NCB31HK-102AY	1000PF 50V CER.CAPACI	
C056	NCB31HK-102AY	1000PF 50V CER.CAPACI	
C057	NCB31HK-102AY	1000PF 50V CER.CAPACI	
C058	NCF31AZ-105AYUU	1MF 10V CER.CAPACI	
C059	NCF31AZ-105AYUU	1MF 10V CER.CAPACI	
C061	NCS21HJ-102	1000PF 50V CER.CAPACI	
C062	NCS21HJ-102	1000PF 50V CER.CAPACI	
C063	NEA71CM-106NZ	10MF 16V E.CAPACITO	
C069	NCB21CK-104AYU	0.1MF 16V CER.CAPACI	
C070	NCB21CK-104AYU	0.1MF 16V CER.CAPACI	
C071	NEA71HM-105NZ	1MF 50V E.CAPACITO	
C072	NEA71HM-105NZ	1MF 50V E.CAPACITO	
C073	NCB31CK-183AY	0.018MF 16V CER.CAPACI	
C074	NCB31CK-183AY	0.018MF 16V CER.CAPACI	
C075	NCB31HK-102AY	1000PF 50V CER.CAPACI	
C076	NCB31HK-102AY	1000PF 50V CER.CAPACI	
C077	NCB31HK-102AY	1000PF 50V CER.CAPACI	
C081	NCS31HD-9R0AYM	9PF 50V CER.CAPACI	
C082	NCS31HD-9R0AYM	9PF 50V CER.CAPACI	
C085	NCB21CK-104AYU	0.1MF 16V CER.CAPACI	
C086	NCB21CK-104AYU	0.1MF 16V CER.CAPACI	
C088	NCB31HK-102AY	1000PF 50V CER.CAPACI	
C089	NCB31HK-102AY	1000PF 50V CER.CAPACI	
C090	NCB31HK-102AY	1000PF 50V CER.CAPACI	
C091	NCB31HK-102AY	1000PF 50V CER.CAPACI	
C092	NCF31AZ-105AYUU	1MF 10V CER.CAPACI	
C095	NCB31HK-102AY	1000PF 50V CER.CAPACI	
C096	NCB31HK-102AY	1000PF 50V CER.CAPACI	
C097	NCF31AZ-105AYUU	1MF 10V CER.CAPACI	
C098	NCB31HK-102AY	1000PF 50V CER.CAPACI	
C099	NCS31HJ-101AY	100PF 50V CER.CAPACI	

△ : SAFETY PARTS

**Resistors**

ITEM	PART NUMBER	DESCRIPTION	AREA
R086	NRSA63J-182NY	METAL GLAZ	
R087	NRSA63J-112NY	METAL GLAZ	
R088	NRSA63J-0R0AY	METAL GLAZ	
R089	NRSA63J-0R0AY	METAL GLAZ	
R090	NRSA63J-0R0AY	METAL GLAZ	
R091	NRSA63J-0R0AY	METAL GLAZ	
R092	NRSA63J-0R0AY	METAL GLAZ	
R093	NRSA63J-0R0AY	METAL GLAZ	
R094	NRSA63J-471N	METAL GLAZ	
R095	NRSA63J-103N	METAL GLAZ	
R096	NRSA63J-103N	METAL GLAZ	
R097	NRSA63J-472NY	METAL GLAZ	
R098	NRSA63J-472NY	METAL GLAZ	
R099	NRSA63J-472NY	METAL GLAZ	
R100	NRSA63J-472NY	METAL GLAZ	

△ : SAFETY PARTS

**Others**

ITEM	PART NUMBER	DESCRIPTION	AREA
K041	EMW10476-003A	CIR.BOARD	
K042	EGA0002-N102Y	FERRITE BEA	
K061	EGA0002-N102Y	FERRITE BEA	
K062	EGA0002-N102Y	FERRITE BEA	
K081	EGA0002-N102Y	FERRITE BEA	
K082	EGA0002-N102Y	FERRITE BEA	
K083	EGA0002-N102Y	FERRITE BEA	
K084	EGA0002-N102Y	FERRITE BEA	
K085	EGA0002-N102Y	FERRITE BEA	
K086	EGA0002-N102Y	FERRITE BEA	
K087	EGA0001-N01Y	FERRITE BEA	
K088	EGA0001-N01Y	FERRITE BEA	
K089	EGA0001-N01Y	FERRITE BEA	
K090	EGA0001-N01Y	FERRITE BEA	
K091	EGA0002-N102Y	FERRITE BEA	
K092	EGA0002-N102Y	FERRITE BEA	
K093	EGA0002-N102Y	FERRITE BEA	
K094	EGA0002-N102Y	FERRITE BEA	
K095	EGA0002-N102Y	FERRITE BEA	
K096	EGA0002-N102Y	FERRITE BEA	
K097	EGA0002-N102Y	FERRITE BEA	
K098	EGA0002-N102Y	FERRITE BEA	
X081	EX0225-792EN9T	CRYSTAL	
LC021	EQF0703-N103NZ	INDUCTOR	
LC041	EQF0703-N103NZ	INDUCTOR	
LC081	EQF0703-N103NZ	INDUCTOR	
LC093	EQF0704-N01YU	INDUCTOR	
LC096	EQF0703-N103NZ	INDUCTOR	

△ : SAFETY PARTS

**Resistors**

ITEM	PART NUMBER	DESCRIPTION	AREA
R021	NRSA63J-104NY	METAL GLAZ	
R022	NRSA63J-104NY	METAL GLAZ	
R023	NRSA63J-103N	METAL GLAZ	
R024	NRSA63J-103N	METAL GLAZ	
R025	NRSA63J-624NY	METAL GLAZ	
R026	NRSA63J-334NY	METAL GLAZ	
R027	NRSA63F-103NY	METAL GLAZ	
R028	NRSA63F-103NY	METAL GLAZ	
R029	NRSA63J-271NY	METAL GLAZ	
R030	NRSA63J-271NY	METAL GLAZ	
R031	NRSA63J-333NY	METAL GLAZ	
R036	NRSA63J-0R0AY	METAL GLAZ	
R037	NRSA63J-0R0AY	METAL GLAZ	
R038	NRSA63J-0R0AY	METAL GLAZ	
R041	NRSA63J-0R0AY	METAL GLAZ	
R042	NRSA63J-0R0AY	METAL GLAZ	
R051	NRSA63J-473NY	METAL GLAZ	
R052	NRSA63J-473NY	METAL GLAZ	
R053	NRSA63J-201NY	METAL GLAZ	
R054	NRSA63J-201NY	METAL GLAZ	
R061	NRSA63J-0R0AY	METAL GLAZ	
R062	NRSA63J-0R0AY	METAL GLAZ	
R071	NRSA63J-473NY	METAL GLAZ	
R072	NRSA63J-473NY	METAL GLAZ	
R073	NRSA63J-201NY	METAL GLAZ	
R074	NRSA63J-201NY	METAL GLAZ	
R081	NRSA63J-0R0AY	METAL GLAZ	
R083	NRSA63J-112NY	METAL GLAZ	
R084	NRSA63J-112NY	METAL GLAZ	
R085	NRSA63J-112NY	METAL GLAZ	

△ : SAFETY PARTS

# Accessories List

Symbol No. 

M	2	M	M
---	---	---	---

⚠	Item	Part Number	Part Name	Q'ty	Description	Area
	1	E30580-2255A	INSTRUCTION BOOK	1		
	2	RM-SR816U	WIRE-LESS REMOTE CONTROL	1		
	3	E03614-004	FM FEEDER ANTENNA	1		
	4	EQB4001-015	LOOP ANTENNA	1		
	5	EMZ2001-014	ADAPTOR PLUG	1		
	6	UM-3(DJ)-2PSA	DRY CELL	1		
	7	QPGA025-03505B	POLY BAG	1		
	-	BT-56001-1	WARRANTY CARD	1		A
	-	ENZ2203-001	ADAPTOR PLUG	1		U
	-	ENZ2203-001	ADAPTOR PLUG	1		UT
	-	E67142-T8R0	FUSE LABEL	1		U
	-	E67142-T8R0	FUSE LABEL	1		UT
⚠	-	QMF51A2-8R0	FUSE	1		U
⚠	-	QMF51A2-8R0	FUSE	1		UT
	-	QPGA005-00703	ENVELOPE	1		U
	-	QPGA005-00703	ENVELOPE	1		UT

**The Marks for Designated Areas**

A ..... Australia                      U ..... Universal Type                      UT ..... Taiwan  
 No mark indicates all area.

# Packing Materials and Part Numbers

Symbol No. 

M	3	M	M
---	---	---	---

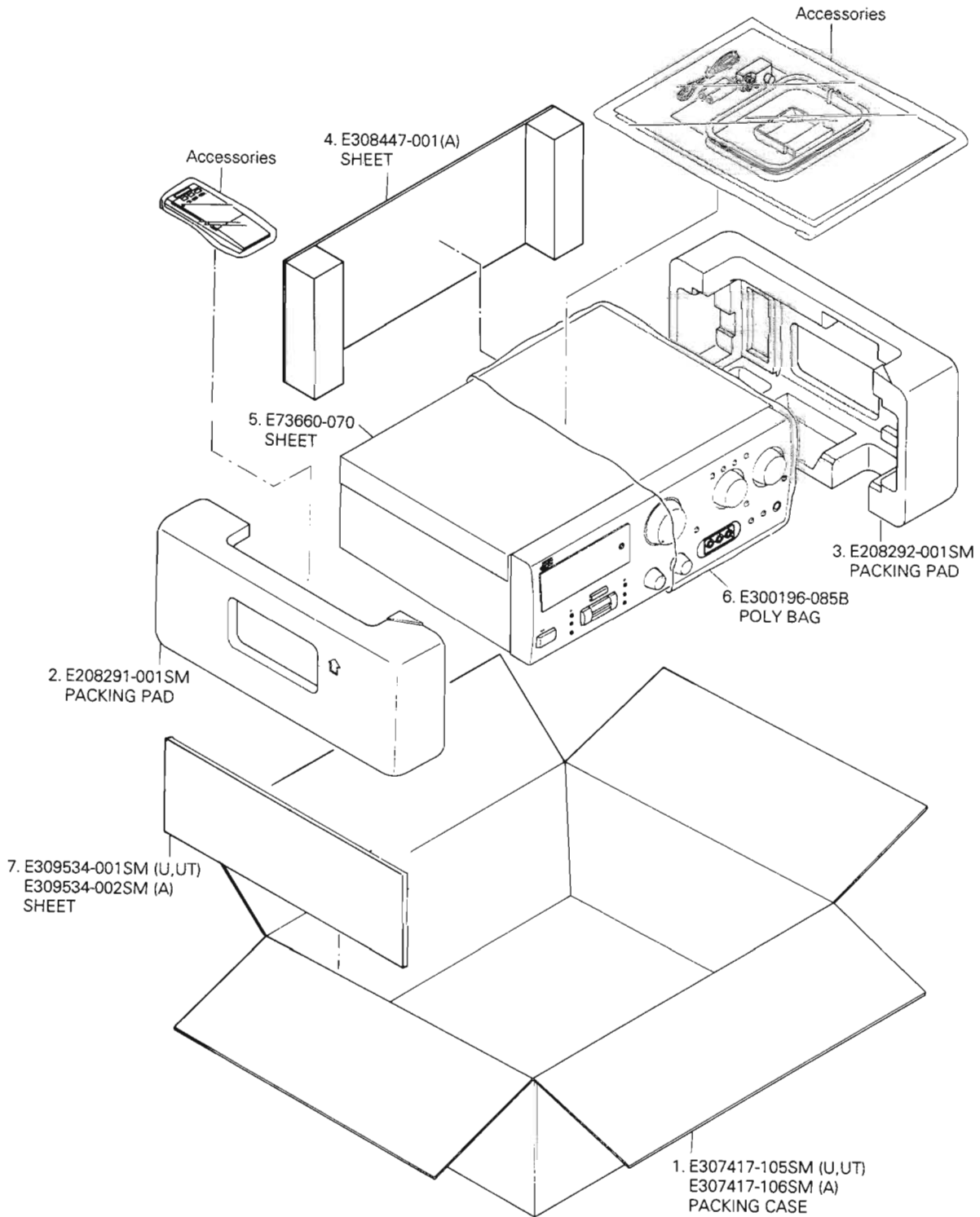

**The Marks for Designated Areas**

A	.....	Australia	U	.....	Universal Type	UT	....	Taiwan
---	-------	-----------	---	-------	----------------	----	------	--------

No mark indicates all area.

# PARTS LIST

**Note : All printed circuit boards assemblies are not available as service parts.**

## Contents

General Exploded View and Parts List .....	3 - 2
Printed Circuit Board Ass'y and Parts List .....	3 - 4
■ ENH-264 □ Amplifier PC Board Ass'y .....	3 - 4
■ ENC-125 □ Input Selector PC Board Ass'y .....	3 - 8
■ ENB-211 □ FL Display PC Board Ass'y .....	3 - 11
■ ENA-163 □ Tuner PC Board Ass'y .....	3 - 14
■ ENP-054 □ DSP PC Board Ass'y .....	3 - 15
Accessories List .....	3 - 17
Packing Materials and Part Numbers .....	3 - 18

# General Exploded View and Parts List

Symbol No. 

M	1	M	M
---	---	---	---

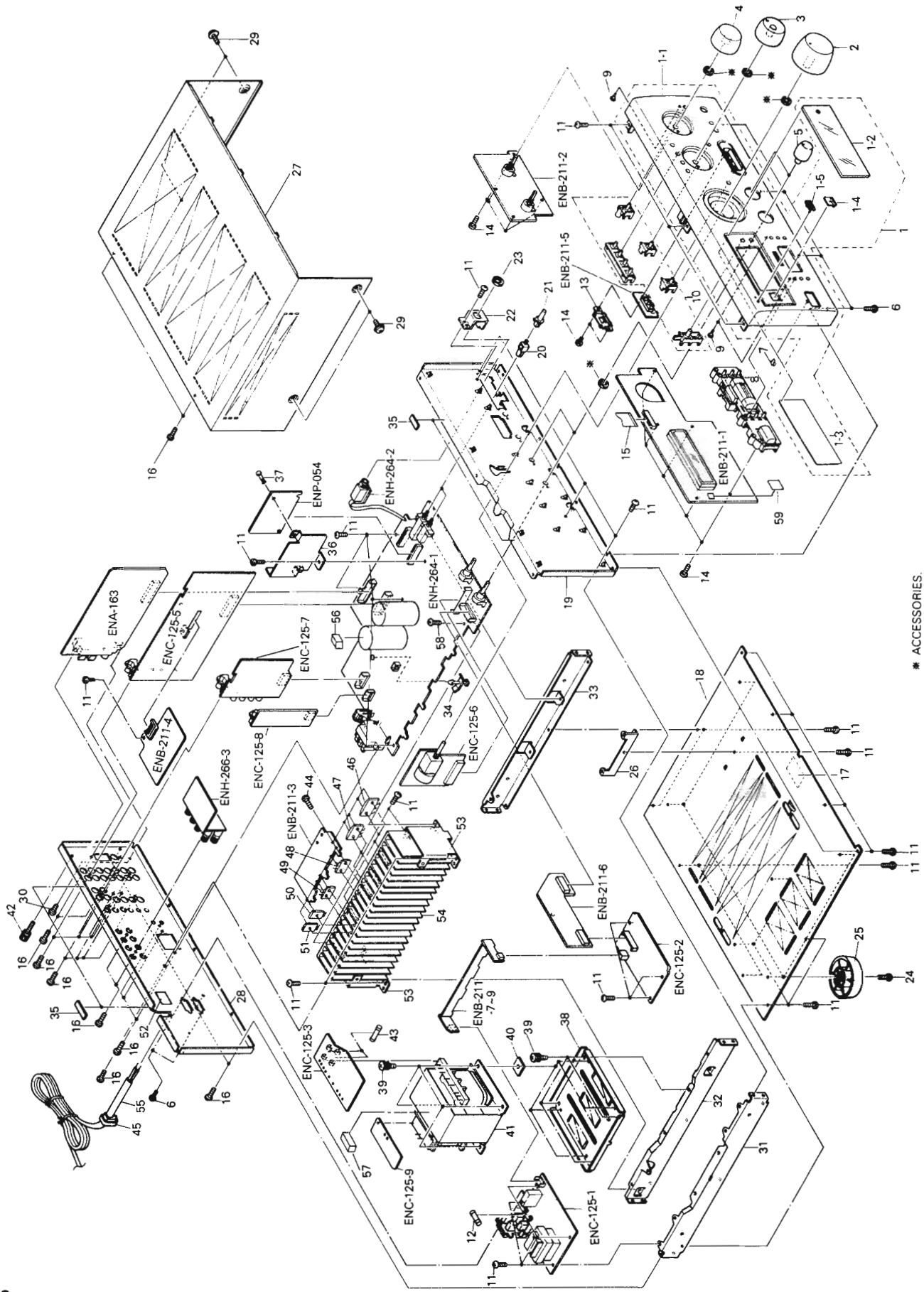

\* ACCESSORIES.

Symbol No. 

M	1	M	M
---	---	---	---

■ PARTS LIST

△	Item	Part Number	Part Name	Q'ty	Description	Area
	1	EFP-RX817VTNJ(S	FRONT PANEL ASS	1		
	1-1	E102909-017SM	FRONT PANEL	1		
	1-2	E309112-011SM	WINDOW SCREEN	1		
	1-3	E408727-001SM	FLOURESCENT DISPL.SCREEN	1		
	1-4	E72436-006	REMORT SCREEN	1		
	1-5	VJD5429-001	JVC MARK	1		
	2	E309465-002SM	VOLUME KNOB	1		
	3	E309110-004SM	VOLUME KNOB	1	TUNER/JOG	
	4	E309110-002SM	SELECT KNOB	1	SOURCE/JOG	
	5	E309111-005SM	BALANCE KNOB	2	TONE,BALANCE	
	6	SDSG3008M	TAPPING SCREW	6		
	7	FSJD4001-002	INDICATOR LENS	1	POWER	
	8	E208276-004SM	PUSH BUTTON	1	SURROUND/POWER	
	9	E408326-001SM	INDICATOR LENS	3	SURROUND/ETC	
	10	E309105-003SM	PUSH BUTTON	1	TUNER/ETC	
△	11	SBSG3008CC	TAPPING SCREW	37		
	12	QMF0007-8R0J1	FUSE	1	F201	
	13	E408713-001SM	P.W.BOARD HOLDER	1		
	14	SDSF2608Z	SCREW	11		
	15	EWR621K-40TTJ2	FFC CABLE	1	FW441	
	16	E73273-006	SPECIAL SCREW	22		
	17	E70115-002	CAUTION LABEL	1	BOTTOM PLATE	C
		E70281-001	CAUTION LABEL	1	BOTTOM PLATE	J
	18	E102820-002SM	BOTTOM PLATE	1		
	19	E102911-002SM	FRONT BRACKET	1		
	20	E407983-001SM	PUSH SHAFT	2		
	21	E407321-001SM	PUSH BUTTON	2	SPEAKER	
	22	E407323-002SM	HEADPHONE BRACKET	1		
	23	VKZ4150-001	NUT	1		
	24	SBST3010Z	TAPPING SCREW	4	FOOT	
	25	VJF4039-00E	FOOT	4		
	26	E407984-001SM	P.W.BOARD HOLDER	1		
	27	E207378-016	METAL COVER	1		
	28	E103041-007SM	REAR PANEL	1		
	29	E61660-004	SPECIAL SCREW	4		
	30	SBST3006M	TAPPING SCREW	1		
	31	E208548-001SM	SIDE BRACKET	1	LEFT	
	32	E208549-001SM	CENTER BRACKET	1		
	33	E208081-003SM	SIDE BRACKET	1	RIGHT	
	34	E406084-002	FASTENER	1		
	35	E306805-146	SPACER	4		
	36	E309458-001SM	SHIELD BRACKET	1		
	37	E48729-008	PLASTIC RIVET	1		
	38	E309459-001SM	TRANSFORMER BRACKET	1		
	39	E65389-006	SPECIAL SCREW	8		
△	40	E406309-002	SPACER	4	POWER TRANSFORMER	
	41	ETP1200-67JAJ	POWER TRANSFORMER	1		
	42	E408091-001	GND TERMINAL	1		
△	43	QMF0007-2R0J1	FUSE	2	F211,F212	
	44	E73525-003	SCREW	14		
△	45	QH53771-108	CORD STOPPER	1		
	46	2SA1494LG(Y,P,G	SI.TRANSISTOR	2	Q733,Q734	
	47	2SC3858LG(Y,P,G	SI.TRANSISTOR	2	Q731,Q732	
	48	2SD2489LG(OPY)	SI.TRANSISTOR	1	Q506	
	49	2SB1621LG(OPY)	SI.TRANSISTOR	1	Q508	
	50	2SA1492LD(O,Y)	SI.TRANSISTOR	1	Q618	
	51	2SC3856LD(O,Y)	SI.TRANSISTOR	1	Q616	
	52	E65507-001	CAUTION LABEL	1	REAR PANEL	C
		E67199-001	CAUTION LABEL	1	REAR PANEL	J
	53	E308836-002SM	HEAT SINK BRACKET	2		
△	54	E309170-002SM	HEAT SINK	1		
	55	QMP1D00-200H	POWER CORD	1		
	56	E306805-167	SPACER	1		
	57	E408834-001	SPACER ASS'Y	1		
	58	E73265-001	SPECIAL SCREW	1		
	59	E72437-013	SHEET	1		
	-	E408632-002	RATING LABEL	1		C

The Marks for Designated Areas

J ..... the U.S.A.

C ..... Canada

No mark indicates all area.

# Printed Circuit Board Ass'y and Parts List

■ ENH-264 □ Amplifier PC Board Assy

Note : ENH-264 □ varies according to the areas employed. See note (1) when placing an order.

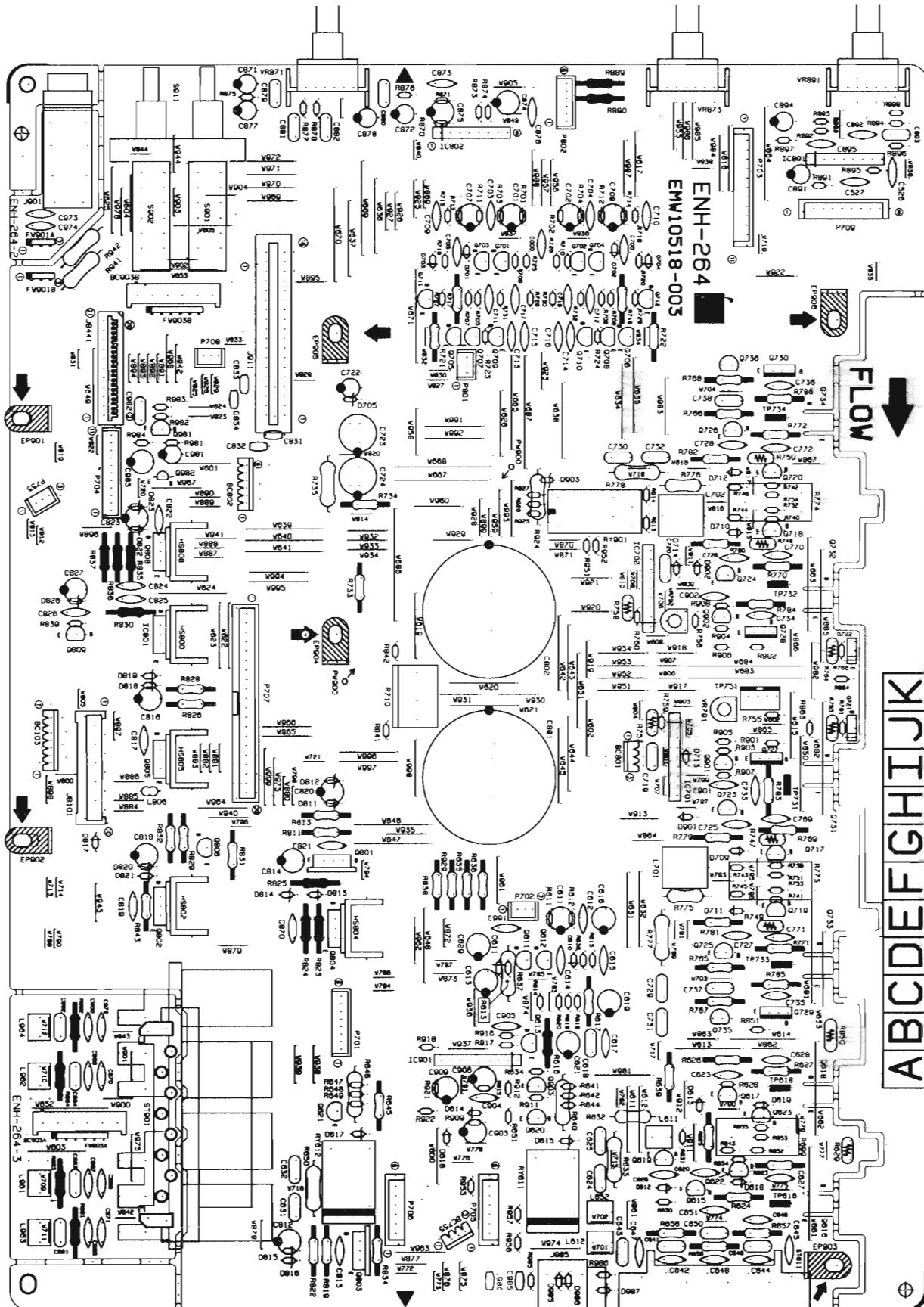

Note (1)

PC Board Ass'y	Version	Designated Areas
ENH-264 <span style="border: 1px solid black; padding: 0 2px;">C</span>	C	Canada
ENH-264 <span style="border: 1px solid black; padding: 0 2px;">D</span>	J	the U.S.A.

Transistors

Δ ITEM	PART NUMBER	DESCRIPTION	AREA
Q611	2SC2240(BL)	SI.TRANSIST	
Q612	2SC2240(BL)	SI.TRANSIST	
Q613	2SA1038(R,S)	SI.TRANSIST ROHM	
Q615	2SC2235(O,Y)	SI.TRANSIST TOSHIBA	
Q617	2SA965(Y)	SI.TRANSIST TOSHIBA	
Q619	2SC1775AV(F1)	SI.TRANSIST HITACHI	
Q620	DTC143TS	DIGITAL TRA ROHM	
Q621	DTC143TS	DIGITAL TRA ROHM	
Q622	2SC2389(S,E)	SI.TRANSIST ROHM	
Q623	2SA1038(R,S)	SI.TRANSIST ROHM	
Q701	2SC1775AV(F1)	SI.TRANSIST HITACHI	
Q702	2SC1775AV(F1)	SI.TRANSIST HITACHI	
Q703	2SC1775AV(F1)	SI.TRANSIST HITACHI	
Q704	2SC1775AV(F1)	SI.TRANSIST HITACHI	
Q705	2SA1038(R,S)	SI.TRANSIST ROHM	
Q706	2SA1038(R,S)	SI.TRANSIST ROHM	
Q707	2SA933LN(R,S)	SI.TRANSIST ROHM	
Q708	2SA933LN(R,S)	SI.TRANSIST ROHM	
Q709	2SA1038(R,S)	SI.TRANSIST ROHM	
Q710	2SA1038(R,S)	SI.TRANSIST ROHM	
Q711	2SC2389(S,E)	SI.TRANSIST ROHM	
Q712	2SC2389(S,E)	SI.TRANSIST ROHM	
Q717	2SC2389(S,E)	SI.TRANSIST ROHM	
Q718	2SC2389(S,E)	SI.TRANSIST ROHM	
Q719	2SA1038(R,S)	SI.TRANSIST ROHM	
Q720	2SA1038(R,S)	SI.TRANSIST ROHM	
Q721	2SD636	SI.TRANSIST MATSUSHITA	
Q722	2SD636	SI.TRANSIST MATSUSHITA	
Q723	2SC2389(S,E)	SI.TRANSIST ROHM	
Q724	2SC2389(S,E)	SI.TRANSIST ROHM	
Q725	2SA1038(R,S)	SI.TRANSIST ROHM	
Q726	2SA1038(R,S)	SI.TRANSIST ROHM	
Q727	2SD669A(B,C)	SI.TRANSIST HITACHI	
Q728	2SD669A(B,C)	SI.TRANSIST HITACHI	
Q729	2SB649A(B,C)	SI.TRANSIST HITACHI	
Q730	2SB649A(B,C)	SI.TRANSIST HITACHI	
Q801	2SB1187(F,G)	SI.TRANSIST ROHM	
Q802	2SD2061(F,G)	SI.TRANSIST ROHM	
Q803	2SD2061(F,G)	SI.TRANSIST ROHM	
Q804	2SD2061(F,G)	SI.TRANSIST ROHM	
Q805	2SD2061(F,G)	SI.TRANSIST ROHM	
Q806	2SC945A	SI.TRANSIST NEC	
Q808	2SD2061(F,G)	SI.TRANSIST ROHM	
Q809	2SD400MP(E,F)	SI.TRANSIST SANYO	
Q901	2SC2389(S,E)	SI.TRANSIST ROHM	
Q902	2SC2389(S,E)	SI.TRANSIST ROHM	
Q903	2SA1038(R,S)	SI.TRANSIST ROHM	
Q981	2SC1685	SI.TRANSIST	
Q982	2SD2144S(VW)	SI.TRANSIST ROHM	

Δ : SAFETY PARTS

I.C.s

Δ ITEM	PART NUMBER	DESCRIPTION	AREA
IC701	VC5022-2	I.C(MONO-AN SANYO	
IC702	VC5022-2	I.C(MONO-AN SANYO	
IC801	NJM78M05FA	I.C(MONO-AN DAINICHI	
IC802	BA15218N	I.C(MONO-AN ROHM	
IC891	BA15218N	I.C(MONO-AN ROHM	
IC901	TA7317P	I.C(MONO-AN TOSHIBA	

Δ : SAFETY PARTS

Diodes

Δ ITEM	PART NUMBER	DESCRIPTION	AREA
D610	1SS133	SI.DIODE ROHM	
D611	MTZ18JC	ZENER DIODE ROHM	
D612	1SS133	SI.DIODE ROHM	
D613	1SS133	SI.DIODE ROHM	
D614	1SS133	SI.DIODE ROHM	
D615	MTZ24JC	ZENER DIODE ROHM	
D616	1SS133	SI.DIODE ROHM	
D617	MTZ24JC	ZENER DIODE ROHM	
D618	1SS133	SI.DIODE ROHM	
D619	1SS133	SI.DIODE ROHM	

Δ : SAFETY PARTS

Diodes

Δ ITEM	PART NUMBER	DESCRIPTION	AREA
D701	1SS133	SI.DIODE ROHM	
D702	1SS133	SI.DIODE ROHM	
D703	1SS133	SI.DIODE ROHM	
D704	1SS133	SI.DIODE ROHM	
D705	MTZ18JC	ZENER DIODE ROHM	
D709	1SS133	SI.DIODE ROHM	
D710	1SS133	SI.DIODE ROHM	
D711	1SS133	SI.DIODE ROHM	
D712	1SS133	SI.DIODE ROHM	
D713	1SS133	SI.DIODE ROHM	
D714	1SS133	SI.DIODE ROHM	
D811	1SS133	SI.DIODE ROHM	
D812	MTZ16JC	ZENER DIODE ROHM	
D813	1SS133	SI.DIODE ROHM	
D814	MTZ6.8JC	ZENER DIODE ROHM	
D815	1SS133	SI.DIODE ROHM	
D816	MTZ13JC	ZENER DIODE ROHM	
D817	1SS133	SI.DIODE ROHM	
D818	1SS133	SI.DIODE ROHM	
D819	MTZ16JC	ZENER DIODE ROHM	
D820	1SS133	SI.DIODE ROHM	
D821	MTZ15JC	ZENER DIODE ROHM	
D822	1SS133	SI.DIODE ROHM	
D823	MTZ6.2JC	ZENER DIODE ROHM	
D826	MTZ7.5JC	ZENER DIODE ROHM	
D901	1SS133	SI.DIODE ROHM	
D902	1SS133	SI.DIODE ROHM	
D903	MTZ24JC	ZENER DIODE ROHM	
D985	1SS133	SI.DIODE ROHM	
D986	1SS133	SI.DIODE ROHM	
D987	MTZ6.2JC	ZENER DIODE ROHM	

Δ : SAFETY PARTS

Capacitors

Δ ITEM	PART NUMBER	DESCRIPTION	AREA
C611	QETB1HM-106	10MF 50V E.CAPACITO	
C612	QCS21HJ-271A	270PF 50V CER.CAPACI	
C613	QETB1EM-106	10MF 25V AL E.CAPAC	
C614	QCS21HJ-101A	100PF 50V CER.CAPACI	
C615	QCS21HJ-5R0	5PF 50V CER.CAPACI	
C616	QETB1CM-476	47MF 16V AL E.CAPAC	
C617	QCS22HJ-330	33PF 500V CER.CAPACI	
C618	QFLB1HJ-103	0.01MF 50V MYLAR CAPA	J
C619	QETB1HM-476	47MF 50V E.CAPACITO	C
C620	QCS22HJ-470A	47PF 500V CER.CAPACI	
C621	QETB1HM-225	2.2MF 50V AL E.CAPAC	
C623	QCS22HJ-470A	47PF 500V CER.CAPACI	
C624	QFLB1HJ-223	0.022MF 50V MYLAR CAPA	J
C624	QFLB1HJ-473	0.047MF 50V MYLAR CAPA	C
C625	QFLB1HJ-473	0.047MF 50V MYLAR CAPA	C
C626	QCF21HP-223A	0.022MF 50V CER.CAPACI	
C627	QCY31HK-332Z	3300PF 50V CER.CAPACI	
C628	QCY31HK-332Z	3300PF 50V CER.CAPACI	
C631	QFLB1HJ-473	0.047MF 50V MYLAR CAPA	
C632	QFLB1HJ-473	0.047MF 50V MYLAR CAPA	
C701	QETB1HM-106	10MF 50V E.CAPACITO	
C702	QETB1HM-106	10MF 50V E.CAPACITO	
C703	QCS21HJ-271A	270PF 50V CER.CAPACI	
C704	QCS21HJ-271A	270PF 50V CER.CAPACI	
C705	QCS21HJ-101A	100PF 50V CER.CAPACI	
C706	QCS21HJ-101A	100PF 50V CER.CAPACI	
C707	QETB1CM-476	47MF 16V AL E.CAPAC	
C708	QETB1CM-476	47MF 16V AL E.CAPAC	
C709	QCS21HJ-5R0	5PF 50V CER.CAPACI	
C710	QCS21HJ-5R0	5PF 50V CER.CAPACI	
C711	QCY31HK-152Z	1500PF 50V CER.CAPACI	
C712	QCY31HK-152Z	1500PF 50V CER.CAPACI	
C713	QCS21HJ-680A	68PF 50V CER.CAPACI	
C714	QCS21HJ-680A	68PF 50V CER.CAPACI	
C715	QCS21HJ-680A	68PF 50V CER.CAPACI	
C716	QCS21HJ-680A	68PF 50V CER.CAPACI	
C717	QCS22HJ-220	22PF 500V CER.CAPACI	
C718	QCS22HJ-220	22PF 500V CER.CAPACI	
C719	QFLB1HJ-472	4700PF 50V MYLAR CAPA	
C720	QFLB1HJ-472	4700PF 50V MYLAR CAPA	
C722	QETB1EM-476	47MF 25V AL E.CAPAC	
C723	QETB2AM-476	47MF 100V AL E.CAPAC	
C724	QETB2AM-476	47MF 100V AL E.CAPAC	
C725	QCS22HJ-470A	47PF 500V CER.CAPACI	
C726	QCS22HJ-470A	47PF 500V CER.CAPACI	
C727	QCS22HJ-470A	47PF 500V CER.CAPACI	
C728	QCS22HJ-470A	47PF 500V CER.CAPACI	
C729	QFLB1HJ-223	0.022MF 50V MYLAR CAPA	J
C729	QFLB1HJ-473	0.047MF 50V MYLAR CAPA	C
C730	QFLB1HJ-223	0.022MF 50V MYLAR CAPA	J
C730	QFLB1HJ-473	0.047MF 50V MYLAR CAPA	C
C731	QFLB1HJ-473	0.047MF 50V MYLAR CAPA	C
C732	QFLB1HJ-473	0.047MF 50V MYLAR CAPA	C
C733	QCF21HP-472	4700PF 50V CER.CAPACI	
C734	QCF21HP-472	4700PF 50V CER.CAPACI	

Δ : SAFETY PARTS



Capacitors

Δ	ITEM	PART NUMBER	DESCRIPTION	AREA
	C735	QCF21HP-472	4700PF 50V CER.CAPACI	
	C736	QCF21HP-472	4700PF 50V CER.CAPACI	
	C737	QFLB1HJ-473	0.047MF 50V MYLAR CAPA	
	C738	QFLB1HJ-473	0.047MF 50V MYLAR CAPA	
	C801	EEW7108-129E	12000MF E.CAPACITO	
	C802	EEW7108-129E	12000MF E.CAPACITO	
	C812	QETB1EM-107	100MF 25V AL E.CAPAC	
	C813	QCF21HP-472	4700PF 50V CER.CAPACI	
	C814	QETB1EM-107	100MF 25V AL E.CAPAC	
	C816	QETB1EM-107	100MF 25V AL E.CAPAC	
	C817	QCF21HP-472	4700PF 50V CER.CAPACI	
	C818	QETB1EM-107	100MF 25V AL E.CAPAC	
	C819	QCF21HP-472	4700PF 50V CER.CAPACI	
	C820	QETB1EM-107	100MF 25V AL E.CAPAC	
	C821	QCF21HP-472	4700PF 50V CER.CAPACI	
	C822	QCF21HP-472	4700PF 50V CER.CAPACI	
	C823	QETB1EM-107	100MF 25V AL E.CAPAC	
	C824	QCF21HP-223A	0.022MF 50V CER.CAPACI	
	C825	QCF21HP-223A	0.022MF 50V CER.CAPACI	
	C826	QCF21HP-223A	0.022MF 50V CER.CAPACI	
	C827	QETB1EM-107	100MF 25V AL E.CAPAC	
	C831	QCBB1HK-121Y	120PF 50V CER.CAPACI	
	C832	QCBB1HK-121Y	120PF 50V CER.CAPACI	
	C833	QCBB1HK-121Y	120PF 50V CER.CAPACI	
	C834	QCBB1HK-121Y	120PF 50V CER.CAPACI	
	C870	QCF21HP-472	4700PF 50V CER.CAPACI	
	C874	QETB1HM-105	1MF 50V AL E.CAPAC	
	C875	QETB1HM-105	1MF 50V AL E.CAPAC	
	C891	QETB1HM-106	10MF 50V E.CAPACITO	
	C892	QCY31HK-103Z	0.01MF 50V CER.CAPACI	
	C893	QFLB1HJ-123	0.012MF 50V MYLAR CAPA	
	C894	QETB1HM-106	10MF 50V E.CAPACITO	
	C895	QCS21HJ-101A	100PF 50V CER.CAPACI	
	C901	QCF21HP-223A	0.022MF 50V CER.CAPACI	
	C902	QCF21HP-223A	0.022MF 50V CER.CAPACI	
	C903	QETB1HM-226E	22MF 50V E.CAPACITO	
	C904	QCF21HP-103A	0.01MF 50V CER.CAPACI	
	C905	QCY31HK-102Z	1000PF 50V CER.CAPACI	
	C906	QETB1AM-476	47MF 10V E.CAPACITO	
	C909	QETB1CM-226	22MF 16V E.CAPACITO	
	C981	QETB1HM-225	2.2MF 50V AL E.CAPAC	
	C982	QFLB1HJ-223	0.022MF 50V MYLAR CAPA	
	C983	QETB1HM-106	10MF 50V E.CAPACITO	
	C985	QCBB1HK-331Y	330PF 50V CER.CAPACI	
	C986	QCHB1EZ-223	0.022MF 25V CER.CAPACI	
	C991	QCF21HP-223A	0.022MF 50V CER.CAPACI	

Δ SAFETY PARTS

Resistors

Δ	ITEM	PART NUMBER	DESCRIPTION	AREA
	R653	QRD167J-151	150 1/6W CARBON RES	
	R654	QRD167J-151	150 1/6W CARBON RES	
	R655	QRD167J-151	150 1/6W CARBON RES	
Δ	R699	ERF032K-R22	0.22 3W CEM.RESIST	
	R701	QRD161J-222	2.2K 1/6W CARBON RES	
	R702	QRD161J-222	2.2K 1/6W CARBON RES	
	R703	QRD161J-104	100K 1/6W CARBON RES	
	R704	QRD161J-104	100K 1/6W CARBON RES	
	R705	QRD161J-202	2K 1/6W CARBON RES	
	R706	QRD161J-202	2K 1/6W CARBON RES	
	R707	QRD161J-202	2K 1/6W CARBON RES	
	R708	QRD161J-202	2K 1/6W CARBON RES	
	R709	QRD167J-822	8.2K 1/6W CARBON RES	
	R710	QRD167J-822	8.2K 1/6W CARBON RES	
	R711	QRD161J-681	680 1/6W CARBON RES	
	R712	QRD161J-681	680 1/6W CARBON RES	
	R713	QRD161J-333	33K 1/6W CARBON RES	
	R714	QRD161J-333	33K 1/6W CARBON RES	
	R715	QRD161J-683	68K 1/6W CARBON RES	
	R716	QRD161J-683	68K 1/6W CARBON RES	
Δ	R717	QRD12CJ-153SX	15K 1/2W UNF.CARBON	
Δ	R718	QRD12CJ-153SX	15K 1/2W UNF.CARBON	
	R719	QRD161J-391	390 1/6W CARBON RES	
	R720	QRD161J-391	390 1/6W CARBON RES	
Δ	R721	QRD14CJ-151SX	150 1/4W UNF.CARBON	
Δ	R722	QRD14CJ-151SX	150 1/4W UNF.CARBON	
	R723	QRD167J-152	1.5K 1/6W CARBON RES	
	R724	QRD167J-152	1.5K 1/6W CARBON RES	
	R725	QRD161J-333	33K 1/6W CARBON RES	
	R726	QRD161J-333	33K 1/6W CARBON RES	
	R727	QRD161J-391	390 1/6W CARBON RES	
	R728	QRD161J-391	390 1/6W CARBON RES	
	R729	QRD167J-152	1.5K 1/6W CARBON RES	
	R730	QRD167J-152	1.5K 1/6W CARBON RES	
	R731	QRD161J-101	100 1/6W CARBON RES	
	R732	QRD161J-101	100 1/6W CARBON RES	
Δ	R733	QRD14CJ-101S	100 1/4W UNF.CARBON	
Δ	R734	QRD14CJ-101S	100 1/4W UNF.CARBON	
Δ	R735	QRG022J-562A	5.6K 2W OXIDE META	
	R739	QRD167J-151	150 1/6W CARBON RES	
	R740	QRD167J-151	150 1/6W CARBON RES	
	R741	QRD167J-151	150 1/6W CARBON RES	
	R742	QRD167J-151	150 1/6W CARBON RES	
	R743	QRD161J-820	82 1/6W CARBON RES	
	R744	QRD161J-820	82 1/6W CARBON RES	
	R745	QRD161J-820	82 1/6W CARBON RES	
	R746	QRD161J-820	82 1/6W CARBON RES	
	R747	ERT-D2WFL351S	350 1/4W NEGATIVE T	
	R748	ERT-D2WFL351S	350 1/4W NEGATIVE T	
	R749	ERT-D2WFL351S	350 1/4W NEGATIVE T	
	R750	ERT-D2WFL351S	350 1/4W NEGATIVE T	
	R751	QRD161J-221	220 1/6W CARBON RES	
	R752	QRD161J-221	220 1/6W CARBON RES	
	R753	QRD161J-221	220 1/6W CARBON RES	
	R754	QRD161J-221	220 1/6W CARBON RES	
	R755	QRD161J-471	470 1/6W CARBON RES	
	R756	QRD161J-471	470 1/6W CARBON RES	
	R757	ERT-D2WFL351S	350 1/4W NEGATIVE T	
	R758	ERT-D2WFL351S	350 1/4W NEGATIVE T	
	R759	QRD161J-101	100 1/6W CARBON RES	
	R760	QRD161J-101	100 1/6W CARBON RES	
	R761	QRD161J-391	390 1/6W CARBON RES	
	R762	QRD161J-391	390 1/6W CARBON RES	
Δ	R765	QRD14CJ-272S	2.7K 1/4W UNF.CARBON	
Δ	R766	QRD14CJ-272S	2.7K 1/4W UNF.CARBON	
Δ	R767	QRD14CJ-271S	270 1/4W UNF.CARBON	
Δ	R768	QRD14CJ-271S	270 1/4W UNF.CARBON	
Δ	R769	QRD14CJ-100SX	10 1/4W UNF.CARBON	C
Δ	R769	QRD14CJ-120SX	12 1/4W UNF.CARBON	J
Δ	R770	QRD14CJ-100SX	10 1/4W UNF.CARBON	C
Δ	R770	QRD14CJ-120SX	12 1/4W UNF.CARBON	J
Δ	R771	QRD14CJ-100SX	10 1/4W UNF.CARBON	C
Δ	R771	QRD14CJ-120SX	12 1/4W UNF.CARBON	J
Δ	R772	QRD14CJ-100SX	10 1/4W UNF.CARBON	C
Δ	R772	QRD14CJ-120SX	12 1/4W UNF.CARBON	J
Δ	R773	ERF032K-R22	0.22 3W CEM.RESIST	
Δ	R774	ERF032K-R22	0.22 3W CEM.RESIST	
Δ	R775	QRD125J-470	47 1/2W UNF.CARBON	
Δ	R776	QRD125J-470	47 1/2W UNF.CARBON	
Δ	R777	QRG022J-100A	10 2W OXIDE META	
Δ	R778	QRG022J-100A	10 2W OXIDE META	
Δ	R779	QRD14CJ-100SX	10 1/4W UNF.CARBON	
Δ	R780	QRD14CJ-100SX	10 1/4W UNF.CARBON	
Δ	R781	QRD14CJ-100SX	10 1/4W UNF.CARBON	
Δ	R782	QRD14CJ-100SX	10 1/4W UNF.CARBON	
Δ	R783	QRD14CJ-100SX	10 1/4W UNF.CARBON	
Δ	R784	QRD14CJ-100SX	10 1/4W UNF.CARBON	
Δ	R785	QRD14CJ-100SX	10 1/4W UNF.CARBON	
Δ	R786	QRD14CJ-100SX	10 1/4W UNF.CARBON	
Δ	R811	QRD14CJ-120SX	12 1/4W UNF.CARBON	
Δ	R813	QRD14CJ-102SX	1K 1/4W UNF.CARBON	
Δ	R819	QRD14CJ-100SX	10 1/4W UNF.CARBON	
Δ	R822	QRD14CJ-272S	2.7K 1/4W UNF.CARBON	

Δ SAFETY PARTS

Resistors

Δ	ITEM	PART NUMBER	DESCRIPTION	AREA
	R611	QRD161J-222	2.2K 1/6W CARBON RES	
	R612	QRD161J-104	100K 1/6W CARBON RES	
	R613	QRD161J-123	12K 1/6W CARBON RES	
	R614	QRD161J-202	2K 1/6W CARBON RES	
	R615	QRD161J-104	100K 1/6W CARBON RES	
Δ	R616	QRD14CJ-181S	180 1/4W UNF.CARBON	
Δ	R617	QRD14CJ-332SX	3.3K 1/4W UNF.CARBON	
	R618	QRD161J-302	3K 1/6W CARBON RES	
	R619	QRD161J-302	3K 1/6W CARBON RES	
	R620	QRD161J-302	3K 1/6W CARBON RES	
Δ	R623	QRD14CJ-471SX	470 1/4W UNF.CARBON	
Δ	R624	QRD14CJ-100SX	10 1/4W UNF.CARBON	
Δ	R625	QRD14CJ-561SX	560 1/4W UNF.CARBON	
Δ	R626	QRD14CJ-100SX	10 1/4W UNF.CARBON	
Δ	R627	QRD14CJ-471SX	470 1/4W UNF.CARBON	
	R628	QRD161J-391	390 1/6W CARBON RES	
	R629	ERT-D2WHL202S	2K 1/4W NEGATIVE T	
	R630	QRD161J-183	18K 1/6W CARBON RES	
	R631	QRD161J-123	12K 1/6W CARBON RES	
	R632	QRD125J-330	33 1/2W UNF.CARBON	
Δ	R633	QRG022J-100A	10 2W OXIDE META	
	R634	QRD161J-104	100K 1/6W CARBON RES	
Δ	R635	QRD14CJ-330SX	33 1/4W UNF.CARBON	
Δ	R636	QRD14CJ-330SX	33 1/4W UNF.CARBON	
Δ	R637	QRG022J-562A	5.6K 2W OXIDE META	
	R638	QRD167J-751	750 1/6W CARBON RES	
	R639	QRD12CJ-470SX	47 1/2W CARBON RES	
Δ	R640	QRG022J-182A	1.8K 2W OXIDE META	
	R641	QRD167J-151	150 1/6W CARBON RES	
	R642	QRD167J-151	150 1/6W CARBON RES	
	R643	QRD161J-102	1K 1/6W CARBON RES	
	R644	QRD167J-151	150 1/6W CARBON RES	
	R645	QRD12CJ-470SX	47 1/2W CARBON RES	
Δ	R646	QRG022J-182A	1.8K 2W OXIDE META	
	R647	QRD167J-151	150 1/6W CARBON RES	
	R648	QRD167J-151	150 1/6W CARBON RES	
	R649	QRD167J-151	150 1/6W CARBON RES	
Δ	R650	QRG022J-100A	10 2W OXIDE META	
	R651	QRD161J-104	100K 1/6W CARBON RES	
	R652	QRD167J-151	150 1/6W CARBON RES	

Δ SAFETY PARTS

**Resistors**

Δ	ITEM	PART NUMBER	DESCRIPTION	AREA
Δ	R823	QRD14CJ-220S	22 1/4W UNF. CARBON	
Δ	R824	QRD14CJ-220S	22 1/4W UNF. CARBON	
Δ	R825	QRD14CJ-332SX	3.3K 1/4W UNF. CARBON	
Δ	R826	QRD14CJ-100SX	10 1/4W UNF. CARBON	
Δ	R828	QRD14CJ-102SX	1K 1/4W UNF. CARBON	
Δ	R829	QRD143J-472S	4.7K 1/4W CARBON RES	
Δ	R830	QRD14CJ-100SX	10 1/4W UNF. CARBON	
Δ	R831	QRD145J-150S	15 1/4W UNF. CARBON	
Δ	R832	QRD12CJ-103S	10K 1/2W UNF. CARBON	
Δ	R834	QRD14CJ-220S	22 1/4W UNF. CARBON	
Δ	R835	QRD14CJ-220S	22 1/4W UNF. CARBON	
Δ	R836	QRD14CJ-220S	22 1/4W UNF. CARBON	
Δ	R837	QRD14CJ-822S	8.2K 1/4W UNF. CARBON	
Δ	R838	QRD12CJ-2R2SX	2.2 1/2W CARBON RES	
Δ	R839	QRD161J-472	4.7K 1/6W CARBON RES	
Δ	R841	QRD161J-104	100K 1/6W CARBON RES	
Δ	R842	QRD161J-104	100K 1/6W CARBON RES	
Δ	R843	QRD14CJ-4R7S	4.7 1/4W UNF. CARBON	
Δ	R870	QRD161J-123	12K 1/6W CARBON RES	
Δ	R871	QRD161J-103	10K 1/6W CARBON RES	
Δ	R873	QRD161J-103	10K 1/6W CARBON RES	
Δ	R874	QRD161J-123	12K 1/6W CARBON RES	
Δ	R889	QRZ0077-680	68 1/4W FUSIBLE RE	
Δ	R890	QRZ0077-680	68 1/4W FUSIBLE RE	
Δ	R891	QRD161J-104	100K 1/6W CARBON RES	
Δ	R892	QRD161J-203	20K 1/6W CARBON RES	
Δ	R893	QRD161J-183	18K 1/6W CARBON RES	
Δ	R894	QRD161J-202	2K 1/6W CARBON RES	
Δ	R895	QRD161J-223	22K 1/6W CARBON RES	
Δ	R896	QRD161J-132	1.3K 1/6W CARBON RES	
Δ	R897	QRD161J-104	100K 1/6W CARBON RES	
Δ	R898	QRD161J-203	20K 1/6W CARBON RES	
Δ	R901	QRD161J-102	1K 1/6W CARBON RES	
Δ	R902	QRD161J-102	1K 1/6W CARBON RES	
Δ	R903	QRD161J-562	5.6K 1/6W CARBON RES	
Δ	R904	QRD161J-562	5.6K 1/6W CARBON RES	
Δ	R905	QRD161J-123	12K 1/6W CARBON RES	
Δ	R906	QRD161J-123	12K 1/6W CARBON RES	
Δ	R907	QRD161J-102	1K 1/6W CARBON RES	
Δ	R908	QRD161J-102	1K 1/6W CARBON RES	
Δ	R909	QRD161J-103	10K 1/6W CARBON RES	
Δ	R911	QRD161J-332	3.3K 1/6W CARBON RES	
Δ	R912	QRD161J-473	47K 1/6W CARBON RES	
Δ	R913	QRD161J-104	100K 1/6W CARBON RES	
Δ	R914	QRD161J-823	82K 1/6W CARBON RES	
Δ	R915	QRD161J-823	82K 1/6W CARBON RES	
Δ	R916	QRD161J-563	56K 1/6W CARBON RES	
Δ	R917	QRD161J-683	68K 1/6W CARBON RES	
Δ	R918	QRD161J-392	3.9K 1/6W CARBON RES	
Δ	R921	QRD161J-224	220K 1/6W CARBON RES	
Δ	R922	QRD161J-562	5.6K 1/6W CARBON RES	
Δ	R924	QRG022J-102AM	1K 2W OXIDE META	
Δ	R925	QRD161J-181	180 1/6W CARBON RES	
Δ	R926	QRD161J-181	180 1/6W CARBON RES	
Δ	R927	QRD161J-181	180 1/6W CARBON RES	
Δ	R929	QRD14CJ-151SX	150 1/4W UNF. CARBON	
Δ	R941	QRG022J-471A	470 2W OXIDE META	
Δ	R942	QRG022J-471A	470 2W OXIDE META	
Δ	R951	QRD161J-333	33K 1/6W CARBON RES	
Δ	R952	QRD161J-333	33K 1/6W CARBON RES	
Δ	R953	QRD161J-333	33K 1/6W CARBON RES	
Δ	R956	QRD161J-223	22K 1/6W CARBON RES	
Δ	R957	QRD161J-391	390 1/6W CARBON RES	
Δ	R981	QRD161J-222	2.2K 1/6W CARBON RES	
Δ	R982	QRD161J-222	2.2K 1/6W CARBON RES	
Δ	R983	QRD161J-105	1M 1/6W CARBON RES	
Δ	R984	QRD161J-103	10K 1/6W CARBON RES	
Δ	R985	QRD161J-100	10 1/6W CARBON RES	
Δ	R986	QRD161J-102	1K 1/6W CARBON RES	
Δ	VR791	QVPA601-501A	500 TRIMMER RE	
Δ	VR792	QVPA601-501A	500 TRIMMER RE	
Δ	VR873	QVDA96W-E15DJ3	100K VARIABLE R	
Δ	VR891	QVDB96C-E15DJ3	100K VARIABLE R	

Δ : SAFETY PARTS

**Others**

Δ	ITEM	PART NUMBER	DESCRIPTION	AREA
	J901	EMW10518-003	PRINTED BOA	
	J911	SBSG3008CC	TAPPING SCR	
	J985	QMS6022-V01	MICROPHONE	
	L611	EMV7164-036	CONNECT TER	
	L701	QMS3501-021	PIN JACK	
	L702	EQL0011-R45J1	INDUCTOR	
	L702	EQL0001-1R0	INDUCTOR	
	P701	EQL0001-1R0	INDUCTOR	
	P702	VMC0075-008N	CONNECT TER	
	P703	EMV5109-003A	MALE CONNec	
	P703	EMV5125-011	MALE CONNec	
	P704	EMV5109-011A	MALE CONNec	
	P705	EMV5125-006	CONNECT TER	
	P706	EMV5125-006	CONNECT TER	
	P707	EMV7163-020	CONNECT TER	
	P708	EMV5109-003A	MALE CONNec	
	P709	EMV5125-008	MALE CONNec	
	P710	EMV5129-003	CONNECTOR	
	P755	EMV5109-003A	MALE CONNec	
	P801	EMV5109-003A	MALE CONNec	
	P802	EMV5109-006A	CONNECT TER	
	BC103	QSP6002-E02J2	PUSH SWITCH	
	BC755	EMS267-A408J	SOCKET WIRE	
	BC801	EMS293-0145	SOCKET WIRE	
	BC802	EMS263-A413J	SOCKET WIRE	
	BC802	EMS296-0120	SOCKET WIRE	
	EP901	EMZ4002-001Z	EARTH PLATE	
	EP902	EMZ4002-001Z	EARTH PLATE	
	EP903	EMZ4002-001Z	EARTH PLATE	
	EP904	EMZ4002-001Z	EARTH PLATE	
	EP905	EMZ4002-001Z	EARTH PLATE	
	FW901	EWR33D-08SS	FLAT WIRE A	
	FW903	EWR36D-45SS	FLAT WIRE A	
	HS800	E70306-001	HEAT SINK	
	HS802	E70306-001	HEAT SINK	
	HS804	E70306-001	HEAT SINK	
	HS805	E70306-001	HEAT SINK	
	HS808	E70306-001	HEAT SINK	
	JB101	EMV5140-010	VOLUME SOCK	
	JB441	EMV7123-021	CONNECT TER	
	P9900	QWE350-10DD	VINYL WIRE	J
	RY611	ESK1D24-11AM	RELAY	
	RY612	ESK1D24-11AM	RELAY	
	RY901	ESK7D24-212D	RELAY	
	ST611	EMB90TV-601G	SPEAKER TER	
	ST901	EMB90TV-806A	SPEAKER TER	
	TP751	QMV5005-004K	PLUG ASSY	

Δ : SAFETY PARTS

■ ENC-125 □ Input Selector PC Board Assy

Note : ENC-125 □ varies according to the areas employed. See note (2) when placing an order.

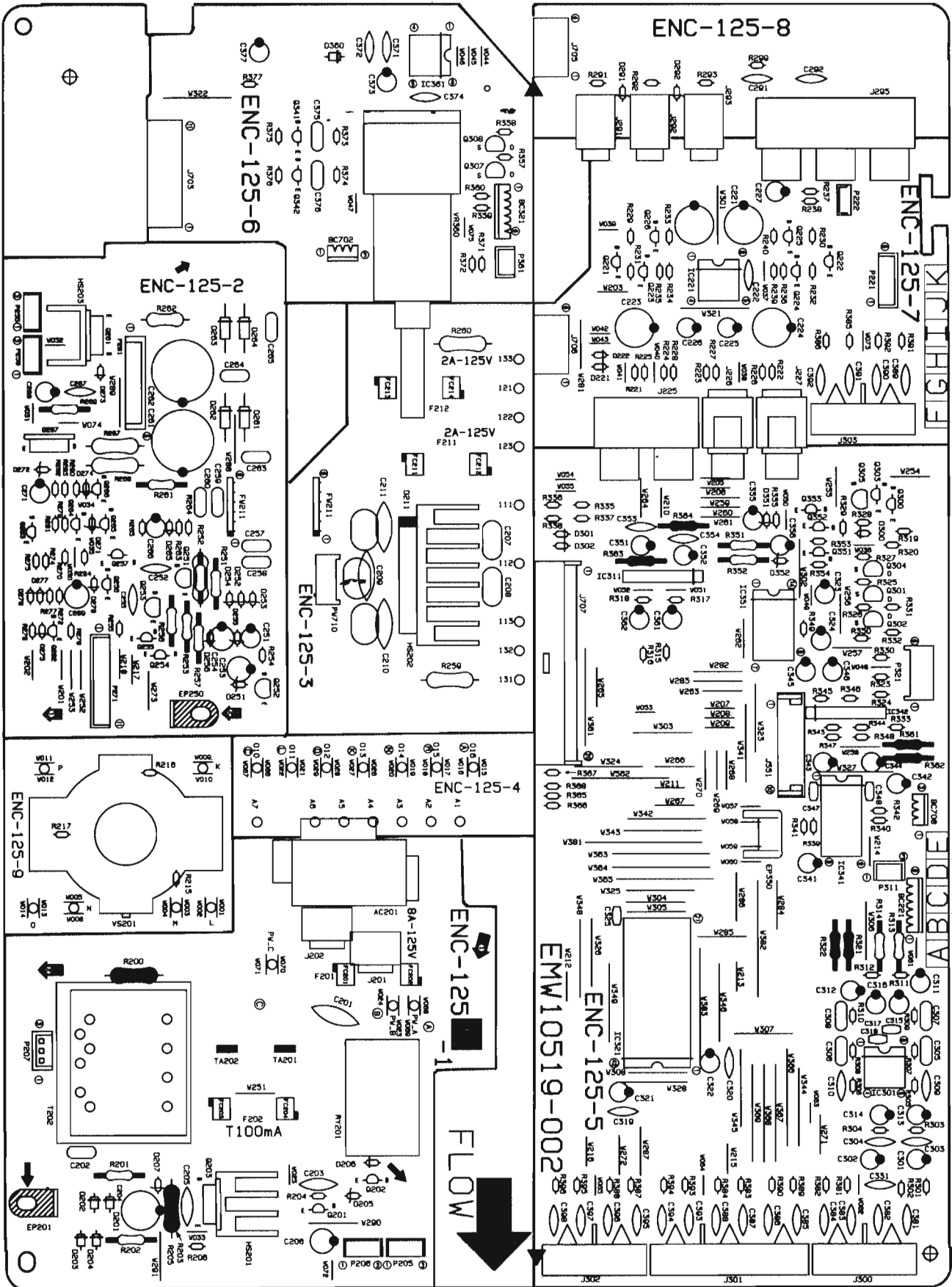

Note (2)

PC Board Ass'y	Version	Designated Areas
ENC-125 <b>F</b>	C	Canada
ENC-125 <b>E</b>	J	the U.S.A.

Transistors

ITEM	PART NUMBER	DESCRIPTION	AREA
Q201	2SC2235(C,Y)	SI. TRANSIST TOSHIBA	
Q202	DTC143TS	DIGITAL TRA ROHM	
Q221	2SC458(C,D)	SI. TRANSIST HITACHI	
Q222	2SC458(C,D)	SI. TRANSIST HITACHI	
Q223	2SA933S(RS)	SI. TRANSIST	
Q224	2SA933S(RS)	SI. TRANSIST	
Q225	DTC114YS	DIGITAL TRA ROHM	
Q226	DTC114YS	DIGITAL TRA ROHM	
Q251	2SA965(Y)	SI. TRANSIST TOSHIBA	
Q252	2SC2240(GR,BL)	SI. TRANSIST TOSHIBA	
Q253	2SA965(Y)	SI. TRANSIST TOSHIBA	
Q254	DTA144ES	DIGITAL TRA ROHM	
Q255	DTC144ES	DIGITAL TRA ROHM	
Q300	DTA114YS	DIGITAL TRA ROHM	
Q301	2SK301(P,Q)	F.E.T.	
Q302	2SK301(P,Q)	F.E.T.	
Q303	DTC144ES	DIGITAL TRA ROHM	
Q304	2SK301(P,Q)	F.E.T.	
Q305	2SK301(P,Q)	F.E.T.	
Q307	2SK301(P,Q)	F.E.T.	
Q308	2SK301(P,Q)	F.E.T.	
Q341	2SD2144S(VW)	SI. TRANSIST ROHM	
Q342	2SD2144S(VW)	SI. TRANSIST ROHM	
Q351	DTC144ES	DIGITAL TRA ROHM	
Q352	DTA144ES	DIGITAL TRA ROHM	
Q353	DTC144ES	DIGITAL TRA ROHM	

Δ : SAFETY PARTS

I.C.s

ITEM	PART NUMBER	DESCRIPTION	AREA
IC221	NJM2246D	I.C(MONO-AN DAINICHI	
IC301	VC4580DD	I.C(MONO-AN DAINICHI	
IC311	BA15218N	I.C(MONO-AN ROHM	
IC321	TC9274N-007	I.C(M) TOSHIBA	
IC341	TC9299P	I.C(DIGI-MO TOSHIBA	
IC342	BA15218N	I.C(MONO-AN ROHM	
IC351	UPD4066BC	I.C(DIGI-MO NEC	
IC361	LB1639-CV	I.C(DIGI-OT SANYO	

Δ : SAFETY PARTS

Diodes

ITEM	PART NUMBER	DESCRIPTION	AREA
D201	1SR139-200	SI. DIODE ROHM	
D202	1SR139-200	SI. DIODE ROHM	
D203	1SR139-200	SI. DIODE ROHM	
D204	1SR139-200	SI. DIODE ROHM	
D205	MTZ6.2JC	ZENER DIODE ROHM	
D206	1SS133	SI. DIODE ROHM	
D211	U6SBA20	DIODE SINDENGEN	
D221	1SS133	SI. DIODE ROHM	
D222	1SS133	SI. DIODE ROHM	
D251	MTZ5.6JC	ZENER DIODE ROHM	
D252	MTZ10JC	ZENER DIODE ROHM	
D253	MTZ16JC	ZENER DIODE ROHM	
D254	1SS133	SI. DIODE ROHM	
D255	MTZ6.8JC	ZENER DIODE ROHM	
D256	1SS133	SI. DIODE ROHM	
D261	10E2-FD	DIODE NIHONINTER	
D262	10E2-FD	DIODE NIHONINTER	
D263	10E2-FD	DIODE NIHONINTER	
D264	10E2-FD	DIODE NIHONINTER	
D265	1SS133	SI. DIODE ROHM	
D291	MTZ6.2JC	ZENER DIODE ROHM	
D292	MTZ6.2JC	ZENER DIODE ROHM	
D300	1SS133	SI. DIODE ROHM	
D301	1SS133	SI. DIODE ROHM	
D302	1SS133	SI. DIODE ROHM	
D351	MTZ8.2JC	ZENER DIODE ROHM	
D352	MTZ8.2JC	ZENER DIODE ROHM	
D360	1SR139-200	SI. DIODE ROHM	

Δ : SAFETY PARTS

Capacitors

ITEM	PART NUMBER	DESCRIPTION	AREA
C201	QCZ9019-472	4700PF 100V C.CAPACITO	
C202	QFN82AK-472	4700PF 100V METAL.MYLA	
C203	QCF21HP-472	4700PF 50V CER.CAPACI	
C204	QETB1EM-227	220MF 25V AL E.CAPAC	
C206	QETB1CM-476	47MF 16V AL E.CAPAC	
C209	QCE22HP-103A	0.01MF 500V CER.CAPACI	
C210	QCE22HP-103A	0.01MF 500V CER.CAPACI	
C211	QCE22HP-103A	0.01MF 500V CER.CAPACI	
C221	QETB1CM-108	1000MF 16V AL E.CAPAC	
C222	QCF21HP-223A	0.022MF 50V CER.CAPACI	
C223	QETBOJM-108N	1000MF 6.3V E.CAPACITO	
C224	QETBOJM-108N	1000MF 6.3V E.CAPACITO	
C225	QETB1HM-475E	4.7MF 50V E.CAPACITO	
C226	QETB1HM-475E	4.7MF 50V E.CAPACITO	
C227	QETB1HM-475E	4.7MF 50V E.CAPACITO	
C251	QETB1HM-476	47MF 50V E.CAPACITO	
C252	QCF21HP-472	4700PF 50V CER.CAPACI	
C253	QETB1EM-107	100MF 25V AL E.CAPAC	
C254	QETB1EM-107	100MF 25V AL E.CAPAC	
C255	QCF21HP-472	4700PF 50V CER.CAPACI	
C257	QFLB1HJ-473	0.047MF 50V MYLAR CAPA	
C258	QFLB1HJ-473	0.047MF 50V MYLAR CAPA	
C261	QETB1VM-228N	2200MF 35V E.CAPACITO	
C262	QETB1VM-228N	2200MF 35V E.CAPACITO	
C263	QFN82AJ-104	0.1MF 100V MYLAR CAPA	
C264	QFN82AJ-104	0.1MF 100V MYLAR CAPA	
C265	QFN82AJ-104	0.1MF 100V MYLAR CAPA	
C266	QETB1HM-225	2.2MF 50V AL E.CAPAC	
C291	QCS31HJ-471Z	470PF 50V CER.CAPACI	
C292	QCS31HJ-471Z	470PF 50V CER.CAPACI	
C301	QETB1HM-475E	4.7MF 50V E.CAPACITO	
C302	QETB1HM-475E	4.7MF 50V E.CAPACITO	
C303	QCS21HJ-101A	100PF 50V CER.CAPACI	
C304	QCS21HJ-101A	100PF 50V CER.CAPACI	
C305	QFLB1HJ-182	1800PF 50V MYLAR CAPA	
C306	QFLB1HJ-182	1800PF 50V MYLAR CAPA	
C307	QFLB1HJ-682	6800PF 50V MYLAR CAPA	
C308	QFLB1HJ-682	6800PF 50V MYLAR CAPA	
C309	QCS21HJ-101A	100PF 50V CER.CAPACI	
C310	QCS21HJ-101A	100PF 50V CER.CAPACI	
C311	QETB1HM-475E	4.7MF 50V E.CAPACITO	
C312	QETB1HM-475E	4.7MF 50V E.CAPACITO	
C313	QETB1AM-107	100MF 10V AL E.CAPAC	
C314	QETB1AM-107	100MF 10V AL E.CAPAC	
C315	QETB1CM-476	47MF 16V AL E.CAPAC	
C316	QETB1CM-476	47MF 16V AL E.CAPAC	
C319	QCF21HP-223A	0.022MF 50V CER.CAPACI	
C320	QCF21HP-223A	0.022MF 50V CER.CAPACI	
C321	QETB1EM-226N	22MF 25V E.CAPACITO	
C322	QETB1EM-226N	22MF 25V E.CAPACITO	
C323	QETB1HM-106	10MF 50V E.CAPACITO	
C324	QETB1HM-106	10MF 50V E.CAPACITO	
C325	QCSB1HK-561Y	560PF 50V CER.CAPACI	
C331	QCF21HP-223A	0.022MF 50V CER.CAPACI	
C341	QETB1HM-475E	4.7MF 50V E.CAPACITO	
C342	QETB1HM-475E	4.7MF 50V E.CAPACITO	
C343	QETB1HM-105	1MF 50V AL E.CAPAC	
C344	QETB1HM-105	1MF 50V AL E.CAPAC	
C345	QETB1EM-106	10MF 25V AL E.CAPAC	
C346	QETB1EM-106	10MF 25V AL E.CAPAC	
C347	QCHB1EZ-223	0.022MF 25V CER.CAPACI	
C348	QCHB1EZ-223	0.022MF 25V CER.CAPACI	
C351	QEK51EM-475G	4.7MF 25V AL E.CAPAC	
C352	QEK51EM-475G	4.7MF 25V AL E.CAPAC	
C353	QCF21HP-223A	0.022MF 50V CER.CAPACI	
C354	QCF21HP-223A	0.022MF 50V CER.CAPACI	
C355	QETB1EM-106	10MF 25V AL E.CAPAC	
C356	QETB1EM-106	10MF 25V AL E.CAPAC	
C361	QER51EM-106	10MF 25V E.CAPACITO	
C362	QER51EM-106	10MF 25V E.CAPACITO	
C371	QCY21HK-331	330PF 50V CER.CAPACI	
C372	QCY21HK-331	330PF 50V CER.CAPACI	
C373	QETB1AM-107	100MF 10V AL E.CAPAC	
C374	QCF21HP-473A	0.047MF 50V CER.CAPACI	
C375	QFLB1HJ-333	0.033MF 50V MYLAR CAPA	
C376	QFLB1HJ-333	0.033MF 50V MYLAR CAPA	
C377	QETB1HM-226E	22MF 50V E.CAPACITO	

Δ : SAFETY PARTS

Resistors

ITEM	PART NUMBER	DESCRIPTION	AREA
R200	QRC128K-275EM	2.7M 1/2W COMPOSITIO	
R201	QRD14CJ-100SX	10 1/4W UNF.CARBON	
R202	QRD14CJ-100SX	10 1/4W UNF.CARBON	
R204	QRD161J-821	820 1/6W CARBON RES	
R221	QRD161J-750	75 1/6W CARBON RES	
R222	QRD161J-680	68 1/6W CARBON RES	
R223	QRD161J-750	75 1/6W CARBON RES	
R224	QRD161J-750	75 1/6W CARBON RES	
R225	QRD161J-473	47K 1/6W CARBON RES	
R226	QRD161J-473	47K 1/6W CARBON RES	

Δ : SAFETY PARTS

Resistors

Δ	ITEM	PART NUMBER	DESCRIPTION			AREA
	R227	QRD161J-331	330	1/6W	CARBON RES	
	R228	QRD161J-331	330	1/6W	CARBON RES	
	R229	QRD167J-152	1.5K	1/6W	CARBON RES	
	R230	QRD167J-152	1.5K	1/6W	CARBON RES	
	R231	QRD167J-151	150	1/6W	CARBON RES	
	R232	QRD167J-151	150	1/6W	CARBON RES	
	R233	QRD167J-152	1.5K	1/6W	CARBON RES	
	R234	QRD161J-473	47K	1/6W	CARBON RES	
	R235	QRD161J-271	270	1/6W	CARBON RES	
	R236	QRD161J-271	270	1/6W	CARBON RES	
	R237	QRD161J-331	330	1/6W	CARBON RES	
	R238	QRD161J-750	75	1/6W	CARBON RES	
	R239	QRD161J-473	47K	1/6W	CARBON RES	
	R240	QRD167J-152	1.5K	1/6W	CARBON RES	
	R251	QRD14CJ-123SX	12K	1/4W	UNF. CARBON	
Δ	R252	QRG022J-391AM	390	2W	OXIDE META	
Δ	R253	QRD14CJ-220S	22	1/4W	UNF. CARBON	
	R254	QRD161J-104	100K	1/6W	CARBON RES	
	R255	QRD161J-270	27	1/6W	CARBON RES	
Δ	R256	QRD14CJ-330SX	33	1/4W	UNF. CARBON	
Δ	R257	QRD14CJ-332SX	33.3K	1/4W	UNF. CARBON	
Δ	R259	QRX022J-1R0AF	1	2W	METAL FILM	
Δ	R260	QRX022J-1R0AF	1	2W	METAL FILM	
Δ	R261	QRD12CJ-2R2SX	2.2	1/2W	CARBON RES	
Δ	R262	QRD12CJ-2R2SX	2.2	1/2W	CARBON RES	
	R263	QRD167J-562	5.6K	1/6W	CARBON RES	
	R264	QRD167J-822	8.2K	1/6W	CARBON RES	
	R265	QRD161J-103	10K	1/6W	CARBON RES	
	R276	QRD161J-102	1K	1/6W	CARBON RES	
	R278	QRD161J-103	10K	1/6W	CARBON RES	
	R291	QRD161J-221	220	1/6W	CARBON RES	
	R292	QRD161J-221	220	1/6W	CARBON RES	
	R293	QRD161J-221	220	1/6W	CARBON RES	
	R299	QRD161J-102	1K	1/6W	CARBON RES	
	R301	QRD161J-222	2.2K	1/6W	CARBON RES	
	R302	QRD161J-222	2.2K	1/6W	CARBON RES	
	R303	QRD161J-473	47K	1/6W	CARBON RES	
	R304	QRD161J-473	47K	1/6W	CARBON RES	
	R305	QRD161J-561	560	1/6W	CARBON RES	
	R306	QRD161J-561	560	1/6W	CARBON RES	
	R307	QRD161J-393	39K	1/6W	CARBON RES	
	R308	QRD161J-393	39K	1/6W	CARBON RES	
	R309	QRD161J-474	470K	1/6W	CARBON RES	
	R310	QRD161J-474	470K	1/6W	CARBON RES	
	R311	QRD161J-104	100K	1/6W	CARBON RES	
	R312	QRD161J-104	100K	1/6W	CARBON RES	
Δ	R313	QRD14CJ-391SX	390	1/4W	UNF. CARBON	
Δ	R314	QRD14CJ-391SX	390	1/4W	UNF. CARBON	
	R315	QRD161J-104	100K	1/6W	CARBON RES	
	R316	QRD161J-104	100K	1/6W	CARBON RES	
	R317	QRD161J-104	100K	1/6W	CARBON RES	
	R318	QRD161J-104	100K	1/6W	CARBON RES	
	R319	QRD161J-753	75K	1/6W	CARBON RES	
	R320	QRD161J-104	100K	1/6W	CARBON RES	
Δ	R321	QRZ0077-680	68	1/4W	FUSIBLE RE	
Δ	R322	QRZ0077-680	68	1/4W	FUSIBLE RE	
	R323	QRD161J-102	1K	1/6W	CARBON RES	
	R324	QRD161J-102	1K	1/6W	CARBON RES	
	R325	QRD161J-103	10K	1/6W	CARBON RES	
	R326	QRD161J-103	10K	1/6W	CARBON RES	
	R327	QRD161J-103	10K	1/6W	CARBON RES	
	R328	QRD161J-103	10K	1/6W	CARBON RES	
	R329	QRD167J-152	1.5K	1/6W	CARBON RES	
	R330	QRD167J-152	1.5K	1/6W	CARBON RES	
	R331	QRD161J-224	220K	1/6W	CARBON RES	
	R332	QRD161J-224	220K	1/6W	CARBON RES	
	R333	QRD161J-224	220K	1/6W	CARBON RES	
	R335	QRD161J-103	10K	1/6W	CARBON RES	
	R336	QRD161J-512	5.1K	1/6W	CARBON RES	
	R337	QRD161J-103	10K	1/6W	CARBON RES	
	R338	QRD161J-512	5.1K	1/6W	CARBON RES	
	R339	QRD161J-104	100K	1/6W	CARBON RES	
	R340	QRD161J-104	100K	1/6W	CARBON RES	
	R341	QRD161J-104	100K	1/6W	CARBON RES	
	R342	QRD161J-104	100K	1/6W	CARBON RES	
	R343	QRD161J-105	1M	1/6W	CARBON RES	
	R344	QRD161J-105	1M	1/6W	CARBON RES	
	R345	QRD161J-823	82K	1/6W	CARBON RES	
	R346	QRD161J-823	82K	1/6W	CARBON RES	
	R347	QRD161J-103	10K	1/6W	CARBON RES	
	R348	QRD161J-103	10K	1/6W	CARBON RES	
	R349	QRD161J-104	100K	1/6W	CARBON RES	
	R350	QRD161J-104	100K	1/6W	CARBON RES	
Δ	R351	QRD14CJ-152SX	1.5K	1/4W	UNF. CARBON	
Δ	R352	QRD14CJ-152SX	1.5K	1/4W	UNF. CARBON	
	R353	QRD161J-563	56K	1/6W	CARBON RES	
	R354	QRD161J-563	56K	1/6W	CARBON RES	
	R355	QRD161J-563	56K	1/6W	CARBON RES	
	R357	QRD161J-103	10K	1/6W	CARBON RES	
	R358	QRD161J-103	10K	1/6W	CARBON RES	

Δ SAFETY PARTS

Resistors

Δ	ITEM	PART NUMBER	DESCRIPTION			AREA
	R359	QRD161J-102	1K	1/6W	CARBON RES	
	R360	QRD161J-102	1K	1/6W	CARBON RES	
Δ	R361	QRZ0077-680	68	1/4W	FUSIBLE RE	
Δ	R362	QRZ0077-680	68	1/4W	FUSIBLE RE	
Δ	R363	QRZ0077-680	68	1/4W	FUSIBLE RE	
Δ	R364	QRZ0077-680	68	1/4W	FUSIBLE RE	
	R365	QRD167J-152	1.5K	1/6W	CARBON RES	
	R366	QRD167J-152	1.5K	1/6W	CARBON RES	
	R367	QRD167J-152	1.5K	1/6W	CARBON RES	
	R368	QRD167J-152	1.5K	1/6W	CARBON RES	
	R369	QRD161J-221	220	1/6W	CARBON RES	
	R371	QRD167J-223	22K	1/6W	CARBON RES	
	R372	QRD167J-223	22K	1/6W	CARBON RES	
	R373	QRD167J-223	22K	1/6W	CARBON RES	
	R374	QRD167J-223	22K	1/6W	CARBON RES	
	R375	QRD161J-222	2.2K	1/6W	CARBON RES	
	R376	QRD161J-222	2.2K	1/6W	CARBON RES	
	R377	QRD161J-202	2K	1/6W	CARBON RES	
	R381	QRD161J-471	470	1/6W	CARBON RES	
	R382	QRD161J-471	470	1/6W	CARBON RES	
	R383	QRD161J-471	470	1/6W	CARBON RES	
	R384	QRD161J-471	470	1/6W	CARBON RES	
	R385	QRD161J-471	470	1/6W	CARBON RES	
	R386	QRD161J-471	470	1/6W	CARBON RES	
	R387	QRD161J-471	470	1/6W	CARBON RES	
	R388	QRD161J-471	470	1/6W	CARBON RES	
	R389	QRD161J-471	470	1/6W	CARBON RES	
	R390	QRD161J-471	470	1/6W	CARBON RES	
	R391	QRD161J-471	470	1/6W	CARBON RES	
	R392	QRD161J-471	470	1/6W	CARBON RES	
	R393	QRD161J-471	470	1/6W	CARBON RES	
	R394	QRD161J-471	470	1/6W	CARBON RES	
	R395	QRD161J-471	470	1/6W	CARBON RES	
	R396	QRD161J-471	470	1/6W	CARBON RES	
	VR360	QVDC94Z-E15EJ5	100K		VARIABLE R	

Δ SAFETY PARTS

Others

Δ	ITEM	PART NUMBER	DESCRIPTION			AREA
		EMW10519-003	PRINTED BOA			
		QWE881-16RR	VINYL WIRE			
		QWE886-16RR	PIN WIRE			
		SBST3008CC	TAPPING SCR			
	J225	EMN00YV-217A	PIN JACK			
	J226	EMN01TV-102A	PIN JACK			
	J227	EMN00TV-116A	PIN JACK			
	J291	QMS3L10-0A0	MICROPHONE			
	J292	QMS3L10-0A0	MICROPHONE			
	J293	QMS3L10-0A0	MICROPHONE			
	J295	EMN00YV-319AJ1	PIN JACK			
	J300	EMN00TV-422AJ2	PIN JACK			
	J301	EMN00TV-615AJ2	PIN JACK			
	J302	EMN00TV-422AJ2	PIN JACK			
	J303	EMN00TV-422AJ2	PIN JACK			
	J551	EMV7159-010	PIN PLUG			
	J703	EMV7125-011R	MALE CONNec			
	J705	EMV7125-006R	CONNECT TER			
	J706	EMV7125-006R	CONNECT TER			
	J707	EMV5163-020R	CONNECT TER			
	P205	VMC0177-003	CONNECT TER			
	P221	EMV5109-006A	CONNECT TER			
	P222	EMV5142-903	CONNECT TER			
	P255	VMC0177-003	CONNECT TER			
	P261	EMV5125-008	MALE CONNec			
	P271	EMV5109-011A	MALE CONNec			
	P311	EMV5109-003A	MALE CONNec			
	P321	EMV5109-006B	CONNECT TER			
	P361	EMV5109-003A	MALE CONNec			
Δ	T202	ETP1000-41JA	POWER TRASN			
Δ	AC201	QMC4002-E02S	AC OUTLET			
	BC221	EWS296-0113	SOCKET WIRE			
	BC321	EWS296-0130	SOCKET WIRE			
	BC702	EWS293-0130	SOCKET WIRE			
	BC708	EWS263-A418	SOCKET WIRE			
	EP201	EMZ4002-001Z	EARTH PLATE			
	EP250	EMZ4002-001Z	EARTH PLATE			
	EP350	E70225-001	EARTH PLATE			
	FC201	VMZ0087-001Z	FUSE HOLDER			
	FC202	VMZ0087-001Z	FUSE HOLDER			
	FC211	VMZ0087-001Z	FUSE HOLDER			
	FC212	VMZ0087-001Z	FUSE HOLDER			
	FC213	VMZ0087-001Z	FUSE HOLDER			
	FC214	VMZ0087-001Z	FUSE HOLDER			
	FW211	EWR368-08SSY	FLAT WIRE			
	HS202	E408032-002SS	HEAT SINK			
	PW710	EWS273-005	SOCKET WIRE			
Δ	RY201	ESK1D12-115	RELAY			
	SH201	E308132-001	SHIELD COVE			
	TA201	EMZ4001-001	TAB			
	TA202	EMZ4001-001	TAB			

Δ SAFETY PARTS



**Transistors**

Δ	ITEM	PART NUMBER	DESCRIPTION	AREA
	Q401	DTC114YS	DIGITAL TRA ROHM	
	Q402	DTC144ES	DIGITAL TRA ROHM	
	Q403	DTC144ES	DIGITAL TRA ROHM	
	Q404	DTA114YS	DIGITAL TRA ROHM	
	Q405	DTA114YS	DIGITAL TRA ROHM	
	Q406	DTC114YS	DIGITAL TRA ROHM	
	Q451	2SC1740S(R,S)	SI.TRANSIST ROHM	
	Q452	2SC1740S(R,S)	SI.TRANSIST ROHM	
	Q457	DTC114YS	DIGITAL TRA ROHM	
	Q458	DTC144ES	DIGITAL TRA ROHM	
	Q459	DTC114YS	DIGITAL TRA ROHM	
	Q501	2SC2240(BL)	SI.TRANSIST	
	Q502	2SC2240(BL)	SI.TRANSIST	
	Q503	2SA1038(R,S)	SI.TRANSIST ROHM	
	Q509	2SC1775AV(F1)	SI.TRANSIST HITACHI	
	Q511	2SC2389(S,E)	SI.TRANSIST ROHM	
	Q512	2SA1038(R,S)	SI.TRANSIST ROHM	

Δ : SAFETY PARTS

**I.C.s**

Δ	ITEM	PART NUMBER	DESCRIPTION	AREA
	IC401	MN172412J5X	I.C(MICRO-C MATSUSHITA	
	IC402	SPS-420-1	INFRARED DE SANYO	
	IC403	MN1281(P,Q)	I.C(DIGI-MO MATSUSHITA	
	IC404	XR1095CP	I.C(MONO-AN EXAR JAPAN	
	IC411	NJU3715L	I.C(MONO-AN DAINICHI	
	IC412	AT24C02-10PC	I.C(EP-ROM) MITSUBISHI	
	IC551	M5243P12	I.C(MONO-AN MITSUBISHI	
	IC552	TC9163N	I.C(DIGI-MO TOSHIBA	

Δ : SAFETY PARTS

**Diodes**

Δ	ITEM	PART NUMBER	DESCRIPTION	AREA
	D401	1SS133	SI.DIODE ROHM	
	D402	1SS133	SI.DIODE ROHM	
	D403	1SS133	SI.DIODE ROHM	
	D404	1SS133	SI.DIODE ROHM	
	D411	SLR-34MC70F124	L.E.D. ROHM	
	D412	SLR-34MC70F124	L.E.D. ROHM	
	D414	SLR-54VCS0F124	L.E.D. ROHM	
	D415	SLR-34VCSF	L.E.D. ROHM	
	D431	1SS133	SI.DIODE ROHM	
	D432	1SS133	SI.DIODE ROHM	
	D433	1SS133	SI.DIODE ROHM	
	D434	1SS133	SI.DIODE ROHM	
	D436	1SS133	SI.DIODE ROHM	
	D437	1SS133	SI.DIODE ROHM	
	D438	MTZ6.2JC	ZENER DIODE ROHM	
	D441	1SS133	SI.DIODE ROHM	
	D442	1SS133	SI.DIODE ROHM	
	D451	MTZ7.5JC	ZENER DIODE ROHM	
	D501	1SS133	SI.DIODE ROHM	
	D502	MTZ18JC	ZENER DIODE ROHM	
	D503	1SS133	SI.DIODE ROHM	
	D504	1SS133	SI.DIODE ROHM	
	D505	1SS133	SI.DIODE ROHM	
	D506	1SS133	SI.DIODE ROHM	
	D551	MTZ6.8JC	ZENER DIODE ROHM	
	D552	MTZ6.8JC	ZENER DIODE ROHM	
	D557	1SS133	SI.DIODE ROHM	
	D558	1SS133	SI.DIODE ROHM	
	D559	1SS133	SI.DIODE ROHM	

Δ : SAFETY PARTS

**Capacitors**

Δ	ITEM	PART NUMBER	DESCRIPTION	AREA
	C401	QETB1AM-227	220MF 10V E.CAPACITO	
	C402	QCZ0202-155	1.5MF 25V CER.RESIST	
	C403	QCHB1EZ-223	0.022MF 25V CER.CAPACI	
	C404	QEK51HM-225G	2.2MF 50V AL E.CAPAC	
	C409	QEAADHZ-479ZB	47000MF E.CAPACITO	
	C411	QETB1HM-225	2.2MF 50V AL E.CAPAC	
	C412	QCZ0202-155	1.5MF 25V CER.RESIST	
	C413	QCHB1EZ-223	0.022MF 25V CER.CAPACI	
	C415	QCHB1EZ-223	0.022MF 25V CER.CAPACI	
	C416	QCHB1EZ-223	0.022MF 25V CER.CAPACI	
	C417	QCB1HK-561Y	560PF 50V CER.CAPACI	
	C451	QCB1HK-331Y	330PF 50V CER.CAPACI	
	C481	QETB1HM-106	10MF 50V E.CAPACITO	
	C482	QCB1HK-102Y	1000PF 50V CER.CAPACI	
	C483	QETB1HM-225	2.2MF 50V AL E.CAPAC	

Δ : SAFETY PARTS

**Capacitors**

Δ	ITEM	PART NUMBER	DESCRIPTION	AREA
	C484	QETB1HM-225	2.2MF 50V AL E.CAPAC	
	C485	QETB1HM-106	10MF 50V E.CAPACITO	
	C500	QCF21HP-223A	0.022MF 50V CER.CAPACI	
	C501	QETB1HM-106	10MF 50V E.CAPACITO	
	C502	QCS21HJ-271A	270PF 50V CER.CAPACI	
	C503	QETB1HM-106	10MF 50V E.CAPACITO	
	C504	QCS21HJ-101A	100PF 50V CER.CAPACI	
	C505	QCS21HJ-5R0	5PF 50V CER.CAPACI	
	C506	QETB1CM-476	47MF 16V AL E.CAPAC	
	C507	QCS22HJ-330	33PF 500V CER.CAPACI	
	C508	QFLB1HJ-103	0.01MF 50V MYLAR CAPA	
	C509	QETB1HM-476	47MF 50V E.CAPACITO	
	C510	QCS22HJ-470A	47PF 500V CER.CAPACI	
	C511	QETB1HM-225	2.2MF 50V AL E.CAPAC	
	C512	QCS22HJ-470A	47PF 500V CER.CAPACI	
	C513	QCF21HP-223A	0.022MF 50V CER.CAPACI	
	C514	QETB2AM-106	10MF 100V AL E.CAPAC	
	C551	QETB1HM-475E	4.7MF 50V E.CAPACITO	
	C552	QETB1HM-475E	4.7MF 50V E.CAPACITO	
	C553	QCB1HK-101Y	100PF 50V CER.CAPACI	
	C554	QCB1HK-101Y	100PF 50V CER.CAPACI	
	C555	QETB1EM-476	47MF 25V AL E.CAPAC	
	C556	QETB1EM-476	47MF 25V AL E.CAPAC	
	C557	QETB1EM-476	47MF 25V AL E.CAPAC	
	C558	QETB1EM-476	47MF 25V AL E.CAPAC	
	C559	QCS21HJ-100	10PF 50V CER.CAPACI	
	C560	QCS21HJ-100	10PF 50V CER.CAPACI	
	C561	QCS21HJ-100	10PF 50V CER.CAPACI	
	C562	QCS21HJ-100	10PF 50V CER.CAPACI	
	C563	QETB1HM-475E	4.7MF 50V E.CAPACITO	
	C564	QETB1HM-475E	4.7MF 50V E.CAPACITO	
	C565	QETB1EM-226N	22MF 25V E.CAPACITO	
	C566	QETB1EM-226N	22MF 25V E.CAPACITO	
	C567	QETB1EM-476	47MF 25V AL E.CAPAC	
	C568	QETB1EM-476	47MF 25V AL E.CAPAC	
	C569	QCHB1EZ-223	0.022MF 25V CER.CAPACI	
	C570	QCHB1EZ-223	0.022MF 25V CER.CAPACI	
	C571	QFLB1HJ-272	2700PF 50V MYLAR CAPA	
	C572	QFLB1HJ-272	2700PF 50V MYLAR CAPA	
	C573	QCB1HK-471Y	470PF 50V CER.CAPACI	
	C574	QCB1HK-471Y	470PF 50V CER.CAPACI	
	C575	QFV81HJ-473	0.047MF 50V THIN FILM	
	C576	QFV81HJ-473	0.047MF 50V THIN FILM	
	C577	QFLB1HJ-822	8200PF 50V MYLAR CAPA	
	C578	QFLB1HJ-822	8200PF 50V MYLAR CAPA	
	C579	QER51HM-684	0.68MF 50V AL E.CAPAC	
	C580	QER51HM-684	0.68MF 50V AL E.CAPAC	
	C581	QFV81HJ-104	0.1MF 50V THIN FILM	
	C582	QFV81HJ-104	0.1MF 50V THIN FILM	
	C583	QCSB1HJ-470	47PF 50V CER.CAPACI	
	C584	QCSB1HJ-470	47PF 50V CER.CAPACI	
	C587	QCS31HJ-561Z	560PF 50V CER.CAPACI	
	C591	QCB1HK-331Y	330PF 50V CER.CAPACI	
	C592	QCB1HK-331Y	330PF 50V CER.CAPACI	
	C593	QCB1HK-331Y	330PF 50V CER.CAPACI	

Δ : SAFETY PARTS

**Resistors**

Δ	ITEM	PART NUMBER	DESCRIPTION	AREA
	R402	QRD161J-103	10K 1/6W CARBON RES	
	R403	QRD161J-103	10K 1/6W CARBON RES	
	R404	QRD161J-103	10K 1/6W CARBON RES	
	R405	QRD161J-104	100K 1/6W CARBON RES	
	R409	QRD161J-331	330 1/6W CARBON RES	
	R410	QRD167J-223	22K 1/6W CARBON RES	
	R411	QRD161J-221	220 1/6W CARBON RES	
	R412	QRD161J-221	220 1/6W CARBON RES	
	R414	QRD161J-221	220 1/6W CARBON RES	
	R415	QRD161J-100	10 1/6W CARBON RES	
	R416	QRD161J-472	4.7K 1/6W CARBON RES	
	R417	QRD161J-472	4.7K 1/6W CARBON RES	
	R418	QRD161J-104	100K 1/6W CARBON RES	
	R419	QRD161J-104	100K 1/6W CARBON RES	
	R421	QRD161J-471	470 1/6W CARBON RES	
	R423	QRD161J-221	220 1/6W CARBON RES	
	R424	QRD161J-471	470 1/6W CARBON RES	
	R425	QRD161J-471	470 1/6W CARBON RES	
	R426	QRD161J-471	470 1/6W CARBON RES	
	R427	QRD161J-471	470 1/6W CARBON RES	
	R428	QRD161J-471	470 1/6W CARBON RES	
	R429	QRD161J-471	470 1/6W CARBON RES	
	R430	QRD161J-471	470 1/6W CARBON RES	
	R431	QRD161J-471	470 1/6W CARBON RES	
	R432	QRD161J-471	470 1/6W CARBON RES	
	R433	QRD161J-471	470 1/6W CARBON RES	
	R434	QRD161J-471	470 1/6W CARBON RES	
	R435	QRD161J-471	470 1/6W CARBON RES	
	R441	QRD161J-104	100K 1/6W CARBON RES	
	R442	QRD161J-104	100K 1/6W CARBON RES	

Δ : SAFETY PARTS

**Resistors**

Δ	ITEM	PART NUMBER	DESCRIPTION			AREA
	R443	QRD161J-104	100K	1/6W	CARBON RES	
	R445	QRD161J-103	10K	1/6W	CARBON RES	
	R446	QRD161J-471	470	1/6W	CARBON RES	
	R451	QRD161J-103	10K	1/6W	CARBON RES	
	R452	QRD161J-473	47K	1/6W	CARBON RES	
	R453	QRD167J-223	22K	1/6W	CARBON RES	
	R454	QRD161J-471	470	1/6W	CARBON RES	
	R455	QRD161J-103	10K	1/6W	CARBON RES	
	R463	QRD161J-471	470	1/6W	CARBON RES	
	R464	QRD161J-471	470	1/6W	CARBON RES	
	R465	QRD161J-103	10K	1/6W	CARBON RES	
	R466	QRD161J-103	10K	1/6W	CARBON RES	
	R467	QRD161J-103	10K	1/6W	CARBON RES	
	R468	QRD161J-103	10K	1/6W	CARBON RES	
	R481	QRD161J-220	22	1/6W	CARBON RES	
	R482	QRD161J-102	1K	1/6W	CARBON RES	
	R483	QRD161J-105	1M	1/6W	CARBON RES	
	R484	QRD161J-105	1M	1/6W	CARBON RES	
	R485	QRD161J-683	68K	1/6W	CARBON RES	
	R486	QRD161J-222	2.2K	1/6W	CARBON RES	
	R491	QRD161J-103	10K	1/6W	CARBON RES	
	R492	QRD161J-221	220	1/6W	CARBON RES	
	R493	QRD161J-103	10K	1/6W	CARBON RES	
	R501	QRD161J-222	2.2K	1/6W	CARBON RES	
	R502	QRD161J-104	100K	1/6W	CARBON RES	
	R503	QRD161J-123	12K	1/6W	CARBON RES	
	R504	QRD161J-202	2K	1/6W	CARBON RES	
	R505	QRD161J-104	100K	1/6W	CARBON RES	
	R506	QRD14CJ-181S	180	1/4W	UNF. CARBON	
Δ	R507	QRD14CJ-332SX	3.3K	1/4W	UNF. CARBON	
	R508	QRD161J-302	3K	1/6W	CARBON RES	
	R509	QRD161J-302	3K	1/6W	CARBON RES	
	R510	QRD161J-302	3K	1/6W	CARBON RES	
Δ	R514	QRD14CJ-100SX	10	1/4W	UNF. CARBON	
Δ	R515	QRD14CJ-561SX	560	1/4W	UNF. CARBON	
Δ	R516	QRD14CJ-100SX	10	1/4W	UNF. CARBON	
	R518	QRD161J-391	390	1/6W	CARBON RES	
	R519	ERT-D2WHL202S	2K	1/4W	NEGATIVE T	
	R520	QRD161J-183	18K	1/6W	CARBON RES	
	R521	QRD161J-123	12K	1/6W	CARBON RES	
Δ	R522	QRD125J-330	33	1/2W	UNF. CARBON	
Δ	R523	QRG022J-562A	5.6K	2W	OXID. META	
	R524	QRD167J-751	750	1/6W	CARBON RES	
	R525	QRD161J-102	1K	1/6W	CARBON RES	
Δ	R526	QRD14CJ-330SX	33	1/4W	UNF. CARBON	
Δ	R527	QRD14CJ-330SX	33	1/4W	UNF. CARBON	
Δ	R528	ERF032K-R22	0.22	3W	CEM. RESIST	
	R529	QRD167J-151	150	1/6W	CARBON RES	
	R530	QRD167J-151	150	1/6W	CARBON RES	
	R531	QRD167J-151	150	1/6W	CARBON RES	
	R532	QRD167J-151	150	1/6W	CARBON RES	
	R553	QRD161J-104	100K	1/6W	CARBON RES	
	R554	QRD161J-104	100K	1/6W	CARBON RES	
	R555	QRD161J-104	100K	1/6W	CARBON RES	
	R556	QRD161J-104	100K	1/6W	CARBON RES	
	R557	QRD161J-103	10K	1/6W	CARBON RES	
	R558	QRD161J-103	10K	1/6W	CARBON RES	
	R559	QRD161J-103	10K	1/6W	CARBON RES	
	R560	QRD161J-103	10K	1/6W	CARBON RES	
	R561	QRD161J-303Y	30K	1/6W	CARBON RES	
	R562	QRD161J-303Y	30K	1/6W	CARBON RES	
	R563	QRD161J-123	12K	1/6W	CARBON RES	
	R564	QRD161J-123	12K	1/6W	CARBON RES	
	R565	QRD161J-472	4.7K	1/6W	CARBON RES	
	R566	QRD161J-472	4.7K	1/6W	CARBON RES	
	R567	QRD161J-183	18K	1/6W	CARBON RES	
	R568	QRD161J-183	18K	1/6W	CARBON RES	
	R569	QRD161J-912	9.1K	1/6W	CARBON RES	
	R570	QRD161J-912	9.1K	1/6W	CARBON RES	
	R571	QRD161J-243	24K	1/6W	CARBON RES	
	R572	QRD161J-243	24K	1/6W	CARBON RES	
	R573	QRD161J-103	10K	1/6W	CARBON RES	
	R574	QRD161J-103	10K	1/6W	CARBON RES	
	R575	QRD161J-333	33K	1/6W	CARBON RES	
	R576	QRD161J-333	33K	1/6W	CARBON RES	
	R577	QRD161J-104	100K	1/6W	CARBON RES	
	R578	QRD161J-104	100K	1/6W	CARBON RES	
Δ	R579	QRD14CJ-681SX	680	1/4W	UNF. CARBON	
Δ	R580	QRD14CJ-681SX	680	1/4W	UNF. CARBON	
Δ	R581	QRD14CJ-680SX	68	1/4W	UNF. CARBON	
Δ	R582	QRD14CJ-680SX	68	1/4W	UNF. CARBON	
	R583	QRD161J-102	1K	1/6W	CARBON RES	
	R584	QRD161J-102	1K	1/6W	CARBON RES	
	R587	QRD161J-473	47K	1/6W	CARBON RES	
	R588	QRD161J-473	47K	1/6W	CARBON RES	
	R591	QRD161J-471	470	1/6W	CARBON RES	
	R592	QRD161J-471	470	1/6W	CARBON RES	
	RA403	QRB079J-104	100K	1/10W	NETWORK RE	
	RA404	QRB139J-104	100K	1/10W	RESISTOR	
	RA407	QRB069J-104	100K	1/10W	NETWORK RE	
	RA408	QRB059J-103	10K	1/10W	NETWORK RE	

Δ : SAFETY PARTS

**Others**

Δ	ITEM	PART NUMBER	DESCRIPTION		AREA
	J205	EMW10520-003	PRINTED BOA		
	J255	VMC0178-003	CONNECT TER		
	J261	EMV7125-008R	MALE CONNec		
	J591	EMN00YP-308A	PIN JACK		
	J709	EMV7125-008R	MALE CONNec		
	L501	EQL0011-R45J1	INDUCTOR		
	P401	EMV5109-012B	CONNECT TER		
	P402	EMV5109-013A	CONNECT TER		
	P551	EMV5159-010R	CONNECT TER		
	S401	ESP0001-023M	TACT SWITCH POWER		
	S402	ESP0001-023M	TACT SWITCH SEA ON/OFF		
	S403	ESP0001-023M	TACT SWITCH SEA FLAT		
	S404	ESP0001-023M	TACT SWITCH SPI/SEA		
	S405	ESP0001-023M	TACT SWITCH EFFECT +		
	S406	ESP0001-023M	TACT SWITCH MODE +		
	S407	ESP0001-023M	TACT SWITCH CURSOL MODE		
	S408	ESP0001-023M	TACT SWITCH DAP ON/OFF		
	S409	ESP0001-023M	TACT SWITCH EFFECT -		
	S410	ESP0001-023M	TACT SWITCH MODE -		
	S411	ESP0001-023M	TACT SWITCH SURROUND ON/OFF		
	S412	ESP0001-023M	TACT SWITCH CENTER MODE		
	S413	ESP0001-023M	TACT SWITCH LOUDNESS		
	S414	ESP0001-023M	TACT SWITCH FM MODE		
	S415	ESP0001-023M	TACT SWITCH CHARACTER		
	S416	ESP0001-023M	TACT SWITCH TUNING/PTY SEARCH		
	S417	ESP0001-023M	TACT SWITCH PRESET/PRESET→TUNING		
	S418	ESP0001-023M	TACT SWITCH ENTER		
	S419	ESP0001-023M	TACT SWITCH TAPE2 MONITOR		
	S420	ESP0001-023M	TACT SWITCH CSR/PEON		
	S422	Q5J4002-E01	PUSH SWITCH SOURCE SELECT		
	S423	Q5J4002-E01	PUSH SWITCH TUNER CONTROL		
	X401	ECXP6R0-001ZA	CRYSTAL		
	BC222	EWS323-A940J	SOCKET WIRE		
	BC271	EWS26B-A426J	SOCKET WIRE		
	BC311	EWS293-0140J	SOCKET WIRE		
	BC361	EWS293-0125	SOCKET WIRE		
	BC401	EWS26B-A408J	SOCKET WIRE		
	BC402	EWS26D-A408J	SOCKET WIRE		
	BC701	EWS26B-A416J	SOCKET WIRE		
	BC704	EWS26B-A422J	SOCKET WIRE		
	FL401	ELU0001-202	FLUORESCENT		
	JA441	EMV7123-021R	CONNECTOR		

Δ : SAFETY PARTS



■ ENA-163 [A] Tuner PC Board Assy

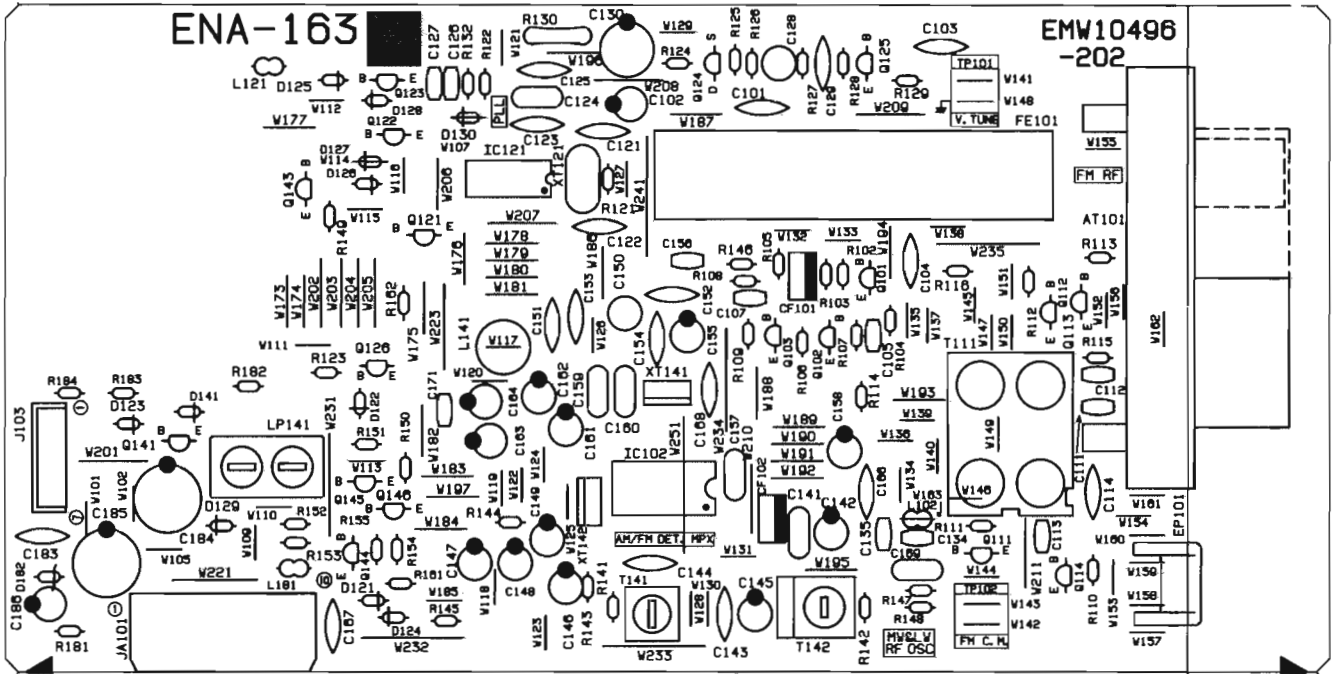

**Transistors**

Δ	ITEM	PART NUMBER	DESCRIPTION	AREA
	Q101	2SC461	SI.TRANSIST	
	Q102	2SC535	SI.TRANSIST HITACHI	
	Q103	2SC461	SI.TRANSIST	
	Q121	DTA144ES	DIGITAL TRA ROHM	
	Q122	DTA144ES	DIGITAL TRA ROHM	
	Q124	2SK301(P,Q)	F.E.T.	
	Q125	2SC458(C,D)	SI.TRANSIST HITACHI	
	Q126	DTC114ES	DIGITAL TRA ROHM	
	Q141	DTC114ES	DIGITAL TRA ROHM	
	Q143	DTC114ES	DIGITAL TRA ROHM	

Δ : SAFETY PARTS

**I.C.s**

Δ	ITEM	PART NUMBER	DESCRIPTION	AREA
	IC102	LA1836M	I.C.(MONO-AN SANYO	
	IC121	LC7218JMX	I.C.(DIGI-MO SANYO	

Δ : SAFETY PARTS

**Diodes**

Δ	ITEM	PART NUMBER	DESCRIPTION	AREA
	D121	1SS133	SI.DIODE ROHM	
	D122	1SS133	SI.DIODE ROHM	
	D123	1SS133	SI.DIODE ROHM	
	D124	1SS133	SI.DIODE ROHM	
	D126	1SS133	SI.DIODE ROHM	
	D129	1SS133	SI.DIODE ROHM	
	D130	1SS133	SI.DIODE ROHM	
	D141	1SS133	SI.DIODE ROHM	
	D182	MTZ5.1JC	ZENER DIODE ROHM	

Δ : SAFETY PARTS

**Capacitors**

Δ	ITEM	PART NUMBER	DESCRIPTION	AREA
	C101	QCF21HP-103A	0.01MF 50V CER.CAPACI	
	C103	QCF21HP-223A	0.022MF 50V CER.CAPACI	
	C104	QCF21HP-223A	0.022MF 50V CER.CAPACI	
	C105	QCHB1EZ-223	0.022MF 25V CER.CAPACI	
	C107	QCHB1EZ-223	0.022MF 25V CER.CAPACI	
	C111	QCHB1EZ-223	0.022MF 25V CER.CAPACI	
	C112	QCT30CH-120Y	12PF 50V CER.CAPACI	
	C114	QCC21EM-473	0.047MF 25V CER.CAPACI	
	C121	QCS21HJ-180A	18PF 50V CER.CAPACI	
	C122	QCS21HJ-180A	18PF 50V CER.CAPACI	

Δ : SAFETY PARTS

**Capacitors**

Δ	ITEM	PART NUMBER	DESCRIPTION	AREA
	C123	QCC21EM-473	0.047MF 25V CER.CAPACI	
	C124	QCZ0202-155	1.5MF 25V CER.RESIST	
	C125	QCF21HP-223A	0.022MF 50V CER.CAPACI	
	C126	QCBB1HK-101Y	100PF 50V CER.CAPACI	
	C127	QCBB1HK-101Y	100PF 50V CER.CAPACI	
	C128	QENB1HM-474	0.47MF 50V NP E.CAPAC	
	C129	QCY31HK-102Z	1000PF 50V CER.CAPACI	
	C130	QETB1CM-227	220MF 16V AL E.CAPAC	
	C141	QFLB3HJ-473	0.047MF 50V MYLAR CAPA	
	C142	QETB1HM-106	10MF 50V E.CAPACITO	
	C143	QCF21HP-223A	0.022MF 50V CER.CAPACI	
	C144	QCC21EM-473	0.047MF 25V CER.CAPACI	
	C145	QETB1HM-475E	4.7MF 50V E.CAPACITO	
	C146	QETB1HM-106	10MF 50V E.CAPACITO	
	C147	QETB1HM-105	1MF 50V AL E.CAPAC	
	C148	QETB1HM-474	0.47MF 50V ELECTRO	
	C149	QETB1HM-105	1MF 50V AL E.CAPAC	
	C150	QETC1HM-225ZM	2.2MF 50V AL E.CAPAC	
	C153	QCY31HK-102Z	1000PF 50V CER.CAPACI	
	C154	QCY31HK-472Z	4700PF 50V CER.CAPACI	
	C155	QETB1EM-476	47MF 25V AL E.CAPAC	
	C156	QCHB1EZ-223	0.022MF 25V CER.CAPACI	
	C157	QCZ0202-155	1.5MF 25V CER.RESIST	
	C158	QETB1HM-106	10MF 50V E.CAPACITO	
	C159	QFLB3HJ-333	0.033MF 50V MYLAR CAPA	
	C160	QFLB3HJ-333	0.033MF 50V MYLAR CAPA	
	C161	QETB1HM-225	2.2MF 50V AL E.CAPAC	
	C162	QETB1HM-225	2.2MF 50V AL E.CAPAC	
	C163	QETB1HM-225	2.2MF 50V AL E.CAPAC	
	C164	QETB1HM-225	2.2MF 50V AL E.CAPAC	
	C166	QCC21EM-473	0.047MF 25V CER.CAPACI	
	C168	QCC21EM-473	0.047MF 25V CER.CAPACI	
	C169	QFV81HJ-274	0.27MF 50V T.FILM CAP	
	C171	QCBB1HK-102Y	1000PF 50V CER.CAPACI	
	C183	QCF21HP-223A	0.022MF 50V CER.CAPACI	
	C184	QETB1CM-227	220MF 16V AL E.CAPAC	
	C185	QETB1CM-477M	470MF 16V E.CAPACITO	
	C186	QETB1HM-475E	4.7MF 50V E.CAPACITO	

Δ : SAFETY PARTS

**Resistors**

Δ	ITEM	PART NUMBER	DESCRIPTION	AREA
	R102	QRD167J-332	3.3K 1/6W CARBON RES	
	R103	QRD161J-221	220 1/6W CARBON RES	
	R104	QRD167J-272	2.7K 1/6W CARBON RES	
	R105	QRD161J-391	390 1/6W CARBON RES	
	R106	QRD161J-102	1K 1/6W CARBON RES	
	R107	QRD161J-681	680 1/6W CARBON RES	
	R108	QRD167J-332	3.3K 1/6W CARBON RES	
	R109	QRD161J-221	220 1/6W CARBON RES	
	R115	QRD161J-104	100K 1/6W CARBON RES	
	R116	QRD161J-222	2.2K 1/6W CARBON RES	

Δ : SAFETY PARTS

**Resistors**

Δ	ITEM	PART NUMBER	DESCRIPTION	AREA
	R121	QRD161J-473	47K 1/6W CARBON RES	
	R122	QRD161J-472	4.7K 1/6W CARBON RES	
	R123	QRD167J-562	5.6K 1/6W CARBON RES	
	R124	QRD161J-222	2.2K 1/6W CARBON RES	
	R125	QRD161J-222	2.2K 1/6W CARBON RES	
	R126	QRD161J-181	180 1/6W CARBON RES	
	R127	QRD167J-822	8.2K 1/6W CARBON RES	
	R128	QRD161J-472	4.7K 1/6W CARBON RES	
	R129	QRD161J-222	2.2K 1/6W CARBON RES	
	R130	QRD14CJ-680SX	68 1/4W UNF. CARBON	
	R132	QRD161J-102	1K 1/6W CARBON RES	
	R141	QRD161J-392	3.9K 1/6W CARBON RES	
	R142	QRD161J-103	10K 1/6W CARBON RES	
	R143	QRD161J-103	10K 1/6W CARBON RES	
	R144	QRD167J-332	3.3K 1/6W CARBON RES	
	R145	QRD161J-103	10K 1/6W CARBON RES	
	R146	QRD161J-222	2.2K 1/6W CARBON RES	
	R147	QRD167J-223	22K 1/6W CARBON RES	
	R148	QRD161J-561	560 1/6W CARBON RES	
	R149	QRD167J-223	22K 1/6W CARBON RES	
	R150	QRD167J-332	3.3K 1/6W CARBON RES	
	R151	QRD167J-332	3.3K 1/6W CARBON RES	
	R152	QRD167J-332	3.3K 1/6W CARBON RES	
	R153	QRD167J-332	3.3K 1/6W CARBON RES	
	R161	QRD161J-473	47K 1/6W CARBON RES	
	R162	QRD161J-222	2.2K 1/6W CARBON RES	
	R181	QRD161J-222	2.2K 1/6W CARBON RES	
	R182	QRD161J-103	10K 1/6W CARBON RES	
	R183	QRD161J-103	10K 1/6W CARBON RES	
	R184	QRD161J-473	47K 1/6W CARBON RES	

Δ : SAFETY PARTS

**Others**

Δ	ITEM	PART NUMBER	DESCRIPTION	AREA
	J103	EMW10496-202A	CIR. BOARD	
	L121	E308963-001	SHIELD BRAC	
	L181	EMV5109-007A	MALE CONNec	
	L121	EQL4007-1R0	INDUCTOR	
	L181	EQL4007-1R0	INDUCTOR	
	T111	EQR7121-004	RF COIL	
	T141	EQT2140-021	I.F. TRANSFO	
	T142	ECB1560-010	CERAMIC FIL	
	AT101	EMB41YV-302K	ANTENNA TER	
	CF101	ECB2123-006R	CERAMIC FIL	
	CF102	ECB2123-006R	CERAMIC FIL	
	EP101	E70225-001	EARTH PLATE	
	FE101	EAF2203-004	FRONT END	
	JA101	EMV7140-L10R	PIN CONNECT	
	LP141	EQF0101-002	LOWPASS FIL	
	XT121	ECX0007-200KWJ1	CRYSTAL	
	XT141	ECXPR46-001A	CRYSTAL	
	XT142	ECB1001-002	CERAMIC FIL	

Δ : SAFETY PARTS

■ ENP-054 A DSP PC Board Assy

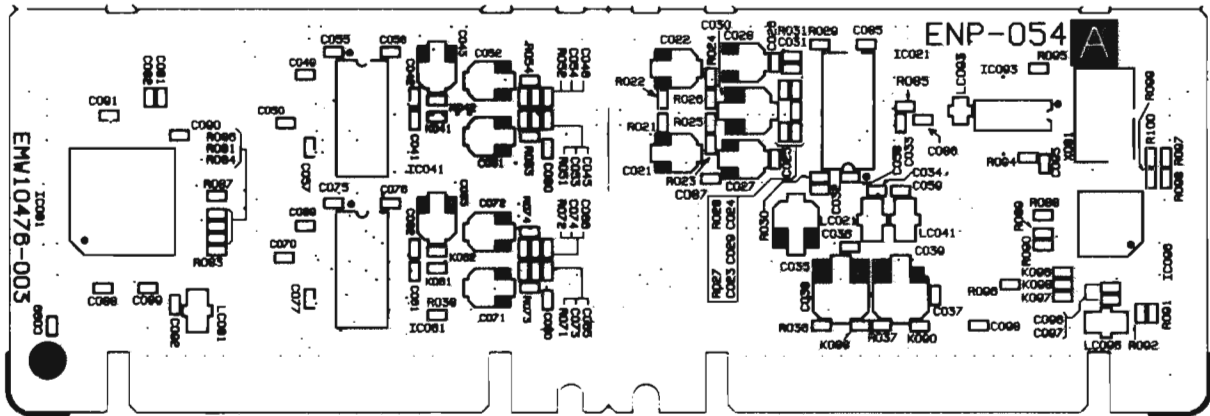

**I.C.s**

Δ	ITEM	PART NUMBER	DESCRIPTION	AREA
	IC021	SAA7366TX	I.C.(DIGI-MO	
	IC041	TDA1386TX	I.C.(MONO-AN	
	IC061	TDA1386TX	I.C.(MONO-AN	
	IC081	TC9332F-010	I.C.(M) TOSHIBA	
	IC093	TC74HC74AFT1	I.C.(DIGI-MO TOSHIBA	
	IC096	TMP87C847U-4195	I.C.(M) TOSHIBA	

Δ : SAFETY PARTS

**Capacitors**

Δ	ITEM	PART NUMBER	DESCRIPTION	AREA
	C021	NEA71EM-475NZ	4.7MF 25V E.CAPACITO	
	C022	NEA71EM-475NZ	4.7MF 25V E.CAPACITO	
	C023	NCS31HJ-680AY	68PF 50V CER.CAPACI	
	C024	NCS31HJ-680AY	68PF 50V CER.CAPACI	
	C025	NCB21CK-473AYU	0.047MF 16V CER.CAPACI	
	C026	NCB21CK-473AYU	0.047MF 16V CER.CAPACI	
	C027	NEA70GM-476NZ	47MF E.CAPACITO	
	C028	NEA70GM-476NZ	47MF E.CAPACITO	
	C029	NCB21CK-473AYU	0.047MF 16V CER.CAPACI	
	C030	NEA70JM-476NZ	47MF 6.3V E.CAPACITO	

Δ : SAFETY PARTS

**Capacitors**

Δ	ITEM	PART NUMBER	DESCRIPTION	AREA
	C031	NCB31CK-223A	0.022MF 16V CER.CAPACI	
	C032	NCB31HK-102AY	1000PF 50V CER.CAPACI	
	C033	NCF31AZ-105AYU1MF	10V CER.CAPACI	
	C035	NEA70JM-476NZ	47MF 6.3V E.CAPACITO	
	C036	NCF31AZ-105AYU1MF	10V CER.CAPACI	
	C037	NCF31AZ-105AYU1MF	10V CER.CAPACI	
	C038	NEA70JM-107NP	100MF 6.3V E.CAPACITO	
	C039	NEA70JM-107NP	100MF 6.3V E.CAPACITO	
	C041	NCS21HJ-102	1000PF 50V CER.CAPACI	
	C042	NCS21HJ-102	1000PF 50V CER.CAPACI	
	C043	NEA71CM-106NZ	10MF 16V E.CAPACITO	
	C049	NCB21CK-104AYU	0.1MF 16V CER.CAPACI	
	C050	NCB21CK-104AYU	0.1MF 16V CER.CAPACI	
	C051	NEA71HM-105NZ	1MF 50V E.CAPACITO	
	C052	NEA71HM-105NZ	1MF 50V E.CAPACITO	
	C053	NCB31CK-183AY	0.018MF 16V CER.CAPACI	
	C054	NCB31CK-183AY	0.018MF 16V CER.CAPACI	
	C055	NCB31HK-102AY	1000PF 50V CER.CAPACI	
	C056	NCB31HK-102AY	1000PF 50V CER.CAPACI	
	C057	NCB31HK-102AY	1000PF 50V CER.CAPACI	
	C058	NCF31AZ-105AYU1MF	10V CER.CAPACI	
	C059	NCF31AZ-105AYU1MF	10V CER.CAPACI	
	C061	NCS21HJ-102	1000PF 50V CER.CAPACI	
	C062	NCS21HJ-102	1000PF 50V CER.CAPACI	
	C063	NEA71CM-106NZ	10MF 16V E.CAPACITO	

Δ : SAFETY PARTS

**Capacitors**

ITEM	PART NUMBER	DESCRIPTION	AREA
C069	NCB21CK-104AYU	0.1MF 16V CER.CAPACI	
C070	NCB21CK-104AYU	0.1MF 16V CER.CAPACI	
C071	NEA71HM-105NZ	1MF 50V E.CAPACITO	
C072	NEA71HM-105NZ	1MF 50V E.CAPACITO	
C073	NCB31CK-183AY	0.018MF 16V CER.CAPACI	
C074	NCB31CK-183AY	0.018MF 16V CER.CAPACI	
C075	NCB31HK-102AY	1000PF 50V CER.CAPACI	
C076	NCB31HK-102AY	1000PF 50V CER.CAPACI	
C077	NCB31HK-102AY	1000PF 50V CER.CAPACI	
C081	NCS31HD-9R0AYM	9PF 50V CER.CAPACI	
C082	NCS31HD-9R0AYM	9PF 50V CER.CAPACI	
C085	NCB21CK-104AYU	0.1MF 16V CER.CAPACI	
C086	NCB21CK-104AYU	0.1MF 16V CER.CAPACI	
C088	NCB31HK-102AY	1000PF 50V CER.CAPACI	
C089	NCB31HK-102AY	1000PF 50V CER.CAPACI	
C090	NCB31HK-102AY	1000PF 50V CER.CAPACI	
C091	NCB31HK-102AY	1000PF 50V CER.CAPACI	
C092	NCF31AZ-105AYU	1MF 10V CER.CAPACI	
C095	NCB31HK-102AY	1000PF 50V CER.CAPACI	
C096	NCB31HK-102AY	1000PF 50V CER.CAPACI	
C097	NCF31AZ-105AYU	1MF 10V CER.CAPACI	
C098	NCB31HK-102AY	1000PF 50V CER.CAPACI	
C099	NCS31HJ-101AY	100PF 50V CER.CAPACI	

▲ SAFETY PARTS

**Resistors**

ITEM	PART NUMBER	DESCRIPTION	AREA
R021	NRSA63J-104NY	METAL GLAZ	
R022	NRSA63J-104NY	METAL GLAZ	
R023	NRSA63J-103N	METAL GLAZ	
R024	NRSA63J-103N	METAL GLAZ	
R025	NRSA63J-624NY	METAL GLAZ	
R026	NRSA63J-334NY	METAL GLAZ	
R027	NRSA63F-103NY	METAL GLAZ	
R028	NRSA63F-103NY	METAL GLAZ	
R029	NRSA63J-271NY	METAL GLAZ	
R030	NRSA63J-271NY	METAL GLAZ	
R031	NRSA63J-333NY	METAL GLAZ	
R036	NRSA63J-0R0AY	METAL GLAZ	
R037	NRSA63J-0R0AY	METAL GLAZ	
R038	NRSA63J-0R0AY	METAL GLAZ	
R041	NRSA63J-0R0AY	METAL GLAZ	
R042	NRSA63J-0R0AY	METAL GLAZ	
R051	NRSA63J-473NY	METAL GLAZ	
R052	NRSA63J-473NY	METAL GLAZ	
R053	NRSA63J-201NY	METAL GLAZ	
R054	NRSA63J-201NY	METAL GLAZ	
R061	NRSA63J-0R0AY	METAL GLAZ	
R062	NRSA63J-0R0AY	METAL GLAZ	
R071	NRSA63J-473NY	METAL GLAZ	
R072	NRSA63J-473NY	METAL GLAZ	
R073	NRSA63J-201NY	METAL GLAZ	
R074	NRSA63J-201NY	METAL GLAZ	
R081	NRSA63J-0R0AY	METAL GLAZ	
R083	NRSA63J-112NY	METAL GLAZ	
R084	NRSA63J-112NY	METAL GLAZ	
R085	NRSA63J-112NY	METAL GLAZ	
R086	NRSA63J-182NY	METAL GLAZ	
R087	NRSA63J-112NY	METAL GLAZ	
R088	NRSA63J-0R0AY	METAL GLAZ	
R089	NRSA63J-0R0AY	METAL GLAZ	
R090	NRSA63J-0R0AY	METAL GLAZ	
R091	NRSA63J-0R0AY	METAL GLAZ	
R092	NRSA63J-0R0AY	METAL GLAZ	
R093	NRSA63J-0R0AY	METAL GLAZ	
R094	NRSA63J-471N	METAL GLAZ	
R095	NRSA63J-103N	METAL GLAZ	
R096	NRSA63J-103N	METAL GLAZ	
R097	NRSA63J-472NY	METAL GLAZ	
R098	NRSA63J-472NY	METAL GLAZ	
R099	NRSA63J-472NY	METAL GLAZ	
R100	NRSA63J-472NY	METAL GLAZ	

▲ SAFETY PARTS

**Others**

ITEM	PART NUMBER	DESCRIPTION	AREA
	EMW10476-003A	CIR.BOARD	
K041	EQA0002-N102Y	FERRITE BEA	
K042	EQA0002-N102Y	FERRITE BEA	
K061	EQA0002-N102Y	FERRITE BEA	
K062	EQA0002-N102Y	FERRITE BEA	
K081	EQA0002-N102Y	FERRITE BEA	
K082	EQA0002-N102Y	FERRITE BEA	
K083	EQA0002-N102Y	FERRITE BEA	
K084	EQA0002-N102Y	FERRITE BEA	
K085	EQA0002-N102Y	FERRITE BEA	
K086	EQA0002-N102Y	FERRITE BEA	
K087	EQA0001-N01Y	FERRITE BEA	
K088	EQA0001-N01Y	FERRITE BEA	
K089	EQA0001-N01Y	FERRITE BEA	
K090	EQA0001-N01Y	FERRITE BEA	
K091	EQA0002-N102Y	FERRITE BEA	
K092	EQA0002-N102Y	FERRITE BEA	
K093	EQA0002-N102Y	FERRITE BEA	
K094	EQA0002-N102Y	FERRITE BEA	
K095	EQA0002-N102Y	FERRITE BEA	
K096	EQA0002-N102Y	FERRITE BEA	
K097	EQA0002-N102Y	FERRITE BEA	
K098	EQA0002-N102Y	FERRITE BEA	
X081	ECX0225-792EN9T	CRYSTAL	
LC021	EQF0703-N103NZ	INDUCTOR	
LC041	EQF0703-N103NZ	INDUCTOR	
LC081	EQF0703-N103NZ	INDUCTOR	
LC093	EQF0704-N01YU	INDUCTOR	
LC096	EQF0703-N103NZ	INDUCTOR	

▲ SAFETY PARTS

# Accessories List

Symbol No. 

M	2	M	M
---	---	---	---

⚠	Item	Part Number	Part Name	Q'ty	Description	Area
	1	E30580-2251A	INSTRUCTION BOOK	1		J
		E30580-2252A	INSTRUCTION BOOK	1		C
	2	RM-SR817U	WIRE-LESS REMOTE CONTROL	1		
	3	R6PRPA-2STSA	DRY CELL	1		
	4	E03614-004	FM FEEDER ANTENNA	1		
	5	EQB4001-015	LOOP ANTENNA	1		
	6	EMZ2001-014	ADAPTOR PLUG	1		
	7	QPGA025-03505B	POLY BAG	1		
	--	BT-20025M	WARRANTY CARD	1		C
	--	BT-20071B	SERVICE NETWORK	1		C
	--	BT-51006-1	REGISTER CARD	1		J
	--	BT-20044G	SAFETY SHEET	1		J

**The Marks for Designated Areas**

J ..... the U.S.A.

C ..... Canada

No mark indicates all area.

# Packing Materials and Part Numbers

Symbol No. 

M	3	M	M
---	---	---	---

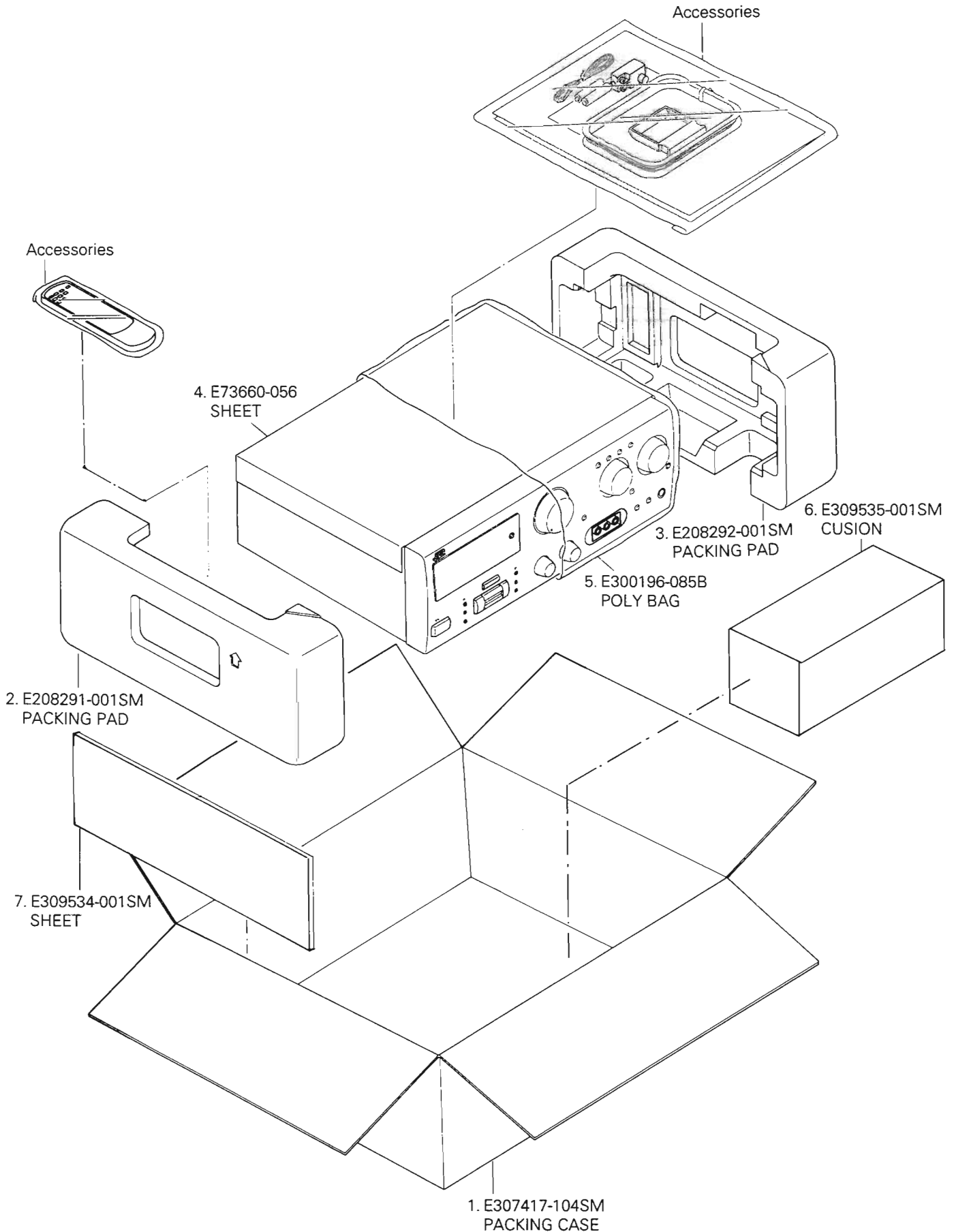



RX-816VBK  
RX-817VTN

**JVC**

VICTOR COMPANY OF JAPAN, LIMITED

AUDIO DIVISION, YAMATO PLANT, 1644, SHIMOTSURUMA, YAMATO-SHI, KANAGAWA-KEN, 242, JAPAN

