

# JVC

## SERVICE MANUAL

### AUDIO/VIDEO CONTROL RECEIVER

# RX-818VBK RX-880VBK

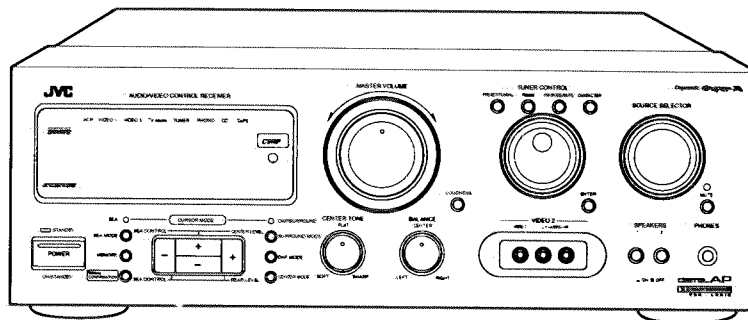
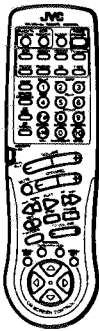

**Area Suffix**  
C ..... Canada  
J ..... the U.S.A.

**COMPU LINK**  
Remote Control Component

**AV COMPU LINK**

## Contents

<i>Safety Precautions</i> .....	1-2	<i>Block Diagrams</i> .....	2-24
<i>Instruction Book</i> .....	1-3	<i>Schematic Diagrams</i> .....	2-26
<i>Description of Major ICs</i> .....	2-1	<i>Printed Circuit Boards</i> .....	2-32
<i>Internal Connection of FL Display</i> .....	2-18	<i>Parts List</i>	
<i>Disassembly Procedures</i> .....	2-20	RX-818VBK .....	3-1
<i>Adjustment Procedures</i> .....	2-22	RX-880VBK .....	4-1

### Safety Precautions

1. The design of this product contains special hardware and many circuits and components specially for safety purposes. For continued protection, no changes should be made to the original design unless authorized in writing by the manufacturer. Replacement parts must be identical to those used in the original circuits. Services should be performed by qualified personnel only.
2. Alterations of the design or circuitry of the product should not be made. Any design alterations of the product should not be made. Any design alterations or additions will void the manufacturer's warranty and will further relieve the manufacture of responsibility for personal injury or property damage resulting therefrom.
3. Many electrical and mechanical parts in the products have special safety-related characteristics. These characteristics are often not evident from visual inspection nor can the protection afforded by them necessarily be obtained by using replacement components rated for higher voltage, wattage, etc. Replacement parts which have these special safety characteristics are identified in the Parts List of Service Manual. Electrical components having such features are identified by shading on the schematics and by ( $\Delta$ ) on the Parts List in the Service Manual. The use of a substitute replacement which does not have the same safety characteristics as the recommended replacement parts shown in the Parts List of Service Manual may create shock, fire, or other hazards.
4. The leads in the products are routed and dressed with ties, clamps, tubings, barriers and the like to be separated from live parts, high temperature parts, moving parts and/or sharp edges for the prevention of electric shock and fire hazard. When service is required, the original lead routing and dress should be observed, and it should be confirmed that they have been returned to normal, after re-assembling.
5. Leakage current check (Electrical shock hazard testing)  
After re-assembling the product, always perform an isolation check on the exposed metal parts of the product (antenna terminals, knobs, metal cabinet, screw heads, headphone jack, control shafts, etc.) to be sure the product is safe to operate without danger of electrical shock.

Do not use a line isolation transformer during this check.

- Plug the AC line cord directly into the AC outlet. Using a "Leakage Current Tester", measure the leakage current from each exposed metal parts of the cabinet, particularly any exposed metal part having a return path to the chassis, to a known good earth ground. Any leakage current must not exceed 0.5mA AC (r.m.s.).

- Alternate check method  
Plug the AC line cord directly into the AC outlet. Use an AC voltmeter having, 1,000 ohms per volt or more sensitivity in the following manner. Connect a 1,500 $\Omega$  10 W resistor paralleled by a 0.15  $\mu$ F AC-type capacitor between an exposed metal part and a known good earth ground.

Measure the AC voltage across the resistor with the AC voltmeter.

Move the resistor connection to each exposed metal part, particularly any exposed metal part having a return path to the chassis, and measure the AC voltage across the resistor.

Now, reverse the plug in the AC outlet and repeat each measurement. Any voltage measured must not exceed 0.75 V AC (r.m.s.). This corresponds to 0.5 mA AC (r.m.s.).

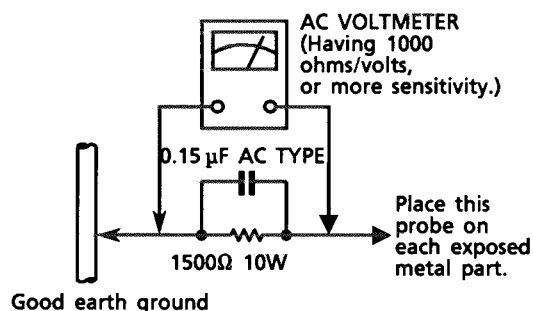

### Warning

1. This equipment has been designed and manufactured to meet international safety standards.
2. It is the legal responsibility of the repairer to ensure that these safety standards are maintained.
3. Repairs must be made in accordance with the relevant safety standards.
4. It is essential that safety critical components are replaced by approved parts.
5. If mains voltage selector is provided, check setting for local voltage.

# Instruction Book

## Getting Started

This section explains how to connect stereo components and speakers to the receiver, and how to connect the power supply.

## Before Installation

- General**
- Be sure your hands are dry.
  - Turn the power off to all components.
  - Read the manuals supplied with the components you are going to connect.

- Locations**
- Install the receiver in a location that is level and protected from moisture.
  - The temperature around the receiver must be between 23° and 104° F (-5° and 40° C).
  - Make sure there is good ventilation around the receiver. Poor ventilation could cause overheating and damage the receiver.

- Handling the receiver**
- Do not insert any metal object into the receiver.
  - Do not disassemble the receiver or remove screws, covers, or cabinet.
  - Do not expose the receiver to rain or moisture.

## Checking the Supplied Accessories

Check to be sure you have all of the following items, which are supplied with the receiver. The number in the parenthesis indicates the quantity of the pieces supplied.

- Remote Control (1)
- Batteries (2)
- AM Loop Antenna (1)
- FM Wire Antenna (1)

If anything is missing, contact your dealer immediately.

## About this manual

This manual explains how to use RX-818VBK and RX-880VBK. These models are identical except the following.

Function	RX-818VBK	RX-880VBK	Reference page
REAR OUT jacks	No	Yes	Page 6
PARTIAL ON-SCREEN Superimpose	No	Yes	Page 32
	No	Yes	Below*

Yes: The model is equipped with the function.  
No: The model is not equipped with the function.

### \* What is Superimpose ?

This function is equipped only for RX-880VBK, and allows you to see the on-screen displays over the pictures shown on the TV screen. So, you can use the on-screen displays such as Menus, Visual Confirmation, and PARTIAL ON-SCREEN while watching TV or video sources. This function cannot be turned off.



This mark indicates that you can also use the Menu to do the same operations. Actual operations using the Menu are explained on pages indicated next to the marks.

The following functions are available only using the Menu.

- Using "TRANSPARENT" to erase the grey background around the Menu items (see page 32)
- Using "AUTO DEMO START" to see the demonstration of the Menu operations (see page 32)
- For RX-880VBK only: Using "PARTIAL ON-SCREEN" to show what you are doing on the bottom of the TV screen (see page 32)

## Table of Contents

Getting Started.....	2
Before Installation.....	2
Checking the Supplied Accessories.....	2
Switches, Buttons and Controls.....	3
Connecting the FM and AM Antennas.....	4
Connecting the Speakers.....	5
Connecting Audio/Video Components.....	7
Connecting Audio Components for the COMPU LINK-3 Remote Control System.....	8
Connecting Video Components for the AV COMPU LINK Remote Control System.....	8
Power Supply through the Receiver to the Connected Components.....	9
Connecting the Power Cord.....	9
Putting Batteries in the Remote Control.....	9
<b>Basic Operations.....</b>	<b>10</b>
Turning the Power On and Off.....	10
Selecting the Source to Play.....	10
Selecting the Front Speakers.....	11
Adjusting the Volume.....	11
Adjusting the Front Speaker Output Balance.....	11
Listening at Low Volume (Loudness).....	12
Muting the Sound.....	12
Listening with Headphones.....	12
Recording a Source.....	12
<b>Receiving Radio Broadcasts.....</b>	<b>13</b>
Tuning in Stations Manually.....	13
Using the Preset Tuning.....	13
Selecting the FM Reception Mode.....	14
Assigning Names to Preset Stations.....	15
Using the SEA Modes.....	16
Selecting Your Favorite SEA Mode.....	16
Creating Your Own SEA Mode.....	17
<b>Using the Digital Surround Processors.....</b>	<b>18</b>
Preparing for the DAP Modes.....	19
Using the DAP Modes.....	20
Preparing for the Surround Modes.....	21
Using the Surround Modes.....	24
<b>Other Features.....</b>	<b>25</b>
Using the CSRP Function.....	25
Using the Sleep Timer.....	25
Using the Visual Confirmation.....	26
<b>Using the On-Screen Display to Control the Receiver.....</b>	<b>27</b>
Basic Procedures.....	27
<b>COMPU LINK Remote Control System.....</b>	<b>33</b>
<b>AV COMPU LINK Remote Control System.....</b>	<b>34</b>
<b>Using the Remote Control for Operating JVC's Audio/Video Components.....</b>	<b>35</b>
<b>Operating Other Manufacturers' VCR, TV, CATV Converters and Satellite Tuners.....</b>	<b>37</b>
<b>Troubleshooting.....</b>	<b>42</b>
<b>Specifications.....</b>	<b>43</b>

**Switches, Buttons and Controls**

Become familiar with the main switches and controls on your receiver before use.

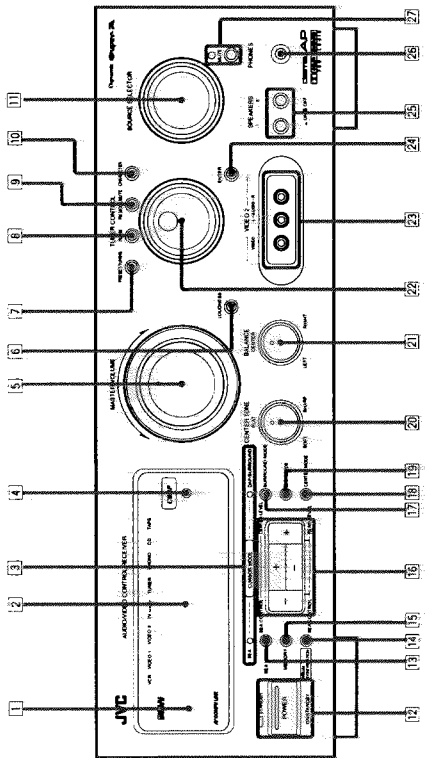

Refer to the pages in parentheses for details.

**Front Panel**

- 1 Remote sensor
- 2 Display (10)
- 3 CURSOR MODE button and indicators (SEA, DAP/SURROUND) (17, 19, 23)
- 4 CSRP button (25)
- 5 MASTER VOLUME control (11)
- 6 LOUDNESS button (12)
- 7 PRESET/TUNING button (13, 14)
- 8 FM/AM button (13)
- 9 CHARACTER button (15)
- 10 SOURCE SELECTOR (10)
- 11 POWER button and STANDBY indicator (10)
- 12 SEA MODE button (16, 17)
- 13 VISUAL CONFIRMATION button (26)
- 14 MEMORY button (17)
- 15 SEA CONTROL/CENTER LEVEL/REAR LEVEL buttons (+/-) (17, 19, 23)
- 16 SURROUND MODE button (21, 24)
- 17 CENTER MODE button (22)
- 18 DAP MODE button (19, 20)
- 19 CENTER TONE control (24)
- 20 BALANCE control (11)
- 21 TUNER CONTROL (13, 14, 15)
- 22 VIDEO 2 input jacks (7)
- 23 ENTER button (14, 15)
- 24 SPEAKERS 1/2 buttons (11)
- 25 PHONES jack (12)
- 26 MUTE button and indicator (12)
- 27 TV/CATV/SAT POWER and VCR POWER buttons (36, 37)
- 28 Source selecting buttons (10)
- 29 CSRP button (25)
- 30 SOUND CONTROL button (16, 19, 21)
- 31 CD DISC button (35)
- 32 CD TRACK button (35)
- 33 Remote control mode selector\* (AUDIO/TV/VCR, CATV/SAT) (10)
- 34 MUTE button (12)
- 35 MENU EXIT button (27)
- 36 SLEEP button (25)
- 37 AUDIO POWER button (10)
- 38 10 keys for selecting preset channel (13): and for adjusting sound (16, 19, 21, 35)
- 39 VOLUME buttons (+/-) (11)
- 40 CHANNEL buttons (+/-) (36, 37)
- 41 Operating buttons for audio/video components (35, 37)
- 42 MENU SET button (27)
- 43 Cursor buttons for operating the menu screens (27)

**\*IMPORTANT**  
When using the Remote Control, check to see if its remote control mode selector is set to the correct position.  
To operate audio system, TVs, and VCRs, set it to the "AUDIO/TV/VCR" position.  
To operate CATV converters and satellite tuners, set it to the "CATV/SAT" position.

**Connecting the FM and AM Antennas**

**FM Antenna Connections**

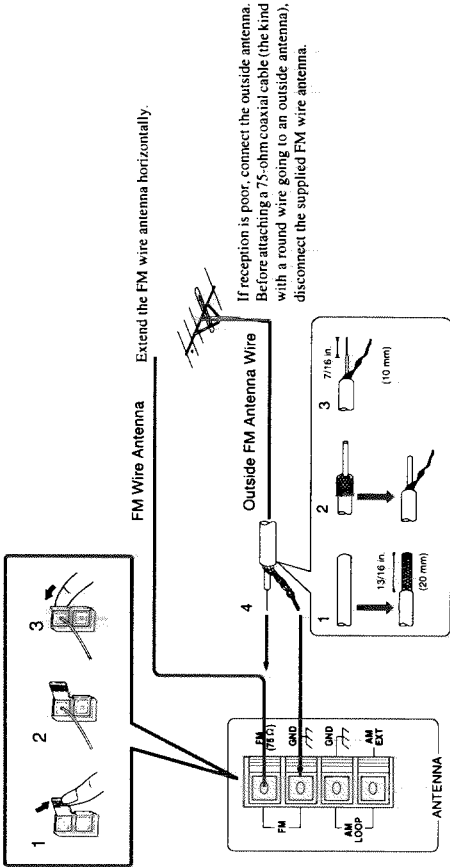

**How to strip the 75-ohm coaxial cable and connect it to the FM terminals**

1. Strip back the outside covering of the 75-ohm coaxial cable to expose the braided metallic mesh.
2. Pull the mesh back and twist it into a single connector, as shown in the illustration above.
3. Strip the insulation about 7/16 inches (10 mm) back from the central wire.
4. Insert the twisted mesh and the central wire to the FM terminals, as shown in the illustration above.

**AM Antenna Connections**

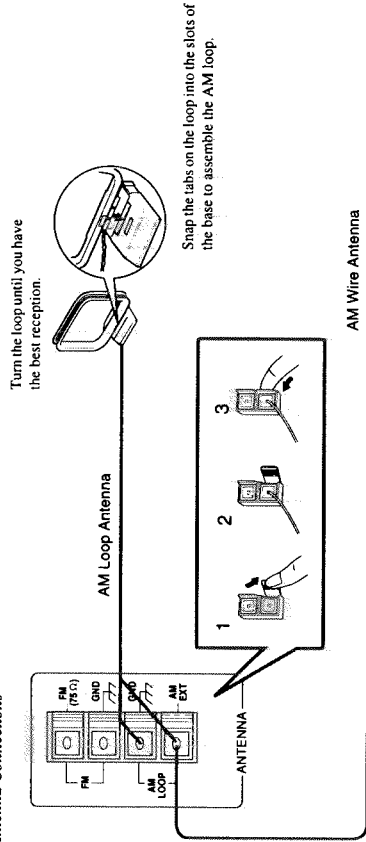

**Note:**  
Make sure the antenna conductors do not touch any other terminals, connecting cords and power cord. This could cause poor reception.

If reception is poor, connect an outdoor single vinyl-covered wire to the AM EXT terminal. (Keep the AM loop antenna connected.)

### Connecting the Speakers

You can connect the following speakers:

- Two sets of front speakers to produce normal stereo sound.
- One set of rear speakers to enjoy the surround effect.
- One center speaker to produce more effective surround effect (to make human voices outstanding).
- One subwoofer speaker to enhance the bass.

For each speaker, connect one end of the speaker signal cable (not supplied) to the speaker terminal on the rear panel and the other end to the speaker. For connecting a subwoofer, see page 6.

1. Open each terminal.
2. Insert the end of the speaker signal cable as shown (be sure to remove the insulation at the end of each wire first).
3. Close the terminals to clamp the speaker signal cables firmly in place.
4. Connect the black (-) and red (+) terminals on the rear panel to the black (-) and red (+) terminals marked on the speakers.

**CAUTION:**  
Use speakers with the **SPEAKER IMPEDANCE** indicated by the speaker terminals.

### Connecting the front speakers

Connect the front speakers to the **FRONT SPEAKERS** terminals and set the **SPEAKER LOAD SELECTOR**.

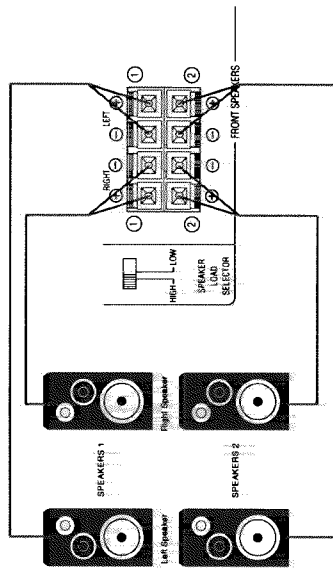

**Notes:**

- To obtain the best possible output power from the receiver, and to prevent the receiver from being overheated, the receiver has the **SPEAKER LOAD SELECTOR** on its rear which should be set to match the impedance of the connected speakers.
- Set this selector according to the indications by the **FRONT SPEAKERS** terminals on the rear.
- When you connect two pairs of the speakers to the **FRONT SPEAKERS** terminals, use the speakers having the impedance within the same range.

### Connecting the rear and center speakers

Connect rear speakers to the **REAR SPEAKERS** terminals, and a center speaker to the **CENTER SPEAKER** terminals.

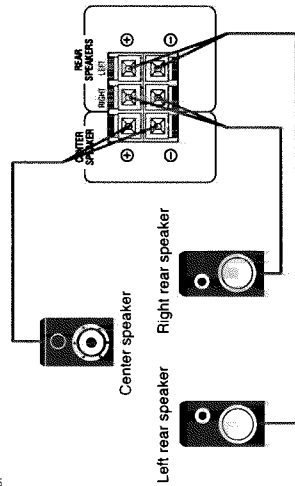

**Note:**  
When you connect rear speakers, make sure that both left and right speakers are connected; otherwise, no sound will come out of the rear speakers.

### Increasing the power for the rear speakers (only for RX-880VBK)

You can use a separate power amplifier to reinforce sounds through the rear speakers.

1. Connect the input jacks of the power amplifier to the **REAR OUT** jacks on the rear panel.
2. Connect the rear speakers to the speaker terminals of the power amplifier.

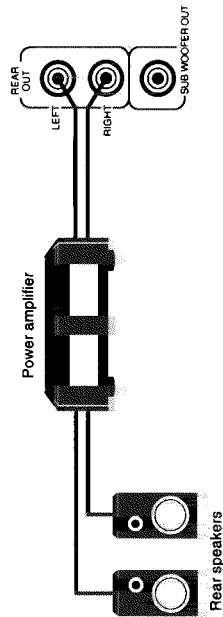

### Enhancing the bass

You can enhance the bass by connecting a subwoofer using a cable with RCA pin plugs. To connect a subwoofer, you also need a separate power amplifier.

1. Connect the input jack of the power amplifier to the **SUB WOOFER OUT** jack on the rear panel.
2. Connect a subwoofer speaker to the speaker terminal of the power amplifier.

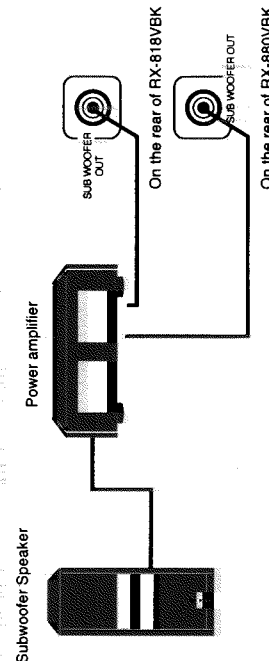

**Connecting Audio/Video Components**

You can connect the other audio/video components to the receiver using cables with RCA pin plugs.

**Notes:**

- Both plugs and jacks are color-coded; the red ones are for right audio signals, the white ones for left audio signals, and yellow ones for video signals.
- Any turntables incorporating a small-output cartridge such as an MC (moving-coil type) must be connected to this receiver through a commercial head amplifier or step-up transformer. Direct connection may result in insufficient volume.

**Audio component connections**

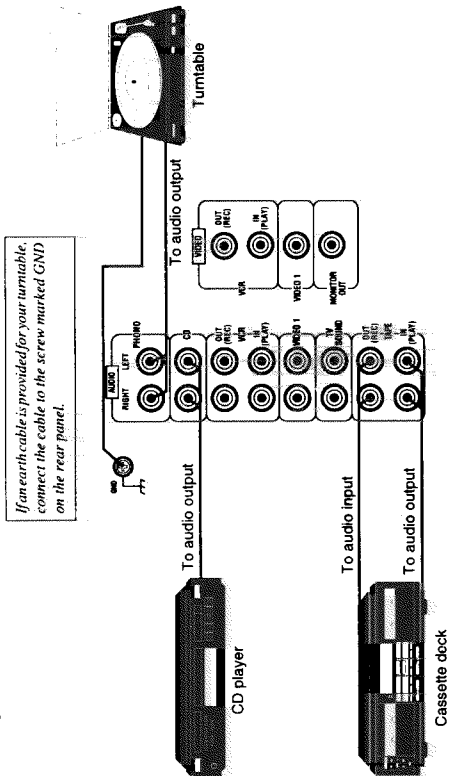

**Video component connections**

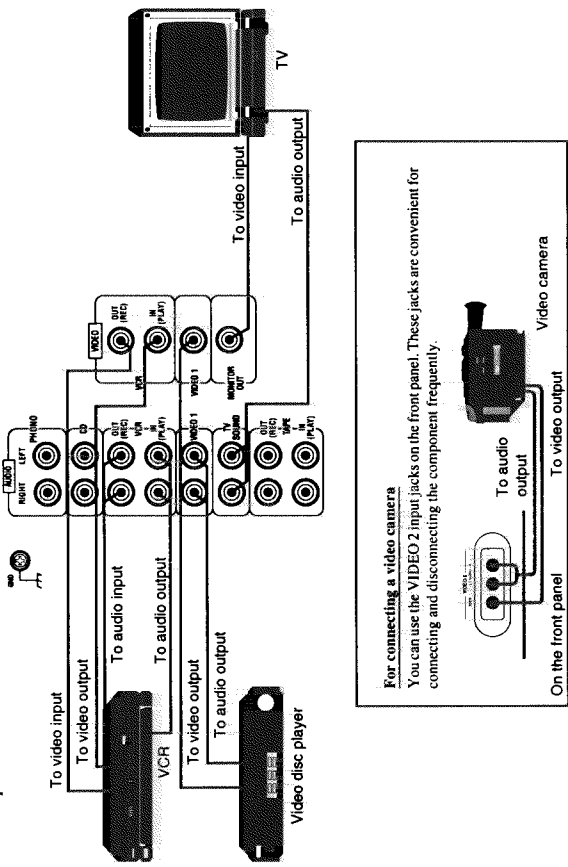

**Connecting Audio Components for the COMPU LINK-3 Remote Control System**

The COMPU LINK-3 remote control system allows you to control other JVC audio components from the receiver or vice versa. To use this system, connect your JVC audio components and the receiver with the cable (monoaural mini-plug) supplied with those components.

If your audio component has two COMPU LINK-3 SYNCHRO jacks, you can use either one. If it has only one COMPU LINK-3 SYNCHRO jack, connect it so that it is the last item in the series of components. (For example, the turntable or CD player in the diagram below)

**Notes:**

- The COMPU LINK-3 remote control system is the upgraded version of the COMPU LINK-1 and COMPU LINK-2. Even if your component has the COMPU LINK-1 or COMPU LINK-2 jacks, you can still connect it in the COMPU LINK-3 remote control system, but some functions may not work correctly.
- For more information about the COMPU LINK-3 (-1 and -2) remote control system, see page 33.

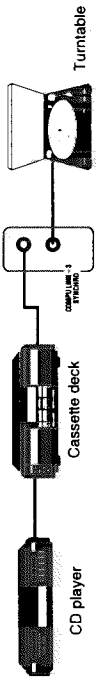

**Connecting Video Components for the AV COMPU LINK Remote Control System**

The AV COMPU LINK remote control system allows you to control other JVC video components from the receiver or vice versa. To use this system, connect your JVC video component and the receiver with the cable (monoaural mini-plug supplied with those components) and the cable with RCA pin plugs (and with S-video plug).

1. Connect your TV to the jack marked TV.
2. Connect your VCR to either one of the remaining two jacks.

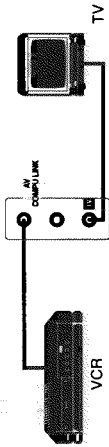

3. Connect the receiver, VCR, and TV as follows using the cables with RCA pin plug (and with S-video plug). See also page 7.

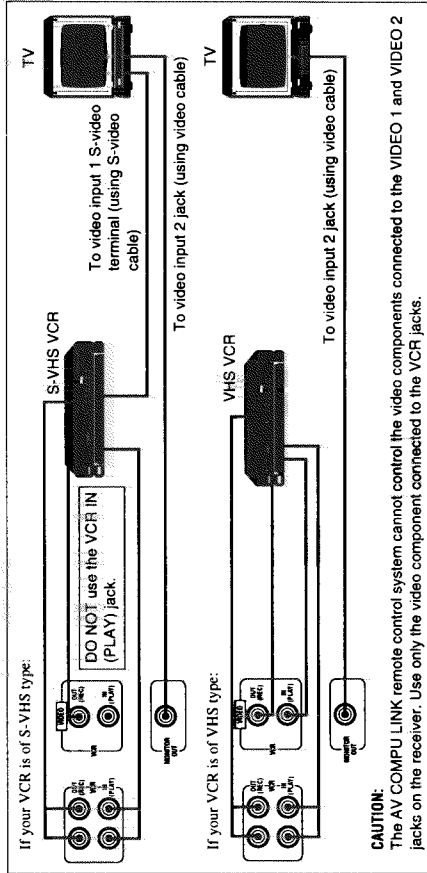

**CAUTION:**  
The AV COMPU LINK remote control system cannot control the video components connected to the VIDEO 1 and VIDEO 2 jacks on the receiver. Use only the video component connected to the VCR jacks.

**Notes:**

- Some VCRs use the AV COMPU LINK jacks for the SWAP editing. However, you cannot use both the AV COMPU LINK remote control and the SWAP editing at the same time. For the SWAP editing, see the manual supplied with the VCR.
- For more information about the AV COMPU LINK remote control system, see page 34.

**Connecting Audio/Video Components**

You can connect the other audio/video components to the receiver using cables with RCA pin plugs.

**Notes:**

- Both plugs and jacks are color-coded; the red ones are for right audio signals, the white ones for left audio signals, and yellow ones for video signals.
- Any turntables incorporating a small-output cartridge such as an MC (moving-coil type) must be connected to this receiver through a commercial head amplifier or step-up transformer. Direct connection may result in insufficient volume.

**Audio component connections**

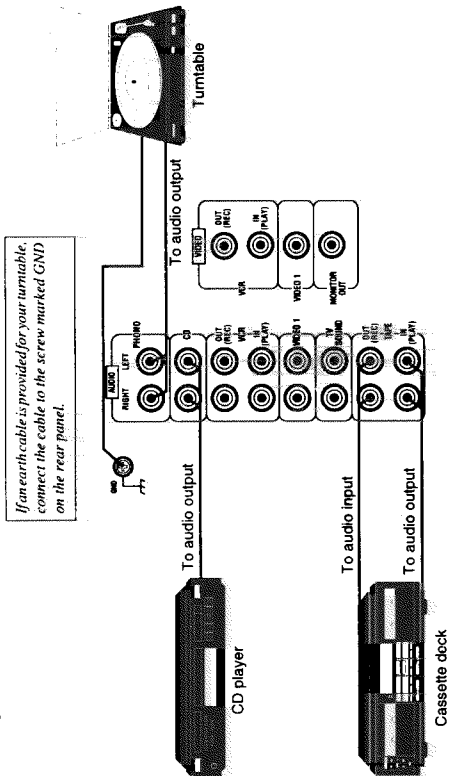

**Video component connections**

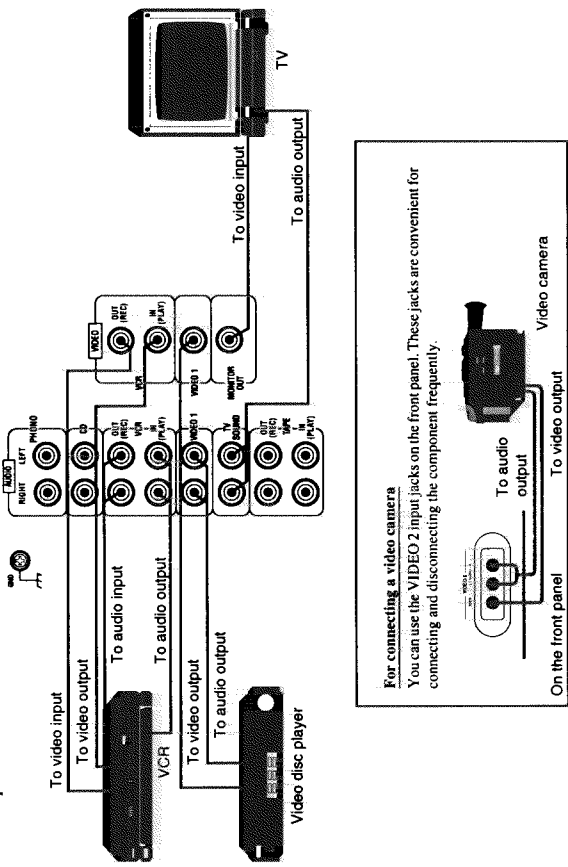

**For connecting a video camera**  
You can use the VIDEO 2 input jacks on the front panel. These jacks are convenient for connecting and disconnecting the component frequently.

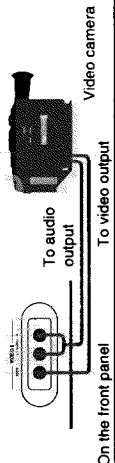

## Basic Operations

The following operations are commonly used when you play any sound source.



**IMPORTANT**  
When using the Remote Control, check to see if its remote control mode selector is set to the correct position:  
To operate audio system, TV, and VCR, set it to the "AUDIO/TV/VCR" position.  
To operate CATV converters and satellite tuners, set it to the "CATV/SAT" position.

### Turning the Power On and Off



To turn on the power, press the POWER button on the front panel or the AUDIO POWER button on the remote control.  
The STANDBY indicator turns off. The name of the current source appears on the display.

On the front panel

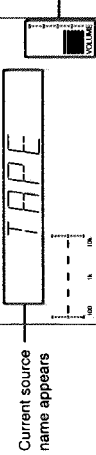

Current source name appears  
Volume level is also shown here whenever the power is on.

From the remote control

To turn off the power, press the POWER button or the AUDIO POWER button again.  
The STANDBY indicator turns on.



See also page 27.

### Selecting the Source to Play

You need to select the source before you start playing any source.

On the front panel:

Turn the SOURCE SELECTOR so that the desired source name appears on the display (at the same time the arrow (▲) on the display points the source).

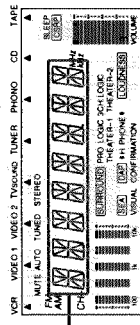

Selected source name appears



On the front panel

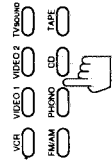

From the remote control

Note:  
When you press one of the source selecting buttons marked above with an asterisk (\*), the receiver automatically turns on.

## Power Supply Through the Receiver to the Connected Components

You can use the AC outlets on the rear of the receiver to supply power to audio components. These AC outlets are "switched" outlets. So when the receiver is off (that is, in standby mode), power is not supplied through these outlets. By turning the receiver on and off, you can turn the connected components on and off at the same time.

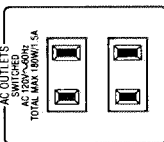

Note:  
Do not use the AC outlets on the rear of the receiver to supply power to the components in the COMPU LINK remote control system; otherwise, the COMPU LINK remote control system may not work correctly.

**CAUTION:**  
Do not plug the components to the AC outlets on the rear if their total power consumption is greater than indicated by the AC outlets.

## Connecting the Power Cord

Before plugging the receiver into an AC outlet, make sure that all connections have been made. When the power cord is connected, the STANDBY indicator above the POWER button lights up.

Keep the power cord away from the connecting cables for the TV, VCR, and antenna. The power cord may cause noise or screen interference. We recommend that you use a coaxial cable to connect the antenna, since it is well-shielded against interference.

Notes:  
• A small amount of power is always consumed even in standby mode. To switch off the power completely, unplug the power cord from the AC outlet.  
• If the power cord is unplugged or a power failure occurs, preset settings will be erased in a few days.

**CAUTIONS:**  
• Do not touch the power cord with wet hands.  
• Do not pull on the power cord to unplug the unit. When unplugging the unit, always grasp the plug itself so as not to damage the cord.

## Putting Batteries in the Remote Control

Before using the remote control, put two supplied batteries first. When using the remote control, aim the remote control directly at the remote sensor on the receiver.

- On the back of the remote control, remove the cover as illustrated.
- Insert batteries. Make sure to observe the proper polarity: (+) to (+) and (-) to (-).
- Replace the cover in.

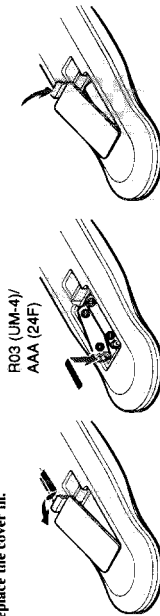

If the range or effectiveness of the remote control decreases, replace the batteries. Use two R03 (UM-4)/AAA (24F) type dry-cell batteries.

**CAUTIONS:**  
Follow these precautions to avoid leaking or cracking cells:  
• Place batteries in the remote control so they match the polarity indicated: (+) to (+) and (-) to (-).  
• Use the correct type of batteries. Batteries that look similar may differ in voltage.  
• Always replace both batteries at the same time.  
• Do not expose batteries to heat or flame.

**Selecting the Front Speakers**

When you have connected two sets of the front speakers, you can select which to use. Pressing in the SPEAKERS 1 or SPEAKERS 2 button on the front panel activates the respective set of the speakers.

- To use the speakers connected to the FRONT SPEAKERS ① terminals, press in the SPEAKERS 1 button (Ⓜ ON), and press out the SPEAKERS 2 button (Ⓜ OFF).
- To use the speakers connected to the FRONT SPEAKERS ② terminals, press in the SPEAKERS 2 button (Ⓜ ON), and press out the SPEAKERS 1 button (Ⓜ OFF).
- To use both sets of the speakers, press in both the SPEAKERS 1 and 2 buttons (Ⓜ ON).
- To use neither set of the speakers, press out both the SPEAKERS 1 and 2 buttons (Ⓜ OFF).



**Note:**

When only one set of the speakers is connected to either the FRONT SPEAKERS ① or ② terminals, do not press in both SPEAKERS 1 and 2 buttons (Ⓜ ON). If you do, no sound comes out of the front speakers.



**Adjusting the Volume**

When you turn on the power or change the volume level, the volume level is shown on the display.



On the front panel

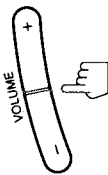

From the remote control

**CAUTION:**

Always set the volume level to the minimum before starting any source. If the volume level is left turned up, the sudden blast of sound energy can permanently damage your hearing and/or ruin your speakers.

**Adjusting the Front Speaker Output Balance**

If the sounds you hear from the right and left front speakers are unequal, you can adjust the speaker output balance with the BALANCE control on the front panel.

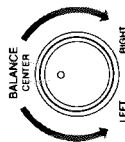

To decrease the left channel sound, turn the BALANCE control clockwise.

To decrease the right channel sound, turn the BALANCE control counterclockwise.

**Listening at Low Volume (Loudness)**

Human ears are not sensitive to bass at low volume. To compensate for this, the loudness function automatically boosts the bass level as you lower the volume.

To use the loudness function, press the LOUDNESS button on the front panel. The LOUDNESS indicator lights up on the display.

To turn the function off, press the LOUDNESS button again. The LOUDNESS indicator goes off.



**Muting the Sound**

You can easily turn off the volume by pressing the MUTE button.

To mute the sound through all speakers and headphones connected, press the MUTE button so that the indicator on the front panel turns on. ("MUTE" also appears on the display.)

To cancel the mute, press the MUTE button again so that the indicator turns off.

When you turn the MASTER VOLUME control or press the VOLUME +/- button, mute is also canceled.

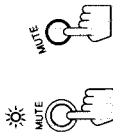

On the front panel From the remote control

**Listening with Headphones**

A standard pair of headphones can be connected to the PHONES jack on the front panel.

To listen with only headphones, press out both the SPEAKERS 1 and 2 buttons (Ⓜ OFF).

**CAUTION:**

Be sure to turn down the volume before connecting or putting on headphones, as high volume can damage both the headphones and your hearing.

**Recording a Source**

You can record any source playing through the receiver to the cassette deck connected to the TAPE jacks, and the VCR connected to the VCR jacks at the same time.

While recording, you can listen to the selected sound source at whatever sound level you like, without affecting the sound levels of the recording.

**Note:**

The output volume level, SEA modes, DAP modes and surround modes will not affect the recording.



## Receiving Radio Broadcasts

You can browse through all the stations or use the preset function to go immediately to a particular station.

See also  
page 28.



### Tuning in Stations Manually

1. Select **TUNER** as the source to play and choose the band.  
On the front panel:

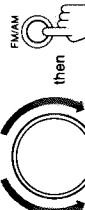

On the front panel

1. Turn the **SOURCE SELECTOR** to select **TUNER**.

The last received station is tuned in.

2. Press the **FM/AM** button.

Each time you press the button, the band (FM and AM) alternates.

From the remote control:

Press the **FM/AM** button.

The last received station is tuned in.

Each time you press the button, the band (FM and AM) alternates.

Note:

If you do not see a preset channel number on the display, the receiver is already in the manual tuning mode, so skip Step 2 below.

2. Press the **PRESET/TUNING** button on the front panel to set the tuning mode to the manual tuning.

When the manual tuning is selected, the preset channel number disappears from the display.

Each time you press the button, the manual tuning and preset tuning modes alternate.

3. Turn the **TUNER CONTROL** on the front panel clockwise or counterclockwise.

Turning it clockwise increases the frequency.

Turning it counterclockwise decreases the frequency.



From the remote control

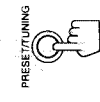

From the remote control

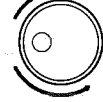

Notes:

- When you turn the **TUNER CONTROL** fast, the frequency keeps changing until you turn the **TUNER CONTROL** again or a station is tuned in.
- When a station of sufficient signal strength is tuned in, the **TUNED** indicator lights up on the display.
- When an FM stereo program is received, the **STEREO** indicator also lights up.

See also  
page 28.



### Using the Preset Tuning

Once a station is assigned to a channel number, the station can be quickly tuned. You can preset up to 40 stations, either AM, FM, or a mixture of both, at random.

### Storing stations into memory

You can preset the stations you want into memory by following the presetting method below.

1. Tune in the station you want to preset (see above).

2. Press the **ENTER** button on the front panel.

"CH. —" appears on the display for 5 seconds.

3. Select a channel number within the 5 seconds.

On the front panel:



From the remote control

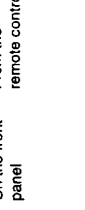

From the remote control

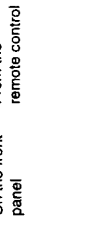

Note:

When you use the 10 keys on the remote control, be sure that they are activated for tuner, not for the CD and others. (See page 35.)



4. Press the **ENTER** button again while the selected channel number is flashing on the display. The selected channel number stops flashing, and the station is assigned to the selected channel number.

To erase a stored station

Storing a new station on a used number erases the previously stored one.

CAUTION:

Preset stations may be erased when power is cut off to the receiver, as when it is unplugged from the AC outlet or a power failure occurs. If the preset stations are lost, simply store the stations again using the above procedure.

### Tuning in a preset station



On the front panel:

1. Turn the **SOURCE SELECTOR** to select **TUNER**.

Note:

If you see a preset channel number on the display, the receiver is already in the preset tuning mode, so skip Step 2 below.

2. Press the **PRESET/TUNING** button to set the tuning mode to the preset tuning.

When the preset tuning is selected, a preset channel number appears on the display.

Each time you press the button, the manual tuning and preset tuning modes alternate.

3. Turn the **TUNER CONTROL** to select a preset channel number.

Turning it clockwise changes preset channels in increasing order.

Turning it counterclockwise changes preset channels in decreasing order.



From the remote control:

1. Press the **FM/AM** button.

The last received station is tuned in.

2. Press the 10 keys to select a preset channel number.

Examples: For channel number 5, press 5. For channel number 15, press +10 then 5.

For channel number 20, press +10 then 10.

Note:

When you use the 10 keys on the remote control, be sure that they are activated for tuner, not for the CD and others. (See page 35.)



### Selecting the FM Reception Mode

You can change the FM reception mode so that reception will be improved.

When an FM stereo broadcast is hard to receive or noisy

Press the **FM MODE/MUTE** button either on the front panel or on the remote control.

The **MUTE AUTO** indicator goes off on the display. Reception will be improved although you will lose the stereo effect. In this mode, you will hear noise while tuning into the stations.

Note:

When you use the **FM MODE/MUTE** button on the remote control, be sure that 10 keys are activated for tuner, not for the CD and others. (See page 35.)

To restore the stereo effect

Press the **FM MODE/MUTE** button again so that the **MUTE AUTO** indicator lights up on the display. In this mode, when a program is broadcast in stereo, you will hear stereo sound; when in monaural, you will hear monaural sounds. This mode is also useful to suppress static noise between stations.

FM MODE/MUTE



On the front panel



From the remote control



**Assigning Names to Preset Stations**

You can assign a name of up to five characters to each preset station (from preset channel number 1 to 20). When a preset station is tuned in, its assigned name will appear on the display.

**On the front panel only:**

1. Tune in a preset station (preset channel number 1 to 20). See page 14 for details.
2. Press the CHARACTER button on the front panel. The first character position starts flashing.

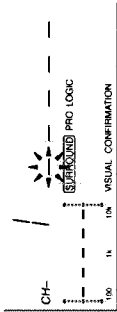

3. Turn the TUNER CONTROL to select the first character. You can use characters listed below.



4. When the character you want appears, press the CHARACTER button. The next character position starts flashing.

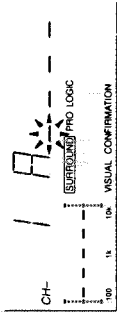

5. Repeat Steps 3 and 4 to enter up to five characters.
6. Press the ENTER button after you have assigned a name.



To erase the input characters Insert blanks using the same procedure described above. When using the Menu, you can erase them more easily. (See page 29.)

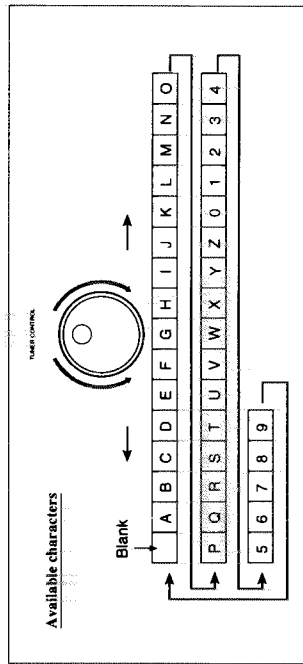

**Using the SEA Modes**

The SEA (Sound Effect Amplifier) modes give you control of the way your music sounds.

**Note:**

The SEA modes cannot be used for recording.

See also  
page 29.



**Selecting Your Favorite SEA Mode**

Selecting the SEA mode



On the front panel:

Press the SEA MODE button repeatedly until the SEA mode you want appears on the display. When you press the button for the first time, the SEA indicator lights up and the previously selected SEA mode comes into effect. Each time you press the button then, the SEA modes change as follows:

On the front panel



1. Press the SOUND CONTROL. Pressing this button activates the 10 keys for adjusting the sounds.



2. Press the SEA MODE button repeatedly until the SEA mode you want appears on the display. When you press the button for the first time, the SEA indicator lights up and the previously selected SEA mode comes into effect. Each time you press the button then, the SEA modes change as follows:

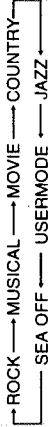

From the remote control

<b>ROCK:</b>	Gives a heavy sound. Both high and low frequencies are boosted.
<b>MUSICAL:</b>	Enhance the mid-frequency range human voice is mostly made up of.
<b>MOVIE:</b>	Adds breath to sounds so you feel like you are in a movie theater.
<b>COUNTRY:</b>	Enhances the high-frequency range so that instruments such as a violin and banjo sound outstanding.
<b>JAZZ:</b>	Gives a feeling of a live atmosphere. Good for acoustic music.
<b>USERMODE:</b>	Your original SEA mode (see page 17).
<b>SEA OFF:</b>	No SEA mode is applied (see below).

**Canceling the SEA mode**

On the front panel:

1. Press the SEA MODE button repeatedly until "SEA OFF" appears on the display. The SEA indicator also turns off.



On the front panel



1. Press the SOUND CONTROL. Pressing this button activates the 10 keys for adjusting the sounds.

2. Press the SEA MODE button repeatedly until "SEA OFF" appears on the display. The SEA indicator also turns off.



From the remote control

## Using the Digital Surround Processor

The built-in digital surround processor provides two groups of programs — DAP (Digital Acoustic Processor) modes and surround modes (Dolby Surround\* and JVC Theater Surround). You cannot use the DAP mode and surround mode at the same time. When you turn on the DAP mode, the surround mode is turned off (if it has been on), and vice versa.

- Notes:**
- The digital surround processor has no effect on nonaural sources.
  - The digital surround processor cannot be used for recording.

### What can the digital surround processor do?

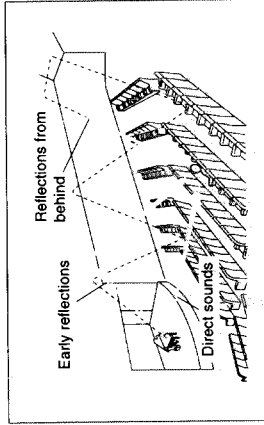

The sound heard in a concert hall or a movie theater consists of direct sound and indirect sound: early reflections and reflections from behind. The reflected sounds are always delayed by the distances of the ceiling and walls from the listener. These reflections are some of the most important elements of the acoustic surround. So, what the digital surround processor does is to reproduce these elements in your listening room.

To use the digital surround processor, you need to connect rear speakers (and a center speaker) as well as the front speakers.

\* Manufactured under license from Dolby Laboratories Licensing Corporation. Additionally licensed under Canadian patent number 1,037,877. "Dolby," "Pro Logic," and the double-D symbol are trademarks of Dolby Laboratories Licensing Corporation.

### Speaker arrangements for the DAP modes and surround modes

The following illustrations show how to obtain the optimum sound environment for various DAP modes and surround modes. Try to find the speaker direction and location to create the optimum sound field.

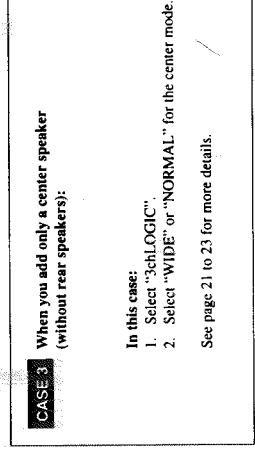
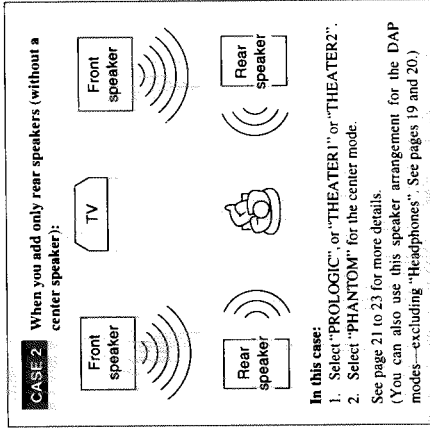
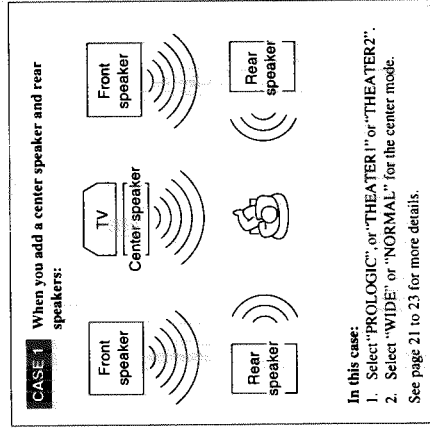

## Creating Your Own SEA Mode

You can adjust the SEA modes as you like and store your setting into memory. If you do not want to store your setting, but rather want to adjust a SEA mode temporarily, skip Step 3 below.

1. Select the SEA mode you want to adjust.

**On the front panel:**

Press the SEA MODE button repeatedly until the SEA mode you want appears on the display. When you press the button for the first time, the SEA indicator lights up and the previously selected SEA mode comes into effect. Each time you press the button then, the SEA modes change as follows:

**From the remote control:**

1. Press the SOUND CONTROL. Pressing this button activates the 10 keys for adjusting the sounds.
2. Press the SEA MODE button repeatedly until the SEA mode you want appears on the display.

When you press the button for the first time, the SEA indicator lights up and the previously selected SEA mode comes into effect. Each time you press the button then, the SEA modes change as follows:

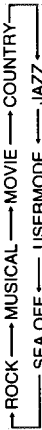

**From the remote control**

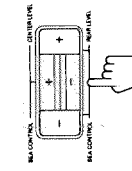

2. Adjust the SEA mode.

**On the front panel only:**

Press the left or right SEA CONTROL button (+/-) on the front panel to change the frequency ranges to adjust.

Press the upper or lower SEA CONTROL button (+/-) to change the level.

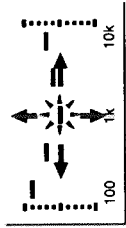

**Note:** When using the SEA CONTROL buttons (+/-), make sure that the SEA indicator on the front panel is turned on. If not, press the CURSOR MODE button once so that these buttons can be used for adjusting the SEA modes.

3. Store the setting.

**On the front panel only:**

Press the MEMORY button so that your setting is stored into USERMODE.

**To erase a stored setting**

Storing a new setting into USERMODE erases the previously stored one.



See also page 29.



See also  
page 30.



**Preparing for the DAP Modes**

You can use five DAP modes — "Dance Club, Live Club, Hall, Pavilion, and Headphones." These modes (except "Headphones") require rear speakers, but do not require a center speaker to enlarge the sound field.

Among the DAP modes, "Headphones" is very special. It can create the same stereo sound as you listen through the speakers in air while listening to a source using headphones. So, you can feel as if you were not using the headphones and listening to music in a certain room.

Only when using the Menu, you can adjust the room size — it affects the effect of "Headphones." To adjust the room size, see page 30.

**Preparation method for the DAP modes**

Once you have set the DAP modes, you can use the same adjustment every time you want to enjoy the DAP mode you want. The receiver memorizes these adjustments for each mode. You need the remote control to complete the entire adjustment process of the DAP modes (even though some steps can be done using the buttons on the front panel).

To use the DAP modes, see "Using the DAP Modes" on page 20.



**From the remote control:**

1. Press the **SOUND CONTROL**.  
Pressing this button activates the 10 keys for adjusting the sounds.
2. Press the **DAP MODE** button repeatedly until the **DAP mode you want appears on the display**.  
When you press the button for the first time, the DAP indicator lights up and the previously selected DAP mode comes into effect. Each time you press the button then, the DAP modes change as follows:

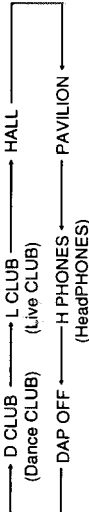

<b>Dance CLUB</b>	Gives a throbbing bass beat.
<b>Live CLUB</b>	Gives the feeling of a live music club with the low ceiling.
<b>HALL</b>	Gives clear vocal and the feeling of a concert hall.
<b>PAVILION</b>	Gives the spacious feeling of a pavilion with the high ceiling.
<b>HeadPHONES*</b>	Gives a spacious stereo effect when listening with headphones.
<b>DAP OFF</b>	No DAP mode is applied.

**Note:**

\* When you select **H PHONES**, the **H PHONE** indicator also lights up on the display.



3. For the DAP modes other than **H PHONES**, press the **REAR** buttons (+/-) repeatedly to set the output levels of the rear speakers.

**Notes:**

- You can adjust the sound level in 1 dB step within the range of  $\pm 10$  dB. The sound level of the left and right rear speakers will be identical.
- You can also use the **REAR LEVEL** buttons (+/-) on the front panel. However, when using the **REAR LEVEL** buttons (+/-), make sure that the **DAP/SURROUND** indicator is turned on. If not, press the **CURSOR MODE** button once so that these buttons can be used for adjusting the output level of the rear speakers.

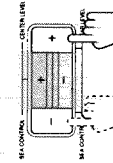

4. For the DAP modes other than **H PHONES**:

Press the **EFFECT** buttons (+/-) repeatedly to select the effect depth among 5 preset levels. Pressing **EFFECT +** repeatedly increases the effect depth ("EFFECT-1" to "EFFECT-5"). Pressing **EFFECT -** repeatedly decreases the effect depth ("EFFECT-5" to "EFFECT-1").

**For H PHONES:**

You can adjust the effect — room size — of the **H PHONES** only by using the Menu (see page 30).

**Using the DAP Modes**

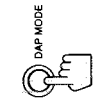

**On the front panel:**

Press the **DAP MODE** button repeatedly until the **DAP mode you want appears on the display**. When you press the button for the first time, the DAP indicator lights up and the previously selected DAP mode comes into effect. Each time you press the button then, the DAP modes change as follows:

**On the front panel**

**From the remote control:**

1. Press the **SOUND CONTROL**.  
Pressing this button activates the 10 keys for adjusting the sounds.



2. Press the **DAP MODE** button repeatedly until the **DAP mode you want appears on the display**.  
When you press the button for the first time, the DAP indicator lights up and the previously selected DAP mode comes into effect. Each time you press the button then, the DAP modes change as follows:

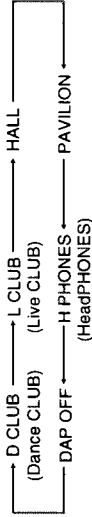

**From the remote control**

To cancel the **DAP mode**, press the **DAP MODE** button repeatedly (after pressing the **SOUND CONTROL** button when using the remote control) until "DAP OFF" appears on the display. The DAP indicator turns off.



See also  
page 30  
and 31.

**Preparing for the Surround Modes**

You can enjoy two types of surround modes — Dolby Surround and JVC's Theater Surround.

**On Dolby Surround**

The Dolby Surround has been developed to reproduce the important elements of the acoustic surround at home.  
To watch the soundtracks of video software bearing the mark which includes the same encoded surround information as found in Dolby Stereo films, the receiver can provide you with 2 Dolby Surround modes (Dolby Pro Logic and Dolby 3ch Logic).  
**Dolby Pro Logic:** Select this mode when optional rear speakers (and a center speaker) are connected.  
**Dolby 3ch Logic:** Select this mode when a center speaker is connected without rear speakers.

**On JVC's Theater (1 and 2) Surround**

In order to reproduce a more realistic sound field in your listening room while playing soundtracks of video software bearing the mark JVC's Theater Surround has been designed to give you clearer vocals and to create the feeling of being there. The sound is reproduced through the front speakers, rear speakers, and center speaker.

**Preparation method for the surround modes**

Once you have set the surround modes, you can use the same adjustment every time you want to enjoy the surround you want. The receiver memorizes surround adjustments for each mode.  
To use the surround modes, see "Using the Surround Modes" on page 24.

1. Select the surround mode you want.

On the front panel:



On the remote control:



From the remote control



<b>PROLOGIC</b>	Use this mode to watch a video source with Dolby Surround when you have connected the rear speakers (and a center speaker).
<b>3chLOGIC</b>	Use this mode to watch a video source with Dolby Surround when you have connected a center speaker and no rear speakers.
<b>THEATER1</b>	Use this mode to watch a video source with Dolby Surround when you have connected the rear speakers (and a center speaker). This mode gives you the feeling of a small movie theater with a seating capacity of 100.
<b>THEATER2</b>	Use this mode to watch a video source with Dolby Surround when you have connected the rear speakers (and a center speaker). This mode gives you the feeling of a large movie theater with a seating capacity of 1000.
<b>SURR OFF (Surround Off)</b>	No surround mode is applied.

2. Select a center mode.

On the front panel only:

Press the CENTER MODE button. Each time you press the CENTER MODE button, the center modes change as follows:

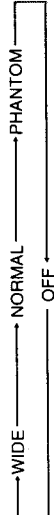

On the front panel



<b>WIDE</b>	Select this mode when the size of the center speaker is the same as that of the front speakers.
<b>NORMAL</b>	Select this mode when the size of the center speaker is smaller than that of the front speakers.
<b>PHANTOM</b>	Select this mode when you don't use a center speaker. (Center channel signals are output through the front speakers.)
<b>OFF</b>	Select this mode to shut off the output of the center channel signal.

Note:

When you have selected 3CH LOGIC, you cannot select PHANTOM.

3. Set the delay time of the delayed sound.

From the remote control only:

Press the DELAY button repeatedly. (If you have not yet pressed the SOUND CONTROL button, press the SOUND CONTROL button before pressing the DELAY button.) Each time you press the DELAY button, the delay time changes among 4 levels as follows:



From the remote control



<b>DELAY-1</b>	When your distance to the rear speakers is greater than that to the front speakers.
<b>DELAY-2</b>	When your distance to the rear speakers is almost equal to that to the front speakers.
<b>DELAY-3</b>	When your distance to the rear speakers is a little less than that to the front speakers.
<b>DELAY-4</b>	When your distance to the rear speakers is much less than that to the front speakers.

Note:

When you have selected 3CH LOGIC, you cannot adjust the delay time.

4. Start checking speaker output balance.

From the remote control only:

Press the TEST button. When you press the button, "TEST" starts flashing and a test tone comes out of speakers in the following order:



From the remote control



Note:

- No test tone comes out of the rear speakers when you have selected 3CH LOGIC.
- No test tone comes out of the center speaker when you select PHANTOM or OFF for the center mode.

To be continued to the next page

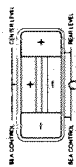

On the front panel

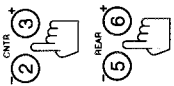

From the remote control



From the remote control



From the remote control

5. Set the output levels of the center and the rear speakers.

On the front panel:

Press the upper or lower CENTER LEVEL button (+/-) repeatedly to set the sound level of the center speaker.  
Press the left or right REAR LEVEL button (+/-) repeatedly to set the sound level of the rear speakers.

From the remote control:

Press the CNTR buttons (+/-) repeatedly to set the sound level of the center speaker.  
Press the REAR button (+/-) repeatedly to set the sound level of the rear speakers.

Notes:

- When you use the CENTER LEVEL buttons (+/-) or REAR LEVEL buttons (+/-), make sure that the DAP/SURROUND indicator is turned on. If not, press the CURSOR MODE button once so that these buttons can be used for adjusting the output level of the center/rear speakers.
- You can adjust these levels in 1 dB step within the range of ±10 dB. The sound levels of the left and right rear speakers will be identical.
- You cannot set the sound level of the rear speakers when you have selected 3CH LOGIC.
- You cannot set the sound level of the center speaker when you select PHANTOM or OFF for the center mode.

6. Finish checking speaker output balance.

From the remote control only:

Press the TEST button again.  
The test tone stops.

7. Only for JVC's Theater Surround:

Select the effect depth among 5 preset levels.

From the remote control only:

Pressing EFFECT + repeatedly increases the effect depth ("EFFECT-1" to "EFFECT-5").  
Pressing EFFECT - repeatedly decreases the effect depth ("EFFECT-5" to "EFFECT-1").

Note:

When you have selected Dolby Surround modes, you cannot select the effect depth.

Using the Surround Modes

On the front panel:

1. Press the SURROUND MODE button repeatedly until the surround mode you want appears on the display.

When you press the button for the first time, the SURROUND indicator lights up and the previously selected surround mode comes into effect. Each time you press the button then, the surround modes change as follows:

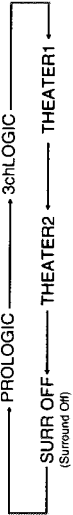

2. Play a sound source which was processed with Dolby Surround and is labeled with the SURROUND mark.

To cancel the surround mode, press the SURROUND MODE button repeatedly until "SURR OFF" appears on the display.  
The SURROUND indicator turns off.

From the remote control:

1. Press the SOUND CONTROL.  
Pressing this button activates the 10 keys for adjusting the sounds.
2. Press the SURR MODE button repeatedly until the surround mode you want appears on the display.

When you press the button for the first time, the SURROUND indicator lights up and the previously selected surround mode comes into effect. Each time you press the button then, the surround modes change as follows:



3. Play a sound source which was processed with Dolby Surround and is labeled with the SURROUND mark.

To cancel the surround mode, press the SURR MODE button repeatedly (after pressing the SOUND CONTROL button when using the remote control) until "SURR OFF" appears on the display.  
The SURROUND indicator turns off.

Making dialogues in movies softer or clearer

By using the CENTER TONE control you can adjust the level of mid-frequency range, which the human voice is mostly made up of.

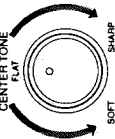

To make dialogues clearer, turn the CENTER TONE control toward SHARP.

To make them softer, turn the CENTER TONE control toward SOFT.

When set to the FLAT position, no adjustment is applied.

Note:

The CENTER TONE control can be used only for the surround modes; however, it cannot be used when sounds do not come out of the center speaker.

## Other Features

The receiver has some other features like the CSRFP function, the Sleep Timer and the Visual Confirmation. By using these useful features your audio/video life will be much improved.

### Using the CSRFP Function

The optimum sound settings differ for each playing source. So, you have to change settings each time you select a different source. The JVC's CSRFP (COMPU LINK Source-Related Preset) function is used to assign and store different sound settings for each different playing source. By using this function, you don't have to change the settings every time you change the source. The stored settings for the newly selected source are automatically recalled.

The following can be stored for each source:

- Volume level (see page 11)
- Loudness (see page 12)
- SEA modes (see page 16)
- DAP mode settings (see page 19)
- Surround mode settings (see page 21)

**Note:**  
If the source is FM or AM, the CSRFP function works only when one of the preset channels from 1 — 20 is tuned in. You can assign a different setting for each preset channel.



On the front panel



From the remote control

### Using the Sleep Timer

Using the Sleep Timer, you can fall asleep to music and know the receiver will turn off by itself rather than play all night.



To set the Sleep Timer

Press the SLEEP button on the remote control repeatedly. The SLEEP indicator lights up and the shut-off time appears on the display. Each time you press the button, the shut-off time on the display changes as follows:

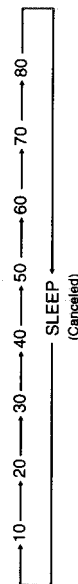

The receiver will turn off after the time you have set.

To check or change the time remaining until the shut-off time

Press the SLEEP button once. The remaining time is displayed in minutes. If you press the button repeatedly, you can change the shut-off time.

To cancel the Sleep Timer

Press the SLEEP button repeatedly until the SLEEP indicator goes off.

### Using the Visual Confirmation

When you press a certain button or turn a control knob on the front panel, you can see what you are doing, by showing the Menus (see pages 27 to 32) on the TV screen. To use this function, you need to connect the TV to the MONITOR OUT jack on the rear panel (see page 7), and set the TV's input mode to the proper position to which the receiver is connected. When the TV's input mode is for TV, you cannot see the on-screen display.

To activate the Visual Confirmation

Press the VISUAL CONFIRMATION button on the front panel so that the VISUAL CONFIRMATION indicator lights up on the display.

EXAMPLES:

When you turn the SOURCE SELECTOR:

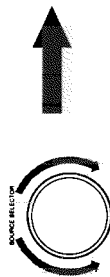

The SOURCESELECT Menu appears for about 5 seconds.

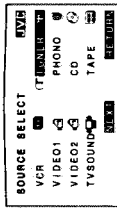

When you press the FM/AM button:



If the tuning mode is "manual":  
The TUNER BAND/TUNING Menu appears for about 5 seconds.



If the tuning mode is "preset":  
The TUNER PRESET CH. Menu appears for about 5 seconds.



To cancel the Visual Confirmation

Press the VISUAL CONFIRMATION button again so that the VISUAL CONFIRMATION indicator goes off.

See also page 31.



### Using the On-Screen Display to Control the Receiver

You can use the Menus on the TV screen to control the receiver. To use this function, you need to connect the TV to the MONITOR OUT jack on the rear panel (see page 7), and set the TV's input mode to the proper position to which the receiver is connected. When the TV's input mode is for TV, you cannot see the on-screen display.

**CAUTION:** When you use the Menus, make sure that you have connected a TV and operate the Menus while watching the on-screen displays on the TV.

**Note:** Menu screens used in the following explanations are of those with the "TRANSPARENT" function set to "ON." If you used the Menu with this function "OFF," the Menu screens you see are slightly different—they will have the grey background around the Menu items. (See page 32.)

#### Basic Procedures

- Press any of the cursor buttons (Δ, ∇, ◀, ▶) or the MENU SET button. The MAIN MENU (see On-Screen 1) appears on the TV screen.
  - Press the cursor buttons (Δ, ∇) to move **CF** to the Sub-Menu you want to set, then press the MENU SET button. The Sub-Menu you want appears.
  - Press the cursor buttons (Δ, ∇, ◀, ▶) to move **CF** to the item you want to set. Δ, ∇: Move **CF** up and down. ◀, ▶: Move **CF** to the left and right.
  - Press the cursor buttons (◀, ▶) to change the setting for the selected item.
  - When you finish, press the MENU EXIT button. The Menu disappears from the TV screen.
- To go back to the MAIN MENU (or previous Menus) any time while using the Menus  
Press the cursor buttons (Δ, ∇, ◀, ▶) to move **CF** to RETURN, then press the MENU SET button.
- To go to the next screens  
Press the cursor buttons (Δ, ∇, ◀, ▶) to move **CF** to NEXT, then press the MENU SET button.



On-Screen 1

#### Adjusting the volume (see also page 11)

- Press any of the cursor buttons (Δ, ∇, ◀, ▶) or the MENU SET button. The MAIN MENU appears on the TV screen.
- Press the cursor buttons (Δ, ∇) to move **CF** to "VOLUME". See On-Screen 2.
- Press the cursor buttons (◀, ▶) to adjust the volume.
- When you finish, press the MENU EXIT button. The Menu disappears from the TV screen.

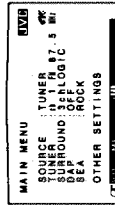

On-Screen 2

#### Selecting the source (see also page 10)

- Press any of the cursor buttons (Δ, ∇, ◀, ▶) or the MENU SET button. The MAIN MENU appears on the TV screen.
- Press the MENU SET button. The SOURCE SELECT Menu (see On-Screen 3) appears.
- Press the cursor buttons (Δ, ∇, ◀, ▶) to move **CF** to the source you want to play, then press the MENU SET button.
- When you finish, press the MENU EXIT button. The Menu disappears from the TV screen.

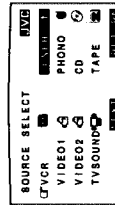

On-Screen 3

#### Tuning into stations and starting into memory (see also page 13)

- Press any of the cursor buttons (Δ, ∇, ◀, ▶) or the MENU SET button. The MAIN MENU appears on the TV screen.
- Press the cursor buttons (Δ, ∇) to move **CF** to "TUNER", then press the MENU SET button. The TUNER PRESET CH. Menu (see On-Screen 4) appears.
- Press the cursor buttons (Δ, ∇, ◀, ▶) to move **CF** to "TUNING", then press the MENU SET button. The TUNER BAND/TUNING Menu (see On-Screen 5) appears.
- Press the cursor buttons (◀, ▶) to select either "FM" or "AM".
- Press the cursor buttons (Δ, ∇) to move **CF** to "TUNING".
- Press the cursor buttons (◀, ▶) to tune in the stations.
- Press the cursor buttons (Δ, ∇) to move **CF** to "MEMORY", then press the MENU SET button. The PRESET CH. MEMORY Menu (see On-Screen 6) appears.

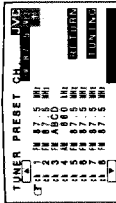

On-Screen 4

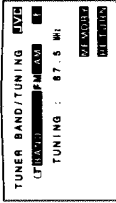

On-Screen 5

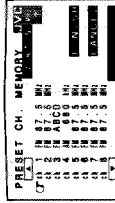

On-Screen 6



On-Screen 7

#### Tuning in a preset station (see also page 14)

- Press any of the cursor buttons (Δ, ∇, ◀, ▶) or the MENU SET button. The MAIN MENU appears on the TV screen.
- Press the cursor buttons (Δ, ∇) to move **CF** to "TUNER", then press the MENU SET button. The TUNER PRESET CH. Menu (see On-Screen 8) appears.
- Press the cursor buttons (Δ, ∇) to move **CF** to the preset station you want, then press the MENU SET button. To go to the next (or previous) screens, move **CF** to "◀" (or "▶"), then press the MENU SET button repeatedly.
- When you finish, press the MENU EXIT button. The Menu disappears from the TV screen.



On-Screen 8



**Assigning names to preset stations (see also page 15)**

1. Press any of the cursor buttons (Δ, ∇, ◀, ▶) or the MENU SET button. The MAIN MENU appears on the TV screen.
2. Press the cursor buttons (Δ, ∇) to move **CF** to "TUNER", then press the MENU SET button. The TUNER PRESET CH. Menu (see On-Screen 9) appears.
3. Press the cursor buttons (Δ, ∇) to move **CF** to a preset station you want, then press the MENU SET button.  
To go to the next (or previous) screens, move **CF** to **▶** (or **◀**) (or **▶** (or **◀**)), then press the MENU SET button repeatedly.
4. Press the cursor buttons (Δ, ∇) to move **CF** to "CHARACTER", then press the MENU SET button. The CHARACTER INPUT Menu (see On-Screen 10) appears.
5. Press the cursor buttons (Δ, ∇, ◀, ▶) to assign a name to the preset channel.  
Δ, ∇: Selects the characters.  
◀, ▶: Move the character input position to the left or right.  
To erase the name, move **CF** to "CLEAR", then press the MENU SET button.
6. Press the cursor button (▶) to move **CF** to "FINISH", then press the MENU SET button. The TUNER PRESET CH. Menu appears again.
7. Repeat steps 3 to 6 until you assign names to other preset stations you want.
8. When you finish, press the MENU EXIT button. The Menu disappears from the TV screen.

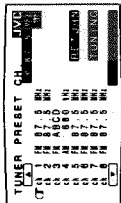

On-Screen 9

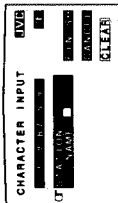

On-Screen 10

**Selecting your favorite SEA mode (see also page 16)**

1. Press any of the cursor buttons (Δ, ∇, ◀, ▶) or the MENU SET button. The MAIN MENU appears on the TV screen.
2. Press the cursor buttons (Δ, ∇) to move **CF** to "SEA", then press the MENU SET button. The SEA MODE Menu (see On-Screen 11) appears.
3. Press the cursor buttons (Δ, ∇) to move **CF** to the SEA mode you want, then press the MENU SET button.
4. When you finish, press the MENU EXIT button. The Menu disappears from the TV screen.



On-Screen 11

**Creating your own SEA mode (see also page 17)**

1. Select the SEA mode using the above procedures (Steps 1 to 3).
2. Press the cursor buttons (Δ, ∇) to move **CF** to "SEA ADJUST", then press the MENU SET button. The SEA MANUAL CONTROL Menu (see On-Screen 12) for the SEA mode you have selected appears.
3. Press the cursor buttons (Δ, ∇, ◀, ▶) to adjust the SEA mode as you want.  
◀, ▶: Select the frequency ranges.  
Δ, ∇: Adjust the frequency levels.
4. Press the cursor button (▶) to move **CF** to "FINISH", then press the MENU SET button. The adjustment is memorized in USER MODE and the SEA MODE Menu appears again.
5. To cancel the adjustment, move **CF** to "CANCEL", then press the MENU SET button. When you finish, press the MENU EXIT button. The Menu disappears from the TV screen.

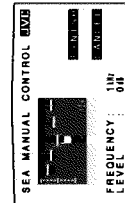

On-Screen 12

**Using the DAP modes (see also page 20)**

1. Press any of the cursor buttons (Δ, ∇, ◀, ▶) or the MENU SET button. The MAIN MENU appears on the TV screen.
2. Press the cursor buttons (Δ, ∇) to move **CF** to "DAP", then press the MENU SET button. The DAP MODE Menu (see On-Screen 13) appears.
3. Press the cursor buttons (Δ, ∇, ◀, ▶) to move **CF** to the DAP mode you want, then press the MENU SET button.
4. When you finish, press the MENU EXIT button. The Menu disappears from the TV screen.

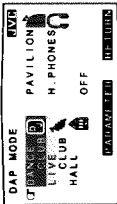

On-Screen 13

**Preparing for the DAP modes (see also page 19)**

You can adjust "DANCE CLUB, LIVE CLUB, HALL, and PAVILION" without using the Menus; however, you can adjust "HEAD PHONES" only using the Menus.

1. Select the DAP mode using the above procedures (steps 1 to 3).
2. Press the cursor buttons (Δ, ∇, ◀, ▶) to move **CF** to "PARAMETER", then press the MENU SET button. The Parameter Setting Menu for the DAP mode you have selected appears.



Example: For DANCE CLUB

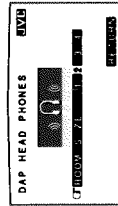

Example: For HEAD PHONES

3. Press the cursor buttons (Δ, ∇, ◀, ▶) to adjust the parameters you want.  
Δ, ∇: Selects the parameters  
◀, ▶: Adjust the parameters  
For "HEADPHONES":  
Selecting the higher number for ROOM SIZE makes you feel as if you were in a larger room. For other modes, see the pages referred above.
4. When you finish, press the MENU EXIT button. The Menu disappears from the TV screen.

**Using the surround modes (see also page 24)**

1. Press any of the cursor buttons (Δ, ∇, ◀, ▶) or the MENU SET button. The MAIN MENU appears on the TV screen.
2. Press the cursor buttons (Δ, ∇) to move **CF** to "SURROUND", then press the MENU SET button. The SURROUND MODE Menu (see On-Screen 14) appears.
3. Press the cursor buttons (Δ, ∇, ◀, ▶) to move **CF** to the surround mode you want, then press the MENU SET button.
4. When you finish, press the MENU EXIT button. The Menu disappears from the TV screen.



On-Screen 14

**Preparing for the surround modes (see also page 21)**

1. Select the surround mode using the above procedures (steps 1 to 3).
2. Press the cursor buttons (Δ, ▽, ◀, ▶) to move **CF** to "PARAMETER", then press the MENU SET button.  
The Parameter Setting Menu for the surround mode you have selected appears.



Example: For PRO LOGIC  
Δ, ▽: Selects the parameters  
◀, ▶: Adjust the parameters  
For more details, see the pages referred above.

3. Press the cursor buttons (Δ, ▽, ◀, ▶) to adjust the parameters you want.
4. When you finish, press the MENU EXIT button.  
The Menu disappears from the TV screen.

**Using the Sleep Timer (see also page 25)**

1. Press any of the cursor buttons (Δ, ▽, ◀, ▶) or the MENU SET button.  
The MAIN MENU appears on the TV screen.
2. Press the cursor buttons (Δ, ▽) to move **CF** to "OTHER SETTINGS", then press the MENU SET button.  
The OTHER SETTINGS Menu appears.

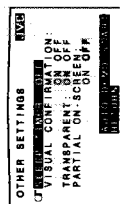
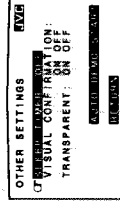

For RX-818VBK

For RX-880VBK

3. Press the cursor buttons (◀, ▶) to select off-time.
4. When you finish, press the MENU EXIT button.  
The Menu disappears from the TV screen.

**Using the Visual Confirmation (see also page 26)**

1. Press any of the cursor buttons (Δ, ▽, ◀, ▶) or the MENU SET button.  
The MAIN MENU appears on the TV screen.
2. Press the cursor buttons (Δ, ▽) to move **CF** to "OTHER SETTINGS", then press the MENU SET button.  
The OTHER SETTINGS Menu appears.
3. Press the cursor buttons (Δ, ▽) to move **CF** to "VISUAL CONFIRMATION".

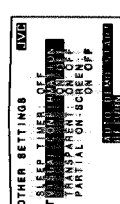

For RX-818VBK

For RX-880VBK

4. Press the cursor buttons (◀, ▶) to switch on or off the Visual Confirmation.
5. When you finish, press the MENU EXIT button.  
The Menu disappears from the TV screen.

**Setting the grey background around the Menu items on the TV screen**

You can put or erase the grey background around the Menu items according to your preference. This setting is possible only using the Menus.

1. Press any of the cursor buttons (Δ, ▽, ◀, ▶) or the MENU SET button.  
The MAIN MENU appears on the TV screen.
2. Press the cursor buttons (Δ, ▽) to move **CF** to "OTHER SETTINGS", then press the MENU SET button.  
The OTHER SETTINGS Menu appears.
3. Press the cursor buttons (Δ, ▽) to move **CF** to "TRANSPARENT".



For RX-818VBK



For RX-880VBK

4. Press the cursor buttons (◀, ▶) to set it "ON" or "OFF".  
ON: to erase the grey background.  
OFF: to put the grey background.
5. When you finish, press the MENU EXIT button.  
The Menu disappears from the TV screen.

**Using the Partial On-Screen Junction (only for RX-880VBK)**

This is convenient when you use RX-880VBK while watching video sources. Some operations you do, listed to the left, will be shown on the bottom of the TV screen. This setting is possible only using the Menus.

1. Press any of the cursor buttons (Δ, ▽, ◀, ▶) or the MENU SET button.  
The MAIN MENU appears on the TV screen.
2. Press the cursor buttons (Δ, ▽) to move **CF** to "OTHER SETTINGS", then press the MENU SET button.  
The OTHER SETTINGS Menu appears.
3. Press the cursor buttons (Δ, ▽) to move **CF** to "PARTIAL ON-SCREEN".  
See On-Screen 15.
4. Press the cursor buttons (◀, ▶) to set it "ON" or "OFF".  
ON: to show what you do on the TV.  
OFF: not to show what you do on the TV.
5. When you finish, press the MENU EXIT button.  
The Menu disappears from the TV screen.



On-Screen 15

**Using the demonstration**

You can see the demonstration of Menu operation. This is possible only using the Menus.

1. Press any of the cursor buttons (Δ, ▽, ◀, ▶) or the MENU SET button.  
The MAIN MENU appears on the TV screen.
2. Press the cursor buttons (Δ, ▽) to move **CF** to "OTHER SETTINGS", then press the MENU SET button.  
The OTHER SETTINGS Menu appears.
3. Press the cursor buttons (Δ, ▽) to move **CF** to "AUTO DEMO START", then press the MENU SET button.



For RX-818VBK



For RX-880VBK

4. When you finish, press the MENU EXIT button.  
The Menu disappears from the TV screen, and the demonstration stops.



The COMPU LINK remote control system allows you to operate JVC audio components through the remote sensor on the receiver.  
To use this remote control system, you need to connect JVC audio components through the COMPU LINK-3 SYNCHRO jacks (see page 8) in addition to the connections using cables with RCA pin plugs (see page 7). This remote control system allows you to use four functions listed below.  
Refer also to the manuals supplied with your audio components.

■ **Remote Control through the Remote Sensor on the Receiver**

You can control all components through the remote sensor on the receiver using this remote control. For details, see page 35.

**Note:**

*Aim the remote control directly at the remote sensor on the receiver.*

■ **Automatic Source Selection**

When you press the play (▶) button on a connected component or on its own remote control, the receiver automatically turns on and changes the source to the component. On the other hand, if you select a new source on the receiver or the remote control, the selected component begins playing immediately.  
In both cases, the previously selected source continues playing without sound for a few seconds.

■ **Automatic Power On/Off (only possible with the COMPU LINK-3 connection)**

Both the CD player and cassette deck turn on and off along with the receiver.  
When you turn on the receiver, the CD player or cassette deck will turn on automatically, depending on which component has been previously selected.  
When you turn off the receiver, both the CD player and cassette deck will turn off.

■ **Synchronized Recording**

Synchronized recording means the cassette deck starts recording as soon as a CD or a record begins playing.

To use synchronized recording, follow these steps:

1. Put a tape in the cassette deck, and a disc in the CD player (or a record on the turntable).
2. Press the record (●) button and the pause (⏸) button on the cassette deck at the same time.  
This puts the cassette deck into recording pause.

**Note:**

*If you do not press the record (●) button and pause (⏸) button at the same time, the synchronized recording feature will not operate.*

3 Press the play (▶) button on the CD player or on the turntable.

The source changes on the receiver, and as soon as play starts, the cassette deck starts recording. When the play ends, the cassette deck enters recording pause, and stops about 4 seconds later.

**Notes:**

- During synchronized recording, the selected source cannot be changed.
- If your CD player is playing in program mode, a 4-second blank is recorded between tracks so that the music scan feature of your cassette deck can be used on the recorded tape.
- If the power of any component is shut off during synchronized recording, the COMPU LINK remote control system may not operate properly. In this case, you must start again from the beginning.



The AV COMPU LINK remote control system allows you to operate JVC video components through the receiver.  
To use this remote control system, you need to connect JVC video components through the AV COMPU LINK jacks in addition to the connections using cables with RCA pin plugs (see pages 7 and 8). However, this remote control system cannot control video components connected to the VIDEO 1 and VIDEO 2 jacks. So, when you connect the VCR you want to operate using the AV COMPU LINK remote control system, connect it to the VCR jacks.

This remote control system allows you to use four functions listed below.

Refer also to the manuals supplied with your video components.

■ **Remote Control of the TV through the Remote Sensor on the Receiver**

You can control the TV through the remote sensor on the receiver using this remote control. For details, see page 36.

**Note:**

*Aim the remote control directly at the remote sensor on the receiver when operating the TV. (However, to operate the VCR, always aim the remote control directly at the remote sensor on the VCR.)*

■ **One-Touch Video Play**

Simply by inserting a video cassette without its safety tab into the VCR, you can enjoy the video playback without setting other switches manually.

The receiver automatically turns on and changes the source to the VCR.

The TV automatically turns on and changes the input mode to the position you can view the VCR playback. When you insert a video cassette with its safety tab, press the play (▶) button on the VCR or on the remote control. So, you can get the same result.

**Note:**

*When you connect an S-VHS VCR as described on page 8, you cannot see the on-screen displays (such as Visual Confirmation and Menus) since the AV COMPU LINK Remote Control System automatically changes the TV input mode to "Video input 1" when you operate the S-VHS VCR.  
If you do not mind stopping watching the video, you can then show the on-screen displays after changing the TV input mode to the position (Video input 2) the receiver is connected to.*

■ **Automatic Selection of TV's Input Mode**

When you select TV SOUND as the source to play on the receiver, the TV automatically changes the input mode to the TV tuner so that you can watch TV.

On the other hand, when you select any other source other than TV SOUND as the source to play on the receiver, the TV automatically changes the input mode to the video input.

**Note:**

*When you select TV SOUND as the source on the receiver, you cannot see the on-screen displays (such as Visual Confirmation and Menus) since the AV COMPU LINK Remote Control System automatically changes the TV input mode to the TV tuner.*

*If you do not mind stopping listening to the TV sounds, you can then show the on-screen displays after changing the TV input mode to the position (Video input 2) the receiver is connected to.*

■ **Automatic Power On/Off**

Both the TV and the VCR turn on and off along with the receiver.

When you turn on the receiver,

- If the previously selected source is VCR, the TV and VCR will turn on automatically.
  - If the previously selected source is VIDEO 1, VIDEO 2 or TV SOUND, only the TV will turn on automatically.
- When you turn off the receiver, both the TV and VCR will turn off.

**Note:**

*If you turn off the receiver while recording on the VCR, the VCR will not turn off, but continue recording.*

## Using the Remote Control for Operating JVC's Audio/Video Components

You can operate JVC's audio and video components with this receiver's remote control, since control signals for JVC components are preset in the remote control.

To operate these components with the remote control, first select a source with the source selecting buttons on the remote control. Then, operate that source using the remote control.

### Notes:

- If you use the buttons on the front panel or the Menu to choose a source, the remote control will not operate that source. To operate a source with the remote control, the source must be selected using buttons on the remote control.
- Check to see if its remote control mode selector is set to the correct position. To operate audio system, TVs, and VCRs, set it to the "AUDIO/TV/VCR" position.
- Refer also to the manuals supplied with your components.

### IMPORTANT:

- JVC's audio components using this remote control:
- You need to connect JVC audio components through the COMPU LINK-3 SYNCHRO jacks (see page 8) in addition to the connections using cables with RCA pin plugs (see page 7).
- Aim the remote control directly at the remote sensor on the receiver.

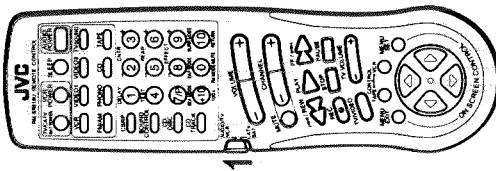

### Tuner

After pressing the FM/AM button (with the remote control mode selector set to the "AUDIO/TV/VCR" position), you can perform the following operations:

- FM/AM:** Alternates between FM and AM.
- 1 — 10, +10:** Selects a preset channel number directly.
- To select channel number 5, press 5. For channel number 15, press +10, then 5. For channel number 20, press +10, then 10.

### FM MODE/MUTE:

Changes the FM reception mode.

### Sound control section (Amplifier)

After pressing the SOUND CONTROL button (with the remote control mode selector set to the "AUDIO/TV/VCR" position), you can perform the following operations:

- SEA MODE:** Changes the SEA modes.
- DAP MODE:** Changes the DAP modes.
- SURR MODE:** Changes the surround modes.
- CNTR +/-:** Changes the center modes for surround modes.
- REAR +/-:** Changes the rear speaker output level for DAP and surround modes.
- EFFECT +/-:** Changes the effect level for DAP and surround modes.
- DELAY:** Changes the delay time for surround modes.
- TEST:** Checks the speaker output level for surround.

### CD player

After pressing the CD button or the CD TRACK button (with the remote control mode selector set to the "AUDIO/TV/VCR" position), you can perform the following operations on a CD player:

- PLAY:** Starts playing.
- ◀▶:** Returns to the beginning of the current (or previous) track.
- ▶▶:** Skips to the beginning of the next track.
- STOP:** Stops playing.
- PAUSE:** Pauses playing. To release it, press the PLAY button.
- 1 — 10, +10:** Selects a track number directly.
- To select track number 5, press 5. For track number 15, press +10, then 5. For track number 20, press +10, then 10.

### CD player-changer

After pressing the CD DISC button (with the remote control mode selector set to the "AUDIO/TV/VCR" position), you can perform the following operations on a CD player-changer:

- PLAY:** Starts playing.
- ◀▶:** Returns to the beginning of the current (or previous) track.
- ▶▶:** Skips to the beginning of the next track.
- STOP:** Stops playing.
- PAUSE:** Pauses playing. To release it, press the PLAY button.
- 1 — 6, 7/P:** Select the number of a disc installed in a CD player-changer.
- After pressing the CD TRACK button:
- 1 — 10, +10:** Selects a track number directly.
- To select track number 5, press 5. For track number 15, press +10, then 5. For track number 20, press +10, then 10.

### Note:

- If you have the CD player-changer XL-MC100C and XL-MC100M, 1 — 6 buttons function as the DISC SKIP button.
- Press 2, 4, or 6 to skip to the next disc.
- Press 1, 3, or 5 to skip back to the previous disc.

### Turntable

After pressing the PHONO button (with the remote control mode selector set to the "AUDIO/TV/VCR" position), you can perform the following operations on a turntable:

- PLAY:** Starts playing.
- STOP:** Stops playing.

### Cassette deck

After pressing the TAPE or TAPE CONTROL button (with the remote control mode selector set to the "AUDIO/TV/VCR" position), you can perform the following operations on a cassette deck:

- PLAY:** Starts playing.
- REW:** First rewinds the tape from right to left.
- FF:** First rewinds the tape from left to right.
- STOP:** Stops operations.
- PAUSE:** Pauses playing or recording temporarily. To release it, press the PLAY button.
- REC ●:** Press this button with the PLAY button to start recording.
- Press this button with the PAUSE button to enter recording pause (standby).

### Note:

You can use either the TAPE button or the TAPE CONTROL button to activate the buttons listed above. If you press the TAPE button, the playing source also changes to "TAPE." On the other hand, if you press the TAPE CONTROL button, the playing source does not change to "TAPE."

### VCR

After pressing the VCR button or the VCR CONTROL button (with the remote control mode selector set to the "AUDIO/TV/VCR" position), you can perform the following operations on the VCR:

- PLAY:** Starts playing.
- REW:** Rewinds a tape.
- FF:** Fast winds a tape.
- STOP:** Stops operations.
- PAUSE:** Pauses playing or recording temporarily. To release it, press the PLAY button.
- REC ●:** Press this button with the PAUSE button to enter recording pause (standby).
- Press this button with the PAUSE button to start recording.
- CHANNEL +/-:** Changes the channels on the VCR.
- 1 — 9, 0:** Selects the channels on the VCR.

### Notes:

- You can use either the VCR button or the VCR CONTROL button to activate the buttons listed above. If you press the VCR button, the playing source also changes to "VCR." On the other hand, if you press the VCR CONTROL button, the playing source does not change to "VCR."
- You can also turn the VCR on and off by pressing the VCR POWER button on the remote control.

### TV

After pressing the TV SOUND button (with the remote control mode selector set to the "AUDIO/TV/VCR" position), you can perform the following operations on a TV:

- CHANNEL +/-:** Changes the channels.
- TV VOLUME +/-:** Adjusts the volume.
- 1 — 9, 0, 100+:** Selects the channels.
- TV/VIDEO:** Sets the input mode (either TV or VIDEO).
- RETURN:** Alternates between the previously selected channel and the current channel.

### Note:

You can also turn the TV on and off by pressing the TV/CATV/SAT POWER button on the remote control.

### CAUTION:

If you press the cursor buttons (Δ, ▽, ◀, ▶) or the MENU SET button, the Menu setting, for example volume level or surround setting, will change though you have not connected a TV to the receiver. When you use the Menu, make sure that you have connected a TV and operate the Menu while watching the on-screen displays on the TV.

**Operating Other Manufacturers' VCR, TV, CATV Converter, and Satellite Tuners**

This remote control supplied with the receiver can transmit control signals for other manufacturers' VCRs, TVs and CATV converters. By changing the transmittable signals from preset ones to the other manufacturers', you can operate the other manufacturer's components using this remote control.

When operating the other manufacturers' components, refer also to the manuals supplied with them. To operate these components with the remote control, first you need to set the manufacturer's code each for VCR, TV, CATV converters, and satellite tuner.

**IMPORTANT**

When using the Remote Control, check to see if its remote control mode selector is set to the correct position:  
**To operate audio system, TVs, and VCRs**, set it to the "AUDIO/TV/VCR" position.  
**To operate CATV converters and satellite tuners**, set it to the "CATV/SAT" position.



**To change the transmittable signals for operating another manufacturer's TV**

1. Set the remote control mode selector to the "AUDIO/TV/VCR" position.
2. Press and hold the TV/CATV/SAT POWER button until you finish the following procedures.
3. Press and hold the TV SOUND button.
4. Enter the manufacturer's code (three digits) using buttons 1 - 9, and 0. See the lists on page 39 to find the code.

5. Release the TV/CATV/SAT POWER button.  
 The following buttons can be used for operating the TV (with the remote control mode selector set to the "AUDIO/TV/VCR" position):

- TV/CATV/SAT POWER: Turns on and off TV.
- CHANNEL +/-: Changes the channels.
- TV VOLUME +/-: Adjusts the volume.
- 1 - 10, 0, +10: Selects the TV channels.
- +10 button will function as the ENTER button if your TV requires pressing the ENTER button after selecting a channel number.
- TV/VIDEO: Sets the input mode (either TV or VIDEO).

Note:  
 Refer also to the manual supplied with your TV.  
 6. Try to operate your TV by pressing the TV/CATV/SAT POWER button. When your TV turns on or off, you have entered the correct code.

7. If there are more than one code listed for your brand of TV, try each one until the correct one is entered.

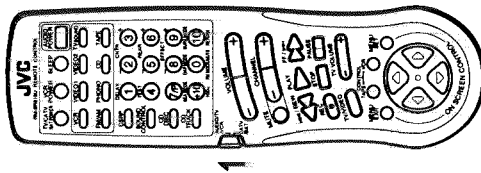

**To change the transmittable signals for operating another manufacturer's CATV converter or satellite tuner**

1. Set the remote control mode selector to the "CATV/SAT" position.
2. Press and hold the TV/CATV/SAT POWER button until you finish the following procedures.
3. Press and hold the TV SOUND button.
4. Enter the manufacturer's code (three digits) using buttons 1 - 9, and 0. See the lists on page 40 to find the code.

5. Release the TV/CATV/SAT POWER button.  
 After setting the remote control mode selector to the "CATV/SAT" position, you can perform the following operations on the CATV converter or on the satellite tuner:

- TV/CATV/SAT POWER: Turns on and off CATV converter or satellite tuner.
- CHANNEL +/-: Changes the channels.
- 1 - 10, 0, +10: Selects the channels.
- +10 button will function as the ENTER button if your CATV converter or satellite tuner requires pressing the ENTER button after selecting a channel number.

Note:  
 Refer also to the manual supplied with your CATV converter or satellite tuner.

6. Try to operate your CATV converter or satellite tuner by pressing the TV/CATV/SAT POWER button. When it turns on or off, you have entered the correct code.
7. If there are more than one code listed for your brand of CATV converter, try each one until the correct one is entered.

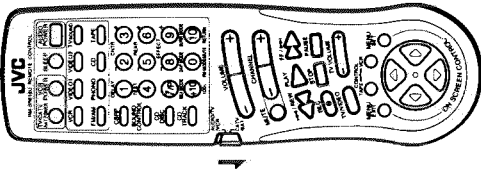

**To change the transmittable signals for operating another manufacturer's VCR**

1. Set the remote control mode selector to the "AUDIO/TV/VCR" position.
2. Press and hold the VCR POWER button until you finish the following procedures.
3. Press and hold the VCR button.
4. Enter the manufacturer's code (three digits) using buttons 1 - 9, and 0. See the lists on page 41 to find the code.

5. Release the VCR POWER button.  
 The following buttons can be used for operating the VCR:

- VCR POWER: Turns on and off VCR.
- After pressing the VCR button or the VCR CONTROL button (with the remote control mode selector set to the "AUDIO/TV/VCR" position), you can perform the following operations on the VCR:
- CHANNEL +/-: Changes the channels on the VCR.
- 1 - 10, 0, +10: Selects the channels on the VCR.
- +10 button will function as the ENTER button if your VCR requires pressing the ENTER button after selecting a channel number.

- PLAY: Starts playback.
- STOP: Stops operations.
- PAUSE: Pauses.
- REW: Rewinds a tape.
- FF: First winds a tape.
- REC: Starts recording or enters recording pause.

Notes:  
 • You can use either the VCR button or the VCR CONTROL button to activate the buttons listed above. If you press the VCR button, the playing source also changes to "VCR." On the other hand, if you press the VCR CONTROL button, the playing source does not change to "VCR."  
 • Refer also to the manual supplied with your VCR.

6. Try to operate your VCR by pressing the VCR POWER button. When your VCR turns on or off, you have entered the correct code.
7. If there are more than one code listed for your brand of VCR, try each one until the correct one is entered.

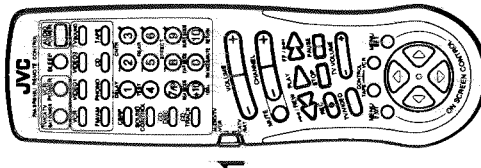

Manufacturers' codes for TV

A-Mark	003
Admiral	093
Adventura	046
Aiko	092
Akai	030
Alleron	179
Ambassador	177
Anam	180
Anam National	055
AOC	003, 019, 030, 052
Archer	003
Audiovox	003, 180
Beicor	019
Bell & Howell	016, 154
Bradford	019
Brockwood	019
Broksonic	003
Candle	030, 046, 056, 186
Carver	054
Celebrity	000
Citizen	030, 039, 046, 056, 060, 092, 186, 280
Concerto	056
Contec	180
Craig	180
Crown	039, 180
Curtis Mathes	030, 039, 060, 154
CXC	180
Daewoo	019, 039, 092, 451
Daytron	017
Dumont	017, 019
Electroland	000
Emerson	019, 038, 039, 154, 177, 178, 179, 180, 236, 280, 282, 463
Envision	030
Fisher	154, 159
Fujitsu	179
Funai	179, 180
Futurtech	180
GE	021, 027, 047, 051, 055, 135, 178, 282, 451
Gibralter	017, 019, 030
GoldStar	019, 030, 039, 056, 178
Grundy	179, 180
Hallmark	178
Harvard	180
Hitachi	038, 056, 145, 151
Ima	180
Infinity	054
Janeil	046
JBL	054
JCB	000
JVC	053, 069, 160, 169
Kaypani	052
KEC	180
Kenwood	019, 030
Klbes	046
KTV	030, 039, 180, 280
Logik	016
Luxman	056
LXI	047, 054, 154, 156, 178
Magnavox	020, 030, 054, 186, 187
Maestic	016
Marantz	003, 145, 178
Megatron	030, 054
Memorex	016, 056, 150, 154, 178
MGA	019, 030, 150, 178

Television	039
Universal	027
Vector Research	030
Victor	053
Vidkron	054
Vidtech	019, 178
Viking	046
Wards	016, 019, 020, 021, 027, 030, 054, 056, 080, 165, 178, 179
Yamaha	080, 165, 178, 179
Zenith	019, 030
Zonda	016, 017
	003

039	
027	
030	
053	
054	
019, 178	
046	
016, 019, 020, 021, 027, 030, 054, 056, 080, 165, 178, 179	
080, 165, 178, 179	
019, 030	
016, 017	
003	

Manufacturers' codes for CATV converters

ABC	003, 007, 008, 011, 013, 014, 017
Archer	153
Beicor	056
Cable Star	056
Century	153
Citizen	153
Comtronics	040
Contec	019
Dae Ryoung	008
Everquest	015, 040
Focus	400
Garrard	153
GC Electronics	056
Gemini	015
General Instrument	011, 276
Goldstar	040, 144
Hamihi	009, 020, 259, 273
Hitachi	011
Hyfex	007
Jasco	153
Jerrold	003, 011, 012, 014, 015, 276
Memorex	000
Novaplex	618
Oak	007, 019
Panasonic	000, 021, 107
Paragon	000
Philips	153
Pioneer	144, 533
Popular Mechanics	400
Pulsar	000
RCA	021
Recoton	400
Regal	020, 259, 273
Rembrandt	011
Rurico	000
Samsung	040, 144
Scientific Atlanta	006, 008, 017, 277
Signal	015, 040
Signature	011
SL Marx	040
Spucer	021
Starcorn	003, 015
Stargate	015, 040
Starquest	015
Televue	040
Tocom	012, 013
Toshiba	000
Tusa	015
Unika	153
United Artists	007
United Cable	003
Universal	056, 153
Zenith	000
Zentek	400

Manufacturers' codes for satellite tuner

General Instrument	361
Jerrold	361
PrimeStar	361
RCA	566
Sony	639

**Troubleshooting**

Use this chart to help you solve daily operational problems. If there is any problem you cannot solve, contact your JVC service center.

PROBLEM	POSSIBLE CAUSE	SOLUTION
The display does not light up.	The power cord is not plugged in.	Plug the power cord into an AC outlet.
No sound from speakers.	Speaker signal cables are not connected.	Check speaker wiring and reconnect if necessary.
	The SPEAKERS 1 and 2 buttons are not set correctly.	Press the SPEAKERS 1 and 2 buttons in or out correctly.
	An incorrect source is selected.	Select the correct source.
	Mute is activated.	Press the MUTE button so that the indicator goes off.
Sound from one speaker only.	Speaker signal cables are not connected properly.	Check speaker wiring and reconnect if necessary.
	The BALANCE control is set to one extreme.	Adjust the BALANCE control properly.
Continuous hiss or buzzing during FM reception.	Incoming signal is too weak.	Connect an outside FM antenna or contact your dealer.
	The station is too far away.	Select a new station.
	An incorrect antenna is used.	Check with your dealer to be sure you have a correct antenna.
	Antennas are not connected properly.	Check connections.
Occasional cracking noise during FM reception.	Ignition noise from automobiles.	Move the antenna farther from automobile traffic.
	The color system of the connected TV is not NTSC.	Connect an NTSC TV.
Howling during record playing.	Your turntable is too close to speakers.	Move speakers away from the turntable.
Remote control does not work.	The remote control mode selector is not set correctly.	Set the selector correctly either to the "AUDIO/TV/VCR" position or to "CATV/SAT" position.
	There is an obstruction in front of the remote sensor on the receiver.	Remove the obstruction.
	Batteries are weak.	Replace batteries.

**Manufacturers' codes for VCR**

Adventura	000
Aiko	278
Aiwa	000
Alcal	041
American High	035
Asha	240
Audiovox	037
Beaumont	240
Bell & Howell	104
Broksonic	121, 184, 211, 295
Calix	037
Canon	035
Capelhart	020
Carver	081
CCE	072, 278
Citizen	037, 278
Colt	072
Craig	037, 047, 072, 240
Curtis Mathies	035, 041, 060
Cybernax	240
Daywoo	020, 045, 278
Daytron	020
Dynaltech	000
Electrohome	037
Electrohome	037
Emerex	032
Emerson	000, 002, 037, 043, 121, 184, 211, 212, 278, 295, 479
Fisher	047, 054, 104
Fuji	033, 035
Funai	000
Garrard	000
GE	035, 060, 202
GoldStar	037, 038
Gradiente	000
Harley Davidson	000
Harman/Kardon	038
Harwood	072
Headquarter	046
Hi-O	047
Hitachi	041, 042, 105
Jensen	041
JVC	008, 041, 067
KEC	037, 278
Kenwood	038, 041, 067
KLH	072
Kodak	035, 037
Lloyd	000
Logik	072
LXI	037
Magnavox	035, 039, 081, 149
Magnin	240
Marantz	035, 081
Marta	037
Matsushita	035
MEI	035
Memorex	000, 035, 037, 039, 046, 047, 048, 104, 240
MGA	043
MGN Technology	240
Minolta	042, 105
Mitsubishi	043, 067
Motorola	035, 048
MTC	000, 240
Multitech	000, 072
NEC	038, 041, 067, 104
Nikko	037
Noblex	240
Olympus	035
Optimus	037, 048, 104, 162
Optonica	062
Orion	295, 479
Panasonic	035, 162, 225
Penney	035, 037, 038, 042, 054, 240
Pentax	042, 105
Philco	035
Philips	035, 062, 081
Pilot	037
Pioneer	067
Portland	020
Protac	072
Pulsar	039
Quarrel	046
Quartz	046
Quasar	035, 162
Radio Shack	000, 037
Radix	037
Randex	042, 060, 105, 149, 202
RCA	000, 035, 037, 046, 047, 048, 062, 104, 240
Realistic	240
Ricoh	034
Rinco	039
Samsung	045, 240
Sanky	039, 048
Sansui	041, 067
Sanyo	046, 047, 104, 240
Scott	043, 045, 121, 184, 211, 212
Sears	035, 037, 042, 046, 047, 054, 104, 105
Sharp	048, 062
Shinomi	072
Shogun	240
Singer	072
Sony	032, 033, 034, 035
STS	042
Sylvania	000, 035, 043, 081
Symphonic	000
Tatung	041
Teac	000, 041
Technics	035, 162
Teknika	000, 035, 037
TMK	240
Toshiba	043, 045, 212
Television	037, 240
Unitech	240
Vector	045
Vector Research	038
Video Concepts	045
Videosonic	240
Wards	000, 035, 042, 047, 048, 060, 062, 072, 149, 212, 240
XR-1000	000, 035, 072
Yamaha	038
Zenith	033, 034, 039

Manufacturers' codes listed on page 39 to 41 are subject to change without notice. If they are changed, this remote control cannot operate the equipment.

**Specifications**

**Amplifier**

Output Power	A1 Stereo operation	120 watts per channel, min. RMS, both channels driven into 8 ohms, 20 Hz to 20 kHz with no more than 0.02% total harmonic distortion.
	At Surround operation Front Channels	100 watts per channel, min. RMS, driven into 8 ohms at 1 kHz with no more than 0.8% total harmonic distortion.
	Center channel	100 watts, min. RMS, driven into 8 ohms at 1 kHz, with no more than 0.8% total harmonic distortion.
	Rear channels	100 watts, min. RMS, driven into 8 ohms at 1 kHz, with no more than 0.8% total harmonic distortion.
Total Harmonic Distortion (8 ohms, 1 kHz)		0.02%* at 120 watts output (* Measured by JVC Audio Analysis System)
Audio Input Sensitivity/ Impedance (1 kHz)	PHONO (MM) CD, TAPE, TV SOUND, VCR, VIDEO 1, VIDEO 2	2.5 mV/47 k ohms 230 mV/47 k ohms
Audio Output Level	TAPE, VCR	230 mV
Signal-to-Noise Ratio (*66 IHF/78 IHF)	PHONO CD, TAPE, TV SOUND, VCR, VIDEO 1, VIDEO 2	70 dB/78 dB (at REC OUT) 91 dB/80 dB
Frequency Response (8 ohms)	PHONO CD, TAPE, TV SOUND, VCR VIDEO 1, VIDEO 2	20 Hz to 20 kHz (±0.5 dB) 10 Hz to 30 kHz (±1 dB)
RIAA Phono Equalization		±0.5 dB (20 Hz to 20 kHz)
LOUDNESS Control (Volume Control at -40 dB)		+6 ±1 dB at 100 Hz +4 ±1 dB at 10 kHz
S.E.A. Control Range	Center Frequencies	100 Hz, 1 kHz, 10 kHz ±10 dB ±2 dB

**Video**

Video Input Sensitivity/ Impedance	VCR, VIDEO 1, VIDEO 2	1 Vp-p/75 ohms
Synchronization		Negative
Signal-to-Noise Ratio		45 dB
On-Screen Color System		NTSC

**FM tuner (IHF)**

Tuning Range	87.5 MHz to 108.0 MHz
Usable Sensitivity	10.8 dBf (0.95 μV/75 ohms)
50 dB Quieting Sensitivity	16.3 dBf (1.8 μV/75 ohms) 38.3 dBf (22.5 μV/75 ohms)
Signal-to-Noise Ratio (IHF-A weighted)	80 dB at 85 dBf 73 dB at 85 dBf
Total Harmonic Distortion	0.15% at 1 kHz 0.2% at 1 kHz
Stereo Separation at REC OUT	40 dB at 1 kHz
Capture Ratio	1.5 dB at 85 dBf
Alternate Channel Selectivity	60 dB (±400 kHz)
Frequency Response	30 Hz to 15 kHz; (+0.5 dB, -3 dB)

**AM tuner**

Tuning Range	530 kHz to 1,710 kHz
Usable Sensitivity	300 μV/m 30 μV
Signal-to-Noise Ratio	50 dB (100mV/m)

**General**

Power Requirements	AC 120V, 60 Hz
Power Consumption	300 watts/400 VA 5 watts (in standby mode)
Dimensions (W x H x D)	17 3/16 x 6 7/16 x 15 7/8 inches (435 x 156 x 396 mm)
Mass	29.1 lbs (13.2 kg)

Designs & specifications are subject to change without notice.



# Description of Major LSIs

## ■ MN171601AK8W (IC401) : SYSTEM CONTROLLER 1

### 1. Terminal Layout

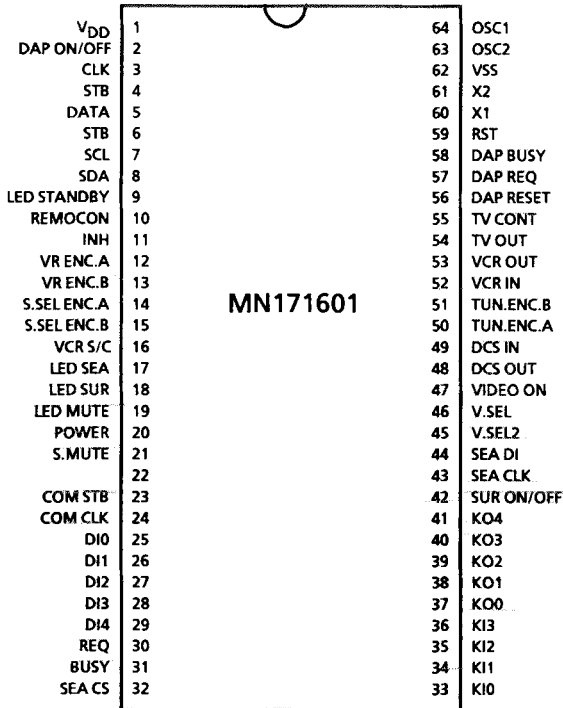

### 2.Key Matrix

	K10 (PIN33)	K11 (PIN34)	K12 (PIN35)	K13 (PIN36)
KO0 (PIN37)	POWER (S400)	SEA MODE (S401)	SEA MEMORY (S402)	VISUAL CONFIRMATION (S403)
KO1 (PIN38)	CENTER LEVEL + (S404)	REAR LEVEL + (S405)	CURSOL MODE (S406)	SURROUND MODE (S407)
KO2 (PIN39)	CENTER LEVEL - (S408)	REAR LEVEL - (S409)	DAP MODE (S410)	CENTER MODE (S411)
KO3 (PIN40)	PRESET /TUNING (S412)	CHARACTER (S491)	FM MODE /MUTE (S414)	FM/AM (S415)
KO4 (PIN41)	LOUDNESS (S416)	ENTER (S492)	MUTE (S490)	CSRP (S418)

### 3. Description

Pin No.	Symbol	I/O	Description	Pin NO.	Symbol	I/O	Description
1	V <sub>DD</sub>	--	Power supply	33	K10	I	Key matrix Input
2	DAP ON/OFF	O	IC322 control	34	K11	I	Key matrix Input
3	CLK	O	Clock to IC305,IC307	35	K12	I	Key matrix Input
4	STB	O	Strbe signal to IC305	36	K13	I	Key matrix Input
5	DATA	O	Data to IC305,IC307	37	KO0	O	Key matrix output
6	STB	O	Strbe signal to IC307	38	KO1	O	Key matrix output
7	SCL	--	Not used(GND)	39	KO2	O	Key matrix output
8	SDA	--	Not used(GND)	40	KO3	O	Key matrix output
9	LED STANDBY	O	STANDBY LED control signal	41	KO4	O	Key matrix output
10	REMOCON	I	Remote signal input	42	SUR ON/OFF	O	SURROUND ON/OFF control
11	INH	I	Inhibit signal input	43	SEA CLK	O	Clock to IC551
12	VR ENC.A	I	R. Encoder control signal input (VOL)	44	SEA DI	O	Data to IC551
13	VR ENC. B	I	R. Encoder control signal input (VOL)	45	V.SEL 2	O	VIDEO SELECT signal output
14	S.SEL ENC.A	I	R. Encoder control signal input(SOURCE)	46	V.SEL	O	VIDEO SELCT signal output
15	S.SEL ENC.B	I	R. Encoder control signal input(SOURCE)	47	VIDEO ON	O	VIDEO ON/OFF control signal
16	VCR S/C	I	VCR S/C signal	48	DCS OUT	O	Compulink signal output
17	LED SEA	O	SEA indication control	49	DCS IN	I	Compulink signal input
18	LED SUR	O	SURROUND indication control	50	TUN.ENC.A	I	R. Encoder control signal input (TUNER)
19	LED MUTE	O	MUTE indication control	51	TUN.ENC.B	I	R. Encoder control signal input (TUNER)
20	POWER	O	POWER ON/OFF control	52	VCR IN	I	AV COMPULINK
21	S.MUTE	O	SOUECE MUTE control	53	VCR OUT	O	AV COMPULINK
22		--		54	TV OUT	O	AV COMPULINK
23	COM STB	O	Strobe signal to IC400	55	TV CONT	O	AV COMPULINK
24	COM CLK	O	Clock to IC400	56	DAP RESET	O	RESET signal for IC096
25	D10	I/O	Data signal to IC400	57	DAP REQ	O	REQUEST signal for IC096
26	D11	I/O	Data signal to IC400	58	DAP BUSY	I	BUSY signal from IC096
27	D12	I/O	Data signal to IC400	59	RST	I	Reset signal input
28	D13	I/O	Data signal to IC400	60	X1	--	GND
29	D14	I/O	Data signal to IC400	61	X2	--	Not used
30	REQ	I	Request signal for IC400	62	VSS	--	GND
31	BUSY	I	Busy signal from IC400	63	OSC2	--	Oscillation terminal
32	OSD CS	I	Chip select RX-818/RX-880	64	OSC1	--	Oscillation terminal

■ MN172412K8X (IC400)  
: SYSTEM CONTROLLER 2

1. Terminal Layout

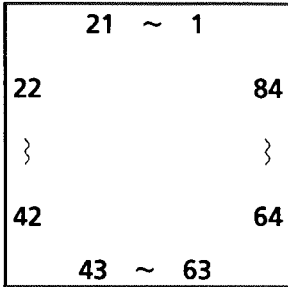

3. Description

Pin No.	Symbol	I/O	Description	Pin No.	Symbol	I/O	Description
1		--	GND	43	OSD SIN	I	Data for IC222
2		--	GND	44	OSD ON	O	ON SCREEN on/off
3		--	GND	45	T.CLK	I	Clock input for IC191
4		--	GND	46	IFDATA	I	Data signal for IC191
5		--	GND	47	T.DATA	I	Datasignal for IC191
6	17G	O	Grid control signal	48	COMSTB	I	Strobe signal for IC401
7	16G	O	Grid control signal	49	COMCLK	I	Clock to IC401
8	15G	O	Grid control signal	50	TUNED	I	TUNED signal to IC104
9	14G	O	Grid control signal	51	STEREO	I	STEREO signal to IC105
10	13G	O	Grid control signal	52	T.MUTE	O	TUNER MUTEsignal output
11	12G	O	Grid control signal	53	T.CS	I	TUNER chip select
12	11G	O	Grid control signal	54	CE	I	Fix the chip enable
13	10G	O	Grid control signal	55		--	GND
14	9G	O	Grid control signal	56		--	GND
15	8G	O	Grid control signal	57		--	GND
16	7G	O	Grid control signal	58		--	GND
17	6G	O	Grid control signal	59		--	GND
18	5G	O	Grid control signal	60	DI0	I/O	Data signal to IC401
19	4G	O	Grid control signal	61	DI1	I/O	Data signal to IC401
20	3G	O	Grid control signal	62	DI2	I/O	Data signal to IC401
21	2G	O	Grid control signal	63	DI3	I/O	Data signal to IC401
22	1G	O	Grid control signal	64	DI4	I/O	Data signal to IC401
23	V <sub>PP</sub>	--	Power supply	65	REQ	O	Request signal for IC401
24	S1	O	Segment control signal	66	BUSY	O	Busy signal from IC401
25	S2	O	Segment control signal	67	INH	I	Inhibit signal input
26	S3	O	Segment control signal	68	RST	I	Reset signal input
27	S4	O	Segment control signal	69	X1	--	GND
28	S5	O	Segment control signal	70	X2	--	Not used
29	S6	O	Segment control signal	71	VSS	--	GND
30	S7	O	Segment control signal	72	OSC2	--	Oscillation terminal
31	S8	O	Segment control signal	73	OSC1	--	Oscillation terminal
32	S9	O	Segment control signal	74	VDD	--	Power supply
33	S10	O	Segment control signal	75	VL/VH	O	RY880,RY881 control
34	S11	O	Segment control signal	76	4/8Ω SEL	I	4/8Ω select
35	S12	O	Segment control signal	77	4/8Ω DETECT	O	4/8Ω detect
36	S13	O	Segment control signal	78		--	Not used
37	S14	O	Segment control signal	79		--	GND
38	S15	O	Segment control signal	80		--	GND
39	S16	O	Segment control signal	81		--	GND
40	OSD CS	O	Chip select signal for IC222	82		--	GND
41	SCK	O	Clock output for IC222	83		--	GND
42	OSD SYNC	I	VIDEO SYNCH. signal from IC221	84		--	GND

■ LC72131M (IC121) : PLL Synthesizer

1. Terminal Layout

XIN	1	20	XOUT
CE	2	19	V <sub>SS</sub>
TDATA	3	18	LPF OUT
CK	4	17	LPF IN
IFDATA	5	16	PD
FM	6	15	V <sub>DD</sub>
MW	7	14	FM OSC
LW	8	13	AM OSC
AUTO/MONO	9	12	IF REQ
POWER	10	11	FM/AM IF

2. Block Diagram

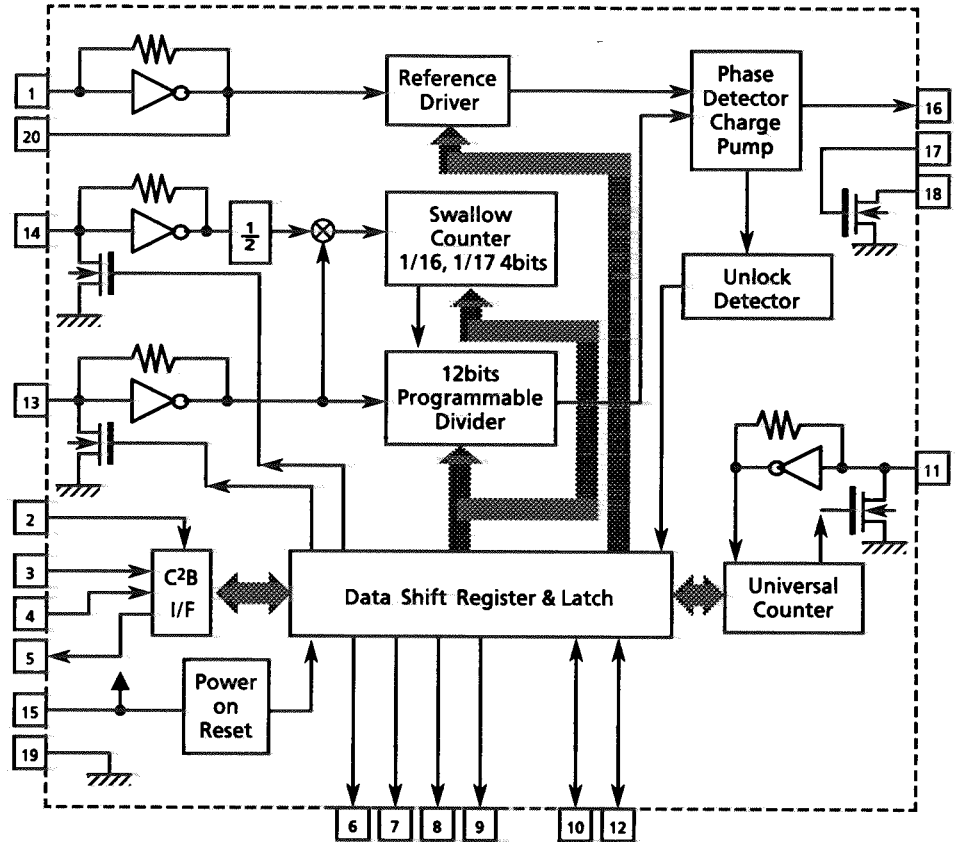

3. Pin Functions

Pin No.	Symbol	I/O	Functions	Pin No.	Symbol	I/O	Functions
1	X in	I	Crystal oscillator (7.2MHz).	11	FM/AM IF	I	Universal counter input
2	CE	I	Fix the chip enable to "H" when inputting (DI) and outputting (DO) the serial data.	12	IF REQ	O	Output the "IF-signal request" to IC102
3	TDATA	I	Receive the control data from the controller (IC201).	13	AM IN	I	Input the local oscillator signal of AM.
4	CK	I	This clock is used to synchronize data when transmitting the data of DI and DO.	14	FM IN	I	Input the local oscillator signal of FM.
5	IFDATA	O	Transmit the data from LC72131M to the controller which is synchronized with CK.	15	V <sub>DD</sub>	-	This is a terminal of power supply.
6	FM	O	It is "L" on FM mode.	16	PD	O	PLL charge pump output : When the local oscillator signal frequency is higher than the reference frequency high level signals will output. When it is lower than the reference frequency, low level signals will output. When it is same as reference frequency signals, it will be floating.
7	MW	O	It is "L" on MW mode.	17	LPF IN	I	Transistor used for the PLL active low-pass filter
8	LW	O	It is "L" on LW mode.	18	LPF OUT	O	Transistor used for the PLL active low-pass filter
9	AUTO/MONO	O	It is "L" on monaural, "H" on auto.	19	V <sub>SS</sub>	-	Connected to GND
10	POWER	O	Regulator control signal PON "H", STANDBY "L"	20	X out	O	Crystal oscillator (7.2MHz).

■ LA1266A (IC104) : FM AM IF AMP & detector

1. The main function descriptions

- (1) Amplify and detect of FM intermodulation frequencies.
- (2) It has local oscillator and mixer for AM, and amplify the AM-IF signal.

2. Top View

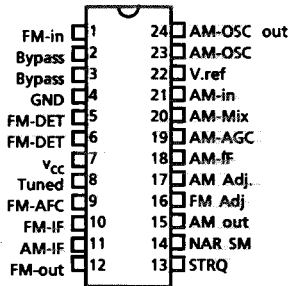

3. Block Diagram

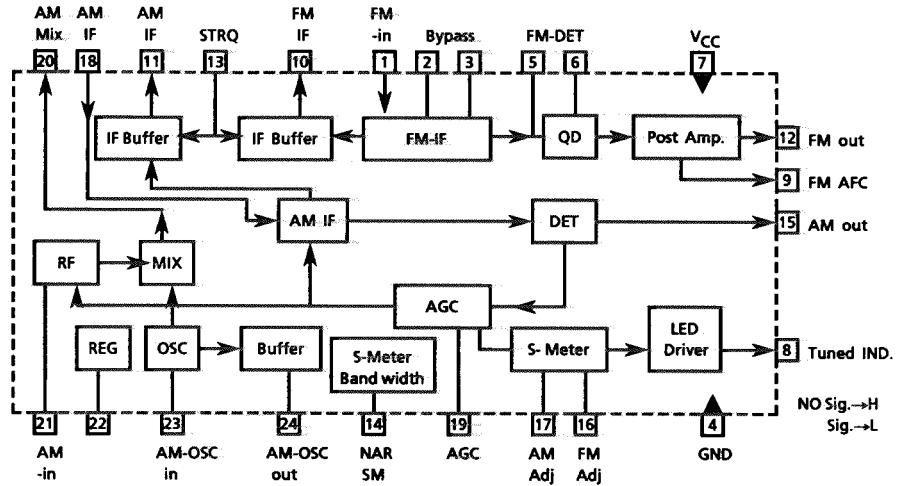

4. Pin Function Description

Pin No.	Symbol	I/O	Functions and Operations
1	FM in	I	This is an input terminal of FM IF Signal.
2, 3	Bypass	--	Bypass of FM IF Amp.
4	GND	--	This is the device ground terminal.
5, 6	FM DET	--	FM detect transformer.
7	V <sub>CC</sub>	--	This is the power supply terminal.
8	Tuned	O	When the set is tuning, this terminal become "L".
9	FM AFC	O	This is an output terminal of voltage for FM - AFC.
10	FM IF out	O	When the IF REQ signal of IC251(LC7218) applies to pin13, the signal of FM IF outputs.
11	AM IF out	O	When the IF REQ signal of IC251(LC7218) applies to pin13, the signal of AM IF outputs.
12	FM out	O	FM detection output.
13	STRQ	I	The IF-signals come out from pin10 (FM-IF) or pin11 (AM-IF) while this terminal goes to "High".
14	NAR SM	--	Control the Band-width of AM signal meter.
15	AM out	O	AM detection output.
16	FM Adj	--	For adjust the stop level (or mute level) of FM.
17	AM Adj	--	For adjust the stop level (or mute level) of AM.
18	AM-IF	I	Input of AM IF Signal.
19	AM-AGC	I	This is an AGC voltage Input terminal for AM.
20	AM-MIX	O	This is an output terminal for AM mixer.
21	AM-IN	I	This is an input terminal for AM RF Signal.
22	V.REF	--	Control the Band-width of FM signal meter.
23	AM-OSC	--	This is a terminal of AM Local oscillation circuit.
24	AM-OSC out	O	AM Local Oscillation Signal output.

■ LA3401 (IC105) : FM MPX Detector

1. The main function descriptions

- (1) Detect the FM Multiplex Signal (Stereo signal).
- (2) When receiving FM Stereo Signal, it outputs the signal for indicator.
- (3) AM / FM Audio Amplifier.

2. Terminal Layout

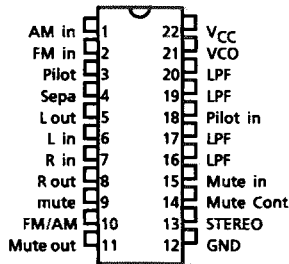

3. Block Diagram

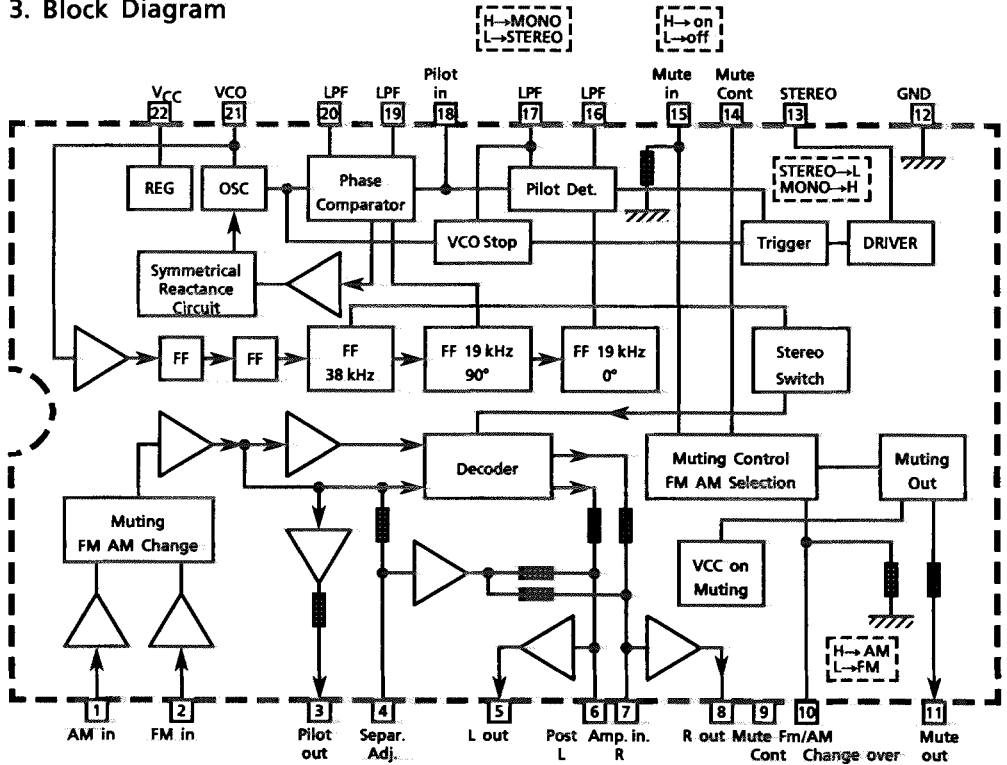

4. Pin Function Description

Pin No.	Symbol	I/O	Functions and Operations
1	AM in	I	This is an input terminal for AM detection signal.
2	FM in	I	This is an input terminal for FM detection signal.
3	Pilot out	O	Output of MPX pilot signal (Connect to Pin18).
4	Sepa. Adj.	--	Separation adjustment.
5	L. out	O	Left channel signal output.
6	L	O	Reversal output of Pin5.
7	R	O	Reversal output of Pin8.
8	R out	O	Right channel signal output
9	Mute Cont	--	The mute time is controlled by the connected capacitor when turning the power switch on.
10	FM / AM	I	Change over the FM / AM input. "H" : AM, "L" : FM
11	Mute out	--	Not use
12	GND	--	Ground terminal.
13	Stereo	O	Stereo indicator output. Stereo : "L", Mono : "H"
14	Mute Cont	--	The mute time is controlled by the connected capacitor when changing over the FM / AM .
15	Mute in	I	Mute signal input. "H" : Mute on, "L" : Mute off.
16	LPF	--	Low pass filter of pilot detector.
17	LPF	--	While this terminal goes to "H", the VCO stop.
18	Pilot in	I	Pilot input.
19	LPF	--	Low-pass filter of PLL.
20	LPF	--	Low-pass filter of PLL.
21	VCO	I	Voltage controlled oscillator terminal.
22	VCC	--	Power supply.

■ TMP87C847U-4195 (IC096) : CMOS 8-bit Microcontroller

1. Terminal Layout

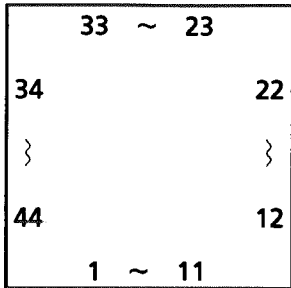

2. Block Diagram

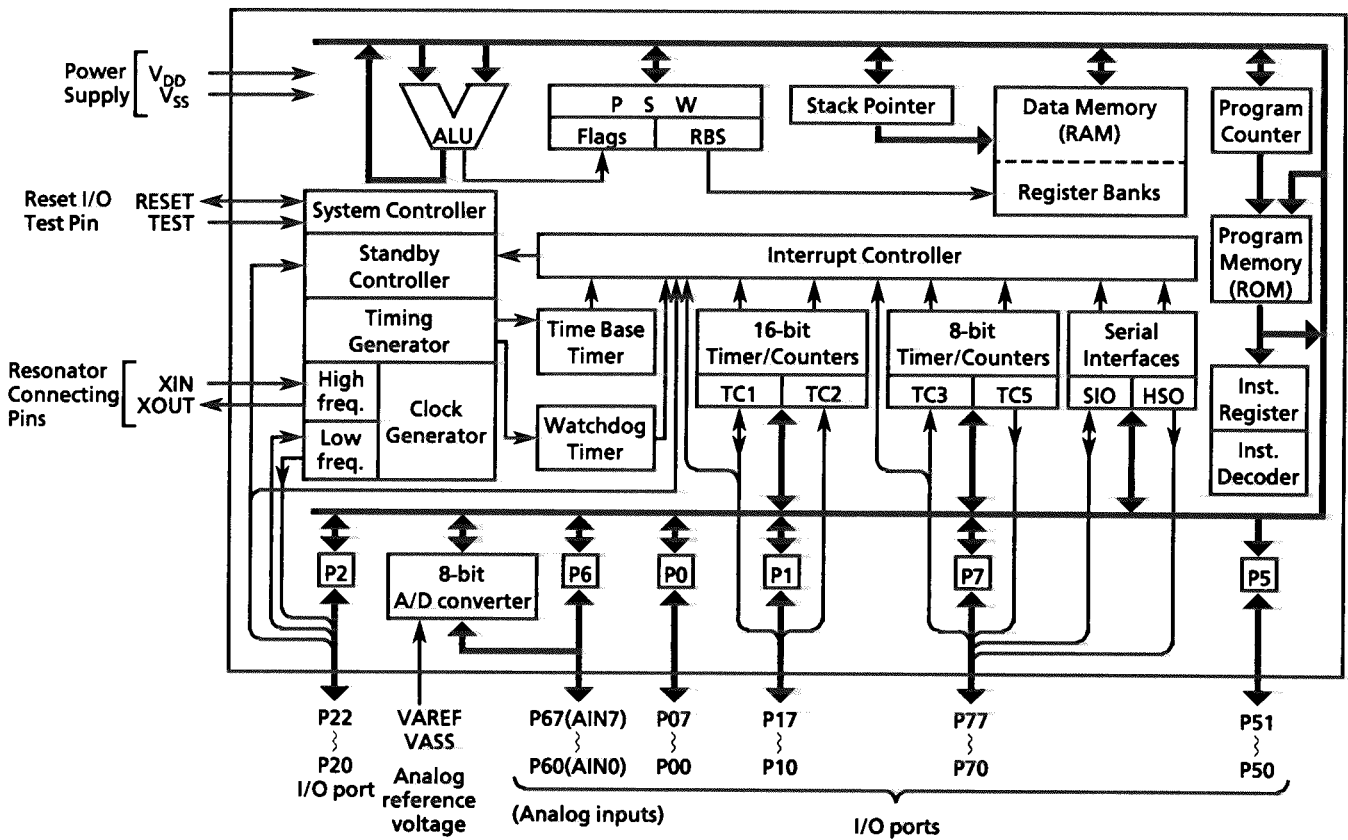

3. Pin Functions

Pin No.	Symbol	I/O	Functions
1	P73 (SCK)	I	Serial clock input from IC401
2	P72 (PWM/PDO)	I/O	Not used
3	P71 (INT4)	I/O	Not used
4	P70 (INT3/TC3)	I/O	Not used
5	P07 (ACK)	I	Acknowledge signal input from IC081
6	P06 (IFCD)	O	Command/data switching signal to IC081

Pin No.	Symbol	I/O	Functions
7	P05 ( $\overline{\text{CS}}$ )	O	Chip select signal output to IC081
8	P04 ( $\overline{\text{RST}}$ )	O	Reset signal output to IC081
9	P03 (TEST0)	I	Test terminal, generally it is used as "L"
10	P02 (TB2)	I	Test terminal, generally it is used as "L"
11	P01 (TB1)	I	Test terminal, generally it is used as "L"
12	P00 (TB0)	I	Test terminal, generally it is used as "L"
13	TEST	I	Test pin for out-going test. Be tied to low
14	$\overline{\text{RESET}}$	I	Reset signal input or watchdog timer output/address-trap-reset output/system-clock-reset output
15	XIN	I	Resonator connecting pins for high-frequency clock. For inputting external clock, XIN is used and XOUT is opened
16	XOUT	O	Not used
17	V <sub>SS</sub>	--	GND
18	VAREF	--	Analog reference voltage
19~26	P60 (AIN0)~ P67 (AIN7)	I/O	Not used
27	P50	O	Not used
28	P51 (MUTE)	O	Mute signal output
29	P10 (INT0)	I/O	Not used
30	P11 ( $\overline{\text{REQ}}$ )	I	External interrupt request signal from IC401
31	P12 ( $\overline{\text{BUSY}}$ )	O	Busy output to IC401
32	P13 (DVO)	I/O	Not used
33	P14 (PPG)	I/O	Not used
34	P15 (VOL STB)	O	Volume strobe signal output for write data to IC341
35	P16 (VOL SI)	O	Volume serial data signal output to IC341
36	P17 (VOL CK)	O	Volume clock output for data transfer to IC341
37	P20 (INT5/STOP)	I/O	Not used
38	P21 (XTIN)	I/O	Not used
39	P22 (XTOUT)	I/O	Not used
40	V <sub>DD</sub>	--	Power supply (5V)
41	P77 (IFDI)	O	Serial data output to IC081
42	P76 (IFCK)	O	Shift clock output to IC081
43	P75 (SO)	I/O	Not used
44	P74 (SI)	I	Serial data input from IC401

■ TC9332F-010 (IC081) : Audio digital signal processor

1. Terminal Layout

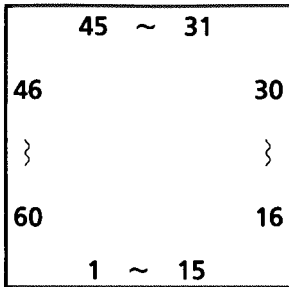

2. Block Diagram

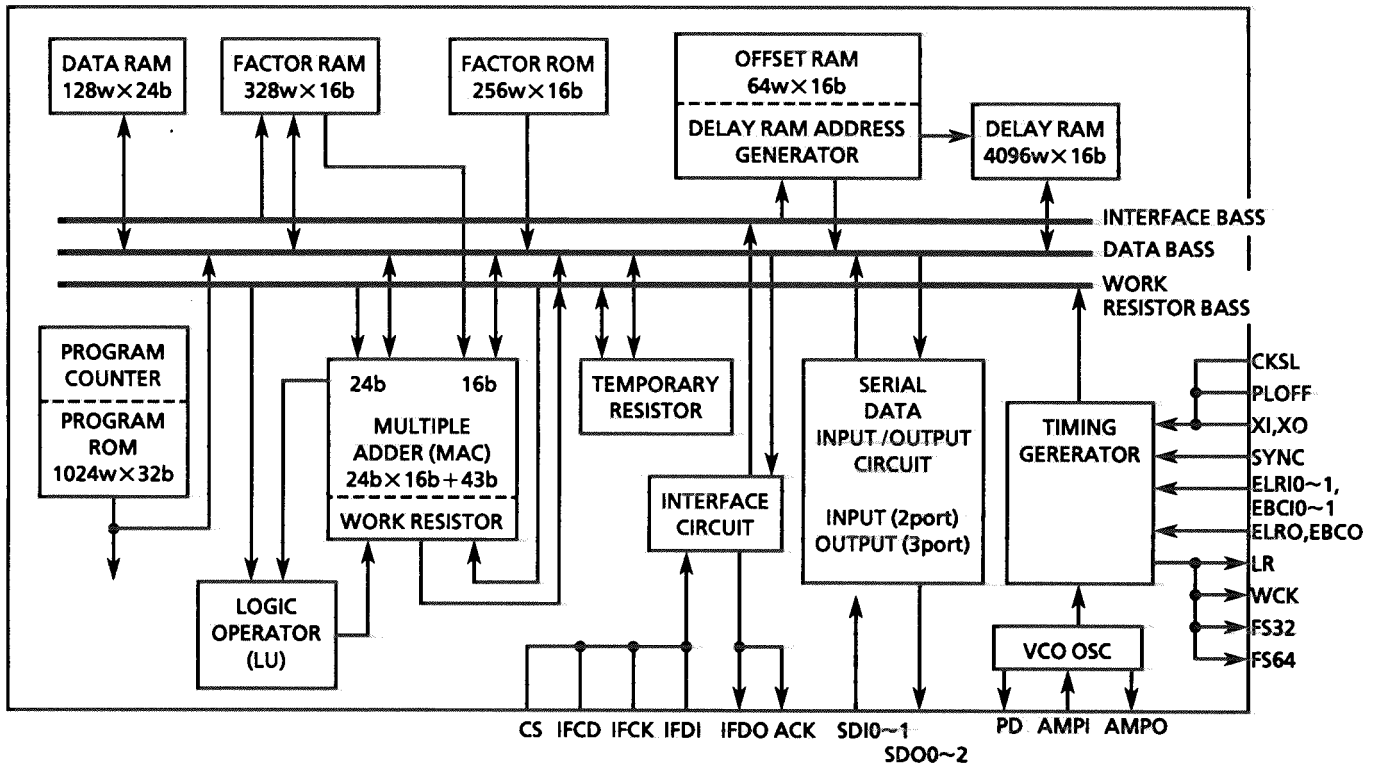

3. Pin Functions

Pin No.	Symbol	I/O	Functions
1~3	TP8~TP6	O	Test data output, Generally it is used as open
4	V <sub>DD</sub>	--	Power supply
5	V <sub>SS</sub>	--	GND
6~11	TP5~TP0	O	Test data output. Generally it is used as open
12	V <sub>SSR</sub>	--	GND for inner delay RAM (DLRAM)
13	V <sub>DDR</sub>	--	Power supply for inner delay RAM (DLRAM) (5V)
14	V <sub>SS</sub>	--	GND
15	SDO2	O	Not used
16	SDO1	O	Serial data output to IC061



Pin No.	Symbol	I/O	Functions
17	SDO0	O	Serial data output to IC041
18	SDI1	I	Not used
19	SDI0	I	Serial data input from IC021
20	LR	O	LR clock output (1fs)
21	WCK	O	Word clock output (2fs)
22	F532	O	Bit clock output (32fs)
23	F564	O	Bit clock output (64fs)
24	EBC0	I	Bit clock input. Shift clock input for SDO 0/1/2 data output
25	EBC11	I	Bit clock input. Shift clock input for SDI 0/1 data input
26	EBC10	I	Bit clock input. Shift clock input for SDI 0/1 data input
27	ELRO	I	LR clock input for SDO 0/1/2 data output
28	ELR11	I	LR clock input for SDI 0/1 data input
29	ELR10	I	LR clock input for SDI 0/1 data input
30	SYNC	I	Synchronizing signal input. SYNC signal edge sets program counter "0" forcefully. The microprocessor controls the polarity
31	V <sub>DD</sub>	--	Power supply (5V)
32	XI	I	X'tal oscillation terminal
33	XO	O	X'tal oscillation terminal
34	VSS	--	GND
35	CKSL	I	Oscillation clock switching terminal L:384fs, H:512fs
36	PLOFF	I	Oscillation mode switching terminal for 'Xtal and VCO. Built-in VCO oscillation mode in "L" and 'Xtal oscillation mode in "H"
37	PD	O	Phase comparison data output
38	VSSA	--	Analog GND
39	AMPO	O	Amplifier output for L.P.F
40	AMPI	I	Amplifier input for L.P.F
41	VDDA	--	Analog Power supply (5V)
42~44	TES0~TES2	I	Test terminal, Generally it is transmitted from $\mu$ -com when cs is lactive
45	$\overline{\text{RST}}$	I	Reset signal input from IC096
46	$\overline{\text{CS}}$	I	Chip select signal input from IC096
47	IFCD	I	It selects command or data input mode from IC096. It recognizes the command in "H" and the data in "L"
48	IFDI	I	$\mu$ -com data input. Firstly, LSB of data and command are received from IC096.
49	IFDO	O	Data output of data bass. LSB of data bus data is transmitted to $\mu$ -com
50	IFCK	I	Shift clock input form IC096
51	$\overline{\text{ACK}}$	O	Acknowledge signal output for IC096. Acknowledge signal is output when command and data's parity are OK
52	VSS	--	GND
53~60	TP16~TP9	O	Test data output. Generally, it is used as open

■ IC551 : LC7522 (Variable Resistor for SEA Control)

(1) Terminal Layout (2) Block Diagram

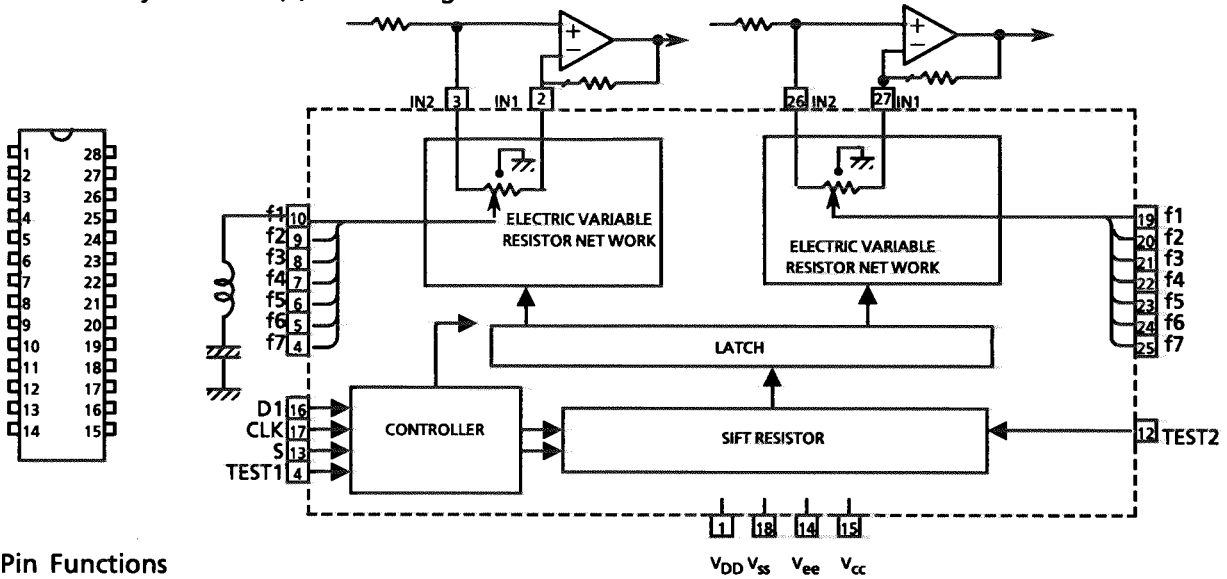

(3) Pin Functions

Pin No.	Pin Name	Functions
1	V <sub>DD</sub>	Power supply +7V for audio signal
18	V <sub>SS</sub>	Ground.
14	V <sub>EE</sub>	Power supply -7V for audio signal.
15	V <sub>CC</sub>	Power supply +5V
2,27	IN 1	Audio signal input
3, 26	IN 2	The inversion signal of the operational amplifier inputs to IN 1 normally. The non-inversion signal of the operational amplifier inputs to IN 2 normally.
16	DI	Data input from the CPU. Schmitt inverter type
17	CLK	Clock signal input from the CPU. Schmitt inverter type
4~10 19~25	f1~f7	For connect to band-pass filter. f1~f7x2 (Left and Right)
11	TEST 1	Not use
12	TEST 2	Not use
13	S	Chip Select
28	NC	Not use

■ M5243P (IC552) : S.E.A. Graphic Equalizer

1. Functions

It makes inductive characteristic instead of coil.

2. Block Diagram

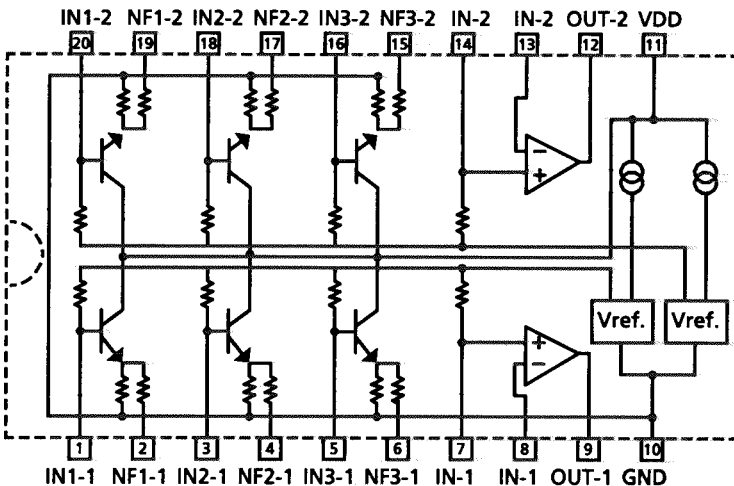

■ IC201 : NJM2279D (Video Switch)

(1) Terminal Layout

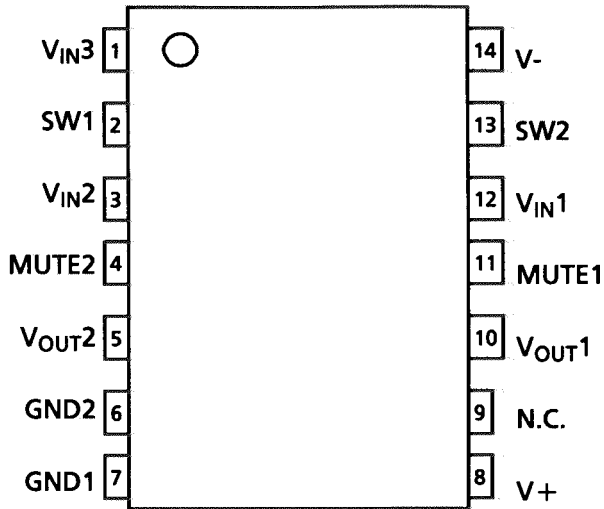

(2) Block Diagram

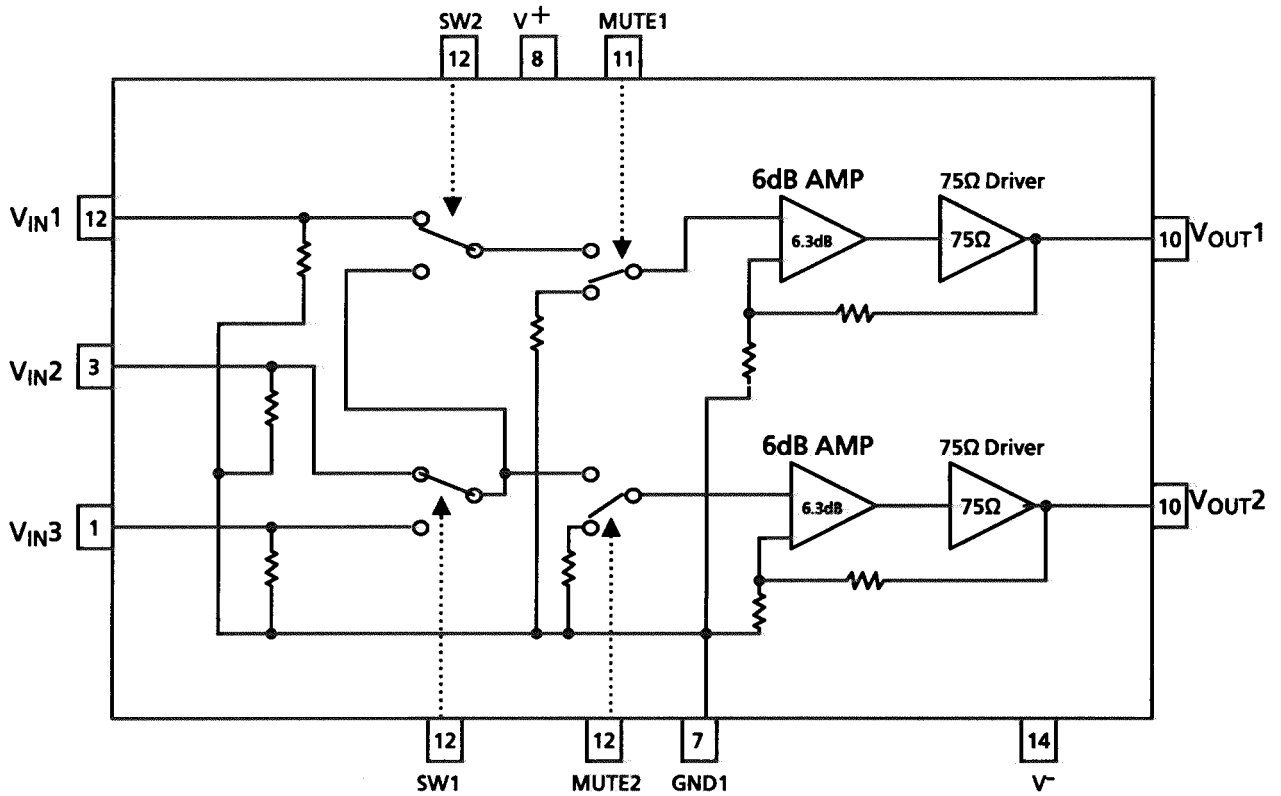

■ IC231 : MB90089 (ON SCREEN IC)

(1) Terminal Layout

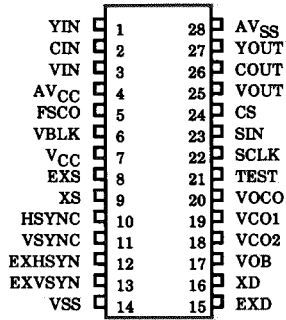

(2) Block Diagram

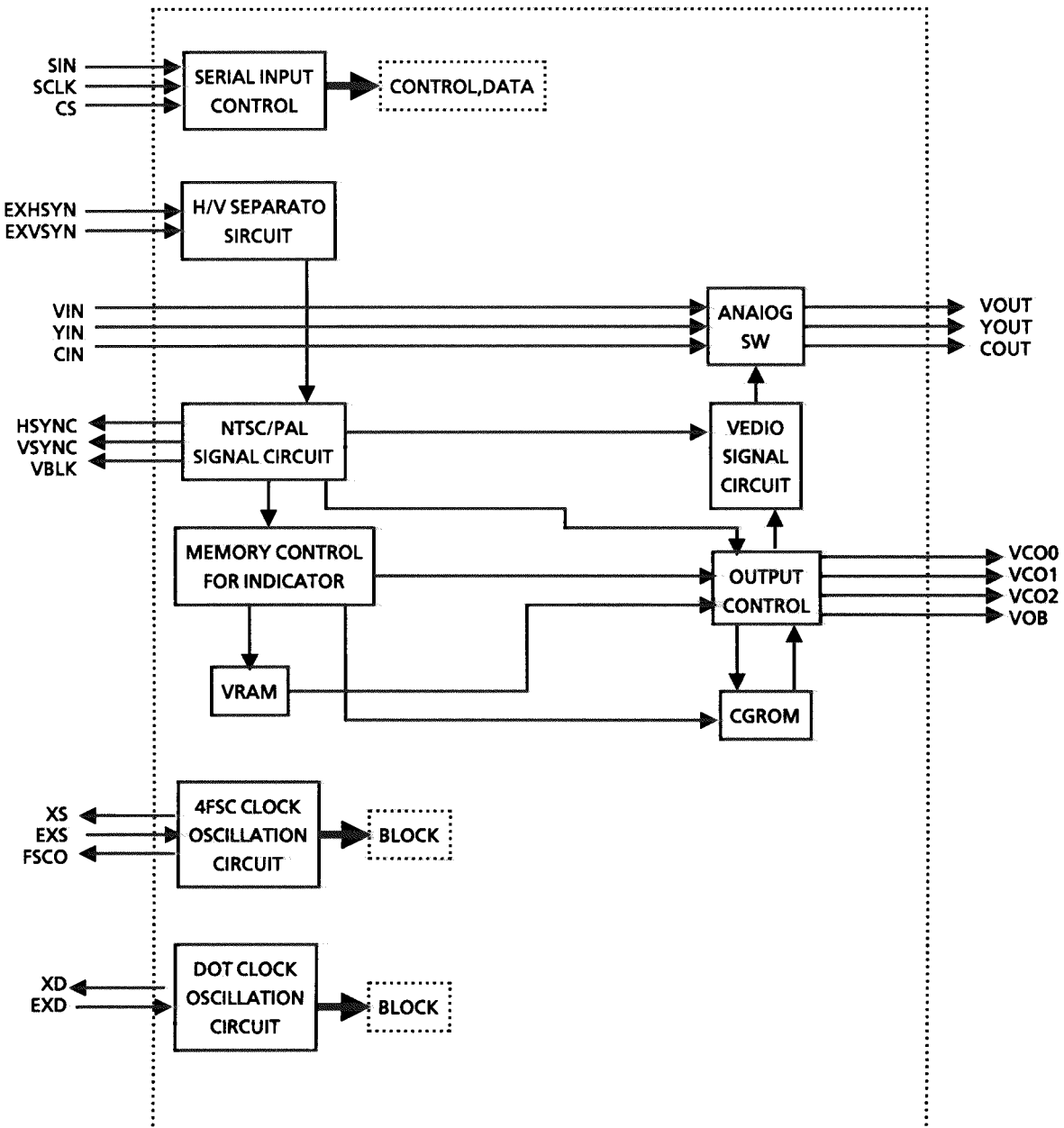

■ IC221 : UPC1860 (ON SCREEN IC) Use for RX-880VBK only

(1) Terminal Layout

NC	1	36	SSI
CV <sub>CC1</sub>	2	36	NC
NC	3	34	VSSI
CIN	4	33	HDF
ACCF	5	32	OSD SINC
NC	6	31	HKO
CKF	7	30	S.GND
COUT	8	29	HSOF1
APCF	9	28	HSOF2
C.GND	10	27	HSOF3
SCOF1	11	26	AFCF
SCOF2	12	25	SV <sub>CC</sub>
SCOF3	13	24	NC
CV <sub>CC2</sub>	14	23	NHSO
CV <sub>CC3</sub>	15	22	NC
VCO0	16	21	NC
NE	17	20	VSO
ESC1	18	19	N/P

(2) Block Diagram

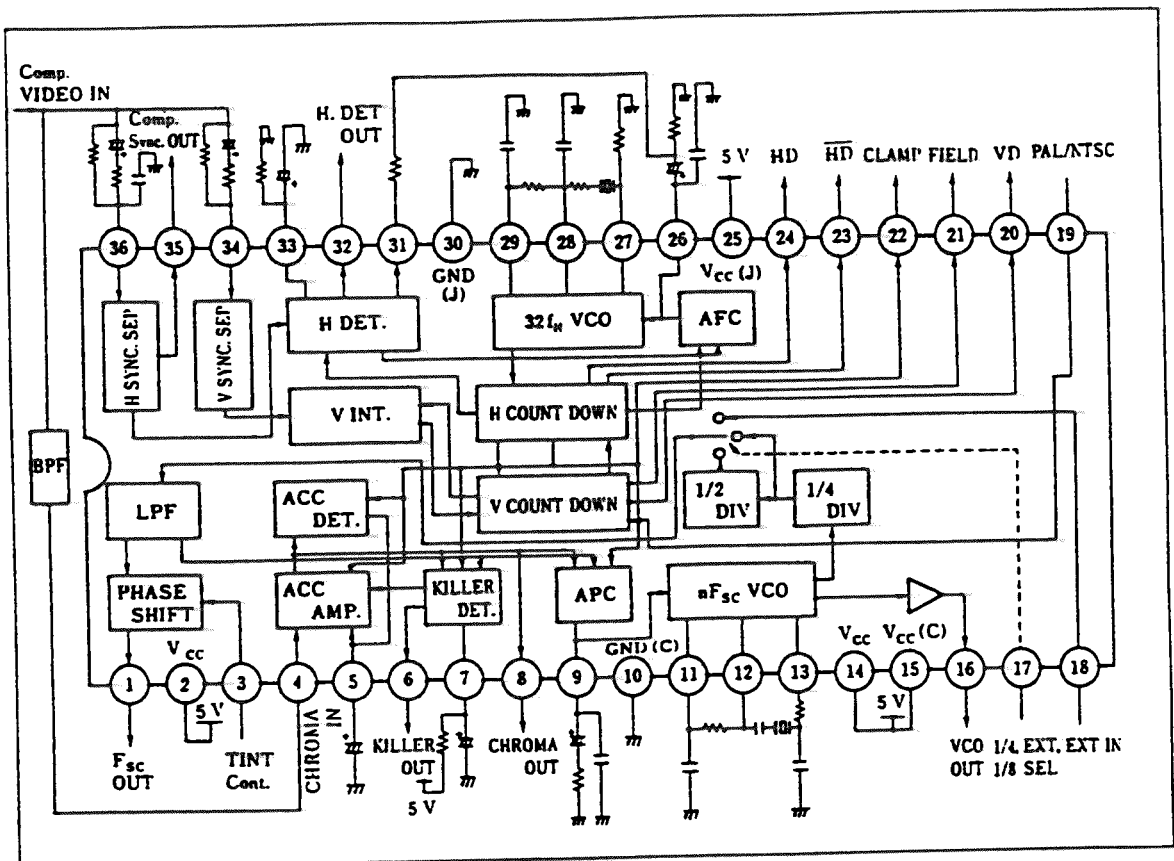

■ SAA7366T (IC021) : A/D Converter

1. Terminal Layout

SFOR	1	24	SLAVE
STDB	2	23	VDDA
OVLD	3	22	VREFL
CKIN	4	21	BIL
VDD	5	20	BOL
VSS	6	19	VDACP
SDO	7	18	VDACN
SWS	8	17	BOR
SCK	9	16	BIR
TEST 1	10	15	VREFR
HPEN	11	14	IREF
TEST B	12	13	VSSA

2. Block Diagram

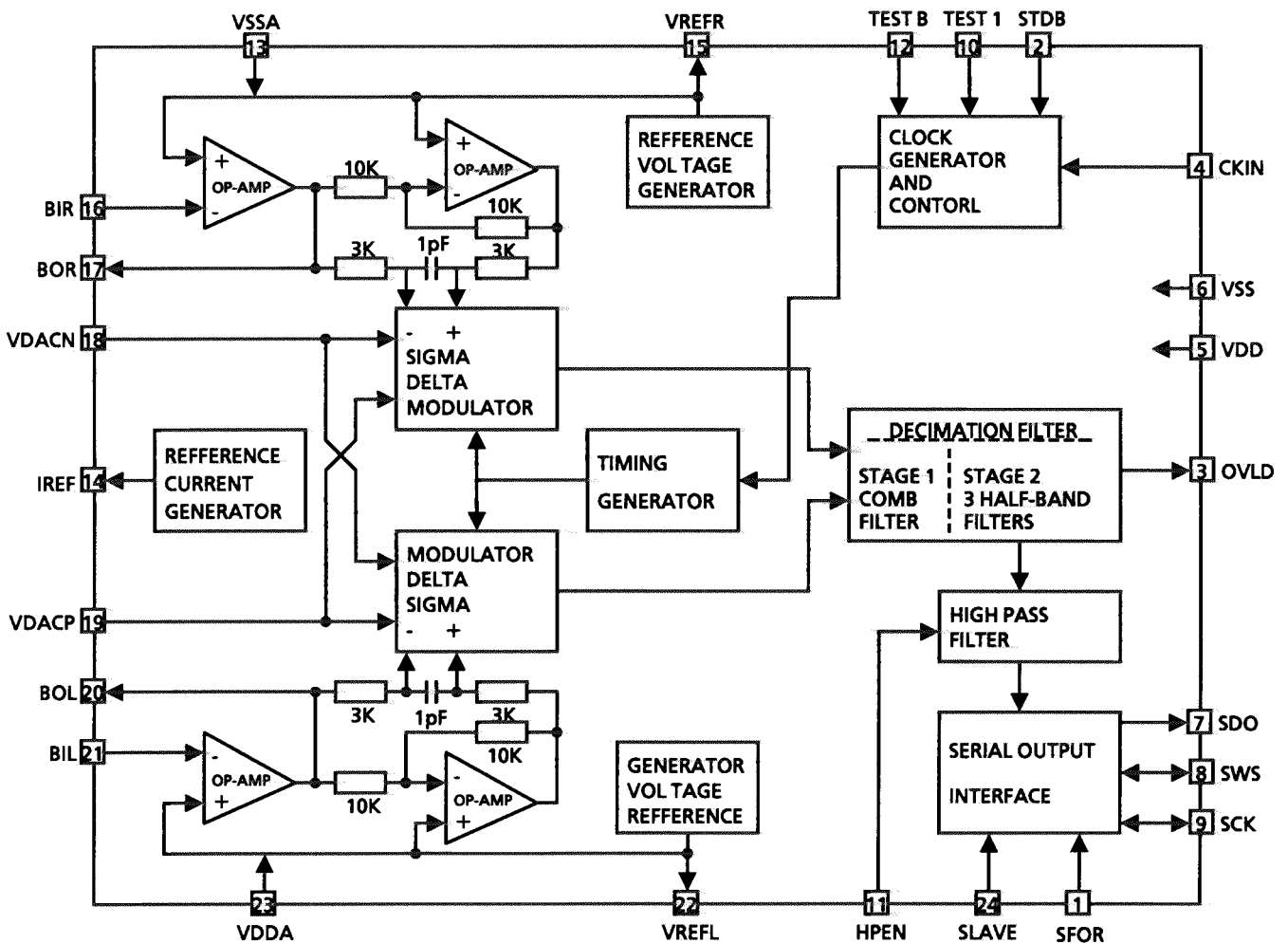

### 3. Pin Functions

Pin No.	Symbol	I/O	Functions
1	SFOR	I	Input for selecting serial interface output format. HIGH=Format 1 LOW=Format 2
2	STDB	I	Input for selecting STANDBY mode HIGH=Normal operation LOW=STANDBY (Low power consumption)
3	OVLD	O	Overload indication output. This pin indicates whether the internal digital signal is within 1dB of maximum. In STANDBY mode this output is in high impedance
4	CKIN	I	System clock input from IC093
5	VDD	--	Supply for the digital section (5V)
6	VSS	--	Ground supply for the digital section
7	SDO	O	Serial interface data output to IC081. In STANDBY mode this output is in high impedance
8	SWS	I/O	Serial interface word select signal. This pin is the word select input to the serial interface.
9	SCK	I/O	Serial interface clock. This pin is the input for the external bit clock.
10	TEST1	I	Test input 1. This pin should be left open circuit
11	HPEN	I	High pass filter enable input. (HPEN HIGH=enabled). If unconnected this pin defaults HIGH
12	TESETB	I	Test input 2. This pin should be left open circuit
13	VSSA	--	Ground supply for the analogue section
14	IREF	--	Current reference mode
15	VREFR	--	VDDA/2 reference generator for the right channel analog section
16	BIR	I	Buffer op-amp inverting input for right channel
17	BOR	O	Buffer op-amp output for right channel
18	VDACN	I	Negative 1 bit DAC reference voltage input, normally connected to 0V
19	VDACP	I	Positive 1 bit DAC reference voltage input, normally connected to 5V
20	BOL	O	Buffer op-amp output for left channel
21	BIL	I	Buffer op-amp inverting input for left channel
22	VREFL	--	VDDA/2 reference generator for the left channel analog section
23	VDDA	--	Supply for the analog section (5V)
24	SLAVE	I	Input for selecting serial interface operating mode MASTER/SLAVE HIGH=SLAVE, LOW=MASTER If unconnected the pin will default LOW

■ TDA1386T (IC041,061) : Noise shaping filter-DAC

1. Terminal Layout

VDDA	1	24	VDDO
VSSA	2	23	VSSO
TEST1	3	22	VREF
BCK	4	21	VOR
WS	5	20	FILTCLR
DATA	6	19	FILTCL
CKSL1	7	18	VOL
CKSL2	8	17	APP0
VSSD	9	16	APP1
VDDD	10	15	APP2
TEST2	11	14	APPL
SYSCLK	12	13	APP3

2. Block Diagram

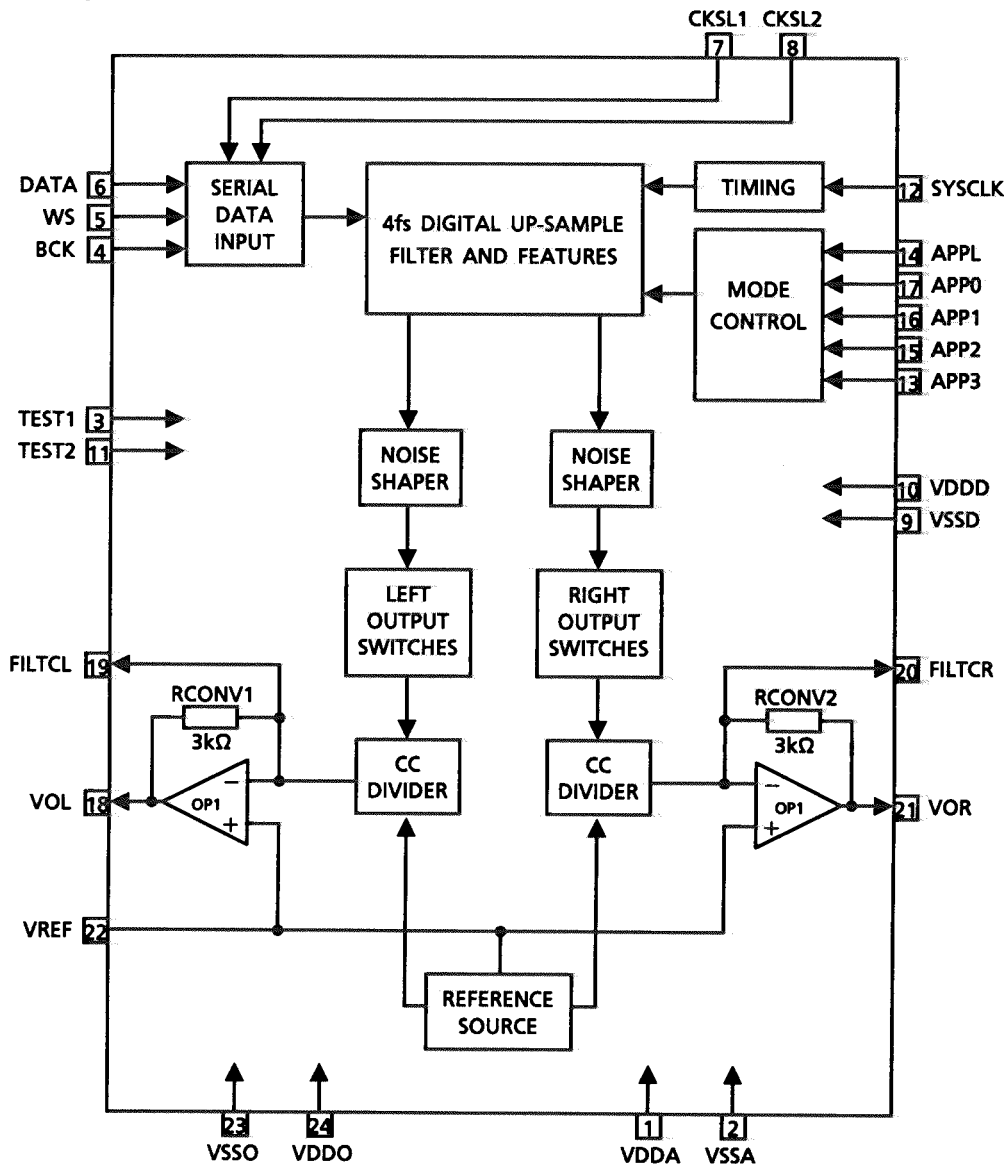



### 3. Pin Functions

Pin No.	Symbol	I/O	Functions
1	VDDA	--	Analog supply voltage (5V)
2	VSSA	--	Analog ground
3	TEST1	--	Test input 1 ; pin should be connected to ground
4	BCK	I	Bit clock input from IC081
5	WS	I	Word select input from IC081
6	DATA	I	Data input from IC081
7	CKSL1	I	Format selection 1
8	CKSL2	I	Format selection 2
9	VSSD	--	Digital ground
10	VDDD	--	Digital supply voltage (5V)
11	TEST2	--	Test input 2 ; pin should be connected to ground
12	SYSCLK	I	System clock 256fs input from IC093
13	APP3	I	Application mode 3 input
14	APPL	I	Application mode selection input
15	APP2	I	Application mode 2 input
16	APP1	I	Application mode 1 input
17	APP0	I	Application mode 0 input
18	VOL	O	Left channel output
19	FILTCL	O	Capacitor for left channel first-order filter function, should be connected between pins 19 and 18
20	FILTCR	O	Capacitor for right channel first-order filter function, should be connected between pins 20 and 21
21	VOR	O	Right channel output
22	VREF	--	Internal reference voltage for output channels (0.5 VDDO typ.)
23	VSSO	--	Operational amplifier ground
24	VDDO	--	Operational amplifier supply voltage (5V)

# Internal Connections of the FL Display

■ELU0001-215 : DI400

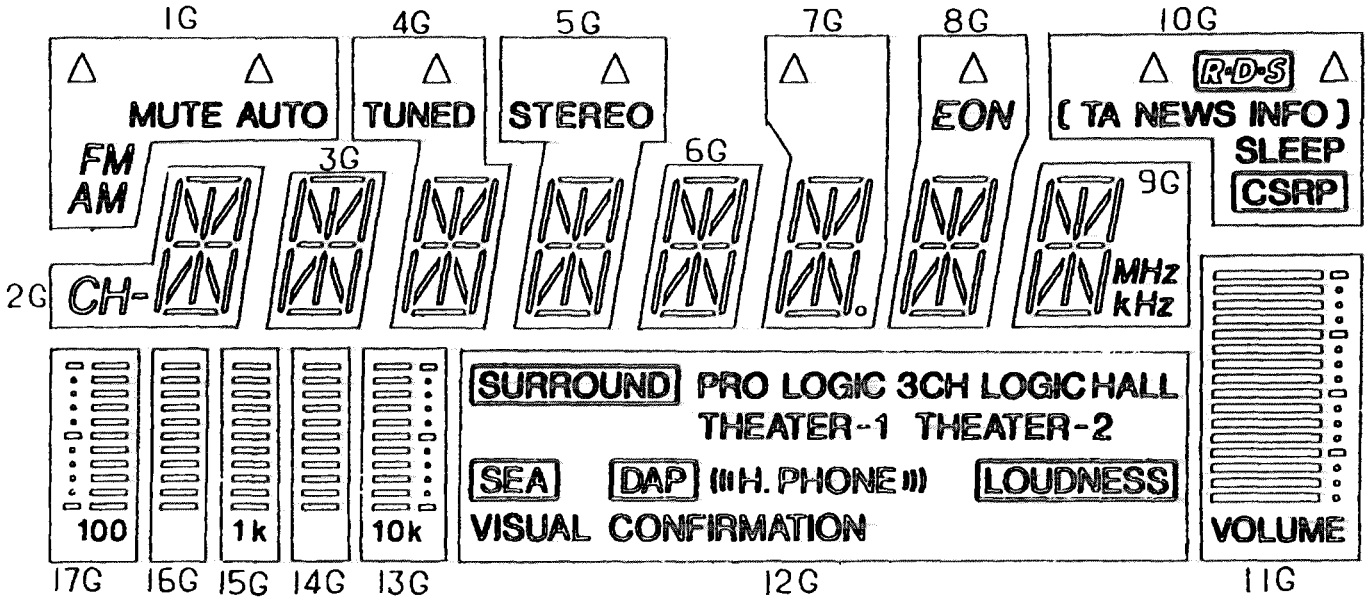

## Pin Connection

TERMINAL NO.	1	2	3	4	5	6	7	8	9	10	11	12	13	14						
ELECTRODE	F1	F1	F1	NP	17G	16G	15G	14G	13G	12G	11G	10G	9G	8G						
TERMINAL NO.	15	16	17	18	19	20	21	22	23	24	25	26	27	28	29	30	31	32	33	34
ELECTRODE	7G	6G	5G	4G	3G	2G	1G	NP	NP	NP	NP	NP	NP	P	P	P	P	P	P	P
TERMINAL NO.								35	36	37	38	39	40	41	42	43	44	45	46	47
ELECTRODE								P	P	P	P	P	P	P	P	P	NP	F2	F2	F2

Notes F: Filament NP: No Pin  
G: Grid  
P: Anode

# Internal Connection · Anode Designation

	1G	2G	3G	4G	5G	6G	7G	8G	9G	10G
S1		a	a	a	a	a	a	a	a	CSRP
S2		b	b	b	b	b	b	b	b	SLEEP
S3		i	i	i	i	i	i	i	i	TA
S4		j	j	j	j	j	j	j	j	NEWS
S5		h	h	h	h	h	h	h	h	[INFO
S6		f	f	f	f	f	f	f	f	]
S7		k	k	k	k	k	k	k	k	$\Delta$ (Right)
S8		g	g	g	g	g	g	g	g	R.D.S
S9		c	c	c	c	c	c	c	c	$\Delta$ (Left)
S10		l	l	l	l	l	l	l	l	
S11	FM	n	n	n	n	n	n	n	n	
S12	AM	m	m	m	m	m	m	m	m	
S13	MUTE AUTO	-	e	e	e	e	e	e	e	
S14		d	d	d	d	d	d	d	d	
S15	$\Delta$ (Left)	CH-		TUNED	STEREO		( $\Delta$ PT)	EDN	MHz	
S16	$\Delta$ (Right)			$\Delta$	$\Delta$		$\Delta$	$\Delta$	KHz	

	11G	12G	13G	14G	15G	16G	17G
S1	A1						
S2	A2	LOUDNESS					Scale(Left)
S3	A3	VISUAL CON- FIRMATION	10k		1k		100
S4	A4						
S5	A5		B1	B1	B1	B1	B1
S6	A6		B2	B2	B2	B2	B2
S7	A7		B3	B3	B3	B3	B3
S8	A8	THEATER-2	B4	B4	B4	B4	B4
S9	A9	HALL	B5	B5	B5	B5	B5
S10	A10	3CH LOGIC	B6	B6	B6	B6	B6
S11	A11	H. PHONE	B7	B7	B7	B7	B7
S12	A12	THEATER-1	B8	B8	B8	B8	B8
S13	A13	PRO LOGIC	B9	B9	B9	B9	B9
S14	A14	DAP	B10	B10	B10	B10	B10
S15	A15	SEA	B11	B11	B11	B11	B11
S16	A16	SURROUND	Scale(Right)				

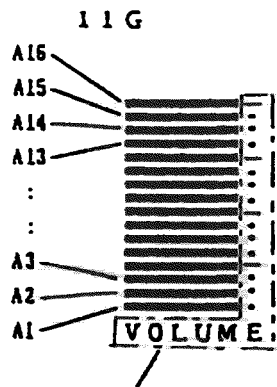
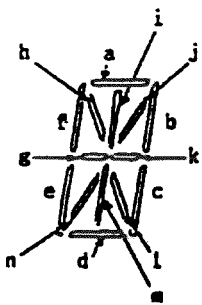

·These segments pattern  
are connected to 11G.

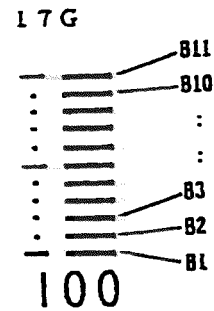

·The segment pattern of  
13G to 16G is same as above.

## Disassembly Procedures

### (1) Removing the top cover

1. Remove 4 screws **A** fastening both sides of top cover, and 3 screws **B** fastening the rear side.
2. Remove the top cover.

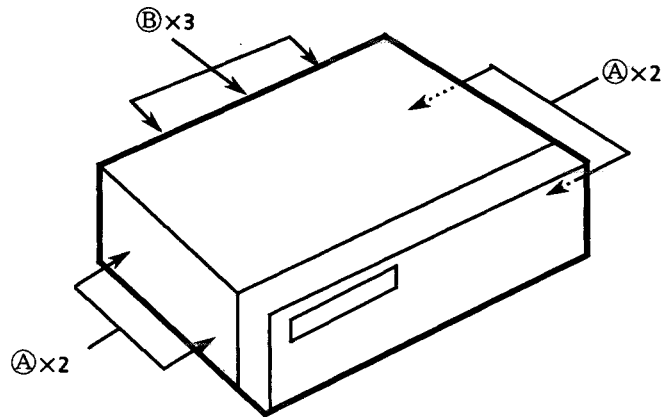

### (2) Removing the Bottom Cover

1. Remove 14 screws **C** and **C''**.
2. Remove the bottom cover.

※ The screw **C''** which secures the bottom cover is also used for ground.  
It is necessary to ground before checking after the bottom cover is removed.

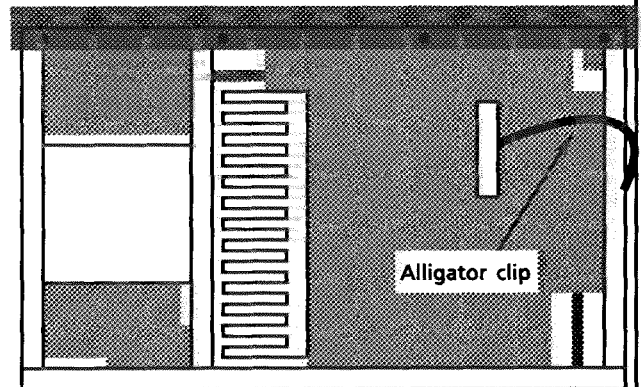
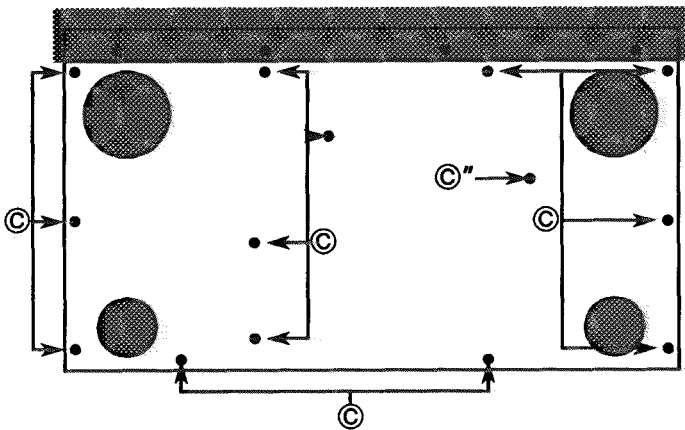

**A** .. E61660-004

**B** ... E73273-003

**C, C''** .... SBSG3008CC

**(3) Removing the Front Panel Assembly**

1. Removing the top cover.
2. Remove 3 screws ③ fastening top of the front panel, and 4 screws ④ fastening bottom of it.
3. Remove the Center tone knob and Balance knob.
4. Remove the front panel disconnecting some wires. (CN401,CN413,CN512,CN513)

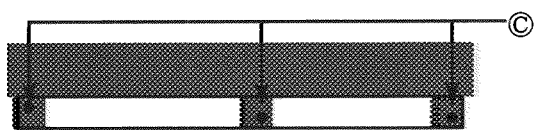

TOP SIDE

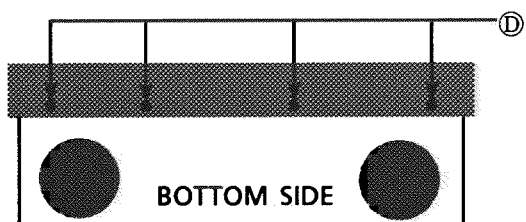

BOTTOM SIDE

**(4) Removing the Front P.C. Board**

1. Removing the top cover.
2. Removing the front panel assembly.
3. Remove 9 screws ⑤.
4. Remove the Master volume knob, tuner control knob and source selector knob.
5. Remove 2 nut fastening the rotary encoder.
6. Remove a nut fastening the Master volume.
7. Remove the front P.C. Board.

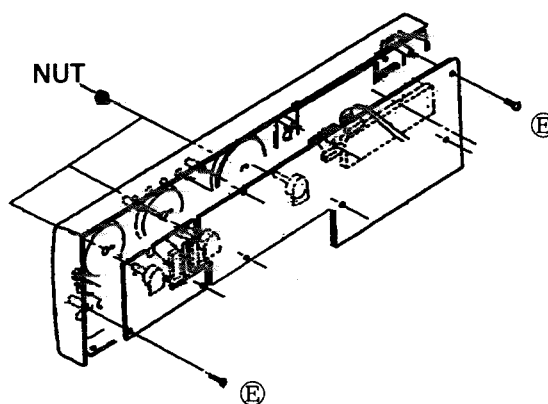

**(5) Removing the Rear Panel**

1. Removing the top cover.
2. Remove 19 screws ⑧, ⑧" and 2 screws ④.
3. Remove 2 screws ③ fastening bottom sides of rear panel.
4. Take it out.

※ 4pcs. of screw ⑧" which secure the rear panel are also used for ground.  
Installing of those screws is required before checking.

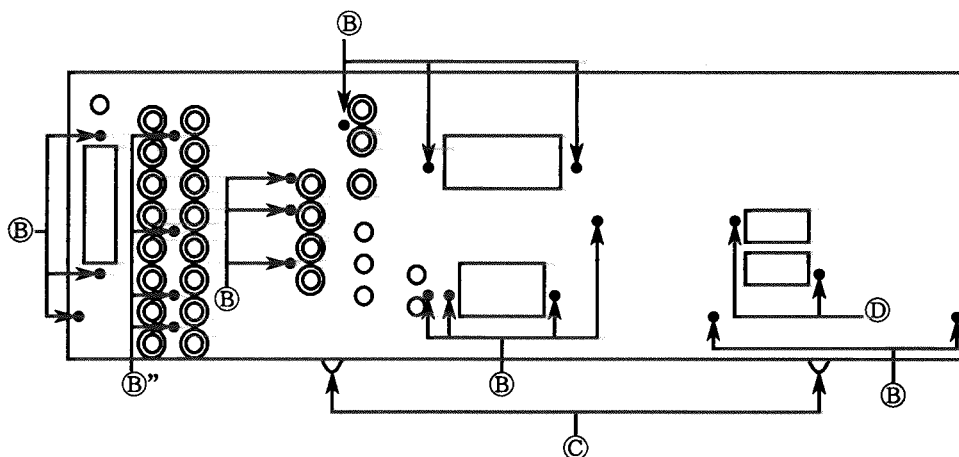

⑧, ⑧" E73273-003

③ SBSG3008CC

④ SDSG3008M

⑤ SDSF2608Z

- (6) Removing the Power Transistor
1. Remove the top cover and bottom cover.
  2. Unsolder the broken transistor.
  3. Remove the some screws (F) fastening it.
  4. Remove it.

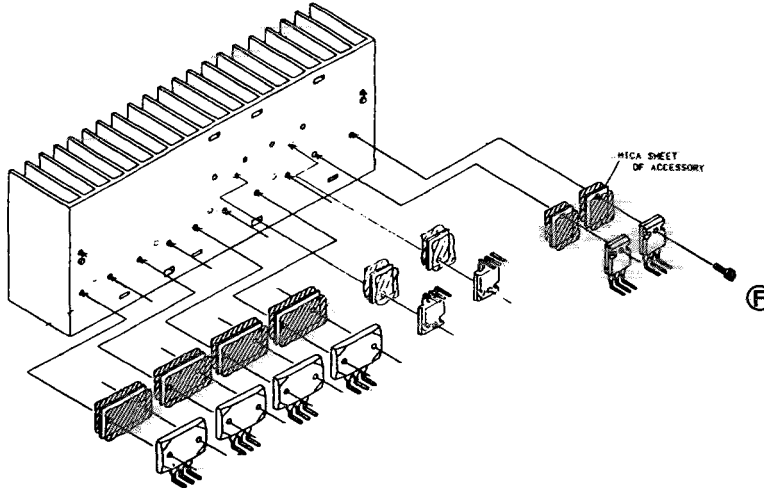

(F) .. E73525-003

## ADJUSTMENT PROCEDURES

### ■ Tuner section

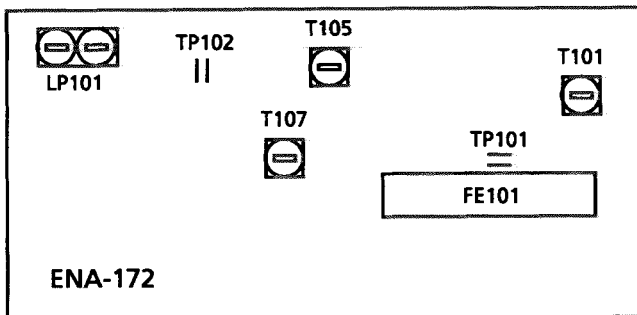

### Tuning range

Area	Range	
	MW (kHz)	FM (MHz)
the U.S.A., Canada	530~1710	87.5MHz~108MHz

### (1) Tuning Voltage

Confirm the voltages in the table at TP101.

#### FM Tuning voltage (Unit : V)

Area	Frequency	
	87.5MHz	108MHz
the U.S.A., Canada,	1.6±1.0	8.0±2.0

#### AM Tuning voltage (Unit : V)

Area	Frequency (MW)						
	522KHz	530KHz	531KHz	1600KHz	1602KHz	1629KHz	1710KHz
the U.S.A., Canada	—	1.0 > 0.5	—	—	—	—	8.0±0.8

### (2) FM Center meter

Receive a broadcast by using the function of 'AUTO STOP'.

Adjust T105 (Detector coil) so taht the voltage at TP102 becomes 0±1.5mV.

■ Power Amplifier section

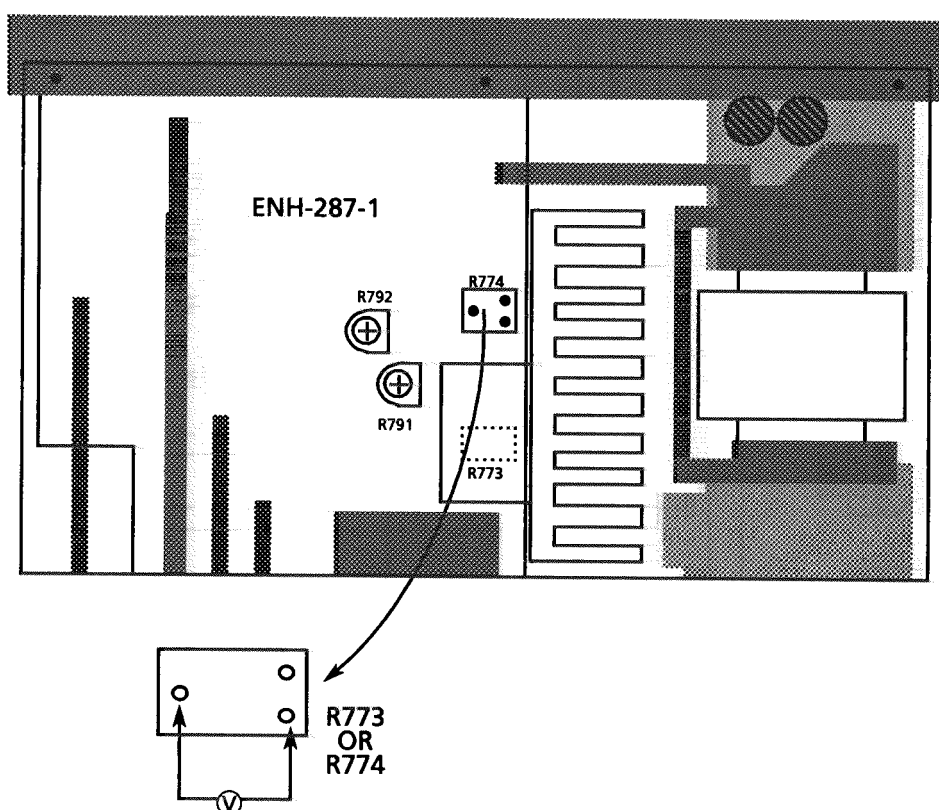

■ Idling current

- (1) Set the volume control to minimum during this adjustment. Set DAP and surround mode "OFF". And set speaker load selector "HIGH".
- (2) Turn R791 and R792 fully counterclockwise to warm up before adjustment. If the heatsink is already warm from previous use the correct adjustment can not be made.
- (3) Connect a DC voltmeter to R773 resistor's leads for left channel, or to R774 for right channel.
- (4) Adjust R773 for left channel, or R774 for right channel, so that the DC voltmeter becomes 1mV~10mV.

# Block Diagrams

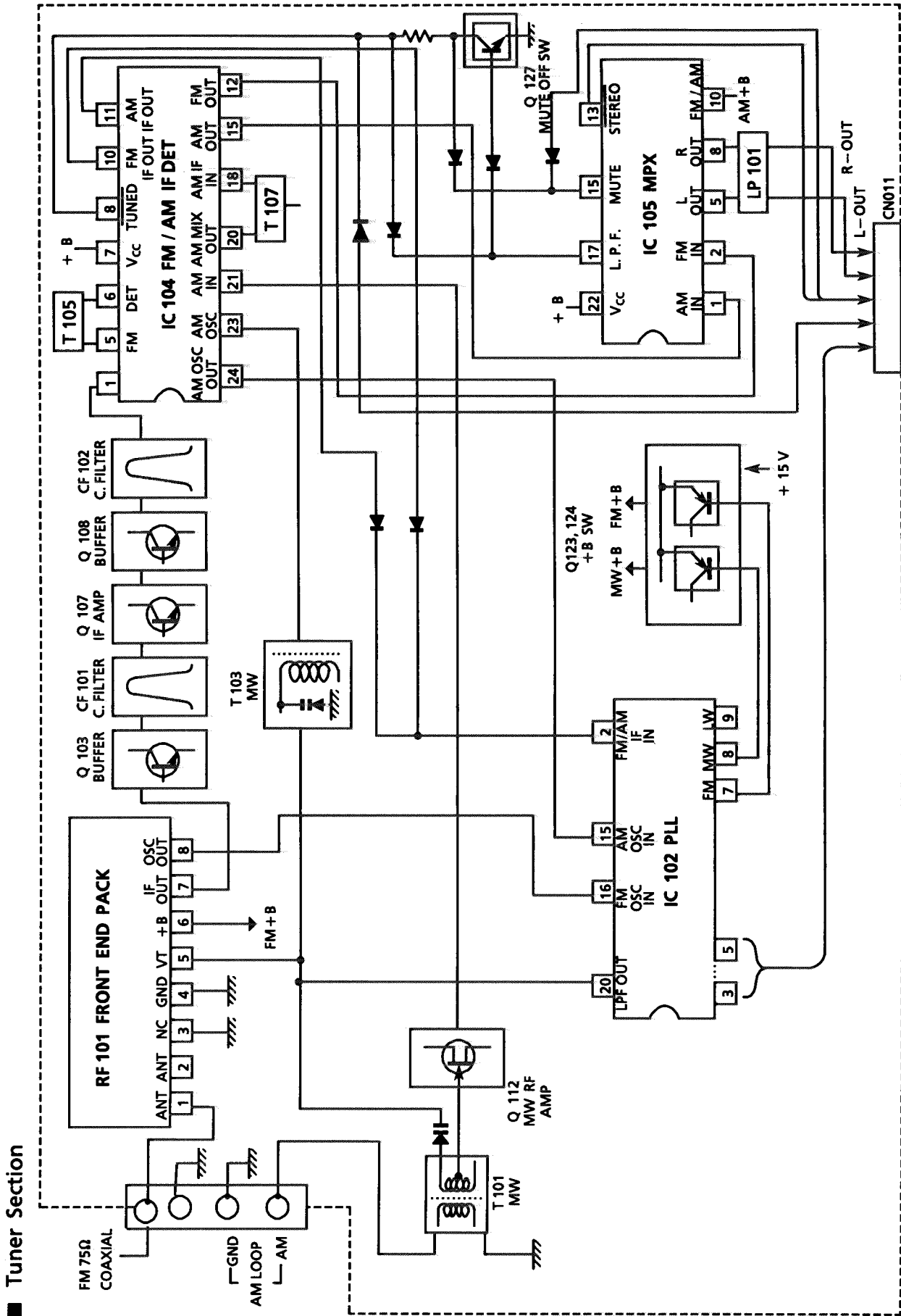





■ DAP Section

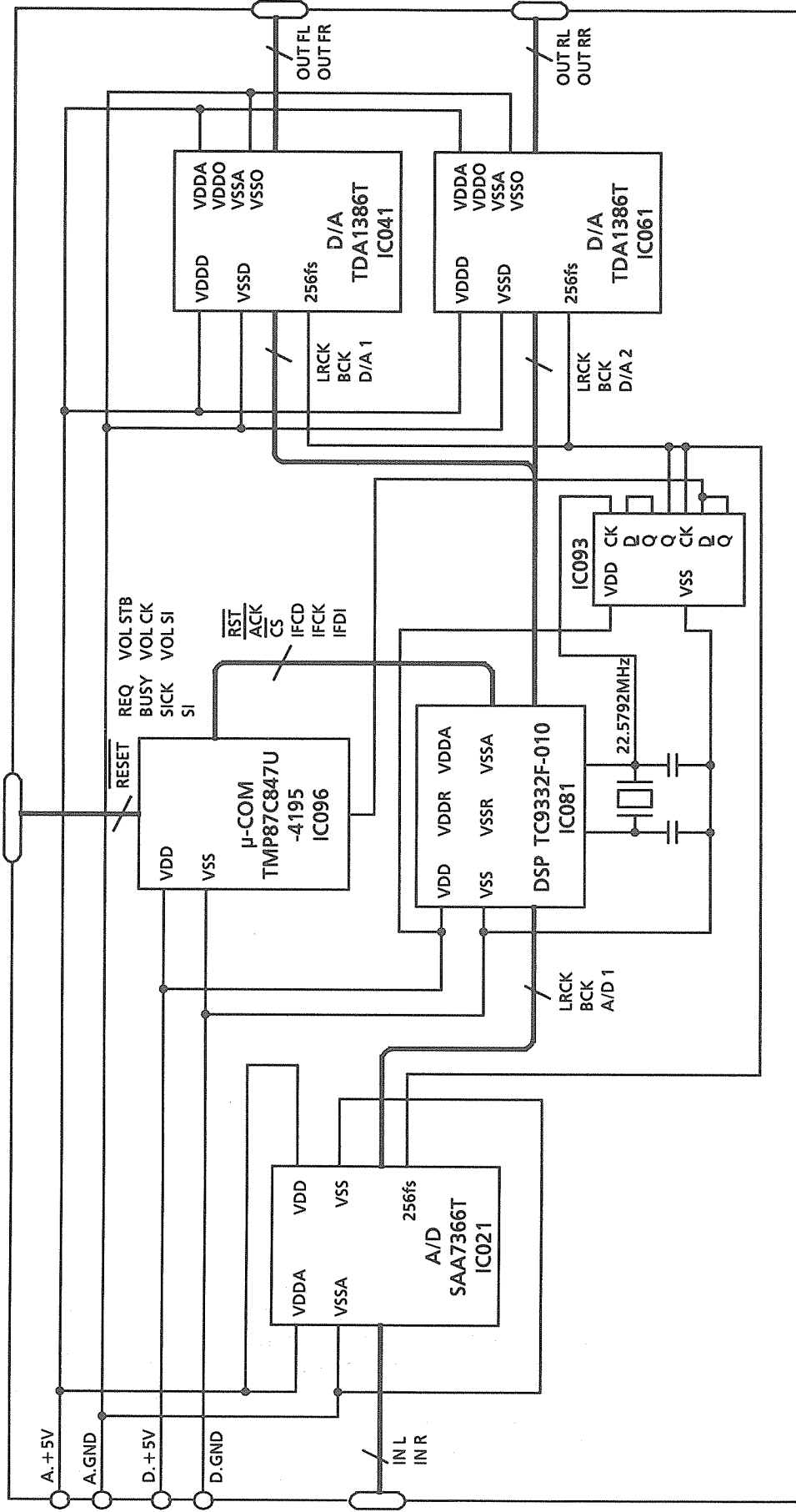

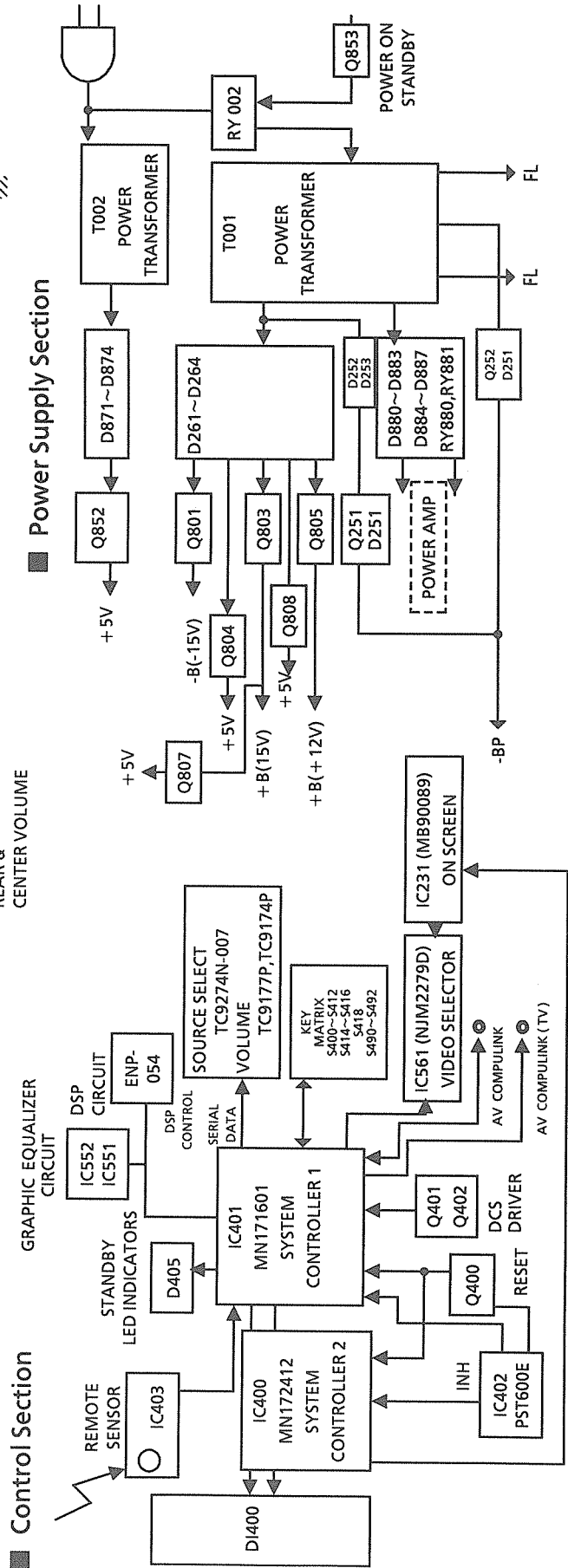
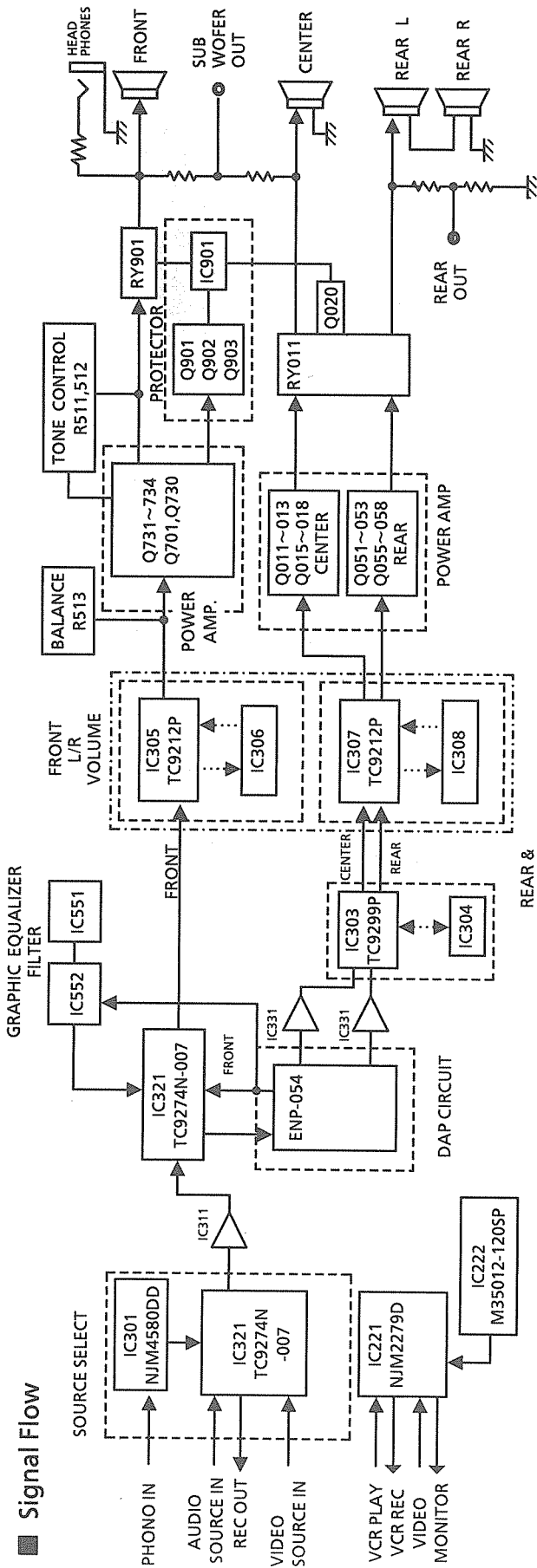

### Power Supply Section

# Schematic Diagrams

## Power Supply Section

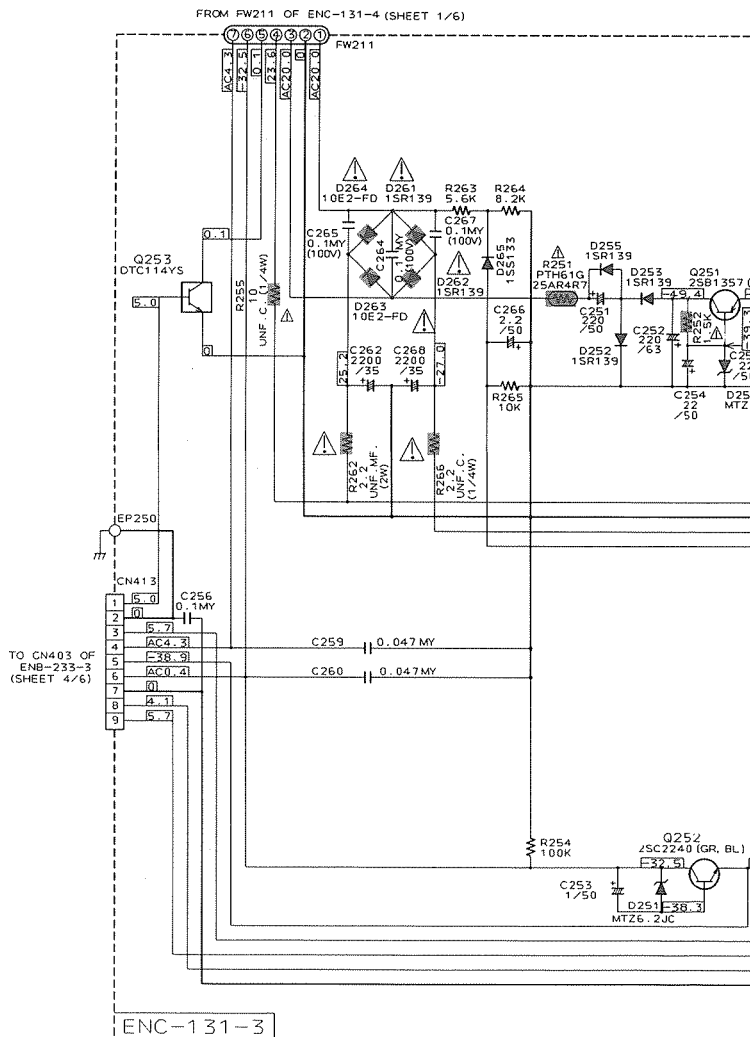
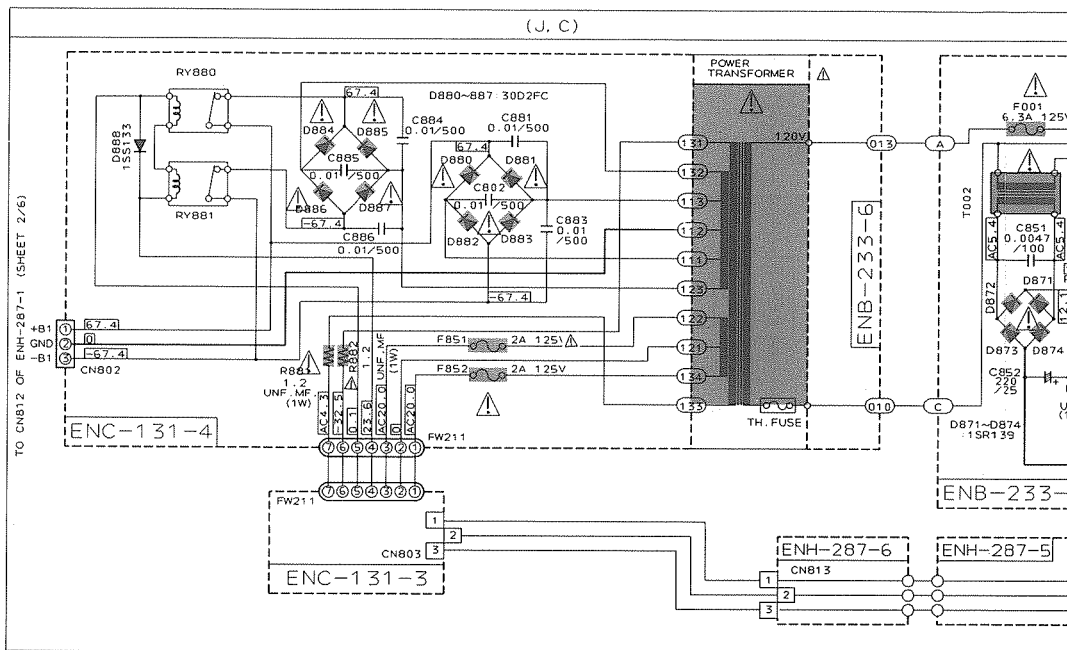

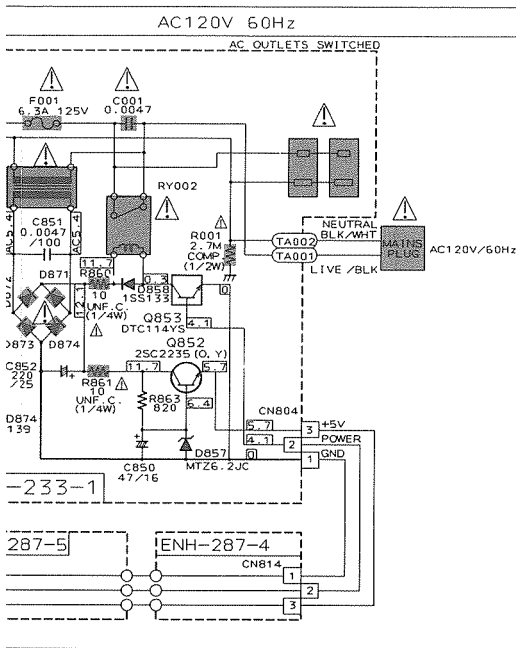

VERSION CODES

J : U.S.A.  
C : CANADA

NOTE :

1. MARK (\*) IS TO SHOW DEVIATION IN VERSIONS. DETAILS ARE EXPLAINED NEAR THE MARK.

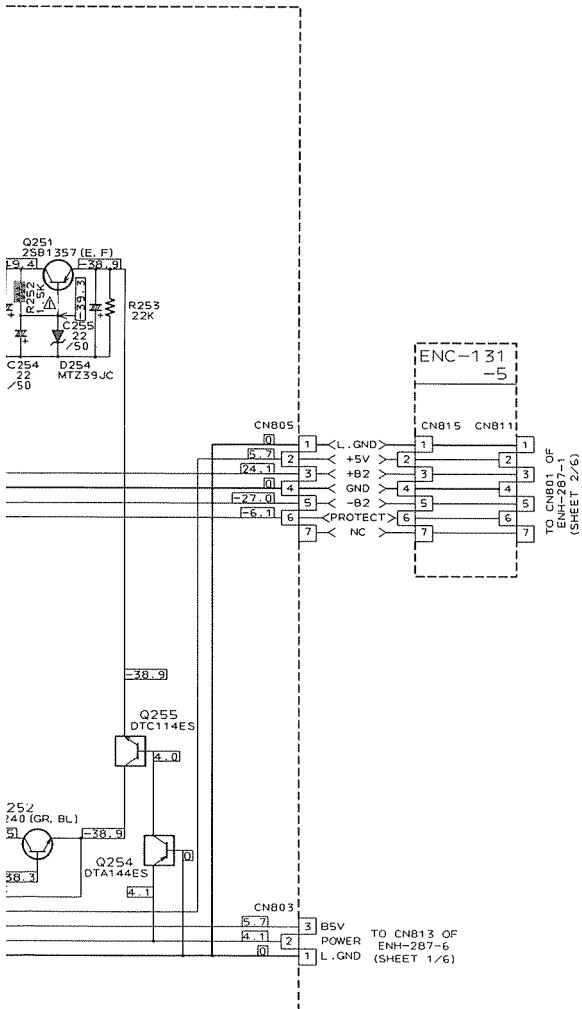

Notes:

1. indicates Main signal path.
2. indicates CENTER signal path.
3. indicates REAR signal path.
4. When replacing the parts in the darkened are ( ) and those marked with , be sure to use the designated parts to ensure safety.
5. This is the standard circuit diagram. The design and contents are subject to change without notice.



P2-27-a

P2-27-b

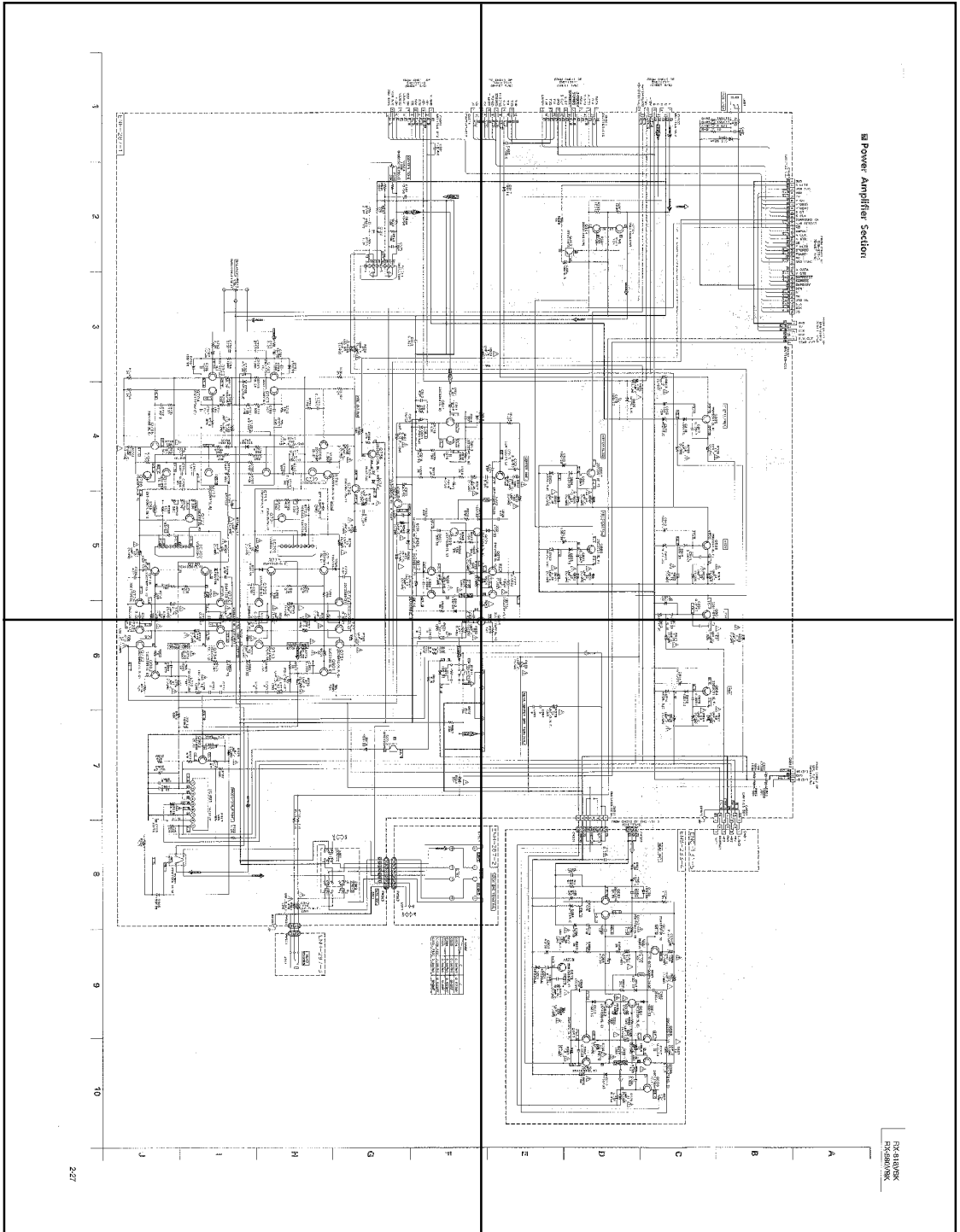

P2-27-c

P2-27-d

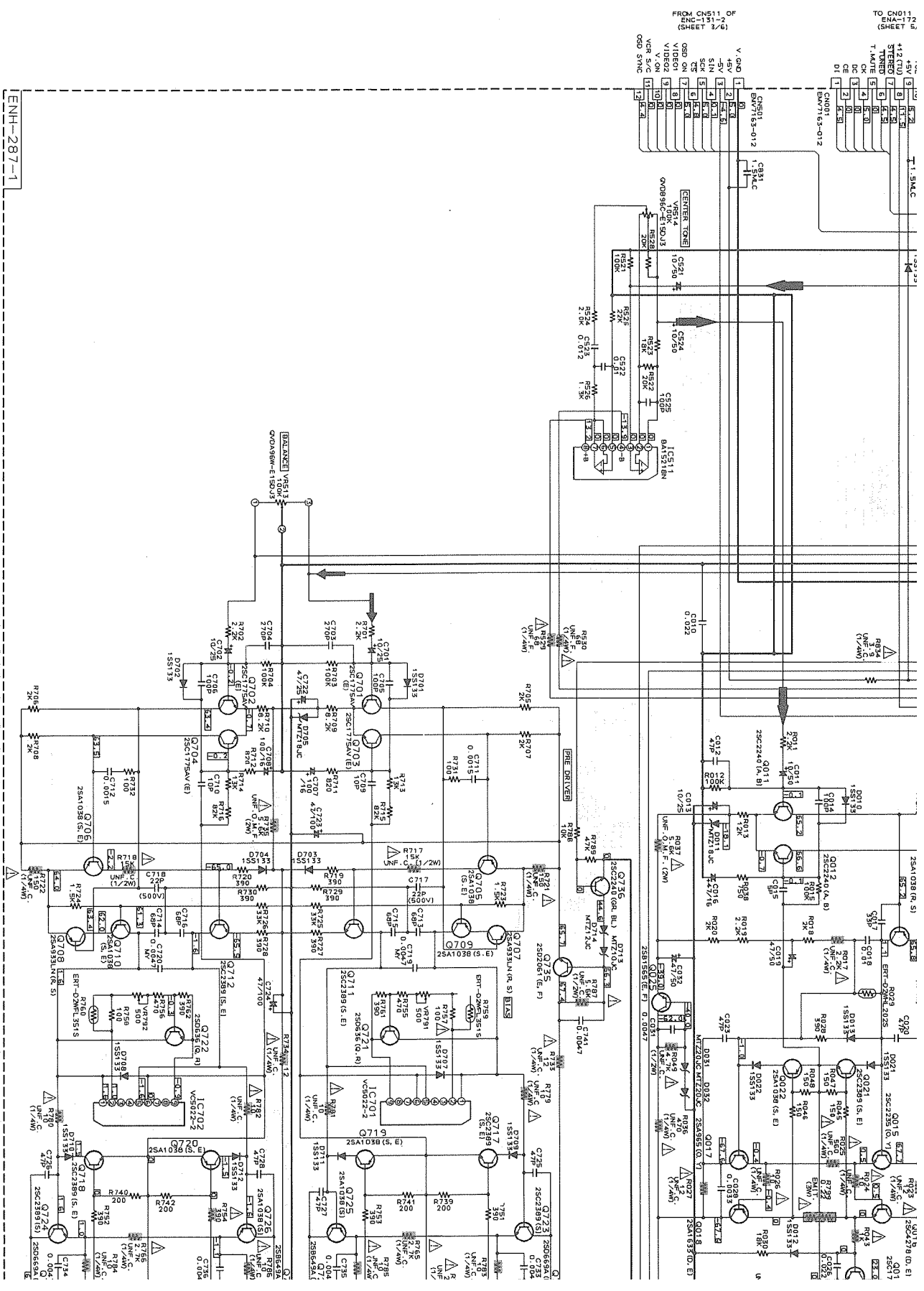

1

2

3

4

5



# Power Amplifier Section

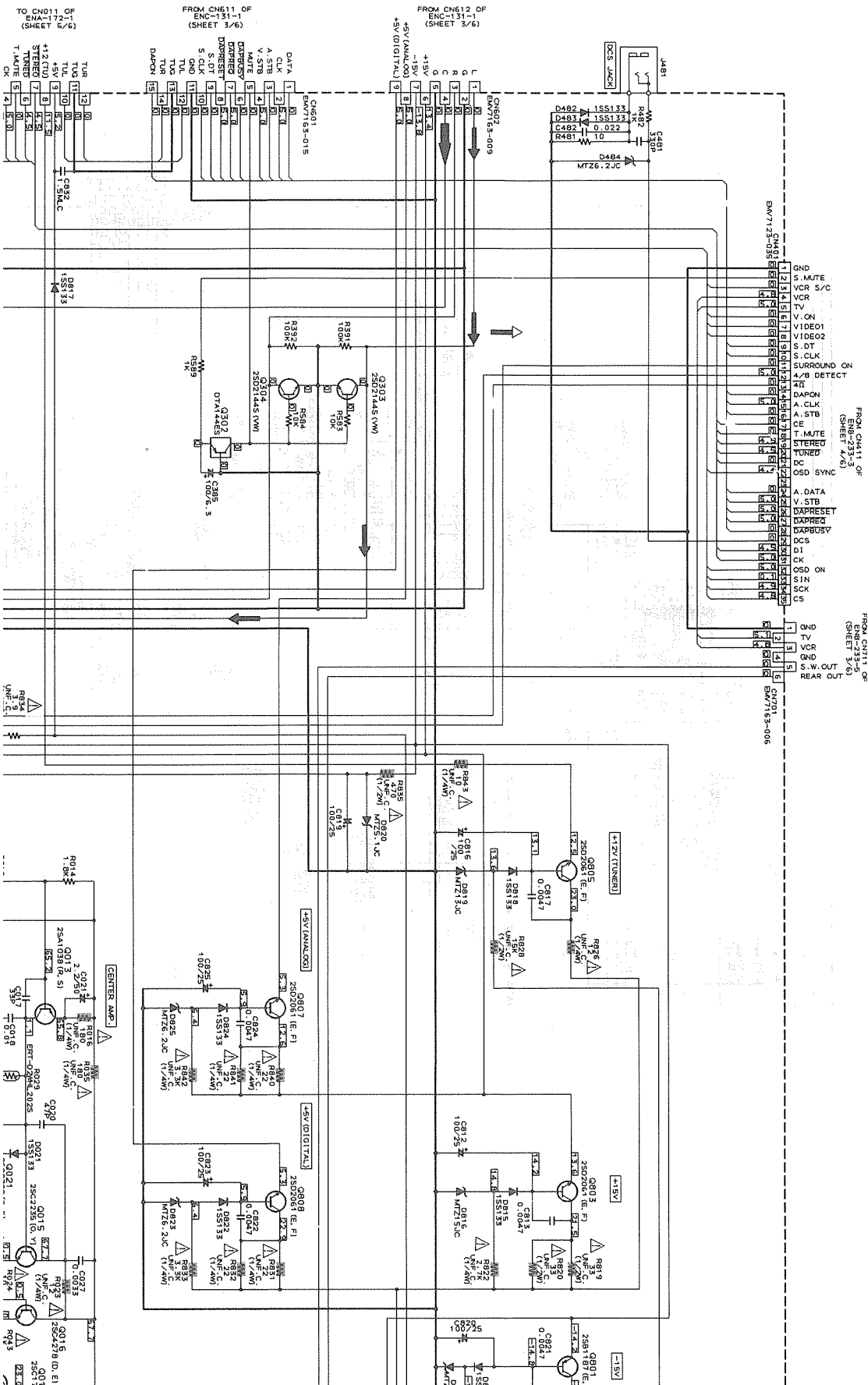

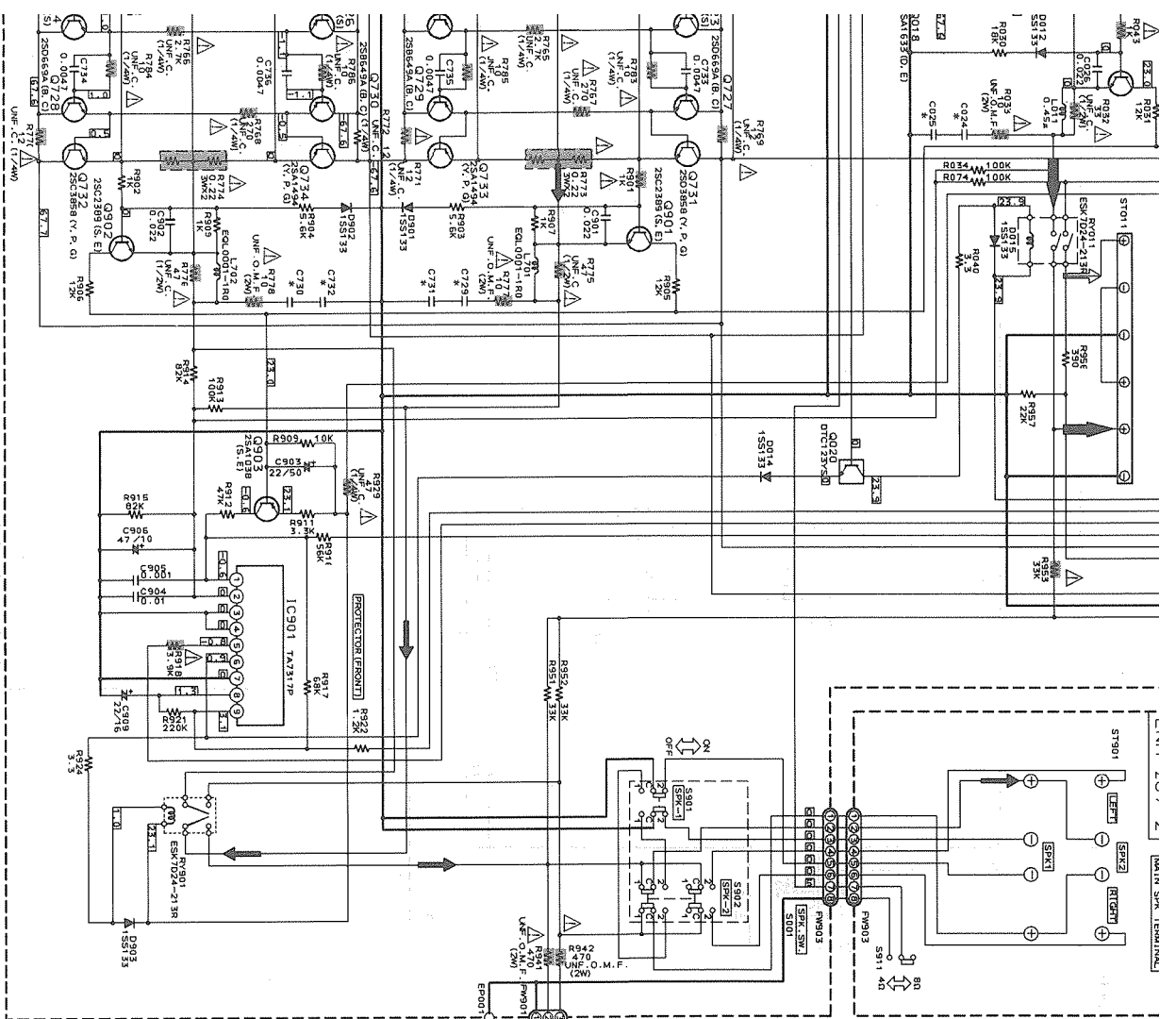

* MARK	C	J
C024	0.047M	0.122M
C025	0.047M	SHORT
C026	0.047M	0.122M
C027	0.047M	SHORT
C028	0.047M	0.122M
C029	0.047M	0.122M
C030	0.047M	SHORT
C031	0.047M	0.122M
C032	0.047M	SHORT
C033	0.047M	0.122M
C034	0.047M	SHORT
C035	0.047M	0.122M
C036	0.047M	SHORT
C037	0.047M	0.122M
C038	0.047M	SHORT
C039	0.047M	0.122M
C040	0.047M	SHORT
C041	0.047M	0.122M
C042	0.047M	SHORT
C043	0.047M	0.122M
C044	0.047M	SHORT
C045	0.047M	0.122M
C046	0.047M	SHORT
C047	0.047M	0.122M
C048	0.047M	SHORT
C049	0.047M	0.122M
C050	0.047M	SHORT
C051	0.047M	0.122M
C052	0.047M	SHORT
C053	0.047M	0.122M
C054	0.047M	SHORT
C055	0.047M	0.122M
C056	0.047M	SHORT
C057	0.047M	0.122M
C058	0.047M	SHORT
C059	0.047M	0.122M
C060	0.047M	SHORT
C061	0.047M	0.122M
C062	0.047M	SHORT
C063	0.047M	0.122M
C064	0.047M	SHORT
C065	0.047M	0.122M
C066	0.047M	SHORT
C067	0.047M	0.122M
C068	0.047M	SHORT
C069	0.047M	0.122M
C070	0.047M	SHORT
C071	0.047M	0.122M
C072	0.047M	SHORT
C073	0.047M	0.122M
C074	0.047M	SHORT
C075	0.047M	0.122M
C076	0.047M	SHORT
C077	0.047M	0.122M
C078	0.047M	SHORT
C079	0.047M	0.122M
C080	0.047M	SHORT
C081	0.047M	0.122M
C082	0.047M	SHORT
C083	0.047M	0.122M
C084	0.047M	SHORT
C085	0.047M	0.122M
C086	0.047M	SHORT
C087	0.047M	0.122M
C088	0.047M	SHORT
C089	0.047M	0.122M
C090	0.047M	SHORT
C091	0.047M	0.122M
C092	0.047M	SHORT
C093	0.047M	0.122M
C094	0.047M	SHORT
C095	0.047M	0.122M
C096	0.047M	SHORT
C097	0.047M	0.122M
C098	0.047M	SHORT
C099	0.047M	0.122M
C100	0.047M	SHORT

6 7 8 9 10

J I H G F

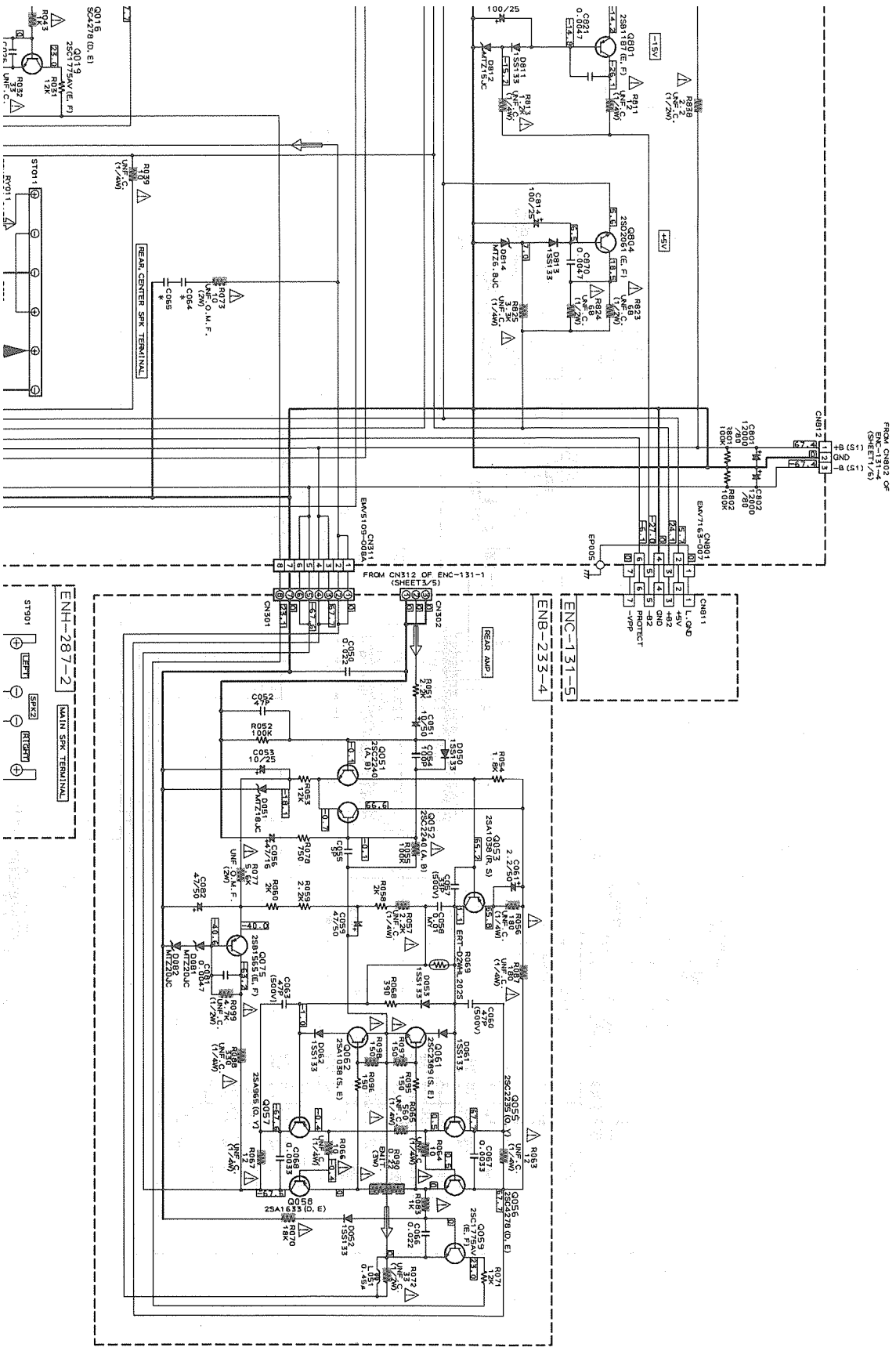



P2-28-a

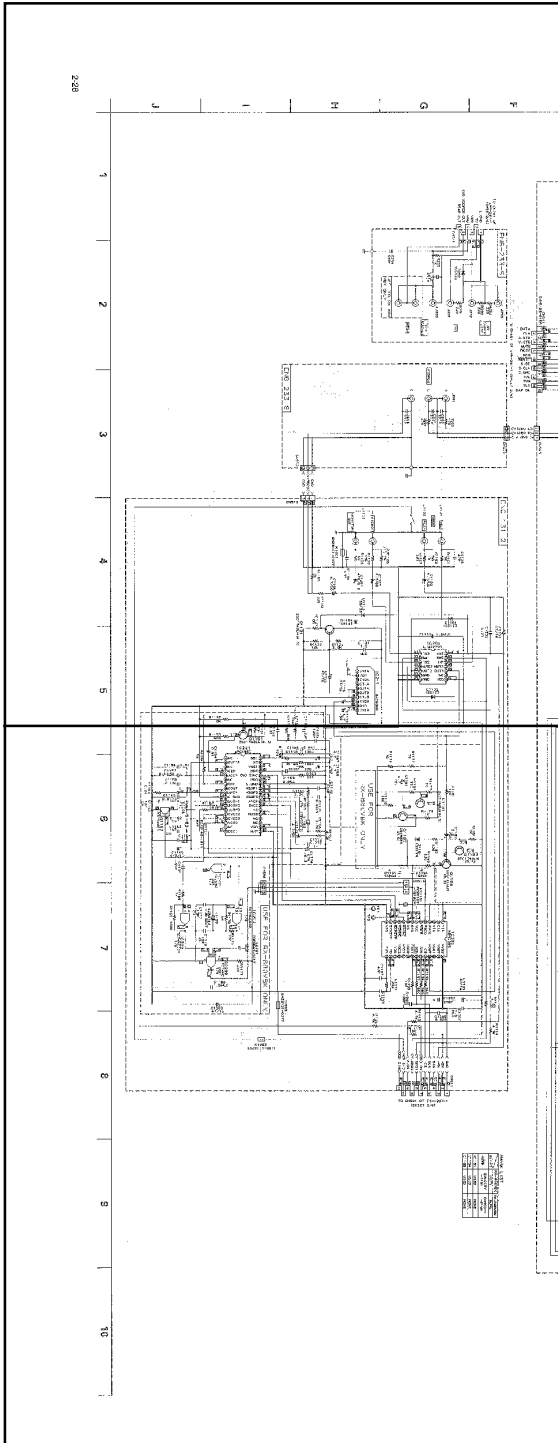

P2-28-c

P2-28-b

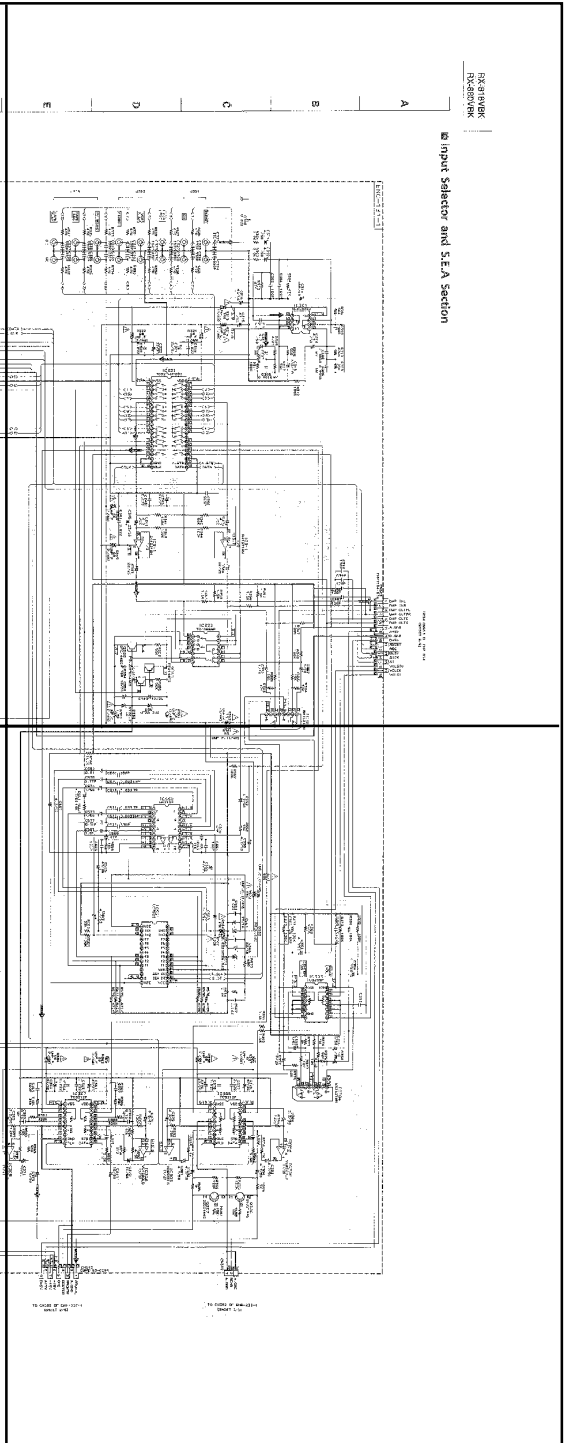

P2-28-d



Input Selector and S.E.A Section

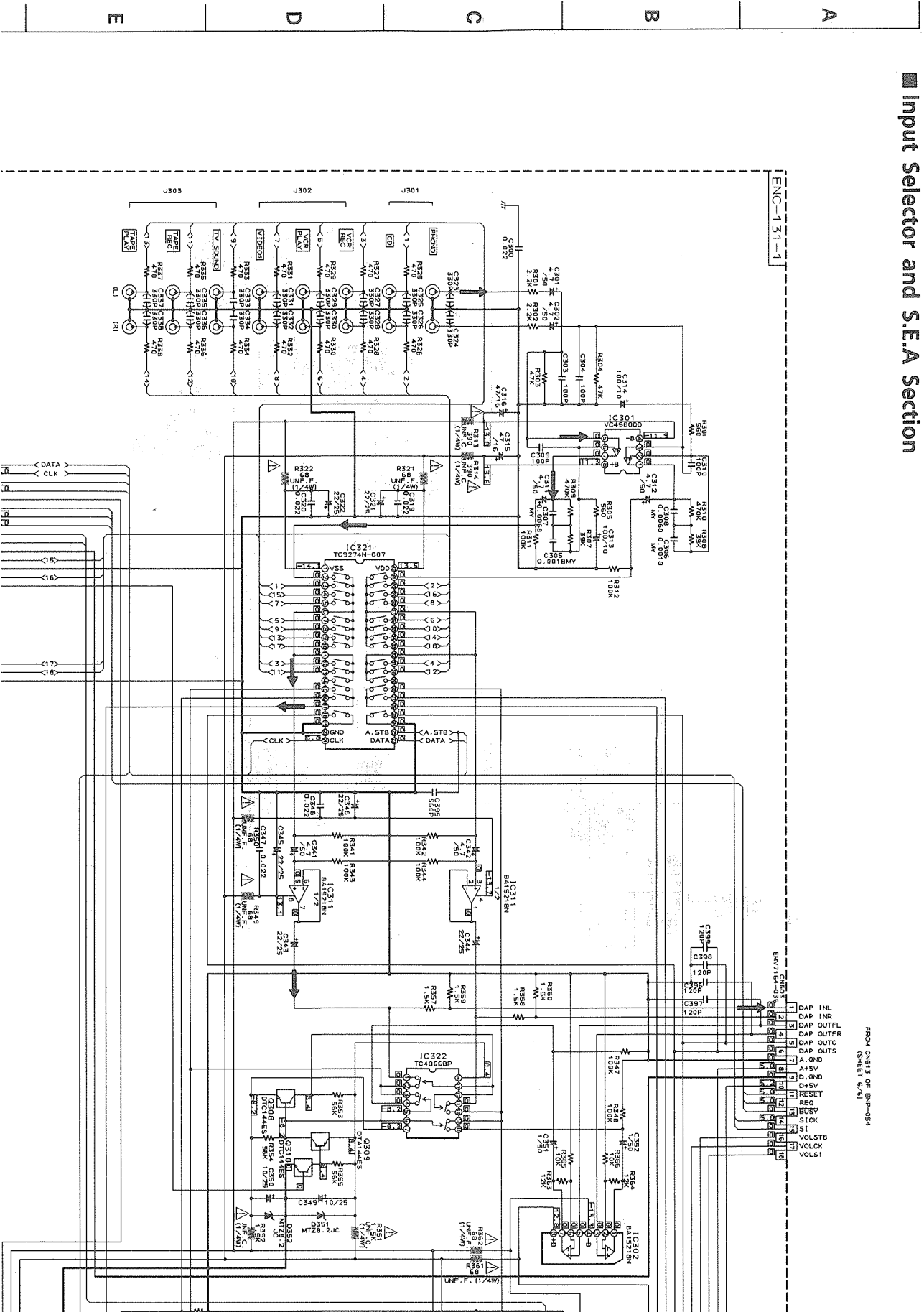

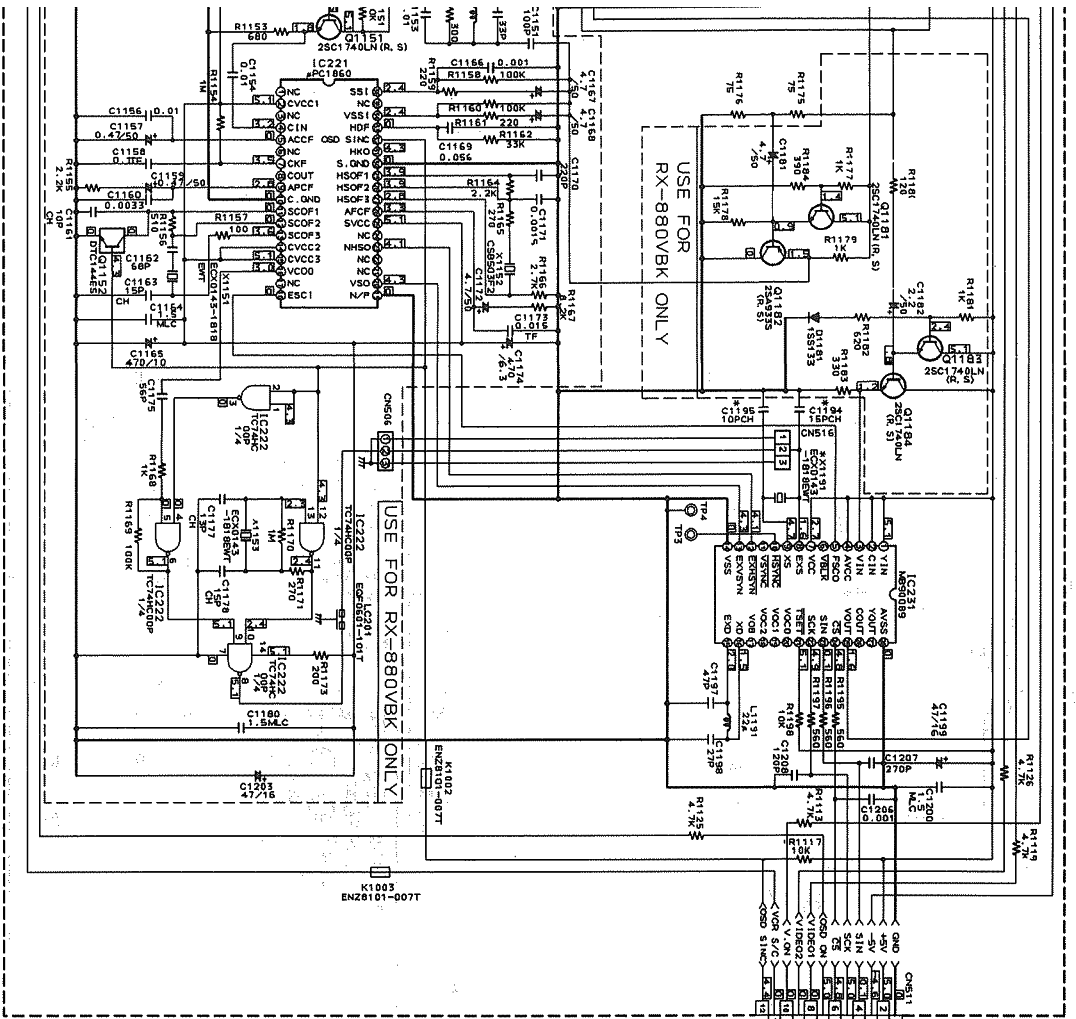

TO CH501 OF ENH-287-1  
(SHEET 2/6)

MARK LIST

MARK	RX-880VBK	RX-880VBK
R117	USED	NONE
V395	EMPOV	EMPOV
X1191	USED	NONE
C1194	USED	NONE
C1195	USED	NONE



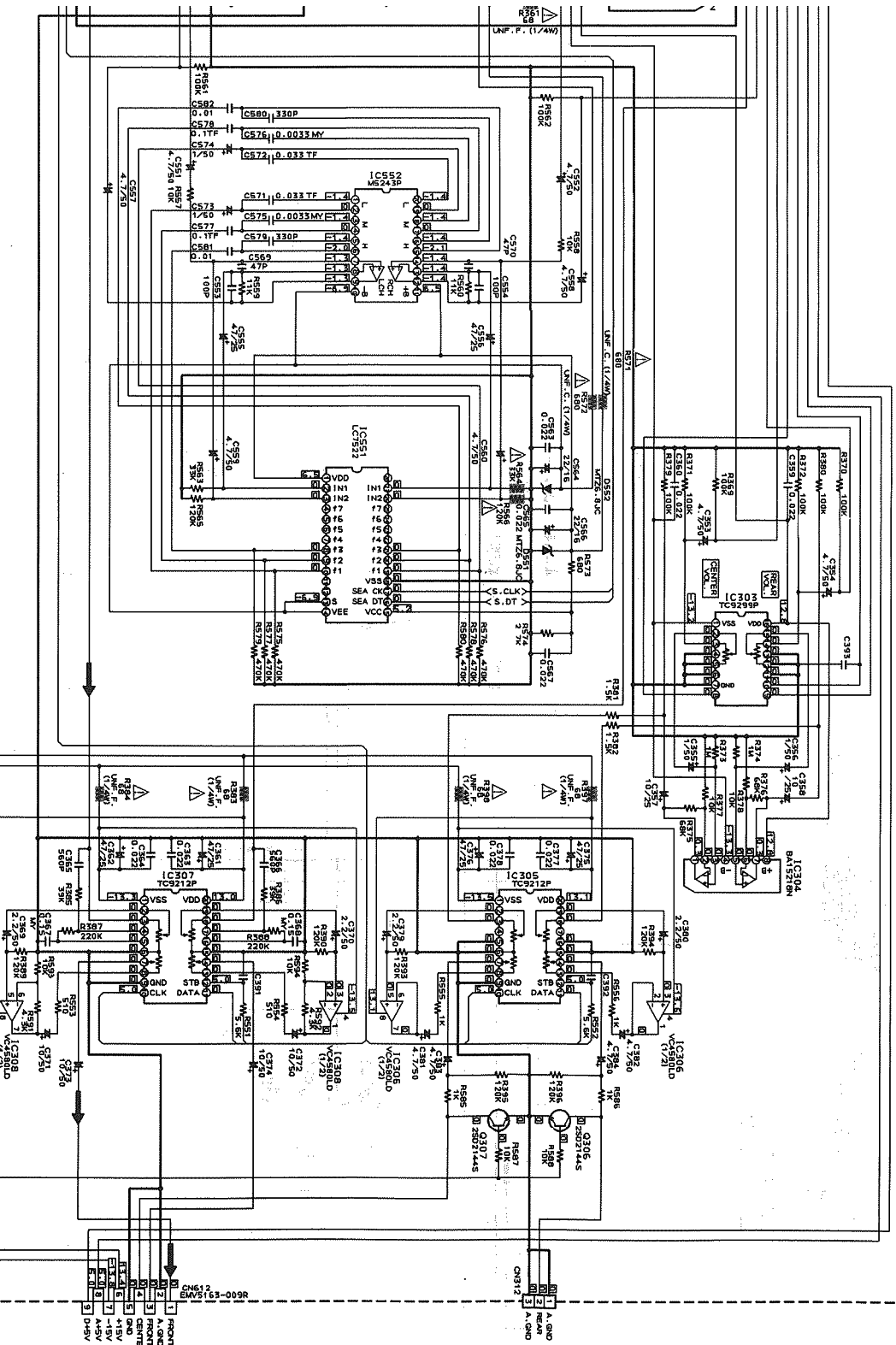

TO CN602 OF ENH-287-1  
(SHEET 2/6)

TO CN102 OF ENH-233-4  
(SHEET 2/6)



P2-29-a

P2-29-b

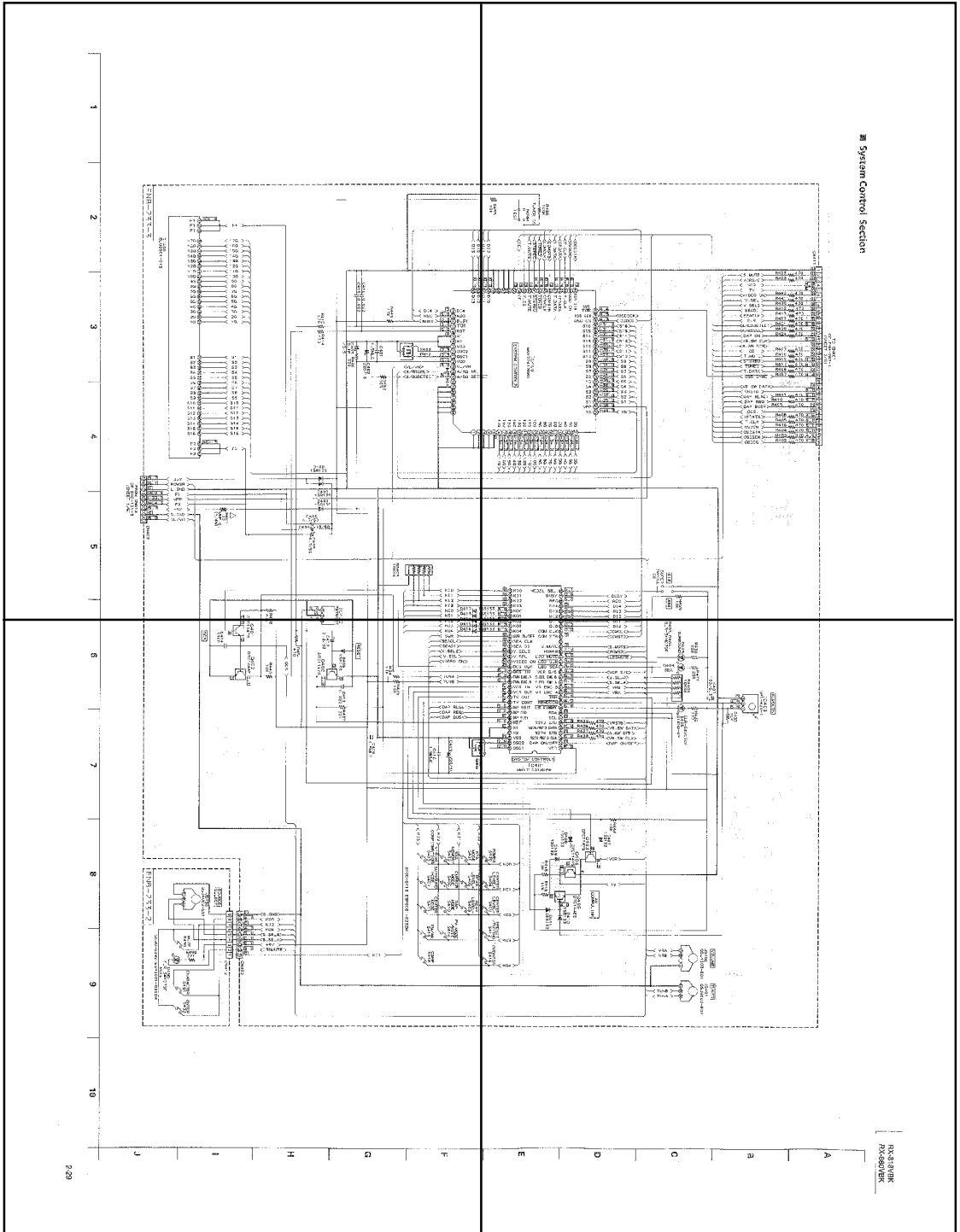

P2-29-c

P2-29-d

1 2 3 4 5

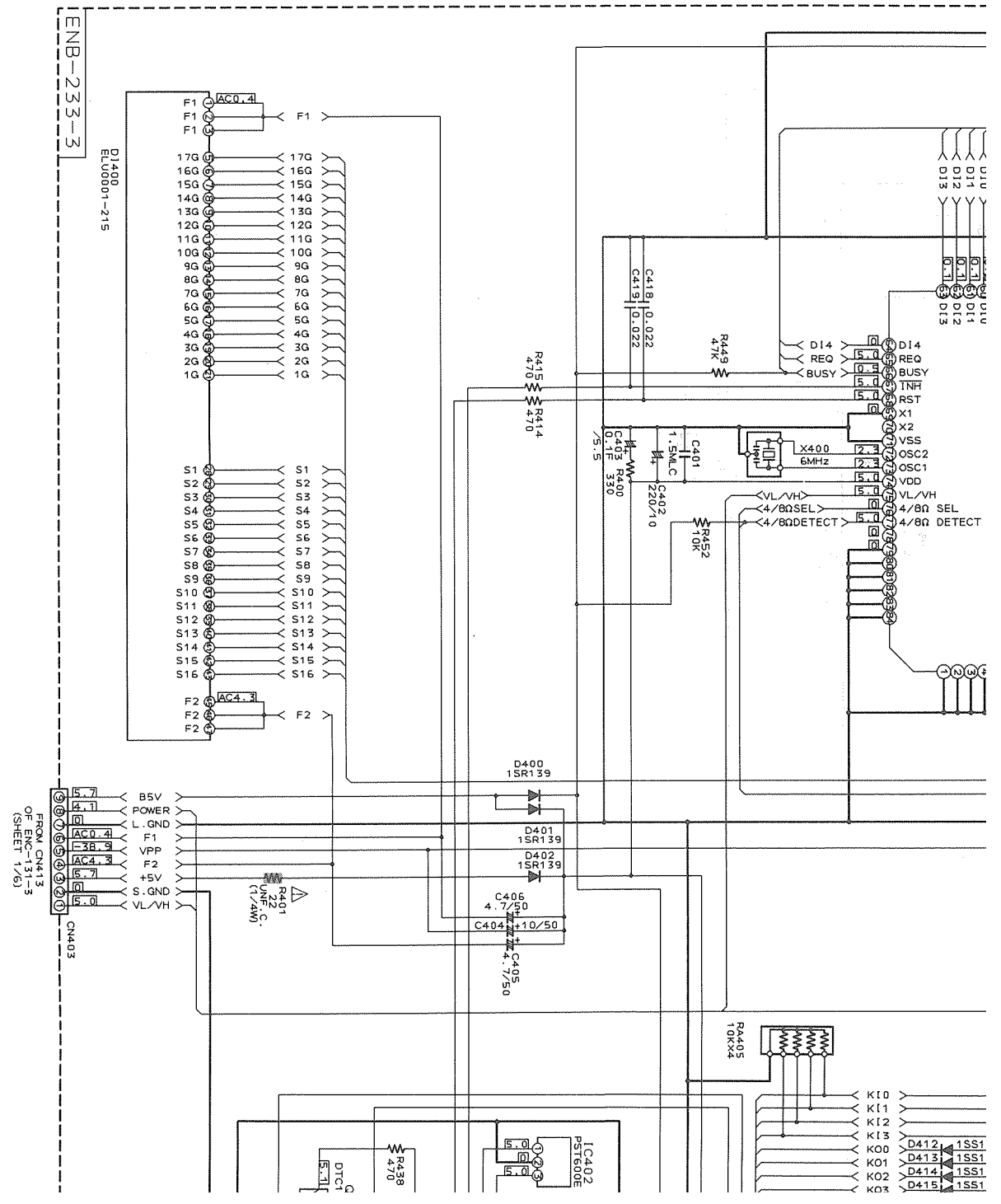

# System Control Section

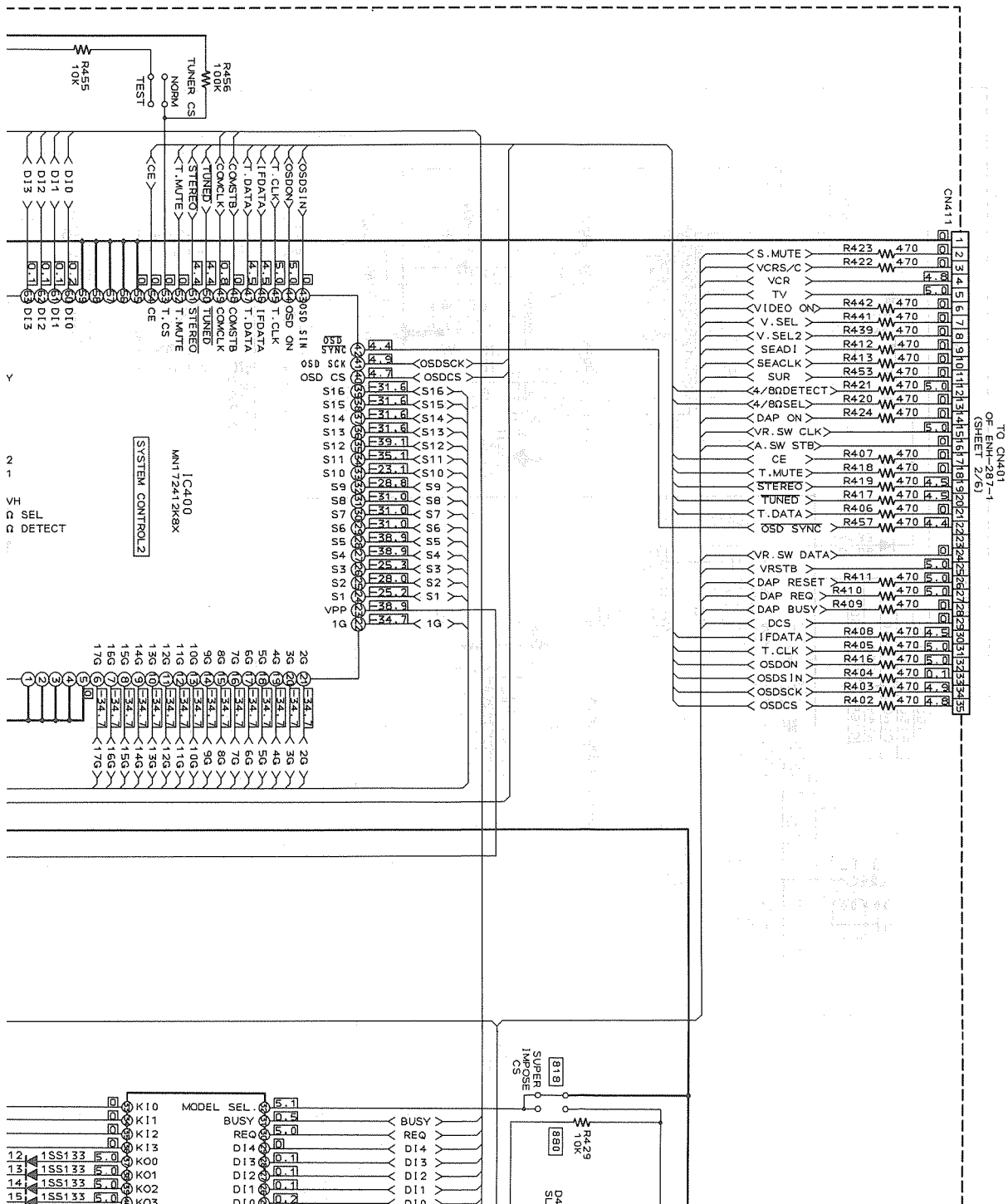

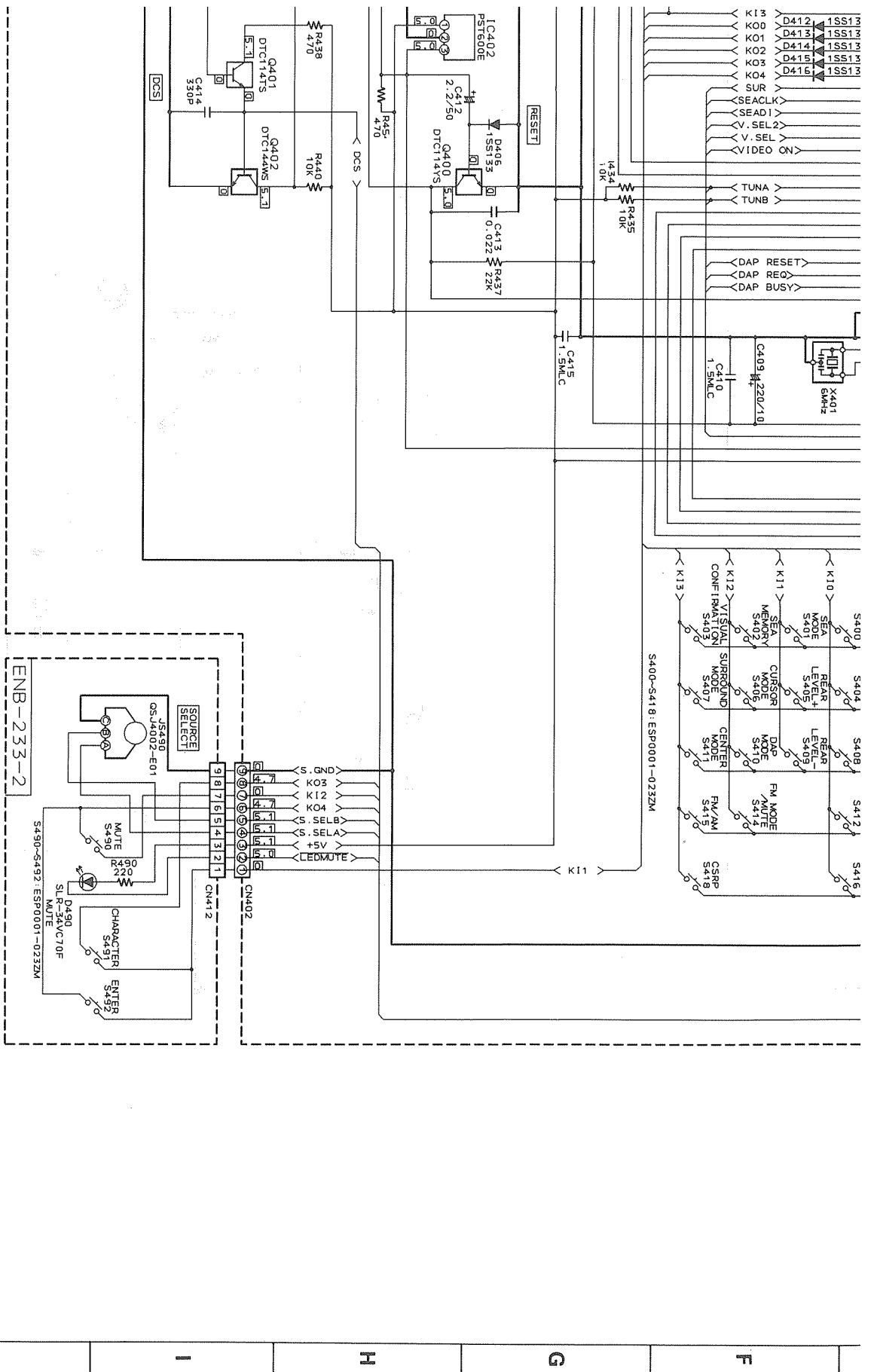

6 7 8 9 10

J I H G F

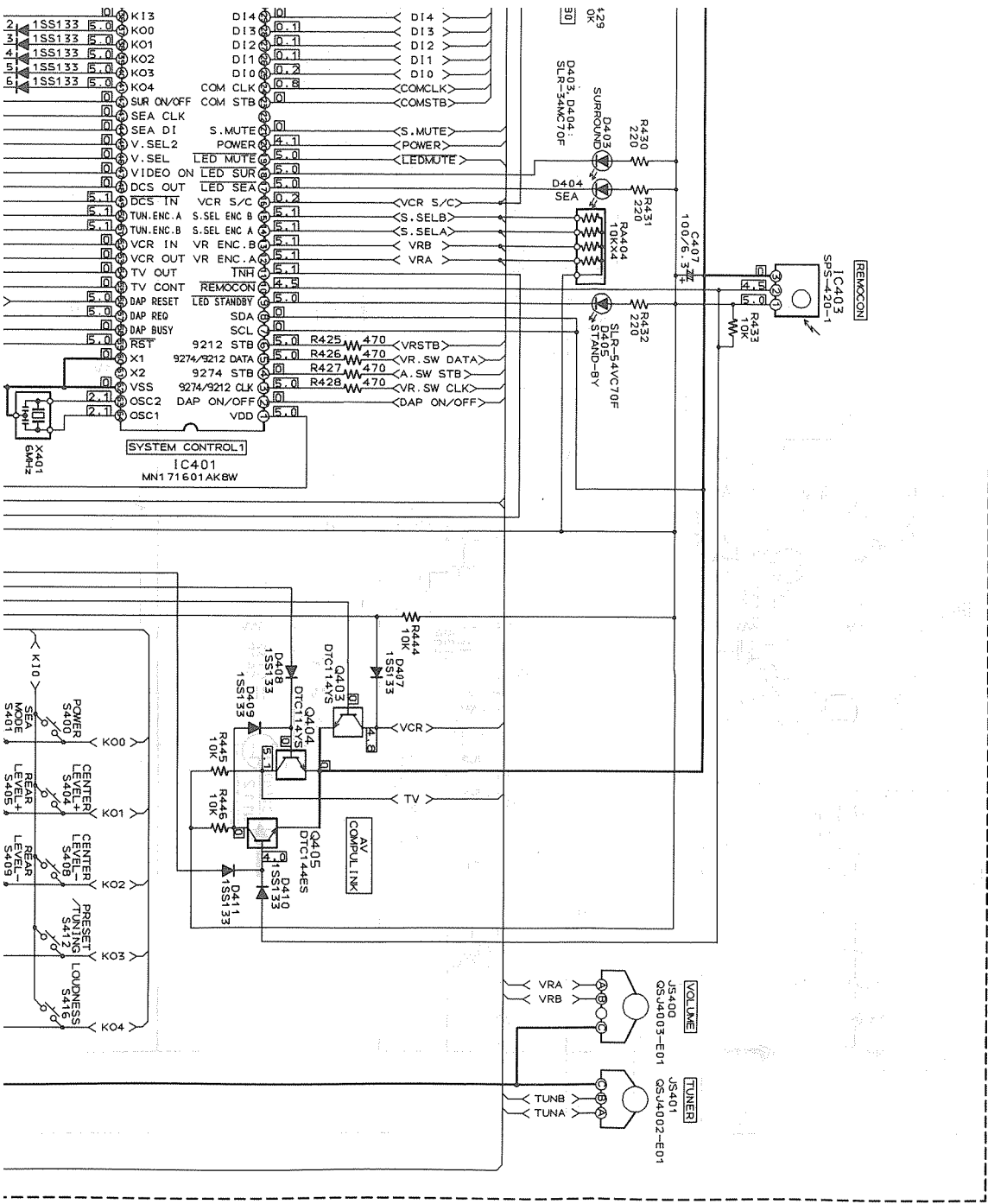

RX-818VBK  
RX-880VBK





P2-30-a

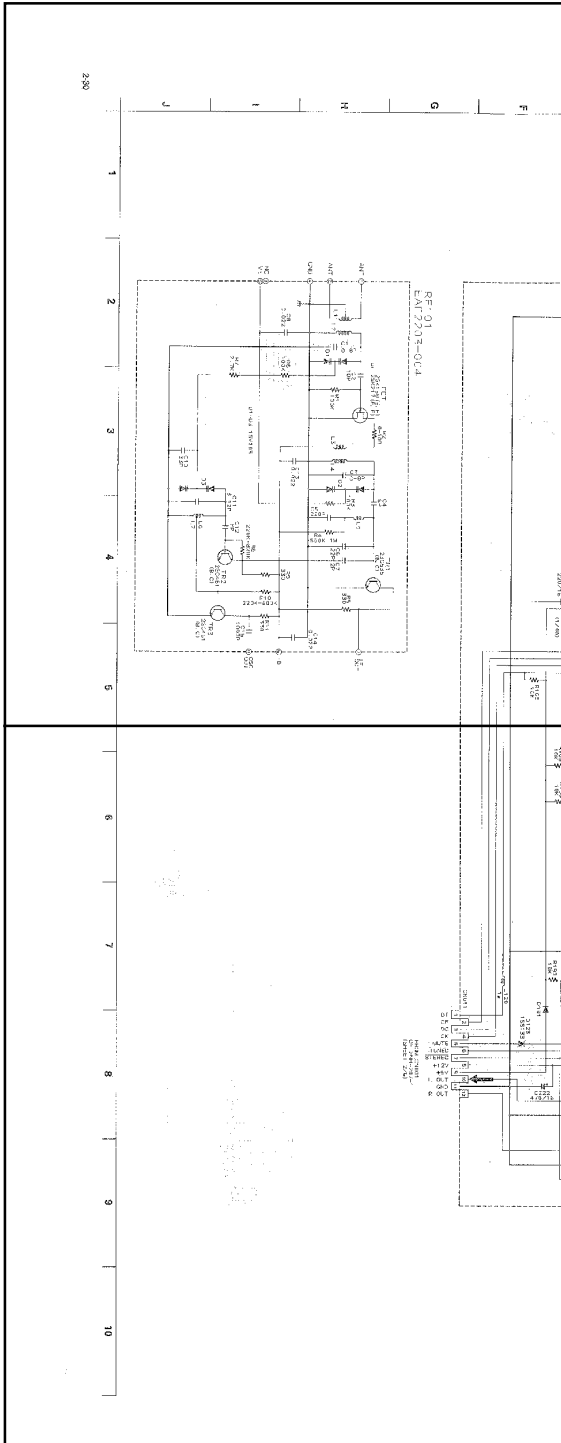

P2-30-c

P2-30-b

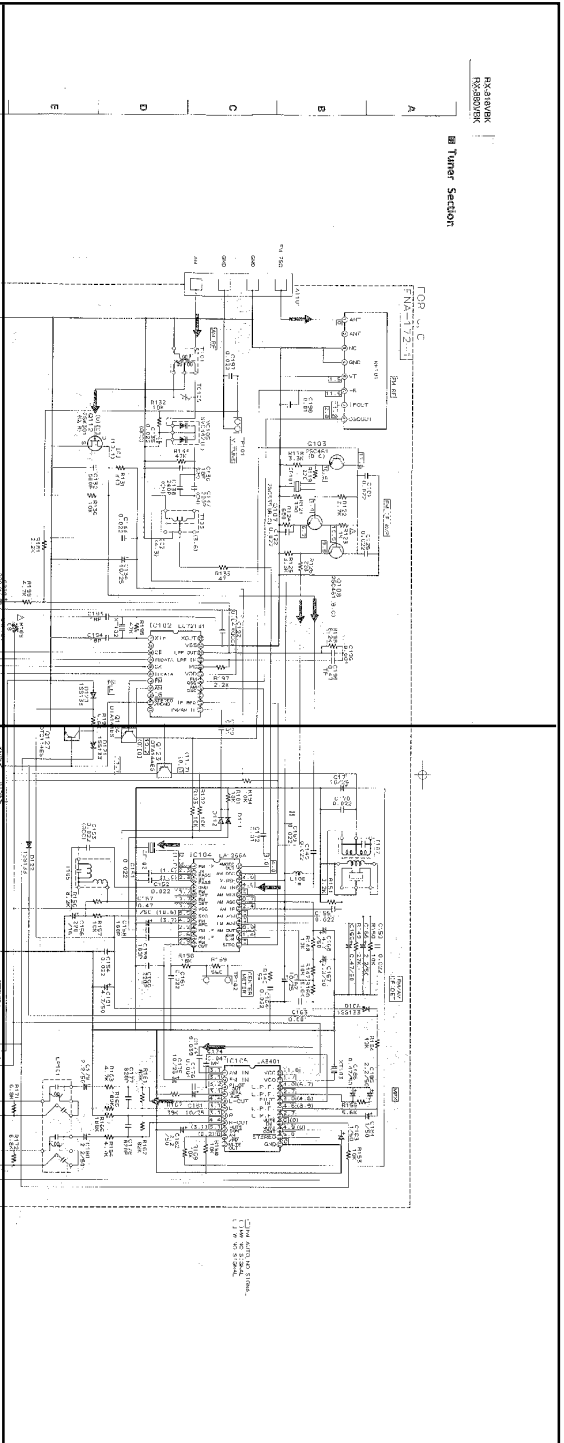

P2-30-d

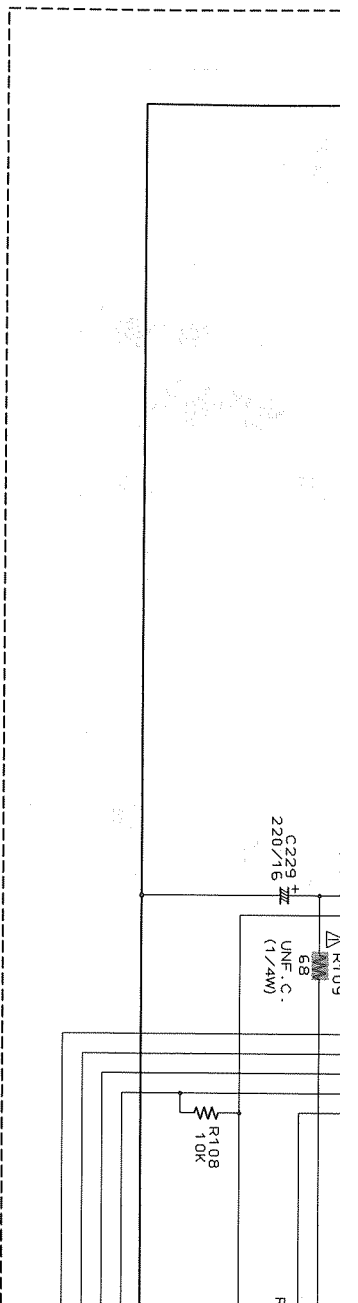

RF101  
EAF2203-004

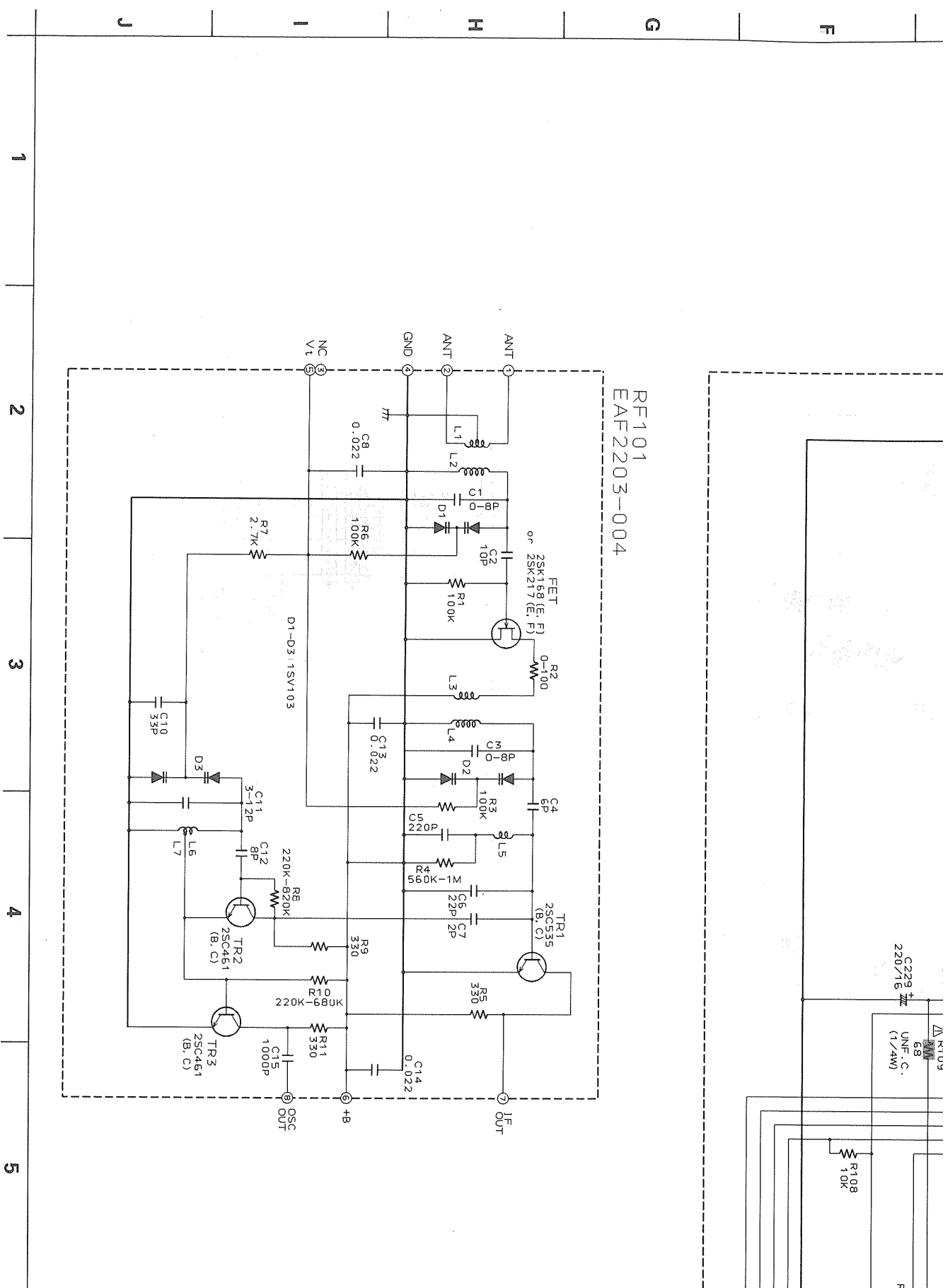
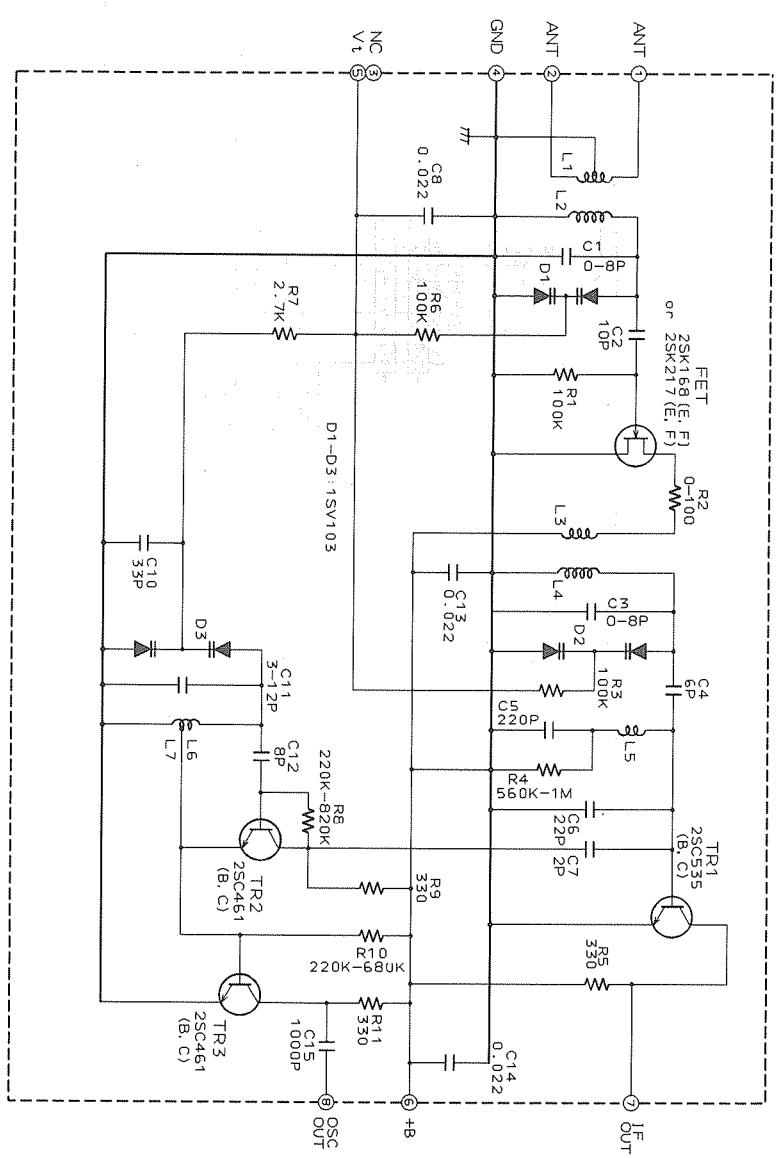

■ Tuner Section

A  
B  
C  
D  
E

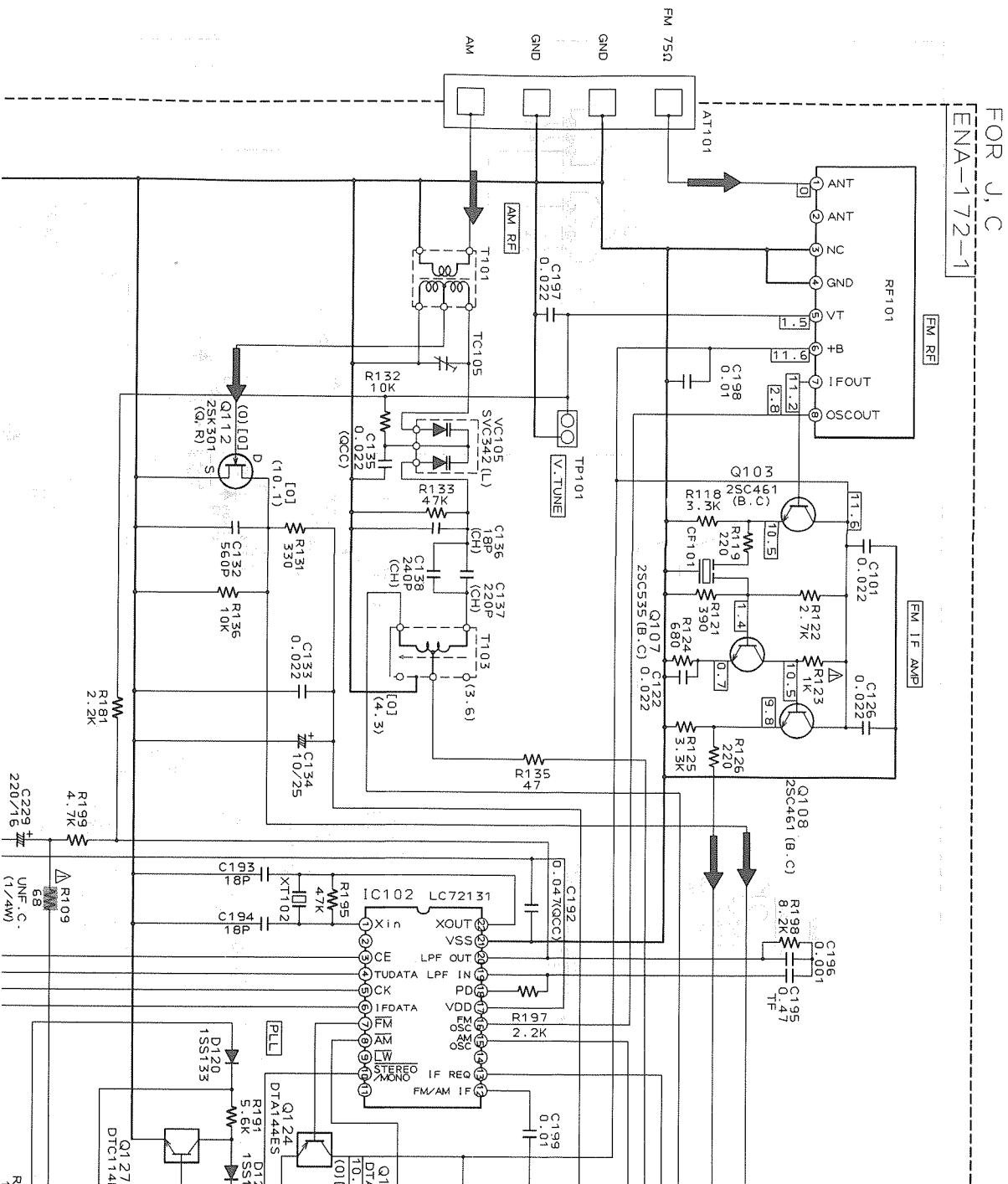

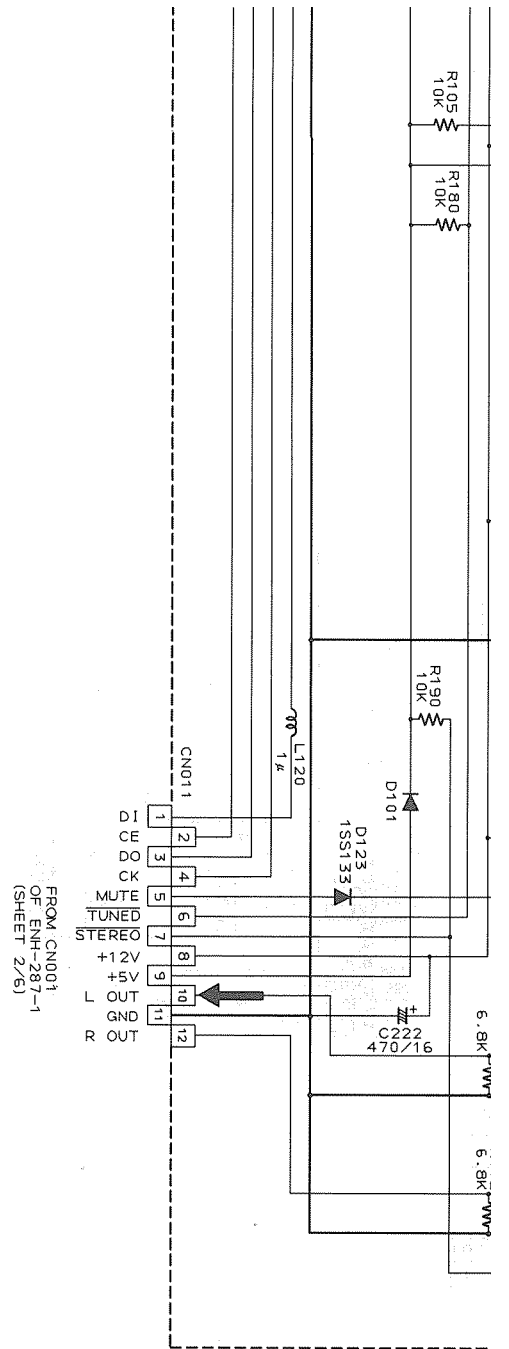

6 7 8 9 10

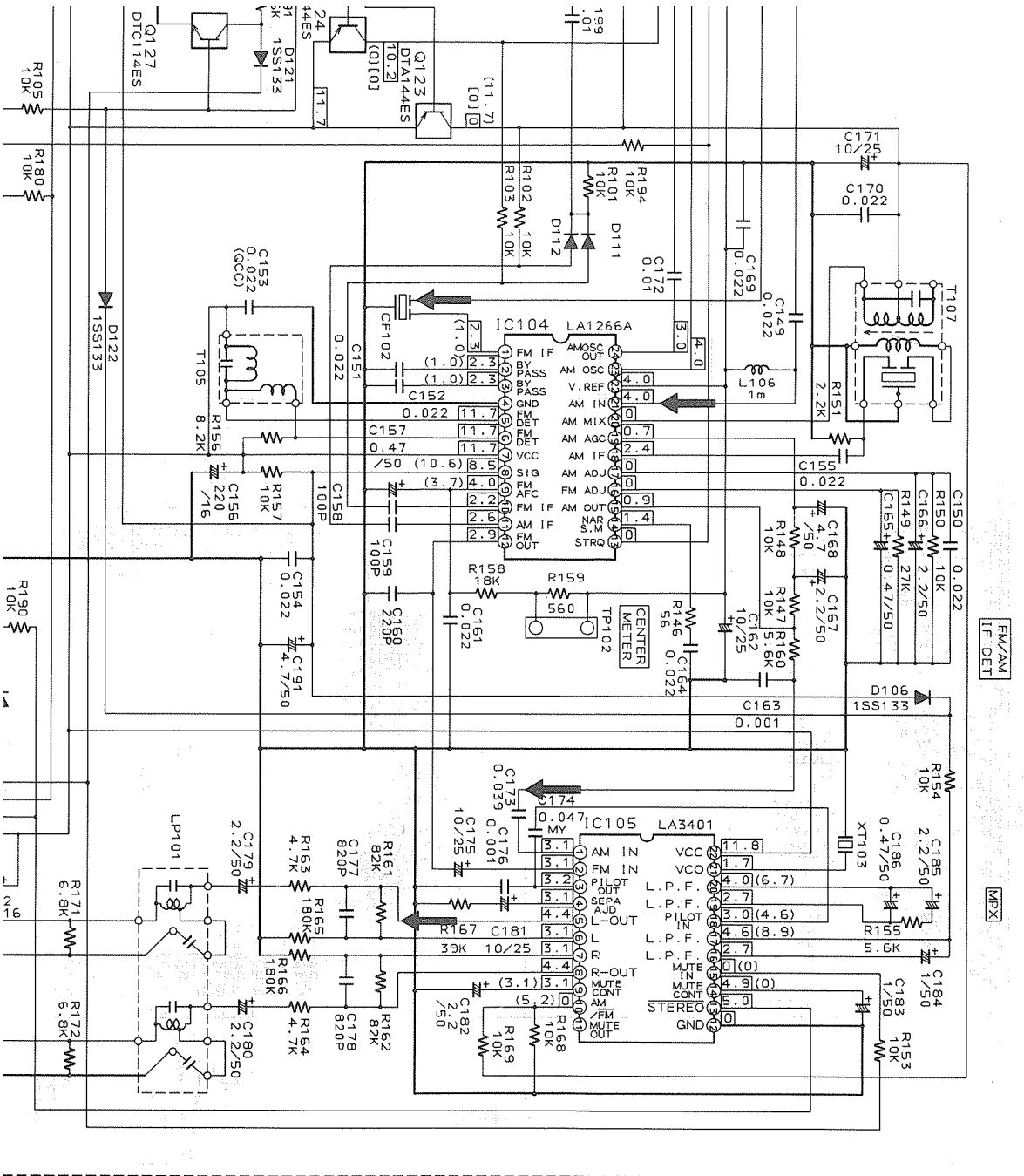

FM AUTO. NO SIGNAL  
 ( ) MW NO SIGNAL  
 [ ] LW NO SIGNAL

# D.S.P Section

A  
B  
C  
D  
E  
F  
G  
H  
I  
J

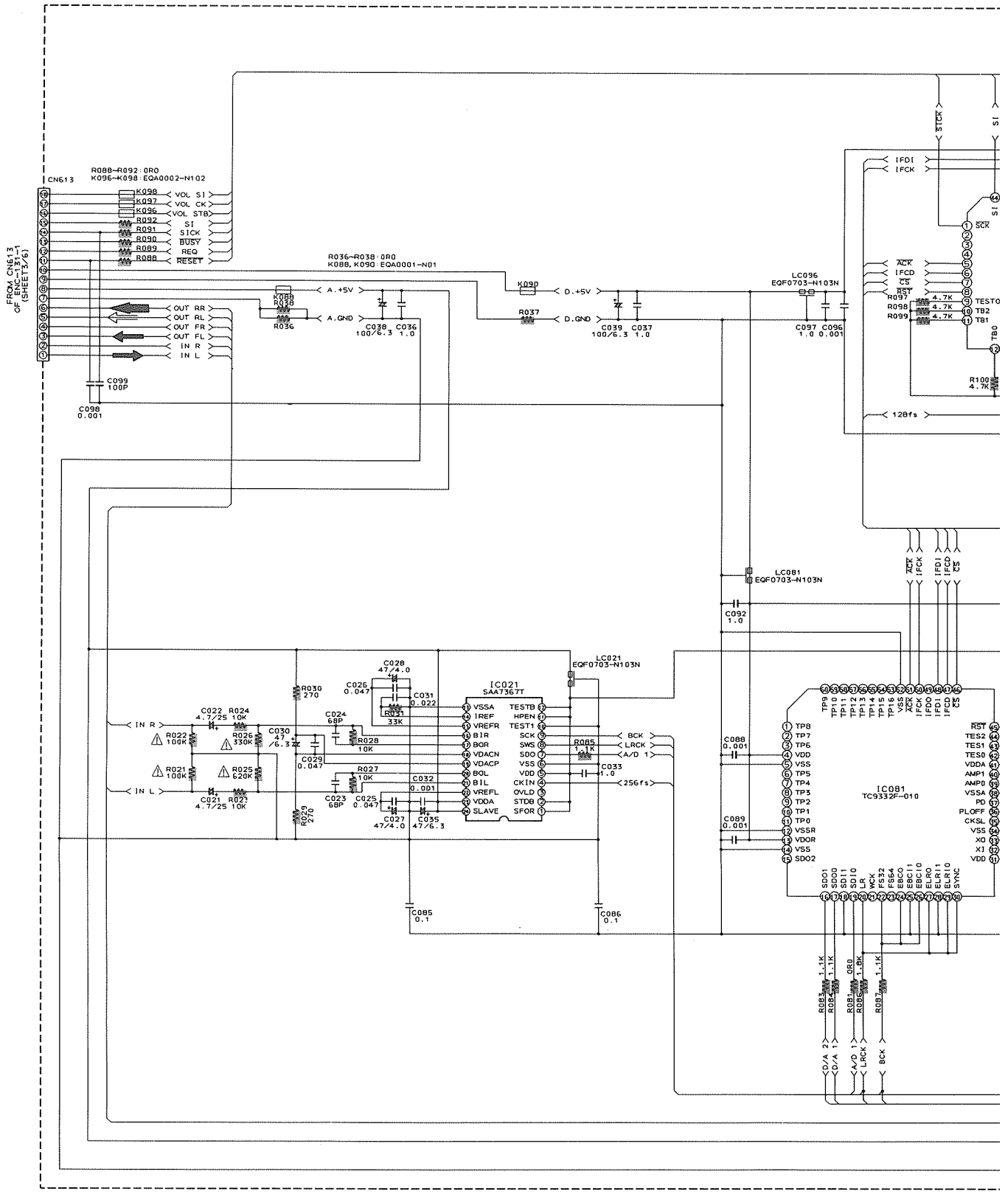

1 2 3 4 5

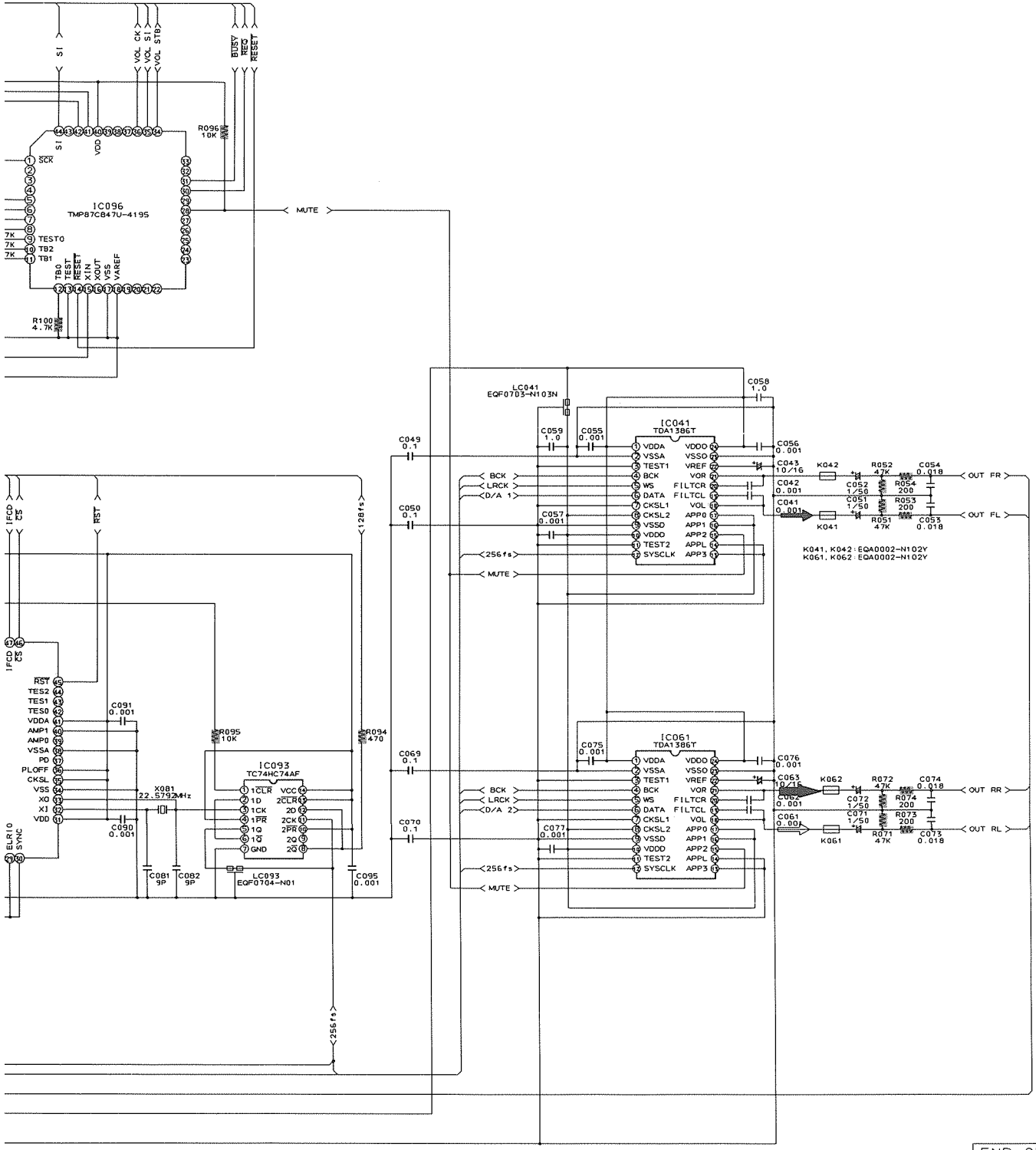

ENP-054

6

7

8

9

10

# Printed Circuit Boards

## System Control & Rear Power Amplifier P.C. Board (ENB-233)

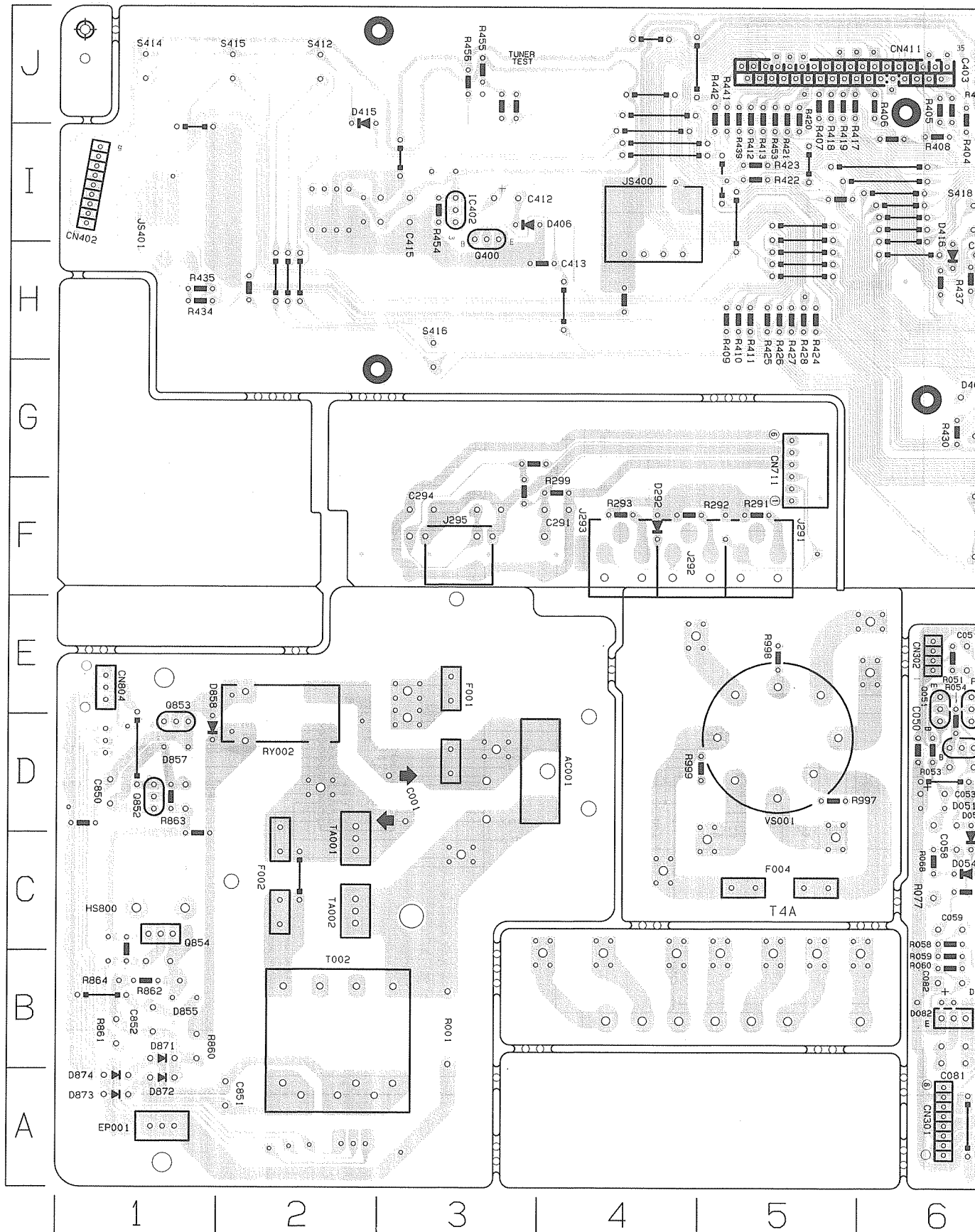





# Power Amplifier P.C. Board (ENH-287)

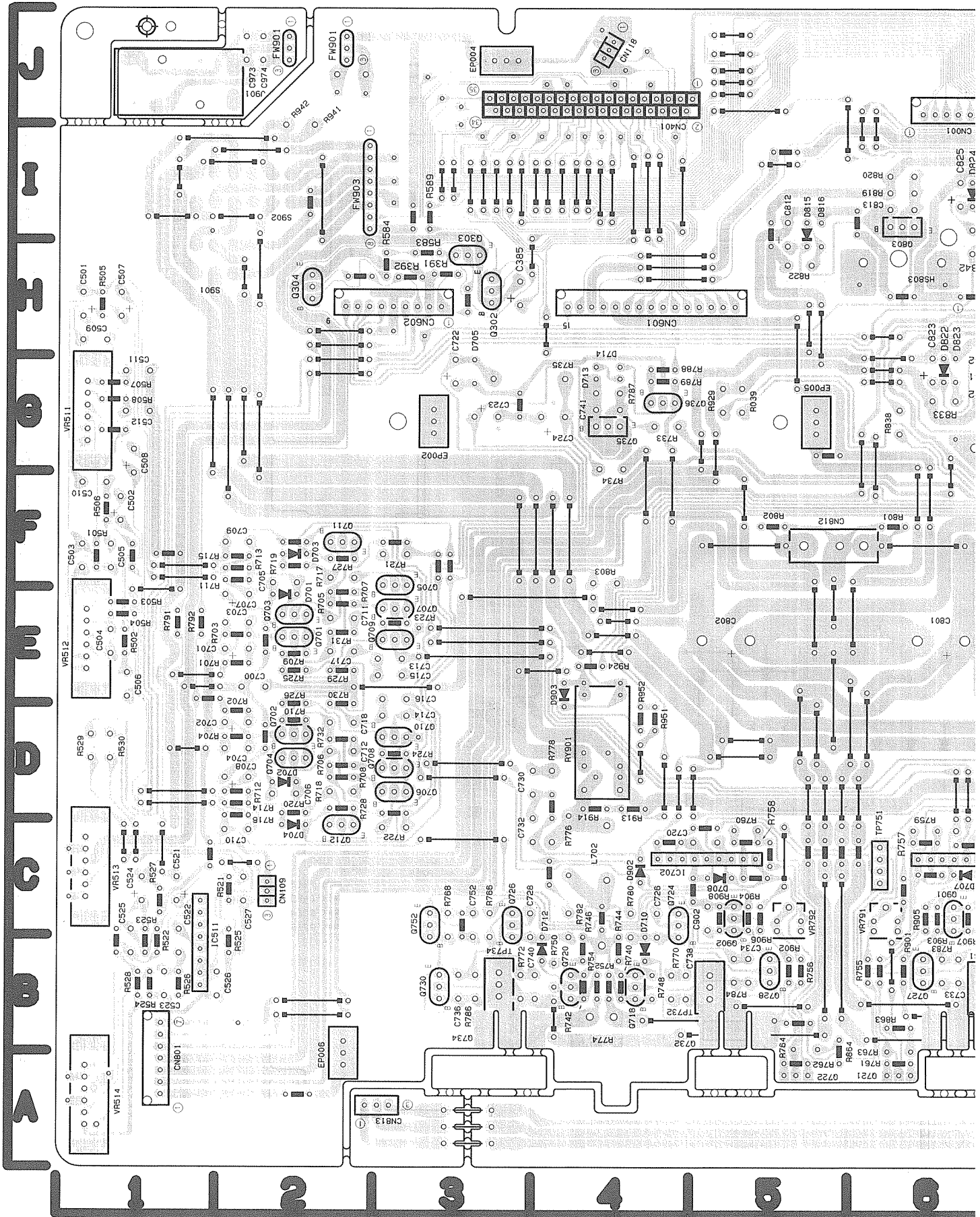

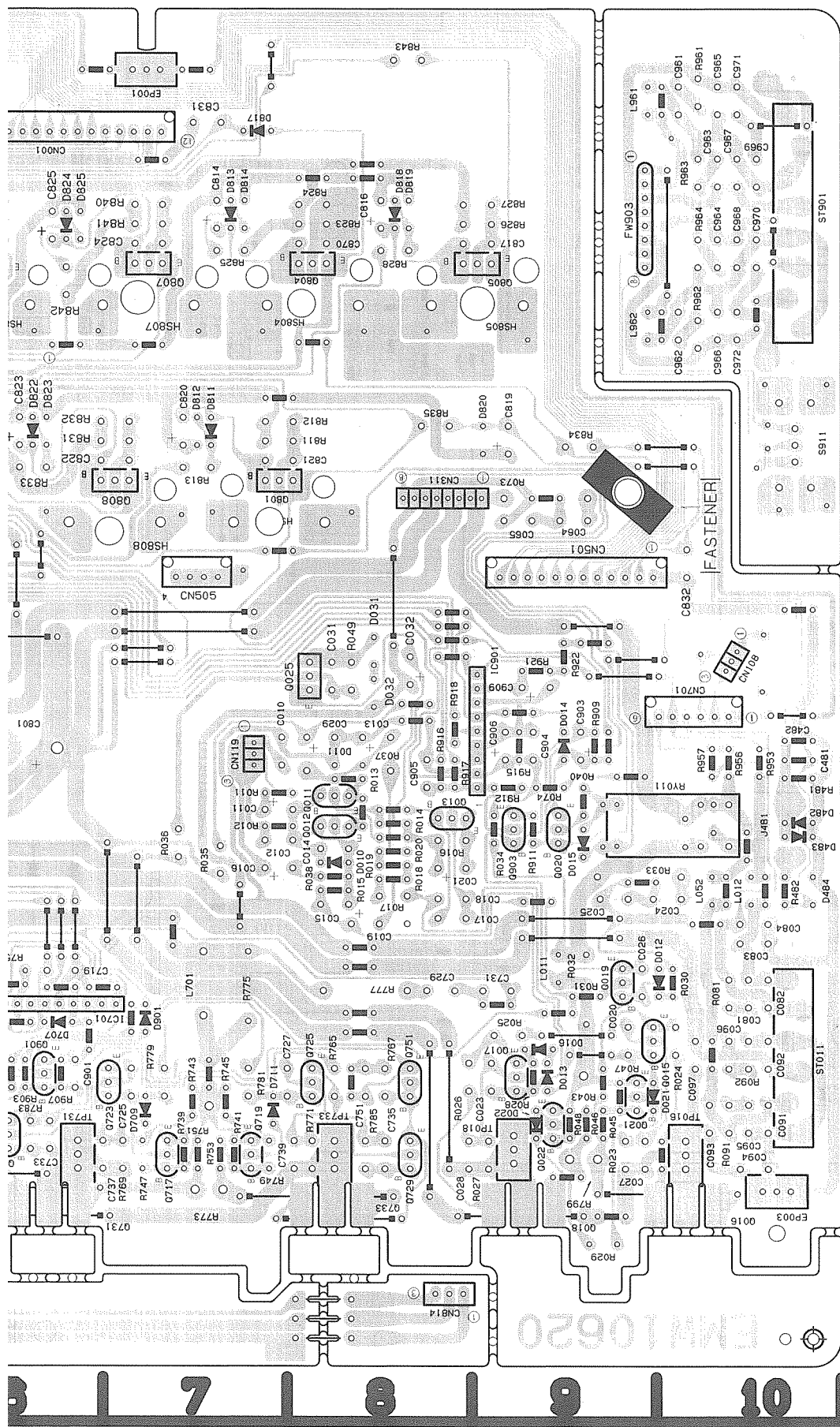

Symbol	X	Y	Symbol	X	Y	Symbol	X	Y	Symbol	X	Y
D010	7	A	C708	2	D	C965	10	H	D824	6	I
D011	7	E	C709	2	F	C967	10	I	D825	6	J
D012	8	D	C710	2	C	C968	10	I	D901	7	C
D013	8	E	C711	2	E	C969	10	I	D902	7	C
D014	8	D	C712	2	D	C970	10	I	F903	4	E
D015	8	E	C713	3	D	C971	10	J	F901A	2	J
D016	7	D	C714	3	D	C972	10	H	F901B	2	J
D017	8	D	C715	3	C	C973	2	J	F903A	9	I
D018	8	D	C716	3	E	C974	2	J	F903B	2	J
D019	8	D	C717	2	E	CM001	7	J	IC511	1	C
D020	8	D	C718	2	D	CM103	10	F	IC701	6	C
D021	8	D	C719	6	C	CM109	2	C	IC702	2	C
D022	8	D	C720	5	C	CM118	4	J	IC901	9	E
D023	9	C	C721	3	G	CM119	7	E	J481	10	D
D024	10	D	C722	3	G	CM119	7	E	J481	10	D
D025	9	D	C723	3	G	CM311	9	J	J901	1	J
D026	9	C	C724	4	G	CM401	3	J	L011	9	D
D027	9	B	C725	7	C	CM501	9	F	L012	10	D
D028	8	D	C726	4	C	CM505	7	F	L022	10	D
D029	8	D	C727	7	C	CM601	5	H	L701	7	D
D030	8	E	C728	3	C	CM602	3	H	L702	4	C
D031	8	E	C729	8	C	CM701	10	H	L961	9	J
D032	8	F	C729	8	C	CM701	10	H	L961	9	J
D033	9	D	C730	4	D	CM801	1	B	L962	9	H
D034	9	D	C731	9	C	CM812	5	F	Q011	8	H
D035	10	I	C732	3	D	CM103	10	F	Q012	9	D
D036	10	I	C733	8	C	CM814	8	A	Q013	9	D
D037	10	D	C734	5	B	CM101	8	D	Q015	9	D
D038	10	D	C735	8	B	CM101	8	D	Q016	9	B
D039	10	D	C736	3	B	CM102	10	C	Q017	9	D
D040	10	D	C737	8	C	CM103	10	F	Q018	9	B
D041	10	B	C738	4	B	CM104	9	E	Q019	9	C
D042	10	B	C739	8	B	CM105	9	D	Q020	9	B
D043	10	B	C740	4	B	CM106	9	D	Q021	9	B
D044	10	C	C741	4	B	CM107	9	C	Q022	9	B
D045	10	C	C742	8	C	CM108	9	C	Q023	9	B
D046	10	C	C743	8	C	CM109	9	C	Q024	9	B
D047	10	C	C744	8	C	CM110	9	C	Q025	9	B
D048	10	C	C745	8	C	CM111	9	C	Q026	9	B
D049	10	C	C746	8	C	CM112	9	C	Q027	9	B
D050	10	C	C747	8	C	CM113	9	C	Q028	9	B
D051	10	C	C748	8	C	CM114	9	C	Q029	9	B
D052	10	C	C749	8	C	CM115	9	C	Q030	9	B
D053	10	C	C750	8	C	CM116	9	C	Q031	9	B
D054	10	C	C751	8	C	CM117	9	C	Q032	9	B
D055	10	C	C752	8	C	CM118	9	C	Q033	9	B
D056	10	C	C753	8	C	CM119	9	C	Q034	2	H
D057	10	C	C754	8	C	CM120	9	C	Q035	2	H
D058	10	C	C755	8	C	CM121	9	C	Q036	2	H
D059	10	C	C756	8	C	CM122	9	C	Q037	2	H
D060	10	C	C757	8	C	CM123	9	C	Q038	2	H
D061	10	C	C758	8	C	CM124	9	C	Q039	2	H
D062	10	C	C759	8	C	CM125	9	C	Q040	2	H
D063	10	C	C760	8	C	CM126	9	C	Q041	2	H
D064	10	C	C761	8	C	CM127	9	C	Q042	2	H
D065	10	C	C762	8	C	CM128	9	C	Q043	2	H
D066	10	C	C763	8	C	CM129	9	C	Q044	2	H
D067	10	C	C764	8	C	CM130	9	C	Q045	2	H
D068	10	C	C765	8	C	CM131	9	C	Q046	2	H
D069	10	C	C766	8	C	CM132	9	C	Q047	2	H
D070	10	C	C767	8	C	CM133	9	C	Q048	2	H
D071	10	C	C768	8	C	CM134	9	C	Q049	2	H
D072	10	C	C769	8	C	CM135	9	C	Q050	2	H
D073	10	C	C770	8	C	CM136	9	C	Q051	2	H
D074	10	C	C771	8	C	CM137	9	C	Q052	2	H
D075	10	C	C772	8	C	CM138	9	C	Q053	2	H
D076	10	C	C773	8	C	CM139	9	C	Q054	2	H
D077	10	C	C774	8	C	CM140	9	C	Q055	2	H
D078	10	C	C775	8	C	CM141	9	C	Q056	2	H
D079	10	C	C776	8	C	CM142	9	C	Q057	2	H
D080	10	C	C777	8	C	CM143	9	C	Q058	2	H
D081	10	C	C778	8	C	CM144	9	C	Q059	2	H
D082	10	C	C779	8	C	CM145	9	C	Q060	2	H
D083	10	C	C780	8	C	CM146	9	C	Q061	2	H
D084	10	C	C781	8	C	CM147	9	C	Q062	2	H
D085	10	C	C782	8	C	CM148	9	C	Q063	2	H
D086	10	C	C783	8	C	CM149	9	C	Q064	2	H
D087	10	C	C784	8	C	CM150	9	C	Q065	2	H
D088	10	C	C785	8	C	CM151	9	C	Q066	2	H
D089	10	C	C786	8	C	CM152	9	C	Q067	2	H
D090	10	C	C787	8	C	CM153	9	C	Q068	2	H
D091	10	C	C788	8	C	CM154	9	C	Q069	2	H
D092	10	C	C789	8	C	CM155	9	C	Q070	3	E
D093	10	C	C790	8	C	CM156	9	C	Q071	3	E
D094	10	C	C791	8	C	CM157	9	C	Q072	3	E
D095	10	C	C792	8	C	CM158	9	C	Q073	2	D
D096	10	C	C793	8	C	CM159	9	C	Q074	2	D
D097	10	C	C794	8	C	CM160	9	C	Q075	3	E
D098	10	C	C795	8	C	CM161	9	C	Q076	3	E
D099	10	C	C796	8	C	CM162	9	C	Q077	3	E
D100	10	C	C797	8	C	CM163	9	C	Q078	3	E
D101	10	C	C798	8	C	CM164	9	C	Q079	3	E
D102	10	C	C799	8	C	CM165	9	C	Q080	3	E
D103	10	C	C800	8	C	CM166	9	C	Q081	3	E
D104	10	C	C801	8	C	CM167	9	C	Q082	3	E
D105	10	C	C802	8	C	CM168	9	C	Q083	3	E
D106	10	C	C803	8	C	CM169	9	C	Q084	2	H
D107	10	C	C804	8	C	CM170	9	C	Q085	2	H
D108	10	C	C805	8	C	CM171	9	C	Q086	2	H
D109	10	C	C806	8	C	CM172	9	C	Q087	2	H
D110	10	C	C807	8	C	CM173	9	C	Q088	2	H
D111	10	C	C808	8	C	CM174	9	C	Q089	2	H
D112	10	C	C809	8	C	CM175	9	C	Q090	2	H
D113	10	C	C810	8	C	CM176	9	C	Q091	2	H
D114	10	C	C811	8	C	CM177	9	C	Q092	2	H
D115	10	C	C812	8	C	CM178	9	C	Q093	2	H
D116	10	C	C813	8	C	CM179	9	C	Q094	2	H
D117	10	C	C814	8	C	CM180	9	C	Q095	2	H
D118	10	C	C815	8	C	CM181	9	C	Q096	2	H
D119	10	C	C816	8	C	CM182	9	C	Q097	2	H
D120	10	C	C817	8	C	CM183	9	C	Q098	2	H
D121	10	C	C818	8	C	CM184	9	C	Q099	2	H
D122	10	C	C819	8	C	CM185	9	C	Q100	2	H
D123	10	C	C820	8	C	CM186	9	C	Q101	2	H
D124	10	C	C821	8	C	CM187	9	C	Q102	2	H
D125	10	C	C822	8	C	CM188	9	C	Q103	2	H
D126	10	C	C823	8	C	CM189	9	C	Q104	2	H
D127	10	C	C824	8	C	CM190	9	C	Q105	2	H
D128	10	C	C825	8	C	CM191	9	C	Q106	2	H
D129	10	C	C826	8	C	CM192	9	C	Q107	2	H
D130	10	C	C827	8	C	CM193	9	C	Q108	2	H
D131	10	C	C828	8	C	CM194	9	C	Q109	2	H
D132	10	C	C829	8	C	CM195	9	C	Q110	2	H
D133	10	C	C830	8	C	CM196	9	C	Q111	2	H
D134	10	C	C831	8	C	CM197	9	C	Q112	2	H
D135	10	C	C832	8	C	CM198	9	C	Q113	2	H
D136	10	C	C833	8	C	CM199	9	C	Q114	2	H
D137	10	C	C834	8	C	CM200	9	C	Q115	2	H
D138	10	C	C835	8	C	CM201	9	C	Q116	2	H
D139	10	C	C836	8	C	CM202	9	C	Q117	2	H
D140	10	C	C837	8	C	CM203	9	C	Q118	2	H
D141	10	C	C838	8	C	CM204	9	C	Q119	2	H
D142	10	C	C839								

■ Input Selector and S.E.A.P.C. Board (ENC-131)

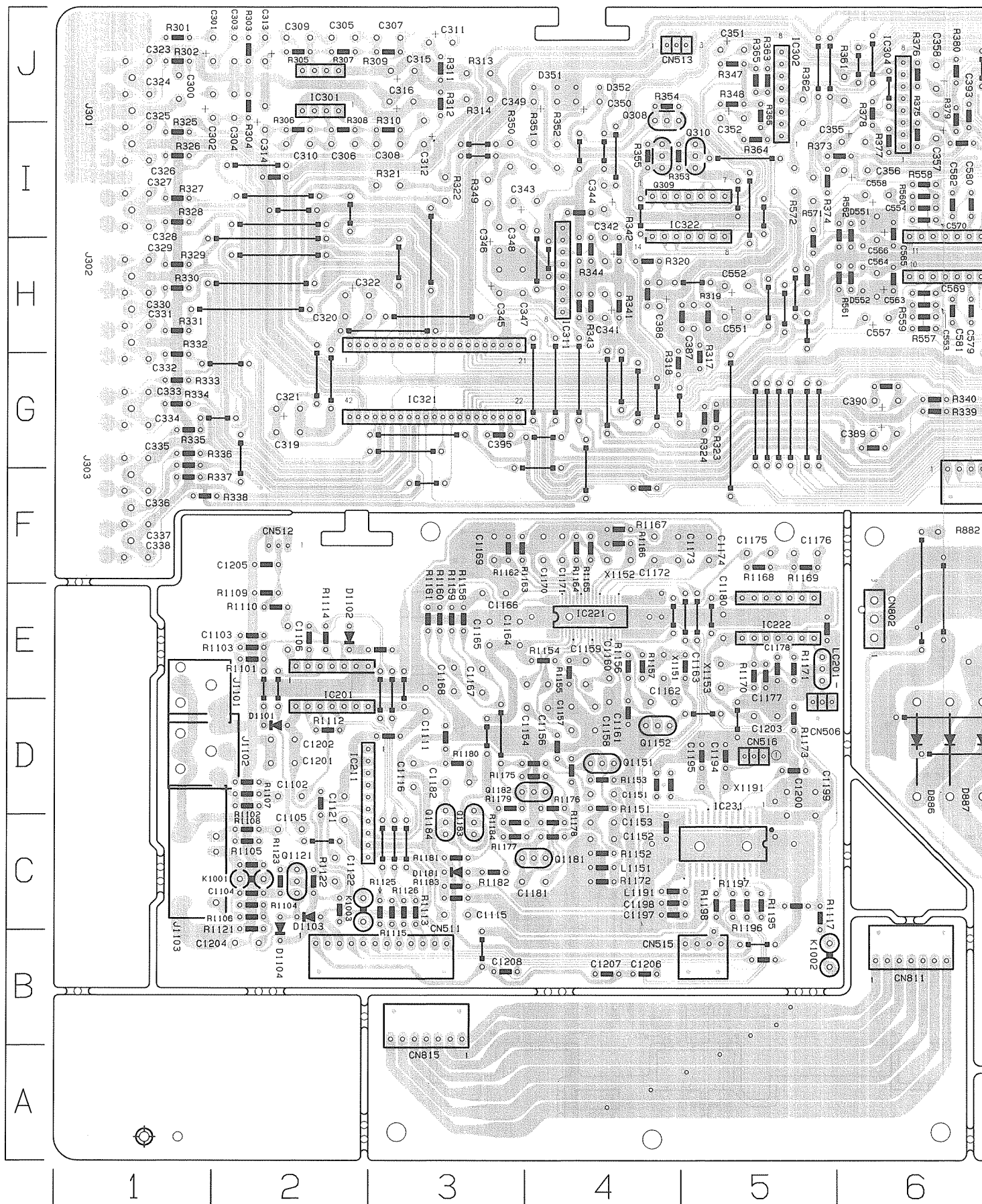



■ Tuner P.C. Board (ENA-172)

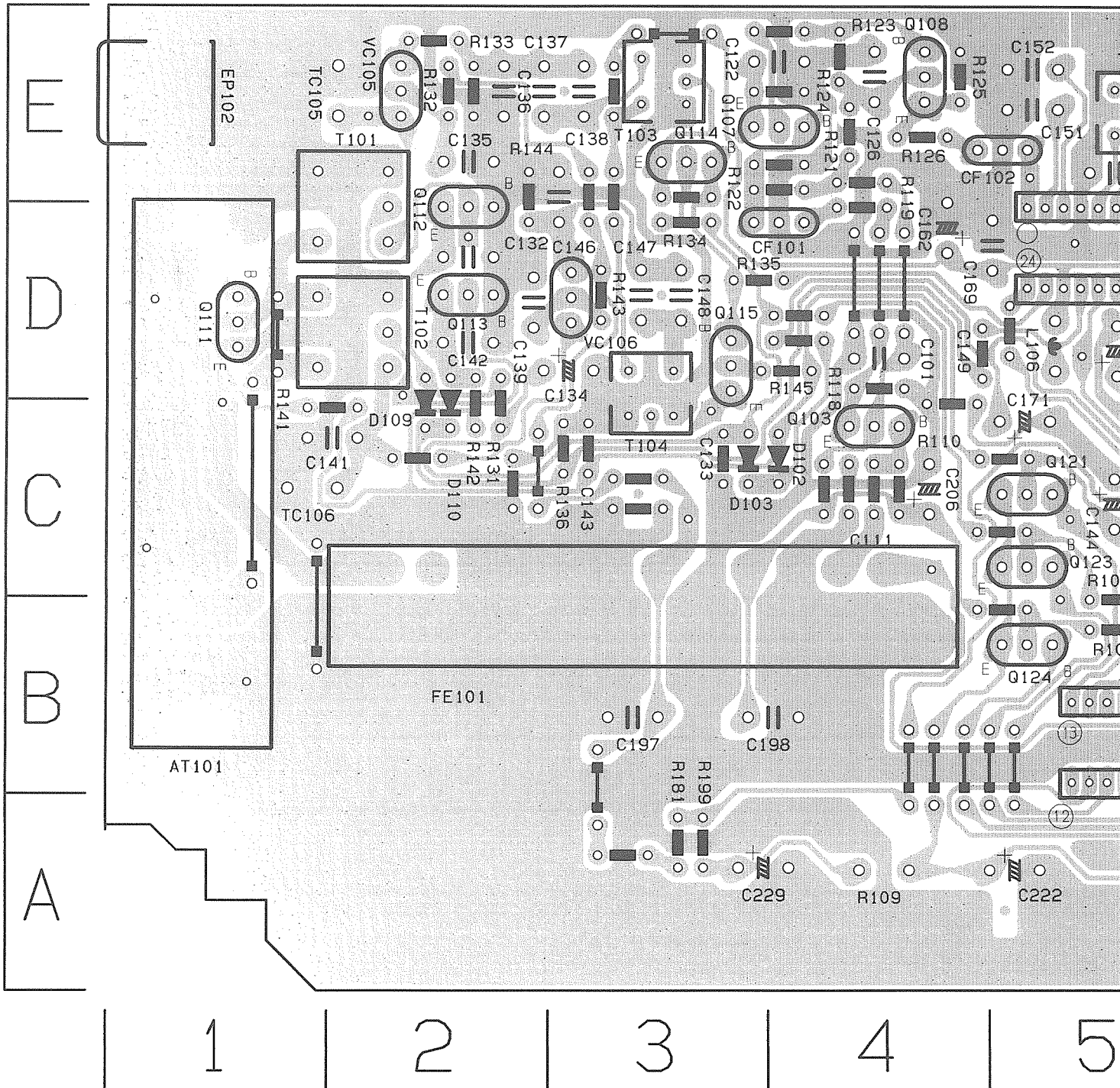



■ D.S.P P.C. Board (ENP-054)

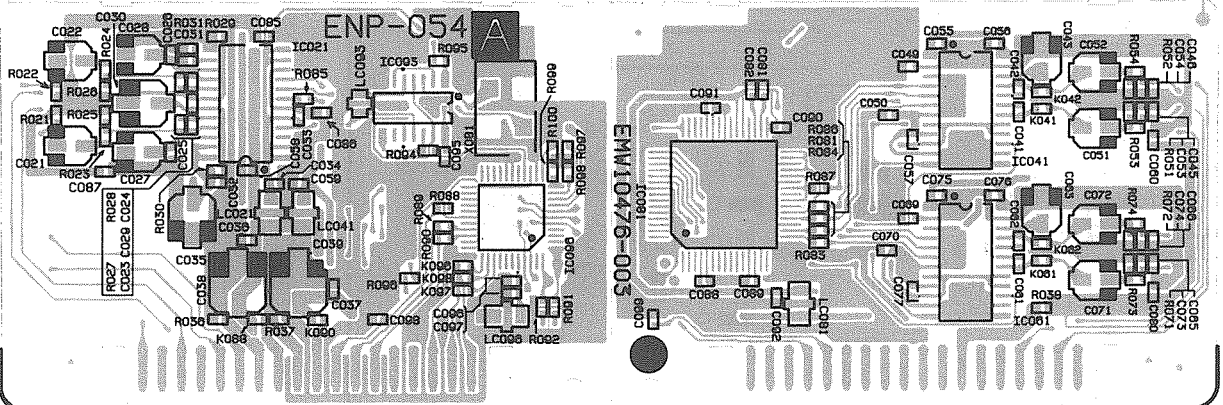



RX-818VBK  
RX-880VBK



# PARTS LIST

## RX-818VBK

**Note : All printed circuit board assemblies are not available as service parts.**

### Contents

General Exploded View and Parts List .....	3-2
Electrical and Parts List .....	3-4
■ ENC-131 Input Selector and S.E.A P.C. Board ass'y .....	3-4
■ ENB-233 System Control & Rear Power Amplifier P.C. Board ass'y .....	3-7
■ ENH-287 Power Amplifier P.C. Board ass'y .....	3-9
■ ENA-172 Tuner P.C. Board ass'y .....	3-12
■ ENP-054 D.S.P PC Board ass'y .....	3-13
Accessories List .....	3-14
Packing Materials and Part Numbers .....	3-15

# General Exploded View and Parts List

Symbol No. 

M	1	M	M
---	---	---	---

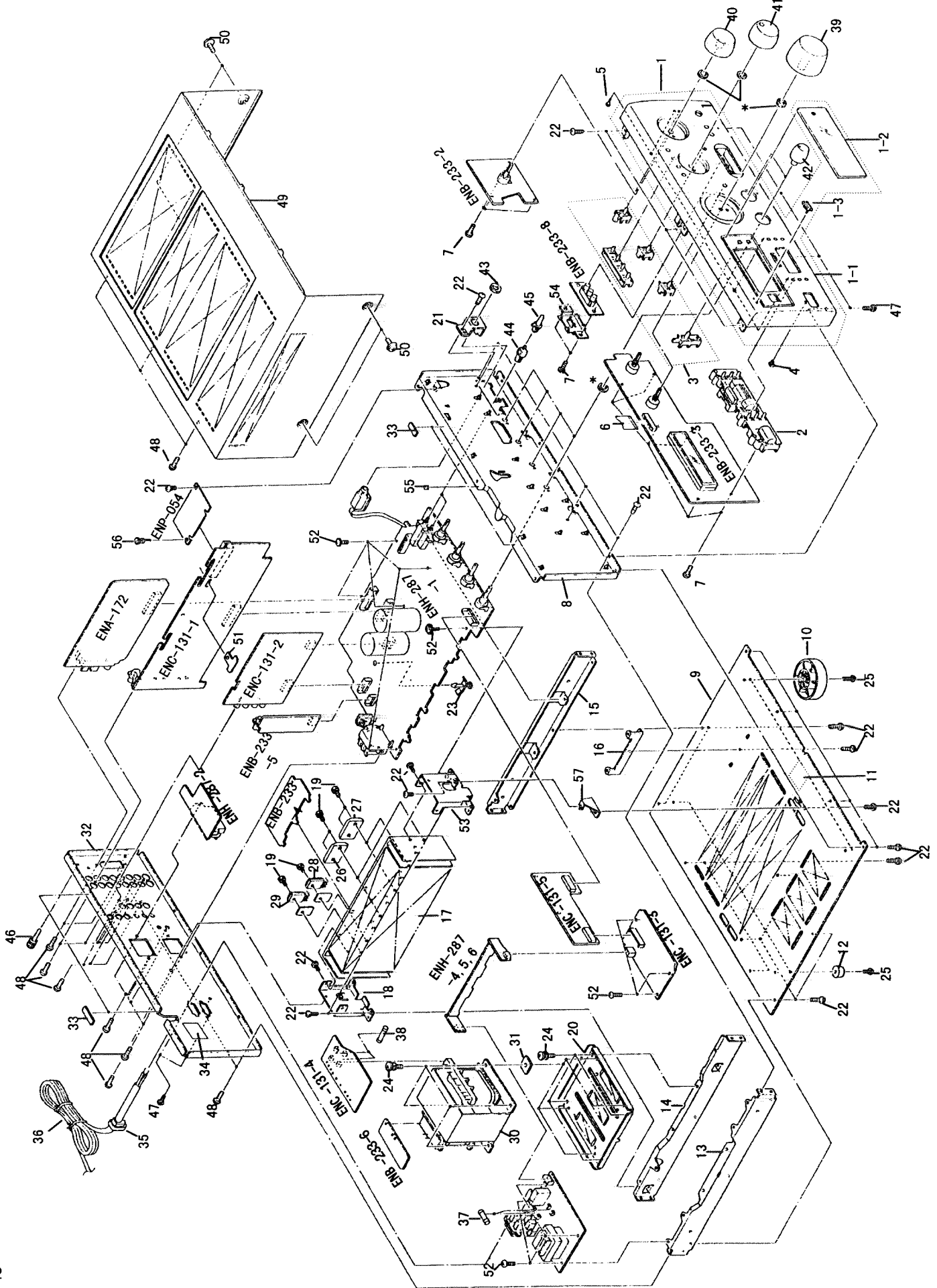

## ■ Parts List

Symbol No. 

M	1	M	M
---	---	---	---

△	Item	Parts Number	Parts Name	Q'ty	Description	Area
	1	EFP-RX818VBKJ(S)	FRONT PANEL	1		
	1-1	E102909-025SM	FRONT PANEL	1		
	1-2	E309112-018SM	WINDOW SCREEN	1		
	1-3	VJD5429-001	JVC MARK	1		
	2	E208276-005SM	PUSH BUTTON	1		
	3	E309105-004SM	PUSH BUTTON	1		
	4	FSJD4001-002	INDICATOR LENS	1		
	5	E408326-001SM	INDICATOR LENS	3		
	6	VWF1235-45PPB	FFC CABLE	1		
	7	SDSF2608Z	SCREW	11		
	8	E102911-003SM	FRONT BRACKET	1		
	9	E102820-004SM	BOTTOM PLATE	1		
	10	VJF4039-00PSM	FOOT ASSY	2	FRONT	
	11	E70115-002	CAUTION LABEL	1		C
	11	E70281-001	CAUTION LABEL	1		J
	12	E47227-036	FOOT	2	REAR	
	13	E208548-001SM	SIDE BRACKET	1	LEFT	
	14	E208549-001SM	CENTER BRACKET	1		
	15	E208081-003SM	SIDE BRACKET	1	RIGHT	
	16	E407984-001SM	C. B. HOLDER	1		
	17	E309170-004SM	HEAT SINK	1		
	18	E308836-003SM	HEAT SINK BRACKET	1	RIGHT	
	19	E73525-003	SCREW	12		
	20	E309459-003SM	TRANS BRACKET	1		
	21	E407323-002SM	HEADPHONE BRACKET	1		
	22	SBSG3008CC	TAPPING SCREW	27		
	23	E406084-002	FASTENER	1		
	24	E65389-006	SPECIAL SCREW	8		
	25	SBST3010Z	TAPPING SCREW	4		
	26	2SA1494LG (Y, P, G)	SI. TRANSISTOR	2	Q733/Q734	
	27	2SC3858LG (Y, P, G)	SI. TRANSISTOR	2	Q731/Q732	
	28	2SA1633LD (D, E)	SI. TRANSISTOR	2	Q018/Q058	
	29	2SC4278LD (D, E)	SI. TRANSISTOR	2	Q016/Q056	
△	30	ETP1200-73JAJ	POWER TRANSFORMER	1		
	31	E406309-002	SPACER	4		
	32	E103041-019SM	REAR PANEL	1		
	33	E306805-146	SPACER	4		
	34	E65507-001	CAUTION LABEL	1		C
	34	E67199-001	CAUTION LABEL	1		J
△	35	QMS3771-108	CORD STOPPER	1		
△	36	QMP1D00-200H	POWER CORD	1		
△	37	QMF0007-8R3J1	FUSE	1	F001	
△	38	QMF0007-2R0J1	FUSE	2	F851/F852	
	39	E309823-001SM	VOLUME KNOB	1		
	40	E309110-001SM	SELECT KNOB	1		
	41	E309110-003SM	SELECT KNOB	1		
	42	E309111-003SM	BALANCE KNOB	2		
	43	VKZ4150-001	NUT	1		
	44	E407983-001SM	PUSH SHAFT	2		
	45	E407321-002SM	PUSH BUTTON	2		
	46	E409257-001	GND. TERMINAL	1		
	47	SDSG3008M	TAPPING SCREW	6		
	48	E73273-003	SPECIAL SCREW	22		
	49	E207378-024	METAL COVER	1		
	50	E61660-004	SPECIAL SCREW	4		
	51	E409374-001SM	SPACER	1		
	52	GBSG3008CC	TAPPING SCREW	13		
	53	E308836-004SM	HEAT SINK BRACKET	1	LEFT	
	54	E408713-001SM	C. B. HOLDER	1		
	55	E306805-028	SPACER	1		
	56	E48729-007	PLASTIC RIVET	1		
	57	E68587-010	BRACKET	1		
	-	E408632-002	RATING LABEL	1		C

Electrical Parts List(ENC131)

Δ	Item	Parts Number	Description	Area
		I. C. S		
	IC201	NJM2279D	I. C (MONO-ANALOG)	
	IC211	BA7604N	I. C (MONO-ANALOG)	
	IC231	MB90089-165	I. C (M)	
	IC301	VC4580DD	I. C (MONO-ANALOG)	
	IC302	BA15218N	I. C (MONO-ANALOG)	
	IC303	TC9299P	I. C (DIGI-MOS)	
	IC304	BA15218N	I. C (MONO-ANALOG)	
	IC305	TC9212P	I. C (DIGI-MOS)	
	IC306	VC4580LD	I. C (MONO-ANALOG)	
	IC307	TC9212P	I. C (DIGI-MOS)	
	IC308	VC4580LD	I. C (MONO-ANALOG)	
	IC311	BA15218N	I. C (MONO-ANALOG)	
	IC321	TC9274N-007	I. C (M)	
	IC322	UPD4066BC	I. C (DIGI-MOS)	
	IC551	LC7522	I. C (DIGI-MOS)	
	IC552	M5243P12	I. C (MONO-ANALOG)	
		DIODES		
	D251	MTZ6.2JC	ZENER DIODE	
	D252	1SR139-200	SI. DIODE	
	D253	1SR139-200	SI. DIODE	
	D254	MTZ39JCT-77	ZENER DIODE	
	D255	1SR139-200	SI. DIODE	
	D261	1SR139-200	SI. DIODE	
	D262	1SR139-200	SI. DIODE	
Δ	D263	10E2-FD	DIODE	
Δ	D264	10E2-FD	DIODE	
	D265	1SS133	SI. DIODE	
	D351	MTZ8.2JC	ZENER DIODE	
	D352	MTZ8.2JC	ZENER DIODE	
	D551	MTZ6.8JC	ZENER DIODE	
	D552	MTZ6.8JC	ZENER DIODE	
Δ	D880	30D2FC	GE. DIODE	
Δ	D881	30D2FC	GE. DIODE	
Δ	D882	30D2FC	GE. DIODE	
Δ	D883	30D2FC	GE. DIODE	
Δ	D884	30D2FC	GE. DIODE	
Δ	D885	30D2FC	GE. DIODE	
Δ	D886	30D2FC	GE. DIODE	
Δ	D887	30D2FC	GE. DIODE	
Δ	D888	1SS133	SI. DIODE	
	D1101	1SS133	SI. DIODE	
	D1102	1SS133	SI. DIODE	
	D1103	1SS133	SI. DIODE	
	D1104	1SS133	SI. DIODE	
		TRANSISTORS		
	Q251	2SB1357 (E, F)	SI. TRANSISTOR	
	Q252	2SC2240 (GR, BL)	SI. TRANSISTOR	
	Q253	DTC114YS	DIGITAL TRANSISTOR	
	Q254	DTA144ES	DIGITAL TRANSISTOR	
	Q255	DTC114ES	DIGITAL TRANSISTOR	
	Q306	2SD2144S (VM)	SI. TRANSISTOR	
	Q307	2SD2144S (VM)	SI. TRANSISTOR	
	Q308	DTC144ES	DIGITAL TRANSISTOR	
	Q309	DTA144ES	DIGITAL TRANSISTOR	
	Q310	DTC144ES	DIGITAL TRANSISTOR	
	Q1121	2SC1740LM (R, S)	SI. TRANSISTOR	
		CAPACITORS		
	C251	QETB1HM-227	220MF 50V E. CAP.	
	C252	QETB1JM-227	220MF 63V AL. E. CAP.	
	C253	QETB1HM-105	1MF 50V AL. E. CAP.	
	C254	QETB1HM-226E	22MF 50V E. CAP.	
	C255	QETB1HM-226E	22MF 50V E. CAP.	
	C256	QFLB1HJ-104	0.1MF 50V MYLAR CAP.	
	C259	QFLB1HJ-473	0.047MF 50V MYLAR CAP.	
	C260	QFLB1HJ-473	0.047MF 50V MYLAR CAP.	
	C262	QETB1VM-228N	2200MF 35V E. CAP.	
	C264	QFN82AJ-104	0.1MF 100V MYLAR CAP.	
	C265	QFN82AJ-104	0.1MF 100V MYLAR CAP.	
	C266	QETB1HM-225	2.2MF 50V AL. E. CAP.	
	C267	QFN82AJ-104	0.1MF 100V MYLAR CAP.	
	C268	QETB1VM-228N	2200MF 35V E. CAP.	
	C300	QCF21HP-223A	0.022MF 50V CER. CAP.	
	C301	QETB1HM-475E	4.7MF 50V E. CAP.	
	C302	QETB1HM-475E	4.7MF 50V E. CAP.	
	C303	QCS21HJ-101A	100PF 50V CER. CAP.	

Δ	Item	Parts Number	Description	Area
	C304	QCS21HJ-101A	100PF 50V CER. CAP.	
	C305	QFLB1HJ-182	1800PF 50V MYLAR CAP.	
	C306	QFLB1HJ-182	1800PF 50V MYLAR CAP.	
	C307	QFLB1HJ-682	6800PF 50V MYLAR CAP.	
	C308	QFLB1HJ-682	6800PF 50V MYLAR CAP.	
	C309	QCS21HJ-101A	100PF 50V CER. CAP.	
	C310	QCS21HJ-101A	100PF 50V CER. CAP.	
	C311	QETB1HM-475E	4.7MF 50V E. CAP.	
	C312	QETB1HM-475E	4.7MF 50V E. CAP.	
	C313	QETB1AM-107	100MF 10V AL. E. CAP.	
	C314	QETB1AM-107	100MF 10V AL. E. CAP.	
	C315	QETB1CM-476	47MF 16V AL. E. CAP.	
	C316	QETB1CM-476	47MF 16V AL. E. CAP.	
	C319	QCF21HP-223A	0.022MF 50V CER. CAP.	
	C320	QCF21HP-223A	0.022MF 50V CER. CAP.	
	C321	QETB1EM-226N	22MF 25V E. CAP.	
	C322	QETB1EM-226N	22MF 25V E. CAP.	
	C333	QCS31HJ-331Z	330PF 50V CER. CAP.	
	C334	QCS31HJ-331Z	330PF 50V CER. CAP.	
	C341	QETB1HM-475E	4.7MF 50V E. CAP.	
	C342	QETB1HM-475E	4.7MF 50V E. CAP.	
	C343	QETB1EM-226N	22MF 25V E. CAP.	
	C344	QETB1EM-226N	22MF 25V E. CAP.	
	C345	QETB1EM-226N	22MF 25V E. CAP.	
	C346	QETB1EM-226N	22MF 25V E. CAP.	
	C347	QCF21HP-223A	0.022MF 50V CER. CAP.	
	C348	QCF21HP-223A	0.022MF 50V CER. CAP.	
	C349	QETB1EM-106	10MF 25V AL. E. CAP.	
	C350	QETB1EM-106	10MF 25V AL. E. CAP.	
	C351	QETB1HM-105	1MF 50V AL. E. CAP.	
	C352	QETB1HM-105	1MF 50V AL. E. CAP.	
	C353	QETB1HM-475E	4.7MF 50V E. CAP.	
	C354	QETB1HM-475E	4.7MF 50V E. CAP.	
	C355	QETB1HM-105	1MF 50V AL. E. CAP.	
	C356	QETB1HM-105	1MF 50V AL. E. CAP.	
	C357	QETB1EM-106	10MF 25V AL. E. CAP.	
	C358	QETB1EM-106	10MF 25V AL. E. CAP.	
	C359	QCF21HP-223A	0.022MF 50V CER. CAP.	
	C360	QCF21HP-223A	0.022MF 50V CER. CAP.	
	C361	QETB1EM-476	47MF 25V AL. E. CAP.	
	C362	QETB1EM-476	47MF 25V AL. E. CAP.	
	C363	QCHB1EZ-223	0.022MF 25V CER. CAP.	
	C364	QCHB1EZ-223	0.022MF 25V CER. CAP.	
	C365	QCBB1HK-561Y	560PF 50V CER. CAP.	
	C366	QCBB1HK-561Y	560PF 50V CER. CAP.	
	C367	QFV81HJ-154	0.15MF 50V THIN FILM CAP.	
	C368	QFV81HJ-154	0.15MF 50V THIN FILM CAP.	
	C369	QETB1HM-225	2.2MF 50V AL. E. CAP.	
	C370	QETB1HM-225	2.2MF 50V AL. E. CAP.	
	C371	QETB1HM-106	10MF 50V E. CAP.	
	C372	QETB1HM-106	10MF 50V E. CAP.	
	C373	QETB1HM-106	10MF 50V E. CAP.	
	C374	QETB1HM-106	10MF 50V E. CAP.	
	C375	QETB1EM-476	47MF 25V AL. E. CAP.	
	C376	QETB1EM-476	47MF 25V AL. E. CAP.	
	C377	QCHB1EZ-223	0.022MF 25V CER. CAP.	
	C378	QCHB1EZ-223	0.022MF 25V CER. CAP.	
	C379	QETB1HM-225	2.2MF 50V AL. E. CAP.	
	C380	QETB1HM-225	2.2MF 50V AL. E. CAP.	
	C381	QETB1HM-475E	4.7MF 50V E. CAP.	
	C382	QETB1HM-475E	4.7MF 50V E. CAP.	
	C383	QETB1HM-475E	4.7MF 50V E. CAP.	
	C384	QETB1HM-475E	4.7MF 50V E. CAP.	
	C395	QCBB1HK-561Y	560PF 50V CER. CAP.	
	C396	QCBB1HK-121Y	120PF 50V CER. CAP.	
	C397	QCBB1HK-121Y	120PF 50V CER. CAP.	
	C398	QCBB1HK-121Y	120PF 50V CER. CAP.	
	C399	QCBB1HK-121Y	120PF 50V CER. CAP.	
	C551	QETB1HM-475E	4.7MF 50V E. CAP.	
	C552	QETB1HM-475E	4.7MF 50V E. CAP.	
	C553	QCBB1HK-101Y	100PF 50V CER. CAP.	
	C554	QCBB1HK-101Y	100PF 50V CER. CAP.	
	C555	QETB1HM-475E	4.7MF 50V E. CAP.	
	C556	QETB1HM-475E	4.7MF 50V E. CAP.	
	C557	QETB1HM-475E	4.7MF 50V E. CAP.	
	C558	QETB1HM-475E	4.7MF 50V E. CAP.	

Electrical Parts List(ENC131)

△	Item	Parts Number	Description	Area	△	Item	Parts Number	Description	Area
	C559	QETB1HM-475E	4.7MF 50V E. CAP.			R325	QRD161J-471	470 1/6W CARBON RES.	
	C560	QETB1HM-475E	4.7MF 50V E. CAP.			R326	QRD161J-471	470 1/6W CARBON RES.	
	C563	QCHB1EZ-223	0.022MF 25V CER. CAP.			R327	QRD161J-471	470 1/6W CARBON RES.	
	C564	QETB1CM-226	22MF 16V E. CAP.			R328	QRD161J-471	470 1/6W CARBON RES.	
	C565	QCHB1EZ-223	0.022MF 25V CER. CAP.			R329	QRD161J-471	470 1/6W CARBON RES.	
	C566	QETB1CM-226	22MF 16V E. CAP.			R330	QRD161J-471	470 1/6W CARBON RES.	
	C567	QCHB1EZ-223	0.022MF 25V CER. CAP.			R331	QRD161J-471	470 1/6W CARBON RES.	
	C569	QCSB1HJ-470	47PF 50V CER. CAP.			R332	QRD161J-471	470 1/6W CARBON RES.	
	C570	QCSB1HJ-470	47PF 50V CER. CAP.			R333	QRD161J-471	470 1/6W CARBON RES.	
	C571	QFV81HJ-333	0.033MF 50V THIN FILM CAP.			R334	QRD161J-471	470 1/6W CARBON RES.	
	C572	QFV81HJ-333	0.033MF 50V THIN FILM CAP.			R335	QRD161J-471	470 1/6W CARBON RES.	
	C573	QETB1HM-105	1MF 50V AL E. CAP.			R336	QRD161J-471	470 1/6W CARBON RES.	
	C574	QETB1HM-105	1MF 50V AL E. CAP.			R337	QRD161J-471	470 1/6W CARBON RES.	
	C575	QFLB1HJ-332	3300PF 50V MYLAR CAP.			R338	QRD161J-471	470 1/6W CARBON RES.	
	C576	QFLB1HJ-332	3300PF 50V MYLAR CAP.			R341	QRD161J-104	100K 1/6W CARBON RES.	
	C577	QFV81HJ-104	0.1MF 50V THIN FILM CAP.			R342	QRD161J-104	100K 1/6W CARBON RES.	
	C578	QFV81HJ-104	0.1MF 50V THIN FILM CAP.			R343	QRD161J-104	100K 1/6W CARBON RES.	
	C579	QCBB1HK-331Y	330PF 50V CER. CAP.			R344	QRD161J-104	100K 1/6W CARBON RES.	
	C580	QCBB1HK-331Y	330PF 50V CER. CAP.			R347	QRD161J-104	100K 1/6W CARBON RES.	
	C581	QCVB1CM-103Y	0.01MF 16V CER. CAP.			R348	QRD161J-104	100K 1/6W CARBON RES.	
	C582	QCVB1CM-103Y	0.01MF 16V CER. CAP.		△	R349	QRZ0077-680	68 1/4W FUSIBLE RES.	
	C881	QCE22HP-103A	0.01MF 500V CER. CAP.		△	R350	QRZ0077-680	68 1/4W FUSIBLE RES.	
	C882	QCE22HP-103A	0.01MF 500V CER. CAP.			R351	QRD14CJ-152SX	1.5K 1/4W UNF. CARBON R	
	C883	QCE22HP-103A	0.01MF 500V CER. CAP.			R352	QRD14CJ-152SX	1.5K 1/4W UNF. CARBON R	
	C884	QCE22HP-103A	0.01MF 500V CER. CAP.			R353	QRD161J-563	56K 1/6W CARBON RES.	
	C885	QCE22HP-103A	0.01MF 500V CER. CAP.			R354	QRD161J-563	56K 1/6W CARBON RES.	
	C886	QCE22HP-103A	0.01MF 500V CER. CAP.			R355	QRD161J-563	56K 1/6W CARBON RES.	
	C1102	QETB1HM-475E	4.7MF 50V E. CAP.			R356	QRD161J-474	470K 1/6W CARBON RES.	
	C1103	QCSB1HJ-470	47PF 50V CER. CAP.			R357	QRD167J-152	1.5K 1/6W CARBON RES.	
	C1104	QCSB1HJ-470	47PF 50V CER. CAP.			R358	QRD167J-152	1.5K 1/6W CARBON RES.	
	C1105	QETB1HM-475E	4.7MF 50V E. CAP.			R359	QRD167J-152	1.5K 1/6W CARBON RES.	
	C1106	QETB1HM-475E	4.7MF 50V E. CAP.			R360	QRD167J-152	1.5K 1/6W CARBON RES.	
	C1111	QCZO205-155	1.5MF 25V C. CAP.		△	R361	QRZ0077-680	68 1/4W FUSIBLE RES.	
	C1115	QETB1HM-475E	4.7MF 50V E. CAP.		△	R362	QRZ0077-680	68 1/4W FUSIBLE RES.	
	C1116	QETB1CM-476	47MF 16V AL E. CAP.			R363	QRD161J-123	12K 1/6W CARBON RES.	
	C1121	QCZO205-155	1.5MF 25V C. CAP.			R364	QRD161J-123	12K 1/6W CARBON RES.	
	C1122	QETB1CM-476	47MF 16V AL E. CAP.			R365	QRD161J-103	10K 1/6W CARBON RES.	
	C1194	QCT30CH-150Y	15PF 50V CER. CAP.			R366	QRD161J-103	10K 1/6W CARBON RES.	
	C1195	QCT30CH-100Y	10PF 50V CER. CAP.			R369	QRD161J-104	100K 1/6W CARBON RES.	
	C1197	QCSB1HJ-470	47PF 50V CER. CAP.			R370	QRD161J-104	100K 1/6W CARBON RES.	
	C1198	QCSB1HJ-270Y	27PF 50V CER. CAP.			R371	QRD161J-104	100K 1/6W CARBON RES.	
	C1199	QETB1AM-477	470MF 10V E. CAP.			R372	QRD161J-104	100K 1/6W CARBON RES.	
	C1200	QCZO205-155	1.5MF 25V C. CAP.			R373	QRD161J-105	1M 1/6W CARBON RES.	
	C1201	QETB1CM-476	47MF 16V AL E. CAP.			R374	QRD161J-105	1M 1/6W CARBON RES.	
	C1202	QCF21HP-103A	0.01MF 50V CER. CAP.			R375	QRD161J-683	68K 1/6W CARBON RES.	
	C1204	QETB0JM-477	470MF 6.3V AL E. CAP.			R376	QRD161J-683	68K 1/6W CARBON RES.	
	C1206	QCBB1HK-102Y	1000PF 50V CER. CAP.			R377	QRD161J-103	10K 1/6W CARBON RES.	
	C1207	QCBB1HK-271Y	270PF 50V CER. CAP.			R378	QRD161J-103	10K 1/6W CARBON RES.	
	C1208	QCBB1HK-121Y	120PF 50V CER. CAP.			R379	QRD161J-104	100K 1/6W CARBON RES.	
		RESISTORS				R380	QRD161J-104	100K 1/6W CARBON RES.	
△	R251	PTH61Q25AR4R7M	POSITIVE THE			R381	QRD167J-152	1.5K 1/6W CARBON RES.	
	R252	QRD167J-152	1.5K 1/6W CARBON RES.			R382	QRD167J-152	1.5K 1/6W CARBON RES.	
	R253	QRD167J-223	22K 1/6W CARBON RES.		△	R383	QRZ0077-680	68 1/4W FUSIBLE RES.	
	R254	QRD161J-104	100K 1/6W CARBON RES.		△	R384	QRZ0077-680	68 1/4W FUSIBLE RES.	
△	R255	QRD14CJ-100SX	10 1/4W UNF. CARBON R			R385	QRD161J-393	39K 1/6W CARBON RES.	
△	R262	QRX022J-2R2A	2.2 2W METAL FILM R			R386	QRD161J-393	39K 1/6W CARBON RES.	
	R263	QRD167J-562	5.6K 1/6W CARBON RES.			R387	QRD161J-224	220K 1/6W CARBON RES.	
	R264	QRD167J-822	8.2K 1/6W CARBON RES.			R388	QRD161J-224	220K 1/6W CARBON RES.	
	R265	QRD161J-103	10K 1/6W CARBON RES.			R389	QRD161J-124	120K 1/6W CARBON RES.	
△	R266	QRD14CJ-2R2SX	2.2 1/4W UNF. CARBON R			R390	QRD161J-124	120K 1/6W CARBON RES.	
	R301	QRD161J-222	2.2K 1/6W CARBON RES.			R393	QRD161J-124	120K 1/6W CARBON RES.	
	R302	QRD161J-222	2.2K 1/6W CARBON RES.			R394	QRD161J-124	120K 1/6W CARBON RES.	
	R303	QRD161J-473	47K 1/6W CARBON RES.			R395	QRD161J-124	120K 1/6W CARBON RES.	
	R304	QRD161J-473	47K 1/6W CARBON RES.			R396	QRD161J-124	120K 1/6W CARBON RES.	
	R305	QRD161J-561	560 1/6W CARBON RES.		△	R397	QRZ0077-680	68 1/4W FUSIBLE RES.	
	R306	QRD161J-561	560 1/6W CARBON RES.		△	R398	QRZ0077-680	68 1/4W FUSIBLE RES.	
	R307	QRD161J-393	39K 1/6W CARBON RES.			R551	QRD167J-562	5.6K 1/6W CARBON RES.	
	R308	QRD161J-393	39K 1/6W CARBON RES.			R552	QRD167J-562	5.6K 1/6W CARBON RES.	
	R309	QRD161J-474	470K 1/6W CARBON RES.			R553	QRD167J-511	510 1/6W CARBON RES.	
	R310	QRD161J-474	470K 1/6W CARBON RES.			R554	QRD167J-511	510 1/6W CARBON RES.	
	R311	QRD161J-104	100K 1/6W CARBON RES.			R555	QRD161J-102	1K 1/6W CARBON RES.	
	R312	QRD161J-104	100K 1/6W CARBON RES.			R556	QRD161J-102	1K 1/6W CARBON RES.	
△	R313	QRD14CJ-391SX	390 1/4W UNF. CARBON R			R557	QRD161J-103	10K 1/6W CARBON RES.	
△	R314	QRD14CJ-391SX	390 1/4W UNF. CARBON R			R558	QRD161J-103	10K 1/6W CARBON RES.	
△	R321	QRZ0077-680	68 1/4W FUSIBLE RES.			R559	QRD167J-113	11K 1/6W CARBON RES.	
△	R322	QRZ0077-680	68 1/4W FUSIBLE RES.			R560	QRD167J-113	11K 1/6W CARBON RES.	

RX-818VBK

Electrical Parts List(ENC131)

Δ	Item	Parts Number	Description	Area
	R561	QRD161J-104	100K 1/6W CARBON RES.	
	R562	QRD161J-104	100K 1/6W CARBON RES.	
	R563	QRD161J-333	33K 1/6W CARBON RES.	
	R564	QRD161J-333	33K 1/6W CARBON RES.	
	R565	QRD161J-124	120K 1/6W CARBON RES.	
	R566	QRD161J-124	120K 1/6W CARBON RES.	
Δ	R571	QRD14CJ-681SX	680 1/4W UNF. CARBON R	
Δ	R572	QRD14CJ-681SX	680 1/4W UNF. CARBON R	
	R573	QRD161J-681	680 1/6W CARBON RES.	
	R574	QRD167J-272	2. 7K 1/6W CARBON RES.	
	R575	QRD161J-474	470K 1/6W CARBON RES.	
	R576	QRD161J-474	470K 1/6W CARBON RES.	
	R577	QRD161J-474	470K 1/6W CARBON RES.	
	R578	QRD161J-474	470K 1/6W CARBON RES.	
	R579	QRD161J-474	470K 1/6W CARBON RES.	
	R580	QRD161J-474	470K 1/6W CARBON RES.	
	R585	QRD161J-102	1K 1/6W CARBON RES.	
	R586	QRD161J-102	1K 1/6W CARBON RES.	
	R587	QRD161J-103	10K 1/6W CARBON RES.	
	R588	QRD161J-103	10K 1/6W CARBON RES.	
	R591	QRD161J-432	4. 3K 1/6W CARBON RES.	
	R592	QRD161J-432	4. 3K 1/6W CARBON RES.	
	R593	QRD161J-103	10K 1/6W CARBON RES.	
	R594	QRD161J-103	10K 1/6W CARBON RES.	
Δ	R881	QRX012J-1R2A	1. 2 1W METAL FILM R	
Δ	R882	QRX012J-1R2A	1. 2 1W METAL FILM R	
	R1101	QRD161J-750	75 1/6W CARBON RES.	
	R1102	QRD161J-750	75 1/6W CARBON RES.	
	R1105	QRD161J-750	75 1/6W CARBON RES.	
	R1106	QRD167J-680	68 1/6W CARBON RES.	
	R1107	QRD161J-331	330 1/6W CARBON RES.	
	R1108	QRD161J-331	330 1/6W CARBON RES.	
	R1109	QRD161J-750	75 1/6W CARBON RES.	
	R1110	QRD161J-331	330 1/6W CARBON RES.	
	R1113	QRD161J-472	4. 7K 1/6W CARBON RES.	
	R1115	QRD161J-472	4. 7K 1/6W CARBON RES.	
	R1117	QRD161J-103	10K 1/6W CARBON RES.	
	R1121	QRD161J-101	100 1/6W CARBON RES.	
	R1122	QRD161J-392	3. 9K 1/6W CARBON RES.	
	R1123	QRD161J-103	10K 1/6W CARBON RES.	
	R1125	QRD161J-472	4. 7K 1/6W CARBON RES.	
	R1126	QRD161J-472	4. 7K 1/6W CARBON RES.	
	R1175	QRD161J-750	75 1/6W CARBON RES.	
	R1176	QRD161J-750	75 1/6W CARBON RES.	
	R1195	QRD161J-561	560 1/6W CARBON RES.	
	R1196	QRD161J-561	560 1/6W CARBON RES.	
	R1197	QRD161J-561	560 1/6W CARBON RES.	
	R1198	QRD161J-103	10K 1/6W CARBON RES.	
		OTHERS		
		EMW10621-002	CIR. BOARD	
	J301	EMN00TV-422AJ2	PIN JACK	
	J302	EMN00TV-622AJ2	PIN JACK	
	J303	EMN00TV-622AJ2	PIN JACK	
	BK880	E310098-001SM	HOLDER	C
	BK884	E310098-001SM	HOLDER	C
	CN312	EMV5109-004A	MALE CONNECTOR	
	CN413	EMV5109-009A	PIN PLUG	
	CN511	EMV5163-012R	CONNECT TERMINAL	
	CN512	EMV5142-903	CONNECT TERMINAL	
	CN513	VMC0075-003	CONNECTOR	
	CN515	EMV5163-004R	CONNECT TERMINAL	
	CN603	EMV7164-036	CONNECT TERMINAL	
	CN611	EMV5163-015R	CONNECT TERMINAL	
	CN612	EMV5163-009R	CONNECT TERMINAL	
	CN802	EWS273-005	SOCKET WIRE ASSY	
	CN803	VMC0177-003	CONNECT TERMINAL	
	CN805	EMV7163-007	CONNECT TERMINAL	
	CN811	EMV5163-007R	CONNECT TERMINAL	
	CN815	EMV5163-007R	CONNECT TERMINAL	
	EP250	EMZ4002-002Z	EARTH PLATE	
	FC881	EMG7331-003Z	FUSE CLIP	
	FC882	EMG7331-003Z	FUSE CLIP	
	FC883	EMG7331-003Z	FUSE CLIP	
	FC884	EMG7331-003Z	FUSE CLIP	
	FW211	EWR37D-13SS	CORD	
	J1101	EMN00TV-116A	PIN JACK	

Δ	Item	Parts Number	Description	Area
	J1102	EMN01TV-102A	PIN JACK	
	J1103	EMN00YV-217A	PIN JACK	
	K1001	ENZ8101-007	INDUCTOR	
	K1002	ENZ8101-007	INDUCTOR	
	K1003	ENZ8101-007	INDUCTOR	
	L1191	EQL4004-220	INDUCTOR	
	RY880	ESK1D12-119J3	RELAY	
	RY881	ESK1D12-119J3	RELAY	
	X1191	ECX0143-1818EW	CRYSTAL	



Electrical Parts Lista(ENB-233)

Δ	Item	Parts Number	Description	Area	Δ	Item	Parts Number	Description	Area
		I. C. S							
	IC400	MN172412K8X	I. C(MICRO-COMPUTER)			C082	QETB1HM-476	47MF 50V E. CAP.	
	IC401	MN171601AK8W	I. C(MICRO-COMPUTER)			C291	QCS31HJ-471Z	470PF 50V CER. CAP.	
	IC402	PST600E-T	I. C(MONO-ANALOG)			C294	QCS31HJ-681Z	680PF 50V CER. CAP.	
	IC403	SPS-420-1	INFRARED DETECT UNIT			C401	QCZ0202-155	1.5MF 25V CER. RES.	
		DIODES				C402	QEK61AM-227ZM	220MF 10V AL. E. CAP.	
	D050	1SS133	SI. DIODE			C403	QEAD0HZ-10AZM	AL. E. CAP.	
	D051	MTZ18JC	ZENER DIODE			C404	QETB1HM-106	10MF 50V E. CAP.	
	D052	1SS133	SI. DIODE			C405	QETB1HM-475E	4.7MF 50V E. CAP.	
	D053	1SS133	SI. DIODE			C406	QETB1HM-475E	4.7MF 50V E. CAP.	
	D061	1SS133	SI. DIODE			C407	QETB0JM-107	100MF 6.3V AL. E. CAP.	
	D062	1SS133	SI. DIODE			C409	QETB1AM-227	220MF 10V E. CAP.	
	D081	MTZ20JC	ZENER DIODE			C410	QCZ0202-155	1.5MF 25V CER. RES.	
	D082	MTZ20JC	ZENER DIODE			C412	QEK51HM-225G	2.2MF 50V AL. E. CAP.	
	D292	1SS133	SI. DIODE			C413	QCHB1EZ-223	0.022MF 25V CER. CAP.	
	D400	1SR139-200	SI. DIODE			C414	QCB81HK-331Y	330PF 50V CER. CAP.	
	D401	1SR139-200	SI. DIODE			C415	QCZ0202-155	1.5MF 25V CER. RES.	
	D402	1SR139-200	SI. DIODE			C418	QCHB1EZ-223	0.022MF 25V CER. CAP.	
	D403	SLR-34MC70F124	L. E. D.			C419	QCHB1EZ-223	0.022MF 25V CER. CAP.	
	D404	SLR-34MC70F124	L. E. D.			C591	QCB81HK-331Y	330PF 50V CER. CAP.	
	D405	SLR-54VC50F124	L. E. D.			C592	QCB81HK-331Y	330PF 50V CER. CAP.	
	D406	1SS133	SI. DIODE			C593	QCB81HK-331Y	330PF 50V CER. CAP.	
	D407	1SS133	SI. DIODE			C850	QETB1CM-476	47MF 16V AL. E. CAP.	
	D408	1SS133	SI. DIODE			C851	QFN82AK-472	4700PF 100V METAL. MYLAR	
	D409	1SS133	SI. DIODE			C852	QETB1EM-227	220MF 25V AL. E. CAP.	
	D410	1SS133	SI. DIODE				RESISTORS		
	D411	1SS133	SI. DIODE		Δ	R001	QR0128K-275EM	2.7M 1/2W COMPOSITION	
	D412	1SS133	SI. DIODE			R051	QRD161J-222	2.2K 1/6W CARBON RES.	
	D413	1SS133	SI. DIODE			R052	QRD161J-104	100K 1/6W CARBON RES.	
	D414	1SS133	SI. DIODE			R053	QRD161J-123	12K 1/6W CARBON RES.	
	D415	1SS133	SI. DIODE			R054	QRD161J-182	1.8K 1/6W CARBON RES.	
	D416	1SS133	SI. DIODE			R055	QRD161J-104	100K 1/6W CARBON RES.	
	D490	SLR-34VC3F	L. E. D.		Δ	R056	QRD14CJ-181S	180 1/4W UNF. CARBON R	
	D857	MTZ6.2JC	ZENER DIODE		Δ	R057	QRD14CJ-222SX	2.2K 1/4W UNF. CARBON R	
	D858	1SS133	SI. DIODE			R058	QRD161J-202	2K 1/6W CARBON RES.	
	D871	1SR139-200	SI. DIODE			R059	QRD161J-222	2.2K 1/6W CARBON RES.	
	D872	1SR139-200	SI. DIODE			R060	QRD161J-202	2K 1/6W CARBON RES.	
	D873	1SR139-200	SI. DIODE		Δ	R063	QRD14CJ-120SX	12 1/4W UNF. CARBON R	
	D874	1SR139-200	SI. DIODE		Δ	R064	QRD14CJ-100SX	10 1/4W UNF. CARBON R	
		TRANSISTORS			Δ	R065	QRD14CJ-561SX	560 1/4W UNF. CARBON R	
	Q051	2SC2240(GR, BL)	SI. TRANSISTOR		Δ	R066	QRD14CJ-100SX	10 1/4W UNF. CARBON R	
	Q052	2SC2240(GR, BL)	SI. TRANSISTOR		Δ	R067	QRD14CJ-120SX	12 1/4W UNF. CARBON R	
	Q053	2SA1038(R, S)	SI. TRANSISTOR			R068	QRD161J-391	390 1/6W CARBON RES.	
	Q055	2SC2235(O, Y)	SI. TRANSISTOR			R069	ERT-02WHL202S	2K 1/4W NEGATIVE THE	
	Q057	2SA965(Y)	SI. TRANSISTOR			R070	QRD161J-183	18K 1/6W CARBON RES.	
	Q059	2SC1775AV(F1)	SI. TRANSISTOR			R071	QRD161J-123	12K 1/6W CARBON RES.	
	Q061	2SC2389(S, E)	SI. TRANSISTOR		Δ	R072	QRD125J-330	33 1/2W UNF. CARBON R	
	Q062	2SA1038(R, S)	SI. TRANSISTOR		Δ	R077	QRG022J-562A	5.6K 2W OXIDE METAL	
	Q075	2SB1565(E, F)	SI. TRANSISTOR			R078	QRD167J-751	750 1/6W CARBON RES.	
	Q400	DTC114YS	DIGITAL TRANSISTOR			R083	QRD161J-102	1K 1/6W CARBON RES.	
	Q401	DTC114TN	DIGITAL TRANSISTOR		Δ	R087	QRD14CJ-181S	180 1/4W UNF. CARBON R	
	Q402	DTC144WS	DIGITAL TRANSISTOR			R088	QRD14CJ-331SX	330 1/4W UNF. CARBON R	
	Q403	DTC114YS	DIGITAL TRANSISTOR		Δ	R090	ERF032K-R22	0.22 3W CEM. RES.	
	Q404	DTC114YS	DIGITAL TRANSISTOR			R095	QRD167J-151	150 1/6W CARBON RES.	
	Q405	DTC144ES	DIGITAL TRANSISTOR			R096	QRD167J-151	150 1/6W CARBON RES.	
	Q852	2SC2235(O, Y)	SI. TRANSISTOR			R097	QRD167J-151	150 1/6W CARBON RES.	
	Q853	DTC114YS	DIGITAL TRANSISTOR			R098	QRD167J-151	150 1/6W CARBON RES.	
		CAPACITORS			Δ	R099	QRD125J-472	4.7K 1/2W UNF. CARBON R	
Δ	C001	QCZ9019-472	4700PF C. CAP.			R291	QRD161J-221	220 1/6W CARBON RES.	
	C050	QCHB1EZ-223	0.022MF 25V CER. CAP.			R292	QRD161J-221	220 1/6W CARBON RES.	
	C051	QETB1HM-106	10MF 50V E. CAP.			R293	QRD161J-221	220 1/6W CARBON RES.	
	C052	QCS21HJ-271A	270PF 50V CER. CAP.			R299	QRD161J-102	1K 1/6W CARBON RES.	
	C053	QETB1EM-106	10MF 25V AL. E. CAP.			R400	QRD161J-101	100 1/6W CARBON RES.	
	C054	QCS21HJ-101A	100PF 50V CER. CAP.		Δ	R401	QRD14CJ-220S	22 1/4W UNF. CARBON R	
	C055	QCS21HJ-5R0	5PF 50V CER. CAP.			R402	QRD161J-471	470 1/6W CARBON RES.	
	C056	QETB1CM-476	47MF 16V AL. E. CAP.			R403	QRD161J-471	470 1/6W CARBON RES.	
	C057	QCS22HJ-330	33PF 500V CER. CAP.			R404	QRD161J-471	470 1/6W CARBON RES.	
	C058	QFLB1HJ-103	0.01MF 50V MYLAR CAP.			R405	QRD161J-471	470 1/6W CARBON RES.	
	C059	QETB1HM-476	47MF 50V E. CAP.			R406	QRD161J-471	470 1/6W CARBON RES.	
	C060	QCS22HJ-470A	47PF 500V CER. CAP.			R407	QRD161J-471	470 1/6W CARBON RES.	
	C061	QETB1HM-225	2.2MF 50V AL. E. CAP.			R408	QRD161J-471	470 1/6W CARBON RES.	
	C063	QCS22HJ-470A	47PF 500V CER. CAP.			R409	QRD161J-471	470 1/6W CARBON RES.	
	C066	QCF21HP-223A	0.022MF 50V CER. CAP.			R410	QRD161J-471	470 1/6W CARBON RES.	
	C067	QCY31HK-332Z	3300PF 50V CER. CAP.			R411	QRD161J-471	470 1/6W CARBON RES.	
	C068	QCY31HK-332Z	3300PF 50V CER. CAP.			R412	QRD161J-471	470 1/6W CARBON RES.	
	C081	QCF21HP-472	4700PF 50V CER. CAP.			R413	QRD161J-471	470 1/6W CARBON RES.	
						R414	QRD161J-471	470 1/6W CARBON RES.	

Electrical Parts Lista(ENB-233)

Δ	Item	Parts Number	Description	Area
	R415	QRD161J-471	470 1/6W CARBON RES.	
	R416	QRD161J-471	470 1/6W CARBON RES.	
	R417	QRD161J-471	470 1/6W CARBON RES.	
	R418	QRD161J-471	470 1/6W CARBON RES.	
	R419	QRD161J-471	470 1/6W CARBON RES.	
	R420	QRD161J-471	470 1/6W CARBON RES.	
	R421	QRD161J-471	470 1/6W CARBON RES.	
	R422	QRD161J-471	470 1/6W CARBON RES.	
	R423	QRD161J-471	470 1/6W CARBON RES.	
	R424	QRD161J-471	470 1/6W CARBON RES.	
	R425	QRD161J-471	470 1/6W CARBON RES.	
	R426	QRD161J-471	470 1/6W CARBON RES.	
	R427	QRD161J-471	470 1/6W CARBON RES.	
	R428	QRD161J-471	470 1/6W CARBON RES.	
	R429	QRD161J-103	10K 1/6W CARBON RES.	
	R430	QRD161J-221	220 1/6W CARBON RES.	
	R431	QRD161J-221	220 1/6W CARBON RES.	
	R432	QRD161J-471	470 1/6W CARBON RES.	
	R433	QRD161J-103	10K 1/6W CARBON RES.	
	R434	QRD161J-103	10K 1/6W CARBON RES.	
	R435	QRD161J-103	10K 1/6W CARBON RES.	
	R437	QRD161J-223	22K 1/6W CARBON RES.	
	R438	QRD161J-471	470 1/6W CARBON RES.	
	R439	QRD161J-471	470 1/6W CARBON RES.	
	R440	QRD161J-103	10K 1/6W CARBON RES.	
	R441	QRD161J-471	470 1/6W CARBON RES.	
	R442	QRD161J-471	470 1/6W CARBON RES.	
	R444	QRD161J-103	10K 1/6W CARBON RES.	
	R445	QRD161J-103	10K 1/6W CARBON RES.	
	R446	QRD161J-103	10K 1/6W CARBON RES.	
	R449	QRD161J-473	47K 1/6W CARBON RES.	
	R452	QRD161J-103	10K 1/6W CARBON RES.	
	R453	QRD161J-471	470 1/6W CARBON RES.	
	R454	QRD161J-471	470 1/6W CARBON RES.	
	R455	QRD161J-103	10K 1/6W CARBON RES.	
	R456	QRD161J-104	100K 1/6W CARBON RES.	
	R457	QRD161J-471	470 1/6W CARBON RES.	
	R490	QRD161J-221	220 1/6W CARBON RES.	
	R591	QRD161J-471	470 1/6W CARBON RES.	
	R592	QRD161J-471	470 1/6W CARBON RES.	
Δ	R860	QRD14CJ-100SX	10 1/4W UNF. CARBON R	
Δ	R861	QRD14CJ-100SX	10 1/4W UNF. CARBON R	
	R863	QRD161J-821	820 1/6W CARBON RES.	
	RA404	QRB049J-103	10K 1/10WRES.	
	RA405	QRB049J-103	10K 1/10WRES.	
	OTHERS			
	EMW10657-002		CIR BOARD	
	EWT011-174		TERMINAL WIRE ASSY	
	QWE881-14RR		VINYL WIRE	
	QWE886-14RR		VINYL WIRE	
	J291	QMS3L10-0A0	MICROPHONE JACK	
	J292	QMS3L10-0A0	MICROPHONE JACK	
	J293	QMS3L10-0A0	MICROPHONE JACK	
	J295	EMN00TV-118A	PIN JACK	
	J591	EMN00YP-308A	PIN JACK	
	L051	EQL0011-R45J1	INDUCTOR	
	S400	ESP0001-023M	TACT SWITCH	
	S401	ESP0001-023M	TACT SWITCH	
	S402	ESP0001-023M	TACT SWITCH	
	S403	ESP0001-023M	TACT SWITCH	
	S404	ESP0001-023M	TACT SWITCH	
	S405	ESP0001-023M	TACT SWITCH	
	S406	ESP0001-023M	TACT SWITCH	
	S407	ESP0001-023M	TACT SWITCH	
	S408	ESP0001-023M	TACT SWITCH	
	S409	ESP0001-023M	TACT SWITCH	
	S410	ESP0001-023M	TACT SWITCH	
	S411	ESP0001-023M	TACT SWITCH	
	S412	ESP0001-023M	TACT SWITCH	
	S414	ESP0001-023M	TACT SWITCH	
	S415	ESP0001-023M	TACT SWITCH	
	S416	ESP0001-023M	TACT SWITCH	
	S418	ESP0001-023M	TACT SWITCH	
	S490	ESP0001-023M	TACT SWITCH	
	S491	ESP0001-023M	TACT SWITCH	
	S492	ESP0001-023M	TACT SWITCH	

Δ	Item	Parts Number	Description	Area
Δ	T002	ETP1000-41JA	POWER TRASNFORMER	
	X400	ECXP6R0-001ZA	CRYSTAL	
	X401	ECXP6R0-001ZA	CRYSTAL	
Δ	AC001	QMCA002-E02S	AC OUTLET	
	BK400	E309106-001SM	FL HOLDER	
	CN301	EWS268-A920J	SOCKET WIRE ASSY	
	CN302	EWS294-0520	SOCKET WIRE	
	CN402	EWS269-A210	SOCKET WIRE ASSY	
	CN403	EWS269-A422J	SOCKET WIRE ASSY	
	CN411	VMC0161-R35	CONNECT TERMINAL	
	CN412	EMV5109-009A	PIN PLUG	
	CN502	EWS323-A945	SOCKET WIRE ASSY	
	CN503	EWS293-0140	SOCKET WIRE	
	CN711	EMV5163-006R	CONNECT TERMINAL	
	CN804	VMC0177-003	CONNECT TERMINAL	
	DI400	ELU0001-215	FLUORESCENT DISPLAY TUBE	
	EP001	EMZ4002-002Z	EARTH PLATE	
	FC001	EMG7331-003Z	FUSE CLIP	
	FC002	EMG7331-003Z	FUSE CLIP	
	FS001	E3400-444	FELT SPACER	
	FS002	E3400-444	FELT SPACER	
	JS400	QJ4003-E01	PUSH SWITCH	
	JS401	QJ4002-E01	PUSH SWITCH	
	JS490	QJ4002-E01	PUSH SWITCH	
	RY002	ESK1D12-119J3	RELAY	
	TA001	EMZ4001-002Z	TAB	
	TA002	EMZ4001-002Z	TAB	

Electrical Parts List(ENH-287)

Item	Parts Number	Description	Area	Item	Parts Number	Description	Area
I. C. S				I. C. S			
IC511	BA15218N	I. C (MONO-ANALOG)		Q718	2SC2389 (S, E)	SI. TRANSISTOR	
IC701	VC5022-2	I. C (MONO-ANALOG)		Q719	2SA1038 (R, S)	SI. TRANSISTOR	
IC702	VC5022-2	I. C (MONO-ANALOG)		Q720	2SA1038 (R, S)	SI. TRANSISTOR	
IC901	TA7317P	I. C (MONO-ANALOG)		Q721	2SD636	SI. TRANSISTOR	
DIODES				DIODES			
D010	1SS133	SI. DIODE		Q722	2SD636	SI. TRANSISTOR	
D011	MTZ18JC	ZENER DIODE		Q723	2SC2389 (S, E)	SI. TRANSISTOR	
D012	1SS133	SI. DIODE		Q724	2SC2389 (S, E)	SI. TRANSISTOR	
D013	1SS133	SI. DIODE		Q725	2SA1038 (R, S)	SI. TRANSISTOR	
D014	1SS133	SI. DIODE		Q726	2SA1038 (R, S)	SI. TRANSISTOR	
D015	1SS133	SI. DIODE		Q727	2SD669A (B, C)	SI. TRANSISTOR	
D021	1SS133	SI. DIODE		Q728	2SD669A (B, C)	SI. TRANSISTOR	
D022	1SS133	SI. DIODE		Q729	2SB649A (B, C)	SI. TRANSISTOR	
D031	MTZ20JC	ZENER DIODE		Q730	2SB649A (B, C)	SI. TRANSISTOR	
D032	MTZ20JC	ZENER DIODE		Q735	2SD2061 (F, G)	SI. TRANSISTOR	
D482	1SS133	SI. DIODE		Q736	2SC2240 (GR, BL)	SI. TRANSISTOR	
D483	1SS133	SI. DIODE		Q801	2SB1187 (F, G)	SI. TRANSISTOR	
D484	MTZ6.2JC	ZENER DIODE		Q803	2SD2061 (F, G)	SI. TRANSISTOR	
D701	1SS133	SI. DIODE		Q804	2SD2061 (F, G)	SI. TRANSISTOR	
D702	1SS133	SI. DIODE		Q805	2SD2061 (F, G)	SI. TRANSISTOR	
D703	1SS133	SI. DIODE		Q807	2SD2061 (F, G)	SI. TRANSISTOR	
D704	1SS133	SI. DIODE		Q808	2SD2061 (F, G)	SI. TRANSISTOR	
D705	MTZ18JC	ZENER DIODE		Q901	2SC2389 (S, E)	SI. TRANSISTOR	
D707	1SS133	SI. DIODE		Q902	2SC2389 (S, E)	SI. TRANSISTOR	
D708	1SS133	SI. DIODE		Q903	2SA1038 (R, S)	SI. TRANSISTOR	
D709	1SS133	SI. DIODE		CAPACITORS			
D710	1SS133	SI. DIODE		C010	QCF21HP-223A	0.022MF 50V CER. CAP.	
D711	1SS133	SI. DIODE		C011	QETB1HM-106	10MF 50V E. CAP.	
D712	1SS133	SI. DIODE		C012	QCS21HJ-470	47PF 50V CER. CAP.	
D713	MTZ10JC	ZENER DIODE		C013	QETB1EM-106	10MF 25V AL. E. CAP.	
D714	MTZ12JC	ZENER DIODE		C014	QCS21HJ-101A	100PF 50V CER. CAP.	
D811	1SS133	SI. DIODE		C015	QCS21HJ-5R0	5PF 50V CER. CAP.	
D812	MTZ15JC	ZENER DIODE		C016	QETB1CM-476	47MF 16V AL. E. CAP.	
D813	1SS133	SI. DIODE		C017	QCS22HJ-330	33PF 500V CER. CAP.	
D814	MTZ6.8JC	ZENER DIODE		C018	QFLB1HJ-103	0.01MF 50V MYLAR CAP.	
D815	1SS133	SI. DIODE		C019	QETB1HM-476	47MF 50V E. CAP.	
D816	MTZ15JC	ZENER DIODE		C020	QCS22HJ-470A	47PF 500V CER. CAP.	
D817	1SS133	SI. DIODE		C021	QETB1HM-225	2.2MF 50V AL. E. CAP.	
D818	1SS133	SI. DIODE		C023	QCS22HJ-470A	47PF 500V CER. CAP.	
D819	MTZ13JC	ZENER DIODE		C024	QFLB1HJ-223	0.022MF 50V MYLAR CAP.	J
D820	MTZ5.1JC	ZENER DIODE		C024	QFLB1HJ-473	0.047MF 50V MYLAR CAP.	C
D822	1SS133	SI. DIODE		C025	QFLB1HJ-473	0.047MF 50V MYLAR CAP.	C
D823	MTZ6.2JC	ZENER DIODE		C026	QCF21HP-223A	0.022MF 50V CER. CAP.	
D824	1SS133	SI. DIODE		C027	QCY31HK-332Z	3300PF 50V CER. CAP.	
D825	MTZ6.2JC	ZENER DIODE		C028	QCY31HK-332Z	3300PF 50V CER. CAP.	
D901	1SS133	SI. DIODE		C031	QCF21HP-472	4700PF 50V CER. CAP.	
D902	1SS133	SI. DIODE		C032	QETB1HM-476	47MF 50V E. CAP.	
D903	1SS133	SI. DIODE		C064	QFLB1HJ-223	0.022MF 50V MYLAR CAP.	J
TRANSISTORS				TRANSISTORS			
Q011	2SC2240 (GR, BL)	SI. TRANSISTOR		C064	QFLB1HJ-473	0.047MF 50V MYLAR CAP.	C
Q012	2SC2240 (GR, BL)	SI. TRANSISTOR		C065	QFLB1HJ-473	0.047MF 50V MYLAR CAP.	C
Q013	2SA1038 (R, S)	SI. TRANSISTOR		C385	QETB0JM-107	100MF 6.3V AL. E. CAP.	
Q015	2SC2235 (O, Y)	SI. TRANSISTOR		C481	QCB1HK-331Y	330PF 50V CER. CAP.	
Q017	2SA965 (Y)	SI. TRANSISTOR		C482	QCHB1EZ-223	0.022MF 25V CER. CAP.	
Q019	2SC1775AV (F1)	SI. TRANSISTOR		C521	QETB1HM-106	10MF 50V E. CAP.	
Q020	DTC123YS	SI. TRANSISTOR		C522	QCY31HK-103Z	0.01MF 50V CER. CAP.	
Q021	2SC2389 (S, E)	SI. TRANSISTOR		C523	QFLB1HJ-123	0.012MF 50V MYLAR CAP.	
Q022	2SA1038 (R, S)	SI. TRANSISTOR		C524	QETB1HM-106	10MF 50V E. CAP.	
Q025	2SB1565 (E, F)	SI. TRANSISTOR		C525	QCS21HJ-101A	100PF 50V CER. CAP.	
Q302	DTA144ES	DIGITAL TRANSISTOR		C701	QETB1HM-106	10MF 50V E. CAP.	
Q303	2SD2144S (VW)	SI. TRANSISTOR		C702	QETB1HM-106	10MF 50V E. CAP.	
Q304	2SD2144S (VW)	SI. TRANSISTOR		C703	QCS21HJ-271A	270PF 50V CER. CAP.	
Q701	2SC1775AV (F1)	SI. TRANSISTOR		C704	QCS21HJ-271A	270PF 50V CER. CAP.	
Q702	2SC1775AV (F1)	SI. TRANSISTOR		C705	QCS21HJ-101A	100PF 50V CER. CAP.	
Q703	2SC1775AV (F1)	SI. TRANSISTOR		C706	QCS21HJ-101A	100PF 50V CER. CAP.	
Q704	2SC1775AV (F1)	SI. TRANSISTOR		C707	QETB1CM-107	100MF 16V AL. E. CAP.	
Q705	2SA1038 (R, S)	SI. TRANSISTOR		C708	QETB1CM-107	100MF 16V AL. E. CAP.	
Q706	2SA1038 (R, S)	SI. TRANSISTOR		C709	QCS21HJ-100	10PF 50V CER. CAP.	
Q707	2SA933LN (R, S)	SI. TRANSISTOR		C710	QCS21HJ-100	10PF 50V CER. CAP.	
Q708	2SA933LN (R, S)	SI. TRANSISTOR		C711	QCY31HK-152Z	1500PF 50V CER. CAP.	
Q709	2SA1038 (R, S)	SI. TRANSISTOR		C712	QCY31HK-152Z	1500PF 50V CER. CAP.	
Q710	2SA1038 (R, S)	SI. TRANSISTOR		C713	QCS21HJ-680A	68PF 50V CER. CAP.	
Q711	2SC2389 (S, E)	SI. TRANSISTOR		C714	QCS21HJ-680A	68PF 50V CER. CAP.	
Q712	2SC2389 (S, E)	SI. TRANSISTOR		C715	QCS21HJ-680A	68PF 50V CER. CAP.	
Q717	2SC2389 (S, E)	SI. TRANSISTOR		C716	QCS21HJ-680A	68PF 50V CER. CAP.	
				C717	QCS22HJ-220	22PF 500V CER. CAP.	
				C718	QCS22HJ-220	22PF 500V CER. CAP.	
				C719	QFLB1HJ-472	4700PF 50V MYLAR CAP.	

Electrical Parts List (ENH-287)

Δ	Item	Parts Number	Description	Area
	C720	QFLB1HJ-472	4700PF 50V MYLAR CAP.	
	C722	QETB1EM-476	47MF 25V AL E. CAP.	
	C723	QETB2AM-476	47MF 100V AL E. CAP.	
	C724	QETB2AM-476	47MF 100V AL E. CAP.	
	C725	QCS22HJ-470A	47PF 500V CER. CAP.	
	C726	QCS22HJ-470A	47PF 500V CER. CAP.	
	C727	QCS22HJ-470A	47PF 500V CER. CAP.	
	C728	QCS22HJ-470A	47PF 500V CER. CAP.	
	C729	QFLB1HJ-223	0.022MF 50V MYLAR CAP.	J
	C729	QFLB1HJ-473	0.047MF 50V MYLAR CAP.	C
	C730	QFLB1HJ-223	0.022MF 50V MYLAR CAP.	J
	C730	QFLB1HJ-473	0.047MF 50V MYLAR CAP.	C
	C731	QFLB1HJ-473	0.047MF 50V MYLAR CAP.	C
	C732	QFLB1HJ-473	0.047MF 50V MYLAR CAP.	C
	C733	QCF21HP-472	4700PF 50V CER. CAP.	
	C734	QCF21HP-472	4700PF 50V CER. CAP.	
	C735	QCF21HP-472	4700PF 50V CER. CAP.	
	C736	QCF21HP-472	4700PF 50V CER. CAP.	
	C741	QCF21HP-472	4700PF 50V CER. CAP.	
	C801	EEW8001-129T	12000MF AL E. CAP.	
	C802	EEW8001-129T	12000MF AL E. CAP.	
	C812	QETB1EM-107	100MF 25V AL E. CAP.	
	C813	QCF21HP-472	4700PF 50V CER. CAP.	
	C814	QETB1EM-107	100MF 25V AL E. CAP.	
	C816	QETB1EM-107	100MF 25V AL E. CAP.	
	C817	QCF21HP-472	4700PF 50V CER. CAP.	
	C819	QETB1EM-107	100MF 25V AL E. CAP.	
	C820	QETB1EM-107	100MF 25V AL E. CAP.	
	C821	QCF21HP-472	4700PF 50V CER. CAP.	
	C822	QCF21HP-472	4700PF 50V CER. CAP.	
	C823	QETB1EM-107	100MF 25V AL E. CAP.	
	C824	QCF21HP-472	4700PF 50V CER. CAP.	
	C825	QETB1EM-107	100MF 25V AL E. CAP.	
	C831	QCZ0202-155	1.5MF 25V CER. RES.	
	C832	QCZ0202-155	1.5MF 25V CER. RES.	
	C870	QCF21HP-472	4700PF 50V CER. CAP.	
	C901	QCF21HP-223A	0.022MF 50V CER. CAP.	
	C902	QCF21HP-223A	0.022MF 50V CER. CAP.	
	C903	QETB1HM-226E	22MF 50V E. CAP.	
	C904	QCF21HP-103A	0.01MF 50V CER. CAP.	
	C905	QCY31HK-102Z	1000PF 50V CER. CAP.	
	C906	QETB1AM-476	47MF 10V E. CAP.	
	C909	QETB1CM-226	22MF 16V E. CAP.	
		RESISTORS		
	R011	QRD161J-222	2.2K 1/6W CARBON RES.	
	R012	QRD161J-104	100K 1/6W CARBON RES.	
	R013	QRD161J-123	12K 1/6W CARBON RES.	
	R014	QRD161J-182	1.8K 1/6W CARBON RES.	
	R015	QRD161J-104	100K 1/6W CARBON RES.	
Δ	R016	QRD14CJ-181S	180 1/4W UNF. CARBON R	
Δ	R017	QRD14CJ-222SX	2.2K 1/4W UNF. CARBON R	
	R018	QRD161J-202	2K 1/6W CARBON RES.	
	R019	QRD161J-222	2.2K 1/6W CARBON RES.	
	R020	QRD161J-202	2K 1/6W CARBON RES.	
Δ	R023	QRD14CJ-120SX	12 1/4W UNF. CARBON R	
Δ	R024	QRD14CJ-100SX	10 1/4W UNF. CARBON R	
Δ	R025	QRD14CJ-561SX	560 1/4W UNF. CARBON R	
Δ	R026	QRD14CJ-100SX	10 1/4W UNF. CARBON R	
Δ	R027	QRD14CJ-120SX	12 1/4W UNF. CARBON R	
	R028	QRD161J-391	390 1/6W CARBON RES.	
	R029	ERT-D2WHL202S	2K 1/4W NEGATIVE THE	
	R030	QRD161J-183	18K 1/6W CARBON RES.	
	R031	QRD161J-123	12K 1/6W CARBON RES.	
Δ	R032	QRD125J-330	33 1/2W UNF. CARBON R	
Δ	R033	ORG022J-100A	10 2W OXIDE METAL	
	R034	QRD161J-104	100K 1/6W CARBON RES.	
Δ	R035	QRD14CJ-181S	180 1/4W UNF. CARBON R	
Δ	R036	QRD14CJ-471SX	470 1/4W UNF. CARBON R	
Δ	R037	ORG022J-562A	5.6K 2W OXIDE METAL	
	R038	QRD167J-751	750 1/6W CARBON RES.	
Δ	R039	QRD14CJ-100SX	10 1/4W UNF. CARBON R	
	R040	QRD161J-3R3	3.3 1/6W CARBON RES.	
	R043	QRD161J-102	1K 1/6W CARBON RES.	
	R045	QRD167J-151	150 1/6W CARBON RES.	
	R046	QRD167J-151	150 1/6W CARBON RES.	
	R047	QRD167J-151	150 1/6W CARBON RES.	

Δ	Item	Parts Number	Description	Area
	R048	QRD167J-151	150 1/6W CARBON RES.	
Δ	R049	QRD125J-472	4.7K 1/2W UNF. CARBON R	
Δ	R073	ORG022J-100A	10 2W OXIDE METAL	
	R074	QRD161J-104	100K 1/6W CARBON RES.	
	R391	QRD161J-104	100K 1/6W CARBON RES.	
	R392	QRD161J-104	100K 1/6W CARBON RES.	
	R481	QRD161J-100	10 1/6W CARBON RES.	
	R482	QRD161J-102	1K 1/6W CARBON RES.	
	R521	QRD161J-104	100K 1/6W CARBON RES.	
	R522	QRD161J-203	20K 1/6W CARBON RES.	
	R523	QRD161J-183	18K 1/6W CARBON RES.	
	R524	QRD161J-202	2K 1/6W CARBON RES.	
	R525	QRD167J-223	22K 1/6W CARBON RES.	
	R526	QRD161J-132	1.3K 1/6W CARBON RES.	
	R528	QRD161J-203	20K 1/6W CARBON RES.	
Δ	R529	QRZ0077-680	68 1/4W FUSIBLE RES.	
Δ	R530	QRZ0077-680	68 1/4W FUSIBLE RES.	
	R583	QRD161J-103	10K 1/6W CARBON RES.	
	R584	QRD161J-103	10K 1/6W CARBON RES.	
	R589	QRD161J-102	1K 1/6W CARBON RES.	
	R701	QRD161J-222	2.2K 1/6W CARBON RES.	
	R702	QRD161J-222	2.2K 1/6W CARBON RES.	
	R703	QRD161J-104	100K 1/6W CARBON RES.	
	R704	QRD161J-104	100K 1/6W CARBON RES.	
	R705	QRD161J-202	2K 1/6W CARBON RES.	
	R706	QRD161J-202	2K 1/6W CARBON RES.	
	R707	QRD161J-202	2K 1/6W CARBON RES.	
	R708	QRD161J-202	2K 1/6W CARBON RES.	
	R709	QRD167J-822	8.2K 1/6W CARBON RES.	
	R710	QRD167J-822	8.2K 1/6W CARBON RES.	
	R711	QRD161J-821	820 1/6W CARBON RES.	
	R712	QRD161J-821	820 1/6W CARBON RES.	
	R713	QRD161J-133Y	13K 1/6W CARBON RES.	
	R714	QRD161J-133Y	13K 1/6W CARBON RES.	
	R715	QRD161J-823	82K 1/6W CARBON RES.	
	R716	QRD161J-823	82K 1/6W CARBON RES.	
	R717	QRD12CJ-153SX	15K 1/2W UNF. CARBON R	
	R718	QRD12CJ-153SX	15K 1/2W UNF. CARBON R	
	R719	QRD161J-391	390 1/6W CARBON RES.	
	R720	QRD161J-391	390 1/6W CARBON RES.	
	R721	QRD14CJ-151SX	150 1/4W UNF. CARBON R	
	R722	QRD14CJ-151SX	150 1/4W UNF. CARBON R	
	R723	QRD167J-152	1.5K 1/6W CARBON RES.	
	R724	QRD167J-152	1.5K 1/6W CARBON RES.	
	R725	QRD161J-333	33K 1/6W CARBON RES.	
	R726	QRD161J-333	33K 1/6W CARBON RES.	
	R727	QRD161J-391	390 1/6W CARBON RES.	
	R728	QRD161J-391	390 1/6W CARBON RES.	
	R729	QRD161J-391	390 1/6W CARBON RES.	
	R730	QRD161J-391	390 1/6W CARBON RES.	
	R731	QRD161J-101	100 1/6W CARBON RES.	
	R732	QRD161J-101	100 1/6W CARBON RES.	
Δ	R733	QRD14CJ-120SX	12 1/4W UNF. CARBON R	
Δ	R734	QRD14CJ-120SX	12 1/4W UNF. CARBON R	
Δ	R735	ORG022J-562A	5.6K 2W OXIDE METAL	
	R739	QRD161J-201	200 1/6W CARBON RES.	
	R740	QRD161J-201	200 1/6W CARBON RES.	
	R741	QRD161J-201	200 1/6W CARBON RES.	
	R742	QRD161J-201	200 1/6W CARBON RES.	
	R751	QRD161J-391	390 1/6W CARBON RES.	
	R752	QRD161J-391	390 1/6W CARBON RES.	
	R753	QRD161J-391	390 1/6W CARBON RES.	
	R754	QRD161J-391	390 1/6W CARBON RES.	
	R755	QRD161J-471	470 1/6W CARBON RES.	
	R756	QRD161J-471	470 1/6W CARBON RES.	
	R757	QRD161J-101	100 1/6W CARBON RES.	
	R758	QRD161J-101	100 1/6W CARBON RES.	
	R759	ERT-D2WFL351S	350 1/4W NEGATIVE THE	
	R760	ERT-D2WFL351S	350 1/4W NEGATIVE THE	
	R761	QRD161J-391	390 1/6W CARBON RES.	
	R762	QRD161J-391	390 1/6W CARBON RES.	
Δ	R765	QRD14CJ-272S	2.7K 1/4W UNF. CARBON R	
Δ	R766	QRD14CJ-272S	2.7K 1/4W UNF. CARBON R	
Δ	R767	QRD14CJ-271S	270 1/4W UNF. CARBON R	
Δ	R768	QRD14CJ-271S	270 1/4W UNF. CARBON R	
Δ	R769	QRD14CJ-120SX	12 1/4W UNF. CARBON R	

Electrical Parts List(ENH-287)

△	Item	Parts Number	Description	Area
△	R770	QRD14CJ-120SX	12 1/4W UNF. CARBON R	
△	R771	QRD14CJ-120SX	12 1/4W UNF. CARBON R	
△	R772	QRD14CJ-120SX	12 1/4W UNF. CARBON R	
△	R773	ERF032K-R22	0.22 3W CEM. RES.	
△	R774	ERF032K-R22	0.22 3W CEM. RES.	
△	R775	QRD129J-470	47 1/2W UNF. CARBON R	
△	R776	QRD129J-470	47 1/2W UNF. CARBON R	
△	R777	QRG022J-100A	10 2W OXIDE METAL	
△	R778	QRG022J-100A	10 2W OXIDE METAL	
△	R779	QRD14CJ-100SX	10 1/4W UNF. CARBON R	
△	R780	QRD14CJ-100SX	10 1/4W UNF. CARBON R	
△	R781	QRD14CJ-100SX	10 1/4W UNF. CARBON R	
△	R782	QRD14CJ-100SX	10 1/4W UNF. CARBON R	
△	R783	QRD14CJ-100SX	10 1/4W UNF. CARBON R	
△	R784	QRD14CJ-100SX	10 1/4W UNF. CARBON R	
△	R785	QRD14CJ-100SX	10 1/4W UNF. CARBON R	
△	R786	QRD14CJ-100SX	10 1/4W UNF. CARBON R	
△	R787	QRD12CJ-562S	5.6K 1/2W UNF. CARBON R	
	R788	QRD161J-103	10K 1/6W CARBON RES.	
	R789	QRD161J-473	47K 1/6W CARBON RES.	
△	R799	ERF032K-R22	0.22 3W CEM. RES.	
	R801	QRD161J-104	100K 1/6W CARBON RES.	
	R802	QRD161J-104	100K 1/6W CARBON RES.	
△	R811	QRD14CJ-120SX	12 1/4W UNF. CARBON R	
△	R813	QRD14CJ-122SX	1.2K 1/4W UNF. CARBON R	
△	R819	QRD12CJ-330S	33 1/2W CARBON RES.	
△	R820	QRD12CJ-330S	33 1/2W CARBON RES.	
△	R822	QRD14CJ-272S	2.7K 1/4W UNF. CARBON R	
△	R823	QRD121J-680	68 1/2W CARBON RES.	
△	R824	QRD121J-680	68 1/2W CARBON RES.	
△	R825	QRD14CJ-332SX	3.3K 1/4W UNF. CARBON R	
△	R826	QRD14CJ-120SX	12 1/4W UNF. CARBON R	
△	R828	QRD12CJ-153SX	15K 1/2W UNF. CARBON R	
△	R831	QRD14CJ-220S	22 1/4W UNF. CARBON R	
△	R832	QRD14CJ-220S	22 1/4W UNF. CARBON R	
△	R833	QRD14CJ-332SX	3.3K 1/4W UNF. CARBON R	
△	R834	QRD14CJ-3R9S	3.9 1/4W UNF. CARBON R	
△	R835	QRD12CJ-471SX	470 1/2W UNF. CARBON R	
△	R838	QRD12CJ-2R2SX	2.2 1/2W CARBON RES.	
△	R840	QRD14CJ-220S	22 1/4W UNF. CARBON R	
△	R841	QRD14CJ-220S	22 1/4W UNF. CARBON R	
△	R842	QRD14CJ-332SX	3.3K 1/4W UNF. CARBON R	
△	R843	QRD14CJ-100SX	10 1/4W UNF. CARBON R	
	R901	QRD161J-102	1K 1/6W CARBON RES.	
	R902	QRD161J-102	1K 1/6W CARBON RES.	
	R903	QRD167J-562	5.6K 1/6W CARBON RES.	
	R904	QRD167J-562	5.6K 1/6W CARBON RES.	
	R905	QRD161J-123	12K 1/6W CARBON RES.	
	R906	QRD161J-123	12K 1/6W CARBON RES.	
	R907	QRD161J-102	1K 1/6W CARBON RES.	
	R908	QRD161J-102	1K 1/6W CARBON RES.	
	R909	QRD161J-103	10K 1/6W CARBON RES.	
	R911	QRD167J-332	3.3K 1/6W CARBON RES.	
	R912	QRD161J-473	47K 1/6W CARBON RES.	
	R913	QRD161J-104	100K 1/6W CARBON RES.	
	R914	QRD161J-823	82K 1/6W CARBON RES.	
	R915	QRD161J-823	82K 1/6W CARBON RES.	
	R916	QRD161J-563	56K 1/6W CARBON RES.	
	R917	QRD161J-683	68K 1/6W CARBON RES.	
	R918	QRD161J-392	3.9K 1/6W CARBON RES.	
	R921	QRD161J-224	220K 1/6W CARBON RES.	
	R922	QRD161J-122	1.2K 1/6W CARBON RES.	
	R924	QRD161J-3R3	3.3 1/6W CARBON RES.	
△	R929	QRD14CJ-470SX	47 1/4W UNF. CARBON R	
△	R941	QRG022J-471A	470 2W OXIDE METAL	
△	R942	QRG022J-471A	470 2W OXIDE METAL	
	R951	QRD161J-333	33K 1/6W CARBON RES.	
	R952	QRD161J-333	33K 1/6W CARBON RES.	
	R953	QRD161J-333	33K 1/6W CARBON RES.	
	R956	QRD161J-223	22K 1/6W CARBON RES.	
	R957	QRD167J-391	390 1/6W CARBON RES.	
	VR513	QVDA96W-E15DJ3	100K VARIABLE RES.	
	VR514	QVDB96C-E15DJ3	100K VARIABLE RES.	
	VR791	QVPA601-501A	500 TRIMMER RES.	
	VR792	QVPA601-501A	500 TRIMMER RES.	
		OTHERS		

△	Item	Parts Number	Description	Area
		EMW10620-002		
		SBSG3008CC	TAPPING SCREW	
	J481	QMS3501-021	PIN JACK	
	J901	QMS6022-V01	MICROPHONE JACK	
	L011	EQL0011-R45J1	INDUCTOR	
	L701	EQL0001-1R0	INDUCTOR	
	L702	EQL0001-1R0	INDUCTOR	
	S001	GSP6002-E02J2	PUSH SWITCH	
	S911	GSS7A12-E01	SLIDE SWITCH	
	CN001	EMV7163-012	CONNECT TERMINAL	
	CN108	EWS293-0145	SOCKET WIRE	
	CN109	EWS293-0130	SOCKET WIRE	
	CN118	VMC0075-003	CONNECTOR	
	CN119	VMC0075-003	CONNECTOR	
	CN311	VMC0075-008N	CONNECT TERMINAL	
	CN401	VMC0163-035	CONNECT TERMINAL	
	CN501	EMV7163-012	CONNECT TERMINAL	
	CN505	EMV7163-004	CONNECT TERMINAL	
	CN601	EMV7163-015	CONNECT TERMINAL	
	CN602	EMV7163-009	CONNECT TERMINAL	
	CN701	EMV7163-006	CONNECT TERMINAL	
	CN801	EMV7163-007	CONNECT TERMINAL	
	CN812	EMV5129-003	CONNECTOR	
	CN813	VMC0178-003	CONNECT TERMINAL	
	CN814	VMC0178-003	CONNECT TERMINAL	
	EP001	EMZ4002-002Z	EARTH PLATE	
	EP003	EMZ4002-002Z	EARTH PLATE	
	EP004	EMZ4002-002Z	EARTH PLATE	
	EP005	EMZ4002-002Z	EARTH PLATE	
	EP006	EMZ4002-002Z	EARTH PLATE	
	FW901	EWK330-08SS	FLAT WIRE ASSY	
	FW903	EWK380-45SS	FLAT WIRE ASSY	
	HS801	E70306-001	HEAT SINK	
	HS803	E70306-001	HEAT SINK	
	HS804	E70306-001	HEAT SINK	
	HS805	E70306-001	HEAT SINK	
	HS807	E70306-001	HEAT SINK	
	HS808	E70306-001	HEAT SINK	
	RY011	ESK7D24-213R	RELAY	
	RY901	ESK7D24-213R	RELAY	
	ST011	EMB90TV-601G	SPEAKER TERMINAL	
	ST901	EMB90TV-806A	SPEAKER TERMINAL	
	TP751	QMV5005-004K	PLUG ASSY	

Electrical Parts List (ENA-172)

Δ	Item	Parts Number	Description	Area
		I. C. S		
	IC102	LC72131	I. C.(M)	
	IC104	LA1266A	I. C.(MONO-ANALOG)	
	IC105	LA3401	I. C.(MONO-ANALOG)	
		DIODES		
	D101	1SS133	SI. DIODE	
	D106	1SS133	SI. DIODE	
	D111	1SS133	SI. DIODE	
	D112	1SS133	SI. DIODE	
	D120	1SS133	SI. DIODE	
	D121	1SS133	SI. DIODE	
	D122	1SS133	SI. DIODE	
	D123	1SS133	SI. DIODE	
	VC105	SVC342(L)	VARI-CAPA DIODE	
		TRANSISTORS		
	Q103	2SC461	SI. TRANSISTOR	
	Q107	2SC535	SI. TRANSISTOR	
	Q108	2SC461	SI. TRANSISTOR	
	Q112	2SK301(P. O)	F. E. T.	
	Q123	DTA144ES	DIGITAL TRANSISTOR	
	Q124	DTA144ES	DIGITAL TRANSISTOR	
	Q127	DTC144ES	DIGITAL TRANSISTOR	
		CAPACITORS		
	C101	QCF21HP-223A	0.022MF 50V CER. CAP.	
	C122	QCF21HP-223A	0.022MF 50V CER. CAP.	
	C126	QCF21HP-223A	0.022MF 50V CER. CAP.	
	C132	QCS31HJ-561Z	560PF 50V CER. CAP.	
	C133	QCHB1EZ-223	0.022MF 25V CER. CAP.	
	C134	QETB1EM-106	10MF 25V AL E. CAP.	
	C135	QCC21EM-223	0.022MF 25V CER. CAP.	
	C136	QCT25CH-180Z	18PF 50V CER. CAP.	
	C137	QCT26CH-221	220PF 50V CER. CAP.	
	C138	QCT26CH-241	240PF 50V CER. CAP.	
	C149	QCHB1EZ-223	0.022MF 25V CER. CAP.	
	C150	QCHB1EZ-223	0.022MF 25V CER. CAP.	
	C151	QCF21HP-223A	0.022MF 50V CER. CAP.	
	C152	QCF21HP-223A	0.022MF 50V CER. CAP.	
	C153	QCC21EM-223	0.022MF 25V CER. CAP.	
	C154	QCF21HP-223A	0.022MF 50V CER. CAP.	
	C155	QCHB1EZ-223	0.022MF 25V CER. CAP.	
	C156	QETB1CM-227	220MF 16V AL E. CAP.	
	C157	QETB1HM-474	0.47MF 50V E. CAP.	
	C158	QCBB1HK-101Y	100PF 50V CER. CAP.	
	C159	QCBB1HK-101Y	100PF 50V CER. CAP.	
	C160	QCBB1HK-221Y	220PF 50V CER. CAP.	
	C161	QCHB1EZ-223	0.022MF 25V CER. CAP.	
	C162	QETB1EM-106	10MF 25V AL E. CAP.	
	C163	QFLB1HJ-102	1000PF 50V MYLAR CAP.	
	C164	QCHB1EZ-223	0.022MF 25V CER. CAP.	
	C165	QETB1HM-474	0.47MF 50V E. CAP.	
	C166	QETB1HM-225	2.2MF 50V AL E. CAP.	
	C167	QETB1HM-225	2.2MF 50V AL E. CAP.	
	C168	QEK51HM-475	4.7MF 50V AL E. CAP.	
	C169	QCF21HP-223A	0.022MF 50V CER. CAP.	
	C170	QCHB1EZ-223	0.022MF 25V CER. CAP.	
	C171	QEK51EM-106	10MF 25V AL E. CAP.	
	C172	QCVB1CM-103Y	0.01MF 16V CER. CAP.	
	C173	QFLB1HJ-393	0.039MF 50V MYLAR CAP.	
	C174	QFLB1HJ-473	0.047MF 50V MYLAR CAP.	
	C175	QETB1EM-106	10MF 25V AL E. CAP.	
	C176	QCY31HK-102Z	1000PF 50V CER. CAP.	
	C177	QCS31HJ-821Z	820PF 50V CER. CAP.	
	C178	QCS31HJ-821Z	820PF 50V CER. CAP.	
	C179	QETB1HM-225	2.2MF 50V AL E. CAP.	
	C180	QETB1HM-225	2.2MF 50V AL E. CAP.	
	C181	QETB1EM-106	10MF 25V AL E. CAP.	
	C182	QETB1HM-225	2.2MF 50V AL E. CAP.	
	C183	QETB1HM-105	1MF 50V AL E. CAP.	
	C184	QETB1HM-105	1MF 50V AL E. CAP.	
	C185	QEK51HM-225G	2.2MF 50V AL E. CAP.	
	C186	QETB1HM-474	0.47MF 50V E. CAP.	
	C191	QETB1HM-475E	4.7MF 50V E. CAP.	
	C192	QCC21EM-473	0.047MF 25V CER. CAP.	
	C193	QCS21HJ-180A	18PF 50V CER. CAP.	
	C194	QCS21HJ-180A	18PF 50V CER. CAP.	
	C195	QFV71HJ-474ZM	0.47MF 50V THIN FILM CAP.	
	C196	QCY31HK-102Z	1000PF 50V CER. CAP.	

Δ	Item	Parts Number	Description	Area
	C197	QCF21HP-223A	0.022MF 50V CER. CAP.	
	C198	QCF21HP-103A	0.01MF 50V CER. CAP.	
	C199	QCVB1CM-103Y	0.01MF 16V CER. CAP.	
	C222	QETB1CM-477M	470MF 16V E. CAP.	
	C229	QETB1CM-227	220MF 16V AL E. CAP.	
	TC105	ENZ1003-006	00MF TRIMMER CAPA	
		RESISTORS		
	R101	QRD161J-103	10K 1/6W CARBON RES.	
	R102	QRD161J-103	10K 1/6W CARBON RES.	
	R103	QRD161J-103	10K 1/6W CARBON RES.	
	R105	QRD161J-103	10K 1/6W CARBON RES.	
	R108	QRD161J-103	10K 1/6W CARBON RES.	
Δ	R109	QRD14CJ-680SX	68 1/4W UNF. CARBON R	
	R118	QRD167J-332	3.3K 1/6W CARBON RES.	
	R119	QRD161J-221	220 1/6W CARBON RES.	
	R121	QRD161J-391	390 1/6W CARBON RES.	
	R122	QRD167J-272	2.7K 1/6W CARBON RES.	
	R123	QRD161J-102	1K 1/6W CARBON RES.	
	R124	QRD161J-681	680 1/6W CARBON RES.	
	R125	QRD167J-332	3.3K 1/6W CARBON RES.	
	R126	QRD161J-221	220 1/6W CARBON RES.	
	R131	QRD161J-331	330 1/6W CARBON RES.	
	R132	QRD161J-103	10K 1/6W CARBON RES.	
	R133	QRD161J-473	47K 1/6W CARBON RES.	
	R135	QRD161J-470	47 1/6W CARBON RES.	
	R136	QRD161J-103	10K 1/6W CARBON RES.	
	R146	QRD167J-560	56 1/6W CARBON RES.	
	R147	QRD161J-103	10K 1/6W CARBON RES.	
	R148	QRD161J-103	10K 1/6W CARBON RES.	
	R149	QRD161J-273	27K 1/6W CARBON RES.	
	R150	QRD161J-103	10K 1/6W CARBON RES.	
	R151	QRD161J-222	2.2K 1/6W CARBON RES.	
	R153	QRD161J-103	10K 1/6W CARBON RES.	
	R154	QRD161J-103	10K 1/6W CARBON RES.	
	R155	QRD167J-562	5.6K 1/6W CARBON RES.	
	R156	QRD167J-822	8.2K 1/6W CARBON RES.	
	R157	QRD161J-103	10K 1/6W CARBON RES.	
	R158	QRD161J-183	18K 1/6W CARBON RES.	
	R159	QRD161J-561	560 1/6W CARBON RES.	
	R160	QRD167J-562	5.6K 1/6W CARBON RES.	
	R161	QRD161J-823	82K 1/6W CARBON RES.	
	R162	QRD161J-823	82K 1/6W CARBON RES.	
	R163	QRD161J-472	4.7K 1/6W CARBON RES.	
	R164	QRD161J-472	4.7K 1/6W CARBON RES.	
	R165	QRD161J-184	180K 1/6W CARBON RES.	
	R166	QRD161J-184	180K 1/6W CARBON RES.	
	R167	QRD161J-393	39K 1/6W CARBON RES.	
	R168	QRD161J-103	10K 1/6W CARBON RES.	
	R169	QRD161J-103	10K 1/6W CARBON RES.	
	R171	QRD167J-682	6.8K 1/6W CARBON RES.	
	R172	QRD167J-682	6.8K 1/6W CARBON RES.	
	R180	QRD161J-103	10K 1/6W CARBON RES.	
	R181	QRD161J-222	2.2K 1/6W CARBON RES.	
	R190	QRD161J-103	10K 1/6W CARBON RES.	
	R191	QRD167J-562	5.6K 1/6W CARBON RES.	
	R194	QRD161J-103	10K 1/6W CARBON RES.	
	R195	QRD161J-473	47K 1/6W CARBON RES.	
	R197	QRD161J-222	2.2K 1/6W CARBON RES.	
	R198	QRD167J-822	8.2K 1/6W CARBON RES.	
	R199	QRD161J-472	4.7K 1/6W CARBON RES.	
		OTHERS		
		EMW10604-003A	PRINTED BOARD	
	L106	EQL3001-102K	INDUCTOR	
	L120	EQL4007-1R0	INDUCTOR	
	T101	EQR1111-014	RF COIL	
	T103	EQR1207-017	RF COIL	
	T105	EQT2140-017	I. F. TRANSFORMER	
	T107	ECB1560-010	CERAMIC FILTER	
	AT101	FMMB10YY-401K	ANTENNA TERMINAL	
	CF101	ECB2123-006R	CERAMIC FILTER	
	CF102	ECB2123-006R	CERAMIC FILTER	
	CNO11	EMV5163-012R	CONNECT TERMINAL	
	FE101	EAF2203-004	FRONT END	
	LP101	EQF0101-002	LOWPASS FILTER	
	XT102	ECX0007-200KJ1	CRYSTAL	
	XT103	ECX0000-456KR	CERAMIC RESONATOR	

Electrical Parts List (ENP-054)

Δ	Item	Parts Number	Description	Area
		I. C. S		
	IC021	SAA7367TX	I. C (DIGI-MOS)	
	IC041	TDA1386TX	I. C (MONO-ANALOG)	
	IC061	TDA1386TX	I. C (MONO-ANALOG)	
	IC081	TC9332F-D10	I. C (DIGI-MOS)	
	IC093	TC74HC74AF11	I. C (DIGI-MOS)	
	IC096	TMP87C847U-4195	I. C (M)	
		CAPACITORS		
	C021	NEA71EM-475NZ	4.7MF 25V E. CAP.	
	C022	NEA71EM-475NZ	4.7MF 25V E. CAP.	
	C023	NCS31HJ-680AY	68PF 50V CER. CAP.	
	C024	NCS31HJ-680AY	68PF 50V CER. CAP.	
	C025	NCB31CK-473AY	0.047MF 16V CER. CAP.	
	C026	NCB31CK-473AY	0.047MF 16V CER. CAP.	
	C027	NEA70GM-476NZ	47MF E. CAP.	
	C028	NEA70GM-476NZ	47MF E. CAP.	
	C029	NCB31CK-473AY	0.047MF 16V CER. CAP.	
	C030	NEA70JM-476NZ	47MF 6.3V E. CAP.	
	C031	NCB31CK-223A	0.022MF 16V CER. CAP.	
	C032	NCB31HK-102AY	1000PF 50V CER. CAP.	
	C033	NCF31AZ-105AYUU	1MF 10V CER. CAP.	
	C035	NEA70JM-476NZ	47MF 6.3V E. CAP.	
	C036	NCF31AZ-105AYUU	1MF 10V CER. CAP.	
	C037	NCF31AZ-105AYUU	1MF 10V CER. CAP.	
	C038	NEA70JM-107NP	100MF 6.3V E. CAP.	
	C039	NEA70JM-107NP	100MF 6.3V E. CAP.	
	C041	NCS31HJ-102AYM	1000PF 50V CER. CAP.	
	C042	NCS31HJ-102AYM	1000PF 50V CER. CAP.	
	C043	NEA71CM-106NZ	10MF 16V E. CAP.	
	C049	NCB31CK-104AY	0.1MF 16V CER. CAP.	
	C050	NCB31CK-104AY	0.1MF 16V CER. CAP.	
	C051	NEA71HM-105NZ	1MF 50V E. CAP.	
	C052	NEA71HM-105NZ	1MF 50V E. CAP.	
	C053	NCB31CK-183AY	0.018MF 16V CER. CAP.	
	C054	NCB31CK-183AY	0.018MF 16V CER. CAP.	
	C055	NCB31HK-102AY	1000PF 50V CER. CAP.	
	C056	NCB31HK-102AY	1000PF 50V CER. CAP.	
	C057	NCB31HK-102AY	1000PF 50V CER. CAP.	
	C058	NCF31AZ-105AYUU	1MF 10V CER. CAP.	
	C059	NCF31AZ-105AYUU	1MF 10V CER. CAP.	
	C061	NCS31HJ-102AYM	1000PF 50V CER. CAP.	
	C062	NCS31HJ-102AYM	1000PF 50V CER. CAP.	
	C063	NEA71CM-106NZ	10MF 16V E. CAP.	
	C069	NCB31CK-104AY	0.1MF 16V CER. CAP.	
	C070	NCB31CK-104AY	0.1MF 16V CER. CAP.	
	C071	NEA71HM-105NZ	1MF 50V E. CAP.	
	C072	NEA71HM-105NZ	1MF 50V E. CAP.	
	C073	NCB31CK-183AY	0.018MF 16V CER. CAP.	
	C074	NCB31CK-183AY	0.018MF 16V CER. CAP.	
	C075	NCB31HK-102AY	1000PF 50V CER. CAP.	
	C076	NCB31HK-102AY	1000PF 50V CER. CAP.	
	C077	NCB31HK-102AY	1000PF 50V CER. CAP.	
	C081	NCS31HD-9ROAYM	9PF 50V CER. CAP.	
	C082	NCS31HD-9ROAYM	9PF 50V CER. CAP.	
	C085	NCB31CK-104AY	0.1MF 16V CER. CAP.	
	C086	NCB31CK-104AY	0.1MF 16V CER. CAP.	
	C088	NCB31HK-102AY	1000PF 50V CER. CAP.	
	C089	NCB31HK-102AY	1000PF 50V CER. CAP.	
	C090	NCB31HK-102AY	1000PF 50V CER. CAP.	
	C091	NCB31HK-102AY	1000PF 50V CER. CAP.	
	C092	NCF31AZ-105AYUU	1MF 10V CER. CAP.	
	C095	NCB31HK-102AY	1000PF 50V CER. CAP.	
	C096	NCB31HK-102AY	1000PF 50V CER. CAP.	
	C097	NCF31AZ-105AYUU	1MF 10V CER. CAP.	
	C098	NCB31HK-102AY	1000PF 50V CER. CAP.	
	C099	NCS31HJ-101AY	100PF 50V CER. CAP.	
		RESISTORS		
	R021	NRSA63J-104NY	METAL GLAZE	
	R022	NRSA63J-104NY	METAL GLAZE	
	R023	NRSA63J-103N	METAL GLAZE	
	R024	NRSA63J-103N	METAL GLAZE	
	R025	NRSA63J-624NY	METAL GLAZE	
	R026	NRSA63J-334NY	METAL GLAZE	
	R027	NRSA63F-103NY	METAL GLAZE	
	R028	NRSA63F-103NY	METAL GLAZE	
	R029	NRSA63J-271NY	METAL GLAZE	

Δ	Item	Parts Number	Description	Area
	R030	NRSA63J-271NY	METAL GLAZE	
	R031	NRSA63J-333NY	METAL GLAZE	
	R036	NRSA63J-0ROAY	METAL GLAZE	
	R037	NRSA63J-0ROAY	METAL GLAZE	
	R038	NRSA63J-0ROAY	METAL GLAZE	
	R041	NRSA63J-0ROAY	METAL GLAZE	
	R042	NRSA63J-0ROAY	METAL GLAZE	
	R051	NRSA63J-473NY	METAL GLAZE	
	R052	NRSA63J-473NY	METAL GLAZE	
	R053	NRSA63J-201NY	METAL GLAZE	
	R054	NRSA63J-201NY	METAL GLAZE	
	R061	NRSA63J-0ROAY	METAL GLAZE	
	R062	NRSA63J-0ROAY	METAL GLAZE	
	R071	NRSA63J-473NY	METAL GLAZE	
	R072	NRSA63J-473NY	METAL GLAZE	
	R073	NRSA63J-201NY	METAL GLAZE	
	R074	NRSA63J-201NY	METAL GLAZE	
	R081	NRSA63J-0ROAY	METAL GLAZE	
	R083	NRSA63J-112NY	METAL GLAZE	
	R084	NRSA63J-112NY	METAL GLAZE	
	R085	NRSA63J-112NY	METAL GLAZE	
	R086	NRSA63J-182NY	METAL GLAZE	
	R087	NRSA63J-112NY	METAL GLAZE	
	R088	NRSA63J-0ROAY	METAL GLAZE	
	R089	NRSA63J-0ROAY	METAL GLAZE	
	R090	NRSA63J-0ROAY	METAL GLAZE	
	R091	NRSA63J-0ROAY	METAL GLAZE	
	R092	NRSA63J-0ROAY	METAL GLAZE	
	R093	NRSA63J-0ROAY	METAL GLAZE	
	R094	NRSA63J-471N	METAL GLAZE	
	R095	NRSA63J-103N	METAL GLAZE	
	R096	NRSA63J-103N	METAL GLAZE	
	R097	NRSA63J-472NY	METAL GLAZE	
	R098	NRSA63J-472NY	METAL GLAZE	
	R099	NRSA63J-472NY	METAL GLAZE	
	R100	NRSA63J-472NY	METAL GLAZE	
		OTHERS		
		EMW10476-101A	CIR. BOARD	
	K041	EQA0002-N102Y	FERRITE BEADS	
	K042	EQA0002-N102Y	FERRITE BEADS	
	K061	EQA0002-N102Y	FERRITE BEADS	
	K062	EQA0002-N102Y	FERRITE BEADS	
	K081	EQA0002-N102Y	FERRITE BEADS	
	K082	EQA0002-N102Y	FERRITE BEADS	
	K083	EQA0002-N102Y	FERRITE BEADS	
	K084	EQA0002-N102Y	FERRITE BEADS	
	K085	EQA0002-N102Y	FERRITE BEADS	
	K086	EQA0002-N102Y	FERRITE BEADS	
	K087	EQA0001-N01Y	FERRITE BEADS	
	K088	EQA0001-N01Y	FERRITE BEADS	
	K089	EQA0001-N01Y	FERRITE BEADS	
	K090	EQA0001-N01Y	FERRITE BEADS	
	K091	EQA0002-N102Y	FERRITE BEADS	
	K092	EQA0002-N102Y	FERRITE BEADS	
	K093	EQA0002-N102Y	FERRITE BEADS	
	K094	EQA0002-N102Y	FERRITE BEADS	
	K095	EQA0002-N102Y	FERRITE BEADS	
	K096	EQA0002-N102Y	FERRITE BEADS	
	K097	EQA0002-N102Y	FERRITE BEADS	
	K098	EQA0002-N102Y	FERRITE BEADS	
	X081	ECX0225-792EN9T	CRYSTAL	
	LC021	EQF0703-N103NZ	INDUCTOR	
	LC041	EQF0703-N103NZ	INDUCTOR	
	LC081	EQF0703-N103NZ	INDUCTOR	
	LC093	EQF0704-N01YU	INDUCTOR	
	LC096	EQF0703-N103NZ	INDUCTOR	

# Accessories List

Symbol No. 

M	3	M	M
---	---	---	---

△	Item	Parts Number	Parts Name	Q'ty	Description	Area
	1	E30580-2416A	INSTRUCTION BOOK	1		J
	1	E30580-2417A	INSTRUCTION BOOK	1		C
	2	RM-SR818U	WIRE-LESS REMOTE CONTROL	1		
	3	R03BPA-2STSA	DRY CELL	1		
	4	EQB4001-015	LOOP ANTENNA	1		
	5	EWP201-011	ANTENNA WIRE	1		
	6	E309758-001	POLY BAG	1		
	-	BT-20044G	SAFETY SHEET	1		J
	-	BT-20071B	SERVICE NETWORK	1		C
	-	BT-51006-1	REGISTER CARD	1		J
	-	BT-52002-1	WARRANTY CARD	1		C



# Packing Materials and Part Numbers

Symbol No. 

M	4	M	M
---	---	---	---

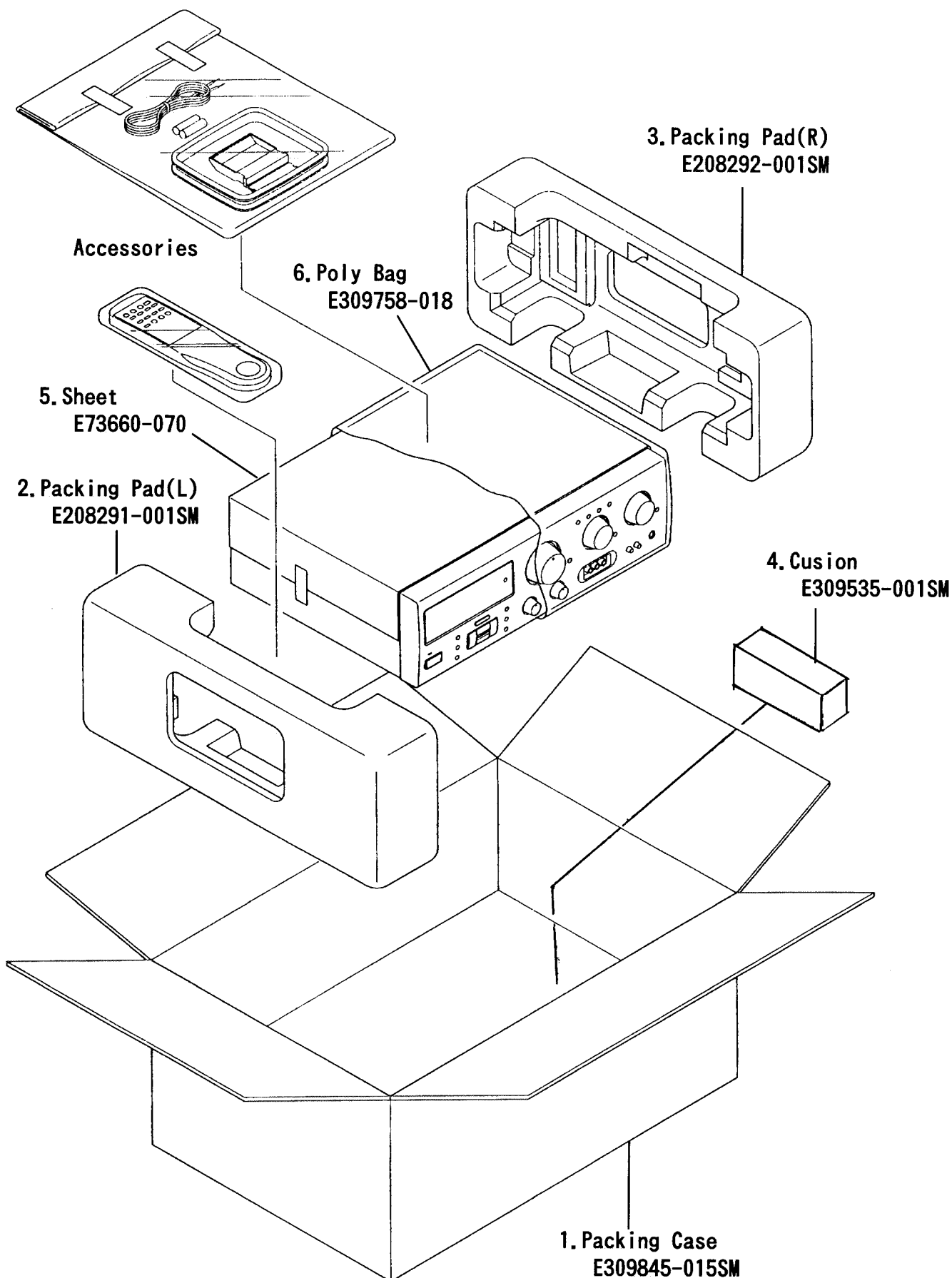

**-MEMO-**

# PARTS LIST

## RX-880VBK

**Note : All printed circuit board assemblies are not available as service parts.**

### Contents

General Exploded View and Parts List .....	4-2
Electrical and Parts List .....	4-4
■ ENC-131 Input Selector and S.E.A P.C. Board ass'y .....	4-4
■ ENB-233 System Control & Rear Power Amplifier P.C. Board ass'y .....	4-7
■ ENH-287 Power Amplifier P.C. Board ass'y .....	4-9
■ ENA-172 Tuner P.C. Board ass'y .....	4-12
■ ENP-054 D.S.P PC Board ass'y .....	4-13
Accessories List .....	4-14
Packing Materials and Part Numbers .....	4-15

# General Exploded View and Parts List

Symbol No. 

M	1	M	M
---	---	---	---

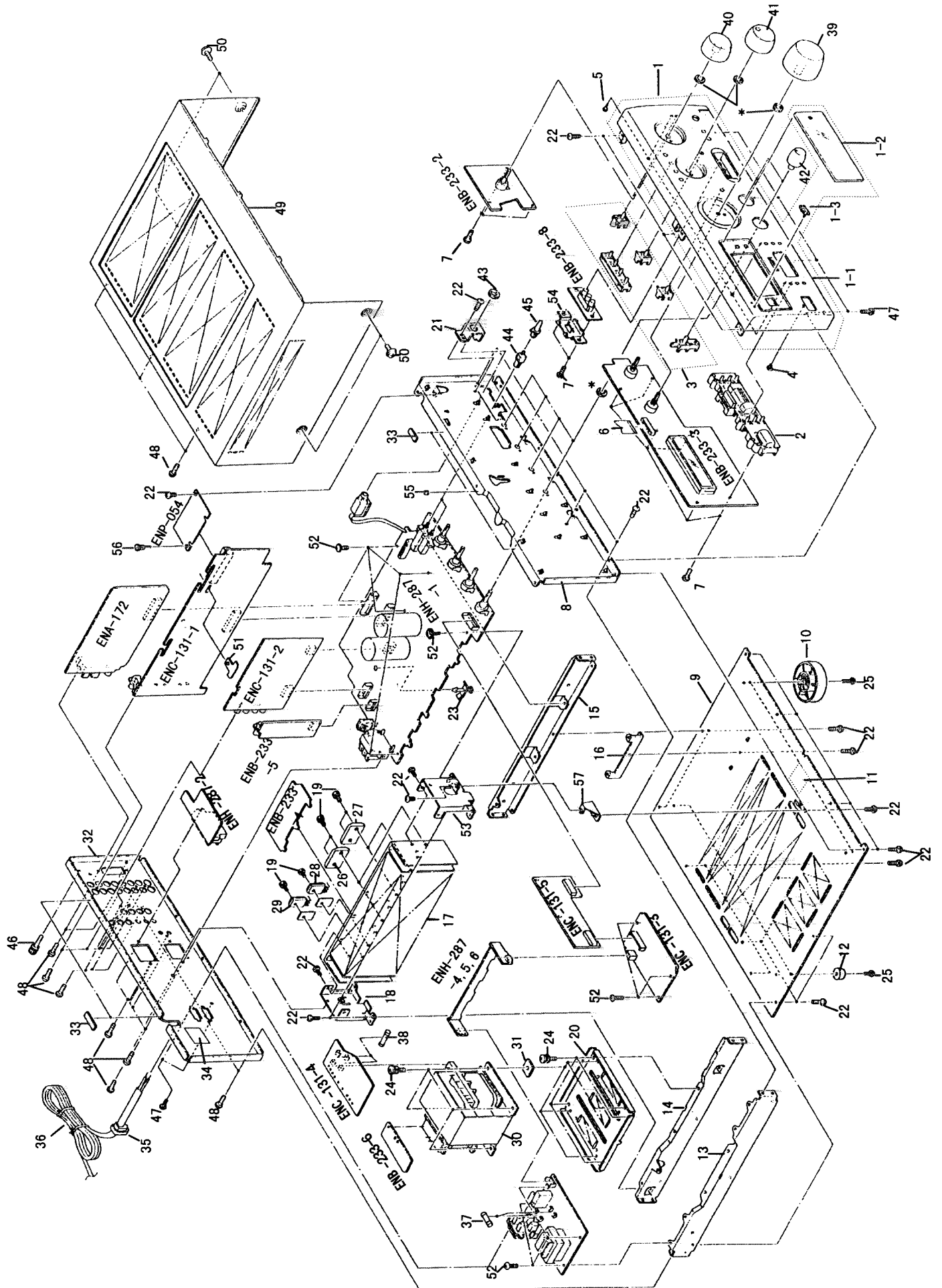

## ■ Parts List

Symbol No. 

M	1	M	M
---	---	---	---

△	Item	Parts Number	Parts Name	Q'ty	Description	Area
	1	EFP-RX880VBKJ(S)	FRONT PANEL	1		
	1-1	E102909-030SM	FRONT PANEL	1		
	1-2	E309112-018SM	WINDOW SCREEN	1		
	1-3	VJD5429-001	JVC MARK	1		
	2	E208276-005SM	PUSH BUTTON	1		
	3	E309105-004SM	PUSH BUTTON	1		
	4	FSJD4001-002	INDICATOR LENS	1		
	5	E408326-001SM	INDICATOR LENS	3		
	6	VWF1235-45PPB	FFC CABLE	1		
	7	SDSF2608Z	SCREW	11		
	8	E102911-003SM	FRONT BRACKET	1		
	9	E102820-004SM	BOTTOM PLATE	1		
	10	VJF4039-00PSM	FOOT ASSY	2	FRONT	
	11	E70115-002	CAUTION LABEL	1		C
	11	E70281-001	CAUTION LABEL	1		J
	12	E47227-036	FOOT	2	REAR	
	13	E208548-001SM	SIDE BRACKET	1	LEFT	
	14	E208549-001SM	CENTER BRACKET	1		
	15	E208081-003SM	SIDE BRACKET	1	RIGHT	
	16	E407984-001SM	C. BOARD HOLDER	1		
	17	E309170-004SM	HEAT SINK	1		
	18	E308836-003SM	HEAT SINK BRACKET	1	RIGHT	
	19	E73525-003	SCREW	12		
	20	E309459-003SM	TRANS BRACKET	1		
	21	E407323-002SM	HEADPHONE BRACKET	1		
	22	SBSG3008CC	TAPPING SCREW	27		
	23	E406084-002	FASTENER	1		
	24	E65389-006	SPECIAL SCREW	8		
	25	SBST3010Z	TAPPING SCREW	4		
	26	2SA1494LG(Y, P, G)	SI. TRANSISTOR	2	Q733/Q734	
	27	2SC3858LG(Y, P, G)	SI. TRANSISTOR	2	Q731/Q732	
	28	2SA1633LD(D, E)	SI. TRANSISTOR	2	Q018/Q058	
	29	2SC4278LD(D, E)	SI. TRANSISTOR	2	Q016/Q056	
△	30	ETP1200-73JAJ	POWER TRANSFORMER	1		
	31	E406309-002	SPACER	4		
	32	E103041-018SM	REAR PANEL	1		
	33	E306805-146	SPACER	4		
	34	E65507-001	CAUTION LABEL	1		C
	34	E67199-001	CAUTION LABEL	1		J
△	35	QHS3771-108	CORD STOPPER	1		
△	36	QMP1D00-200H	POWER CORD	1		
△	37	QMF0007-6R3J1	FUSE	1	F001	
△	38	QMF0007-2R0J1	FUSE	2	F851/F852	
	39	E309823-001SM	VOLUME KNOB	1		
	40	E309110-001SM	SELECT KNOB	1		
	41	E309110-003SM	SELECT KNOB	1		
	42	E309111-003SM	BALANCE KNOB	2		
	43	VKZ4150-001	NUT	1		
	44	E407983-001SM	PUSH SHAFT	2		
	45	E407321-002SM	PUSH BUTTON	2		
	46	E409257-001	EARTH TERMINAL	1		
	47	SDSG3008M	TAPPING SCREW	6		
	48	E73273-003	SPECIAL SCREW	22		
	49	E207378-024	METAL COVER	1		
	50	E61660-004	SPECIAL SCREW	4		
	51	E409374-001SM	SPACER	1		
	52	GBSG3008CC	TAPPING SCREW	13		
	53	E308836-004SM	HEAT SINK BRACKET	1	LEFT	
	54	E408713-001SM	C. BOARD HOLDER	1		
	55	E306805-028	SPACER	1		
	56	E48729-007	PLASTIC RIVET	1		
	57	E68587-010	BRACKET	1		
	-	E408632-002	RATING LABEL	1		C

Electrical Parts List(ENC-131)

Δ	Item	Parts Number	Description	Area	Δ	Item	Parts Number	Description	Area
		I. C. S							
	IC201	NJM2279D	I. C (MONO-ANALOG)			C265	QFN82AJ-104	0.1MF 100V MYLAR CAP.	
	IC211	BA7604N	I. C (MONO-ANALOG)			C266	QETB1HM-225	2.2MF 50V AL E. CAP.	
	IC221	UPC1860	I. C (MONO-ANALOG)			C267	QFN82AJ-104	0.1MF 100V MYLAR CAP.	
	IC222	TC74HC00AP	I. C (DIGI-MOS)			C268	QETB1VM-228N	2200MF 35V E. CAP.	
	IC231	MB90089-165	I. C (M)			C300	QCF21HP-223A	0.022MF 50V CER. CAP.	
	IC301	VC4580DD	I. C (MONO-ANALOG)			C301	QETB1HM-475E	4.7MF 50V E. CAP.	
	IC302	BA15218N	I. C (MONO-ANALOG)			C302	QETB1HM-475E	4.7MF 50V E. CAP.	
	IC303	TC9299P	I. C (DIGI-MOS)			C303	QCS21HJ-101A	100PF 50V CER. CAP.	
	IC304	BA15218N	I. C (MONO-ANALOG)			C304	QCS21HJ-101A	100PF 50V CER. CAP.	
	IC305	TC9212P	I. C (DIGI-MOS)			C305	QFLB1HJ-182	1800PF 50V MYLAR CAP.	
	IC306	VC4580LD	I. C (MONO-ANALOG)			C306	QFLB1HJ-182	1800PF 50V MYLAR CAP.	
	IC307	TC9212P	I. C (DIGI-MOS)			C307	QFLB1HJ-682	6800PF 50V MYLAR CAP.	
	IC308	VC4580LD	I. C (MONO-ANALOG)			C308	QFLB1HJ-682	6800PF 50V MYLAR CAP.	
	IC311	BA15218N	I. C (MONO-ANALOG)			C309	QCS21HJ-101A	100PF 50V CER. CAP.	
	IC321	TC9274N-007	I. C (M)			C310	QCS21HJ-101A	100PF 50V CER. CAP.	
	IC322	UPD4066BC	I. C (DIGI-MOS)			C311	QETB1HM-475E	4.7MF 50V E. CAP.	
	IC551	LC7522	I. C (DIGI-MOS)			C312	QETB1HM-475E	4.7MF 50V E. CAP.	
	IC552	M5243P12	I. C (MONO-ANALOG)			C313	QETB1AM-107	100MF 10V AL E. CAP.	
		DIODES				C314	QETB1AM-107	100MF 10V AL E. CAP.	
	D251	MTZ6.2JC	ZENER DIODE			C315	QETB1CM-476	47MF 16V AL E. CAP.	
	D252	1SR139-200	SI. DIODE			C316	QETB1CM-476	47MF 16V AL E. CAP.	
	D253	1SR139-200	SI. DIODE			C319	QCF21HP-223A	0.022MF 50V CER. CAP.	
	D254	MTZ39JCT-77	ZENER DIODE			C320	QCF21HP-223A	0.022MF 50V CER. CAP.	
	D255	1SR139-200	SI. DIODE			C321	QETB1EM-226N	22MF 25V E. CAP.	
	D261	1SR139-200	SI. DIODE			C322	QETB1EM-226N	22MF 25V E. CAP.	
	D262	1SR139-200	SI. DIODE			C333	QCS31HJ-331Z	330PF 50V CER. CAP.	
Δ	D263	10E2-FD	DIODE			C334	QCS31HJ-331Z	330PF 50V CER. CAP.	
Δ	D264	10E2-FD	DIODE			C341	QETB1HM-475E	4.7MF 50V E. CAP.	
	D265	1SS133	SI. DIODE			C342	QETB1HM-475E	4.7MF 50V E. CAP.	
	D351	MTZ6.2JC	ZENER DIODE			C343	QETB1EM-226N	22MF 25V E. CAP.	
	D352	MTZ6.2JC	ZENER DIODE			C344	QETB1EM-226N	22MF 25V E. CAP.	
	D551	MTZ6.8JC	ZENER DIODE			C345	QETB1EM-226N	22MF 25V E. CAP.	
	D552	MTZ6.8JC	ZENER DIODE			C346	QETB1EM-226N	22MF 25V E. CAP.	
Δ	D880	30D2FC	GE. DIODE			C347	QCF21HP-223A	0.022MF 50V CER. CAP.	
Δ	D881	30D2FC	GE. DIODE			C348	QCF21HP-223A	0.022MF 50V CER. CAP.	
Δ	D882	30D2FC	GE. DIODE			C349	QETB1EM-106	10MF 25V AL E. CAP.	
Δ	D883	30D2FC	GE. DIODE			C350	QETB1EM-106	10MF 25V AL E. CAP.	
Δ	D884	30D2FC	GE. DIODE			C351	QETB1HM-105	1MF 50V AL E. CAP.	
Δ	D885	30D2FC	GE. DIODE			C352	QETB1HM-105	1MF 50V AL E. CAP.	
Δ	D886	30D2FC	GE. DIODE			C353	QETB1HM-475E	4.7MF 50V E. CAP.	
Δ	D887	30D2FC	GE. DIODE			C354	QETB1HM-475E	4.7MF 50V E. CAP.	
Δ	D888	1SS133	SI. DIODE			C355	QETB1HM-105	1MF 50V AL E. CAP.	
	D1101	1SS133	SI. DIODE			C356	QETB1HM-105	1MF 50V AL E. CAP.	
	D1102	1SS133	SI. DIODE			C357	QETB1EM-106	10MF 25V AL E. CAP.	
	D1103	1SS133	SI. DIODE			C358	QETB1EM-106	10MF 25V AL E. CAP.	
	D1104	1SS133	SI. DIODE			C359	QCF21HP-223A	0.022MF 50V CER. CAP.	
	D1181	1SS133	SI. DIODE			C360	QCF21HP-223A	0.022MF 50V CER. CAP.	
		TRANSISTORS				C361	QETB1EM-476	47MF 25V AL E. CAP.	
	Q251	2SB1357 (E, F)	SI. TRANSISTOR			C362	QETB1EM-476	47MF 25V AL E. CAP.	
	Q252	2SC2240 (GR, BL)	SI. TRANSISTOR			C363	QCHB1EZ-223	0.022MF 25V CER. CAP.	
	Q253	DTC114YS	DIGITAL TRANSISTOR			C364	QCHB1EZ-223	0.022MF 25V CER. CAP.	
	Q254	DTA144ES	DIGITAL TRANSISTOR			C365	QCBB1HK-561Y	560PF 50V CER. CAP.	
	Q255	DTC114ES	DIGITAL TRANSISTOR			C366	QCBB1HK-561Y	560PF 50V CER. CAP.	
	Q306	2SD2144S (VM)	SI. TRANSISTOR			C367	QFV81HJ-154	0.15MF 50V THIN FILM CAP.	
	Q307	2SD2144S (VM)	SI. TRANSISTOR			C368	QFV81HJ-154	0.15MF 50V THIN FILM CAP.	
	Q308	DTC144ES	DIGITAL TRANSISTOR			C369	QETB1HM-225	2.2MF 50V AL E. CAP.	
	Q309	DTA144ES	DIGITAL TRANSISTOR			C370	QETB1HM-225	2.2MF 50V AL E. CAP.	
	Q310	DTC144ES	DIGITAL TRANSISTOR			C371	QETB1HM-106	10MF 50V E. CAP.	
	Q1121	2SC1740LN (R, S)	SI. TRANSISTOR			C372	QETB1HM-106	10MF 50V E. CAP.	
	Q1151	2SC1740LN (R, S)	SI. TRANSISTOR			C373	QETB1HM-106	10MF 50V E. CAP.	
	Q1152	DTC144ES	DIGITAL TRANSISTOR			C374	QETB1HM-106	10MF 50V E. CAP.	
	Q1181	2SC1740LN (R, S)	SI. TRANSISTOR			C375	QETB1EM-476	47MF 25V AL E. CAP.	
	Q1182	2SA933S (RS)	SI. TRANSISTOR			C376	QETB1EM-476	47MF 25V AL E. CAP.	
	Q1183	2SC1740LN (R, S)	SI. TRANSISTOR			C377	QCHB1EZ-223	0.022MF 25V CER. CAP.	
	Q1184	2SC1740LN (R, S)	SI. TRANSISTOR			C378	QCHB1EZ-223	0.022MF 25V CER. CAP.	
		CAPACITORS				C379	QETB1HM-225	2.2MF 50V AL E. CAP.	
	C251	QETB1HM-227	220MF 50V E. CAP.			C380	QETB1HM-225	2.2MF 50V AL E. CAP.	
	C252	QETB1JM-227	220MF 63V AL E. CAP.			C381	QETB1HM-475E	4.7MF 50V E. CAP.	
	C253	QETB1HM-105	1MF 50V AL E. CAP.			C382	QETB1HM-475E	4.7MF 50V E. CAP.	
	C254	QETB1HM-226E	22MF 50V E. CAP.			C383	QETB1HM-475E	4.7MF 50V E. CAP.	
	C255	QETB1HM-226E	22MF 50V E. CAP.			C384	QETB1HM-475E	4.7MF 50V E. CAP.	
	C256	QFLB1HJ-104	0.1MF 50V MYLAR CAP.			C385	QCBB1HK-561Y	560PF 50V CER. CAP.	
	C259	QFLB1HJ-473	0.047MF 50V MYLAR CAP.			C396	QCBB1HK-121Y	120PF 50V CER. CAP.	
	C260	QFLB1HJ-473	0.047MF 50V MYLAR CAP.			C397	QCBB1HK-121Y	120PF 50V CER. CAP.	
	C262	QETB1VM-228N	2200MF 35V E. CAP.			C398	QCBB1HK-121Y	120PF 50V CER. CAP.	
	C264	QFN82AJ-104	0.1MF 100V MYLAR CAP.			C399	QCBB1HK-121Y	120PF 50V CER. CAP.	
						C551	QETB1HM-475E	4.7MF 50V E. CAP.	

Electrical Parts List(ENC-131)

Item	Parts Number	Description	Area	Item	Parts Number	Description	Area
C552	QETB1HM-475E	4. 7MF 50V E. CAP.		C1201	QETB1CM-476	47MF 16V AL. E. CAP.	
C553	QCBB1HK-101Y	100PF 50V CER. CAP.		C1202	QCF21HP-103A	0. 01MF 50V CER. CAP.	
C554	QCBB1HK-101Y	100PF 50V CER. CAP.		C1203	QETB1CM-476	47MF 16V AL. E. CAP.	
C555	QETB1HM-475E	4. 7MF 50V E. CAP.		C1204	QETBOJM-477	470MF 6. 3V AL. E. CAP.	
C556	QETB1HM-475E	4. 7MF 50V E. CAP.		C1206	QCBB1HK-102Y	1000PF 50V CER. CAP.	
C557	QETB1HM-475E	4. 7MF 50V E. CAP.		C1207	QCBB1HK-271Y	270PF 50V CER. CAP.	
C558	QETB1HM-475E	4. 7MF 50V E. CAP.		C1208	QCBB1HK-121Y	120PF 50V CER. CAP.	
C559	QETB1HM-475E	4. 7MF 50V E. CAP.			RESISTORS		
C560	QETB1HM-475E	4. 7MF 50V E. CAP.		△ R251	PTH61G25AR4R7M	POSITIVE THE	
C563	QCHB1EZ-223	0. 022MF 25V CER. CAP.		R252	QRD167J-152	1. 5K 1/6W CARBON RES.	
C564	QETB1CM-226	22MF 16V E. CAP.		R253	QRD167J-223	22K 1/6W CARBON RES.	
C565	QCHB1EZ-223	0. 022MF 25V CER. CAP.		R254	QRD161J-104	100K 1/6W CARBON RES.	
C566	QETB1CM-226	22MF 16V E. CAP.		△ R255	QRD14CJ-100SX	10 1/4W UNF. CARBON R	
C567	QCHB1EZ-223	0. 022MF 25V CER. CAP.		△ R262	QRX022J-2R2A	2. 2 2W METAL FILM R	
C569	QCSB1HJ-470	47PF 50V CER. CAP.		R263	QRD167J-562	5. 6K 1/6W CARBON RES.	
C570	QCSB1HJ-470	47PF 50V CER. CAP.		R264	QRD167J-822	8. 2K 1/6W CARBON RES.	
C571	QFV81HJ-333	0. 033MF 50V THIN FILM CAP.		R265	QRD161J-103	10K 1/6W CARBON RES.	
C572	QFV81HJ-333	0. 033MF 50V THIN FILM CAP.		△ R266	QRD14CJ-2R2SX	2. 2 1/4W UNF. CARBON R	
C573	QETB1HM-105	1MF 50V AL. E. CAP.		R301	QRD161J-222	2. 2K 1/6W CARBON RES.	
C574	QETB1HM-105	1MF 50V AL. E. CAP.		R302	QRD161J-222	2. 2K 1/6W CARBON RES.	
C575	QFLB1HJ-332	3300PF 50V MYLAR CAP.		R303	QRD161J-473	47K 1/6W CARBON RES.	
C576	QFLB1HJ-332	3300PF 50V MYLAR CAP.		R304	QRD161J-473	47K 1/6W CARBON RES.	
C577	QFV81HJ-104	0. 1MF 50V THIN FILM CAP.		R305	QRD161J-561	560 1/6W CARBON RES.	
C578	QFV81HJ-104	0. 1MF 50V THIN FILM CAP.		R306	QRD161J-561	560 1/6W CARBON RES.	
C579	QCBB1HK-331Y	330PF 50V CER. CAP.		R307	QRD161J-393	39K 1/6W CARBON RES.	
C580	QCBB1HK-331Y	330PF 50V CER. CAP.		R308	QRD161J-393	39K 1/6W CARBON RES.	
C581	QCVB1CM-103Y	0. 01MF 18V CER. CAP.		R309	QRD161J-474	470K 1/6W CARBON RES.	
C582	QCVB1CM-103Y	0. 01MF 18V CER. CAP.		R310	QRD161J-474	470K 1/6W CARBON RES.	
C881	QCE22HP-103A	0. 01MF 500V CER. CAP.		R311	QRD161J-104	100K 1/6W CARBON RES.	
C882	QCE22HP-103A	0. 01MF 500V CER. CAP.		R312	QRD161J-104	100K 1/6W CARBON RES.	
C883	QCE22HP-103A	0. 01MF 500V CER. CAP.		△ R313	QRD14CJ-391SX	390 1/4W UNF. CARBON R	
C884	QCE22HP-103A	0. 01MF 500V CER. CAP.		△ R314	QRD14CJ-391SX	390 1/4W UNF. CARBON R	
C885	QCE22HP-103A	0. 01MF 500V CER. CAP.		△ R321	QRZ0077-680	68 1/4W FUSIBLE RES.	
C886	QCE22HP-103A	0. 01MF 500V CER. CAP.		△ R322	QRZ0077-680	68 1/4W FUSIBLE RES.	
C1102	QETB1HM-475E	4. 7MF 50V E. CAP.		R325	QRD161J-471	470 1/6W CARBON RES.	
C1103	QCSB1HJ-470	47PF 50V CER. CAP.		R326	QRD161J-471	470 1/6W CARBON RES.	
C1104	QCSB1HJ-470	47PF 50V CER. CAP.		R327	QRD161J-471	470 1/6W CARBON RES.	
C1105	QETB1HM-475E	4. 7MF 50V E. CAP.		R328	QRD161J-471	470 1/6W CARBON RES.	
C1106	QETB1HM-475E	4. 7MF 50V E. CAP.		R329	QRD161J-471	470 1/6W CARBON RES.	
C1111	QCZ0205-155	1. 5MF 25V C. CAP.		R330	QRD161J-471	470 1/6W CARBON RES.	
C1115	QETB1HM-475E	4. 7MF 50V E. CAP.		R331	QRD161J-471	470 1/6W CARBON RES.	
C1116	QETB1CM-476	47MF 16V AL. E. CAP.		R332	QRD161J-471	470 1/6W CARBON RES.	
C1121	QCZ0205-155	1. 5MF 25V C. CAP.		R333	QRD161J-471	470 1/6W CARBON RES.	
C1122	QETB1CM-476	47MF 16V AL. E. CAP.		R334	QRD161J-471	470 1/6W CARBON RES.	
C1151	QCS21HJ-101A	100PF 50V CER. CAP.		R335	QRD161J-471	470 1/6W CARBON RES.	
C1152	QCS31HJ-330Z	33PF 50V CER. CAP.		R336	QRD161J-471	470 1/6W CARBON RES.	
C1153	QCF21HP-103A	0. 01MF 50V CER. CAP.		R337	QRD161J-471	470 1/6W CARBON RES.	
C1154	QCF21HP-103A	0. 01MF 50V CER. CAP.		R338	QRD161J-471	470 1/6W CARBON RES.	
C1156	QCF21HP-103A	0. 01MF 50V CER. CAP.		R341	QRD161J-104	100K 1/6W CARBON RES.	
C1157	QETB1HM-474	0. 47MF 50V E. CAP.		R342	QRD161J-104	100K 1/6W CARBON RES.	
C1158	QFV81HJ-104	0. 1MF 50V THIN FILM CAP.		R343	QRD161J-104	100K 1/6W CARBON RES.	
C1159	QETB1HM-474	0. 47MF 50V E. CAP.		R344	QRD161J-104	100K 1/6W CARBON RES.	
C1160	QCY31HK-332Z	3300PF 50V CER. CAP.		R347	QRD161J-104	100K 1/6W CARBON RES.	
C1161	QCT30CH-100Y	10PF 50V CER. CAP.		R348	QRD161J-104	100K 1/6W CARBON RES.	
C1162	QCS21HJ-680A	68PF 50V CER. CAP.		△ R349	QRZ0077-680	68 1/4W FUSIBLE RES.	
C1163	QCT30CH-150Y	15PF 50V CER. CAP.		△ R350	QRZ0077-680	68 1/4W FUSIBLE RES.	
C1164	QCZ0205-155	1. 5MF 25V C. CAP.		R351	QRD14CJ-152SX	1. 5K 1/4W UNF. CARBON R	
C1165	QETB1AM-477	470MF 10V E. CAP.		R352	QRD14CJ-152SX	1. 5K 1/4W UNF. CARBON R	
C1166	QCY31HK-102Z	1000PF 50V CER. CAP.		R353	QRD161J-563	56K 1/6W CARBON RES.	
C1167	QETB1HM-475E	4. 7MF 50V E. CAP.		R354	QRD161J-563	56K 1/6W CARBON RES.	
C1168	QETB1HM-475E	4. 7MF 50V E. CAP.		R355	QRD161J-563	56K 1/6W CARBON RES.	
C1169	QFV71HJ-563ZM	0. 056MF 50V THIN FILM CAP.		R356	QRD161J-474	470K 1/6W CARBON RES.	
C1170	QCS21HJ-221	220PF 50V CER. CAP.		R357	QRD167J-152	1. 5K 1/6W CARBON RES.	
C1171	QCY31HK-152Z	1500PF 50V CER. CAP.		R358	QRD167J-152	1. 5K 1/6W CARBON RES.	
C1172	QETB1HM-475E	4. 7MF 50V E. CAP.		R359	QRD167J-152	1. 5K 1/6W CARBON RES.	
C1173	QFV71HJ-153	0. 015MF 50V THIN FILM CAP.		R360	QRD167J-152	1. 5K 1/6W CARBON RES.	
C1174	QETBOJM-477	470MF 6. 3V AL. E. CAP.		△ R361	QRZ0077-680	68 1/4W FUSIBLE RES.	
C1175	QCS21HJ-560	56PF 50V CER. CAP.		△ R362	QRZ0077-680	68 1/4W FUSIBLE RES.	
C1177	QCT30CH-130Y	13PF 50V CER. CAP.		R363	QRD161J-123	12K 1/6W CARBON RES.	
C1178	QCT30CH-150Y	15PF 50V CER. CAP.		R364	QRD161J-123	12K 1/6W CARBON RES.	
C1180	QCZ0205-155	1. 5MF 25V C. CAP.		R365	QRD161J-103	10K 1/6W CARBON RES.	
C1181	QETB1HM-475E	4. 7MF 50V E. CAP.		R366	QRD161J-103	10K 1/6W CARBON RES.	
C1182	QETB1HM-225	2. 2MF 50V AL. E. CAP.		R369	QRD161J-104	100K 1/6W CARBON RES.	
C1197	QCSB1HJ-470	47PF 50V CER. CAP.		R370	QRD161J-104	100K 1/6W CARBON RES.	
C1198	QCSB1HJ-270Y	27PF 50V CER. CAP.		R371	QRD161J-104	100K 1/6W CARBON RES.	
C1199	QETB1AM-477	470MF 10V E. CAP.		R372	QRD161J-104	100K 1/6W CARBON RES.	
C1200	QCZ0205-155	1. 5MF 25V C. CAP.		R373	QRD161J-105	1M 1/6W CARBON RES.	

Electrical Parts List(ENC-131)

Item	Parts Number	Description	Area	Item	Parts Number	Description	Area
R374	QRD161J-105	1M 1/6W CARBON RES.		R1154	QRD161J-105	1M 1/6W CARBON RES.	
R375	QRD161J-683	68K 1/6W CARBON RES.		R1155	QRD161J-222	2.2K 1/6W CARBON RES.	
R376	QRD161J-683	68K 1/6W CARBON RES.		R1156	QRD167J-511	510 1/6W CARBON RES.	
R377	QRD161J-103	10K 1/6W CARBON RES.		R1157	QRD161J-101	100 1/6W CARBON RES.	
R378	QRD161J-103	10K 1/6W CARBON RES.		R1158	QRD161J-104	100K 1/6W CARBON RES.	
R379	QRD161J-104	100K 1/6W CARBON RES.		R1159	QRD161J-221	220 1/6W CARBON RES.	
R380	QRD161J-104	100K 1/6W CARBON RES.		R1160	QRD161J-104	100K 1/6W CARBON RES.	
R381	QRD167J-152	1.5K 1/6W CARBON RES.		R1161	QRD161J-221	220 1/6W CARBON RES.	
R382	QRD167J-152	1.5K 1/6W CARBON RES.		R1162	QRD161J-333	33K 1/6W CARBON RES.	
R383	QRZ0077-680	68 1/4W FUSIBLE RES.		R1164	QRD161J-222	2.2K 1/6W CARBON RES.	
R384	QRZ0077-680	68 1/4W FUSIBLE RES.		R1165	QRD161J-271	270 1/6W CARBON RES.	
R385	QRD161J-393	39K 1/6W CARBON RES.		R1166	QRD167J-272	2.7K 1/6W CARBON RES.	
R386	QRD161J-393	39K 1/6W CARBON RES.		R1167	QRD167J-822	8.2K 1/6W CARBON RES.	
R387	QRD161J-224	220K 1/6W CARBON RES.		R1168	QRD161J-102	1K 1/6W CARBON RES.	
R388	QRD161J-224	220K 1/6W CARBON RES.		R1169	QRD161J-104	100K 1/6W CARBON RES.	
R389	QRD161J-124	120K 1/6W CARBON RES.		R1170	QRD161J-105	1M 1/6W CARBON RES.	
R390	QRD161J-124	120K 1/6W CARBON RES.		R1171	QRD161J-271	270 1/6W CARBON RES.	
R393	QRD161J-124	120K 1/6W CARBON RES.		R1172	QRD161J-301	300 1/6W CARBON RES.	
R394	QRD161J-124	120K 1/6W CARBON RES.		R1173	QRD161J-201	200 1/6W CARBON RES.	
R395	QRD161J-124	120K 1/6W CARBON RES.		R1175	QRD161J-750	75 1/6W CARBON RES.	
R396	QRD161J-124	120K 1/6W CARBON RES.		R1176	QRD161J-750	75 1/6W CARBON RES.	
R397	QRZ0077-680	68 1/4W FUSIBLE RES.		R1177	QRD161J-102	1K 1/6W CARBON RES.	
R398	QRZ0077-680	68 1/4W FUSIBLE RES.		R1178	QRD167J-153	15K 1/6W CARBON RES.	
R551	QRD167J-562	5.6K 1/6W CARBON RES.		R1179	QRD161J-102	1K 1/6W CARBON RES.	
R552	QRD167J-562	5.6K 1/6W CARBON RES.		R1180	QRD167J-121	120 1/6W CARBON RES.	
R553	QRD167J-511	510 1/6W CARBON RES.		R1181	QRD161J-102	1K 1/6W CARBON RES.	
R554	QRD167J-511	510 1/6W CARBON RES.		R1182	QRD161J-621	620 1/6W CARBON RES.	
R555	QRD161J-102	1K 1/6W CARBON RES.		R1183	QRD161J-331	330 1/6W CARBON RES.	
R556	QRD161J-102	1K 1/6W CARBON RES.		R1184	QRD161J-391	390 1/6W CARBON RES.	
R557	QRD161J-103	10K 1/6W CARBON RES.		R1195	QRD161J-561	560 1/6W CARBON RES.	
R558	QRD161J-103	10K 1/6W CARBON RES.		R1196	QRD161J-561	560 1/6W CARBON RES.	
R559	QRD167J-113	11K 1/6W CARBON RES.		R1197	QRD161J-561	560 1/6W CARBON RES.	
R560	QRD167J-113	11K 1/6W CARBON RES.		R1198	QRD161J-103	10K 1/6W CARBON RES.	
R561	QRD161J-104	100K 1/6W CARBON RES.			OTHERS		
R562	QRD161J-104	100K 1/6W CARBON RES.			EMW10621-002	CIR. BOARD	
R563	QRD161J-333	33K 1/6W CARBON RES.		J301	EMN00TV-422AJ2	PIN JACK	
R564	QRD161J-333	33K 1/6W CARBON RES.		J302	EMN00TV-622AJ2	PIN JACK	
R565	QRD161J-124	120K 1/6W CARBON RES.		J303	EMN00TV-622AJ2	PIN JACK	
R566	QRD161J-124	120K 1/6W CARBON RES.		BK880	E310098-001SM	HOLDER	C
R571	QRD14CJ-681SX	680 1/4W UNF. CARBON R		BK884	E310098-001SM	HOLDER	C
R572	QRD14CJ-681SX	680 1/4W UNF. CARBON R		CN312	EMV5109-004A	MALE CONNECTOR	
R573	QRD161J-681	680 1/6W CARBON RES.		CN413	EMV5109-009A	PIN PLUG	
R574	QRD167J-272	2.7K 1/6W CARBON RES.		CN506	EWS293-0110	CONNECTOR WIRE ASSY	
R575	QRD161J-474	470K 1/6W CARBON RES.		CN511	EMV5163-012R	CONNECT TERMINAL	
R576	QRD161J-474	470K 1/6W CARBON RES.		CN512	EMV5142-903	CONNECT TERMINAL	
R577	QRD161J-474	470K 1/6W CARBON RES.		CN513	VMC0075-003	CONNECTOR	
R578	QRD161J-474	470K 1/6W CARBON RES.		CN515	EMV5163-004R	CONNECT TERMINAL	
R579	QRD161J-474	470K 1/6W CARBON RES.		CN516	VMC0075-003	CONNECTOR	
R580	QRD161J-474	470K 1/6W CARBON RES.		CN603	EMV7164-036	CONNECT TERMINAL	
R585	QRD161J-102	1K 1/6W CARBON RES.		CN611	EMV5163-015R	CONNECT TERMINAL	
R586	QRD161J-102	1K 1/6W CARBON RES.		CN612	EMV5163-009R	CONNECT TERMINAL	
R587	QRD161J-103	10K 1/6W CARBON RES.		CN802	EWS273-005	SOCKET WIRE ASSY	
R588	QRD161J-103	10K 1/6W CARBON RES.		CN803	VMC0177-003	CONNECT TERMINAL	
R591	QRD161J-432	4.3K 1/6W CARBON RES.		CN805	EMV7163-007	CONNECT TERMINAL	
R592	QRD161J-432	4.3K 1/6W CARBON RES.		CN811	EMV5163-007R	CONNECT TERMINAL	
R593	QRD161J-103	10K 1/6W CARBON RES.		CN815	EMV5163-007R	CONNECT TERMINAL	
R594	QRD161J-103	10K 1/6W CARBON RES.		EP250	EMZ4002-002Z	EARTH PLATE	
R881	QRX012J-1R2A	1.2 1W METAL FILM R		FC881	EMG7331-003Z	FUSE CLIP	
R882	QRX012J-1R2A	1.2 1W METAL FILM R		FC882	EMG7331-003Z	FUSE CLIP	
R1101	QRD161J-750	75 1/6W CARBON RES.		FC883	EMG7331-003Z	FUSE CLIP	
R1102	QRD161J-750	75 1/6W CARBON RES.		FC884	EMG7331-003Z	FUSE CLIP	
R1105	QRD161J-750	75 1/6W CARBON RES.		FW211	EWR37D-13SS	CORD	
R1106	QRD167J-680	68 1/6W CARBON RES.		J1101	EMN00TV-116A	PIN JACK	
R1107	QRD161J-331	330 1/6W CARBON RES.		J1102	EMN01TV-102A	PIN JACK	
R1108	QRD161J-331	330 1/6W CARBON RES.		J1103	EMN00YV-217A	PIN JACK	
R1109	QRD161J-750	75 1/6W CARBON RES.		K1001	ENZ8101-007	INDUCTOR	
R1110	QRD161J-331	330 1/6W CARBON RES.		K1002	ENZ8101-007	INDUCTOR	
R1113	QRD161J-472	4.7K 1/6W CARBON RES.		K1003	ENZ8101-007	INDUCTOR	
R1115	QRD161J-472	4.7K 1/6W CARBON RES.		LC201	EQF0601-101T	EMI FILTER 1M	
R1121	QRD161J-101	100 1/6W CARBON RES.		L1151	EQL4007-150T	INDUCTOR	
R1122	QRD161J-392	3.9K 1/6W CARBON RES.		L1191	EQL4004-220	INDUCTOR	
R1123	QRD161J-103	10K 1/6W CARBON RES.		RY880	ESK1D12-119J3	RELAY	
R1125	QRD161J-472	4.7K 1/6W CARBON RES.		RY881	ESK1D12-119J3	RELAY	
R1126	QRD161J-472	4.7K 1/6W CARBON RES.		X1151	ECX0143-1818EWT	CRYSTAL	
R1151	QRD161J-103	10K 1/6W CARBON RES.		X1152	ECX0000-503KS	CERAMIC RESONATOR	
R1152	QRD161J-103	10K 1/6W CARBON RES.		X1153	ECX0143-1818EWT	CRYSTAL	
R1153	QRD161J-681	680 1/6W CARBON RES.					



## Electrical Parts List(ENB-233)

△	Item	Parts Number	Description	Area	△	Item	Parts Number	Description	Area
		I. C. S							
	IC400	MN172412K8X	I. C(MICRO-COMPUTER)			C082	QETB1HM-476	47MF 50V E. CAP.	
	IC401	MN171601AK8W	I. C(MICRO-COMPUTER)			C291	QCS31HJ-471Z	470PF 50V CER. CAP.	
	IC402	PST600E-T	I. C(MONO-ANALOG)			C294	QCS31HJ-681Z	680PF 50V CER. CAP.	
	IC403	SPS-420-1	INFRARED DETECT UNIT			C401	QCZ0202-155	1.5MF 25V CER. RES.	
		DIODES				C402	QEK61AM-227ZM	220MF 10V AL E. CAP.	
	D050	1SS133	SI. DIODE			C403	QEAD0HZ-10AZM	AL E. CAP.	
	D051	MTZ18JC	ZENER DIODE			C404	QETB1HM-106	10MF 50V E. CAP.	
	D052	1SS133	SI. DIODE			C405	QETB1HM-475E	4.7MF 50V E. CAP.	
	D053	1SS133	SI. DIODE			C406	QETB1HM-475E	4.7MF 50V E. CAP.	
	D061	1SS133	SI. DIODE			C407	QETBOJM-107	100MF 6.3V AL E. CAP.	
	D062	1SS133	SI. DIODE			C409	QETB1AM-227	220MF 10V E. CAP.	
	D081	MTZ20JC	ZENER DIODE			C410	QCZ0202-155	1.5MF 25V CER. RES.	
	D082	MTZ20JC	ZENER DIODE			C412	QEK51HM-225G	2.2MF 50V AL E. CAP.	
	D292	1SS133	SI. DIODE			C413	QCHB1EZ-223	0.022MF 25V CER. CAP.	
	D400	1SR139-200	SI. DIODE			C414	QCBB1HK-331Y	330PF 50V CER. CAP.	
	D401	1SR139-200	SI. DIODE			C415	QCZ0202-155	1.5MF 25V CER. RES.	
	D402	1SR139-200	SI. DIODE			C418	QCHB1EZ-223	0.022MF 25V CER. CAP.	
	D403	SLR-34MC70F124	L. E. D.			C419	QCHB1EZ-223	0.022MF 25V CER. CAP.	
	D404	SLR-34MC70F124	L. E. D.			C591	QCBB1HK-331Y	330PF 50V CER. CAP.	
	D405	SLR-54VC50F124	L. E. D.			C592	QCBB1HK-331Y	330PF 50V CER. CAP.	
	D406	1SS133	SI. DIODE			C593	QCBB1HK-331Y	330PF 50V CER. CAP.	
	D407	1SS133	SI. DIODE			C850	QETB1CM-476	47MF 16V AL E. CAP.	
	D408	1SS133	SI. DIODE			C851	QFN82AK-472	4700PF 100V METAL. MYLAR	
	D409	1SS133	SI. DIODE			C852	QETB1EM-227	220MF 25V AL E. CAP.	
	D410	1SS133	SI. DIODE				RESISTORS		
	D411	1SS133	SI. DIODE		△	R001	QRC128K-275EM	2.7M 1/2W COMPOSITION	
	D412	1SS133	SI. DIODE			R051	QRD161J-222	2.2K 1/6W CARBON RES.	
	D413	1SS133	SI. DIODE			R052	QRD161J-104	100K 1/6W CARBON RES.	
	D414	1SS133	SI. DIODE			R053	QRD161J-123	12K 1/6W CARBON RES.	
	D415	1SS133	SI. DIODE			R054	QRD161J-182	1.8K 1/6W CARBON RES.	
	D416	1SS133	SI. DIODE			R055	QRD161J-104	100K 1/6W CARBON RES.	
	D490	SLR-34VC3F	L. E. D.		△	R056	QRD14CJ-181S	180 1/4W UNF. CARBON R	
	D857	MTZ6.2JC	ZENER DIODE		△	R057	QRD14CJ-222SX	2.2K 1/4W UNF. CARBON R	
	D858	1SS133	SI. DIODE			R058	QRD161J-202	2K 1/6W CARBON RES.	
	D871	1SR139-200	SI. DIODE			R059	QRD161J-222	2.2K 1/6W CARBON RES.	
	D872	1SR139-200	SI. DIODE			R060	QRD161J-202	2K 1/6W CARBON RES.	
	D873	1SR139-200	SI. DIODE		△	R063	QRD14CJ-120SX	12 1/4W UNF. CARBON R	
	D874	1SR139-200	SI. DIODE		△	R064	QRD14CJ-100SX	10 1/4W UNF. CARBON R	
		TRANSISTORS			△	R065	QRD14CJ-561SX	560 1/4W UNF. CARBON R	
	Q051	2SC2240 (GR, BL)	SI. TRANSISTOR		△	R066	QRD14CJ-100SX	10 1/4W UNF. CARBON R	
	Q052	2SC2240 (GR, BL)	SI. TRANSISTOR		△	R067	QRD14CJ-120SX	12 1/4W UNF. CARBON R	
	Q053	2SA1038 (R, S)	SI. TRANSISTOR			R068	QRD161J-391	390 1/6W CARBON RES.	
	Q055	2SC2235 (O, Y)	SI. TRANSISTOR			R069	ERT-02WHL202S	2K 1/4W NEGATIVE THE	
	Q057	2SA965 (Y)	SI. TRANSISTOR			R070	QRD161J-183	18K 1/6W CARBON RES.	
	Q059	2SC1775AV (F1)	SI. TRANSISTOR			R071	QRD161J-123	12K 1/6W CARBON RES.	
	Q061	2SC2389 (S, E)	SI. TRANSISTOR		△	R072	QRD125J-330	33 1/2W UNF. CARBON R	
	Q062	2SA1038 (R, S)	SI. TRANSISTOR		△	R077	QRG022J-562A	5.6K 2W OXIDE METAL	
	Q075	2SB1565 (E, F)	SI. TRANSISTOR			R078	QRD167J-751	750 1/6W CARBON RES.	
	Q400	DTC114YS	DIGITAL TRANSISTOR			R083	QRD161J-102	1K 1/6W CARBON RES.	
	Q401	DTC114TN	DIGITAL TRANSISTOR		△	R087	QRD14CJ-181S	180 1/4W UNF. CARBON R	
	Q402	DTC144WS	DIGITAL TRANSISTOR			R088	QRD14CJ-331SX	330 1/4W UNF. CARBON R	
	Q403	DTC114YS	DIGITAL TRANSISTOR		△	R090	ERF032K-R22	0.22 3W CEM. RES.	
	Q404	DTC114YS	DIGITAL TRANSISTOR			R095	QRD167J-151	150 1/6W CARBON RES.	
	Q405	DTC144ES	DIGITAL TRANSISTOR			R096	QRD167J-151	150 1/6W CARBON RES.	
	Q852	2SC2235 (O, Y)	SI. TRANSISTOR			R097	QRD167J-151	150 1/6W CARBON RES.	
	Q853	DTC114YS	DIGITAL TRANSISTOR			R098	QRD167J-151	150 1/6W CARBON RES.	
		CAPACITORS			△	R099	QRD125J-472	4.7K 1/2W UNF. CARBON R	
△	C001	QCZ9019-472	4700PF C. CAP.			R291	QRD161J-221	220 1/6W CARBON RES.	
	C050	QCHB1EZ-223	0.022MF 25V CER. CAP.			R292	QRD161J-221	220 1/6W CARBON RES.	
	C051	QETB1HM-106	10MF 50V E. CAP.			R293	QRD161J-221	220 1/6W CARBON RES.	
	C052	QCS21HJ-271A	270PF 50V CER. CAP.			R299	QRD161J-102	1K 1/6W CARBON RES.	
	C053	QETB1EM-106	10MF 25V AL E. CAP.			R400	QRD161J-101	100 1/6W CARBON RES.	
	C054	QCS21HJ-101A	100PF 50V CER. CAP.		△	R401	QRD14CJ-220S	22 1/4W UNF. CARBON R	
	C055	QCS21HJ-5R0	5PF 50V CER. CAP.			R402	QRD161J-471	470 1/6W CARBON RES.	
	C056	QETB1CM-476	47MF 16V AL E. CAP.			R403	QRD161J-471	470 1/6W CARBON RES.	
	C057	QCS22HJ-330	33PF 500V CER. CAP.			R404	QRD161J-471	470 1/6W CARBON RES.	
	C058	QFLB1HJ-103	0.01MF 50V MYLAR CAP.			R405	QRD161J-471	470 1/6W CARBON RES.	
	C059	QETB1HM-476	47MF 50V E. CAP.			R406	QRD161J-471	470 1/6W CARBON RES.	
	C060	QCS22HJ-470A	47PF 500V CER. CAP.			R407	QRD161J-471	470 1/6W CARBON RES.	
	C061	QETB1HM-225	2.2MF 50V AL E. CAP.			R408	QRD161J-471	470 1/6W CARBON RES.	
	C063	QCS22HJ-470A	47PF 500V CER. CAP.			R409	QRD161J-471	470 1/6W CARBON RES.	
	C066	QCF21HP-223A	0.022MF 50V CER. CAP.			R410	QRD161J-471	470 1/6W CARBON RES.	
	C067	QCY31HK-332Z	3300PF 50V CER. CAP.			R411	QRD161J-471	470 1/6W CARBON RES.	
	C068	QCY31HK-332Z	3300PF 50V CER. CAP.			R412	QRD161J-471	470 1/6W CARBON RES.	
	C081	QCF21HP-472	4700PF 50V CER. CAP.			R413	QRD161J-471	470 1/6W CARBON RES.	
						R414	QRD161J-471	470 1/6W CARBON RES.	

Electrical Parts List(ENB-233)

△	Item	Parts Number	Description	Area
	R415	QRD161J-471	470 1/6W CARBON RES.	
	R416	QRD161J-471	470 1/6W CARBON RES.	
	R417	QRD161J-471	470 1/6W CARBON RES.	
	R418	QRD161J-471	470 1/6W CARBON RES.	
	R419	QRD161J-471	470 1/6W CARBON RES.	
	R420	QRD161J-471	470 1/6W CARBON RES.	
	R421	QRD161J-471	470 1/6W CARBON RES.	
	R422	QRD161J-471	470 1/6W CARBON RES.	
	R423	QRD161J-471	470 1/6W CARBON RES.	
	R424	QRD161J-471	470 1/6W CARBON RES.	
	R425	QRD161J-471	470 1/6W CARBON RES.	
	R426	QRD161J-471	470 1/6W CARBON RES.	
	R427	QRD161J-471	470 1/6W CARBON RES.	
	R428	QRD161J-471	470 1/6W CARBON RES.	
	R429	QRD161J-103	10K 1/6W CARBON RES.	
	R430	QRD161J-221	220 1/6W CARBON RES.	
	R431	QRD161J-221	220 1/6W CARBON RES.	
	R432	QRD161J-471	470 1/6W CARBON RES.	
	R433	QRD161J-103	10K 1/6W CARBON RES.	
	R434	QRD161J-103	10K 1/6W CARBON RES.	
	R435	QRD161J-103	10K 1/6W CARBON RES.	
	R437	QRD161J-223	22K 1/6W CARBON RES.	
	R438	QRD161J-471	470 1/6W CARBON RES.	
	R439	QRD161J-471	470 1/6W CARBON RES.	
	R440	QRD161J-103	10K 1/6W CARBON RES.	
	R441	QRD161J-471	470 1/6W CARBON RES.	
	R442	QRD161J-471	470 1/6W CARBON RES.	
	R444	QRD161J-103	10K 1/6W CARBON RES.	
	R445	QRD161J-103	10K 1/6W CARBON RES.	
	R446	QRD161J-103	10K 1/6W CARBON RES.	
	R449	QRD161J-473	47K 1/6W CARBON RES.	
	R452	QRD161J-103	10K 1/6W CARBON RES.	
	R453	QRD161J-471	470 1/6W CARBON RES.	
	R454	QRD161J-471	470 1/6W CARBON RES.	
	R455	QRD161J-103	10K 1/6W CARBON RES.	
	R456	QRD161J-104	100K 1/6W CARBON RES.	
	R457	QRD161J-471	470 1/6W CARBON RES.	
	R490	QRD161J-221	220 1/6W CARBON RES.	
	R591	QRD161J-471	470 1/6W CARBON RES.	
	R592	QRD161J-471	470 1/6W CARBON RES.	
△	R860	QRD14CJ-100SX	10 1/4W UNF. CARBON R	
△	R861	QRD14CJ-100SX	10 1/4W UNF. CARBON R	
	R863	QRD161J-821	820 1/6W CARBON RES.	
	RA404	QRBO49J-103	10K 1/10WRES.	
	RA405	QRBO49J-103	10K 1/10WRES.	
	OTHERS			
	EMW10657-002		CIR BOARD	
	EWT011-174		TERMINAL WIRE ASSY	
	QWE881-14RR		VINYL WIRE	
	QWE886-14RR		VINYL WIRE	
	J291	QMS3L10-0A0	MICROPHONE JACK	
	J292	QMS3L10-0A0	MICROPHONE JACK	
	J293	QMS3L10-0A0	MICROPHONE JACK	
	J295	EMN00YV-319AJ1	PIN JACK	
	J591	EMN00YP-308A	PIN JACK	
	L051	EQL0011-R45J1	INDUCTOR	
	S400	ESPO001-023M	TACT SWITCH	
	S401	ESPO001-023M	TACT SWITCH	
	S402	ESPO001-023M	TACT SWITCH	
	S403	ESPO001-023M	TACT SWITCH	
	S404	ESPO001-023M	TACT SWITCH	
	S405	ESPO001-023M	TACT SWITCH	
	S406	ESPO001-023M	TACT SWITCH	
	S407	ESPO001-023M	TACT SWITCH	
	S408	ESPO001-023M	TACT SWITCH	
	S409	ESPO001-023M	TACT SWITCH	
	S410	ESPO001-023M	TACT SWITCH	
	S411	ESPO001-023M	TACT SWITCH	
	S412	ESPO001-023M	TACT SWITCH	
	S414	ESPO001-023M	TACT SWITCH	
	S415	ESPO001-023M	TACT SWITCH	
	S416	ESPO001-023M	TACT SWITCH	
	S418	ESPO001-023M	TACT SWITCH	
	S490	ESPO001-023M	TACT SWITCH	
	S491	ESPO001-023M	TACT SWITCH	
	S492	ESPO001-023M	TACT SWITCH	

△	Item	Parts Number	Description	Area
△	T002	ETP1000-41JA	POWER TRANSFORMER	
	X400	ECXP6R0-001ZA	CRYSTAL	
	X401	ECXP6R0-001ZA	CRYSTAL	
△	AC001	QMC A002-E02S	AC OUTLET	
	BK400	E309106-001SM	FL HOLDER	
	CN301	EWS268-A920J	SOCKET WIRE ASSY	
	CN302	EWS294-0520	SOCKET WIRE	
	CN402	EWS269-A210	SOCKET WIRE ASSY	
	CN403	EWS269-A422J	SOCKET WIRE ASSY	
	CN411	VMC0161-R35	CONNECT TERMINAL	
	CN412	EMV5109-009A	PIN PLUG	
	CN502	EWS323-A945	SOCKET WIRE ASSY	
	CN503	EWS293-0140	SOCKET WIRE	
	CN711	EMV5163-006R	CONNECT TERMINAL	
	CN804	VMC0177-003	CONNECT TERMINAL	
	DI400	ELU0001-215	FLUORESCENT DISPLAY TUBE	
	EP001	EMZ4002-002Z	EARTH PLATE	
	FC001	EMG7331-003Z	FUSE CLIP	
	FC002	EMG7331-003Z	FUSE CLIP	
	FS001	E3400-444	FELT SPACER	
	FS002	E3400-444	FELT SPACER	
	JS400	QSJ4003-E01	PUSH SWITCH	
	JS401	QSJ4002-E01	PUSH SWITCH	
	JS490	QSJ4002-E01	PUSH SWITCH	
	RY002	ESK1D12-119J3	RELAY	
	TA001	EMZ4001-002Z	TAB	
	TA002	EMZ4001-002Z	TAB	

## Electrical Parts List(ENH-287)

Δ	Item	Parts Number	Description	Area	Δ	Item	Parts Number	Description	Area
		I. C. S							
	IC511	BA15218N	I. C(MONO-ANALOG)			Q718	2SC2389 (S, E)	SI. TRANSISTOR	
	IC701	VC5022-2	I. C(MONO-ANALOG)			Q719	2SA1038 (R, S)	SI. TRANSISTOR	
	IC702	VC5022-2	I. C(MONO-ANALOG)			Q720	2SA1038 (R, S)	SI. TRANSISTOR	
	IC901	TA7317P	I. C(MONO-ANALOG)			Q721	2SD636	SI. TRANSISTOR	
		DIODES				Q722	2SD636	SI. TRANSISTOR	
	D010	1SS133	SI. DIODE			Q723	2SC2389 (S, E)	SI. TRANSISTOR	
	D011	MTZ18JC	ZENER DIODE			Q724	2SC2389 (S, E)	SI. TRANSISTOR	
	D012	1SS133	SI. DIODE			Q725	2SA1038 (R, S)	SI. TRANSISTOR	
	D013	1SS133	SI. DIODE			Q726	2SA1038 (R, S)	SI. TRANSISTOR	
	D014	1SS133	SI. DIODE			Q727	2SD669A (B, C)	SI. TRANSISTOR	
	D015	1SS133	SI. DIODE			Q728	2SD669A (B, C)	SI. TRANSISTOR	
	D021	1SS133	SI. DIODE			Q729	2SB649A (B, C)	SI. TRANSISTOR	
	D022	1SS133	SI. DIODE			Q730	2SB649A (B, C)	SI. TRANSISTOR	
	D031	MTZ20JC	ZENER DIODE			Q735	2SD2061 (F, G)	SI. TRANSISTOR	
	D032	MTZ20JC	ZENER DIODE			Q736	2SC2240 (GR, BL)	SI. TRANSISTOR	
	D482	1SS133	SI. DIODE			Q801	2SB1187 (F, G)	SI. TRANSISTOR	
	D483	1SS133	SI. DIODE			Q803	2SD2061 (F, G)	SI. TRANSISTOR	
	D484	MTZ6.2JC	ZENER DIODE			Q804	2SD2061 (F, G)	SI. TRANSISTOR	
	D701	1SS133	SI. DIODE			Q805	2SD2061 (F, G)	SI. TRANSISTOR	
	D702	1SS133	SI. DIODE			Q807	2SD2061 (F, G)	SI. TRANSISTOR	
	D703	1SS133	SI. DIODE			Q808	2SD2061 (F, G)	SI. TRANSISTOR	
	D704	1SS133	SI. DIODE			Q901	2SC2389 (S, E)	SI. TRANSISTOR	
	D705	MTZ18JC	ZENER DIODE			Q902	2SC2389 (S, E)	SI. TRANSISTOR	
	D707	1SS133	SI. DIODE			Q903	2SA1038 (R, S)	SI. TRANSISTOR	
	D708	1SS133	SI. DIODE				CAPACITORS		
	D709	1SS133	SI. DIODE			C010	QCF21HP-223A	0.022MF 50V CER. CAP.	
	D710	1SS133	SI. DIODE			C011	QETB1HM-106	10MF 50V E. CAP.	
	D711	1SS133	SI. DIODE			C012	QCS21HJ-470	47PF 50V CER. CAP.	
	D712	1SS133	SI. DIODE			C013	QETB1EM-106	10MF 25V AL. E. CAP.	
	D713	MTZ10JC	ZENER DIODE			C014	QCS21HJ-101A	100PF 50V CER. CAP.	
	D714	MTZ12JC	ZENER DIODE			C015	QCS21HJ-5R0	5PF 50V CER. CAP.	
	D811	1SS133	SI. DIODE			C016	QETB1CM-476	47MF 16V AL. E. CAP.	
	D812	MTZ15JC	ZENER DIODE			C017	QCS22HJ-330	33PF 500V CER. CAP.	
	D813	1SS133	SI. DIODE			C018	QFLB1HJ-103	0.01MF 50V NYLAR CAP.	
	D814	MTZ6.8JC	ZENER DIODE			C019	QETB1HM-476	47MF 50V E. CAP.	
	D815	1SS133	SI. DIODE			C020	QCS22HJ-470A	47PF 500V CER. CAP.	
	D816	MTZ15JC	ZENER DIODE			C021	QETB1HM-225	2.2MF 50V AL. E. CAP.	
	D817	1SS133	SI. DIODE			C023	QCS22HJ-470A	47PF 500V CER. CAP.	
	D818	1SS133	SI. DIODE			C024	QFLB1HJ-223	0.022MF 50V NYLAR CAP.	J
	D819	MTZ13JC	ZENER DIODE			C024	QFLB1HJ-473	0.047MF 50V NYLAR CAP.	C
	D820	MTZ5.1JC	ZENER DIODE			C025	QFLB1HJ-473	0.047MF 50V NYLAR CAP.	C
	D822	1SS133	SI. DIODE			C026	QCF21HP-223A	0.022MF 50V CER. CAP.	
	D823	MTZ6.2JC	ZENER DIODE			C027	QCY31HK-332Z	3300PF 50V CER. CAP.	
	D824	1SS133	SI. DIODE			C028	QCY31HK-332Z	3300PF 50V CER. CAP.	
	D825	MTZ6.2JC	ZENER DIODE			C031	QCF21HP-472	4700PF 50V CER. CAP.	
	D901	1SS133	SI. DIODE			C032	QETB1HM-476	47MF 50V E. CAP.	
	D902	1SS133	SI. DIODE			C064	QFLB1HJ-223	0.022MF 50V NYLAR CAP.	J
	D903	1SS133	SI. DIODE			C064	QFLB1HJ-473	0.047MF 50V NYLAR CAP.	C
		TRANSISTORS				C065	QFLB1HJ-473	0.047MF 50V NYLAR CAP.	C
	Q011	2SC2240 (GR, BL)	SI. TRANSISTOR			C385	QETB0JM-107	100MF 6.3V AL. E. CAP.	
	Q012	2SC2240 (GR, BL)	SI. TRANSISTOR			C481	QCB1HK-331Y	330PF 50V CER. CAP.	
	Q013	2SA1038 (R, S)	SI. TRANSISTOR			C482	QCHB1EZ-223	0.022MF 25V CER. CAP.	
	Q015	2SC2235 (O, Y)	SI. TRANSISTOR			C521	QETB1HM-106	10MF 50V E. CAP.	
	Q017	2SA965 (Y)	SI. TRANSISTOR			C522	QCY31HK-103Z	0.01MF 50V CER. CAP.	
	Q019	2SC1775AV (F1)	SI. TRANSISTOR			C523	QFLB1HJ-123	0.012MF 50V NYLAR CAP.	
	Q020	DTG123YS	SI. TRANSISTOR			C524	QETB1HM-106	10MF 50V E. CAP.	
	Q021	2SC2389 (S, E)	SI. TRANSISTOR			C525	QCS21HJ-101A	100PF 50V CER. CAP.	
	Q022	2SA1038 (R, S)	SI. TRANSISTOR			C701	QETB1HM-106	10MF 50V E. CAP.	
	Q025	2SB1565 (E, F)	SI. TRANSISTOR			C702	QETB1HM-106	10MF 50V E. CAP.	
	Q302	DTA144ES	DIGITAL TRANSISTOR			C703	QCS21HJ-271A	270PF 50V CER. CAP.	
	Q303	2SD2144S (VW)	SI. TRANSISTOR			C704	QCS21HJ-271A	270PF 50V CER. CAP.	
	Q304	2SD2144S (VW)	SI. TRANSISTOR			C705	QCS21HJ-101A	100PF 50V CER. CAP.	
	Q701	2SC1775AV (F1)	SI. TRANSISTOR			C706	QCS21HJ-101A	100PF 50V CER. CAP.	
	Q702	2SC1775AV (F1)	SI. TRANSISTOR			C707	QETB1CM-107	100MF 16V AL. E. CAP.	
	Q703	2SC1775AV (F1)	SI. TRANSISTOR			C708	QETB1CM-107	100MF 16V AL. E. CAP.	
	Q704	2SC1775AV (F1)	SI. TRANSISTOR			C709	QCS21HJ-100	10PF 50V CER. CAP.	
	Q705	2SA1038 (R, S)	SI. TRANSISTOR			C710	QCS21HJ-100	10PF 50V CER. CAP.	
	Q706	2SA1038 (R, S)	SI. TRANSISTOR			C711	QCY31HK-152Z	1500PF 50V CER. CAP.	
	Q707	2SA933LN (R, S)	SI. TRANSISTOR			C712	QCY31HK-152Z	1500PF 50V CER. CAP.	
	Q708	2SA933LN (R, S)	SI. TRANSISTOR			C713	QCS21HJ-680A	68PF 50V CER. CAP.	
	Q709	2SA1038 (R, S)	SI. TRANSISTOR			C714	QCS21HJ-680A	68PF 50V CER. CAP.	
	Q710	2SA1038 (R, S)	SI. TRANSISTOR			C715	QCS21HJ-680A	68PF 50V CER. CAP.	
	Q711	2SC2389 (S, E)	SI. TRANSISTOR			C716	QCS21HJ-680A	68PF 50V CER. CAP.	
	Q712	2SC2389 (S, E)	SI. TRANSISTOR			C717	QCS22HJ-220	22PF 500V CER. CAP.	
	Q717	2SC2389 (S, E)	SI. TRANSISTOR			C718	QCS22HJ-220	22PF 500V CER. CAP.	
						C719	QFLB1HJ-472	4700PF 50V NYLAR CAP.	

Electrical Parts List(ENH-287)

Δ	Item	Parts Number	Description	Area
	C720	QFLB1HJ-472	4700PF 50V MYLAR CAP.	
	C722	QETB1EM-476	47MF 25V AL E. CAP.	
	C723	QETB2AM-476	47MF 100V AL E. CAP.	
	C724	QETB2AM-476	47MF 100V AL E. CAP.	
	C725	QCS22HJ-470A	47PF 500V CER. CAP.	
	C726	QCS22HJ-470A	47PF 500V CER. CAP.	
	C727	QCS22HJ-470A	47PF 500V CER. CAP.	
	C728	QCS22HJ-470A	47PF 500V CER. CAP.	
	C729	QFLB1HJ-223	0.022MF 50V MYLAR CAP.	J
	C729	QFLB1HJ-473	0.047MF 50V MYLAR CAP.	C
	C730	QFLB1HJ-223	0.022MF 50V MYLAR CAP.	J
	C730	QFLB1HJ-473	0.047MF 50V MYLAR CAP.	C
	C731	QFLB1HJ-473	0.047MF 50V MYLAR CAP.	C
	C732	QFLB1HJ-473	0.047MF 50V MYLAR CAP.	C
	C733	QCF21HP-472	4700PF 50V CER. CAP.	
	C734	QCF21HP-472	4700PF 50V CER. CAP.	
	C735	QCF21HP-472	4700PF 50V CER. CAP.	
	C736	QCF21HP-472	4700PF 50V CER. CAP.	
	C741	QCF21HP-472	4700PF 50V CER. CAP.	
	C801	EEW8001-129T	12000MF AL E. CAP.	
	C802	EEW8001-129T	12000MF AL E. CAP.	
	C812	QETB1EM-107	100MF 25V AL E. CAP.	
	C813	QCF21HP-472	4700PF 50V CER. CAP.	
	C814	QETB1EM-107	100MF 25V AL E. CAP.	
	C816	QETB1EM-107	100MF 25V AL E. CAP.	
	C817	QCF21HP-472	4700PF 50V CER. CAP.	
	C819	QETB1EM-107	100MF 25V AL E. CAP.	
	C820	QETB1EM-107	100MF 25V AL E. CAP.	
	C821	QCF21HP-472	4700PF 50V CER. CAP.	
	C822	QCF21HP-472	4700PF 50V CER. CAP.	
	C823	QETB1EM-107	100MF 25V AL E. CAP.	
	C824	QCF21HP-472	4700PF 50V CER. CAP.	
	C825	QETB1EM-107	100MF 25V AL E. CAP.	
	C831	QCZ0202-155	1.5MF 25V CER. RES.	
	C832	QCZ0202-155	1.5MF 25V CER. RES.	
	C870	QCF21HP-472	4700PF 50V CER. CAP.	
	C901	QCF21HP-223A	0.022MF 50V CER. CAP.	
	C902	QCF21HP-223A	0.022MF 50V CER. CAP.	
	C903	QETB1EM-226E	22MF 50V E. CAP.	
	C904	QCF21HP-103A	0.01MF 50V CER. CAP.	
	C905	QCY31HK-102Z	1000PF 50V CER. CAP.	
	C906	QETB1AM-476	47MF 10V E. CAP.	
	C909	QETB1CM-226	22MF 16V E. CAP.	
		RESISTORS		
	R011	QRD161J-222	2.2K 1/6W CARBON RES.	
	R012	QRD161J-104	100K 1/6W CARBON RES.	
	R013	QRD161J-123	12K 1/6W CARBON RES.	
	R014	QRD161J-182	1.8K 1/6W CARBON RES.	
	R015	QRD161J-104	100K 1/6W CARBON RES.	
Δ	R016	QRD14CJ-181S	180 1/4W UNF. CARBON R	
Δ	R017	QRD14CJ-222SX	2.2K 1/4W UNF. CARBON R	
	R018	QRD161J-202	2K 1/6W CARBON RES.	
	R019	QRD161J-222	2.2K 1/6W CARBON RES.	
	R020	QRD161J-202	2K 1/6W CARBON RES.	
Δ	R023	QRD14CJ-120SX	12 1/4W UNF. CARBON R	
Δ	R024	QRD14CJ-100SX	10 1/4W UNF. CARBON R	
Δ	R025	QRD14CJ-561SX	560 1/4W UNF. CARBON R	
Δ	R026	QRD14CJ-100SX	10 1/4W UNF. CARBON R	
Δ	R027	QRD14CJ-120SX	12 1/4W UNF. CARBON R	
	R028	QRD161J-391	390 1/6W CARBON RES.	
	R029	ERT-D2WFL202S	2K 1/4W NEGATIVE THE	
	R030	QRD161J-183	18K 1/6W CARBON RES.	
	R031	QRD161J-123	12K 1/6W CARBON RES.	
Δ	R032	QRD125J-330	33 1/2W UNF. CARBON R	
Δ	R033	QRG022J-100A	10 2W OXIDE METAL	
	R034	QRD161J-104	100K 1/6W CARBON RES.	
Δ	R035	QRD14CJ-181S	180 1/4W UNF. CARBON R	
Δ	R036	QRD14CJ-471SX	470 1/4W UNF. CARBON R	
Δ	R037	QRG022J-562A	5.6K 2W OXIDE METAL	
	R038	QRD167J-751	750 1/6W CARBON RES.	
Δ	R039	QRD14CJ-100SX	10 1/4W UNF. CARBON R	
	R040	QRD161J-3R3	3.3 1/6W CARBON RES.	
	R043	QRD161J-102	1K 1/6W CARBON RES.	
	R045	QRD167J-151	150 1/6W CARBON RES.	
	R046	QRD167J-151	150 1/6W CARBON RES.	
	R047	QRD167J-151	150 1/6W CARBON RES.	

Δ	Item	Parts Number	Description	Area
	R048	QRD167J-151	150 1/6W CARBON RES.	
Δ	R049	QRD125J-472	4.7K 1/2W UNF. CARBON R	
Δ	R073	QRG022J-100A	10 2W OXIDE METAL	
	R074	QRD161J-104	100K 1/6W CARBON RES.	
	R391	QRD161J-104	100K 1/6W CARBON RES.	
	R392	QRD161J-104	100K 1/6W CARBON RES.	
	R481	QRD161J-100	10 1/6W CARBON RES.	
	R482	QRD161J-102	1K 1/6W CARBON RES.	
	R521	QRD161J-104	100K 1/6W CARBON RES.	
	R522	QRD161J-203	20K 1/6W CARBON RES.	
	R523	QRD161J-183	18K 1/6W CARBON RES.	
	R524	QRD161J-202	2K 1/6W CARBON RES.	
	R525	QRD167J-223	22K 1/6W CARBON RES.	
	R526	QRD161J-132	1.3K 1/6W CARBON RES.	
	R528	QRD161J-203	20K 1/6W CARBON RES.	
Δ	R529	QRZ0077-680	68 1/4W FUSIBLE RES.	
Δ	R530	QRZ0077-680	68 1/4W FUSIBLE RES.	
	R583	QRD161J-103	10K 1/6W CARBON RES.	
	R584	QRD161J-103	10K 1/6W CARBON RES.	
	R589	QRD161J-102	1K 1/6W CARBON RES.	
	R701	QRD161J-222	2.2K 1/6W CARBON RES.	
	R702	QRD161J-222	2.2K 1/6W CARBON RES.	
	R703	QRD161J-104	100K 1/6W CARBON RES.	
	R704	QRD161J-104	100K 1/6W CARBON RES.	
	R705	QRD161J-202	2K 1/6W CARBON RES.	
	R706	QRD161J-202	2K 1/6W CARBON RES.	
	R707	QRD161J-202	2K 1/6W CARBON RES.	
	R708	QRD161J-202	2K 1/6W CARBON RES.	
	R709	QRD167J-822	8.2K 1/6W CARBON RES.	
	R710	QRD167J-822	8.2K 1/6W CARBON RES.	
	R711	QRD161J-821	820 1/6W CARBON RES.	
	R712	QRD161J-821	820 1/6W CARBON RES.	
	R713	QRD161J-133Y	13K 1/6W CARBON RES.	
	R714	QRD161J-133Y	13K 1/6W CARBON RES.	
	R715	QRD161J-823	82K 1/6W CARBON RES.	
	R716	QRD161J-823	82K 1/6W CARBON RES.	
	R717	QRD12CJ-153SX	15K 1/2W UNF. CARBON R	
	R718	QRD12CJ-153SX	15K 1/2W UNF. CARBON R	
	R719	QRD161J-391	390 1/6W CARBON RES.	
	R720	QRD161J-391	390 1/6W CARBON RES.	
	R721	QRD14CJ-151SX	150 1/4W UNF. CARBON R	
	R722	QRD14CJ-151SX	150 1/4W UNF. CARBON R	
	R723	QRD167J-152	1.5K 1/6W CARBON RES.	
	R724	QRD167J-152	1.5K 1/6W CARBON RES.	
	R725	QRD161J-333	33K 1/6W CARBON RES.	
	R726	QRD161J-333	33K 1/6W CARBON RES.	
	R727	QRD161J-391	390 1/6W CARBON RES.	
	R728	QRD161J-391	390 1/6W CARBON RES.	
	R729	QRD161J-391	390 1/6W CARBON RES.	
	R730	QRD161J-391	390 1/6W CARBON RES.	
	R731	QRD161J-101	100 1/6W CARBON RES.	
	R732	QRD161J-101	100 1/6W CARBON RES.	
Δ	R733	QRD14CJ-120SX	12 1/4W UNF. CARBON R	
Δ	R734	QRD14CJ-120SX	12 1/4W UNF. CARBON R	
Δ	R735	QRG022J-562A	5.6K 2W OXIDE METAL	
	R739	QRD161J-201	200 1/6W CARBON RES.	
	R740	QRD161J-201	200 1/6W CARBON RES.	
	R741	QRD161J-201	200 1/6W CARBON RES.	
	R742	QRD161J-201	200 1/6W CARBON RES.	
	R751	QRD161J-391	390 1/6W CARBON RES.	
	R752	QRD161J-391	390 1/6W CARBON RES.	
	R753	QRD161J-391	390 1/6W CARBON RES.	
	R754	QRD161J-391	390 1/6W CARBON RES.	
	R755	QRD161J-471	470 1/6W CARBON RES.	
	R756	QRD161J-471	470 1/6W CARBON RES.	
	R757	QRD161J-101	100 1/6W CARBON RES.	
	R758	QRD161J-101	100 1/6W CARBON RES.	
	R759	ERT-D2WFL351S	350 1/4W NEGATIVE THE	
	R760	ERT-D2WFL351S	350 1/4W NEGATIVE THE	
	R761	QRD161J-391	390 1/6W CARBON RES.	
	R762	QRD161J-391	390 1/6W CARBON RES.	
Δ	R765	QRD14CJ-272S	2.7K 1/4W UNF. CARBON R	
Δ	R766	QRD14CJ-272S	2.7K 1/4W UNF. CARBON R	
Δ	R767	QRD14CJ-271S	270 1/4W UNF. CARBON R	
Δ	R768	QRD14CJ-271S	270 1/4W UNF. CARBON R	
Δ	R769	QRD14CJ-120SX	12 1/4W UNF. CARBON R	

Electrical Parts List(ENH-287)

△	Item	Parts Number	Description	Area
△	R770	QRD14CJ-120SX	12 1/4W UNF. CARBON R	
△	R771	QRD14CJ-120SX	12 1/4W UNF. CARBON R	
△	R772	QRD14CJ-120SX	12 1/4W UNF. CARBON R	
△	R773	ERF032K-R22	0.22 3W CEM. RES.	
△	R774	ERF032K-R22	0.22 3W CEM. RES.	
△	R775	QRD129J-470	47 1/2W UNF. CARBON R	
△	R776	QRD129J-470	47 1/2W UNF. CARBON R	
△	R777	QRG022J-100A	10 2W OXIDE METAL	
△	R778	QRG022J-100A	10 2W OXIDE METAL	
△	R779	QRD14CJ-100SX	10 1/4W UNF. CARBON R	
△	R780	QRD14CJ-100SX	10 1/4W UNF. CARBON R	
△	R781	QRD14CJ-100SX	10 1/4W UNF. CARBON R	
△	R782	QRD14CJ-100SX	10 1/4W UNF. CARBON R	
△	R783	QRD14CJ-100SX	10 1/4W UNF. CARBON R	
△	R784	QRD14CJ-100SX	10 1/4W UNF. CARBON R	
△	R785	QRD14CJ-100SX	10 1/4W UNF. CARBON R	
△	R786	QRD14CJ-100SX	10 1/4W UNF. CARBON R	
△	R787	QRD12CJ-562S	5.6K 1/2W UNF. CARBON R	
	R788	QRD161J-103	10K 1/6W CARBON RES.	
	R789	QRD161J-473	47K 1/6W CARBON RES.	
△	R799	ERF032K-R22	0.22 3W CEM. RES.	
	R801	QRD161J-104	100K 1/6W CARBON RES.	
	R802	QRD161J-104	100K 1/6W CARBON RES.	
△	R811	QRD14CJ-120SX	12 1/4W UNF. CARBON R	
△	R813	QRD14CJ-122SX	1.2K 1/4W UNF. CARBON R	
△	R819	QRD12CJ-330S	33 1/2W CARBON RES.	
△	R820	QRD12CJ-330S	33 1/2W CARBON RES.	
△	R822	QRD14CJ-272S	2.7K 1/4W UNF. CARBON R	
△	R823	QRD121J-680	68 1/2W CARBON RES.	
△	R824	QRD121J-680	68 1/2W CARBON RES.	
△	R825	QRD14CJ-332SX	3.3K 1/4W UNF. CARBON R	
△	R826	QRD14CJ-120SX	12 1/4W UNF. CARBON R	
△	R828	QRD12CJ-153SX	15K 1/2W UNF. CARBON R	
△	R831	QRD14CJ-220S	22 1/4W UNF. CARBON R	
△	R832	QRD14CJ-220S	22 1/4W UNF. CARBON R	
△	R833	QRD14CJ-332SX	3.3K 1/4W UNF. CARBON R	
△	R834	QRD14CJ-3R9S	3.9 1/4W UNF. CARBON R	
△	R835	QRD12CJ-471SX	470 1/2W UNF. CARBON R	
△	R838	QRD12CJ-2R2SX	2.2 1/2W CARBON RES.	
△	R840	QRD14CJ-220S	22 1/4W UNF. CARBON R	
△	R841	QRD14CJ-220S	22 1/4W UNF. CARBON R	
△	R842	QRD14CJ-332SX	3.3K 1/4W UNF. CARBON R	
△	R843	QRD14CJ-100SX	10 1/4W UNF. CARBON R	
	R901	QRD161J-102	1K 1/6W CARBON RES.	
	R902	QRD161J-102	1K 1/6W CARBON RES.	
	R903	QRD167J-562	5.6K 1/6W CARBON RES.	
	R904	QRD167J-562	5.6K 1/6W CARBON RES.	
	R905	QRD161J-123	12K 1/6W CARBON RES.	
	R906	QRD161J-123	12K 1/6W CARBON RES.	
	R907	QRD161J-102	1K 1/6W CARBON RES.	
	R908	QRD161J-102	1K 1/6W CARBON RES.	
	R909	QRD161J-103	10K 1/6W CARBON RES.	
	R911	QRD167J-332	3.3K 1/6W CARBON RES.	
	R912	QRD161J-473	47K 1/6W CARBON RES.	
	R913	QRD161J-104	100K 1/6W CARBON RES.	
	R914	QRD161J-823	82K 1/6W CARBON RES.	
	R915	QRD161J-823	82K 1/6W CARBON RES.	
	R916	QRD161J-563	56K 1/6W CARBON RES.	
	R917	QRD161J-683	68K 1/6W CARBON RES.	
	R918	QRD161J-392	3.9K 1/6W CARBON RES.	
	R921	QRD161J-224	220K 1/6W CARBON RES.	
	R922	QRD161J-122	1.2K 1/6W CARBON RES.	
	R924	QRD161J-3R3	3.3 1/6W CARBON RES.	
△	R929	QRD14CJ-470SX	47 1/4W UNF. CARBON R	
△	R941	QRG022J-471A	470 2W OXIDE METAL	
△	R942	QRG022J-471A	470 2W OXIDE METAL	
	R951	QRD161J-333	33K 1/6W CARBON RES.	
	R952	QRD161J-333	33K 1/6W CARBON RES.	
	R953	QRD161J-333	33K 1/6W CARBON RES.	
	R956	QRD161J-223	22K 1/6W CARBON RES.	
	R957	QRD167J-391	390 1/6W CARBON RES.	
	VR513	QVDA96W-E15DJ3	100K VARIABLE RES.	
	VR514	QVDB96C-E15DJ3	100K VARIABLE RES.	
	VR791	QVPA601-501A	500 TRIMMER RES.	
	VR792	QVPA601-501A	500 TRIMMER RES.	
		OTHERS		

△	Item	Parts Number	Description	Area
		EMW10620-002	CIR. BOARD	
		SBSG3008CC	TAPPING SCREW	
	J481	QMS3501-021	PIN JACK	
	J901	QMS6022-V01	MICROPHONE JACK	
	L011	EQL0011-R45J1	INDUCTOR	
	L701	EQL0001-1R0	INDUCTOR	
	L702	EQL0001-1R0	INDUCTOR	
	S001	QSP6002-E02J2	PUSH SWITCH	
	S911	QSS7A12-E01	SLIDE SWITCH	
	CN001	EMV7163-012	CONNECT TERMINAL	
	CN108	EWS293-0145	SOCKET WIRE	
	CN109	EWS293-0130	SOCKET WIRE	
	CN118	VMC0075-003	CONNECTOR	
	CN119	VMC0075-003	CONNECTOR	
	CN311	VMC0075-008N	CONNECT TERMINAL	
	CN401	VMC0163-035	CONNECT TERMINAL	
	CN501	EMV7163-012	CONNECT TERMINAL	
	CN505	EMV7163-004	CONNECT TERMINAL	
	CN601	EMV7163-015	CONNECT TERMINAL	
	CN602	EMV7163-009	CONNECT TERMINAL	
	CN701	EMV7163-006	CONNECT TERMINAL	
	CN801	EMV7163-007	CONNECT TERMINAL	
	CN812	EMV5129-003	CONNECTOR	
	CN813	VMC0178-003	CONNECT TERMINAL	
	CN814	VMC0178-003	CONNECT TERMINAL	
	EP001	EMZ4002-002Z	EARTH PLATE	
	EP003	EMZ4002-002Z	EARTH PLATE	
	EP004	EMZ4002-002Z	EARTH PLATE	
	EP005	EMZ4002-002Z	EARTH PLATE	
	EP006	EMZ4002-002Z	EARTH PLATE	
	FW901	EWR33D-08SS	FLAT WIRE ASSY	
	FW903	EWR38D-45SS	FLAT WIRE ASSY	
	HS801	E70306-001	HEAT SINK	
	HS803	E70306-001	HEAT SINK	
	HS804	E70306-001	HEAT SINK	
	HS805	E70306-001	HEAT SINK	
	HS807	E70306-001	HEAT SINK	
	HS808	E70306-001	HEAT SINK	
	RY011	ESK7D24-213R	RELAY	
	RY901	ESK7D24-213R	RELAY	
	ST011	EMB90TV-601G	SPEAKER TERMINAL	
	ST901	EMB90TV-806A	SPEAKER TERMINAL	
	TP751	QMV5005-004K	PLUG ASSY	

Electrical Parts List(ENA-172)

△	Item	Parts Number	Description	Area
		I. C. S		
	IC102	LC72131	I. C(M)	
	IC104	LA1266A	I. C(MONO-ANALOG)	
	IC105	LA3401	I. C(MONO-ANALOG)	
		DIODES		
	D101	1SS133	SI. DIODE	
	D106	1SS133	SI. DIODE	
	D111	1SS133	SI. DIODE	
	D112	1SS133	SI. DIODE	
	D120	1SS133	SI. DIODE	
	D121	1SS133	SI. DIODE	
	D122	1SS133	SI. DIODE	
	D123	1SS133	SI. DIODE	
	VC105	SVC342(L)	VARI-CAPA DIODE	
		TRANSISTORS		
	Q103	2SC461	SI. TRANSISTOR	
	Q107	2SC535	SI. TRANSISTOR	
	Q108	2SC461	SI. TRANSISTOR	
	Q112	2SK301(P, Q)	F. E. T.	
	Q123	DTA144ES	DIGITAL TRANSISTOR	
	Q124	DTA144ES	DIGITAL TRANSISTOR	
	Q127	DTC144ES	DIGITAL TRANSISTOR	
		CAPACITORS		
	C101	QCF21HP-223A	0.022MF 50V CER. CAP.	
	C122	QCF21HP-223A	0.022MF 50V CER. CAP.	
	C126	QCF21HP-223A	0.022MF 50V CER. CAP.	
	C132	QCS31HJ-561Z	560PF 50V CER. CAP.	
	C133	QCHB1EZ-223	0.022MF 25V CER. CAP.	
	C134	QETB1EM-106	10MF 25V AL. E. CAP.	
	C135	QCC21EM-223	0.022MF 25V CER. CAP.	
	C136	QCT25CH-180Z	18PF 50V CER. CAP.	
	C137	QCT26CH-221	220PF 50V CER. CAP.	
	C138	QCT26CH-241	240PF 50V CER. CAP.	
	C149	QCHB1EZ-223	0.022MF 25V CER. CAP.	
	C150	QCHB1EZ-223	0.022MF 25V CER. CAP.	
	C151	QCF21HP-223A	0.022MF 50V CER. CAP.	
	C152	QCF21HP-223A	0.022MF 50V CER. CAP.	
	C153	QCC21EM-223	0.022MF 25V CER. CAP.	
	C154	QCF21HP-223A	0.022MF 50V CER. CAP.	
	C155	QCHB1EZ-223	0.022MF 25V CER. CAP.	
	C156	QETB1CM-227	220MF 16V AL. E. CAP.	
	C157	QETB1HM-474	0.47MF 50V E. CAP.	
	C158	QCBB1HK-101Y	100PF 50V CER. CAP.	
	C159	QCBB1HK-101Y	100PF 50V CER. CAP.	
	C160	QCBB1HK-221Y	220PF 50V CER. CAP.	
	C161	QCHB1EZ-223	0.022MF 25V CER. CAP.	
	C162	QETB1EM-106	10MF 25V AL. E. CAP.	
	C163	QFLB1HJ-102	1000PF 50V NYLAR CAP.	
	C164	QCHB1EZ-223	0.022MF 25V CER. CAP.	
	C165	QETB1HM-474	0.47MF 50V E. CAP.	
	C166	QETB1HM-225	2.2MF 50V AL. E. CAP.	
	C167	QETB1HM-225	2.2MF 50V AL. E. CAP.	
	C168	QEK51HM-475	4.7MF 50V AL. E. CAP.	
	C169	QCF21HP-223A	0.022MF 50V CER. CAP.	
	C170	QCHB1EZ-223	0.022MF 25V CER. CAP.	
	C171	QEK51EM-106	10MF 25V AL. E. CAP.	
	C172	QCVB1CM-103Y	0.01MF 16V CER. CAP.	
	C173	QFLB1HJ-393	0.039MF 50V NYLAR CAP.	
	C174	QFLB1HJ-473	0.047MF 50V NYLAR CAP.	
	C175	QETB1EM-106	10MF 25V AL. E. CAP.	
	C176	QCY31HK-102Z	1000PF 50V CER. CAP.	
	C177	QCS31HJ-821Z	820PF 50V CER. CAP.	
	C178	QCS31HJ-821Z	820PF 50V CER. CAP.	
	C179	QETB1HM-225	2.2MF 50V AL. E. CAP.	
	C180	QETB1HM-225	2.2MF 50V AL. E. CAP.	
	C181	QETB1EM-106	10MF 25V AL. E. CAP.	
	C182	QETB1HM-225	2.2MF 50V AL. E. CAP.	
	C183	QETB1HM-105	1MF 50V AL. E. CAP.	
	C184	QETB1HM-105	1MF 50V AL. E. CAP.	
	C185	QEK51HM-225G	2.2MF 50V AL. E. CAP.	
	C186	QETB1HM-474	0.47MF 50V E. CAP.	
	C191	QETB1HM-475E	4.7MF 50V E. CAP.	
	C192	QCC21EM-473	0.047MF 25V CER. CAP.	
	C193	QCS21HJ-180A	18PF 50V CER. CAP.	
	C194	QCS21HJ-180A	18PF 50V CER. CAP.	
	C195	QFV71HJ-474ZM	0.47MF 50V THIN FILM CAP.	
	C196	QCY31HK-102Z	1000PF 50V CER. CAP.	

△	Item	Parts Number	Description	Area
	C197	QCF21HP-223A	0.022MF 50V CER. CAP.	
	C198	QCF21HP-103A	0.01MF 50V CER. CAP.	
	C199	QCVB1CM-103Y	0.01MF 16V CER. CAP.	
	C222	QETB1CM-477M	470MF 16V E. CAP.	
	C229	QETB1CM-227	220MF 16V AL. E. CAP.	
	TC105	ENZ1003-006	00MF TRIMMER CAPA	
		RESISTORS		
	R101	QRD161J-103	10K 1/6W CARBON RES.	
	R102	QRD161J-103	10K 1/6W CARBON RES.	
	R103	QRD161J-103	10K 1/6W CARBON RES.	
	R105	QRD161J-103	10K 1/6W CARBON RES.	
	R108	QRD161J-103	10K 1/6W CARBON RES.	
△	R109	QRD14CJ-680SX	68 1/4W UNF. CARBON R	
	R118	QRD167J-332	3.3K 1/6W CARBON RES.	
	R119	QRD161J-221	220 1/6W CARBON RES.	
	R121	QRD161J-391	390 1/6W CARBON RES.	
	R122	QRD167J-272	2.7K 1/6W CARBON RES.	
	R123	QRD161J-102	1K 1/6W CARBON RES.	
	R124	QRD161J-681	680 1/6W CARBON RES.	
	R125	QRD167J-332	3.3K 1/6W CARBON RES.	
	R126	QRD161J-221	220 1/6W CARBON RES.	
	R131	QRD161J-331	330 1/6W CARBON RES.	
	R132	QRD161J-103	10K 1/6W CARBON RES.	
	R133	QRD161J-473	47K 1/6W CARBON RES.	
	R135	QRD161J-470	47 1/6W CARBON RES.	
	R136	QRD161J-103	10K 1/6W CARBON RES.	
	R148	QRD167J-560	56 1/6W CARBON RES.	
	R147	QRD161J-103	10K 1/6W CARBON RES.	
	R148	QRD161J-103	10K 1/6W CARBON RES.	
	R149	QRD161J-273	27K 1/6W CARBON RES.	
	R150	QRD161J-103	10K 1/6W CARBON RES.	
	R151	QRD161J-222	2.2K 1/6W CARBON RES.	
	R153	QRD161J-103	10K 1/6W CARBON RES.	
	R154	QRD161J-103	10K 1/6W CARBON RES.	
	R155	QRD167J-562	5.6K 1/6W CARBON RES.	
	R156	QRD167J-822	8.2K 1/6W CARBON RES.	
	R157	QRD161J-103	10K 1/6W CARBON RES.	
	R158	QRD161J-183	18K 1/6W CARBON RES.	
	R159	QRD161J-561	560 1/6W CARBON RES.	
	R160	QRD167J-562	5.6K 1/6W CARBON RES.	
	R161	QRD161J-823	82K 1/6W CARBON RES.	
	R162	QRD161J-823	82K 1/6W CARBON RES.	
	R163	QRD161J-472	4.7K 1/6W CARBON RES.	
	R164	QRD161J-472	4.7K 1/6W CARBON RES.	
	R165	QRD161J-184	180K 1/6W CARBON RES.	
	R166	QRD161J-184	180K 1/6W CARBON RES.	
	R167	QRD161J-393	39K 1/6W CARBON RES.	
	R168	QRD161J-103	10K 1/6W CARBON RES.	
	R169	QRD161J-103	10K 1/6W CARBON RES.	
	R171	QRD167J-682	6.8K 1/6W CARBON RES.	
	R172	QRD167J-682	6.8K 1/6W CARBON RES.	
	R180	QRD161J-103	10K 1/6W CARBON RES.	
	R181	QRD161J-222	2.2K 1/6W CARBON RES.	
	R190	QRD161J-103	10K 1/6W CARBON RES.	
	R191	QRD167J-562	5.6K 1/6W CARBON RES.	
	R194	QRD161J-103	10K 1/6W CARBON RES.	
	R195	QRD161J-473	47K 1/6W CARBON RES.	
	R197	QRD161J-222	2.2K 1/6W CARBON RES.	
	R198	QRD167J-822	8.2K 1/6W CARBON RES.	
	R199	QRD161J-472	4.7K 1/6W CARBON RES.	
		OTHERS		
		EMW10604-003A	PRINTED BOARD	
	L106	EQL3001-102K	INDUCTOR	
	L120	EQL4007-1R0	INDUCTOR	
	T101	EQR1111-014	RF COIL	
	T103	EQR1207-017	RF COIL	
	T105	EQT2140-017	I. F. TRANSFORMER	
	T107	ECB1560-010	CERAMIC FILTER	
	AT101	FMMB10YV-401K	ANTENNA TERMINAL	
	CF101	ECB2123-006R	CERAMIC FILTER	
	CF102	ECB2123-006R	CERAMIC FILTER	
	CN011	EMV5163-012R	CONNECT TERMINAL	
	FE101	EAF2203-004	FRONT END	
	LP101	EQF0101-002	LOWPASS FILTER	
	XT102	ECX0007-200KJ1	CRYSTAL	
	XT103	ECX0000-456KR	CERAMIC RESONATOR	

Electrical Parts List (ENP-054)

Δ	Item	Parts Number	Description	Area
		I. C. S		
	IC021	SAA7367TX	I. C (DIGI-MOS)	
	IC041	TDA1386TX	I. C (MONO-ANALOG)	
	IC061	TDA1386TX	I. C (MONO-ANALOG)	
	IC081	TC9332F-010	I. C (DIGI-MOS)	
	IC093	TC74HC74AFT1	I. C (DIGI-MOS)	
	IC096	TMP87C847U-4195	I. C (M)	
		CAPACITORS		
	C021	NEA71EM-475NZ	4.7MF 25V E. CAP.	
	C022	NEA71EM-475NZ	4.7MF 25V E. CAP.	
	C023	NCS31HJ-680AY	68PF 50V CER. CAP.	
	C024	NCS31HJ-680AY	68PF 50V CER. CAP.	
	C025	NCB31CK-473AY	0.047MF 16V CER. CAP.	
	C026	NCB31CK-473AY	0.047MF 16V CER. CAP.	
	C027	NEA70GM-476NZ	47MF E. CAP.	
	C028	NEA70GM-476NZ	47MF E. CAP.	
	C029	NCB31CK-473AY	0.047MF 16V CER. CAP.	
	C030	NEA70JM-476NZ	47MF 6.3V E. CAP.	
	C031	NCB31CK-223A	0.022MF 16V CER. CAP.	
	C032	NCB31HK-102AY	1000PF 50V CER. CAP.	
	C033	NCF31AZ-105AYUU	1MF 10V CER. CAP.	
	C035	NEA70JM-476NZ	47MF 6.3V E. CAP.	
	C036	NCF31AZ-105AYUU	1MF 10V CER. CAP.	
	C037	NCF31AZ-105AYUU	1MF 10V CER. CAP.	
	C038	NEA70JM-107NP	100MF 6.3V E. CAP.	
	C039	NEA70JM-107NP	100MF 6.3V E. CAP.	
	C041	NCS31HJ-102AYM	1000PF 50V CER. CAP.	
	C042	NCS31HJ-102AYM	1000PF 50V CER. CAP.	
	C043	NEA71CM-106NZ	10MF 16V E. CAP.	
	C049	NCB31CK-104AY	0.1MF 16V CER. CAP.	
	C050	NCB31CK-104AY	0.1MF 16V CER. CAP.	
	C051	NEA71HM-105NZ	1MF 50V E. CAP.	
	C052	NEA71HM-105NZ	1MF 50V E. CAP.	
	C053	NCB31CK-183AY	0.018MF 16V CER. CAP.	
	C054	NCB31CK-183AY	0.018MF 16V CER. CAP.	
	C055	NCB31HK-102AY	1000PF 50V CER. CAP.	
	C056	NCB31HK-102AY	1000PF 50V CER. CAP.	
	C057	NCB31HK-102AY	1000PF 50V CER. CAP.	
	C058	NCF31AZ-105AYUU	1MF 10V CER. CAP.	
	C059	NCF31AZ-105AYUU	1MF 10V CER. CAP.	
	C061	NCS31HJ-102AYM	1000PF 50V CER. CAP.	
	C062	NCS31HJ-102AYM	1000PF 50V CER. CAP.	
	C063	NEA71CM-106NZ	10MF 16V E. CAP.	
	C069	NCB31CK-104AY	0.1MF 16V CER. CAP.	
	C070	NCB31CK-104AY	0.1MF 16V CER. CAP.	
	C071	NEA71HM-105NZ	1MF 50V E. CAP.	
	C072	NEA71HM-105NZ	1MF 50V E. CAP.	
	C073	NCB31CK-183AY	0.018MF 16V CER. CAP.	
	C074	NCB31CK-183AY	0.018MF 16V CER. CAP.	
	C075	NCB31HK-102AY	1000PF 50V CER. CAP.	
	C076	NCB31HK-102AY	1000PF 50V CER. CAP.	
	C077	NCB31HK-102AY	1000PF 50V CER. CAP.	
	C081	NCS31HD-9ROAYM	9PF 50V CER. CAP.	
	C082	NCS31HD-9ROAYM	9PF 50V CER. CAP.	
	C085	NCB31CK-104AY	0.1MF 16V CER. CAP.	
	C086	NCB31CK-104AY	0.1MF 16V CER. CAP.	
	C088	NCB31HK-102AY	1000PF 50V CER. CAP.	
	C089	NCB31HK-102AY	1000PF 50V CER. CAP.	
	C090	NCB31HK-102AY	1000PF 50V CER. CAP.	
	C091	NCB31HK-102AY	1000PF 50V CER. CAP.	
	C092	NCF31AZ-105AYUU	1MF 10V CER. CAP.	
	C095	NCB31HK-102AY	1000PF 50V CER. CAP.	
	C096	NCB31HK-102AY	1000PF 50V CER. CAP.	
	C097	NCF31AZ-105AYUU	1MF 10V CER. CAP.	
	C098	NCB31HK-102AY	1000PF 50V CER. CAP.	
	C099	NCS31HJ-101AY	100PF 50V CER. CAP.	
		RESISTORS		
	R021	NRSA63J-104NY	METAL GLAZE	
	R022	NRSA63J-104NY	METAL GLAZE	
	R023	NRSA63J-103N	METAL GLAZE	
	R024	NRSA63J-103N	METAL GLAZE	
	R025	NRSA63J-624NY	METAL GLAZE	
	R026	NRSA63J-334NY	METAL GLAZE	
	R027	NRSA63F-103NY	METAL GLAZE	
	R028	NRSA63F-103NY	METAL GLAZE	
	R029	NRSA63J-271NY	METAL GLAZE	

Δ	Item	Parts Number	Description	Area
	R030	NRSA63J-271NY	METAL GLAZE	
	R031	NRSA63J-333NY	METAL GLAZE	
	R036	NRSA63J-0ROAY	METAL GLAZE	
	R037	NRSA63J-0ROAY	METAL GLAZE	
	R038	NRSA63J-0ROAY	METAL GLAZE	
	R041	NRSA63J-0ROAY	METAL GLAZE	
	R042	NRSA63J-0ROAY	METAL GLAZE	
	R051	NRSA63J-473NY	METAL GLAZE	
	R052	NRSA63J-473NY	METAL GLAZE	
	R053	NRSA63J-201NY	METAL GLAZE	
	R054	NRSA63J-201NY	METAL GLAZE	
	R061	NRSA63J-0ROAY	METAL GLAZE	
	R062	NRSA63J-0ROAY	METAL GLAZE	
	R071	NRSA63J-473NY	METAL GLAZE	
	R072	NRSA63J-473NY	METAL GLAZE	
	R073	NRSA63J-201NY	METAL GLAZE	
	R074	NRSA63J-201NY	METAL GLAZE	
	R081	NRSA63J-0ROAY	METAL GLAZE	
	R083	NRSA63J-112NY	METAL GLAZE	
	R084	NRSA63J-112NY	METAL GLAZE	
	R085	NRSA63J-112NY	METAL GLAZE	
	R086	NRSA63J-182NY	METAL GLAZE	
	R087	NRSA63J-112NY	METAL GLAZE	
	R088	NRSA63J-0ROAY	METAL GLAZE	
	R089	NRSA63J-0ROAY	METAL GLAZE	
	R090	NRSA63J-0ROAY	METAL GLAZE	
	R091	NRSA63J-0ROAY	METAL GLAZE	
	R092	NRSA63J-0ROAY	METAL GLAZE	
	R093	NRSA63J-0ROAY	METAL GLAZE	
	R094	NRSA63J-471N	METAL GLAZE	
	R095	NRSA63J-103N	METAL GLAZE	
	R096	NRSA63J-103N	METAL GLAZE	
	R097	NRSA63J-472NY	METAL GLAZE	
	R098	NRSA63J-472NY	METAL GLAZE	
	R099	NRSA63J-472NY	METAL GLAZE	
	R100	NRSA63J-472NY	METAL GLAZE	
		OTHERS		
		EMW10476-101A	CIR. BOARD	
	K041	EQA0002-N102Y	FERRITE BEADS	
	K042	EQA0002-N102Y	FERRITE BEADS	
	K061	EQA0002-N102Y	FERRITE BEADS	
	K062	EQA0002-N102Y	FERRITE BEADS	
	K081	EQA0002-N102Y	FERRITE BEADS	
	K082	EQA0002-N102Y	FERRITE BEADS	
	K083	EQA0002-N102Y	FERRITE BEADS	
	K084	EQA0002-N102Y	FERRITE BEADS	
	K085	EQA0002-N102Y	FERRITE BEADS	
	K086	EQA0002-N102Y	FERRITE BEADS	
	K087	EQA0001-N01Y	FERRITE BEADS	
	K088	EQA0001-N01Y	FERRITE BEADS	
	K089	EQA0001-N01Y	FERRITE BEADS	
	K090	EQA0001-N01Y	FERRITE BEADS	
	K091	EQA0002-N102Y	FERRITE BEADS	
	K092	EQA0002-N102Y	FERRITE BEADS	
	K093	EQA0002-N102Y	FERRITE BEADS	
	K094	EQA0002-N102Y	FERRITE BEADS	
	K095	EQA0002-N102Y	FERRITE BEADS	
	K096	EQA0002-N102Y	FERRITE BEADS	
	K097	EQA0002-N102Y	FERRITE BEADS	
	K098	EQA0002-N102Y	FERRITE BEADS	
	X081	ECX0225-792EN9T	CRYSTAL	
	LC021	EQF0703-N103NZ	INDUCTOR	
	LC041	EQF0703-N103NZ	INDUCTOR	
	LC081	EQF0703-N103NZ	INDUCTOR	
	LC093	EQF0704-N01YU	INDUCTOR	
	LC096	EQF0703-N103NZ	INDUCTOR	

# Accessories List

Symbol No. 

M	3	M	M
---	---	---	---

△	Item	Parts Number	Parts Name	Q'ty	Description	Area
	1	E30580-2416A	INSTRUCTION BOOK	1		J
	1	E30580-2417A	INSTRUCTION BOOK	1		C
	2	RM-SR818U	WIRE-LESS REMOTE CONTROL	1		
	3	R03BPA-2STSA	DRY CELL	2		
	4	EQB4001-015	LOOP ANTENNA	1		
	5	EWP201-011	ANTENNA WIRE	1		
	6	E309758-001	POLY BAG	1		
	-	BT-20044G	SAFETY SHEET	1		J
	-	BT-20071B	SERVICE NETWORK	1		C
	-	BT-51006-1	REGISTER CARD	1		J
	-	BT-52002-1	WARRANTY CARD	1		C



# Packing Materials and Part Numbers

Symbol No. 

M	4	M	M
---	---	---	---

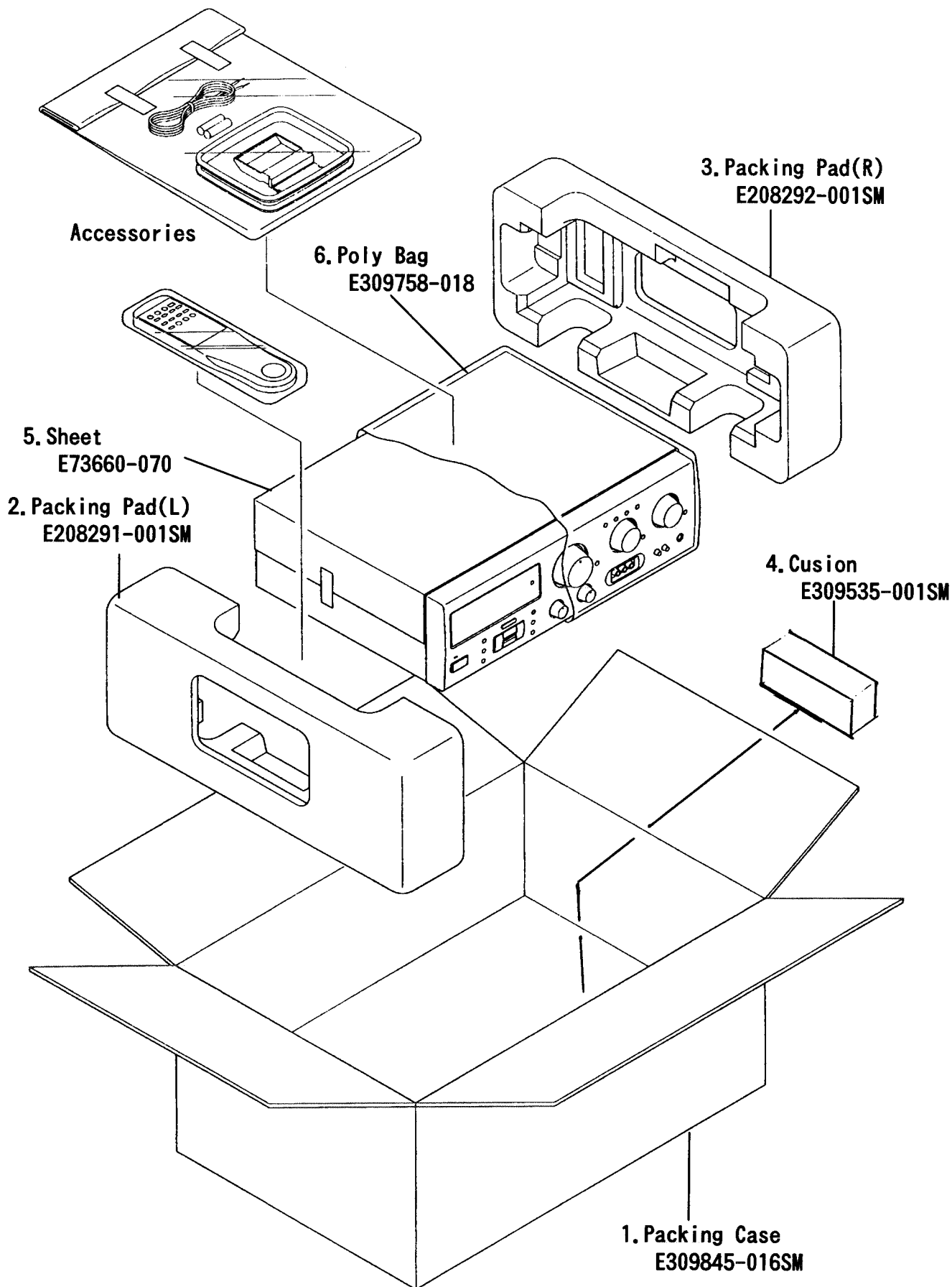

**-MEMO-**

RX-818VBK  
RX-880VBK

RX-818VBK  
RX-880VBK

**JVC**

VICTOR COMPANY OF JAPAN, LIMITED  
AUDIO PRODUCT DIVISION 1644, SHIMOTSURUMA, YAMATO-SHI, KANAGAWA-KEN, 242, JAPAN