

JVC

SERVICE MANUAL

AUDIO/VIDEO CONTROL RECEIVER

RX-DP10VBK RX-DP10VSL RX-DP10RSL

RX-DP10VBK
Area suffix J ----- U.S.A.
RX-DP10VSL
Area suffix C ----- Canada
RX-DP10RSL
Area suffix B ----- U.K. E ----- Continental Europe EN ----- Northern Europe

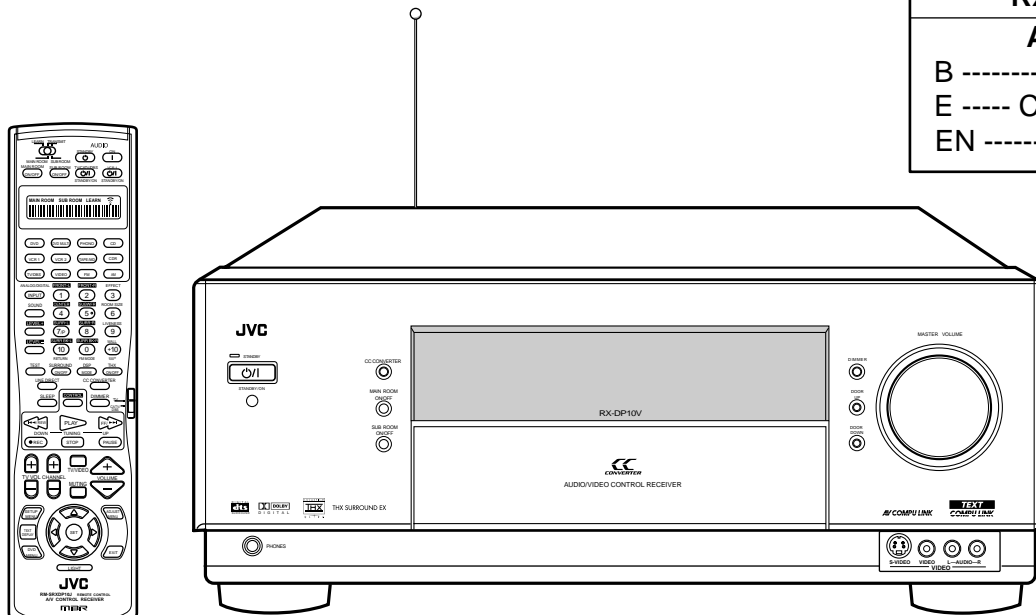

AV COMPU LINK THX SURROUND EX



Model	RF remote unit	Video SEP board	Color
RX-DP10VBK	○	○	Black
RX-DP10VSL	○	○	Silver
RX-DP10RSL	×	×	Silver

Contents

Safety precautions	1-2
Importance administering point on the safety	1-4
Disassembly method	1-5
Adjustment method	1-14
Description of major ICs	1-16~37

Safety Precautions

1. This design of this product contains special hardware and many circuits and components specially for safety purposes. For continued protection, no changes should be made to the original design unless authorized in writing by the manufacturer. Replacement parts must be identical to those used in the original circuits. Services should be performed by qualified personnel only.
2. Alterations of the design or circuitry of the product should not be made. Any design alterations of the product should not be made. Any design alterations or additions will void the manufacturer's warranty and will further relieve the manufacture of responsibility for personal injury or property damage resulting therefrom.
3. Many electrical and mechanical parts in the products have special safety-related characteristics. These characteristics are often not evident from visual inspection nor can the protection afforded by them necessarily be obtained by using replacement components rated for higher voltage, wattage, etc. Replacement parts which have these special safety characteristics are identified in the Parts List of Service Manual. Electrical components having such features are identified by shading on the schematics and by (\triangle) on the Parts List in the Service Manual. The use of a substitute replacement which does not have the same safety characteristics as the recommended replacement parts shown in the Parts List of Service Manual may create shock, fire, or other hazards.
4. The leads in the products are routed and dressed with ties, clamps, tubings, barriers and the like to be separated from live parts, high temperature parts, moving parts and/or sharp edges for the prevention of electric shock and fire hazard. When service is required, the original lead routing and dress should be observed, and it should be confirmed that they have been returned to normal, after re-assembling.

5. Leakage current check (Electrical shock hazard testing)

After re-assembling the product, always perform an isolation check on the exposed metal parts of the product (antenna terminals, knobs, metal cabinet, screw heads, headphone jack, control shafts, etc.) to be sure the product is safe to operate without danger of electrical shock.

Do not use a line isolation transformer during this check.

- Plug the AC line cord directly into the AC outlet. Using a "Leakage Current Tester", measure the leakage current from each exposed metal parts of the cabinet, particularly any exposed metal part having a return path to the chassis, to a known good earth ground. Any leakage current must not exceed 0.5mA AC (r.m.s.).

- Alternate check method

Plug the AC line cord directly into the AC outlet. Use an AC voltmeter having, 1,000 ohms per volt or more sensitivity in the following manner. Connect a 1,500 Ω 10W resistor paralleled by a 0.15 μ F AC-type capacitor between an exposed metal part and a known good earth ground. Measure the AC voltage across the resistor with the AC voltmeter.

Move the resistor connection to each exposed metal part, particularly any exposed metal part having a return path to the chassis, and measure the AC voltage across the resistor. Now, reverse the plug in the AC outlet and repeat each measurement. Voltage measured any must not exceed 0.75 V AC (r.m.s.). This corresponds to 0.5 mA AC (r.m.s.).

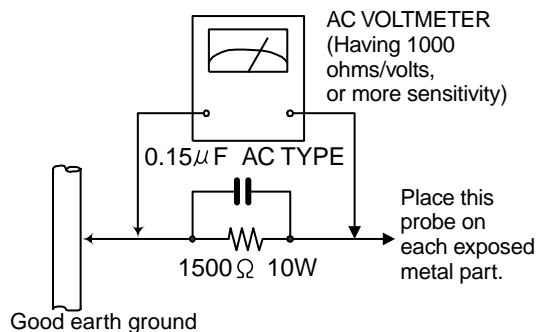

Warning

1. This equipment has been designed and manufactured to meet international safety standards.
2. It is the legal responsibility of the repairer to ensure that these safety standards are maintained.
3. Repairs must be made in accordance with the relevant safety standards.
4. It is essential that safety critical components are replaced by approved parts.
5. If mains voltage selector is provided, check setting for local voltage.

CAUTION

Burrs formed during molding may be left over on some parts of the chassis. Therefore, pay attention to such burrs in the case of preforming repair of this system.

In regard with component parts appearing on the silk-screen printed side (parts side) of the PWB diagrams, the parts that are printed over with black such as the resistor (■), diode (▣) and ICP (●) or identified by the " \triangle " mark nearby are critical for safety.

When replacing them, be sure to use the parts of the same type and rating as specified by the manufacturer. (Except the J&C version)

Safety precautions (U.K only)

1. This design of this product contains special hardware and many circuits and components specially for safety purposes. For continued protection, no changes should be made to the original design unless authorized in writing by the manufacturer. Replacement parts must be identical to those used in the original circuits.
2. Any unauthorised design alterations or additions will void the manufacturer's guarantee ; furthermore the manufacturer cannot accept responsibility for personal injury or property damage resulting therefrom.
3. Essential safety critical components are identified by () on the Parts List and by shading on the schematics, and must never be replaced by parts other than those listed in the manual. Please note however that many electrical and mechanical parts in the product have special safety related characteristics. These characteristics are often not evident from visual inspection. Parts other than specified by the manufacturer may not have the same safety characteristics as the recommended replacement parts shown in the Parts List of the Service Manual and may create shock, fire, or other hazards.
4. The leads in the products are routed and dressed with ties, clamps, tubings, barriers and the like to be separated from live parts, high temperature parts, moving parts and/or sharp edges for the prevention of electric shock and fire hazard. When service is required, the original lead routing and dress should be observed, and it should be confirmed that they have been returned to normal, after re-assembling.

Warning

1. Service should be performed by qualified personnel only.
2. This equipment has been designed and manufactured to meet international safety standards.
3. It is the legal responsibility of the repairer to ensure that these safety standards are maintained.
4. Repairs must be made in accordance with the relevant safety standards.
5. It is essential that safety critical components are replaced by approved parts.
6. If mains voltage selector is provided, check setting for local voltage.

 **CAUTION** Burrs formed during molding may be left over on some parts of the chassis. Therefore, pay attention to such burrs in the case of performing repair of this system.

Importance administering point on the safety

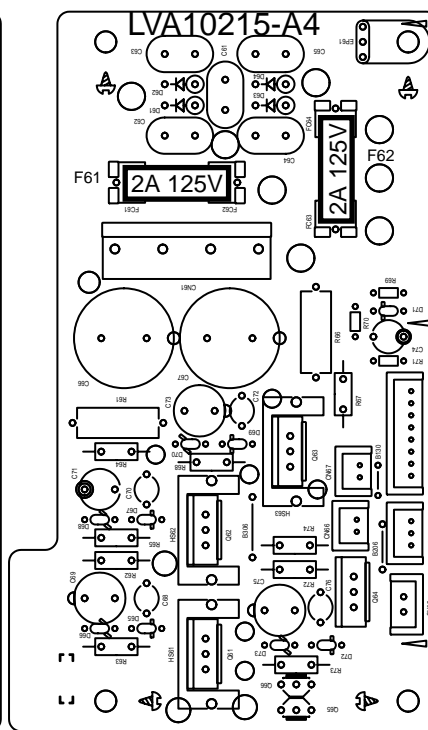
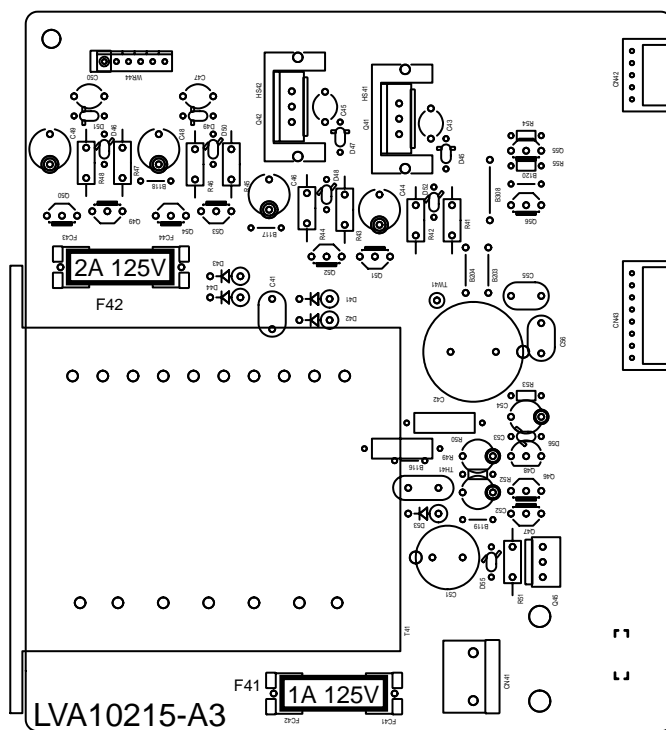
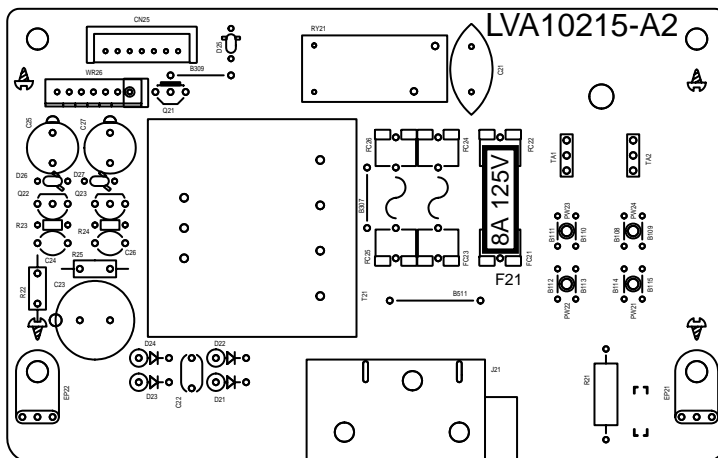

For USA and Canada / pour États - Unis d' Amérique et Canada

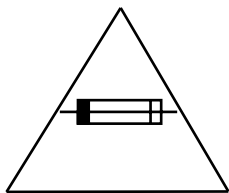

Caution: For continued protection against risk of fire, replace only with same type 1A/125V for F41, 2A/125V for F61, F62 and F42, 8A/ 125V for F21. This symbol specifies type of fast operating fuse.

Précaution: Pour éviter risques de feux, remplacez le fusible de sûreté de et F41 comme le meme type que 1A/125V, et 2A/125V pour F61, F62 et F42, 8A/125V pour F21. Ce sont des fusibles sûretes qui fonctionnes rapide.

Disassembly method

■ Removing the top cover (See Fig.1)

1. Remove the eight screws **A** attaching the top cover on both sides of the body.
2. Remove the three screws **B** on the back of the body.
3. Remove the top cover from behind in the direction of the arrow while pulling both sides outward.

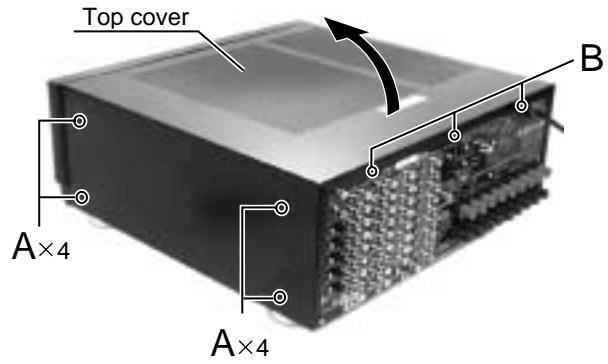

Fig.1

■ Removing the front panel assembly (See Fig.2 and 3)

- Prior to performing the following procedure, remove the top cover.

1. Cut off the tie band fixing the harness.
2. Disconnect the harness from the connector CN971, CN977, CN983 and CN985 on the system control board (see fig.5) and CN973 on the front AV in board (see Front panel assembly section/ fig.2).
3. Remove the screws **a** and **b**, and remove each earth wires.
4. Remove the three screws **C** attaching the front panel assembly.
5. Remove the four screws **D** attaching the front panel assembly on the bottom of the body. Detach the front panel assembly toward the front.

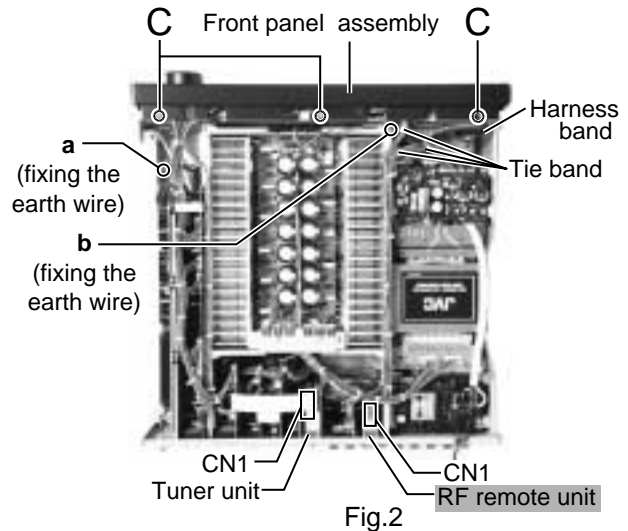

Fig.2

■ Removing the tuner unit & RF remote unit (See Fig.2 and 4)

Note : RF remote unit is not in B/E/EN version.

- Prior to performing the following procedure, remove the top cover.

1. Disconnect the card wire from the connector CN1 on the tuner unit.
2. Remove the two screws **E'** attaching the tuner unit to the rear panel.
3. Disconnect the harness from the connector CN1 on the RF remote unit.
4. Remove the nut **E''** attaching the RF remote unit to the rear panel.

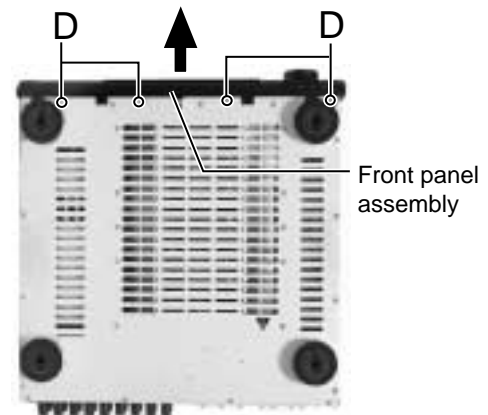

Fig.3

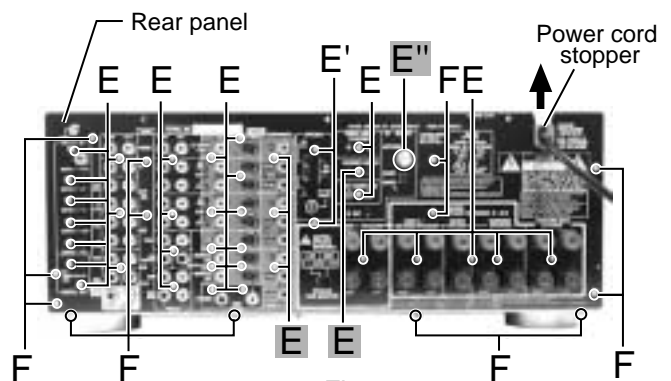

Fig.4

THE INTRODUCTORY NOTES in Figs :
Gray parts do not correspond to B/E/EN version.

■ Removing the rear panel (See Fig.4)

- Prior to performing the following procedure, remove the top cover.
1. Remove the power cord stopper from the rear panel by moving it in the direction of the arrow.
 2. Remove the thirty six (B/E/EN version is thirty two) screws **E** attaching the each boards to the rear panel on the back of the body.
 3. Remove the thirteen screws **F** attaching the rear panel on the back of the body and bottom.

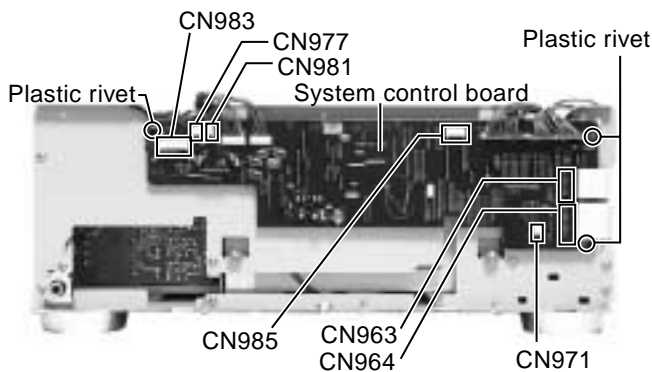

Fig.5

■ Removing the system control board (See Fig.5 and 6)

- Prior to performing the following procedure, remove the top cover and front panel assembly.
1. Disconnect the card wires and harness from connector CN963, CN964 and CN981 on the system control board.
 2. Cut off the tie bands fixing the harnesses.
 3. Disconnect the harness from connector CN43 on the power supply 2 board and CN25 on the power/ fuse board.
 4. Disconnect the connector CN324 on the audio signal 2 board and CN205, CN234, CN208(J/C only) on the audio signal 1 board.
 5. Remove the three plastic rivet.

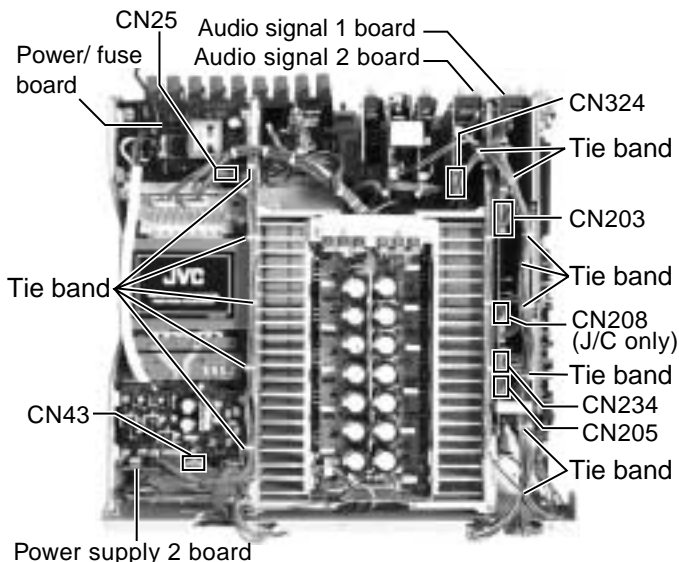

Fig.6

■ Removing the DSP board (See Fig.6 and 7)

- Prior to performing the following procedure, remove the top cover and the rear panel.
1. Disconnect the connector CN631 on the DSP board.
 2. Disconnect the connector CN203 on the audio signal 1 board.
 3. Removing the two plastic rivet and disconnect the connector CN633 on the DSP board.

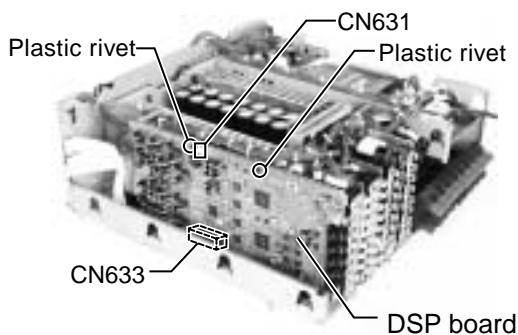

Fig.7

■ Removing the shield cover (See Fig.8)

- Prior to performing the following procedure, remove the top cover and the rear panel.
1. Removing the screw **G** attaching the shield cover.
 2. Shift the shield cover before, and pull upward.

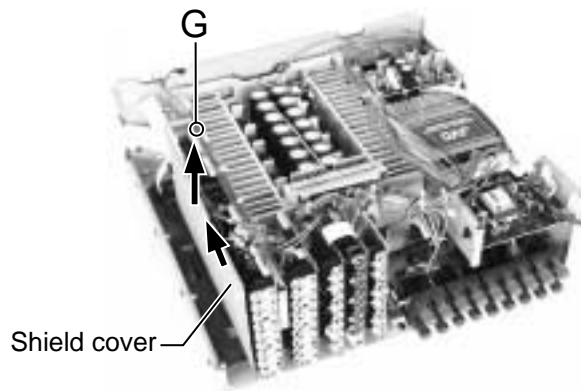

Fig.8

■ Removing the audio signal 1 board (See Fig.9)

- Prior to performing the following procedure, remove the top cover, the rear panel and the DSP board.

1. Disconnect the harness from the connector CN224, CN207, CN218(J/C only) and CN223 on the audio signal 1 board.
2. Removing the plastic rivet.
3. Disconnect the connector CN206 and CN221 on the audio signal 1 board.

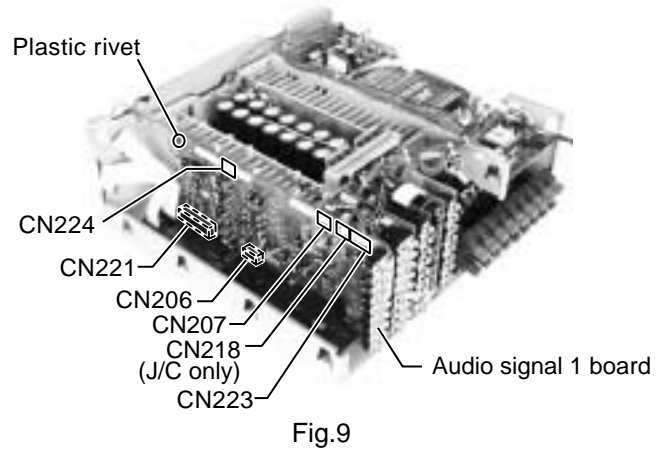

Fig.9

■ Removing the audio signal 2 board & s video board (See Fig.10 to 12)

- Prior to performing the following procedure, remove the top cover and the rear panel.

1. Disconnect the harness from connector CN973 on the front AV in board (see Front panel assembly section/ fig.2).

2. Cut off the tie band c.

3. Disconnect the harness from connector CN324 on the audio signal 2 board.

4. Disconnect the connector CN321 and CN325. While removing the claw of the connector CN15, pull out the audio signal 2 board.

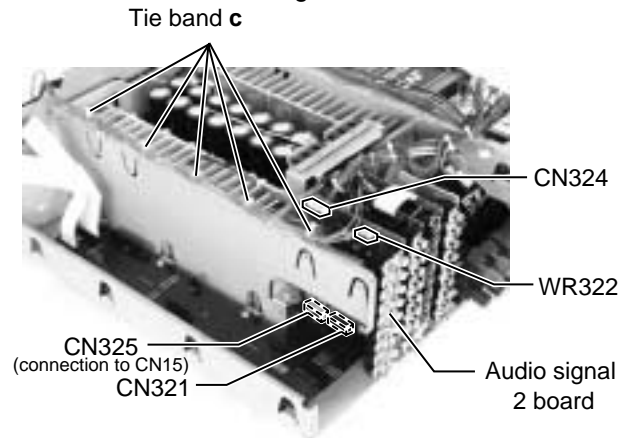

Fig.10

5. Cut off the tie band d.

6. Disconnect the card wire from connector CN402 on the video board.

7. Pull out the video board upward.

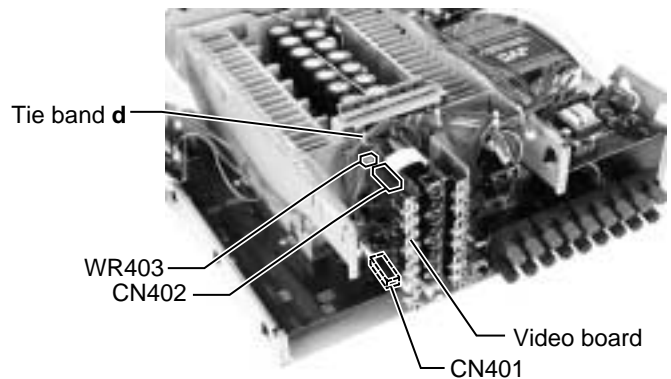

Fig.11

8. Cut off the tie band e.

9. Disconnect the card wire from connector CN432 on the s video board.

10. Disconnect the connector CN431 on the s video board. While removing the claw of the connector CN8, pull out the s video board.

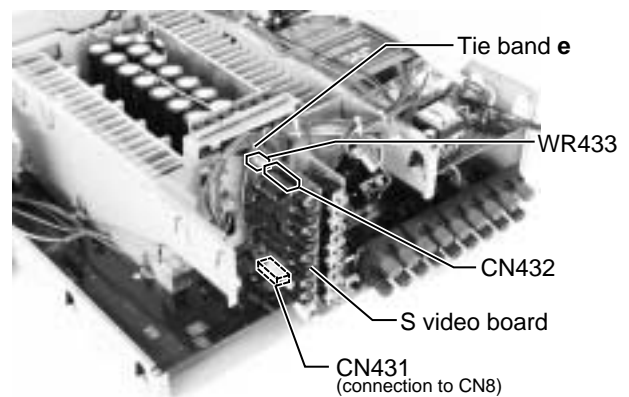

Fig.12

■ Removing the video SEP board (See Fig.13)

Note : Video SEP board is not in B/E/EN version.

- Prior to performing the following procedures, remove the top cover and the rear panel.

1. Disconnect the connector CN501 on the video SEP board. While removing the claw of the connector CN9, pull out the video SEP board.

■ Removing the input base board (See Fig.14)

- Prior to performing the following procedure, remove the top cover, rear panel, DSP board, audio signal 1 board, audio signal 2 board, video board, s video board and video SEP board.

1. Cut off the tie bands fixing the harnesses.
2. Disconnect the harnesses from the connector CN11, CN16 and CN17 on the input base board.
3. Disconnect the harnesses from the connector CN63 on the power supply 1 board and CN42 on the power supply 2 board.
4. Disconnect the harnesses from the connector CN 743 on the speaker board.
5. Remove the seven screws **H** attaching the input base board.

■ Removing the speaker board (See Fig.14)

- Prior to performing the following procedure, remove the top cover and rear panel.

Attention : Speaker board is attached the rear panel by screws.

1. Cut off the tie band fixing the harnesses.
2. Disconnect the harnesses from the connector CN741, CN742 and CN743 on the speaker board.

■ Removing the compu link board (See Fig.15)

- Prior to performing the following procedure, remove the top cover and rear panel.

Attention : Compu link board is attached the rear panel by screws.

1. Cut off the tie band fixing the harnesses.
2. Disconnect the harness from the connector CN301 on the compu link board.

THE INTRODUCTORY NOTES in Figs :
Gray parts do not correspond to B/E/EN version.

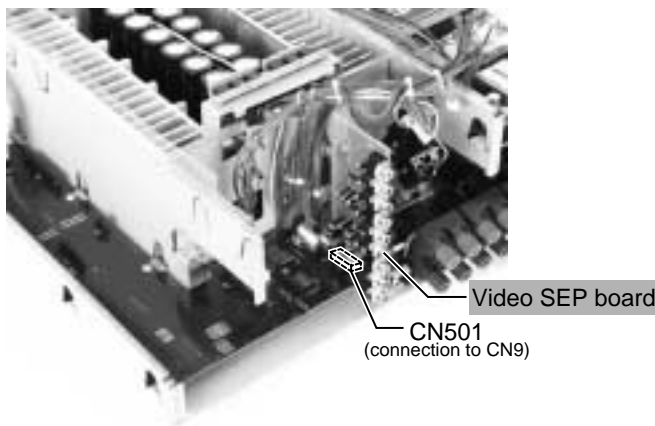

Fig.13

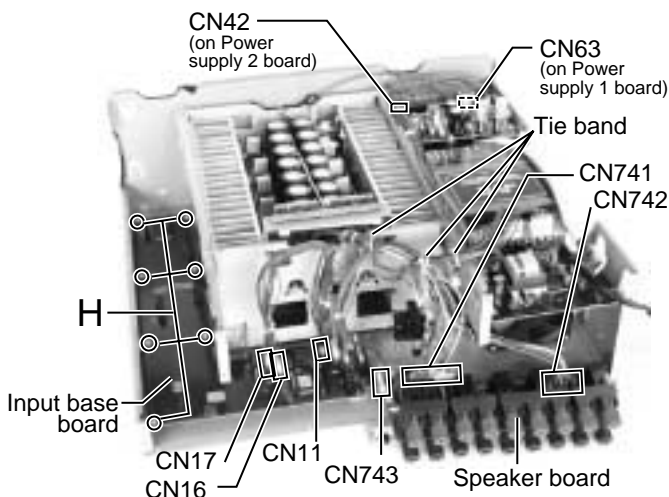

Fig.14

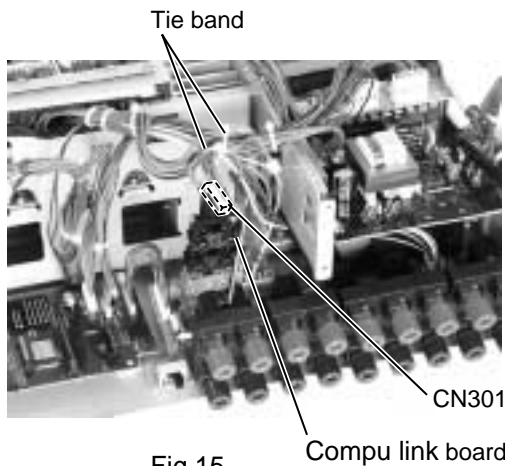

Fig.15

■ Removing the power supply 1 board
(See Fig.16)

- Prior to performing the following procedure, remove the top cover.

1. Cut off the tie band fixing the harnesses.
2. Disconnect the harnesses from the connector CN61, CN63, CN64 and CN65 on the power supply 1 board.
3. Remove the four screws **I** attaching the power supply 1 board.

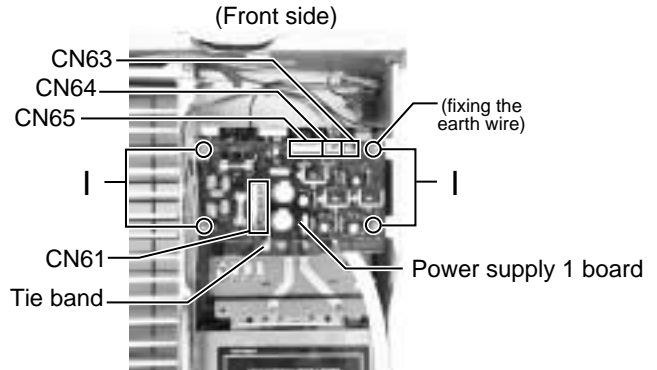

Fig.16

■ Removing the regulator board
(See Fig.17)

- Prior to performing the following procedure, remove the top cover and power supply 1 board.

1. Disconnect the harness from the connector CN45 on the regulator board.
2. Remove the screw **J** attaching the bracket and regulator board.

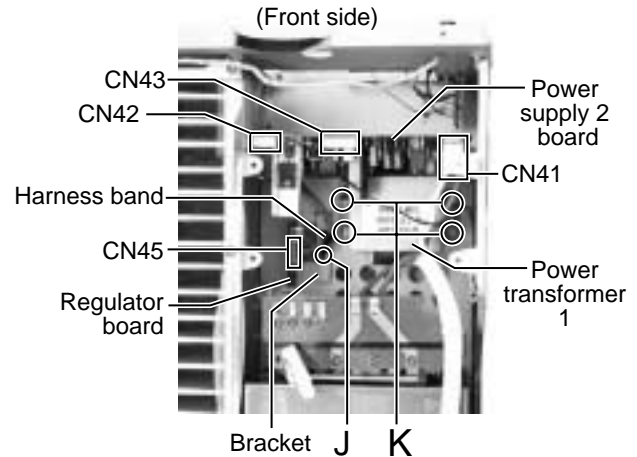

Fig.17

■ Removing the power transformer 1
(See Fig.17)

- Prior to performing the following procedure, remove the top cover and power supply 1 board.

1. Disconnect the harnesses from the connector CN41, CN42 and CN43 on the power supply 2 board and CN45 on the regulator board.
2. Remove the four screws **K** attaching the power transformer 1.

■ Removing the power/ fuse board
(See Fig.18)

- Prior to performing the following procedure, remove the top cover.

1. Unsolder the solder points TA1, TA2 and PW21, PW22, PW23, PW24 on the power/ fuse board.
2. Remove the four screws **L** attaching the power/ fuse board.

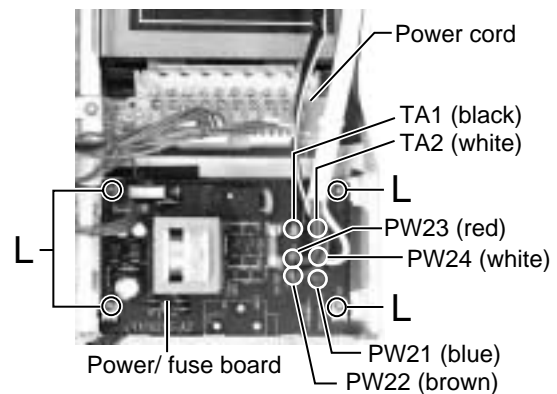

Fig.18

■ Removing the power transformer 2
(See Fig.19)

- Prior to performing the following procedure, remove the top cover and power supply 1 board.

1. Cut off the tie band fixing the harnesses.
2. Disconnect the harnesses from the connector CN83 and CN84 on the power trans 2 board.
3. Unsolder the solder points PW81 and PW82 on the power supply 1 board.
4. Remove the four screws **M** attaching the power transformer 2.

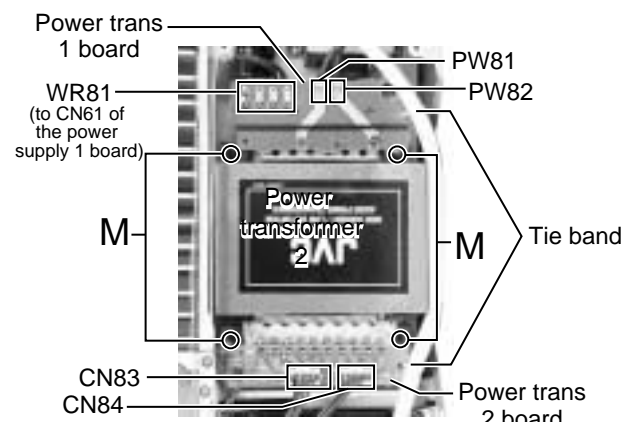

Fig.19

■ Removing the head phone board (See Fig.20 and 21)

• Prior to performing the following procedures, remove the top cover, rear panel and front panel assembly.

1. Disconnect the harnesses from the connector CN981 on the system control board (see fig.5) and CN738 on the power amp. board.
2. Removing the nut **L** fixing the head phone board.
3. Removing the screw **M** attaching the earth wire and bracket.

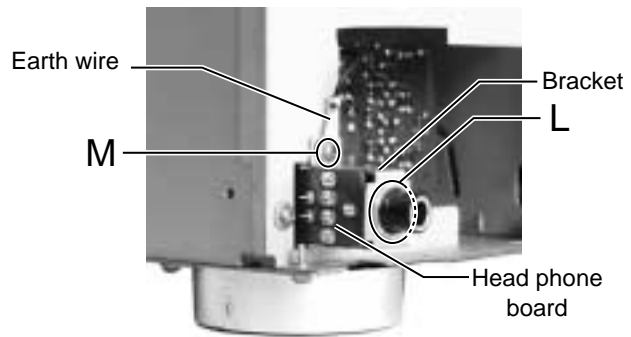

Fig.20

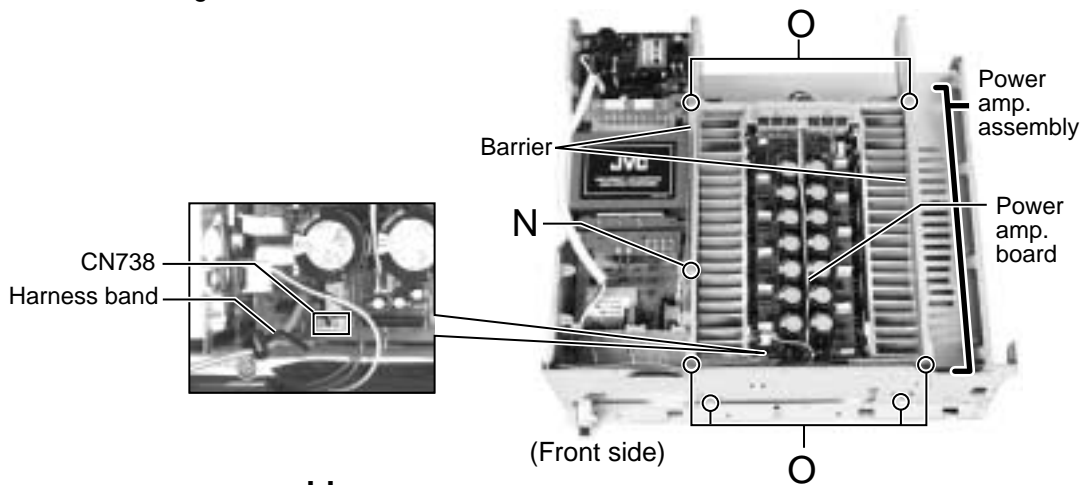

Fig.21

■ Removing the power amp. assembly (See Fig.21 and 22)

• Prior to performing the following procedures, remove the top cover, rear panel, front panel assembly, system control board, DSP board, shield cover, audio signal 1 board, audio signal 2 board, video board, s video board and input base board.

1. Remove the three screws **N** fixing the barriers, and remove the tow barriers.
2. Remove the eight screws **O** attaching the power amp. assembly.
3. Pull up the power amp. assembly.

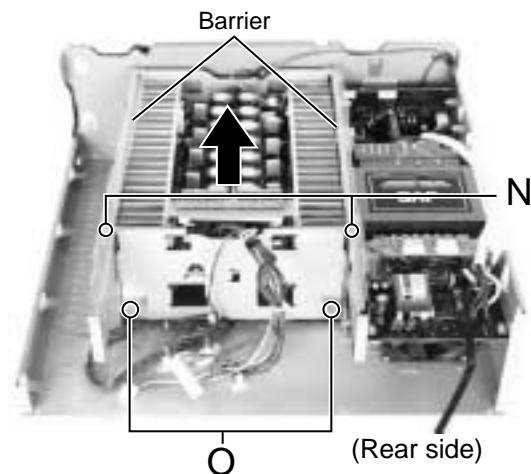

Fig.22

■ Removing the fan motor (See Fig.23)

• Prior to performing the following procedures, remove the top cover and rear panel.

1. Disconnect the harness from the connector CN65 on the power supply 1 board (see fig.16).
2. Removing the four screws **P** attaching the fan motor.

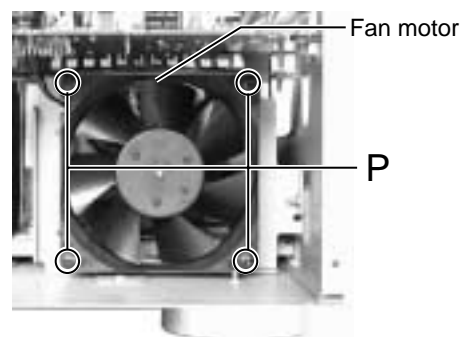

Fig.23

<Power amp. assembly section>

■ Removing the relay board & Rch pre amp. & Lch pre amp. & center pre amp. & surround pre amp. (See Fig.1 to 3)

- Prior to performing the following procedure, remove the power amp. assembly.

1. Cut off the tie band fixing the harnesses.
2. Disconnect the harness from two connectors CN70 on the thermal compensation board (up side).
3. Remove the two screws **A** attaching the relay board.
4. Disconnect the harness from five connectors CN70 on the thermal compensation board (bottom side).
5. Pull up Lch pre amp., center pre amp., surround pre amp. and Rch pre amp. with the relay board from the power amp. board.
6. Remove each pre amp. board from the connector CN721, CN821, CN781 and CN761 on the relay board.

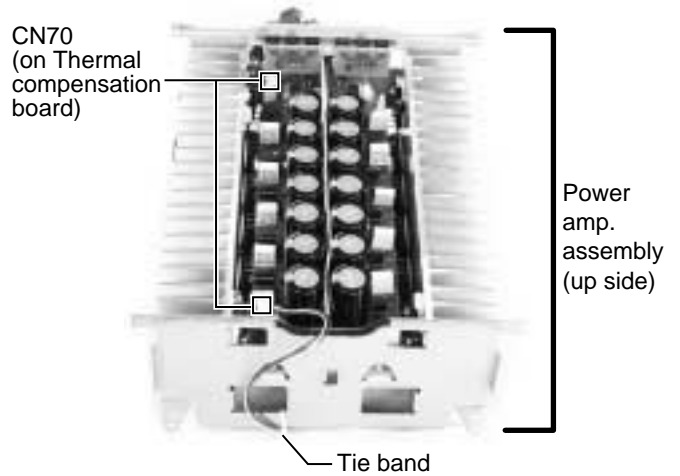

Fig.1

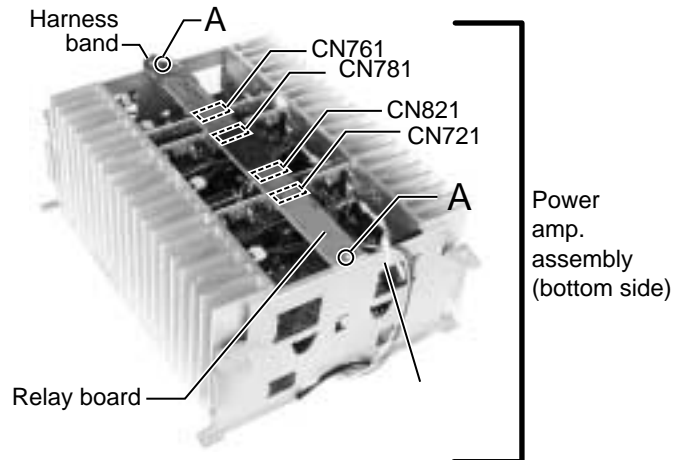

Fig.2

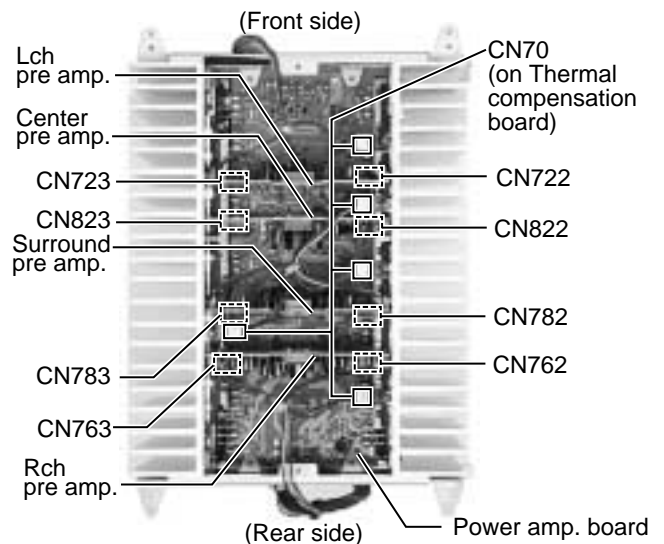

Fig.3

■ **Removing the amp. sub Lo board & amp. sub Hi board (See Fig.4)**

- Prior to performing the following procedure, remove the power amp. assembly.

1. Remove the two screws **B** attaching the bracket.

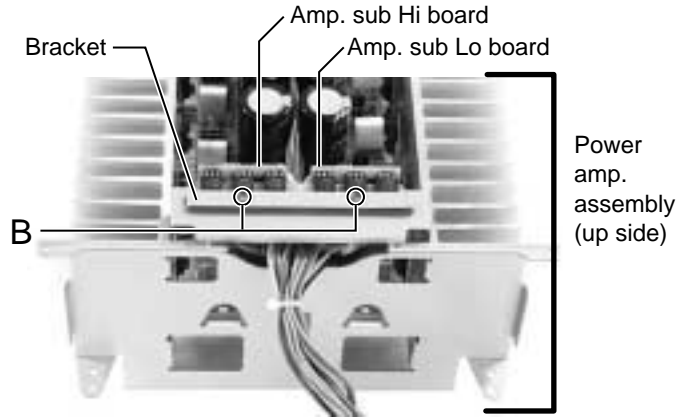

Fig.4

■ **Removing the heat sink (See Fig.5 to 7)**

- Prior to performing the following procedure, remove the power amp. assembly, relay board, each pre amp., amp. sub Lo board and amp. sub Hi board.

1. Remove the eight screws **C** attaching the heat sink both side.
2. Remove the eight screws **D** attaching the power ICs (up side).
3. Remove the twenty screws **D** attaching the power ICs (bottom side).

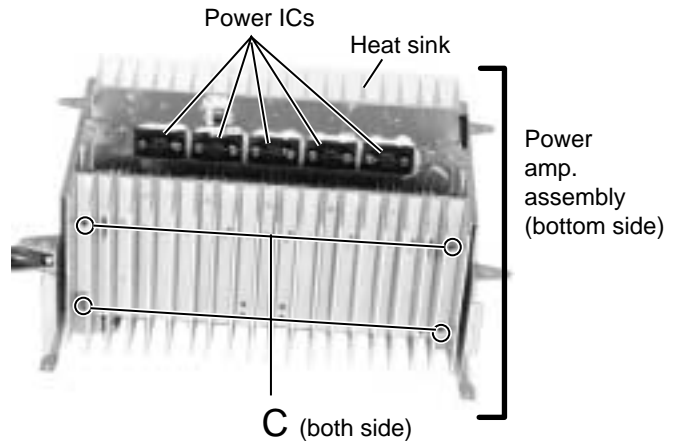

Fig.5

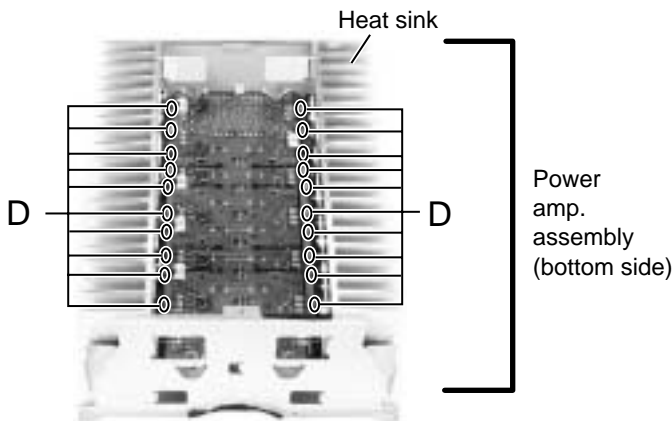

Fig.7

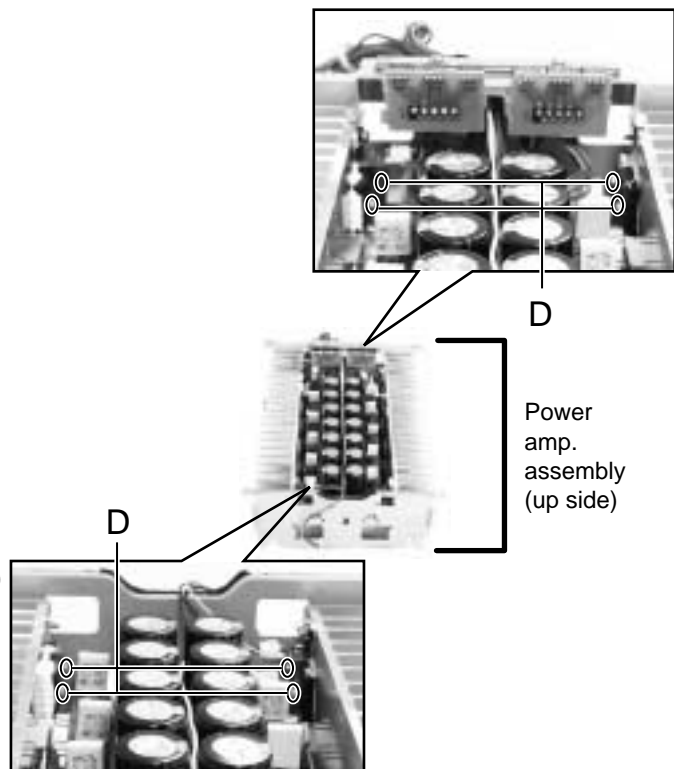

Fig.6

<Front panel assembly section>

■ Removing the FL display board & front AV in board (See Fig.1 and 2)

- Prior to performing the following procedure, remove the top cover and the front panel assembly.

1. Pull out the volume knob on the front side of the front panel assembly and remove the nut attaching the FL display board.
2. Disconnect the harness from the connector CN973 on the front AV in board.
3. Remove the three screws **A** attaching the front AV in board.
4. Remove the nine screws **B** attaching the FL display board on the back of the front panel.
5. Disconnect the harnesses from connector CN969, CN975 and CN982 on the FL display board.

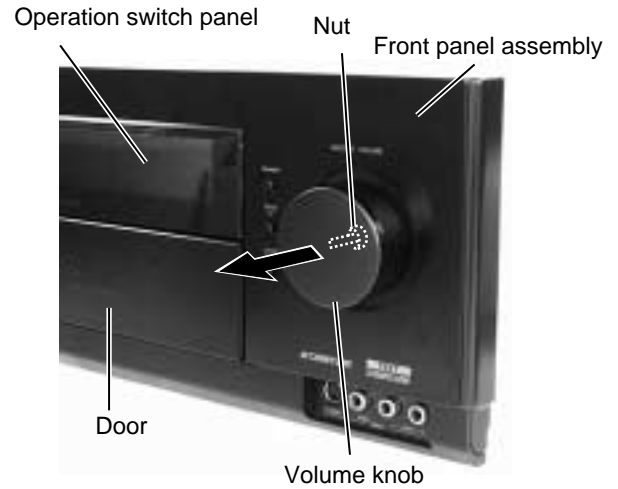

Fig.1

■ Removing the power switch board & motor assembly (See Fig.3)

- Prior to performing the following procedure, remove the front panel assembly and the FL display board.

1. Remove the four screws **C** attaching the power switch board.
2. Remove the three screws **D** attaching the motor assembly on the back of the front panel.
3. Remove the belt and the two screws **a** attaching the motor.

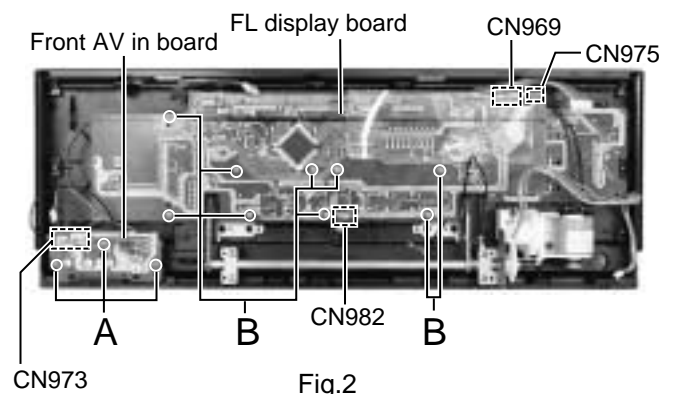

Fig.2

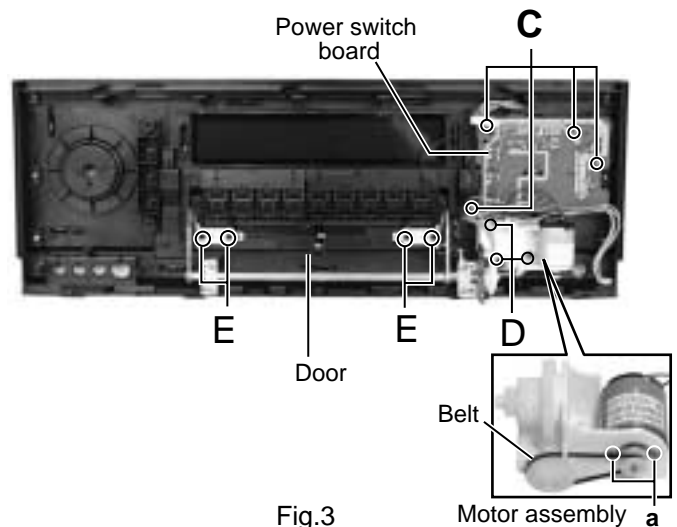

Fig.3

■ Removing the door input board (See Fig.3 and 4)

- Prior to performing the following procedure, remove the front panel assembly and the FL display board.

1. Remove the four screws **E** attaching the door and remove the door from front panel assembly.
2. Remove the six screws **F** attaching the door input board.

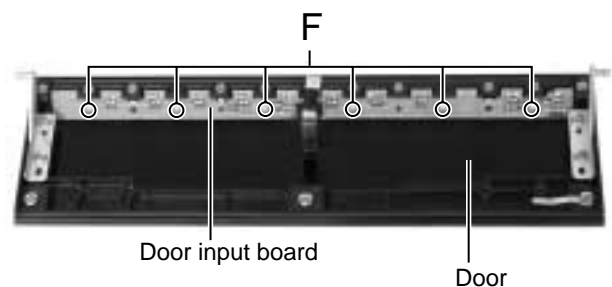

Fig.4

Adjustment method

■ Power amplifier section

Adjustment of idling current

/// Measuring point ///

Lch : B903 & B904
Rch : B911 & B912
Cch : B907 & B908
SLch : B905 & B906
SRch : B909 & B910
SBLch : B901 & B902
SBRch : B913 & B914

/// Alignment point ///

Lch : VR701
Rch : VR751
Cch : VR801
SLch : VR771
SRch : VR772
SBLch : VR702
SBRch : VR752

*** Measuring condition ***

- No load, No signal and Rated line voltage
- SURROUND : OFF
- Speaker load SW : HIGH (J/C only)
- Room temperature : 20~25°C

Attention

This adjustment does not obtain a correct adjustment value immediately after the amplifier is used (state that an internal temperature has risen).

Please adjust immediately after using the amplifier after turning off the power supply of the amplifier and falling an internal temperature.

<Adjustment method>

1. Prior to turning the power ON, fully turn the adjusting resistor (VR701, VR702, VR751, VR752, VR771, VR772, VR801) counterclockwise direction and connect the DC voltmeter to the measuring terminal (B901-B902, B903-B904, B905-B906, B907-B908, B909-B910, B911-B912, B913-B914).
2. Adjust the resistor so that the measured value becomes 2.0mV just after the power supply is turned on.
3. Adjust the resistor so that the measured value becomes 2.5mV more than 60 seconds after the power supply is turned on.
4. After stability is 1.0-4.0mV.

The "idling current" graph of the following page is referred to.

* It is not abnormal though the idling current might not become 0mA even if it is finished to turn variable resistance (VR701, VR702, VR751, VR752, VR771, VR772, VR801) in the direction of counterclockwise.

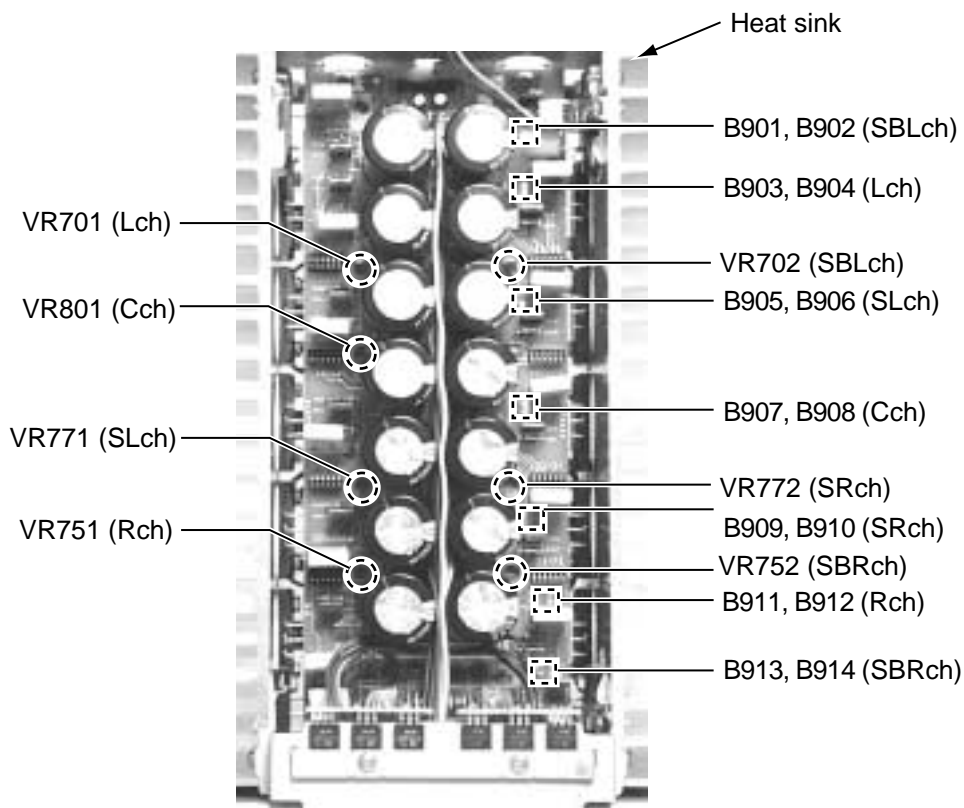

RX-DP10 Idling Current

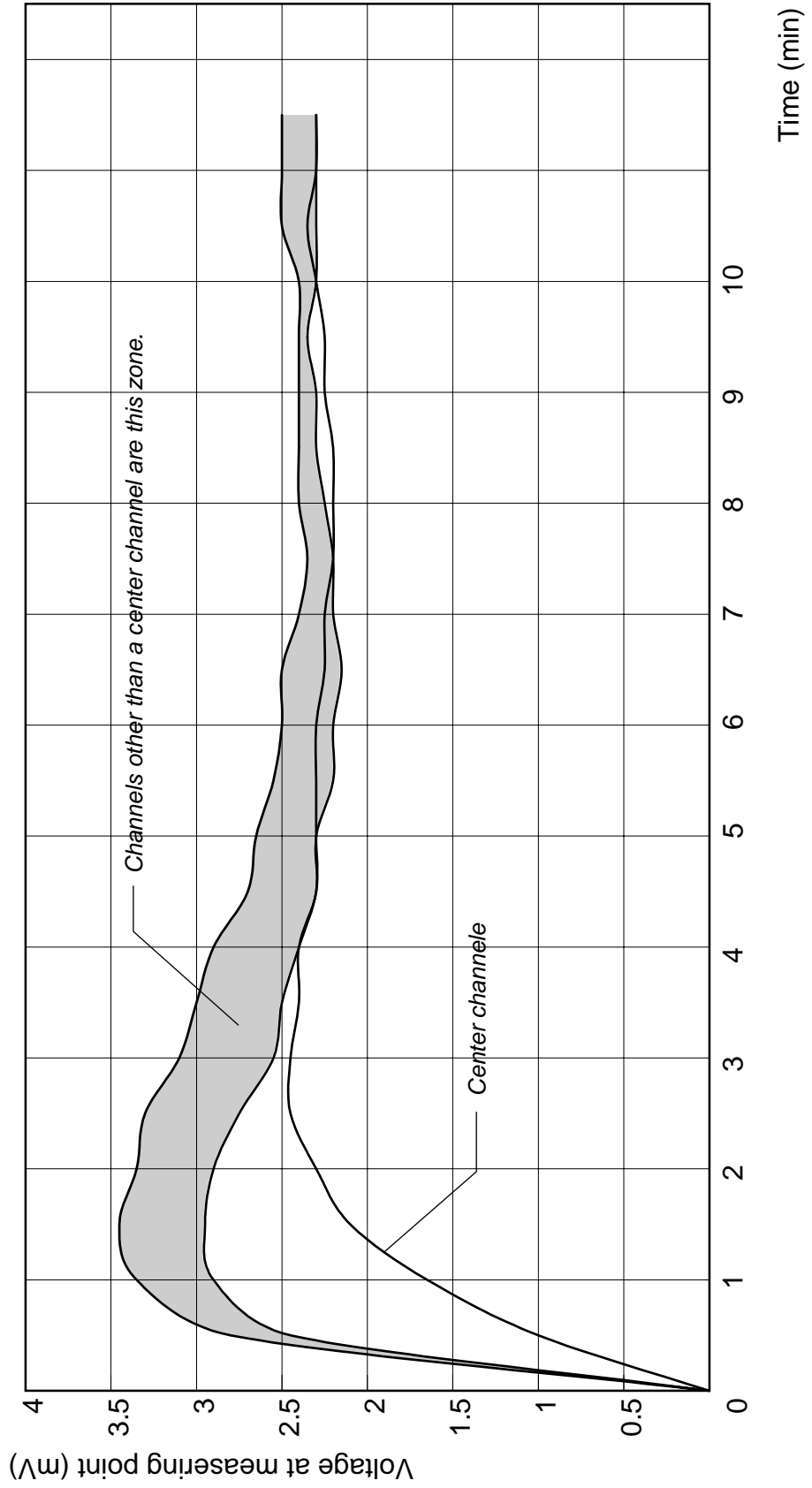

Description of major ICs

■ AK4112 (IC673) : Digital audio receiver

1.Pin layout

DVDD	1	●	28	CM0/CDTO
DVSS	2		27	CM1/CDT1
TVDD	3		26	OCKS1/CCLK
V/TX	4		25	OCKS0/CSN
XTI	5		24	MCKO1
XTO	6		23	MCKO2
PDN	7		22	DAUX
R	8		21	BICK
AVDD	9		20	SDTO
AVSS	10		19	LRCK
RX1	11		18	ERF
RX2/DIF0	12		17	FS96
RX3/DIF1	13		16	P/SN
RX4/DIF2	14		15	AUTO

2.Pin function

Pin No.	Symbol	I/O	Function
1	DVDD	-	Digital Power Supply Pin, 3.3V
2	DVSS	-	Digital Ground Pin
3	TVDD	-	Input Buffer Power Supply Pin, 3.3V or 5V
4	V	O	Validity Flag Output Pin in Parallel Mode
	TX	O	Transmit channel (through data) Output Pin in Serial Mode
5	XTI	I	X'tal Input Pin
6	XTO	O	X'tal Output Pin
7	PDN	I	Power-Down Mode Pin
			When "L", the AK4112A is powered-down and reset.
8	R	-	External Resistor Pin
			18kΩ +/-1% resistor to AVSS externally.
9	AVDD	-	Analog Power Supply Pin
10	AVSS	-	Analog Ground Pin
11	RX1	I	Receiver Channel 1
			This channel is selected in Parallel Mode or default of Serial Mode.
12	DIF0	I	Audio Data Interface Format 0 Pin in Parallel Mode
	RX2	I	Receiver Channel 2 in Serial Mode
13	DIF1	I	Audio Data Interface Format 1 Pin in Parallel Mode
	RX3	I	Receiver Channel 3 in Serial Mode
14	DIF2	I	Audio Data Interface Format 2 Pin in Parallel Mode
	RX4	I	Receiver Channel 4 in Serial Mode
15	AUTO	O	Non-PCM Detect Pin
			"L": No detect, "H": Detect
16	P/S	I	Parallel/Serial Select Pin
			"L": Serial Mode, "H": Parallel Mode
17	FS96	O	96kHz Sampling Detect Pin
			(RX Mode) "H": fs=88.2kHz or more, "L": fs=54kHz or less.
			(X'tal Mode) "H": XFS96=1, "L": XFS96=0.
18	ERF	O	Unlock & Parity Error Output Pin
			"L": No Error, "H": Error
19	LRCK	I/O	Output Channel Clock Pin
20	SDTO	O	Audio Serial Data Output Pin
21	BICK	I/O	Audio Serial Data Clock Pin
22	DAUX	I	Auxiliary Audio Data Input Pin
23	MCKO2	O	Master Clock #2 Output Pin
24	MCKO1	O	Master Clock #1 Output Pin
25	OCKS0	I	Output Clock Select 0 Pin in Parallel Mode
	CSN	I	Chip Select Pin in Serial Mode
26	OCKS1	I	Output Clock Select 1 Pin in Parallel Mode
	CCLK	I	Control Data Clock Pin in Serial Mode
27	CM1	I	Master Clock Operation Mode Pin0 in Parallel Mode
	CDTI	I	Control Data Input Pin in Serial Mode
28	CM0	I	Master Clock Operation Mode Pin1 in Parallel Mode
	CDTO	O	Control Data Output Pin in Serial Mode

Note 1: All input pins except internal pull-down pins should not be left floating.

3. Block diagram

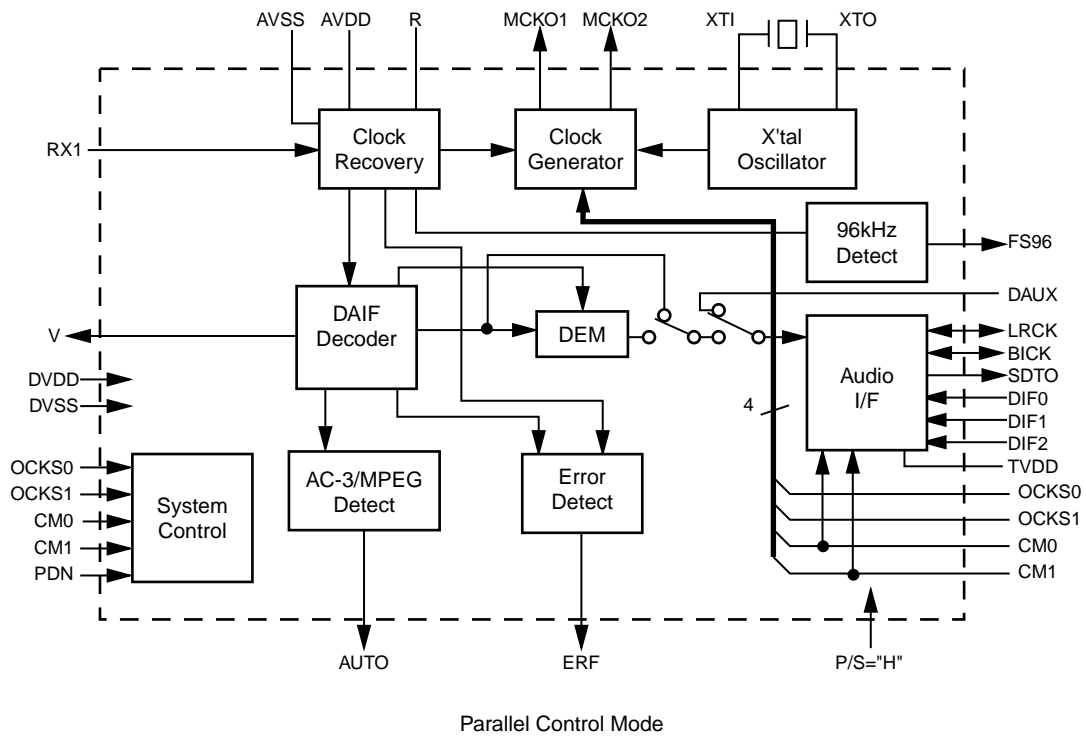
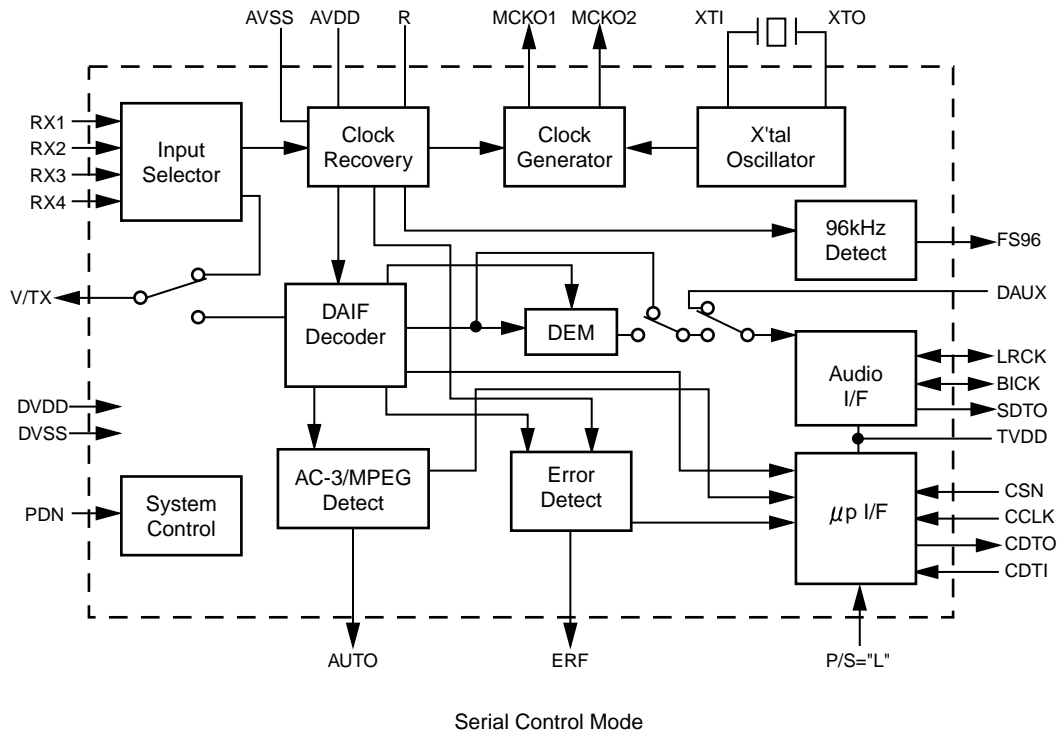

AK5383VF (IC657) : A/D converter

1. Pin layout

VRFEL	1	28	VREFR
GNDL	2	27	GNDR
VCOML	3	26	VCOMR
AINL+	4	25	AINR+
AINL-	5	24	AINR-
ZCAL	6	23	VA
VD	7	22	AGND
DGND	8	21	BGND
CAL	9	20	TEST
RST	10	19	HPFE
SMODW2	11	18	DFS
SMODE1	12	17	MCLK
LRCK	13	16	FSYNC
SCLK	14	15	SDATA

2. Block diagram

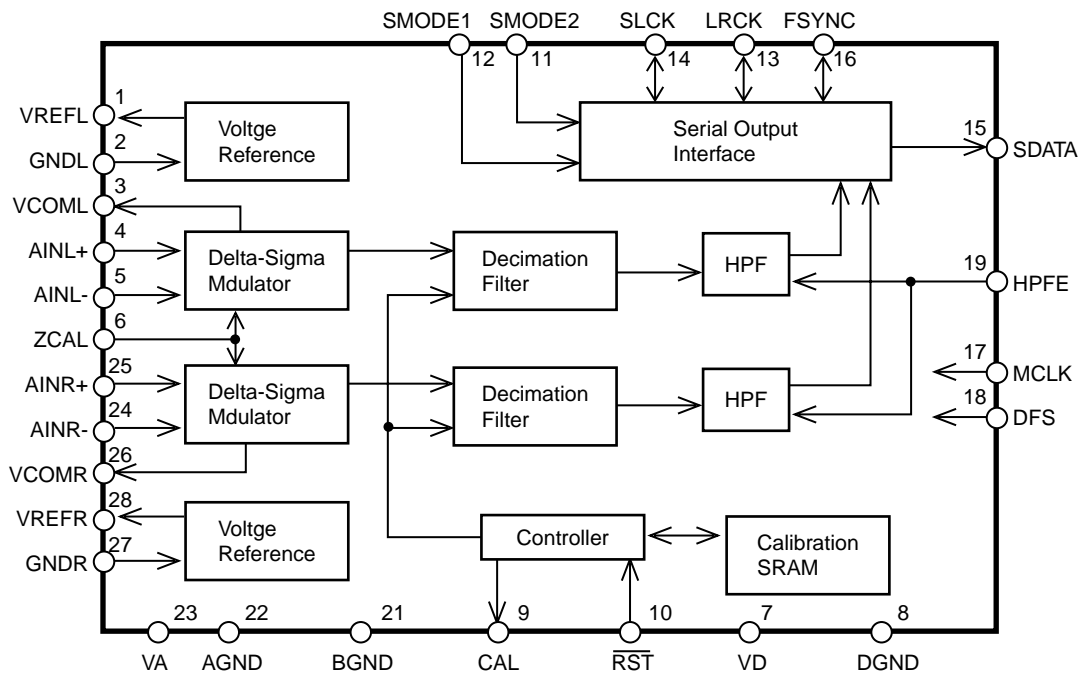

3. Pin function

(1/2)

Pin No.	Pin name	I/O	Function
1	VRFEL	O	Lch Reference Voltage Pin, 3.75V Normally connected to GNDL with a 10 μ F electrolytic capacitor and a 0.1 μ F ceramic capacitor.
2	GNDL	-	Lch Reference Ground Pin, 0V
3	VCOML	O	Lch Common Voltage Pin, 2.75V
4	AINL+	I	Lch Analog positive input Pin
5	AINL-	I	Lch Analog negative input Pin
6	ZCAL	I	Zero Calibration Control Pin This pin controls the calibration reference signal. "L": VCOML and VCOMR "H": Analog Input Pins (AINL \pm , AINR \pm)
7	VD	-	Digital Power Supply Pin, 3.3V
8	DGND	-	Digital Ground Pin, 0V

3. Pin function

(2/2)

Pin No.	Pin name	I/O	Function																				
9	CAL	O	Calibration Active Signal Pin "H" means the offset calibration cycle is in progress. Offset calibration starts when RST goes "H". CAL goes "L" after 8704 LRCK cycles for DFS="L", 17408 LRCK cycles for DFS="H".																				
10	RST	I	Reset Pin When "L", Digital section is powered-down. Upon returning "H", an offset calibration cycle is started. An offset calibration cycle should always be initiated after power-up.																				
11 12	SMODE2 SMODE1	I I	Serial Interface Mode Select Pin MSB first, 2's compliment. <table style="margin-left: 20px;"> <tr> <td>SMODE2</td> <td>SMODE1</td> <td>MODE</td> <td>LRCK</td> </tr> <tr> <td>L</td> <td>L</td> <td>Slave mode : MSB justified</td> <td>: H/L</td> </tr> <tr> <td>L</td> <td>H</td> <td>Master mode : Similar to I2S</td> <td>: H/L</td> </tr> <tr> <td>H</td> <td>L</td> <td>Slave mode : I2S</td> <td>: L/H</td> </tr> <tr> <td>H</td> <td>H</td> <td>Master mode : I2S</td> <td>: L/H</td> </tr> </table>	SMODE2	SMODE1	MODE	LRCK	L	L	Slave mode : MSB justified	: H/L	L	H	Master mode : Similar to I2S	: H/L	H	L	Slave mode : I2S	: L/H	H	H	Master mode : I2S	: L/H
SMODE2	SMODE1	MODE	LRCK																				
L	L	Slave mode : MSB justified	: H/L																				
L	H	Master mode : Similar to I2S	: H/L																				
H	L	Slave mode : I2S	: L/H																				
H	H	Master mode : I2S	: L/H																				
13	LRCK	I/O	Left/Right Channel Select Clock Pin LRCK goes "H" at SMODE2="L" and "L" at SMODE2="H" during reset when SMODE1 "H".																				
14	SCLK	I/O	Serial Data Clock Pin Data is clocked out on the falling edge of SCLK. Slave mode: SCLK requires more than 48fs clock. Master mode: SCLK outputs a 128fs(DFS="L") or 64fs (DFS="H")clock. SCLK stays "L" during reset.																				
15	SDATA	O	Serial Data Output Pin MSB first, 2's complement. SDATA stays "L" during reset.																				
16	FSYNC	I/O	Frame Synchronization Signal Pin Slave mode: When "H", the data bits are clocked out on SDATA. In I2S mode, FSYNC is Don't care. Master mode: FSYNC outputs 2fs clock. FSYNC stays "L" during reset.																				
17	MCLK	I	Master Clock Input Pin 256fs at DFS="L", 128fs at DFS="H".																				
18	DFS	I	Double Speed Sampling mode Pin "L": Normal Speed "H": Double Speed																				
19	HPFE	I	High Pass Filter Enable Pin "L": Disable "H": Enable																				
20	TEST	I	Test Pin (pull-down pin) Should be connected to GND.																				
21	BGND	-	Substrate Ground Pin, 0V																				
22	AGND	-	Analog Ground Pin, 0V																				
23	VA	-	Analog Supply Pin, 5V																				
24	AINR-	I	Rch Analog negative input Pin																				
25	AINR+	I	Rch Analog positive input Pin																				
26	VCOMR	O	Rch Common Voltage Pin, 2.75V																				
27	GNDR	-	Rch Reference Ground Pin, 0V																				
28	VREFR	O	Rch Reference Voltage Pin, 3.75V Normally connected to GNDR with a 10μF electrolytic capacitor and a 0.1 F ceramic capacitor																				

Note: All digital inputs should not be left floating.

■ JCV8006 (IC635, IC640, IC645, IC650) : CC converter

1. Pin layout

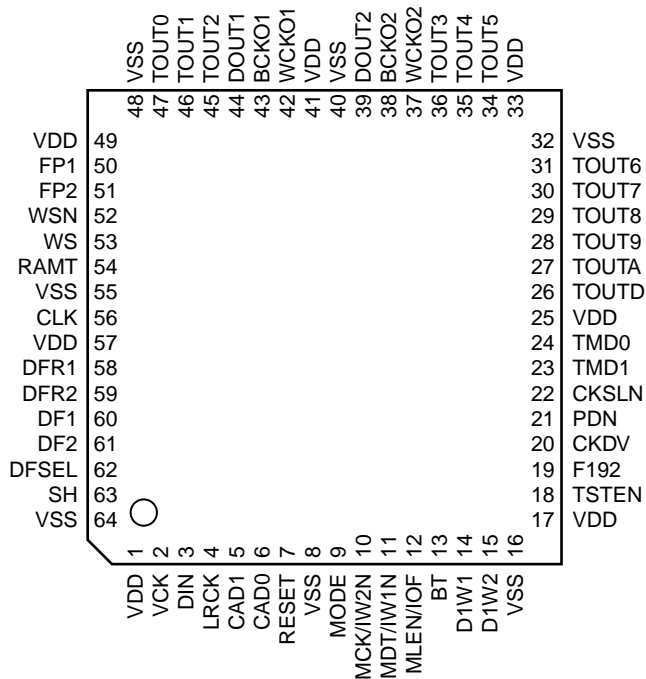

2. Pin function

(1/2)

Pin No.	Pin name	I/O	Function
1	VDD	-	Power supply : All VDD pins must be connected externally
2	BCK	I1	Bit clock input :Bit click if serial data into the DIN ; Must run continuously, "5V tolerant"
3	DIN	I1	Serial audio data input, "5V tolerant"
4	LRCK	I1	Left/Right clock input ; sampling frequency (fs) for DIN ; Must run continuously, "5V tolerant"
5	CAD1	Ip2	Chip address 1 ; available on MODE=H
6	CAD0	Ip2	Chip address 0 ; available on MODE=H
7	RESET	I1	System reset ; the internal state is reset to the default setting when L, "5V tolerant"
8	VSS	-	Ground ; All VSS pins must be connected externally
9	MODE	Ip2	System control mode select input : (H=Software mode ; L=Hardware mode)
10	MCK/IW2N	I1	Control clock input ; MODE=H, /Select input audio data word length input2 ; MODE=L, "5V tolerant"
11	MDT/IW1N	I1	Control data input ; MODE=H, /Select input audio data word length input 1 ; MODE=L, "5V tolerant"
12	MLEN/IOF	I1	Control data latch input ; MODE=H, /select input and output audio data format input ; MODE=L, "5V tolerant"
13	BTR	Ip2	Select BIT-UP through mode input ; MODE=L
14	D1W1	Ip2	Select output 1 audio data word length and enable control 1 ; MODE=L
15	D1W2	Ip2	Select output 1 audio data word length and enable control 2 ; MODE=L
16	VSS	-	Ground ; All VSS pins must be connected externally
17	VDD	-	Power supply ; All VSS pins must be connected externally
18	TSTEN	Ip2	Test control input ; in normal operation this pin should be terminated to ground
19	F192	Ip2	Select system clock for 192kHz input sampling frequency input : MODE=L, (supported for FS-UP only)
20	CKDV	Ip2	Internal click divider select input ; MODE=L,(L=1, H=1/2)

I=CMOS, I1=Schmitt, Ip2=Schmitt with pull-down resistor, O=CMOS

(H=VDD, L=VSS)

2. Pin function

(2/2)

Pin No.	Pin name	I/O	Function
21	PDN	Ip2	Power down control input ; MODE=L, (L=normal, H=power down)
22	CKSLN	Ip2	System clock select input ; MODE=L, (L=512fs, H=384fs)
23	TMD1	Ip2	Test input ; in normal operation this pin should be terminated to ground
24	TMD0	Ip2	Test input ; in normal operation this pin should be terminated to ground
25	VDD	-	Power supply ; All VDD pins must be connected externally
26	TOUTD	O	Test output ; this pin should be left open
27	TOUTA	O	Test output ; this pin should be left open
28	TOUT9	O	Test output ; this pin should be left open
29	TOUT8	O	Test output ; this pin should be left open
30	TOUT7	O	Test output ; this pin should be left open
31	TOUT6	O	Test output ; this pin should be left open
32	VSS	-	Ground ; All VSS pins must be connected externally
33	VDD	-	Power supply ; All VDD pins must be connected externally
34	TOUT5	O	Test output ; this pin should be left open
35	TOUT4	O	Test output ; this pin should be left open
36	TOUT3	O	Test output ; this pin should be left open
37	WCKO2	O	L/R clock output 2 ; the left or right channel for the DOUT2
38	BCKO2	O	Bit clock output 2 ; bit clock of serial data for the DOUT2
39	DOUT2	O	Serial audio data output 2
40	VSS	-	Ground ; All VSS pins must be connected externally
41	VDD	-	Power supply ; All VDD pins must be connected externally
42	WCKO1	O	L/R clock output 1 ; the left or right channel for the DOUT 1
43	BCKO1	O	Bit clock output 1 ; bit clock of serial data for the DOUT1
44	DOUT1	O	Serial audio output 1
45	TOUT2	O	Test output ; this pin should be left open
46	TOUT1	O	Test output ; this pin should be left open
47	TOUT0	O	Test output ; this pin should be left open
48	VSS	-	Ground ; All VSS pins must be connected externally
49	VDD	-	Power supply ; All VDD pins must be connected externally
50	FP1	Ip2	Select FS-UP peak data compensation coefficient input 1 ; MODE=L
51	FP2	Ip2	Select FS-UP peak data compensation coefficient input 2 ; MODE=L
52	WSN	Ip2	Select FS-UP waveform compensation function control for 16fd to 9fd input ; MODE=L
53	WS	Ip2	Select FS-UP waveform compensation function control for 8fd to 2fd input ; MODE=L
54	RAMT	Ip2	RAM test control input ; in normal operation this pin should be terminated to ground
55	VSS	-	Ground ; All VSS pins must be connected externally
56	CLK	I	Master clock input ; Must run continuously normal operation, "5V tolerant"
57	VDD	-	Power supply ; All VDD pins must be connected externally
58	DFR1	Ip2	Select DF over sampling rate control 1 input for FS-UP and output 2 ; MODE=L
59	DFR2	Ip2	Select DF over sampling rate control 2 input for FS-UP and output 2 ; MODE=L
60	DF1	Ip2	Select DF over sampling rate control 1 input for output 1 ; MODE=L
61	DF2	Ip2	Select DF over sampling rate control 2 input for output 1 ; MODE=L
62	DFSEL	Ip2	Select DF internal digital fitter ; MODE=L, (L=84tap FIR, H=169tap FIR)
63	SH	Ip2	Select SH mode control input ; MODE=L, (L=ON, H=OFF)
64	VSS	-	Ground ; All VSS pins must be connected externally

I=CMOS, I1=Schmitt, Ip2=Schmitt with pull-down resistor, O=CMOS

(H=VDD, L=VSS)

■ XCA56367PV150 (IC661, IC666) : DSP

1. Pin layout

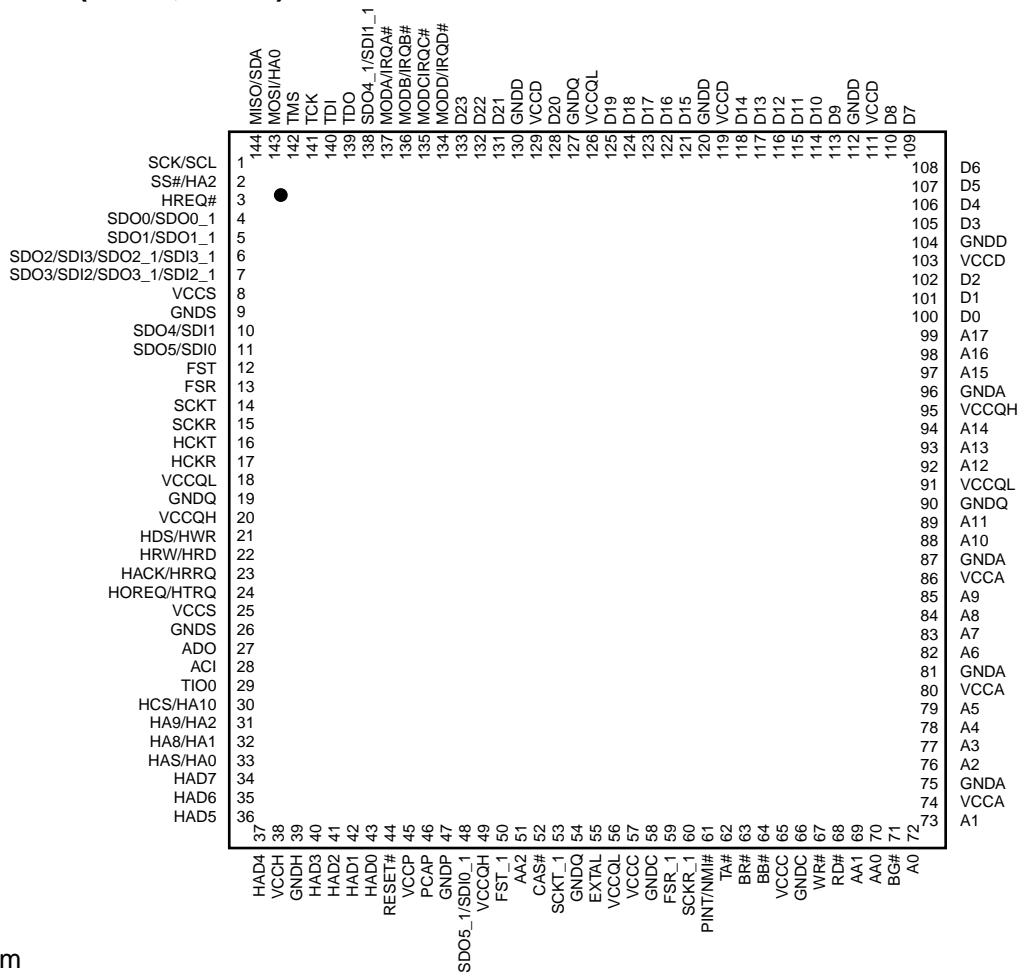

2. Block diagram

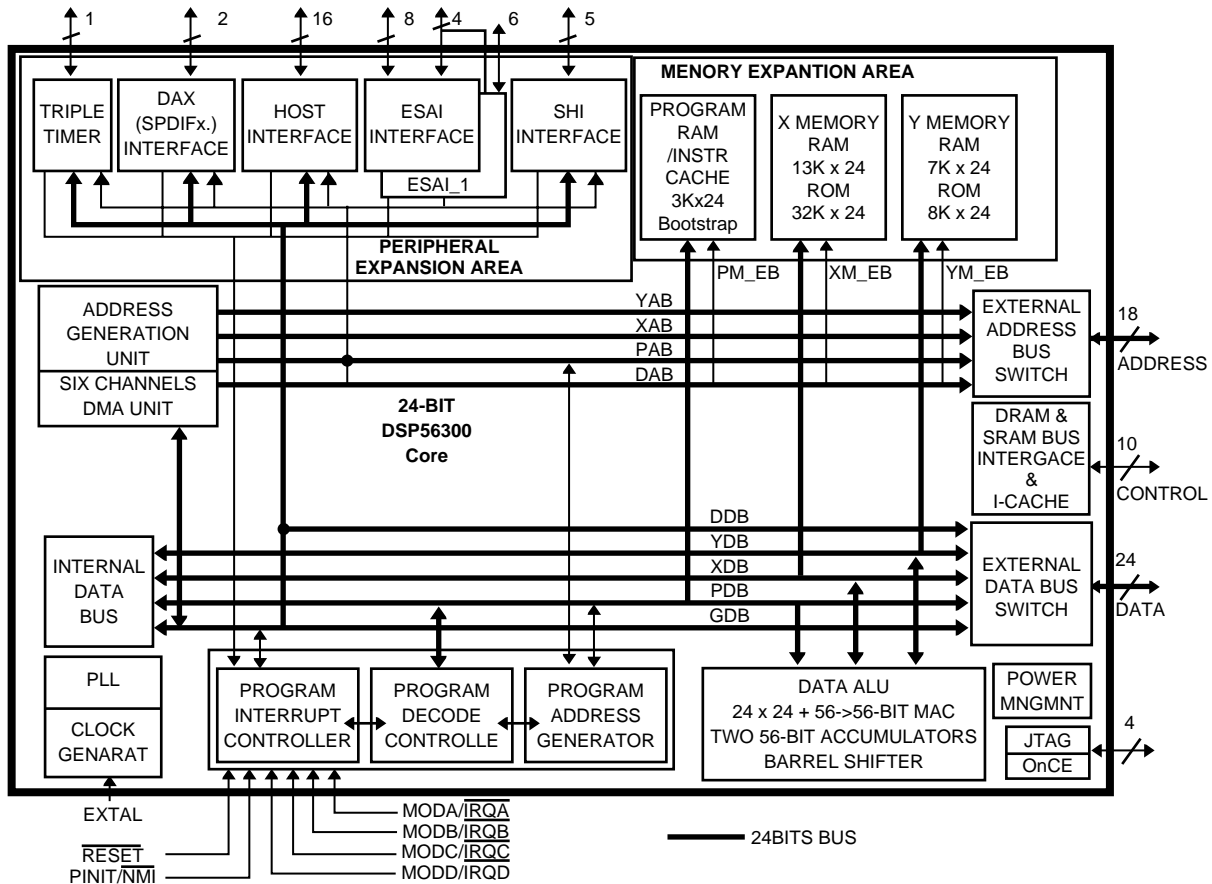

3. Signal groupings

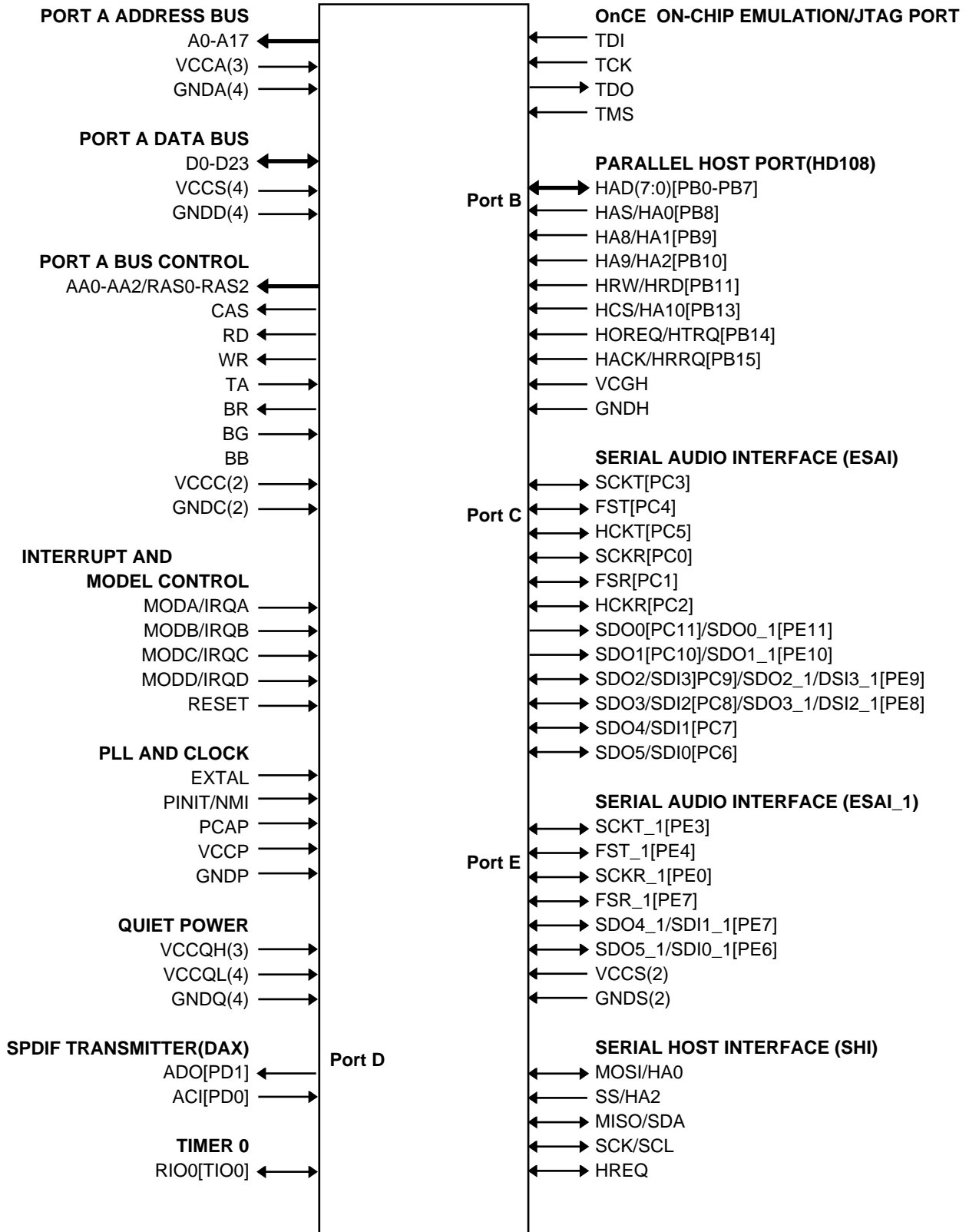

■ **BA7625 (IC401, IC431, IC451, IC471) : Video selector**

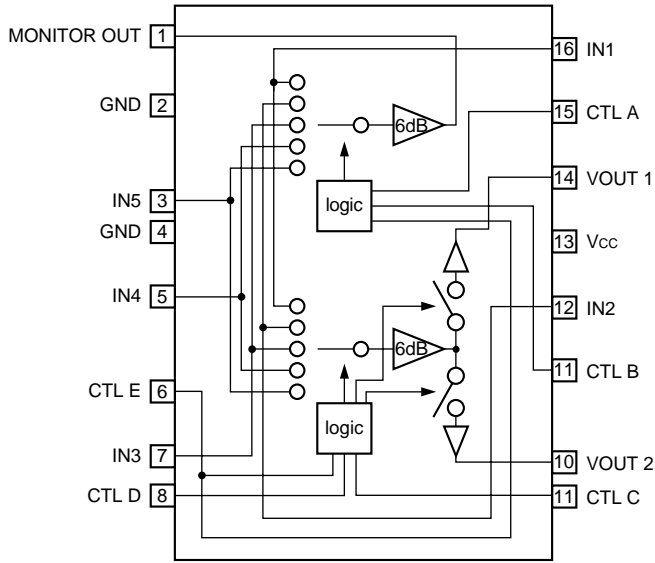

A	B	E	MONITOR OUT
L	L	*	IN1
H	L	*	IN2
L	H	*	IN3
H	H	L	IN4
H	H	H	IN5

C	D	E	VOUT1
L	L	*	--
H	L	*	IN2
L	H	*	IN3
H	H	L	IN4
H	H	H	IN5

C	D	E	VOUT2
L	L	*	IN1
H	L	*	--
L	H	*	IN3
H	H	L	IN4
H	H	H	IN5

■ **BA7626 (IC472, IC732) : Video selector**

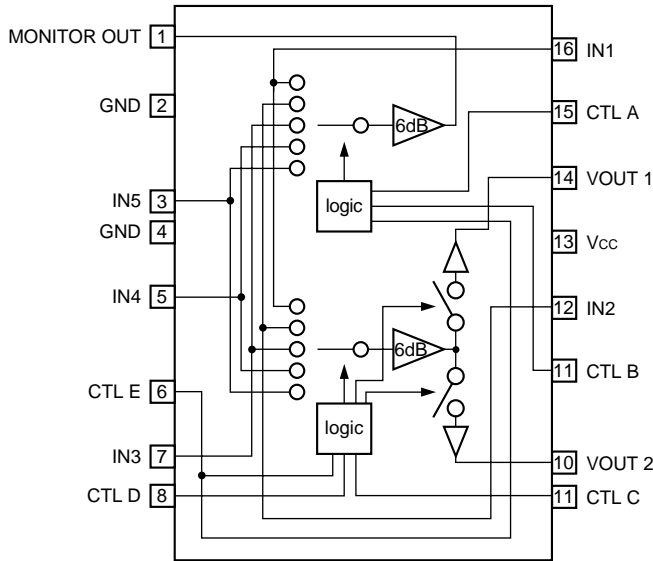

A	B	E	MONITOR OUT
L	L	*	IN1
H	L	*	IN2
L	H	*	IN3
H	H	L	IN4
H	H	H	IN5

C	D	E	VOUT1
L	L	*	--
H	L	*	IN2
L	H	*	IN3
H	H	L	IN4
H	H	H	IN5

C	D	E	VOUT2
L	L	*	IN1
H	L	*	--
L	H	*	IN3
H	H	L	IN4
H	H	H	IN5

■ **MAX4018ESD (IC503, IC544) : Op. amp.**

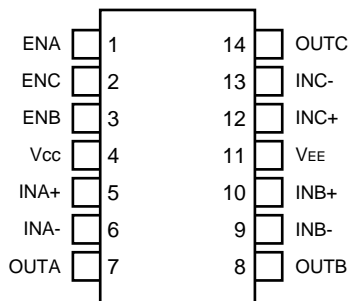

■ BU4051BC (IC461) : Analog multiplexer/ DE multiplexer

1. Pin layout

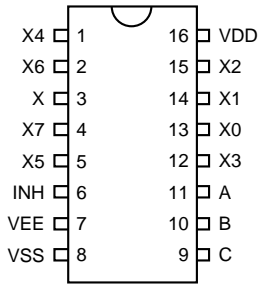

2. Block diagram

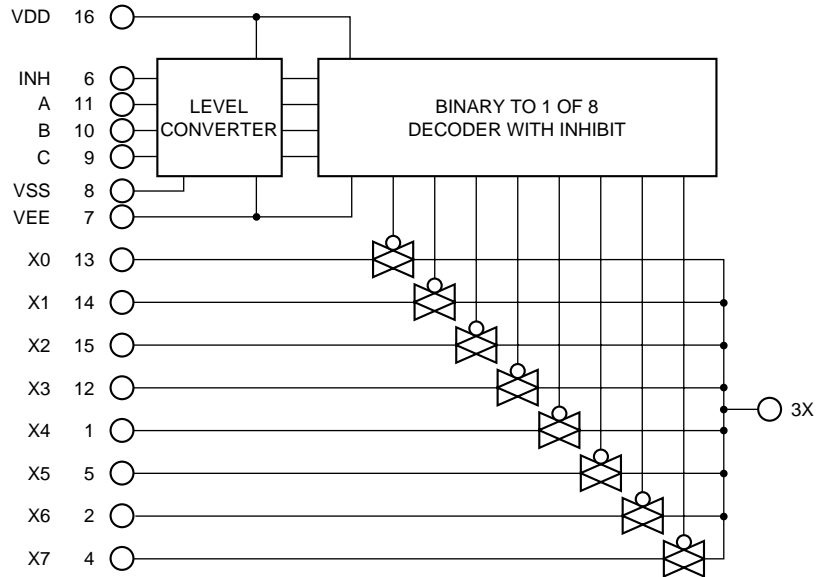

■ NJM2285V (IC402, IC452) : Video switch

1. Block diagram

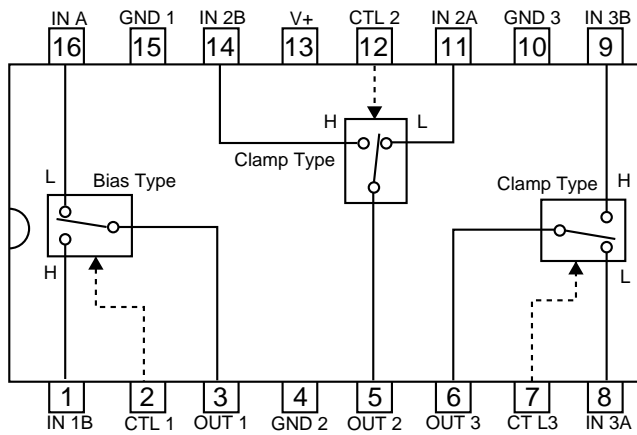

■ NJM4580E (IC201, 204, 241, 242, 251, 252, 253, 254, 261, 263, 271, 272, 273, 281, 631, 632, 633, 636, 637, 638, 641, 642, 643, 646, 647, 648, 655, 656, 686, 687) : L.P.F.

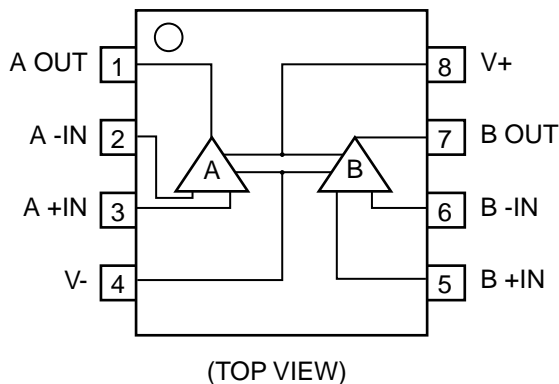

■ **M62446FP (IC653) : 6CH master volume**

1. Block diagram

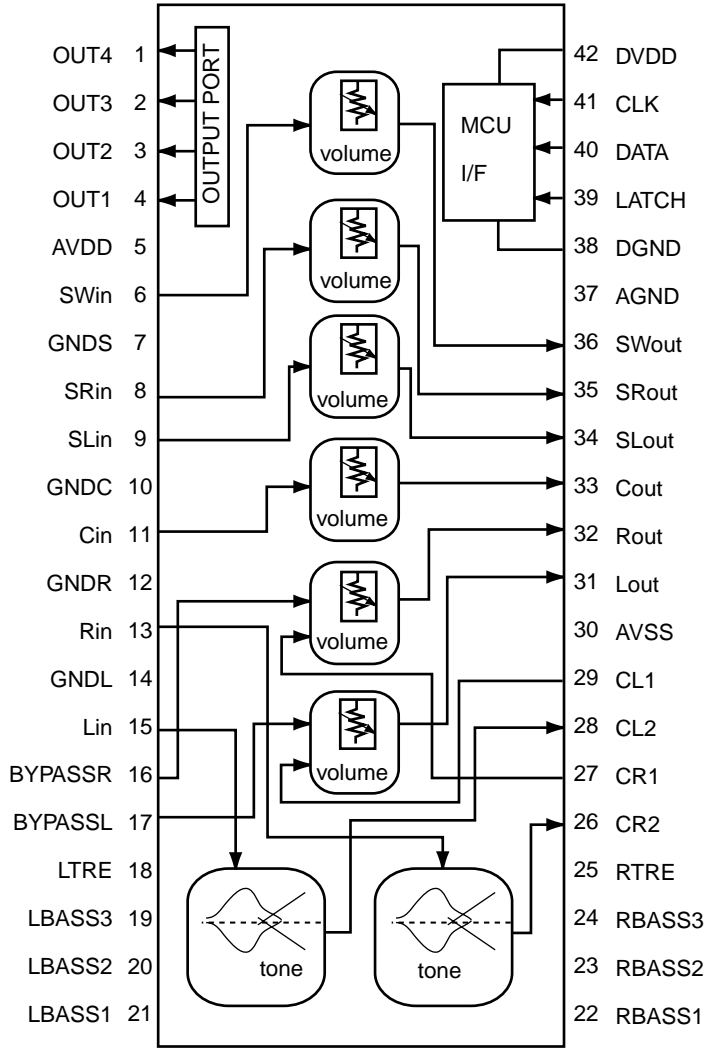

2. Pin functions

Pin No.	Symbol	I/O	Descriptions
1	OUT 4	O	PORT output
2	OUT 3	O	PORT output
3	OUT 2	O	PORT output
4	OUT 1	O	PORT output
5	AVDD	-	Analog positive power supply terminal
6	SWin	I	SUB Woofer ch volume signal input terminal
7	A.GND	-	Analog ground terminal
8	SR in	I	SR ch volume signal input terminal
9	SL in	I	SL ch volume signal input terminal
10	A.GND	-	Analog ground terminal
11	C in	I	Center ch volume signal input terminal
12	A.GND	-	Analog ground terminal
13	R in	I	R ch volume signal input terminal
14	A.GND	-	Analog ground terminal
15	L in	I	L ch volume signal input terminal
16,17		-	Non connect
18		-	Frequency adjustment terminal tone/treble
19~21		-	Frequency adjustment terminal tone/bass
22		O	Tone output terminal
23,24		-	Frequency adjustment terminal tone/bass
25		-	Frequency adjustment terminal tone/treble
26		-	Frequency adjustment terminal tone/bass
27		I	L/R volume input terminal
28		O	Tone output terminal
29		I	L/R volume input terminal
30	AVSS	-	Analog negative power supply terminal
31	L out	O	L ch output
32	R out	O	R ch output
33	C out	O	Center ch volume signal output terminal
34	SL out	O	SL ch volume signal output terminal
35	SR out	O	SR ch volume signal output terminal
36	SW out	O	SUB Woofer ch volume signal output terminal
37	A.GND	-	Analog ground terminal
38	D.GND	-	Digital ground terminal
39	LATCH	I	Latch input terminal
40	VOL DATA	I	Volume data input terminal
41	VOL CLK	I	Clock input terminal for data transfer
42	DVDD	-	Digital power supply terminal

■ **BA15218N (IC381, IC382) : Dual op. amp.**

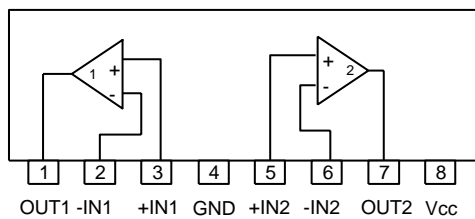

■ NJM2903M (IC282, IC998) : Temperature detector

1. Pin layout

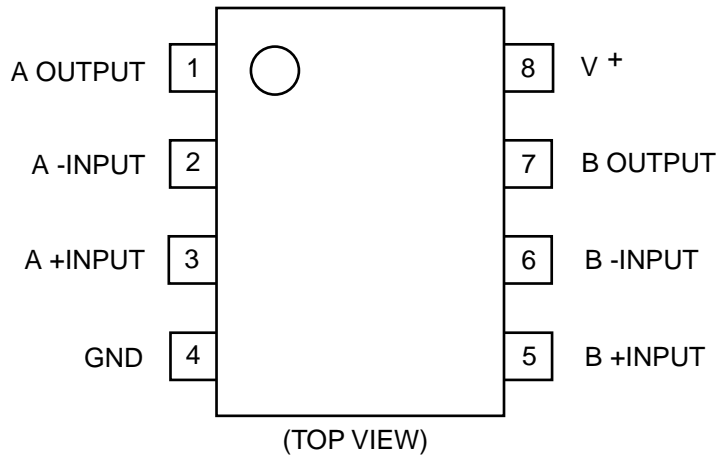

2. Block diagram

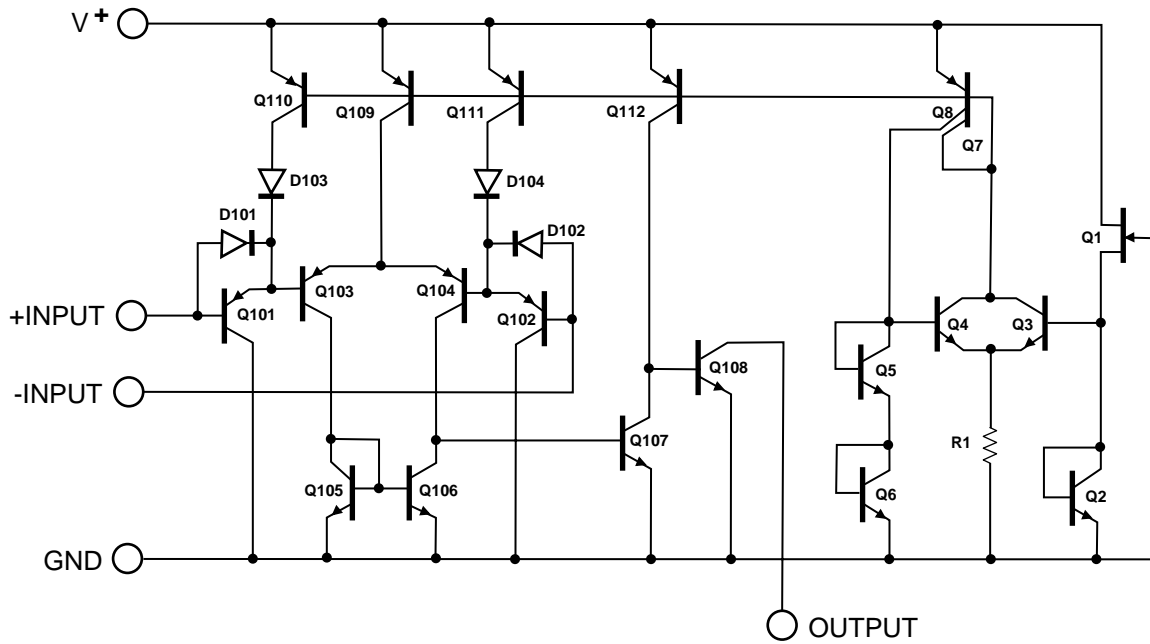

■ PQ20VZ11 (IC690) : Regulator

1. Pin layout

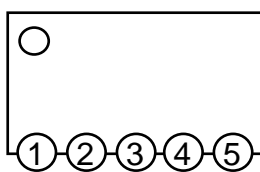

2. Block diagram

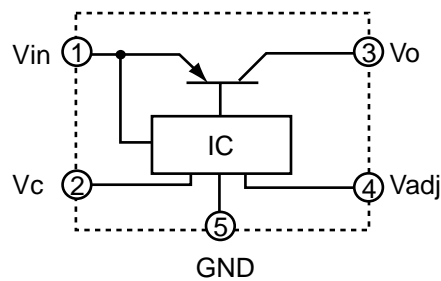

■ VC5022-2 (IC601, IC603, IC605, IC606, IC607) : Advanced super A

1. Pin layout

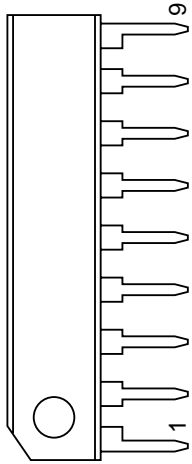

2. Block diagram

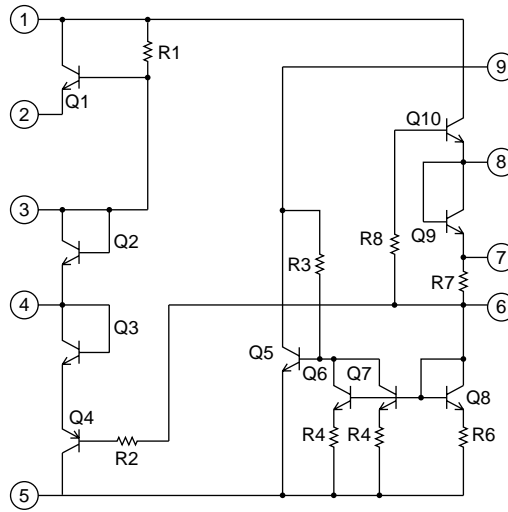

■ TA7317P (IC951) : Protector

1. Pin layout

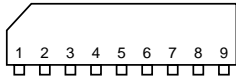

2. Block diagram

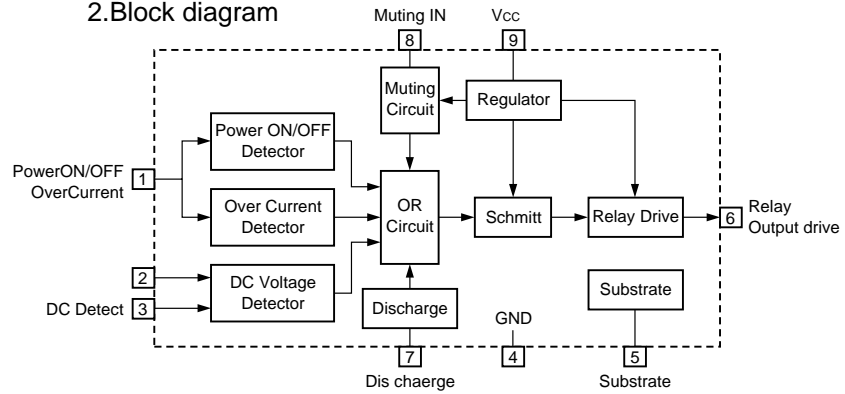

■ TA8409S (IC967) : Motor driver

1. Pin layout

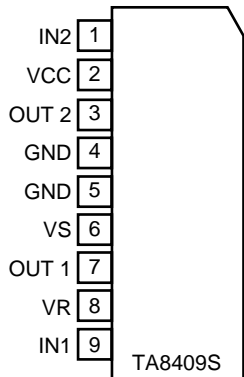

2. Truth table

INPUT		OUTPUT		MODE
IN1	IN2	OUT1	OUT2	MOTOR
0	0	∞	∞	STOP
1	0	H	L	CW/CCW
0	1	L	H	CCW/CW
1	1	L	L	BRAKE

■ SAA6588 (IC311) : RDS detector

1.Pin layout



2.Pin function

Pin No.	Symbol	I/O	Function
1	MRO	O	Multi-path rectifier output
2	NC	-	Non connect
3	GND	I	Test control input pin
4	OSCO	O	Oscillator output
5	OSCI	I	Oscillator input
6	VSSD	-	Digital ground (0V)
7	VDDD	-	Digital power supply (5V)
8	DAVN	O	Data available output (active LOW)
9	SDA	I/O	I2C-bus serial data I/O
10	SCL	I	I2C-bus serial clock input
11	NC	-	Non connect
12	GND	-	Connect to ground
13	NC	-	Non connect
14	VDDA	-	Analog power supply (5V)
15	VSSA	-	Connect to ground
16	MPX	I	Multiplex input signal
17	Vref	O	Reference voltage output
18	SCOUT	O	Band-pass filter output
19	CIN	O	Comparator input
20	NC	I	Level input

3.Block diagram

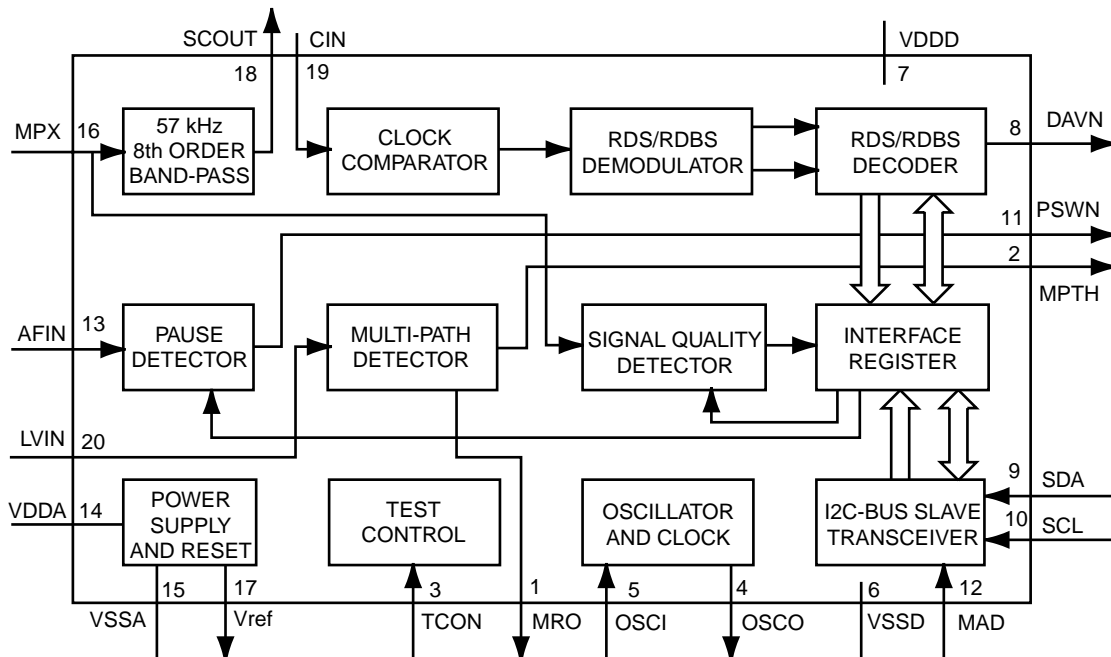

■ 39VF0207CWHM03 (IC667) : EEPROM

1. Pin layout

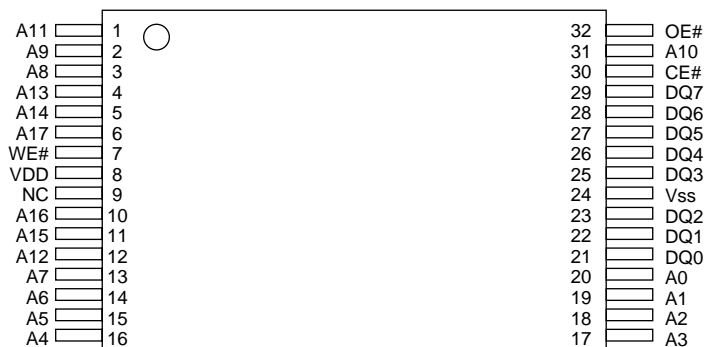

2. Block diagram

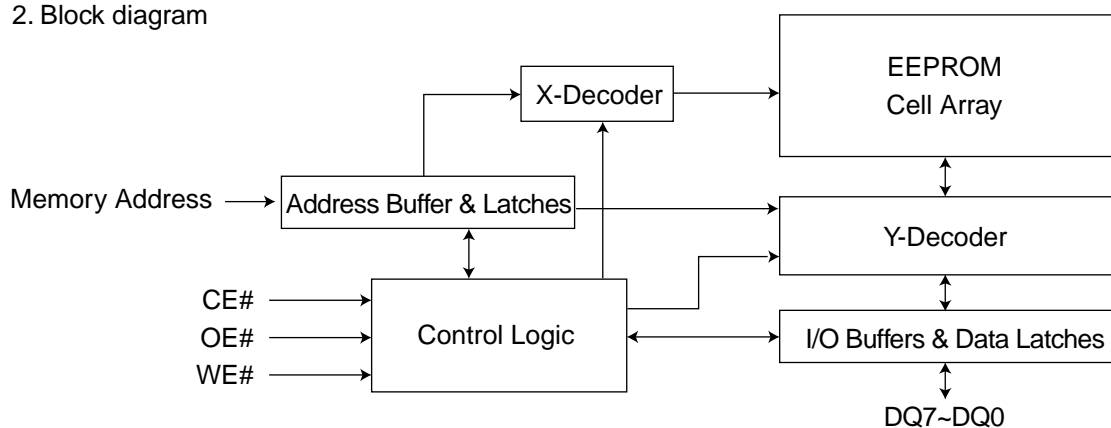

3. Pin function

Symbol	Pin name	Function
AMS- A0	Address Inputs	To provide memory address. During Sector-Erase AMS-A12 address lines will select the sector.
DQ7- DQ0	Data Input/Output	To output data during read cycles and receive input data during write cycles. Data is internally latched during a write cycle. The outputs are in tri-state when OE# or CE# is high.
CE#	Chip Enable	To active the device when CE# is low.
OE#	Output Enable	To gate the data output buffers.
WE#	Write Enable	To control the write operations.
VDD	Power Supply	To provide power supply voltage: 3.0-3.6V for SST39LF512/010/020/040 2.7-3.6V for SST39VF512/010/010/040
Vss	Ground	
NC	No Connection	Unconnected Pins

■ **TC74HC4053AF (IC501, IC502, IC541, IC542, IC543) : Multiplexer**

1. Pin layout

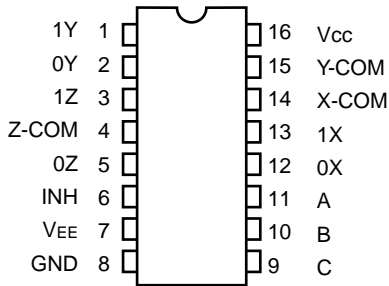

2. Truth table

CONTROL INPUTS				"ON" CHANNEL
INHIBIT	C	B	A	
L	L	L	L	0X, 0Y, 0Z
L	L	L	H	1X, 0Y, 0Z
L	L	H	L	0X, 1Y, 0Z
L	L	H	H	1X, 1Y, 0Z
L	H	L	L	0X, 0Y, 1Z
L	H	L	H	1X, 0Y, 1Z
L	H	H	L	0X, 1Y, 1Z
L	H	H	H	1X, 1Y, 1Z
H	X	X	X	NONE

X: Don't Care.

■ **TC74VHC157FT (IC681, IC682) : Multiplexer**

1. Pin layout

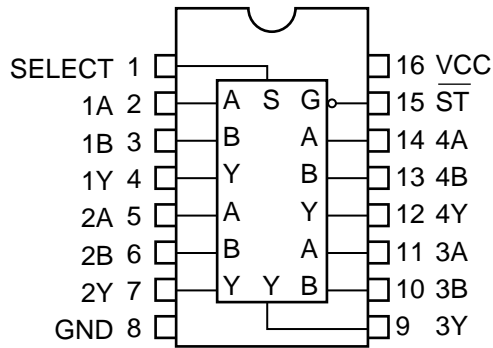

2. Truth table

INPUT				OUTPUT
ST	SELECT	A	B	
H	X	X	X	L
L	L	L	X	L
L	L	H	X	H
L	H	X	L	L
L	H	X	H	H

X: Don't care

■ **TC74HCT04AF (IC654) : Inverter**

1. Pin layout

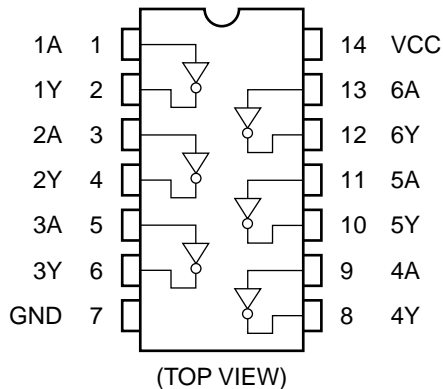

2. Truth table

A	Y
L	H
H	L

■ **TC9162AF (IC211, IC212, IC213) : Analog switch**

1. Pin layout

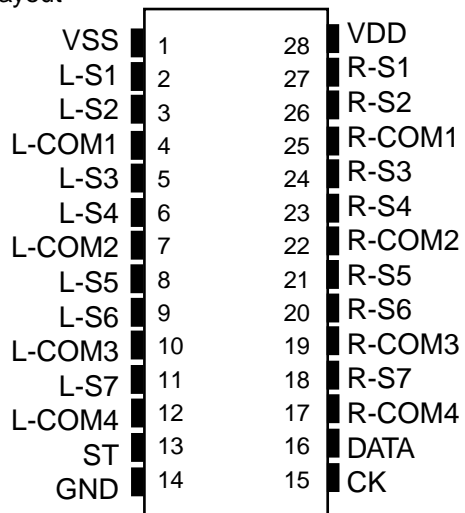

2. Block diagram

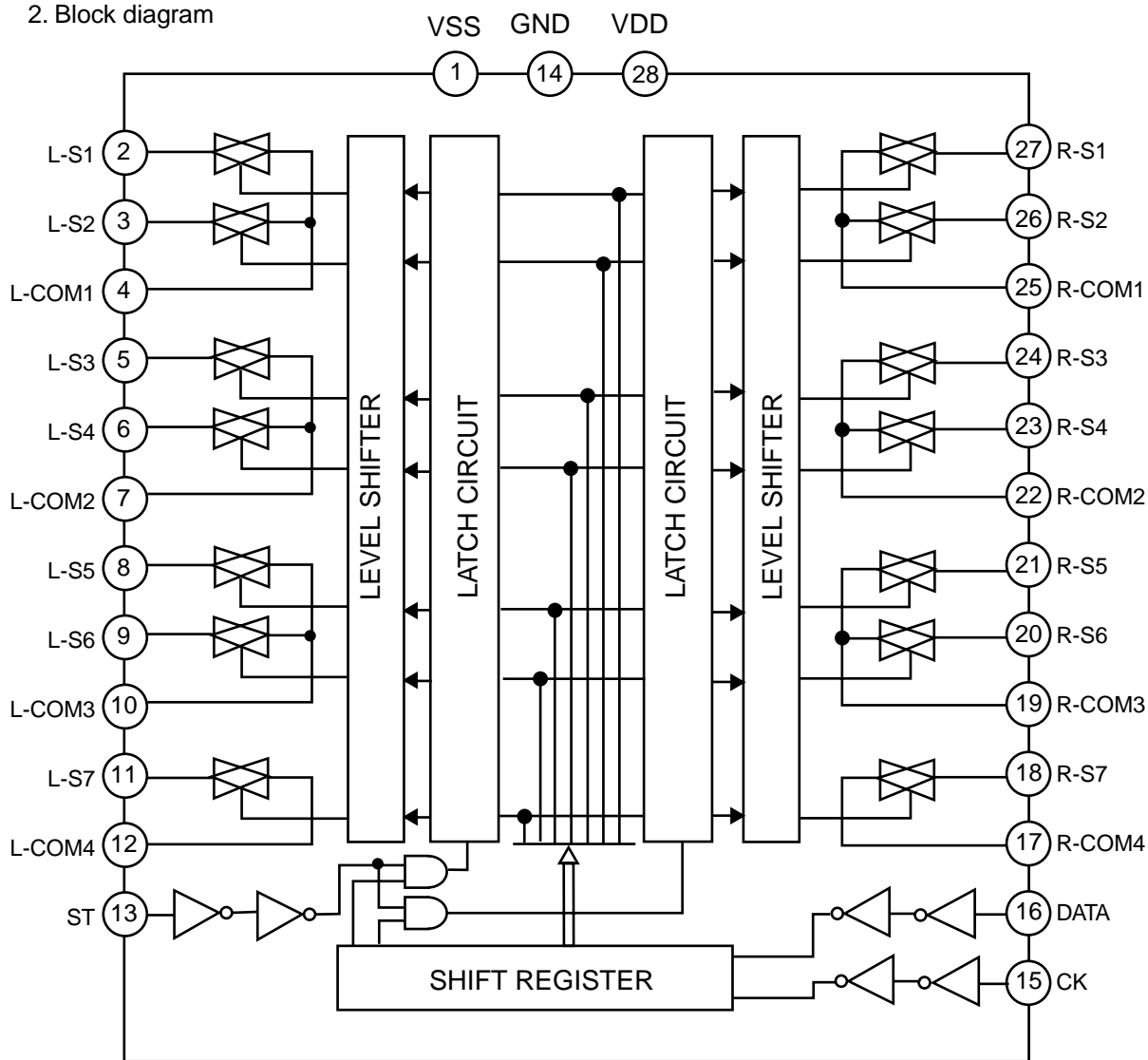

TC9163AF (IC321, IC322) : Analog switch

1. Pin layout

VSS	1	28	VDD
L-S1	2	27	R-S1
L-S2	3	26	R-S2
L-S3	4	25	R-S3
L-COM1	5	24	R-COM1
L-S4	6	23	R-S4
L-S5	7	22	R-S5
L-S6	8	21	R-S6
L-COM2	9	20	R-COM2
L-S7	10	19	R-S7
L-S8	11	18	R-S8
L-COM3	12	17	R-COM3
ST	13	16	DATA
GND	14	15	CK

2. Block diagram

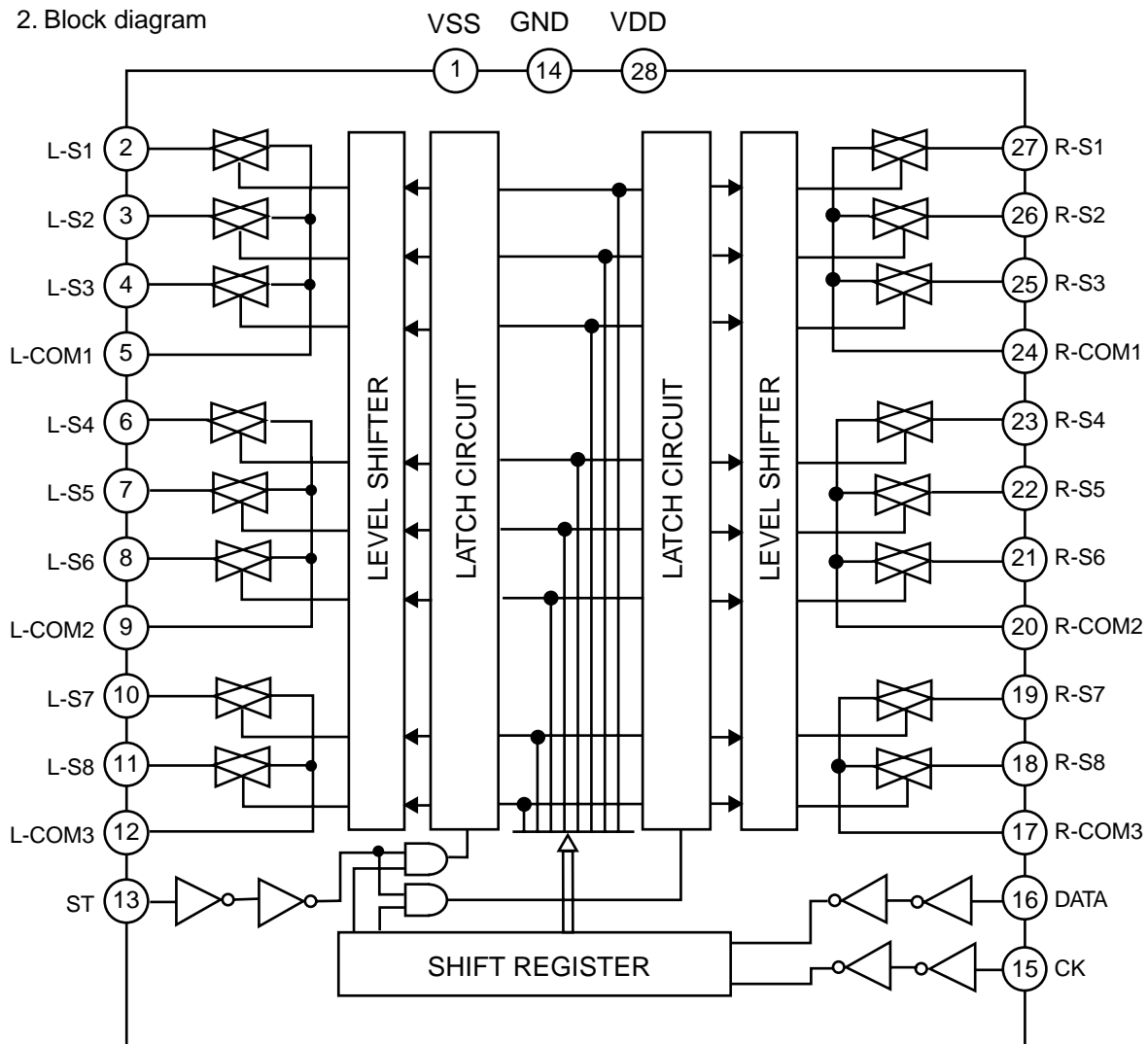

■ TC9459F (IC221, IC222, IC223, IC224, IC262) : Electronic volume control

1.Pin layout

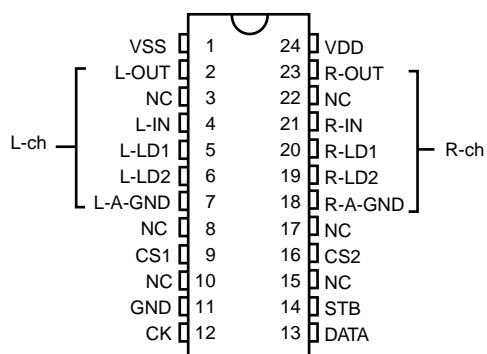

2. Block diagram

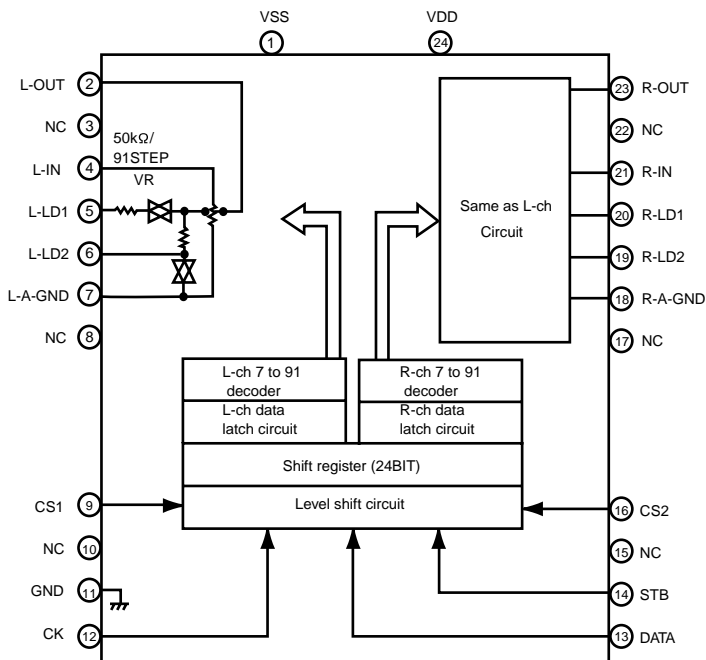

3.Pin function

Pin No.	Symbol	Function	Pin No.	Symbol	Function
1	VSS	Negative power supply pin	13	DATA	Data input pin
2	L-OUT	Volume output pin	14	STB	Strobe input pin
3	NC	No connection	15	NC	No connection
4	L-IN	Volume input pin	16	CS2	Chip select input pin
5	L-LD1	Loudness tap output pin	17	NC	No connection
6	L-LD2	Loudness tap output pin	18	R-A-GND	Analog GND pin
7	L-A-GND	Analog GND pin	19	R-LD2	Loudness tap output pin
8	NC	No connection	20	R-LD1	Loudness tap output pin
9	CS1	Chip select input pin	21	R-IN	Volume input pin
10	NC	No connection	22	NC	No connection
11	GND	Digital GND pin	23	R-OUT	Volume output pin
12	CK	Clock input pin	24	VDD	Positive power supply pin

MB90088 (IC403) : Screen display controller

1. Pin layout

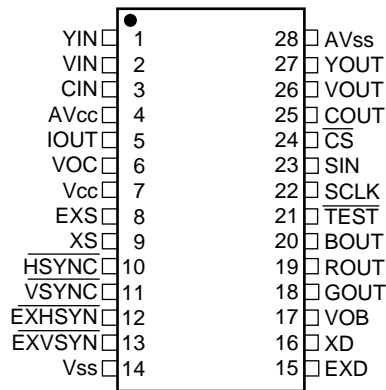

2. Pin functions

Pin No.	Symbol	I/O	Function
1	YIN	I	Lux signal Input terminal for Superinpause indication
2	VIN	I	Composite video signal input terminal for Superinpause indication
3	CIN	I	Contrast signal input terminal for Superinpause indication
4	AVcc	-	Analog power supply terminal
5	IOUT	O	Color (Lux) signal output terminal
6	VOC	O	Character output terminal
7	Vcc	-	Power supply terminal
8	EXS	I	Clock generater outside circuit terminal for color burst
9	XS	O	
10	HSYNC	O	Horizontal signal output terminal
11	VSYN	O	Vertical signal output terminal
12	EXHSYN	I	EXT horizontal signal input terminal
13	EXVSYN	I	EXT vertical signal input terminal
14	Vss	-	GND
15	EXD	I	Dot clock generater outside circuit signal terminal for indication
16	XD	O	
17	VOB	O	Character & background signal output terminal
18	GOUT	O	Color signal (Green, Red, Blue)
19	ROUT		
20	BOUT		
21	TEST	I	Test signal input terminal
22	SCLK	I	Shift clock input terminal for serial transmission
23	SIN	I	Serial data input terminal
24	CS	I	Chip select terminal
25	COUT	O	Contrast signal output terminal
26	VOUT	O	Composite video signal output terminal
27	YOUT	O	Lux signal output terminal
28	AVss	-	Analog GND terminal

3. Block diagram

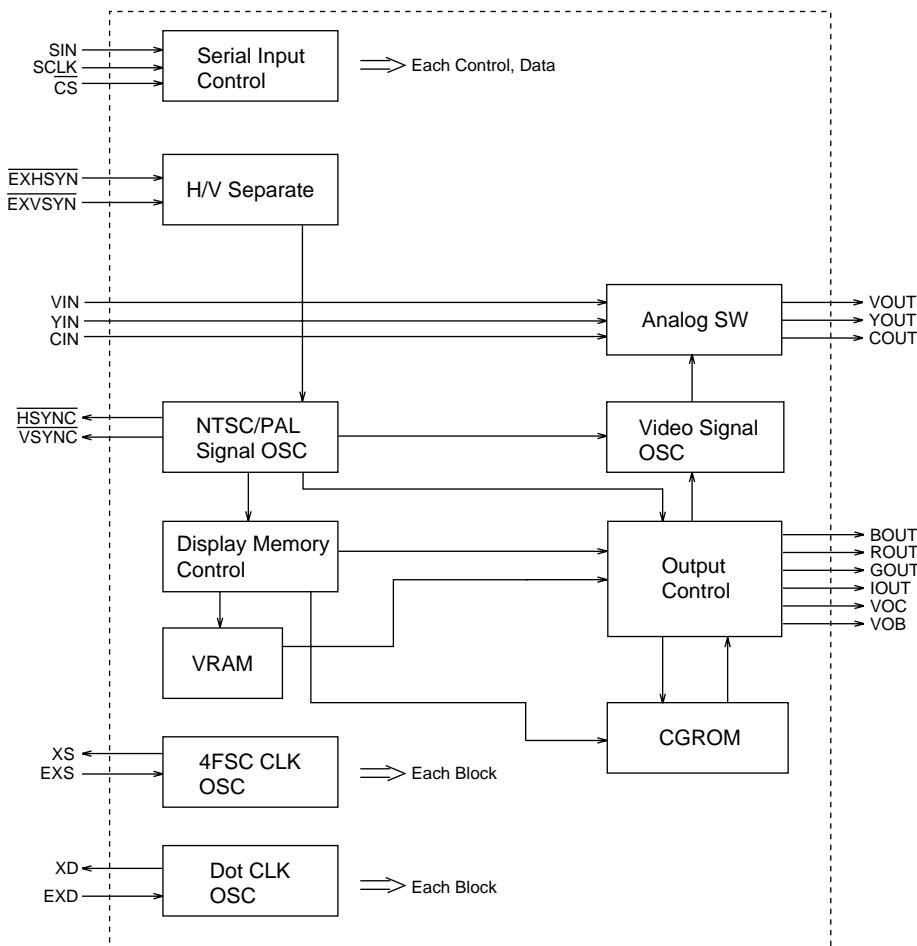

■ **W24L010AJ-12 (IC668, IC669, IC670) : SRAM**

1. Pin layout

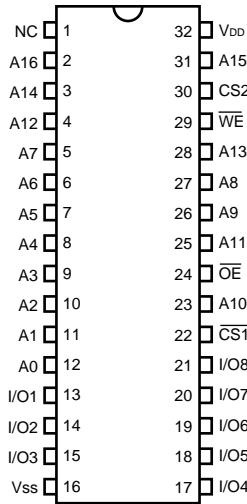

2. Block diagram

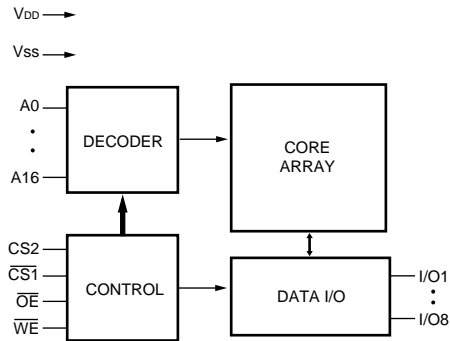

3. Pin function

SYMBOL	DESCRIPTION
A0 - A16	Address Input
I/O1 - I/O8	Data Input/Output
CS1, CS2	Chip Select Inputs
WE	Write Enable Input
OE	Output Enable Input
VDD	Power Supply
VSS	Ground
NC	No Connection

■ **TC74VHC74FT (IC683) : Flip-flop**

1. Pin layout

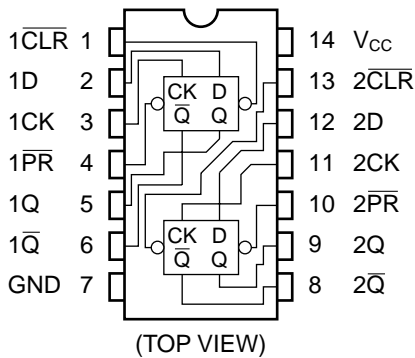

■ **TC7WH74FU (IC659, IC684) : Clock buffer**

1. Pin layout

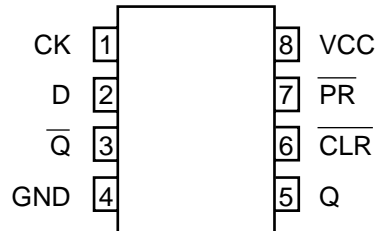

■ **PQ3DZ53 (IC691, IC692, IC693, IC695, IC696) : Regulator IC**

1. Block diagram

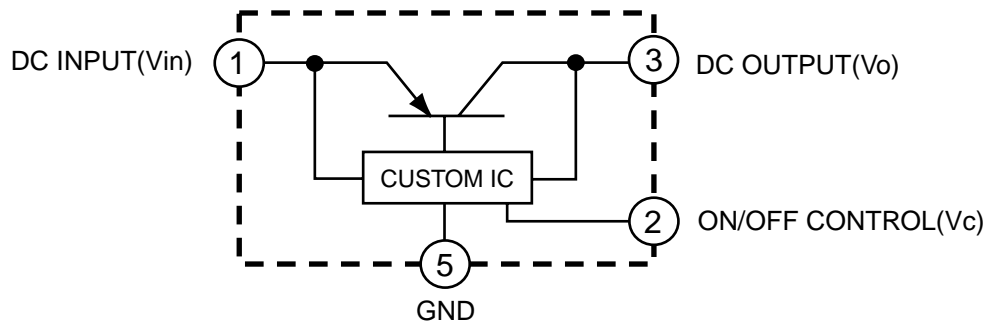

■ MN35505 (IC634, IC639, IC644, IC649) : D/A converter

1.Pin layout

M5	1	28	M6
DIN	2	27	M4
LRCK	3	26	M8
BCK	4	25	M7
M3	5	24	DVDD1
DVDD2	6	23	VCOF
CKO	7	22	XIN
DVSS2	8	21	XOUT
M2	9	20	DVSS1
M1	10	19	M9
OUT1C	11	18	OUT2C
AVDD1	12	17	AVDD2
OUT1D	13	16	OUT2D
AVSS1	14	15	AVSS2

2.Block diagram

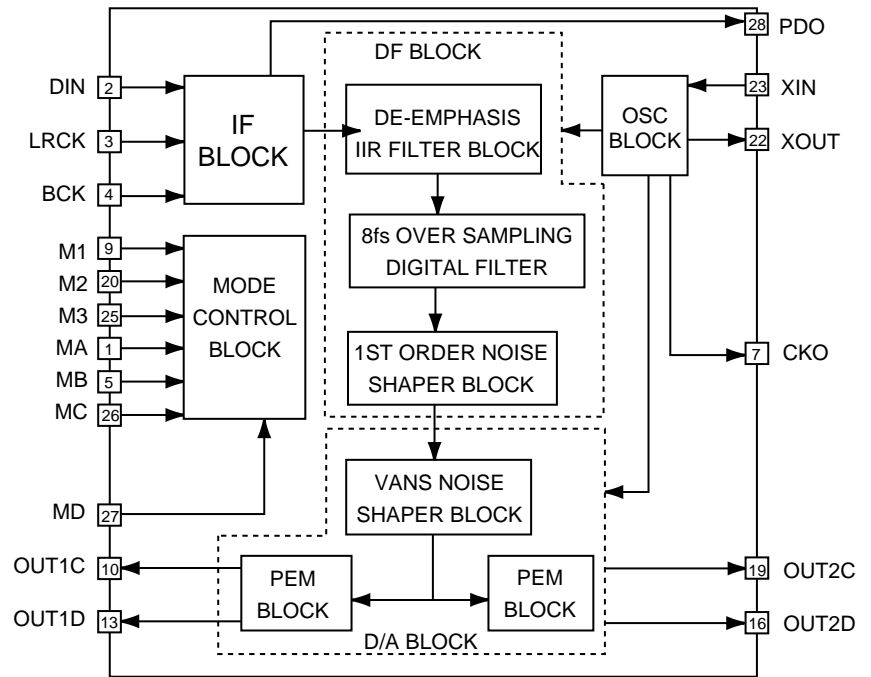

3.Pin function

Pin No.	Symbol	I/O	Function	Pin No.	Symbol	I/O	Function
1	M5	I	Connected to VDD	15	AVSS2	-	Analog ground 2
2	DIN	I	Data input	16	OUT2D	O	2D PEM output
3	LRCK	I	L/R clock input	17	AVDD2	-	Analog power supply 2
4	BCK	I	Bit clock input	18	OUT2C	O	2C PEM output
5	M3	I	Connected to ground	19	M9	I	NC
6	DVDD2	-	Digital power supply2	20	DVSS1	-	Digital ground pin 1
7	CKO	I	NC	21	XOUT	O	Crystal oscillator output
8	DVSS2	-	Digital ground 2	22	XIN	I	Crystal oscillator input
9	M2	I	Connected to ground	23	VCOF	I	VCO Filter
10	M1	I	Connected to ground	24	DVDD1	-	Digital power supply 1
11	OUT1C	O	1C PEM output	25	M7	I	System clock rate selection
12	AVDD1	-	Analog power supply 1	26	M8	I	System clock rate selection
13	OUT1D	O	1d PEM output	27	M4	I	Reset signal
14	AVSS1	-	Analog ground 1	28	M6	I	Connected to VDD

RX-DP10VBK/RX-DP10VSL
RX-DP10VSL

JVC

VICTOR COMPANY OF JAPAN, LIMITED

AUDIO & COMMUNICATION BUSINESS DIVISION

PERSONAL & MOBILE NETWORK BUSINESS UNIT. 10-1,1chome,Ohwatari-machi,Maebashi-city,371-8543,Japan

Block diagrams

■ Signal I/O & Main block section

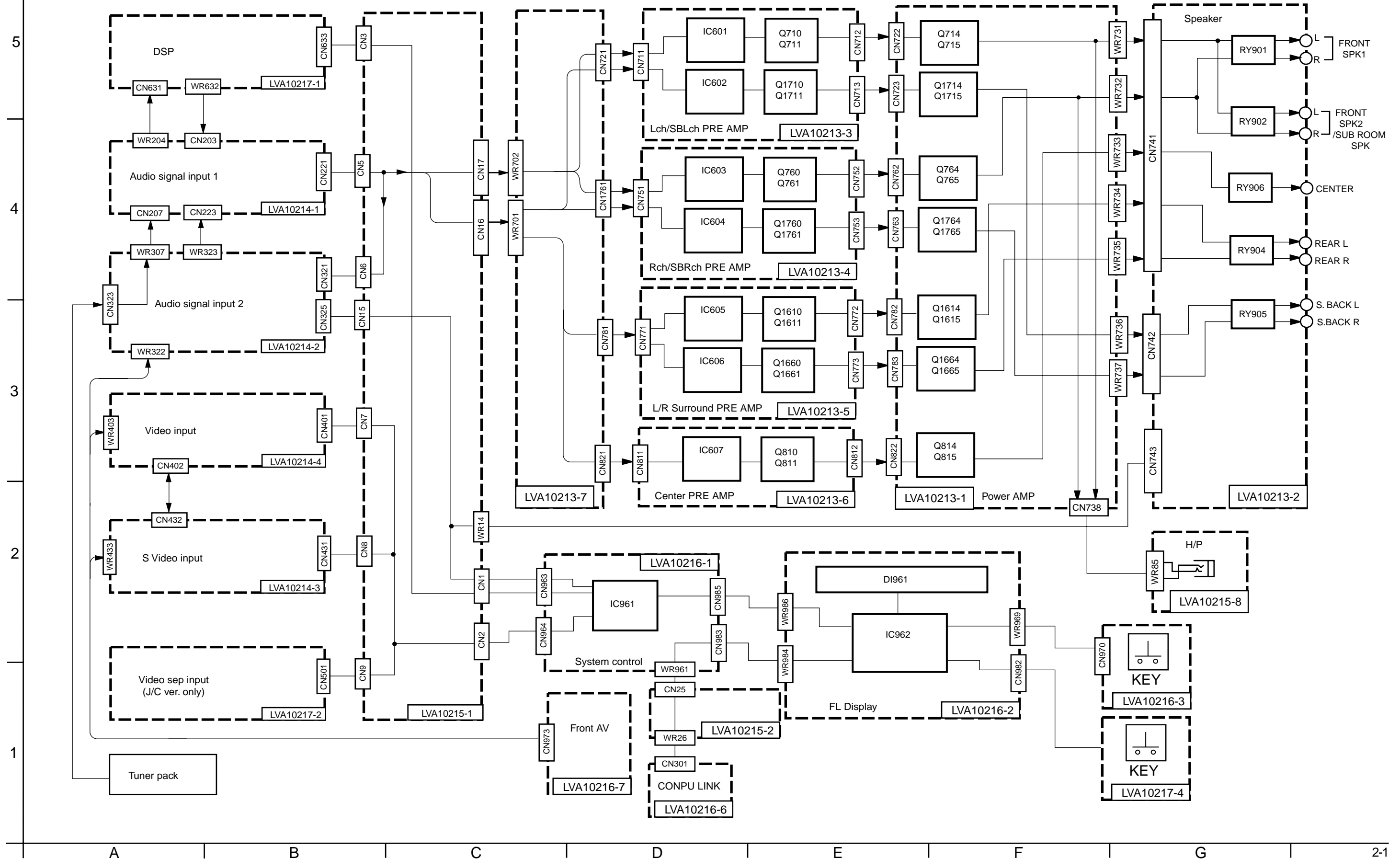

■ Audio signal input 1 section

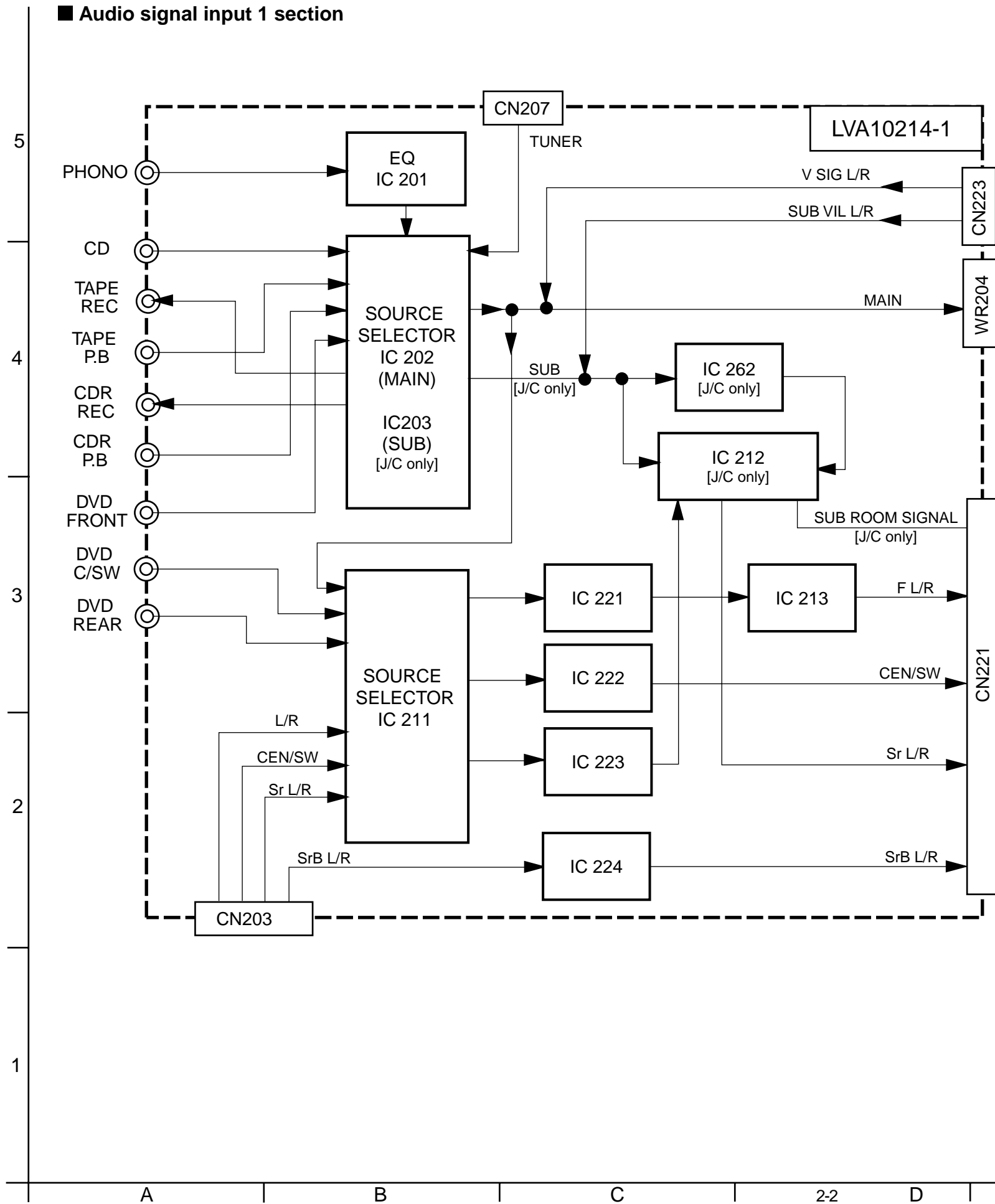

■ Audio signal input 2 section

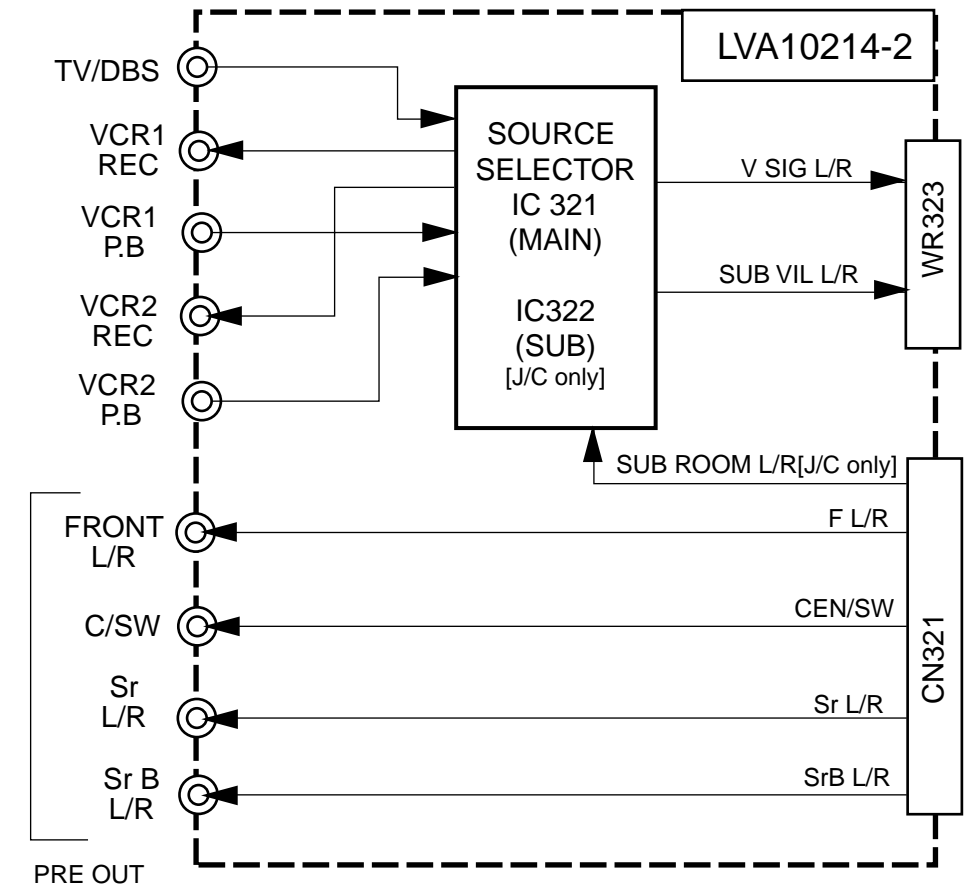

■ Video SEP input section (J/C ver. only)

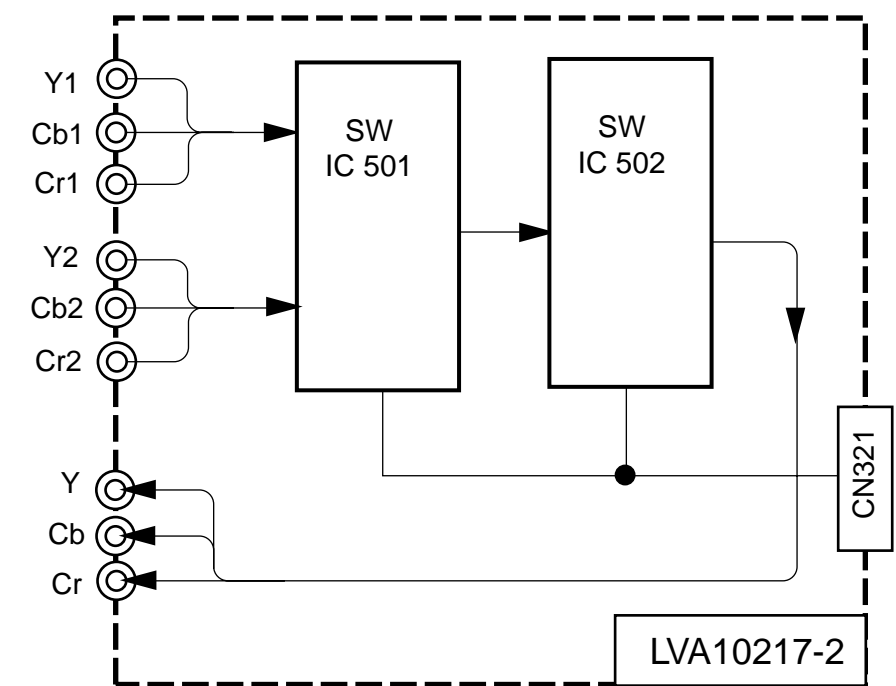

■ Video input section

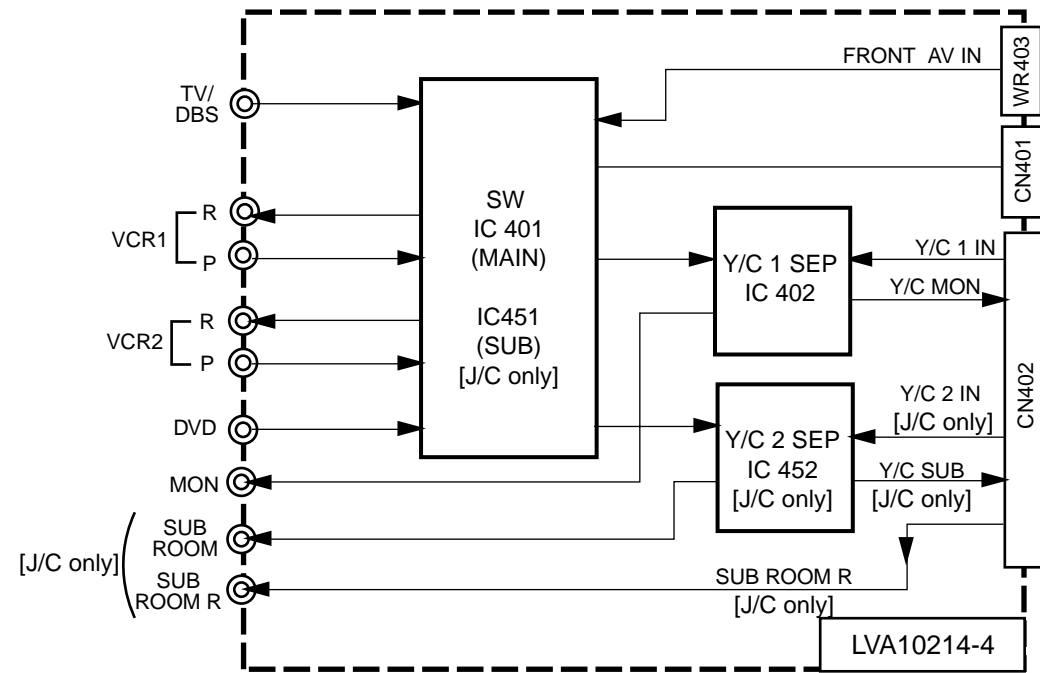

■ S Video input section

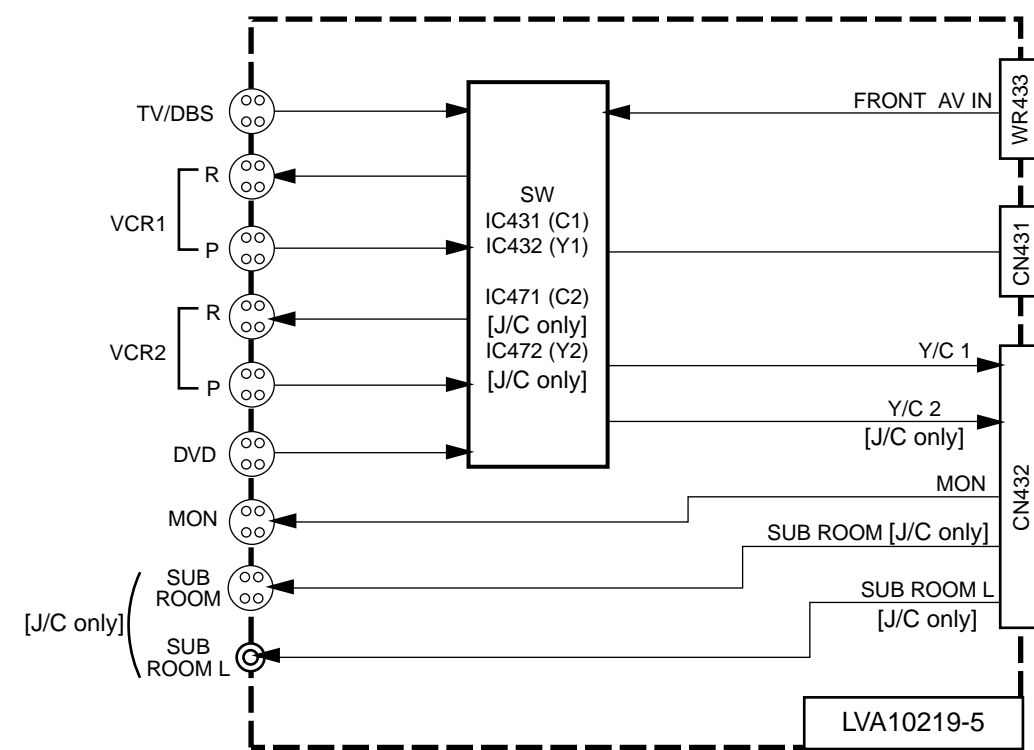

■ DSP section

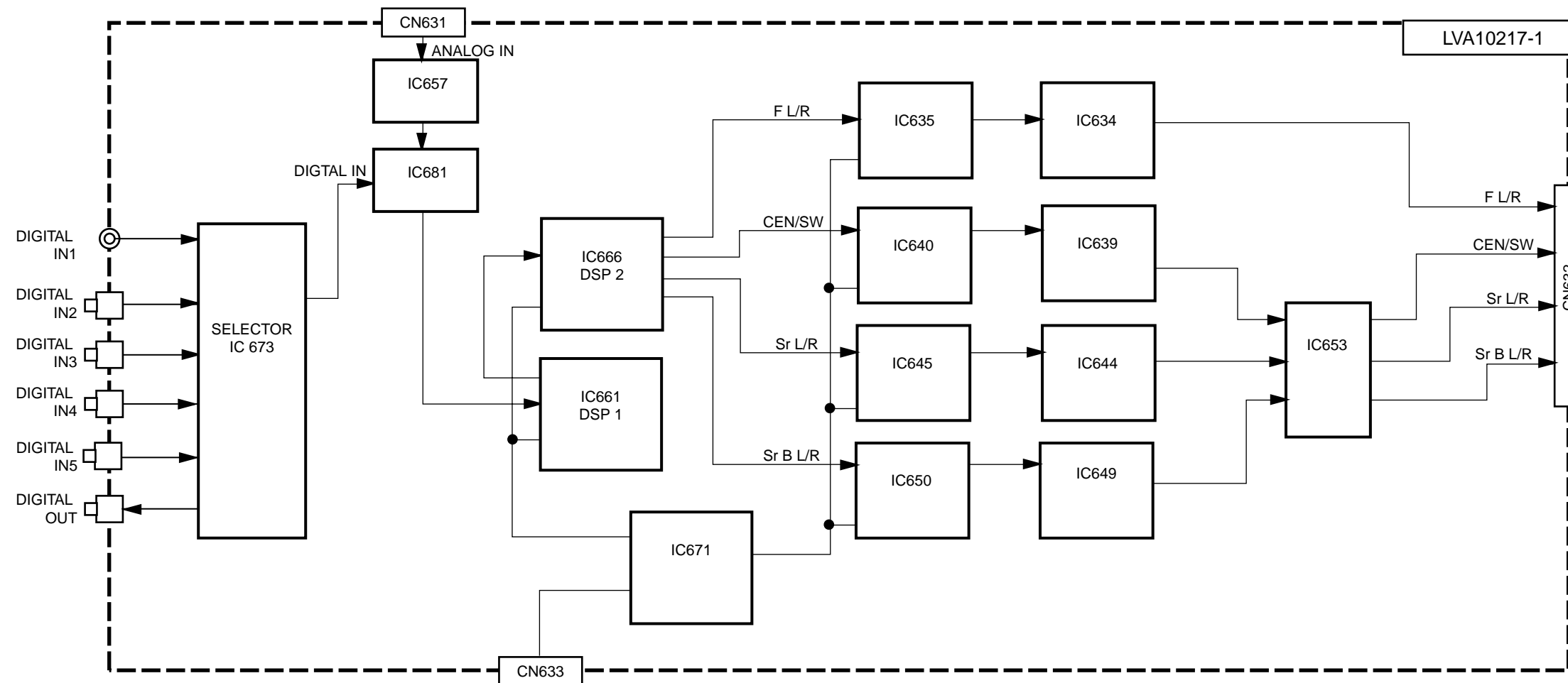

Standard schematic diagrams

■ Power supply section

5

Sheet 9/10

Sheet 4/10

4

Sheet 4/10

3

Sheet 5/10

2

Sheet 6/10

Sheet 6/10

Sheet 7/10

1

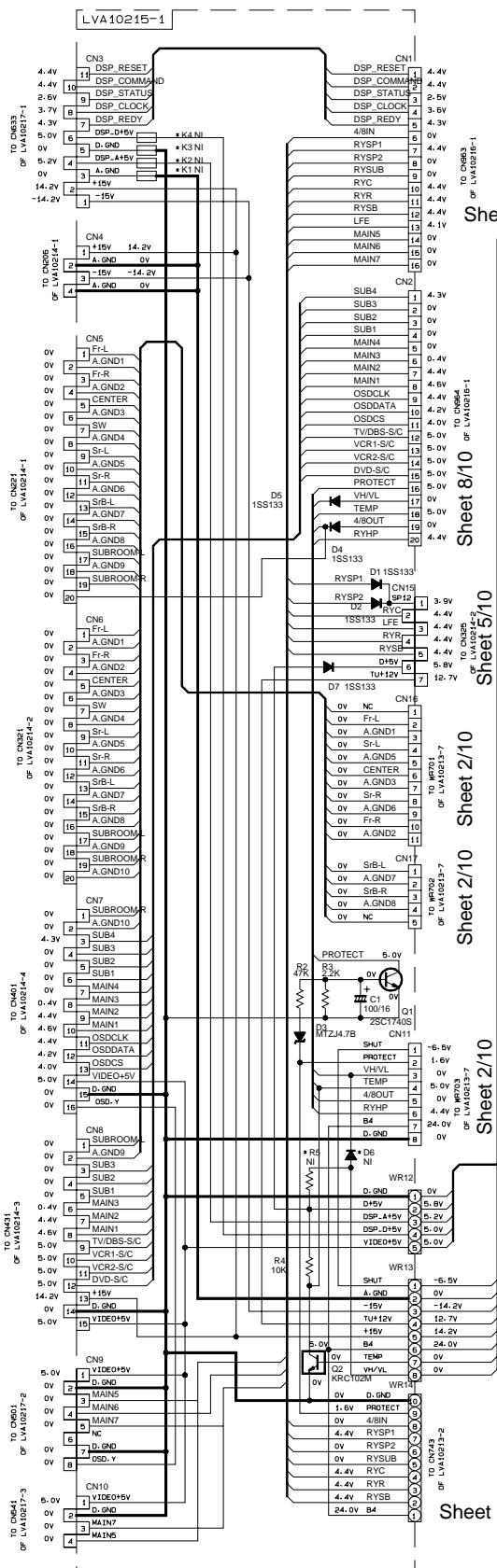

Sheet 8/10

Sheet 8/10

Sheet 5/10

Sheet 2/10

Sheet 2/10

Sheet 8/10

Sheet 3/10

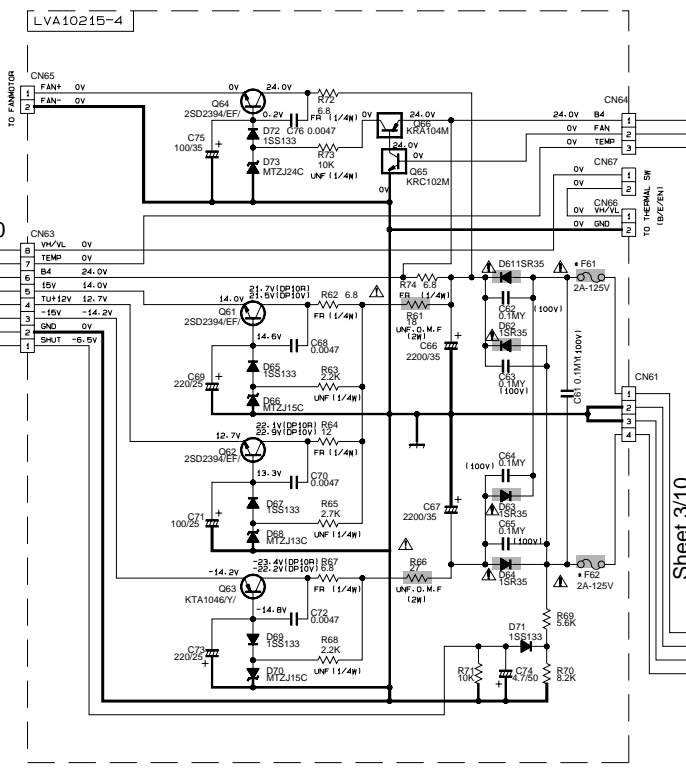

Sheet 3/10

Sheet 3/10

Sheet 3/10

Sheet 8/10

Sheet 8/10

Sheet 8/10

Sheet 3/10

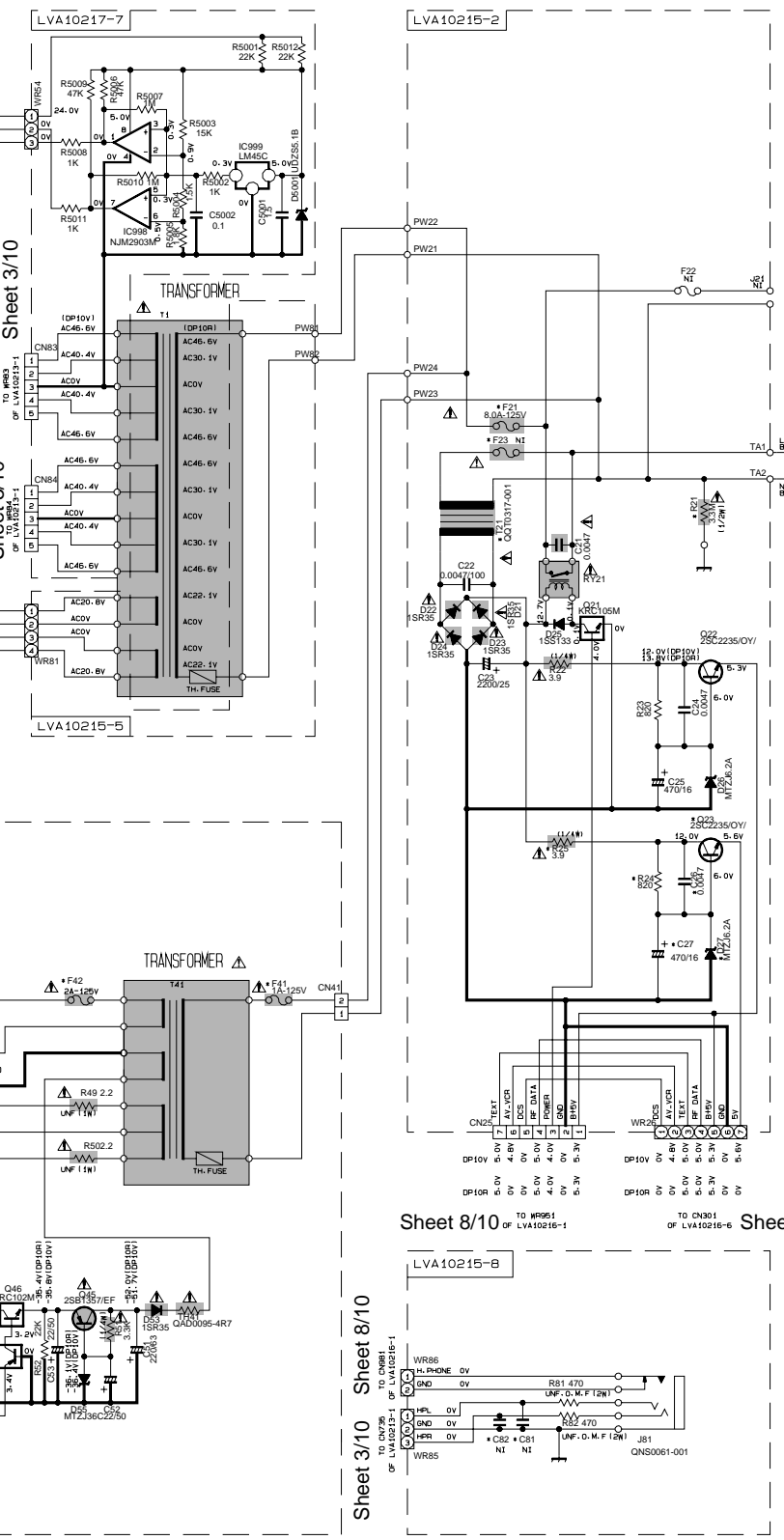

MAINS PLUG
AC120V/60Hz (J/C)
AC230V/50Hz (B/E/EN)

VERSION CODES
J - U.S.A.
C - CANADA
B - U.K.
E - CONTINENTAL EUROPE
EN - MISC. COUNTRIES

SHEET NUMBER	CIRCUIT DISCUPTION
1/10	Power supply
2/10	Pre amp.
3/10	Power amp.
4/10	Audio signal input 1
5/10	Audio signal input 2
6/10	Video signal input 1
7/10	Video signal input 2
8/10	FL display & system control
9/10	DSP
10/10	

* MARK LIST

MARK	DP10 J/C	DP10 B/E/EN
F21	8A-125V	4A-250V
F23	500mA	100mA-250V
T21	09T0317-001	09T0281-003
R21	3.3K	NONE
R22	3.9	NONE
R24	R20	NONE
C26	0.0047	NONE
C27	470/16	NONE
Q23	2SC2235/01V	NONE
D27	MTZJ6.2A	NONE
F41	1A-125V	500mA-250V
F42	2A-125V	2A-250V
F61	2A-125V	2A-250V
F62	2A-125V	2A-250V
C81-C82	NONE	330P
D8	NONE	1SS133
R5	NONE	10K
K1-K3	NONE	09P0779-001Z
K2-K4	SHORT	09P0779-001Z

⚠ Parts are safety assurance parts.
When replacing those parts make
sure to use the specified.

NOTES
1. VOLTAGES ARE DC-MEASURED WITH A DIGITAL VOLT METER WITHOUT INPUT SIGNAL.
CONDITION --- COLD START. POWER ON. D.V. ANALOG SURROUND ON. VOL. MINIMUM

Pre amp. section

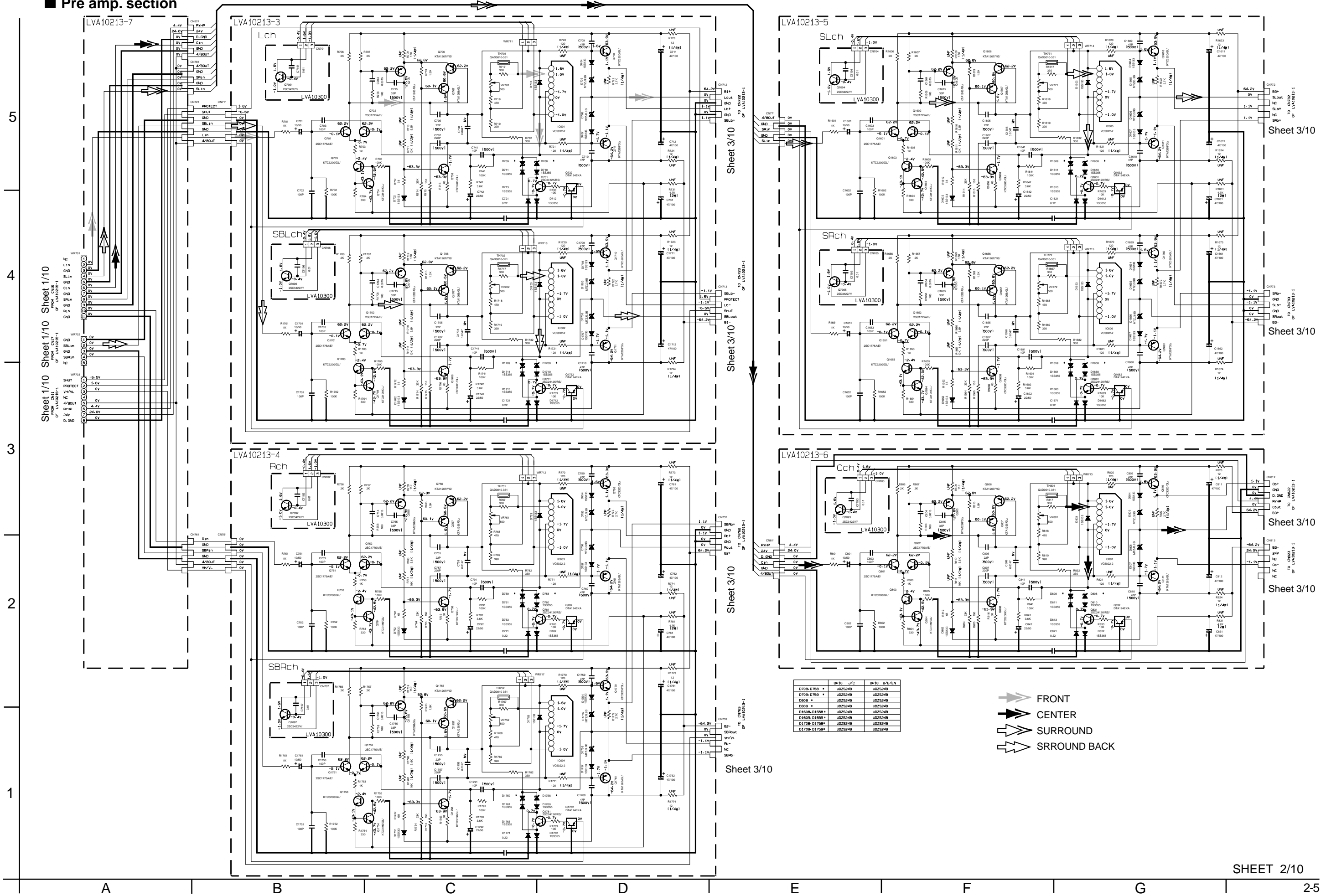

Power amp. section

5
4
3
2
1

Sheet 2/10
Sheet 2/10
Sheet 2/10
Sheet 2/10
Sheet 2/10
Sheet 2/10
Sheet 2/10
Sheet 2/10

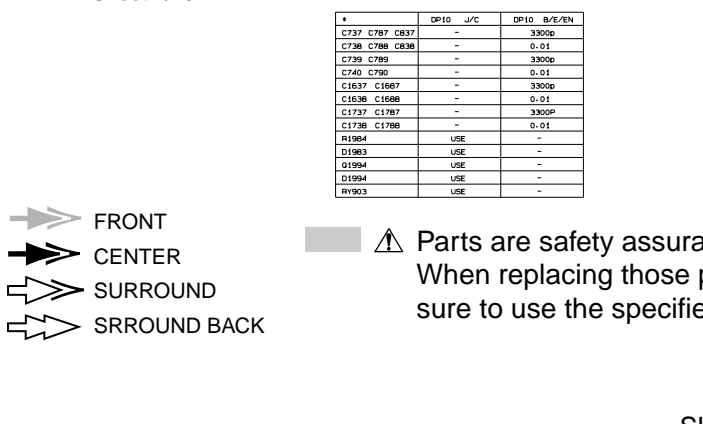
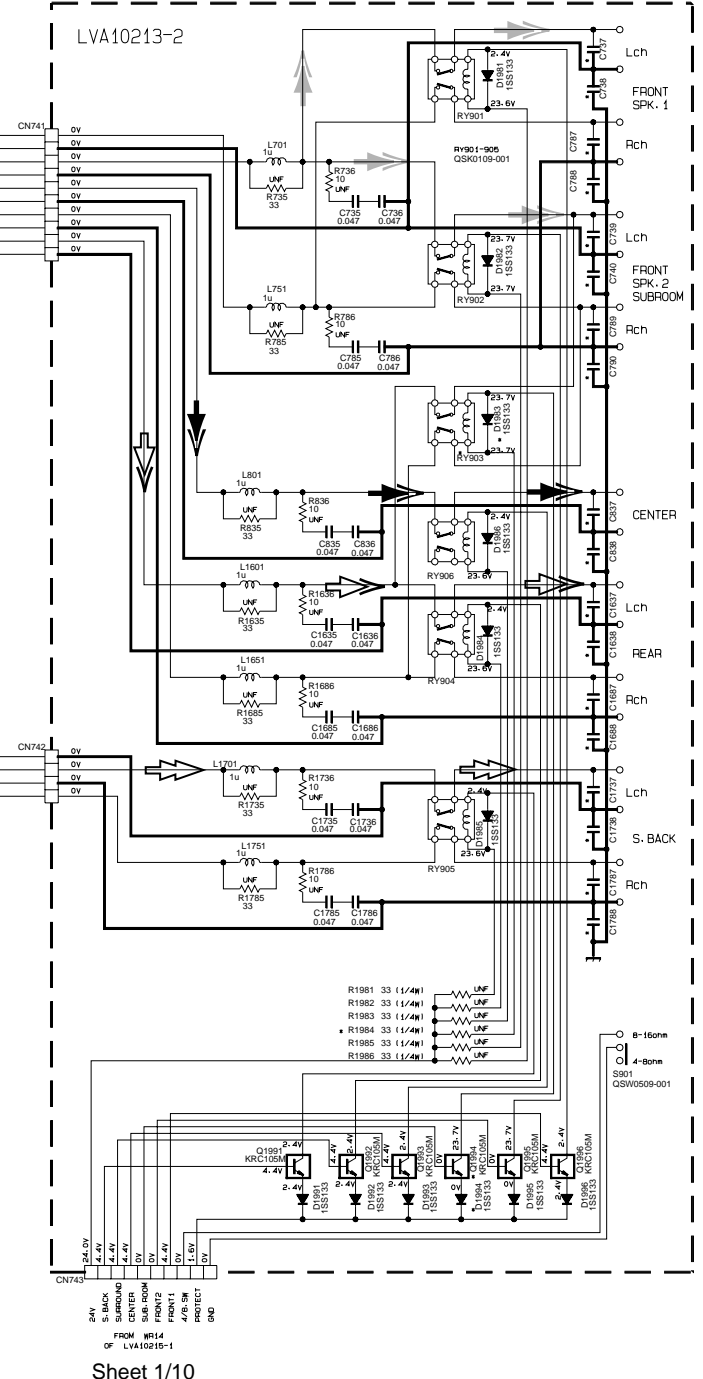
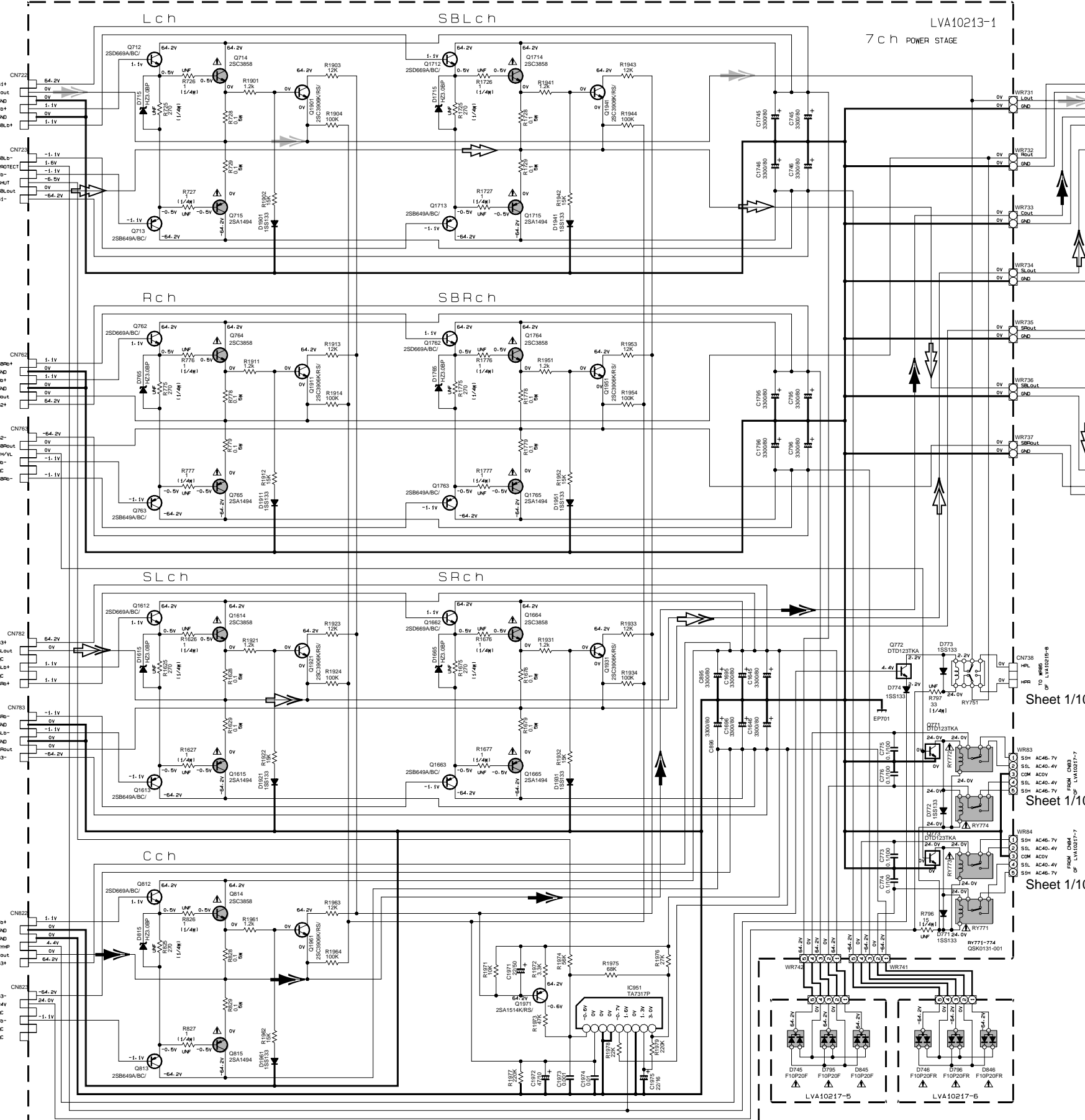

Audio signal input 1 section

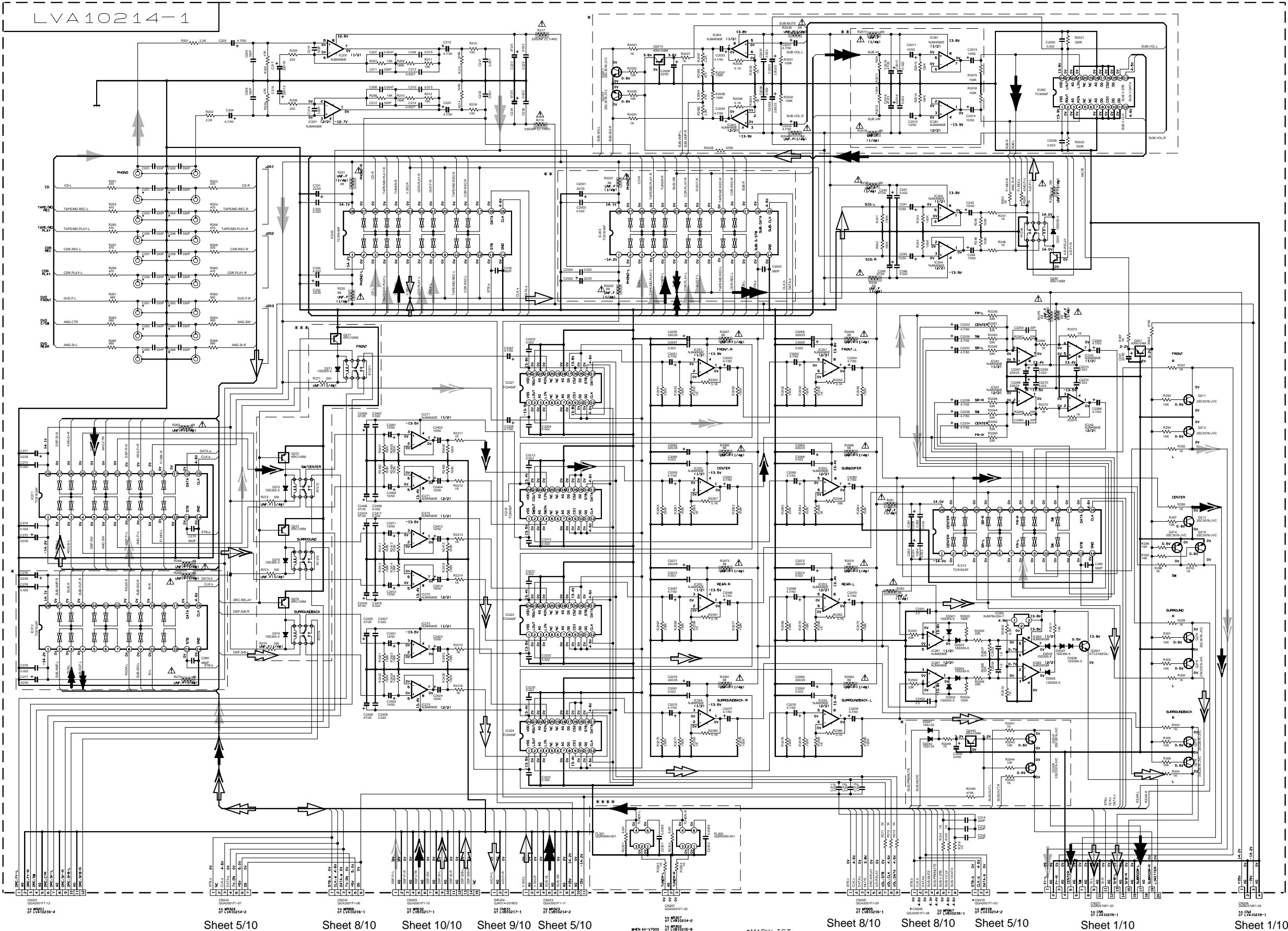

- ▶ AUDIO
- ▶ TUNER
- ▶ PHONO
- ▶ MAIN
- ▶ SUB
- ▶ FRONT
- ▶ CENTER
- ▶ SURROUND
- ▶ SRROUND BACK

Parts are safety assurance parts. When replacing those parts make sure to use the specified.

Sheet 5/10 Sheet 8/10 Sheet 10/10 Sheet 9/10 Sheet 5/10 Sheet 5/10 Sheet 8/10 Sheet 8/10 Sheet 5/10 Sheet 1/10 Sheet 1/10

*MARKLIST

	DPSVJ-C	DP10VJ-C	DP10RB-E-EN	V7000
C251-C266	NONE	NONE	USED	NONE
CN208	NONE	USED	NONE	NONE
CN218	NONE	USED	NONE	USED

* [] DP10VJ-C ONLY *** [] V7000 ONLY
** [] DP10VJ-C&V7000 ONLY **** [] EXCEPT V7000

Audio signal input 2 section

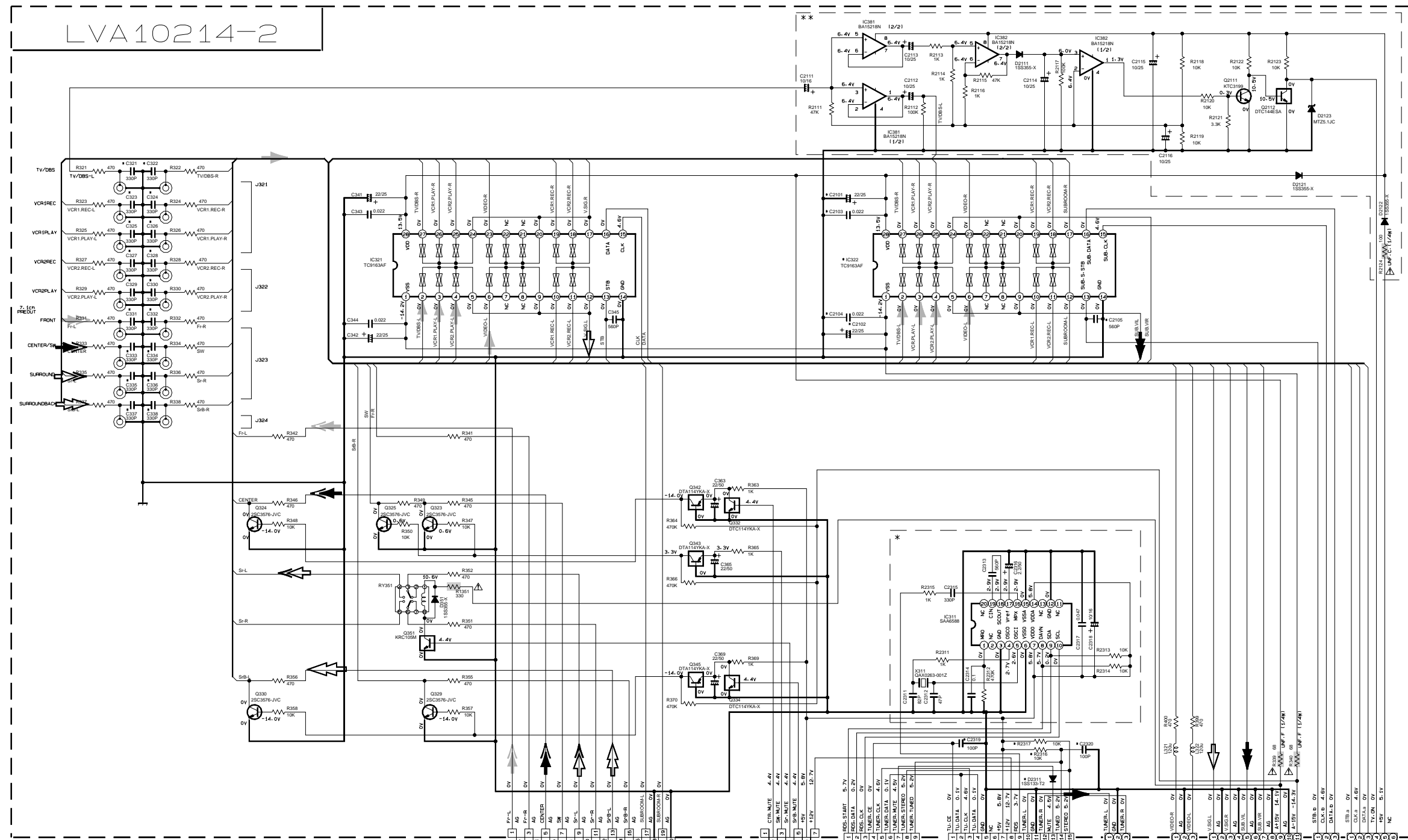

* MARK LIST

	DP9VJ.C	DP10VJ.C	DP10RB.E.EN	V7000
C321-C338	NONE	NONE	USED	NONE
C2101-C2105	NONE	USED	NONE	USED
IC322	NONE	USED	NONE	USED
WR307, CN323, 324	USED	USED	USED	NONE
WR318	NONE	USED	NONE	USED
C2319, C2320	USED	USED	USED	NONE
R2316, R2317	USED	USED	USED	NONE
D2311	USED	USED	USED	NONE

* RX-DP10RB.E.EN ONLY
 ** RX-DP10VJ.C&AX-V7000 ONLY

Sheet 1/10

Sheet 1/10

Sheet 8/10

Sheet 4/10

Sheet 8/10

Sheet 4/10

AUDIO TUNER MAIN SUB FRONT CENTER SURROUND SURROUND BACK

Parts are safety assurance parts. When replacing those parts make sure to use the specified.

Video signal input 1 section

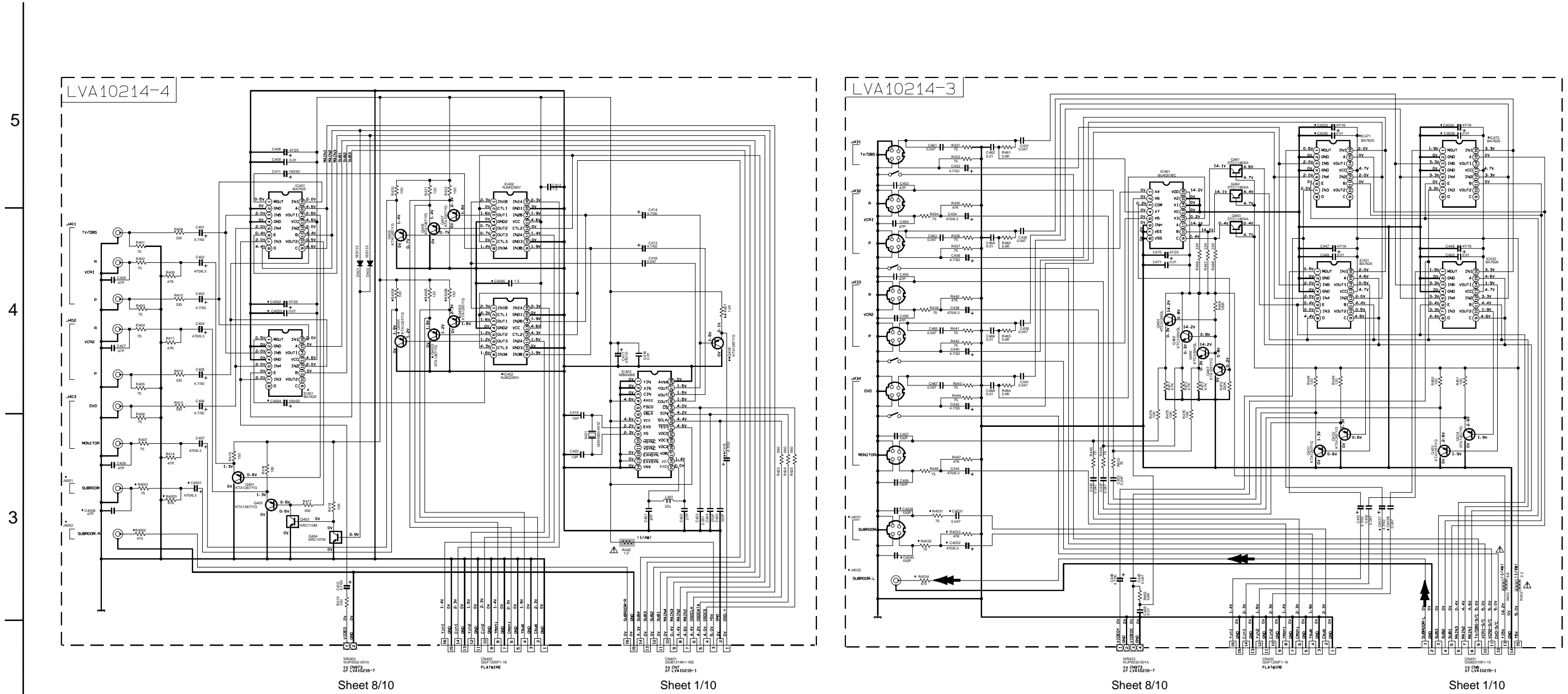

Sheet 8/10

Sheet 1/10

Sheet 8/10

Sheet 1/10

* MARK LIST

	DP9VJ.C	DP10VJ.C	DP10RB.E.EN	V7000
*	NONE	USED	NONE	NONE
**	USED	USED	NONE	USED

➡ SUB

⚠ Parts are safety assurance parts. When replacing those parts make sure to use the specified.

Video signal input 2 section

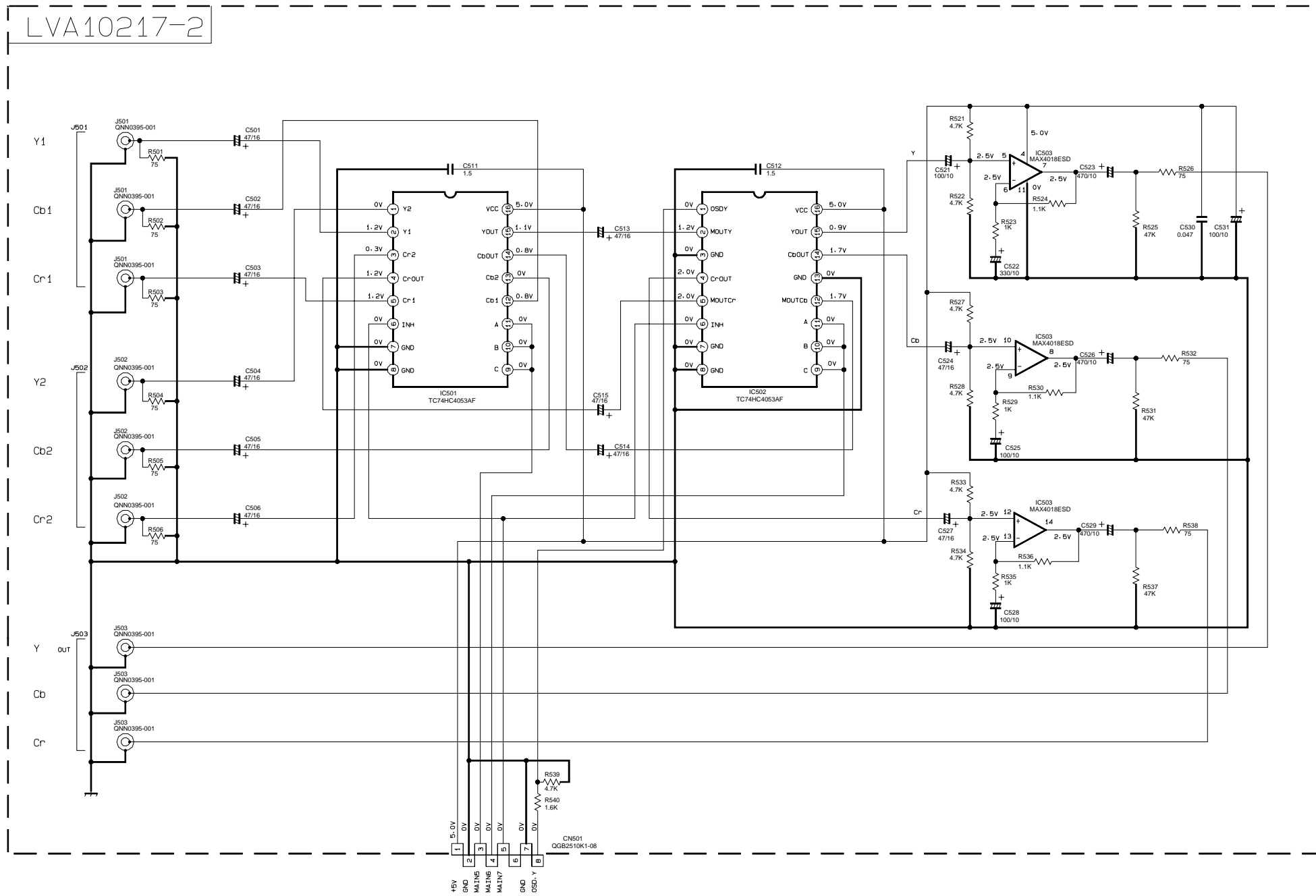

Sheet 1/10

FL display & system control section

Sheet 1/10

Sheet 1/10

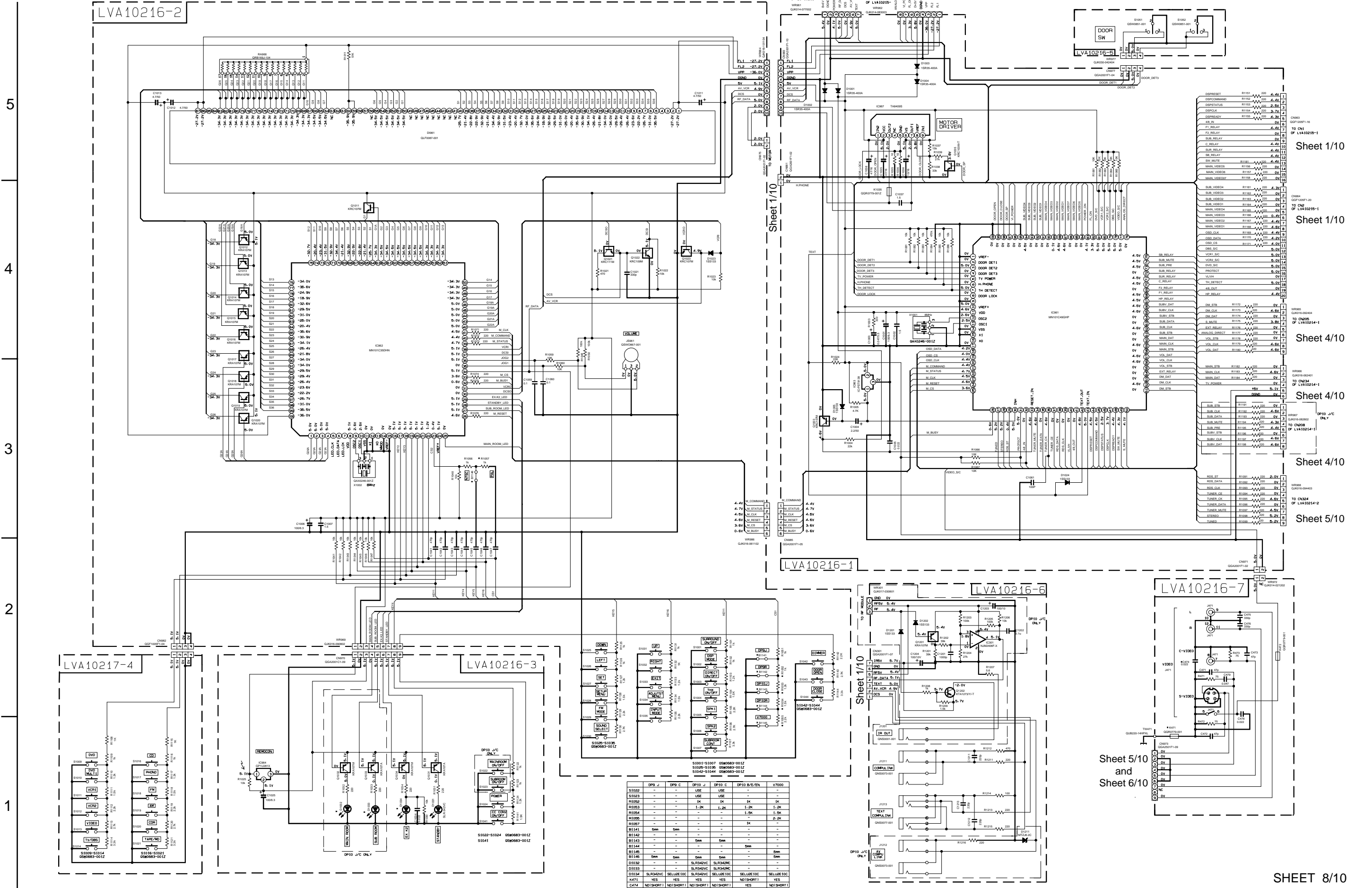

Sheet 1/10

Sheet 1/10

Sheet 1/10

Sheet 1/10

Sheet 1/10

Sheet 1/10

Sheet 1/10

Sheet 1/10

Sheet 4/10

Sheet 4/10

Sheet 4/10

Sheet 5/10

SHEET 8/10

DP9 J	DP9 C	DP10 J	DP10 C	DP10 B/E/EN	V7000
S1002	-	-	USE	USE	-
S1003	-	-	USE	USE	-
R1002	-	-	1k	1k	1k
R1003	-	-	1.2k	1.2k	1.2k
R1004	-	-	1.2k	1.2k	1.2k
R1005	-	-	1.2k	1.2k	1.2k
R1006	-	-	1.2k	1.2k	1.2k
R1007	-	-	1k	1k	1k
B1141	5mm	5mm	-	-	-
B1142	-	-	-	-	-
B1143	-	-	-	-	-
B1144	-	-	-	-	-
B1145	5mm	5mm	-	-	-
B1146	5mm	5mm	-	-	-
D1032	-	-	SLR342VC	SLR342NC	-
D1033	-	-	SLR342VC	SLR342NC	-
S1034	SLR342VC	SEL10C	SLR342VC	SEL10C	SEL10C
K471	YES	YES	YES	YES	YES
K474	NO(SHORT)	NO(SHORT)	NO(SHORT)	NO(SHORT)	YES

Sheet 5/10
and
Sheet 6/10

DSP section

5

4

3

2

1

Sheet 4/10

Sheet 10/10

Sheet 10/10

Sheet 10/10

SHEET 9/10

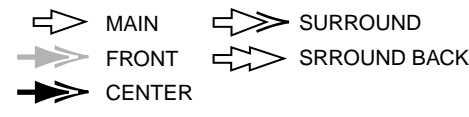
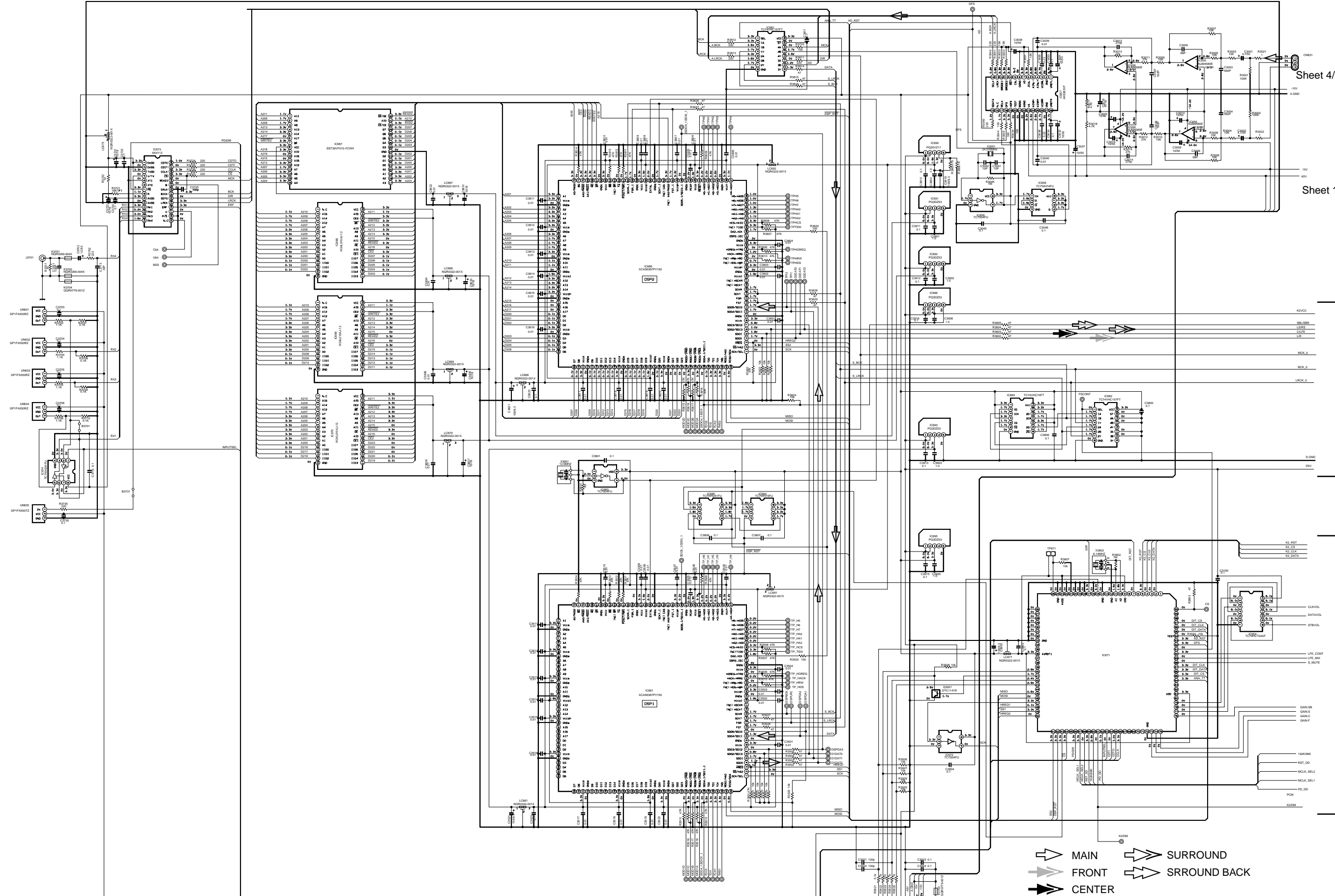

Sheet 1/10

Sheet 9/10

Sheet 9/10

Sheet 4/10

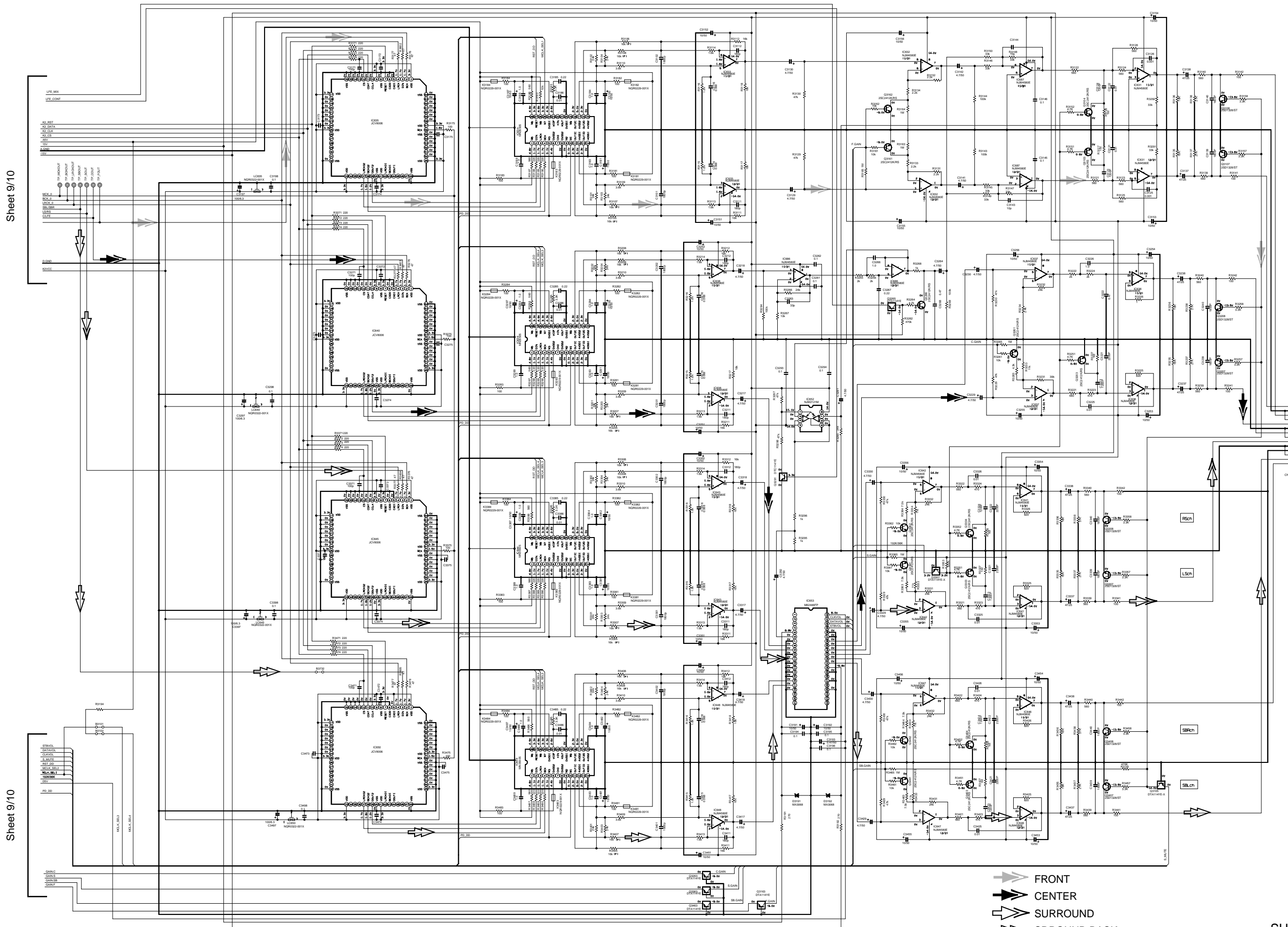

- FRONT
- CENTER
- SURROUND
- SURROUND BACK

Printed circuit boards

■ Amp. board (Reverse side)

5

4

3

2

1

Relay board

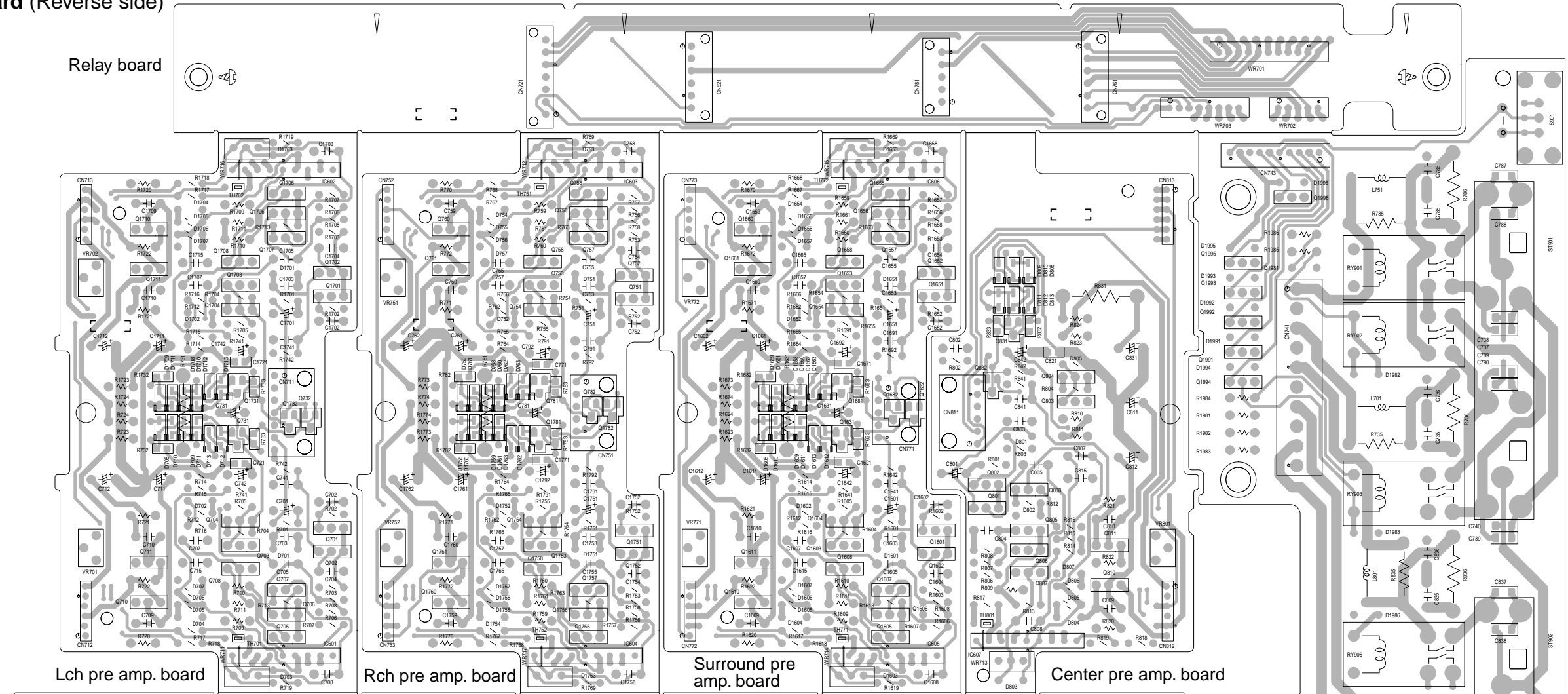

Speaker board

Lch pre amp. board

Rch pre amp. board

Surround pre amp. board

Center pre amp. board

Power amp. board

A

B

C

2-14

D

E

F

G

H

■ Amp. board (Forward side)

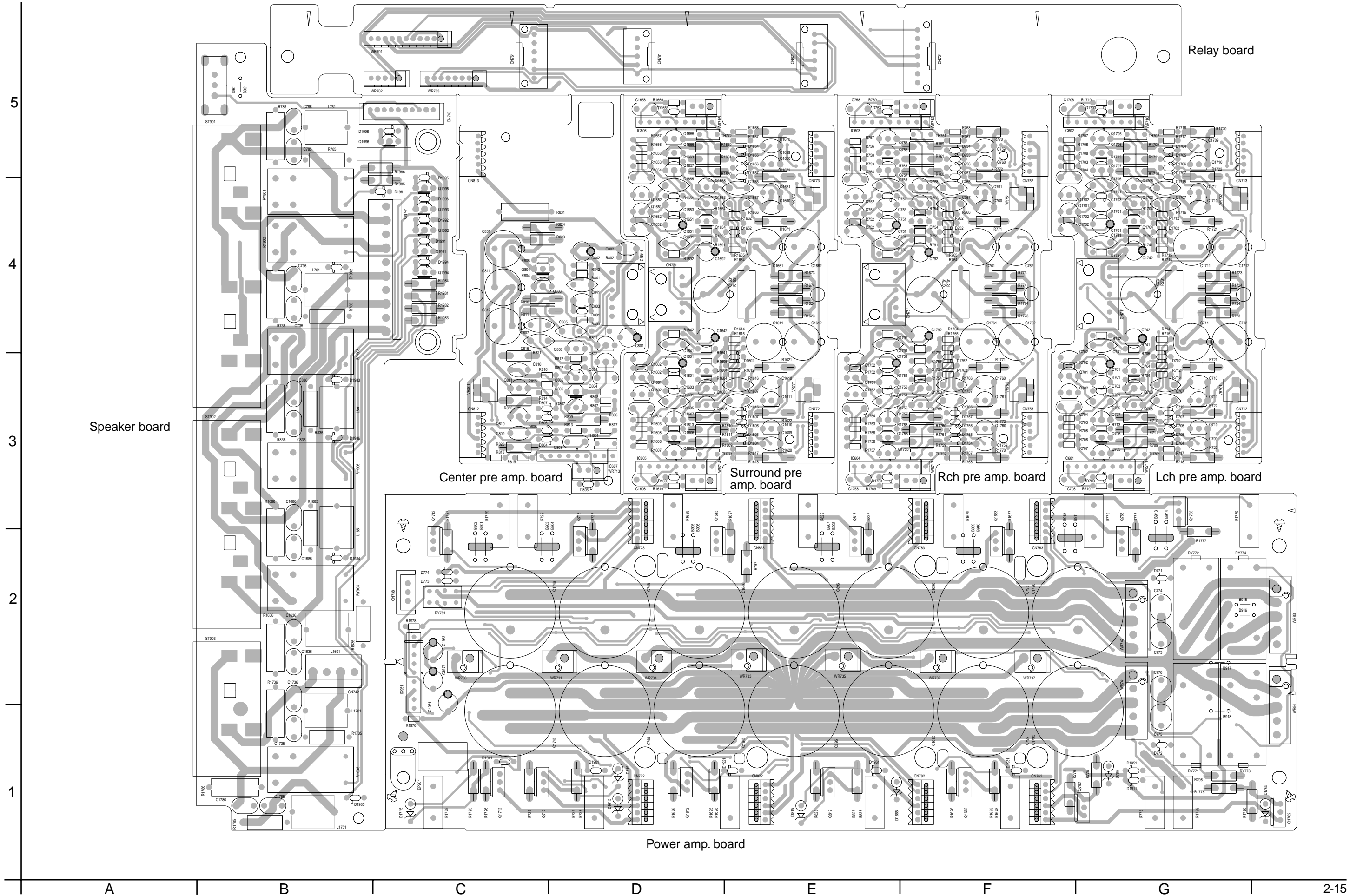

■ Audio/ video board (Reverse side)

5

Audio signal 1 board

4

3

2

1

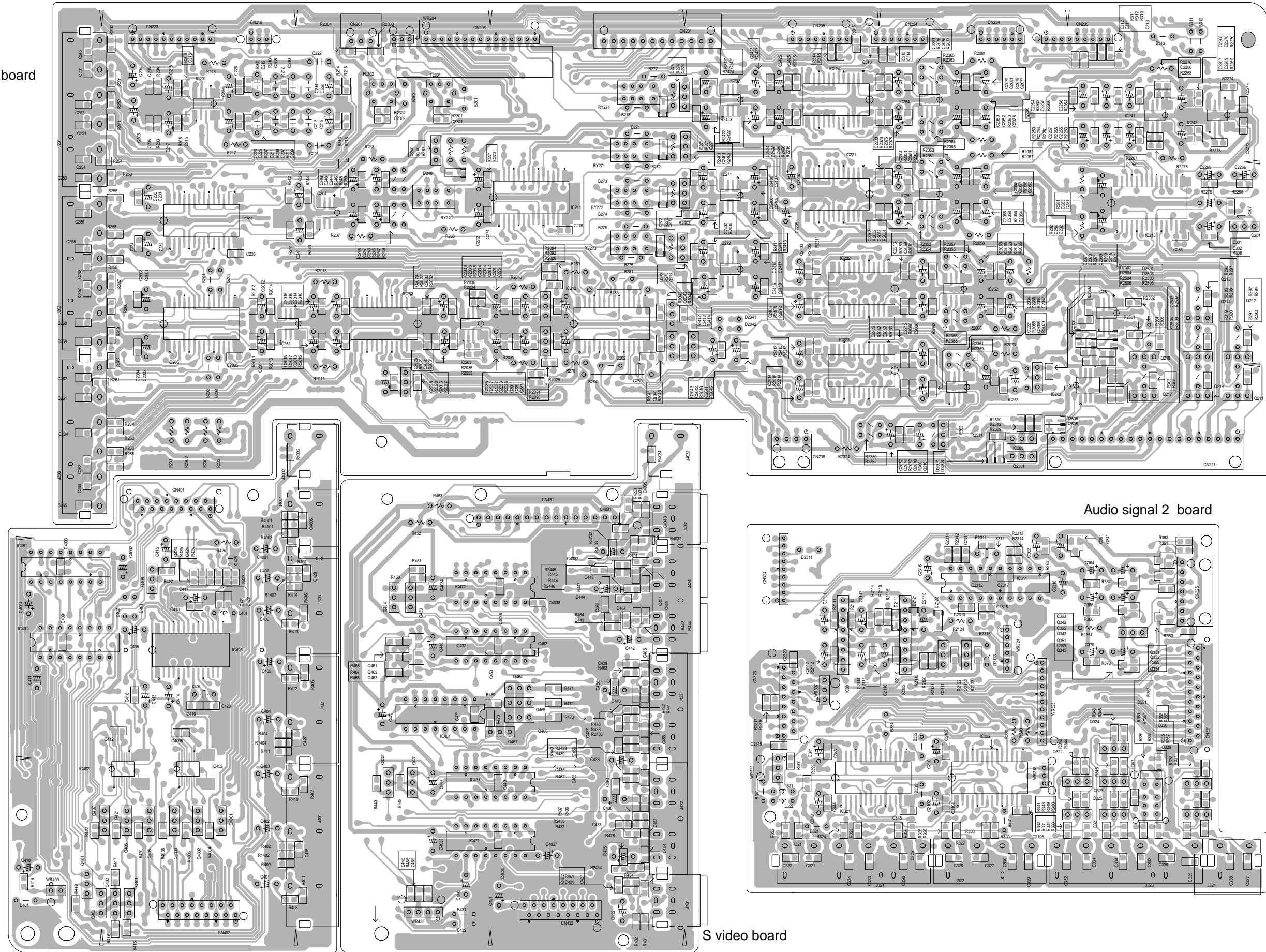

Video board

Audio signal 2 board

S video board

A

B

C

2-16

D

E

F

G

H

■ Audio/ video board (Forward side)

Audio signal 1 board

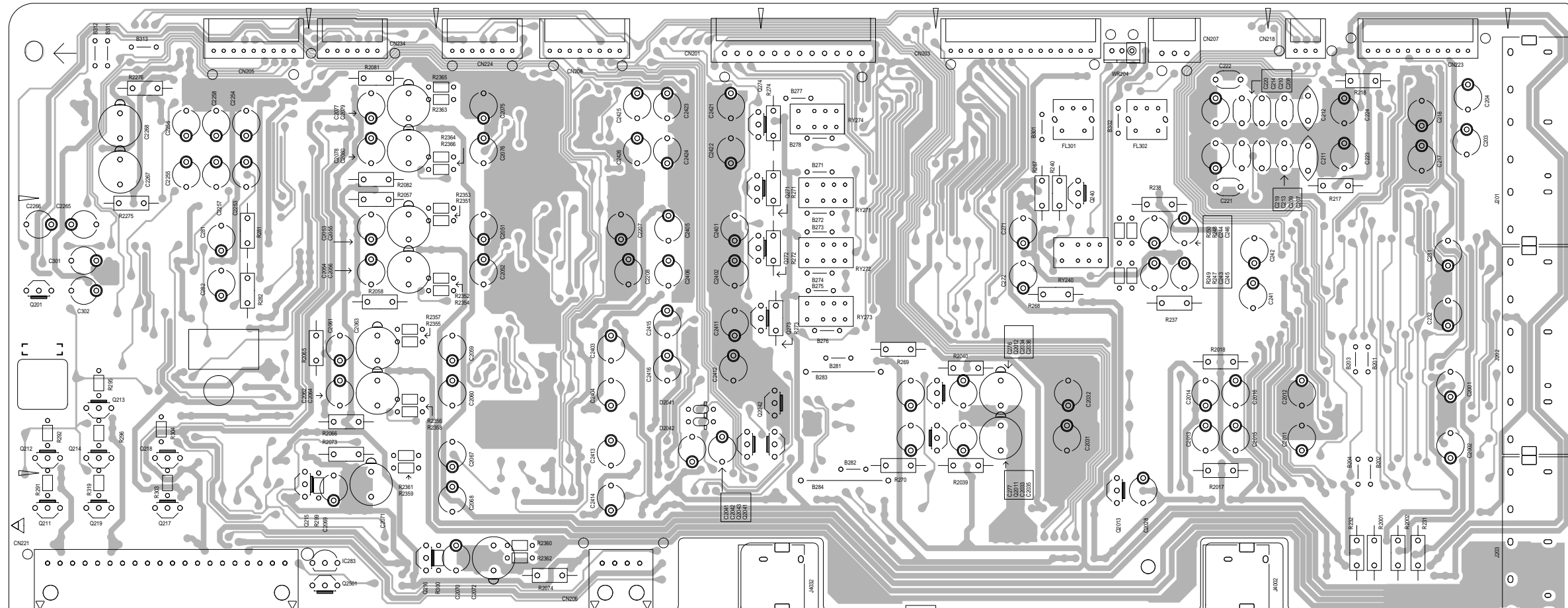

Audio singla 2 board

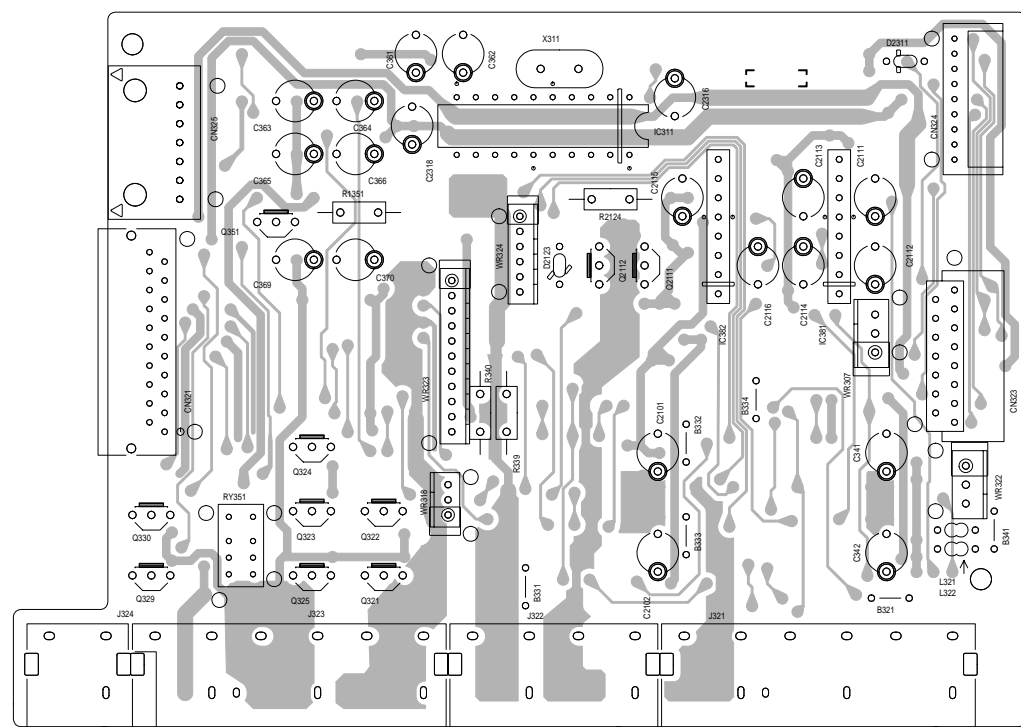

S video board

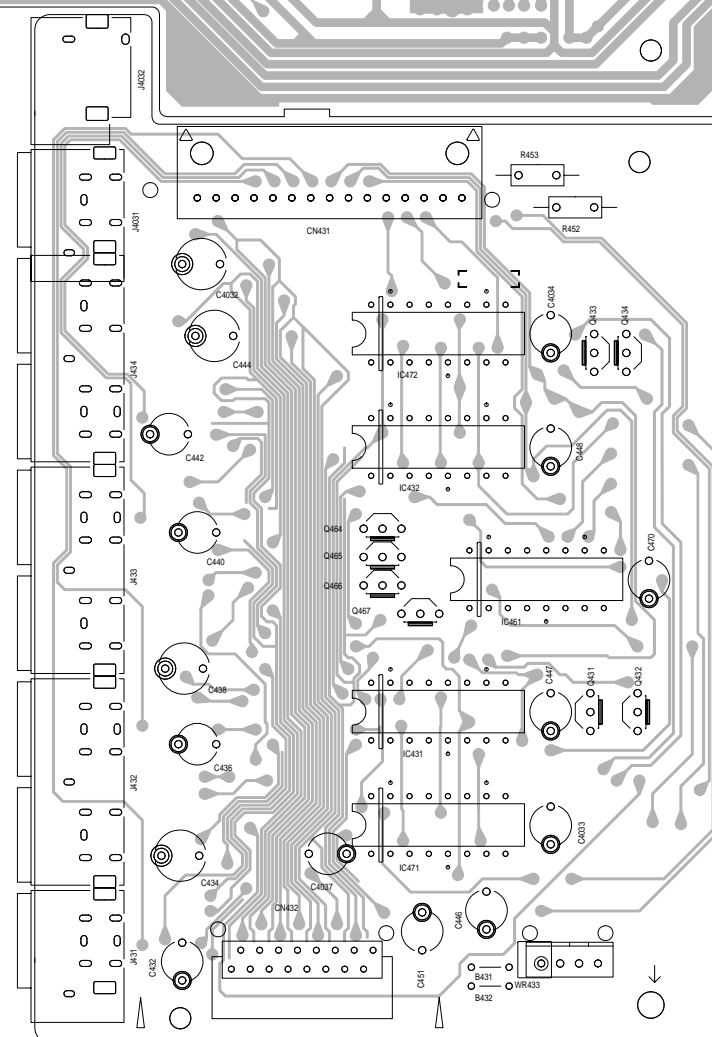

Video board

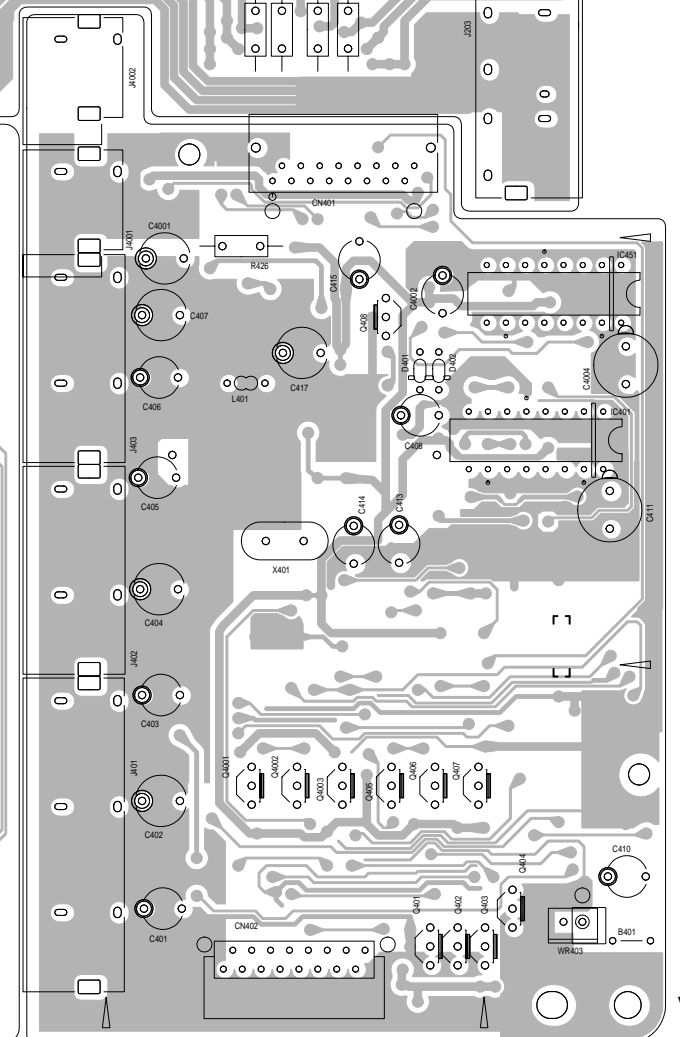

5
4
3
2
1

A B C D E F G 2-17

■ Power supply board

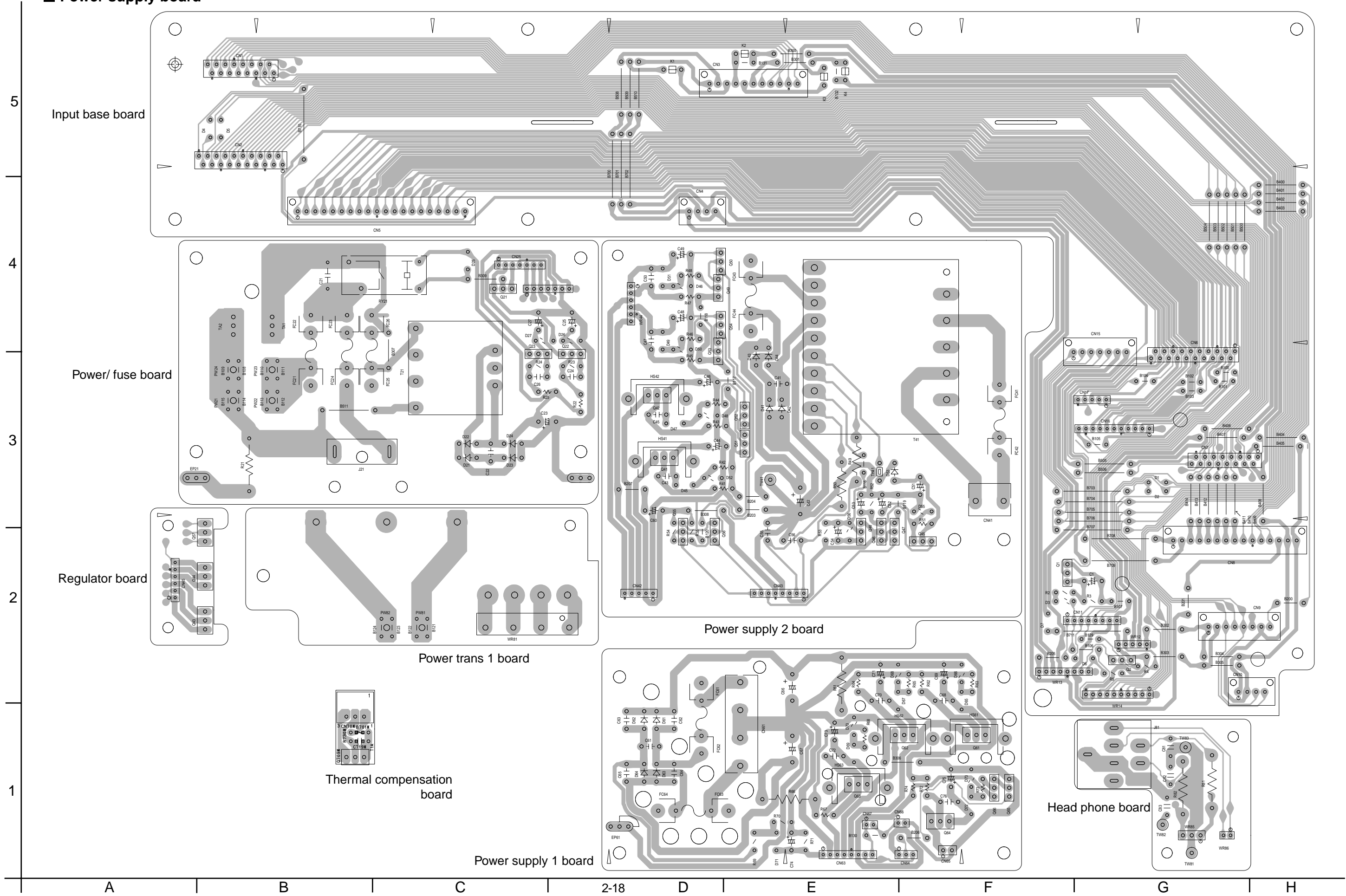

5

Input base board

4

Power/fuse board

3

Regulator board

2

Power supply 2 board

1

Thermal compensation board

Power trans 1 board

Head phone board

Power supply 1 board

A

B

C

2-18

D

E

F

G

H

■ FL display board

5

4

3

2

1

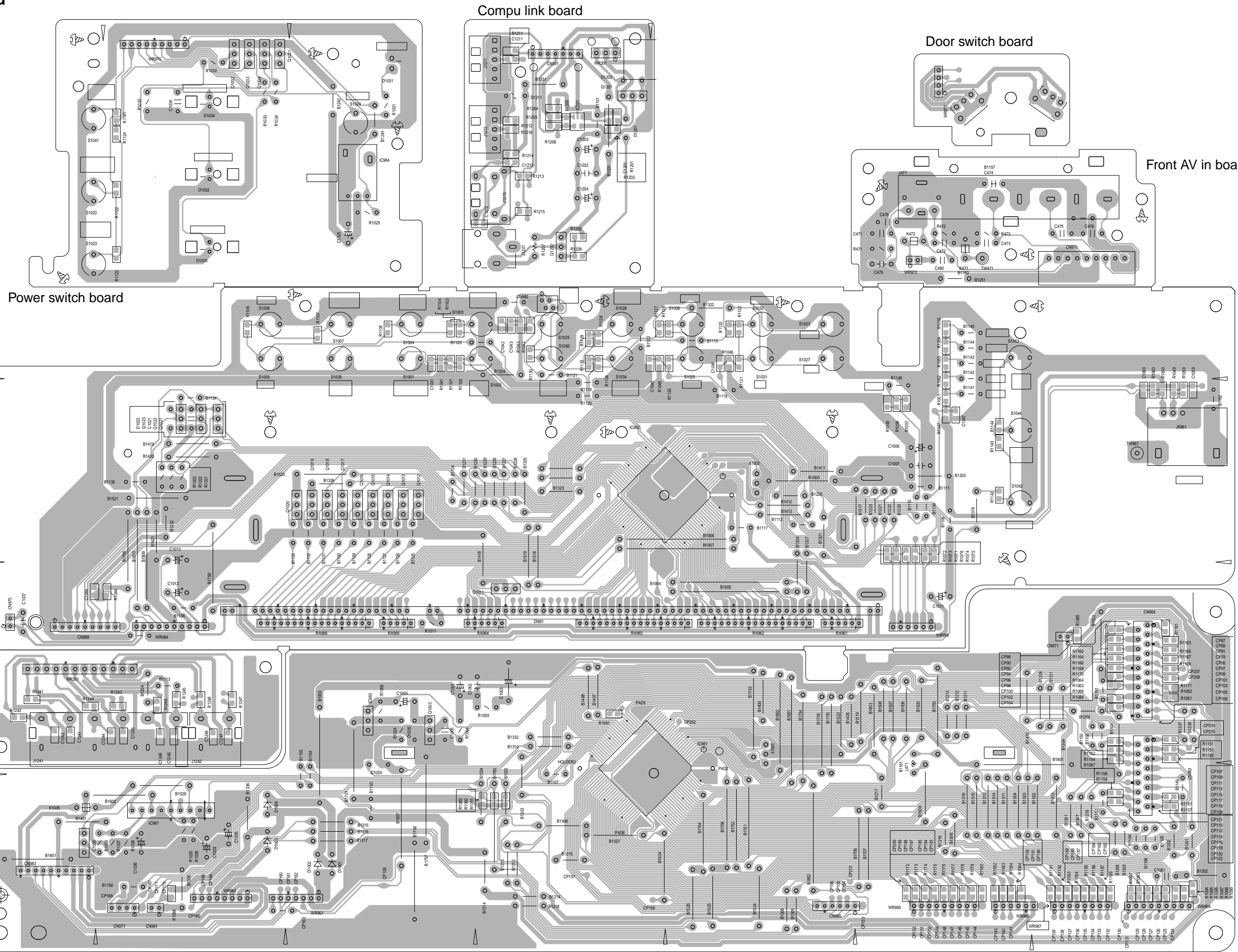

Power switch board

Compu link board

Door switch board

Front AV in board

System control board

■ DSP board (Reverse side)

5
4
3
2
1

Power trans 2 board

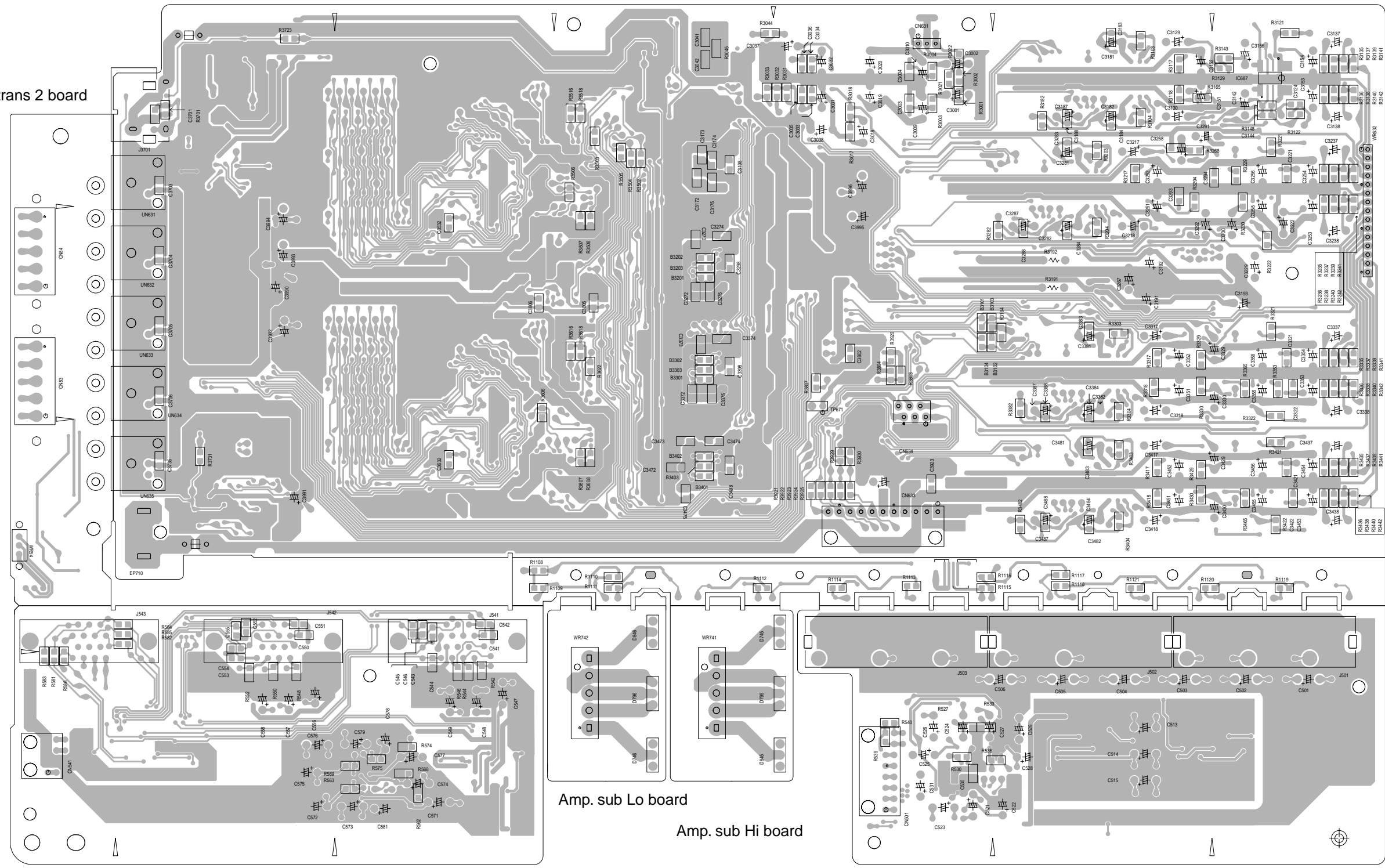

Door input board

Amp. sub Lo board

Amp. sub Hi board

D4 video board

Video SEP board

A B C 2-20 D E F G H

■ DSP board (Forward side)

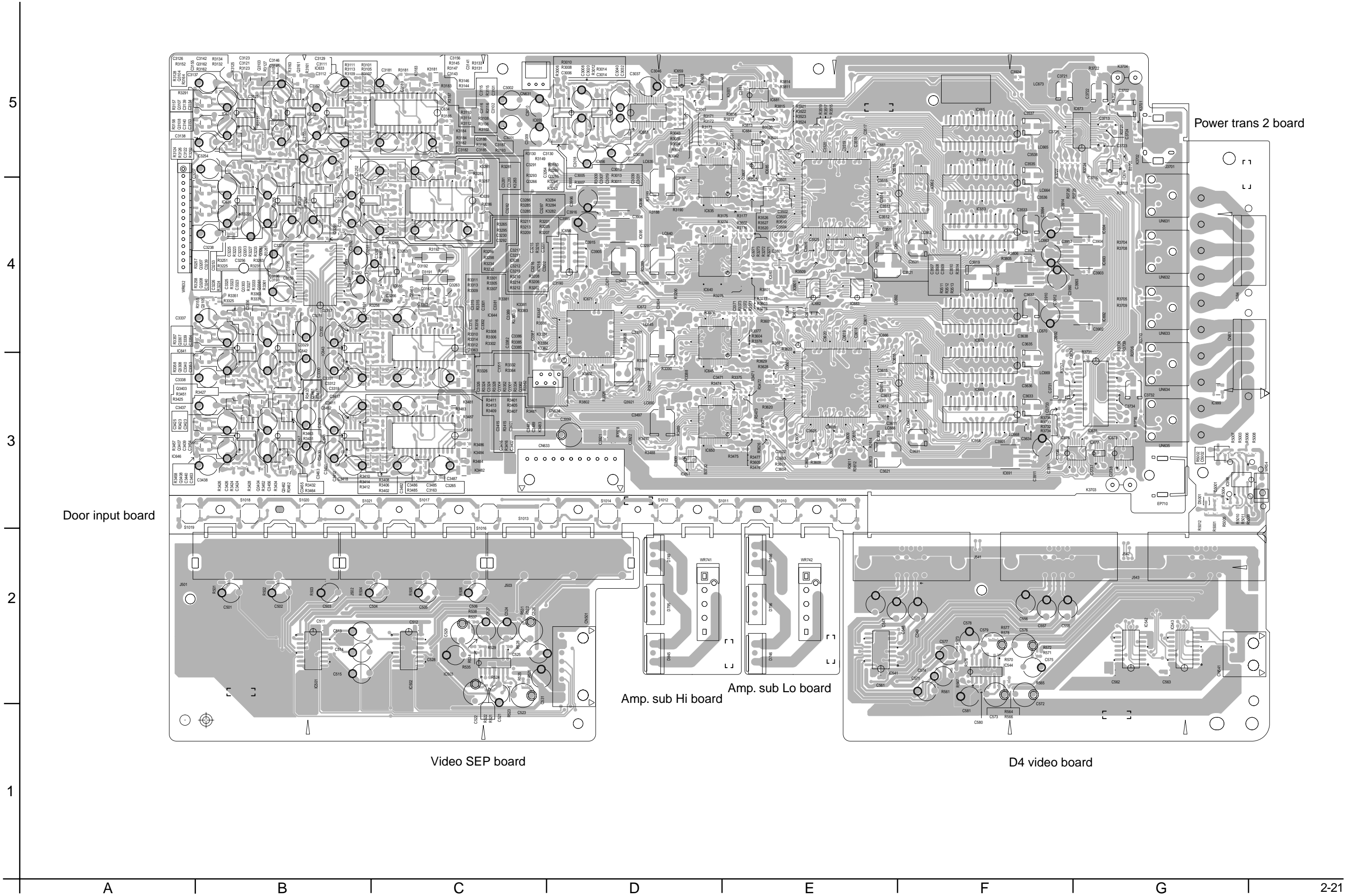

Power trans 2 board

Door input board

Video SEP board

Amp. sub Hi board

Amp. sub Lo board

D4 video board

PARTS LIST

[RX-DP10VBK]

[RX-DP10VSL]

* All printed circuit boards and its assemblies are not available as service parts.

RX-DP10VBK
Area suffix
J ----- U.S.A.
RX-DP10VSL
Area suffix
C ----- Canada

- Contents -

Exploded view of general assembly and parts list (Block No.M1)	3- 3
Electrical parts list (Block No.01~06)	3- 8
Packing materials and accessories parts list (Block No.M3,M5)	3-36

RX-DP10VBK/RX-DP10VSL

RX-DP10RSL

< M E M O >

Exploded view of general assembly and parts list

Block No. **M 1 M M**

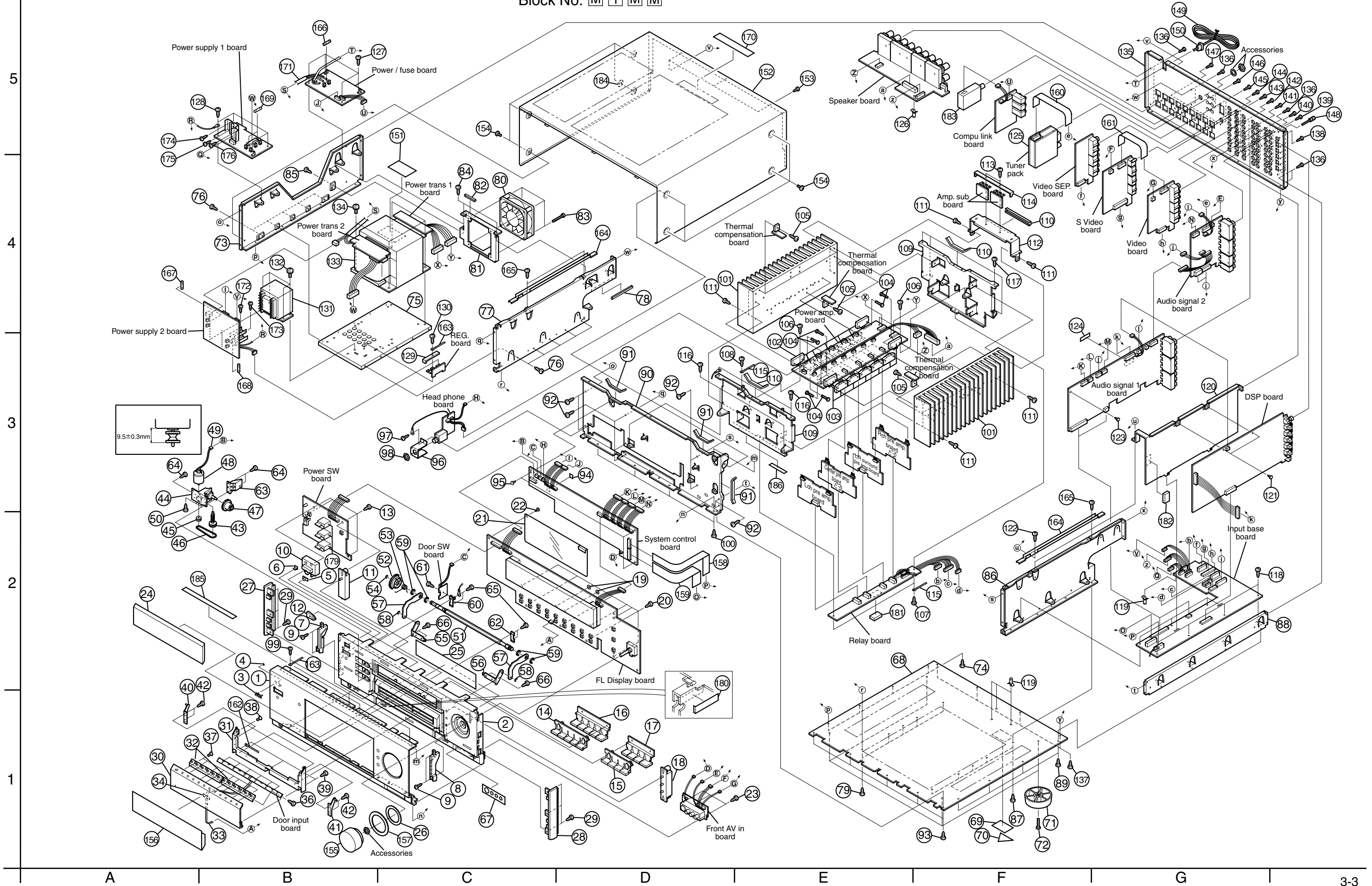

RX-DP10VBK/RX-DP10VSL
RX-DP10RSL

RX-DP10VBK/RX-DP10VSL
RX-DP10RSL

■ Parts list (General assembly)

Block No. M1MM

■ Parts list (General assembly)

Block No. M1MM

△	Item	Parts number	Parts name	Q'ty	Description	Area
	1	LV10535-011A	FRONT PANEL	1		C
		LV10535-015A	FRONT PANEL	1		J
	2	LV10536-018A	FRONT BASE	1		C
		LV10536-020A	FRONT BASE	1		J
	3	VJD5429-002SS	JVC MARK	1		C
		VJD5429-001SS	JVC MARK	1		J
	4	E60912-003	SPEED NUT	1		
	5	E408131-001	REMOTE LENS	1		C
		E408131-002	REMOTE LENS	1		J
	6	LV42395-001A	INDICATOR	1		
	7	LV32831-002A	GUIDE(L)	1		
	8	LV32832-002A	GUIDE(R)	1		
	9	QYSDSF2608M	TAP SCREW	4	GUIDE	
	10	LV32812-001A	PUSH BUTTON	1		C
		LV32812-002A	PUSH BUTTON	1		J
	11	LV32813-003A	PUSH BUTTON	1		J
		LV32813-001A	PUSH BUTTON	1		C
	12	LV32826-003A	INDICATOR	3		
	13	QYSDSF2608Z	SCREW	4	P.C.B	
	14	LV32815-004A	PUSH BUTTON	1		C
		LV32815-005A	PUSH BUTTON	1		J
	15	LV32816-003A	PUSH BUTTON	1		J
		LV32816-001A	PUSH BUTTON	1		C
	16	LV32817-002A	PUSH BUTTON	1		C
		LV32817-005A	PUSH BUTTON	1		J
	17	LV32818-001A	PUSH BUTTON	1		C
		LV32818-003A	PUSH BUTTON	1		J
	18	LV32814-002A	PUSH BUTTON	1		J
		LV32814-001A	PUSH BUTTON	1		C
	19	FSYS4004-004	WASHER	2		
	20	QYSDSF2608Z	SCREW	9	P.C.B	
	21	LV42684-001A	BARRIER	1		
	22	E310243-002	PLASTIC RIVET	1		
	23	QYSDSF2608Z	SCREW	3	F.VIDEO P.C.B	
	24	LV32811-001A	LENS	1		
	25	LV42095-003A	FL SCREEN	1		
	26	LV42726-001A	VOL.SPACER	1		
	27	LV21063-001A	SIDE FITTING(L)	1		C
		LV21063-002A	SIDE FITTING(L)	1		J
	28	LV21064-001A	SIDE FITTING(R)	1		C
		LV21064-002A	SIDE FITTING(R)	1		J
	29	QYSBSF3008Z	SCREW	6	S.FITTING	
	30	LV21061-006A	DOOR	1		J
		LV21061-005A	DOOR	1		C
	31	LV21062-003A	DOOR BASE	1		C
		LV21062-004A	DOOR BASE	1		J
	32	LV21065-001A	PUSH BUTTON	2		C
		LV21065-002A	PUSH BUTTON	2		J

△	Item	Parts number	Parts name	Q'ty	Description	Area
	33	WJT0073-001A	E-CARD WIRE	1		
	34	LV30225-074A	SPACER	1		
	36	QYSDSF2004Z	SCREW	6	P.C.B	
	37	QYSSSG2004Z	SCREW	8	DOOR-BUTTON	
	38	QYSSSG2004Z	SCREW	2	DOOR UPPER	
	39	QYSDSF2606Z	SCREW	3	DOOR LOWER	
	40	LV32835-002A	G.P. BKT(L)ASSY	1		
	41	LV32836-002A	G.P.BKT(R)ASSY	1		
	42	QYSDSF2606Z	SCREW	4	D.BASE-BKT	
	43	LV42478-001A	WORM GEAR	1		
	44	LV32837-002A	MOTOR BASE	1		
	45	LV41536-201A	PULLEY	1		
	46	LV41598-001A	BELT	1		
	47	LV32838-001A	WORM WHEEL	1		
	48	QAR0100-001	DC MOTOR	1		
	49	WJM0233-001A	E-SI C WIRE C-F	1		
	50	QYSPSP3004Z	SCREW	2	M.BASE-DC MOTOR	
	51	LV32830-001A	MAIN SHAFT	1		
	52	LV42400-001A	MAIN GEAR	1		
	53	LV42729-001A	SPRING	1		
	54	QYREE3000X	E RING	1		
	55	LV32833-002A	H.BKT(L) ASS'Y	1		
	56	LV32834-002A	H.BKT(R) ASS'Y	1		
	57	LV42396-001A	ARM	2		
	58	QYREE3000X	E RING	2		
	59	QYREE6000X	E RING	4		
	60	LV42397-001A	S.STOPPER(L)	1		
	61	QYSDSG2606Z	SCREW	1	P.C.B	
	62	LV42398-001A	S.STOPPER(R)	1		
	63	LV32839-001A	WHEEL STOPPER	1		
	64	QYSBSF3008Z	SCREW	3	W.STOPPER & M.ASSY	
	65	QYSDSF2608Z	SCREW	4	S.STOPPER	
	66	QYSDSF2606M	SCREW	4	D.BASE-H.BKT	
	67	LV42426-005A	SHEET	1		J
		LV42426-004A	SHEET	1		C
	68	LV10537-001A	BOTTOM PLATE	1		
	69	E70115-002	CAUTION LABEL	1		C
	70	VND4113-001	G CAUTION	1		J
	71	QZF6018-001	FOOT	4		J
		QZF6018-003	FOOT	4		C
	72	QYSBST3010Z	T.SCREW	4	FOOT	
	73	LV10541-002A	SIDE BKT(L)	1		
	74	QYSBSGG3008E	T.SCREW	4		
	75	LV10542-003A	TRANS BASE	1		
	76	QYSDSG3008E	T.SCREW	10	C.BKT & S.BKT	
	77	LV10543-002A	CENTER BKT(L)	1		
	78	LV30225-071A	SPACER	1		
	79	QYSBSGG3008E	T.SCREW	5	BOTTOM	

■ Parts list (General assembly)

Block No. M1MM

△	Item	Parts number	Parts name	Q'ty	Description	Area
	80	QAR0198-001	FAN MOTOR	1		
	81	LV33162-001A	FAN BKT	1		
	82	LV30225-074A	SPACER	1		
	83	QYSBSG3030Z	T.SCREW	4		
	84	QYSDSG3008E	T.SCREW	2		
	85	QYSDSG3008E	T.SCREW	1		
	86	LV10544-001A	CENTER BKT(R)	1		
	87	QYSBSGG3008E	T.SCREW	5	BOTTOM	
	88	LV21066-001A	SIDE BKT(R)	1		
	89	QYSBSGG3008E	T.SCREW	4	BOTTOM	
	90	LV10539-001A	FRONT BKT	1		
	91	LV30225-071A	SPACER	3		
	92	QYSBSGG3008E	T.SCREW	9	C.BKT & S.BKT	
	93	QYSBSGG3008E	T.SCREW	5	BOTTOM	
	94	LV30225-0C8A	SPACER	1		
	95	E310243-002	PLASTIC RIVET	3		
	96	LV42094-003A	H.P BKT	1		
	97	QYSBSGG3008E	T.SCREW	1	H.P BKT	
	98	VKZ4150-001	SPECIAL NUT	1		
	99	QYSBSGG3008E	T.SCREW	3	F.PANEL UPPER	
	100	QYSBSGG3008E	T.SCREW	4	F.PANEL LOWER	
	101	LV32828-004A	HEAT SINK	2		
△	102	2SA1494/PG/-F1	TRANSISTOR	2	Q1715,Q1765	
△		2SA1494/PG/-F1	TRANSISTOR	3	Q715,Q765,Q815	
△		2SA1494/PG/-F1	TRANSISTOR	2	Q1615,Q1665	
△	103	2SC3858/PG/-F1	TRANSISTOR	3	Q714,Q764,Q814	
△		2SC3858/PG/-F1	TRANSISTOR	2	Q1614,Q1664	
△		2SC3858/PG/-F1	TRANSISTOR	2	Q1714,Q1764	
	104	E73525-003SS	SCREW	28	TRANSISTOR	
	105	QYSBSGG3010E	T.SCREW	7		
	106	QYSBSGG3010E	T.SCREW	4	P.C.B	
	107	QYSBSGG3010E	T.SCREW	2	P.C.B	
	108	QYSBSGG3010E	T.SCREW	1		
	109	LV21067-001A	H.SINK BKT	2		
	110	LV30225-071A	SPACER	3		
	111	QYSBSGG3010E	T.SCREW	8	H.SINK	
	112	LV32829-002A	H.SINK HOLDER	1		
	113	QYSDSG3008E	T.SCREW	2	H.SINK	
	114	LV42704-001A	HOLDER	1		
	115	VKZ4001-111	WIRE HOLDER	2		
	116	QYSBSGG3008E	T.SCREW	4	H.S ASSY FRONT	
	117	QYSBSGG3008E	T.SCREW	4	H.S ASSY REAR	
	118	QYSBSGG3008E	T.SCREW	7	P.C.B	
	119	E310244-003	FASTNER	4		
	120	LV21068-001A	SHIELD COVER	1		
	121	E310243-002	PLASTIC RIVET	2		
	122	QYSBSGG3008E	T.SCREW	1	C.BKT	
	123	E310243-002	PLASTIC RIVET	1		

■ Parts list (General assembly)

Block No. M1MM

△	Item	Parts number	Parts name	Q'ty	Description	Area
	124	LV30225-0C7A	SPACER	1		
	125	QAU0233-001	TUNER	1		
	126	E310244-003	FASTNER	1		
	127	QYSBSGG3008E	T.SCREW	4	PRIMARY	
	128	QYSBSGG3008E	T.SCREW	4	ANALOG P.SUPPLY	
	129	LV41603-001A	LEAF SPRING	1		
	130	QYSDSG3008E	T.SCREW	1	LEAF SPRING	
△	131	QQT0336-001	POWER TRANSF	1	T41	
	132	QYSDSTL4008E	SPECIAL SCREW	4	TRANS.	
△	133	QQT0338-002	POWER TRANSF	1	T1	
	134	QYSDSTL4008E	SPECIAL SCREW	4	TRANS.	
	135	LV10540-008A	REAR PANEL	1		C
		LV10540-014A	REAR PANEL	1		J
	136	QYSBSGY3008E	SPECIAL SCREW	8	S.BKT/C.BKT	
	137	QYSBSGY3008E	SPECIAL SCREW	4	BOTTOM	
	138	QYSBSGY3008E	SPECIAL SCREW	7	DSP	
	139	QYSBSGY3008E	SPECIAL SCREW	1	SHIELD	
	140	QYSBSGY3008E	SPECIAL SCREW	3	AUDIO	
	141	QYSBSGY3008E	SPECIAL SCREW	4	V-AUDIO	
	142	QYSBSGY3008E	SPECIAL SCREW	5	C-V	
	143	QYSBSGY3008E	SPECIAL SCREW	6	S-V	
	144	QYSBSGY3008E	SPECIAL SCREW	3	COMP-V	
	145	QYSBSGY3008E	SPECIAL SCREW	2	TUNER	
	146	QYSBSGY3008E	SPECIAL SCREW	3	DCS	
	147	QYSBSGY3008E	SPECIAL SCREW	5	SPK	
	148	E409257-001	GND TERMINAL	1		
△	149	QMPD220-200-JD	POWER CORD	1		
△	150	QZW0033-001	STRAIN RELIEF	1		
	151	LV40911-001A	LABEL	1		
	152	LV10538-004A/S/	TOP COVER	1		J
		LV10538-003A/S/	TOP COVER	1		C
	153	QYSBSGY3008E	SPECIAL SCREW	3	TOP COVER	
	154	E406308-004	SPECIAL SCREW	8	TOP SL-MODEL	C
		E406308-003	SPECIAL SCREW	8	TOP SL-MODEL	J
	155	LV32819-001A	VOL KNOB	1		C
		LV32819-002A	VOL KNOB	1		J
	156	LV33243-001A	PROTECT SHEET	1		
	157	LV42405-001A	VOL RING	1		C
		LV42405-002A	VOL RING	1		J
	158	QUQ412-1619DJ	FFC WIRE	1	FRONT1-MOTHER	
	159	QUQ412-2019DJ	FFC WIRE	1	FRONT1-MOTHER	
	160	QUQ412-1513DJ	FFC WIRE	1	TUNER-AUDIO2	
	161	QUQ412-1605DJ	FFC WIRE	1	VIDEO1-VIDEO2	
	162	VKZ4001-018	WIRE HOLDER	1		
	163	VKZ4001-111S	WIRE CLAMP	2		
	164	LV33163-001A	BARRIER	2		
	165	QYSBSGG3008E	T.SCREW	3		
△	166	QMF51U1-8R0-J8	FUSE	1	F21	

■ Parts list (General assembly)

Block No. M1MM

△	Item	Parts number	Parts name	Q'ty	Description	Area
△	167	QMF51U1-1R0-J8	FUSE	1	F41	
△	168	QMF51U1-2R0-J8	FUSE	1	F42	
△	169	QMF51U1-2R0-J8	FUSE	2	F61,F62	
	170	E409396-002	CAUTION LABEL	1		C
		E409396-001	CAUTION LABEL	1		J
	171	QWTJ809-240	GLASS TUBE	1		
	172	QYSBSG3008E	T.SCREW	1	HS41	
	173	QYSBSG3008E	T.SCREW	1	HS42	
	174	QYSBSG3008E	T.SCREW	1	HS61	
	175	QYSBSG3008E	T.SCREW	1	HS62	
	176	QYSBSG3008E	T.SCREW	1	HS63	
	179	LV32827-002A	LED HOLDER	3	D1032-D1034	
	180	LV42783-001A	EARTH PLATE	1		
	181	LV30225-0D3A	SPACERW	1		
	182	LV30225-0D4A	SPACER	1		
	183	QAU0237-002	RF MODULE UNIT	1		
	184	LV30226-029A	SPACER	1		
	185	EXO150010H09S11	FELT SPACER	1		
	186	LV30225-074A	SPACER	1		

■ Electrical parts list (Amp. board)

Block No. 01

△	Item	Parts number	Parts name	Remarks	Area	△	Item	Parts number	Parts name	Remarks	Area
	C 701	QEZO538-106Z	E CAPACITOR	10MF			C 896	QEZO544-338	E CAPACITOR	3300MF	
	C 702	QCS32HJ-101Z	C CAPACITOR	100PF 5% 500V			CN711	QGB2510K2-07	CONNECTOR		
	C 703	QCS32HJ-101Z	C CAPACITOR	100PF 5% 500V			CN712	QGB2012K1-06	CONNECTOR		
	C 704	QFN31HJ-152Z	M CAPACITOR	1500PF 5% 50V			CN713	QGB2012K1-06	CONNECTOR		
	C 705	QCS32HJ-220Z	C CAPACITOR	22PF 5% 500V			CN721	QGB2510J1-07	CONNECTOR		
	C 707	QCS32HJ-221Z	C CAPACITOR	220PF 5% 500V			CN722	QGB2012J1-06	CONNECTOR		
	C 708	QFN31HJ-472Z	M CAPACITOR	4700PF 5% 50V			CN723	QGB2012J1-06	CONNECTOR		
	C 709	QCS32HJ-470Z	C CAPACITOR	47PF 5% 500V			CN738	QGA2501C1-03	3P CONNECTOR		
	C 710	QCS32HJ-470Z	C CAPACITOR	47PF 5% 500V			CN741	QGA3901C1-10	10P CONNECTOR		
	C 711	QEZO539-476Z	E CAPACITOR	47MF			CN742	QGA3901C1-04	4P CONNECTOR		
	C 712	QEZO539-476Z	E CAPACITOR	47MF			CN743	QGA2001C1-10	10P PLUG ASSY		
	C 715	QCS32HJ-330Z	C CAPACITOR	33PF 5% 500V			CN751	QGB2510K2-06	CONNECTOR		
	C 721	NCF21EZ-224X	E CAPACITOR				CN752	QGB2012K1-06	CONNECTOR		
	C 731	QEZO539-476Z	E CAPACITOR	47MF			CN753	QGB2012K1-06	CONNECTOR		
	C 735	QFLC1HJ-473Z	M CAPACITOR	0.047MF 5% 50V			CN761	QGB2510J1-06	CONNECTOR		
	C 736	QFLC1HJ-473Z	M CAPACITOR	0.047MF 5% 50V			CN762	QGB2012J1-06	CONNECTOR		
	C 741	QCS32HJ-100Z	C CAPACITOR	10PF 5% 500V			CN763	QGB2012J1-06	CONNECTOR		
	C 742	QEZO538-226Z	E CAPACITOR	22MF			CN771	QGB2510K2-05	CONNECTOR		
	C 745	QEZO544-338	E CAPACITOR	3300MF			CN772	QGB2012K1-06	CONNECTOR		
	C 746	QEZO544-338	E CAPACITOR	3300MF			CN773	QGB2012K1-06	CONNECTOR		
	C 751	QEZO538-106Z	E CAPACITOR	10MF			CN781	QGB2510J1-05	CONNECTOR		
	C 752	QCS32HJ-101Z	C CAPACITOR	100PF 5% 500V			CN782	QGB2012J1-06	CONNECTOR		
	C 753	QCS32HJ-101Z	C CAPACITOR	100PF 5% 500V			CN783	QGB2012J1-06	CONNECTOR		
	C 754	QFN31HJ-152Z	M CAPACITOR	1500PF 5% 50V			CN811	QGB2510K2-06	CONNECTOR		
	C 755	QCS32HJ-220Z	C CAPACITOR	22PF 5% 500V			CN812	QGB2012K1-06	CONNECTOR		
	C 757	QCS32HJ-221Z	C CAPACITOR	220PF 5% 500V			CN813	QGB2012K1-06	CONNECTOR		
	C 758	QFN31HJ-472Z	M CAPACITOR	4700PF 5% 50V			CN821	QGB2510J1-06	CONNECTOR		
	C 759	QCS32HJ-470Z	C CAPACITOR	47PF 5% 500V			CN822	QGB2012J1-06	CONNECTOR		
	C 760	QCS32HJ-470Z	C CAPACITOR	47PF 5% 500V			CN823	QGB2012J1-06	CONNECTOR		
	C 761	QEZO539-476Z	E CAPACITOR	47MF			C1601	QEZO538-106Z	E CAPACITOR	10MF	
	C 762	QEZO539-476Z	E CAPACITOR	47MF			C1602	QCS32HJ-101Z	C CAPACITOR	100PF 5% 500V	
	C 765	QCS32HJ-330Z	C CAPACITOR	33PF 5% 500V			C1603	QCS32HJ-101Z	C CAPACITOR	100PF 5% 500V	
	C 771	NCF21EZ-224X	E CAPACITOR				C1604	QFN31HJ-152Z	M CAPACITOR	1500PF 5% 50V	
	C 773	QFV72AJ-104Z	MF CAPACITOR	0.1MF 5% 100V			C1605	QCS32HJ-220Z	C CAPACITOR	22PF 5% 500V	
	C 774	QFV72AJ-104Z	MF CAPACITOR	0.1MF 5% 100V			C1607	QCS32HJ-221Z	C CAPACITOR	220PF 5% 500V	
	C 775	QFV72AJ-104Z	MF CAPACITOR	0.1MF 5% 100V			C1608	QFN31HJ-472Z	M CAPACITOR	4700PF 5% 50V	
	C 776	QFV72AJ-104Z	MF CAPACITOR	0.1MF 5% 100V			C1609	QCS32HJ-470Z	C CAPACITOR	47PF 5% 500V	
	C 781	QEZO539-476Z	E CAPACITOR	47MF			C1610	QCS32HJ-470Z	C CAPACITOR	47PF 5% 500V	
	C 785	QFLC1HJ-473Z	M CAPACITOR	0.047MF 5% 50V			C1611	QEZO539-476Z	E CAPACITOR	47MF	
	C 786	QFLC1HJ-473Z	M CAPACITOR	0.047MF 5% 50V			C1612	QEZO539-476Z	E CAPACITOR	47MF	
	C 791	QCS32HJ-100Z	C CAPACITOR	10PF 5% 500V			C1615	QCS32HJ-330Z	C CAPACITOR	33PF 5% 500V	
	C 792	QEZO538-226Z	E CAPACITOR	22MF			C1621	NCF21EZ-224X	E CAPACITOR		
	C 795	QEZO544-338	E CAPACITOR	3300MF			C1631	QEZO539-476Z	E CAPACITOR	47MF	
	C 796	QEZO544-338	E CAPACITOR	3300MF			C1635	QFLC1HJ-473Z	M CAPACITOR	0.047MF 5% 50V	
	C 801	QEZO538-106Z	E CAPACITOR	10MF			C1636	QFLC1HJ-473Z	M CAPACITOR	0.047MF 5% 50V	
	C 802	QCS32HJ-101Z	C CAPACITOR	100PF 5% 500V			C1641	QCS32HJ-100Z	C CAPACITOR	10PF 5% 500V	
	C 803	QCS32HJ-101Z	C CAPACITOR	100PF 5% 500V			C1642	QEZO538-226Z	E CAPACITOR	22MF	
	C 804	QFN31HJ-152Z	M CAPACITOR	1500PF 5% 50V			C1645	QEZO544-338	E CAPACITOR	3300MF	
	C 805	QCS32HJ-220Z	C CAPACITOR	22PF 5% 500V			C1646	QEZO544-338	E CAPACITOR	3300MF	
	C 807	QCS32HJ-221Z	C CAPACITOR	220PF 5% 500V			C1651	QEZO538-106Z	E CAPACITOR	10MF	
	C 808	QFN31HJ-472Z	M CAPACITOR	4700PF 5% 50V			C1652	QCS32HJ-101Z	C CAPACITOR	100PF 5% 500V	
	C 809	QCS32HJ-470Z	C CAPACITOR	47PF 5% 500V			C1653	QCS32HJ-101Z	C CAPACITOR	100PF 5% 500V	
	C 810	QCS32HJ-470Z	C CAPACITOR	47PF 5% 500V			C1654	QFN31HJ-152Z	M CAPACITOR	1500PF 5% 50V	
	C 811	QEZO539-476Z	E CAPACITOR	47MF			C1655	QCS32HJ-220Z	C CAPACITOR	22PF 5% 500V	
	C 812	QEZO539-476Z	E CAPACITOR	47MF			C1657	QCS32HJ-221Z	C CAPACITOR	220PF 5% 500V	
	C 815	QCS32HJ-330Z	C CAPACITOR	33PF 5% 500V			C1658	QFN31HJ-472Z	M CAPACITOR	4700PF 5% 50V	
	C 821	NCF21EZ-224X	E CAPACITOR				C1659	QCS32HJ-470Z	C CAPACITOR	47PF 5% 500V	
	C 831	QEZO539-476Z	E CAPACITOR	47MF			C1660	QCS32HJ-470Z	C CAPACITOR	47PF 5% 500V	
	C 835	QFLC1HJ-473Z	M CAPACITOR	0.047MF 5% 50V			C1661	QEZO539-476Z	E CAPACITOR	47MF	
	C 836	QFLC1HJ-473Z	M CAPACITOR	0.047MF 5% 50V			C1662	QEZO539-476Z	E CAPACITOR	47MF	
	C 841	QCS32HJ-100Z	C CAPACITOR	10PF 5% 500V			C1665	QCS32HJ-330Z	C CAPACITOR	33PF 5% 500V	
	C 842	QEZO538-226Z	E CAPACITOR	22MF			C1671	NCF21EZ-224X	E CAPACITOR		
	C 895	QEZO544-338	E CAPACITOR	3300MF			C1685	QFLC1HJ-473Z	M CAPACITOR	0.047MF 5% 50V	

■ Electrical parts list (Amp. board)

Block No. 01

△	Item	Parts number	Parts name	Remarks	Area	△	Item	Parts number	Parts name	Remarks	Area
	C1686	QFLC1HJ-473Z	M CAPACITOR	0.047MF 5% 50V			D 754	1SS133-T2	SI DIODE		
	C1691	QCS32HJ-100Z	C CAPACITOR	10PF 5% 500V			D 755	MTZJ3.9B-T2	ZENER DIODE		
	C1692	QEZ0538-226Z	E CAPACITOR	22MF			D 756	MTZJ3.9B-T2	ZENER DIODE		
	C1695	QEZ0544-338	E CAPACITOR	3300MF			D 757	1SS133-T2	SI DIODE		
	C1696	QEZ0544-338	E CAPACITOR	3300MF			D 758	UDZS24B-X	ZENER DIODE		
	C1701	QEZ0538-106Z	E CAPACITOR	10MF			D 759	UDZS24B-X	ZENER DIODE		
	C1702	QCS32HJ-101Z	C CAPACITOR	100PF 5% 500V			D 760	1SS355-X	DIODE		
	C1703	QCS32HJ-101Z	C CAPACITOR	100PF 5% 500V			D 761	1SS355-X	DIODE		
	C1704	QFN31HJ-152Z	M CAPACITOR	1500PF 5% 50V			D 762	1SS355-X	DIODE		
	C1705	QCS32HJ-220Z	C CAPACITOR	22PF 5% 500V			D 763	1SS355-X	DIODE		
	C1707	QCS32HJ-221Z	C CAPACITOR	220PF 5% 500V			D 765	HZ3.0BP	ZENER DIODE		
	C1708	QFN31HJ-472Z	M CAPACITOR	4700PF 5% 50V			D 771	1SS133-T2	SI DIODE		
	C1709	QCS32HJ-470Z	C CAPACITOR	47PF 5% 500V			D 772	1SS133-T2	SI DIODE		
	C1710	QCS32HJ-470Z	C CAPACITOR	47PF 5% 500V			D 773	1SS133-T2	SI DIODE		
	C1711	QEZ0539-476Z	E CAPACITOR	47MF			D 774	1SS133-T2	SI DIODE		
	C1712	QEZ0539-476Z	E CAPACITOR	47MF			D 802	1SS133-T2	SI DIODE		
	C1715	QCS32HJ-330Z	C CAPACITOR	33PF 5% 500V			D 803	1SS133-T2	SI DIODE		
	C1721	NCF21EZ-224X	E CAPACITOR				D 804	1SS133-T2	SI DIODE		
	C1735	QFLC1HJ-473Z	M CAPACITOR	0.047MF 5% 50V			D 805	MTZJ3.9B-T2	ZENER DIODE		
	C1736	QFLC1HJ-473Z	M CAPACITOR	0.047MF 5% 50V			D 806	MTZJ3.9B-T2	ZENER DIODE		
	C1741	QCS32HJ-100Z	C CAPACITOR	10PF 5% 500V			D 807	1SS133-T2	SI DIODE		
	C1742	QEZ0538-226Z	E CAPACITOR	22MF			D 808	UDZS24B-X	ZENER DIODE		
	C1745	QEZ0544-338	E CAPACITOR	3300MF			D 809	UDZS24B-X	ZENER DIODE		
	C1746	QEZ0544-338	E CAPACITOR	3300MF			D 810	1SS355-X	DIODE		
	C1751	QEZ0538-106Z	E CAPACITOR	10MF			D 811	1SS355-X	DIODE		
	C1752	QCS32HJ-101Z	C CAPACITOR	100PF 5% 500V			D 812	1SS355-X	DIODE		
	C1753	QCS32HJ-101Z	C CAPACITOR	100PF 5% 500V			D 813	1SS355-X	DIODE		
	C1754	QFN31HJ-152Z	M CAPACITOR	1500PF 5% 50V			D 815	HZ3.0BP	ZENER DIODE		
	C1755	QCS32HJ-220Z	C CAPACITOR	22PF 5% 500V			D1602	1SS133-T2	SI DIODE		
	C1757	QCS32HJ-221Z	C CAPACITOR	220PF 5% 500V			D1603	1SS133-T2	SI DIODE		
	C1758	QFN31HJ-472Z	M CAPACITOR	4700PF 5% 50V			D1604	1SS133-T2	SI DIODE		
	C1759	QCS32HJ-470Z	C CAPACITOR	47PF 5% 500V			D1605	MTZJ3.9B-T2	ZENER DIODE		
	C1760	QCS32HJ-470Z	C CAPACITOR	47PF 5% 500V			D1606	MTZJ3.9B-T2	ZENER DIODE		
	C1761	QEZ0539-476Z	E CAPACITOR	47MF			D1607	1SS133-T2	SI DIODE		
	C1762	QEZ0539-476Z	E CAPACITOR	47MF			D1608	UDZS24B-X	ZENER DIODE		
	C1765	QCS32HJ-330Z	C CAPACITOR	33PF 5% 500V			D1609	UDZS24B-X	ZENER DIODE		
	C1771	NCF21EZ-224X	E CAPACITOR				D1610	1SS355-X	DIODE		
	C1785	QFLC1HJ-473Z	M CAPACITOR	0.047MF 5% 50V			D1611	1SS355-X	DIODE		
	C1786	QFLC1HJ-473Z	M CAPACITOR	0.047MF 5% 50V			D1612	1SS355-X	DIODE		
	C1791	QCS32HJ-100Z	C CAPACITOR	10PF 5% 500V			D1613	1SS355-X	DIODE		
	C1792	QEZ0538-226Z	E CAPACITOR	22MF			D1615	HZ3.0BP	ZENER DIODE		
	C1795	QEZ0544-338	E CAPACITOR	3300MF			D1652	1SS133-T2	SI DIODE		
	C1796	QEZ0544-338	E CAPACITOR	3300MF			D1653	1SS133-T2	SI DIODE		
	C1971	QETN1HM-226Z	E CAPACITOR	22MF 20% 50V			D1654	1SS133-T2	SI DIODE		
	C1972	QETN1EM-476Z	E CAPACITOR	47MF 20% 25V			D1655	MTZJ3.9B-T2	ZENER DIODE		
	C1973	NCS21HJ-102X	C CAPACITOR				D1656	MTZJ3.9B-T2	ZENER DIODE		
	C1974	NCF21HZ-103X	C CAPACITOR				D1657	1SS133-T2	SI DIODE		
	C1975	QETN1HM-226Z	E CAPACITOR	22MF 20% 50V			D1658	UDZS24B-X	ZENER DIODE		
	D 702	1SS133-T2	SI DIODE				D1659	UDZS24B-X	ZENER DIODE		
	D 703	1SS133-T2	SI DIODE				D1660	1SS355-X	DIODE		
	D 704	1SS133-T2	SI DIODE				D1661	1SS355-X	DIODE		
	D 705	MTZJ3.9B-T2	ZENER DIODE				D1662	1SS355-X	DIODE		
	D 706	MTZJ3.9B-T2	ZENER DIODE				D1663	1SS355-X	DIODE		
	D 707	1SS133-T2	SI DIODE				D1665	HZ3.0BP	ZENER DIODE		
	D 708	UDZS24B-X	ZENER DIODE				D1702	1SS133-T2	SI DIODE		
	D 709	UDZS24B-X	ZENER DIODE				D1703	1SS133-T2	SI DIODE		
	D 710	1SS355-X	DIODE				D1704	1SS133-T2	SI DIODE		
	D 711	1SS355-X	DIODE				D1705	MTZJ3.9B-T2	ZENER DIODE		
	D 712	1SS355-X	DIODE				D1706	MTZJ3.9B-T2	ZENER DIODE		
	D 713	1SS355-X	DIODE				D1707	1SS133-T2	SI DIODE		
	D 715	HZ3.0BP	ZENER DIODE				D1708	UDZS24B-X	ZENER DIODE		
	D 752	1SS133-T2	SI DIODE				D1709	UDZS24B-X	ZENER DIODE		
	D 753	1SS133-T2	SI DIODE				D1710	1SS355-X	DIODE		

■ Electrical parts list (Amp. board)

Block No. 01

△	Item	Parts number	Parts name	Remarks	Area	△	Item	Parts number	Parts name	Remarks	Area
	D1711	1SS355-X	DIODE				Q 712	2SD669A/BC/	TRANSISTOR		
	D1712	1SS355-X	DIODE				Q 713	2SB649A/BC/	TRANSISTOR		
	D1713	1SS355-X	DIODE				Q 731	2SC2412K/RS/-X	CHIP TRANSISTOR		
	D1715	HZ3.0BP	ZENER DIODE				Q 732	DTA124EKA-X	DIGI TRANSISTOR		
	D1752	1SS133-T2	SI DIODE				Q 751	2SC1775A/E/-T	TRANSISTOR		
	D1753	1SS133-T2	SI DIODE				Q 752	2SC1775A/E/-T	TRANSISTOR		
	D1754	1SS133-T2	SI DIODE				Q 753	KTC3200/GL/-T	TRANSISTOR		
	D1755	MTZJ3.9B-T2	ZENER DIODE				Q 754	KTC3199/GL/-T	TRANSISTOR		
	D1756	MTZJ3.9B-T2	ZENER DIODE				Q 755	KTA1268/GL/-T	TRANSISTOR		
	D1757	1SS133-T2	SI DIODE				Q 756	KTA1267/YG/-T	TRANSISTOR		
	D1758	UDZS24B-X	ZENER DIODE				Q 757	KTA1268/GL/-T	TRANSISTOR		
	D1759	UDZS24B-X	ZENER DIODE				Q 758	KTC3200/GL/-T	TRANSISTOR		
	D1760	1SS355-X	DIODE				Q 759	KTC3199/GL/-T	TRANSISTOR		C
	D1761	1SS355-X	DIODE				Q 760	KTC3200/GL/-T	TRANSISTOR		
	D1762	1SS355-X	DIODE				Q 761	KTA1268/GL/-T	TRANSISTOR		
	D1763	1SS355-X	DIODE				Q 762	2SD669A/BC/	TRANSISTOR		
	D1765	HZ3.0BP	ZENER DIODE				Q 763	2SB649A/BC/	TRANSISTOR		
	D1901	1SS133-T2	SI DIODE				Q 771	DTD123TK-X	CHIP D TRANSISTOR		
	D1911	1SS133-T2	SI DIODE				Q 772	DTD123TK-X	CHIP D TRANSISTOR		
	D1921	1SS133-T2	SI DIODE				Q 773	DTD123TK-X	CHIP D TRANSISTOR		
	D1931	1SS133-T2	SI DIODE				Q 781	2SC2412K/RS/-X	CHIP TRANSISTOR		
	D1941	1SS133-T2	SI DIODE				Q 782	DTA124EKA-X	DIGI TRANSISTOR		
	D1951	1SS133-T2	SI DIODE				Q 801	2SC1775A/E/-T	TRANSISTOR		
	D1961	1SS133-T2	SI DIODE				Q 802	2SC1775A/E/-T	TRANSISTOR		
	D1981	1SS133-T2	SI DIODE				Q 803	KTC3200/GL/-T	TRANSISTOR		
	D1982	1SS133-T2	SI DIODE				Q 804	KTC3199/GL/-T	TRANSISTOR		
	D1983	1SS133-T2	SI DIODE				Q 805	KTA1268/GL/-T	TRANSISTOR		
	D1984	1SS133-T2	SI DIODE				Q 806	KTA1267/YG/-T	TRANSISTOR		
	D1985	1SS133-T2	SI DIODE				Q 807	KTA1267/YG/-T	TRANSISTOR		
	D1986	1SS133-T2	SI DIODE				Q 808	KTC3200/GL/-T	TRANSISTOR		
	D1991	1SS133-T2	SI DIODE				Q 809	KTC3199/GL/-T	TRANSISTOR		C
	D1992	1SS133-T2	SI DIODE				Q 810	KTC3200/GL/-T	TRANSISTOR		
	D1993	1SS133-T2	SI DIODE				Q 811	KTA1268/GL/-T	TRANSISTOR		
	D1994	1SS133-T2	SI DIODE				Q 812	2SD669A/BC/	TRANSISTOR		
	D1995	1SS133-T2	SI DIODE				Q 813	2SB649A/BC/	TRANSISTOR		
	D1996	1SS133-T2	SI DIODE				Q 831	2SC2412K/RS/-X	CHIP TRANSISTOR		
	EP701	QNZ0136-001Z	EARTH PLATE				Q 832	DTA124EKA-X	DIGI TRANSISTOR		
	IC601	VC5022-2	IC				Q1601	2SC1775A/E/-T	TRANSISTOR		
	IC602	VC5022-2	IC				Q1602	2SC1775A/E/-T	TRANSISTOR		
	IC603	VC5022-2	IC				Q1603	KTC3200/GL/-T	TRANSISTOR		
	IC604	VC5022-2	IC				Q1604	KTC3199/GL/-T	TRANSISTOR		
	IC605	VC5022-2	IC				Q1605	KTA1268/GL/-T	TRANSISTOR		
	IC606	VC5022-2	IC				Q1606	KTA1267/YG/-T	TRANSISTOR		
	IC607	VC5022-2	IC				Q1607	KTA1268/GL/-T	TRANSISTOR		
	IC951	TA7317P	IC				Q1608	KTC3200/GL/-T	TRANSISTOR		
	L 701	QQLZ003-1R0	INDUCTOR				Q1609	KTC3199/GL/-T	TRANSISTOR		C
	L 751	QQLZ003-1R0	INDUCTOR				Q1610	KTC3200/GL/-T	TRANSISTOR		
	L 801	QQLZ003-1R0	INDUCTOR				Q1611	KTA1268/GL/-T	TRANSISTOR		
	L1601	QQLZ003-1R0	INDUCTOR				Q1612	2SD669A/BC/	TRANSISTOR		
	L1651	QQLZ003-1R0	INDUCTOR				Q1613	2SB649A/BC/	TRANSISTOR		
	L1701	QQLZ003-1R0	INDUCTOR				Q1631	2SC2412K/RS/-X	CHIP TRANSISTOR		
	L1751	QQLZ003-1R0	INDUCTOR				Q1632	DTA124EKA-X	DIGI TRANSISTOR		
	Q 701	2SC1775A/E/-T	TRANSISTOR				Q1651	2SC1775A/E/-T	TRANSISTOR		
	Q 702	2SC1775A/E/-T	TRANSISTOR				Q1652	2SC1775A/E/-T	TRANSISTOR		
	Q 703	KTC3200/GL/-T	TRANSISTOR				Q1653	KTC3200/GL/-T	TRANSISTOR		
	Q 704	KTC3199/GL/-T	TRANSISTOR				Q1654	KTC3199/GL/-T	TRANSISTOR		
	Q 705	KTA1268/GL/-T	TRANSISTOR				Q1655	KTA1268/GL/-T	TRANSISTOR		
	Q 706	KTA1267/YG/-T	TRANSISTOR				Q1656	KTA1267/YG/-T	TRANSISTOR		
	Q 707	KTA1268/GL/-T	TRANSISTOR				Q1657	KTA1268/GL/-T	TRANSISTOR		
	Q 708	KTC3200/GL/-T	TRANSISTOR				Q1658	KTC3200/GL/-T	TRANSISTOR		
	Q 709	KTC3199/GL/-T	TRANSISTOR		C		Q1659	KTC3199/GL/-T	TRANSISTOR		C
	Q 710	KTC3200/GL/-T	TRANSISTOR				Q1660	KTC3200/GL/-T	TRANSISTOR		
	Q 711	KTA1268/GL/-T	TRANSISTOR				Q1661	KTA1268/GL/-T	TRANSISTOR		

■ Electrical parts list (Amp. board)

Block No. 01

△	Item	Parts number	Parts name	Remarks	Area	△	Item	Parts number	Parts name	Remarks	Area
	Q1662	2SD669A/BC/	TRANSISTOR			R 716	QRE141J-680Y	C RESISTOR	68 5% 1/4W		
	Q1663	2SB649A/BC/	TRANSISTOR			R 717	QRE141J-331Y	C RESISTOR	330 5% 1/4W		
	Q1681	2SC2412K/RS/-X	CHIP TRANSISTOR			R 718	QRE141J-471Y	C RESISTOR	470 5% 1/4W		
	Q1682	DTA124EKA-X	DIGI TRANSISTOR			R 719	QRE141J-391Y	C RESISTOR	390 5% 1/4W		
	Q1701	2SC1775A/E/-T	TRANSISTOR			R 720	QRJ146J-121X	UNF C RESISTOR	120 5% 1/4W		
	Q1702	2SC1775A/E/-T	TRANSISTOR			R 721	QRJ146J-121X	UNF C RESISTOR	120 5% 1/4W		
	Q1703	KTC3200/GL/-T	TRANSISTOR			R 722	QRJ146J-272X	UNF C RESISTOR	2.7K 5% 1/4W		
	Q1704	KTC3199/GL/-T	TRANSISTOR			R 723	QRJ146J-120X	UNF C RESISTOR	12 5% 1/4W		
	Q1705	KTA1268/GL/-T	TRANSISTOR			R 724	QRJ146J-120X	UNF C RESISTOR	12 5% 1/4W		
	Q1706	KTA1267/YG/-T	TRANSISTOR			R 725	QRJ146J-271X	UNF C RESISTOR	270 5% 1/4W		
	Q1707	KTA1268/GL/-T	TRANSISTOR			R 726	QRJ146J-1R0X	UNF C RESISTOR	1.0 5% 1/4W		
	Q1708	KTC3200/GL/-T	TRANSISTOR			R 727	QRJ146J-1R0X	UNF C RESISTOR	1.0 5% 1/4W		
	Q1709	KTC3199/GL/-T	TRANSISTOR		C	R 728	QRZ0182-R10	EMIT RESISTOR	1/1W		
	Q1710	KTC3200/GL/-T	TRANSISTOR			R 729	QRZ0182-R10	EMIT RESISTOR	1/1W		
	Q1711	KTA1268/GL/-T	TRANSISTOR			R 731	QRL027J-472	UNF OMF RESISTOR	4.7K 5% 1/2W		
	Q1712	2SD669A/BC/	TRANSISTOR			R 732	NRSA02J-331X	MG RESISTOR			
	Q1713	2SB649A/BC/	TRANSISTOR			R 733	NRSA02J-103X	MG RESISTOR			
	Q1731	2SC2412K/RS/-X	CHIP TRANSISTOR			R 735	QRJ125J-330	UNF C RESISTOR	33 5% 1/2W		
	Q1732	DTA124EKA-X	DIGI TRANSISTOR			R 736	QRL027J-100	UNF OMF RESISTOR	10 5% 1/2W		
	Q1751	2SC1775A/E/-T	TRANSISTOR			R 741	QRA14CF-1003Y	MF RESISTOR	10 1/4W		
	Q1752	2SC1775A/E/-T	TRANSISTOR			R 742	QRA14CF-3601Y	MF RESISTOR	36 1/4W		
	Q1753	KTC3200/GL/-T	TRANSISTOR			R 751	QRA14CF-1001Y	MF RESISTOR	10 1/4W		
	Q1754	KTC3199/GL/-T	TRANSISTOR			R 752	QRA14CF-1003Y	MF RESISTOR	10 1/4W		
	Q1755	KTA1268/GL/-T	TRANSISTOR			R 753	QRE141J-102Y	C RESISTOR	1.0K 5% 1/4W		
	Q1756	KTA1267/YG/-T	TRANSISTOR			R 754	QRE141J-331Y	C RESISTOR	330 5% 1/4W		
	Q1757	KTA1268/GL/-T	TRANSISTOR			R 755	QRE141J-104Y	C RESISTOR	100K 5% 1/4W		
	Q1758	KTC3200/GL/-T	TRANSISTOR			R 756	QRE141J-202Y	C RESISTOR	2.0K 5% 1/4W		
	Q1759	KTC3199/GL/-T	TRANSISTOR		C	R 757	QRE141J-202Y	C RESISTOR	2.0K 5% 1/4W		
	Q1760	KTC3200/GL/-T	TRANSISTOR			R 758	QRE141J-101Y	C RESISTOR	100 5% 1/4W		
	Q1761	KTA1268/GL/-T	TRANSISTOR			R 759	QRJ146J-151X	UNF C RESISTOR	150 5% 1/4W		
	Q1762	2SD669A/BC/	TRANSISTOR			R 760	QRJ146J-562X	UNF C RESISTOR	5.6K 5% 1/4W		
	Q1763	2SB649A/BC/	TRANSISTOR			R 761	QRK126J-103X	UNF C RESISTOR	10K 5% 1/2W		
	Q1781	2SC2412K/RS/-X	CHIP TRANSISTOR			R 762	QRE141J-680Y	C RESISTOR	68 5% 1/4W		
	Q1782	DTA124EKA-X	DIGI TRANSISTOR			R 763	QRE141J-152Y	C RESISTOR	1.5K 5% 1/4W		
	Q1901	2SC3906K/RS/-X	HIP TRANSISTOR			R 764	QRE141J-333Y	C RESISTOR	33K 5% 1/4W		
	Q1911	2SC3906K/RS/-X	HIP TRANSISTOR			R 765	QRE141J-151Y	C RESISTOR	150 5% 1/4W		
	Q1921	2SC3906K/RS/-X	HIP TRANSISTOR			R 766	QRE141J-680Y	C RESISTOR	68 5% 1/4W		
	Q1931	2SC3906K/RS/-X	HIP TRANSISTOR			R 767	QRE141J-331Y	C RESISTOR	330 5% 1/4W		
	Q1941	2SC3906K/RS/-X	HIP TRANSISTOR			R 768	QRE141J-471Y	C RESISTOR	470 5% 1/4W		
	Q1951	2SC3906K/RS/-X	HIP TRANSISTOR			R 769	QRE141J-391Y	C RESISTOR	390 5% 1/4W		
	Q1961	2SC3906K/RS/-X	HIP TRANSISTOR			R 770	QRJ146J-121X	UNF C RESISTOR	120 5% 1/4W		
	Q1971	2SA1514K/RS/-X	HIP TRANSISTOR			R 771	QRJ146J-121X	UNF C RESISTOR	120 5% 1/4W		
	Q1991	KRC105M-T	D TRANSISTOR			R 772	QRJ146J-272X	UNF C RESISTOR	2.7K 5% 1/4W		
	Q1992	KRC105M-T	D TRANSISTOR			R 773	QRJ146J-120X	UNF C RESISTOR	12 5% 1/4W		
	Q1993	KRC105M-T	D TRANSISTOR			R 774	QRJ146J-120X	UNF C RESISTOR	12 5% 1/4W		
	Q1994	KRC105M-T	D TRANSISTOR			R 775	QRJ146J-271X	UNF C RESISTOR	270 5% 1/4W		
	Q1995	KRC105M-T	D TRANSISTOR			R 776	QRJ146J-1R0X	UNF C RESISTOR	1.0 5% 1/4W		
	Q1996	KRC105M-T	D TRANSISTOR			R 777	QRJ146J-1R0X	UNF C RESISTOR	1.0 5% 1/4W		
	R 701	QRA14CF-1001Y	MF RESISTOR	10 1/4W		R 778	QRZ0182-R10	EMIT RESISTOR	1/1W		
	R 702	QRA14CF-1003Y	MF RESISTOR	10 1/4W		R 779	QRZ0182-R10	EMIT RESISTOR	1/1W		
	R 703	QRE141J-102Y	C RESISTOR	1.0K 5% 1/4W		R 781	QRL027J-472	UNF OMF RESISTOR	4.7K 5% 1/2W		
	R 704	QRE141J-331Y	C RESISTOR	330 5% 1/4W		R 782	NRSA02J-331X	MG RESISTOR			
	R 705	QRE141J-104Y	C RESISTOR	100K 5% 1/4W		R 783	NRSA02J-103X	MG RESISTOR			
	R 706	QRE141J-202Y	C RESISTOR	2.0K 5% 1/4W		R 785	QRJ125J-330	UNF C RESISTOR	33 5% 1/2W		
	R 707	QRE141J-202Y	C RESISTOR	2.0K 5% 1/4W		R 786	QRL027J-100	UNF OMF RESISTOR	10 5% 1/2W		
	R 708	QRE141J-101Y	C RESISTOR	100 5% 1/4W		R 791	QRA14CF-1003Y	MF RESISTOR	10 1/4W		
	R 709	QRJ146J-151X	UNF C RESISTOR	150 5% 1/4W		R 792	QRA14CF-3601Y	MF RESISTOR	36 1/4W		
	R 710	QRJ146J-562X	UNF C RESISTOR	5.6K 5% 1/4W		R 796	QRJ146J-150X	UNF C RESISTOR	15 5% 1/4W		
	R 711	QRK126J-103X	UNF C RESISTOR	10K 5% 1/2W		R 797	QRJ146J-330X	UNF C RESISTOR	33 5% 1/4W		
	R 712	QRE141J-680Y	C RESISTOR	68 5% 1/4W		R 801	QRA14CF-1001Y	MF RESISTOR	10 1/4W		
	R 713	QRE141J-152Y	C RESISTOR	1.5K 5% 1/4W		R 802	QRA14CF-1003Y	MF RESISTOR	10 1/4W		
	R 714	QRE141J-333Y	C RESISTOR	33K 5% 1/4W		R 803	QRE141J-102Y	C RESISTOR	1.0K 5% 1/4W		
	R 715	QRE141J-151Y	C RESISTOR	150 5% 1/4W		R 804	QRE141J-331Y	C RESISTOR	330 5% 1/4W		

■ Electrical parts list (Amp. board)

Block No. 01

△	Item	Parts number	Parts name	Remarks	Area	△	Item	Parts number	Parts name	Remarks	Area
	R 805	QRE141J-104Y	C RESISTOR	100K 5% 1/4W			R1621	QRJ146J-121X	UNF C RESISTOR	120 5% 1/4W	
	R 806	QRE141J-202Y	C RESISTOR	2.0K 5% 1/4W			R1622	QRJ146J-272X	UNF C RESISTOR	2.7K 5% 1/4W	
	R 807	QRE141J-202Y	C RESISTOR	2.0K 5% 1/4W			R1623	QRJ146J-120X	UNF C RESISTOR	12 5% 1/4W	
	R 808	QRE141J-101Y	C RESISTOR	100 5% 1/4W			R1624	QRJ146J-120X	UNF C RESISTOR	12 5% 1/4W	
	R 809	QRJ146J-151X	UNF C RESISTOR	150 5% 1/4W			R1625	QRJ146J-271X	UNF C RESISTOR	270 5% 1/4W	
	R 810	QRJ146J-562X	UNF C RESISTOR	5.6K 5% 1/4W			R1626	QRJ146J-1R0X	UNF C RESISTOR	1.0 5% 1/4W	
	R 811	QRK126J-103X	UNF C RESISTOR	10K 5% 1/2W			R1627	QRJ146J-1R0X	UNF C RESISTOR	1.0 5% 1/4W	
	R 812	QRE141J-680Y	C RESISTOR	68 5% 1/4W			R1628	QRZ0182-R10	EMIT RESISTOR	1/1W	
	R 813	QRE141J-152Y	C RESISTOR	1.5K 5% 1/4W			R1629	QRZ0182-R10	EMIT RESISTOR	1/1W	
	R 814	QRE141J-333Y	C RESISTOR	33K 5% 1/4W			R1631	QRL027J-472	UNF OMF RESISTOR	4.7K 5% 1/2W	
	R 815	QRE141J-151Y	C RESISTOR	150 5% 1/4W			R1632	NRSA02J-331X	MG RESISTOR		
	R 816	QRE141J-680Y	C RESISTOR	68 5% 1/4W			R1633	NRSA02J-103X	MG RESISTOR		
	R 817	QRE141J-331Y	C RESISTOR	330 5% 1/4W			R1635	QRJ125J-330	UNF C RESISTOR	33 5% 1/2W	
	R 818	QRE141J-471Y	C RESISTOR	470 5% 1/4W			R1636	QRL027J-100	UNF OMF RESISTOR	10 5% 1/2W	
	R 819	QRE141J-391Y	C RESISTOR	390 5% 1/4W			R1641	QRA14CF-1003Y	MF RESISTOR	10 1/4W	
	R 820	QRJ146J-121X	UNF C RESISTOR	120 5% 1/4W			R1642	QRA14CF-3601Y	MF RESISTOR	36 1/4W	
	R 821	QRJ146J-121X	UNF C RESISTOR	120 5% 1/4W			R1651	QRA14CF-1001Y	MF RESISTOR	10 1/4W	
	R 822	QRJ146J-272X	UNF C RESISTOR	2.7K 5% 1/4W			R1652	QRA14CF-1003Y	MF RESISTOR	10 1/4W	
	R 823	QRJ146J-120X	UNF C RESISTOR	12 5% 1/4W			R1653	QRE141J-102Y	C RESISTOR	1.0K 5% 1/4W	
	R 824	QRJ146J-120X	UNF C RESISTOR	12 5% 1/4W			R1654	QRE141J-331Y	C RESISTOR	330 5% 1/4W	
	R 825	QRJ146J-271X	UNF C RESISTOR	270 5% 1/4W			R1655	QRE141J-104Y	C RESISTOR	100K 5% 1/4W	
	R 826	QRJ146J-1R0X	UNF C RESISTOR	1.0 5% 1/4W			R1656	QRE141J-202Y	C RESISTOR	2.0K 5% 1/4W	
	R 827	QRJ146J-1R0X	UNF C RESISTOR	1.0 5% 1/4W			R1657	QRE141J-202Y	C RESISTOR	2.0K 5% 1/4W	
	R 828	QRZ0182-R10	EMIT RESISTOR	1/1W			R1658	QRE141J-101Y	C RESISTOR	100 5% 1/4W	
	R 829	QRZ0182-R10	EMIT RESISTOR	1/1W			R1659	QRJ146J-151X	UNF C RESISTOR	150 5% 1/4W	
	R 831	QRL027J-472	UNF OMF RESISTOR	4.7K 5% 1/2W			R1660	QRJ146J-562X	UNF C RESISTOR	5.6K 5% 1/4W	
	R 832	NRSA02J-331X	MG RESISTOR				R1661	QRK126J-103X	UNF C RESISTOR	10K 5% 1/2W	
	R 833	NRSA02J-103X	MG RESISTOR				R1662	QRE141J-680Y	C RESISTOR	68 5% 1/4W	
	R 835	QRJ125J-330	UNF C RESISTOR	33 5% 1/2W			R1663	QRE141J-152Y	C RESISTOR	1.5K 5% 1/4W	
	R 836	QRL027J-100	UNF OMF RESISTOR	10 5% 1/2W			R1664	QRE141J-333Y	C RESISTOR	33K 5% 1/4W	
	R 841	QRA14CF-1003Y	MF RESISTOR	10 1/4W			R1665	QRE141J-151Y	C RESISTOR	150 5% 1/4W	
	R 842	QRA14CF-3601Y	MF RESISTOR	36 1/4W			R1666	QRE141J-680Y	C RESISTOR	68 5% 1/4W	
	RY751	QSK0112-001	RELAY				R1667	QRE141J-331Y	C RESISTOR	330 5% 1/4W	
△	RY771	QSK0131-001	RELAY				R1668	QRE141J-471Y	C RESISTOR	470 5% 1/4W	
△	RY772	QSK0131-001	RELAY				R1669	QRE141J-391Y	C RESISTOR	390 5% 1/4W	
△	RY773	QSK0131-001	RELAY				R1670	QRJ146J-121X	UNF C RESISTOR	120 5% 1/4W	
△	RY774	QSK0131-001	RELAY				R1671	QRJ146J-121X	UNF C RESISTOR	120 5% 1/4W	
	RY901	QSK0109-001	RELAY				R1672	QRJ146J-272X	UNF C RESISTOR	2.7K 5% 1/4W	
	RY902	QSK0109-001	RELAY				R1673	QRJ146J-120X	UNF C RESISTOR	12 5% 1/4W	
	RY903	QSK0109-001	RELAY				R1674	QRJ146J-120X	UNF C RESISTOR	12 5% 1/4W	
	RY904	QSK0109-001	RELAY				R1675	QRJ146J-271X	UNF C RESISTOR	270 5% 1/4W	
	RY905	QSK0109-001	RELAY				R1676	QRJ146J-1R0X	UNF C RESISTOR	1.0 5% 1/4W	
	RY906	QSK0109-001	RELAY				R1677	QRJ146J-1R0X	UNF C RESISTOR	1.0 5% 1/4W	
	R1601	QRA14CF-1001Y	MF RESISTOR	10 1/4W			R1678	QRZ0182-R10	EMIT RESISTOR	1/1W	
	R1602	QRA14CF-1003Y	MF RESISTOR	10 1/4W			R1679	QRZ0182-R10	EMIT RESISTOR	1/1W	
	R1603	QRE141J-102Y	C RESISTOR	1.0K 5% 1/4W			R1682	NRSA02J-331X	MG RESISTOR		
	R1604	QRE141J-331Y	C RESISTOR	330 5% 1/4W			R1683	NRSA02J-103X	MG RESISTOR		
	R1605	QRE141J-104Y	C RESISTOR	100K 5% 1/4W			R1685	QRJ125J-330	UNF C RESISTOR	33 5% 1/2W	
	R1606	QRE141J-202Y	C RESISTOR	2.0K 5% 1/4W			R1686	QRL027J-100	UNF OMF RESISTOR	10 5% 1/2W	
	R1607	QRE141J-202Y	C RESISTOR	2.0K 5% 1/4W			R1691	QRA14CF-1003Y	MF RESISTOR	10 1/4W	
	R1608	QRE141J-101Y	C RESISTOR	100 5% 1/4W			R1692	QRA14CF-3601Y	MF RESISTOR	36 1/4W	
	R1609	QRJ146J-151X	UNF C RESISTOR	150 5% 1/4W			R1701	QRA14CF-1001Y	MF RESISTOR	10 1/4W	
	R1610	QRJ146J-562X	UNF C RESISTOR	5.6K 5% 1/4W			R1702	QRA14CF-1003Y	MF RESISTOR	10 1/4W	
	R1611	QRK126J-103X	UNF C RESISTOR	10K 5% 1/2W			R1703	QRE141J-102Y	C RESISTOR	1.0K 5% 1/4W	
	R1612	QRE141J-680Y	C RESISTOR	68 5% 1/4W			R1704	QRE141J-331Y	C RESISTOR	330 5% 1/4W	
	R1613	QRE141J-152Y	C RESISTOR	1.5K 5% 1/4W			R1705	QRE141J-104Y	C RESISTOR	100K 5% 1/4W	
	R1614	QRE141J-333Y	C RESISTOR	33K 5% 1/4W			R1706	QRE141J-202Y	C RESISTOR	2.0K 5% 1/4W	
	R1615	QRE141J-151Y	C RESISTOR	150 5% 1/4W			R1707	QRE141J-202Y	C RESISTOR	2.0K 5% 1/4W	
	R1616	QRE141J-680Y	C RESISTOR	68 5% 1/4W			R1708	QRE141J-101Y	C RESISTOR	100 5% 1/4W	
	R1617	QRE141J-331Y	C RESISTOR	330 5% 1/4W			R1709	QRJ146J-151X	UNF C RESISTOR	150 5% 1/4W	
	R1618	QRE141J-471Y	C RESISTOR	470 5% 1/4W			R1710	QRJ146J-562X	UNF C RESISTOR	5.6K 5% 1/4W	
	R1619	QRE141J-391Y	C RESISTOR	390 5% 1/4W			R1711	QRK126J-103X	UNF C RESISTOR	10K 5% 1/2W	
	R1620	QRJ146J-121X	UNF C RESISTOR	120 5% 1/4W			R1712	QRE141J-680Y	C RESISTOR	68 5% 1/4W	

■ Electrical parts list (Amp. board)

Block No. 01

△	Item	Parts number	Parts name	Remarks	Area	△	Item	Parts number	Parts name	Remarks	Area
	R1713	QRE141J-152Y	C RESISTOR	1.5K 5% 1/4W			R1912	NRSA02J-153X	MG RESISTOR		
	R1714	QRE141J-333Y	C RESISTOR	33K 5% 1/4W			R1913	NRSA02J-123X	MG RESISTOR		
	R1715	QRE141J-151Y	C RESISTOR	150 5% 1/4W			R1914	NRSA02J-104X	MG RESISTOR		
	R1716	QRE141J-680Y	C RESISTOR	68 5% 1/4W			R1921	NRSA02J-122X	MG RESISTOR		
	R1717	QRE141J-331Y	C RESISTOR	330 5% 1/4W			R1922	NRSA02J-153X	MG RESISTOR		
	R1718	QRE141J-471Y	C RESISTOR	470 5% 1/4W			R1923	NRSA02J-123X	MG RESISTOR		
	R1719	QRE141J-391Y	C RESISTOR	390 5% 1/4W			R1924	NRSA02J-104X	MG RESISTOR		
	R1720	QRJ146J-121X	UNF C RESISTOR	120 5% 1/4W			R1931	NRSA02J-122X	MG RESISTOR		
	R1721	QRJ146J-121X	UNF C RESISTOR	120 5% 1/4W			R1932	NRSA02J-153X	MG RESISTOR		
	R1722	QRJ146J-272X	UNF C RESISTOR	2.7K 5% 1/4W			R1933	NRSA02J-123X	MG RESISTOR		
	R1723	QRJ146J-120X	UNF C RESISTOR	12 5% 1/4W			R1934	NRSA02J-104X	MG RESISTOR		
	R1724	QRJ146J-120X	UNF C RESISTOR	12 5% 1/4W			R1941	NRSA02J-122X	MG RESISTOR		
	R1725	QRJ146J-271X	UNF C RESISTOR	270 5% 1/4W			R1942	NRSA02J-153X	MG RESISTOR		
	R1726	QRJ146J-1R0X	UNF C RESISTOR	1.0 5% 1/4W			R1943	NRSA02J-123X	MG RESISTOR		
	R1727	QRJ146J-1R0X	UNF C RESISTOR	1.0 5% 1/4W			R1944	NRSA02J-104X	MG RESISTOR		
	R1728	QRZ0182-R10	EMIT RESISTOR	1/1W			R1951	NRSA02J-122X	MG RESISTOR		
	R1729	QRZ0182-R10	EMIT RESISTOR	1/1W			R1952	NRSA02J-153X	MG RESISTOR		
	R1732	NRSA02J-331X	MG RESISTOR				R1953	NRSA02J-123X	MG RESISTOR		
	R1733	NRSA02J-103X	MG RESISTOR				R1954	NRSA02J-104X	MG RESISTOR		
	R1735	QRJ125J-330	UNF C RESISTOR	33 5% 1/2W			R1961	NRSA02J-122X	MG RESISTOR		
	R1736	QRL027J-100	UNF OMF RESISTOR	10 5% 1/2W			R1962	NRSA02J-153X	MG RESISTOR		
	R1741	QRA14CF-1003Y	MF RESISTOR	10 1/4W			R1963	NRSA02J-123X	MG RESISTOR		
	R1742	QRA14CF-3601Y	MF RESISTOR	36 1/4W			R1964	NRSA02J-104X	MG RESISTOR		
	R1751	QRA14CF-1001Y	MF RESISTOR	10 1/4W			R1971	NRSA02J-103X	MG RESISTOR		
	R1752	QRA14CF-1003Y	MF RESISTOR	10 1/4W			R1972	NRSA02J-332X	MG RESISTOR		
	R1753	QRE141J-102Y	C RESISTOR	1.0K 5% 1/4W			R1973	NRSA02J-473X	MG RESISTOR		
	R1754	QRE141J-331Y	C RESISTOR	330 5% 1/4W			R1974	NRSA02J-563X	MG RESISTOR		
	R1755	QRE141J-104Y	C RESISTOR	100K 5% 1/4W			R1975	NRSA02J-683X	MG RESISTOR		
	R1756	QRE141J-202Y	C RESISTOR	2.0K 5% 1/4W			R1976	QRE141J-273Y	C RESISTOR	27K 5% 1/4W	
	R1757	QRE141J-202Y	C RESISTOR	2.0K 5% 1/4W			R1977	NRSA02J-224X	MG RESISTOR		
	R1758	QRE141J-101Y	C RESISTOR	100 5% 1/4W			R1978	QRE141J-223Y	C RESISTOR	22K 5% 1/4W	
	R1759	QRJ146J-151X	UNF C RESISTOR	150 5% 1/4W			R1979	NRSA02J-224X	MG RESISTOR		
	R1760	QRJ146J-562X	UNF C RESISTOR	5.6K 5% 1/4W			R1981	QRJ146J-330X	UNF C RESISTOR	33 5% 1/4W	
	R1761	QRK126J-103X	UNF C RESISTOR	10K 5% 1/2W			R1982	QRJ146J-330X	UNF C RESISTOR	33 5% 1/4W	
	R1762	QRE141J-680Y	C RESISTOR	68 5% 1/4W			R1983	QRJ146J-330X	UNF C RESISTOR	33 5% 1/4W	
	R1763	QRE141J-152Y	C RESISTOR	1.5K 5% 1/4W			R1984	QRJ146J-330X	UNF C RESISTOR	33 5% 1/4W	
	R1764	QRE141J-333Y	C RESISTOR	33K 5% 1/4W			R1985	QRJ146J-330X	UNF C RESISTOR	33 5% 1/4W	
	R1765	QRE141J-151Y	C RESISTOR	150 5% 1/4W			R1986	QRJ146J-330X	UNF C RESISTOR	33 5% 1/4W	
	R1766	QRE141J-680Y	C RESISTOR	68 5% 1/4W			S 901	QSW0509-001	SLIDE SWITCH		
	R1767	QRE141J-331Y	C RESISTOR	330 5% 1/4W			ST901	QNB0110-001	SPK TERMINAL		
	R1768	QRE141J-471Y	C RESISTOR	470 5% 1/4W			ST902	QNB0109-001	SPK TERMINAL		
	R1769	QRE141J-391Y	C RESISTOR	390 5% 1/4W			ST903	QNB0108-001	SPK TERMINAL		
	R1770	QRJ146J-121X	UNF C RESISTOR	120 5% 1/4W			TH701	QAD0010-351	THERMISTOR		
	R1771	QRJ146J-121X	UNF C RESISTOR	120 5% 1/4W			TH702	QAD0010-351	THERMISTOR		
	R1772	QRJ146J-272X	UNF C RESISTOR	2.7K 5% 1/4W			TH751	QAD0010-351	THERMISTOR		
	R1773	QRJ146J-120X	UNF C RESISTOR	12 5% 1/4W			TH752	QAD0010-351	THERMISTOR		
	R1774	QRJ146J-120X	UNF C RESISTOR	12 5% 1/4W			TH771	QAD0010-351	THERMISTOR		
	R1775	QRJ146J-271X	UNF C RESISTOR	270 5% 1/4W			TH772	QAD0010-351	THERMISTOR		
	R1776	QRJ146J-1R0X	UNF C RESISTOR	1.0 5% 1/4W			TH801	QAD0010-351	THERMISTOR		
	R1777	QRJ146J-1R0X	UNF C RESISTOR	1.0 5% 1/4W			VR701	QVP0008-501Z	SEMI V RESISTOR		
	R1778	QRZ0182-R10	EMIT RESISTOR	1/1W			VR702	QVP0008-501Z	SEMI V RESISTOR		
	R1779	QRZ0182-R10	EMIT RESISTOR	1/1W			VR751	QVP0008-501Z	SEMI V RESISTOR		
	R1782	NRSA02J-331X	MG RESISTOR				VR752	QVP0008-501Z	SEMI V RESISTOR		
	R1783	NRSA02J-103X	MG RESISTOR				VR771	QVP0008-501Z	SEMI V RESISTOR		
	R1785	QRJ125J-330	UNF C RESISTOR	33 5% 1/2W			VR772	QVP0008-501Z	SEMI V RESISTOR		
	R1786	QRL027J-100	UNF OMF RESISTOR	10 5% 1/2W			VR801	QVP0008-501Z	SEMI V RESISTOR		
	R1791	QRA14CF-1003Y	MF RESISTOR	10 1/4W			WR 83	QJK015-053200	SIN CR C-B WIRE		
	R1792	QRA14CF-3601Y	MF RESISTOR	36 1/4W			WR 84	QJK015-053402	SIN CR C-B WIRE		
	R1901	NRSA02J-122X	MG RESISTOR				WR701	QJK016-113801	SIN CR C-B WIRE		
	R1902	NRSA02J-153X	MG RESISTOR				WR702	QJK016-053800	SIN CR C-B WIRE		
	R1903	NRSA02J-123X	MG RESISTOR				WR703	QJK016-083603	SIN CR C-B WIRE		
	R1904	NRSA02J-104X	MG RESISTOR				WR711	WJK0139-001A	E-SI C WIRE C-B		
	R1911	NRSA02J-122X	MG RESISTOR				WR712	WJK0139-001A	E-SI C WIRE C-B		

RX-DP10VBK/RX-DP10VSL

RX-DP10RSL

■ Electrical parts list (Amp. board)

Block No. 01

△	Item	Parts number	Parts name	Remarks	Area
	WR713	WJK0139-002A	E-SI C WIRE C-B		
	WR714	WJK0139-003A	E-SI C WIRE C-B		
	WR715	WJK0139-002A	E-SI C WIRE C-B		
	WR716	WJK0140-001A	E-SI C WIRE C-B		
	WR717	WJK0140-001A	E-SI C WIRE C-B		
	WR731	WJK0128-001A	E-SI C WIRE C-B		
	WR736	WJK0129-001A	E-SI C WIRE C-B		
	WR741	QJL005-051003	SIN CR B-B WIRE		
	WR742	QJL005-051001	SIN CR B-B WIRE		

■ Electrical parts list
(Audio/video input & output board)

Block No. 02

△	Item	Parts number	Parts name	Remarks	Area	△	Item	Parts number	Parts name	Remarks	Area
	C 201	NCB31HK-331X	C CAPACITOR				C 343	NCB31HK-223X	C CAPACITOR		
	C 202	NCB31HK-331X	C CAPACITOR				C 344	NCB31HK-223X	C CAPACITOR		
	C 203	QETN1HM-475Z	E CAPACITOR	4.7MF 20% 50V			C 345	NCB31HK-561X	C CAPACITOR		
	C 204	QETN1HM-475Z	E CAPACITOR	4.7MF 20% 50V			C 363	QETN1HM-226Z	E CAPACITOR	22MF 20% 50V	
	C 205	NCS31HJ-101X	C CAPACITOR				C 365	QETN1HM-226Z	E CAPACITOR	22MF 20% 50V	
	C 206	NCS31HJ-101X	C CAPACITOR				C 369	QETN1HM-226Z	E CAPACITOR	22MF 20% 50V	
	C 207	QFN31HJ-472Z	M CAPACITOR	4700PF 5% 50V			C 401	QETN1HM-475Z	E CAPACITOR	4.7MF 20% 50V	
	C 208	QFN31HJ-472Z	M CAPACITOR	4700PF 5% 50V			C 402	QETN0JM-477Z	E CAPACITOR	470MF 20% 6.3V	
	C 209	QFN31HJ-153Z	M CAPACITOR	0.015MF 5% 50V			C 403	QETN1HM-475Z	E CAPACITOR	4.7MF 20% 50V	
	C 210	QFN31HJ-153Z	M CAPACITOR	0.015MF 5% 50V			C 404	QETN0JM-477Z	E CAPACITOR	470MF 20% 6.3V	
	C 211	QCS31HJ-331Z	C CAPACITOR	330PF 5% 50V			C 405	QETN1HM-475Z	E CAPACITOR	4.7MF 20% 50V	
	C 212	QCS31HJ-331Z	C CAPACITOR	330PF 5% 50V			C 406	QETN1HM-475Z	E CAPACITOR	4.7MF 20% 50V	
	C 213	QFN31HJ-272Z	M CAPACITOR	2700PF 5% 50V			C 407	QETN0JM-477Z	E CAPACITOR	470MF 20% 6.3V	
	C 214	QFN31HJ-272Z	M CAPACITOR	2700PF 5% 50V			C 408	QETN1EM-476Z	E CAPACITOR	47MF 20% 25V	
	C 215	NCS31HJ-101X	C CAPACITOR				C 409	NCB31HK-103X	C CAPACITOR		
	C 216	NCS31HJ-101X	C CAPACITOR				C 410	QETN1HM-475Z	E CAPACITOR	4.7MF 20% 50V	
	C 217	QETN1AM-227Z	E CAPACITOR	220MF 20% 10V			C 411	QETN1HM-107Z	E CAPACITOR	100MF 20% 50V	
	C 218	QETN1AM-227Z	E CAPACITOR	220MF 20% 10V			C 412	NCF21CZ-225X	C CAPACITOR		
	C 219	QETN1HM-475Z	E CAPACITOR	4.7MF 20% 50V			C 413	QETN1HM-475Z	E CAPACITOR	4.7MF 20% 50V	
	C 220	QETN1HM-475Z	E CAPACITOR	4.7MF 20% 50V			C 414	QETN1HM-475Z	E CAPACITOR	4.7MF 20% 50V	
	C 221	QFN31HJ-102Z	M CAPACITOR	1000PF 5% 50V			C 415	QETN1HM-475Z	E CAPACITOR	4.7MF 20% 50V	
	C 222	QFN31HJ-102Z	M CAPACITOR	1000PF 5% 50V			C 416	NCF31HZ-473X	C CAPACITOR		
	C 223	QETN1EM-476Z	E CAPACITOR	47MF 20% 25V			C 417	QETN1AM-477Z	E CAPACITOR	470MF 20% 10V	
	C 224	QETN1EM-476Z	E CAPACITOR	47MF 20% 25V			C 418	NCB31HK-103X	C CAPACITOR		
	C 225	NCB31HK-223X	C CAPACITOR				C 419	NCS31HJ-150X	C CAPACITOR		
	C 226	NCB31HK-223X	C CAPACITOR				C 420	NCS31HJ-100X	C CAPACITOR		
	C 231	QETN1EM-226Z	E CAPACITOR	22MF 20% 25V			C 421	NCS31HJ-470X	C CAPACITOR		
	C 232	QETN1EM-226Z	E CAPACITOR	22MF 20% 25V			C 422	NCS31HJ-270X	C CAPACITOR		
	C 233	NCB31HK-223X	C CAPACITOR				C 423	NCB31HK-102X	C CAPACITOR		
	C 234	NCB31HK-223X	C CAPACITOR				C 424	NCS31HJ-271X	C CAPACITOR		
	C 235	NCB31HK-561X	C CAPACITOR				C 425	NCS31HJ-121X	C CAPACITOR		
	C 241	QTE1H46-106Z	E CAPACITOR				C 426	NCS31HJ-470X	C CAPACITOR		
	C 242	QTE1H46-106Z	E CAPACITOR				C 427	NCS31HJ-470X	C CAPACITOR		
	C 243	QTE1H46-106Z	E CAPACITOR				C 428	NCS31HJ-470X	C CAPACITOR		
	C 244	QTE1H46-106Z	E CAPACITOR				C 431	NCF31HZ-473X	C CAPACITOR		
	C 245	QETN1EM-476Z	E CAPACITOR	47MF 20% 25V			C 432	QETN1HM-475Z	E CAPACITOR	4.7MF 20% 50V	
	C 246	QETN1EM-476Z	E CAPACITOR	47MF 20% 25V			C 433	NCF31HZ-473X	C CAPACITOR		
	C 247	NCB31HK-223X	C CAPACITOR				C 434	QETN0JM-477Z	E CAPACITOR	470MF 20% 6.3V	
	C 248	NCB31HK-223X	C CAPACITOR				C 435	NCF31HZ-473X	C CAPACITOR		
	C 271	QETN1EM-226Z	E CAPACITOR	22MF 20% 25V			C 436	QETN1HM-475Z	E CAPACITOR	4.7MF 20% 50V	
	C 272	QETN1EM-226Z	E CAPACITOR	22MF 20% 25V			C 437	NCF31HZ-473X	C CAPACITOR		
	C 273	NCB31HK-223X	C CAPACITOR				C 438	QETN0JM-477Z	E CAPACITOR	470MF 20% 6.3V	
	C 274	NCB31HK-223X	C CAPACITOR				C 439	NCF31HZ-473X	C CAPACITOR		
	C 275	NCB31HK-561X	C CAPACITOR				C 440	QETN1HM-475Z	E CAPACITOR	4.7MF 20% 50V	
	C 276	QETN1EM-226Z	E CAPACITOR	22MF 20% 25V			C 441	NCF31HZ-473X	C CAPACITOR		
	C 277	QETN1EM-226Z	E CAPACITOR	22MF 20% 25V			C 442	QETN1HM-475Z	E CAPACITOR	4.7MF 20% 50V	
	C 278	NCB31HK-223X	C CAPACITOR				C 443	NCF31HZ-473X	C CAPACITOR		
	C 279	NCB31HK-223X	C CAPACITOR				C 444	QETN0JM-477Z	E CAPACITOR	470MF 20% 6.3V	
	C 280	NCB31HK-561X	C CAPACITOR				C 445	NCF31HZ-473X	C CAPACITOR		
	C 281	QETN1EM-226Z	E CAPACITOR	22MF 20% 25V			C 446	QETN1HM-475Z	E CAPACITOR	4.7MF 20% 50V	
	C 282	QETN1EM-226Z	E CAPACITOR	22MF 20% 25V			C 447	QETN1EM-476Z	E CAPACITOR	47MF 20% 25V	
	C 283	NCB31HK-223X	C CAPACITOR				C 448	QETN1EM-476Z	E CAPACITOR	47MF 20% 25V	
	C 284	NCB31HK-223X	C CAPACITOR				C 449	NCB31HK-103X	C CAPACITOR		
	C 285	NCB31HK-561X	C CAPACITOR				C 450	NCB31HK-103X	C CAPACITOR		
	C 301	QETN1HM-226Z	E CAPACITOR	22MF 20% 50V			C 451	QETN1HM-475Z	E CAPACITOR	4.7MF 20% 50V	
	C 311	NCS31HJ-221X	C CAPACITOR				C 452	NCF31HZ-473X	C CAPACITOR		
	C 312	NCS31HJ-221X	C CAPACITOR				C 453	NCS31HJ-470X	C CAPACITOR		
	C 313	NCS31HJ-221X	C CAPACITOR				C 454	NCS31HJ-470X	C CAPACITOR		
	C 314	NCS31HJ-221X	C CAPACITOR				C 455	NCS31HJ-470X	C CAPACITOR		
	C 315	NCS31HJ-221X	C CAPACITOR				C 456	NCS31HJ-470X	C CAPACITOR		
	C 316	NCS31HJ-221X	C CAPACITOR				C 457	NCS31HJ-101X	C CAPACITOR		
	C 341	QETN1EM-226Z	E CAPACITOR	22MF 20% 25V			C 458	NCS31HJ-101X	C CAPACITOR		
	C 342	QETN1EM-226Z	E CAPACITOR	22MF 20% 25V			C 461	NCF31HZ-473X	C CAPACITOR		

■ Electrical parts list
(Audio/video input & outpat board)

Block No. 02

△	Item	Parts number	Parts name	Remarks	Area	△	Item	Parts number	Parts name	Remarks	Area
	C 462	NCB31HK-103X	C CAPACITOR				C2061	QTE1H46-475Z	E CAPACITOR		
	C 463	NCF31HZ-473X	C CAPACITOR				C2062	QTE1H46-475Z	E CAPACITOR		
	C 464	NCB31HK-103X	C CAPACITOR				C2063	QETN1EM-227Z	E CAPACITOR	220MF 20% 25V	
	C 465	NCF31HZ-473X	C CAPACITOR				C2064	QETN1EM-227Z	E CAPACITOR	220MF 20% 25V	
	C 466	NCB31HK-103X	C CAPACITOR				C2065	NCB31HK-223X	C CAPACITOR		
	C 467	NCF31HZ-473X	C CAPACITOR				C2066	NCB31HK-223X	C CAPACITOR		
	C 468	NCB31HK-103X	C CAPACITOR				C2067	QETN1HM-475Z	E CAPACITOR	4.7MF 20% 50V	
	C 469	NCB31HK-103X	C CAPACITOR				C2068	QETN1HM-475Z	E CAPACITOR	4.7MF 20% 50V	
	C 470	QETN1EM-476Z	E CAPACITOR	47MF 20% 25V			C2069	QETN1HM-475Z	E CAPACITOR	4.7MF 20% 50V	
	C 471	NCB31HK-103X	C CAPACITOR				C2070	QETN1HM-475Z	E CAPACITOR	4.7MF 20% 50V	
	CN203	QGA2001F1-15	15P PLUG ASSY				C2071	QETN1EM-227Z	E CAPACITOR	220MF 20% 25V	
	CN205	QGA2001F1-09	9P SOCKET				C2072	QETN1EM-227Z	E CAPACITOR	220MF 20% 25V	
	CN206	QGB2510K1-04	CONNECTOR				C2073	NCB31HK-223X	C CAPACITOR		
	CN207	QGA2501F1-03	CONNECTOR				C2074	NCB31HK-223X	C CAPACITOR		
	CN208	QGA2001F1-08	CONNECTOR				C2075	QETN1HM-475Z	E CAPACITOR	4.7MF 20% 50V	
	CN218	QGA2001F1-03	CONNECTOR				C2076	QETN1HM-475Z	E CAPACITOR	4.7MF 20% 50V	
	CN221	QGB2510K1-20	B TO B CONNE				C2077	QETN1HM-475Z	E CAPACITOR	4.7MF 20% 50V	
	CN223	QGA2001F1-11	11P CN RIG				C2078	QETN1HM-475Z	E CAPACITOR	4.7MF 20% 50V	
	CN224	QGA2001F1-07	CONNECTOR				C2079	QETN1EM-227Z	E CAPACITOR	220MF 20% 25V	
	CN234	QGA2001F1-06	6P PLUG ASSY				C2080	QETN1EM-227Z	E CAPACITOR	220MF 20% 25V	
	CN321	QGB1214K1-20S	CONNECTOR				C2081	NCB31HK-223X	C CAPACITOR		
	CN323	QGF1205F1-15	CONNECTOR				C2082	NCB31HK-223X	C CAPACITOR		
	CN324	QGA2001F1-09	9P SOCKET				C2101	QETN1EM-226Z	E CAPACITOR	22MF 20% 25V	
	CN325	QGB2510K2-07	CONNECTOR				C2102	QETN1EM-226Z	E CAPACITOR	22MF 20% 25V	
	CN401	QGB1214K1-16S	CONNECTOR				C2103	NCB31HK-223X	C CAPACITOR		
	CN402	QGF1205F1-16	CONNECTOR				C2104	NCB31HK-223X	C CAPACITOR		
	CN431	QGB2510K2-15	CONNECTOR				C2105	NCB31HK-561X	C CAPACITOR		
	CN432	QGF1205F1-16	CONNECTOR				C2111	QETN1EM-106Z	E CAPACITOR	10MF 20% 25V	
	C2001	QETN1EM-226Z	E CAPACITOR	22MF 20% 25V			C2112	QETN1EM-106Z	E CAPACITOR	10MF 20% 25V	
	C2002	QETN1EM-226Z	E CAPACITOR	22MF 20% 25V			C2113	QETN1EM-106Z	E CAPACITOR	10MF 20% 25V	
	C2003	NCB31HK-223X	C CAPACITOR				C2114	QETN1EM-106Z	E CAPACITOR	10MF 20% 25V	
	C2004	NCB31HK-223X	C CAPACITOR				C2115	QETN1EM-106Z	E CAPACITOR	10MF 20% 25V	
	C2005	NCB31HK-561X	C CAPACITOR				C2116	QETN1EM-106Z	E CAPACITOR	10MF 20% 25V	
	C2011	QETN1HM-106Z	E CAPACITOR	10MF 20% 50V			C2203	NCB31HK-223X	C CAPACITOR		
	C2012	QETN1HM-106Z	E CAPACITOR	10MF 20% 50V			C2204	NCB31HK-223X	C CAPACITOR		
	C2013	QETN1HM-106Z	E CAPACITOR	10MF 20% 50V			C2207	QTE1H46-475Z	E CAPACITOR		
	C2014	QETN1HM-106Z	E CAPACITOR	10MF 20% 50V			C2208	QTE1H46-475Z	E CAPACITOR		
	C2015	QETN1EM-476Z	E CAPACITOR	47MF 20% 25V			C2212	NCB31HK-223X	C CAPACITOR		
	C2016	QETN1EM-476Z	E CAPACITOR	47MF 20% 25V			C2213	NCB31HK-223X	C CAPACITOR		
	C2017	NCB31HK-223X	C CAPACITOR				C2221	NCB31HK-223X	C CAPACITOR		
	C2018	NCB31HK-223X	C CAPACITOR				C2222	NCB31HK-223X	C CAPACITOR		
	C2025	NCB31HK-223X	C CAPACITOR				C2230	NCB31HK-223X	C CAPACITOR		
	C2026	NCB31HK-223X	C CAPACITOR				C2231	NCB31HK-223X	C CAPACITOR		
	C2028	QETN1HM-226Z	E CAPACITOR	22MF 20% 50V			C2253	QETN1HM-475Z	E CAPACITOR	4.7MF 20% 50V	
	C2031	QETN1HM-475Z	E CAPACITOR	4.7MF 20% 50V			C2254	QETN1HM-475Z	E CAPACITOR	4.7MF 20% 50V	
	C2032	QETN1HM-475Z	E CAPACITOR	4.7MF 20% 50V			C2255	QETN1HM-475Z	E CAPACITOR	4.7MF 20% 50V	
	C2033	QETN1HM-475Z	E CAPACITOR	4.7MF 20% 50V			C2256	QETN1HM-475Z	E CAPACITOR	4.7MF 20% 50V	
	C2034	QETN1HM-475Z	E CAPACITOR	4.7MF 20% 50V			C2257	QETN1HM-475Z	E CAPACITOR	4.7MF 20% 50V	
	C2035	QETN1EM-227Z	E CAPACITOR	220MF 20% 25V			C2258	QETN1HM-475Z	E CAPACITOR	4.7MF 20% 50V	
	C2036	QETN1EM-227Z	E CAPACITOR	220MF 20% 25V			C2259	NCS31HJ-330X	C CAPACITOR		
	C2037	NCB31HK-223X	C CAPACITOR				C2260	NCS31HJ-330X	C CAPACITOR		
	C2038	NCB31HK-223X	C CAPACITOR				C2265	QETN1HM-475Z	E CAPACITOR	4.7MF 20% 50V	
	C2042	QETN1HM-226Z	E CAPACITOR	22MF 20% 50V			C2266	QETN1HM-475Z	E CAPACITOR	4.7MF 20% 50V	
	C2051	QTE1H46-475Z	E CAPACITOR				C2267	QETN1EM-227Z	E CAPACITOR	220MF 20% 25V	
	C2052	QTE1H46-475Z	E CAPACITOR				C2268	QETN1EM-227Z	E CAPACITOR	220MF 20% 25V	
	C2053	QTE1H46-475Z	E CAPACITOR				C2269	NCB31HK-223X	C CAPACITOR		
	C2054	QTE1H46-475Z	E CAPACITOR				C2270	NCB31HK-223X	C CAPACITOR		
	C2055	QETN1EM-227Z	E CAPACITOR	220MF 20% 25V			C2273	NCB31HK-223X	C CAPACITOR		
	C2056	QETN1EM-227Z	E CAPACITOR	220MF 20% 25V			C2274	NCB31HK-223X	C CAPACITOR		
	C2057	NCB31HK-223X	C CAPACITOR				C2301	NCB31HK-562X	C CAPACITOR		
	C2058	NCB31HK-223X	C CAPACITOR				C2302	NCB31HK-562X	C CAPACITOR		
	C2059	QTE1H46-475Z	E CAPACITOR				C2319	NCS31HJ-101X	C CAPACITOR		
	C2060	QTE1H46-475Z	E CAPACITOR				C2320	NCS31HJ-101X	C CAPACITOR		

■ Electrical parts list

(Audio/video input & output board)

Block No. 02

△	Item	Parts number	Parts name	Remarks	Area	△	Item	Parts number	Parts name	Remarks	Area
	C2401	QTE1H46-106Z	E CAPACITOR				FL301	QQR0590-001	FILTER		
	C2402	QTE1H46-106Z	E CAPACITOR				FL302	QQR0590-001	FILTER		
	C2403	QTE1H46-106Z	E CAPACITOR				IC201	NJM4580E-W	IC		
	C2404	QTE1H46-106Z	E CAPACITOR				IC202	TC9164AF-X	IC		
	C2405	QETN1EM-476Z	E CAPACITOR	47MF 20% 25V			IC203	TC9164AF-X	IC		
	C2406	QETN1EM-476Z	E CAPACITOR	47MF 20% 25V			IC204	NJM4580E-W	IC		
	C2407	NCB31HK-223X	C CAPACITOR				IC211	TC9162AF-X	IC		
	C2408	NCB31HK-223X	C CAPACITOR				IC212	TC9162AF-X	IC		
	C2411	QETN1HM-106Z	E CAPACITOR	10MF 20% 50V			IC213	TC9162AF-X	IC		
	C2412	QETN1HM-106Z	E CAPACITOR	10MF 20% 50V			IC221	TC9459F-X	IC		
	C2413	QETN1HM-106Z	E CAPACITOR	10MF 20% 50V			IC222	TC9459F-X	IC		
	C2414	QETN1HM-106Z	E CAPACITOR	10MF 20% 50V			IC223	TC9459F-X	IC		
	C2415	QETN1EM-476Z	E CAPACITOR	47MF 20% 25V			IC224	TC9459F-X	IC		
	C2416	QETN1EM-476Z	E CAPACITOR	47MF 20% 25V			IC241	NJM4580E-W	IC		
	C2417	NCB31HK-223X	C CAPACITOR				IC242	NJM4580E-W	IC		
	C2418	NCB31HK-223X	C CAPACITOR				IC251	NJM4580E-W	IC		
	C2421	QETN1HM-106Z	E CAPACITOR	10MF 20% 50V			IC252	NJM4580E-W	IC		
	C2422	QETN1HM-106Z	E CAPACITOR	10MF 20% 50V			IC253	NJM4580E-W	IC		
	C2423	QETN1HM-106Z	E CAPACITOR	10MF 20% 50V			IC254	NJM4580E-W	IC		
	C2424	QETN1HM-106Z	E CAPACITOR	10MF 20% 50V			IC261	NJM4580E-W	IC		
	C2425	QETN1EM-476Z	E CAPACITOR	47MF 20% 25V			IC262	TC9459F-X	IC		
	C2426	QETN1EM-476Z	E CAPACITOR	47MF 20% 25V			IC263	NJM4580E-W	IC		
	C2427	NCB31HK-223X	C CAPACITOR				IC271	NJM4580E-W	IC		
	C2428	NCB31HK-223X	C CAPACITOR				IC272	NJM4580E-W	IC		
	C2501	NCF21CZ-225X	C CAPACITOR				IC273	NJM4580E-W	IC		
	C2502	NCF21CZ-225X	C CAPACITOR				IC281	NJM4580E-W	IC		
	C2503	NCF21CZ-105X	C CAPACITOR				IC282	NJM2903M-XE	IC		
	C2504	NCF21CZ-105X	C CAPACITOR				IC283	NJM78L05A-T	IC		
	C4001	QETN0JM-477Z	E CAPACITOR	470MF 20% 6.3V			IC321	TC9163AF-X	IC		
	C4002	QETN1EM-476Z	E CAPACITOR	47MF 20% 25V			IC322	TC9163AF-X	IC		
	C4003	NCB31HK-103X	C CAPACITOR				IC381	BA15218N	IC		
	C4004	QETN1HM-107Z	E CAPACITOR	100MF 20% 50V			IC382	BA15218N	IC		
	C4005	NCF21CZ-225X	C CAPACITOR				IC401	BA7625	IC		
	C4006	NCS31HJ-470X	C CAPACITOR				IC402	NJM2285V-W	IC		
	C4031	NCF31HZ-473X	C CAPACITOR				IC403	MB90088PF-131	IC		
	C4032	QETN0JM-477Z	E CAPACITOR	470MF 20% 6.3V			IC431	BA7625	IC		
	C4033	QETN1EM-476Z	E CAPACITOR	47MF 20% 25V			IC432	BA7626	IC		
	C4034	QETN1EM-476Z	E CAPACITOR	47MF 20% 25V			IC451	BA7625	IC		
	C4035	NCB31HK-103X	C CAPACITOR				IC452	NJM2285V-W	IC		
	C4036	NCB31HK-103X	C CAPACITOR				IC461	BU4051BC	IC		
	C4037	QETN1HM-475Z	E CAPACITOR	4.7MF 20% 50V			IC471	BA7625	IC		
	C4038	NCF31HZ-473X	C CAPACITOR				IC472	BA7626	IC		
	C4039	NCS31HJ-101X	C CAPACITOR				J 201	QNN0392-001	PIN JACK		
	C4040	NCS31HJ-101X	C CAPACITOR				J 202	QNN0392-001	PIN JACK		
	D 240	1SS355-X	DIODE				J 203	QNN0396-001	PIN JACK		
	D 351	1SS355-X	DIODE				J 321	QNN0392-001	PIN JACK		
	D 401	1SS133-T2	SI DIODE				J 322	QNN0393-001	PIN JACK		
	D 402	1SS133-T2	SI DIODE				J 323	QNN0396-001	PIN JACK		
	D2041	1SS133-T2	SI DIODE				J 324	QNN0394-001	PIN JACK		
	D2042	1SS133-T2	SI DIODE				J 401	QNN0402-001	PIN JACK		
	D2111	1SS355-X	DIODE				J 402	QNN0403-001	PIN JACK		
	D2121	1SS355-X	DIODE				J 403	QNN0403-001	PIN JACK		
	D2122	1SS355-X	DIODE				J 431	QND0090-001	S JACK		
	D2123	MTZJ5.1C-T2	ZENER DIODE				J 432	QND0029-001	DIN CONNECTOR		
	D2311	1SS133-T2	SI DIODE				J 433	QND0029-001	DIN CONNECTOR		
	D2501	1SS355-X	DIODE				J 434	QND0089-001	S JACK		
	D2502	1SS355-X	DIODE				J4001	QNN0405-001	PIN JACK		
	D2503	1SS355-X	DIODE				J4002	QNN0407-001	PIN JACK		
	D2504	1SS355-X	DIODE				J4031	QND0027-001	DIN CONNECTOR		
	D2505	1SS355-X	DIODE				J4032	QNN0406-001	PIN JACK		
	D2506	1SS355-X	DIODE				L 321	QQL231K-121Y	INDUCTOR		
	D2507	1SS355-X	DIODE				L 322	QQL231K-121Y	INDUCTOR		
	D2508	1SS355-X	DIODE				L 401	QQL231K-220Y	INDUCTOR		

■ Electrical parts list
(Audio/video input & output board)

Block No. 02

△	Item	Parts number	Parts name	Remarks	Area	△	Item	Parts number	Parts name	Remarks	Area
	Q 201	KRA104M-T	D TRANSISTOR				R 211	NRSA63J-103X	MG RESISTOR		
	Q 211	2SC3576-JVC-T	TRANSISTOR				R 212	NRSA63J-103X	MG RESISTOR		
	Q 212	2SC3576-JVC-T	TRANSISTOR				R 213	NRSA63J-104X	MG RESISTOR		
	Q 213	2SC3576-JVC-T	TRANSISTOR				R 214	NRSA63J-104X	MG RESISTOR		
	Q 214	2SC3576-JVC-T	TRANSISTOR				R 215	NRSA63J-101X	MG RESISTOR		
	Q 215	2SC3576-JVC-T	TRANSISTOR				R 216	NRSA63J-101X	MG RESISTOR		
	Q 216	2SC3576-JVC-T	TRANSISTOR			△	R 217	QRJ146J-331X	UNF C RESISTOR	330 5% 1/4W	
	Q 217	2SC3576-JVC-T	TRANSISTOR			△	R 218	QRJ146J-331X	UNF C RESISTOR	330 5% 1/4W	
	Q 218	2SC3576-JVC-T	TRANSISTOR			△	R 231	QRZ9005-680X	F RESISTOR	68 1/4W	
	Q 219	2SC3576-JVC-T	TRANSISTOR			△	R 232	QRZ9005-680X	F RESISTOR	68 1/4W	
	Q 240	KRC105M-T	D TRANSISTOR			△	R 237	QRZ9005-680X	F RESISTOR	68 1/4W	
	Q 323	2SC3576-JVC-T	TRANSISTOR			△	R 238	QRZ9005-680X	F RESISTOR	68 1/4W	
	Q 324	2SC3576-JVC-T	TRANSISTOR			△	R 240	QRZ9005-331X	F RESISTOR	330 1/4W	
	Q 325	2SC3576-JVC-T	TRANSISTOR				R 241	NRSA63J-104X	MG RESISTOR		
	Q 329	2SC3576-JVC-T	TRANSISTOR				R 242	NRSA63J-104X	MG RESISTOR		
	Q 330	2SC3576-JVC-T	TRANSISTOR				R 243	NRSA63J-104X	MG RESISTOR		
	Q 332	DTC114YKA-X	CHIP D TRANSISTOR				R 244	NRSA63J-104X	MG RESISTOR		
	Q 334	DTC114YKA-X	CHIP D TRANSISTOR				R 245	NRSA63J-104X	MG RESISTOR		
	Q 342	DTA114YKA-X	TRANSISTOR				R 246	NRSA63J-104X	MG RESISTOR		
	Q 343	DTA114YKA-X	TRANSISTOR				R 247	QRA14CF-1001Y	MF RESISTOR	10 1/4W	
	Q 345	DTA114YKA-X	TRANSISTOR				R 248	QRA14CF-1001Y	MF RESISTOR	10 1/4W	
	Q 351	KRC105M-T	D TRANSISTOR				R 249	QRA14CF-1001Y	MF RESISTOR	10 1/4W	
	Q 401	KTA1267/YG/-T	TRANSISTOR				R 250	QRA14CF-1001Y	MF RESISTOR	10 1/4W	
	Q 402	KTA1267/YG/-T	TRANSISTOR				R 251	NRSA63J-471X	MG RESISTOR		
	Q 403	KRC110M-T	TRANSISTOR				R 252	NRSA63J-471X	MG RESISTOR		
	Q 404	KRC107M-T	D TRANSISTOR				R 253	NRSA63J-471X	MG RESISTOR		
	Q 405	KTA1267/YG/-T	TRANSISTOR				R 254	NRSA63J-471X	MG RESISTOR		
	Q 406	KTA1267/YG/-T	TRANSISTOR				R 255	NRSA63J-471X	MG RESISTOR		
	Q 407	KTA1267/YG/-T	TRANSISTOR				R 256	NRSA63J-471X	MG RESISTOR		
	Q 408	KTA1267/YG/-T	TRANSISTOR				R 257	NRSA63J-471X	MG RESISTOR		
	Q 431	KTA1267/YG/-T	TRANSISTOR				R 258	NRSA63J-471X	MG RESISTOR		
	Q 432	KTA1267/YG/-T	TRANSISTOR				R 259	NRSA63J-471X	MG RESISTOR		
	Q 433	KTA1267/YG/-T	TRANSISTOR				R 260	NRSA63J-471X	MG RESISTOR		
	Q 434	KTA1267/YG/-T	TRANSISTOR				R 261	NRSA63J-561X	MG RESISTOR		
	Q 461	DTC114EKA-X	TRANSISTOR				R 262	NRSA63J-561X	MG RESISTOR		
	Q 462	DTC114EKA-X	TRANSISTOR				R 263	NRSA63J-561X	MG RESISTOR		
	Q 463	DTC114EKA-X	TRANSISTOR				R 264	NRSA63J-561X	MG RESISTOR		
	Q 464	KTC3199/GL/-T	TRANSISTOR				R 265	NRSA63J-561X	MG RESISTOR		
	Q 465	KTC3199/GL/-T	TRANSISTOR				R 266	NRSA63J-561X	MG RESISTOR		
	Q 466	KTC3199/GL/-T	TRANSISTOR			△	R 267	QRZ9005-680X	F RESISTOR	68 1/4W	
	Q 467	KTA1267/YG/-T	TRANSISTOR			△	R 268	QRZ9005-680X	F RESISTOR	68 1/4W	
	Q2011	2SC3576-JVC-T	TRANSISTOR			△	R 269	QRZ9005-680X	F RESISTOR	68 1/4W	
	Q2012	2SC3576-JVC-T	TRANSISTOR			△	R 270	QRZ9005-680X	F RESISTOR	68 1/4W	
	Q2013	KRA104M-T	D TRANSISTOR			△	R 281	QRZ9005-680X	F RESISTOR	68 1/4W	
	Q2041	2SC3576-JVC-T	TRANSISTOR			△	R 282	QRZ9005-680X	F RESISTOR	68 1/4W	
	Q2042	2SC3576-JVC-T	TRANSISTOR				R 291	QRA14CF-1001Y	MF RESISTOR	10 1/4W	
	Q2043	KRA104M-T	D TRANSISTOR				R 292	QRA14CF-1001Y	MF RESISTOR	10 1/4W	
	Q2111	KTC3199/GL/-T	TRANSISTOR				R 293	NRSA63J-103X	MG RESISTOR		
	Q2112	DTC144ESA-T	D TRANSISTOR				R 294	NRSA63J-103X	MG RESISTOR		
	Q2501	KTC3199/GL/-T	TRANSISTOR				R 295	QRA14CF-1001Y	MF RESISTOR	10 1/4W	
	Q4001	KTA1267/YG/-T	TRANSISTOR				R 296	QRA14CF-1001Y	MF RESISTOR	10 1/4W	
	Q4002	KTA1267/YG/-T	TRANSISTOR				R 297	NRSA63J-103X	MG RESISTOR		
	Q4003	KTA1267/YG/-T	TRANSISTOR				R 298	NRSA63J-103X	MG RESISTOR		
	R 201	NRSA63J-222X	MG RESISTOR				R 299	QRA14CF-1001Y	MF RESISTOR	10 1/4W	
	R 202	NRSA63J-222X	MG RESISTOR				R 300	QRA14CF-1001Y	MF RESISTOR	10 1/4W	
	R 203	NRSA63J-473X	MG RESISTOR				R 301	NRSA63J-103X	MG RESISTOR		
	R 204	NRSA63J-473X	MG RESISTOR				R 302	NRSA63J-103X	MG RESISTOR		
	R 205	NRSA63J-221X	MG RESISTOR				R 303	QRA14CF-1001Y	MF RESISTOR	10 1/4W	
	R 206	NRSA63J-221X	MG RESISTOR				R 304	QRA14CF-1001Y	MF RESISTOR	10 1/4W	
	R 207	NRSA63J-153X	MG RESISTOR				R 305	NRSA63J-103X	MG RESISTOR		
	R 208	NRSA63J-153X	MG RESISTOR				R 306	NRSA63J-103X	MG RESISTOR		
	R 209	NRSA63J-184X	MG RESISTOR				R 307	NRSA63J-102X	MG RESISTOR		
	R 210	NRSA63J-184X	MG RESISTOR				R 308	NRSA63J-474X	MG RESISTOR		

■ Electrical parts list
(Audio/video input & output board)

Block No. 02

△	Item	Parts number	Parts name	Remarks	Area	△	Item	Parts number	Parts name	Remarks	Area
	R 311	NRSA63J-102X	MG RESISTOR				R 414	NRSA63J-473X	MG RESISTOR		
	R 312	NRSA63J-102X	MG RESISTOR				R 415	NRSA63J-151X	MG RESISTOR		
	R 313	NRSA63J-102X	MG RESISTOR				R 416	NRSA63J-151X	MG RESISTOR		
	R 314	NRSA63J-102X	MG RESISTOR				R 417	NRSA63J-301X	MG RESISTOR		
	R 315	NRSA63J-102X	MG RESISTOR				R 418	NRSA63J-103X	MG RESISTOR		
	R 316	NRSA63J-102X	MG RESISTOR				R 419	NRSA63J-331X	MG RESISTOR		
	R 319	QRA14CF-1001Y	MF RESISTOR	10 1/4W			R 420	NRSA63J-101X	MG RESISTOR		
	R 320	NRSA63J-103X	MG RESISTOR				R 421	NRSA63J-121X	MG RESISTOR		
	R 321	NRSA63J-471X	MG RESISTOR				R 422	NRSA63J-151X	MG RESISTOR		
	R 322	NRSA63J-471X	MG RESISTOR				R 423	NRSA63J-561X	MG RESISTOR		
	R 323	NRSA63J-471X	MG RESISTOR				R 424	NRSA63J-561X	MG RESISTOR		
	R 324	NRSA63J-471X	MG RESISTOR				R 425	NRSA63J-561X	MG RESISTOR		
	R 325	NRSA63J-471X	MG RESISTOR			△	R 426	QRJ146J-1R0X	UNF C RESISTOR	1.0 5% 1/4W	
	R 326	NRSA63J-471X	MG RESISTOR				R 427	NRSA63J-222X	MG RESISTOR		
	R 327	NRSA63J-471X	MG RESISTOR				R 431	NRSA63J-750X	MG RESISTOR		
	R 328	NRSA63J-471X	MG RESISTOR				R 432	NRSA63J-750X	MG RESISTOR		
	R 329	NRSA63J-471X	MG RESISTOR				R 433	NRSA63J-750X	MG RESISTOR		
	R 330	NRSA63J-471X	MG RESISTOR				R 434	NRSA63J-750X	MG RESISTOR		
	R 331	NRSA63J-471X	MG RESISTOR				R 435	NRSA63J-473X	MG RESISTOR		
	R 332	NRSA63J-471X	MG RESISTOR				R 436	NRSA63J-750X	MG RESISTOR		
	R 333	NRSA63J-471X	MG RESISTOR				R 437	NRSA63J-750X	MG RESISTOR		
	R 334	NRSA63J-471X	MG RESISTOR				R 438	NRSA63J-750X	MG RESISTOR		
	R 335	NRSA63J-471X	MG RESISTOR				R 439	NRSA63J-750X	MG RESISTOR		
	R 336	NRSA63J-471X	MG RESISTOR				R 440	NRSA63J-473X	MG RESISTOR		
	R 337	NRSA63J-471X	MG RESISTOR				R 441	NRSA63J-750X	MG RESISTOR		
	R 338	NRSA63J-471X	MG RESISTOR				R 442	NRSA63J-750X	MG RESISTOR		
△	R 339	QRZ9005-680X	F RESISTOR	68 1/4W			R 443	NRSA63J-750X	MG RESISTOR		
△	R 340	QRZ9005-680X	F RESISTOR	68 1/4W			R 444	NRSA63J-750X	MG RESISTOR		
	R 341	NRSA63J-471X	MG RESISTOR				R 445	NRSA63J-750X	MG RESISTOR		
	R 342	NRSA63J-471X	MG RESISTOR				R 446	NRSA63J-750X	MG RESISTOR		
	R 345	NRSA63J-471X	MG RESISTOR				R 447	NRSA63J-473X	MG RESISTOR		
	R 346	NRSA63J-471X	MG RESISTOR				R 448	NRSA63J-121X	MG RESISTOR		
	R 347	NRSA63J-103X	MG RESISTOR				R 449	NRSA63J-121X	MG RESISTOR		
	R 348	NRSA63J-103X	MG RESISTOR				R 450	NRSA63J-151X	MG RESISTOR		
	R 349	NRSA63J-471X	MG RESISTOR				R 451	NRSA63J-151X	MG RESISTOR		
	R 350	NRSA63J-103X	MG RESISTOR			△	R 452	QRJ146J-6R8X	UNF C RESISTOR	6.8 5% 1/4W	
	R 351	NRSA63J-471X	MG RESISTOR			△	R 453	QRJ146J-2R2X	UNF C RESISTOR	2.2 5% 1/4W	
	R 352	NRSA63J-471X	MG RESISTOR				R 461	NRSA63J-562X	MG RESISTOR		
	R 355	NRSA63J-471X	MG RESISTOR				R 462	NRSA63J-562X	MG RESISTOR		
	R 356	NRSA63J-471X	MG RESISTOR				R 463	NRSA63J-562X	MG RESISTOR		
	R 357	NRSA63J-103X	MG RESISTOR				R 464	NRSA63J-562X	MG RESISTOR		
	R 358	NRSA63J-103X	MG RESISTOR				R 465	NRSA63J-562X	MG RESISTOR		
	R 363	NRSA63J-102X	MG RESISTOR				R 466	NRSA63J-223X	MG RESISTOR		
	R 364	NRSA63J-474X	MG RESISTOR				R 467	NRSA63J-223X	MG RESISTOR		
	R 365	NRSA63J-102X	MG RESISTOR				R 468	NRSA63J-223X	MG RESISTOR		
	R 366	NRSA63J-474X	MG RESISTOR				R 469	NRSA63J-104X	MG RESISTOR		
	R 369	NRSA63J-102X	MG RESISTOR				R 470	NRSA63J-334X	MG RESISTOR		
	R 370	NRSA63J-474X	MG RESISTOR				R 471	NRSA63J-472X	MG RESISTOR		
	R 399	NRSA63J-471X	MG RESISTOR				R 472	NRSA63J-472X	MG RESISTOR		
	R 400	NRSA63J-471X	MG RESISTOR				R 473	NRSA63J-472X	MG RESISTOR		
	R 401	NRSA63J-750X	MG RESISTOR				R 474	NRSA63J-103X	MG RESISTOR		
	R 402	NRSA63J-750X	MG RESISTOR				R 475	NRSA63J-103X	MG RESISTOR		
	R 403	NRSA63J-750X	MG RESISTOR				R 476	NRSA63J-103X	MG RESISTOR		
	R 404	NRSA63J-750X	MG RESISTOR				RY240	QSK0125-001	RELAY		
	R 405	NRSA63J-750X	MG RESISTOR				RY351	QSK0125-001	RELAY		
	R 406	NRSA63J-750X	MG RESISTOR			△	R1351	QRZ9005-331X	F RESISTOR	330 1/4W	
	R 407	NRSA63J-750X	MG RESISTOR			△	R2001	QRZ9005-680X	F RESISTOR	68 1/4W	
	R 408	NRSA63J-331X	MG RESISTOR			△	R2002	QRZ9005-680X	F RESISTOR	68 1/4W	
	R 409	NRSA63J-473X	MG RESISTOR				R2011	NRSA63J-104X	MG RESISTOR		
	R 410	NRSA63J-331X	MG RESISTOR				R2012	NRSA63J-104X	MG RESISTOR		
	R 411	NRSA63J-473X	MG RESISTOR				R2013	NRSA63J-104X	MG RESISTOR		
	R 412	NRSA63J-331X	MG RESISTOR				R2014	NRSA63J-104X	MG RESISTOR		
	R 413	NRSA63J-331X	MG RESISTOR				R2015	NRSA63J-104X	MG RESISTOR		

■ Electrical parts list
(Audio/video input & output board)

Block No. 02

△	Item	Parts number	Parts name	Remarks	Area	△	Item	Parts number	Parts name	Remarks	Area
	R2016	NRSA63J-104X	MG RESISTOR				R2111	NRSA63J-473X	MG RESISTOR		
△	R2017	QRZ9005-680X	F RESISTOR	68 1/4W			R2112	NRSA63J-104X	MG RESISTOR		
△	R2018	QRZ9005-680X	F RESISTOR	68 1/4W			R2113	NRSA63J-102X	MG RESISTOR		
	R2021	NRSA63J-334X	MG RESISTOR				R2114	NRSA63J-102X	MG RESISTOR		
	R2022	NRSA63J-334X	MG RESISTOR				R2115	NRSA63J-473X	MG RESISTOR		
	R2023	NRSA63J-102X	MG RESISTOR				R2116	NRSA63J-102X	MG RESISTOR		
	R2024	NRSA63J-102X	MG RESISTOR				R2117	NRSA63J-104X	MG RESISTOR		
	R2025	NRSA63J-103X	MG RESISTOR				R2118	NRSA63J-103X	MG RESISTOR		
	R2026	NRSA63J-103X	MG RESISTOR				R2119	NRSA63J-103X	MG RESISTOR		
	R2027	NRSA63J-102X	MG RESISTOR				R2120	NRSA63J-103X	MG RESISTOR		
	R2028	NRSA63J-474X	MG RESISTOR				R2121	NRSA63J-332X	MG RESISTOR		
	R2031	NRSA63J-104X	MG RESISTOR				R2122	NRSA63J-103X	MG RESISTOR		
	R2032	NRSA63J-104X	MG RESISTOR				R2123	NRSA63J-103X	MG RESISTOR		
	R2033	NRSA63J-102X	MG RESISTOR			△	R2124	QRJ146J-101X	UNF C RESISTOR	100 5% 1/4W	
	R2034	NRSA63J-102X	MG RESISTOR				R2211	NRSA63J-102X	MG RESISTOR		
	R2035	NRSA63J-512X	MG RESISTOR				R2212	NRSA63J-102X	MG RESISTOR		
	R2036	NRSA63J-512X	MG RESISTOR				R2213	NRSA63J-102X	MG RESISTOR		
	R2037	NRSA63J-104X	MG RESISTOR				R2214	NRSA63J-102X	MG RESISTOR		
	R2038	NRSA63J-104X	MG RESISTOR				R2215	NRSA63J-102X	MG RESISTOR		
△	R2039	QRZ9005-680X	F RESISTOR	68 1/4W			R2216	NRSA63J-102X	MG RESISTOR		
△	R2040	QRZ9005-680X	F RESISTOR	68 1/4W			R2259	NRSA63J-333X	MG RESISTOR		
	R2041	NRSA63J-102X	MG RESISTOR				R2260	NRSA63J-333X	MG RESISTOR		
	R2042	NRSA63J-102X	MG RESISTOR				R2261	NRSA63J-333X	MG RESISTOR		
	R2043	NRSA63J-103X	MG RESISTOR				R2262	NRSA63J-333X	MG RESISTOR		
	R2044	NRSA63J-103X	MG RESISTOR				R2263	NRSA63J-333X	MG RESISTOR		
	R2045	NRSA63J-474X	MG RESISTOR				R2264	NRSA63J-333X	MG RESISTOR		
	R2046	NRSA63J-102X	MG RESISTOR				R2265	NRSA63J-333X	MG RESISTOR		
	R2051	NRSA63J-334X	MG RESISTOR				R2266	NRSA63J-333X	MG RESISTOR		
	R2052	NRSA63J-334X	MG RESISTOR				R2267	NRSA63J-333X	MG RESISTOR		
	R2053	NRSA63J-104X	MG RESISTOR				R2268	NRSA63J-333X	MG RESISTOR		
	R2054	NRSA63J-104X	MG RESISTOR				R2269	NRSA63J-102X	MG RESISTOR		
	R2055	NRSA63J-104X	MG RESISTOR				R2270	NRSA63J-102X	MG RESISTOR		
	R2056	NRSA63J-104X	MG RESISTOR				R2271	NRSA63J-102X	MG RESISTOR		
△	R2057	QRZ9005-680X	F RESISTOR	68 1/4W			R2272	NRSA63J-102X	MG RESISTOR		
△	R2058	QRZ9005-680X	F RESISTOR	68 1/4W		△	R2275	QRZ9005-680X	F RESISTOR	68 1/4W	
	R2059	NRSA63J-334X	MG RESISTOR			△	R2276	QRZ9005-680X	F RESISTOR	68 1/4W	
	R2060	NRSA63J-334X	MG RESISTOR				R2301	NRSA63J-682X	MG RESISTOR		
	R2061	NRSA63J-104X	MG RESISTOR				R2302	NRSA63J-682X	MG RESISTOR		
	R2062	NRSA63J-104X	MG RESISTOR				R2303	NRSA63J-102X	MG RESISTOR		
	R2063	NRSA63J-104X	MG RESISTOR				R2304	NRSA63J-102X	MG RESISTOR		
	R2064	NRSA63J-104X	MG RESISTOR				R2316	NRSA63J-103X	MG RESISTOR		
△	R2065	QRZ9005-680X	F RESISTOR	68 1/4W			R2317	NRSA63J-103X	MG RESISTOR		
△	R2066	QRZ9005-680X	F RESISTOR	68 1/4W			R2351	QRA14CF-1001Y	MF RESISTOR	10 1/4W	
	R2067	NRSA63J-334X	MG RESISTOR				R2352	QRA14CF-1001Y	MF RESISTOR	10 1/4W	
	R2068	NRSA63J-334X	MG RESISTOR				R2353	QRA14CF-5101Y	MF RESISTOR	51 1/4W	
	R2069	NRSA63J-104X	MG RESISTOR				R2354	QRA14CF-5101Y	MF RESISTOR	51 1/4W	
	R2070	NRSA63J-104X	MG RESISTOR				R2355	QRA14CF-1001Y	MF RESISTOR	10 1/4W	
	R2071	NRSA63J-104X	MG RESISTOR				R2356	QRA14CF-1001Y	MF RESISTOR	10 1/4W	
	R2072	NRSA63J-104X	MG RESISTOR				R2357	QRA14CF-5101Y	MF RESISTOR	51 1/4W	
△	R2073	QRZ9005-680X	F RESISTOR	68 1/4W			R2358	QRA14CF-1802Y	MF RESISTOR	18 1/4W	
△	R2074	QRZ9005-680X	F RESISTOR	68 1/4W			R2359	QRA14CF-1001Y	MF RESISTOR	10 1/4W	
	R2075	NRSA63J-334X	MG RESISTOR				R2360	QRA14CF-1001Y	MF RESISTOR	10 1/4W	
	R2076	NRSA63J-334X	MG RESISTOR				R2361	QRA14CF-5101Y	MF RESISTOR	51 1/4W	
	R2077	NRSA63J-104X	MG RESISTOR				R2362	QRA14CF-5101Y	MF RESISTOR	51 1/4W	
	R2078	NRSA63J-104X	MG RESISTOR				R2363	QRA14CF-1001Y	MF RESISTOR	10 1/4W	
	R2079	NRSA63J-104X	MG RESISTOR				R2364	QRA14CF-1001Y	MF RESISTOR	10 1/4W	
	R2080	NRSA63J-104X	MG RESISTOR				R2365	QRA14CF-5101Y	MF RESISTOR	51 1/4W	
△	R2081	QRZ9005-680X	F RESISTOR	68 1/4W			R2366	QRA14CF-5101Y	MF RESISTOR	51 1/4W	
△	R2082	QRZ9005-680X	F RESISTOR	68 1/4W			R2401	NRSA63J-104X	MG RESISTOR		
	R2091	NRSA63J-222X	MG RESISTOR				R2402	NRSA63J-104X	MG RESISTOR		
	R2092	NRSA63J-222X	MG RESISTOR				R2403	NRSA63J-104X	MG RESISTOR		
	R2093	NRSA63J-471X	MG RESISTOR				R2404	NRSA63J-104X	MG RESISTOR		
	R2094	NRSA63J-471X	MG RESISTOR				R2405	NRSA63J-104X	MG RESISTOR		

■ Electrical parts list

(Audio/video input & output board)

Block No. 02

△	Item	Parts number	Parts name	Remarks	Area
	R2406	NRSA63J-104X	MG RESISTOR		
	R2411	NRSA63J-104X	MG RESISTOR		
	R2412	NRSA63J-104X	MG RESISTOR		
	R2413	NRSA63J-104X	MG RESISTOR		
	R2414	NRSA63J-104X	MG RESISTOR		
	R2415	NRSA63J-104X	MG RESISTOR		
	R2416	NRSA63J-104X	MG RESISTOR		
	R2421	NRSA63J-104X	MG RESISTOR		
	R2422	NRSA63J-104X	MG RESISTOR		
	R2423	NRSA63J-104X	MG RESISTOR		
	R2424	NRSA63J-104X	MG RESISTOR		
	R2425	NRSA63J-104X	MG RESISTOR		
	R2426	NRSA63J-104X	MG RESISTOR		
	R2501	NRSA63J-333X	MG RESISTOR		
	R2502	NRSA63J-333X	MG RESISTOR		
	R2503	NRSA63J-104X	MG RESISTOR		
	R2504	NRSA63J-104X	MG RESISTOR		
	R2505	NRSA63J-223X	MG RESISTOR		
	R2506	NRSA63J-223X	MG RESISTOR		
	R2507	NRSA63J-333X	MG RESISTOR		
	R2508	NRSA63J-333X	MG RESISTOR		
	R2509	NRSA63J-622X	MG RESISTOR		
	R2510	NRSA63J-102X	MG RESISTOR		
	R2511	NRSA63J-103X	MG RESISTOR		
	R4001	NRSA63J-750X	MG RESISTOR		
	R4002	NRSA63J-471X	MG RESISTOR		
	R4003	NRSA63J-473X	MG RESISTOR		
	R4004	NRSA63J-101X	MG RESISTOR		
	R4005	NRSA63J-121X	MG RESISTOR		
	R4006	NRSA63J-151X	MG RESISTOR		
	R4031	NRSA63J-750X	MG RESISTOR		
	R4032	NRSA63J-750X	MG RESISTOR		
	R4033	NRSA63J-473X	MG RESISTOR		
	R4034	NRSA63J-471X	MG RESISTOR		
	SP403	VYH7653-001	IC HOLDER		
	WR204	QJK016-031803	SIN CR C-B WIRE		
	WR307	QJP001-031001	SHI CR C-B WIRE		
	WR318	QJK016-031403	SIN CR C-B WIRE		
	WR322	WJP0032-001A	E-SH C WIRE C-B		
	WR323	QJK016-111401	SIN CR C-B WIRE		
	WR324	WJK0130-001A	E-SI C WIRE C-B		
	X 401	QAX0260-001Z	CRYSTAL		

■ Electrical parts list (Power supply board)

Block No. 03

△	Item	Parts number	Parts name	Remarks	Area	△	Item	Parts number	Parts name	Remarks	Area
	C 1	QER61CM-107Z	E CAPACITOR	100MF 20% 16V			D 1	1SS133-T2	SI DIODE		
△	C 21	QCZ9104-472	C CAPACITOR	4700PF			D 2	1SS133-T2	SI DIODE		
	C 22	QFN32AK-472Z	M CAPACITOR	4700PF 10% 100V			D 3	MTZJ4.7B-T2	ZENER DIODE		
	C 23	QETM1EM-228	E CAPACITOR	2200MF 20% 25V			D 4	1SS133-T2	SI DIODE		
	C 24	QCF31HZ-472Z	C CAPACITOR	4700PF +80:-20%			D 5	1SS133-T2	SI DIODE		
	C 25	QETN1CM-477Z	E CAPACITOR	470MF 20% 16V			D 7	1SS133-T2	SI DIODE		
	C 26	QCF31HZ-472Z	C CAPACITOR	4700PF +80:-20%		△	D 21	1SR35-400A-T5	DIODE		
	C 27	QETN1CM-477Z	E CAPACITOR	470MF 20% 16V		△	D 22	1SR35-400A-T5	DIODE		
	C 41	QFVJ1HJ-104Z	MF CAPACITOR	0.1MF 5% 50V		△	D 23	1SR35-400A-T5	DIODE		
	C 42	QETM1EM-478	E CAPACITOR	4700MF 20% 25V		△	D 24	1SR35-400A-T5	DIODE		
	C 43	QCF31HZ-472Z	C CAPACITOR	4700PF +80:-20%			D 25	1SS133-T2	SI DIODE		
	C 44	QEHR1EM-107Z	E CAPACITOR	100MF 20% 25V			D 26	MTZJ6.2A-T2	ZENER DIODE		
	C 45	QCF31HZ-472Z	C CAPACITOR	4700PF +80:-20%			D 27	MTZJ6.2A-T2	ZENER DIODE		
	C 46	QEHR1EM-107Z	E CAPACITOR	100MF 20% 25V		△	D 41	1GWJ42-T5	DIODE		
	C 47	QCF31HZ-472Z	C CAPACITOR	4700PF +80:-20%		△	D 42	1GWJ42-T5	DIODE		
	C 48	QEHR1EM-107Z	E CAPACITOR	100MF 20% 25V		△	D 43	1GWJ42-T5	DIODE		
	C 49	QEHR1EM-107Z	E CAPACITOR	100MF 20% 25V		△	D 44	1GWJ42-T5	DIODE		
	C 50	QCF31HZ-472Z	C CAPACITOR	4700PF +80:-20%			D 45	1SS133-T2	SI DIODE		
	C 51	QETN1JM-227Z	E CAPACITOR	220MF 20% 63V			D 46	MTZJ6.2C-T2	ZENER DIODE		
	C 52	QETN1HM-226Z	E CAPACITOR	22MF 20% 50V			D 47	1SS133-T2	SI DIODE		
	C 53	QETN1HM-226Z	E CAPACITOR	22MF 20% 50V			D 48	MTZJ6.2C-T2	ZENER DIODE		
	C 54	QETN1HM-105Z	E CAPACITOR	1.0MF 20% 50V			D 49	1SS133-T2	SI DIODE		
	C 55	QFN31HJ-473Z	M CAPACITOR	0.047MF 5% 50V			D 50	MTZJ6.2C-T2	ZENER DIODE		
	C 56	QFN31HJ-473Z	M CAPACITOR	0.047MF 5% 50V			D 51	1SS133-T2	SI DIODE		
	C 60	QEHC1EM-227Z	E CAPACITOR	220MF 20% 25V			D 52	MTZJ6.8C-T2	ZENER DIODE		
	C 61	QFN32AJ-104Z	M CAPACITOR	0.1MF 5% 100V		△	D 53	1SR35-400A-T5	DIODE		
	C 62	QFN32AJ-104Z	M CAPACITOR	0.1MF 5% 100V			D 55	MTZJ36C-T2	ZENER DIODE		
	C 63	QFN32AJ-104Z	M CAPACITOR	0.1MF 5% 100V			D 56	MTZJ8.2C-T2	ZENER DIODE		
	C 64	QFN32AJ-104Z	M CAPACITOR	0.1MF 5% 100V		△	D 61	1SR35-400A-T5	DIODE		
	C 65	QFN32AJ-104Z	M CAPACITOR	0.1MF 5% 100V		△	D 62	1SR35-400A-T5	DIODE		
	C 66	QETM1VM-228	E CAPACITOR	2200MF 20% 35V		△	D 63	1SR35-400A-T5	DIODE		
	C 67	QETM1VM-228	E CAPACITOR	2200MF 20% 35V		△	D 64	1SR35-400A-T5	DIODE		
	C 68	QCF31HZ-472Z	C CAPACITOR	4700PF +80:-20%			D 65	1SS133-T2	SI DIODE		
	C 69	QEHC1EM-227Z	E CAPACITOR	220MF 20% 25V			D 66	MTZJ15C-T2	ZENER DIODE		
	C 70	QCF31HZ-472Z	C CAPACITOR	4700PF +80:-20%			D 67	1SS133-T2	SI DIODE		
	C 71	QEHC1EM-107Z	E CAPACITOR	100MF 20% 25V			D 68	MTZJ13C-T2	ZENER DIODE		
	C 72	QCF31HZ-472Z	C CAPACITOR	4700PF +80:-20%			D 69	1SS133-T2	SI DIODE		
	C 73	QEHC1EM-227Z	E CAPACITOR	220MF 20% 25V			D 70	MTZJ15C-T2	ZENER DIODE		
	C 74	QETN1HM-475Z	E CAPACITOR	4.7MF 20% 50V			D 71	1SS133-T2	SI DIODE		
	C 75	QEHR1VM-107Z	E CAPACITOR	100MF 20% 35V			D 72	1SS133-T2	SI DIODE		
	C 76	QCF31HZ-472Z	C CAPACITOR	4700PF +80:-20%			D 73	MTZJ24C-T2	ZENER DIODE		
	CN 1	QGF1205C1-16	CONNECTOR				EP 21	QNZ0136-001Z	EARTH PLATE		
	CN 2	QGF1205C1-20	CONNECTOR				EP 22	QNZ0136-001Z	EARTH PLATE		
	CN 3	QGB2510J1-11	CONNECTOR				EP 61	QNZ0136-001Z	EARTH PLATE		
	CN 4	QGB2510J1-04	CONNECTOR				FC 21	QNG0020-001Z	FUSE CLIP	F21	
	CN 5	QGB2510J1-20	CONNECTOR				FC 22	QNG0020-001Z	FUSE CLIP	F21	
	CN 6	QGB1214J1-20S	CONNECTOR				FC 41	QNG0020-001Z	FUSE CLIP	F41	
	CN 7	QGB1214J1-16S	CONNECTOR				FC 42	QNG0020-001Z	FUSE CLIP	F41	
	CN 8	QGB2510J1-15	CONNECTOR				FC 43	QNG0020-001Z	FUSE CLIP	F42	
	CN 9	QGB2510J1-08	CONNECTOR				FC 44	QNG0020-001Z	FUSE CLIP	F42	
	CN 11	QGA2001C1-08	8P PLUG ASSY				FC 61	QNG0020-001Z	FUSE CLIP	F61	
	CN 15	QGB2510J1-07	CONNECTOR				FC 62	QNG0020-001Z	FUSE CLIP	F61	
	CN 16	QGA2001C1-11	11P PLUG ASSY				FC 63	QNG0020-001Z	FUSE CLIP	F62	
	CN 17	QGA2001C1-05	5P PLUG ASSY				FC 64	QNG0020-001Z	FUSE CLIP	F62	
	CN 25	QGA2001C1-07	7P PLUG ASSY				HS 41	E70306-005	HEAT SINK		
	CN 41	QGA7901C1-02	CONNECTOR				HS 42	E70306-005	HEAT SINK		
	CN 42	QGA2001F1-05	5P PLUG ASSY				HS 61	E70306-001	HEAT SINK		
	CN 43	QGA2001F1-08	CONNECTOR				HS 62	E70306-001	HEAT SINK		
	CN 45	QGA2001F1-06	6P PLUG ASSY				HS 63	E70306-001	HEAT SINK		
	CN 61	QGA7901C1-04	CONNECTOR				J 81	QNS0061-001	6.3 JACK		
	CN 63	QGA2001C1-08	8P PLUG ASSY				PW 23	WJK0132-001A	E-SI C WIRE C-B		
	CN 64	QGA2001C1-03	3P PLUG ASSY				Q 1	2SC1740S/RS-T	TRANSISTOR		
	CN 65	QGA2501C1-02	2P CONNECTOR				Q 2	KRC102M-T	D TRANSISTOR		

■ Electrical parts list (Power supply board) Block No. 03

△	Item	Parts number	Parts name	Remarks	Area
	Q 21	KRC105M-T	D TRANSISTOR		
	Q 22	2SC2235/OY/-T	TRANSISTOR		
	Q 23	2SC2235/OY/-T	TRANSISTOR		
	Q 41	2SD2394/EF/	TRANSISTOR		
	Q 42	2SD2394/EF/	TRANSISTOR		
	Q 43	2SD2394/EF/	TRANSISTOR		
	Q 44	2SD2394/EF/	TRANSISTOR		
△	Q 45	2SB1357/EF/-T	TRANSISTOR		
	Q 46	KRC102M-T	D TRANSISTOR		
	Q 47	KRA104M-T	D TRANSISTOR		
	Q 48	KTC3200/GL/-T	TRANSISTOR		
	Q 49	KRA104M-T	D TRANSISTOR		
	Q 50	KRC102M-T	D TRANSISTOR		
	Q 51	KRA104M-T	D TRANSISTOR		
	Q 52	KRC102M-T	D TRANSISTOR		
	Q 53	KRA104M-T	D TRANSISTOR		
	Q 54	KRC102M-T	D TRANSISTOR		
	Q 55	KRC102M-T	D TRANSISTOR		
	Q 56	KRC102M-T	D TRANSISTOR		
	Q 61	2SD2394/EF/	TRANSISTOR		
	Q 62	2SD2394/EF/	TRANSISTOR		
	Q 63	KTA1046/Y/	TRANSISTOR		
	Q 64	2SD2394/EF/	TRANSISTOR		
	Q 65	KRC102M-T	D TRANSISTOR		
	Q 66	KRA104M-T	D TRANSISTOR		
	R 2	QRE141J-222Y	C RESISTOR	2.2K 5% 1/4W	
	R 3	QRE141J-473Y	C RESISTOR	47K 5% 1/4W	
	R 4	QRE141J-103Y	C RESISTOR	10K 5% 1/4W	
△	R 21	QRZ9037-335	COMP RESISTOR	3.3M 1/4W	
△	R 22	QRJ146J-3R9X	UNF C RESISTOR	3.9 5% 1/4W	
	R 23	QRE141J-821Y	C RESISTOR	820 5% 1/4W	
	R 24	QRE141J-821Y	C RESISTOR	820 5% 1/4W	
△	R 25	QRJ146J-3R9X	UNF C RESISTOR	3.9 5% 1/4W	
	R 41	QRJ146J-1R0X	UNF C RESISTOR	1.0 5% 1/4W	
	R 42	QRJ146J-122X	UNF C RESISTOR	1.2K 5% 1/4W	
	R 43	QRJ146J-1R0X	UNF C RESISTOR	1.0 5% 1/4W	
	R 44	QRJ146J-122X	UNF C RESISTOR	1.2K 5% 1/4W	
	R 45	QRJ146J-1R0X	UNF C RESISTOR	1.0 5% 1/4W	
	R 46	QRJ146J-122X	UNF C RESISTOR	1.2K 5% 1/4W	
	R 47	QRJ146J-1R0X	UNF C RESISTOR	1.0 5% 1/4W	
	R 48	QRJ146J-122X	UNF C RESISTOR	1.2K 5% 1/4W	
△	R 49	QRT017J-2R2	MF RESISTOR	2.2 5% 1/1W	
△	R 50	QRT017J-2R2	MF RESISTOR	2.2 5% 1/1W	
△	R 51	QRJ146J-332X	UNF C RESISTOR	3.3K 5% 1/4W	
	R 52	QRE141J-223Y	C RESISTOR	22K 5% 1/4W	
	R 53	QRE141J-104Y	C RESISTOR	100K 5% 1/4W	
	R 54	QRE141J-103Y	C RESISTOR	10K 5% 1/4W	
	R 55	QRE141J-103Y	C RESISTOR	10K 5% 1/4W	
△	R 61	QRL027J-180	UNF MF RESISTOR	18 5% 1/2W	
	R 62	QRZ9006-6R8X	F RESISTOR	6.8 1/4W	
	R 63	QRJ146J-222X	UNF C RESISTOR	2.2K 5% 1/4W	
	R 64	QRZ9005-120X	F RESISTOR	12 1/4W	
	R 65	QRJ146J-272X	UNF C RESISTOR	2.7K 5% 1/4W	
△	R 66	QRL027J-270	UNF MF RESISTOR	27 5% 1/2W	
	R 67	QRZ9006-6R8X	F RESISTOR	6.8 1/4W	
	R 68	QRJ146J-222X	UNF C RESISTOR	2.2K 5% 1/4W	
	R 69	QRE141J-562Y	C RESISTOR	5.6K 5% 1/4W	
	R 70	QRE141J-822Y	C RESISTOR	8.2K 5% 1/4W	
	R 71	QRE141J-103Y	C RESISTOR	10K 5% 1/4W	
	R 72	QRZ9006-6R8X	F RESISTOR	6.8 1/4W	
	R 73	QRJ146J-103X	UNF C RESISTOR	10K 5% 1/4W	
	R 74	QRZ9006-6R8X	F RESISTOR	6.8 1/4W	
	R 81	QRL027J-471	UNF OMF RESISTOR	470 5% 1/2W	

△	Item	Parts number	Parts name	Remarks	Area
	R 82	QRL027J-471	UNF OMF RESISTOR	470 5% 1/2W	
△	RY 21	QSK0098-001	RELAY		
△	T 21	QQT0317-001	POWER TRANSF		
	TA 1	QNZ0079-001Z	TAB		
	TA 2	QNZ0079-001Z	TAB		
△	TH 41	QAD0095-4R7Z	POSISTOR		
	WR 12	QJK016-055600	SIN CR C-B WIRE		
	WR 13	QJK016-086003	SIN CR C-B WIRE		
	WR 14	QJK016-100700	SIN CR C-B WIRE		
	WR 26	QJK016-071502	SIN CR C-B WIRE		
	WR 44	QJK016-060901	SIN CR C-B WIRE		
	WR 81	WJK0131-001A	E-SI C WIRE C-B		
	WR 85	QJP001-033801	SHI CR C-B WIRE		
	WR 86	QJK016-022402	SIN CR C-B WIRE		

RX-DP10RSL

■ Electrical parts list

(Front & system control board)

Block No. 04

△	Item	Parts number	Parts name	Remarks	Area	△	Item	Parts number	Parts name	Remarks	Area
	BK961	LV42093-001A	FL HOLDER(L)				D1031	SLR-342VC-T	LED		
	BK962	LV42092-001A	FL HOLDER(R)				D1032	SLR-342MC3F	LED		C
	C 471	QCSB1HJ-470Y	C CAPACITOR	47PF 5% 50V			D1032	SLA-370LT3F	LED		J
	C 472	QCSB1HJ-470Y	C CAPACITOR	47PF 5% 50V			D1033	SLA-370LT3F	LED		J
	C 473	QCSB1HJ-470Y	C CAPACITOR	47PF 5% 50V			D1033	SLR-342MC3F	LED		C
	C 475	QCBB1HK-331Y	C CAPACITOR	330PF 10% 50V			D1034	SLA-370LT3F	LED		J
	C 476	QCBB1HK-331Y	C CAPACITOR	330PF 10% 50V			D1034	SELU2E10C	LED		C
	C 478	QDVB1EZ-223Y	C CAPACITOR				D1201	1SS133-T2	SI DIODE		
	C 479	QFN31HJ-473Z	M CAPACITOR	0.047MF 5% 50V			D1202	1SS133-T2	SI DIODE		
	CN301	QGA2001F1-07	CONNECTOR				D1211	MTZJ6.2C-T2	ZENER DIODE		
	CN963	QGF1205F1-16	CONNECTOR				FS961	E3400-444	FELT SPACER		
	CN964	QGF1205F1-20	CONNECTOR				FS962	E3400-444	FELT SPACER		
	CN969	QGA2001C1-09	9P PLUG ASSY				IC301	NJM2406F-X	IC		
	CN971	QGA2001F1-02	2P CONNECTOR				IC657	AK5383VF-X	IC		
	CN973	QGA2501F1-09	CONNECTOR				IC961	MN101C49GJR	IC		
	CN975	QGA2001F1-02	2P CONNECTOR				IC962	MN101C35DHN	IC		
	CN977	QGA2001F1-04	4P PLUG ASSY				IC963	IC-PST9139-T	IC		
	CN981	QGA2001F1-02	2P CONNECTOR				IC964	GP1U271X	RM RECIVER		
	CN982	QGF1005F1-04	4P PLUG ASSY				IC967	TA8409S	IC		
	CN983	QGA2001F1-10	10P PLUG ASSY				J 471	QND0026-001	S JACK		
	CN985	QGA2001F1-06	6P PLUG ASSY				JS961	QSW0867-001	ROTARY ENCODER		
	C1001	QEKCOJM-107Z	E CAPACITOR	100MF 20% 6.3V			J1201	QNS0001-001	3.5 JACK		
	C1002	QCZ0202-155Z	ML C CAPACITOR	1.5MF			J1211	QNS0073-001	JACK		
	C1003	QEZ0361-479	E.D.L.CAPACITOR	47000MF			J1212	QNS0073-001	JACK		
	C1004	QEKCIHM-225Z	E CAPACITOR	2.2MF 20% 50V			J1213	QNS0077-001	3.5 JACK		
	C1005	QDVB1EZ-223Y	C CAPACITOR				K 472	QQR0779-001Z	INDUCTOR		
	C1006	QEKCOJM-107Z	E CAPACITOR	100MF 20% 6.3V			K1035	QQR1183-001Z	F BEADS		
	C1007	QCZ0202-155Z	ML CAPACITOR	1.5MF			Q1003	KRC107M-T	D TRANSISTOR		
	C1011	QEKCIHM-475Z	E CAPACITOR	4.7MF 20% 50V			Q1011	KRC107M-T	D TRANSISTOR		
	C1012	QEKCIHM-475Z	E CAPACITOR	4.7MF 20% 50V			Q1012	KRA107M-T	D TRANSISTOR		
	C1013	QEKCIHM-475Z	E CAPACITOR	4.7MF 20% 50V			Q1013	KRA107M-T	D TRANSISTOR		
	C1021	QCBB1HK-331Y	C CAPACITOR	330PF 10% 50V			Q1014	KRA107M-T	D TRANSISTOR		
	C1025	QEKCOJM-107Z	E CAPACITOR	100MF 20% 6.3V			Q1015	KRA107M-T	D TRANSISTOR		
	C1034	QDVB1EZ-223Y	C CAPACITOR				Q1016	KRA107M-T	D TRANSISTOR		
	C1035	QEKCIHM-476Z	E CAPACITOR	47MF 20% 16V			Q1017	KRA107M-T	D TRANSISTOR		
	C1036	QEKCIHM-106Z	E CAPACITOR	10MF 20% 16V			Q1018	KRA107M-T	D TRANSISTOR		
	C1037	QCZ0202-155Z	ML C CAPACITOR	1.5MF			Q1019	KRA107M-T	D TRANSISTOR		
	C1038	QEKCIHM-476Z	E CAPACITOR	47MF 20% 16V			Q1020	KRA107M-T	D TRANSISTOR		
	C1041	NCB31HK-471X	C CAPACITOR				Q1021	KRC111M-T	TRANSISTOR		
	C1042	NCB31HK-471X	C CAPACITOR				Q1022	KRC109M-T	D TRANSISTOR		
	C1043	NCB31HK-471X	C CAPACITOR				Q1023	KRC107M-T	D TRANSISTOR		
	C1044	NCB31HK-471X	C CAPACITOR				Q1031	KRA107M-T	D TRANSISTOR		
	C1045	NCB31HK-471X	C CAPACITOR				Q1032	KRA107M-T	D TRANSISTOR		
	C1046	NCB31HK-471X	C CAPACITOR				Q1033	KRA107M-T	D TRANSISTOR		
	C1047	NCB31HK-471X	C CAPACITOR				Q1034	KRA107M-T	D TRANSISTOR		
	C1059	NCF31CZ-104X	C CAPACITOR				Q1035	KRC103M-T	TRANSISTOR		
	C1060	NCF31CZ-104X	C CAPACITOR				Q1201	KRA107M-T	D TRANSISTOR		
	C1061	QCBB1HK-101Y	C CAPACITOR	100PF 10% 50V			Q1202	KTA1273Y/T	TRANSISTOR		
	C1201	NCB31HK-102X	C CAPACITOR				R 471	QRE141J-750Y	C RESISTOR	75 5% 1/4W	
	C1202	QFLC1HJ-104Z	M CAPACITOR	0.1MF 5% 50V			R 472	QRE141J-750Y	C RESISTOR	75 5% 1/4W	
	C1203	QETN1AM-107Z	E CAPACITOR	100MF 20% 10V			R 473	QRE141J-750Y	C RESISTOR	75 5% 1/4W	
	C1204	QETN1AM-107Z	E CAPACITOR	100MF 20% 10V			RA966	QRB169J-104	R NETWORK	100K 5% 1/6W	
	C1211	NCB31HK-221X	C CAPACITOR				R1003	QRE141J-331Y	C RESISTOR	330 5% 1/4W	
	C1212	NCB31HK-221X	C CAPACITOR				R1004	QRE141J-223Y	C RESISTOR	22K 5% 1/4W	
	C1213	NCB31HK-221X	C CAPACITOR				R1005	QRE141J-472Y	C RESISTOR	4.7K 5% 1/4W	
	DI961	QLF0087-001	FL TUBE				R1011	QRE141J-513Y	C RESISTOR	51K 5% 1/4W	
	D1001	1SR35-400A-T5	DIODE				R1021	QRE141J-471Y	C RESISTOR	470 5% 1/4W	
	D1002	1SR35-400A-T5	DIODE				R1022	QRE141J-103Y	C RESISTOR	10K 5% 1/4W	
	D1003	1SR35-400A-T5	DIODE				R1023	QRE141J-103Y	C RESISTOR	10K 5% 1/4W	
	D1004	1SR35-400A-T5	DIODE				R1024	QRE141J-223Y	C RESISTOR	22K 5% 1/4W	
	D1005	1SS133-T2	SI DIODE				R1025	QRE141J-103Y	C RESISTOR	10K 5% 1/4W	
	D1023	1SS133-T2	SI DIODE				R1030	QRE141J-103Y	C RESISTOR	10K 5% 1/4W	
	D1024	1SS133-T2	SI DIODE				R1031	QRE141J-221Y	C RESISTOR	220 5% 1/4W	

■ Electrical parts list

(Front & system control board)

Block No. 04

△	Item	Parts number	Parts name	Remarks	Area	△	Item	Parts number	Parts name	Remarks	Area
	R1032	QRE141J-221Y	C RESISTOR	220 5% 1/4W	C		R1126	NRSA63J-102X	MG RESISTOR		
	R1033	QRE141J-221Y	C RESISTOR	220 5% 1/4W			R1127	NRSA63J-122X	MG RESISTOR		
	R1034	QRD161J-122	C RESISTOR	1.2K 5% 1/6W			R1128	NRSA63J-152X	MG RESISTOR		
	R1035	QRE141J-100Y	C RESISTOR	10 5% 1/4W			R1129	NRSA63J-222X	MG RESISTOR		
	R1036	QRE141J-100Y	C RESISTOR	10 5% 1/4W			R1130	NRSA63J-272X	MG RESISTOR		
	R1037	QRE141J-153Y	C RESISTOR	15K 5% 1/4W			R1131	NRSA63J-102X	MG RESISTOR		
	R1038	QRE141J-333Y	C RESISTOR	33K 5% 1/4W			R1132	NRSA63J-102X	MG RESISTOR		
	R1039	QRE141J-273Y	C RESISTOR	27K 5% 1/4W			R1133	NRSA63J-122X	MG RESISTOR		
	R1041	NRSA63J-103X	MG RESISTOR				R1134	NRSA63J-152X	MG RESISTOR		
	R1042	NRSA63J-103X	MG RESISTOR				R1135	NRSA63J-222X	MG RESISTOR		
	R1043	NRSA63J-103X	MG RESISTOR			R1141	NRSA63J-152X	MG RESISTOR			
	R1044	NRSA63J-103X	MG RESISTOR			R1142	NRSA63J-222X	MG RESISTOR			
	R1045	NRSA63J-103X	MG RESISTOR			R1143	NRSA63J-272X	MG RESISTOR			
	R1046	NRSA63J-103X	MG RESISTOR			R1144	NRSA63J-332X	MG RESISTOR			
	R1047	NRSA63J-103X	MG RESISTOR			R1151	NRSA63J-221X	MG RESISTOR			
	R1048	NRSA63J-103X	MG RESISTOR			R1152	NRSA63J-221X	MG RESISTOR			
	R1049	NRSA63J-103X	MG RESISTOR			R1153	NRSA63J-221X	MG RESISTOR			
	R1050	NRSA63J-103X	MG RESISTOR			R1154	NRSA63J-221X	MG RESISTOR			
	R1051	NRSA63J-102X	MG RESISTOR			R1155	NRSA63J-221X	MG RESISTOR			
	R1052	NRSA63J-102X	MG RESISTOR			R1156	NRSA63J-221X	MG RESISTOR			
	R1053	NRSA63J-122X	MG RESISTOR			R1157	NRSA63J-221X	MG RESISTOR			
	R1056	NRSA63J-102X	MG RESISTOR			R1158	NRSA63J-221X	MG RESISTOR			
	R1059	NRSA63J-104X	MG RESISTOR			R1161	NRSA63J-221X	MG RESISTOR			
	R1060	NRSA63J-104X	MG RESISTOR			R1162	NRSA63J-221X	MG RESISTOR			
	R1061	NRSA63J-103X	MG RESISTOR			R1163	NRSA63J-221X	MG RESISTOR			
	R1062	NRSA63J-103X	MG RESISTOR			R1164	NRSA63J-221X	MG RESISTOR			
	R1063	NRSA63J-103X	MG RESISTOR			R1165	NRSA63J-221X	MG RESISTOR			
	R1064	NRSA63J-103X	MG RESISTOR			R1166	NRSA63J-221X	MG RESISTOR			
	R1065	NRSA63J-103X	MG RESISTOR			R1167	NRSA63J-221X	MG RESISTOR			
	R1066	NRSA63J-103X	MG RESISTOR			R1168	NRSA63J-221X	MG RESISTOR			
	R1067	NRSA63J-103X	MG RESISTOR			R1169	NRSA63J-221X	MG RESISTOR			
	R1071	NRSA63J-221X	MG RESISTOR			R1170	NRSA63J-221X	MG RESISTOR			
	R1072	NRSA63J-221X	MG RESISTOR			R1171	NRSA63J-221X	MG RESISTOR			
	R1073	NRSA63J-221X	MG RESISTOR			R1172	NRSA63J-221X	MG RESISTOR			
	R1074	NRSA63J-221X	MG RESISTOR			R1173	NRSA63J-221X	MG RESISTOR			
	R1075	NRSA63J-221X	MG RESISTOR			R1174	NRSA63J-221X	MG RESISTOR			
	R1076	NRSA63J-221X	MG RESISTOR			R1175	NRSA63J-221X	MG RESISTOR			
	R1081	NRSA63J-103X	MG RESISTOR			R1176	NRSA63J-221X	MG RESISTOR			
	R1082	NRSA63J-103X	MG RESISTOR			R1177	NRSA63J-221X	MG RESISTOR			
	R1083	NRSA63J-103X	MG RESISTOR			R1178	NRSA63J-221X	MG RESISTOR			
	R1084	NRSA63J-474X	MG RESISTOR			R1179	NRSA63J-221X	MG RESISTOR			
	R1085	NRSA63J-103X	MG RESISTOR			R1180	NRSA63J-221X	MG RESISTOR			
	R1086	NRSA63J-103X	MG RESISTOR			R1181	NRSA63J-221X	MG RESISTOR			
	R1091	NRSA63J-221X	MG RESISTOR			R1182	NRSA63J-221X	MG RESISTOR			
	R1092	NRSA63J-221X	MG RESISTOR			R1183	NRSA63J-221X	MG RESISTOR			
	R1093	NRSA63J-221X	MG RESISTOR			R1184	NRSA63J-221X	MG RESISTOR			
	R1094	NRSA63J-221X	MG RESISTOR			R1191	NRSA63J-221X	MG RESISTOR			
	R1095	NRSA63J-221X	MG RESISTOR			R1192	NRSA63J-221X	MG RESISTOR			
	R1096	NRSA63J-221X	MG RESISTOR			R1193	NRSA63J-221X	MG RESISTOR			
	R1097	NRSA63J-221X	MG RESISTOR			R1194	NRSA63J-221X	MG RESISTOR			
	R1098	NRSA63J-221X	MG RESISTOR			R1195	NRSA63J-221X	MG RESISTOR			
	R1099	NRSA63J-221X	MG RESISTOR			R1196	NRSA63J-221X	MG RESISTOR			
	R1101	NRSA63J-102X	MG RESISTOR			R1197	NRSA63J-221X	MG RESISTOR			
	R1102	NRSA63J-102X	MG RESISTOR			R1198	NRSA63J-221X	MG RESISTOR			
	R1103	NRSA63J-122X	MG RESISTOR			R1201	NRSA63J-393X	MG RESISTOR			
	R1104	NRSA63J-152X	MG RESISTOR			R1202	NRSA63J-393X	MG RESISTOR			
	R1105	NRSA63J-222X	MG RESISTOR			R1203	NRSA63J-104X	MG RESISTOR			
	R1106	NRSA63J-272X	MG RESISTOR			R1204	NRSA63J-273X	MG RESISTOR			
	R1107	NRSA63J-332X	MG RESISTOR			R1205	NRSA63J-104X	MG RESISTOR			
	R1122	NRSA63J-102X	MG RESISTOR			R1206	NRSA63J-103X	MG RESISTOR			
	R1123	NRSA63J-102X	MG RESISTOR			R1207	QRJ146J-5R6X	UNF C RESISTOR	5.6 5% 1/4W		
	R1124	NRSA63J-122X	MG RESISTOR			R1208	NRSA63J-102X	MG RESISTOR			
	R1125	NRSA63J-102X	MG RESISTOR			R1209	NRSA63J-152X	MG RESISTOR			

■ Electrical parts list

(Front & system control board)

Block No. 04

△	Item	Parts number	Parts name	Remarks	Area
	R1211	NRSA63J-221X	MG RESISTOR		
	R1212	NRSA63J-471X	MG RESISTOR		
	R1213	NRSA63J-221X	MG RESISTOR		
	R1214	NRSA63J-101X	MG RESISTOR		
	R1215	NRSA63J-221X	MG RESISTOR		
	R1216	NRSA63J-221X	MG RESISTOR		
	S1001	QSW0683-001Z	PUSH SWITCH	(SURROUND)	
	S1002	QSW0683-001Z	PUSH SWITCH	(DSP MODE)	
	S1003	QSW0683-001Z	PUSH SWITCH	(DIRECT)	
	S1004	QSW0683-001Z	PUSH SWITCH	(THX)	
	S1005	QSW0683-001Z	PUSH SWITCH	(SPK1)	
	S1006	QSW0683-001Z	PUSH SWITCH	(SPK2)	
	S1007	QSW0683-001Z	PUSH SWITCH	(SUBROOM CONT)	
	S1022	QSW0683-001Z	PUSH SWITCH	(MAIN ROOM)	
	S1023	QSW0683-001Z	PUSH SWITCH	(SUB ROOM)	
	S1024	QSW0683-001Z	PUSH SWITCH	(POWER)	
	S1025	QSW0683-001Z	PUSH SWITCH	(DOWN)	
	S1026	QSW0683-001Z	PUSH SWITCH	(LEFT)	
	S1027	QSW0683-001Z	PUSH SWITCH	(SET)	
	S1028	QSW0683-001Z	PUSH SWITCH	(SETUP)	
	S1029	QSW0683-001Z	PUSH SWITCH	(FM MODE)	
	S1030	QSW0683-001Z	PUSH SWITCH	(SOUND SEL)	
	S1031	QSW0683-001Z	PUSH SWITCH	(UP)	
	S1032	QSW0683-001Z	PUSH SWITCH	(RIGHT)	
	S1033	QSW0683-001Z	PUSH SWITCH	(EXIT)	
	S1034	QSW0683-001Z	PUSH SWITCH	(ADJUST)	
	S1035	QSW0683-001Z	PUSH SWITCH	(INPUT MODE)	
	S1041	QSW0683-001Z	PUSH SWITCH	(EX K2)	
	S1042	QSW0683-001Z	PUSH SWITCH	(DIMMER)	
	S1043	QSW0683-001Z	PUSH SWITCH	(DOOR OPEN)	
	S1044	QSW0683-001Z	PUSH SWITCH	(DOOR CLOSE)	
	S1051	QSW0851-001	DETECT SWITCH		
	S1052	QSW0851-001	DETECT SWITCH		
	WR301	QJK017-030803	SIN CR C-B WIRE		
	WR961	QJK030-075002	SIN CR C-B WIRE		
	WR962	QJK030-081803	SIN CR C-B WIRE		
	WR965	QJK016-092404	SIN CR C-B WIRE		
	WR966	QJK016-062401	SIN CR C-B WIRE		
	WR967	QJK016-082802	SIN CR C-B WIRE		
	WR968	QJK016-094403	SIN CR C-B WIRE		
	WR970	QJK016-090802	SIN CR C-B WIRE		
	WR972	QJK016-021002	SIN CR C-B WIRE		
	WR977	QJK030-042404	SIN CR C-B WIRE		
	WR984	QJK016-101104	SIN CR C-B WIRE		
	WR986	QJK016-061102	SIN CR C-B WIRE		
	X1001	QAX0246-001Z	RESONATOR		
	X1002	QAX0246-001Z	RESONATOR		

■ Electrical parts list (DSP board)

Block No. 05

▲	Item	Parts number	Parts name	Remarks	Area	▲	Item	Parts number	Parts name	Remarks	Area
	C 501	QETN1CM-476Z	E CAPACITOR	47MF 20% 16V			C3122	NCB31HK-103X	C CAPACITOR		
	C 502	QETN1CM-476Z	E CAPACITOR	47MF 20% 16V			C3125	NCB31HK-102X	C CAPACITOR		
	C 503	QETN1CM-476Z	E CAPACITOR	47MF 20% 16V			C3126	NCB31HK-102X	C CAPACITOR		
	C 504	QETN1CM-476Z	E CAPACITOR	47MF 20% 16V			C3129	QETN1HM-475Z	E CAPACITOR	4.7MF 20% 50V	
	C 505	QETN1CM-476Z	E CAPACITOR	47MF 20% 16V			C3130	QETN1HM-475Z	E CAPACITOR	4.7MF 20% 50V	
	C 506	QETN1CM-476Z	E CAPACITOR	47MF 20% 16V			C3137	QETN1HM-475Z	E CAPACITOR	4.7MF 20% 50V	
	C 511	NCF21CZ-225X	C CAPACITOR				C3138	QETN1HM-475Z	E CAPACITOR	4.7MF 20% 50V	
	C 512	NCF21CZ-225X	C CAPACITOR				C3139	NCB31HK-182X	C CAPACITOR		
	C 513	QETN1CM-476Z	E CAPACITOR	47MF 20% 16V			C3140	NCB31HK-182X	C CAPACITOR		
	C 514	QETN1CM-476Z	E CAPACITOR	47MF 20% 16V			C3141	QETN1HM-475Z	E CAPACITOR	4.7MF 20% 50V	
	C 515	QETN1CM-476Z	E CAPACITOR	47MF 20% 16V			C3142	QETN1HM-475Z	E CAPACITOR	4.7MF 20% 50V	
	C 521	QETN1AM-107Z	E CAPACITOR	100MF 20% 10V			C3143	NCS31HJ-100X	C CAPACITOR		
	C 522	QETN1AM-337Z	E CAPACITOR	330MF 20% 10V			C3144	NCS31HJ-100X	C CAPACITOR		
	C 523	QETN1AM-477Z	E CAPACITOR	470MF 20% 10V			C3145	NCF31CZ-104X	C CAPACITOR		
	C 524	QETN1CM-476Z	E CAPACITOR	47MF 20% 16V			C3146	NCF31CZ-104X	C CAPACITOR		
	C 525	QETN1AM-107Z	E CAPACITOR	100MF 20% 10V			C3151	QETN1HM-106Z	E CAPACITOR	10MF 20% 50V	
	C 526	QETN1AM-477Z	E CAPACITOR	470MF 20% 10V			C3152	QETN1HM-106Z	E CAPACITOR	10MF 20% 50V	
	C 527	QETN1CM-476Z	E CAPACITOR	47MF 20% 16V			C3153	QETN1HM-106Z	E CAPACITOR	10MF 20% 50V	
	C 528	QETN1AM-107Z	E CAPACITOR	100MF 20% 10V			C3154	QETN1HM-106Z	E CAPACITOR	10MF 20% 50V	
	C 529	QETN1AM-477Z	E CAPACITOR	470MF 20% 10V			C3155	NCF31CZ-104X	C CAPACITOR		
	C 530	NCF31HZ-473X	C CAPACITOR				C3156	NCF31CZ-104X	C CAPACITOR		
	C 531	QETN1AM-107Z	E CAPACITOR	100MF 20% 10V			C3171	NCS31HJ-101X	C CAPACITOR		
	CN 83	QGA3901C1-05	5P CONNECTOR				C3172	NCB31HK-103X	C CAPACITOR		
	CN 84	QGA3901C1-05	5P CONNECTOR				C3173	NCB31HK-103X	C CAPACITOR		
	CN501	QGB2510K2-08	CONNECTOR				C3174	NCB31HK-103X	C CAPACITOR		
	CN631	QGA2001F1-03	CONNECTOR				C3175	NCB31HK-103X	C CAPACITOR		
	CN633	QGB2510K1-11	CONNECTOR				C3181	QETN1HM-106Z	E CAPACITOR	10MF 20% 50V	
	C3001	QETN1HM-475Z	E CAPACITOR	4.7MF 20% 50V			C3182	QETN1HM-106Z	E CAPACITOR	10MF 20% 50V	
	C3002	QETN1HM-475Z	E CAPACITOR	4.7MF 20% 50V			C3183	NCB30JK-105X	C CAPACITOR		
	C3003	NCB31HK-561X	C CAPACITOR				C3184	NCB30JK-105X	C CAPACITOR		
	C3004	NCB31HK-561X	C CAPACITOR				C3185	NCB31AK-224X	C CAPACITOR		
	C3005	NCS31HJ-680X	C CAPACITOR				C3186	NCB31HK-103X	C CAPACITOR		
	C3006	NCS31HJ-680X	C CAPACITOR				C3187	QETN1HM-106Z	E CAPACITOR	10MF 20% 50V	
	C3007	NCS31HJ-181X	C CAPACITOR				C3188	NCB30JK-105X	C CAPACITOR		
	C3008	NCS31HJ-181X	C CAPACITOR				C3189	NCB30JK-105X	C CAPACITOR		
	C3009	QETN1HM-106Z	E CAPACITOR	10MF 20% 50V			C3190	NCF31CZ-104X	C CAPACITOR		
	C3010	QETN1HM-106Z	E CAPACITOR	10MF 20% 50V			C3191	QETN1HM-106Z	E CAPACITOR	10MF 20% 50V	
	C3013	NCS31HJ-330X	C CAPACITOR				C3192	QETN1HM-106Z	E CAPACITOR	10MF 20% 50V	
	C3014	NCS31HJ-330X	C CAPACITOR				C3193	QETN1HM-474Z	E CAPACITOR	0.47MF 20% 50V	
	C3018	QETN1CM-476Z	E CAPACITOR	47MF 20% 16V			C3194	NCF31CZ-104X	C CAPACITOR		
	C3019	QETN1HM-106Z	E CAPACITOR	10MF 20% 50V			C3195	NCF31CZ-104X	C CAPACITOR		
	C3020	QETN1HM-106Z	E CAPACITOR	10MF 20% 50V			C3196	NCF31CZ-104X	C CAPACITOR		
	C3031	QETN1HM-106Z	E CAPACITOR	10MF 20% 50V			C3197	NEA70JM-107X	E CAPACITOR		
	C3032	QETN1HM-106Z	E CAPACITOR	10MF 20% 50V			C3198	NCF31CZ-104X	C CAPACITOR		
	C3033	NCB31CK-104X	C CAPACITOR				C3201	NCB31HK-182X	C CAPACITOR		
	C3034	NCB31CK-104X	C CAPACITOR				C3202	NCB31HK-182X	C CAPACITOR		
	C3035	NCB31AK-224X	C CAPACITOR				C3211	NCS31HJ-181X	C CAPACITOR		
	C3036	NCB31AK-224X	C CAPACITOR				C3212	NCS31HJ-181X	C CAPACITOR		
	C3037	QETN1HM-106Z	E CAPACITOR	10MF 20% 50V			C3215	NCB31CK-683X	C CAPACITOR		
	C3038	QETN1HM-106Z	E CAPACITOR	10MF 20% 50V			C3216	NCB31CK-683X	C CAPACITOR		
	C3039	NCS31HJ-101X	C CAPACITOR				C3217	QETN1HM-475Z	E CAPACITOR	4.7MF 20% 50V	
	C3040	NCS31HJ-101X	C CAPACITOR				C3218	QETN1HM-475Z	E CAPACITOR	4.7MF 20% 50V	
	C3041	NCS31HJ-100X	C CAPACITOR				C3221	NCB31HK-222X	C CAPACITOR		
	C3042	NCS31HJ-100X	C CAPACITOR				C3222	QETN1HM-474Z	E CAPACITOR	0.47MF 20% 50V	
	C3045	NCF31CZ-104X	C CAPACITOR				C3223	NCB31HK-122X	C CAPACITOR		
	C3046	NCF31CZ-104X	C CAPACITOR				C3225	NCB31HK-103X	C CAPACITOR		
	C3101	NCB31HK-182X	C CAPACITOR				C3226	NCB30JK-105X	C CAPACITOR		
	C3102	NCB31HK-182X	C CAPACITOR				C3229	QETN1HM-475Z	E CAPACITOR	4.7MF 20% 50V	
	C3111	NCS31HJ-181X	C CAPACITOR				C3230	QETN1HM-475Z	E CAPACITOR	4.7MF 20% 50V	
	C3112	NCS31HJ-181X	C CAPACITOR				C3237	QETN1HM-475Z	E CAPACITOR	4.7MF 20% 50V	
	C3115	NCB31CK-683X	C CAPACITOR				C3238	QETN1HM-475Z	E CAPACITOR	4.7MF 20% 50V	
	C3116	NCB31CK-683X	C CAPACITOR				C3239	NCB31HK-182X	C CAPACITOR		
	C3121	NCB31HK-103X	C CAPACITOR				C3240	NCB31HK-182X	C CAPACITOR		

■ Electrical parts list (DSP board)

Block No. 05

△	Item	Parts number	Parts name	Remarks	Area	△	Item	Parts number	Parts name	Remarks	Area
	C3251	QETN1HM-106Z	E CAPACITOR	10MF 20% 50V			C3375	NCB31HK-103X	C CAPACITOR		
	C3252	QETN1HM-106Z	E CAPACITOR	10MF 20% 50V			C3381	QETN1HM-106Z	E CAPACITOR	10MF 20% 50V	
	C3253	QETN1HM-106Z	E CAPACITOR	10MF 20% 50V			C3382	QETN1HM-106Z	E CAPACITOR	10MF 20% 50V	
	C3254	QETN1HM-106Z	E CAPACITOR	10MF 20% 50V			C3383	NCB30JK-105X	C CAPACITOR		
	C3255	QETN1HM-106Z	E CAPACITOR	10MF 20% 50V			C3384	NCB30JK-105X	C CAPACITOR		
	C3256	QETN1HM-106Z	E CAPACITOR	10MF 20% 50V			C3385	NCB31AK-224X	C CAPACITOR		
	C3261	NCF31CZ-104X	C CAPACITOR				C3386	NCB31HK-103X	C CAPACITOR		
	C3262	NCF31CZ-104X	C CAPACITOR				C3387	QETN1HM-106Z	E CAPACITOR	10MF 20% 50V	
	C3263	NCS31HJ-330X	C CAPACITOR				C3388	NCB30JK-105X	C CAPACITOR		
	C3264	QETN1HM-475Z	E CAPACITOR	4.7MF 20% 50V			C3389	NCB30JK-105X	C CAPACITOR		
	C3266	NCB30JK-105X	C CAPACITOR				C3397	NEA70JM-107X	E CAPACITOR		
	C3267	QETN1HM-224Z	E CAPACITOR	0.22MF 20% 50V			C3398	NCF31CZ-104X	C CAPACITOR		
	C3268	NCB31AK-474X	C CAPACITOR				C3401	NCB31HK-182X	C CAPACITOR		
	C3271	NCS31HJ-101X	C CAPACITOR				C3402	NCB31HK-182X	C CAPACITOR		
	C3272	NCB31HK-103X	C CAPACITOR				C3411	NCS31HJ-181X	C CAPACITOR		
	C3273	NCB31HK-103X	C CAPACITOR				C3412	NCS31HJ-181X	C CAPACITOR		
	C3274	NCB31HK-103X	C CAPACITOR				C3415	NCB31CK-683X	C CAPACITOR		
	C3275	NCB31HK-103X	C CAPACITOR				C3416	NCB31CK-683X	C CAPACITOR		
	C3281	QETN1HM-106Z	E CAPACITOR	10MF 20% 50V			C3417	QETN1HM-475Z	E CAPACITOR	4.7MF 20% 50V	
	C3282	QETN1HM-106Z	E CAPACITOR	10MF 20% 50V			C3418	QETN1HM-475Z	E CAPACITOR	4.7MF 20% 50V	
	C3283	NCB30JK-105X	C CAPACITOR				C3421	NCB31HK-222X	C CAPACITOR		
	C3284	NCB30JK-105X	C CAPACITOR				C3422	NCB31HK-222X	C CAPACITOR		
	C3285	NCB31AK-224X	C CAPACITOR				C3423	NCB31HK-122X	C CAPACITOR		
	C3286	NCB31HK-103X	C CAPACITOR				C3424	NCB31HK-122X	C CAPACITOR		
	C3287	QETN1HM-106Z	E CAPACITOR	10MF 20% 50V			C3425	NCB31HK-103X	C CAPACITOR		
	C3288	NCB30JK-105X	C CAPACITOR				C3426	NCB31HK-103X	C CAPACITOR		
	C3289	NCB30JK-105X	C CAPACITOR				C3429	QETN1HM-475Z	E CAPACITOR	4.7MF 20% 50V	
	C3291	QETN1HM-475Z	E CAPACITOR	4.7MF 20% 50V			C3430	QETN1HM-475Z	E CAPACITOR	4.7MF 20% 50V	
	C3292	QETN1HM-475Z	E CAPACITOR	4.7MF 20% 50V			C3437	QETN1HM-475Z	E CAPACITOR	4.7MF 20% 50V	
	C3293	NCF31CZ-104X	C CAPACITOR				C3438	QETN1HM-475Z	E CAPACITOR	4.7MF 20% 50V	
	C3294	NCF31CZ-104X	C CAPACITOR				C3439	NCB31HK-182X	C CAPACITOR		
	C3297	NEA70JM-107X	E CAPACITOR				C3440	NCB31HK-182X	C CAPACITOR		
	C3298	NCF31CZ-104X	C CAPACITOR				C3451	QETN1HM-106Z	E CAPACITOR	10MF 20% 50V	
	C3301	NCB31HK-182X	C CAPACITOR				C3452	QETN1HM-106Z	E CAPACITOR	10MF 20% 50V	
	C3302	NCB31HK-182X	C CAPACITOR				C3453	QETN1HM-106Z	E CAPACITOR	10MF 20% 50V	
	C3311	NCS31HJ-181X	C CAPACITOR				C3454	QETN1HM-106Z	E CAPACITOR	10MF 20% 50V	
	C3312	NCS31HJ-181X	C CAPACITOR				C3455	QETN1HM-106Z	E CAPACITOR	10MF 20% 50V	
	C3315	NCB31CK-683X	C CAPACITOR				C3456	QETN1HM-106Z	E CAPACITOR	10MF 20% 50V	
	C3316	NCB31CK-683X	C CAPACITOR				C3471	NCS31HJ-101X	C CAPACITOR		
	C3317	QETN1HM-475Z	E CAPACITOR	4.7MF 20% 50V			C3472	NCB31HK-103X	C CAPACITOR		
	C3318	QETN1HM-475Z	E CAPACITOR	4.7MF 20% 50V			C3473	NCB31HK-103X	C CAPACITOR		
	C3321	NCB31HK-222X	C CAPACITOR				C3474	NCB31HK-103X	C CAPACITOR		
	C3322	NCB31HK-222X	C CAPACITOR				C3475	NCB31HK-103X	C CAPACITOR		
	C3323	NCB31HK-122X	C CAPACITOR				C3481	QETN1HM-106Z	E CAPACITOR	10MF 20% 50V	
	C3324	NCB31HK-122X	C CAPACITOR				C3482	QETN1HM-106Z	E CAPACITOR	10MF 20% 50V	
	C3325	NCB31HK-103X	C CAPACITOR				C3483	NCB30JK-105X	C CAPACITOR		
	C3326	NCB31HK-103X	C CAPACITOR				C3484	NCB30JK-105X	C CAPACITOR		
	C3329	QETN1HM-475Z	E CAPACITOR	4.7MF 20% 50V			C3485	NCB31AK-224X	C CAPACITOR		
	C3330	QETN1HM-475Z	E CAPACITOR	4.7MF 20% 50V			C3486	NCB31HK-103X	C CAPACITOR		
	C3337	QETN1HM-475Z	E CAPACITOR	4.7MF 20% 50V			C3487	QETN1HM-106Z	E CAPACITOR	10MF 20% 50V	
	C3338	QETN1HM-475Z	E CAPACITOR	4.7MF 20% 50V			C3488	NCB30JK-105X	C CAPACITOR		
	C3339	NCB31HK-182X	C CAPACITOR				C3489	NCB30JK-105X	C CAPACITOR		
	C3340	NCB31HK-182X	C CAPACITOR				C3497	NEA70JM-107X	E CAPACITOR		
	C3351	QETN1HM-106Z	E CAPACITOR	10MF 20% 50V			C3498	NCF31CZ-104X	C CAPACITOR		
	C3352	QETN1HM-106Z	E CAPACITOR	10MF 20% 50V			C3501	NCB31HK-103X	C CAPACITOR		
	C3353	QETN1HM-106Z	E CAPACITOR	10MF 20% 50V			C3502	NCB31HK-103X	C CAPACITOR		
	C3354	QETN1HM-106Z	E CAPACITOR	10MF 20% 50V			C3503	NCB31HK-103X	C CAPACITOR		
	C3355	QETN1HM-106Z	E CAPACITOR	10MF 20% 50V			C3504	NCB31HK-103X	C CAPACITOR		
	C3356	QETN1HM-106Z	E CAPACITOR	10MF 20% 50V			C3505	NCB31HK-103X	C CAPACITOR		
	C3371	NCS31HJ-101X	C CAPACITOR				C3506	NCB31HK-103X	C CAPACITOR		
	C3372	NCB31HK-103X	C CAPACITOR				C3507	NCB31HK-103X	C CAPACITOR		
	C3373	NCB31HK-103X	C CAPACITOR				C3508	NCB31HK-103X	C CAPACITOR		
	C3374	NCB31HK-103X	C CAPACITOR				C3509	NCB31HK-103X	C CAPACITOR		

■ Electrical parts list (DSP board)

Block No. 05

▲	Item	Parts number	Parts name	Remarks	Area	▲	Item	Parts number	Parts name	Remarks	Area
	C3510	NCB31HK-103X	C CAPACITOR				C3805	NCF31CZ-104X	C CAPACITOR		
	C3511	NCB31HK-103X	C CAPACITOR				C3806	NCF31CZ-104X	C CAPACITOR		
	C3512	NCB31HK-103X	C CAPACITOR				C3807	NCF31CZ-104X	C CAPACITOR		
	C3513	NCB31HK-103X	C CAPACITOR				C3808	NCF31CZ-104X	C CAPACITOR		
	C3514	NCB31HK-103X	C CAPACITOR				C3811	NCF31CZ-104X	C CAPACITOR		
	C3515	NCB31HK-103X	C CAPACITOR				C3900	NCB30JK-105X	C CAPACITOR		
	C3516	NCB31HK-103X	C CAPACITOR				C3901	NCB30JK-105X	C CAPACITOR		
	C3517	NCB31HK-103X	C CAPACITOR				C3902	NCB30JK-105X	C CAPACITOR		
	C3518	NCB31HK-103X	C CAPACITOR				C3903	NCB30JK-105X	C CAPACITOR		
	C3519	NCB31HK-103X	C CAPACITOR				C3905	NCB30JK-105X	C CAPACITOR		
	C3520	NCB31HK-103X	C CAPACITOR				C3906	NCB30JK-105X	C CAPACITOR		
	C3521	NEA70JM-107X	E CAPACITOR				C3910	NCF31CZ-104X	C CAPACITOR		
	C3523	NCF31CZ-104X	C CAPACITOR				C3911	NCF31CZ-104X	C CAPACITOR		
	C3525	NCB31HK-123X	C CAPACITOR				C3912	NCF31CZ-104X	C CAPACITOR		
	C3601	NCB31HK-103X	C CAPACITOR				C3913	NCF31CZ-104X	C CAPACITOR		
	C3602	NCB31HK-103X	C CAPACITOR				C3915	NCF31CZ-104X	C CAPACITOR		
	C3603	NCB31HK-103X	C CAPACITOR				C3916	NCF31CZ-104X	C CAPACITOR		
	C3604	NCB31HK-103X	C CAPACITOR				C3919	NEA70JM-107X	E CAPACITOR		
	C3605	NCB31HK-103X	C CAPACITOR				C3921	NCS31HJ-101X	C CAPACITOR		
	C3606	NCB31HK-103X	C CAPACITOR				C3922	NCS31HJ-101X	C CAPACITOR		
	C3607	NCB31HK-103X	C CAPACITOR				C3923	NCF31CZ-104X	C CAPACITOR		
	C3608	NCB31HK-103X	C CAPACITOR				C3924	NCF31CZ-104X	C CAPACITOR		
	C3609	NCB31HK-103X	C CAPACITOR				C3990	QETN1AM-107Z	E CAPACITOR	100MF 20% 10V	
	C3610	NCB31HK-103X	C CAPACITOR				C3991	QETN1AM-107Z	E CAPACITOR	100MF 20% 10V	
	C3611	NCB31HK-103X	C CAPACITOR				C3992	QETN1AM-107Z	E CAPACITOR	100MF 20% 10V	
	C3612	NCB31HK-103X	C CAPACITOR				C3993	QETN1AM-107Z	E CAPACITOR	100MF 20% 10V	
	C3613	NCB31HK-103X	C CAPACITOR				C3995	QETN1AM-227Z	E CAPACITOR	220MF 20% 10V	
	C3614	NCB31HK-103X	C CAPACITOR				C3996	QETN1AM-227Z	E CAPACITOR	220MF 20% 10V	
	C3615	NCB31HK-103X	C CAPACITOR				C3999	QETN1AM-477Z	E CAPACITOR	470MF 20% 10V	
	C3616	NCB31HK-103X	C CAPACITOR				C5001	NCB30JK-105X	C CAPACITOR		
	C3617	NCB31HK-103X	C CAPACITOR				C5002	NCB31AK-224X	C CAPACITOR		
	C3618	NCB31HK-103X	C CAPACITOR			▲	D 745	F10P20F	DIODE		
	C3619	NCB31HK-103X	C CAPACITOR			▲	D 746	F10P20FR	DIODE		
	C3620	NCB31HK-103X	C CAPACITOR			▲	D 795	F10P20F	DIODE		
	C3621	NEA70JM-107X	E CAPACITOR			▲	D 796	F10P20FR	DIODE		
	C3623	NCF31CZ-104X	C CAPACITOR			▲	D 845	F10P20F	DIODE		
	C3625	NCB31HK-123X	C CAPACITOR			▲	D 846	F10P20FR	DIODE		
	C3631	NEA71CM-106X	E CAPACITOR				D3191	MA3068/M-X	ZENER DIODE		
	C3632	NCB31HK-103X	C CAPACITOR				D3192	MA3068/M-X	ZENER DIODE		
	C3633	NEA71CM-106X	E CAPACITOR				D5001	UDZS5.1B-X	ZENER DIODE		
	C3634	NCB31HK-103X	C CAPACITOR				EP710	E409182-001SM	GRAND TERMINAL		
	C3635	NEA71CM-106X	E CAPACITOR				IC501	TC74HC4053AF-X	IC		
	C3636	NCB31HK-103X	C CAPACITOR				IC502	TC74HC4053AF-X	IC		
	C3637	NEA71CM-106X	E CAPACITOR				IC503	MAX4018ESD-X	IC		
	C3638	NCB31HK-103X	C CAPACITOR				IC631	NJM4580E-W	IC		
	C3701	NCS31HJ-101X	C CAPACITOR				IC632	NJM4580E-W	IC		
	C3702	NEA71HM-105X	E CAPACITOR				IC633	NJM4580E-W	IC		
	C3703	NCF31CZ-104X	C CAPACITOR				IC634	MN35505-X	IC		
	C3704	NCF31CZ-104X	C CAPACITOR				IC635	JCV8006	IC		
	C3705	NCF31CZ-104X	C CAPACITOR				IC636	NJM4580E-W	IC		
	C3706	NCF31CZ-104X	C CAPACITOR				IC637	NJM4580E-W	IC		
	C3713	NCS31HJ-330X	C CAPACITOR				IC638	NJM4580E-W	IC		
	C3715	NCF31CZ-104X	C CAPACITOR				IC639	MN35505-X	IC		
	C3721	NEA71CM-106X	E CAPACITOR				IC640	JCV8006	IC		
	C3722	NEA71CM-106X	E CAPACITOR				IC641	NJM4580E-W	IC		
	C3723	NCF31CZ-104X	C CAPACITOR				IC642	NJM4580E-W	IC		
	C3724	NCF31CZ-104X	C CAPACITOR				IC643	NJM4580E-W	IC		
	C3725	NCS31HJ-101X	C CAPACITOR				IC644	MN35505-X	IC		
	C3735	NCF31CZ-104X	C CAPACITOR				IC645	JCV8006	IC		
	C3801	NCF31CZ-104X	C CAPACITOR				IC646	NJM4580E-W	IC		
	C3802	NCF31CZ-104X	C CAPACITOR				IC647	NJM4580E-W	IC		
	C3803	NEA70JM-107X	E CAPACITOR				IC648	NJM4580E-W	IC		
	C3804	NCF31CZ-104X	C CAPACITOR				IC649	MN35505-X	IC		

■ Electrical parts list (DSP board)

Block No. 05

△	Item	Parts number	Parts name	Remarks	Area	△	Item	Parts number	Parts name	Remarks	Area
	IC650	JCV8006	IC				LC666	NQR0322-001X	EMI FILTER		
	IC652	NJM2121M-X	IC				LC667	NQR0322-001X	EMI FILTER		
	IC653	M62446FP-X	IC				LC668	NQR0322-001X	EMI FILTER		
	IC654	TC74HCT04AF-X	IC				LC669	NQR0322-001X	EMI FILTER		
	IC655	NJM4580E-W	IC				LC670	NQR0322-001X	EMI FILTER		
	IC656	NJM4580E-W	IC				LC671	NQR0322-001X	EMI FILTER		
	IC658	TC7S04FU-X	IC				LC673	NQR0322-001X	EMI FILTER		
	IC659	TC7WH74FU-X	IC				LC691	NQR0322-001X	EMI FILTER		
	IC660	TC7S04FU-X	IC				LC692	NQR0322-001X	EMI FILTER		
	IC661	XCA56367PV150	IC				Q3103	2SC2412K/RS/-X	CHIP TRANSISTOR		
	IC666	XCA56367PV150	IC				Q3104	2SC2412K/RS/-X	CHIP TRANSISTOR		
	IC667	39VF0207CWHM03	IC				Q3105	DTA114YE-X	TRANSISTOR		
	IC668	W24L010AJ-12-X	IC				Q3107	2SD1328/ST/-X	TRANSISTOR		
	IC669	W24L010AJ-12-X	IC				Q3108	2SD1328/ST/-X	TRANSISTOR		
	IC670	W24L010AJ-12-X	IC				Q3161	2SC2412K/RS/-X	CHIP TRANSISTOR		
	IC671	UPD784215AGC165	IC				Q3162	2SC2412K/RS/-X	CHIP TRANSISTOR		
	IC672	TC7S04FU-X	IC				Q3163	DTA114YE-X	TRANSISTOR		
	IC673	AK4112AVF-X	IC				Q3203	2SC2412K/RS/-X	CHIP TRANSISTOR		
	IC674	TC7WH241FU-X	IC				Q3207	2SD1328/ST/-X	TRANSISTOR		
	IC681	TC74VHC157FT-X	IC				Q3208	2SD1328/ST/-X	TRANSISTOR		
	IC682	TC74VHC157FT-X	IC				Q3261	2SC2412K/RS/-X	CHIP TRANSISTOR		
	IC683	TC74VHC74FT-X	IC				Q3263	DTA114YE-X	TRANSISTOR		
	IC684	TC7WH74FU-X	IC				Q3265	DTA114YE-X	TRANSISTOR		
	IC685	TC7WH241FU-X	IC				Q3266	2SD1328/ST/-X	TRANSISTOR		
	IC686	NJM4580E-W	IC				Q3291	DTC114YE-X	TRANSISTOR		
	IC687	NJM4580E-W	IC				Q3301	DTA114YE-X	TRANSISTOR		
	IC690	PQ20VZ11-X	IC				Q3303	2SC2412K/RS/-X	CHIP TRANSISTOR		
	IC691	PQ3DZ53-X	IC				Q3304	2SC2412K/RS/-X	CHIP TRANSISTOR		
	IC692	PQ3DZ53-X	IC				Q3307	2SD1328/ST/-X	TRANSISTOR		
	IC693	PQ3DZ53-X	IC				Q3308	2SD1328/ST/-X	TRANSISTOR		
	IC695	PQ3DZ53-X	IC				Q3361	2SC2412K/RS/-X	CHIP TRANSISTOR		
	IC696	PQ3DZ53-X	IC				Q3362	2SC2412K/RS/-X	CHIP TRANSISTOR		
	IC998	NJM2903M-XE	IC				Q3363	DTA114YE-X	TRANSISTOR		
	IC999	LM45CIM3-X	IC				Q3403	2SC2412K/RS/-X	CHIP TRANSISTOR		
	J 501	QNN0448-001	PIN JACK				Q3404	2SC2412K/RS/-X	CHIP TRANSISTOR		
	J 502	QNN0448-001	PIN JACK				Q3407	2SD1328/ST/-X	TRANSISTOR		
	J 503	QNN0448-001	PIN JACK				Q3408	2SD1328/ST/-X	TRANSISTOR		
	J3701	QNN0404-001	PIN JACK				Q3461	2SC2412K/RS/-X	CHIP TRANSISTOR		
	K3181	NQR0229-001X	FERRITE BEADS				Q3462	2SC2412K/RS/-X	CHIP TRANSISTOR		
	K3182	NQR0229-001X	FERRITE BEADS				Q3463	DTA114YE-X	TRANSISTOR		
	K3183	NQR0229-001X	FERRITE BEADS				Q3921	DTC114YE-X	TRANSISTOR		
	K3184	NQR0229-001X	FERRITE BEADS				R 501	NRSA63J-750X	MG RESISTOR		
	K3281	NQR0229-001X	FERRITE BEADS				R 502	NRSA63J-750X	MG RESISTOR		
	K3282	NQR0229-001X	FERRITE BEADS				R 503	NRSA63J-750X	MG RESISTOR		
	K3283	NQR0229-001X	FERRITE BEADS				R 504	NRSA63J-750X	MG RESISTOR		
	K3284	NQR0229-001X	FERRITE BEADS				R 505	NRSA63J-750X	MG RESISTOR		
	K3381	NQR0229-001X	FERRITE BEADS				R 506	NRSA63J-750X	MG RESISTOR		
	K3382	NQR0229-001X	FERRITE BEADS				R 521	NRSA63J-472X	MG RESISTOR		
	K3383	NQR0229-001X	FERRITE BEADS				R 522	NRSA63J-472X	MG RESISTOR		
	K3384	NQR0229-001X	FERRITE BEADS				R 523	NRSA63J-102X	MG RESISTOR		
	K3481	NQR0229-001X	FERRITE BEADS				R 524	NRSA63J-112X	MG RESISTOR		
	K3482	NQR0229-001X	FERRITE BEADS				R 525	NRSA63J-473X	MG RESISTOR		
	K3483	NQR0229-001X	FERRITE BEADS				R 526	NRSA63J-750X	MG RESISTOR		
	K3484	NQR0229-001X	FERRITE BEADS				R 527	NRSA63J-472X	MG RESISTOR		
	K3701	NQR0269-004X	FERRITE BEADS				R 528	NRSA63J-472X	MG RESISTOR		
	K3702	NQR0269-004X	FERRITE BEADS				R 529	NRSA63J-102X	MG RESISTOR		
	K3703	QQR0779-001Z	INDUCTOR				R 530	NRSA63J-112X	MG RESISTOR		
	K3704	QQR0779-001Z	INDUCTOR				R 531	NRSA63J-473X	MG RESISTOR		
	LC635	NQR0322-001X	EMI FILTER				R 532	NRSA63J-750X	MG RESISTOR		
	LC640	NQR0322-001X	EMI FILTER				R 533	NRSA63J-472X	MG RESISTOR		
	LC645	NQR0322-001X	EMI FILTER				R 534	NRSA63J-472X	MG RESISTOR		
	LC650	NQR0322-001X	EMI FILTER				R 535	NRSA63J-102X	MG RESISTOR		
	LC661	NQR0322-001X	EMI FILTER				R 536	NRSA63J-112X	MG RESISTOR		

■ Electrical parts list (DSP board)

Block No. 05

△	Item	Parts number	Parts name	Remarks	Area	△	Item	Parts number	Parts name	Remarks	Area
	R 537	NRSA63J-473X	MG RESISTOR				R3118	NRSA63J-183X	MG RESISTOR		
	R 538	NRSA63J-750X	MG RESISTOR				R3121	NRSA63J-561X	MG RESISTOR		
	R 539	NRSA63J-472X	MG RESISTOR				R3122	NRSA63J-561X	MG RESISTOR		
	R 540	NRSA63J-162X	MG RESISTOR				R3123	NRSA63J-561X	MG RESISTOR		
	R1108	NRSA63J-102X	MG RESISTOR				R3124	NRSA63J-561X	MG RESISTOR		
	R1109	NRSA63J-102X	MG RESISTOR				R3125	NRSA63J-561X	MG RESISTOR		
	R1110	NRSA63J-122X	MG RESISTOR				R3126	NRSA63J-561X	MG RESISTOR		
	R1111	NRSA63J-152X	MG RESISTOR				R3127	NRSA63J-105X	MG RESISTOR		
	R1112	NRSA63J-222X	MG RESISTOR				R3128	NRSA63J-105X	MG RESISTOR		
	R1113	NRSA63J-272X	MG RESISTOR				R3129	NRSA63J-473X	MG RESISTOR		
	R1114	NRSA63J-332X	MG RESISTOR				R3130	NRSA63J-473X	MG RESISTOR		
	R1115	NRSA63J-102X	MG RESISTOR				R3131	NRSA63J-222X	MG RESISTOR		
	R1116	NRSA63J-102X	MG RESISTOR				R3132	NRSA63J-222X	MG RESISTOR		
	R1117	NRSA63J-122X	MG RESISTOR				R3133	NRSA63J-222X	MG RESISTOR		
	R1118	NRSA63J-152X	MG RESISTOR				R3134	NRSA63J-222X	MG RESISTOR		
	R1119	NRSA63J-222X	MG RESISTOR				R3135	NRSA63J-183X	MG RESISTOR		
	R1120	NRSA63J-272X	MG RESISTOR				R3136	NRSA63J-183X	MG RESISTOR		
	R1121	NRSA63J-332X	MG RESISTOR				R3137	NRSA63J-104X	MG RESISTOR		
	R3001	NRSA63J-104X	MG RESISTOR				R3138	NRSA63J-104X	MG RESISTOR		
	R3002	NRSA63J-104X	MG RESISTOR				R3139	NRSA63J-561X	MG RESISTOR		
	R3003	NRSA63J-103X	MG RESISTOR				R3140	NRSA63J-561X	MG RESISTOR		
	R3004	NRSA63J-103X	MG RESISTOR				R3141	NRSA63J-101X	MG RESISTOR		
	R3005	NRSA63J-103X	MG RESISTOR				R3142	NRSA63J-101X	MG RESISTOR		
	R3006	NRSA63J-103X	MG RESISTOR				R3143	NRSA63J-104X	MG RESISTOR		
	R3007	NRSA63J-103X	MG RESISTOR				R3144	NRSA63J-104X	MG RESISTOR		
	R3008	NRSA63J-103X	MG RESISTOR				R3145	NRSA63J-333X	MG RESISTOR		
	R3009	NRSA63J-103X	MG RESISTOR				R3146	NRSA63J-333X	MG RESISTOR		
	R3010	NRSA63J-103X	MG RESISTOR				R3147	NRSA63J-333X	MG RESISTOR		
	R3011	NRSA63J-273X	MG RESISTOR				R3148	NRSA63J-333X	MG RESISTOR		
	R3012	NRSA63J-273X	MG RESISTOR				R3149	NRSA63J-333X	MG RESISTOR		
	R3013	NRSA63J-273X	MG RESISTOR				R3150	NRSA63J-333X	MG RESISTOR		
	R3014	NRSA63J-273X	MG RESISTOR				R3151	NRSA63J-472X	MG RESISTOR		
	R3017	NRSA63J-472X	MG RESISTOR				R3152	NRSA63J-472X	MG RESISTOR		
	R3018	NRSA63J-472X	MG RESISTOR				R3155	NRSA63J-474X	MG RESISTOR		
	R3021	NRSA63J-1R0X	MG RESISTOR				R3157	NRSA63J-332X	MG RESISTOR		
	R3022	NRSA63J-1R0X	MG RESISTOR				R3158	NRSA63J-332X	MG RESISTOR		
	R3031	NRSA63J-103X	MG RESISTOR				R3161	NRSA63J-103X	MG RESISTOR		
	R3032	NRSA63J-103X	MG RESISTOR				R3162	NRSA63J-103X	MG RESISTOR		
	R3033	NRSA63J-103X	MG RESISTOR				R3163	NRSA63J-105X	MG RESISTOR		
	R3034	NRSA63J-103X	MG RESISTOR				R3164	NRSA63J-105X	MG RESISTOR		
	R3035	NRSA63J-103X	MG RESISTOR				R3165	NRSA63J-105X	MG RESISTOR		
	R3041	NRSA63J-221X	MG RESISTOR				R3171	NRSA63J-221X	MG RESISTOR		
	R3042	NRSA63J-221X	MG RESISTOR				R3172	NRSA63J-221X	MG RESISTOR		
	R3043	NRSA63J-221X	MG RESISTOR				R3173	NRSA63J-221X	MG RESISTOR		
	R3044	NRSA63J-101X	MG RESISTOR				R3174	NRSA63J-221X	MG RESISTOR		
	R3045	NRSA63J-105X	MG RESISTOR				R3175	NRSA63J-101X	MG RESISTOR		
	R3101	NRSA63J-243X	MG RESISTOR				R3176	NRSA63J-470X	MG RESISTOR		
	R3102	NRSA63J-243X	MG RESISTOR				R3177	NRSA63J-470X	MG RESISTOR		
	R3103	NRSA63J-243X	MG RESISTOR				R3181	NRSA63J-101X	MG RESISTOR		
	R3104	NRSA63J-243X	MG RESISTOR				R3182	NRSA63J-101X	MG RESISTOR		
	R3105	NRSA63F-163X	MG RESISTOR				R3183	NRSA63J-101X	MG RESISTOR		
	R3106	NRSA63F-163X	MG RESISTOR				R3184	NRSA63J-101X	MG RESISTOR		
	R3107	NRSA63F-163X	MG RESISTOR				R3185	NRSA63J-332X	MG RESISTOR		
	R3108	NRSA63F-163X	MG RESISTOR				R3186	NRSA63J-561X	MG RESISTOR		
	R3109	NRSA63J-362X	MG RESISTOR				R3187	NRSA63J-561X	MG RESISTOR		
	R3110	NRSA63J-362X	MG RESISTOR				R3188	NRSA63J-221X	MG RESISTOR		
	R3111	NRSA63J-163X	MG RESISTOR				R3189	NRSA63J-221X	MG RESISTOR		
	R3112	NRSA63J-163X	MG RESISTOR				R3190	NRSA63J-221X	MG RESISTOR		
	R3113	NRSA63J-162X	MG RESISTOR				R3191	QRJ146J-271X	UNF C RESISTOR	270 5% 1/4W	
	R3114	NRSA63J-162X	MG RESISTOR				R3192	QRJ146J-271X	UNF C RESISTOR	270 5% 1/4W	
	R3115	NRSA63J-182X	MG RESISTOR				R3193	NRSA63J-561X	MG RESISTOR		
	R3116	NRSA63J-182X	MG RESISTOR				R3194	NRSA63J-561X	MG RESISTOR		
	R3117	NRSA63J-183X	MG RESISTOR				R3201	NRSA63J-243X	MG RESISTOR		

■ Electrical parts list (DSP board)

Block No. 05

△	Item	Parts number	Parts name	Remarks	Area	△	Item	Parts number	Parts name	Remarks	Area
	R3202	NRSA63J-243X	MG RESISTOR				R3286	NRSA63J-561X	MG RESISTOR		
	R3203	NRSA63J-243X	MG RESISTOR				R3287	NRSA63J-561X	MG RESISTOR		
	R3204	NRSA63J-243X	MG RESISTOR				R3288	NRSA63J-221X	MG RESISTOR		
	R3205	NRSA63F-163X	MG RESISTOR				R3289	NRSA63J-221X	MG RESISTOR		
	R3206	NRSA63F-163X	MG RESISTOR				R3290	NRSA63J-221X	MG RESISTOR		
	R3207	NRSA63F-163X	MG RESISTOR				R3291	NRSA63J-333X	MG RESISTOR		
	R3208	NRSA63F-163X	MG RESISTOR				R3292	NRSA63J-333X	MG RESISTOR		
	R3209	NRSA63J-362X	MG RESISTOR				R3293	NRSA63J-243X	MG RESISTOR		
	R3210	NRSA63J-362X	MG RESISTOR				R3294	NRSA63J-104X	MG RESISTOR		
	R3211	NRSA63J-163X	MG RESISTOR				R3295	NRSA63J-102X	MG RESISTOR		
	R3212	NRSA63J-163X	MG RESISTOR				R3296	NRSA63J-102X	MG RESISTOR		
	R3213	NRSA63J-162X	MG RESISTOR				R3297	NRSA63J-473X	MG RESISTOR		
	R3214	NRSA63J-162X	MG RESISTOR				R3298	NRSA63J-473X	MG RESISTOR		
	R3215	NRSA63J-182X	MG RESISTOR				R3301	NRSA63J-243X	MG RESISTOR		
	R3216	NRSA63J-182X	MG RESISTOR				R3302	NRSA63J-243X	MG RESISTOR		
	R3217	NRSA63J-183X	MG RESISTOR				R3303	NRSA63J-243X	MG RESISTOR		
	R3221	NRSA63J-561X	MG RESISTOR				R3304	NRSA63J-243X	MG RESISTOR		
	R3222	NRSA63J-202X	MG RESISTOR				R3305	NRSA63F-163X	MG RESISTOR		
	R3223	NRSA63J-471X	MG RESISTOR				R3306	NRSA63F-163X	MG RESISTOR		
	R3224	NRSA63J-202X	MG RESISTOR				R3307	NRSA63F-163X	MG RESISTOR		
	R3225	NRSA63J-821X	MG RESISTOR				R3308	NRSA63F-163X	MG RESISTOR		
	R3226	NRSA63J-1R0X	MG RESISTOR				R3309	NRSA63J-362X	MG RESISTOR		
	R3227	NRSA63J-105X	MG RESISTOR				R3310	NRSA63J-362X	MG RESISTOR		
	R3229	NRSA63J-473X	MG RESISTOR				R3311	NRSA63J-163X	MG RESISTOR		
	R3230	NRSA63J-473X	MG RESISTOR				R3312	NRSA63J-163X	MG RESISTOR		
	R3231	NRSA63J-393X	MG RESISTOR				R3313	NRSA63J-162X	MG RESISTOR		
	R3232	NRSA63J-133X	MG RESISTOR				R3314	NRSA63J-162X	MG RESISTOR		
	R3233	NRSA63J-113X	MG RESISTOR				R3315	NRSA63J-182X	MG RESISTOR		
	R3234	NRSA63J-242X	MG RESISTOR				R3316	NRSA63J-182X	MG RESISTOR		
	R3235	NRSA63J-183X	MG RESISTOR				R3317	NRSA63J-183X	MG RESISTOR		
	R3236	NRSA63J-183X	MG RESISTOR				R3318	NRSA63J-183X	MG RESISTOR		
	R3237	NRSA63J-104X	MG RESISTOR				R3321	NRSA63J-561X	MG RESISTOR		
	R3238	NRSA63J-104X	MG RESISTOR				R3322	NRSA63J-561X	MG RESISTOR		
	R3239	NRSA63J-561X	MG RESISTOR				R3323	NRSA63J-471X	MG RESISTOR		
	R3240	NRSA63J-561X	MG RESISTOR				R3324	NRSA63J-471X	MG RESISTOR		
	R3241	NRSA63J-101X	MG RESISTOR				R3325	NRSA63J-821X	MG RESISTOR		
	R3242	NRSA63J-101X	MG RESISTOR				R3326	NRSA63J-821X	MG RESISTOR		
	R3251	NRSA63J-472X	MG RESISTOR				R3327	NRSA63J-105X	MG RESISTOR		
	R3255	NRSA63J-202X	MG RESISTOR				R3328	NRSA63J-105X	MG RESISTOR		
	R3256	NRSA63J-202X	MG RESISTOR				R3329	NRSA63J-473X	MG RESISTOR		
	R3257	NRSA63J-332X	MG RESISTOR				R3330	NRSA63J-473X	MG RESISTOR		
	R3258	NRSA63J-332X	MG RESISTOR				R3331	NRSA63J-243X	MG RESISTOR		
	R3261	NRSA63J-103X	MG RESISTOR				R3332	NRSA63J-243X	MG RESISTOR		
	R3262	NRSA63J-474X	MG RESISTOR				R3333	NRSA63J-113X	MG RESISTOR		
	R3263	NRSA63J-912X	MG RESISTOR				R3334	NRSA63J-113X	MG RESISTOR		
	R3264	NRSA63J-472X	MG RESISTOR				R3335	NRSA63J-183X	MG RESISTOR		
	R3265	NRSA63J-105X	MG RESISTOR				R3336	NRSA63J-183X	MG RESISTOR		
	R3266	NRSA63J-243X	MG RESISTOR				R3337	NRSA63J-104X	MG RESISTOR		
	R3267	NRSA63J-103X	MG RESISTOR				R3338	NRSA63J-104X	MG RESISTOR		
	R3268	NRSA63J-102X	MG RESISTOR				R3339	NRSA63J-561X	MG RESISTOR		
	R3269	NRSA63J-104X	MG RESISTOR				R3340	NRSA63J-561X	MG RESISTOR		
	R3271	NRSA63J-221X	MG RESISTOR				R3341	NRSA63J-101X	MG RESISTOR		
	R3272	NRSA63J-221X	MG RESISTOR				R3342	NRSA63J-101X	MG RESISTOR		
	R3273	NRSA63J-221X	MG RESISTOR				R3351	NRSA63J-472X	MG RESISTOR		
	R3274	NRSA63J-221X	MG RESISTOR				R3352	NRSA63J-472X	MG RESISTOR		
	R3275	NRSA63J-101X	MG RESISTOR				R3353	NRSA63J-474X	MG RESISTOR		
	R3276	NRSA63J-470X	MG RESISTOR				R3357	NRSA63J-332X	MG RESISTOR		
	R3277	NRSA63J-470X	MG RESISTOR				R3358	NRSA63J-332X	MG RESISTOR		
	R3281	NRSA63J-101X	MG RESISTOR				R3361	NRSA63J-103X	MG RESISTOR		
	R3282	NRSA63J-101X	MG RESISTOR				R3362	NRSA63J-103X	MG RESISTOR		
	R3283	NRSA63J-101X	MG RESISTOR				R3363	NRSA63J-752X	MG RESISTOR		
	R3284	NRSA63J-101X	MG RESISTOR				R3364	NRSA63J-752X	MG RESISTOR		
	R3285	NRSA63J-332X	MG RESISTOR				R3365	NRSA63J-105X	MG RESISTOR		

■ Electrical parts list (DSP board)

Block No. 05

△	Item	Parts number	Parts name	Remarks	Area	△	Item	Parts number	Parts name	Remarks	Area
	R3371	NRSA63J-221X	MG RESISTOR				R3463	NRSA63J-752X	MG RESISTOR		
	R3372	NRSA63J-221X	MG RESISTOR				R3464	NRSA63J-752X	MG RESISTOR		
	R3373	NRSA63J-221X	MG RESISTOR				R3465	NRSA63J-105X	MG RESISTOR		
	R3374	NRSA63J-221X	MG RESISTOR				R3471	NRSA63J-221X	MG RESISTOR		
	R3375	NRSA63J-101X	MG RESISTOR				R3472	NRSA63J-221X	MG RESISTOR		
	R3376	NRSA63J-470X	MG RESISTOR				R3473	NRSA63J-221X	MG RESISTOR		
	R3377	NRSA63J-470X	MG RESISTOR				R3474	NRSA63J-221X	MG RESISTOR		
	R3381	NRSA63J-101X	MG RESISTOR				R3475	NRSA63J-101X	MG RESISTOR		
	R3382	NRSA63J-101X	MG RESISTOR				R3476	NRSA63J-470X	MG RESISTOR		
	R3383	NRSA63J-101X	MG RESISTOR				R3477	NRSA63J-470X	MG RESISTOR		
	R3384	NRSA63J-101X	MG RESISTOR				R3481	NRSA63J-101X	MG RESISTOR		
	R3385	NRSA63J-332X	MG RESISTOR				R3482	NRSA63J-101X	MG RESISTOR		
	R3386	NRSA63J-561X	MG RESISTOR				R3483	NRSA63J-101X	MG RESISTOR		
	R3387	NRSA63J-561X	MG RESISTOR				R3484	NRSA63J-101X	MG RESISTOR		
	R3388	NRSA63J-221X	MG RESISTOR				R3485	NRSA63J-332X	MG RESISTOR		
	R3389	NRSA63J-221X	MG RESISTOR				R3486	NRSA63J-561X	MG RESISTOR		
	R3390	NRSA63J-221X	MG RESISTOR				R3487	NRSA63J-561X	MG RESISTOR		
	R3401	NRSA63J-243X	MG RESISTOR				R3488	NRSA63J-221X	MG RESISTOR		
	R3402	NRSA63J-243X	MG RESISTOR				R3489	NRSA63J-221X	MG RESISTOR		
	R3403	NRSA63J-243X	MG RESISTOR				R3490	NRSA63J-221X	MG RESISTOR		
	R3404	NRSA63J-243X	MG RESISTOR				R3501	NRSA63J-473X	MG RESISTOR		
	R3405	NRSA63F-163X	MG RESISTOR				R3502	NRSA63J-470X	MG RESISTOR		
	R3406	NRSA63F-163X	MG RESISTOR				R3503	NRSA63J-470X	MG RESISTOR		
	R3407	NRSA63F-163X	MG RESISTOR				R3504	NRSA63J-470X	MG RESISTOR		
	R3408	NRSA63F-163X	MG RESISTOR				R3505	NRSA63J-470X	MG RESISTOR		
	R3409	NRSA63J-362X	MG RESISTOR				R3506	NRSA63J-473X	MG RESISTOR		
	R3410	NRSA63J-362X	MG RESISTOR				R3507	NRSA63J-473X	MG RESISTOR		
	R3411	NRSA63J-163X	MG RESISTOR				R3508	NRSA63J-473X	MG RESISTOR		
	R3412	NRSA63J-163X	MG RESISTOR				R3509	NRSA63J-473X	MG RESISTOR		
	R3413	NRSA63J-162X	MG RESISTOR				R3510	NRSA63J-473X	MG RESISTOR		
	R3414	NRSA63J-162X	MG RESISTOR				R3511	NRSA63J-473X	MG RESISTOR		
	R3415	NRSA63J-182X	MG RESISTOR				R3512	NRSA63J-473X	MG RESISTOR		
	R3416	NRSA63J-182X	MG RESISTOR				R3513	NRSA63J-473X	MG RESISTOR		
	R3417	NRSA63J-183X	MG RESISTOR				R3514	NRSA63J-473X	MG RESISTOR		
	R3418	NRSA63J-183X	MG RESISTOR				R3515	NRSA63J-473X	MG RESISTOR		
	R3421	NRSA63J-561X	MG RESISTOR				R3516	NRSA63J-473X	MG RESISTOR		
	R3422	NRSA63J-561X	MG RESISTOR				R3517	NRSA63J-473X	MG RESISTOR		
	R3423	NRSA63J-471X	MG RESISTOR				R3518	NRSA63J-473X	MG RESISTOR		
	R3424	NRSA63J-471X	MG RESISTOR				R3519	NRSA63J-473X	MG RESISTOR		
	R3425	NRSA63J-821X	MG RESISTOR				R3520	NRSA63J-101X	MG RESISTOR		
	R3426	NRSA63J-821X	MG RESISTOR				R3521	NRSA63J-103X	MG RESISTOR		
	R3427	NRSA63J-105X	MG RESISTOR				R3522	NRSA63J-103X	MG RESISTOR		
	R3428	NRSA63J-105X	MG RESISTOR				R3523	NRSA63J-103X	MG RESISTOR		
	R3429	NRSA63J-473X	MG RESISTOR				R3524	NRSA63J-103X	MG RESISTOR		
	R3430	NRSA63J-473X	MG RESISTOR				R3525	NRSA63J-103X	MG RESISTOR		
	R3431	NRSA63J-243X	MG RESISTOR				R3526	NRSA63J-470X	MG RESISTOR		
	R3432	NRSA63J-243X	MG RESISTOR				R3527	NRSA63J-470X	MG RESISTOR		
	R3433	NRSA63J-113X	MG RESISTOR				R3601	NRSA63J-473X	MG RESISTOR		
	R3434	NRSA63J-113X	MG RESISTOR				R3602	NRSA63J-470X	MG RESISTOR		
	R3435	NRSA63J-183X	MG RESISTOR				R3603	NRSA63J-470X	MG RESISTOR		
	R3436	NRSA63J-183X	MG RESISTOR				R3604	NRSA63J-470X	MG RESISTOR		
	R3437	NRSA63J-104X	MG RESISTOR				R3605	NRSA63J-470X	MG RESISTOR		
	R3438	NRSA63J-104X	MG RESISTOR				R3606	NRSA63J-473X	MG RESISTOR		
	R3439	NRSA63J-561X	MG RESISTOR				R3607	NRSA63J-473X	MG RESISTOR		
	R3440	NRSA63J-561X	MG RESISTOR				R3608	NRSA63J-473X	MG RESISTOR		
	R3441	NRSA63J-101X	MG RESISTOR				R3609	NRSA63J-473X	MG RESISTOR		
	R3442	NRSA63J-101X	MG RESISTOR				R3610	NRSA63J-473X	MG RESISTOR		
	R3451	NRSA63J-472X	MG RESISTOR				R3611	NRSA63J-473X	MG RESISTOR		
	R3452	NRSA63J-472X	MG RESISTOR				R3612	NRSA63J-473X	MG RESISTOR		
	R3457	NRSA63J-332X	MG RESISTOR				R3613	NRSA63J-473X	MG RESISTOR		
	R3458	NRSA63J-332X	MG RESISTOR				R3614	NRSA63J-473X	MG RESISTOR		
	R3461	NRSA63J-103X	MG RESISTOR				R3615	NRSA63J-473X	MG RESISTOR		
	R3462	NRSA63J-103X	MG RESISTOR				R3616	NRSA63J-473X	MG RESISTOR		

■ Electrical parts list (DSP board)

Block No. 05

△	Item	Parts number	Parts name	Remarks	Area
	R3617	NRSA63J-473X	MG RESISTOR		
	R3618	NRSA63J-473X	MG RESISTOR		
	R3620	NRSA63J-101X	MG RESISTOR		
	R3621	NRSA63J-103X	MG RESISTOR		
	R3622	NRSA63J-103X	MG RESISTOR		
	R3623	NRSA63J-103X	MG RESISTOR		
	R3624	NRSA63J-103X	MG RESISTOR		
	R3626	NRSA63J-470X	MG RESISTOR		
	R3627	NRSA63J-470X	MG RESISTOR		
	R3628	NRSA63J-470X	MG RESISTOR		
	R3629	NRSA63J-470X	MG RESISTOR		
	R3701	NRSA63J-750X	MG RESISTOR		
	R3702	NRSA63J-221X	MG RESISTOR		
	R3703	NRSA63J-112X	MG RESISTOR		
	R3704	NRSA63J-112X	MG RESISTOR		
	R3705	NRSA63J-112X	MG RESISTOR		
	R3706	NRSA63J-112X	MG RESISTOR		
	R3707	NRSA63J-512X	MG RESISTOR		
	R3708	NRSA63J-512X	MG RESISTOR		
	R3709	NRSA63J-512X	MG RESISTOR		
	R3710	NRSA63J-512X	MG RESISTOR		
	R3721	NRSA63F-183X	MG RESISTOR		
	R3722	NRSA63J-100X	MG RESISTOR		
	R3723	NRSA63J-101X	MG RESISTOR		
	R3724	NRSA63J-221X	MG RESISTOR		
	R3725	NRSA63J-221X	MG RESISTOR		
	R3726	NRSA63J-221X	MG RESISTOR		
	R3727	NRSA63J-221X	MG RESISTOR		
	R3735	NRSA63J-221X	MG RESISTOR		
	R3801	NRSA63J-105X	MG RESISTOR		
	R3802	NRSA63J-105X	MG RESISTOR		
	R3803	NRSA63J-470X	MG RESISTOR		
	R3805	NRSA63F-511X	MG RESISTOR		
	R3806	NRSA63F-102X	MG RESISTOR		
	R3807	NRSA63J-103X	MG RESISTOR		
	R3811	NRSA63J-221X	MG RESISTOR		
	R3812	NRSA63J-221X	MG RESISTOR		
	R3813	NRSA63J-221X	MG RESISTOR		
	R3814	NRSA63J-470X	MG RESISTOR		
	R3815	NRSA63J-470X	MG RESISTOR		
	R3816	NRSA63J-470X	MG RESISTOR		
	R3920	NRSA63J-103X	MG RESISTOR		
	R3921	NRSA63J-512X	MG RESISTOR		
	R3922	NRSA63J-512X	MG RESISTOR		
	R3923	NRSA63J-221X	MG RESISTOR		
	R3924	NRSA63J-512X	MG RESISTOR		
	R3925	NRSA63J-512X	MG RESISTOR		
	R3926	NRSA63J-103X	MG RESISTOR		
	R3927	NRSA63J-103X	MG RESISTOR		
	R3928	NRSA63J-103X	MG RESISTOR		
	R3929	NRSA63J-103X	MG RESISTOR		
	R3930	NRSA63J-103X	MG RESISTOR		
	R5001	NRSA63J-223X	MG RESISTOR		
	R5002	NRSA63J-102X	MG RESISTOR		
	R5003	NRSA63J-153X	MG RESISTOR		
	R5004	NRSA63J-112X	MG RESISTOR		
	R5005	NRSA63J-222X	MG RESISTOR		
	R5006	NRSA63J-473X	MG RESISTOR		
	R5007	NRSA63J-105X	MG RESISTOR		
	R5008	NRSA63J-102X	MG RESISTOR		
	R5009	NRSA63J-473X	MG RESISTOR		
	R5010	NRSA63J-105X	MG RESISTOR		
	R5011	NRSA63J-102X	MG RESISTOR		

△	Item	Parts number	Parts name	Remarks	Area
	R5012	NRSA63J-223X	MG RESISTOR		
	S1009	NSW0059-001X	TACT SWITCH		
	S1010	NSW0059-001X	TACT SWITCH		
	S1011	NSW0059-001X	TACT SWITCH		
	S1012	NSW0059-001X	TACT SWITCH		
	S1013	NSW0059-001X	TACT SWITCH		
	S1014	NSW0059-001X	TACT SWITCH		
	S1016	NSW0059-001X	TACT SWITCH		
	S1017	NSW0059-001X	TACT SWITCH		
	S1018	NSW0059-001X	TACT SWITCH		
	S1019	NSW0059-001X	TACT SWITCH		
	S1020	NSW0059-001X	TACT SWITCH		
	S1021	NSW0059-001X	TACT SWITCH		
	TP671	QMV5005-002K	2P PLUG ASSY		
	UN631	GP1FA550RZ	OPT RECEIVER		
	UN632	GP1FA550RZ	OPT RECEIVER		
	UN633	GP1FA550RZ	OPT RECEIVER		
	UN634	GP1FA550RZ	OPT RECEIVER		
	UN635	GP1FA550TZ	OPT TRANSMITTER		
	WR 54	QJK016-035203	SIN CR C-B WIRE		
	WR632	QJK016-153000	SIN CR C-B WIRE		
	X3001	NAX0435-001X	CRYSTAL		
	X3801	NAX0308-001X	RESONATOR		
	X3802	NAX0275-001X	1COSCIALLATOR		

■ Electrical parts list
(Thermal compensation board)

Block No. 06

△	Item	Parts number	Parts name	Remarks	Area
	B7015	QGA2501F1-03	CONNECTOR		C
	CN701	QGA2501F1-03	CONNECTOR		
	CN702	QGA2501F1-03	CONNECTOR		
	CN703	QGA2501F1-03	CONNECTOR		
	CN704	QGA2501F1-03	CONNECTOR		
	CN705	QGA2501F1-03	CONNECTOR		
	CN706	QGA2501F1-03	CONNECTOR		
	CN707	QGA2501F1-03	CONNECTOR		
	C7191	QDVB1EZ-103Y	C CAPACITOR		
	C7192	QDVB1EZ-103Y	C CAPACITOR		
	C7193	QDVB1EZ-103Y	C CAPACITOR		
	C7194	QDVB1EZ-103Y	C CAPACITOR		
	C7195	QDVB1EZ-103Y	C CAPACITOR		J
	C7195	QGA2501F1-03	CONNECTOR		C
	C7196	QDVB1EZ-103Y	C CAPACITOR		
	C7197	QDVB1EZ-103Y	C CAPACITOR		
	Q7091	2SC3422/OY/	TRANSISTOR		
	Q7092	2SC3422/OY/	TRANSISTOR		
	Q7093	2SC3422/OY/	TRANSISTOR		
	Q7094	2SC3422/OY/	TRANSISTOR		
	Q7095	2SC3422/OY/	TRANSISTOR		
	Q7096	2SC3422/OY/	TRANSISTOR		
	Q7097	2SC3422/OY/	TRANSISTOR		

< MEMO >

Packing materials and accessories parts list

Block No.

M	3	M	M
---	---	---	---

Block No.

M	5	M	M
---	---	---	---

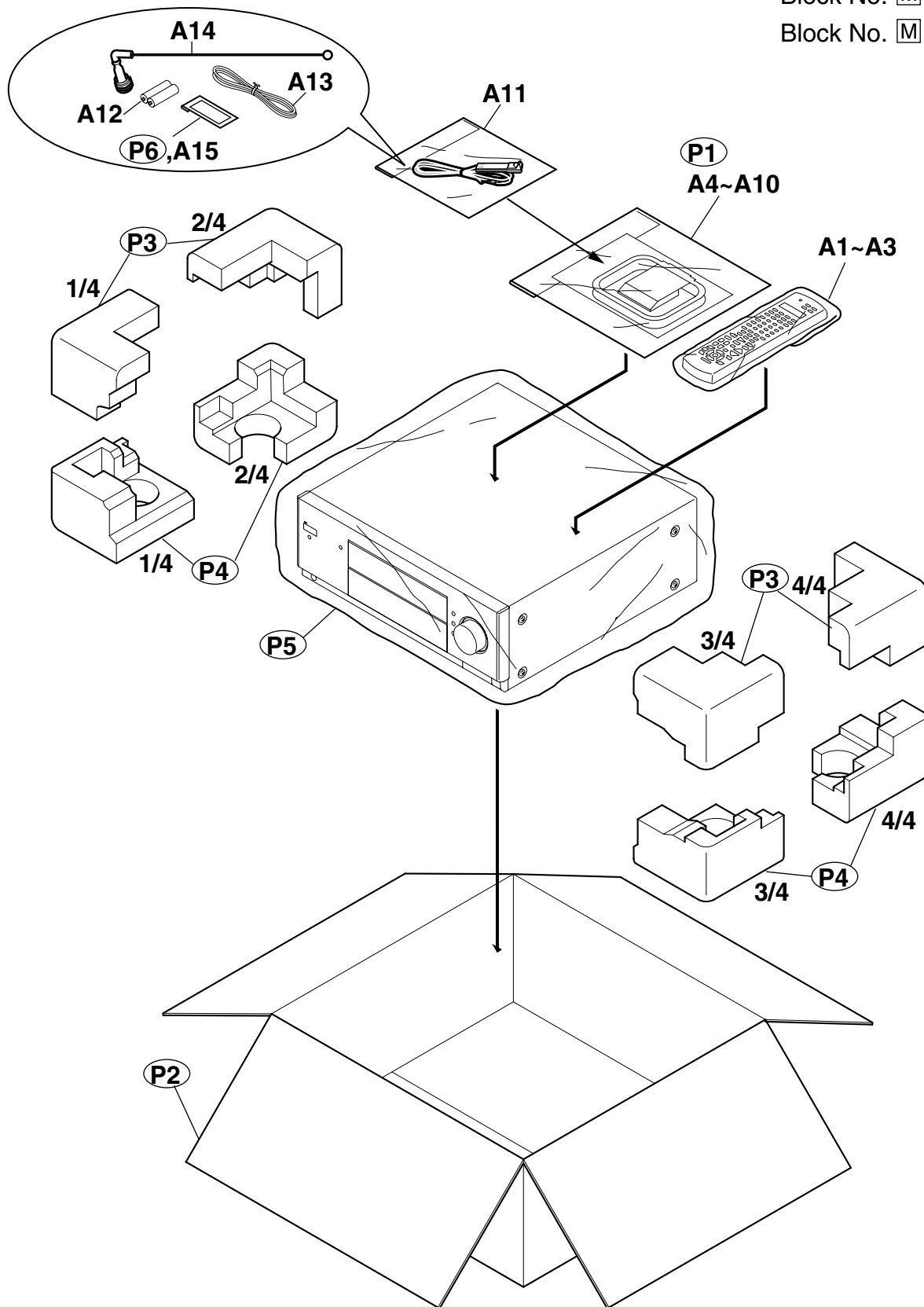

■ Parts list (Packing)

Block No. M3MM

△	Item	Parts number	Parts name	Q'ty	Description	Area
	P 1	QPA02503505P	POLY BAG	1	INST BOOK	
	P 2	LV21071-009A	CARTON BOX	1		C
		LV21071-013A	CARTON BOX	1		J
	P 3	LV21069-001A	CUSHION	1		
	P 4	LV21070-001A	CUSHION	1		
	P 5	QPC08008015P	POLY BAG	1	SET	
	P 6	QPC00501205	POLY BAG	1	COVER	

■ Parts list (Accessories)

Block No. M5MM

△	Item	Parts number	Parts name	Q'ty	Description	Area
	A 1	RM-SRXDP10J	REMOCON	1		
	A 2	LV42570-001A	SHEET	1		
	A 3	LV30256-007A	SHEET	1		
	A 4	LVT0722-003A	INST BOOK	1	ENG	J
		LVT0722-004A	INST BOOK	1	ENG,FRE	C
	A 5	BT-20071B	JVC CENTER LIST	1		C
	A 6	BT-52004-1	WARRANTY CARD	1		C
	A 7	BT-51028-1	J=REGIST CARD	1		J
	A 8	YU20333	SAFETY INST	1		J
	A 10	QAL0204-001	AM LOOP ANT	1		
	A 11	QAL0219-001	LED CABLE ASSY	1		
	A 12	-----	AL BATTERY	2		
	A 13	EWP503-001C	ANT.WIRE	1		
	A 14	QAL0236-001	ANTENNA	1		
	A 15	LV32823-002A	COVER ASSY	1		J
		LV32823-001A	COVER ASSY	1		C

RX-DP10VBK/RX-DP10VSL

RX-DP10RSL

< M E M O >

PARTS LIST

[RX-DP10RSL]

* All printed circuit boards and its assemblies are not available as service parts.

Area suffix

B ----- U.K.
 E ----- Continental Europe
 EN ----- Northern Europe

- Contents -

Exploded view of general assembly and parts list (Block No.M1)	3-41
Electrical parts list (Block No.01~06)	3-45
Packing materials and accessories parts list (Block No.M3,M5)	3-72

RX-DP10VBK/RX-DP10VSL

RX-DP10RSL

< M E M O >

Exploded view of general assembly and parts list

Block No. **M 1 M M**

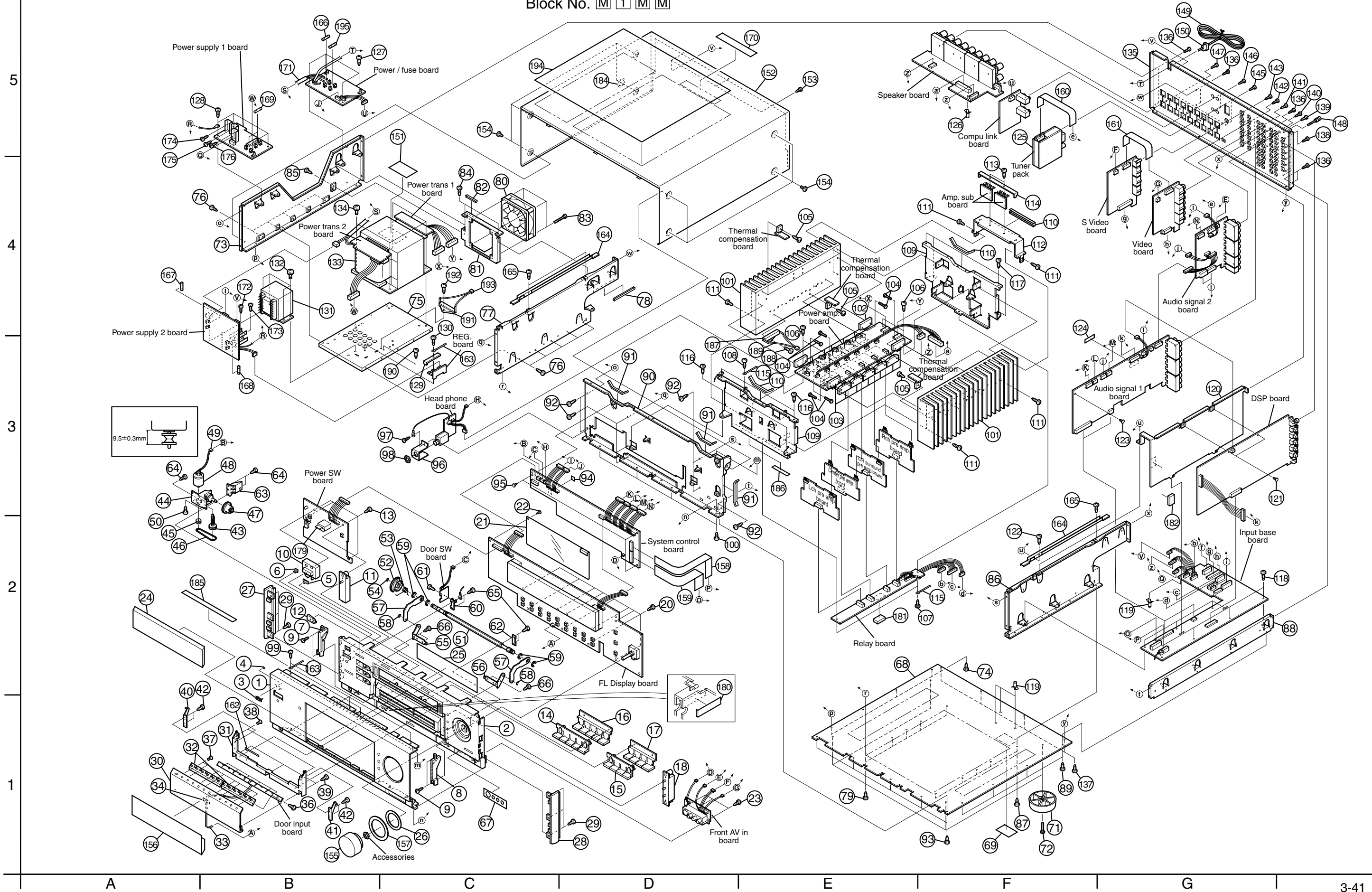

RX-DP10VBK/RX-DP10VSL
RX-DP10RSL
Block No. M1MM

■ Parts list (General assembly)

△	Item	Parts number	Parts name	Q'ty	Description	Area
	1	LV10535-012A	FRONT PANEL	1		
	2	LV10536-018A	FRONT BASE	1		
	3	VJD5429-002SS	JVC MARK	1		
	4	E60912-003	SPEED NUT	1		
	5	E408131-001	REMOTE LENS	1		
	6	LV42395-001A	INDICATOR	1		
	7	LV32831-002A	GUIDE(L)	1		
	8	LV32832-002A	GUIDE(R)	1		
	9	QYSDSF2608M	TAP SCREW	4	GUIDE	
	10	LV32812-001A	PUSH BUTTON	1		
	11	LV32813-002A	PUSH BUTTON	1		
	12	LV32826-003A	INDICATOR	1		
	13	QYSDSF2608Z	SCREW	4	P.C.B	
	14	LV32815-001A	PUSH BUTTON	1		
	15	LV32816-001A	PUSH BUTTON	1		
	16	LV32817-001A	PUSH BUTTON	1		
	17	LV32818-001A	PUSH BUTTON	1		
	18	LV32814-001A	PUSH BUTTON	1		
	20	QYSDSF2608Z	SCREW	9	P.C.B	
	21	LV42684-001A	BARRIER	1		
	22	E310243-002	PLASTIC RIVET	1		
	23	QYSDSF2608Z	SCREW	3	F.VIDEO P.C.B	
	24	LV32811-003A	LENS	1		
	25	LV42095-003A	FL SCREEN	1		
	26	LV42726-001A	VOL SPACER	1		
	27	LV21063-001A	SIDE FITTING(L)	1		
	28	LV21064-001A	SIDE FITTING(R)	1		
	29	QYSBSF3008Z	SCREW	6	S.FITTING	
	30	LV21061-005A	DOOR	1		
	31	LV21062-003A	DOOR BASE	1		
	32	LV21065-001A	PUSH BUTTON	2		
	33	WJT0073-001A	E-CARD WIRE	1		
	34	LV30225-074A	SPACER	1		
	36	QYSDSF2004Z	SCREW	6	P.C.B	
	37	QYSSSG2004Z	SCREW	8	DOOR-BUTTON	
	38	QYSSSG2004Z	SCREW	2	DOOR UPPER	
	39	QYSDSF2606Z	SCREW	3	DOOR LOWER	
	40	LV32835-002A	G.P.BKT(L)ASSY	1		
	41	LV32836-002A	G.P.BKT(R)ASSY	1		
	42	QYSDSF2606Z	SCREW	4	D.BASE-BKT	
	43	LV42478-001A	WORM GEAR	1		
	44	LV32837-002A	MOTOR BASE	1		
	45	LV41536-201A	PULLEY	1		
	46	LV41598-001A	BELT	1		
	47	LV32838-001A	WORM WHEEL	1		
	48	QAR0100-001	DC MOTOR	1		
	49	WJM0233-001A	E-SI C WIRE C-F	1		
	50	QYSPSP3004Z	SCREW	2	M.BASE-DC MOTOR	

RX-DP10VBK/RX-DP10VSL
RX-DP10RSL

■ Parts list (General assembly)

Block No. M1MM

△	Item	Parts number	Parts name	Q'ty	Description	Area
	51	LV32830-001A	MAIN SHAFT	1		
	52	LV42400-001A	MAIN GEAR	1		
	53	LV42729-001A	SPRING	1		
	54	QYREE3000X	E RING	1		
	55	LV32833-002A	H.BKT(L) ASS'Y	1		
	56	LV32834-002A	H.BKT(R) ASS'Y	1		
	57	LV42396-001A	ARM	2		
	58	QYREE3000X	E RING	2		
	59	QYREE6000X	E RING	4		
	60	LV42397-001A	S.STOPPER(L)	1		
	61	QYSDSG2606Z	SCREW	1	P.C.B	
	62	LV42398-001A	S.STOPPER(R)	1		
	63	LV32839-001A	WHEEL STOPPER	1		
	64	QYSBSF3008Z	SCREW	3	W.STOPPER & M.ASSY	
	65	QYSDSF2608Z	SCREW	4	S.STOPPER	
	66	QYSDSF2606M	SCREW	4	D.BASE-H.BKT	
	67	LV42426-004A	SHEET	1		
	68	LV10537-001A	BOTTOM PLATE	1		
	69	E70115-002	CAUTION LABEL	1		
	71	QZF6018-003	FOOT	4		
	72	QYSBST3010Z	T.SCREW	4	FOOT	
	73	LV10541-002A	SIDE BKT(L)	1		
	74	QYSBSGG3008E	T.SCREW	4		
	75	LV10542-003A	TRANS BASE	1		
	76	QYSDSG3008E	T.SCREW	10	C.BKT & S.BKT	
	77	LV10543-002A	CENTER BKT(L)	1		
	78	LV30225-071A	SPACER	1		
	79	QYSBSGG3008E	T.SCREW	5	BOTTOM	
	80	QAR0198-001	FAN MOTOR	1		
	81	LV33162-001A	FAN BKT	1		
	82	LV30225-074A	SPACER	1		
	83	QYSBSG3030Z	T.SCREW	4		
	84	QYSDSG3008E	T.SCREW	2		
	85	QYSDSG3008E	T.SCREW	1		
	86	LV10544-001A	CENTER BKT(R)	1		
	87	QYSBSGG3008E	T.SCREW	5	BOTTOM	
	88	LV21066-001A	SIDE BKT(R)	1		
	89	QYSBSGG3008E	T.SCREW	4	BOTTOM	
	90	LV10539-001A	FRONT BKT	1		
	91	LV30225-071A	SPACER	3		
	92	QYSBSGG3008E	T.SCREW	9	C.BKT & S.BKT	
	93	QYSBSGG3008E	T.SCREW	5	BOTTOM	
	94	LV30225-0C8A	SPACER	1		
	95	E310243-002	PLASTIC RIVET	3		
	96	LV42094-003A	H.P BKT	1		
	97	QYSBSGG3008E	T.SCREW	1	H.P BKT	
	98	VKZ4150-001	SPECIAL NUT	1		
	99	QYSBSGG3008E	T.SCREW	3	F.PANEL UPPER	

■ Parts list (General assembly)

Block No. M1MM

△	Item	Parts number	Parts name	Q'ty	Description	Area
	100	QYSBSGG3008E	T.SCREW	4	F.PANEL LOWER	
	101	LV32828-004A	HEAT SINK	2		
△	102	2SA1494/PG/-F1	TRANSISTOR	3	Q715,Q765,Q815	
△		2SA1494/PG/-F1	TRANSISTOR	2	Q1715,Q1765	
△		2SA1494/PG/-F1	TRANSISTOR	2	Q1615,Q1665	
△	103	2SC3858/PG/-F1	TRANSISTOR	2	Q1614,Q1664	
△		2SC3858/PG/-F1	TRANSISTOR	2	Q1714,Q1764	
△		2SC3858/PG/-F1	TRANSISTOR	3	Q714,Q764,Q814	
	104	E73525-003SS	SCREW	28	TRANSISTOR	
	105	QYSBSGG3010E	T.SCREW	7		
	106	QYSBSGG3010E	T.SCREW	4	P.C.B	
	107	QYSBSGG3010E	T.SCREW	2	P.C.B	
	108	QYSBSGG3010E	T.SCREW	1		
	109	LV21067-001A	H.SINK BKT	2		
	110	LV30225-071A	SPACER	3		
	111	QYSBSGG3010E	T.SCREW	8	H.SINK	
	112	LV32829-002A	H.SINK HOLDER	1		
	113	QYSDSG3008E	T.SCREW	2	H.SINK	
	114	LV42704-001A	HOLDER	1		
	115	VKZ4001-111	WIRE HOLDER	2		
	116	QYSBSGG3008E	T.SCREW	4	H.S ASSY FRONT	
	117	QYSBSGG3008E	T.SCREW	4	H.S ASSY REAR	
	118	QYSBSGG3008E	T.SCREW	7	P.C.B	
	119	E310244-003	FASTNER	4		
	120	LV21068-001A	SHIELD COVER	1		
	121	E310243-002	PLASTIC RIVET	2		
	122	QYSBSGG3008E	T.SCREW	1	C.BKT	
	123	E310243-002	PLASTIC RIVET	1		
	124	LV30225-0C7A	SPACER	1		
	125	QAU0241-001	TUNER	1		
	126	E310244-003	FASTNER	1		
	127	QYSBSGG3008E	T.SCREW	4	PRIMARY	
	128	QYSBSGG3008E	T.SCREW	4	ANALOG P.SUPPLY	
	129	LV41603-001A	LEAF SPRING	1		
	130	QYSDSG3008E	T.SCREW	1	LEAF SPRING	
△	131	QQT0337-001	POWER TRANSF	1	T41	
	132	QYSDSTL4008E	SPECIAL SCREW	4	TRANS.	
△	133	QQT0343-002	POWER TRANSF	1	T1	
	134	QYSDSTL4008E	SPECIAL SCREW	4	TRANS.	
	135	LV10540-009A	REAR PANEL	1		
	136	QYSBSGY3008E	SPECIAL SCREW	8	S.BKT/C.BKT	
	137	QYSBSGY3008E	SPECIAL SCREW	4	BOTTOM	
	138	QYSBSGY3008E	SPECIAL SCREW	7	DSP	
	139	QYSBSGY3008E	SPECIAL SCREW	1	SHIELD	
	140	QYSBSGY3008E	SPECIAL SCREW	3	AUDIO	
	141	QYSBSGY3008E	SPECIAL SCREW	4	V-AUDIO	
	142	QYSBSGY3008E	SPECIAL SCREW	3	C-V EXCEPT	
	143	QYSBSGY3008E	SPECIAL SCREW	4	S-V EXCEPT	

■ Parts list (General assembly)

Block No. M1MM

△	Item	Parts number	Parts name	Q'ty	Description	Area
	145	QYSBSGY3008E	SPECIAL SCREW	2	TUNER	
	146	QYSBSGY3008E	SPECIAL SCREW	2	DCS	
	147	QYSBSGY3008E	SPECIAL SCREW	5	SPK	
	148	E409257-001	GND TERMINAL	1		
△	149	QMPK230-205-JC	POWER CORD	1		E,EN
△		QMPN100-200-JD	POWER CORD	1		B
△	150	QZW0033-001	STRAIN RELIEF	1		
	151	LV40911-001A	LABEL	1		
	152	LV10538-005A/S/	TOP COVER	1		
	153	QYSBSGY3008E	SPECIAL SCREW	3	TOP COVER	
	154	E406308-004	SPECIAL SCREW	8	TOP SL-MODEL	
	155	LV32819-001A	VOL KNOB	1		
	156	LV33243-001A	PROTECT SHEET	1		
	157	LV42405-001A	VOL RING	1		
	158	QUQ412-1619DJ	FFC WIRE	1	FRONT1-MOTHER	
	159	QUQ412-2019DJ	FFC WIRE	1	FRONT1-MOTHER	
	160	QUQ412-1513DJ	FFC WIRE	1	TUNER-AUDIO2	
	161	QUQ412-1605DJ	FFC WIRE	1	VIDEO1-VIDEO2	
	162	VKZ4001-018	WIRE HOLDER	1		
	163	VKZ4001-111S	WIRE CLAMP	2		
	164	LV33163-001A	BARRIER	2		
	165	QYSBSGG3008E	T.SCREW	3		
△	166	QMF51E2-4R0-J1	FUSE	1	F21	
△	167	QMF51E2-R50-J1	FUSE	1	F41	
△	168	QMF51E2-2R0-J1	FUSE	1	F42	
△	169	QMF51E2-2R0-J1	FUSE	2	F61,F62	
	170	E409396-002	CAUTION LABEL	1		
	171	QWTJ809-240	GLASS TUBE	1		
	172	QYSBSG3008E	T.SCREW	1	HS41	
	173	QYSBSG3008E	T.SCREW	1	HS42	
	174	QYSBSG3008E	T.SCREW	1	HS61	
	175	QYSBSG3008E	T.SCREW	1	HS62	
	176	QYSBSG3008E	T.SCREW	1	HS63	
	179	LV32827-002A	LED HOLDER	1	D1034	
	180	LV42783-001A	EARTH PLATE	1		
	181	LV30225-0D3A	SPACERW	1		
	182	LV30225-0D4A	SPACER	1		
	184	LV30226-029A	SPACER	1		
	185	EXO150010H09S11	FELT SPACER	1		
	186	LV30225-074A	SPACER	1		
	187	QMR0008-001	TH PROTECTOR	1	TF2	
	188	QYSBSG3008E	T.SCREW	1		
	189	WJM0260-001A	E-SI C WIRE C-F	1		
	190	QYSDSG3008E	T.SCREW	1		
	191	QMR0007-001	TH PROTECTOR	1	TF1	
	192	QYSBSG3008E	T.SCREW	1		
	193	WJM0261-001A	E-SI C WIRE C-F	1		
	194	LV32842-001A	PROTECT SHEET	1		
△	195	QMF51E2-R10-J1	FUSE	1	F23	

■ Electrical parts list (Amp. board)

Block No. 01

△	Item	Parts number	Parts name	Remarks	Area	△	Item	Parts number	Parts name	Remarks	Area
	C 701	QEZO538-106Z	E CAPACITOR	10MF			C 815	QCS32HJ-330Z	C CAPACITOR	33PF 5% 500V	
	C 702	QCS32HJ-101Z	C CAPACITOR	100PF 5% 500V			C 821	NCF21EZ-224X	E CAPACITOR		
	C 703	QCS32HJ-101Z	C CAPACITOR	100PF 5% 500V			C 831	QEZO539-476Z	E CAPACITOR	47MF	
	C 704	QFN31HJ-152Z	M CAPACITOR	1500PF 5% 50V			C 835	QFLC1HJ-473Z	M CAPACITOR	0.047MF 5% 50V	
	C 705	QCS32HJ-220Z	C CAPACITOR	22PF 5% 500V			C 836	QFLC1HJ-473Z	M CAPACITOR	0.047MF 5% 50V	
	C 707	QCS32HJ-221Z	C CAPACITOR	220PF 5% 500V			C 837	NFV41HJ-332X	M CAPACITOR		
	C 708	QFN31HJ-472Z	M CAPACITOR	4700PF 5% 50V			C 838	NFV41HJ-103X	M CAPACITOR		
	C 709	QCS32HJ-470Z	C CAPACITOR	47PF 5% 500V			C 841	QCS32HJ-100Z	C CAPACITOR	10PF 5% 500V	
	C 710	QCS32HJ-470Z	C CAPACITOR	47PF 5% 500V			C 842	QEZO538-226Z	E CAPACITOR	22MF	
	C 711	QEZO539-476Z	E CAPACITOR	47MF			C 895	QEZO544-338	E CAPACITOR	3300MF	
	C 712	QEZO539-476Z	E CAPACITOR	47MF			C 896	QEZO544-338	E CAPACITOR	3300MF	
	C 715	QCS32HJ-330Z	C CAPACITOR	33PF 5% 500V			CN711	QGB2510K2-07	CONNECTOR		
	C 721	NCF21EZ-224X	E CAPACITOR				CN712	QGB2012K1-06	CONNECTOR		
	C 731	QEZO539-476Z	E CAPACITOR	47MF			CN713	QGB2012K1-06	CONNECTOR		
	C 735	QFLC1HJ-473Z	M CAPACITOR	0.047MF 5% 50V			CN721	QGB2510J1-07	CONNECTOR		
	C 736	QFLC1HJ-473Z	M CAPACITOR	0.047MF 5% 50V			CN722	QGB2012J1-06	CONNECTOR		
	C 737	NFV41HJ-332X	M CAPACITOR				CN723	QGB2012J1-06	CONNECTOR		
	C 738	NFV41HJ-103X	M CAPACITOR				CN738	QGA2501C1-03	3P CONNECTOR		
	C 739	NFV41HJ-332X	M CAPACITOR				CN741	QGA3901C1-10	10P CONNECTOR		
	C 740	NFV41HJ-103X	M CAPACITOR				CN742	QGA3901C1-04	4P CONNECTOR		
	C 741	QCS32HJ-100Z	C CAPACITOR	10PF 5% 500V			CN743	QGA2001C1-10	10P PLUG ASSY		
	C 742	QEZO538-226Z	E CAPACITOR	22MF			CN751	QGB2510K2-06	CONNECTOR		
	C 745	QEZO544-338	E CAPACITOR	3300MF			CN752	QGB2012K1-06	CONNECTOR		
	C 746	QEZO544-338	E CAPACITOR	3300MF			CN753	QGB2012K1-06	CONNECTOR		
	C 751	QEZO538-106Z	E CAPACITOR	10MF			CN761	QGB2510J1-06	CONNECTOR		
	C 752	QCS32HJ-101Z	C CAPACITOR	100PF 5% 500V			CN762	QGB2012J1-06	CONNECTOR		
	C 753	QCS32HJ-101Z	C CAPACITOR	100PF 5% 500V			CN763	QGB2012J1-06	CONNECTOR		
	C 754	QFN31HJ-152Z	M CAPACITOR	1500PF 5% 50V			CN771	QGB2510K2-05	CONNECTOR		
	C 755	QCS32HJ-220Z	C CAPACITOR	22PF 5% 500V			CN772	QGB2012K1-06	CONNECTOR		
	C 757	QCS32HJ-221Z	C CAPACITOR	220PF 5% 500V			CN773	QGB2012K1-06	CONNECTOR		
	C 758	QFN31HJ-472Z	M CAPACITOR	4700PF 5% 50V			CN781	QGB2510J1-05	CONNECTOR		
	C 759	QCS32HJ-470Z	C CAPACITOR	47PF 5% 500V			CN782	QGB2012J1-06	CONNECTOR		
	C 760	QCS32HJ-470Z	C CAPACITOR	47PF 5% 500V			CN783	QGB2012J1-06	CONNECTOR		
	C 761	QEZO539-476Z	E CAPACITOR	47MF			CN811	QGB2510K2-06	CONNECTOR		
	C 762	QEZO539-476Z	E CAPACITOR	47MF			CN812	QGB2012K1-06	CONNECTOR		
	C 765	QCS32HJ-330Z	C CAPACITOR	33PF 5% 500V			CN813	QGB2012K1-06	CONNECTOR		
	C 771	NCF21EZ-224X	E CAPACITOR				CN821	QGB2510J1-06	CONNECTOR		
	C 773	QFV72AJ-104Z	MF CAPACITOR	0.1MF 5% 100V			CN822	QGB2012J1-06	CONNECTOR		
	C 774	QFV72AJ-104Z	MF CAPACITOR	0.1MF 5% 100V			CN823	QGB2012J1-06	CONNECTOR		
	C 775	QFV72AJ-104Z	MF CAPACITOR	0.1MF 5% 100V			C1601	QEZO538-106Z	E CAPACITOR	10MF	
	C 776	QFV72AJ-104Z	MF CAPACITOR	0.1MF 5% 100V			C1602	QCS32HJ-101Z	C CAPACITOR	100PF 5% 500V	
	C 781	QEZO539-476Z	E CAPACITOR	47MF			C1603	QCS32HJ-101Z	C CAPACITOR	100PF 5% 500V	
	C 785	QFLC1HJ-473Z	M CAPACITOR	0.047MF 5% 50V			C1604	QFN31HJ-152Z	M CAPACITOR	1500PF 5% 50V	
	C 786	QFLC1HJ-473Z	M CAPACITOR	0.047MF 5% 50V			C1605	QCS32HJ-220Z	C CAPACITOR	22PF 5% 500V	
	C 787	NFV41HJ-332X	M CAPACITOR				C1607	QCS32HJ-221Z	C CAPACITOR	220PF 5% 500V	
	C 788	NFV41HJ-103X	M CAPACITOR				C1608	QFN31HJ-472Z	M CAPACITOR	4700PF 5% 50V	
	C 789	NFV41HJ-332X	M CAPACITOR				C1609	QCS32HJ-470Z	C CAPACITOR	47PF 5% 500V	
	C 790	NFV41HJ-103X	M CAPACITOR				C1610	QCS32HJ-470Z	C CAPACITOR	47PF 5% 500V	
	C 791	QCS32HJ-100Z	C CAPACITOR	10PF 5% 500V			C1611	QEZO539-476Z	E CAPACITOR	47MF	
	C 792	QEZO538-226Z	E CAPACITOR	22MF			C1612	QEZO539-476Z	E CAPACITOR	47MF	
	C 795	QEZO544-338	E CAPACITOR	3300MF			C1615	QCS32HJ-330Z	C CAPACITOR	33PF 5% 500V	
	C 796	QEZO544-338	E CAPACITOR	3300MF			C1621	NCF21EZ-224X	E CAPACITOR		
	C 801	QEZO538-106Z	E CAPACITOR	10MF			C1631	QEZO539-476Z	E CAPACITOR	47MF	
	C 802	QCS32HJ-101Z	C CAPACITOR	100PF 5% 500V			C1635	QFLC1HJ-473Z	M CAPACITOR	0.047MF 5% 50V	
	C 803	QCS32HJ-101Z	C CAPACITOR	100PF 5% 500V			C1636	QFLC1HJ-473Z	M CAPACITOR	0.047MF 5% 50V	
	C 804	QFN31HJ-152Z	M CAPACITOR	1500PF 5% 50V			C1637	NFV41HJ-332X	M CAPACITOR		
	C 805	QCS32HJ-220Z	C CAPACITOR	22PF 5% 500V			C1638	NFV41HJ-103X	M CAPACITOR		
	C 807	QCS32HJ-221Z	C CAPACITOR	220PF 5% 500V			C1641	QCS32HJ-100Z	C CAPACITOR	10PF 5% 500V	
	C 808	QFN31HJ-472Z	M CAPACITOR	4700PF 5% 50V			C1642	QEZO538-226Z	E CAPACITOR	22MF	
	C 809	QCS32HJ-470Z	C CAPACITOR	47PF 5% 500V			C1645	QEZO544-338	E CAPACITOR	3300MF	
	C 810	QCS32HJ-470Z	C CAPACITOR	47PF 5% 500V			C1646	QEZO544-338	E CAPACITOR	3300MF	
	C 811	QEZO539-476Z	E CAPACITOR	47MF			C1651	QEZO538-106Z	E CAPACITOR	10MF	
	C 812	QEZO539-476Z	E CAPACITOR	47MF			C1652	QCS32HJ-101Z	C CAPACITOR	100PF 5% 500V	

■ Electrical parts list (Amp. board)

Block No. 01

△	Item	Parts number	Parts name	Remarks	Area	△	Item	Parts number	Parts name	Remarks	Area
	C1653	QCS32HJ-101Z	C CAPACITOR	100PF 5% 500V			C1973	NCS21HJ-102X	C CAPACITOR		
	C1654	QFN31HJ-152Z	M CAPACITOR	1500PF 5% 50V			C1974	NCF21HZ-103X	C CAPACITOR		
	C1655	QCS32HJ-220Z	C CAPACITOR	22PF 5% 500V			C1975	QETN1HM-226Z	E CAPACITOR	22MF 20% 50V	
	C1657	QCS32HJ-221Z	C CAPACITOR	220PF 5% 500V			D 702	1SS133-T2	SI DIODE		
	C1658	QFN31HJ-472Z	M CAPACITOR	4700PF 5% 50V			D 703	1SS133-T2	SI DIODE		
	C1659	QCS32HJ-470Z	C CAPACITOR	47PF 5% 500V			D 704	1SS133-T2	SI DIODE		
	C1660	QCS32HJ-470Z	C CAPACITOR	47PF 5% 500V			D 705	MTZJ3.9B-T2	ZENER DIODE		
	C1661	QEZ0539-476Z	E CAPACITOR	47MF			D 706	MTZJ3.9B-T2	ZENER DIODE		
	C1662	QEZ0539-476Z	E CAPACITOR	47MF			D 707	1SS133-T2	SI DIODE		
	C1665	QCS32HJ-330Z	C CAPACITOR	33PF 5% 500V			D 708	UDZS24B-X	ZENER DIODE		
	C1671	NCF21EZ-224X	E CAPACITOR				D 709	UDZS24B-X	ZENER DIODE		
	C1685	QFLC1HJ-473Z	M CAPACITOR	0.047MF 5% 50V			D 710	1SS355-X	DIODE		
	C1686	QFLC1HJ-473Z	M CAPACITOR	0.047MF 5% 50V			D 711	1SS355-X	DIODE		
	C1687	NFV41HJ-332X	M CAPACITOR				D 712	1SS355-X	DIODE		
	C1688	NFV41HJ-103X	M CAPACITOR				D 713	1SS355-X	DIODE		
	C1691	QCS32HJ-100Z	C CAPACITOR	10PF 5% 500V			D 715	HZ3.0BP	ZENER DIODE		
	C1692	QEZ0538-226Z	E CAPACITOR	22MF			D 752	1SS133-T2	SI DIODE		
	C1695	QEZ0544-338	E CAPACITOR	3300MF			D 753	1SS133-T2	SI DIODE		
	C1696	QEZ0544-338	E CAPACITOR	3300MF			D 754	1SS133-T2	SI DIODE		
	C1701	QEZ0538-106Z	E CAPACITOR	10MF			D 755	MTZJ3.9B-T2	ZENER DIODE		
	C1702	QCS32HJ-101Z	C CAPACITOR	100PF 5% 500V			D 756	MTZJ3.9B-T2	ZENER DIODE		
	C1703	QCS32HJ-101Z	C CAPACITOR	100PF 5% 500V			D 757	1SS133-T2	SI DIODE		
	C1704	QFN31HJ-152Z	M CAPACITOR	1500PF 5% 50V			D 758	UDZS24B-X	ZENER DIODE		
	C1705	QCS32HJ-220Z	C CAPACITOR	22PF 5% 500V			D 759	UDZS24B-X	ZENER DIODE		
	C1707	QCS32HJ-221Z	C CAPACITOR	220PF 5% 500V			D 760	1SS355-X	DIODE		
	C1708	QFN31HJ-472Z	M CAPACITOR	4700PF 5% 50V			D 761	1SS355-X	DIODE		
	C1709	QCS32HJ-470Z	C CAPACITOR	47PF 5% 500V			D 762	1SS355-X	DIODE		
	C1710	QCS32HJ-470Z	C CAPACITOR	47PF 5% 500V			D 763	1SS355-X	DIODE		
	C1711	QEZ0539-476Z	E CAPACITOR	47MF			D 765	HZ3.0BP	ZENER DIODE		
	C1712	QEZ0539-476Z	E CAPACITOR	47MF			D 771	1SS133-T2	SI DIODE		
	C1715	QCS32HJ-330Z	C CAPACITOR	33PF 5% 500V			D 772	1SS133-T2	SI DIODE		
	C1721	NCF21EZ-224X	E CAPACITOR				D 773	1SS133-T2	SI DIODE		
	C1735	QFLC1HJ-473Z	M CAPACITOR	0.047MF 5% 50V			D 774	1SS133-T2	SI DIODE		
	C1736	QFLC1HJ-473Z	M CAPACITOR	0.047MF 5% 50V			D 802	1SS133-T2	SI DIODE		
	C1737	NFV41HJ-332X	M CAPACITOR				D 803	1SS133-T2	SI DIODE		
	C1738	NFV41HJ-103X	M CAPACITOR				D 804	1SS133-T2	SI DIODE		
	C1741	QCS32HJ-100Z	C CAPACITOR	10PF 5% 500V			D 805	MTZJ3.9B-T2	ZENER DIODE		
	C1742	QEZ0538-226Z	E CAPACITOR	22MF			D 806	MTZJ3.9B-T2	ZENER DIODE		
	C1745	QEZ0544-338	E CAPACITOR	3300MF			D 807	1SS133-T2	SI DIODE		
	C1746	QEZ0544-338	E CAPACITOR	3300MF			D 808	UDZS24B-X	ZENER DIODE		
	C1751	QEZ0538-106Z	E CAPACITOR	10MF			D 809	UDZS24B-X	ZENER DIODE		
	C1752	QCS32HJ-101Z	C CAPACITOR	100PF 5% 500V			D 810	1SS355-X	DIODE		
	C1753	QCS32HJ-101Z	C CAPACITOR	100PF 5% 500V			D 811	1SS355-X	DIODE		
	C1754	QFN31HJ-152Z	M CAPACITOR	1500PF 5% 50V			D 812	1SS355-X	DIODE		
	C1755	QCS32HJ-220Z	C CAPACITOR	22PF 5% 500V			D 813	1SS355-X	DIODE		
	C1757	QCS32HJ-221Z	C CAPACITOR	220PF 5% 500V			D 815	HZ3.0BP	ZENER DIODE		
	C1758	QFN31HJ-472Z	M CAPACITOR	4700PF 5% 50V			D1602	1SS133-T2	SI DIODE		
	C1759	QCS32HJ-470Z	C CAPACITOR	47PF 5% 500V			D1603	1SS133-T2	SI DIODE		
	C1760	QCS32HJ-470Z	C CAPACITOR	47PF 5% 500V			D1604	1SS133-T2	SI DIODE		
	C1761	QEZ0539-476Z	E CAPACITOR	47MF			D1605	MTZJ3.9B-T2	ZENER DIODE		
	C1762	QEZ0539-476Z	E CAPACITOR	47MF			D1606	MTZJ3.9B-T2	ZENER DIODE		
	C1765	QCS32HJ-330Z	C CAPACITOR	33PF 5% 500V			D1607	1SS133-T2	SI DIODE		
	C1771	NCF21EZ-224X	E CAPACITOR				D1608	UDZS24B-X	ZENER DIODE		
	C1785	QFLC1HJ-473Z	M CAPACITOR	0.047MF 5% 50V			D1609	UDZS24B-X	ZENER DIODE		
	C1786	QFLC1HJ-473Z	M CAPACITOR	0.047MF 5% 50V			D1610	1SS355-X	DIODE		
	C1787	NFV41HJ-332X	M CAPACITOR				D1611	1SS355-X	DIODE		
	C1788	NFV41HJ-103X	M CAPACITOR				D1612	1SS355-X	DIODE		
	C1791	QCS32HJ-100Z	C CAPACITOR	10PF 5% 500V			D1613	1SS355-X	DIODE		
	C1792	QEZ0538-226Z	E CAPACITOR	22MF			D1615	HZ3.0BP	ZENER DIODE		
	C1795	QEZ0544-338	E CAPACITOR	3300MF			D1652	1SS133-T2	SI DIODE		
	C1796	QEZ0544-338	E CAPACITOR	3300MF			D1653	1SS133-T2	SI DIODE		
	C1971	QETN1HM-226Z	E CAPACITOR	22MF 20% 50V			D1654	1SS133-T2	SI DIODE		
	C1972	QETN1EM-476Z	E CAPACITOR	47MF 20% 25V			D1655	MTZJ3.9B-T2	ZENER DIODE		

■ Electrical parts list (Amp. board)

Block No. 01

△	Item	Parts number	Parts name	Remarks	Area	△	Item	Parts number	Parts name	Remarks	Area
	D1656	MTZJ3.9B-T2	ZENER DIODE				L 801	QQLZ003-1R0	INDUCTOR		
	D1657	1SS133-T2	SI DIODE				L1601	QQLZ003-1R0	INDUCTOR		
	D1658	UDZS24B-X	ZENER DIODE				L1651	QQLZ003-1R0	INDUCTOR		
	D1659	UDZS24B-X	ZENER DIODE				L1701	QQLZ003-1R0	INDUCTOR		
	D1660	1SS355-X	DIODE				L1751	QQLZ003-1R0	INDUCTOR		
	D1661	1SS355-X	DIODE				Q 701	2SC1775A/E/-T	TRANSISTOR		
	D1662	1SS355-X	DIODE				Q 702	2SC1775A/E/-T	TRANSISTOR		
	D1663	1SS355-X	DIODE				Q 703	KTC3200/GL/-T	TRANSISTOR		
	D1665	HZ3.0BP	ZENER DIODE				Q 704	KTC3199/GL/-T	TRANSISTOR		
	D1702	1SS133-T2	SI DIODE				Q 705	KTA1268/GL/-T	TRANSISTOR		
	D1703	1SS133-T2	SI DIODE				Q 706	KTA1267/YG/-T	TRANSISTOR		
	D1704	1SS133-T2	SI DIODE				Q 707	KTA1268/GL/-T	TRANSISTOR		
	D1705	MTZJ3.9B-T2	ZENER DIODE				Q 708	KTC3200/GL/-T	TRANSISTOR		
	D1706	MTZJ3.9B-T2	ZENER DIODE				Q 710	KTC3200/GL/-T	TRANSISTOR		
	D1707	1SS133-T2	SI DIODE				Q 711	KTA1268/GL/-T	TRANSISTOR		
	D1708	UDZS24B-X	ZENER DIODE				Q 712	2SD669A/BC/	TRANSISTOR		
	D1709	UDZS24B-X	ZENER DIODE				Q 713	2SB649A/BC/	TRANSISTOR		
	D1710	1SS355-X	DIODE				Q 731	2SC2412K/RS/-X	CHIP TRANSISTOR		
	D1711	1SS355-X	DIODE				Q 732	DTA124EKA-X	DIGI TRANSISTOR		
	D1712	1SS355-X	DIODE				Q 751	2SC1775A/E/-T	TRANSISTOR		
	D1713	1SS355-X	DIODE				Q 752	2SC1775A/E/-T	TRANSISTOR		
	D1715	HZ3.0BP	ZENER DIODE				Q 753	KTC3200/GL/-T	TRANSISTOR		
	D1752	1SS133-T2	SI DIODE				Q 754	KTC3199/GL/-T	TRANSISTOR		
	D1753	1SS133-T2	SI DIODE				Q 755	KTA1268/GL/-T	TRANSISTOR		
	D1754	1SS133-T2	SI DIODE				Q 756	KTA1267/YG/-T	TRANSISTOR		
	D1755	MTZJ3.9B-T2	ZENER DIODE				Q 757	KTA1268/GL/-T	TRANSISTOR		
	D1756	MTZJ3.9B-T2	ZENER DIODE				Q 758	KTC3200/GL/-T	TRANSISTOR		
	D1757	1SS133-T2	SI DIODE				Q 760	KTC3200/GL/-T	TRANSISTOR		
	D1758	UDZS24B-X	ZENER DIODE				Q 761	KTA1268/GL/-T	TRANSISTOR		
	D1759	UDZS24B-X	ZENER DIODE				Q 762	2SD669A/BC/	TRANSISTOR		
	D1760	1SS355-X	DIODE				Q 763	2SB649A/BC/	TRANSISTOR		
	D1761	1SS355-X	DIODE				Q 771	DTD123TK-X	CHIP D TRANSISTOR		
	D1762	1SS355-X	DIODE				Q 772	DTD123TK-X	CHIP D TRANSISTOR		
	D1763	1SS355-X	DIODE				Q 773	DTD123TK-X	CHIP D TRANSISTOR		
	D1765	HZ3.0BP	ZENER DIODE				Q 781	2SC2412K/RS/-X	CHIP TRANSISTOR		
	D1901	1SS133-T2	SI DIODE				Q 782	DTA124EKA-X	DIGI TRANSISTOR		
	D1911	1SS133-T2	SI DIODE				Q 801	2SC1775A/E/-T	TRANSISTOR		
	D1921	1SS133-T2	SI DIODE				Q 802	2SC1775A/E/-T	TRANSISTOR		
	D1931	1SS133-T2	SI DIODE				Q 803	KTC3200/GL/-T	TRANSISTOR		
	D1941	1SS133-T2	SI DIODE				Q 804	KTC3199/GL/-T	TRANSISTOR		
	D1951	1SS133-T2	SI DIODE				Q 805	KTA1268/GL/-T	TRANSISTOR		
	D1961	1SS133-T2	SI DIODE				Q 806	KTA1267/YG/-T	TRANSISTOR		
	D1981	1SS133-T2	SI DIODE				Q 807	KTA1268/GL/-T	TRANSISTOR		
	D1982	1SS133-T2	SI DIODE				Q 808	KTC3200/GL/-T	TRANSISTOR		
	D1984	1SS133-T2	SI DIODE				Q 810	KTC3200/GL/-T	TRANSISTOR		
	D1985	1SS133-T2	SI DIODE				Q 811	KTA1268/GL/-T	TRANSISTOR		
	D1986	1SS133-T2	SI DIODE				Q 812	2SD669A/BC/	TRANSISTOR		
	D1991	1SS133-T2	SI DIODE				Q 813	2SB649A/BC/	TRANSISTOR		
	D1992	1SS133-T2	SI DIODE				Q 831	2SC2412K/RS/-X	CHIP TRANSISTOR		
	D1993	1SS133-T2	SI DIODE				Q 832	DTA124EKA-X	DIGI TRANSISTOR		
	D1995	1SS133-T2	SI DIODE				Q1601	2SC1775A/E/-T	TRANSISTOR		
	D1996	1SS133-T2	SI DIODE				Q1602	2SC1775A/E/-T	TRANSISTOR		
	EP701	QNZ0136-001Z	EARTH PLATE				Q1603	KTC3200/GL/-T	TRANSISTOR		
	IC601	VC5022-2	IC				Q1604	KTC3199/GL/-T	TRANSISTOR		
	IC602	VC5022-2	IC				Q1605	KTA1268/GL/-T	TRANSISTOR		
	IC603	VC5022-2	IC				Q1606	KTA1267/YG/-T	TRANSISTOR		
	IC604	VC5022-2	IC				Q1607	KTA1268/GL/-T	TRANSISTOR		
	IC605	VC5022-2	IC				Q1608	KTC3200/GL/-T	TRANSISTOR		
	IC606	VC5022-2	IC				Q1610	KTC3200/GL/-T	TRANSISTOR		
	IC607	VC5022-2	IC				Q1611	KTA1268/GL/-T	TRANSISTOR		
	IC951	TA7317P	IC				Q1612	2SD669A/BC/	TRANSISTOR		
	L 701	QQLZ003-1R0	INDUCTOR				Q1613	2SB649A/BC/	TRANSISTOR		
	L 751	QQLZ003-1R0	INDUCTOR				Q1631	2SC2412K/RS/-X	CHIP TRANSISTOR		

■ Electrical parts list (Amp. board)

Block No. 01

△	Item	Parts number	Parts name	Remarks	Area	△	Item	Parts number	Parts name	Remarks	Area
	Q1632	DTA124EKA-X	DIGI TRANSISTOR				R 708	QRE141J-101Y	C RESISTOR	100 5% 1/4W	
	Q1651	2SC1775A/E/-T	TRANSISTOR				R 709	QRJ146J-151X	UNF C RESISTOR	150 5% 1/4W	
	Q1652	2SC1775A/E/-T	TRANSISTOR				R 710	QRJ146J-562X	UNF C RESISTOR	5.6K 5% 1/4W	
	Q1653	KTC3200/GL/-T	TRANSISTOR				R 711	QRK126J-103X	UNF C RESISTOR	10K 5% 1/2W	
	Q1654	KTC3199/GL/-T	TRANSISTOR				R 712	QRE141J-680Y	C RESISTOR	68 5% 1/4W	
	Q1655	KTA1268/GL/-T	TRANSISTOR				R 713	QRE141J-152Y	C RESISTOR	1.5K 5% 1/4W	
	Q1656	KTA1267/YG/-T	TRANSISTOR				R 714	QRE141J-333Y	C RESISTOR	33K 5% 1/4W	
	Q1657	KTA1268/GL/-T	TRANSISTOR				R 715	QRE141J-151Y	C RESISTOR	150 5% 1/4W	
	Q1658	KTC3200/GL/-T	TRANSISTOR				R 716	QRE141J-680Y	C RESISTOR	68 5% 1/4W	
	Q1660	KTC3200/GL/-T	TRANSISTOR				R 717	QRE141J-331Y	C RESISTOR	330 5% 1/4W	
	Q1661	KTA1268/GL/-T	TRANSISTOR				R 718	QRE141J-471Y	C RESISTOR	470 5% 1/4W	
	Q1662	2SD669A/BC/	TRANSISTOR				R 719	QRE141J-391Y	C RESISTOR	390 5% 1/4W	
	Q1663	2SB649A/BC/	TRANSISTOR				R 720	QRJ146J-121X	UNF C RESISTOR	120 5% 1/4W	
	Q1681	2SC2412K/RS/-X	CHIP TRANSISTOR				R 721	QRJ146J-121X	UNF C RESISTOR	120 5% 1/4W	
	Q1682	DTA124EKA-X	DIGI TRANSISTOR				R 722	QRJ146J-272X	UNF C RESISTOR	2.7K 5% 1/4W	
	Q1701	2SC1775A/E/-T	TRANSISTOR				R 723	QRJ146J-120X	UNF C RESISTOR	12 5% 1/4W	
	Q1702	2SC1775A/E/-T	TRANSISTOR				R 724	QRJ146J-120X	UNF C RESISTOR	12 5% 1/4W	
	Q1703	KTC3200/GL/-T	TRANSISTOR				R 725	QRJ146J-271X	UNF C RESISTOR	270 5% 1/4W	
	Q1704	KTC3199/GL/-T	TRANSISTOR				R 726	QRJ146J-1R0X	UNF C RESISTOR	1.0 5% 1/4W	
	Q1705	KTA1268/GL/-T	TRANSISTOR				R 727	QRJ146J-1R0X	UNF C RESISTOR	1.0 5% 1/4W	
	Q1706	KTA1267/YG/-T	TRANSISTOR				R 728	QRZ0182-R10	EMIT RESISTOR	1/1W	
	Q1707	KTA1268/GL/-T	TRANSISTOR				R 729	QRZ0182-R10	EMIT RESISTOR	1/1W	
	Q1708	KTC3200/GL/-T	TRANSISTOR				R 731	QRL027J-472	UNF OMF RESISTOR	4.7K 5% 1/2W	
	Q1710	KTC3200/GL/-T	TRANSISTOR				R 732	NRSA02J-331X	MG RESISTOR		
	Q1711	KTA1268/GL/-T	TRANSISTOR				R 733	NRSA02J-103X	MG RESISTOR		
	Q1712	2SD669A/BC/	TRANSISTOR				R 735	QRJ125J-330	UNF C RESISTOR	33 5% 1/2W	
	Q1713	2SB649A/BC/	TRANSISTOR				R 736	QRL027J-100	UNF OMF RESISTOR	10 5% 1/2W	
	Q1731	2SC2412K/RS/-X	CHIP TRANSISTOR				R 741	QRA14CF-1003Y	MF RESISTOR	10 1/4W	
	Q1732	DTA124EKA-X	DIGI TRANSISTOR				R 742	QRA14CF-3601Y	MF RESISTOR	36 1/4W	
	Q1751	2SC1775A/E/-T	TRANSISTOR				R 751	QRA14CF-1001Y	MF RESISTOR	10 1/4W	
	Q1752	2SC1775A/E/-T	TRANSISTOR				R 752	QRA14CF-1003Y	MF RESISTOR	10 1/4W	
	Q1753	KTC3200/GL/-T	TRANSISTOR				R 753	QRE141J-102Y	C RESISTOR	1.0K 5% 1/4W	
	Q1754	KTC3199/GL/-T	TRANSISTOR				R 754	QRE141J-331Y	C RESISTOR	330 5% 1/4W	
	Q1755	KTA1268/GL/-T	TRANSISTOR				R 755	QRE141J-104Y	C RESISTOR	100K 5% 1/4W	
	Q1756	KTA1267/YG/-T	TRANSISTOR				R 756	QRE141J-202Y	C RESISTOR	2.0K 5% 1/4W	
	Q1757	KTA1268/GL/-T	TRANSISTOR				R 757	QRE141J-202Y	C RESISTOR	2.0K 5% 1/4W	
	Q1758	KTC3200/GL/-T	TRANSISTOR				R 758	QRE141J-101Y	C RESISTOR	100 5% 1/4W	
	Q1760	KTC3200/GL/-T	TRANSISTOR				R 759	QRJ146J-151X	UNF C RESISTOR	150 5% 1/4W	
	Q1761	KTA1268/GL/-T	TRANSISTOR				R 760	QRJ146J-562X	UNF C RESISTOR	5.6K 5% 1/4W	
	Q1762	2SD669A/BC/	TRANSISTOR				R 761	QRK126J-103X	UNF C RESISTOR	10K 5% 1/2W	
	Q1763	2SB649A/BC/	TRANSISTOR				R 762	QRE141J-680Y	C RESISTOR	68 5% 1/4W	
	Q1781	2SC2412K/RS/-X	CHIP TRANSISTOR				R 763	QRE141J-152Y	C RESISTOR	1.5K 5% 1/4W	
	Q1782	DTA124EKA-X	DIGI TRANSISTOR				R 764	QRE141J-333Y	C RESISTOR	33K 5% 1/4W	
	Q1901	2SC3906K/RS/-X	HIP TRANSISTOR				R 765	QRE141J-151Y	C RESISTOR	150 5% 1/4W	
	Q1911	2SC3906K/RS/-X	HIP TRANSISTOR				R 766	QRE141J-680Y	C RESISTOR	68 5% 1/4W	
	Q1921	2SC3906K/RS/-X	HIP TRANSISTOR				R 767	QRE141J-331Y	C RESISTOR	330 5% 1/4W	
	Q1931	2SC3906K/RS/-X	HIP TRANSISTOR				R 768	QRE141J-471Y	C RESISTOR	470 5% 1/4W	
	Q1941	2SC3906K/RS/-X	HIP TRANSISTOR				R 769	QRE141J-391Y	C RESISTOR	390 5% 1/4W	
	Q1951	2SC3906K/RS/-X	HIP TRANSISTOR				R 770	QRJ146J-121X	UNF C RESISTOR	120 5% 1/4W	
	Q1961	2SC3906K/RS/-X	HIP TRANSISTOR				R 771	QRJ146J-121X	UNF C RESISTOR	120 5% 1/4W	
	Q1971	2SA1514K/RS/-X	HIP TRANSISTOR				R 772	QRJ146J-272X	UNF C RESISTOR	2.7K 5% 1/4W	
	Q1991	KRC105M-T	D TRANSISTOR				R 773	QRJ146J-120X	UNF C RESISTOR	12 5% 1/4W	
	Q1992	KRC105M-T	D TRANSISTOR				R 774	QRJ146J-120X	UNF C RESISTOR	12 5% 1/4W	
	Q1993	KRC105M-T	D TRANSISTOR				R 775	QRJ146J-271X	UNF C RESISTOR	270 5% 1/4W	
	Q1995	KRC105M-T	D TRANSISTOR				R 776	QRJ146J-1R0X	UNF C RESISTOR	1.0 5% 1/4W	
	Q1996	KRC105M-T	D TRANSISTOR				R 777	QRJ146J-1R0X	UNF C RESISTOR	1.0 5% 1/4W	
	R 701	QRA14CF-1001Y	MF RESISTOR	10 1/4W			R 778	QRZ0182-R10	EMIT RESISTOR	1/1W	
	R 702	QRA14CF-1003Y	MF RESISTOR	10 1/4W			R 779	QRZ0182-R10	EMIT RESISTOR	1/1W	
	R 703	QRE141J-102Y	C RESISTOR	1.0K 5% 1/4W			R 781	QRL027J-472	UNF OMF RESISTOR	4.7K 5% 1/2W	
	R 704	QRE141J-331Y	C RESISTOR	330 5% 1/4W			R 782	NRSA02J-331X	MG RESISTOR		
	R 705	QRE141J-104Y	C RESISTOR	100K 5% 1/4W			R 783	NRSA02J-103X	MG RESISTOR		
	R 706	QRE141J-202Y	C RESISTOR	2.0K 5% 1/4W			R 785	QRJ125J-330	UNF C RESISTOR	33 5% 1/2W	
	R 707	QRE141J-202Y	C RESISTOR	2.0K 5% 1/4W			R 786	QRL027J-100	UNF OMF RESISTOR	10 5% 1/2W	

■ Electrical parts list (Amp. board)

Block No. 01

△	Item	Parts number	Parts name	Remarks	Area	△	Item	Parts number	Parts name	Remarks	Area
	R 791	QRA14CF-1003Y	MF RESISTOR	10 1/4W			R1614	QRE141J-333Y	C RESISTOR	33K 5% 1/4W	
	R 792	QRA14CF-3601Y	MF RESISTOR	36 1/4W			R1615	QRE141J-151Y	C RESISTOR	150 5% 1/4W	
	R 796	QRJ146J-150X	UNF C RESISTOR	15 5% 1/4W			R1616	QRE141J-680Y	C RESISTOR	68 5% 1/4W	
	R 797	QRJ146J-330X	UNF C RESISTOR	33 5% 1/4W			R1617	QRE141J-331Y	C RESISTOR	330 5% 1/4W	
	R 801	QRA14CF-1001Y	MF RESISTOR	10 1/4W			R1618	QRE141J-471Y	C RESISTOR	470 5% 1/4W	
	R 802	QRA14CF-1003Y	MF RESISTOR	10 1/4W			R1619	QRE141J-391Y	C RESISTOR	390 5% 1/4W	
	R 803	QRE141J-102Y	C RESISTOR	1.0K 5% 1/4W			R1620	QRJ146J-121X	UNF C RESISTOR	120 5% 1/4W	
	R 804	QRE141J-331Y	C RESISTOR	330 5% 1/4W			R1621	QRJ146J-121X	UNF C RESISTOR	120 5% 1/4W	
	R 805	QRE141J-104Y	C RESISTOR	100K 5% 1/4W			R1622	QRJ146J-272X	UNF C RESISTOR	2.7K 5% 1/4W	
	R 806	QRE141J-202Y	C RESISTOR	2.0K 5% 1/4W			R1623	QRJ146J-120X	UNF C RESISTOR	12 5% 1/4W	
	R 807	QRE141J-202Y	C RESISTOR	2.0K 5% 1/4W			R1624	QRJ146J-120X	UNF C RESISTOR	12 5% 1/4W	
	R 808	QRE141J-101Y	C RESISTOR	100 5% 1/4W			R1625	QRJ146J-271X	UNF C RESISTOR	270 5% 1/4W	
	R 809	QRJ146J-151X	UNF C RESISTOR	150 5% 1/4W			R1626	QRJ146J-1R0X	UNF C RESISTOR	1.0 5% 1/4W	
	R 810	QRJ146J-562X	UNF C RESISTOR	5.6K 5% 1/4W			R1627	QRJ146J-1R0X	UNF C RESISTOR	1.0 5% 1/4W	
	R 811	QRK126J-103X	UNF C RESISTOR	10K 5% 1/2W			R1628	QRZ0182-R10	EMIT RESISTOR	1/1W	
	R 812	QRE141J-680Y	C RESISTOR	68 5% 1/4W			R1629	QRZ0182-R10	EMIT RESISTOR	1/1W	
	R 813	QRE141J-152Y	C RESISTOR	1.5K 5% 1/4W			R1631	QRL027J-472	UNF OMF RESISTOR	4.7K 5% 1/2W	
	R 814	QRE141J-333Y	C RESISTOR	33K 5% 1/4W			R1632	NRSA02J-331X	MG RESISTOR		
	R 815	QRE141J-151Y	C RESISTOR	150 5% 1/4W			R1633	NRSA02J-103X	MG RESISTOR		
	R 816	QRE141J-680Y	C RESISTOR	68 5% 1/4W			R1635	QRJ125J-330	UNF C RESISTOR	33 5% 1/2W	
	R 817	QRE141J-331Y	C RESISTOR	330 5% 1/4W			R1636	QRL027J-100	UNF OMF RESISTOR	10 5% 1/2W	
	R 818	QRE141J-471Y	C RESISTOR	470 5% 1/4W			R1641	QRA14CF-1003Y	MF RESISTOR	10 1/4W	
	R 819	QRE141J-391Y	C RESISTOR	390 5% 1/4W			R1642	QRA14CF-3601Y	MF RESISTOR	36 1/4W	
	R 820	QRJ146J-121X	UNF C RESISTOR	120 5% 1/4W			R1651	QRA14CF-1001Y	MF RESISTOR	10 1/4W	
	R 821	QRJ146J-121X	UNF C RESISTOR	120 5% 1/4W			R1652	QRA14CF-1003Y	MF RESISTOR	10 1/4W	
	R 822	QRJ146J-272X	UNF C RESISTOR	2.7K 5% 1/4W			R1653	QRE141J-102Y	C RESISTOR	1.0K 5% 1/4W	
	R 823	QRJ146J-120X	UNF C RESISTOR	12 5% 1/4W			R1654	QRE141J-331Y	C RESISTOR	330 5% 1/4W	
	R 824	QRJ146J-120X	UNF C RESISTOR	12 5% 1/4W			R1655	QRE141J-104Y	C RESISTOR	100K 5% 1/4W	
	R 825	QRJ146J-271X	UNF C RESISTOR	270 5% 1/4W			R1656	QRE141J-202Y	C RESISTOR	2.0K 5% 1/4W	
	R 826	QRJ146J-1R0X	UNF C RESISTOR	1.0 5% 1/4W			R1657	QRE141J-202Y	C RESISTOR	2.0K 5% 1/4W	
	R 827	QRJ146J-1R0X	UNF C RESISTOR	1.0 5% 1/4W			R1658	QRE141J-101Y	C RESISTOR	100 5% 1/4W	
	R 828	QRZ0182-R10	EMIT RESISTOR	1/1W			R1659	QRJ146J-151X	UNF C RESISTOR	150 5% 1/4W	
	R 829	QRZ0182-R10	EMIT RESISTOR	1/1W			R1660	QRJ146J-562X	UNF C RESISTOR	5.6K 5% 1/4W	
	R 831	QRL027J-472	UNF OMF RESISTOR	4.7K 5% 1/2W			R1661	QRK126J-103X	UNF C RESISTOR	10K 5% 1/2W	
	R 832	NRSA02J-331X	MG RESISTOR				R1662	QRE141J-680Y	C RESISTOR	68 5% 1/4W	
	R 833	NRSA02J-103X	MG RESISTOR				R1663	QRE141J-152Y	C RESISTOR	1.5K 5% 1/4W	
	R 835	QRJ125J-330	UNF C RESISTOR	33 5% 1/2W			R1664	QRE141J-333Y	C RESISTOR	33K 5% 1/4W	
	R 836	QRL027J-100	UNF OMF RESISTOR	10 5% 1/2W			R1665	QRE141J-151Y	C RESISTOR	150 5% 1/4W	
	R 841	QRA14CF-1003Y	MF RESISTOR	10 1/4W			R1666	QRE141J-680Y	C RESISTOR	68 5% 1/4W	
	R 842	QRA14CF-3601Y	MF RESISTOR	36 1/4W			R1667	QRE141J-331Y	C RESISTOR	330 5% 1/4W	
	RY751	QSK0112-001	RELAY				R1668	QRE141J-471Y	C RESISTOR	470 5% 1/4W	
△	RY771	QSK0131-001	RELAY				R1669	QRE141J-391Y	C RESISTOR	390 5% 1/4W	
△	RY772	QSK0131-001	RELAY				R1670	QRJ146J-121X	UNF C RESISTOR	120 5% 1/4W	
△	RY773	QSK0131-001	RELAY				R1671	QRJ146J-121X	UNF C RESISTOR	120 5% 1/4W	
△	RY774	QSK0131-001	RELAY				R1672	QRJ146J-272X	UNF C RESISTOR	2.7K 5% 1/4W	
	RY901	QSK0109-001	RELAY				R1673	QRJ146J-120X	UNF C RESISTOR	12 5% 1/4W	
	RY902	QSK0109-001	RELAY				R1674	QRJ146J-120X	UNF C RESISTOR	12 5% 1/4W	
	RY904	QSK0109-001	RELAY				R1675	QRJ146J-271X	UNF C RESISTOR	270 5% 1/4W	
	RY905	QSK0109-001	RELAY				R1676	QRJ146J-1R0X	UNF C RESISTOR	1.0 5% 1/4W	
	RY906	QSK0109-001	RELAY				R1677	QRJ146J-1R0X	UNF C RESISTOR	1.0 5% 1/4W	
	R1601	QRA14CF-1001Y	MF RESISTOR	10 1/4W			R1678	QRZ0182-R10	EMIT RESISTOR	1/1W	
	R1602	QRA14CF-1003Y	MF RESISTOR	10 1/4W			R1679	QRZ0182-R10	EMIT RESISTOR	1/1W	
	R1603	QRE141J-102Y	C RESISTOR	1.0K 5% 1/4W			R1682	NRSA02J-331X	MG RESISTOR		
	R1604	QRE141J-331Y	C RESISTOR	330 5% 1/4W			R1683	NRSA02J-103X	MG RESISTOR		
	R1605	QRE141J-104Y	C RESISTOR	100K 5% 1/4W			R1685	QRJ125J-330	UNF C RESISTOR	33 5% 1/2W	
	R1606	QRE141J-202Y	C RESISTOR	2.0K 5% 1/4W			R1686	QRL027J-100	UNF OMF RESISTOR	10 5% 1/2W	
	R1607	QRE141J-202Y	C RESISTOR	2.0K 5% 1/4W			R1691	QRA14CF-1003Y	MF RESISTOR	10 1/4W	
	R1608	QRE141J-101Y	C RESISTOR	100 5% 1/4W			R1692	QRA14CF-3601Y	MF RESISTOR	36 1/4W	
	R1609	QRJ146J-151X	UNF C RESISTOR	150 5% 1/4W			R1701	QRA14CF-1001Y	MF RESISTOR	10 1/4W	
	R1610	QRJ146J-562X	UNF C RESISTOR	5.6K 5% 1/4W			R1702	QRA14CF-1003Y	MF RESISTOR	10 1/4W	
	R1611	QRK126J-103X	UNF C RESISTOR	10K 5% 1/2W			R1703	QRE141J-102Y	C RESISTOR	1.0K 5% 1/4W	
	R1612	QRE141J-680Y	C RESISTOR	68 5% 1/4W			R1704	QRE141J-331Y	C RESISTOR	330 5% 1/4W	
	R1613	QRE141J-152Y	C RESISTOR	1.5K 5% 1/4W			R1705	QRE141J-104Y	C RESISTOR	100K 5% 1/4W	

■ Electrical parts list (Amp. board)

Block No. 01

△	Item	Parts number	Parts name	Remarks	Area
	R1706	QRE141J-202Y	C RESISTOR	2.0K 5% 1/4W	
	R1707	QRE141J-202Y	C RESISTOR	2.0K 5% 1/4W	
	R1708	QRE141J-101Y	C RESISTOR	100 5% 1/4W	
	R1709	QRJ146J-151X	UNF C RESISTOR	150 5% 1/4W	
	R1710	QRJ146J-562X	UNF C RESISTOR	5.6K 5% 1/4W	
	R1711	QRK126J-103X	UNF C RESISTOR	10K 5% 1/2W	
	R1712	QRE141J-680Y	C RESISTOR	68 5% 1/4W	
	R1713	QRE141J-152Y	C RESISTOR	1.5K 5% 1/4W	
	R1714	QRE141J-333Y	C RESISTOR	33K 5% 1/4W	
	R1715	QRE141J-151Y	C RESISTOR	150 5% 1/4W	
	R1716	QRE141J-680Y	C RESISTOR	68 5% 1/4W	
	R1717	QRE141J-331Y	C RESISTOR	330 5% 1/4W	
	R1718	QRE141J-471Y	C RESISTOR	470 5% 1/4W	
	R1719	QRE141J-391Y	C RESISTOR	390 5% 1/4W	
	R1720	QRJ146J-121X	UNF C RESISTOR	120 5% 1/4W	
	R1721	QRJ146J-121X	UNF C RESISTOR	120 5% 1/4W	
	R1722	QRJ146J-272X	UNF C RESISTOR	2.7K 5% 1/4W	
	R1723	QRJ146J-120X	UNF C RESISTOR	12 5% 1/4W	
	R1724	QRJ146J-120X	UNF C RESISTOR	12 5% 1/4W	
	R1725	QRJ146J-271X	UNF C RESISTOR	270 5% 1/4W	
	R1726	QRJ146J-1R0X	UNF C RESISTOR	1.0 5% 1/4W	
	R1727	QRJ146J-1R0X	UNF C RESISTOR	1.0 5% 1/4W	
	R1728	QRZ0182-R10	EMIT RESISTOR	1/1W	
	R1729	QRZ0182-R10	EMIT RESISTOR	1/1W	
	R1732	NRSA02J-331X	MG RESISTOR		
	R1733	NRSA02J-103X	MG RESISTOR		
	R1735	QRJ125J-330	UNF C RESISTOR	33 5% 1/2W	
	R1736	QRL027J-100	UNF OMF RESISTOR	10 5% 1/2W	
	R1741	QRA14CF-1003Y	MF RESISTOR	10 1/4W	
	R1742	QRA14CF-3601Y	MF RESISTOR	36 1/4W	
	R1751	QRA14CF-1001Y	MF RESISTOR	10 1/4W	
	R1752	QRA14CF-1003Y	MF RESISTOR	10 1/4W	
	R1753	QRE141J-102Y	C RESISTOR	1.0K 5% 1/4W	
	R1754	QRE141J-331Y	C RESISTOR	330 5% 1/4W	
	R1755	QRE141J-104Y	C RESISTOR	100K 5% 1/4W	
	R1756	QRE141J-202Y	C RESISTOR	2.0K 5% 1/4W	
	R1757	QRE141J-202Y	C RESISTOR	2.0K 5% 1/4W	
	R1758	QRE141J-101Y	C RESISTOR	100 5% 1/4W	
	R1759	QRJ146J-151X	UNF C RESISTOR	150 5% 1/4W	
	R1760	QRJ146J-562X	UNF C RESISTOR	5.6K 5% 1/4W	
	R1761	QRK126J-103X	UNF C RESISTOR	10K 5% 1/2W	
	R1762	QRE141J-680Y	C RESISTOR	68 5% 1/4W	
	R1763	QRE141J-152Y	C RESISTOR	1.5K 5% 1/4W	
	R1764	QRE141J-333Y	C RESISTOR	33K 5% 1/4W	
	R1765	QRE141J-151Y	C RESISTOR	150 5% 1/4W	
	R1766	QRE141J-680Y	C RESISTOR	68 5% 1/4W	
	R1767	QRE141J-331Y	C RESISTOR	330 5% 1/4W	
	R1768	QRE141J-471Y	C RESISTOR	470 5% 1/4W	
	R1769	QRE141J-391Y	C RESISTOR	390 5% 1/4W	
	R1770	QRJ146J-121X	UNF C RESISTOR	120 5% 1/4W	
	R1771	QRJ146J-121X	UNF C RESISTOR	120 5% 1/4W	
	R1772	QRJ146J-272X	UNF C RESISTOR	2.7K 5% 1/4W	
	R1773	QRJ146J-120X	UNF C RESISTOR	12 5% 1/4W	
	R1774	QRJ146J-120X	UNF C RESISTOR	12 5% 1/4W	
	R1775	QRJ146J-271X	UNF C RESISTOR	270 5% 1/4W	
	R1776	QRJ146J-1R0X	UNF C RESISTOR	1.0 5% 1/4W	
	R1777	QRJ146J-1R0X	UNF C RESISTOR	1.0 5% 1/4W	
	R1778	QRZ0182-R10	EMIT RESISTOR	1/1W	
	R1779	QRZ0182-R10	EMIT RESISTOR	1/1W	
	R1782	NRSA02J-331X	MG RESISTOR		
	R1783	NRSA02J-103X	MG RESISTOR		
	R1785	QRJ125J-330	UNF C RESISTOR	33 5% 1/2W	
	R1786	QRL027J-100	UNF OMF RESISTOR	10 5% 1/2W	

△	Item	Parts number	Parts name	Remarks	Area
	R1791	QRA14CF-1003Y	MF RESISTOR	10 1/4W	
	R1792	QRA14CF-3601Y	MF RESISTOR	36 1/4W	
	R1901	NRSA02J-122X	MG RESISTOR		
	R1902	NRSA02J-153X	MG RESISTOR		
	R1903	NRSA02J-123X	MG RESISTOR		
	R1904	NRSA02J-104X	MG RESISTOR		
	R1911	NRSA02J-122X	MG RESISTOR		
	R1912	NRSA02J-153X	MG RESISTOR		
	R1913	NRSA02J-123X	MG RESISTOR		
	R1914	NRSA02J-104X	MG RESISTOR		
	R1921	NRSA02J-122X	MG RESISTOR		
	R1922	NRSA02J-153X	MG RESISTOR		
	R1923	NRSA02J-123X	MG RESISTOR		
	R1924	NRSA02J-104X	MG RESISTOR		
	R1931	NRSA02J-122X	MG RESISTOR		
	R1932	NRSA02J-153X	MG RESISTOR		
	R1933	NRSA02J-123X	MG RESISTOR		
	R1934	NRSA02J-104X	MG RESISTOR		
	R1941	NRSA02J-122X	MG RESISTOR		
	R1942	NRSA02J-153X	MG RESISTOR		
	R1943	NRSA02J-123X	MG RESISTOR		
	R1944	NRSA02J-104X	MG RESISTOR		
	R1951	NRSA02J-122X	MG RESISTOR		
	R1952	NRSA02J-153X	MG RESISTOR		
	R1953	NRSA02J-123X	MG RESISTOR		
	R1954	NRSA02J-104X	MG RESISTOR		
	R1961	NRSA02J-122X	MG RESISTOR		
	R1962	NRSA02J-153X	MG RESISTOR		
	R1963	NRSA02J-123X	MG RESISTOR		
	R1964	NRSA02J-104X	MG RESISTOR		
	R1971	NRSA02J-103X	MG RESISTOR		
	R1972	NRSA02J-332X	MG RESISTOR		
	R1973	NRSA02J-473X	MG RESISTOR		
	R1974	NRSA02J-563X	MG RESISTOR		
	R1975	NRSA02J-683X	MG RESISTOR		
	R1976	QRE141J-273Y	C RESISTOR	27K 5% 1/4W	
	R1977	NRSA02J-224X	MG RESISTOR		
	R1978	QRE141J-223Y	C RESISTOR	22K 5% 1/4W	
	R1979	NRSA02J-224X	MG RESISTOR		
	R1981	QRJ146J-330X	UNF C RESISTOR	33 5% 1/4W	
	R1982	QRJ146J-330X	UNF C RESISTOR	33 5% 1/4W	
	R1983	QRJ146J-330X	UNF C RESISTOR	33 5% 1/4W	
	R1985	QRJ146J-330X	UNF C RESISTOR	33 5% 1/4W	
	R1986	QRJ146J-330X	UNF C RESISTOR	33 5% 1/4W	
	ST901	QNB0130-001	SPK TERMINAL		
	ST902	QNB0128-001	SPK TERMINAL		
	ST903	QNB0129-001	SPK TERMINAL		
	TH701	QAD0010-351	THERMISTOR		
	TH702	QAD0010-351	THERMISTOR		
	TH751	QAD0010-351	THERMISTOR		
	TH752	QAD0010-351	THERMISTOR		
	TH771	QAD0010-351	THERMISTOR		
	TH772	QAD0010-351	THERMISTOR		
	TH801	QAD0010-351	THERMISTOR		
	VR701	QVP0008-501Z	SEMI V RESISTOR		
	VR702	QVP0008-501Z	SEMI V RESISTOR		
	VR751	QVP0008-501Z	SEMI V RESISTOR		
	VR752	QVP0008-501Z	SEMI V RESISTOR		
	VR771	QVP0008-501Z	SEMI V RESISTOR		
	VR772	QVP0008-501Z	SEMI V RESISTOR		
	VR801	QVP0008-501Z	SEMI V RESISTOR		
	WR 83	QJK015-053200	SIN CR C-B WIRE		
	WR 84	QJK015-053402	SIN CR C-B WIRE		

■ Electrical parts list (Amp. board)

Block No. 01

△	Item	Parts number	Parts name	Remarks	Area
	WR701	QJK016-113801	SIN CR C-B WIRE		
	WR702	QJK016-053800	SIN CR C-B WIRE		
	WR703	QJK016-083603	SIN CR C-B WIRE		
	WR711	WJK0139-001A	E-SI C WIRE C-B		
	WR712	WJK0139-001A	E-SI C WIRE C-B		
	WR713	WJK0139-002A	E-SI C WIRE C-B		
	WR714	WJK0139-003A	E-SI C WIRE C-B		
	WR715	WJK0139-002A	E-SI C WIRE C-B		
	WR716	WJK0140-001A	E-SI C WIRE C-B		
	WR717	WJK0140-001A	E-SI C WIRE C-B		
	WR731	WJK0128-001A	E-SI C WIRE C-B		
	WR736	WJK0129-001A	E-SI C WIRE C-B		
	WR741	QJL005-051003	SIN CR B-B WIRE		
	WR742	QJL005-051001	SIN CR B-B WIRE		

■ Electrical parts list
(Audio/video input & outpat board)

Block No. 02

△	Item	Parts number	Parts name	Remarks	Area	△	Item	Parts number	Parts name	Remarks	Area
	C 201	NCB31HK-331X	C CAPACITOR				C 284	NCB31HK-223X	C CAPACITOR		
	C 202	NCB31HK-331X	C CAPACITOR				C 285	NCB31HK-561X	C CAPACITOR		
	C 203	QETN1HM-475Z	E CAPACITOR	4.7MF 20% 50V			C 301	QETN1HM-226Z	E CAPACITOR	22MF 20% 50V	
	C 204	QETN1HM-475Z	E CAPACITOR	4.7MF 20% 50V			C 311	NCS31HJ-221X	C CAPACITOR		
	C 205	NCS31HJ-101X	C CAPACITOR				C 312	NCS31HJ-221X	C CAPACITOR		
	C 206	NCS31HJ-101X	C CAPACITOR				C 313	NCS31HJ-221X	C CAPACITOR		
	C 207	QFN31HJ-472Z	M CAPACITOR	4700PF 5% 50V			C 321	NCB31HK-331X	C CAPACITOR		
	C 208	QFN31HJ-472Z	M CAPACITOR	4700PF 5% 50V			C 322	NCB31HK-331X	C CAPACITOR		
	C 209	QFN31HJ-153Z	M CAPACITOR	0.015MF 5% 50V			C 323	NCB31HK-331X	C CAPACITOR		
	C 210	QFN31HJ-153Z	M CAPACITOR	0.015MF 5% 50V			C 324	NCB31HK-331X	C CAPACITOR		
	C 211	QCS31HJ-331Z	C CAPACITOR	330PF 5% 50V			C 325	NCB31HK-331X	C CAPACITOR		
	C 212	QCS31HJ-331Z	C CAPACITOR	330PF 5% 50V			C 326	NCB31HK-331X	C CAPACITOR		
	C 213	QFN31HJ-272Z	M CAPACITOR	2700PF 5% 50V			C 327	NCB31HK-331X	C CAPACITOR		
	C 214	QFN31HJ-272Z	M CAPACITOR	2700PF 5% 50V			C 328	NCB31HK-331X	C CAPACITOR		
	C 215	NCS31HJ-101X	C CAPACITOR				C 329	NCB31HK-331X	C CAPACITOR		
	C 216	NCS31HJ-101X	C CAPACITOR				C 330	NCB31HK-331X	C CAPACITOR		
	C 217	QETN1AM-227Z	E CAPACITOR	220MF 20% 10V			C 331	NCB31HK-331X	C CAPACITOR		
	C 218	QETN1AM-227Z	E CAPACITOR	220MF 20% 10V			C 332	NCB31HK-331X	C CAPACITOR		
	C 219	QETN1HM-475Z	E CAPACITOR	4.7MF 20% 50V			C 333	NCB31HK-331X	C CAPACITOR		
	C 220	QETN1HM-475Z	E CAPACITOR	4.7MF 20% 50V			C 334	NCB31HK-331X	C CAPACITOR		
	C 221	QFN31HJ-102Z	M CAPACITOR	1000PF 5% 50V			C 335	NCB31HK-331X	C CAPACITOR		
	C 222	QFN31HJ-102Z	M CAPACITOR	1000PF 5% 50V			C 336	NCB31HK-331X	C CAPACITOR		
	C 223	QETN1EM-476Z	E CAPACITOR	47MF 20% 25V			C 337	NCB31HK-331X	C CAPACITOR		
	C 224	QETN1EM-476Z	E CAPACITOR	47MF 20% 25V			C 338	NCB31HK-331X	C CAPACITOR		
	C 225	NCB31HK-223X	C CAPACITOR				C 341	QETN1EM-226Z	E CAPACITOR	22MF 20% 25V	
	C 226	NCB31HK-223X	C CAPACITOR				C 342	QETN1EM-226Z	E CAPACITOR	22MF 20% 25V	
	C 231	QETN1EM-226Z	E CAPACITOR	22MF 20% 25V			C 343	NCB31HK-223X	C CAPACITOR		
	C 232	QETN1EM-226Z	E CAPACITOR	22MF 20% 25V			C 344	NCB31HK-223X	C CAPACITOR		
	C 233	NCB31HK-223X	C CAPACITOR				C 345	NCB31HK-561X	C CAPACITOR		
	C 234	NCB31HK-223X	C CAPACITOR				C 363	QETN1HM-226Z	E CAPACITOR	22MF 20% 50V	
	C 235	NCB31HK-561X	C CAPACITOR				C 365	QETN1HM-226Z	E CAPACITOR	22MF 20% 50V	
	C 241	QTE1H46-106Z	E CAPACITOR				C 369	QETN1HM-226Z	E CAPACITOR	22MF 20% 50V	
	C 242	QTE1H46-106Z	E CAPACITOR				C 401	QETN1HM-475Z	E CAPACITOR	4.7MF 20% 50V	
	C 243	QTE1H46-106Z	E CAPACITOR				C 402	QETN0JM-477Z	E CAPACITOR	470MF 20% 6.3V	
	C 244	QTE1H46-106Z	E CAPACITOR				C 403	QETN1HM-475Z	E CAPACITOR	4.7MF 20% 50V	
	C 245	QETN1EM-476Z	E CAPACITOR	47MF 20% 25V			C 404	QETN0JM-477Z	E CAPACITOR	470MF 20% 6.3V	
	C 246	QETN1EM-476Z	E CAPACITOR	47MF 20% 25V			C 405	QETN1HM-475Z	E CAPACITOR	4.7MF 20% 50V	
	C 247	NCB31HK-223X	C CAPACITOR				C 406	QETN1HM-475Z	E CAPACITOR	4.7MF 20% 50V	
	C 248	NCB31HK-223X	C CAPACITOR				C 407	QETN0JM-477Z	E CAPACITOR	470MF 20% 6.3V	
	C 251	NCB31HK-331X	C CAPACITOR				C 408	QETN1EM-476Z	E CAPACITOR	47MF 20% 25V	
	C 252	NCB31HK-331X	C CAPACITOR				C 409	NCB31HK-103X	C CAPACITOR		
	C 253	NCB31HK-331X	C CAPACITOR				C 410	QETN1HM-475Z	E CAPACITOR	4.7MF 20% 50V	
	C 254	NCB31HK-331X	C CAPACITOR				C 411	QETN1HM-107Z	E CAPACITOR	100MF 20% 50V	
	C 255	NCB31HK-331X	C CAPACITOR				C 412	NCF21CZ-225X	C CAPACITOR		
	C 256	NCB31HK-331X	C CAPACITOR				C 413	QETN1HM-475Z	E CAPACITOR	4.7MF 20% 50V	
	C 257	NCB31HK-331X	C CAPACITOR				C 414	QETN1HM-475Z	E CAPACITOR	4.7MF 20% 50V	
	C 258	NCB31HK-331X	C CAPACITOR				C 415	QETN1HM-475Z	E CAPACITOR	4.7MF 20% 50V	
	C 259	NCB31HK-331X	C CAPACITOR				C 416	NCF31HZ-473X	C CAPACITOR		
	C 260	NCB31HK-331X	C CAPACITOR				C 417	QETN1AM-477Z	E CAPACITOR	470MF 20% 10V	
	C 261	NCB31HK-331X	C CAPACITOR				C 418	NCB31HK-103X	C CAPACITOR		
	C 262	NCB31HK-331X	C CAPACITOR				C 419	NCS31HJ-150X	C CAPACITOR		
	C 263	NCB31HK-331X	C CAPACITOR				C 420	NCS31HJ-100X	C CAPACITOR		
	C 264	NCB31HK-331X	C CAPACITOR				C 421	NCS31HJ-470X	C CAPACITOR		
	C 265	NCB31HK-331X	C CAPACITOR				C 422	NCS31HJ-270X	C CAPACITOR		
	C 266	NCB31HK-331X	C CAPACITOR				C 423	NCB31HK-102X	C CAPACITOR		
	C 271	QETN1EM-226Z	E CAPACITOR	22MF 20% 25V			C 424	NCS31HJ-271X	C CAPACITOR		
	C 272	QETN1EM-226Z	E CAPACITOR	22MF 20% 25V			C 425	NCS31HJ-121X	C CAPACITOR		
	C 273	NCB31HK-223X	C CAPACITOR				C 426	NCS31HJ-470X	C CAPACITOR		
	C 274	NCB31HK-223X	C CAPACITOR				C 427	NCS31HJ-470X	C CAPACITOR		
	C 275	NCB31HK-561X	C CAPACITOR				C 428	NCS31HJ-470X	C CAPACITOR		
	C 281	QETN1EM-226Z	E CAPACITOR	22MF 20% 25V			C 431	NCF31HZ-473X	C CAPACITOR		
	C 282	QETN1EM-226Z	E CAPACITOR	22MF 20% 25V			C 432	QETN1HM-475Z	E CAPACITOR	4.7MF 20% 50V	
	C 283	NCB31HK-223X	C CAPACITOR				C 433	NCF31HZ-473X	C CAPACITOR		

■ Electrical parts list

(Audio/video input & output board)

Block No. 02

△	Item	Parts number	Parts name	Remarks	Area	△	Item	Parts number	Parts name	Remarks	Area
	C 434	QETN0JM-477Z	E CAPACITOR	470MF 20% 6.3V			C2062	QTE1H46-475Z	E CAPACITOR		
	C 435	NCF31HZ-473X	C CAPACITOR				C2063	QETN1EM-227Z	E CAPACITOR	220MF 20% 25V	
	C 436	QETN1HM-475Z	E CAPACITOR	4.7MF 20% 50V			C2064	QETN1EM-227Z	E CAPACITOR	220MF 20% 25V	
	C 437	NCF31HZ-473X	C CAPACITOR				C2065	NCB31HK-223X	C CAPACITOR		
	C 438	QETN0JM-477Z	E CAPACITOR	470MF 20% 6.3V			C2066	NCB31HK-223X	C CAPACITOR		
	C 439	NCF31HZ-473X	C CAPACITOR				C2067	QETN1HM-475Z	E CAPACITOR	4.7MF 20% 50V	
	C 440	QETN1HM-475Z	E CAPACITOR	4.7MF 20% 50V			C2068	QETN1HM-475Z	E CAPACITOR	4.7MF 20% 50V	
	C 441	NCF31HZ-473X	C CAPACITOR				C2069	QETN1HM-475Z	E CAPACITOR	4.7MF 20% 50V	
	C 442	QETN1HM-475Z	E CAPACITOR	4.7MF 20% 50V			C2070	QETN1HM-475Z	E CAPACITOR	4.7MF 20% 50V	
	C 443	NCF31HZ-473X	C CAPACITOR				C2071	QETN1EM-227Z	E CAPACITOR	220MF 20% 25V	
	C 444	QETN0JM-477Z	E CAPACITOR	470MF 20% 6.3V			C2072	QETN1EM-227Z	E CAPACITOR	220MF 20% 25V	
	C 445	NCF31HZ-473X	C CAPACITOR				C2073	NCB31HK-223X	C CAPACITOR		
	C 446	QETN1HM-475Z	E CAPACITOR	4.7MF 20% 50V			C2074	NCB31HK-223X	C CAPACITOR		
	C 447	QETN1EM-476Z	E CAPACITOR	47MF 20% 25V			C2075	QETN1HM-475Z	E CAPACITOR	4.7MF 20% 50V	
	C 448	QETN1EM-476Z	E CAPACITOR	47MF 20% 25V			C2076	QETN1HM-475Z	E CAPACITOR	4.7MF 20% 50V	
	C 449	NCB31HK-103X	C CAPACITOR				C2077	QETN1HM-475Z	E CAPACITOR	4.7MF 20% 50V	
	C 450	NCB31HK-103X	C CAPACITOR				C2078	QETN1HM-475Z	E CAPACITOR	4.7MF 20% 50V	
	C 451	QETN1HM-475Z	E CAPACITOR	4.7MF 20% 50V			C2079	QETN1EM-227Z	E CAPACITOR	220MF 20% 25V	
	C 452	NCF31HZ-473X	C CAPACITOR				C2080	QETN1EM-227Z	E CAPACITOR	220MF 20% 25V	
	C 453	NCS31HJ-470X	C CAPACITOR				C2081	NCB31HK-223X	C CAPACITOR		
	C 454	NCS31HJ-470X	C CAPACITOR				C2082	NCB31HK-223X	C CAPACITOR		
	C 455	NCS31HJ-470X	C CAPACITOR				C2203	NCB31HK-223X	C CAPACITOR		
	C 456	NCS31HJ-470X	C CAPACITOR				C2204	NCB31HK-223X	C CAPACITOR		
	C 457	NCS31HJ-101X	C CAPACITOR				C2207	QTE1H46-475Z	E CAPACITOR		
	C 458	NCS31HJ-101X	C CAPACITOR				C2208	QTE1H46-475Z	E CAPACITOR		
	C 461	NCF31HZ-473X	C CAPACITOR				C2212	NCB31HK-223X	C CAPACITOR		
	C 462	NCB31HK-103X	C CAPACITOR				C2213	NCB31HK-223X	C CAPACITOR		
	C 463	NCF31HZ-473X	C CAPACITOR				C2221	NCB31HK-223X	C CAPACITOR		
	C 464	NCB31HK-103X	C CAPACITOR				C2222	NCB31HK-223X	C CAPACITOR		
	C 465	NCF31HZ-473X	C CAPACITOR				C2230	NCB31HK-223X	C CAPACITOR		
	C 466	NCB31HK-103X	C CAPACITOR				C2231	NCB31HK-223X	C CAPACITOR		
	C 467	NCF31HZ-473X	C CAPACITOR				C2253	QETN1HM-475Z	E CAPACITOR	4.7MF 20% 50V	
	C 468	NCB31HK-103X	C CAPACITOR				C2254	QETN1HM-475Z	E CAPACITOR	4.7MF 20% 50V	
	C 469	NCB31HK-103X	C CAPACITOR				C2255	QETN1HM-475Z	E CAPACITOR	4.7MF 20% 50V	
	C 470	QETN1EM-476Z	E CAPACITOR	47MF 20% 25V			C2256	QETN1HM-475Z	E CAPACITOR	4.7MF 20% 50V	
	C 471	NCB31HK-103X	C CAPACITOR				C2257	QETN1HM-475Z	E CAPACITOR	4.7MF 20% 50V	
	CN203	QGA2001F1-15	15P PLUG ASSY				C2258	QETN1HM-475Z	E CAPACITOR	4.7MF 20% 50V	
	CN205	QGA2001F1-09	9P SOCKET				C2259	NCS31HJ-330X	C CAPACITOR		
	CN206	QGB2510K1-04	CONNECTOR				C2260	NCS31HJ-330X	C CAPACITOR		
	CN207	QGA2501F1-03	CONNECTOR				C2265	QETN1HM-475Z	E CAPACITOR	4.7MF 20% 50V	
	CN221	QGB2510K1-20	B TO B CONNE				C2266	QETN1HM-475Z	E CAPACITOR	4.7MF 20% 50V	
	CN223	QGA2001F1-11	11P CN RIG				C2267	QETN1EM-227Z	E CAPACITOR	220MF 20% 25V	
	CN224	QGA2001F1-07	CONNECTOR				C2268	QETN1EM-227Z	E CAPACITOR	220MF 20% 25V	
	CN234	QGA2001F1-06	6P PLUG ASSY				C2269	NCB31HK-223X	C CAPACITOR		
	CN321	QGB1214K1-20S	CONNECTOR				C2270	NCB31HK-223X	C CAPACITOR		
	CN323	QGF1205F1-15	CONNECTOR				C2273	NCB31HK-223X	C CAPACITOR		
	CN324	QGA2001F1-09	9P SOCKET				C2274	NCB31HK-223X	C CAPACITOR		
	CN325	QGB2510K2-07	CONNECTOR				C2301	NCB31HK-562X	C CAPACITOR		
	CN401	QGB1214K1-16S	CONNECTOR				C2302	NCB31HK-562X	C CAPACITOR		
	CN402	QGF1205F1-16	CONNECTOR				C2311	NCS31HJ-820X	C CAPACITOR		
	CN431	QGB2510K2-15	CONNECTOR				C2312	NCS31HJ-470X	C CAPACITOR		
	CN432	QGF1205F1-16	CONNECTOR				C2313	NCB31HK-561X	C CAPACITOR		
	C2051	QTE1H46-475Z	E CAPACITOR				C2314	NCB31CK-104X	C CAPACITOR		
	C2052	QTE1H46-475Z	E CAPACITOR				C2315	NCB31HK-331X	C CAPACITOR		
	C2053	QTE1H46-475Z	E CAPACITOR				C2316	QETN1HM-225Z	E CAPACITOR	2.2MF 20% 50V	
	C2054	QTE1H46-475Z	E CAPACITOR				C2317	NCF31HZ-473X	C CAPACITOR		
	C2055	QETN1EM-227Z	E CAPACITOR	220MF 20% 25V			C2318	QETN1CM-106Z	E CAPACITOR	10MF 20% 16V	
	C2056	QETN1EM-227Z	E CAPACITOR	220MF 20% 25V			C2319	NCS31HJ-101X	C CAPACITOR		
	C2057	NCB31HK-223X	C CAPACITOR				C2320	NCS31HJ-101X	C CAPACITOR		
	C2058	NCB31HK-223X	C CAPACITOR				C2401	QTE1H46-106Z	E CAPACITOR		
	C2059	QTE1H46-475Z	E CAPACITOR				C2402	QTE1H46-106Z	E CAPACITOR		
	C2060	QTE1H46-475Z	E CAPACITOR				C2403	QTE1H46-106Z	E CAPACITOR		
	C2061	QTE1H46-475Z	E CAPACITOR				C2404	QTE1H46-106Z	E CAPACITOR		

■ Electrical parts list
(Audio/video input & output board)

Block No. 02

△	Item	Parts number	Parts name	Remarks	Area	△	Item	Parts number	Parts name	Remarks	Area
	C2405	QETN1EM-476Z	E CAPACITOR	47MF 20% 25V			IC402	NJM2285V-W	IC		
	C2406	QETN1EM-476Z	E CAPACITOR	47MF 20% 25V			IC403	MB90088PF-131	IC		
	C2407	NCB31HK-223X	C CAPACITOR				IC431	BA7625	IC		
	C2408	NCB31HK-223X	C CAPACITOR				IC432	BA7626	IC		
	C2411	QETN1HM-106Z	E CAPACITOR	10MF 20% 50V			IC461	BU4051BC	IC		
	C2412	QETN1HM-106Z	E CAPACITOR	10MF 20% 50V			J 201	QNN0392-001	PIN JACK		
	C2413	QETN1HM-106Z	E CAPACITOR	10MF 20% 50V			J 202	QNN0392-001	PIN JACK		
	C2414	QETN1HM-106Z	E CAPACITOR	10MF 20% 50V			J 203	QNN0396-001	PIN JACK		
	C2415	QETN1EM-476Z	E CAPACITOR	47MF 20% 25V			J 321	QNN0392-001	PIN JACK		
	C2416	QETN1EM-476Z	E CAPACITOR	47MF 20% 25V			J 322	QNN0393-001	PIN JACK		
	C2417	NCB31HK-223X	C CAPACITOR				J 323	QNN0396-001	PIN JACK		
	C2418	NCB31HK-223X	C CAPACITOR				J 324	QNN0394-001	PIN JACK		
	C2421	QETN1HM-106Z	E CAPACITOR	10MF 20% 50V			J 401	QNN0402-001	PIN JACK		
	C2422	QETN1HM-106Z	E CAPACITOR	10MF 20% 50V			J 402	QNN0403-001	PIN JACK		
	C2423	QETN1HM-106Z	E CAPACITOR	10MF 20% 50V			J 403	QNN0403-001	PIN JACK		
	C2424	QETN1HM-106Z	E CAPACITOR	10MF 20% 50V			J 431	QND0090-001	S JACK		
	C2425	QETN1EM-476Z	E CAPACITOR	47MF 20% 25V			J 432	QND0029-001	DIN CONNECTOR		
	C2426	QETN1EM-476Z	E CAPACITOR	47MF 20% 25V			J 433	QND0029-001	DIN CONNECTOR		
	C2427	NCB31HK-223X	C CAPACITOR				J 434	QND0089-001	S JACK		
	C2428	NCB31HK-223X	C CAPACITOR				L 321	QLL231K-121Y	INDUCTOR		
	C2501	NCF21CZ-225X	C CAPACITOR				L 322	QLL231K-121Y	INDUCTOR		
	C2502	NCF21CZ-225X	C CAPACITOR				L 401	QLL231K-220Y	INDUCTOR		
	C2503	NCF21CZ-105X	C CAPACITOR				Q 201	KRA104M-T	D TRANSISTOR		
	C2504	NCF21CZ-105X	C CAPACITOR				Q 211	2SC3576-JVC-T	TRANSISTOR		
	D 240	1SS355-X	DIODE				Q 212	2SC3576-JVC-T	TRANSISTOR		
	D 351	1SS355-X	DIODE				Q 213	2SC3576-JVC-T	TRANSISTOR		
	D 401	1SS133-T2	SI DIODE				Q 214	2SC3576-JVC-T	TRANSISTOR		
	D 402	1SS133-T2	SI DIODE				Q 215	2SC3576-JVC-T	TRANSISTOR		
	D2311	1SS133-T2	SI DIODE				Q 216	2SC3576-JVC-T	TRANSISTOR		
	D2501	1SS355-X	DIODE				Q 217	2SC3576-JVC-T	TRANSISTOR		
	D2502	1SS355-X	DIODE				Q 218	2SC3576-JVC-T	TRANSISTOR		
	D2503	1SS355-X	DIODE				Q 219	2SC3576-JVC-T	TRANSISTOR		
	D2504	1SS355-X	DIODE				Q 240	KRC105M-T	D TRANSISTOR		
	D2505	1SS355-X	DIODE				Q 323	2SC3576-JVC-T	TRANSISTOR		
	D2506	1SS355-X	DIODE				Q 324	2SC3576-JVC-T	TRANSISTOR		
	D2507	1SS355-X	DIODE				Q 325	2SC3576-JVC-T	TRANSISTOR		
	D2508	1SS355-X	DIODE				Q 329	2SC3576-JVC-T	TRANSISTOR		
	FL301	QQR0590-001	FILTER				Q 330	2SC3576-JVC-T	TRANSISTOR		
	FL302	QQR0590-001	FILTER				Q 332	DTC114YKA-X	CHIP D TRANSISTOR		
	IC201	NJM4580E-W	IC				Q 334	DTC114YKA-X	CHIP D TRANSISTOR		
	IC202	TC9164AF-X	IC				Q 342	DTA114YKA-X	TRANSISTOR		
	IC204	NJM4580E-W	IC				Q 343	DTA114YKA-X	TRANSISTOR		
	IC211	TC9162AF-X	IC				Q 345	DTA114YKA-X	TRANSISTOR		
	IC213	TC9162AF-X	IC				Q 351	KRC105M-T	D TRANSISTOR		
	IC221	TC9459F-X	IC				Q 401	KTA1267/YG/-T	TRANSISTOR		
	IC222	TC9459F-X	IC				Q 402	KTA1267/YG/-T	TRANSISTOR		
	IC223	TC9459F-X	IC				Q 403	KRC110M-T	TRANSISTOR		
	IC224	TC9459F-X	IC				Q 404	KRC107M-T	D TRANSISTOR		
	IC241	NJM4580E-W	IC				Q 405	KTA1267/YG/-T	TRANSISTOR		
	IC242	NJM4580E-W	IC				Q 406	KTA1267/YG/-T	TRANSISTOR		
	IC251	NJM4580E-W	IC				Q 407	KTA1267/YG/-T	TRANSISTOR		
	IC252	NJM4580E-W	IC				Q 431	KTA1267/YG/-T	TRANSISTOR		
	IC253	NJM4580E-W	IC				Q 432	KTA1267/YG/-T	TRANSISTOR		
	IC254	NJM4580E-W	IC				Q 433	KTA1267/YG/-T	TRANSISTOR		
	IC271	NJM4580E-W	IC				Q 434	KTA1267/YG/-T	TRANSISTOR		
	IC272	NJM4580E-W	IC				Q 461	DTC114EKA-X	TRANSISTOR		
	IC273	NJM4580E-W	IC				Q 462	DTC114EKA-X	TRANSISTOR		
	IC281	NJM4580E-W	IC				Q 463	DTC114EKA-X	TRANSISTOR		
	IC282	NJM2903M-XE	IC				Q 464	KTC3199/GL/-T	TRANSISTOR		
	IC283	NJM78L05A-T	IC				Q 465	KTC3199/GL/-T	TRANSISTOR		
	IC311	SAA6588	IC				Q 466	KTC3199/GL/-T	TRANSISTOR		
	IC321	TC9163AF-X	IC				Q 467	KTA1267/YG/-T	TRANSISTOR		
	IC401	BA7625	IC				Q2501	KTC3199/GL/-T	TRANSISTOR		

■ Electrical parts list

(Audio/video input & output board)

Block No. 02

△	Item	Parts number	Parts name	Remarks	Area	△	Item	Parts number	Parts name	Remarks	Area
	R 201	NRSA63J-222X	MG RESISTOR				R 301	NRSA63J-103X	MG RESISTOR		
	R 202	NRSA63J-222X	MG RESISTOR				R 302	NRSA63J-103X	MG RESISTOR		
	R 203	NRSA63J-473X	MG RESISTOR				R 303	QRA14CF-1001Y	MF RESISTOR	10 1/4W	
	R 204	NRSA63J-473X	MG RESISTOR				R 304	QRA14CF-1001Y	MF RESISTOR	10 1/4W	
	R 205	NRSA63J-221X	MG RESISTOR				R 305	NRSA63J-103X	MG RESISTOR		
	R 206	NRSA63J-221X	MG RESISTOR				R 306	NRSA63J-103X	MG RESISTOR		
	R 207	NRSA63J-153X	MG RESISTOR				R 307	NRSA63J-102X	MG RESISTOR		
	R 208	NRSA63J-153X	MG RESISTOR				R 308	NRSA63J-474X	MG RESISTOR		
	R 209	NRSA63J-184X	MG RESISTOR				R 311	NRSA63J-102X	MG RESISTOR		
	R 210	NRSA63J-184X	MG RESISTOR				R 312	NRSA63J-102X	MG RESISTOR		
	R 211	NRSA63J-103X	MG RESISTOR				R 313	NRSA63J-102X	MG RESISTOR		
	R 212	NRSA63J-103X	MG RESISTOR				R 319	QRA14CF-1001Y	MF RESISTOR	10 1/4W	
	R 213	NRSA63J-104X	MG RESISTOR				R 320	NRSA63J-103X	MG RESISTOR		
	R 214	NRSA63J-104X	MG RESISTOR				R 321	NRSA63J-471X	MG RESISTOR		
	R 215	NRSA63J-101X	MG RESISTOR				R 322	NRSA63J-471X	MG RESISTOR		
	R 216	NRSA63J-101X	MG RESISTOR				R 323	NRSA63J-471X	MG RESISTOR		
△	R 217	QRJ146J-331X	UNF C RESISTOR	330 5% 1/4W			R 324	NRSA63J-471X	MG RESISTOR		
△	R 218	QRJ146J-331X	UNF C RESISTOR	330 5% 1/4W			R 325	NRSA63J-471X	MG RESISTOR		
△	R 231	QRZ9005-680X	F RESISTOR	68 1/4W			R 326	NRSA63J-471X	MG RESISTOR		
△	R 232	QRZ9005-680X	F RESISTOR	68 1/4W			R 327	NRSA63J-471X	MG RESISTOR		
△	R 237	QRZ9005-680X	F RESISTOR	68 1/4W			R 328	NRSA63J-471X	MG RESISTOR		
△	R 238	QRZ9005-680X	F RESISTOR	68 1/4W			R 329	NRSA63J-471X	MG RESISTOR		
△	R 240	QRZ9005-331X	F RESISTOR	330 1/4W			R 330	NRSA63J-471X	MG RESISTOR		
	R 241	NRSA63J-104X	MG RESISTOR				R 331	NRSA63J-471X	MG RESISTOR		
	R 242	NRSA63J-104X	MG RESISTOR				R 332	NRSA63J-471X	MG RESISTOR		
	R 243	NRSA63J-104X	MG RESISTOR				R 333	NRSA63J-471X	MG RESISTOR		
	R 244	NRSA63J-104X	MG RESISTOR				R 334	NRSA63J-471X	MG RESISTOR		
	R 245	NRSA63J-104X	MG RESISTOR				R 335	NRSA63J-471X	MG RESISTOR		
	R 246	NRSA63J-104X	MG RESISTOR				R 336	NRSA63J-471X	MG RESISTOR		
	R 247	QRA14CF-1001Y	MF RESISTOR	10 1/4W			R 337	NRSA63J-471X	MG RESISTOR		
	R 248	QRA14CF-1001Y	MF RESISTOR	10 1/4W			R 338	NRSA63J-471X	MG RESISTOR		
	R 249	QRA14CF-1001Y	MF RESISTOR	10 1/4W			△ R 339	QRZ9005-680X	F RESISTOR	68 1/4W	
	R 250	QRA14CF-1001Y	MF RESISTOR	10 1/4W			△ R 340	QRZ9005-680X	F RESISTOR	68 1/4W	
	R 251	NRSA63J-471X	MG RESISTOR				R 341	NRSA63J-471X	MG RESISTOR		
	R 252	NRSA63J-471X	MG RESISTOR				R 342	NRSA63J-471X	MG RESISTOR		
	R 253	NRSA63J-471X	MG RESISTOR				R 345	NRSA63J-471X	MG RESISTOR		
	R 254	NRSA63J-471X	MG RESISTOR				R 346	NRSA63J-471X	MG RESISTOR		
	R 255	NRSA63J-471X	MG RESISTOR				R 347	NRSA63J-103X	MG RESISTOR		
	R 256	NRSA63J-471X	MG RESISTOR				R 348	NRSA63J-103X	MG RESISTOR		
	R 257	NRSA63J-471X	MG RESISTOR				R 349	NRSA63J-471X	MG RESISTOR		
	R 258	NRSA63J-471X	MG RESISTOR				R 350	NRSA63J-103X	MG RESISTOR		
	R 259	NRSA63J-471X	MG RESISTOR				R 351	NRSA63J-471X	MG RESISTOR		
	R 260	NRSA63J-471X	MG RESISTOR				R 352	NRSA63J-471X	MG RESISTOR		
	R 261	NRSA63J-561X	MG RESISTOR				R 355	NRSA63J-471X	MG RESISTOR		
	R 262	NRSA63J-561X	MG RESISTOR				R 356	NRSA63J-471X	MG RESISTOR		
	R 263	NRSA63J-561X	MG RESISTOR				R 357	NRSA63J-103X	MG RESISTOR		
	R 264	NRSA63J-561X	MG RESISTOR				R 358	NRSA63J-103X	MG RESISTOR		
	R 265	NRSA63J-561X	MG RESISTOR				R 363	NRSA63J-102X	MG RESISTOR		
	R 266	NRSA63J-561X	MG RESISTOR				R 364	NRSA63J-474X	MG RESISTOR		
	R 267	QRZ9005-680X	F RESISTOR	68 1/4W			R 365	NRSA63J-102X	MG RESISTOR		
△	R 268	QRZ9005-680X	F RESISTOR	68 1/4W			R 366	NRSA63J-474X	MG RESISTOR		
△	R 281	QRZ9005-680X	F RESISTOR	68 1/4W			R 369	NRSA63J-102X	MG RESISTOR		
△	R 282	QRZ9005-680X	F RESISTOR	68 1/4W			R 370	NRSA63J-474X	MG RESISTOR		
	R 291	QRA14CF-1001Y	MF RESISTOR	10 1/4W			R 399	NRSA63J-471X	MG RESISTOR		
	R 292	QRA14CF-1001Y	MF RESISTOR	10 1/4W			R 400	NRSA63J-471X	MG RESISTOR		
	R 293	NRSA63J-103X	MG RESISTOR				R 401	NRSA63J-750X	MG RESISTOR		
	R 294	NRSA63J-103X	MG RESISTOR				R 402	NRSA63J-750X	MG RESISTOR		
	R 295	QRA14CF-1001Y	MF RESISTOR	10 1/4W			R 403	NRSA63J-750X	MG RESISTOR		
	R 296	QRA14CF-1001Y	MF RESISTOR	10 1/4W			R 404	NRSA63J-750X	MG RESISTOR		
	R 297	NRSA63J-103X	MG RESISTOR				R 405	NRSA63J-750X	MG RESISTOR		
	R 298	NRSA63J-103X	MG RESISTOR				R 406	NRSA63J-750X	MG RESISTOR		
	R 299	QRA14CF-1001Y	MF RESISTOR	10 1/4W			R 407	NRSA63J-750X	MG RESISTOR		
	R 300	QRA14CF-1001Y	MF RESISTOR	10 1/4W			R 408	NRSA63J-331X	MG RESISTOR		

■ Electrical parts list
(Audio/video input & output board)

Block No. 02

△	Item	Parts number	Parts name	Remarks	Area	△	Item	Parts number	Parts name	Remarks	Area
	R 409	NRSA63J-473X	MG RESISTOR				R2054	NRSA63J-104X	MG RESISTOR		
	R 410	NRSA63J-331X	MG RESISTOR				R2055	NRSA63J-104X	MG RESISTOR		
	R 411	NRSA63J-473X	MG RESISTOR				R2056	NRSA63J-104X	MG RESISTOR		
	R 412	NRSA63J-331X	MG RESISTOR			△	R2057	QRZ9005-680X	F RESISTOR	68 1/4W	
	R 413	NRSA63J-331X	MG RESISTOR			△	R2058	QRZ9005-680X	F RESISTOR	68 1/4W	
	R 414	NRSA63J-473X	MG RESISTOR				R2059	NRSA63J-334X	MG RESISTOR		
	R 415	NRSA63J-151X	MG RESISTOR				R2060	NRSA63J-334X	MG RESISTOR		
	R 416	NRSA63J-151X	MG RESISTOR				R2061	NRSA63J-104X	MG RESISTOR		
	R 417	NRSA63J-301X	MG RESISTOR				R2062	NRSA63J-104X	MG RESISTOR		
	R 418	NRSA63J-103X	MG RESISTOR				R2063	NRSA63J-104X	MG RESISTOR		
	R 419	NRSA63J-331X	MG RESISTOR				R2064	NRSA63J-104X	MG RESISTOR		
	R 420	NRSA63J-101X	MG RESISTOR			△	R2065	QRZ9005-680X	F RESISTOR	68 1/4W	
	R 421	NRSA63J-121X	MG RESISTOR			△	R2066	QRZ9005-680X	F RESISTOR	68 1/4W	
	R 422	NRSA63J-151X	MG RESISTOR				R2067	NRSA63J-334X	MG RESISTOR		
	R 423	NRSA63J-561X	MG RESISTOR				R2068	NRSA63J-334X	MG RESISTOR		
	R 424	NRSA63J-561X	MG RESISTOR				R2069	NRSA63J-104X	MG RESISTOR		
	R 425	NRSA63J-561X	MG RESISTOR				R2070	NRSA63J-104X	MG RESISTOR		
△	R 426	QRJ146J-1R0X	UNF C RESISTOR	1.0 5% 1/4W			R2071	NRSA63J-104X	MG RESISTOR		
	R 431	NRSA63J-750X	MG RESISTOR				R2072	NRSA63J-104X	MG RESISTOR		
	R 432	NRSA63J-750X	MG RESISTOR			△	R2073	QRZ9005-680X	F RESISTOR	68 1/4W	
	R 433	NRSA63J-750X	MG RESISTOR			△	R2074	QRZ9005-680X	F RESISTOR	68 1/4W	
	R 434	NRSA63J-750X	MG RESISTOR				R2075	NRSA63J-334X	MG RESISTOR		
	R 435	NRSA63J-473X	MG RESISTOR				R2076	NRSA63J-334X	MG RESISTOR		
	R 436	NRSA63J-750X	MG RESISTOR				R2077	NRSA63J-104X	MG RESISTOR		
	R 437	NRSA63J-750X	MG RESISTOR				R2078	NRSA63J-104X	MG RESISTOR		
	R 438	NRSA63J-750X	MG RESISTOR				R2079	NRSA63J-104X	MG RESISTOR		
	R 439	NRSA63J-750X	MG RESISTOR				R2080	NRSA63J-104X	MG RESISTOR		
	R 440	NRSA63J-473X	MG RESISTOR			△	R2081	QRZ9005-680X	F RESISTOR	68 1/4W	
	R 441	NRSA63J-750X	MG RESISTOR			△	R2082	QRZ9005-680X	F RESISTOR	68 1/4W	
	R 442	NRSA63J-750X	MG RESISTOR				R2211	NRSA63J-102X	MG RESISTOR		
	R 443	NRSA63J-750X	MG RESISTOR				R2212	NRSA63J-102X	MG RESISTOR		
	R 444	NRSA63J-750X	MG RESISTOR				R2213	NRSA63J-102X	MG RESISTOR		
	R 445	NRSA63J-750X	MG RESISTOR				R2214	NRSA63J-102X	MG RESISTOR		
	R 446	NRSA63J-750X	MG RESISTOR				R2215	NRSA63J-102X	MG RESISTOR		
	R 447	NRSA63J-473X	MG RESISTOR				R2216	NRSA63J-102X	MG RESISTOR		
	R 448	NRSA63J-121X	MG RESISTOR				R2259	NRSA63J-333X	MG RESISTOR		
	R 449	NRSA63J-121X	MG RESISTOR				R2260	NRSA63J-333X	MG RESISTOR		
	R 450	NRSA63J-151X	MG RESISTOR				R2261	NRSA63J-333X	MG RESISTOR		
	R 451	NRSA63J-151X	MG RESISTOR				R2262	NRSA63J-333X	MG RESISTOR		
△	R 452	QRJ146J-6R8X	UNF C RESISTOR	6.8 5% 1/4W			R2263	NRSA63J-333X	MG RESISTOR		
△	R 453	QRJ146J-2R2X	UNF C RESISTOR	2.2 5% 1/4W			R2264	NRSA63J-333X	MG RESISTOR		
	R 461	NRSA63J-562X	MG RESISTOR				R2265	NRSA63J-333X	MG RESISTOR		
	R 462	NRSA63J-562X	MG RESISTOR				R2266	NRSA63J-333X	MG RESISTOR		
	R 463	NRSA63J-562X	MG RESISTOR				R2267	NRSA63J-333X	MG RESISTOR		
	R 464	NRSA63J-562X	MG RESISTOR				R2268	NRSA63J-333X	MG RESISTOR		
	R 465	NRSA63J-562X	MG RESISTOR				R2269	NRSA63J-102X	MG RESISTOR		
	R 466	NRSA63J-223X	MG RESISTOR				R2270	NRSA63J-102X	MG RESISTOR		
	R 467	NRSA63J-223X	MG RESISTOR				R2273	NRSA63J-102X	MG RESISTOR		
	R 468	NRSA63J-223X	MG RESISTOR				R2274	NRSA63J-102X	MG RESISTOR		
	R 469	NRSA63J-104X	MG RESISTOR			△	R2275	QRZ9005-680X	F RESISTOR	68 1/4W	
	R 470	NRSA63J-334X	MG RESISTOR			△	R2276	QRZ9005-680X	F RESISTOR	68 1/4W	
	R 471	NRSA63J-472X	MG RESISTOR				R2301	NRSA63J-682X	MG RESISTOR		
	R 472	NRSA63J-472X	MG RESISTOR				R2302	NRSA63J-682X	MG RESISTOR		
	R 473	NRSA63J-472X	MG RESISTOR				R2303	NRSA63J-102X	MG RESISTOR		
	R 474	NRSA63J-103X	MG RESISTOR				R2304	NRSA63J-102X	MG RESISTOR		
	R 475	NRSA63J-103X	MG RESISTOR				R2311	NRSA63J-102X	MG RESISTOR		
	R 476	NRSA63J-103X	MG RESISTOR				R2312	NRSA63J-474X	MG RESISTOR		
	RY240	QSK0125-001	RELAY				R2313	NRSA63J-103X	MG RESISTOR		
	RY351	QSK0125-001	RELAY				R2314	NRSA63J-103X	MG RESISTOR		
△	R1351	QRZ9005-331X	F RESISTOR	330 1/4W			R2315	NRSA63J-102X	MG RESISTOR		
	R2051	NRSA63J-334X	MG RESISTOR				R2316	NRSA63J-103X	MG RESISTOR		
	R2052	NRSA63J-334X	MG RESISTOR				R2317	NRSA63J-103X	MG RESISTOR		
	R2053	NRSA63J-104X	MG RESISTOR				R2351	QRA14CF-1001Y	MF RESISTOR	10 1/4W	

■ Electrical parts list
(Audio/video input & output board)

Block No. 02

△	Item	Parts number	Parts name	Remarks	Area
	R2352	QRA14CF-1001Y	MF RESISTOR	10 1/4W	
	R2353	QRA14CF-5101Y	MF RESISTOR	51 1/4W	
	R2354	QRA14CF-5101Y	MF RESISTOR	51 1/4W	
	R2355	QRA14CF-1001Y	MF RESISTOR	10 1/4W	
	R2356	QRA14CF-1001Y	MF RESISTOR	10 1/4W	
	R2357	QRA14CF-5101Y	MF RESISTOR	51 1/4W	
	R2358	QRA14CF-1802Y	MF RESISTOR	18 1/4W	
	R2359	QRA14CF-1001Y	MF RESISTOR	10 1/4W	
	R2360	QRA14CF-1001Y	MF RESISTOR	10 1/4W	
	R2361	QRA14CF-5101Y	MF RESISTOR	51 1/4W	
	R2362	QRA14CF-5101Y	MF RESISTOR	51 1/4W	
	R2363	QRA14CF-1001Y	MF RESISTOR	10 1/4W	
	R2364	QRA14CF-1001Y	MF RESISTOR	10 1/4W	
	R2365	QRA14CF-5101Y	MF RESISTOR	51 1/4W	
	R2366	QRA14CF-5101Y	MF RESISTOR	51 1/4W	
	R2401	NRSA63J-104X	MG RESISTOR		
	R2402	NRSA63J-104X	MG RESISTOR		
	R2403	NRSA63J-104X	MG RESISTOR		
	R2404	NRSA63J-104X	MG RESISTOR		
	R2405	NRSA63J-104X	MG RESISTOR		
	R2406	NRSA63J-104X	MG RESISTOR		
	R2411	NRSA63J-104X	MG RESISTOR		
	R2412	NRSA63J-104X	MG RESISTOR		
	R2413	NRSA63J-104X	MG RESISTOR		
	R2414	NRSA63J-104X	MG RESISTOR		
	R2415	NRSA63J-104X	MG RESISTOR		
	R2416	NRSA63J-104X	MG RESISTOR		
	R2421	NRSA63J-104X	MG RESISTOR		
	R2422	NRSA63J-104X	MG RESISTOR		
	R2423	NRSA63J-104X	MG RESISTOR		
	R2424	NRSA63J-104X	MG RESISTOR		
	R2425	NRSA63J-104X	MG RESISTOR		
	R2426	NRSA63J-104X	MG RESISTOR		
	R2501	NRSA63J-333X	MG RESISTOR		
	R2502	NRSA63J-333X	MG RESISTOR		
	R2503	NRSA63J-104X	MG RESISTOR		
	R2504	NRSA63J-104X	MG RESISTOR		
	R2505	NRSA63J-223X	MG RESISTOR		
	R2506	NRSA63J-223X	MG RESISTOR		
	R2507	NRSA63J-333X	MG RESISTOR		
	R2508	NRSA63J-333X	MG RESISTOR		
	R2509	NRSA63J-622X	MG RESISTOR		
	R2510	NRSA63J-102X	MG RESISTOR		
	R2511	NRSA63J-103X	MG RESISTOR		
	SP403	VYH7653-001	IC HOLDER		
	WR204	QJK016-031803	SIN CR C-B WIRE		
	WR307	QJP001-031001	SHI CR C-B WIRE		
	WR322	WJP0032-001A	E-SH C WIRE C-B		
	WR323	QJK016-111401	SIN CR C-B WIRE		
	WR324	WJK0130-001A	E-SI C WIRE C-B		
	X 311	QAX0263-001Z	CRYSTAL		
	X 401	QAX0261-001Z	CRYSTAL		

■ Electrical parts list (Power supply board)

Block No. 03

△	Item	Parts number	Parts name	Remarks	Area	△	Item	Parts number	Parts name	Remarks	Area
	C 1	QER61CM-107Z	E CAPACITOR	100MF 20% 16V			CN 66	QGA2001C1-02	2P PLUG ASSY		
△	C 21	QCZ9104-472	C CAPACITOR	4700PF			CN 67	QGA2001C1-02	2P PLUG ASSY		
	C 22	QFN32AK-472Z	M CAPACITOR	4700PF 10% 100V			D 1	1SS133-T2	SI DIODE		
	C 23	QETM1EM-228	E CAPACITOR	2200MF 20% 25V			D 2	1SS133-T2	SI DIODE		
	C 24	QCF31HZ-472Z	C CAPACITOR	4700PF +80:-20%			D 3	MTZJ4.7B-T2	ZENER DIODE		
	C 25	QETN1CM-477Z	E CAPACITOR	470MF 20% 16V			D 4	1SS133-T2	SI DIODE		
	C 41	QFVJ1HJ-104Z	MF CAPACITOR	0.1MF 5% 50V			D 5	1SS133-T2	SI DIODE		
	C 42	QETM1EM-478	E CAPACITOR	4700MF 20% 25V			D 6	1SS133-T2	SI DIODE		
	C 43	QCF31HZ-472Z	C CAPACITOR	4700PF +80:-20%			D 7	1SS133-T2	SI DIODE		
	C 44	QEHR1EM-107Z	E CAPACITOR	100MF 20% 25V			△ D 21	1SR35-400A-T5	DIODE		
	C 45	QCF31HZ-472Z	C CAPACITOR	4700PF +80:-20%		△	D 22	1SR35-400A-T5	DIODE		
	C 46	QEHR1EM-107Z	E CAPACITOR	100MF 20% 25V		△	D 23	1SR35-400A-T5	DIODE		
	C 47	QCF31HZ-472Z	C CAPACITOR	4700PF +80:-20%		△	D 24	1SR35-400A-T5	DIODE		
	C 48	QEHR1EM-107Z	E CAPACITOR	100MF 20% 25V			D 25	1SS133-T2	SI DIODE		
	C 49	QEHR1EM-107Z	E CAPACITOR	100MF 20% 25V			D 26	MTZJ6.2A-T2	ZENER DIODE		
	C 50	QCF31HZ-472Z	C CAPACITOR	4700PF +80:-20%		△	D 41	1GWJ42-T5	DIODE		
	C 51	QETN1JM-227Z	E CAPACITOR	220MF 20% 63V		△	D 42	1GWJ42-T5	DIODE		
	C 52	QETN1HM-226Z	E CAPACITOR	22MF 20% 50V		△	D 43	1GWJ42-T5	DIODE		
	C 53	QETN1HM-226Z	E CAPACITOR	22MF 20% 50V		△	D 44	1GWJ42-T5	DIODE		
	C 54	QETN1HM-105Z	E CAPACITOR	1.0MF 20% 50V			D 45	1SS133-T2	SI DIODE		
	C 55	QFN31HJ-473Z	M CAPACITOR	0.047MF 5% 50V			D 46	MTZJ6.2C-T2	ZENER DIODE		
	C 56	QFN31HJ-473Z	M CAPACITOR	0.047MF 5% 50V			D 47	1SS133-T2	SI DIODE		
	C 60	QEHC1EM-227Z	E CAPACITOR	220MF 20% 25V			D 48	MTZJ6.2C-T2	ZENER DIODE		
	C 61	QFN32AJ-104Z	M CAPACITOR	0.1MF 5% 100V			D 49	1SS133-T2	SI DIODE		
	C 62	QFN32AJ-104Z	M CAPACITOR	0.1MF 5% 100V			D 50	MTZJ6.2C-T2	ZENER DIODE		
	C 63	QFN32AJ-104Z	M CAPACITOR	0.1MF 5% 100V			D 51	1SS133-T2	SI DIODE		
	C 64	QFN32AJ-104Z	M CAPACITOR	0.1MF 5% 100V			D 52	MTZJ6.8C-T2	ZENER DIODE		
	C 65	QFN32AJ-104Z	M CAPACITOR	0.1MF 5% 100V		△	D 53	1SR35-400A-T5	DIODE		
	C 66	QETM1VM-228	E CAPACITOR	2200MF 20% 35V			D 55	MTZJ36C-T2	ZENER DIODE		
	C 67	QETM1VM-228	E CAPACITOR	2200MF 20% 35V			D 56	MTZJ8.2C-T2	ZENER DIODE		
	C 68	QCF31HZ-472Z	C CAPACITOR	4700PF +80:-20%		△	D 61	1SR35-400A-T5	DIODE		
	C 69	QEHC1EM-227Z	E CAPACITOR	220MF 20% 25V		△	D 62	1SR35-400A-T5	DIODE		
	C 70	QCF31HZ-472Z	C CAPACITOR	4700PF +80:-20%		△	D 63	1SR35-400A-T5	DIODE		
	C 71	QEHC1EM-107Z	E CAPACITOR	100MF 20% 25V		△	D 64	1SR35-400A-T5	DIODE		
	C 72	QCF31HZ-472Z	C CAPACITOR	4700PF +80:-20%			D 65	1SS133-T2	SI DIODE		
	C 73	QEHC1EM-227Z	E CAPACITOR	220MF 20% 25V			D 66	MTZJ15C-T2	ZENER DIODE		
	C 74	QETN1HM-475Z	E CAPACITOR	4.7MF 20% 50V			D 67	1SS133-T2	SI DIODE		
	C 75	QEHR1VM-107Z	E CAPACITOR	100MF 20% 35V			D 68	MTZJ13C-T2	ZENER DIODE		
	C 76	QCF31HZ-472Z	C CAPACITOR	4700PF +80:-20%			D 69	1SS133-T2	SI DIODE		
	C 81	QCBB1HK-331Y	C CAPACITOR	330PF 10% 50V			D 70	MTZJ15C-T2	ZENER DIODE		
	C 82	QCBB1HK-331Y	C CAPACITOR	330PF 10% 50V			D 71	1SS133-T2	SI DIODE		
	C 83	QCBB1HK-331Y	C CAPACITOR	330PF 10% 50V			D 72	1SS133-T2	SI DIODE		
	CN 1	QGF1205C1-16	CONNECTOR				D 73	MTZJ24C-T2	ZENER DIODE		
	CN 2	QGF1205C1-20	CONNECTOR				EP 22	QNZ0136-001Z	EARTH PLATE		
	CN 3	QGB2510J1-11	CONNECTOR				EP 61	QNZ0136-001Z	EARTH PLATE		
	CN 4	QGB2510J1-04	CONNECTOR				FC 21	QNG0020-001Z	FUSE CLIP	F21	
	CN 5	QGB2510J1-20	CONNECTOR				FC 22	QNG0020-001Z	FUSE CLIP	F21	
	CN 6	QGB1214J1-20S	CONNECTOR				FC 25	QNG0020-001Z	FUSE CLIP	F23	
	CN 7	QGB1214J1-16S	CONNECTOR				FC 26	QNG0020-001Z	FUSE CLIP	F23	
	CN 8	QGB2510J1-15	CONNECTOR				FC 41	QNG0020-001Z	FUSE CLIP	F41	
	CN 11	QGA2001C1-08	8P PLUG ASSY				FC 42	QNG0020-001Z	FUSE CLIP	F41	
	CN 15	QGB2510J1-07	CONNECTOR				FC 43	QNG0020-001Z	FUSE CLIP	F42	
	CN 16	QGA2001C1-11	11P PLUG ASSY				FC 44	QNG0020-001Z	FUSE CLIP	F42	
	CN 17	QGA2001C1-05	5P PLUG ASSY				FC 61	QNG0020-001Z	FUSE CLIP	F61	
	CN 25	QGA2001C1-07	7P PLUG ASSY				FC 62	QNG0020-001Z	FUSE CLIP	F61	
	CN 41	QGA7901C1-02	CONNECTOR				FC 63	QNG0020-001Z	FUSE CLIP	F62	
	CN 42	QGA2001F1-05	5P PLUG ASSY				FC 64	QNG0020-001Z	FUSE CLIP	F62	
	CN 43	QGA2001F1-08	CONNECTOR				HS 41	E70306-005	HEAT SINK		
	CN 45	QGA2001F1-06	6P PLUG ASSY				HS 42	E70306-005	HEAT SINK		
	CN 61	QGA7901C1-04	CONNECTOR				HS 61	E70306-001	HEAT SINK		
	CN 63	QGA2001C1-08	8P PLUG ASSY				HS 62	E70306-001	HEAT SINK		
	CN 64	QGA2001C1-03	3P PLUG ASSY				HS 63	E70306-001	HEAT SINK		
	CN 65	QGA2501C1-02	2P CONNECTOR				J 81	QNS0061-001	6.3 JACK		

■ Electrical parts list (power supply board) Block No. 03

△	Item	Parts number	Parts name	Remarks	Area
	K 2	QQR0779-001Z	INDUCTOR		
	K 4	QQR0779-001Z	INDUCTOR		
	PW 23	WJK0132-001A	E-SI C WIRE C-B		
	Q 1	2SC1740S/RS/-T	TRANSISTOR		
	Q 2	KRC102M-T	D TRANSISTOR		
	Q 21	KRC105M-T	D TRANSISTOR		
	Q 22	2SC2235/OY/-T	TRANSISTOR		
	Q 41	2SD2394/EF/	TRANSISTOR		
	Q 42	2SD2394/EF/	TRANSISTOR		
	Q 43	2SD2394/EF/	TRANSISTOR		
	Q 44	2SD2394/EF/	TRANSISTOR		
△	Q 45	2SB1357/EF/-T	TRANSISTOR		
	Q 46	KRC102M-T	D TRANSISTOR		
	Q 47	KRA104M-T	D TRANSISTOR		
	Q 48	KTC3200/GL/-T	TRANSISTOR		
	Q 49	KRA104M-T	D TRANSISTOR		
	Q 50	KRC102M-T	D TRANSISTOR		
	Q 51	KRA104M-T	D TRANSISTOR		
	Q 52	KRC102M-T	D TRANSISTOR		
	Q 53	KRA104M-T	D TRANSISTOR		
	Q 54	KRC102M-T	D TRANSISTOR		
	Q 55	KRC102M-T	D TRANSISTOR		
	Q 56	KRC102M-T	D TRANSISTOR		
	Q 61	2SD2394/EF/	TRANSISTOR		
	Q 62	2SD2394/EF/	TRANSISTOR		
	Q 63	KTA1046/Y/	TRANSISTOR		
	Q 64	2SD2394/EF/	TRANSISTOR		
	Q 65	KRC102M-T	D TRANSISTOR		
	Q 66	KRA104M-T	D TRANSISTOR		
	R 2	QRE141J-222Y	C RESISTOR	2.2K 5% 1/4W	
	R 3	QRE141J-473Y	C RESISTOR	47K 5% 1/4W	
	R 4	QRE141J-103Y	C RESISTOR	10K 5% 1/4W	
	R 5	QRE141J-103Y	C RESISTOR	10K 5% 1/4W	
△	R 22	QRZ9015-3R9X	F RESISTOR	3.9 1/4W	
	R 23	QRE141J-821Y	C RESISTOR	820 5% 1/4W	
	R 41	QRJ146J-1R0X	UNF C RESISTOR	1.0 5% 1/4W	
	R 42	QRJ146J-122X	UNF C RESISTOR	1.2K 5% 1/4W	
	R 43	QRJ146J-1R0X	UNF C RESISTOR	1.0 5% 1/4W	
	R 44	QRJ146J-122X	UNF C RESISTOR	1.2K 5% 1/4W	
	R 45	QRJ146J-1R0X	UNF C RESISTOR	1.0 5% 1/4W	
	R 46	QRJ146J-122X	UNF C RESISTOR	1.2K 5% 1/4W	
	R 47	QRJ146J-1R0X	UNF C RESISTOR	1.0 5% 1/4W	
	R 48	QRJ146J-122X	UNF C RESISTOR	1.2K 5% 1/4W	
△	R 49	QRT017J-2R2	MF RESISTOR	2.2 5% 1/1W	
△	R 50	QRT017J-2R2	MF RESISTOR	2.2 5% 1/1W	
△	R 51	QRJ146J-332X	UNF C RESISTOR	3.3K 5% 1/4W	
	R 52	QRE141J-223Y	C RESISTOR	22K 5% 1/4W	
	R 53	QRE141J-104Y	C RESISTOR	100K 5% 1/4W	
	R 54	QRE141J-103Y	C RESISTOR	10K 5% 1/4W	
	R 55	QRE141J-103Y	C RESISTOR	10K 5% 1/4W	
△	R 61	QRL027J-180	UNF MF RESISTOR	18 5% 1/2W	
	R 62	QRZ9006-6R8X	F RESISTOR	6.8 1/4W	
	R 63	QRJ146J-222X	UNF C RESISTOR	2.2K 5% 1/4W	
	R 64	QRZ9005-120X	F RESISTOR	12 1/4W	
	R 65	QRJ146J-272X	UNF C RESISTOR	2.7K 5% 1/4W	
△	R 66	QRL027J-270	UNF MF RESISTOR	27 5% 1/2W	
	R 67	QRZ9006-6R8X	F RESISTOR	6.8 1/4W	
	R 68	QRJ146J-222X	UNF C RESISTOR	2.2K 5% 1/4W	
	R 69	QRE141J-562Y	C RESISTOR	5.6K 5% 1/4W	
	R 70	QRE141J-822Y	C RESISTOR	8.2K 5% 1/4W	
	R 71	QRE141J-103Y	C RESISTOR	10K 5% 1/4W	
	R 72	QRZ9006-6R8X	F RESISTOR	6.8 1/4W	
	R 73	QRJ146J-103X	UNF C RESISTOR	10K 5% 1/4W	

△	Item	Parts number	Parts name	Remarks	Area
	R 74	QRZ9006-6R8X	F RESISTOR	6.8 1/4W	
	R 81	QRL027J-471	UNF OMF RESISTOR	470 5% 1/2W	
	R 82	QRL027J-471	UNF OMF RESISTOR	470 5% 1/2W	
△	RY 21	QSK0098-001	RELAY		
△	T 21	QQT0281-002	POWER TRANSF		
	TA 1	QNZ0079-001Z	TAB		
	TA 2	QNZ0079-001Z	TAB		
△	TH 41	QAD0095-4R7Z	POSISTOR		
	WR 12	QJK016-055600	SIN CR C-B WIRE		
	WR 13	QJK016-086003	SIN CR C-B WIRE		
	WR 14	QJK016-100700	SIN CR C-B WIRE		
	WR 26	QJK016-071502	SIN CR C-B WIRE		
	WR 44	QJK016-060901	SIN CR C-B WIRE		
	WR 81	WJK0131-001A	E-SI C WIRE C-B		
	WR 85	QJP001-033801	SHI CR C-B WIRE		
	WR 86	QJK016-022402	SIN CR C-B WIRE		

■ Electrical parts list

(Front & system control board)

Block No. 04

△	Item	Parts number	Parts name	Remarks	Area	△	Item	Parts number	Parts name	Remarks	Area
	BK961	LV42093-001A	FL HOLDER(L)				IC961	MN101C49GJR	IC		
	BK962	LV42092-001A	FL HOLDER(R)				IC962	MN101C35DHN	IC		
	C 471	QCSB1HJ-470Y	C CAPACITOR	47PF 5% 50V			IC963	IC-PST9139-T	IC		
	C 472	QCSB1HJ-470Y	C CAPACITOR	47PF 5% 50V			IC964	GP1U271X	RM RECIVER		
	C 473	QCSB1HJ-470Y	C CAPACITOR	47PF 5% 50V			IC967	TA8409S	IC		
	C 474	QDVB1EZ-223Y	C CAPACITOR				J 471	QND0026-001	S JACK		
	C 475	QCBB1HK-331Y	C CAPACITOR	330PF 10% 50V			JS961	QSW0867-001	ROTARY ENCODER		
	C 476	QCBB1HK-331Y	C CAPACITOR	330PF 10% 50V			J1211	QNS0073-001	JACK		
	C 478	QDVB1EZ-223Y	C CAPACITOR				J1213	QNS0077-001	3.5 JACK		
	C 479	QFN31HJ-473Z	M CAPACITOR	0.047MF 5% 50V			K 472	QQR0779-001Z	INDUCTOR		
	CN301	QGA2001F1-07	CONNECTOR				K1035	QQR1183-001Z	F BEADS		
	CN963	QGF1205F1-16	CONNECTOR				Q1003	KRC107M-T	D TRANSISTOR		
	CN964	QGF1205F1-20	CONNECTOR				Q1011	KRC107M-T	D TRANSISTOR		
	CN969	QGA2001C1-09	9P PLUG ASSY				Q1012	KRA107M-T	D TRANSISTOR		
	CN971	QGA2001F1-02	2P CONNECTOR				Q1013	KRA107M-T	D TRANSISTOR		
	CN973	QGA2501F1-09	CONNECTOR				Q1014	KRA107M-T	D TRANSISTOR		
	CN975	QGA2001F1-02	2P CONNECTOR				Q1015	KRA107M-T	D TRANSISTOR		
	CN977	QGA2001F1-04	4P PLUG ASSY				Q1016	KRA107M-T	D TRANSISTOR		
	CN981	QGA2001F1-02	2P CONNECTOR				Q1017	KRA107M-T	D TRANSISTOR		
	CN982	QGF1005F1-04	4P PLUG ASSY				Q1018	KRA107M-T	D TRANSISTOR		
	CN983	QGA2001F1-10	10P PLUG ASSY				Q1019	KRA107M-T	D TRANSISTOR		
	CN985	QGA2001F1-06	6P PLUG ASSY				Q1020	KRA107M-T	D TRANSISTOR		
	C1001	QEKC0JM-107Z	E CAPACITOR	100MF 20% 6.3V			Q1021	KRC111M-T	TRANSISTOR		
	C1002	QCZ0202-155Z	ML C CAPACITOR	1.5MF			Q1022	KRC109M-T	D TRANSISTOR		
	C1003	QEZ0361-479	E.D.L. CAPACITOR	47000MF			Q1031	KRA107M-T	D TRANSISTOR		
	C1004	QEKC1HM-225Z	E CAPACITOR	2.2MF 20% 50V			Q1034	KRA107M-T	D TRANSISTOR		
	C1005	QDVB1EZ-223Y	C CAPACITOR				Q1035	KRC103M-T	TRANSISTOR		
	C1006	QEKC0JM-107Z	E CAPACITOR	100MF 20% 6.3V			R 471	QRE141J-750Y	C RESISTOR	75 5% 1/4W	
	C1007	QCZ0202-155Z	ML C CAPACITOR	1.5MF			R 472	QRE141J-750Y	C RESISTOR	75 5% 1/4W	
	C1011	QEKC1HM-475Z	E CAPACITOR	4.7MF 20% 50V			R 473	QRE141J-750Y	C RESISTOR	75 5% 1/4W	
	C1012	QEKC1HM-475Z	E CAPACITOR	4.7MF 20% 50V			RA966	QRB169J-104	R NETWORK	100K 5% 1/6W	
	C1013	QEKC1HM-475Z	E CAPACITOR	4.7MF 20% 50V			R1003	QRE141J-331Y	C RESISTOR	330 5% 1/4W	
	C1021	QCBB1HK-331Y	C CAPACITOR	330PF 10% 50V			R1004	QRE141J-223Y	C RESISTOR	22K 5% 1/4W	
	C1025	QEKC0JM-107Z	E CAPACITOR	100MF 20% 6.3V			R1005	QRE141J-472Y	C RESISTOR	4.7K 5% 1/4W	
	C1034	QDVB1EZ-223Y	C CAPACITOR				R1011	QRE141J-513Y	C RESISTOR	51K 5% 1/4W	
	C1035	QEKC1CM-476Z	E CAPACITOR	47MF 20% 16V			R1021	QRE141J-471Y	C RESISTOR	470 5% 1/4W	
	C1036	QEKC1CM-106Z	E CAPACITOR	10MF 20% 16V			R1022	QRE141J-103Y	C RESISTOR	10K 5% 1/4W	
	C1037	QCZ0202-155Z	ML C CAPACITOR	1.5MF			R1024	QRE141J-223Y	C RESISTOR	22K 5% 1/4W	
	C1038	QEKC1CM-476Z	E CAPACITOR	47MF 20% 16V			R1025	QRE141J-103Y	C RESISTOR	10K 5% 1/4W	
	C1041	NCB31HK-471X	C CAPACITOR				R1030	QRE141J-103Y	C RESISTOR	10K 5% 1/4W	
	C1042	NCB31HK-471X	C CAPACITOR				R1031	QRE141J-221Y	C RESISTOR	220 5% 1/4W	
	C1043	NCB31HK-471X	C CAPACITOR				R1034	QRD161J-122	C RESISTOR	1.2K 5% 1/6W	
	C1044	NCB31HK-471X	C CAPACITOR				R1035	QRE141J-100Y	C RESISTOR	10 5% 1/4W	
	C1045	NCB31HK-471X	C CAPACITOR				R1036	QRE141J-100Y	C RESISTOR	10 5% 1/4W	
	C1046	NCB31HK-471X	C CAPACITOR				R1037	QRE141J-153Y	C RESISTOR	15K 5% 1/4W	
	C1047	NCB31HK-471X	C CAPACITOR				R1038	QRE141J-333Y	C RESISTOR	33K 5% 1/4W	
	C1059	NCF31CZ-104X	C CAPACITOR				R1039	QRE141J-273Y	C RESISTOR	27K 5% 1/4W	
	C1060	NCF31CZ-104X	C CAPACITOR				R1041	NRSA63J-103X	MG RESISTOR		
	C1061	QCBB1HK-101Y	C CAPACITOR	100PF 10% 50V			R1042	NRSA63J-103X	MG RESISTOR		
	C1211	NCB31HK-221X	C CAPACITOR				R1043	NRSA63J-103X	MG RESISTOR		
	C1212	NCB31HK-221X	C CAPACITOR				R1044	NRSA63J-103X	MG RESISTOR		
	C1213	NCB31HK-221X	C CAPACITOR				R1045	NRSA63J-103X	MG RESISTOR		
	DI961	QLF0087-001	FL TUBE				R1046	NRSA63J-103X	MG RESISTOR		
	D1001	1SR35-400A-T5	DIODE				R1047	NRSA63J-103X	MG RESISTOR		
	D1002	1SR35-400A-T5	DIODE				R1048	NRSA63J-103X	MG RESISTOR		
	D1003	1SR35-400A-T5	DIODE				R1049	NRSA63J-103X	MG RESISTOR		
	D1004	1SR35-400A-T5	DIODE				R1050	NRSA63J-103X	MG RESISTOR		
	D1005	1SS133-T2	SI DIODE				R1051	NRSA63J-102X	MG RESISTOR		
	D1024	1SS133-T2	SI DIODE				R1052	NRSA63J-102X	MG RESISTOR		
	D1031	SLR-342VC-T	LED				R1053	NRSA63J-122X	MG RESISTOR		
	D1034	SELU2E10C	LED				R1054	NRSA63J-152X	MG RESISTOR		
	FS961	E3400-444	FELT SPACER				R1056	NRSA63J-102X	MG RESISTOR		
	FS962	E3400-444	FELT SPACER				R1057	NRSA63J-102X	MG RESISTOR		

■ Electrical parts list

(Front & system control board)

Block No. 04

△	Item	Parts number	Parts name	Remarks	Area	△	Item	Parts number	Parts name	Remarks	Area
	R1059	NRSA63J-104X	MG RESISTOR				R1161	NRSA63J-221X	MG RESISTOR		
	R1060	NRSA63J-104X	MG RESISTOR				R1162	NRSA63J-221X	MG RESISTOR		
	R1061	NRSA63J-103X	MG RESISTOR				R1163	NRSA63J-221X	MG RESISTOR		
	R1062	NRSA63J-103X	MG RESISTOR				R1164	NRSA63J-221X	MG RESISTOR		
	R1063	NRSA63J-103X	MG RESISTOR				R1165	NRSA63J-221X	MG RESISTOR		
	R1064	NRSA63J-103X	MG RESISTOR				R1166	NRSA63J-221X	MG RESISTOR		
	R1065	NRSA63J-103X	MG RESISTOR				R1167	NRSA63J-221X	MG RESISTOR		
	R1066	NRSA63J-103X	MG RESISTOR				R1168	NRSA63J-221X	MG RESISTOR		
	R1067	NRSA63J-103X	MG RESISTOR				R1169	NRSA63J-221X	MG RESISTOR		
	R1071	NRSA63J-221X	MG RESISTOR				R1170	NRSA63J-221X	MG RESISTOR		
	R1072	NRSA63J-221X	MG RESISTOR				R1171	NRSA63J-221X	MG RESISTOR		
	R1073	NRSA63J-221X	MG RESISTOR				R1172	NRSA63J-221X	MG RESISTOR		
	R1074	NRSA63J-221X	MG RESISTOR				R1173	NRSA63J-221X	MG RESISTOR		
	R1075	NRSA63J-221X	MG RESISTOR				R1174	NRSA63J-221X	MG RESISTOR		
	R1076	NRSA63J-221X	MG RESISTOR				R1175	NRSA63J-221X	MG RESISTOR		
	R1081	NRSA63J-103X	MG RESISTOR				R1176	NRSA63J-221X	MG RESISTOR		
	R1082	NRSA63J-103X	MG RESISTOR				R1177	NRSA63J-221X	MG RESISTOR		
	R1083	NRSA63J-103X	MG RESISTOR				R1178	NRSA63J-221X	MG RESISTOR		
	R1084	NRSA63J-474X	MG RESISTOR				R1179	NRSA63J-221X	MG RESISTOR		
	R1085	NRSA63J-103X	MG RESISTOR				R1180	NRSA63J-221X	MG RESISTOR		
	R1086	NRSA63J-103X	MG RESISTOR				R1181	NRSA63J-221X	MG RESISTOR		
	R1091	NRSA63J-221X	MG RESISTOR				R1182	NRSA63J-221X	MG RESISTOR		
	R1092	NRSA63J-221X	MG RESISTOR				R1183	NRSA63J-221X	MG RESISTOR		
	R1093	NRSA63J-221X	MG RESISTOR				R1184	NRSA63J-221X	MG RESISTOR		
	R1094	NRSA63J-221X	MG RESISTOR				R1191	NRSA63J-221X	MG RESISTOR		
	R1095	NRSA63J-221X	MG RESISTOR				R1192	NRSA63J-221X	MG RESISTOR		
	R1096	NRSA63J-221X	MG RESISTOR				R1193	NRSA63J-221X	MG RESISTOR		
	R1097	NRSA63J-221X	MG RESISTOR				R1194	NRSA63J-221X	MG RESISTOR		
	R1098	NRSA63J-221X	MG RESISTOR				R1195	NRSA63J-221X	MG RESISTOR		
	R1099	NRSA63J-221X	MG RESISTOR				R1196	NRSA63J-221X	MG RESISTOR		
	R1101	NRSA63J-102X	MG RESISTOR				R1197	NRSA63J-221X	MG RESISTOR		
	R1102	NRSA63J-102X	MG RESISTOR				R1198	NRSA63J-221X	MG RESISTOR		
	R1103	NRSA63J-122X	MG RESISTOR				R1211	NRSA63J-221X	MG RESISTOR		
	R1104	NRSA63J-152X	MG RESISTOR				R1212	NRSA63J-471X	MG RESISTOR		
	R1105	NRSA63J-222X	MG RESISTOR				R1213	NRSA63J-221X	MG RESISTOR		
	R1106	NRSA63J-272X	MG RESISTOR				R1214	NRSA63J-101X	MG RESISTOR		
	R1107	NRSA63J-332X	MG RESISTOR				R1215	NRSA63J-221X	MG RESISTOR		
	R1122	NRSA63J-102X	MG RESISTOR				S1001	QSW0683-001Z	PUSH SWITCH	(SURROUND)	
	R1123	NRSA63J-102X	MG RESISTOR				S1002	QSW0683-001Z	PUSH SWITCH	(DSP MODE)	
	R1124	NRSA63J-122X	MG RESISTOR				S1003	QSW0683-001Z	PUSH SWITCH	(DIRECT)	
	R1125	NRSA63J-102X	MG RESISTOR				S1004	QSW0683-001Z	PUSH SWITCH	(THX)	
	R1126	NRSA63J-102X	MG RESISTOR				S1005	QSW0683-001Z	PUSH SWITCH	(SPK1)	
	R1127	NRSA63J-122X	MG RESISTOR				S1006	QSW0683-001Z	PUSH SWITCH	(SPK2)	
	R1128	NRSA63J-152X	MG RESISTOR				S1007	QSW0683-001Z	PUSH SWITCH	(SUBROOM CONT)	
	R1129	NRSA63J-222X	MG RESISTOR				S1024	QSW0683-001Z	PUSH SWITCH	(POWER)	
	R1130	NRSA63J-272X	MG RESISTOR				S1025	QSW0683-001Z	PUSH SWITCH	(DOWN)	
	R1131	NRSA63J-102X	MG RESISTOR				S1026	QSW0683-001Z	PUSH SWITCH	(LEFT)	
	R1132	NRSA63J-102X	MG RESISTOR				S1027	QSW0683-001Z	PUSH SWITCH	(SET)	
	R1133	NRSA63J-122X	MG RESISTOR				S1028	QSW0683-001Z	PUSH SWITCH	(SETUP)	
	R1134	NRSA63J-152X	MG RESISTOR				S1029	QSW0683-001Z	PUSH SWITCH	(FM MODE)	
	R1135	NRSA63J-222X	MG RESISTOR				S1030	QSW0683-001Z	PUSH SWITCH	(SOUND SEL)	
	R1141	NRSA63J-152X	MG RESISTOR				S1031	QSW0683-001Z	PUSH SWITCH	(UP)	
	R1142	NRSA63J-222X	MG RESISTOR				S1032	QSW0683-001Z	PUSH SWITCH	(RIGHT)	
	R1143	NRSA63J-272X	MG RESISTOR				S1033	QSW0683-001Z	PUSH SWITCH	(EXIT)	
	R1144	NRSA63J-332X	MG RESISTOR				S1034	QSW0683-001Z	PUSH SWITCH	(ADJUST)	
	R1151	NRSA63J-221X	MG RESISTOR				S1035	QSW0683-001Z	PUSH SWITCH	(INPUT MODE)	
	R1152	NRSA63J-221X	MG RESISTOR				S1041	QSW0683-001Z	PUSH SWITCH	(EX K2)	
	R1153	NRSA63J-221X	MG RESISTOR				S1042	QSW0683-001Z	PUSH SWITCH	(DIMMER)	
	R1154	NRSA63J-221X	MG RESISTOR				S1043	QSW0683-001Z	PUSH SWITCH	(DOOR OPEN)	
	R1155	NRSA63J-221X	MG RESISTOR				S1044	QSW0683-001Z	PUSH SWITCH	(DOOR CLOSE)	
	R1156	NRSA63J-221X	MG RESISTOR				S1051	QSW0851-001	DETECT SWITCH		
	R1157	NRSA63J-221X	MG RESISTOR				S1052	QSW0851-001	DETECT SWITCH		
	R1158	NRSA63J-221X	MG RESISTOR				WR961	QJK030-075002	SIN CR C-B WIRE		

RX-DP10VBK/RX-DP10VSL

RX-DP10RSL

■ Electrical parts list

(Front & system control board)

Block No. 04

△	Item	Parts number	Parts name	Remarks	Area
	WR962	QJK030-081803	SIN CR C-B WIRE		
	WR965	QJK016-092404	SIN CR C-B WIRE		
	WR966	QJK016-062401	SIN CR C-B WIRE		
	WR968	QJK016-094403	SIN CR C-B WIRE		
	WR970	QJK016-090802	SIN CR C-B WIRE		
	WR972	QJK016-021002	SIN CR C-B WIRE		
	WR977	QJK030-042404	SIN CR C-B WIRE		
	WR984	QJK016-101104	SIN CR C-B WIRE		
	WR986	QJK016-061102	SIN CR C-B WIRE		
	X1001	QAX0246-001Z	RESONATOR		
	X1002	QAX0246-001Z	RESONATOR		

■ Electrical parts list (DSP board)

Block No. 05

△	Item	Parts number	Parts name	Remarks	Area	△	Item	Parts number	Parts name	Remarks	Area
	CN 83	QGA3901C1-05	5P CONNECTOR				C3173	NCB31HK-103X	C CAPACITOR		
	CN 84	QGA3901C1-05	5P CONNECTOR				C3174	NCB31HK-103X	C CAPACITOR		
	CN631	QGA2001F1-03	CONNECTOR				C3175	NCB31HK-103X	C CAPACITOR		
	CN633	QGB2510K1-11	CONNECTOR				C3181	QETN1HM-106Z	E CAPACITOR	10MF 20% 50V	
	C3001	QETN1HM-475Z	E CAPACITOR	4.7MF 20% 50V			C3182	QETN1HM-106Z	E CAPACITOR	10MF 20% 50V	
	C3002	QETN1HM-475Z	E CAPACITOR	4.7MF 20% 50V			C3183	NCB30JK-105X	C CAPACITOR		
	C3003	NCB31HK-561X	C CAPACITOR				C3184	NCB30JK-105X	C CAPACITOR		
	C3004	NCB31HK-561X	C CAPACITOR				C3185	NCB31AK-224X	C CAPACITOR		
	C3005	NCS31HJ-680X	C CAPACITOR				C3186	NCB31HK-103X	C CAPACITOR		
	C3006	NCS31HJ-680X	C CAPACITOR				C3187	QETN1HM-106Z	E CAPACITOR	10MF 20% 50V	
	C3007	NCS31HJ-181X	C CAPACITOR				C3188	NCB30JK-105X	C CAPACITOR		
	C3008	NCS31HJ-181X	C CAPACITOR				C3189	NCB30JK-105X	C CAPACITOR		
	C3009	QETN1HM-106Z	E CAPACITOR	10MF 20% 50V			C3190	NCF31CZ-104X	C CAPACITOR		
	C3010	QETN1HM-106Z	E CAPACITOR	10MF 20% 50V			C3191	QETN1HM-106Z	E CAPACITOR	10MF 20% 50V	
	C3013	NCS31HJ-330X	C CAPACITOR				C3192	QETN1HM-106Z	E CAPACITOR	10MF 20% 50V	
	C3014	NCS31HJ-330X	C CAPACITOR				C3193	QETN1HM-474Z	E CAPACITOR	0.47MF 20% 50V	
	C3018	QETN1CM-476Z	E CAPACITOR	47MF 20% 16V			C3194	NCF31CZ-104X	C CAPACITOR		
	C3019	QETN1HM-106Z	E CAPACITOR	10MF 20% 50V			C3195	NCF31CZ-104X	C CAPACITOR		
	C3020	QETN1HM-106Z	E CAPACITOR	10MF 20% 50V			C3196	NCF31CZ-104X	C CAPACITOR		
	C3031	QETN1HM-106Z	E CAPACITOR	10MF 20% 50V			C3197	NEA70JM-107X	E CAPACITOR		
	C3032	QETN1HM-106Z	E CAPACITOR	10MF 20% 50V			C3198	NCF31CZ-104X	C CAPACITOR		
	C3033	NCB31CK-104X	C CAPACITOR				C3201	NCB31HK-182X	C CAPACITOR		
	C3034	NCB31CK-104X	C CAPACITOR				C3202	NCB31HK-182X	C CAPACITOR		
	C3035	NCB31AK-224X	C CAPACITOR				C3211	NCS31HJ-181X	C CAPACITOR		
	C3036	NCB31AK-224X	C CAPACITOR				C3212	NCS31HJ-181X	C CAPACITOR		
	C3037	QETN1HM-106Z	E CAPACITOR	10MF 20% 50V			C3215	NCB31CK-683X	C CAPACITOR		
	C3038	QETN1HM-106Z	E CAPACITOR	10MF 20% 50V			C3216	NCB31CK-683X	C CAPACITOR		
	C3039	NCS31HJ-101X	C CAPACITOR				C3217	QETN1HM-475Z	E CAPACITOR	4.7MF 20% 50V	
	C3040	NCS31HJ-101X	C CAPACITOR				C3218	QETN1HM-475Z	E CAPACITOR	4.7MF 20% 50V	
	C3041	NCS31HJ-100X	C CAPACITOR				C3221	NCB31HK-222X	C CAPACITOR		
	C3042	NCS31HJ-100X	C CAPACITOR				C3222	QETN1HM-474Z	E CAPACITOR	0.47MF 20% 50V	
	C3045	NCF31CZ-104X	C CAPACITOR				C3223	NCB31HK-122X	C CAPACITOR		
	C3046	NCF31CZ-104X	C CAPACITOR				C3225	NCB31HK-103X	C CAPACITOR		
	C3101	NCB31HK-182X	C CAPACITOR				C3226	NCB30JK-105X	C CAPACITOR		
	C3102	NCB31HK-182X	C CAPACITOR				C3229	QETN1HM-475Z	E CAPACITOR	4.7MF 20% 50V	
	C3111	NCS31HJ-181X	C CAPACITOR				C3230	QETN1HM-475Z	E CAPACITOR	4.7MF 20% 50V	
	C3112	NCS31HJ-181X	C CAPACITOR				C3237	QETN1HM-475Z	E CAPACITOR	4.7MF 20% 50V	
	C3115	NCB31CK-683X	C CAPACITOR				C3238	QETN1HM-475Z	E CAPACITOR	4.7MF 20% 50V	
	C3116	NCB31CK-683X	C CAPACITOR				C3239	NCB31HK-182X	C CAPACITOR		
	C3121	NCB31HK-103X	C CAPACITOR				C3240	NCB31HK-182X	C CAPACITOR		
	C3122	NCB31HK-103X	C CAPACITOR				C3251	QETN1HM-106Z	E CAPACITOR	10MF 20% 50V	
	C3125	NCB31HK-102X	C CAPACITOR				C3252	QETN1HM-106Z	E CAPACITOR	10MF 20% 50V	
	C3126	NCB31HK-102X	C CAPACITOR				C3253	QETN1HM-106Z	E CAPACITOR	10MF 20% 50V	
	C3129	QETN1HM-475Z	E CAPACITOR	4.7MF 20% 50V			C3254	QETN1HM-106Z	E CAPACITOR	10MF 20% 50V	
	C3130	QETN1HM-475Z	E CAPACITOR	4.7MF 20% 50V			C3255	QETN1HM-106Z	E CAPACITOR	10MF 20% 50V	
	C3137	QETN1HM-475Z	E CAPACITOR	4.7MF 20% 50V			C3256	QETN1HM-106Z	E CAPACITOR	10MF 20% 50V	
	C3138	QETN1HM-475Z	E CAPACITOR	4.7MF 20% 50V			C3261	NCF31CZ-104X	C CAPACITOR		
	C3139	NCB31HK-182X	C CAPACITOR				C3262	NCF31CZ-104X	C CAPACITOR		
	C3140	NCB31HK-182X	C CAPACITOR				C3263	NCS31HJ-330X	C CAPACITOR		
	C3141	QETN1HM-475Z	E CAPACITOR	4.7MF 20% 50V			C3264	QETN1HM-475Z	E CAPACITOR	4.7MF 20% 50V	
	C3142	QETN1HM-475Z	E CAPACITOR	4.7MF 20% 50V			C3266	NCB30JK-105X	C CAPACITOR		
	C3143	NCS31HJ-100X	C CAPACITOR				C3267	QETN1HM-224Z	E CAPACITOR	0.22MF 20% 50V	
	C3144	NCS31HJ-100X	C CAPACITOR				C3268	NCB31AK-474X	C CAPACITOR		
	C3145	NCF31CZ-104X	C CAPACITOR				C3271	NCS31HJ-101X	C CAPACITOR		
	C3146	NCF31CZ-104X	C CAPACITOR				C3272	NCB31HK-103X	C CAPACITOR		
	C3151	QETN1HM-106Z	E CAPACITOR	10MF 20% 50V			C3273	NCB31HK-103X	C CAPACITOR		
	C3152	QETN1HM-106Z	E CAPACITOR	10MF 20% 50V			C3274	NCB31HK-103X	C CAPACITOR		
	C3153	QETN1HM-106Z	E CAPACITOR	10MF 20% 50V			C3275	NCB31HK-103X	C CAPACITOR		
	C3154	QETN1HM-106Z	E CAPACITOR	10MF 20% 50V			C3281	QETN1HM-106Z	E CAPACITOR	10MF 20% 50V	
	C3155	NCF31CZ-104X	C CAPACITOR				C3282	QETN1HM-106Z	E CAPACITOR	10MF 20% 50V	
	C3156	NCF31CZ-104X	C CAPACITOR				C3283	NCB30JK-105X	C CAPACITOR		
	C3171	NCS31HJ-101X	C CAPACITOR				C3284	NCB30JK-105X	C CAPACITOR		
	C3172	NCB31HK-103X	C CAPACITOR				C3285	NCB31AK-224X	C CAPACITOR		

■ Electrical parts list (DSP board)

Block No. 05

△	Item	Parts number	Parts name	Remarks	Area	△	Item	Parts number	Parts name	Remarks	Area
	C3286	NCB31HK-103X	C CAPACITOR				C3424	NCB31HK-122X	C CAPACITOR		
	C3287	QETN1HM-106Z	E CAPACITOR	10MF 20% 50V			C3425	NCB31HK-103X	C CAPACITOR		
	C3288	NCB30JK-105X	C CAPACITOR				C3426	NCB31HK-103X	C CAPACITOR		
	C3289	NCB30JK-105X	C CAPACITOR				C3429	QETN1HM-475Z	E CAPACITOR	4.7MF 20% 50V	
	C3291	QETN1HM-475Z	E CAPACITOR	4.7MF 20% 50V			C3430	QETN1HM-475Z	E CAPACITOR	4.7MF 20% 50V	
	C3292	QETN1HM-475Z	E CAPACITOR	4.7MF 20% 50V			C3437	QETN1HM-475Z	E CAPACITOR	4.7MF 20% 50V	
	C3293	NCF31CZ-104X	C CAPACITOR				C3438	QETN1HM-475Z	E CAPACITOR	4.7MF 20% 50V	
	C3294	NCF31CZ-104X	C CAPACITOR				C3439	NCB31HK-182X	C CAPACITOR		
	C3297	NEA70JM-107X	E CAPACITOR				C3440	NCB31HK-182X	C CAPACITOR		
	C3298	NCF31CZ-104X	C CAPACITOR				C3451	QETN1HM-106Z	E CAPACITOR	10MF 20% 50V	
	C3301	NCB31HK-182X	C CAPACITOR				C3452	QETN1HM-106Z	E CAPACITOR	10MF 20% 50V	
	C3302	NCB31HK-182X	C CAPACITOR				C3453	QETN1HM-106Z	E CAPACITOR	10MF 20% 50V	
	C3311	NCS31HJ-181X	C CAPACITOR				C3454	QETN1HM-106Z	E CAPACITOR	10MF 20% 50V	
	C3312	NCS31HJ-181X	C CAPACITOR				C3455	QETN1HM-106Z	E CAPACITOR	10MF 20% 50V	
	C3315	NCB31CK-683X	C CAPACITOR				C3456	QETN1HM-106Z	E CAPACITOR	10MF 20% 50V	
	C3316	NCB31CK-683X	C CAPACITOR				C3471	NCS31HJ-101X	C CAPACITOR		
	C3317	QETN1HM-475Z	E CAPACITOR	4.7MF 20% 50V			C3472	NCB31HK-103X	C CAPACITOR		
	C3318	QETN1HM-475Z	E CAPACITOR	4.7MF 20% 50V			C3473	NCB31HK-103X	C CAPACITOR		
	C3321	NCB31HK-222X	C CAPACITOR				C3474	NCB31HK-103X	C CAPACITOR		
	C3322	NCB31HK-222X	C CAPACITOR				C3475	NCB31HK-103X	C CAPACITOR		
	C3323	NCB31HK-122X	C CAPACITOR				C3481	QETN1HM-106Z	E CAPACITOR	10MF 20% 50V	
	C3324	NCB31HK-122X	C CAPACITOR				C3482	QETN1HM-106Z	E CAPACITOR	10MF 20% 50V	
	C3325	NCB31HK-103X	C CAPACITOR				C3483	NCB30JK-105X	C CAPACITOR		
	C3326	NCB31HK-103X	C CAPACITOR				C3484	NCB30JK-105X	C CAPACITOR		
	C3329	QETN1HM-475Z	E CAPACITOR	4.7MF 20% 50V			C3485	NCB31AK-224X	C CAPACITOR		
	C3330	QETN1HM-475Z	E CAPACITOR	4.7MF 20% 50V			C3486	NCB31HK-103X	C CAPACITOR		
	C3337	QETN1HM-475Z	E CAPACITOR	4.7MF 20% 50V			C3487	QETN1HM-106Z	E CAPACITOR	10MF 20% 50V	
	C3338	QETN1HM-475Z	E CAPACITOR	4.7MF 20% 50V			C3488	NCB30JK-105X	C CAPACITOR		
	C3339	NCB31HK-182X	C CAPACITOR				C3489	NCB30JK-105X	C CAPACITOR		
	C3340	NCB31HK-182X	C CAPACITOR				C3497	NEA70JM-107X	E CAPACITOR		
	C3351	QETN1HM-106Z	E CAPACITOR	10MF 20% 50V			C3498	NCF31CZ-104X	C CAPACITOR		
	C3352	QETN1HM-106Z	E CAPACITOR	10MF 20% 50V			C3501	NCB31HK-103X	C CAPACITOR		
	C3353	QETN1HM-106Z	E CAPACITOR	10MF 20% 50V			C3502	NCB31HK-103X	C CAPACITOR		
	C3354	QETN1HM-106Z	E CAPACITOR	10MF 20% 50V			C3503	NCB31HK-103X	C CAPACITOR		
	C3355	QETN1HM-106Z	E CAPACITOR	10MF 20% 50V			C3504	NCB31HK-103X	C CAPACITOR		
	C3356	QETN1HM-106Z	E CAPACITOR	10MF 20% 50V			C3505	NCB31HK-103X	C CAPACITOR		
	C3371	NCS31HJ-101X	C CAPACITOR				C3506	NCB31HK-103X	C CAPACITOR		
	C3372	NCB31HK-103X	C CAPACITOR				C3507	NCB31HK-103X	C CAPACITOR		
	C3373	NCB31HK-103X	C CAPACITOR				C3508	NCB31HK-103X	C CAPACITOR		
	C3374	NCB31HK-103X	C CAPACITOR				C3509	NCB31HK-103X	C CAPACITOR		
	C3375	NCB31HK-103X	C CAPACITOR				C3510	NCB31HK-103X	C CAPACITOR		
	C3381	QETN1HM-106Z	E CAPACITOR	10MF 20% 50V			C3511	NCB31HK-103X	C CAPACITOR		
	C3382	QETN1HM-106Z	E CAPACITOR	10MF 20% 50V			C3512	NCB31HK-103X	C CAPACITOR		
	C3383	NCB30JK-105X	C CAPACITOR				C3513	NCB31HK-103X	C CAPACITOR		
	C3384	NCB30JK-105X	C CAPACITOR				C3514	NCB31HK-103X	C CAPACITOR		
	C3385	NCB31AK-224X	C CAPACITOR				C3515	NCB31HK-103X	C CAPACITOR		
	C3386	NCB31HK-103X	C CAPACITOR				C3516	NCB31HK-103X	C CAPACITOR		
	C3387	QETN1HM-106Z	E CAPACITOR	10MF 20% 50V			C3517	NCB31HK-103X	C CAPACITOR		
	C3388	NCB30JK-105X	C CAPACITOR				C3518	NCB31HK-103X	C CAPACITOR		
	C3389	NCB30JK-105X	C CAPACITOR				C3519	NCB31HK-103X	C CAPACITOR		
	C3397	NEA70JM-107X	E CAPACITOR				C3520	NCB31HK-103X	C CAPACITOR		
	C3398	NCF31CZ-104X	C CAPACITOR				C3521	NEA70JM-107X	E CAPACITOR		
	C3401	NCB31HK-182X	C CAPACITOR				C3523	NCF31CZ-104X	C CAPACITOR		
	C3402	NCB31HK-182X	C CAPACITOR				C3525	NCB31HK-123X	C CAPACITOR		
	C3411	NCS31HJ-181X	C CAPACITOR				C3601	NCB31HK-103X	C CAPACITOR		
	C3412	NCS31HJ-181X	C CAPACITOR				C3602	NCB31HK-103X	C CAPACITOR		
	C3415	NCB31CK-683X	C CAPACITOR				C3603	NCB31HK-103X	C CAPACITOR		
	C3416	NCB31CK-683X	C CAPACITOR				C3604	NCB31HK-103X	C CAPACITOR		
	C3417	QETN1HM-475Z	E CAPACITOR	4.7MF 20% 50V			C3605	NCB31HK-103X	C CAPACITOR		
	C3418	QETN1HM-475Z	E CAPACITOR	4.7MF 20% 50V			C3606	NCB31HK-103X	C CAPACITOR		
	C3421	NCB31HK-222X	C CAPACITOR				C3607	NCB31HK-103X	C CAPACITOR		
	C3422	NCB31HK-222X	C CAPACITOR				C3608	NCB31HK-103X	C CAPACITOR		
	C3423	NCB31HK-122X	C CAPACITOR				C3609	NCB31HK-103X	C CAPACITOR		

■ Electrical parts list (DSP board)

Block No. 05

▲	Item	Parts number	Parts name	Remarks	Area	▲	Item	Parts number	Parts name	Remarks	Area
	C3610	NCB31HK-103X	C CAPACITOR				C3991	QETN1AM-107Z	E CAPACITOR	100MF 20% 10V	
	C3611	NCB31HK-103X	C CAPACITOR				C3992	QETN1AM-107Z	E CAPACITOR	100MF 20% 10V	
	C3612	NCB31HK-103X	C CAPACITOR				C3993	QETN1AM-107Z	E CAPACITOR	100MF 20% 10V	
	C3613	NCB31HK-103X	C CAPACITOR				C3995	QETN1AM-227Z	E CAPACITOR	220MF 20% 10V	
	C3614	NCB31HK-103X	C CAPACITOR				C3996	QETN1AM-227Z	E CAPACITOR	220MF 20% 10V	
	C3615	NCB31HK-103X	C CAPACITOR				C3999	QETN1AM-477Z	E CAPACITOR	470MF 20% 10V	
	C3616	NCB31HK-103X	C CAPACITOR				C5001	NCB30JK-105X	C CAPACITOR		
	C3617	NCB31HK-103X	C CAPACITOR				C5002	NCB31AK-224X	C CAPACITOR		
	C3618	NCB31HK-103X	C CAPACITOR			▲	D 745	F10P20F	DIODE		
	C3619	NCB31HK-103X	C CAPACITOR			▲	D 746	F10P20FR	DIODE		
	C3620	NCB31HK-103X	C CAPACITOR			▲	D 795	F10P20F	DIODE		
	C3621	NEA70JM-107X	E CAPACITOR			▲	D 796	F10P20FR	DIODE		
	C3623	NCF31CZ-104X	C CAPACITOR			▲	D 845	F10P20F	DIODE		
	C3625	NCB31HK-123X	C CAPACITOR			▲	D 846	F10P20FR	DIODE		
	C3631	NEA71CM-106X	E CAPACITOR				D3191	MA3068/M/-X	ZENER DIODE		
	C3632	NCB31HK-103X	C CAPACITOR				D3192	MA3068/M/-X	ZENER DIODE		
	C3633	NEA71CM-106X	E CAPACITOR				D5001	UDZS5.1B-X	ZENER DIODE		
	C3634	NCB31HK-103X	C CAPACITOR				EP710	E409182-001SM	GRAND TERMINAL		
	C3635	NEA71CM-106X	E CAPACITOR				IC631	NJM4580E-W	IC		
	C3636	NCB31HK-103X	C CAPACITOR				IC632	NJM4580E-W	IC		
	C3637	NEA71CM-106X	E CAPACITOR				IC633	NJM4580E-W	IC		
	C3638	NCB31HK-103X	C CAPACITOR				IC634	MN35505-X	IC		
	C3701	NCS31HJ-101X	C CAPACITOR				IC635	JCV8006	IC		
	C3702	NEA71HM-105X	E CAPACITOR				IC636	NJM4580E-W	IC		
	C3703	NCF31CZ-104X	C CAPACITOR				IC637	NJM4580E-W	IC		
	C3704	NCF31CZ-104X	C CAPACITOR				IC638	NJM4580E-W	IC		
	C3705	NCF31CZ-104X	C CAPACITOR				IC639	MN35505-X	IC		
	C3706	NCF31CZ-104X	C CAPACITOR				IC640	JCV8006	IC		
	C3713	NCS31HJ-330X	C CAPACITOR				IC641	NJM4580E-W	IC		
	C3715	NCF31CZ-104X	C CAPACITOR				IC642	NJM4580E-W	IC		
	C3721	NEA71CM-106X	E CAPACITOR				IC643	NJM4580E-W	IC		
	C3722	NEA71CM-106X	E CAPACITOR				IC644	MN35505-X	IC		
	C3723	NCF31CZ-104X	C CAPACITOR				IC645	JCV8006	IC		
	C3724	NCF31CZ-104X	C CAPACITOR				IC646	NJM4580E-W	IC		
	C3725	NCS31HJ-101X	C CAPACITOR				IC647	NJM4580E-W	IC		
	C3735	NCF31CZ-104X	C CAPACITOR				IC648	NJM4580E-W	IC		
	C3801	NCF31CZ-104X	C CAPACITOR				IC649	MN35505-X	IC		
	C3802	NCF31CZ-104X	C CAPACITOR				IC650	JCV8006	IC		
	C3803	NEA70JM-107X	E CAPACITOR				IC652	NJM2121M-X	IC		
	C3804	NCF31CZ-104X	C CAPACITOR				IC653	M62446FP-X	IC		
	C3805	NCF31CZ-104X	C CAPACITOR				IC654	TC74HCT04AF-X	IC		
	C3806	NCF31CZ-104X	C CAPACITOR				IC655	NJM4580E-W	IC		
	C3807	NCF31CZ-104X	C CAPACITOR				IC656	NJM4580E-W	IC		
	C3808	NCF31CZ-104X	C CAPACITOR				IC657	AK5383VF-X	IC		
	C3811	NCF31CZ-104X	C CAPACITOR				IC658	TC7S04FU-X	IC		
	C3900	NCB30JK-105X	C CAPACITOR				IC659	TC7WH74FU-X	IC		
	C3901	NCB30JK-105X	C CAPACITOR				IC660	TC7S04FU-X	IC		
	C3902	NCB30JK-105X	C CAPACITOR				IC661	XCA56367PV150	IC		
	C3903	NCB30JK-105X	C CAPACITOR				IC666	XCA56367PV150	IC		
	C3905	NCB30JK-105X	C CAPACITOR				IC667	39VF0207CWHM03	IC		
	C3906	NCB30JK-105X	C CAPACITOR				IC668	W24L010AJ-12-X	IC		
	C3910	NCF31CZ-104X	C CAPACITOR				IC669	W24L010AJ-12-X	IC		
	C3911	NCF31CZ-104X	C CAPACITOR				IC670	W24L010AJ-12-X	IC		
	C3912	NCF31CZ-104X	C CAPACITOR				IC671	UPD784215AGC165	IC		
	C3913	NCF31CZ-104X	C CAPACITOR				IC672	TC7S04FU-X	IC		
	C3915	NCF31CZ-104X	C CAPACITOR				IC673	AK4112AVF-X	IC		
	C3916	NCF31CZ-104X	C CAPACITOR				IC674	TC7WH241FU-X	IC		
	C3919	NEA70JM-107X	E CAPACITOR				IC681	TC74VHC157FT-X	IC		
	C3921	NCS31HJ-101X	C CAPACITOR				IC682	TC74VHC157FT-X	IC		
	C3922	NCS31HJ-101X	C CAPACITOR				IC683	TC74VHC74FT-X	IC		
	C3923	NCF31CZ-104X	C CAPACITOR				IC684	TC7WH74FU-X	IC		
	C3924	NCF31CZ-104X	C CAPACITOR				IC685	TC7WH241FU-X	IC		
	C3990	QETN1AM-107Z	E CAPACITOR	100MF 20% 10V			IC686	NJM4580E-W	IC		

■ Electrical parts list (DSP board)

Block No. 05

△	Item	Parts number	Parts name	Remarks	Area	△	Item	Parts number	Parts name	Remarks	Area
	IC687	NJM4580E-W	IC				Q3307	2SD1328/ST/-X	TRANSISTOR		
	IC690	PQ20VZ11-X	IC				Q3308	2SD1328/ST/-X	TRANSISTOR		
	IC691	PQ3DZ53-X	IC				Q3361	2SC2412K/RS/-X	CHIP TRANSISTOR		
	IC692	PQ3DZ53-X	IC				Q3362	2SC2412K/RS/-X	CHIP TRANSISTOR		
	IC693	PQ3DZ53-X	IC				Q3363	DTA114YE-X	TRANSISTOR		
	IC695	PQ3DZ53-X	IC				Q3403	2SC2412K/RS/-X	CHIP TRANSISTOR		
	IC696	PQ3DZ53-X	IC				Q3404	2SC2412K/RS/-X	CHIP TRANSISTOR		
	IC998	NJM2903M-XE	IC				Q3407	2SD1328/ST/-X	TRANSISTOR		
	IC999	LM45CIM3-X	IC				Q3408	2SD1328/ST/-X	TRANSISTOR		
	J3701	QNN0404-001	PIN JACK				Q3461	2SC2412K/RS/-X	CHIP TRANSISTOR		
	K3181	NQR0229-001X	FERRITE BEADS				Q3462	2SC2412K/RS/-X	CHIP TRANSISTOR		
	K3182	NQR0229-001X	FERRITE BEADS				Q3463	DTA114YE-X	TRANSISTOR		
	K3183	NQR0229-001X	FERRITE BEADS				Q3921	DTC114YE-X	TRANSISTOR		
	K3184	NQR0229-001X	FERRITE BEADS				R1108	NRSA63J-102X	MG RESISTOR		
	K3281	NQR0229-001X	FERRITE BEADS				R1109	NRSA63J-102X	MG RESISTOR		
	K3282	NQR0229-001X	FERRITE BEADS				R1110	NRSA63J-122X	MG RESISTOR		
	K3283	NQR0229-001X	FERRITE BEADS				R1111	NRSA63J-152X	MG RESISTOR		
	K3284	NQR0229-001X	FERRITE BEADS				R1112	NRSA63J-222X	MG RESISTOR		
	K3381	NQR0229-001X	FERRITE BEADS				R1113	NRSA63J-272X	MG RESISTOR		
	K3382	NQR0229-001X	FERRITE BEADS				R1114	NRSA63J-332X	MG RESISTOR		
	K3383	NQR0229-001X	FERRITE BEADS				R1115	NRSA63J-102X	MG RESISTOR		
	K3384	NQR0229-001X	FERRITE BEADS				R1116	NRSA63J-102X	MG RESISTOR		
	K3481	NQR0229-001X	FERRITE BEADS				R1117	NRSA63J-122X	MG RESISTOR		
	K3482	NQR0229-001X	FERRITE BEADS				R1118	NRSA63J-152X	MG RESISTOR		
	K3483	NQR0229-001X	FERRITE BEADS				R1119	NRSA63J-222X	MG RESISTOR		
	K3484	NQR0229-001X	FERRITE BEADS				R1120	NRSA63J-272X	MG RESISTOR		
	K3701	NQR0269-004X	FERRITE BEADS				R1121	NRSA63J-332X	MG RESISTOR		
	K3702	NQR0269-004X	FERRITE BEADS				R3001	NRSA63J-104X	MG RESISTOR		
	K3703	QQR0779-001Z	INDUCTOR				R3002	NRSA63J-104X	MG RESISTOR		
	K3704	QQR0779-001Z	INDUCTOR				R3003	NRSA63J-103X	MG RESISTOR		
	LC635	NQR0450-001X	EMI FILTER				R3004	NRSA63J-103X	MG RESISTOR		
	LC640	NQR0450-001X	EMI FILTER				R3005	NRSA63J-103X	MG RESISTOR		
	LC645	NQR0450-001X	EMI FILTER				R3006	NRSA63J-103X	MG RESISTOR		
	LC650	NQR0450-001X	EMI FILTER				R3007	NRSA63J-103X	MG RESISTOR		
	LC661	NQR0450-001X	EMI FILTER				R3008	NRSA63J-103X	MG RESISTOR		
	LC666	NQR0450-001X	EMI FILTER				R3009	NRSA63J-103X	MG RESISTOR		
	LC667	NQR0450-001X	EMI FILTER				R3010	NRSA63J-103X	MG RESISTOR		
	LC668	NQR0450-001X	EMI FILTER				R3011	NRSA63J-273X	MG RESISTOR		
	LC669	NQR0450-001X	EMI FILTER				R3012	NRSA63J-273X	MG RESISTOR		
	LC670	NQR0450-001X	EMI FILTER				R3013	NRSA63J-273X	MG RESISTOR		
	LC671	NQR0450-001X	EMI FILTER				R3014	NRSA63J-273X	MG RESISTOR		
	LC673	NQR0450-001X	EMI FILTER				R3017	NRSA63J-472X	MG RESISTOR		
	LC691	NQR0450-001X	EMI FILTER				R3018	NRSA63J-472X	MG RESISTOR		
	LC692	NQR0450-001X	EMI FILTER				R3021	NRSA63J-1R0X	MG RESISTOR		
	Q3103	2SC2412K/RS/-X	CHIP TRANSISTOR				R3022	NRSA63J-1R0X	MG RESISTOR		
	Q3104	2SC2412K/RS/-X	CHIP TRANSISTOR				R3031	NRSA63J-103X	MG RESISTOR		
	Q3105	DTA114YE-X	TRANSISTOR				R3032	NRSA63J-103X	MG RESISTOR		
	Q3107	2SD1328/ST/-X	TRANSISTOR				R3033	NRSA63J-103X	MG RESISTOR		
	Q3108	2SD1328/ST/-X	TRANSISTOR				R3034	NRSA63J-103X	MG RESISTOR		
	Q3161	2SC2412K/RS/-X	CHIP TRANSISTOR				R3035	NRSA63J-103X	MG RESISTOR		
	Q3162	2SC2412K/RS/-X	CHIP TRANSISTOR				R3041	NRSA63J-221X	MG RESISTOR		
	Q3163	DTA114YE-X	TRANSISTOR				R3042	NRSA63J-221X	MG RESISTOR		
	Q3203	2SC2412K/RS/-X	CHIP TRANSISTOR				R3043	NRSA63J-221X	MG RESISTOR		
	Q3207	2SD1328/ST/-X	TRANSISTOR				R3044	NRSA63J-101X	MG RESISTOR		
	Q3208	2SD1328/ST/-X	TRANSISTOR				R3045	NRSA63J-105X	MG RESISTOR		
	Q3261	2SC2412K/RS/-X	CHIP TRANSISTOR				R3101	NRSA63J-243X	MG RESISTOR		
	Q3263	DTA114YE-X	TRANSISTOR				R3102	NRSA63J-243X	MG RESISTOR		
	Q3265	DTA114YE-X	TRANSISTOR				R3103	NRSA63J-243X	MG RESISTOR		
	Q3266	2SD1328/ST/-X	TRANSISTOR				R3104	NRSA63J-243X	MG RESISTOR		
	Q3291	DTC114YE-X	TRANSISTOR				R3105	NRSA63F-163X	MG RESISTOR		
	Q3301	DTA114YE-X	TRANSISTOR				R3106	NRSA63F-163X	MG RESISTOR		
	Q3303	2SC2412K/RS/-X	CHIP TRANSISTOR				R3107	NRSA63F-163X	MG RESISTOR		
	Q3304	2SC2412K/RS/-X	CHIP TRANSISTOR				R3108	NRSA63F-163X	MG RESISTOR		

■ Electrical parts list (DSP board)

Block No. 05

△	Item	Parts number	Parts name	Remarks	Area	△	Item	Parts number	Parts name	Remarks	Area
	R3109	NRSA63J-362X	MG RESISTOR				R3187	NRSA63J-561X	MG RESISTOR		
	R3110	NRSA63J-362X	MG RESISTOR				R3188	NRSA63J-221X	MG RESISTOR		
	R3111	NRSA63J-163X	MG RESISTOR				R3189	NRSA63J-221X	MG RESISTOR		
	R3112	NRSA63J-163X	MG RESISTOR				R3190	NRSA63J-221X	MG RESISTOR		
	R3113	NRSA63J-162X	MG RESISTOR				R3191	QRJ146J-271X	UNF C RESISTOR	270 5% 1/4W	
	R3114	NRSA63J-162X	MG RESISTOR				R3192	QRJ146J-271X	UNF C RESISTOR	270 5% 1/4W	
	R3115	NRSA63J-182X	MG RESISTOR				R3193	NRSA63J-561X	MG RESISTOR		
	R3116	NRSA63J-182X	MG RESISTOR				R3194	NRSA63J-561X	MG RESISTOR		
	R3117	NRSA63J-183X	MG RESISTOR				R3201	NRSA63J-243X	MG RESISTOR		
	R3118	NRSA63J-183X	MG RESISTOR				R3202	NRSA63J-243X	MG RESISTOR		
	R3121	NRSA63J-561X	MG RESISTOR				R3203	NRSA63J-243X	MG RESISTOR		
	R3122	NRSA63J-561X	MG RESISTOR				R3204	NRSA63J-243X	MG RESISTOR		
	R3123	NRSA63J-561X	MG RESISTOR				R3205	NRSA63F-163X	MG RESISTOR		
	R3124	NRSA63J-561X	MG RESISTOR				R3206	NRSA63F-163X	MG RESISTOR		
	R3125	NRSA63J-561X	MG RESISTOR				R3207	NRSA63F-163X	MG RESISTOR		
	R3126	NRSA63J-561X	MG RESISTOR				R3208	NRSA63F-163X	MG RESISTOR		
	R3127	NRSA63J-105X	MG RESISTOR				R3209	NRSA63J-362X	MG RESISTOR		
	R3128	NRSA63J-105X	MG RESISTOR				R3210	NRSA63J-362X	MG RESISTOR		
	R3129	NRSA63J-473X	MG RESISTOR				R3211	NRSA63J-163X	MG RESISTOR		
	R3130	NRSA63J-473X	MG RESISTOR				R3212	NRSA63J-163X	MG RESISTOR		
	R3131	NRSA63J-222X	MG RESISTOR				R3213	NRSA63J-162X	MG RESISTOR		
	R3132	NRSA63J-222X	MG RESISTOR				R3214	NRSA63J-162X	MG RESISTOR		
	R3133	NRSA63J-222X	MG RESISTOR				R3215	NRSA63J-182X	MG RESISTOR		
	R3134	NRSA63J-222X	MG RESISTOR				R3216	NRSA63J-182X	MG RESISTOR		
	R3135	NRSA63J-183X	MG RESISTOR				R3217	NRSA63J-183X	MG RESISTOR		
	R3136	NRSA63J-183X	MG RESISTOR				R3221	NRSA63J-561X	MG RESISTOR		
	R3137	NRSA63J-104X	MG RESISTOR				R3222	NRSA63J-202X	MG RESISTOR		
	R3138	NRSA63J-104X	MG RESISTOR				R3223	NRSA63J-471X	MG RESISTOR		
	R3139	NRSA63J-561X	MG RESISTOR				R3224	NRSA63J-202X	MG RESISTOR		
	R3140	NRSA63J-561X	MG RESISTOR				R3225	NRSA63J-821X	MG RESISTOR		
	R3141	NRSA63J-101X	MG RESISTOR				R3226	NRSA63J-1R0X	MG RESISTOR		
	R3142	NRSA63J-101X	MG RESISTOR				R3227	NRSA63J-105X	MG RESISTOR		
	R3143	NRSA63J-104X	MG RESISTOR				R3229	NRSA63J-473X	MG RESISTOR		
	R3144	NRSA63J-104X	MG RESISTOR				R3230	NRSA63J-473X	MG RESISTOR		
	R3145	NRSA63J-333X	MG RESISTOR				R3231	NRSA63J-393X	MG RESISTOR		
	R3146	NRSA63J-333X	MG RESISTOR				R3232	NRSA63J-133X	MG RESISTOR		
	R3147	NRSA63J-333X	MG RESISTOR				R3233	NRSA63J-113X	MG RESISTOR		
	R3148	NRSA63J-333X	MG RESISTOR				R3234	NRSA63J-242X	MG RESISTOR		
	R3149	NRSA63J-333X	MG RESISTOR				R3235	NRSA63J-183X	MG RESISTOR		
	R3150	NRSA63J-333X	MG RESISTOR				R3236	NRSA63J-183X	MG RESISTOR		
	R3151	NRSA63J-472X	MG RESISTOR				R3237	NRSA63J-104X	MG RESISTOR		
	R3152	NRSA63J-472X	MG RESISTOR				R3238	NRSA63J-104X	MG RESISTOR		
	R3155	NRSA63J-474X	MG RESISTOR				R3239	NRSA63J-561X	MG RESISTOR		
	R3157	NRSA63J-332X	MG RESISTOR				R3240	NRSA63J-561X	MG RESISTOR		
	R3158	NRSA63J-332X	MG RESISTOR				R3241	NRSA63J-101X	MG RESISTOR		
	R3161	NRSA63J-103X	MG RESISTOR				R3242	NRSA63J-101X	MG RESISTOR		
	R3162	NRSA63J-103X	MG RESISTOR				R3251	NRSA63J-472X	MG RESISTOR		
	R3163	NRSA63J-105X	MG RESISTOR				R3255	NRSA63J-202X	MG RESISTOR		
	R3164	NRSA63J-105X	MG RESISTOR				R3256	NRSA63J-202X	MG RESISTOR		
	R3165	NRSA63J-105X	MG RESISTOR				R3257	NRSA63J-332X	MG RESISTOR		
	R3171	NRSA63J-221X	MG RESISTOR				R3258	NRSA63J-332X	MG RESISTOR		
	R3172	NRSA63J-221X	MG RESISTOR				R3261	NRSA63J-103X	MG RESISTOR		
	R3173	NRSA63J-221X	MG RESISTOR				R3262	NRSA63J-474X	MG RESISTOR		
	R3174	NRSA63J-221X	MG RESISTOR				R3263	NRSA63J-912X	MG RESISTOR		
	R3175	NRSA63J-101X	MG RESISTOR				R3264	NRSA63J-472X	MG RESISTOR		
	R3176	NRSA63J-470X	MG RESISTOR				R3265	NRSA63J-105X	MG RESISTOR		
	R3177	NRSA63J-470X	MG RESISTOR				R3266	NRSA63J-243X	MG RESISTOR		
	R3181	NRSA63J-101X	MG RESISTOR				R3267	NRSA63J-103X	MG RESISTOR		
	R3182	NRSA63J-101X	MG RESISTOR				R3268	NRSA63J-102X	MG RESISTOR		
	R3183	NRSA63J-101X	MG RESISTOR				R3269	NRSA63J-104X	MG RESISTOR		
	R3184	NRSA63J-101X	MG RESISTOR				R3271	NRSA63J-221X	MG RESISTOR		
	R3185	NRSA63J-332X	MG RESISTOR				R3272	NRSA63J-221X	MG RESISTOR		
	R3186	NRSA63J-561X	MG RESISTOR				R3273	NRSA63J-221X	MG RESISTOR		

■ Electrical parts list (DSP board)

Block No. 05

△	Item	Parts number	Parts name	Remarks	Area	△	Item	Parts number	Parts name	Remarks	Area
	R3274	NRSA63J-221X	MG RESISTOR				R3352	NRSA63J-472X	MG RESISTOR		
	R3275	NRSA63J-101X	MG RESISTOR				R3353	NRSA63J-474X	MG RESISTOR		
	R3276	NRSA63J-470X	MG RESISTOR				R3357	NRSA63J-332X	MG RESISTOR		
	R3277	NRSA63J-470X	MG RESISTOR				R3358	NRSA63J-332X	MG RESISTOR		
	R3281	NRSA63J-101X	MG RESISTOR				R3361	NRSA63J-103X	MG RESISTOR		
	R3282	NRSA63J-101X	MG RESISTOR				R3362	NRSA63J-103X	MG RESISTOR		
	R3283	NRSA63J-101X	MG RESISTOR				R3363	NRSA63J-752X	MG RESISTOR		
	R3284	NRSA63J-101X	MG RESISTOR				R3364	NRSA63J-752X	MG RESISTOR		
	R3285	NRSA63J-332X	MG RESISTOR				R3365	NRSA63J-105X	MG RESISTOR		
	R3286	NRSA63J-561X	MG RESISTOR				R3371	NRSA63J-221X	MG RESISTOR		
	R3287	NRSA63J-561X	MG RESISTOR				R3372	NRSA63J-221X	MG RESISTOR		
	R3288	NRSA63J-221X	MG RESISTOR				R3373	NRSA63J-221X	MG RESISTOR		
	R3289	NRSA63J-221X	MG RESISTOR				R3374	NRSA63J-221X	MG RESISTOR		
	R3290	NRSA63J-221X	MG RESISTOR				R3375	NRSA63J-101X	MG RESISTOR		
	R3291	NRSA63J-333X	MG RESISTOR				R3376	NRSA63J-470X	MG RESISTOR		
	R3292	NRSA63J-333X	MG RESISTOR				R3377	NRSA63J-470X	MG RESISTOR		
	R3293	NRSA63J-243X	MG RESISTOR				R3381	NRSA63J-101X	MG RESISTOR		
	R3294	NRSA63J-104X	MG RESISTOR				R3382	NRSA63J-101X	MG RESISTOR		
	R3295	NRSA63J-102X	MG RESISTOR				R3383	NRSA63J-101X	MG RESISTOR		
	R3296	NRSA63J-102X	MG RESISTOR				R3384	NRSA63J-101X	MG RESISTOR		
	R3297	NRSA63J-473X	MG RESISTOR				R3385	NRSA63J-332X	MG RESISTOR		
	R3298	NRSA63J-473X	MG RESISTOR				R3386	NRSA63J-561X	MG RESISTOR		
	R3301	NRSA63J-243X	MG RESISTOR				R3387	NRSA63J-561X	MG RESISTOR		
	R3302	NRSA63J-243X	MG RESISTOR				R3388	NRSA63J-221X	MG RESISTOR		
	R3303	NRSA63J-243X	MG RESISTOR				R3389	NRSA63J-221X	MG RESISTOR		
	R3304	NRSA63J-243X	MG RESISTOR				R3390	NRSA63J-221X	MG RESISTOR		
	R3305	NRSA63F-163X	MG RESISTOR				R3401	NRSA63J-243X	MG RESISTOR		
	R3306	NRSA63F-163X	MG RESISTOR				R3402	NRSA63J-243X	MG RESISTOR		
	R3307	NRSA63F-163X	MG RESISTOR				R3403	NRSA63J-243X	MG RESISTOR		
	R3308	NRSA63F-163X	MG RESISTOR				R3404	NRSA63J-243X	MG RESISTOR		
	R3309	NRSA63J-362X	MG RESISTOR				R3405	NRSA63F-163X	MG RESISTOR		
	R3310	NRSA63J-362X	MG RESISTOR				R3406	NRSA63F-163X	MG RESISTOR		
	R3311	NRSA63J-163X	MG RESISTOR				R3407	NRSA63F-163X	MG RESISTOR		
	R3312	NRSA63J-163X	MG RESISTOR				R3408	NRSA63F-163X	MG RESISTOR		
	R3313	NRSA63J-162X	MG RESISTOR				R3409	NRSA63J-362X	MG RESISTOR		
	R3314	NRSA63J-162X	MG RESISTOR				R3410	NRSA63J-362X	MG RESISTOR		
	R3315	NRSA63J-182X	MG RESISTOR				R3411	NRSA63J-163X	MG RESISTOR		
	R3316	NRSA63J-182X	MG RESISTOR				R3412	NRSA63J-163X	MG RESISTOR		
	R3317	NRSA63J-183X	MG RESISTOR				R3413	NRSA63J-162X	MG RESISTOR		
	R3318	NRSA63J-183X	MG RESISTOR				R3414	NRSA63J-162X	MG RESISTOR		
	R3321	NRSA63J-561X	MG RESISTOR				R3415	NRSA63J-182X	MG RESISTOR		
	R3322	NRSA63J-561X	MG RESISTOR				R3416	NRSA63J-182X	MG RESISTOR		
	R3323	NRSA63J-471X	MG RESISTOR				R3417	NRSA63J-183X	MG RESISTOR		
	R3324	NRSA63J-471X	MG RESISTOR				R3418	NRSA63J-183X	MG RESISTOR		
	R3325	NRSA63J-821X	MG RESISTOR				R3421	NRSA63J-561X	MG RESISTOR		
	R3326	NRSA63J-821X	MG RESISTOR				R3422	NRSA63J-561X	MG RESISTOR		
	R3327	NRSA63J-105X	MG RESISTOR				R3423	NRSA63J-471X	MG RESISTOR		
	R3328	NRSA63J-105X	MG RESISTOR				R3424	NRSA63J-471X	MG RESISTOR		
	R3329	NRSA63J-473X	MG RESISTOR				R3425	NRSA63J-821X	MG RESISTOR		
	R3330	NRSA63J-473X	MG RESISTOR				R3426	NRSA63J-821X	MG RESISTOR		
	R3331	NRSA63J-243X	MG RESISTOR				R3427	NRSA63J-105X	MG RESISTOR		
	R3332	NRSA63J-243X	MG RESISTOR				R3428	NRSA63J-105X	MG RESISTOR		
	R3333	NRSA63J-113X	MG RESISTOR				R3429	NRSA63J-473X	MG RESISTOR		
	R3334	NRSA63J-113X	MG RESISTOR				R3430	NRSA63J-473X	MG RESISTOR		
	R3335	NRSA63J-183X	MG RESISTOR				R3431	NRSA63J-243X	MG RESISTOR		
	R3336	NRSA63J-183X	MG RESISTOR				R3432	NRSA63J-243X	MG RESISTOR		
	R3337	NRSA63J-104X	MG RESISTOR				R3433	NRSA63J-113X	MG RESISTOR		
	R3338	NRSA63J-104X	MG RESISTOR				R3434	NRSA63J-113X	MG RESISTOR		
	R3339	NRSA63J-561X	MG RESISTOR				R3435	NRSA63J-183X	MG RESISTOR		
	R3340	NRSA63J-561X	MG RESISTOR				R3436	NRSA63J-183X	MG RESISTOR		
	R3341	NRSA63J-101X	MG RESISTOR				R3437	NRSA63J-104X	MG RESISTOR		
	R3342	NRSA63J-101X	MG RESISTOR				R3438	NRSA63J-104X	MG RESISTOR		
	R3351	NRSA63J-472X	MG RESISTOR				R3439	NRSA63J-561X	MG RESISTOR		

■ Electrical parts list (DSP board)

Block No. 05

△	Item	Parts number	Parts name	Remarks	Area	△	Item	Parts number	Parts name	Remarks	Area
	R3440	NRSA63J-561X	MG RESISTOR				R3608	NRSA63J-473X	MG RESISTOR		
	R3441	NRSA63J-101X	MG RESISTOR				R3609	NRSA63J-473X	MG RESISTOR		
	R3442	NRSA63J-101X	MG RESISTOR				R3610	NRSA63J-473X	MG RESISTOR		
	R3451	NRSA63J-472X	MG RESISTOR				R3611	NRSA63J-473X	MG RESISTOR		
	R3452	NRSA63J-472X	MG RESISTOR				R3612	NRSA63J-473X	MG RESISTOR		
	R3457	NRSA63J-332X	MG RESISTOR				R3613	NRSA63J-473X	MG RESISTOR		
	R3458	NRSA63J-332X	MG RESISTOR				R3614	NRSA63J-473X	MG RESISTOR		
	R3461	NRSA63J-103X	MG RESISTOR				R3615	NRSA63J-473X	MG RESISTOR		
	R3462	NRSA63J-103X	MG RESISTOR				R3616	NRSA63J-473X	MG RESISTOR		
	R3463	NRSA63J-752X	MG RESISTOR				R3617	NRSA63J-473X	MG RESISTOR		
	R3464	NRSA63J-752X	MG RESISTOR				R3618	NRSA63J-473X	MG RESISTOR		
	R3465	NRSA63J-105X	MG RESISTOR				R3620	NRSA63J-101X	MG RESISTOR		
	R3471	NRSA63J-221X	MG RESISTOR				R3621	NRSA63J-103X	MG RESISTOR		
	R3472	NRSA63J-221X	MG RESISTOR				R3622	NRSA63J-103X	MG RESISTOR		
	R3473	NRSA63J-221X	MG RESISTOR				R3623	NRSA63J-103X	MG RESISTOR		
	R3474	NRSA63J-221X	MG RESISTOR				R3624	NRSA63J-103X	MG RESISTOR		
	R3475	NRSA63J-101X	MG RESISTOR				R3626	NRSA63J-470X	MG RESISTOR		
	R3476	NRSA63J-470X	MG RESISTOR				R3627	NRSA63J-470X	MG RESISTOR		
	R3477	NRSA63J-470X	MG RESISTOR				R3628	NRSA63J-470X	MG RESISTOR		
	R3481	NRSA63J-101X	MG RESISTOR				R3629	NRSA63J-470X	MG RESISTOR		
	R3482	NRSA63J-101X	MG RESISTOR				R3701	NRSA63J-750X	MG RESISTOR		
	R3483	NRSA63J-101X	MG RESISTOR				R3702	NRSA63J-221X	MG RESISTOR		
	R3484	NRSA63J-101X	MG RESISTOR				R3703	NRSA63J-112X	MG RESISTOR		
	R3485	NRSA63J-332X	MG RESISTOR				R3704	NRSA63J-112X	MG RESISTOR		
	R3486	NRSA63J-561X	MG RESISTOR				R3705	NRSA63J-112X	MG RESISTOR		
	R3487	NRSA63J-561X	MG RESISTOR				R3706	NRSA63J-112X	MG RESISTOR		
	R3488	NRSA63J-221X	MG RESISTOR				R3707	NRSA63J-512X	MG RESISTOR		
	R3489	NRSA63J-221X	MG RESISTOR				R3708	NRSA63J-512X	MG RESISTOR		
	R3490	NRSA63J-221X	MG RESISTOR				R3709	NRSA63J-512X	MG RESISTOR		
	R3501	NRSA63J-473X	MG RESISTOR				R3710	NRSA63J-512X	MG RESISTOR		
	R3502	NRSA63J-470X	MG RESISTOR				R3721	NRSA63F-183X	MG RESISTOR		
	R3503	NRSA63J-470X	MG RESISTOR				R3722	NRSA63J-100X	MG RESISTOR		
	R3504	NRSA63J-470X	MG RESISTOR				R3723	NRSA63J-101X	MG RESISTOR		
	R3505	NRSA63J-470X	MG RESISTOR				R3724	NRSA63J-221X	MG RESISTOR		
	R3506	NRSA63J-473X	MG RESISTOR				R3725	NRSA63J-221X	MG RESISTOR		
	R3507	NRSA63J-473X	MG RESISTOR				R3726	NRSA63J-221X	MG RESISTOR		
	R3508	NRSA63J-473X	MG RESISTOR				R3727	NRSA63J-221X	MG RESISTOR		
	R3509	NRSA63J-473X	MG RESISTOR				R3735	NRSA63J-221X	MG RESISTOR		
	R3510	NRSA63J-473X	MG RESISTOR				R3801	NRSA63J-105X	MG RESISTOR		
	R3511	NRSA63J-473X	MG RESISTOR				R3802	NRSA63J-105X	MG RESISTOR		
	R3512	NRSA63J-473X	MG RESISTOR				R3803	NRSA63J-470X	MG RESISTOR		
	R3513	NRSA63J-473X	MG RESISTOR				R3805	NRSA63F-511X	MG RESISTOR		
	R3514	NRSA63J-473X	MG RESISTOR				R3806	NRSA63F-102X	MG RESISTOR		
	R3515	NRSA63J-473X	MG RESISTOR				R3807	NRSA63J-103X	MG RESISTOR		
	R3516	NRSA63J-473X	MG RESISTOR				R3811	NRSA63J-221X	MG RESISTOR		
	R3517	NRSA63J-473X	MG RESISTOR				R3812	NRSA63J-221X	MG RESISTOR		
	R3518	NRSA63J-473X	MG RESISTOR				R3813	NRSA63J-221X	MG RESISTOR		
	R3519	NRSA63J-473X	MG RESISTOR				R3814	NRSA63J-470X	MG RESISTOR		
	R3520	NRSA63J-101X	MG RESISTOR				R3815	NRSA63J-470X	MG RESISTOR		
	R3521	NRSA63J-103X	MG RESISTOR				R3816	NRSA63J-470X	MG RESISTOR		
	R3522	NRSA63J-103X	MG RESISTOR				R3920	NRSA63J-103X	MG RESISTOR		
	R3523	NRSA63J-103X	MG RESISTOR				R3921	NRSA63J-512X	MG RESISTOR		
	R3524	NRSA63J-103X	MG RESISTOR				R3922	NRSA63J-512X	MG RESISTOR		
	R3525	NRSA63J-103X	MG RESISTOR				R3923	NRSA63J-221X	MG RESISTOR		
	R3526	NRSA63J-470X	MG RESISTOR				R3924	NRSA63J-512X	MG RESISTOR		
	R3527	NRSA63J-470X	MG RESISTOR				R3925	NRSA63J-512X	MG RESISTOR		
	R3601	NRSA63J-473X	MG RESISTOR				R3926	NRSA63J-103X	MG RESISTOR		
	R3602	NRSA63J-470X	MG RESISTOR				R3927	NRSA63J-103X	MG RESISTOR		
	R3603	NRSA63J-470X	MG RESISTOR				R3928	NRSA63J-103X	MG RESISTOR		
	R3604	NRSA63J-470X	MG RESISTOR				R3929	NRSA63J-103X	MG RESISTOR		
	R3605	NRSA63J-470X	MG RESISTOR				R3930	NRSA63J-103X	MG RESISTOR		
	R3606	NRSA63J-473X	MG RESISTOR				R5001	NRSA63J-223X	MG RESISTOR		
	R3607	NRSA63J-473X	MG RESISTOR				R5002	NRSA63J-102X	MG RESISTOR		

■ Electrical parts list (DSP board)

Block No. 05

△	Item	Parts number	Parts name	Remarks	Area
	R5003	NRSA63J-153X	MG RESISTOR		
	R5004	NRSA63J-112X	MG RESISTOR		
	R5005	NRSA63J-222X	MG RESISTOR		
	R5006	NRSA63J-473X	MG RESISTOR		
	R5007	NRSA63J-105X	MG RESISTOR		
	R5008	NRSA63J-102X	MG RESISTOR		
	R5009	NRSA63J-473X	MG RESISTOR		
	R5010	NRSA63J-105X	MG RESISTOR		
	R5011	NRSA63J-102X	MG RESISTOR		
	R5012	NRSA63J-223X	MG RESISTOR		
	S1009	NSW0059-001X	TACT SWITCH		
	S1010	NSW0059-001X	TACT SWITCH		
	S1011	NSW0059-001X	TACT SWITCH		
	S1012	NSW0059-001X	TACT SWITCH		
	S1013	NSW0059-001X	TACT SWITCH		
	S1014	NSW0059-001X	TACT SWITCH		
	S1016	NSW0059-001X	TACT SWITCH		
	S1017	NSW0059-001X	TACT SWITCH		
	S1018	NSW0059-001X	TACT SWITCH		
	S1019	NSW0059-001X	TACT SWITCH		
	S1020	NSW0059-001X	TACT SWITCH		
	S1021	NSW0059-001X	TACT SWITCH		
	TP671	QMV5005-002K	2P PLUG ASSY		
	UN631	GP1FA550RZ	OPT RECEIVER		
	UN632	GP1FA550RZ	OPT RECEIVER		
	UN633	GP1FA550RZ	OPT RECEIVER		
	UN634	GP1FA550RZ	OPT RECEIVER		
	UN635	GP1FA550TZ	OPT TRANSMITTER		
	WR 54	QJK016-035203	SIN CR C-B WIRE		
	WR632	QJK016-153000	SIN CR C-B WIRE		
	X3001	NAX0435-001X	CRYSTAL		
	X3801	NAX0308-001X	RESONATOR		
	X3802	NAX0275-001X	1COSCIALLATOR		

■ Electrical parts list
(Thermal compensation board)

Block No. 06

△	Item	Parts number	Parts name	Remarks	Area
	CN701	QGA2501F1-03	CONNECTOR		
	CN702	QGA2501F1-03	CONNECTOR		
	CN703	QGA2501F1-03	CONNECTOR		
	CN704	QGA2501F1-03	CONNECTOR		
	CN705	QGA2501F1-03	CONNECTOR		
	CN706	QGA2501F1-03	CONNECTOR		
	CN707	QGA2501F1-03	CONNECTOR		
	C7191	QDVB1EZ-103Y	C CAPACITOR		
	C7192	QDVB1EZ-103Y	C CAPACITOR		
	C7193	QDVB1EZ-103Y	C CAPACITOR		
	C7194	QDVB1EZ-103Y	C CAPACITOR		
	C7195	QDVB1EZ-103Y	C CAPACITOR		
	C7196	QDVB1EZ-103Y	C CAPACITOR		
	C7197	QDVB1EZ-103Y	C CAPACITOR		
	Q7091	2SC3422/OY/	TRANSISTOR		
	Q7092	2SC3422/OY/	TRANSISTOR		
	Q7093	2SC3422/OY/	TRANSISTOR		
	Q7094	2SC3422/OY/	TRANSISTOR		
	Q7095	2SC3422/OY/	TRANSISTOR		
	Q7096	2SC3422/OY/	TRANSISTOR		
	Q7097	2SC3422/OY/	TRANSISTOR		

< MEMO >

Packing materials and accessories parts list

Block No.

M	3	M	M
---	---	---	---

Block No.

M	5	M	M
---	---	---	---

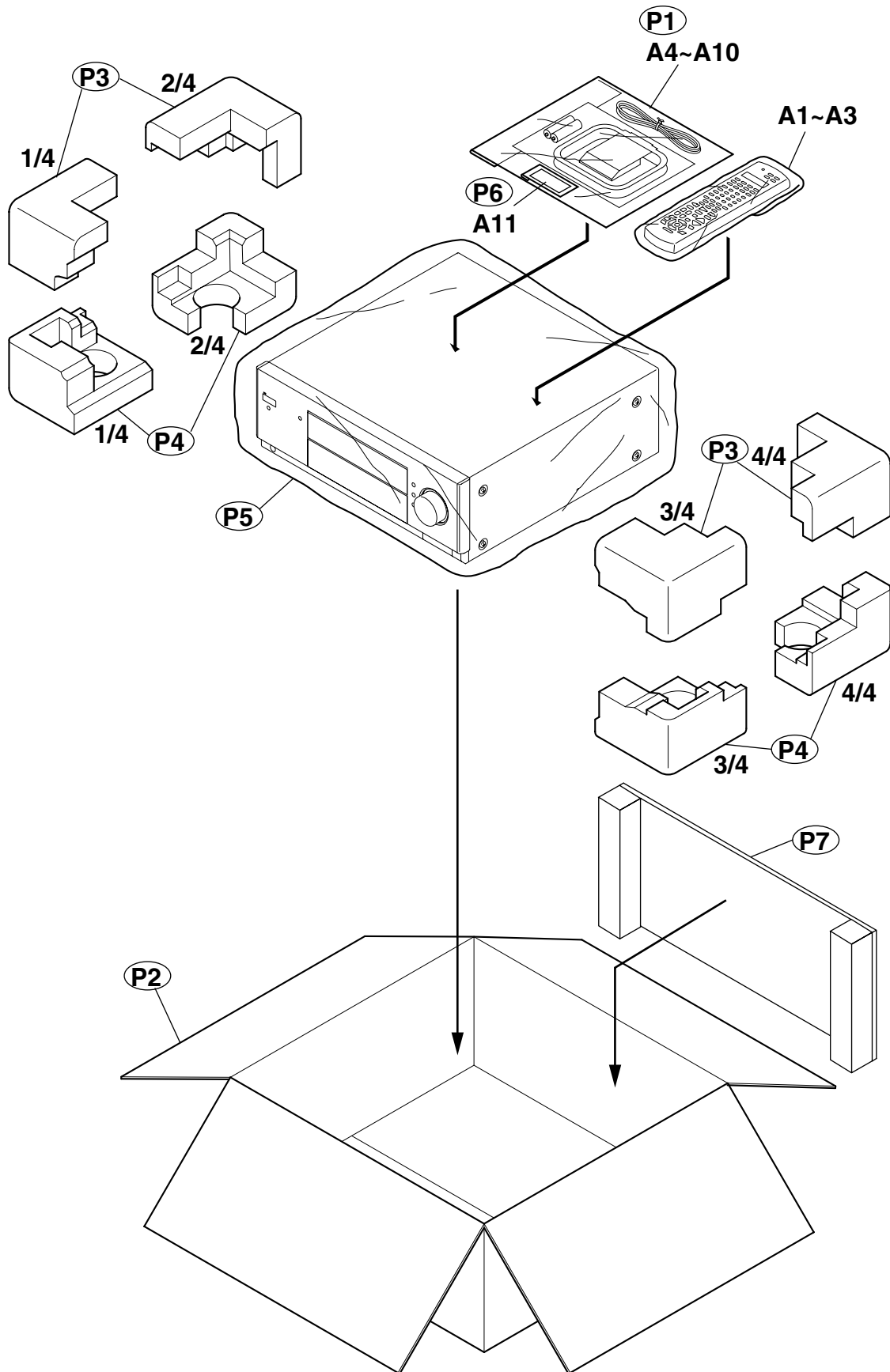

■ Parts list (Packing)

Block No. M3MM

△	Item	Parts number	Parts name	Q'ty	Description	Area
	P 1	QPA02504505P	POLY BAG	1	INST BOOK	EN
		QPA02503505P	POLY BAG	1	INST BOOK	B,E
	P 2	LV21071-016A	CARTON BOX	1		B,E
		LV21071-015A	CARTON BOX	1		EN
	P 3	LV21069-001A	CUSHION	1		
	P 4	LV21070-001A	CUSHION	1		
	P 5	QPC08008015P	POLY BAG	1	SET	
	P 6	QPC00501205	POLY BAG	1	COVER	
	P 7	LV30385-008A	SHEET	1		

■ Parts list (Accessories)

Block No. M5MM

△	Item	Parts number	Parts name	Q'ty	Description	Area
	A 1	RM-SRXDP10R	REMOCON	1		
	A 2	LV42570-001A	SHEET	1		
	A 3	LV30256-007A	SHEET	1		
	A 4	LVT0722-007B	INST BOOK	1	SWE,FIN,DAN,GER	EN
		LVT0722-006A	INST BOOK	1	GER,FRE,DUT	E
		LVT0722-007B	INST BOOK	1	FRE,SPA,ITA	EN
		LVT0722-005A	INST BOOK	1	ENG	B
	A 5	VNA3000-204	REGIST.CARD	1		B
	A 6	E43486-340A	BS=SAFETY INST	1		B
	A 7	BT-54013-2	WARRANTY CARD	1		E
		BT-54008-2	WARRANTY CARD	1		B,EN
	A 8	-----	AL BATTERY	2		
	A 9	EWP503-001C	ANT.WIRE	1		
	A 10	QAL0204-001	AM LOOP ANT	1		
	A 11	LV32823-001A	COVER ASSY	1		