

# JVC

# SERVICE MANUAL

## HOME CINEMA CONTROL CENTER

### RX-E112RSL RX-E111RSL

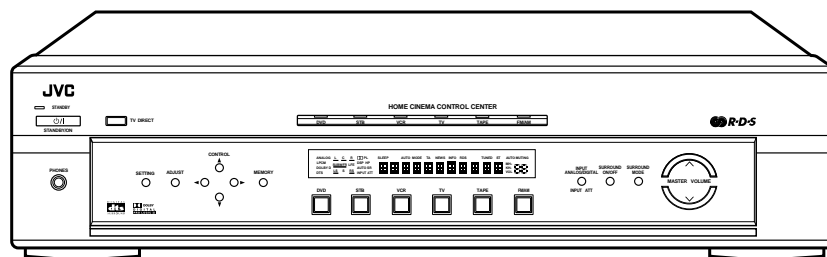
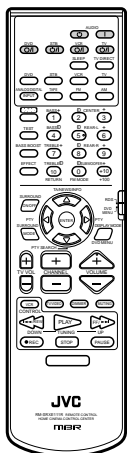

#### Area suffix

B ----- U.K.  
E ---- Continental Europe  
EN ---- Northern Europe  
EV ----- Eastern Europe

DIGITAL  
**dts**  
SURROUND

**DD** **DOLBY**  
**DIGITAL**  
**PRO LOGIC II**

**R-D-S**

#### Each difference points

MODEL	Source indication lens color
RX-E112RSL	GRAY SMOKE
RX-E111RSL	CLEAR LIGHT GREEN

## Contents

Safety precautions .....	1- 2
Disassembly method .....	1- 3
Adjustment method .....	1- 8
Description of major ICs .....	1- 9~22

## Safety Precautions

1. This design of this product contains special hardware and many circuits and components specially for safety purposes. For continued protection, no changes should be made to the original design unless authorized in writing by the manufacturer. Replacement parts must be identical to those used in the original circuits. Services should be performed by qualified personnel only.
2. Alterations of the design or circuitry of the product should not be made. Any design alterations of the product should not be made. Any design alterations or additions will void the manufacturer's warranty and will further relieve the manufacture of responsibility for personal injury or property damage resulting therefrom.
3. Many electrical and mechanical parts in the products have special safety-related characteristics. These characteristics are often not evident from visual inspection nor can the protection afforded by them necessarily be obtained by using replacement components rated for higher voltage, wattage, etc. Replacement parts which have these special safety characteristics are identified in the Parts List of Service Manual. Electrical components having such features are identified by shading on the schematics and by ( $\triangle$ ) on the Parts List in the Service Manual. The use of a substitute replacement which does not have the same safety characteristics as the recommended replacement parts shown in the Parts List of Service Manual may create shock, fire, or other hazards.
4. The leads in the products are routed and dressed with ties, clamps, tubings, barriers and the like to be separated from live parts, high temperature parts, moving parts and/or sharp edges for the prevention of electric shock and fire hazard. When service is required, the original lead routing and dress should be observed, and it should be confirmed that they have been returned to normal, after re-assembling.

### 5. Leakage current check (Electrical shock hazard testing)

After re-assembling the product, always perform an isolation check on the exposed metal parts of the product (antenna terminals, knobs, metal cabinet, screw heads, headphone jack, control shafts, etc.) to be sure the product is safe to operate without danger of electrical shock.

Do not use a line isolation transformer during this check.

- Plug the AC line cord directly into the AC outlet. Using a "Leakage Current Tester", measure the leakage current from each exposed metal parts of the cabinet, particularly any exposed metal part having a return path to the chassis, to a known good earth ground. Any leakage current must not exceed 0.5mA AC (r.m.s.).

- Alternate check method

Plug the AC line cord directly into the AC outlet. Use an AC voltmeter having, 1,000 ohms per volt or more sensitivity in the following manner. Connect a 1,500  $\Omega$  10W resistor paralleled by a 0.15  $\mu$ F AC-type capacitor between an exposed metal part and a known good earth ground.

Measure the AC voltage across the resistor with the AC voltmeter.

Move the resistor connection to each exposed metal part, particularly any exposed metal part having a return path to the chassis, and measure the AC voltage across the resistor. Now, reverse the plug in the AC outlet and repeat each measurement. Voltage measured any must not exceed 0.75 V AC (r.m.s.). This corresponds to 0.5 mA AC (r.m.s.).

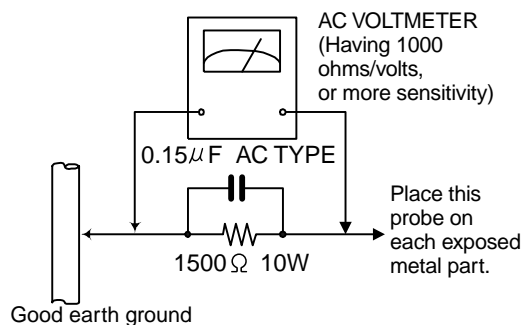

## Warning

1. This equipment has been designed and manufactured to meet international safety standards.
2. It is the legal responsibility of the repairer to ensure that these safety standards are maintained.
3. Repairs must be made in accordance with the relevant safety standards.
4. It is essential that safety critical components are replaced by approved parts.
5. If mains voltage selector is provided, check setting for local voltage.



## CAUTION

**Burrs formed during molding may be left over on some parts of the chassis. Therefore, pay attention to such burrs in the case of preforming repair of this system.**

In regard with component parts appearing on the silk-screen printed side (parts side) of the PWB diagrams, the parts that are printed over with black such as the resistor ( $\blacksquare$ ), diode ( $\blacktriangle$ ) and ICP ( $\bullet$ ) or identified by the " $\triangle$ " mark nearby are critical for safety.

(This regulation does not correspond to J and C version.)

## Disassembly method

### ■ Removing the top cover (See Fig.1)

1. Remove the four screws **A** attaching the top cover on both sides of the body.
2. Remove the three screws **B** on the back of the body.
3. Remove the top cover from behind in the direction of the arrow while pulling both sides outward.

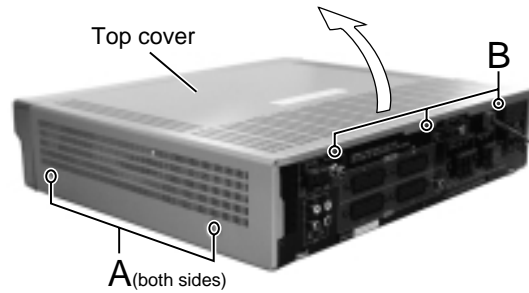

Fig.1

### ■ Removing the front panel assembly (See Fig.2 and 3)

- Prior to performing the following procedure, remove the top cover.

1. Cut off the tie band fixing the harness, if needed.
2. Disconnect the card wire from the connector CN411 on the audio board, CN412 on the input board and CN204 on the power supply board.
3. Disconnect the harness from the connector CN209 on the power supply board.
4. Remove the three screws **C** attaching the front panel assembly.
5. Remove the screw **D** attaching the headphone jack board.
6. Remove the four screws **E** attaching the front panel assembly on the bottom of the body. Detach the front panel assembly toward the front.

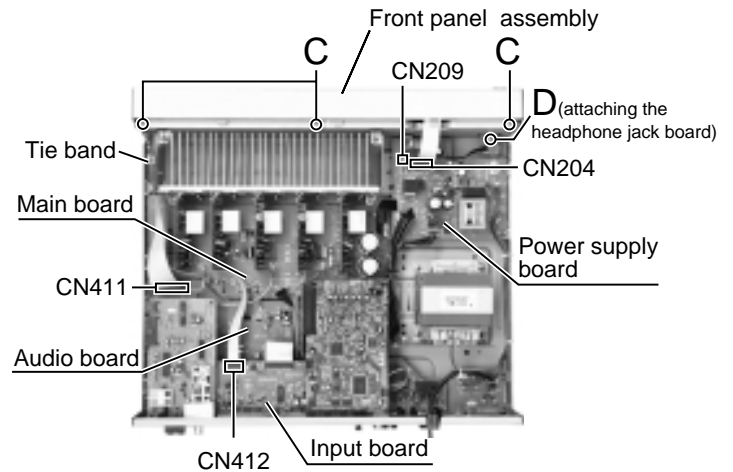

Fig.2

(Bottom side)

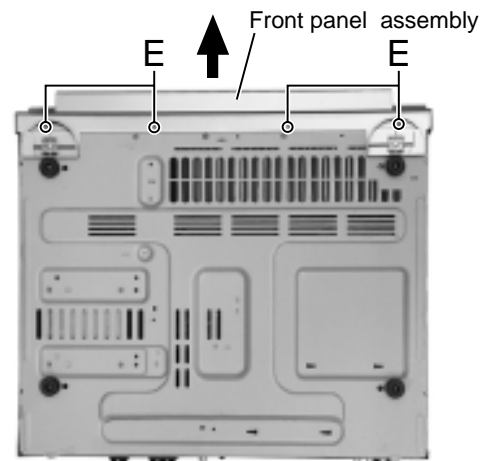

Fig.3

### ■ Removing the rear panel (See Fig.4)

- Prior to performing the following procedure, remove the top cover.

1. Remove the power cord stopper from the rear panel by moving it in the direction of the arrow.
2. Remove the nineteen screws **F** & **G** attaching the each boards to the rear panel.
3. Remove the four screws **H** attaching the rear panel on the back of the body.

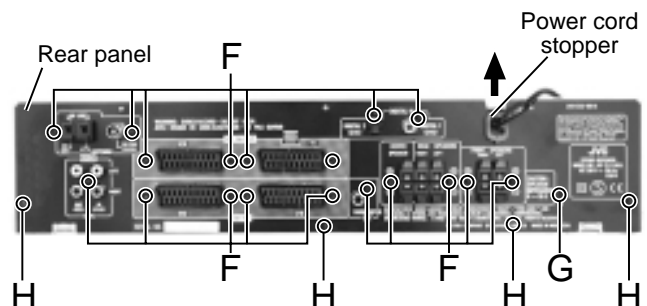

Fig.4

**■ Removing the input board (See Fig.5)**

• Prior to performing the following procedure, remove the top cover and rear panel.

1. Disconnect the card wire from the connector CN412 and CN512 on the input board.

**■ Removing the tuner board (See Fig.5 and 6)**

• Prior to performing the following procedure, remove the top cover and rear panel.

1. Disconnect the connector CN111 and CN112 on the tuner board and draw out the tuner board in the direction of the arrow (see fig.5).
2. Disconnect the connector CN513 and CN514 on the relay board (tuner) and draw out the relay board (tuner) in the direction of the arrow (see fig. 6).

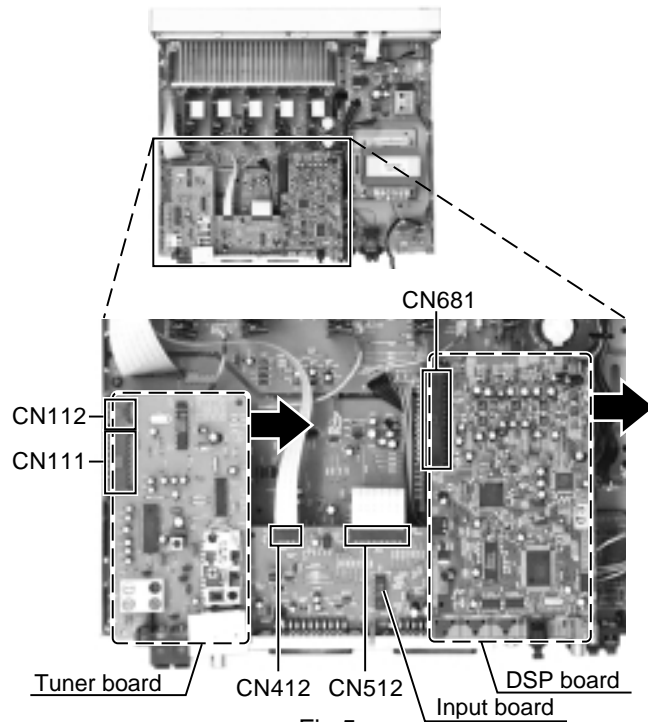

Fig.5

**■ Removing the DSP board (See Fig.5 and 6)**

• Prior to performing the following procedure, remove the top cover and rear panel.

1. Disconnect the connector CN681 on the DSP board and draw out the DSP board in the direction of the arrow (see fig.5).
2. Disconnect the connector CN511 on the relay board (DSP) and draw out the relay board (DSP) in the direction of the arrow (see fig.6).

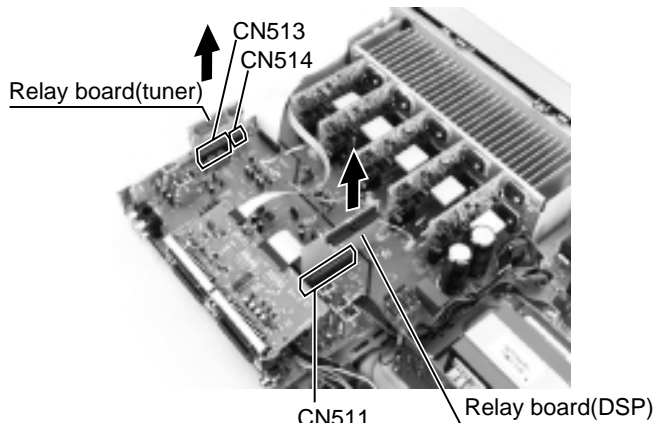

Fig.6

**■ Removing the audio board (See Fig.7)**

• Prior to performing the following procedure, remove the top cover, rear panel, input board, tuner board, DSP board and relay boards (tuner & DSP).

1. Remove the harness band[1] fixing the harness.
2. Disconnect the card wire from the connector CN411 on the audio board.
3. Disconnect the harness from the connector CN224 /CN225 on the audio board.
4. Disconnect the harness from the connector CN515, CN516 and CN517 on the main board.
5. Remove the three screws I attaching the audio board.

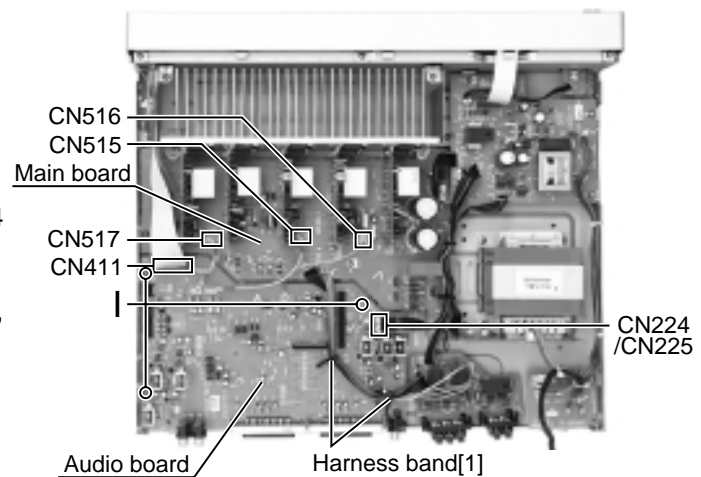

Fig.7

**■Removing the main board with speaker board (See Fig.8 to 10)**

• Prior to performing the following procedure, remove the top cover, rear panel, input board, DSP board and relay board (DSP).

1. Disconnect the harness from the connector CN515, CN516 and CN517 on the main board (see fig.7).
2. Remove the harness band[1] (see fig.7) and harness band[2] fixing the harness.
3. Disconnect the harness from the connector CN707 on the power supply board .
4. Disconnect the harness from the connector CN202 and CN226/CN227 on the main board .
5. Remove the five screws **J** and two screws **K** attaching the main board.
6. Remove the two screws **L** attaching the heat sink to the main board.
7. Disconnect the connector of each amp. board.

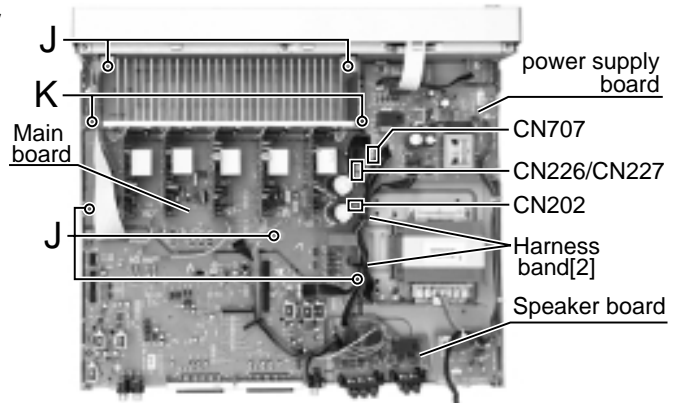

Fig.8

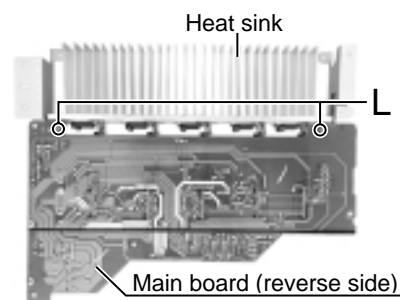

Fig.9

**■Removing the each amp. board of Cch, Lch, Rch, SLch and SRch (See Fig.11)**

• Prior to performing the following procedure, remove the top cover and main board.

1. Remove the two screws **M** attaching the Cch amp. board and remove the Cch amp. board.
2. Remove the two screws **N** attaching the Lch amp. board and remove the Lch amp. board.
3. Remove the two screws **O** attaching the Rch amp. board and remove the Rch amp. board.
4. Remove the two screws **P** attaching the SLch amp. board and remove the SLch amp. board.
5. Remove the two screws **Q** attaching the SRch amp. board and remove the SRch amp. board.

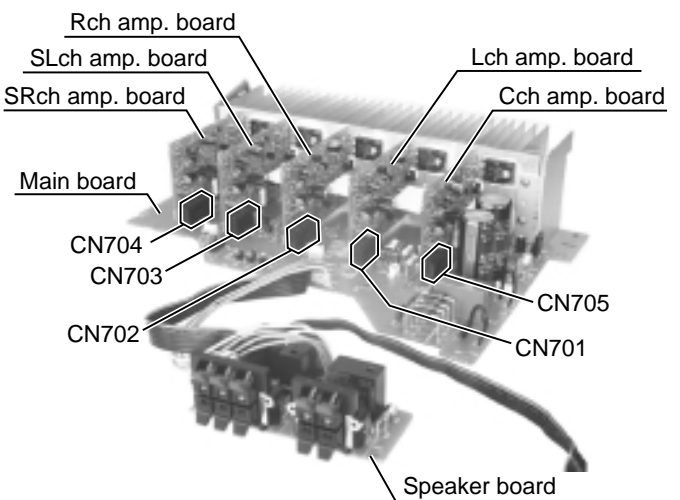

Fig.10

**■Removing the Heat sink (See Fig.11)**

• Prior to performing the following procedure, remove the top cover, main board and each amp. board.

1. Remove the four screws **R** attaching the two brackets to the heat sink and remove the two brackets.

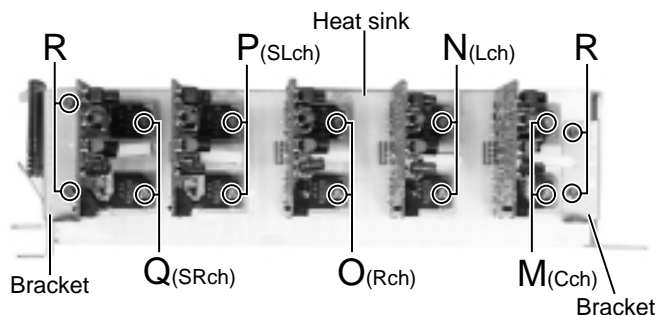

Fig.11

**■ Removing the power supply board**  
(See Fig.12)

- Prior to performing the following procedure, remove the top cover.
- 1. Disconnect the card wire from the connector CN204 on the power supply board.
- 2. Disconnect the harness from the connector CN201, CN209 and CN707 on the power supply board.
- 3. Disconnect the harness from the connector CN226 /CN227 on the main board
- 4. Remove the three screws **S** attaching the power supply board and pull out the power supply board removing the hook.
- 5. Unsolder the three harness connected to the power supply board (If necessary, cut off the band fixing the harness on the side of the base chassis).

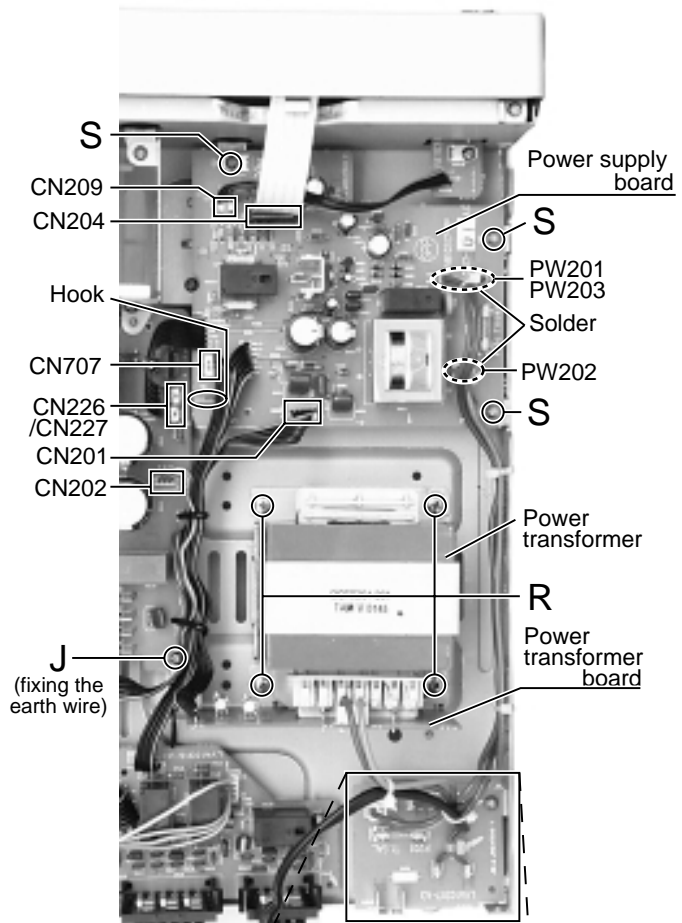

Fig.12

**■ Removing the power transformer**  
(See Fig.12 and 13)

- Prior to performing the following procedures, remove the top cover.
- 1. Cut off the tie band.
- 2. Disconnect the harness from the connector CN217 on the power/fuse board.
- 3. Disconnect the harness from the connector CN201 on the power supply board and CN202 on the main board.
- 4. Remove the one screw **J** and remove the earth wire.
- 5. Remove the four screws **R** attaching the power transformer.

**■ Removing the power/fuse board**  
(See Fig.13)

- Prior to performing the following procedure, remove the top cover.
- 1. Remove the screw **G** attaching the power/fuse board to the rear panel (see fig. 4).
- 2. Disconnect the harness from the connector CN217 on the power/fuse board (If necessary, cut off the band fixing the harness on the side of the base chassis).
- 3. Remove the screw **U** attaching the power/fuse board.
- 4. Unsolder the power cord and other harness connected to the power/fuse board.

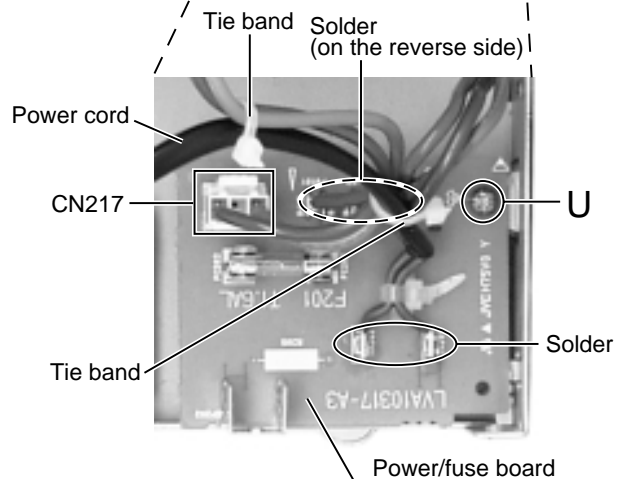

Fig.13

<Front panel assembly>

■ Removing the system control board with power switch board (See Fig.1 to 3)

• Prior to performing the following procedure, remove the top cover and front panel assembly.

1. Remove the two screws **A** attaching the power switch board.
2. Remove the eight screws **B** attaching the system control board.
3. Disconnect the card wire from the connector CN401, CN402 and CN412 on the system control board.
4. Remove the switch buttons and indicator esc., if needed.

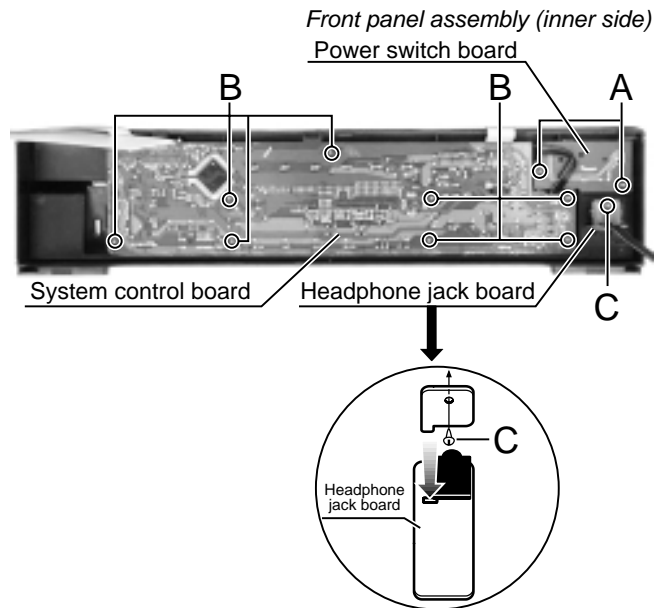

Fig.1

■ Removing the headphone jack board (See Fig.1)

• Prior to performing the following procedure, remove the top cover and front panel assembly.

1. Remove the screw **C** attaching the headphone jack board to the front panel assembly.

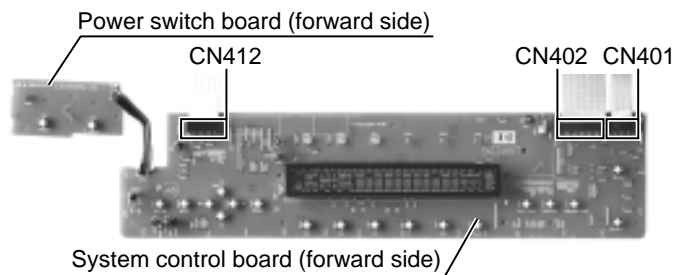

Fig.2

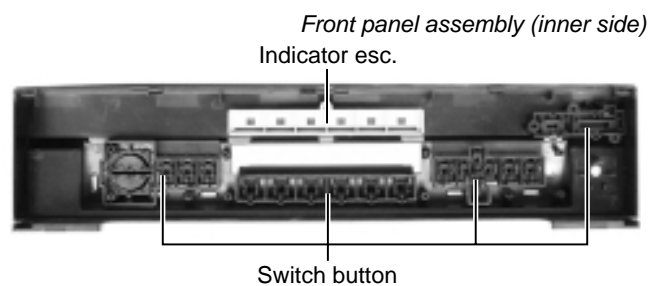

Fig.3

## Adjustment method

### ■ Power amplifier section

#### Adjustment of idling current

Measurement terminal      B451-B452(Lch) , B453-B454(Rch)

Adjustment volume        VR301(Lch) , VR302(Rch)

#### Attention

**This adjustment does not obtain a correct adjustment value immediately after the amplifier is used (state that an internal temperature has risen).**

**Please adjust immediately after using the amplifier after turning off the power supply of the amplifier and falling an internal temperature.**

<Adjustment method>

1. Prior to turning the power ON, fully turn the adjusting resistor (VR301(Lch),VR302(Rch)) counterclockwise direction and connect the DC voltmeter to the measuring terminal(B451-B452(Lch) , B453-B454(Rch)).
2. Set the surround mode OFF.
3. Adjust the resistor so that the measured value becomes 3.2mV immediately after turning the power ON.
4. When the idling current has been stable (about 30 minutes after the power is turned ON), confirm that the measured value falls within 1.0mV~10mV(2.7mV).

\* It is not abnormal though the idling current might not become 0mA even if it is finished to turn variable resistance (VR301VR302) in the direction of counterclockwise.

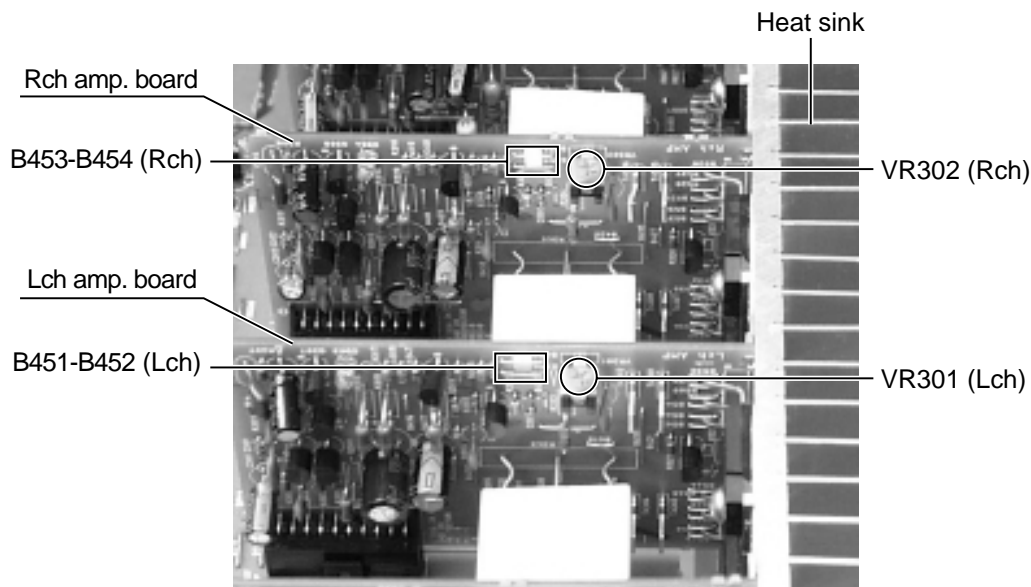



## Description of major ICs

### ■ UPD784215AGC (IC671) : Unit CPU

#### 1.Pin layout

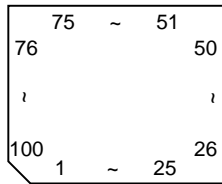

#### 2.Pin function

Pin No.	Symbol	I/O	Function
1~8		-	Non connect
9	VDD	-	Power supply terminal
10	X2	O	Connecting the crystal oscillator for system main clock
11	X1	I	Connecting the crystal oscillator for system main clock
12	VSS	-	Connect to GND
13	XT2	O	Connecting the crystal oscillator for system sub clock
14	XT1	I	Connecting the crystal oscillator for system sub clock
15	RESET	I	System reset signal input
16	AUTODATA	I	Output of DSP to general-purpose port
17	LOCK	I	Output of DSP to general-purpose port
18	DIGITAL0	I	Output of DSP to general-purpose port
19	FORMAT	I	Output of DSP to general-purpose port
20	CHANNEL	I	Output of DSP to general-purpose port
21	ERR	I	Output of DSP to general-purpose port
22	RSTDET	I	Reset signal input
23	AVDD	-	Power supply terminal
24	AVREF0	-	Connect to GND
25~32		-	Connect to GND
33	AVSS	-	Connect to GND
34,35		-	Non connect
36	AV REF1	-	Power supply terminal
37,38	RX,TX	-	Not use
39		-	Non connect
40	DSPCOM	I	Communication port
41	DSPSTS	O	Status communication port
42	DSPCLK	I	Clock input
43	DSPRDY	I	Ready signal input
44		-	Non connect
45,46	MIDIO_IN/OUT	I/O	Interface I/O terminal with microcomputer
47	MICK	O	Interface I/O terminal with microcomputer of clock signal
48	MICS	O	Interface I/O terminal with microcomputer of chip select
49	MILP	O	Interface I/O terminal with microcomputer
50	MIACK	O	Interface I/O terminal with microcomputer
51,52		-	Non connect
53	DSPRST	O	Reset signal output of DSP
54~63		-	Non connect
64,65	CDTI/CDTO	I/O	Interface I/O terminal with microcomputer
66	CCLK	O	Interface I/O terminal with microcomputer of clock signal
67	CS	O	Interface I/O terminal with microcomputer of chip select
68	XTS	O	OSC Select
69,70		-	Non connect
71	PD	O	Reset signal output
72	GND	-	Connect to GND
73~80		-	Non connect
81	VDD	-	Power supply
82,83		-	Non connect
84	ANA/T-TONE	O	Test tone control
85	LEF-MIX	O	Control at output destination of LFE channel
86		-	Non connect
87		O	Mute of the digital out terminal is controlled
88	S.MUTE	O	Mute of the audio signal is controlled
89		-	Non connect
90~93	ASW1~4	O	Selection of digital input selector
94	TEST	-	Test terminal
95~100		-	Non connect

■ AK4527B (IC601) : A/D,D/A Converter

1.Pin layout

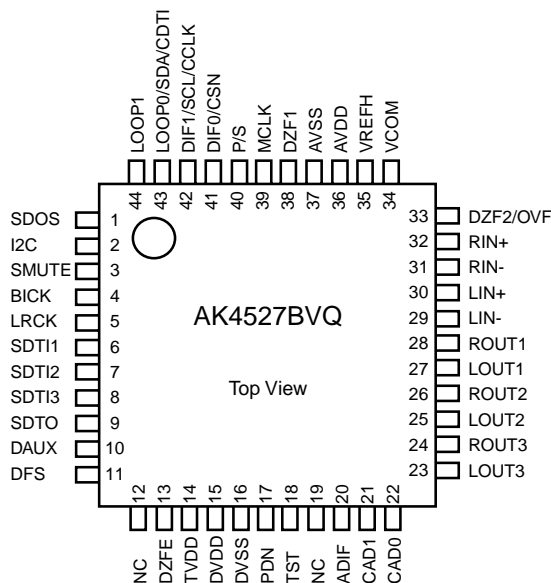

2. Pin function

(1/2)

No.	Pin name	I/O	Function
1	SDOS	I	SDTO Source Select Pin (Note 1) "L" : Internal ADC output, "H" : DAUX input
2	I2C	I	Control Mode Select Pin "L" : 3-wire Serial, "H" : I2C Bus
3	SMUTE	I	Soft Mute Pin (Note 1) When this pin goes to "H", soft mute cycle is initialized. When returning to "L", the output mute releases.
4	BICK	I	Audio Serial Data Clock Pin
5	LRCK	I/O	Input Channel Clock Pin
6	SDTI1	I	DAC1 Audio Serial Data Input Pin
7	SDTI2	I	DAC2 Audio Serial Data Input Pin
8	SDTI3	I	DAC3 Audio Serial Data Input Pin
9	SDTO	O	Audio Serial Data Output Pin
10	DAUX	I	Sub Audio Serial Data Input Pin
11	DFS	I	Double Speed Sampling Mode Pin (Note 1) "L" : Normal Speed, "H" : Double Speed
12	NC	-	No Connect No internal bonding.
13	DZEF	I	Zero Input Detect Enable Pin "L" : mode 7 (disable) at parallel mode, zero detect mode is selectable by DZFM2-0 bits at serial mode. "H" : mode 0 (DZF is AND of all six channels)
14	TVDD	-	Output Buffer Power supply Pin, 2.7V~5.5V
15	DVDD	-	Digital Power Supply Pin, 4.5V~5.5V
16	DVSS	-	De-emphasis Pin, 0V
17	PDN	I	Power-Down & Reset Pin When "L", the AK4527B is powered-down and the control registers are reset to default state. If the state of P/S or CAD0-1 changes, then the AK4527B must be reset by PDN.
18	TST	I	Test Pin This pin should be connected to DVSS.

## 2. Pin function

(2/2)

No.	Pin name	I/O	Function
19	NC	-	No Connect No internal bonding.
20	ADIF	I	Analog Input Format Select Pin "H" : Full-differential input, "L" : Single-ended input
21	CAD1	I	Chip Address 1 Pin
22	CAD0	I	Chip Address 0 Pin
23	LOUT3	O	DAC3 Lch Analog Output Pin
24	ROUT3	O	DAC3 Rch Analog Output Pin
25	LOUT2	O	DAC2 Lch Analog Output Pin
26	ROUT2	O	DAC2 Rch Analog Output Pin
27	LOUT1	O	DAC1 Lch Analog Output Pin
28	ROUT1	O	DAC1 Rch Analog Output Pin
29	LIN-	I	Lch Analog Negative Input Pin
30	LIN+	I	Lch Analog Positive Input Pin
31	RIN-	I	Rch Analog Negative Input Pin
32	RIN+	I	Rch Analog Positive Input Pin
33	DZF2	O	Zero Input Detect 2 Pin (Note 2) When the input data of the group 1 follow total 8192LRCK cycles with "0" input data, this pin goes to "H".
	OVF	O	Analog Input Overflow Detect Pin (Note 3) This pin goes to "H" if the analog input of Lch or Rch is overflows.
34	VCOM	O	Common Voltage Output Pin,AVDD/2 Large external capacitor around 2.2uF is used to reduce power-supply noise.
35	VREFH	I	Positive Voltage Reference Input Pin,AVDD
36	AVDD	-	Analog Power Supply Pin,4.5V~5.5V
37	AVSS	-	Analog Ground Pin,0V
38	DZF1	O	Zero Input Detect 1 Pin (Note 2) When the input data of the group 1 follow total 8192 LRCK cycles with "0" input data, this pin goes to "H".
39	MCLK	I	Master Clock Input Pin
40	P/S	I	Parallel / Serial Select Pin "L" : Serial control mode, "H" : Parallel control mode
41	DIF0	I	Audio Data Interface Format 0 Pin in parallel mode
	CSN	I	Chip select pin in 3-wire serial control mode This pin should be connected to DVDD at I2C bus control mode
42	DIF1	I	Audio Data Interface Format 1 Pin in parallel mode
	SCL/CCLK	I	Control Data Clock Pin in serial control mode I2C = "L" : CCLK(3-wire Serial), I2C = "H" : SCL(I2CBus)
43	LOOP0	I	Loopback Mode 0 Pin in parallel control mode Enables digital loop-back from ADC to 3 DACs.
	SAD/CDTI	I/O	Control Data Input Pin in serial control mode I2C = "L" : CDTI(3-wire Serial), I2C = "H" : SDA(I2CBus)
44	LOOP1	I	Loopback Mode 1 Pin (Note 1) Enable all 3 DAC channels to be input from SDTII.

- Notes : 1. SDOS, SMUTE, DFS, and LOOP1 pins are ORed with register data if P/S = "L".  
2. The group 1 and 2 can be selected by DZFM2-0 bit if P/S = "L" and DZFM2 = "L".  
3. This pin becomes OVF pin if OVFE bit is set to "1" at serial control mode.  
4. All input pins should not be left floating.

■ M61501FP (IC501) : Analog sound processor

1. Block diagram

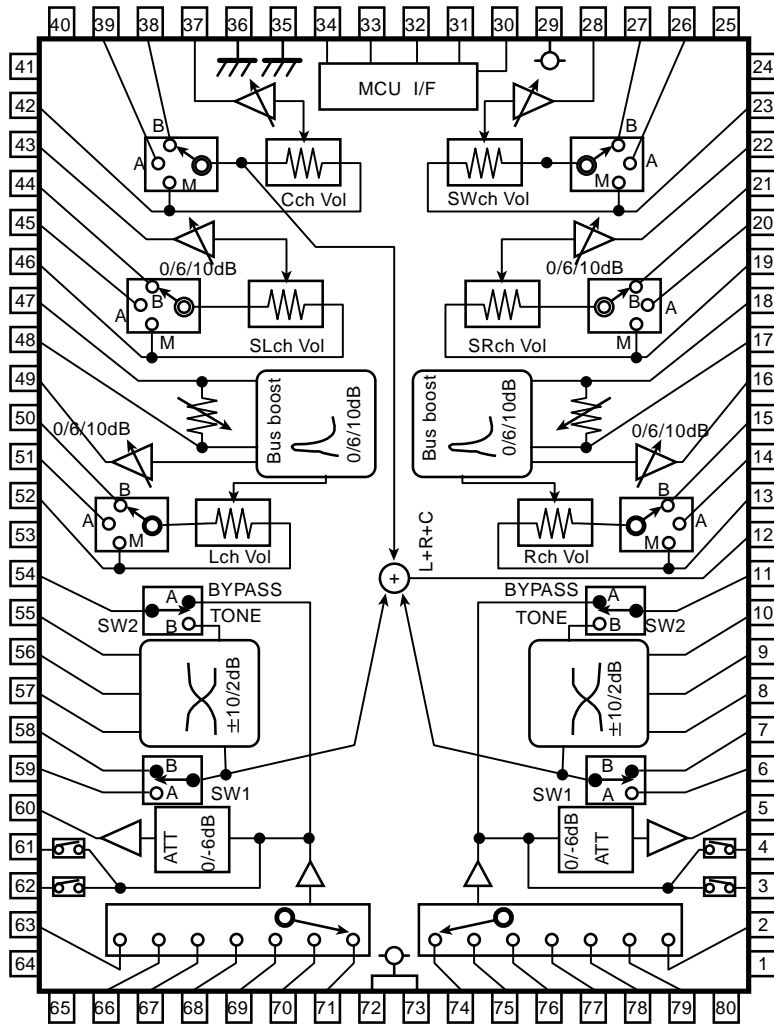

2. Pin function

(1/2)

Pin No.	Symbol	I/O	Function
1	NC	-	No connect
2	ING1	I	G signal input of right side input selector
3	RECOUT1B	O	B through signal output of right side
4	RECOUT1A	O	A through signal output of right side
5	SELOUT1	O	Signal output after 0/-6dB of right side
6	TINA1	I	Tone A signal input of right side
7	TINB1	I	Tone B signal input of right side
8	TCC	I	Tone C control of right side
9	TCB1	I	Tone B control of right side
10	TCA1	I	Tone A control of right side
11	TONEOUT1	O	Tone signal output of right side
12	SWOUT	O	L+R+C signal output
13	AGND	-	Analog ground for Rch
14	RchAIN	I	A select signal input of Rch
15	RchBIN	I	B select signal input of Rch
16	RchOUT	O	Signal output of Rch
17	RchBBO	O	Bus boost control output of Rch
18	RchBBI	I	Bus boost control input of Rch
19	AGND	-	Analog ground for SRch
20	SRchAIN	I	A signal input of SRch
21	SRchBIN	I	B signal input of SRch

## 2. Pin function

(2/2)

Pin No.	Symbol	I/O	Function
22	SRchOUT	O	Signal output of SRch
23	AGND	-	Analog ground for SWch
24	NC	-	No connect
25	NC	-	No connect
26	SWchAIN	I	A select signal input of SWch
27	SWchBIN	I	B select signal input of SWch
28	SWchOUT	O	Signal output of SWch
29	AVSS	-	Analog power supply
30	DVDD	-	Digital power supply
31	CLOCK	I	Digital clock input
32	DATA	I	Digital data input
33	LATCH	I	Digital latch input
34	DGND	-	Digital ground
35	AGND	-	Analog ground
36	AGND	-	Analog ground
37	CchOUT	O	Signal output of Cch
38	CchBIN	I	B select signal input of Cch
39	CchAIN	I	A select signal input of Cch
40	NC	-	No connect
41	NC	-	No connect
42	AGND	-	Analog ground for Cch
43	SLchOUT	O	Signal output of SLch
44	SLchBIN	I	B select signal input of SLch
45	SLchAIN	I	A select signal input of SLch
46	AGND	-	Analog ground for SLch
47	LchBBI	I	Bus boost control input of Lch
48	LchBBO	O	bus boost control output of Lch
49	LchOUT	O	Signal output of Lch
50	LchBIN	I	B select signal input of Lch
51	LchAIN	I	A select signal input of Lch
52	AGND	-	Analog ground for Lch
53	NC	-	No connect
54	TONEOUT2	O	Tone signal output of left side
55	TCA2	I	Tone A control of left side
56	TCB2	I	Tone B control of left side
57	TCC2	I	Tone C control of left side
58	TINB2	I	Tone B signal input of left side
59	TINA2	I	Tone A signal input of left side
60	SELOUT2	O	Signal output after 0/-6dB of left side
61	RECOUT2A	O	A through signal output of left side
62	RECOUT2B	O	B through signal output of left side
63	ING2	I	G signal input of left side input selector
64	NC	-	No connector
65	NC	-	No connector
66	INF2	I	F signal input of left side input selector
67	INE2	I	E signal input of left side input selector
68	IND2	I	D signal input of left side input selector
69	INC2	I	C signal input of left side input selector
70	INB2	I	B signal input of left side input selector
71	INA2	I	A signal input of left side input selector
72	AVDD	-	Analog power supply
73	AVDD	-	Analog power supply
74	INA1	I	A signal input of right side input selector
75	INB1	I	B signal input of right side input selector
76	INC1	I	C signal input of right side input selector
77	IND1	I	D signal input of right side input selector
78	INE1	I	E signal input of right side input selector
79	ING1	I	F signal input of right side input selector
80	NC	-	No connect

■ LA1838(IC102) : FM AM IF amp. & detector, FM MPX decoder

1. Block diagram

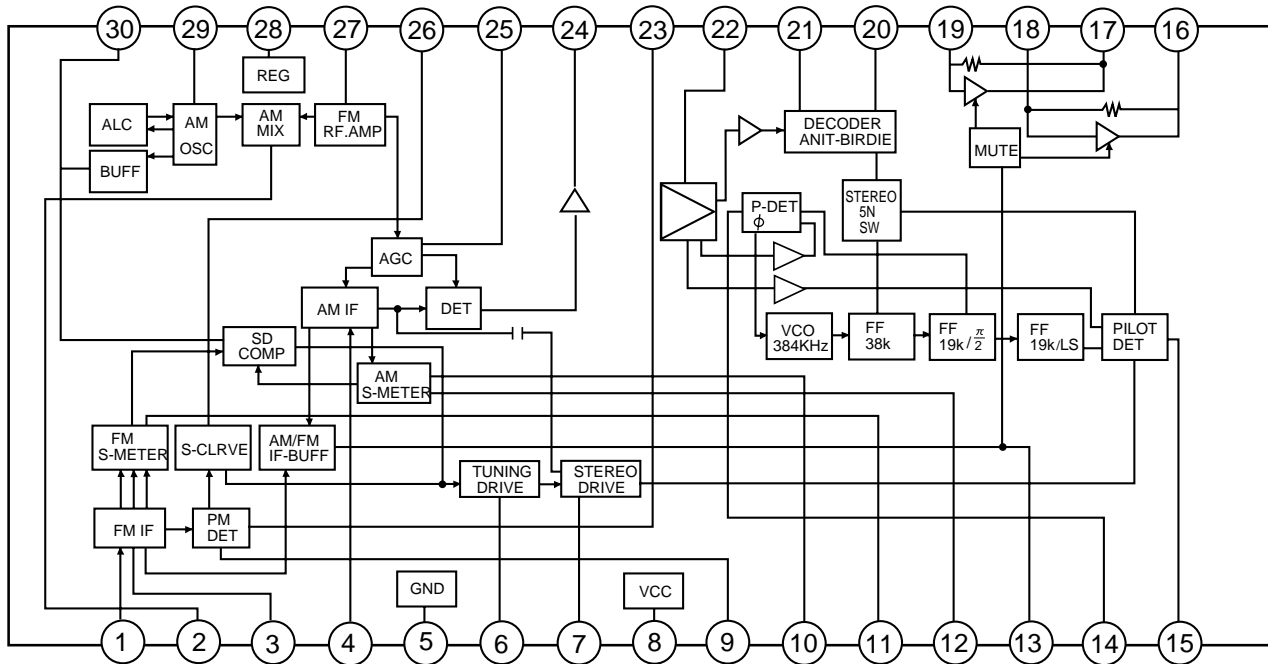

2. Pin function

Pin No.	Symbol	I/O	Function	Pin No.	Symbol	I/O	Function
1	FM IN	I	This is an input terminal of FM IF signal.	16	L OUT	O	Left channel signal output.
2	AM MIX	O	This is an out put terminal for AM mixer.	17	R OUT	O	Right channel signal output.
3	FM IF	I	Bypass of FM IF	18	L IN	I	Input terminal of the left channel post AMP.
4	AM IF	I	Input of AM IF Signal.	19	R IN	I	Input terminal of the right channel post AMP.
5	GND	-	This is the device ground terminal.	20	RO	O	Mpx Right channel signal output.
6	TUNED	O	When the set is tuning, this terminal becomes "L".	21	LO	O	Mpx Left channel signal output.
7	STEREO	O	Stereo indicator output. Stereo "L", Mono: "H"	22	IF IN	I	Mpx input terminal
8	VCC	-	This is the power supply terminal.	23	FM OUT	O	FM detection output.
9	FM DET	-	FM detect transformer.	24	AM DET	O	AM detection output.
10	AM SD	-	This is a terminal of AM ceramic filter.	25	AM AGC	I	This is an AGC voltage input terminal for AM
11	FM VSM	O	Adjust FM SD sensitivity.	26	AFC	-	This is an output terminal of voltage for FM-AFC.
12	AM VSM	O	Adjust AM SD sensitivity.	27	AM RF	I	AM RF signal input.
13	MUTE	I/O	When the signal of IF REQ of IC121( LC72131) appear, the signal of FM/AM IF output. //Muting control input.	28	REG	O	Register value between pin 26 and pin28 desides the frequency width of the input signal.
14	FM/AM	I	Change over the FM/AM input. "H" :FM, "L" : AM	29	AM OSC	-	This is a terminal of AM Local oscillation circuit.
15	MONO/ST	O	Stereo : "H", Mono: "L"	30	OSC BUFFER	O	AM Local oscillation Signal output.

■ LC72136N (IC121) : PLL frequency synthesizer

1. Pin layout

XT	1	22	XT
FM/AM	2	21	GND
CE	3	20	LPFOUT
DI	4	19	LPFIN
CLOCK	5	18	PD
DO	6	17	VCC
FM/ST/VCO	7	16	FMIN
AM/FM	8	15	AMIN
	9	14	
	10	13	IFCONT
SDIN	11	12	IFIN

2. Block diagram

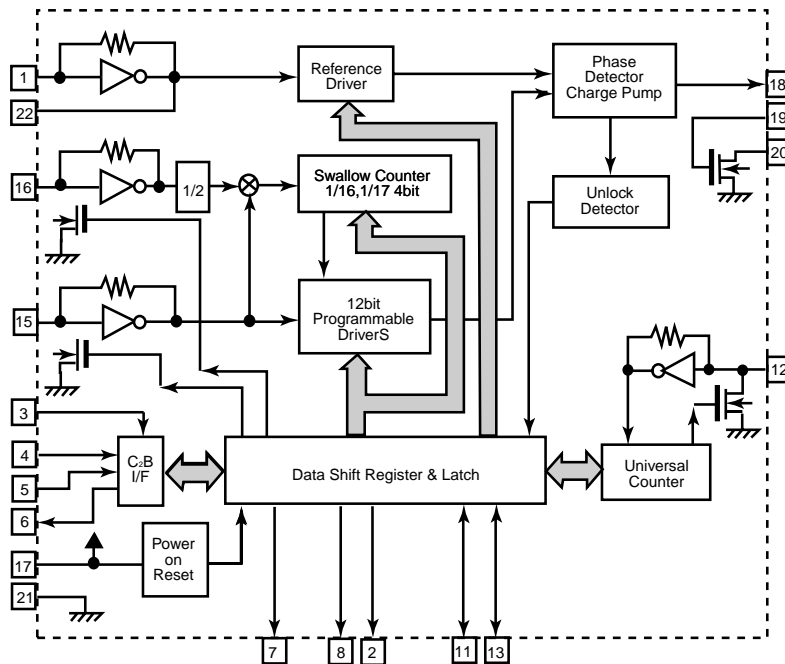

3. Pin function

Pin No.	Symbol	I/O	Function	Pin No.	Symbol	I/O	Function
1	XT	I	X'tal oscillator connect (75kHz)	12	IFIN	I	IF counter signal input
2	FM/AM	O	LOW:FM mode	13	IFCONT	O	IF signal output
3	CE	I	When data output/input for 4pin(input) and 6pin(output): H	14		-	Not use
4	DI	I	Input for receive the serial data from controller	15	AMIN	I	AM Local OSC signal output
5	CLOCK	I	Sync signal input use	16	FMIN	I	FM Local OSC signal input
6	DO	O	Data output for Controller Output port	17	VCC	-	Power supply(VDD=4.5-5.5V) When power ON:Reset circuit move
7	FM/ST/VCO	O	"Low": MW mode	18	PD	O	PLL charge pump output(H: Local OSC frequency Height than Reference frequency. L: Low Agreement: Height impedance)
8	AM/FM	O	Open state after the power on reset	19	LPFIN	I	Input for active lowpassfilter of PLL
9	LW	I/O	Input/output port	20	LPFOUT	O	Output for active lowpassfilter of PLL
10	MW	I/O	Input/output port	21	GND	-	Connected to GND
11	SDIN	I/O	Data input/output	22	XT	I	X'tal oscillator(75KHz)

■ NJU3713 (IC402) : L.E.D. driver

1.Pin layout

P5	1	18	V <sub>DD</sub>
P6	2	17	P4
P7	3	16	P3
P8	4	15	P2
V <sub>SS</sub>	5	14	P1
P9	6	13	CLR
P10	7	12	STB
p11	8	11	CLK
P12	9	10	DATA

2.Block diagram

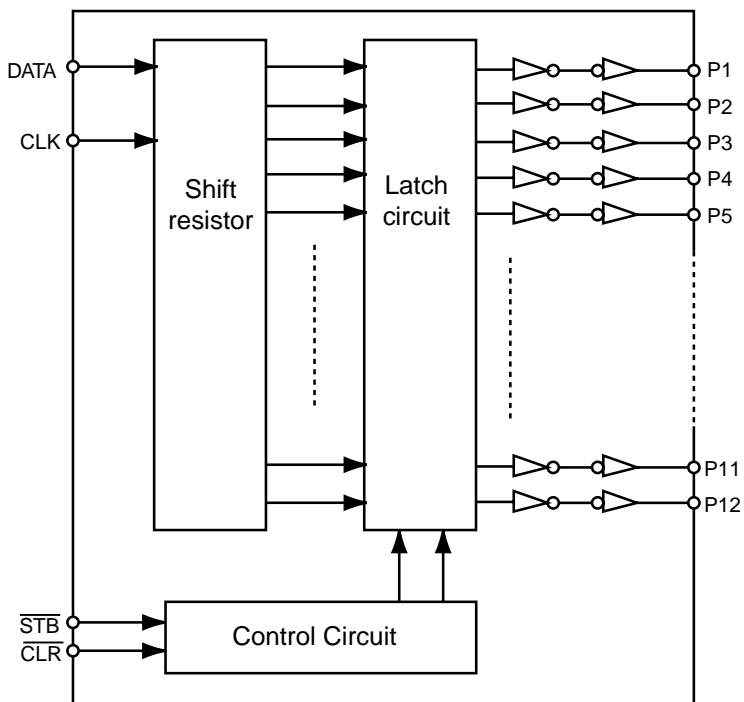

3.Pin function

PIN No.	I/O	Symbol	Function
1~4	O	P5, P6, P7, P8	Parallel conversion data output terminal.
5	-	V <sub>SS</sub>	Connect to GND.
6~9	O	P9, P10, P11, P12	Parallel conversion data output terminal.
10	O	DATA	Serial data input terminal.
11	I	CLK	Clock signal input terminal.
12	I	STB	Strobe signal input terminal.
13	I	CLR	Clear signal input terminal.
14	O	P1	Parallel conversion data output terminal.
15	O	P2	Parallel conversion data output terminal.
16~17	O	P3, p4,	Parallel conversion data output terminal.
18	-	V <sub>DD</sub>	Power supply terminal.



■ SAA6588 (IC191) : RDS detector

1. Pin layout



2. Pin function

Pin No.	Symbol	I/O	Function
1	MRO	O	Multi-path rectifier output
2	NC	-	Non connect
3	GND	I	Test control input pin
4	OSCO	O	Oscillator output
5	OSCI	I	Oscillator input
6	VSSD	-	Digital ground (0V)
7	VDDD	-	Digital power supply (5V)
8	DAVN	O	Data available output (active LOW)
9	SDA	I/O	IC-bus serial data I/O
10	SCL	I	IC-bus serial clock input
11	NC	-	Non connect
12	GND	-	Connect to ground
13	NC	-	Non connect
14	VDDA	-	Analog power supply (5V)
15	VSSA	-	Connect to ground
16	MPX	I	Multiplex input signal
17	Vref	O	Reference voltage output
18	SCOUT	O	Band-pass filter output
19	CIN	O	Comparator output
20	NC	I	Level input

3. Block diagram

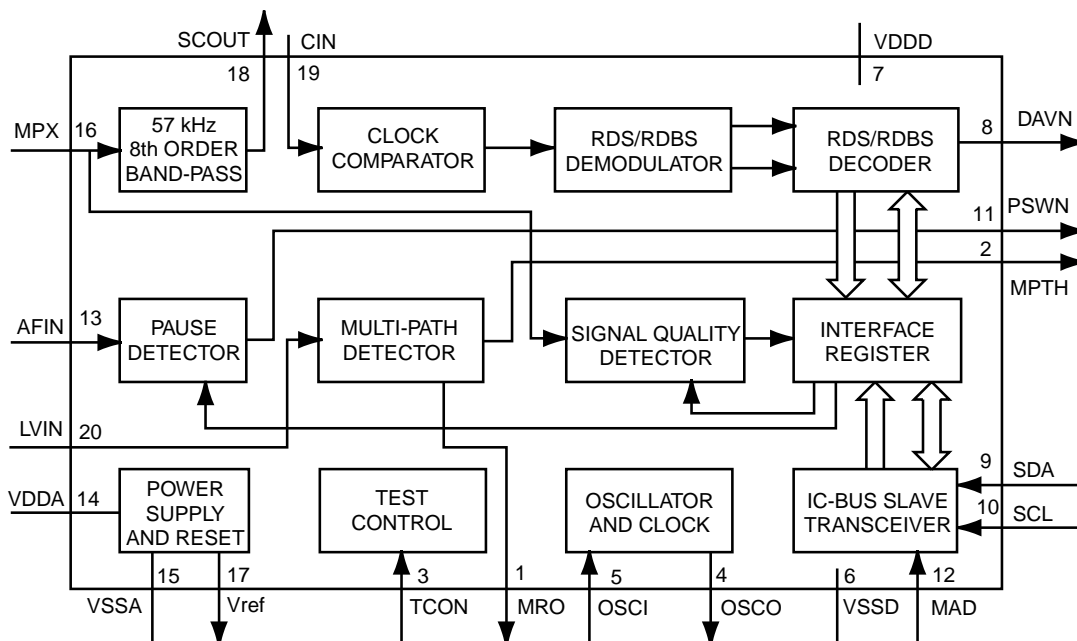

**TC9446F-025 (IC631) : Audio digital processor**

1. Block diagram

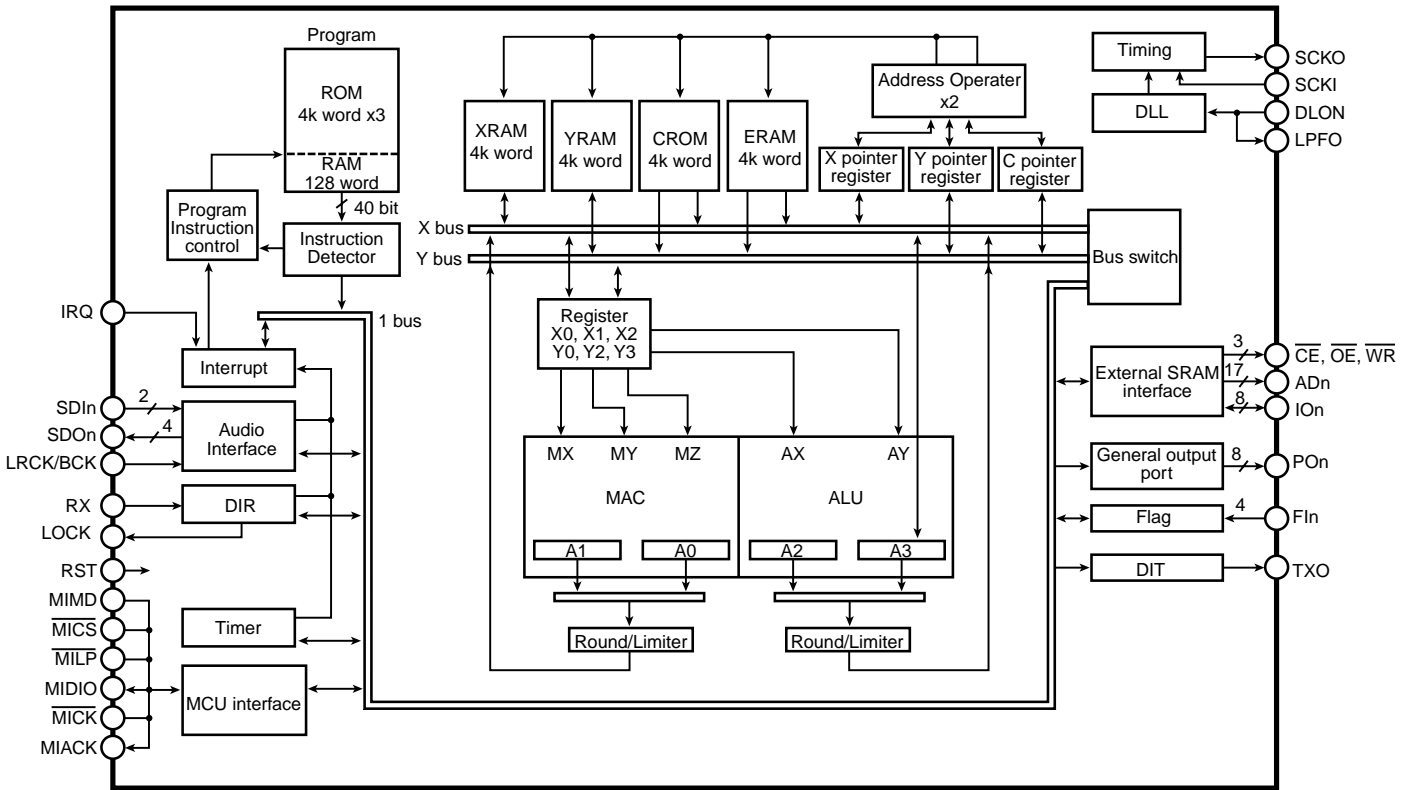

2. Pin function

Pin No.	Symbol	I/O	Function
1	RST	I	Reset signal input terminal (L:reset H:normal operation)
2	MIMD	I	Mode select input for MCU interface (L:serial H:IC bus)
3	MICS	I	Chip select input for MCU interface
4	MILP	I	Latch pulse input for MCU interface
5	MIDIO	I/O	Data I/O for MCU interface
6	MICK	I	Clock input for MCU interface
7	MIACK	O	Acknowledge output for MCU interface
8-11	FI0-3	I	Flag input 0-3
12	IRQ	I	Interrupt input
13	VSS	-	Digital ground
14	LRCKA	I	LR clock input-A for audio interface
15	BCKA	I	Bit clock input-A for audio interface
16-19	SDO0-3	O	Data output-0-3 for audio interface
20	LRCKB	I	LR clock input-B for audio interface
21	BCKB	I	Bit clock input-B for audio interface
22, 23	SDI0, 1	I	Data input-0, 1 for audio interface
24	VDD	-	Digital power supply
25	LRCKOA	O	LR clock output-A for audio interface
26	BCKOA	O	Bit clock output-A for audio interface
27, 28	TEST0,1	I	Test input-0, 1 (L:test H:normal operation)
29	LRCKOB	O	LR clock output-B for audio interface
30	BCKOB	O	Bit clock output-B for audio interface
31	TXO	O	SPDIF output
32,33	TEST2,3	I	Test input-2, 3 (L:test H:normal operation)
34	RX	I	SPDIF input
35	VSS	-	Digital ground
36	TSTSUB0	I	Test sub input-0 (L:test H:normal operation)
37	FCONT	O	Frequency control output for VCO circuit
38	TSTSUB1	I	Test sub input-1, 2
39	TSTSUB2	I	(L:test H:normal operation)
40	PDO	O	Phase detect signal output

Pin No.	Symbol	I/O	Function
41	VDDA	-	Analog power supply
42	PLON	I	Clock selection input (L:external clock H:VCO clock)
43	AMPI	I	AMP input for LPF
44	AMPO	O	AMP output for LPF
45	CKI	I	External clock input
46	VSSA	-	Analog ground
47	CKO	O	DIR clock output
48	LOCK	O	VCO lock output
49	VSS	-	Digital ground
50	WR	O	Writing signal output for external SRAM
51	OE	O	Enable signal output for external SRAM
52	CE	O	Chip enable signal output for external SRAM
53	VDD	-	Digital power supply
54-61	IO7-0	I/O	Data I/O-7-0 for external SRAM
62	VSS	-	Digital ground
63-70	AD0-7	O	Address output-0-7 for external SRAM
71	VDD	-	Digital power supply
72-80	AD8-16	O	Address output-8-16 for external SRAM
81	VSS	-	Digital ground
82-89	PO0-7	O	General output port-0-7
90	VDDDL	-	Power supply for DLL circuit
91	LPFO	O	LPF output for DLL circuit
92	DLON	I	*
93	DLCKS	I	*
94	SCKO	O	ASP clock output
95	VSSDL	-	Ground for DLL circuit
96	SCKI	I	External system clock input
97	VSSX	-	Ground for crystal oscillator
98, 99	XO,XI	I/O	Crystal oscillator I/O
100	VDDX	-	Digital power supply

\*

DLCKS pin	DLON pin	DLL clock setting
L	L	SCKI input (DLL circuit OFF)
L	H	Four times XI clock
H	L	Three times XI clock
H	H	Six times XI clock

■ **BA033LBSG (IC683) : Standard voltage power supply**

1. Block diagram

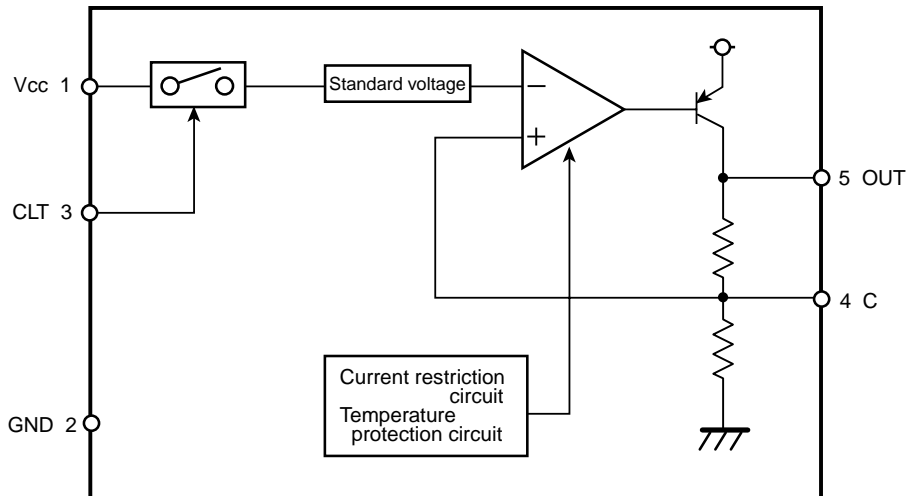

■ **BA15218F (IC503, IC609, IC610, IC650, IC651, IC661, IC690, IC691) : OP amp.**

1. Block diagram

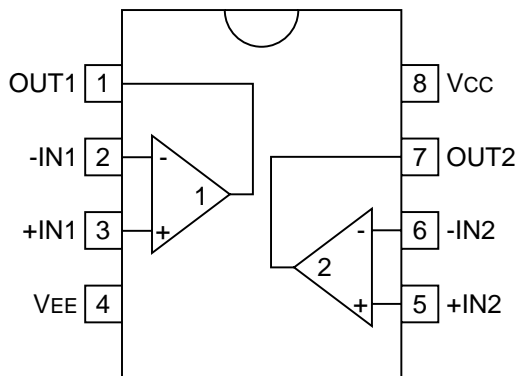

■ **BA7625 (IC514) : Video selector**

1. Block diagram

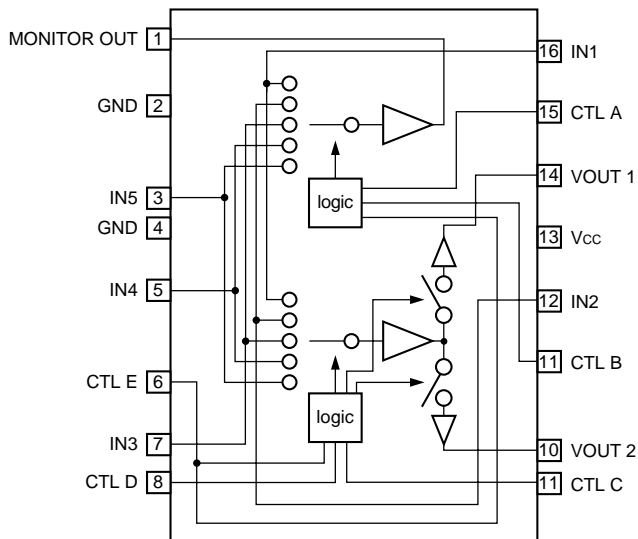

2. Truth table

A	B	E	MONITOR OUT
L	L	*	IN1
H	L	*	IN2
L	H	*	IN3
H	H	L	IN4
H	H	H	IN5

C	D	E	VOUT1
L	L	*	--
H	L	*	IN2
L	H	*	IN3
H	H	L	IN4
H	H	H	IN5

C	D	E	VOUT2
L	L	*	IN1
H	L	*	--
L	H	*	IN3
H	H	L	IN4
H	H	H	IN5

■ **TC74HC08AF (IC611) : AND gate**

1. Pin layout

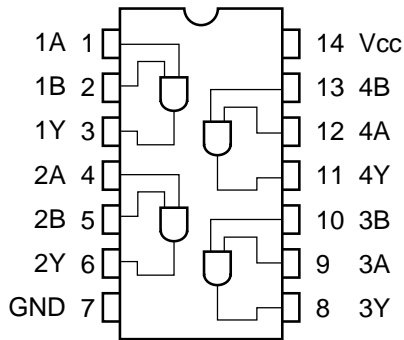

2. Truth table

A	B	Y
L	L	L
L	H	L
H	L	L
H	H	H

■ **TC74HC4072AF (IC612) : OR gate**

1. Pin layout

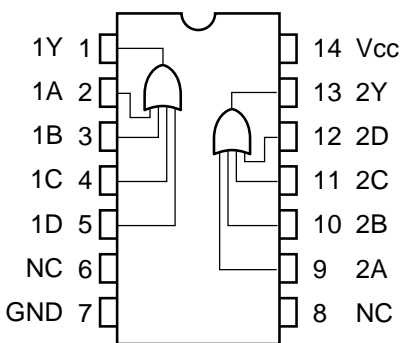

2. Truth table

A	B	C	D	Y
H	X	X	X	H
X	H	X	X	H
X	X	H	X	H
X	X	X	H	H
L	L	L	L	L

X : Don't care

■ **TC74HC4053A (IC515) : Multiplexer**

1. Pin layout

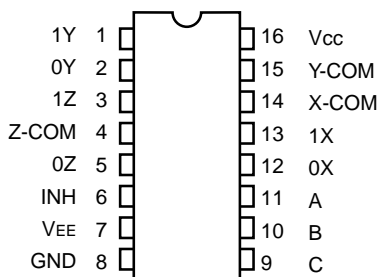

2. Truth table

CONTROL INPUTS				"ON" CHANNEL
INHIBIT	C	B	A	
L	L	L	L	0X, 0Y, 0Z
L	L	L	H	1X, 0Y, 0Z
L	L	H	L	0X, 1Y, 0Z
L	L	H	H	1X, 1Y, 0Z
L	H	L	L	0X, 0Y, 1Z
L	H	L	H	1X, 0Y, 1Z
L	H	H	L	0X, 1Y, 1Z
L	H	H	H	1X, 1Y, 1Z
H	X	X	X	NONE

X: Don't Care.

■ NJM2246M (IC511, IC512, IC513) : Video switch

1. Block diagram

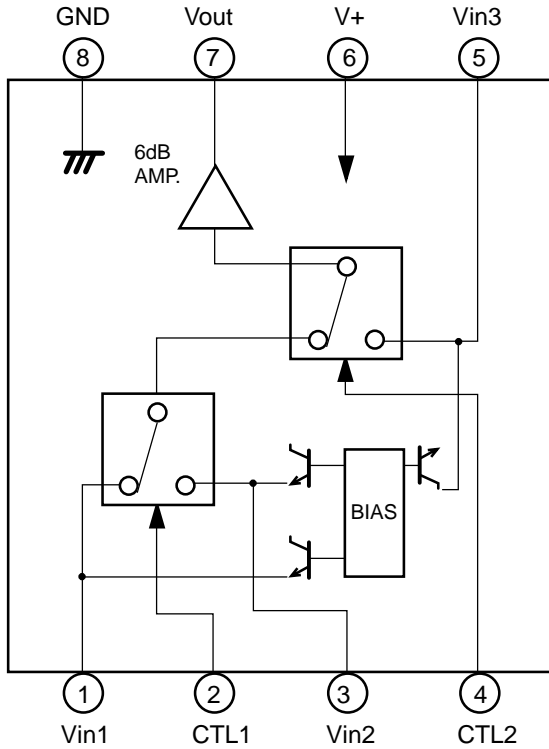

INPUT CONTROL SIGNAL- OUTPUT SIGNAL

CTL1	CTL2	OUTPUT SIGNAL
L	L	Vin1
H	L	Vin2
L/H	H	Vin3

■ TC74HCU04AF (IC621) : Inverter

1. Pin layout

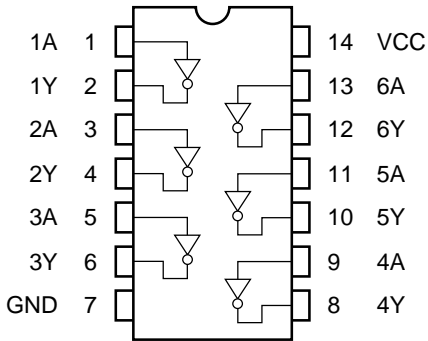

A	Y
L	H
H	L

■ TC7SET32FU (IC672) : 2 input or gate

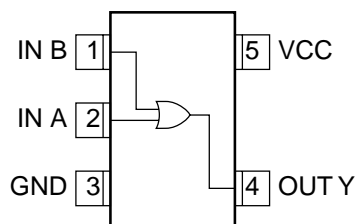
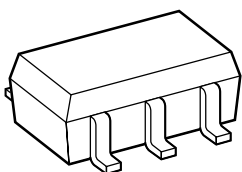

■ W24L010AJ-12 (IC641) : CMOS SRAM

1. Pin layout

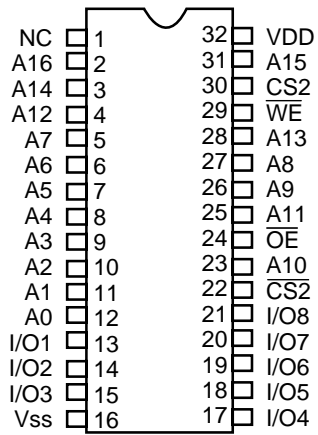

2. Block diagram

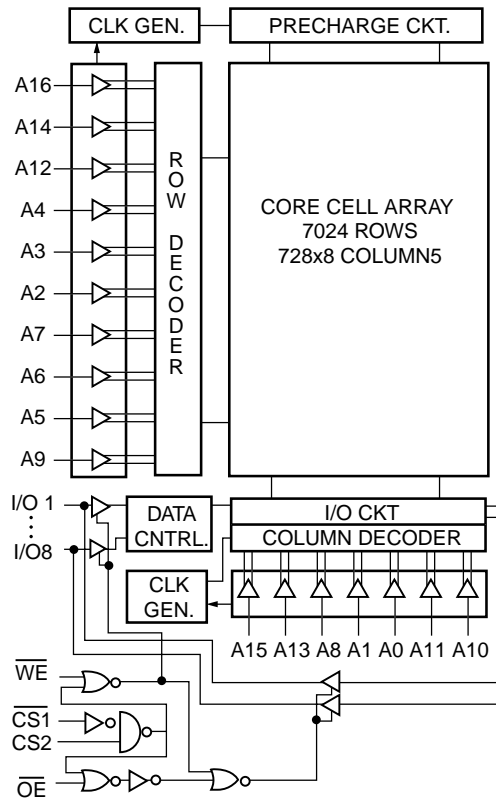

# Block diagram

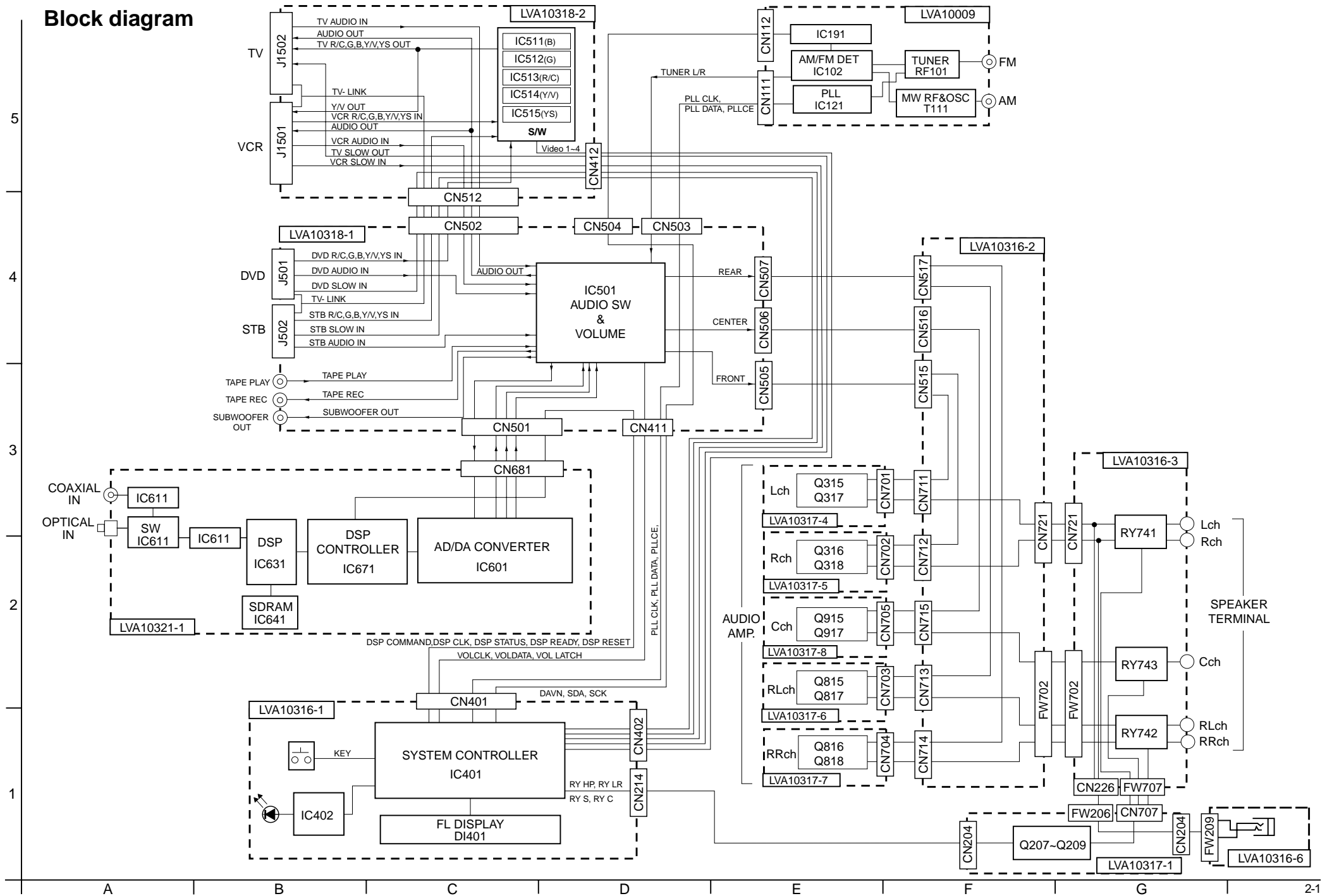

# Standard schematic diagrams

## Power supply section

SHEET NUMBER	CIRCUIT DESCRIPTION
1 / 8	POWER SUPPLY
2 / 8	SPEAKER TERMINAL
3 / 8	AUDIO AMP
4 / 8	AUDIO SIGNAL INPUT TERMINAL
5 / 8	VIDEO&AUDIO SIGNAL INPUT TERMINAL
6 / 8	SYSTEM CONTROL & FL DISPLAY
7 / 8	DSP
8 / 8	TUNER

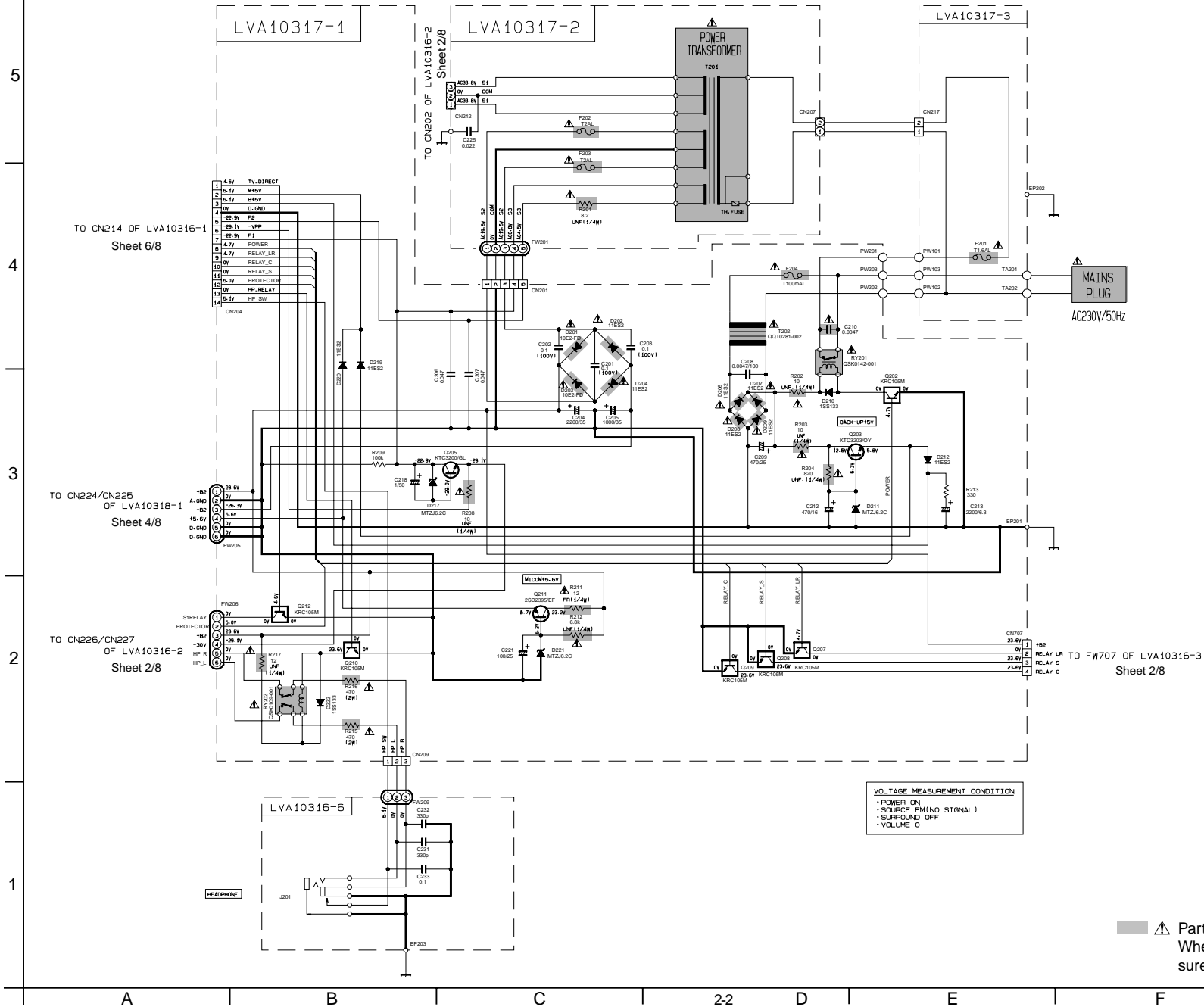

▲ Parts are safety assurance parts.  
When replacing those parts, make sure to use the specified parts.



■ Speaker terminal section

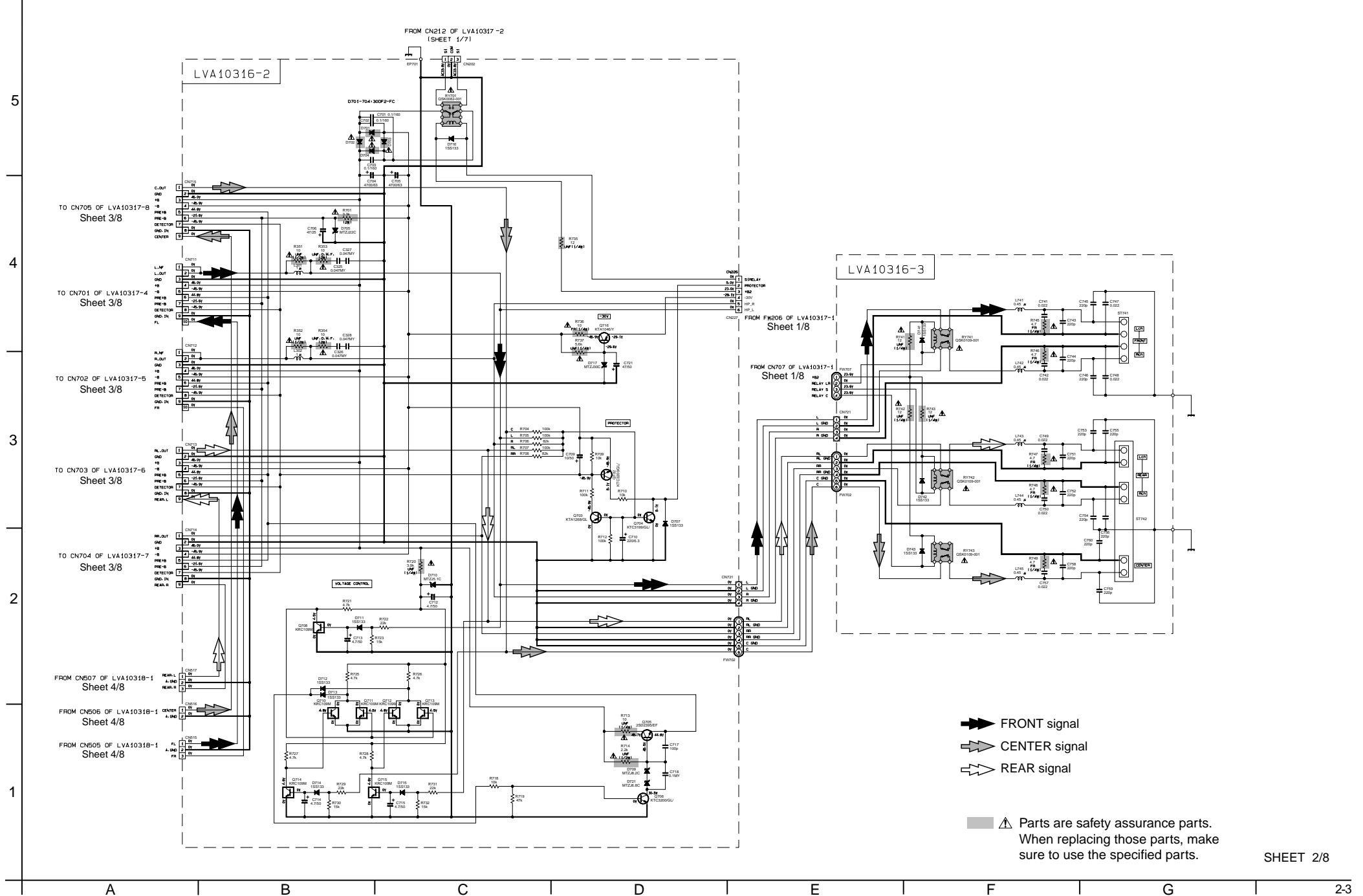

■ Audio amp section

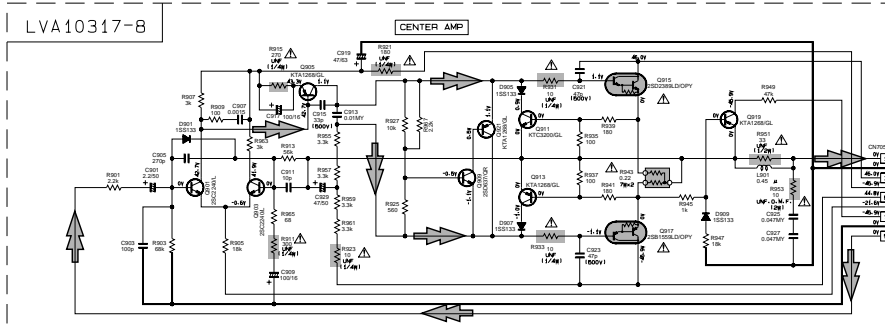

FROM CN715 OF LVA10316-2 Sheet 2/8

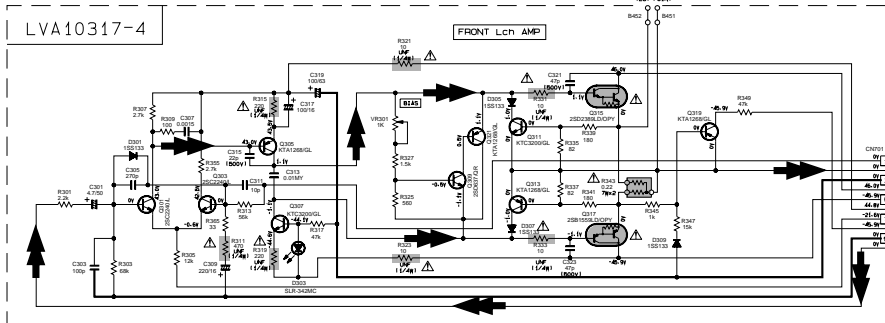

FROM CN711 OF LVA10316-2 Sheet 2/8

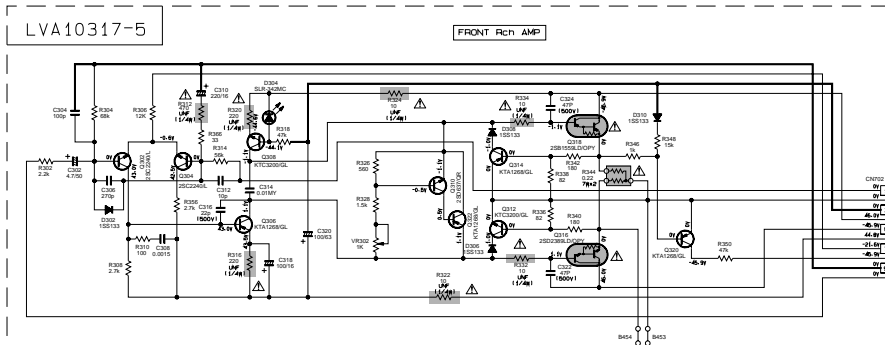

FROM CN712 OF LVA10316-2 Sheet 2/8

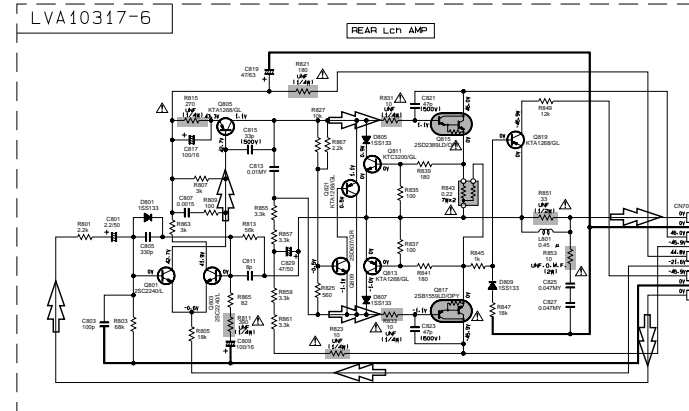

FROM CN713 OF LVA10316-2 Sheet 2/8

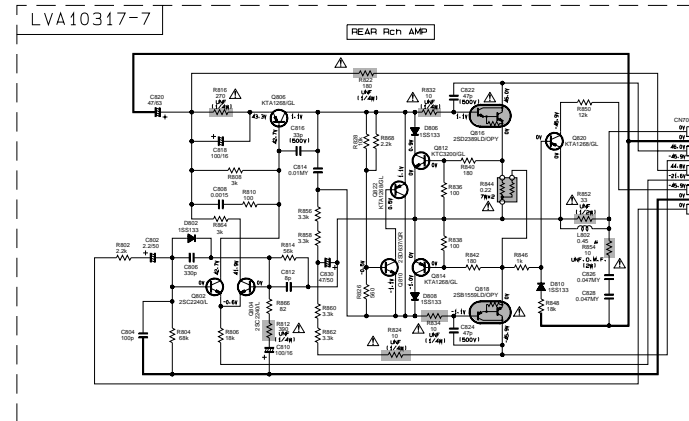

FROM CN714 OF LVA10316-2 Sheet 2/8

- ➡ FRONT signal
- ➡ CENTER signal
- ➡ REAR signal

⚠ Parts are safety assurance parts.  
When replacing those parts, make sure to use the specified parts.

5

4

3

2

1

■ Audio signal input terminal section

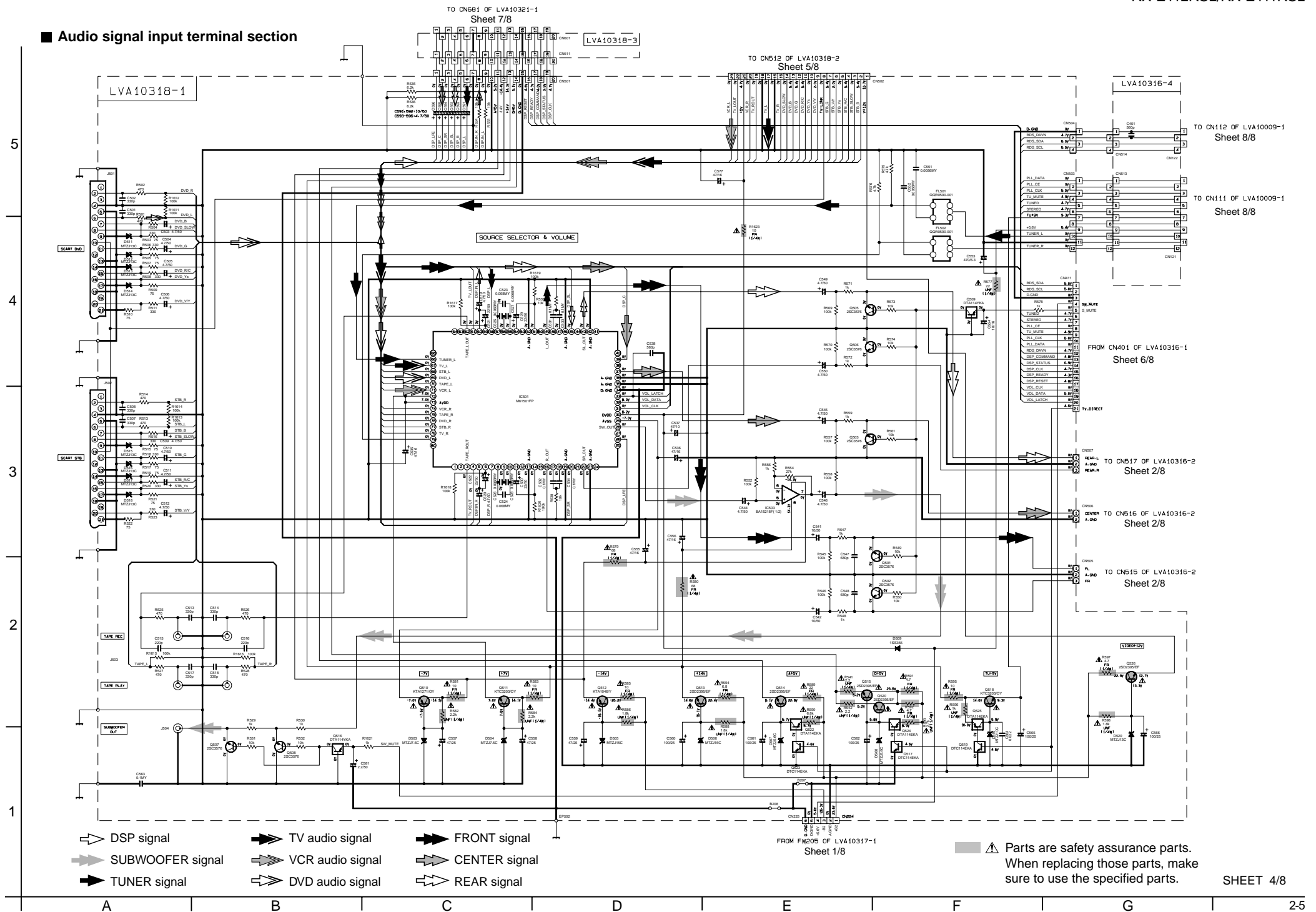

- ⇨ DSP signal
- ⇨ TV audio signal
- ⇨ FRONT signal
- ⇨ SUBWOOFER signal
- ⇨ VCR audio signal
- ⇨ CENTER signal
- ⇨ TUNER signal
- ⇨ DVD audio signal
- ⇨ REAR signal

Parts are safety assurance parts.  
When replacing those parts, make  
sure to use the specified parts.

Video & Audio input terminal section

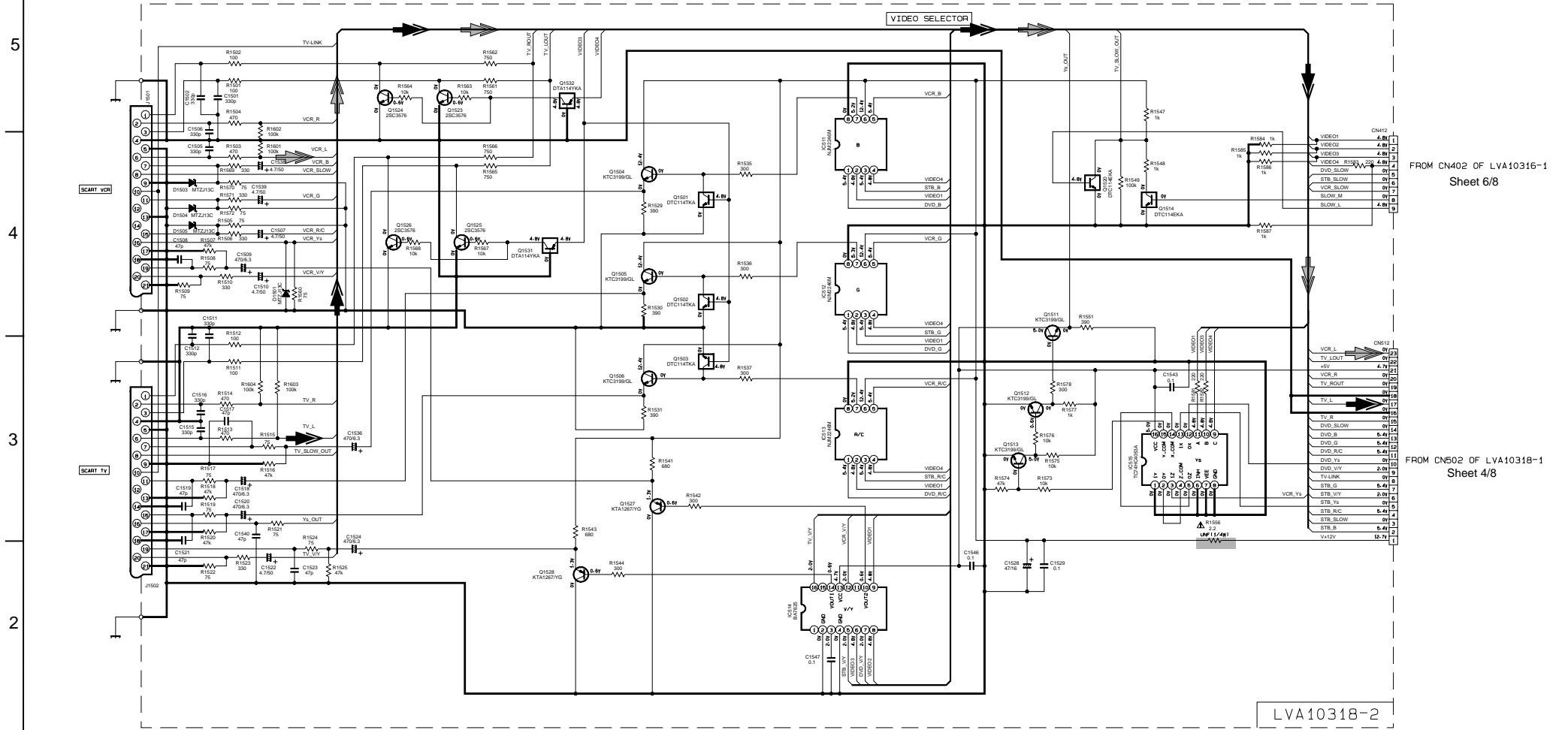

CONTROL LOGIC

SOURCE	VIDEO1	VIDEO2	VIDEO3	VIDEO4
DVD	L	H	L	L
STB	H	H	L	L
VCR	H	L	L	H
TV	L	L	H	L
TAPE	H	H	H	H
FM/AM	H	H	H	H

TV audio signal  
 VCR audio signal

Parts are safety assurance parts.  
 When replacing those parts, make sure to use the specified parts.

■ System control & FL display section

5  
4  
3  
2  
1

LVA10316-1

LVA10316-5

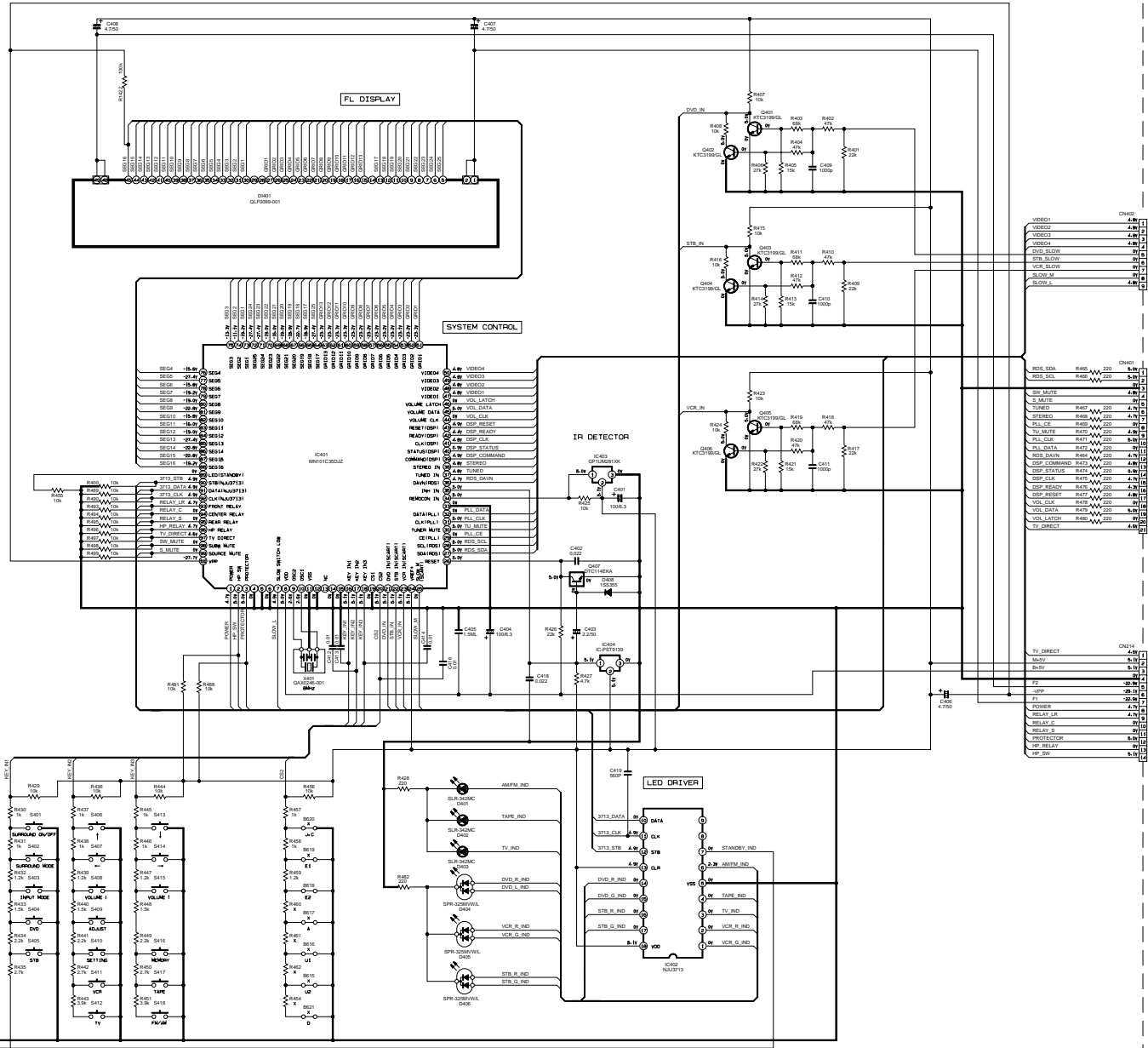

TO CN412 OF LVA10318-2  
Sheet 5/8

TO CN411 OF LVA10318-1  
Sheet 4/8

FROM CN204 OF LVA10317-1  
Sheet 1/8

■ DSP section

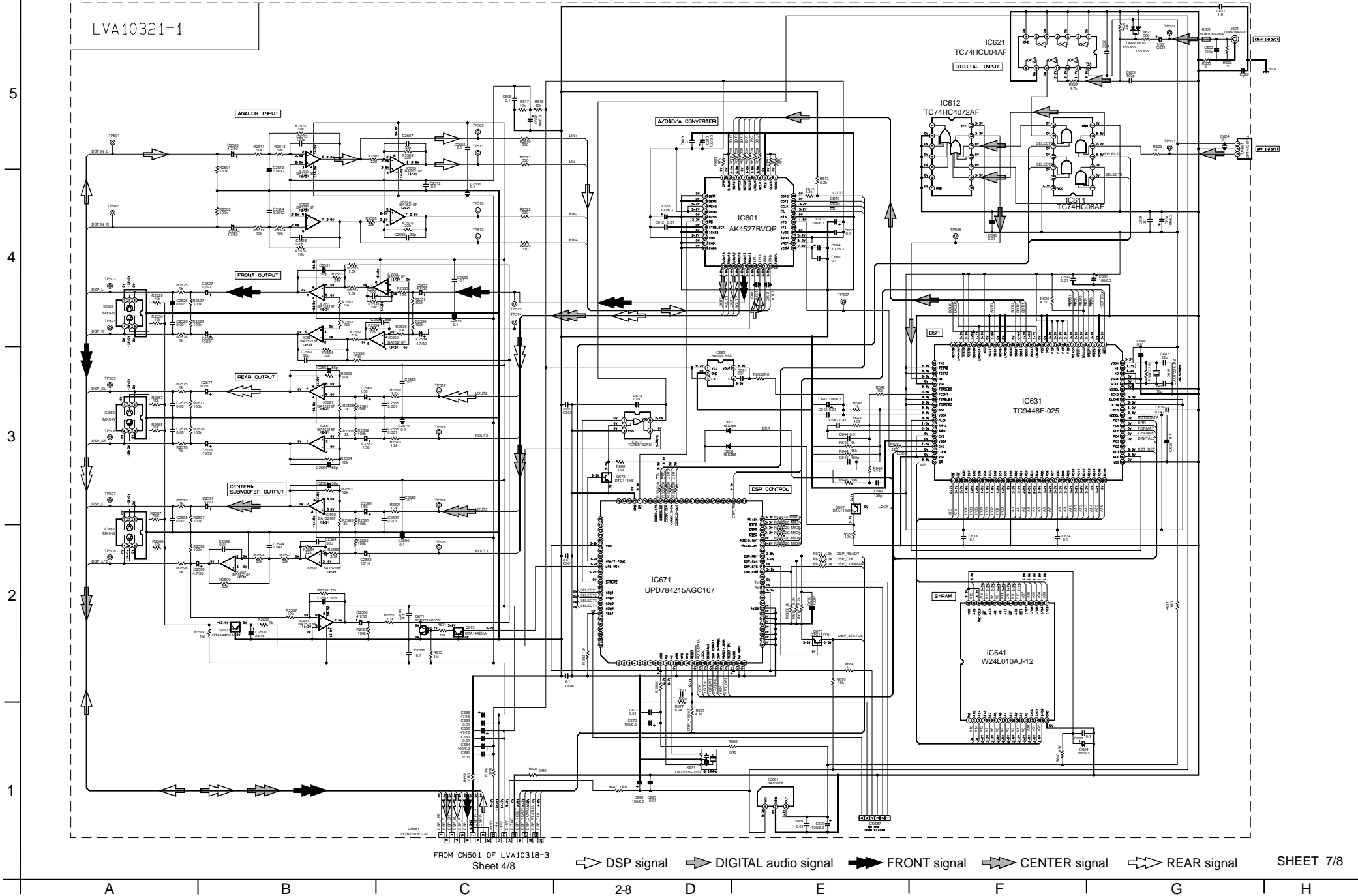

FROM CN601 OF LVA10318-3  
Sheet 4/8

Tuner section

FOR E/EN/B (WITH RDS)

LVA10009

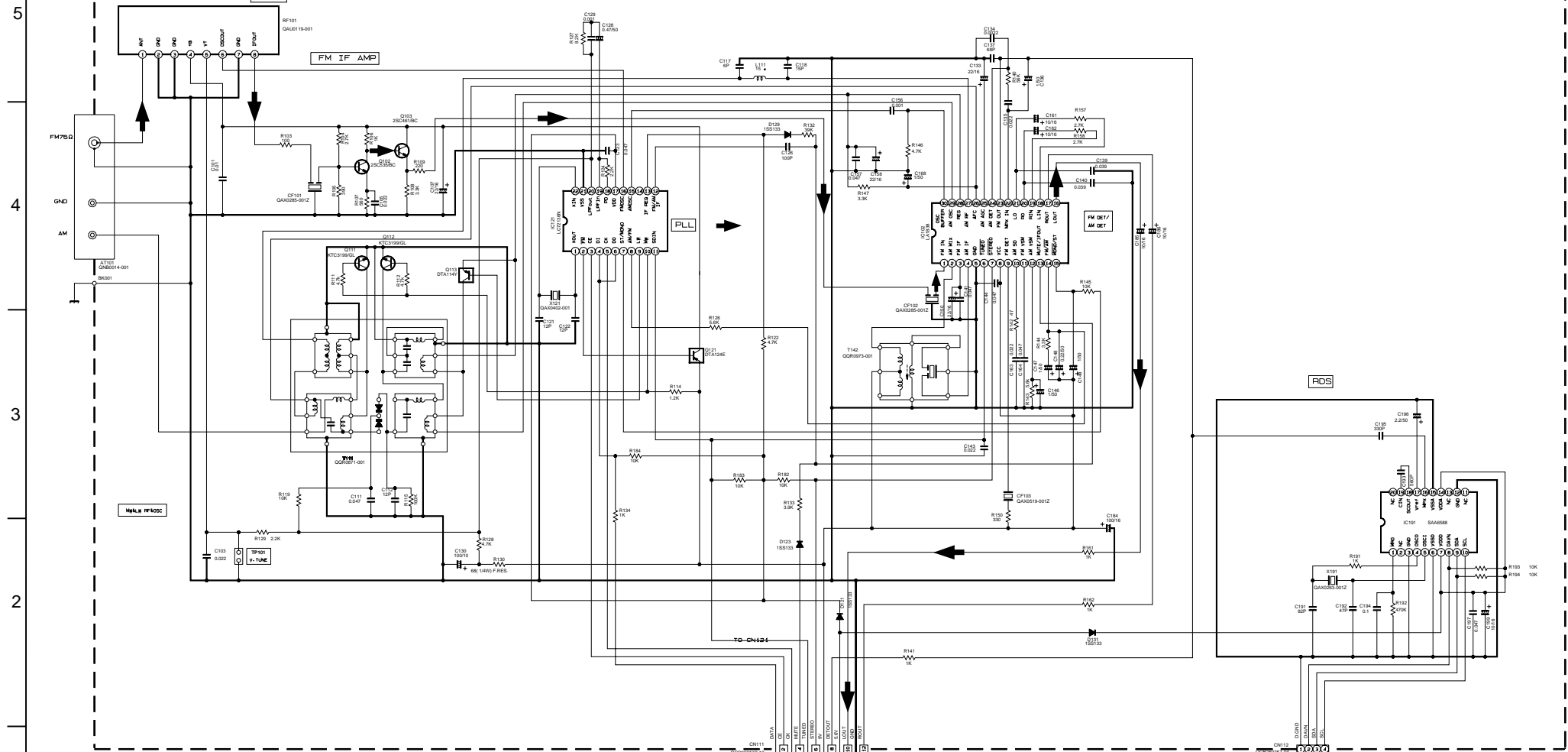

5  
4  
3  
2  
1

A B C D E F G

To CN121  
Sheet 4/8

To CN122  
Sheet 4/8

TUNER signal

# Printed circuit boards

## ■ Main & system control board

5  
4  
3  
2  
1  
A B C 2-10 D E F G H

System control board

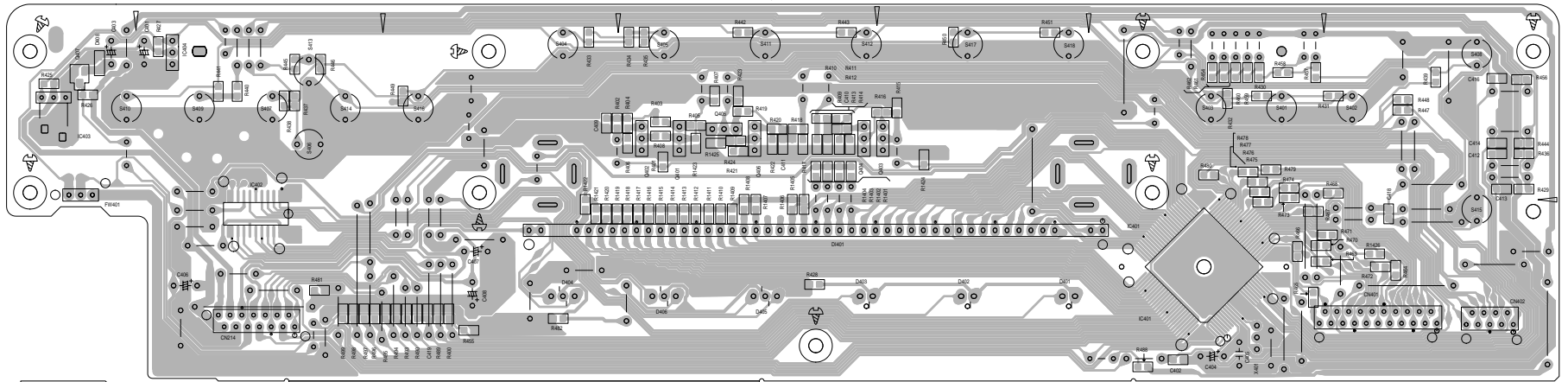

Speaker board

Headphone jack board

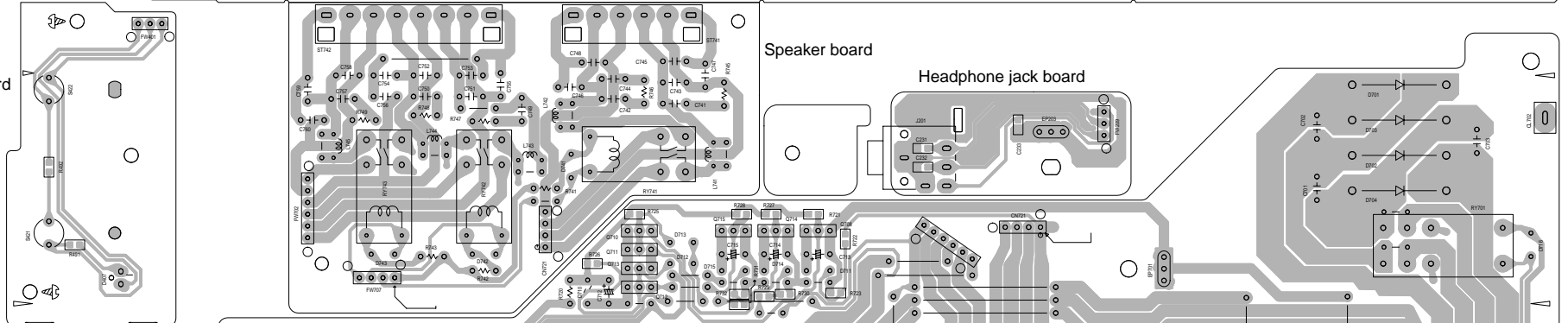

Power switch board

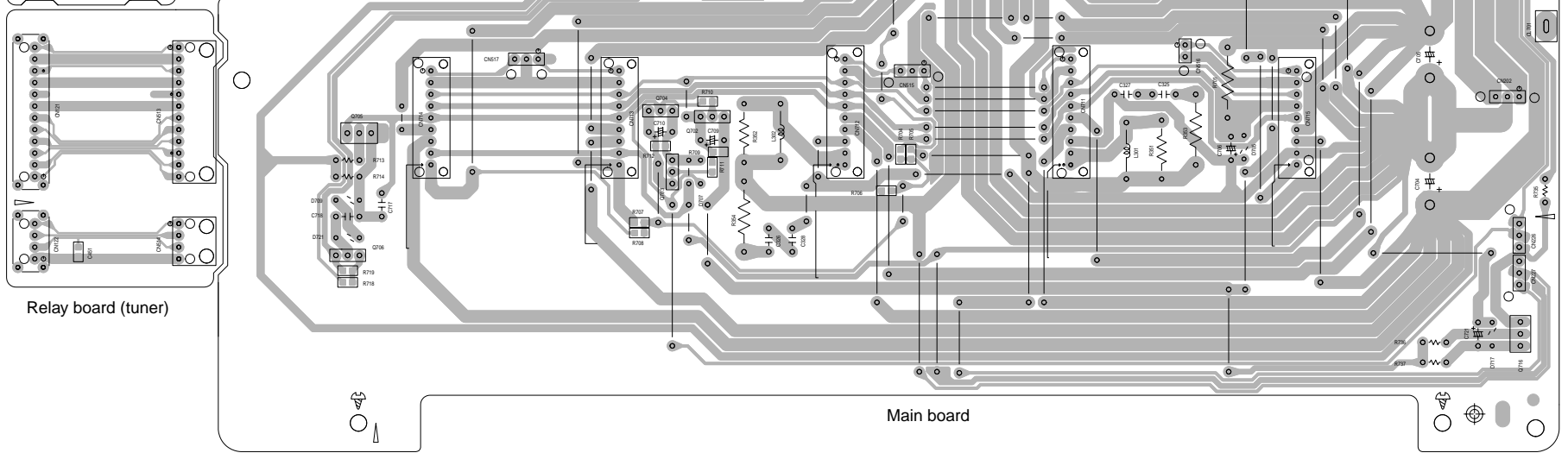

Relay board (tuner)

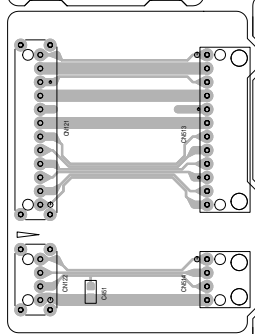

Main board



■ Audio signal input board

5

4

3

2

1

Audio board

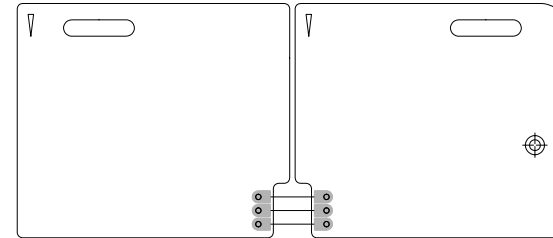
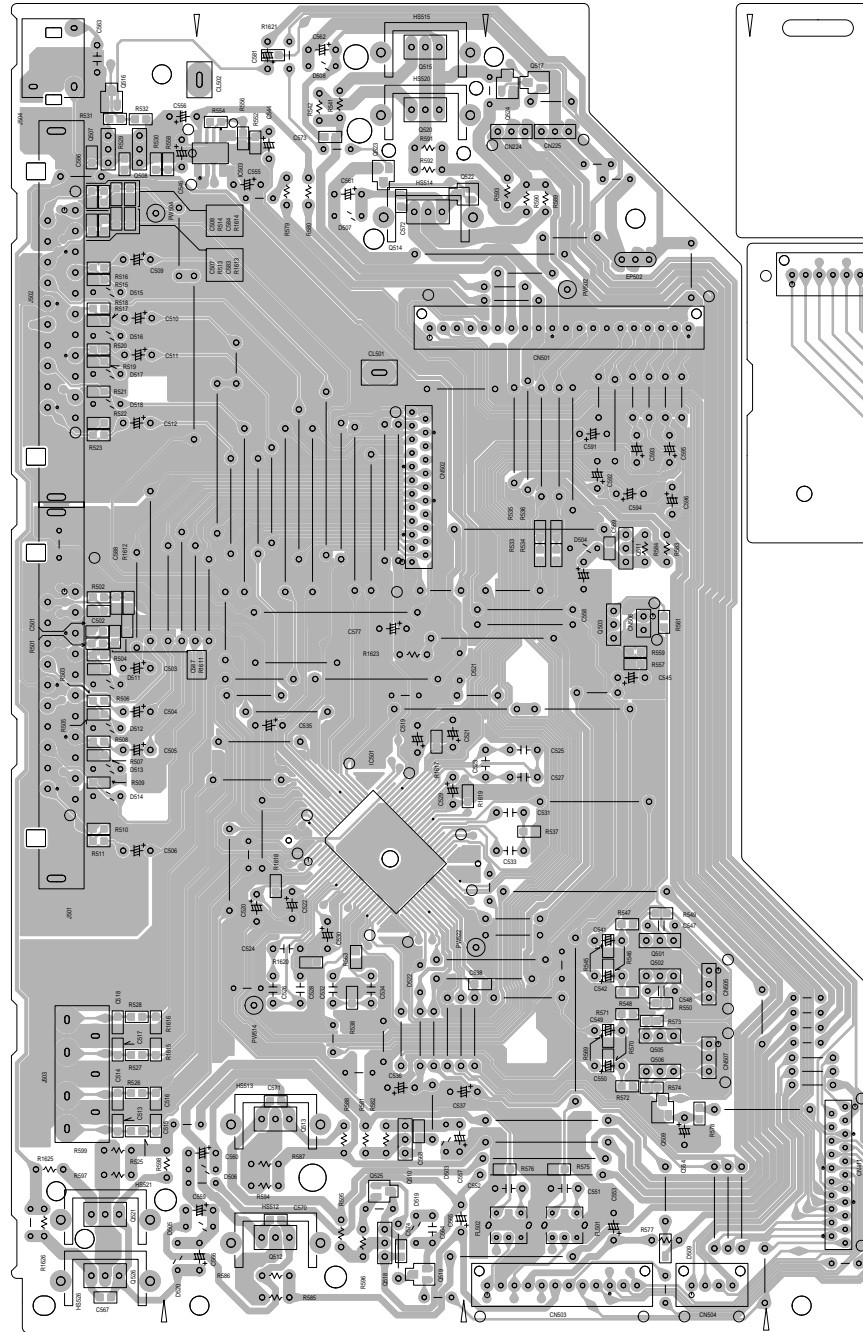

Relay board (DSP)

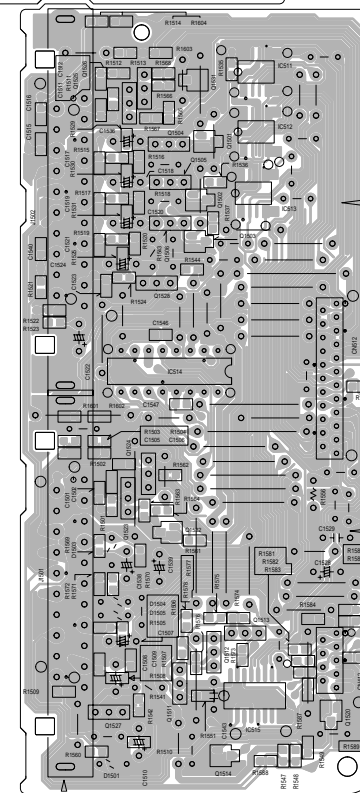

Input board

A

B

C

D

E

F

G

■ Power amp. board

5

4

3

2

1

Power transformer board

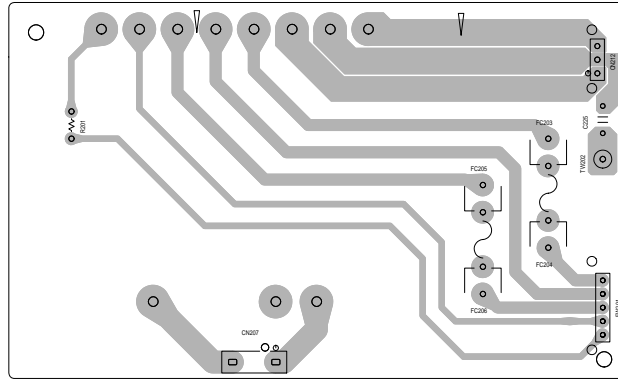

Power supply board

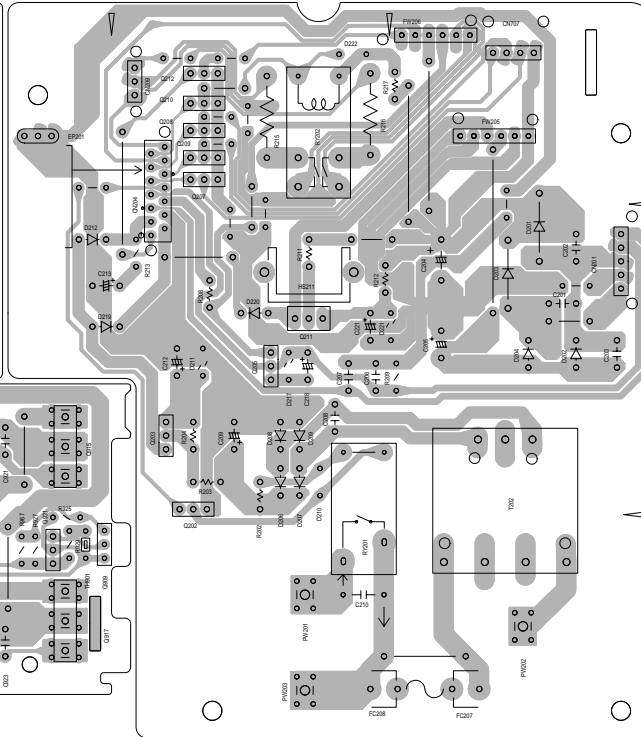

Power/fuse board

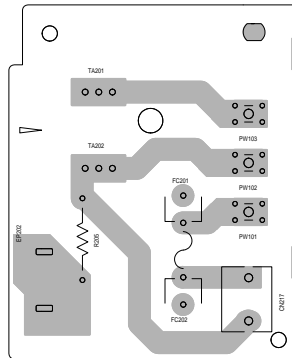

Cch amp. board

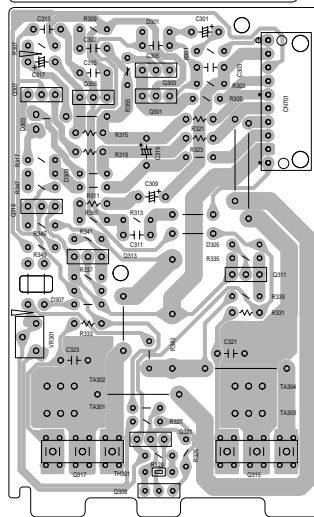
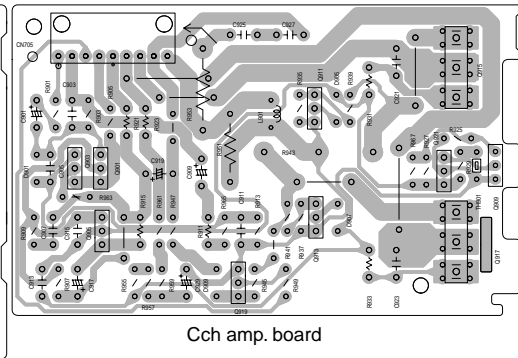

Lch amp. board

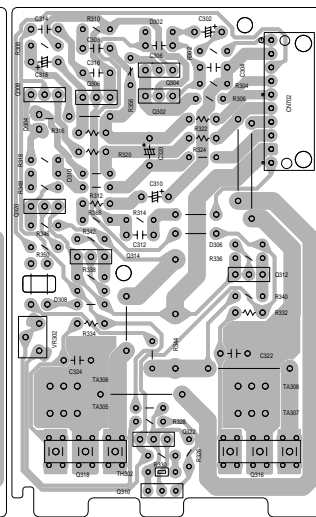

Rch amp. board

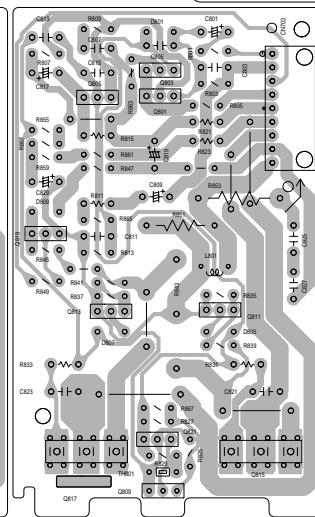

SLch amp. board

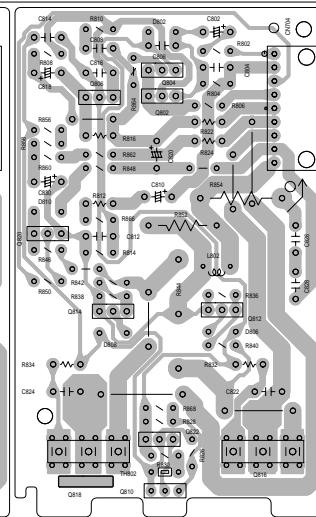

SRch amp. board

A

B

C

2-12

D

E

F

G

H

■ DSP board

(Forward side)

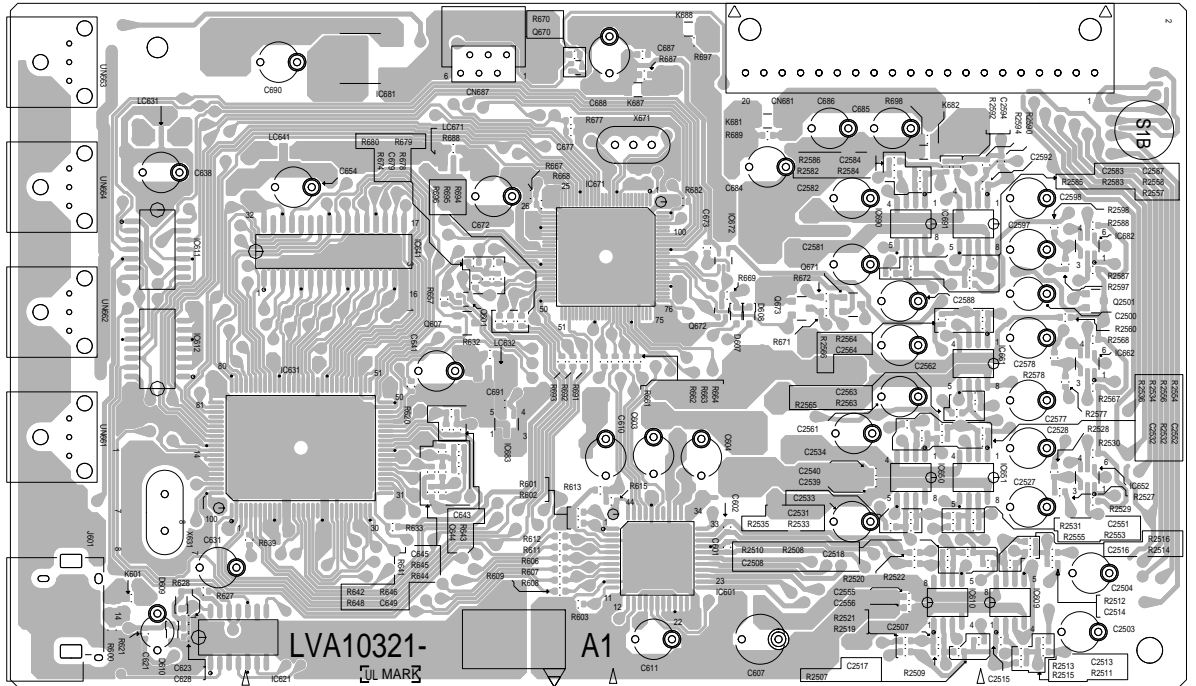

(Reverse side)

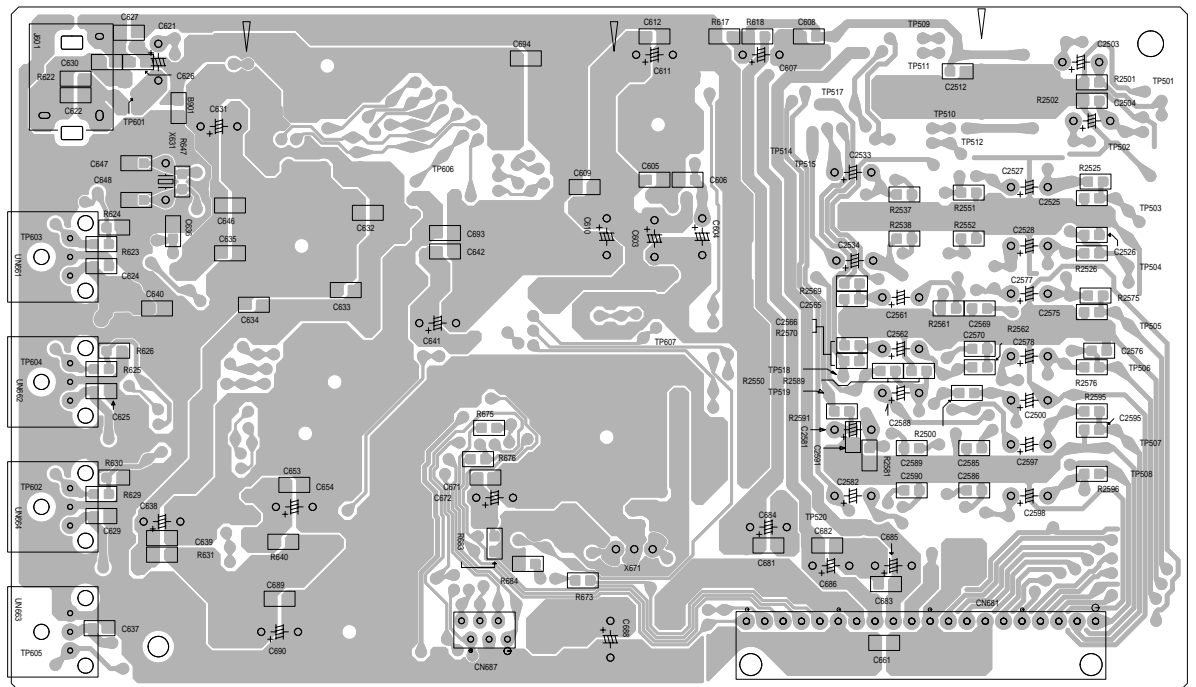

A

B

C

D

■ Tuner board

5

4

3

2

1

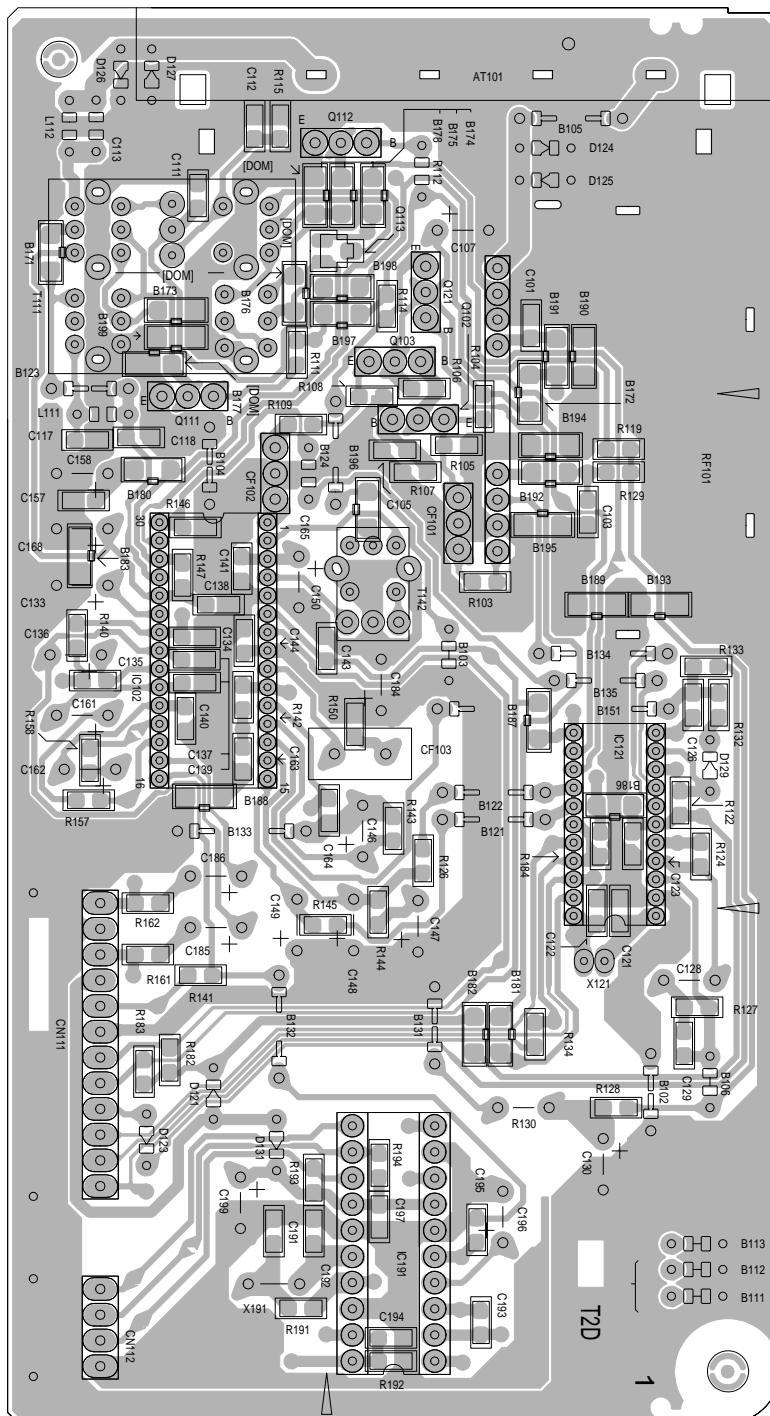

A

B

C

D

2-14

PARTS LIST

[ RX-E112RSL ]  
[ RX-E111RSL ]

\* All printed circuit boards and its assemblies are not available as service parts.

Area suffix

B	-----	U.K.
E	-----	Continental Europe
EN	-----	Northern Europe
EV	-----	Eastern Europe

- Contents -

Exploded view of general assembly and parts list .....	3- 3
Electrical parts list .....	3- 5
Packing materials and accessories parts list .....	3-18

# Exploded view of general assembly and parts list

Block No. **M 1 M M**

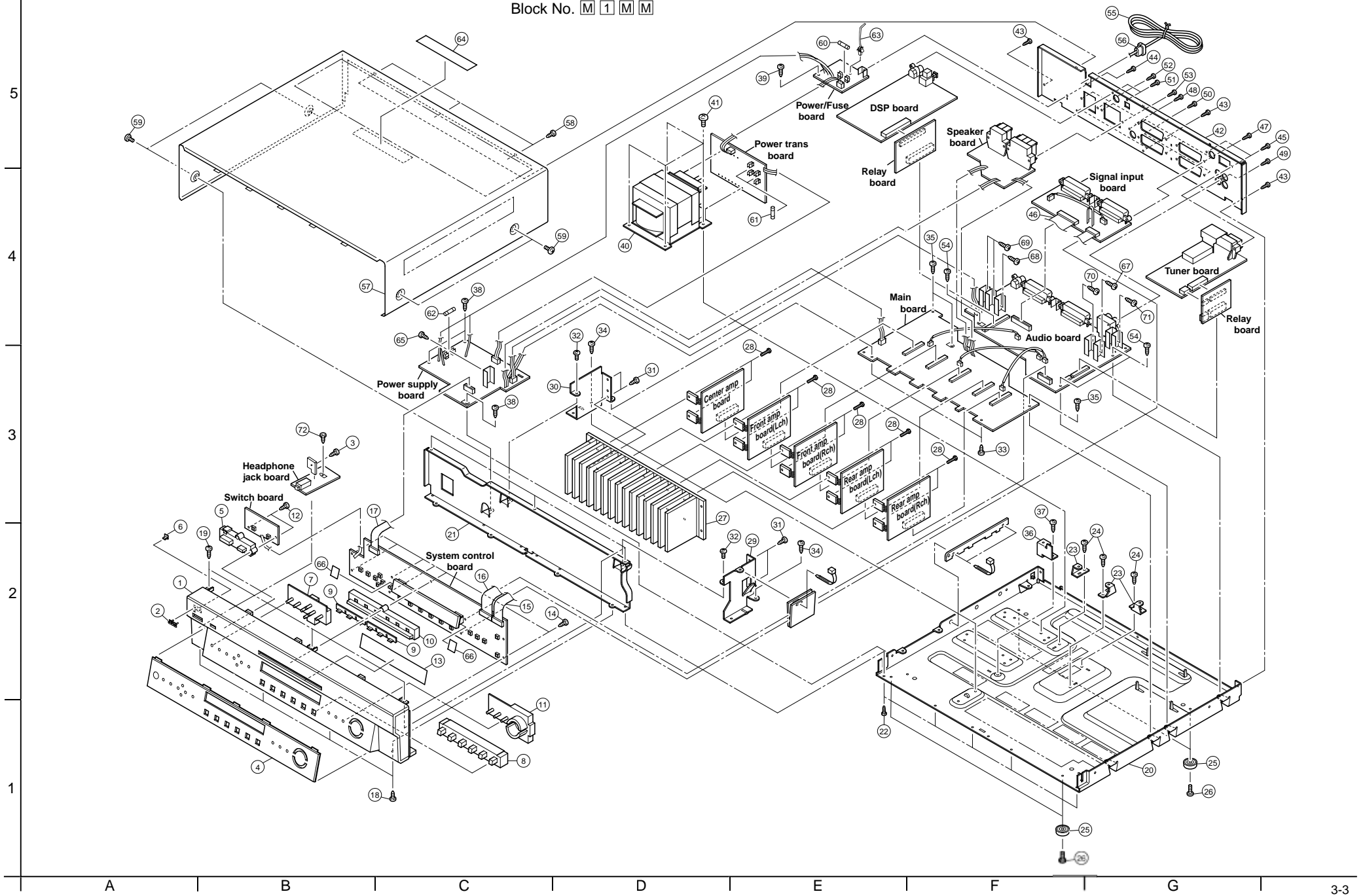

RX-E112RSL/RX-E111RSL

RX-E112RSL/RX-E111RSL

■ Parts list (General assembly)

Block No. M1MM

△	Item	Parts number	Parts name	Q'ty	Description	Area
	1	LV10482-005A	FRONT PANEL	1	RX-E112RSL	
		LV10482-004A	FRONT PANEL	1	RX-E111RSL	
	2	VJD5429-002SS	JVC MARK	1		
	3	QYSBSF2608Z	T.SCREW	1	FOR PHONE PWB	
	4	LV20958-010A	LENS	1	RX-E112RSL	
		LV20958-009A	LENS	1	RX-E111RSL	
	5	LV20991-001A	POWER BUTTON	1		
	6	LV42096-001A	INDICATOR	1		
	7	LV32517-002A	CONTROL BUTTON	1		
	8	LV20959-005A	SOURCE BUTTON	1		
	9	LV32519-001A	SOURCE INDICATO	2		
	10	LV32552-005A	INDI.ESCUTCHEON	1		
	11	LV20992-001A	VOLUME BUTTON	1		
	12	QYSBSF2608Z	T.SCREW	2	BIND TO BRAIZER	
	13	LV42195-001A	FL SCREEN	1	TO FRONT PANEL	
	14	QYSBSF2608Z	T.SCREW	8	BIND TO BRAIZER	
	15	QUQ412-0946CJ	FFC WIRE	1		
	16	QUQ412-2138CJ	FFC WIRE	1		
	17	QUQ412-1413CJ	FFC WIRE	1		
	18	QYSBSG3006Z	T.SCREW	4	F.PANEL+F.BKT(BOTT.)	
	19	QYSBSG3006Z	T.SCREW	3	F.PANEL+F.BKT(UP)	
	20	LV10019-004A	CHASSIS BASE	1		
	21	LV10483-002A	FRONT BRACKET	1		
	22	QYSBSG3006Z	T.SCREW	5	C.BASE+F.BKT	
	23	E68587-223SM	CB BKT	3		
	24	QYSBSG3006Z	T.SCREW	3	CB BKT+C.BASE	
	25	E47227-020	FOOT	4		
	26	QYSBSG3008Z	T.SCREW	4	FOOT ASS'Y+C.BASE	
	27	LV21236-001A	HEAT SINK	1		
	28	QYSBSG3012E	SCREW	10		
	29	LV32433-001A	H.S BRACKET(R)	1		
	30	LV32434-001A	H.S BRACKET(L)	1		
	31	QYSBSG3008Z	T.SCREW	4	H.SINK BKT+H.SINK	
	32	QYSBSG3006Z	T.SCREW	2	H.SINK BKT+F.BKT	
	33	QYSBSG3006Z	T.SCREW	2	AMP M.C.B+H.SINK	
	34	QYSBSG3006Z	T.SCREW	2	H.SINK BKT+C.BASE	
	35	QYSBSG3006Z	T.SCREW	3	A.M.C.B+C.B.&CB BKT	
	36	LV42098-001A	C.B BKT	1		
	37	QYSBSG3006Z	T.SCREW	1	C.B.BKT+C.BASE	
	38	QYSBSG3006Z	T.SCREW	3	T.C.B+C.BASE&F.BKT	
	39	QYSBSG3006Z	T.SCREW	1	P.CORD C.B+C.BASE	
	40	QQT0364-001	POWER TRANSF	1	T 201	
	41	QYSDSTL4008E	SPECIAL SCREW	4	P.TRANS	
	42	LV21232-005A	REAR PANEL	1	RX-E111RSL	B,E,EN
		LV21232-006A	REAR PANEL	1	RX-E111RSL	EV
		LV21232-007A	REAR PANEL	1	RX-E112RSL	B,E,EN
		LV21232-008A	REAR PANEL	1	RX-E112RSL	EV
	43	QYSBSGY3008M	SPECIAL SCREW	4	R.PANEL+C.BASE	

■ Parts list (General assembly)

Block No. M1MM

△	Item	Parts number	Parts name	Q'ty	Description	Area
	44	QYSBSGY3008M	SPECIAL SCREW	1		
	45	QYSBSGY3008M	SPECIAL SCREW	2	TUNER	
	46	QUQ412-2306CJ	FFC WIRE	1	I.M.C.B TO SCAR	
	47	QYSBSGY3008M	SPECIAL SCREW	4	SCART 2	
	48	QYSBSGY3008M	SPECIAL SCREW	1	SUB WOOFER	
	49	QYSBSGY3008M	SPECIAL SCREW	1	TAPE	
	50	QYSBSGY3008M	SPECIAL SCREW	4	SCART	
	51	QYSBSGY3008M	SPECIAL SCREW	2	DIGITAL	
	52	QYSBSGY3008M	SPECIAL SCREW	2	F.SPK TERM.+R.P	
	53	QYSBSGY3008M	SPECIAL SCREW	2	R.SPK TERM.+R.P	
	54	QYSBSG3006Z	T.SCREW	3	INPUT M.C.B+C.B	
△	55	QMPK250-205-JV	POWER CORD	1		E,EN,EV
△		QMPN100-200-JD	POWER CORD	1		B
△	56	QZW0033-001	STRAIN RELIEF	1		
	57	LV20962-004A/S/	TOP COVER	1		
	58	QYSBSGY3008M	SPECIAL SCREW	3		
	59	E406308-004	SPECIAL SCREW	4		
△	60	QMF51W2-1R6-J8	FUSE	1	F 201	
△	61	QMF51W2-2R0-J8	FUSE	2	F 202 F 203	
△	62	QMF51E2-R10-J1	FUSE	1	F 204	
	63	E307572-001	FASTENER	1	TIE POWER CORD	
	64	E409396-003	CAUTION LABEL	1		
	65	QYSBSG3008E	T.SCREW	1		
	66	LV30225-0C1A	FELT SPACER	2	FS400 FS401	
	67	QYSBSG3008E	T.SCREW	1		
	68	QYSBSG3008E	T.SCREW	1		
	69	QYSBSG3008E	T.SCREW	2		
	70	QYSBSG3008E	T.SCREW	1		
	71	QYSBSG3008E	T.SCREW	1		
	72	QYSBSG3006Z	T.SCREW	1	PHONE PWB	

■ Electrical parts list (Power amp board) Block No. 01

△	Item	Parts number	Parts name	Remarks	Area	△	Item	Parts number	Parts name	Remarks	Area
	C 201	QFLC2AJ-104Z	M CAPACITOR	.10MF 5% 100V			C 825	QFLC1HJ-473Z	M CAPACITOR	.047MF 5% 50V	
	C 202	QFLC2AJ-104Z	M CAPACITOR	.10MF 5% 100V			C 826	QFLC1HJ-473Z	M CAPACITOR	.047MF 5% 50V	
	C 203	QFLC2AJ-104Z	M CAPACITOR	.10MF 5% 100V			C 827	QFLC1HJ-473Z	M CAPACITOR	.047MF 5% 50V	
	C 204	QETM1VM-228	E.CAPACITOR	2200MF 20% 35V			C 828	QFLC1HJ-473Z	M CAPACITOR	.047MF 5% 50V	
	C 205	QETM1VM-108	E.CAPACITOR	1000MF 20% 35V			C 829	QETN1HM-476Z	E CAPACITOR	47MF 20% 50V	
	C 206	QFLC1HJ-473Z	M CAPACITOR	.047MF 5% 50V			C 830	QETN1HM-476Z	E CAPACITOR	47MF 20% 50V	
	C 207	QFLC1HJ-473Z	M CAPACITOR	.047MF 5% 50V			C 901	QETN1HM-225Z	E CAPACITOR	2.2MF 20% 50V	
	C 208	QFLC2AJ-472Z	M CAPACITOR	4700PF 5% 100V			C 903	QCS31HJ-101Z	C CAPACITOR	100PF 5% 50V	
	C 209	QETN1EM-477Z	E CAPACITOR	470MF 20% 25V			C 905	QCS31HJ-271Z	C CAPACITOR	270PF 5% 50V	
△	C 210	QCZ9104-472	C CAPACITOR	4700PF			C 907	QCB31HK-152Z	C CAPACITOR	1500PF 10% 50V	
	C 212	QETN1CM-477Z	E CAPACITOR	470MF 20% 16V			C 909	QETN1CM-107Z	E CAPACITOR	100MF 20% 16V	
	C 213	QETN0JM-228Z	E CAPACITOR	2200MF 20% 6.3V			C 911	QCS31HJ-100Z	C CAPACITOR	10PF 5% 50V	
	C 218	QEKC1HM-105Z	E CAPACITOR	1.0MF 20% 50V			C 913	QFLC1HJ-103Z	M CAPACITOR	.010MF 5% 50V	
	C 221	QETN1EM-107Z	E CAPACITOR	100MF 20% 25V			C 915	QCS32HJ-330Z	C CAPACITOR	33PF 5% 500V	
	C 225	QDVB1EZ-223Y	C CAPACITOR	0.022MF			C 917	QETN1CM-107Z	E CAPACITOR	100MF 20% 16V	
	C 301	QTE1H28-475Z	E CAPACITOR	4.7MF 20% 500V			C 919	QETN1JM-476Z	E CAPACITOR	47MF 20% 63V	
	C 302	QTE1H28-475Z	E CAPACITOR				C 921	QCS32HJ-470Z	C CAPACITOR	47PF 5% 500V	
	C 303	QCS31HJ-101Z	C CAPACITOR	100PF 5% 50V			C 923	QCS32HJ-470Z	C CAPACITOR	47PF 5% 500V	
	C 304	QCS31HJ-101Z	C CAPACITOR	100PF 5% 50V			C 925	QFLC1HJ-473Z	M CAPACITOR	.047MF 5% 50V	
	C 305	QCS31HJ-271Z	C CAPACITOR	270PF 5% 50V			C 927	QFLC1HJ-473Z	M CAPACITOR	.047MF 5% 50V	
	C 306	QCS31HJ-271Z	C CAPACITOR	270PF 5% 50V			C 929	QETN1HM-476Z	E CAPACITOR	47MF 20% 50V	
	C 307	QCB31HK-152Z	C CAPACITOR	1500PF 10% 50V			CN201	QGD2501C1-05Z	SOCKET I.M		
	C 308	QCB31HK-152Z	C CAPACITOR	1500PF 10% 50V			CN204	QGF1205C1-14	CONNECTOR		
	C 309	QETN1CM-227Z	E CAPACITOR	220MF 20% 16V			CN207	WJK0037-001A	E-SI C WIRE C-B		
	C 310	QETN1CM-227Z	E CAPACITOR	220MF 20% 16V			CN209	QGD2501C1-03Z	SOCKET		
	C 311	QCS31HJ-100Z	C CAPACITOR	10PF 5% 50V			CN212	QJK017-031301	SIN CR C-B WIRE		
	C 312	QCS31HJ-100Z	C CAPACITOR	10PF 5% 50V			CN217	QGA7901C1-02	CONNECTOR		
	C 313	QFLC1HJ-103Z	M CAPACITOR	.010MF 5% 50V			CN701	QGB2510K1-10	CONNECTOR		
	C 314	QFLC1HJ-103Z	M CAPACITOR	.010MF 5% 50V			CN702	QGB2510K1-10	CONNECTOR		
	C 315	QCS32HJ-220Z	C CAPACITOR	22PF 5% 500V			CN703	QGB2510K1-09	CONNECTOR		
	C 316	QCS32HJ-220Z	C CAPACITOR	22PF 5% 500V			CN704	QGB2510K1-09	CONNECTOR		
	C 317	QETN1CM-107Z	E CAPACITOR	100MF 20% 16V			CN705	QGB2510K1-09	CONNECTOR		
	C 318	QETN1CM-107Z	E CAPACITOR	100MF 20% 16V			CN707	QGD2501C1-04Z	SOCKET		
	C 319	QETN1JM-107Z	E CAPACITOR	100MF 20% 63V			△	D 201	10E2-FD	DIODE	
	C 320	QETN1JM-107Z	E CAPACITOR	100MF 20% 63V			△	D 202	11ES2-T4	DIODE I.M	
	C 321	QCS32HJ-470Z	C CAPACITOR	47PF 5% 500V			△	D 203	10E2-FD	DIODE	
	C 322	QCS32HJ-470Z	C CAPACITOR	47PF 5% 500V			△	D 204	11ES2-T4	DIODE I.M	
	C 323	QCS32HJ-470Z	C CAPACITOR	47PF 5% 500V			△	D 206	11ES2-T4	DIODE I.M	
	C 324	QCS32HJ-470Z	C CAPACITOR	47PF 5% 500V			△	D 207	11ES2-T4	DIODE I.M	
	C 801	QETN1HM-225Z	E CAPACITOR	2.2MF 20% 50V			△	D 208	11ES2-T4	DIODE I.M	
	C 802	QETN1HM-225Z	E CAPACITOR	2.2MF 20% 50V			△	D 209	11ES2-T4	DIODE I.M	
	C 803	QCS31HJ-101Z	C CAPACITOR	100PF 5% 50V				D 210	1SS133-T2	SI DIODE IM	
	C 804	QCS31HJ-101Z	C CAPACITOR	100PF 5% 50V				D 211	MTZJ6.2C-T2	Z DIODE I/M	
	C 805	QCS31HJ-331Z	C CAPACITOR	330PF 5% 50V				D 212	11ES2-T4	DIODE I.M	
	C 806	QCS31HJ-331Z	C CAPACITOR	330PF 5% 50V				D 217	MTZJ6.2C-T2	Z DIODE I/M	
	C 807	QCB31HK-152Z	C CAPACITOR	1500PF 10% 50V				D 219	11ES2-T4	DIODE I.M	
	C 808	QCB31HK-152Z	C CAPACITOR	1500PF 10% 50V				D 220	11ES2-T4	DIODE I.M	
	C 809	QETN1CM-107Z	E CAPACITOR	100MF 20% 16V				D 221	MTZJ6.2C-T2	Z DIODE I/M	
	C 810	QETN1CM-107Z	E CAPACITOR	100MF 20% 16V				D 222	1SS133-T2	SI DIODE IM	
	C 811	QCS31HJ-8R0Z	C CAPACITOR	8.0PF 5% 50V				D 301	1SS133-T2	SI DIODE IM	
	C 812	QCS31HJ-8R0Z	C CAPACITOR	8.0PF 5% 50V				D 302	1SS133-T2	SI DIODE IM	
	C 813	QFLC1HJ-103Z	M CAPACITOR	.010MF 5% 50V				D 303	SLR-342MC-T	LED	
	C 814	QFLC1HJ-103Z	M CAPACITOR	.010MF 5% 50V				D 304	SLR-342MC-T	LED	
	C 815	QCS32HJ-330Z	C CAPACITOR	33PF 5% 500V				D 305	1SS133-T2	SI DIODE IM	
	C 816	QCS32HJ-330Z	C CAPACITOR	33PF 5% 500V				D 306	1SS133-T2	SI DIODE IM	
	C 817	QETN1CM-107Z	E CAPACITOR	100MF 20% 16V				D 307	1SS133-T2	SI DIODE IM	
	C 818	QETN1CM-107Z	E CAPACITOR	100MF 20% 16V				D 308	1SS133-T2	SI DIODE IM	
	C 819	QETN1JM-476Z	E CAPACITOR	47MF 20% 63V				D 309	1SS133-T2	SI DIODE IM	
	C 820	QETN1JM-476Z	E CAPACITOR	47MF 20% 63V				D 310	1SS133-T2	SI DIODE IM	
	C 821	QCS32HJ-470Z	C CAPACITOR	47PF 5% 500V				D 801	1SS133-T2	SI DIODE IM	
	C 822	QCS32HJ-470Z	C CAPACITOR	47PF 5% 500V				D 802	1SS133-T2	SI DIODE IM	
	C 823	QCS32HJ-470Z	C CAPACITOR	47PF 5% 500V				D 805	1SS133-T2	SI DIODE IM	
	C 824	QCS32HJ-470Z	C CAPACITOR	47PF 5% 500V				D 806	1SS133-T2	SI DIODE IM	



■ Electrical parts list (Power amp board) Block No. 01

△	Item	Parts number	Parts name	Remarks	Area	△	Item	Parts number	Parts name	Remarks	Area
	D 807	1SS133-T2	SI DIODE IM				Q 810	2SD637/QR/	TRANSISTOR		
	D 808	1SS133-T2	SI DIODE IM				Q 811	KTC3200/GL-T	TRANSISTOR		
	D 809	1SS133-T2	SI DIODE IM				Q 812	KTC3200/GL-T	TRANSISTOR		
	D 810	1SS133-T2	SI DIODE IM				Q 813	KTA1268/GL-T	TRANSISTOR		
	D 901	1SS133-T2	SI DIODE IM				Q 814	KTA1268/GL-T	TRANSISTOR		
	D 905	1SS133-T2	SI DIODE IM			△	Q 815	2SD2389/OPY/-F6	TRANSISTOR		
	D 907	1SS133-T2	SI DIODE IM			△	Q 816	2SD2389/OPY/-F6	TRANSISTOR		
	D 909	1SS133-T2	SI DIODE IM			△	Q 817	2SB1559/OPY/-F6	TRANSISTOR		
	EP201	QNZ0136-001Z	EARTH PLATE			△	Q 818	2SB1559/OPY/-F6	TRANSISTOR		
	EP202	E409182-001SM	GRAND TERMINAL				Q 819	KTA1268/GL-T	TRANSISTOR		
	FC201	QNG0020-001Z	FUSE CLIP	(F201)			Q 820	KTA1268/GL-T	TRANSISTOR		
	FC202	QNG0020-001Z	FUSE CLIP	(F201)			Q 821	KTA1268/GL-T	TRANSISTOR		
	FC203	QNG0020-001Z	FUSE CLIP	(F202)			Q 822	KTA1268/GL-T	TRANSISTOR		
	FC204	QNG0020-001Z	FUSE CLIP	(F202)			Q 901	2SC2240/L-T	TR.I/M		
	FC205	QNG0020-001Z	FUSE CLIP	(F203)			Q 903	2SC2240/L-T	TR.I/M		
	FC206	QNG0020-001Z	FUSE CLIP	(F203)			Q 905	KTA1268/GL-T	TRANSISTOR		
	FC207	QNG0020-001Z	FUSE CLIP	(F204)			Q 909	2SD637/QR/	TRANSISTOR		
	FC208	QNG0020-001Z	FUSE CLIP	(F204)			Q 911	KTC3200/GL-T	TRANSISTOR		
	FW201	QUM135-20DGZ4	PARA RIBON WIRE				Q 913	KTA1268/GL-T	TRANSISTOR		
	FW205	QUM136-23DGZ4	PARA RIBON WIRE			△	Q 915	2SD2389/OPY/-F6	TRANSISTOR		
	FW206	QUM136-09DGZ4	PARA RIBON WIRE			△	Q 917	2SB1559/OPY/-F6	TRANSISTOR		
	HS211	E70306-001	HEAT SINK				Q 919	KTA1268/GL-T	TRANSISTOR		
	L 801	QQLZ005-R45	INDUCTOR				Q 921	KTA1268/GL-T	TRANSISTOR		
	L 802	QQLZ005-R45	INDUCTOR			△	R 201	QRJ146J-8R2X	UNF C RESISTOR	8.2 5% 1/4W	
	L 901	QQLZ005-R45	INDUCTOR			△	R 202	QRJ146J-100X	UNF C RESISTOR	10 5% 1/4W	
	Q 202	KRC105M-T	D.TR.I.M.			△	R 203	QRJ146J-100X	UNF C RESISTOR	10 5% 1/4W	
	Q 203	KTC3203/OY-T	TRANSISTOR			△	R 204	QRJ146J-821X	UNF C RESISTOR	820 5% 1/4W	
	Q 205	KTC3200/GL-T	TRANSISTOR			△	R 208	QRJ146J-100X	UNF C RESISTOR	10 5% 1/4W	
	Q 207	KRC105M-T	D.TR.I.M.				R 209	QRE141J-104Y	C RESISTOR	100K 5% 1/4W	
	Q 208	KRC105M-T	D.TR.I.M.			△	R 211	QRZ9005-120X	F RESISTOR	12 1/4W	
	Q 209	KRC105M-T	D.TR.I.M.			△	R 212	QRJ146J-682X	UNF C RESISTOR	6.8K 5% 1/4W	
	Q 210	KRC105M-T	D.TR.I.M.				R 213	QRE141J-331Y	C RESISTOR	330 5% 1/4W	
	Q 211	2SD2395/EF/	TRANSISTOR			△	R 215	QRL027J-471	UNF OMF RESISTO	470 5% 1/2W	
	Q 212	KRC105M-T	D.TR.I.M.			△	R 216	QRL027J-471	UNF OMF RESISTO	470 5% 1/2W	
	Q 301	2SC2240/L-T	TR.I/M			△	R 217	QRJ146J-120X	UNF C RESISTOR	12 5% 1/4W	
	Q 302	2SC2240/L-T	TR.I/M				R 301	QRE141J-222Y	C RESISTOR	2.2K 5% 1/4W	
	Q 303	2SC2240/L-T	TR.I/M				R 302	QRE141J-222Y	C RESISTOR	2.2K 5% 1/4W	
	Q 304	2SC2240/L-T	TR.I/M				R 303	QRE141J-683Y	C RESISTOR	68K 5% 1/4W	
	Q 305	KTA1268/GL-T	TRANSISTOR				R 304	QRE141J-683Y	C RESISTOR	68K 5% 1/4W	
	Q 306	KTA1268/GL-T	TRANSISTOR				R 305	QRE141J-123Y	C RESISTOR	12K 5% 1/4W	
	Q 307	KTC3200/GL-T	TRANSISTOR				R 306	QRE141J-123Y	C RESISTOR	12K 5% 1/4W	
	Q 308	KTC3200/GL-T	TRANSISTOR				R 307	QRE141J-272Y	C RESISTOR	2.7K 5% 1/4W	
	Q 309	2SD637/QR/	TRANSISTOR				R 308	QRE141J-272Y	C RESISTOR	2.7K 5% 1/4W	
	Q 310	2SD637/QR/	TRANSISTOR				R 309	QRE141J-101Y	C RESISTOR	100 5% 1/4W	
	Q 311	KTC3200/GL-T	TRANSISTOR				R 310	QRE141J-101Y	C RESISTOR	100 5% 1/4W	
	Q 312	KTC3200/GL-T	TRANSISTOR			△	R 311	QRJ146J-471X	UNF C RESISTOR	470 5% 1/4W	
	Q 313	KTA1268/GL-T	TRANSISTOR			△	R 312	QRJ146J-471X	UNF C RESISTOR	470 5% 1/4W	
	Q 314	KTA1268/GL-T	TRANSISTOR				R 313	QRE141J-563Y	C RESISTOR	56K 5% 1/4W	
△	Q 315	2SD2389/OPY/-F6	TRANSISTOR				R 314	QRE141J-563Y	C RESISTOR	56K 5% 1/4W	
△	Q 316	2SD2389/OPY/-F6	TRANSISTOR			△	R 315	QRJ146J-221X	UNF C RESISTOR	220 5% 1/4W	
△	Q 317	2SB1559/OPY/-F6	TRANSISTOR			△	R 316	QRJ146J-221X	UNF C RESISTOR	220 5% 1/4W	
△	Q 318	2SB1559/OPY/-F6	TRANSISTOR				R 317	QRE141J-473Y	C RESISTOR	47K 5% 1/4W	
	Q 319	KTA1268/GL-T	TRANSISTOR				R 318	QRE141J-473Y	C RESISTOR	47K 5% 1/4W	
	Q 320	KTA1268/GL-T	TRANSISTOR			△	R 319	QRJ146J-221X	UNF C RESISTOR	220 5% 1/4W	
	Q 321	KTA1268/GL-T	TRANSISTOR			△	R 320	QRJ146J-221X	UNF C RESISTOR	220 5% 1/4W	
	Q 322	KTA1268/GL-T	TRANSISTOR			△	R 321	QRJ146J-100X	UNF C RESISTOR	10 5% 1/4W	
	Q 801	2SC2240/L-T	TR.I/M			△	R 322	QRJ146J-100X	UNF C RESISTOR	10 5% 1/4W	
	Q 802	2SC2240/L-T	TR.I/M			△	R 323	QRJ146J-100X	UNF C RESISTOR	10 5% 1/4W	
	Q 803	2SC2240/L-T	TR.I/M			△	R 324	QRJ146J-100X	UNF C RESISTOR	10 5% 1/4W	
	Q 804	2SC2240/L-T	TR.I/M				R 325	QRE141J-561Y	C RESISTOR	560 5% 1/4W	
	Q 805	KTA1268/GL-T	TRANSISTOR				R 326	QRE141J-561Y	C RESISTOR	560 5% 1/4W	
	Q 806	KTA1268/GL-T	TRANSISTOR				R 327	QRE141J-152Y	C RESISTOR	1.5K 5% 1/4W	
	Q 809	2SD637/QR/	TRANSISTOR				R 328	QRE141J-152Y	C RESISTOR	1.5K 5% 1/4W	

■ Electrical parts list (Power amp board) Block No. 01

△	Item	Parts number	Parts name	Remarks	Area	△	Item	Parts number	Parts name	Remarks	Area
△	R 331	QRJ146J-100X	UNF C RESISTOR	10 5% 1/4W			R 850	QRE141J-123Y	C RESISTOR	12K 5% 1/4W	
△	R 332	QRJ146J-100X	UNF C RESISTOR	10 5% 1/4W		△	R 851	QRJ125J-330	UNF OMF RESISTO	33 5% 1/2W	
△	R 333	QRJ146J-100X	UNF C RESISTOR	10 5% 1/4W		△	R 852	QRJ125J-330	UNF OMF RESISTO	33 5% 1/2W	
△	R 334	QRJ146J-100X	UNF C RESISTOR	10 5% 1/4W		△	R 853	QRL027J-100	UNF OMF RESISTO	10 5% 1/2W	
	R 335	QRE141J-820Y	C RESISTOR	82 5% 1/4W		△	R 854	QRL027J-100	UNF OMF RESISTO	10 5% 1/2W	
	R 336	QRE141J-820Y	C RESISTOR	82 5% 1/4W			R 855	QRE141J-332Y	C RESISTOR	3.3K 5% 1/4W	
	R 337	QRE141J-820Y	C RESISTOR	82 5% 1/4W			R 856	QRE141J-332Y	C RESISTOR	3.3K 5% 1/4W	
	R 338	QRE141J-820Y	C RESISTOR	82 5% 1/4W			R 857	QRE141J-332Y	C RESISTOR	3.3K 5% 1/4W	
	R 339	QRE141J-181Y	C RESISTOR	180 5% 1/4W			R 858	QRE141J-332Y	C RESISTOR	3.3K 5% 1/4W	
	R 340	QRE141J-181Y	C RESISTOR	180 5% 1/4W			R 859	QRE141J-332Y	C RESISTOR	3.3K 5% 1/4W	
	R 341	QRE141J-181Y	C RESISTOR	180 5% 1/4W			R 860	QRE141J-332Y	C RESISTOR	3.3K 5% 1/4W	
	R 342	QRE141J-181Y	C RESISTOR	180 5% 1/4W			R 861	QRE141J-332Y	C RESISTOR	3.3K 5% 1/4W	
△	R 343	QRZ0218-R22	C RESISTOR	7W			R 862	QRE141J-332Y	C RESISTOR	3.3K 5% 1/4W	
△	R 344	QRZ0218-R22	C RESISTOR	7W			R 863	QRE141J-302Y	C RESISTOR	3.0K 5% 1/4W	
	R 345	QRE141J-102Y	C RESISTOR	1.0K 5% 1/4W			R 864	QRE141J-302Y	C RESISTOR	3.0K 5% 1/4W	
	R 346	QRE141J-102Y	C RESISTOR	1.0K 5% 1/4W			R 865	QRE141J-820Y	C RESISTOR	82 5% 1/4W	
	R 347	QRE141J-153Y	C RESISTOR	15K 5% 1/4W			R 866	QRE141J-820Y	C RESISTOR	82 5% 1/4W	
	R 348	QRE141J-153Y	C RESISTOR	15K 5% 1/4W			R 867	QRE141J-222Y	C RESISTOR	2.2K 5% 1/4W	
	R 349	QRE141J-473Y	C RESISTOR	47K 5% 1/4W			R 868	QRE141J-222Y	C RESISTOR	2.2K 5% 1/4W	
	R 350	QRE141J-473Y	C RESISTOR	47K 5% 1/4W			R 901	QRE141J-222Y	C RESISTOR	2.2K 5% 1/4W	
	R 355	QRE141J-272Y	C RESISTOR	2.7K 5% 1/4W			R 903	QRE141J-683Y	C RESISTOR	68K 5% 1/4W	
	R 356	QRE141J-272Y	C RESISTOR	2.7K 5% 1/4W			R 905	QRE141J-183Y	C RESISTOR	18K 5% 1/4W	
	R 365	QRE141J-330Y	C RESISTOR	33 5% 1/4W			R 907	QRE141J-302Y	C RESISTOR	3.0K 5% 1/4W	
	R 366	QRE141J-330Y	C RESISTOR	33 5% 1/4W			R 909	QRE141J-101Y	C RESISTOR	100 5% 1/4W	
	R 801	QRE141J-222Y	C RESISTOR	2.2K 5% 1/4W		△	R 911	QRJ146J-301X	UNF C RESISTOR	300 5% 1/4W	
	R 802	QRE141J-222Y	C RESISTOR	2.2K 5% 1/4W			R 913	QRE141J-563Y	C RESISTOR	56K 5% 1/4W	
	R 803	QRE141J-683Y	C RESISTOR	68K 5% 1/4W		△	R 915	QRJ146J-271X	UNF C RESISTOR	270 5% 1/4W	
	R 804	QRE141J-683Y	C RESISTOR	68K 5% 1/4W		△	R 921	QRJ146J-181X	UNF C RESISTOR	180 5% 1/4W	
	R 805	QRE141J-183Y	C RESISTOR	18K 5% 1/4W		△	R 923	QRJ146J-100X	UNF C RESISTOR	10 5% 1/4W	
	R 806	QRE141J-183Y	C RESISTOR	18K 5% 1/4W			R 925	QRE141J-561Y	C RESISTOR	560 5% 1/4W	
	R 807	QRE141J-302Y	C RESISTOR	3.0K 5% 1/4W			R 927	QRE141J-103Y	C RESISTOR	10K 5% 1/4W	
	R 808	QRE141J-302Y	C RESISTOR	3.0K 5% 1/4W		△	R 931	QRJ146J-100X	UNF C RESISTOR	10 5% 1/4W	
	R 809	QRE141J-101Y	C RESISTOR	100 5% 1/4W		△	R 933	QRJ146J-100X	UNF C RESISTOR	10 5% 1/4W	
	R 810	QRE141J-101Y	C RESISTOR	100 5% 1/4W			R 935	QRE141J-101Y	C RESISTOR	100 5% 1/4W	
△	R 811	QRJ146J-391X	UNF C RESISTOR	390 5% 1/4W			R 937	QRE141J-101Y	C RESISTOR	100 5% 1/4W	
△	R 812	QRJ146J-391X	UNF C RESISTOR	390 5% 1/4W			R 939	QRE141J-181Y	C RESISTOR	180 5% 1/4W	
	R 813	QRE141J-563Y	C RESISTOR	56K 5% 1/4W			R 941	QRE141J-181Y	C RESISTOR	180 5% 1/4W	
	R 814	QRE141J-563Y	C RESISTOR	56K 5% 1/4W		△	R 943	QRZ0218-R22	C RESISTOR	7W	
△	R 815	QRJ146J-271X	UNF C RESISTOR	270 5% 1/4W			R 945	QRE141J-102Y	C RESISTOR	1.0K 5% 1/4W	
△	R 816	QRJ146J-271X	UNF C RESISTOR	270 5% 1/4W			R 947	QRE141J-183Y	C RESISTOR	18K 5% 1/4W	
△	R 821	QRJ146J-181X	UNF C RESISTOR	180 5% 1/4W			R 949	QRE141J-473Y	C RESISTOR	47K 5% 1/4W	
△	R 822	QRJ146J-181X	UNF C RESISTOR	180 5% 1/4W		△	R 951	QRJ125J-330	UNF OMF RESISTO	33 5% 1/2W	
△	R 823	QRJ146J-100X	UNF C RESISTOR	10 5% 1/4W		△	R 953	QRL027J-100	UNF OMF RESISTO	10 5% 1/2W	
△	R 824	QRJ146J-100X	UNF C RESISTOR	10 5% 1/4W			R 955	QRE141J-332Y	C RESISTOR	3.3K 5% 1/4W	
	R 825	QRE141J-561Y	C RESISTOR	560 5% 1/4W			R 957	QRE141J-332Y	C RESISTOR	3.3K 5% 1/4W	
	R 826	QRE141J-561Y	C RESISTOR	560 5% 1/4W			R 959	QRE141J-332Y	C RESISTOR	3.3K 5% 1/4W	
	R 827	QRE141J-103Y	C RESISTOR	10K 5% 1/4W			R 961	QRE141J-332Y	C RESISTOR	3.3K 5% 1/4W	
	R 828	QRE141J-103Y	C RESISTOR	10K 5% 1/4W			R 963	QRE141J-302Y	C RESISTOR	3.0K 5% 1/4W	
△	R 831	QRJ146J-100X	UNF C RESISTOR	10 5% 1/4W			R 965	QRE141J-680Y	C RESISTOR	68 5% 1/4W	
△	R 832	QRJ146J-100X	UNF C RESISTOR	10 5% 1/4W			R 967	QRE141J-222Y	C RESISTOR	2.2K 5% 1/4W	
△	R 833	QRJ146J-100X	UNF C RESISTOR	10 5% 1/4W		△	RY201	QSK0142-001	RELAY		
△	R 834	QRJ146J-100X	UNF C RESISTOR	10 5% 1/4W		△	RY202	QSK0109-001	RELAY		
	R 835	QRE141J-101Y	C RESISTOR	100 5% 1/4W		△	T 202	QQT0281-002	POWER TRANSF		
	R 836	QRE141J-101Y	C RESISTOR	100 5% 1/4W			TA201	QNZ0079-001Z	TAB IM		
	R 837	QRE141J-101Y	C RESISTOR	100 5% 1/4W			TA202	QNZ0079-001Z	TAB IM		
	R 838	QRE141J-101Y	C RESISTOR	100 5% 1/4W			TA301	QNZ0079-001Z	TAB IM		
	R 839	QRE141J-181Y	C RESISTOR	180 5% 1/4W			TA302	QNZ0079-001Z	TAB IM		
	R 840	QRE141J-181Y	C RESISTOR	180 5% 1/4W			TA303	QNZ0079-001Z	TAB IM		
	R 841	QRE141J-181Y	C RESISTOR	180 5% 1/4W			TA304	QNZ0079-001Z	TAB IM		
	R 842	QRE141J-181Y	C RESISTOR	180 5% 1/4W			TA305	QNZ0079-001Z	TAB IM		
△	R 843	QRZ0218-R22	RESISTOR	7W			TA306	QNZ0079-001Z	TAB IM		
△	R 844	QRZ0218-R22	RESISTOR	7W			TA307	QNZ0079-001Z	TAB IM		
	R 845	QRE141J-102Y	C RESISTOR	1.0K 5% 1/4W			TA308	QNZ0079-001Z	TAB IM		
	R 846	QRE141J-102Y	C RESISTOR	1.0K 5% 1/4W			TW202	QUB220-08HPDM	SIN TWIST WIRE		
	R 847	QRE141J-183Y	C RESISTOR	18K 5% 1/4W			VR301	QVP0008-102Z	SEMI V RESISTOR		
	R 848	QRE141J-183Y	C RESISTOR	18K 5% 1/4W			VR302	QVP0008-102Z	SEMI V RESISTOR		
	R 849	QRE141J-123Y	C RESISTOR	12K 5% 1/4W							

# RX-E112RSL/RX-E111RSL

## ■ Electrical parts list (Main & System control board) Block No. 02

△	Item	Parts number	Parts name	Remarks	Area	△	Item	Parts number	Parts name	Remarks	Area
	BK401	LV32554-001A	FL HOLDER(L)				CL702	QZW0038-001	WIRE CLAMP		
	BK402	LV32555-001A	FL HOLDER(R)				CN121	QGB2501J1-12	CONNECTOR		
	C 231	NCS31HJ-331X	C.CAPA. C.M				CN122	QGB2501J1-04	CONNECTOR		
	C 232	NCS31HJ-331X	C.CAPA. C.M				CN202	QGA2501C1-03	3P CONNECTOR		
	C 233	NCF31CZ-104X	C CAPACITOR				CN214	QGF1205F1-14	CONNECTOR		
	C 325	QFLC1HJ-473Z	M CAPACITOR	.047MF 5% 50V			CN226	QGD2501C1-03Z	SOCKET		
	C 326	QFLC1HJ-473Z	M CAPACITOR	.047MF 5% 50V			CN227	QGD2501C1-03Z	SOCKET		
	C 327	QFLC1HJ-473Z	M CAPACITOR	.047MF 5% 50V			CN401	QGF1205F1-21	CONNECTOR		
	C 328	QFLC1HJ-473Z	M CAPACITOR	.047MF 5% 50V			CN402	QGF1205F1-09	CONNECTOR		
	C 401	QEKCOJM-107Z	E CAPACITOR	100MF 20% 6.3V			CN513	QGB2510K1-12	CONNECTOR		
	C 402	NCB31CK-223X	C CAPACITOR				CN514	QGB2510K1-04	CONNECTOR		
	C 403	QEKC1HM-225Z	E CAPACITOR	2.2MF 20% 50V			CN515	QGA2501C1-03	3P CONNECTOR		
	C 404	QEKCOJM-107Z	E CAPACITOR	100MF 20% 6.3V			CN516	QGA2501C1-02	2P CONNECTOR		
	C 405	QCZ0202-155Z	ML C CAPA I/M	1.5MF			CN517	QGA2501C1-03	3P CONNECTOR		
	C 406	QEKC1HM-475Z	E CAPACITOR	4.7MF 20% 50V			CN711	QGB2510J1-10	CONNECTOR		
	C 407	QEKC1HM-475Z	E CAPACITOR	4.7MF 20% 50V			CN712	QGB2510J1-10	CONNECTOR		
	C 408	QEKC1HM-475Z	E CAPACITOR	4.7MF 20% 50V			CN713	QGB2510J1-09	CONNECTOR		
	C 409	NCB31HK-102X	C CAPACITOR				CN714	QGB2510J1-09	CONNECTOR		
	C 410	NCB31HK-102X	C CAPACITOR				CN715	QGB2510J1-09	CONNECTOR		
	C 411	NCB31HK-102X	C CAPACITOR				CN721	QJL009-042604	SIN CR B-B WIRE		
	C 412	NCB31HK-103X	C CAPACITOR				D 401	SLR-342MC-T	LED		
	C 413	NCB31HK-103X	C CAPACITOR				D 402	SLR-342MC-T	LED		
	C 414	NCB31HK-103X	C CAPACITOR				D 403	SLR-342MC-T	LED		
	C 416	NCB31HK-103X	C CAPACITOR				D 404	SPR-325MVW/L/-T	LED		
	C 418	NCB31CK-223X	C CAPACITOR				D 405	SPR-325MVW/L/-T	LED		
	C 419	NCB31HK-561X	C CAPACITOR				D 406	SPR-325MVW/L/-T	LED		
	C 451	NCB31HK-561X	C CAPACITOR				D 407	SLR-342VC-T	LED		
	C 701	QFZ9076-104Z	MM CAPACITOR	.10MF			D 408	1SS355-X	DIODE C.M		
	C 702	QFZ9076-104Z	MM CAPACITOR	.10MF		△	D 701	30DF2-FC	DIODE		
	C 703	QFZ9076-104Z	MM CAPACITOR	.10MF		△	D 702	30DF2-FC	DIODE		
	C 704	QEZ0571-478	E CAPACITER	4700MF		△	D 703	30DF2-FC	DIODE		
	C 705	QEZ0571-478	E CAPACITER	4700MF		△	D 704	30DF2-FC	DIODE		
	C 706	QETN1EM-476Z	E CAPACITOR	47MF 20% 25V			D 705	MTZJ22C-T2	ZENER DIODE		
	C 709	QEKC1HM-106Z	E CAPACITOR	10MF 20% 50V			D 707	1SS133-T2	SI DIODE IM		
	C 710	QETNOJM-227Z	E CAPACITOR	220MF 20% 6.3V			D 709	MTZJ8.2C-T2	ZENER DIODE		
	C 712	QEKC1HM-475Z	E CAPACITOR	4.7MF 20% 50V			D 710	MTZJ5.1C-T2	ZENER DIODE		
	C 713	QEKC1HM-475Z	E CAPACITOR	4.7MF 20% 50V			D 711	1SS133-T2	SI DIODE IM		
	C 714	QEKC1HM-475Z	E CAPACITOR	4.7MF 20% 50V			D 712	1SS133-T2	SI DIODE IM		
	C 715	QEKC1HM-475Z	E CAPACITOR	4.7MF 20% 50V			D 713	1SS133-T2	SI DIODE IM		
	C 717	QCS31HJ-101Z	C CAPACITOR	100PF 5% 50V			D 714	1SS133-T2	SI DIODE IM		
	C 718	QFLC1HJ-104Z	M CAPACITOR	.10MF 5% 50V			D 715	1SS133-T2	SI DIODE IM		
	C 721	QETN1HM-476Z	E CAPACITOR	47MF 20% 50V			D 716	1SS133-T2	SI DIODE IM		
	C 741	QFLC1HJ-223Z	M CAPACITOR	.022MF 5% 50V			D 717	MTZJ30C-T2	ZENER DIODE		
	C 742	QFLC1HJ-223Z	M CAPACITOR	.022MF 5% 50V			D 721	MTZJ6.8C-T2	Z DIODE I/M		
	C 743	QCS31HJ-221Z	C CAPACITOR	220PF 5% 50V			D 741	1SS133-T2	SI DIODE IM		
	C 744	QCS31HJ-221Z	C CAPACITOR	220PF 5% 50V			D 742	1SS133-T2	SI DIODE IM		
	C 745	QCS31HJ-221Z	C CAPACITOR	220PF 5% 50V			D 743	1SS133-T2	SI DIODE IM		
	C 746	QCS31HJ-221Z	C CAPACITOR	220PF 5% 50V			DI401	QLF0099-001	FL TUBE		
	C 747	QCF31HZ-223Z	C CAPACITOR	.022MF +80:-20%			EP203	QNZ0136-001Z	EARTH PLATE		
	C 748	QCF31HZ-223Z	C CAPACITOR	.022MF +80:-20%			EP701	QNZ0136-001Z	EARTH PLATE		
	C 749	QFLC1HJ-223Z	M CAPACITOR	.022MF 5% 50V			FW209	QUM133-13DGZ4	PARA RIBON WIRE		
	C 750	QFLC1HJ-223Z	M CAPACITOR	.022MF 5% 50V			FW401	QUM133-08Z4Z4	PARA RIBON WIRE		
	C 751	QCS31HJ-221Z	C CAPACITOR	220PF 5% 50V			FW702	QUM136-23Z4Z4	PARA RIBON WIRE		
	C 752	QCS31HJ-221Z	C CAPACITOR	220PF 5% 50V			FW707	QUM134-22DGZ4	PARA RIBON WIRE		
	C 753	QCS31HJ-221Z	C CAPACITOR	220PF 5% 50V			IC401	MN101C35DJZ	IC		
	C 754	QCS31HJ-221Z	C CAPACITOR	220PF 5% 50V			IC402	NJU3713G-X	IC		
	C 755	QCS31HJ-221Z	C CAPACITOR	220PF 5% 50V			IC403	GP1UM281XK	IR DETECT UNIT		
	C 756	QCS31HJ-221Z	C CAPACITOR	220PF 5% 50V			IC404	IC-PST9139-T	IC I.M		
	C 757	QFLC1HJ-223Z	M CAPACITOR	.022MF 5% 50V			J 201	QNS0014-001	JACK		
	C 758	QCS31HJ-221Z	C CAPACITOR	220PF 5% 50V			L 301	QQLZ003-1R0	INDUCTOR		
	C 759	QCS31HJ-221Z	C CAPACITOR	220PF 5% 50V			L 302	QQLZ003-1R0	INDUCTOR		
	C 760	QCS31HJ-221Z	C CAPACITOR	220PF 5% 50V			L 741	QQLZ005-R45	INDUCTOR		
	CL701	QZW0038-001	WIRE CLAMP				L 742	QQLZ005-R45	INDUCTOR		

■ Electrical parts list (Main & System control board) Block No. 02

△	Item	Parts number	Parts name	Remarks	Area	△	Item	Parts number	Parts name	Remarks	Area
	L 743	QQLZ005-R45	INDUCTOR				R 436	NRSA63J-103X	MG RESISTOR		
	L 744	QQLZ005-R45	INDUCTOR				R 437	NRSA63J-102X	MG RESISTOR		
	L 745	QQLZ005-R45	INDUCTOR				R 438	NRSA63J-102X	MG RESISTOR		
	Q 401	KTC3199/GL-T	TRANSISTOR				R 439	NRSA63J-122X	MG RESISTOR		
	Q 402	KTC3199/GL-T	TRANSISTOR				R 440	NRSA63J-152X	MG RESISTOR		
	Q 403	KTC3199/GL-T	TRANSISTOR				R 441	NRSA63J-222X	MG RESISTOR		
	Q 404	KTC3199/GL-T	TRANSISTOR				R 442	NRSA63J-272X	MG RESISTOR		
	Q 405	KTC3199/GL-T	TRANSISTOR				R 443	NRSA63J-392X	MG RESISTOR		
	Q 406	KTC3199/GL-T	TRANSISTOR				R 444	NRSA63J-103X	MG RESISTOR		
	Q 407	DTC114EKA-X	TRANSISTOR				R 445	NRSA63J-102X	MG RESISTOR		
	Q 702	KTC3200/GL-T	TRANSISTOR				R 446	NRSA63J-102X	MG RESISTOR		
	Q 703	KTA1268/GL-T	TRANSISTOR				R 447	NRSA63J-122X	MG RESISTOR		
	Q 704	KTC3199/GL-T	TRANSISTOR				R 448	NRSA63J-152X	MG RESISTOR		
	Q 705	2SD2395/EF/	TRANSISTOR				R 449	NRSA63J-222X	MG RESISTOR		
	Q 706	KTC3200/GL-T	TRANSISTOR				R 450	NRSA63J-272X	MG RESISTOR		
	Q 708	KRC109M-T	D.TR.I.M.				R 451	NRSA63J-392X	MG RESISTOR		
	Q 710	KRC109M-T	D.TR.I.M.				R 455	NRSA63J-103X	MG RESISTOR		
	Q 711	KRC109M-T	D.TR.I.M.				R 456	NRSA63J-103X	MG RESISTOR		
	Q 712	KRC109M-T	D.TR.I.M.				R 457	NRSA63J-102X	MG RESISTOR		
	Q 713	KRC109M-T	D.TR.I.M.				R 458	NRSA63J-102X	MG RESISTOR		
	Q 714	KRC109M-T	D.TR.I.M.				R 459	NRSA63J-122X	MG RESISTOR		
	Q 715	KRC109M-T	D.TR.I.M.				R 464	NRSA63J-221X	MG RESISTOR		
	Q 716	KTA1046/Y/	TRANSISTOR				R 465	NRSA63J-221X	MG RESISTOR		
△	R 351	QRJ125J-100	UNF C RESISTOR	10 5% 1/2W			R 466	NRSA63J-221X	MG RESISTOR		
△	R 352	QRJ125J-100	UNF C RESISTOR	10 5% 1/2W			R 467	NRSA63J-221X	MG RESISTOR		
△	R 353	QRL027J-100	UNF OMF RESISTO	10 5% 1/2W			R 468	NRSA63J-221X	MG RESISTOR		
△	R 354	QRL027J-100	UNF OMF RESISTO	10 5% 1/2W			R 469	NRSA63J-221X	MG RESISTOR		
	R 400	NRSA63J-103X	MG RESISTOR				R 470	NRSA63J-221X	MG RESISTOR		
	R 401	NRSA63J-223X	MG RESISTOR				R 471	NRSA63J-221X	MG RESISTOR		
	R 402	NRSA63J-473X	MG RESISTOR				R 472	NRSA63J-221X	MG RESISTOR		
	R 403	NRSA63J-683X	MG RESISTOR				R 473	NRSA63J-221X	MG RESISTOR		
	R 404	NRSA63J-473X	MG RESISTOR				R 474	NRSA63J-221X	MG RESISTOR		
	R 405	NRSA63J-153X	MG RESISTOR				R 475	NRSA63J-221X	MG RESISTOR		
	R 406	NRSA63J-273X	MG RESISTOR				R 476	NRSA63J-221X	MG RESISTOR		
	R 407	NRSA63J-103X	MG RESISTOR				R 477	NRSA63J-221X	MG RESISTOR		
	R 408	NRSA63J-103X	MG RESISTOR				R 478	NRSA63J-221X	MG RESISTOR		
	R 409	NRSA63J-223X	MG RESISTOR				R 479	NRSA63J-221X	MG RESISTOR		
	R 410	NRSA63J-473X	MG RESISTOR				R 480	NRSA63J-221X	MG RESISTOR		
	R 411	NRSA63J-683X	MG RESISTOR				R 481	NRSA63J-103X	MG RESISTOR		
	R 412	NRSA63J-473X	MG RESISTOR				R 482	NRSA63J-221X	MG RESISTOR		
	R 413	NRSA63J-153X	MG RESISTOR				R 488	NRSA63J-103X	MG RESISTOR		
	R 414	NRSA63J-273X	MG RESISTOR				R 489	NRSA63J-103X	MG RESISTOR		
	R 415	NRSA63J-103X	MG RESISTOR				R 490	NRSA63J-103X	MG RESISTOR		
	R 416	NRSA63J-103X	MG RESISTOR				R 491	NRSA63J-221X	MG RESISTOR		
	R 417	NRSA63J-223X	MG RESISTOR				R 492	NRSA63J-392X	MG RESISTOR		
	R 418	NRSA63J-473X	MG RESISTOR				R 493	NRSA63J-103X	MG RESISTOR		
	R 419	NRSA63J-683X	MG RESISTOR				R 494	NRSA63J-103X	MG RESISTOR		
	R 420	NRSA63J-473X	MG RESISTOR				R 495	NRSA63J-103X	MG RESISTOR		
	R 421	NRSA63J-153X	MG RESISTOR				R 496	NRSA63J-103X	MG RESISTOR		
	R 422	NRSA63J-273X	MG RESISTOR				R 497	NRSA63J-103X	MG RESISTOR		
	R 423	NRSA63J-103X	MG RESISTOR				R 498	NRSA63J-103X	MG RESISTOR		
	R 424	NRSA63J-103X	MG RESISTOR				R 499	NRSA63J-103X	MG RESISTOR		
	R 425	NRSA63J-103X	MG RESISTOR				△ R 701	QRL027J-332	UNF OMF RESISTO	3.3K 5% 1/2W	
	R 426	NRSA63J-223X	MG RESISTOR				R 704	NRSA63J-104X	MG RESISTOR		
	R 427	NRSA63J-472X	MG RESISTOR				R 705	NRSA63J-104X	MG RESISTOR		
	R 428	NRSA63J-221X	MG RESISTOR				R 706	NRSA63J-823X	MG RESISTOR		
	R 429	NRSA63J-103X	MG RESISTOR				R 707	NRSA63J-104X	MG RESISTOR		
	R 430	NRSA63J-102X	MG RESISTOR				R 708	NRSA63J-823X	MG RESISTOR		
	R 431	NRSA63J-102X	MG RESISTOR				R 709	NRSA63J-103X	MG RESISTOR		
	R 432	NRSA63J-122X	MG RESISTOR				R 710	NRSA63J-103X	MG RESISTOR		
	R 433	NRSA63J-152X	MG RESISTOR				R 711	NRSA63J-104X	MG RESISTOR		
	R 434	NRSA63J-222X	MG RESISTOR				R 712	NRSA63J-104X	MG RESISTOR		
	R 435	NRSA63J-272X	MG RESISTOR				△ R 713	QRJ146J-100X	UNF C RESISTOR	10 5% 1/4W	

# RX-E112RSL/RX-E111RSL

## ■ Electrical parts list (Main & System control board) Block No. 02

△	Item	Parts number	Parts name	Remarks	Area
△	R 714	QRK126J-222X	UNF C.RES 1/M	2.2K 5% 1/2W	
	R 718	NRSA63J-103X	MG RESISTOR		
	R 719	NRSA63J-473X	MG RESISTOR		
△	R 720	QRJ146J-392X	UNF C RESISTOR	3.9K 5% 1/4W	
	R 721	NRSA63J-472X	MG RESISTOR		
	R 722	NRSA63J-223X	MG RESISTOR		
	R 723	NRSA63J-153X	MG RESISTOR		
	R 725	NRSA63J-472X	MG RESISTOR		
	R 726	NRSA63J-472X	MG RESISTOR		
	R 727	NRSA63J-472X	MG RESISTOR		
	R 728	NRSA63J-472X	MG RESISTOR		
	R 729	NRSA63J-223X	MG RESISTOR		
	R 730	NRSA63J-153X	MG RESISTOR		
	R 731	NRSA63J-223X	MG RESISTOR		
	R 732	NRSA63J-153X	MG RESISTOR		
△	R 735	QRJ146J-120X	UNF C RESISTOR	12 5% 1/4W	
△	R 736	QRZ9005-100X	F RESISTOR	10 1/4W	
△	R 737	QRJ146J-562X	UNF C RESISTOR	5.6K 5% 1/4W	
△	R 741	QRJ146J-120X	UNF C RESISTOR	12 5% 1/4W	
△	R 742	QRJ146J-120X	UNF C RESISTOR	12 5% 1/4W	
△	R 743	QRJ146J-120X	UNF C RESISTOR	12 5% 1/4W	
△	R 745	QRZ9006-4R7X	F RESISTOR	4.7 1/4W	
△	R 746	QRZ9006-4R7X	F RESISTOR	4.7 1/4W	
△	R 747	QRZ9006-4R7X	F RESISTOR	4.7 1/4W	
△	R 748	QRZ9006-4R7X	F RESISTOR	4.7 1/4W	
△	R 749	QRZ9006-4R7X	F RESISTOR	4.7 1/4W	
△	RY701	QSK0082-001	RELAY		
△	RY741	QSK0109-001	RELAY		
△	RY742	QSK0109-001	RELAY		
△	RY743	QSK0109-001	RELAY		
	R1422	NRSA63J-104X	MG RESISTOR		
	S 401	QSW0683-001Z	PUSH SWITCH	SURROUND	
	S 402	QSW0683-001Z	PUSH SWITCH	SURR MODE	
	S 403	QSW0683-001Z	PUSH SWITCH	INPUT MODE	
	S 404	QSW0683-001Z	PUSH SWITCH	DVD	
	S 405	QSW0683-001Z	PUSH SWITCH	STB	
	S 406	QSW0683-001Z	PUSH SWITCH	UP	
	S 407	QSW0683-001Z	PUSH SWITCH	LEFT	
	S 408	QSW0683-001Z	PUSH SWITCH	VOL.DOWN	
	S 409	QSW0683-001Z	PUSH SWITCH	ADJUST	
	S 410	QSW0683-001Z	PUSH SWITCH	SETTING	
	S 411	QSW0683-001Z	PUSH SWITCH	VCR	
	S 412	QSW0683-001Z	PUSH SWITCH	TV	
	S 413	QSW0683-001Z	PUSH SWITCH	DOWN	
	S 414	QSW0683-001Z	PUSH SWITCH	RIGHT	
	S 415	QSW0683-001Z	PUSH SWITCH	VOL.UP	
	S 416	QSW0683-001Z	PUSH SWITCH	MEMORY	
	S 417	QSW0683-001Z	PUSH SWITCH	TAPE	
	S 418	QSW0683-001Z	PUSH SWITCH	FM/AM	
	S 421	QSW0683-001Z	PUSH SWITCH	POWER	
	S 422	QSW0683-001Z	PUSH SWITCH	AMP/SWITCH	
	ST741	QNB0139-001	SPK TERMINAL	FRONT	
	ST742	QNB0140-001	SPK TERMINAL	CNT/SR	
	X 401	QAX0246-001Z	C RESONATOR		

■ Electrical parts list (Audio signal input board) Block No. 03

△	Item	Parts number	Parts name	Remarks	Area
	C 501	NCS31HJ-331X	C.CAPA. C.M		
	C 502	NCS31HJ-331X	C.CAPA. C.M		
	C 503	QEK1HM-475Z	E CAPACITOR	4.7MF 20% 50V	
	C 504	QEK1HM-475Z	E CAPACITOR	4.7MF 20% 50V	
	C 505	QEK1HM-475Z	E CAPACITOR	4.7MF 20% 50V	
	C 506	QEK1HM-475Z	E CAPACITOR	4.7MF 20% 50V	
	C 507	NCS31HJ-331X	C.CAPA. C.M		
	C 508	NCS31HJ-331X	C.CAPA. C.M		
	C 509	QEK1HM-475Z	E CAPACITOR	4.7MF 20% 50V	
	C 510	QEK1HM-475Z	E CAPACITOR	4.7MF 20% 50V	
	C 511	QEK1HM-475Z	E CAPACITOR	4.7MF 20% 50V	
	C 512	QEK1HM-475Z	E CAPACITOR	4.7MF 20% 50V	
	C 513	NCS31HJ-331X	C.CAPA. C.M		
	C 514	NCS31HJ-331X	C.CAPA. C.M		
	C 515	NCS31HJ-221X	C.CAPA. C.M		
	C 516	NCS31HJ-221X	C.CAPA. C.M		
	C 517	NCS31HJ-331X	C.CAPA. C.M		
	C 518	NCS31HJ-331X	C.CAPA. C.M		
	C 519	QETN1HM-475Z	E CAPACITOR	4.7MF 20% 50V	
	C 520	QETN1HM-475Z	E CAPACITOR	4.7MF 20% 50V	
	C 521	QETN1HM-226Z	E CAPACITOR	22MF 20% 50V	
	C 522	QETN1HM-226Z	E CAPACITOR	22MF 20% 50V	
	C 523	QFLC1HJ-683Z	M CAPACITOR	.068MF 5% 50V	
	C 524	QFLC1HJ-683Z	M CAPACITOR	.068MF 5% 50V	
	C 525	QFLC1HJ-682Z	M CAPACITOR	6800PF 5% 50V	
	C 526	QFLC1HJ-682Z	M CAPACITOR	6800PF 5% 50V	
	C 527	QFLC1HJ-682Z	M CAPACITOR	6800PF 5% 50V	
	C 528	QFLC1HJ-682Z	M CAPACITOR	6800PF 5% 50V	
	C 529	QETN1HM-226Z	E CAPACITOR	22MF 20% 50V	
	C 530	QETN1HM-226Z	E CAPACITOR	22MF 20% 50V	
	C 531	QFLC1HJ-104Z	M CAPACITOR	.10MF 5% 50V	
	C 532	QFLC1HJ-104Z	M CAPACITOR	.10MF 5% 50V	
	C 533	QFLC1HJ-104Z	M CAPACITOR	.10MF 5% 50V	
	C 534	QFLC1HJ-104Z	M CAPACITOR	.10MF 5% 50V	
	C 535	QEK1CM-476Z	E CAPACITOR	47MF 20% 16V	
	C 536	QEK1CM-476Z	E CAPACITOR	47MF 20% 16V	
	C 537	QEK1AM-476Z	E CAPACITOR	47MF 20% 10V	
	C 538	NCB31HK-561X	C CAPACITOR		
	C 541	QTE1H28-106Z	E CAPACITOR		
	C 542	QTE1H28-106Z	E CAPACITOR		
	C 544	QETN1HM-475Z	E CAPACITOR	4.7MF 20% 50V	
	C 545	QETN1HM-475Z	E CAPACITOR	4.7MF 20% 50V	
	C 546	QETN1HM-475Z	E CAPACITOR	4.7MF 20% 50V	
	C 547	QCB1HK-681Y	C CAPACITOR	680PF 10% 50V	
	C 548	QCB1HK-681Y	C CAPACITOR	680PF 10% 50V	
	C 549	QETN1HM-475Z	E CAPACITOR	4.7MF 20% 50V	
	C 550	QETN1HM-475Z	E CAPACITOR	4.7MF 20% 50V	
	C 551	QFLC1HJ-562Z	M CAPACITOR	5600PF 5% 50V	
	C 552	QFLC1HJ-562Z	M CAPACITOR	5600PF 5% 50V	
	C 553	QETN0JM-477Z	E CAPACITOR	470MF 20% 6.3V	
	C 554	QEK1CM-106Z	E CAPACITOR	10MF 20% 16V	
	C 555	QEK1CM-476Z	E CAPACITOR	47MF 20% 16V	
	C 556	QEK1CM-476Z	E CAPACITOR	47MF 20% 16V	
	C 557	QETN1EM-476Z	E CAPACITOR	47MF 20% 25V	
	C 558	QETN1EM-476Z	E CAPACITOR	47MF 20% 25V	
	C 559	QETN1EM-476Z	E CAPACITOR	47MF 20% 25V	
	C 560	QETN1EM-107Z	E CAPACITOR	100MF 20% 25V	
	C 561	QETN1EM-107Z	E CAPACITOR	100MF 20% 25V	
	C 562	QETN1EM-107Z	E CAPACITOR	100MF 20% 25V	
	C 563	QFLC1HJ-104Z	M CAPACITOR	.10MF 5% 50V	
	C 564	QCF31HZ-223Z	C CAPACITOR	.022MF +80:-20%	
	C 565	QETN1EM-107Z	E CAPACITOR	100MF 20% 25V	
	C 566	QETN1EM-107Z	E CAPACITOR	100MF 20% 25V	

△	Item	Parts number	Parts name	Remarks	Area
	C 577	QETN1CM-476Z	E CAPACITOR	47MF 20% 16V	
	C 581	QEK1HM-225Z	E CAPACITOR	2.2MF 20% 50V	
	C 591	QETN1HM-106Z	E CAPACITOR	10MF 20% 50V	
	C 592	QETN1HM-106Z	E CAPACITOR	10MF 20% 50V	
	C 593	QETN1HM-475Z	E CAPACITOR	4.7MF 20% 50V	
	C 594	QETN1HM-475Z	E CAPACITOR	4.7MF 20% 50V	
	C 595	QETN1HM-475Z	E CAPACITOR	4.7MF 20% 50V	
	C 596	QETN1HM-475Z	E CAPACITOR	4.7MF 20% 50V	
	CL501	QZW0038-001	WIRE CLAMP		
	CL502	QZW0038-001	WIRE CLAMP		
	CN224	QGD2501C1-03Z	SOCKET		
	CN225	QGD2501C1-03Z	SOCKET		
	CN411	QGF1205C1-21	CONNECTOR		
	CN412	QGF1205F1-09	CONNECTOR		
	CN501	QGB2510J1-20	CONNECTOR		
	CN502	QGF1205C1-23	CONNECTOR		
	CN503	QGB2510J1-12	CONNECTOR		
	CN504	QGB2510J1-04	CONNECTOR		
	CN505	QJP001-031401	SHI CR C-B WIRE		
	CN506	QJP002-021401	SHI CR C-B WIRE		
	CN507	QJP001-030801	SHI CR C-B WIRE		
	CN511	QGB2510K1-20	B TO B CONNE		
	CN512	QGF1205F1-23	CONNECTOR		
	CN601	QGB2510J1-20	CONNECTOR		
	C1501	NCS31HJ-331X	C.CAPA. C.M		
	C1502	NCS31HJ-331X	C.CAPA. C.M		
	C1505	NCS31HJ-331X	C.CAPA. C.M		
	C1506	NCS31HJ-331X	C.CAPA. C.M		
	C1507	QEK1HM-475Z	E CAPACITOR	4.7MF 20% 50V	
	C1508	NCS31HJ-470X	C.CAPA. C.M		
	C1509	QETN0JM-477Z	E CAPACITOR	470MF 20% 6.3V	
	C1510	QEK1HM-475Z	E CAPACITOR	4.7MF 20% 50V	
	C1511	NCS31HJ-331X	C.CAPA. C.M		
	C1512	NCS31HJ-331X	C.CAPA. C.M		
	C1515	NCS31HJ-331X	C.CAPA. C.M		
	C1516	NCS31HJ-331X	C.CAPA. C.M		
	C1517	NCS31HJ-470X	C.CAPA. C.M		
	C1518	QETN0JM-477Z	E CAPACITOR	470MF 20% 6.3V	
	C1519	NCS31HJ-470X	C.CAPA. C.M		
	C1520	QETN0JM-477Z	E CAPACITOR	470MF 20% 6.3V	
	C1521	NCS31HJ-470X	C.CAPA. C.M		
	C1522	QEK1HM-475Z	E CAPACITOR	4.7MF 20% 50V	
	C1523	NCS31HJ-470X	C.CAPA. C.M		
	C1524	QETN0JM-477Z	E CAPACITOR	470MF 20% 6.3V	
	C1528	QEK1CM-476Z	E CAPACITOR	47MF 20% 16V	
	C1529	QFLC1HJ-104Z	M CAPACITOR	.10MF 5% 50V	
	C1536	QETN0JM-477Z	E CAPACITOR	470MF 20% 6.3V	
	C1538	QEK1HM-475Z	E CAPACITOR	4.7MF 20% 50V	
	C1539	QEK1HM-475Z	E CAPACITOR	4.7MF 20% 50V	
	C1540	NCS31HJ-470X	C.CAPA. C.M		
	C1543	QFLC1HJ-104Z	M CAPACITOR	.10MF 5% 50V	
	C1546	NCF31CZ-104X	C CAPACITOR		
	C1547	NCF31CZ-104X	C CAPACITOR		
	D 503	MTZJ7.5C-T2	ZENER DIODE		
	D 504	MTZJ7.5C-T2	ZENER DIODE		
	D 505	MTZJ15C-T2	Z DIODE		
	D 506	MTZJ15C-T2	Z DIODE		
	D 507	MTZJ5.6C-T2	ZENER DIODE		
	D 508	MTZJ5.6C-T2	ZENER DIODE		
	D 509	1SS355-X	DIODE C.M		
	D 511	MTZJ13C-T2	ZENER DIODE		
	D 512	MTZJ13C-T2	ZENER DIODE		
	D 513	MTZJ13C-T2	ZENER DIODE		

■ Electrical parts list (Audio signal input board) Block No. 03

△	Item	Parts number	Parts name	Remarks	Area
	D 514	MTZJ13C-T2	ZENER DIODE		
	D 515	MTZJ13C-T2	ZENER DIODE		
	D 516	MTZJ13C-T2	ZENER DIODE		
	D 517	MTZJ13C-T2	ZENER DIODE		
	D 518	MTZJ13C-T2	ZENER DIODE		
	D 519	MTZJ10C-T2	Z.DIODE I.M		
	D 520	MTZJ13C-T2	ZENER DIODE		
	D1501	MTZJ13C-T2	ZENER DIODE		
	D1503	MTZJ13C-T2	ZENER DIODE		
	D1504	MTZJ13C-T2	ZENER DIODE		
	D1505	MTZJ13C-T2	ZENER DIODE		
	EP502	QNZ0136-001Z	EARTH PLATE		
	FL501	QQR0590-001	FILTER		
	FL502	QQR0590-001	FILTER		
	HS512	E70306-001	HEAT SINK		
	HS513	E70306-001	HEAT SINK		
	HS514	E70306-001	HEAT SINK		
	HS515	E70306-001	HEAT SINK		
	HS520	E70306-001	HEAT SINK		
	HS526	E70306-001	HEAT SINK		
	IC501	M61501FP	IC		
	IC503	BA15218F-XE	IC		
	IC511	NJM2246M-X	IC		
	IC512	NJM2246M-X	IC		
	IC513	NJM2246M-X	IC		
	IC514	BA7625	IC		
	IC515	TC74HC4053AF-X	I.C C.M		
	J 501	QNZ0516-001	RGB CONNECTOR	DVD	
	J 502	QNZ0516-001	RGB CONNECTOR	STB	
	J 503	QNN0163-001	PIN JACK		
	J 504	QNN0060-001	PIN JACK	SUBWOOFER OUT	
	J1501	QNZ0516-001	RGB CONNECTOR	VCR	
	J1502	QNZ0516-001	RGB CONNECTOR	TV	
	Q 501	2SC3576-JVC-T	TRANSISTOR I/M		
	Q 502	2SC3576-JVC-T	TRANSISTOR I/M		
	Q 503	2SC3576-JVC-T	TRANSISTOR I/M		
	Q 505	2SC3576-JVC-T	TRANSISTOR I/M		
	Q 506	2SC3576-JVC-T	TRANSISTOR I/M		
	Q 507	2SC3576-JVC-T	TRANSISTOR I/M		
	Q 508	2SC3576-JVC-T	TRANSISTOR I/M		
	Q 509	DTA114YKA-X	TRANSISTOR		
△	Q 510	KTA1271/OY/-T	TRANSISTOR		
△	Q 511	KTC3203/OY/-T	TRANSISTOR		
△	Q 512	KTA1046/Y/	TRANSISTOR		
△	Q 513	2SD2395/EF/	TRANSISTOR		
△	Q 514	2SD2395/EF/	TRANSISTOR		
△	Q 515	2SD2395/EF/	TRANSISTOR		
	Q 516	DTA114YKA-X	TRANSISTOR		
	Q 517	DTC114EKA-X	TRANSISTOR		
△	Q 518	KTC3203/OY/-T	TRANSISTOR		
	Q 519	DTC114EKA-X	TRANSISTOR		
△	Q 520	2SD2395/EF/	TRANSISTOR		
	Q 522	DTA114EKA-X	DIGITAL.TRANSIS		
	Q 523	DTC114EKA-X	TRANSISTOR		
	Q 524	DTA114EKA-X	DIGITAL.TRANSIS		
	Q 525	DTA114EKA-X	DIGITAL.TRANSIS		
△	Q 526	2SD2395/EF/	TRANSISTOR		
	Q1501	DTC114TKA-X	TRANSISTOR		
	Q1502	DTC114TKA-X	TRANSISTOR		
	Q1503	DTC114TKA-X	TRANSISTOR		
	Q1504	KTC3199/GL/-T	TRANSISTOR		
	Q1505	KTC3199/GL/-T	TRANSISTOR		
	Q1506	KTC3199/GL/-T	TRANSISTOR		

△	Item	Parts number	Parts name	Remarks	Area
	Q1511	KTC3199/GL/-T	TRANSISTOR		
	Q1512	KTC3199/GL/-T	TRANSISTOR		
	Q1513	KTC3199/GL/-T	TRANSISTOR		
	Q1514	DTC114EKA-X	TRANSISTOR		
	Q1520	DTC114EKA-X	TRANSISTOR		
	Q1523	2SC3576-JVC-T	TRANSISTOR I/M		
	Q1524	2SC3576-JVC-T	TRANSISTOR I/M		
	Q1525	2SC3576-JVC-T	TRANSISTOR I/M		
	Q1526	2SC3576-JVC-T	TRANSISTOR I/M		
	Q1527	KTA1267/YG/-T	TRANSISTOR		
	Q1528	KTA1267/YG/-T	TRANSISTOR		
	Q1531	DTA114YKA-X	TRANSISTOR		
	Q1532	DTA114YKA-X	TRANSISTOR		
	R 501	NRSA63J-471X	MG RESISTOR		
	R 502	NRSA63J-471X	MG RESISTOR		
	R 503	NRSA63J-750X	MG RESISTOR		
	R 504	NRSA63J-331X	MG RESISTOR		
	R 505	NRSA63J-750X	MG RESISTOR		
	R 506	NRSA63J-331X	MG RESISTOR		
	R 507	NRSA63J-750X	MG RESISTOR		
	R 508	NRSA63J-331X	MG RESISTOR		
	R 509	NRSA63J-750X	MG RESISTOR		
	R 510	NRSA63J-750X	MG RESISTOR		
	R 511	NRSA63J-331X	MG RESISTOR		
	R 513	NRSA63J-471X	MG RESISTOR		
	R 514	NRSA63J-471X	MG RESISTOR		
	R 515	NRSA63J-750X	MG RESISTOR		
	R 516	NRSA63J-331X	MG RESISTOR		
	R 517	NRSA63J-750X	MG RESISTOR		
	R 518	NRSA63J-331X	MG RESISTOR		
	R 519	NRSA63J-750X	MG RESISTOR		
	R 520	NRSA63J-331X	MG RESISTOR		
	R 521	NRSA63J-750X	MG RESISTOR		
	R 522	NRSA63J-750X	MG RESISTOR		
	R 523	NRSA63J-331X	MG RESISTOR		
	R 525	NRSA63J-471X	MG RESISTOR		
	R 526	NRSA63J-471X	MG RESISTOR		
	R 527	NRSA63J-471X	MG RESISTOR		
	R 528	NRSA63J-471X	MG RESISTOR		
	R 529	NRSA63J-102X	MG RESISTOR		
	R 530	NRSA63J-102X	MG RESISTOR		
	R 531	NRSA63J-103X	MG RESISTOR		
	R 532	NRSA63J-103X	MG RESISTOR		
	R 533	NRSA63J-103X	MG RESISTOR		
	R 534	NRSA63J-103X	MG RESISTOR		
	R 535	NRSA63J-622X	MG RESISTOR		
	R 536	NRSA63J-622X	MG RESISTOR		
	R 537	NRSA63J-103X	MG RESISTOR		
	R 538	NRSA63J-103X	MG RESISTOR		
△	R 541	QRJ146J-2R2X	UNF C RESISTOR	2.2 5% 1/4W	
△	R 542	QRJ146J-2R2X	UNF C RESISTOR	2.2 5% 1/4W	
	R 545	NRSA63J-104X	MG RESISTOR		
	R 546	NRSA63J-104X	MG RESISTOR		
	R 547	NRSA63J-102X	MG RESISTOR		
	R 548	NRSA63J-102X	MG RESISTOR		
	R 549	NRSA63J-103X	MG RESISTOR		
	R 550	NRSA63J-103X	MG RESISTOR		
	R 552	NRSA63J-104X	MG RESISTOR		
	R 554	NRSA63J-273X	MG RESISTOR		
	R 556	NRSA63J-102X	MG RESISTOR		
	R 557	NRSA63J-104X	MG RESISTOR		
	R 558	NRSA63J-104X	MG RESISTOR		
	R 559	NRSA63J-102X	MG RESISTOR		

■ Electrical parts list (Audio signal input board) Block No. 03

△	Item	Parts number	Parts name	Remarks	Area
	R 561	NRSA63J-103X	MG RESISTOR		
	R 563	NRSA63J-0R0X	MG RESISTOR		
	R 569	NRSA63J-104X	MG RESISTOR		
	R 570	NRSA63J-104X	MG RESISTOR		
	R 571	NRSA63J-102X	MG RESISTOR		
	R 572	NRSA63J-102X	MG RESISTOR		
	R 573	NRSA63J-103X	MG RESISTOR		
	R 574	NRSA63J-103X	MG RESISTOR		
	R 575	NRSA63J-472X	MG RESISTOR		
	R 576	NRSA63J-472X	MG RESISTOR		
△	R 577	QRJ146J-220X	UNF C RESISTOR	22 5% 1/4W	
	R 578	NRSA63J-102X	MG RESISTOR		
△	R 579	QRZ9005-680X	F RESISTOR	68 1/4W	
△	R 580	QRZ9005-680X	F RESISTOR	68 1/4W	
△	R 581	QRZ9005-100X	F RESISTOR	10 1/4W	
△	R 582	QRJ146J-222X	UNF C RESISTOR	2.2K 5% 1/4W	
△	R 583	QRZ9005-100X	F RESISTOR	10 1/4W	
△	R 584	QRJ146J-222X	UNF C RESISTOR	2.2K 5% 1/4W	
△	R 585	QRZ9005-100X	F RESISTOR	10 1/4W	
△	R 586	QRJ146J-182X	UNF C RESISTOR	1.8K 5% 1/4W	
△	R 588	QRJ146J-182X	UNF C RESISTOR	1.8K 5% 1/4W	
△	R 589	QRZ9005-220X	F RESISTOR	22 1/4W	
△	R 590	QRJ146J-682X	UNF C RESISTOR	6.8K 5% 1/4W	
△	R 591	QRZ9006-4R7X	F RESISTOR	4.7 1/4W	
△	R 592	QRZ9006-4R7X	F RESISTOR	4.7 1/4W	
△	R 593	QRJ146J-272X	UNF C RESISTOR	2.7K 5% 1/4W	
△	R 594	QRZ9006-6R8X	F RESISTOR	6.8 1/4W	
△	R 595	QRZ9005-100X	F RESISTOR	10 1/4W	
△	R 596	QRJ146J-102X	UNF C RESISTOR	1.0K 5% 1/4W	
△	R 597	QRZ9006-4R7X	F RESISTOR	4.7 1/4W	
△	R 598	QRJ146J-182X	UNF C RESISTOR	1.8K 5% 1/4W	
	R1501	NRSA63J-101X	MG RESISTOR		
	R1502	NRSA63J-101X	MG RESISTOR		
	R1503	NRSA63J-471X	MG RESISTOR		
	R1504	NRSA63J-471X	MG RESISTOR		
	R1505	NRSA63J-750X	MG RESISTOR		
	R1506	NRSA63J-331X	MG RESISTOR		
	R1507	NRSA63J-473X	MG RESISTOR		
	R1508	NRSA63J-750X	MG RESISTOR		
	R1509	NRSA63J-750X	MG RESISTOR		
	R1510	NRSA63J-331X	MG RESISTOR		
	R1511	NRSA63J-101X	MG RESISTOR		
	R1512	NRSA63J-101X	MG RESISTOR		
	R1513	NRSA63J-471X	MG RESISTOR		
	R1514	NRSA63J-471X	MG RESISTOR		
	R1515	NRSA63J-750X	MG RESISTOR		
	R1516	NRSA63J-473X	MG RESISTOR		
	R1517	NRSA63J-750X	MG RESISTOR		
	R1518	NRSA63J-473X	MG RESISTOR		
	R1519	NRSA63J-750X	MG RESISTOR		
	R1520	NRSA63J-473X	MG RESISTOR		
	R1521	NRSA63J-750X	MG RESISTOR		
	R1522	NRSA63J-750X	MG RESISTOR		
	R1523	NRSA63J-331X	MG RESISTOR		
	R1524	NRSA63J-750X	MG RESISTOR		
	R1525	NRSA63J-473X	MG RESISTOR		
	R1529	NRSA63J-391X	MG RESISTOR		
	R1530	NRSA63J-391X	MG RESISTOR		
	R1531	NRSA63J-391X	MG RESISTOR		
	R1535	NRSA63J-301X	MG RESISTOR		
	R1536	NRSA63J-301X	MG RESISTOR		
	R1537	NRSA63J-301X	MG RESISTOR		
	R1541	QRE141J-681Y	C RESISTOR	680 5% 1/4W	

△	Item	Parts number	Parts name	Remarks	Area
	R1542	NRSA63J-301X	MG RESISTOR		
	R1543	QRE141J-681Y	C RESISTOR	680 5% 1/4W	
	R1544	NRSA63J-301X	MG RESISTOR		
	R1547	NRSA63J-102X	MG RESISTOR		
	R1548	NRSA63J-102X	MG RESISTOR		
	R1549	NRSA63J-104X	MG RESISTOR		
	R1551	NRSA63J-391X	MG RESISTOR		
△	R1556	QRJ146J-2R2X	UNF C RESISTOR	2.2 5% 1/4W	
	R1560	NRSA63J-750X	MG RESISTOR		
	R1561	NRSA63J-751X	MG.RES C.M		
	R1562	NRSA63J-751X	MG.RES C.M		
	R1563	NRSA63J-103X	MG RESISTOR		
	R1564	NRSA63J-103X	MG RESISTOR		
	R1565	NRSA63J-751X	MG.RES C.M		
	R1566	NRSA63J-751X	MG.RES C.M		
	R1567	NRSA63J-103X	MG RESISTOR		
	R1568	NRSA63J-103X	MG RESISTOR		
	R1569	NRSA63J-331X	MG RESISTOR		
	R1570	NRSA63J-750X	MG RESISTOR		
	R1571	NRSA63J-331X	MG RESISTOR		
	R1572	NRSA63J-750X	MG RESISTOR		
	R1573	NRSA63J-103X	MG RESISTOR		
	R1574	NRSA63J-473X	MG RESISTOR		
	R1575	NRSA63J-103X	MG RESISTOR		
	R1576	NRSA63J-103X	MG RESISTOR		
	R1577	NRSA63J-102X	MG RESISTOR		
	R1578	NRSA63J-301X	MG RESISTOR		
	R1581	NRSA63J-221X	MG RESISTOR		
	R1582	NRSA63J-221X	MG RESISTOR		
	R1583	NRSA63J-221X	MG RESISTOR		
	R1584	NRSA63J-102X	MG RESISTOR		
	R1585	NRSA63J-102X	MG RESISTOR		
	R1586	NRSA63J-102X	MG RESISTOR		
	R1587	NRSA63J-102X	MG RESISTOR		
	R1588	NRSA63J-0R0X	MG RESISTOR		
	R1589	NRSA63J-0R0X	MG RESISTOR		
	R1590	NRSA63J-0R0X	MG RESISTOR		
	R1601	NRSA63J-104X	MG RESISTOR		
	R1602	NRSA63J-104X	MG RESISTOR		
	R1603	NRSA63J-104X	MG RESISTOR		
	R1604	NRSA63J-104X	MG RESISTOR		
	R1611	NRSA63J-104X	MG RESISTOR		
	R1612	NRSA63J-104X	MG RESISTOR		
	R1613	NRSA63J-104X	MG RESISTOR		
	R1614	NRSA63J-104X	MG RESISTOR		
	R1615	NRSA63J-104X	MG RESISTOR		
	R1616	NRSA63J-104X	MG RESISTOR		
	R1617	NRSA63J-104X	MG RESISTOR		
	R1618	NRSA63J-104X	MG RESISTOR		
	R1619	NRSA63J-104X	MG RESISTOR		
	R1620	NRSA63J-104X	MG RESISTOR		
	R1621	NRSA63J-102X	MG RESISTOR		
△	R1623	QRZ9005-100X	F RESISTOR	10 1/4W	



■ Electrical parts list (DSP board)

Block No. 04

△	Item	Parts number	Parts name	Remarks	Area
	C 601	NCB31HK-102X	C CAPACITOR		
	C 602	NCB31HK-102X	C CAPACITOR		
	C 603	QEKCOJM-107Z	E CAPACITOR	100MF 20% 6.3V	
	C 604	QEKCOJM-107Z	E CAPACITOR	100MF 20% 6.3V	
	C 605	NCF31CZ-104X	C CAPACITOR		
	C 606	NCF31CZ-104X	C CAPACITOR		
	C 607	QEKCOJM-107Z	E CAPACITOR	100MF 20% 6.3V	
	C 608	NCF31CZ-104X	C CAPACITOR		
	C 609	NCF31CZ-104X	C CAPACITOR		
	C 610	QEKCOJM-107Z	E CAPACITOR	100MF 20% 6.3V	
	C 611	QEKCOJM-107Z	E CAPACITOR	100MF 20% 6.3V	
	C 612	NCB31CK-103X	C CAPACITOR		
	C 621	QEKCHM-105Z	E CAPACITOR	1.0MF 20% 50V	
	C 622	NCS31HJ-101X	C.CAPA. C.M		
	C 623	NCS31HJ-101X	C.CAPA. C.M		
	C 624	NCF31CZ-104X	C CAPACITOR		
	C 626	NCF31AZ-105X	C CAPACITOR		
	C 627	NCF31AZ-105X	C CAPACITOR		
	C 628	NCB31CK-103X	C CAPACITOR		
	C 631	QEKCOJM-107Z	E CAPACITOR	100MF 20% 6.3V	
	C 632	NCB31CK-103X	C CAPACITOR		
	C 633	NCF31CZ-104X	C CAPACITOR		
	C 634	NCF31CZ-104X	C CAPACITOR		
	C 635	NCF31CZ-104X	C CAPACITOR		
	C 636	NCB31CK-473X	C CAPACITOR		
	C 638	QEKCOJM-107Z	E CAPACITOR	100MF 20% 6.3V	
	C 639	NCB31CK-103X	C CAPACITOR		
	C 640	NCB31CK-103X	C CAPACITOR		
	C 641	QEKCOJM-107Z	E CAPACITOR	100MF 20% 6.3V	
	C 642	NCB31CK-103X	C CAPACITOR		
	C 643	NCB31AK-474X	C CAPACITOR		
	C 644	NCB31CK-103X	C CAPACITOR		
	C 645	NCS31HJ-101X	C.CAPA. C.M		
	C 646	NCB31CK-103X	C CAPACITOR		
	C 647	NCS31HJ-220X	C CAPACITOR		
	C 648	NCS31HJ-180X	C CAPACITOR		
	C 649	NCS31HJ-121X	C CAPACITOR		
	C 653	NCB31CK-104X	C CAPACITOR		
	C 654	QEKCOJM-107Z	E CAPACITOR	100MF 20% 6.3V	
	C 661	NCB31CK-103X	C CAPACITOR		
	C 671	NCB31CK-103X	C CAPACITOR		
	C 672	QEKCOJM-107Z	E CAPACITOR	100MF 20% 6.3V	
	C 673	NCB31CK-103X	C CAPACITOR		
	C 677	NCS31HJ-101X	C.CAPA. C.M		
	C 679	NCS31HJ-101X	C.CAPA. C.M		
	C 681	NCB31CK-103X	C CAPACITOR		
	C 682	NCB31CK-103X	C CAPACITOR		
	C 683	NCB31CK-103X	C CAPACITOR		
	C 684	QEKCOJM-107Z	E CAPACITOR	100MF 20% 6.3V	
	C 685	QEKCHM-476Z	E CAPACITOR	47MF 20% 16V	
	C 686	QEKCHM-476Z	E CAPACITOR	47MF 20% 16V	
	C 687	NCB31CK-103X	C CAPACITOR		
	C 688	QEKCOJM-107Z	E CAPACITOR	100MF 20% 6.3V	
	C 689	NCB31CK-103X	C CAPACITOR		
	C 690	QEKCOJM-107Z	E CAPACITOR	100MF 20% 6.3V	
	C 691	NCB31HK-103X	C CAPACITOR		
	C 693	NCB31CK-103X	C CAPACITOR		
	C 694	NCF31CZ-104X	C CAPACITOR		
	CN681	QGB2510K1-20	B TO B CONNE		
	C2500	QEKCHM-226Z	E CAPACITOR	22MF 20% 16V	
	C2503	QETN1HM-475Z	E CAPACITOR	4.7MF 20% 50V	
	C2504	QETN1HM-475Z	E CAPACITOR	4.7MF 20% 50V	
	C2507	NCS31HJ-330X	C CAPACITOR		

△	Item	Parts number	Parts name	Remarks	Area
	C2508	NCS31HJ-330X	C CAPACITOR		
	C2512	NCF31CZ-104X	C CAPACITOR		
	C2513	NCB31HK-122X	C CAPACITOR		
	C2514	NCB31HK-122X	C CAPACITOR		
	C2515	NCS31HJ-121X	C CAPACITOR		
	C2516	NCS31HJ-121X	C CAPACITOR		
	C2525	NCB31HK-102X	C CAPACITOR		
	C2526	NCB31HK-102X	C CAPACITOR		
	C2527	QETN1HM-106Z	E CAPACITOR	10MF 20% 50V	
	C2528	QETN1HM-106Z	E CAPACITOR	10MF 20% 50V	
	C2531	NCS31HJ-560X	C CAPACITOR		
	C2532	NCS31HJ-560X	C CAPACITOR		
	C2533	QETN1HM-475Z	E CAPACITOR	4.7MF 20% 50V	
	C2534	QETN1HM-475Z	E CAPACITOR	4.7MF 20% 50V	
	C2539	NCF31CZ-104X	C CAPACITOR		
	C2540	NCF31CZ-104X	C CAPACITOR		
	C2551	NCS31HJ-560X	C CAPACITOR		
	C2552	NCS31HJ-560X	C CAPACITOR		
	C2555	NCF31CZ-104X	C CAPACITOR		
	C2556	NCF31CZ-104X	C CAPACITOR		
	C2561	QETN1HM-105Z	E CAPACITOR	1.0MF 20% 50V	
	C2562	QETN1HM-105Z	E CAPACITOR	1.0MF 20% 50V	
	C2563	NCS31HJ-560X	C CAPACITOR		
	C2564	NCS31HJ-560X	C CAPACITOR		
	C2565	NCB31HK-102X	C CAPACITOR		
	C2566	NCB31HK-102X	C CAPACITOR		
	C2569	NCF31CZ-104X	C CAPACITOR		
	C2570	NCF31CZ-104X	C CAPACITOR		
	C2575	NCB31HK-102X	C CAPACITOR		
	C2576	NCB31HK-102X	C CAPACITOR		
	C2577	QETN1HM-106Z	E CAPACITOR	10MF 20% 50V	
	C2578	QETN1HM-106Z	E CAPACITOR	10MF 20% 50V	
	C2581	QETN1HM-105Z	E CAPACITOR	1.0MF 20% 50V	
	C2582	QETN1CM-106Z	E CAPACITOR	10MF 20% 16V	
	C2583	NCS31HJ-560X	C CAPACITOR		
	C2584	NCS31HJ-560X	C CAPACITOR		
	C2585	NCF31CZ-104X	C CAPACITOR		
	C2586	NCF31CZ-104X	C CAPACITOR		
	C2587	NCS31HJ-560X	C CAPACITOR		
	C2588	QETN1HM-475Z	E CAPACITOR	4.7MF 20% 50V	
	C2589	NCF31CZ-104X	C CAPACITOR		
	C2590	NCF31CZ-104X	C CAPACITOR		
	C2591	NCB31HK-102X	C CAPACITOR		
	C2592	NCB31HK-103X	C CAPACITOR		
	C2594	NCB31CK-473X	C CAPACITOR		
	C2595	NCB31HK-102X	C CAPACITOR		
	C2597	QETN1HM-106Z	E CAPACITOR	10MF 20% 50V	
	C2598	QETN1HM-475Z	E CAPACITOR	4.7MF 20% 50V	
	D 607	1SS355-X	DIODE C.M		
	D 608	1SS355-X	DIODE C.M		
	D 609	1SS355-X	DIODE C.M		
	D 610	1SS355-X	DIODE C.M		
	IC601	AK4527BVQP	IC		
	IC609	BA15218F-XE	IC		
	IC610	BA15218F-XE	IC		
	IC611	TC74HC08AF-X	IC		
	IC612	TC74HC4072AF-X	IC		
	IC621	TC74HCU04AF-W	IC		
	IC631	TC9446F-025	IC		
	IC641	W24L010AJ-12-X	IC		
	IC650	BA15218F-XE	IC		
	IC651	BA15218F-XE	IC		
	IC652	IMX9-W	IC		

## ■ Electrical parts list (DSP board)

Block No. 04

△	Item	Parts number	Parts name	Remarks	Area	△	Item	Parts number	Parts name	Remarks	Area
	IC661	BA15218F-XE	IC				R 677	NRSA63J-822X	MG RESISTOR		
	IC662	IMX9-W	IC				R 678	NRSA63J-822X	MG RESISTOR		
	IC671	UPD784215AGC167	IC(MICRO C ROM)				R 679	NRSA63J-822X	MG RESISTOR		
	IC672	TC7SET32FU-X	IC				R 680	NRSA63J-822X	MG RESISTOR		
	IC681	BA033FP-X	I.C.				R 682	NRSA63J-103X	MG RESISTOR		
	IC682	IMX9-W	IC				R 683	NRSA63J-0R0X	MG RESISTOR		
	IC683	BA033LBSG-W	IC				R 684	NRSA63J-0R0X	MG RESISTOR		
	IC690	BA15218F-XE	IC				R 687	NRSA63J-0R0X	MG RESISTOR		
	IC691	BA15218F-XE	IC				R 688	NRSA63J-0R0X	MG RESISTOR		
	J 601	QNN0347-001	PIN JACK				R 689	NRSA63J-0R0X	MG RESISTOR		
	K 601	NQR0269-004X	FERRITE BEADS				R 691	NRSA63J-221X	MG RESISTOR		
	Q 607	DTA144EKA-X	TRANSISTOR				R 692	NRSA63J-221X	MG RESISTOR		
	Q 670	DTC114YE-X	TRANSISTOR				R 693	NRSA63J-221X	MG RESISTOR		
	Q 671	2SD2114K/VW/-X	CHIP TRANSISTOR				R 694	NRSA63J-221X	MG RESISTOR		
	Q 672	DTC114YE-X	TRANSISTOR				R 695	NRSA63J-221X	MG RESISTOR		
	Q 673	DTA144EKA-X	TRANSISTOR				R 696	NRSA63J-221X	MG RESISTOR		
	Q2501	DTA144EKA-X	TRANSISTOR				R 697	NRSA63J-0R0X	MG RESISTOR		
	R 600	NRSA63J-0R0X	MG RESISTOR				R 698	NRSA63J-0R0X	MG RESISTOR		
	R 601	NRSA63J-473X	MG RESISTOR				R2500	NRSA63J-102X	MG RESISTOR		
	R 602	NRSA63J-473X	MG RESISTOR				R2501	NRSA63J-104X	MG RESISTOR		
	R 603	NRSA63J-473X	MG RESISTOR				R2502	NRSA63J-104X	MG RESISTOR		
	R 606	NRSA63J-221X	MG RESISTOR				R2507	NRSA63J-223X	MG RESISTOR		
	R 607	NRSA63J-221X	MG RESISTOR				R2508	NRSA63J-223X	MG RESISTOR		
	R 608	NRSA63J-221X	MG RESISTOR				R2509	NRSA63J-223X	MG RESISTOR		
	R 609	NRSA63J-221X	MG RESISTOR				R2510	NRSA63J-223X	MG RESISTOR		
	R 611	NRSA63J-221X	MG RESISTOR				R2511	NRSA63J-103X	MG RESISTOR		
	R 612	NRSA63J-221X	MG RESISTOR				R2512	NRSA63J-103X	MG RESISTOR		
	R 613	NRSA63J-822X	MG RESISTOR				R2513	NRSA63J-103X	MG RESISTOR		
	R 615	NRSA63J-432X	MG RESISTOR				R2514	NRSA63J-103X	MG RESISTOR		
	R 617	NRSA63J-103X	MG RESISTOR				R2515	NRSA63J-103X	MG RESISTOR		
	R 618	NRSA63J-103X	MG RESISTOR				R2516	NRSA63J-103X	MG RESISTOR		
	R 620	NRSA63J-221X	MG RESISTOR				R2519	NRSA63J-331X	MG RESISTOR		
	R 621	NRSA63J-561X	MG RESISTOR				R2520	NRSA63J-331X	MG RESISTOR		
	R 622	NRSA63J-750X	MG RESISTOR				R2521	NRSA63J-331X	MG RESISTOR		
	R 623	NRSA63J-0R0X	MG RESISTOR				R2522	NRSA63J-331X	MG RESISTOR		
	R 627	NRSA63J-472X	MG RESISTOR				R2525	NRSA63J-102X	MG RESISTOR		
	R 628	NRSA63J-333X	MG RESISTOR				R2526	NRSA63J-102X	MG RESISTOR		
	R 631	NRSA63J-0R0X	MG RESISTOR				R2527	NRSA63J-104X	MG RESISTOR		
	R 632	NRSA63J-0R0X	MG RESISTOR				R2528	NRSA63J-104X	MG RESISTOR		
	R 639	NRSA63J-472X	MG RESISTOR				R2529	NRSA63J-103X	MG RESISTOR		
	R 640	NRSA63J-0R0X	MG RESISTOR				R2530	NRSA63J-103X	MG RESISTOR		
	R 641	NRSA63F-102X	MG RESISTOR				R2531	NRSA63J-752X	MG RESISTOR		
	R 642	NRSA63J-103X	MG RESISTOR				R2532	NRSA63J-752X	MG RESISTOR		
	R 643	NRSA63J-101X	MG RESISTOR				R2533	NRSA63J-103X	MG RESISTOR		
	R 644	NRSA63J-153X	MG RESISTOR				R2534	NRSA63J-103X	MG RESISTOR		
	R 645	NRSA63F-102X	MG RESISTOR				R2535	NRSA63J-103X	MG RESISTOR		
	R 646	NRSA63J-103X	MG RESISTOR				R2536	NRSA63J-103X	MG RESISTOR		
	R 647	NRSA63J-225X	MG RESISTOR				R2537	NRSA63J-104X	MG RESISTOR		
	R 648	NRSA63J-472X	MG RESISTOR				R2538	NRSA63J-104X	MG RESISTOR		
	R 657	NRSA63J-103X	MG RESISTOR				R2550	NRSA63J-272X	MG RESISTOR		
	R 661	NRSA63J-221X	MG RESISTOR				R2551	NRSA63J-103X	MG RESISTOR		
	R 662	NRSA63J-221X	MG RESISTOR				R2552	NRSA63J-103X	MG RESISTOR		
	R 663	NRSA63J-221X	MG RESISTOR				R2553	NRSA63J-243X	MG RESISTOR		
	R 664	NRSA63J-221X	MG RESISTOR				R2554	NRSA63J-243X	MG RESISTOR		
	R 668	NRSA63J-0R0X	MG RESISTOR				R2555	NRSA63J-752X	MG RESISTOR		
	R 669	NRSA63J-103X	MG RESISTOR				R2556	NRSA63J-752X	MG RESISTOR		
	R 670	NRSA63J-103X	MG RESISTOR				R2557	NRSA63J-103X	MG RESISTOR		
	R 671	NRSA63J-103X	MG RESISTOR				R2558	NRSA63J-273X	MG RESISTOR		
	R 672	NRSA63J-105X	MG RESISTOR				R2560	NRSA63J-105X	MG RESISTOR		
	R 673	NRSA63J-432X	MG RESISTOR				R2561	NRSA63J-104X	MG RESISTOR		
	R 674	NRSA63J-432X	MG RESISTOR				R2562	NRSA63J-104X	MG RESISTOR		
	R 675	NRSA63J-432X	MG RESISTOR				R2563	NRSA63J-103X	MG RESISTOR		
	R 676	NRSA63J-432X	MG RESISTOR				R2564	NRSA63J-103X	MG RESISTOR		

# RX-E112RSL/RX-E111RSL

## ■ Electrical parts list (DSP board)

Block No. 04

△	Item	Parts number	Parts name	Remarks	Area
	R2565	NRSA63J-202X	MG RESISTOR		
	R2566	NRSA63J-202X	MG RESISTOR		
	R2567	NRSA63J-103X	MG RESISTOR		
	R2568	NRSA63J-103X	MG RESISTOR		
	R2569	NRSA63J-122X	MG RESISTOR		
	R2570	NRSA63J-122X	MG RESISTOR		
	R2575	NRSA63J-102X	MG RESISTOR		
	R2576	NRSA63J-102X	MG RESISTOR		
	R2577	NRSA63J-104X	MG RESISTOR		
	R2578	NRSA63J-104X	MG RESISTOR		
	R2581	NRSA63J-104X	MG RESISTOR		
	R2582	NRSA63J-104X	MG RESISTOR		
	R2583	NRSA63J-123X	MG RESISTOR		
	R2584	NRSA63J-223X	MG RESISTOR		
	R2585	NRSA63J-302X	MG RESISTOR		
	R2586	NRSA63J-332X	MG RESISTOR		
	R2587	NRSA63J-103X	MG RESISTOR		
	R2588	NRSA63J-103X	MG RESISTOR		
	R2589	NRSA63J-104X	MG RESISTOR		
	R2590	NRSA63J-333X	MG RESISTOR		
	R2591	NRSA63J-122X	MG RESISTOR		
	R2592	NRSA63J-333X	MG RESISTOR		
	R2594	NRSA63J-333X	MG RESISTOR		
	R2595	NRSA63J-102X	MG RESISTOR		
	R2596	NRSA63J-102X	MG RESISTOR		
	R2597	NRSA63J-104X	MG RESISTOR		
	R2598	NRSA63J-104X	MG RESISTOR		
	UN661	GP1FA351RZ	OPT RECEIVER		
	X 631	QAX0722-001Z	CRYSTAL		
	X 671	QAX0719-001Z	1COSCIALLATOR		

■ Electrical parts list (Tuner board)

Block No. 05

△	Item	Parts number	Parts name	Remarks	Area
	AT101	QNB0014-001	ANT TERMINAL		
	BK 1	LV31618-001A	SHIELD BKT		
	C 101	NCB21HK-103X	C CAPACITOR		
	C 103	NCB21HK-223X	C CAPACITOR		
	C 105	NCB21HK-223X	C CAPACITOR		
	C 107	QEK1CM-226Z	E CAPACITOR	22MF 20% 16V	
	C 111	NCB21HK-473X	C CAPACITOR		
	C 112	NDC21HJ-120X	C CAPACITOR		
	C 113	QCSB1HJ-120Y	C CAPACITOR	12PF 5% 50V	
	C 121	NDC21HJ-120X	C CAPACITOR		
	C 122	NDC21HJ-120X	C CAPACITOR		
	C 123	NCB21HK-473X	C CAPACITOR		
	C 126	NCS21HJ-101X	C CAPACITOR		
	C 128	QENC1HM-474Z	NP E CAPACITOR	.47MF 20% 50V	
	C 129	NCB21HK-102X	C CAPACITOR		
	C 130	QEK1AM-107Z	E CAPACITOR	100MF 20% 10V	
	C 133	QEK1CM-226Z	E CAPACITOR	22MF 20% 16V	
	C 134	NCB21HK-222X	C CAPACITOR		
	C 135	NCB21HK-223X	C CAPACITOR		
	C 136	QEK1HM-105Z	E CAPACITOR	1.0MF 20% 50V	
	C 137	NCS21HJ-680X	C CAPACITOR		
	C 139	NCB21HK-473X	C CAPACITOR		
	C 140	NCB21HK-473X	C CAPACITOR		
	C 141	NCB21HK-473X	C CAPACITOR		
	C 143	NCB21HK-223X	C CAPACITOR		
	C 144	NCB21HK-473X	C CAPACITOR		
	C 146	QEK1HM-105Z	E CAPACITOR	1.0MF 20% 50V	
	C 147	QEK1HM-105Z	E CAPACITOR	1.0MF 20% 50V	
	C 148	QEK1HM-224Z	E CAPACITOR	.22MF 20% 50V	
	C 149	QEK1HM-105Z	E CAPACITOR	1.0MF 20% 50V	
	C 150	QEK1CM-226Z	E CAPACITOR	22MF 20% 16V	
	C 156	QDGB1HK-102Y	C CAPACITOR		
	C 157	NCB21HK-473X	C CAPACITOR		
	C 158	QEK1CM-226Z	E CAPACITOR	22MF 20% 16V	
	C 161	QEK1CM-106Z	E CAPACITOR	10MF 20% 16V	
	C 162	QEK1CM-106Z	E CAPACITOR	10MF 20% 16V	
	C 163	NCB21HK-223X	C CAPACITOR		
	C 164	NCB21HK-473X	C CAPACITOR		
	C 168	QEK1HM-105Z	E CAPACITOR	1.0MF 20% 50V	
	C 184	QEK1CM-107Z	E CAPACITOR	100MF 20% 16V	
	C 185	QEK1CM-106Z	E CAPACITOR	10MF 20% 16V	
	C 186	QEK1CM-106Z	E CAPACITOR	10MF 20% 16V	
	C 191	NCS21HJ-820X	C CAPACITOR		
	C 192	NCS21HJ-470X	C CAPACITOR		
	C 193	NCB21HK-561X	C CAPACITOR		
	C 194	NCB21HK-104X	C CAPACITOR		
	C 195	NCB21HK-331X	C.CAPA. C.M		
	C 196	QEK1HM-225Z	E CAPACITOR	2.2MF 20% 50V	
	C 197	NCB21HK-473X	C CAPACITOR		
	C 199	QEK1CM-106Z	E CAPACITOR	10MF 20% 16V	
	CF101	QAX0704-001Z	C.FILTER		
	CF102	QAX0704-001Z	C.FILTER		
	CF103	QAX0519-001Z	C FILTER		
	CN111	QGB2501K2-12	CONNECTOR		
	CN112	QGB2501K1-04	CONNECTOR		
	D 121	1SS133-T2	SI DIODE IM		
	D 123	1SS133-T2	SI DIODE IM		
	D 129	1SS133-T2	SI DIODE IM		
	D 131	1SS133-T2	SI DIODE IM		
	IC102	LA1838	IC		
	IC121	LC72136N	IC		
	IC191	SAA6588	IC(RDS)		
	L 112	QQL231K-2R7Y	INDUCTOR		

△	Item	Parts number	Parts name	Remarks	Area
	Q 102	2SC535/BC-T	TRANSISTOR		
	Q 103	2SC461/BC-T	TRANSISTOR		
	Q 111	KTC3199/GL-T	TRANSISTOR		
	Q 112	KTC3199/GL-T	TRANSISTOR		
	Q 113	DTA114YKA-X	TRANSISTOR		
	Q 121	KRA103M-T	TRANSISTOR		
	R 103	NRSA02J-101X	MG RESISTOR		
	R 104	NRSA02J-272X	MG RESISTOR		
	R 105	NRSA02J-391X	MG RESISTOR		
	R 106	NRSA02J-102X	MG RESISTOR		
	R 107	NRSA02J-561X	MG RESISTOR		
	R 108	NRSA02J-332X	MG RESISTOR		
	R 109	NRSA02J-221X	MG RESISTOR		
	R 111	NRSA02J-182X	MG RESISTOR		
	R 112	QRE141J-182Y	C RESISTOR	1.8K 5% 1/4W	
	R 114	NRSA02J-272X	MG RESISTOR		
	R 115	NRSA02J-104X	MG RESISTOR		
	R 119	NRSA02J-103X	MG RESISTOR		
	R 122	NRSA02J-472X	MG RESISTOR		
	R 124	NRSA02J-222X	MG RESISTOR		
	R 126	NRSA02J-562X	MG RESISTOR		
	R 127	NRSA02J-822X	MG RESISTOR		
	R 128	NRSA02J-472X	MG RESISTOR		
	R 129	NRSA02J-222X	MG RESISTOR		
	R 130	QRZ9005-680X	F RESISTOR	68 1/4W	
	R 132	NRSA02J-393X	MG RESISTOR		
	R 133	NRSA02J-392X	MG RESISTOR		
	R 134	NRSA02J-102X	MG RESISTOR		
	R 140	NRSA02J-563X	MG RESISTOR		
	R 141	NRSA02J-102X	MG RESISTOR		
	R 142	NRSA02J-470X	MG RESISTOR		
	R 143	NRSA02J-562X	MG RESISTOR		
	R 144	NRSA02J-332X	MG RESISTOR		
	R 145	NRSA02J-103X	MG RESISTOR		
	R 146	NRSA02J-472X	MG RESISTOR		
	R 147	NRSA02J-332X	MG RESISTOR		
	R 150	NRSA02J-331X	MG RESISTOR		
	R 157	NRSA02J-272X	MG RESISTOR		
	R 158	NRSA02J-272X	MG RESISTOR		
	R 161	NRSA02J-102X	MG RESISTOR		
	R 162	NRSA02J-102X	MG RESISTOR		
	R 182	NRSA02J-103X	MG RESISTOR		
	R 183	NRSA02J-103X	MG RESISTOR		
	R 184	NRSA02J-103X	MG RESISTOR		
	R 191	NRSA02J-102X	MG RESISTOR		
	R 192	NRSA02J-474X	MG RESISTOR		
	R 193	NRSA02J-103X	MG RESISTOR		
	R 194	NRSA02J-103X	MG RESISTOR		
	RF101	QAU0119-001	FRONT END	FOR FTZ	
	T 111	QQR0871-001	COIL BLOCK		
	T 142	QQR0973-001	IFT		
	X 121	QAX0402-001	CRYSTAL		
	X 191	QAX0263-001Z	CRYSTAL		

# Packing materials and accessories parts list

Block No. 

M	3	M	M
---	---	---	---

Block No. 

M	5	M	M
---	---	---	---

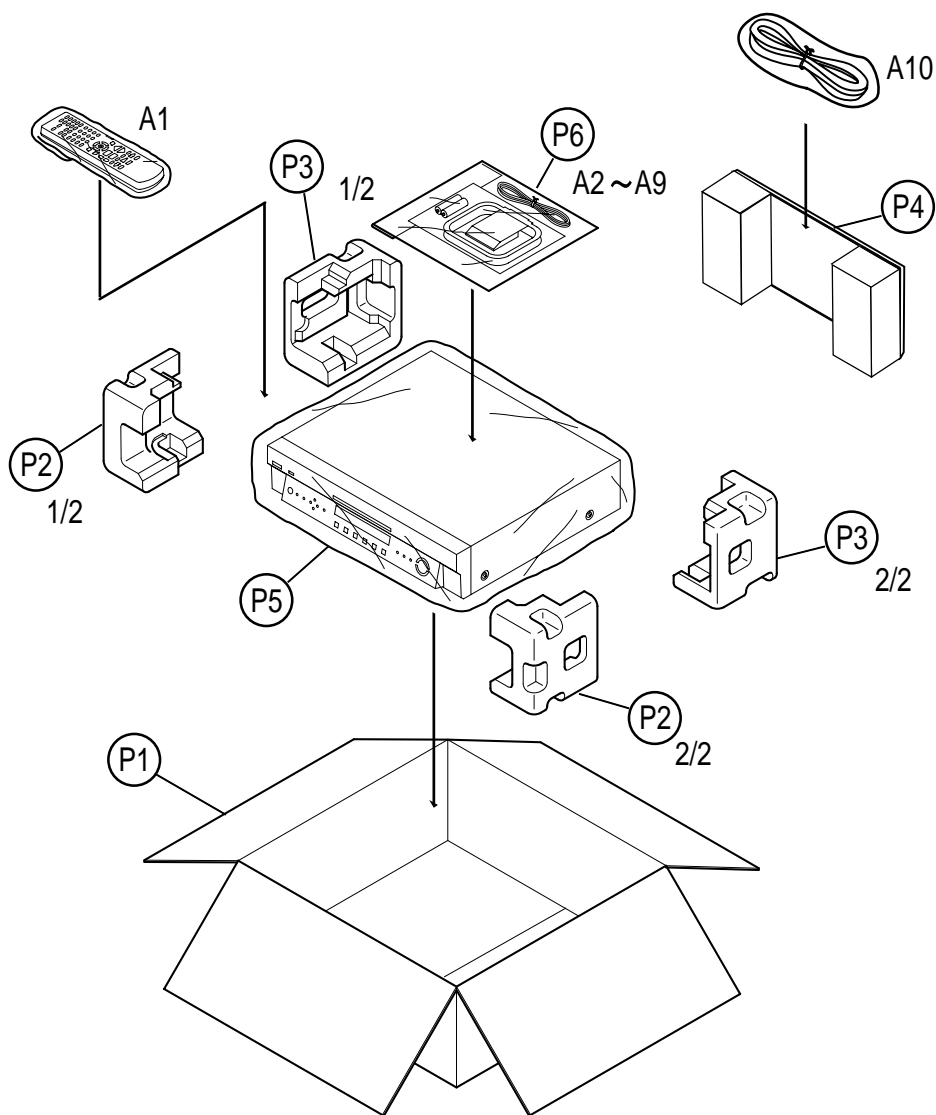

**■ Parts list (Packing)**

Block No. M3MM

△	Item	Parts number	Parts name	Q'ty	Description	Area
	P 1	LV33537-004A	CARTON BOX	1	RX-E112RSL	
		LV33537-003A	CARTON BOX	1	RX-E111RSL	
	P 2	LV20963-002A	CUSHION(FRONT)	1		
	P 3	LV20964-001A	CUSHION(REAR)	1		
	P 4	LV32804-001A	PACKING SHEET	1		
	P 5	QPC06507015P	POLY BAG	1		
	P 6	QPA02503505P	POLY BAG	1	FOR INST.	

**■ Parts list (Accessories)**

Block No. M5MM

△	Item	Parts number	Parts name	Q'ty	Description	Area
	A 1	RM-SRXE111R	REMOCON	1		
	A 2	-----	BATTERY	2		
	A 3	LVT0858-001A	INST.BOOK	1	ENG	B
		LVT0858-002A	INST.BOOK	1	GER,FRE,DUT	E
		LVT0858-003A	INST.BOOK	1	SEW,FIN,DAN,GER	EN
		LVT0858-003A	INST.BOOK	1	FRE,SPA,ITA	EN
		LVT0858-004A	INST.BOOK	1	CZE,POR,HUN,RUS	EV
	A 4	EWP503-001C	ANT.WIRE	1		
	A 5	QAL0204-001	AM LOOP ANT	1		
	A 6	E43486-340B	SAFETY INST	1		B
	A 7	VNA3000-204	REGIST.CARD	1		B
	A 8	BT-54013-2	W.CARD	1		
	A 9	LV43034-001A	SHEET	1		
	A 10	LV42656-001A	SYSTEM CABLE	1		