

JVC

SERVICE MANUAL

HOME CINEMA CONTROL CENTER

RX-E11S, RX-E12B

Area suffix

B ----- U.K.
E ----- Continental Europe
EN ----- Northern Europe
EV ----- Eastern Europe

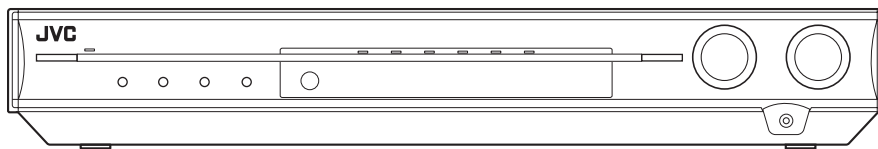
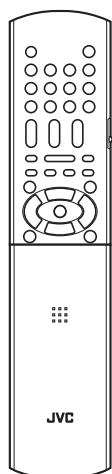

TABLE OF CONTENTS

1	PRECAUTIONS	1-3
2	SPECIFIC SERVICE INSTRUCTIONS	1-5
3	DISASSEMBLY	1-6
4	ADJUSTMENT	1-16
5	TROUBLESHOOTING	1-17

SPECIFICATION

Amplifier			
Output Power	At stereo operation	Front channels	60 W per channel, min. RMS, both channels driven into 6 Ω at 1 kHz with no more than 10% total harmonic distortion. (IEC268-3)
	At surround operation	Front channels	60 W per channel, min. RMS, driven into 6 Ω at 1 kHz with no more than 10% total harmonic distortion.
		Center channel	60 W, min. RMS, driven into 6 Ω at 1 kHz, with no more than 10% total harmonic distortion.
		Surround channels	60 W per channel, min. RMS, driven into 6 Ω at 1 kHz, with no more than 10% total harmonic distortion.
Audio	Audio Input Sensitivity/Impedance	DVR/DVD, VCR, TV, VIDEO	170 mV(p-p)/47 kΩ
	Audio Input (DIGITAL IN)*	Coaxial: DIGITAL IN 1(DVR/DVD)	0.5 V(p-p)/75 Ω
		Optical: DIGITAL IN 2(VIDEO)	-21 dBm to -15 dBm (660 nm ±30 nm)
	Audio Output Level	DVR/DVD, VCR, TV	170 mV
	Signal-to-Noise Ratio ('66 IHF/DIN)		87 dB/62 dB
	Frequency Response (6 Ω)		20 Hz to 20 kHz (±1 dB)
	Bass Boost		+4 dB ±1 dB at 100 Hz
	Equalization	Center frequency	63 Hz, 250 Hz, 1 kHz, 4 kHz, 16 kHz
Control range		±8 dB	
Video	Video Input Sensitivity/Impedance	Composite video:DVR/DVD, VCR, TV, VIDEO	1 V(p-p)/75 Ω
		S-video:DVR/DVD, VCR	Y (luminance):1 V(p-p)/75 Ω C (chrominance, burst):0.3 V(p-p)/75 Ω
		RGB:DVR/DVD, VCR	0.7 V(p-p)/75 Ω
		Component:DVR/DVD	Y (luminance):1 V(p-p)/75 Ω PB, PR:0.7 V(p-p)/75 Ω
	Video Output Level/Impedance	Composite videoDVR/DVD, VCR, TV	1 V(p-p)/75 Ω
		S-video: TV	Y (luminance):1 V(p-p)/75 Ω C (chrominance, burst):0.3 V(p-p)/75 Ω
		RGB:TV	0.7 V(p-p)/75 Ω
		Component:MONITOR OUT	Y (luminance):1 V(p-p)/75 Ω PB, PR:0.7 V(p-p)/75 Ω
	Synchronization		Negative
	FM tuner (IHF)		
Tuning Range		87.50 MHz to 108.00 MHz	
Usable Sensitivity	Monaural	17.0 dBf (1.95 μV/75 Ω)	
50 dB Quieting Sensitivity	Monaural	21.3 dBf (3.2 μV/75 Ω)	
	Stereo	41.3 dBf (31.5 μV/75 Ω)	
Stereo Separation at Rec Out		35 dB at 1 kHz	
AM (MW) tuner			
Tuning Range		522 kHz to 1 629 kHz	
General			
Power Requirements		AC 230 V , 50 Hz	
Power Consumption		120 W (at operation) 1 W (in standby mode)	
Dimensions (W × H × D)		435 mm × 70 mm × 325 mm	
Mass		5.6 kg	

* Corresponding to Linear PCM, Dolby Digital, and DTS (with sampling frequency-32 kHz, 44.1 kHz, 48 kHz).

Design and specifications are subject to change without notice.

SECTION 1 PRECAUTIONS

1.1 Safety Precautions

- (1) This design of this product contains special hardware and many circuits and components specially for safety purposes. For continued protection, no changes should be made to the original design unless authorized in writing by the manufacturer. Replacement parts must be identical to those used in the original circuits. Services should be performed by qualified personnel only.
- (2) Alterations of the design or circuitry of the product should not be made. Any design alterations of the product should not be made. Any design alterations or additions will void the manufacturer's warranty and will further relieve the manufacturer of responsibility for personal injury or property damage resulting therefrom.
- (3) Many electrical and mechanical parts in the products have special safety-related characteristics. These characteristics are often not evident from visual inspection nor can the protection afforded by them necessarily be obtained by using replacement components rated for higher voltage, wattage, etc. Replacement parts which have these special safety characteristics are identified in the Parts List of Service Manual. Electrical components having such features are identified by shading on the schematics and by (Δ) on the Parts List in the Service Manual. The use of a substitute replacement which does not have the same safety characteristics as the recommended replacement parts shown in the Parts List of Service Manual may create shock, fire, or other hazards.
- (4) The leads in the products are routed and dressed with ties, clamps, tubings, barriers and the like to be separated from live parts, high temperature parts, moving parts and/or sharp edges for the prevention of electric shock and fire hazard. When service is required, the original lead routing and dress should be observed, and it should be confirmed that they have been returned to normal, after reassembling.
- (5) Leakage shock hazard testing

After reassembling the product, always perform an isolation check on the exposed metal parts of the product (antenna terminals, knobs, metal cabinet, screw heads, headphone jack, control shafts, etc.) to be sure the product is safe to operate without danger of electrical shock. Do not use a line isolation transformer during this check.

- Plug the AC line cord directly into the AC outlet. Using a "Leakage Current Tester", measure the leakage current from each exposed metal part of the cabinet, particularly any exposed metal part having a return path to the chassis, to a known good earth ground. Any leakage current must not exceed 0.5mA AC (r.m.s.).
- Alternate check method
Plug the AC line cord directly into the AC outlet. Use an AC voltmeter having, 1,000 Ω per volt or more sensitivity in the following manner. Connect a 1,500 Ω 10W resistor paralleled by a 0.15 μ F AC-type capacitor between an exposed metal part and a known good earth ground. Measure the AC voltage across the resistor with the AC

voltmeter.

Move the resistor connection to each exposed metal part, particularly any exposed metal part having a return path to the chassis, and measure the AC voltage across the resistor. Now, reverse the plug in the AC outlet and repeat each measurement. Voltage measured any must not exceed 0.75 V AC (r.m.s.). This corresponds to 0.5 mA AC (r.m.s.).

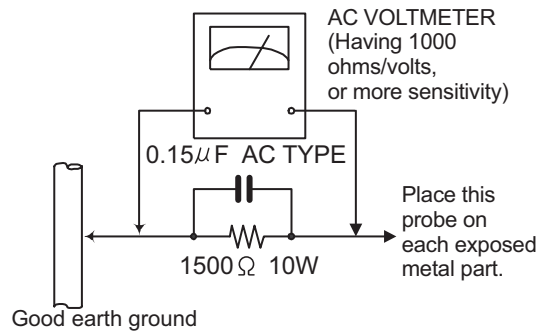

1.2 Warning

- (1) This equipment has been designed and manufactured to meet international safety standards.
- (2) It is the legal responsibility of the repairer to ensure that these safety standards are maintained.
- (3) Repairs must be made in accordance with the relevant safety standards.
- (4) It is essential that safety critical components are replaced by approved parts.
- (5) If mains voltage selector is provided, check setting for local voltage.

1.3 Caution

Burrs formed during molding may be left over on some parts of the chassis.

Therefore, pay attention to such burrs in the case of pre-forming repair of this system.

1.4 Critical parts for safety

In regard with component parts appearing on the silk-screen printed side (parts side) of the PWB diagrams, the parts that are printed over with black such as the resistor (\blacksquare), diode (\blacksquare) and ICP (\bullet) or identified by the " Δ " mark nearby are critical for safety. When replacing them, be sure to use the parts of the same type and rating as specified by the manufacturer. (This regulation does not Except the J and C version)

1.5 Safety Precautions (U.K only)

- (1) This design of this product contains special hardware and many circuits and components specially for safety purposes. For continued protection, no changes should be made to the original design unless authorized in writing by the manufacturer. Replacement parts must be identical to those used in the original circuits.
- (2) Any unauthorised design alterations or additions will void the manufacturer's guarantee; furthermore the manufacturer cannot accept responsibility for personal injury or property damage resulting therefrom.
- (3) Essential safety critical components are identified by () on the Parts List and by shading on the schematics, and must never be replaced by parts other than those listed in the manual. Please note however that many electrical and mechanical parts in the product have special safety related characteristics. These characteristics are often not evident from visual inspection. Parts other than specified by the manufacturer may not have the same safety characteristics as the recommended replacement parts shown in the Parts List of the Service Manual and may create shock, fire, or other hazards.
- (4) The leads in the products are routed and dressed with ties, clamps, tubings, barriers and the like to be separated from live parts, high temperature parts, moving parts and/or sharp edges for the prevention of electric shock and fire hazard. When service is required, the original lead routing and dress should be observed, and it should be confirmed that they have been returned to normal, after re-assembling.

1.5.1 Warning

- (1) Service should be performed by qualified personnel only.
- (2) This equipment has been designed and manufactured to meet international safety standards.
- (3) It is the legal responsibility of the repairer to ensure that these safety standards are maintained.
- (4) Repairs must be made in accordance with the relevant safety standards.
- (5) It is essential that safety critical components are replaced by approved parts.
- (6) If mains voltage selector is provided, check setting for local voltage.



CAUTION Burrs formed during molding may be left over on some parts of the chassis. Therefore, pay attention to such burrs in the case of preforming repair of this system.

SECTION 2
SPECIFIC SERVICE INSTRUCTIONS

This service manual does not describe SPECIFIC SERVICE INSTRUCTIONS.

SECTION 3 DISASSEMBLY

3.1 Main body section

3.1.1 Removing the top cover

(See Figs. 1 and 2)

- (1) From the both sides of the main body, remove the two screws **A** attaching the top cover. (See Fig.1)
- (2) From the back side of the main body, remove the five screws **B** attaching the top cover. (See Fig.2)

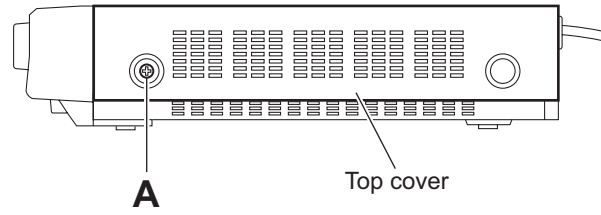

Fig.1

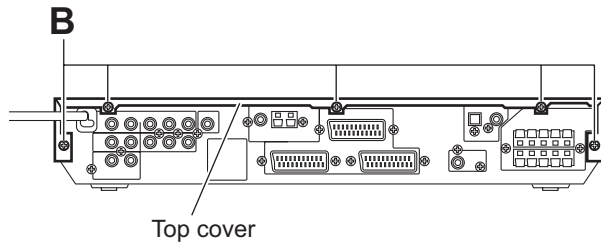

Fig.2

3.1.2 Removing the front panel assembly (See Figs. 3 to 5)

- Remove the top cover.

(1) From the top side of the main body, disconnect the wire from the connector **CN412** on the regulator board. (See Fig.3)

Reference:

After reassembling, fix the wires with the wire holders as before. (See Fig.3.)

(2) Disconnect the wire from the connector **CN421** on the connection 2 board. (See Fig.3)

(3) Remove the two screws **C** and screw **C'** attaching the front panel assembly. (See Fig.3)

Reference:

- When attaching the screw **C**, attach the earth wires with them. (See Fig.3.)
- When attaching the screw **C'**, attach a wire holder with it. (See Fig.3.)

(4) From the bottom side of the main body, remove the four screws **D** attaching the front panel assembly and release the joint **a**. (See Fig.4)

(5) From the both sides of the main body, release the joints **b** and take out the front panel assembly in the direction of the arrow. (See Fig.5)

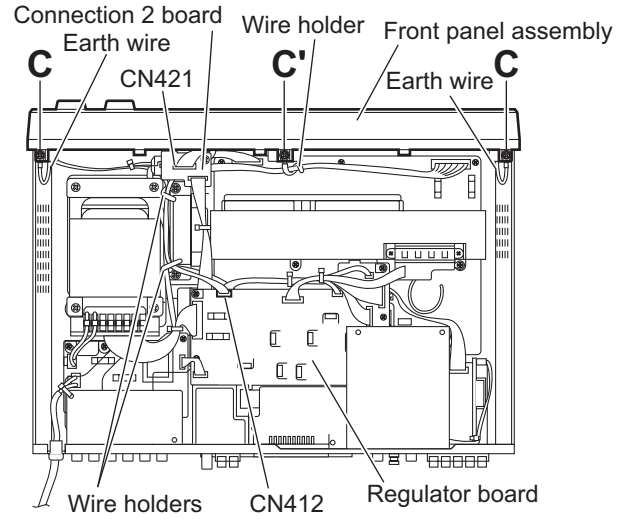

Fig.3

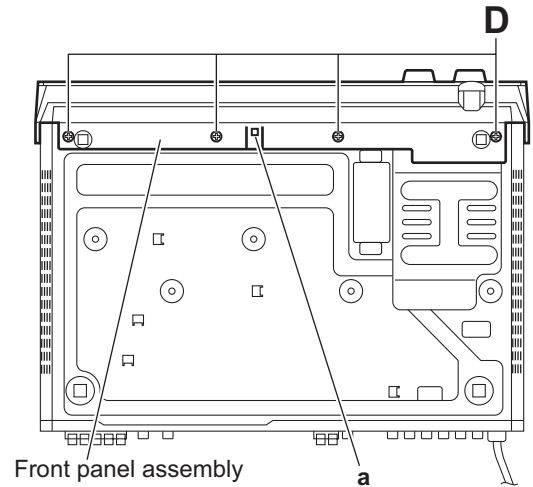

Fig.4

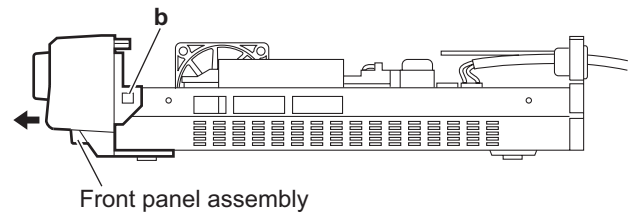

Fig.5

3.1.3 Removing the rear panel (See Fig. 6)

- Remove the top cover.

(1) From the back side of the main body, remove strain relief from the rear panel in the direction of the arrow.

(2) Remove the nineteen screws **E** attaching the rear panel.

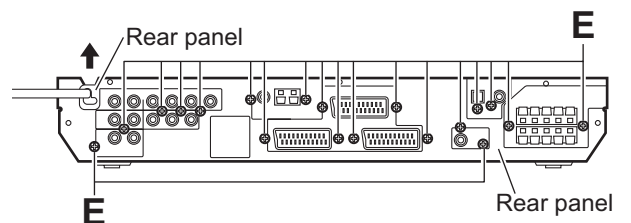

Fig.6

3.1.4 Removing the tuner (See Figs. 7 and 8)

- Remove the top cover.
 - (1) From the top side of the main body, disconnect the card wire from the connector [CN1](#) on the tuner. (See Fig.7)
 - (2) From the back side of the main body, remove the two screws **F** attaching the tuner to the rear panel. (See Fig.8)

3.1.5 Removing the PAL prg board (See Figs. 7 and 8)

- Remove the top cover.
 - (1) From the back side of the main body, remove the four screws **G** attaching the PAL prg board to the rear panel. (See Fig.8)
 - (2) From the top side of the main body, remove the tie band fixing the power cord. (See fig.7.)

Reference:

After reassembling, fix the power cord with a new tie band as before. (See Fig.7.)

- (3) Take out the PAL prg board and disconnect the card wire from the connector [CN751](#) on the forward side of the PAL prg board. (See Fig.7)

3.1.6 Removing the DSP board (See Figs. 7 and 8)

- Remove the top cover.
 - (1) From the back side of the main body, remove the two screws **H** attaching the DSP board to the rear panel. (See Fig.8)
 - (2) From the top side of the main body, disconnect the connector [CN601](#) on the DSP board from the connection 1 board. (See Fig.7)
 - (3) Take out the DSP board and disconnect the card wire from the connector [CN602](#) on the forward side of the DSP board. (See Fig.7)

3.1.7 Removing the S.S.S. board (See Fig 7)

- Remove the top cover.
 - (1) From the top side of the main body, remove the tie band and disconnect the wire from the connector [CN725](#) on the S.S.S. board.

Reference:

After attaching the S.S.S. board, fix the wire with a new tie band as before.

- (2) Disconnect the connector [CN728](#) on the S.S.S. board from the SPK term. board.
- (3) Take out the S.S.S. board.

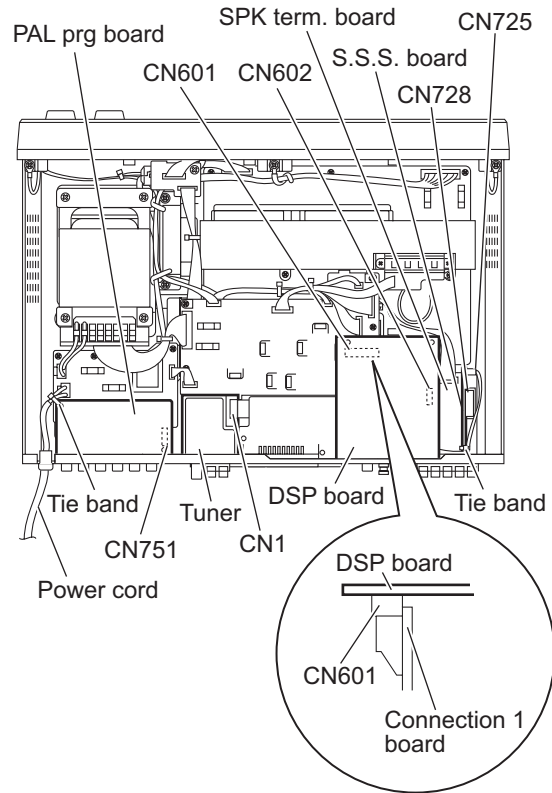

Fig.7

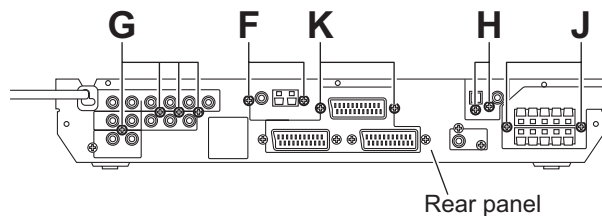

Fig.8

3.1.8 Removing the SPK term. board (See Figs. 8 and 9)

- Remove the top cover, DSP board and S.S.S. board.
 - (1) From the back side of the main body, remove the two screws **J** attaching the SPK term. board to the rear panel. (See Fig.8)
 - (2) From the top side of the main body, disconnect the wires from the connectors ([CN301](#), [CN801](#)) on the SPK term. board. (See Fig.9)
 - (3) Take out the SPK term. board.

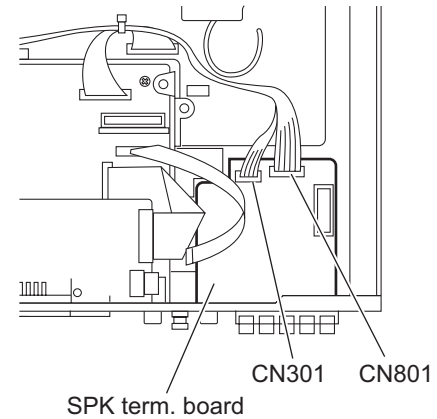

Fig.9

3.1.9 Removing the SCART board (See Figs. 8 and 10)

- Remove the top cover and DSP board.
 - (1) From the back side of the main body, remove the two screws **K** attaching the SCART board to the rear panel. (See Fig.8)
 - (2) From the top side of the main body, disconnect the card wires from the connectors ([CN513](#), [CN514](#)) on the SCART board. (See Fig.10)
 - (3) Take out the SCART board.

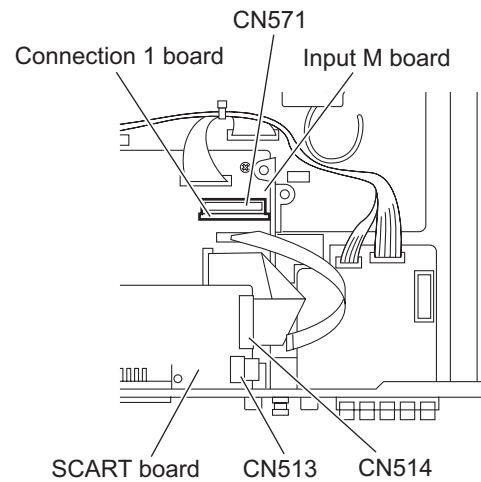

Fig.10

3.1.10 Removing the connection 1 board (See Fig. 10)

- Remove the top cover and DSP board.
 - (1) From the top side of the main body, disconnect the connector [CN571](#) on the connection 1 board from the input M board.
 - (2) Take out the connection 1 board.

3.1.11 Removing the regulator board (See Fig. 11)

- Remove the top cover, tuner and DSP board.
 - From the top side of the main body, disconnect the wires from the connectors (CN201, CN207, CN208, CN261, CN412, CN510, CN520, CN721) on the regulator board.
 - Remove the four screws L attaching the regulator board.
 - Take out the regulator board.

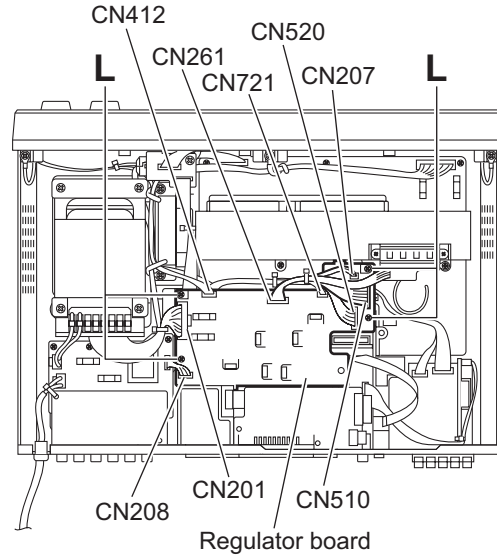

Fig.11

3.1.12 Removing the amp. board (See Fig. 12)

- Remove the top cover, tuner, DSP board and regulator board.
 - From the top side of the main body, remove the tie bands bundling the wires.

Reference:

After reassembling, bundle the wires with the new tie bands as before.

- Release the wire holders fixing the wires.

Reference:

After reassembling, fix the wires with the wire holders as before.

- Release the claws c to open a noise filter and remove the wires from the noise filter.
- Disconnect the wire from the connector CN506 on the input M board.
- Disconnect the wires from the connectors (CN206, CN519, CN701) on the amp. board.
- Disconnect the wires from the connectors (CN301, CN801) on the SPK term. board.
- Remove the two screws M, screw N and screw N' attaching the amp. board

Reference:

When attaching the screw N', attach the earth wire with it.

- Take out the amp. board.

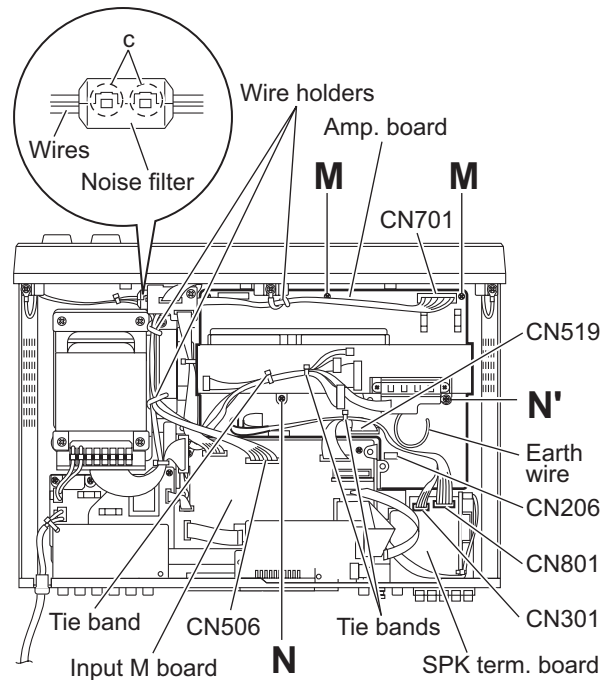

Fig.12

3.1.13 Removing the heat sink
(See Figs. 13 and 14)

- Remove the top cover, tuner, DSP board, regulator board and amp. board.
 - From the front side of the amp. board, remove the five screws **P** attaching the IC bracket and take out the IC bracket. (See Fig.13)
 - From the bottom side of the amp. board, remove the two screws **Q** attaching the heat sink. (See Fig.14)
 - Move the heat sink in the direction of the arrow to release the three claws **d** and remove the heat sink. (See Figs.13 and 14)

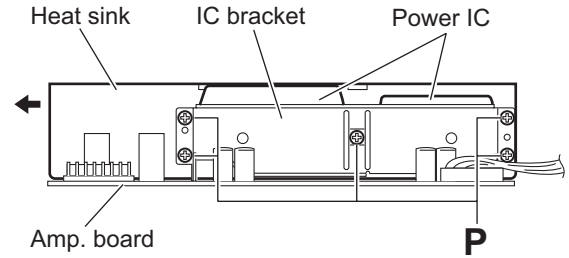

Fig.13

3.1.14 Removing the power IC
(See Fig. 14)

- Remove the top cover, tuner, DSP board, regulator board and amp. board and heat sink.
 - From the bottom side of the amp. board, remove the solders from the soldered points **e**.
 - Take out the power IC from the forward side of the amp. board.

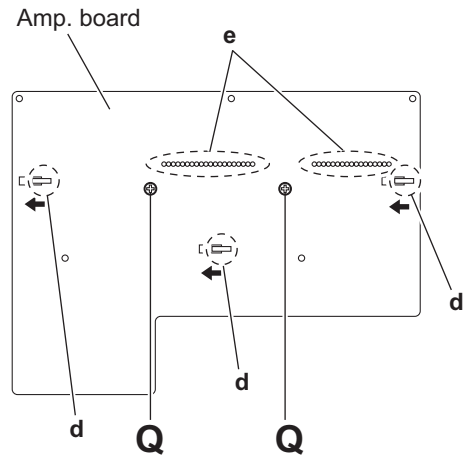

Fig.14

3.1.15 Removing the primary board
(See Fig. 15)

- Remove the top cover and PAL prg board.
 - From the top side of the main body, disconnect the wires from the connectors (CN202, CN203) on the primary board.
 - Disconnect the wire from the connector CN208 on the regulator board.
 - Remove the tie band bundling the wires.

Reference:

After reassembly, bundle the wires with the new tie band as before.

- Remove the four screws **R** and screw **R'** attaching the primary board.

Reference:

When attaching the screw **R'**, attach the barrier with it as before.

- Take out the primary board.

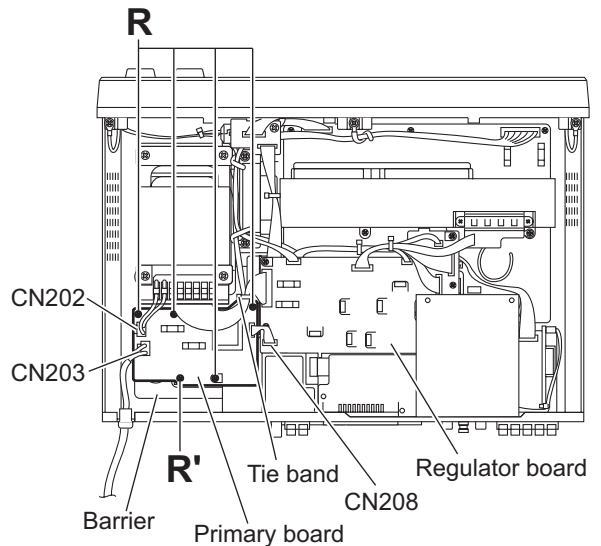

Fig.15

3.1.16 Removing the input M board (See Fig. 16)

- Remove the top cover, rear panel, tuner, PAL prg board, DSP board, SCART board, Connection 1 board, regulator board and primary board.

- From the top side of the main body, disconnect the wires from the connectors (CN451, CN506) on the input M board.
- Remove the tie bands fixing the wires.

Reference:

After reassembling, fix the wires with the new tie bands as before.

- Disconnect the wire from the connector CN725 on the S.S.S. board.
- Disconnect the wire from the connector CN519 on the amp. board.
- Remove the screw S and screw S' attaching the input M board.

Reference:

When attaching the screw S', attach the wire holder with it as before.

- Take out the input M board.

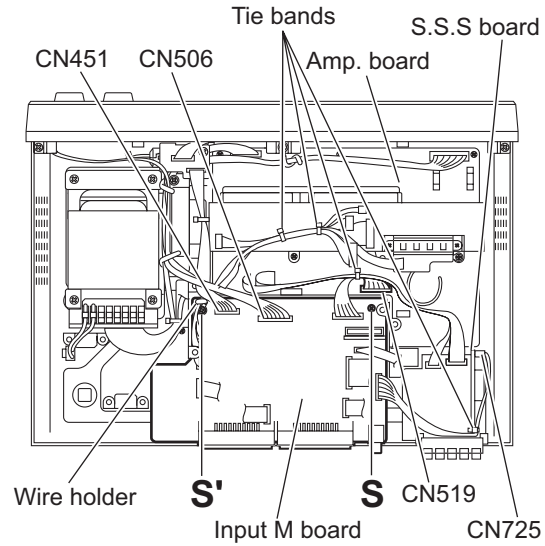

Fig.16

3.1.17 Removing the power transformer (See Fig. 17)

- Remove the top cover.

- From the top side of the main body, remove the tie band bundling the wire.

Reference:

After reassembling, fix the wires with the new tie band as before.

- Disconnect the wire from the connector CN201 on the regulator board.
- Disconnect the wire from the connector CN202 on the primary board.
- Release the wire holders fixing the wires.

Reference:

When reassembling, fix the wires with the wire holders as before.

- Disconnect the wire from the connector CN701 on the amp. board.
- Remove the four screws T attaching the power transformer and take out the power transformer.

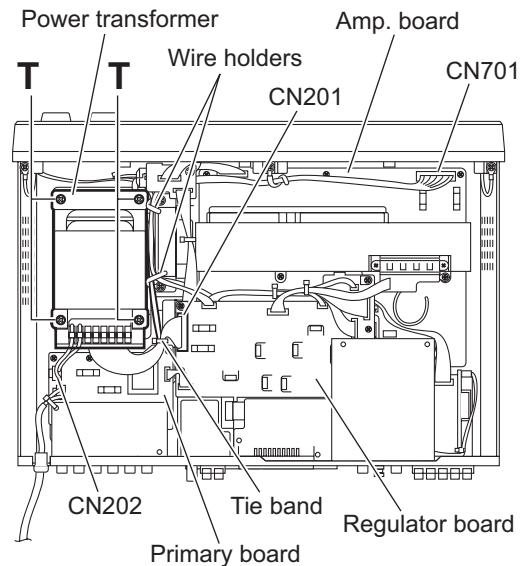

Fig.17

3.1.18 Removing the fan motor (See Figs. 18 and 19)

- Remove the top cover.

Reference:

Remove the power transformer as required.

- (1) From the top side of the main body, remove the tie bands bundling the wires.

Reference:

After reassembling, bundle the wires with the new tie bands as before.

- (2) Disconnect the wire from the connector [CN207](#) on the regulator board. (See Fig.18)
- (3) Remove the two screw **U** attaching the fan assembly and take out the fan assembly. (See Fig.18)

Reference:

After attaching the screws **U**, attach the wire holders with them as before.

- (4) Remove the screw **V** and screw **V'** attaching the fan motor to the fan bracket. (See Fig.19)

Reference:

When attaching the screw **V'**, attach the fan cover with it as before.

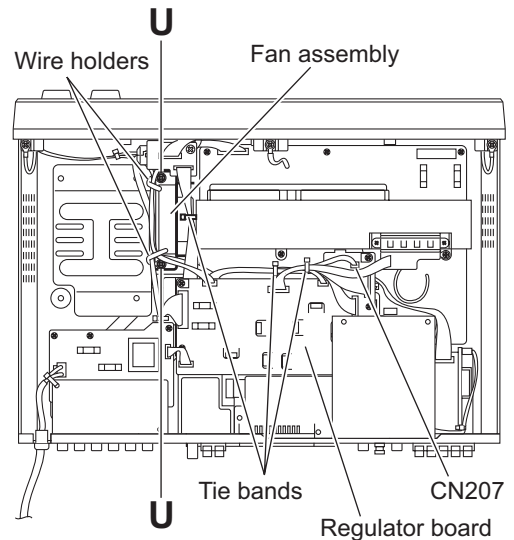

Fig.18

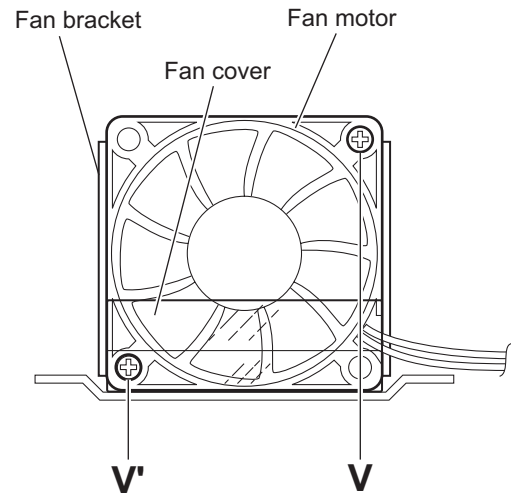

Fig.19

3.1.19 Removing the connection 2 board (See Fig. 20)

- Remove the top cover, tuner, DSP board and regulator board.
 - From the top side of the main body, remove the tie band fixing the wire.

Reference:

After reassembling, fix the wire with a new tie band as before.

- Disconnect the wire from the connector [CN451](#) on the input M board.
- Disconnect the wire from the connector [CN421](#) on the connection 2 board.
- Remove the screw **W** attaching the connection 2 board and take out the connection 2 board.

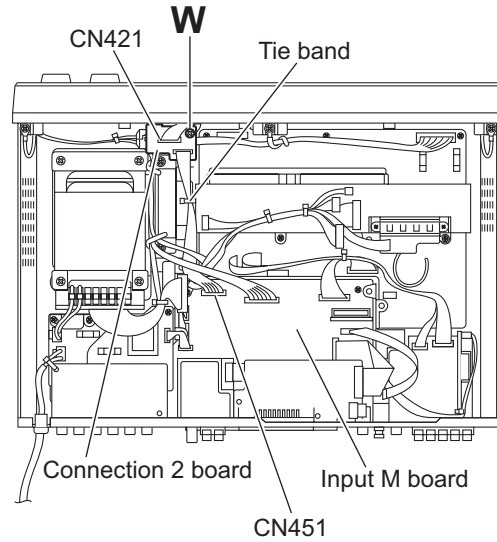

Fig.20

3.1.20 Removing the H.P board (See Fig. 21)

- Remove the top cover and front panel assembly.
 - From the front side of the main body, remove the screw **X** attaching the H.P board.
 - Remove the solders from the soldered point **f** on the H.P board.

Reference:

Remove the solders from the soldered point **f** as required.

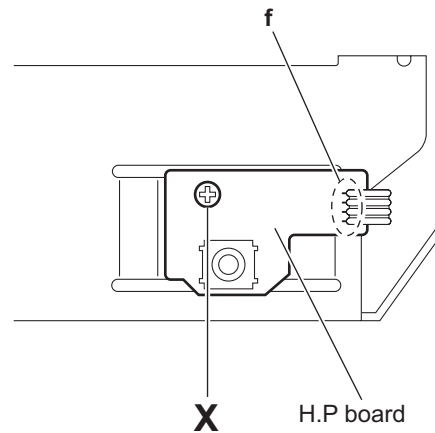

Fig.21

3.2 Front panel assembly section

3.2.1 Removing the JOG board

(See Figs. 22 and 23)

- Remove the top cover and front panel assembly.
 - From the inside of the front panel assembly, remove the four screws **Y** attaching the JOG board. (See Fig.22.)
 - Take out the Jog board while lifting the JOG board from the front panel assembly little by little. (See Fig.22.)

Reference:

The volume knob and MULTI JOG knob are removed from the front side simultaneously. (See Fig.23.)

- From the forward side of the JOG board, disconnect the wire from the connector [CN413](#). (See Fig.22)

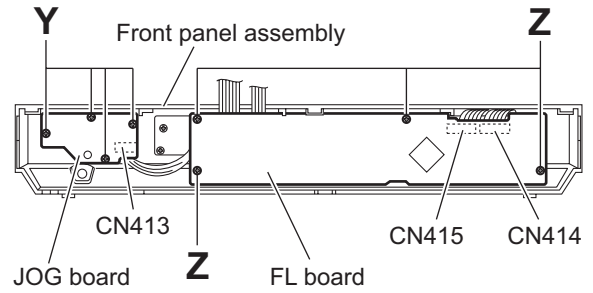

Fig.22

3.2.2 Removing the FL board

(See Fig. 22)

- Remove the top cover and front panel assembly.
 - From the inside of the front panel assembly, disconnect the wire from the connector [CN413](#) on the JOG board. (See Fig.22.)

Reference:

Remove the JOG board as required.

- Remove the four screws **Z** attaching the FL board and take out the FL board.
- From the forward side of the FL board, disconnect the wires from the connectors [CN414](#), [CN415](#).

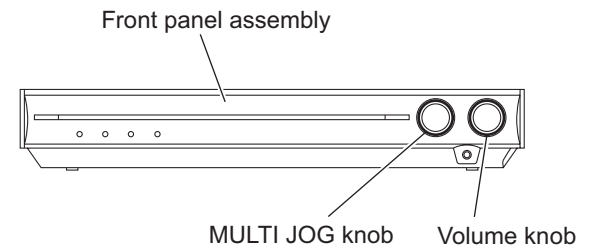

Fig.23

3.2.3 Removing the key board

(See Fig. 24)

- Remove the top cover, front panel assembly and FL board.
 - From the inside of the front panel assembly, remove the seven screws **AA** attaching the key board.
 - Take out the key board.

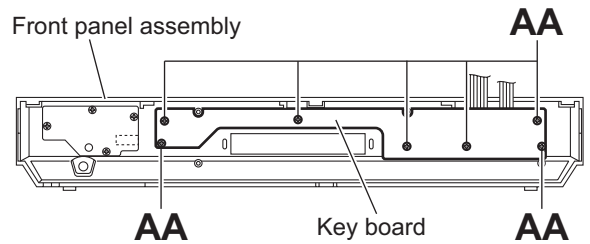

Fig.24

SECTION 4 ADJUSTMENT

This service manual does not describe ADJUSTMENT.

SECTION 5 TROUBLESHOOTING

This service manual does not describe TROUBLESHOOTING.



JVC

Victor Company of Japan, Limited
AV & MULTIMEDIA COMPANY AUDIO/VIDEO SYSTEMS CATEGORY 10-1,1chome,Ohwatari-machi,Maebashi-city,371-8543,Japan

(No.MB387)

PARTS LIST

[RX-E11S] [RX-E12B]

* All printed circuit boards and its assemblies are not available as service parts.

Area suffix

B ----- U.K.
E ----- Continental Europe
EN ----- Northern Europe
EV ----- Eastern Europe

- Contents -

Exploded view of general assembly and parts list (Block No.M1)	3- 2
Electrical parts list (Block No.01~03)	3- 6
Packing materials and accessories parts list (Block No.M3)	3-16

Exploded view of general assembly and parts list

Block No. **M 1 M M**

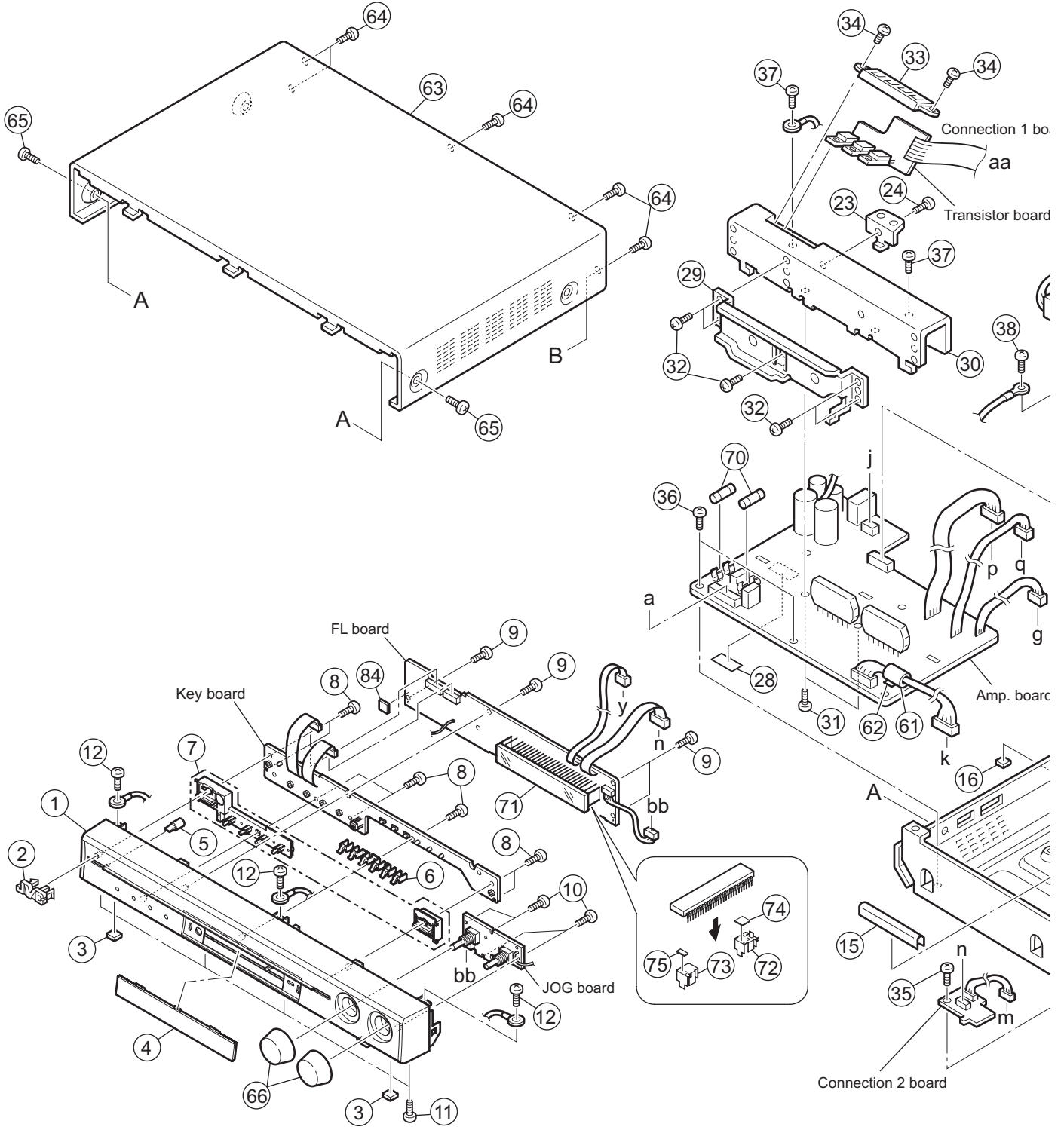

1 M M

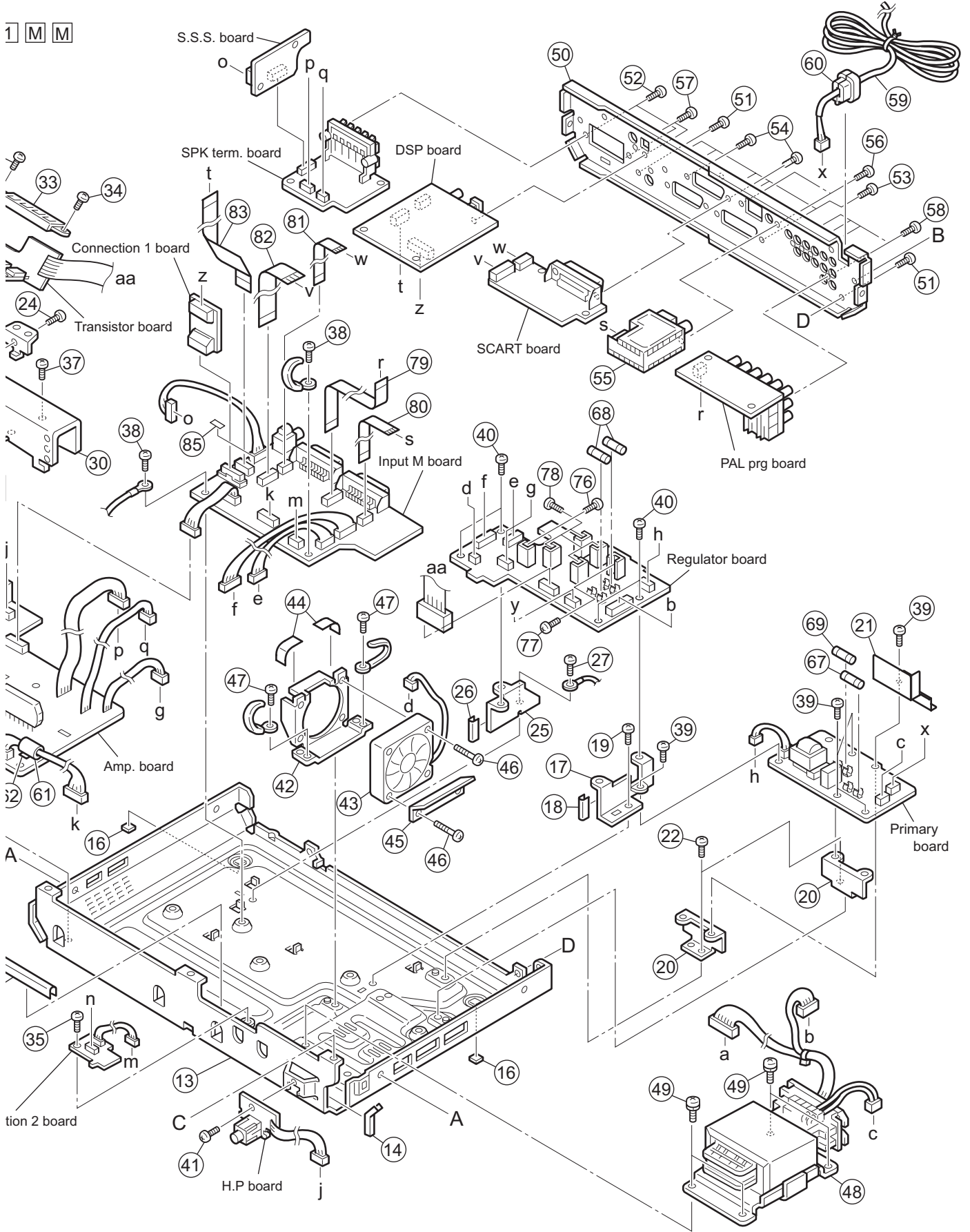

General Assembly

Block No. [M][1][M][M]

△	Symbol No.	Part No.	Part Name	Description	Local
	1	LV11043-004A	FRONT PANEL		E11SB,E11SE,E11SEN,E11SEV
	1	LV11043-006A	FRONT PANEL		E12BB,E12BE,E12BEN,E12BEV
	2	LV43338-002A	JVC MARK		
	3	LV43622-002A	FOOT	(x2)	
	4	LV35692-001A	LENS		
	5	LV44135-001A	INDICATOR(POWER		
	6	LV35693-001A	INDICATOR(SOURC		
	7	LV21903-001A	PUSH BUTTON		E11SB,E11SE,E11SEN,E11SEV
	7	LV21903-002A	PUSH BUTTON		E12BB,E12BE,E12BEN,E12BEV
	8	QYSBSF2608ZA	TAP SCREW	M2.6 x 8mm(x7)	
	9	QYSBSF2608ZA	TAP SCREW	M2.6 x 8mm(x4)	
	10	QYSBSF2608ZA	TAP SCREW	M2.6 x 8mm(x4)	
	11	QYSDSG3006ZA	TAP SCREW	M3 x 6mm(x4)	
	12	QYSBSG3006ZA	TAP SCREW	M3 x 6mm(x3)	
	13	LV10868-003A	CHASSIS BASE		
	14	LV30225-0F4A	SPACER		
	15	LV30225-0T1A	SPACER		
	16	LV43622-002A	FOOT	(x2)	
	17	LV34681-002A	SUPPORT BRACKET		
	18	LV30225-0F4A	SPACER		
	19	QYSBST3005EA	TAP SCREW	M3 x 5mm	
	20	LV34679-001A	PWB BRACKET	(x2)	
	21	LV35264-001A	BARRIER		
	22	QYSBST3005EA	TAP SCREW	M3 x 5mm(x2)	
	23	LV34682-001A	C.B BRACKET		
	24	QYSBSG3006ZA	TAP SCREW	M3 x 6mm	
	25	LV34784-001A	SUPPORT BKT(B)		
	26	LV30225-0F4A	SPACER		
	27	QYSBST3005EA	TAP SCREW	M3 x 5mm	
	28	LV30225-0H3A	SPACER		
	29	LV34688-001A	I.C BRACKET		
	30	LV21638-002A	HEAT SINK		
	31	QYSBSG3006ZA	TAP SCREW	M3 x 6mm(x2)	
	32	QYSBSG3006ZA	TAP SCREW	M3 x 6mm(x5)	
	33	LV35043-002A	TRANSISTOR HOLD		
	34	QYSBSG3006ZA	TAP SCREW	M3 x 6mm(x2)	
	35	QYSBSG3006ZA	TAP SCREW	M3 x 6mm	
	36	QYSBSG3006ZA	TAP SCREW	M3 x 6mm(x2)	
	37	QYSBSG3008EA	TAP SCREW	M3 x 8mm(x2)	
	38	QYSBSG3006ZA	TAP SCREW	M3 x 6mm(x2)	
	39	QYSBSG3006ZA	TAP SCREW	M3 x 6mm(x5)	
	40	QYSBSG3006ZA	TAP SCREW	M3 x 6mm(x4)	
	41	QYSBSG3006ZA	TAP SCREW	M3 x 6mm	
	42	LV34676-002A	FAN BRACKET		
	43	QAR0312-002	FAN MOTER		
	44	LV30225-0Y9A	SPACER	(x2)	
	45	LV35129-001A	FAN COVER		
	46	QYSBSG3020ZA	TAP SCREW	M3 x 20mm(x2)	
	47	QYSBST3005EA	TAP SCREW	M3 x 5mm(x2)	
△	48	QQT0444-001	POWER TRANSF		
	49	QYSDSTL4006EA	TAP SCREW	M4 x 6mm(x4)	
	50	LV21639-036A	REAR PANEL		E11SB,E11SE,E11SEN
	50	LV21639-037A	REAR PANEL		E11SEV
	50	LV21639-043A	REAR PANEL		E12BB,E12BE,E12BEN,E12BEV
	51	QYSBSGY3008EA	TAP SCREW	M3 x 8mm(x2)	
	52	QYSBSGY3008EA	TAP SCREW	M3 x 8mm(x2)	
	53	QYSBSGY3008EA	TAP SCREW	M3 x 8mm(x5)	
	54	QYSBSGY3008EA	TAP SCREW	M3 x 8mm(x2)	
	55	QAU0278-003	TUNER		
	56	QYSBSGY3008EA	TAP SCREW	M3 x 8mm(x2)	
	57	QYSBSGY3008EA	TAP SCREW	M3 x 8mm(x2)	
	58	QYSBSGY3008EA	TAP SCREW	M3 x 8mm(x4)	
△	59	QMPN160-200-JD	POWER CORD(EK)	2m BLACK	E11SB,E12BB
△	59	QMPK210-205-JN	POWER CORD(EK)	2.05m BLACK	E11SE,E11SEN,E11SEV,E12BE, E12BEN,E12BEV
△	60	QZW0033-001	STRAIN RELIEF		
	61	QQR0491-001	NOISE FILTER	TDK (GRAY)	
	62	VYSH101-009	SPACER		
	63	LV21640-002A	TOP COVER		E11SB,E11SE,E11SEN,E11SEV
	63	LV21640-003A	TOP COVER		E12BB,E12BE,E12BEN,E12BEV
	64	QYSBSGY3008EA	TAP SCREW	M3 x 8mm(x5)	
	65	QYSDSG3008NA	TAP SCREW	M3 x 8mm(x2)	E11SB,E11SE,E11SEN,E11SEV
	65	QYSDSG3008MA	TAP SCREW	M3 x 8mm(x2)	E12BB,E12BE,E12BEN,E12BEV
	66	LV43684-002A	JOG KNOB ASSY	(x2)	E11SB,E11SE,E11SEN,E11SEV

△	Symbol No.	Part No.	Part Name	Description	Local
	66	LV43684-003A	JOG KNOB ASSY	(x2)	E12BB,E12BE,E12BEN,E12BEV
△	67	QMF51W2-1R0-J8	FUSE	1A AC250V	
△	68	QMF51W2-2R0-J8	FUSE	2A AC250V	
△	69	QMF5AE2-R10-J1	FUSE	0.1A AC250V	
△	70	QMF51W2-4R0-J8	FUSE	4A AC250V	
	71	QLF0135-001	FL TUBE		
	72	LV34673-001A	FL HOLDER(L)		
	73	LV34687-001A	FL HOLDER(R)		
	74	VYSH101-009	SPACER		
	75	LV30225-0S4A	SPACER		
	76	QYSBSG3008EA	TAP SCREW	M3 x 8mm	
	77	QYSBSG3008EA	TAP SCREW	M3 x 8mm	
	78	QYSBSG3008EA	TAP SCREW	M3 x 8mm(x4)	
	79	QUQ412-1212CJ	FFC WIRE	12pin 12cm	
	80	QUQ412-1111CJ	FFC WIRE	11pin 11cm	
	81	QUQ412-0914CJ	FFC WIRE	9pin 14cm	
	82	QUQ412-2214CJ	FFC WIRE	22pin 14cm	
	83	QUQ412-1115CJ	FFC WIRE	11pin 15cm	
	84	VYSH101-009	SPACER		
	85	LV30225-0F4A	SPACER		

Electrical parts list

Main board

Block No. [0][1]

△ Symbol No.	Part No.	Part Name	Description	Local
IC401	MN101C35DMF	IC		
IC402	GP1UM271XKVF	IR DETECT UNIT		
Q201	KRC105S-X	DIGI TRANSISTOR		
Q203	KTC3203/OY/-T	TRANSISTOR		
Q204	KTC3200/GL/-T	TRANSISTOR		
△ Q205	KTA1046/Y/	TRANSISTOR *		
△ Q207	KTA1046/Y/	TRANSISTOR *		
△ Q208	2SD2394/EF/	TRANSISTOR		
△ Q209	2SD2394/EF/	TRANSISTOR		
△ Q210	2SD2394/EF/	TRANSISTOR		
△ Q211	2SD2394/EF/	TRANSISTOR		
△ Q212	2SD2394/EF/	TRANSISTOR		
△ Q213	2SD2394/EF/	TRANSISTOR		
Q214	KRA102S-X	DIGI TRANSISTOR		
Q215	KRC102S-X	DIGI TRANSISTOR		
Q216	KRA102S-X	DIGI TRANSISTOR		
Q217	KRC102S-X	DIGI TRANSISTOR		
Q218	KRA102S-X	DIGI TRANSISTOR		
Q219	KRC102S-X	DIGI TRANSISTOR		
Q220	KRC111S-X	TRANSISTOR		
Q221	KRC111S-X	TRANSISTOR		
Q222	KRC111S-X	TRANSISTOR		
Q223	KRC111S-X	TRANSISTOR		
Q224	KRC111S-X	TRANSISTOR		
△ Q226	2SD2394/EF/	TRANSISTOR		
Q231	KRC102S-X	DIGI TRANSISTOR		
Q404	KRA107S-X	TRANSISTOR		
Q405	KRA107S-X	TRANSISTOR		
Q406	KRA107S-X	TRANSISTOR		
Q407	KRA107S-X	TRANSISTOR		
Q408	KRA107S-X	TRANSISTOR		
Q409	KRA107S-X	TRANSISTOR		
Q410	KRC107S-X	DIGI TRANSISTOR		
△ D201	1A3G-T1	DIODE		
△ D202	1A3G-T1	DIODE		
△ D203	1A3G-T1	DIODE		
△ D204	1A3G-T1	DIODE		
D205	MA111-X	DIODE C.M		
D207	MTZJ6.2C-T2	Z DIODE		
△ D208	1A3G-T1	DIODE		
△ D209	1A3G-T1	DIODE		
△ D210	1A3G-T1	DIODE		
△ D211	1A3G-T1	DIODE		
D212	1A3G-T1	DIODE		
D213	1A3G-T1	DIODE		
D215	MTZJ7.5C-T2	Z DIODE		
D216	MTZJ7.5C-T2	Z DIODE		
D217	MTZJ6.2C-T2	Z DIODE		
D218	MTZJ10B-T2	Z DIODE		
D219	MTZJ5.6C-T2	Z DIODE		
D220	MTZJ5.6C-T2	Z DIODE		
D221	MA111-X	DIODE C.M		
D222	1A3G-T1	DIODE		
D223	MTZJ22C-T2	Z DIODE		
D224	MTZJ6.2C-T2	Z DIODE		
D227	MTZJ7.5C-T2	Z DIODE		
△ D231	1A3G-T1	DIODE		
△ D233	1A3G-T1	DIODE		
△ D234	1A3G-T1	DIODE		
D401	SLR-343VC-T	LED		
D402	SLR-343VC-T	LED		
D403	SLR-343VC-T	LED		
D404	SPR-325MVWL/-T	LED	GREEN-RED	
D405	SPR-325MVWL/-T	LED	GREEN-RED	
D406	SPR-325MVWL/-T	LED	GREEN-RED	
D410	MA111-X	DIODE C.M		
D411	SLR-343VC-T	LED		
△ C201	QCZ9104-472	C CAPACITOR	4700pF	
C202	QFLC2AJ-472Z	M CAPACITOR	4700pF 100V J	

△ Symbol No.	Part No.	Part Name	Description	Local
C203	QETN1EM-227Z	E CAPACITOR	220uF 25V M	
C205	NCB31HK-472X	C CAPACITOR	4700pF 50V K	
C206	QETN1CM-477Z	E CAPACITOR	470uF 16V M	
C207	QFLC2AJ-104Z	M CAPACITOR	0.1uF 100V J	
C208	QFLC2AJ-104Z	M CAPACITOR	0.1uF 100V J	
C209	QFLC2AJ-104Z	M CAPACITOR	0.1uF 100V J	
C210	QETM1EM-338	E CAPACITOR	3300uF 25V M	
C211	QETM1EM-108	E CAPACITOR	1000uF 25V M	
C212	QFLC1HJ-473Z	M CAPACITOR	0.047uF 50V J	
C213	QFLC1HJ-473Z	M CAPACITOR	0.047uF 50V J	
C214	QEK1HM-105Z	E CAPACITOR	1uF 50V M	
C215	QETN1HM-476Z	E CAPACITOR	47uF 50V M	
C221	QETN1CM-107Z	E CAPACITOR	100uF 16V M	
C222	QETN1CM-107Z	E CAPACITOR	100uF 16V M	
C223	QETN1CM-107Z	E CAPACITOR	100uF 16V M	
C224	QETM1EM-108	E CAPACITOR	1000uF 25V M	
C225	QETN1CM-107Z	E CAPACITOR	100uF 16V M	
C226	QETN1CM-107Z	E CAPACITOR	100uF 16V M	
C227	QETN1CM-107Z	E CAPACITOR	100uF 16V M	
C231	QETN1CM-107Z	E CAPACITOR	100uF 16V M	
C241	QETN1HM-227Z	E CAPACITOR	220uF 50V M	
C242	QETN2AM-107Z	E CAPACITOR	100uF 100V M	
C243	QETN2AM-107Z	E CAPACITOR	100uF 100V M	
C251	QEK1CM-226Z	E CAPACITOR	22uF 16V M	
C401	NCB31HK-103X	C CAPACITOR	0.01uF 50V K	
C402	NCB31HK-103X	C CAPACITOR	0.01uF 50V K	
C403	NCB31HK-103X	C CAPACITOR	0.01uF 50V K	
C404	NCB31HK-103X	C CAPACITOR	0.01uF 50V K	
C405	NCB31HK-103X	C CAPACITOR	0.01uF 50V K	
C406	QCZ0202-155Z	C CAPACITOR	1.5uF 25V Z	
C407	QEK0JM-107Z	E CAPACITOR	100uF 6.3V M	
C408	QEK0JM-107Z	E CAPACITOR	100uF 6.3V M	
C409	QEK1HM-475Z	E CAPACITOR	4.7uF 50V M	
C410	QER61HM-475Z	E CAPACITOR	4.7uF 50V M	
C411	QEK1HM-475Z	E CAPACITOR	4.7uF 50V M	
C412	NCF31CZ-104X	C CAPACITOR	0.1uF 16V Z	
C413	NCF31CZ-104X	C CAPACITOR	0.1uF 16V Z	
C414	NCF31CZ-104X	C CAPACITOR	0.1uF 16V Z	
C415	NCF31CZ-104X	C CAPACITOR	0.1uF 16V Z	
C418	NCF31CZ-104X	C CAPACITOR	0.1uF 16V Z	
C421	NCB31HK-102X	C CAPACITOR	1000pF 50V K	
C425	NDC31HJ-331X	C CAPACITOR	330pF 50V J	
C426	NDC31HJ-331X	C CAPACITOR	330pF 50V J	
C427	NDC31HJ-331X	C CAPACITOR	330pF 50V J	
C428	NDC31HJ-331X	C CAPACITOR	330pF 50V J	
C429	NCB31HK-103X	C CAPACITOR	0.01uF 50V K	
C431	NCF31CZ-104X	C CAPACITOR	0.1uF 16V Z	
C432	NCF31CZ-104X	C CAPACITOR	0.1uF 16V Z	
C433	NCF31CZ-104X	C CAPACITOR	0.1uF 16V Z	
C434	NCF31CZ-104X	C CAPACITOR	0.1uF 16V Z	
C435	NCB31HK-103X	C CAPACITOR	0.01uF 50V K	
C436	NCB31HK-103X	C CAPACITOR	0.01uF 50V K	
△ R202	QRJ146J-100X	UNF C RESISTOR	10Ω 1/4W J	
△ R203	QRJ146J-100X	UNF C RESISTOR	10Ω 1/4W J	
△ R206	QRJ146J-681X	UNF C RESISTOR	680Ω 1/4W J	
△ R207	QRJ146J-8R2X	UNF C RESISTOR	8.2Ω 1/4W J	
R208	NRSA63J-104X	MG RESISTOR	100kΩ 1/16W J	
△ R209	QRJ146J-100X	UNF C RESISTOR	10Ω 1/4W J	
△ R210	QRZ9005-100X	FUSI RESISTOR	10Ω	
△ R211	QRK126J-562X	UNF C RESISTOR	5.6kΩ 1/2W J	
△ R215	QRZ9005-100X	FUSI RESISTOR	10Ω	
△ R216	QRJ146J-152X	UNF C RESISTOR	1.5kΩ 1/4W J	
△ R217	QRZ9006-8R2X	FUSI RESISTOR	8.2Ω	
△ R218	QRJ146J-152X	UNF C RESISTOR	1.5kΩ 1/4W J	
R219	NRSA63J-223X	MG RESISTOR	22kΩ 1/16W J	
R220	NRSA63J-473X	MG RESISTOR	47kΩ 1/16W J	
△ R221	QRZ9005-100X	FUSI RESISTOR	10Ω	
△ R222	QRJ146J-332X	UNF C RESISTOR	3.3kΩ 1/4W J	
R223	NRSA63J-102X	MG RESISTOR	1kΩ 1/16W J	
R224	NRSA63J-104X	MG RESISTOR	100kΩ 1/16W J	
△ R225	QRZ9005-100X	FUSI RESISTOR	10Ω	
△ R226	QRJ146J-102X	UNF C RESISTOR	1kΩ 1/4W J	
R227	NRSA63J-393X	MG RESISTOR	39kΩ 1/16W J	
R228	NRSA63J-473X	MG RESISTOR	47kΩ 1/16W J	
△ R229	QRZ9006-4R7X	FUSI RESISTOR	4.7Ω 1/4W J	

△ Symbol No.	Part No.	Part Name	Description	Local	△ Symbol No.	Part No.	Part Name	Description	Local
△ R230	QRZ9006-4R7X	FUSI RESISTOR	4.7Ω 1/4W J		CN412	QGA2001C1-05	CONNECTOR	W-B (1-5)	
△ R231	QRJ146J-182X	UNF C RESISTOR	1.8kΩ 1/4W J		CN413	QGA2001F1-05	CONNECTOR	W-B (1-5)	
△ R232	QRJ146J-2R2X	UNF C RESISTOR	2.2Ω 1/4W J		CN414	QGA2001F1-09	CONNECTOR	W-B (1-9)	
△ R233	QRJ146J-2R2X	UNF C RESISTOR	2.2Ω 1/4W J		CN415	QGA2001F1-08	CONNECTOR	W-B (1-8)	
R234	NRSA63J-102X	MG RESISTOR	1kΩ 1/16W J		CN421	QGA2001C1-09	CONNECTOR	W-B (1-9)	
R235	NRSA63J-104X	MG RESISTOR	100kΩ 1/16W J		CN431	QJK034-092204-E	SIN CR C-B WIR		
△ R236	QRZ9005-100X	FUSI RESISTOR	10Ω		CN510	QGA2501C1-09	CONNECTOR	W-B (1-9)	
△ R237	QRJ146J-332X	UNF C RESISTOR	3.3kΩ 1/4W J		CN520	QGA2501C1-07	CONNECTOR	W-B (1-7)	
R238	NRSA63J-102X	MG RESISTOR	1kΩ 1/16W J		CN721	QGA2001C1-04	CONNECTOR	W-B (1-4)	
R239	NRSA63J-104X	MG RESISTOR	100kΩ 1/16W J		EP201	QNZ0136-001Z	EARTH PLATE		
R242	NRSA63J-222X	MG RESISTOR	2.2kΩ 1/16W J		EP202	QNZ0136-001Z	EARTH PLATE		
△ R245	QRJ146J-2R2X	UNF C RESISTOR	2.2Ω 1/4W J		EP204	QNZ0136-001Z	EARTH PLATE		
△ R247	QRZ9006-4R7X	FUSI RESISTOR	4.7Ω 1/4W J		FC202	QNG0020-001Z	FUSE CLIP I.M		
△ R248	QRJ146J-152X	UNF C RESISTOR	1.5kΩ 1/4W J		FC203	QNG0020-001Z	FUSE CLIP I.M		
R249	NRSA63J-511X	MG RESISTOR	510Ω 1/16W J		FC204	QNG0020-001Z	FUSE CLIP I.M		
R250	NRSA63J-104X	MG RESISTOR	100kΩ 1/16W J		FC205	QNG0020-001Z	FUSE CLIP I.M		
△ R252	QRJ146J-2R2X	UNF C RESISTOR	2.2Ω 1/4W J		FC212	QNG0020-001Z	FUSE CLIP I.M		
△ R253	QRJ146J-2R2X	UNF C RESISTOR	2.2Ω 1/4W J		FC213	QNG0020-001Z	FUSE CLIP I.M		
△ R254	QRJ146J-100X	UNF C RESISTOR	10Ω 1/4W J		FC214	QNG0020-001Z	FUSE CLIP I.M		
△ R255	QRJ146J-2R2X	UNF C RESISTOR	2.2Ω 1/4W J		FC215	QNG0020-001Z	FUSE CLIP I.M		
△ R256	QRJ146J-2R2X	UNF C RESISTOR	2.2Ω 1/4W J		FW251	WJS0045-001A-E	E-FL/RB WIRE		
R401	NRSA63J-103X	MG RESISTOR	10kΩ 1/16W J		FW401	WJS0038-002A-E	E-FL/RB WIRE		
R402	NRSA63J-102X	MG RESISTOR	1kΩ 1/16W J		FW402	WJS0039-001A-E	E-FL/RB WIRE		
R403	NRSA63J-102X	MG RESISTOR	1kΩ 1/16W J		FW404	WJS0064-001A-E	E-FL/RB WIRE		
R404	NRSA63J-103X	MG RESISTOR	10kΩ 1/16W J		FW405	WJS0063-001A-E	E-FL/RB WIRE		
R405	NRSA63J-102X	MG RESISTOR	1kΩ 1/16W J		HS205	E70306-006	HEAT SINK		
R406	NRSA63J-102X	MG RESISTOR	1kΩ 1/16W J		HS207	E70306-006	HEAT SINK		
R407	NRSA63J-122X	MG RESISTOR	1.2kΩ 1/16W J		HS208	E70306-006	HEAT SINK		
R408	NRSA63J-103X	MG RESISTOR	10kΩ 1/16W J		HS209	E70306-006	HEAT SINK		
R409	NRSA63J-102X	MG RESISTOR	1kΩ 1/16W J		HS213	E70306-006	HEAT SINK		
R410	NRSA63J-102X	MG RESISTOR	1kΩ 1/16W J		JS401	QSW1016-001	ROTARY ENCODER		
R411	NRSA63J-103X	MG RESISTOR	10kΩ 1/16W J		JS402	QSW1022-002	ROTARY ENCODER		
R412	NRSA63J-102X	MG RESISTOR	1kΩ 1/16W J		△ RY201	QSK0128-001	RELAY		
R413	NRSA63J-102X	MG RESISTOR	1kΩ 1/16W J		S401	QSW0683-001Z	PUSH SW I.M		
R414	NRSA63J-122X	MG RESISTOR	1.2kΩ 1/16W J		S402	QSW0683-001Z	PUSH SW I.M		
R419	NRSA63J-103X	MG RESISTOR	10kΩ 1/16W J		S403	QSW0683-001Z	PUSH SW I.M		
R420	NRSA63J-102X	MG RESISTOR	1kΩ 1/16W J		S404	QSW0683-001Z	PUSH SW I.M		
R421	NRSA63J-102X	MG RESISTOR	1kΩ 1/16W J		S405	QSW0683-001Z	PUSH SW I.M		
R422	NRSA63J-122X	MG RESISTOR	1.2kΩ 1/16W J		S407	QSW0683-001Z	PUSH SW I.M		
R423	NRSA63J-152X	MG RESISTOR	1.5kΩ 1/16W J		△ TH201	QAD0095-4R7Z	PISTOSITOR I.M	4.7Ω M	
R430	NRSA63J-221X	MG RESISTOR	220Ω 1/16W J		X401	QAX0246-001Z	RESONATOR	8.00MHZ	
R431	NRSA63J-103X	MG RESISTOR	10kΩ 1/16W J						
R432	NRSA63J-103X	MG RESISTOR	10kΩ 1/16W J						
R433	NRSA63J-103X	MG RESISTOR	10kΩ 1/16W J						
R434	NRSA63J-103X	MG RESISTOR	10kΩ 1/16W J						
R435	NRSA63J-103X	MG RESISTOR	10kΩ 1/16W J						
R436	NRSA63J-221X	MG RESISTOR	220Ω 1/16W J						
R437	NRSA63J-221X	MG RESISTOR	220Ω 1/16W J						
R438	NRSA63J-331X	MG RESISTOR	330Ω 1/16W J						
R439	NRSA63J-221X	MG RESISTOR	220Ω 1/16W J						
R440	NRSA63J-221X	MG RESISTOR	220Ω 1/16W J						
R441	NRSA63J-221X	MG RESISTOR	220Ω 1/16W J						
R442	NRSA63J-221X	MG RESISTOR	220Ω 1/16W J						
R443	NRSA63J-221X	MG RESISTOR	220Ω 1/16W J						
R444	NRSA63J-221X	MG RESISTOR	220Ω 1/16W J						
R445	NRSA63J-104X	MG RESISTOR	100kΩ 1/16W J						
R447	NRSA63J-103X	MG RESISTOR	10kΩ 1/16W J						
R448	NRSA63J-103X	MG RESISTOR	10kΩ 1/16W J						
R449	NRSA63J-103X	MG RESISTOR	10kΩ 1/16W J						
R450	NRSA63J-103X	MG RESISTOR	10kΩ 1/16W J						
R452	NRSA63J-221X	MG RESISTOR	220Ω 1/16W J						
R453	NRSA63J-103X	MG RESISTOR	10kΩ 1/16W J						
R454	NRSA63J-103X	MG RESISTOR	10kΩ 1/16W J						
R455	NRSA63J-103X	MG RESISTOR	10kΩ 1/16W J						
R456	NRSA63J-103X	MG RESISTOR	10kΩ 1/16W J						
R457	NRSA63J-0R0X	MG RESISTOR	0Ω 1/16W J						
R458	NRSA63J-0R0X	MG RESISTOR	0Ω 1/16W J						
△ T202	QQT0478-002	POWER TRANSF							
CN201	QGA3901C1-09	CONNECTOR	W-B (1-9)						
△ CN202	QGA7901C1-02	CONNECTOR	W-B (1-2)						
△ CN203	QGA7901C1-02	CONNECTOR	W-B (1-2)						
CN207	QGA2501C1-02	CONNECTOR	W-B (1-2)						
CN208	QGA2501C1-04	CONNECTOR	W-B (1-4)						
CN218	QJK025-040604-E	SIN CR C-B							
CN261	QGA2001C1-07	CONNECTOR	W-B (1-7)						
CN403	QJK018-050800-E	SIN CR C-B							

Amp. board

Block No. [0][2]

△ Symbol No.	Part No.	Part Name	Description	Local
△ IC301	STK412-400	IC		
IC751	MM1504XN-X	IC		
IC752	MM1506XN-X	IC		
IC753	MM1506XN-X	IC		
△ IC801	STK413-400	IC		
Q301	KTC3200/GL-T	TRANSISTOR		
Q302	KTC3200/GL-T	TRANSISTOR		
Q721	KTA1268/GL-T	TRANSISTOR		
Q771	KTC3200/GL-T	TRANSISTOR		
Q772	KTA1268/GL-T	TRANSISTOR		
Q773	KTC3199/GL-T	TRANSISTOR		
Q781	KRC105S-X	DIGI TRANSISTOR		
Q801	KTC3200/GL-T	TRANSISTOR		
Q802	KTC3200/GL-T	TRANSISTOR		
Q901	KTC3200/GL-T	TRANSISTOR		
Q1303	KRC105S-X	DIGI TRANSISTOR		
Q1803	KRC105S-X	DIGI TRANSISTOR		
Q1902	KRC105S-X	DIGI TRANSISTOR		
Q5701	KTA1267/YG-T	TRANSISTOR		
D301	MA8150/M-X	Z DIODE		
D302	MA8150/M-X	Z DIODE		
D303	MA111-X	DIODE C.M		
D304	MA111-X	DIODE C.M		
D701	MA111-X	DIODE C.M		
D702	MA111-X	DIODE C.M		

△ Symbol No.	Part No.	Part Name	Description	Local	△ Symbol No.	Part No.	Part Name	Description	Local
△ D703	UF304G-F82	DIODE			C1301	QFLC1HJ-104Z	M CAPACITOR	0.1uF 50V J	
△ D704	UF304G-F82	DIODE			C1302	QFLC1HJ-104Z	M CAPACITOR	0.1uF 50V J	
△ D705	UF304G-F82	DIODE			C1303	QFLC1HJ-104Z	M CAPACITOR	0.1uF 50V J	
△ D706	UF304G-F82	DIODE			C1304	QFLC1HJ-104Z	M CAPACITOR	0.1uF 50V J	
△ D707	UF304G-F82	DIODE			C1305	QCS32HJ-221Z	C CAPACITOR	220pF 500V J	
△ D708	UF304G-F82	DIODE			C1306	QCS32HJ-221Z	C CAPACITOR	220pF 500V J	
△ D709	UF304G-F82	DIODE			C1307	QCS32HJ-221Z	C CAPACITOR	220pF 500V J	
△ D710	UF304G-F82	DIODE			C1308	QCS32HJ-221Z	C CAPACITOR	220pF 500V J	
D771	MA111-X	DIODE C.M			C1309	QCS32HJ-221Z	C CAPACITOR	220pF 500V J	
D781	MA111-X	DIODE C.M			C1310	QCS32HJ-221Z	C CAPACITOR	220pF 500V J	
D801	MA8150/M/-X	Z DIODE			C1801	QFLC1HJ-104Z	M CAPACITOR	0.1uF 50V J	
D802	MA8150/M/-X	Z DIODE			C1802	QFLC1HJ-104Z	M CAPACITOR	0.1uF 50V J	
D803	MA111-X	DIODE C.M			C1803	QFLC1HJ-104Z	M CAPACITOR	0.1uF 50V J	
D804	MA111-X	DIODE C.M			C1804	QFLC1HJ-104Z	M CAPACITOR	0.1uF 50V J	
D901	MA111-X	DIODE C.M			C1805	QCS32HJ-221Z	C CAPACITOR	220pF 500V J	
D1301	MA111-X	DIODE C.M			C1806	QCS32HJ-221Z	C CAPACITOR	220pF 500V J	
D1801	MA111-X	DIODE C.M			C1807	QCS32HJ-221Z	C CAPACITOR	220pF 500V J	
D1901	MA111-X	DIODE C.M			C1808	QCS32HJ-221Z	C CAPACITOR	220pF 500V J	
					C1809	QCS32HJ-221Z	C CAPACITOR	220pF 500V J	
C301	QFLC1HJ-471Z	M CAPACITOR	470pF 50V J		C1810	QCS32HJ-221Z	C CAPACITOR	220pF 500V J	
C302	QFLC1HJ-471Z	M CAPACITOR	470pF 50V J		C1903	QFLC1HJ-104Z	M CAPACITOR	0.1uF 50V J	
C303	QEK1HM-225Z	E CAPACITOR	2.2uF 50V M		C1904	QFLC1HJ-104Z	M CAPACITOR	0.1uF 50V J	
C304	QEK1HM-225Z	E CAPACITOR	2.2uF 50V M		C1905	QCS32HJ-221Z	C CAPACITOR	220pF 500V J	
C305	QEK1CM-107Z	E CAPACITOR	100uF 16V M		C1906	QCS31HJ-331Z	C CAPACITOR	330pF 50V J	
C306	QEK1CM-107Z	E CAPACITOR	100uF 16V M		C1907	QCS31HJ-331Z	C CAPACITOR	330pF 50V J	
C307	NDC31HJ-101X	C CAPACITOR	100pF 50V J		C5704	NDC31HJ-100X	C CAPACITOR	10pF 50V J	
C308	NDC31HJ-101X	C CAPACITOR	100pF 50V J		C5705	NDC31HJ-100X	C CAPACITOR	10pF 50V J	
C309	NDC31HJ-3R0X	C CAPACITOR	3pF 50V J		C5706	NDC31HJ-100X	C CAPACITOR	10pF 50V J	
C310	NDC31HJ-3R0X	C CAPACITOR	3pF 50V J		C5707	NDC31HJ-100X	C CAPACITOR	10pF 50V J	
C311	QETN2AM-107Z	E CAPACITOR	100uF 100V M		C5708	NDC31HJ-100X	C CAPACITOR	10pF 50V J	
C312	QETN2AM-107Z	E CAPACITOR	100uF 100V M		C5709	NDC31HJ-100X	C CAPACITOR	10pF 50V J	
C313	NCB31HK-222X	C CAPACITOR	2200pF 50V K		C5713	QETN1EM-476Z	E CAPACITOR	47uF 25V M	
C314	NCB31HK-222X	C CAPACITOR	2200pF 50V K		C5714	QEK1HM-475Z	E CAPACITOR	4.7uF 50V M	
C315	QFLC1HJ-473Z	M CAPACITOR	0.047uF 50V J		C5715	QEK1HM-475Z	E CAPACITOR	4.7uF 50V M	
C316	QFLC1HJ-473Z	M CAPACITOR	0.047uF 50V J		C5716	QETN0JM-477Z	E CAPACITOR	470uF 6.3V M	
C317	QFLC1HJ-473Z	M CAPACITOR	0.047uF 50V J		C5717	QETN1CM-107Z	E CAPACITOR	100uF 16V M	
C318	QFLC1HJ-473Z	M CAPACITOR	0.047uF 50V J		C5718	QETN1CM-107Z	E CAPACITOR	100uF 16V M	
C701	QCE22HP-103	C CAPACITOR	0.01uF 500V P		C5721	NDC31HJ-331X	C CAPACITOR	330pF 50V J	
C702	QCE22HP-103	C CAPACITOR	0.01uF 500V P		C5722	NDC31HJ-331X	C CAPACITOR	330pF 50V J	
C703	QFZ9076-104Z	MM CAPACITOR	0.1uF		C5723	NDC31HJ-331X	C CAPACITOR	330pF 50V J	
C704	QCE22HP-103	C CAPACITOR	0.01uF 500V P		C5724	NDC31HJ-331X	C CAPACITOR	330pF 50V J	
C705	QCE22HP-103	C CAPACITOR	0.01uF 500V P		C5725	NDC31HJ-331X	C CAPACITOR	330pF 50V J	
C706	QFZ9076-104Z	MM CAPACITOR	0.1uF		C5726	NDC31HJ-331X	C CAPACITOR	330pF 50V J	
C709	NCB31HK-223X	C CAPACITOR	0.022uF 50V K		C5741	QEK1CM-476Z	E CAPACITOR	47uF 16V M	
C711	QEZ0695-478	E CAPACITOR	4700uF		C5742	NCF31CZ-104X	C CAPACITOR	0.1uF 16V Z	
C712	QEZ0695-478	E CAPACITOR	4700uF		C5752	NCF31CZ-104X	C CAPACITOR	0.1uF 16V Z	
C713	QEZ0677-338	E CAPACITER	3300uF		C5753	NCF31CZ-104X	C CAPACITOR	0.1uF 16V Z	
C714	QEZ0677-338	E CAPACITER	3300uF		C5754	NCF31CZ-104X	C CAPACITOR	0.1uF 16V Z	
C721	QETN2AM-106Z	E CAPACITOR	10uF 100V M		C5763	QEK1HM-475Z	E CAPACITOR	4.7uF 50V M	
C771	QEK1EM-106Z	E CAPACITOR	10uF 25V M						
C772	QEK1CM-476Z	E CAPACITOR	47uF 16V M		R301	NRSA63J-102X	MG RESISTOR	1kΩ 1/16W J	
C801	QFLC1HJ-471Z	M CAPACITOR	470pF 50V J		R302	NRSA63J-102X	MG RESISTOR	1kΩ 1/16W J	
C802	QFLC1HJ-471Z	M CAPACITOR	470pF 50V J		R303	NRSA63J-563X	MG RESISTOR	56kΩ 1/16W J	
C803	QEK1HM-225Z	E CAPACITOR	2.2uF 50V M		R304	NRSA63J-563X	MG RESISTOR	56kΩ 1/16W J	
C804	QEK1HM-225Z	E CAPACITOR	2.2uF 50V M		△ R305	QRJ146J-271X	UNF C RESISTOR	270Ω 1/4W J	
C805	QEK1CM-107Z	E CAPACITOR	100uF 16V M		△ R306	QRJ146J-271X	UNF C RESISTOR	270Ω 1/4W J	
C806	QEK1CM-107Z	E CAPACITOR	100uF 16V M		R307	NRSA63J-333X	MG RESISTOR	33kΩ 1/16W J	
C807	NDC31HJ-101X	C CAPACITOR	100pF 50V J		△ R308	QRJ146J-2R2X	UNF C RESISTOR	2.2Ω 1/4W J	
C808	NDC31HJ-101X	C CAPACITOR	100pF 50V J		△ R309	QRJ146J-2R2X	UNF C RESISTOR	2.2Ω 1/4W J	
C809	NDC31HJ-3R0X	C CAPACITOR	3pF 50V J		R310	NRSA63J-563X	MG RESISTOR	56kΩ 1/16W J	
C810	NDC31HJ-3R0X	C CAPACITOR	3pF 50V J		R311	NRSA63J-563X	MG RESISTOR	56kΩ 1/16W J	
C811	QFLC1HJ-473Z	M CAPACITOR	0.047uF 50V J		△ R312	QRJ146J-101X	UNF C RESISTOR	100Ω 1/4W J	
C812	QFLC1HJ-473Z	M CAPACITOR	0.047uF 50V J		△ R315	QRL017J-152	OMF RESISTOR	1.5kΩ 1W J	
C813	QFLC1HJ-473Z	M CAPACITOR	0.047uF 50V J		△ R316	QRL017J-152	OMF RESISTOR	1.5kΩ 1W J	
C814	QFLC1HJ-473Z	M CAPACITOR	0.047uF 50V J		△ R317	QRJ146J-471X	UNF C RESISTOR	470Ω 1/4W J	
C821	QETN2AM-107Z	E CAPACITOR	100uF 100V M		△ R318	QRJ146J-471X	UNF C RESISTOR	470Ω 1/4W J	
C822	QETN2AM-107Z	E CAPACITOR	100uF 100V M		R319	NRSA63J-102X	MG RESISTOR	1kΩ 1/16W J	
C901	QFLC1HJ-471Z	M CAPACITOR	470pF 50V J		R320	NRSA63J-102X	MG RESISTOR	1kΩ 1/16W J	
C902	QEK1HM-225Z	E CAPACITOR	2.2uF 50V M		R321	NRSA63J-183X	MG RESISTOR	18kΩ 1/16W J	
C903	QEK1CM-107Z	E CAPACITOR	100uF 16V M		R322	NRSA63J-183X	MG RESISTOR	18kΩ 1/16W J	
C904	NDC31HJ-101X	C CAPACITOR	100pF 50V J		R323	NRSA63J-473X	MG RESISTOR	47kΩ 1/16W J	
C905	NDC31HJ-3R0X	C CAPACITOR	3pF 50V J		R324	NRSA63J-473X	MG RESISTOR	47kΩ 1/16W J	
C906	QFLC1HJ-473Z	M CAPACITOR	0.047uF 50V J		△ R325	QRZ0224-R22	EMIT.RESISTOR	0.22Ω	
C907	QFLC1HJ-473Z	M CAPACITOR	0.047uF 50V J		△ R326	QRZ0224-R22	EMIT.RESISTOR	0.22Ω	
C908	NDC31HJ-151X	C CAPACITOR	150pF 50V J		△ R327	QRJ146J-2R2X	UNF C RESISTOR	2.2Ω 1/4W J	
C950	NCB31HK-102X	C CAPACITOR	1000pF 50V K		△ R328	QRJ146J-2R2X	UNF C RESISTOR	2.2Ω 1/4W J	
C951	NCB31HK-102X	C CAPACITOR	1000pF 50V K		△ R329	QRJ146J-330X	UNF C RESISTOR	33Ω 1/4W J	
C952	NCB31HK-102X	C CAPACITOR	1000pF 50V K		△ R330	QRJ146J-330X	UNF C RESISTOR	33Ω 1/4W J	

△ Symbol No.	Part No.	Part Name	Description	Local	△ Symbol No.	Part No.	Part Name	Description	Local
△ R331	QRL027J-100	OMF RESISTOR	10Ω 2W J		R5704	NRSA63J-750X	MG RESISTOR	75Ω 1/16W J	
△ R332	QRL027J-100	OMF RESISTOR	10Ω 2W J		R5705	NRSA63J-750X	MG RESISTOR	75Ω 1/16W J	
△ R333	QRL027J-471	OMF RESISTOR	470Ω 2W J		R5706	NRSA63J-750X	MG RESISTOR	75Ω 1/16W J	
△ R334	QRL027J-471	OMF RESISTOR	470Ω 2W J		R5707	NRSA63J-750X	MG RESISTOR	75Ω 1/16W J	
△ R701	QRJ146J-820X	UNF C RESISTOR	82Ω 1/4W J		R5708	NRSA63J-750X	MG RESISTOR	75Ω 1/16W J	
△ R702	QRJ146J-820X	UNF C RESISTOR	82Ω 1/4W J		R5709	NRSA63J-750X	MG RESISTOR	75Ω 1/16W J	
R721	NRSA63J-103X	MG RESISTOR	10kΩ 1/16W J		R5721	NRSA63J-471X	MG RESISTOR	470Ω 1/16W J	
R722	NRSA63J-104X	MG RESISTOR	100kΩ 1/16W J		R5722	NRSA63J-471X	MG RESISTOR	470Ω 1/16W J	
R761	NRSA63J-122X	MG RESISTOR	1.2kΩ 1/16W J		R5723	NRSA63J-473X	MG RESISTOR	47kΩ 1/16W J	
R762	NRSA63J-471X	MG RESISTOR	470Ω 1/16W J		R5724	NRSA63J-473X	MG RESISTOR	47kΩ 1/16W J	
R771	NRSA63J-104X	MG RESISTOR	100kΩ 1/16W J		R5725	NRSA63J-471X	MG RESISTOR	470Ω 1/16W J	
R772	NRSA63J-823X	MG RESISTOR	82kΩ 1/16W J		R5726	NRSA63J-471X	MG RESISTOR	470Ω 1/16W J	
R773	NRSA63J-104X	MG RESISTOR	100kΩ 1/16W J		R5727	NRSA63J-104X	MG RESISTOR	100kΩ 1/16W J	
R774	NRSA63J-104X	MG RESISTOR	100kΩ 1/16W J		R5728	NRSA63J-104X	MG RESISTOR	100kΩ 1/16W J	
R775	NRSA63J-104X	MG RESISTOR	100kΩ 1/16W J		R5729	NRSA63J-471X	MG RESISTOR	470Ω 1/16W J	
R776	NRSA63J-104X	MG RESISTOR	100kΩ 1/16W J		R5730	NRSA63J-471X	MG RESISTOR	470Ω 1/16W J	
R777	NRSA63J-104X	MG RESISTOR	100kΩ 1/16W J		R5731	NRSA63J-473X	MG RESISTOR	47kΩ 1/16W J	
R778	NRSA63J-103X	MG RESISTOR	10kΩ 1/16W J		R5732	NRSA63J-473X	MG RESISTOR	47kΩ 1/16W J	
R779	NRSA63J-103X	MG RESISTOR	10kΩ 1/16W J		△ R5741	QRZ9006-4R7X	FUSI RESISTOR	4.7Ω 1/4W J	
R780	NRSA63J-101X	MG RESISTOR	100Ω 1/16W J		R5751	NRSA63J-470X	MG RESISTOR	47Ω 1/16W J	
△ R781	QRJ146J-820X	UNF C RESISTOR	82Ω 1/4W J		△ R5752	QRJ146J-331X	UNF C RESISTOR	330Ω 1/4W J	
R801	NRSA63J-102X	MG RESISTOR	1kΩ 1/16W J		△ R5753	QRJ146J-331X	UNF C RESISTOR	330Ω 1/4W J	
R802	NRSA63J-102X	MG RESISTOR	1kΩ 1/16W J		R5765	NRSA63J-331X	MG RESISTOR	330Ω 1/16W J	
R803	NRSA63J-563X	MG RESISTOR	56kΩ 1/16W J		R5766	NRSA63J-750X	MG RESISTOR	75Ω 1/16W J	
R804	NRSA63J-563X	MG RESISTOR	56kΩ 1/16W J		L301	QQLZ005-R45	COIL	0.45uH	
△ R805	QRJ146J-561X	UNF C RESISTOR	560Ω 1/4W J		L302	QQLZ005-R45	COIL	0.45uH	
△ R806	QRJ146J-561X	UNF C RESISTOR	560Ω 1/4W J		L303	QQLZ005-R45	COIL	0.45uH	
R807	NRSA63J-333X	MG RESISTOR	33kΩ 1/16W J		L304	QQLZ005-R45	COIL	0.45uH	
△ R808	QRJ146J-2R2X	UNF C RESISTOR	2.2Ω 1/4W J		L801	QQLZ005-R45	COIL	0.45uH	
△ R809	QRJ146J-2R2X	UNF C RESISTOR	2.2Ω 1/4W J		L802	QQLZ005-R45	COIL	0.45uH	
R810	NRSA63J-563X	MG RESISTOR	56kΩ 1/16W J		L803	QQLZ005-R45	COIL	0.45uH	
R811	NRSA63J-563X	MG RESISTOR	56kΩ 1/16W J		L804	QQLZ005-R45	COIL	0.45uH	
△ R812	QRJ146J-101X	UNF C RESISTOR	100Ω 1/4W J		L901	QQLZ005-R45	COIL	0.45uH	
△ R815	QRL017J-152	OMF RESISTOR	1.5kΩ 1W J		L902	QQLZ005-R45	COIL	0.45uH	
△ R816	QRL017J-152	OMF RESISTOR	1.5kΩ 1W J		CN206	QGA2001C1-04	CONNECTOR	W-B (1-4)	
△ R817	QRJ146J-471X	UNF C RESISTOR	470Ω 1/4W J		CN301	QGA2001C1-04	CONNECTOR	W-B (1-4)	
△ R818	QRJ146J-471X	UNF C RESISTOR	470Ω 1/4W J		CN516	WJP0071-002A-E	E-SH C WIRE C-B		
R819	NRSA63J-102X	MG RESISTOR	1kΩ 1/16W J		CN519	QGA2501C1-10	CONNECTOR	W-B (1-10)	
R820	NRSA63J-102X	MG RESISTOR	1kΩ 1/16W J		CN701	QGA3901C1-09	CONNECTOR	W-B (1-9)	
R821	NRSA63J-183X	MG RESISTOR	18kΩ 1/16W J		CN727	QGB2510J1-08	CONNECTOR	B-B (1-8)	
R822	NRSA63J-183X	MG RESISTOR	18kΩ 1/16W J		CN751	QGF1205C1-12	CONNECTOR	FFC/FPC (1-12)	
△ R825	QRZ0224-R22	EMIT.RESISTOR	0.22Ω		CN801	QGA2001C1-08	CONNECTOR	W-B (1-8)	
△ R826	QRZ0224-R22	EMIT.RESISTOR	0.22Ω		FC701	QNG0020-001Z	FUSE CLIP I.M		
△ R827	QRJ146J-2R2X	UNF C RESISTOR	2.2Ω 1/4W J		FC702	QNG0020-001Z	FUSE CLIP I.M		
△ R828	QRJ146J-2R2X	UNF C RESISTOR	2.2Ω 1/4W J		FC703	QNG0020-001Z	FUSE CLIP I.M		
△ R829	QRJ146J-330X	UNF C RESISTOR	33Ω 1/4W J		FC704	QNG0020-001Z	FUSE CLIP I.M		
△ R830	QRJ146J-330X	UNF C RESISTOR	33Ω 1/4W J		FW301	WJS0042-001A-E	E-FL/RB WIRE		
△ R831	QRL027J-100	OMF RESISTOR	10Ω 2W J		FW711	WJS0040-001A-E	E-FL/RB WIRE		
△ R832	QRL027J-100	OMF RESISTOR	10Ω 2W J		FW801	WJS0043-002A-E	E-FL/RB WIRE		
R833	NRSA63J-473X	MG RESISTOR	47kΩ 1/16W J		J5701	QNN0611-001	PIN JACK		
R834	NRSA63J-473X	MG RESISTOR	47kΩ 1/16W J		J5702	QNN0612-001	PIN JACK		
R901	NRSA63J-102X	MG RESISTOR	1kΩ 1/16W J		J5703	QNN0017-002	PIN JACK		
R902	NRSA63J-563X	MG RESISTOR	56kΩ 1/16W J		J7001	QNB0192-001	SPEAKER TERMINA		
△ R903	QRJ146J-391X	UNF C RESISTOR	390Ω 1/4W J		△ RY301	QSK0127-001	RELAY		
△ R904	QRZ0224-R22	EMIT.RESISTOR	0.22Ω		△ RY701	QSK0127-002	RELAY		
R905	NRSA63J-563X	MG RESISTOR	56kΩ 1/16W J		△ RY702	QSK0127-002	RELAY		
R906	NRSA63J-102X	MG RESISTOR	1kΩ 1/16W J		RY781	QSK0127-001	RELAY		
R907	NRSA63J-473X	MG RESISTOR	47kΩ 1/16W J		△ RY801	QSK0127-001	RELAY		
R908	NRSA63J-183X	MG RESISTOR	18kΩ 1/16W J		△ RY901	QSK0127-001	RELAY		
△ R910	QRJ146J-330X	UNF C RESISTOR	33Ω 1/4W J		△ TH761	QAD0157-351	N THERMISTOR	350Ω	
△ R911	QRL027J-100	OMF RESISTOR	10Ω 2W J						
R945	NRS181J-0R0X	MG RESISTOR	0Ω 1/8W J						
R946	NRS181J-0R0X	MG RESISTOR	0Ω 1/8W J						
R948	NRSA63J-0R0X	MG RESISTOR	0Ω 1/16W J						
R949	NRSA63J-0R0X	MG RESISTOR	0Ω 1/16W J						
△ R1301	QRJ146J-820X	UNF C RESISTOR	82Ω 1/4W J						
△ R1302	QRJ146J-3R9X	UNF C RESISTOR	3.9Ω 1/4W J						
△ R1303	QRJ146J-3R9X	UNF C RESISTOR	3.9Ω 1/4W J						
R1304	NRS016J-103X	MG RESISTOR	10kΩ 1W J						
R1305	NRS016J-103X	MG RESISTOR	10kΩ 1W J						
△ R1801	QRJ146J-820X	UNF C RESISTOR	82Ω 1/4W J						
△ R1802	QRJ146J-3R9X	UNF C RESISTOR	3.9Ω 1/4W J						
△ R1803	QRJ146J-3R9X	UNF C RESISTOR	3.9Ω 1/4W J						
R1804	NRS016J-103X	MG RESISTOR	10kΩ 1W J						
R1805	NRS016J-103X	MG RESISTOR	10kΩ 1W J						
△ R1901	QRJ146J-820X	UNF C RESISTOR	82Ω 1/4W J						
△ R1902	QRJ146J-3R9X	UNF C RESISTOR	3.9Ω 1/4W J						
R1903	NRS016J-103X	MG RESISTOR	10kΩ 1W J						

Input board

Block No. [0][3]

Symbol No.	Part No.	Part Name	Description	Local
IC311	NJM4565M-WE	IC		
IC501	MN101C49GMZ	IC		
IC502	BD3843FS-X	IC		
IC503	BD3813KS	IC		
IC504	NJM4565M-WE	IC		
IC505	BU1924F-X	IC		
IC506	IC-PST9139-T	IC		
IC511	MM1502XN-X	IC		
IC512	MM1502XN-X	IC		
IC513	MM1502XN-X	IC		
IC514	MM1501XN-X	IC		
IC515	CD74HC4053NS-X	IC		
IC516	NJM2246M-X	IC		
IC517	MM1117XF-XE	IC		
IC601	NJM4565M-WE	IC		
IC602	NJM4565M-WE	IC		
IC611	NJM4565M-WE	IC		
IC612	NJM4565M-WE	IC		
IC613	NJM4565M-WE	IC		
IC615	NJM4565M-WE	IC		
IC622	NJM4565M-WE	IC		
IC631	NJM2120M-X	IC		
IC632	NJM4565M-WE	IC		
IC633	NJM4565M-WE	IC		
IC634	NJM4565M-WE	IC		
IC661	DSPA56370AF	IC		
IC662	SN74LVC1GU04K-X	IC		
IC667	CS42518-CQZ-C-W	IC		
IC671	UPD784217AGC266	IC		
IC672	SN74AHCT1G32K-X	IC		
IC673	SN74LVC1G04K-X	IC		
IC691	BA3259HFP-W	IC		
IC811	NJM4565M-WE	IC		
IC911	NJM4565M-WE	IC		
Q501	2SC3576-JVC-T	NSISTOR I/M		
Q502	2SC3576-JVC-T	NSISTOR I/M		
Q503	KRA104S-X	DIGI TRANSISTOR		
Q504	KTC3199/GL/-T	TRANSISTOR		
Q505	KTC3199/GL/-T	TRANSISTOR		
Q506	KTC3199/GL/-T	TRANSISTOR		
Q507	KTC3199/GL/-T	TRANSISTOR		
Q510	KRC102S-X	DIGI TRANSISTOR		
Q511	KRA104S-X	DIGI TRANSISTOR		
Q512	KRA104S-X	DIGI TRANSISTOR		
Q513	2SC3576-JVC-T	NSISTOR I/M		
Q514	2SC3576-JVC-T	NSISTOR I/M		
Q515	2SC3576-JVC-T	NSISTOR I/M		
Q516	2SC3576-JVC-T	NSISTOR I/M		
Q517	2SC3576-JVC-T	NSISTOR I/M		
Q518	2SC3576-JVC-T	NSISTOR I/M		
Q519	2SC3576-JVC-T	NSISTOR I/M		
Q521	2SC3576-JVC-T	NSISTOR I/M		
Q522	2SC3576-JVC-T	NSISTOR I/M		
Q523	KRA104S-X	DIGI TRANSISTOR		
Q525	2SC3576-JVC-T	NSISTOR I/M		
Q526	2SC3576-JVC-T	NSISTOR I/M		
Q527	2SC3576-JVC-T	NSISTOR I/M		
Q528	2SC3576-JVC-T	NSISTOR I/M		
Q531	2SD2394/EF/	TRANSISTOR		
Q532	KRA102S-X	DIGI TRANSISTOR		
Q533	KRC102S-X	DIGI TRANSISTOR		
Q536	KRC102S-X	DIGI TRANSISTOR		
Q541	KTC3199/GL/-T	TRANSISTOR		
Q551	KRA104S-X	DIGI TRANSISTOR		
Q552	KRA104S-X	DIGI TRANSISTOR		
Q601	2SD2114K/VV/-X	TRANSISTOR		
Q602	2SD2114K/VV/-X	TRANSISTOR		
Q603	2SC2412K/RS/-X	TRANSISTOR		
Q604	2SC2412K/RS/-X	TRANSISTOR		
Q611	2SD2114K/VV/-X	TRANSISTOR		
Q612	2SD2114K/VV/-X	TRANSISTOR		
Q613	2SD2114K/VV/-X	TRANSISTOR		
Q614	2SD2114K/VV/-X	TRANSISTOR		

Symbol No.	Part No.	Part Name	Description	Local
Q621	2SD2114K/VV/-X	TRANSISTOR		
Q622	2SC2412K/RS/-X	TRANSISTOR		
Q631	2SD2114K/VV/-X	TRANSISTOR		
Q632	2SD2114K/VV/-X	TRANSISTOR		
Q1301	KRC104S-X	TRANSISTOR		
Q1302	KRC104S-X	TRANSISTOR		
Q1801	KRC104S-X	TRANSISTOR		
Q1802	KRC104S-X	TRANSISTOR		
Q1901	KRC104S-X	TRANSISTOR		
Q2601	KRC107S-X	DIGI TRANSISTOR		
Q2602	KRC107S-X	DIGI TRANSISTOR		
Q2603	KRC107S-X	DIGI TRANSISTOR		
Q2604	KRA107S-X	TRANSISTOR		
Q2605	KRA107S-X	TRANSISTOR		
Q2606	KRA107S-X	TRANSISTOR		
Q2608	KRA107S-X	TRANSISTOR		
Q2609	KRA107S-X	TRANSISTOR		
Q2610	KRC107S-X	DIGI TRANSISTOR		
Q3501	KTA1267/YG/-T	TRANSISTOR		
Q3502	KRA121S-X	DIGI TRANSISTOR		
Q3503	KTA1267/YG/-T	TRANSISTOR		
Q3504	KRA121S-X	DIGI TRANSISTOR		
Q3505	KTA1267/YG/-T	TRANSISTOR		
Q3506	KRA121S-X	DIGI TRANSISTOR		
Q3507	KTA1267/YG/-T	TRANSISTOR		
Q3508	KRA121S-X	DIGI TRANSISTOR		
Q3509	KTA1267/YG/-T	TRANSISTOR		
Q3510	KRA121S-X	DIGI TRANSISTOR		
Q3511	KTC3199/GL/-T	TRANSISTOR		
Q3512	KTC3199/GL/-T	TRANSISTOR		
Q3513	KTC3199/GL/-T	TRANSISTOR		
Q3514	KRC102S-X	DIGI TRANSISTOR		
Q3515	KRC102S-X	DIGI TRANSISTOR		
Q3517	KTA1267/YG/-T	TRANSISTOR		
Q3518	KRA121S-X	DIGI TRANSISTOR		
Q3519	KTA1267/YG/-T	TRANSISTOR		
D509	MA111-X	DIODE C.M		
D511	MA111-X	DIODE C.M		
D515	MA111-X	DIODE C.M		
D517	UDZS13B-X	Z DIODE		
D518	UDZS8.2B-X	SI DIODE		
D1321	MA704A-X	S.K.DIODE		
D1322	MA704A-X	S.K.DIODE		
D1323	UDZS4.7B-X	Z DIODE		
D1324	UDZS4.7B-X	Z DIODE		
D1701	UDZS7.5B-X	Z DIODE		
D1702	UDZS7.5B-X	Z DIODE		
D1821	MA704A-X	S.K.DIODE		
D1822	MA704A-X	S.K.DIODE		
D1823	UDZS4.7B-X	Z DIODE		
D1824	UDZS4.7B-X	Z DIODE		
D1921	MA704A-X	S.K.DIODE		
D1922	UDZS4.7B-X	Z DIODE		
D3505	UDZS12B-X	Z DIODE		
C501	NDC31HJ-471X	C CAPACITOR	470pF 50V J	
C502	NDC31HJ-471X	C CAPACITOR	470pF 50V J	
C503	QEK1HM-475Z	E CAPACITOR	4.7uF 50V M	
C504	QEK1HM-475Z	E CAPACITOR	4.7uF 50V M	
C505	QEK1HM-475Z	E CAPACITOR	4.7uF 50V M	
C506	QEK1HM-475Z	E CAPACITOR	4.7uF 50V M	
C507	NDC31HJ-471X	C CAPACITOR	470pF 50V J	
C508	NDC31HJ-471X	C CAPACITOR	470pF 50V J	
C509	QEK1HM-475Z	E CAPACITOR	4.7uF 50V M	
C510	QEK1HM-475Z	E CAPACITOR	4.7uF 50V M	
C511	QEK1HM-475Z	E CAPACITOR	4.7uF 50V M	
C512	QEK1HM-475Z	E CAPACITOR	4.7uF 50V M	
C519	NCB31HK-102X	C CAPACITOR	1000pF 50V K	
C520	NCB31HK-102X	C CAPACITOR	1000pF 50V K	
C522	NCB31HK-561X	C CAPACITOR	560pF 50V K	
C523	QEK1CM-476Z	E CAPACITOR	47uF 16V M	
C524	QEK1CM-476Z	E CAPACITOR	47uF 16V M	
C525	QEK1HM-475Z	E CAPACITOR	4.7uF 50V M	
C526	QETN0JM-228Z	E CAPACITOR	2200uF 6.3V M	
C527	QEK0JM-107Z	E CAPACITOR	100uF 6.3V M	
C528	QCZ0202-155Z	C CAPACITOR	1.5uF 25V Z	
C529	NCB31CK-223X	C CAPACITOR	0.022uF 16V K	

△ Symbol No.	Part No.	Part Name	Description	Local	△ Symbol No.	Part No.	Part Name	Description	Local
C530	QEKC1HM-225Z	E CAPACITOR	2.2uF 50V M		C638	QEKC1HM-475Z	E CAPACITOR	4.7uF 50V M	
C531	NCB31CK-223X	C CAPACITOR	0.022uF 16V K		C639	NCF31CZ-104X	C CAPACITOR	0.1uF 16V Z	
C532	NCB31HK-561X	C CAPACITOR	560pF 50V K		C640	NCF31CZ-104X	C CAPACITOR	0.1uF 16V Z	
C533	NCF31CZ-104X	C CAPACITOR	0.1uF 16V Z		C641	NDC31HJ-330X	C CAPACITOR	33pF 50V J	
C534	QEKC1CM-476Z	E CAPACITOR	47uF 16V M		C642	NDC31HJ-330X	C CAPACITOR	33pF 50V J	
C535	NCF31CZ-104X	C CAPACITOR	0.1uF 16V Z		C643	QEKC1HM-475Z	E CAPACITOR	4.7uF 50V M	
C536	QEKC1CM-476Z	E CAPACITOR	47uF 16V M		C644	QEKC1HM-475Z	E CAPACITOR	4.7uF 50V M	
C537	QETN1HM-106Z	E CAPACITOR	10uF 50V M		C651	NCF31CZ-104X	C CAPACITOR	0.1uF 16V Z	
C538	QETN1HM-106Z	E CAPACITOR	10uF 50V M		C652	NCF31CZ-104X	C CAPACITOR	0.1uF 16V Z	
C539	QETN1HM-106Z	E CAPACITOR	10uF 50V M		C653	NCB31HK-182X	C CAPACITOR	1800pF 50V K	
C540	QETN1HM-106Z	E CAPACITOR	10uF 50V M		C654	NCB31HK-182X	C CAPACITOR	1800pF 50V K	
C541	QETN1HM-106Z	E CAPACITOR	10uF 50V M		C655	NCB31HK-182X	C CAPACITOR	1800pF 50V K	
C542	QETN1HM-106Z	E CAPACITOR	10uF 50V M		C656	NCB31HK-182X	C CAPACITOR	1800pF 50V K	
C545	NCB31CK-104X	C CAPACITOR	0.1uF 16V K		C657	NCB31HK-103X	C CAPACITOR	0.01uF 50V K	
C546	NCB31CK-104X	C CAPACITOR	0.1uF 16V K		C658	NCB31HK-103X	C CAPACITOR	0.01uF 50V K	
C547	NCB31CK-104X	C CAPACITOR	0.1uF 16V K		C1321	NCB31HK-152X	C CAPACITOR	1500pF 50V K	
C548	NCB31CK-104X	C CAPACITOR	0.1uF 16V K		C1322	NCB31HK-152X	C CAPACITOR	1500pF 50V K	
C549	QEKC1CM-476Z	E CAPACITOR	47uF 16V M		C1323	QEKC1HM-105Z	E CAPACITOR	1uF 50V M	
C550	QEKC1CM-476Z	E CAPACITOR	47uF 16V M		C1324	QEKC1HM-105Z	E CAPACITOR	1uF 50V M	
C551	QETN1HM-106Z	E CAPACITOR	10uF 50V M		C1325	QEKC1HM-225Z	E CAPACITOR	2.2uF 50V M	
C552	QETN1HM-106Z	E CAPACITOR	10uF 50V M		C1326	QEKC1HM-225Z	E CAPACITOR	2.2uF 50V M	
C553	QEKC1HM-475Z	E CAPACITOR	4.7uF 50V M		C1327	QEKC1HM-475Z	E CAPACITOR	4.7uF 50V M	
C554	QEKC1HM-475Z	E CAPACITOR	4.7uF 50V M		C1328	QEKC1HM-475Z	E CAPACITOR	4.7uF 50V M	
C555	QEKC1HM-475Z	E CAPACITOR	4.7uF 50V M		C1511	NDC31HJ-471X	C CAPACITOR	470pF 50V J	
C556	QEKC1HM-475Z	E CAPACITOR	4.7uF 50V M		C1512	NDC31HJ-471X	C CAPACITOR	470pF 50V J	
C557	QEKC1HM-475Z	E CAPACITOR	4.7uF 50V M		C1513	QETN0JM-477Z	E CAPACITOR	470uF 6.3V M	
C558	QEKC1EM-106Z	E CAPACITOR	10uF 25V M		C1514	NDC31HJ-470X	C CAPACITOR	47pF 50V J	
C559	QEKC1CM-226Z	E CAPACITOR	22uF 16V M		C1515	NDC31HJ-471X	C CAPACITOR	470pF 50V J	
C561	NCB31HK-681X	C CAPACITOR	680pF 50V K		C1516	NDC31HJ-471X	C CAPACITOR	470pF 50V J	
C562	NCB31HK-681X	C CAPACITOR	680pF 50V K		C1517	QETN0JM-477Z	E CAPACITOR	470uF 6.3V M	
C563	NCB31HK-562X	C CAPACITOR	5600pF 50V K		C1518	NDC31HJ-470X	C CAPACITOR	47pF 50V J	
C564	NCB31HK-562X	C CAPACITOR	5600pF 50V K		C1521	NDC31HJ-471X	C CAPACITOR	470pF 50V J	
C565	QETN1CM-477Z	E CAPACITOR	470uF 16V M		C1522	NDC31HJ-471X	C CAPACITOR	470pF 50V J	
C566	NDC31HJ-101X	C CAPACITOR	100pF 50V J		C1523	NDC31HJ-471X	C CAPACITOR	470pF 50V J	
C567	NDC31HJ-330X	C CAPACITOR	33pF 50V J		C1524	NDC31HJ-471X	C CAPACITOR	470pF 50V J	
C568	NDC31HJ-330X	C CAPACITOR	33pF 50V J		C1531	QEKC1EM-106Z	E CAPACITOR	10uF 25V M	
C570	NCB31HK-561X	C CAPACITOR	560pF 50V K		C1532	QEKC1EM-106Z	E CAPACITOR	10uF 25V M	
C571	NDC31HJ-271X	C CAPACITOR	270pF 50V J		C1551	QEKC0JM-107Z	E CAPACITOR	100uF 6.3V M	
C572	QEKC1HM-225Z	E CAPACITOR	2.2uF 50V M		C1552	NCB31HK-102X	C CAPACITOR	1000pF 50V K	
C573	NCF31CZ-104X	C CAPACITOR	0.1uF 16V Z		C1601	NCB31HK-561X	C CAPACITOR	560pF 50V K	
C574	QEKC1CM-476Z	E CAPACITOR	47uF 16V M		C1602	NCB31HK-561X	C CAPACITOR	560pF 50V K	
C578	NCF31CZ-104X	C CAPACITOR	0.1uF 16V Z		C1603	QEKC1HM-225Z	E CAPACITOR	2.2uF 50V M	
C581	QEKC1EM-106Z	E CAPACITOR	10uF 25V M		C1604	QEKC1HM-225Z	E CAPACITOR	2.2uF 50V M	
C585	QETN1HM-106Z	E CAPACITOR	10uF 50V M		C1605	QEKC1HM-105Z	E CAPACITOR	1uF 50V M	
C587	NCF31CZ-104X	C CAPACITOR	0.1uF 16V Z		C1606	QEKC1HM-105Z	E CAPACITOR	1uF 50V M	
C591	QETN1HM-106Z	E CAPACITOR	10uF 50V M		C1613	NCF31CZ-104X	C CAPACITOR	0.1uF 16V Z	
C592	QETN1HM-106Z	E CAPACITOR	10uF 50V M		C1614	NCF31CZ-104X	C CAPACITOR	0.1uF 16V Z	
C593	QEKC1HM-475Z	E CAPACITOR	4.7uF 50V M		C1615	NCB31HK-561X	C CAPACITOR	560pF 50V K	
C594	QEKC1HM-475Z	E CAPACITOR	4.7uF 50V M		C1616	NCB31HK-561X	C CAPACITOR	560pF 50V K	
C595	QEKC1HM-475Z	E CAPACITOR	4.7uF 50V M		C1617	NCB31HK-561X	C CAPACITOR	560pF 50V K	
C596	QEKC1HM-475Z	E CAPACITOR	4.7uF 50V M		C1618	NCB31HK-561X	C CAPACITOR	560pF 50V K	
C601	QEKC1HM-475Z	E CAPACITOR	4.7uF 50V M		C1619	NCB31HK-103X	C CAPACITOR	0.01uF 50V K	
C602	QEKC1HM-475Z	E CAPACITOR	4.7uF 50V M		C1620	NCB31HK-103X	C CAPACITOR	0.01uF 50V K	
C605	NDC31HJ-330X	C CAPACITOR	33pF 50V J		C1621	NCB31HK-561X	C CAPACITOR	560pF 50V K	
C606	NDC31HJ-330X	C CAPACITOR	33pF 50V J		C1622	QEKC1HM-225Z	E CAPACITOR	2.2uF 50V M	
C609	NCF31CZ-104X	C CAPACITOR	0.1uF 16V Z		C1623	NCF31CZ-104X	C CAPACITOR	0.1uF 16V Z	
C610	NCF31CZ-104X	C CAPACITOR	0.1uF 16V Z		C1624	NCF31CZ-104X	C CAPACITOR	0.1uF 16V Z	
C613	NDC31HJ-330X	C CAPACITOR	33pF 50V J		C1625	NDC31HJ-330X	C CAPACITOR	33pF 50V J	
C614	NDC31HJ-330X	C CAPACITOR	33pF 50V J		C1626	QEKC1HM-225Z	E CAPACITOR	2.2uF 50V M	
C618	QETN1EM-476Z	E CAPACITOR	47uF 25V M		C1627	NCF31CZ-104X	C CAPACITOR	0.1uF 16V Z	
C619	NCF31CZ-104X	C CAPACITOR	0.1uF 16V Z		C1628	NCF31CZ-104X	C CAPACITOR	0.1uF 16V Z	
C620	NCF31CZ-104X	C CAPACITOR	0.1uF 16V Z		C1629	NCB31HK-102X	C CAPACITOR	1000pF 50V K	
C621	NCB31HK-102X	C CAPACITOR	1000pF 50V K		C1630	NCB31HK-102X	C CAPACITOR	1000pF 50V K	
C622	NCB31HK-102X	C CAPACITOR	1000pF 50V K		C1631	NCB31HK-103X	C CAPACITOR	0.01uF 50V K	
C623	QEKC1HM-475Z	E CAPACITOR	4.7uF 50V M		C1641	NCB31HK-561X	C CAPACITOR	560pF 50V K	
C624	QEKC1HM-475Z	E CAPACITOR	4.7uF 50V M		C1642	QEKC1HM-475Z	E CAPACITOR	4.7uF 50V M	
C625	NCF31CZ-104X	C CAPACITOR	0.1uF 16V Z		C1643	NCF31CZ-104X	C CAPACITOR	0.1uF 16V Z	
C626	NCF31CZ-104X	C CAPACITOR	0.1uF 16V Z		C1644	NCF31CZ-104X	C CAPACITOR	0.1uF 16V Z	
C627	NCB31HK-331X	C CAPACITOR	330pF 50V K		C1645	NCF31CZ-104X	C CAPACITOR	0.1uF 16V Z	
C628	NCB31HK-331X	C CAPACITOR	330pF 50V K		C1646	NCF31CZ-104X	C CAPACITOR	0.1uF 16V Z	
C629	NCB31HK-272X	C CAPACITOR	2700pF 50V K		C1647	NCB31CK-823X	C CAPACITOR	0.082uF 16V K	
C630	NCB31HK-272X	C CAPACITOR	2700pF 50V K		C1648	QFN31HJ-333Z	M CAPACITOR	0.033uF 50V J	
C631	QEKC1HM-475Z	E CAPACITOR	4.7uF 50V M		C1649	QEKC1HM-475Z	E CAPACITOR	4.7uF 50V M	
C633	NCF31CZ-104X	C CAPACITOR	0.1uF 16V Z		C1650	NCB31CK-823X	C CAPACITOR	0.082uF 16V K	
C634	NCF31CZ-104X	C CAPACITOR	0.1uF 16V Z		C1651	QFN31HJ-333Z	M CAPACITOR	0.033uF 50V J	
C635	NDC31HJ-330X	C CAPACITOR	33pF 50V J		C1652	NDC31HJ-330X	C CAPACITOR	33pF 50V J	
C636	NDC31HJ-330X	C CAPACITOR	33pF 50V J		C1653	QEKC1HM-475Z	E CAPACITOR	4.7uF 50V M	
C637	QEKC1HM-475Z	E CAPACITOR	4.7uF 50V M		C1654	NCB31HK-471X	C CAPACITOR	470pF 50V K	

△ Symbol No.	Part No.	Part Name	Description	Local	△ Symbol No.	Part No.	Part Name	Description	Local
C1655	NCB31HK-471X	C CAPACITOR	470pF 50V K		C2686	NCF31CZ-104X	C CAPACITOR	0.1uF 16V Z	
C1656	NCB31HK-332X	C CAPACITOR	3300pF 50V K		C2687	QETN1CM-107Z	E CAPACITOR	100uF 16V M	
C1701	QETN1EM-476Z	E CAPACITOR	47uF 25V M		C2688	NCF31CZ-104X	C CAPACITOR	0.1uF 16V Z	
C1702	QETN1EM-476Z	E CAPACITOR	47uF 25V M		C2689	NCF31CZ-104X	C CAPACITOR	0.1uF 16V Z	
C1703	NCF31CZ-104X	C CAPACITOR	0.1uF 16V Z		C2695	NCF31AZ-105X	C CAPACITOR	1uF 10V Z	
C1704	NCF31CZ-104X	C CAPACITOR	0.1uF 16V Z		C2696	NCF31AZ-105X	C CAPACITOR	1uF 10V Z	
C1705	NCF31CZ-104X	C CAPACITOR	0.1uF 16V Z		C3501	NDC31HJ-331X	C CAPACITOR	330pF 50V J	
C1706	NCF31CZ-104X	C CAPACITOR	0.1uF 16V Z		C3502	NDC31HJ-331X	C CAPACITOR	330pF 50V J	
C1707	NCF31CZ-104X	C CAPACITOR	0.1uF 16V Z		C3503	NDC31HJ-331X	C CAPACITOR	330pF 50V J	
C1708	NCF31CZ-104X	C CAPACITOR	0.1uF 16V Z		C3504	NDC31HJ-331X	C CAPACITOR	330pF 50V J	
C1821	NCB31HK-152X	C CAPACITOR	1500pF 50V K		C3505	NDC31HJ-470X	C CAPACITOR	47pF 50V J	
C1822	NCB31HK-152X	C CAPACITOR	1500pF 50V K		C3506	NDC31HJ-470X	C CAPACITOR	47pF 50V J	
C1823	QEKC1HM-105Z	E CAPACITOR	1uF 50V M		C3507	NDC31HJ-470X	C CAPACITOR	47pF 50V J	
C1824	QEKC1HM-105Z	E CAPACITOR	1uF 50V M		C3508	QETN0JM-477Z	E CAPACITOR	470uF 6.3V M	
C1825	QEKC1HM-225Z	E CAPACITOR	2.2uF 50V M		C3509	QETN0JM-477Z	E CAPACITOR	470uF 6.3V M	
C1826	QEKC1HM-225Z	E CAPACITOR	2.2uF 50V M		C3510	NDC31HJ-470X	C CAPACITOR	47pF 50V J	
C1827	QEKC1HM-475Z	E CAPACITOR	4.7uF 50V M		C3511	QEKC1HM-475Z	E CAPACITOR	4.7uF 50V M	
C1828	QEKC1HM-475Z	E CAPACITOR	4.7uF 50V M		C3512	NDC31HJ-470X	C CAPACITOR	47pF 50V J	
C1921	NCB31HK-152X	C CAPACITOR	1500pF 50V K		C3513	QETN0JM-477Z	E CAPACITOR	470uF 6.3V M	
C1922	QEKC1HM-105Z	E CAPACITOR	1uF 50V M		C3514	QETN0JM-477Z	E CAPACITOR	470uF 6.3V M	
C1923	QEKC1HM-225Z	E CAPACITOR	2.2uF 50V M		C3515	NDC31HJ-221X	C CAPACITOR	220pF 50V J	
C1924	QEKC1HM-475Z	E CAPACITOR	4.7uF 50V M		C3516	NDC31HJ-221X	C CAPACITOR	220pF 50V J	
C2601	QETN1CM-107Z	E CAPACITOR	100uF 16V M		C3525	QEKC1HM-475Z	E CAPACITOR	4.7uF 50V M	
C2602	NCF31CZ-104X	C CAPACITOR	0.1uF 16V Z		C3526	NCF31CZ-104X	C CAPACITOR	0.1uF 16V Z	
C2603	NCF31CZ-104X	C CAPACITOR	0.1uF 16V Z		C3533	QEKC1CM-476Z	E CAPACITOR	47uF 16V M	
C2604	NCF31CZ-104X	C CAPACITOR	0.1uF 16V Z		C3534	NCF31CZ-104X	C CAPACITOR	0.1uF 16V Z	
C2605	NCF31CZ-104X	C CAPACITOR	0.1uF 16V Z		C3536	QEKC1EM-476Z	E CAPACITOR	47uF 25V M	
C2606	NCF31CZ-104X	C CAPACITOR	0.1uF 16V Z		C3541	NDC31HJ-390X	C CAPACITOR	39pF 50V J	
C2607	NCF31CZ-104X	C CAPACITOR	0.1uF 16V Z		C3542	NDC31HJ-390X	C CAPACITOR	39pF 50V J	
C2608	NCB31HK-102X	C CAPACITOR	1000pF 50V K		C3543	NDC31HJ-390X	C CAPACITOR	39pF 50V J	
C2609	NCF31CZ-104X	C CAPACITOR	0.1uF 16V Z		C3544	NDC31HJ-390X	C CAPACITOR	39pF 50V J	
C2610	NCF31CZ-104X	C CAPACITOR	0.1uF 16V Z		C3545	NDC31HJ-390X	C CAPACITOR	39pF 50V J	
C2611	NCF31CZ-104X	C CAPACITOR	0.1uF 16V Z		C7501	NDC31HJ-331X	C CAPACITOR	330pF 50V J	
C2612	NCF31CZ-104X	C CAPACITOR	0.1uF 16V Z		C7502	NDC31HJ-331X	C CAPACITOR	330pF 50V J	
C2613	NCF31CZ-104X	C CAPACITOR	0.1uF 16V Z		C7503	NCF31CZ-104X	C CAPACITOR	0.1uF 16V Z	
C2614	NCF31CZ-104X	C CAPACITOR	0.1uF 16V Z						
C2615	NDC31HJ-820X	C CAPACITOR	82pF 50V J		R501	NRSA63J-471X	MG RESISTOR	470Ω 1/16W J	
C2616	NDC31HJ-820X	C CAPACITOR	82pF 50V J		R502	NRSA63J-471X	MG RESISTOR	470Ω 1/16W J	
C2617	NCF31CZ-104X	C CAPACITOR	0.1uF 16V Z		R503	NRSA63J-750X	MG RESISTOR	75Ω 1/16W J	
C2621	QEKC1EM-106Z	E CAPACITOR	10uF 25V M		R504	NRSA63J-331X	MG RESISTOR	330Ω 1/16W J	
C2622	QEKC1EM-106Z	E CAPACITOR	10uF 25V M		R505	NRSA63J-750X	MG RESISTOR	75Ω 1/16W J	
C2623	QEKC1EM-106Z	E CAPACITOR	10uF 25V M		R506	NRSA63J-331X	MG RESISTOR	330Ω 1/16W J	
C2624	NCF31CZ-104X	C CAPACITOR	0.1uF 16V Z		R507	NRSA63J-750X	MG RESISTOR	75Ω 1/16W J	
C2625	NCF31CZ-104X	C CAPACITOR	0.1uF 16V Z		R508	NRSA63J-331X	MG RESISTOR	330Ω 1/16W J	
C2626	NCB31HK-221X	C CAPACITOR	220pF 50V K		R509	NRSA63J-750X	MG RESISTOR	75Ω 1/16W J	
C2627	NCB31HK-221X	C CAPACITOR	220pF 50V K		R510	NRSA63J-750X	MG RESISTOR	75Ω 1/16W J	
C2628	QEKC1HM-475Z	E CAPACITOR	4.7uF 50V M		R511	NRSA63J-331X	MG RESISTOR	330Ω 1/16W J	
C2629	NCF31CZ-104X	C CAPACITOR	0.1uF 16V Z		R513	NRSA63J-104X	MG RESISTOR	100kΩ 1/16W J	
C2630	QETN1CM-107Z	E CAPACITOR	100uF 16V M		R514	NRSA63J-104X	MG RESISTOR	100kΩ 1/16W J	
C2631	NCF31CZ-104X	C CAPACITOR	0.1uF 16V Z		R515	NRSA63J-471X	MG RESISTOR	470Ω 1/16W J	
C2632	NCF31CZ-104X	C CAPACITOR	0.1uF 16V Z		R516	NRSA63J-471X	MG RESISTOR	470Ω 1/16W J	
C2633	NCB31CK-223X	C CAPACITOR	0.022uF 16V K		R517	NRSA63J-750X	MG RESISTOR	75Ω 1/16W J	
C2634	NCB31HK-102X	C CAPACITOR	1000pF 50V K		R518	NRSA63J-331X	MG RESISTOR	330Ω 1/16W J	
C2635	NCF31CZ-104X	C CAPACITOR	0.1uF 16V Z		R519	NRSA63J-750X	MG RESISTOR	75Ω 1/16W J	
C2636	NCF31CZ-104X	C CAPACITOR	0.1uF 16V Z		R520	NRSA63J-331X	MG RESISTOR	330Ω 1/16W J	
C2637	NCF31CZ-104X	C CAPACITOR	0.1uF 16V Z		R521	NRSA63J-750X	MG RESISTOR	75Ω 1/16W J	
C2638	NCB31EK-103X	C CAPACITOR	0.01uF 25V K		R522	NRSA63J-331X	MG RESISTOR	330Ω 1/16W J	
C2639	NCB31EK-103X	C CAPACITOR	0.01uF 25V K		R523	NRSA63J-750X	MG RESISTOR	75Ω 1/16W J	
C2640	NCB31EK-103X	C CAPACITOR	0.01uF 25V K		R524	NRSA63J-750X	MG RESISTOR	75Ω 1/16W J	
C2641	NCB31EK-103X	C CAPACITOR	0.01uF 25V K		R525	NRSA63J-331X	MG RESISTOR	330Ω 1/16W J	
C2642	NCB31EK-103X	C CAPACITOR	0.01uF 25V K		R527	NRSA63J-473X	MG RESISTOR	47kΩ 1/16W J	
C2651	QETN1CM-107Z	E CAPACITOR	100uF 16V M		R528	NRSA63J-473X	MG RESISTOR	47kΩ 1/16W J	
C2652	NCB31EK-103X	C CAPACITOR	0.01uF 25V K		R529	NRSA63J-221X	MG RESISTOR	220Ω 1/16W J	
C2653	NDC31HJ-101X	C CAPACITOR	100pF 50V J		R530	NRSA63J-221X	MG RESISTOR	220Ω 1/16W J	
C2654	NCF31CZ-104X	C CAPACITOR	0.1uF 16V Z		R531	NRSA63J-221X	MG RESISTOR	220Ω 1/16W J	
C2655	NCF31CZ-104X	C CAPACITOR	0.1uF 16V Z		R532	NRSA63J-221X	MG RESISTOR	220Ω 1/16W J	
C2656	QETN1EM-476Z	E CAPACITOR	47uF 25V M		R541	NRSA63J-223X	MG RESISTOR	22kΩ 1/16W J	
C2661	NDC31HJ-101X	C CAPACITOR	100pF 50V J		R542	NRSA63J-473X	MG RESISTOR	47kΩ 1/16W J	
C2662	NCF31CZ-104X	C CAPACITOR	0.1uF 16V Z		R543	NRSA63J-683X	MG RESISTOR	68kΩ 1/16W J	
C2666	NCB31EK-103X	C CAPACITOR	0.01uF 25V K		R544	NRSA63J-473X	MG RESISTOR	47kΩ 1/16W J	
C2667	NCB31EK-103X	C CAPACITOR	0.01uF 25V K		R545	NRSA63J-153X	MG RESISTOR	15kΩ 1/16W J	
C2668	NCB31EK-103X	C CAPACITOR	0.01uF 25V K		R546	NRSA63J-273X	MG RESISTOR	27kΩ 1/16W J	
C2670	NDC31HJ-270X	C CAPACITOR	27pF 50V J		R547	NRSA63J-103X	MG RESISTOR	10kΩ 1/16W J	
C2681	QEKC1EM-106Z	E CAPACITOR	10uF 25V M		R548	NRSA63J-103X	MG RESISTOR	10kΩ 1/16W J	
C2682	QEKC1EM-106Z	E CAPACITOR	10uF 25V M		R549	NRSA63J-223X	MG RESISTOR	22kΩ 1/16W J	
C2683	QETN1EM-476Z	E CAPACITOR	47uF 25V M		R550	NRSA63J-473X	MG RESISTOR	47kΩ 1/16W J	
C2684	QETN0JM-227Z	E CAPACITOR	220uF 6.3V M		R551	NRSA63J-683X	MG RESISTOR	68kΩ 1/16W J	
C2685	QETN1CM-107Z	E CAPACITOR	100uF 16V M		R552	NRSA63J-473X	MG RESISTOR	47kΩ 1/16W J	

△ Symbol No.	Part No.	Part Name	Description	Local	△ Symbol No.	Part No.	Part Name	Description	Local
R1527	NRSA63J-102X	MG RESISTOR	1kΩ 1/16W J		R1640	NRSA63J-181X	MG RESISTOR	180Ω 1/16W J	
R1529	NRSA63J-103X	MG RESISTOR	10kΩ 1/16W J		R1641	NRSA63J-472X	MG RESISTOR	4.7kΩ 1/16W J	
R1530	NRSA63J-103X	MG RESISTOR	10kΩ 1/16W J		R1642	NRSA63J-181X	MG RESISTOR	180Ω 1/16W J	
R1531	NRSA63J-221X	MG RESISTOR	220Ω 1/16W J		R1643	NRSA63J-472X	MG RESISTOR	4.7kΩ 1/16W J	
R1532	NRSA63J-221X	MG RESISTOR	220Ω 1/16W J		R1644	NRSA63J-472X	MG RESISTOR	4.7kΩ 1/16W J	
R1533	NRSA63J-221X	MG RESISTOR	220Ω 1/16W J		R1651	NRSA63J-103X	MG RESISTOR	10kΩ 1/16W J	
R1534	NRSA63J-221X	MG RESISTOR	220Ω 1/16W J		R1652	NRSA63J-102X	MG RESISTOR	1kΩ 1/16W J	
R1535	NRSA63J-751X	MG RESISTOR	750Ω 1/16W J		R1653	NRSA63J-104X	MG RESISTOR	100kΩ 1/16W J	
R1536	NRSA63J-751X	MG RESISTOR	750Ω 1/16W J		R1654	NRSA63J-473X	MG RESISTOR	47kΩ 1/16W J	
R1537	NRSA63J-751X	MG RESISTOR	750Ω 1/16W J		R1655	NRSA63J-473X	MG RESISTOR	47kΩ 1/16W J	
R1538	NRSA63J-751X	MG RESISTOR	750Ω 1/16W J		R1656	NRSA63J-222X	MG RESISTOR	2.2kΩ 1/16W J	
R1539	NRSA63J-103X	MG RESISTOR	10kΩ 1/16W J		R1657	NRSA63J-103X	MG RESISTOR	10kΩ 1/16W J	
R1540	NRSA63J-103X	MG RESISTOR	10kΩ 1/16W J		R1658	NRSA63J-100X	MG RESISTOR	10Ω 1/16W J	
R1541	NRSA63J-102X	MG RESISTOR	1kΩ 1/16W J		R1659	NRSA63J-103X	MG RESISTOR	10kΩ 1/16W J	
R1542	NRSA63J-102X	MG RESISTOR	1kΩ 1/16W J		R1660	NRSA63J-103X	MG RESISTOR	10kΩ 1/16W J	
R1543	NRSA63J-103X	MG RESISTOR	10kΩ 1/16W J		R1661	NRSA63J-100X	MG RESISTOR	10Ω 1/16W J	
R1544	NRSA63J-103X	MG RESISTOR	10kΩ 1/16W J		R1662	NRSA63J-103X	MG RESISTOR	10kΩ 1/16W J	
R1545	NRSA63J-102X	MG RESISTOR	1kΩ 1/16W J		R1663	NRSA63J-103X	MG RESISTOR	10kΩ 1/16W J	
R1551	NRSA63J-302X	MG RESISTOR	3kΩ 1/16W J		R1664	NRSA63J-473X	MG RESISTOR	47kΩ 1/16W J	
R1552	NRSA63J-302X	MG RESISTOR	3kΩ 1/16W J		R1665	NRSA63J-333X	MG RESISTOR	33kΩ 1/16W J	
R1553	NRSA63J-124X	MG RESISTOR	120kΩ 1/16W J		R1666	NRSA63J-104X	MG RESISTOR	100kΩ 1/16W J	
R1554	NRSA63J-103X	MG RESISTOR	10kΩ 1/16W J		R1667	NRSA63J-472X	MG RESISTOR	4.7kΩ 1/16W J	
R1555	NRSA63J-103X	MG RESISTOR	10kΩ 1/16W J		R1668	NRSA63J-181X	MG RESISTOR	180Ω 1/16W J	
R1556	NRSA63J-183X	MG RESISTOR	18kΩ 1/16W J		R1669	NRSA63J-472X	MG RESISTOR	4.7kΩ 1/16W J	
R1557	NRSA63J-103X	MG RESISTOR	10kΩ 1/16W J		R1670	NRSA63J-181X	MG RESISTOR	180Ω 1/16W J	
R1558	NRSA63J-103X	MG RESISTOR	10kΩ 1/16W J		R1671	NRSA63J-472X	MG RESISTOR	4.7kΩ 1/16W J	
R1559	NRSA63J-102X	MG RESISTOR	1kΩ 1/16W J		R1672	NRSA63J-472X	MG RESISTOR	4.7kΩ 1/16W J	
R1560	NRSA63J-102X	MG RESISTOR	1kΩ 1/16W J		△ R1701	QRK126J-561X	UNF C RESISTOR	560Ω 1/2W J	
△ R1561	QRZ9005-100X	FUSI RESISTOR	10Ω		△ R1702	QRK126J-561X	UNF C RESISTOR	560Ω 1/2W J	
△ R1562	QRJ146J-561X	UNF C RESISTOR	560Ω 1/4W J		R1821	NRSA63J-153X	MG RESISTOR	15kΩ 1/16W J	
R1563	NRSA63J-0R0X	MG RESISTOR	0Ω 1/16W J		R1822	NRSA63J-153X	MG RESISTOR	15kΩ 1/16W J	
R1565	NRSA63J-0R0X	MG RESISTOR	0Ω 1/16W J		R1823	NRSA63J-0R0X	MG RESISTOR	0Ω 1/16W J	
R1567	NRSA63J-103X	MG RESISTOR	10kΩ 1/16W J		R1824	NRSA63J-0R0X	MG RESISTOR	0Ω 1/16W J	
R1568	NRSA63J-0R0X	MG RESISTOR	0Ω 1/16W J		R1825	NRSA63J-473X	MG RESISTOR	47kΩ 1/16W J	
R1569	NRSA63J-474X	MG RESISTOR	470kΩ 1/16W J		R1826	NRSA63J-473X	MG RESISTOR	47kΩ 1/16W J	
R1570	NRSA63J-474X	MG RESISTOR	470kΩ 1/16W J		R1827	NRSA63J-472X	MG RESISTOR	4.7kΩ 1/16W J	
R1584	NRSA63J-103X	MG RESISTOR	10kΩ 1/16W J		R1828	NRSA63J-472X	MG RESISTOR	4.7kΩ 1/16W J	
R1585	NRSA63J-103X	MG RESISTOR	10kΩ 1/16W J		R1829	NRSA63J-474X	MG RESISTOR	470kΩ 1/16W J	
R1587	NRSA63J-103X	MG RESISTOR	10kΩ 1/16W J		R1830	NRSA63J-474X	MG RESISTOR	470kΩ 1/16W J	
R1588	NRSA63J-221X	MG RESISTOR	220Ω 1/16W J		R1831	NRSA63J-104X	MG RESISTOR	100kΩ 1/16W J	
R1591	NRSA63J-103X	MG RESISTOR	10kΩ 1/16W J		R1832	NRSA63J-104X	MG RESISTOR	100kΩ 1/16W J	
R1592	NRSA63J-102X	MG RESISTOR	1kΩ 1/16W J		R1833	NRSA63J-470X	MG RESISTOR	47Ω 1/16W J	
R1593	NRSA63J-102X	MG RESISTOR	1kΩ 1/16W J		R1834	NRSA63J-470X	MG RESISTOR	47Ω 1/16W J	
R1594	NRSA63J-102X	MG RESISTOR	1kΩ 1/16W J		R1835	NRSA63J-102X	MG RESISTOR	1kΩ 1/16W J	
R1596	NRSA63J-103X	MG RESISTOR	10kΩ 1/16W J		R1836	NRSA63J-102X	MG RESISTOR	1kΩ 1/16W J	
R1597	NRSA63J-103X	MG RESISTOR	10kΩ 1/16W J		R1921	NRSA63J-153X	MG RESISTOR	15kΩ 1/16W J	
R1599	NRSA63J-103X	MG RESISTOR	10kΩ 1/16W J		R1922	NRSA63J-0R0X	MG RESISTOR	0Ω 1/16W J	
R1601	NRSA63J-103X	MG RESISTOR	10kΩ 1/16W J		R1923	NRSA63J-473X	MG RESISTOR	47kΩ 1/16W J	
R1602	NRSA63J-103X	MG RESISTOR	10kΩ 1/16W J		R1924	NRSA63J-472X	MG RESISTOR	4.7kΩ 1/16W J	
R1603	NRSA63J-102X	MG RESISTOR	1kΩ 1/16W J		R1925	NRSA63J-474X	MG RESISTOR	470kΩ 1/16W J	
R1604	NRSA63J-102X	MG RESISTOR	1kΩ 1/16W J		R1926	NRSA63J-470X	MG RESISTOR	47Ω 1/16W J	
R1605	NRSA63J-104X	MG RESISTOR	100kΩ 1/16W J		R1927	NRSA63J-104X	MG RESISTOR	100kΩ 1/16W J	
R1606	NRSA63J-104X	MG RESISTOR	100kΩ 1/16W J		R1928	NRSA63J-102X	MG RESISTOR	1kΩ 1/16W J	
R1607	NRSA63J-103X	MG RESISTOR	10kΩ 1/16W J		R2601	NRSA63J-221X	MG RESISTOR	220Ω 1/16W J	
R1608	NRSA63J-103X	MG RESISTOR	10kΩ 1/16W J		R2602	NRSA63J-221X	MG RESISTOR	220Ω 1/16W J	
R1609	NRSA63J-103X	MG RESISTOR	10kΩ 1/16W J		R2603	NRSA63J-221X	MG RESISTOR	220Ω 1/16W J	
R1610	NRSA63J-103X	MG RESISTOR	10kΩ 1/16W J		R2604	NRSA63J-221X	MG RESISTOR	220Ω 1/16W J	
R1617	NRSA63J-752X	MG RESISTOR	7.5kΩ 1/16W J		R2605	NRSA63J-102X	MG RESISTOR	1kΩ 1/16W J	
R1618	NRSA63J-752X	MG RESISTOR	7.5kΩ 1/16W J		R2606	NRSA63J-102X	MG RESISTOR	1kΩ 1/16W J	
R1619	NRSA63J-181X	MG RESISTOR	180Ω 1/16W J		R2607	NRSA63J-102X	MG RESISTOR	1kΩ 1/16W J	
R1620	NRSA63J-181X	MG RESISTOR	180Ω 1/16W J		R2608	NRSA63J-102X	MG RESISTOR	1kΩ 1/16W J	
R1621	NRSA63J-472X	MG RESISTOR	4.7kΩ 1/16W J		R2609	NRSA63J-103X	MG RESISTOR	10kΩ 1/16W J	
R1622	NRSA63J-472X	MG RESISTOR	4.7kΩ 1/16W J		R2611	NRSA63J-103X	MG RESISTOR	10kΩ 1/16W J	
R1623	NRSA63J-181X	MG RESISTOR	180Ω 1/16W J		R2612	NRSA63J-103X	MG RESISTOR	10kΩ 1/16W J	
R1624	NRSA63J-181X	MG RESISTOR	180Ω 1/16W J		R2613	NRSA63J-103X	MG RESISTOR	10kΩ 1/16W J	
R1625	NRSA63J-472X	MG RESISTOR	4.7kΩ 1/16W J		R2614	NRSA63J-103X	MG RESISTOR	10kΩ 1/16W J	
R1626	NRSA63J-472X	MG RESISTOR	4.7kΩ 1/16W J		R2615	NRSA63J-103X	MG RESISTOR	10kΩ 1/16W J	
R1627	NRSA63J-752X	MG RESISTOR	7.5kΩ 1/16W J		R2616	NRSA63J-105X	MG RESISTOR	1MΩ 1/16W J	
R1628	NRSA63J-752X	MG RESISTOR	7.5kΩ 1/16W J		R2617	NRSA63J-221X	MG RESISTOR	220Ω 1/16W J	
R1631	NRSA63J-103X	MG RESISTOR	10kΩ 1/16W J		R2618	NRSA63J-103X	MG RESISTOR	10kΩ 1/16W J	
R1632	NRSA63J-102X	MG RESISTOR	1kΩ 1/16W J		R2619	NRSA63J-103X	MG RESISTOR	10kΩ 1/16W J	
R1633	NRSA63J-104X	MG RESISTOR	100kΩ 1/16W J		R2620	NRSA63J-103X	MG RESISTOR	10kΩ 1/16W J	
R1634	NRSA63J-473X	MG RESISTOR	47kΩ 1/16W J		R2621	NRSA63J-103X	MG RESISTOR	10kΩ 1/16W J	
R1635	NRSA63J-334X	MG RESISTOR	330kΩ 1/16W J		R2622	NRSA63J-103X	MG RESISTOR	10kΩ 1/16W J	
R1636	NRSA63J-433X	MG RESISTOR	43kΩ 1/16W J		R2623	NRSA63J-103X	MG RESISTOR	10kΩ 1/16W J	
R1637	NRSA63J-103X	MG RESISTOR	10kΩ 1/16W J		R2624	NRSA63J-103X	MG RESISTOR	10kΩ 1/16W J	
R1638	NRSA63J-104X	MG RESISTOR	100kΩ 1/16W J		R2625	NRSA63J-103X	MG RESISTOR	10kΩ 1/16W J	
R1639	NRSA63J-472X	MG RESISTOR	4.7kΩ 1/16W J		R2626	NRSA63J-103X	MG RESISTOR	10kΩ 1/16W J	

△ Symbol No.	Part No.	Part Name	Description	Local	△ Symbol No.	Part No.	Part Name	Description	Local
R2627	NRSA63J-103X	MG RESISTOR	10kΩ 1/16W J		△ R3524	QRJ146J-331X	UNF C RESISTOR	330Ω 1/4W J	
R2628	NRSA63J-103X	MG RESISTOR	10kΩ 1/16W J		△ R3525	QRJ146J-331X	UNF C RESISTOR	330Ω 1/4W J	
R2629	NRSA63J-103X	MG RESISTOR	10kΩ 1/16W J		R3526	NRSA63J-471X	MG RESISTOR	470Ω 1/16W J	
R2630	NRSA63J-103X	MG RESISTOR	10kΩ 1/16W J		△ R3527	QRJ146J-331X	UNF C RESISTOR	330Ω 1/4W J	
R2631	NRSA63J-332X	MG RESISTOR	3.3kΩ 1/16W J		△ R3528	QRJ146J-331X	UNF C RESISTOR	330Ω 1/4W J	
R2633	NRSA63J-103X	MG RESISTOR	10kΩ 1/16W J		R3529	NRSA63J-471X	MG RESISTOR	470Ω 1/16W J	
R2634	NRSA63J-221X	MG RESISTOR	220Ω 1/16W J		△ R3530	QRJ146J-221X	UNF C RESISTOR	220Ω 1/4W J	
R2635	NRSA63J-221X	MG RESISTOR	220Ω 1/16W J		△ R3531	QRJ146J-221X	UNF C RESISTOR	220Ω 1/4W J	
R2636	NRSA63J-103X	MG RESISTOR	10kΩ 1/16W J		R3532	NRSA63J-102X	MG RESISTOR	1kΩ 1/16W J	
R2637	NRSA63J-103X	MG RESISTOR	10kΩ 1/16W J		△ R3533	QRJ146J-221X	UNF C RESISTOR	220Ω 1/4W J	
R2638	NRSA63J-221X	MG RESISTOR	220Ω 1/16W J		△ R3534	QRJ146J-221X	UNF C RESISTOR	220Ω 1/4W J	
R2639	NRSA63J-221X	MG RESISTOR	220Ω 1/16W J		R3535	NRSA63J-102X	MG RESISTOR	1kΩ 1/16W J	
R2640	NRSA63J-221X	MG RESISTOR	220Ω 1/16W J		△ R3536	QRJ146J-221X	UNF C RESISTOR	220Ω 1/4W J	
R2641	NRSA63J-221X	MG RESISTOR	220Ω 1/16W J		△ R3537	QRJ146J-221X	UNF C RESISTOR	220Ω 1/4W J	
R2643	NRSA63J-822X	MG RESISTOR	8.2kΩ 1/16W J		R3538	NRSA63J-102X	MG RESISTOR	1kΩ 1/16W J	
R2644	NRSA63J-432X	MG RESISTOR	4.3kΩ 1/16W J		R3540	NRSA63J-102X	MG RESISTOR	1kΩ 1/16W J	
R2645	NRSA63J-221X	MG RESISTOR	220Ω 1/16W J		△ R3547	QRJ146J-391X	UNF C RESISTOR	390Ω 1/4W J	
R2646	NRSA63J-103X	MG RESISTOR	10kΩ 1/16W J		R3551	NRSA63J-473X	MG RESISTOR	47kΩ 1/16W J	
R2647	NRSA63J-103X	MG RESISTOR	10kΩ 1/16W J		R3552	NRSA63J-103X	MG RESISTOR	10kΩ 1/16W J	
R2648	NRSA63J-103X	MG RESISTOR	10kΩ 1/16W J		R3553	NRSA63J-103X	MG RESISTOR	10kΩ 1/16W J	
R2649	NRSA63J-103X	MG RESISTOR	10kΩ 1/16W J		R3554	NRSA63J-103X	MG RESISTOR	10kΩ 1/16W J	
R2650	NRSA63J-103X	MG RESISTOR	10kΩ 1/16W J		R3555	NRSA63J-102X	MG RESISTOR	1kΩ 1/16W J	
R2651	NRSA63J-103X	MG RESISTOR	10kΩ 1/16W J		R3556	NRSA63J-301X	MG RESISTOR	300Ω 1/16W J	
R2652	NRSA63J-102X	MG RESISTOR	1kΩ 1/16W J		R3557	NRSA63J-391X	MG RESISTOR	390Ω 1/16W J	
R2653	NRSA63J-102X	MG RESISTOR	1kΩ 1/16W J		R3558	NRSA63J-104X	MG RESISTOR	100kΩ 1/16W J	
R2654	NRSA63J-822X	MG RESISTOR	8.2kΩ 1/16W J		R3559	NRSA63J-102X	MG RESISTOR	1kΩ 1/16W J	
R2655	NRSA63J-432X	MG RESISTOR	4.3kΩ 1/16W J		R3560	NRSA63J-102X	MG RESISTOR	1kΩ 1/16W J	
R2656	NRSA63J-822X	MG RESISTOR	8.2kΩ 1/16W J		R3561	NRSA63J-221X	MG RESISTOR	220Ω 1/16W J	
R2657	NRSA63J-432X	MG RESISTOR	4.3kΩ 1/16W J		R3562	NRSA63J-221X	MG RESISTOR	220Ω 1/16W J	
R2658	NRSA63J-221X	MG RESISTOR	220Ω 1/16W J		R3563	NRSA63J-221X	MG RESISTOR	220Ω 1/16W J	
R2659	NRSA63J-221X	MG RESISTOR	220Ω 1/16W J		△ R3572	QRZ9006-4R7X	FUSI RESISTOR	4.7Ω 1/4W J	
R2660	NRSA63J-221X	MG RESISTOR	220Ω 1/16W J		R3575	NRSA63J-0R0X	MG RESISTOR	0Ω 1/16W J	
R2661	NRSA63J-221X	MG RESISTOR	220Ω 1/16W J		R3581	NRSA02J-0R0X	MG RESISTOR	0Ω 1/10W J	
R2662	NRSA63J-221X	MG RESISTOR	220Ω 1/16W J		R3582	NRSA63J-0R0X	MG RESISTOR	0Ω 1/16W J	
R2663	NRSA63J-221X	MG RESISTOR	220Ω 1/16W J		R7501	NRSA63J-470X	MG RESISTOR	47Ω 1/16W J	
R2664	NRSA63J-221X	MG RESISTOR	220Ω 1/16W J		R7502	NRSA63J-470X	MG RESISTOR	47Ω 1/16W J	
R2665	NRSA63J-221X	MG RESISTOR	220Ω 1/16W J		R7503	NRSA63J-0R0X	MG RESISTOR	0Ω 1/16W J	
R2666	NRSA63J-221X	MG RESISTOR	220Ω 1/16W J		CN451	QGA2001C1-09	CONNECTOR	W-B (1-9)	
R2667	NRSA63J-221X	MG RESISTOR	220Ω 1/16W J		CN501	QGB2510J1-11	CONNECTOR	B-B (1-11)	
R2668	NRSA63J-221X	MG RESISTOR	220Ω 1/16W J		CN502	QGF1205C1-11	CONNECTOR	FFC/FPC (1-11)	
R2669	NRSA63J-221X	MG RESISTOR	220Ω 1/16W J		CN503	QGF1205C1-09	CONNECTOR	FFC/FPC (1-9)	
R2670	NRSA63J-102X	MG RESISTOR	1kΩ 1/16W J		CN504	QGF1205C1-22	CONNECTOR	FFC/FPC (1-22)	
R2671	NRSA63J-103X	MG RESISTOR	10kΩ 1/16W J		CN505	QGF1205C1-11	CONNECTOR	FFC/FPC (1-11)	
R2672	NRSA63J-105X	MG RESISTOR	1MΩ 1/16W J		CN506	QGA2501C1-11	CONNECTOR	W-B (1-11)	
R2673	NRSA63J-105X	MG RESISTOR	1MΩ 1/16W J		CN507	QGF1205C1-12	CONNECTOR	FFC/FPC (1-12)	
R2674	NRSA63J-105X	MG RESISTOR	1MΩ 1/16W J		CN508	QJK025-100805-E	SIN CR C-B		
R2675	NRSA63J-102X	MG RESISTOR	1kΩ 1/16W J		CN513	QGF1205F1-09	CONNECTOR	FFC/FPC (1-9)	
R2676	NRSA63J-105X	MG RESISTOR	1MΩ 1/16W J		CN514	QGF1205F1-22	CONNECTOR	FFC/FPC (1-22)	
R2677	NRSA63J-105X	MG RESISTOR	1MΩ 1/16W J		CN525	QJK025-072302-E	SIN CR C-B		
R2681	NRSA63J-221X	MG RESISTOR	220Ω 1/16W J		CN530	QJK025-092704-E	SIN CR C-B		
R2682	NRSA63J-392X	MG RESISTOR	3.9kΩ 1/16W J		CN540	QJK025-072302-E	SIN CR C-B		
R2686	NRSA63J-750X	MG RESISTOR	75Ω 1/16W J		CN571	QGB2510K1-11	CONNECTOR	B-B (1-11)	
R2687	NRSA63J-102X	MG RESISTOR	1kΩ 1/16W J		CN572	QGB2510K1-11	CONNECTOR	B-B (1-11)	
R2688	NRSA63J-222X	MG RESISTOR	2.2kΩ 1/16W J		CN601	QGB2510J1-11	CONNECTOR	B-B (1-11)	
R2691	NRSA63J-182X	MG RESISTOR	1.8kΩ 1/16W J		CN602	QGF1205C1-11	CONNECTOR	FFC/FPC (1-11)	
R2692	NRSA63J-112X	MG RESISTOR	1.1kΩ 1/16W J		CN725	QGA2501C1-07	CONNECTOR	W-B (1-7)	
R2693	NRSA63J-102X	MG RESISTOR	1kΩ 1/16W J		CN728	QGB2510K1-08	CONNECTOR	B-B (1-8)	
R2694	NRSA63J-102X	MG RESISTOR	1kΩ 1/16W J		EP501	QNZ0136-001Z	EARTH PLATE		
R2695	NRSA63J-102X	MG RESISTOR	1kΩ 1/16W J		EP502	QNZ0136-001Z	EARTH PLATE		
R3501	NRSA63J-101X	MG RESISTOR	100Ω 1/16W J		FL501	QQR1372-001	LPF		
R3502	NRSA63J-101X	MG RESISTOR	100Ω 1/16W J		FL502	QQR1372-001	LPF		
R3503	NRSA63J-471X	MG RESISTOR	470Ω 1/16W J		FW226	WJS0041-002A-E	E-FL/RB WI		
R3504	NRSA63J-471X	MG RESISTOR	470Ω 1/16W J		J501	QNZ0625-001	RGB CONNECTOR		
R3505	NRSA63J-680X	MG RESISTOR	68Ω 1/16W J		J502	QNZ0625-001	RGB CONNECTOR		
R3506	NRSA63J-473X	MG RESISTOR	47kΩ 1/16W J		J504	QNN0610-001	PIN JACK		
R3507	NRSA63J-680X	MG RESISTOR	68Ω 1/16W J		J681	QNN0481-001	PIN JACK		
R3508	NRSA63J-473X	MG RESISTOR	47kΩ 1/16W J		J3501	QNZ0625-001	RGB CONNECTOR		
R3509	NRSA63J-680X	MG RESISTOR	68Ω 1/16W J		J7501	QNS0231-001	JACK		
R3510	NRSA63J-473X	MG RESISTOR	47kΩ 1/16W J		K2681	NQR0269-004X	FERRITE BEADS		
R3511	NRSA63J-750X	MG RESISTOR	75Ω 1/16W J		UN682	GP1FAV50RKOF	OPT RECEIVER		
R3512	NRSA63J-750X	MG RESISTOR	75Ω 1/16W J		X501	QAX0246-001Z	RESONATOR	8.00MHz	
R3513	NRSA63J-331X	MG RESISTOR	330Ω 1/16W J		X502	QAX0263-001Z	CRYSTAL	4.332MHz	
R3514	NRSA63J-620X	MG RESISTOR	62Ω 1/16W J		X661	QAX0722-001Z	CRYSTAL	24.576MHz	
R3517	NRSA63J-473X	MG RESISTOR	47kΩ 1/16W J		X671	QAX0719-001Z	1COSCIALLATOR	6.144MHz	
R3518	NRSA63J-473X	MG RESISTOR	47kΩ 1/16W J						
△ R3521	QRJ146J-331X	UNF C RESISTOR	330Ω 1/4W J						
△ R3522	QRJ146J-331X	UNF C RESISTOR	330Ω 1/4W J						
R3523	NRSA63J-471X	MG RESISTOR	470Ω 1/16W J						

Packing materials and accessories parts list

Block No. M 3 M M

No additional / supplemental order of WARRANTY CARDS are available.

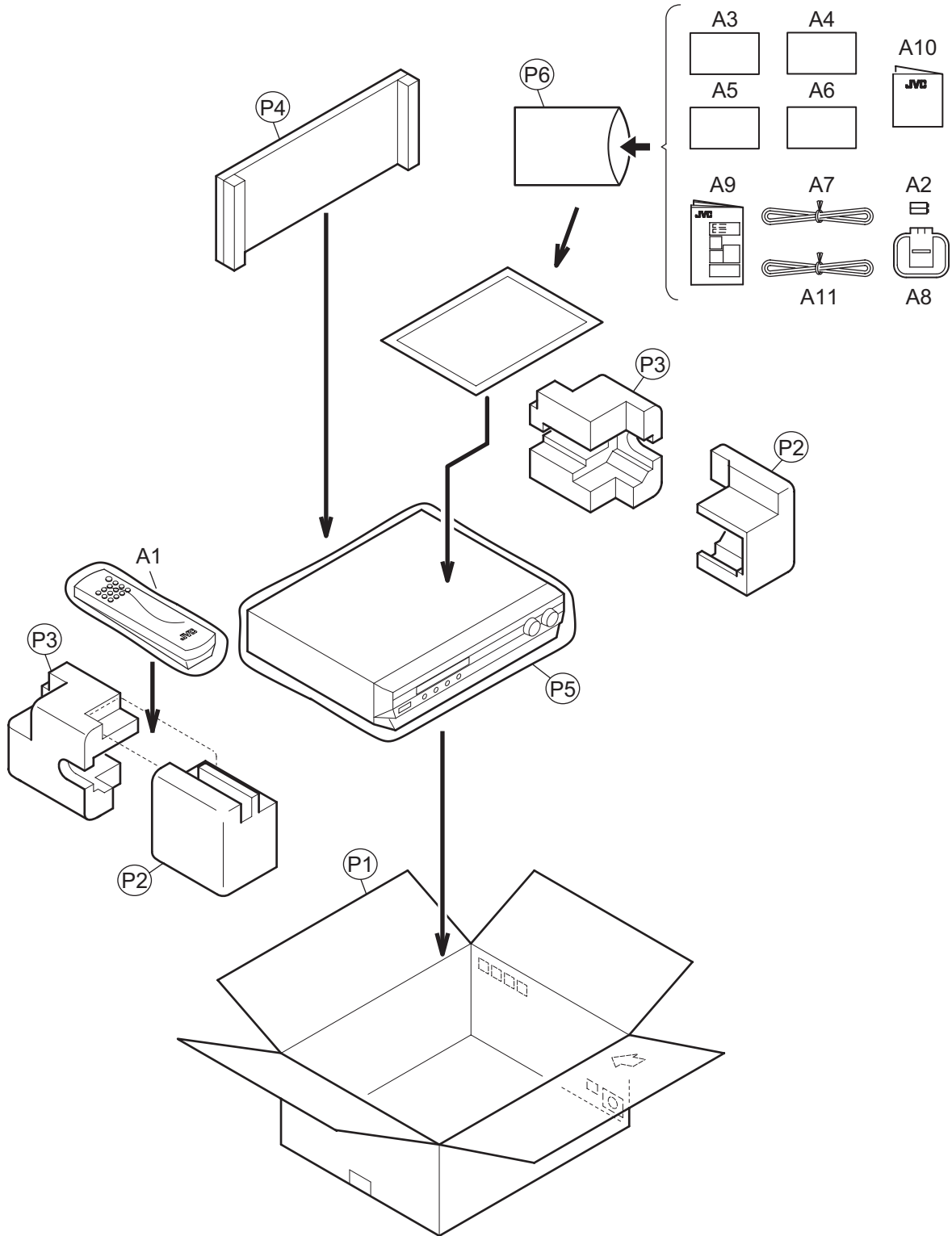

Packing and Accessories

Block No. [M][3][M][M]

△ Symbol No.	Part No.	Part Name	Description	Local
A 1	RM-SRXE5R	REMOCON		
A 2	R6UW/2STS	BATTERY	(x2)	
A 3	LV43880-001A	SETTING SHEET		E11SB,E11SE,E11SEN,E12BB,E12BE, E12BEN
A 3	LV43880-002A	SETTING SHEET		E11SEV,E12BEV
A 4	LVT1301-005A	INST BOOK	ENG	E11SB,E12BB
A 4	LVT1301-001A	INST BOOK	GER FRE	E11SE,E11SEN,E12BE,E12BEN
A 4	LVT1301-006A	INST BOOK	CZE POL HUN RUS	E11SEV,E12BEV
A 5	LVT1301-002A	INST BOOK	DUT	E11SE,E12BE
A 5	LVT1301-003A	INST BOOK	SWE FIN DAN	E11SEN,E12BEN
A 6	QAL0457-001	ANT.WIRE		E11SE
A 6	LVT1301-004A	INST BOOK	SPA ITA	E11SEN,E12BEN
A 7	QAL0457-001	ANT.WIRE		E11SB,E11SEN,E11SEV,E12BB,E12BE, E12BEN,E12BEV
A 8	QAL0014-001	AM LOOP ANT		
A 9	-----	WARRANTY CARD	BT-54023-1	
A 10	QAM0199-002	PIN CABLE		E11SE
A 10	VNA3000-204	REGIST CARD		E11SB,E12BB
A 11	QAM0199-002	PIN CABLE		E11SB,E11SEN,E11SEV,E12BB,E12BE, E12BEN,E12BEV
P 1	LV35696-002A	CARTON BOX		E11SB
P 1	LV35696-001A	CARTON BOX		E11SE,E11SEN,E11SEV
P 1	LV35696-007A	CARTON BOX		E12BB
P 1	LV35696-006A	CARTON BOX		E12BE,E12BEN,E12BEV
P 2	LV21907-001A	CUSHION(FRONT)		
P 3	LV21908-001A	CUSHION(REAR))		
P 4	LV34107-006A	PACKING SHEET		E11SB,E12BB
P 5	QPC06507015P	POLY BAG	65cm x 70cm	
P 6	QPA02503505P	POLY BAG	25cm x 35cm	

JVC

SCHEMATIC DIAGRAMS

HOME CINEMA CONTROL CENTER

RX-E11S, RX-E12B

CD-ROM No.SML200502

Area suffix

B ----- U.K.
E ----- Continental Europe
EN ----- Northern Europe
EV ----- Eastern Europe

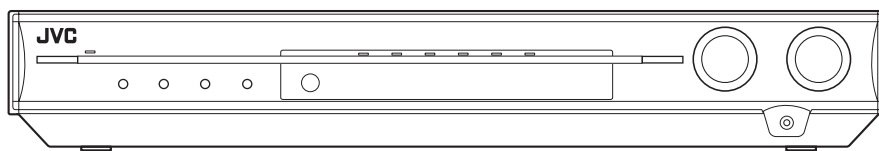
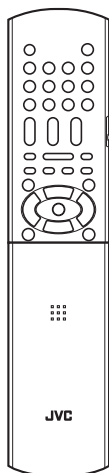

Contents

Block diagram	2-1
Standard schematic diagrams	2-2
Printed circuit boards	2-8 to 13

In regard with component parts appearing on the silk-screen printed side (parts side) of the PWB diagrams, the parts that are printed over with black such as the resistor (■), diode (⊣) and ICP (●) or identified by the "⚠" mark nearby are critical for safety.

Block diagram

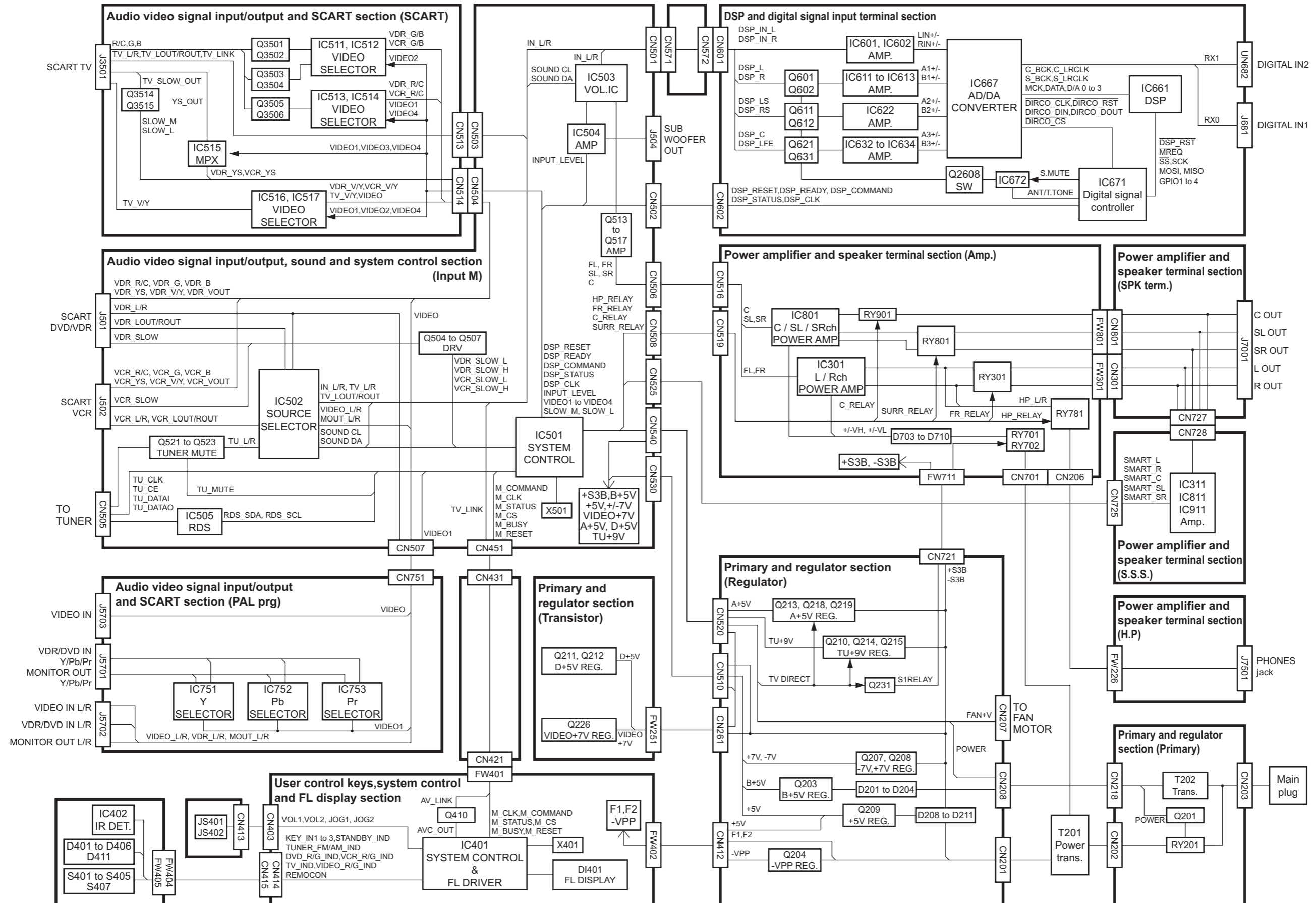

Standard schematic diagrams

Primary and regulator section

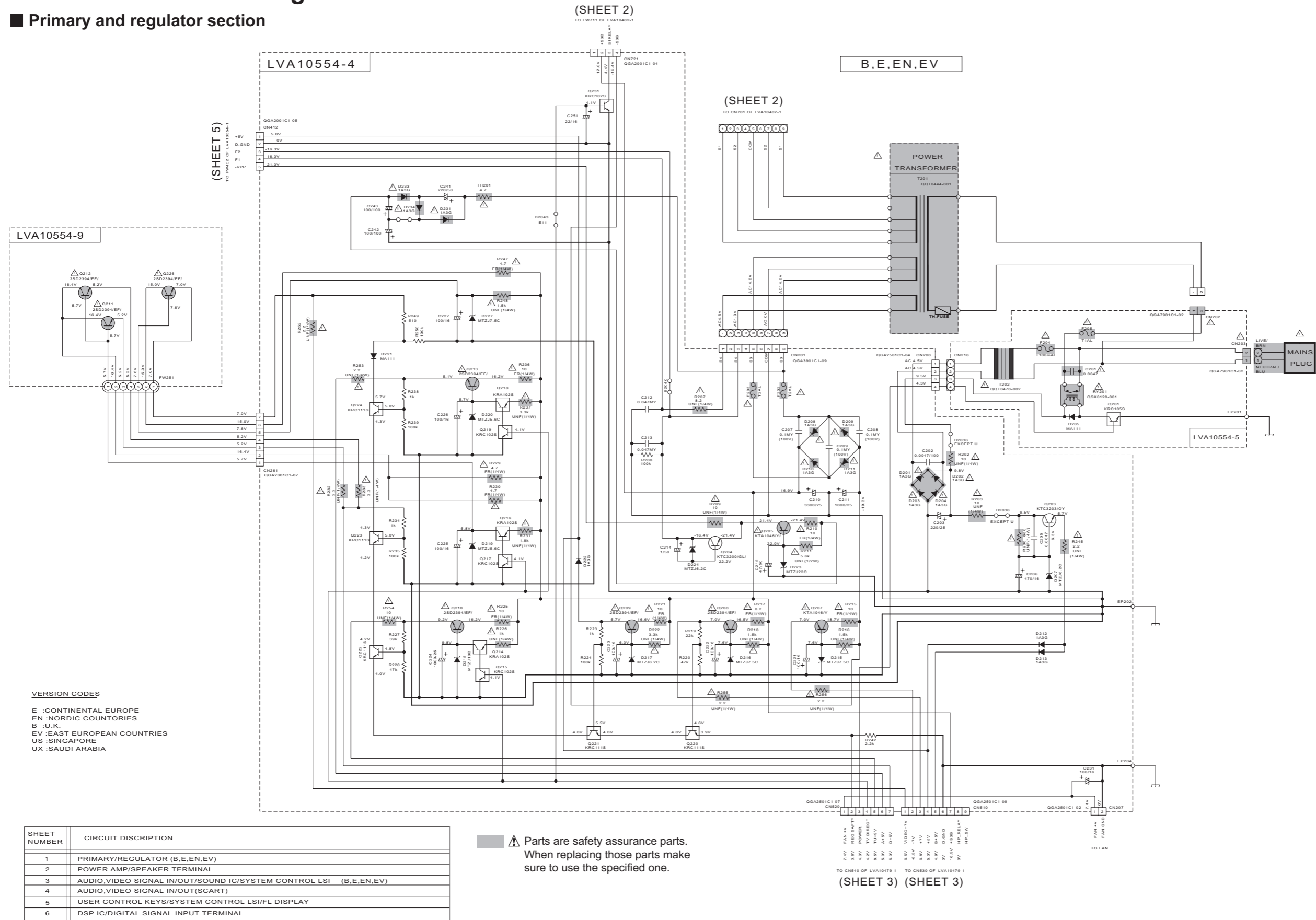

Power amplifier and speaker terminal section

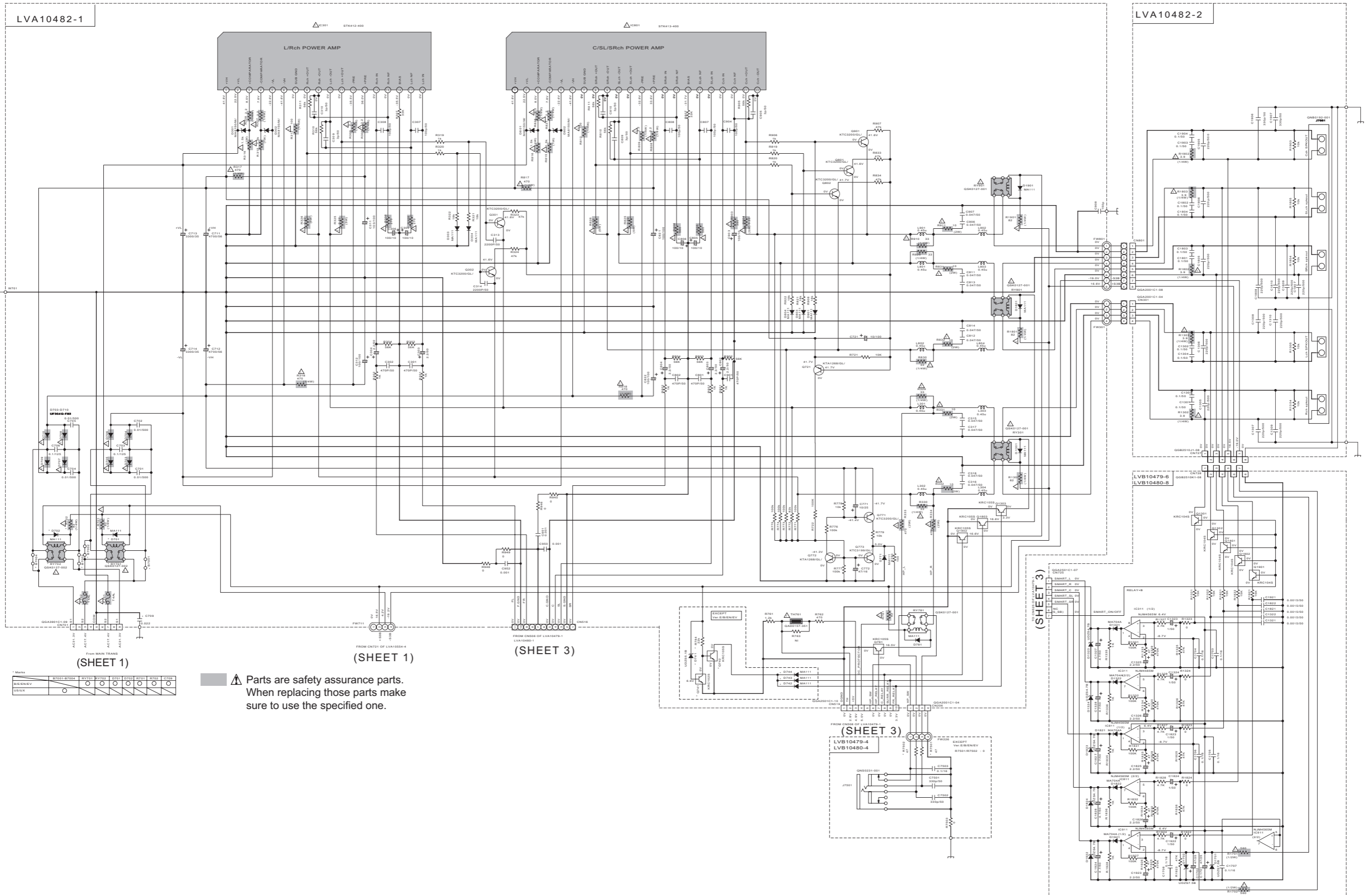

Parts

BI-ENVEV	Q5041-001	RY701	RY702	Q201	Q202	Q203	Q204	Q205	Q206
USUK									

⚠ Parts are safety assurance parts.
When replacing those parts make sure to use the specified one.

■ Audio video signal input/output, sound and system control section

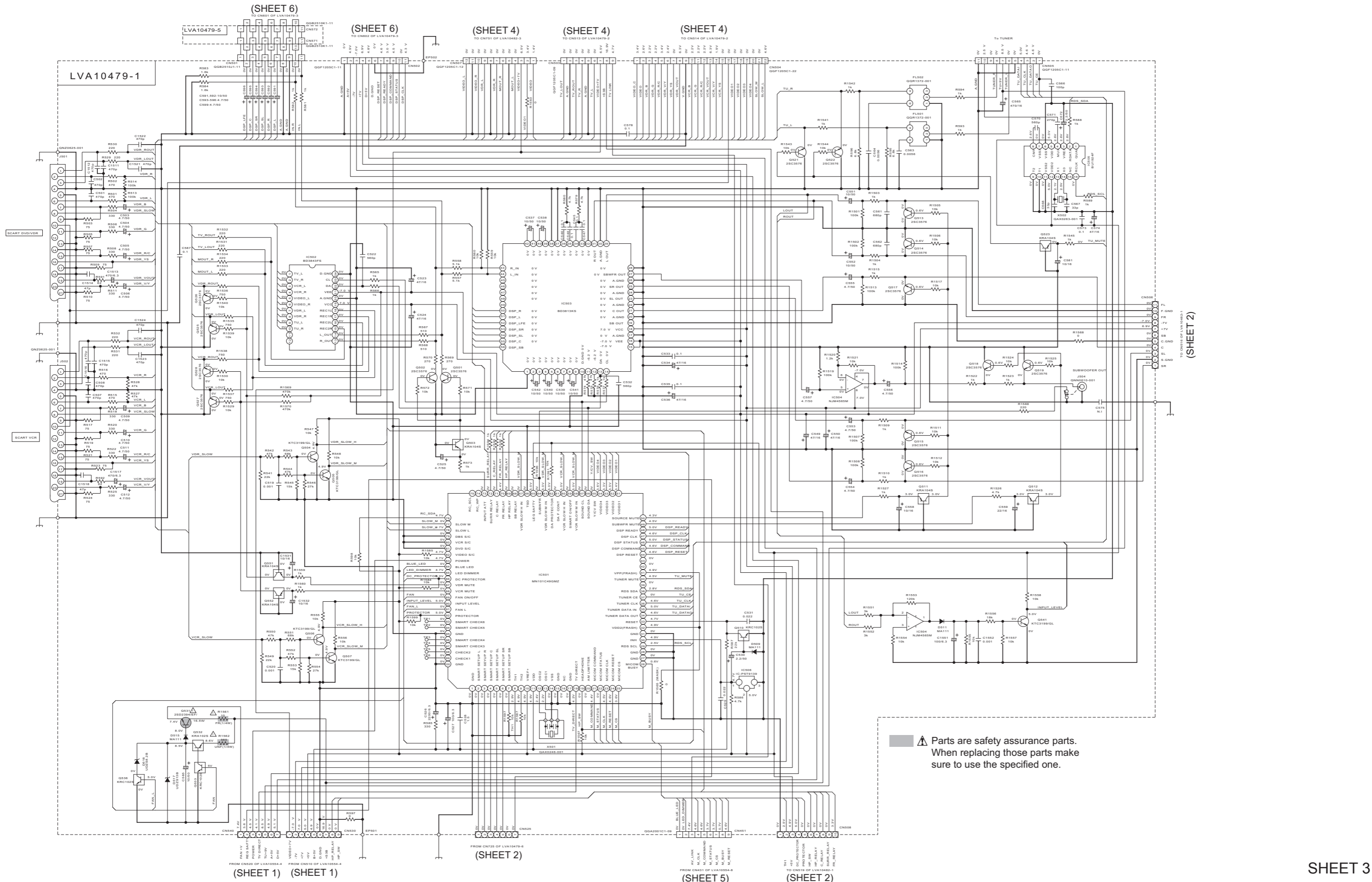

■ User control keys, system control and FL display section

LVA10554-1

LVA10554-3

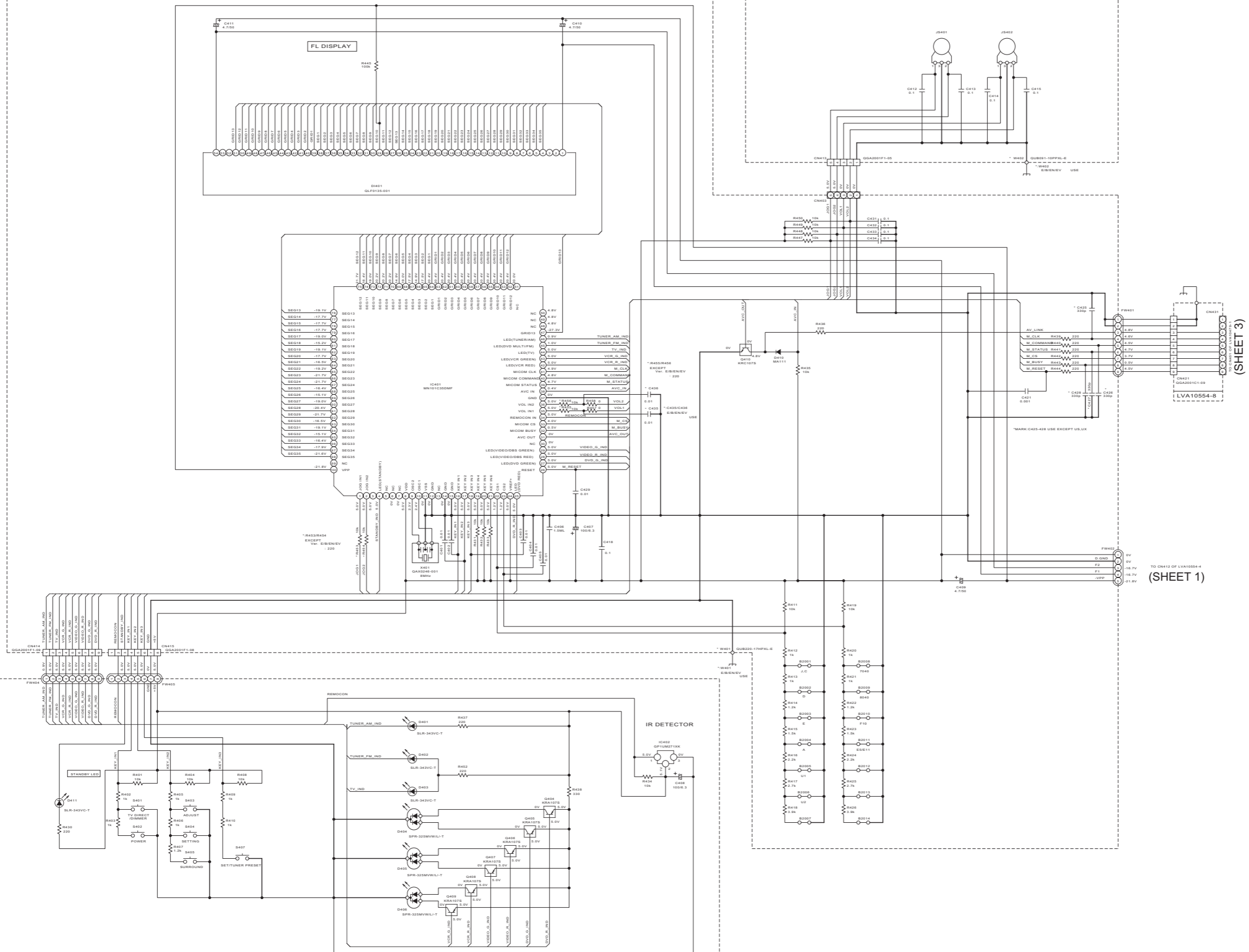

LVA10554-2

(SHEET 1)

(SHEET 3)

■ DSP and digital signal input terminal section

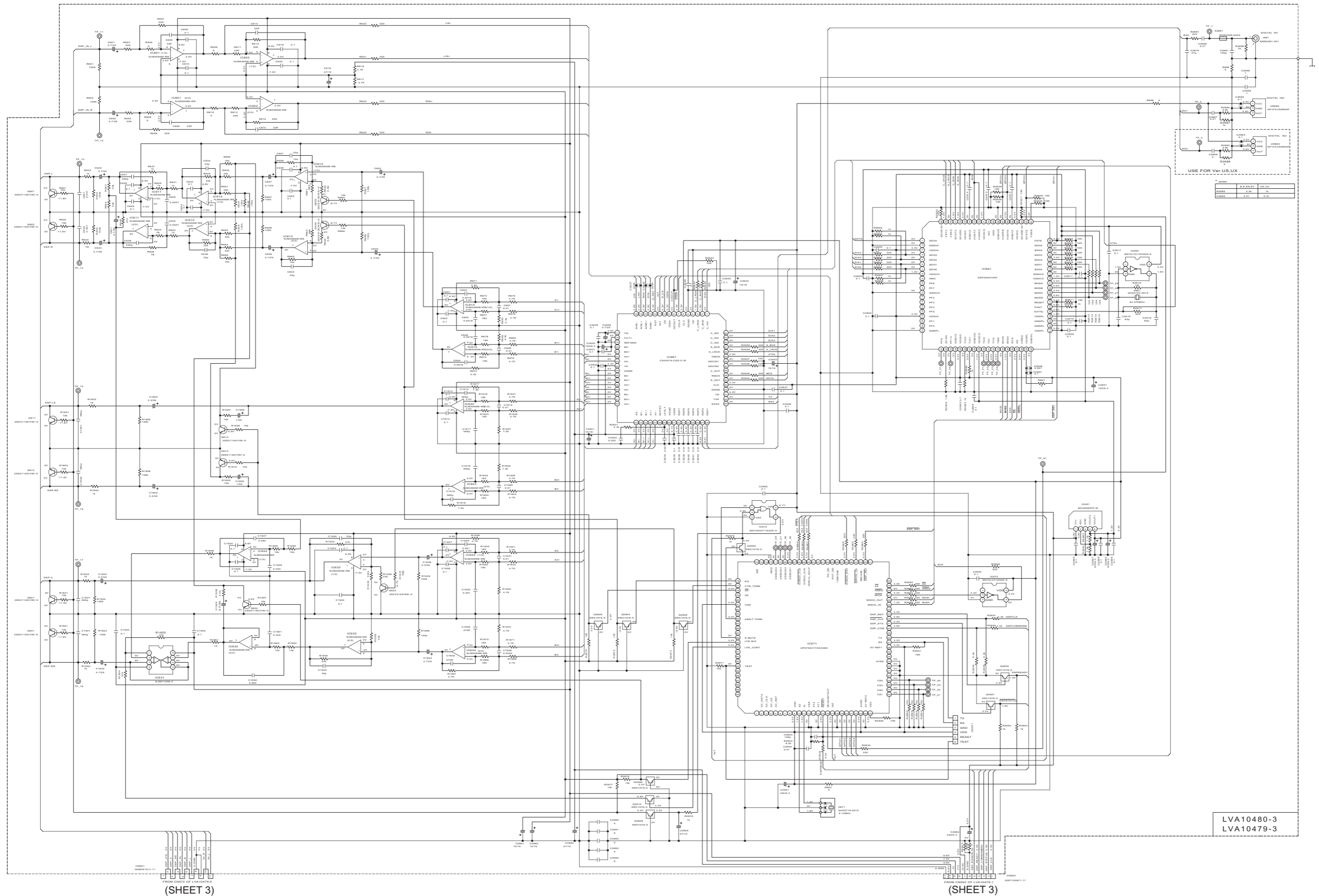

LVA10480-3
LVA10479-3

Printed circuit boards

■ Front board

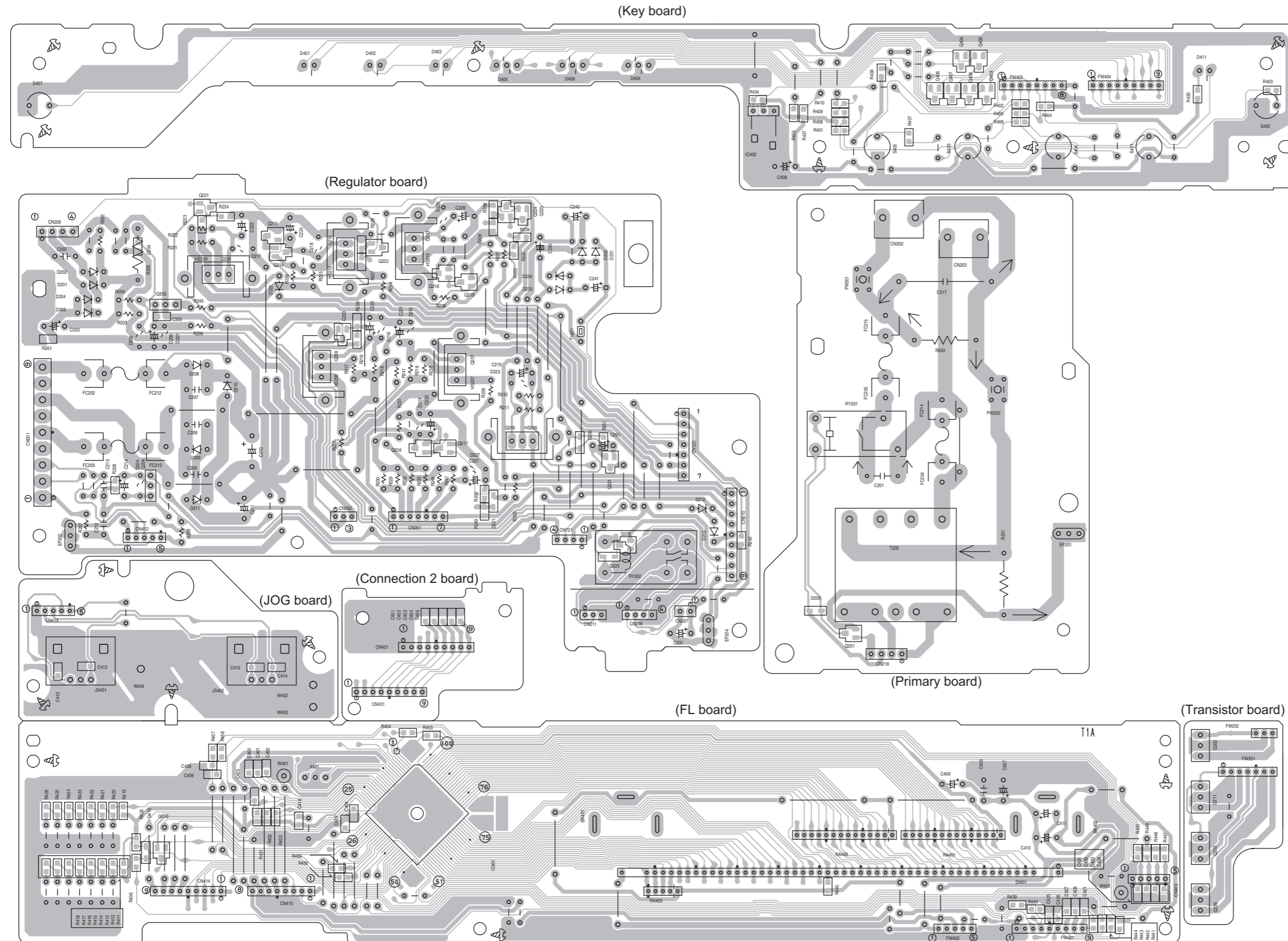

■ Amplifier board

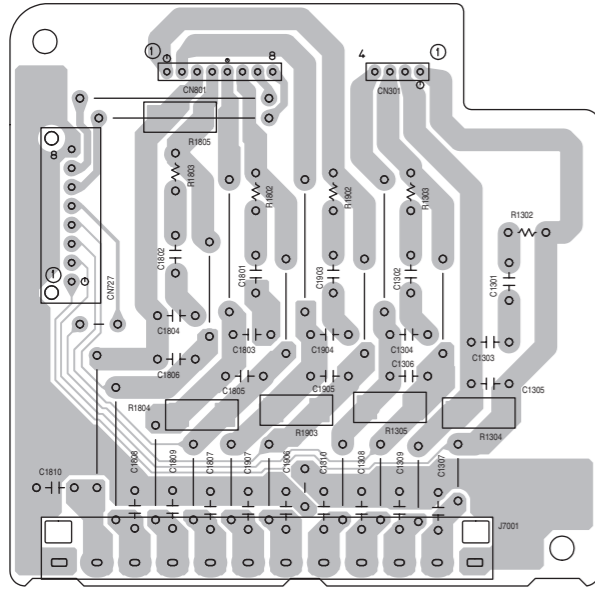

(SPK term. board)

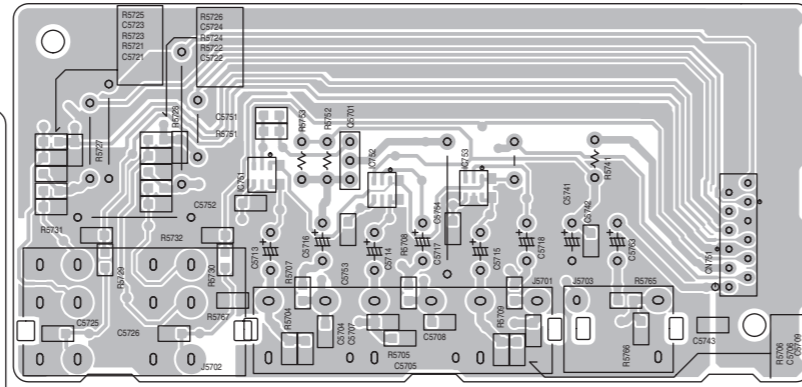

(PAL prg board)

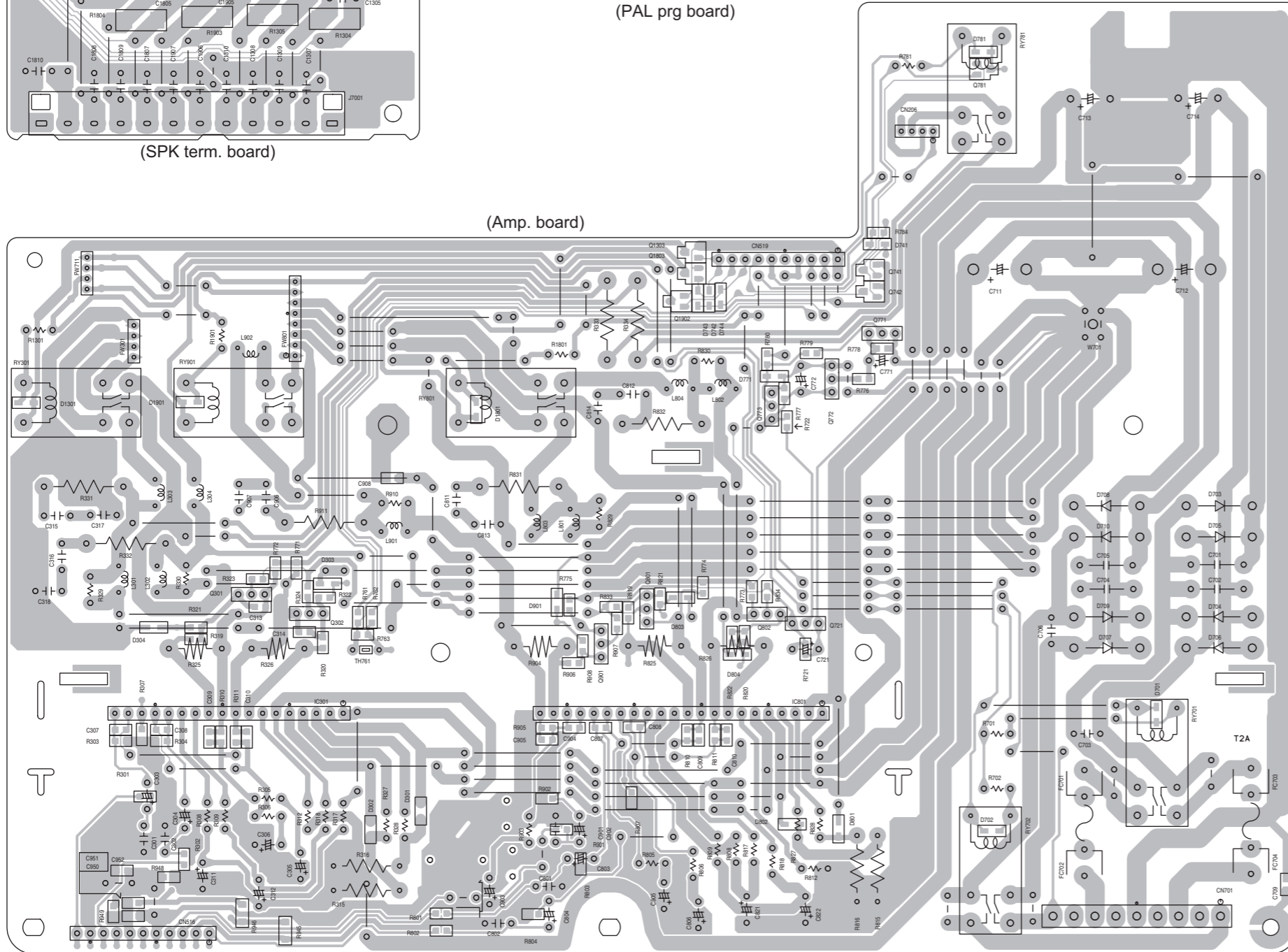

(Amp. board)

■ DSP board (1/3)

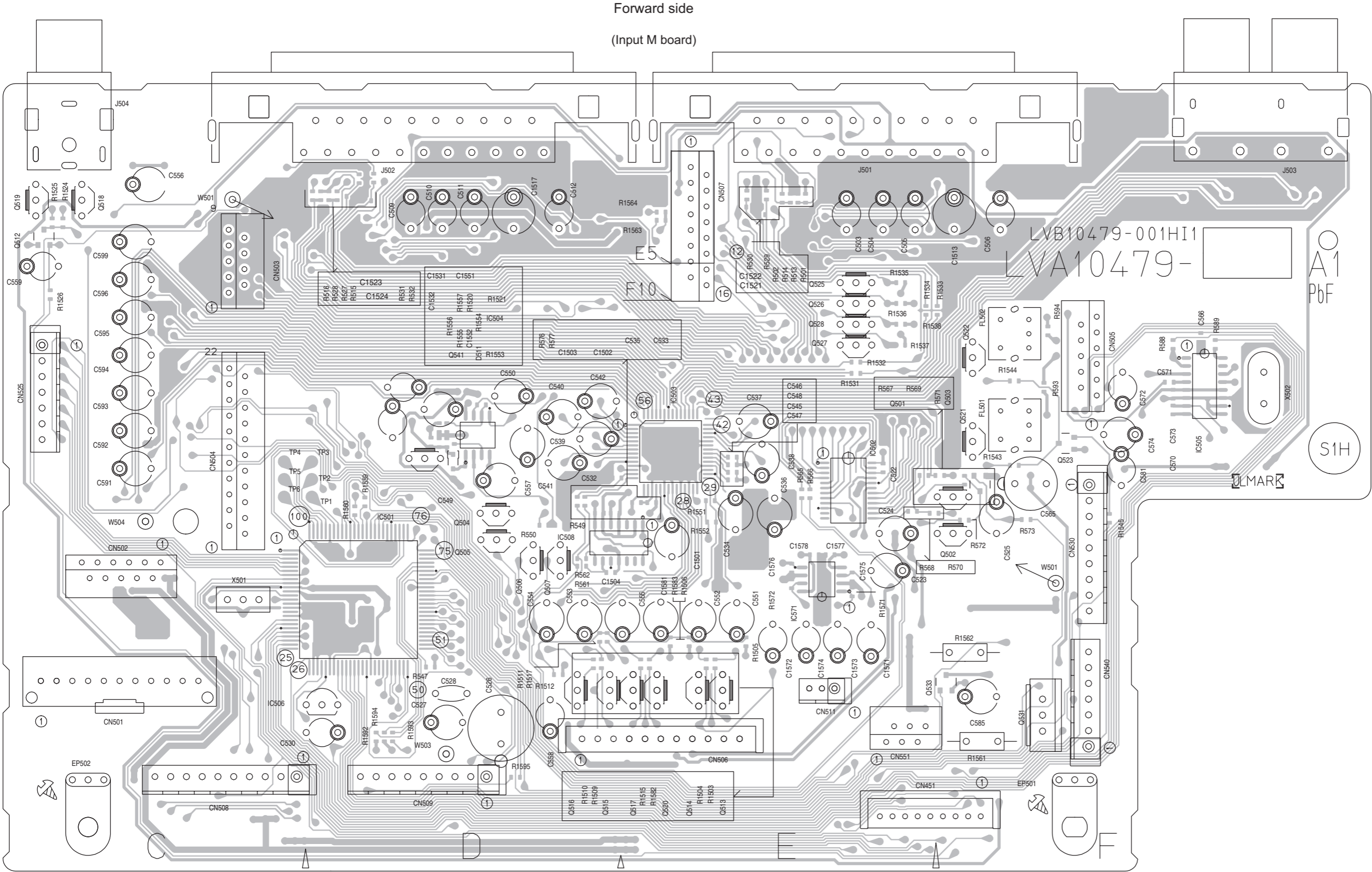

Reverse side

(Input M board)

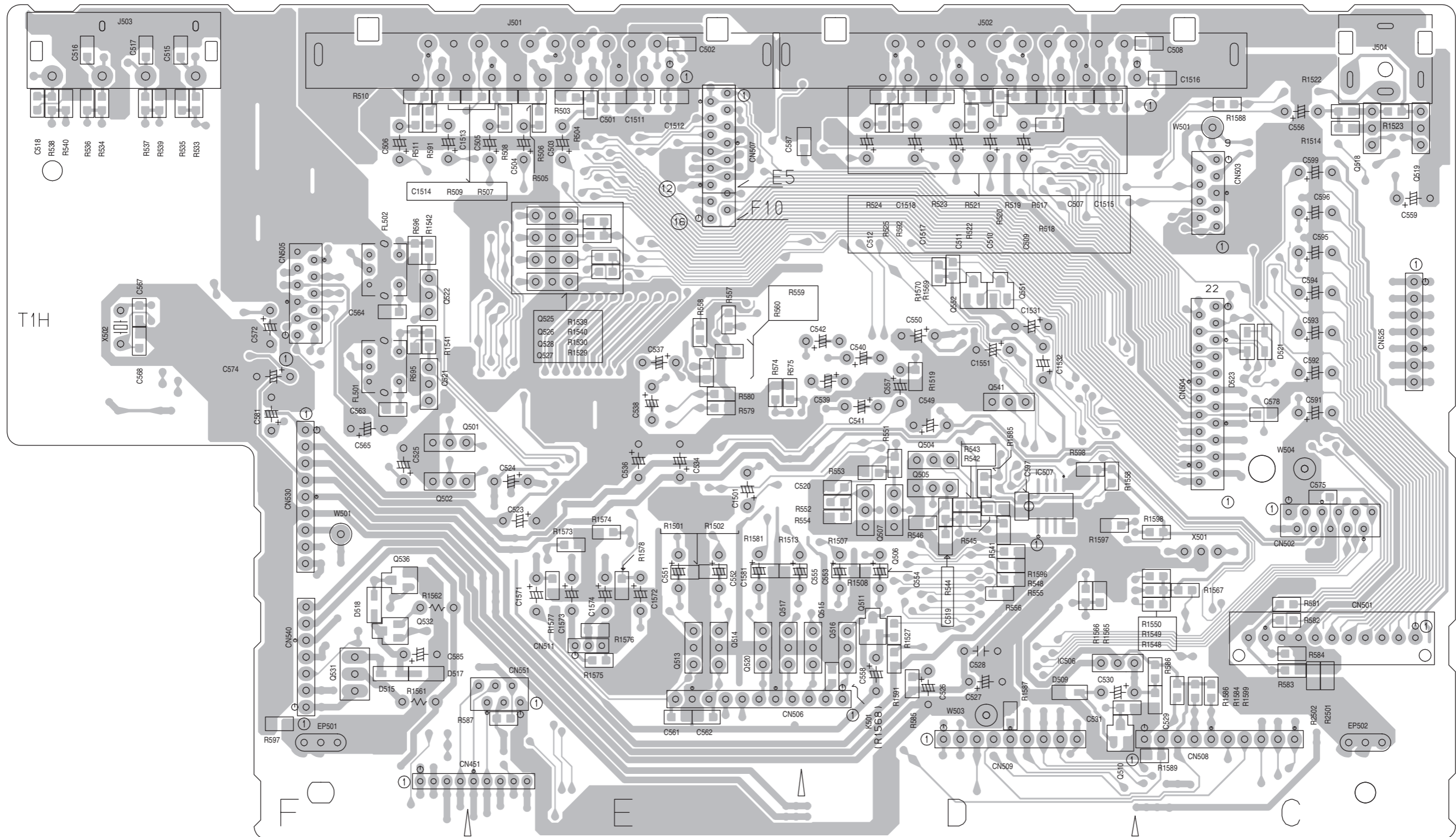

JVC

Victor Company of Japan, Limited

AV & MULTIMEDIA COMPANY AUDIO/VIDEO SYSTEMS CATEGORY 10-1, 1chome, Ohwatari-machi, Maebashi-city, 371-8543, Japan

(No.MB387SCH)



Printed in Japan
VPT

JVC



HOME CINEMA CONTROL CENTER

RX-E11S/RX-E12B

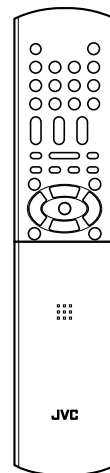
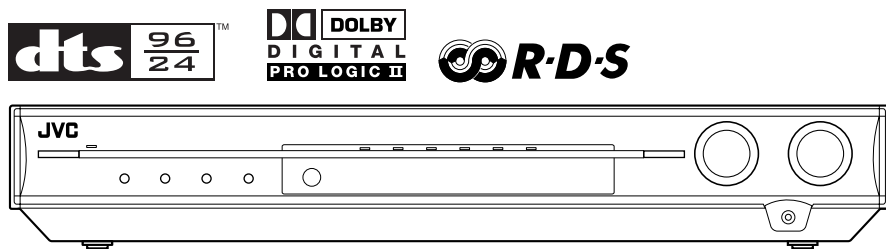

INSTRUCTIONS

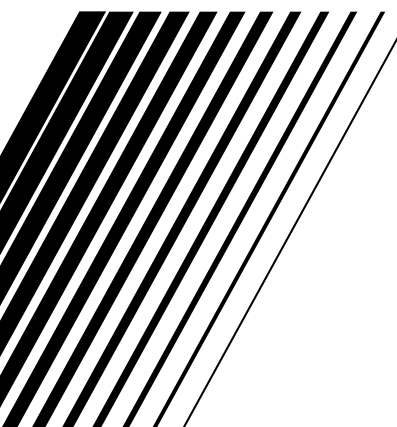

Warnings, Cautions and Others

IMPORTANT for the U.K.

DO NOT cut off the mains plug from this equipment. If the plug fitted is not suitable for the power points in your home or the cable is too short to reach a power point, then obtain an appropriate safety approved extension lead or consult your dealer.

BE SURE to replace the fuse only with an identical approved type, as originally fitted.

If nonetheless the mains plug is cut off ensure to remove the fuse and dispose of the plug immediately, to avoid a possible shock hazard by inadvertent connection to the mains supply.

If this product is not supplied fitted with a mains plug then follow the instructions given below:

IMPORTANT:

DO NOT make any connection to the terminal which is marked with the letter E or by the safety earth symbol or coloured green or green-and-yellow.

The wires in the mains lead on this product are coloured in accordance with the following code:

Blue : Neutral
Brown : Live

As these colours may not correspond with the coloured markings identifying the terminals in your plug proceed as follows:

The wire which is coloured blue must be connected to the terminal which is marked with the letter N or coloured black.

The wire which is coloured brown must be connected to the terminal which is marked with the letter L or coloured red.

IF IN DOUBT - CONSULT A COMPETENT ELECTRICIAN.

Caution—⏻/I STANDBY/ON button!

Disconnect the mains plug to shut the power off completely. The ⏻/I STANDBY/ON button in any position does not disconnect the mains line. The power can be remote controlled.

CAUTION

To reduce the risk of electrical shocks, fire, etc.:

1. Do not remove screws, covers or cabinet.
2. Do not expose this appliance to rain or moisture.

CAUTION

- Do not block the ventilation openings or holes. (If the ventilation openings or holes are blocked by a newspaper or cloth, etc., the heat may not be able to get out.)
- Do not place any naked flame sources, such as lighted candles, on the apparatus.
- When discarding batteries, environmental problems must be considered and local rules or laws governing the disposal of these batteries must be followed strictly.
- Do not expose this apparatus to rain, moisture, dripping or splashing and that no objects filled with liquids such as vases, shall be placed on the apparatus.

Caution: Proper Ventilation

To avoid risk of electric shock and fire and to protect from damage.

Locate the apparatus as follows:

Front: No obstructions open spacing.

Sides: No obstructions in 10 cm from the sides.

Back: No obstructions in 15 cm from the back.

Bottom: No obstructions, place on the level surface.

In addition, maintain the best possible air circulation as illustrated.

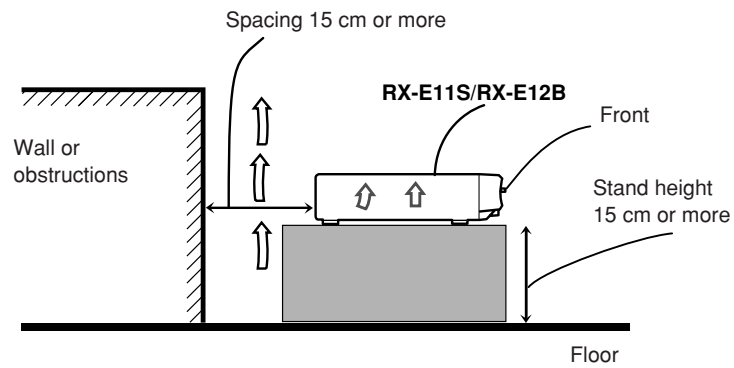

SAFETY INSTRUCTIONS
“SOME DOS AND DON'TS ON THE SAFE USE OF EQUIPMENT”

This equipment has been designed and manufactured to meet international safety standards but, like any electrical equipment, care must be taken if you are to obtain the best results and safety is to be assured.

Do read the operating instructions before you attempt to use the equipment.

Do ensure that all electrical connections (including the mains plug, extension leads and interconnections between pieces of equipment) are properly made and in accordance with the manufacturer's instructions. Switch off and withdraw the mains plug when making or changing connections.

Do consult your dealer if you are ever in doubt about the installation, operation or safety of your equipment.

Do be careful with glass panels or doors on equipment.

DON'T continue to operate the equipment if you are in any doubt about it working normally, or if it is damaged in any way—switch off, withdraw the mains plug and consult your dealer.

DON'T remove any fixed cover as this may expose dangerous voltages.

DON'T leave equipment switched on when it is unattended unless it is specifically stated that it is designed for unattended operation or has a standby mode.
Switch off using the switch on the equipment and make sure that your family know how to do this.
Special arrangements may need to be made for infirm or handicapped people.

DON'T use equipment such as personal stereos or radios so that you are distracted from the requirements of traffic safety. It is illegal to watch television whilst driving.

DON'T listen to headphones at high volume as such use can permanently damage your hearing.

DON'T obstruct the ventilation of the equipment, for example with curtains or soft furnishings.

Overheating will cause damage and shorten the life of the equipment.

DON'T use makeshift stands and NEVER fix legs with wood screws—to ensure complete safety always fit the manufacturer's approved stand or legs with the fixings provided according to the instructions.

DON'T allow electrical equipment to be exposed to rain or moisture.

ABOVE ALL

- NEVER let anyone, especially children, push anything into holes, slots or any other opening in the case—this could result in a fatal electrical shock.;
- NEVER guess or take chances with electrical equipment of any kind—it is better to be safe than sorry!

Table of Contents

Parts identification	2
Getting started	4
Before Installation	4
Checking the supplied accessories	4
Putting batteries in the remote control	4
Connecting the FM and AM (MW) antennas	5
Connecting the speakers	6
Connecting video components	7
Connecting the power cord	9
Basic operations	10
1 Turn on the power	10
2 Select the source to play	10
3 Adjust the volume	11
Selecting the digital decode mode	11
Adjusting the subwoofer audio position	12
Activating TV Direct	12
Turning off the sounds temporarily	13
Changing the display brightness	13
Turning off the power with the Sleep Timer	13
Basic settings	14
Setting the speaker information automatically —Smart Surround Setup	14
Basic setting items	15
Operating procedure	16
Setting the speakers	16
Setting bass sound	17
Setting the virtual surround back speaker—VIRTUAL SB ...	18
Selecting the main or sub channel—DUAL MONO	18
Using the Midnight mode—MIDNIGHT M.	18
Setting the digital input (DIGITAL IN) terminals —DIGITAL IN1/2	19
Setting Auto Surround—AUTO SURRND	19
Setting the Auto Function mode—AUTO MODE	19
Sound adjustments	20
Basic adjustment items	20
Operating procedure	20
Adjusting speaker output level	21
Adjusting the sound parameters for the Surround/DSP modes	21
Adjusting the bass sounds	22
Adjusting the equalization patterns —D EQ 63Hz/250Hz/1kHz/4kHz/16kHz	22
Tuner operations	23
Tuning in to stations manually	23
Using preset tuning	23
Selecting the FM reception mode	24
Using the Radio Data System (RDS) to receive FM stations	25
Searching for a program by PTY codes	26
Switching to broadcast program of your choice temporarily	28
Creating realistic sound fields	29
Reproducing theatre ambience	29
Introducing the Surround modes	29
Introducing the DSP modes	31
Using the Surround/DSP modes	32
Operating other JVC products	34
Operating other manufacturers' products	36
Troubleshooting	39
Specifications	40

Parts identification

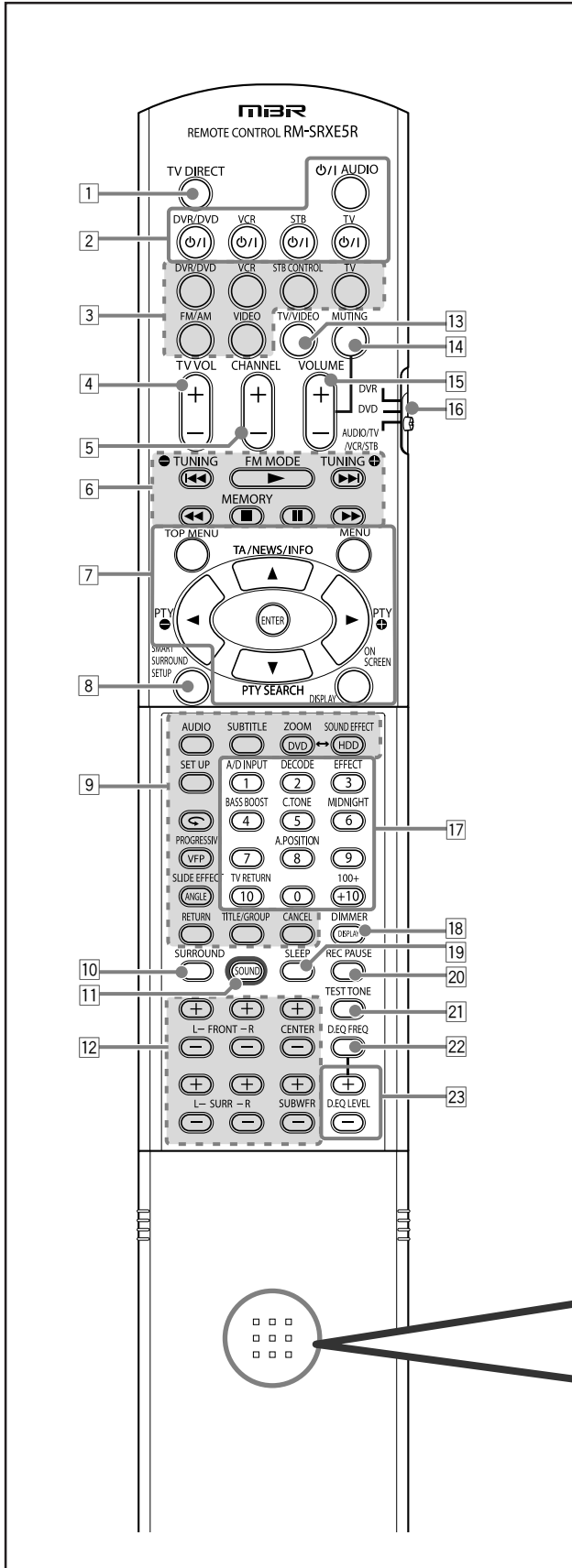

Remote control

See pages in parentheses for details.

- 1 TV DIRECT button (12)
- 2 Standby/on buttons (10, 34 – 38)
 ◻/I AUDIO, DVR/DVD ◻/I, VCR ◻/I, STB ◻/I, TV ◻/I
- 3 • Source selecting buttons (10, 12, 23, 34, 36, 37)
 DVR/DVD, VCR, TV, FM/AM, VIDEO
 • STB CONTROL button (38)
- 4 TV VOL (volume) +/- button (34, 36)
- 5 CHANNEL +/- button (34 – 38)
- 6 • Operating buttons for video components (34, 35, 37)
 ◀◀, ▶▶, ▶▶▶, ◀◀◀, ■, II, ▶▶▶
 • Operating buttons for tuner (23, 24)
 ◻ TUNING, FM MODE, TUNING ◻, MEMORY
- 7 • Operating buttons for DVD recorder or DVD player* (35)
 TOP MENU, MENU, cursor buttons (▶, ◀, ▲, ▼), ENTER, ON SCREEN
 • Operating buttons for RDS (25, 26, 28)
 PTY ◻, PTY ◻, TA/NEWS/INFO, PTY SEARCH, DISPLAY
- 8 SMART SURROUND SETUP button (14)
- 9 Operating buttons for DVD recorder or DVD player* (35)
 AUDIO, SUBTITLE, DVD, ZOOM, HDD, SOUND EFFECT, SET UP, ◻, VFP, PROGRESSIVE, ANGLE, SLIDE EFFECT, RETURN, TITLE/GROUP, CANCEL
- 10 SURROUND button (32)
- 11 SOUND button (10 – 12, 18, 21, 22)
- 12 Adjusting buttons for speaker and subwoofer output levels (21)
 FRONT L +/-, FRONT R +/-, CENTER +/-, SURR L +/-, SURR R +/-, SUBWFR +/-
- 13 TV/VIDEO button (34, 36)
- 14 MUTING button (13)
- 15 VOLUME +/- button (11)
- 16 Mode selector (10, 34 – 38)
 DVR, DVD, AUDIO/TV/VCR/STB
- 17 • Numeric buttons (24, 34 – 38)
 • Adjusting buttons (10 – 12, 18, 21, 22)
 A/D INPUT, DECODE, EFFECT, BASS BOOST, C.TONE, MIDNIGHT, A.POSITION
 • TV RETURN button (34)
- 18 • DISPLAY button* (35)
- 19 DIMMER button (13, 35)
- 20 SLEEP button (13)
- 21 REC PAUSE button (35)
- 22 TEST TONE button (21)
- 23 D.EQ FREQ button (22)
- 24 D.EQ LEVEL +/- buttons (22)

* These buttons can be used for operating a JVC DVD recorder or DVD player with the mode selector set to "DVR" or "DVD" (see page 35).

If these buttons do not function normally, use the remote control supplied with your DVD recorder or DVD player. Refer also to the manuals supplied with the DVD recorder or DVD player for details.

To open the cover of the remote control, push here then slide downward.

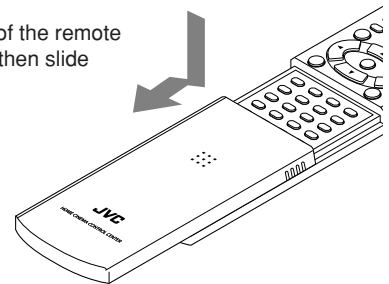

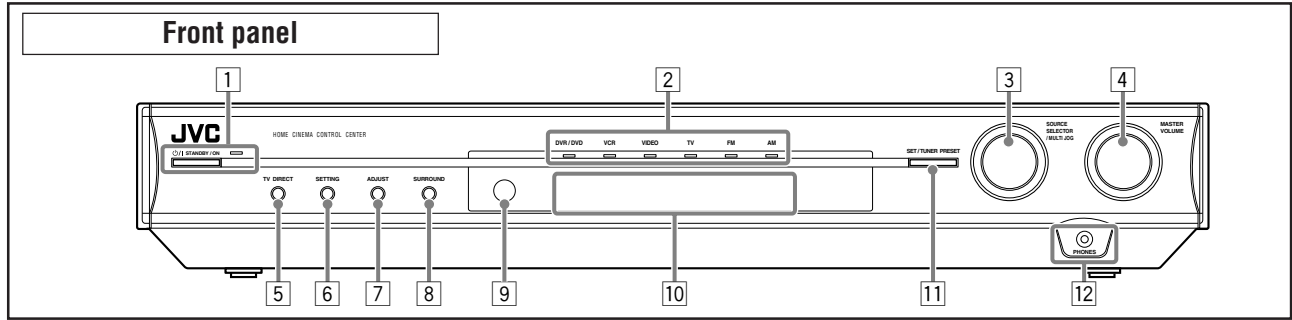

- | | | | |
|---|--|----|---|
| 1 | ⏻/I STANDBY/ON button and standby lamp (10) | 7 | ADJUST button (20) |
| 2 | Source lamps
DVR/DVD, VCR, VIDEO, TV, FM, AM | 8 | SURROUND button (33) |
| 3 | • SOURCE SELECTOR (10, 24)
• MULTI JOG (16, 20, 24, 33) | 9 | Remote sensor (4) |
| 4 | MASTER VOLUME control (11) | 10 | Display window (see below) |
| 5 | TV DIRECT button (12) | 11 | • SET button (16, 20)
• TUNER PRESET button (24) |
| 6 | SETTING button (16) | 12 | PHONES jack (11) |

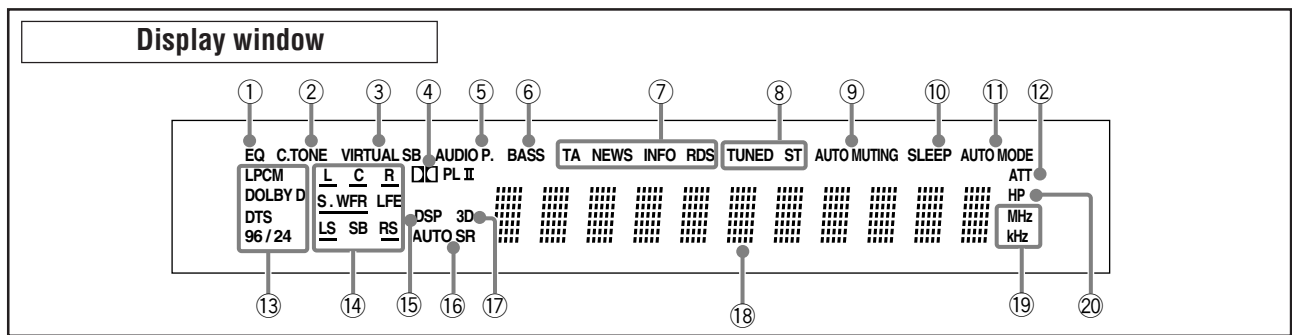

- | | | | |
|----|--|----|---|
| 1 | EQ indicator (22) | 11 | AUTO MODE indicator (19) |
| 2 | C.TONE indicator (21) | 12 | ATT (attenuator) indicator (22) |
| 3 | VIRTUAL SB indicator (18, 29, 30) | 13 | Digital signal format indicators (11)
LPCM (Linear PCM), DOLBY D (Dolby Digital), DTS, 96/24 |
| 4 | PL II indicator (29) | 14 | Signal and speaker indicators (13) |
| 5 | AUDIO P. (position) indicator (12) | 15 | DSP indicator (30, 31) |
| 6 | BASS indicator (22) | 16 | AUTO SR (surround) indicator (19) |
| 7 | RDS operation indicators (25, 28)
TA, NEWS, INFO, RDS | 17 | 3D indicator (30, 31) |
| 8 | Tuner operation indicators (23)
TUNED, ST (stereo) | 18 | Main display |
| 9 | AUTO MUTING indicator (24) | 19 | Frequency unit indicators
MHz (for FM station), kHz (for AM station) |
| 10 | SLEEP indicator (13) | 20 | HP (headphones) indicator (11, 30, 31) |

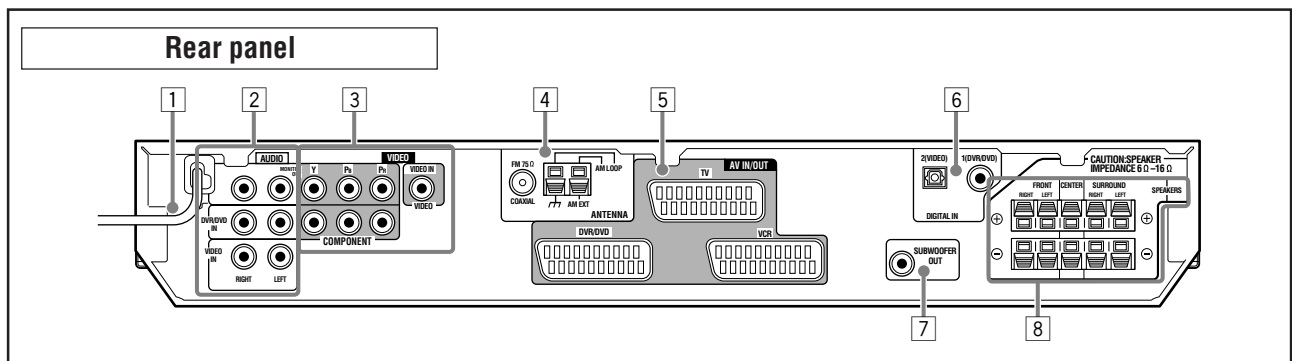

- | | | | |
|---|---|---|--|
| 1 | Power cord (9) | 6 | DIGITAL IN terminals (9)
Coaxial: 1(DVR/DVD)
Optical: 2(VIDEO) |
| 2 | AUDIO jacks (8, 9)
MONITOR OUT, DVR/DVD IN, VIDEO IN | 7 | SUBWOOFER OUT jack (6) |
| 3 | VIDEO jacks (8, 9)
COMPONENT (Y, Pb, Pr): MONITOR OUT, DVR/DVD IN
VIDEO (composite video): VIDEO IN | 8 | SPEAKERS terminals (6)
FRONT, CENTER, SURROUND |
| 4 | ANTENNA terminals (5) | | |
| 5 | AV IN/OUT terminals (7)
TV, DVR/DVD, VCR | | |

Parts identification

Getting started

Before Installation

General precautions

- Be sure your hands are dry.
- Turn the power off to all components.
- Read the manuals supplied with the components you are going to connect.

Locations

- Install the receiver in a location that is level and protected from moisture and dust.
- The temperature around the receiver must be between -5°C and 35°C .
- Make sure there is good ventilation around the receiver. Poor ventilation could cause overheating and damage the receiver.

Handling the receiver

- Do not insert any metal object into the receiver.
- Do not disassemble the receiver or remove screws, covers, or cabinet.
- Do not expose the receiver to rain or moisture.

The receiver has a built-in cooling fan which operates while the receiver is turned on. Be sure to leave enough ventilation to obtain sufficient cooling effect.

CAUTION:

Do not connect the AC power plug to the wall outlet until all connections are completed.

Checking the supplied accessories

Check to be sure you have all of the following supplied accessories. If anything is missing, contact your dealer immediately.

- Remote control (× 1)
- Batteries (× 2)
- AM (MW) loop antenna (× 1)
- FM antenna (× 1)
- Digital coaxial cable (× 1)

Putting batteries in the remote control

Before using the remote control, put two supplied batteries first.

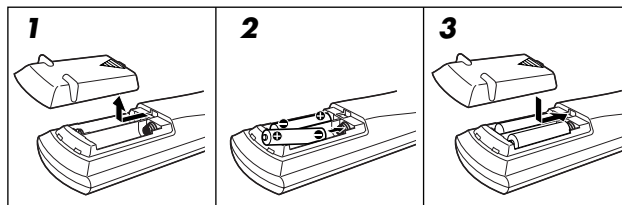

1 Press and slide the battery cover on the back of the remote control.

2 Insert batteries.

Make sure to match the polarity: (+) to (+) and (-) to (-).

3 Replace the cover.

If the range or effectiveness of the remote control decreases, replace the batteries. Use two R6(SUM-3)/AA(15F) type dry-cell batteries.

- Supplied batteries are for initial setup. Replace for continued use.

CAUTION:

Follow these precautions to avoid leaking or cracking cells:

- Place batteries in the remote control so they match the polarity: (+) to (+) and (-) to (-).
- Use the correct type of batteries. Batteries that look similar may differ in voltage.
- Always replace both batteries at the same time.
- Do not expose batteries to heat or flame.

When using the remote control, aim the remote control directly at the remote sensor on the front panel.

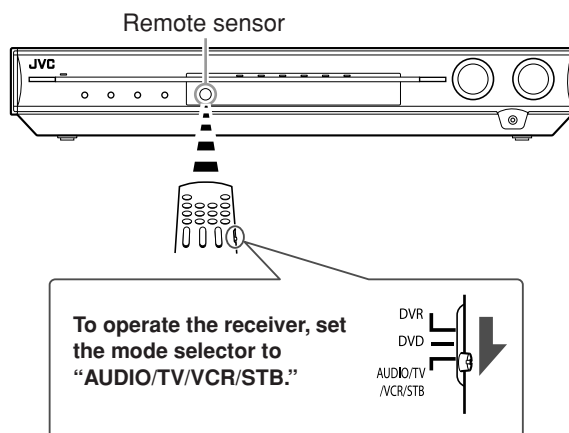

Connecting the FM and AM (MW) antennas

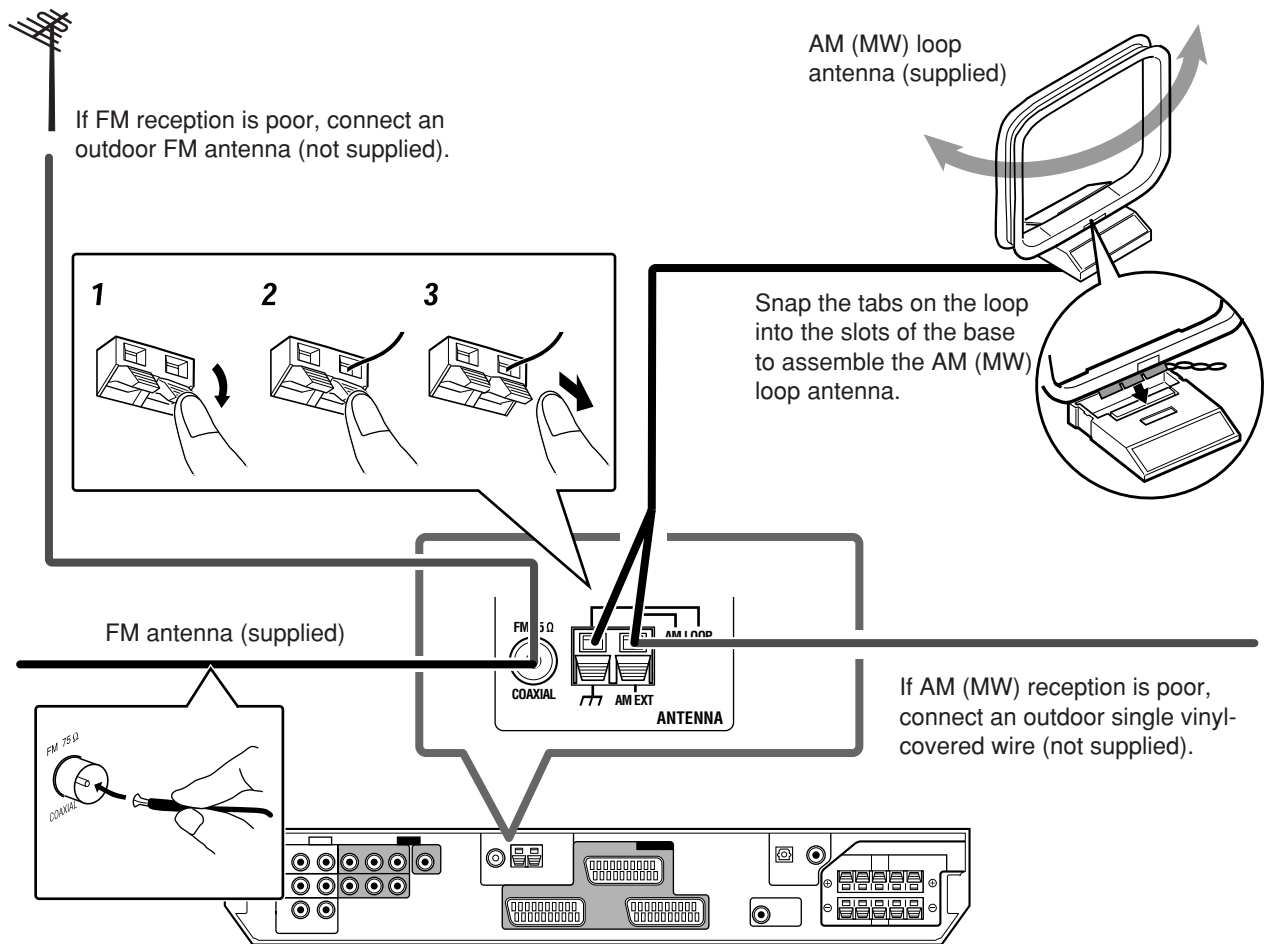

AM (MW) antenna connection

Connect the AM (MW) loop antenna supplied to the AM LOOP terminals.
 Turn the loop until you have the best reception.

- If the reception is poor, connect an outdoor single vinyl-covered wire (not supplied) to the AM EXT terminal. Keep the AM (MW) loop antenna connected.

FM antenna connection

Connect the FM antenna supplied to the FM 75 Ω COAXIAL terminal as a temporary measure.
 Extend the supplied FM antenna horizontally.

- If the reception is poor, connect an outdoor FM antenna (not supplied). Before attaching a 75 Ω coaxial cable with a connector (IEC or DIN 45325), disconnect the supplied FM antenna.

NOTES

- If the AM (MW) loop antenna wire is covered with vinyl, remove the vinyl while twisting it as shown on the right.
- Make sure the antenna conductors do not touch any other terminals, connecting cords and power cord. This could cause poor reception.

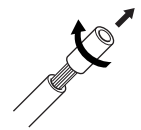

Connecting the speakers

Speaker Layout Diagram

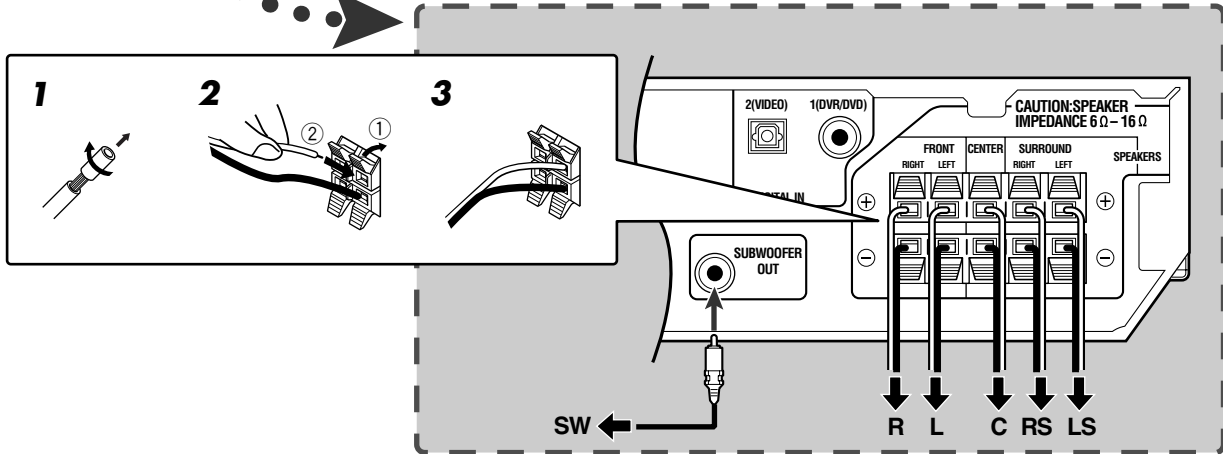
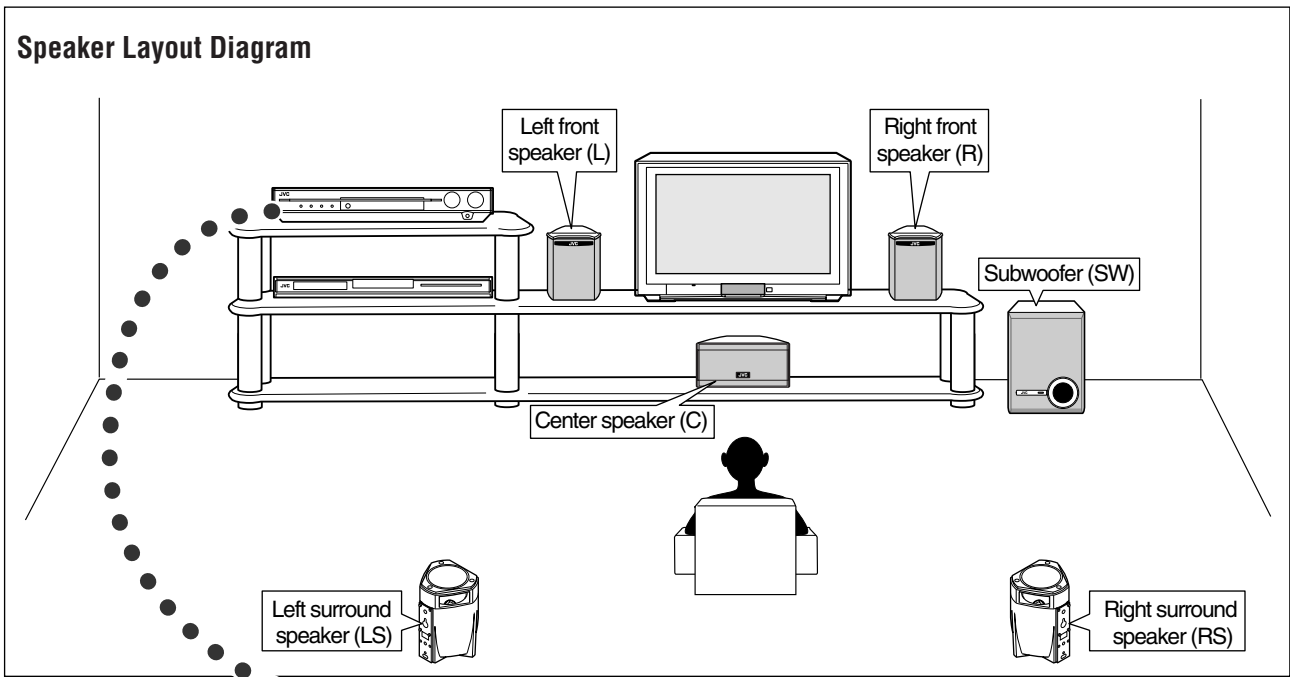

Getting started

Connecting the front, center, and surround speakers

Turn off all components before making connections.

- 1** Twist and remove the insulation at the end of each speaker cord.
- 2** Press and hold the clamp of the speaker terminal (①), then insert the speaker cord (②).
 - For each speaker, connect the (+) and (-) terminals on the rear panel to the (+) and (-) terminals marked on the speakers.
- 3** Release the finger from the clamp.

CAUTIONS:

- Use speakers with the SPEAKER IMPEDANCE indicated by the speaker terminals (6 Ω – 16 Ω).
- DO NOT connect more than one speaker to one speaker terminal.

Connecting the subwoofer

By connecting a subwoofer, you can enhance the bass or reproduce the original LFE signals recorded in digital software.

Connect the input jack of a powered subwoofer to the SUBWOOFER OUT jack on the rear panel, using a cord with RCA pin plugs (not supplied).

- Refer also to the manual supplied with your subwoofer.

After connecting all the speakers and/or a subwoofer, set the speaker setting information properly to obtain the best possible surround effect. For details, see pages 14 to 17.

NOTE

You can place a subwoofer wherever you like since bass sound is non-directional. Normally place it in front of you.

Connecting video components

SCART connection

You can enjoy pictures and sounds from playback components simply by connecting with the SCART cable.

- If your video components have digital output terminal, also connect them using the digital terminals explained in "Digital connection" (see page 9). By using these terminals, you can get better sound quality.

CAUTION:

If you connect a sound-enhancing device such as a graphic equalizer between the source components and this receiver, the sound output through this receiver may be distorted.

DO NOT use a TV through a VCR or a TV with a built-in VCR; otherwise, the picture may be distorted.

Turn off all components before making connections.

- Illustrations of the input/output terminals are typical examples. When you connect other components, refer also to their manuals since the terminal names actually printed on the rear vary among different components.

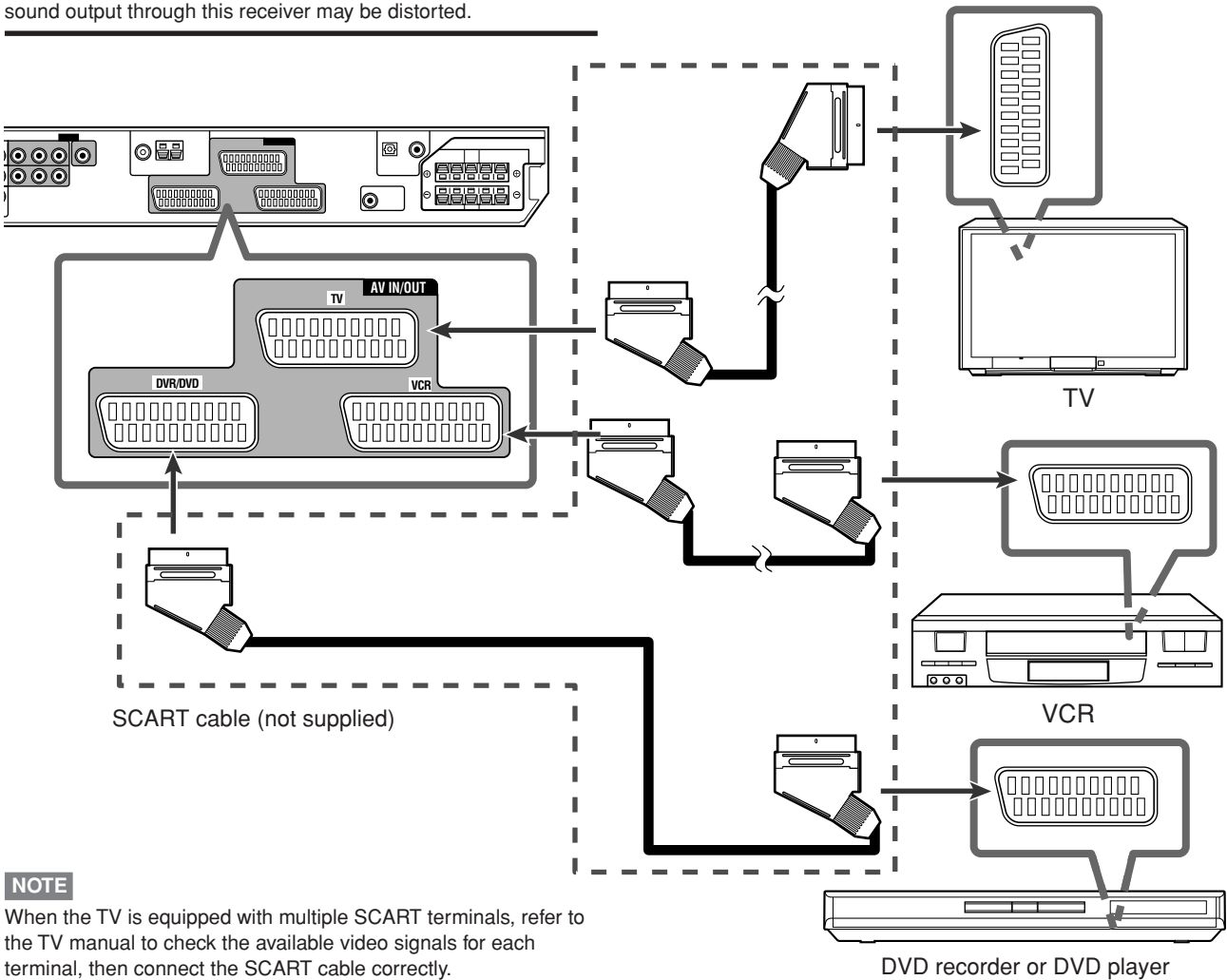

NOTE

When the TV is equipped with multiple SCART terminals, refer to the TV manual to check the available video signals for each terminal, then connect the SCART cable correctly.

Getting started

SCART Terminal Specifications

				Terminal name		
				TV	VCR	DVR/DVD
Input	Audio	L/R	○	○	○	
	Video	Composite	○	○	○	
		S-video (Y/C)	—	○	○	
		RGB	—	○	○	
Output	Audio	L/R	○*1	○	○	
	Video	Composite	○*2*3	○*2*3	○*2*3	
		S-video (Y/C)	○*3	—	—	
		RGB	○*3	—	—	
T-V LINK			○*4	○*4	○*4	

○: Available —: Not available

*1 Only when TV Direct is in use (see page 12).

*2 The signals input from a SCART terminal cannot be output through the same SCART terminal.

*3 The video format of the output video signals are consistent with that of the input video signals. For example, if S-video signals are input to this receiver, no signals other than S-video signals can be output from this receiver. Refer to the manuals supplied with the video components to check the setting of the input/output video signals.

*4 The signals for the T-V LINK function are always going through the receiver.

CONTINUED ON THE NEXT PAGE

For TV and video format

This receiver cannot convert the video signals. When the video signal of one video component is different from that of the other (for example, one is S-video, the other is Composite), you may not see the pictures appropriately. In this case, unify the video signals of all the video components, or you need to switch the video signal of TV each time you change the source.

For an analogue decoder

To watch through or to record a scrambled program on your VCR, connect the analogue decoder to your VCR and select the scrambled channel on your VCR. If there is not an appropriate terminal for the decoder connection on your VCR, connect the decoder to your TV. Refer also to the manuals supplied with these components.

For T-V LINK

- You can use the T-V LINK function if you connect a T-V LINK compatible TV and VCR to this receiver with a fully wired SCART cables. For details on T-V LINK, refer also to the manuals supplied with the TV and the VCR.
- Connect a SCART cable to EXT-2 terminal on the JVC's T-V LINK compatible TV for the T-V LINK function.
- Some video components support the data communication like T-V LINK. For complete details, refer also to the manuals supplied with these components.

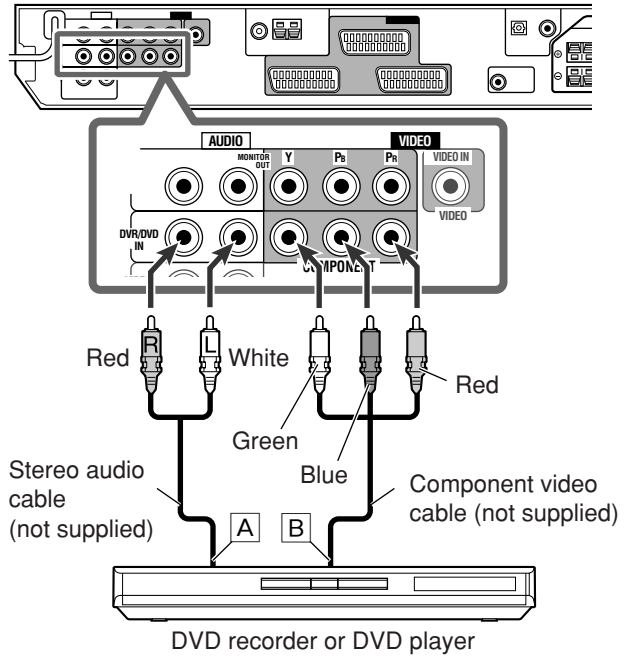

- A** To left/right audio channel output
- B** To component video output

NOTES

- Connect Y, Pb, and Pr correctly.
- Do not connect different components to the AUDIO DVR/DVD IN jacks and AV IN/OUT DVR/DVD terminal; otherwise, sounds from both components are come out of the speakers at the same time.

Audio/video connection

In addition to the SCART terminals, this receiver is equipped with the following video terminals:

- Component video input/output: DVR/DVD IN, MONITOR OUT
- Composite video input: VIDEO IN

NOTE

When recording the sounds and pictures onto the DVD recorder or VCR, record them through the SCART terminals.

IMPORTANT

The component video signals from the COMPONENT VIDEO jacks are transmitted only through the MONITOR OUT jacks. Therefore, if the TV is connected to the receiver through the SCART terminal (TV) and a playing video component is connected to the receiver through the component video jacks (DVR/DVD IN), you cannot view the playback picture on the TV.

Turn off all components before making connections.

■ Connecting a DVD recorder or DVD player to the DVR/DVD IN jacks

To fully enjoy Dolby Digital and DTS multi-channel software (including Dual Mono software), connect the DVD recorder or DVD player through the digital input/output terminals (see page 9).

■ Connecting a TV to the MONITOR OUT jacks

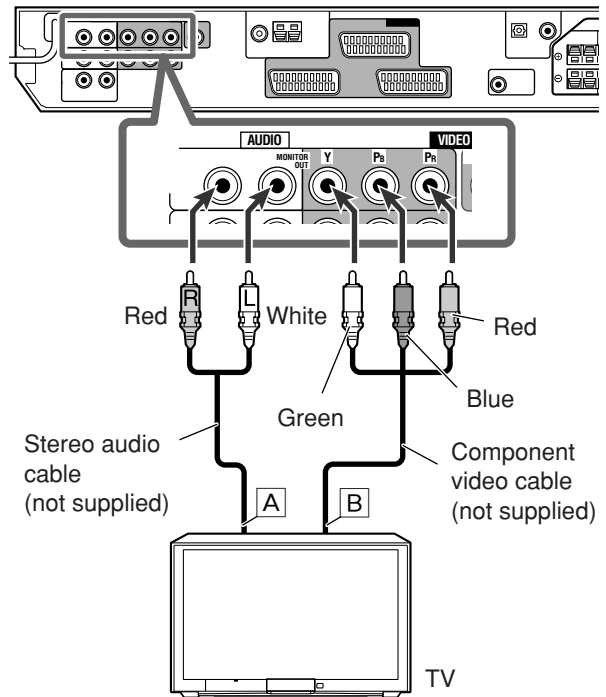

- A** To left/right audio channel input
- B** To component video input

IMPORTANT

Audio signals come out through the AUDIO MONITOR OUT (RIGHT/LEFT) jacks ONLY when TV Direct is in use (see page 12).

NOTE

Connect Y, Pb, and Pr correctly.

■ Connecting a video component to the VIDEO IN jacks

You can connect a video component such as another VCR to the VIDEO IN jacks using a composite video cable and stereo audio cable. Such component is referred to as the source "VIDEO" in this manual.

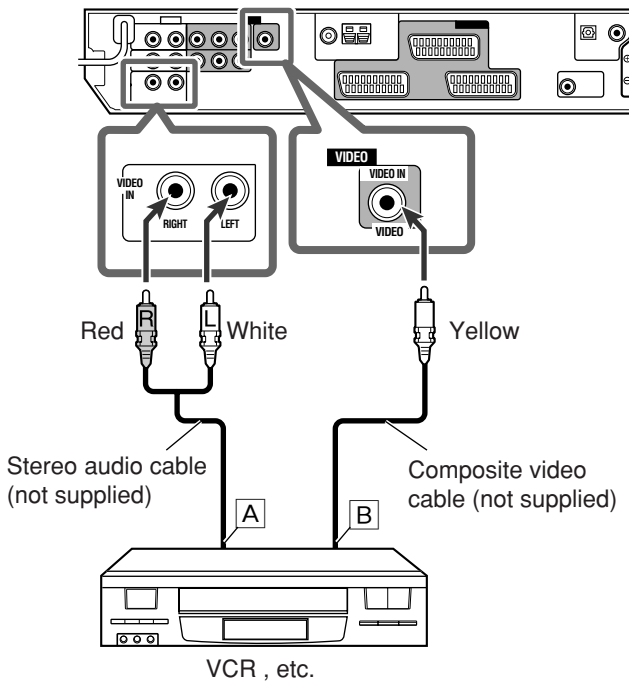

- A To left/right audio channel output
- B To composite video output

NOTE

To view the picture, connect the TV to the receiver using the SCART cable.

Digital connection

Turn off all components before making connections.

This receiver is equipped with two DIGITAL IN terminals—a digital coaxial terminal and digital optical terminal.

To reproduce the digital sound, use the digital connection in addition to the analogue connection methods described on pages 7 to 9.

Digital coaxial cable (supplied: 1 cable)



Digital optical cable (not supplied)

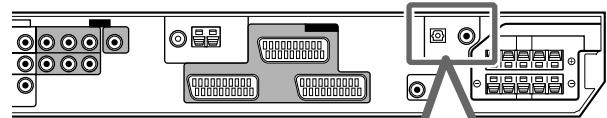

When the component has a digital coaxial output terminal, connect it to the 1(DVR/DVD) terminal, using a digital coaxial cable (supplied).

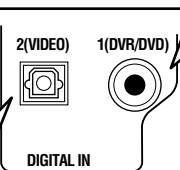

When the component has a digital optical output terminal, connect it to the 2(VIDEO) terminal, using a digital optical cable (not supplied).

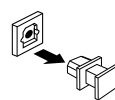

Before connecting a digital optical cable, unplug the protective plug.

NOTES

- When shipped from the factory, the DIGITAL IN terminals have been set for use with the following components:
 - 1(DVR/DVD): For DVD recorder or DVD player
 - 2(VIDEO): For the component connected to the VIDEO IN jacks

If you connect other components, change the digital input (DIGITAL IN) terminal setting correctly. See "Setting the digital input (DIGITAL IN) terminals—DIGITAL IN1/2" on page 19.

- Select the correct digital input mode. See "Selecting the analogue or digital input mode" on page 10.

Connecting the power cord

When all the audio/video connections have been made, connect the AC power plug to the wall outlet. Make sure that the plugs are inserted firmly. The standby lamp lights in red.

CAUTIONS:

- Do not touch the power cord with wet hands.
- Do not alter, twist or pull the power cord, or put anything heavy on it, which may cause fire, electric shock, or other accidents.
- If the cord is damaged, consult a dealer and have the power cord replaced with a new one.

NOTES

- Keep the power cord away from the connecting cables and the antenna. The power cord may cause noise or screen interference.
- The preset settings such as preset channels and sound adjustment may be erased in a few days in the following cases:
 - When you unplug the power cord.
 - When a power failure occurs.

Basic operations

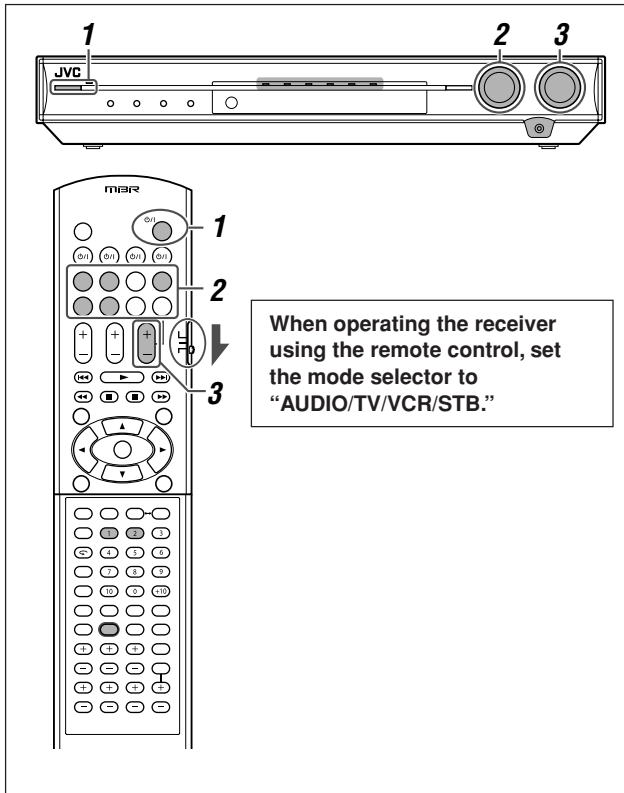

1 Turn on the power

Press **STANDBY/ON** (or **AUDIO** on the remote control).

The standby lamp goes off and the source lamp of the current source lights in red.

Current source name appears.

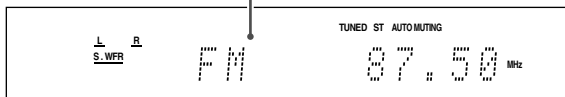

To turn off the power (into standby)

Press **STANDBY/ON** (or **AUDIO** on the remote control) again.

The standby lamp lights in red.

NOTE

A small amount of power is consumed in standby mode. To turn the power off completely, unplug the AC power cord.

2 Select the source to play

On the front panel:

Turn **SOURCE SELECTOR** until the source name you want appears on the display.

The source lamp corresponding to the selected source lights in red.

- As you turn **SOURCE SELECTOR**, the source changes as follows:



DVR/DVD (DGT) ↔ VCR (DIGITAL) ↔
VIDEO (DGTL) ↔ TV (DIGITAL) ↔
FM ↔ AM ↔ (Back to the beginning)

- DVR/DVD (DGT)*: Select the DVD recorder or DVD player.
- VCR (DIGITAL)*: Select the VCR.
- VIDEO (DGTL)*: Select the component connected to the VIDEO IN jacks on the rear of the receiver.
- TV (DIGITAL)*: Select the TV.
- FM: Select an FM broadcast.
- AM: Select an AM (MW) broadcast.

From the remote control:

Press one of the source selecting buttons.

- For the tuner, press FM/AM. Each time you press FM/AM, the band alternates between FM and AM (MW).

* Selecting the analogue or digital input mode

For a component you have connected using both the analogue connection and the digital connection methods (see pages 7 to 9), you need to select the correct input mode.

- You can select the digital input only for sources which you have selected digital input terminals for. (See "Setting the digital input (DIGITAL IN) terminals—DIGITAL IN1/2" on page 19.)

From the remote control ONLY:

Press **SOUND**, then press **A/D INPUT** to select the analogue or digital input mode.

- Each time you press **A/D INPUT**, the input mode alternates between the analogue input ("ANALOGUE") and the digital input ("DGTL AUTO").

DGTL AUTO: Select for the digital input mode. The receiver automatically detects the incoming signal format, then the digital signal format indicator (LPCM, DOLBY D, DTS, or DTS 96/24) for the detected signal lights up.

ANALOGUE: Select for the analogue input mode.

Initial setting: ANALOGUE

NOTE

After pressing **SOUND**, the numeric buttons work for sound adjustments. To use the numeric buttons to operate your target source, press the corresponding source selecting button before operation; otherwise, the remote control may not work as you intend.

3 Adjust the volume

To increase the volume, turn **MASTER VOLUME** control clockwise (or press **VOLUME +** on the remote control).

To decrease the volume, turn **MASTER VOLUME** control counterclockwise (or press **VOLUME -** on the remote control).

- When you adjust the volume, the volume level indication appears on the display for a while.

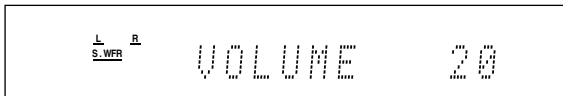

CAUTION:

Always set the volume to the minimum before starting any sources. If the volume is set at its high level, the sudden blast of sound energy can permanently damage your hearing and/or ruin your speakers.

NOTE

The volume level can be adjusted within the range of "0" (minimum) to "50" (maximum).

Listening with headphones

You can enjoy not only stereo software but also multi-channel software through the headphones. (Sounds are down-mixed to the front channels while playing multi-channel software.)

Connect a pair of headphones to the PHONES jack on the front panel to activate the HEADPHONE mode.

- The HP (headphone) indicator lights up on the display.
- You can also enjoy the Surround/DSP mode through the headphones—3D HEADPHONE mode. For details, see pages 30 and 31.
- Disconnecting a pair of headphones from the PHONES jack cancels the HEADPHONE (or 3D HEADPHONE) mode and activates the speakers.

CAUTION:

Be sure to turn down the volume:

- Before connecting or putting on headphones, as high volume can damage both the headphones and your hearing.
- Before removing headphones, as high volume may output from the speakers.

Selecting the digital decode mode

If the following symptoms occur while playing Dolby Digital or DTS software with "DGTL AUTO" selected (see page 10), follow the procedure below:

- Sound does not come out at the beginning of playback.
- Noise comes out while searching for or skipping chapters or tracks.

From the remote control ONLY:

1 Press SOUND, then press A/D INPUT to select "DGTL AUTO."

2 Press DECODE to select "DGTL D.D." or "DGTL DTS."

- Each time you press the button, the digital decode mode changes as follows:

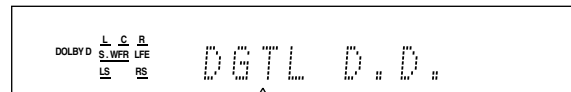

DGTL AUTO → DGTL D.D. →
DGTL DTS → (Back to the beginning)

- To play back software encoded with Dolby Digital, select "DGTL D.D."
- To play back software encoded with DTS, select "DGTL DTS."

NOTES

- When you turn off the power or select another source, "DGTL D.D." or "DGTL DTS" is canceled and the digital decode mode is automatically reset to "DGTL AUTO."
- After pressing SOUND, the numeric buttons work for sound adjustments. To use the numeric buttons to operate your target source, press the corresponding source selecting button before operation; otherwise, the remote control may not work as you intend.

The following digital signal format indicators on the display indicate what type of signal comes into the receiver.

LPCM: Lights up when Linear PCM signal comes in.

DOLBY D: • Lights up when Dolby Digital signal comes in.
• Flashes when "DGTL D.D." is selected for any software other than Dolby Digital.

DTS: • Lights up when conventional DTS signal comes in.
• Flashes when "DGTL DTS" is selected for any software other than DTS.

DTS 96/24: Lights up when DTS 96/24 signal comes in.

NOTE

When "DGTL AUTO" cannot recognize the incoming signal, no digital signal format indicator lights up on the display.

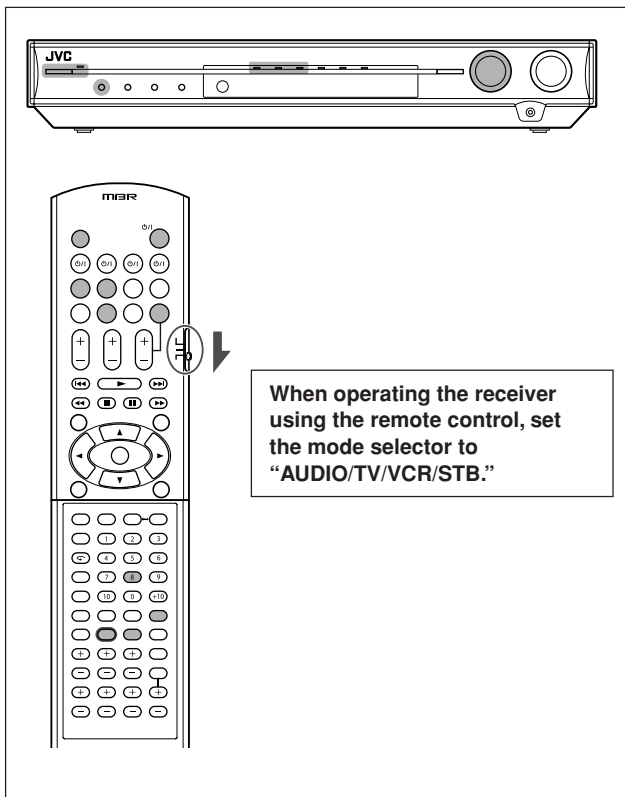

Adjusting the subwoofer audio position

If the subwoofer sound is reinforced for stereo sound compared to the sound reproduced with multi-channel, set the subwoofer audio position. The subwoofer output level is automatically decreased by the selected value when you are listening in stereo.

The AUDIO P. indicator lights up when this function is activated.

- Once you have made an adjustment, it is memorized for each source.

From the remote control ONLY:

Press SOUND, then press A.POSITION repeatedly.

- Each time you press A.POSITION, the subwoofer audio position level changes as follows:

AUDIO P. indicator

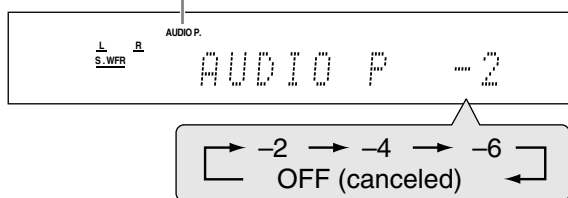

The smaller the number becomes, the more the level decreases automatically when listening in stereo.

- If no adjustment is required, select "OFF" (initial setting).

NOTES

- The maximum subwoofer output level is -10 dB.
Ex.: When setting the subwoofer output level to " -8 (dB)" and the subwoofer audio position to " -4 (dB)," the subwoofer output level when listening in stereo will be -10 dB.
To adjust the subwoofer output level, see page 21.
- This function is not available when the Surround/DSP mode is activated.
- After pressing SOUND, the numeric buttons work for sound adjustments. To use the numeric buttons to operate your target source, press the corresponding source selecting button before operation; otherwise, the remote control may not work as you intend.

Activating TV Direct

TV Direct enables you to use this receiver as an AV selector **while the receiver is turned off.**

When TV Direct is activated, the pictures and sounds go from the video components such as DVD player to the TV through this receiver. Thus, you can use the video components and the TV as if they were connected directly.

- This function takes effect for the following sources—DVR/DVD, VCR, and VIDEO.

To activate (or deactivate) TV Direct, follow the procedure below:

1 Press TV DIRECT.

All the indications disappear, then the source lamp of the current source lights in green.

2 Turn on the video component and TV.

3 Select the target video component.

On the front panel:

Turn SOURCE SELECTOR until one of the source lamps—DVR/DVD, VCR, or VIDEO—lights in green.

From the remote control:

Press one of the source selecting buttons—DVR/DVD, VCR, or VIDEO.

The source lamp corresponding to the selected source lights in green.

To cancel TV Direct and turn off the receiver, press O/I STANDBY/ON on the front panel (or O/I AUDIO on the remote control).

The receiver is turned off and the standby lamp lights up.

To cancel TV Direct and turn on the receiver, press TV DIRECT again.

The receiver is turned on and the source lamp currently selected lights in red.

NOTES

- When TV Direct is activated, you cannot enjoy any of the sound effects the receiver produces, and cannot use the speakers connected to the receiver.
- You can use the T-V LINK function between the TV and VCR while TV Direct is activated. (For T-V LINK functions, refer to the manuals supplied with the TV and the VCR.)

Turning off the sounds temporarily

From the remote control ONLY:

Press MUTING to turn off the sound through all connected speakers and headphones connected.

“MUTING” appears on the display and the volume turns off.

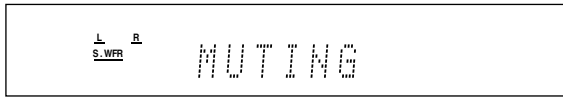

To restore the sound, press MUTING again.

- Pressing VOLUME +/- (or turning MASTER VOLUME control on the front panel) also restores the sound.

Changing the display brightness

You can dim the display—Dimmer.

From the remote control ONLY:

Press DIMMER repeatedly.

- Each time you press the button, the display brightness changes as follows:
 - DIMMER 1: Dims the display slightly.
 - DIMMER 2: Dims the display more than DIMMER 1.
 - DIMMER 3: Turns off the display. (Temporarily canceled when you operate the receiver.)*
- DIMMER OFF: Cancels the Dimmer (normal display).

* Except when activating or deactivating TV Direct.

Turning off the power with the Sleep Timer

You can fall asleep while listening to music—Sleep Timer.

From the remote control ONLY:

Press SLEEP repeatedly.

- Each time you press the button, the shut-off time changes in 10 minute intervals. The SLEEP indicator lights up on the display.

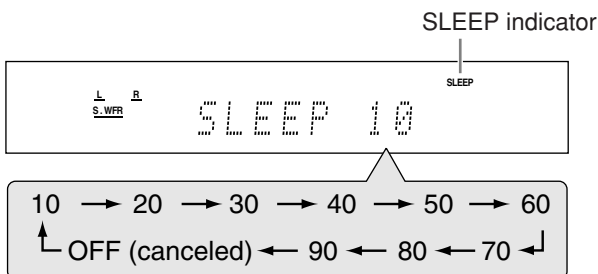

When the shut-off time comes:

The receiver turns off automatically.

To check or change the remaining time until the shut-off time:

Press SLEEP once.

The remaining time (in minutes) until the shut-off time appears.

- To change the shut-off time, press SLEEP repeatedly.

To cancel the Sleep Timer:

Press SLEEP repeatedly so that “SLEEP OFF” appears on the display. (The SLEEP indicator goes off.)

- The Sleep Timer is also canceled when:
 - You turn off the receiver, or
 - TV Direct is activated.

Basic adjustment of auto memory

This receiver memorizes sound settings for each source:

- when you turn off the power,
- when you change the source, and
- when you change the analogue/digital input mode (see page 10).

When you change the source, the memorized settings for the newly selected source are automatically recalled.

The following can be stored for each source:

- Analogue/digital input mode (see page 10)
- Speaker output level (see page 21)
- Subwoofer audio position (see page 12)
- Subwoofer phase (see page 22)
- Digital equalization pattern (see page 22)
- Bass boost (see page 22)
- Input attenuator mode (see page 22)
- Surround/DSP mode selection (see pages 32 and 33)

NOTE

If the source is FM or AM (MW), you can assign a different setting for each band.

Signal and speaker indicators on the display

Signal indicators

Speaker indicators

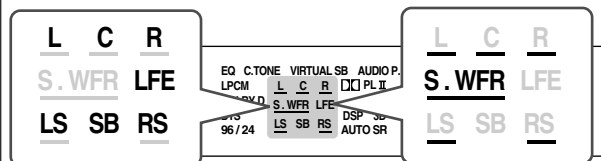

The signal indicators light up as follows:

- L:
 - **When digital input is selected:** Lights up when the left channel signal comes in.
 - **When analogue input is selected:** Always lights up.
- R:
 - **When digital input is selected:** Lights up when the right channel signal comes in.
 - **When analogue input is selected:** Always lights up.
- C: Lights up when the center channel signal comes in.
- LS*: Lights up when the left surround channel signal comes in.
- RS*: Lights up when the right surround channel signal comes in.
- SB: Lights up when the surround back channel signal comes in.
- LFE: Lights up when the LFE channel signal comes in.

* When monaural surround signal comes in, only “S” lights up.

The speaker indicators light up as follows:

- The subwoofer indicator (**S.WFR**) lights up when “SUBWOOFER” is set to “SUBWFR :YES.” For details, see page 16.
- The other speaker indicators light up only when the corresponding speaker is set to “SML (small)” or “LRG (large),” and also when required for the current playback.

Basic settings

To obtain the best possible sound effect from Surround/DSP modes (see pages 29 to 33), you need to set up the speaker and subwoofer information after all the connections are completed. From pages 14 to 19, how to set speakers and other basic items of the receiver are explained.

Setting the speaker information automatically—Smart Surround Setup

The distance from your listening point to the speakers is one of the important elements to obtain the best possible sound effect for the Surround/DSP modes.

By using Smart Surround Setup, the following are automatically calculated by one simple action—clapping hands.

- Speaker distance (compared to that of the closest speaker)
- Speaker output level

NOTES

- To set the speaker information effectively using Smart Surround Setup, unplug the power cords of all the components connected to this receiver and the subwoofer which may cause noise.
- Before starting Smart Surround Setup, set the speaker information correctly (SML, LRG, or NO) according to your speakers except the subwoofer (see page 16).
- When the setting is made by Smart Surround Setup, the speaker distance and output level you have set before will be inactive.
- If you have turned off the display, cancel the Dimmer (see page 13); otherwise, you cannot see the information on the display during Smart Surround Setup.
- Smart Surround Setup will not be done correctly if you or other object blocks the sound.
- When you change your speakers, do the following procedure again.

From the remote control ONLY:

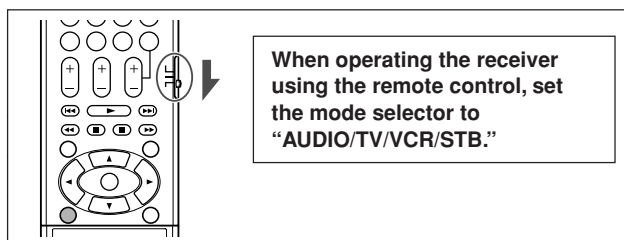

1 Take your position where you listen to the sound.

- Make sure speaker cables are connected firmly.

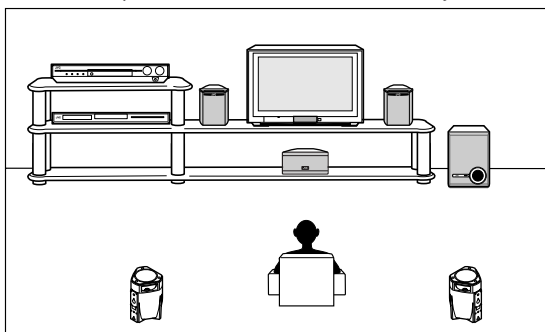

2 Press and hold SMART SURROUND SETUP until “SETTING UP” flashes on the display.

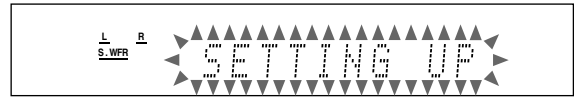

3 Confirm that “SETTING UP” stops flashing, then clap your hands over your head once while “SETTING UP” still remains on the display.

The receiver starts detecting the level of the sound coming through each speakers (except the subwoofer).

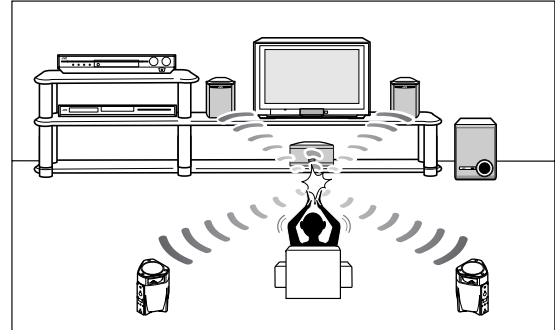

When your clapping sound is detected successfully,

“SUCCESSFUL” appears on the display, then the values set are shown as follows:

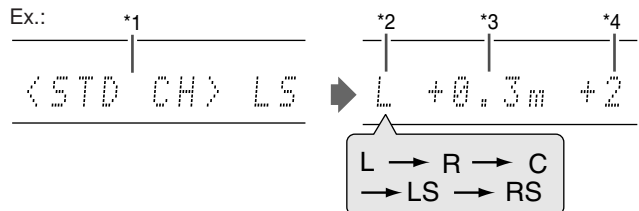

► **COMPLETED** ► Then the receiver returns to normal operation mode.

- *1 Standard channel (the closest speaker). This speaker position now works as the reference position (“0m/ft”) and other speakers’ distance is shown by the difference with this reference speaker position.
- *2 **L:** Left front speaker
R: Right front speaker
C: Center speaker
LS: Left surround speaker
RS: Right surround speaker
- *3 Difference of each speaker position in distance (in meters or feet).
- *4 Each speaker’s output level (–6 to +6).

When your clapping sound is not detected correctly,

“SETTING UP” appears again after one of the following messages appears on the display.

- SILENT:**
 - The receiver detects sound from only the left and right front speakers.
 - The receiver detects no sound from the front speakers and detects sound from at least one of other speakers.
- SILENT-ALL:** The receiver cannot detect any sound from any speakers for about 15 seconds.
- FAILED:** The receiver cannot detect sound from the left or right front speaker.

In this case, repeat step 3.

In the following cases, set the speakers manually.

- **When the receiver detects the sound as “SILENT” twice in succession.**

The setting is made. (The distance of the speakers from which sound has not been detected is set to “+9.0m (+30ft).”) The receiver exits from Smart Surround Setup.

- **When the receiver fails to detect the sound three times.**

“MANUAL” appears on the display. The receiver exits from Smart Surround Setup.

To cancel Smart Surround Setup, press SMART SURROUND SETUP while “SETTING UP” flashes on the display.

- No other operations can be done after “SETTING UP” stops flashing. Complete the Smart Surround Setup.

To check the setting made by Smart Surround Setup, press SMART SURROUND SETUP while the receiver is in normal operation mode.

The setting values appear one after another (see page 14).

- If you have changed speaker distance and/or output level manually after using Smart Surround Setup, “MANUAL” appears.
- If you have not used Smart Surround Setup, “NO S.S.S.” appears.

NOTES

- The speaker distance and output level manually set will be applied instead of those set by using Smart Surround Setup in the following cases:
 - When you change one of the speaker distance (see page 17).
 - When you change one of the speaker output level (see page 21).
 - When you change one of the speaker size either from “NO” to “SML” or “LRG,” or from “SML” or “LRG” to “NO” (see page 16).
- When you want to adjust the speaker distance and output level manually, see pages 17 and 21.
- Do not clap your hands so hard that it may hurt your hands.

Basic setting items

You can adjust the following items. See pages in parentheses for details.

- You cannot select the items which is not available with the current setting.

Items	To do
SUBWOOFER	Register your subwoofer. (16)
FRONT SPK	Register your front speaker size. (16)
CENTER SPK	Register your center speaker size. (16)
SURRND SPK	Register your surround speaker size. (16)
DIST UNIT	Select the measuring unit for the speaker distance. (17)
FRNT L DIST*	Register the distance from the left front speaker to your listening point. (17)
FRNT R DIST*	Register the distance from the right front speaker to your listening point. (17)
CENTER DIST*	Register the distance from the center speaker to your listening point. (17)
SURR L DIST*	Register the distance from the left surround speaker to your listening point. (17)
SURR R DIST*	Register the distance from the right surround speaker to your listening point. (17)
SUBWFR OUT	Select sounds emitted from the subwoofer. (17)
VIRTUAL SB	Set the virtual surround back speaker. (18)
DUAL MONO	Select the Dual Mono sound channel. (18)
CROSS OVER	Select the cutoff frequency to the subwoofer. (17)
LFE ATT	Attenuate the bass (LFE) sounds. (17)
MIDNIGHT M.	Reproduce a powerful sound at night. (18)
DIGITAL IN1	Select the component connected to the digital coaxial terminal. (19)
DIGITAL IN2	Select the component connected to the digital optical terminal. (19)
AUTO SURRND	Select Auto Surround mode. (19)
AUTO MODE	Select Auto Function mode. (19)

* If you have used Smart Surround Setup on page 14, these settings are not required.

Operating procedure

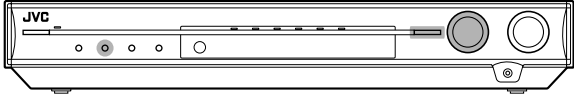

On the front panel ONLY:

Before you start, remember...

There is a time limit in doing the following steps. If the setting is canceled before you finish, start from step 1 again.

Ex.: When setting DIGITAL IN 1 terminal.

1 Press SETTING.

MULTI JOG now works for the setting operation.

2 Turn MULTI JOG until the item you want to set appears on the display.

- As you turn MULTI JOG, the setting items change as follows:

L S.WFR R
DIGITAL IN1

SUBWOOFER	↔	FRONT SPK	↔
CENTER SPK	↔	SURRND SPK	↔
DIST UNIT	↔	FRNT L DIST	↔
FRNT R DIST	↔	CENTER DIST	↔
SURR L DIST	↔	SURR R DIST	↔
SUBWFR OUT	↔	VIRTUAL SB	↔
DUAL MONO	↔	CROSS OVER	↔
LFE ATT	↔	MIDNIGHT M.	↔
DIGITAL IN1	↔	DIGITAL IN2	↔
AUTO SURRND	↔	AUTO MODE	↔

(Back to the beginning)

3 Press SET.

The current setting of the selected item appears.

L S.WFR R
D1 DVR/DVD

4 Turn MULTI JOG to select the appropriate setting.

L S.WFR R
D1 VCR

→ DVR/DVD ↔ VIDEO ←

→ TV ↔ VCR ←

Your setting is stored.

5 Press SET.

6 Repeat steps 2 to 5 to set other items if necessary.

Setting the speakers

Setting subwoofer information—SUBWOOFER

Each time the receiver turns on, the receiver detects the subwoofer connection and automatically changes the setting of the subwoofer.

When you want to change the setting manually, select either one below.

SUBWFR : YES Select when you have connected a subwoofer. The subwoofer indicator (**S.WFR**) lights up on the display. You can adjust the subwoofer output level (see page 21).

SUBWFR : NO Select when you have disconnected a subwoofer. Selecting this changes the front speaker size to "LRG" (see below).

NOTE

You need to change the setting each time you turn on the receiver if you want to change the subwoofer information set automatically.

Setting the speaker size—FRONT SPK (front speakers), CENTER SPK (center speaker), SURRND SPK (surround speakers)

Register the sizes of all the connected speakers.

LRG (large)	Select when the cone speaker size is larger than 12 cm.
SML (small)	Select when the cone speaker size is smaller than 12 cm.
NO	Select when you have disconnected a speaker. (Not selectable for the front speakers.)

Initial setting: SML for all speakers*

* When "SUBWOOFER" is set to "SUBWFR : NO," the front speaker size is fixed to "LRG" (and you cannot select "SML").

NOTES

- If you have selected "SML (small)" for the front speaker size, you cannot select "LRG (large)" for the center and surround speaker sizes.
- If you change the center and/or surround speaker size either from "NO" to "SML" or "LRG," or from "SML" or "LRG" to "NO," the distance and output levels set by Smart Surround Setup will be ineffective.

Setting the speaker distance

The distance from your listening point to the speakers is one of the important elements to obtain the best possible sound effect from the Surround/DSP modes.

By referring to the speaker distance, the receiver automatically sets the delay time of the sound through each speaker so that sounds through all the speakers can reach you at the same time.

- If you have used Smart Surround Setup on page 14, this setting is not required.

■ Measuring unit—DIST UNIT

Select which measuring unit you use.

UNIT :meter Select to set the distance in meters.

UNIT : feet Select to set the distance in feet.

Initial setting: UNIT :meter

■ Speaker distance—

**FRNT L DIST (for the left front speaker),
FRNT R DIST (for the right front speaker),
CENTER DIST (for the center speaker),
SURR L DIST (for the left surround speaker),
SURR R DIST (for the right surround speaker)**

Adjustable range: 0.3 m to 9.0 m in 0.3 m intervals
(1 ft to 30 ft in 1 ft intervals)

Initial setting: 3.0 m (10 ft) for all speakers

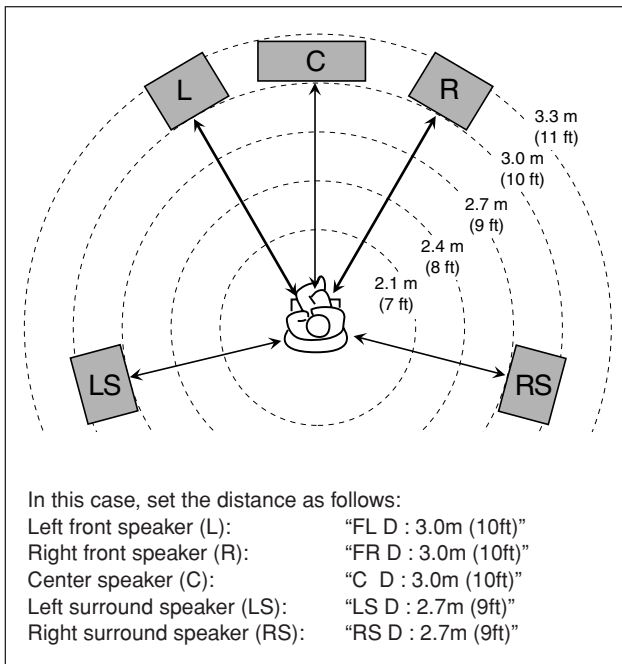

NOTES

- You cannot set the speaker distance for the speakers you have set to "NO."
- If you change speaker distance, the distance and output level set manually will be applied instead of those set by Smart Surround Setup.

Setting bass sound

Setting subwoofer output—SUBWFR OUT

You can select the type of the signal which can be transmitted through the subwoofer. In other words, you can determine whether or not the bass elements of the front speaker channels are transmitted through the subwoofer regardless of the front speaker size setting (either "SML" or "LRG").

SW: LFE

Select to emit only the LFE signals (while playing Dolby Digital and DTS software) or the bass elements of the "SML (small)" front speakers (while playing any source other than above).

SW:LFE+MAIN

Select to always emit the bass elements of the front speaker channels (MAIN). While playing Dolby Digital and DTS software, the bass elements and the LFE signals are both emitted.

Initial setting: SW: LFE

NOTE

When "SUBWOOFER" is set to "SUBWFR : NO" (see page 16), this function is not available.

Setting the crossover frequency—CROSS OVER

Small speakers cannot reproduce the bass sounds efficiently. If you use a small speaker in any position, this receiver automatically reallocates the bass sound elements assigned to the small speaker to the large speakers.

To use this function properly, set this crossover frequency level according to the size of the small speaker connected.

- If you have selected "LRG (large)" for all speakers (see page 16), this function will not take effect ("CROSS: OFF" appears).

CROSS: 80Hz

Select when the cone speaker unit built in the speaker is about 12 cm.

CROSS:100Hz

Select when the cone speaker unit built in the speaker is about 10 cm.

CROSS:120Hz

Select when the cone speaker unit built in the speaker is about 8 cm.

CROSS:150Hz

Select when the cone speaker unit built in the speaker is about 6 cm.

CROSS:200Hz

Select when the cone speaker unit built in the speaker is less than 5 cm.

Initial setting: CROSS:150Hz

NOTE

Crossover frequency is not valid for the HEADPHONE and 3D HEADPHONE modes.

Setting the low frequency effect attenuator—LFE ATT

If the bass sound is distorted while playing back software encoded with **Dolby Digital** or **DTS**, set the LFE level to eliminate distortion.

- This function takes effect only when the LFE signals come in.

LFE : 0dB

Normally select this.

LFE : -10dB

Select when the bass sound is distorted.

Initial setting: LFE : 0dB

Setting the virtual surround back speaker—VIRTUAL SB

You can enjoy the surround back channel while playing back **Dolby Digital Surround EX** software or **DTS-ES** software without the surround back speaker—Virtual Surround Back. This function creates the great surround effect from the behind as if you have connected the surround back speaker.
Select "V SB : ON" when activating the Virtual Surround Back.

V SB : OFF	Select to deactivate the Virtual Surround Back.
V SB : ON	While you play Dolby Digital Surround EX software or DTS-ES software, the VIRTUAL SB (Surround Back) indicator lights up.

Initial setting: V SB : OFF

NOTES

- When "SURREND SPK" is set to "NO" (see page 16), this function is not available.
- While playing back DTS-ES Matrix software with DTS 96/24, DTS 96/24 processing will not be performed with the Virtual Surround Back activated. To apply the processing, deactivate the Virtual Surround Back.
- Virtual Surround Back may not be applied to some software.

Selecting the main or sub channel—DUAL MONO

You can select the playback sound (channel) you want while playing digital software recorded (or broadcast) in Dual Mono mode (see page 30), which includes two monaural channels separately.

D MONO: SUB	Select to play back the sub-channel (Ch 2).* Signal indicator "R" lights up while playing back this channel.
D MONO:MAIN	Select to play back the main channel (Ch 1).* Signal indicator "L" lights up while playing back this channel.
D MONO: ALL	Select to play back both the main and sub-channels (Ch 1/Ch 2).* Signal indicators "L" and "R" light up while playing back these channels.

Initial setting: D MONO:MAIN

* Dual Mono signals can be heard from the following speakers—L (left front speaker), R (right front speaker), and C (center speaker), with respect to the current Surround setting:

Dual Mono setting	Without Surround		With Surround Activated				
			Center speaker setting				
	L	R	SML/LRG			NO	
		L	C	R	L	R	
SUB	Ch 2	Ch 2	—	Ch 2	—	Ch 2	Ch 2
MAIN	Ch 1	Ch 1	—	Ch 1	—	Ch 1	Ch 1
ALL	Ch 1	Ch 2	—	Ch 1+Ch 2	—	Ch 1+Ch 2	Ch 1+Ch 2

NOTE

The Dual Mono format is not identical with bilingual broadcasting for TV programs. So this setting does not take effect while watching such bilingual programs.

Using the Midnight mode—MIDNIGHT M.

You can enjoy a powerful sound at night using the Midnight mode.

NIGHT :OFF	Select when you want to enjoy surround with its full dynamic range. (No effect applied.)
NIGHT : 1	Select when you want to reduce the dynamic range a little.
NIGHT : 2	Select when you want to apply the compression effect fully (useful at night).

Initial setting: NIGHT :OFF

From the remote control:

Press **SOUND**, then press **MIDNIGHT** repeatedly to select either one of above.

NOTE

After pressing **SOUND**, the numeric buttons work for sound adjustments. To use the numeric buttons to operate your target source, press the corresponding source selecting button before operation; otherwise, the remote control may not work as you intend.

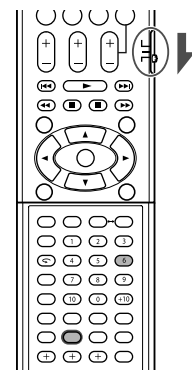

Setting the digital input (DIGITAL IN) terminals—DIGITAL IN1/2

When you use the digital input terminals, register what components are connected to which terminals—DIGITAL IN1/2 (see page 9) so that the correct source name will appear when you select the digital source.

For **DIGITAL IN 1(DVR/DVD)** terminal:

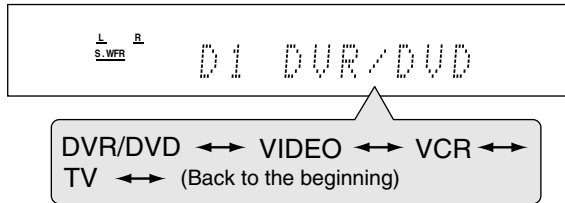

For **DIGITAL IN 2(VIDEO)** terminal:

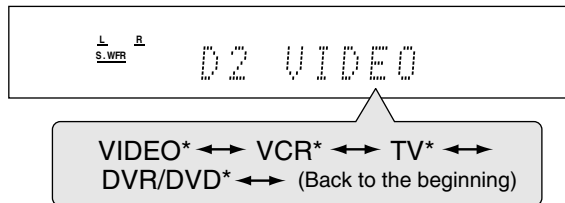

* The one selected for "DIGITAL IN1" will be skipped.

DVR/DVD	For DVD player (or DVD recorder).
VIDEO	For the component connected to the VIDEO IN jack on the rear of the receiver.
VCR	For VCR.
TV	For TV.

Initial setting: DVR/DVD (for "DIGITAL IN1")
VIDEO (for "DIGITAL IN2")

Setting Auto Surround—AUTO SURRND

You can enjoy the Surround mode simply by selecting the source (with digital input selected for that source).

- Auto Surround also works when the input mode changes from analogue to digital.
- For details about the Surround/DSP modes, see pages 29 to 31. Select "AUTO SR: ON" when activating Auto Surround.

AUTO SR: ON

- The AUTO SR indicator lights up on the display.
- If a multi-channel signal comes in, an appropriate Surround mode will be turned on.
 - If a Dolby Digital 2-channel or DTS 2-channel signal with surround signal comes in, "PLII MOVIE" will be selected.
 - If a Dolby Digital 2-channel or DTS 2-channel signal without surround signal comes in, "SURRND OFF (stereo)" will be selected.
 - If a Linear PCM signal comes in, nothing will change.

AUTO SR:OFF

Select to deactivate Auto Surround.

Initial setting: AUTO SR:OFF

NOTES

- This function does not take effect in the following cases:
 - While playing an analogue source,
 - While selecting any of DSP modes (see page 31), or one of the fixed digital decode mode—"DGTL D.D." or "DGTL DTS" (see page 11), and
 - While listening with the headphones.
- If you press SURROUND with Auto Surround activated, Auto Surround will be canceled temporarily for the currently selected source. Auto Surround setting will be restored in the following cases:
 - When you turn the receiver off and on,
 - When you change the source,
 - When you change the analogue/digital input, and
 - When you select "AUTO SR: ON" again.

Setting the Auto Function mode—AUTO MODE

The source will be selected automatically simply by turning on a video component.

- This function takes effect for the video components connected to the receiver using the SCART cable—DVR/DVD and VCR.

Auto Function mode works as follows:

- When a video component is turned on, the receiver selects the video component as the source (and the TV input is changed automatically).
- When a video component currently selected as the source is turned off, the receiver changes the source to the video source previously selected—DVR/DVD, VCR, or VIDEO.

MODE: AUTO1	Auto Function mode works when the receiver is turned on or when TV Direct is activated.
MODE: AUTO2	Auto Function mode works when the receiver is turned on or off, or when TV Direct is activated. (When a video component is turned on while the receiver is off, TV Direct is activated and the receiver selects the video component as the source.)

MODE:MANUAL You need to select the source manually.

Initial setting: MODE:MANUAL

When "MODE: AUTO1" or "MODE: AUTO2" is selected, the AUTO MODE indicator lights up on the display.

NOTES

- When selecting VCR as the source, "MODE: AUTO1" or "MODE: AUTO2" may not work if you only turn on the VCR. If this happens, you may need to start playback to activate Auto Function mode.
- When Auto Function mode is set to "MODE: AUTO2," the TV Direct may be activated after recovery from a power failure.

Sound adjustments

You can make sound adjustment to your preference after completing basic setting.

Basic adjustment items

You can adjust the following items. See pages in parentheses for details.

- You cannot select the items which is not available with the current setting.

Items	To do
SUBWFR LVL	Adjust the subwoofer output level. (21)
FRONT L LVL*	Adjust the left front speaker output level. (21)
FRONT R LVL*	Adjust the right front speaker output level. (21)
CENTER LVL*	Adjust the center speaker output level. (21)
SURR L LVL*	Adjust the left surround speaker output level. (21)
SURR R LVL*	Adjust the right surround speaker output level. (21)
EFFECT	Adjust the effect level. (21)
PANORAMA	Add "wraparound" sound effect with side-wall image. (21)
BASS BOOST	Boost the bass level. (22)
INPUT ATT	Attenuate the input level of analogue source. (22)
CENTER TONE	Make the center tone soft or sharp. (21)
D EQ 63Hz	Adjust the equalization pattern of each band. (22)
D EQ 250Hz	
D EQ 1kHz	
D EQ 4kHz	
D EQ 16kHz	
SBWFR PHASE	Select the subwoofer sound phase. (22)

* If you have used Smart Surround Setup on page 14, these settings are not required.

You can also use the remote control for sound adjustment except for "PANORAMA," "INPUT ATT," and "SBWFR PHASE."

Operating procedure



On the front panel:

Before you start, remember...

There is a time limit in doing the following steps. If the setting is canceled before you finish, start from step 1 again.

Ex.: When adjusting subwoofer output level.

1 Press ADJUST.

MULTI JOG now works for the sound adjustment.

2 Turn MULTI JOG until the item you want to adjust appears on the display.

- As you turn MULTI JOG, the adjustment items change as follows:

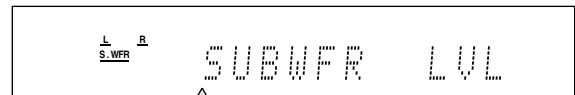

SUBWFR LVL	↔	FRONT L LVL	↔
FRONT R LVL	↔	CENTER LVL	↔
SURR L LVL	↔	SURR R LVL	↔
EFFECT	↔	PANORAMA	↔
BASS BOOST	↔	INPUT ATT	↔
CENTER TONE	↔	D EQ 63Hz	↔
D EQ 250Hz	↔	D EQ 1kHz	↔
D EQ 4kHz	↔	D EQ 16kHz	↔
SBWFR PHASE	↔	(Back to the beginning)	

3 Press SET.

The current setting for the selected item appears.

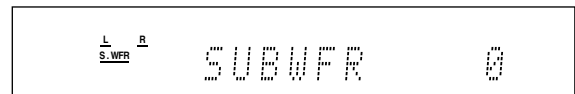

4 Turn MULTI JOG to adjust the selected item.

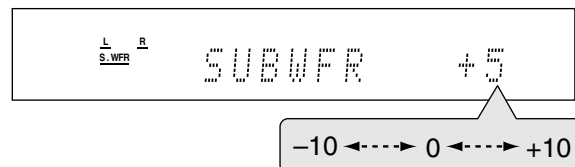

Your adjustment is stored.

5 Press SET.

6 Repeat steps 2 to 5 to adjust other items if necessary.

Adjusting speaker output level

- SUBWFR LVL (subwoofer output level),
- FRONT L LVL (left front speaker output level),
- FRONT R LVL (right front speaker output level),
- CENTER LVL (center speaker output level),
- SURR L LVL (left surround speaker output level),
- SURR R LVL (right surround speaker output level)

You can adjust the speaker output levels.

Adjust all the speakers' output levels so that you can listen sounds from all speakers at the same level.

- Once you have made an adjustment, it is memorized for each source.

Adjustable range: -10 (dB) to +10 (dB) (in 1 step intervals)

Initial setting: 0 (dB) for all speakers

NOTES

- If you have selected "NO" for a speaker (see page 16), the output level for the corresponding speaker is not adjustable.
- While using headphones, you can adjust only the left and right front speakers' output level.
- If you change one of these settings (except the subwoofer output level) manually, the distance and output levels set by Smart Surround Setup will be cleared and those manually set will be effective.

From the remote control:

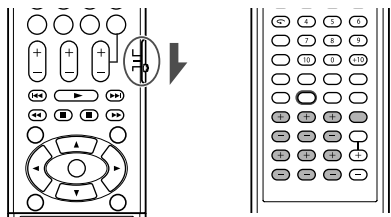

1 Press TEST TONE to check the speakers' output balance.

"TEST L" starts flashing on the display, and a test tone comes out of the speakers in the following order:

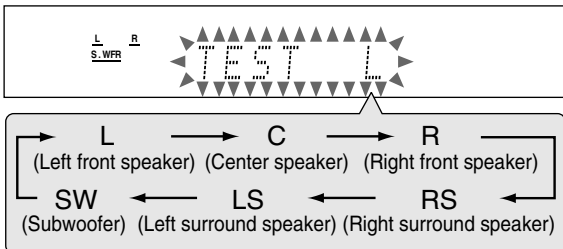

2 Adjust the speaker output levels.

When you press the level adjustment buttons corresponding to each speaker once, the current level for the speaker appears on the display, and the test tone comes out of the speaker.

EX.: When adjusting output level for the center speaker:
Press CENTER +/-.

The test tone comes out of the center speaker.

If no adjustment is done for about 4 seconds, the test tone comes out of the next speaker.

3 Press TEST TONE again to stop the test tone.

NOTES

- You can adjust the speaker output levels without the test tone.
- No test tone is available when the HEADPHONE (or 3D HEADPHONE) mode is in use.

Adjusting the sound parameters for the Surround/DSP modes

You can adjust the Surround/DSP sound parameters to your preference.

- For details about the Surround/DSP modes, see pages 29 to 33.

Adjusting the effect level for DSP modes—EFFECT

This setting is available only when one of the DSP modes (except ALL CH ST.) is in use. To activate DSP mode, see pages 32 and 33.

- Once you have made an adjustment, it is memorized for each DSP mode.

Adjustable range: 1 to 5 (in 1 step intervals)

Initial setting: EFFECT 3

As the number increases, the effect becomes stronger. Normally, select "3."

Adjusting the panorama control for Pro Logic II Music—PANORAMA

This setting is available only when Pro Logic II Music is in use. To activate Pro Logic II Music, see pages 32 and 33.

- Once you have made an adjustment, it is memorized until you change the setting.
- You cannot use the remote control for this setting.

PANORAMA ON Select to add "wraparound" sound effect with side-wall image.

PANORAMA OFF Select to listen to originally recorded sound.

Initial setting: PANORAMA OFF

Adjusting the center tone—CENTER TONE

This setting is available when one of the Surround/DSP modes is in use.

- If you have set "CENTER SPK" to "NO" (see page 16), the center tone is not adjustable.
- This setting is common to all Surround modes, and is memorized separately for DSP modes.

Adjustable range: 1 to 5 (in 1 step intervals)

Initial setting: CNT TONE 3

As the number increases, the dialogue becomes stronger. Normally, select "3."

- When the center tone is set to other than "CNT TONE 3," the C.TONE indicator lights up on the display.

From the remote control:

To adjust the effect level:

Press SOUND, then press EFFECT repeatedly.

To adjust the center tone:

Press SOUND, then press C.TONE repeatedly.

NOTE

After pressing SOUND, the numeric buttons work for sound adjustments. To use the numeric buttons to operate your target source, press the corresponding source selecting button before operation; otherwise, the remote control may not work as you intend.

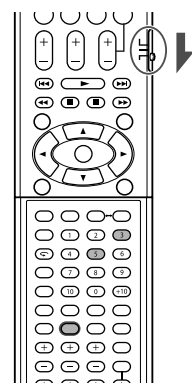

Adjusting the bass sounds

Reinforcing the bass—BASS BOOST

You can boost the bass level—Bass Boost.

- Once you have made an adjustment, it is memorized for each source.

B.BOOST ON Select to boost the bass level.
The BASS indicator lights up on the display.

B.BOOST OFF Select to deactivate the Bass Boost.

Initial setting: B.BOOST OFF

NOTE

This function affects only the sound coming out through the front speakers.

From the remote control:

Press **SOUND**, then press **BASS BOOST** repeatedly.

- Each time you press BASS BOOST, the Bass Boost turns on and off alternately.

NOTE

After pressing SOUND, the numeric buttons work for sound adjustments. To use the numeric buttons to operate your target source, press the corresponding source selecting button before operation; otherwise, the remote control may not work as you intend.

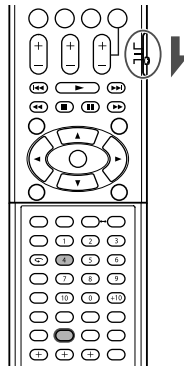

Attenuating the input signal—INPUT ATT

When the input level of **analogue source** is too high, the sound will be distorted. If this happens, you need to attenuate the input signal level to prevent the sound distortion.

- Once you have made an adjustment, it is memorized for each source.
- You cannot use the remote control for this setting.

ATT ON Select to attenuate the input signal level.
The ATT indicator lights up on the display.

ATT NORMAL Select to deactivate attenuation.

Initial setting: ATT NORMAL

Selecting the subwoofer sound phase—SBWFR PHASE

You can change the subwoofer sound phase to your preference.

- Once you have made an adjustment, it is memorized for each source.
- You cannot use the remote control for this setting.

PHASE NORM. Normally select this.

PHASE REV. Select this when you feel the bass sound is better with this mode rather than with “PHASE NORM.”

Initial setting: PHASE NORM.

NOTE

This function takes effect only when “SUBWOOFER” is set to “SUBWFR :YES” (see page 16).

Adjusting the equalization patterns—D EQ 63Hz/250Hz/1kHz/4kHz/16kHz

You can adjust equalization patterns in five frequency bands (center frequency: 63 Hz, 250 Hz, 1 kHz, 4 kHz, 16 kHz) for the front speakers.

- Once you have made an adjustment, it is memorized for each source.

Adjustable range: –8 (dB) to +8 (dB) (in 2 dB intervals)

Initial setting: 0 (dB) for all bands

- When adjustment is made, the EQ indicator lights up on the display.

To flatten the equalization pattern, set all the frequency bands to “0 (dB).”

- The EQ indicator goes off from the display.

From the remote control:

- 1 Press **D.EQ FREQ** repeatedly to select the band you want to adjust.
- 2 Press **D.EQ LEVEL +/-** to adjust the equalization pattern of the selected band.

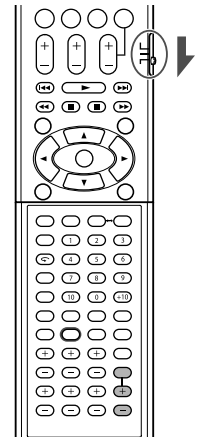

Tuner operations

Tuner operations are mainly done from the remote control.

When you have selected "FM" or "AM" by using SOURCE SELECTOR on the front panel, press FM/AM on the remote control to use the remote control for tuner operations.

When operating the receiver using the remote control, set the mode selector to "AUDIO/TV/VCR/STB."

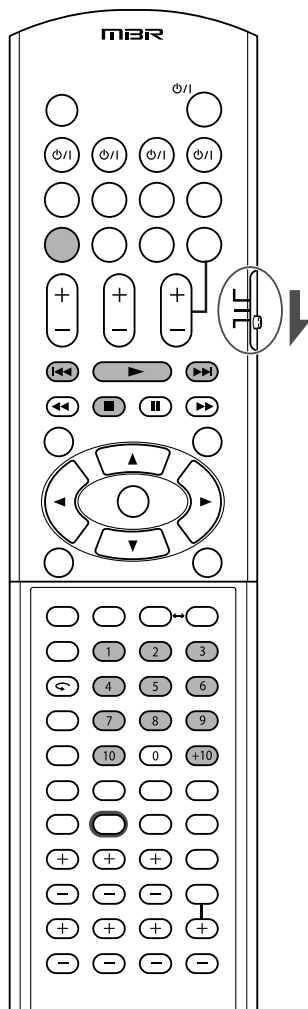

Tuning in to stations manually

From the remote control **ONLY**:

1 Press FM/AM to select the band.

- The last received station of the selected band is tuned in.
- Each time you press the button, the band alternates between FM and AM (MW).

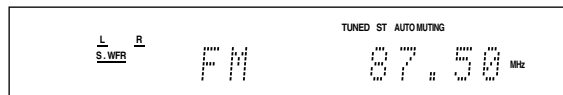

2 Press repeatedly or hold TUNING + or TUNING - until the station you want is tuned in.

- Pressing (or holding) TUNING + increases the frequency.
- Pressing (or holding) TUNING - decreases the frequency.

NOTES

- When you hold and release TUNING + or TUNING -, the frequency keeps changing until a station is tuned in.
- When a station of sufficient signal strength is tuned in, the TUNED indicator lights up on the display.
- When an FM stereo program is received, the ST (stereo) indicator also lights up.

Using preset tuning

Once a station is assigned a channel number, the station can be quickly tuned simply by selecting the number. You can preset up to 30 FM and 15 AM (MW) stations.

To store the preset stations

Before you start, remember...

There is a time limit in doing the following steps. If the setting is canceled before you finish, start from step 2 again.

From the remote control **ONLY**:

1 Tune in to the station you want to preset (see "Tuning in to stations manually" above).

- If you want to store the FM reception mode for this station, select the FM reception mode you want. See "Selecting the FM reception mode" on page 24.

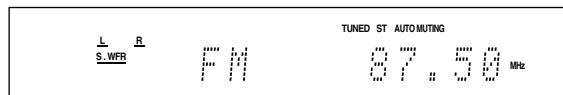

2 Press MEMORY.

The channel number position starts flashing on the display for about 5 seconds.

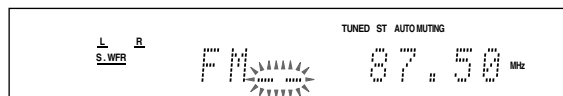

3 Press the numeric buttons (1 – 10, +10) to select a channel number while the channel number position is flashing.

- For channel number 5, press 5.
- For channel number 15, press +10, then 5.
- For channel number 30, press +10, +10, then 10.



4 Press MEMORY again while the selected channel number is flashing on the display.

The selected channel number stops flashing.
The station is assigned to the selected channel number.

5 Repeat steps 1 to 4 until you store all the stations you want.

To erase a stored preset station

Storing a new station on a used channel number erases the previously stored one.

To tune in a preset station

From the remote control:

1 Press FM/AM to select the band.

The last received station of the selected band is tuned in and the numeric buttons now work for tuner operations.

- Each time you press the button, the band alternates between FM and AM (MW).

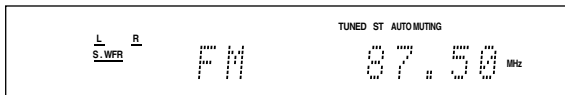

2 Press the numeric buttons (1 – 10, +10) to select a preset channel number.

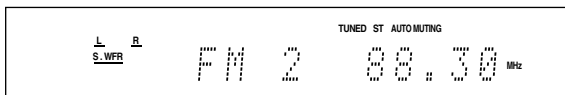

- For channel number 5, press 5.
- For channel number 15, press +10, then 5.
- For channel number 30, press +10, +10, then 10.

On the front panel:

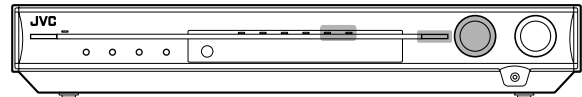

Before you start, remember...

There is a time limit in doing the following steps. If the setting is canceled before you finish, start from step 2 again.

1 Turn SOURCE SELECTOR to select “FM” or “AM.”

The last received station of the selected band is tuned in.

2 Press TUNER PRESET.

“P” appears on the display and MULTI JOG now works for selecting preset channels.

3 Turn MULTI JOG to select a preset channel number while “P” appears on the display.

- To increase the preset channel numbers, turn MULTI JOG clockwise.
- To decrease the preset channel numbers, turn MULTI JOG counterclockwise.

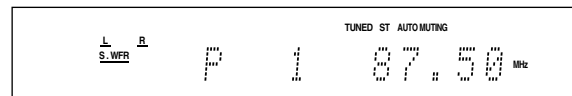

Selecting the FM reception mode

When an FM stereo broadcast is hard to receive or noisy, you can change the FM reception mode while receiving an FM broadcast.

- You can store the FM reception mode for each preset station (see page 23).

From the remote control ONLY:

While listening to an FM station, press FM MODE.

- Each time you press the button, the FM reception mode alternates between “AUTO MUTING” and “MONO.”

AUTO MUTING:

Normally select this.

When a program is broadcast in stereo, you will hear stereo sound; when in monaural, you will hear monaural sound. This mode is also useful to suppress static noise between stations. The AUTO MUTING indicator lights up on the display.

MONO:

Select this to improve the reception (but stereo effect will be lost).

In this mode, you will hear noise while tuning in to the stations. The AUTO MUTING indicator goes off from the display. (The ST indicator also goes off.)

Initial setting: AUTO MUTING

Using the Radio Data System (RDS) to receive FM stations

Only the buttons on the remote control are used for RDS operations.

When operating the receiver using the remote control, set the mode selector to "AUDIO/TV/VCR/STB."

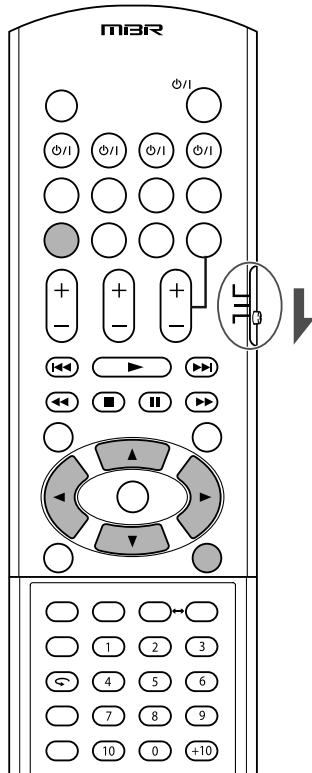

RDS allows FM stations to send an additional signal along with their regular program signals. For example, the stations send their station names, as well as information about what type of program they broadcast, such as sports or music, etc.

When an FM station which provides the RDS service is tuned in, the RDS indicator lights up on the display.

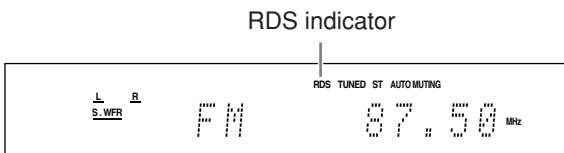

With the receiver, you can receive the following types of RDS signals:

PS (Program Service):	Shows commonly known station names.
PTY (Program Type):	Shows types of broadcast programs.
RT (Radio Text):	Shows text messages the station sends.
Enhanced Other Networks:	See page 28.

NOTES

- RDS is not available for AM (MW) broadcasts.
- RDS may not operate correctly if the station tuned is not transmitting RDS signal properly or if the signal strength is weak.

What information can RDS signals provide?

You can see the RDS signals the station sends on the display.

Press DISPLAY while listening to an FM station.

- Each time you press the button, the display changes to show the following information:

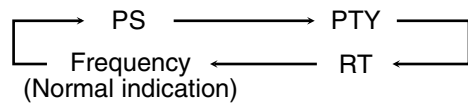

PS (Program Service):

While searching, "PS" appears and then the station names will be displayed. "NO PS" appears if no signal is sent.

PTY (Program Type):

While searching, "PTY" appears and then the type of the broadcast program will be displayed. "NO PTY" appears if no signal is sent.

RT (Radio Text):

While searching, "RT" appears and then text messages the station sends will be displayed. "NO RT" appears if no signal is sent.

Frequency:

Station frequency (non-RDS service).

About characters shown on the display

When the display shows PS, PTY, or RT signals, the following characters are used:

- The display cannot show accented letters, "A" for instance, may stand for accented "A's" like "Å, Ä, Å, Å, Å, Å, å, å, å, å, and â."

NOTE

If searching finishes at once, "PS," "PTY," and "RT" will not appear on the display.

Searching for a program by PTY codes

One of the advantages of the RDS service is that you can locate a particular kind of program from the preset channels (see pages 23 and 24) by specifying the PTY codes.

To search for a program using the PTY codes

Before you start, remember...

- To stop searching any time, press PTY SEARCH while searching.
- There is a time limit in doing the following steps. If the setting is canceled before you finish, start from step 1 again.

1 Press PTY SEARCH while listening to an FM station.

"PTY SELECT" flashes on the display.

2 While "PTY SELECT" is flashing, press PTY or PTY until the PTY code you want appears on the display.

3 Press PTY SEARCH again while the PTY code selected in the previous step is still on the display.

While searching, "SEARCH" and the selected PTY code alternatively appears on the display.

The receiver searches 30 preset FM stations, stops when it finds the one you have selected, and tunes in to that station.

- If no program is found, "NOT FOUND" appears on the display.

To continue searching after the first stop

Press PTY SEARCH again while the indications on the display are flashing.

PTY codes



- For details about each code, see "Description of the PTY codes" on page 27.

Description of the PTY codes:

News:	News.
Affairs:	Topical program expanding or enlarging upon the news—debate or analysis.
Info (Information):	Programs the purpose of which is to impart advice in the widest sense.
Sport:	Programs concerned with any aspect of sports.
Educate (Education):	Educational programs.
Drama:	All radio plays and serials.
Culture:	Programs concerning any aspect of national or regional culture, including language, theatre, etc.
Science:	Programs about natural sciences and technology.
Varied:	Used for mainly speech-based programs such as quizzes, panel games and personality interviews.
Pop M (Music):	Commercial music of current popular appeal.
Rock M (Music):	Rock music.
Easy M (Music):	Current contemporary music considered to be “easy-listening.”
Light M (Music):	Instrumental music, and vocal or choral works.
Classics:	Performances of major orchestral works, symphonies, chamber music, etc.
Other M (Music):	Music not fitting into any of the other categories.
Weather:	Weather reports and forecasts.
Finance:	Stock Market reports, commerce, trading, etc.
Children:	Programs targeted at a young audience.

Social:	Programs about sociology, history, geography, psychology and society.
Religion:	Religious programs.
Phone In:	Involving members of the public expressing their views either by phone or at a public forum.
Travel:	Travel information.
Leisure:	Programs about recreational activities.
Jazz:	Jazz music.
Country:	Songs which originate from, or continue the musical tradition of the American Southern States.
Nation M (Music):	Current popular music of the nation or region in that country’s language.
Oldies:	Music from the so-called “golden age” of popular music.
Folk M (Music):	Music which has its roots in the musical culture of a particular nation.
Document:	Programs concerning factual matters, presented in an investigative style.
TEST:	Broadcasts for testing emergency broadcast equipment or unit.
Alarm !:	Emergency announcement.
None:	No program type, unidentified program, or difficult to categorize into particular types.

Classification of the PTY codes for some FM stations may be different from the above list.

Switching to broadcast program of your choice temporarily

Another convenient RDS service is called “Enhanced Other Networks.”

This allows the receiver to switch temporarily to a broadcast program of your choice (TA, NEWS, and/or INFO) from a different station except in the following case:

- The Enhanced Other Networks mode only works when receiving an FM station with the Enhanced Other Networks code.

Before you start, remember...

The Enhanced Other Networks function is only applicable to preset FM stations.

Press TA/NEWS/INFO repeatedly until the program type you want appears on the display.

- Each time you press the button, the program type(s) change, and the corresponding indicator(s) light up as follows:

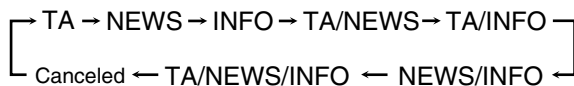

TA:	Traffic Announcement in your area.
NEWS:	News.
INFO:	Program the purpose of which is to impart advice in the widest sense.

How the Enhanced Other Networks function actually works:

If another FM station starts broadcasting the program type you have selected while you are listening to an FM station

The receiver automatically switches to the station. The indicator of the received program type starts flashing.



When the program is over, the receiver goes back to the station previously tuned in, but still remains in Enhanced Other Networks standby mode. The indicator of the received program type stops flashing and remains lit.

If the station currently tuned in starts broadcasting the program type you have selected

The receiver continues to receive the station, but the indicator of the received program type starts flashing.



When the program is over, the indicator of the received program type stops flashing and remains lit, but the receiver remains in Enhanced Other Networks standby mode.

To stop listening to the program selected by Enhanced Other Networks

Press TA/NEWS/INFO repeatedly again so that the program type (TA/NEWS/INFO) indicator goes off from the display. The receiver exits from Enhanced Other Networks standby mode and goes back to the previously selected station.

When an emergency broadcast (Alarm ! signal) is sent from an FM station

The receiver automatically tunes in to the station except in the following cases:

- When you are listening to non-RDS Networks—all AM (MW) stations, some FM stations and other sources.
- When the receiver is in standby mode or TV Direct mode.

While receiving an emergency broadcast, “Alarm !” appears on the display.

The TEST signal is used for equipment test—whether it can receive the Alarm ! signal correctly

The TEST signal makes the receiver work in the same way as the Alarm ! signal does. If the TEST signal is received, the receiver automatically switches to the station broadcasting the TEST signal.

While receiving the TEST signal, “TEST” appears on the display.

NOTES

- Enhanced Other Networks data sent from some stations may not be compatible with this receiver.
- Enhanced Other Networks does not function for some FM stations with RDS service.
- While listening to a program tuned in by the Enhanced Other Networks function, the station does not change even if another network station starts broadcasting a program of the same Enhanced Other Networks data.
- While listening to a program tuned in by the Enhanced Other Networks function, you can only use the TA/NEWS/INFO and DISPLAY.

CAUTION:

If the stations alternate intermittently between the station tuned by the Enhanced Other Networks function and the currently tuned station, press TA/NEWS/INFO repeatedly to cancel the Enhanced Other Networks function.

If you do not press the button, the currently tuned station is received finally, and the indication of the Enhanced Other Networks data type flashing on the display disappears.

Creating realistic sound fields

Reproducing theatre ambience

In a movie theatre, many speakers are located on the walls to reproduce impressive multi-surround sound, reaching you from all directions.

With these many speakers, sound localization and sound movement can be expressed.

Surround/DSP modes built in this receiver can create almost the same Surround sound as you can feel in a real movie theatre.

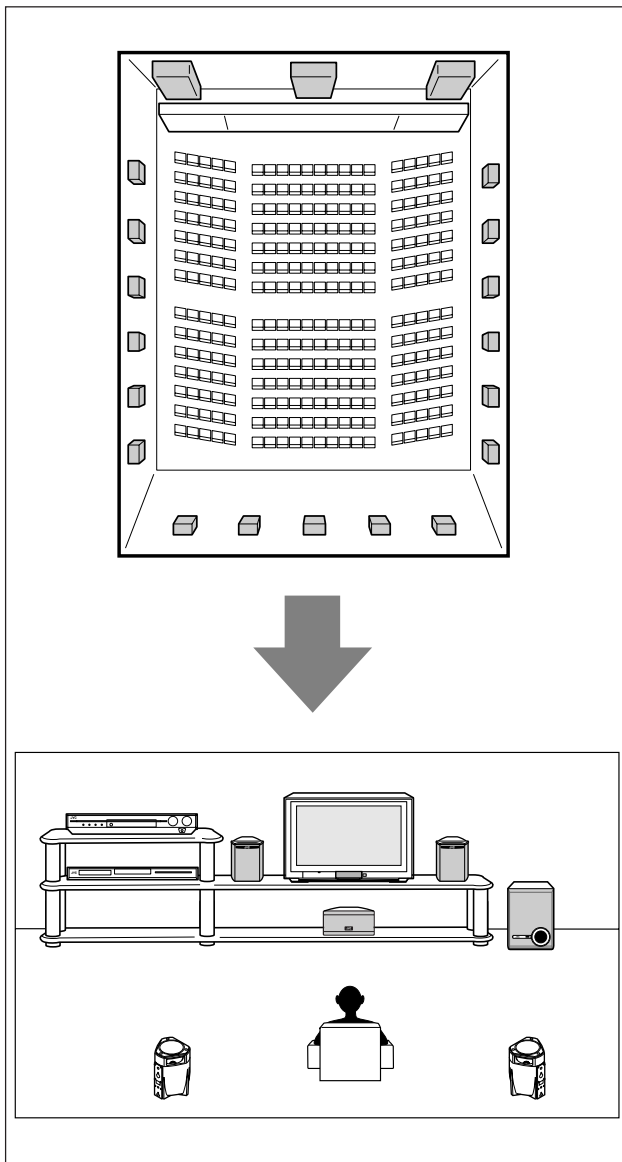

Introducing the Surround modes

■ Dolby Digital*

Dolby Digital is a digital signal compression method, developed by Dolby Laboratories, and enables multi-channel encoding and decoding (1ch up to 5.1ch).

- When Dolby Digital signal is detected through the digital input, the **DOLBY D** indicator lights up on the display.

Dolby Digital 5.1CH

Dolby Digital 5.1CH (DOLBY D) encoding method records and digitally compresses the left front channel, right front channel, center channel, left surround channel, right surround channel, and LFE channel signals (total 6 channels, but the LFE channel is counted as 0.1 channel. Therefore, called 5.1 channel).

Dolby Digital enables stereo surround sounds, and sets the cutoff frequency of the surround treble at 20 kHz, compared to 7 kHz for Dolby Pro Logic. As such, the sound movement and “being-there” feeling are enhanced much more than Dolby Pro Logic.

Another digital surround encoding format introduced by Dolby Laboratories is **Dolby Digital EX**, which adds the third surround channels, called “surround back.”

Compared to the conventional Dolby Digital 5.1CH, these newly added surround back channels can reproduce more detailed movements behind you while viewing the video software. In addition, surround sound localization will become more stable.

- You can use Virtual Surround Back (see page 18) when playing back Dolby Digital Surround EX software. This function creates the great surround effect from the behind as if you have connected the surround back speaker. The **VIRTUAL SB** indicator lights up on the display.

Dolby Pro Logic II

Dolby Pro Logic II is a multi-channel playback format to convert 2-channel software into 5-channel (plus subwoofer). The matrix-based conversion method used for Dolby Pro Logic II makes no limitation for the cutoff frequency of the surround treble and enables stereo surround sound.

- This receiver provides two types of Dolby Pro Logic II modes—**Pro Logic II Movie** (PLII MOVIE) and **Pro Logic II Music** (PLII MUSIC).

When Dolby Pro Logic II is activated, the **PLII** indicator lights up on the display.

PLII MOVIE: Suitable for playing any Dolby Surround encoded software. You can enjoy a sound field very close to the one created with discrete 5.1-channel sounds.

PLII MUSIC: Suitable for playing any 2-channel stereo software. You can enjoy wide and deep sounds.

- To enjoy software encoded with Dolby Digital, connect the source component using the digital terminal on the rear of this receiver. (See page 9.)

* Manufactured under license from Dolby Laboratories. “Dolby”, “Pro Logic”, and the double-D symbol are trademarks of Dolby Laboratories.

■ DTS**

DTS is another digital signal compression method, developed by Digital Theater Systems, Inc., and enables multi-channel encoding and decoding (1ch up to 6.1ch).

- When DTS signal is detected through the digital input, the **DTS** indicator lights up on the display.

DTS Digital Surround

DTS Digital Surround (DTS) is another discrete 5.1 channel digital audio format available on CD, LD, and DVD software.

Compared to Dolby Digital, the DTS Digital Surround format has a lower audio compression rate which enables it to add breadth and depth to the sounds reproduced. As such, DTS Digital Surround features natural, solid, and clear sound.

Another multi-channel digital surround encoding format introduced by Digital Theater Systems, Inc. is **DTS Extended Surround (DTS-ES)**.

It greatly improves the 360-degree surround impression and space expression by adding the third surround channel—surround back channel.

DTS-ES includes two signal formats with different surround signal recording methods—**DTS-ES Discrete 6.1ch** and **DTS-ES Matrix 6.1ch**.

- You can use the Virtual Surround Back (see page 18) when playing back DTS-ES software. This function creates the great surround effect from the behind as if you have connected the surround back speaker. The VIRTUAL SB indicator lights up on the display.

DTS 96/24

In recent years, there has been increasing interest in higher sampling rates both for recording and for reproducing at home. Higher sampling rates allow wider frequency range and greater bit depths provide extended dynamic range.

DTS 96/24 is a multi-channel digital signal format (fs 96 kHz/24 bits) introduced by Digital Theater Systems, Inc. to deliver “better-than-CD sound quality” into the home.

- When DTS 96/24 signal is detected, the **DTS** and **96/24** indicators light up. You can enjoy its 5.1-channel sound with full-quality.

**“DTS” and “DTS 96/24” are trademarks of Digital Theater Systems, Inc.

When using Surround mode, the sounds come out of the activated speakers which the Surround mode requires.

- If either the surround speakers or center speaker is set to “NO” in the speaker setting (see page 16), the corresponding channel signals are allocated to and emitted through the front speakers.
- If both the surround speakers and center speaker are set to “NO” in the speaker setting (see page 16), JVC’s original 3D-PHONIC processing (which has been developed to create the surround effect through the front speakers only) is used. The 3D indicator lights up on the display.

3D HEADPHONE mode

If you connect a pair of headphones while one of the Surround modes is in use, the 3D HEADPHONE mode is activated without respect to the type of software played back.

“3DHEADPHONE” appears on the display and the DSP, 3D, and HP indicators light up.

About other digital signals

Linear PCM

Uncompressed digital audio data used for DVDs, CDs, and Video CDs.

DVDs support 2 channels with sampling rates of 48/96 kHz, at quantization of 16/20/24 bits. On the other hand, CDs and Video CDs are limited to 2 channels with 44.1 kHz at 16 bits.

- When Linear PCM signal is detected, the LPCM indicator lights up.

Dual Mono

Dual Mono can be easily understood when you think of the bilingual broadcast for TV programs (however, the Dual Mono format is not identical with those analogue formats).

This format is now adopted in Dolby Digital, DTS, and so on. It allows two independent channels (called main channel and sub-channel) to be recorded separately.

- You can select either channel you want to listen to (see page 18).

Introducing the DSP modes

The sound heard in a concert hall, club, etc. consists of direct sound and indirect sound—early reflections and reflections from behind. Direct sounds reach the listener directly without any reflection. On the other hand, indirect sounds are delayed by the distances of the ceiling and walls. These direct sounds and indirect sounds are the most important elements of the acoustic surround effects.

The DSP modes can create these important elements, and give you a real “being there” feeling.

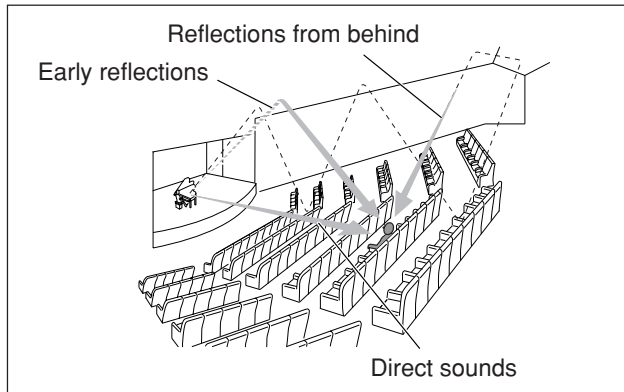

The DSP modes include the following modes:

- Digital Acoustic Processor (DAP) modes—HALL1, HALL2, LIVE CLUB, DANCE CLUB, PAVILION, THEATRE1, THEATRE2
- MONO FILM—Used for all types of 2-channel signals (including Dual Mono signal)
- All Channel Stereo mode (ALL CH ST.)

When one of the DSP modes is activated, the DSP indicator lights up on the display.

Digital Acoustic Processor (DAP) modes

You can use the following DAP modes in order to reproduce a more acoustic sound field in your listening room.

HALL1	Reproduces the spatial feeling of a large shoebox-shaped hall designed primarily for classical concerts. (Its seating capacity is about 2000.)
HALL2	Reproduces the spatial feeling of a large vineyard-shaped hall designed primarily for classical concerts. (Its seating capacity is about 2000.)
LIVE CLUB	Reproduces the spatial feeling of a live music club with a low ceiling.
DANCE CLUB	Reproduces the spatial feeling of a rocking dance club.
PAVILION	Reproduces the spatial feeling of an exhibition hall with a high ceiling.
THEATRE1	Reproduces the spatial feeling of a large theatre where the seating capacity is about 600.
THEATRE2	Reproduces the spatial feeling of a small theatre where the seating capacity is about 300.

NOTE

When “THEATRE1” or “THEATRE2” is activated while playing back 2-channel analogue or digital source, the built-in Dolby Pro Logic II decoder is activated and the PL II indicator lights up.

When using the DAP mode, the sounds come out of all the connected and activated speakers.

- If the surround speakers are set to “NO” in the speaker setting (see page 16), JVC’s original 3D-PHONIC processing (which has been developed to create the surround effect through the front speakers only) is used. The 3D indicator lights up on the display.

MONO FILM

In order to reproduce a more acoustic sound field in your listening room while viewing monaural sound video software (analogue and 2-channel digital signals including Dual Mono signal), you can use this mode.

The surround effect will be added, and the sound localization of actor’s words will be improved.

This mode cannot be used for multi-channel digital signals.

When “MONO FILM” is used, sounds come out of all the connected (and activated) speakers.

- If the surround speakers are set to “NO” in the speaker setting (see page 16), JVC’s original 3D-PHONIC processing (which has been developed to create the surround effect through the front speakers only) is used. The 3D indicator lights up on the display.
- If incoming signals change from 2-channel digital signal to another digital signal type, “MONO FILM” is canceled and an appropriate Surround mode is activated.

All Channel Stereo mode (ALL CH ST.)

This mode can reproduce a larger stereo sound field using all the connected (and activated) speakers. **This mode cannot be used without activating the surround speakers.**

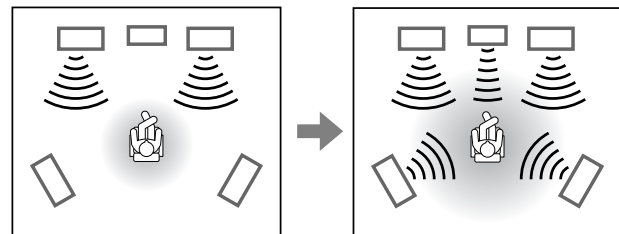

Sound reproduced from normal stereo

Sound reproduced from All Channel Stereo mode

3D HEADPHONE mode

If you connect a pair of headphones while one of the DSP modes is in use, the 3D HEADPHONE mode is activated without respect to the type of software played back. “3DHEADPHONE” appears on the display and the DSP, 3D, and HP indicators light up.

Using the Surround/DSP modes

Available Surround/DSP modes vary depending on the incoming signal.
For details, see "Available Surround and DSP modes according to the incoming signal" on page 33.

Activating one of the Surround/DSP modes for a source automatically recalls the memorized settings and adjustments.

- To adjust the speaker output level, see page 21.
- To adjust the effect level for the DSP mode (except All Channel Stereo mode), see page 21.
- To add "wraparound" sound effect to PLII MUSIC (PANORAMA control), see page 21.

NOTE

You cannot select All Channel Stereo mode if the surround speakers are set to "NO" in the speaker setting (see page 16).

If "AUTO SURRND (Auto Surround)" is set to "ON"

You can enjoy Surround mode simply by playing back multi-channel software (with digital input selected for that source).
To activate Auto Surround, see page 19.

From the remote control:

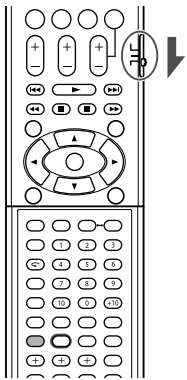

When operating the receiver using the remote control, set the mode selector to "AUDIO/TV/VCR/STB."

1 Select and play any source you like.

- Make sure you have selected the input mode (analogue or digital) correctly.

2 Press SURROUND repeatedly to select the Surround/DSP mode you want.

- For Dolby Digital multi-channel software (except 2-channel and Dual Mono software):

DOLBY D L C R
S.WFR LFE
LS RS **DOLBY D**

DOLBY D	→	HALL1	→
HALL2	→	LIVE CLUB	→
DANCE CLUB	→	PAVILION	→
THEATRE1	→	THEATRE2	→
ALL CH ST.	→	SURRND OFF	→

(Back to the beginning)

- For DTS multi-channel software (except 2-channel and Dual Mono software):

DTS L C R
S.WFR LFE
LS RS **DTS**

DTS	→	HALL1	→
HALL2	→	LIVE CLUB	→
DANCE CLUB	→	PAVILION	→
THEATRE1	→	THEATRE2	→
ALL CH ST.	→	SURRND OFF	→

(Back to the beginning)

- For Dual Mono software:

You can select the channel you listen to (see page 18).

DOLBY D L
S.WFR R **DUAL MONO**

DUAL MONO	→	HALL1	→
HALL2	→	LIVE CLUB	→
DANCE CLUB	→	PAVILION	→
THEATRE1	→	THEATRE2	→
MONO FILM	→	ALL CH ST.	→
SURRND OFF	→	(Back to the beginning)	

- For digital 2-channel software or analogue sources:

Ex.: When Linear PCM is coming in.

LPCM L R DD PLII
S.WFR PLII **PLII MOVIE**

PLII MOVIE	→	PLII MUSIC	→
HALL1	→	HALL2	→
LIVE CLUB	→	DANCE CLUB	→
PAVILION	→	THEATRE1	→
THEATRE2	→	MONO FILM	→
ALL CH ST.	→	SURRND OFF	→

(Back to the beginning)

Virtual Surround Back

When playing **Dolby Digital Surround EX** or **DTS-ES** software, you can enjoy surround back channel playback using the Virtual Surround Back.

Ex.: When playing back DTS-ES software.

DTS VIRTUAL SB
L C R
S.WFR LFE
LS RS **DTS**

To activate the Virtual Surround Back, see page 18.

To cancel Surround/DSP modes

Press SURROUND repeatedly so that "SURRND OFF" appears on the display.

On the front panel:



Before you start, remember...

There is a time limit in doing the following steps. If the setting is canceled before you finish, start from step **2** again.

1 Select and play any source you like.

- Make sure you have selected the input mode (analogue or digital) correctly.

2 Press SURROUND.

3 Turn MULTI JOG to select the Surround/DSP mode you want.

- For Dolby Digital multi-channel software (except 2-channel and Dual Mono software):

DOLBY D

DOLBY D	↔	HALL1	↔	
HALL2	↔	LIVE CLUB	↔	
DANCE CLUB	↔	PAVILION	↔	
THEATRE1	↔	THEATRE2	↔	
ALL CH ST.	↔	SURRND OFF	↔	

(Back to the beginning)

- For DTS multi-channel software (except 2-channel and Dual Mono software):

DTS

DTS	↔	HALL1	↔	
HALL2	↔	LIVE CLUB	↔	
DANCE CLUB	↔	PAVILION	↔	
THEATRE1	↔	THEATRE2	↔	
ALL CH ST.	↔	SURRND OFF	↔	

(Back to the beginning)

- For Dual Mono software:

You can select the channel you listen to (see page 18).

DUAL MONO

DUAL MONO	↔	HALL1	↔	
HALL2	↔	LIVE CLUB	↔	
DANCE CLUB	↔	PAVILION	↔	
THEATRE1	↔	THEATRE2	↔	
MONO FILM	↔	ALL CH ST.	↔	
SURRND OFF	↔	(Back to the beginning)	↔	

- For digital 2-channel software or analogue sources:

Ex.: When Linear PCM is coming in.

PL II MOVIE

PLII MOVIE	↔	PLII MUSIC	↔	
HALL1	↔	HALL2	↔	
LIVE CLUB	↔	DANCE CLUB	↔	
PAVILION	↔	THEATRE1	↔	
THEATRE2	↔	MONO FILM	↔	
ALL CH ST.	↔	SURRND OFF	↔	

(Back to the beginning)

Virtual Surround Back

When playing **Dolby Digital Surround EX** or **DTS-ES** software, you can enjoy surround back channel playback using the Virtual Surround Back.

Ex.: When playing back DTS-ES software.

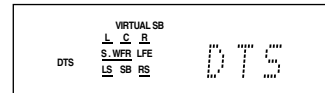

To activate the Virtual Surround Back, see page 18.

To cancel Surround/DSP modes

Turn MULTI JOG so that "SURRND OFF" appears on the display.

Available Surround and DSP modes according to the incoming signal

Modes Incoming signal	Surround modes	DSP modes	HEADPHONE mode	Surround/DSP off
Dolby Digital (multi-channel)	DOLBY D	HALL1/2, LIVE CLUB, DANCE CLUB, PAVILION, THEATRE1/2, ALL CH ST.*2	HEADPHONE, 3D HEADPHONE	SURRND OFF (stereo)
Dolby Digital Surround EX	DOLBY D (Virtual Surround Back*1)			
DTS (multi-channel)	DTS	HALL1/2, LIVE CLUB, DANCE CLUB, PAVILION, THEATRE1/2, MONO FILM, ALL CH ST.*2	HEADPHONE, 3D HEADPHONE	SURRND OFF (stereo)
DTS-ES	DTS (Virtual Surround Back)			
Dual Mono	DUAL MONO	HALL1/2, LIVE CLUB, DANCE CLUB, PAVILION, THEATRE1/2, MONO FILM, ALL CH ST.*2	HEADPHONE, 3D HEADPHONE	SURRND OFF (stereo)
Dolby Digital (2-channel)	PLII MOVIE, PLII MUSIC			
DTS (2-channel)				
Linear PCM				
Analogue				

*1 Virtual Surround Back may not be applied to some software.

*2 Not selectable if the surround speakers are set to "NO" in the speaker setting (see page 16).

Operating other JVC products

You can use the supplied remote control to operate not only the receiver/DVD player but also other JVC products.

- Refer also to the manuals supplied with the other products.
 - Some JVC VCRs can accept two types of the control signals—remote codes “A” and “B.” This remote control can operate a VCR whose remote control code is set to “A.”
 - Some JVC DVD recorders can accept four types of the control signals. This remote control can operate a DVD recorder whose remote control code is set to the initial code. For details, refer to the manual supplied with the DVD recorder.
- To operate other products, aim the remote control directly at the remote sensor on the target product.

■ TV

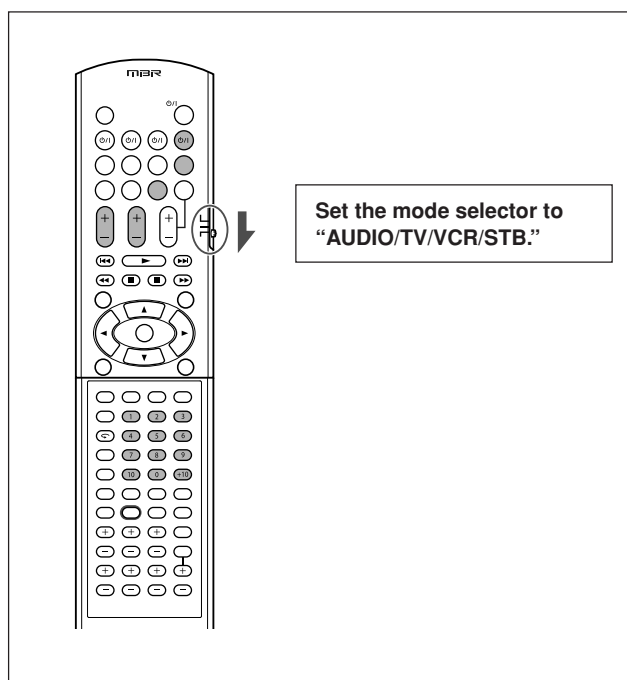

You can always perform the following operations:

TV \odot/I:	Turn on or off the TV.
TV VOL +/-:	Adjust the volume on the TV.
TV/VIDEO:	Change the input mode (either video input or TV tuner) on the TV.

After pressing TV, you can perform the following operations on the TV.

CHANNEL +/-:	Change the channel numbers.
1 – 9, 0, 100+:	Select the channel numbers.
TV RETURN (10):	Function as the TV RETURN button.

■ VCR

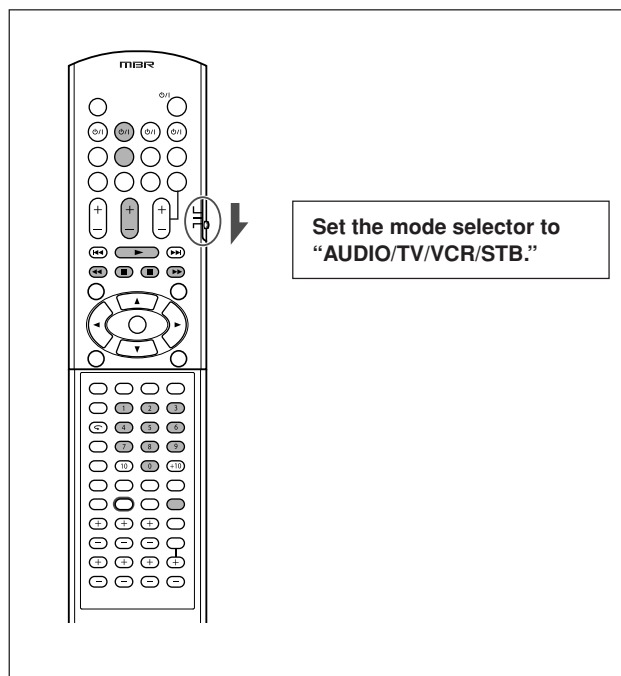

You can always perform the following operation:

VCR \odot/I:	Turn on or off the VCR.
---	-------------------------

After pressing VCR, you can perform the following operations on the VCR.

CHANNEL +/-:	Change the channel numbers on the VCR.
1 – 9, 0:	Select the channel numbers on the VCR.
▶:	Start playback.
■:	Stop playback.
 :	Pause playback. To release it, press ▶.
▶▶:	Fast-wind a tape.
◀◀:	Rewind a tape.
REC PAUSE:	Enter recording pause. To start recording, press this button then ▶.

■ DVD recorder or DVD player

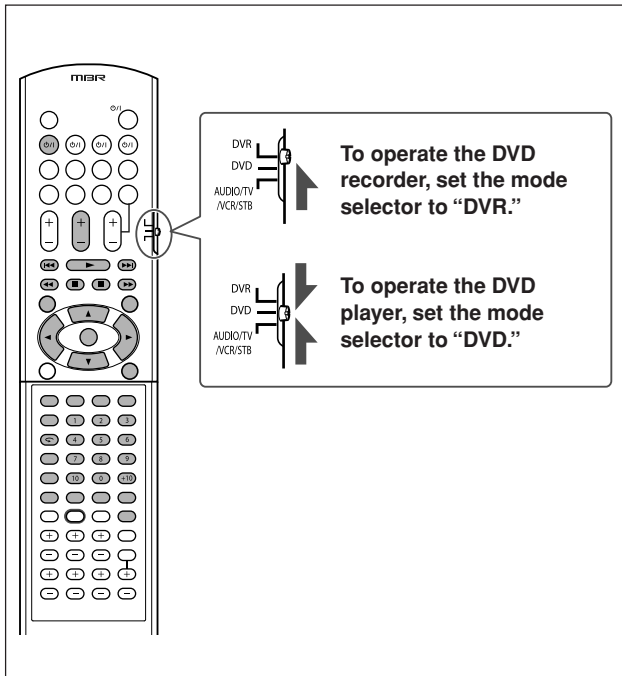

After setting the mode selector, you can perform the following operations on the DVD recorder or DVD player.

See the instructions supplied with the DVD recorder or DVD player for details.

DVR/DVD : Turn on or off the DVD recorder or DVD player.

CHANNEL +/- (for DVD recorder only):
Change the channel numbers on the DVD recorder.

▶: Start playback.

■: Stop playback.

||: Pause playback. To release it, press **▶**.

▶▶: Skip to the beginning of the next chapter.

◀◀: Return to the beginning of the current (or previous) chapter.

▶▶▶: Fast-forward playback.

◀◀◀: Fast-reverse playback.

TOP MENU/MENU:
Display the menu recorded on DVD VIDEO discs.

ON SCREEN: Shows the on-screen bar.

▲/▼/▶/◀: Select an item on the menu screen.

ENTER: Enter the selected item, channel number, or track number.

1 – 9, 0 (for DVD recorder):
Select channel numbers or track numbers. (Press ENTER to enter the number.)

1 – 10, 0, +10 (for DVD player):
Select a track number, menu item, etc.

You can also use the following buttons to operate JVC DVD recorder or DVD player if it supports the corresponding function:

For various settings:

AUDIO: Select the audio language/channel.
SUBTITLE: Select the subtitle language.
SET UP: Display the Preference display.
VFP: Adjust the picture.
PROGRESSIVE*: Change the scanning mode.
ANGLE: Select the view angle.

For various playback:

TITLE/GROUP: Make the numeric buttons work for selecting the title/group number.
ZOOM (for DVD player only): Zoom in and out.
◀ (one touch replay): Move the playback position back 10 seconds before the current position.
RETURN: Return to the main menu during menu operation.
CANCEL: Cancel the programmed track, etc.
SLIDE EFFECT*: Select the effect for the slide show playback for JPEG discs.
SOUND EFFECT (for DVD player only): Select the sound effect.

For recording (for DVD recorder ONLY):

REC PAUSE: Enter recording pause. To release it, press **▶**.

For other functions:

DVD, HDD (for DVD recorder incorporated with HDD deck):
Select the DVD recorder or HDD deck.
DISPLAY: Change the display information.
DIMMER*: Change the display brightness.

NOTES

- Press and hold when using the buttons marked with an asterisk (*).
- If these buttons do not function normally, use the remote control supplied with your DVD recorder or DVD player. Refer also to the manuals supplied with the DVD recorder or DVD player for details.

Operating other manufacturers' products

By changing the transmittable signals, you can use the supplied remote control to operate other manufacturers' products.

- Refer also to the manuals supplied with the other products.
- To operate those components with the remote control, first you need to set the manufacturers' codes each for the TV, VCR, and STB.
- After replacing batteries of the remote control, set the manufacturers' codes again.

□ Changing the transmittable signals for operating a TV

Set the mode selector to "AUDIO/TV/VCR/STB."

1 Press and hold TV ϕ /I.

2 Press TV.

3 Enter the manufacturer's code using buttons 1 – 9, and 0.

See "Manufacturers' codes for TV" on the right column.

4 Release TV ϕ /I.

Now, you can perform the following operations on the TV.

TV ϕ /I:	Turn on or off the TV.
TV VOL +/-:	Adjust the volume on the TV.
TV/VIDEO:	Change the input mode (either TV or VIDEO).

After pressing TV, you can perform the following operations on the TV.

CHANNEL +/-:	Change the channel numbers.
1 – 9, 0, +10 (100+):	Select the channel numbers.

See the instructions supplied with the TV for details.

5 Try to operate your TV by pressing TV ϕ /I.

When your TV turns on or off, you have entered the correct code.

If more than one code is listed for your brand of TV, try each one until the correct one is entered.

Manufacturers' codes for TV

Manufacturer	Codes
JVC	01
Akai	02, 05
Blaupunkt	03
Daewoo	09, 30, 31
Fenner	04, 30, 31
Fisher	05
Grundig	06
Hitachi	07, 08
Irradio	02, 05
Magnavox	09
Mitsubishi	10, 32
Miver	03
Nokia	11, 33
Nordmende	12, 13, 17, 25, 26, 27
Orion	14
Panasonic	15, 16
Philips	09
Saba	12, 13, 17, 25, 26, 27
Samsung	09, 18, 31
Sanyo	05
Schneider	02, 05
Sharp	19
Sony	20, 21, 22, 23, 24
Telefunken	12, 13, 17, 25, 26, 27
Thomson	12, 13, 17, 25, 26, 27, 29
Toshiba	28

Initial setting: 01

❑ **Changing the transmittable signals for operating a VCR**

Set the mode selector to "AUDIO/TV/VCR/STB."

- 1 Press and hold VCR** \odot/I .
- 2 Press VCR.**

3 Enter the manufacturer's code using buttons 1 – 9, and 0.

See "Manufacturers' codes for VCR" on right column.

4 Release VCR \odot/I .

Now, you can perform the following operation on the VCR.

VCR \odot/I :	Turn on or off the VCR.
-------------------------------	-------------------------

After pressing VCR, you can perform the following operations on the VCR.

CHANNEL +/- :	Change the channel numbers on the VCR.
----------------------	--

1 – 9, 0 :	Select the channel numbers on the VCR.
-------------------	--

▶ :	Start playback.
------------	-----------------

■ :	Stop playback.
------------	----------------

II :	Pause playback.
-------------	-----------------

▶▶ :	Fast-wind a tape.
-------------	-------------------

◀◀ :	Rewind a tape.
-------------	----------------

See the instructions supplied with the VCR for details.

5 Try to operate your VCR by pressing VCR \odot/I .

When your VCR turns on or off, you have entered the correct code.

If more than one code is listed for your brand of VCR, try each one until the correct one is entered.

Manufacturers' codes for VCR

Manufacturer	Codes
JVC	01
Akai	02, 36
Bell+Howell	03, 16
Blaupunkt	04
CGM	03, 05, 16
Daewoo	34
Digital	05
Fisher	03, 16
GE	06
Grundig	07
Hitachi	08, 09
Loewe	05, 10, 11
Magnavox	04, 05
Mitsubishi	12, 13, 14, 15
Nokia	16
Nordmende	17, 18, 19, 31
Orion	20
Panasonic	21
Philips	05, 22
Phonola	05
Saba	17, 18, 19, 23, 31
Samsung	24, 25
Sanyo	03, 16
Sharp	26, 27
Siemens	07
Sony	28, 29, 30, 35
Telefunken	17, 18, 19, 31, 32
Toshiba	33

Initial setting: 01

Manufacturers' codes are subject to change without notice. If they are changed, this remote control cannot operate the equipment.

❑ **Changing the transmittable signals for operating an STB**

Set the mode selector to "AUDIO/TV/VCR/STB."

- 1 Press and hold STB** \odot/I .
- 2 Press STB CONTROL.**
- 3 Enter the manufacturer's code using buttons 1 – 9, and 0.**

See "Manufacturers' codes for STB" on the right column.

4 Release STB \odot/I .

Now, you can perform the following operation on the STB.

STB \odot/I : Turn on or off the STB.

After pressing STB CONTROL, you can perform the following operations on the STB.

CHANNEL +/-: Change the channel numbers on the STB.

1 – 9, 0: Select the channel numbers on the STB.

See the instructions supplied with the STB for details.

5 Try to operate your STB by pressing STB \odot/I .

When your STB turns on or off, you have entered the correct code.

If more than one code is listed for your brand of STB, try each one until the correct one is entered.

Manufacturers' codes for STB

Manufacturer	Codes
JVC	01, 02
Amstrad	03, 04, 05, 06, 33
BT	01
Canal Stellite	22
Canal +	22
D-Box	26
Echostar	19, 20, 21, 23
Finlux	11
Force	30
Galaxis	29
Grundig	07, 08
Hirschmann	07, 19, 39
ITT Nokia	11
Jerrold	16
Kathrein	13, 14, 36
Luxor	11
Mascom	34
Maspro	13
Nokia	26, 28, 35
Pace	10, 27, 33
Panasonic	15
Philips	09, 25
RFT	12
Saba	37
Sagem	24, 31
Salora	11
Selector	31
Skymaster	12, 38
Thomson	37
TPS	24
Triax	32
Videoway	17, 18
Wisi	07

Initial setting: 01

Manufacturers' codes are subject to change without notice. If they are changed, this remote control cannot operate the equipment.

Troubleshooting

Use this chart to help you solve daily operational problems. If there are any problems you cannot solve, contact your JVC's service center.

Power

The power does not come on.

- ➔ The power cord is not plugged in. Plug the power cord into an AC outlet.

The receiver turns off (enters standby mode).

- ➔ Speakers are overloaded because of high volume.
 1. Stop the playback source.
 2. Turn on the receiver again, then turn the volume down.
- ➔ Speakers are overloaded because of a short circuit at the speaker terminals. Check the speaker wiring. If speaker wiring is not short-circuited, contact your dealer.
- ➔ The receiver is overloaded because of a high voltage. Consult your dealer after unplugging the power cord.

"OVER HEAT" flashes on the display, then the receiver turns off.

- ➔ The receiver is overheated because of high volume or long time usage. Turn on the receiver again. If the receiver turns off soon, consult your dealer after unplugging the power cord.

Sound

No sound from speakers.

- ➔ Speaker signal cables are not connected. Check speaker wiring, then reconnect if necessary (see page 6) after unplugging the power cord.
- ➔ Connections are incorrect. Check the audio connections (see pages 7 to 9) after unplugging the power cord.
- ➔ An incorrect source is selected. Select the correct source.
- ➔ Muting is activated. Press MUTING to cancel the mute (see page 13).
- ➔ An incorrect input mode (analogue or digital) is selected. Select the correct input mode (analogue or digital).
- ➔ TV Direct is activated. Deactivate TV Direct (see page 12).

Sound from one speaker only.

- ➔ Speaker signal cables are not connected properly. Check speaker wiring and reconnect if necessary (see page 6) after unplugging the power cord.

Bass sound is reinforced too much when listening in stereo.

- ➔ Adjust audio position level (see page 12).

Sounds are intermittently distorted by the outside noise such as a lightning discharge.

- ➔ When you use the digital coaxial connection, the sounds may be intermittently distorted by the outside noise such as a lightning discharge but the sound will be restored automatically. This is not a malfunction.

Remote control

Remote control does not operate as you intend.

- ➔ The remote control is not ready for your intended operation. Set the mode selector correctly, then press the corresponding source selecting button or SOUND before operation.

Remote control does not work.

- ➔ There is an obstruction hiding the remote sensor on the receiver. Remove the obstruction.
- ➔ Batteries are weak. Replace batteries.
- ➔ The mode selector is set to the incorrect position. Set the mode selector to the proper position.

Buttons cannot be used.

- ➔ TV Direct is activated. Deactivate TV Direct (see page 12).

Tuner

Continuous hiss or buzzing during FM reception.

- ➔ Incoming signal is too weak. Connect an outdoor FM antenna or contact your dealer.
- ➔ The station is too far away. Select another station.
- ➔ The wrong antenna is being used. Check with your dealer to be sure you have the correct antenna.
- ➔ Antennas are not connected properly. Check the connections.

Occasional cracking noise during FM reception.

- ➔ Ignition noise from automobiles. Move the antenna farther from automobile traffic.

Specifications

Designs and specifications are subject to change without notice.

Amplifier

Output Power

At stereo operation:

Front channels: 60 W per channel, min. RMS, both channels driven into 6 Ω at 1 kHz with no more than 10% total harmonic distortion. (IEC268-3)

At surround operation:

Front channels: 60 W per channel, min. RMS, driven into 6 Ω at 1 kHz with no more than 10% total harmonic distortion.

Center channel: 60 W, min. RMS, driven into 6 Ω at 1 kHz, with no more than 10% total harmonic distortion.

Surround channels: 60 W per channel, min. RMS, driven into 6 Ω at 1 kHz, with no more than 10% total harmonic distortion.

Audio

Audio Input Sensitivity/Impedance:

DVR/DVD, VCR, TV, VIDEO: 170 mV(p-p)/47 k Ω

Audio Input (DIGITAL IN)*:

Coaxial: DIGITAL IN 1(DVR/DVD):
0.5 V(p-p)/75 Ω

Optical: DIGITAL IN 2(VIDEO): -21 dBm to -15 dBm
(660 nm \pm 30 nm)

* Corresponding to Linear PCM, Dolby Digital, and DTS (with sampling frequency—32 kHz, 44.1 kHz, 48 kHz).

Audio Output Level

DVR/DVD, VCR, TV: 170 mV

Signal-to-Noise Ratio ('66 IHF/DIN): 87 dB/62 dB

Frequency Response (6 Ω): 20 Hz to 20 kHz (\pm 1 dB)

Bass Boost: +4 dB \pm 1 dB at 100 Hz

Equalization:

Center frequency: 63 Hz, 250 Hz, 1 kHz, 4 kHz, 16 kHz

Control range: \pm 8 dB

Video

Video Input Sensitivity/Impedance:

Composite video: DVR/DVD, VCR, TV, VIDEO:
1 V(p-p)/75 Ω

S-video: DVR/DVD, VCR:

Y (luminance): 1 V(p-p)/75 Ω

C (chrominance, burst): 0.3 V(p-p)/75 Ω

RGB: DVR/DVD, VCR: 0.7 V(p-p)/75 Ω

Component: DVR/DVD:

Y (luminance): 1 V(p-p)/75 Ω

PB, PR: 0.7 V(p-p)/75 Ω

Video Output Level/Impedance:

Composite video: DVR/DVD, VCR, TV:
1 V(p-p)/75 Ω

S-video: TV:

Y (luminance): 1 V(p-p)/75 Ω

C (chrominance, burst): 0.3 V(p-p)/75 Ω

RGB: TV: 0.7 V(p-p)/75 Ω

Component: MONITOR OUT:

Y (luminance): 1 V(p-p)/75 Ω

PB, PR: 0.7 V(p-p)/75 Ω

Synchronization:

Negative

FM tuner (IHF)

Tuning Range: 87.50 MHz to 108.00 MHz

Usable Sensitivity:

Monaural: 17.0 dBf (1.95 μ V/75 Ω)

50 dB Quieting Sensitivity:

Monaural: 21.3 dBf (3.2 μ V/75 Ω)

Stereo: 41.3 dBf (31.5 μ V/75 Ω)

Stereo Separation at Rec Out:

35 dB at 1 kHz

AM (MW) tuner

Tuning Range: 522 kHz to 1 629 kHz

General

Power Requirements: AC 230 V \sim , 50 Hz

Power Consumption: 120 W (at operation)
1 W (in standby mode)

Dimensions (W x H x D): 435 mm x 70 mm x 325 mm

Mass: 5.6 kg

RX-E11S/RX-E12B

HOME CINEMA CONTROL CENTER

JVC

