

# JVC

## SERVICE MANUAL

### S.E.A. GRAPHIC EQUALIZER

MODEL **SEA-11/SEA-11B**



SEA-11



SEA-11B

## Contents

Safety Precautions .....	1-1
1. Specifications .....	1-2
2. Block Diagram .....	1-2
3. Service Precautions	
3-(1) Operation and Output .....	1-3
3-(2) Replacement of Parts .....	1-3
4. Removal Procedures	
4-(1) Front Panel Section .....	1-3
4-(2) Slide Volume P.C. Board Section .....	1-3
Parts List .....	Separate-volume Insertion
5. SEA-11/SEA-11B Schematic Diagram .....	1-4

# Safety Precautions

1. The design of this product contains special hardware, many circuits and components specially for safety purposes.

For continued protection, no changes should be made to the original design unless authorized in writing by the manufacturer. Replacement parts must be identical to those used in the original circuits. Service should be performed by qualified personnel only.

2. Alterations of the design or circuitry of the product should not be made. Any design alterations or additions will void the manufacturer's warranty and will further relieve the manufacturer of responsibility for personal injury or property damage resulting therefrom.
3. Many electrical and mechanical parts in the product have special safety-related characteristics. These characteristics are often not evident from visual inspection nor can the protection afforded by them necessarily be obtained by using replacement components rated for higher voltage, wattage, etc. Replacement parts which have these special safety characteristics are identified in the parts list of Service manual. Electrical components having such features are identified by shading on the schematics and by (  $\Delta$  ) on the parts list in Service manual. The use of a substitute replacement which does not have the same safety characteristics as the recommended replacement part shown in the parts list in Service manual may create shock, fire, or other hazards.
4. The leads in the products are routed and dressed with ties, clamps, tubings, barriers and/or the like to be separated from live parts, high temperature parts, moving parts and/or sharp edges for the prevention of electric shock and fire hazard.

When service is required, the original lead routing and dress should be observed, and they should be confirmed to be returned to normal, after re-assembling.

5. Leakage current check

(Safety for electrical shock hazard)

After re-assembling the product always perform an isolation check on the exposed metal parts of the Products (antenna terminals, knobs, metal cabinet, screw heads, headphone jack, control shafts, etc.) to be sure the product is safe to operate without danger of electrical shock.

Do not use a line isolation transformer during this check.

- Plug the AC line cord directly into the AC outlet. Using a "Leakage Current Tester", measure the leakage current from each exposed metal part of the cabinet, particularly any exposed metal part having a return path to the chassis, to a known good earth ground. Any leakage current must not exceed 0.5 mA AC (r.m.s.).

- Alternate check method.

Plug the AC line cord directly into the AC outlet. Use an AC voltmeter having 1,000 ohms per volt or more sensitivity in the following manner. Connect a 1500  $\Omega$  10 W resistor paralleled by a 0.15  $\mu$ F AC-type capacitor between an exposed metal part and a known good earth ground.

Measure the AC voltage across the resistor with the AC voltmeter.

Move the resistor connection to each exposed metal part, particularly any exposed metal part having a return path to the chassis, and measure the AC voltage across the resistor. Now, reverse the plug in the AC outlet and repeat each measurement. Any voltage measured must not exceed 0.75 V AC (r.m.s.). This corresponds to 0.5 mA AC (r.m.s.).

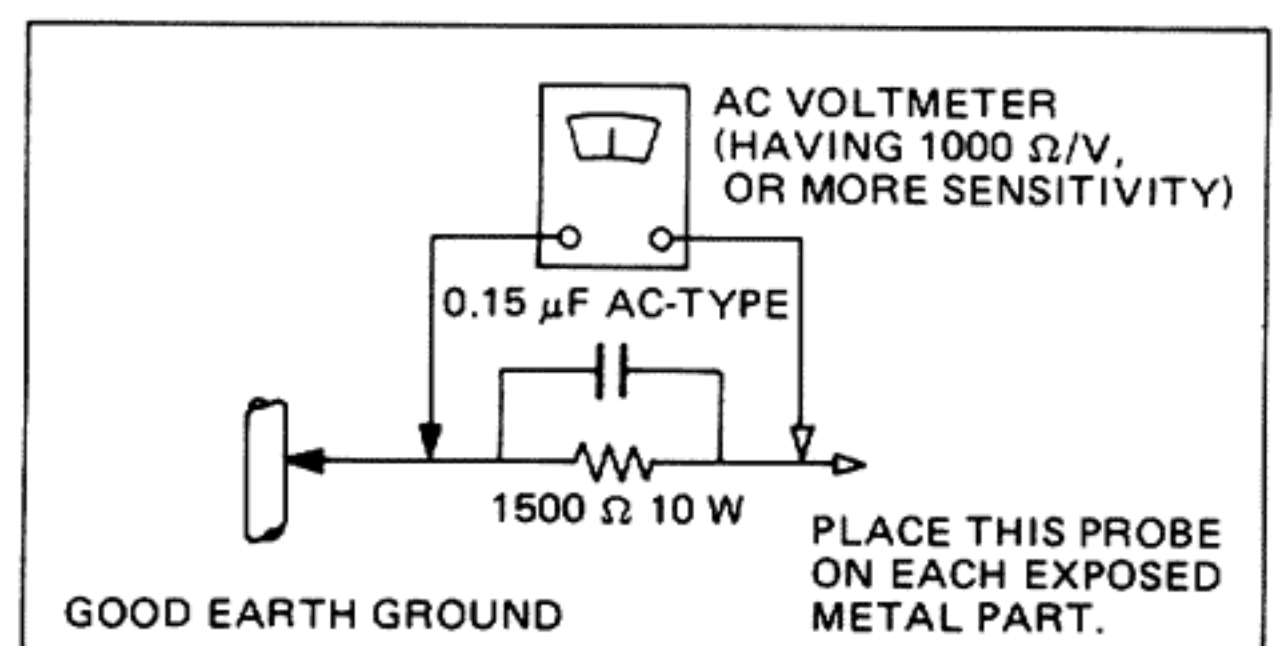
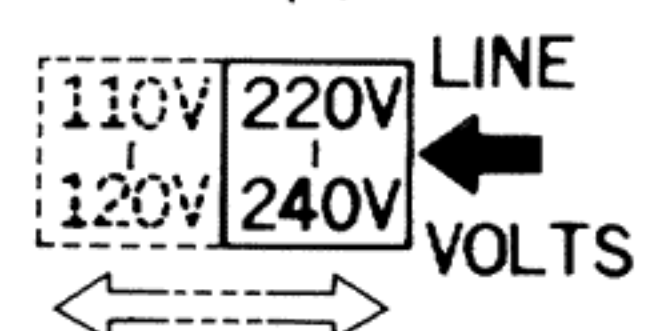

Fig. 1

## CHECKING YOUR LINE VOLTAGE (Except for U.S.A., Canada, Australia, U.K. and Continental Europe)

Before inserting the power plug, please check this setting to see that it corresponds with the line voltage in your area. If it doesn't, be sure to adjust the voltage selector switch to the proper setting before operating this equipment. The voltage selector switch is located on the rear panel.

**CAUTION:** Before selecting the "Voltage selector switch" to proper voltage, disconnect the power plug.



# 1. Specifications

## Circuitry

Semiconductor-L circuit : Transistor-inductor circuit

## Input section

LINE : Input impedance; 47 k-ohms  
 TAPE MONITOR : Input impedance; 47 k-ohms

## Output section

LINE OUT : Output impedance; 2.2 k-ohms  
 Rated output : 1 V RMS (all S.E.A. controls positioned at "0")  
 Max. output : 4.5 V RMS (all S.E.A. controls positioned at "0")  
 Total harmonic distortion : 0.03% (1 kHz, rated output)

Gain : 0 dB (S.E.A. flat)  
 Frequency response : 10 Hz – 50 kHz  
 (+0, –2 dB S.E.A. flat)  
 S/N ratio : 110 dB (at rated output, IHF A-network short circuited)

## Control section

SEA center frequencies : 63 Hz, 160 Hz, 400 Hz, 1 kHz, 2.5 kHz, 6.3 kHz, 16 kHz  
 SEA control range : ± 10 dB

## General

Power source : See attached table.  
 Dimensions : 61 (H) x 435 (W) x 198 (D) mm  
 (2-3/8" x 17-1/8" x 7-3/4")  
 Weight (NET) : 1.9 kg (4.2 lbs)

## POWER SPECIFICATIONS

	U.S.A. & Canada	Continental Europe	Australia	U.K.	U.S. Military Market & Other Areas
Power Supply	AC 120 V~, 60 Hz	AC 220 V~, 50 Hz	AC 240 V~, 50 Hz	AC 240 V~, 50 Hz	AC 110–120/220–240 V~ selectable, 50/60 Hz
Power Consumption	5 watts	5 watts	5 watts	5 watts	5 watts
AC Outlet	Fitted	Not Fitted	Not Fitted	Not Fitted	Fitted
Fuse (Primary) (F801)	QMF61U1-R50 (0.5 A)	QMF51A2-R25S (T250 mA)	QMF51A2-R25S (T250 mA)	QMF51E2-R25SBS (T250 mA)	QMF51A2-R25S (T250 mA)

Design and specifications are subject to change without notice.

# 2. Block Diagram

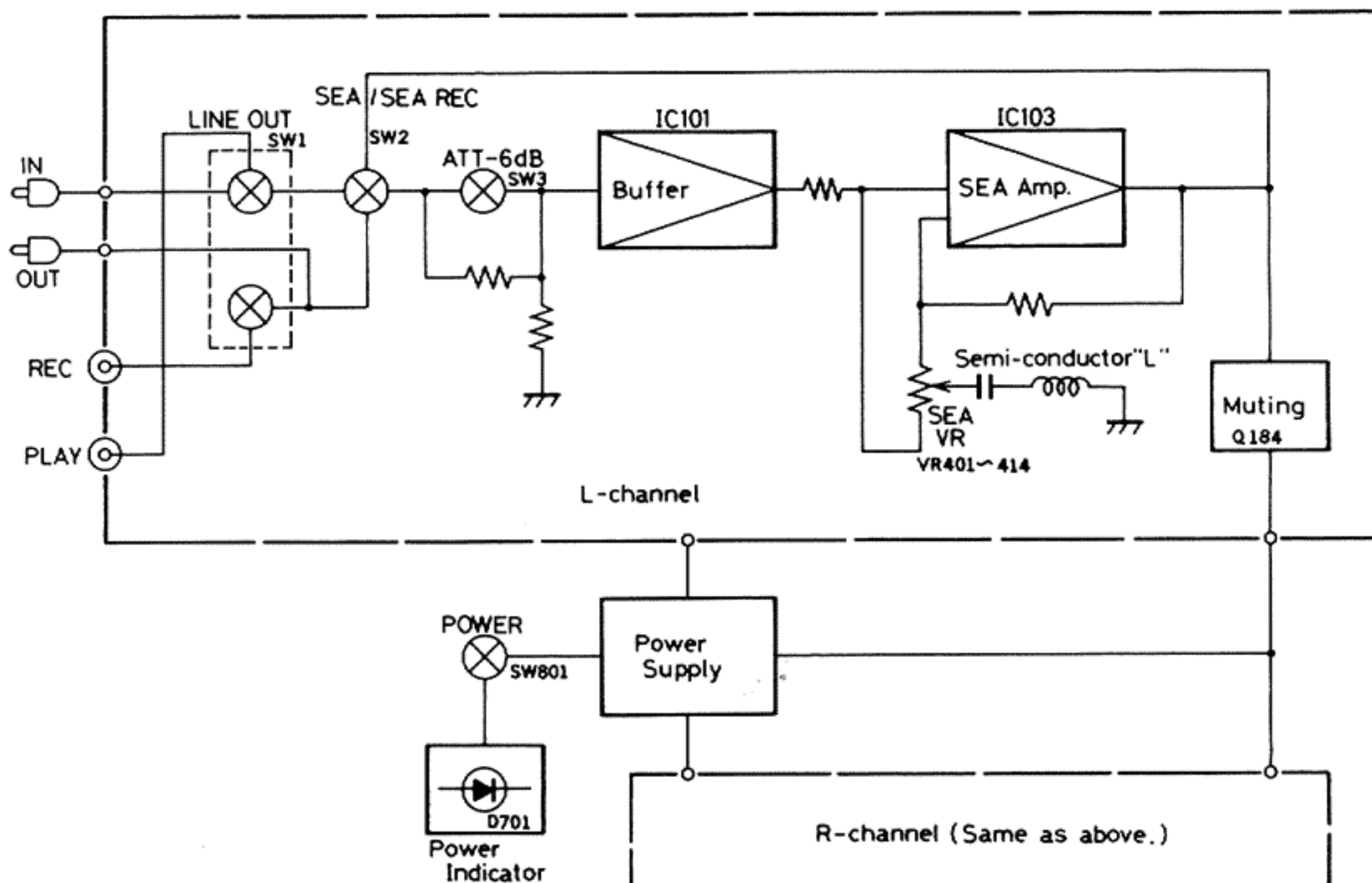

Fig. 2

## 3. Service Precautions

### 3-(1) Operation and Output

LINE OUT Switch	Output at the TAPE REC terminals	Output at the LINE OUT terminals
ON	LINE IN signal (without S.E.A. effect)	LINE IN signal (either with or without S.E.A. effect)
OFF	Open (Non signal)	TAPE signal (either with or without S.E.A. effect)

### 3-(2) Replacement of Parts

1. This unit is made up from of the parts shown in "Exploded View" of Parts List. The P.C. board assemblies are mounted on the chassis using screws.  
To mount or demount these assemblies, refer to "Exploded View".
2. The push knobs are fixed to the front panel. The slide knobs are inserted in slide VR controls. When replacing them, remove the front panel in advance.
3. The right and left slide VR boards are each secured by 5 screws at mounting holes 1, 4 and 7 in the upper side and mounting holes 2 and 6 in the lower side.

## 4. Removal Procedures (Refer to item (6) : Exploded View).

### 4-(1) Front Panel Section

1. Remove the 5 screws ❶ retaining the top cover.
2. Remove the 3 plastic rivets ❷ in the upper side and 3 screws ❸ in the lower side retaining the front panel.

### 4-(2) Slide Volume P.C. Board Section

1. Remove the front panel. (Refer to item 4-(1).)
2. Remove the 14 slide knobs ❹; 7 from the right channel side and other 7 from the left channel side.
3. Remove the 10 screws ❺ retaining the slide VR P.C. boards; 7 from the right board and 7 from the left board.

# 5. SEA-11/SEA-11B Schematic Diagram

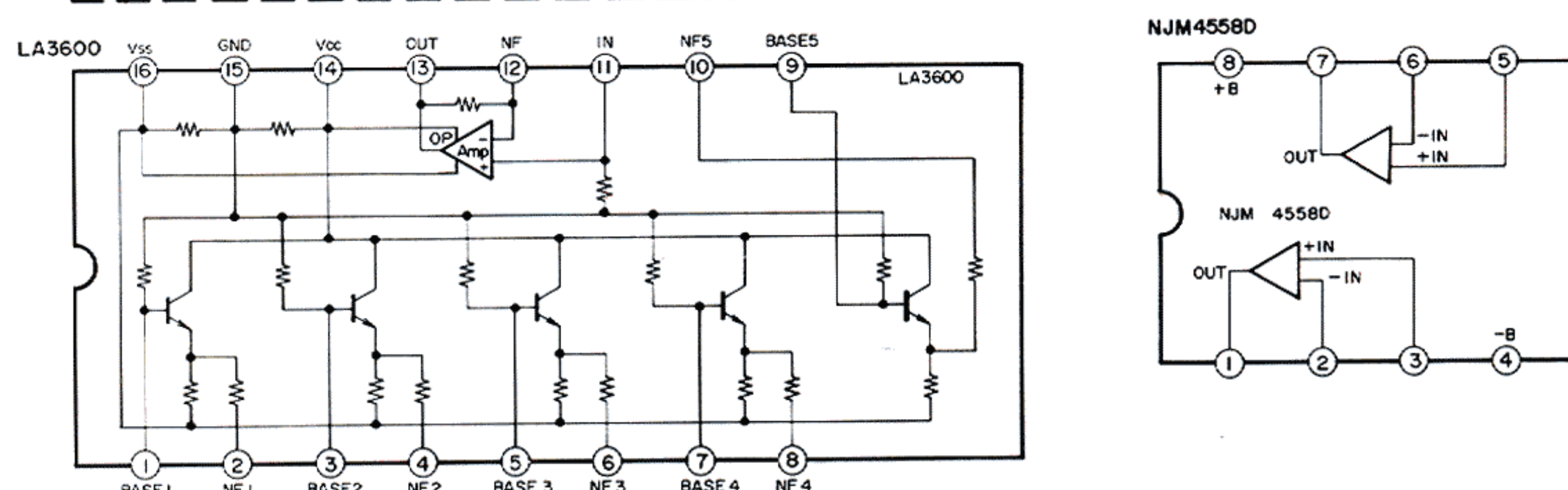
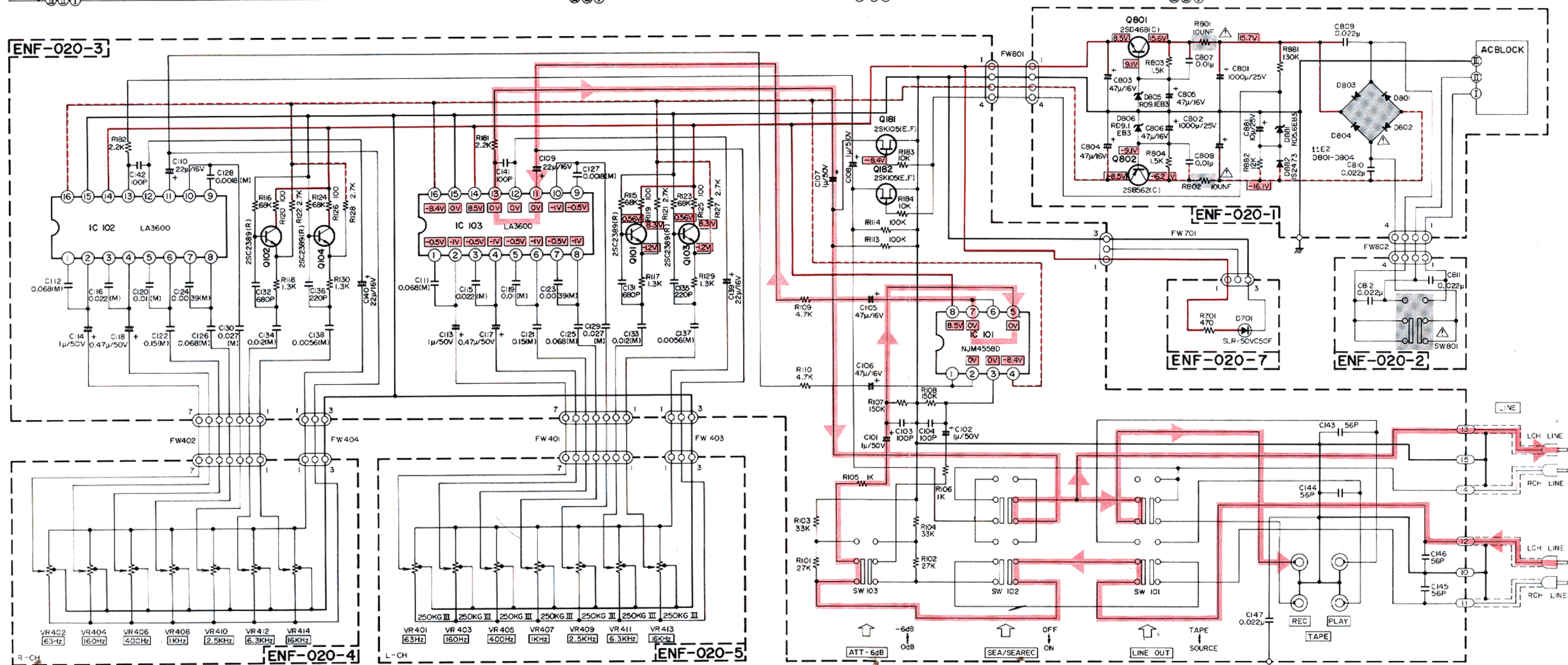
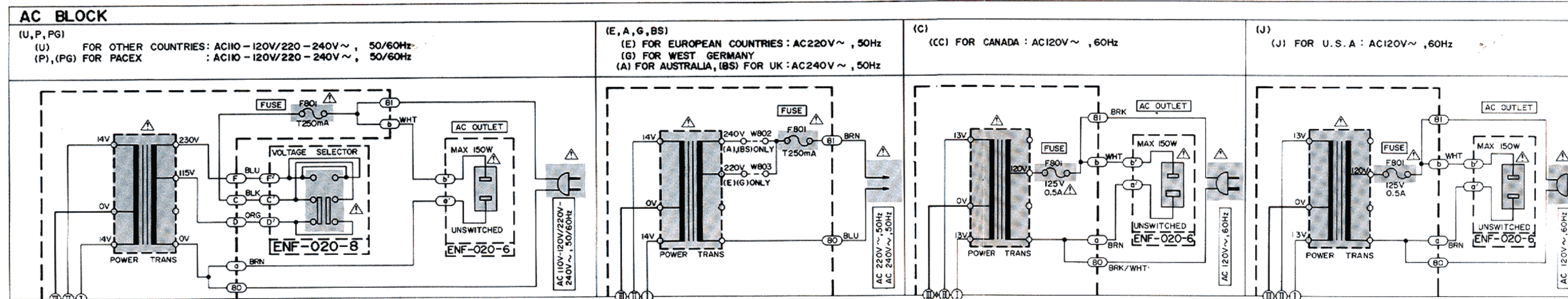

- Notes:**
1. ■ shows DC voltage to the chassis with no signal input.
  2. — indicates positive B power supply.
  3. - - - indicates negative B power supply.
  4. ■ indicates signal path.
  5. When replacing the parts in the darkened area (■) and those marked with ⚠, be sure to use the designated parts to ensure safety.
  6. This is the standard circuit diagram. The design and contents are subject to change without notice.

# 6. Exploded View

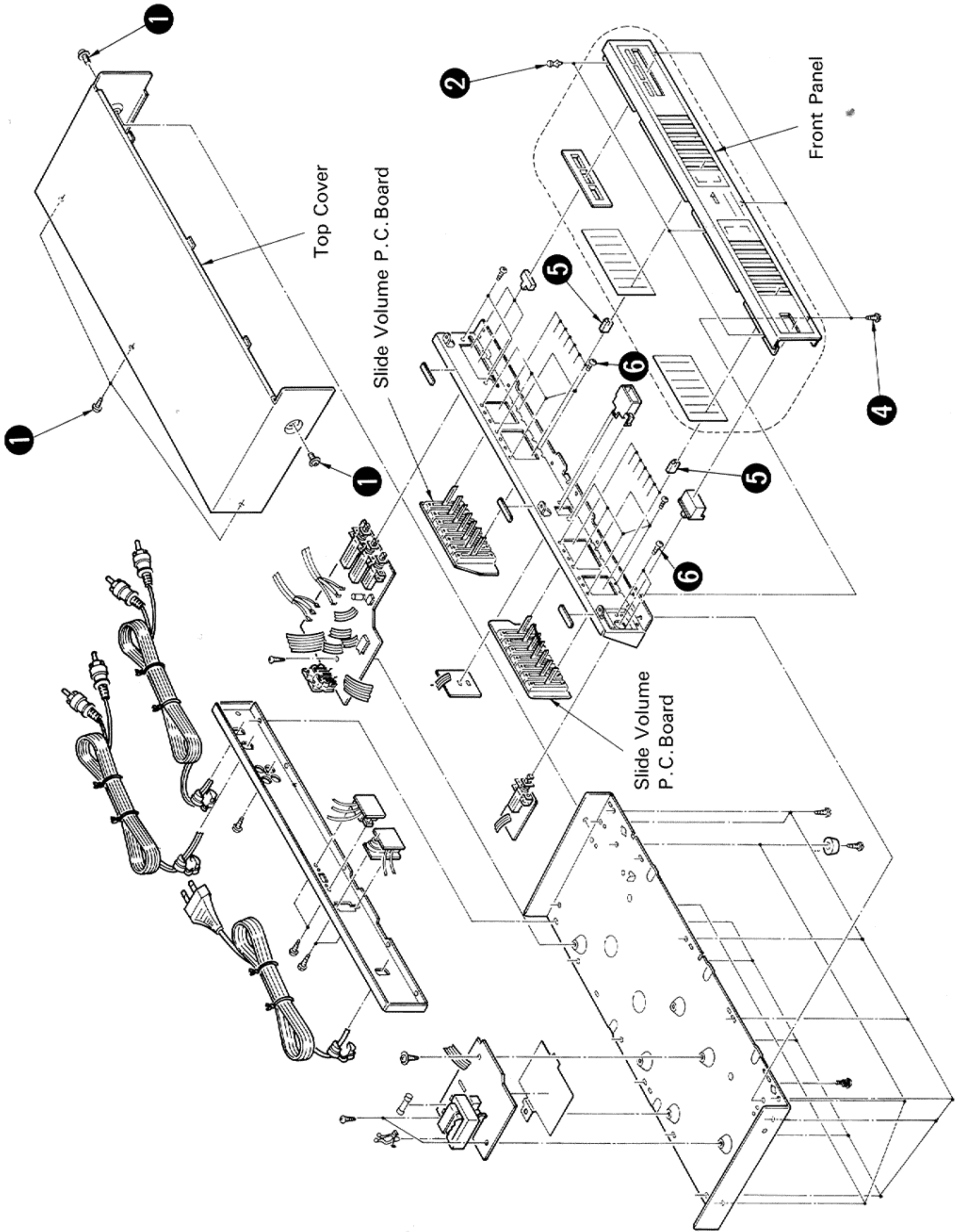



# JVC

VICTOR COMPANY OF JAPAN, LIMITED  
STEREO DIVISION, YAMATO PLANT, 1644, Shimotsuruma, Yamato-shi, Kanagawa-ken, 242, JAPAN