

JVC

SERVICE MANUAL

MODEL
SEA-80
S.E.A. GRAPHIC EQUALIZER

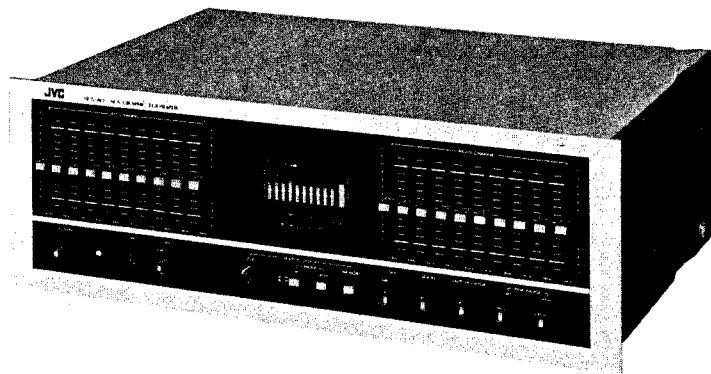

No. 2478
APR. 1979

Contents

	Page
1. Specifications	2
2. Descriptions	
2-(1) Panoramic Spectrum Analyzer	3
2-(2) Pink Noise	3
3. How to Operate the Panoramic Spectrum Analyzer	4
3-(1) Measuring the Frequency Spectrum of a Sound Source	4
3-(2) Measuring the Frequency Spectrum of Program Source such as Tapes, Records and Broadcasts	4
3-(3) Measuring the Transmission Characteristics in a Listening Room	5
4. How to Compensate for Room Acoustics	5
5. How to use S.E.A. during Recording	6
6. New Technologies	
6-(1) Block Diagram	7
6-(2) Semiconductor Inductor	8
6-(3) Graphic Display Circuit	9
6-(4) Pink Noise Generator	10
6-(5) Graphic Equalizer DC Amplification	10
6-(6) Service Precautions	11
7. Adjustment Procedures	
7-(1) Center Voltage Adjustment	11
7-(2) Gain Adjustment	11
8. Removal Procedures	
8-(1) Top and Bottom Covers	12
8-(2) Graphic Display	12
8-(3) Graphic Display Driver (TXX-189-1) P.C. Board Ass'y	13
9. Main Parts Location	14
10. Exploded View and Part Numbers	
10-(1) Front Panel	14
10-(2) Front and Chassis View	15
10-(3) Rear Panel	15
11. Connection Diagram	16
12. Printed Circuit Board Ass'y and Parts List	
12-(1) TXX-189 Graphic Display Driver, Filter, Pin Jacks and Shield P.C. Board Ass'y	17
12-(2) TXX-190 SEA Amp., MIC/MIXER and Pushswitch P.C. Board Ass'y	19
12-(3) TXX-191 Semiconductor Inductor and Slide Volume P.C. Board Ass'y	22
12-(4) TPS-222 Voltage Regulator P.C. Board Ass'y	24
12-(5) TPS-224 (or TPS-197) AC Primary P.C. Board Ass'y	25
13. Accessories List	26
14. Packing Materials and Part Numbers	26
15. Parts List with Specified Numbers for Designated Areas	27
16. SEA-80 Schematic Diagram	28, 29

1. Specifications

Circuitry

- Buffer amplifier : FET-equipped, ICL-input, double-differential, equiphase-feedback circuit
- S.E.A. amplifier : Double-differential input, DC configuration circuit
- Semiconductor-L circuit : Transistor-inductor circuit

Input section

- SEA INPUT : Input impedance 47 k-ohms
- TAPE MONI : Input impedance 47 k-ohms

Output section

- SEA OUTPUT : Output impedance 100 ohms
- TAPE REC : Output impedance 100 ohms (during SEA-recording)
- Rated output : 2 V RMS (with all S.E.A. controls positioned at "0")

- Total harmonic distortion : 0.003 % (at 1 kHz, rated output)
- Intermodulation distortion : 0.003 % (with all S.E.A. controls positioned at "0")
- Gain : 0 dB with SEA switch OFF
0 dB with SEA switch ON
-6 dB with SEA switch at -6 dB

- Frequency response : 10 - 100kHz (+0, -2 dB)
- S/N ratio : 118 dB (at rated output, IHF A-network short-circuit)

Control section

- SEA center frequencies : 31.5 Hz, 63 Hz, 125 Hz, 250 Hz, 500 Hz, 1 kHz, 2 kHz, 4 kHz, 8 kHz, 16 kHz
- SEA control range : ± 12 dB

Pink noise section

- Output : 50 mV RMS

Microphone amplifier

- *Matching microphone sensitivity : More than -72 dB
- Matching microphone impedance : Less than 1 k-ohm
- Microphone attenuator : -20 dB

Graphic display section

- MIC switch at OFF : Indicates the level of signals leaving the SEA OUTPUT terminals
- MIC switch at ON or -20 dB : Indicates the level of input signals to the microphone
- Display modes : L, R, L + R, OFF
- Memory : Normal display is restored a few seconds after the MEMORY switch is released to OFF.

General

- *Power source : See attached table.
- Power consumption : See attached table.
- Dimensions : 450(W) x 158(H) x 319(D) mm
- Weight : 8 kg

Note:

- For easy viewability, the indication for the FULL RANGE position on the SPECTRUM ANALYZER display is referred to a level about -18 dB lower than that of the other sections.
- The input sensitivity of the SPECTRUM ANALYZER is as follows (input sensitivity means a level at which the 20 dB dot lights):

LEVEL control setting	Input sensitivity (RMS) at 1 kHz	
	Divided bands	Full range
MAX.	47 mV	330 mV
Middle	100 mV	700 mV
LEFT	400 mV	2.8 V

*These are voltages applied to the INPUT terminals when the SEA switch is set to OFF.

POWER SPECIFICATIONS

	Canada & U.S.A.	Europe, U.K., & Australia	Military Market & Other Areas
Power Supply	AC 120 V \sim , 50/60 Hz	AC 110 V/120 V/220 V/240 V \sim selectable, 50/60 Hz	AC 110 V/120 V/220 V/240 V \sim selectable, 50/60 Hz
Power Consumption	26 W	26 W	26 W
Power Outlet	Fitted	Not Fitted	Fitted
FUSE (Primary) (F751)	QMF61U1-R80 (0.8 A)	QMF51A2-R20L (200 mA)	AC 110, 120 V Areas QMF51A2-R50L (500 mA) AC 220, 240 V Areas QMF51A2-R20L (200 mA)

2. Descriptions

2-(1) Panoramic Spectrum Analyzer

The Panoramic Spectrum Analyzer of the SEA-80 analyzes the spectrum of the sound signal and gives a fluorescent display, dividing the frequency spectrum into 10 frequency bands corresponding to the 10 S.E.A. controls. This enables you to see at a glance the frequency distribution of the music you are listening to.

The FULL RANGE display on the right shows the overall sound level, in much the same way as a VU meter.

Its scale has 26 divisions, each corresponding to approx. 1 dB.

Since the analyzer is connected to the SEA-80's output circuitry, it shows the frequency distribution of the signal being output to the speakers.

One application for which it can conveniently be used in conjunction with a microphone is the analysis of room acoustics.

So that indications are easy to read, the fluorescent display tubes have quick-rise, slow-fall characteristics.

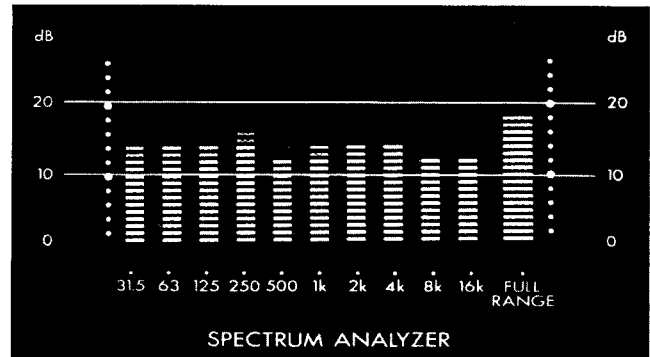

Fig. 1

2-(2) Pink Noise

- The pink noise can be used for measuring the room acoustics.
- The pink noise contains signals over a wide frequency range and its energy distribution for different frequency bands is uniform (i.e. the amount of energy of the signal in each one-octave frequency span, 100 Hz – 200 Hz, 200 Hz – 400 Hz, 400 Hz – 800 Hz, for example, is identical with one another). Also the actual signal levels can easily correspond to the effect they have on auditory perception. Therefore, the pink noise is used most often for measuring purposes.
- Because the pink noise is a kind of "noise", it is constantly subject to drastic level fluctuations. These level fluctuations are observed on the SPECTRUM ANALYZER indicator and are apt to make actual measurements rather difficult. We recommend that you gather several sample measurements and use their average as the reference for your adjustments.
- The graphic display is subject to fluctuations as the signal level fluctuates. But it can give you a clear, visual idea of what the acoustics of your listening room are like. If you want to tabulate the measured data, press the MEMORY button and make a note of several stationary readings in order to obtain their average.

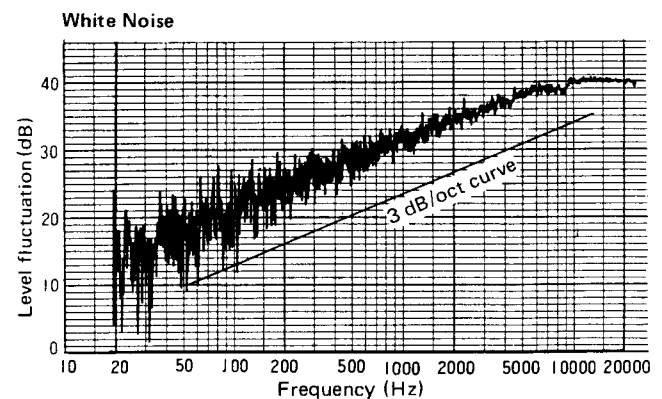

Fig. 2

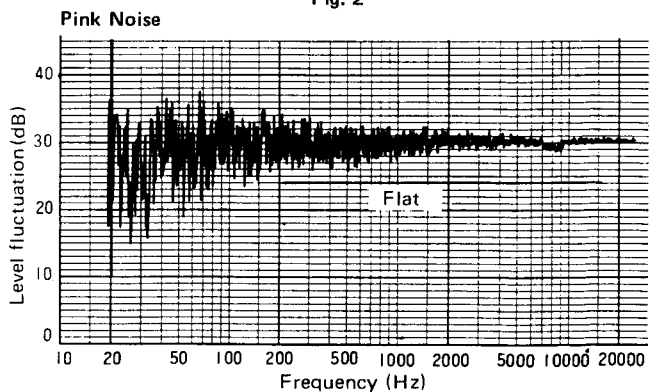

Fig. 3

3. How to Operate the Panoramic Spectrum Analyzer

3-(1) Measuring the Frequency Spectrum of a Sound Source

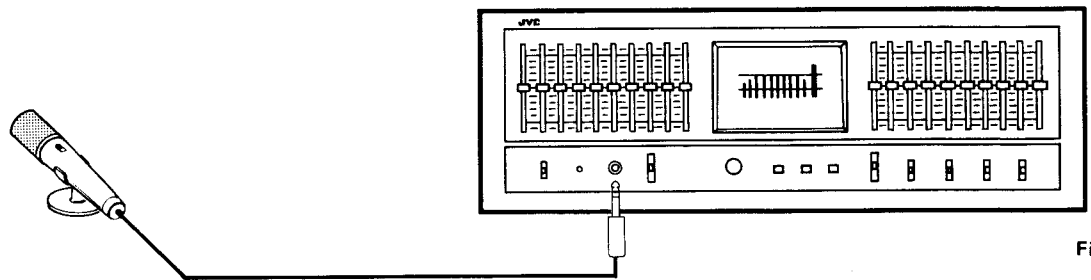

Fig. 4

- The SPECTRUM ANALYZER indicator provides a direct readout of the frequency spectrum made up of human voices, musical instruments, music, noise, etc.
- Connect a microphone to the SEA-80 as illustrated. Set the MIC switch to ON and both MODE buttons to OFF. Position the microphone at a suitable position and adjust the LEVEL control so that the graphic display can be obtained at an easy-to-read position. If the sound source is too loud, set the MIC switch to “-20 dB”.
- The SPECTRUM ANALYZER indicator shows the frequency spectrum of the input signal, applied to the microphone.
- To view an instantaneous frequency spectrum in more detail, press the MEMORY button. This button does not lock in.

3-(2) Measuring the Frequency Spectrum of Program Source such as Tapes, Records and Broadcasts

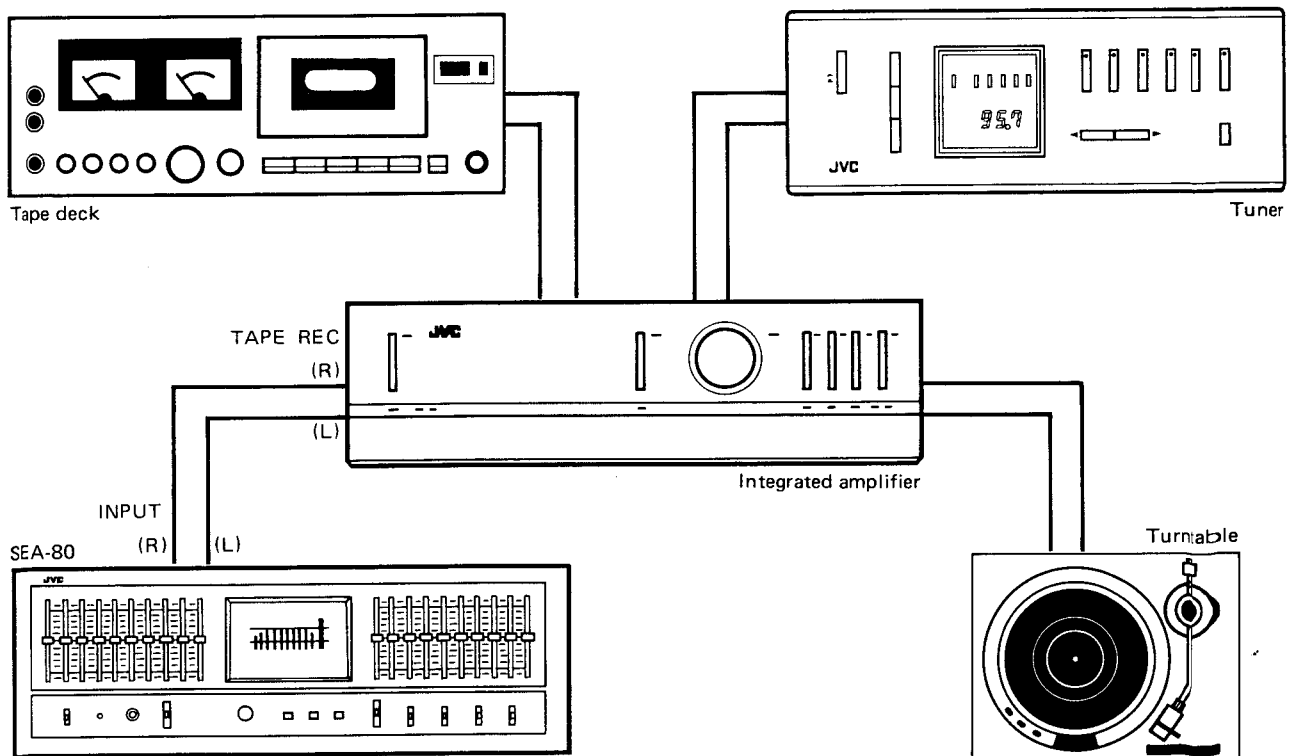

Fig. 5

- The SPECTRUM ANALYZER indicator displays the frequency spectrum of the signal that's at the OUTPUT terminals.
- Set the MIC switch to OFF.
- Select the channel with the MODE buttons.

3-(3) Measuring the Transmission Characteristics in a Listening Room

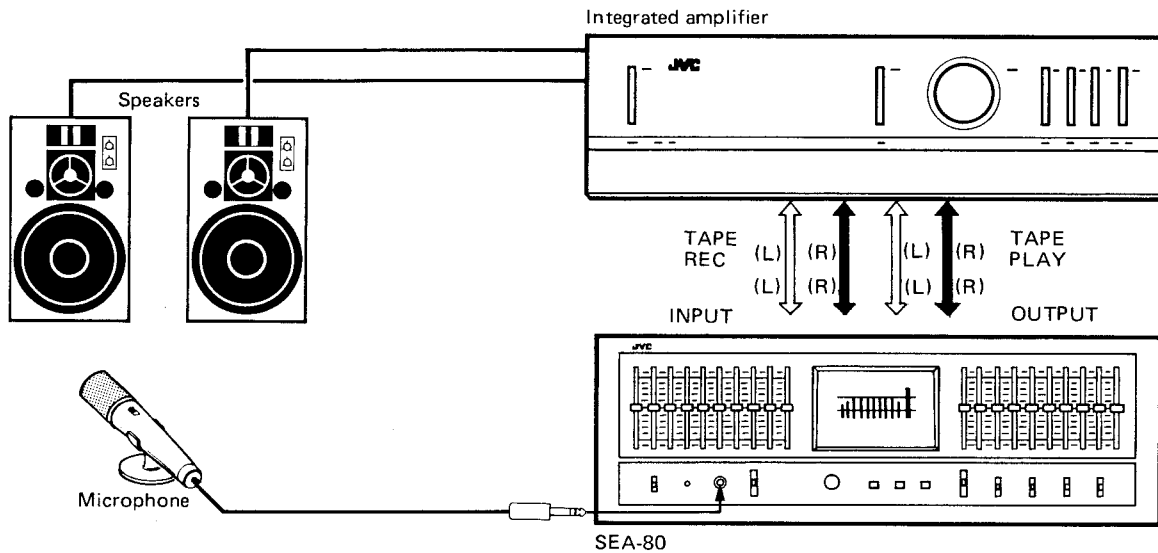

Fig. 6

- Measuring the room acoustics (frequency characteristics of a listening room)
- Measuring the frequency response of speakers

Connect a microphone and set the MIC switch to ON. Set both MODE switches to OFF. Produce pink noise from either of the channels by setting the LEFT or RIGHT PINK NOISE switch to ON and adjust the volume with the amplifier's volume control. Place the microphone in a normal listening position. The SPECTRUM ANALYZER now indicates the frequency response of the listening room; which frequency component is more likely to be boosted or absorbed.

If the microphone is brought close to a speaker in a room with less reflections, the speaker's frequency response itself will be displayed.

- Notes:
- A recommended microphone for use with the SEA-80 is the MU-S80. Its frequency response is flat from 30 Hz to 16 000 Hz (± 2 dB) and can be considered to be ideal for measuring purposes. For this reason, there may be a great difference in the graphic display on the indicator when you use the MU-S80 and when you use an ordinary microphone. Taking advantage of this fact, it is possible to know the characteristics of a microphone.
 - When using the pink noise, set the SEA switch to OFF or, if the SEA switch is set to ON, place each of the S.E.A. controls at its middle position.
 - Each channel should be checked independently.

4. How to Compensate for Room Acoustics

The transmission characteristics at your listening position can be made flat using the S.E.A. controls.

Measure the frequency characteristics in your listening room using a microphone, pink noise and SPECTRUM ANALYZER as described on page 4.

If you observe big peaks or dips on the SPECTRUM ANALYZER indicator, set the SEA switch to ON and adjust the corresponding S.E.A. control so that the peak or dip can be corrected.

For your reference, more natural sound can be obtained if the frequency response shows a gradually dropping curve for frequencies above 2 kHz. Make adjustments for the other channel, too.

- Notes:
- Minute correction of the room acoustics cannot be done with the S.E.A. graphic equalizer.
 - The SEA-80 provides level control for each frequency band within ± 12 dB. Variations of levels exceeding this control range cannot be corrected.
 - The amount of level variations on the SPECTRUM ANALYZER indicator may not correspond exactly with the amount of movement of the S.E.A. controls.

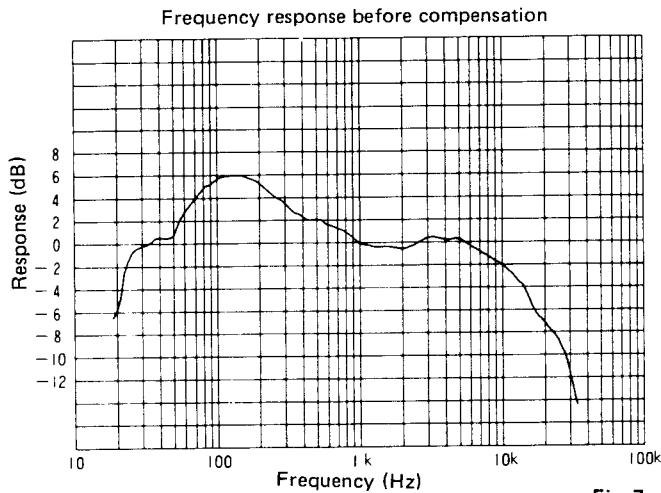

Fig. 7

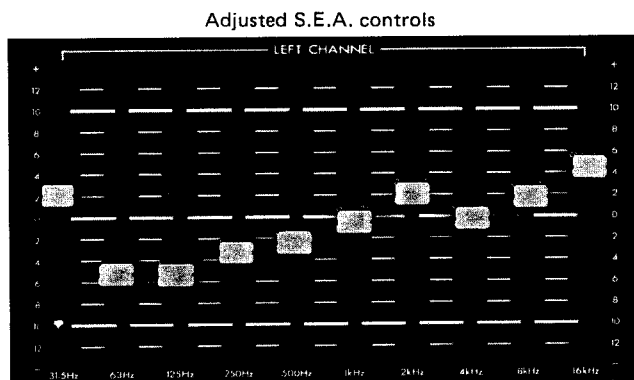

Fig. 9

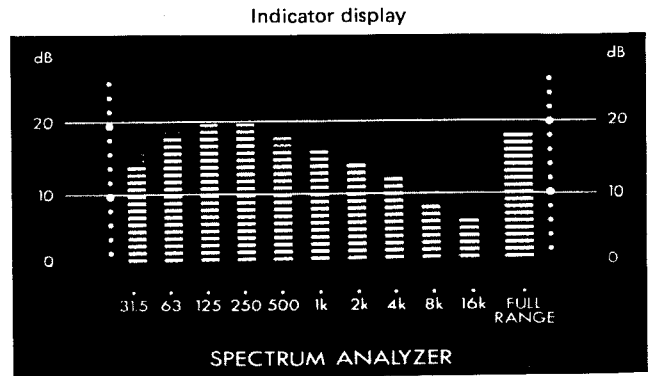

Fig. 8

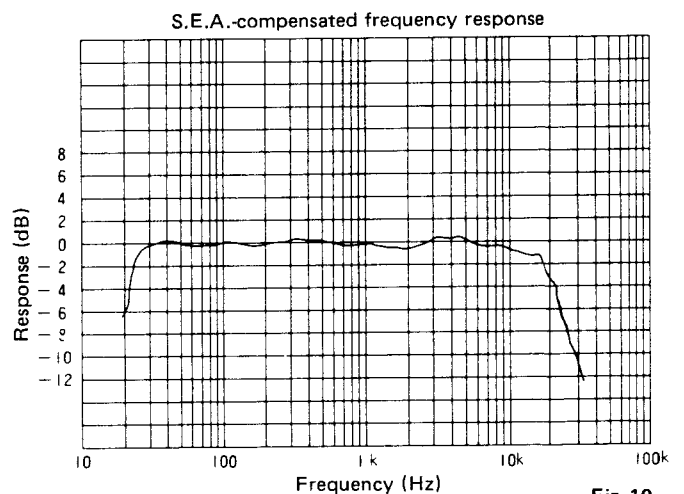

Fig. 10

5. How to Use S.E.A. during Recording

● Reducing tape hiss

Hiss noise is noticeable with "normal" cassette tapes. This hiss noise can be reduced during playback listening in the following way: Make a recording with the S.E.A. controls above 4 kHz set to +4 dB and play it back with those controls set to -4 dB.

● Making cassette tape recordings with less distortion

Cassette tapes are likely to have problems in handling high-frequency high-level signals. When recording music, adjustment of high-frequency ranges with the S.E.A. controls will reduce distortion, making full utilization of the tape's capacity.

If the music you are going to record is dominated by musical instruments producing high-frequency sounds, it is recommended that the 8 kHz S.E.A. control be set to -2 dB and the 16 kHz control to -4 dB. When this recording is played back with the 8 kHz control set at +2 dB and the 16 kHz control at +4 dB, you can enjoy a reproduced music having less distortion.

● S.E.A. recording of "tailored" sound

A true S.E.A. recording is one in which you adjust the sound to suit your preference with the S.E.A. controls and record this "tailored" sound onto tapes. Experiment at devising your own personalized sound and take pleasure in recording it for future listening.

- Notes:
- For recording tapes with the added S.E.A. effect with the tape deck connected to the SEA-80, set the SEA REC switch to ON.
 - A microphone mixer is needed for making S.E.A. recordings of live sound.
 - S.E.A. recording of the sound from a microphone connected to the tape deck cannot be performed.

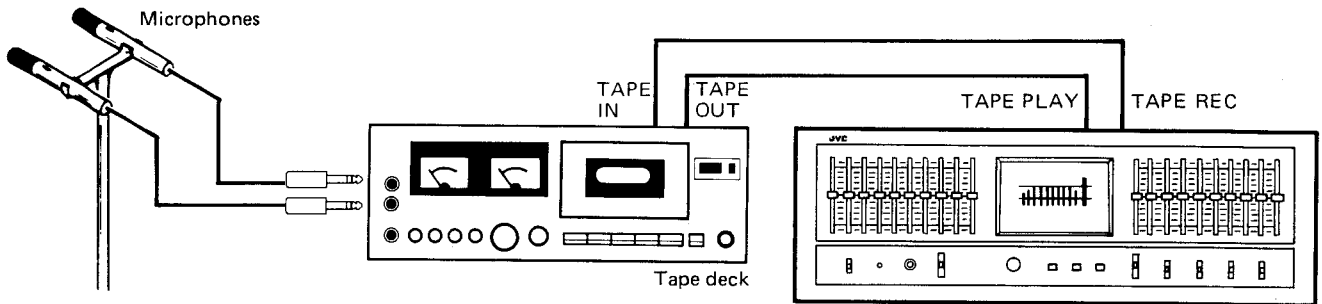

Fig. 11

SEA-80

6. New Technologies

6-(1) Block Diagram

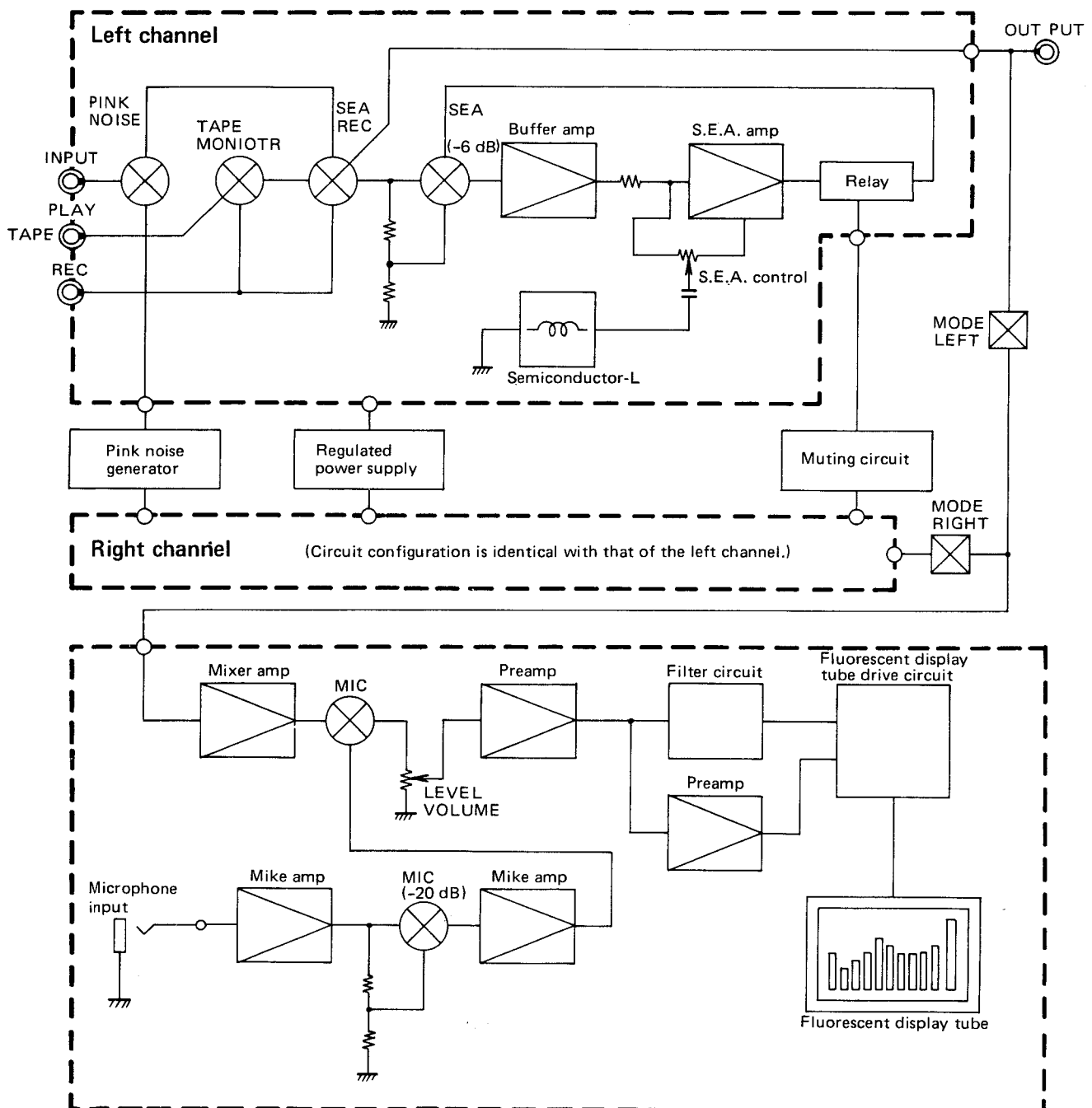

Fig. 12

6-(2) Semiconductor Inductor

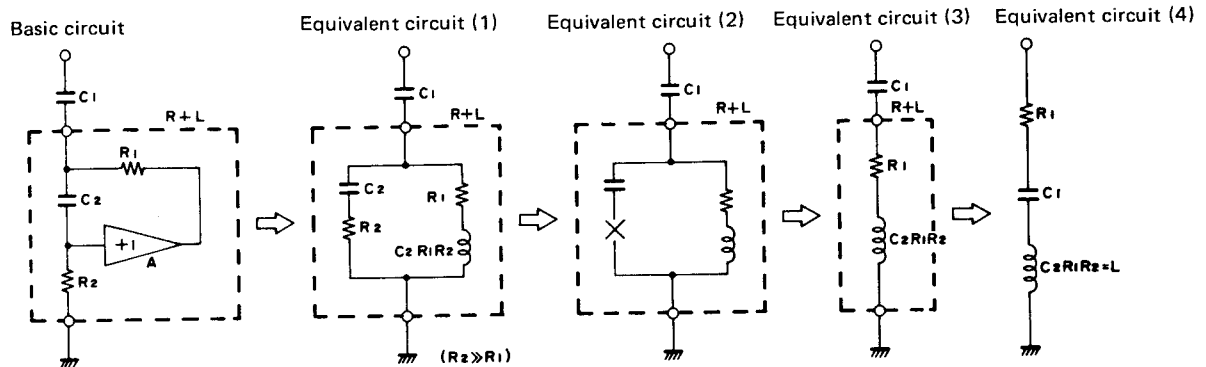

Fig. 13 Process of analyzing the semiconductor inductance circuit

Fig. 13 illustrates the process of analyzing the semiconductor-inductor employed in the SEA-80 from the basic to the grounded series resonance circuit.

Fig. 14 shows a more detailed analysis of the "R + L" part enclosed by the dotted in Fig. 13.

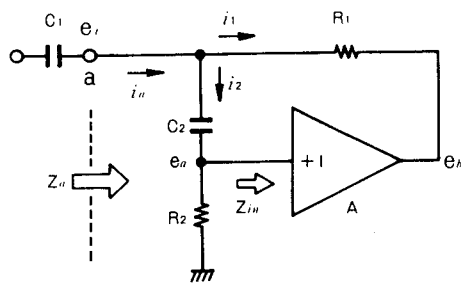

Fig. 14 Semiconductor-inductor equivalent circuit

Conditions:

1. A is a buffer amplifier rated at $Z_{in} = \text{infinity}$, $Z_{out} = 0$ and gain = 1.
2. Relation between R_1 and R_2 is $R_2 \gg R_1$.

Result:

$$Z_a = \frac{e_i}{i_a} = R_1 + j\omega C_2 R_1 R_2 \quad \dots \dots \dots (1)$$

Since A in Fig. 14 is a buffer amplifier having a gain of 1, resulting in $e_a = e_b$, and e_a is a voltage divided by C_2 and R_2 .

$$e_a = \frac{R_2}{1 + j\omega C_2 R_2} \cdot e_i = \frac{j\omega C_2 R_2}{1 + j\omega C_2 R_2} \cdot e_i = e_b \quad \dots \dots (2)$$

i_2 is negligible compared with i_1 due to the conditions of $Z_{in} = \text{infinity}$ and $R_2 \gg R_1$. Therefore, with $i_a \approx i_1$,

$$i_a = i_1 = \frac{e_i - e_b}{R_1} = \frac{e_i - \frac{j\omega C_2 R_2}{1 + j\omega C_2 R_2} \cdot e_i}{R_1} = \frac{e_i}{R_1 + j\omega C_2 R_1 R_2} \quad \dots \dots \dots (3)$$

Therefore, input impedance Z_a from terminal "a" to the circuit is given by:

$$Z_a = \frac{e_i}{i_a} = \frac{e_i}{\frac{e_i}{R_1 + j\omega C_2 R_1 R_2}} = R_1 + j\omega C_2 R_1 R_2$$

This is the result of analysis shown by equation (1). The resonance frequency f_0 , Q and other circuit constants of the resonance circuit employing the semiconductor-inductor are designed as determined by the following equations:

$$f_0 = \frac{1}{2\pi\sqrt{C_1 C_2 R_1 R_2}}, \quad Q = \sqrt{\frac{C_2 R_2}{C_1 R_1}} \quad \text{or} \quad Q = \frac{1}{2\pi f_0 R_1 C_1}$$

$$C_1 = \frac{1}{2\pi f_0 R_1 Q}, \quad C_2 = \frac{Q}{2\pi f_0 R_2}$$

$$R_1 = \frac{1}{2\pi f_0 C_1 Q}, \quad R_2 = \frac{Q}{2\pi f_0 C_2}$$

In the SEA-80, with the circuit constants determined by these equations, the load on the buffer amplifier is greatly reduced compared with the semiconductor-inductors previously employed by JVC. This has made it possible to greatly expand the dynamic range of the semiconductor-inductor.

The condition $R_2 \gg R_1$ should be satisfied when the equivalent circuit (1) is transformed into (2) in Fig. 13. However, in practice, it is impossible to make R_2 infinite and certain circuit technique is employed for practical use in order to eliminate the effect of R_2 .

The values of C_1 and C_2 have been reduced compared with the semiconductor-inductors previously employed by JVC. This made possible the employment of Mylar capacitors instead of electrolytic capacitors which are subject greater loss, resulting in excellent resonance characteristics with good skirts.

6-(3) Graphic Display Circuit

Block Diagram

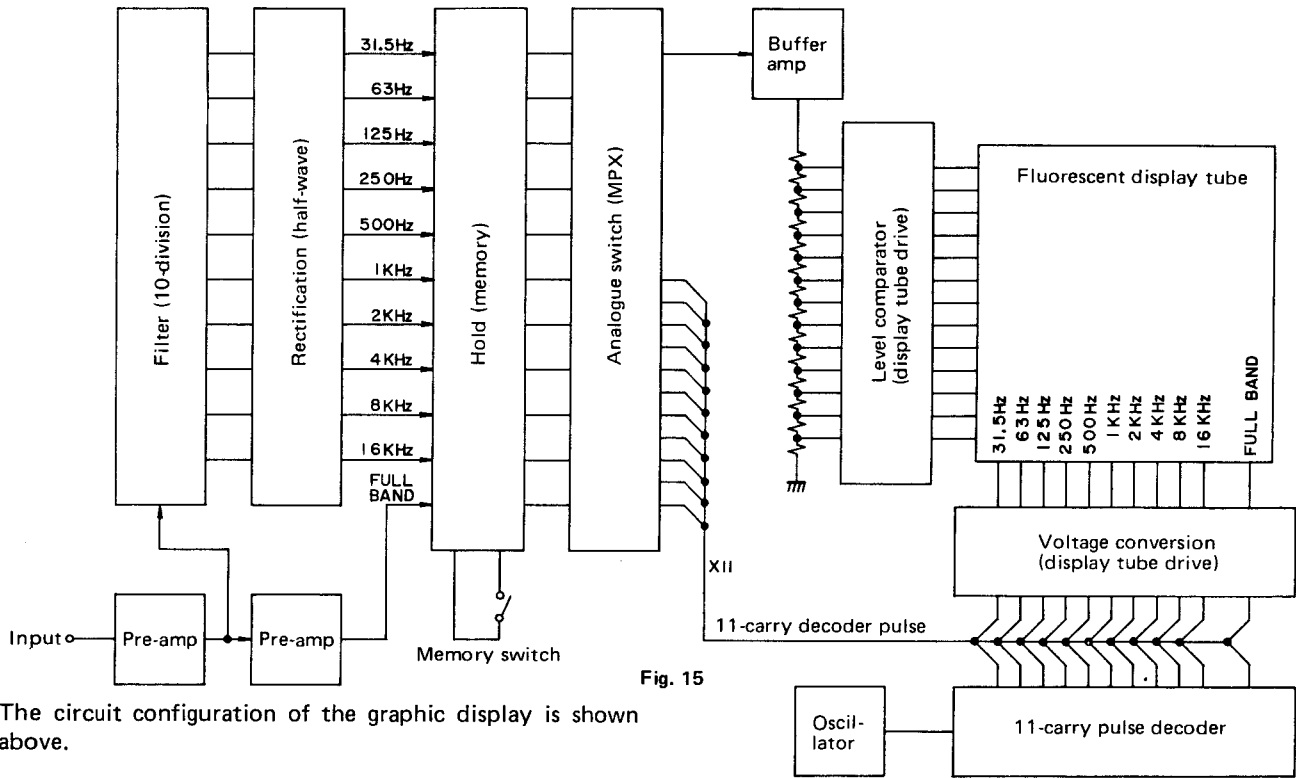

Fig. 15

The circuit configuration of the graphic display is shown above.

Operation description

- (1) The signal amplified by the pre-amp is applied to the 10-division filters, and the respective output is rectified, and converted to a DC level.
- (2) This DC voltage controls the discharge of the LLC electrolytic capacitor in the analogue gate memory circuit. [The internal impedance of ICs 901 – 903 (TC4016BP) is increased by operating the memory switch and the discharge of the capacitor is stopped. This maintains the signal level at a specified level.]
- (3) The 11-carry pulse is generated with the oscillator frequency at ICs 920 and 921 (TC4017BP).

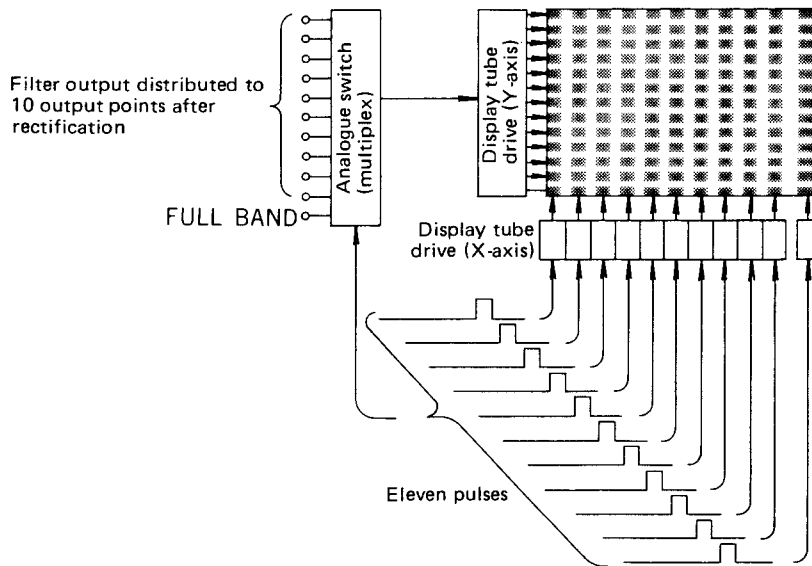

Fig. 16

- (4) ICs 914 – 919 (NJM4558D) for X-axis drive turn on when pulses occur, and signals are applied to the eleven X-axis display tube.
- (5) The eleven pulses go to the MPX circuit consisting of ICs 904 – 906 (TC4016BP) at the same time. They sequentially select the 10 filter outputs so that the outputs are transmitted to the level comparator.
- (6) ICs 907 – 913 (NJM4558D) for the Y-axis drive turn on through the action of the comparator, and a voltage is applied to the Y-axis.
- (7) The fluorescent tubes light where a voltage is applied to both the X-axis and the Y-axis at the same time.

6-(4) Pink Noise Generator

Block diagram

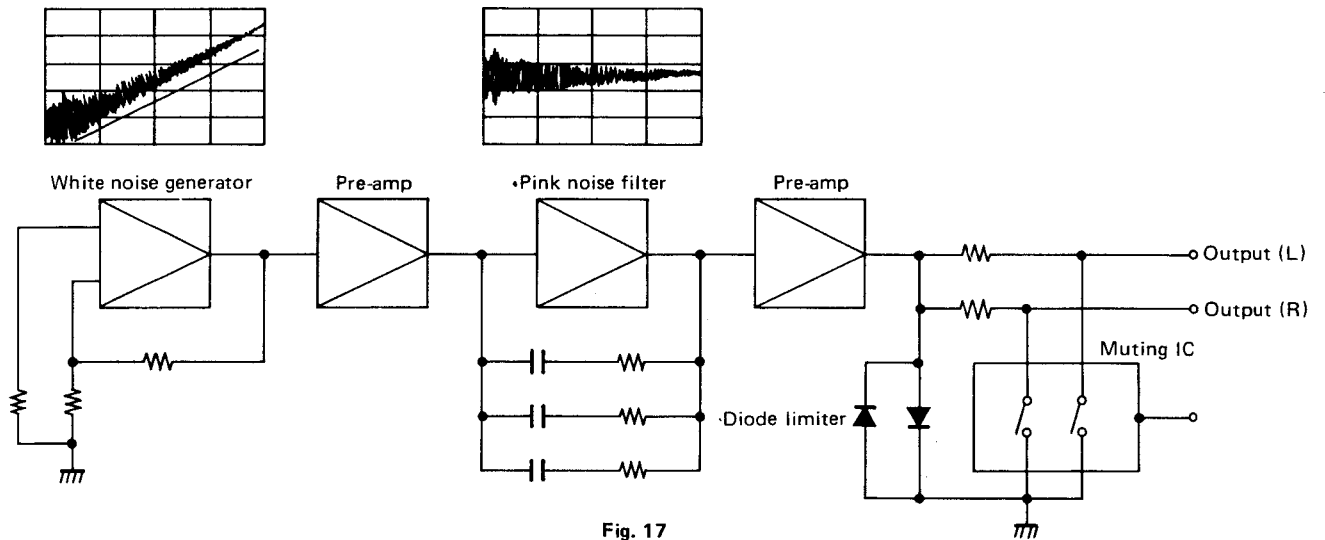

Fig. 17

The white noise is generated by amplifying thermal noise from resistors: It is converted to pink noise by amplification and passing through the -3 dB/Oct filter. This pink noise is further amplified to an effective level.

The pink noise generator is provided with a muting circuit utilizing TC4016BP (IC864) and a diode limiter in order to eliminate noise caused when the power-supply switch is switched ON and OFF.

6-(5) Graphic Equalizer DC Amplification

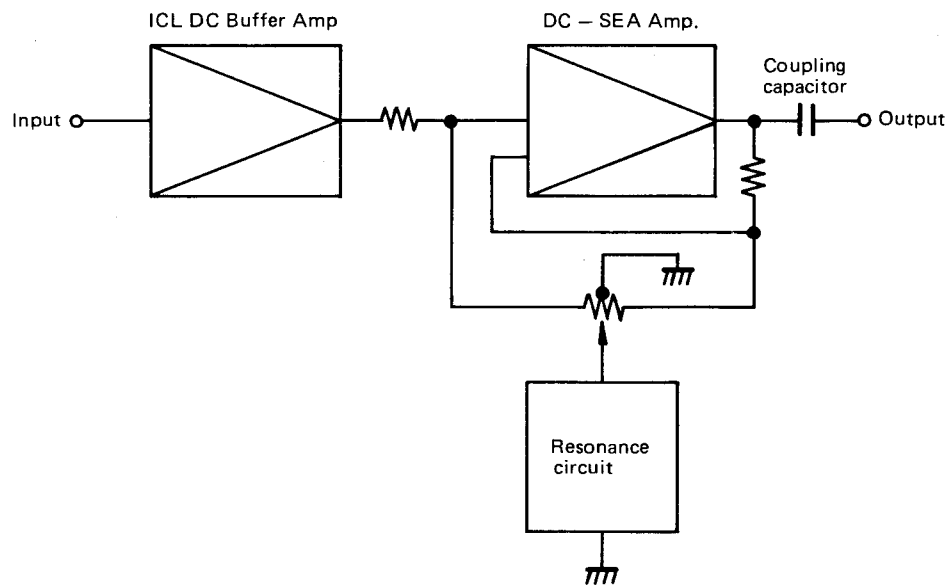

Fig. 18

DC amplification is adopted to improve sound quality. Only one coupling capacitor is used in the output portion.

7. Adjustment Procedures

6-(6) Service Precautions

Spectrum Analyzer

The level of music sound or pink noise displayed on the screen is far lower than the full range energy because the signal frequency is divided into 10 portions by the spectrum analyzer display. Because of this, the input of the full range portion is displayed at a far higher level than that of the analyzer portion if the input level is made the same for the spectrum analyzer unit and the full range unit. This would make the level observation on the screen difficult. For this reason, the level of the full range portion is set to -18 dB lower than the level of the spectrum analyzer portion in the SEA-80.

Spectrum Analyzer Input Sensitivity

Level control position	Input sensitivity (r.m.s) with 1 kHz signal	
	Analyzer portion	Full Range portion
Max	47 mV	330 mV
Mid-point	100 mV	700 mV
Left	400 mV	2.8 V

The above voltages are those inputs to the input terminals when the SEA is switched OFF.

Available outputs at different switch settings

TAPE MONITOR switch	SEA REC switch	Output at the TAPE REC OUT terminals	Output at the OUTPUT terminals
OFF	OFF	Input signal (without S.E.A. effect)	Input signal (either with or without S.E.A. effect)
ON	OFF	Input signal (without S.E.A. effect)	Tape signal (either with or without S.E.A. effect)
ON	ON	Input signal (either with or without S.E.A. effect)	Tape signal (without S.E.A. effect*)
OFF	ON	Input signal (either with or without S.E.A. effect)	Input signal (either with or without S.E.A. effect)

*When the PINK NOISE switch is set to ON, the pink noise is the input signal.

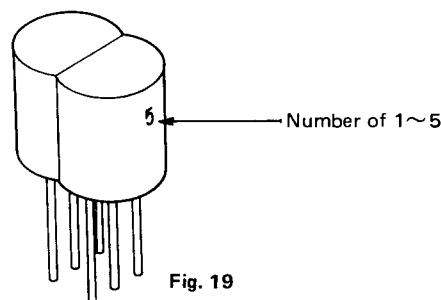

Fig. 19

Cautions

- Push-button switch cannot be pulled out as it is assembled together with the front panel.
- The F.E.T. used for differential amplification in the first stage of the buffer amplifier is a specially selected F.E.T. with a high S/N ratio, suitable for use as a DC amp. It has the number of 1 ~ 5 on one side for identification, instead of "2SK106W (C)" which would be difficult to mark on the side face because of its shape.

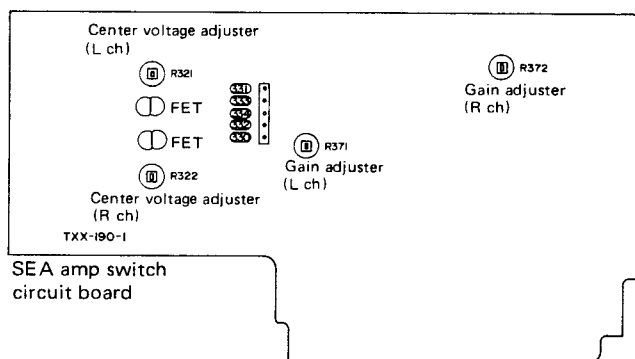

Fig. 20

7-(1) Center Voltage Adjustment

Employ a DC VTVM with DC 1 mV.

	Adjustment point	Measuring test point	Adjustment/check voltage
Left Channel	R321	Between 333 - 334 (ground)	0 V
	Voltage Check	Between 331 - 334	Normal within ± 15 mV
Right Channel	R322	Between 332 - 334	0 V
	Voltage Check	Between 330 - 334	Normal within ± 15 mV

7-(2) Gain Adjustment

- Preparation:
1. Set all SEA controls to their central positions.
 2. Set the pink noise switch to OFF.
 3. Set the tape monitor switch to OFF.
 4. Apply the test signal (1 kHz, 0 dBm = 0.775 V) to the INPUT terminals.

	Adjustment point	Adjusting procedure
L ch	R371	Adjustment should be performed so that the gains with the SEA switch set to ON and OFF are the same.
R ch	R372	

8. Removal Procedures

8-(1) Top and Bottom Covers

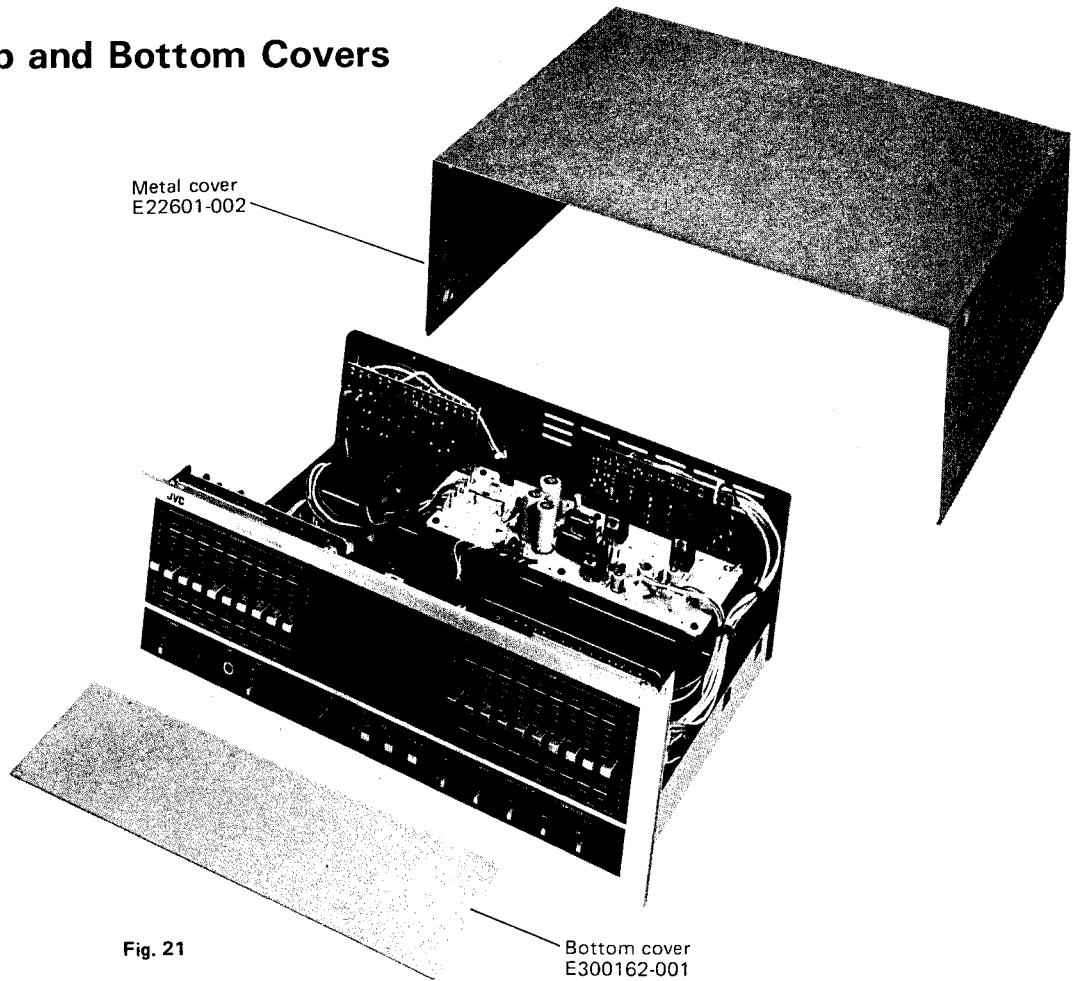

Fig. 21

8-(2) Graphic Display

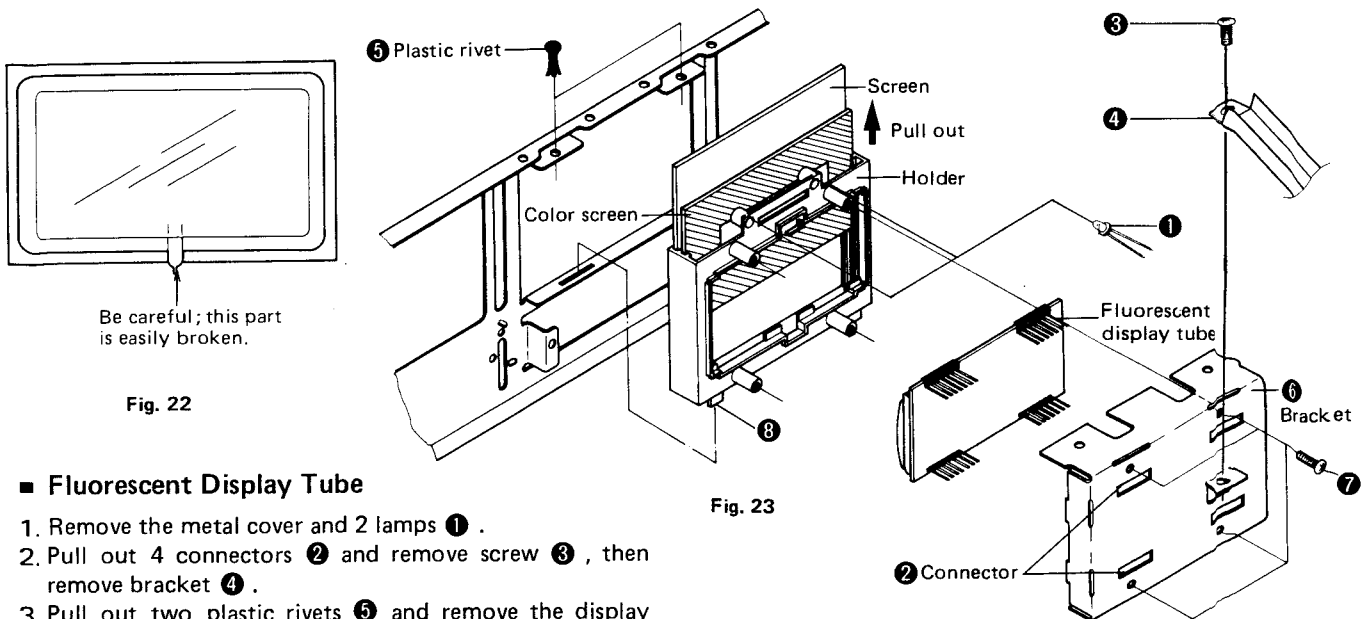

Fig. 22

Fig. 23

■ Fluorescent Display Tube

1. Remove the metal cover and 2 lamps ① .
2. Pull out 4 connectors ② and remove screw ③ , then remove bracket ④ .
3. Pull out two plastic rivets ⑤ and remove the display tube assembly by inclining bracket top ⑥ backward.
4. Remove 4 bracket fixing screws ⑦ and remove the fluorescent display tube.

(Note) Be careful when handling the fluorescent display tube since it is glass.

5. Insert holder bottom claw ⑧ into the front bracket holder fixing hole when assembling.

8-(3) Graphic Display Driver (TXX-189-1) P.C. Board Ass'y

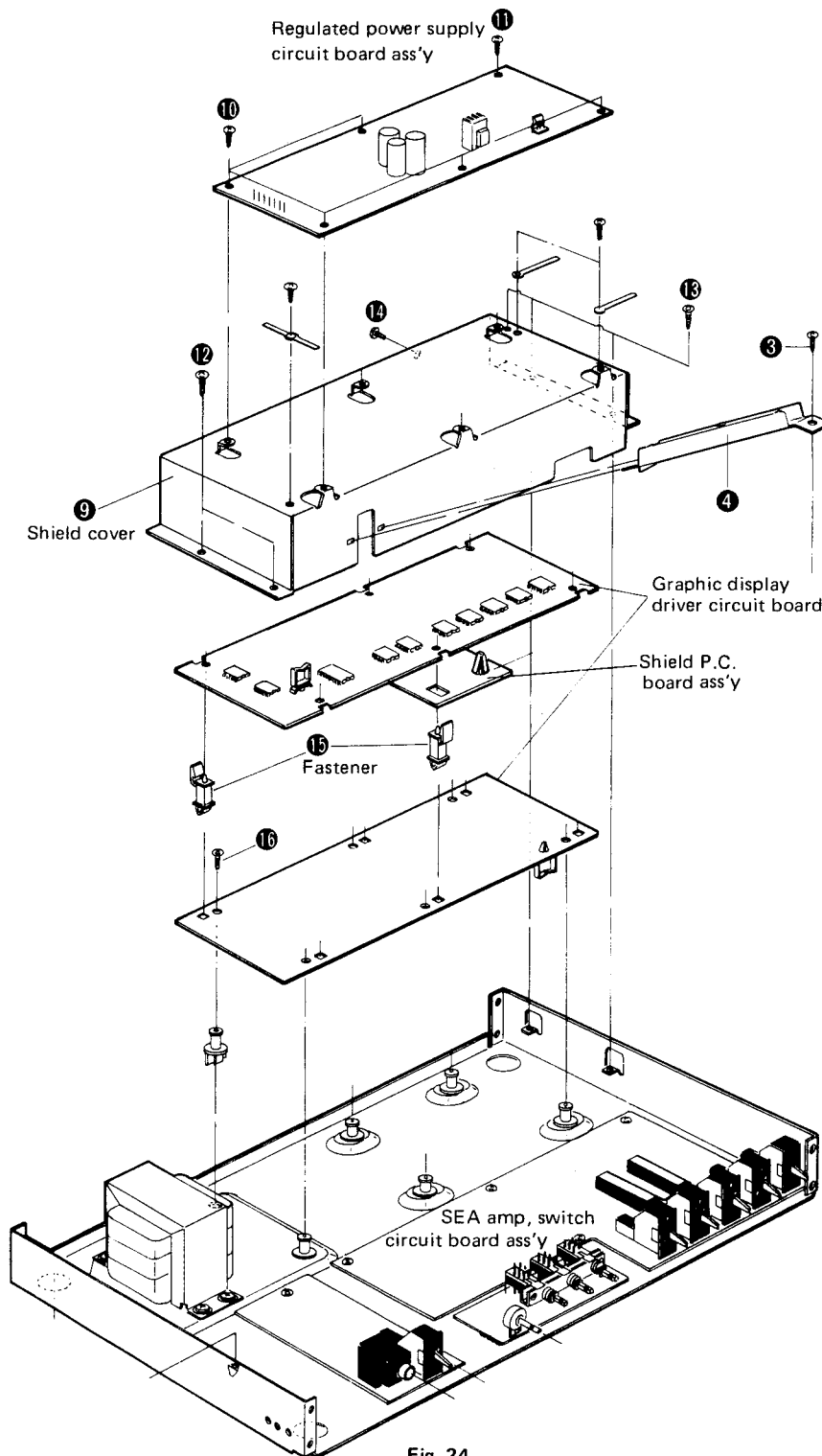
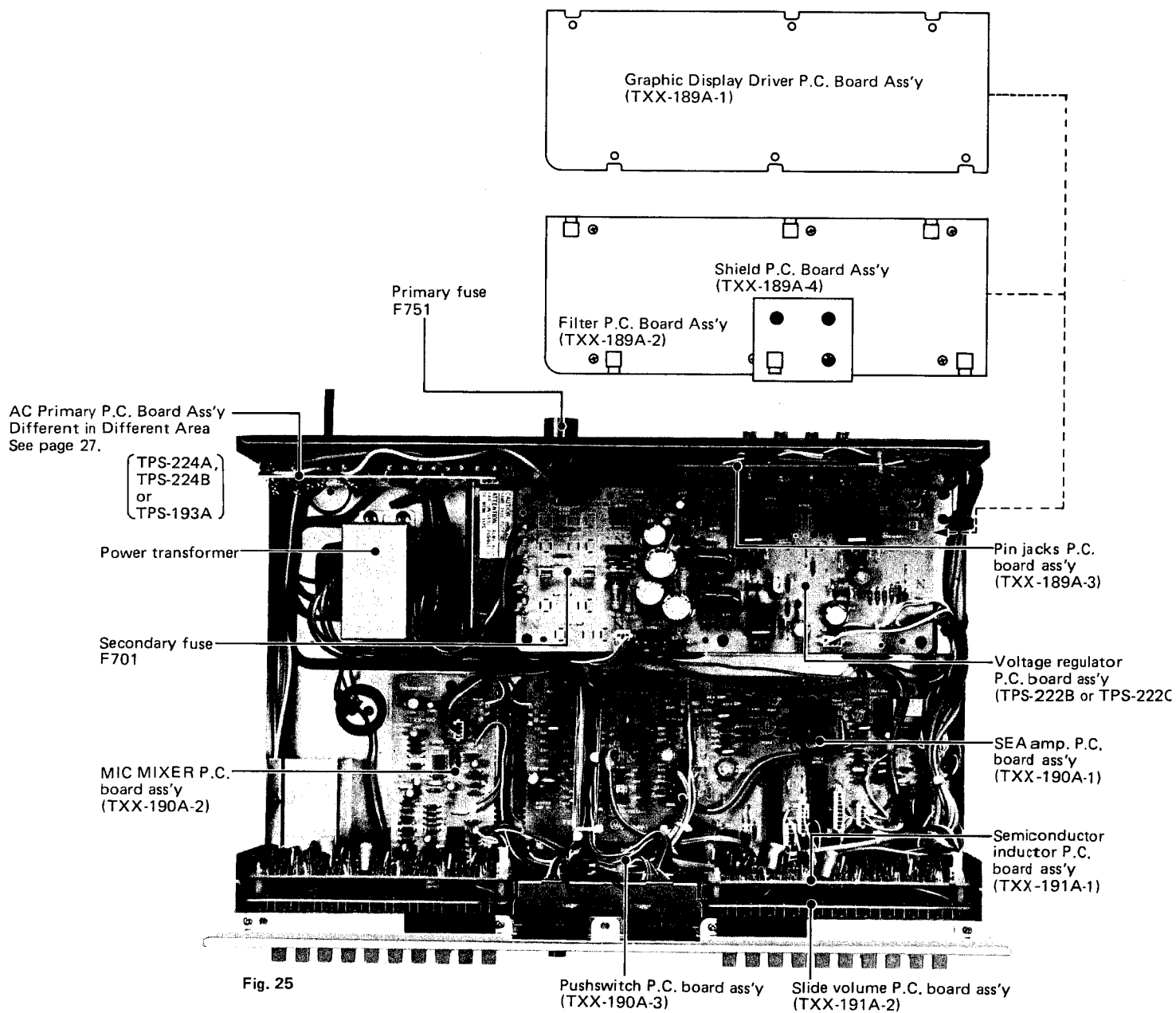

Fig. 24

1. Disconnect the 2 link connectors which connect the shield cover ⑨ to the SEA amp switch circuit board.
2. Disconnect the 4 link connectors from the fluorescent display tube.
3. Remove screw ③ and bracket ④ .
4. Remove 5 screws ⑩ and screw ⑪ , then dismount the voltage regulator circuit board.
5. Remove 2 screws ⑫ , 3 screws ⑬ and screw ⑭ , then remove the shield cover.
6. Remove fasteners ⑮ and 6 screws ⑯ , then the display drive circuit board can be removed from the chassis.

9. Main Parts Location



10. Exploded View and Part Numbers

10-(1) Front Panel

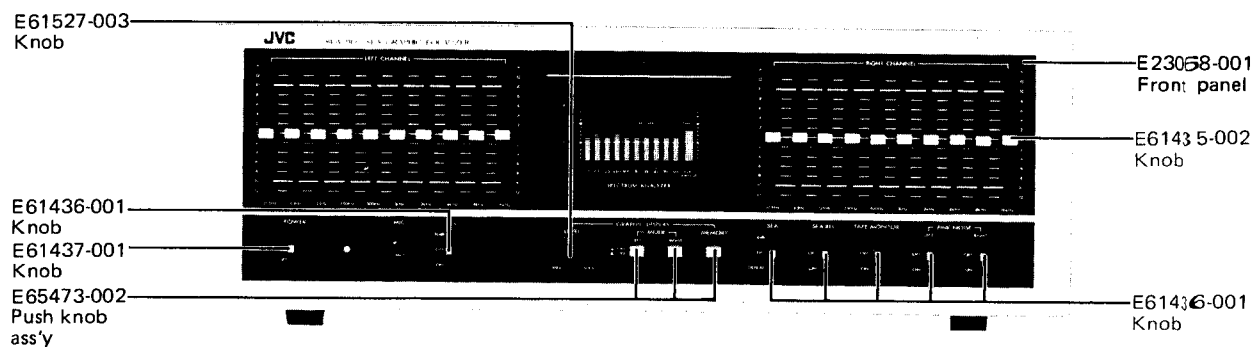
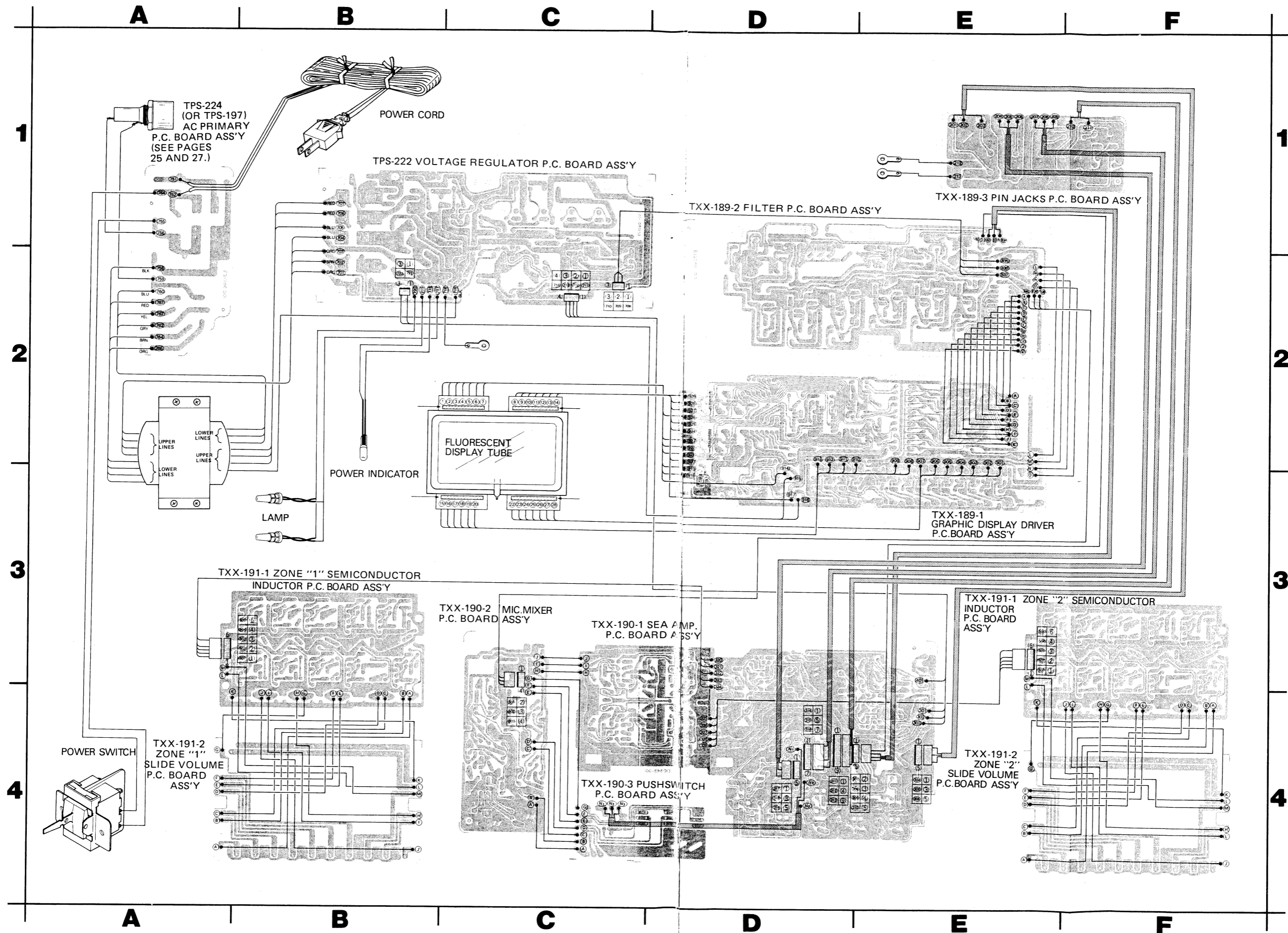

Fig. 26

11. Connection Diagram



12. Printed Circuit Board Ass'y and Parts List

12-(1) TXX-189 Graphic Display Driver, Filter, Pin Jacks and Shield P.C. Board Ass'y

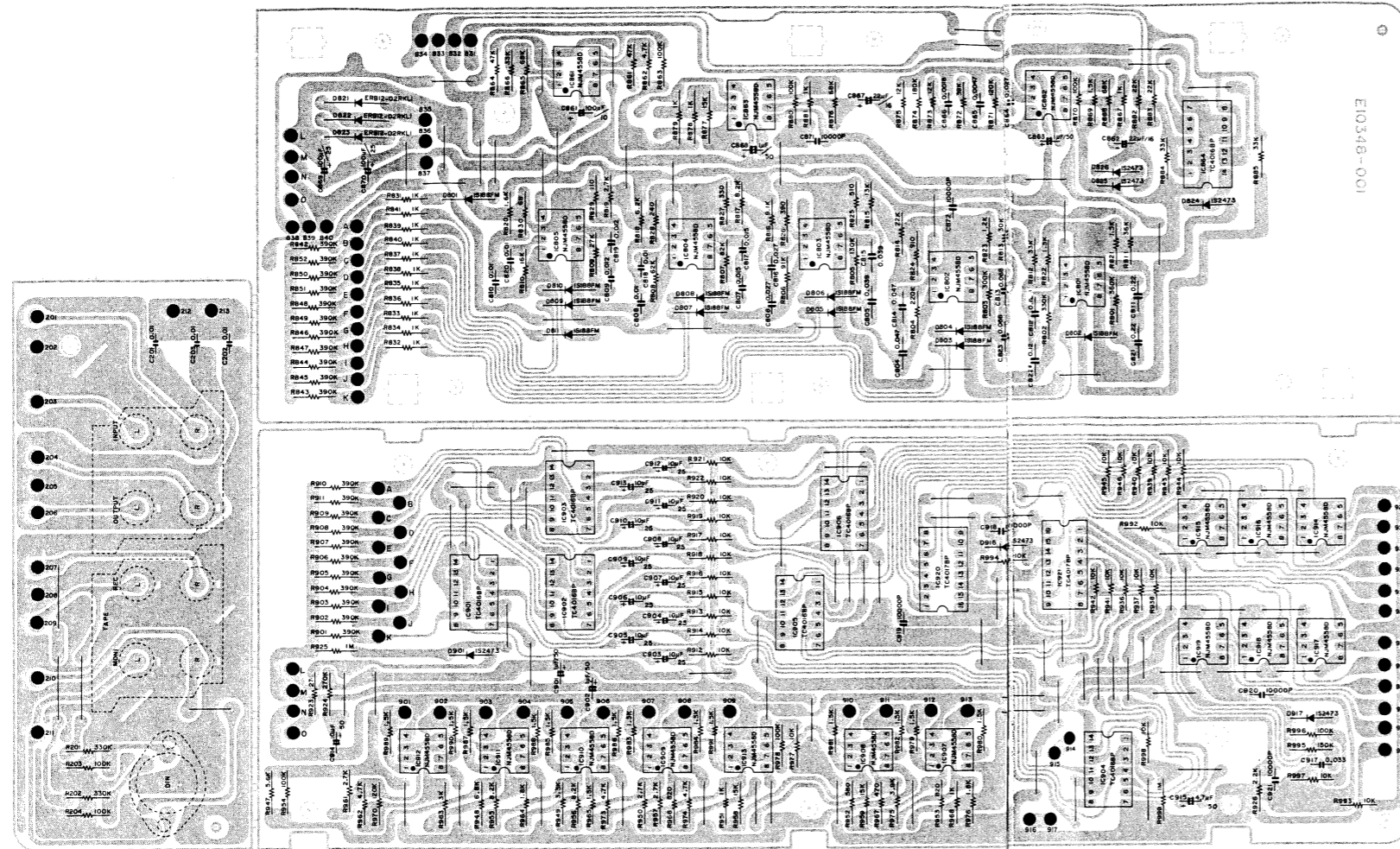

Integrated Circuits

Item No.	Part Number	Rating		Description	Maker
		Pc	IC		
IC801	NJM4558D	0.5 W	IC		JRC
IC802	NJM4558D	"	"		"
IC803	NJM4558D	"	"		"
IC804	NJM4558D	"	"		"
IC805	NJM4558D	"	"		"
IC861	NJM4558D	"	"		"
IC862	NJM4558D	"	"		"
IC863	NJM4558D	"	"		"
IC864	TC4016BP	"	"		Toshiba
IC901	TC4016BP	"	"		"
IC902	TC4016BP	"	"		"
IC903	TC4016BP	"	"		"
IC904	TC4016BP	"	"		"
IC905	TC4016BP	"	"		"
IC906	TC4016BP	"	"		"
IC907	NJM4558D	0.5 W	"		JRC
IC908	NJM4558D	"	"		"
IC909	NJM4558D	"	"		"
IC910	NJM4558D	"	"		"
IC911	NJM4558D	"	"		"
IC912	NJM4558D	"	"		"
IC913	NJM4558D	"	"		"
IC914	NJM4558D	"	"		"
IC915	NJM4558D	"	"		"
IC916	NJM4558D	"	"		"
IC917	NJM4558D	"	"		"
IC918	NJM4558D	"	"		"
IC919	NJM4558D	"	"		"

Integrated Circuits

Item No.	Part Number	Rating		Description	Maker
		Pc	IC		
IC920	TC4017BP	-	IC		Toshiba
IC921	TC4017BP	-	"		"

Diodes

Item No.	Part Number	Rating	Description	
			Material	Maker
D801	1S188FM	35 V	Germanium	Sanyo
D802	1S188FM	"	"	"
D803	1S188FM	"	"	"
D804	1S188FM	"	"	"
D805	1S188FM	"	"	"
D806	1S188FM	"	"	"
D807	1S188FM	"	"	"
D808	1S188FM	"	"	"
D809	1S188FM	"	"	"
D810	1S188FM	"	"	"
D811	1S188FM	"	"	"
D821	ERB12-02RKL1	1 A, 200 V	Silicon	Fujidenki
D822	ERB12-02RKL1	"	"	"
D823	ERB12-02RKL1	"	"	"
D824	1S2473	35 V	"	Toyo Dengu
D825	1S2473	"	"	"
D826	1S2473	"	"	"
D901	1S2473	"	"	"
D916	1S2473	"	"	"
D917	1S2473	"	"	"

Capacitors

Item No.	Part Number	Rating		Description
		Value	Voltage	
C201	QFM31HK-103	0.01 μ F	50 V	Mylar
C202	QFM31HK-103	"	"	"
C301	QFM31HK-103	"	"	"
C804	QFM31HJ-473	0.047 μ F	"	"
C805	QFM31HJ-393	0.039 μ F	"	"
C806	QFM31HJ-273Z	0.027 μ F	"	"
C807	QFM31HJ-153	0.015 μ F	"	"
C808	QFM31HJ-103Z	0.01 μ F	"	"
C809	QFM31HJ-123Z	0.012 μ F	"	"
C810	QFM31HJ-103Z	0.01 μ F	"	"
C811	QFM31HJ-224	0.22 μ F	"	"
C812	QFM31HJ-124	0.12 μ F	"	"
C813	QFM31HJ-683	0.068 μ F	"	"
C814	QFM31HJ-473	0.047 μ F	"	"
C815	QFM31HJ-393	0.039 μ F	"	"
C816	QFM31HJ-273	0.027 μ F	"	"
C817	QFM31HJ-153	0.015 μ F	"	"
C818	QFM31HJ-103	0.01 μ F	"	"
C819	QFM31HJ-123	0.012 μ F	"	"
C820	QFM31HJ-103	0.01 μ F	"	"
C821	QFM31HJ-224	0.22 μ F	"	"
C822	QFM31HJ-124	0.12 μ F	"	"
C823	QFM31HJ-683	0.068 μ F	"	"
C861	QET51AR-107	100 μ F	10 V	Electrolytic
C862	QET61CR-226Z	22 μ F	16 V	"
C863	QET61HR-105Z	1 μ F	50 V	"
C864	QFM31HJ-273Z	0.027 μ F	"	Mylar
C865	QFM31HJ-472Z	4700 pF	"	"
C866	QFM31HJ-182Z	1800 pF	"	"

Capacitors

Item No.	Part Number	Rating		Description
		Value	Voltage	
C867	QET61CR-226Z	22 μ F	16 V	Electrolytic
C868	QET61HR-105Z	1 μ F	50 V	"
C869	QET61ER-107Z	100 μ F	25 V	"
C870	QET61ER-107Z	"	"	"
C871	QCF31HP-103Z	0.01 μ F	50 V	Ceramic
C872	QCF21HP-103	"	"	"
C901	QET51HR-105	1 μ F	"	Electrolytic
C902	QET51HR-105	"	"	"
C903	QEB51EM-106	10 μ F	25 V	Low Leak Current Electrolytic
C904	QEB51EM-106	"	"	"
C905	QEB51EM-106	"	"	"
C906	QEB51EM-106	"	"	"
C907	QEB51EM-106	"	"	"
C908	QEB51EM-106	"	"	"
C909	QEB51EM-106	"	"	"
C910	QEB51EM-106	"	"	"
C911	QEB51EM-106	"	"	"
C912	QEB51EM-106	"	"	"
C913	QEB51EM-106	"	"	"
C914	QET61HR-106Z	"	50 V	Electrolytic
C915	QET61HR-475Z	4.7 μ F	"	"
C917	QFM31HJ-333	0.033 μ F	"	Mylar
C918	QCF31HP-103Z	0.01 μ F	"	Ceramic
C919	QCF31HP-103Z	"	"	"
C920	QCF21HP-103	"	"	"
C921	QCF31HP-103Z	"	"	"

Resistors

Item No.	Part Number	Rating		Description
		Value	Power	
R201	QRD141J-334S	330 k Ω	1/4 W	Carbon
R202	QRD141J-334S	"	"	"
R203	QRD141J-104S	100 k Ω	"	"
R204	QRD141J-104S	"	"	"
R801	QRD141J-364S	360 k Ω	"	"
R802	QRD141J-334S	330 k Ω	"	"
R803	QRD141J-304S	300 k Ω	"	"
R804	QRD141J-224S	220 k Ω	"	"
R805	QRD141J-134S	130 k Ω	"	"
R806	QRD141J-913S	91 k Ω	"	"
R807	QRD141J-823S	82 k Ω	"	"
R808	QRD141J-623S	62 k Ω	"	"
R809	QRD141J-273S	27 k Ω	"	"
R810	QRD141J-163S	16 k Ω	"	"
R811	QRD141J-363S	36 k Ω	"	"
R812	QRD141J-333S	33 k Ω	"	"
R813	QRD141J-303S	30 k Ω	"	"
R814	QRD141J-223S	22 k Ω	"	"
R815	QRD141J-133S	13 k Ω	"	"
R816	QRD141J-912S	9.1 k Ω	"	"
R817	QRD141J-822S	8.2 k Ω	"	"
R818	QRD141J-622S	6.2 k Ω	"	"
R819	QRD141J-272S	2.7 k Ω	"	"
R820	QRD141J-162S	1.6 k Ω	"	"
R821	QRD141J-152S	1.5 k Ω	"	"
R822	QRD141J-132S	1.3 k Ω	"	"
R823	QRD141J-122S	1.2 k Ω	"	"
R824	QRD141J-911S	910 Ω	"	"
R825	QRD141J-511S	510 Ω	"	"
R826	QRD141J-391S	390 Ω	"	"
R827	QRD141J-331S	330 Ω	"	"
R828	QRD141J-241S	240 Ω	"	"
R829	QRD141J-111S	110 Ω	"	"
R830	QRD141J-680S	68 Ω	"	"
R831	QRD141J-102S	1 k Ω	"	"
R832	QRD141J-102S	"	"	"
R833	QRD141J-102S	"	"	"
R834	QRD141J-102S	"	"	"
R835	QRD141J-102S	"	"	"
R836	QRD141J-102S	"	"	"
R837	QRD141J-102S	"	"	"
R838	QRD141J-102S	"	"	"
R839	QRD141J-102S	"	"	"
R840	QRD141J-102S	"	"	"

Resistors

Item No.	Part Number	Rating		Description
R841	QRD141J-102S	1 kΩ	1/4 W	Carbon
R842	QRD141J-394S	390 kΩ	"	"
R843	QRD141J-394S	"	"	"
R844	QRD141J-394S	"	"	"
R845	QRD141J-394S	"	"	"
R846	QRD141J-394S	"	"	"
R847	QRD141J-394S	"	"	"
R848	QRD141J-394S	"	"	"
R849	QRD141J-394S	"	"	"
R850	QRD141J-394S	"	"	"
R851	QRD141J-394S	"	"	"
R852	QRD141J-394S	"	"	"
R861	QRD141J-473SY	47 kΩ	"	"
R862	QRD141J-472S	4.7 kΩ	"	"
R863	QRD141J-104S	100 kΩ	"	"
R864	QRD141J-473S	47 kΩ	"	"
R865	QRD141J-683S	68 kΩ	"	"
R866	QRD141J-333S	33 kΩ	"	"
R867	QRD141J-102S	1 kΩ	"	"
R868	QRD141J-683S	68 kΩ	"	"
R869	QRD141J-152SY	1.5 kΩ	"	"
R870	QRD141J-104S	100 kΩ	"	"
R871	QRD141J-124S	120 kΩ	"	"
R872	QRD141J-393S	39 kΩ	"	"
R873	QRD141J-123S	12 kΩ	"	"
R874	QRD141J-184SY	180 kΩ	"	"
R875	QRD141J-123S	12 kΩ	"	"
R876	QRD141J-683S	68 kΩ	"	"
R877	QRG129J-153	15 kΩ	1/2 W	Oxide Metal Film
R878	QRG129J-102	1 kΩ	"	"
R879	QRG129J-102	"	"	"
R880	QRD141J-104S	100 kΩ	1/4 W	Carbon
R881	QRD141J-102S	1 kΩ	"	"
R882	QRD141J-223S	22 kΩ	"	"
R883	QRD141J-223S	"	"	"
R884	QRD141J-333S	33 kΩ	"	"
R885	QRD141J-333S	"	"	"
R901	QRD141J-394S	390 kΩ	"	"
R902	QRD141J-394S	"	"	"
R903	QRD141J-394S	"	"	"
R904	QRD141J-394S	"	"	"
R905	QRD141J-394S	"	"	"
R906	QRD141J-394S	"	"	"
R907	QRD141J-394S	"	"	"
R908	QRD141J-394S	"	"	"
R909	QRD141J-394S	"	"	"
R910	QRD141J-394S	"	"	"
R911	QRD141J-394S	"	"	"
R912	QRD141J-103S	10 kΩ	"	"
R913	QRD141J-103S	"	"	"
R914	QRD141J-103S	"	"	"
R915	QRD141J-103S	"	"	"
R916	QRD141J-103S	"	"	"
R917	QRD141J-103S	"	"	"
R918	QRD141J-103S	"	"	"
R919	QRD141J-103S	"	"	"
R920	QRD141J-103S	"	"	"
R921	QRD141J-103S	"	"	"
R922	QRD141J-103S	"	"	"
R923	QRD141J-100S	10 Ω	"	"
R924	QRD141J-274S	270 kΩ	"	"
R925	QRD141J-105S	1 MΩ	"	"
R926	QRD141J-222S	2.2 kΩ	"	"
R936	QRD141J-103S	10 kΩ	"	"
R937	QRD141J-103S	"	"	"
R938	QRD141J-103S	"	"	"
R939	QRD141J-103S	"	"	"
R940	QRD141J-103S	"	"	"
R941	QRD141J-103S	"	"	"
R942	QRD141J-103S	"	"	"
R943	QRD141J-103S	"	"	"
R944	QRD141J-103S	"	"	"
R945	QRD141J-103S	"	"	"

Resistors

Item No.	Part Number	Rating		Description
R946	QRD141J-103S	10 kΩ	1/4 W	Carbon
R947	QRD141J-562S	5.6 kΩ	"	"
R948	QRD141J-682S	6.8 kΩ	"	"
R949	QRD141J-332S	3.3 kΩ	"	"
R950	QRD141J-272S	2.7 kΩ	"	"
R951	QRD141J-102S	1 kΩ	"	"
R952	QRD141J-561S	560 Ω	"	"
R953	QRD141J-821S	820 Ω	"	"
R954	QRD141J-104S	100 kΩ	"	"
R955	QRD141J-822S	8.2 kΩ	"	"
R956	QRD141J-822S	"	"	"
R957	QRD141J-272S	2.7 kΩ	"	"
R958	QRD141J-153S	15 kΩ	"	"
R959	QRD141J-153S	"	"	"
R961	QRD141J-272S	2.7 kΩ	"	"
R962	QRD141J-472S	4.7 kΩ	"	"
R963	QRD141J-302S	3 kΩ	"	"
R964	QRD141J-182S	1.8 kΩ	"	"
R965	QRD141J-152S	1.5 kΩ	"	"
R966	QRD141J-821S	820 Ω	"	"
R967	QRD141J-471S	470 Ω	"	"
R968	QRD141J-102S	1 kΩ	"	"
R970	QRD141J-124S	120 kΩ	"	"
R973	QRD141J-472S	4.7 kΩ	"	"
R974	QRD141J-472S	"	"	"
R975	QRD141J-392S	3.9 kΩ	"	"
R976	QRD141J-182S	1.8 kΩ	"	"
R977	QRD141J-103SY	10 kΩ	"	"
R978	QRD141J-104SY	100 kΩ	"	"
R979	QRD141J-152S	1.5 kΩ	"	"
R980	QRD141J-152S	"	"	"
R981	QRD141J-152S	"	"	"
R982	QRD141J-152S	"	"	"
R983	QRD141J-152S	"	"	"
R984	QRD141J-152S	"	"	"
R985	QRD141J-152S	"	"	"
R986	QRD141J-152S	"	"	"
R987	QRD141J-152S	"	"	"
R988	QRD141J-152S	"	"	"
R989	QRD141J-152S	"	"	"
R990	QRD141J-152S	"	"	"
R991	QRD141J-152S	"	"	"
R992	QRD141J-103S	10 kΩ	"	"
R993	QRD141J-103S	"	"	"
R994	QRD141J-103S	"	"	"
R995	QRD141J-154S	150 kΩ	"	"
R996	QRD141J-104S	100 kΩ	"	"
R997	QRD141J-103S	10 kΩ	"	"
R998	QRD141J-103S	"	"	"
R999	QRD141J-105S	1 MΩ	"	"

Others

Item No.	Part Number	Rating	Description
	EWT011-005 E03591-42D E03623-003 E10348-001 E300332-001		Lug Wire Ass'y Pin Jack Ass'y DIN Socket Circuit Board Fastener
3P	QHW4110-001		Wire Clamp
3P	EWS013-003		SKT Wire Ass'y
4P	EWS014-006		"
5P	EWS015-002		Pink Noise SKT Wire Ass'y
5P	EWS015-003		Input SKT Wire Ass'y
5P	EWS015-004		Output "
7P	EWS017-005		Tape Rec. "
7P	EWS027-001		Display (Red) "
7P	EWS027-002		" (Black) "
7P	EWS027-003		" (Green) "
7P	EWS027-004		" (Blue) "
9P	EWS019-001		Tape Monitor "

12-(2) TXX-190 SEA Amp., MIC/MIXER and Pushswitch P.C. Board Ass'y

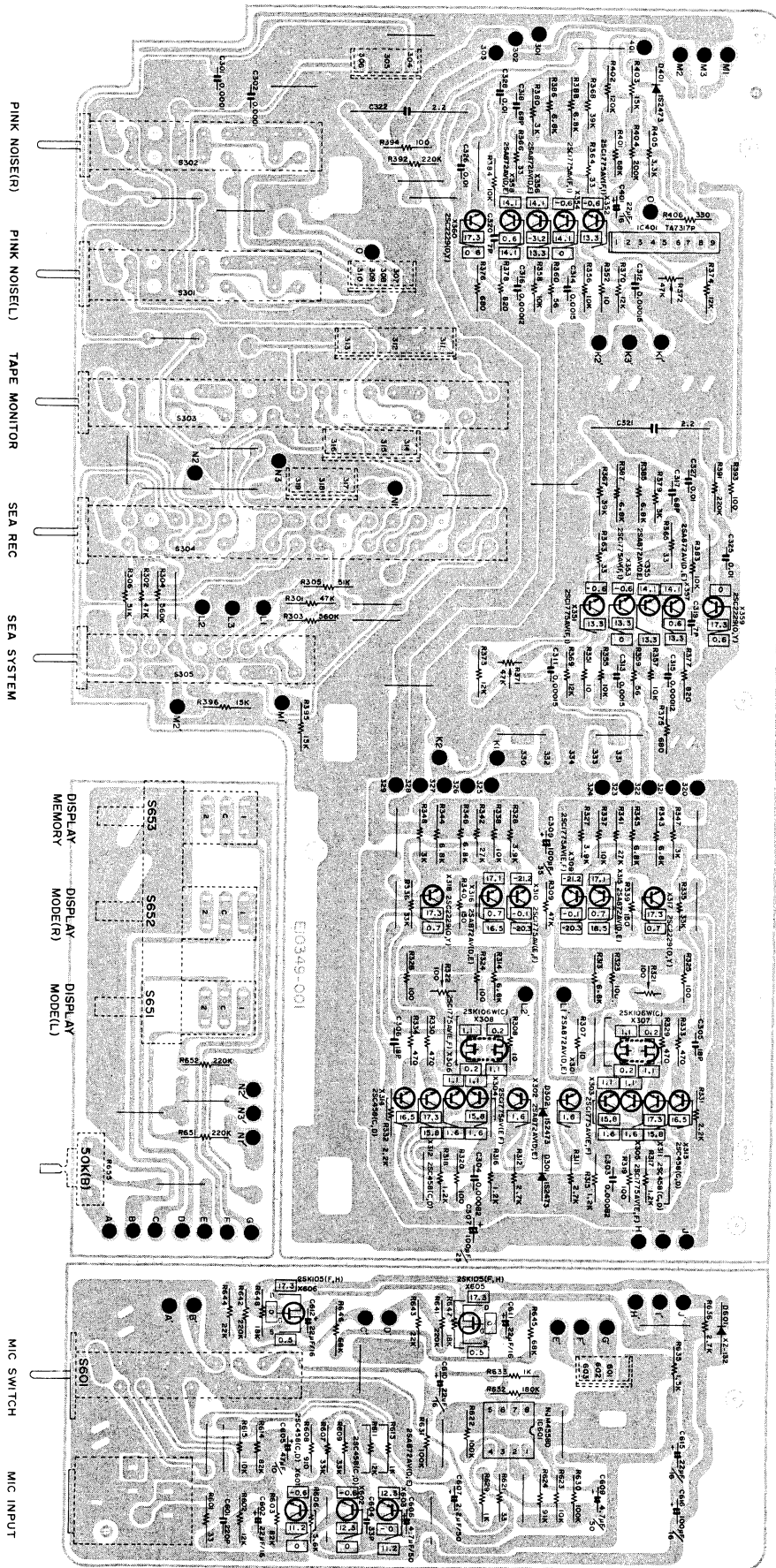

Transistors

Item No.	Part Number	Rating		Description	
		Pc	fT		Maker
X301	2SA872AV(D, E)	0.3 W	120 MHz	Silicon	Hitachi
X302	2SA872AV(D, E)	"	"	"	"
X303	2SC1775AV(E, F)	0.3 W	200 MHz	"	"
X304	2SC1775AV(E, F)	"	"	"	"
X305	2SC1775AV(E, F)	"	"	"	"
X306	2SC1775AV(E, F)	"	"	"	"
X307	2SK106W(C)	"	"	Silicon N-Channel	"
X308	2SK106W(C)	"	"	"	"
X309	2SC1775AV(E, F)	"	200 MHz	Silicon	"
X310	2SC1775AV(E, F)	"	"	"	"
X311	2SC458(C, D)	0.2 W	100 MHz	"	"
X312	2SC458(C, D)	"	"	"	"
X313	2SC458(C, D)	"	"	"	"
X314	2SC458(C, D)	"	"	"	"
X315	2SA872AV(D, E)	0.3 W	120 MHz	"	"
X316	2SA872AV(D, E)	"	"	"	"
X317	2SC2229(O, Y)	0.8 W	"	"	Toshiba
X318	2SC2229(O, Y)	"	"	"	"
X351	2SC1775AV(F1)	0.3 W	200 MHz	"	Hitachi
X352	2SC1775AV(F1)	"	"	"	"
X353	2SC1775AV(F1)	"	"	"	"
X354	2SC1775AV(F1)	"	"	"	"
X355	2SA872AV(D, E)	"	120 MHz	"	Hitachi
X356	2SA872AV(D, E)	"	"	"	"
X357	2SA872AV(D, E)	"	"	"	"
X358	2SA872AV(D, E)	"	"	"	"
X359	2SC2229(O, Y)	0.8 W	"	"	Toshiba
X360	2SC2229(O, Y)	"	"	"	"
X601	2SC458(C, D)	0.2 W	100 MHz	"	Hitachi
X602	2SC458(C, D)	"	"	"	"
X603	2SA872AV(D, E)	0.3 W	120 MHz	"	"
X605	2SK105(F, H)	0.25 W	"	Silicon N-Channel	NEC
X606	2SK105(F, H)	"	"	"	"

Capacitors

Item No.	Part Number	Rating		Description
C301	QFP31HJ-101	100 pF	50 V	Polypropylene
C302	QFP31HJ-101	"	"	"
C303	QFP31HJ-821	820 pF	"	"
C304	QFP31HJ-821	"	"	"
C305	QCS31HJ-180Z	18 pF	"	Ceramic
C306	QCS31HJ-180Z	"	"	"
C307	QET51ER-107	100 μF	25 V	Electrolytic
C309	QET51VR-107	"	35 V	"
C311	QFP31HJ-151	160 pF	50 V	Polypropylene
C312	QFP31HJ-151	"	"	"
C313	QFM31HJ-152Z	1500 pF	"	Mylar
C314	QFM31HJ-152Z	"	"	"
C315	QFP31HJ-121	120 pF	"	Polypropylene
C316	QFP31HJ-121	"	"	"
C317	QCS21HJ-680	68 pF	"	Ceramic
C318	QCS21HJ-680	"	"	"
C319	QCS21HJ-7R0	7 pF	"	"
C320	QCS21HJ-7R0	"	"	"
C321	QFZ0074-225	2.2 μF	250 V	Film
C322	QFZ0074-225	"	"	"
C325	QFM31HK-103Z	0.01 μF	50 V	Mylar
C326	QFM31HK-103Z	"	"	"
C327	QFM31HK-103Z	"	"	"
C328	QFM31HK-103	"	"	"
C401	QET51CR-226	22 μF	16 V	Electrolytic
C601	QCS31HJ-221Z	220 pF	50 V	Ceramic
C602	QET61CR-226Z	22 μF	16 V	Electrolytic
C603	QCS31HJ-820Z	82 pF	50 V	Ceramic
C604	QCS31HJ-330Z	33 pF	"	"
C605	QET61AR-476Z	47 μF	10 V	Electrolytic
C606	QET61HR-475Z	4.7 μF	50 V	"
C607	QET61HR-225Z	2.2 μF	"	"
C609	QET61HR-475Z	4.7 μF	"	"
C610	QET51CR-226	22 μF	16 V	"
C611	QET51CR-226	"	"	"
C612	QET61CR-226Z	"	"	"
C615	QET61CR-226Z	"	"	"
C616	QET61CR-107Z	100 μF	"	"

Integrated Circuits

Item No.	Part Number	Rating		Description	
		PC			Maker
IC401	TA7317P	0.5 W		IC Muting	Toshiba
IC601	NJM4558D	"		"	JRC

Diodes

Item No.	Part Number	Rating	Description	
				Maker
D301	1S2473	35 V	Silicon	Toyo Dengu
D302	1S2473	"	"	"
D401	1S2473	"	"	"
D601	XZ-132	13.2 V, 0.5 W	"	JRC

Resistors

Item No.	Part Number	Rating		Description
R301	QRD141J-473SY	47 kΩ	1/4 W	Carbon
R302	QRD141J-473SY	"	"	"
R303	QRD141J-564SY	560 kΩ	"	"
R304	QRD141J-564SY	"	"	"
R305	QRD141J-513SY	51 kΩ	"	"
R306	QRD141J-513SY	"	"	"
R307	QRD141J-100S	10 Ω	"	"
R308	QRD141J-100S	"	"	"
R309	QRD141J-473S	47 kΩ	"	"
R311	QRD141J-272S	2.7 kΩ	"	"
R312	QRD141J-272S	"	"	"
R313	QRD141J-682S	6.8 kΩ	"	"
R314	QRD141J-682S	"	"	"
R315	QRD141J-122S	1.2 kΩ	"	"
R316	QRD141J-122S	"	"	"
R317	QRD141J-122S	"	"	"
R318	QRD141J-122S	"	"	"
R319	QRD141J-101S	100 Ω	"	"
R320	QRD141J-101S	"	"	"

Resistors

Item No.	Part Number	Rating		Description
R321	QVP4A0B-101	100 Ω	1/4 W	Variable Semi Fix
R322	QVP4A0B-101	"	"	"
R323	QRD141J-101S	"	1/4 W	Carbon
R324	QRD141J-101S	"	"	"
R325	QRD141J-101S	"	"	"
R326	QRD141J-101S	"	"	"
R327	QRD141J-392S	3.9 kΩ	"	"
R328	QRD141J-392S	"	"	"
R329	QRD141J-471S	470 Ω	"	"
R330	QRD141J-471S	"	"	"
R331	QRD141J-222S	2.2 kΩ	"	"
R332	QRD141J-222S	"	"	"
R333	QRD141J-471S	470 Ω	"	"
R334	QRD141J-471S	"	"	"
R335	QRD141J-333S	33 kΩ	"	"
R336	QRD141J-333S	"	"	"
R337	QRD141J-103S	10 kΩ	"	"
R338	QRD141J-103S	"	"	"
R339	QRD141J-151S	150 Ω	"	"
R340	QRD141J-151S	"	"	"
R341	QRD141J-273S	27 kΩ	"	"
R342	QRD141J-273S	"	"	"
R343	QRD129J-682	6.8 kΩ	1/2 W	"
R344	QRD129J-682	"	"	"
R345	QRD129J-682	"	"	"
R346	QRD129J-682	"	"	"
R347	QRD141J-302S	3 kΩ	1/4 W	"
R348	QRD141J-302S	"	"	"
R351	QRD141J-100S	10 Ω	"	"
R352	QRD141J-100S	"	"	"
R354	QRD141J-100S	"	"	"
R355	QRD141J-103S	10 kΩ	"	"
R356	QRD141J-103S	"	"	"
R357	QRD141J-103S	"	"	"
R358	QRD141J-103S	"	"	"
R359	QRD141J-560S	56 Ω	"	"
R360	QRD141J-560S	"	"	"
R363	QRD141J-330S	33 Ω	"	"
R364	QRD141J-330S	"	"	"
R365	QRD141J-330S	"	"	"
R366	QRD141J-330S	"	"	"
R367	QRD141J-393S	39 kΩ	"	"
R368	QRD141J-393S	"	"	"
R369	QRD141J-123S	12 kΩ	"	"
R370	QRD141J-123S	"	"	"
R371	QVP4A0B-473	47 kΩ	1/4 W	Variable Semi Fix
R372	QVP4A0B-473	"	"	"
R373	QRD141J-123S	12 kΩ	1/4 W	Carbon
R374	QRD141J-123S	"	"	"
R375	QRD141J-681S	680 Ω	"	"
R376	QRD141J-681S	"	"	"
R377	QRD141J-821S	820 Ω	"	"
R378	QRD141J-821S	"	"	"
R379	QRD141J-302S	3 kΩ	"	"
R380	QRD141J-302S	"	"	"
R383	QRD141J-103S	10 kΩ	"	"
R384	QRD141J-103S	"	"	"
R385	QRD129J-682	6.8 kΩ	1/2 W	"
R386	QRD129J-682	"	"	"
R387	QRD129J-682	"	"	"
R388	QRD129J-682	"	"	"
R391	QRD141J-224S	220 kΩ	1/4 W	"
R392	QRD141J-224S	"	"	"

Resistors

Item No.	Part Number	Rating		Description
R393	QRD141J-101S	100 Ω	1/4 W	Carbon
R394	QRD141J-101S	"	"	"
R395	QRD141J-153S	15 kΩ	"	"
R396	QRD141J-153S	"	"	"
R401	QRD141J-683S	68 kΩ	"	"
R402	QRD141J-124S	120 kΩ	"	"
R403	QRD141J-153S	15 kΩ	"	"
R404	QRD141J-204S	200 kΩ	"	"
R405	QRD141J-332S	3.3 kΩ	"	"
R406	QRD149J-331S	330 Ω	"	"
R601	QRD141J-330S	33 Ω	"	"
R602	QRD141J-123S	12 kΩ	"	"
R603	QRD141J-823S	82 kΩ	"	"
R606	QRD141J-562S	5.6 kΩ	"	"
R607	QRD141J-333S	33 kΩ	"	"
R608	QRD141J-911S	910 Ω	"	"
R609	QRD141J-333SY	33 kΩ	"	"
R611	QRD141J-123S	12 kΩ	"	"
R613	QRD141J-102S	1 kΩ	"	"
R614	QRD141J-823S	82 kΩ	"	"
R615	QRD141J-103S	10 kΩ	"	"
R621	QRD141J-330S	33 Ω	"	"
R622	QRD141J-104S	100 kΩ	"	"
R623	QRD141J-103S	10 kΩ	"	"
R624	QRD141J-913S	91 kΩ	"	"
R629	QRD141J-102S	1 kΩ	"	"
R630	QRD141J-104S	100 kΩ	"	"
R631	QRD141J-104S	"	"	"
R632	QRD141J-184S	180 kΩ	"	"
R633	QRD141J-102S	1 kΩ	"	"
R635	QRD149J-152S	1.5 kΩ	"	"
R636	QRD149J-272S	2.7 kΩ	"	"
R641	QRD141J-224S	220 kΩ	"	"
R642	QRD141J-224S	"	"	"
R643	QRD141J-223S	22 kΩ	"	"
R644	QRD141J-223S	"	"	"
R645	QRD141J-683S	68 kΩ	"	"
R646	QRD141J-683S	"	"	"
R647	QRD141J-183SY	18 kΩ	"	"
R648	QRD141J-183SY	"	"	"
R651	QRD141J-224S	220 kΩ	"	"
R652	QRD141J-224S	"	"	"
R655	QVG4A2B-054V	50 kΩ	—	Variable Semi Fix

Others

Item No.	Part Number	Rating	Description
	E03628-5UD		
	E10349-001		Circuit Board
5P	QMV5005-005		Input, Output, Socket
7P	QMV5005-007		Tape Rec. Socket
9P	QMV5005-009		Tape Monitor, Socket
	S8-084T		Push Switch, Tanaka
MIC	QMS6302-201		H. Phone Jack, Hoshiden
4P	EWS014-005		Power, SKT Wire Ass'y
6P	EWS016-001		S.E.A., L ch "
6P	EWS016-002		S.E.A., R ch "
S301	QSL4210-003E		Lever Switch, Tanaka
S302	QSL4210-003E		"
S303	QSL8210-002		"
S304	QSL8210-002		"
S305	QSL4310-001E		"
S601	QSL4310-001E		"
G.D.4	QMV5005-004		G.D. Drive, SKT Wire Ass'y
RY401	ESK2D12-212		Relay, Omron

12-(3) TXX-191 Semiconductor Inductor and Slide Volume P.C. Board Ass'y

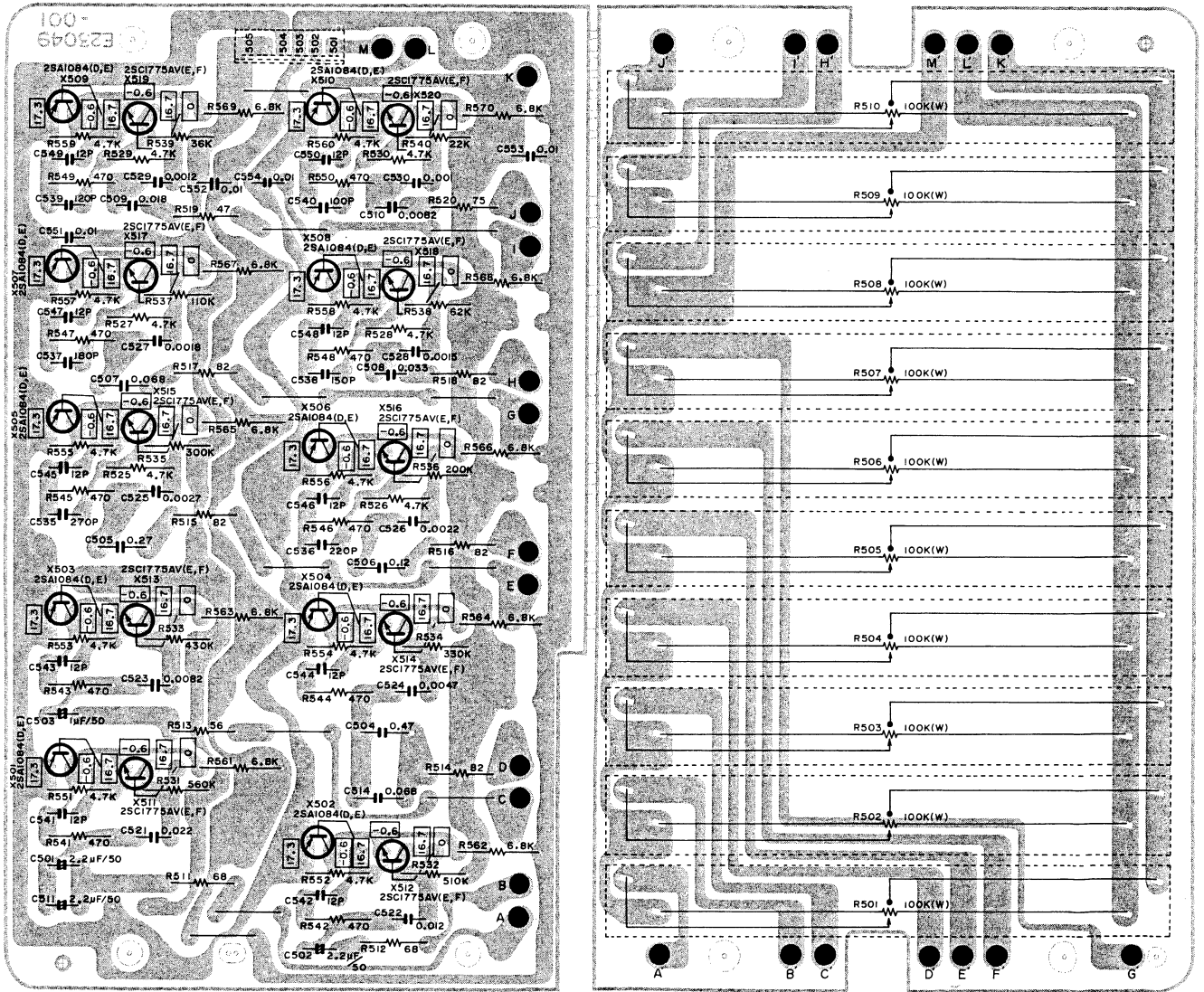

Transistors

Item No.	Part Number	Rating		Description	
		Pc	fT	Maker	
X501	2SA1084(D, E)	0.4 W	90 MHz	Silicon	Hitachi
X502	2SA1084(D, E)	"	"	"	"
X503	2SA1084(D, E)	"	"	"	"
X504	2SA1084(D, E)	"	"	"	"
X505	2SA1084(D, E)	"	"	"	"
X506	2SA1084(D, E)	"	"	"	"
X507	2SA1084(D, E)	"	"	"	"
X508	2SA1084(D, E)	"	"	"	"
X509	2SA1084(D, E)	"	"	"	"
X510	2SA1084(D, E)	"	"	"	"

Transistors

Item No.	Part Number	Rating		Description	
		Pc	fT	Maker	
X511	2SC1775AV(E, F)	0.3 W	120 MHz	Silicon	Hitachi
X512	2SC1775AV(E, F)	"	"	"	"
X513	2SC1775AV(E, F)	"	"	"	"
X514	2SC1775AV(E, F)	"	"	"	"
X515	2SC1775AV(E, F)	"	"	"	"
X516	2SC1775AV(E, F)	"	"	"	"
X517	2SC1775AV(E, F)	"	"	"	"
X518	2SC1775AV(E, F)	"	"	"	"
X519	2SC1775AV(E, F)	"	"	"	"
X520	2SC1775AV(E, F)	"	"	"	"

Capacitors

Item No.	Part Number	Rating		Description
C501 (U.P.)	QEZ0046-225	2.2 μ F	50 V	Electrolytic (N.P.)
C502	QEZ0046-225	"	"	"
C503	QEZ0046-105	1 μ F	"	"
C504	QFM31HJ-474	0.47 μ F	"	Mylar
C505	QFM31HJ-274	0.27 μ F	"	"
C506	QFM31HJ-124	0.12 μ F	"	"
C507	QFM31HJ-683	0.068 μ F	"	"
C508	QFM31HJ-333	0.033 μ F	"	"
C509	QFM31HJ-183	0.018 μ F	"	"
C510	QFM31HJ-822	8200 pF	"	"
C511	QEZ0046-225	2.2 μ F	"	Electrolytic
C514	QFM31HJ-683	0.068 μ F	"	Mylar
C521	QFM31HJ-223	0.022 μ F	"	"
C522	QFM31HJ-123	0.012 μ F	"	"
C523	QFM31HJ-822	8200 pF	"	"
C524	QFM31HJ-472	4700 pF	"	"
C525	QFM31HJ-272	2700 pF	"	"
C526	QFM31HJ-222	2200 pF	"	"
C527	QFM31HJ-182Z	1800 pF	"	"
C528	QFM31HJ-152Z	1500 pF	"	"
C529	QFM31HJ-122	1200 pF	"	"
C530	QFM31HJ-102Z	1000 pF	"	"
C535	QCS31HJ-271Z	270 pF	"	Ceramic
C536	QCS31HJ-221Z	220 pF	"	"
C537	QCS31HJ-181Z	180 pF	"	"
C538	QCS31HJ-151Z	160 pF	"	"
C539	QCS31HJ-121Z	120 pF	"	"
C540	QCS21HJ-101	100 pF	"	"
C541	QCS31HJ-120Z	12 pF	"	"
C542	QCS21HJ-120	"	"	"
C543	QCS31HJ-120Z	"	"	"
C544	QCS31HJ-120Z	"	"	"
C545	QCS21HJ-120	"	"	"
C546	QCS21HJ-120	"	"	"
C547	QCS21HJ-120	"	"	"
C548	QCS21HJ-120	"	"	"
C549	QCS21HJ-120	"	"	"
C550	QCS21HJ-120	"	"	"
C551	QFM31HK-103	0.01 μ F	"	Mylar
C552	QFM31HK-103	"	"	"
C553	QFM31HK-103Z	"	"	"
C554	QFM31HK-103	"	"	"

Resistors

Item No.	Part Number	Rating		Description
R501	QVT6C2W-815	100 k Ω	1/4 W	Volume
R502	QVT6C2W-815	"	"	"
R503	QVT6C2W-815	"	"	"
R504	QVT6C2W-815	"	"	"
R505	QVT6C2W-815	"	"	"
R506	QVT6C2W-815	"	"	"
R507	QVT6C2W-815	"	"	"
R508	QVT6C2W-815	"	"	"
R509	QVT6C2W-815	"	"	"
R510	QVT6C2W-815	"	"	"
R511	QRD141J-680S	68 Ω	"	Carbon
R512	QRD141J-680S	"	"	"

Resistors

Item No.	Part Number	Rating		Description
R513	QRD141J-560S	56 Ω	1/4 W	Carbon
R514	QRD141J-820S	82 Ω	"	"
R515	QRD141J-820S	"	"	"
R516	QRD141J-820S	"	"	"
R517	QRD141J-820S	"	"	"
R518	QRD141J-820S	"	"	"
R519	QRD141J-470S	47 Ω	"	"
R520	QRD141J-750S	75 Ω	"	"
R525	QRD141J-472S	4.7 k Ω	"	"
R526	QRD141J-472S	"	"	"
R527	QRD141J-472S	"	"	"
R528	QRD141J-472S	"	"	"
R529	QRD141J-472S	"	"	"
R530	QRD141J-472S	"	"	"
R531	QRD141J-564S	560 k Ω	"	"
R532	QRD141J-514S	510 k Ω	"	"
R533	QRD141J-434S	430 k Ω	"	"
R534	QRD141J-334S	330 k Ω	"	"
R535	QRD141J-304S	300 k Ω	"	"
R536	QRD141J-204S	200 k Ω	"	"
R537	QRD141J-114S	110 k Ω	"	"
R538	QRD141J-623S	62 k Ω	"	"
R539	QRD141J-363S	36 k Ω	"	"
R540	QRD141J-223S	22 k Ω	"	"
R541	QRD141J-471S	470 Ω	"	"
R542	QRD141J-471S	"	"	"
R543	QRD141J-471S	"	"	"
R544	QRD141J-471S	"	"	"
R545	QRD141J-471S	"	"	"
R546	QRD141J-471S	"	"	"
R547	QRD141J-471S	"	"	"
R548	QRD141J-471S	"	"	"
R549	QRD141J-471S	"	"	"
R550	QRD141J-471S	"	"	"
R551	QRD141J-472S	4.7 k Ω	"	"
R552	QRD141J-472S	"	"	"
R553	QRD141J-472S	"	"	"
R554	QRD141J-472S	"	"	"
R555	QRD141J-472S	"	"	"
R556	QRD141J-472S	"	"	"
R557	QRD141J-472S	"	"	"
R558	QRD141J-472S	"	"	"
R559	QRD141J-472S	"	"	"
R560	QRD141J-472S	"	"	"
R561	QRD129J-682	6.8 k Ω	1/2 W	"
R562	QRD129J-682	"	"	"
R563	QRD129J-682	"	"	"
R564	QRD129J-682	"	"	"
R565	QRD129J-682	"	"	"
R566	QRD129J-682	"	"	"
R567	QRD129J-682	"	"	"
R568	QRD129J-682	"	"	"
R569	QRD129J-682	"	"	"
R570	QRD129J-682	"	"	"

Others

Item No.	Part Number	Rating	Description
6P	E23049-001		Circuit Board
	E300167-001		Fastener
	QMV5005-006		Socket

12-(4) TPS-222 Voltage Regulator P.C. Board Ass'y

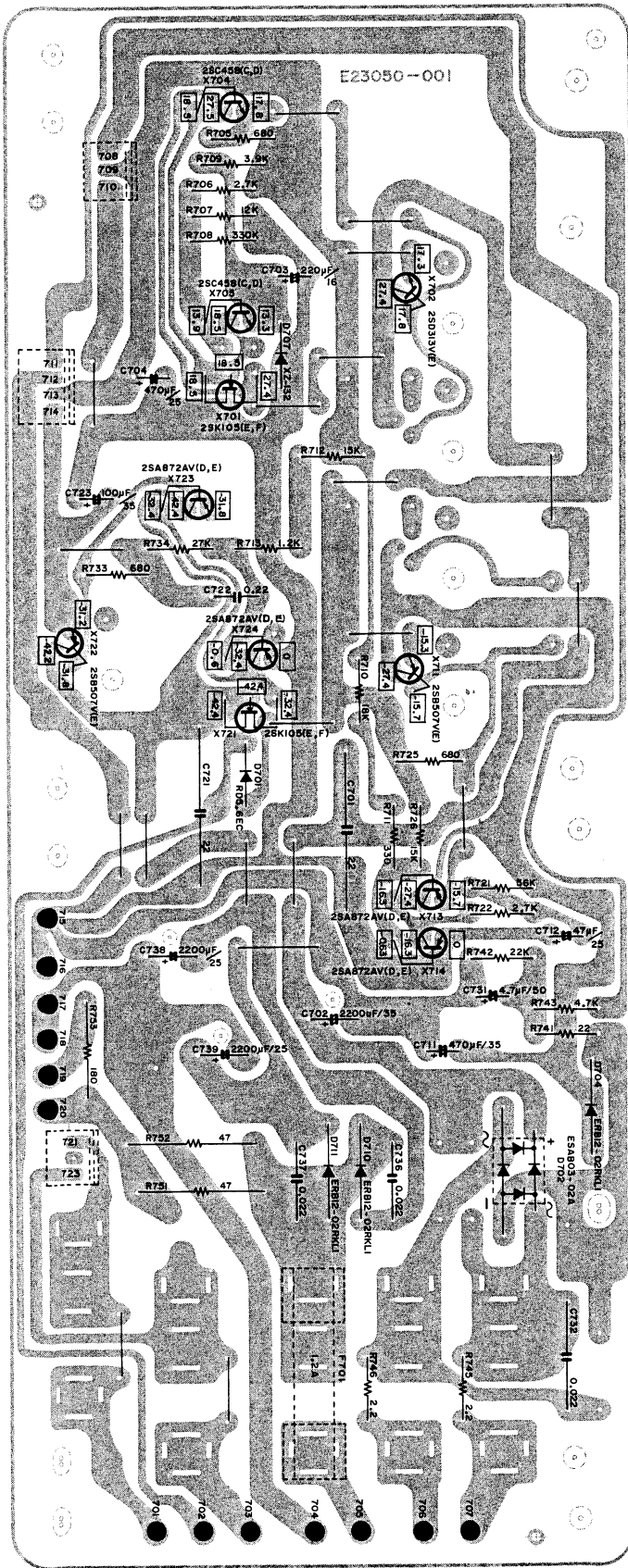

Transistors

Item No.	Part Number	Rating		Description	
		Pc	fT		Maker
X701	2SK105(E, F)	0.25 W		Silicon N-Channel	NEC
X702	2SD313V(E)	30 W	8 MHz	Silicon	Sanyo
X711	2SB507(E)	"	"	"	"
X713	2SA872AV(D, E)	0.3 W	120 MHz	"	Hitachi
X714	2SA872AV(D, E)	"	"	"	"
X721	2SK105(E, F)	0.25 W		"	NEC
X722	2SB507V(E)	30 W	8 MHz	Silicon N-Channel	Sanyo
X723	2SA872AV(D, E)	0.3 W	120 MHz	Silicon	Hitachi
X724	2SA872AV(D, E)	"	"	"	"

Diodes

Item No.	Part Number	Rating	Description	
				Maker
D701	RD5.6EC	0.4 W, 5.6 V	Silicon	NEC
D702	ESAB03-02A	1 A, 200 V	"	Fujidenki
D704	ERB12-02RKL1	1 A, 200 V	"	"
D707	XZ-132	0.5 W, 13.2 V	"	JRC
D710	ERB12-02RKL1	1 A, 200 V	"	Fujidenki
D711	ERB12-02RKL1	"	"	"

Capacitors

Item No.	Part Number	Rating	Description
C701	QFZ0074-225	2.2 μ F 250 V	Film
C702	QET51VR-228	2200 μ F 35 V	Electrolytic
C703	QET51CR-227	220 μ F 16 V	"
C704	QET51ER-477	470 μ F 25 V	"
C711	QET51VR-477	" 35 V	"
C712	QET51ER-476	47 μ F 25 V	"
C721	QFZ0074-225	2.2 μ F 250 V	Film
C722	QFM31HK-224	0.22 μ F 50 V	Mylar
C723	QET51VR-107	100 μ F 35 V	Electrolytic
C731	QET51HR-475	4.7 μ F 50 V	"
C732	QFZ0072-223	0.022 μ F 600 V	Film
C736	QFZ0072-223	"	"
C737	QFZ0072-223	"	"
C738	QET51ER-228	2200 μ F 25 V	Electrolytic
C739	QET51ER-228	"	"

Resistors

Item No.	Part Number	Rating	Description
R705	QRD149J-681S	680 Ω 1/4 W	Carbon
R706	QRD141J-272S	2.7 k Ω	"
R707	QRD141J-123S	12 k Ω	"
R708	QRD141J-334S	330 k Ω	"
R709	QRD141J-392S	3.9 k Ω	"
R710	QRD141J-183S	18 k Ω	"
R711	QRD141J-331S	330 Ω	"
R712	QRD141J-153S	15 k Ω	"
R713	QRD141J-122S	1.2 k Ω	"
R721	QRD141J-563S	56 k Ω	"
R722	QRD141J-272S	2.7 k Ω	"
R725	QRD149J-681S	680 Ω	"
R726	QRD141J-153S	15 k Ω	"
R733	QRD149J-681S	680 Ω	"
R734	QRD141J-273S	27 k Ω	"
R741	QRD149J-220S	22 Ω	"
R742	QRD141J-223S	22 k Ω	"
R743	QRD141J-472S	4.7 k Ω	"
R745	QRD149J-2R2S	2.2 Ω	"
R745	QRD149J-2R2S	"	"
R746	QRD149J-2R2S	"	"
R746	QRD149J-2R2S	"	"
R751	QRG027J-470	47 Ω 2 W	Oxide Metal Film
R752	QRG027J-470	"	"
R753	QRG017J-181S	180 Ω 1 W	"

15. Parts List with Specified Numbers for Designated Areas

Description	U.S.A.	Canada	Other Countries	U.S. Military Market	Europe	Australia	U.K.
Power Switch Δ	QSL2224-002	QSL2224-002	QSL2224-003	QSL2224-003	QSL2224-003	QSL2224-003	QSL2224-003
Power Cord Δ	QMP1200-200	QMP1200-200	QMP7600-250	QMP7600-250	QMP3900-200	QMP2610-200	QMP9017-008
Fuse (Primary) (F751) Δ	QMF61U1-R80 (0.8 A)	QMF61U1-R80 (0.8 A)	QMF51A2-R50L (500 mA)	QMF51A2-R50L (500 mA)	QMF51A2-R20L (200 mA)	QMF51A2-R20L (200 mA)	QMF51A2-R20L (200 mA)
Fuse (Secondary) (F701) Δ	QMF61U1-2R0 (2 A)	QMF61U1-2R0 (2 A)	QMF51A2-R20L (200 mA)	QMF51A2-R20L (200 mA)	QMF51A2-1R25L (1.25 AT)	QMF51A2-1R25L (1.25 AT)	QMF51A2-R25L (1.25 AT)
(F702, F703, F704, F705) Δ	—	—	QMF51A2-R80L (800 mA)	QMF51A2-R80L (800 mA)	QMF51A2-R80L (800 mA)	QMF51A2-R80L (800 mA)	QMF51A2-R80L (800 mA)
AC Socket Δ	QMP0231-003	QMP0231-003	QMP0231-003	QMP0231-003	—	—	—
AC Socket Mask Plate	—	—	—	—	E65515-003	E65515-003	E65515-003
Voltage Selector Mask Plate	E66196-001	E66196-001	—	—	—	—	—
AC Primary P.C. Board Ass'y Δ	TPS-224A	TPS-224A	TPS-224B	TPS-224B	TPS-197A	TPS-197A	TPS-197A
Power Supply P.C. Board Ass'y Δ	TPS-222B	TPS-222B	TPS-222C	TPS-222C	TPS-222C	TPS-222C	TPS-222C
Fuse Holder	QMG0201-003	QMG0201-003	QMG0301-003	QMG0301-003	QMG0301-003	QMG0301-003	QMG0301-003

16. SEA-80 Schematic Diagram

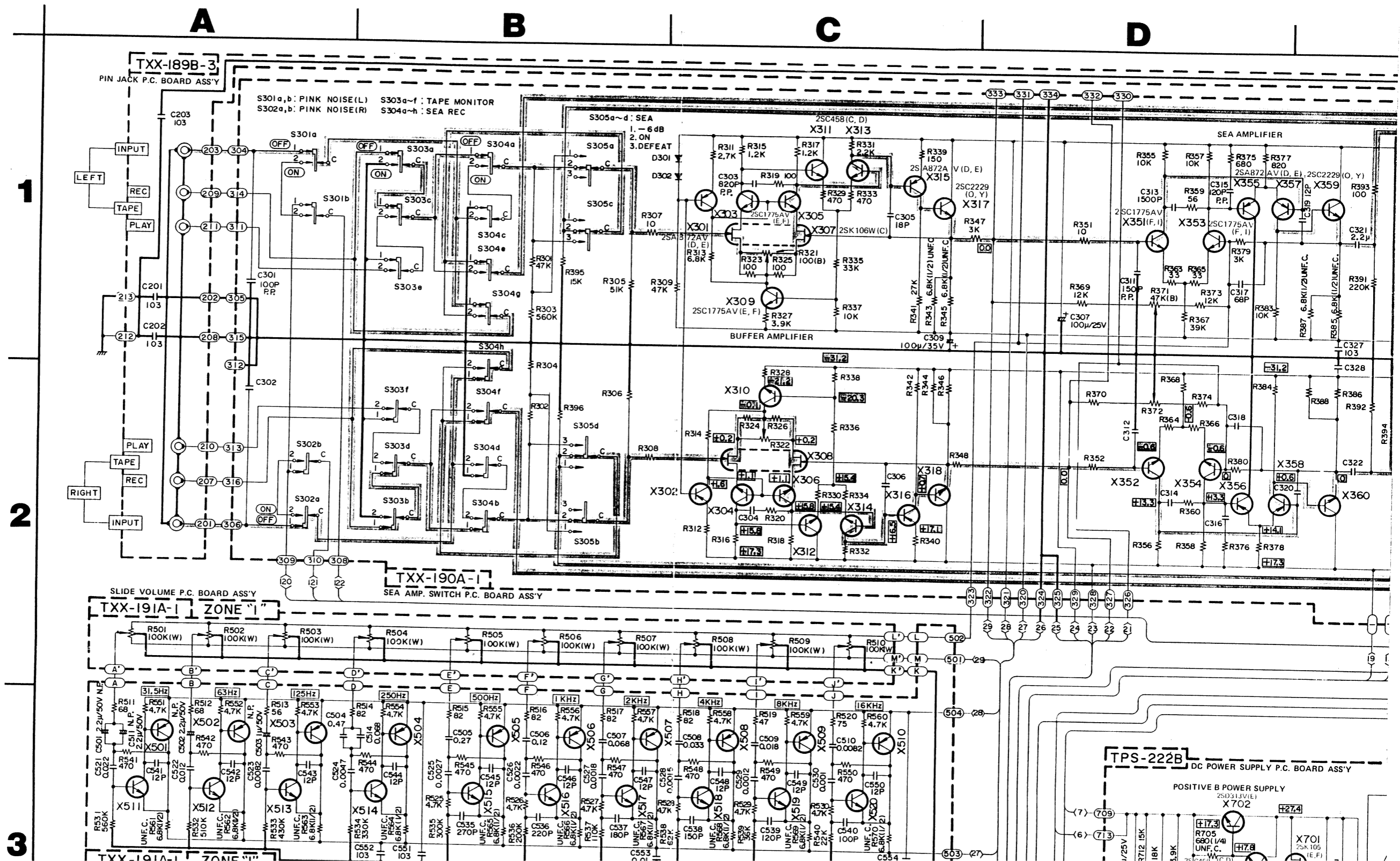

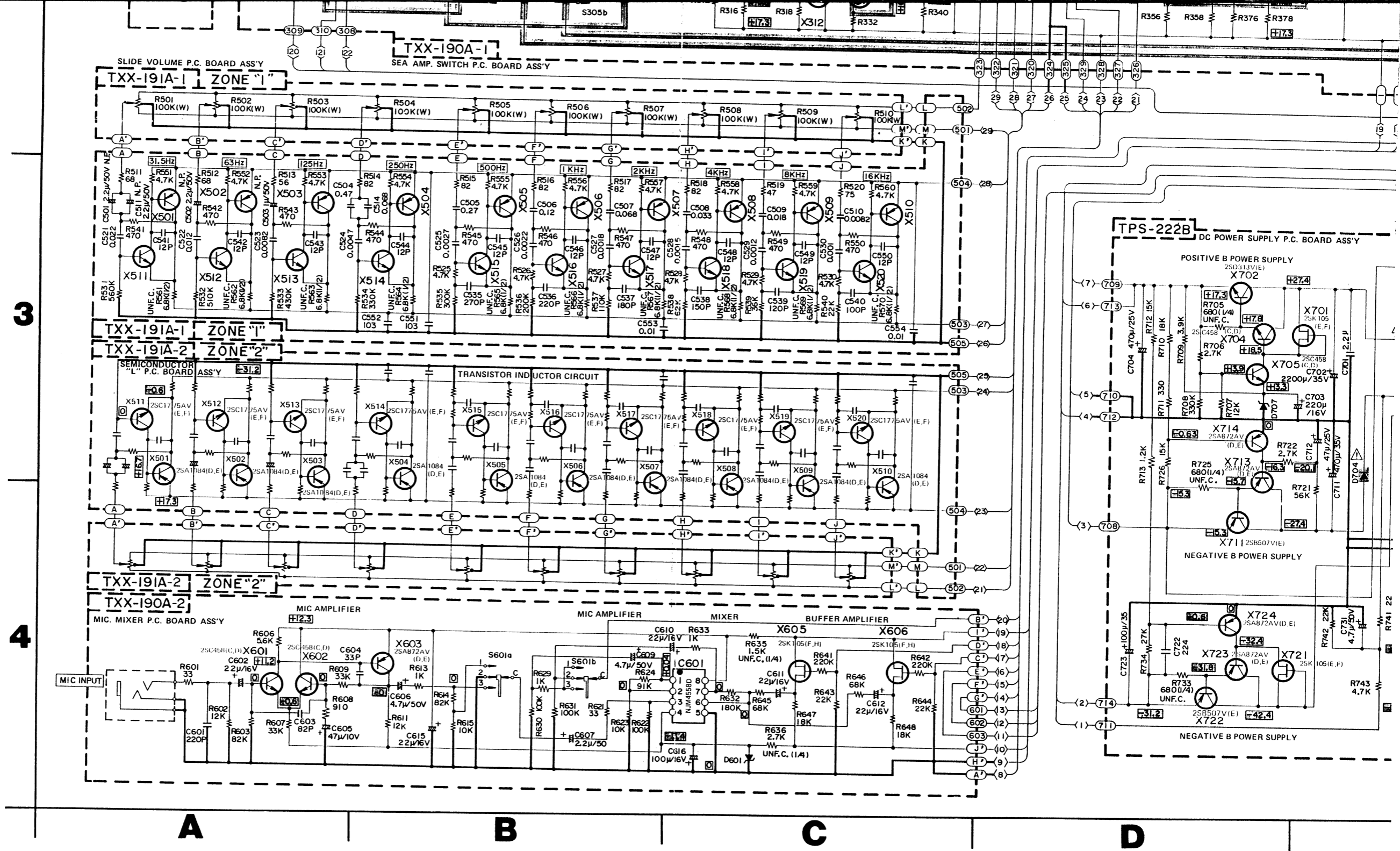

Printed Circuit Board Ass'y Locations

P.C. Board Ass'y	Description	Page
TXX-189	Graphic Display Driver, Filter, Pin Jacks and Shield P.C. Board Ass'y	17
TXX-190	SEA Amp., MIC/MIXER and Pushswitch P.C. Board Ass'y	19
TXX-191	Semiconductor Inductor and Slide Volume P.C. Board Ass'y	22
TPS-222	Voltage Regulator P.C. Board Ass'y	24
TPS-224 (or TPS-197)	AC Primary P.C. Board Ass'y	25

How to utilize the circuit diagram

- indicates positive B power supply.
- indicates negative B power supply.
- indicates earth.
- indicates the signal path.
- Voltage values measured with a tester (impedance 20 kΩ/V) in mode of "no signal" are indicated as below:
Example: **0.3** (unit: V)
0.0 (unit: V)
- Control knobs are indicated, for easy reference, with white characters on a black background:
Example: Medium potential control
- Transistor numbers and voltage values, are identical for both left and right channels, therefore, they are indicated only on one side.
- When replacing the Δ marked parts, be sure to use the designated parts to ensure safety.

9. Resistors are indicated as follows:

- *Unit No indication : Ω
- K : k Ω
- M : M Ω
- W : watt
- *Deviation No indication : $\pm 5\%$
- J : $\pm 5\%$
- K : $\pm 10\%$

*Type No indication : Carbon resistor

10. Capacitors are indicated as follows:

- *Unit No indication : μF
- μ : μF
- P : pF

11. This is the standard circuit diagram. The design and constants are subject to change notice.

ram

B

C

D

E

F

03a-f : TAPE MONITOR
04a-h : SEA REC

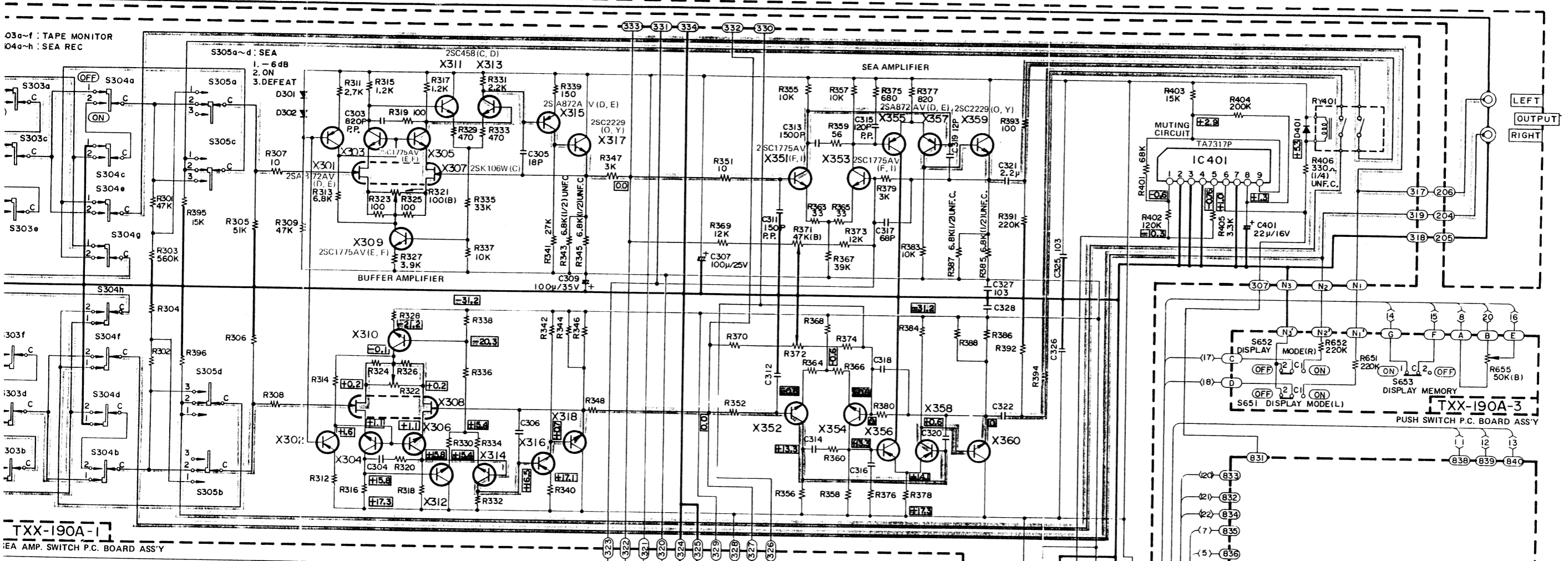

TXX-190A-1
SEA AMP. SWITCH P.C. BOARD ASS'Y

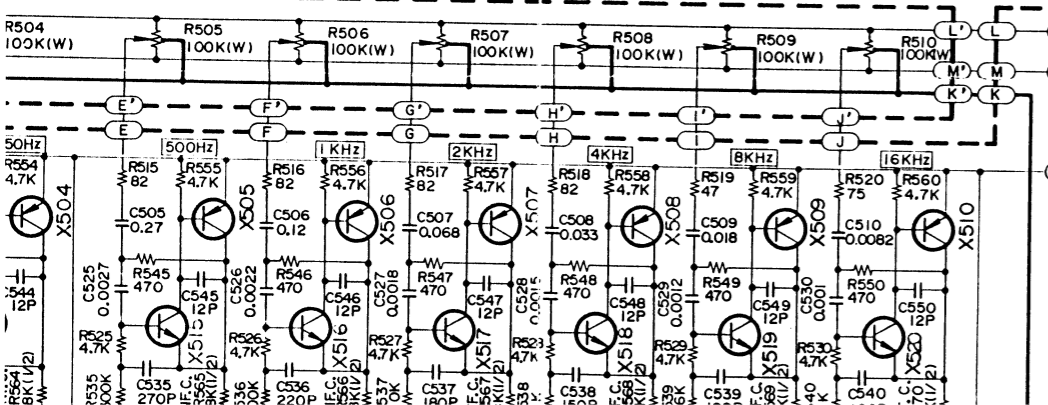

TPS-222B
DC POWER SUPPLY P.C. BOARD ASS'Y

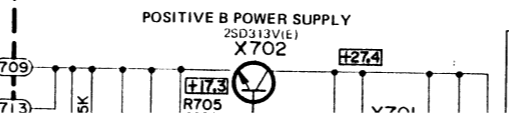

GRAPHIC DISPLAY DRIVE C.B. ASS'Y
TXX-189B

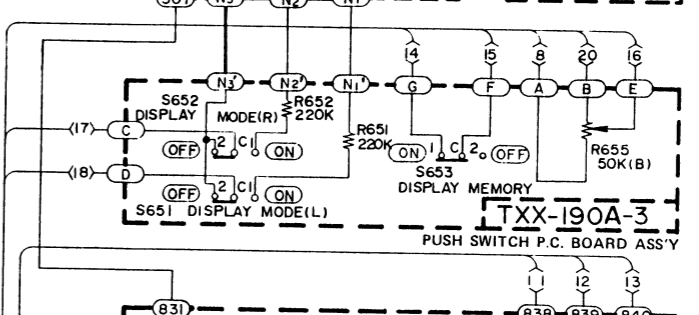

(J) FOR AMERICA
(C) FOR CANADA : AC120V 50/60Hz

TPS-224A

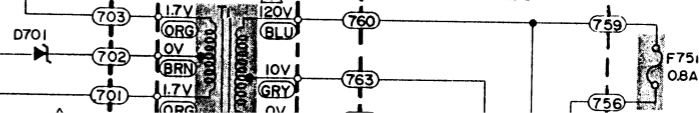

1

2

LEFT
OUTPUT
RIGHT

A

B

C

D

1

2

3

TXX-189B-2 FILTER P.C. BOARD ASS'Y

TXX-189B-1 GRAPHIC DISPLAY DRIVE P.C. BOARD ASS'Y

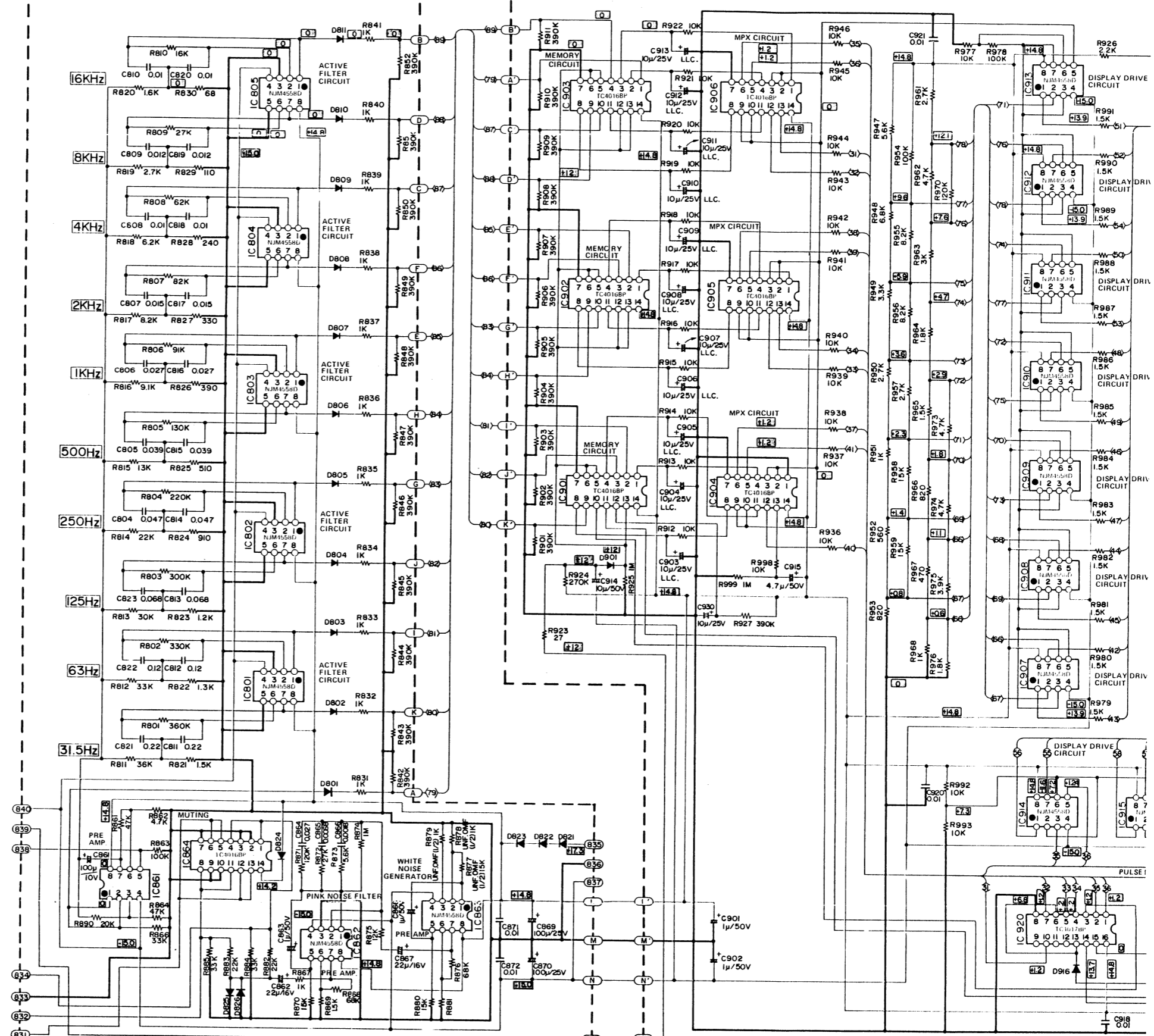

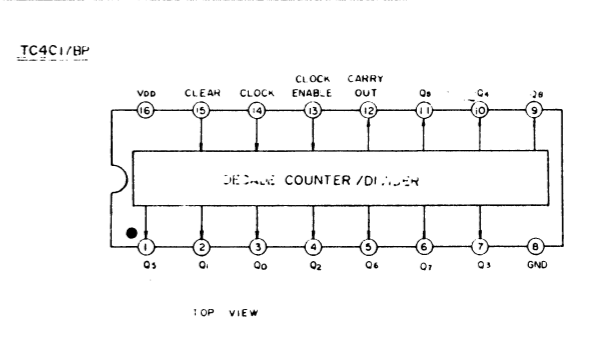
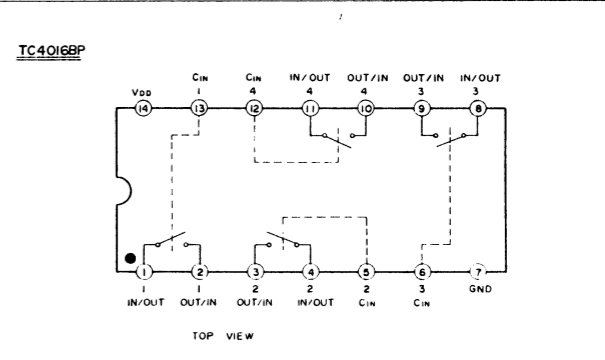
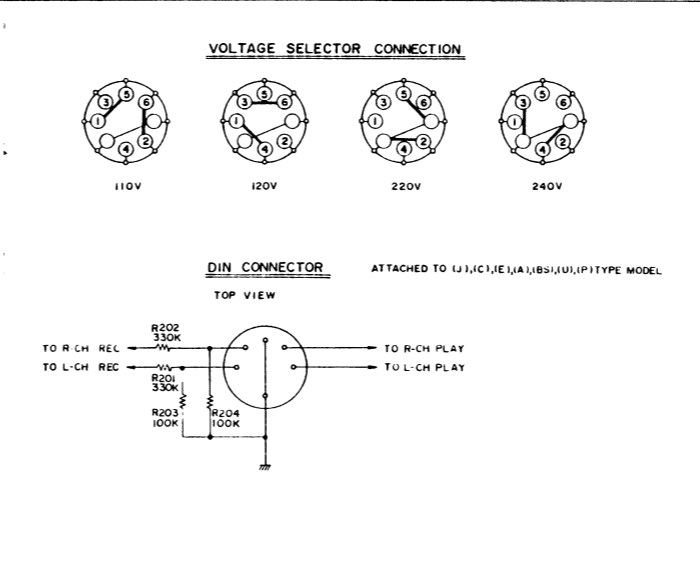
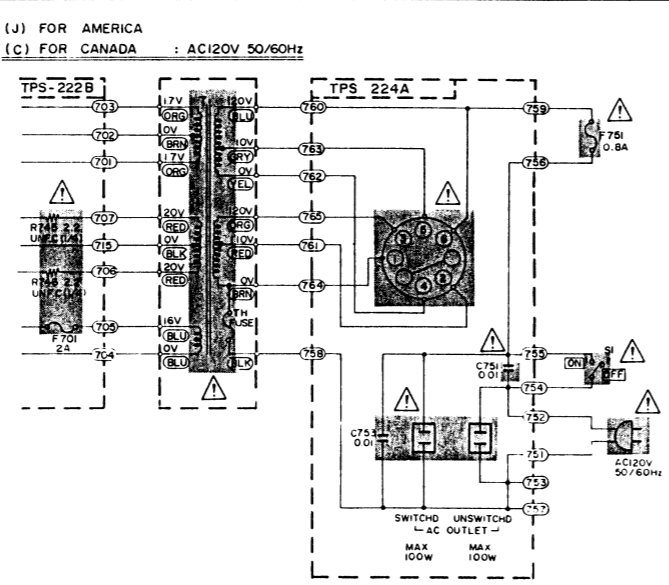
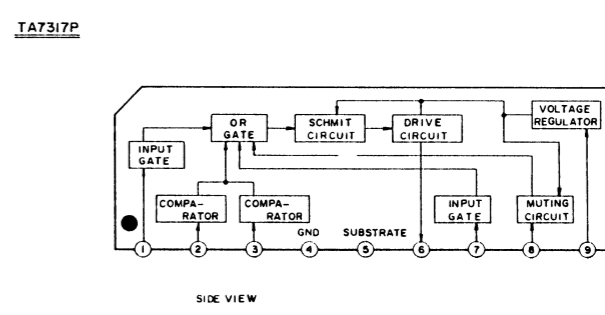
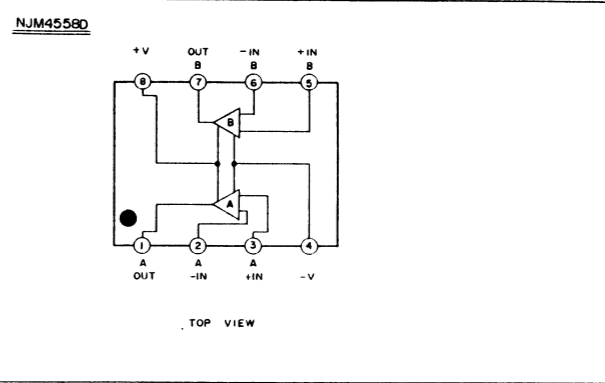
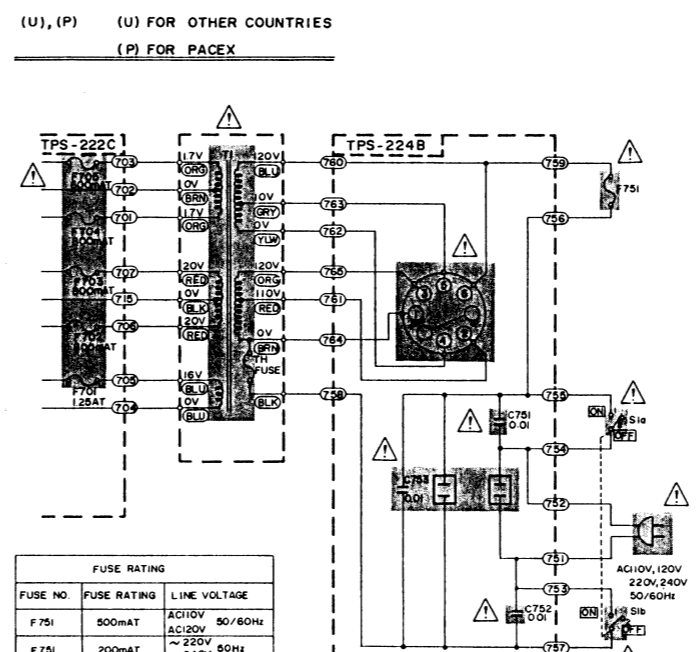
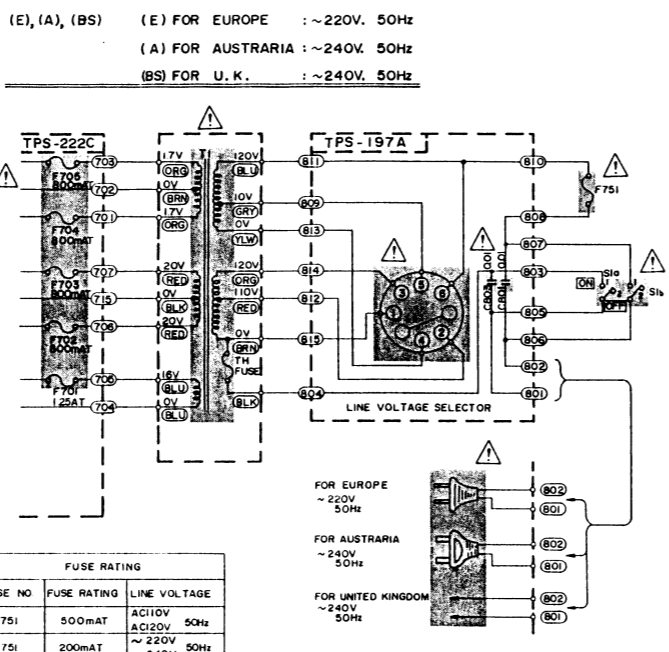
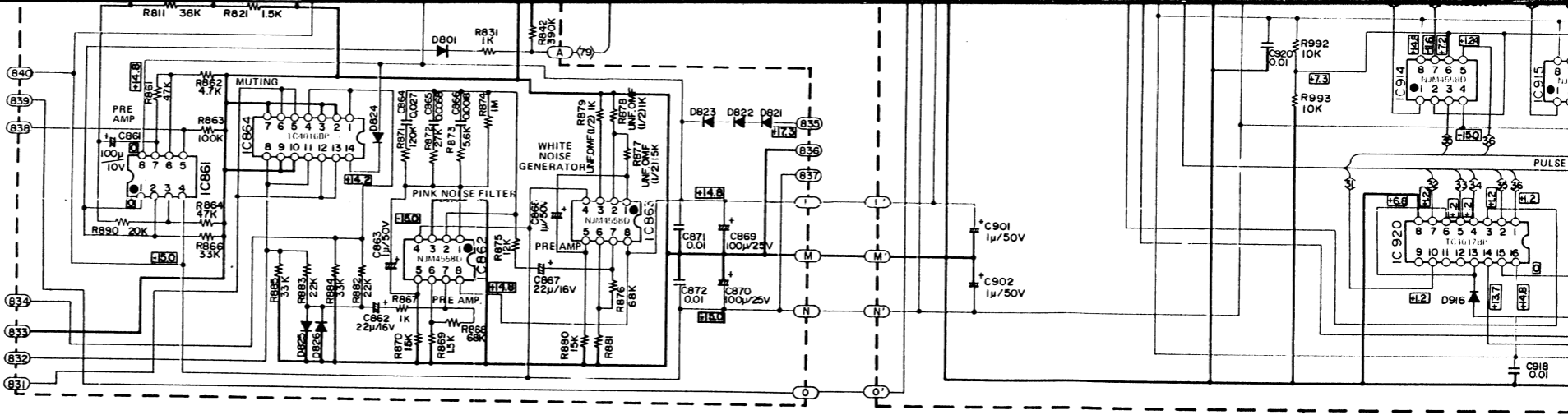

B

C

D

E

F

TXX-189B-1 GRAPHIC DISPLAY DRIVE P.C. BOARD ASS'Y

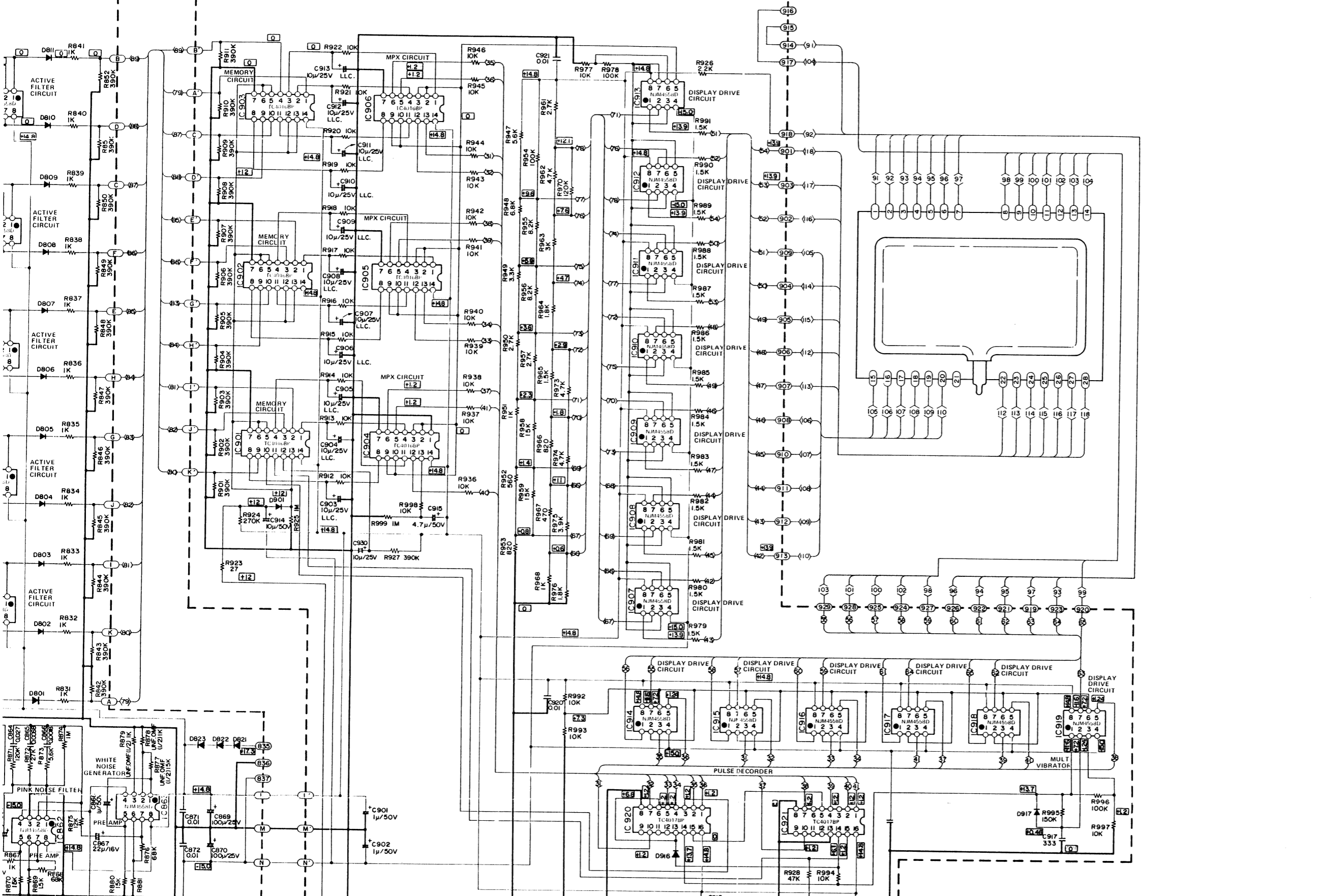

1

2

3

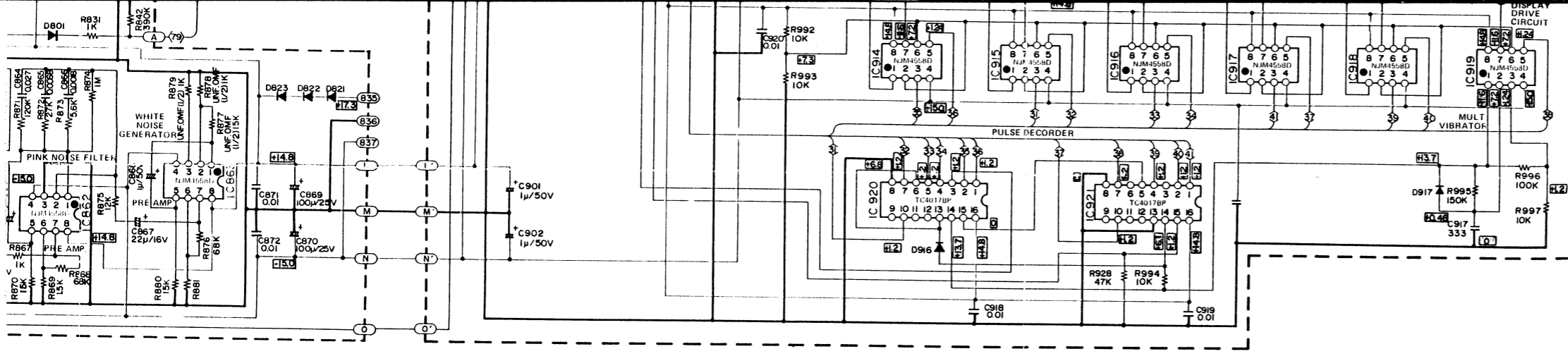

3

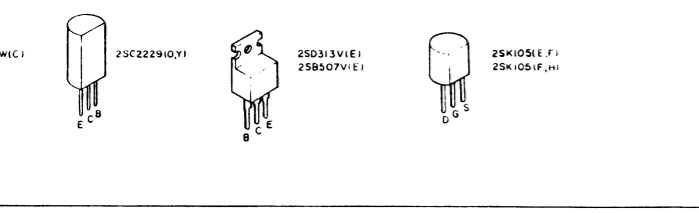
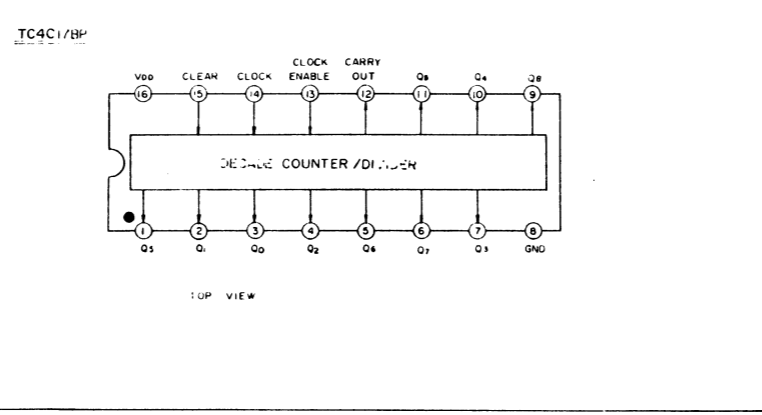
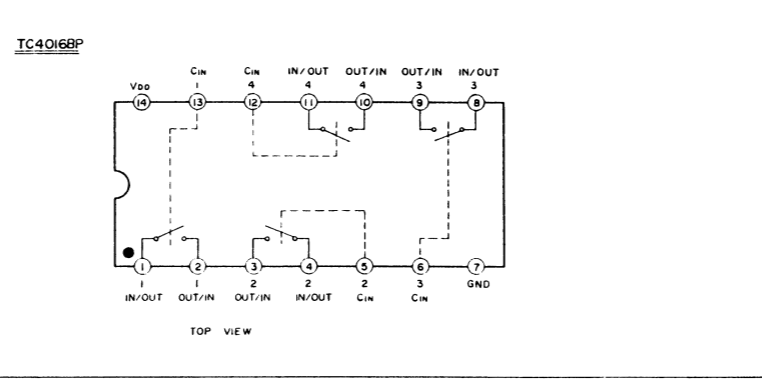
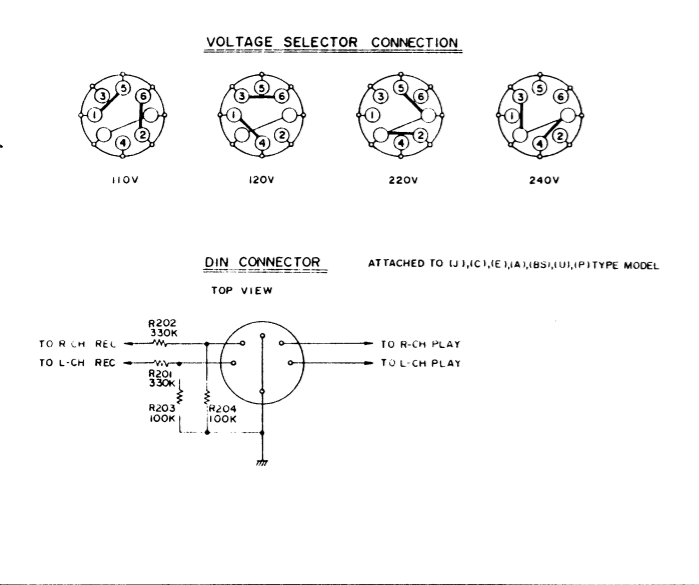
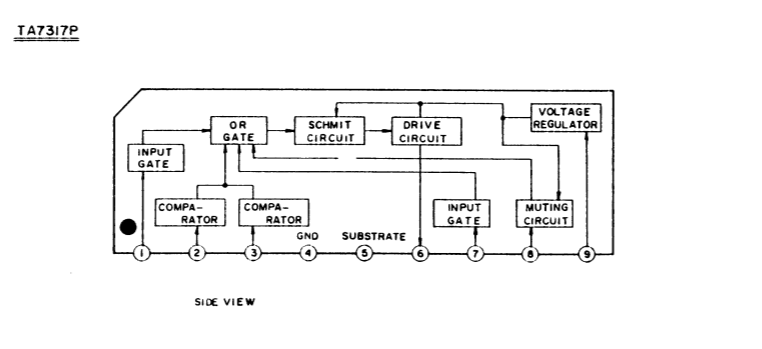
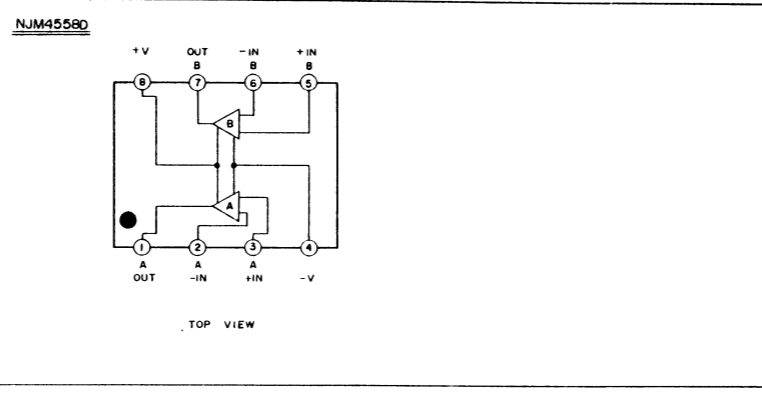
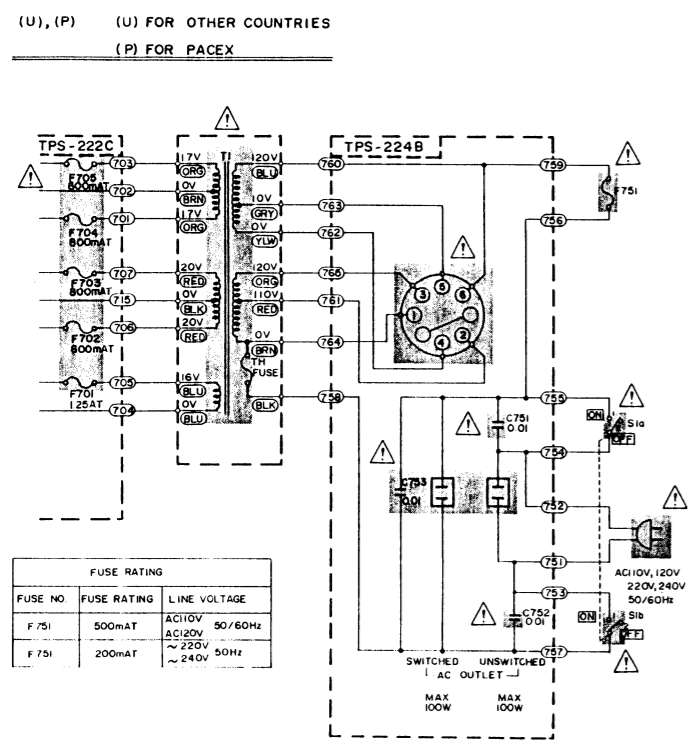

- How to utilize the circuit diagram
- indicates positive B power supply.
 - indicates negative B power supply.
 - indicates earth.
 - Voltage values measured with a tester (impedance 20 kΩ/V) in mode of "no signal" are indicated as below:
Example: 0.3 (unit: V)
9.0 (unit: V)
 - Resistors are indicated as follows:
*Unit No indication : Ω
K : kΩ
M : MΩ
W : watt
*Deviation No indication : ±5 %
J : ±5 %
K : ±10 %
*Type No indication : Carbon resistor
 - Capacitors are indicated as follows:
*Unit No indication : μF
μ : μF
P : pF
 - This is the standard circuit diagram.
The design and constants are subject to change without notice.

4

5

6

B

C

D

E

F