

MAIN VOLTAGE ADJUSTMENT

When you move to an area where power of a different voltage is supplied, reset the voltage changing switch (100~120V↔200~240V).

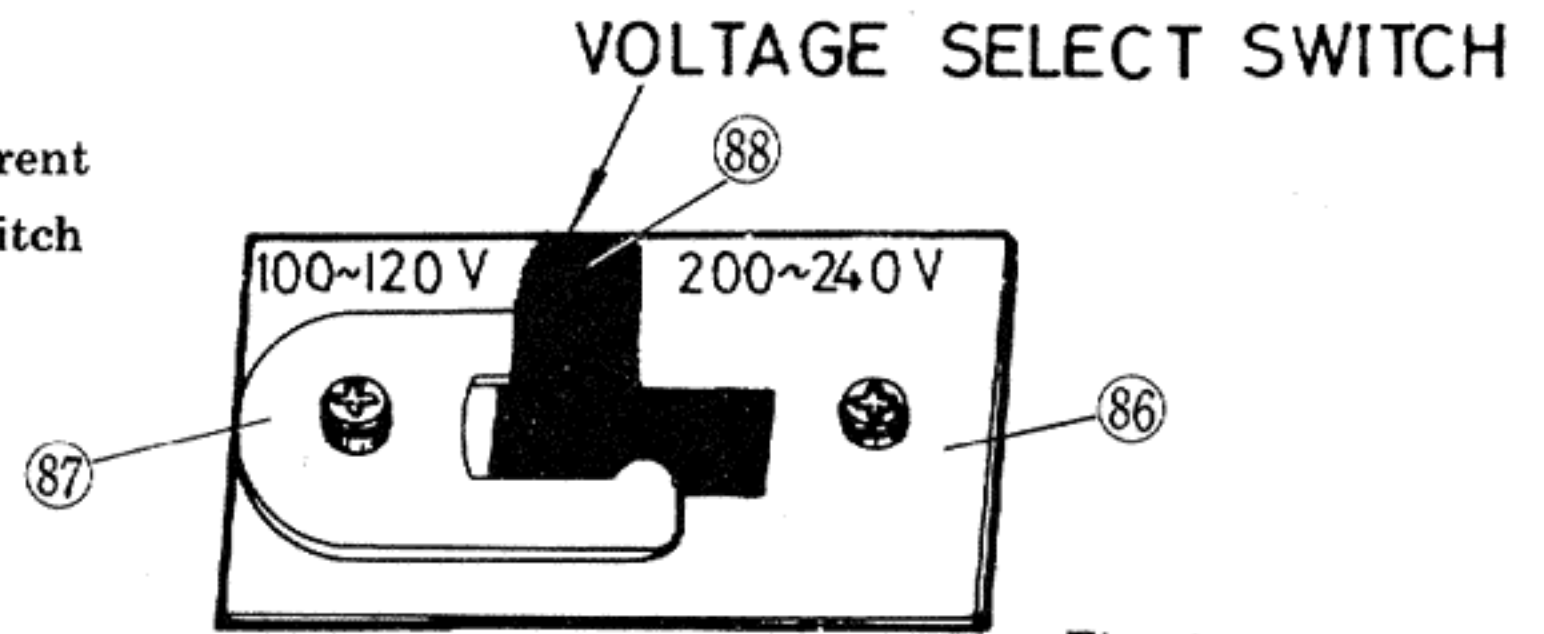

Fig. 1

CYCLE ALTERATION

If the supply cycle differs from 50 to 60Hz, or vice versa, replace motor pulley only.

REPLACING STYLUS

Worn out stylus makes noise and sound. Take off worn out stylus and insert new one (A) into (B). Replacement stylus=DT-33H (Diamond stylus life : 1,000~2,000 hours)

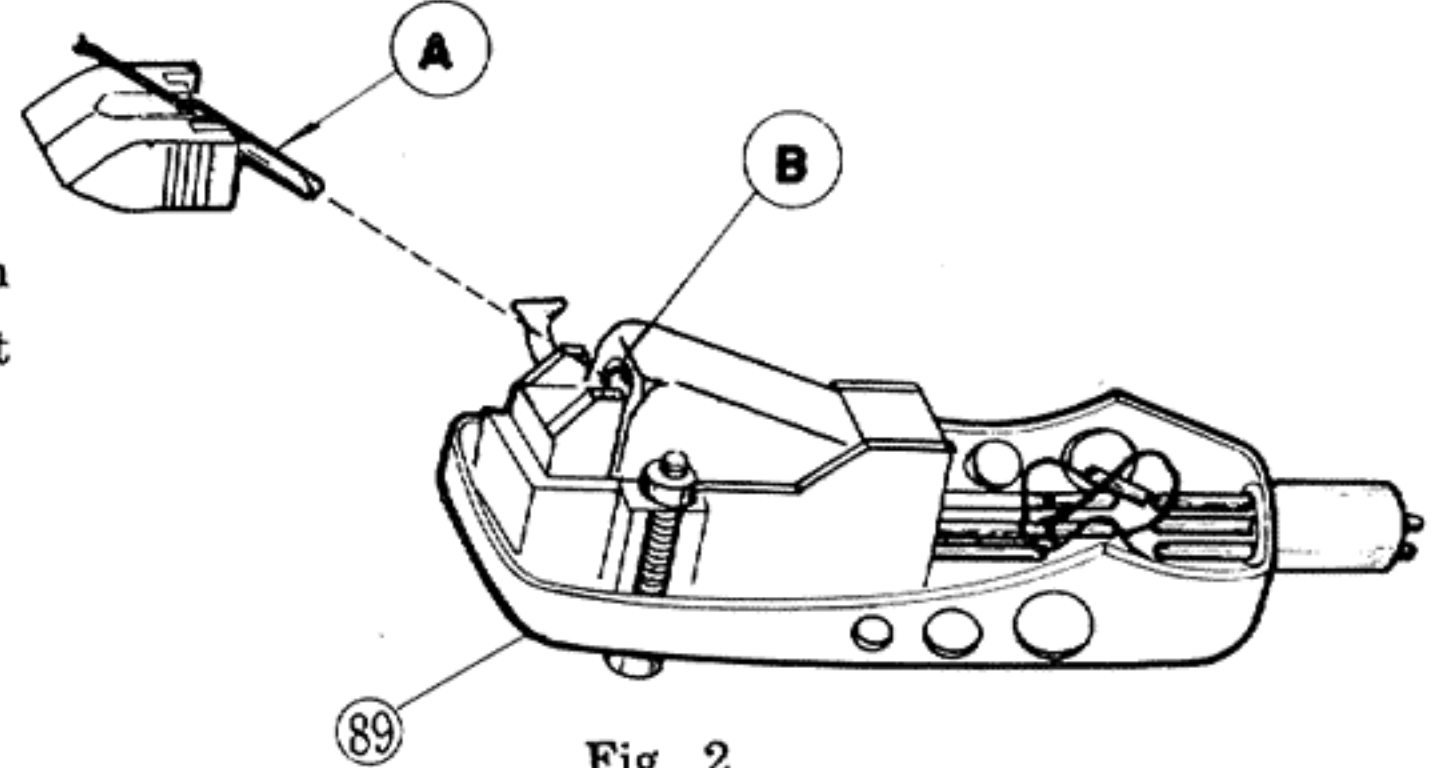

Fig. 2

REPLACING CARTRIDGE

The tone arm accepts universal at your choice. To replace the cartridge, remove the head by rotating the connector not counter-clockwise. Replace the desired cartridge, with special care for the correct polarity of wiring. Replacing with the same cartridge requires stylus pressure adjustment for 2.5g. Replacing with the another type cartridge requires balance and stylus pressure adjustments.

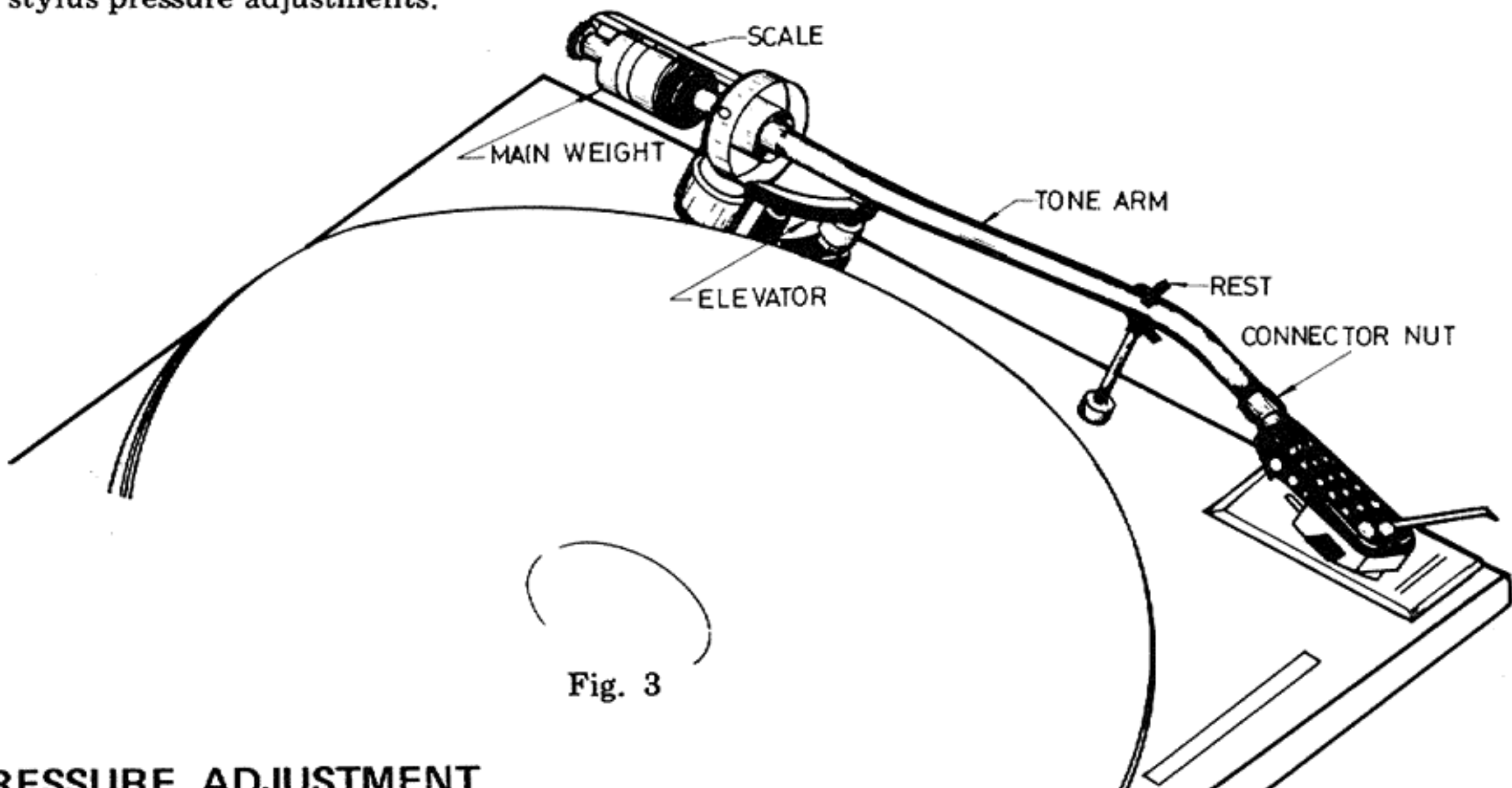

Fig. 3

STYLUS PRESSURE ADJUSTMENT

When replacing the stylus and the cartridge, stylus pressure should be adjusted. Adjust the stylus tip to be on the record level by rotating the main weight (Fig. 4).

To fix the main weight not to turn by hand, rotate the dialing to "O" position. (Fig. 5)

Then, adjust the main weight to required stylus pressure value. (Fig. 6)

(If the require stylus pressure is 3 g, the dial well show as in Fig. 6 when the weight is adjusted.)

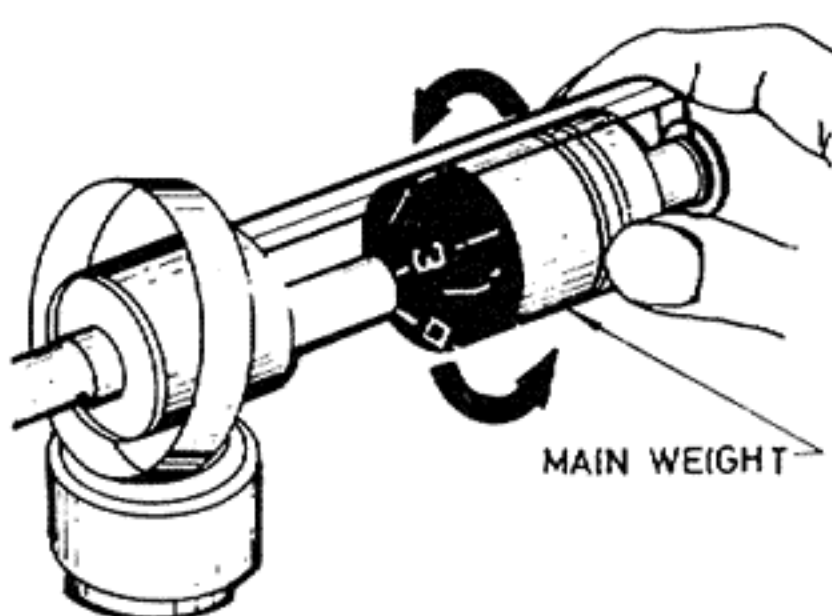

Fig. 4

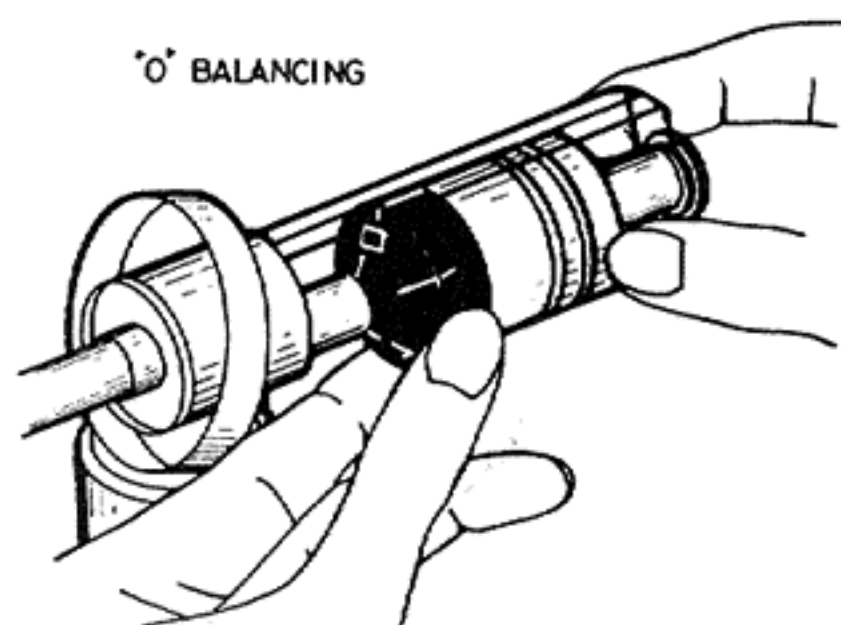

Fig. 5

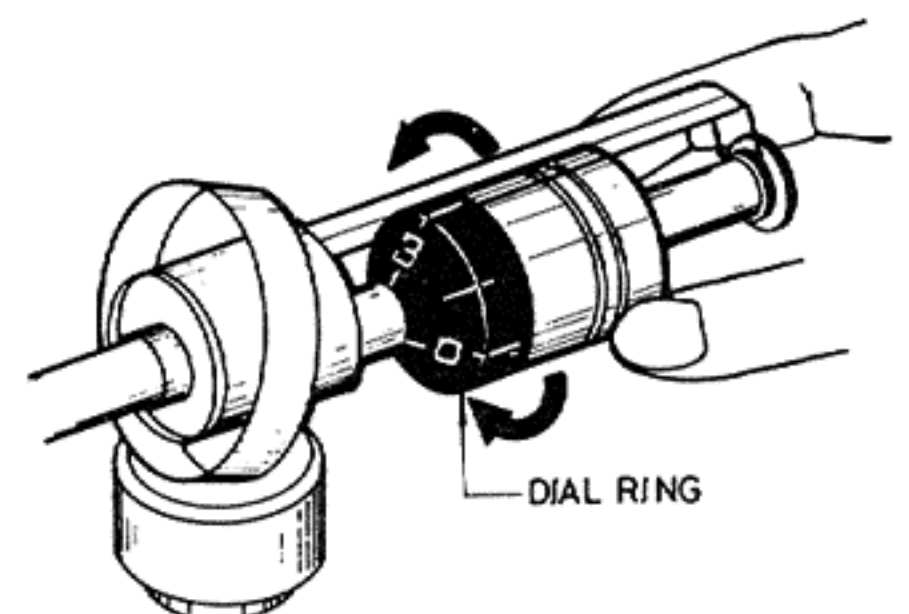

Fig. 6

Auto-Up/Auto-Stop Function

1) At the moment when the disc has been played back to the end, the pick-up goes into the inside turn of the sound groove. At that time the rotating arm pushes the stop plate to push the stopper away from the position shown by the dotted line. (Fig. 7)

The stopper intersects with the turntable pin, so that it is pushed further away by the pin. This causes the gear, which has been locked during the playback, to get free and come into engagement with the turntable gear. The gearing then begins to rotate. (Fig. 8)

2) The slide plate moves in the direction of the arrow along the cam provided under the gearing to lift up the lifting arm. The pick-up rises automatically. (Fig. 9)

3) The rotation of the gearing causes the slide plate and the switching lever to push the contact after the pick-up has fully risen. The motor is automatically switched off (Auto-Stop). The pick-up remains in the upper position; it does not return. (Fig. 10)

4) The stop plate must be in the position shown by the dotted line when the next disc is to be played. To locate it in place, pull the "START" lever, and the gearing will begin to rotate. The stop plate will be moved to the correct position by means of a spring on the gearing. It is ready for the next auto-up function. (Fig. 11)

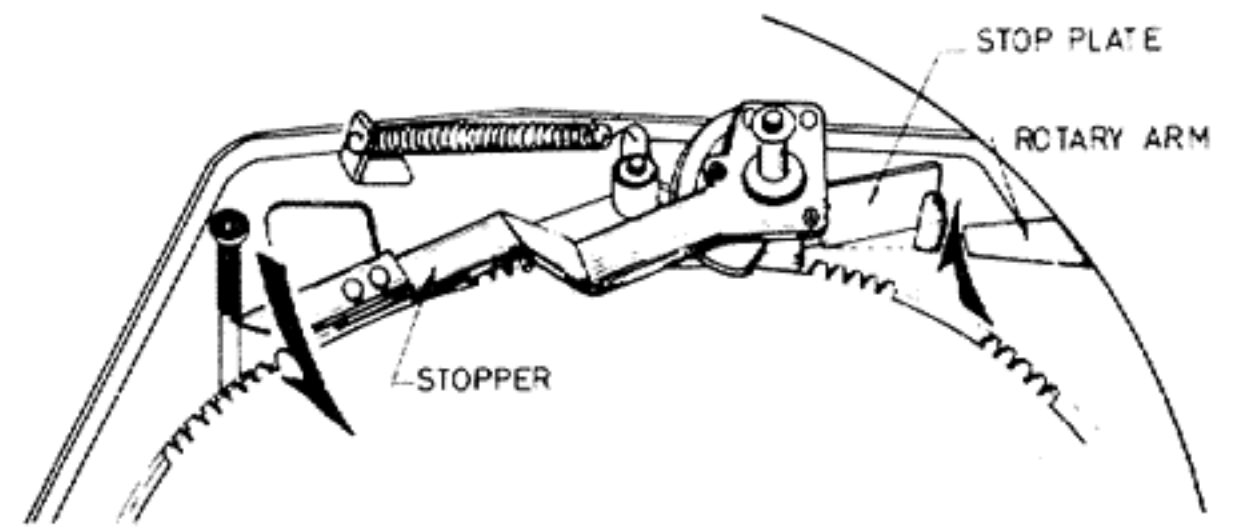

Fig. 7

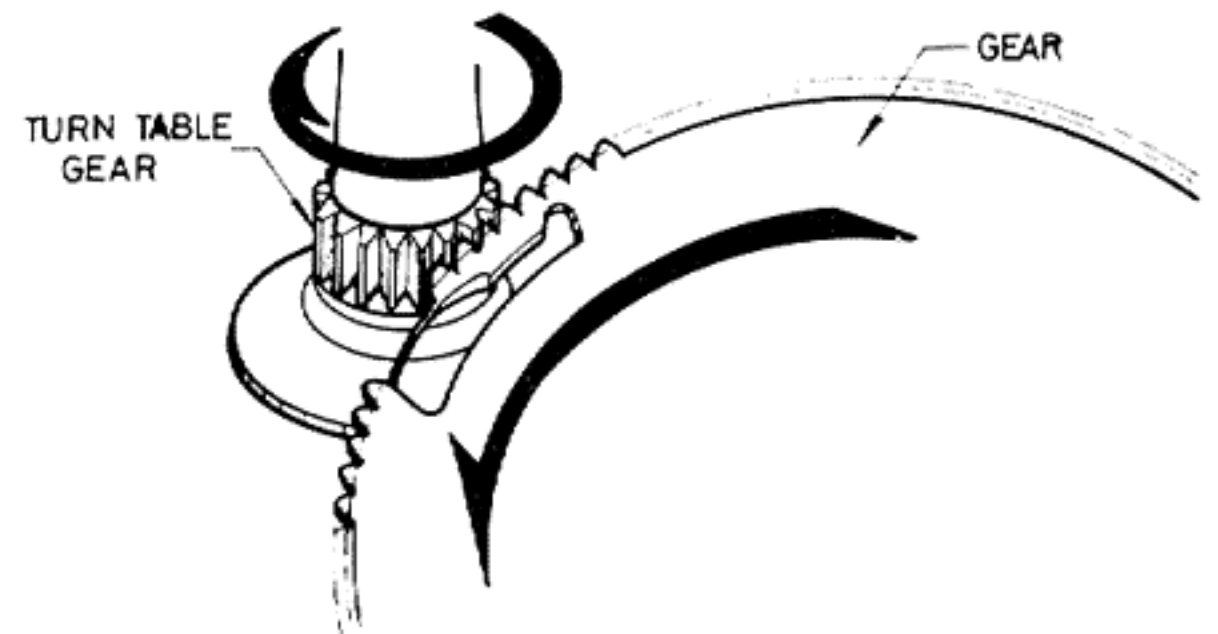

Fig. 8

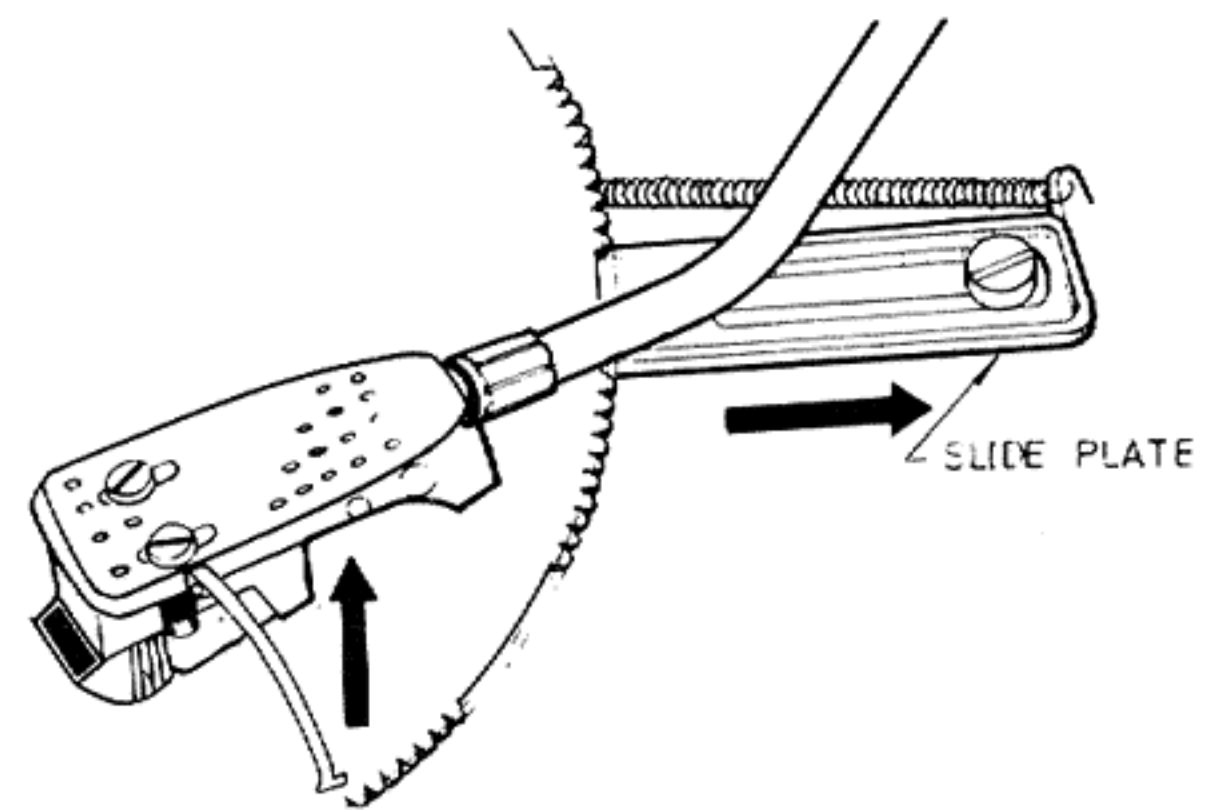

Fig. 9

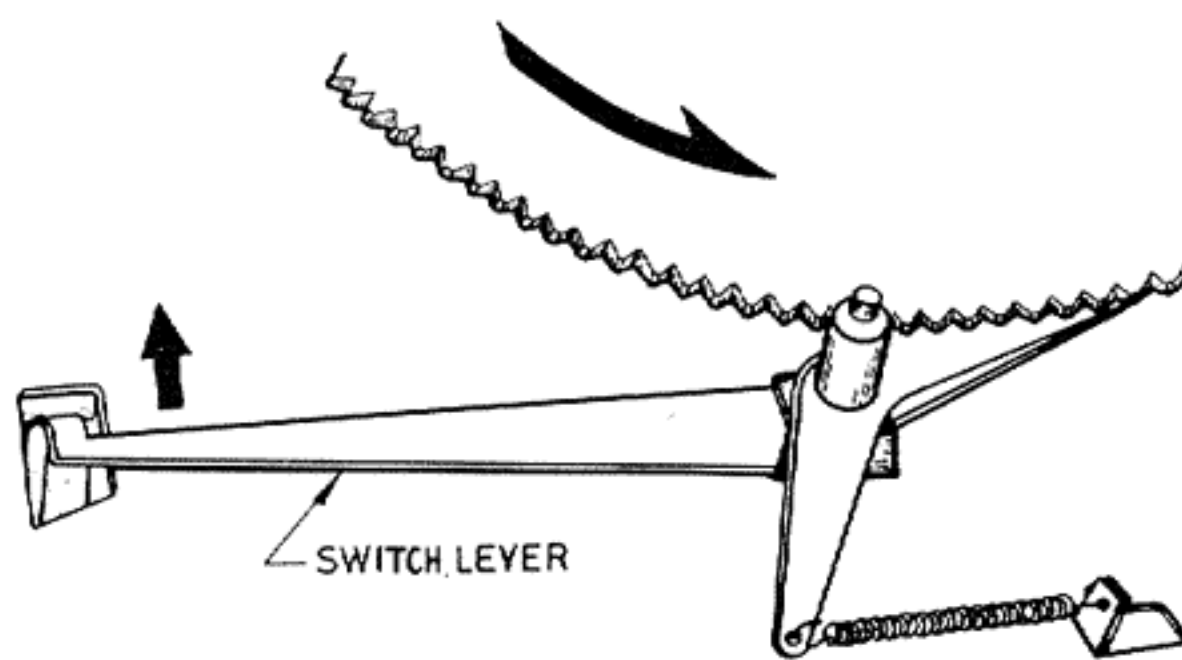

Fig. 10

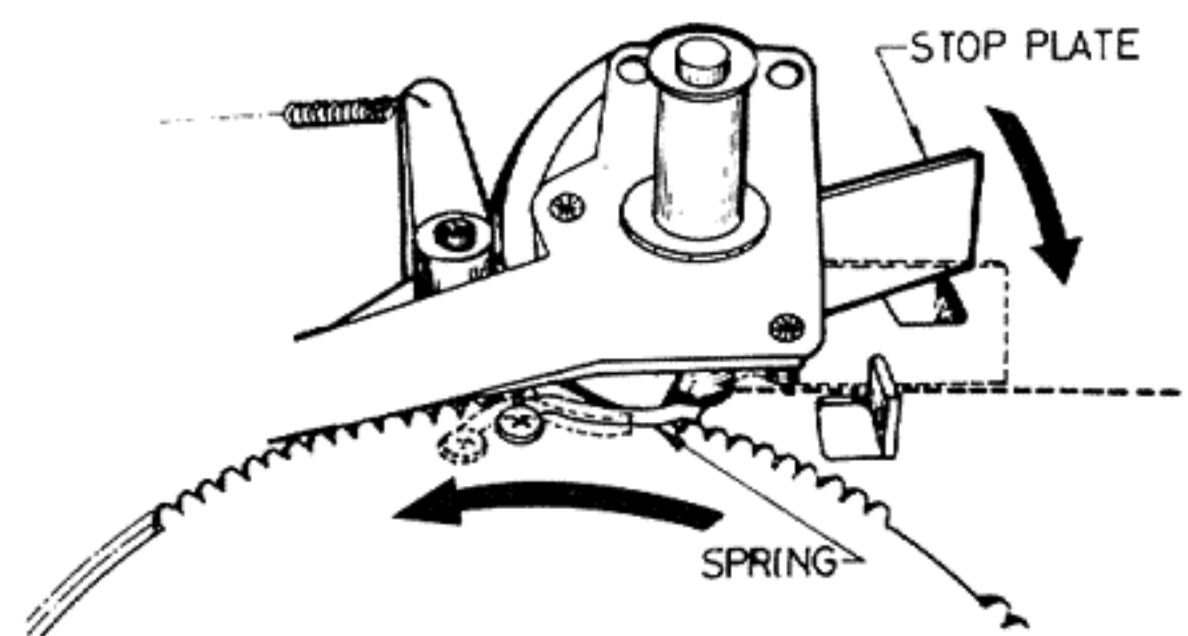

Fig. 11

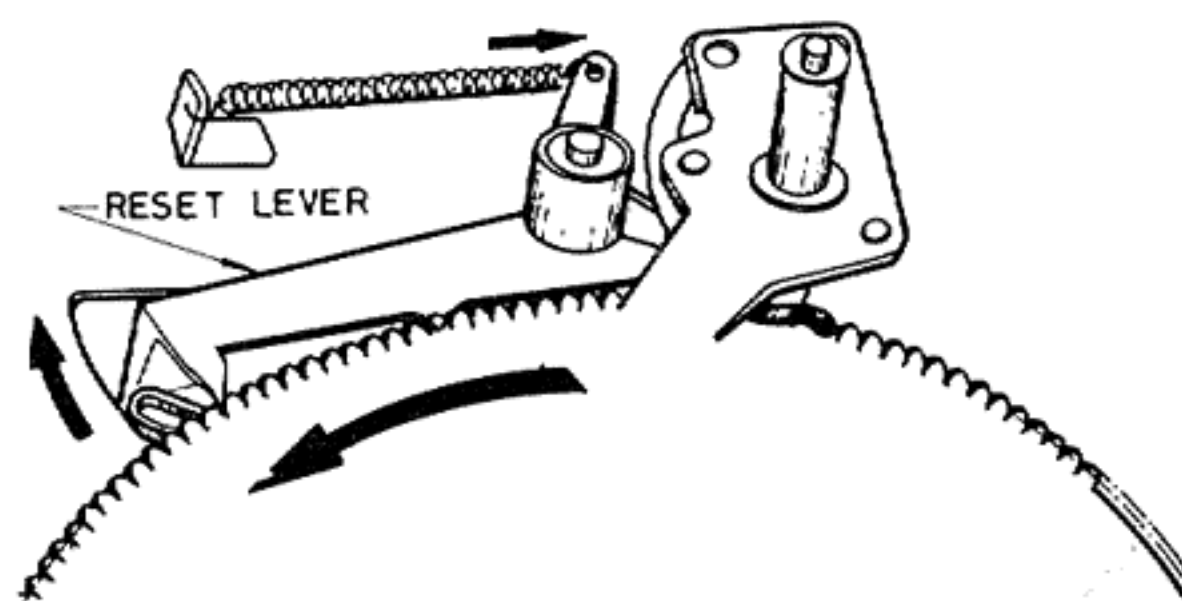

Fig. 12-(a)

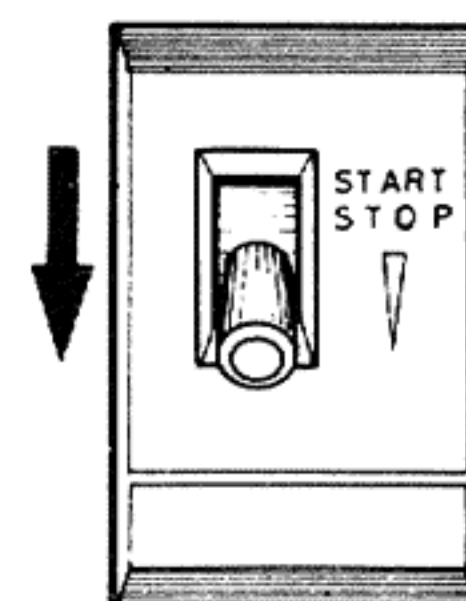
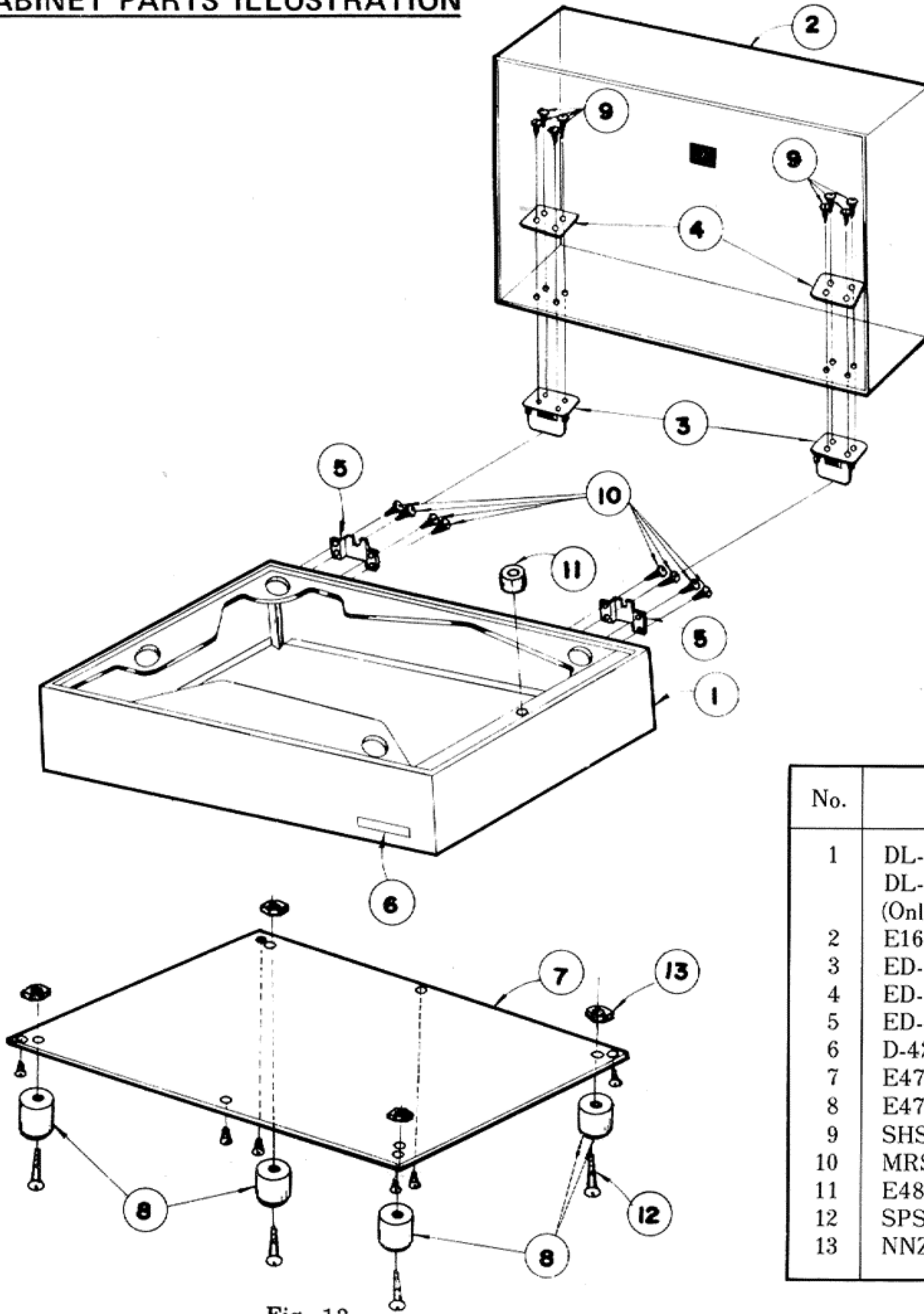

Fig. 12-(b)

CABINET PARTS ILLUSTRATION



No.	Parts No.	Parts Name
1	DL-ED92254 DL-ED92315 (Only Europe)	Cabinet Ass'y Cabinet Ass'y
2	E1603-002	Cover Ass'y
3	ED-35375-001S	Hinge Ass'y
4	ED-42992-001	Plate
5	ED-42991-001	Lock Plate
6	D-42758-002	Mark
7	E47000-001	Bottom Board
8	E47267-001	Foot Ass'y
9	SHSP3016RS	Screw
10	MRSP2710M	Wood Screw
11	E48472-001	Shell Stand
12	SPSP4025ZS	Screw
13	NNZ4000ZS	Nut

Fig. 13

SCHEMATIC DIAGRAM

M.M Cartridge

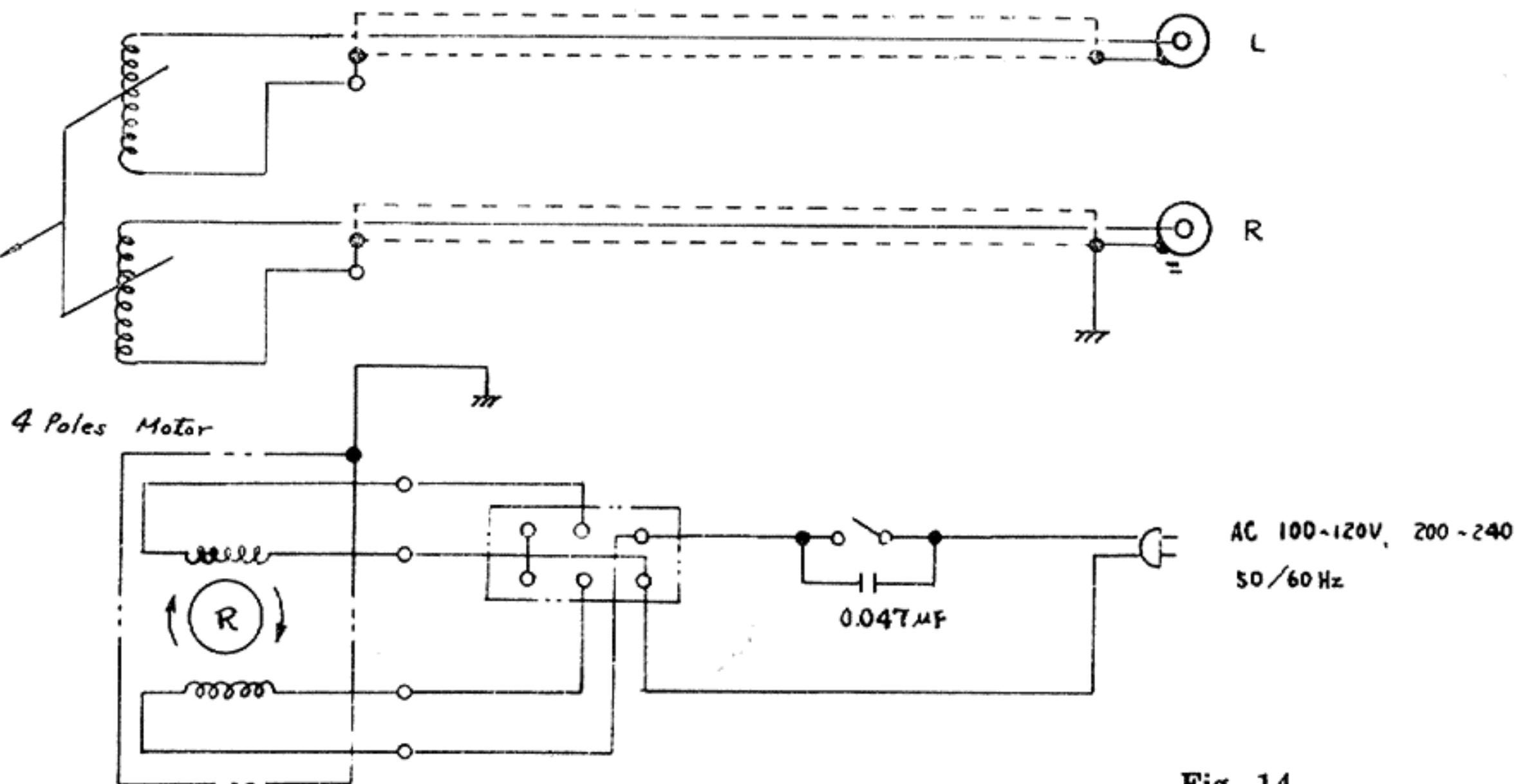

Fig. 14

PLAYER DISASSEMBLY

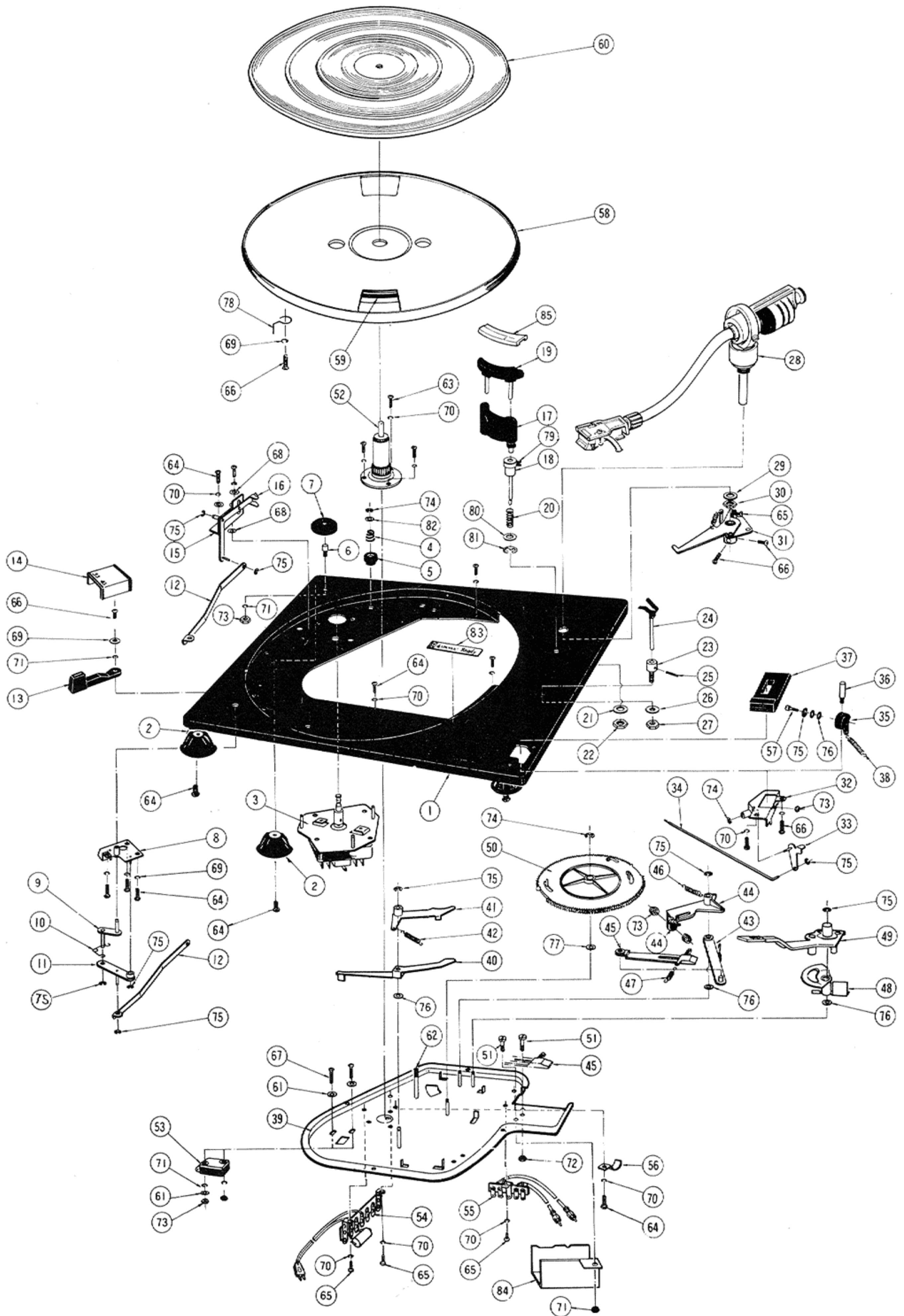

Fig. 15

REPLACEMENT PARTS LIST FOR RECORD PLAYER

No.	Parts No.	Parts Name	No.	Parts No.	Parts Name
1	EG-10486	Panel	45	EG-10154	Slide Plate
2	E46927-002	Foot	46	EG-10228	Reset Lever Spring
3	m-710F	Motor Ass'y	47	EG-10227	Slide Plate Spring
4	E48503-001	Conical Spring	48	EG-10326	Stoper B Unit
5	EG-10176	Cushion Rubber	49	EG-10506	Stopper Unit
6	EG-10201	E.P. Adaptor Holder	50	EG-10536	Gear Ass'y
7	EG-10199	E.P. Adaptor	51	EG-10215	Special Screw
8	EG-10224	Lever Base Unit	52	EG-10235	Spindle Shaft Ass'y
9	EG-10195	Change Lever Unit	53	E03541-001	Micro Switch
10	EG10306	Click Spring	54	QML-1010-073	Lug Strip Ass'y
11	EG-10194	Shift Lever Unit	55	Q03001-51	Lug Strip Ass'y
12	EG-10187	Joint Plate	56	G4084	Cord Clamp
13	EG-10135	Reject Lever	57	EG-10207	Shaft
14	EG-10503	Change Cover Unit	58	EG-10372	Turntable Ass'y
15	EG-10189	Shifter Base Unit	59	EG-10259	Belt
16	EG-10190	Belt Shifter Unit	60	G2501A	Turntable Sheet
17	EG-10323	Elevator Stand	61	EG-10350	Special Washer
18	EG-10339	Elevator Shaft Ass'y	62	E48456-001	Stopper Cushion
19	EG-10322	Elevator Plate	63	SPSP4008ZS	Screw
20	EG-10346	Elevator Spring	64	SPSP4006ZS	Screw
21	EG-10347	Special Washer	65	SPSP3014ZS	Screw
22	EG-10348	Special Nut	66	SPSP3006ZS	Screw
23	E48476-001	Rest Stand	67	SPSP3008ZS	Screw
24	EG-10173	Rest Shaft	68	WNB400	Washer
25	TFB3003S	Ass'y Screw	69	WNB3000	Washer
26	WNS8000Z	Washer	70	WLS4000	Spring Washer
27	NNZ8000Z	Nut	71	WLS3000	Spring Washer
28	MP-127SZ	Pick-up Ass'y (Cartridge Less)	72	NNZ3000ZS	Nut
	MD-1016HZ	Cartridge (Stylus Less)	73	NNZ3000ZS	Nut
29	EG-85089	Washer	74	REE4000	E Ring
30	EG-85060	Nut	75	REE3000	E Ring
31	EG-10504	Rotary Arm Ass'y	76	E48432-001~003	Special Washer (For Adjustment)
32	EG-10208	Start Base Unit	77	EG-10256	Special Washer
33	EG-10209	Push Lever Unit	78	EG-10226	Turntable Pin
34	EG-10300B	Push Rod	79	EG-10345	Elevator Screw
35	EG-10203	Start Cam	80	EG-10160	Special Washer
36	EG-10206	Start Knob	81	REE3000	E Ring
37	EG-10202	Start Stop Cover	82	EG-10210	Rubber Bush
38	EG-10229	Coil Spring	83	EG-10488	Name PLATE
39	EG-10223	Sub Panel Unit	84	EG-10370	Shield Cover
40	EG-10197	Switch Lever	85	EG-10413	Elevator Rubber
41	EG-10225	Push Lever Unit	86	EG10495	Plate
42	E48464-001	Push Lever Spring	87	E48457-001	Lock Plate
43	EG-10191	Return Lever Unit	88	E03545-002	Slide Switch
44	EG-10146	Reset Lever	89	EG11568	Head Shell(W/O Cartridge) Fig. 2