

JVC

SERVICE MANUAL

MODEL
T-10XL

FM/MW/LW STEREO TUNER

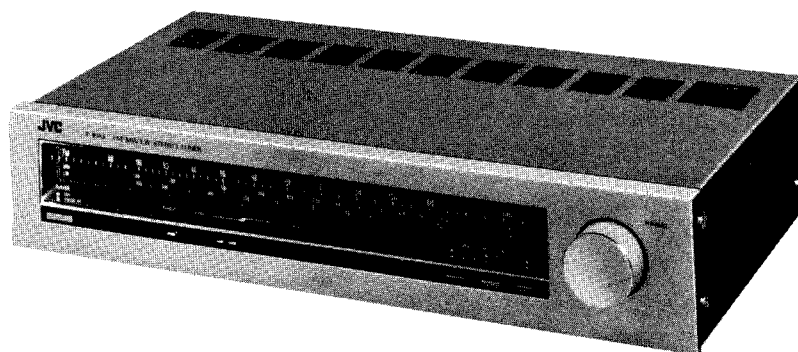

No. 2545
DEC., 1980

Contents

	Page		Page
1. Specifications	1	7. Printed Circuit Board Ass'y and Parts List	9
2. Main Parts Location and Part Numbers	2	7-(1) TXX-296E/296I Tuner & Other	
2-(1) Top View	2	Function Split P.C. Board Ass'y	9
2-(2) Front View	2	8. Packing Materials and Part Numbers	13
2-(3) Rear View	3	9. T-10XL Schematic Diagram	14
3. Dial Stringing Procedure	3	10. Accessories List	16
4. Block Diagram	4	11. Parts List with Specified Numbers for	
5. FM/MW/LW Tuner Alignment Procedures	5	Designated Areas	16
5-(1) FM Section	6		
5-(2) MW/LW Section	6		
6. Exploded View and Part Numbers	7		

Warning When replacing the parts marked with \triangle , be sure to use the designated parts to ensure safety.

1. Specifications

FM Tuner Section

Tuning Range : 87.6 MHz – 108 MHz
 Usable Sensitivity (IHF) : 11.2 dBf 1.0 μ V/75 Ω
 46 dB Quieting Sensitivity
 Mono : 23.3 dBf 4.0 μ V/75 Ω
 Stereo : 43.3 dBf 40.0 μ V/75 Ω
 Signal to Noise Ratio
 Mono : 72 dB DIN, (78 dB IHF)
 Stereo : 62 dB DIN, (70 dB IHF)
 Total Harmonics Distortion (DIN)
 Mono : 0.10 % (1 kHz)
 Stereo : 0.20 % (1 kHz)
 Selectivity : 45 dB \pm 300 kHz DIN
 (63 dB \pm 400 kHz IHF)
 Capture Ratio : 1.0 dB
 IF Rejection : 80 dB at 98 MHz
 Image Rejection : 60 dB at 98 MHz
 Stereo Separation : 1 kHz – 45 dB
 Output Level : 400 mV DIN
 (800 mV/3.3 k Ω IHF)

MW Tuner Section

Tuning Range : 525 kHz – 1605 kHz
 Usable Sensitivity : 300 μ V/m (Bar antenna)
 50 μ V (Ext. antenna)
 Signal to Noise Ratio : 50 dB
 Distortion : 0.5 %
 Selectivity : 40 dB, \pm 9 kHz (43 dB, \pm 10 kHz)
LW Tuner Section
 Tuning Range : 150 kHz – 350 kHz
 Usable Sensitivity : 500 μ V/m (Bar antenna)
 80 μ V (Ext. antenna)
 Signal to Noise Ratio : 50 dB
 Distortion : 0.5 %
 Selectivity : 40 dB, \pm 9 kHz (43 dB, \pm 10 kHz)
 Dimensions : 3-3/8"(H) x 16-1/2"(W) x 11-3/8"(D)
 (86.5 mm x 420 mm x 290 mm)
 Weight : 6.17 lbs. (2.8 kg)

Design and specifications subject to change without notice.

Power Specifications

Designated Areas	Line Voltage & Frequency	Power Consumption
CONTINENTAL EUROPE	AC 220 V \sim , 50 Hz	8 W
UNITED KINGDOM	AC 240 V \sim , 50 Hz	8 W

2. Main Parts Location and Part Numbers

2-(1) Top View

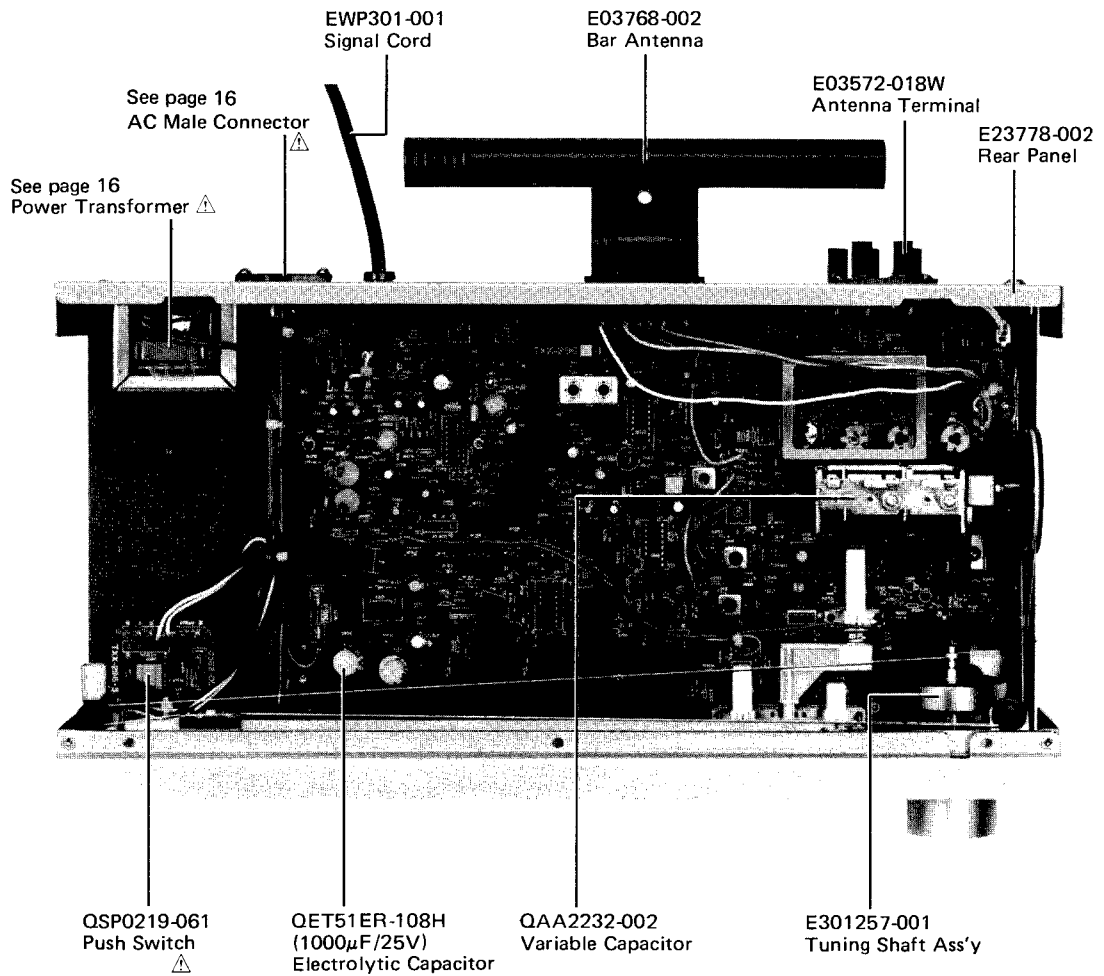

Fig. 1

2-(2) Front View

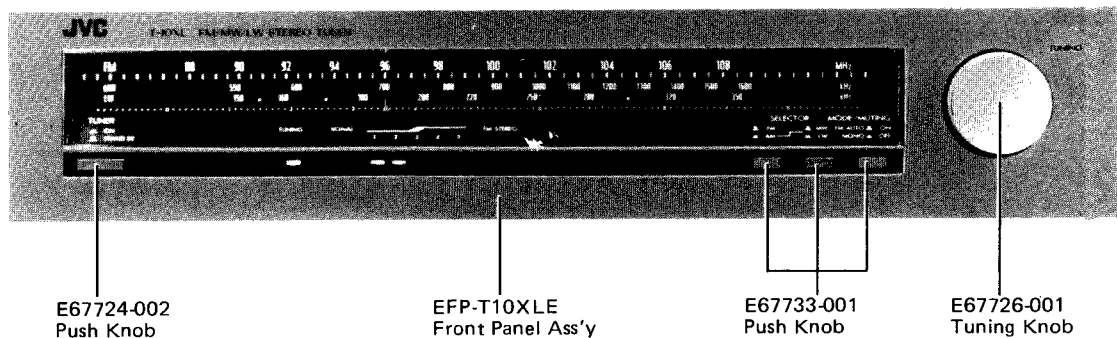

Fig. 2

2-(3) Rear View

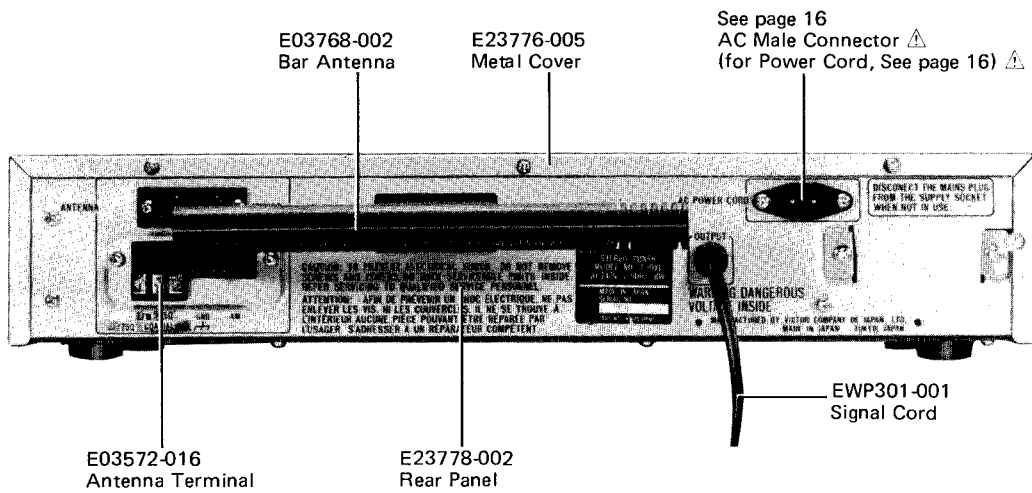

Fig. 3

3. Dial Stringing Procedure

Note: No dial stringing is necessary in normal condition. If it becomes necessary, perform it as follows. Before removing FM/MW/LW Tuner P.C. Board, wrap the dial drum together with dial cord by using a scotch tape and remove the dial drum carefully and then fix it on the side of chassis until replacement of this P.C. Board is completed.

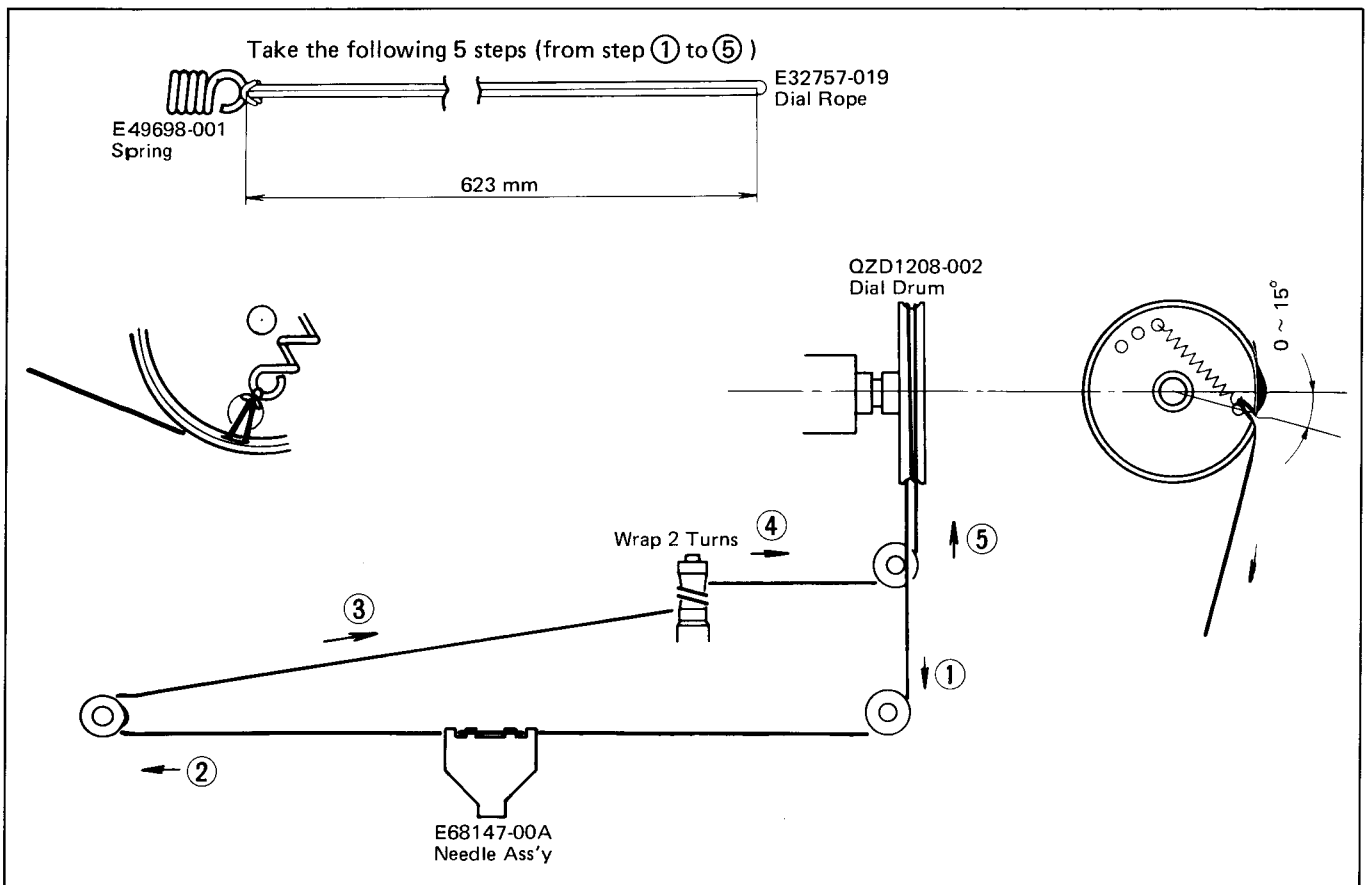

Fig. 4

4. Block Diagram

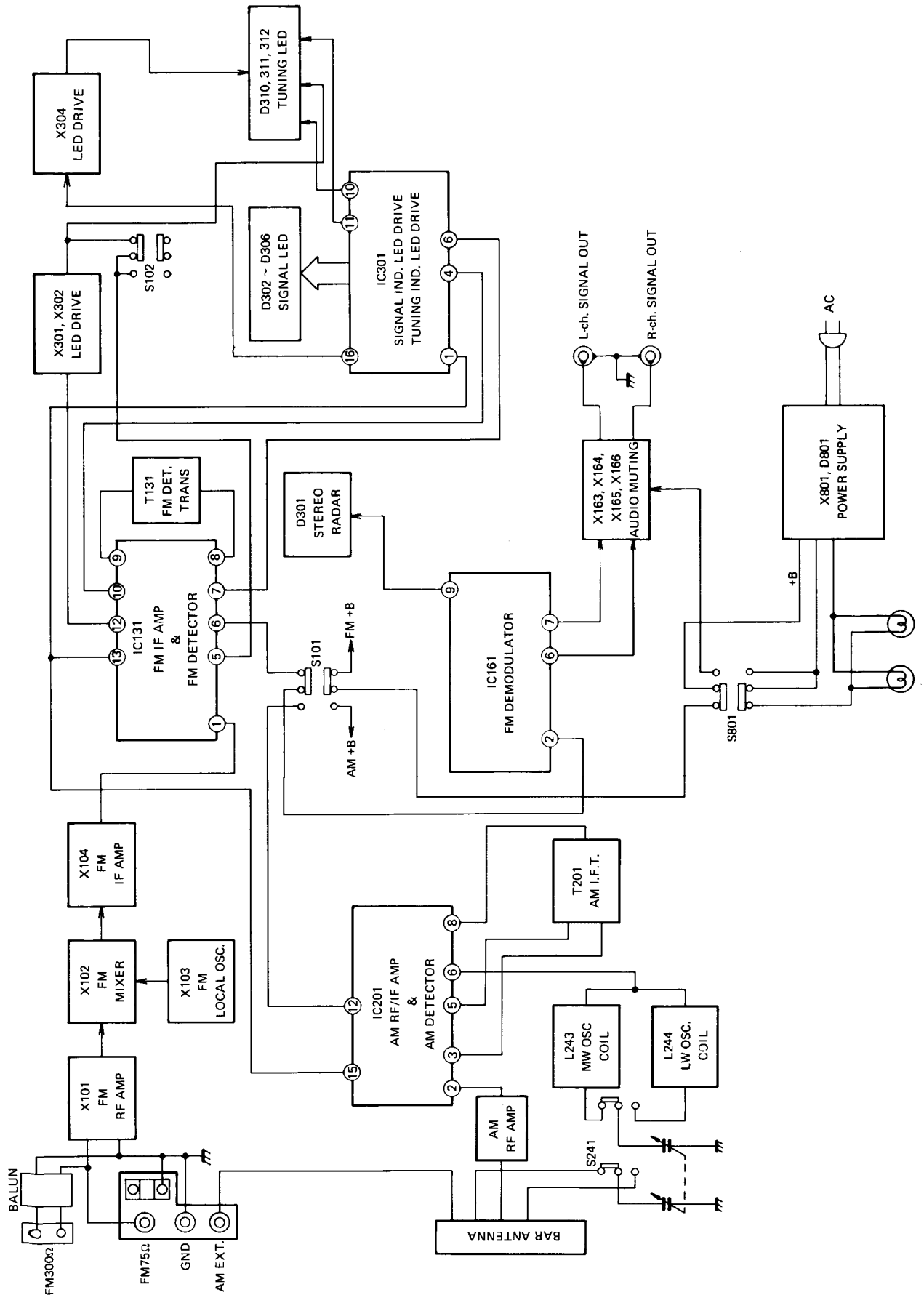

Fig. 5

5. FM/MW/LW Tuner Alignment Procedures

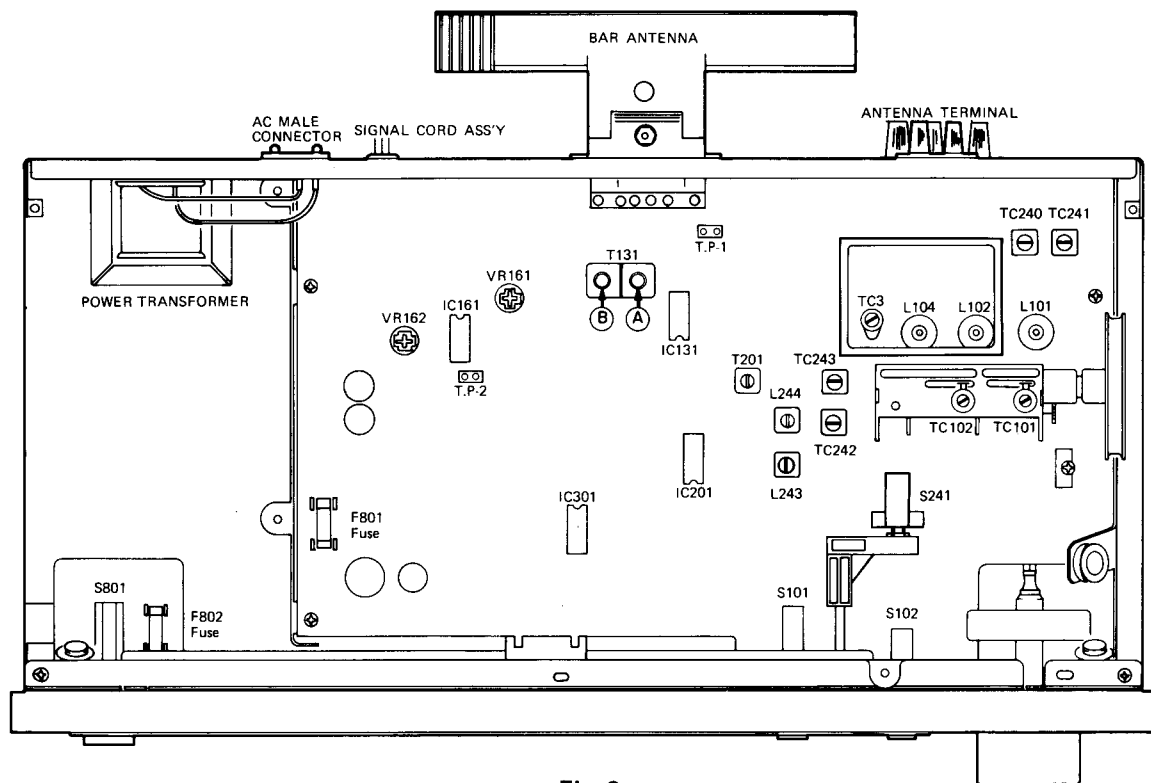

Fig. 6

FM Connection

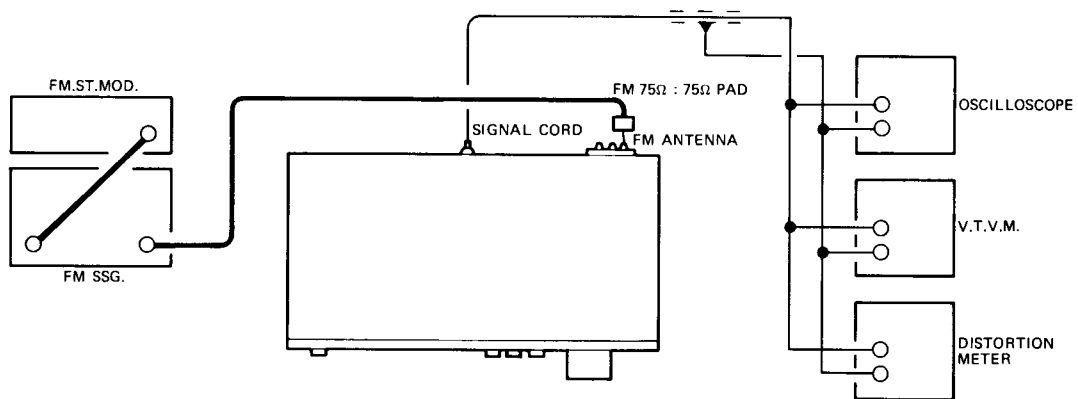

Fig. 7

MW/LW Connection

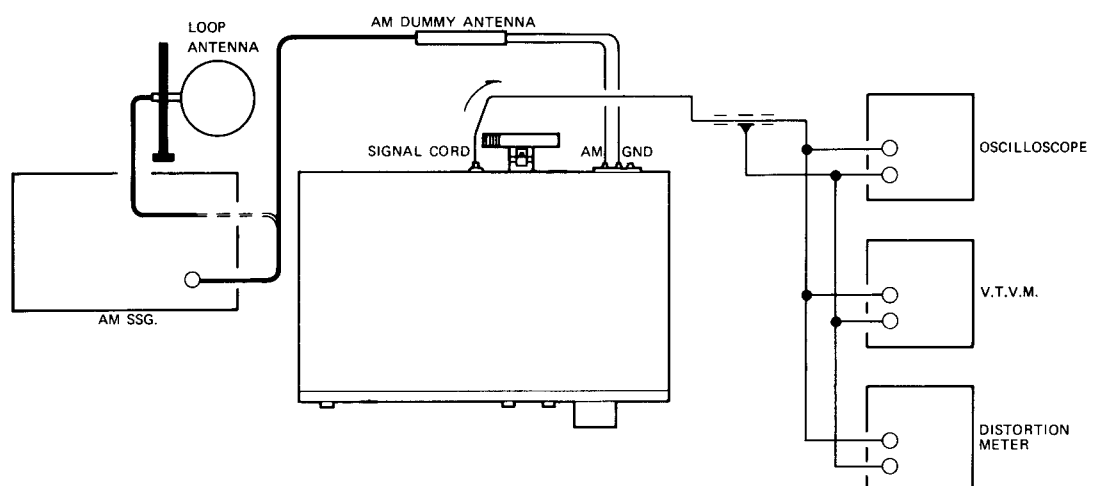

Fig. 8

5-(1) FM Section

Note: Keep in the muting pushbutton off during this procedure.

Low Frequency

1. Connect an RF generator, 1 kHz modulation and 75 kHz deviation, to the antenna terminals on the rear panel through a dummy antenna.
2. Set the RF Generator to 88 MHz, a modulation of 1 kHz and a deviation of 75 kHz, to provide an input of $2\ \mu\text{V}$.
3. Connect a VTVM and oscilloscope to Signal Cord.
4. Set the dial pointer to 88 MHz.
5. Adjust the three coils L104, L102 and L101 in the tuning gang to maximize the output.

High Frequency

6. Set the RF Generator to 108 MHz, a modulation of 1 kHz and a deviation of 75 kHz, to provide an input of $2\ \mu\text{V}$.
7. Set the dial pointer to 108 MHz.
8. Adjust the FM Trimmers TC3, TC102 and TC101 in the tuning gang to maximize the output.
9. Repeat these high and low frequencies adjustment alternately until maximum sensitivity is obtained.

Discriminator, Center Meter, Distortion and Signal Gain

1. Connect an oscilloscope, distortion meter and AC VTVM to Signal Cord.
2. Connect a DC VTVM to TP-1.
3. Tune to frequency where there is no broadcasting.
4. Adjust the core shown arrow **A** of T131 so that the DC VTVM indicates "0" (zero).
5. Set the Generator to 98 MHz.
6. Set the dial pointer to 98 MHz.
7. Adjust the core shown arrow **B** of T131 so that the distortion is minimized at a value less than 0.4 %.

Multiplex and Stereo Separation

Multiplex

1. Set the stereo signal generator as follows: 400 Hz modulation frequency, 7.5 kHz deviation pilot, 67.5 kHz main and sub carriers. Connect its output to an RF generator.
2. Connect the RF Generator to the antenna terminal through a dummy antenna.
3. Connect a VTVM, an Oscilloscope and a Distortion Meter to Signal Cord.
4. Set the RF Generator to the 98 MHz and an output of 1 mV.
5. Set the dial pointer to 98 MHz.
6. Connect the Frequency Counter to the TP-2.
7. Switch off the pilot signal of Stereo Modulator.
8. Adjust VR161 so that the Frequency Counter indicates 19 kHz (+0, -50 Hz).

Stereo Separation

9. Switch the selector of the Stereo Modulator to Left channel modulation.
10. Adjust VR162 so that the output of the Right channel is minimized.
11. Switch the selector of the modulator to Right channel modulation.
12. Adjust VR162 so that the Left channel is minimized.
13. Set VR162 to average, if the separation of Right and Left are different.

5-(2) MW/LW Section

MW(LW) Tracking and Sensitivity

Low Frequency

1. Connect the RF Generator to the antenna terminal on the rear panel, set this to 600 kHz (160 kHz) with 30 % modulation at 400 Hz.
2. Connect an AC VTVM and an Oscilloscope to Signal Cord.
3. Set the dial pointer to the 600 kHz (160 kHz).
4. Adjust OSC Transformer L243 (L244) and the ferrite bar antenna adjusting the MW (LW) coil to maximize the output signal.

High Frequency

5. Set the RF Generator to 1400 kHz (350 kHz) with 30 % modulation at 400 Hz.
6. Set the dial pointer to 1400 kHz (350 kHz).
7. Adjust the trimmers TC242 (TC243) and TC240 (TC241) in the tuning gang so that the output signal is maximized.
8. Repeat these high and low frequencies adjustment procedures alternately until maximum sensitivity is obtained.

6. Exploded View and Part Numbers

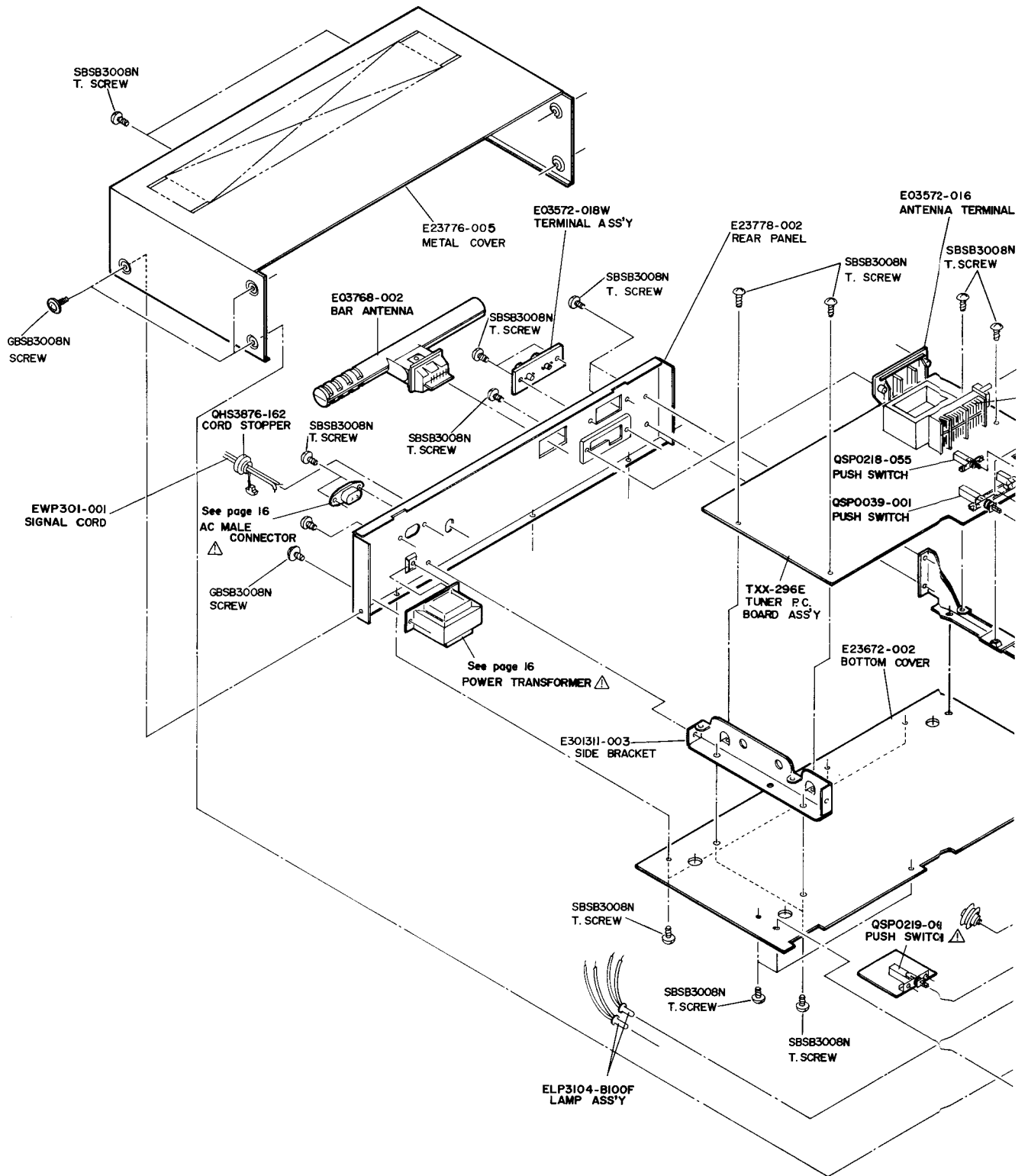

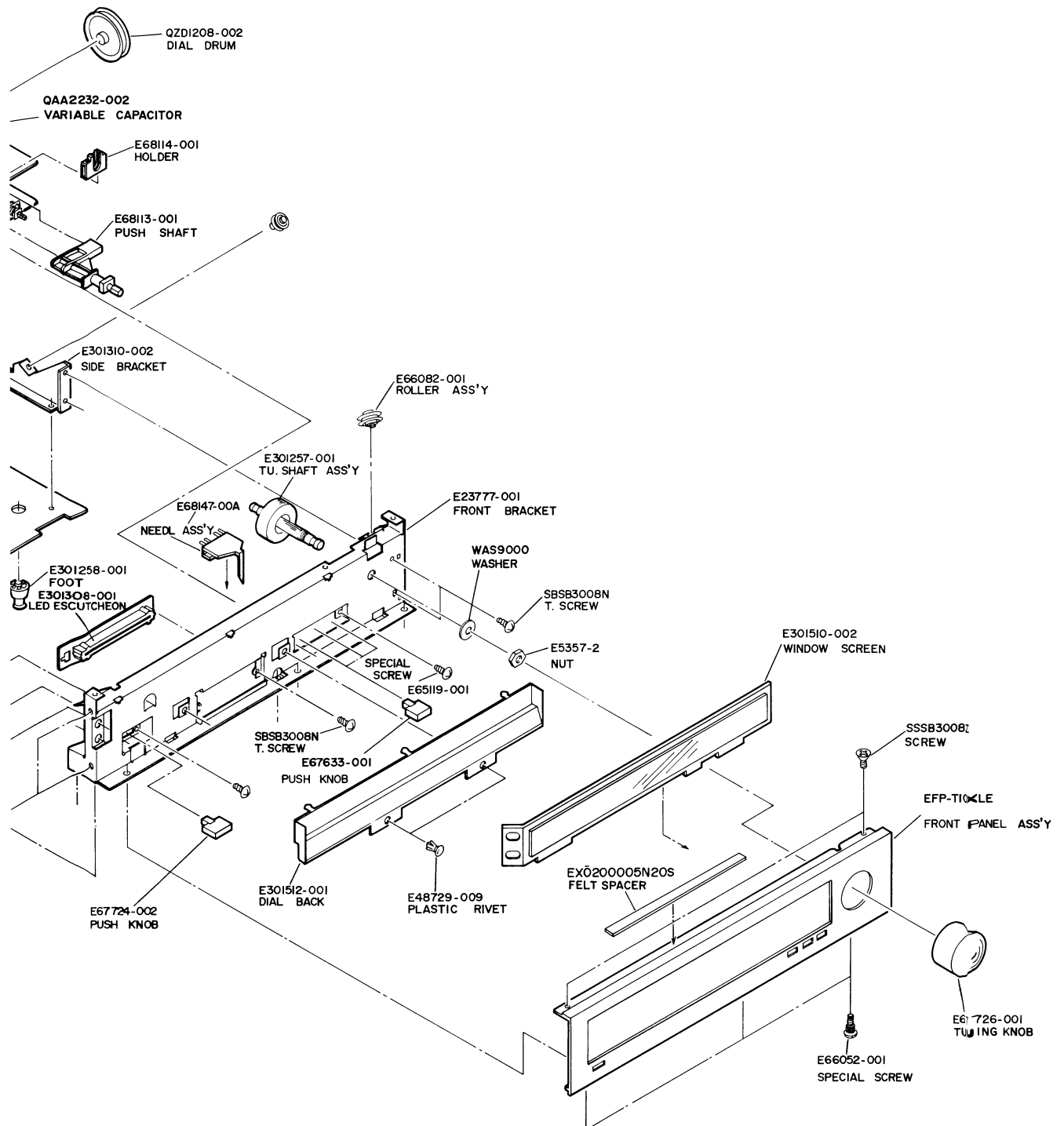

7. Printed Circuit Board Ass'y and Parts List

7-(1) TXX-296E/296I Tuner and Other Function Split P.C.Board Ass'y

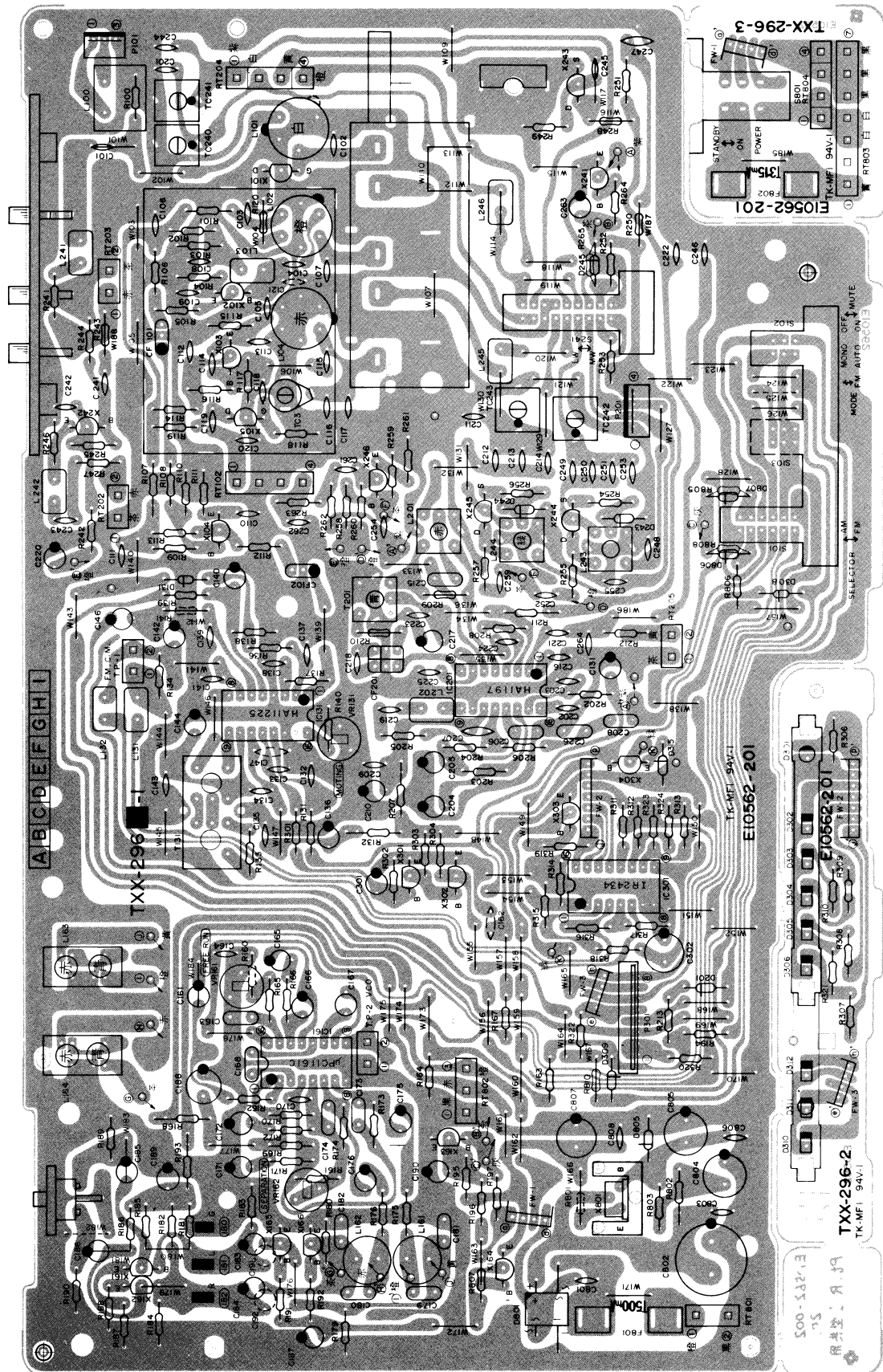

T-10XL
No.2545

Fig. 10

Each Individual P.C. Board Location

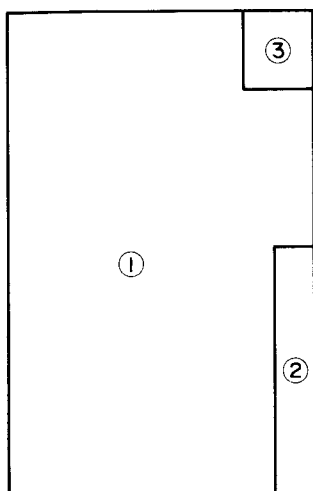

- ① TXX-296-1 Tuner C. Board Ass'y
- ② TXX-296-2 L.E.D. C. Board Ass'y
- ③ TXX-296-3 Power Switch C. Board Ass'y

Note: The specific symbols (赤, 黒, 白, . . . etc.) on a surface of P.C. Board are actually unrelated to the repair service and are significant denotement in order to process the proper assembly of P.C. Board at the factory.

Fig. 11

Transistors

Item No.	Part Number	Rating		Description		
		Pc	fT			Maker
X101	2SK168(F)	0.2 W		FET		Hitachi
X102	2SC535(B)	0.1 W	940 MHz	Silicon		"
X103	2SC1342(C)	"	410 MHz	"		Sanyo
X104	2SC535(B,C)	"	940 MHz	"		Hitachi
X163	2SC458(C,D)	0.2 W	230 MHz	"		"
X164	2SA1029(C,D)	"	200 MHz	"		"
X165	2SD655(E,F)	0.5 W	250 MHz	"		"
X166	2SD655(E,F)	"	"	"		"
X243	2SK105(F,H)	0.25W	230 MHz	FET		NEC
X244	2SK105(F,H)	"	"	"		"
X245	2SK105(F,H)	"	"	"		"
X246	2SC461(B,C)	0.2 W	"	Silicon		Hitachi
X301	2SC458(C)	"	"	"		"
X302	2SC458(C)	"	"	"		"
X304	2SA1029(C)	"	200 MHz	"		"
X801	2SD313V(E)	1.75W	8 MHz	"		Sanyo

Diodes

Item No.	Part Number	Rating		Description	
		Pc			Maker
D131	1S2076-31	0.25 W		Silicon	Hitachi
D201	1S2076-31	"		"	"
D243	1S2076-31	"		"	"
D244	1S2076-31	"		"	"
D301	TLR206	0.056 W		L.E.D.	Toshiba
D302	TLR205	"		"	"
D303	TLR205	"		"	"
D304	TLR205	"		"	"
D305	TLR205	"		"	"
C306	TLR205	"		"	"
D308	1S2076-31	0.25 W		Silicon	Hitachi
D309	1S2076-31	"		"	"
D310	TLR205	0.056 W		L.E.D.	Toshiba
D311	TLG205	"		"	"
D312	TLR205	"		"	"
D315	1S2076-31	0.25 W		Silicon	Hitachi
D801	ESAB03-02A	"		"	Fuji
D805	RD13EB3	"		(Zener)	NEC

Integrated Circuits

Item No.	Part Number	Rating		Description	
		Pc			Maker
IC131	HA11225	0.59 W		I.C.	Hitachi
IC161	UPC1161C	0.4 W		"	NEC
IC201	HA1197	0.45 W		"	Hitachi
IC301	IR2434	1 W		"	Sharp

Coils & Transformers

Item No.	Part Number	Rating	Description
L100	E03177-005		Balun
L101	E03477-031		RF Coil
L102	E03477-035		"
L103	E03522-1R5KY		Choke Coil
L104	E03477-034		RF Coil
L131	E03522-2R2KY		Choke Coil
L132	E03522-2R2KY		"
L161	Y00118-103		Ferry Inductor
L162	Y00118-103		"
L202	E03522-391KY		Choke Coil
L243	EQR1210-002		MW Osc Coil
L244	EQR1310-001		LW Osc Coil
L245	E03522-2R2KY		Choke Coil
L246	E03522-2R2KY		"
TC3	QAT3001-005		Trimmer Capacitor
T131	E03793-001		FM D.F.T. Transformer
T201	E03613-017		I.F. Transformer

Capacitors

Item No.	Part Number	Rating	Description
C102	QCS31HJ-120Z	12 pF 50 V	Ceramic
C103	QCF31HP-103Z	0.01 μF "	"
C104	QCS31HJ-4R0Z	4 pF "	"
C105	QCS31HJ-2R0Z	2 pF "	"
C106	QCF31HP-103Z	0.01 μF "	"
C107	QCS31HJ-180Z	18 pF "	"
C108	QCS31HJ-151Z	150 pF "	"
C109	QCF31HP-103Z	0.01 μF "	"
C110	QCF31HP-223Z	0.022 μF "	"
C111	QCF31HP-223Z	" "	"
C112	QCF31HP-103Z	0.01 μF "	"
C113	QCT25CH-100Z	10 pF "	"
C114	QCT25CH-220Z	22 pF "	"
C115	QCT25CH-7R0Z	7 pF "	"
C116	QCT25RH-100Z	10 pF "	"
C117	QCT25PH-100Z	10 pF "	"
C131	QET61HR-105ZM	1 μF 50 V	Electrolytic
C132	QCF31HP-223Z	0.022 μF "	Ceramic
C133	QCF31HP-223Z	" "	"
C134	QCF31HP-223Z	" "	"
C135	QCF31HP-223Z	" "	"
C136	QET61CR-476ZM	47 μF 16 V	Electrolytic
C137	QCF31HP-223Z	0.022 μF 50 V	Ceramic
C138	QCF31HP-223Z	" "	"
C139	QCS31HJ-330Z	33 pF "	"
C140	QET61ER-106ZM	10 μF 25 V	Electrolytic
C141	QCF31HP-223Z	0.022 μF 50 V	Ceramic
C142	QET61HR-474ZM	0.47 μF "	Electrolytic
C143	QCF31HP-223Z	0.022 μF "	Ceramic
C144	QET61CR-476ZM	47 μF 16 V	Electrolytic
C146	QET61HR-475ZM	4.7 μF 50 V	"
C163	QFP31HJ-471	470 pF "	Polypropylene
C164	QCF31HP-103Z	0.01 μF "	Ceramic
C165	QEB51EM-335	3.3 μF 25 V	Low Leak Current Electrolytic
C166	QEB51HM-105	1 μF 50 V	"
C167	QEZ0046-224	0.22 μF "	Electrolytic
C168	QFM31HK-473Z	0.047 μF 50 V	Mylar
C170	QCS31HJ-101Z	100 pF "	Ceramic
C171	QET61ER-106ZM	10 μF 25 V	Electrolytic
C172	QET61ER-106ZM	" "	"
C173	QFM31HK-122Z	1200 pF 50V	Mylar
C174	QFM31HK-122Z	" "	"
C175	QET61HR-225ZM	2.2 μF "	Electrolytic
C176	QET61HR-225ZM	" "	"
C179	QFM31HK-182Z	1800 pF "	Mylar
C180	QFM31HK-182Z	" "	"
C181	QFM31HK-682Z	6800 pF "	"
C182	QFM31HK-682Z	" "	"
C183	QET61HR-105ZM	1 μF "	Electrolytic
C184	QET61HR-105ZM	" "	"
C188	QET51CR-227	220 μF 16 V	"
C190	QET61HR-225ZM	2.2 μF 50 V	"
C202	QCF31HP-223Z	0.022 μF "	Ceramic
C203	QCF31HP-223Z	" "	"
C204	QET61HR-105ZM	1 μF "	Electrolytic
C205	QET61ER-106ZM	10 μF 25 V	"
C206	QFM31HK-102Z	1000 pF 50 V	Mylar
C207	QCF31HP-223Z	0.022 μF "	Ceramic
C208	QFM31HK-103Z	0.01 μF "	Mylar
C209	QCF31HP-223Z	0.022 μF "	Ceramic
C210	QET61CR-476ZM	47 μF 16 V	Electrolytic
C211	QCT25UJ-470Z	47 pF 50 V	Ceramic
C212	QCT25CH-101Z	100 pF "	"
C213	QCT25CH-151Z	160 pF "	"
C214	QCT25CH-220Z	22 pF "	"
C216	QCF31HP-223Z	0.022 μF 50 V	Ceramic
C217	QET61CR-476ZM	47 μF 16 V	Electrolytic
C218	QCS31HJ-560Z	56 pF 50 V	Ceramic
C219	QCS31HJ-331Z	330 pF "	"

Capacitors

Item No.	Part Number	Rating	Description
C221	QCF31HP-223Z	0.022 μF 50 V	Ceramic
C223	QCF31HP-223Z	" "	"
C224	QCF31HP-223Z	" "	"
C226	QFM31HK-222Z	2200 pF "	Mylar
C244	QCS31HJ-100Z	10 pF "	Ceramic
C245	QCF31HP-223Z	0.022 μF "	"
C246	QCF31HP-223Z	" "	"
C247	QCF31HP-223Z	" "	"
C248	QCF31HP-223Z	" "	"
C249	QCT25CH-151Z	160 pF "	"
C250	QCT25CH-151Z	" "	"
C251	QCS31HJ-270Z	27 pF 50 V	"
C252	QCF31HP-223Z	0.022 μF "	"
C253	QCT25UJ-7R0Z	7 pF "	"
C255	QCF31HP-223Z	0.022 μF 50 V	"
C259	QCF31HP-223Z	" "	"
C261	QCF31HP-223Z	" "	"
C301	QET61HR-474ZM	0.47 μF "	Electrolytic
C302	QET61CR-107ZM	100 μF 16 V	"
C801	QCF31HP-103Z	0.01 μF 50 V	Ceramic
C802	QET51ER-108H	1000 μF 25 V	Electrolytic
C804	QET51ER-477H	470 μF 25 V	Electrolytic
C805	QET61CR-107ZM	100 μF 16 V	"
C806	QCF31HP-103Z	0.01 μF 50 V	Ceramic
C807	QET61CR-107ZM	100 μF 16 V	Electrolytic
C808	QCF31HP-103Z	0.01 μF 50 V	Ceramic

Resistors

Item No.	Part Number	Rating	Description
R101	QRD141J-391S	390 Ω 1/4 W	Carbon
R102	QRD141J-223S	22 kΩ "	"
R103	QRD141J-472S	4.7 kΩ "	"
R104	QRD141J-102S	1 kΩ "	"
R105	QRD141J-101S	100 Ω "	"
R106	QRD141J-561S	560 Ω "	"
R107	QRZ0052-330	33 Ω "	Fusible
R108	QRD141J-221S	220 Ω "	Carbon
R109	QRD141J-273S	27 kΩ "	"
R110	QRD141J-103S	10 kΩ "	"
R111	QRD141J-471S	470 Ω "	"
R112	QRD141J-101S	100 Ω "	"
R113	QRD141J-331S	330 Ω "	"
R114	QRD141J-222S	2.2 kΩ "	"
R115	QRD141J-272S	2.7 kΩ "	"
R116	QRD141J-103S	10 kΩ "	"
R117	QRD141J-682S	6.8 kΩ "	"
R131	QRD141J-913S	91 kΩ "	"
R132	QRD149J-470S	47 Ω "	"
R133	QRD141J-332S	3.3 kΩ "	"
R134	QRD141J-123S	12 kΩ "	"
R136	QRD141J-103S	10 kΩ "	"
R137	QRD141J-391S	390 Ω "	"
R138	QRD141J-473S	47 kΩ "	"
R139	QRD141J-123S	12 kΩ "	"
R140	QRD141J-562S	5.6 kΩ "	"
R162	QRD141J-473S	47 kΩ "	"
R164	QRD141J-683S	68 kΩ "	"
R165	QRD141J-163S	16 kΩ "	"
R166	QRD141J-102S	1 kΩ "	"
R167	QRD141J-102S	" "	"
R168	QRZ0052-330	33 Ω "	Fusible
R169	QRD141J-223S	22 kΩ "	Carbon
R170	QRD141J-223S	" "	"
R171	QRD141J-103S	10 kΩ "	"
R172	QRD141J-103S	" "	"
R173	QRD141J-513S	51 kΩ "	"

Resistors

Item No.	Part Number	Rating	Description
R174	QRD141J-513S	51 kΩ	1/4 W Carbon
R175	QRD141J-152S	1.5 kΩ	" "
R176	QRD141J-152S	1.5 kΩ	" "
R179	QRD141J-332S	3.3 kΩ	" "
R180	QRD141J-332S	"	" "
R183	QRD141J-104S	100 kΩ	" "
R184	QRD141J-104S	"	" "
R191	QRD141J-223S	22 kΩ	" "
R192	QRD141J-223S	"	" "
R194	QRD141J-103S	10 kΩ	" "
R195	QRD141J-223S	22 kΩ	" "
R196	QRD141J-683S	68 kΩ	" "
R197	QRD141J-683S	"	" "
R202	QRD141J-562S	5.6 kΩ	" "
R203	QRD141J-103S	10 kΩ	" "
R204	QRD141J-103S	"	" "
R205	QRD141J-331S	330 Ω	" "
R206	QRD141J-273S	27 kΩ	" "
R207	QRD149J-221S	220 Ω	" "
R208	QRD141J-152S	1.5 kΩ	" "
R211	QRD149J-221S	220 Ω	" "
R213	QRD141J-103S	10 kΩ	" "
R248	QRD141J-151S	150 Ω	" "
R249	QRD141J-105S	1 MΩ	" "
R251	QRD141J-681S	680 Ω	" "
R252	QRD141J-683S	68 kΩ	" "
R253	QRD141J-102S	1 kΩ	" "
R254	QRD141J-272S	2.7 kΩ	" "
R255	QRD141J-682S	6.8 kΩ	" "
R256	QRD141J-472S	4.7 kΩ	" "
R257	QRD141J-682S	6.8 kΩ	" "
R258	QRD141J-394S	390 kΩ	" "
R259	QRD141J-683S	68 kΩ	" "
R260	QRD141J-472S	4.7 kΩ	" "
R261	QRD141J-221S	220 Ω	" "
R262	QRD141J-561S	560 Ω	" "
R265	QRD141J-683S	68 kΩ	" "
R301	QRD141J-563S	56 kΩ	" "
R302	QRD141J-563S	"	" "
R303	QRD141J-333S	33 kΩ	" "
R304	QRD141J-102S	1 kΩ	" "
R306	QRD141J-222S	2.2 kΩ	" "
R307	QRD141J-152S	1.5 kΩ	" "
R308	QRD141J-152S	"	" "
R309	QRD141J-152S	"	" "
R310	QRD141J-152S	1.5 kΩ	" "
R311	QRD141J-152S	"	" "
R315	QRD141J-751S	750 Ω	" "
R316	QRD141J-102S	1 kΩ	" "
R317	QRD141J-303S	30 kΩ	" "
R318	QRD141J-333S	33 kΩ	" "
R319	QRD141J-104S	100 kΩ	" "
R321	QRD141J-222S	2.2 kΩ	" "
R322	QRD141J-102S	1 kΩ	" "
R323	QRD141J-152S	1.5 kΩ	" "
R324	QRD141J-152S	"	" "
R802	QRD129J-681	680 Ω	1/2 W
R803	QRD141J-271S	270 Ω	1/4 W
R805	QRD141J-683S	68 kΩ	" "
R806	QRD141J-683S	"	" "
R808	QRD141J-683S	"	" "

Others

Item No.	Part Number	Rating	Description
FW-1	EWR34A-35NN		Flat Wire
FW-2	EWR37A-15NN		"
RW-3	EWR34A-15NN		"
F801	E48965-002		Fuse Clip
F802	E48965-002		"
P101	QMV5005-003		3 Pin Plug Ass'y
S101	QSP0039-001		Push Switch
S241	QSP0218-055		"
S801	QSP0219-061		"
CF101	E03357-009		Ceramic Filter
CF102	E03357-009		"
CF201	E03613-016		"
RT202	E67764-002		Terminal Ass'y
RT204	E67764-004		"
RT801	E67764-102		Wrapping Terminal
RT803	E67764-007		Terminal Ass'y
T.P-1	E67764-002		"
T.P-2	E67764-002		"
TC240	QAT2001-001		Trimmer Capacitor
TC241	QAT2001-005		"
TC242	QAT2001-005		"
TC243	QAT2001-005		"
VR161	QVP4A0B-472		V. Resistor
VR162	QVP4A0B-474		"
	E03572-016		Ant, Terminal
	E10562-201		Cir. Board
	E301508-001		LED. ESC.
	E65396-001		Earth Plate
	E65508-002		Tab
	E67854-001		Shield Cover
	QAA2232-002		V. Capacitor

8. Packing Materials and Part Numbers

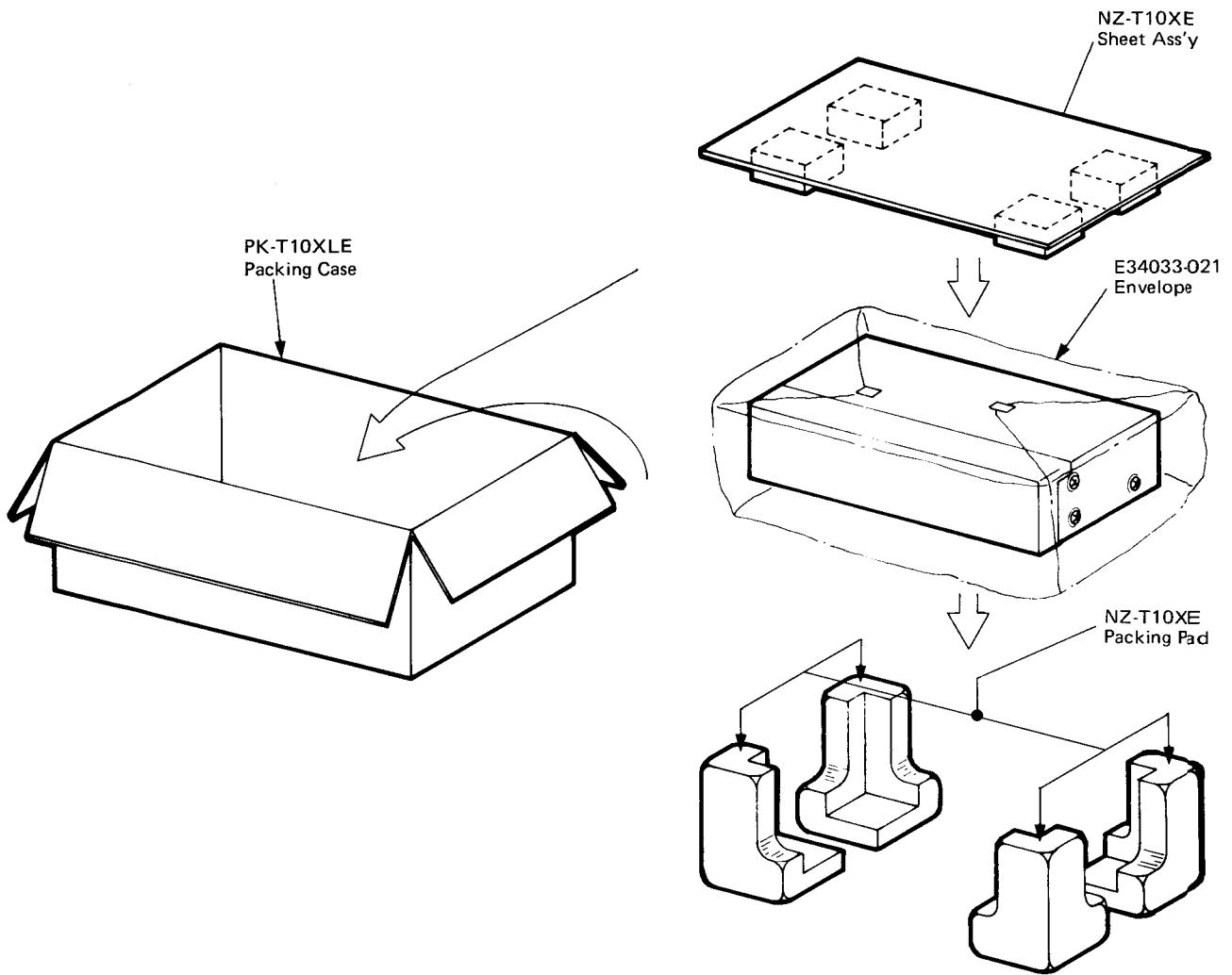

Fig. 12

D

E

F

1

2

3

4

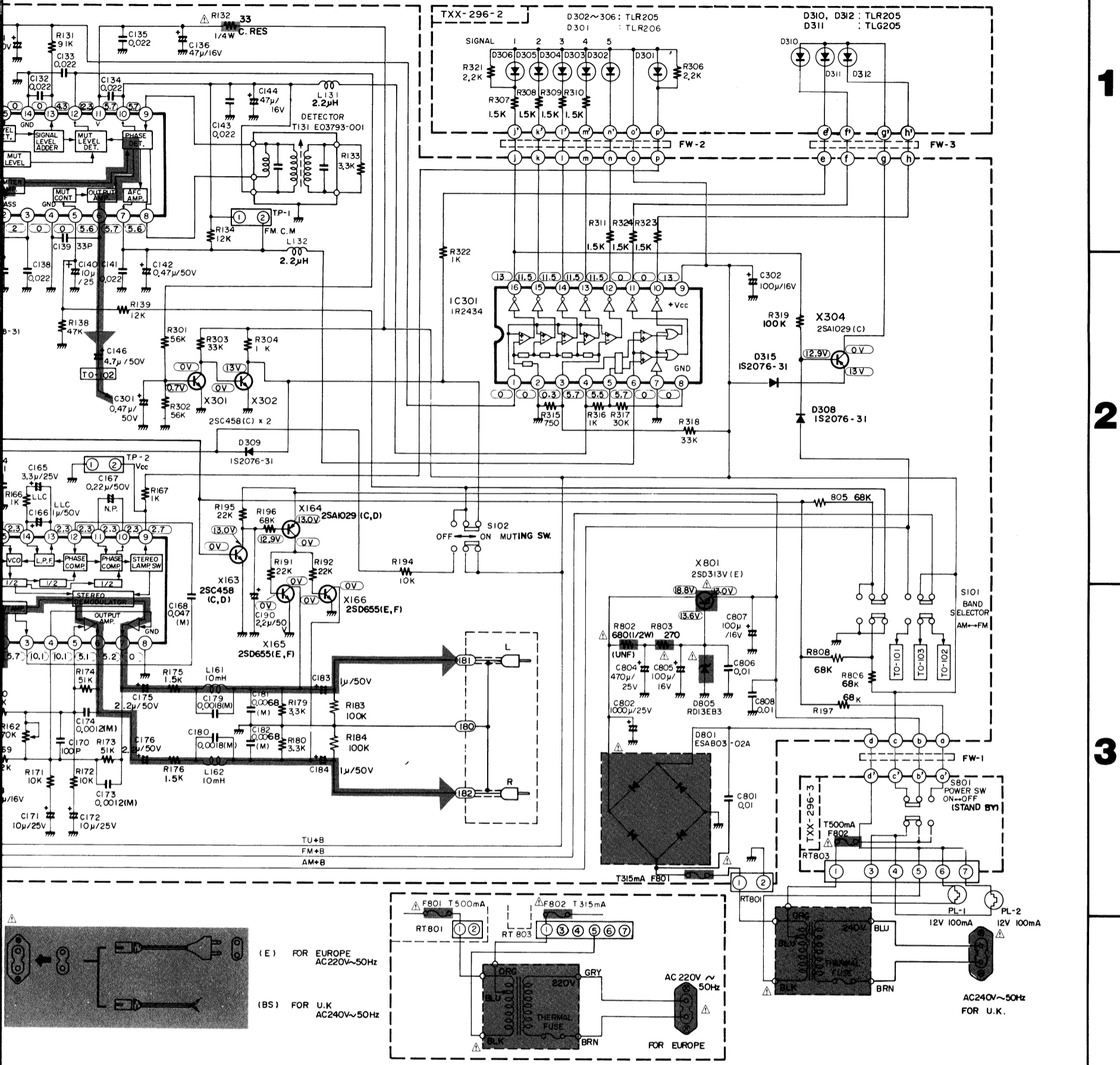

D

E





F

itive.
er supply.
e darkened area () and
re to use the designated parts
or ICs.
ram.
subject to change without

10. Accessories List

Part Number	Description	Q'ty
See below	Instruction Book	1
See below	Warranty Card	1
E41202-2	Envelope for Instruction Book and Warranty Card	1
E03614-004	FM Antenna	1
See below	Power Cord	1

11. Parts List with Specified Numbers for Designated Areas

Page	Item No.	Description	Continental Europe	United Kingdom
2	2-(1)	AC Male Connector 	QMC0239-002	QMC0239-002BS
2	2-(1)	Power Transformer 	E03042-38D	E03042-38EBS
5	5	Fuse (F802) 	QMF51A2-R315L	QMF51A2-R315LBS
5	5	Fuse (F801) 	QMF51A2-R50L	QMF51A2-R50LBS
16	10	Instruction Book	E30580-887A	E30580-887ABS
16	10	BS Warranty Card	—	BT20013C
3	2-(3)	Power Cord 	QMP3950-183	QMP9017-009BS
9	7-(1)	Tuner P.C. Board Ass'y	TXX-296E	TXX-296I