

# JVC

## SERVICE MANUAL

### STEREO CASSETTE DECK

# TD-V1050 A/B/C/E/G/J

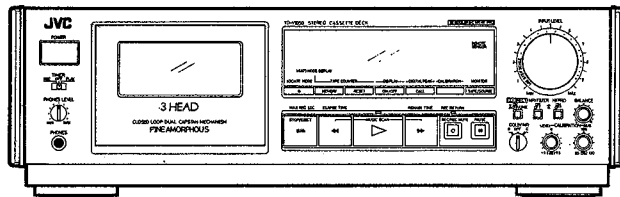

#### Area suffix

A	.....	Australia
B	.....	UK
C	.....	Canada
E	.....	Continental Europe
G	.....	Germany
J	.....	U.S.A.

## Contents

	Page
Safety Precautions .....	2
Instructions (Extraction) .....	6
<b>1</b> Location of Main Parts .....	12
<b>2</b> Removal of Main Parts .....	13
<b>3</b> Jig List .....	18
<b>4</b> Main Adjustments .....	19
<b>5</b> Block Diagram .....	24
<b>6</b> Wiring Connections .....	25
<b>7</b> Standard Schematic Diagram ..	26
<b>8</b> Location of P.C. Board and P.C. Board List .....	28
<b>9</b> Exploded View of Enclosure Assembly .....	34
<b>10</b> Exploded View of Mechanism Assembly .....	36
<b>11</b> Packing .....	39

## FEATURES

### 1. Pure and direct design with 3-head mechanism

- Closed-loop dual-capstan mechanism
- Pulse servo capstan D.D. (direct drive) system
- Record/playback head (Fine Amorphous) + Erase head (2-Gap Ferrite)
- PCOCC (Pure Copper by Ohno Continuous Casting) head winding wire for the superior signal transmission
- 2 pairs of line input jacks including CD direct input

- High bias frequency of 210 kHz for improved recording
- FET differential input, high-S/N headamplifier

### 2. Uni base minimizes vibration

- Cassette shell stabilizer minimizes vibrations.

### 3. Electrically driven cassette holder

### 4. Dolby\* HX PRO headroom extension

### 5. Dolby B/C noise reduction systems

### 6. Caribration function for according to the characteristics of individual tapes

- Recording bias and level can be adjusted (built-in oscillator).

### 7. Multi-function buttons

- It is possible to find out the tape remaining time or to locate the recoring start position.

### 8. Other features

- Music Scan  
"Under license from Staar S.A., Brussels Belgium"
- DISPLAY ON/OFF button
- 4 digit linear counter/digital peak level and level meter display
- Auto monitor
- Auto tape select mechanism
- Wireless remote control for operational convenience.

### 9. Timer start mechanism

### 10. DDRP (Dynamics Detection Recording Processor)

With the DDRP function, the recording level is adjusted automatically so that recording is performed in optimum condition.

### 11. COMPU LINK-1/SYNCHRO terminal

\* Dolby noise reduction and HX Pro headroom extension manufactured under license from Dolby Laboratories Licensing Corporation. HX Pro originated by Bang & Olufsen. "Dolby", the double-D symbol  $\square\square$  and "HX PRO" are trademarks of Dolby Laboratories Licensing Corporation.

# Safety Precautions

1. The design of this product contains special hardware and many circuits and components specially for safety purposes. For continued protection, no changes should be made to the original design unless authorized in writing by the manufacturer. Replacement parts must be identical to those used in the original circuits. Service should be performed by qualified personnel only.
2. Alterations of the design or circuitry of the product should not be made. Any design alterations of the product should not be made. Any design alterations or additions will void the manufacturer's warranty and will further relieve the manufacturer or responsibility for personal injury or property damage resulting therefrom.
3. Many electrical and mechanical parts in the product have special safety-related characteristics. These characteristics are often not evident from visual inspection nor can the protection afforded by them necessarily be obtained by using replacement components rated for higher voltage, wattage, etc. Replacement parts which have these special safety characteristics are identified in the Parts List of Service Manual. Electrical components having such features are identified by ( $\Delta$ ) on the schematic diagram and Parts List in Service Manual. The use of a substitute replacement which does not have the same safety characteristics as the recommended replacement part shown in the Parts List in Service Manual may create shock, fire, or other hazards.
4. The leads in the products are routed and dressed with ties, clamps, tubings, barriers and the like to be separated from live parts, high temperature parts, moving parts and/or sharp edges for the prevention of electric shock and fire hazard.

When service is required, the original lead routing and dress should be observed, and it should be confirmed that they have been returned to normal, after re-assembling.

## 5. Leakage current check (Electrical shock hazard testing)

After re-assembling the product, always perform an isolation check on the exposed metal parts of the product (antenna terminals, knobs, metal cabinet, screw heads, headphone jack, control shafts, etc.) to be sure the product is safe to operate without danger of electrical shock.

Do not use a line isolation transformer during this check.

- Plug the AC line cord directly into the AC outlet. Using a "Leakage Current Tester", measure the leakage current from each exposed metal part of the cabinet, particularly any exposed metal part having a return path to the chassis, to a known good earth ground. Any leakage current must not exceed 0.5 mA AC (r.m.s.).
- Alternate check method

Plug the AC line cord directly into the AC outlet. Use an AC voltmeter having 1,000 ohms per volt or more sensitivity in the following manner. Connect a 1,500  $\Omega$  10 W resistor paralleled by a 0.15  $\mu$ F AC-type capacitor between an exposed metal part and a known good earth ground.

Measure the AC voltage across the resistor with the AC voltmeter.

Move the resistor connection to each exposed metal part, particularly any exposed metal part having a return path to the chassis, and measure the AC voltage across the resistor. Now, reverse the plug in the AC outlet and repeat each measurement. Any voltage measured must not exceed 0.75 V AC (r.m.s.).

This corresponds to 0.5 mA AC (r.m.s.).

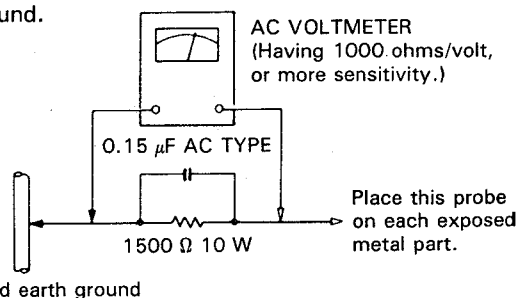

## Warning

1. This equipment has been designed and manufactured to meet international safety standards.
2. It is the legal responsibility of the repairer to ensure that these safety standards are maintained.
3. Repairs must be made in accordance with the relevant safety standards.
4. It is essential that safety critical components are replaced by approved parts.
5. If mains voltage selector is provided, check setting for local voltage.

## SELECTING THE AC SUPPLY VOLTAGE

(A/B/E/G version only)

The C/J version is not provided with voltage selector.

When this deck is used in an area where the supply voltage is different from the preset voltage, reset the voltage selector to the correct position.

Slide the voltage selector with a screwdriver so that the desired voltage marking is in the window.

### Caution:

Disconnect supply cord before changing the voltage.

A/B/E/G Version

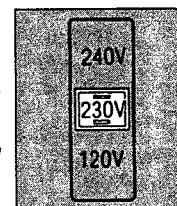

# ■ Safety Precautions about TD-V1050

## ■ Important Management Points Regarding Safety (Items Demanding special safety precautions)

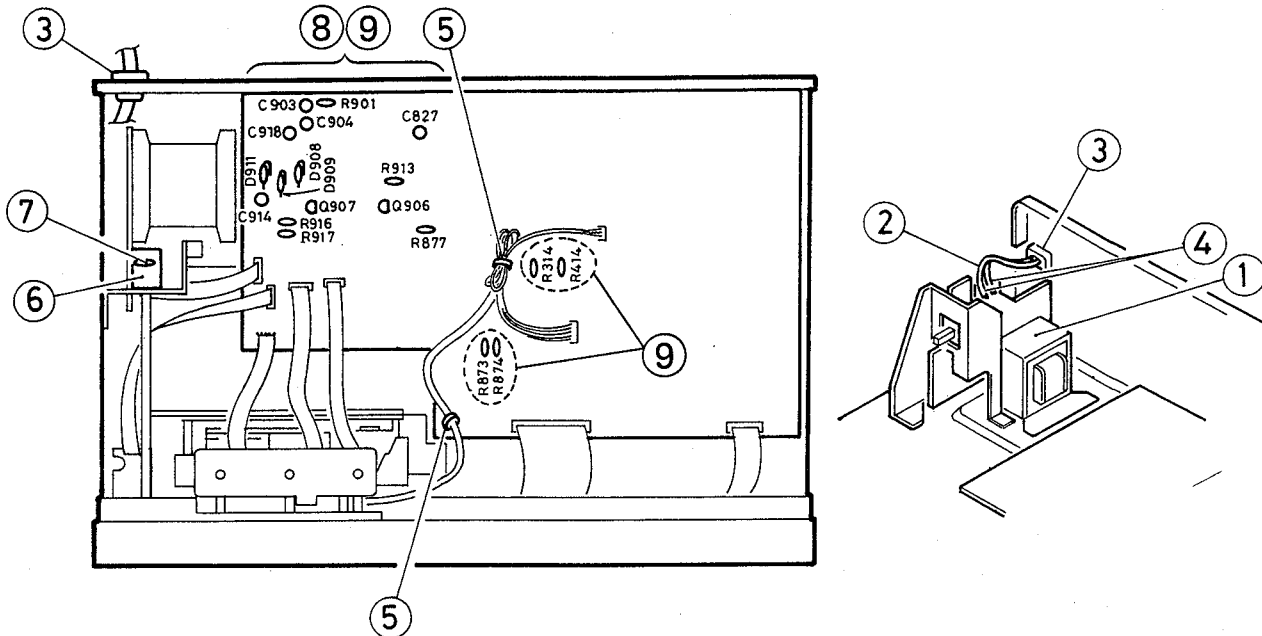

1. Securely fix the power transformer while confirming its marking specified in the following.

J version : BD14A9-0017 (UL approved No.)  
 C version : VTP57A9-021B  
 B/E/A/G : VTP57H9-011B

2. Confirm the marking of the power cord and the plug.

Suffix	B	E/G	A	C/J
POWER CORD	BASS BS6500	< VDE >	LTSA-2F	SPT-2
POWER CORD PLUG	—	Ⓢ	KP-560	KP-10

3. Install the cord bushing by the specified tool while confirming the marking.

Bushion : NIFCO 2271

4. a) When installing the power cord, wind it around the terminal by the end before soldering.

b) Arrange the wires while binding them nearby the terminal.

5. When arranging every wire and cable, avoid the active power parts, mobiles, heat generating parts, sharpedged parts etc.

6. Confirmation of the marking "M7" of the power switch.

7. Marking of spark killer capacitor.

J:

Confirm B/E/G: RME265MB510.

8. For C903, C904, C914, C827, C918, make sure to use the specified part of the following rating.

C903/C904 : 3300  $\mu$ F/25 V

C914 : 330  $\mu$ F/25 V

C827 : 100  $\mu$ F/25 V

C918 : 2200  $\mu$ F/25 V

9. Since the following parts are heat generating ones, they must not contact with electrolytic capacitors, wires, etc.

- Parts in parentheses ( ) are inflammables. Make sure of their lift-up condition for this purpose.

- Parts in box   are out of JVC control.

(R901) (R913) (R917) (R314) (R414)

(R877) (R916)

R873 R874 Q906 Q907 D911 D908 R909

R902, R913, R301, R401, R831, R832, R808

R809, R816, R817

Q903, Q905

D901, D902, D903, D904, D912, D716

**SPECIFICATIONS**

(A/C/J-Version)

Type	: Stereo cassette deck
Track system	: 4-track, 2-channel
Tape speed	: 4.8cm/sec. (1-7/8 inch/sec.)
Frequency response	: (-20 dB recording) Type IV tape; 10 - 23,000 Hz 15 - 21,000 Hz ( $\pm 3$ dB) Type II tape; 10 - 21,000 Hz 15 - 19,000 Hz ( $\pm 3$ dB) Type I tape; 10 - 21,000 Hz 15 - 19,000 Hz ( $\pm 3$ dB)
S/N ratio	: 61 dB (S = 315 Hz, k3 = 3 %, N = A-weighted, Type IV tape) The S/N is improved by about 15 dB at 500 Hz and by max. 20 dB at 1 kHz ~ 10 kHz with Dolby C NR on and improved by 5 dB at 1 kHz and by 10 dB at above 5 kHz with DOLBY B NR on.
Improvement of MOL	: 4 dB at 10 kHz with Dolby C NR on.
Wow and flutter	: 0.022 % (WRMS)
Channel separation	: 40 dB (1 kHz)
Crosstalk	: 65 dB (1 kHz)
Harmonic distortion	: k3; 0.6% (Type IV tape, 315 Hz, 0 VU)
Heads	: Record (amorphous) $\times 1$ , Playback (amorphous) $\times 1$ , Erase(2-gap ferrite) $\times 1$
Motors	: Pulse servo DD motor for capstan $\times 1$ DC motor for reel $\times 1$ DC motor for mechanism drive $\times 1$
Fast forward/Rewind time	: Approx. 100 sec. with C-60 cassette
Input terminals CD DIRECT ( $\times 1$ circuit)	: Min. Input level; 80 mV (0 VU) Input impedance; 50 k $\Omega$
LINE IN ( $\times 1$ circuit)	: Input sensitivity; 80 mV (0 VU) Input impedance; 50 k $\Omega$
Output terminals LINE OUT ( $\times 1$ circuit)	: Output level; 300 mV (0VU) Output impedance; 5 k $\Omega$
Headphones $\times 1$	: Output level; 0 ~ 1 mW/8 $\Omega$ (0 VU) Matching impedance 8 $\Omega$ - 1 k $\Omega$
Other terminals	: COMPU LINK-1/ SYN-CHRO $\times 2$
Power requirement A version	: AC 240/230/120 V, 50/60 Hz
C/J version	: AC 120V, 60 Hz
Power consumption	: 21 W
Dimensions (W $\times$ H $\times$ D)	: 452 $\times$ 143 $\times$ 335 mm (17-13/16" $\times$ 5-11/16" $\times$ 13-1/4")
Weight	: 7.7 kg (17.0 lbs.)
Accessories	: Pin plug cord $\times 2$ Remote cable $\times 1$ Remote control $\times 1$ Battery (AA/R6) $\times 2$

Design and specifications are subject to change without notice.

**SPECIFICATIONS**

(B-version)

Type	: Stereo cassette deck
Track system	: 4-track, 2-channel
Tape speed	: 4.8cm/sec.
Frequency response	: (-20 dB recording) Type IV tape; 15 - 21,000 Hz ( $\pm 3$ dB) Type II tape 15 - 19,000 Hz ( $\pm 3$ dB) Type I tape 15 - 19,000 Hz ( $\pm 3$ dB)
S/N ratio	: 61 dB (S = 315 Hz, k3 = 3 %, N = A-weighted, Type IV tape) The S/N is improved by about 15 dB at 500 Hz and by max. 20 dB at 1 kHz ~ 10 kHz with Dolby C NR on and improved by 5 dB at 1 kHz and by 10 dB at above 5 kHz with DOLBY B NR on.
Improvement of MOL	: 4 dB at 10 kHz with Dolby C NR on.
Wow and flutter	: $\pm 0.065$ % (DIN/IEC)
Channel separation	: 40 dB (1 kHz)
Crosstalk	: 65 dB (1 kHz)
Harmonic distortion	: k3; 0.6% (Type IV tape, 1 kHz, 0 VU)
Heads	: Record (amorphous) $\times 1$ , Playback (amorphous) $\times 1$ , Erase (2-gap ferrite) $\times 1$
Motors	: Pulse servo direct drive motor for capstan $\times 1$ DC motor for reel $\times 1$ DC motor for mechanism drive $\times 1$
Fast forward/Rewind time	: Approx. 100 sec. with C-60 cassette
Input terminals CD DIRECT ( $\times 1$ circuit)	: Input sensitivity; 80 mV (0 VU) Input impedance; 50 k $\Omega$
LINE IN ( $\times 1$ circuit)	: Input sensitivity; 80 mV (0 VU) Input impedance; 50 k $\Omega$
Output terminals LINE OUT ( $\times 1$ circuit)	: Output level; 300 mV (0VU) Output impedance; 5 k $\Omega$
PHONES $\times 1$	: Output level; 0 ~ 1 mW/8 $\Omega$ (0 VU) Matching impedance; 8 $\Omega$ - 1 k $\Omega$
Other terminals	: COMPU LINK-1/ SYN-CHRO $\times 2$
Power requirement:	: AC 240/230/120 V, 50/60 Hz
Power consumption	: 21 W
Dimensions (W $\times$ H $\times$ D)	: 452 $\times$ 143 $\times$ 335 mm
Weight	: 7.7 kg
Accessories	: Pin plug cord $\times 2$ Remote cable $\times 1$ Remote control $\times 1$ Battery (AA/R6) $\times 2$

Design and specifications are subject to change without notice.

**TECHNISCHE DATEN**

(G-Version)

Typ	: Stereo-Cassetendack
Spursystem	: 4-Spur, 2-Kanal
Bandgeschwindigkeit	: 4,8 cm/Sek.
Frequenzgang	: (-20 dB-Aufnahme) Type IV band; 10 - 23.000 Hz (DIN) 15 - 21.000 Hz ( $\pm 3$ dB) Type II band; 10 - 21.000 Hz (DIN) 15 - 19.000 Hz ( $\pm 3$ dB) Type I band; 10 - 21.000 Hz (DIN) 15 - 19.000 Hz ( $\pm 3$ dB)
Signal-Rauschabstand	: 61 dB (S=315 Hz, K3=3%, N=A-gewichtige, Type IV band) Der Signal-Rauschabstand ist um 15 dB bei 500 Hz und um max. 20 dB bei 1 kHz - 10 kHz mit eingeschalteter Dolby C NR verbessert und um 5 dB bei 1 kHz und um 10 dB über 5 kHz mit eingeschalteter Dolby B NR.
Verbesserung des Höchstaussgangspiegels	: 4 dB bei 10 kHz mit eingeschalteter DOLBY C NR.
Gleichlaufschwankungen	: $\pm 0,065\%$ (DIN/IEC)
Kanaltrennung	: 40 dB (1 kHz)
Übersprechdämpfung	: 65 dB (1 kHz)
Klirrfaktor	: K3; 0,6% (Type IV band, 315 Hz, 0 VU)
Köpfe	: Amorpher-Aufnahmekopf x 1, Amorpher-Wiedergabekopf x 1, 2-Spalt-ferrit-Löschkopf x 1
Motoren	: Impuls-Servo Direktantriebs motor für Capstan x 1, Gleichstrommotor für Wickelspule x 1 Gleichstrommotor für Laufwerk x 1
Schnellvorlaufzeit/Rückspulzeit	: Ca. 100 Sekunden (C-60 Cassette)
Eingänge	
CD DIRECT (x1 Schaltung)	: Eingangspegel; 80 mV (0 VU) Eingangsimpedanz; 50 k $\Omega$
LINE IN (x1 Schaltung)	: Eingangspegel; 80 mV (0 VU) Eingangsimpedanz; 50 k $\Omega$
Ausgänge	
LINE OUT (x1 Schaltung)	: Ausgangspegel; 300 mV (0 VU) Ausgangsimpedanz; 5 k $\Omega$
PHONES x 1	: Ausgangspegel; 0 ~ 1 mW/8 $\Omega$ (0 VU) Geeignete Impedanz; 8 $\Omega$ - 1 k $\Omega$
Weitere Anschlüsse	: COMPU LINK-1 / SYNCHRO x 2
Spannungsversorgung	: Netz 240/230/120 V 50/60 Hz
Leistungsaufnahme	: 21 W
Abmessungen (B x H x T)	: 452 x 143 x 335 mm
Gewicht	: 7,7 kg
Zubehör	: Cinchkabel.....2 Fernbedienkabel.....1 Fernbedienung.....1 Batterie (R6/AA).....2

**CARACTERISTIQUES TECHNIQUES** (Version E)

Type	: Platine d'enregistrement stéréo
Système de pistes	: 4 pistes, 2 canaux
Vitesse de défilement	: 4,8 cm/sec.
Réponse en fréquence	: (Enregistrement à -20 dB) Bande "Type IV"; 10 à 23.000 Hz (DIN) 15 à 21.000 Hz ( $\pm 3$ dB) Bande "Type II"; 10 à 21.000 Hz (DIN) 15 à 19.000 Hz ( $\pm 3$ dB) Bande "Type I"; 10 à 21.000 Hz (DIN) 15 à 19.000 Hz ( $\pm 3$ dB)
Rapport signal/Bruit	: 61 dB (S=315 Hz, K3 = 3%, N=A-ponderé, Bande "Type IV") Le rapport S/B est amélioré de 15 dB environ à 500 Hz et de 20 dB maximum à 1 kHz-10 kHz avec le Dolby C NR en circuit, et amélioré de 5 dB à 1 kHz et 10 dB environ à 5 kHz avec le Dolby B NR en circuit.
Amélioration du niveau de sortie max	: 4 dB à 10 kHz avec le Dolby C NR en circuit.
Pleurage et scintillement	: $\pm 0,065\%$ (DIN/IEC)
Séparation des canaux	: 40 dB (1 kHz)
Diaphonie	: 65 dB (1 kHz)
Distorsion harmonique	: K3; 0,6% (bande "Type IV", 315 Hz, 0 VU)
Têtes	: Enregistrement (amorphe) x 1, Lecture (amorphe) x 1, Effacement (ferrite 2 entrefers) x 1
Moteurs	: Moteur à commande directe d'asservissement par impulsions x 1 Moteur CC pour bobine x 1 Moteur CC pour l'entraînement mécanique x 1
Temps d'avance rapide/Temps de réembobinage	: Environ 100 secondes, avec une cassette C-60
Bornes d'entrée	
CD DIRECT (x1 circuit)	: Sensibilité d'entrée; 80 mV (0 VU) Impédance d'entrée; 50 k $\Omega$
LINE IN (x1 circuit)	: Sensibilité d'entrée; 80 mV (0 VU) Impédance d'entrée; 50 k $\Omega$
Borne de sortie	
LINE OUT (x1 circuit)	: Niveau de sortie; 300 mV (0 VU) Impédance de sortie; 5 k $\Omega$
PHONES x 1	: Niveau de sortie; 0 ~ 1 mW/8 $\Omega$ (0 VU) Impédance caractéristique: 8 $\Omega$ - 1 k $\Omega$
Autres prises	: COMPU LINK-1/ SYNCHRO x 2
Alimentation	: 240/230/120 V CA, 50/60 Hz
Consommation	: 21 W
Dimensions (L x H x P)	: 452 x 143 x 335 mm
Poids	: 7,7 kg

Accessoires	: Câble à broches.....2 Câble de télécommande.....1 Télécommande.....1 Pile (R6/AA).....2
-------------	----------------------------------------------------------------------------------------------------

Présentation et caractéristiques modifiables sans préavis

# Instructions (Extraction)

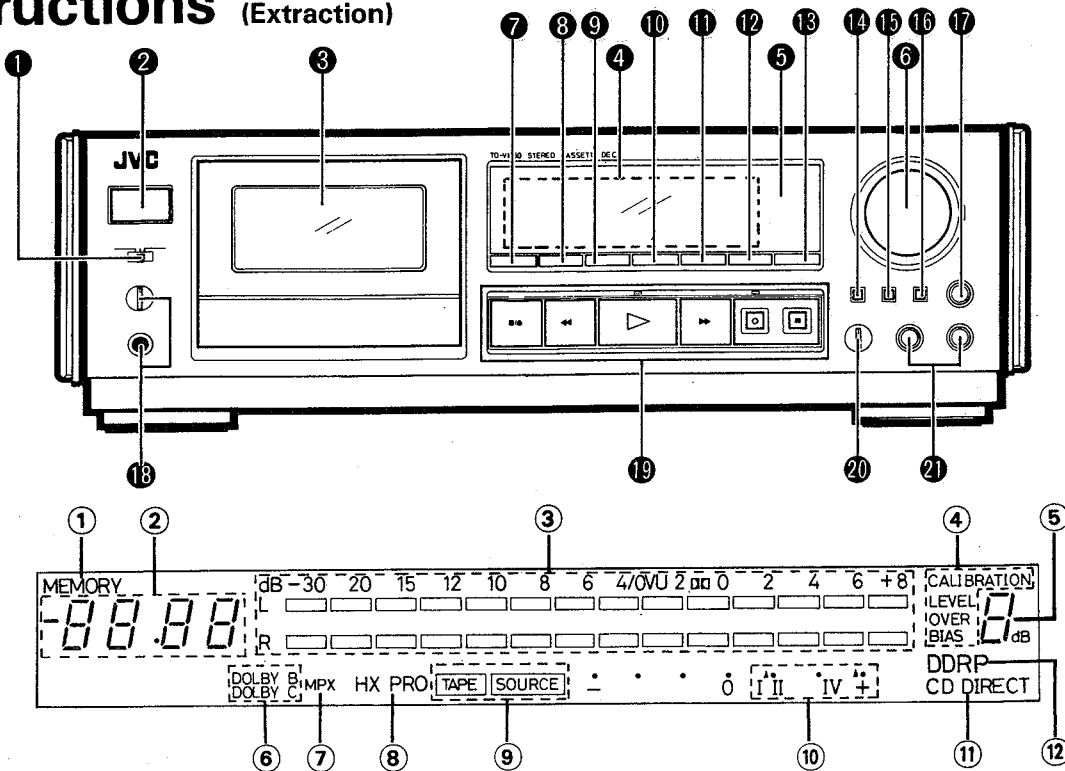

## NAMES OF PARTS AND THEIR FUNCTIONS

- 1 TIMER switch**  
When an optional timer is used, recording and playback can be performed at any desired time.
- 2 POWER switch**
- 3 Cassette holder**
- 4 MULTI MODE display**

  - 1 MEMORY Indicator
  - 2 Tape counter indicator
  - 3 PEAK LEVEL METER  
0 dB: IEC (DIN) STANDARD LEVEL (250 nWb/m)  
0 VU: EIAJ STANDARD LEVEL (160 nWb/m)  
00: DOLBY NR STANDARD LEVEL
  - 4 CALIBRATION indicator
  - 5 Digital peak indicator
  - 6 DOLBY NR mode indicator
  - 7 MPX filter indicator
  - 8 HX PRO indicator
  - 9 Monitor indicator
  - 10 Tape types and recording guide indicators
  - 11 CD DIRECT input indicator
  - 12 DDRP indicator
- 5 REMOTE SENSOR**
- 6 INPUT LEVEL control**  
Adjust the recording level with this control.
- 7 TIME/LOCATE button**  
It is able to find the tape remaining time, locate the start of a recording, and do other things, using together with cassette operation buttons.
- 8 MEMORY button**
- 9 RESET button**  
Press to reset the tape counter to "0.00".
- 10 DISPLAY ON/OFF button**
- 11 CALL button (Digital peak)**  
Press to call up the stored (memorized) maximum value or to reset the memory.
- 12 CALIBRATION button**
- 13 MONITOR button**  
When this button is pressed, it changes between source monitoring and tape monitoring.
- 14 CD DIRECT switch**  
ON: Press this switch to set to ON when recording directly from a CD player.  
OFF/LINE: Press this switch to set to OFF/LINE when recording from a stereo amplifier.
- 15 MPX FILTER switch**  
When an FM stereo broadcast is to be recorded using Dolby NR, set this to ON to prevent the Dolby NR circuit from malfunctioning (otherwise the sound quality could deteriorate.)
- 16 Dolby HX PRO switch**  
Used to record sources which contain many high frequency components.
- 17 BALANCE control**  
Adjusts the balance between the signals input via the left and right LINE IN jacks.
- 18 PHONES jack and PHONES LEVEL control**  
Connect headphones (with an impedance of 8 Ω to 1 kΩ).
- 19 Cassette operation buttons and lamps (> and O buttons)**

  - / ▲ STOP/EJECT: Press to stop the tape. Pressing this button after the tape stops, opens the cassette holder.
  - ◀ (rewind) button: Press to rewind the tape.
  - ▷ (play) button: Press to start recording or playback.  
Press this button with either the ◀◀ or ▶▶ button for music scanning.
  - ▶▶ (fast forward) button: Press to fast forward the tape.
  - REC/REC MUTE: Press the ▷ (play) button while pressing this button to start recording, and press to leave an appropriate non-recorded section.
  - PAUSE: Press to stop the tape temporarily during recording and playback.  
Press the ▷ (play) button to release the pause mode.  
When pressed together with the ○ REC/REC MUTE button before recording, the unit will enter the record-pause mode.
- 20 DOLBY NR switch**  
Set to B or C for recording using the Dolby NR system or for playing back a tape that was recorded using the Dolby NR system.  
Set to OFF when the Dolby NR system is not used.
- 21 CALIBRATION controls**  
To adjust the recording bias and sensitivity according to the tape to be used. If adjustment is not performed, set to the center position.

## REMOTE CONTROL OPERATIONS

### Correct use of the remote control

- Press the button (s) while pointing the top of the remote control unit at the remote sensor on the front panel of the main unit.
- The operable range is about 7 meters (approx. 23 ft) away from the main unit. If operated at an angle, the range will be shorter.
- Do not allow direct sunlight or strong light from a fluorescent light, etc. to strike the remote sensor, do not place anything between the remote control and remote sensor. (The remote control may not work.)

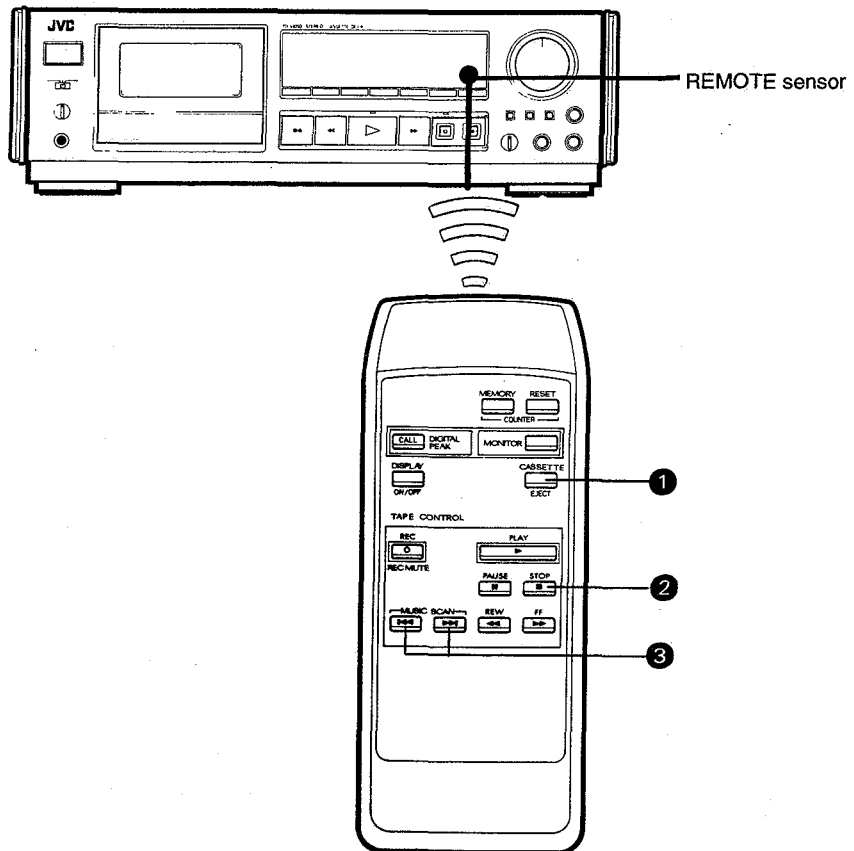

### 1 CASSETTE EJECT button

Press this button to open and close the cassette holder. During recording, the button does not work.

### 2 ■ STOP button

Press this button to stop the tape. (The cassette holder cannot be opened.)

### 3 ◀▶ MUSIC SCAN buttons

During music scanning, press this button to find the start of a piece of music.

\* Other control buttons have the same functions as those on the front panel of the main unit.

## PLAYBACK

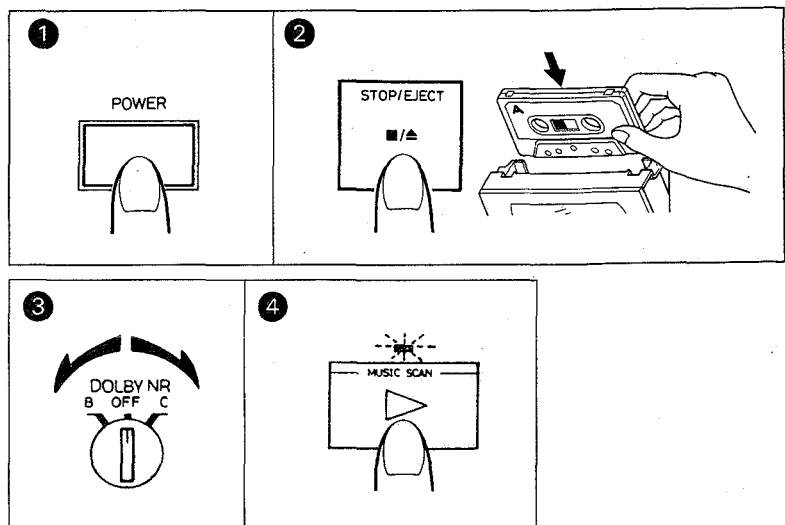
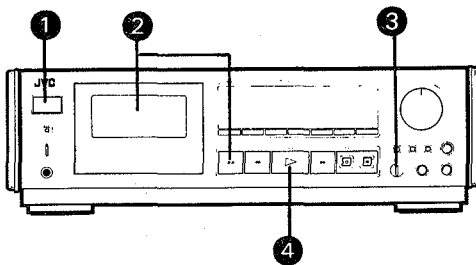

Operate in the order of the numbers in the illustration.

- 1 Press the POWER switch to set to ON (  $\text{—}$  ).
- 2 Load a prerecorded cassette.
- 3 Set the DOLBY NR switch to the same position as when the tape was recorded.
- 4 Press the  $\triangleright$  (play) button to start playback.
  - It changes to the tape monitor mode automatically and "TAPE" will appear on the display.
  - To stop playing back midway.....Press the  $\blacksquare$  /  $\blacktriangle$  STOP/EJECT button.

### Automatic slack tape removal operation:

When a cassette is inserted, slack tape will be taken up automatically. This will also happen if the power is switched on with a tape loaded.

### Tape counter display

When the tape runs, the counter functions as 4 digit linear tape counter. With a C-46L, C-60, or C-90 cassette, the approximate running time is displayed in minutes and seconds (count down function included). There may be up to a one-minute discrepancy between the actual running time and the displayed time. With a C-30, C-46, or C-80 cassette, the discrepancy may be greater. And even if used cassettes having the same playing time, different times may be displayed because of different tape thicknesses.

### Music scan

The music scan mechanism functions by detecting non-recorded sections between tunes. The lengths of non-recorded sections should be more than 4-5 sec for Music Scan to be effective.

1. Press the ▷ (play) and ◀◀ (or ▶▶) buttons simultaneously.
  - During scanning, the lamp of ▷ (play) button flashes rapidly.
2. When a non-recorded section is detected, playback starts automatically.

### Notes:

In the following cases, the mechanism may not operate correctly. This is not a malfunction; use the mechanism according to the type of program.

- Tapes with tunes having long pianissimo passages (very quiet parts) or non-recorded portions during tunes
- Tapes with short non-recorded sections
- Tape with noise or hum between tunes

### Memory button

Press the MEMORY button at the point to which you want the tape to be rewound and from which you want to listen to during recording or playback.

The tape stops automatically at the point where the MEMORY button is pressed in either the fast forward or rewind mode.

- The point where the MEMORY button is pressed is stored during any mode (recording, playback or stop), but the memory function (automatic stop) operates only in the fast forward or rewind mode.
- If pressing the memory button again, the memory will be cleared. It will also be cleared if pressed the RESET button and reset the counter to "0.00".

### To set the counter to "0.00".

Press the RESET button. (The counter is also reset when the power is switched off and on again.)

To clear indication in the DISPLAY window... press the DISPLAY ON/OFF button, and the digital noise from the DISPLAY window is reduced. If the button is pressed again, the indication reappears.

- Press the DISPLAY ON/OFF button to turn off the display. Although the display will come back on if the mode changes to Fast Forward, Rewind, Pause, or Stop (except for Recording and Playback).
- Even when the display is turned off, the tape counter, meter and digital peak indicator will continue to operate. It is also possible to check these contents after recording or playback have ended.

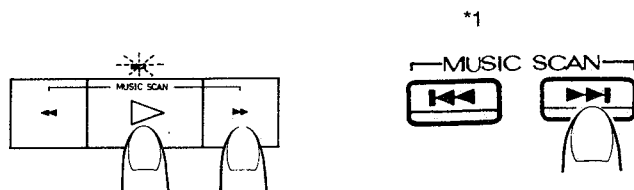

- Next tune detection (Fast forward scanning)

\*1 Using the remote control.

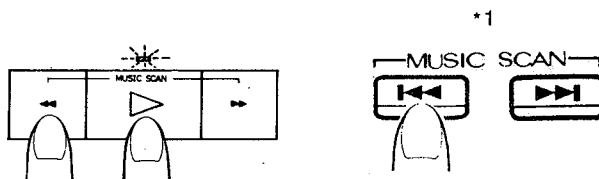

- Present tune detection (Rewind scanning)

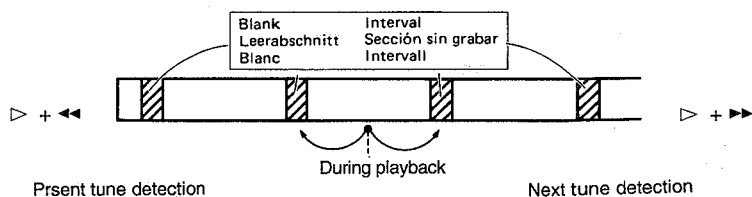



## RECORDING

Operate in the order of the numbers in the illustration.

- Set the **TIMER** switch to **OFF** before switching the power on.
- Make sure the safety tab of the cassette has not been broken off.

### • Manual recording

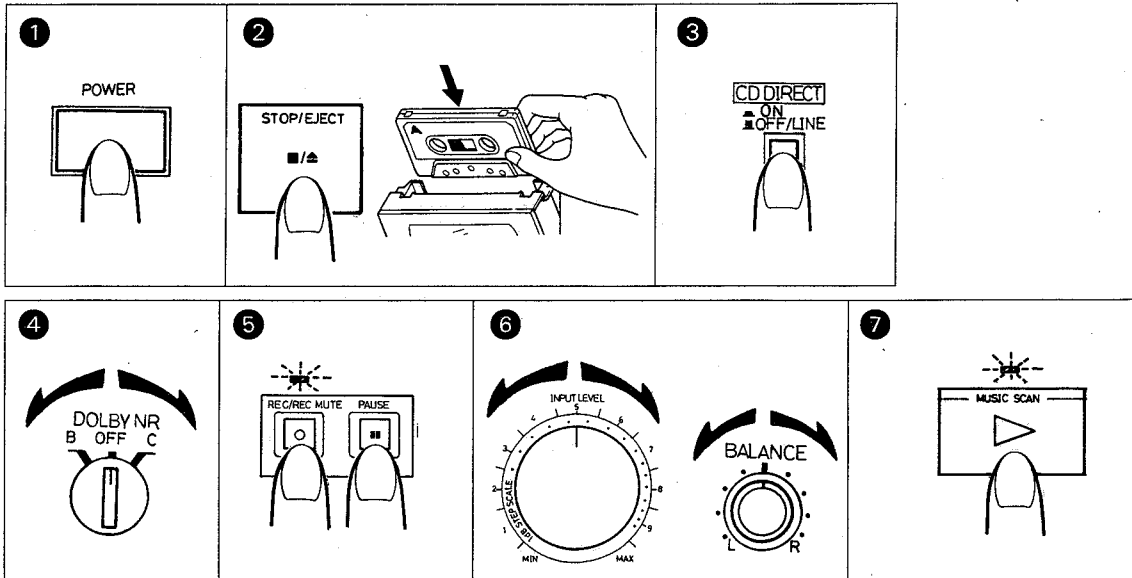
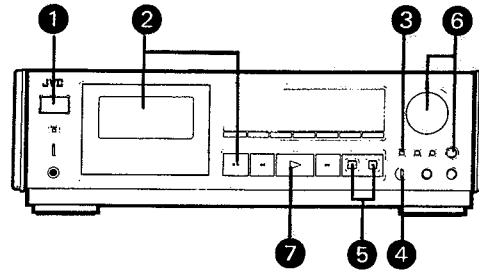

- 1 Press the **POWER** switch to set to **ON** ( ).
- 2 Load a cassette for recording.
- 3 Select the recording input.
- 4 Set the **DOLBY NR** switch as required.
- 5 Press the **PAUSE** button and **REC/REC MUTE** button at the same time (record-pause mode). The **REC** lamp lights.
- 6 Adjust the recording level and balance. (See page 33.)  
The **BALANCE** control only works with line input.
- 7 Press the (play) button to start recording.
  - It changes to the tape monitor mode automatically and "TAPE" will appear on the display.

#### WARNING

It may be unlawful to record or playback copyrighted material without the consent of the copyright owner.

### DDRP (Dynamics Detection Recording Processor) recording

- DDRP recording is performed with suitable JVC CD players and the recording level adjustment is performed automatically.
- Since recording level adjustment is performed automatically for different types of tape (normal, CrO<sub>2</sub> and metal), the adjustment of **INPUT LEVEL** and **BALANCE** controls are not required.
- Read the instruction book of your CD player carefully.

### DOLBY NR and DOLBY HX-PRO switches

#### Dolby NR System

To reduce the hiss inherent in tape recording, use the Dolby NR System when making recordings. When listening to a tape recorded with the Dolby NR System, set the **DOLBY NR** switch to **B** or **C** according to the system selected in the recording mode.

#### Note:

The sound quality will change if the positions of the **DOLBY NR** switch are different in recording and playback.

**Dolby HX PRO headroom extension**

When a source which contains many high-frequency components is recorded, these high-frequency signals have the same function as bias and therefore, the effective bias current changes. This will result in phenomena such as changes in the level of low-frequency signal and subsequent distortion and reduction of the high-frequency saturation level.

Dolby HX PRO headroom extension system controls the bias current so that the effective bias is constant even when there are fluctuations in the high-frequency components of the input signal.

This greatly improves the high-frequency saturation level while reducing the low-frequency signal level variations and distortion.

- The dynamic sound recorded with this system sounds the same even when the tape is played back in a deck that does not have Dolby HX PRO.
- This system automatically works when in recording; however, Dolby HX PRO is not a noise reduction system.

**DIGITAL PEAK indicator and its use in recording level adjustment**

It is best to adjust so that the maximum sound level of the source to be recorded reaches the very limit of the saturation level of the tape to be used.

- When the recording level is too low, the hiss noise inherent in the tape will be conspicuous.
- When the recording level is too high, exceeding the saturation level, the recording will contain cracking noise and will be distorted.

**Saturation level means:**

When the recording input is increased gradually, the output increases proportionally. However, once it reaches a certain level, the output cannot increase any further. Moreover, the output will be distorted if the input is increased beyond this point. The level at which this occurs is called the tape's "saturation level".

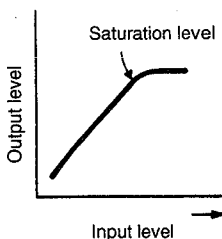

**How to adjust the recording level**

- ① Set to the source mode (record-pause).
- ② Adjust the recording level using the INPUT LEVEL control.

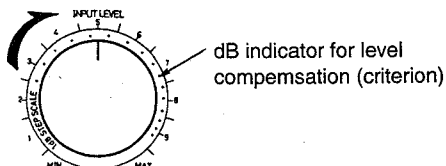

**With metal tape**

Because of metal tape's higher saturation level, it is OK that "+ 6" lights occasionally.

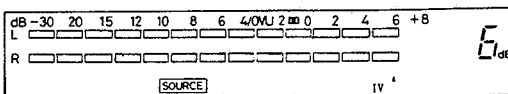

**With normal or chrome tape**

It is OK that "+ 2" lights occasionally.

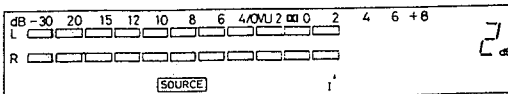

**Digital Peak Indicator**

This is a digital display that shows the recording/playback level and is interlocked with the peak level meter under the control of the meter microcomputer. A maximum peak level memory function is provided so that the peak level can be checked after as well as during recording.

For 0 dB and under:

For +8 dB and over:



**Calling up the maximum level and resetting the memory**

When the digital peak "CALL" button is pressed once, the peak level held in memory flickers in the display for approximately 5 seconds. If the CALL button is pressed again while the peak value is displayed, the previous contents of memory will be cleared and this newly input maximum level will be held in memory as the peak level.

In addition, the digital peak function holds the level of whichever of the left or right channels is the higher and displays it.

**Calibration operation**

There are various types of cassette tapes, and their characteristics differ slightly even when they are of the same type.

Generally, the bias current and equalization characteristics suitable for the type of tape being used can be obtained by the Auto Tape Select system.

However, to optimize the response of the tape to be used, it is better to adjust the recording bias so that distortion is minimized and the frequency characteristics are as flat as possible.

When recording using Dolby NR, the recording and playback levels should be matched to achieve the best Dolby NR effect.



**How to adjust**

Adjust the bias current to compensate for the tape sensitivity while recording the test tone.

1. Press the  $\triangleright$  button while pressing the CALIBRATION button.  
The meter changes to calibration mode and the test tone recorded.
2. Adjust the BIAS control so that the upper and lower meters show the same level.
3. Adjust the level control that the upper and lower meters show "0".
4. Press the  $\blacksquare/\blacktriangle$  STOP/EJECT button to stop the tape.  
The level meter works when the  $\blacksquare/\blacktriangle$  STOP/EJECT button is pressed. This is not a malfunction.  
The optimum bias is set and the tape sensitivity is compensated for by the above procedures. To start recording, rewind the tape and erase the test tone.

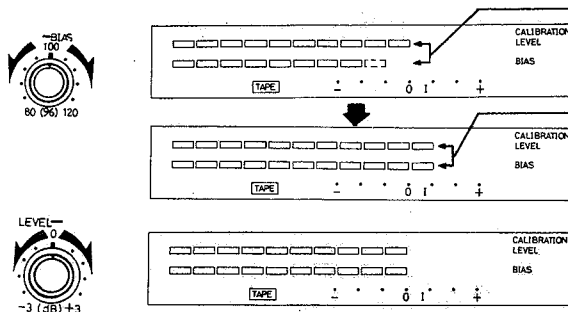

Meter for the calibration

Adjust to give the same level on the upper and lower meters.

**Notes:**

- When using metal tape, the change in the frequency characteristic when the bias control is adjusted is small compared with the change when using normal- or high-position tape. The optimum bias may not be obtained within adjusting range ( $\pm 20\%$ ) of this deck due to tape characteristic difference
- During calibration, monitoring is impossible regardless of whether the monitor mode is set to "tape" or "source".
- The tape cannot be returned to the record start position by pressing the TIME/LOCATE button.

When the bias is low (80% position) or high (120% position), the frequency response is as shown in the right diagram.  
Wenn die Vormagnetisierung niedrig (80%-Position) oder hoch (120%-

Position) ist, ist der Frequenzgang wie im Diagramm rechts dargestellt.  
Quand la polarisation est basse (position 80%) ou haute (position 120%), la réponse de fréquence est comme indiqué sur le diagramme de la droite.

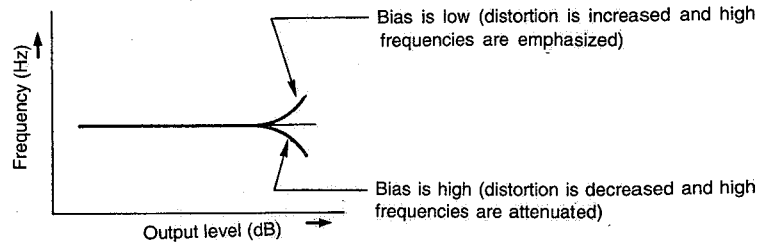

**Erasing**

When recording on a prerecorded tape, the previous recording is automatically erased and only the new program is recorded on the tape. To erase a tape without making a new recording... Follow the section "RECORDING" but in step ⑤, set the INPUT LEVEL control to MIN.

**Automatic record muting**

This facility is used to eliminate undesired sections and leave an appropriate non-recorded section.

**A. To leave non-recorded sections of about 4-5 seconds automatically**

- ① When the undesired section comes during recording, press the  $\circ$  REC/REC MUTE button and release it.
- ② The REC button lamp flashes and non-recorded section is made  
About 4 - 5 seconds later, the tape automatically stops, and the unit enters the record-pause mode.
- ③ Press the  $\triangleright$  (play) button to restart recording.

**B. To leave non-recorded sections of more than 4-5 seconds**

- ① Keep the  $\circ$  REC/REC MUTE button pressed continuously as long as you want to make a non-recorded section. By releasing the finger from the button after the above operation, the unit enters the record-pause mode.
- ② Press the  $\triangleright$  (play) button to restart recording.

**C. To leave non-recorded section of less than 4 seconds**

- When the undesired section comes during recording... After the  $\circ$  REC/REC MUTE button is pressed, press the PLAY button before the unit enters the pause mode to start recording again, or press the  $\blacksquare$  PAUSE button to enter the record-pause mode.
- The PEAK LEVEL INDICATOR lights even during record muting according to the input level which can be heard from the speakers or headphones so that recording can be resumed at the exact point on the tape.

**Automatic record muting using the remote control unit**

When the  $\circ$  REC/REC MUTE button is pressed a non-recorded section of approx. 4 seconds is automatically left and the deck enters the record-pause mode. Even if you continue to press the button, the non-recorded section will not be longer than 4 seconds.

**MONITOR button**

Since the unit is a three-head deck with separate record, play and erase heads, the sound from the source can easily be compared with that recorded on the tape by switching this button.

**A. Source monitoring**

Press the MONITOR button to indicate "SOURCE" in the display to monitor the sound from the source. The PEAK LEVEL METER and DIGITAL PEAK indicators show the level of the input signal; adjust the recording level while monitoring the source.

**B. Tape monitoring**

Press the MONITOR button to indicate "TAPE" in the display to monitor the signal picked up by the play head after it has been recorded on the tape. In this way, you can check whether it has deteriorated because of dirt on the head, etc.  
This unit automatically enters the source monitor mode when the record-pause mode is engaged, and the tape monitor mode when the record or playback mode is engaged.

**CD DIRECT input**

When a CD player or other component is connected to the CD DIRECT terminals as shown in "CONNECTIONS" on page 11, a direct signal will be input without passing through the stereo amplifier.  
Also, since the BALANCE control of the deck is no longer be concerned, the signal path will be shortened and sound quality can be improved. To record with these sources, set the CD DIRECT switch according to the input.

# 1 Location of Main Parts

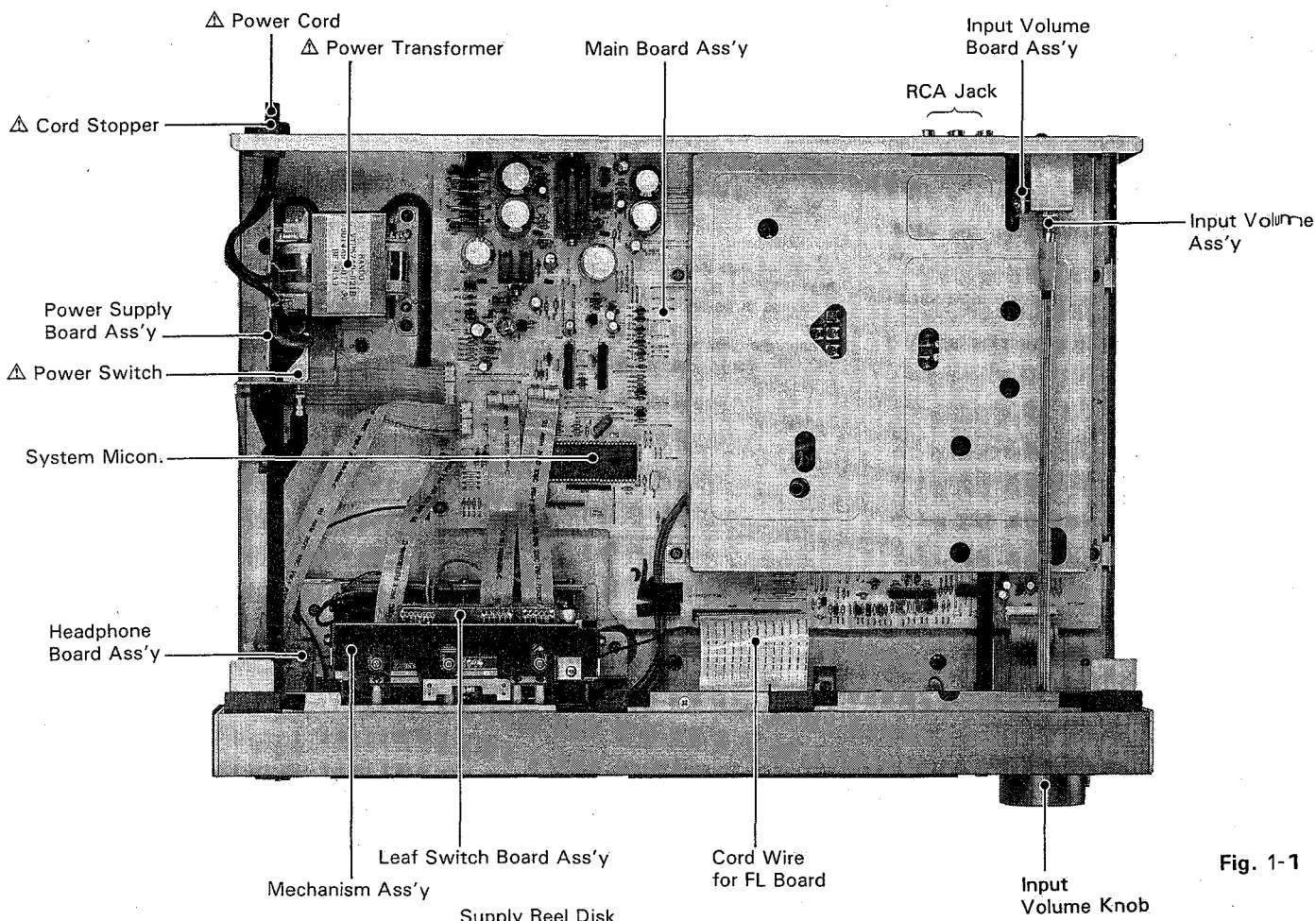

Fig. 1-1

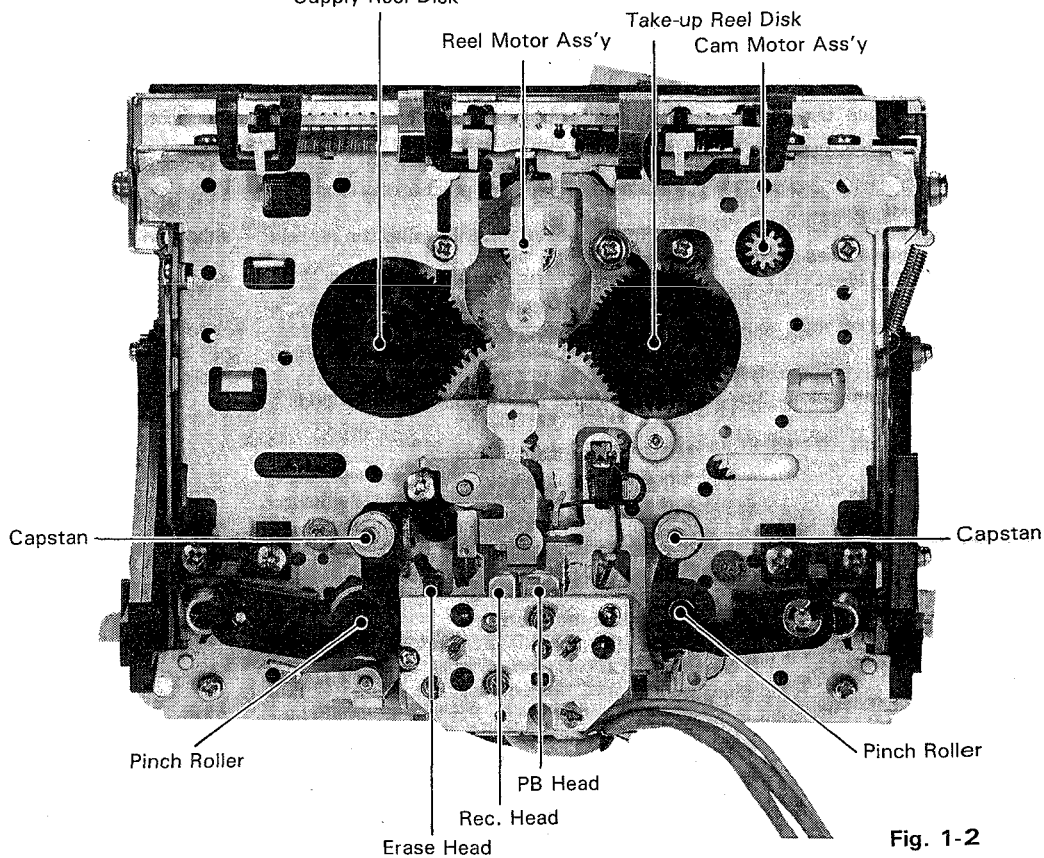

Fig. 1-2

## 2 Removal of Main Parts

### <Enclosure Section>

Assembly parts for order of removal	Top cover	Cassette door lid	Front plate and fitting	Front panel assembly	Volume PC board assembly (Balance Calibration)	Mechanism assembly (Remove back light solder)	FL PC board assembly	Headphone PC board assembly	Headphone volume assembly	Timer switch PC board assembly	Input volume assembly	Main PC board shield case	CD direct switch bar	Main PC board assembly
Cassette lid	1													
Front panel assembly	1	2		3										
Volume PC board assembly	1		2		3									
FL PC board assembly	1						3					2		
Headphone volume PC board assembly	1		2					3						
Timer switch PC board assembly	1		2						3	4				
Headphone PC board assembly	1		2				3							
Mechanism assembly	1					2								
Main PC board assembly	1			2							4	3	5	6
Input level volume assembly	1										2			

\* Remove in the order of the numbers of the assembly parts for removal

### External Parts

#### ■ Top Cover

1. Remove the six screws (1) on the left and right sides and the two attachment screws (2) on the back side.
2. Remove the top cover by pushing towards back.

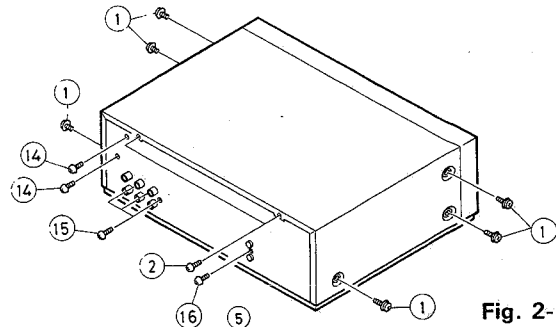

Fig. 2-1

#### ■ Front Cover and Fitting

1. Remove the screw (3) retaining the center of the front plate.
2. Remove the three screws (4) retaining the bottom plate fitting on the bottom (see Figure 2-3).
3. Press the two points (A) on the mold section to remove the catches on the inner side of the front cover and then remove the front cover towards you.
4. Pull the fitting toward the front and remove.

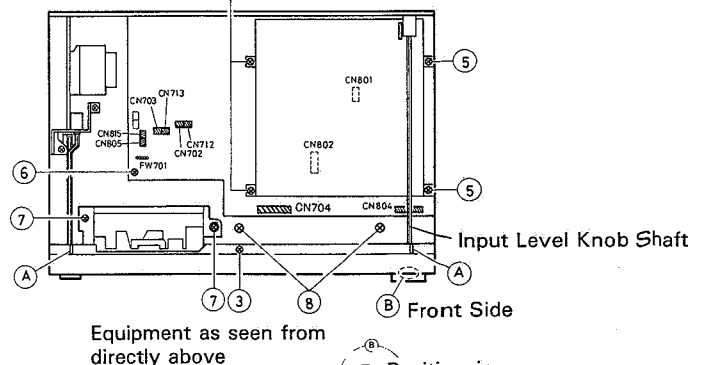
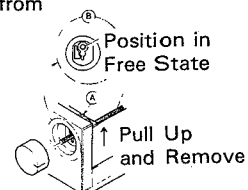

Fig. 2-2



## ■ Cassette Door Cover (Lid)

1. Turn the power ON and press the eject button to open the cassette door.  
Pull the cover up to remove.

## Assembly Parts

### ■ When removing as the front panel assembly (with mechanism)

1. Remove the top cover of the external parts. Remove the front plate to prevent scratching.
2. Remove the cassette cover.
3. Pull out the input level knob. Pull the shaft knob section upward to set it in the free position (see Figure 2-2).
4. Remove the four screws (5) retaining the PC board shield case (see Figure 2-2).
5. Remove the wire from the main PC board (see Figure 2-2).
  - a) Remove CN804 of the Dolby switch/calibration volume.
  - b) Remove the wires CN802, CN801 for record/playback and erasing heads.
  - c) Remove CN704 going to the FL PC board.
  - d) Remove CN703, CN713, CN702 and CN712 going to the leaf switch PC board.
  - e) Remove CN805 and CN815 going to the headphone PC board.
6. Remove the cam switch wire (FW701) from the mechanism PC board connector.
7. Remove the screw (6) retaining the headphone PC board grounding wire.
8. Remove the two screws (7) retaining the mechanism assembly on the chassis.
9. Remove the two screws (8) retaining the front panel and chassis on the bottom plate.

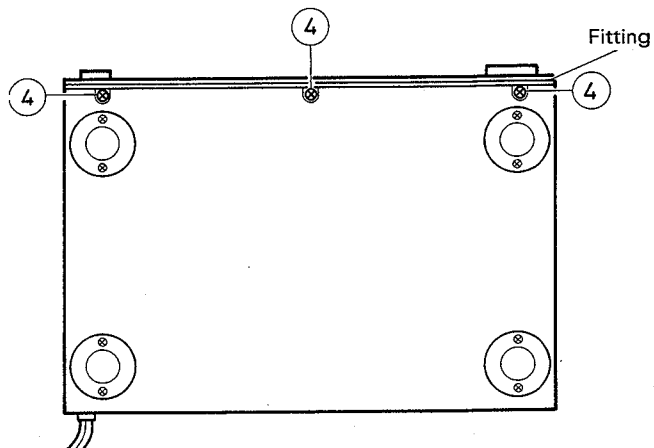

Fig. 2-3

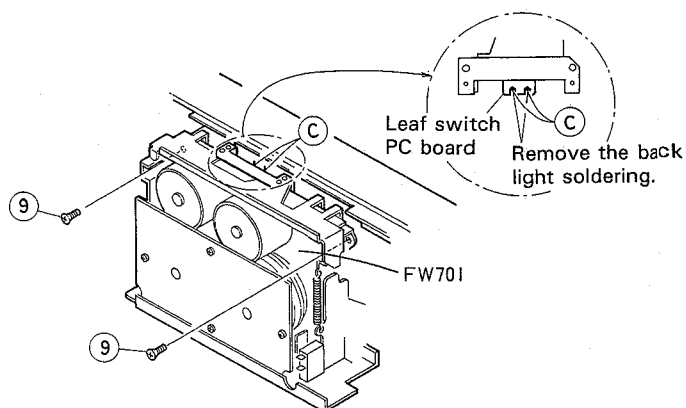

Fig. 2-4

### ■ PC board assembly inside front panel

(see Figures 2-4 and 2-5).

1. Remove the front panel assembly.

#### ● Volume PC board assembly.

1. Pull out the volume knob.
2. Remove the three screws (10) retaining the volume PC board.

#### ● FL PC board assembly

1. Remove the volume PC board.
2. Remove the mechanism assembly (removing the back light soldering (C)).
3. Remove the nine screws (11) retaining the FL PC board.

#### ● Headphone PC board assembly

1. Remove the screw (hexagonal) retaining the headphone jack.

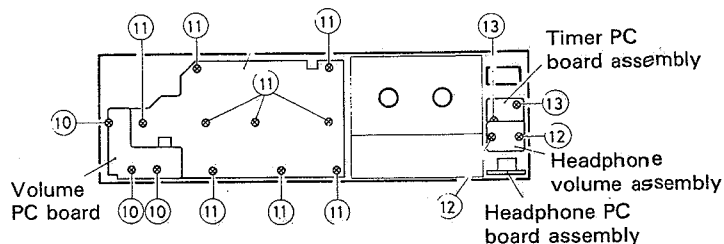

Fig. 2-5

### ● Headphone volume PC board assembly/timer switch PC board assembly

1. Pull out and remove the headphone volume knob.
2. Remove the two screws (12) retaining the headphone volume PC board (see Figure 2-5).
3. Remove the two screws (13) retaining the timer switch PC board (see Figure 2-5).

### ■ Main PC Board Assembly

1. Pull out and remove the input level volume knob.
2. Remove the two screws (14) retaining the volume on the back panel (see Figure 2-1).
3. Remove the three screws (15) retaining the pin jacks (see Figure 2-1).
4. Remove the screw (16) retaining the DCS jack (see Figure 2-1).
5. Push up the input volume shaft so that the shaft goes into a free state from the front panel (see Figure 2-2).
6. Pull out and remove the input volume assembly straight up.
7. Remove the four screws (5) retaining the amp shield case (see Figure 2-2).
8. Remove the screw (6) that is tightened with the headphone grounding.
9. Remove the CD direct switch bar (see Figure 2-6).
  - 1 Turn the switch ON.
  - 2 Pull the remote bar only from position 1.
  - 3 Remove the remote bar (from the switch shaft on the in L201: 562 side and remove by pushing to the back.
10. Pull the main PC board assembly slightly forward and bring it up from the back.
11. Since the headphone grounding will float up when a current is passed, connect it separately to the chassis.

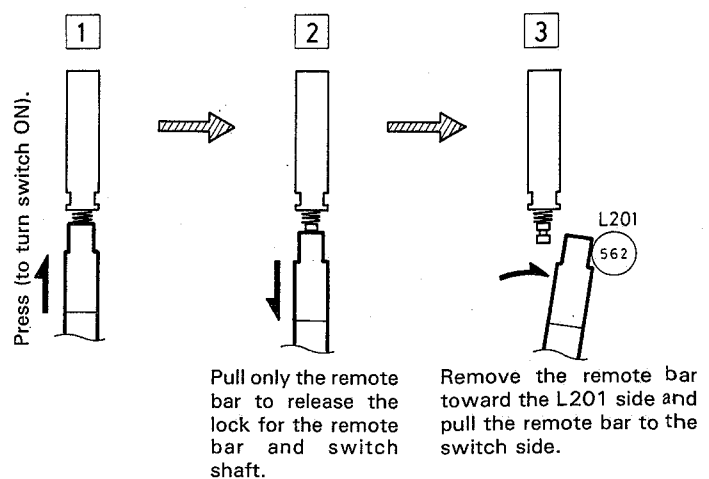

Fig. 2-6

### ● When removing only the mechanism assembly

1. Remove the top cover.
2. Remove the four screws (5) retaining the main PC board shield case (see Figure 2-2).
3. Remove the wires from the main PC board (see Figure 2-2).
  - a) Remove the wires CN802 and CN801 for record/playback and erase heads.
  - b) Remove CN703, CN713, CN702 and CN712 going to the leaf switch PC board.
4. Remove the cam switch wire (FW701) from the mechanism PC board connector (see Figure 2-2).
5. Remove the two screws (9) retaining the mechanism on the front panel assembly (see Figure 2-4).
6. Remove the two screws (7) retaining the mechanism assembly on the chassis (see Figure 2-2).
7. Remove the cassette back light soldering (C) on the center of the upper surface of the mechanism (Figure 2-4).

### ● When removing the front panel assembly (after removing the mechanism)

1. In case the mechanism assembly is included, carry out steps 1,2,3 of "Assembly Parts" on page 14.
2. Remove the wires from the main PC board (see Figure 2-2).
  - a) Remove CN804 for the Dolby switch/calibration volume.
  - b) Remove CN704 going to the FL PC board.
  - c) Remove CN805 and CN815 going to the headphone PC board.
3. Remove the cam switch wire (FW701) from the mechanism PC board connector.
4. Remove the screw (6) retaining the headphone PC board grounding wire (see Figure 2-2).
5. Remove the two screws (9) retaining the mechanism assembly to the front panel assembly (see Figure 2-4).
6. Remove the two screws (8) retaining the front panel and chassis to the bottom plate (see Figure 2-2).

### [Order for Disassembly of Mechanism]

- Remove the mechanism assembly from the mechanism holder.

#### ■ Replacing the Leaf Switch

1. Remove the two screws (1) retaining the switch arm assembly (also removing the collar at this time).
2. Remove the switch arm tension spring.
3. Remove the switch arm assembly, being careful not to bend the leaf switch.
4. Remove the three screws (2) retaining the leaf switch PC board assembly.
5. Remove the leaf switch.

#### ■ Replacing the Pinch Roller

##### (Right Side)

1. Remove the E washer (3) of the pinch roller shaft.
2. Pull the pinch roller assembly up slightly and remove the return spring (thin black spring) on the shaft side from the pinch roller.

##### (Left Side)

(Height must be adjusted with M300 gauge after replacement)

1. Remove the pinch roller arm shaft height adjustment screw (using a 4 mm nut remover (box)).
2. Remove the return spring on the chassis side.

#### ■ Replacing the head

(Be sure to re-adjust if you have turned the attachment screws).

1. Remove the three screws (5) for adjusting the head base height.
2. When removing the playback head, remove the two screws (6).
  - If the head base is removed, the height adjustment spring will also come off. (Be careful not to lose it).
3. When the head base is removed, there is a recording head below this that can be removed by removing the three screws (7) and (8).
  - (Be careful not to misplace the spring below the head).
4. Remove the attachment screw (9) to remove the erase head.

To remove the head mount base (when removing as the head block), remove the three screws (10), (11) and (12).

(Be careful at this time not to exert any stress on the playback head base).

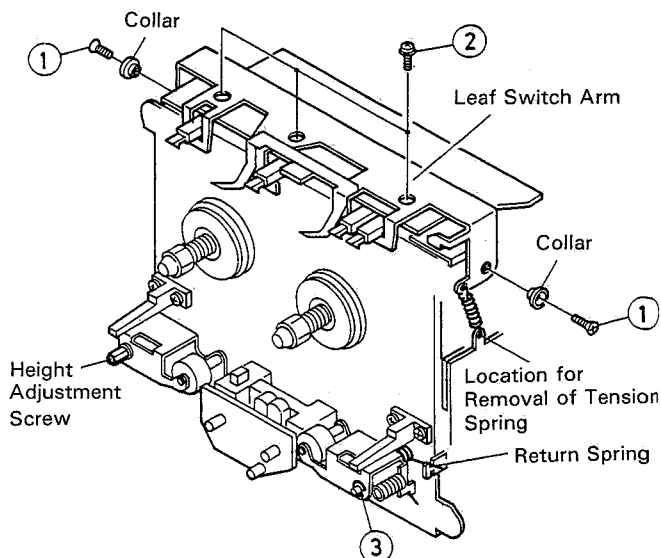

Fig. 2-7

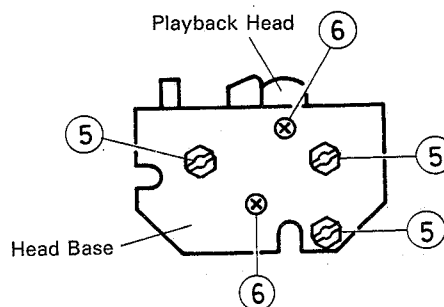

Fig. 2-8

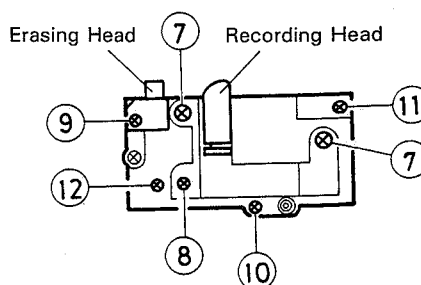

Fig. 2-9



**■ Capstan Assembly (Including Flywheel)**

1. Remove the pinch roller arm assembly (left and right).
2. Remove the ten screws (13), (14), (15), (16), (17) retaining the mechanism chassis and capstan motor assembly.
3. Loosening the Phillips head screw will facilitate removal of the capstan motor assembly.

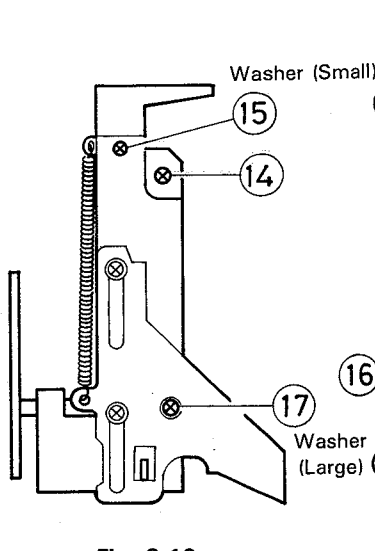

Fig. 2-10

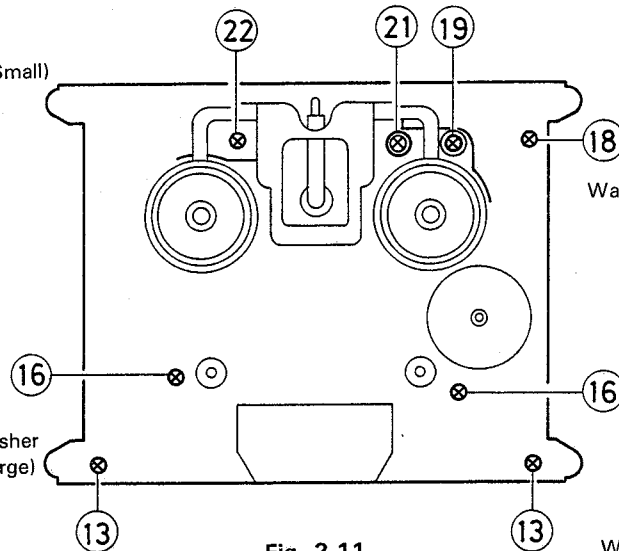

Fig. 2-11

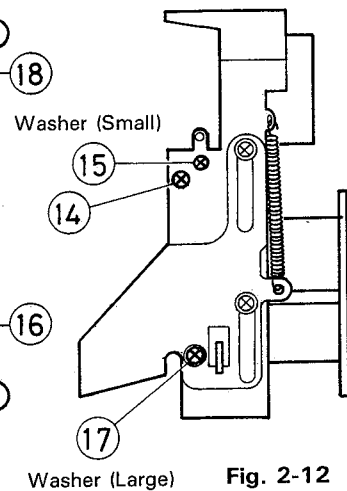

Fig. 2-12

**■ Cam Motor Assembly/Reel Motor Assembly**

1. Remove the motor terminal PC board and then remove the two screws (18) and (19) retaining the cam motor assembly. Remove the motor terminal PC board and then remove the two screws (22) and (21) retaining the reel motor assembly.
2. Or, if the cam motor assembly and reel motor assembly are removed at the same time, it is also possible to remove the terminal PC board assembly.

**■ Cam Switch Assembly**

Remove the screw (23) retaining the cam switch assembly. This can be removed by removing the disk brake lever from the reel disk.

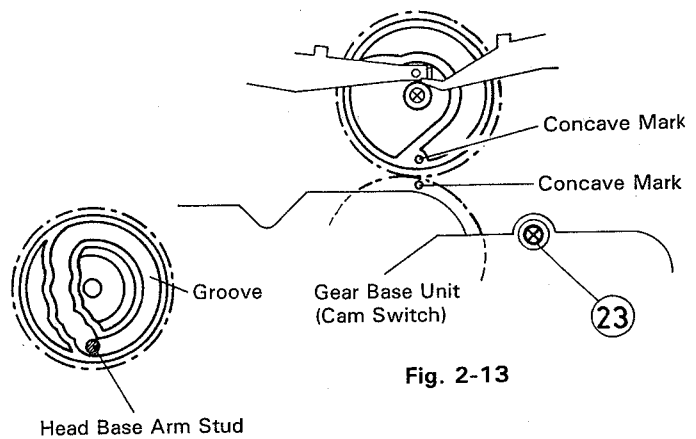

Fig. 2-13

Head Base Arm Stud

Fig. 2-14

**■ Replacing the Motor Belt and Flywheel**

Remove the four screws (24) retaining the motor bracket (being careful of grease when belt comes off).

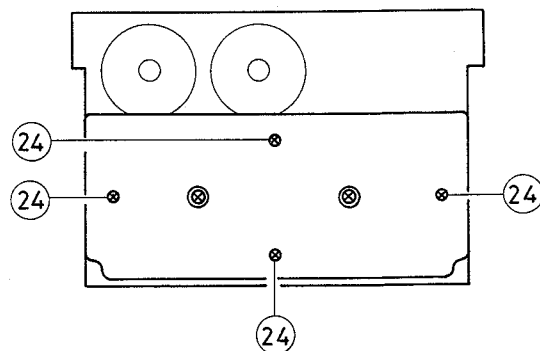

Fig. 2-15

## 3 Jig List

### 1. Mechanism Adjusting Jig

M300

Head adjusting screw driver

Box

: Adjustment of head angle and tape running

: Adjustment of head angle and height of tape guid

: Adjustment of pinch roller height

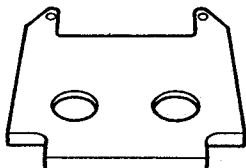
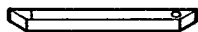

M300 gauge

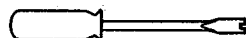

Mechanism screw driver

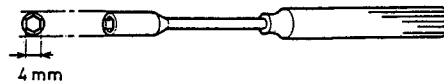

Box

Fig. 3-1

### 2. TEST TAPE

Tape No.	Frequency	Purposes
TS-12 (UD) TS-10 (SA) TS-11 (ME)		Normal standard recording tape (for deck) Standard crawling recording tape (AC-513) Standard metal recording tape (AC-712)
VTT712 VTT724 TMT735 VTT739 TMT6447 TMT6448 TMT702 CTG-N	3 kHz 1 kHz 1 kHz 12.5 kHz 63 Hz, 1 kHz, 10 kHz  14 kHz	Measurement of tape speed/wow and flutter Replaying level standard tape Check of replaying frequency characteristics Check of replaying frequency characteristics Confirmation of music selection action (YES) Confirmation of music selection action (NO) Adjustment of replay head angle (azimuth) Measurement of PLAY, FF and REW torques
Mirrored tape		For confirmation of tape running

### 3.

Audio frequency oscillator Frequency range: 50 Hz ~ 20 kHz and output: more than 0 dBs (0.775 V) with 600  $\Omega$  impedance

Attenuator

Electronic voltmeter

Distortion gauge (with band pass filter)

Wow and flutter gauge

Tape counter gauge tape speed and Bias frequency adjustment.

DC voltmeter L304 and L404 adjustment

## 4 Main Adjustment

### ■ Mechanical Adjustment

When replacing head, check the height and tilt (rough adjustment) of each head as follows.

#### Tape travel adjustment

Use tool M300. Be careful not to damage head.

#### Tape guide adjustment

Reflector position  
(guide post)

Gauge moving direction

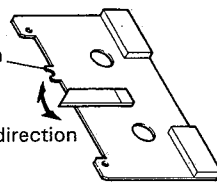

#### Tilt adjustment

Reflector position  
(guide post)

Gauge moving direction

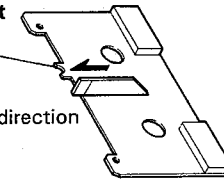

Fig. 4-1

### ■ Location of adjustment

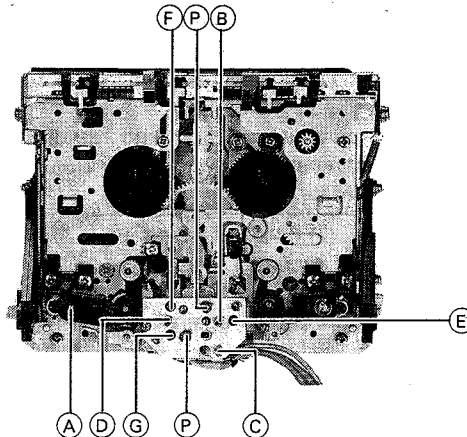
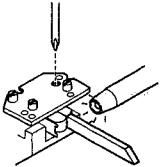
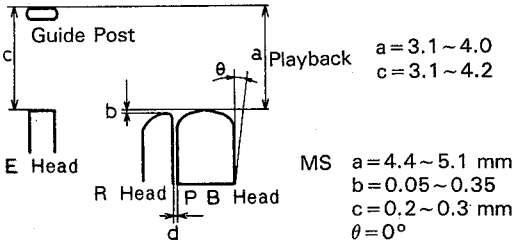
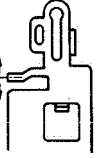
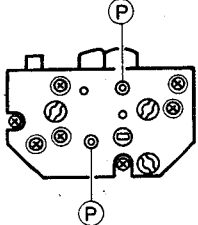

Fig. 4-2

### ■ Mechanical adjustment procedures

	Item	Method	Standard Value	
1	Fly wheel and thrust check	Check by feeling	0.2 ~0.5 mm	
2	Pinch roller fastening order check	Right pinch roller should fasten to capstan shaft before left pinch roller.		
3	Pinch roller guide height adjustment	Use M300 gauge and adjust (A) so that 3.8 mm gauge can pass.		
4	Playback head height and tilt adjustment	<ol style="list-style-type: none"> <li>1) Use M300 gauge and adjust playback head tape guide with (B) screw so that 3.8 mm gauge can pass.</li> <li>2) Adjust (C) screw so that playback head is not tilted and that there is no gap between the gauge and head.</li> <li>3) Gauge will touch gap face, adjust carefully. Hold a flash light from the opposite side and check for light leakage.</li> <li>4) Re-check gauge height. If gauge touches, re-adjust upper 1), 2).</li> </ol>		<p>Head guide height adjustment</p> <p>Pinch roller guide height adjustment</p> <p>Playback head tilt adjustment</p>

	Item	Method	Standard Value	
5	Playback azimuth adjustment	Playback TMT702 (14 kHz) and adjust screw (D) to maximum output position with no phase difference.		
6	Tape travel check	Use C-90 padded tape and check that tape head is not curled at beginning of wind.		Use mirror tape to check tape travel.
7	Recording head height, tilt. Azimuth adjustment	1) Record and playback 10 kHz and adjust screw (E) to maximum output position with no phase difference. (azimuth adjustment) 2) Record and playback 10 kHz and adjust screw (F) to maximum output position with no phase difference. (height adjustment) 3) Use M300 gauge and adjust recording head tilt with screw (G) following the procedure for adjusting playback head tilt. 4) Record and playback 10 kHz and re-adjust azimuth adjusting screw (E) to maximum output position. Match L/R phases.		 Recording head tilt adjustment
8	Head position	Use M300 gauge and adjust so that playback head is in front of recording head. Other standards are as follows. The measurements are as against guide post (H).   Bend and adjust head base so that a is within 4.4~5.1 mm at MS.   Excessive = Bend in ↑ direction Insufficient = Bend in ↓ direction	0.05 ~0.35 mm	 Head position adjustment Adjust screw (P) so that playback head is "b" measurement in front of recording head. [re-adjust playback, recording azimuth after adjusting (P).]
9	Confirmation of tape speed	By replaying VTT712, confirm that the reading of F counter is 3,000 ± 15 Hz.	3000 ± 15Hz	
10.	Confirmation of one flatter	By replaying VTT712, confirm that the flatter meter value is not more than 0.04 % (WTD).	0.04% (WTD)	
11	Replay torque FF/REW torque	By using the CT-120M gauge, confirm that the replay torque is 35 g - 70 g cm. By using the CT-F gauge, confirm that the FF/REW torque is 70 - 200 g cm	Replay: 35 - 70 g·cm FF/REW: 70 ~ 200g·cm	
12	Confirmation of MS action	After selection with the TMT6447 tape, start playing action. Confirm that any selection action cannot be performed with the TMT6448 tape.		

### ■ Electric Circuit Adjustment Location

Main Amplifier Base (Parts Side)

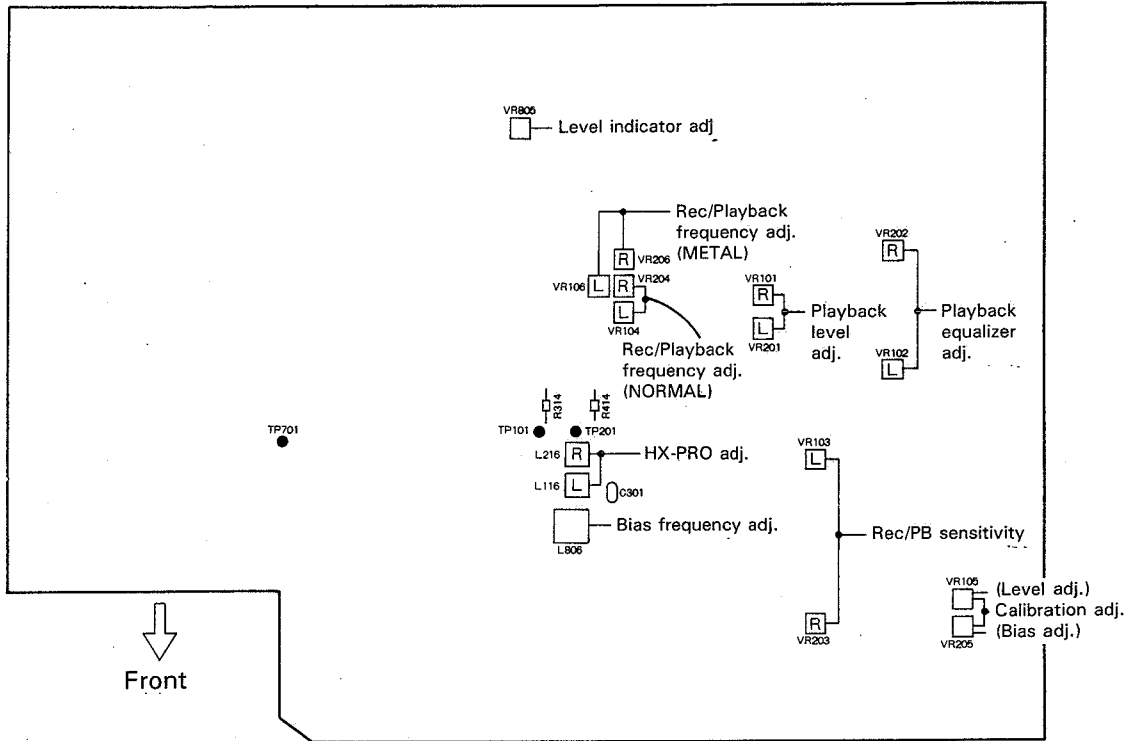

### ■ Electrical Circuit Adjustment Procedures

Make the following adjustment after the tape travel and head angle adjustment.

- In principle, the adjustments should be made in the order described.
- Adjustments required after head replacement are marked with an asterisk (\*)

0dB ≙ 0.775V

Item		Adjustment and Check Methods			
1	Dolby circuit recording check (record mode)	Record, Dolby B	INPUT: LINE IN (-8 dBs) Measurement Point: IC803, pins ⑬ ⑭ Measurement point reference level: 400 Hz -6 dBs (388 mV) (= Cal. level)	Frequency Level	Output Value and Deviation
				1 kHz Cal -40 dB	+5.7 dB ± 2 dB
				5 kHz Cal -20 dB	+3.5 dB ± 1.5 dB
		Record, Dolby C		1 kHz Cal	0 dB ± 0.5 dB
				1 kHz Cal -40 dB	+16.2 dB ± 1 dB
				5 kHz Cal -20 dB	+2.9 dB ± 2.5 dB
		1 kHz Cal	0 dB ± 1 dB		

Item	Adjustment Method	Adjustment Location	Standard Value	Remarks	
*2	Playback level adjustment	1) Play the VTT724 (1 kHz) test tape and adjust VR101 and VR201 so that the LINE OUT output is -7.5 dBs (the L-R channel output differential must be 0.5 dBs or less). 2) Headphone output check -17.5 dBs ± 3 dB L-R differential 2 dB or less	VR101, VR201	-7.5 dBs ± 0.5 dB  Phones level -17.5 dBs ± 3 dB	The playback level changes when the head is replaced and must be adjusted. use an electronic voltmeter with an impedance of 100 kΩ or more.
*3	Playback equalizer adjustment	Play the TMT735 (1 kHz, 12.5 kHz) test tape and adjust VR102 and VR202 so that the output value is standard at 1 kHz and 12.5 kHz.	VR102, VR202	With 1 kHz as reference, 0.5 ± 0.5 dB at 12.5 kHz	NR: OFF 63 kHz: +2 dB ± 3 dB (check) (VTT739)
4	Bias frequency adjustment	Connect a frequency counter to the body of C301 and adjust L806 so that the counter reads 210 kHz ± 3 kHz	L806	210 kHz ± 3 kHz	METAL TAPE Position (Attach a probe to the measuring instrument lead terminal and plug in the connector plug.)

	Item	Adjustment Method	Adjustment Location	Standard Value	Remarks
5	HX PRO coil adjustment	This step must be performed after the bias frequency adjustment. Load a metal tape and set the deck to the recording mode. Adjust L116(L) and L216 (R) to minimum respective voltage of TP101(L) and TP201(R).	L116, L216	Minimum output value	DC voltmeter TP101: R314 TP201: R414
*6	Recording/playback frequency adjustment	Record 1 kHz at the Ref - 20 dB input then record 63 Hz and 12.5 kHz and adjust VR104 and VR204 so that the difference between the 63 Hz and 12.5 kHz outputs is the standard value in relation to the 1 kHz output during playback. (Basically, adjust so that the 1 kHz and 12.5 kHz outputs are the standard values.) Next, record and replay a metal tape, and adjust the difference within 0 + 1 dB by means of VR106 and VR206.	Normal VR104, VR204 Center the bias adjustment volume (VR807) (control on the front panel). Metal VR106, VR206	With 1 kHz as reference, Normal 0.5 ± 0.5 dB at 12.5 kHz. CrO <sub>2</sub> /Metal 0 ± 0.5 dB at 12.5 kHz	Ref - 20 dB: value - 20 dB below the reference input value ± - 28 dB Also adjust for normal tape and the left and right channels. • The bias value is set in accordance with the voltage shift for normal at chrome and metal. • When the bias current is not correctly adjusted, the recording characteristics will become as shown to the left.
*7	Recording/playback sensitivity adjustment	1) Input to the LINE IN terminal so that the source monitor output is - 7.5 dBs. 2) Adjust VR103 and VR203 so that the recording signal current is - 7.5 dBs during recording and playback.	VR103, VR203	Normal - 7.5 dBs ± 0.5 dB Chrome, metal: - 7.5 dBs ± 1.5 dB	The right and left level differential must be 1 dB or less for both normal and metal. Make adjustment by using normal tape, and make sure that the level fluctuation for chrome and metal tapes is within 1.5 dB, and that the left/right level difference is within 1.0 dB. During adjustment, set the balance volume to the center position. After adjustment, turn the volume and confirm that the Lch and Rch are correct.
*8	Adjustment of calibration	1. Connect TP701 to the earth when turning off the power source. 2. After turning on the power source, set the monitor to the [SOURCE], and press the calibration button and play button at the same time. 3. Adjust VR105 (LEVEL) and VR205 (BIAS) so that the leveling indicators [LEVEL] and [BIAS] on the FL indicator section turn on at [0 LEVEL], the lowest levels.	VR105 VR205	Lowest point where the FL 0 level is turned on.	
Confirmation of calibration volume					
The values of the recording and replaying (monitor) levels, which are by - 20 dB lower than the reference (0 Vu) at 10 kHz, should be decreased and increased when turning the calibration bias adjusting VR counterclockwise and clockwise respectively.		Calibration bias volume	Clockwise: Decrease Counterclockwise: Increase	VR807	
The values of the recording and replaying (monitor) levels, which are by - 20 dB lower than the reference (0 Vu) at 1 kHz, should be increased and decreased when turning the calibration bias adjusting VR counterclockwise and clockwise respectively.		Calibration level volume	Clockwise: Increase Counterclockwise: Decrease	VR801	

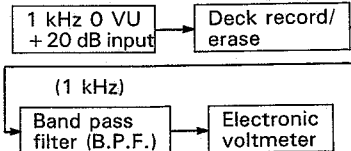
	Item	Adjustment Method	Adjustment Location	Standard Value	Remarks										
9	Adjustment and confirmation of level indicator	1) While applying 1 kHz signal, adjust the input on the monitor (SOURCE) so that the line output level becomes $-34$ dBs. Adjust VR805 so that ( $-30$ dB" of the FL level indicator is turned on and both or one of the indicators are turned on at $-36$ dBs. 2) <table border="1" data-bbox="328 584 691 712"> <thead> <tr> <th>Indicator</th> <th>Line output level</th> </tr> </thead> <tbody> <tr> <td>0</td> <td><math>-4</math> dBs <math>\pm 1</math> dB</td> </tr> <tr> <td>+8</td> <td><math>+2</math> dBs <math>\pm 2</math> dB</td> </tr> <tr> <td>-10</td> <td><math>-14</math> dBs <math>\pm 2</math> dB</td> </tr> <tr> <td>-30</td> <td><math>-34</math> dBs <math>\pm 3</math> dB</td> </tr> </tbody> </table>	Indicator	Line output level	0	$-4$ dBs $\pm 1$ dB	+8	$+2$ dBs $\pm 2$ dB	-10	$-14$ dBs $\pm 2$ dB	-30	$-34$ dBs $\pm 3$ dB	VR805	Output ON at $-34$ dB OFF at $-36$ dB	1) Whenever the output is by $+1$ dB greater than the specified input, 1, 2, 3... will successively be indicated. 2) When the output is less than the specified input, the maximum value will be held for about 2 sec. 3) Press the [CALL] button to indicate [OVER 12 dB] for 5 sec. by flickering.
Indicator	Line output level														
0	$-4$ dBs $\pm 1$ dB														
+8	$+2$ dBs $\pm 2$ dB														
-10	$-14$ dBs $\pm 2$ dB														
-30	$-34$ dBs $\pm 3$ dB														
10	Recording/playback distortion check	1) Record a 1 kHz signal so that the LINE OUT output is $-2$ dBs and the level indicator is $+6$ dVB. 2) Use a distortion gauge to check if the output is the standard value during playback.		Normal tape: 2% or less Chrome tape: 3% or less Metal tape: 2% or less	Check after adjusting the bias current and recording level.										
11	Recording/playback S/N ratio check	1) Record 1 kHz, 0 dB input and then remove the input and record without a signal. 2) Playback this recording and measure the difference between the 0 dB recording and no-signal recording. The standard values must be satisfied.		Normal: 38 dB or more Chrome: 42 dB or more Metal: 42 dB or more											
12	Erase ratio check	1) Apply a 1 kHz signal from LINE IN and adjust the INPUT LEVEL knob so that the input level is $-8$ dBs. 2) Increase the signal level to 20 dB and record. 3) Rewind and erase the recorded section of the tape. 4) Measure the output ratio between the signal and no-signal sections of the tape with an electronic voltmeter.		55 dB or more	Connect a B.P.F (band pass filter) between the deck and the electronic voltmeter. <div style="text-align: center; margin-top: 10px;">  </div>										

# 5 Block Diagram

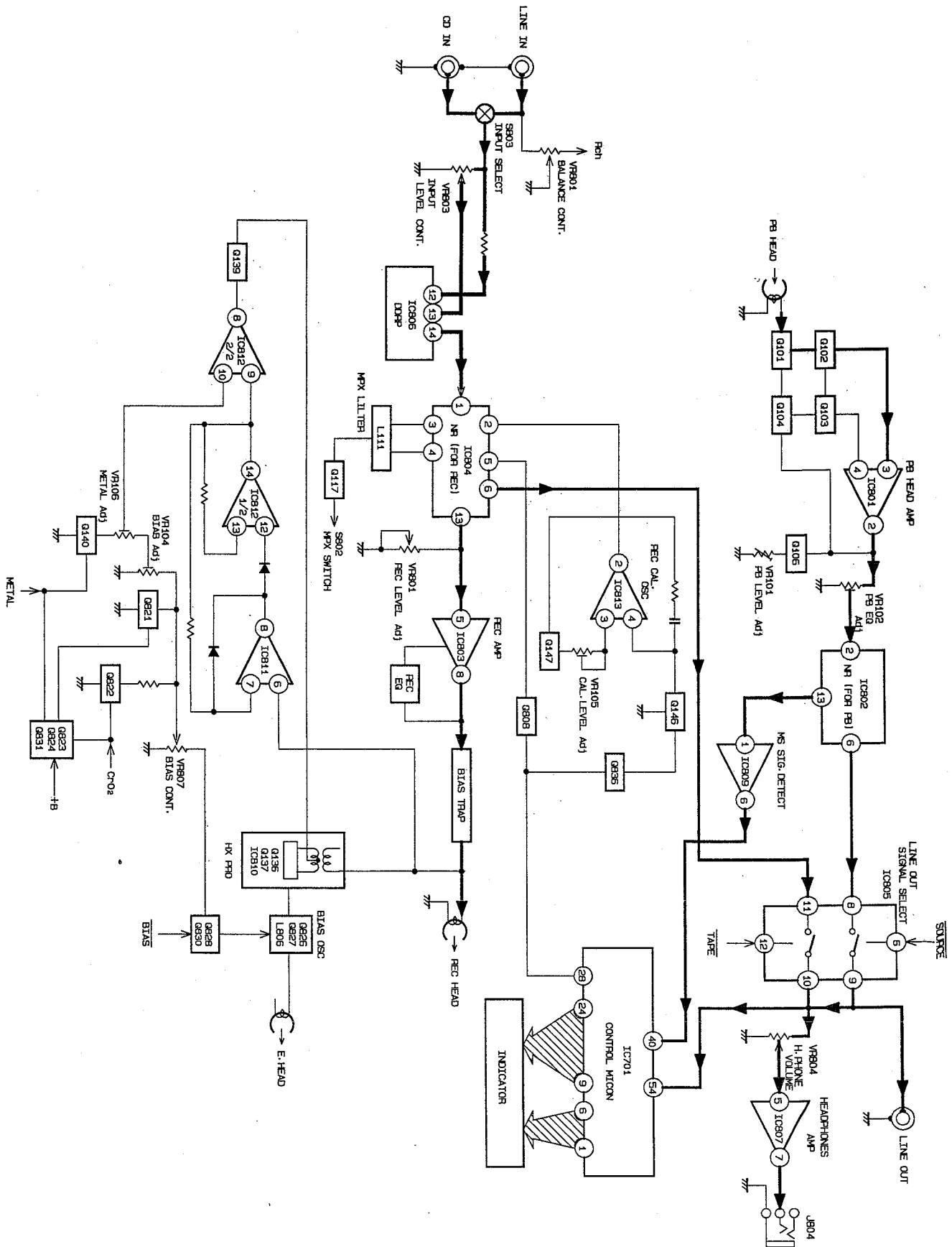

Fig. 5-1



# 6 Wiring Connections

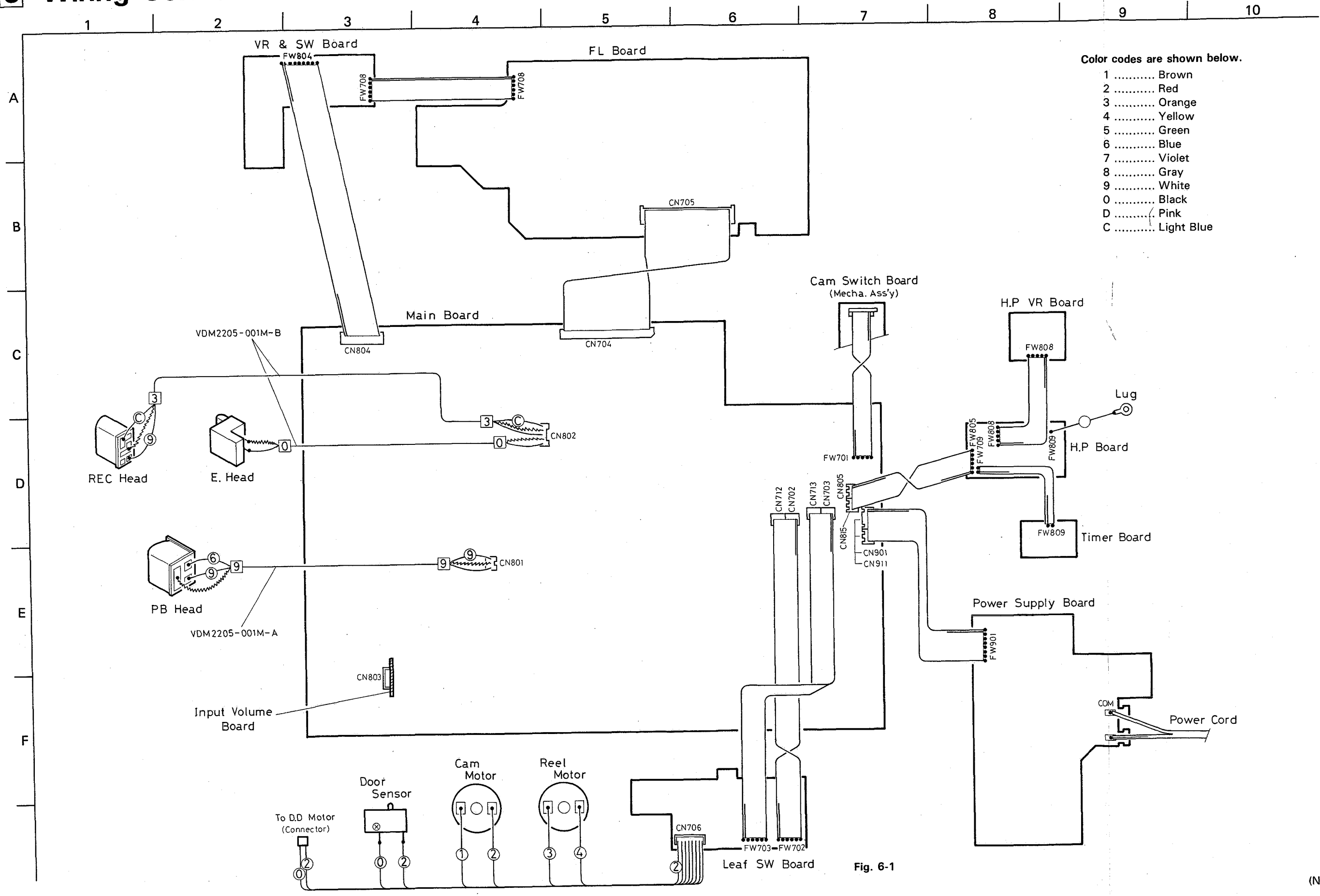

Fig. 6-1

# 7 Standard Schematic Diagram

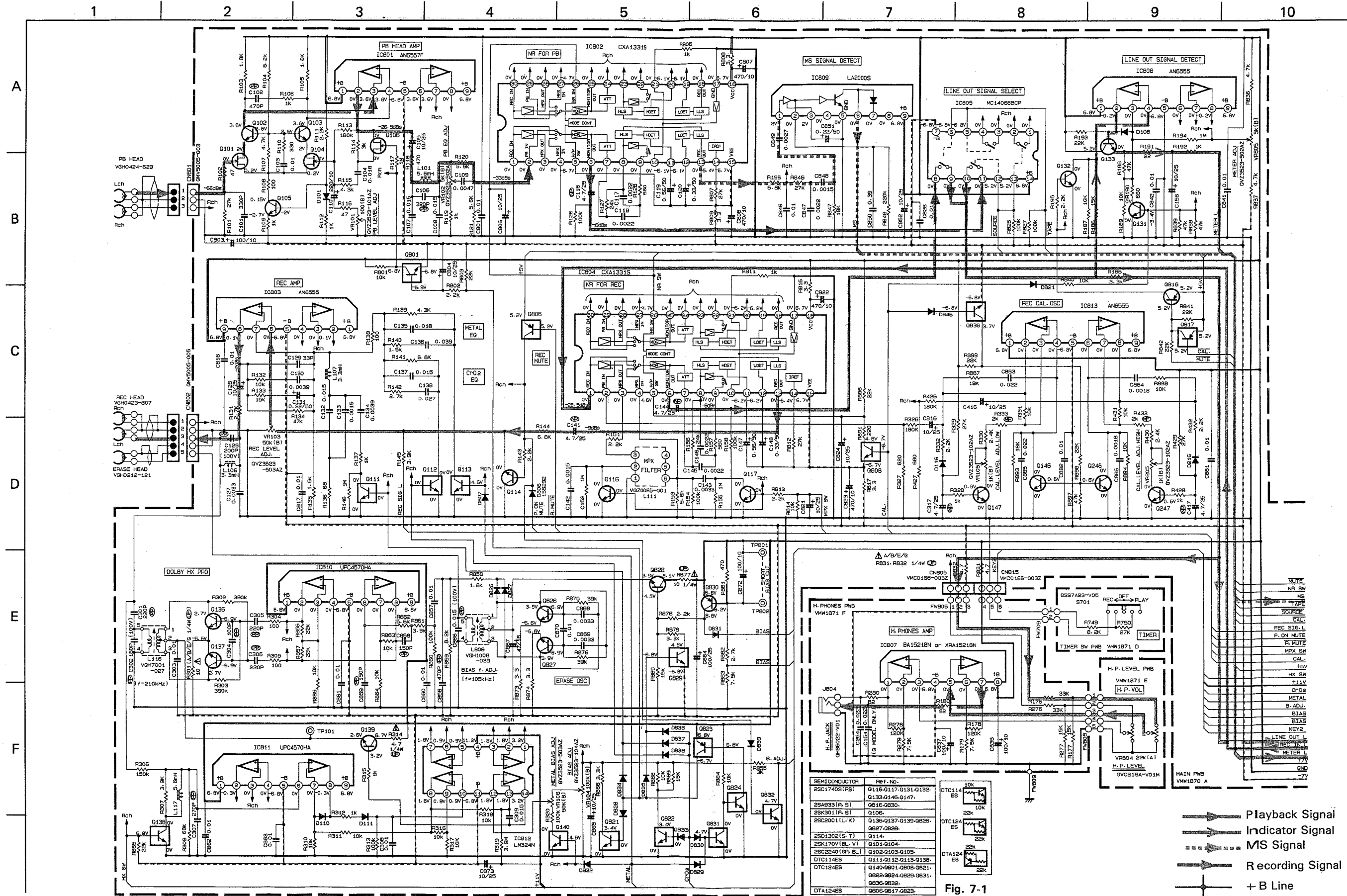

Fig. 7-1  
 Δ parts are safety assurance parts.  
 When replacing those parts, make sure to use the specified one.

11 12 13 14 15 16 17 18 19 20

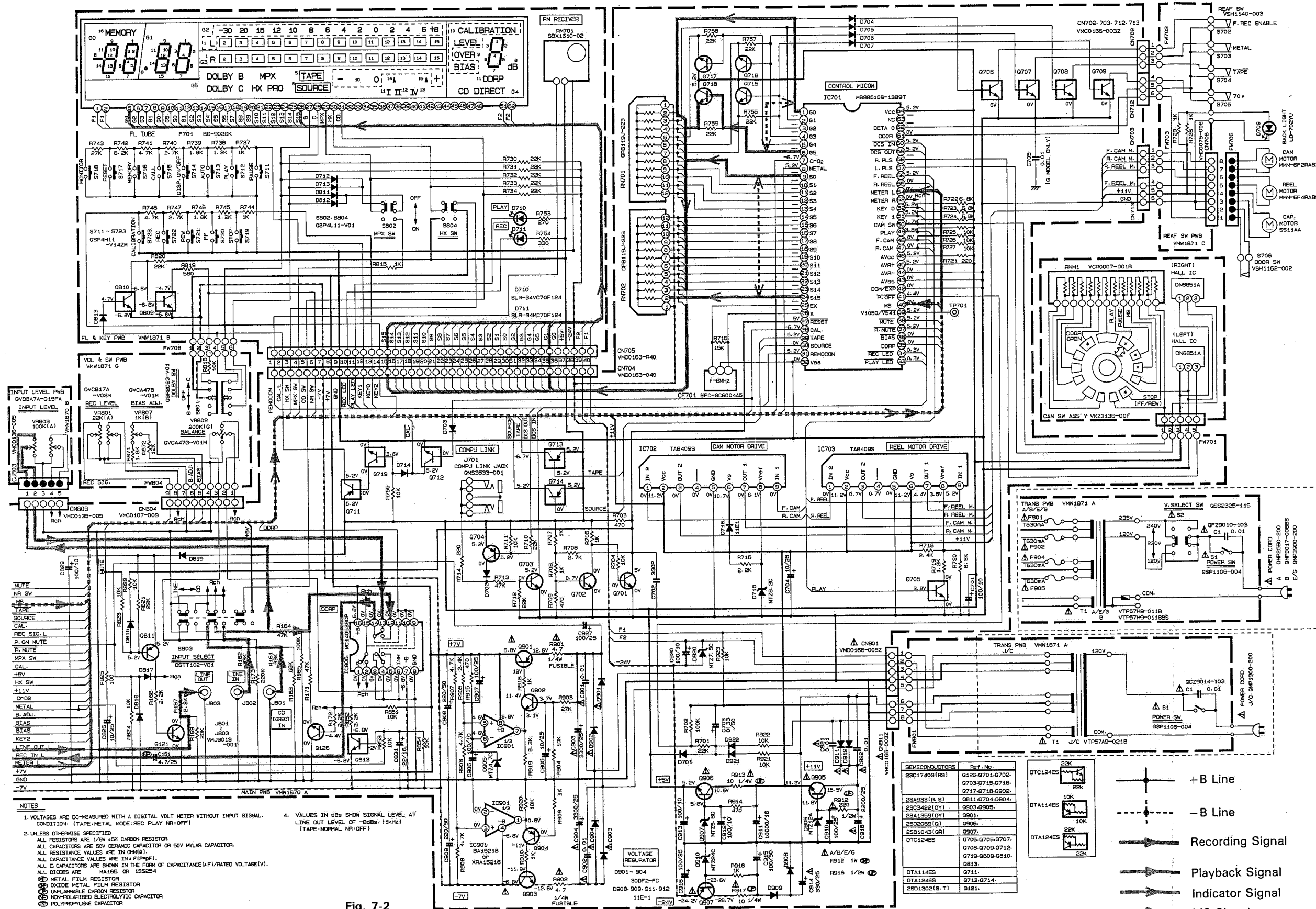

Fig. 7-2

Δ parts are safety assurance parts. When replacing those parts, make sure to use the specified one.

# 8 Location of P.C. Board and P.C. Board Parts List

BLOCK NO. 01

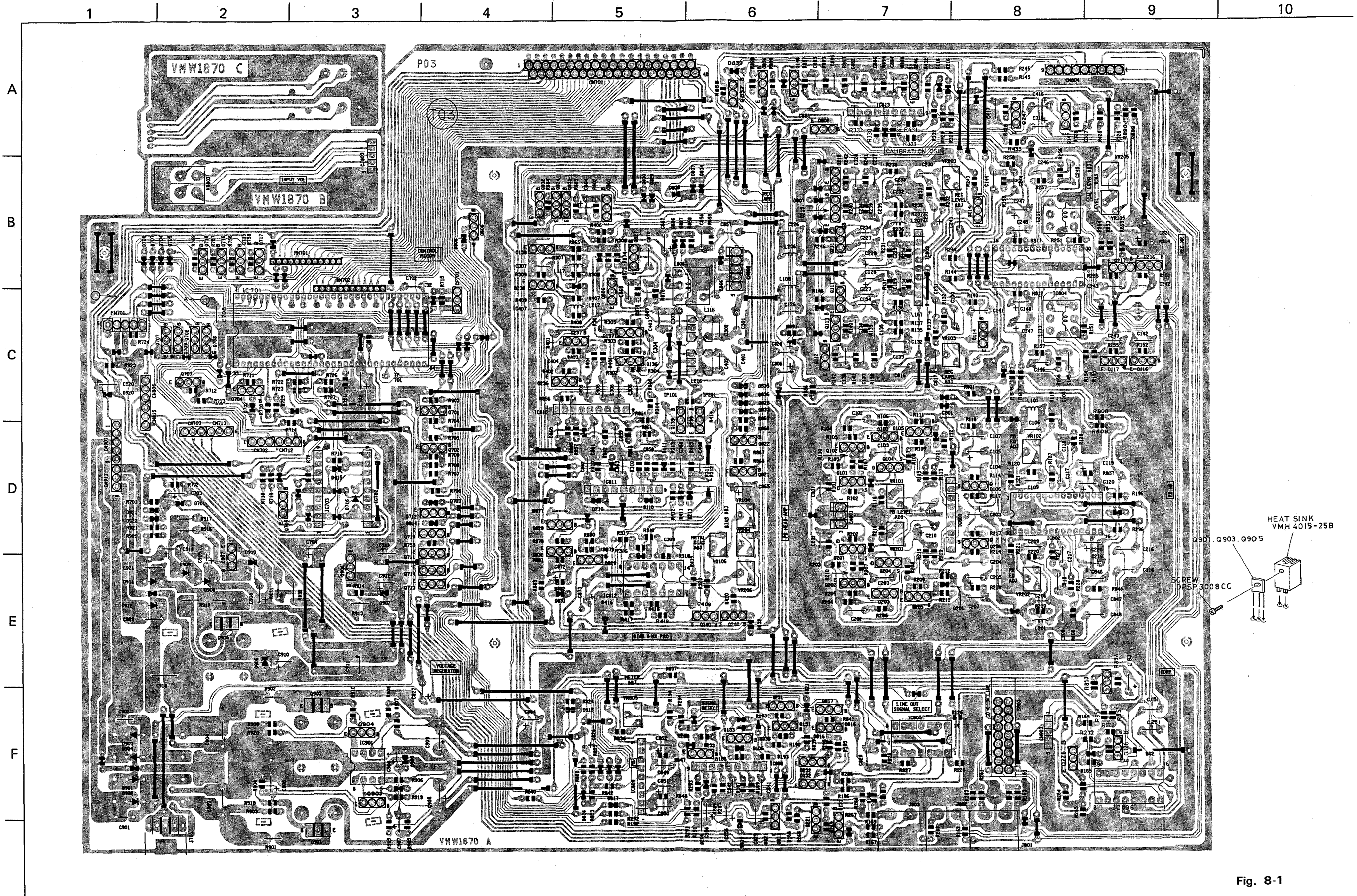

Fig. 8-1

△ Parts are safety assurance parts.  
When replacing those parts, make

● Main Board Parts List sure to use the specified one.

BLOCK NO. 01

△	REF.	PARTS NO.	PARTS NAME
	C 101	EFZ0101-331ZS	NH CAPACITOR
	C 102	QFP31HJ-471ZM	PP.CAPACITOR
	C 103	QFV41HJ-103	FILM CAPACITOR
	C 104	QFV41HJ-183	TF CAPACITOR
	C 105	VCE0036-106	E CAP(TAPING)
	C 106	QFP31HJ-391ZM	PP CAPACITOR
	C 107	QFV71HJ-153ZM	FILM CAPACITOR
	C 108	QFV71HJ-153ZM	FILM CAPACITOR
	C 109	QFN41HJ-472	M CAPACITOR
	C 110	VCE0063-227Z	E CAPACITOR
	C 116	VCE0033-475	E CAP(TAPING)
	C 117	QFN41HJ-222	M CAPACITOR
	C 118	QFN41HJ-222	M CAPACITOR
	C 119	QETC1HM-564ZM	E CAPACITOR
	C 120	QETC1HM-334ZM	E CAPACITOR
	C 126	QFP32AJ-201ZM	PP CAPACITOR
	C 127	QFN41HJ-332	M CAPACITOR
	C 128	VCE0036-106	E CAP(TAPING)
	C 129	QCS11HJ-330	C CAPACITOR
	C 130	QFN41HJ-392	M CAPACITOR
	C 131	QETC1HM-224ZM	E CAPACITOR
	C 132	QFV71HJ-153ZM	FILM CAPACITOR
	C 133	QFN41HJ-152	M CAPACITOR
	C 134	QFN41HJ-392	M CAPACITOR
	C 135	QFV41HJ-183	TF CAPACITOR
	C 136	QFV71HJ-393ZM	FILM CAPACITOR
	C 137	QFV41HJ-223	FILM CAPACITOR
	C 138	QFV71HJ-273ZM	TF.CAPACITOR
	C 141	VCE0033-475	E CAP(TAPING)
	C 142	QFN41HJ-152	M CAPACITOR
	C 143	QFN41HJ-332	M CAPACITOR
	C 144	VCE0033-475	E CAP(TAPING)
	C 145	QFN41HJ-222	M CAPACITOR
	C 146	QFN41HJ-222	M CAPACITOR
	C 147	QETC1HM-564ZM	E CAPACITOR
	C 148	QETC1HM-334ZM	E CAPACITOR
	C 151	VCE0033-475	E CAP(TAPING)
	C 156	QETC1EM-106ZM	E CAPACITOR
	C 201	EFZ0101-331ZS	NH CAPACITOR
	C 202	QFP31HJ-471ZM	PP.CAPACITOR
	C 203	QFV41HJ-103	FILM CAPACITOR
	C 204	QFV41HJ-183	TF CAPACITOR
	C 205	VCE0036-106	E CAP(TAPING)
	C 206	QFP31HJ-391ZM	PP CAPACITOR
	C 207	QFV71HJ-153ZM	FILM CAPACITOR
	C 208	QFV71HJ-153ZM	FILM CAPACITOR
	C 209	QFN41HJ-472	M CAPACITOR
	C 210	VCE0063-227Z	E CAPACITOR
	C 216	VCE0033-475	E CAP(TAPING)
	C 217	QFN41HJ-222	M CAPACITOR
	C 218	QFN41HJ-222	M CAPACITOR
	C 219	QETC1HM-564ZM	E CAPACITOR
	C 220	QETC1HM-334ZM	E CAPACITOR
	C 226	QFP32AJ-201ZM	PP CAPACITOR
	C 227	QFN41HJ-332	M CAPACITOR
	C 228	VCE0036-106	E CAP(TAPING)
	C 229	QCS11HJ-330	C CAPACITOR
	C 230	QFN41HJ-392	M CAPACITOR
	C 231	QETC1HM-224ZM	E CAPACITOR
	C 232	QFV71HJ-153ZM	FILM CAPACITOR
	C 233	QFN41HJ-152	M CAPACITOR
	C 234	QFN41HJ-392	M CAPACITOR
	C 235	QFV41HJ-183	TF CAPACITOR
	C 236	QFV71HJ-393ZM	FILM CAPACITOR
	C 237	QFV41HJ-223	FILM CAPACITOR
	C 238	QFV71HJ-273ZM	TF.CAPACITOR
	C 241	VCE0033-475	E CAP(TAPING)
	C 242	QFN41HJ-152	M CAPACITOR
	C 243	QFN41HJ-332	M CAPACITOR
	C 244	VCE0033-475	E CAP(TAPING)
	C 245	QFN41HJ-222	M CAPACITOR
	C 246	QFN41HJ-222	M CAPACITOR
	C 247	QETC1HM-564ZM	E CAPACITOR
	C 248	QETC1HM-334ZM	E CAPACITOR
	C 251	VCE0033-475	E CAP(TAPING)
	C 256	QETC1EM-106ZM	E CAPACITOR
	C 301	QFP41HJ-221	PP CAPACITOR
	C 302	QFP32AJ-181ZM	PP.CAPACITOR
	C 303	QCVB1CM-103Y	C CAPACITOR
	C 304	QFP31HJ-101ZM	PP CAPACITOR
	C 305	QFP41HJ-221	PP CAPACITOR
	C 306	QFP41HJ-221	PP CAPACITOR
	C 307	QFP31HJ-271ZM	PP CAPACITOR
	C 308	QFV41HJ-103	FILM CAPACITOR
	C 309	QFV71HJ-153ZM	FILM CAPACITOR

△	REF.	PARTS NO.	PARTS NAME
	C 316	QETC1EM-106ZM	E CAPACITOR
	C 317	VCE0033-475	E CAP(TAPING)
	C 401	QFP41HJ-221	PP CAPACITOR
	C 402	QFP32AJ-181ZM	PP.CAPACITOR
	C 403	QCVB1CM-103Y	C CAPACITOR
	C 404	QFP31HJ-101ZM	PP CAPACITOR
	C 405	QFP41HJ-221	PP CAPACITOR
	C 406	QFP41HJ-221	PP CAPACITOR
	C 407	QFP31HJ-271ZM	PP CAPACITOR
	C 408	QFV41HJ-103	FILM CAPACITOR
	C 409	QFV71HJ-153ZM	FILM CAPACITOR
	C 416	QETC1EM-106ZM	E CAPACITOR
	C 417	VCE0033-475	E CAP(TAPING)
	C 701	QETC1AM-107ZM	E CAPACITOR
	C 702	QCVB1CM-103Y	C CAPACITOR
	C 703	QETC1HM-334ZM	E CAPACITOR
	C 704	QETC1EM-106ZM	E CAPACITOR
	C 705	QCVB1CM-103Y	C CAPACITOR
	C 801	QCVB1CM-103Y	C CAPACITOR
	C 803	QETC1AM-107ZM	E CAPACITOR
	C 804	QETC1EM-106ZM	E CAPACITOR
	C 806	QETC1EM-106ZM	E CAPACITOR
	C 807	VCE0065-477Z	E CAP(TAPING)
	C 808	VCE0065-477Z	E CAP(TAPING)
	C 816	QCVB1CM-103Y	C CAPACITOR
	C 817	QCVB1CM-103Y	C CAPACITOR
	C 821	QETC1EM-106ZM	E CAPACITOR
	C 822	VCE0065-477Z	E CAP(TAPING)
	C 823	VCE0065-477Z	E CAP(TAPING)
	C 824	QETC1EM-106ZM	E CAPACITOR
	C 826	QETC1EM-106ZM	E CAPACITOR
	C 827	QETC1EM-107ZM	E CAPACITOR
	C 828	QCVB1CM-103Y	C CAPACITOR
	C 829	QETC1AM-107ZM	E CAPACITOR
	C 831	QETC1CM-226ZM	E CAPACITOR
	C 841	QCVB1CM-103Y	C CAPACITOR
	C 842	QCVB1CM-103Y	C CAPACITOR
	C 846	QFV41HJ-103	FILM CAPACITOR
	C 847	QFN41HJ-222	M CAPACITOR
	C 848	QFN41HJ-152	M CAPACITOR
	C 849	QFN41HJ-272	M CAPACITOR
	C 850	QFV81HJ-394	FILM CAPACITOR
	C 851	QETC1HM-224ZM	E CAPACITOR
	C 852	QETC1EM-106ZM	E CAPACITOR
	C 856	QFP31HJ-471ZM	PP.CAPACITOR
	C 857	QFV41HJ-103	FILM CAPACITOR
	C 858	QFP31HJ-151ZM	PP CAPACITOR
	C 859	QFP31HJ-151ZM	PP CAPACITOR
	C 860	QCVB1CM-103Y	C CAPACITOR
	C 861	QCVB1CM-103Y	C CAPACITOR
	C 862	QCVB1CM-103Y	C CAPACITOR
	C 863	QCVB1CM-103Y	C CAPACITOR
	C 864	QETC1EM-107ZM	E CAPACITOR
	C 865	QETC1EM-106ZM	E CAPACITOR
	C 866	QFP82AJ-153	P.P.CAPACITOR
	C 867	QETC1CM-476ZM	E CAPACITOR
	C 868	QFN41HJ-332	M CAPACITOR
	C 869	QFN41HJ-332	M CAPACITOR
	C 870	QFV41HJ-103	FILM CAPACITOR
	C 872	QETC1AM-107ZM	E CAPACITOR
	C 873	QETC1EM-106ZM	E CAPACITOR
	C 881	QCVB1CM-103Y	C CAPACITOR
	C 882	QCVB1CM-103Y	C CAPACITOR
	C 883	QFV41HJ-223	FILM CAPACITOR
	C 884	QFN41HJ-182	M CAPACITOR
	C 885	QFV41HJ-223	FILM CAPACITOR
	C 886	QFN41HJ-182	M CAPACITOR
△	C 901	QFV41HJ-103	FILM CAPACITOR
△	C 902	QFV41HJ-103	FILM CAPACITOR
△	C 903	VCE0064-338	E CAPACITOR
△	C 904	VCE0064-338	E CAPACITOR
	C 905	QETC1EM-106ZM	E CAPACITOR
	C 906	QETC1AM-107ZM	E CAPACITOR
	C 907	QETC1EM-107ZM	E CAPACITOR
	C 908	VCE0034-227	E CAPACITOR
	C 909	VCE0034-227	E CAPACITOR
	C 910	QETC1EM-107ZM	E CAPACITOR
	C 911	QETB1CM-109N	E CAPACITOR
△	C 912	QETC1AM-107ZM	E CAPACITOR
	C 913	QETC1AM-107ZM	E CAPACITOR
△	C 914	VCE0062-337	E CAPACITOR
	C 915	QETC1HM-107ZM	E CAPACITOR
	C 916	QETC1EM-107ZM	E CAPACITOR
	C 918	QETB1EM-228N	E CAPACITOR
	C 920	QETC1AM-107ZM	E CAPACITOR

REF.	PARTS NO.	PARTS NAME
△ C 921	QFV41HJ-103	FILM CAPACITOR
△ C 922	QFV41HJ-103	FILM CAPACITOR
CF701	EFD-GC6004A5	CERA LOCK
CJ803	VMC0136-005	CONNECTOR
CN702	VMC0166-003Z	CONNECTOR
CN703	VMC0166-003Z	CONNECTOR
CN704	VMC0163-040	CONNECTOR
CN712	VMC0166-003Z	CONNECTOR
CN713	VMC0166-003Z	CONNECTOR
CN801	QMV5005-003	CONNECTOR
CN802	QMV5005-005	PLUG
CN803	VMC0135-005	CONNECTOR
CN804	VMC0107-009	CONNECTOR
CN805	VMC0166-003Z	CONNECTOR
CN815	VMC0166-003Z	CONNECTOR
CN901	VMC0166-005Z	CONNECTOR
CN911	VMC0166-003Z	CONNECTOR
D 101	1SS254	SI DIODE
D 106	1SS254	SI DIODE
D 110	1SS254	SI DIODE
D 111	1SS254	SI DIODE
D 116	1SS254	SI DIODE
D 201	1SS254	SI DIODE
D 206	1SS254	SI DIODE
D 210	1SS254	SI DIODE
D 211	1SS254	SI DIODE
D 216	1SS254	SI DIODE
D 701	1SS254	SI DIODE
D 702	1SS254	SI DIODE
D 703	1SS254	SI DIODE
D 704	1SS254	SI DIODE
D 705	1SS254	SI DIODE
D 706	1SS254	SI DIODE
D 707	1SS254	SI DIODE
D 714	1SS254	SI DIODE
D 715	MTZ8.2C	ZENER DIODE
D 716	11E1	SI DIODE
D 806	1SS292	SI DIODE
D 807	1SS254	SI DIODE
D 816	1SS254	SI DIODE
D 817	1SS254	SI DIODE
D 818	1SS254	SI DIODE
D 819	1SS254	SI DIODE
D 821	1SS254	SI DIODE
D 826	1SS254	SI DIODE
D 827	1SS254	SI DIODE
D 828	1SS254	SI DIODE
D 829	1SS254	SI DIODE
D 830	1SS254	SI DIODE
D 831	1SS254	SI DIODE
D 832	1SS254	SI DIODE
D 833	1SS254	SI DIODE
D 834	1SS254	SI DIODE
D 835	1SS254	SI DIODE
D 836	1SS254	SI DIODE
D 837	1SS254	SI DIODE
D 838	1SS254	SI DIODE
D 839	1SS254	SI DIODE
D 846	1SS254	SI DIODE
△ D 901	30DF2-FC	SI DIODE
△ D 902	30DF2-FC	SI DIODE
△ D 903	30DF2-FC	SI DIODE
△ D 904	30DF2-FC	SI DIODE
D 905	MTZ4.7C	Z. DIODE(IM)
D 906	MTZ12A	ZENER DIODE
D 907	MTZ5.6C	ZENER DIODE
D 908	11E1	SI DIODE
D 909	11E1	SI DIODE
D 910	MTZ24C	ZENER DIODE
△ D 911	11E1	SI DIODE
△ D 912	11E1	SI DIODE
D 920	MTZ7.5C	ZENER DIODE
D 921	1SS254	SI DIODE
D 922	1SS254	SI DIODE
IC701	MB88515B-1389T	IC
IC702	TA8409S	IC
IC703	TA8409S	IC
IC801	AN6557F	IC
IC802	CXA1331S	DOLBY IC
IC803	AN6555	IC
IC804	CXA1331S	DOLBY IC
IC805	MC14066BCP	IC
IC806	MC14053BCP	IC
IC808	AN6555	IC
IC809	LA2000S	IC
IC810	UPC4570HA	IC
IC811	UPC4570HA	IC
IC812	LM324N	IC
IC813	AN6555	IC
IC901	XRA15218	IC

REF.	PARTS NO.	PARTS NAME
J 701	QMS3533-001	JACK
J 801	VMJ3013-001	PIN JACK
J 802	VMJ3013-001	PIN JACK
J 803	VMJ3013-001	PIN JACK
L 101	VQP0001-562ZS	INDUCTOR
L 106	VQP0001-332ZS	INDUCTOR
L 107	VQP0001-332ZS	INDUCTOR
L 111	VQZ0065-001	FILTER
L 116	VQH7001-027	OSC COIL(BIAS)
L 117	VQP0001-562ZS	INDUCTOR
L 201	VQP0001-562ZS	INDUCTOR
L 206	VQP0001-332ZS	INDUCTOR
L 207	VQP0001-332ZS	INDUCTOR
L 211	VQZ0065-001	FILTER
L 216	VQH7001-027	OSC COIL(BIAS)
L 217	VQP0001-562ZS	INDUCTOR
L 806	VQH1008-039	OSC COIL(BIAS)
Q 101	2SK170V(BL,V)	FET
Q 102	2SC2240(GR,BL)	TRANSISTOR
Q 103	2SC2240(GR,BL)	TRANSISTOR
Q 104	2SK170V(BL,V)	FET
Q 105	2SC2240(GR,BL)	TRANSISTOR
Q 106	2SK301(R,S)	TRANSISTOR
Q 111	DTC114ES	DIGI. TRANSISTOR
Q 112	DTC114ES	DIGI. TRANSISTOR
Q 113	DTC114ES	DIGI. TRANSISTOR
Q 114	2SD1302(S,T)	TRANSISTOR
Q 116	2SC1740S(RS)	TRANSISTOR
Q 117	2SC1740S(RS)	TRANSISTOR
Q 121	2SD1302(S,T)	TRANSISTOR
Q 126	2SC1740S(RS)	TRANSISTOR
Q 131	2SC1740S(RS)	TRANSISTOR
Q 132	2SC1740S(RS)	TRANSISTOR
Q 133	2SC1740S(RS)	TRANSISTOR
Q 136	2SC2001(L,K)	TRANSISTOR
Q 137	2SC2001(L,K)	TRANSISTOR
Q 138	DTC114ES	DIGI. TRANSISTOR
Q 139	2SC2001(L,K)	TRANSISTOR
Q 140	DTC124ES	TRANSISTOR
Q 146	2SC1740S(RS)	TRANSISTOR
Q 147	2SC1740S(RS)	TRANSISTOR
Q 201	2SK170V(BL,V)	FET
Q 202	2SC2240(GR,BL)	TRANSISTOR
Q 203	2SC2240(GR,BL)	TRANSISTOR
Q 204	2SK170V(BL,V)	FET
Q 205	2SC2240(GR,BL)	TRANSISTOR
Q 206	2SK301(R,S)	TRANSISTOR
Q 211	DTC114ES	DIGI. TRANSISTOR
Q 212	DTC114ES	DIGI. TRANSISTOR
Q 213	DTC114ES	DIGI. TRANSISTOR
Q 214	2SD1302(S,T)	TRANSISTOR
Q 216	2SC1740S(RS)	TRANSISTOR
Q 217	2SC1740S(RS)	TRANSISTOR
Q 221	2SD1302(S,T)	TRANSISTOR
Q 226	2SC1740S(RS)	TRANSISTOR
Q 231	2SC1740S(RS)	TRANSISTOR
Q 232	2SC1740S(RS)	TRANSISTOR
Q 233	2SC1740S(RS)	TRANSISTOR
Q 236	2SC2001(L,K)	TRANSISTOR
Q 237	2SC2001(L,K)	TRANSISTOR
Q 238	DTC114ES	DIGI. TRANSISTOR
Q 239	2SC2001(L,K)	TRANSISTOR
Q 240	DTC124ES	TRANSISTOR
Q 246	2SC1740S(RS)	TRANSISTOR
Q 247	2SC1740S(RS)	TRANSISTOR
Q 701	2SC1740S(RS)	TRANSISTOR
Q 702	2SC1740S(RS)	TRANSISTOR
Q 703	2SC1740S(RS)	TRANSISTOR
Q 704	2SA933(R,S)	TRANSISTOR
Q 705	DTC124ES	TRANSISTOR
Q 706	DTC124ES	TRANSISTOR
Q 707	DTC124ES	TRANSISTOR
Q 708	DTC124ES	TRANSISTOR
Q 709	DTC124ES	TRANSISTOR
Q 711	DTA114ES	DIGITAL-TR
Q 712	DTC124ES	TRANSISTOR
Q 713	DTA124ES	TRANSISTOR
Q 714	DTA124ES	TRANSISTOR
Q 715	2SC1740S(RS)	TRANSISTOR
Q 716	2SC1740S(RS)	TRANSISTOR
Q 717	2SC1740S(RS)	TRANSISTOR
Q 718	2SC1740S(RS)	TRANSISTOR
Q 719	DTC124ES	TRANSISTOR
Q 801	DTC124ES	TRANSISTOR
Q 806	DTA124ES	TRANSISTOR
Q 808	DTC124ES	TRANSISTOR
Q 811	2SA933(R,S)	TRANSISTOR
Q 813	DTC124ES	TRANSISTOR
Q 816	2SA933(R,S)	TRANSISTOR
Q 817	DTA124ES	TRANSISTOR

REF.	PARTS NO.	PARTS NAME
Q 821	DTC124ES	TRANSISTOR
Q 822	DTC124ES	TRANSISTOR
Q 823	DTA124ES	TRANSISTOR
Q 824	DTC124ES	TRANSISTOR
Q 826	2SC2001(L,K)	TRANSISTOR
Q 827	2SC2001(L,K)	TRANSISTOR
Q 828	2SC2001(L,K)	TRANSISTOR
Q 829	DTC124ES	TRANSISTOR
Q 830	2SA933(R,S)	TRANSISTOR
Q 831	DTC124ES	TRANSISTOR
Q 832	DTC124ES	TRANSISTOR
Q 836	DTC124ES	TRANSISTOR
Q 901	2SA1359(OY)	TRANSISTOR
Q 902	2SC1740S(RS)	TRANSISTOR
Q 903	2SC3422(OY)	TRANSISTOR
Q 904	2SA933(R,S)	TRANSISTOR
Q 905	2SC3422(OY)	TRANSISTOR
Q 906	2SD2069(Q)	TRANSISTOR
Q 907	2SB1043(QR)	TRANSISTOR
R 101	QRD161J-273	CARBON RESISTOR
R 102	QRD161J-470	CARBON RESISTOR
R 103	QRD161J-182	CARBON RESISTOR
R 104	QRD161J-822	CARBON RESISTOR
R 105	QRD161J-182	CARBON RESISTOR
R 106	QRD161J-102	CARBON RESISTOR
R 107	QRD161J-472	CARBON RESISTOR
R 108	QRD161J-101	CARBON RESISTOR
R 109	QRD161J-102	CARBON RESISTOR
R 110	QRD161J-331	CARBON RESISTOR
R 111	QRD161J-222	CARBON RESISTOR
R 112	QRD161J-102	CARBON RESISTOR
R 113	QRD161J-184	CARBON RESISTOR
R 114	QRD161J-302	CARBON RESISTOR
R 115	QRD161J-432Y	CARBON RESISTOR
R 116	QRD161J-470	CARBON RESISTOR
R 117	QRD161J-105	CARBON RESISTOR
R 118	QRD161J-471	CARBON RESISTOR
R 119	QRD161J-102	CARBON RESISTOR
R 120	QRD161J-562	CARBON RESISTOR
R 121	QRD161J-562	CARBON RESISTOR
R 126	QRD161J-104	CARBON RESISTOR
R 127	QRD161J-243	CARBON RESISTOR
R 128	QRD161J-561	CARBON RESISTOR
R 131	QRD161J-272	CARBON RESISTOR
R 132	QRD161J-103	CARBON RESISTOR
R 133	QRD161J-153	CARBON RESISTOR
R 134	QRD161J-473	CARBON RESISTOR
R 135	QRD161J-152	CARBON RESISTOR
R 136	QRD161J-680	CARBON RESISTOR
R 137	QRD161J-102	CARBON RESISTOR
R 138	QRD161J-101	CARBON RESISTOR
R 139	QRD161J-432Y	CARBON RESISTOR
R 140	QRD161J-152	CARBON RESISTOR
R 141	QRD161J-682	CARBON RESISTOR
R 142	QRD161J-272	CARBON RESISTOR
R 143	QRD161J-222	CARBON RESISTOR
R 144	QRD161J-682	CARBON RESISTOR
R 145	QRD161J-392	CARBON RESISTOR
R 146	QRD161J-105	CARBON RESISTOR
R 151	QRD161J-222	CARBON RESISTOR
R 152	QRD161J-105	CARBON RESISTOR
R 153	QRD161J-562	CARBON RESISTOR
R 154	QRD161J-104	CARBON RESISTOR
R 155	QRD161J-105	CARBON RESISTOR
R 156	QRD161J-243	CARBON RESISTOR
R 157	QRD161J-561	CARBON RESISTOR
R 158	QRD161J-104	CARBON RESISTOR
R 161	QRD161J-333	CARBON RESISTOR
R 162	QRD161J-333	CARBON RESISTOR
R 163	QRD161J-683	CARBON RESISTOR
R 164	QRD161J-473	CARBON RESISTOR
R 165	QRD161J-104	CARBON RESISTOR
R 166	QRD161J-332	CARBON RESISTOR
R 167	QRD161J-222	CARBON RESISTOR
R 168	QRD161J-222	CARBON RESISTOR
R 169	QRD161J-203	CARBON RESISTOR
R 171	QRD161J-473	CARBON RESISTOR
R 172	QRD161J-222	CARBON RESISTOR
R 173	QRD161J-224	CARBON RESISTOR
R 186	QRD161J-153	CARBON RESISTOR
R 187	QRD161J-103	CARBON RESISTOR
R 188	QRD161J-473	CARBON RESISTOR
R 189	QRD161J-105	CARBON RESISTOR
R 190	QRD161J-681	CARBON RESISTOR
R 191	QRD161J-220	CARBON RESISTOR
R 192	QRD161J-102	CARBON RESISTOR
R 193	QRD161J-223	CARBON RESISTOR
R 194	QRD161J-105	CARBON RESISTOR
R 195	QRD161J-222	CARBON RESISTOR
R 196	QRD161J-682	CARBON RESISTOR

REF.	PARTS NO.	PARTS NAME
R 201	QRD161J-273	CARBON RESISTOR
R 202	QRD161J-470	CARBON RESISTOR
R 203	QRD161J-182	CARBON RESISTOR
R 204	QRD161J-822	CARBON RESISTOR
R 205	QRD161J-182	CARBON RESISTOR
R 206	QRD161J-102	CARBON RESISTOR
R 207	QRD161J-472	CARBON RESISTOR
R 208	QRD161J-101	CARBON RESISTOR
R 209	QRD161J-102	CARBON RESISTOR
R 210	QRD161J-331	CARBON RESISTOR
R 211	QRD161J-222	CARBON RESISTOR
R 212	QRD161J-102	CARBON RESISTOR
R 213	QRD161J-184	CARBON RESISTOR
R 214	QRD161J-302	CARBON RESISTOR
R 215	QRD161J-432Y	CARBON RESISTOR
R 216	QRD161J-470	CARBON RESISTOR
R 217	QRD161J-105	CARBON RESISTOR
R 218	QRD161J-471	CARBON RESISTOR
R 219	QRD161J-102	CARBON RESISTOR
R 220	QRD161J-562	CARBON RESISTOR
R 221	QRD161J-562	CARBON RESISTOR
R 226	QRD161J-104	CARBON RESISTOR
R 227	QRD161J-243	CARBON RESISTOR
R 228	QRD161J-561	CARBON RESISTOR
R 231	QRD161J-272	CARBON RESISTOR
R 232	QRD161J-103	CARBON RESISTOR
R 233	QRD161J-153	CARBON RESISTOR
R 234	QRD161J-473	CARBON RESISTOR
R 235	QRD161J-152	CARBON RESISTOR
R 236	QRD161J-680	CARBON RESISTOR
R 237	QRD161J-102	CARBON RESISTOR
R 238	QRD161J-101	CARBON RESISTOR
R 239	QRD161J-432Y	CARBON RESISTOR
R 240	QRD161J-152	CARBON RESISTOR
R 241	QRD161J-682	CARBON RESISTOR
R 242	QRD161J-272	CARBON RESISTOR
R 243	QRD161J-222	CARBON RESISTOR
R 244	QRD161J-682	CARBON RESISTOR
R 245	QRD161J-392	CARBON RESISTOR
R 246	QRD161J-105	CARBON RESISTOR
R 251	QRD161J-222	CARBON RESISTOR
R 252	QRD161J-105	CARBON RESISTOR
R 253	QRD161J-562	CARBON RESISTOR
R 254	QRD161J-104	CARBON RESISTOR
R 255	QRD161J-105	CARBON RESISTOR
R 256	QRD161J-243	CARBON RESISTOR
R 257	QRD161J-561	CARBON RESISTOR
R 258	QRD161J-104	CARBON RESISTOR
R 261	QRD161J-333	CARBON RESISTOR
R 262	QRD161J-333	CARBON RESISTOR
R 263	QRD161J-683	CARBON RESISTOR
R 264	QRD161J-473	CARBON RESISTOR
R 265	QRD161J-104	CARBON RESISTOR
R 266	QRD161J-332	CARBON RESISTOR
R 267	QRD161J-222	CARBON RESISTOR
R 268	QRD161J-222	CARBON RESISTOR
R 269	QRD161J-203	CARBON RESISTOR
R 271	QRD161J-473	CARBON RESISTOR
R 272	QRD161J-222	CARBON RESISTOR
R 273	QRD161J-224	CARBON RESISTOR
R 286	QRD161J-153	CARBON RESISTOR
R 287	QRD161J-103	CARBON RESISTOR
R 288	QRD161J-473	CARBON RESISTOR
R 289	QRD161J-103	CARBON RESISTOR
R 290	QRD161J-681	CARBON RESISTOR
R 291	QRD161J-220	CARBON RESISTOR
R 292	QRD161J-102	CARBON RESISTOR
R 293	QRD161J-223	CARBON RESISTOR
R 294	QRD161J-105	CARBON RESISTOR
R 295	QRD161J-222	CARBON RESISTOR
R 296	QRD161J-682	CARBON RESISTOR
R 301	QRD161J-100	CARBON RESISTOR
R 302	QRD161J-394	CARBON RESISTOR
R 303	QRD161J-394	CARBON RESISTOR
R 304	QRD161J-101	CARBON RESISTOR
R 305	QRD161J-101	CARBON RESISTOR
R 306	QRD161J-154	CARBON RESISTOR
R 307	QRD161J-392	CARBON RESISTOR
R 309	QRD161J-683	CARBON RESISTOR
R 310	QRD161J-103	CARBON RESISTOR
R 311	QRD161J-103	CARBON RESISTOR
R 312	QRD161J-102	CARBON RESISTOR
R 313	QRD161J-104	CARBON RESISTOR
R 314	QRZ0077-4R7X	FUSE RESISTOR
R 315	QRD161J-102	CARBON RESISTOR
R 316	QRD161J-103	CARBON RESISTOR
R 317	QRD161J-103	CARBON RESISTOR
R 318	QRD161J-103	CARBON RESISTOR
R 319	QRD161J-395	CARBON RESISTOR
R 320	QRD161J-104	CARBON RESISTOR

REF.	PARTS NO.	PARTS NAME
R 326	QRD161J-184	CARBON RESISTOR
R 328	QRD161J-102	CARBON RESISTOR
R 329	QRD161J-273	CARBON RESISTOR
R 330	QRD161J-242Y	CARBON RESISTOR
R 331	QRD161J-103	CARBON RESISTOR
R 332	QRD161J-222	CARBON RESISTOR
R 333	QRV141F-2001AY	CMF RESISTOR
R 401	QRD161J-100	CARBON RESISTOR
R 402	QRD161J-394	CARBON RESISTOR
R 403	QRD161J-394	CARBON RESISTOR
R 404	QRD161J-101	CARBON RESISTOR
R 405	QRD161J-101	CARBON RESISTOR
R 406	QRD161J-154	CARBON RESISTOR
R 407	QRD161J-392	CARBON RESISTOR
R 409	QRD161J-683	CARBON RESISTOR
R 410	QRD161J-103	CARBON RESISTOR
R 411	QRD161J-103	CARBON RESISTOR
R 412	QRD161J-102	CARBON RESISTOR
R 413	QRD161J-104	CARBON RESISTOR
R 414	QRZ0077-4R7X	FUSE RESISTOR
R 415	QRD161J-102	CARBON RESISTOR
R 416	QRD161J-103	CARBON RESISTOR
R 417	QRD161J-103	CARBON RESISTOR
R 418	QRD161J-103	CARBON RESISTOR
R 419	QRD161J-395	CARBON RESISTOR
R 420	QRD161J-104	CARBON RESISTOR
R 426	QRD161J-184	CARBON RESISTOR
R 428	QRD161J-102	CARBON RESISTOR
R 429	QRD161J-273	CARBON RESISTOR
R 430	QRD161J-242Y	CARBON RESISTOR
R 431	QRD161J-103	CARBON RESISTOR
R 432	QRD161J-222	CARBON RESISTOR
R 433	QRV141F-2001AY	CMF RESISTOR
R 701	QRD161J-223	CARBON RESISTOR
R 702	QRD161J-104	CARBON RESISTOR
R 703	QRD161J-471	CARBON RESISTOR
R 704	QRD161J-103	CARBON RESISTOR
R 705	QRD161J-102	CARBON RESISTOR
R 706	QRD161J-272	CARBON RESISTOR
R 707	QRD161J-102	CARBON RESISTOR
R 708	QRD161J-102	CARBON RESISTOR
R 709	QRD161J-471	CARBON RESISTOR
R 710	QRD161J-223	CARBON RESISTOR
R 711	QRD161J-103	CARBON RESISTOR
R 712	QRD161J-223	CARBON RESISTOR
R 713	QRD161J-473	CARBON RESISTOR
R 714	QRD161J-221	CARBON RESISTOR
R 715	QRD161J-153	CARBON RESISTOR
R 716	QRD161J-222	CARBON RESISTOR
R 718	QRD161J-242Y	CARBON RESISTOR
R 719	QRD161J-122	CARBON RESISTOR
R 720	QRD161J-682	CARBON RESISTOR
R 721	QRD161J-221	CARBON RESISTOR
R 722	QRD161J-682	CARBON RESISTOR
R 723	QRD161J-682	CARBON RESISTOR
R 724	QRD161J-682	CARBON RESISTOR
R 725	QRD161J-103	CARBON RESISTOR
R 726	QRD161J-103	CARBON RESISTOR
R 727	QRD161J-103	CARBON RESISTOR
R 755	QRD161J-103	CARBON RESISTOR
R 756	QRD161J-223	CARBON RESISTOR
R 757	QRD161J-223	CARBON RESISTOR
R 758	QRD161J-223	CARBON RESISTOR
R 759	QRD161J-223	CARBON RESISTOR
R 801	QRD161J-103	CARBON RESISTOR
R 802	QRD161J-222	CARBON RESISTOR
R 803	QRD161J-223	CARBON RESISTOR
R 806	QRD161J-102	CARBON RESISTOR
R 807	QRD161J-273	CARBON RESISTOR
R 808	QRD161J-3R3	CARBON RESISTOR
R 809	QRD161J-3R3	CARBON RESISTOR
R 811	QRD161J-102	CARBON RESISTOR
R 812	QRD161J-273	CARBON RESISTOR
R 813	QRD161J-222	CARBON RESISTOR
R 814	QRD161J-103	CARBON RESISTOR
R 816	QRD161J-3R3	CARBON RESISTOR
R 817	QRD161J-3R3	CARBON RESISTOR
R 821	QRD161J-223	CARBON RESISTOR
R 822	QRD161J-103	CARBON RESISTOR
R 823	QRD161J-103	CARBON RESISTOR
R 824	QRD161J-103	CARBON RESISTOR
R 825	QRD161J-101	CARBON RESISTOR
R 826	QRD161J-104	CARBON RESISTOR
R 827	QRD161J-104	CARBON RESISTOR
R 831	QRD161J-4R7	CARBON RESISTOR
R 832	QRD161J-4R7	CARBON RESISTOR
R 836	QRD161J-472	CARBON RESISTOR
R 837	QRD161J-472	CARBON RESISTOR
R 838	QRD161J-473	CARBON RESISTOR
R 839	QRD161J-473	CARBON RESISTOR

REF.	PARTS NO.	PARTS NAME
R 840	QRD161J-103	CARBON RESISTOR
R 841	QRD161J-223	CARBON RESISTOR
R 842	QRD161J-223	CARBON RESISTOR
R 846	QRD161J-273	CARBON RESISTOR
R 847	QRD161J-183	CARBON RESISTOR
R 848	QRD161J-224	CARBON RESISTOR
R 851	QRD161J-103	CARBON RESISTOR
R 852	QRD161J-222	CARBON RESISTOR
R 853	QRD161J-103	CARBON RESISTOR
R 854	QRD161J-103	CARBON RESISTOR
R 855	QRD161J-302	CARBON RESISTOR
R 856	QRD161J-223	CARBON RESISTOR
R 857	QRD161J-223	CARBON RESISTOR
R 858	QRD161J-182	CARBON RESISTOR
R 859	QRD161J-822	CARBON RESISTOR
R 860	QRD161J-104	CARBON RESISTOR
R 861	QRD161J-392	CARBON RESISTOR
R 862	QRD161J-562	CARBON RESISTOR
R 863	QRD161J-103	CARBON RESISTOR
R 864	QRD161J-103	CARBON RESISTOR
R 865	QRD161J-223	CARBON RESISTOR
R 866	QRD161J-332	CARBON RESISTOR
R 868	QRD161J-103	CARBON RESISTOR
R 869	QRD161J-153	CARBON RESISTOR
R 873	QRD161J-3R3	CARBON RESISTOR
R 874	QRD161J-3R3	CARBON RESISTOR
R 875	QRD161J-393	CARBON RESISTOR
R 876	QRD161J-393	CARBON RESISTOR
R 877	QRZ0077-100X	F. RESISTOR
R 878	QRD161J-222	CARBON RESISTOR
R 879	QRD161J-333	CARBON RESISTOR
R 880	QRD161J-153	CARBON RESISTOR
R 881	QRD161J-471	CARBON RESISTOR
R 882	QRD161J-272	CARBON RESISTOR
R 883	QRD161J-752Y	CARBON RESISTOR
R 884	QRD161J-103	CARBON RESISTOR
R 885	QRD161J-103	CARBON RESISTOR
R 886	QRD161J-223	CARBON RESISTOR
R 887	QRD161J-183	CARBON RESISTOR
R 888	QRD161J-103	CARBON RESISTOR
R 889	QRD161J-621Y	CARBON RESISTOR
R 890	QRD161J-681	CARBON RESISTOR
R 891	QRD161J-221	CARBON RESISTOR
R 893	QRD161J-183	CARBON RESISTOR
R 894	QRD161J-103	CARBON RESISTOR
R 897	QRD161J-473	CARBON RESISTOR
R 898	QRD161J-223	CARBON RESISTOR
R 899	QRD161J-223	CARBON RESISTOR
R 901	QRZ0077-4R7X	FUSE RESISTOR
R 902	QRZ0077-4R7X	FUSE RESISTOR
R 903	QRD161J-273	CARBON RESISTOR
R 904	QRD161J-103	CARBON RESISTOR
R 905	QRD161J-242Y	CARBON RESISTOR
R 906	QRD161J-472	CARBON RESISTOR
R 907	QRD161J-472	CARBON RESISTOR
R 908	QRD161J-472	CARBON RESISTOR
R 909	QRD161J-102	CARBON RESISTOR
R 910	QRD161J-102	CARBON RESISTOR
R 912	QRD129J-221	CARBON RESISTOR
R 913	QRZ0077-100X	F. RESISTOR
R 914	QRD161J-471	CARBON RESISTOR
R 915	QRD161J-471	CARBON RESISTOR
R 916	QRD121J-102	CARBON RESISTOR
R 917	QRZ0077-100X	F. RESISTOR
R 918	QRD161J-102	CARBON RESISTOR
R 919	QRD161J-332	CARBON RESISTOR
R 920	QRD161J-103	CARBON RESISTOR
R 921	QRD161J-103	CARBON RESISTOR
R 922	QRD161J-103	CARBON RESISTOR
R 923	QRD161J-103	CARBON RESISTOR
RN701	QRB119J-223	R NETWORK
RN702	QRB119J-223	R NETWORK
S 803	QSTT102-V01	PUSH SWITCH
TP101	VMZ0015-003	POST PIN
TP201	VMZ0015-003	POST PIN
TP701	VMZ0015-003	POST PIN
VR101	QVZ3523-101AZ	V RESISTOR
VR102	QVZ3523-502AZ	V. RESISTOR
VR103	QVZ3523-503AZ	V. RESISTOR
VR104	QVZ3523-104AZ	V. RESISTOR
VR105	QVZ3523-102AZ	V RESISTER
VR106	QVZ3523-503AZ	V RESISTOR
VR201	QVZ3523-101AZ	V RESISTOR
VR202	QVZ3523-502AZ	V. RESISTOR
VR203	QVZ3523-503AZ	V RESISTOR
VR204	QVZ3523-104AZ	V. RESISTOR
VR205	QVZ3523-102AZ	V RESISTER
VR206	QVZ3523-503AZ	V RESISTOR
VR803	QVD8A7A-015FA	V RESISTOR
VR805	QVZ3523-502AZ	V. RESISTOR



Other Board

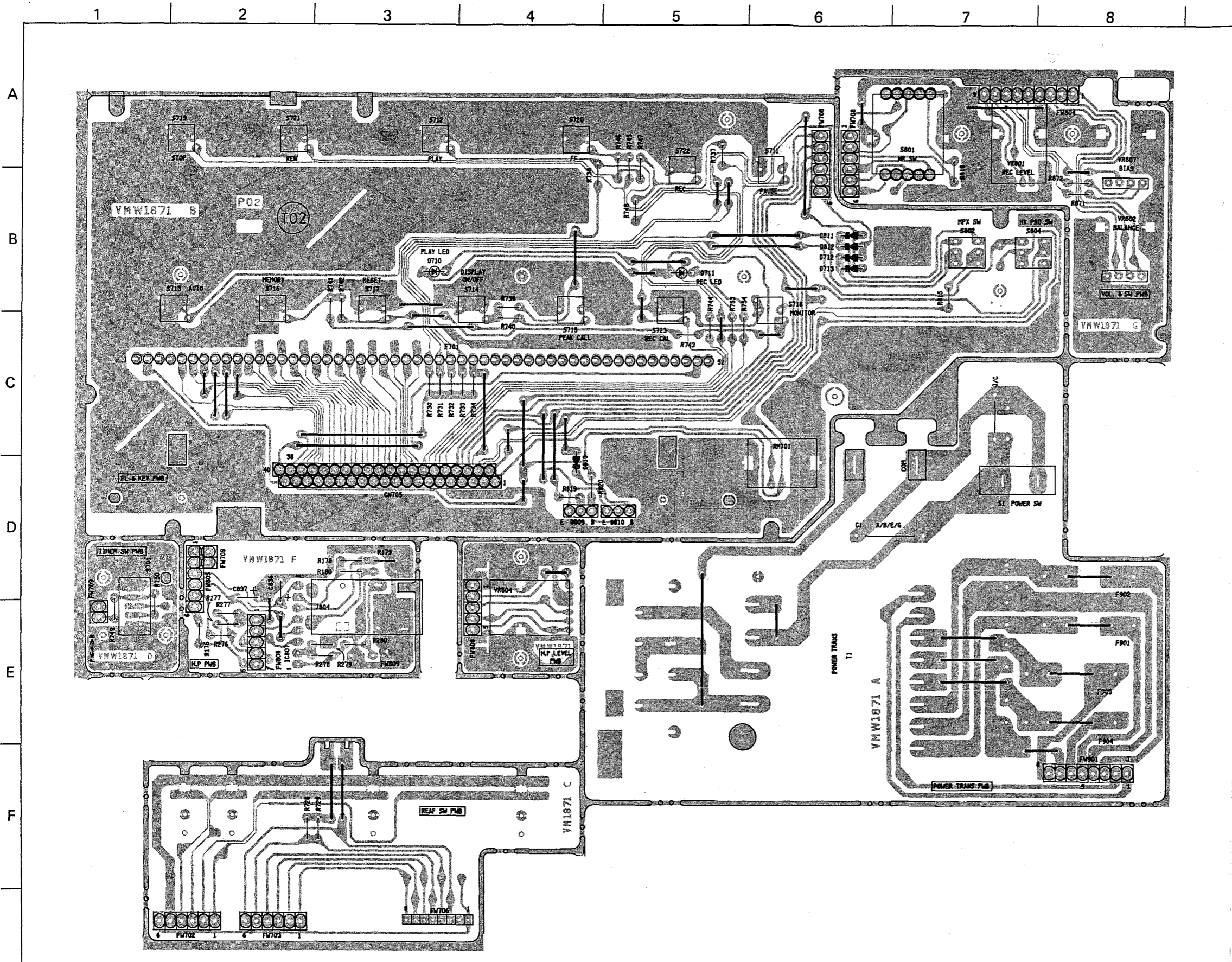

Other Board Parts List BLOCK NO. 02

REF.	PARTS NO.	PARTS NAME
C 1	QF29010-103	M. CAPACITOR
C 154	QCF11HP-223	C CAPACITOR
C 254	QCF11HP-223	C CAPACITOR
C 836	QETC1AM-107ZN	E CAPACITOR
C 837	QETC1AM-107ZN	E CAPACITOR
CN705	VMC0163-R40	CONNECTOR
CN706	VMC0075-008	CONNECTOR
D 710	SLR-34MC70F124	LED
D 711	SLR-34VC70F124	LED
D 712	1SS254	SI DIODE
D 713	1SS254	SI DIODE
D 811	1SS254	SI DIODE
D 812	1SS254	SI DIODE
D 813	1SS254	SI DIODE
F 701	BG-902GK	FL TUBE
IC807	XRA15218N	IC
J 804	QMS6022-V01	JACK
Q 809	DTC124ESTP	TRANSISTOR
Q 810	DTC124ESTP	TRANSISTOR
R 176	QRD161J-333	CARBON RESISTOR
R 177	QRD161J-153	CARBON RESISTOR
R 178	QRD161J-124	CARBON RESISTOR
R 179	QRD161J-752Y	CARBON RESISTOR
R 180	QRD161J-820	CARBON RESISTOR
R 276	QRD161J-333	CARBON RESISTOR
R 277	QRD161J-153	CARBON RESISTOR
R 278	QRD161J-124	CARBON RESISTOR
R 279	QRD161J-752Y	CARBON RESISTOR
R 280	QRD161J-820	CARBON RESISTOR
R 728	QRD161J-102	CARBON RESISTOR
R 729	QRD161J-102	CARBON RESISTOR
R 730	QRD161J-223	CARBON RESISTOR
R 731	QRD161J-223	CARBON RESISTOR
R 732	QRD161J-223	CARBON RESISTOR
R 733	QRD161J-223	CARBON RESISTOR
R 734	QRD161J-223	CARBON RESISTOR
R 737	QRD161J-102	CARBON RESISTOR
R 738	QRD161J-122	CARBON RESISTOR
R 739	QRD161J-182	CARBON RESISTOR
R 740	QRD161J-272	CARBON RESISTOR
R 741	QRD161J-472	CARBON RESISTOR
R 742	QRD161J-822	CARBON RESISTOR
R 743	QRD161J-273	CARBON RESISTOR
R 744	QRD161J-102	CARBON RESISTOR
R 745	QRD161J-122	CARBON RESISTOR
R 746	QRD161J-182	CARBON RESISTOR
R 747	QRD161J-272	CARBON RESISTOR
R 748	QRD161J-472	CARBON RESISTOR
R 749	QRD161J-822	CARBON RESISTOR
R 750	QRD161J-273	CARBON RESISTOR
R 753	QRD161J-271	CARBON RESISTOR
R 754	QRD161J-331	CARBON RESISTOR
R 815	QRD161J-102	CARBON RESISTOR
R 818	QRD161J-103	CARBON RESISTOR
R 819	QRD161J-561	CARBON RESISTOR
R 820	QRD161J-223	CARBON RESISTOR
R 871	QRD161J-182	CARBON RESISTOR
R 872	QRD161J-123	CARBON RESISTOR
RM701	SBX1610-02	RM RECIVER
S 1	QSP1106-004	PUSH SWITCH
S 2	QSS2325-119	SLIDE SWITCH
S 701	QSS7A23-V05	SLIDE SWITCH
S 711	QSP4H11-V14 Z	TACT SWITCH
S 712	QSP4H11-V14 Z	TACT SWITCH
S 713	QSP4H11-V14 Z	TACT SWITCH
S 714	QSP4H11-V14 Z	TACT SWITCH
S 715	QSP4H11-V14 Z	TACT SWITCH
S 716	QSP4H11-V14 Z	TACT SWITCH
S 717	QSP4H11-V14 Z	TACT SWITCH
S 718	QSP4H11-V14 Z	TACT SWITCH
S 719	QSP4H11-V14 Z	TACT SWITCH
S 720	QSP4H11-V14 Z	TACT SWITCH
S 721	QSP4H11-V14 Z	TACT SWITCH
S 722	QSP4H11-V14 Z	TACT SWITCH
S 723	QSP4H11-V14 Z	TACT SWITCH
S 801	QSR2D23-V01	ROTARY SWITCH
S 802	QSP4L11-V01	PUSH SWITCH
S 804	QSP4L11-V01	PUSH SWITCH
VR801	QVCB17A-V02 M	V RESISTOR
VR802	QVCA47G-V01 M	V RESISTOR
VR804	QVCB16A-V01 M	V RESISTOR
VR807	QVCA47B-V01 M	V RESISTOR

# 9 Exploded View of Enclosure Assembly

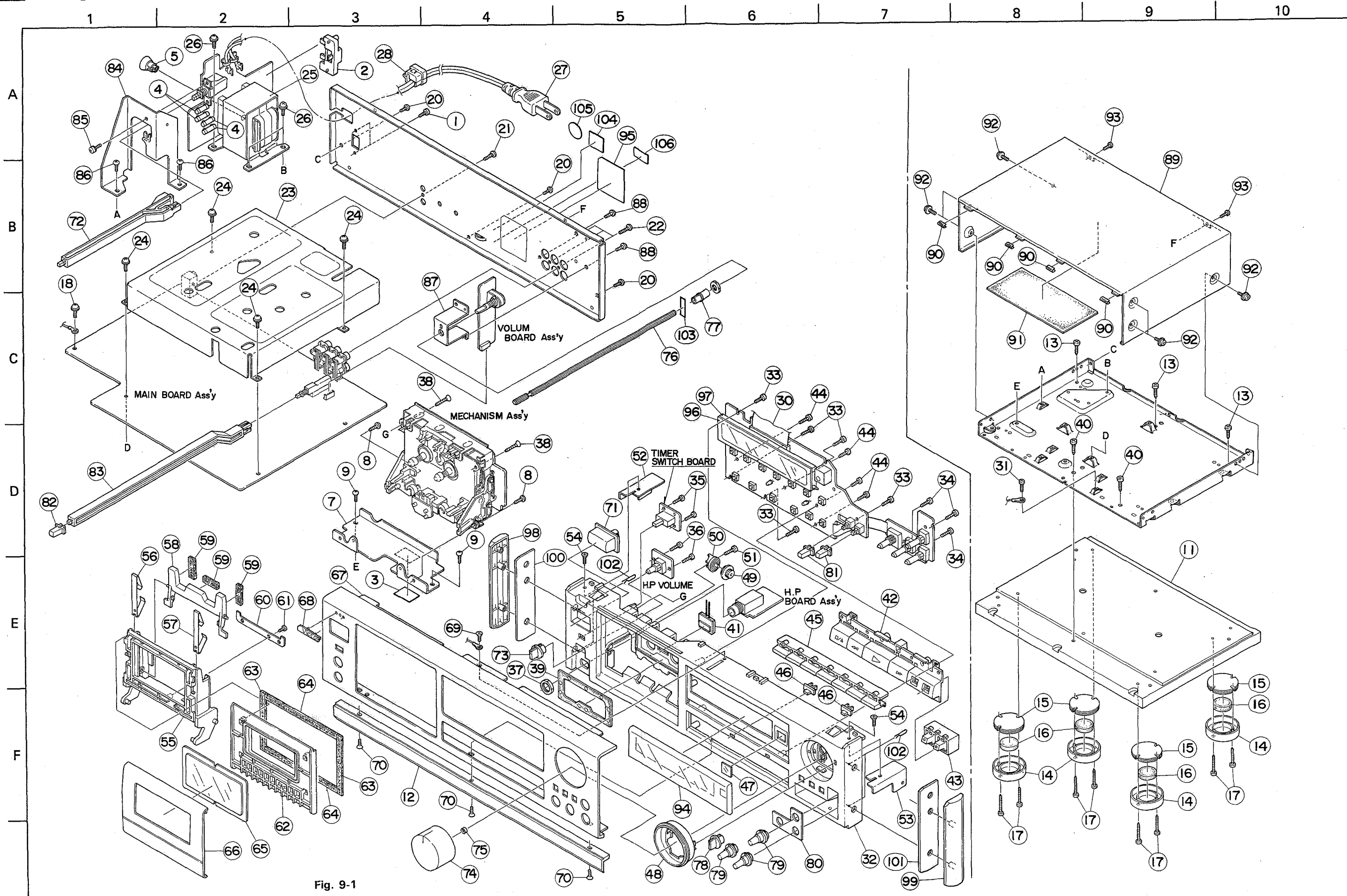

Fig. 9-1

△ parts are safety assurance parts.  
When replacing those parts, make  
sure to use the specified one.

## ● Enclosure Component Parts List

BLOCK NO. **M1MM**

△	REF.	PARTS NO.	PARTS NAME	REMARKS	QTY
	55~61 62~66	ZCTDV1050K-CH ZCTDV1050K-CLTN	CASSETTE HOLDER ASS'Y CASSETTE LID ASS'Y	SERVICE PARTS SERVICE PARTS	
	1	SBSF3008M	SCREW	A/B/E/G(V-SELECT)	2
	2	VKS5011-001	VOLTAGE CONTACT	A/B/E/G(V-SELECT)	1
	3	VYSA1R4-084	SPACER	FOR HEAD WIRE	1
△	4	QMF51A2-R63	FUSE A/E/G VER.	F901/902/904/905C	4
△		QMF51E2-R63BS	FUSE B VERSION	F901/902/904/905C	4
	5	VYH7620-001	CAP	A/B/E/G VETSION	1
	7	VKM3465-001	MECHA BRACKET		1
	8	SBST3006Z	SCREW	FOR MECHA.BOTTOM	2
	9	SBST3006Z	SCREW	FOR MECHA.BRACKET	2
	10	VKL1334-002	CHASSIS BASE		1
	11	VJD1154-002	ARK BASE		1
	12	VJD2369-002	ARK BASE PLATE		1
	13	SDSA4014M	SCREW	FOR ARK BASE	3
	14	E75538-005	FOOT	FOR MOLDER	4
	15	VYTP432-001	SPACER	FOR FOOT	4
	16	VJF4003-013	FOOT		4
	17	SDSA3010Z	SCREW	FOR FOOT	8
	18	GBST3008Z	SCREW	FOR MAIN BOARD	1
	19	VJC2415-004	REAR PANEL	A/B/E/G VERSION	1
		VJC2415-005	REAR PANEL	C/J VERSION	1
	20	SBST3006M	SCREW	FOR REAR	3
	21	SBSF3008M	SCREW	FOR DCS JACK	1
	22	SBSF3008M	SCREW	FOR PIN JACK	3
	23	VKL2602-001	SHEILD CASE	FOR MAIN BOARD	1
	24	GBST3008Z	SCREW	FOR SHILD CASE	4
△	25	VTP57A9-021B	POWER TRANS	T1 C/J VERSION	1
△		VTP57H9-011B	POWER TRANS	T1 A/E/G VERSION	1
△		VTP57H9-011BBS	POWER TRANS	T1 B VERSION	1
	26	GBST3006Z	SCREW	FOR POWER TRANS	3
△	27	QMP1900-200	POWER CORD	C/J VERSION	1
△		QMP2560-200	POWER CORD	A VERSION	1
△		QMP3900-200	POWER CORD	E/G VERSION	1
△		QMP9017-008BS	POWER CORD	B VERSION	1
△	28	QHS3771-108	CORD STOPPER		1
△		QHS3771-108BS	CORD STOPPER	B VERSION ONLY	1
	30	VWH140-15C2C2-I	CARD WIRE	FOR FL BOARD	1
	31	SBST3006Z	SCREW	FOR LUG WIER	1
	32	VJC1965-006	FRONT PANEL	A/B/E/G VERSION	1
		VJC1965-007UL	FRONT PANEL	C/J VERSION	1
	33	SBSF3008Z	SCREW	FOR FL BOARD	5
	34	SBSF3008Z	SCREW	FOR VOLUME BOARD	3
	35	SBSF3008Z	SCREW	FOR TIMER BOARD	2
	36	SBSF3008Z	SCREW	FOR H.PHONE VOLUM	2
	37	VKZ4150-001	SPECIAL NUT	FOR P.PHONE	1
	38	SSSF3010Z	SCREW	FOR MECHANISM	2
	39	VJD5201-002	PAD	FOR FRONT PANEL	1
	40	SDSA4014M	SCREW	FOR FRONT PANEL	2
	41	LD-702YU	L.E.D	FOR BACK LIGHT	1
	42	VXP3415-005	MECHA BUTTON		1
	43	VXP5018-002	MECHA BUTTON		1
	44	SBSF3008Z	SCREW	FOR MECHA BUTTON	4
	45	VXP3416-002	PUSH BUTTON		1
	46	VJD5339-001	LED LENS	FOR PLAY/REC	2
	47	VJD5029-001	RC FILTER		1
	48	VJD5343-002	INPUT ESCUTCHED		1
	49	VYH5601-002	GEAR	FOR DAMPER	1
	50	VYH5602-002	DAMPER HOLDER		1
	51	SBSF3008Z	SCREW	FOR DAMPER	1
	52	VKL7135-001	FRONT BKT(L)		1
	53	VKL7136-001	FRONT BKT(R)		1

△	REF.	PARTS NO.	PARTS NAME	REMARKS	QTY
	54	SSSP3008Z	SCREW	FOR FRONT BRACKET	2
	55	VJT2267-003	CASSETTE HOLDER		1
	56	VKY4382-007	CASSETTE SPRING	FOR LEFT	1
	57	VKY4382-008	CASSETTE SPRING	FOR RIGHT	1
	58	VJT3314-004	STABILIZER		1
	59	VJD5341-001	PAD	FOR STABILIZER	3
	60	VKY4638-001	SPRING	FOR STABILIZER	1
	61	SDSF2605Z	SCREW	FOR SPRING	1
	62	VJT3312-002	CASSETTE LID		1
	63	VJD5341-002	PAD	FOR CASSETTE LID	2
	64	VJD5341-003	PAD	FOR CASSETTE LID	2
	65	VJD3870-001	CASSETTE LENS		1
	66	VJT3313-003	LID PLATE		1
	67	VJC1966-006	FRONT PLATE		1
	68	E72968-001	JVC MARK		1
	69	SSSF3010Z	SCREW	FOR FRONT PLATE	1
	70	SSSF3010Z	SCREW	FOR FRONT PLATE	3
	71	VXP5033-001	PUSH BUTTON	FOR POWER	1
	72	VKS3450-002	REMOTE BAR	FOR POWER SWITCH	1
	73	E304525-009	VOLUME KNOB	FOR HEADPHONE VOL	1
	74	VXL3012-003	INPUT KNOB		1
	75	VKW4901-002	KNOB SPRING	FOR INPUT KNOB	1
	76	VKH5474-001	VOLUME SHAFT	FOR INPUT	1
	77	VKS4992-004	VOLUME CONTACT	FOR INPUT	1
	78	E304525-009	VOLUME KNOB	FOR DOLBY	1
	79	E406163-007	KNOB	CALIBRATION/BALAN	3
	80	VJD5372-002	VOL PLATE	CALIBRATION/BALAN	1
	81	VXP4814-002	PUSH BUTTON	HX PRO/MPX FILTER	2
	82	VXP4814-002	PUSH BUTTON	CD DIRECTION	1
	83	VKS3505-001	REMOTE BAR	FOR CD DIRECTION	1
	84	VKM3466-001	POWER BRACKET		1
	85	LPSP3008Z	SCREW	FOR POWER SWITCH	1
	86	GBST3006Z	SCREW	FOR POWER BRACKET	2
	87	VKL7009-001	VOLUME BRACKET		1
	88	SBST3006M	SCREW	FOR VOLUME BRACKE	2
	89	VJC1980-002	TOP COVER		1
	90	VYSH105-034	SPACER	FOR TOP COVER	4
	91	VYTR435-001	SPACER	BOTTOM SIDE OF TO	1
	92	VKZ4614-001	SPECIAL SCREW	FOR TOP COVER	6
	93	SBST3006M	SCREW	FOR TOP COVER	2
	94	VJK3534-003	FINDER		1
	95	VYN2295-002PA	NAME PLATE	A VERSION	1
		VYN2295-002PA	NAME PLATE	B VERSION	1
		VYN2295-002PA	NAME PLATE	G VERSION	1
		VYN2295-004PA	NAME PLATE	C VERSION	1
		VYN2295-005PA	NAME PLATE	E VERSION	1
		VYN2295-006PA	NAME PLATE	J VERSION	1
	98	VJD3915-001	FITTING(L)		1
	99	VJD3916-001	FITTING(R)		1
	100	VJD5387-001	PLATE(L)		1
	101	VJD5388-001	PLATE(R)		1
	102	VYH7599-001	SNAP PIN	FOR FITTING	4
	103	VYSA1R2-008	SPACER	FOR VOLUME SHAFT	1
	104	T44362-001	CSA LABEL	C VERSION	1
	105	VND4037-002	F MARK	G VERSION	1
	106	QZL1007-001	BEAB LABEL		1

# 10 Exploded View of Mechanism Assembly

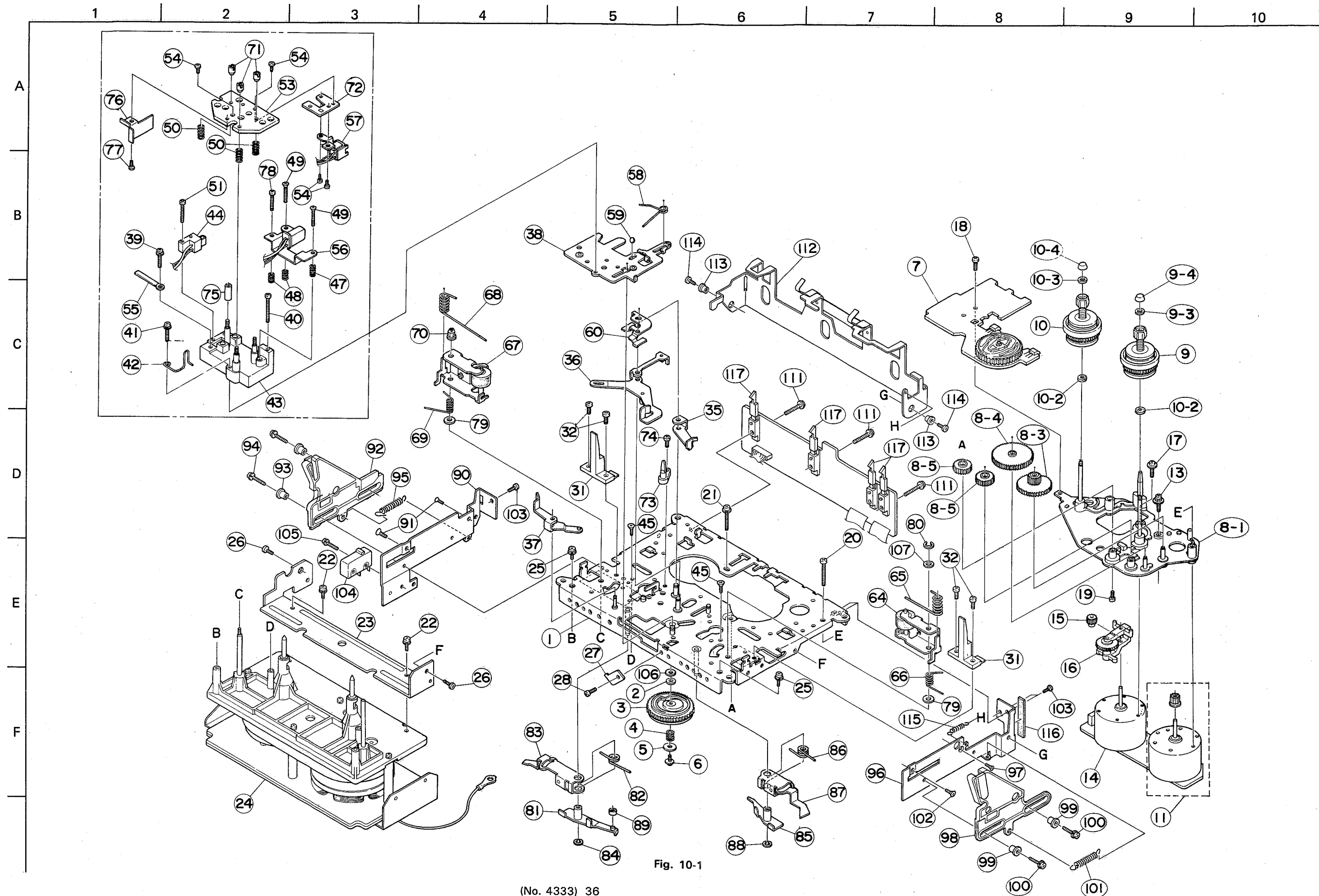

Fig. 10-1

## ● Mechanism Component Parts List

BLOCK NO.   

△	REF.	PARTS NO.	PARTS NAME	REMARKS	QTY
	1	VKL2449-00X	CHAS.BASE ASS'Y		1
	2	VKZ4003-015	FELT	PINCH ROLLER CAM	1
	3	VKS2202-002	P.ROLLER CAM		1
	4	VKW3001-276	C.SPRING	PINCH ROLLER CAM	1
	5	VKL5116-005	PLATE	PINCH ROLLER CAM	1
	6	VKZ4340-002	SCREW	PINCH ROLLER CAM	1
	7	VKZ3136-00F	CAM SWITCH ASSY		1
	8-1	VKL2303-003	DISK BASE	J24	1
	8-3	VKR3001-001	GEAR(2)		1
	8-4	VKR3001-002T	GEAR 2		1
	8-5	VKR3000-001	GEAR(1)		2
	9	VKR4598-00A	REEL DISK ASS'Y		1
	9-3	VKR4170-001	RING		1
	9-4	VKS4131-001	REEL STOPPER		1
	10	VKR4598-00A	REEL DISK ASS'Y		1
	10-2	VKZ4003-010	FELT		2
	10-3	VKR4170-001	RING		1
	10-4	VKS4131-001	REEL STOPPER		1
	11	MMN6F2RA8Z-SA1	DC MOTOR ASS'Y	FOR CAM	1
	13	DPSP2608Z	SCREW	FOR CAM MOTOR	1
	14	MMN-6F4RA38	D.C.MOTOR	REEL MOTOR	1
	15	VKR3000-003	GEAR(1)	FOR REEL MOTOR	1
	16	VKS4503-00D	F/R ARM ASS'Y		1
	17	SWSP2608Z	SCREW	FOR REEL MOTOR	1
	18	SDST2604Z	SCREW	FOR DISK BASE UNI	1
	19	LPSP2608Z	SCREW	FOR DISK BASE UNI	1
	20	SPSP2615Z	SCREW	FOR CAM MOTOR	1
	21	LPSP2614Z	SCREW	FOR REEL MOTOR	1
	22	LPSP2606Z	SCREW	FOR MOTOR BRACKET	2
	23	VKL6562-002	MOTOR BRACKET		1
	24	SS11BB	DD MOTOR ASS'Y		1
	25	LPSP2606Z	SCREW	FOR DD MOTOR	2
	26	SDST2605Z	SCREW	FOR MOTOR BRACKET	2
	27	VKL5398-001	BRACKET		1
	28	SSST2604Z	SCREW	FOR BRACKET	1
	31	VKS4901-002	CASSETTE GUIDE	J24	2
	32	SDST2605Z	SCREW	FOR CASSETTE GUID	4
	35	VKL5316-00G	H.BASE ARM ASSY		1
	36	VKL3879-00B	P.R.LEVER(1)		1
	37	VKL6190-00C	P.R.LEVER(2)		1
	38	VKM3192-002	HEAD BASE		1
	39	LPSP2010N	SCREW	FOR WIRE HOLDER	1
	40	SPSP2016N	SCREW	FOR HEAD BASE	1
	41	LPSP2012Z	SCREW	HOR WIRE HOLDER	1
	42	VKZ4437-001	WIRE HOLDER		1
	43	VKZ3137-00C	H.BASE ASS'Y		1
	44	VGH0212-121	ERASE HEAD		1
	45	SSSP2608Z	SCREW	FOR DD MOTOR	2
	47	VKW3001-067	SPRING	FOR REC HEAD	1
	48	VKW3001-099	SPRING	FOR REC HEAD	2
	49	VKZ4463-00B	SPECIAL SCREW	FOR REC HEAD	2
	50	VKW3001-223	SPRING	FOR PB HEAD	3
	51	LPSP2012N	SCREW	FOR E HEAD	1
	53	VKL6192-005	P.B. HEAD BASE		1
	54	VKZ4194-001	S.SCREW	FOR PB HEAD	4
	55	VKZ4001-013	WIRE HOLDER	FOR HEAD WIER	1

△	REF.	PARTS NO.	PARTS NAME	REMARKS	QTY
	56	VGH0423-607	REC HEAD ASS'Y		1
	57	VGH0424-629	P.B. HEAD ASS'Y		1
	58	VKW4467-005	TORSION SPRING	HOR HEAD BASE	1
	59	T41615-004	STEEL BALL		1
	60	VKY4559-002	SPRING PLATE		1
	64	VKP4210-00A	P.ROLLER ASS'Y	RIGHT	1
	65	VKW3006-056	TORSION SPRING	FOR P.ROLLER	1
	66	VKW3006-057	TORSION SPRING	FOR RETURN	1
	67	VKP4129-00K	P.ROLLER ASS'Y	LEFT	1
	68	VKW4735-003	TORSION SPRING	FOR PINCH ROLLER	1
	69	VKW3006-060	TORSION SPRING	FOR PINCH ROLLER	1
	70	VKS4513-001	ADJUST SCREW	FOR PINCH ROLLER	1
	71	VKH5137-001	ADJUST SCREW	FOR PB HEAD	3
	72	VKL6422-001	HEAD BASE	FOR PB HEAD	1
	73	VKS4512-003	GUID POST		1
	74	SDST2605Z	SCREW	FOR GUIDE POST	1
	75	QXTS400-010	SHURINK TUBE		1
	76	VKL6581-001	SHIELD PLATE	FOR PB HEAD	1
	77	SPSK2025M	MINI SCREW	FOR SHIELD PLATE	1
	78	VKZ4464-00B	SPECIAL SCREW	FOR REC HEAD	1
	79	WNS3000N	WASHER	FOR PINCH ROLLER	1
		WNS3000N	WASHER	FOR PINCH ROLLER	1
	80	REE2500	E.RING	FOR PINCH ROLLER	1
	81	VKL6830-00E	LEVER L1 ASS,Y		1
	82	VKW4872-001	T.SPRING	FOR LEVER L1	1
	83	VKL6832-001	LEVER L2		1
	84	WDL266025-4	SLIT WASHER	FOR LEVER L1	1
	85	VKL6843-00C	LEVER R1 ASS,Y		1
	86	VKW4873-001	T.SPRING		1
	87	VKL6845-001	LEVER R2		1
	88	WDL266025-4	SLIT WASHER	FOR LEVER R1	1
	89	VKH3000-147	COLLAR	FOR LEVER L1	1
	90	VKM3336-003	SIDE BRACKET L		1
	91	VKZ4128-002	S.SCREW	FOR SIDE BRACKET	2
	92	VKS2211-001	SLIDE LEVER L		1
	93	VKH3001-085	F.COLLAR	FOR SLIDE LEVER	2
	94	LPSP2008Z	SCREW	FOR SLIDE LEVER	2
	95	VKW3002-272	SPRING	FOR SLIDE LEVER	1
	96	VKM3337-003	SIDE BRACKET R		1
	97	VKZ4128-002	S.SCREW		1
	98	VKS2212-002	SLIDE LEVER R		1
	99	VKH3001-085	F.COLLAR	FOR SLIDE LEVER	2
	100	LPSP2008Z	SCREW	FOR SLIDE LEVER	2
	101	VKW3002-268	SPRING	FOR SLIDE LEVER	1
	102	SSST2605Z	SCREW	FOR SIDE BRACKET	1
	103	SDST2605Z	SCREW	FOR SIDE BRACKET	3
	104	VSH1162-002	SWITCH	FOR DOOR OPEN DET	1
	105	VKZ4231-006	SCREW	FOR SWITCH	1
	106	WFM467550	WASHER	PINCH ROLLER CAM	1
	107	WFM316025	S.WASHER	FOR PINCH ROLLER	1
	111	VKZ4345-004	SPECIAL SCREW	FOR LEAF SWITCH P	3
	112	VKM3359-00D	SW ARM ASS'Y		1
	113	VKH5380-001	COLLAR	FOR SWITCH ARM	2
	114	SDSP2605Z	SCREW	FOR SWITCH ARM	2
	115	VKW3002-269	T.SPRING	FOR SWITCH ARM	1
	116	VYSS101-032	SPACER	FOR MECHA.TOP SID	1
	117	VSH1140-003	LEAF SWITCH	S702/S703/S704/S7	4
	801	VKL2303-003	DISK BASE	J24	1
	803	VKR3001-001	GEAR(2)		1

# 11 Packing

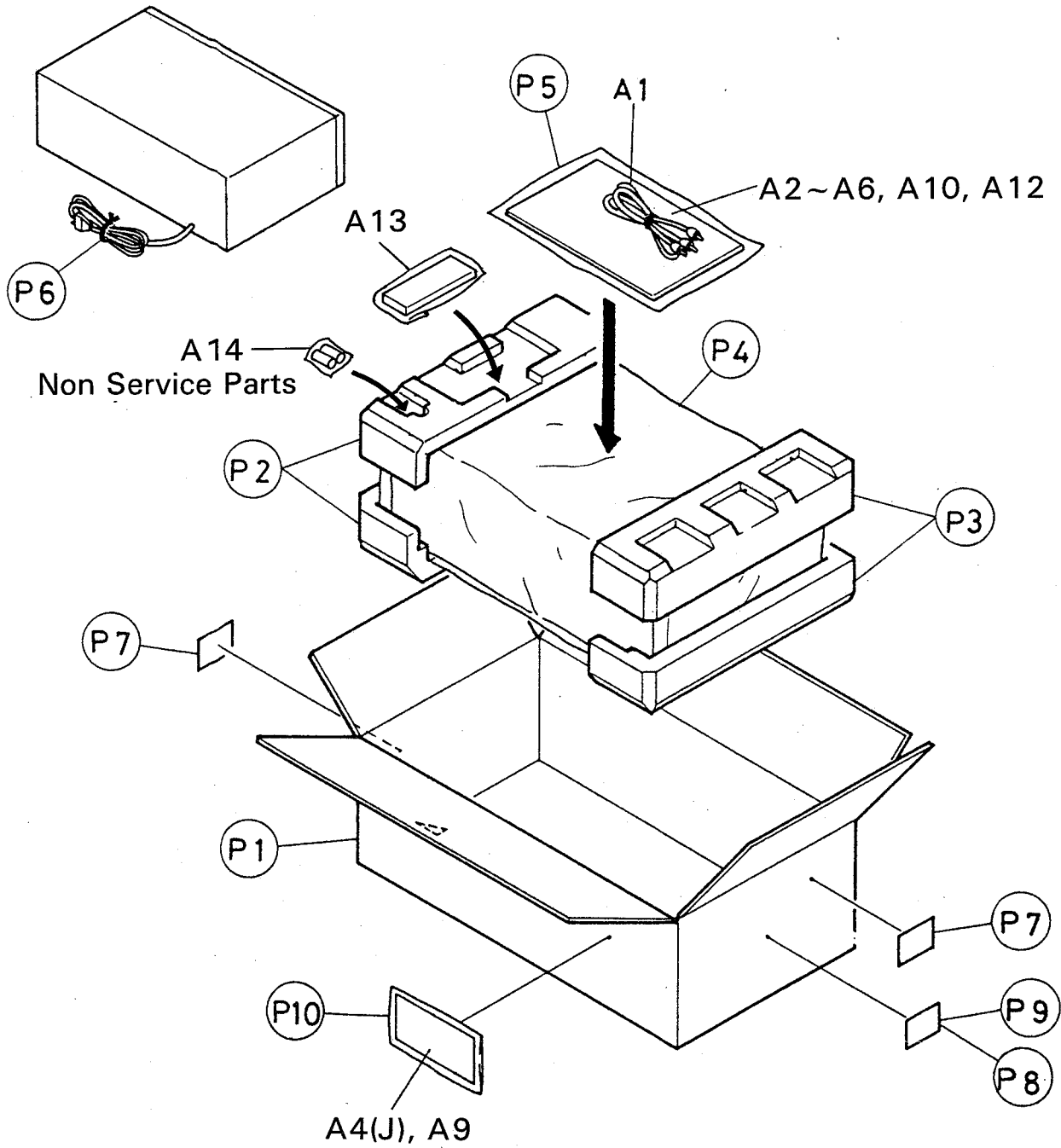

Fig. 11-1

## ● Packing Parts List

BLOCK NO. M3MM

△	REF.	PARTS NO.	PARTS NAME	REMARKS	QTY
	A 1	VMP0039-00D	PIN CORD		1
	A 2	VNN2295-471	INST BOOK	E VERSION	1
		VNN2295-661	INST BOOK		1
	A 3	TCN-3379	TAPE PAMPHLET	B/E/G VERSION	1
		TCP-3428	TAPE PAMPHLET	A VERSION	1
	A 4	TCU-3492	TAPE PAMPHLET	C/J VERSION	1
		BT-20025K	WARRANTY CARD	C VERSION	1
		BT-20047F	WARRANTY CARD	J VERSION	1
		BT-20060	WARRANTY CARD	B VERSION	1
		BT-20066A	WARRANTY CARD	B VERSION	1
		BT-20117	WARRANTY CARD	G VERSION FOR JED	1
		BT-20122	WARRANTY CARD	A VERSION	1
		BT-20122-1	WARRANTY CARD	A VERSION	1
	A 5	EWP805-001E	REMOTE WIRE		1
	A 6	BT-20044G	SAFETY GUIDE	J VERSION	1
	A 9	BT-20108A	SERVICE NETWORK	J VERSION	1
	A 10	BT-20071A	JVC CENTER LIST	C VERSION	1
	A 12	E43486-340A	SAFETY I.SHEET	B VERSION	1
	A 13	RRT4001-9703R	REMOCON ASS'Y		1
	A 14	UM4NV-2P	BATTERY	FOR REMOCON(NON S	2
	P 1	VPC2295-002	CARTON		1
	P 2	VPH2405-001	CUSHION(L)		1
	P 3	VPH2406-001	CUSHION(R)		1
	P 4	E300196-031B	ENVELOPE	FOR UNIT	1
	P 5	VPE3005-007	POLY BAG	FOR INSTRUCTION	1
	P 6	Q04141H	WIRE CLAMP	FOR POWER CORD	1
	P 7	VND3044-001	SIRIAL TICKET	A VERSION	1
		VND3044-002	SIRIAL TICKET	J VERSION	2
		VND3044-003	SIRIAL TICKET	E VERSION	1
		VND3044-004	SIRIAL TICKET	B VERSION	1
		VND3044-005	SIRIAL TICKET	G VERSION	1
		VND3044-006	SIRIAL TICKET	C VERSION	2
	P 8	VND3069-031	EAN CODE LABEL	A/B/E/G VERSION	1
	P 9	VND3065-033	UPC CODE LABEL	C/J VERSION	1
	P 10	E66416-003	ENVELOPE	J VERSION-WARRANT	1

# JVC

VICTOR COMPANY OF JAPAN, LIMITED  
PERSONAL AUDIO PRODUCTS DIVISION 10-1, 1-chome, Ohwatari-machi, Maebashi-city, Japan