

JVC

SCHEMATIC DIAGRAMS

DVD DIGITAL CINEMA SYSTEM

TH-A25

CD-ROM No.SML200403

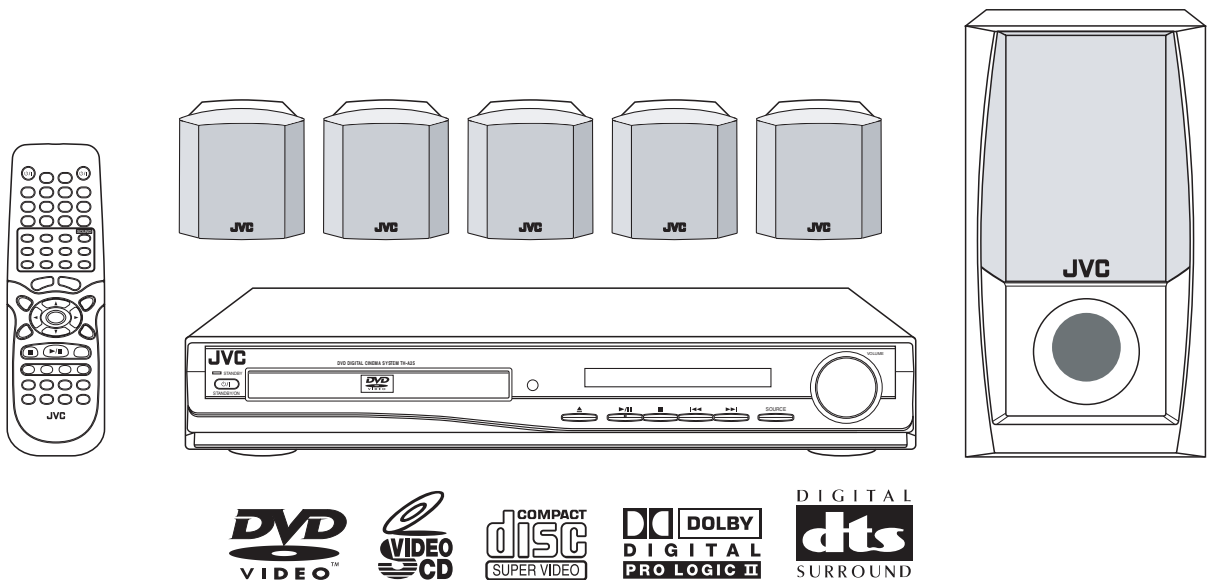

Area suffix

US ----- Singapore
UB ----- Hong Kong
UW ----- Brazil, Mexico, Peru
UX ----- Saudi Arabia
UG -- Turkey, South Africa, Egypt

Since the printed circuit board of DVD was changed, the schematic diagram and printed circuit board which were changed are published.

Contents

Standard schematic diagrams -----	2-1
Printed circuit board -----	2-5

In regard with component parts appearing on the silk-screen printed side (parts side) of the PWB diagrams, the parts that are printed over with black such as the resistor (■), diode (▣) and ICP (●) or identified by the "△" mark nearby are critical for safety.

(This regulation does not correspond to J and C version.)

Standard schematic diagrams

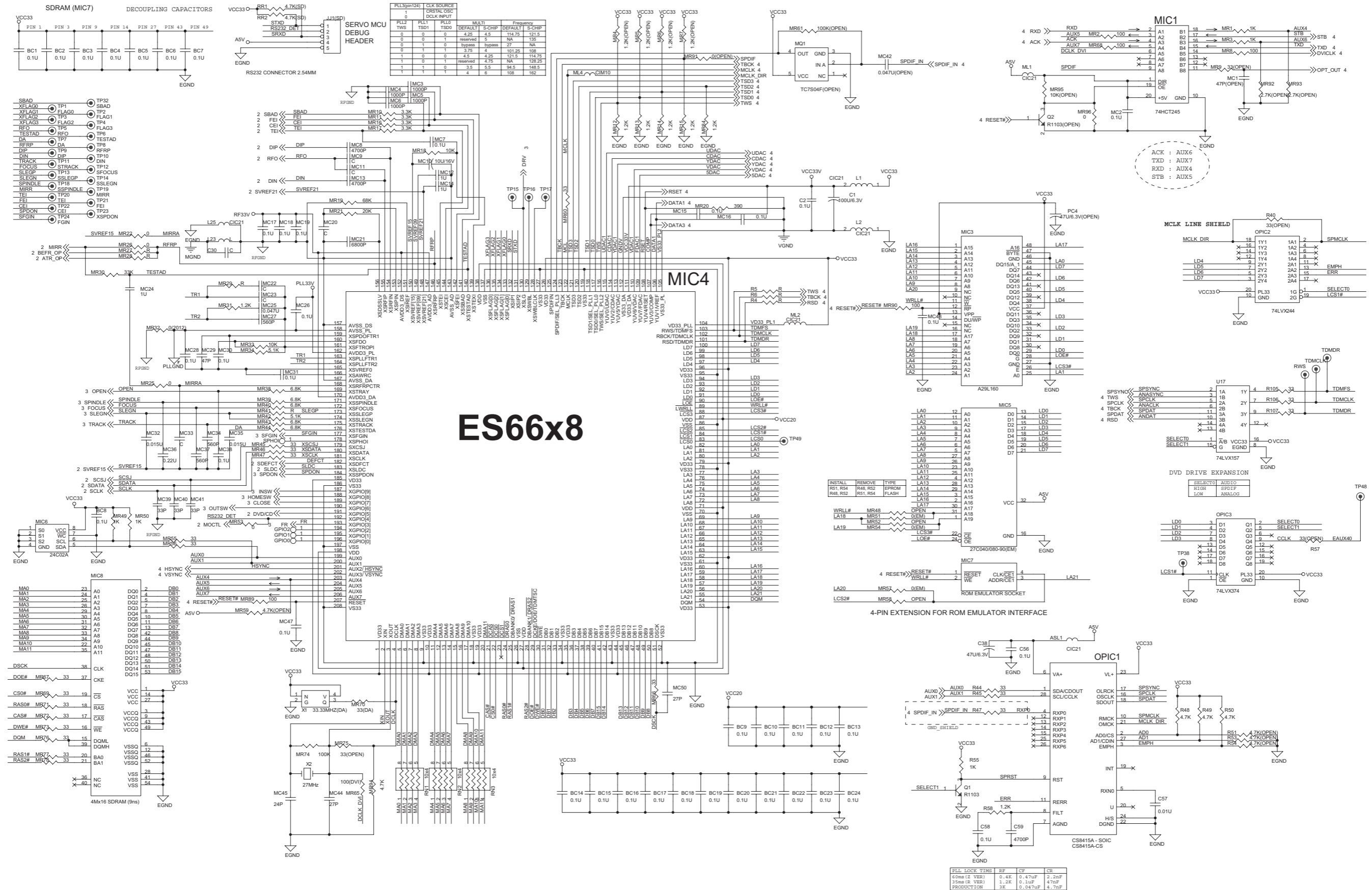

ES66x8

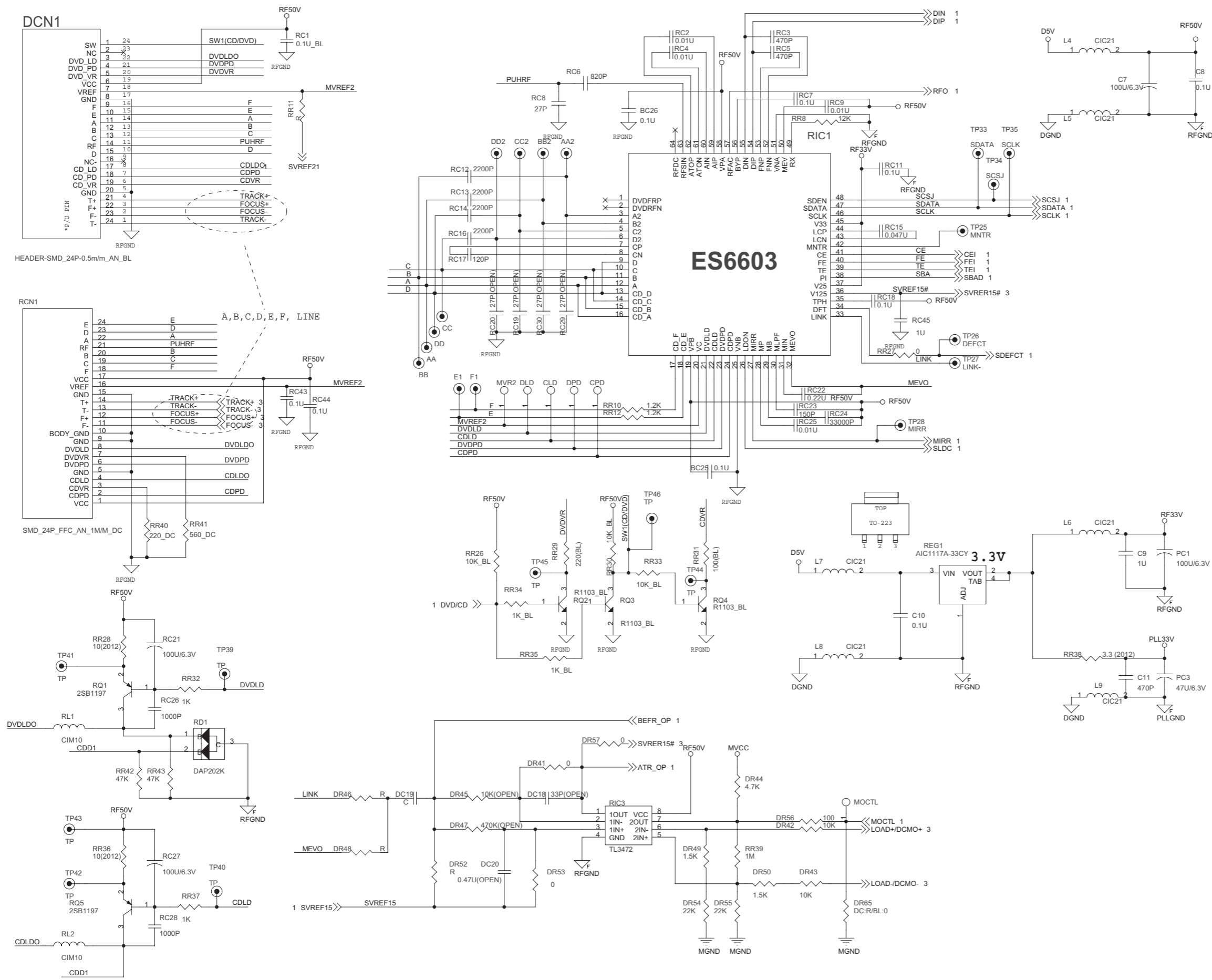

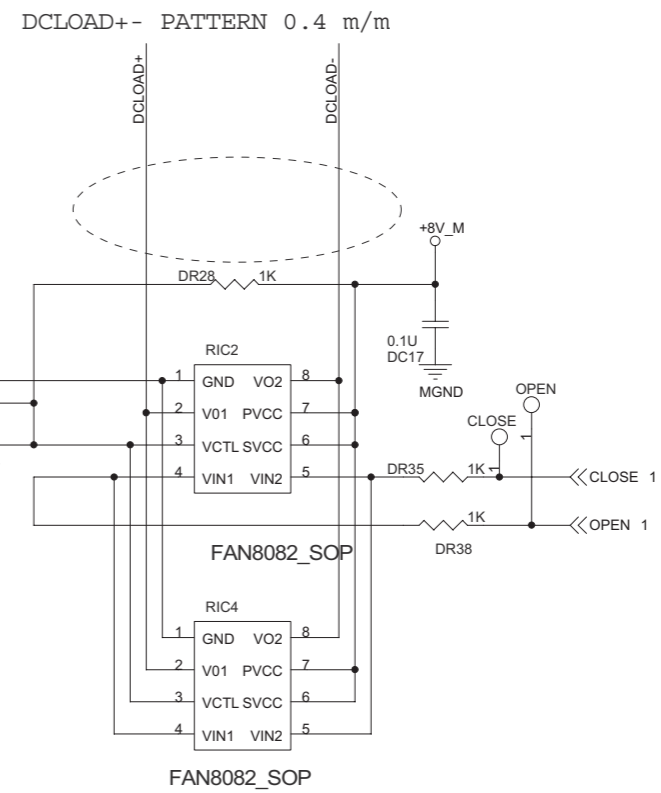
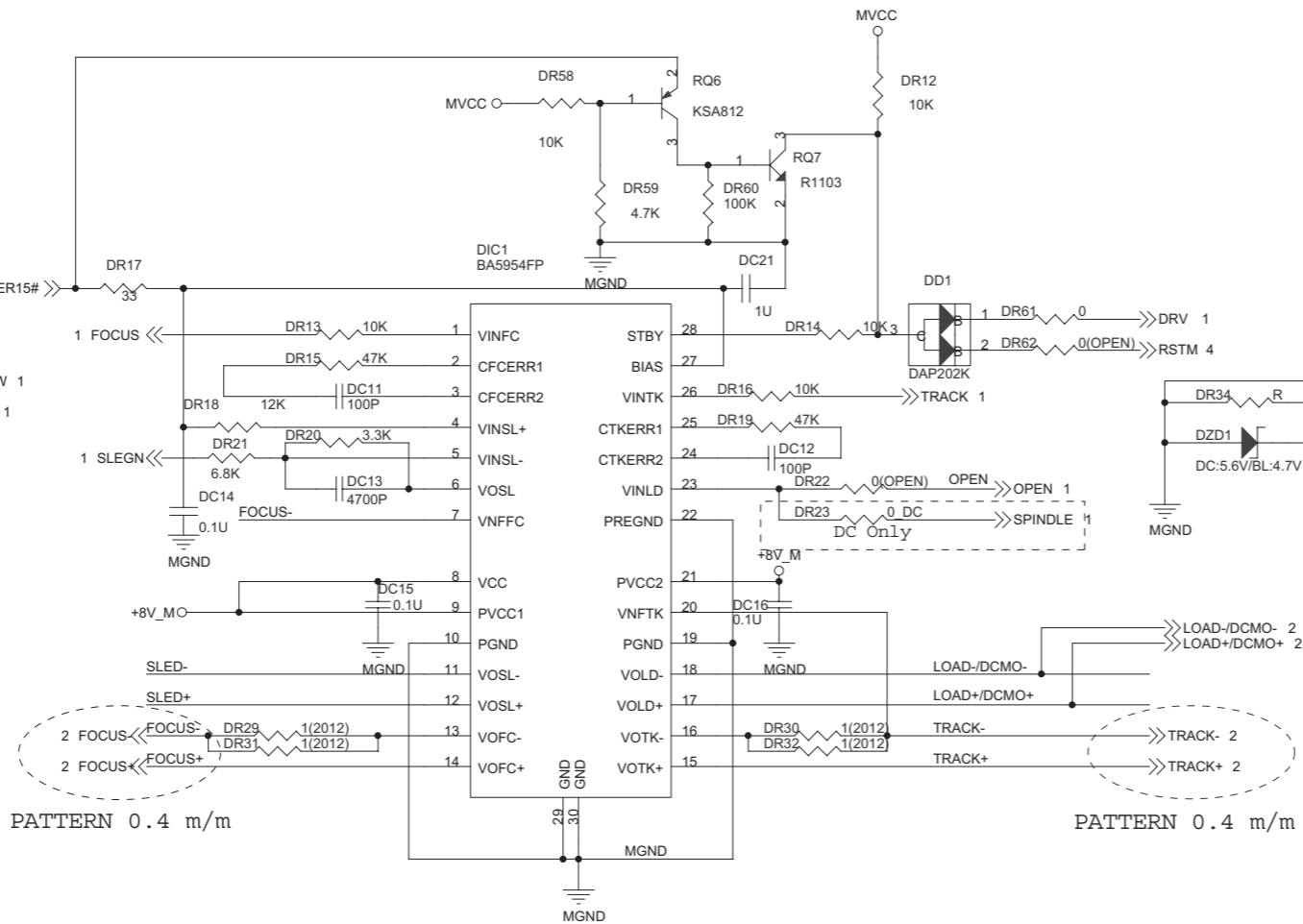
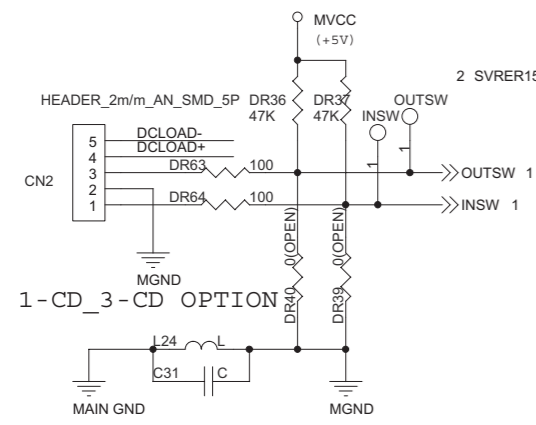
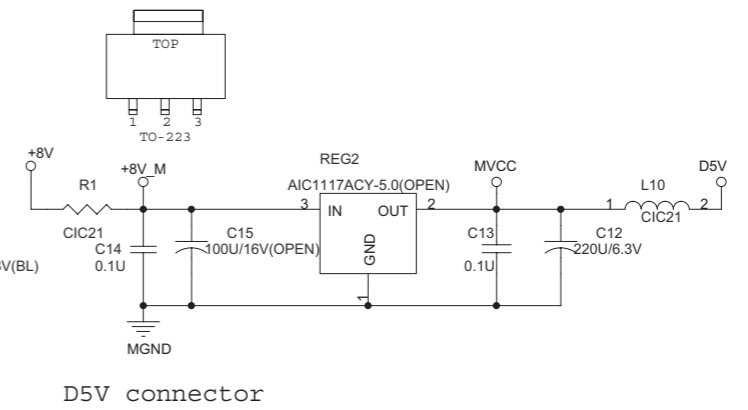
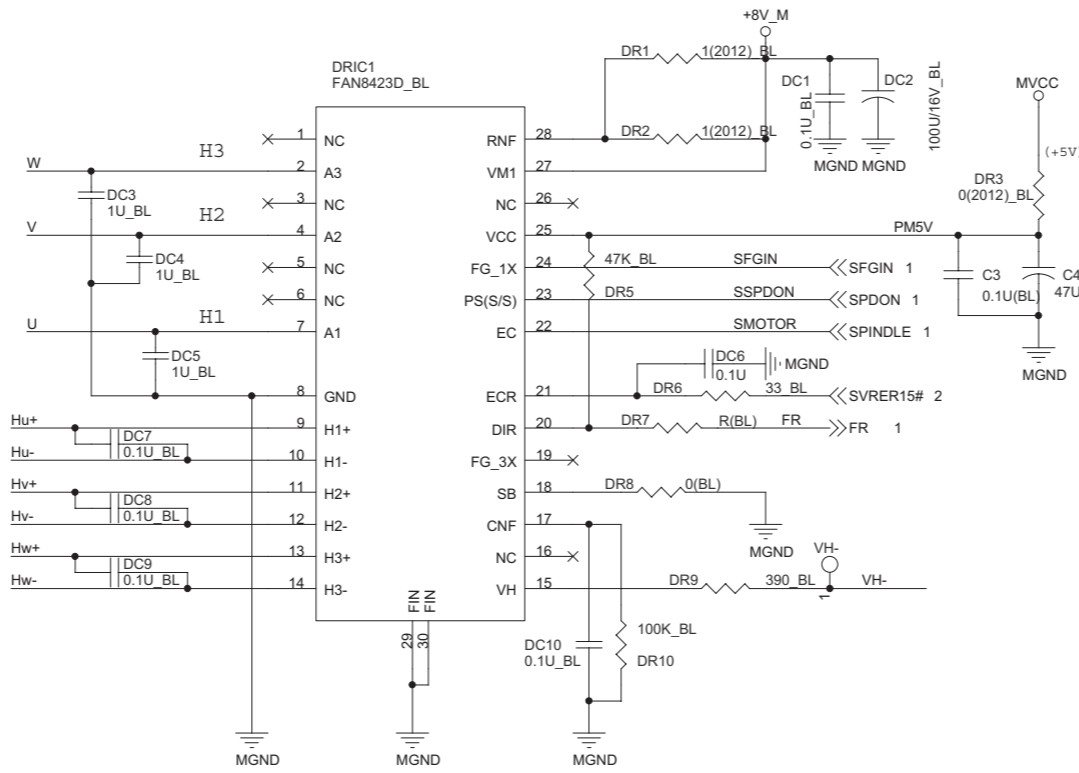
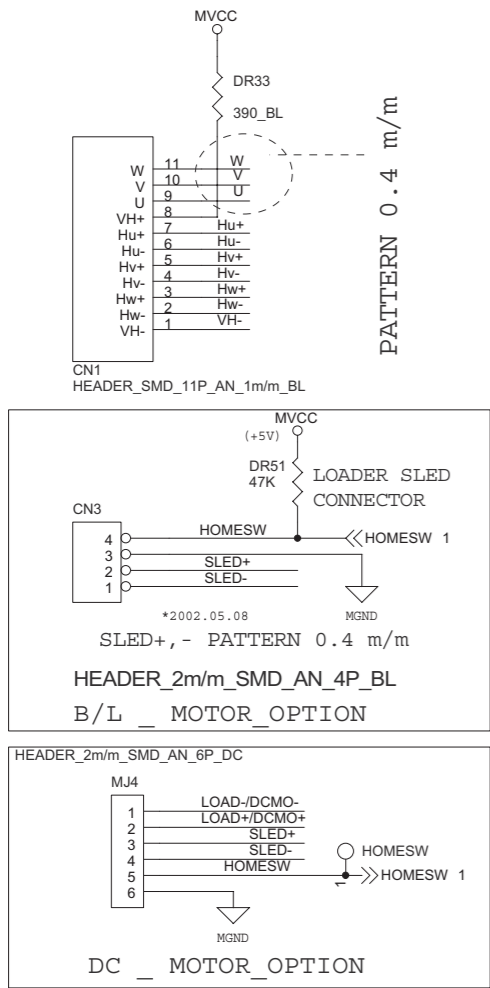

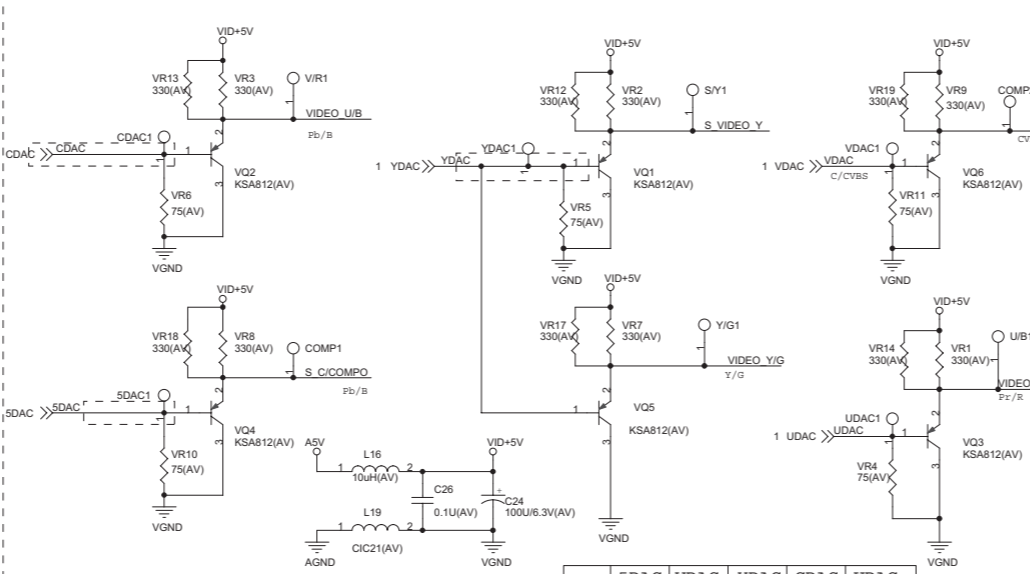
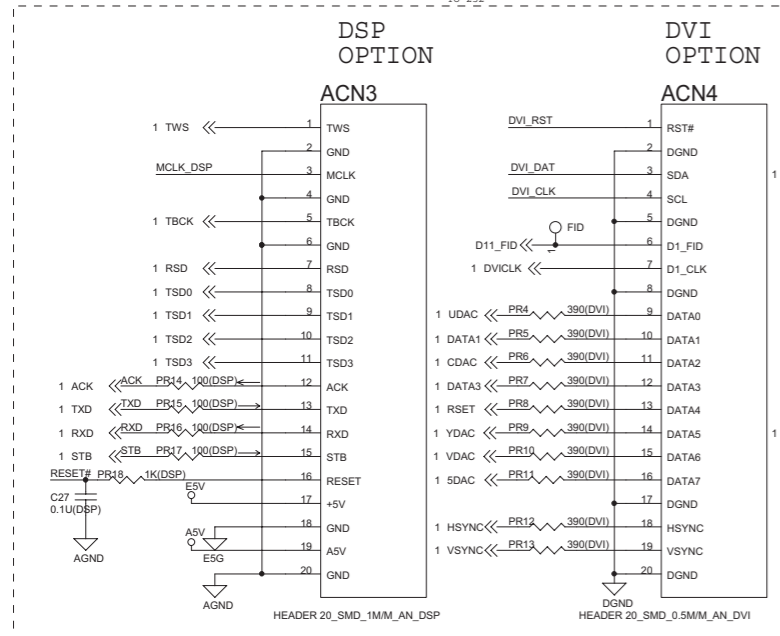
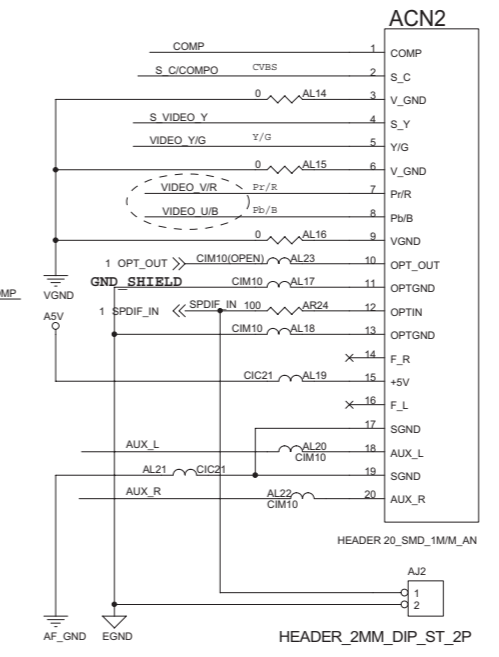
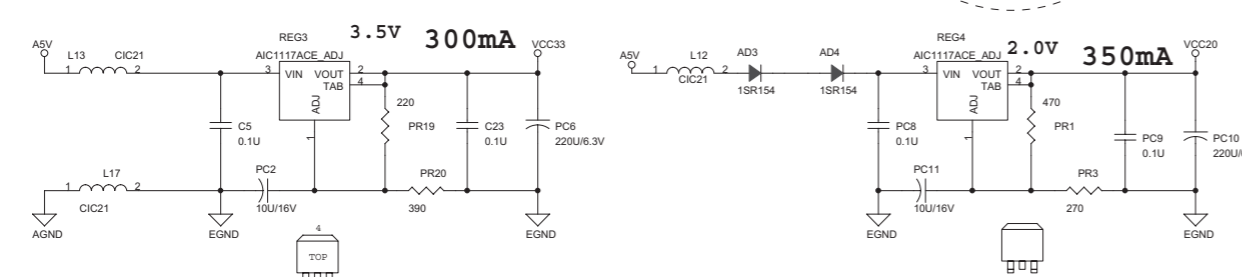
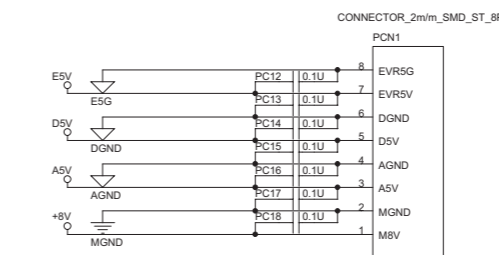
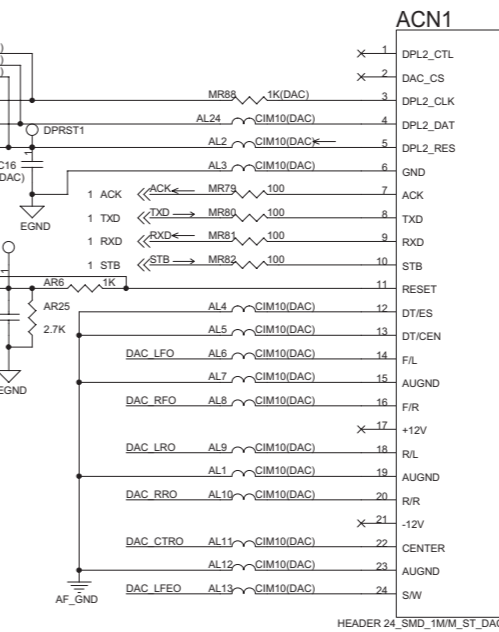
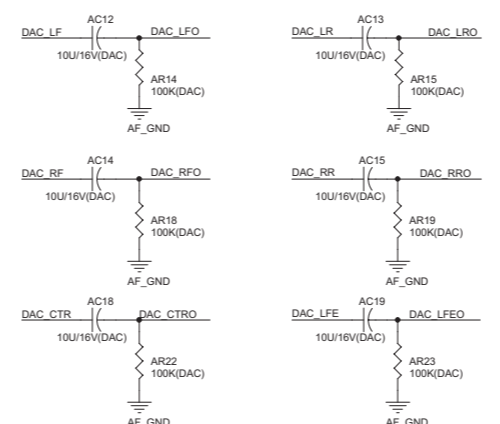
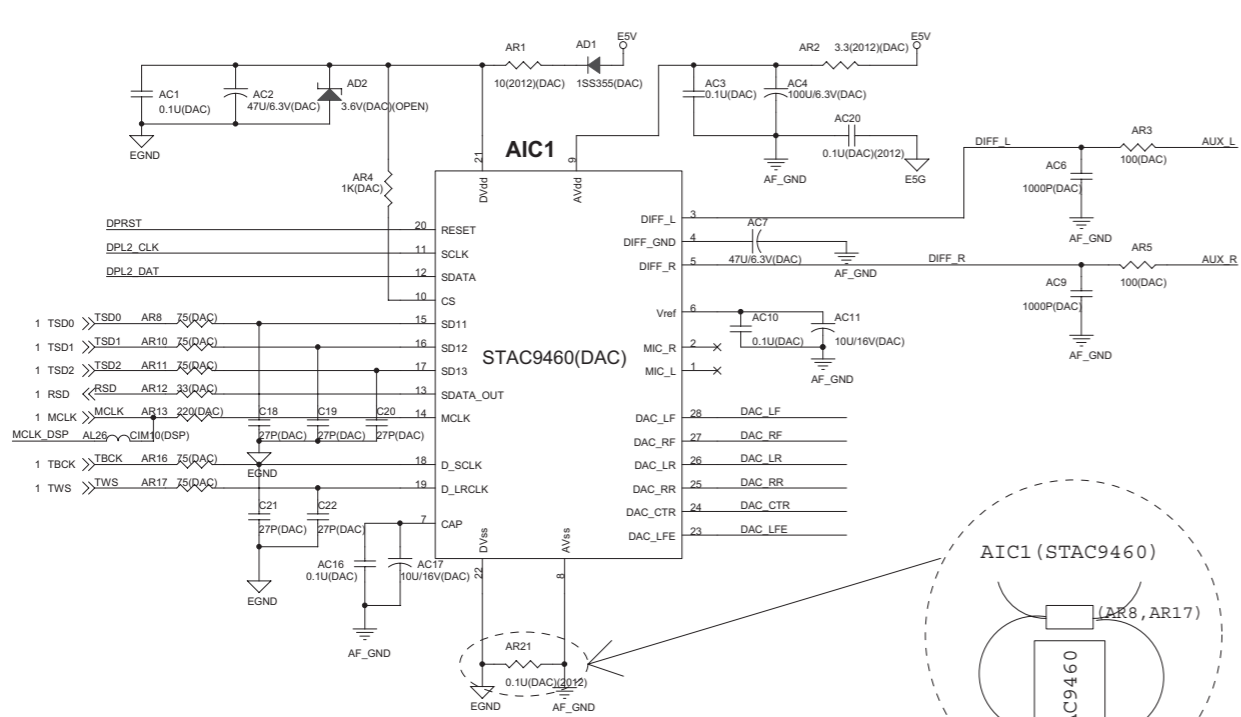

	5DAC	VDAC	YDAC	CDAC	UDAC
NTSC	C	CVBS	Y	Pb	Pr
PAL	CVBS	CVBS	G	B	R

Printed circuit board

(Forward side)

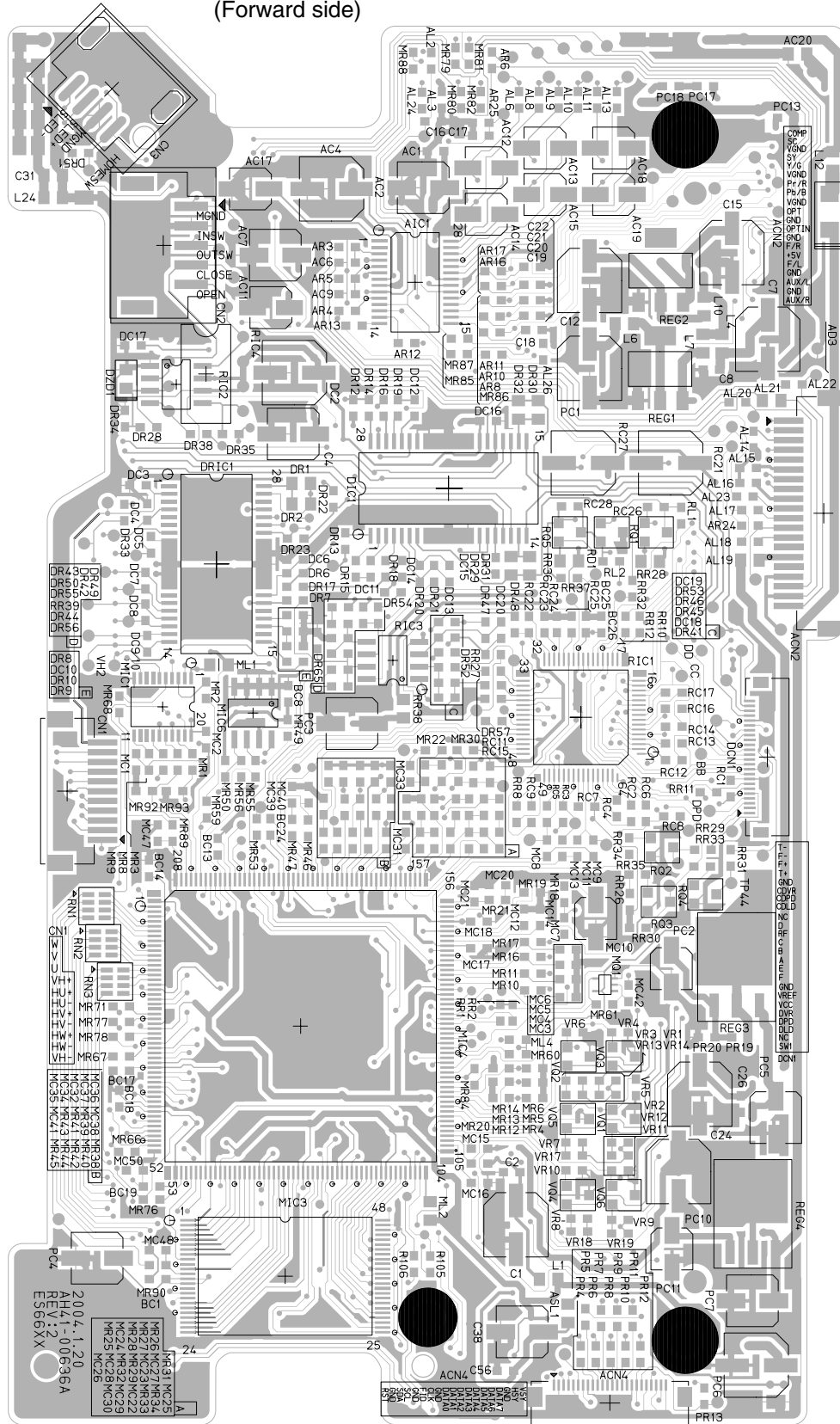

(Reverse side)

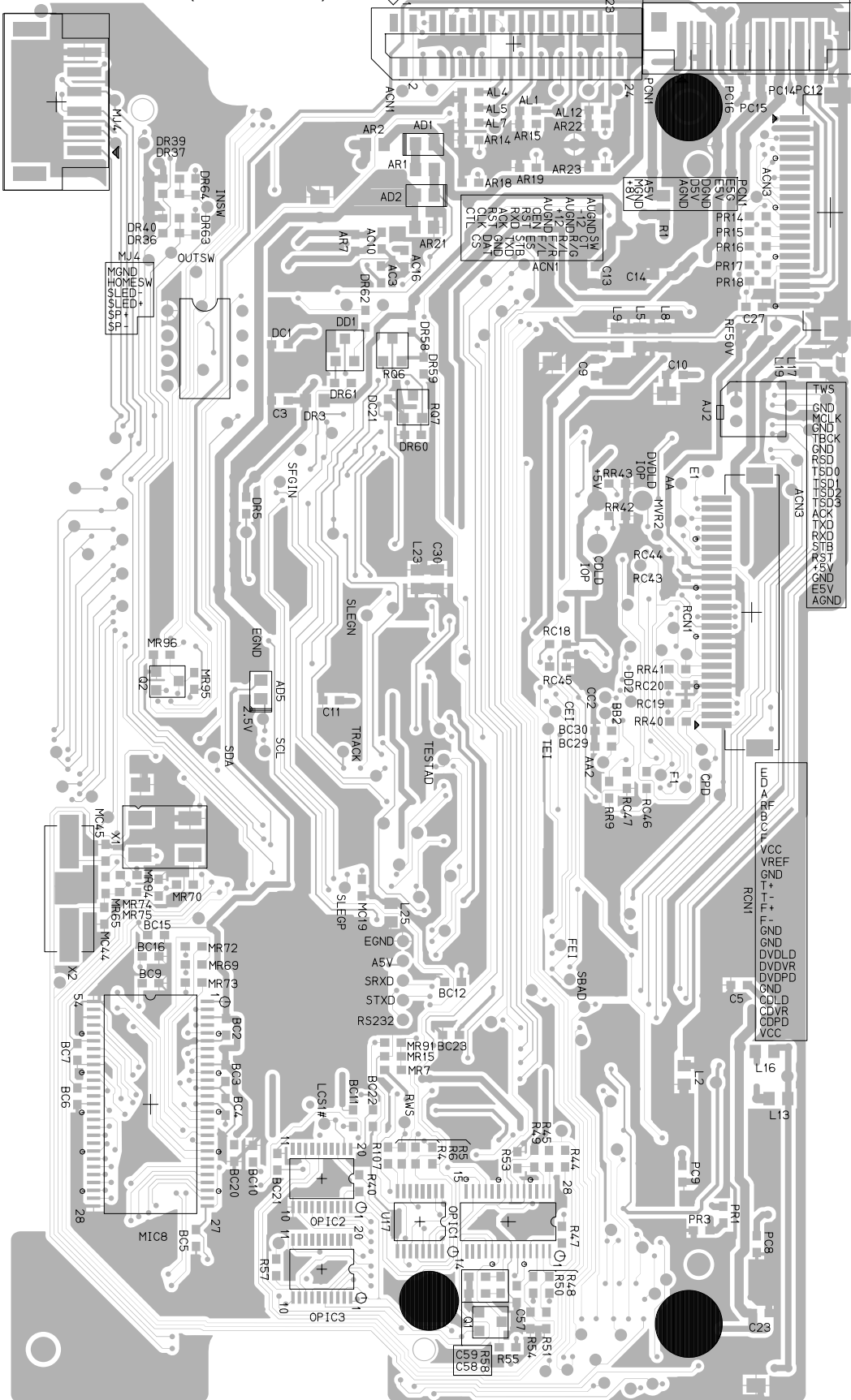

< MEMO >

JVC

VICTOR COMPANY OF JAPAN, LIMITED

AV & MULTIMEDIA COMPANY AUDIO/VIDEO SYSTEMS CATEGORY 10-1, 1chome, Ohwatari-machi, Maebashi-city, 371-8543, Japan

(No.MB143BSCH)



Printed in Japan
WPC

PARTS LIST

[TH-A25]

* All printed circuit boards and its assemblies are not available as service parts.

Area suffix

US ----- Singapore
UB ----- Hong Kong
UW ----- Brazil, Mexico, Peru
UX ----- Saudi Arabia
UG - Turkey, South Africa, Egypt

- Contents -

Electrical parts list (Block No.05) 3 - 2

Electrical parts list

DVD pack board

Block No. [0][5][0][0]

△ Symbol No.	Part No.	Part Name	Description	Local
Q1	0504-000128	DIGI TRANSISTOR	NPN 200MW	
D2	1SS355	FR DIODE	0401-001090	
PC1	2203-005005	CHIP CAPACITOR	100NF 10% 16V	
PC2	2402-001042	E.CAPACITOR SMD	100UF 20% 16V	
PC3	2402-001059	E.CAPACITOR SMD	220UF 20% 6.3V	
PC4	2203-005005	CHIP CAPACITOR	100NF 10% 16V	
PC8	2203-005005	CHIP CAPACITOR	100NF 10% 16V	
PC9	2203-005005	CHIP CAPACITOR	100NF 10% 16V	
PC10	2402-000107	E.CAPACITOR SMD	100UF 20% 6.3V	
PC11	2402-000009	E CAPACITOR	47UF 20% 6.3V	
PC12	2203-005005	CHIP CAPACITOR	100NF 10% 16V	
PC13	2402-000107	E.CAPACITOR SMD	100UF 20% 6.3V	
PC14	2203-005005	CHIP CAPACITOR	100NF 10% 16V	
C11	2402-000176	E.CAPACITOR SMD	10UF 20% 16V	
C38	2402-000009	E CAPACITOR	47UF 20% 6.3V	
C39	2203-005005	CHIP CAPACITOR	100NF 10% 16V	
C40	2402-000009	E CAPACITOR	47UF 20% 6.3V	
C43	2203-005065	CHIP CAPACITOR	1000NF +80-20%	
C48	2203-005065	CHIP CAPACITOR	1000NF +80-20%	
C51	2203-000681	CHIP CAPACITOR	0.027NF 5% 50V	
C52	2203-000681	CHIP CAPACITOR	0.027NF 5% 50V	
C53	2203-000681	CHIP CAPACITOR	0.027NF 5% 50V	
C54	2203-000681	CHIP CAPACITOR	0.027NF 5% 50V	
C55	2203-000681	CHIP CAPACITOR	0.027NF 5% 50V	
C56	2203-005005	CHIP CAPACITOR	100NF 10% 16V	
C57	2203-000257	CHIP CAPACITOR	10NF 10% 50V	
C58	2203-005005	CHIP CAPACITOR	100NF 10% 16V	
C59	2203-000888	CHIP CAPACITOR	4.7NF 10% 50V	
C60	2203-005005	CHIP CAPACITOR	100NF 10% 16V	
C61	2203-005005	CHIP CAPACITOR	100NF 10% 16V	
C62	2203-005005	CHIP CAPACITOR	100NF 10% 16V	
C63	2203-005005	CHIP CAPACITOR	100NF 10% 16V	
C64	2203-005005	CHIP CAPACITOR	100NF 10% 16V	
C65	2203-005005	CHIP CAPACITOR	100NF 10% 16V	
C66	2402-000009	E CAPACITOR	47UF 20% 6.3V	
C67	2203-005005	CHIP CAPACITOR	100NF 10% 16V	
C68	2203-005005	CHIP CAPACITOR	100NF 10% 16V	
C69	2402-000009	E CAPACITOR	47UF 20% 6.3V	
C70	2402-000009	E CAPACITOR	47UF 20% 6.3V	
C71	2203-005005	CHIP CAPACITOR	100NF 10% 16V	
C72	2203-005005	CHIP CAPACITOR	100NF 10% 16V	
C73	2402-000009	E CAPACITOR	47UF 20% 6.3V	
C74	2402-000176	E.CAPACITOR SMD	10UF 20% 16V	
C75	2203-005005	CHIP CAPACITOR	100NF 10% 16V	
C76	2203-005005	CHIP CAPACITOR	100NF 10% 16V	
C77	2203-005005	CHIP CAPACITOR	100NF 10% 16V	
C78	2203-005005	CHIP CAPACITOR	100NF 10% 16V	
C81	2203-005005	CHIP CAPACITOR	100NF 10% 16V	
C82	2203-005005	CHIP CAPACITOR	100NF 10% 16V	
C83	2203-005005	CHIP CAPACITOR	100NF 10% 16V	
C84	2203-005005	CHIP CAPACITOR	100NF 10% 16V	
C85	2203-005005	CHIP CAPACITOR	100NF 10% 16V	
C86	2203-000384	CHIP CAPACITOR	0.015NF 5% 50V	
C87	2203-005005	CHIP CAPACITOR	100NF 10% 16V	
C88	2402-000009	E CAPACITOR	47UF 20% 6.3V	
C89	2203-005005	CHIP CAPACITOR	100NF 10% 16V	
C90	2402-000009	E CAPACITOR	47UF 20% 6.3V	
C93	2007-000084	CHIP RESISTOR	4.7KOHM 5% 1/10	
C95	2203-005005	CHIP CAPACITOR	100NF 10% 16V	
C96	2203-005005	CHIP CAPACITOR	100NF 10% 16V	
C98	2203-005005	CHIP CAPACITOR	100NF 10% 16V	
C99	2203-005005	CHIP CAPACITOR	100NF 10% 16V	
C100	2203-005005	CHIP CAPACITOR	100NF 10% 16V	
C101	2203-000998	CHIP CAPACITOR	0.047NF 5% 50V	
C102	2203-005005	CHIP CAPACITOR	100NF 10% 16V	
C103	2203-005005	CHIP CAPACITOR	100NF 10% 16V	
C104	2203-005005	CHIP CAPACITOR	100NF 10% 16V	
C105	2402-000009	E CAPACITOR	47UF 20% 6.3V	
C106	2203-005005	CHIP CAPACITOR	100NF 10% 16V	

△ Symbol No.	Part No.	Part Name	Description	Local
C107	2203-005005	CHIP CAPACITOR	100NF 10% 16V	
C108	2203-005005	CHIP CAPACITOR	100NF 10% 16V	
C109	2203-005005	CHIP CAPACITOR	100NF 10% 16V	
C110	2203-005005	CHIP CAPACITOR	100NF 10% 16V	
C111	2203-005005	CHIP CAPACITOR	100NF 10% 16V	
C113	2203-005005	CHIP CAPACITOR	100NF 10% 16V	
C115	2203-000681	CHIP CAPACITOR	0.027NF 5% 50V	
C116	2203-000646	CHIP CAPACITOR	0.024NF 5% 50V	
C119	2203-005005	CHIP CAPACITOR	100NF 10% 16V	
TC1	2203-000257	CHIP CAPACITOR	10NF 10% 50V	
TC2	2203-000280	CHIP CAPACITOR	0.01NF 0.5PF 50	
TC3	2203-000280	CHIP CAPACITOR	0.01NF 0.5PF 50	
TC4	2203-000280	CHIP CAPACITOR	0.01NF 0.5PF 50	
TC5	2203-000280	CHIP CAPACITOR	0.01NF 0.5PF 50	
TC6	2203-000280	CHIP CAPACITOR	0.01NF 0.5PF 50	
TC7	2203-000280	CHIP CAPACITOR	0.01NF 0.5PF 50	
VC1	2402-000107	E.CAPACITOR SMD	100UF 20% 6.3V	
VC2	2203-005005	CHIP CAPACITOR	100NF 10% 16V	
R1	2007-000075	CHIP RESISTOR	220OHM 5% 1/10W	
R2	2007-000118	CHIP RESISTOR	390OHM 5% 1/10W	
R14	2007-001042	CHIP RESISTOR	56OHM 1% 1/10W	
R19	2007-000084	CHIP RESISTOR	4.7KOHM 5% 1/10	
R22	2007-000113	CHIP RESISTOR	33OHM 5% 1/10W	
R23	2007-000074	CHIP RESISTOR	100OHM 5% 1/10W	
R24	2007-000074	CHIP RESISTOR	100OHM 5% 1/10W	
R25	2007-000074	CHIP RESISTOR	100OHM 5% 1/10W	
R26	2007-000078	CHIP RESISTOR	1KOHM 5% 1/10W	
R27	2007-000074	CHIP RESISTOR	100OHM 5% 1/10W	
R28	2007-000078	CHIP RESISTOR	1KOHM 5% 1/10W	
R34	2007-000081	CHIP RESISTOR	2.7KOHM 5% 1/10	
R35	2007-000078	CHIP RESISTOR	1KOHM 5% 1/10W	
R43	2007-000090	CHIP RESISTOR	10KOHM 5% 1/10W	
R44	2007-000113	CHIP RESISTOR	33OHM 5% 1/10W	
R45	2007-000113	CHIP RESISTOR	33OHM 5% 1/10W	
R47	2007-000070	CHIP RESISTOR	0OHM 5% 1/10W	
R48	2007-000084	CHIP RESISTOR	4.7KOHM 5% 1/10	
R49	2007-000084	CHIP RESISTOR	4.7KOHM 5% 1/10	
R50	2007-000084	CHIP RESISTOR	4.7KOHM 5% 1/10	
R55	2007-000078	CHIP RESISTOR	1KOHM 5% 1/10W	
R57	2007-000113	CHIP RESISTOR	33OHM 5% 1/10W	
R58	2007-000122	CHIP RESISTOR	1.2KOHM 5% 1/10	
R59	2007-000643	CHIP RESISTOR	270OHM 5% 1/10W	
R60	2007-000799	CHIP RESISTOR	360OHM 5% 1/10W	
R61	2007-000084	CHIP RESISTOR	4.7KOHM 5% 1/10	
R67	2007-000113	CHIP RESISTOR	33OHM 5% 1/10W	
R72	2007-000084	CHIP RESISTOR	4.7KOHM 5% 1/10	
R73	2007-000084	CHIP RESISTOR	4.7KOHM 5% 1/10	
R74	2007-000084	CHIP RESISTOR	4.7KOHM 5% 1/10	
R76	2007-000084	CHIP RESISTOR	4.7KOHM 5% 1/10	
R78	2007-000084	CHIP RESISTOR	4.7KOHM 5% 1/10	
R79	2007-000084	CHIP RESISTOR	4.7KOHM 5% 1/10	
R83	3301-001069	BEAD-SMD	AB 1.6X0.8X0.8M	
R85	2007-000113	CHIP RESISTOR	33OHM 5% 1/10W	
R86	2007-000113	CHIP RESISTOR	33OHM 5% 1/10W	
R87	2007-000070	CHIP RESISTOR	0OHM 5% 1/10W	
R88	2007-000074	CHIP RESISTOR	100OHM 5% 1/10W	
R89	2007-000113	CHIP RESISTOR	33OHM 5% 1/10W	
R90	2007-001167	CHIP RESISTOR	75OHM 5% 1/10W	
R91	2007-000539	CHIP RESISTOR	200OHM 5% 1/10W	
R92	2007-000113	CHIP RESISTOR	33OHM 5% 1/10W	
R93	2007-000113	CHIP RESISTOR	33OHM 5% 1/10W	
R94	2007-000113	CHIP RESISTOR	33OHM 5% 1/10W	
R95	2007-000113	CHIP RESISTOR	33OHM 5% 1/10W	
R96	2007-000070	CHIP RESISTOR	0OHM 5% 1/10W	
R98	2007-000113	CHIP RESISTOR	33OHM 5% 1/10W	

△ Symbol No.	Part No.	Part Name	Description	Local	△ Symbol No.	Part No.	Part Name	Description	Local
R99	2007-000070	CHIP RESISTOR	00HM 5% 1/10W		AL21	3301-001495	BEAD-SMD	AB 120OHM	
R102	2007-000078	CHIP RESISTOR	1KOHM 5% 1/10W		AR1	2007-000078	CHIP RESISTOR	1KOHM 5% 1/10W	
R103	2007-000078	CHIP RESISTOR	1KOHM 5% 1/10W		AR3	2007-000308	CHIP RESISTOR	100HM 5% 1/8W	
R104	2007-000102	CHIP RESISTOR	100KOHM 5% 1/10		AR4	2007-000694	CHIP RESISTOR	3.30HM 5% 1/8W	
R105	2007-000113	CHIP RESISTOR	33OHM 5% 1/10W		AR8	2007-000029	CHIP RESISTOR	00HM 5% 1/8W	
R106	2007-000113	CHIP RESISTOR	33OHM 5% 1/10W		AR9	2007-001167	CHIP RESISTOR	75OHM 5% 1/10W	
R107	2007-000113	CHIP RESISTOR	33OHM 5% 1/10W		AR10	2007-001167	CHIP RESISTOR	75OHM 5% 1/10W	
R110	2007-000084	CHIP RESISTOR	4.7KOHM 5% 1/10		AR11	2007-001167	CHIP RESISTOR	75OHM 5% 1/10W	
R112	2007-000070	CHIP RESISTOR	00HM 5% 1/10W		AR12	2007-000113	CHIP RESISTOR	33OHM 5% 1/10W	
TR1	2007-000074	CHIP RESISTOR	100OHM 5% 1/10W		AR13	2007-000075	CHIP RESISTOR	220OHM 5% 1/10W	
TR2	2007-000090	CHIP RESISTOR	10KOHM 5% 1/10W		AR14	2007-001167	CHIP RESISTOR	75OHM 5% 1/10W	
VR1	2007-000115	CHIP RESISTOR	82OHM 5% 1/10W		AR15	2007-001167	CHIP RESISTOR	75OHM 5% 1/10W	
VR2	2007-000402	CHIP RESISTOR	150OHM 5% 1/10W		AR16	2007-000102	CHIP RESISTOR	100KOHM 5% 1/10	
VR15	2007-000115	CHIP RESISTOR	82OHM 5% 1/10W		AR20	2007-000102	CHIP RESISTOR	100KOHM 5% 1/10	
VR18	2007-000402	CHIP RESISTOR	150OHM 5% 1/10W		AR24	2007-000102	CHIP RESISTOR	100KOHM 5% 1/10	
VR20	2007-000402	CHIP RESISTOR	150OHM 5% 1/10W		AR28	2007-000102	CHIP RESISTOR	100KOHM 5% 1/10	
VR21	2007-000115	CHIP RESISTOR	82OHM 5% 1/10W		AR32	2007-000102	CHIP RESISTOR	100KOHM 5% 1/10	
VR22	2007-000402	CHIP RESISTOR	150OHM 5% 1/10W		AR36	2007-000102	CHIP RESISTOR	100KOHM 5% 1/10	
VR24	2007-000115	CHIP RESISTOR	82OHM 5% 1/10W		AR40	2007-000074	CHIP RESISTOR	100OHM 5% 1/10W	
VR25	2007-000402	CHIP RESISTOR	150OHM 5% 1/10W		AR44	2007-000074	CHIP RESISTOR	100OHM 5% 1/10W	
L4	2007-000029	CHIP RESISTOR	00HM 5% 1/8W		AR51	2007-000074	CHIP RESISTOR	100OHM 5% 1/10W	
L28	3301-001069	BEAD-SMD	AB 1.6X0.8X0.8M		AR52	2007-000078	CHIP RESISTOR	1KOHM 5% 1/10W	
L29	2007-000074	CHIP RESISTOR	100OHM 5% 1/10W		ASL1	3301-001495	BEAD-SMD	AB 120OHM	
L31	3301-001069	BEAD-SMD	AB 1.6X0.8X0.8M		ATL3	2007-000070	CHIP RESISTOR	00HM 5% 1/10W	
L32	2007-000074	CHIP RESISTOR	100OHM 5% 1/10W		ATL4	2007-000070	CHIP RESISTOR	00HM 5% 1/10W	
L33	2007-000074	CHIP RESISTOR	100OHM 5% 1/10W		CN1	3708-001807	CONNECTOR	11P 1MM	
L34	2007-000074	CHIP RESISTOR	100OHM 5% 1/10W		CN3	3711-002533	CONNECTOR	BOX 5P 1R 2MM	
L35	2007-000074	CHIP RESISTOR	100OHM 5% 1/10W		CN4	3711-005306	CONNECTOR	BOX 4P 1R 2MM	
L38	2007-000029	CHIP RESISTOR	00HM 5% 1/8W		DC1	2203-005005	CHIP CAPACITOR	100NF 10% 16V	
L40	3301-001495	BEAD-SMD	AB 120OHM		DC2	2203-000236	CHIP CAPACITOR	0.1NF 5% 50V	
L41	3301-001495	BEAD-SMD	AB 120OHM		DC3	2203-000236	CHIP CAPACITOR	0.1NF 5% 50V	
AC3	2203-005005	CHIP CAPACITOR	100NF 10% 16V		DC4	2203-000888	CHIP CAPACITOR	4.7NF 10% 50V	
AC4	2402-000009	E CAPACITOR	47UF 20% 6.3V		DC5	2203-005005	CHIP CAPACITOR	100NF 10% 16V	
AC5	2203-005005	CHIP CAPACITOR	100NF 10% 16V		DC6	2203-005005	CHIP CAPACITOR	100NF 10% 16V	
AC6	2402-000009	E CAPACITOR	47UF 20% 6.3V		DC8	2203-005005	CHIP CAPACITOR	100NF 10% 16V	
AC7	2203-005005	CHIP CAPACITOR	100NF 10% 16V		DC9	2402-000179	E.CAPACITOR SMD	47UF 20% 16V	
AC8	2402-000176	E.CAPACITOR SMD	10UF 20% 16V		DC10	2402-000170	E.CAPACITOR SMD	1UF 20% 50V	
AC9	2203-005005	CHIP CAPACITOR	100NF 10% 16V		DC12	2402-000170	E.CAPACITOR SMD	1UF 20% 50V	
AC10	2402-000176	E.CAPACITOR SMD	10UF 20% 16V		DC13	2203-005005	CHIP CAPACITOR	100NF 10% 16V	
AC14	2402-000176	E.CAPACITOR SMD	10UF 20% 16V		DC14	2402-000170	E.CAPACITOR SMD	1UF 20% 50V	
AC17	2402-000176	E.CAPACITOR SMD	10UF 20% 16V		DC15	2203-005005	CHIP CAPACITOR	100NF 10% 16V	
AC21	2402-000176	E.CAPACITOR SMD	10UF 20% 16V		DC16	2203-005005	CHIP CAPACITOR	100NF 10% 16V	
AC24	2402-000176	E.CAPACITOR SMD	10UF 20% 16V		DC17	2203-005005	CHIP CAPACITOR	100NF 10% 16V	
AC28	2402-000176	E.CAPACITOR SMD	10UF 20% 16V		DC18	2203-005005	CHIP CAPACITOR	100NF 10% 16V	
AC31	2203-000440	CHIP CAPACITOR	1NF 10% 50V		DC19	2203-005005	CHIP CAPACITOR	100NF 10% 16V	
AC35	2203-000440	CHIP CAPACITOR	1NF 10% 50V		DR1	2007-000097	CHIP RESISTOR	47KOHM 5% 1/10W	
AC36	2402-000176	E.CAPACITOR SMD	10UF 20% 16V		DR2	2007-000090	CHIP RESISTOR	10KOHM 5% 1/10W	
AC38	2402-000009	E CAPACITOR	47UF 20% 6.3V		DR5	2007-000134	CHIP RESISTOR	33KOHM 5% 1/10W	
AC39	2402-000176	E.CAPACITOR SMD	10UF 20% 16V		DR6	2007-000090	CHIP RESISTOR	10KOHM 5% 1/10W	
AC40	2402-000176	E.CAPACITOR SMD	10UF 20% 16V		DR7	2007-000097	CHIP RESISTOR	47KOHM 5% 1/10W	
AD3	1SR154-400	FR DIODE	0402-000309		DR8	2007-000134	CHIP RESISTOR	33KOHM 5% 1/10W	
AD4	1SR154-400	FR DIODE	0402-000309		DR10	2007-000113	CHIP RESISTOR	33OHM 5% 1/10W	
AIC1	STAC9460S	IC	1205-002215		DR11	2007-000091	CHIP RESISTOR	12KOHM 5% 1/10W	
AJ1	3708-001805	CONNECTOR	20P 1MM		DR12	2007-000097	CHIP RESISTOR	47KOHM 5% 1/10W	
AJS1	3708-001615	CONNECTOR	24P 1MM		DR13	2007-000082	CHIP RESISTOR	3.3KOHM 5% 1/10	
AL2	3301-001069	BEAD-SMD	AB 1.6X0.8X0.8M		DR15	2007-000129	CHIP RESISTOR	27KOHM 5% 1/10W	
AL4	3301-001069	BEAD-SMD	AB 1.6X0.8X0.8M		DR16	2007-000097	CHIP RESISTOR	47KOHM 5% 1/10W	
AL5	3301-001069	BEAD-SMD	AB 1.6X0.8X0.8M		DR17	2007-000097	CHIP RESISTOR	47KOHM 5% 1/10W	
AL6	3301-001069	BEAD-SMD	AB 1.6X0.8X0.8M		DR30	2007-000483	CHIP RESISTOR	10HM 5% 1/8W	
AL7	3301-001069	BEAD-SMD	AB 1.6X0.8X0.8M		DR31	2007-000483	CHIP RESISTOR	10HM 5% 1/8W	
AL9	3301-001069	BEAD-SMD	AB 1.6X0.8X0.8M		DR34	2007-000483	CHIP RESISTOR	10HM 5% 1/8W	
AL16	3301-001069	BEAD-SMD	AB 1.6X0.8X0.8M		DR35	2007-000483	CHIP RESISTOR	10HM 5% 1/8W	
AL17	3301-001069	BEAD-SMD	AB 1.6X0.8X0.8M		DR37	2007-000483	CHIP RESISTOR	10HM 5% 1/8W	
AL18	3301-001495	BEAD-SMD	AB 120OHM		DR38	2007-000029	CHIP RESISTOR	00HM 5% 1/8W	
AL19	3301-001069	BEAD-SMD	AB 1.6X0.8X0.8M		DR40	2007-000483	CHIP RESISTOR	10HM 5% 1/8W	
AL20	3301-001069	BEAD-SMD	AB 1.6X0.8X0.8M						

△ Symbol No.	Part No.	Part Name	Description	Local	△ Symbol No.	Part No.	Part Name	Description	Local
DR44	2007-000076	CHIP RESISTOR	330OHM 5% 1/10W		RC14	2203-001636	CHIP CAPACITOR	0.033NF 5% 50V	
DR46	2007-000078	CHIP RESISTOR	1KOHM 5% 1/10W		RC15	2203-001126	CHIP CAPACITOR	0.68NF 10% 50V	
DR48	2007-000113	CHIP RESISTOR	330OHM 5% 1/10W		RC16	2203-001636	CHIP CAPACITOR	0.033NF 5% 50V	
DR49	2007-000078	CHIP RESISTOR	1KOHM 5% 1/10W		RC17	2203-000972	CHIP CAPACITOR	47NF 10% 16V	
DR50	2007-000078	CHIP RESISTOR	1KOHM 5% 1/10W		RC18	2203-001126	CHIP CAPACITOR	0.68NF 10% 50V	
DR52	2007-000070	CHIP RESISTOR	0OHM 5% 1/10W		RC19	2203-001126	CHIP CAPACITOR	0.68NF 10% 50V	
DR53	2007-000076	CHIP RESISTOR	330OHM 5% 1/10W		RC20	2402-000107	E.CAPACITOR SMD	100UF 20% 6.3V	
DR54	2007-000102	CHIP RESISTOR	100KOHM 5% 1/10		RC21	2203-000236	CHIP CAPACITOR	0.1NF 5% 50V	
DR56	2007-000029	CHIP RESISTOR	0OHM 5% 1/8W		RC22	2203-000440	CHIP CAPACITOR	1NF 10% 50V	
DR57	2007-000029	CHIP RESISTOR	0OHM 5% 1/8W		RC23	2203-005005	CHIP CAPACITOR	100NF 10% 16V	
DR59	2007-000097	CHIP RESISTOR	47KOHM 5% 1/10W		RC26	2203-000440	CHIP CAPACITOR	1NF 10% 50V	
DR60	2007-000070	CHIP RESISTOR	0OHM 5% 1/10W		RC28	2203-005005	CHIP CAPACITOR	100NF 10% 16V	
DR61	2007-000070	CHIP RESISTOR	0OHM 5% 1/10W		RC29	2203-005005	CHIP CAPACITOR	100NF 10% 16V	
DRIC1	BA5954FM	IC	1003-001450		RC30	2203-005005	CHIP CAPACITOR	100NF 10% 16V	
DRIC2	FAN8423D3TF	IC	1003-001507		RC34	2402-000009	E CAPACITOR	47UF 20% 6.3V	
DRIC3	FAN8082DTF	IC	1003-001508		RC35	2203-005005	CHIP CAPACITOR	100NF 10% 16V	
DZD1	UDZ4.7B	Z DIODE	0403-001062		RC36	2203-005005	CHIP CAPACITOR	100NF 10% 16V	
DZD2	UDZ3.6B	Z DIODE	0403-001376		RC37	2402-000009	E CAPACITOR	47UF 20% 6.3V	
JR1	2007-000872	CHIP RESISTOR	4.7KOHM 5% 1/8W		RC38	2203-005005	CHIP CAPACITOR	100NF 10% 16V	
LC1	2203-005005	CHIP CAPACITOR	100NF 10% 16V		RC39	2203-001636	CHIP CAPACITOR	0.033NF 5% 50V	
LC2	2203-005005	CHIP CAPACITOR	100NF 10% 16V		RC40	2203-005005	CHIP CAPACITOR	100NF 10% 16V	
LC3	2203-005005	CHIP CAPACITOR	100NF 10% 16V		RC41	2203-005005	CHIP CAPACITOR	100NF 10% 16V	
LR1	2007-000124	CHIP RESISTOR	2.2KOHM 5% 1/10		RC42	2203-001652	CHIP CAPACITOR	470NF +80-20% 1	
LR2	2007-000124	CHIP RESISTOR	2.2KOHM 5% 1/10		RC43	2203-005005	CHIP CAPACITOR	100NF 10% 16V	
MC6	2203-005065	CHIP CAPACITOR	1000NF +80-20%		RC44	2203-005005	CHIP CAPACITOR	100NF 10% 16V	
MC7	2203-005005	CHIP CAPACITOR	100NF 10% 16V		RC45	2402-000009	E CAPACITOR	47UF 20% 6.3V	
MC8	2203-005005	CHIP CAPACITOR	100NF 10% 16V		RC46	2203-000681	CHIP CAPACITOR	0.027NF 5% 50V	
MIC4	ES6628	IC	AH09-00098A		RC47	2203-001071	CHIP CAPACITOR	0.056NF 5% 50V	
MQ1	7S04	IC	0801-002345		RC48	2203-001071	CHIP CAPACITOR	0.056NF 5% 50V	
MR12	2007-000076	CHIP RESISTOR	330OHM 5% 1/10W		RCN2	3708-001808	CONNECTOR	24P 0.5MM	
MR14	2007-000076	CHIP RESISTOR	330OHM 5% 1/10W		RD1	DAP202K	FR DIODE	0407-000116	
MR15	2007-000076	CHIP RESISTOR	330OHM 5% 1/10W		RD2	DAP202K	FR DIODE	0407-000116	
MR16	2007-000076	CHIP RESISTOR	330OHM 5% 1/10W		REG2	AIC1117ACE	IC	1203-002935	
MR17	2007-000076	CHIP RESISTOR	330OHM 5% 1/10W		REG3	AIC1117ACE	IC	1203-002935	
MR18	2007-000070	CHIP RESISTOR	0OHM 5% 1/10W		REG4	AP1117	IC	1203-002425	
MR19	2007-000076	CHIP RESISTOR	330OHM 5% 1/10W		RIC1	ES6603	IC	1201-001790	
MR21	2007-000078	CHIP RESISTOR	1KOHM 5% 1/10W		RIC2	TL3472CD	IC	1201-001842	
MR22	2007-000070	CHIP RESISTOR	0OHM 5% 1/10W		RL1	3301-001069	BEAD-SMD	AB 1.6X0.8X0.8M	
MR23	2007-000084	CHIP RESISTOR	4.7KOHM 5% 1/10		RL2	3301-001069	BEAD-SMD	AB 1.6X0.8X0.8M	
MR26	2007-000094	CHIP RESISTOR	22KOHM 5% 1/10W		RN1	2011-000651	R-NET	10OHM 5% 1/16W	
MR30	2007-000070	CHIP RESISTOR	0OHM 5% 1/10W		RN2	2011-000651	R-NET	10OHM 5% 1/16W	
MR32	2007-000070	CHIP RESISTOR	0OHM 5% 1/10W		RN3	2011-000651	R-NET	10OHM 5% 1/16W	
OPIC1	CS8415A-CZ	IC	1001-001170		RQ1	2SB1197K	TRANSISTOR	0501-000632	
OPIC2	74LCX244	IC	0802-001007		RQ2	2SB1197K	TRANSISTOR	0501-000632	
OPIC3	74LCX374	IC	0802-001025		RQ3	0504-000128	DIGI TRANSISTOR	NPN 200MW	
PCB	AH41-00571A	PCB	HT-DB300 EOPXY		RQ4	0504-000128	DIGI TRANSISTOR	NPN 200MW	
PCN1	3711-005307	CONNECTOR	BOX 8P 1R 2MM		RQ5	0504-000128	DIGI TRANSISTOR	NPN 200MW	
PL1	3301-001495	BEAD-SMD	AB 120OHM		RR1	2007-000308	CHIP RESISTOR	10OHM 5% 1/8W	
PL3	3301-001495	BEAD-SMD	AB 120OHM		RR2	2007-000070	CHIP RESISTOR	0OHM 5% 1/10W	
PL5	2007-000029	CHIP RESISTOR	0OHM 5% 1/8W		RR3	2007-000078	CHIP RESISTOR	1KOHM 5% 1/10W	
PL7	3301-001495	BEAD-SMD	AB 120OHM		RR4	2007-001179	CHIP RESISTOR	8.2KOHM 5% 1/10	
PL8	3301-001495	BEAD-SMD	AB 120OHM		RR5	2007-000113	CHIP RESISTOR	330OHM 5% 1/10W	
PL10	3301-001495	BEAD-SMD	AB 120OHM		RR6	2007-000070	CHIP RESISTOR	0OHM 5% 1/10W	
PL13	3301-001495	BEAD-SMD	AB 120OHM		RR7	2007-000070	CHIP RESISTOR	0OHM 5% 1/10W	
PL17	3301-001495	BEAD-SMD	AB 120OHM		RR8	2007-000113	CHIP RESISTOR	330OHM 5% 1/10W	
PL18	3301-001495	BEAD-SMD	AB 120OHM		RR9	2007-000113	CHIP RESISTOR	330OHM 5% 1/10W	
PL19	3301-001495	BEAD-SMD	AB 120OHM		RR10	2007-000308	CHIP RESISTOR	100OHM 5% 1/8W	
PR1	2007-000308	CHIP RESISTOR	10OHM 5% 1/8W		RR11	2007-000070	CHIP RESISTOR	0OHM 5% 1/10W	
RC1	2203-005005	CHIP CAPACITOR	100NF 10% 16V		RR12	2007-000078	CHIP RESISTOR	1KOHM 5% 1/10W	
RC2	2203-005005	CHIP CAPACITOR	100NF 10% 16V		RR13	2007-000124	CHIP RESISTOR	2.2KOHM 5% 1/10	
RC3	2203-005005	CHIP CAPACITOR	100NF 10% 16V		RR14	2007-000124	CHIP RESISTOR	2.2KOHM 5% 1/10	
RC4	2203-005005	CHIP CAPACITOR	100NF 10% 16V		RR15	2007-000090	CHIP RESISTOR	10KOHM 5% 1/10W	
RC7	2402-000107	E.CAPACITOR SMD	100UF 20% 6.3V		RR16	2007-000090	CHIP RESISTOR	10KOHM 5% 1/10W	
RC8	2203-005005	CHIP CAPACITOR	100NF 10% 16V		RR18	2007-000075	CHIP RESISTOR	220OHM 5% 1/10W	
RC9	2203-001126	CHIP CAPACITOR	0.68NF 10% 50V		RR19	2007-000090	CHIP RESISTOR	10KOHM 5% 1/10W	
RC10	2203-000440	CHIP CAPACITOR	1NF 10% 50V		RR20	2007-000074	CHIP RESISTOR	100OHM 5% 1/10W	
RC11	2203-005005	CHIP CAPACITOR	100NF 10% 16V		RR21	2007-000070	CHIP RESISTOR	0OHM 5% 1/10W	
RC12	2203-001636	CHIP CAPACITOR	0.033NF 5% 50V		RR23	2007-000090	CHIP RESISTOR	10KOHM 5% 1/10W	
RC13	2203-001126	CHIP CAPACITOR	0.68NF 10% 50V		RR24	2007-000078	CHIP RESISTOR	1KOHM 5% 1/10W	
					RR25	2007-000098	CHIP RESISTOR	56KOHM 5% 1/10W	
					RR26	2007-000088	CHIP RESISTOR	7.5KOHM 5% 1/10W	
					RR27	2007-000070	CHIP RESISTOR	0OHM 5% 1/10W	

△ Symbol No.	Part No.	Part Name	Description	Local	△ Symbol No.	Part No.	Part Name	Description	Local
RR28	2007-000107	CHIP RESISTOR	470KOHM 5% 1/10		U11	74HCT245	IC	0801-002683	
RR30	2007-001179	CHIP RESISTOR	8.2KOHM 5% 1/10		U14	H1606	IC	1105-001369	
RR31	2007-000078	CHIP RESISTOR	1KOHM 5% 1/10W		U15	M29W800DT	IC	1107-001416	
SC1	2203-000972	CHIP CAPACITOR	47NF 10% 16V		U16	S524A40X21-SCTO	IC	1103-001292	
SC2	2203-001052	CHIP CAPACITOR	0.56NF 10% 50V		U17	74LCX157	IC	0801-002518	
SC3	2402-001059	E.CAPACITOR SMD	220UF 20% 6.3V		VL1	2703-000125	INDUCTOR-SMD	10UH 10% 2012	
SC4	2203-005005	CHIP CAPACITOR	100NF 10% 16V		VL2	2007-000029	CHIP RESISTOR	0OHM 5% 1/8W	
SC5	2203-005005	CHIP CAPACITOR	100NF 10% 16V		VL3	3301-001495	BEAD-SMD	AB 120OHM	
SC6	2203-000998	CHIP CAPACITOR	0.047NF 5% 50V		VQ1	KSA812	TRANSISTOR	0501-000314	
SC8	2203-005005	CHIP CAPACITOR	100NF 10% 16V		VQ3	KSA812	TRANSISTOR	0501-000314	
SC9	2203-005005	CHIP CAPACITOR	100NF 10% 16V		VQ4	KSA812	TRANSISTOR	0501-000314	
SC11	2203-000440	CHIP CAPACITOR	1NF 10% 50V		VQ5	KSA812	TRANSISTOR	0501-000314	
SC12	2203-001103	CHIP CAPACITOR	6.8NF 10% 50V		VQ6	KSA812	TRANSISTOR	0501-000314	
SC13	2203-001652	CHIP CAPACITOR	470NF +80-20% 1		X2	2801-004284	CRYSTAL	27MHZ 10PPM	
SC14	2203-000972	CHIP CAPACITOR	47NF 10% 16V						
SC15	2203-001656	CHIP CAPACITOR	0.47NF 5% 50V						
SC16	2203-001656	CHIP CAPACITOR	0.47NF 5% 50V						
SC17	2203-005005	CHIP CAPACITOR	100NF 10% 16V						
SC18	2203-005005	CHIP CAPACITOR	100NF 10% 16V						
SC19	2203-000440	CHIP CAPACITOR	1NF 10% 50V						
SC20	2203-000440	CHIP CAPACITOR	1NF 10% 50V						
SC21	2203-005005	CHIP CAPACITOR	100NF 10% 16V						
SC22	2203-005005	CHIP CAPACITOR	100NF 10% 16V						
SC23	2203-005005	CHIP CAPACITOR	100NF 10% 16V						
SC24	2203-005005	CHIP CAPACITOR	100NF 10% 16V						
SC25	2203-005005	CHIP CAPACITOR	100NF 10% 16V						
SC26	2203-005005	CHIP CAPACITOR	100NF 10% 16V						
SC27	2203-005005	CHIP CAPACITOR	100NF 10% 16V						
SC28	2203-000998	CHIP CAPACITOR	0.047NF 5% 50V						
SC29	2203-001573	CHIP CAPACITOR	0.012NF 5% 50V						
SC31	2203-005005	CHIP CAPACITOR	100NF 10% 16V						
SC32	2203-005005	CHIP CAPACITOR	100NF 10% 16V						
SC35	2203-001573	CHIP CAPACITOR	0.012NF 5% 50V						
SC37	2203-005005	CHIP CAPACITOR	100NF 10% 16V						
SC38	2203-005005	CHIP CAPACITOR	100NF 10% 16V						
SC39	2203-005005	CHIP CAPACITOR	100NF 10% 16V						
SC40	2203-005005	CHIP CAPACITOR	100NF 10% 16V						
SR1	2007-000122	CHIP RESISTOR	1.2KOHM 5% 1/10						
SR2	2007-000131	CHIP RESISTOR	91KOHM 5% 1/10W						
SR3	2007-000131	CHIP RESISTOR	91KOHM 5% 1/10W						
SR5	2007-000084	CHIP RESISTOR	4.7KOHM 5% 1/10						
SR7	2007-000093	CHIP RESISTOR	20KOHM 5% 1/10W						
SR8	2007-001010	CHIP RESISTOR	51KOHM 5% 1/10W						
SR9	2007-000082	CHIP RESISTOR	3.3KOHM 5% 1/10						
SR10	2007-000082	CHIP RESISTOR	3.3KOHM 5% 1/10						
SR11	2007-000082	CHIP RESISTOR	3.3KOHM 5% 1/10						
SR12	2007-000084	CHIP RESISTOR	4.7KOHM 5% 1/10						
SR13	2007-000070	CHIP RESISTOR	0OHM 5% 1/10W						
SR14	2007-000097	CHIP RESISTOR	47KOHM 5% 1/10W						
SR15	2007-000113	CHIP RESISTOR	330OHM 5% 1/10W						
SR17	2007-000082	CHIP RESISTOR	3.3KOHM 5% 1/10						
SR18	2007-000084	CHIP RESISTOR	4.7KOHM 5% 1/10						
SR19	2007-000070	CHIP RESISTOR	0OHM 5% 1/10W						
SR21	2007-000962	CHIP RESISTOR	5.1KOHM 1% 1/10						
SR22	2007-000078	CHIP RESISTOR	1KOHM 5% 1/10W						
SR23	2007-000309	CHIP RESISTOR	10OHM 5% 1/10W						
SR24	2007-000090	CHIP RESISTOR	10KOHM 5% 1/10W						
SR26	2007-000309	CHIP RESISTOR	10OHM 5% 1/10W						
SR27	2007-000097	CHIP RESISTOR	47KOHM 5% 1/10W						
SR28	2007-000090	CHIP RESISTOR	10KOHM 5% 1/10W						
SR29	2007-000962	CHIP RESISTOR	5.1KOHM 1% 1/10						
SR31	2007-000084	CHIP RESISTOR	4.7KOHM 5% 1/10						
SR33	2007-000094	CHIP RESISTOR	22KOHM 5% 1/10W						
SR34	2007-000076	CHIP RESISTOR	330OHM 5% 1/10W						
SR35	2007-000076	CHIP RESISTOR	330OHM 5% 1/10W						
SR36	2007-000076	CHIP RESISTOR	330OHM 5% 1/10W						
SR37	2007-000076	CHIP RESISTOR	330OHM 5% 1/10W						