

# PARTS LIST

[ TH-A30R ]

\* All printed circuit boards and its assemblies are not available as service parts.

Area suffix	
B	U.K.
E	Continental Europe
EN	Northern Europe
EV	Eastern Europe
EE	Russian Federation

- Contents -

Exploded view of general assembly and parts list (Block No.M1)	3- 2
DVD mechanism assembly and parts list (Block No.MJ)	3- 4
Electrical parts list (Block No.01~05)	3- 6
Packing materials and accessories parts list (Block No.M3,M5)	3-22

# Exploded view of general assembly and parts list

Block No. 

M	1	M	M
---	---	---	---

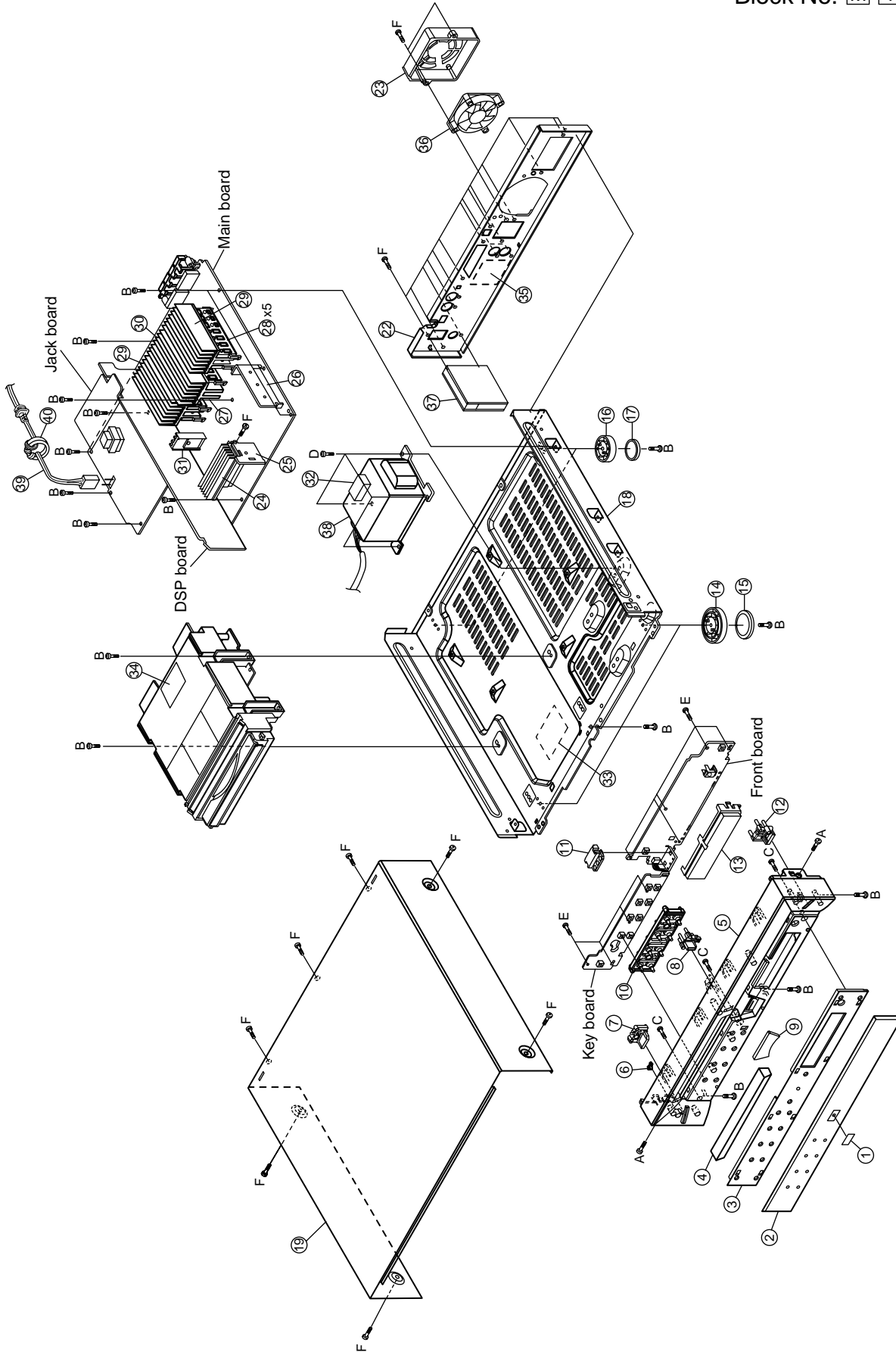

**Parts list (General assembly)**

Block No. M1MM

⚠	Item	Parts number	Parts name	Q'ty	Description	Area
	A	6002-000126	SCREW	2	FH 3X10 BLK	
	B	6003-000398	SCREW	18	BH 2S 3X6 YEL	
	C	6003-000276	SCREW	3	BH M3X10 YEL	
	D	AH60-10107A	SCREW	4	M4X6 YEL	
	E	AH60-10020D	SCREW	9	RH 2.6X8 YEL	
	F	AH60-00025A	SCREW	25	BH 3X10 SILVER	
	1	AH64-01539A	DVD BADGE	1		
	2	AH64-02066B	WINDOW FRONT	1		
	3	AH61-00834A	FRONT CAP	1		
	4	AH64-01453B	TRAY DOOR	1		
	5	AH64-01452A	FRONT CABINET	1		
	6	AH67-00129A	POWER LENS	1		
	7	AH64-01454A	KNOB POWER	1		
	8	AH64-01455A	KNOB OPEN	1		
	9	AH67-00128A	LENS FRONT	1		
	10	AH64-01457A	KNOB FUNCTION	1		
	11	AH61-00836A	HOLDER LED	1		
	12	AH64-01456A	KNOB PLAY	1		
	13	AH61-00835A	VFD HOLDER	1		
	14	AH61-00766A	FOOT HOLDER	2	FRONT	
	15	AH69-00503A	CUSHION FOOT	2	FRONT	
	16	AH61-00777A	FOOT HOLDER	2	REAR	
	17	AH69-00503B	CUSHION FOOT	2	REAR	
	18	AH64-01586A	CABINET BOTTOM	1		
	19	AH64-01587A	CABINET TOP	1		
	22	AH64-01813H	CABINET REAR	1		
	23	AH63-00303A	COVER FAN	1		
	24	AH62-00051C	HEAT SINK D	1		
	25	AH62-00051D	HEAT SINK B	1		
	26	AH62-00052B	HEAT SINK	1		
	27	AH61-00855A	IC HOLDER	1		
	28	AH61-00779A	IC HOLDER	5		
	29	AH62-00050A	HEAT SINK	2		
	30	AH62-00050B	HEAT SINK M	1		
	31	AH62-00062A	HEAT SINK	1	TRANSISTOR	
	32	AH69-00188B	POWER CUSHION	1		
	33	AH68-00967A	LABEL DTS	1		
	34	AH68-50275D	STICKER CD	1		
	35	AH68-01158E	LABEL RATING	1		EE
		AH68-01158D	LABEL RATING	1		B,E,EN,EV
	36	AH31-00029A	MOTOR FAN	1		
	37	AH40-00021A	TUNER PACK	1	FM MW RDS	
⚠	38	AH26-00202A	TRANS POWER	1		
⚠	39	AH39-00257F	POWER CORD	1	CP2 250V 2.5A 1	E,EN,EV,EE
⚠		AH39-00258P	POWER CORD	1	VP840 BS	B
	40	3301-001525	AC CORD RING	1		

# DVD mechanism assembly and parts list

CMSD100

Block No. M J M M

DVD MPEG board

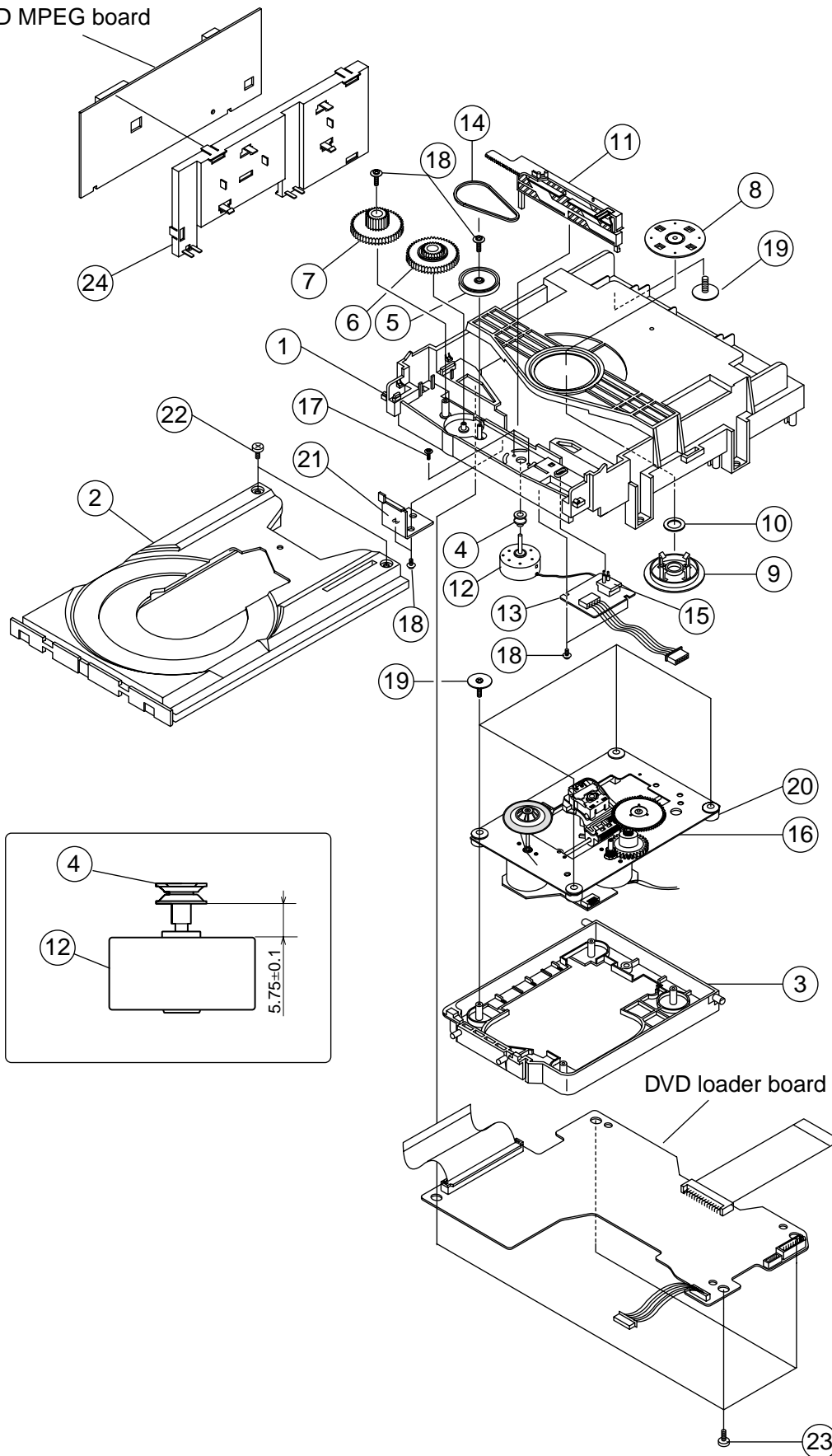

## ■ Parts list (DVD mechanism)

Block No. MJMM

△	Item	Parts number	Parts name	Q'ty	Description	Area
	1	AH61-00746A	BASE-MAIN	1	BLK	
	2	AH63-00294A	TRAY-DISC	1	D/GRAY	
	3	AH66-00159A	LEVER-LIFT	1	BLK	
	4	AH66-00160A	PULLEY-MOTOR	1		
	5	AH66-00161A	GEAR-PULLEY	1		
	6	AH66-00162A	GEAR-MIDDLE	1		
	7	AH66-00163A	GEAR-TRAY	1		
	8	AH66-00164A	CLAMPER-UPPER	1	UPPER	
	9	AH66-00165A	CLAMPER-LOWER	1	LOWER	
	10	AH61-00747A	BRACKET-CHUCK	1	T1.0	
	11	AH66-00166A	SLIDE-CAM	1		
	12	AH31-00030A	MOTOR-DC	1	RF-300CA-11440	
	13	-----	PCB-SWITCH	1	26.5 X 21.6	
	14	AH66-00167A	BELT-PULLEY	1	CR 1.5	
	15	3409-001119	SWITCH-DETECTOR	1	JDS2200	
	16	AH59-00130A	DVD DECK	1	CMS-S21MG6	
	17	6001-001257	SCREW-MACHINE	2	1.7 X 3(W4.5)	
	18	AJ60-10001A	SCREW-TAP	6	2 X 5(W7)	
	19	6003-001210	SCREW-TAP	5	2.6 X 6(W12)	
	20	AH73-00025B	RUBBER-CD	4	BUTYL 15	
	21	AH61-00958A	BRACKET-GUIDE	1	SECC 1.0T	
	22	6003-000283	SCREW-TAP	2	3 X 8	
	23	6003-000276	SCREW-TAP	4	3 X 10	
	24	AH61-00828A	HOLDER-PCB	1	ABS BLK	

## ■ Electrical parts list (Main board)

Block No. 01

△	Item	Parts number	Parts name	Remarks	Area	△	Item	Parts number	Parts name	Remarks	Area
	ABD1	0402-001408	DIODE	KBP005G 50V			AZD2	0403-000352	ZENER DIODE	UZ4.7BM 4.7V	
	ABD2	0402-001258	BRIDGE DIODE	GBU606 600V			AZD3	0403-000379	ZENER DIODE	UZP12B 12V	
	ABD4	0402-001258	BRIDGE DIODE	GBU606 600V			CE4FR	2201-000565	CHIP CAPACITOR	47NF 50V	
	ABD5	0402-001258	BRIDGE DIODE	GBU606 600V			CE5C	2203-000495	CHIP CAPACITOR	2.2NF 10% 50V	
△	ACW1	3711-000190	CONNECTOR	2P			CE5FL	2203-000495	CHIP CAPACITOR	2.2NF 10% 50V	
	ACW2	3711-004848	CONNECTOR	3P			CE5FR	2203-000495	CHIP CAPACITOR	2.2NF 10% 50V	
	ACW3	3711-001098	CONNECTOR	7P 2.5MM			CE5RL	2203-000495	CHIP CAPACITOR	2.2NF 10% 50V	
	ACW4	3711-003111	CONNECTOR	6P 2.5MM			CE5RR	2203-000495	CHIP CAPACITOR	2.2NF 10% 50V	
	ACW5	3711-000963	CONNECTOR	4P 2.5MM			CE5W	2203-000495	CHIP CAPACITOR	2.2NF 10% 50V	
△	AC1	2201-000546	CHIP CAPACITOR	4.7NF 20% 400V			CE6C	2203-000892	CHIP CAPACITOR	4.7NF 10% 50V	
	AC10	2401-001912	E.CAPACITOR	1UF 20% 50V			CE6FL	2203-000892	CHIP CAPACITOR	4.7NF 10% 50V	
	AC11	2401-000830	E.CAPACITOR	220UF 20% 25V			CE6FR	2203-000892	CHIP CAPACITOR	4.7NF 10% 50V	
	AC12	2401-001954	E.CAPACITOR	4.7UF 20% 50V			CE6RL	2203-000892	CHIP CAPACITOR	4.7NF 10% 50V	
	AC13	2401-001954	E.CAPACITOR	4.7UF 20% 50V			CE6RR	2203-000892	CHIP CAPACITOR	4.7NF 10% 50V	
	AC14	2201-000161	CHIP CAPACITOR	10NF +80-20% 500V			CE6W	2203-000892	CHIP CAPACITOR	4.7NF 10% 50V	
	AC15	2201-000161	CHIP CAPACITOR	10NF +80-20% 500V			CW5	3711-004110	CONNECTOR	12P 2MM	
	AC16	2201-000161	CHIP CAPACITOR	10NF +80-20% 500V			CW6	3711-004110	CONNECTOR	12P 2MM	
	AC17	2201-000161	CHIP CAPACITOR	10NF +80-20% 500V			CW7	3711-004110	CONNECTOR	12P 2MM	
	AC18	2401-003772	E.CAPACITOR	2200UF 20% 63V			CW8	3708-001094	CONNECTOR	13P 1.25MM	
	AC19	2401-003116	E.CAPACITOR	4700UF 20% 35V			C202L	2203-000787	CHIP CAPACITOR	0.33NF 5% 50V	
△	AC2	2201-000546	CHIP CAPACITOR	4.7NF 20% 400V			C202R	2203-000787	CHIP CAPACITOR	0.33NF 5% 50V	
	AC20	2401-003116	E.CAPACITOR	4700UF 20% 35V			C26	2401-000325	E.CAPACITOR	100UF 20% 35V	
	AC21	2401-003772	E.CAPACITOR	2200UF 20% 63V			C27	2401-000325	E.CAPACITOR	100UF 20% 35V	
	AC22	2401-001959	E.CAPACITOR	4700UF 20% 25V			C28	2401-000475	E.CAPACITOR	10UF 20% 50V	
	AC23	2401-001959	E.CAPACITOR	4700UF 20% 25V			C29	2401-000475	E.CAPACITOR	10UF 20% 50V	
△	AC3	2201-000546	CHIP CAPACITOR	4.7NF 20% 400V			C30	2401-001364	E.CAPACITOR	470UF 20% 16V	
△	AC5	2201-000546	CHIP CAPACITOR	4.7NF 20% 400V			C31	2401-001364	E.CAPACITOR	470UF 20% 16V	
	AC8	2401-000475	E.CAPACITOR	10UF 20% 50V			C33C	2201-000282	CHIP CAPACITOR	1NF +80-20% 50V	
	AC9	2401-001413	E.CAPACITOR	470UF 20% 35V			C33FL	2201-000282	CHIP CAPACITOR	1NF +80-20% 50V	
△	AD1	0402-000127	DIODE	1N4002 100V 1A			C33FR	2201-000282	CHIP CAPACITOR	1NF +80-20% 50V	
△	AD11	0402-000127	DIODE	1N4002 100V 1A			C33RL	2201-000282	CHIP CAPACITOR	1NF +80-20% 50V	
△	AD2	0402-000127	DIODE	1N4002 100V 1A			C33RR	2201-000282	CHIP CAPACITOR	1NF +80-20% 50V	
	AD3	0402-000127	DIODE	1N4002 100V 1A			C33W	2201-000282	CHIP CAPACITOR	1NF +80-20% 50V	
	AD4	0401-000101	DIODE	1N4148 100V			C34	2401-000385	E.CAPACITOR	10UF 20% 100V	
△	AD6	0402-000127	DIODE	1N4002 100V 1A			C35	2401-001361	E.CAPACITOR	470UF 20% 16V	
△	AD8	0402-000127	DIODE	1N4002 100V 1A			C36	2401-001912	E.CAPACITOR	1UF 20% 50V	
△	AFU2	3601-000263	FUSE	250V 3.15A			C37	2401-001975	E.CAPACITOR	47UF 20% 16V	
△	AFU3	3601-000319	FUSE	80MA 250V			C38	2401-001912	E.CAPACITOR	1UF 20% 50V	
	AIC1	1203-000276	IC	7805 3P			C39	2401-001538	E.CAPACITOR	47UF 20% 25V	
	AIC2	1201-000163	IC	BA4560 8P			C40C	2401-000438	E.CAPACITOR	10UF 20% 25V	
△	AL1	AH27-10001F	CHOKE COIL	27UH			C40FL	2401-001912	E.CAPACITOR	1UF 20% 50V	
△	AL2	AH27-10001F	CHOKE COIL	27UH			C40FR	2401-001912	E.CAPACITOR	1UF 20% 50V	
	AL3C	AH27-90001A	SPRING COIL	2.2UH			C40RL	2401-000438	E.CAPACITOR	10UF 20% 25V	
	AL3FL	AH27-90001A	SPRING COIL	2.2UH			C40RR	2401-000438	E.CAPACITOR	10UF 20% 25V	
	AL3FR	AH27-90001A	SPRING COIL	2.2UH			C40W	2401-000407	E.CAPACITOR	10UF 20% 16V	
	AL3RL	AH27-90001A	SPRING COIL	2.2UH			C41C	2203-001214	CHIP CAPACITOR	8.2NF 10% 50V	
	AL3RR	AH27-90001A	SPRING COIL	2.2UH			C41FL	2203-001214	CHIP CAPACITOR	8.2NF 10% 50V	
	AL3W	AH27-90001A	SPRING COIL	2.2UH			C41FR	2203-001214	CHIP CAPACITOR	8.2NF 10% 50V	
	AQ2	0501-000010	TRANSISTOR	KSC1008			C41RL	2203-001214	CHIP CAPACITOR	8.2NF 10% 50V	
	AQ3	0501-000010	TRANSISTOR	KSC1008			C41RR	2203-001214	CHIP CAPACITOR	8.2NF 10% 50V	
	AR11	2001-000786	CARBON RESISTOR	47K 5% 1/8W			C41W	2203-001214	CHIP CAPACITOR	8.2NF 10% 50V	
	AR12	2001-000258	CARBON RESISTOR	1.8K 5% 1/8W			C43C	2401-000759	E.CAPACITOR	220NF 20% 50V	
	AR15	2001-000702	CARBON RESISTOR	39K 5% 1/8W			C43FL	2401-001645	E.CAPACITOR	0.68UF 20% 50V	
	AR2	2001-000890	CARBON RESISTOR	6.8K 5% 1/8W			C43FR	2401-001645	E.CAPACITOR	0.68UF 20% 50V	
	AR3	2001-000449	CARBON RESISTOR	2.2K 5% 1/8W			C43RL	2401-000759	E.CAPACITOR	220NF 20% 50V	
	AR4	2001-000052	CARBON RESISTOR	3.3K 5% 1/2W			C43RR	2401-000759	E.CAPACITOR	220NF 20% 50V	
	AR5	2007-000300	CHIP RESISTOR	10K 5% 1/10W			C43W	2401-001625	E.CAPACITOR	6.8UF 20% 50V	
	AR6	2007-000941	CHIP RESISTOR	47K 5% 1/10W			C44C	2203-000710	CHIP CAPACITOR	2PF 0.25PF 50V	
	AR7	2001-001045	CARBON RESISTOR	1.2K 5% 1/2W			C44FL	2203-000710	CHIP CAPACITOR	2PF 0.25PF 50V	
	AR8	2001-000435	CARBON RESISTOR	1M 5% 1/8W			C44FR	2203-000710	CHIP CAPACITOR	2PF 0.25PF 50V	
	AR9	2001-000591	CARBON RESISTOR	3.3K 5% 1/8W			C44RL	2203-000710	CHIP CAPACITOR	2PF 0.25PF 50V	
	AUX1	3722-001727	PIN JACK	2P 8.3PI			C44RR	2203-000710	CHIP CAPACITOR	2PF 0.25PF 50V	
	AZD1	0403-000354	ZENER DIODE	UZ5.1B 5.1V			C44W	2203-000295	CHIP CAPACITOR	0.01NF 5% 50V	

## ■ Electrical parts list (Main board)

Block No. 01

▲	Item	Parts number	Parts name	Remarks	Area	▲	Item	Parts number	Parts name	Remarks	Area
	C46W	2203-001611	CHIP CAPACITOR	0.022NF 5% 50V			D38C	0401-001090	DIODE	1SS355 80V	
	C47C	2301-000375	M.CAPACITOR	100NF 10% 50V			D38FL	0401-001090	DIODE	1SS355 80V	
	C47FL	2301-000375	M.CAPACITOR	100NF 10% 50V			D38FR	0401-001090	DIODE	1SS355 80V	
	C47FR	2301-000375	M.CAPACITOR	100NF 10% 50V			D38RL	0401-001090	DIODE	1SS355 80V	
	C47RL	2301-000375	M.CAPACITOR	100NF 10% 50V			D38RR	0401-001090	DIODE	1SS355 80V	
	C47RR	2301-000375	M.CAPACITOR	100NF 10% 50V			D38W	0401-001090	DIODE	1SS355 80V	
	C47W	2301-000375	M.CAPACITOR	100NF 10% 50V			D39W	0402-001484	DIODE	S2B 100V 1.5A	
	C49C	2203-000295	CHIP CAPACITOR	0.01NF 5% 50V			D40C	0402-000309	DIODE	1SR154-400 400V	
	C49FL	2203-000295	CHIP CAPACITOR	0.01NF 5% 50V			D40FL	0402-000309	DIODE	1SR154-400 400V	
	C49FR	2203-000295	CHIP CAPACITOR	0.01NF 5% 50V			D40FR	0402-000309	DIODE	1SR154-400 400V	
	C49RL	2203-000295	CHIP CAPACITOR	0.01NF 5% 50V			D40RL	0402-000309	DIODE	1SR154-400 400V	
	C49RR	2203-000295	CHIP CAPACITOR	0.01NF 5% 50V			D40RR	0402-000309	DIODE	1SR154-400 400V	
	C49W	2203-001525	CHIP CAPACITOR	56PF 5% 50V			D40W	0402-001484	DIODE	S2B 100V 1.5A	
	C52	2401-001975	E.CAPACITOR	47UF 20% 16V			D41C	0402-000309	DIODE	1SR154-400 400V	
	C53	2401-000475	E.CAPACITOR	10UF 20% 50V			D41FL	0402-000309	DIODE	1SR154-400 400V	
	C54RL	2401-001975	E.CAPACITOR	47UF 20% 16V			D41FR	0402-000309	DIODE	1SR154-400 400V	
	C54RR	2401-001975	E.CAPACITOR	47UF 20% 16V			D41RL	0402-000309	DIODE	1SR154-400 400V	
	C54W	2401-001975	E.CAPACITOR	47UF 20% 16V			D41RR	0402-000309	DIODE	1SR154-400 400V	
	C55	2401-001975	E.CAPACITOR	47UF 20% 16V			D41W	0402-001484	DIODE	S2B 100V 1.5A	
	D01FL	0401-001090	DIODE	1SS355 80V			D42W	0402-001484	DIODE	S2B 100V 1.5A	
	D01FR	0401-001090	DIODE	1SS355 80V		▲	D5	2003-000603	OMF RESISTOR	270 5% 1W	
	D01RL	0401-001090	DIODE	1SS355 80V		▲	D7	2003-000603	OMF RESISTOR	270 5% 1W	
	D01RR	0401-001090	DIODE	1SS355 80V			FCW11	3708-001033	CONNECTOR	22P 1.25MM	
	D010C	0401-001090	DIODE	1SS355 80V			HAFU2	3602-000147	FUSE CLIP		
	D010W	0401-001090	DIODE	1SS355 80V			HAFU3	3602-000147	FUSE CLIP		
	D02FL	0401-001090	DIODE	1SS355 80V			HR3	2007-000282	CHIP RESISTOR	100K 5% 1/10W	
	D02FR	0401-001090	DIODE	1SS355 80V			IC3	1203-000242	IC	7812 3P	
	D02RL	0401-001090	DIODE	1SS355 80V			IC4	1203-000110	IC	7912 3P	
	D02RR	0401-001090	DIODE	1SS355 80V			IC5	1201-000163	IC	BA4560 8P	
	D020C	0401-001090	DIODE	1SS355 80V			IC6	1201-000163	IC	BA4560 8P	
	D020W	0401-001090	DIODE	1SS355 80V			IC7	1201-000163	IC	BA4560 8P	
	D03FL	0401-001090	DIODE	1SS355 80V			JVC1	2401-001952	E.CAPACITOR	4.7UF 20% 50V	
	D03FR	0401-001090	DIODE	1SS355 80V			JVC10	2201-000783	CHIP CAPACITOR	100NF +80-20% 50V	
	D03RL	0401-001090	DIODE	1SS355 80V			JVC11	2201-000783	CHIP CAPACITOR	100NF +80-20% 50V	
	D03RR	0401-001090	DIODE	1SS355 80V			JVC12	2401-001952	E.CAPACITOR	4.7UF 20% 50V	
	D030C	0401-001090	DIODE	1SS355 80V			JVC13	2201-000783	CHIP CAPACITOR	100NF +80-20% 50V	
	D030W	0401-001090	DIODE	1SS355 80V			JVC14	2201-000783	CHIP CAPACITOR	100NF +80-20% 50V	
	D12	0401-001090	DIODE	1SS355 80V			JVC2	2203-000761	CHIP CAPACITOR	330NF 10% 16V	
	D13	0401-001090	DIODE	1SS355 80V			JVC3	2401-001975	E.CAPACITOR	47UF 20% 16V	
	D14	0401-001090	DIODE	1SS355 80V			JVC4	2201-000783	CHIP CAPACITOR	100NF +80-20% 50V	
	D15	0401-001090	DIODE	1SS355 80V			JVC5	2401-001952	E.CAPACITOR	4.7UF 20% 50V	
	D16	0401-001090	DIODE	1SS355 80V			JVC6	2401-001952	E.CAPACITOR	4.7UF 20% 50V	
	D17	0401-001090	DIODE	1SS355 80V			JVC7	2203-000761	CHIP CAPACITOR	330NF 10% 16V	
	D20	0401-001090	DIODE	1SS355 80V			JVC8	2203-000761	CHIP CAPACITOR	330NF 10% 16V	
	D21	0401-001090	DIODE	1SS355 80V			JVC9	2203-000761	CHIP CAPACITOR	330NF 10% 16V	
	D22	0402-000127	DIODE	1N4002 100V 1A			JVIC1	1001-001173	IC	BA7612F 8P 173	
	D23	0402-000127	DIODE	1N4002 100V 1A			JVIC2	1001-001173	IC	BA7612F 8P 173	
	D24	0402-000127	DIODE	1N4002 100V 1A			JVIC3	1001-001173	IC	BA7612F 8P 173	
	D28	0401-001090	DIODE	1SS355 80V			JVJ2	3722-001682	JACK SCART	21P	
	D29	0401-000101	DIODE	1N4148 100V			JVQ1	0504-000118	DEGI TRANSISTOR	KSR1003	
	D30	0401-001090	DIODE	1SS355 80V			JVQ2	0504-000118	DEGI TRANSISTOR	KSR1003	
	D31	0401-001090	DIODE	1SS355 80V			JVQ3	0501-000637	TRANSISTOR	2SC1740S	
	D32	0401-001090	DIODE	1SS355 80V			JVQ4	0504-001003	DIGI TRANSISTOR	KSR2003	
	D33	0401-001090	DIODE	1SS355 80V			JVQ5	0504-001003	DIGI TRANSISTOR	KSR2003	
	D34	0401-001090	DIODE	1SS355 80V			JVR1	2001-000734	CARBON RESISTOR	4.7K 5% 1/8W	
	D35C	0401-001090	DIODE	1SS355 80V			JVR10	3301-000353	BEAD	AB 120 OHM	
	D35FL	0401-001090	DIODE	1SS355 80V			JVR11	2001-000290	CARBON RESISTOR	10K 5% 1/8W	
	D35FR	0401-001090	DIODE	1SS355 80V			JVR12	2001-000449	CARBON RESISTOR	2.2K 5% 1/8W	
	D35RL	0401-001090	DIODE	1SS355 80V			JVR13	2001-000780	CARBON RESISTOR	470 5% 1/8W	
	D35RR	0401-001090	DIODE	1SS355 80V			JVR14	2001-000221	CARBON RESISTOR	1.2K 5% 1/8W	
	D35W	0401-001090	DIODE	1SS355 80V			JVR15	2001-000241	CARBON RESISTOR	1.5K 5% 1/8W	
	D36W	0401-001090	DIODE	1SS355 80V			JVR16	2001-000869	CARBON RESISTOR	56 5% 1/8W	
	D37W	0401-001090	DIODE	1SS355 80V			JVR17	2001-000969	CARBON RESISTOR	75 5% 1/8W	

■ Electrical parts list (Main board)

Block No. 01

△	Item	Parts number	Parts name	Remarks	Area
	JVR18	2001-000969	CARBON RESISTOR	75 5% 1/8W	
	JVR19	2001-000869	CARBON RESISTOR	56 5% 1/8W	
	JVR2	2001-000857	CARBON RESISTOR	560 5% 1/8W	
	JVR20	2001-000273	CARBON RESISTOR	100K 5% 1/8W	
	JVR21	2001-000645	CARBON RESISTOR	330K 5% 1/8W	
	JVR22	2001-000273	CARBON RESISTOR	100K 5% 1/8W	
	JVR23	2001-000273	CARBON RESISTOR	100K 5% 1/8W	
	JVR24	2001-000645	CARBON RESISTOR	330K 5% 1/8W	
	JVR3	2001-000591	CARBON RESISTOR	3.3K 5% 1/8W	
	JVR4	2001-000515	CARBON RESISTOR	220 5% 1/8W	
	JVR6	2001-000938	CARBON RESISTOR	68 5% 1/8W	
	JVR7	2001-000429	CARBON RESISTOR	1K 5% 1/8W	
	JVR8	2001-000241	CARBON RESISTOR	1.5K 5% 1/8W	
	JVR9	2001-000429	CARBON RESISTOR	1K 5% 1/8W	
	JVW2	3708-000347	CONNECTOR	10P 1MM	
	JW001	2007-000029	CHIP RESISTOR	0 5% 1/10W	
	JW002	2007-000029	CHIP RESISTOR	0 5% 1/10W	
	JW003	2007-000029	CHIP RESISTOR	0 5% 1/10W	
	JW004	2007-000029	CHIP RESISTOR	0 5% 1/10W	
	JW005	2007-000029	CHIP RESISTOR	0 5% 1/10W	
	JW006	2007-000029	CHIP RESISTOR	0 5% 1/10W	
	JW007	2007-000029	CHIP RESISTOR	0 5% 1/10W	
	JW008	2007-000029	CHIP RESISTOR	0 5% 1/10W	
	JW009	2007-000029	CHIP RESISTOR	0 5% 1/10W	
	JW010	2007-000029	CHIP RESISTOR	0 5% 1/10W	
	JW011	2007-000029	CHIP RESISTOR	0 5% 1/10W	
	JW014	2007-000029	CHIP RESISTOR	0 5% 1/10W	
	JW017	2007-000029	CHIP RESISTOR	0 5% 1/10W	
	JW018	2007-000029	CHIP RESISTOR	0 5% 1/10W	
	JW019	2007-000029	CHIP RESISTOR	0 5% 1/10W	
	JW020	2007-000029	CHIP RESISTOR	0 5% 1/10W	
	JW021	2007-000029	CHIP RESISTOR	0 5% 1/10W	
	JW023	2007-000029	CHIP RESISTOR	0 5% 1/10W	
	JW024	2007-000029	CHIP RESISTOR	0 5% 1/10W	
	JW025	2007-000029	CHIP RESISTOR	0 5% 1/10W	
	JW030	2007-000029	CHIP RESISTOR	0 5% 1/10W	
	JW055	2007-000029	CHIP RESISTOR	0 5% 1/10W	
	JW122	2007-000029	CHIP RESISTOR	0 5% 1/10W	
	MJW88	2701-000298	INDUCTOR	470UH 10%	
	MW1	AH38-00008A	MONO WIRE	BLK 120MM	
	MW3	AH38-00008A	MONO WIRE	BLK 120MM	
	PBD1	0402-001258	BRIDGE DIODE	GBU606 600V	
△	PBD2	0402-001077	BRIDGE DIODE	KBP202G 200V	
	PC	2401-000357	E.CAPACITOR	100UF 0.2 50V	
	PC-1	2401-000357	E.CAPACITOR	100UF 0.2 50V	
	PC13	2401-000475	E.CAPACITOR	10UF 20% 50V	
	PC14	2401-001893	E.CAPACITOR	100UF 20% 16V	
	PC15	2401-001893	E.CAPACITOR	100UF 20% 16V	
	PC16	2401-000475	E.CAPACITOR	10UF 20% 50V	
	PC17	2401-001893	E.CAPACITOR	100UF 20% 16V	
	PC18	2401-000475	E.CAPACITOR	10UF 20% 50V	
	PC19	2201-000161	CHIP CAPACITOR	10NF +80-20% 500V	
	PC2	2401-001572	E.CAPACITOR	47UF 20% 50V	
	PC20	2201-000161	CHIP CAPACITOR	10NF +80-20% 500V	
	PC3	2401-001879	E.CAPACITOR	10000UF 20% 16V	
	PC4	2401-001879	E.CAPACITOR	10000UF 20% 16V	
	PC5	2401-001052	E.CAPACITOR	3300UF 20% 25V	
	PC50	2401-003681	E.CAPACITOR	6800UF 20%	
	PC6	2401-000475	E.CAPACITOR	10UF 20% 50V	
	PC7	2401-001893	E.CAPACITOR	100UF 20% 16V	
	PC9	2401-001893	E.CAPACITOR	100UF 20% 16V	
	PD1	0402-000127	DIODE	1N4002 100V 1A	
	PD2	0401-000101	DIODE	1N4148 100V	

△	Item	Parts number	Parts name	Remarks	Area
	PD3	0401-000101	DIODE	1N4148 100V	
	PQ1	1203-001589	IC	278R05 4P	
	PQ2	1203-001006	IC	78R05 4P	
	PQ3	0502-000303	POWER TRANSISTOR	KSD882	
	PQ4	1203-001586	IC	278R33 4P	
	PQ5	1203-001697	IC	78R08 4P	
	PQ6	1203-000276	IC	7805 3P	
	PR002	2001-001153	CARBON RESISTOR	47 5% 1/2W	
	PR003	2001-001153	CARBON RESISTOR	47 5% 1/2W	
	PR004	2001-000019	CARBON RESISTOR	10 5% 1/2W	
	PR005	2003-000689	OMF RESISTOR	4.7 5% 1W	
	PR006	2003-000689	OMF RESISTOR	4.7 5% 1W	
	PR007	2007-000300	CHIP RESISTOR	10K 5% 1/10W	
	PR008	2001-000019	CARBON RESISTOR	10 5% 1/2W	
	PR010	2001-000019	CARBON RESISTOR	10 5% 1/2W	
	PR011	2001-001140	CARBON RESISTOR	39 5% 1/2W	
	PR012	2003-000708	OMF RESISTOR	47 5% 1W	
	PR013	2003-000689	OMF RESISTOR	4.7 5% 1W	
	PR1	2003-000603	OMF RESISTOR	270 5% 1W	
	PR21	2007-000355	CHIP RESISTOR	12K 5% 1/10W	
	PR6	2007-000586	CHIP RESISTOR	22K 5% 1/10W	
	PR7	2007-000653	CHIP RESISTOR	27K 5% 1/10W	
	PR8	2007-000409	CHIP RESISTOR	15K 5% 1/10W	
	PR9	2007-000586	CHIP RESISTOR	22K 5% 1/10W	
△	PT1	AH26-00143C	POWER TRANS	6.276V 24V/9V 0	
	PW3	3711-004110	CONNECTOR	12P 2MM	
	PW4	AH39-00291A	LEAD CONNECTOR	RCA300 6P	
	PZD1	0403-000564	ZENER DIODE	TZP16A 16V	
	PZD2	0403-000564	ZENER DIODE	TZP16A 16V	
	PZD5	0403-000398	ZENER DIODE	UZP8.2B 8.2V	
	Q1	0504-000118	DEGI TRANSISTOR	KSR1003	
	Q10	0501-000398	TRANSISTOR	KSC945	
	Q11	0501-000398	TRANSISTOR	KSC945	
	Q12	0504-001003	DIGI TRANSISTOR	KSR2003	
	Q13	0501-000303	TRANSISTOR	KSA733	
	Q14	0501-000398	TRANSISTOR	KSC945	
	Q15	0501-000398	TRANSISTOR	KSC945	
	Q16	0501-000303	TRANSISTOR	KSA733	
	Q17C	0501-000341	TRANSISTOR	KSC1623-L	
	Q17FL	0501-000341	TRANSISTOR	KSC1623-L	
	Q17FR	0501-000341	TRANSISTOR	KSC1623-L	
	Q17RL	0501-000341	TRANSISTOR	KSC1623-L	
	Q17RR	0501-000341	TRANSISTOR	KSC1623-L	
	Q17W	0501-000341	TRANSISTOR	KSC1623-L	
	Q19C	0501-000398	TRANSISTOR	KSC945	
	Q19FL	0501-000398	TRANSISTOR	KSC945	
	Q19FR	0501-000398	TRANSISTOR	KSC945	
	Q19RL	0501-000398	TRANSISTOR	KSC945	
	Q19RR	0501-000398	TRANSISTOR	KSC945	
	Q19W	0501-000354	TRANSISTOR	KSC1845-F	
	Q20C	0501-000303	TRANSISTOR	KSA733	
	Q20FL	0501-000303	TRANSISTOR	KSA733	
	Q20FR	0501-000303	TRANSISTOR	KSA733	
	Q20RL	0501-000303	TRANSISTOR	KSA733	
	Q20RR	0501-000303	TRANSISTOR	KSA733	
	Q20W	0501-002188	TRANSISTOR	KSA992	
	Q21C	0501-000294	TRANSISTOR	KSA708-Y	
	Q21FL	0501-000294	TRANSISTOR	KSA708-Y	
	Q21FR	0501-000294	TRANSISTOR	KSA708-Y	
	Q21RL	0501-000294	TRANSISTOR	KSA708-Y	
	Q21RR	0501-000294	TRANSISTOR	KSA708-Y	
	Q21W	0501-002332	TRANSISTOR	KSA910	
	Q22C	0501-000010	TRANSISTOR	KSC1008	



## ■ Electrical parts list (Main board)

Block No. 01

△	Item	Parts number	Parts name	Remarks	Area	△	Item	Parts number	Parts name	Remarks	Area
	Q22FL	0501-000010	TRANSISTOR	KSC1008			Q37	0504-000156	DIGI TRANSISTOR	KSR2103	
	Q22FR	0501-000010	TRANSISTOR	KSC1008			Q38RL	0504-000156	DIGI TRANSISTOR	KSR2103	
	Q22RL	0501-000010	TRANSISTOR	KSC1008			Q38RR	0504-000156	DIGI TRANSISTOR	KSR2103	
	Q22RR	0501-000010	TRANSISTOR	KSC1008			Q38W	0504-000156	DIGI TRANSISTOR	KSR2103	
	Q22W	0501-000359	TRANSISTOR	KSC2310-Y			Q39	0504-000156	DIGI TRANSISTOR	KSR2103	
	Q23C	0501-000010	TRANSISTOR	KSC1008			Q4	0501-000294	TRANSISTOR	KSA708-Y	
	Q23FL	0501-000010	TRANSISTOR	KSC1008			Q40	0502-000299	POWER TRANSISTOR	KSD73	
	Q23FR	0501-000010	TRANSISTOR	KSC1008			Q5	0501-000398	TRANSISTOR	KSC945	
	Q23RL	0501-000010	TRANSISTOR	KSC1008			Q6	0501-000610	TRANSISTOR	KSA928A-Y	
	Q23RR	0501-000010	TRANSISTOR	KSC1008			Q7	0501-000314	TRANSISTOR	KSA812	
	Q25C	0501-000010	TRANSISTOR	KSC1008			Q8	0501-000341	TRANSISTOR	KSC1623-L	
	Q25FL	0501-000010	TRANSISTOR	KSC1008			Q9	0501-000010	TRANSISTOR	KSC1008	
	Q25FR	0501-000010	TRANSISTOR	KSC1008			RCA1P	AH37-00005A	RCA JACK	1P S440B	
	Q25RL	0501-000010	TRANSISTOR	KSC1008		△	RE1	3501-001214	REALY	12V 0.45W	
	Q25RR	0501-000010	TRANSISTOR	KSC1008		△	RE3	3501-001008	REALY	12VDC 530MW 10A	
	Q26C	0501-000294	TRANSISTOR	KSA708-Y			RE5	3501-001197	RELAY	12VDC 0.54W	
	Q26FL	0501-000294	TRANSISTOR	KSA708-Y			RE6	3501-001197	RELAY	12VDC 0.54W	
	Q26FR	0501-000294	TRANSISTOR	KSA708-Y			RE7	3501-001197	RELAY	12VDC 0.54W	
	Q26RL	0501-000294	TRANSISTOR	KSA708-Y			RS01W	2007-000300	CHIP RESISTOR	10K 5% 1/10W	
	Q26RR	0501-000294	TRANSISTOR	KSA708-Y			RS02W	2007-000300	CHIP RESISTOR	10K 5% 1/10W	
	Q28C	0501-000294	TRANSISTOR	KSA708-Y			R10	2007-000282	CHIP RESISTOR	100K 5% 1/10W	
	Q28FL	0501-000294	TRANSISTOR	KSA708-Y			R105	2007-000572	CHIP RESISTOR	220 5% 1/10W	
	Q28FR	0501-000294	TRANSISTOR	KSA708-Y			R108	2007-000941	CHIP RESISTOR	47K 5% 1/10W	
	Q28RL	0501-000294	TRANSISTOR	KSA708-Y			R113	2007-000941	CHIP RESISTOR	47K 5% 1/10W	
	Q28RR	0501-000294	TRANSISTOR	KSA708-Y			R114C	2001-000515	CARBON RESISTOR	220 5% 1/8W	
	Q29C	0502-001048	POWER TRANSISTOR	KSD1691			R114W	2001-000515	CARBON RESISTOR	220 5% 1/8W	
	Q29FL	0502-001048	POWER TRANSISTOR	KSD1691			R116W	2007-000572	CHIP RESISTOR	220 5% 1/10W	
	Q29FR	0502-001048	POWER TRANSISTOR	KSD1691			R117C	2007-000468	CHIP RESISTOR	1K 5% 1/10W	
	Q29RL	0502-001048	POWER TRANSISTOR	KSD1691			R117W	2007-000493	CHIP RESISTOR	2.2K 5% 1/10W	
	Q29RR	0502-001048	POWER TRANSISTOR	KSD1691			R118C	2007-000300	CHIP RESISTOR	10K 5% 1/10W	
	Q29W	0503-001014	DRT TRANSISTOR	2SD2495-P			R118W	2007-000300	CHIP RESISTOR	10K 5% 1/10W	
	Q30W	0503-001014	DRT TRANSISTOR	2SD2495-P			R119W	2007-000941	CHIP RESISTOR	47K 5% 1/10W	
	Q31C	0502-001048	POWER TRANSISTOR	KSD1691			R12	2007-000586	CHIP RESISTOR	22K 5% 1/10W	
	Q31FL	0502-001048	POWER TRANSISTOR	KSD1691			R127	2007-000572	CHIP RESISTOR	220 5% 1/10W	
	Q31FR	0502-001048	POWER TRANSISTOR	KSD1691			R13	2007-000282	CHIP RESISTOR	100K 5% 1/10W	
	Q31RL	0502-001048	POWER TRANSISTOR	KSD1691			R131	2007-000572	CHIP RESISTOR	220 5% 1/10W	
	Q31RR	0502-001048	POWER TRANSISTOR	KSD1691			R134	2007-000572	CHIP RESISTOR	220 5% 1/10W	
	Q31W	0503-001014	DRT TRANSISTOR	2SD2495-P			R135	2007-000941	CHIP RESISTOR	47K 5% 1/10W	
	Q32C	0502-001210	POWER TRANSISTOR	KSB1151			R139C	2007-000468	CHIP RESISTOR	1K 5% 1/10W	
	Q32FL	0502-001210	POWER TRANSISTOR	KSB1151			R139W	2007-000468	CHIP RESISTOR	1K 5% 1/10W	
	Q32FR	0502-001210	POWER TRANSISTOR	KSB1151			R14	2007-000830	CHIP RESISTOR	39K 5% 1/10W	
	Q32RL	0502-001210	POWER TRANSISTOR	KSB1151			R142	2007-000586	CHIP RESISTOR	22K 5% 1/10W	
	Q32RR	0502-001210	POWER TRANSISTOR	KSB1151			R143	2007-000586	CHIP RESISTOR	22K 5% 1/10W	
	Q32W	0503-001016	DRT TRANSISTOR	2SB1626-P			R15	2007-000941	CHIP RESISTOR	47K 5% 1/10W	
	Q33W	0503-001016	DRT TRANSISTOR	2SB1626-P			R16	2007-000518	CHIP RESISTOR	2.7K 5% 1/10W	
	Q34C	0502-001210	POWER TRANSISTOR	KSB1151			R17	2007-000941	CHIP RESISTOR	47K 5% 1/10W	
	Q34FL	0502-001210	POWER TRANSISTOR	KSB1151			R19	2007-000774	CHIP RESISTOR	33K 5% 1/10W	
	Q34FR	0502-001210	POWER TRANSISTOR	KSB1151			R20	2007-000774	CHIP RESISTOR	33K 5% 1/10W	
	Q34RL	0502-001210	POWER TRANSISTOR	KSB1151			R200L	2007-000686	CHIP RESISTOR	3.3K 5% 1/10W	
	Q34RR	0502-001210	POWER TRANSISTOR	KSB1151			R200R	2007-000686	CHIP RESISTOR	3.3K 5% 1/10W	
	Q34W	0503-001016	DRT TRANSISTOR	2SB1626-P			R201L	2007-000774	CHIP RESISTOR	33K 5% 1/10W	
	Q35C	0501-000398	TRANSISTOR	KSC945			R201R	2007-000774	CHIP RESISTOR	33K 5% 1/10W	
	Q35FL	0501-000398	TRANSISTOR	KSC945			R21	2007-000586	CHIP RESISTOR	22K 5% 1/10W	
	Q35FR	0501-000398	TRANSISTOR	KSC945			R22	2007-000586	CHIP RESISTOR	22K 5% 1/10W	
	Q35RL	0501-000398	TRANSISTOR	KSC945			R30W	2007-000941	CHIP RESISTOR	47K 5% 1/10W	
	Q35RR	0501-000398	TRANSISTOR	KSC945			R31W	2007-000686	CHIP RESISTOR	3.3K 5% 1/10W	
	Q35W	0501-000331	TRANSISTOR	KSC1009-Y			R32C	2007-000493	CHIP RESISTOR	2.2K 5% 1/10W	
	Q36C	0502-001048	POWER TRANSISTOR	KSD1691			R32FL	2007-000493	CHIP RESISTOR	2.2K 5% 1/10W	
	Q36FL	0502-001048	POWER TRANSISTOR	KSD1691			R32FR	2007-000493	CHIP RESISTOR	2.2K 5% 1/10W	
	Q36FR	0502-001048	POWER TRANSISTOR	KSD1691			R32RL	2007-000493	CHIP RESISTOR	2.2K 5% 1/10W	
	Q36RL	0502-001048	POWER TRANSISTOR	KSD1691			R32RR	2007-000493	CHIP RESISTOR	2.2K 5% 1/10W	
	Q36RR	0502-001048	POWER TRANSISTOR	KSD1691			R32W	2007-000241	CHIP RESISTOR	1.5K 5% 1/10W	
	Q36W	0502-001048	POWER TRANSISTOR	KSD1691			R33C	2007-000586	CHIP RESISTOR	22K 5% 1/10W	

## ■ Electrical parts list (Main board)

Block No. 01

△	Item	Parts number	Parts name	Remarks	Area	△	Item	Parts number	Parts name	Remarks	Area
	R33FL	2007-000586	CHIP RESISTOR	22K 5% 1/10W			R66	2007-000872	CHIP RESISTOR	4.7K 5% 1/10W	
	R33FR	2007-000586	CHIP RESISTOR	22K 5% 1/10W			R67	2007-000586	CHIP RESISTOR	22K 5% 1/10W	
	R33RL	2007-000586	CHIP RESISTOR	22K 5% 1/10W			R68	2007-000872	CHIP RESISTOR	4.7K 5% 1/10W	
	R33RR	2007-000586	CHIP RESISTOR	22K 5% 1/10W			R69	2007-000774	CHIP RESISTOR	33K 5% 1/10W	
	R33W	2007-000653	CHIP RESISTOR	27K 5% 1/10W			R70	2007-000774	CHIP RESISTOR	33K 5% 1/10W	
	R34C	2007-000401	CHIP RESISTOR	150 5% 1/10W			R71	2007-000300	CHIP RESISTOR	10K 5% 1/10W	
	R34FL	2007-000401	CHIP RESISTOR	150 5% 1/10W			R72	2007-001177	CHIP RESISTOR	8.2K 5% 1/10W	
	R34FR	2007-000401	CHIP RESISTOR	150 5% 1/10W			R73	2007-000710	CHIP RESISTOR	3.9K 5% 1/10W	
	R34RL	2007-000401	CHIP RESISTOR	150 5% 1/10W			R74	2001-000290	CARBON RESISTOR	10K 5% 1/8W	
	R34RR	2007-000401	CHIP RESISTOR	150 5% 1/10W			R75C	2007-000941	CHIP RESISTOR	47K 5% 1/10W	
	R34W	2007-000290	CHIP RESISTOR	100 5% 1/10W			R75FL	2007-000941	CHIP RESISTOR	47K 5% 1/10W	
	R35C	2007-000493	CHIP RESISTOR	2.2K 5% 1/10W			R75FR	2007-000941	CHIP RESISTOR	47K 5% 1/10W	
	R35FL	2007-000493	CHIP RESISTOR	2.2K 5% 1/10W			R75RL	2007-000941	CHIP RESISTOR	47K 5% 1/10W	
	R35FR	2007-000493	CHIP RESISTOR	2.2K 5% 1/10W			R75RR	2007-000941	CHIP RESISTOR	47K 5% 1/10W	
	R35RL	2007-000493	CHIP RESISTOR	2.2K 5% 1/10W			R75W	2007-000941	CHIP RESISTOR	47K 5% 1/10W	
	R35RR	2007-000493	CHIP RESISTOR	2.2K 5% 1/10W			R76C	2007-000468	CHIP RESISTOR	1K 5% 1/10W	
	R35W	2007-000241	CHIP RESISTOR	1.5K 5% 1/10W			R76FL	2007-000468	CHIP RESISTOR	1K 5% 1/10W	
	R36C	2001-000522	CARBON RESISTOR	22K 5% 1/8W			R76FR	2007-000468	CHIP RESISTOR	1K 5% 1/10W	
	R36FL	2007-000586	CHIP RESISTOR	22K 5% 1/10W			R76RL	2007-000468	CHIP RESISTOR	1K 5% 1/10W	
	R36FR	2001-000522	CARBON RESISTOR	22K 5% 1/8W			R76RR	2007-000468	CHIP RESISTOR	1K 5% 1/10W	
	R36RL	2007-000586	CHIP RESISTOR	22K 5% 1/10W			R78C	2007-001039	CHIP RESISTOR	56K 5% 1/10W	
	R36RR	2001-000522	CARBON RESISTOR	22K 5% 1/8W			R78FL	2007-001039	CHIP RESISTOR	56K 5% 1/10W	
	R36W	2007-000653	CHIP RESISTOR	27K 5% 1/10W			R78FR	2007-001039	CHIP RESISTOR	56K 5% 1/10W	
	R37C	2007-000401	CHIP RESISTOR	150 5% 1/10W			R78RL	2007-001039	CHIP RESISTOR	56K 5% 1/10W	
	R37FL	2007-000401	CHIP RESISTOR	150 5% 1/10W			R78RR	2007-001039	CHIP RESISTOR	56K 5% 1/10W	
	R37FR	2007-000401	CHIP RESISTOR	150 5% 1/10W			R78W	2007-001039	CHIP RESISTOR	56K 5% 1/10W	
	R37RL	2007-000401	CHIP RESISTOR	150 5% 1/10W			R79FL	2007-000267	CHIP RESISTOR	1.8K 5% 1/10W	
	R37RR	2007-000401	CHIP RESISTOR	150 5% 1/10W			R79FR	2007-000267	CHIP RESISTOR	1.8K 5% 1/10W	
	R37W	2007-000290	CHIP RESISTOR	100 5% 1/10W			R79RL	2007-000078	CHIP RESISTOR	1K 5% 1/16W	
	R38	2003-000710	OMF RESISTOR	47 5% 2W			R79RR	2007-000078	CHIP RESISTOR	1K 5% 1/16W	
	R38C	2007-001039	CHIP RESISTOR	56K 5% 1/10W			R79W	2007-000267	CHIP RESISTOR	1.8K 5% 1/10W	
	R38FL	2007-001039	CHIP RESISTOR	56K 5% 1/10W			R80C	2007-001039	CHIP RESISTOR	56K 5% 1/10W	
	R38FR	2007-001039	CHIP RESISTOR	56K 5% 1/10W			R80FL	2007-001039	CHIP RESISTOR	56K 5% 1/10W	
	R38RL	2007-001039	CHIP RESISTOR	56K 5% 1/10W			R80FR	2007-001039	CHIP RESISTOR	56K 5% 1/10W	
	R38RR	2007-001039	CHIP RESISTOR	56K 5% 1/10W			R80RL	2007-001039	CHIP RESISTOR	56K 5% 1/10W	
	R38W	2007-001039	CHIP RESISTOR	56K 5% 1/10W			R80RR	2007-001039	CHIP RESISTOR	56K 5% 1/10W	
	R39	2003-000578	OMF RESISTOR	220 5% 2W			R80W	2007-001039	CHIP RESISTOR	56K 5% 1/10W	
	R39FL	2007-000941	CHIP RESISTOR	47K 5% 1/10W			R81C	2007-000872	CHIP RESISTOR	4.7K 5% 1/10W	
	R39FR	2007-000941	CHIP RESISTOR	47K 5% 1/10W			R81FL	2007-000872	CHIP RESISTOR	4.7K 5% 1/10W	
	R40	2007-000586	CHIP RESISTOR	22K 5% 1/10W			R81FR	2007-000872	CHIP RESISTOR	4.7K 5% 1/10W	
	R41	2001-000052	CARBON RESISTOR	3.3K 5% 1/2W			R81RL	2007-000872	CHIP RESISTOR	4.7K 5% 1/10W	
	R43	2007-000774	CHIP RESISTOR	33K 5% 1/10W			R81RR	2007-000872	CHIP RESISTOR	4.7K 5% 1/10W	
	R44	2003-000674	OMF RESISTOR	39 5% 1W			R81W	2007-000300	CHIP RESISTOR	10K 5% 1/10W	
	R45	2003-000807	OMF RESISTOR	82 5% 2W			R82C	2007-000686	CHIP RESISTOR	3.3K 5% 1/10W	
	R47	2007-000872	CHIP RESISTOR	4.7K 5% 1/10W			R82FL	2007-000686	CHIP RESISTOR	3.3K 5% 1/10W	
	R48	2007-000941	CHIP RESISTOR	47K 5% 1/10W			R82FR	2007-000686	CHIP RESISTOR	3.3K 5% 1/10W	
	R49	2007-000941	CHIP RESISTOR	47K 5% 1/10W			R82RL	2007-000686	CHIP RESISTOR	3.3K 5% 1/10W	
	R50	2007-000300	CHIP RESISTOR	10K 5% 1/10W			R82RR	2007-000686	CHIP RESISTOR	3.3K 5% 1/10W	
	R51	2007-000300	CHIP RESISTOR	10K 5% 1/10W			R82W	2007-000686	CHIP RESISTOR	3.3K 5% 1/10W	
	R52	2007-000766	CHIP RESISTOR	330 5% 1/10W			R83C	2007-000686	CHIP RESISTOR	3.3K 5% 1/10W	
	R53	2007-000023	CHIP RESISTOR	120 5% 1/10W			R83FL	2007-000686	CHIP RESISTOR	3.3K 5% 1/10W	
	R54	2007-000300	CHIP RESISTOR	10K 5% 1/10W			R83FR	2007-000686	CHIP RESISTOR	3.3K 5% 1/10W	
	R55	2007-000586	CHIP RESISTOR	22K 5% 1/10W			R83RL	2007-000686	CHIP RESISTOR	3.3K 5% 1/10W	
	R56	2007-000300	CHIP RESISTOR	10K 5% 1/10W			R83RR	2007-000686	CHIP RESISTOR	3.3K 5% 1/10W	
	R57	2007-000586	CHIP RESISTOR	22K 5% 1/10W			R84C	2007-000300	CHIP RESISTOR	10K 5% 1/10W	
	R58	2007-000300	CHIP RESISTOR	10K 5% 1/10W			R84FL	2007-000300	CHIP RESISTOR	10K 5% 1/10W	
	R59	2007-000586	CHIP RESISTOR	22K 5% 1/10W			R84FR	2007-000300	CHIP RESISTOR	10K 5% 1/10W	
	R60	2007-001118	CHIP RESISTOR	680 5% 1/10W			R84RL	2007-000300	CHIP RESISTOR	10K 5% 1/10W	
	R61	2007-000774	CHIP RESISTOR	33K 5% 1/10W			R84RR	2007-000300	CHIP RESISTOR	10K 5% 1/10W	
	R62	2007-000586	CHIP RESISTOR	22K 5% 1/10W			R85W	2001-000515	CARBON RESISTOR	220 5% 1/8W	
	R63	2007-000300	CHIP RESISTOR	10K 5% 1/10W			R86C	2007-000931	CHIP RESISTOR	470 5% 1/10W	
	R64	2007-000355	CHIP RESISTOR	12K 5% 1/10W			R86FL	2007-000931	CHIP RESISTOR	470 5% 1/10W	
	R65	2007-000300	CHIP RESISTOR	10K 5% 1/10W			R86FR	2007-000931	CHIP RESISTOR	470 5% 1/10W	

## ■ Electrical parts list (Main board)

Block No. 01

△	Item	Parts number	Parts name	Remarks	Area	△	Item	Parts number	Parts name	Remarks	Area
	R86RL	2007-000931	CHIP RESISTOR	470 5% 1/10W			SPK2	3716-001173	BLOCK TERMINAL	SOLDER 8P	
	R86RR	2007-000931	CHIP RESISTOR	470 5% 1/10W			STD1	0404-000156	SCHOTTKY DIODE	RB441Q 10V	
	R86W	2001-000780	CARBON RESISTOR	470 5% 1/8W			STR1	2007-000686	CHIP RESISTOR	3.3K 5% 1/10W	
	R87C	2007-000981	CHIP RESISTOR	5.6K 5% 1/10W			SW1	AH34-00015A	SWITCH SLIDE	KSA-2272AB	
	R87FL	2007-000981	CHIP RESISTOR	5.6K 5% 1/10W			VC7	2401-001538	E.CAPACITOR	47UF 20% 25V	
	R87FR	2007-000981	CHIP RESISTOR	5.6K 5% 1/10W			VR12	3301-001495	BEAD	AB 120 OHM	
	R87RL	2007-000981	CHIP RESISTOR	5.6K 5% 1/10W			VR14	2001-000969	CARBON RESISTOR	75 5% 1/8W	
	R87RR	2007-000981	CHIP RESISTOR	5.6K 5% 1/10W			VR24	2001-000645	CARBON RESISTOR	330K 5% 1/8W	
	R87W	2007-000981	CHIP RESISTOR	5.6K 5% 1/10W			VR25	2001-000969	CARBON RESISTOR	75 5% 1/8W	
	R88C	2007-000493	CHIP RESISTOR	2.2K 5% 1/10W			VR3	2001-000969	CARBON RESISTOR	75 5% 1/8W	
	R88FL	2007-000493	CHIP RESISTOR	2.2K 5% 1/10W			VR8	2001-000449	CARBON RESISTOR	2.2K 5% 1/8W	
	R88FR	2007-000493	CHIP RESISTOR	2.2K 5% 1/10W			VR9	2001-000780	CARBON RESISTOR	470 5% 1/8W	
	R88RL	2007-000493	CHIP RESISTOR	2.2K 5% 1/10W			VW1	3711-004110	CONNECTOR	12P 2MM	
	R88RR	2007-000493	CHIP RESISTOR	2.2K 5% 1/10W			ZD13	0403-000004	ZENER DIODE	UZ12BM 12V	
	R88W	2007-000493	CHIP RESISTOR	2.2K 5% 1/10W			ZD5C	0403-001079	ZENER DIODE	UDZ3.9B 7%	
	R89C	2007-000931	CHIP RESISTOR	470 5% 1/10W			ZD5FL	0403-001079	ZENER DIODE	UDZ3.9B 7%	
	R89FL	2007-000931	CHIP RESISTOR	470 5% 1/10W			ZD5FR	0403-001079	ZENER DIODE	UDZ3.9B 7%	
	R89FR	2007-000931	CHIP RESISTOR	470 5% 1/10W			ZD5RL	0403-001079	ZENER DIODE	UDZ3.9B 7%	
	R89RL	2007-000931	CHIP RESISTOR	470 5% 1/10W			ZD5RR	0403-001079	ZENER DIODE	UDZ3.9B 7%	
	R89RR	2007-000931	CHIP RESISTOR	470 5% 1/10W			ZD5W	0403-001079	ZENER DIODE	UDZ3.9B 7%	
	R89W	2001-000780	CARBON RESISTOR	470 5% 1/8W			ZD6C	0403-001079	ZENER DIODE	UDZ3.9B 7%	
	R90W	2001-000515	CARBON RESISTOR	220 5% 1/8W			ZD6FL	0403-001079	ZENER DIODE	UDZ3.9B 7%	
	R91C	2007-000766	CHIP RESISTOR	330 5% 1/10W			ZD6FR	0403-001079	ZENER DIODE	UDZ3.9B 7%	
	R91FL	2007-000766	CHIP RESISTOR	330 5% 1/10W			ZD6RL	0403-001079	ZENER DIODE	UDZ3.9B 7%	
	R91FR	2007-000766	CHIP RESISTOR	330 5% 1/10W			ZD6RR	0403-001079	ZENER DIODE	UDZ3.9B 7%	
	R91RL	2007-000766	CHIP RESISTOR	330 5% 1/10W			ZD6W	0403-001079	ZENER DIODE	UDZ3.9B 7%	
	R91RR	2007-000766	CHIP RESISTOR	330 5% 1/10W			ZD7C	0403-001376	ZENER DIODE	UDZ3.6B	
	R93C	2007-000766	CHIP RESISTOR	330 5% 1/10W			ZD7FL	0403-001376	ZENER DIODE	UDZ3.6B	
	R93FL	2007-000766	CHIP RESISTOR	330 5% 1/10W			ZD7FR	0403-001376	ZENER DIODE	UDZ3.6B	
	R93FR	2007-000766	CHIP RESISTOR	330 5% 1/10W			ZD7RL	0403-001376	ZENER DIODE	UDZ3.6B	
	R93RL	2007-000766	CHIP RESISTOR	330 5% 1/10W			ZD7RR	0403-001376	ZENER DIODE	UDZ3.6B	
	R93RR	2007-000766	CHIP RESISTOR	330 5% 1/10W			ZD7W	0403-001062	ZENER DIODE	UDZ4.7B	
	R94C	2007-000766	CHIP RESISTOR	330 5% 1/10W			ZD8C	0403-001376	ZENER DIODE	UDZ3.6B	
	R94FL	2007-000766	CHIP RESISTOR	330 5% 1/10W			ZD8FL	0403-001376	ZENER DIODE	UDZ3.6B	
	R94FR	2007-000766	CHIP RESISTOR	330 5% 1/10W			ZD8FR	0403-001376	ZENER DIODE	UDZ3.6B	
	R94RL	2007-000766	CHIP RESISTOR	330 5% 1/10W			ZD8RL	0403-001376	ZENER DIODE	UDZ3.6B	
	R94RR	2007-000766	CHIP RESISTOR	330 5% 1/10W			ZD8RR	0403-001376	ZENER DIODE	UDZ3.6B	
	R96C	2007-000766	CHIP RESISTOR	330 5% 1/10W			114FR	2007-000572	CHIP RESISTOR	220 5% 1/10W	
	R96FL	2007-000766	CHIP RESISTOR	330 5% 1/10W			114RL	2001-000515	CARBON RESISTOR	220 5% 1/8W	
	R96FR	2007-000766	CHIP RESISTOR	330 5% 1/10W			116RL	2001-000515	CARBON RESISTOR	220 5% 1/8W	
	R96RL	2007-000766	CHIP RESISTOR	330 5% 1/10W			116RR	2007-000572	CHIP RESISTOR	220 5% 1/10W	
	R96RR	2007-000766	CHIP RESISTOR	330 5% 1/10W			117FL	2007-000468	CHIP RESISTOR	1K 5% 1/10W	
	R97C	2007-008317	CHIP RESISTOR	0.15 5% 1W			117FR	2007-000468	CHIP RESISTOR	1K 5% 1/10W	
	R97FL	2007-008317	CHIP RESISTOR	0.15 5% 1W			117RL	2007-000468	CHIP RESISTOR	1K 5% 1/10W	
	R97FR	2007-008317	CHIP RESISTOR	0.15 5% 1W			117RR	2007-000468	CHIP RESISTOR	1K 5% 1/10W	
	R97RL	2007-008317	CHIP RESISTOR	0.15 5% 1W			118FL	2007-000300	CHIP RESISTOR	10K 5% 1/10W	
	R97RR	2007-008317	CHIP RESISTOR	0.15 5% 1W			118FR	2007-000300	CHIP RESISTOR	10K 5% 1/10W	
	R97W	2009-001117	PLATE RESISTOR	0.1 5% 5W			118RL	2007-000300	CHIP RESISTOR	10K 5% 1/10W	
	R98C	2007-008317	CHIP RESISTOR	0.15 5% 1W			118RR	2007-000300	CHIP RESISTOR	10K 5% 1/10W	
	R98FL	2007-008317	CHIP RESISTOR	0.15 5% 1W			119RL	2007-000941	CHIP RESISTOR	47K 5% 1/10W	
	R98FR	2007-008317	CHIP RESISTOR	0.15 5% 1W			119RR	2007-000941	CHIP RESISTOR	47K 5% 1/10W	
	R98RL	2007-008317	CHIP RESISTOR	0.15 5% 1W			139FL	2007-000468	CHIP RESISTOR	1K 5% 1/10W	
	R98RR	2007-008317	CHIP RESISTOR	0.15 5% 1W			139FR	2007-000468	CHIP RESISTOR	1K 5% 1/10W	
	R98W	2009-001117	PLATE RESISTOR	0.1 5% 5W			139RL	2007-000468	CHIP RESISTOR	1K 5% 1/10W	
	R98W0	2007-008317	CHIP RESISTOR	0.15 5% 1W			139RR	2007-000468	CHIP RESISTOR	1K 5% 1/10W	
	R99C	2001-000019	CARBON RESISTOR	10 5% 1/2W							
	R99FL	2001-000019	CARBON RESISTOR	10 5% 1/2W							
	R99FR	2001-000019	CARBON RESISTOR	10 5% 1/2W							
	R99RL	2001-000019	CARBON RESISTOR	10 5% 1/2W							
	R99RR	2001-000019	CARBON RESISTOR	10 5% 1/2W							
	R99W	2003-000471	OMF RESISTOR	10 5% 2W							
	SJACK	3722-001502	DIN JACK	4P							
	SPK1	3716-001132	BLOCK TERMINAL	SOLDER 4P							

## ■ Electrical parts list (Front board)

Block No. 02

△	Item	Parts number	Parts name	Remarks	Area
	FCW1	3708-000454	CONNECTOR	22P 1.25MM	
	FCW2	3708-000452	CONNECTOR	19P 1.25MM	
	FW2	3711-000906	CONNECTOR	3P 1R 2MM	
	FW3	AH39-00176A	LEAD CONNECTOR		
	JW001	2007-000029	CHIP RESISTOR	0 5% 1/10W	
	JW005	2007-000029	CHIP RESISTOR	0 5% 1/10W	
	JW008	2007-000029	CHIP RESISTOR	0 5% 1/10W	
	R22	2007-000290	CHIP RESISTOR	100 5% 1/10W	
	SW1	3404-001182	TACT SWITCH	DC12V 50MA	
	SW10	3404-001182	TACT SWITCH	DC12V 50MA	
	SW11	3404-001182	TACT SWITCH	DC12V 50MA	
	SW2	3404-001182	TACT SWITCH	DC12V 50MA	
	SW3	3404-001182	TACT SWITCH	DC12V 50MA	
	SW4	3404-001182	TACT SWITCH	DC12V 50MA	
	SW5	3404-001182	TACT SWITCH	DC12V 50MA	
	SW6	3404-001182	TACT SWITCH	DC12V 50MA	
	SW7	3404-001182	TACT SWITCH	DC12V 50MA	
	SW8	3404-001182	TACT SWITCH	DC12V 50MA	
	SW9	3404-001182	TACT SWITCH	DC12V 50MA	
	UC1	2201-000783	C.CAPASITOR	100NF +80-20% 50V	
	UC10	2401-001934	E.CAPACITOR	220UF 20% 6.3V	
	UC101	2401-001934	E.CAPACITOR	220UF 20% 6.3V	
	UC11	2203-000979	CHIP CAPACITOR	47NF 10% 50V	
	UC12	2401-001952	E.CAPACITOR	4.7UF 20% 50V	
	UC15	2201-000163	C.CAPASITOR	10NF +80-20% 50V	
	UC2	2201-000783	C.CAPASITOR	100NF +80-20% 50V	
	UC6	2203-000979	CHIP CAPACITOR	47NF 10% 50V	
	UC7	2401-000243	E.CAPACITOR	100UF 20% 10V	
	UC8	2201-000565	C.CAPASITOR	47NF +80-20% 50V	
	UD11	0401-001090	DIODE	1SS355 80V	
	UD17	0401-001090	DIODE	1SS355 80V	
	UD18	0401-001090	DIODE	1SS355 80V	
	UD19	0401-001090	DIODE	1SS355 80V	
	UD20	0401-001090	DIODE	1SS355 80V	
	UD21	0401-001090	DIODE	1SS355 80V	
	UD22	0401-001090	DIODE	1SS355 80V	
	UD3	0401-001090	DIODE	1SS355 80V	
	UD7	0401-001090	DIODE	1SS355 80V	
	UEYE	AC59-60060A	REMOCON EYE	GP1U281R 38KHZ	
	UIC1	0903-001015	IC	LC86P6548 100P	
	ULD1	0601-001238	LED	RED 3.1MM 697NM	
	ULD2	0601-001490	LED	BLUE 3MM	
	UQ2	0501-000341	TRANSISTOR	KSC1623-L	
	UQ3	0504-001003	DIGI TRANSISTOR	KSR2003	
	UQ5	0504-000118	DEGI TRANSISTOR	KSR1003	
	UQ6	0504-000118	DEGI TRANSISTOR	KSR1003	
	UR002	2007-001654	CHIP RESISTOR	10M 1% 1/10W	
	UR006	2001-000613	CARBON RESISTOR	3.9K 5% 1/8W	
	UR007	2001-000802	CARBON RESISTOR	5.6K 5% 1/8W	
	UR008	2001-000290	CARBON RESISTOR	10K 5% 1/8W	
	UR016	2007-000290	CHIP RESISTOR	100 5% 1/10W	
	UR017	2007-001039	CHIP RESISTOR	56K 5% 1/10W	
	UR050	2007-000300	CHIP RESISTOR	10K 5% 1/10W	
	UR051	2007-000300	CHIP RESISTOR	10K 5% 1/10W	
	UR1	2007-000941	CHIP RESISTOR	47K 5% 1/10W	
	UR10	2007-000941	CHIP RESISTOR	47K 5% 1/10W	
	UR11	2007-000941	CHIP RESISTOR	47K 5% 1/10W	
	UR12	2007-000941	CHIP RESISTOR	47K 5% 1/10W	
	UR13	2007-000941	CHIP RESISTOR	47K 5% 1/10W	
	UR180	2007-000029	CHIP RESISTOR	0 5% 1/10W	
	UR2	2007-000941	CHIP RESISTOR	47K 5% 1/10W	
	UR23	2007-000290	CHIP RESISTOR	100 5% 1/10W	
	UR28	2007-000290	CHIP RESISTOR	100 5% 1/10W	

△	Item	Parts number	Parts name	Remarks	Area
	UR3	2007-000941	CHIP RESISTOR	47K 5% 1/10W	
	UR30	2007-000290	CHIP RESISTOR	100 5% 1/10W	
	UR34	2007-000290	CHIP RESISTOR	100 5% 1/10W	
	UR36	2007-000290	CHIP RESISTOR	100 5% 1/10W	
	UR37	2007-000290	CHIP RESISTOR	100 5% 1/10W	
	UR38	2007-000290	CHIP RESISTOR	100 5% 1/10W	
	UR39	2007-000290	CHIP RESISTOR	100 5% 1/10W	
	UR4	2007-000941	CHIP RESISTOR	47K 5% 1/10W	
	UR40	2007-000290	CHIP RESISTOR	100 5% 1/10W	
	UR41	2007-000290	CHIP RESISTOR	100 5% 1/10W	
	UR42	2007-000290	CHIP RESISTOR	100 5% 1/10W	
	UR44	2007-000290	CHIP RESISTOR	100 5% 1/10W	
	UR45	2001-000429	CARBON RESISTOR	1K 5% 1/8W	
	UR5	2007-000941	CHIP RESISTOR	47K 5% 1/10W	
	UR50	2007-000290	CHIP RESISTOR	100 5% 1/10W	
	UR53	2001-000221	CARBON RESISTOR	1.2K 5% 1/8W	
	UR54	2007-000290	CHIP RESISTOR	100 5% 1/10W	
	UR551	2007-000290	CHIP RESISTOR	100 5% 1/10W	
	UR56	2007-000290	CHIP RESISTOR	100 5% 1/10W	
	UR57	2007-000290	CHIP RESISTOR	100 5% 1/10W	
	UR58	2007-000290	CHIP RESISTOR	100 5% 1/10W	
	UR59	2007-000290	CHIP RESISTOR	100 5% 1/10W	
	UR6	2007-000941	CHIP RESISTOR	47K 5% 1/10W	
	UR65	2007-000290	CHIP RESISTOR	100 5% 1/10W	
	UR67	2007-000290	CHIP RESISTOR	100 5% 1/10W	
	UR68	2001-000258	CARBON RESISTOR	1.8K 5% 1/8W	
	UR69	2007-000300	CHIP RESISTOR	10K 5% 1/10W	
	UR71	2001-000241	CARBON RESISTOR	1.5K 5% 1/8W	
	UR79	2007-000565	CHIP RESISTOR	220K 5% 1/10W	
	UR80	2001-000472	CARBON RESISTOR	2.7K 5% 1/8W	
	UR81	2007-000872	CHIP RESISTOR	4.7K 5% 1/10W	
	UR82	2007-000401	CHIP RESISTOR	150 5% 1/10W	
	UR83	2007-000872	CHIP RESISTOR	4.7K 5% 1/10W	
	UR84	2007-000493	CHIP RESISTOR	2.2K 5% 1/10W	
	UR9	2007-000941	CHIP RESISTOR	47K 5% 1/10W	
	UR91	2001-000411	CARBON RESISTOR	18K 5% 1/8W	
	UR92	2001-000864	CARBON RESISTOR	56K 5% 1/8W	
	UR93	2001-000554	CARBON RESISTOR	270 5% 1/8W	
	UR94	2001-000290	CARBON RESISTOR	10K 5% 1/8W	
	UR95	2001-000111	CARBON RESISTOR	150 5% 1/4W	
	UX1	2802-001157	RESONATOR	6MHZ	
	VFD	AH07-00081A	VFD	HNV-11SS34T	

## ■ Electrical parts list (DSP board)

Block No. 03

▲	Item	Parts number	Parts name	Remarks	Area	▲	Item	Parts number	Parts name	Remarks	Area
	BBC1	2401-001975	E.CAPACITOR	47UF 20% 16V			BC196	2203-000840	CHIP CAPACITOR	0.39NF 5% 50V	
	BC02	2203-000979	CHIP CAPACITOR	47NF 10% 50V			BC197	2203-000840	CHIP CAPACITOR	0.39NF 5% 50V	
	BC021	2203-000761	CHIP CAPACITOR	330NF 10% 16V			BC198	2203-000840	CHIP CAPACITOR	0.39NF 5% 50V	
	BC03	2401-000438	E.CAPACITOR	10UF 20% 25V			BC199	2203-000840	CHIP CAPACITOR	0.39NF 5% 50V	
	BC04	2203-000979	CHIP CAPACITOR	47NF 10% 50V			BC20	2203-000661	CHIP CAPACITOR	0.27NF 5% 50V	
	BC080	2401-001975	E.CAPACITOR	47UF 20% 16V			BC210	2203-000840	CHIP CAPACITOR	0.39NF 5% 50V	
	BC081	2401-002180	E.CAPACITOR	2.2UF 20% 50V			BC211	2203-000840	CHIP CAPACITOR	0.39NF 5% 50V	
	BC082	2401-002180	E.CAPACITOR	2.2UF 20% 50V			BC213	2203-000840	CHIP CAPACITOR	0.39NF 5% 50V	
	BC085	2203-000295	CHIP CAPACITOR	0.01NF 5% 50V			BC214	2203-000840	CHIP CAPACITOR	0.39NF 5% 50V	
	BC090	2203-000361	CHIP CAPACITOR	0.15NF 5% 50V			BC216	2203-000840	CHIP CAPACITOR	0.39NF 5% 50V	
	BC1	2203-001036	CHIP CAPACITOR	5.6NF 10% 50V			BC217	2203-000840	CHIP CAPACITOR	0.39NF 5% 50V	
	BC10	2301-000430	M.CAPACITOR	33NF 10% 50V			BC23	2401-001975	E.CAPACITOR	47UF 20% 16V	
	BC100	2203-000716	CHIP CAPACITOR	3.3NF 10% 50V			BC25	2203-000203	CHIP CAPACITOR	100NF 10% 16V	
	BC101	2401-000438	E.CAPACITOR	10UF 20% 25V			BC26	2203-000716	CHIP CAPACITOR	3.3NF 10% 50V	
	BC102	2203-001537	CHIP CAPACITOR	1NF 10% 50V			BC27	2203-001518	CHIP CAPACITOR	1.8NF 10% 50V	
	BC103	2203-000203	CHIP CAPACITOR	100NF 10% 16V			BC28	2401-000438	E.CAPACITOR	10UF 20% 25V	
	BC104	2203-000892	CHIP CAPACITOR	4.7NF 10% 50V			BC29	2301-000430	M.CAPACITOR	33NF 10% 50V	
	BC105	2401-001975	E.CAPACITOR	47UF 20% 16V			BC3	2203-000203	CHIP CAPACITOR	100NF 10% 16V	
	BC106	2203-000661	CHIP CAPACITOR	0.27NF 5% 50V			BC33	2203-000661	CHIP CAPACITOR	0.27NF 5% 50V	
	BC107	2203-000239	CHIP CAPACITOR	0.1NF 5% 50V			BC34	2203-001036	CHIP CAPACITOR	5.6NF 10% 50V	
	BC108	2401-001912	E.CAPACITOR	1UF 20% 50V			BC36	2203-001518	CHIP CAPACITOR	1.8NF 10% 50V	
	BC109	2203-000203	CHIP CAPACITOR	100NF 10% 16V			BC37	2203-000661	CHIP CAPACITOR	0.27NF 5% 50V	
	BC11	2401-002180	E.CAPACITOR	2.2UF 20% 50V			BC38	2203-000203	CHIP CAPACITOR	100NF 10% 16V	
	BC110	2203-000575	CHIP CAPACITOR	220NF 10% 25V			BC39	2203-000203	CHIP CAPACITOR	100NF 10% 16V	
	BC111	2401-002180	E.CAPACITOR	2.2UF 20% 50V			BC4	2201-000783	C.CAPASITOR	100NF +80-20% 50V	
	BC112	2203-000203	CHIP CAPACITOR	100NF 10% 16V			BC40	2401-001975	E.CAPACITOR	47UF 20% 16V	
	BC113	2203-000575	CHIP CAPACITOR	220NF 10% 25V			BC43	2203-000716	CHIP CAPACITOR	3.3NF 10% 50V	
	BC114	2401-002180	E.CAPACITOR	2.2UF 20% 50V			BC44	2401-001975	E.CAPACITOR	47UF 20% 16V	
	BC115	2401-000438	E.CAPACITOR	10UF 20% 25V			BC45	2203-000661	CHIP CAPACITOR	0.27NF 5% 50V	
	BC116	2401-002180	E.CAPACITOR	2.2UF 20% 50V			BC46	2401-000438	E.CAPACITOR	10UF 20% 25V	
	BC117	2401-000438	E.CAPACITOR	10UF 20% 25V			BC49	2401-000438	E.CAPACITOR	10UF 20% 25V	
	BC118	2203-000203	CHIP CAPACITOR	100NF 10% 16V			BC50	2401-002180	E.CAPACITOR	2.2UF 20% 50V	
	BC119	2203-001537	CHIP CAPACITOR	1NF 10% 50V			BC501	2401-002180	E.CAPACITOR	2.2UF 20% 50V	
	BC120	2203-000661	CHIP CAPACITOR	0.27NF 5% 50V			BC502	2401-001919	E.CAPACITOR	2.2UF 20% 50V	
	BC121	2203-001518	CHIP CAPACITOR	1.8NF 10% 50V			BC503	2401-002180	E.CAPACITOR	2.2UF 20% 50V	
	BC122	2203-000787	CHIP CAPACITOR	0.33NF 5% 50V			BC51	2203-000661	CHIP CAPACITOR	0.27NF 5% 50V	
	BC123	2203-000892	CHIP CAPACITOR	4.7NF 10% 50V			BC52	2401-002180	E.CAPACITOR	2.2UF 20% 50V	
	BC124	2203-000203	CHIP CAPACITOR	100NF 10% 16V			BC53	2401-000438	E.CAPACITOR	10UF 20% 25V	
	BC125	2401-000830	E.CAPACITOR	220UF 20% 25V			BC54	2203-001518	CHIP CAPACITOR	1.8NF 10% 50V	
	BC126	2203-000477	CHIP CAPACITOR	1UF +80-20% 16V			BC55	2203-001518	CHIP CAPACITOR	1.8NF 10% 50V	
	BC127	2401-001887	E.CAPACITOR	100NF 20% 50V			BC57	2203-000979	CHIP CAPACITOR	47NF 10% 50V	
	BC128	2401-000438	E.CAPACITOR	10UF 20% 25V			BC58	2401-000438	E.CAPACITOR	10UF 20% 25V	
	BC129	2203-000716	CHIP CAPACITOR	3.3NF 10% 50V			BC60	2203-000716	CHIP CAPACITOR	3.3NF 10% 50V	
	BC13	2401-002180	E.CAPACITOR	2.2UF 20% 50V			BC61	2401-001975	E.CAPACITOR	47UF 20% 16V	
	BC131	2203-000661	CHIP CAPACITOR	0.27NF 5% 50V			BC62	2203-000661	CHIP CAPACITOR	0.27NF 5% 50V	
	BC132	2203-001036	CHIP CAPACITOR	5.6NF 10% 50V			BC63	2401-001975	E.CAPACITOR	47UF 20% 16V	
	BC133	2401-001975	E.CAPACITOR	47UF 20% 16V			BC67	2203-000661	CHIP CAPACITOR	0.27NF 5% 50V	
	BC134	2401-000438	E.CAPACITOR	10UF 20% 25V			BC68	2203-000417	CHIP CAPACITOR	18NF 10% 50V	
	BC135	2401-000438	E.CAPACITOR	10UF 20% 25V			BC69	2401-001238	E.CAPACITOR	4.7UF 20% 25V	
	BC136	2203-000203	CHIP CAPACITOR	100NF 10% 16V			BC7	2401-002180	E.CAPACITOR	2.2UF 20% 50V	
	BC137	2401-000830	E.CAPACITOR	220UF 20% 25V			BC70	2401-001238	E.CAPACITOR	4.7UF 20% 25V	
	BC139	2401-001975	E.CAPACITOR	47UF 20% 16V			BC71	2203-000761	CHIP CAPACITOR	330NF 10% 16V	
	BC140	2203-000239	CHIP CAPACITOR	0.1NF 5% 50V			BC72	2203-000716	CHIP CAPACITOR	3.3NF 10% 50V	
	BC141	2203-000239	CHIP CAPACITOR	0.1NF 5% 50V			BC73	2203-001137	CHIP CAPACITOR	68NF +80-20% 50V	
	BC142	2203-000239	CHIP CAPACITOR	0.1NF 5% 50V			BC74	2401-001975	E.CAPACITOR	47UF 20% 16V	
	BC143	2201-000783	C.CAPASITOR	100NF +80-20% 50V			BC75	2203-000239	CHIP CAPACITOR	0.1NF 5% 50V	
	BC15	2401-002180	E.CAPACITOR	2.2UF 20% 50V			BC76	2203-000609	CHIP CAPACITOR	22NF 10% 50V	
	BC16	2401-001975	E.CAPACITOR	47UF 20% 16V			BC77	2203-000661	CHIP CAPACITOR	0.27NF 5% 50V	
	BC17	2401-001975	E.CAPACITOR	47UF 20% 16V			BC78	2203-000203	CHIP CAPACITOR	100NF 10% 16V	
	BC18	2203-001518	CHIP CAPACITOR	1.8NF 10% 50V			BC79	2203-000609	CHIP CAPACITOR	22NF 10% 50V	
	BC19	2401-002180	E.CAPACITOR	2.2UF 20% 50V			BC8	2401-002180	E.CAPACITOR	2.2UF 20% 50V	
	BC194	2203-000840	CHIP CAPACITOR	0.39NF 5% 50V			BC80	2203-000203	CHIP CAPACITOR	100NF 10% 16V	
	BC195	2203-000840	CHIP CAPACITOR	0.39NF 5% 50V			BC81	2203-000203	CHIP CAPACITOR	100NF 10% 16V	

## ■ Electrical parts list (DSP board)

Block No. 03

△	Item	Parts number	Parts name	Remarks	Area	△	Item	Parts number	Parts name	Remarks	Area
	BC82	2203-000979	CHIP CAPACITOR	47NF 10% 50V			BR30	2007-000290	CHIP RESISTOR	100 5% 1/10W	
	BC83	2203-000979	CHIP CAPACITOR	47NF 10% 50V			BR34	2007-000290	CHIP RESISTOR	100 5% 1/10W	
	BC84	2203-000203	CHIP CAPACITOR	100NF 10% 16V			BR35	2007-001177	CHIP RESISTOR	8.2K 5% 1/10W	
	BC85	2203-000575	CHIP CAPACITOR	220NF 10% 25V			BR36	2007-000449	CHIP RESISTOR	180 5% 1/10W	
	BC86	2203-000575	CHIP CAPACITOR	220NF 10% 25V			BR37	2007-000290	CHIP RESISTOR	100 5% 1/10W	
	BC87	2203-000575	CHIP CAPACITOR	220NF 10% 25V			BR4	2007-000586	CHIP RESISTOR	22K 5% 1/10W	
	BC88	2203-000575	CHIP CAPACITOR	220NF 10% 25V			BR40	2007-000290	CHIP RESISTOR	100 5% 1/10W	
	BC89	2203-000979	CHIP CAPACITOR	47NF 10% 50V			BR41	2007-001177	CHIP RESISTOR	8.2K 5% 1/10W	
	BC9	2203-001518	CHIP CAPACITOR	1.8NF 10% 50V			BR42	2007-000290	CHIP RESISTOR	100 5% 1/10W	
	BC90	2203-001036	CHIP CAPACITOR	5.6NF 10% 50V			BR43	2007-000290	CHIP RESISTOR	100 5% 1/10W	
	BC91	2203-001132	CHIP CAPACITOR	0.68NF 5% 50V			BR44	2007-000290	CHIP RESISTOR	100 5% 1/10W	
	BC92	2401-001912	E.CAPACITOR	1UF 20% 50V			BR45	2007-000290	CHIP RESISTOR	100 5% 1/10W	
	BC93	2203-000787	CHIP CAPACITOR	0.33NF 5% 50V			BR46	2007-001177	CHIP RESISTOR	8.2K 5% 1/10W	
	BC94	2203-000661	CHIP CAPACITOR	0.27NF 5% 50V			BR47	2007-000468	CHIP RESISTOR	1K 5% 1/10W	
	BC95	2203-000495	CHIP CAPACITOR	2.2NF 10% 50V			BR48	2007-000468	CHIP RESISTOR	1K 5% 1/10W	
	BC96	2203-000203	CHIP CAPACITOR	100NF 10% 16V			BR49	2007-001177	CHIP RESISTOR	8.2K 5% 1/10W	
	BC97	2401-001975	E.CAPACITOR	47UF 20% 16V			BR50	2007-000449	CHIP RESISTOR	180 5% 1/10W	
	BC98	2203-001132	CHIP CAPACITOR	0.68NF 5% 50V			BR501	2007-000444	CHIP RESISTOR	180K 5% 1/10W	
	BC99	2401-001912	E.CAPACITOR	1UF 20% 50V			BR502	2007-000444	CHIP RESISTOR	180K 5% 1/10W	
	BD090	0401-000101	DIODE	1N4148 100V			BR503	2007-000444	CHIP RESISTOR	180K 5% 1/10W	
	BD091	0401-000101	DIODE	1N4148 100V			BR51	2007-001177	CHIP RESISTOR	8.2K 5% 1/10W	
	BD1	0403-000399	ZENER DIODE	UZP9.1B 1W			BR52	2007-000449	CHIP RESISTOR	180 5% 1/10W	
	BD2	0403-000399	ZENER DIODE	UZP9.1B 1W			BR55	2007-001177	CHIP RESISTOR	8.2K 5% 1/10W	
	BD5	0403-001284	ZENER DIODE	RLZ3.3A			BR58	2007-000774	CHIP RESISTOR	33K 5% 1/10W	
	BD6	0403-001284	ZENER DIODE	RLZ3.3A			BR59	2007-000457	CHIP RESISTOR	18K 5% 1/10W	
	BD7	0403-001284	ZENER DIODE	RLZ3.3A			BR60	2007-001177	CHIP RESISTOR	8.2K 5% 1/10W	
	BD8	0403-001284	ZENER DIODE	RLZ3.3A			BR61	2007-001039	CHIP RESISTOR	56K 5% 1/10W	
	BQ080	0504-000156	DIGI TRANSISTOR	KSR2103			BR62	2007-001177	CHIP RESISTOR	8.2K 5% 1/10W	
	BQ081	0501-000341	TRANSISTOR	KSC1623-L			BR63	2007-000449	CHIP RESISTOR	180 5% 1/10W	
	BQ082	0501-000341	TRANSISTOR	KSC1623-L			BR64	2007-000778	CHIP RESISTOR	330K 5% 1/10W	
	BR01	2007-000468	CHIP RESISTOR	1K 5% 1/10W			BR65	2007-001039	CHIP RESISTOR	56K 5% 1/10W	
	BR02	2007-000468	CHIP RESISTOR	1K 5% 1/10W			BR66	2007-000653	CHIP RESISTOR	270 5% 1/10W	
	BR03	2007-000468	CHIP RESISTOR	1K 5% 1/10W			BR68	2007-000449	CHIP RESISTOR	180 5% 1/10W	
	BR04	2001-001004	CARBON RESISTOR	82 5% 1/4W			BR69	2007-001177	CHIP RESISTOR	8.2K 5% 1/10W	
	BR080	2007-000395	CHIP RESISTOR	150K 5% 1/10W			BR70	2001-000028	CARBON RESISTOR	100 5% 1/2W	
	BR081	2007-000565	CHIP RESISTOR	220K 5% 1/10W			BR71	2007-000468	CHIP RESISTOR	1K 5% 1/10W	
	BR082	2007-000774	CHIP RESISTOR	33K 5% 1/10W			BR72	2007-000872	CHIP RESISTOR	4.7K 5% 1/10W	
	BR083	2007-000774	CHIP RESISTOR	33K 5% 1/10W			BR73	2007-000409	CHIP RESISTOR	15K 5% 1/10W	
	BR086	2007-000572	CHIP RESISTOR	220 5% 1/10W			BR74	2007-000941	CHIP RESISTOR	47K 5% 1/10W	
	BR087	2007-000941	CHIP RESISTOR	47K 5% 1/10W			BR75	2007-001177	CHIP RESISTOR	8.2K 5% 1/10W	
	BR090	2007-000931	CHIP RESISTOR	470 5% 1/10W			BR76	2007-000355	CHIP RESISTOR	12K 5% 1/10W	
	BR10	2007-000586	CHIP RESISTOR	22K 5% 1/10W			BR77	2007-000300	CHIP RESISTOR	10K 5% 1/10W	
	BR100	2007-001177	CHIP RESISTOR	8.2K 5% 1/10W			BR78	2007-000001	CHIP RESISTOR	68K 5% 1/10W	
	BR109	2007-000029	CHIP RESISTOR	0 5% 1/10W			BR79	2007-001177	CHIP RESISTOR	8.2K 5% 1/10W	
	BR11	2007-001177	CHIP RESISTOR	8.2K 5% 1/10W			BR80	2007-000449	CHIP RESISTOR	180 5% 1/10W	
	BR110	2007-000029	CHIP RESISTOR	0 5% 1/10W			BR81	2007-000409	CHIP RESISTOR	15K 5% 1/10W	
	BR111	2007-000941	CHIP RESISTOR	47K 5% 1/10W			BR82	2007-000941	CHIP RESISTOR	47K 5% 1/10W	
	BR112	2007-000941	CHIP RESISTOR	47K 5% 1/10W			BR83	2007-000001	CHIP RESISTOR	68K 5% 1/10W	
	BR12	2007-001177	CHIP RESISTOR	8.2K 5% 1/10W			BR84	2007-001177	CHIP RESISTOR	8.2K 5% 1/10W	
	BR13	2007-000449	CHIP RESISTOR	180 5% 1/10W			BR85	2007-000449	CHIP RESISTOR	180 5% 1/10W	
	BR14	2007-001177	CHIP RESISTOR	8.2K 5% 1/10W			BR86	2007-001177	CHIP RESISTOR	8.2K 5% 1/10W	
	BR15	2007-000468	CHIP RESISTOR	1K 5% 1/10W			BR87	2007-000572	CHIP RESISTOR	220 5% 1/10W	
	BR16	2007-000586	CHIP RESISTOR	22K 5% 1/10W			BR88	2007-000572	CHIP RESISTOR	220 5% 1/10W	
	BR2	2007-001177	CHIP RESISTOR	8.2K 5% 1/10W			BR89	2007-000468	CHIP RESISTOR	1K 5% 1/10W	
	BR22	2007-001177	CHIP RESISTOR	8.2K 5% 1/10W			BR9	2007-000468	CHIP RESISTOR	1K 5% 1/10W	
	BR23	2007-000449	CHIP RESISTOR	180 5% 1/10W			BR90	2007-000872	CHIP RESISTOR	4.7K 5% 1/10W	
	BR24	2007-000468	CHIP RESISTOR	1K 5% 1/10W			BR91	2007-001177	CHIP RESISTOR	8.2K 5% 1/10W	
	BR25	2007-001177	CHIP RESISTOR	8.2K 5% 1/10W			BR92	2007-000355	CHIP RESISTOR	12K 5% 1/10W	
	BR26	2007-000586	CHIP RESISTOR	22K 5% 1/10W			BR93	2007-000119	CHIP RESISTOR	560 5% 1/16W	
	BR27	2007-001177	CHIP RESISTOR	8.2K 5% 1/10W			BR93	2007-000642	CHIP RESISTOR	270 5% 1/10W	
	BR28	2007-001177	CHIP RESISTOR	8.2K 5% 1/10W			BR94	2007-001177	CHIP RESISTOR	8.2K 5% 1/10W	
	BR29	2007-000449	CHIP RESISTOR	180 5% 1/10W			BR95	2007-000449	CHIP RESISTOR	180 5% 1/10W	
	BR3	2007-000468	CHIP RESISTOR	1K 5% 1/10W			BR96	2007-000282	CHIP RESISTOR	100K 5% 1/10W	

## ■ Electrical parts list (DSP board)

Block No. 03

△	Item	Parts number	Parts name	Remarks	Area
	BR97	2007-000282	CHIP RESISTOR	100K 5% 1/10W	
	BR98	2007-001177	CHIP RESISTOR	8.2K 5% 1/10W	
	BR99	2007-000449	CHIP RESISTOR	180 5% 1/10W	
	DC01	2203-000979	CHIP CAPACITOR	47NF 10% 50V	
	J1	3708-001601	CONNECTOR	19P 1.25MM	
	J2	3710-001422	CONNECTOR	12P 1R 2MM	
	J3	3708-001464	CONNECTOR	24P 1MM	
	J5	3710-001422	CONNECTOR	12P 1R 2MM	
	J6	3710-001422	CONNECTOR	12P 1R 2MM	
	J7	3710-001422	CONNECTOR	12P 1R 2MM	
	J8	3710-001422	CONNECTOR	12P 1R 2MM	
	J9	3711-000820	CONNECTOR	2P 1R 2.5MM	
	R67	2007-001177	CHIP RESISTOR	8.2K 5% 1/10W	
	UR032	2007-000070	CHIP RESISTOR	0 5% 1/16W	
	U1	1201-000163	IC	BA4560 8P	
	U11	1204-001472	IC	M62463FP 64P	
	U12	1204-001454	IC	TDA7449L 20P	
	U13	1201-000163	IC	BA4560 8P	
	U2	1204-001465	IC	TDA7440D 28P	
	U3	1201-000163	IC	BA4560 8P	
	U5	1201-000163	IC	BA4560 8P	
	U6	1002-001285	IC	AK4355VF 28P	
	U7	1204-001454	IC	TDA7449L 20P	
	U9	1201-000163	IC	BA4560 8P	

## ■ Electrical parts list (DVD loader board)

Block No. 04

△	Item	Parts number	Parts name	Remarks	Area	△	Item	Parts number	Parts name	Remarks	Area
	CPUR6	2007-000113	CHIP RESISTOR	33 5% 1/16W			DR101	2007-000113	CHIP RESISTOR	33 5% 1/16W	
	CPUR7	2007-000113	CHIP RESISTOR	33 5% 1/16W			DR102	2007-000072	CHIP RESISTOR	47 5% 1/16W	
	CPUR8	2007-000113	CHIP RESISTOR	33 5% 1/16W			DR103	2007-000113	CHIP RESISTOR	33 5% 1/16W	
	CPUR9	2007-000113	CHIP RESISTOR	33 5% 1/16W			DR107	2007-000090	CHIP RESISTOR	10K 5% 1/16W	
	CPU11	2007-000113	CHIP RESISTOR	33 5% 1/16W			DR108	2007-000090	CHIP RESISTOR	10K 5% 1/16W	
	CPU13	2007-000113	CHIP RESISTOR	33 5% 1/16W			DR109	2007-000090	CHIP RESISTOR	10K 5% 1/16W	
	CPU17	2007-000113	CHIP RESISTOR	33 5% 1/16W			DR110	2007-000090	CHIP RESISTOR	10K 5% 1/16W	
	CPU18	2007-000113	CHIP RESISTOR	33 5% 1/16W			DR111	2007-000090	CHIP RESISTOR	10K 5% 1/16W	
	DC32	2203-000178	CHIP CAPACITOR	100NF +80-20% 25V			DR112	2007-000090	CHIP RESISTOR	10K 5% 1/16W	
	DC33	2203-000972	CHIP CAPACITOR	47NF 10% 16V			DR113	2007-000090	CHIP RESISTOR	10K 5% 1/16W	
	DC34	2203-001052	CHIP CAPACITOR	0.56NF 10% 50V			DR114	2007-000090	CHIP RESISTOR	10K 5% 1/16W	
	DC35	2203-000178	CHIP CAPACITOR	100NF +80-20% 25V			DR115	2007-000090	CHIP RESISTOR	10K 5% 1/16W	
	DC36	2203-000178	CHIP CAPACITOR	100NF +80-20% 25V			DR116	2007-000090	CHIP RESISTOR	10K 5% 1/16W	
	DC37	2203-000998	CHIP CAPACITOR	0.047NF 5% 50V			DR117	2007-000090	CHIP RESISTOR	10K 5% 1/16W	
	DC38	2203-000178	CHIP CAPACITOR	100NF +80-20% 25V			DR118	2007-000090	CHIP RESISTOR	10K 5% 1/16W	
	DC39	2203-000178	CHIP CAPACITOR	100NF +80-20% 25V			DR119	2007-000090	CHIP RESISTOR	10K 5% 1/16W	
	DC40	2203-000440	CHIP CAPACITOR	1NF 10% 50V			DR120	2007-000090	CHIP RESISTOR	10K 5% 1/16W	
	DC42	2203-001103	CHIP CAPACITOR	6.8NF 10% 50V			DR121	2007-000090	CHIP RESISTOR	10K 5% 1/16W	
	DC43	2203-002494	CHIP CAPACITOR	470NF 10% 16V			DR122	2007-000074	CHIP RESISTOR	100 5% 1/16W	
	DC44	2203-000972	CHIP CAPACITOR	47NF 10% 16V			DR123	2007-000074	CHIP RESISTOR	100 5% 1/16W	
	DC45	2203-001656	CHIP CAPACITOR	0.47NF 5% 50V			DR124	2007-000074	CHIP RESISTOR	100 5% 1/16W	
	DC46	2203-001656	CHIP CAPACITOR	0.47NF 5% 50V			DR125	2007-000074	CHIP RESISTOR	100 5% 1/16W	
	DC48	2203-000178	CHIP CAPACITOR	100NF +80-20% 25V			DR126	2007-000074	CHIP RESISTOR	100 5% 1/16W	
	DC49	2203-000178	CHIP CAPACITOR	100NF +80-20% 25V			DR127	2007-000074	CHIP RESISTOR	100 5% 1/16W	
	DC50	2203-000440	CHIP CAPACITOR	1NF 10% 50V			DR128	2007-000074	CHIP RESISTOR	100 5% 1/16W	
	DC51	2203-000440	CHIP CAPACITOR	1NF 10% 50V			DR129	2007-000074	CHIP RESISTOR	100 5% 1/16W	
	DC52	2203-000178	CHIP CAPACITOR	100NF +80-20% 25V			DR130	2007-000074	CHIP RESISTOR	100 5% 1/16W	
	DC54	2203-001573	CHIP CAPACITOR	0.012NF 5% 50V			DR131	2007-000074	CHIP RESISTOR	100 5% 1/16W	
	DC56	2203-001573	CHIP CAPACITOR	0.012NF 5% 50V			DR132	2007-000074	CHIP RESISTOR	100 5% 1/16W	
	DC62	2203-005261	CHIP CAPACITOR	1000NF 10% 25V			DR133	2007-000074	CHIP RESISTOR	100 5% 1/16W	
	DC66	2203-000280	CHIP CAPACITOR	0.01NF 0.5PF 50V			DR134	2007-000074	CHIP RESISTOR	100 5% 1/16W	
	DC67	2203-000280	CHIP CAPACITOR	0.01NF 0.5PF 50V			DR135	2007-000074	CHIP RESISTOR	100 5% 1/16W	
	DC68	2203-000280	CHIP CAPACITOR	0.01NF 0.5PF 50V			DR136	2007-000074	CHIP RESISTOR	100 5% 1/16W	
	DC69	2203-000280	CHIP CAPACITOR	0.01NF 0.5PF 50V			DR137	2007-000074	CHIP RESISTOR	100 5% 1/16W	
	DC70	2203-000280	CHIP CAPACITOR	0.01NF 0.5PF 50V			DR138	2007-000124	CHIP RESISTOR	2.2K 5% 1/16W	
	DC71	2203-000280	CHIP CAPACITOR	0.01NF 0.5PF 50V			DR139	2007-000124	CHIP RESISTOR	2.2K 5% 1/16W	
	DC72	2203-000178	CHIP CAPACITOR	100NF +80-20% 25V			DR146	2007-000308	CHIP RESISTOR	10 5% 1/10W	
	DC73	2203-000178	CHIP CAPACITOR	100NF +80-20% 25V			DR183	2007-000078	CHIP RESISTOR	1K 5% 1/16W	
	DC74	2203-000178	CHIP CAPACITOR	100NF +80-20% 25V			DR184	2007-000078	CHIP RESISTOR	1K 5% 1/16W	
	DC75	2203-000178	CHIP CAPACITOR	100NF +80-20% 25V			DR188	2007-000070	CHIP RESISTOR	0 5% 1/16W	
	DC76	2203-000178	CHIP CAPACITOR	100NF +80-20% 25V			DR190	2007-000090	CHIP RESISTOR	10K 5% 1/16W	
	DC77	2203-000178	CHIP CAPACITOR	100NF +80-20% 25V			DR191	2007-000090	CHIP RESISTOR	10K 5% 1/16W	
	DC78	2203-000178	CHIP CAPACITOR	100NF +80-20% 25V			DR28	2007-001243	CHIP RESISTOR	91K 5% 1/10W	
	DC79	2203-000178	CHIP CAPACITOR	100NF +80-20% 25V			DR29	2007-000070	CHIP RESISTOR	0 5% 1/16W	
	DC80	2203-000178	CHIP CAPACITOR	100NF +80-20% 25V			DR30	2007-001243	CHIP RESISTOR	91K 5% 1/10W	
	DC81	2203-000178	CHIP CAPACITOR	100NF +80-20% 25V			DR31	2007-000122	CHIP RESISTOR	1.2K 5% 1/16W	
	DC82	2203-000178	CHIP CAPACITOR	100NF +80-20% 25V			DR32	2007-000113	CHIP RESISTOR	33 5% 1/16W	
	DC83	2203-000178	CHIP CAPACITOR	100NF +80-20% 25V			DR33	2007-000113	CHIP RESISTOR	33 5% 1/16W	
	DC84	2203-000178	CHIP CAPACITOR	100NF +80-20% 25V			DR34	2007-000113	CHIP RESISTOR	33 5% 1/16W	
	DC85	2203-000178	CHIP CAPACITOR	100NF +80-20% 25V			DR35	2007-000962	CHIP RESISTOR	5.1K 1% 1/16W	
	DC86	2203-000178	CHIP CAPACITOR	100NF +80-20% 25V			DR36	2007-000113	CHIP RESISTOR	33 5% 1/16W	
	DC87	2203-000178	CHIP CAPACITOR	100NF +80-20% 25V			DR37	2007-000090	CHIP RESISTOR	10K 5% 1/16W	
	DC88	2203-000178	CHIP CAPACITOR	100NF +80-20% 25V			DR38	2007-000084	CHIP RESISTOR	4.7K 5% 1/16W	
	DC89	2203-000257	CHIP CAPACITOR	10NF 10% 50V			DR39	2007-000093	CHIP RESISTOR	20K 5% 1/16W	
	DC90	2203-000257	CHIP CAPACITOR	10NF 10% 50V			DR40	2007-001010	CHIP RESISTOR	51K 5% 1/16W	
	DC91	2203-000178	CHIP CAPACITOR	100NF +80-20% 25V			DR42	2007-000082	CHIP RESISTOR	3.3K 5% 1/16W	
	DJ3	3708-001645	CONNECTOR	40P 1MM			DR43	2007-000082	CHIP RESISTOR	3.3K 5% 1/16W	
	DJ6	3711-003111	CONNECTOR	6P 1R 2.5MM			DR44	2007-000082	CHIP RESISTOR	3.3K 5% 1/16W	
	DL4	3301-001495	BEAD	AB 120OHM 2012			DR45	2007-000084	CHIP RESISTOR	4.7K 5% 1/16W	
	DL5	3301-001495	BEAD	AB 120OHM 2012			DR46	2007-000097	CHIP RESISTOR	47K 5% 1/16W	
	DL6	3301-001495	BEAD	AB 120OHM 2012			DR47	2007-000113	CHIP RESISTOR	33 5% 1/16W	
	DL7	3301-001495	BEAD	AB 120OHM 2012			DR49	2007-000082	CHIP RESISTOR	3.3K 5% 1/16W	
	DR100	2007-000072	CHIP RESISTOR	47 5% 1/16W			DR50	2007-000084	CHIP RESISTOR	4.7K 5% 1/16W	



## ■ Electrical parts list (DVD loader board)

Block No. 04

△	Item	Parts number	Parts name	Remarks	Area	△	Item	Parts number	Parts name	Remarks	Area
	DR51	2007-000962	CHIP RESISTOR	5.1K 1% 1/16W			MR173	2007-000102	CHIP RESISTOR	100K 5% 1/16W	
	DR52	2007-000113	CHIP RESISTOR	33 5% 1/16W			MR174	2007-000102	CHIP RESISTOR	100K 5% 1/16W	
	DR53	2007-000113	CHIP RESISTOR	33 5% 1/16W			MR175	2007-000102	CHIP RESISTOR	100K 5% 1/16W	
	DR54	2007-000113	CHIP RESISTOR	33 5% 1/16W			MR177	2007-000078	CHIP RESISTOR	1K 5% 1/16W	
	DR55	2007-000070	CHIP RESISTOR	0 5% 1/16W			MR180	2007-000078	CHIP RESISTOR	1K 5% 1/16W	
	DR57	2007-000309	CHIP RESISTOR	10 5% 1/16W			MR182	2007-000078	CHIP RESISTOR	1K 5% 1/16W	
	DR60	2007-000097	CHIP RESISTOR	47K 5% 1/16W			MU10	1003-001418	IC	FAN8082 8P	
	DR80	2007-000094	CHIP RESISTOR	22K 5% 1/16W			MU9	1003-001450	IC	BA5954FM 28P	
	DR81	2007-000084	CHIP RESISTOR	4.7K 5% 1/16W			MZD1	0403-000357	DIODE	UZ5.6BM 5.6V	
	DR84	2007-000090	CHIP RESISTOR	10K 5% 1/16W			RC1	2203-000178	CHIP CAPACITOR	100NF +80-20% 25V	
	DR85	2007-000090	CHIP RESISTOR	10K 5% 1/16W			RC10	2203-001636	CHIP CAPACITOR	0.033NF 5% 50V	
	DR86	2007-000090	CHIP RESISTOR	10K 5% 1/16W			RC11	2203-001636	CHIP CAPACITOR	0.033NF 5% 50V	
	DR87	2007-000090	CHIP RESISTOR	10K 5% 1/16W			RC12	2203-000178	CHIP CAPACITOR	100NF +80-20% 25V	
	DR88	2007-000090	CHIP RESISTOR	10K 5% 1/16W			RC13	2203-001636	CHIP CAPACITOR	0.033NF 5% 50V	
	DR89	2007-000090	CHIP RESISTOR	10K 5% 1/16W			RC14	2203-001126	CHIP CAPACITOR	0.68NF 10% 50V	
	DR90	2007-000090	CHIP RESISTOR	10K 5% 1/16W			RC15	2203-001126	CHIP CAPACITOR	0.68NF 10% 50V	
	DR91	2007-000090	CHIP RESISTOR	10K 5% 1/16W			RC16	2203-000972	CHIP CAPACITOR	47NF 10% 16V	
	DR92	2007-000113	CHIP RESISTOR	33 5% 1/16W			RC17	2203-001126	CHIP CAPACITOR	0.68NF 10% 50V	
	DR93	2007-000113	CHIP RESISTOR	33 5% 1/16W			RC18	2203-001126	CHIP CAPACITOR	0.68NF 10% 50V	
	DR94	2007-000113	CHIP RESISTOR	33 5% 1/16W			RC19	2203-000236	CHIP CAPACITOR	0.1NF 5% 50V	
	DR95	2007-000113	CHIP RESISTOR	33 5% 1/16W			RC2	2203-000178	CHIP CAPACITOR	100NF +80-20% 25V	
	DR96	2007-000113	CHIP RESISTOR	33 5% 1/16W			RC20	2203-000440	CHIP CAPACITOR	1NF 10% 50V	
	DR97	2007-000113	CHIP RESISTOR	33 5% 1/16W			RC21	2203-000178	CHIP CAPACITOR	100NF +80-20% 25V	
	DR98	2007-000072	CHIP RESISTOR	47 5% 1/16W			RC26	2203-000178	CHIP CAPACITOR	100NF +80-20% 25V	
	DR99	2007-000072	CHIP RESISTOR	47 5% 1/16W			RC27	2203-000178	CHIP CAPACITOR	100NF +80-20% 25V	
	DTC10	2401-000795	E.CAPACITOR	220UF 20% 16V			RC28	2203-000178	CHIP CAPACITOR	100NF +80-20% 25V	
	DTC11	2401-001893	E.CAPACITOR	100UF 20% 10V			RC29	2203-000178	CHIP CAPACITOR	100NF +80-20% 25V	
	DTC12	2401-001893	E.CAPACITOR	100UF 20% 10V			RC3	2203-000178	CHIP CAPACITOR	100NF +80-20% 25V	
	DTC13	2401-001893	E.CAPACITOR	100UF 20% 10V			RC31	2203-000178	CHIP CAPACITOR	100NF +80-20% 25V	
	DTC6	2401-000243	E.CAPACITOR	100UF 20% 10V			RC32	2203-000178	CHIP CAPACITOR	100NF +80-20% 25V	
	DTC7	2401-001975	E.CAPACITOR	47UF 20% 16V			RC34	2203-000178	CHIP CAPACITOR	100NF +80-20% 25V	
	DTC9	2401-000795	E.CAPACITOR	220UF 20% 16V			RC35	2203-001636	CHIP CAPACITOR	0.033NF 5% 50V	
	DU3	1204-001936	IC	M5705 176P			RC36	2203-002494	CHIP CAPACITOR	470NF 10% 16V	
	DU5	1107-001203	IC	W29EE512P 32P			RC4	2203-000178	CHIP CAPACITOR	100NF +80-20% 25V	
	DU6	1203-001369	IC	61AN1902 3P			RC6	2203-000440	CHIP CAPACITOR	1NF 10% 50V	
	DU7	1105-001372	IC	K4E151512D			RC7	2203-000178	CHIP CAPACITOR	100NF +80-20% 25V	
	DU8	1203-001293	IC	033 T0-252 3P			RC8	2203-000440	CHIP CAPACITOR	1NF 10% 50V	
	DXT1	2801-000261	CRYSTAL	33.8688MHZ 50PPM			RC9	2203-001126	CHIP CAPACITOR	0.68NF 10% 50V	
	MCE1	2401-001975	E.CAPACITOR	47UF 20% 16V			RD1	0407-000116	DIODE	DAP202K 80V	
	MC81	2203-000178	CHIP CAPACITOR	100NF +80-20% 25V			RL1	2703-000001	INDUCTOR	10UH 10%	
	MC82	2203-000592	CHIP CAPACITOR	0.22NF 5% 50V			RL2	2703-000001	INDUCTOR	10UH 10%	
	MC83	2203-001408	CHIP CAPACITOR	0.27NF 5% 50V			RQ1	0501-000632	TRANSISTOR	2SB1197K	
	MC84	2203-000888	CHIP CAPACITOR	4.7NF 10% 50V			RQ2	0501-000632	TRANSISTOR	2SB1197K	
	MC87	2203-000178	CHIP CAPACITOR	100NF +80-20% 25V			RR1	2007-000309	CHIP RESISTOR	10 5% 1/16W	
	MD1	0407-000116	DIODE	DAP202K 80V			RR13	2007-000122	CHIP RESISTOR	1.2K 5% 1/16W	
	MJ4	AH39-00368A	LEAD CONNECTOR	6P 50MM			RR16	2007-000122	CHIP RESISTOR	1.2K 5% 1/16W	
	MJ5	3711-001018	CONNECTOR	5P 1R 2MM			RR17	2007-000090	CHIP RESISTOR	10K 5% 1/16W	
	MR148	2007-000134	CHIP RESISTOR	33K 5% 1/16W			RR18	2007-000090	CHIP RESISTOR	10K 5% 1/16W	
	MR149	2007-000090	CHIP RESISTOR	10K 5% 1/16W			RR2	2007-000309	CHIP RESISTOR	10 5% 1/16W	
	MR150	2007-000090	CHIP RESISTOR	10K 5% 1/16W			RR20	2007-000075	CHIP RESISTOR	220 5% 1/16W	
	MR151	2007-000097	CHIP RESISTOR	47K 5% 1/16W			RR21	2007-000119	CHIP RESISTOR	560 5% 1/16W	
	MR152	2007-000134	CHIP RESISTOR	33K 5% 1/16W			RR23	2007-000070	CHIP RESISTOR	0 5% 1/16W	
	MR153	2007-000113	CHIP RESISTOR	33 5% 1/16W			RR25	2007-001179	CHIP RESISTOR	8.2K 5% 1/16W	
	MR154	2007-000091	CHIP RESISTOR	12K 5% 1/16W			RR28	2007-000098	CHIP RESISTOR	56K 5% 1/16W	
	MR155	2007-000125	CHIP RESISTOR	3.9K 5% 1/16W			RR29	2007-000088	CHIP RESISTOR	7.5K 5% 1/16W	
	MR156	2007-000082	CHIP RESISTOR	3.3K 5% 1/16W			RR3	2007-000078	CHIP RESISTOR	1K 5% 1/16W	
	MR157	2007-000090	CHIP RESISTOR	10K 5% 1/16W			RR30	2007-000070	CHIP RESISTOR	0 5% 1/16W	
	MR158	2007-000070	CHIP RESISTOR	0 5% 1/16W			RR31	2007-000107	CHIP RESISTOR	470K 5% 1/16W	
	MR164	2007-000483	CHIP RESISTOR	1 5% 1/10W			RR4	2007-000078	CHIP RESISTOR	1K 5% 1/16W	
	MR165	2007-000483	CHIP RESISTOR	1 5% 1/10W			RR5	2007-000070	CHIP RESISTOR	0 5% 1/16W	
	MR167	2007-000483	CHIP RESISTOR	1 5% 1/10W			RR6	2007-001179	CHIP RESISTOR	8.2K 5% 1/16W	
	MR168	2007-000483	CHIP RESISTOR	1 5% 1/10W			RR7	2007-000070	CHIP RESISTOR	0 5% 1/16W	
	MR172	2007-000070	CHIP RESISTOR	0 5% 1/16W			RTC1	2401-000795	E.CAPACITOR	220UF 20% 16V	

## ■ Electrical parts list (DVD loader board)

Block No. 04

△	Item	Parts number	Parts name	Remarks	Area
	RTC2	2401-001893	E.CAPACITOR	100UF 20% 16V	
	RTC4	2401-001893	E.CAPACITOR	100UF 20% 16V	
	RTC5	2401-001893	E.CAPACITOR	100UF 20% 16V	
	RU1	1201-001790	IC	SP3721A 64P	
	RU2	1201-001842	IC	TL3472CD 8P	

## ■ Electrical parts list (DVD MPEG board)

Block No. 05

▲	Item	Parts number	Parts name	Remarks	Area	▲	Item	Parts number	Parts name	Remarks	Area
	C101	2203-000178	CHIP CAPACITOR	100NF +80-20%			L1	3301-001495	BEAD	AB 120OHM 2012	
	C102	2203-000257	CHIP CAPACITOR	10NF 10% 1608			L30	3301-000353	BEAD	AB 120OHM	
	C103	2203-000178	CHIP CAPACITOR	100NF +80-20%			L32	3301-000353	BEAD	AB 120OHM	
	C104	2203-000178	CHIP CAPACITOR	100NF +80-20%			L38	3301-001495	BEAD	AB 120OHM 2012	
	C105	2203-000178	CHIP CAPACITOR	100NF +80-20%			L39	3301-001495	BEAD	AB 120OHM 2012	
	C106	2203-000178	CHIP CAPACITOR	100NF +80-20%			L40	3301-000353	BEAD	AB 120OHM	
	C107	2203-000178	CHIP CAPACITOR	100NF +80-20%			L41	3301-000353	BEAD	AB 120OHM	
	C28	2402-001059	E.CAPACITOR	220UF 20% 6.3V			L42	3301-000353	BEAD	AB 120OHM	
	C29	2203-000178	CHIP CAPACITOR	100NF +80-20%			L43	3301-000353	BEAD	AB 120OHM	
	C30	2402-001059	E.CAPACITOR	220UF 20% 6.3V			L44	3301-000353	BEAD	AB 120OHM	
	C31	2203-000178	CHIP CAPACITOR	100NF +80-20%			L47	3301-000353	BEAD	AB 120OHM	
	C32	2203-000178	CHIP CAPACITOR	100NF +80-20%			L48	3301-000353	BEAD	AB 120OHM	
	C33	2402-000179	E.CAPACITOR	47UF 20% 16V			L49	3301-000353	BEAD	AB 120OHM	
	C36	2203-000178	CHIP CAPACITOR	100NF +80-20%			L50	3301-001495	BEAD	AB 120OHM 2012	
	C37	2203-000178	CHIP CAPACITOR	100NF +80-20%			L52	3301-000353	BEAD	AB 120OHM	
	C38	2402-000179	E.CAPACITOR	47UF 20% 16V			L53	3301-000353	BEAD	AB 120OHM	
	C46	2203-000178	CHIP CAPACITOR	100NF +80-20%			L54	3301-000353	BEAD	AB 120OHM	
	C48	2402-000179	E.CAPACITOR	47UF 20% 16V			L55	3301-001495	BEAD	AB 120OHM 2012	
	C50	2203-000178	CHIP CAPACITOR	100NF +80-20%			L56	3301-001495	BEAD	AB 120OHM 2012	
	C51	2203-000178	CHIP CAPACITOR	100NF +80-20%			OL1	3301-000353	BEAD	AB 120OHM	
	C54	2203-000178	CHIP CAPACITOR	100NF +80-20%			OL2	3301-000353	BEAD	AB 120OHM	
	C55	2203-000178	CHIP CAPACITOR	100NF +80-20%			PL1	3301-000353	BEAD	AB 120OHM	
	C59	2203-000178	CHIP CAPACITOR	100NF +80-20%			PL3	3301-000325	BEAD		
	C61	2203-000178	CHIP CAPACITOR	100NF +80-20%			Q3	0501-000314	TRANSISTOR	KSA812	
	C62	2203-000178	CHIP CAPACITOR	100NF +80-20%			Q4	0501-000314	TRANSISTOR	KSA812	
	C64	2203-000178	CHIP CAPACITOR	100NF +80-20%			Q5	0501-000314	TRANSISTOR	KSA812	
	C66	2203-000178	CHIP CAPACITOR	100NF +80-20%			Q6	0501-000314	TRANSISTOR	KSA812	
	C67	2203-000178	CHIP CAPACITOR	100NF +80-20%			Q7	0501-000314	TRANSISTOR	KSA812	
	C68	2402-000179	E.CAPACITOR	47UF 20% 16V			Q8	0501-000314	TRANSISTOR	KSA812	
	C69	2402-001059	E.CAPACITOR	220UF 20% 6.3V			R10	2007-000070	CHIP RESISTOR	0 5% 1608	
	C70	2203-000178	CHIP CAPACITOR	100NF +80-20%			R107	2007-000086	CHIP RESISTOR	5.6K 5% 1608	
	C71	2203-000178	CHIP CAPACITOR	100NF +80-20%			R108	2007-000084	CHIP RESISTOR	4.7K 5% 1608	
	C73	2402-001059	E.CAPACITOR	220UF 20% 6.3V			R109	2007-000084	CHIP RESISTOR	4.7K 5% 1608	
	C75	2203-000178	CHIP CAPACITOR	100NF +80-20%			R110	2007-000084	CHIP RESISTOR	4.7K 5% 1608	
	C76	2203-000178	CHIP CAPACITOR	100NF +80-20%			R111	2007-000084	CHIP RESISTOR	4.7K 5% 1608	
	C77	2203-000178	CHIP CAPACITOR	100NF +80-20%			R112	2007-000084	CHIP RESISTOR	4.7K 5% 1608	
	C79	2203-000178	CHIP CAPACITOR	100NF +80-20%			R114	2007-000070	CHIP RESISTOR	0 5% 1608	
	C80	2203-000178	CHIP CAPACITOR	100NF +80-20%			R31	2007-000084	CHIP RESISTOR	4.7K 5% 1608	
	C82	2402-000179	E.CAPACITOR	47UF 20% 16V			R32	2007-000084	CHIP RESISTOR	4.7K 5% 1608	
	C84	2402-000176	E.CAPACITOR	10UF 20% 16V			R34	2007-000070	CHIP RESISTOR	0 5% 1608	
	C85	2402-001059	E.CAPACITOR	220UF 20% 6.3V			R5V	2007-000070	CHIP RESISTOR	0 5% 1608	
	C86	2203-000178	CHIP CAPACITOR	100NF +80-20%			R53	2007-000084	CHIP RESISTOR	4.7K 5% 1608	
	C87	2203-000178	CHIP CAPACITOR	100NF +80-20%			R55	2007-000122	CHIP RESISTOR	1.2K 5% 1608	
	C88	2203-000178	CHIP CAPACITOR	100NF +80-20%			R56	2007-000084	CHIP RESISTOR	4.7K 5% 1608	
	C89	2203-000178	CHIP CAPACITOR	100NF +80-20%			R57	2007-000113	CHIP RESISTOR	33 5% 1608	
	C90	2203-000178	CHIP CAPACITOR	100NF +80-20%			R58	2007-000113	CHIP RESISTOR	33 5% 1608	
	C96	2203-000384	CHIP CAPACITOR	0.015NF 5% 1608			R59	2007-000113	CHIP RESISTOR	33 5% 1608	
	C97	2203-000552	CHIP CAPACITOR	0.02NF 5% 1608			R6	2007-000113	CHIP RESISTOR	33 5% 1608	
	C98	2203-000178	CHIP CAPACITOR	100NF +80-20%			R60	2007-000075	CHIP RESISTOR	220 5% 1608	
	C99	2203-000178	CHIP CAPACITOR	100NF +80-20%			R61	2007-000116	CHIP RESISTOR	120 5% 1608	
	DC1	2203-000178	CHIP CAPACITOR	100NF +80-20%			R63	2007-000113	CHIP RESISTOR	33 5% 1608	
	DR1	2007-000074	CHIP RESISTOR	100 5% 1608			R64	2007-000113	CHIP RESISTOR	33 5% 1608	
	DR2	2007-000074	CHIP RESISTOR	100 5% 1608			R66	2007-000113	CHIP RESISTOR	33 5% 1608	
	DR3	2007-000074	CHIP RESISTOR	100 5% 1608			R68	2007-000113	CHIP RESISTOR	33 5% 1608	
	DR4	2007-000074	CHIP RESISTOR	100 5% 1608			R71	2007-000113	CHIP RESISTOR	33 5% 1608	
	DR5	2007-000074	CHIP RESISTOR	100 5% 1608			R73	2007-000113	CHIP RESISTOR	33 5% 1608	
	DR6	2007-000074	CHIP RESISTOR	100 5% 1608			R75	2007-000113	CHIP RESISTOR	33 5% 1608	
	DR7	2007-000074	CHIP RESISTOR	100 5% 1608			R78	2007-000113	CHIP RESISTOR	33 5% 1608	
	DR8	2007-000074	CHIP RESISTOR	100 5% 1608			R79	2007-000113	CHIP RESISTOR	33 5% 1608	
	DR9	2007-000074	CHIP RESISTOR	100 5% 1608			R8	2007-000113	CHIP RESISTOR	33 5% 1608	
	J14	3708-001615	CONNECTOR	24P 1MM			R80	2007-000113	CHIP RESISTOR	33 5% 1608	
	J21	3708-001646	CONNECTOR	10P 1MM			R81	2007-000113	CHIP RESISTOR	33 5% 1608	
	J6	3708-001645	CONNECTOR	40P 1MM			R82	2007-000113	CHIP RESISTOR	33 5% 1608	

## ■ Electrical parts list (DVD MPEG board)

Block No. 05

△	Item	Parts number	Parts name	Remarks	Area
	R83	2007-000113	CHIP RESISTOR	33 5% 1608	
	R84	2007-000113	CHIP RESISTOR	33 5% 1608	
	R85	2007-000113	CHIP RESISTOR	33 5% 1608	
	R86	2007-000113	CHIP RESISTOR	33 5% 1608	
	R88	2007-000113	CHIP RESISTOR	33 5% 1608	
	R9	2007-000070	CHIP RESISTOR	0 5% 1608	
	R90	2007-000113	CHIP RESISTOR	33 5% 1608	
	R98	2007-000084	CHIP RESISTOR	4.7K 5% 1608	
	R99	2007-000078	CHIP RESISTOR	1K 5% 1608	
	U10	0802-001109	IC	74LVT573	
	U11	0802-001109	IC	74LVT573	
	U12	0802-001109	IC	74LVT573	
	U15	0801-002683	IC	74HCT245	
	U5	1105-001376	IC	W986432DH-7	
	U6	1107-001318	IC	SST39VF800A	
	U8	1204-001863	IC	ZIVA-5XI 208P	
	U9	1203-002369	REGULATOR	AMS317 3P	
	VC10	2203-000178	CHIP CAPACITOR	100NF +80-20%	
	VJL1	2007-000029	CHIP RESISTOR	0 5% 2012	
	VL1	3301-000353	BEAD	AB 120OHM	
	VR1	2007-000402	CHIP RESISTOR	150 5% 1608	
	VR10	2007-000402	CHIP RESISTOR	150 5% 1608	
	VR11	2007-000070	CHIP RESISTOR	0 5% 1608	
	VR12	2007-000115	CHIP RESISTOR	82 5% 1608	
	VR13	2007-000402	CHIP RESISTOR	150 5% 1608	
	VR14	2007-000070	CHIP RESISTOR	0 5% 1608	
	VR15A	2007-001043	CHIP RESISTOR	56 5% 1/10W 2012	
	VR16	2007-000402	CHIP RESISTOR	150 5% 1608	
	VR17	2007-000070	CHIP RESISTOR	0 5% 1608	
	VR2A	2007-000115	CHIP RESISTOR	82 5% 1608	
	VR3	2007-000070	CHIP RESISTOR	0 5% 1608	
	VR4	2007-000115	CHIP RESISTOR	82 5% 1608	
	VR5	2007-000402	CHIP RESISTOR	150 5% 1608	
	VR6	2007-000070	CHIP RESISTOR	0 5% 1608	
	VR7	2007-000402	CHIP RESISTOR	150 5% 1608	
	VR8	2007-000070	CHIP RESISTOR	0 5% 1608	
	VR9	2007-000115	CHIP RESISTOR	82 5% 1608	
	X1	2801-004132	CRYSTAL	13.5MHZ 24P	

< MEMO >

# Packing materials and accessories parts list

Block No. 

M	3	M	M
---	---	---	---

Block No. 

M	5	M	M
---	---	---	---

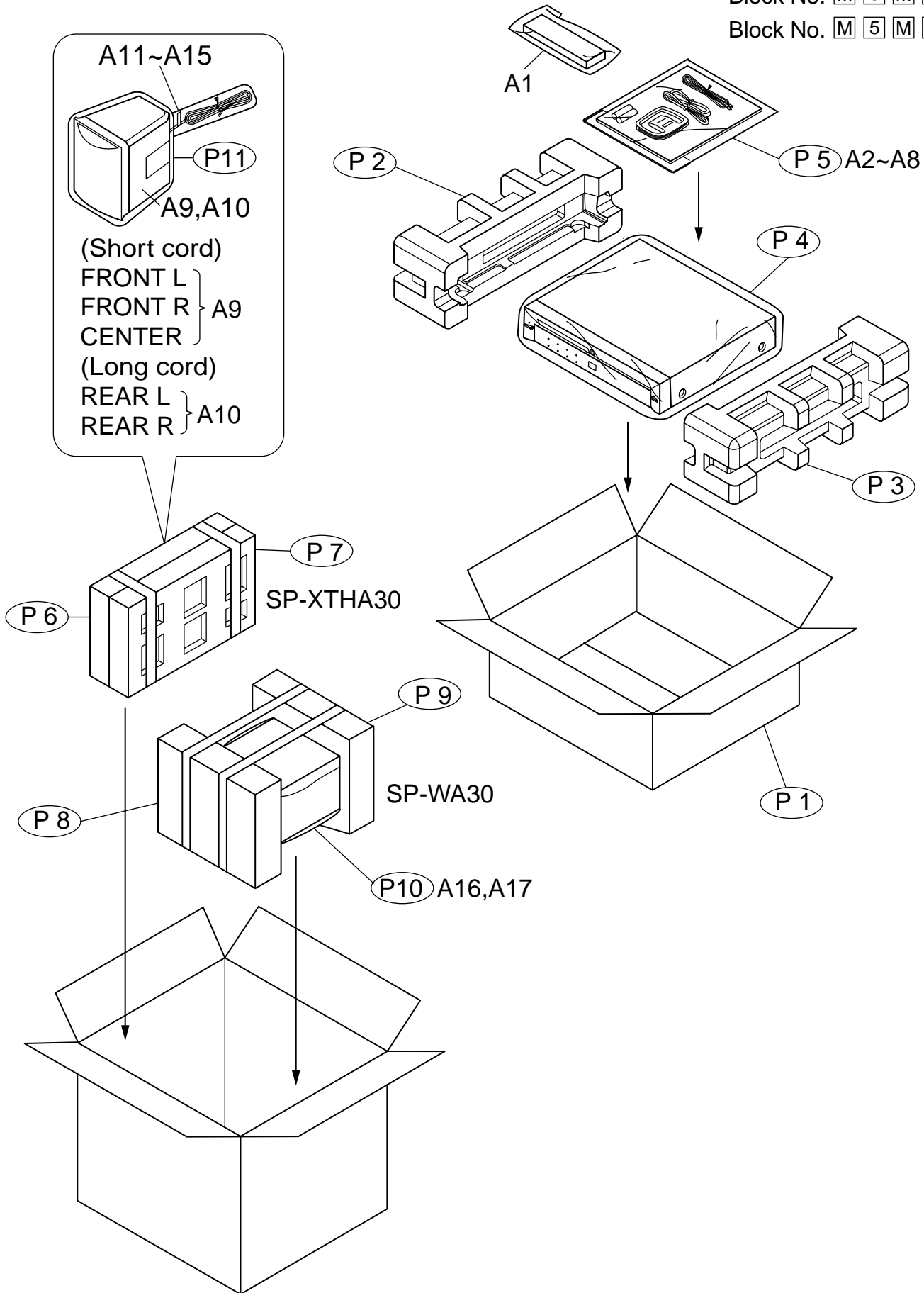

### ■ Parts list (Packing)

Block No. M3MM

△	Item	Parts number	Parts name	Q'ty	Description	Area
	P 1	AH69-00761D	PACKING CASE	1	SET	
	P 2	AH69-00740A	CUSHION L	1	SET	
	P 3	AH69-00741A	CUSHION R	1	SET	
	P 4	AH69-10081J	POLY BAG	1	SET	
	P 5	AH69-00525B	POLY BAG	1	INSTRUCTIONS	
	P 6	AH81-00841H	CUSHION TOP	1	SPEAKER BOX	
	P 7	AH81-00841J	CUSHION BOTTOM	1	SPEAKER BOX	
	P 8	AH81-00843G	CUSHION TOP	1	SPEAKER BOX	
	P 9	AH81-00843H	CUSHION BOTTOM	1	SPEAKER BOX	
	P10	AH81-00843F	POLY BAG	1	SPEAKER BOX	
	P11	AH81-00841G	POLY BAG	1	SPEAKER BOX	
	P12	AH81-00843M	PACKING CASE	1	SPEAKER BOX	

### ■ Parts list (Accessories)

Block No. M5MM

△	Item	Parts number	Parts name	Q'ty	Description	Area
	A 1	AH59-01096B	REMOCON ASSY	1		
	A 2	AH68-01150F	INSTRUCTIONS	1	SWE,FIN,DAN	EN
		AH68-01150F	INSTRUCTIONS	1	GER,FRE,SPA,ITA	EN
		AH68-01150D	INSTRUCTIONS	1	ENG	B
		AH68-01150E	INSTRUCTIONS	1	FRE,FRE,DUT	E
		AH68-01150G	INSTRUCTIONS	1	POL,HUN,CZE	EV
		AH68-01150K	INSTRUCTIONS	1	RUS	EE
	A 3	AH68-00415F	WARANTY CARD	1		EV,EE
		AH68-00415D	WARANTY CARD	1		B,E,EN
	A 4	AH68-00415C	IMPORTANT CARD	1		B
	A 5	AH38-10001A	FM ANT	1		
	A 6	AH42-20001P	AM ANT	1		
	A 7	AH39-40001V	RCA CABLE	1		
	A 8	-----	BATTERY	2		
	A 9	AH81-00825P	SPEAKER BOX	3	FRONT/CENTER	
	A10	AH81-00825Q	SPEAKER BOX	2	REAR	
	A11	AH81-00842K	SPK CORD LABEL	1	FRONT L	
	A12	AH81-00842L	SPK CORD LABEL	1	FRONT R	
	A13	AH81-00842M	SPK CORD LABEL	1	CENTER	
	A14	AH81-00842N	SPK CORD LABEL	1	REAR L	
	A15	AH81-00842P	SPK CORD LABEL	1	REAR R	
	A16	AH81-00825R	SPEAKER BOX	1	SUBWOOFER	
	A17	AH81-00842Q	SPK CORD LABEL	1	SUBWOOFER	

# JVC

## SERVICE MANUAL

### DVD DIGITAL CINEMA SYSTEM

## TH-A30R

#### Area suffix

B ----- U.K.  
 E ----- Continental Europe  
 EN ----- Northern Europe  
 EV ----- Eastern Europe  
 EE ---- Russian Federation

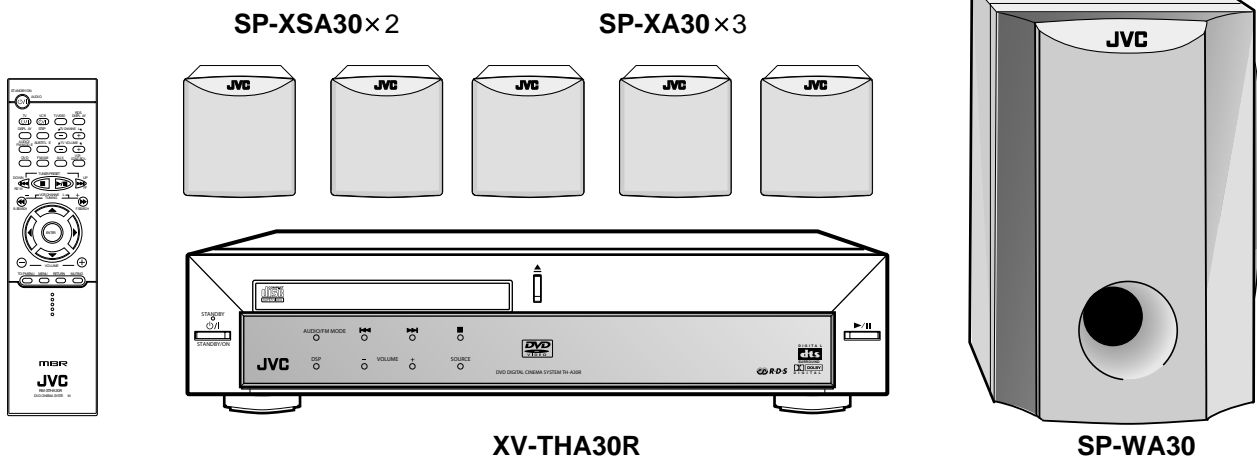

### Contents

Safety precautions .....	1-2	Disassembly method .....	1-6
Preventing static electricity .....	1-4	Wiring connection .....	1-12
Important for laser products .....	1-5	Description of major ICs .....	1-13~30



## Safety Precautions

1. This design of this product contains special hardware and many circuits and components specially for safety purposes. For continued protection, no changes should be made to the original design unless authorized in writing by the manufacturer. Replacement parts must be identical to those used in the original circuits. Services should be performed by qualified personnel only.
2. Alterations of the design or circuitry of the product should not be made. Any design alterations of the product should not be made. Any design alterations or additions will void the manufacturer's warranty and will further relieve the manufacture of responsibility for personal injury or property damage resulting therefrom.
3. Many electrical and mechanical parts in the products have special safety-related characteristics. These characteristics are often not evident from visual inspection nor can the protection afforded by them necessarily be obtained by using replacement components rated for higher voltage, wattage, etc. Replacement parts which have these special safety characteristics are identified in the Parts List of Service Manual. Electrical components having such features are identified by shading on the schematics and by ( $\triangle$ ) on the Parts List in the Service Manual. The use of a substitute replacement which does not have the same safety characteristics as the recommended replacement parts shown in the Parts List of Service Manual may create shock, fire, or other hazards.
4. The leads in the products are routed and dressed with ties, clamps, tubings, barriers and the like to be separated from live parts, high temperature parts, moving parts and/or sharp edges for the prevention of electric shock and fire hazard. When service is required, the original lead routing and dress should be observed, and it should be confirmed that they have been returned to normal, after re-assembling.
5. Leakage current check (Electrical shock hazard testing)  
After re-assembling the product, always perform an isolation check on the exposed metal parts of the product (antenna terminals, knobs, metal cabinet, screw heads, headphone jack, control shafts, etc.) to be sure the product is safe to operate without danger of electrical shock.  
Do not use a line isolation transformer during this check.

- Plug the AC line cord directly into the AC outlet. Using a "Leakage Current Tester", measure the leakage current from each exposed metal parts of the cabinet, particularly any exposed metal part having a return path to the chassis, to a known good earth ground. Any leakage current must not exceed 0.5mA AC (r.m.s.).

- Alternate check method

Plug the AC line cord directly into the AC outlet. Use an AC voltmeter having, 1,000 ohms per volt or more sensitivity in the following manner. Connect a  $1,500\ \Omega$  10W resistor paralleled by a  $0.15\ \mu\text{F}$  AC-type capacitor between an exposed metal part and a known good earth ground. Measure the AC voltage across the resistor with the AC voltmeter.

Move the resistor connection to each exposed metal part, particularly any exposed metal part having a return path to the chassis, and measure the AC voltage across the resistor. Now, reverse the plug in the AC outlet and repeat each measurement. Voltage measured any must not exceed 0.75 V AC (r.m.s.). This corresponds to 0.5 mA AC (r.m.s.).

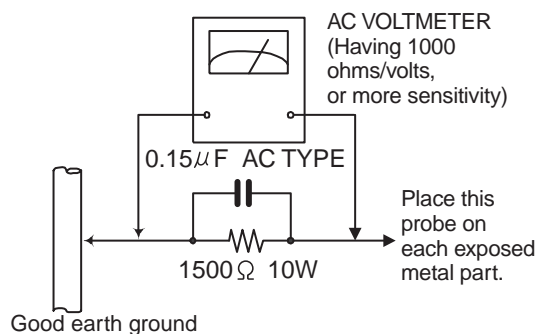

## Warning

1. This equipment has been designed and manufactured to meet international safety standards.
2. It is the legal responsibility of the repairer to ensure that these safety standards are maintained.
3. Repairs must be made in accordance with the relevant safety standards.
4. It is essential that safety critical components are replaced by approved parts.
5. If mains voltage selector is provided, check setting for local voltage.

## CAUTION

**Burrs formed during molding may be left over on some parts of the chassis. Therefore, pay attention to such burrs in the case of preforming repair of this system.**

In regard with component parts appearing on the silk-screen printed side (parts side) of the PWB diagrams, the parts that are printed over with black such as the resistor ( $\blacksquare$ ), diode ( $\blacksquare$ ) and ICP ( $\bullet$ ) or identified by the " $\triangle$ " mark nearby are critical for safety.

(This regulation does not correspond to J and C version.)

## **Safety precautions** (U.K only)

1. This design of this product contains special hardware and many circuits and components specially for safety purposes. For continued protection, no changes should be made to the original design unless authorized in writing by the manufacturer. Replacement parts must be identical to those used in the original circuits.
2. Any unauthorised design alterations or additions will void the manufacturer's guarantee ; furthermore the manufacturer cannot accept responsibility for personal injury or property damage resulting therefrom.
3. Essential safety critical components are identified by (  ) on the Parts List and by shading on the schematics, and must never be replaced by parts other than those listed in the manual. Please note however that many electrical and mechanical parts in the product have special safety related characteristics. These characteristics are often not evident from visual inspection. Parts other than specified by the manufacturer may not have the same safety characteristics as the recommended replacement parts shown in the Parts List of the Service Manual and may create shock, fire, or other hazards.
4. The leads in the products are routed and dressed with ties, clamps, tubings, barriers and the like to be separated from live parts, high temperature parts, moving parts and/or sharp edges for the prevention of electric shock and fire hazard. When service is required, the original lead routing and dress should be observed, and it should be confirmed that they have been returned to normal, after re-assembling.

## **Warning**

1. Service should be performed by qualified personnel only.
2. This equipment has been designed and manufactured to meet international safety standards.
3. It is the legal responsibility of the repairer to ensure that these safety standards are maintained.
4. Repairs must be made in accordance with the relevant safety standards.
5. It is essential that safety critical components are replaced by approved parts.
6. If mains voltage selector is provided, check setting for local voltage.

 **CAUTION** Burrs formed during molding may be left over on some parts of the chassis. Therefore, pay attention to such burrs in the case of preforming repair of this system.

## Preventing static electricity

### 1. Grounding to prevent damage by static electricity

Electrostatic discharge (ESD), which occurs when static electricity stored in the body, fabric, etc. is discharged, can destroy the laser diode in the traverse unit (optical pickup). Take care to prevent this when performing repairs.

### 2. About the earth processing for the destruction prevention by static electricity

Static electricity in the work area can destroy the optical pickup (laser diode) in devices such as CD players.

Be careful to use proper grounding in the area where repairs are being performed.

#### 2-1 Ground the workbench

Ground the workbench by laying conductive material (such as a conductive sheet) or an iron plate over it before placing the traverse unit (optical pickup) on it.

#### 2-2 Ground yourself

Use an anti-static wrist strap to release any static electricity built up in your body.

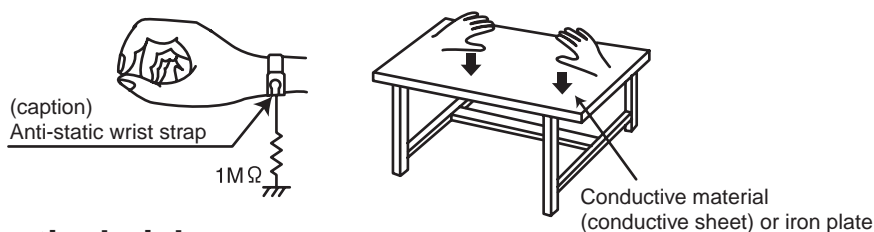

### 3. Handling the optical pickup

1. In order to maintain quality during transport and before installation, both sides of the laser diode on the replacement optical pickup are shorted. After replacement, return the shorted parts to their original condition. (Refer to the text.)
2. Do not use a tester to check the condition of the laser diode in the optical pickup. The tester's internal power source can easily destroy the laser diode.

### 4. Handling the traverse unit (optical pickup)

1. Do not subject the traverse unit (optical pickup) to strong shocks, as it is a sensitive, complex unit.
2. Cut off the shorted part of the flexible cable using nippers, etc. after replacing the optical pickup. For specific details, refer to the replacement procedure in the text. Remove the anti-static pin when replacing the traverse unit. Be careful not to take too long a time when attaching it to the connector.
3. Handle the flexible cable carefully as it may break when subjected to strong force.
4. It is not possible to adjust the semi-fixed resistor that adjusts the laser power. Do not turn it.

### Attention when traverse unit is decomposed

**\*Please refer to "Disassembly method" in the text for pick-up and how to detach the substrate.**

1. Solder is put up before the card wire is removed from connector on the pick up board as shown in Figure. (When the wire is removed without putting up solder, the CD pick-up assembly might destroy.)
2. Please remove solder after connecting the card wire with when you install picking up in the substrate.

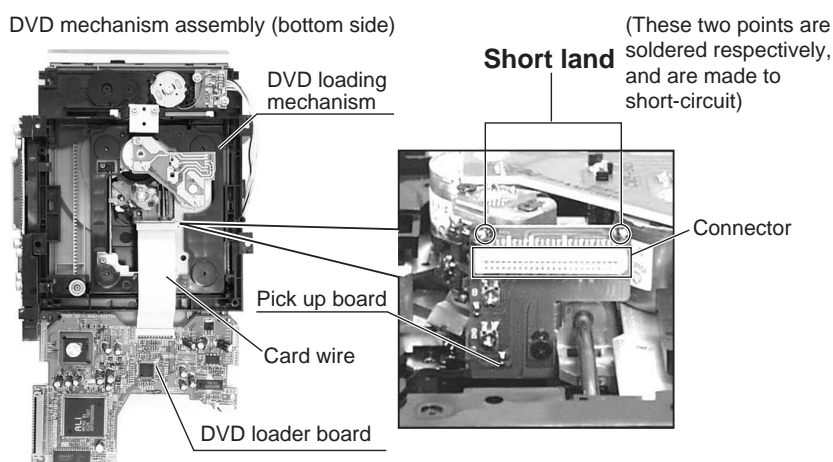

# Important for laser products

## 1.CLASS 1 LASER PRODUCT

**2.DANGER** : Invisible laser radiation when open and inter lock failed or defeated. Avoid direct exposure to beam.

**3.CAUTION** : There are no serviceable parts inside the Laser Unit. Do not disassemble the Laser Unit. Replace the complete Laser Unit if it malfunctions.

**4.CAUTION** : The compact disc player uses invisible laser radiation and is equipped with safety switches which prevent emission of radiation when the drawer is open and the safety interlocks have failed or are defeated. It is dangerous to defeat the safety switches.

**5.CAUTION** : If safety switches malfunction, the laser is able to function.

**6.CAUTION** : Use of controls, adjustments or performance of procedures other than those specified herein may result in hazardous radiation exposure.

**CAUTION** Please use enough caution not to see the beam directly or touch it in case of an adjustment or operation check.

**VARNING** : Osynlig laserstrålning är denna del är öppnad och spårren är urkopplad. Betrakta ej strålen.

**VARO** : Avattaessa ja suojalukitus ohitettaessa olet alltiina näkymättömälle lasersäteilylle.Älä katso säteeseen.

**ADVARSEL** : Usynlig laserstrålning ved åbning , når sikkerhedsafbrydere er ude af funktion. Undgå udsættelse for stråling.

**ADVARSEL** : Usynlig laserstrålning ved åbning,når sikkerhedsbryteren er avslott. unngå utsettelse for stråling.

## REPRODUCTION AND POSITION OF LABELS

### CLASS 1 LASER PRODUCT

CLASS 1 LASER PRODUCT  
KLASSE 1 LASER PRODUKT  
LUOKAN 1 LASER LAITE  
KLASS 1 LASER APPARAT  
PRODUCTO LASER CLASE 1



### WARNING LABEL

CAUTION: INVISIBLE LASER RADIATION WHEN OPEN AND INTERLOCKS DEFEATED AVOID EXPOSURE TO BEAM  
ADVARSEL: USYNLIG LASERSTRÅLING VED ÅBNING NÅR SIKKERHEDSafbrydere ER UDE AF FUNKTION UNDGÅ UDSÆTTELSE FOR STRÅLING  
VARO: AVATTAESSA JA SUOJALUKITUS OHITETAESSA OLET ALLTIINA NÄKYMÄTTÖMÄLLE LASERSÄTEILYLLE ÄLÄ KATSO SÄTEESEEN!  
VARNING: OSYNLIG LASERSTRÅLNING NÅR DENNA DEL ÄR ÖPPNAD OCH SPÅRREN ÄR URKOPPLAD BETRAKTA EJ STRÅLEN!

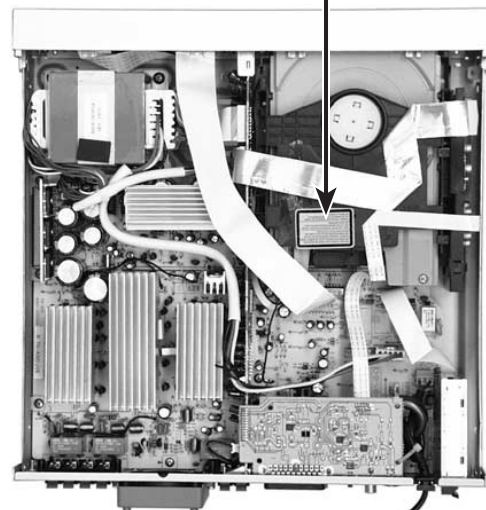

## Disassembly method

### ■ Removing the top cover (See Fig.1)

1. Remove the four screws **A** attaching the top cover on both sides of the body.
2. Remove the three screws **B** on back of the body.
3. Remove the top cover from behind in the direction of the arrow while pulling both sides outward.

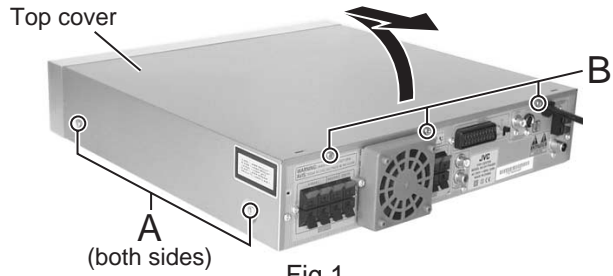

Fig.1

### ■ Removing the front panel assembly (See Fig.2A, 2B and 3)

- Prior to performing the following procedure, remove the top cover.
1. Remove the three screws **C** attaching the front panel assembly on bottom of the body.
  2. Remove the two screws **D** attaching the front panel assembly on both sides of the body.
  3. Remove the claw1, claw2 and claw3, and detach the front panel assembly toward the front.
  4. Disconnect the card wire from the connector FCW1 and FCW2 on the display board.

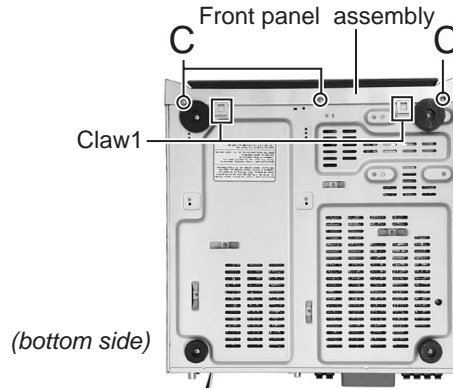

Fig.2A

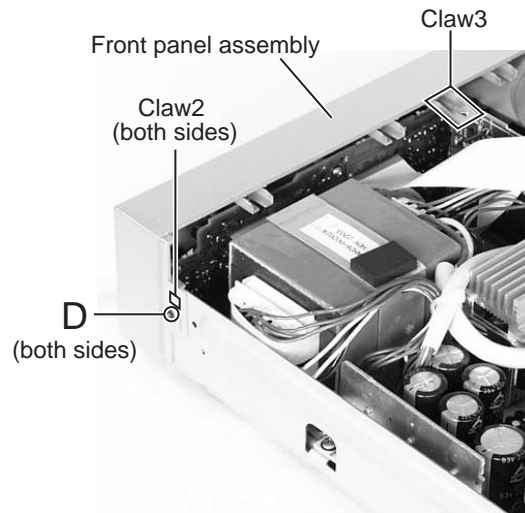

Fig.2B

### ■ Removing the power cord (See Fig.4)

- Prior to performing the following procedure, remove the top cover.
1. Cut off the tie bands fixing the power cord.
  2. Disconnect the power cord from the connector ACW1 on the main board and pull up the cord stopper upward.

Notes : The power cord is exchangeable.

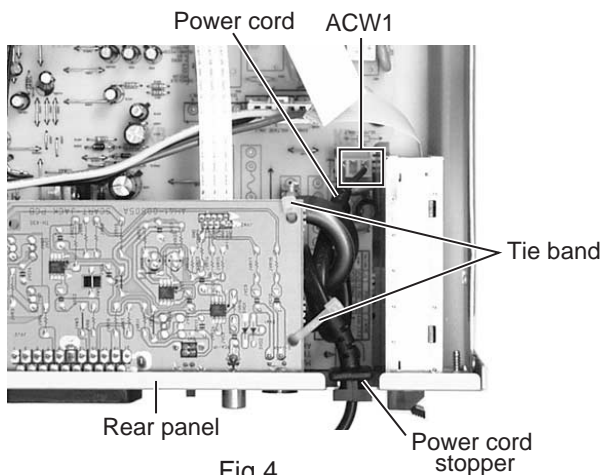

Fig.4

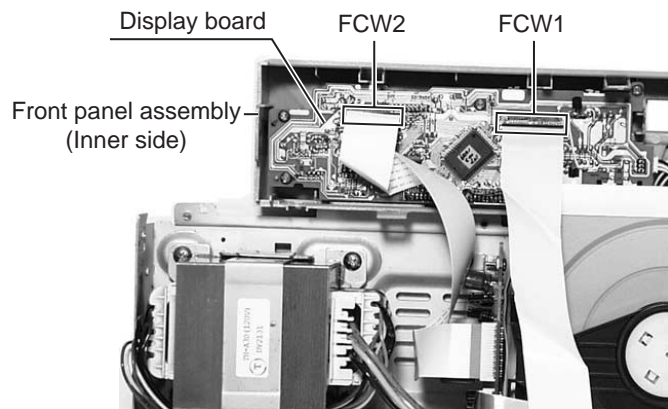

Fig.3

**■ Removing the DVD mechanism assembly (See Fig.5 and 6)**

• Prior to performing the following procedure, remove the top cover.

1. Disconnect the card wire from the connector J14 and J21 on the DVD MPEG board.
2. Remove the two screws **E** attaching the DVD mechanism assembly and pull up with drawing out.
3. Disconnect the harness from the connector DJ6 on the DVD loader board.

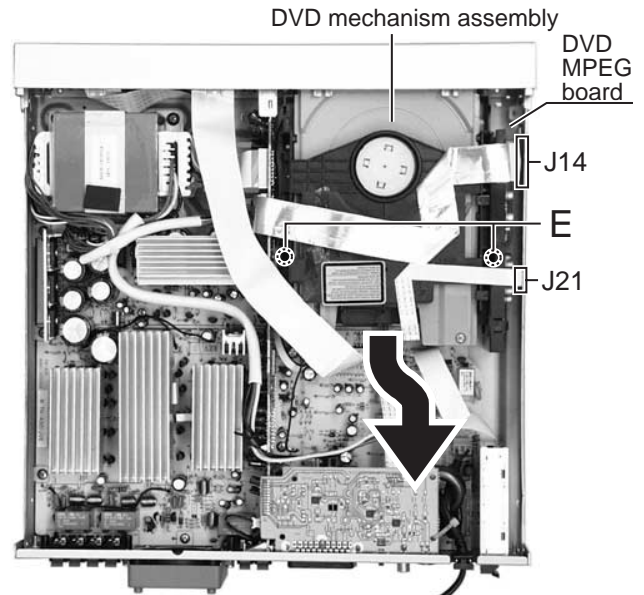

Fig.5

**■ Removing the rear panel (See Fig.7 and 8)**

• Prior to performing the following procedure, remove the top cover and power cord stopper.

1. Disconnect the harness from the connector J9 on the DSP board.
2. Remove the two screws **F**, four screws **G**, one screw **I** and five screws **J** attaching the each board to the rear panel. And remove the three screws **K** attaching the rear panel on back of the body.

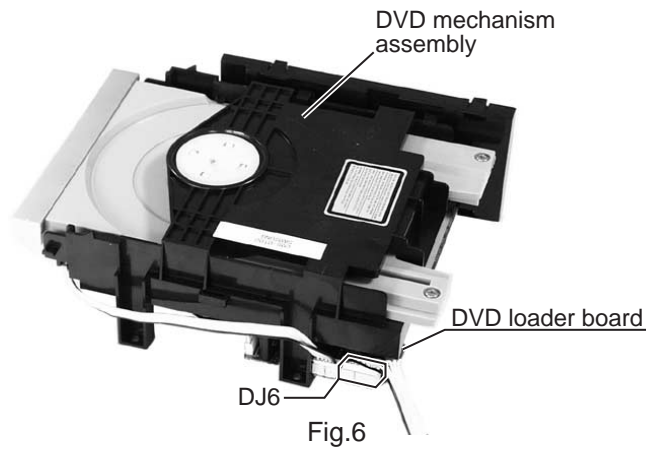

Fig.6

**■ Removing the tuner pack (See Fig.7 and 8)**

• Prior to performing the following procedure, remove the top cover.

1. Disconnect the card wire from the connector CON01 on the tuner pack.
2. Remove the two screws **F** attaching the tuner pack to the rear panel.

**■ Removing the jack board (See Fig.7 and 8)**

• Prior to performing the following procedure, remove the top cover.

1. Cut off the tie bands fixing the power cord.
2. Disconnect the card wire from the connector JW2 on the jack board.
3. Remove the four screws **G** attaching the jack board to the rear panel.
4. Disconnect the connector VW1 and remove the DSP board.

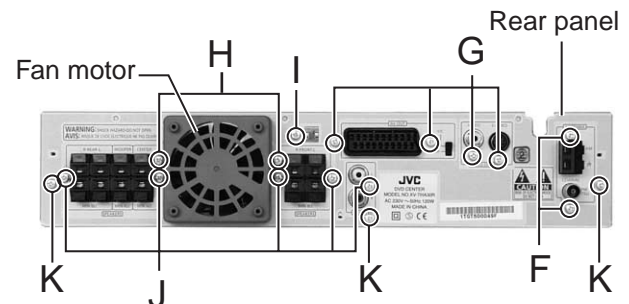

Fig.7

**■ Removing the fan motor (See Fig.7 and 8)**

• Prior to performing the following procedures, remove the top cover .

1. Disconnect the harness from the connector J9 on the DSP board .
2. Removing the two screws **H** attaching the fan motor to the rear panel.

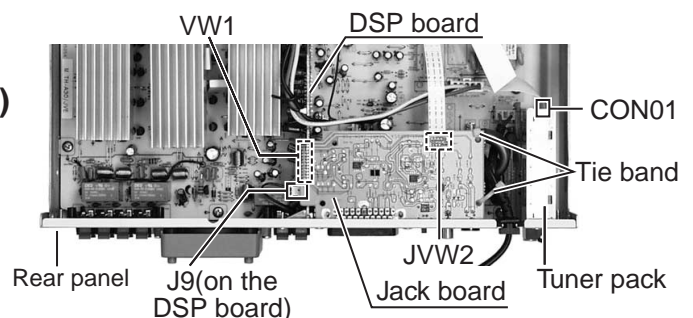

Fig.8

**■ Removing the DSP board (See Fig.9)**

• Prior to performing the following procedure, remove the top cover, front panel assembly, DVD mechanism assembly and jack board.

1. Remove the harness band fixing the harness.
2. Disconnect the harness from the connector J9 on the DSP board.
3. Disconnect the card wire from the connector J1 and J3 on the DSP board.
4. Remove the one screw **L** attaching the DSP board.
5. Remove the screw **M1** and remove the earth wire.
6. Remove the one screw **I** attaching the DSP board to the rear panel (see fig.7).
7. Pull up the DSP board from the front side upwards disconnecting the connector J2, J5, J6 and J7.

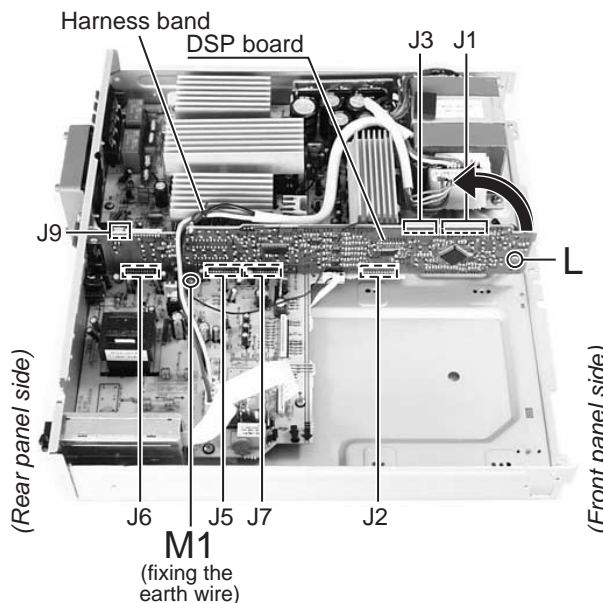

Fig.9

**■ Removing the main board (See Fig.10)**

• Prior to performing the following procedure, remove the top cover, front panel assembly, power cord, DVD mechanism assembly, jack board and DSP board.

1. Disconnect the card wire from the connector CW8 on the main board.
2. Disconnect the harness from the connector ACW2, ACW3, ACW4 and ACW5 on the main board.
3. Remove the five screws **J** attaching the speaker terminals and jack to the rear panel (see fig.7).
4. Remove the nine screws **M2** attaching the main board.
5. When the rear panel is not removed, pull up the main board from front side.

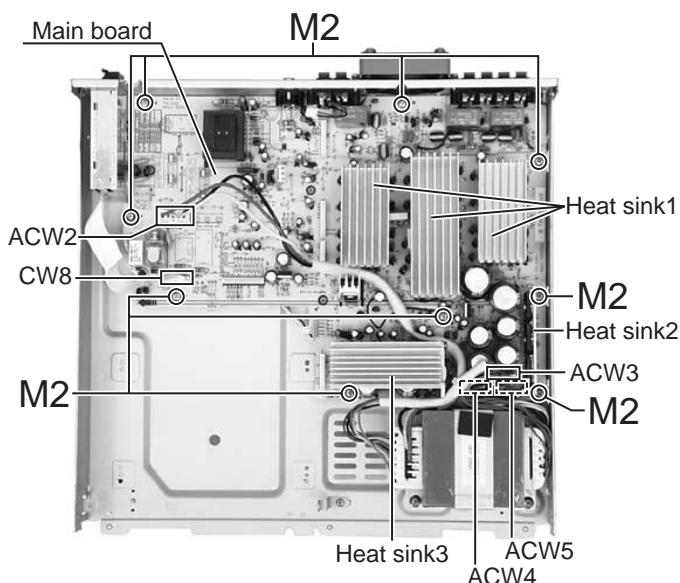

Fig.10

**■ Removing the power transistor & power IC (See Fig.10 to 12)**

• Prior to performing the following procedure, remove the top cover, front panel assembly, DVD mechanism assembly, jack board, DSP board and main board.

1. After removing the solder part 1 soldered to the main board, remove each screw and remove the heat sink from the power transistor.
2. After removing the solder part 2 soldered to the main board, remove each screw and remove the heat sink from the power IC.

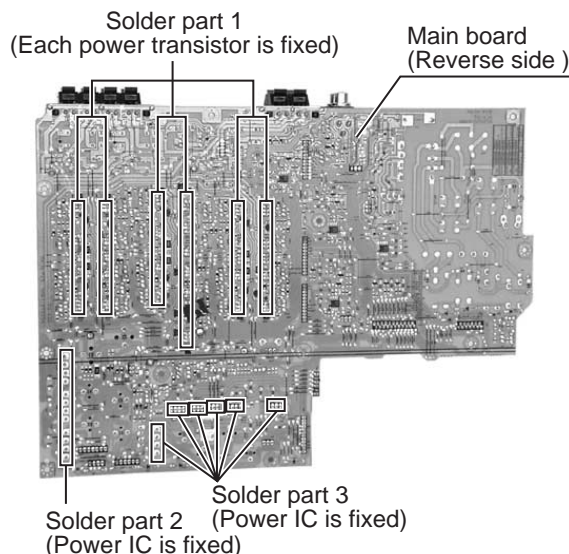

Fig.11

3. The power ICs fixed to the heat sink 3 can be removed individually that it is easy to remove screws (in meaning that a screw driver reaches). It is not necessary to remove whole like above-mentioned 1. and 2. .

After removing each screw which is fixing each power IC to the heat sink 3, the solder part 3 to which it corresponds on the main board is removed.

In addition, probably, the way after removing the whole will be safe when a screw driver does not reach too.

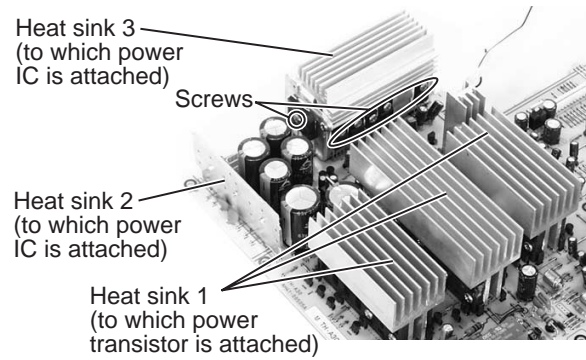

Fig.12

**■ Removing the power transformer (See Fig.13)**

• Prior to performing the following procedure, remove the top cover.

1. Cut off the tie band fixing the harness, if needed.
2. Disconnect the harness from the connector ACW2 (see fig.10), ACW3, ACW4 and ACW5 on the main board.
3. Remove the four screws **N** attaching the power transformer.

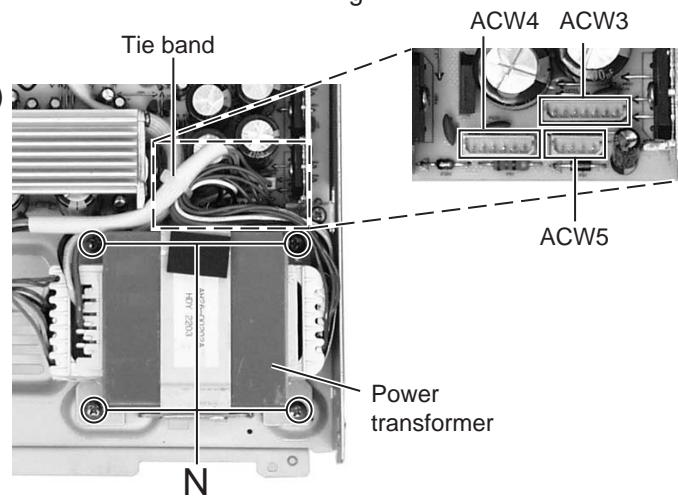

Fig.13

**<Front panel assembly section>**

**■ Removing the display board & switch board (See Fig.1 and 2)**

• Prior to performing the following procedure, remove the top cover and the front panel assembly.

1. Disconnect the card wire from the connector FCW1 and FCW2 on the display board.
2. Remove the five screws **A** attaching the display board on the inner of the front panel assembly.
3. Remove the four screws **B** attaching the switch board on the inner of the front panel assembly.
4. Disconnect the harness from connector FW2 on the display board, if needed.

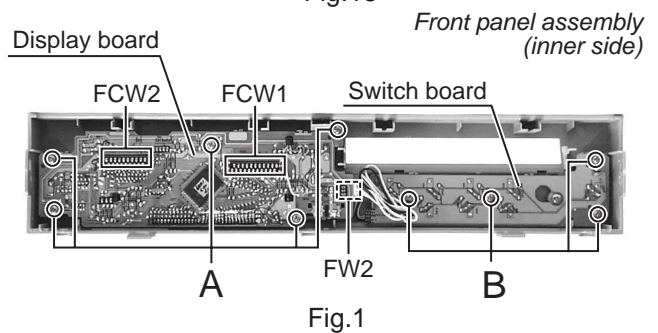

Fig.1

Front panel assembly (inner side)

Front panel assembly (inner side)

**■ Removing the front window (See Fig.2 and 3)**

• Prior to performing the following procedure, remove the top cover, front panel assembly, display board and switch board.

1. Remove the switch buttons, if needed.
2. Remove the three screws **C** attaching the front window on the front panel.
3. Remove the eight claws fixing the front window on the front panel.

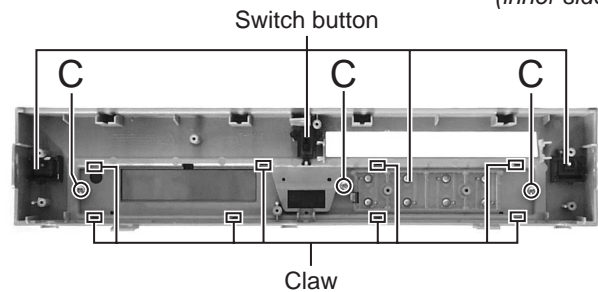

Fig.2

Front panel assembly (front side)



Front window

Fig.3



## <DVD mechanism assembly section>

### ■ Removing the DVD loader board (See Fig.1 to 3)

• Prior to performing the following procedure, remove the top cover and DVD mechanism assembly.

1. Disconnect the card wire from the connector J6 on the DVD MPEG board.
2. Disconnect the harness from the connector on the motor board.
3. Disconnect the harness from the connector MJ5 on the DVD loader board.
4. Remove the four screws **A** attaching the DVD loader board to DVD mechanism assembly.

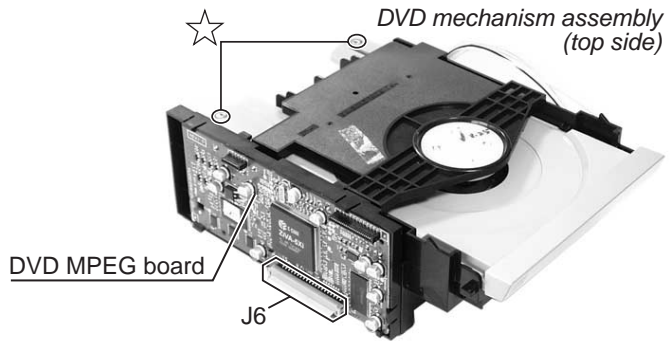

Fig.1

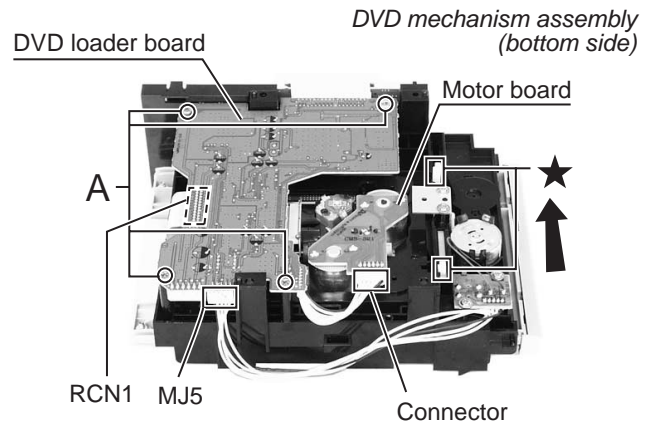

Fig.2

**CAUTION!!**

(see fig.3)

Before removing the card wire which connects the pickup board and DVD loader board, solder the two soldering parts and make it short-circuit. Moreover, while having removed the card wire, don't remove these solder.

5. Disconnect the card wire from the connector RCN1 on the DVD loader board.

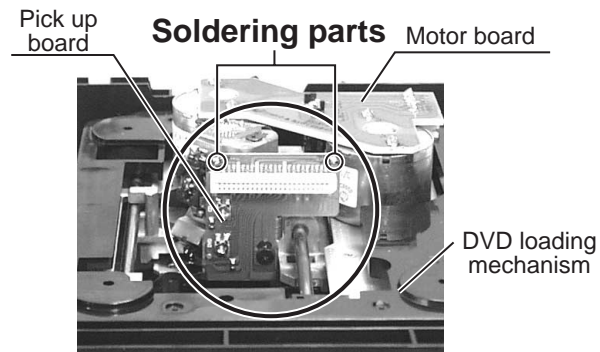

Fig.3

**ONE POINT**

#### ■ How to eject the DVD tray manually (see fig.2)

The white lever of the ★ mark is moved in the direction of the arrow. Then, the tray will be opened.

Moreover, the tray is separable from a DVD mechanism assembly by removing two screws of the ☆ mark (see fig.1) and drawing out the tray.

### ■ Removing the DVD loading mechanism (See Fig.4)

• Prior to performing the following procedure, remove the top cover, DVD mechanism assembly and DVD loader board.

1. Remove the two screws **B** and remove the bracket.
2. Remove the one screw **C** fixing the DVD loading mechanism.
3. Move the lever in the direction of the arrow **X**.
4. Remove the DVD loading mechanism from the DVD mechanism assembly by moving it in the direction of the arrow **Y**.

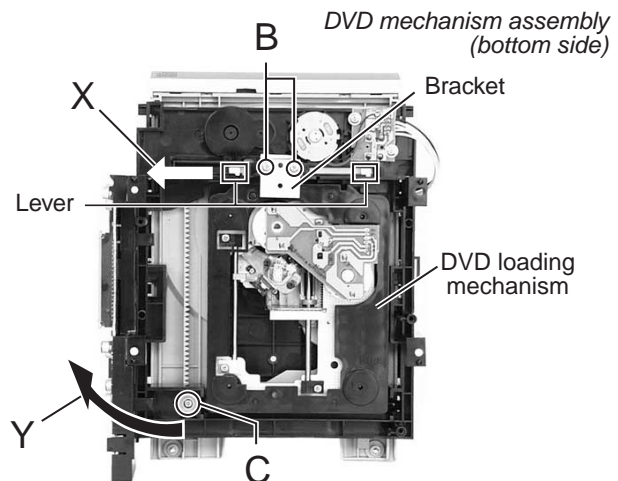

Fig.4

**■ Removing the DVD traverse mechanism**  
(See Fig.5)

- Prior to performing the following procedure, remove the top cover, DVD mechanism assembly, DVD loader board and DVD loading mechanism.
1. Remove the four screws **D** attaching the DVD traverse mechanism to DVD loading mechanism.

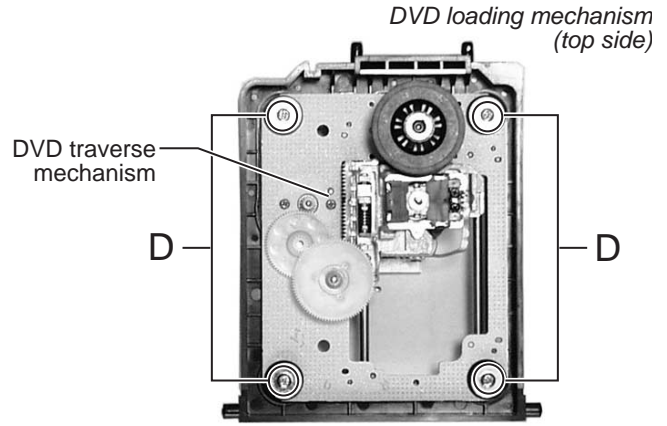

Fig.5

**■ Removing the holder & DVD MPEG board**  
(See Fig.6 and 7)

- Prior to performing the following procedure, remove the top cover, DVD mechanism assembly and DVD loader board.

1. Remove the two claws1, and remove the holder from the DVD mechanism assembly as it is pushed down.

*Note: When removing only the DVD MPEG board, it is not necessary to remove this holder.*

2. Remove the four claws2 and remove the DVD MPEG board from the holder.

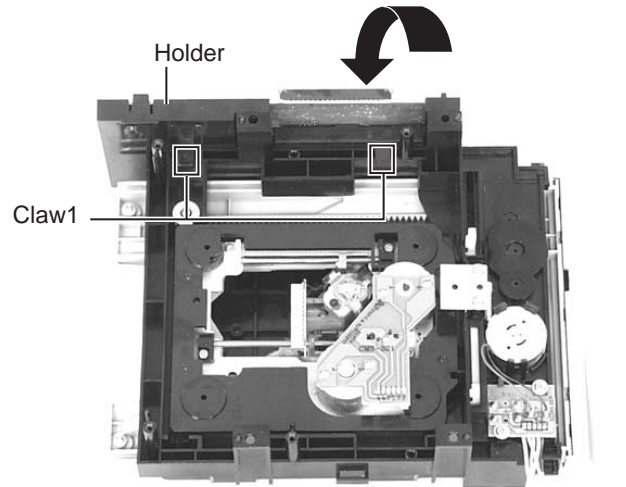

DVD mechanism assembly (bottom side)  
Fig.6

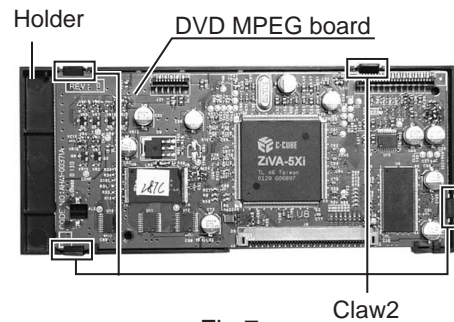

Fig.7

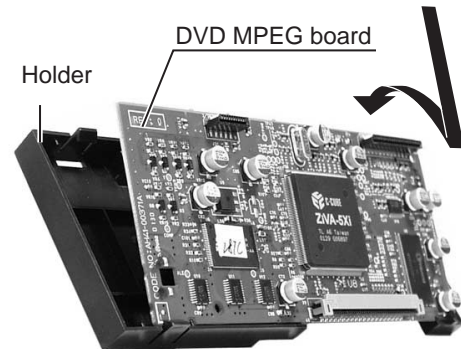

Fig.8

**ONE POINT**

- When inserting DVD MPEG board in holder. (see fig.8)

Insert in after uniting with a lower claws, when inserting DVD MPEG board in holder.

**< Speaker section >**

- It is exchange in a unit. Please do not decompose.

# Wiring connection

Color codes are shown below.

- |   |       |        |   |       |        |
|---|-------|--------|---|-------|--------|
| 1 | ----- | Brown  | 6 | ----- | Blue   |
| 2 | ----- | Red    | 7 | ----- | Violet |
| 3 | ----- | Orange | 8 | ----- | Gray   |
| 4 | ----- | Yellow | 9 | ----- | White  |
| 5 | ----- | Green  | 0 | ----- | Black  |

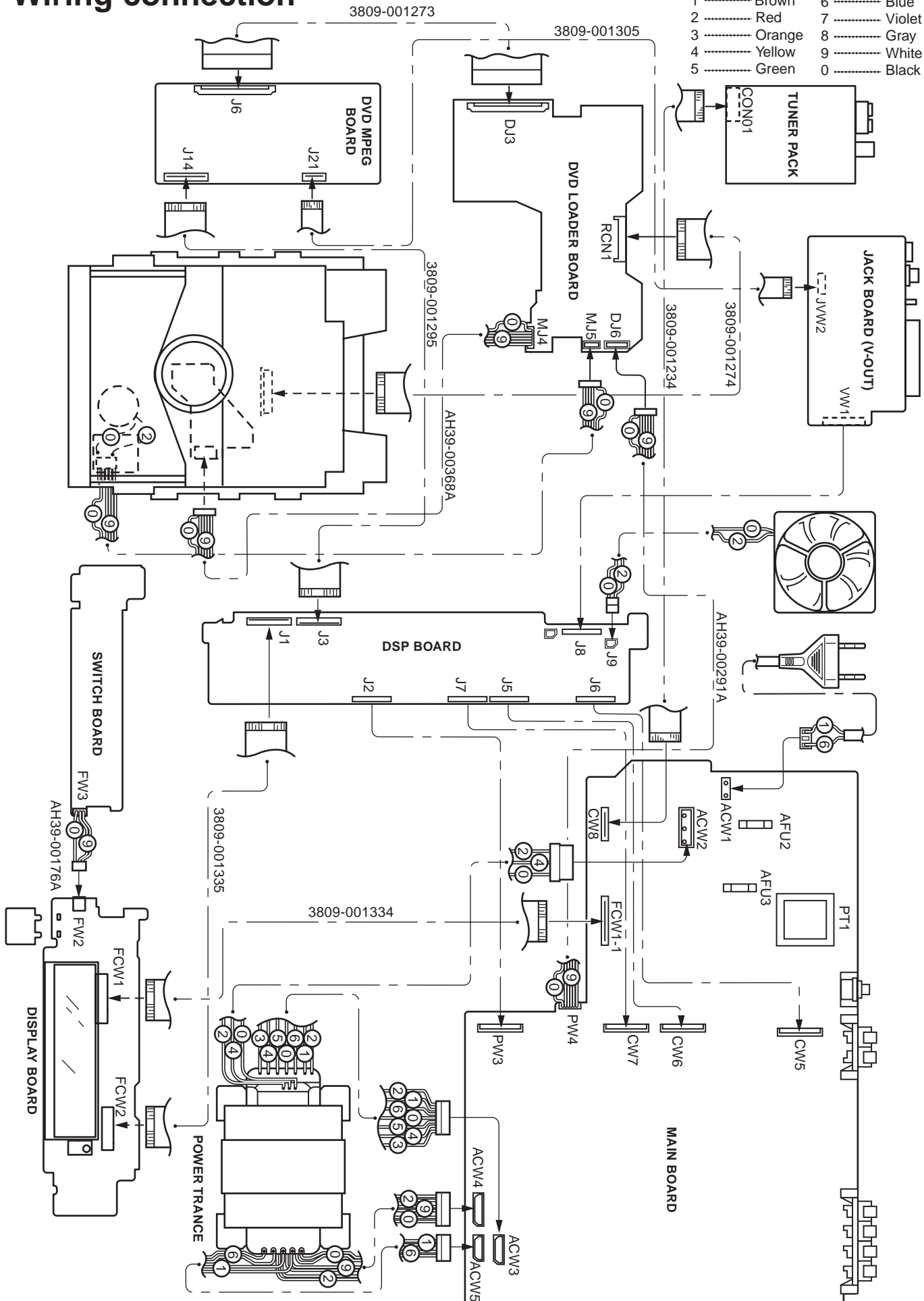

# Description of major ICs

## ■ W986432DH-7 (U5) : 32 Bits SDRAM

### 1.Pin layout

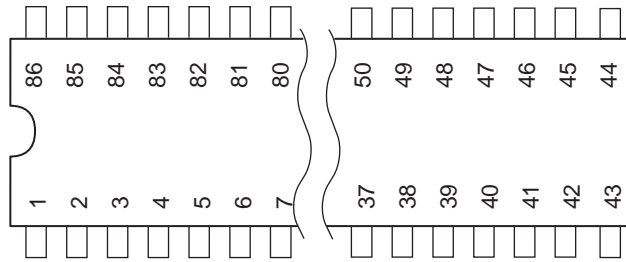

### 2.Pin function

Pin No.	I/O	Symbol	Function
1	-	V <sub>cc</sub>	Power for input buffers and logic circuit inside DRAM. (+3.3V)
2	I/O	DQ0	Multiplexed pins for data out put and input.
3	I/O	V <sub>cc</sub> Q	Separated power from VCC, to improve DQ noise immunity. (+3.3V)
4~5	I/O	DQ1~DQ2	Multiplexed pins for data out put and input.
6	I/O	V <sub>ss</sub> Q	Separated power from VSS, to improve DQ noise immunity.
7~8	I/O	DQ3~DQ4	Multiplexed pins for data out put and input.
9	I/O	V <sub>cc</sub> Q	Separated power from VCC, to improve DQ noise immunity.
10~11	I/O	DQ5~DQ6	Multiplexed pins for data out put and input.
12	I/O	V <sub>ss</sub> Q	Separated power from VSS, to improve DQ noise immunity.
13	I/O	DQ7	Multiplexed pins for data out put and input.
14	-	NC	No connection
15	-	V <sub>cc</sub>	Power for input buffers and logic circuit inside DRAM. (+3.3V)
16	I/O	DQM0	The output buffer is placed at Hi-Z (with latency of 2) when DQM is sampled high in read cycle. In write cycle, sampling DQM high will block the write operation with zero latency.
17	-	$\overline{WE}$	Referred to $\overline{RAS}$
18	-	$\overline{CAS}$	Referred to $\overline{RAS}$
19	-	$\overline{RAS}$	Command input. When sampled at the rising edge of the clock $\overline{RAS}$ , $\overline{CAS}$ and $\overline{WE}$ define the operation to be executed.
20	-	$\overline{CS}$	Disable or enable the command decoder. When command decoder is disabled, new command is ignored and previous operation continues.
21	-	NC	No connection
22~23	-	BS0 BS1	Select bank to activate dining row address latch time, or bank to read / write during address latch time.
24~27	-	A0~A10	Multiplexed pins for row and column address. Row address: A0-A10. Column address:A0-A7.A10 is sampled during a recharge command to determine if all banks are to be recharged or bank selected by BS0, BS1.
28	I/O	DQM2	The output buffer is placed at Hi-Z (with latency of 2) when DQM is sampled high in read cycle. In write cycle, sampling DQM high will block the write operation with zero latency.
29	-	V <sub>cc</sub>	Power for input buffers and logic circuit inside DRAM. (+3.3V)
30	-	NC	No connection
31	I/O	DQ16	Multiplexed pins for data out put and input.
32	I/O	V <sub>ss</sub> Q	Separated power from VSS, to improve DQ noise immunity.
33~34	I/O	DQ17~18	Multiplexed pins for data out put and input.
35	I/O	V <sub>ss</sub> Q	Separated power from VCC, to improve DQ noise immunity.

Pin No.	I/O	Symbol	Function
36~37	I/O	DQ19~20	Multiplexed pins for data out put and input.
38	I/O	VssQ	Separated power from VSS, to improve DQ noise immunity.
39~40	I/O	DQ21~22	Multiplexed pins for data out put and input.
41	-	VccQ	Separated power from VCC, to improve DQ noise immunity. (+3.3V)
42	I/O	DQ23	Multiplexed pins for data out put and input.
43	-	Vcc	Power for input buffers and logic circuit inside DRAM. (+3.3V)
44	-	Vss	Ground for input buffers and logic circuit inside DRAM.
45	I/O	DQ24	Multiplexed pins for data out put and input.
46	I/O	VssQ	Separated power from VSS, to improve DQ noise immunity.
47~48	I/O	DQ25~26	Multiplexed pins for data out put and input.
49	-	VccQ	Separated power from VCC, to improve DQ noise immunity. (+3.3V)
50~51	I/O	DQ27~28	Multiplexed pins for data out put and input.
52	I/O	VssQ	Separated power from VSS, to improve DQ noise immunity.
53~54	I/O	DQ29~30	Multiplexed pins for data out put and input.
55	-	VccQ	Separated power from VCC, to improve DQ noise immunity. (+3.3V)
56	I/O	DQ31	Multiplexed pins for data out put and input.
57	-	NC	No connection
58	-	Vss	Ground for input buffers and logic circuit inside DRAM.
59	I/O	DQM3	The output buffer is placed at Hi-Z (with latency of 2) when DQM is sampled high in read cycle. In write cycle, sampling DQM high will block the write operation with zero latency.
60~66	-	A3~A9	Multiplexed pins for row and column address. Row address: Ao-A10. Column address:A0-A7.A10 is sampled during a recharge command to determine if all banks are to be recharged or bank selected by BS0, BS1
67	-	CKE	CKE controls the clock activation and deactivation. When CKE is low, Power Down rising edge of clock.
68	I	CLK	System clock used to sample inputs on the rising edge of clock.
69~70	-	NC	No connection
71	I/O	DQM1	The output buffer is placed at Hi-Z (with latency of 2) when DQM is sampled high in read cycle. In write cycle, sampling DQM high will block the write operation with zero latency.
72	-	Vss	Ground for input buffers and logic circuit inside DRAM.
73	I/O	NC	No connection
74	I/O	DQ8	Multiplexed pins for data out put and input.
75	I/O	VccQ	Separated power from VCC, to improve DQ noise immunity. (+3.3V)
76~77	I/O	DQ9~10	Multiplexed pins for data out put and input.
78	I/O	VssQ	Separated power from VSS, to improve DQ noise immunity.
79~80	I/O	DQ11~12	Multiplexed pins for data out put and input.
81	I/O	VccQ	Separated power from VCC, to improve DQ noise immunity. (+3.3V)
82~83	I/O	DQ13~14	Multiplexed pins for data out put and input.
84	I/O	VssQ	Separated power from VSS, to improve DQ noise immunity.
85	I/O	DQ15	Multiplexed pins for data out put and input.
86	-	Vss	Ground for input buffers and logic circuit inside DRAM.

3. Block diagram

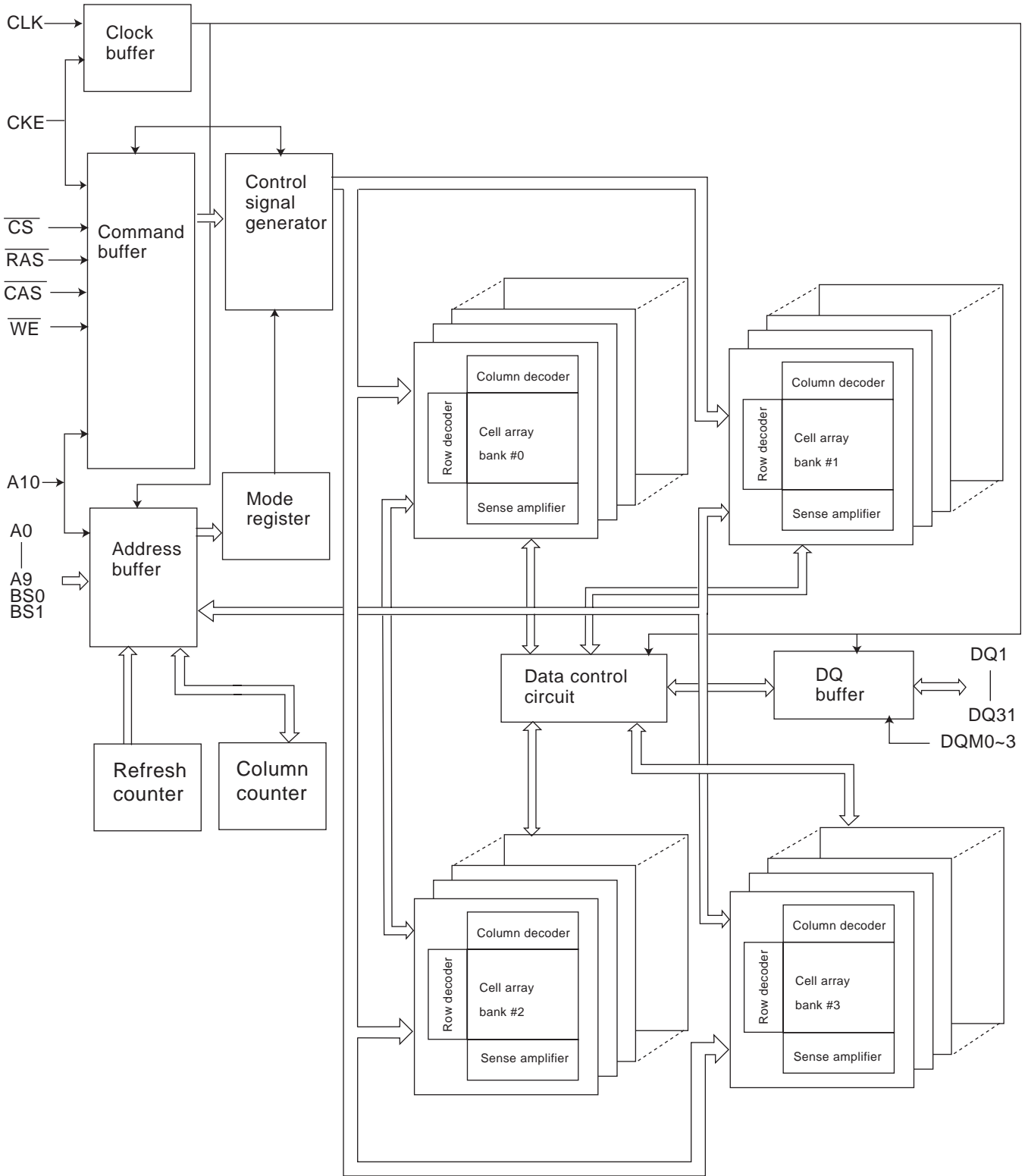

NOTE:  
The cell array configuration is 2048 \* 256 \* 32

# ZiVA-5 (U8) : DVD controller

## 1. Pin layout

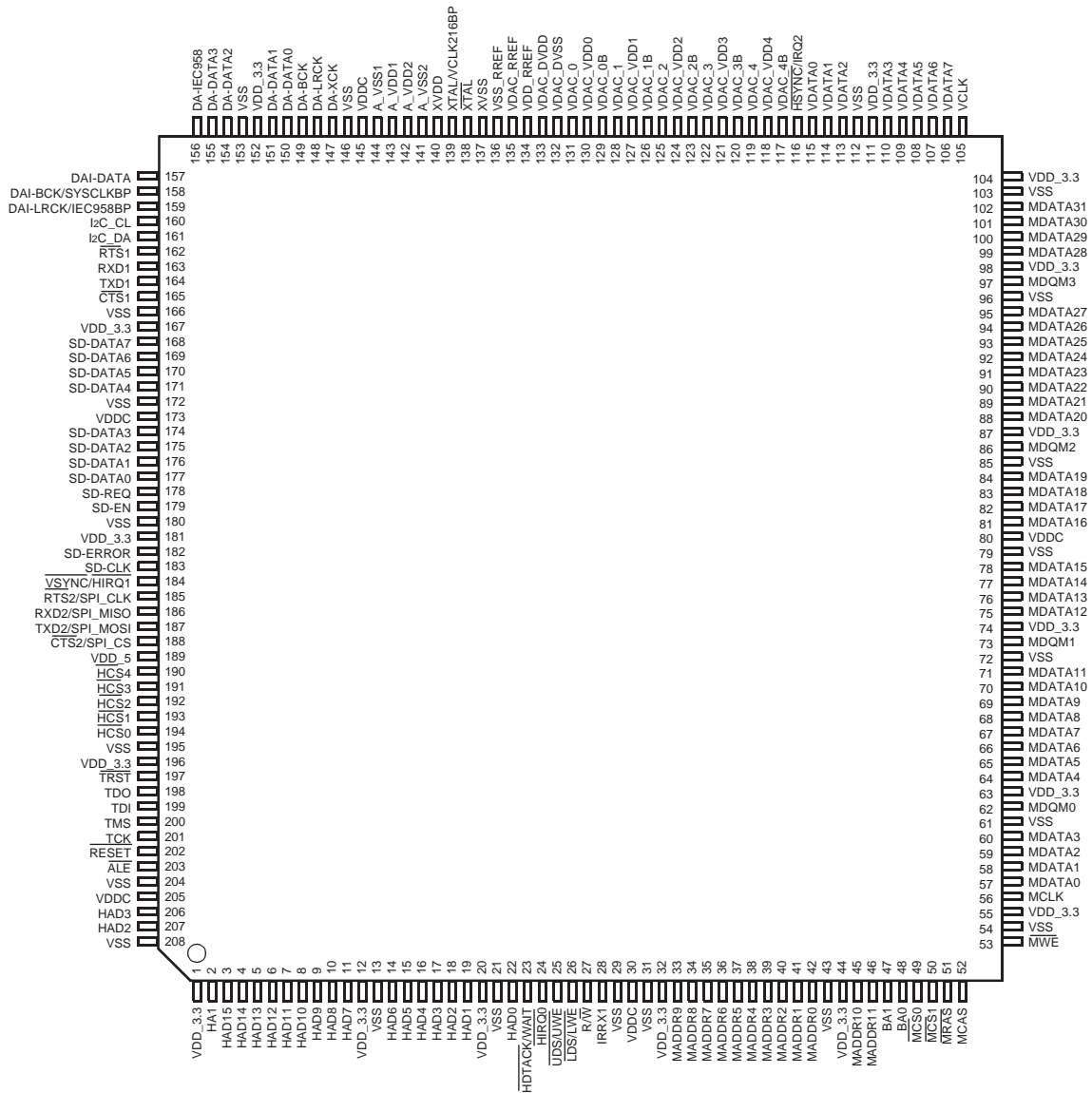

## 2. Pin function

(1/4)

	Name	Pin No.	Type <sup>1</sup>	Description
System Services	RESET	202	I	Active Low Reset. Assert for at least 5-milliseconds in the presence of clock to reset the entire chip.
	VCLK	105	I/O	Video clock that outputs 27 MHz.
	XOUT	138	O	Crystal output. When the internal DCXO is used, a 13.5 MHz crystal should be connected between this pin and the XIN pin.
	XIN/bypass clk_216	139	I	Crystal input. When the internal DCXO is used, a 13.5 MHz crystal should be connected between this pin and the XOUT pin. When an external oscillator or VCXO is used, its output should be connected to this pin. When configured for an external bypass clock, a 216 MHz clock should be connected to this pin. The frequency of an external VCXO can be either 27 or 13.5 MHz.

1. I - input, O - output, OD - open drain, PU - requires external pull-up resistor.

## 2. Pin function

(2/4)

	Name	Pin No.	Type <sup>1</sup>	Description
Power and Ground	VNW	189	Power	5-V supply voltage for 5V-tolerant I/O signals.
	VDDP	12, 20, 111, 152, 167, 181, 196	Power	3.3-V supply voltage for I/O signals
	VDD25	32, 44, 55, 63, 74, 87, 98, 104	Power	3.3-V supply voltage for SDRAM I/O signals
	XVDD	140	Power	3.3V Crystal interface power
	VDD	30, 80, 145, 173, 205	Power	1.8-V supply voltage for core logic
	VDD_VDAC[4:0]	118, 121, 124, 127, 130	Power	Analog Video DAC Power
	VDAC_DVDD	133		3.3V Digital supply for 5 DACs
	A_VDD[2:1]	142, 143		3.3-V Analog PLL Power
	VDAC_REFVDD	134	Power	3.3V Analog Video Reference Voltage
	GNDP	13, 21, 112, 153, 166, 180, 195, 208	Ground	Ground for I/O signals
	GND	29, 79, 146, 172, 204	Ground	Ground for core logic
	GND25	31, 43, 54, 61, 72, 85, 96, 103	Ground	Ground for SDRAM I/O signals
	VDAC_DVSS	132	Ground	Digital VSS for DACs
	AVSS[2:1]	141, 144	Ground	Analog PLL Ground
	VDAC_REFVSS	136	Ground	Video Analog Ground
XVSS	137	Ground	Crystal interface ground	
Host Interface	HCS[4:2]/GPIO[41:43]	190-192	O	Host chip select. Host asserts HCS to select the controller for a read or write operation. The falling edge of this signal triggers the read or write operation. General Purpose I/Os 41, 42, and 43, respectively.
	HCS[1:0]	193, 192	I	Host chip select. Host asserts HCS to select the controller for a read or write operation. The falling edge of this signal triggers the read or write operation.
	HA[3:1]	206, 207, 2	I/O	Host (muxed address) address bus. 3-bit address bus selects one of eight host inter-face registers. These signals are not muxed in ATAPI master mode.
	HA[15:0]	3-11, 14-19, 22	I/O	HA[15:0] is the 16-bit (muxed address and data) bi-directional host data bus through which the host writes data to the decoder Code FIFO. MSB of the 32-bit word is writ-ten first. The host also reads and writes the decoder internal registers and local SDRAM/ROM via HA[7:0]. These signals are not muxed for ATAPI master mode.
	HDTACK/WAIT	23	I/OD	Host Data Transfer Acknowledge.
	HIRQ0	24	I/O	Host interrupt. Open drain signal, must be pulled-up via 4.7k $\Omega$ to 3.3 volts. Driven high for 10 ns before tristate.
	HUDS/UWE	25	I/O	Host Upper Data Strobe. Host high byte data, HA[15:8], is valid when this pin is active.
	HLDS/LWE	26	I/O	Host Lower Data Strobe. Host low byte data, HA[7:0], is valid when this pin is active.
	HREAD	27	I/O	Read/write strobe
	ALE	203	I/O	Address latch enable
SDRAM Interface	MCS[1:0]	50, 49	O	Memory chip select.
	MCAS	52	O	Active LOW SDRAM Column Address Strobe.
	MRAS	51	O	Active LOW SDRAM Row Address Strobe.
	MDQM[3:0]	97, 86, 73, 62	O	These pins are the bytes masks corresponding to MD[7:0], [15:8], [23:16] and [31:24]. They allow for byte reads/writes to SDRAM.
	MA[11:0]	46, 45, 33-42	O	SDRAM Address
	MD[31:0]	102-99, 95-88, 84-81, 78-75, 71-64, 60-57	I/O	SDRAM Data
	MWE	53	O	SDRAM Write Enable. Specifies transaction to SDRAM: read (=1) or write (=0).
	MCLK	56	O	SDRAM Clock
BA[1:0]	47, 48	O	SDRAM bank select	
Digital Video Input/Output	HSYNC/HIRQ2/ GPIO1[9]	116	I/O	Horizontal sync. The decoder begins outputting pixel data for a new horizontal line after the falling (active) edge of HSYNC. Host Interrupt Request 2 General Purpose I/O 9
	VCLK	105	I/O	Video clock. Clocks out data on input. VDATA[7:0]. Clock is typically 27 MHz.
	VDATA[7:0]/GPIO[1:7]	106-110, 113-115	I/O	Video data bus. Byte serial CbYCrY data synchronous with VCLK. At powerup, the decoder does not drive VDATA. During boot-up, the decoder uses configuration parameters to drive or 3-state VDATA. General Purpose I/Os [1:7]
	VSYNC/HIRQ1/ GPIO36	184	I/O	Vertical sync. Bi-directional, the decoder outputs the top border of a new field on the first HSYNC after the falling edge of VSYNC. VSYNC can accept vertical synchroni-zation or top/bottom field notification from an external source. (VSYNC HIGH = bot-tom field. VSYNC LOW = Top field) Active Low Host Interrupt Pin General Purpose I/O 36

1. I - input, O - output, OD - open drain, PU - requires external pull-up resistor.



## 2. Pin function

(3/4)

	Name	Pin No.	Type <sup>1</sup>	Description
Parallel DVD/CD or Serial CD Interface	SDDATA[7]/VDATA2[7] /HDMARQ/GPIO24	168	I	Compressed data from DVD DSP. Bit 7. In parallel mode, bit 7 is the first (earliest in time) bit in the bitstream, while bit 0 is the last bit. Video Data Bus 2, Bit 7 Host DMA Request General Purpose I/O 24
	SDDATA6/VDATA2[6] /HXCVR_EN/GPIO25	169		Compressed data from DVD DSP. Bit 6. Video Data Bus 2, Bit 6 ATAPI Transceiver Enable General Purpose I/O 25
	SDDATA5/VDATA2[5] HDMACK/GPIO26	170		Compressed data from DVD DSP. Bit 5. Video Data Bus 2, Bit 5 Host DMA Acknowledge General Purpose I/O 26
	SDDATA4/VDATA2[4] GPIO27	171		Compressed data from DVD DSP. Bit 4. Video Data Bus 2, Bit 4 General Purpose I/O 27
	SDDATA3/ VDATA2[3]/GPIO28	174		Compressed data from DVD DSP. Bit 3. Video Data Bus 2, Bit 3 General Purpose I/O 28
	SDDATA2/ VDATA2[2]/GPIO29	175		Compressed data from DVD DSP. Bit 2. Video Data Bus 2, Bit 2 General Purpose I/O 29
	SDDATA1/ VDATA2[1]/GPIO30	176		Compressed data from DVD DSP. Bit 1. Video Data Bus 2, Bit 1 General Purpose I/O 30
	SDDATA0/ VDATA2[0]/GPIO31	177		In serial mode, bit 0 should be used as the input, with the unused bits either used as GPIOs or tied to ground. Video Data Bus 2, Bit 0 General Purpose I/O 31
	SDCLK	183	I	Data clock. The maximum frequency is 25 MHz for parallel mode, and ??? MHz for serial mode. The polarity of this signal is programmable.
	SDERROR	182	I	Error in input data. This signal carries the error bit associated with the channel data type (if set, the byte is corrupted).
	SDEN/GPIO33	179	I	Data enable. Assertion indicates that data on SDDATA[7:0] is valid. The polarity of this signal is programmable. General Purpose I/O [33]
SDREQ/GPIO32	178	O	Bitstream request. controller asserts SDREQ to indicate that the bitstream input buffer has available space. General Purpose I/O 32	
Analog Video Output	VDAC_[4B:0B]	117, 120, 123, 126, 129	Analog O	Video DAC Bias Bits[4:0]
	VDAC_4	119	Analog O	DAC video output format: R, V, C, or CVBS. Macrovision encoded.
	VDAC_3V	122	Analog O	DAC video output format: B, U, C, or CVBS. Macrovision encoded.
	DAC_2	125	Analog O	DAC video output format: G or Y. Macrovision encoded.
	VDAC_1	128	Analog O	DAC video output format: C. Macrovision encoded.
	VDAC_0	131	Analog O	DAC video output format: CVBS or Y. Macrovision encoded.
	VDAC_REF	135	Analog I	Video DACs Reference Resistor. Connecting to pin 136 through a 1.18K+/- 1% resistor is required.
	VCLK	105	I/O	System clock that drives internal PLLs. ZIVA-5 27-MHz TTL oscillator. (See description of VCLK for Digital Video Output.) Also optional video clock for internal PLLs or external encoder.
Audio Interface	ADATA[3:0]/GPIO[4:1]	155, 154, 151, 150	O	PCM Data Out. Eight channels. Serial audio samples relative to BCK and LRCK. General Purpose I/Os [4:1]
	BCK	149	O	PCM Bit Clock. BCK can be either 48 or 32 times the sampling frequency
	LRCK	148	O	PCM Left Clock. Identifies the channel for each sample. The polarity is programmable.
	XCK	147	I/O	Audio External Frequency clock input or output. BCK and LRCK are derived from this clock.
	IEC958/GPIO14	156	O	PCM data out (IEC-958 format ) or compressed data out (IEC-1937 format). General Purpose I/O [14]
Digital Mic In	DAI_DATA/GPIO15	157	I	PCM data input. General Purpose I/O [15]
	DAI_BCK/ BYPASS_SYSCLK/ GPIO16	158	I	PCM input bit clock. BYPASS_SYSCLK: Alternate function TBS. General Purpose I/O [16]
	DAI_LRCK/ IEC958BP/GPIO17	159	I	PCM left/right clock. IEC958 input bypass General Purpose I/O [17]

1. I - input, O - output, OD - open drain, PU - requires external pull-up resistor.

2. Pin function

(4/4)

	Name	Pin No.	Type <sup>1</sup>	Description
IR	IRRX1/GPIO0	28	I	IR Remote Receive. This input connects to an integrated (photo diode, band pass, demodulator) IR receiver. General Purpose I/O 0
	IDC_CL/GPIO18	160	I/O	Serial clock signal for IDC data transfer. It should be pulled up to the positive supply voltage, depending on the device) using an external pull-up resistor. General Purpose I/O [18]
IDC	IDC_DA/GPIO19	161		Serial data signal for IDC data transfer. It should be pulled up to the supply voltage using an external pull-up resistor. General Purpose I/O [19]
	RTS1/GPIO20	162	O	Ready to send, UART1 General Purpose I/O [20]
UART1	RXD1/GPIO21	163	I	Receive data, UART1 General Purpose I/O [21]
	TXD1/GPIO22	164	O	Transmit data, UART1 General Purpose I/O [22]
	CTS1/GPIO23	165	I	Clear to send, UART1 General Purpose I/O [23]
UART2	RTS2/SPI_CLK/ GPIO37	185	O	Ready to send, UART2 Serial Peripheral Interface Clock General Purpose I/O [37]
	RXD2/SPI_MISO/ GPIO38	186	I	Receive data, UART2 Serial Peripheral Interface - Master Input/Slave Output General Purpose I/O [38]
	TXD2/SPI_MOSI/ GPIO39	187	O	Transmit data, UART2 Serial Peripheral Interface - Master Output/Slave Input General Purpose I/O [39]
	CTS2/SPI_CS/ GPIO40	188	I	Clear to send, UART2 Serial Peripheral Interface ???? General Purpose I/O [40]
JTAG	TRST	197	I	Test reset. BST reset - resets the TAP controller. This signal must be pulled low.
	TDO	198	O	Test data Out. BST serial data output.
	TDI/GPIO	199	I	Test data In. BST serial data chain input. General Purpose Input pin 0.
	TMS/GPI1	200	I	Test mode select. Controls state of test access port (TAP) controller. General Purpose Input pin 1.
	TCK	201	I	Test clock. Boundary scan test (BST) serial data clock.

1. I - input, O - output, OD - open drain, PU - requires external pull-up resistor.

3. Block diagram

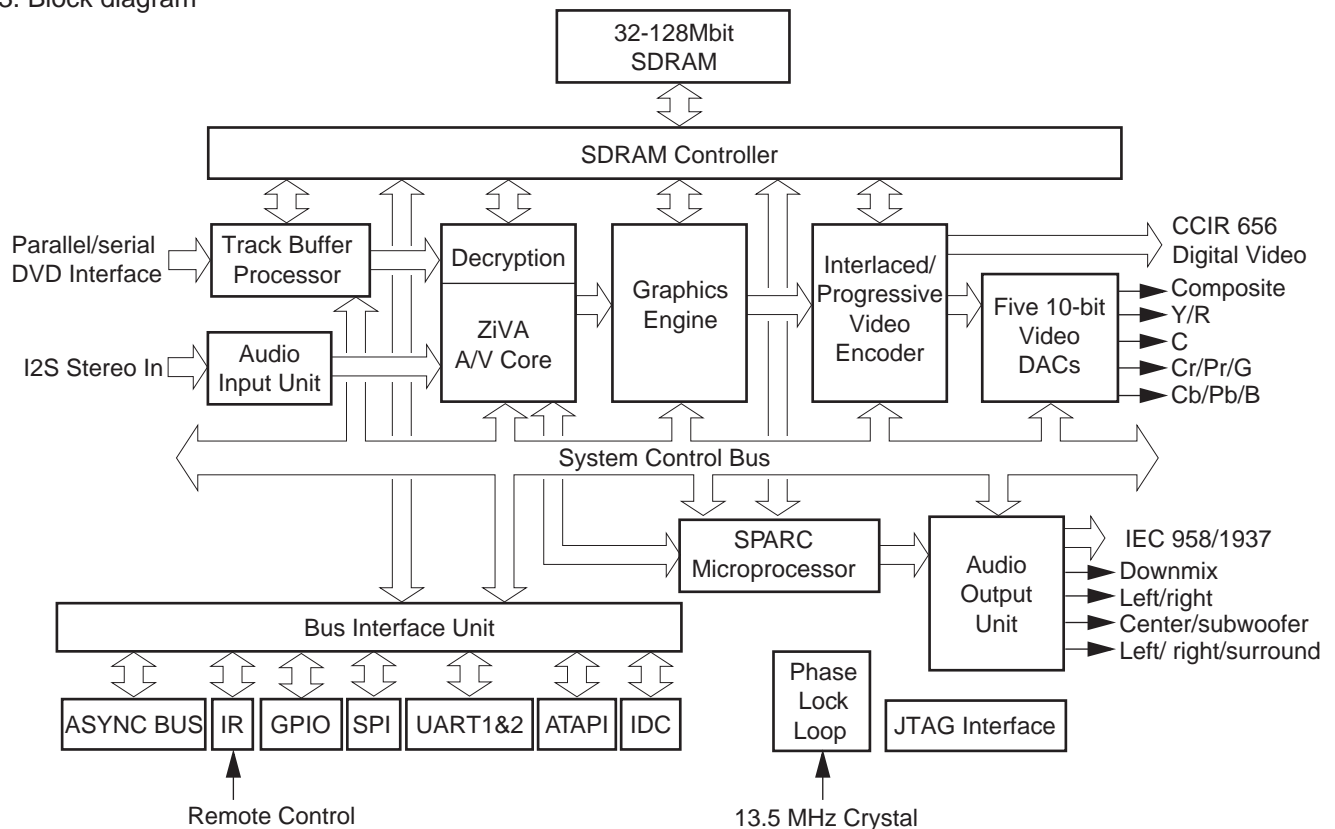

# ■ LC86P6548 (UIC1) : Microcontroller

## 1.Pin layout

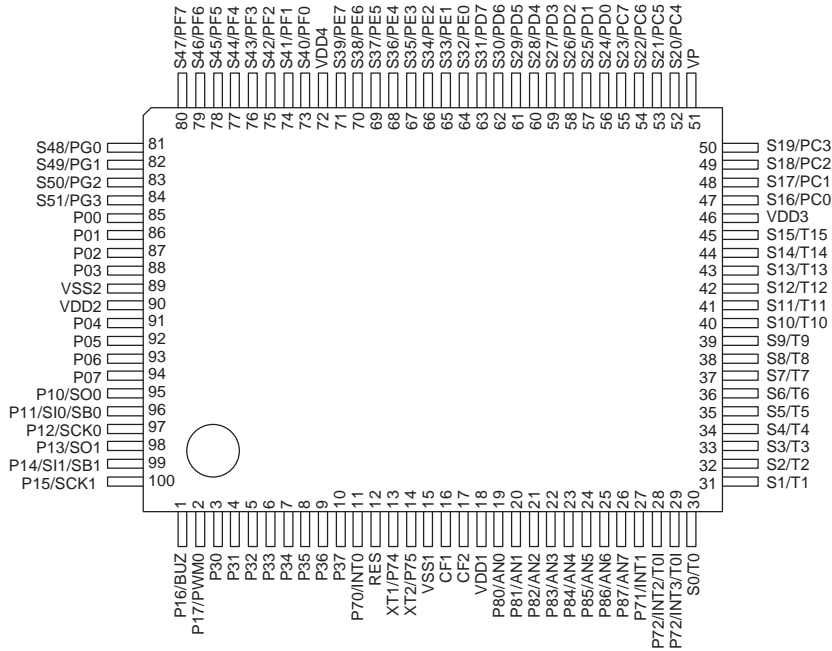

## 2.Block diagram

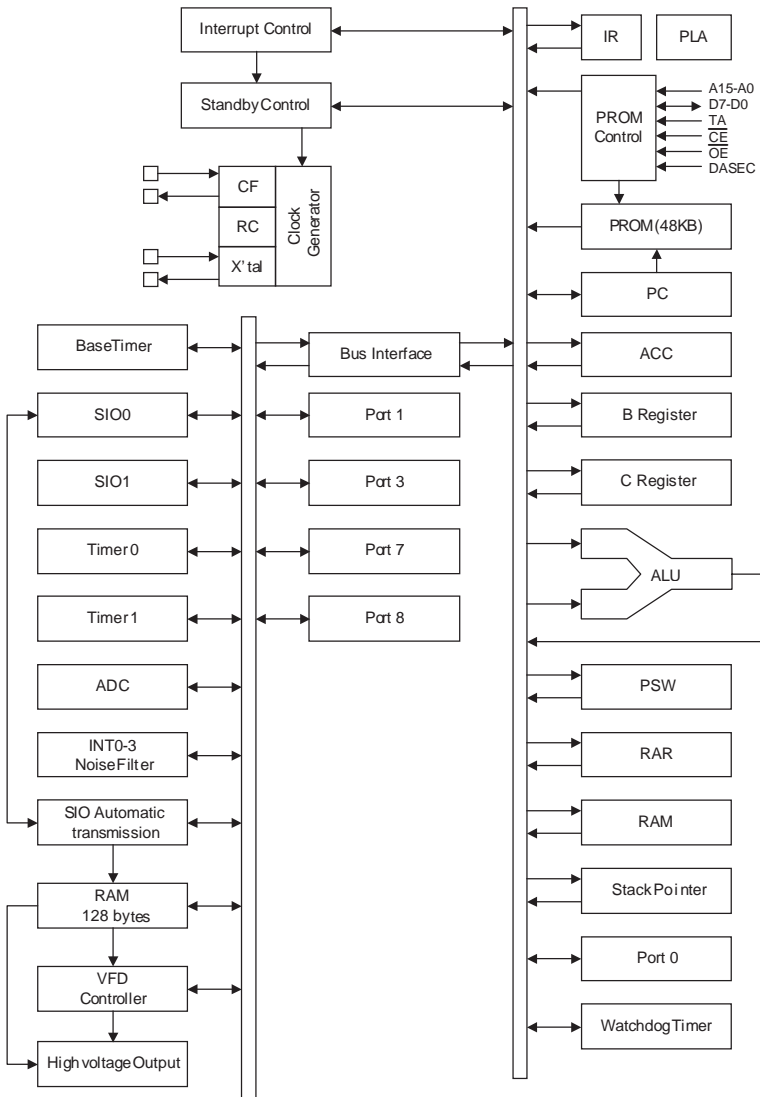

## 3. Pin function

Pin No.	Symbol	I/O	Function
1	P16/BUZ	I/O	Buzzer output
2	P17/PWM0	I/O	Timer 1 output (PWM0 output)
3 to 10	P30 to P37	I/O	8bit input/output port Input/output in bit unit 15V withstand at N-channel open drain output
11	P70/INT0	I/O	INT0 input /HOLD release/N-channel Tr. ouptput forwatchdog timer
12	RES	I	Reset pin
13	XT1/P74	I	32.768kHz crystal oscillation terminal XT1
14	XT2/P75	I	32.768kHz crystal oscillation terminal XT2
15	VSS1	-	Power pin (-)
16	CF1	I	Input pin for the ceramic resonator oscillation
17	CF2	O	Output pin for the ceramic resonator oscillation
18	VDD1	-	Power pin (+)
19 to 22	P80/AN0 to P83/AN3	I	4-bit input port Input /output in bit unit
23 to 26	P84/AN4 to P87/AN7	O	
27	P71/INT1	I	INT1 input/HOLD release input
28	P72/INT2/T0I	I	INT2 input/timer 0 event input
29	P72/INT3/T0I		
30 to 36	S0/T0 to S6/T6	O	Output for VFD display controller segment/timing incommon
37 to 45	S7/T7 to S15/T15	O	Output for VFD display controller segment/timing withinternal pull-down resistor in common Internal pull-down resistor output
46	VDD3	-	Power pin (+)
47 to 50	S16/PC0 to P19/PC3	I/O	Output for VFD display controller High voltage input port PC0 to PC3
51	VP	-	Power pin (+) for the VFD output pull-down resist
52 to 63	S20/PC4 to S31/PD7	I/O	Output for VFD display controller High voltage input port PC4 to PC7, PD0 to PD7
64 to 71	S32/PE0 to S39/PE7	I/O	Output for VFD displaya controller segment High voltage input port PE0 to PE7
72	VDD4	-	Power pin (+)
73 to 80	S40/PF0 to S47/PF7	I/O	Output for VFD displaya controller segment High voltage input port PF0 to PF7
81 to 84	S48/PG0 to S51/PG3	I/O	Output for VFD displaya controller segment High voltage I/O port PG0 to PG3
85	P00	I/O	8-bit input/output port. Input for port0 interrupt. Input/output in nibble unit Input for HOLD release 15V withstand at N-channel open drain output
86	P01		
87	P02		
88	P03		
89	VSS2	-	Power pin (-)
90	VDD2	-	Power pin (+)
91	P04	I/O	8-bit input/output port. Input for port0 interrupt. Input/output in nibble unit Input for HOLD release 15V withstand at N-channel open drain output
92	P05		
93	P06		
94	P07		
95	P10/SO0	I/O	SIO0 data output
96	P11/SI0/SB0		SIO0 data input/bus input/output
97	P12/SCK0		SIO0 clock input/output
98	P13/SO1		SIO1 data output
99	P14/SI1/SB1		SIO1 data input/bus input/output
100	P15/SCK1		SIO1 clock input/output
			8-bit input/output port Input/output can be specified in a bit unit

■ BA5954 (MU9) : Motor driver

1. Block diagram

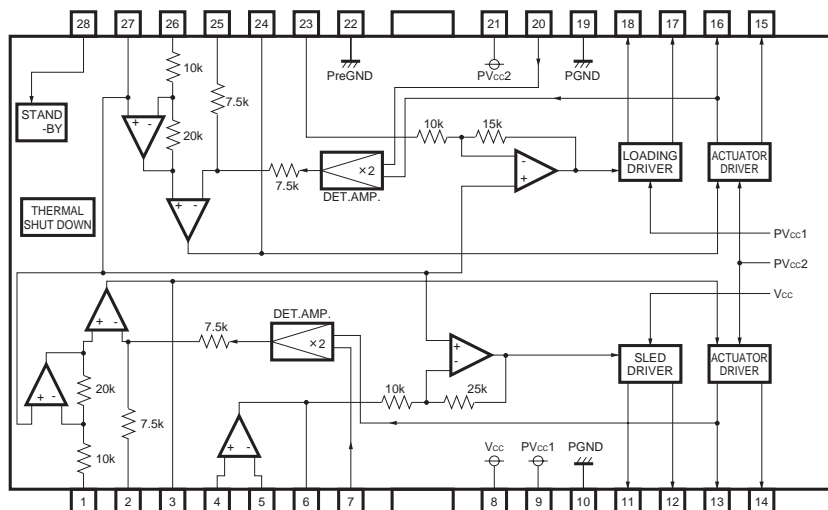

2. Pin function

Pin No.	Symbol	Function
1	VINFC	Focus driver input
2	CFCerr1	Capacitor connection terminal for error amplifier filter
3	CFCerr2	Capacitor connection terminal for error amplifier filter
4	VinSL +	Operational amplifier input for thread driver (+)
5	VinSL -	Operational amplifier input for thread driver (-)
6	VOSL	Operational amplifier output for thread driver
7	VNFFC	Focal driver return terminal
8	VCC	Pre VCC, thread driver part power VCC
9	PVcc1	Power
10	PGND	Loading driver part power VCC
11	VOSL -	Thread driver part output (-)
12	VOSL +	Thread driver part output (+)
13	VOFC -	Focus driver part output (-)
14	VOFC +	Focus driver part output (+)
15	VOTK +	Tracking driver output (+)
16	VOTK -	Tracking driver output (-)
17	VOLD +	Loading driver output (+)
18	VOLD -	Loading driver output (-)
19	PGND	Power GND
20	VNFTK	Tracking driver return terminal
21	PVcc2	Actuator driver part power VCC
22	PreGND	Pre GND
23	VinLD	Loading driver input
24	CTKerr2	Capacitor connection terminal for error amplifier filter
25	CTKerr1	Capacitor connection terminal for error amplifier filter
26	VinTK	Tracking driver input
27	BIAS	Bias input
28	STBY	Standby terminal

## ■ SST39VF800A (U6) : 8M Flash memory

### 1. Pin layout

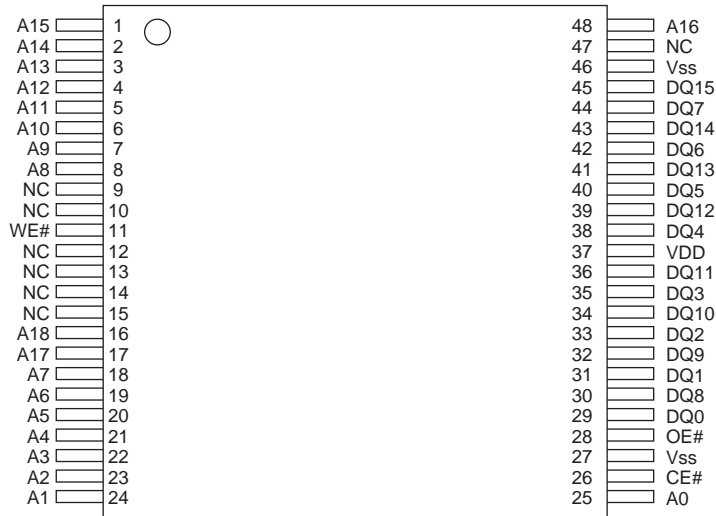

### 2. Block diagram

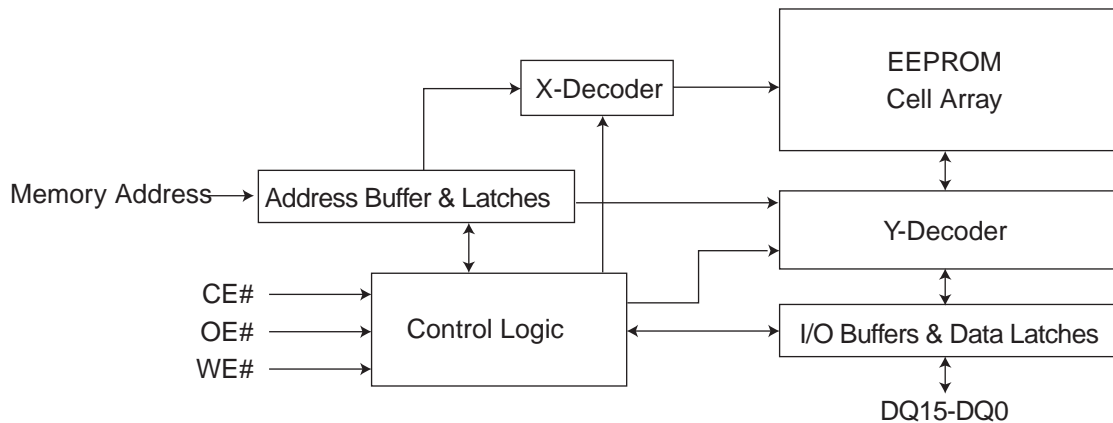

### 3. Pin function

Symbol	Pin name	Function
AMS- A0	Address Inputs	To provide memory addresses. During Sector-Erase AMS-A11 address lines will select the sector. During Block-Erase AMS-A15 address lines will select the block.
DQ15- DQ0	Data Input/Output	To output data during Read cycles and receive input data during Write cycles. Data is internally latched during a Write cycle. The outputs are in tri-state when OE# or CE# is high.
CE#	Chip Enable	To activate the device when CE# is low.
OE#	Output Enable	To gate the data output buffers.
WE#	Write Enable	To control the Write operations.
VDD	Power Supply	To provide power supply voltage: 2.7-3.6V
Vss	Ground	
NC	No Connection	Unconnected pins.

■ AK4355 (U6) : DAC

1.Pin layout

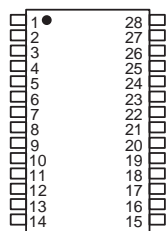

2.Block diagram

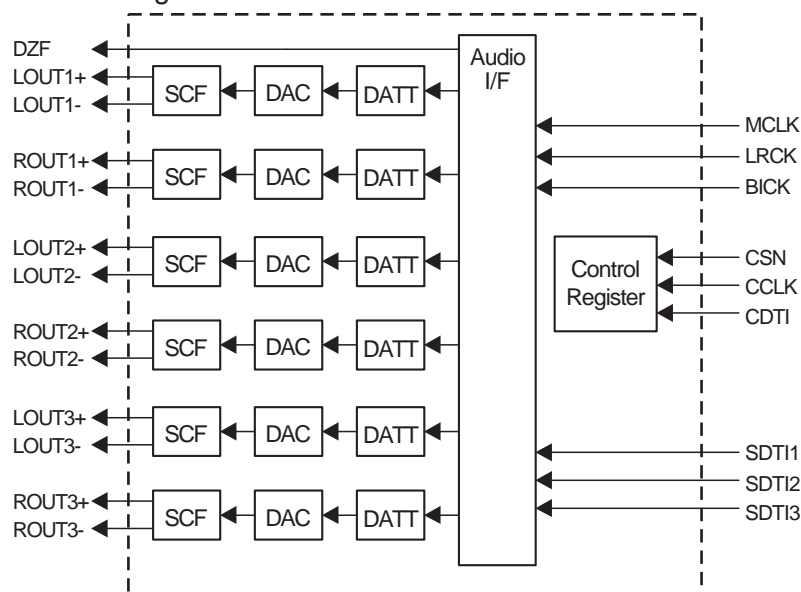

3.Pin function

Pin No.	Symbol	I/O	Function
1	VREF	I	Positive Voltage Reference Input Pin
2	DZF	O	Zero Input Detect Pin
3	PDN	I	Power-Down Mode Pin When at "L", the AK4355 is in the power-down mode and is held in reset. The AK4355 should always be reset upon power-up.
4	MCLK	I	Master Clock Input Pin An external TTL clock should be input on this pin.
5	BICK	I	Audio Serial Data Clock Pin
6	SDTI1	I	DAC1 Audio Serial Data Input Pin
7	SDTI2	I	DAC2 Audio Serial Data Input Pin
8	SDTI3	I	DAC3 Audio Serial Data Input Pin
9	LRCK	I	L/R Clock Pin
10	CSN	I	Chip Select Pin
11	CCLK	I	Control Clock Pin
12	CDTI	I	Control Data Input Pin
13	DVDD	-	Digital Power Supply Pin
14	DVSS	-	Digital Ground Pin
15	ROUT3-	O	DAC3 Rch Negative Analog Output Pin
16	ROUT3+	O	DAC3 Rch Positive Analog Output Pin
17	LOUT3-	O	DAC3 Lch Negative Analog Output Pin
18	LOUT3+	O	DAC3 Lch Positive Analog Output Pin
19	ROUT2-	O	DAC2 Rch Negative Analog Output Pin
20	ROUT2+	O	DAC2 Rch Positive Analog Output Pin
21	LOUT2-	O	DAC2 Lch Negative Analog Output Pin
22	LOUT2+	O	DAC2 Lch Positive Analog Output Pin
23	ROUT1-	O	DAC1 Rch Negative Analog Output Pin
24	ROUT1+	O	DAC1 Rch Positive Analog Output Pin
25	LOUT1-	O	DAC1 Lch Negative Analog Output Pin
26	LOUT1+	O	DAC1 Lch Positive Analog Output Pin
27	AVSS	-	Analog Ground Pin
28	AVDD	-	Analog Power Supply Pin

Note: All input pins should not be left floating.

**M62463FP (U11) : Surround decoder**

1. Pin layout

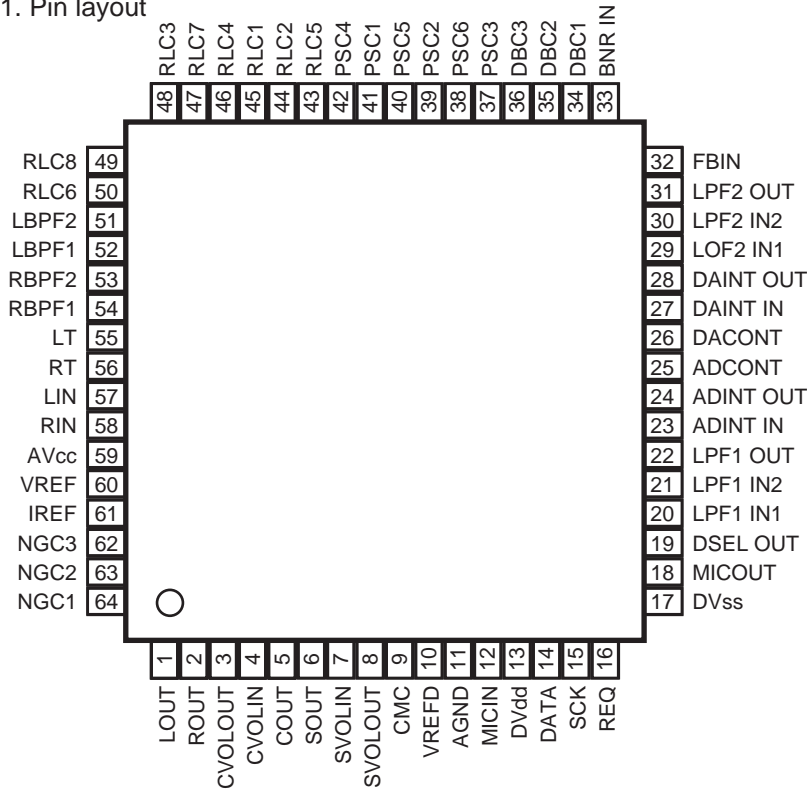

2. Block diagram

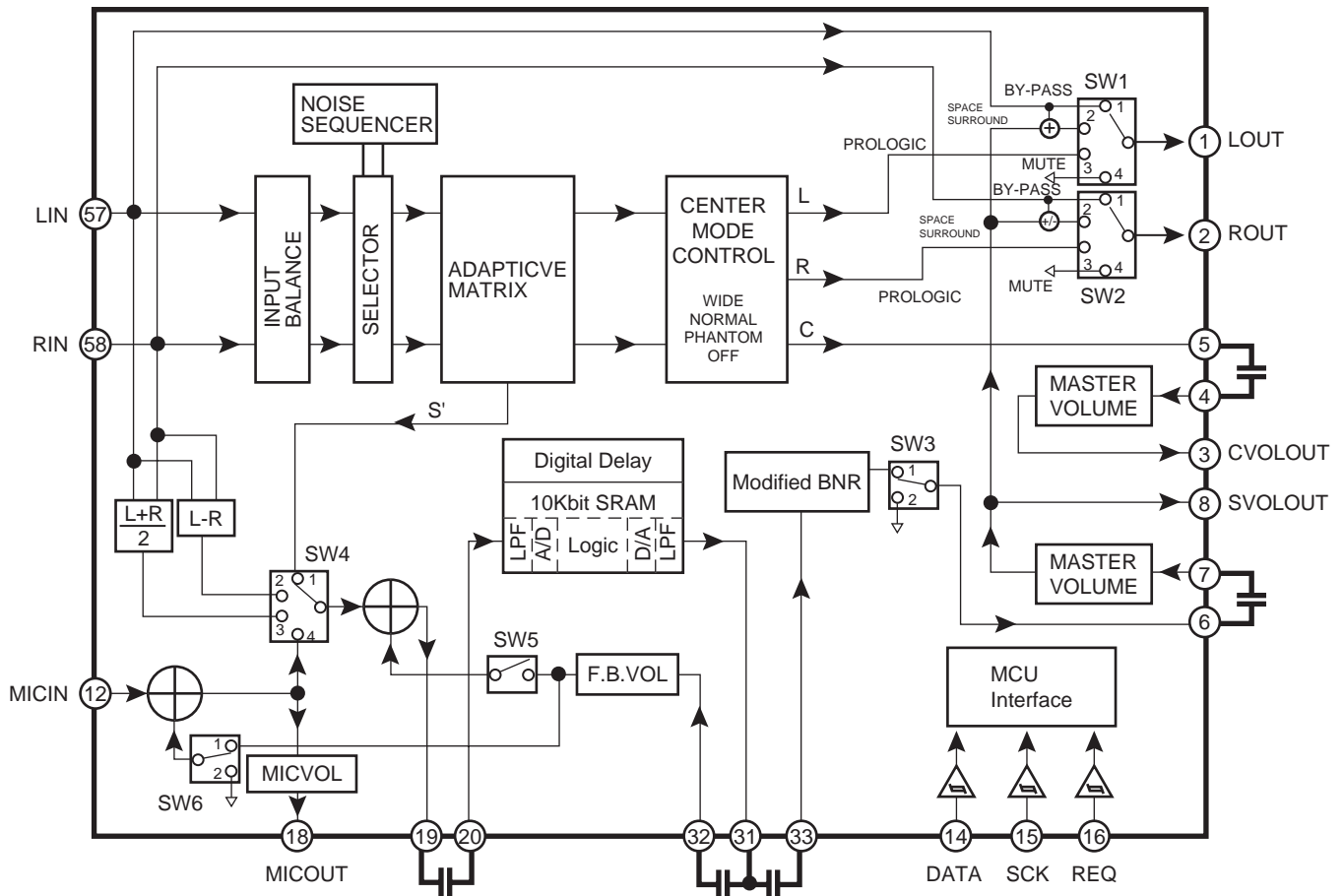



## ■ SP3721A (RU1) : DVD analog front end chip

### 1.Pin layout

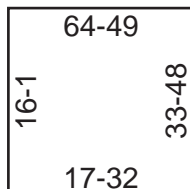

### 2.Pin function

Pin No.	Symblo	I/O	Function
1,2	DVDRFP,VDVDRFN	I	RF Signal Inputs
3,4	PD1,PD2	I	CD Photodetector Interface Inputs
5-8	A2,B2,C2,D2	I	Photo Detector Interface Inputs
9	CP	I/O	Differential Phase tracking LPF pin
10	CN	I/O	Differential Phase tracking LPF pin
11-14	A,B,C,D	I	Photo Detector Interface Inputs
15,16	E,F	I	CD trackin Error Inputs
17	CDTE	-	CD Tracking
18	VCI2	-	Reference Voltage Input
19	NC	-	No Connct
20	VNB	-	Ground
21	DVDPD	I	APC Input
22	DVDLD	O	APC ouput
23	CDPD	I	APC Input
24	CDLD	O	APC output
25	LDON#	I	APC Output On/Off
26	VC	-	Reference Voltage output
27	VCI	-	Reference Voltage Input
28	VPB	-	Power
29	MIRR	O	Mirror Detect Output
30	MP	-	MIRR signal Peak hold pin
31	MB	-	MIRR signal Bottom hold pin
32	FDCHG#	I	Low Impedance Enalle
33	MLPF	-	MIRR signal LPF pin
34	MEVO	O	SIGO Bottom Envelope Output
35	MIN	I	RF signal Input for Mirror
36	PI	O	Pull-in Signal Output
37	DFT	O	Defect Output
38	TPH	-	PI Top Hold pin
39	MEV	-	Sigo Bottom Envelope pin
40	MEI	I	Mirror Envelope Input
41	TE	O	Tracking Error Signal Output
42	FE	O	Focusing Error Signal Output
43	CE	O	Center Error Signal Output
44	LCN	-	Center Error LPF pin
45	LCP	-	Center Error LPF pin
46	SCLK	I	Serial Clock
47	SDATA	I/O	Serial Data
48	SDEN	I	Serial Data Enable
49	HOLD1	I	Hold Control
50	VNA	-	Ground
51,52	FNP,FNN	O	Differential Normal Output
53,54	DIP,DIN	I	Analog inputs for RF Single Buffer
55	RX	-	Reference Resistor Input
56	BYP	I/O	
57	SIGO	O	Single Ended Normal Output
58	VPA	-	Power
59,60	AIP,AIN	I	AGC Amplifier Inputs
61,62	ATOP/ATON	O	Differential Attenuator Output
63	CDRF	I	RF Signal Input
64	CDRFDC	O	CD RF signal Output

■ BA4560 (AIC2, IC5, IC6, IC7, U1, U3, U5, U9, U13) : Dual op amp.

1.Pin layout

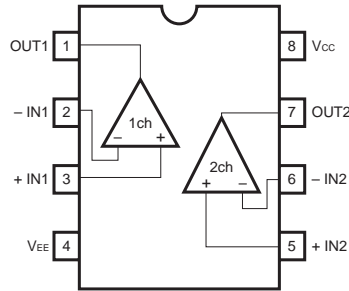

■ 74LVT573 (U10, U11, U12) : Latch

1. Pin layout

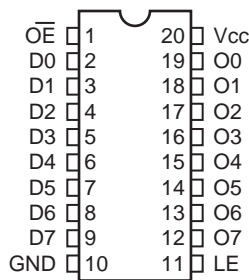

2. Pin function

Symbol	Function
D0-D7	Data Inputs
LE	Latch Enable Input
OE	Output Enable Input
O0-O7	3-STATE Latch Outputs

3. Truth table

Inputs			Outputs
LE	OE	D <sub>n</sub>	O <sub>n</sub>
X	H	X	Z
H	L	L	L
H	L	H	H
L	L	X	O0

H:HIGH Voltage Level  
 L:LOW Voltage Level  
 Z:High Impedance  
 X:Immaterial  
 O0:Previous O0 before HIGH to LOW transition of Latch Enable

■ FAN8082 (MU10) : DC motor driver

1.Pin layout

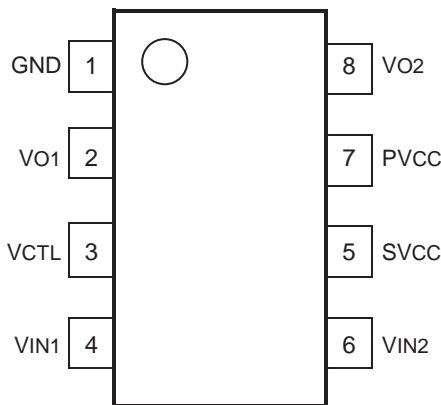

2. Block diagram

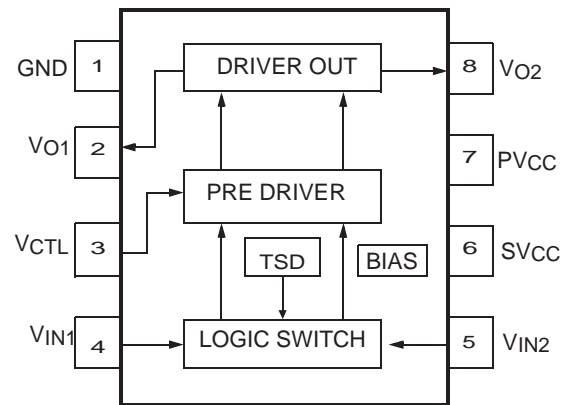

3. Pin function

Pin No.	Symbol	I/O	Function
1	GND	-	Ground
2	VO1	O	Output 1
3	VCTL	I	Motor speed control
4	VIN1	I	Input 1
5	VIN2	I	Input 2
6	SVCC	-	Supply voltage (Signal)
7	PVCC	-	Supply voltage (Power)
8	VO2	O	Output 2

■ 74HCT245 (U15) : Transceiver

1.Pin layout

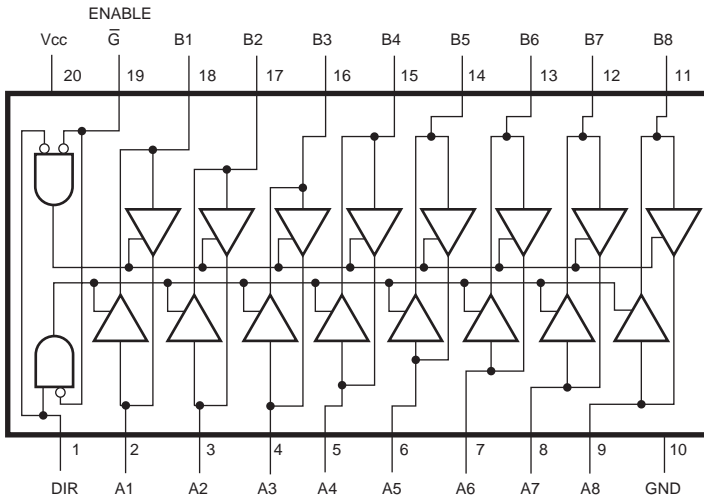

2.Truth table

Control Inputs		Operation
$\bar{G}$	DIR	245
L	L	B data to A bus
L	H	A data to B bus
H	X	isolation

H = HIGH Level  
L = LOW Level  
X = Irrelevant

■ M5705 (DU3) : DVD-ROM controller

1.Block diagram

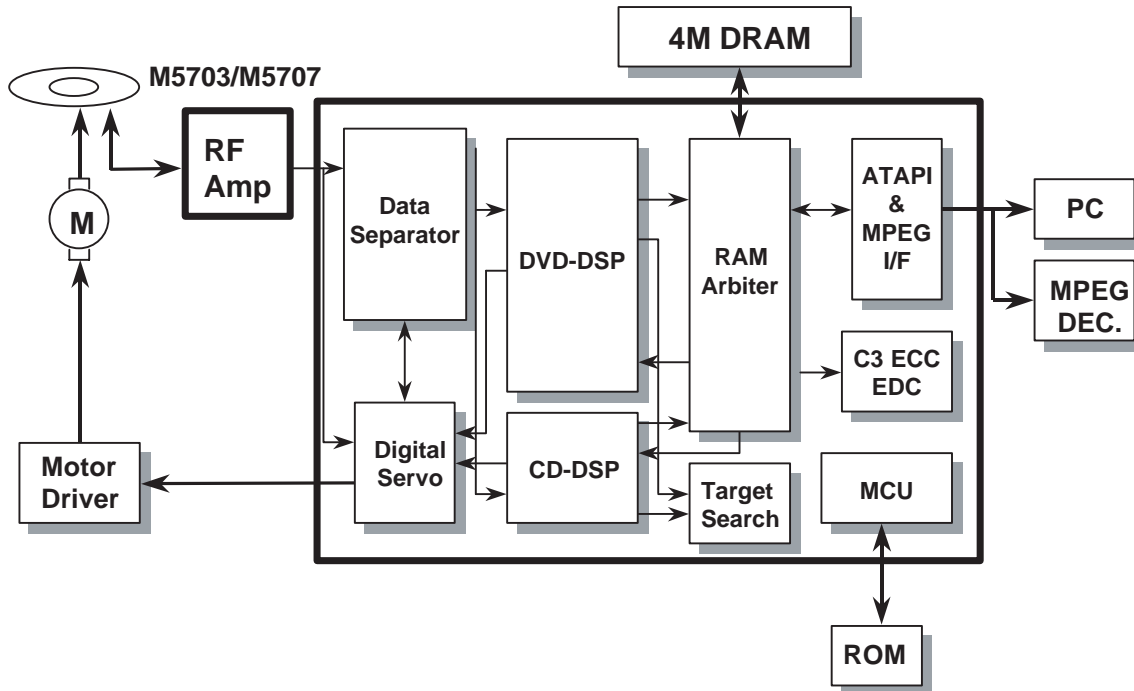

■ BA7612F (JVIC1, JVIC2, JVIC3) : Video signal switcher

1. Block diagram

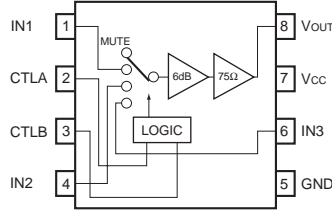

2. Truth table

CTL A	CTL B	OUT
L (OPEN)	L (OPEN)	IN1
L (OPEN)	H	IN2
H	L (OPEN)	IN3
H	H	MUTE

■ TDA7440D (U2) : Audio processor

1. Terminal layout

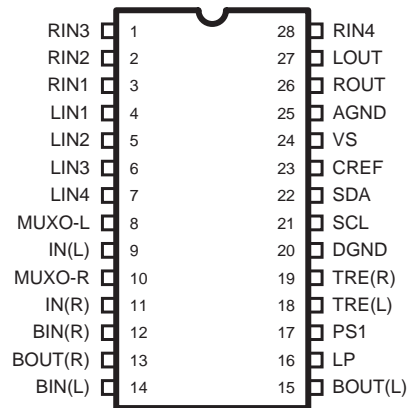

2. Block diagram

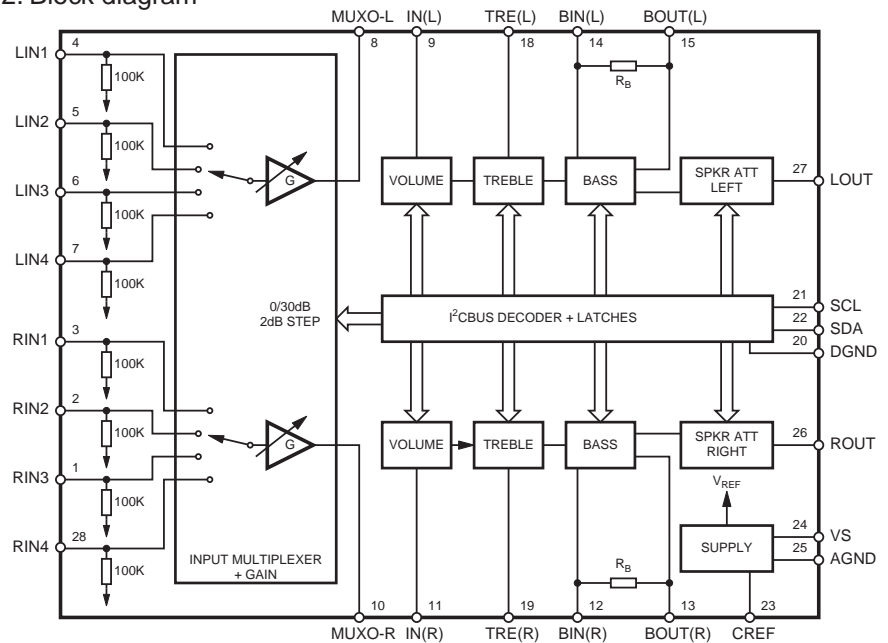

■ W29EE512 (DU5) : Flash memory

1. Pin layout

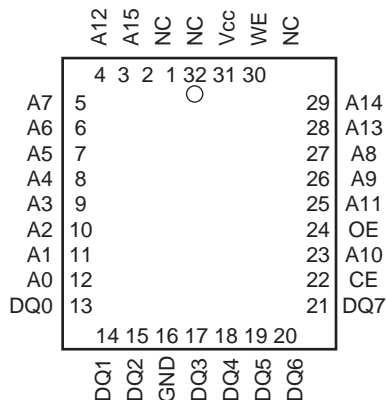

2. Block diagram

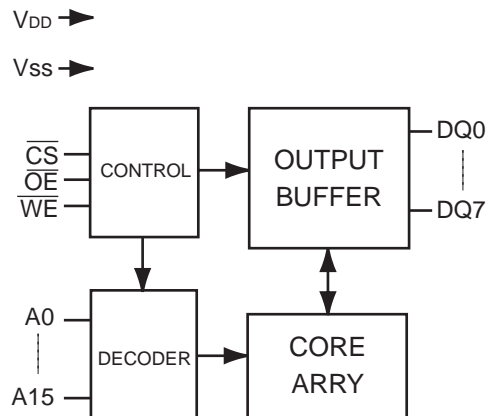

3. Pin function

Symbol	Function
A0~A15	Address input
DQ0~DQ7	Data I/O
$\overline{CE}$	Chip enable
$\overline{OE}$	Output enable
$\overline{WE}$	Write enable
Vcc	Power
GND	Ground
NC	No connect

■ TDA7449L (U7, U12) : Audio processor

1.Pin layout

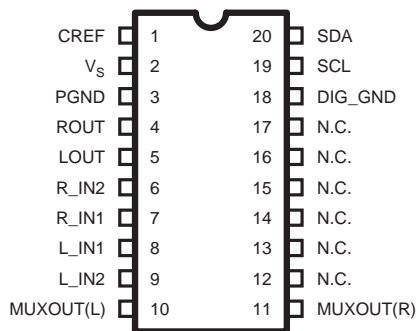

2.Block diagram

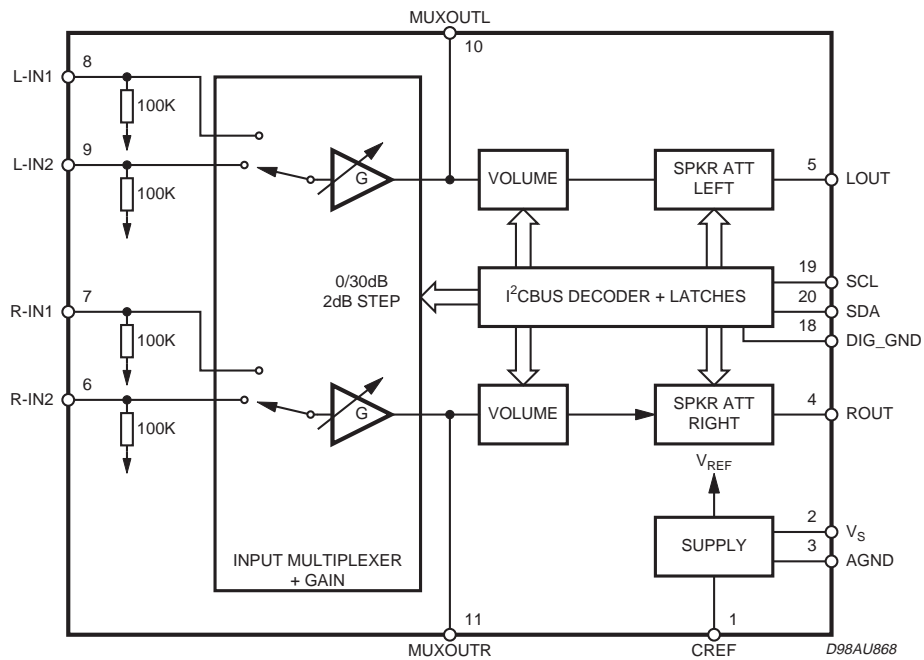

■ TL3472 (RU2) : Op. amp.

1.Pin layout

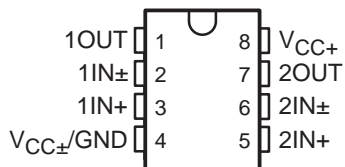

< MEMO >

**JVC**

VICTOR COMPANY OF JAPAN, LIMITED

AUDIO & COMMUNICATION BUSINESS DIVISION

PERSONAL & MOBILE NETWORK BUSINESS UNIT. 10-1,1chome,Ohwatari-machi,Maebashi-city,371-8543,Japan

# JVC

# SCHEMATIC DIAGRAMS

## DVD DIGITAL CINEMA SYSTEM

### TH-A30R

CD-ROM No.SML200212

Area suffix	
B -----	U.K.
E -----	Continental Europe
EN -----	Northern Europe
EV -----	Eastern Europe
EE ----	Russian Federation

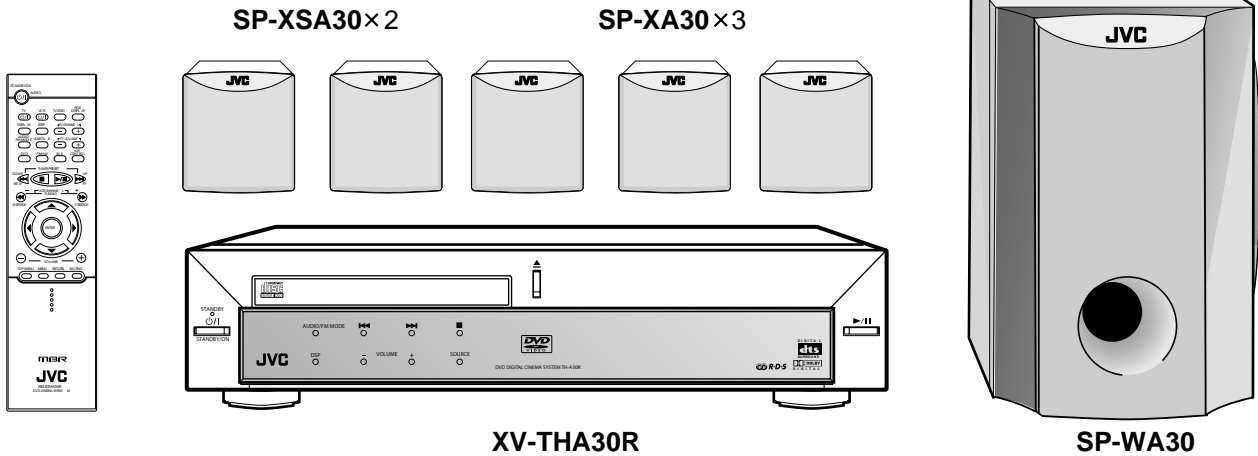

### Contents

Block diagrams .....	2-1
Standard schematic diagrams .....	2-3
Printed circuit boards .....	2-8~12



In regard with component parts appearing on the silk-screen printed side (parts side) of the PWB diagrams, the parts that are printed over with black such as the resistor (■), diode (▬) and ICP (●) or identified by the "△" mark nearby are critical for safety.

(This regulation does not correspond to J and C version.)

# Block diagrams

■ Main section

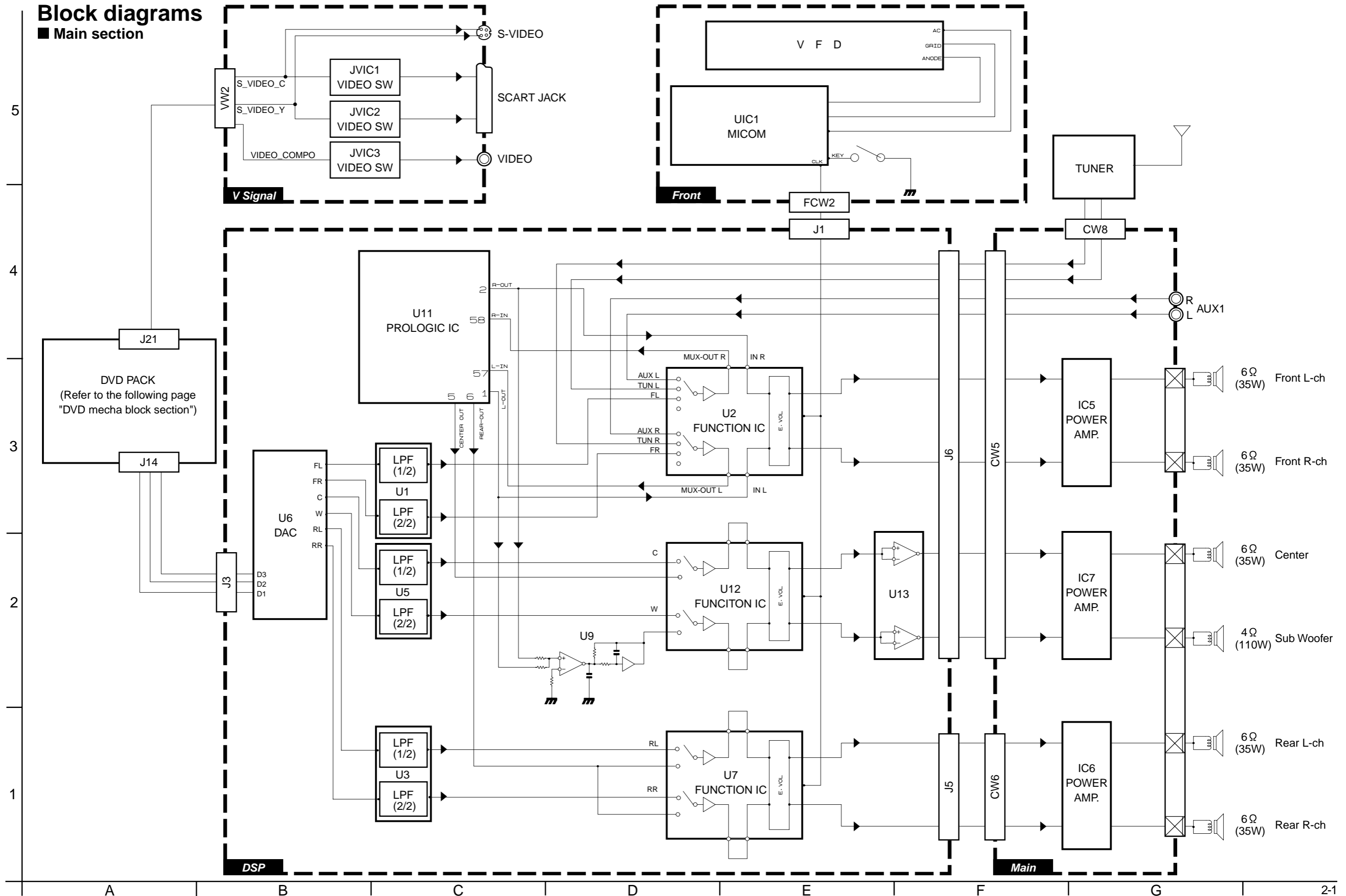

■ DVD mecha block section

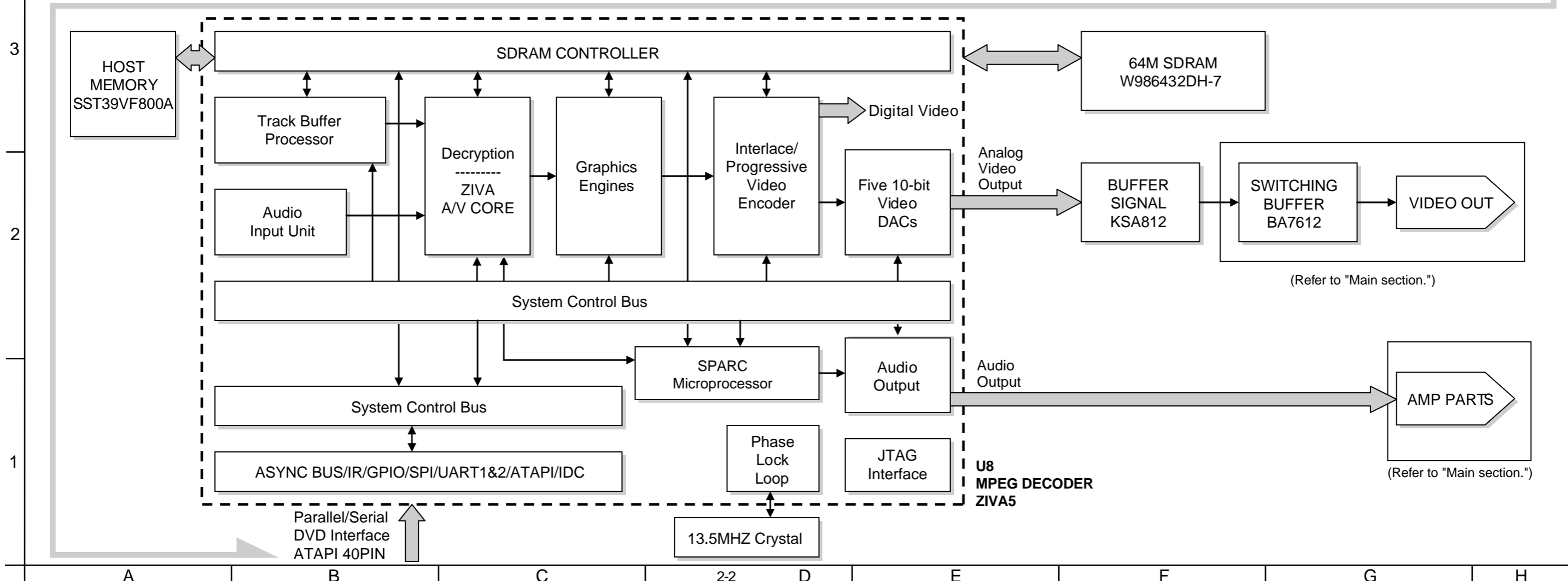
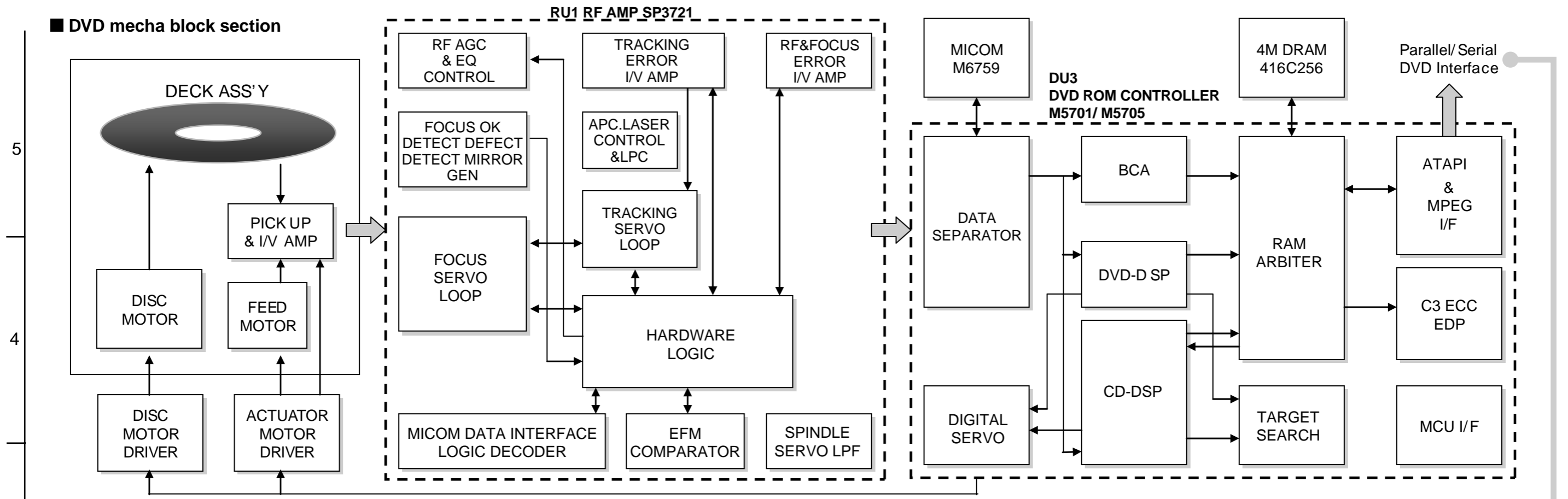

(Refer to "Main section.")

(Refer to "Main section.")

# Standard schematic diagrams

■ Main section /Power supply section

5  
4  
3  
2  
1

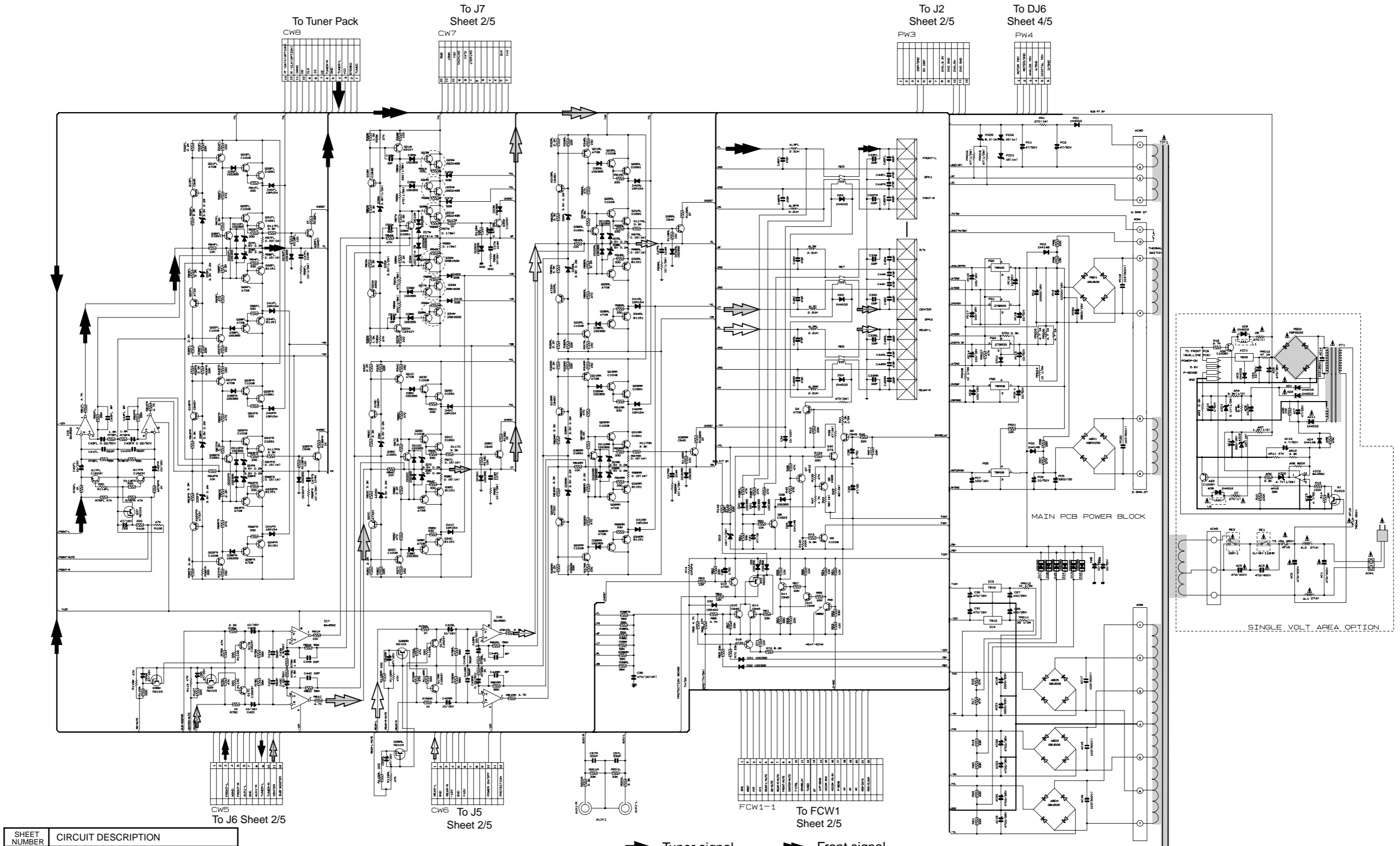

SHEET NUMBER	CIRCUIT DESCRIPTION
1/5	Main /Power supply
2/5	FL display & System control /DSP
3/5	Video signal output
4/5	DVD loader
5/5	DVD MPEG

➔ Tuner signal  
 ➔ Front signal  
 ➔ Center signal  
 ➔ Rear signal

⚠ Parts are safety assurance parts. When replacing those parts, make sure to use the specified parts.

A B C D E F G 2-3

FL display & System control section / DSP section

Tuner signal Digital audio signal Front signal Center signal Rear signal

5

4

3

2

1

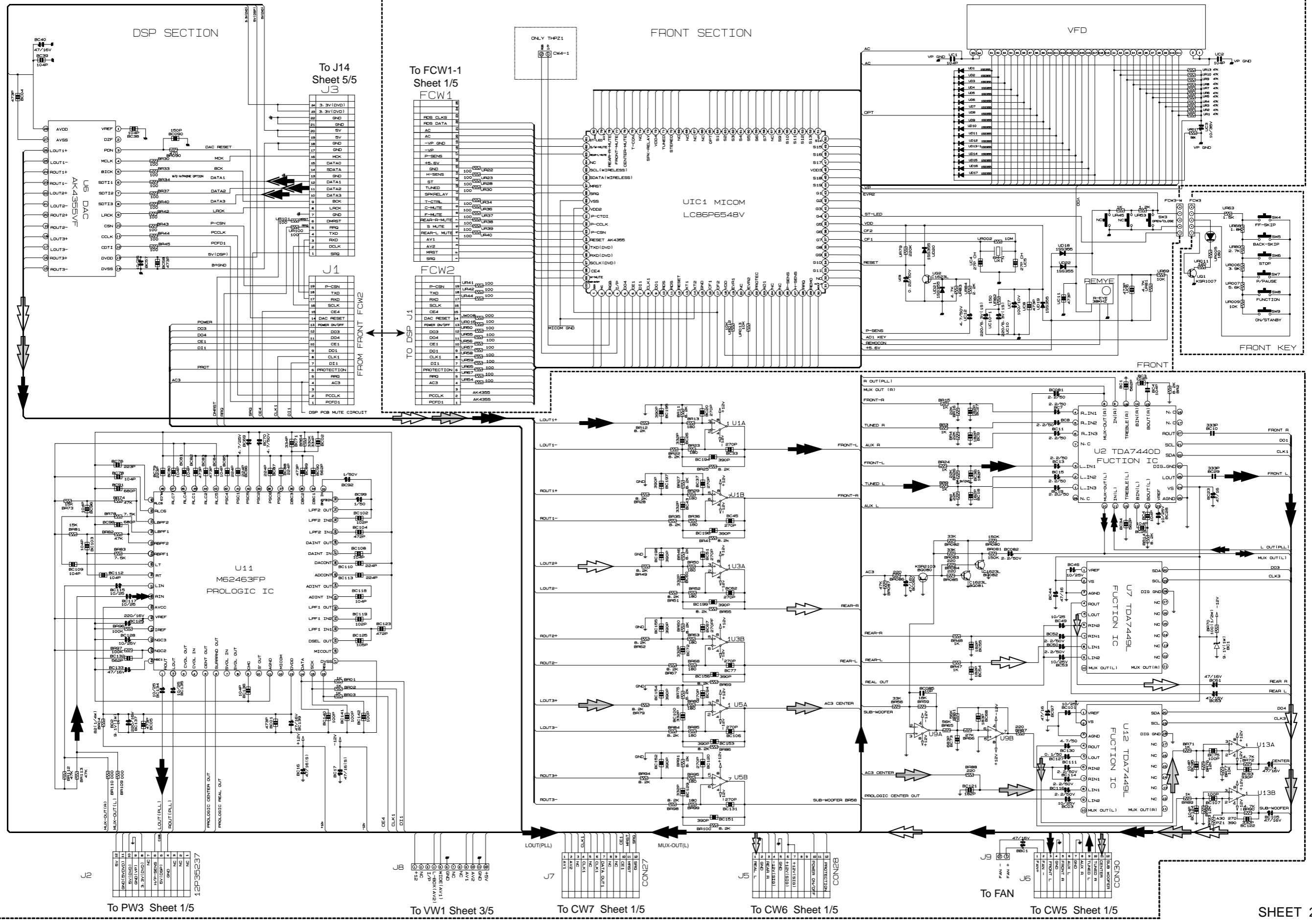

A B C D E F G H

Video signal output section

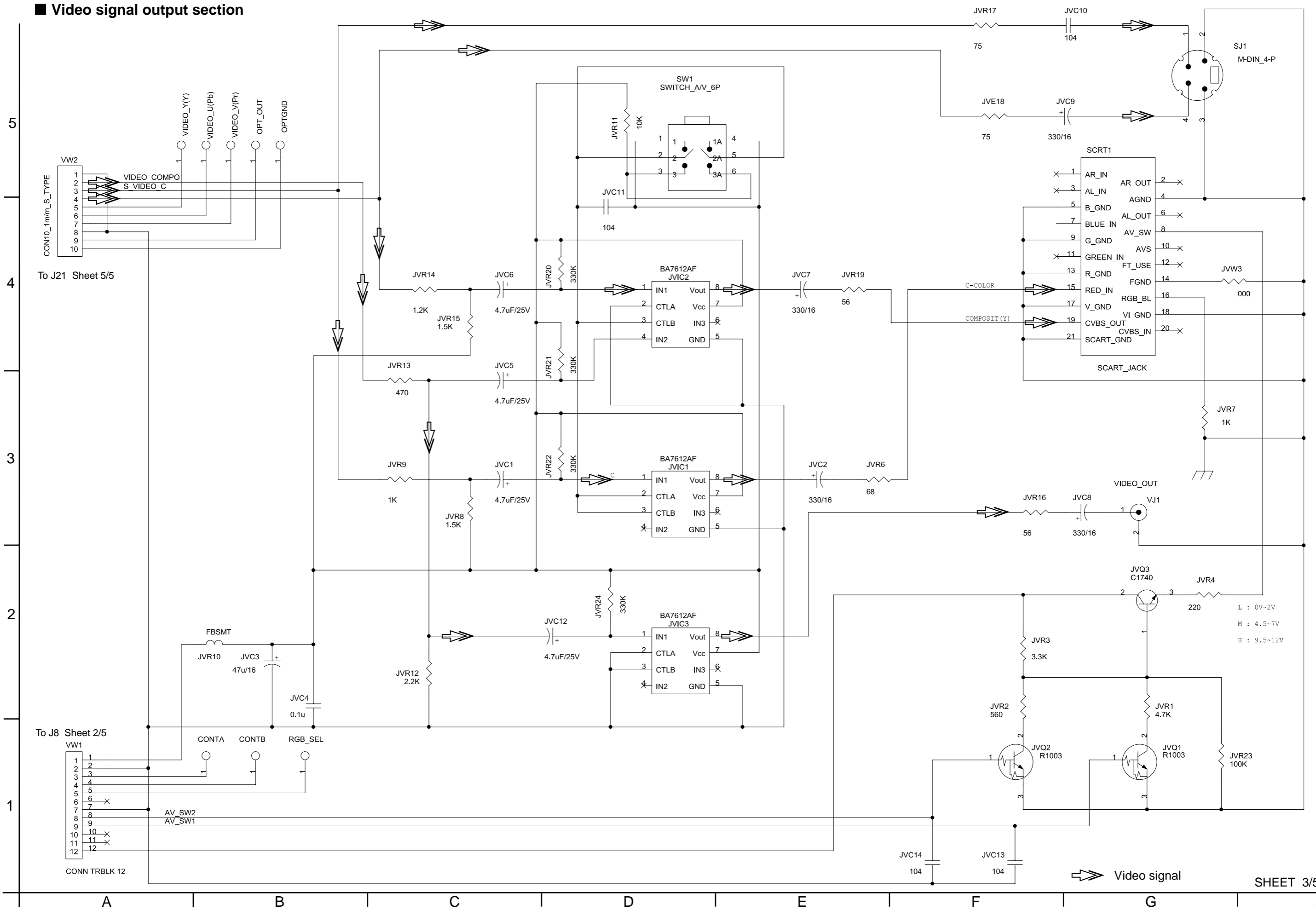

DVD loader section

5

4

3

2

1

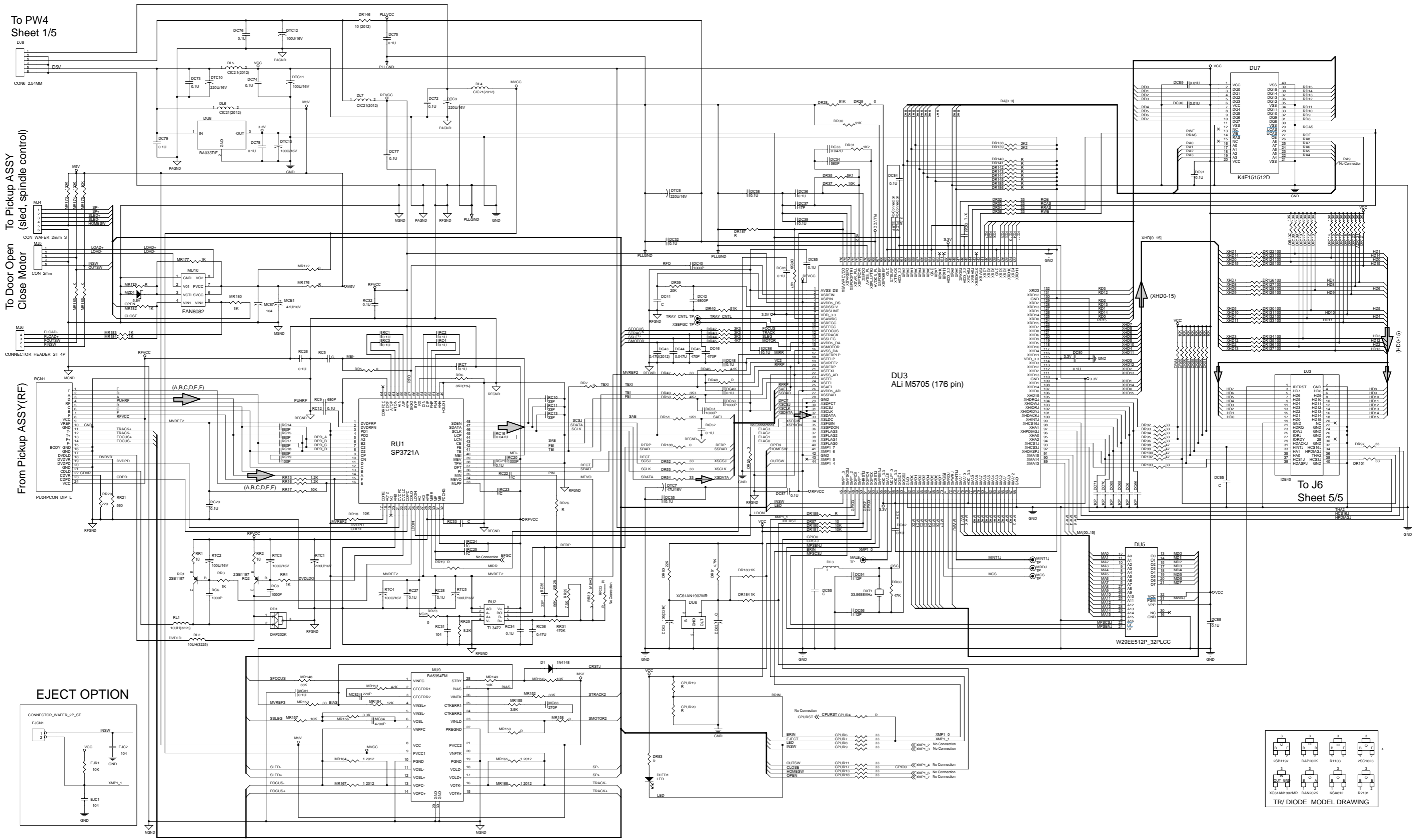

To PW4 Sheet 1/5

To Door Open Close Motor

From Pickup ASSY (RF)

To J6 Sheet 5/5

EJECT OPTION

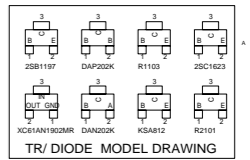
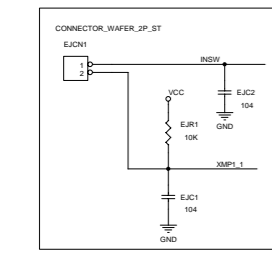

Digital data signal

DVD MPEG section

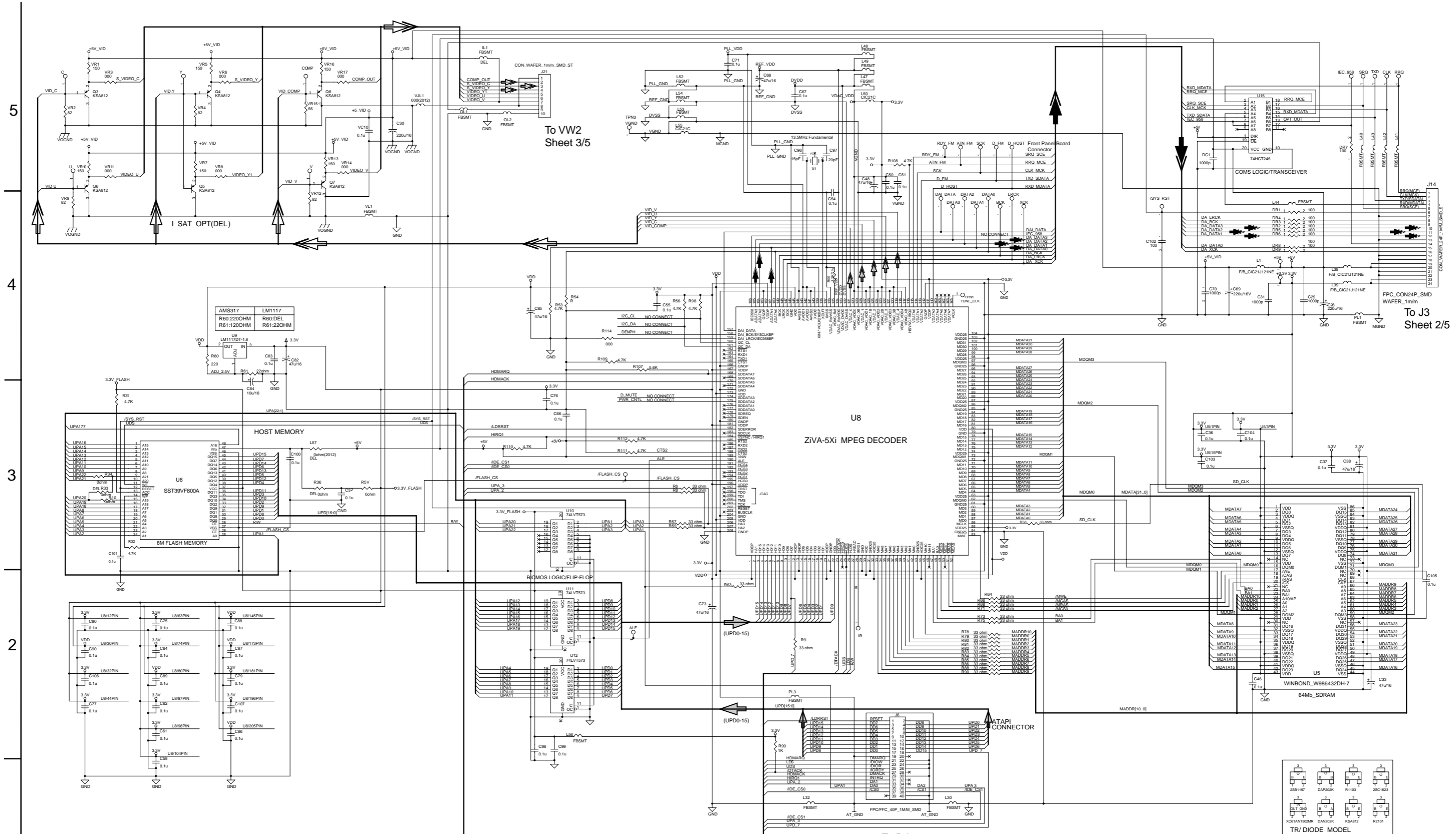

- ➡ Digital data signal
- ➡ Digital audio signal
- ➡ Video signal



# Printed circuit boards

## ■ Front board

### NOTICE

Insert LED after  
inserting machinery parts  
(AH61-00836A,Holder-LED)

5  
4  
3  
2  
1

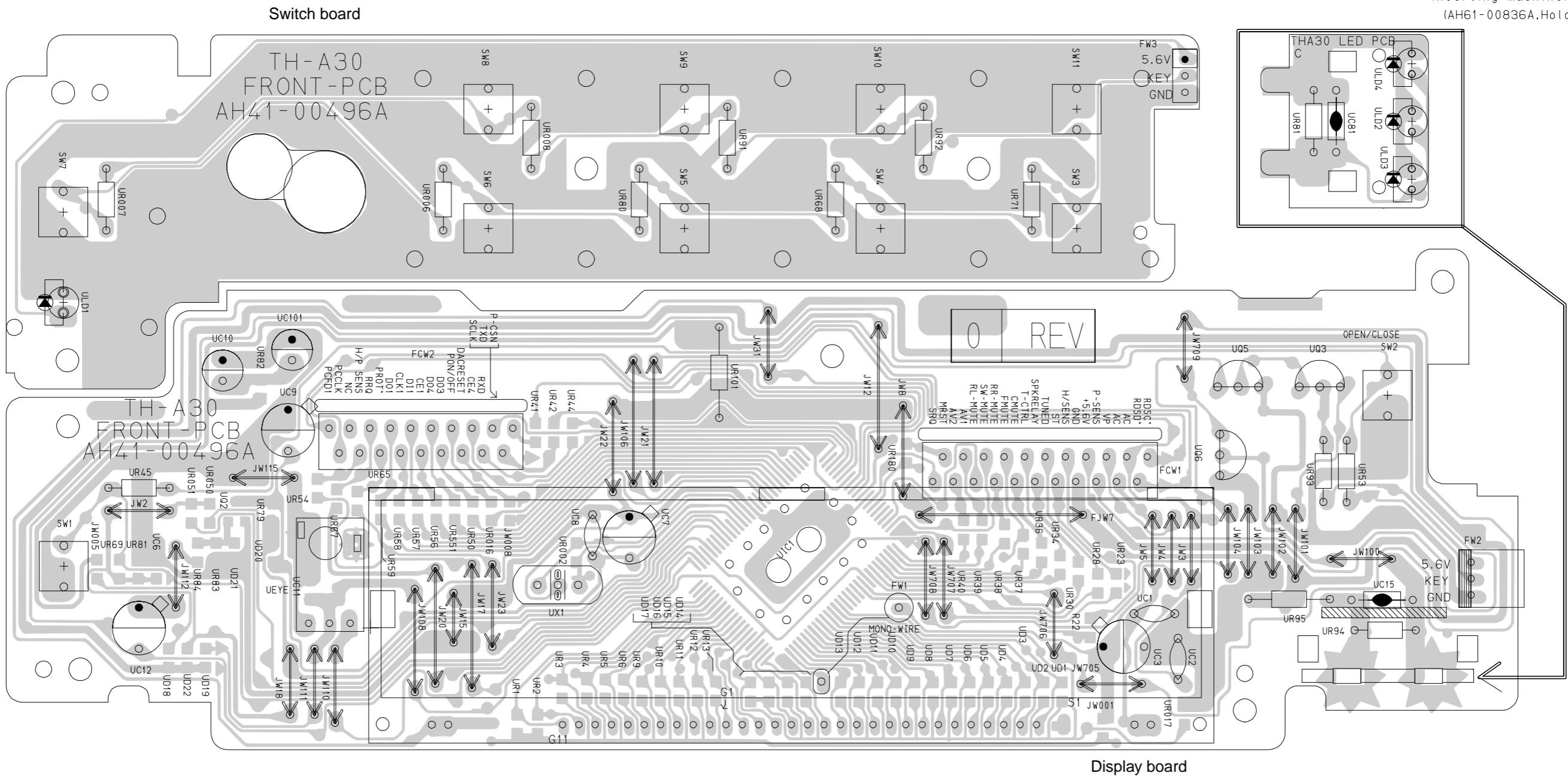

A B C D E F G H

■ Main board

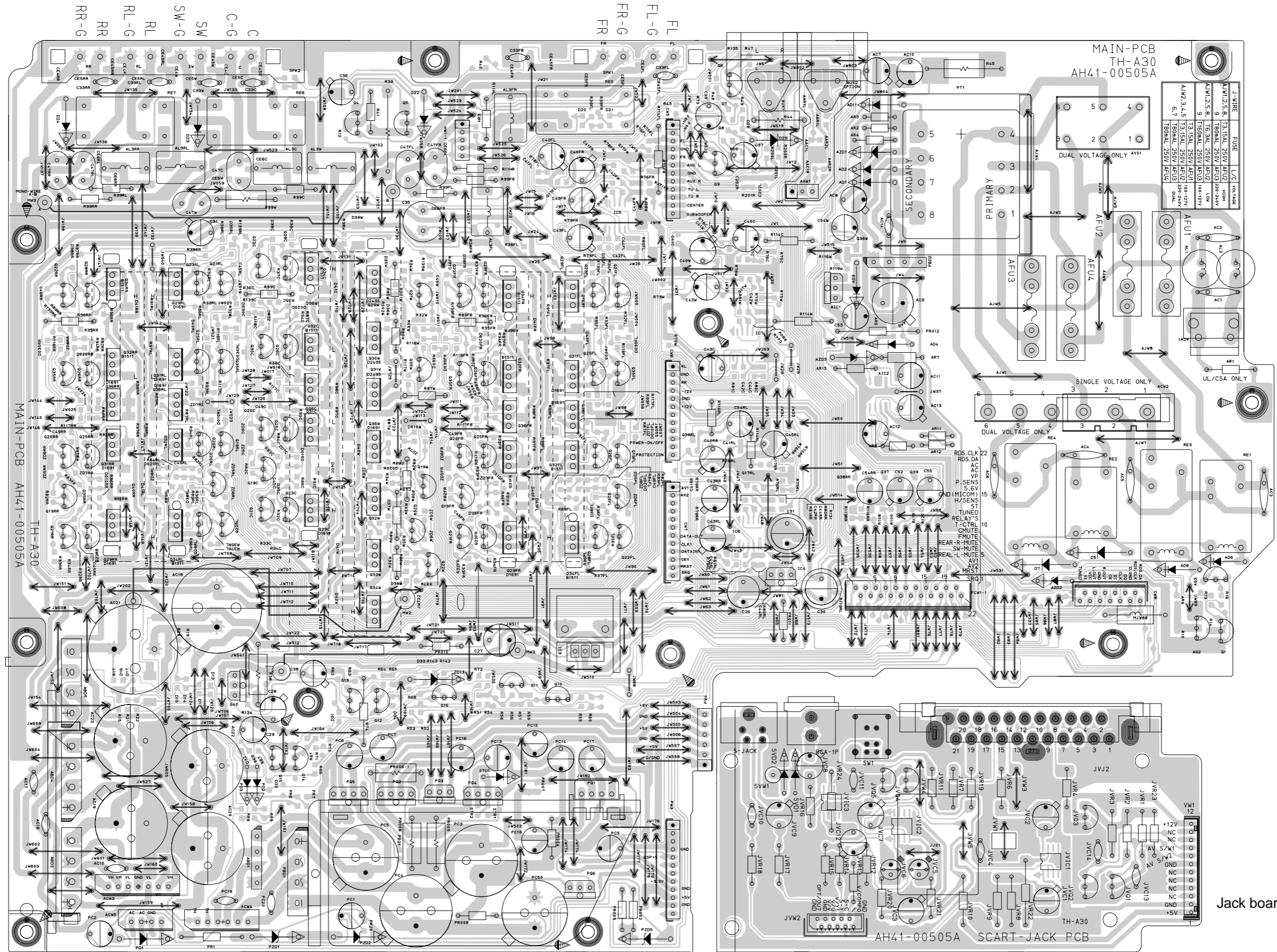

5

4

3

2

1

A B C D E F G

■ DVD loader board (Forward side)

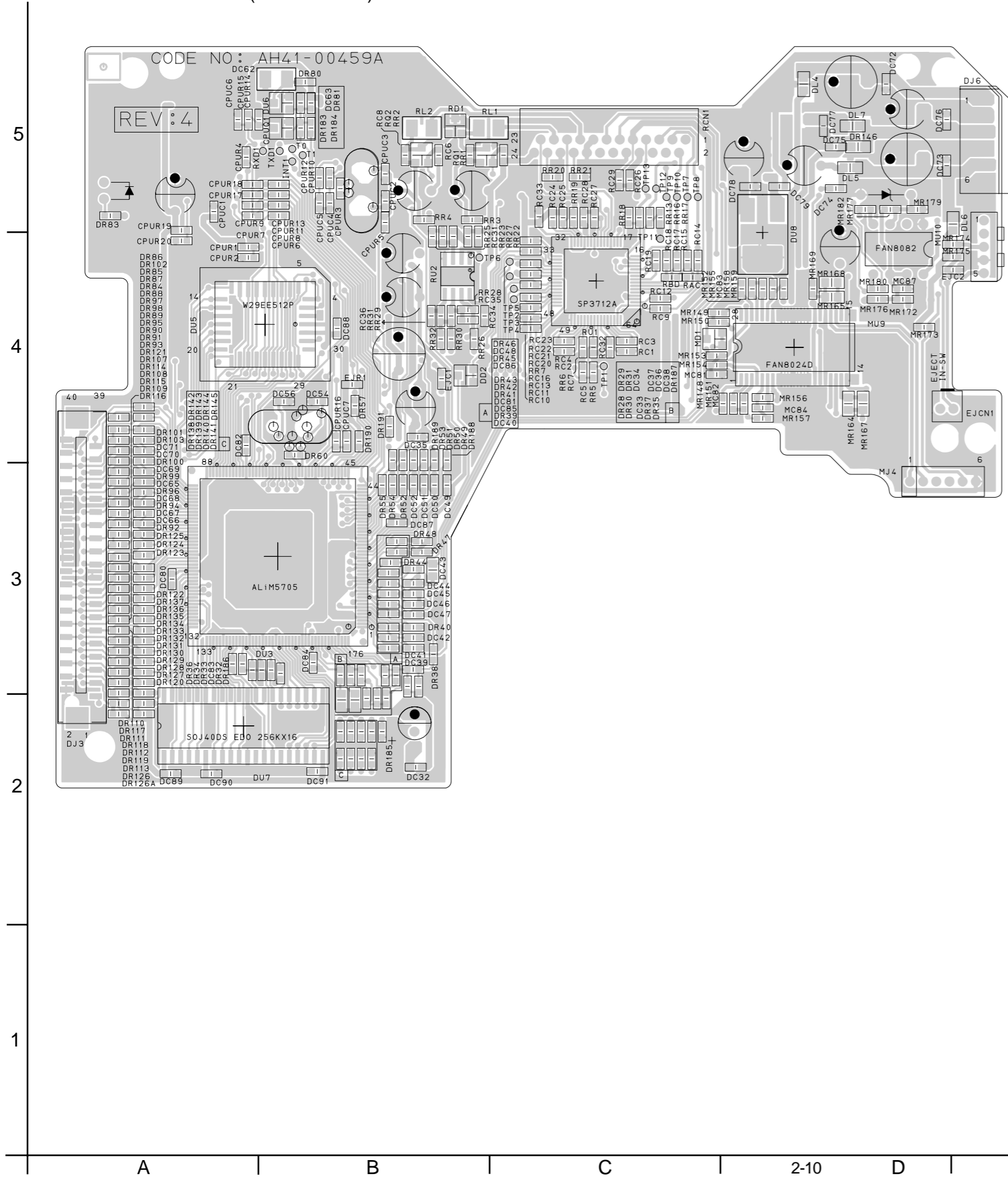

■ DVD MPEG board (Forward side)

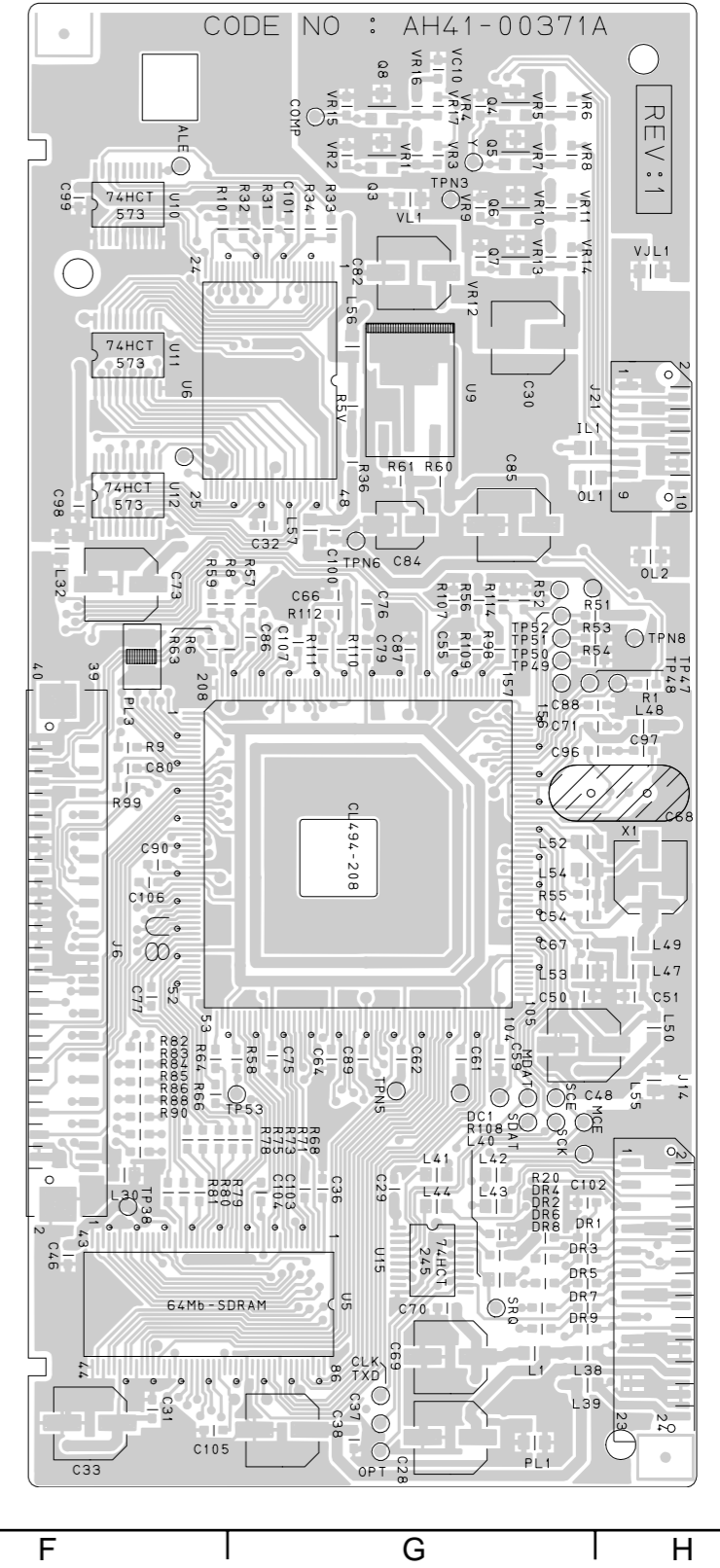



■ DSP board

(Forward side)

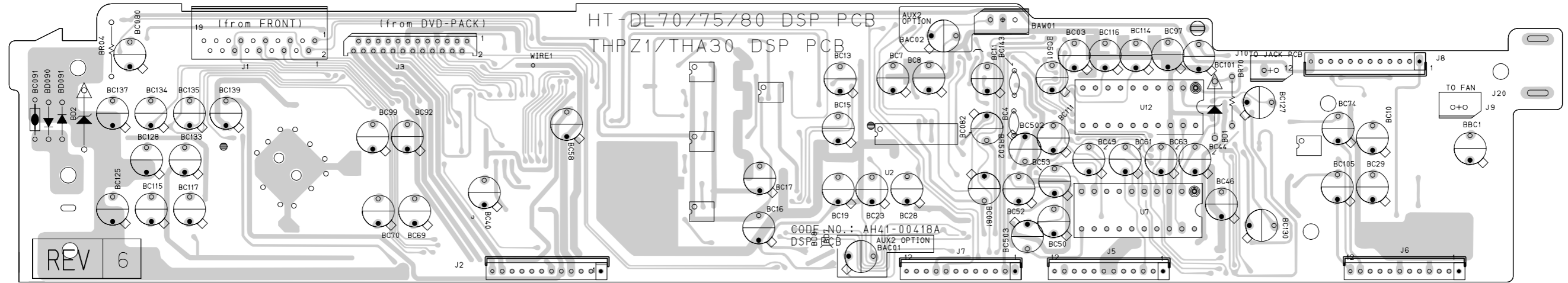

(Reverse side)

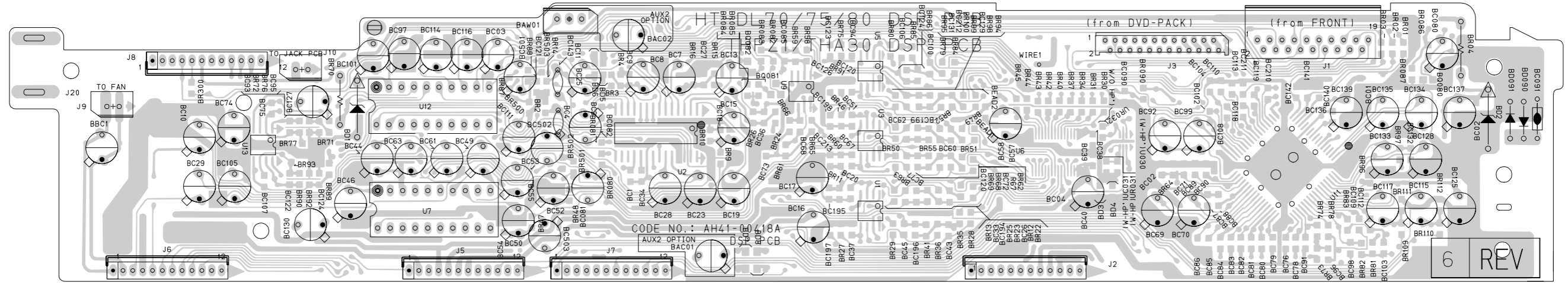

5  
4  
3  
2  
1

A B C 2-12 D E F G H

< M E M O >

**JVC**

VICTOR COMPANY OF JAPAN, LIMITED

AUDIO & COMMUNICATION BUSINESS DIVISION

PERSONAL & MOBILE NETWORK BUSINESS UNIT. 10-1,1chome,Ohwatari-machi,Maebashi-city,371-8543,Japan