

JVC

SERVICE MANUAL

DVD DIGITAL THEATER SYSTEM

TH-C30J, TH-C30C, TH-C20J, TH-C20C

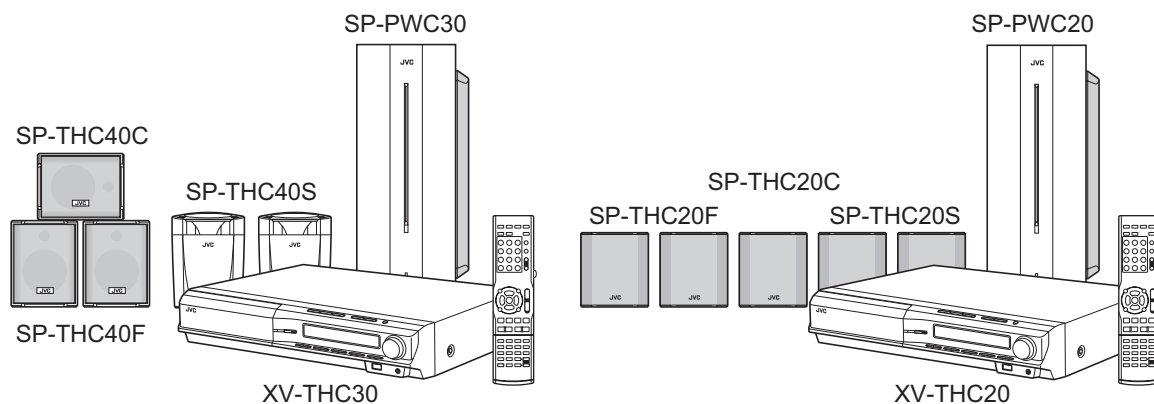

Lead free solder used in the board (material : Sn-Ag-Cu, melting point : 219 Centigrade)

TABLE OF CONTENTS

1	PRECAUTION.....	1-4
2	SPECIFIC SERVICE INSTRUCTIONS.....	1-7
3	DISASSEMBLY.....	1-8
4	ADJUSTMENT.....	1-29
5	TROUBLESHOOTING.....	1-33

SPECIFICATION

Center unit (XV-THC30/XV-THC20)

Audio section	Total Harmonic Distortion *1	0.02%
	Digital input *2	DIGITAL IN (DBS) (OPTICAL) : -21 dBm to -15 dBm (660 nm ± 30 nm)
Video section	Video System	NTSC
	Horizontal Resolution	500 lines
	Signal-to-Noise Ratio	64 dB
	Video output level	Composite : 1.0 V(p-p)/75 Ω S-video-Y : 1.0 V(p-p)/75 Ω S-video-C : 0.286 V(p-p)/75 Ω Component-Y : 1.0 V(p-p)/75 Ω Component-PB/PR : 0.7 V(p-p)/75 Ω
	Video input sensitivity/Impedance (VCR IN)	Composite : 1.0 V(p-p)/75 Ω S-video-Y : 1.0 V(p-p)/75 Ω S-video-C : 0.286 V(p-p)/75 Ω
USB storage	USB specification	Compatible with the USB 2.0 Full-Speed
	Compatible device	Mass Storage Class
	Compatible file system	FAT16, FAT32
	Bus power supply	Max. 500 mA
Tuner section	Tuning Range	FM : 87.5 MHz to 108.0 MHz AM : 530 kHz to 1 710 kHz
General	Power Requirements	AC 120 V , 60 Hz
	Power Consumption	25 W (at operation) 0.6 W (in standby mode)
	Dimensions (W × H × D)	400 mm × 85 mm × 316 mm (15-3/4 inches × 3-3/8 inches × 12-1/2 inches)
	Mass	3.8 kg (8.4 lbs)

*1: This value is measured at System cord CONNECTOR for reference.

*2: Corresponding to Linear PCM, Dolby Digital, and DTS Digital Surround (with sampling frequency -32 kHz, 44.1 kHz, 48 kHz)

Subwoofer (SP-PWC30)

Amplifier section	Front/Center/Surround	167 W per channel, RMS at 3 Ω at 1 kHz, with 10 % total harmonic distortion.
	Subwoofer	167 W, RMS at 3 Ω at 100 Hz, with 10 % total harmonic distortion.
Speaker section	Speaker unit	16 cm (6-5/16 inches) Bass-reflex
	Power Handling Capacity	170 W
	Impedance	3 Ω
	Frequency Range	30 Hz to 200 Hz
	Sound Pressure Level	73 dB/W-m
General	Power Requirements	AC 120 V , 60 Hz
	Power Consumption	160 W (at operation) 0 W (in standby mode)
	Dimensions (W × H × D)	170 mm × 411 mm × 458 mm (6-3/4 inches × 16-3/16 inches × 18-1/16 inches)
	Mass	11.5 kg (25.4 lbs)

Subwoofer (SP-PWC20)

Amplifier section	Front/Center/Surround	135 W per channel, RMS at 4 Ω at 1 kHz, with 10 % total harmonic distortion.
	Subwoofer	135 W, RMS at 4 Ω at 100 Hz, with 10 % total harmonic distortion.
Speaker section	Speaker unit	16 cm (6-5/16 inches) Bass-reflex
	Power Handling Capacity	140 W
	Impedance	4 Ω
	Frequency Range	30 Hz to 200 Hz
	Sound Pressure Level	74 dB/W-m
General	Power Requirements	AC 120 V , 60 Hz
	Power Consumption	135 W (at operation) 0 W (in standby mode)
	Dimensions (W × H × D)	170 mm × 411 mm × 458 mm (6-3/4 inches × 16-3/16 inches × 18-1/16 inches)
	Mass	11.5 kg (25.4 lbs)

Satellite Speakers - SP-XTHC30

Front speakers (SP-THC40F)	Type	2-way 2-speaker Bass reflex type (Magnetically shielded Type)
	Speaker	8.0 cm (3-3/16 inches) cone × 1 1.5 cm (5/8 inches) dome × 1
	Power Handling Capacity	170 W
	Impedance	3 Ω
	Frequency Range	80 Hz to 20 000 Hz
	Sound Pressure Level	77 dB/W·m
	Dimensions (W × H × D)	104.5 mm × 139 mm × 101 mm (4-1/8 inches × 5-1/2 inches × 4 inches)
	Mass	0.56 kg (1.3 lbs) each
Center speaker (SP-THC40C)	Type	2-way 2-speaker Bass reflex type (Magnetically shielded Type)
	Speaker	8.0 cm (3-3/16 inches) cone × 1 1.5 cm (5/8 inches) dome × 1
	Power Handling Capacity	170 W
	Impedance	3 Ω
	Frequency Range	80 Hz to 20 000 Hz
	Sound Pressure Level	77 dB/W·m
	Dimensions (W × H × D)	137 mm × 105 mm × 104.5 mm (5-7/16 inches × 4-3/16 inches × 4-1/8 inches)
	Mass	0.57 kg (1.3 lbs)
Surround speakers (SP-THC40S)	Type	1-way Bass reflex type
	Speaker	8.0 cm (3-3/16 inches) cone × 1
	Power Handling Capacity	170 W
	Impedance	3 Ω
	Frequency Range	80 Hz to 20 000 Hz
	Sound Pressure Level	70 dB/W·m
	Dimensions (W × H × D)	111.5 mm × 148 mm × 106.5 mm (4-7/16 inches × 5-7/8 inches × 4-1/4 inches)
	Mass	0.56 kg (1.3 lbs) each

Satellite Speakers - SP-XTHC20

Front speakers (SP-THC20F)	Type	1-way Bass reflex type (Magnetically shielded Type)
	Speaker	8.0 cm (3-3/16 inches) cone × 1
	Power Handling Capacity	140 W
	Impedance	4 Ω
	Frequency Range	90 Hz to 20 000 Hz
	Sound Pressure Level	78 dB/W·m
	Dimensions (W × H × D)	106 mm × 119.5 mm × 102 mm (4-3/16 inches × 4-3/4 inches × 4-1/16 inches)
	Mass	0.55 kg (1.3 lbs) each
Center speaker (SP-THC20C)	Type	1-way Bass reflex type (Magnetically shielded Type)
	Speaker	8.0 cm (3-3/16 inches) cone × 1
	Power Handling Capacity	140 W
	Impedance	4 Ω
	Frequency Range	90 Hz to 20 000 Hz
	Sound Pressure Level	78 dB/W·m
	Dimensions (W × H × D)	106 mm × 119.5 mm × 102 mm (4-3/16 inches × 4-3/4 inches × 4-1/16 inches)
	Mass	0.55 kg (1.3 lbs)
Surround speakers (SP-THC20S)	Type	1-way Bass reflex type
	Speaker	8.0 cm (3-3/16 inches) cone × 1
	Power Handling Capacity	140 W
	Impedance	4 Ω
	Frequency Range	90 Hz to 20 000 Hz
	Sound Pressure Level	76 dB/W·m
	Dimensions (W × H × D)	106 mm × 119.5 mm × 102 mm (4-3/16 inches × 4-3/4 inches × 4-1/16 inches)
	Mass	0.63 kg (1.4 lbs) each

Designs & specifications are subject to change without notice.

SECTION 1 PRECAUTION

1.1 Safety Precautions

- (1) This design of this product contains special hardware and many circuits and components specially for safety purposes. For continued protection, no changes should be made to the original design unless authorized in writing by the manufacturer. Replacement parts must be identical to those used in the original circuits. Services should be performed by qualified personnel only.
- (2) Alterations of the design or circuitry of the product should not be made. Any design alterations of the product should not be made. Any design alterations or additions will void the manufacturer's warranty and will further relieve the manufacturer of responsibility for personal injury or property damage resulting therefrom.
- (3) Many electrical and mechanical parts in the products have special safety-related characteristics. These characteristics are often not evident from visual inspection nor can the protection afforded by them necessarily be obtained by using replacement components rated for higher voltage, wattage, etc. Replacement parts which have these special safety characteristics are identified in the Parts List of Service Manual. Electrical components having such features are identified by shading on the schematics and by (Δ) on the Parts List in the Service Manual. The use of a substitute replacement which does not have the same safety characteristics as the recommended replacement parts shown in the Parts List of Service Manual may create shock, fire, or other hazards.
- (4) The leads in the products are routed and dressed with ties, clamps, tubings, barriers and the like to be separated from live parts, high temperature parts, moving parts and/or sharp edges for the prevention of electric shock and fire hazard. When service is required, the original lead routing and dress should be observed, and it should be confirmed that they have been returned to normal, after reassembling.

(5) Leakage shock hazard testing

After reassembling the product, always perform an isolation check on the exposed metal parts of the product (antenna terminals, knobs, metal cabinet, screw heads, headphone jack, control shafts, etc.) to be sure the product is safe to operate without danger of electrical shock. Do not use a line isolation transformer during this check.

- Plug the AC line cord directly into the AC outlet. Using a "Leakage Current Tester", measure the leakage current from each exposed metal part of the cabinet, particularly any exposed metal part having a return path to the chassis, to a known good earth ground. Any leakage current must not exceed 0.5mA AC (r.m.s.).
- Alternate check method
Plug the AC line cord directly into the AC outlet. Use an AC voltmeter having, 1,000 Ω per volt or more sensitivity in the following manner. Connect a 1,500 Ω 10W resistor paralleled by a 0.15 μ F AC-type capacitor between an exposed metal part and a known good earth ground. Measure the AC voltage across the resistor with the AC

voltmeter.

Move the resistor connection to each exposed metal part, particularly any exposed metal part having a return path to the chassis, and measure the AC voltage across the resistor. Now, reverse the plug in the AC outlet and repeat each measurement. Voltage measured any must not exceed 0.75 V AC (r.m.s.). This corresponds to 0.5 mA AC (r.m.s.).

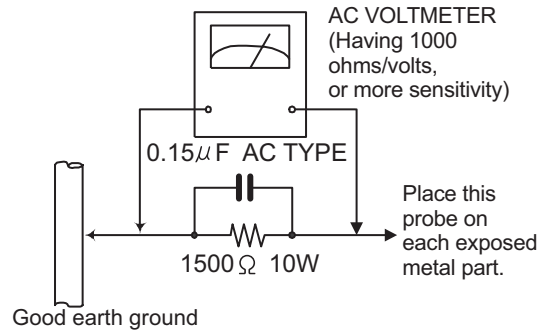

1.2 Warning

- (1) This equipment has been designed and manufactured to meet international safety standards.
- (2) It is the legal responsibility of the repairer to ensure that these safety standards are maintained.
- (3) Repairs must be made in accordance with the relevant safety standards.
- (4) It is essential that safety critical components are replaced by approved parts.
- (5) If mains voltage selector is provided, check setting for local voltage.

1.3 Caution

Burrs formed during molding may be left over on some parts of the chassis.

Therefore, pay attention to such burrs in the case of pre-forming repair of this system.

1.4 Critical parts for safety

In regard with component parts appearing on the silk-screen printed side (parts side) of the PWB diagrams, the parts that are printed over with black such as the resistor (■), diode (■) and ICP (●) or identified by the " Δ " mark nearby are critical for safety. When replacing them, be sure to use the parts of the same type and rating as specified by the manufacturer. (This regulation does not Except the J and C version)

1.5 Preventing static electricity

Electrostatic discharge (ESD), which occurs when static electricity stored in the body, fabric, etc. is discharged, can destroy the laser diode in the traverse unit (optical pickup). Take care to prevent this when performing repairs.

1.5.1 Grounding to prevent damage by static electricity

Static electricity in the work area can destroy the optical pickup (laser diode) in devices such as laser products. Be careful to use proper grounding in the area where repairs are being performed.

(1) Ground the workbench

Ground the workbench by laying conductive material (such as a conductive sheet) or an iron plate over it before placing the traverse unit (optical pickup) on it.

(2) Ground yourself

Use an anti-static wrist strap to release any static electricity built up in your body.

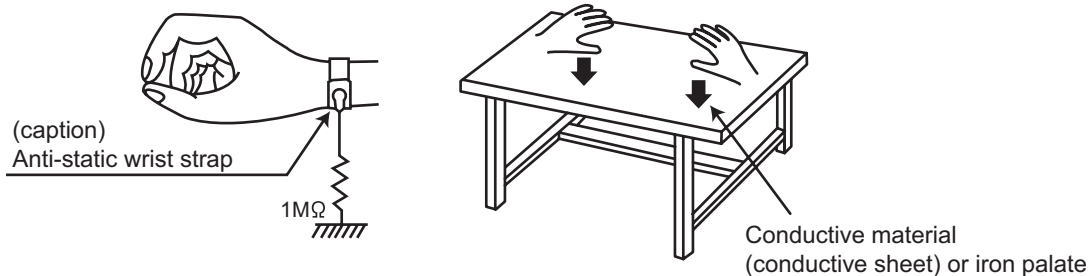

(3) Handling the optical pickup

- In order to maintain quality during transport and before installation, both sides of the laser diode on the replacement optical pickup are shorted. After replacement, return the shorted parts to their original condition. (Refer to the text.)
- Do not use a tester to check the condition of the laser diode in the optical pickup. The tester's internal power source can easily destroy the laser diode.

1.6 Handling the traverse unit (optical pickup)

- (1) Do not subject the traverse unit (optical pickup) to strong shocks, as it is a sensitive, complex unit.
- (2) Cut off the shorted part of the flexible cable using nippers, etc. after replacing the optical pickup. For specific details, refer to the replacement procedure in the text. Remove the anti-static pin when replacing the traverse unit. Be careful not to take too long a time when attaching it to the connector.
- (3) Handle the flexible cable carefully as it may break when subjected to strong force.
- (4) It is not possible to adjust the semi-fixed resistor that adjusts the laser power. Do not turn it.

1.7 Attention when traverse unit is decomposed

***Please refer to "Disassembly method" in the text for the pickup unit.**

- Apply solder to the short land sections before the flexible wire is disconnected from the connector on the servo board. (If the flexible wire is disconnected without applying solder, the pickup may be destroyed by static electricity.)
- In the assembly, be sure to remove solder from the short land sections after connecting the flexible wire.

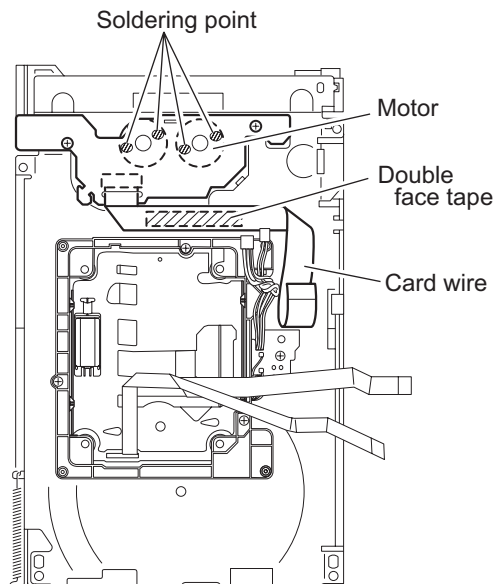

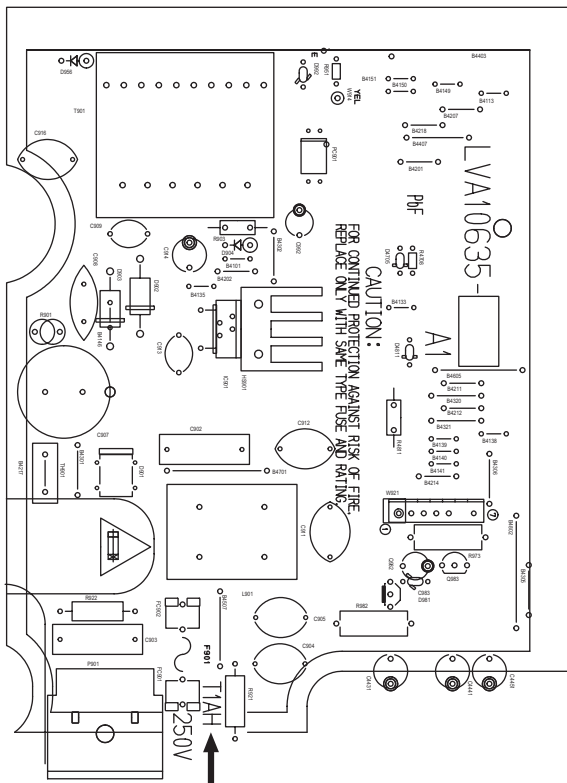

1.8 Importance administering point on the safety

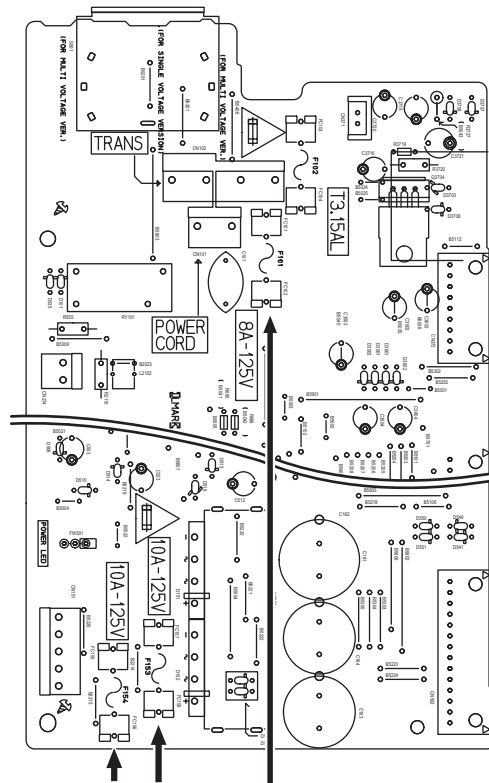

slow blow type / type à fusion lent

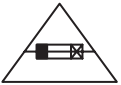
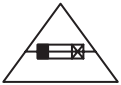

fast blow type / type à fusion rapide

<p>Full Fuse Replacement Marking</p> <p>Graphic symbol mark (This symbol means slow blow type fuse.)</p>  <p>should be read as follows ;</p>	<p>Marquage Pour Le Remplacement Complet De Fusible</p> <p>Le symbole graphique (Ce symbole signifie fusible de type à fusion lent.)</p>  <p>doit être interprété comme suit ;</p>
<p>FUSE CAUTION</p>	<p>PRECAUTIONS SUR LES FUSIBLES</p>
<p>FOR CONTINUED PROTECTION AGAINST RISK OF FIRE, REPLACE ONLY WITH SAME TYPE AND RATING OF FUSES ;</p> <p>F901 : T1AH 250V</p>	<p>POUR UNE PROTECTION CONTINUE CONTRE DES RISQUES D'INCENDIE, REMPLACER SEULEMENT PAR UN FUSIBLE DU MEME TYPE ;</p> <p>F901 : T1AH 250V</p>
<p>Full Fuse Replacement Marking</p> <p>Graphic symbol mark (This symbol means fast blow type fuse.)</p>  <p>should be read as follows ;</p>	<p>Marquage Pour Le Remplacement Complet De Fusible</p> <p>Le symbole graphique (Ce symbole signifie fusible de type à fusion rapide.)</p>  <p>doit être interprété comme suit ;</p>
<p>FUSE CAUTION</p>	<p>PRECAUTIONS SUR LES FUSIBLES</p>
<p>FOR CONTINUED PROTECTION AGAINST RISK OF FIRE, REPLACE ONLY WITH SAME TYPE AND RATING OF FUSES ;</p> <p>F101 : 8A 125V F153 : 10A 125V F154 : 10A 125V</p>	<p>POUR UNE PROTECTION CONTINUE CONTRE DES RISQUES D'INCENDIE, REMPLACER SEULEMENT PAR UN FUSIBLE DU MEME TYPE ;</p> <p>F101 : 8A 125V F153 : 10A 125V F154 : 10A 125V</p>

SECTION 2
SPECIFIC SERVICE INSTRUCTIONS

This service manual does not describe SPECIFIC SERVICE INSTRUCTIONS.

SECTION 3 DISASSEMBLY

3.1 Main body

3.1.1 Removing the top cover (See Fig.1 and 2)

- (1) Remove the four screws **A** (both side) attaching the top cover. (See Fig.1)
- (2) Remove the three screws **B** attaching the top cover from back side. (See Fig.2)

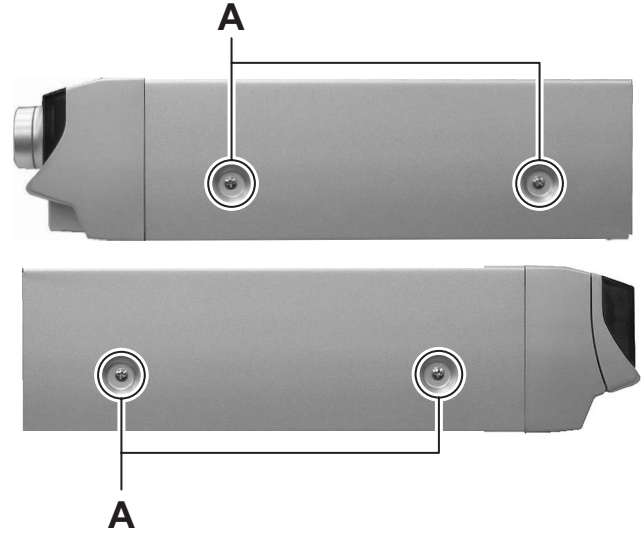

Fig.1

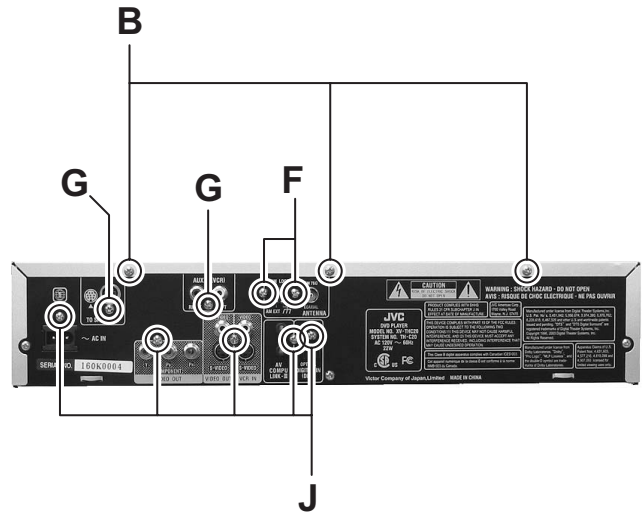

Fig.2

3.1.2 Removing the front panel assembly (See Fig.3 to 5)

- (1) Disconnect the card wire from front board connected [CN450](#) and [CN451](#) of main board. (See Fig.3)
- (2) Disconnect the card wire from operation board connected [CN457](#) of main board. (See Fig.3)
- (3) Remove the one screw **C** attaching the ground wire of front board. (See Fig.3)
- (4) Remove the two screws **D** attaching the front panel from bottom side. (See Fig.4)
- (5) Disengage the hook **a** of bottom side and hook **b** of both side of front panel assembly. (See Fig.4 and 5)

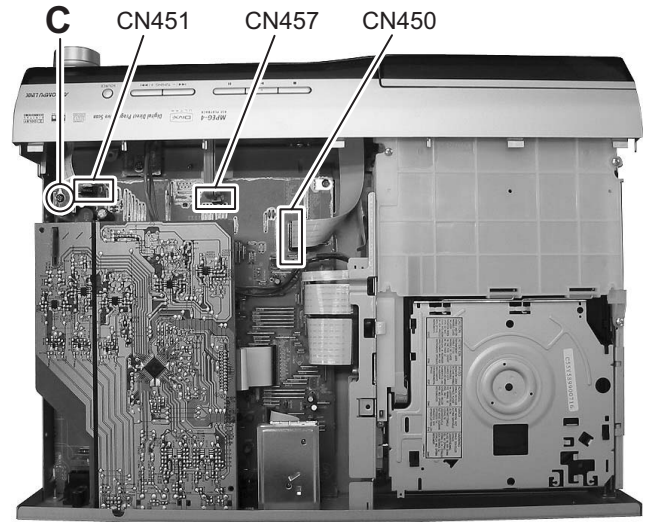

Fig.3

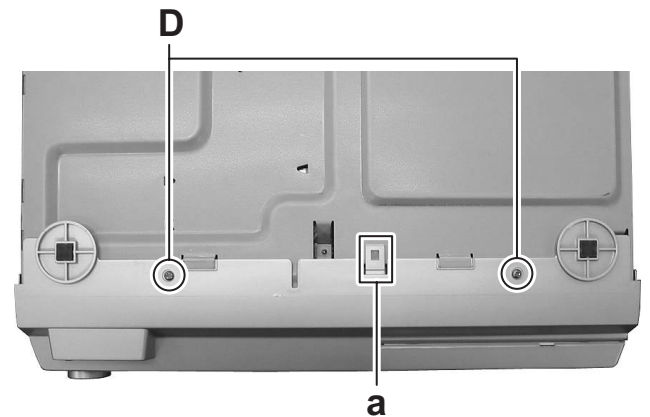

Fig.4

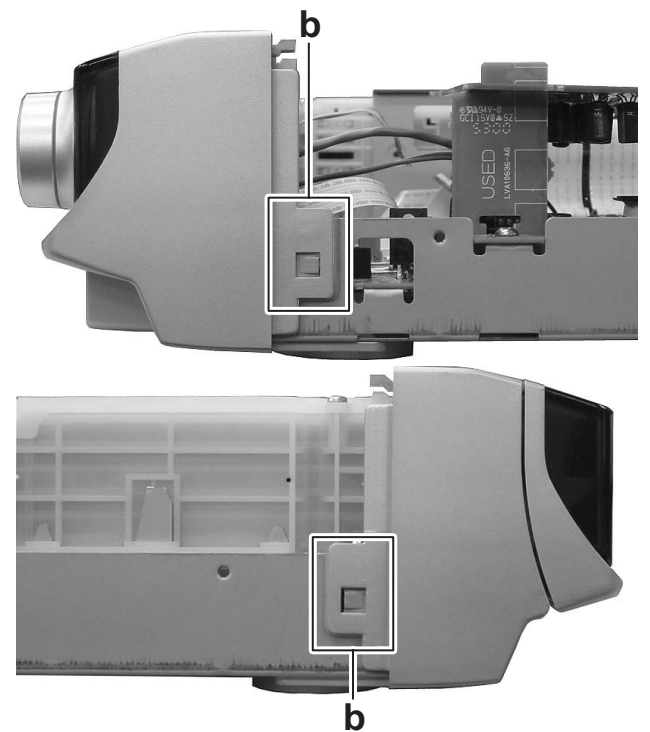

Fig.5

3.1.3 Removing the DVD mechanism assembly (See Fig. 6 and 7)

- (1) Disconnect the card wire from DVD mechanism assembly connected to [CN402](#), [CN403](#) and [CN404](#) of main board. (See Fig.6)
- (2) Disconnect the connector wire from USB jack board connected to [CN811](#) of DVD module board. (See Fig.7)
- (3) Remove the four screws **E** attaching the DVD mechanism assembly. (See Fig.6)

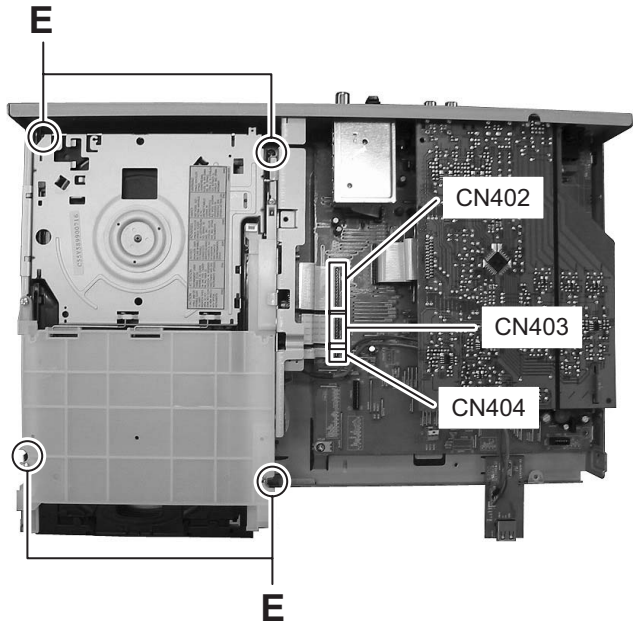

Fig.6

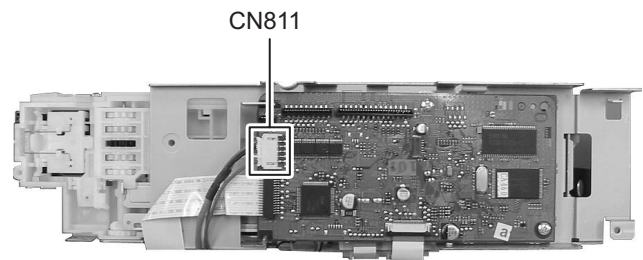

Fig.7

3.1.4 Removing the tuner pack (See Fig.2 and 8)

- (1) Disconnect the card wire from tuner pack connected to [CN410](#) of main board. (See Fig.8)
- (2) Remove the two screws **F** attaching the tuner pack. (See Fig.2)

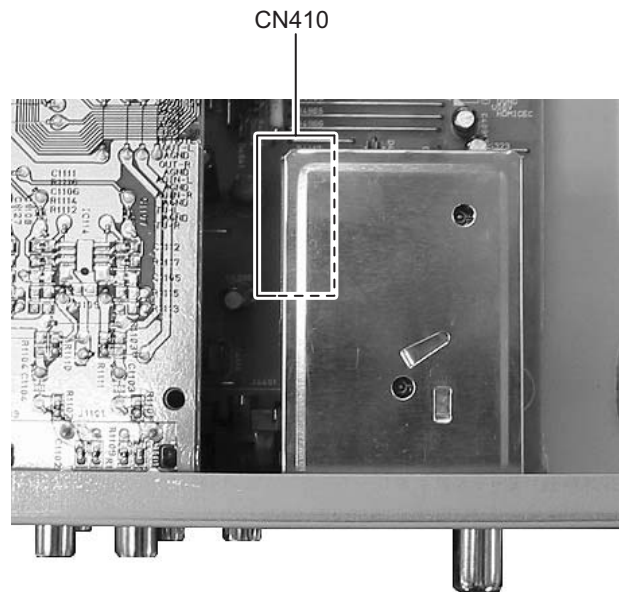

Fig.8

3.1.5 Removing the audio and digital input board (See Fig.2 and 9)

- (1) Remove the two screws **G** attaching the audio and digital input board. (See Fig.2)
- (2) Disconnect the card wire from main board connected to [CN102](#). (See Fig.9)
- (3) Disconnect the connection board from [CN101](#), and then shift to direction the arrow and take off the audio and digital input board. (See Fig.9)

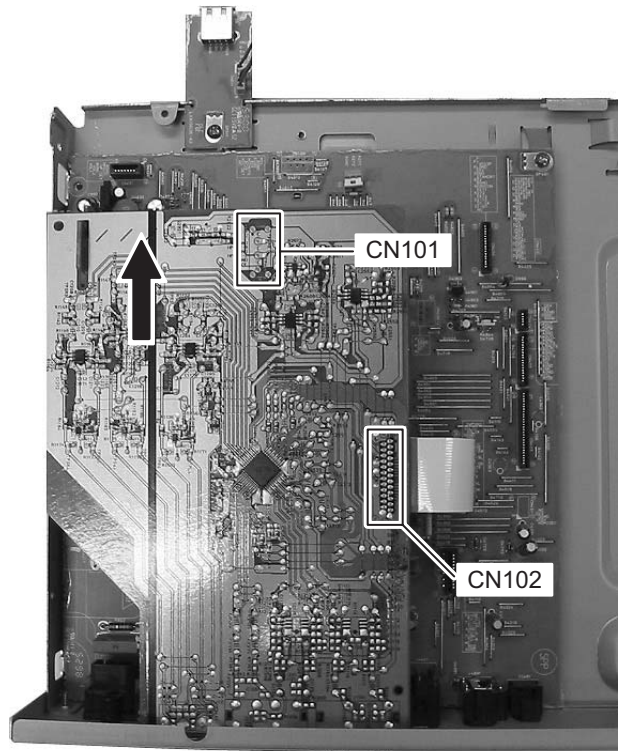

Fig.9

3.1.6 Removing the USB jack board (See Fig.10)

- (1) Remove the one screw **H** attaching the USB jack board. (See Fig.10)



Fig.10

3.1.7 Removing the main board (See Fig.2 and 11)

- (1) Remove the five screws **J** attaching the main board from back side. (See Fig.2)
- (2) Remove the four screws **K** attaching the main board. (See Fig.11)

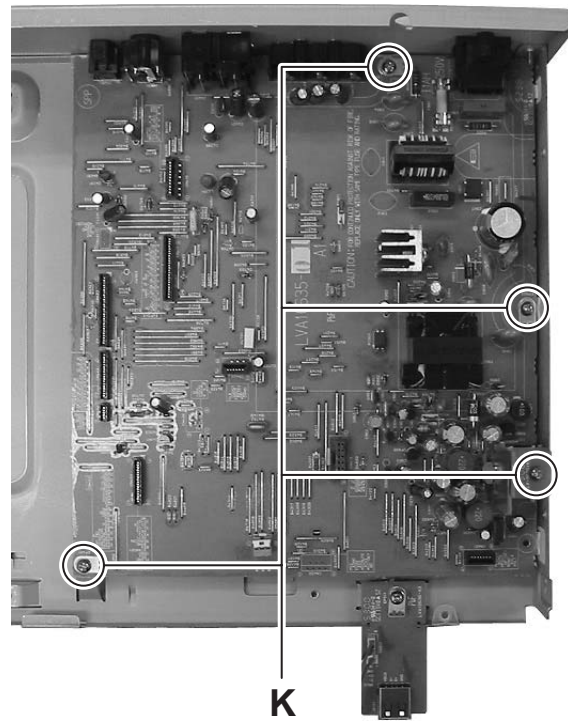

Fig.11

3.1.8 Removing the operation board (See Fig.12 and 13)

- (1) Pull out the volume knob.
- (2) Remove the one screw **L** attaching the volume. (See Fig.12)
- (3) Remove the one screw **M** attaching the bracket board. (See Fig.13)
- (4) Remove the three screws **N** attaching the operation board. (See Fig.13)



Fig.12

3.1.9 Removing the front board (See Fig.13)

- (1) Remove the seven screws **P** attaching the front board.

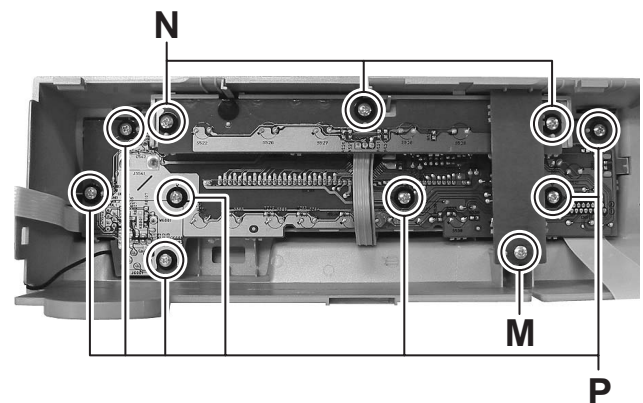

Fig.13

3.2 Subwoofer

3.2.1 Removing the amplifier assembly

(See Fig.1 to 4)

- (1) Remove the eight screws **A** attaching the amplifier assembly from bottom side. (See Fig.1)
- (2) Remove the two screws **B**, one screw **C** and six screws **D** attaching the rear panel. (See Fig.2)
- (3) Disconnect the connector wire from fan motor connected to [CN371](#). (See Fig.3)
- (4) Pull out the amplifier assembly and disconnect the connector wire from speaker connected to [CN274](#). (See Fig.4)

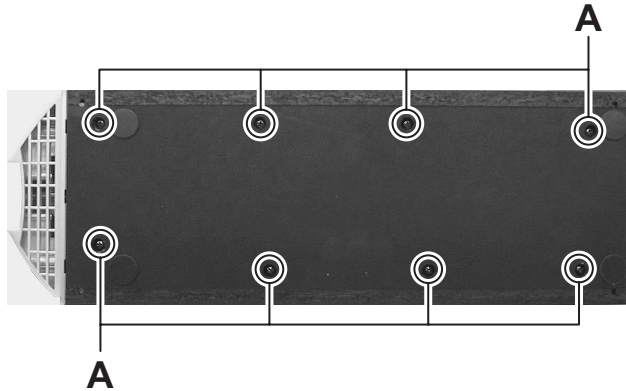

Fig.1

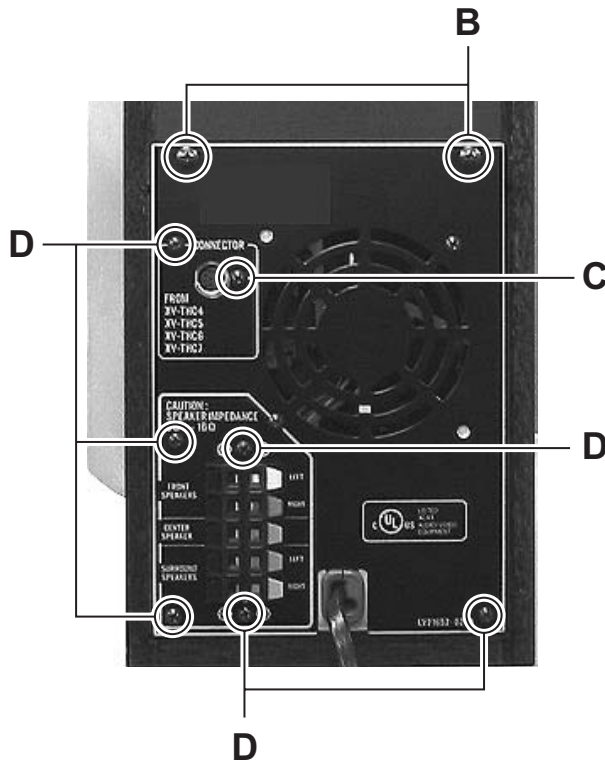
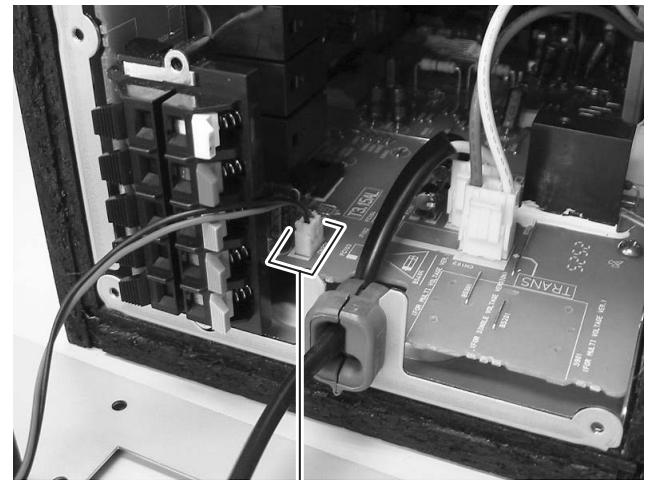

Fig.2



CN371
Fig.3

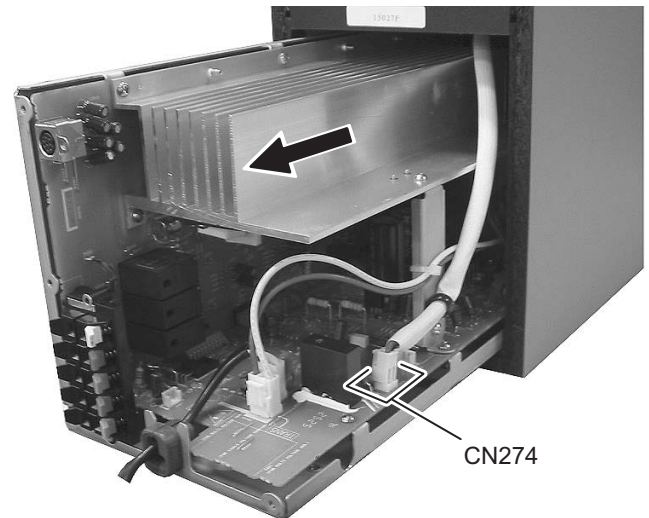

Fig.4

3.2.2 Removing the mother board (See Fig.5 and 6)

- (1) Disconnect the connector wire from power transformer connected to [CN102](#) and [CN151](#). (See Fig.5)
- (2) Disconnect the power cord connected to [CN101](#). (See Fig.5)
- (3) Remove the four screws **E** attaching the heat sink bracket. (See Fig.5)
- (4) Remove the two screws **F** attaching the mother board. (See Fig.5)
- (5) Disconnect the connector connected to amplifier board [CN372](#), [CN501](#) and [CN502](#). (See Fig.6)

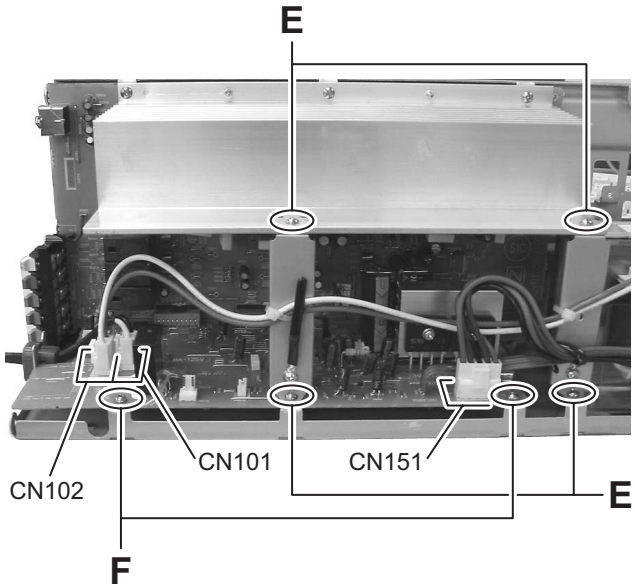

Fig.5

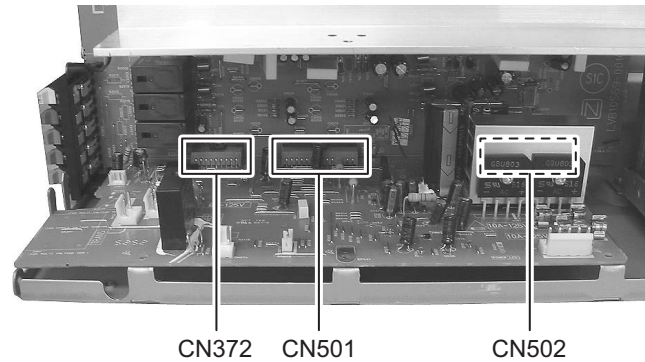

Fig.6

3.2.3 Removing the amplifier board (See Fig.7)

- (1) Remove the nine screws **G** attaching the amplifier board.

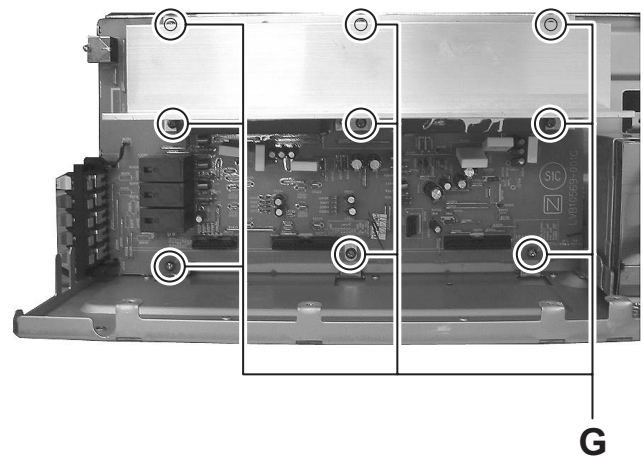

Fig.7

3.2.4 Removing the heat sink (See Fig.8 and 9)

- (1) Remove the three screws **H** attaching the heat sink from bottom side of amplifier board. (See Fig.8)
- (2) Remove the four screws **J** attaching the power IC. (See Fig.9)

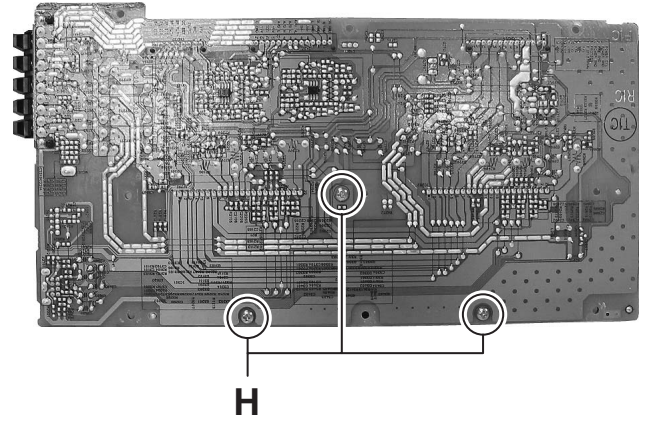

Fig.8

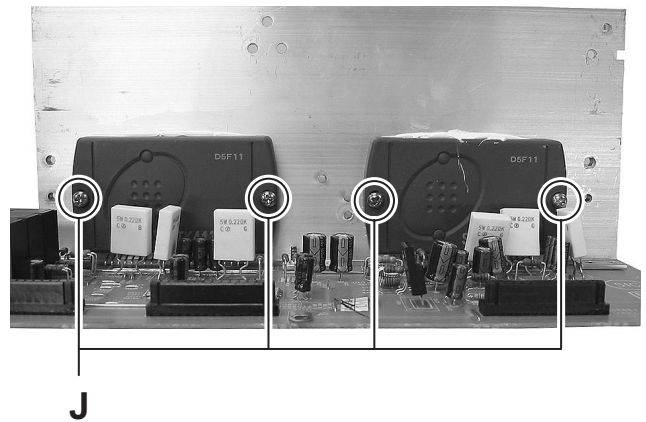

Fig.9

3.3 DVD mechanism section

3.3.1 Removing the DVD module board

(See Fig.1)

- (1) Disconnect the card wire connected to [CN451](#), [CN452](#), [CN453](#), [CN101](#) and [CN102](#) of DVD module board. (See Fig.1)
- (2) Remove the two screws **A** attaching the DVD module board. (See Fig.1)

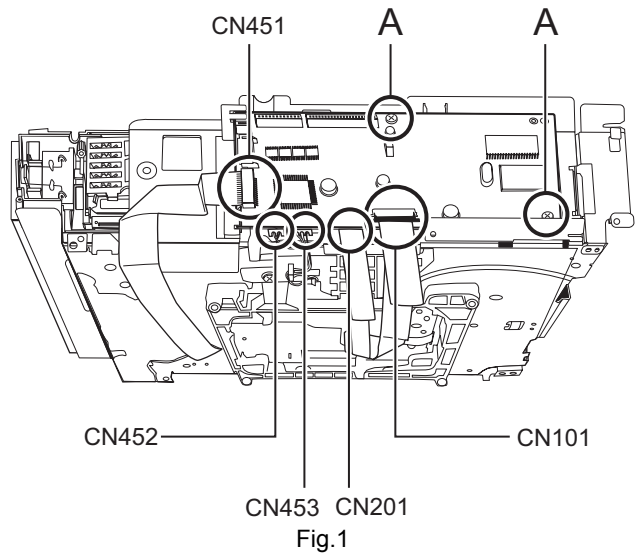

3.3.2 Removing the PWB bracket and wire holder

(See Fig.2)

- (1) Remove the two screws **B** attaching the wire holder.
- (2) Remove the one screw **C** attaching the PWB bracket.

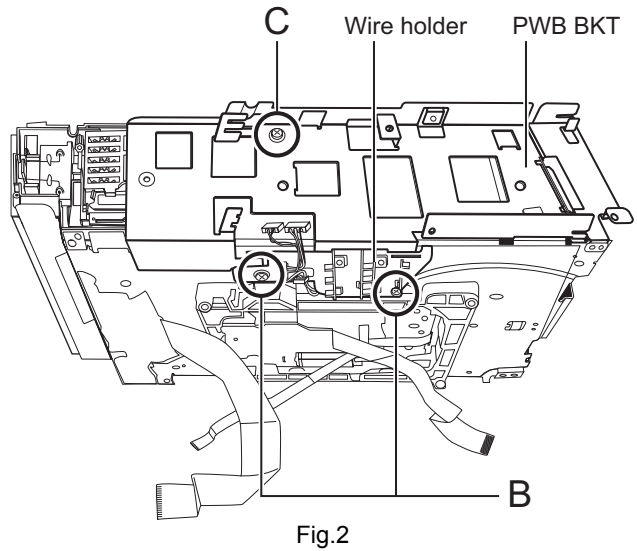

3.3.3 Removing the tray assembly (See Fig.3 to 7)

- (1) Remove the two screws **D** from the top cover and release the two joints **a** on both sides of the body. (See Fig.3)
- (2) Remove the top cover with the two rods attached to the top cover and lifter assembly respectively. (See Fig.4)
- (3) Remove the open detect lever on the left side of the body. (See Fig.5)
- (4) Push part **b** of the slide (R) assembly on the right side of the body to unlock the tray assembly. Draw out the trays toward the front. (See Fig.6)

Attention:

The tray can be locked if all tray assemblies are attached.

- (5) From top of the body, move the stopper tab **c** in the direction of the arrow and release. Pull out the tray assemblies from the body. (See Fig.6 and 7)

Caution:

Remove the tray assembly from top tray 5 in order.

Attention:

When reattaching the sub tray of the tray assembly, or when removing the DVD mechanism inside, refer to another section.

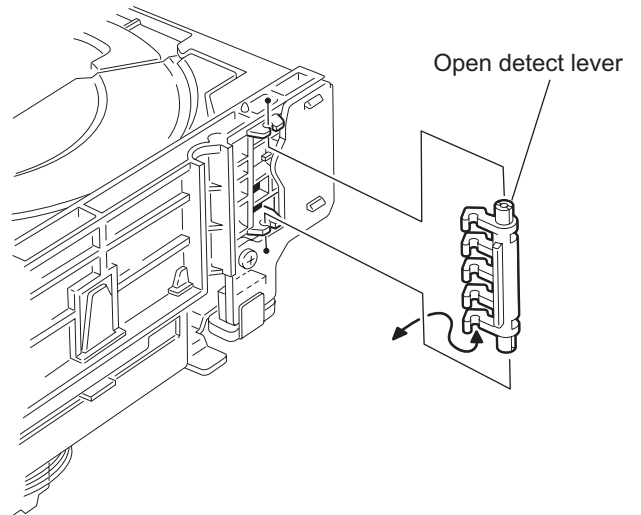

Fig.5

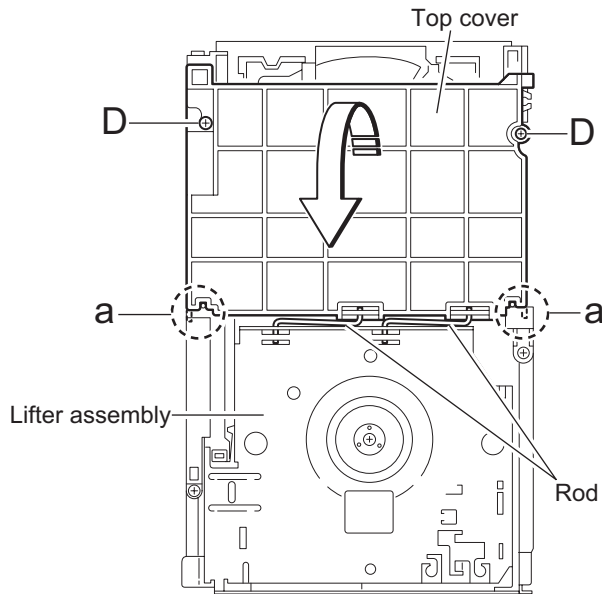

Fig.3

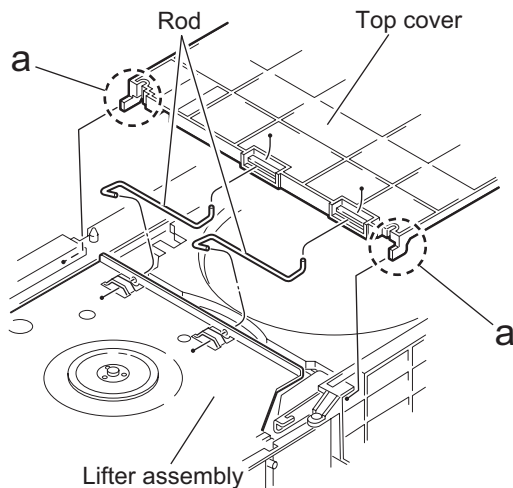

Fig.4

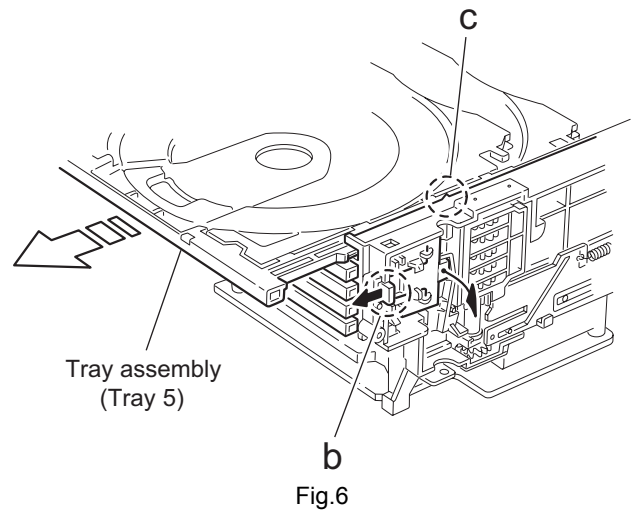

Fig.6

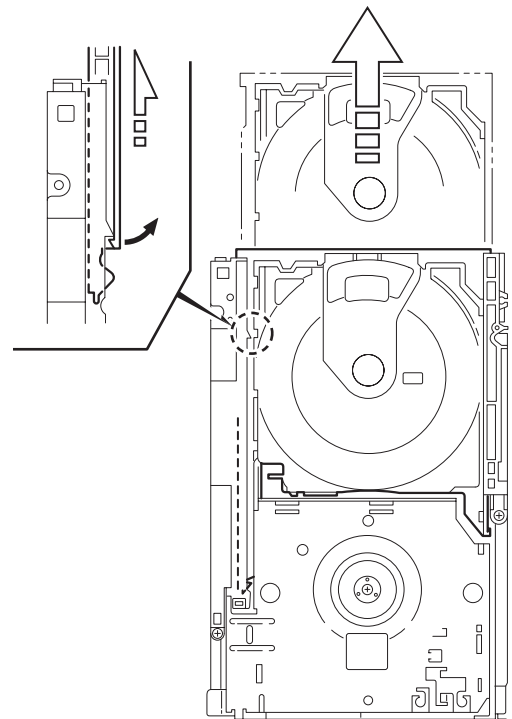

Fig.7

3.3.4 Removing the motor board (See Fig.8)

- (1) Remove the two screws **D** attaching the motor board.
- (2) Remove the spacer fixing the motor board and tray switch-board, and disconnect the connector **CN2** on the motor board.
- (3) Disconnect the card wire from connector **CN1** on the motor board.

Caution:

When reconnection the card wire, let the card wire through the slot **d** of the motor board and attach it to bottom of the body using a double face tape.

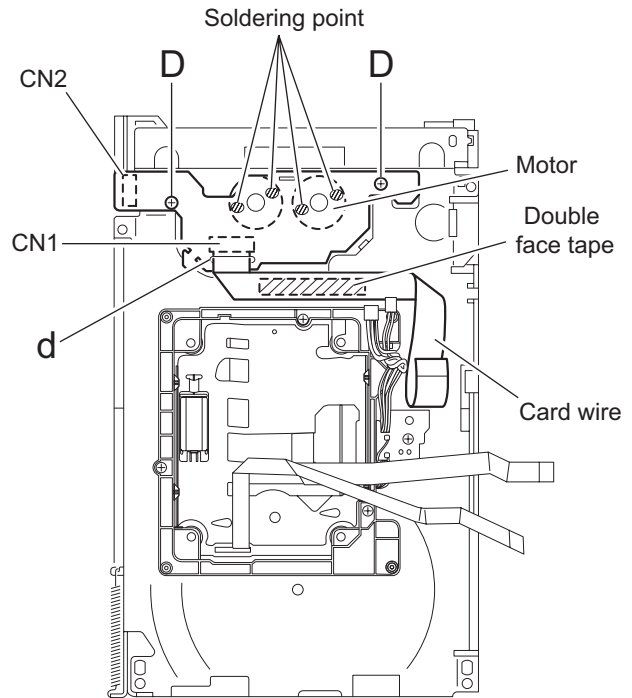
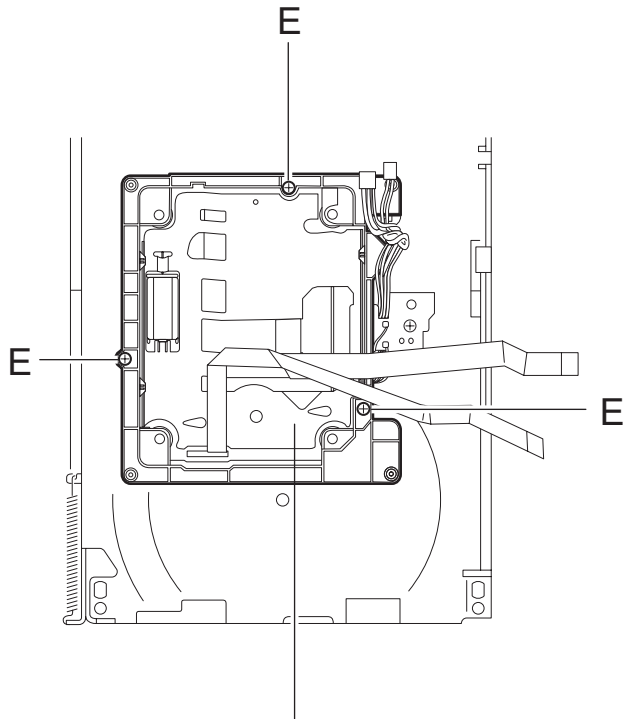

Fig.8

3.3.5 Removing the DVD tramecha assembly (See Fig.9)

- (1) Remove the three screws **E** attaching the DVD tramecha assembly.



DVD Tramecha assembly
Fig.9

3.3.6 Removing the pickup (See Fig.10 and 11)

- (1) Remove the one screw **F** and **G** attaching the spring holder. (See Fig.10)
- (2) Lift up the shaft from the tramecha assembly. (See Fig.10)
- (3) Remove the two screws **H** attaching the lack. (See Fig.11)

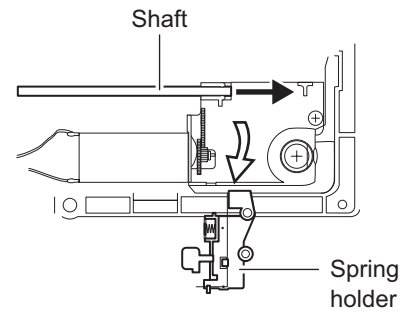
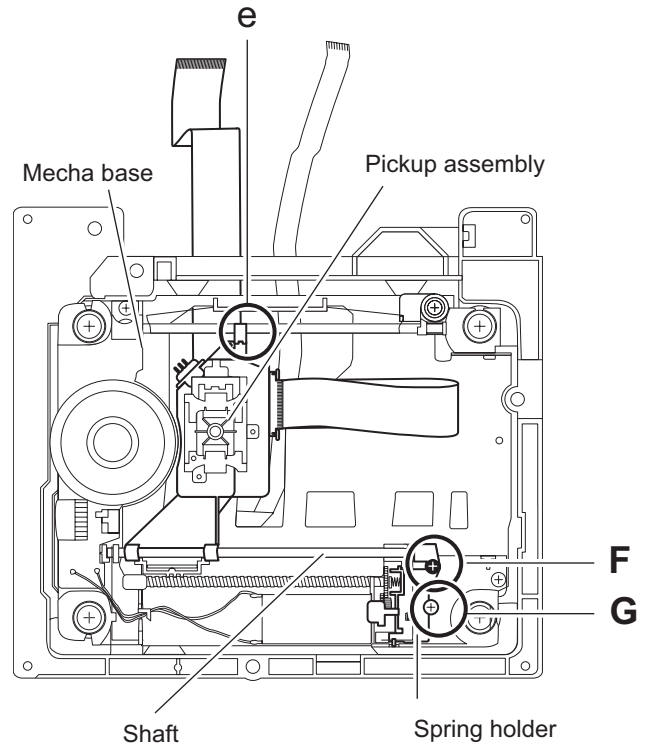

Fig.10

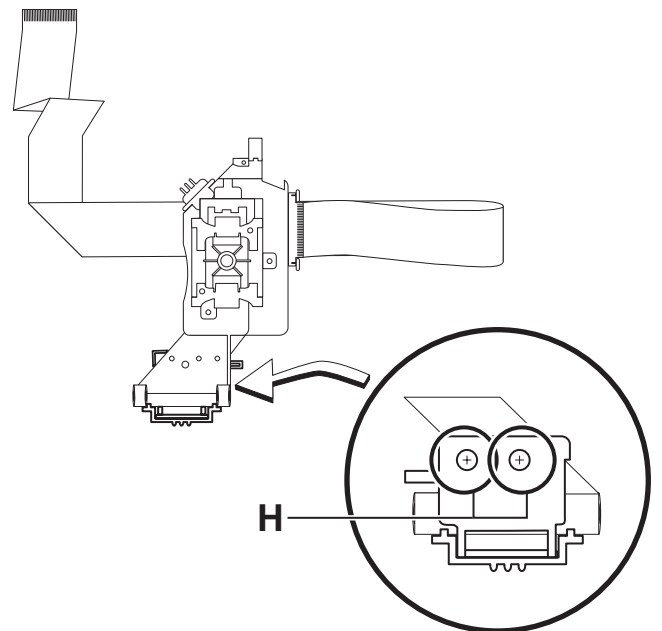

Fig.11

3.3.7 Removing the side (L)
(See Fig.12 to 14)

- (1) Remove the two screws **J** attaching the side (L). (See Fig.12)
- (2) From the side of body, remove the spacer fixing the tray switch board and motor board. Disconnect connector **CN3** on the tray switch board and detach the side (L) upward. (See Fig.13)
- (3) Remove the one screw **K** attaching the tray switch board. (See Fig.14)
- (4) Push the joint tab **d** of the side (L) in the direction of the arrow and remove the tray switch board outward, then release joint **f**. (See Fig.14)

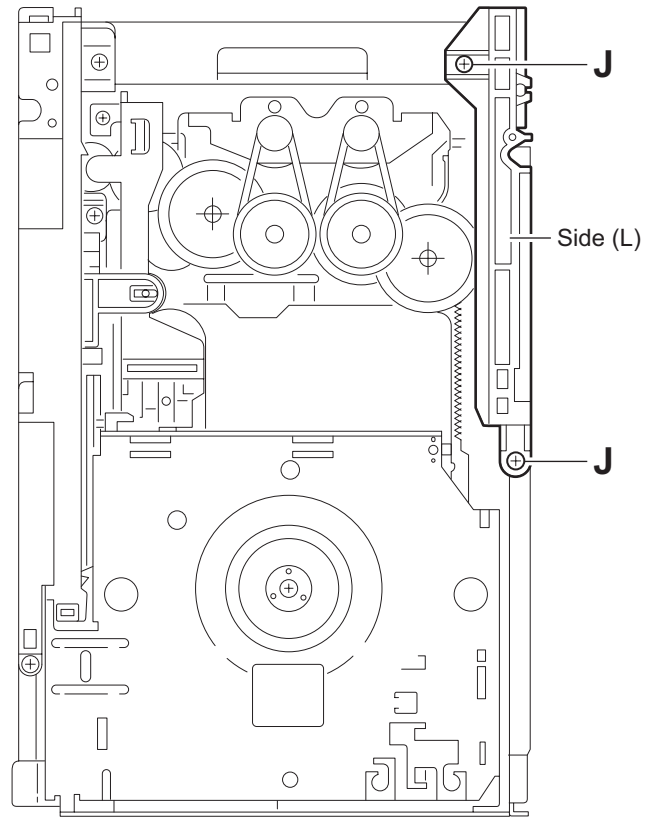

Fig.12

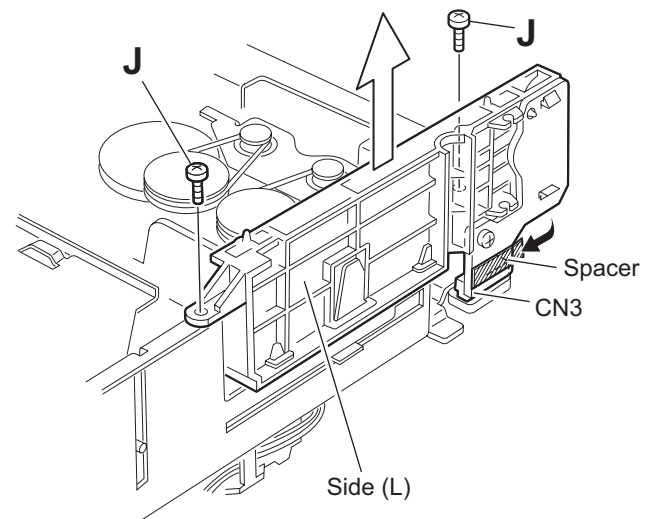

Fig.13

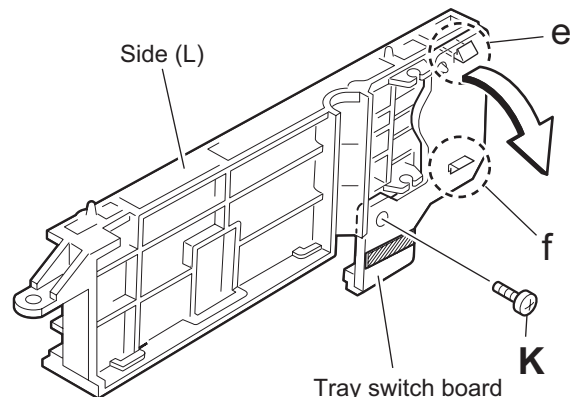

Fig.14

3.3.8 Removing the side (R) assembly (See Fig.15 to 19)

- (1) Remove the three screws **L** attaching the side (R) assembly. (See Fig.15)
- (2) Remove the spring attached to part **g** of the hook on the right side of the body. (See Fig.16)
- (3) Push and release the two tabs **h** of the gear cover through the notches inside the side (R) assembly. Remove the gear cover outward. (See Fig.17)
- (4) From top of the body, turn the 1 gear clockwise to move the elevator cam rearward. Move the two slots **k** and joint **m** of the elevator cam as shown Fig.18 and remove the elevator cam outward.
- (5) Remove the three screws **M** and detach the side (R) upward. (See Fig.19)

Caution:

When reattaching the side (R) assembly, make sure to fit the shaft into the slot of the select lever.

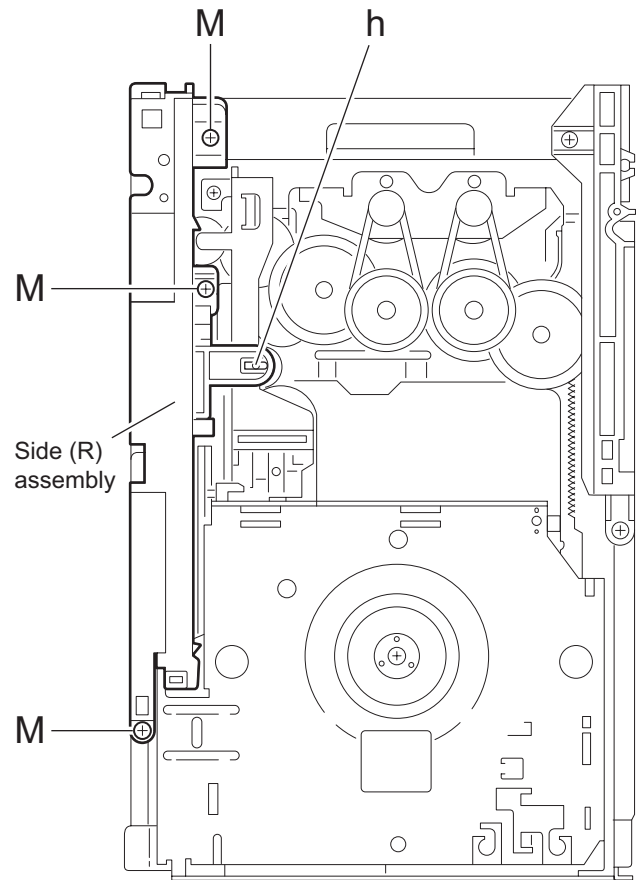
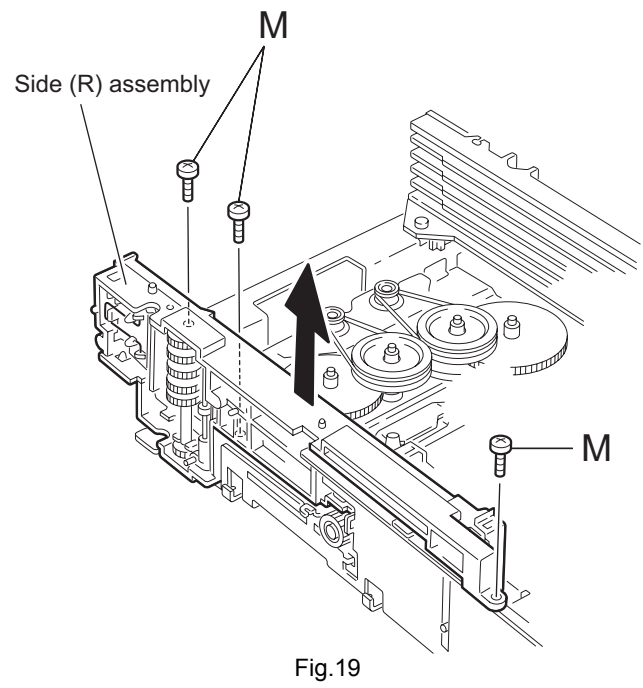
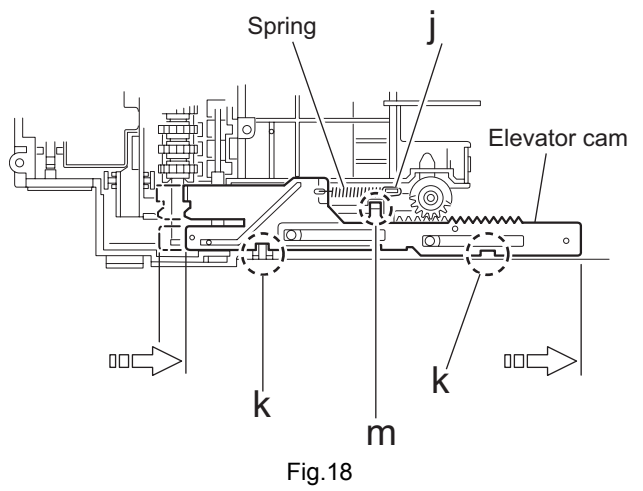
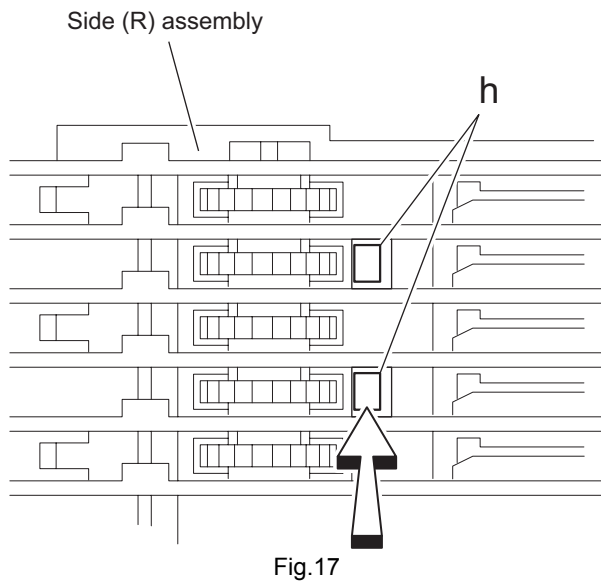
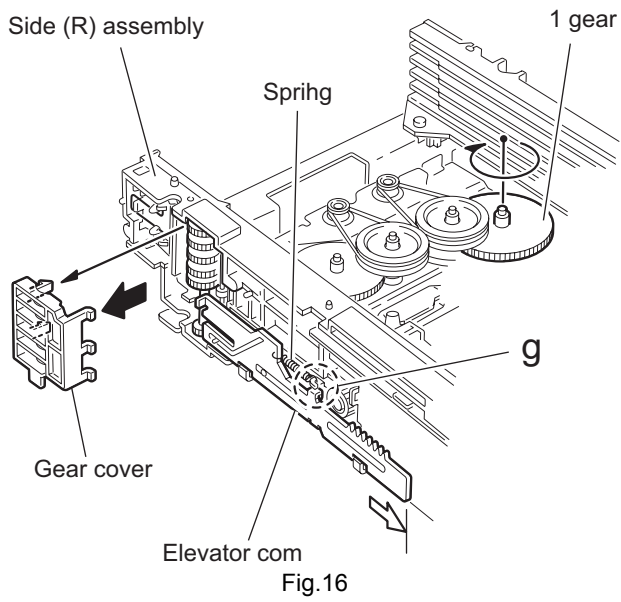

Fig.15



3.3.9 Removing the lifter assembly (See Fig.20 to 24)

- (1) From top of the body, turn the 1 gear clockwise to move the lifter assembly upward. (See Fig.20)
- (2) From top of the body, turn 2 gear clockwise to move the hook toward the front until it stops. (See Fig.20)
- (3) Move the hook stopper in the direction of the arrow while pushing the tab **n** of the hook stopper to unlock it. Release four joints **p** to detach from rack holder. Release the rod from part **q**. (See Fig.21 and 22)
- (4) Turn 1 gear clockwise again to move the lifter assembly upward. (See Fig.23)
- (5) Remove the lifter assembly from the body upward at position **r** where the four pins on the right and left sides of the lifter assembly fit to the notches of the **s**. Move the lifter assembly toward the front and release from the gook. (See Fig.23 and 24)

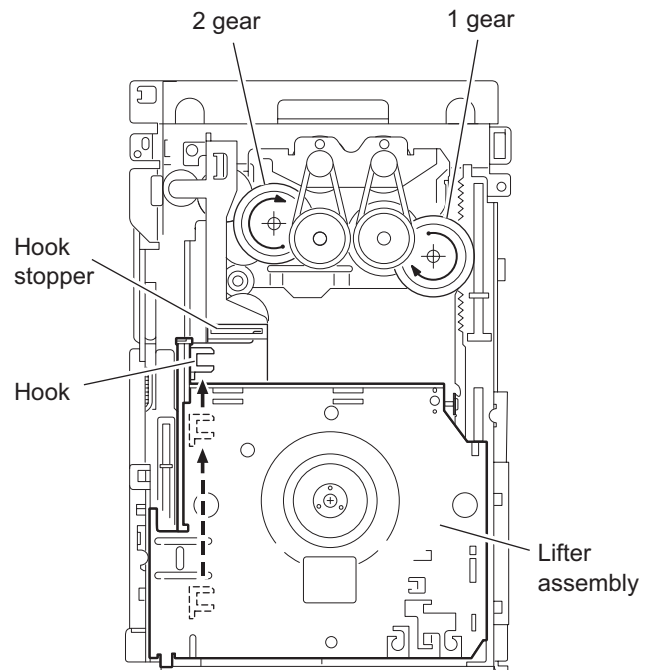

Fig.20

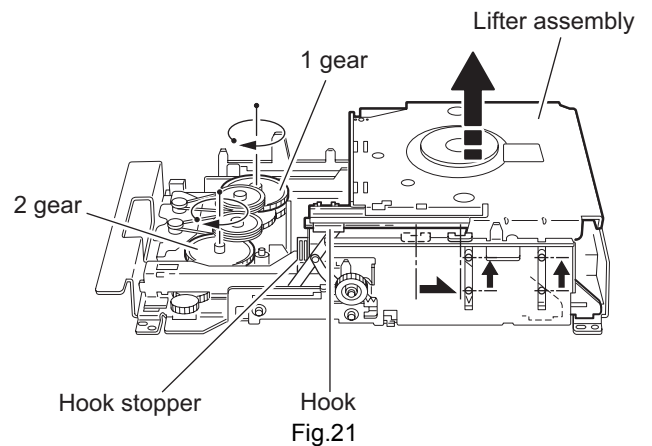

Fig.21

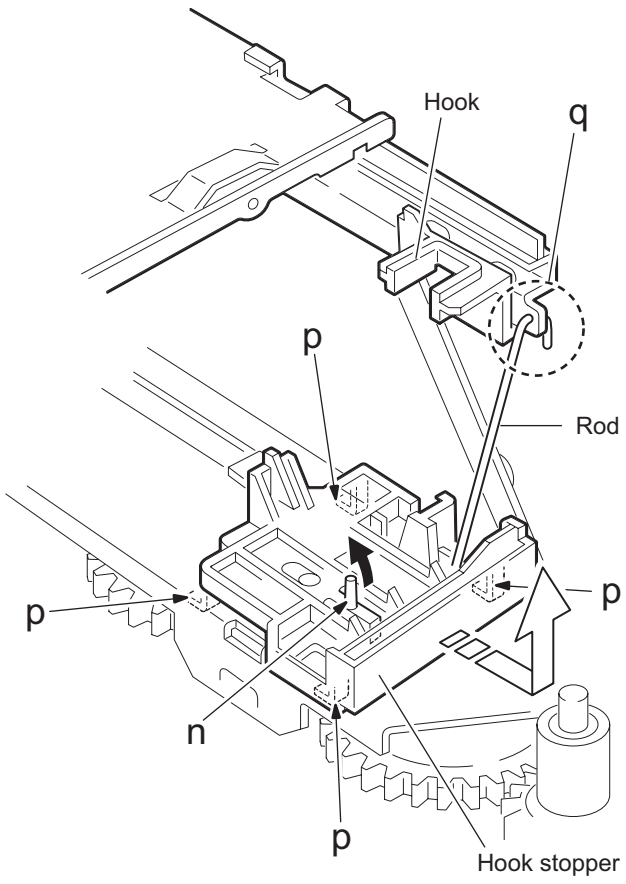

Fig.22

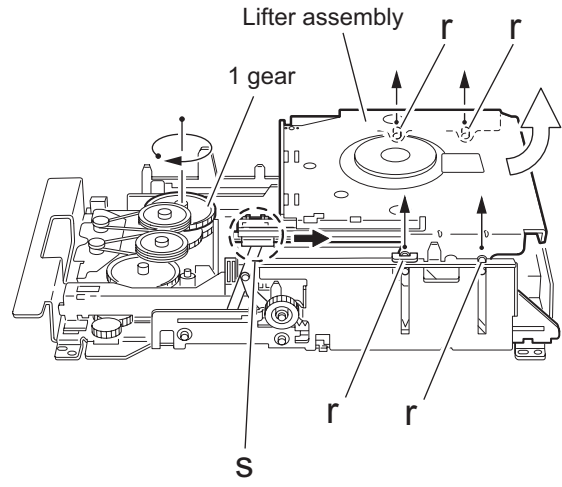

Fig.23

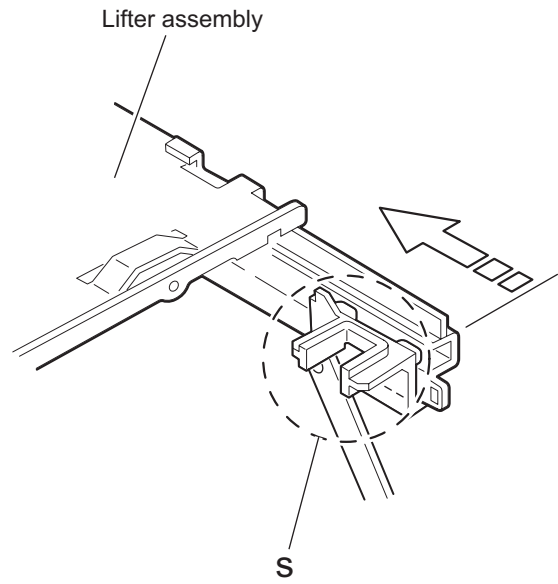

Fig.24

3.3.10 Removing the rack holder assembly / sensor assembly (See Fig.25 to 30)

Attention:

If the slide gear of the body places at joint **u** of the rack holder assembly, turn the 1 gear counterclockwise to move the slide gear toward the front. Remove the rack holder assembly.

- (1) Remove the three screws **N** attaching the rack holder assembly. Release joint **u** from the notch.

Caution:

When reattaching the rack holder assembly, do not nip the wire **v** extending from the sensor assembly.

- (2) Move the sensor assembly in the direction of the arrow to release from slot at joint **y**.
- (3) Remove the spring attached to the bottom of the sensor assembly from the boss **z** on the sensor slider.
- (4) Remove the screw **P** and **Q** attaching the sensor board and SV resister respectively. If necessary, unsolder the sensor board.

Caution:

When reattaching the SV resister, attach the sensor slider to the sensor bracket and fit the lever on the bottom of the SC resister into slot **a'** of the sensor slider.

Caution:

When reattaching the rack holder assembly, turn the 1 gear clockwise to move the slide gear and slide lever inside the body rearward.

- Let the wire extending from the sensor assembly through notch **x** to the bottom of the body.
- Fix pin **c'** of the slide lever into hole **b'** on the sensor slider on the bottom of the sensor assembly while attaching the spring to the boss **z** of the sensor slider.
- Engage joint **y** of the sensor assembly to the notch of the body.

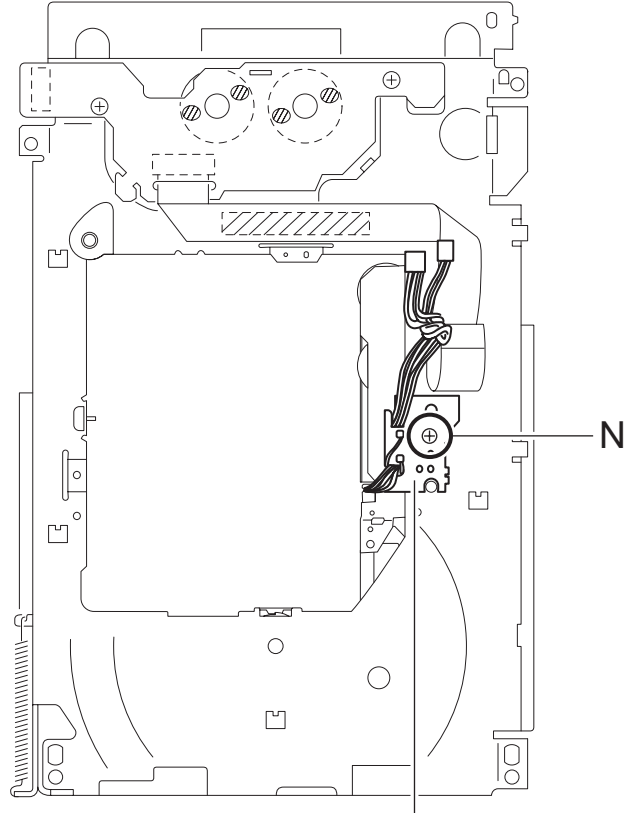

Switch board
Fig.25

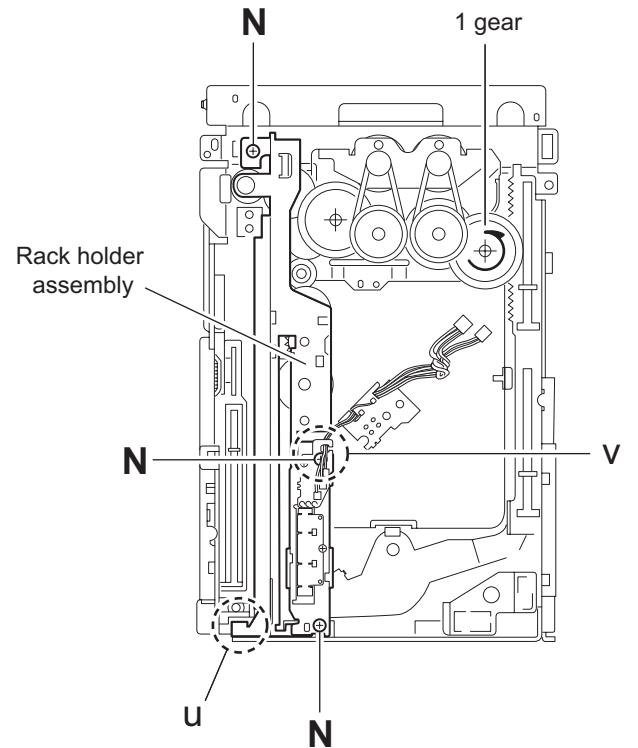

Fig.26

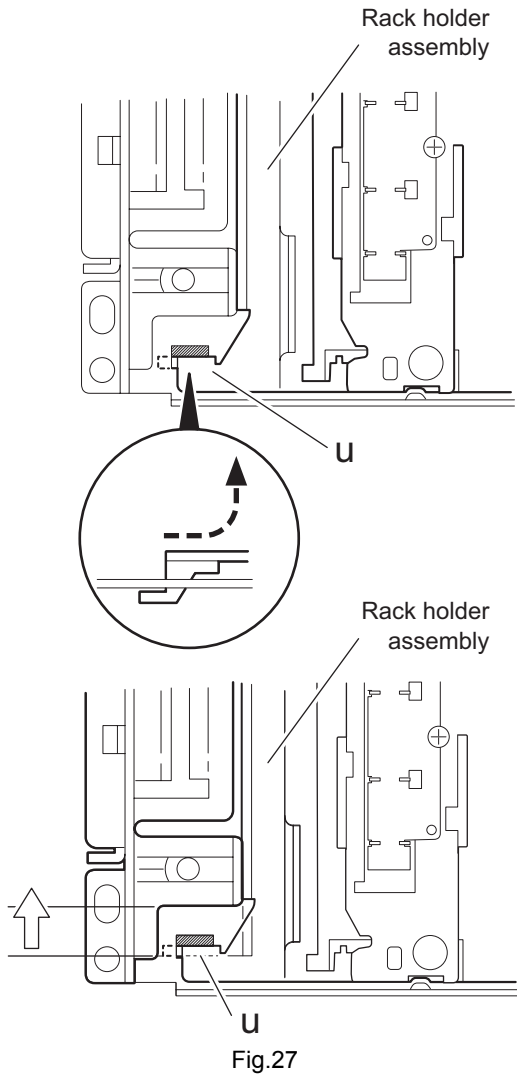

Fig.27

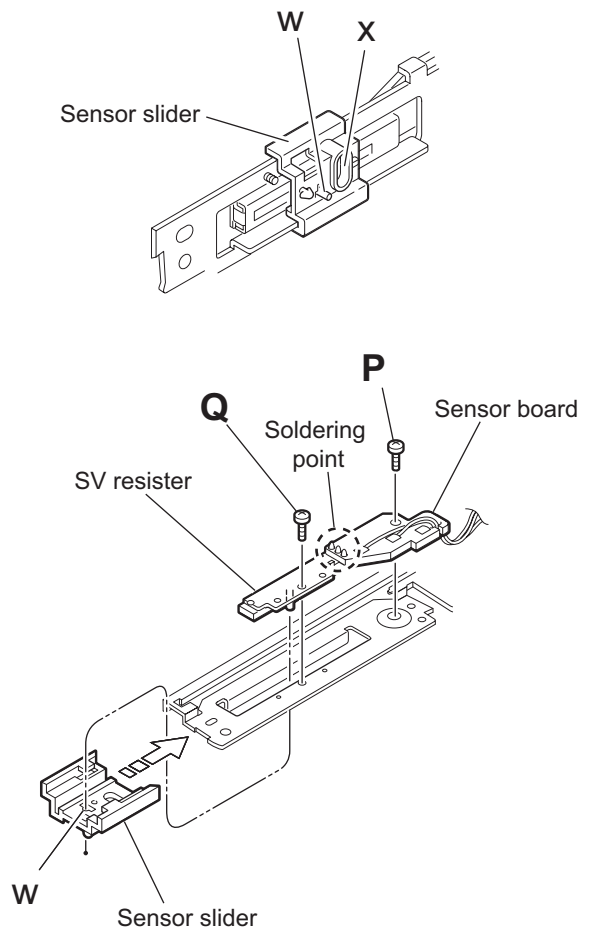

Fig.29

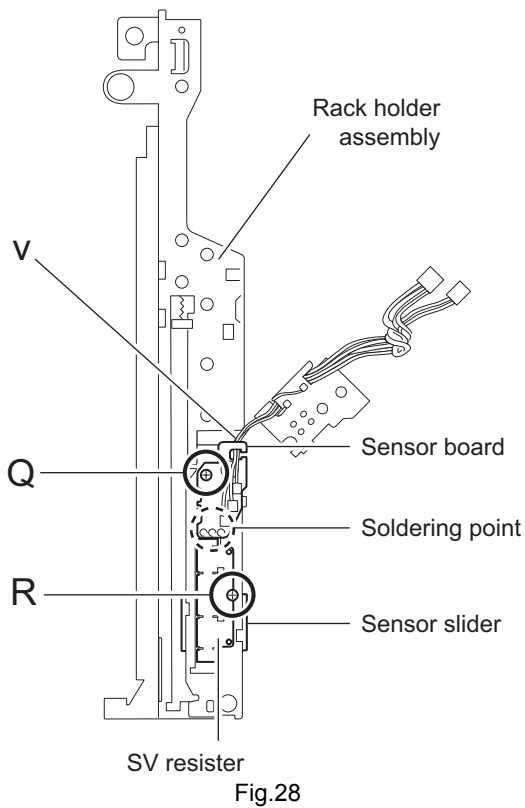

Fig.28

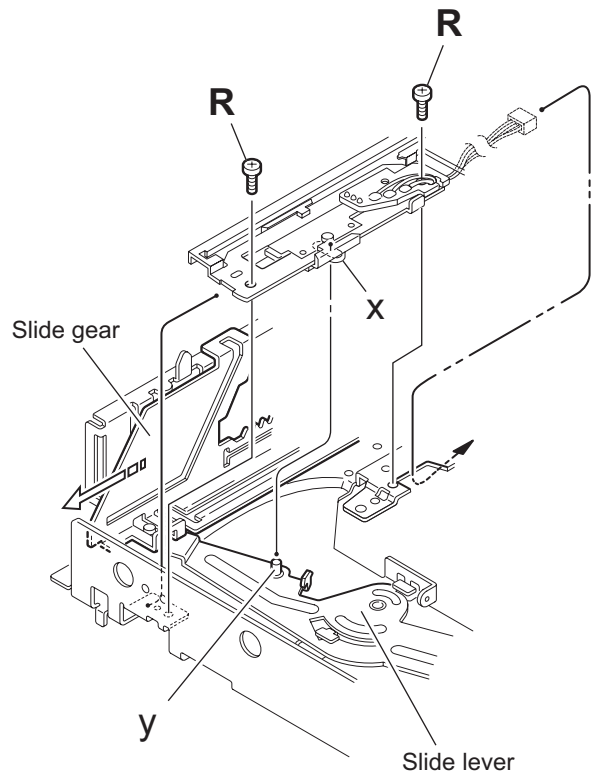

Fig.30

3.3.11 Removing the motor (See Fig.31 and 32)

Attention:

- You need not to remove the tray assembly, and in such case, move it.
- (1) Remove the two belts on top of the body.
 - (2) Remove the two screws **S** attaching the motor.
 - (3) Remove the motor from the bottom of the body.

Attention:

When removing the motor board with the motor, you need not to unsolder four solder parts.

Caution:

When reattaching the motor, turn the side where the label should be put to the front side.

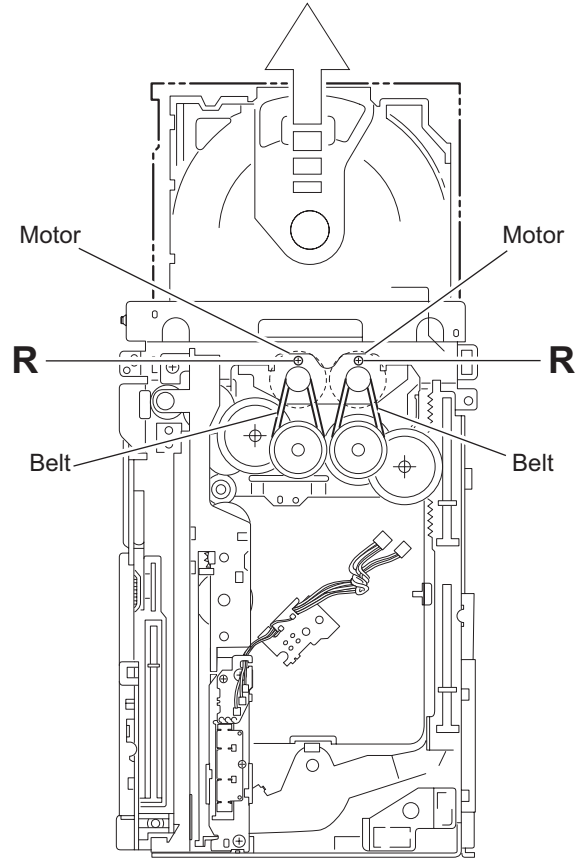

Fig.31

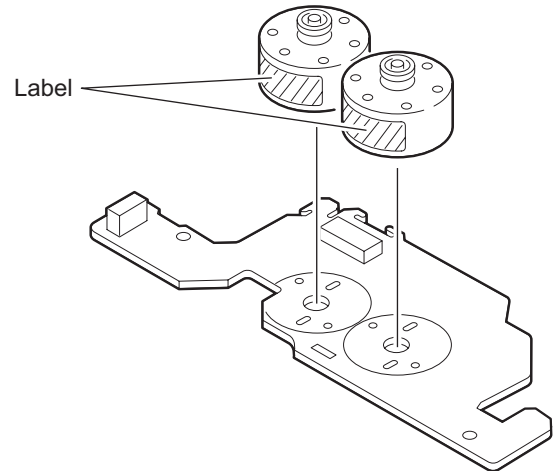

Fig.32

3.3.12 Taking out the disc in play mode (See Fig.33 to 36)

Attention:

Refer to "Removing the tray assembly".

- (1) Remove the top cover upward.
- (2) Unlock the tray assembly and draw out the tray assembly toward the front.
- (3) From top of the body, turn the 1 gear clockwise to move the lifter assembly upward.
- (4) From top of the body, turn 2 gear clockwise to move the sub tray remaining inside the lifter assembly toward the front, then pull out.
- (5) Take out the disc on the sub tray.
- (6) After clearing away the disc, insert the sub tray into the main tray.

Caution:

When reattaching the sub tray, move the tray stopper on the bottom of the tray in the direction of the arrow to lock the sub tray certainly.

- (7) Push the tray assembly toward to body and reattach.

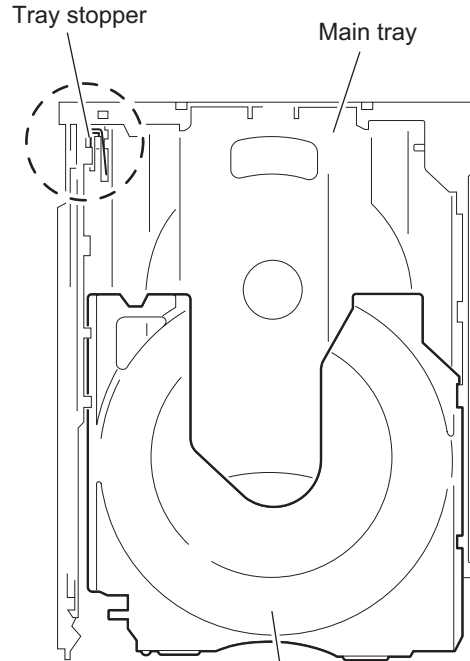

Sub tray
Fig.35

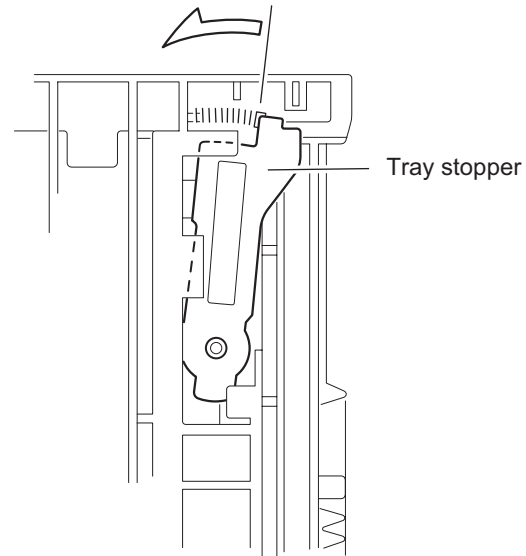

Fig.36

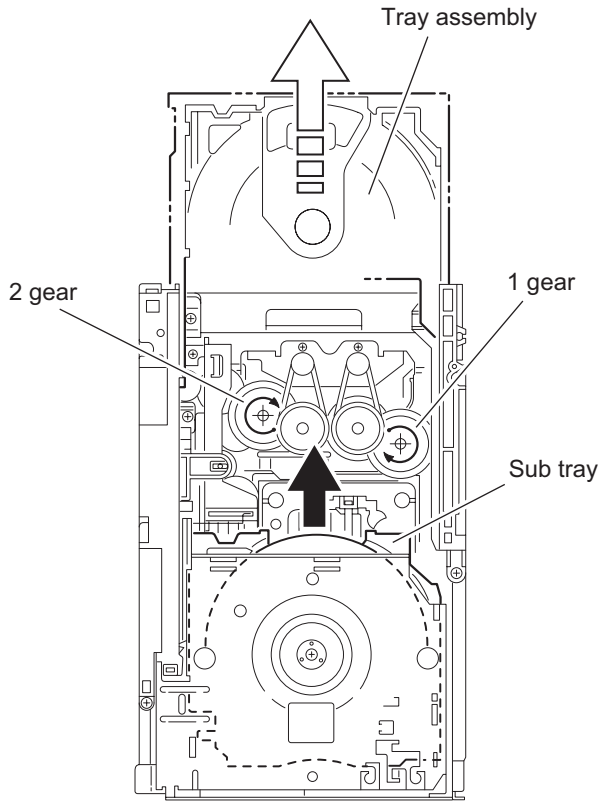

Fig.33

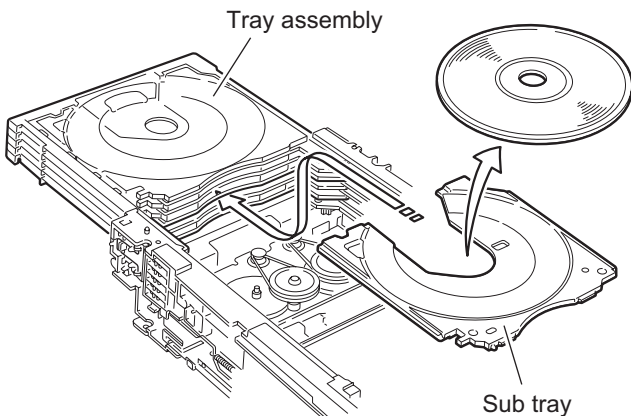

Fig.34

SECTION 4 ADJUSTMENT

4.1 ATTENTION IN SERVICE OF DVD SECTION

- (1) When pickup, Flash ROM ,DVD module board were changed, initialize EEPROM by all means.
- (2) When full initialization was excuted, excute learning with a DVD test disc by all means.
 Test disc : VT-501, VT-502
 Learning method : It is adjusted automatically by normal playback of a DVD disc.

4.2 TEST MODE

4.2.1 OUTLINE

To the set which is using the DVD module, in order to perform common correspondence in production, TEST mode is prepared. Table 1 is corresponded in TEST mode.

MODE	CONTENTS
The destination, a region, study state check mode	Indication the distination code, region number and study state fo DVD micon.
NORMAL initialize, FULL initialize	Mode of DVD micon initialize. Initialize has NORMAL initialize and FULL initialize. NORMAL initialize : Initialize the value of user setting item, like a indication contents of SETUP OSD. FULL initialize : Plus the contents of study which are carrying out the memory by FRONT END for lead shortening are initialized for NORMAL initialize contents.
Device key write (CPPM, CPRM)	For device key writing mode. Device key have CPPM(DVD Audio) and CPRM(VR).
Device key check sum indication mode	Indication the wrote device key check sum. Indication this value, it can check the device key was wrote or not.
Micon version indication mode	Indication System micon, DVD micon, other ROM version. With a set, correspondence and the contents of correspondence shall be individual, and shall be decided.
FL all on mode	Mode of FL (LCD) all on. With a set, correspondence and the contents of correspondence shall be individual, and shall be decided.
FRONT END check mode	Mode of relation of FRONT END.

Table 1. Contents corresponding to TEST mode.

4.2.2 SET OPERATE

TEST mode performs correspondence by operation specially so that a user cannot enter.

- TEST MODE start should be press PLAY key & POWER key of main unit together and keep condition, connect AC.
- After set up TEST MODE, mode select by MENU key.

The changes to the key in TEST mode are shown in Fig. 1.

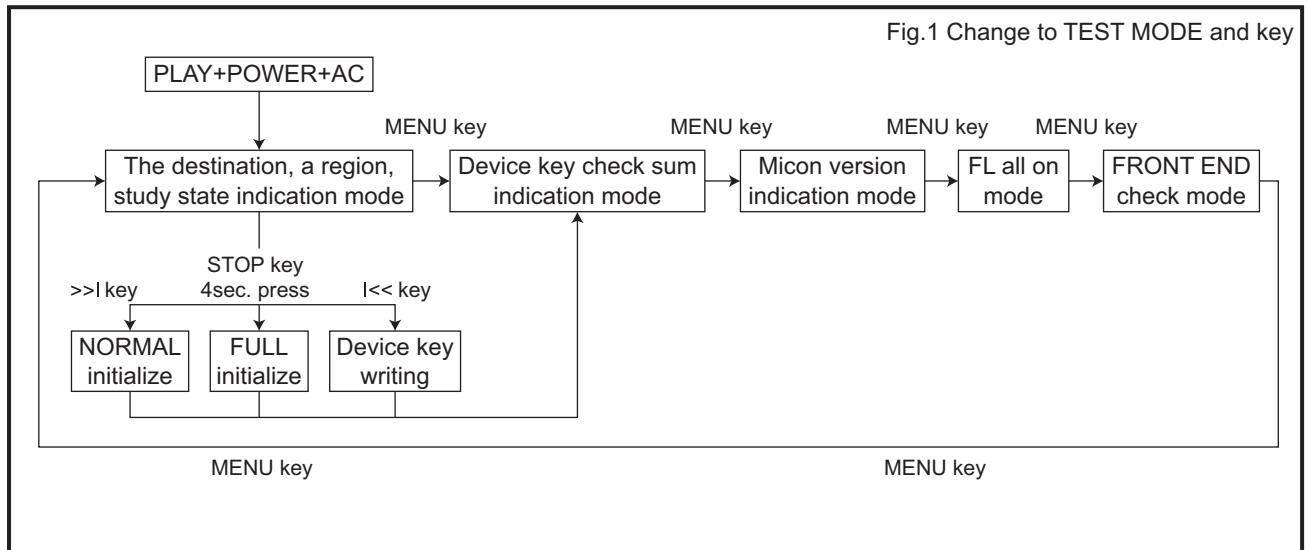

(*1) : Shift from destination, region and study state indication mode to NORMAL initialize, FULL initialize and device writing mode should only can main unit key.

4.2.3 PROCESS

Below, FL (LCD) display to operation and communication with a DVD back end micon are shown.

- Since the number of beams changes with sets about FL (LCD) display, also set differing from the contents of specification to O.K.
- Since there are arrangement and a relation of existence with a set also about a key, also set differing from the contents of specification to O.K.

STEP	OPERATION	MOVEMENT	FL (LCD) indication													REMARKS				
			1	2	3	4	5	6	7	8	9	10	11	12	13					
1	Release AC, press PLAY & POWER key together of main unit.																			
2	Keep STEP 1, connect AC.	The destination, a region, study state indication mode. Indication the destination by TEST mode power on.	T		J	C	#	*	*											
	① Press >>I key of main unit. (NORMAL initialize)		T		J	C	#	*	*											
	② Long press(4sec) STOP key of main unit. (FULL initialize)		T		J	C	#	*	*											
	③ Press << key of main unit.	Mode to device key writing mode	D		K	E	Y													
3	Press MENU key of remocon.	Device key check sum indication mode. Indication check sum of device key for FL. (4byte)	①	②	③	④	⑤	⑥	⑦	⑧										
4	① Press MENU key of remocon.	Indication the micon version and Backend version for FL.	a	b	b		c	c	c	c										
	② Press MENU key of remocon.	Indication the mecha micon version for FL.	d	e	e															
5	Press MENU key of remocon.	All on the FL and LED.																		
6	Press MENU key of remocon.	Indication the FRONT END check mode for FL.	C	H	E	C	K													
	① Press 1 at 10 key of remocon.	Disc startup and through playback (Playback starts from the start position).	C	H	E	C	K													
	② Press 4 at 10 key of remocon.	CD_LD on & Laser current indication.	*	*	*	*	*	*	*	*	*	*	*	*	*	*	*	*	*	*
	③ Press 5 at 10 key of remocon.	DVD_LD on & Laser current indication.	*	*	*	*	*	*	*	*	*	*	*	*	*	*	*	*	*	*
	④ Press 6 at 10 key of remocon.	DVD_SL x 1 jitter measurement mode.	*	*	*	*	*	*	*	*	*	*	*	*	*	*	*	*	*	*

STEP	OPERATION	MOVEMENT	FL (LCD) indication													REMARKS		
			1	2	3	4	5	6	7	8	9	10	11	12	13			
7	⑤ Press 10 at 10 key of remocon.	DVD-DL (parallel, opposite), Serch & jitter measurement of the specified position of DVD-SL.	*	*	*	*	*	*	*	*	*	*	*	*	*			Upper:0x00-0x06 (Measured position with VT-501) Lower:Jitter value
	⑥ Press STOP key of main unit/ remocon.	Disc stop, LD-OFF.		C	H	E	C	K										
	⑦ Press OPEN/CLOSE key of main unit/remocon.	Tray open/close.																
	⑧ Press PLAY key of main unit/ remocon.	Disc playback.	*	*	*	*	*	*	*	*	*	*	*	*	*	*	*	Upper:Laser current value (Backup value, Real measured value) Lower:Jitter value
7	Press MENU key of remocon.	Return to STEP2.																
	Press POWER key of main unit.	Releasr the TEST MODE.																When this key is pushed any STEP, the test mode is canceled.

*1 Mode toggle by press MENU key.

*2 STEP2-3 and STEP3 are only for DVD-AUDIO or VR correspondence model.

4.3 DVD special mode

4.3.1 Special mode

Mode name	Operation	Function
DVD up grade	Load up grade disc	Do the update the DVD firmware.
ROM CORR (System micon)	Load ROM CORR disc	Do the repair of system micon problem. Model number of ROM CORR is A300
ROM CORR (Mecha micon)	Load ROM CORR disc	Do the repair of mecha micon problem. Invalid the inside of TEST mode.

4.3.2 DVD upgrade

Processing	FL indication	Display (OSD) indication	Remarks
TOC READ	"READING"	NOW READING	TOC reading
DATA READ	"UPGRADE"	VERSION UP DISC PROGRAM&DESTINATION MODE CURRENT VERSION **** NEW VERSION **** READING.. SECTOR ****	Disc data reading Indicate firm current versin, new version and reminder sector quantity. Only [POWER] [OPEN/CLOSE] key of a main unit is validated.
WRITING	"_OPEN_"	VERSION UP DISC PROGRAM&DESTINATION MODE CURRENT VERSION **** NEW VERSION **** WRITING..	Writing the data to flash rom. Input a main unit and all the key of remote control are forbidden.
END	"_OPEN_"	OPEN	Upgrade completed. Prohibition of a key input is canceled as initialization end status.

4.3.3 ROM correction (System micon)

Processing	FL indication	Display (OSD) indication	Remarks
TOC READ	"READING"	NOW READING	TOC reading
DATA READ	"ROM_CORR"	VERSION UP DISC SYSICON UPG MODE CURRENT VERSION **** READING.. SECTOR 1	Disc data reading Indicate firm current versin. Only [POWER] [OPEN/CLOSE] key of a main unit is validated.
WRITING	"ROM_CORR"	VERSION UP DISC SYSICON UPG MODE CURRENT VERSION **** WRITING..	Writing the data to EEPROM. Input a main unit and all the key of remote control are forbidden.
END	"COMPLETE"	VERSION UP DISC SYSICON UP MODE CURRENT VERSION **** WRITING..	ROM CORRECTION completed. Prohibition of a key input is canceled as ROM CORR completed status.

*ROM CORR data confirm

The following processings are performed in order to prevent that fault occurs, when a new micon / the old micon / ROM collection is intermingled.

The data (ID) which a micon should make a judgment standard is stored in a [E2PROM] start address [2 bytes].

A data format presupposes that it is free (the version of the data which can be differentiated etc. is desirable).

When the [ROM coll data area] of [E2PROM] is read at the time of a reset start and data exists, it processes by judging whether it is by the [ROM coll] data which should be applied.

In the case of the data which should be applied [good] : It progresses to the following step by un-processing.

In the case of the data which should be applied and which does not come out, it is [no] : All the [ROM coll data area] of [E2PROM] is cleared (FF).

4.3.4 ROM correction (Mecha micon)

Processing	FL indication	Display (OSD) indication	Remarks
TOC READ	"READING_"	NOW READING	TOC reading
DATA READ	"READING_" "READING_"	VERSION UP DISC SYSCON UPG MODE CURRENT VERSION **** READING.. SECTOR 1	Disc data reading Indicate firm current versin. Only [POWER] [OPEN/CLOSE] key of a main unit is validated.
WRITING	"REDING_"	VERSION UP DISC SYSCON UPG MODE CURRENT VERSION **** WRITING..	Writing the data to EEPROM. Input a main unit and all the key of remote control are forbidden.
END	"MECH_OK_"	VERSION UP DISC SYSCON UP MODE CURRENT VERSION **** WRITING..	ROM CORRECTION completed. Prohibition of a key input is canceled as without disc type is UPGRADE status.

4.4 Key special mode

Mode name	Operation	Function
Tuner 9k/10k select (U*version)	Press STOP key & PLAY key together at TUNER AM then 9kHz step.	9kHz/10kHz step select of TUNER AM band. Indication "9k STEP" , "10k STEP"
	Press STOP key & PAUSE key together at TUNER AM then 10kHz step.	
TRAY LOCK	Press STOP key & EJECT1 key together at P.OFF.	Do the TRAY LOCK mode select. Temporarily P.ON operation, select "LOCKED", "UNLOCKED". (Not done P.ON operation). Transience (2sec.) indication end, and then return to P.OFF mode. When press the EJECT key at LOCK mode, at P.OFF condition temporarily P.ON operation and then transience (2sec.) indication "LOCKED". At P.ON condition, transience (2sec.) indication "LOCKED".
DVD TEST MODE	At AC off line condition, press PLAY+POWER together and keep condition, connect AC.	"Operation to TEST mode to on of DVD backend. Operation of internal TEST MODE is refer the TEST mode."

4.5 Remocon special mode

Mode name	Operation	Function
COLD START	2-times input at P.OFF.	"Fix by 2 time input, operation temporarily P.ON and then transience(3sec.) indication "COLD SET". Indication end, done the P.OFF mode. AC to off line, operation the COLD START.B330 : remote controller press POWER + STOP + 0 key together."
FL all on Preset frequency writeing	Input at P.ON.	"Rewrite preset frequency, LED on chek(each 300ms), FL all on. LED on turn: STANDBY - ILLUMI - REMOCON<VOL+> - <VOL->Volume control of key input, keep high-speed mode until POWER OFF. B331 : Remocon POWER + STOP + 1 key together"
Version indication	Input at P.ON.	"Indication turn Syscon version - Unit version - Distination, Chip select by transience(5 sec.). Syscon version : "SC ## \$\$" (## : Sys version,\$: Sys ROM-corr) Unit version : "BE %%%%"(%%%% : Unit version) Distination, Chip select 1 : "\$K%H%"(\$\$: sys distination, K% : KARAOKE H% : HDMI CS, S% : SOURCE CS % are each select status 0 or 1) B33E : Press remocon POWER + STOP + 10 key together."

SECTION 5 TROUBLESHOOTING

This service manual does not describe TROUBLESHOOTING.



JVC

Victor Company of Japan, Limited
Audio/Video Systems Category 10-1, 1chome, Ohwatari-machi, Maebashi-city, 371-8543, Japan

(No.MB506)

PARTS LIST

TH-C30J,TH-C30C,TH-C20J,TH-C20C

* All printed circuit boards and its assemblies are not available as service parts.

- Contents -

Exploded view of general assembly and parts list (Block No.M1)	3- 2
Speaker assembly and parts list(Subwoofer) (Block No.M2)	3- 5
DVD mechanism assembly and parts list (Block No.MJ)	3- 7
DVD changer mechanism assembly and parts list (Block No.MK)	3- 9
Electrical parts list (Block No.01~05)	3-11
Packing materials and accessories parts list (Block No.M3)	3-22

Exploded view of general assembly and parts list

Block No.

M	1	M	M
---	---	---	---

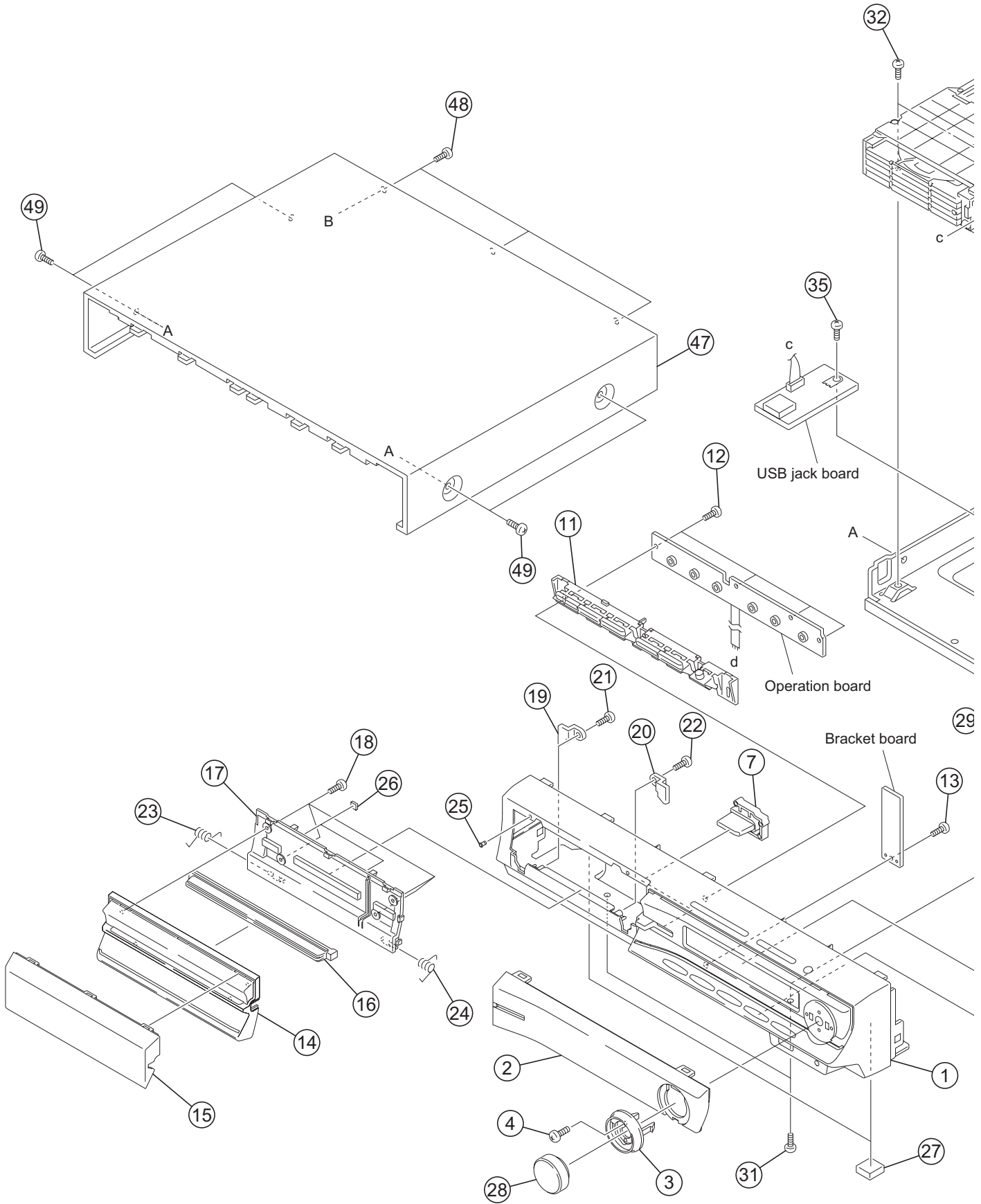

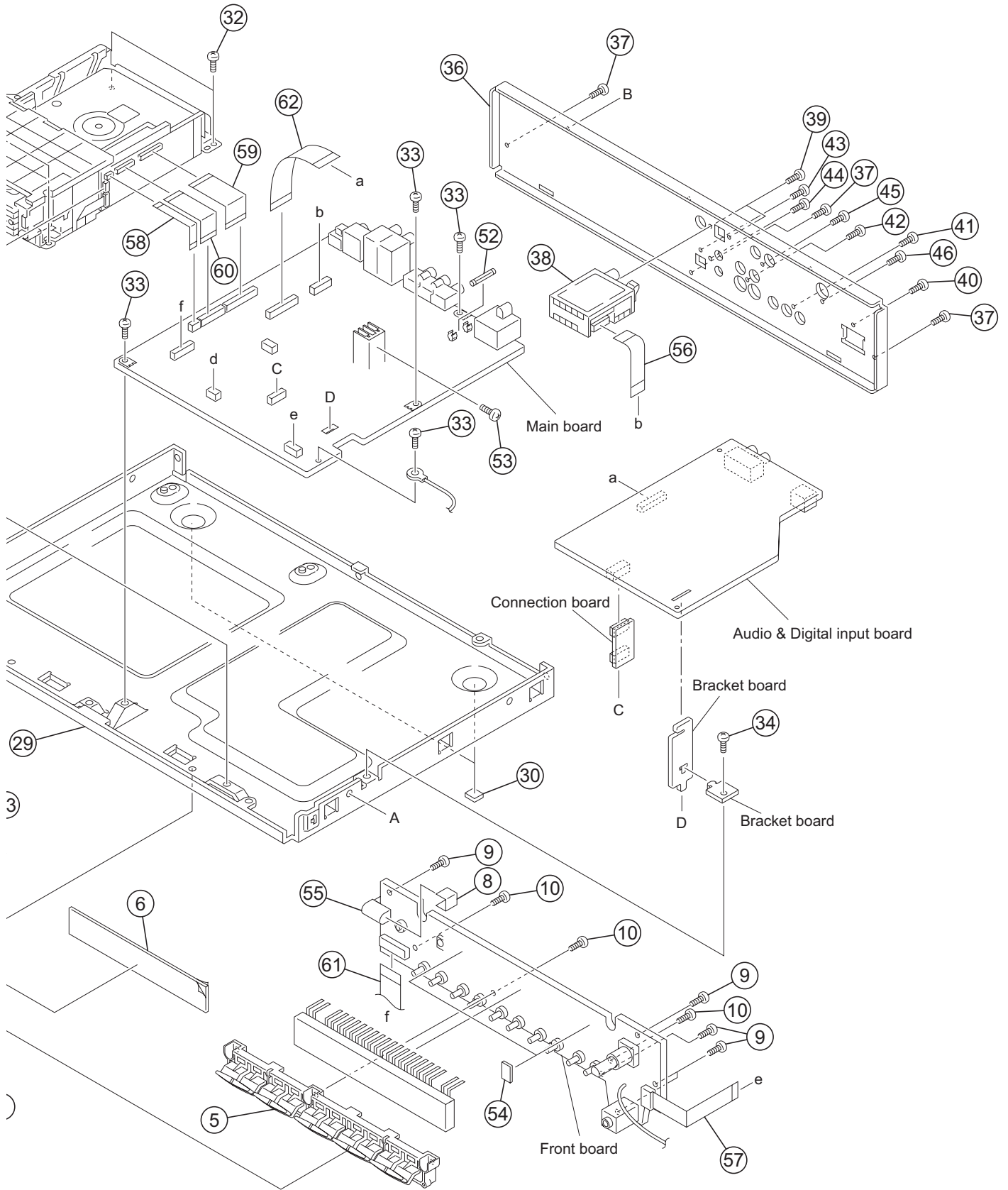

General Assembly

Block No. [M][1][M][M]

△	Symbol No.	Part No.	Part Name	Description	Local
	1	LV11209-003A	FRONT PANEL		
	2	LV22243-001A	FRONT LENS		
	3	LV34588-001A	VOL RING		
	4	QYSDSF2608ZA	TAP SCREW	M2.6 x 8mm	
	5	LV22242-002A	BUTTON(DISC)		
	6	LV42851-006A	FL SCREEN		
	7	LV36581-001A	POWER BTN ASSY		
	8	LV30227-045A	SPACER		
	9	QYSBSF2610ZA	TAP SCREW	M2.6 x 10mm(x5)	
	10	QYSBSF2610ZA	TAP SCREW	M2.6 x 10mm(x3)	
	11	LV22244-001A	BUTTON(TOP)		
	12	QYSBSF2610ZA	TAP SCREW	M2.6 x 10mm(x4)	
	13	QYSBSF2610ZA	TAP SCREW	M2.6 x 10mm	
	14	LV22246-002A	DOOR COVER		
	15	LV22247-005A	DOOR LENS		C30J,C30C
	15	LV22247-003A	DOOR LENS		C20J,C20C
	16	LV36583-001A	ILLUMI LENS		
	17	LV22245-001A	DOOR BASE		
	18	QYSDSF2608ZA	TAP SCREW	M2.6 x 8mm(x4)	
	19	LV41694-201A	DOOR BKT(L)		
	20	LV41695-201A	DOOR BKT(R)		
	21	QYSDSF2608ZA	TAP SCREW	M2.6 x 8mm	
	22	QYSDSF2608ZA	TAP SCREW	M2.6 x 8mm	
	23	LV44491-001A	DOOR SPRING(L)		
	24	LV44492-001A	DOOR SPRING(R)		
	25	E69897-002	CUSHION		
	26	LV30227-050A	SPACER	(x2)	
	27	LV40301-002A	FELT SPACER	(x2)	
	28	LV34594-001A	VOLUME KNOB		
	29	LV11210-001A	CHASSIS BASE		
	30	LV40301-002A	FELT SPACER	(x2)	
	31	QYSBST3006EA	TAP SCREW	M3 x 6mm(x2)	
	32	QYSBST3006EA	TAP SCREW	M3 x 6mm(x4)	
	33	QYSBST3006EA	TAP SCREW	M3 x 6mm(x4)	
	34	QYSBST3006EA	TAP SCREW	M3 x 6mm	
	35	QYSBST3006EA	TAP SCREW	M3 x 6mm	
	36	LV22249-019A	REAR PANEL		C30J,C30C
	36	LV22249-018A	REAR PANEL		C20J,C20C
	37	QYSBSGY3008EA	TAP SCREW	M3 x 8mm(x3)	
	38	QAU0412-001	TUNER		
	39	QYSBSGY3008EA	TAP SCREW	M3 x 8mm(x2)	
	40	QYSBSGY3008EA	TAP SCREW	M3 x 8mm	
	41	QYSBSGY3008EA	TAP SCREW	M3 x 8mm	
	42	QYSBSGY3008EA	TAP SCREW	M3 x 8mm	
	43	QYSBSGY3008EA	TAP SCREW	M3 x 8mm	
	44	QYSBSGY3008EA	TAP SCREW	M3 x 8mm	
	45	QYSBSGY3008EA	TAP SCREW	M3 x 8mm	
	46	QYSBST3006EA	TAP SCREW	M3 x 6mm	
	47	LV22248-001A/S/	METAL COVER		
	48	QYSBSGY3008EA	TAP SCREW	M3 x 8mm(x3)	
	49	E406308-007	SPECIAL SCREW	(x4)	
△	52	QMFZ059-1R0-E	FUSE	F901	1A
	53	QYSBSE3008ZA	TAP SCREW	M3 x 8mm	
	54	LV30227-051A	SPACER	(x2)	
	55	LV36587-001A	LED HOLDER		
	56	QUQQ12-1107CJ-E	FFC WIRE	11pin 7cm	
	57	QUQQ12-0712CJ-E	FFC WIRE	7pin 12cm	
	58	QUQV10-0507CJ-E	FFC WIRE	5pin 7cm	
	59	QUQV10-2807CJ-E	FFC WIRE	28pin 7cm	
	60	QUQV10-1807CJ-E	FFC WIRE	18pin 7cm	
	61	QUQV10-1715CJ-E	FFC WIRE	17pin 15cm	
	62	QUQV10-2507CJ-E	FFC WIRE	25pin 7cm	

Speaker assembly and parts list

Block No. M 2 M M

(Subwoofer)

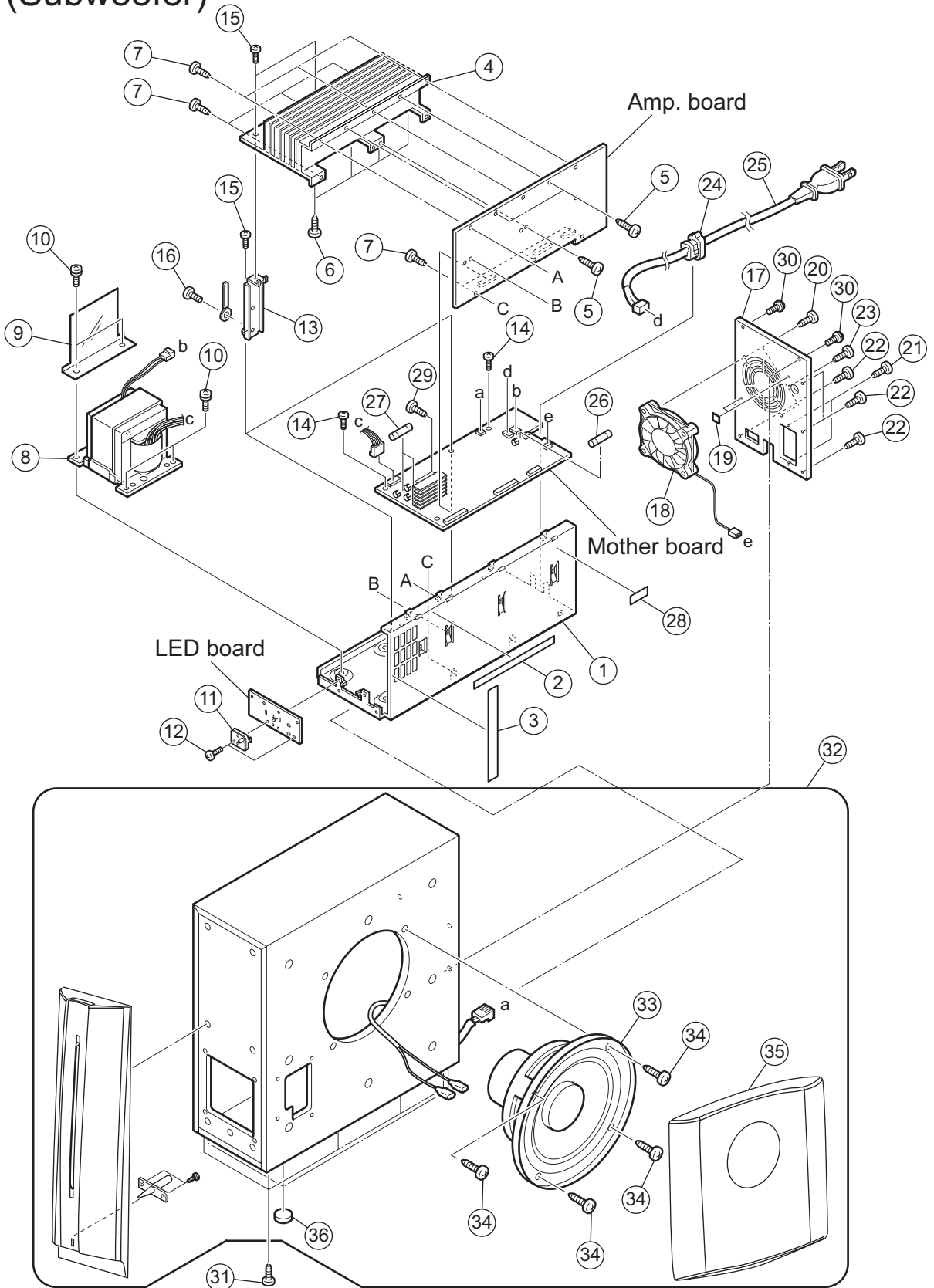

The parts without symbol number are not service.

Speaker(Subwoofer)

Block No. [M][2][M][M]

△	Symbol No.	Part No.	Part Name	Description	Local
	1	LV10875-002A	CHASSIS BASE		
	2	LV30225-0T5A	SPACER		
	3	LV30225-0T6A	SPACER		
	4	LV10951-201A	HEAT SINK		
	5	QYSBSG3010EA	TAP SCREW	M3 x 10mm(x3)	
	6	QYSBSG3016EA	TAP SCREW	M3 x 16mm(x4)	
	7	QYSBSG3010EA	TAP SCREW	M3 x 10mm(x9)	
△	8	QQT0482-004	POWER TRANSF		
	9	LV44309-201A	BARRIER		
	10	QYSBSTL4008EA	TAP SCREW	M4 x 8mm(x4)	
	11	LV43692-002A	LED HOLDER		
	12	QYSBSG3010EA	TAP SCREW	M3 x 10mm(x2)	
	13	LV34712-001A	HEAT SINK BKT	(x2)	
	14	QYSBSG3010EA	TAP SCREW	M3 x 10mm(x2)	
	15	QYSBSG3010EA	TAP SCREW	M3 x 10mm(x4)	
	16	QYSBSG3006ZA	TAP SCREW	M3 x 6mm(x2)	
	17	LV21652-027A	REAR PANEL		C30J,C30C
	18	LV21652-024A	REAR PANEL		C20J,C20C
	19	QAR0377-001	COOLING FAN		
	20	LV30225-0D5A	SPACER	(x2)	
	21	QYSBSGY3008MA	TAP SCREW	M3 x 8mm(x2)	
	22	QYSBSGY3008MA	TAP SCREW	M3 x 8mm(x2)	
	23	QYSBSGY3008MA	TAP SCREW	M3 x 8mm(x4)	
	24	QYSBST3006EA	TAP SCREW	M3 x 6mm	
△	25	QZW0033-001	STRAIN RELIEF		
△	26	QMPD330-200-JD	POWER CORD(US/CA)	2m BLACK	
△	27	QMF51U1-8R0-J8	FUSE	F101 8A AC125V	
△	28	QMF51U1-100-J8	FUSE	F153 F154 10A AC125V(x2)	
	29	LV43583-001A	LABEL		
	30	QYSPSPD3008ZA	SCREW	M3 x 8mm(x2)	
	31	QYSDSA4016MA	TAP SCREW	M4 x 16mm(x2)	
	32	QYSDST4014MA	TAP SCREW	M4 x 14mm(x8)	
	33	QAS0418-001	SPEAKER BOX	SPK WITH BOX-WO	
	34	LE10016-063A	CONE SPK		
	35	7001541606	TAPPING SCREW	(x4)	
	36	9916013701	SIDE PANEL ASSY		
		9000007961	FOOT	(x4)	

DVD mechanism assembly and parts list

Block No. M J M M

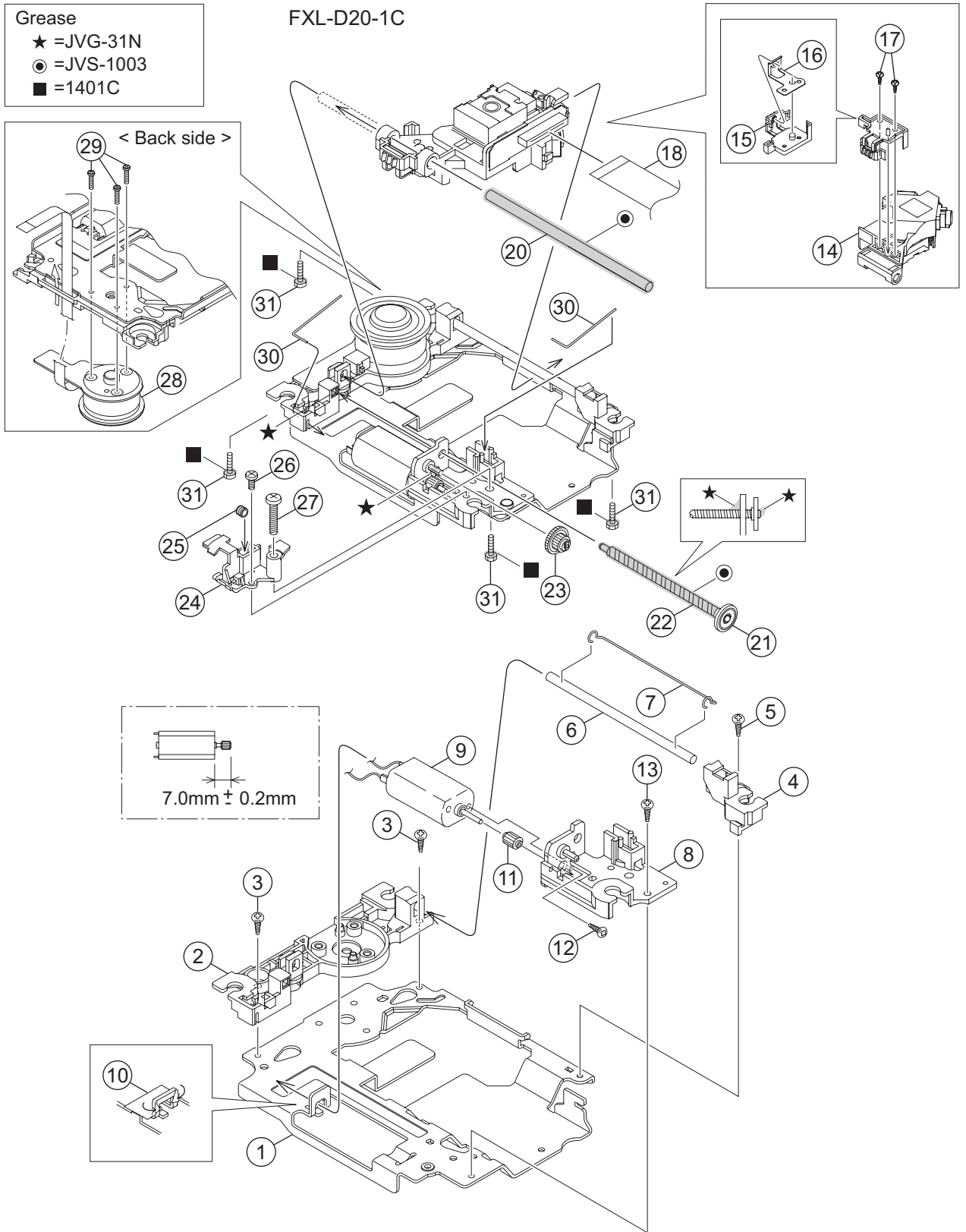

DVD mechanism

Block No. [M][J][M][M]

△	Symbol No.	Part No.	Part Name	Description	Local
	1	LV22234-001A	TM.CHASSIS		
	2	LV22294-001A	C.SPINDLE BASE		
	3	QYSDST2005ZA	TAP SCREW	M2 x 5mm(x2)	
	4	LV36791-001A	C.G.S.HOLDER		
	5	QYSDST2005ZA	TAP SCREW	M2 x 5mm	
	6	LV44041-002A	GUIDE SHAFT		
	7	LV44479-001A	BAR SPRING		
	8	LV22236-001A	FEED HOLDER		
	9	QAR0165-001	FEED MOTOR		
	10	LV30225-0X5A	SPACER		
	11	LV36557-001A	F.M.GEAR		
	12	QYSPSPT2030MA	SCREW	M2 x 3mm	
	13	QYSDST2005ZA	TAP SCREW	M2 x 5mm	
	14	QAL0786-002	P.UP		
	15	LV22237-001A	RACK ARM		
	16	LV36560-001A	RACK ARM SPRING		
	17	QYSPSFU1740ZA	TAP SCREW	M1.7 x 4mm(x2)	
	18	QUQK05-2424AC-E	FFC WIRE	24pin 24cm	
	20	LV44041-002A	GUIDE SHAFT		
	21	LV36559-001A	L.S.GEAR		
	22	LV41517-003A	LEAD SCREW		
	23	LV36558-001A	MIDDLE GEAR		
	24	LV36556-001A	SPRING HOLDER		
	25	LV44623-001A	COMP.SPRING		
	26	QYSDST2005ZA	TAP SCREW	M2 x 5mm	
	27	QYSDST2616MA	TAP SCREW	M2.6 x 16mm	
	28	QAR0387-001	S.MOTOR		
	29	QYSPSPU1775ZA	SCREW	M1.7 x 7.5mm(x3)	
	30	LV44042-001A	ROD SPRING	(x2)	
	31	LE40858-002A	SPECIAL SCREW	(x4)	

DVD changer mechanism assembly and parts list

Block No. M K M M

Grease
 ★=JVG-31N
 ▲=JVS-1003

FMU-SB1-1C

CH6-BASE-1M

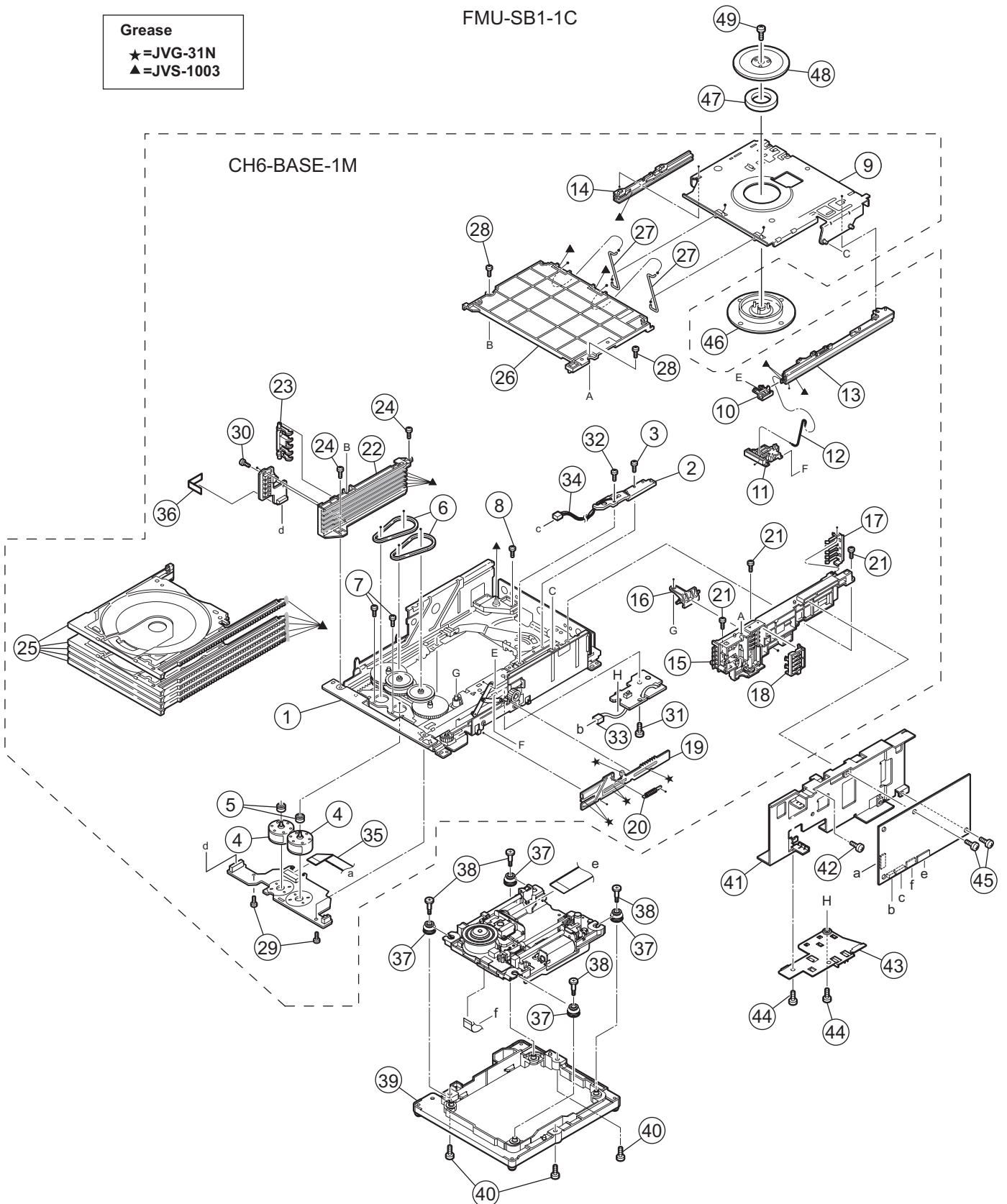

The parts without symbol number are not service.

DVD changer mechanism

Block No. [M][K][M][M]

△	Symbol No.	Part No.	Part Name	Description	Local
	1	LV10913-007A	LOADER ASSY		
	2	QVY0027-B14	S V RESISTOR		
	3	QYSDST2004ZA	TAP SCREW	M2 x 4mm	
	4	QAR0164-001	MOTOR	(x2)	
	5	LV42340-001A	MOTOR PULLEY	(x2)	
	6	LV41431-002A	BELT	(x2)	
	7	QYSPSPU1725NA	SCREW	M1.7 x 2.5mm(x2)	
	8	QYSDST2605ZA	TAP SCREW	M2.6 x 5mm	
	9	LV33965-008A	LIFTER ASSY		
	10	LV33963-001A	HOOK		
	11	LV33964-002A	HOOK STOPPER		
	12	LV43285-001A	ROD (L)		
	13	LV21408-002A	RAIL(R)		
	14	LV21409-002A	RAIL(L)		
	15	LV21520-005A	SIDE(R) ASSY		
	16	LV33974-002A	SELECT LEVER		
	17	LV33977-002A	CLICK SPRING		
	18	LV33975-001A	GEAR COVER		
	19	LV33976-002A	ELEVATOR CAM		
	20	LV43287-001A	ELEVATOR SPRING		
	21	QYSDST2605ZA	TAP SCREW	M2.6 x 5mm(x3)	
	22	LV10749-003A	SIDE(L)		
	23	LV33980-002A	OPEN DET.LEVER		
	24	QYSDST2605ZA	TAP SCREW	M2.6 x 5mm(x2)	
	25	LV10746-007A	TRAY ASSY	(x5)	
	26	LV10750-003A	TOP COVER		
	27	LV43289-003A	ROD	(x2)	
	28	QYSDSF2608ZA	TAP SCREW	M2.6 x 8mm(x2)	
	29	QYSDST2605ZA	TAP SCREW	M2.6 x 5mm(x2)	
	30	QYSDSF2608ZA	TAP SCREW	M2.6 x 8mm	
	31	QYSDST2605ZA	TAP SCREW	M2.6 x 5mm	
	32	QYSDST2004ZA	TAP SCREW	M2 x 4mm	
	33	WJM0330-002A-E	E-SI C WIRE C-F		
	34	WJM0331-001A-E	E-SI C WIRE C-F		
	35	QUQW10-1521BF-E	FFC WIRE	15pin 21cm	
	36	LV30227-044A	SPACER		
	37	LE40900-003A	INSULATOR	(x4)	
	38	LV44045-001A	SPECIAL SCREW	(x4)	
	39	LV11252-002A	C.TM.HOLDER		
	40	QYSDST2605ZA	TAP SCREW	M2.6 x 5mm(x3)	
	41	LV22274-001A	PWB BKT		
	42	QYSDSF2608ZA	TAP SCREW	M2.6 x 8mm	
	43	LV22275-001A	WIRE HOLDER		
	44	QYSDST2605ZA	TAP SCREW	M2.6 x 5mm(x2)	
	45	QYSDST2605ZA	TAP SCREW	M2.6 x 5mm(x2)	
	46	LV32417-001A	CLAMPER		
	47	LV42930-003A	P.C.MAGNET		
	48	LV33992-001A	DVD YOKE		
	49	LE40906-002A	SPECIAL SCREW		

Electrical parts list

Main board

Block No. [0][1]

△ Symbol No.	Part No.	Part Name	Description	Local	△ Symbol No.	Part No.	Part Name	Description	Local
					D4962	1SS133-T2	SI DIODE IM		
					D4963	1SS133-T2	SI DIODE IM		
					△ PC901	PC123Y22FZ	PHOTO COUPLER		
IC411	MM1233XF-X	IC C/M			△ C902	QFZ9073-683	MM CAPACITOR	0.068uF AC250V M	
IC431	MM1623XF-X	IC			△ C903	QFZ9073-683	MM CAPACITOR	0.068uF AC250V M	
IC471	MN101C49GPW	IC MASK			△ C904	QCZ9079-102	C CAPACITOR	1000pF AC250V M	
IC472	S-80840CNNB-G-W	IC			△ C905	QCZ9079-102	C CAPACITOR	1000pF AC250V M	
IC473	SN74AHCT08NS-X	IC			△ C907	QETM2DM-157	E CAPACITOR	150uF 200V M	
IC477	BR24L08F-W-X	IC(DIGITAL)			△ C908	QCZ0401-222	C CAPACITOR	2200pF	
IC481	TORX147	OPT RECEIVER			C909	QCZ0131-331	C CAPACITOR	330pF 2kV K	
IC491	KIA7805API	IC			C910	NDC31HJ-120X	C CAPACITOR	12pF 50V J	
△ IC901	MIP4170MYSLJ	IC			C913	QCZ0403-221	C CAPACITOR	220pF	
					C914	QEZO658-476Z	E CAPACITOR	47uF	
Q951	2SC3576-JVC-T	TRANSISTOR			△ C916	QCZ9079-222	C CAPACITOR	2200pF AC250V M	
Q953	KTA1267/YG/-T	TRANSISTOR			C918	NCB31HK-104X	C CAPACITOR	0.1uF 50V K	
Q954	RTR030P02-X	MOS FET			C920	NCB31HK-104X	C CAPACITOR	0.1uF 50V K	
Q958	KTA1273/Y/-T	TRANSISTOR			C921	NCB31HK-104X	C CAPACITOR	0.1uF 50V K	
Q959	RT1N241C-X	DIGITAL TR			C950	NDC31HJ-221X	C CAPACITOR	220pF 50V J	
Q965	RT1P441C-X	DIGI TRANSISTOR			C951	NDC31HJ-221X	C CAPACITOR	220pF 50V J	
Q969	RT1N241C-X	DIGITAL TR			C952	QCZ0136-101Z	C CAPACITOR	100pF 1kV K	
Q974	RTR030P02-X	MOS FET			C954	NDC31HJ-221X	C CAPACITOR	220pF 50V J	
Q979	RT1N241C-X	DIGITAL TR			C955	NDC31HJ-221X	C CAPACITOR	220pF 50V J	
Q980	RT1N241C-X	DIGITAL TR			C956	NDC31HJ-221X	C CAPACITOR	220pF 50V J	
Q982	KTA1267/YG/-T	TRANSISTOR			C957	NDC31HJ-221X	C CAPACITOR	220pF 50V J	
Q983	KTC3203/OY/-T	TRANSISTOR			C960	QEZO655-826Z	E CAPACITOR	82uF	
Q984	RTR030P02-X	MOS FET			C961	QCZ0202-155Z	C CAPACITOR	1.5uF 25V Z	
Q989	RT1N241C-X	DIGITAL TR			C962	QETN1HM-226Z	E CAPACITOR	22uF 50V M	
Q991	KTC3875/YG/-X	TRANSISTOR			C963	QEZO658-396Z	E CAPACITOR	39uF	
Q4091	KTA1271/OY/-T	TRANSISTOR			C964	QEZO658-226Z	E CAPACITOR	22uF	
Q4092	2SC3928A/QR/-X	TRANSISTOR			C968	NCB31CK-104X	C CAPACITOR	0.1uF 16V K	
Q4701	RT1N140C-X	DIGI TRANSISTOR			C969	QETN1AM-227Z	E CAPACITOR	220uF 10V M	
Q4703	RT1N141C-X	DIGI TRANSISTOR			C973	NDC31HJ-101X	C CAPACITOR	100pF 50V J	
Q4811	RT1P141C-X	DIGI TRANSISTOR			C975	QEZO654-108Z	E CAPACITOR	1000uF	
Q4812	RT1N141C-X	DIGI TRANSISTOR			C976	QEZO654-477Z	E CAPACITOR	470uF 10V M	
Q4821	RT1N141C-X	DIGI TRANSISTOR			C977	NCB31CK-104X	C CAPACITOR	0.1uF 16V K	
Q4822	2SD2114K/VVW/-X	TRANSISTOR			C978	NCB31CK-104X	C CAPACITOR	0.1uF 16V K	
Q4831	RT1N141C-X	DIGI TRANSISTOR			C979	QETN1AM-227Z	E CAPACITOR	220uF 10V M	
Q4832	RT1P430C-X	TRANSISTOR			C981	QCZ0202-155Z	C CAPACITOR	1.5uF 25V Z	
Q4833	RT1N430C-X	TRANSISTOR			C982	QEZO656-567Z	E CAPACITOR	560uF	
Q4961	KTC3203/OY/-T	TRANSISTOR			C983	QETN1CM-107Z	E CAPACITOR	100uF 16V M	
△ D901	DI106	BRIDGE DIODE			C984	QEZO655-227Z	E CAPACITOR	220uF	
D902	20NFA60-FC5	FR DIODE			C989	NCB31HK-104X	C CAPACITOR	0.1uF 50V K	
D904	FR104S-T5	FR DIODE			C990	QETN1EM-107Z	E CAPACITOR	100uF 25V M	
D911	RB160M-30-X	SB DIODE			C991	QCZ0202-155Z	C CAPACITOR	1.5uF 25V Z	
D950	MTZJ24D-T2	Z DIODE I/M			C992	QETN1HM-226Z	E CAPACITOR	22uF 50V M	
D951	FR104S-T5	FR DIODE			C993	NCB31HK-104X	C CAPACITOR	0.1uF 50V K	
D952	FR104S-T5	FR DIODE			C994	QCBB1HK-223Y	C CAPACITOR	0.022uF 50V K	
△ D954	UF202G-F26	FR EIODE			C996	NRSA63J-0R0X	MG RESISTOR	0Ω 1/16W J	
D955	MA111-X	DIODE C.M			C997	QEZO655-227Z	E CAPACITOR	220uF	
△ D956	FR104S-T5	FR DIODE			C998	NDC31HJ-331X	C CAPACITOR	330pF 50V J	
D960	MTZJ2.2A-T2	S.B.DIODE			C999	QEZO655-827Z	E CAPACITOR	820uF	
△ D973	SB360-F82	FUSEIODE			C4002	NRSA63J-0R0X	MG RESISTOR	0Ω 1/16W J	
D981	MTZJ4.3B-T2	Z DIODE		C30J	C4006	NCF21CZ-105X	C CAPACITOR	1uF 16V Z	
D992	MTZJ2.0A-T2	Z DIODE			C4011	NDC31HJ-221X	C CAPACITOR	220pF 50V J	
D993	MTZJ3.3B-T2	Z DIODE			C4012	NDC31HJ-221X	C CAPACITOR	220pF 50V J	
△ D998	1N4003S-T5	SI DIODE			C4017	NCF21CZ-225X	C CAPACITOR	2.2uF 16V Z	
△ D999	1N4003S-T5	SI DIODE			C4031	NCB31HK-562X	C CAPACITOR	5600pF 50V K	
D4091	1SS133-T2	SI DIODE IM			C4032	NCB31HK-562X	C CAPACITOR	5600pF 50V K	
D4092	MTZJ6.8A-T2	Z DIODE			C4033	NCB31HK-562X	C CAPACITOR	5600pF 50V K	
D4093	1SS133-T2	SI DIODE IM			C4034	NCB31HK-562X	C CAPACITOR	5600pF 50V K	
D4703	MTZJ4.7B-T2	Z DIODE			C4035	NCB31HK-562X	C CAPACITOR	5600pF 50V K	
D4705	1SS133-T2	SI DIODE IM			C4036	NCB31HK-562X	C CAPACITOR	5600pF 50V K	
D4708	1SS133-T2	SI DIODE IM			C4091	QETN1CM-226Z	E CAPACITOR	22uF 16V M	
D4709	10EDB20-T4	DIODE			C4092	QETN1CM-107Z	E CAPACITOR	100uF 16V M	
D4811	1SS133-T2	SI DIODE IM			C4101	NCB30JK-105X	C CAPACITOR	1uF 6.3V K	
D4831	1SS133-T2	SI DIODE IM			C4102	NDC31HJ-470X	C CAPACITOR	47pF 50V J	
D4832	1SS133-T2	SI DIODE IM			C4111	QFLC1HJ-103Z	M CAPACITOR	0.01uF 50V J	
D4833	1SS133-T2	SI DIODE IM			C4112	NDC31HJ-470X	C CAPACITOR	47pF 50V J	
D4834	1SS133-T2	SI DIODE IM			C4121	NCB30JK-105X	C CAPACITOR	1uF 6.3V K	
D4835	MTZJ6.8A-T2	Z DIODE			C4122	NDC31HJ-470X	C CAPACITOR	47pF 50V J	
D4841	MTZJ2.0A-T2	Z DIODE			C4171	NCB30JK-105X	C CAPACITOR	1uF 6.3V K	
D4842	MTZJ3.3A-T2	ZENER DIODE I/M			C4172	NCB30JK-105X	C CAPACITOR	1uF 6.3V K	
D4891	MTZJ6.2C-T2	Z DIODE			C4173	NCB30JK-105X	C CAPACITOR	1uF 6.3V K	
D4961	MTZJ4.7A-T2	Z DIODE			C4191	QETN1EM-476Z	E CAPACITOR	47uF 25V M	

△ Symbol No.	Part No.	Part Name	Description	Local	△ Symbol No.	Part No.	Part Name	Description	Local
C4192	NCB31HK-103X	C CAPACITOR	0.01uF 50V K		R985	QRE141J-132Y	C RESISTOR	1.3kΩ 1/4W J	
C4301	NCB30JK-105X	C CAPACITOR	1uF 6.3V K		R986	NRSA63J-203X	MG RESISTOR	20kΩ 1/16W J	
C4311	NCB31HK-103X	C CAPACITOR	0.01uF 50V K		R987	NRSA63J-151X	MG RESISTOR	150Ω 1/16W J	
C4321	NCB30JK-105X	C CAPACITOR	1uF 6.3V K		R988	NRSA63J-103X	MG RESISTOR	10kΩ 1/16W J	
C4331	NCB30JK-105X	C CAPACITOR	1uF 6.3V K		R989	NRSA63J-471X	MG RESISTOR	470Ω 1/16W J	
C4341	NCB30JK-105X	C CAPACITOR	1uF 6.3V K		R990	NRSA63J-333X	MG RESISTOR	33kΩ 1/16W J	
C4351	NCB30JK-105X	C CAPACITOR	1uF 6.3V K		R991	NRSA63J-203X	MG RESISTOR	20kΩ 1/16W J	
C4391	QETN1AM-477Z	E CAPACITOR	470uF 10V M		R4011	NRSA63J-102X	MG RESISTOR	1kΩ 1/16W J	
C4392	NCB31CK-104X	C CAPACITOR	0.1uF 16V K		R4012	NRSA63J-102X	MG RESISTOR	1kΩ 1/16W J	
C4394	NCB31CK-104X	C CAPACITOR	0.1uF 16V K		R4091	NRSA63J-472X	MG RESISTOR	4.7kΩ 1/16W J	
C4395	QETN1HM-226Z	E CAPACITOR	22uF 50V M		R4092	NRSA63J-103X	MG RESISTOR	10kΩ 1/16W J	
C4401	QETN1AM-477Z	E CAPACITOR	470uF 10V M		R4093	NRSA63J-821X	MG RESISTOR	820Ω 1/16W J	
C4402	NDC31HJ-470X	C CAPACITOR	47pF 50V J		R4101	NRSA63J-750X	MG RESISTOR	75Ω 1/16W J	
C4411	NCB31HK-103X	C CAPACITOR	0.01uF 50V K		R4111	NRSA63J-750X	MG RESISTOR	75Ω 1/16W J	
C4412	NDC31HJ-470X	C CAPACITOR	47pF 50V J		R4121	NRSA63J-750X	MG RESISTOR	75Ω 1/16W J	
C4421	QETN1AM-477Z	E CAPACITOR	470uF 10V M		R4191	NRSA63J-0R0X	MG RESISTOR	0Ω 1/16W J	
C4423	NDC31HJ-470X	C CAPACITOR	47pF 50V J		R4201	NRSA63J-621X	MG RESISTOR	620Ω 1/16W J	
C4431	QETN1AM-477Z	E CAPACITOR	470uF 10V M		R4202	NRSA63J-301X	MG RESISTOR	300Ω 1/16W J	
C4432	NDC31HJ-470X	C CAPACITOR	47pF 50V J		R4211	NRSA63J-621X	MG RESISTOR	620Ω 1/16W J	
C4441	QETN1AM-477Z	E CAPACITOR	470uF 10V M		R4212	NRSA63J-301X	MG RESISTOR	300Ω 1/16W J	
C4442	NDC31HJ-470X	C CAPACITOR	47pF 50V J		R4221	NRSA63J-621X	MG RESISTOR	620Ω 1/16W J	
C4451	QETN1AM-477Z	E CAPACITOR	470uF 10V M		R4222	NRSA63J-331X	MG RESISTOR	330Ω 1/16W J	
C4452	NDC31HJ-470X	C CAPACITOR	47pF 50V J		R4231	NRSA63J-511X	MG RESISTOR	510Ω 1/16W J	
C4705	NCB31HK-103X	C CAPACITOR	0.01uF 50V K		R4232	NRSA63J-331X	MG RESISTOR	330Ω 1/16W J	
C4706	NCB31HK-103X	C CAPACITOR	0.01uF 50V K		R4241	NRSA63J-511X	MG RESISTOR	510Ω 1/16W J	
C4707	QETN1AM-477Z	E CAPACITOR	470uF 10V M		R4242	NRSA63J-331X	MG RESISTOR	330Ω 1/16W J	
C4708	NCB31HK-103X	C CAPACITOR	0.01uF 50V K		R4251	NRSA63J-511X	MG RESISTOR	510Ω 1/16W J	
C4709	NCB31HK-103X	C CAPACITOR	0.01uF 50V K		R4252	NRSA63J-331X	MG RESISTOR	330Ω 1/16W J	
C4710	NCB31HK-103X	C CAPACITOR	0.01uF 50V K		R4401	NRSA63J-750X	MG RESISTOR	75Ω 1/16W J	
C4711	QETN1CM-107Z	E CAPACITOR	100uF 16V M		R4411	NRSA63J-750X	MG RESISTOR	75Ω 1/16W J	
C4718	NCB31HK-103X	C CAPACITOR	0.01uF 50V K		R4421	NRSA63J-750X	MG RESISTOR	75Ω 1/16W J	
C4719	NCB31HK-103X	C CAPACITOR	0.01uF 50V K		R4431	NRSA63J-750X	MG RESISTOR	75Ω 1/16W J	
C4771	NCB31CK-104X	C CAPACITOR	0.1uF 16V K		R4441	NRSA63J-750X	MG RESISTOR	75Ω 1/16W J	
C4772	NCB31CK-104X	C CAPACITOR	0.1uF 16V K		R4451	NRSA63J-750X	MG RESISTOR	75Ω 1/16W J	
C4773	NCB31CK-104X	C CAPACITOR	0.1uF 16V K		R4702	NRSA63J-102X	MG RESISTOR	1kΩ 1/16W J	
C4774	NCB31CK-104X	C CAPACITOR	0.1uF 16V K		R4703	NRSA63J-102X	MG RESISTOR	1kΩ 1/16W J	
C4791	NCB31CK-104X	C CAPACITOR	0.1uF 16V K		R4704	NRSA63J-103X	MG RESISTOR	10kΩ 1/16W J	
C4844	NCF21CZ-105X	C CAPACITOR	1uF 16V Z		R4705	NRSA63J-223X	MG RESISTOR	22kΩ 1/16W J	
C4891	NCB31HK-221X	C CAPACITOR	220pF 50V K		R4707	NRSA63J-103X	MG RESISTOR	10kΩ 1/16W J	
C4892	NCB31HK-221X	C CAPACITOR	220pF 50V K		R4708	QRE141J-221Y	C RESISTOR	220Ω 1/4W J	
C4893	NCB31CK-104X	C CAPACITOR	0.1uF 16V K		R4709	NRSA63J-101X	MG RESISTOR	100Ω 1/16W J	
C4902	NCB31HK-103X	C CAPACITOR	0.01uF 50V K		R4710	NRSA63J-104X	MG RESISTOR	100kΩ 1/16W J	
C4903	QETN1CM-107Z	E CAPACITOR	100uF 16V M		R4711	NRSA63J-331X	MG RESISTOR	330Ω 1/16W J	
C4904	NCB31HK-103X	C CAPACITOR	0.01uF 50V K		R4712	NRSA63J-331X	MG RESISTOR	330Ω 1/16W J	
C4961	QETN1CM-107Z	E CAPACITOR	100uF 16V M		R4713	NRSA63J-331X	MG RESISTOR	330Ω 1/16W J	
					R4714	NRSA63J-103X	MG RESISTOR	10kΩ 1/16W J	
R521	NRSA63J-332X	MG RESISTOR	3.3kΩ 1/16W J		R4752	NRSA63J-273X	MG RESISTOR	27kΩ 1/16W J	
R522	NRSA63J-392X	MG RESISTOR	3.9kΩ 1/16W J		R4753	NRSA63J-103X	MG RESISTOR	10kΩ 1/16W J	
R526	NRSA63J-332X	MG RESISTOR	3.3kΩ 1/16W J		R4754	NRSA63J-103X	MG RESISTOR	10kΩ 1/16W J	
R527	NRSA63J-392X	MG RESISTOR	3.9kΩ 1/16W J		R4755	NRSA63J-103X	MG RESISTOR	10kΩ 1/16W J	
R528	NRSA63J-682X	MG RESISTOR	6.8kΩ 1/16W J		R4756	NRSA63J-103X	MG RESISTOR	10kΩ 1/16W J	
R901	QRL02DJ-683X	OMF RESISTOR	68kΩ 2W J		R4757	NRSA63J-103X	MG RESISTOR	10kΩ 1/16W J	
△ R903	QRZ9005-270X	FUSI RESISTOR	27Ω		R4758	NRSA63J-103X	MG RESISTOR	10kΩ 1/16W J	
R904	NRSA63J-183X	MG RESISTOR	18kΩ 1/16W J		R4759	NRSA63J-103X	MG RESISTOR	10kΩ 1/16W J	
R905	NRSA63J-123X	MG RESISTOR	12kΩ 1/16W J		R4760	NRSA63J-222X	MG RESISTOR	2.2kΩ 1/16W J	
R908	NRSA63J-332X	MG RESISTOR	3.3kΩ 1/16W J		R4761	NRSA63J-103X	MG RESISTOR	10kΩ 1/16W J	
R909	NRSA63J-432X	MG RESISTOR	4.3kΩ 1/16W J		R4762	NRSA63J-103X	MG RESISTOR	10kΩ 1/16W J	
△ R921	QRZ9037-335	COMP RESISTOR	3.3MΩ 1/2W K		R4763	NRSA63J-273X	MG RESISTOR	27kΩ 1/16W J	
△ R922	QRZ9037-335	COMP RESISTOR	3.3MΩ 1/2W K		R4772	NRSA63J-103X	MG RESISTOR	10kΩ 1/16W J	
R951	QRE141J-150Y	C RESISTOR	15Ω 1/4W J		R4774	NRSA63J-103X	MG RESISTOR	10kΩ 1/16W J	
R952	NRSA63J-103X	MG RESISTOR	10kΩ 1/16W J		R4775	NRSA63J-331X	MG RESISTOR	330Ω 1/16W J	
R953	NRSA02J-223X	MG RESISTOR	22kΩ 1/10W J		R4776	NRSA63J-331X	MG RESISTOR	330Ω 1/16W J	
△ R954	QRZ9005-100X	FUSI RESISTOR	10Ω		R4777	NRSA63J-101X	MG RESISTOR	100Ω 1/16W J	
R955	NRSA63J-223X	MG RESISTOR	22kΩ 1/16W J		R4778	NRSA63J-101X	MG RESISTOR	100Ω 1/16W J	
R960	NRSA63J-332X	MG RESISTOR	3.3kΩ 1/16W J		R4791	NRSA02J-221X	MG RESISTOR	220Ω 1/10W J	
R961	NRSA63J-223X	MG RESISTOR	22kΩ 1/16W J		△ R4811	QRZ9006-4R7X	FUSI RESISTOR	4.7Ω	
R963	NRSA63D-121X	MG RESISTOR	120Ω 1/16W D		R4821	QRE141J-181Y	C RESISTOR	180Ω 1/4W J	
R965	NRSA63J-132X	MG RESISTOR	1.3kΩ 1/16W J		R4822	QRE141J-151Y	C RESISTOR	150Ω 1/4W J	
R968	NRSA63D-222X	MG RESISTOR	2.2kΩ 1/16W D		R4823	NRSA63J-392X	MG RESISTOR	3.9kΩ 1/16W J	
R969	NRSA63J-222X	MG RESISTOR	2.2kΩ 1/16W J		R4824	QRE141J-151Y	C RESISTOR	150Ω 1/4W J	
R971	NRSA63J-223X	MG RESISTOR	22kΩ 1/16W J		R4825	QRE141J-151Y	C RESISTOR	150Ω 1/4W J	
R972	NRSA63J-153X	MG RESISTOR	15kΩ 1/16W J		R4826	QRE141J-151Y	C RESISTOR	150Ω 1/4W J	
R973	QRT027J-R30	MF RESISTOR	0.3Ω 2W J		R4827	QRE141J-151Y	C RESISTOR	150Ω 1/4W J	
R980	NRSA63J-332X	MG RESISTOR	3.3kΩ 1/16W J		R4831	NRSA63J-123X	MG RESISTOR	12kΩ 1/16W J	
R981	NRSA63J-223X	MG RESISTOR	22kΩ 1/16W J		R4833	NRSA63J-123X	MG RESISTOR	12kΩ 1/16W J	
R982	QRT027J-R56	MF RESISTOR	0.56Ω 2W J		R4834	NRSA63J-393X	MG RESISTOR	39kΩ 1/16W J	
R983	NRSA63J-102X	MG RESISTOR	1kΩ 1/16W J		R4835	NRSA63J-472X	MG RESISTOR	4.7kΩ 1/16W J	
R984	NRSA63J-243X	MG RESISTOR	24kΩ 1/16W J		R4841	NRSA63J-681X	MG RESISTOR	680Ω 1/16W J	

Symbol No.	Part No.	Part Name	Description	Local
R4843	QRT017J-2R2	MF RESISTOR	2.2Ω 1W J	
△ R4844	QRZ9005-470X	FUSI RESISTOR	47Ω	
R4846	NRSA63J-103X	MG RESISTOR	10kΩ 1/16W J	
R4848	NRSA63J-103X	MG RESISTOR	10kΩ 1/16W J	
R4849	NRSA63J-103X	MG RESISTOR	10kΩ 1/16W J	
R4851	NRSA63J-103X	MG RESISTOR	10kΩ 1/16W J	
R4861	NRSA63J-222X	MG RESISTOR	2.2kΩ 1/16W J	
R4863	NRSA63J-222X	MG RESISTOR	2.2kΩ 1/16W J	
R4864	NRSA63J-222X	MG RESISTOR	2.2kΩ 1/16W J	
R4866	NRSA63J-272X	MG RESISTOR	2.7kΩ 1/16W J	
R4871	NRSA63J-331X	MG RESISTOR	330Ω 1/16W J	
R4872	NRSA63J-331X	MG RESISTOR	330Ω 1/16W J	
R4873	NRSA63J-331X	MG RESISTOR	330Ω 1/16W J	
R4875	NRSA63J-331X	MG RESISTOR	330Ω 1/16W J	
R4876	NRSA63J-331X	MG RESISTOR	330Ω 1/16W J	
R4881	NRSA63J-472X	MG RESISTOR	4.7kΩ 1/16W J	
R4882	NRSA63J-101X	MG RESISTOR	100Ω 1/16W J	
R4883	NRSA63J-472X	MG RESISTOR	4.7kΩ 1/16W J	
R4884	NRSA63J-472X	MG RESISTOR	4.7kΩ 1/16W J	
R4886	NRSA63J-562X	MG RESISTOR	5.6kΩ 1/16W J	
R4891	NRSA63J-221X	MG RESISTOR	220Ω 1/16W J	
R4892	NRSA63J-221X	MG RESISTOR	220Ω 1/16W J	
R4893	NRSA63J-101X	MG RESISTOR	100Ω 1/16W J	
△ R4921	QRZ9005-100X	FUSI RESISTOR	10Ω	
R4961	QRE141J-271Y	C RESISTOR	270Ω 1/4W J	
△ L901	QQR0908-001	LINE FILTER		
L951	QQL244K-R22Z	COIL	0.22uH K	
L955	QQL31AK-220Z	COIL	22uH K	
L957	QQL26AK-100Z	COIL	10uH K	
L972	QQL31AK-220Z	COIL	22uH K	
L4391	QQL25CK-221Z	COIL	220uH K	
△ T901	QQS0371-001	SW TRANSF		
CN402	QGF1036C2-28	CONNECTOR	FFC/FPC (1-28)	
CN403	QGF1036C2-18	CONNECTOR	FFC/FPC (1-18)	
CN404	QGF1036C2-05	CONNECTOR	FFC/FPC (1-5)	
CN410	QGF1205C2-11	CONNECTOR	FFC/FPC (1-11)	
CN411	QGF1036C2-25	CONNECTOR	FFC/FPC (1-25)	
CN413	QGB2501J1-06	CONNECTOR	B-B (1-6)	
CN450	QGF1036C2-17	CONNECTOR	FFC/FPC (1-17)	
CN451	QGF1205C2-07	CONNECTOR	FFC/FPC (1-7)	
CN457	QGD2504C1-03Z	CONNECTOR	(1-3)	
△ CP951	ICP-N10-T	IC PROTECTOR	400mA	
△ CP999	ICP-N20-T	IC PROTECTOR	800mA	
EP401	QNZ0870-001	EARTH PLATE		
EP901	QNZ0870-001	EARTH PLATE		
EP903	QNZ0870-001	EARTH PLATE		
FC901	QNG0003-001Z	FUSE CLIP		
FC902	QNG0003-001Z	FUSE CLIP		
FW521	QUM213-08DGZ4-E	PARA RIBON WIRE		
HS901	LV40057-002A	HEAT SINK		
J4401	QNN0570-001	PIN JACK		
J4402	QNN0572-001	PIN JACK		
J4891	QNS0089-001	3.5 JACK		
K4702	QQR0621-001Z	COIL		
△ P901	QNC0082-001	AC INLET		
PP401	QZW0112-001	WIRE CLAMP		
PP402	QZW0112-001	WIRE CLAMP		
PP403	QZW0112-001	WIRE CLAMP		
PP404	QZW0112-001	WIRE CLAMP		
S522	QSW1120-001Z	PUSH SW I.M		
S523	QSW1120-001Z	PUSH SW I.M		
S526	QSW1120-001Z	PUSH SW I.M		
S527	QSW1120-001Z	PUSH SW I.M		
S528	QSW1120-001Z	PUSH SW I.M		
S529	QSW1120-001Z	PUSH SW I.M		
X4701	QAX0246-001Z	C RESONATOR	8.00MHz	

Audio board

Block No. [0][2]

Symbol No.	Part No.	Part Name	Description	Local
IC101	R2S15902FP	IC		
IC111	RC4580ID-X	IC		
IC112	RC4580ID-X	IC		
IC113	RC4580ID-X	IC		
IC121	RC4580ID-X	IC		
IC131	RC4580ID-X	IC		
IC501	PT6315	IC		
IC511	GP1UM261XKVF	IR DETECT UNIT		
Q1101	2SA1530A/QR/-X	TRANSISTOR		
Q1102	RT1N141C-X	DIGI TRANSISTOR		
Q1121	IMX9-W	TRANSISTOR		
Q1122	IMX9-W	TRANSISTOR		
Q1123	IMX9-W	TRANSISTOR		
Q1131	RT1N141C-X	DIGI TRANSISTOR		
Q1132	2SA1530A/QR/-X	TRANSISTOR		
Q1133	IMX9-W	TRANSISTOR		
Q2921	KTC3203/OY/-T	TRANSISTOR		
D511	SLR-343VC/NPQ-T	LED		
D551	SELU2E10C-P	LED		
D2921	MTZJ11C-T2	Z DIODE		
D2922	1SS133-T2	SI DIODE IM		
C506	NCB30JK-105X	C CAPACITOR	1uF 6.3V K	
C507	NCB31HK-103X	C CAPACITOR	0.01uF 50V K	
C511	NCB21CK-105X	C CAPACITOR	1uF 16V K	
C515	NCB31HK-103X	C CAPACITOR	0.01uF 50V K	
C517	NCB31HK-102X	C CAPACITOR	1000pF 50V K	
C518	NCB31HK-102X	C CAPACITOR	1000pF 50V K	
C541	NCB31HK-103X	C CAPACITOR	0.01uF 50V K	
C542	NCB31HK-103X	C CAPACITOR	0.01uF 50V K	
C1101	NDC31HJ-331X	C CAPACITOR	330pF 50V J	
C1102	NDC31HJ-331X	C CAPACITOR	330pF 50V J	
C1103	QETN1HM-475Z	E CAPACITOR	4.7uF 50V M	
C1104	QETN1HM-475Z	E CAPACITOR	4.7uF 50V M	
C1111	NRSA63J-0R0X	MG RESISTOR	0Ω 1/16W J	
C1112	NRSA63J-0R0X	MG RESISTOR	0Ω 1/16W J	
C1170	NCB31HK-103X	C CAPACITOR	0.01uF 50V K	
C1171	NCB31HK-103X	C CAPACITOR	0.01uF 50V K	
C1172	NCB31HK-103X	C CAPACITOR	0.01uF 50V K	
C1203	QETN1HM-475Z	E CAPACITOR	4.7uF 50V M	
C1204	QETN1HM-475Z	E CAPACITOR	4.7uF 50V M	
C1205	QETN1HM-475Z	E CAPACITOR	4.7uF 50V M	
C1206	QETN1HM-475Z	E CAPACITOR	4.7uF 50V M	
C1209	QETN1HM-475Z	E CAPACITOR	4.7uF 50V M	
C1210	QETN1HM-475Z	E CAPACITOR	4.7uF 50V M	
C1211	QETN1HM-475Z	E CAPACITOR	4.7uF 50V M	
C1212	QETN1HM-475Z	E CAPACITOR	4.7uF 50V M	
C1215	QETN1HM-475Z	E CAPACITOR	4.7uF 50V M	
C1216	QETN1HM-475Z	E CAPACITOR	4.7uF 50V M	
C1217	QETN1HM-225Z	E CAPACITOR	2.2uF 50V M	
C1218	QETN1HM-475Z	E CAPACITOR	4.7uF 50V M	
C1221	NDC31HJ-470X	C CAPACITOR	47pF 50V J	
C1222	NDC31HJ-470X	C CAPACITOR	47pF 50V J	
C1223	NDC31HJ-470X	C CAPACITOR	47pF 50V J	
C1224	NDC31HJ-470X	C CAPACITOR	47pF 50V J	
C1225	NDC31HJ-471X	C CAPACITOR	470pF 50V J	
C1226	NDC31HJ-470X	C CAPACITOR	47pF 50V J	
C1441	NCB31HK-222X	C CAPACITOR	2200pF 50V K	
C1442	NCB31HK-222X	C CAPACITOR	2200pF 50V K	
C1443	QCBB1HK-222Y	C CAPACITOR	2200pF 50V K	
C1443	or QDXB1CM-222Y	C CAPACITOR	2200pF 16V M	
C1444	QCBB1HK-222Y	C CAPACITOR	2200pF 50V K	
C1444	or QDXB1CM-222Y	C CAPACITOR	2200pF 16V M	
C1445	QCBB1HK-222Y	C CAPACITOR	2200pF 50V K	
C1445	or QDXB1CM-222Y	C CAPACITOR	2200pF 16V M	
C1446	QCBB1HK-222Y	C CAPACITOR	2200pF 50V K	
C1446	or QDXB1CM-222Y	C CAPACITOR	2200pF 16V M	
C2501	QETN1HM-105Z	E CAPACITOR	1uF 50V M	
C2502	QETN1HM-105Z	E CAPACITOR	1uF 50V M	
C2503	NCB21CK-224X	C CAPACITOR	0.22uF 16V K	
C2504	NCB21CK-224X	C CAPACITOR	0.22uF 16V K	
C2505	NCB21CK-224X	C CAPACITOR	0.22uF 16V K	

△ Symbol No.	Part No.	Part Name	Description	Local	△ Symbol No.	Part No.	Part Name	Description	Local
C2506	QETN1HM-475Z	E CAPACITOR	4.7uF 50V M		R1136	NRSA63J-332X	MG RESISTOR	3.3kΩ 1/16W J	
C2511	QETN1HM-106Z	E CAPACITOR	10uF 50V M		R1137	NRSA63J-104X	MG RESISTOR	100kΩ 1/16W J	
C2512	QETN1HM-106Z	E CAPACITOR	10uF 50V M		R1138	NRSA63J-104X	MG RESISTOR	100kΩ 1/16W J	
C2513	NCB21CK-224X	C CAPACITOR	0.22uF 16V K		R1141	NRSA63J-102X	MG RESISTOR	1kΩ 1/16W J	
C2514	NCB21CK-224X	C CAPACITOR	0.22uF 16V K		R1142	NRSA63J-102X	MG RESISTOR	1kΩ 1/16W J	
C2515	NCB31CK-393X	C CAPACITOR	0.039uF 16V K		R1143	NRSA63J-332X	MG RESISTOR	3.3kΩ 1/16W J	
C2516	NCB31CK-393X	C CAPACITOR	0.039uF 16V K		R1144	NRSA63J-332X	MG RESISTOR	3.3kΩ 1/16W J	
C2517	QETN1HM-475Z	E CAPACITOR	4.7uF 50V M		R1145	NRSA63J-104X	MG RESISTOR	100kΩ 1/16W J	
C2518	QETN1HM-475Z	E CAPACITOR	4.7uF 50V M		R1146	NRSA63J-104X	MG RESISTOR	100kΩ 1/16W J	
C2521	QETN1HM-475Z	E CAPACITOR	4.7uF 50V M		R1149	NRSA63J-102X	MG RESISTOR	1kΩ 1/16W J	
C2522	QETN1HM-475Z	E CAPACITOR	4.7uF 50V M		R1150	NRSA63J-102X	MG RESISTOR	1kΩ 1/16W J	
C2530	QETN1CM-107Z	E CAPACITOR	100uF 16V M		R1151	NRSA63J-332X	MG RESISTOR	3.3kΩ 1/16W J	
C2531	NCB31CK-104X	C CAPACITOR	0.1uF 16V K		R1152	NRSA63J-332X	MG RESISTOR	3.3kΩ 1/16W J	
C2532	NCB31CK-153X	C CAPACITOR	0.015uF 16V K		R1155	NRSA63J-104X	MG RESISTOR	100kΩ 1/16W J	
C2533	QETN1CM-107Z	E CAPACITOR	100uF 16V M		R1156	NRSA63J-104X	MG RESISTOR	100kΩ 1/16W J	
C2534	NCB31HK-473X	C CAPACITOR	0.047uF 50V K		R1158	NRSA63J-103X	MG RESISTOR	10kΩ 1/16W J	
C2535	NCB31HK-473X	C CAPACITOR	0.047uF 50V K		R1159	NRSA63J-103X	MG RESISTOR	10kΩ 1/16W J	
C2536	QFV61HJ-473Z	MF CAPACITOR	0.047uF 50V J		R1160	NRSA63J-103X	MG RESISTOR	10kΩ 1/16W J	
C2537	QFV61HJ-154Z	MF CAPACITOR	0.15uF 50V J		R1161	NRSA63J-103X	MG RESISTOR	10kΩ 1/16W J	
C2538	QFV61HJ-473Z	MF CAPACITOR	0.047uF 50V J		R1162	NRSA63J-103X	MG RESISTOR	10kΩ 1/16W J	C30J,C30C
C2539	QFV61HJ-154Z	MF CAPACITOR	0.15uF 50V J		R1162	NRSA63J-683X	MG RESISTOR	68kΩ 1/16W J	C20J,C20C
C2540	QFV61HJ-223Z	MF CAPACITOR	0.022uF 50V J		R1163	NRSA63J-103X	MG RESISTOR	10kΩ 1/16W J	C30J,C30C
C2541	QFV61HJ-223Z	MF CAPACITOR	0.022uF 50V J		R1163	NRSA63J-683X	MG RESISTOR	68kΩ 1/16W J	C20J,C20C
C2550	QETN1HM-225Z	E CAPACITOR	2.2uF 50V M		R1164	NRSA63J-103X	MG RESISTOR	10kΩ 1/16W J	
C2551	QETN1HM-226Z	E CAPACITOR	22uF 50V M		R1165	NRSA63J-103X	MG RESISTOR	10kΩ 1/16W J	
C2552	QETN1EM-476Z	E CAPACITOR	47uF 25V M		R1166	NRSA63J-103X	MG RESISTOR	10kΩ 1/16W J	
C2553	QETN1HM-475Z	E CAPACITOR	4.7uF 50V M		R1167	NRSA63J-183X	MG RESISTOR	18kΩ 1/16W J	
C2554	NCB31HK-104X	C CAPACITOR	0.1uF 50V K		R1168	NRSA63J-103X	MG RESISTOR	10kΩ 1/16W J	
C2556	NCB31CK-473X	C CAPACITOR	0.047uF 16V K		R1169	NRSA63J-273X	MG RESISTOR	27kΩ 1/16W J	
C2557	NCB31CK-473X	C CAPACITOR	0.047uF 16V K		R1171	NRSA63J-104X	MG RESISTOR	100kΩ 1/16W J	
C2560	QETN1HM-476Z	E CAPACITOR	47uF 50V M		R1172	NRSA63J-104X	MG RESISTOR	100kΩ 1/16W J	
C2601	NDC31HJ-560X	C CAPACITOR	56pF 50V J		R1173	NRSA63J-104X	MG RESISTOR	100kΩ 1/16W J	
C2602	NDC31HJ-560X	C CAPACITOR	56pF 50V J		R1174	NRSA63J-104X	MG RESISTOR	100kΩ 1/16W J	
C2603	QETN1AM-227Z	E CAPACITOR	220uF 10V M		R1175	NRSA63J-104X	MG RESISTOR	100kΩ 1/16W J	
C2604	QETN1AM-227Z	E CAPACITOR	220uF 10V M		R1176	NRSA63J-104X	MG RESISTOR	100kΩ 1/16W J	
C2610	NCB31CK-104X	C CAPACITOR	0.1uF 16V K		R1181	NRSA63J-102X	MG RESISTOR	1kΩ 1/16W J	
C2611	QETN1HM-106Z	E CAPACITOR	10uF 50V M		R1182	NRSA63J-102X	MG RESISTOR	1kΩ 1/16W J	
C2921	QETN1EM-476Z	E CAPACITOR	47uF 25V M		R1183	NRSA63J-102X	MG RESISTOR	1kΩ 1/16W J	
C2922	QETN1CM-107Z	E CAPACITOR	100uF 16V M		R1184	NRSA63J-102X	MG RESISTOR	1kΩ 1/16W J	
C6001	NCB31CK-223X	C CAPACITOR	0.022uF 16V K		R1185	NRSA63J-102X	MG RESISTOR	1kΩ 1/16W J	
C6002	NCB31CK-223X	C CAPACITOR	0.022uF 16V K		R1186	NRSA63J-102X	MG RESISTOR	1kΩ 1/16W J	
C6003	NCB31CK-104X	C CAPACITOR	0.1uF 16V K		R2501	NRSA63J-101X	MG RESISTOR	100Ω 1/16W J	
C6004	NCB31HK-103X	C CAPACITOR	0.01uF 50V K		R2502	NRSA63J-101X	MG RESISTOR	100Ω 1/16W J	
C6101	NCB31HK-182X	C CAPACITOR	1800pF 50V K		R2503	NRSA63J-102X	MG RESISTOR	1kΩ 1/16W J	
C6102	NCB31HK-182X	C CAPACITOR	1800pF 50V K		R2504	NRSA63J-102X	MG RESISTOR	1kΩ 1/16W J	
C6103	NDC31HJ-150X	C CAPACITOR	15pF 50V J		R2505	NRSA63J-102X	MG RESISTOR	1kΩ 1/16W J	
C6104	NDC31HJ-150X	C CAPACITOR	15pF 50V J		R2506	NRSA63J-102X	MG RESISTOR	1kΩ 1/16W J	
C6105	NCB31HK-103X	C CAPACITOR	0.01uF 50V K		R2511	NRSA63J-223X	MG RESISTOR	22kΩ 1/16W J	
C6205	NCB31HK-103X	C CAPACITOR	0.01uF 50V K		R2512	NRSA63J-223X	MG RESISTOR	22kΩ 1/16W J	
R501	NRSA63J-102X	MG RESISTOR	1kΩ 1/16W J		R2513	NRSA63J-473X	MG RESISTOR	47kΩ 1/16W J	
R502	NRSA63J-102X	MG RESISTOR	1kΩ 1/16W J		R2514	NRSA63J-473X	MG RESISTOR	47kΩ 1/16W J	
R503	NRSA63J-102X	MG RESISTOR	1kΩ 1/16W J		R2520	NRSA63J-472X	MG RESISTOR	4.7kΩ 1/16W J	
R505	NRSA63J-823X	MG RESISTOR	82kΩ 1/16W J		R2521	NRSA63J-472X	MG RESISTOR	4.7kΩ 1/16W J	
R506	NRSA63J-330X	MG RESISTOR	33Ω 1/16W J		R2551	NRSA63J-223X	MG RESISTOR	22kΩ 1/16W J	
R511	NRSA63J-221X	MG RESISTOR	220Ω 1/16W J		R2552	NRSA63J-473X	MG RESISTOR	47kΩ 1/16W J	
R531	NRSA63J-332X	MG RESISTOR	3.3kΩ 1/16W J		R2553	NRSA63J-822X	MG RESISTOR	8.2kΩ 1/16W J	
R532	NRSA63J-392X	MG RESISTOR	3.9kΩ 1/16W J		R2554	NRSA63J-103X	MG RESISTOR	10kΩ 1/16W J	
R533	NRSA63J-682X	MG RESISTOR	6.8kΩ 1/16W J		R2555	NRSA63J-472X	MG RESISTOR	4.7kΩ 1/16W J	
R534	NRSA63J-153X	MG RESISTOR	15kΩ 1/16W J		R2556	NRSA63J-102X	MG RESISTOR	1kΩ 1/16W J	
R536	NRSA63J-332X	MG RESISTOR	3.3kΩ 1/16W J		R2557	NRSA63J-562X	MG RESISTOR	5.6kΩ 1/16W J	
R537	NRSA63J-392X	MG RESISTOR	3.9kΩ 1/16W J		R2558	NRSA63J-103X	MG RESISTOR	10kΩ 1/16W J	
R538	NRSA63J-682X	MG RESISTOR	6.8kΩ 1/16W J		R2559	NRSA63J-223X	MG RESISTOR	22kΩ 1/16W J	
R539	NRSA63J-153X	MG RESISTOR	15kΩ 1/16W J		R2560	NRSA63J-103X	MG RESISTOR	10kΩ 1/16W J	
R541	NRSA63J-103X	MG RESISTOR	10kΩ 1/16W J		R2561	NRSA63J-103X	MG RESISTOR	10kΩ 1/16W J	
R542	NRSA63J-103X	MG RESISTOR	10kΩ 1/16W J		R2601	NRSA63J-103X	MG RESISTOR	10kΩ 1/16W J	
R552	NRSA63J-121X	MG RESISTOR	120Ω 1/16W J		R2602	NRSA63J-103X	MG RESISTOR	10kΩ 1/16W J	
R1101	NRSA63J-471X	MG RESISTOR	470Ω 1/16W J		R2603	NRSA63J-103X	MG RESISTOR	10kΩ 1/16W J	
R1102	NRSA63J-471X	MG RESISTOR	470Ω 1/16W J		R2604	NRSA63J-103X	MG RESISTOR	10kΩ 1/16W J	
R1108	NRSA63J-334X	MG RESISTOR	330kΩ 1/16W J		R2605	NRSA63J-472X	MG RESISTOR	4.7kΩ 1/16W J	
R1109	NRSA63J-334X	MG RESISTOR	330kΩ 1/16W J		R2606	NRSA63J-472X	MG RESISTOR	4.7kΩ 1/16W J	
R1110	NRSA63J-273X	MG RESISTOR	27kΩ 1/16W J		R2607	NRSA63J-472X	MG RESISTOR	4.7kΩ 1/16W J	
R1111	NRSA63J-273X	MG RESISTOR	27kΩ 1/16W J		R2608	NRSA63J-472X	MG RESISTOR	4.7kΩ 1/16W J	
R1116	NRSA63J-102X	MG RESISTOR	1kΩ 1/16W J		R2609	QRE141J-390Y	C RESISTOR	39Ω 1/4W J	
R1117	NRSA63J-102X	MG RESISTOR	1kΩ 1/16W J		R2610	QRE141J-390Y	C RESISTOR	39Ω 1/4W J	
R1133	NRSA63J-102X	MG RESISTOR	1kΩ 1/16W J		R2611	QRE141J-100Y	C RESISTOR	10Ω 1/4W J	
R1134	NRSA63J-102X	MG RESISTOR	1kΩ 1/16W J		R2612	QRE141J-100Y	C RESISTOR	10Ω 1/4W J	
R1135	NRSA63J-332X	MG RESISTOR	3.3kΩ 1/16W J		R2613	NRSA63J-222X	MG RESISTOR	2.2kΩ 1/16W J	
					R2614	NRSA63J-222X	MG RESISTOR	2.2kΩ 1/16W J	

△ Symbol No.	Part No.	Part Name	Description	Local	△ Symbol No.	Part No.	Part Name	Description	Local
R2620	NRSA63J-223X	MG RESISTOR	22kΩ 1/16W J		Q2301	2SA1530A/QR/-X	TRANSISTOR		
R2621	NRSA63J-222X	MG RESISTOR	2.2kΩ 1/16W J		Q2401	2SA1530A/QR/-X	TRANSISTOR		
R2922	NRSA63J-102X	MG RESISTOR	1kΩ 1/16W J		Q2501	2SA1530A/QR/-X	TRANSISTOR		
R6001	NRSA63J-102X	MG RESISTOR	1kΩ 1/16W J		Q2601	2SA1530A/QR/-X	TRANSISTOR		
R6107	NRSA63J-390X	MG RESISTOR	39Ω 1/16W J		Q2701	2SC3928A/QR/-X	TRANSISTOR		
R6207	NRSA63J-390X	MG RESISTOR	39Ω 1/16W J		Q2702	KTA1046/Y/	TRANSISTOR		
					Q2703	RT1N141C-X	DIGI TRANSISTOR		
CN101	QGB2501J1-06	CONNECTOR	B-B (1-6)		Q2707	KTA1267/YG/-T	TRANSISTOR		
CN102	QGF1036F2-25	CONNECTOR	FFC/FPC (1-25)		Q2708	KTC3199/GL/-T	TRANSISTOR		
CN414	QGB2501K2-06	CONNECTOR	B-B (1-6)		Q3702	RT1P141C-X	DIGI TRANSISTOR		
CN415	QGB2501K2-06	CONNECTOR	B-B (1-6)		Q3703	RT1N241C-X	DIGITAL TR		
CN501	QGF1036F2-17	CONNECTOR	FFC/FPC (1-17)		Q3704	KTC2026/Y/	TRANSISTOR		
CN502	QGF1205F2-07	CONNECTOR	FFC/FPC (1-7)						
CN511	WJP0079-002A-E	E-SH C WIRE C-B			D101	1SS133-T2	SI DIODE IM		
DI501	QLF0168-001	FL TUBE			△ D151	GBU803	BRIDGE DIODE		
EP511	QNZ0870-001	EARTH PLATE			△ D152	GBU803	BRIDGE DIODE		
J1101	QNN0598-001	PIN JACK			D154	1SS133-T2	SI DIODE IM		
J1103	QND0118-001	DIN CONNECTOR			D163	1SS133-T2	SI DIODE IM		
J6001	QNS0231-001	JACK			D164	MTZJ6.2B-T2	Z DIODE		
J6101	QNZ0851-001	USB CONNECTOR			D165	MTZJ6.8C-T2	Z DIODE		
JS541	QSW1059-001	JOG VOLUME			D166	MTZJ6.8C-T2	Z DIODE		
K501	NRSA63J-0R0X	MG RESISTOR	0Ω 1/16W J		D501	1SS133-T2	SI DIODE IM		
K502	NRSA63J-0R0X	MG RESISTOR	0Ω 1/16W J		D504	1SS133-T2	SI DIODE IM		
K503	NRSA63J-0R0X	MG RESISTOR	0Ω 1/16W J		D505	UDZS5.1B-X	Z DIODE		
K504	NRSA63J-0R0X	MG RESISTOR	0Ω 1/16W J		D506	1SS133-T2	SI DIODE IM		
K6001	NQR0007-002X	FERRITE BEADS			D507	1SS355-X	DIODE C.M		
K6002	NQR0007-002X	FERRITE BEADS			D510	1SS133-T2	SI DIODE IM		
K6003	NQR0007-002X	FERRITE BEADS			D514	1SS133-T2	SI DIODE IM		
K6004	NQR0007-002X	FERRITE BEADS			D515	1SS133-T2	SI DIODE IM		
K6101	NQR0502-001X	FERRITE BEADS			D516	MTZJ30C-T2	Z DIODE		
K6102	NQR0022-002X	FERRITE BEADS			D521	MTZJ6.8C-T2	Z DIODE		
K6103	NQR0022-002X	FERRITE BEADS			D535	1SS133-T2	SI DIODE IM		
K6104	NRSA63J-0R0X	MG RESISTOR	0Ω 1/16W J		D541	1SS133-T2	SI DIODE IM		
S521	QSW1120-001Z	PUSH SW I.M			D543	1SS133-T2	SI DIODE IM		
S531	QSW0522-002Z	PUSH SW I.M			D546	1SS133-T2	SI DIODE IM		
S532	QSW0522-002Z	PUSH SW I.M			D548	1SS133-T2	SI DIODE IM		
S533	QSW0522-002Z	PUSH SW I.M			D549	1SS133-T2	SI DIODE IM		
S534	QSW0522-002Z	PUSH SW I.M			D550	1SS133-T2	SI DIODE IM		
S535	QSW0522-002Z	PUSH SW I.M			D551	1SS133-T2	SI DIODE IM		
S536	QSW0522-002Z	PUSH SW I.M			D553	1SS133-T2	SI DIODE IM		
S537	QSW0522-002Z	PUSH SW I.M			D561	SLR-342MC-T12	LED		
S538	QSW0522-002Z	PUSH SW I.M			D611	1SS133-T2	SI DIODE IM		
S539	QSW0522-002Z	PUSH SW I.M			D612	1SS133-T2	SI DIODE IM		
S540	QSW0522-002Z	PUSH SW I.M			D2101	1SS133-T2	SI DIODE IM		

Mother board

Block No. [0][3]

△ Symbol No.	Part No.	Part Name	Description	Local	△ Symbol No.	Part No.	Part Name	Description	Local
△ IC201	STK413-430	IC		C30J,C30C	D2701	1SS133-T2	SI DIODE IM		
△ IC201	STK413-400	IC		C20J,C20C	D2702	MTZJ15C-T2	Z DIODE		
△ IC202	STK413-430	IC		C30J,C30C	D2703	MTZJ16C-T2	Z DIODE		
△ IC202	STK413-400	IC		C20J,C20C	D2704	1SS133-T2	SI DIODE IM		
IC301	RC4558D-X	IC			D2705	1SS133-T2	SI DIODE IM		
IC302	RC4558D-X	IC			D3101	1SS133-T2	SI DIODE IM		
IC303	RC4558D-X	IC			D3102	1SS133-T2	SI DIODE IM		
IC601	MN101C427NB	IC			D3201	1SS133-T2	SI DIODE IM		
					D3202	1SS133-T2	SI DIODE IM		
Q152	KTC2026/Y/	TRANSISTOR			D3301	1SS133-T2	SI DIODE IM		
Q501	RT1P441C-X	DIGI TRANSISTOR			D3302	1SS133-T2	SI DIODE IM		
Q502	2SC3928A/QR/-X	TRANSISTOR			D3401	1SS133-T2	SI DIODE IM		
Q503	2SC3928A/QR/-X	TRANSISTOR			D3402	1SS133-T2	SI DIODE IM		
Q504	2SA1530A/QR/-X	TRANSISTOR			D3501	1SS133-T2	SI DIODE IM		
Q505	RT1N44HC-X	DIGI TRANSISTOR			D3502	1SS133-T2	SI DIODE IM		
Q517	RT1N431C-X	TRANSISTOR			D3601	1SS133-T2	SI DIODE IM		
Q523	2SC3928A/QR/-X	TRANSISTOR			D3602	1SS133-T2	SI DIODE IM		
Q524	2SA1530A/QR/-X	TRANSISTOR			D3703	MTZJ15C-T2	Z DIODE		
Q525	2SC3928A/QR/-X	TRANSISTOR							
Q542	RT1N136C-X	DIGI TRANSISTOR			△ C101	QCZ9105-472	C CAPACITOR	4700pF 250V M	
Q603	2SC3928A/QR/-X	TRANSISTOR			C153	NCF21HZ-473X	C CAPACITOR	0.047uF 50V Z	
Q604	KTC3265/Y/-X	TRANSISTOR			C154	NCF21HZ-473X	C CAPACITOR	0.047uF 50V Z	
Q2101	2SA1530A/QR/-X	TRANSISTOR			C155	NCF21HZ-473X	C CAPACITOR	0.047uF 50V Z	
Q2201	2SA1530A/QR/-X	TRANSISTOR			C156	NCF21HZ-473X	C CAPACITOR	0.047uF 50V Z	
					C157	NCF21HZ-223X	C CAPACITOR	0.022uF 50V Z	
					C159	NCF21HZ-223X	C CAPACITOR	0.022uF 50V Z	
					C161	QEZ0736-478	E CAPACITER	4700uF	C30J,C30C
					C161	QETM1HM-338	E CAPACITOR	3300uF 50V M	C20J,C20C
					C162	QEZ0736-478	E CAPACITER	4700uF	C30J,C30C

△ Symbol No.	Part No.	Part Name	Description	Local	△ Symbol No.	Part No.	Part Name	Description	Local
C162	QETM1HM-338	E CAPACITOR	3300uF 50V M	C20J,C20C	C3404	QETN1HM-225Z	E CAPACITOR	2.2uF 50V M	
C163	QETM1EM-478	E CAPACITOR	4700uF 25V M		C3501	NCB31HK-152X	C CAPACITOR	1500pF 50V K	
C164	QETM1EM-478	E CAPACITOR	4700uF 25V M		C3504	QETN1HM-225Z	E CAPACITOR	2.2uF 50V M	
C167	QETN1EM-476Z	E CAPACITOR	47uF 25V M		C3601	NCB31HK-152X	C CAPACITOR	1500pF 50V K	
C168	QETN1CM-107Z	E CAPACITOR	100uF 16V M		C3604	QETN1HM-106Z	E CAPACITOR	10uF 50V M	
C171	QETN1CM-107Z	E CAPACITOR	100uF 16V M		C3701	NCF31HZ-103X	C CAPACITOR	0.01uF 50V Z	
C172	QETN1CM-107Z	E CAPACITOR	100uF 16V M		C3702	NCF31HZ-103X	C CAPACITOR	0.01uF 50V Z	
C501	QETN1HM-475Z	E CAPACITOR	4.7uF 50V M		C3703	NCF31HZ-103X	C CAPACITOR	0.01uF 50V Z	
C503	QETN1HM-475Z	E CAPACITOR	4.7uF 50V M		C3704	NCF31HZ-103X	C CAPACITOR	0.01uF 50V Z	
C512	QETN1HM-475Z	E CAPACITOR	4.7uF 50V M		C3705	NCF31HZ-103X	C CAPACITOR	0.01uF 50V Z	
C522	QETN1HM-106Z	E CAPACITOR	10uF 50V M		C3706	NCF31HZ-103X	C CAPACITOR	0.01uF 50V Z	
C523	QETN1EM-107Z	E CAPACITOR	100uF 25V M		C3720	QETN1EM-476Z	E CAPACITOR	47uF 25V M	
C571	NCF31HZ-103X	C CAPACITOR	0.01uF 50V Z		C3721	QEK1CM-107Z	E CAPACITOR	100uF 16V M	
C591	NCF31HZ-103X	C CAPACITOR	0.01uF 50V Z		R152	NRSA63J-222X	MG RESISTOR	2.2kΩ 1/16W J	
C592	NCF31HZ-103X	C CAPACITOR	0.01uF 50V Z		△R163	QRJ146J-221X	UNF C RESISTOR	220Ω 1/4W J	
C601	QETN1CM-107Z	E CAPACITOR	100uF 16V M		R164	QRE141J-332Y	C RESISTOR	3.3kΩ 1/4W J	
C604	NCF31HZ-103X	C CAPACITOR	0.01uF 50V Z		R165	QRL027J-391	OMF RESISTOR	390Ω 2W J	
C605	NCF31HZ-103X	C CAPACITOR	0.01uF 50V Z		R166	QRL027J-391	OMF RESISTOR	390Ω 2W J	
C606	QETN1HM-106Z	E CAPACITOR	10uF 50V M		△R171	QRL027J-470	OMF RESISTOR	47Ω 2W J	
C2102	NCB31CK-473X	C CAPACITOR	0.047uF 16V K		R501	NRSA63J-472X	MG RESISTOR	4.7kΩ 1/16W J	
C2103	QETN1HM-475Z	E CAPACITOR	4.7uF 50V M		R502	NRSA63J-104X	MG RESISTOR	100kΩ 1/16W J	
C2104	QETN1CM-107Z	E CAPACITOR	100uF 16V M		R504	NRSA63J-102X	MG RESISTOR	1kΩ 1/16W J	
C2105	NDC31HJ-101X	C CAPACITOR	100pF 50V J		R505	NRSA63J-102X	MG RESISTOR	1kΩ 1/16W J	
C2106	NDC31HJ-3R0X	C CAPACITOR	3pF 50V J		R506	NRSA63J-103X	MG RESISTOR	10kΩ 1/16W J	
C2107	NCB21HK-104X	C CAPACITOR	0.1uF 50V K		R508	NRSA63J-223X	MG RESISTOR	22kΩ 1/16W J	
C2108	NCB21HK-104X	C CAPACITOR	0.1uF 50V K		R510	NRSA63J-472X	MG RESISTOR	4.7kΩ 1/16W J	
C2202	NCB31HK-471X	C CAPACITOR	470pF 50V K		R523	NRSA63J-223X	MG RESISTOR	22kΩ 1/16W J	
C2203	QETN1HM-475Z	E CAPACITOR	4.7uF 50V M		R533	NRSA63J-103X	MG RESISTOR	10kΩ 1/16W J	
C2204	QETN1CM-107Z	E CAPACITOR	100uF 16V M		R534	NRSA63J-103X	MG RESISTOR	10kΩ 1/16W J	
C2205	NDC31HJ-101X	C CAPACITOR	100pF 50V J		R535	NRSA63J-104X	MG RESISTOR	100kΩ 1/16W J	
C2206	NDC31HJ-3R0X	C CAPACITOR	3pF 50V J		R536	NRSA63J-103X	MG RESISTOR	10kΩ 1/16W J	
C2207	NCB21HK-104X	C CAPACITOR	0.1uF 50V K		R540	NRSA63J-472X	MG RESISTOR	4.7kΩ 1/16W J	
C2208	NCB21HK-104X	C CAPACITOR	0.1uF 50V K		R553	NRSA63J-153X	MG RESISTOR	15kΩ 1/16W J	
C2302	NCB31HK-471X	C CAPACITOR	470pF 50V K		R554	NRSA63J-223X	MG RESISTOR	22kΩ 1/16W J	
C2303	QETN1HM-475Z	E CAPACITOR	4.7uF 50V M		R555	QRJ146J-271X	UNF C RESISTOR	270Ω 1/4W J	
C2304	QETN1CM-107Z	E CAPACITOR	100uF 16V M		R558	NRSA63J-223X	MG RESISTOR	22kΩ 1/16W J	
C2305	NDC31HJ-101X	C CAPACITOR	100pF 50V J		R559	NRSA63J-223X	MG RESISTOR	22kΩ 1/16W J	
C2306	NDC31HJ-3R0X	C CAPACITOR	3pF 50V J		R560	NRSA63J-223X	MG RESISTOR	22kΩ 1/16W J	
C2307	NCB21HK-104X	C CAPACITOR	0.1uF 50V K		R561	NRSA63J-822X	MG RESISTOR	8.2kΩ 1/16W J	
C2308	NCB21HK-104X	C CAPACITOR	0.1uF 50V K		R562	NRSA63J-393X	MG RESISTOR	39kΩ 1/16W J	
C2402	NCB31HK-471X	C CAPACITOR	470pF 50V K		R563	NRSA63J-223X	MG RESISTOR	22kΩ 1/16W J	
C2403	QETN1HM-475Z	E CAPACITOR	4.7uF 50V M		R574	NRSA02J-151X	MG RESISTOR	150Ω 1/10W J	
C2404	QETN1CM-107Z	E CAPACITOR	100uF 16V M		R601	NRSA63J-103X	MG RESISTOR	10kΩ 1/16W J	
C2405	NDC31HJ-101X	C CAPACITOR	100pF 50V J		R602	NRSA63J-392X	MG RESISTOR	3.9kΩ 1/16W J	
C2406	NDC31HJ-3R0X	C CAPACITOR	3pF 50V J		R603	NRSA63J-222X	MG RESISTOR	2.2kΩ 1/16W J	
C2407	NCB21HK-104X	C CAPACITOR	0.1uF 50V K		R612	NRSA63J-223X	MG RESISTOR	22kΩ 1/16W J	
C2408	NCB21HK-104X	C CAPACITOR	0.1uF 50V K		R613	NRSA63J-223X	MG RESISTOR	22kΩ 1/16W J	
C2502	NCB31HK-471X	C CAPACITOR	470pF 50V K		R614	NRSA63J-223X	MG RESISTOR	22kΩ 1/16W J	
C2503	QETN1HM-475Z	E CAPACITOR	4.7uF 50V M		R621	NRSA63J-103X	MG RESISTOR	10kΩ 1/16W J	
C2504	QETN1CM-107Z	E CAPACITOR	100uF 16V M		R622	NRSA63J-223X	MG RESISTOR	22kΩ 1/16W J	
C2505	NDC31HJ-101X	C CAPACITOR	100pF 50V J		R623	NRSA63J-103X	MG RESISTOR	10kΩ 1/16W J	
C2506	NDC31HJ-3R0X	C CAPACITOR	3pF 50V J		R624	NRSA63J-472X	MG RESISTOR	4.7kΩ 1/16W J	
C2507	NCB21HK-104X	C CAPACITOR	0.1uF 50V K		R625	NRSA63J-472X	MG RESISTOR	4.7kΩ 1/16W J	
C2508	NCB21HK-104X	C CAPACITOR	0.1uF 50V K		R626	NRSA63J-103X	MG RESISTOR	10kΩ 1/16W J	
C2602	NCB31HK-471X	C CAPACITOR	470pF 50V K		R627	NRSA63J-102X	MG RESISTOR	1kΩ 1/16W J	
C2603	QETN1HM-475Z	E CAPACITOR	4.7uF 50V M		R628	NRSA63J-223X	MG RESISTOR	22kΩ 1/16W J	
C2604	QETN1CM-107Z	E CAPACITOR	100uF 16V M		R629	NRSA63J-103X	MG RESISTOR	10kΩ 1/16W J	
C2605	NDC31HJ-101X	C CAPACITOR	100pF 50V J		R646	NRSA63J-102X	MG RESISTOR	1kΩ 1/16W J	
C2606	NDC31HJ-3R0X	C CAPACITOR	3pF 50V J		R667	NRSA63J-472X	MG RESISTOR	4.7kΩ 1/16W J	
C2607	NCB21HK-104X	C CAPACITOR	0.1uF 50V K		R671	NRSA63J-102X	MG RESISTOR	1kΩ 1/16W J	
C2608	NCB21HK-104X	C CAPACITOR	0.1uF 50V K		R2101	NRSA63J-103X	MG RESISTOR	10kΩ 1/16W J	
C2701	QETN1HM-107Z	E CAPACITOR	100uF 50V M		R2103	NRSA63J-563X	MG RESISTOR	56kΩ 1/16W J	
C2702	QETN1EM-476Z	E CAPACITOR	47uF 25V M		R2104	NRSA63J-561X	MG RESISTOR	560Ω 1/16W J	
C2703	QETN1HM-107Z	E CAPACITOR	100uF 50V M		R2105	NRSA63J-563X	MG RESISTOR	56kΩ 1/16W J	
C2704	QETN1HM-476Z	E CAPACITOR	47uF 50V M		R2106	QRZ0224-R22	EMIT RESISTOR	0.22Ω	
C2705	QETN1HM-107Z	E CAPACITOR	100uF 50V M		R2107	NRSA63J-102X	MG RESISTOR	1kΩ 1/16W J	
C2706	QETN1HM-107Z	E CAPACITOR	100uF 50V M		R2108	NRSA63J-153X	MG RESISTOR	15kΩ 1/16W J	
C2707	QETN1HM-106Z	E CAPACITOR	10uF 50V M		R2109	NRSA63J-473X	MG RESISTOR	47kΩ 1/16W J	
C2711	QETN1HM-106Z	E CAPACITOR	10uF 50V M		R2110	QRK126J-4R7X	UNF C RESISTOR	4.7Ω 1/2W J	
C2712	NCF31HZ-103X	C CAPACITOR	0.01uF 50V Z		R2111	QRJ146J-100X	UNF C RESISTOR	10Ω 1/4W J	
C2713	NCF31HZ-103X	C CAPACITOR	0.01uF 50V Z		R2112	NRSA63J-393X	MG RESISTOR	39kΩ 1/16W J	
C3101	NCB31HK-152X	C CAPACITOR	1500pF 50V K		R2113	NRSA63J-222X	MG RESISTOR	2.2kΩ 1/16W J	
C3104	QETN1HM-225Z	E CAPACITOR	2.2uF 50V M		R2114	NRSA63J-104X	MG RESISTOR	100kΩ 1/16W J	
C3201	NCB31HK-152X	C CAPACITOR	1500pF 50V K		R2201	NRSA63J-103X	MG RESISTOR	10kΩ 1/16W J	
C3204	QETN1HM-225Z	E CAPACITOR	2.2uF 50V M		R2203	NRSA63J-563X	MG RESISTOR	56kΩ 1/16W J	
C3301	NCB31HK-152X	C CAPACITOR	1500pF 50V K		R2204	NRSA63J-561X	MG RESISTOR	560Ω 1/16W J	
C3304	QETN1HM-225Z	E CAPACITOR	2.2uF 50V M		R2205	NRSA63J-563X	MG RESISTOR	56kΩ 1/16W J	
C3401	NCB31HK-152X	C CAPACITOR	1500pF 50V K						

△ Symbol No.	Part No.	Part Name	Description	Local	△ Symbol No.	Part No.	Part Name	Description	Local
R2206	QRZ0224-R22	EMIT RESISTOR	0.22Ω		R3105	NRSA63J-474X	MG RESISTOR	470kΩ 1/16W J	
R2207	NRSA63J-102X	MG RESISTOR	1kΩ 1/16W J		R3106	NRSA63J-470X	MG RESISTOR	47Ω 1/16W J	
R2208	NRSA63J-153X	MG RESISTOR	15kΩ 1/16W J		R3107	NRSA63J-334X	MG RESISTOR	330kΩ 1/16W J	
R2209	NRSA63J-473X	MG RESISTOR	47kΩ 1/16W J		R3109	NRSA63J-102X	MG RESISTOR	1kΩ 1/16W J	
R2210	QRK126J-4R7X	UNF C RESISTOR	4.7Ω 1/2W J		R3110	NRSA63J-104X	MG RESISTOR	100kΩ 1/16W J	
R2211	QRJ146J-100X	UNF C RESISTOR	10Ω 1/4W J		R3111	NRSA63J-471X	MG RESISTOR	470Ω 1/16W J	
R2212	NRSA63J-302X	MG RESISTOR	3kΩ 1/16W J		R3201	NRSA63J-203X	MG RESISTOR	20kΩ 1/16W J	
R2213	NRSA63J-222X	MG RESISTOR	2.2kΩ 1/16W J		R3204	NRSA63J-223X	MG RESISTOR	22kΩ 1/16W J	
R2214	NRSA63J-104X	MG RESISTOR	100kΩ 1/16W J		R3205	NRSA63J-474X	MG RESISTOR	470kΩ 1/16W J	
R2301	NRSA63J-103X	MG RESISTOR	10kΩ 1/16W J		R3206	NRSA63J-470X	MG RESISTOR	47Ω 1/16W J	
R2303	NRSA63J-563X	MG RESISTOR	56kΩ 1/16W J		R3207	NRSA63J-334X	MG RESISTOR	330kΩ 1/16W J	
R2304	NRSA63J-561X	MG RESISTOR	560Ω 1/16W J		R3209	NRSA63J-102X	MG RESISTOR	1kΩ 1/16W J	
R2305	NRSA63J-563X	MG RESISTOR	56kΩ 1/16W J		R3210	NRSA63J-104X	MG RESISTOR	100kΩ 1/16W J	
R2306	QRZ0224-R22	EMIT RESISTOR	0.22Ω		R3211	NRSA63J-471X	MG RESISTOR	470Ω 1/16W J	
R2307	NRSA63J-102X	MG RESISTOR	1kΩ 1/16W J		R3301	NRSA63J-203X	MG RESISTOR	20kΩ 1/16W J	
R2308	NRSA63J-153X	MG RESISTOR	15kΩ 1/16W J		R3304	NRSA63J-223X	MG RESISTOR	22kΩ 1/16W J	
R2309	NRSA63J-473X	MG RESISTOR	47kΩ 1/16W J		R3305	NRSA63J-474X	MG RESISTOR	470kΩ 1/16W J	
R2310	QRK126J-4R7X	UNF C RESISTOR	4.7Ω 1/2W J		R3306	NRSA63J-470X	MG RESISTOR	47Ω 1/16W J	
R2311	QRJ146J-100X	UNF C RESISTOR	10Ω 1/4W J		R3307	NRSA63J-334X	MG RESISTOR	330kΩ 1/16W J	
R2312	NRSA63J-302X	MG RESISTOR	3kΩ 1/16W J		R3309	NRSA63J-102X	MG RESISTOR	1kΩ 1/16W J	
R2313	NRSA63J-222X	MG RESISTOR	2.2kΩ 1/16W J		R3310	NRSA63J-104X	MG RESISTOR	100kΩ 1/16W J	
R2314	NRSA63J-104X	MG RESISTOR	100kΩ 1/16W J		R3311	NRSA63J-471X	MG RESISTOR	470Ω 1/16W J	
R2401	NRSA63J-103X	MG RESISTOR	10kΩ 1/16W J		R3401	NRSA63J-203X	MG RESISTOR	20kΩ 1/16W J	
R2403	NRSA63J-563X	MG RESISTOR	56kΩ 1/16W J		R3404	NRSA63J-223X	MG RESISTOR	22kΩ 1/16W J	
R2404	NRSA63J-561X	MG RESISTOR	560Ω 1/16W J		R3405	NRSA63J-474X	MG RESISTOR	470kΩ 1/16W J	
R2405	NRSA63J-563X	MG RESISTOR	56kΩ 1/16W J		R3406	NRSA63J-470X	MG RESISTOR	47Ω 1/16W J	
R2406	QRZ0224-R22	EMIT RESISTOR	0.22Ω		R3407	NRSA63J-334X	MG RESISTOR	330kΩ 1/16W J	
R2407	NRSA63J-102X	MG RESISTOR	1kΩ 1/16W J		R3409	NRSA63J-102X	MG RESISTOR	1kΩ 1/16W J	
R2408	NRSA63J-153X	MG RESISTOR	15kΩ 1/16W J		R3410	NRSA63J-104X	MG RESISTOR	100kΩ 1/16W J	
R2409	NRSA63J-473X	MG RESISTOR	47kΩ 1/16W J		R3411	NRSA63J-471X	MG RESISTOR	470Ω 1/16W J	
R2410	QRK126J-4R7X	UNF C RESISTOR	4.7Ω 1/2W J		R3501	NRSA63J-203X	MG RESISTOR	20kΩ 1/16W J	
R2411	QRJ146J-100X	UNF C RESISTOR	10Ω 1/4W J		R3504	NRSA63J-223X	MG RESISTOR	22kΩ 1/16W J	
R2412	NRSA63J-622X	MG RESISTOR	6.2kΩ 1/16W J		R3505	NRSA63J-474X	MG RESISTOR	470kΩ 1/16W J	
R2413	NRSA63J-222X	MG RESISTOR	2.2kΩ 1/16W J		R3506	NRSA63J-470X	MG RESISTOR	47Ω 1/16W J	
R2414	NRSA63J-104X	MG RESISTOR	100kΩ 1/16W J		R3507	NRSA63J-334X	MG RESISTOR	330kΩ 1/16W J	
R2501	NRSA63J-103X	MG RESISTOR	10kΩ 1/16W J		R3509	NRSA63J-102X	MG RESISTOR	1kΩ 1/16W J	
R2503	NRSA63J-563X	MG RESISTOR	56kΩ 1/16W J		R3510	NRSA63J-104X	MG RESISTOR	100kΩ 1/16W J	
R2504	NRSA63J-561X	MG RESISTOR	560Ω 1/16W J		R3511	NRSA63J-471X	MG RESISTOR	470Ω 1/16W J	
R2505	NRSA63J-563X	MG RESISTOR	56kΩ 1/16W J		R3601	NRSA63J-203X	MG RESISTOR	20kΩ 1/16W J	
R2506	QRZ0224-R22	EMIT RESISTOR	0.22Ω		R3604	NRSA63J-223X	MG RESISTOR	22kΩ 1/16W J	
R2507	NRSA63J-102X	MG RESISTOR	1kΩ 1/16W J		R3605	NRSA63J-154X	MG RESISTOR	150kΩ 1/16W J	
R2508	NRSA63J-153X	MG RESISTOR	15kΩ 1/16W J		R3607	NRSA63J-104X	MG RESISTOR	100kΩ 1/16W J	
R2509	NRSA63J-473X	MG RESISTOR	47kΩ 1/16W J		R3610	NRSA63J-104X	MG RESISTOR	100kΩ 1/16W J	
R2510	QRK126J-4R7X	UNF C RESISTOR	4.7Ω 1/2W J		R3611	NRSA63J-471X	MG RESISTOR	470Ω 1/16W J	
R2511	QRJ146J-100X	UNF C RESISTOR	10Ω 1/4W J		R3717	NRSA63J-103X	MG RESISTOR	10kΩ 1/16W J	
R2512	NRSA63J-622X	MG RESISTOR	6.2kΩ 1/16W J		R3719	QRE141J-102Y	C RESISTOR	1kΩ 1/4W J	
R2513	NRSA63J-222X	MG RESISTOR	2.2kΩ 1/16W J		△ R3720	QRJ146J-100X	UNF C RESISTOR	10Ω 1/4W J	
R2514	NRSA63J-104X	MG RESISTOR	100kΩ 1/16W J		R3721	NRSA63J-221X	MG RESISTOR	220Ω 1/16W J	
R2601	NRSA63J-103X	MG RESISTOR	10kΩ 1/16W J		△ R3727	QRL01DJ-180X	OMF RESISTOR	18Ω 1W J	
R2603	NRSA63J-563X	MG RESISTOR	56kΩ 1/16W J		R3732	NRSA63J-153X	MG RESISTOR	15kΩ 1/16W J	
R2604	NRSA63J-561X	MG RESISTOR	560Ω 1/16W J		L2101	QQLZ005-R45	COIL	0.45uH	
R2605	NRSA63J-563X	MG RESISTOR	56kΩ 1/16W J		L2201	QQLZ005-R45	COIL	0.45uH	
R2606	QRZ0224-R22	EMIT RESISTOR	0.22Ω		L2301	QQLZ005-R45	COIL	0.45uH	
R2607	NRSA63J-102X	MG RESISTOR	1kΩ 1/16W J		L2401	QQLZ005-R45	COIL	0.45uH	
R2608	NRSA63J-153X	MG RESISTOR	15kΩ 1/16W J		L2501	QQLZ005-R45	COIL	0.45uH	
R2609	NRSA63J-473X	MG RESISTOR	47kΩ 1/16W J		L2601	QQLZ005-R45	COIL	0.45uH	
R2610	QRK126J-4R7X	UNF C RESISTOR	4.7Ω 1/2W J		△ CN101	QGA7901C1-02	CONNECTOR	W-B (1-2)	
R2611	QRJ146J-100X	UNF C RESISTOR	10Ω 1/4W J		△ CN102	QGA7901C1-02	CONNECTOR	W-B (1-2)	
R2612	NRSA63J-302X	MG RESISTOR	3kΩ 1/16W J		CN151	QGA3901C1-05	CONNECTOR	W-B (1-5)	
R2613	NRSA63J-222X	MG RESISTOR	2.2kΩ 1/16W J		CN271	QGB2510J1-14	CONNECTOR	B-B (1-14)	
R2614	NRSA63J-104X	MG RESISTOR	100kΩ 1/16W J		CN272	QGB2510J1-09	CONNECTOR	B-B (1-9)	
△ R2701	QRZ9005-220X	FUSI RESISTOR	22Ω		CN273	QGB2510J1-14	CONNECTOR	B-B (1-14)	
△ R2702	QRJ146J-220X	UNF C RESISTOR	22Ω 1/4W J		CN274	QGA3901C1-02	CONNECTOR	W-B (1-2)	
R2703	NRSA63J-471X	MG RESISTOR	470Ω 1/16W J		CN371	QGA2501C1-02	CONNECTOR	W-B (1-2)	
R2704	NRSA63J-471X	MG RESISTOR	470Ω 1/16W J		CN372	QGB2510K2-09	CONNECTOR	B-B (1-9)	
R2705	NRSA63J-333X	MG RESISTOR	33kΩ 1/16W J		CN501	QGB2510K2-14	CONNECTOR	B-B (1-14)	
△ R2706	QRZ9006-4R7X	FUSI RESISTOR	4.7Ω		CN502	QGB2510K2-14	CONNECTOR	B-B (1-14)	
△ R2707	QRZ9006-4R7X	FUSI RESISTOR	4.7Ω		EP201	QNZ0136-001Z	EARTH PLATE		
△ R2708	QRZ9006-4R7X	FUSI RESISTOR	4.7Ω		EP501	QNZ0136-001Z	EARTH PLATE		
△ R2709	QRZ9006-4R7X	FUSI RESISTOR	4.7Ω		FC102	QNG0019-001Z	FUSE CLIP		
△ R2710	QRZ9005-100X	FUSI RESISTOR	10Ω		FC156	QNG0019-001Z	FUSE CLIP		
R2711	NRSA63J-333X	MG RESISTOR	33kΩ 1/16W J		FC158	QNG0019-001Z	FUSE CLIP		
R2712	NRSA63J-562X	MG RESISTOR	5.6kΩ 1/16W J		FW501	QUM213-28Z4Z4-E	RIBBON WIRE		
R2713	NRSA63J-562X	MG RESISTOR	5.6kΩ 1/16W J		HS151	QZW0138-001	HEAT SINK		
R2721	QRE141J-472Y	C RESISTOR	4.7kΩ 1/4W J		J2701	QND0118-001	DIN CONNECTOR		
R2722	QRE141J-472Y	C RESISTOR	4.7kΩ 1/4W J		J2702	QNB0195-001	SPEAKER TERMINA		
R3101	NRSA63J-203X	MG RESISTOR	20kΩ 1/16W J						
R3104	NRSA63J-223X	MG RESISTOR	22kΩ 1/16W J						

△ Symbol No.	Part No.	Part Name	Description	Local
△ RY101	QSK0142-001	RELAY		
RY271	QSK0127-001	RELAY		
RY272	QSK0127-001	RELAY		
RY273	QSK0127-001	RELAY		
TH271	NAD0025-103X	N THERMISTOR	10kΩ	
WC201	QZW0112-001	WIRE CLAMP		
X601	QAX0246-001Z	C RESONATOR	8.00MHz	

DVD servo board

Block No. [0][4]

△ Symbol No.	Part No.	Part Name	Description	Local
IC201	LA6502-X	IC		
IC301	MN2DS0016AA	IC		
IC302	MM1701CH-X	IC		
IC303	XC2164A51FM-X	IC		
IC305	MM1563DF-X	IC		
IC451	MN101C61GNW	IC		
IC452	BR93L56RF-W-X	IC		
IC453	S-80830CNNB-G-W	IC		
IC505	K4S641632H-UC75	IC		
IC505	or K4S641632K-UC75	IC		
IC509	SG32M90TFIR3	IC(MICRO C ROM)		
IC509	or SG32A90TFIR3	IC(MICRO C ROM)		
IC510	BR24L16F-W-X	IC		
IC701	AK4387ET-X	IC		
IC702	AK4387ET-X	IC		
IC703	AK4387ET-X	IC		
IC704	AK5358ET-X	IC		
IC705	MM1615AN-X	IC		
IC801	MM1565AF-X	IC		
IC811	ISP1106DH-X	IC		
Q101	KTA1001/Y/-X	TRANSISTOR		
Q101	or 2SB1424/R/-W	TRANSISTOR		
Q102	2SC4617/R/-X	TRANSISTOR		
Q103	KTA1001/Y/-X	TRANSISTOR		
Q103	or 2SB1424/R/-W	TRANSISTOR		
Q104	2SC4617/R/-X	TRANSISTOR		
Q801	KRA104S-X	DIGI TRANSISTOR		
Q801	or UN2113-X	DIGI TRANSISTOR		
C101	NCF31EZ-104X	C CAPACITOR	0.1uF 25V Z	
C102	NCF31EZ-104X	C CAPACITOR	0.1uF 25V Z	
C103	NCF31EZ-104X	C CAPACITOR	0.1uF 25V Z	
C104	NCF31EZ-104X	C CAPACITOR	0.1uF 25V Z	
C105	NEAF0JM-476X	E CAPACITOR	47uF 6.3V M	
C106	NBE20JM-226X	TA E CAPACITOR	22uF 6.3V M	
C107	NCF31EZ-104X	C CAPACITOR	0.1uF 25V Z	
C108	NBE20JM-226X	TA E CAPACITOR	22uF 6.3V M	
C201	NDC31HJ-221X	C CAPACITOR	220pF 50V J	
C202	NDC31HJ-221X	C CAPACITOR	220pF 50V J	
C203	NCB31HK-103X	C CAPACITOR	0.01uF 50V K	
C204	NCF31EZ-104X	C CAPACITOR	0.1uF 25V Z	
C205	NCB31HK-271X	C CAPACITOR	270pF 50V K	
C206	NDC31HJ-151X	C CAPACITOR	150pF 50V J	
C210	NCF31AZ-105X	C CAPACITOR	1uF 10V Z	
C211	NCB31HK-223X	C CAPACITOR	0.022uF 50V K	
C217	NCF31EZ-104X	C CAPACITOR	0.1uF 25V Z	
C251	NCB31AK-474X	C CAPACITOR	0.47uF 10V K	
C256	NCB31CK-104X	C CAPACITOR	0.1uF 16V K	
C257	NCB31HK-822X	C CAPACITOR	8200pF 50V K	
C258	NCB31CK-153X	C CAPACITOR	0.015uF 16V K	
C259	NCB31CK-153X	C CAPACITOR	0.015uF 16V K	
C260	NCB31HK-223X	C CAPACITOR	0.022uF 50V K	
C261	NCB31HK-223X	C CAPACITOR	0.022uF 50V K	
C262	NCB31HK-223X	C CAPACITOR	0.022uF 50V K	
C263	NEAF1CM-107X	E CAPACITOR	100uF 16V M	
C301	NEAF0GM-227X	E CAPACITOR	220uF 4V M	
C302	NEAF0GM-476X	E CAPACITOR	47uF 4V M	
C303	NEAF0GM-476X	E CAPACITOR	47uF 4V M	
C304	NCB30JK-105X	C CAPACITOR	1uF 6.3V K	
C305	NCF31EZ-104X	C CAPACITOR	0.1uF 25V Z	

△ Symbol No.	Part No.	Part Name	Description	Local
C306	NCF31EZ-104X	C CAPACITOR	0.1uF 25V Z	
C307	NCF31EZ-104X	C CAPACITOR	0.1uF 25V Z	
C308	NCF31EZ-104X	C CAPACITOR	0.1uF 25V Z	
C309	NCF31EZ-104X	C CAPACITOR	0.1uF 25V Z	
C310	NCF31EZ-104X	C CAPACITOR	0.1uF 25V Z	
C311	NCF31EZ-104X	C CAPACITOR	0.1uF 25V Z	
C312	NCF31EZ-104X	C CAPACITOR	0.1uF 25V Z	
C314	NCF31EZ-104X	C CAPACITOR	0.1uF 25V Z	
C316	NCF31EZ-104X	C CAPACITOR	0.1uF 25V Z	
C317	NCF31EZ-104X	C CAPACITOR	0.1uF 25V Z	
C318	NCF31EZ-104X	C CAPACITOR	0.1uF 25V Z	
C319	NCF31EZ-104X	C CAPACITOR	0.1uF 25V Z	
C320	NCB31CK-104X	C CAPACITOR	0.1uF 16V K	
C321	NCB31CK-104X	C CAPACITOR	0.1uF 16V K	
C322	NCB31CK-104X	C CAPACITOR	0.1uF 16V K	
C323	NCB31CK-104X	C CAPACITOR	0.1uF 16V K	
C324	NCB30JK-105X	C CAPACITOR	1uF 6.3V K	
C325	NDC31HJ-120X	C CAPACITOR	12pF 50V J	
C326	NDC31HJ-120X	C CAPACITOR	12pF 50V J	
C327	NCF31EZ-104X	C CAPACITOR	0.1uF 25V Z	
C328	NCB31HK-103X	C CAPACITOR	0.01uF 50V K	
C330	NCF31EZ-104X	C CAPACITOR	0.1uF 25V Z	
C331	NCB31CK-333X	C CAPACITOR	0.033uF 16V K	
C332	NCF31EZ-104X	C CAPACITOR	0.1uF 25V Z	
C333	NCF31EZ-104X	C CAPACITOR	0.1uF 25V Z	
C334	NCF31EZ-104X	C CAPACITOR	0.1uF 25V Z	
C335	NCF31EZ-104X	C CAPACITOR	0.1uF 25V Z	
C337	NCB31CK-183X	C CAPACITOR	0.018uF 16V K	
C338	NCB31HK-562X	C CAPACITOR	5600pF 50V K	
C339	NBE20JM-106X	TA E CAPACITOR	10uF 6.3V M	
C340	NCB30JK-105X	C CAPACITOR	1uF 6.3V K	
C341	NCB30JK-105X	C CAPACITOR	1uF 6.3V K	
C345	NCF31EZ-104X	C CAPACITOR	0.1uF 25V Z	
C347	NCB31CK-104X	C CAPACITOR	0.1uF 16V K	
C348	NCB31CK-104X	C CAPACITOR	0.1uF 16V K	
C349	NCF31EZ-104X	C CAPACITOR	0.1uF 25V Z	
C350	NCB31HK-103X	C CAPACITOR	0.01uF 50V K	
C351	NCB31HK-103X	C CAPACITOR	0.01uF 50V K	
C352	NCB31CK-153X	C CAPACITOR	0.015uF 16V K	
C353	NCB31HK-561X	C CAPACITOR	560pF 50V K	
C354	NCB31HK-561X	C CAPACITOR	560pF 50V K	
C356	NCB30JK-105X	C CAPACITOR	1uF 6.3V K	
C359	NCB30JK-105X	C CAPACITOR	1uF 6.3V K	
C370	NCF31EZ-104X	C CAPACITOR	0.1uF 25V Z	
C371	NCF31AZ-105X	C CAPACITOR	1uF 10V Z	
C372	NCF31EZ-104X	C CAPACITOR	0.1uF 25V Z	
C373	NCF31EZ-104X	C CAPACITOR	0.1uF 25V Z	
C374	NCF31EZ-104X	C CAPACITOR	0.1uF 25V Z	
C375	NCF31EZ-104X	C CAPACITOR	0.1uF 25V Z	
C378	NCF31EZ-104X	C CAPACITOR	0.1uF 25V Z	
C379	NCF31EZ-104X	C CAPACITOR	0.1uF 25V Z	
C380	NCB21CK-105X	C CAPACITOR	1uF 16V K	
C381	NCB21AK-225X	C CAPACITOR	2.2uF 10V K	
C382	NCB31HK-471X	C CAPACITOR	470pF 50V K	
C383	NCF31EZ-104X	C CAPACITOR	0.1uF 25V Z	
C393	NCB31HK-103X	C CAPACITOR	0.01uF 50V K	
C451	NCF31EZ-104X	C CAPACITOR	0.1uF 25V Z	
C452	NCF31EZ-104X	C CAPACITOR	0.1uF 25V Z	
C453	NCF31EZ-104X	C CAPACITOR	0.1uF 25V Z	
C454	NCB31HK-103X	C CAPACITOR	0.01uF 50V K	
C455	NCB31HK-103X	C CAPACITOR	0.01uF 50V K	
C551	NCF31EZ-104X	C CAPACITOR	0.1uF 25V Z	
C555	NCF31EZ-104X	C CAPACITOR	0.1uF 25V Z	
C557	NCB31HK-102X	C CAPACITOR	1000pF 50V K	
C558	NBE20JM-226X	TA E CAPACITOR	22uF 6.3V M	
C559	NCF31EZ-104X	C CAPACITOR	0.1uF 25V Z	
C560	NCF31EZ-104X	C CAPACITOR	0.1uF 25V Z	
C562	NCF31AZ-105X	C CAPACITOR	1uF 10V Z	
C563	NCF31EZ-104X	C CAPACITOR	0.1uF 25V Z	
C564	NCF31EZ-104X	C CAPACITOR	0.1uF 25V Z	
C701	NCF31EZ-104X	C CAPACITOR	0.1uF 25V Z	
C702	NCF31EZ-104X	C CAPACITOR	0.1uF 25V Z	
C703	NCF31EZ-104X	C CAPACITOR	0.1uF 25V Z	
C704	NEAF0JM-476X	E CAPACITOR	47uF 6.3V M	
C706	NEAF1CM-106X	E CAPACITOR	10uF 16V M	
C707	NCF31EZ-104X	C CAPACITOR	0.1uF 25V Z	
C708	NCF31EZ-104X	C CAPACITOR	0.1uF 25V Z	

△ Symbol No.	Part No.	Part Name	Description	Local	△ Symbol No.	Part No.	Part Name	Description	Local
C709	NCF31EZ-104X	C CAPACITOR	0.1uF 25V Z		R347	NRSA63J-203X	MG RESISTOR	20kΩ 1/16W J	
C711	NCB21CK-105X	C CAPACITOR	1uF 16V K		R348	NRSA63J-0R0X	MG RESISTOR	0Ω 1/16W J	
C712	NCB31HK-103X	C CAPACITOR	0.01uF 50V K		R350	NRSA63J-911X	MG RESISTOR	910Ω 1/16W J	
C713	NCB21CK-105X	C CAPACITOR	1uF 16V K		R351	NRSA63J-471X	MG RESISTOR	470Ω 1/16W J	
C740	NCB31CK-104X	C CAPACITOR	0.1uF 16V K		R352	NRSA63J-105X	MG RESISTOR	1MΩ 1/16W J	
C741	NCF31AZ-105X	C CAPACITOR	1uF 10V Z		R353	NRSA63J-101X	MG RESISTOR	100Ω 1/16W J	
C742	NCF31EZ-104X	C CAPACITOR	0.1uF 25V Z		R357	NRSA63J-221X	MG RESISTOR	220Ω 1/16W J	
C743	NCF31EZ-104X	C CAPACITOR	0.1uF 25V Z		R358	NRSA63J-221X	MG RESISTOR	220Ω 1/16W J	
C744	NEAF1CM-106X	E CAPACITOR	10uF 16V M		R359	NRSA63J-221X	MG RESISTOR	220Ω 1/16W J	
C745	NEAF1CM-106X	E CAPACITOR	10uF 16V M		R360	NRSA63J-221X	MG RESISTOR	220Ω 1/16W J	
C801	NCB21CK-105X	C CAPACITOR	1uF 16V K		R362	NRSA63J-470X	MG RESISTOR	47Ω 1/16W J	
C802	NCB21AK-225X	C CAPACITOR	2.2uF 10V K		R367	NRSA63J-221X	MG RESISTOR	220Ω 1/16W J	
C803	NEAF0JM-227X	E CAPACITOR	220uF 6.3V M		R371	NRSA63D-203X	MG RESISTOR	20kΩ 1/16W D	
C804	NCB31HK-471X	C CAPACITOR	470pF 50V K		R372	NRSA63J-103X	MG RESISTOR	10kΩ 1/16W J	
C811	NCF31EZ-104X	C CAPACITOR	0.1uF 25V Z		R373	NRSA63J-103X	MG RESISTOR	10kΩ 1/16W J	
C812	NCF31EZ-104X	C CAPACITOR	0.1uF 25V Z		R375	NRSA63J-471X	MG RESISTOR	470Ω 1/16W J	
					R376	NRSA63J-102X	MG RESISTOR	1kΩ 1/16W J	
R101	NRSA63J-101X	MG RESISTOR	100Ω 1/16W J		R383	NRSA63J-101X	MG RESISTOR	100Ω 1/16W J	
R102	NRSA63J-101X	MG RESISTOR	100Ω 1/16W J		R384	NRSA63J-102X	MG RESISTOR	1kΩ 1/16W J	
R103	NRSA63J-562X	MG RESISTOR	5.6kΩ 1/16W J		R385	NRSA63J-102X	MG RESISTOR	1kΩ 1/16W J	
R104	NRSA63J-432X	MG RESISTOR	4.3kΩ 1/16W J		R392	NRSA63J-103X	MG RESISTOR	10kΩ 1/16W J	
R105	NRS181J-180X	MG RESISTOR	18Ω 1/8W J		R452	NRSA63J-222X	MG RESISTOR	2.2kΩ 1/16W J	
R106	NRSA63J-2R2X	MG RESISTOR	2.2Ω 1/16W J		R453	NRSA63J-103X	MG RESISTOR	10kΩ 1/16W J	
R107	NRSA63J-102X	MG RESISTOR	1kΩ 1/16W J		R454	NRSA63J-103X	MG RESISTOR	10kΩ 1/16W J	
R108	NRSA63J-471X	MG RESISTOR	470Ω 1/16W J		R455	NRSA63J-103X	MG RESISTOR	10kΩ 1/16W J	
R109	NRSA63J-331X	MG RESISTOR	330Ω 1/16W J		R456	NRSA63J-103X	MG RESISTOR	10kΩ 1/16W J	
R111	NRSA63J-562X	MG RESISTOR	5.6kΩ 1/16W J		R457	NRSA63J-101X	MG RESISTOR	100Ω 1/16W J	
R112	NRSA63J-432X	MG RESISTOR	4.3kΩ 1/16W J		R458	NRSA63J-102X	MG RESISTOR	1kΩ 1/16W J	
R113	NRS181J-180X	MG RESISTOR	18Ω 1/8W J		R461	NRSA63J-101X	MG RESISTOR	100Ω 1/16W J	
R114	NRSA63J-2R2X	MG RESISTOR	2.2Ω 1/16W J		R463	NRSA63J-101X	MG RESISTOR	100Ω 1/16W J	
R115	NRSA63J-102X	MG RESISTOR	1kΩ 1/16W J		R464	NRSA63J-101X	MG RESISTOR	100Ω 1/16W J	
R116	NRSA63J-471X	MG RESISTOR	470Ω 1/16W J		R465	NRSA63J-102X	MG RESISTOR	1kΩ 1/16W J	
R117	NRSA63J-331X	MG RESISTOR	330Ω 1/16W J		R531	NRSA63J-103X	MG RESISTOR	10kΩ 1/16W J	
R125	NRSA63J-1R0X	MG RESISTOR	1Ω 1/16W J		R535	NRSA63J-473X	MG RESISTOR	47kΩ 1/16W J	
R127	NRSA63J-432X	MG RESISTOR	4.3kΩ 1/16W J		R541	NRSA63J-473X	MG RESISTOR	47kΩ 1/16W J	
R128	NRSA63J-562X	MG RESISTOR	5.6kΩ 1/16W J		R542	NRSA63J-473X	MG RESISTOR	47kΩ 1/16W J	
R201	NRSA63J-471X	MG RESISTOR	470Ω 1/16W J		R701	NRSA63J-2R2X	MG RESISTOR	2.2Ω 1/16W J	
R202	NRSA63J-102X	MG RESISTOR	1kΩ 1/16W J		R714	NRSA63J-101X	MG RESISTOR	100Ω 1/16W J	
R204	NRSA63J-273X	MG RESISTOR	27kΩ 1/16W J		R715	NRSA63J-101X	MG RESISTOR	100Ω 1/16W J	
R205	NRSA63J-273X	MG RESISTOR	27kΩ 1/16W J		R716	NRSA63J-471X	MG RESISTOR	470Ω 1/16W J	
R206	NRSA63J-303X	MG RESISTOR	30kΩ 1/16W J		R718	NRSA63J-473X	MG RESISTOR	47kΩ 1/16W J	
R207	NRSA63J-473X	MG RESISTOR	47kΩ 1/16W J		R719	NRSA63J-473X	MG RESISTOR	47kΩ 1/16W J	
R213	NRSA63J-103X	MG RESISTOR	10kΩ 1/16W J		R721	NRSA63J-471X	MG RESISTOR	470Ω 1/16W J	
R214	NRSA63J-103X	MG RESISTOR	10kΩ 1/16W J		R722	NRSA63J-0R0X	MG RESISTOR	0Ω 1/16W J	
R219	NRSA63J-183X	MG RESISTOR	18kΩ 1/16W J		R723	NRSA63J-471X	MG RESISTOR	470Ω 1/16W J	
R220	NRSA63J-243X	MG RESISTOR	24kΩ 1/16W J		R724	NRSA63J-471X	MG RESISTOR	470Ω 1/16W J	
R221	NRSA63J-682X	MG RESISTOR	6.8kΩ 1/16W J		R725	NRSA63J-471X	MG RESISTOR	470Ω 1/16W J	
R251	NRS125J-R39X	MG RESISTOR	0.39Ω 1/2W J		R726	NRSA63J-0R0X	MG RESISTOR	0Ω 1/16W J	
R259	NRSA63J-103X	MG RESISTOR	10kΩ 1/16W J		R727	NRSA63J-471X	MG RESISTOR	470Ω 1/16W J	
R303	NRSA63J-220X	MG RESISTOR	22Ω 1/16W J		R728	NRSA63J-471X	MG RESISTOR	470Ω 1/16W J	
R306	NRSA63J-102X	MG RESISTOR	1kΩ 1/16W J		R730	NRSA63J-331X	MG RESISTOR	330Ω 1/16W J	
R307	NRSA63J-102X	MG RESISTOR	1kΩ 1/16W J		R732	NRSA63J-102X	MG RESISTOR	1kΩ 1/16W J	
R309	NRSA63J-104X	MG RESISTOR	100kΩ 1/16W J		R741	NRSA63J-0R0X	MG RESISTOR	0Ω 1/16W J	
R310	NRSA63J-101X	MG RESISTOR	100Ω 1/16W J		R742	NRSA63J-5R1X	MG RESISTOR	5.1Ω 1/16W J	
R311	NRSA63J-331X	MG RESISTOR	330Ω 1/16W J		R799	NRSA63J-0R0X	MG RESISTOR	0Ω 1/16W J	
R312	NRSA63J-331X	MG RESISTOR	330Ω 1/16W J		R811	NRS125J-330X	MG RESISTOR	33Ω 1/2W J	
R316	NRSA63J-102X	MG RESISTOR	1kΩ 1/16W J		R812	NRS125J-330X	MG RESISTOR	33Ω 1/2W J	
R318	NRSA63J-220X	MG RESISTOR	22Ω 1/16W J		R813	NRSA63J-153X	MG RESISTOR	15kΩ 1/16W J	
R319	NRSA63J-103X	MG RESISTOR	10kΩ 1/16W J		R814	NRSA63J-153X	MG RESISTOR	15kΩ 1/16W J	
R322	NRSA63J-331X	MG RESISTOR	330Ω 1/16W J		R819	NRSA63J-0R0X	MG RESISTOR	0Ω 1/16W J	
R323	NRSA63J-331X	MG RESISTOR	330Ω 1/16W J		R821	NRSA63J-221X	MG RESISTOR	220Ω 1/16W J	
R324	NRSA63J-331X	MG RESISTOR	330Ω 1/16W J		R822	NRSA63J-221X	MG RESISTOR	220Ω 1/16W J	
R325	NRSA63J-331X	MG RESISTOR	330Ω 1/16W J		R823	NRSA63J-221X	MG RESISTOR	220Ω 1/16W J	
R326	NRSA63J-103X	MG RESISTOR	10kΩ 1/16W J		R851	NRSA63J-102X	MG RESISTOR	1kΩ 1/16W J	
R327	NRSA63J-103X	MG RESISTOR	10kΩ 1/16W J		R855	NRSA63J-102X	MG RESISTOR	1kΩ 1/16W J	
R332	NRSA63J-221X	MG RESISTOR	220Ω 1/16W J		R856	NRSA63J-102X	MG RESISTOR	1kΩ 1/16W J	
R333	NRSA63J-331X	MG RESISTOR	330Ω 1/16W J		R857	NRSA63J-221X	MG RESISTOR	220Ω 1/16W J	
R334	NRSA63J-0R0X	MG RESISTOR	0Ω 1/16W J		R858	NRSA63J-221X	MG RESISTOR	220Ω 1/16W J	
R335	NRSA63J-0R0X	MG RESISTOR	0Ω 1/16W J		R859	NRSA63J-102X	MG RESISTOR	1kΩ 1/16W J	
R336	NRSA63J-0R0X	MG RESISTOR	0Ω 1/16W J		R860	NRSA63J-102X	MG RESISTOR	1kΩ 1/16W J	
R337	NRSA63J-0R0X	MG RESISTOR	0Ω 1/16W J		R861	NRSA63J-473X	MG RESISTOR	47kΩ 1/16W J	
R338	NRSA63J-0R0X	MG RESISTOR	0Ω 1/16W J						
R339	NRSA63J-0R0X	MG RESISTOR	0Ω 1/16W J		CN101	QGF0523F3-24W	CONNECTOR	FFC/FPC (1-24)	
R340	NRSA63D-303X	MG RESISTOR	30kΩ 1/16W D		CN201	QGF1016F8-08W	CONNECTOR	FFC/FPC (1-8)	
R341	NRSA63D-512X	MG RESISTOR	5.1kΩ 1/16W D		CN451	QGF1016F8-15W	CONNECTOR	FFC/FPC (1-15)	
R342	NRSA63D-222X	MG RESISTOR	2.2kΩ 1/16W D		CN452	QGA2001F6-02X	CONNECTOR	W-B (1-2)	
R345	NRSA63J-221X	MG RESISTOR	220Ω 1/16W J		CN453	QGA2001F6-03X	CONNECTOR	W-B (1-3)	
R346	NRSA63J-223X	MG RESISTOR	22kΩ 1/16W J		CN701	QGF1016C6-28W	CONNECTOR	FFC/FPC (1-28)	

Symbol No.	Part No.	Part Name	Description	Local
CN702	QGF1016C6-18W	CONNECTOR	FFC/FPC (1-18)	
CN801	QGF1016C6-05W	CONNECTOR	FFC/FPC (1-5)	
CN811	QGA2001F6-05X	CONNECTOR	W-B (1-5)	
K101	NQR0502-001X	FERRITE BEADS		
K351	NQR0502-001X	FERRITE BEADS		
K352	NQR0502-001X	FERRITE BEADS		
K353	NQR0502-001X	FERRITE BEADS		
K354	NQR0022-002X	FERRITE BEADS		
K454	NRSA63J-0R0X	MG RESISTOR	0Ω 1/16W J	
K455	NRSA63J-0R0X	MG RESISTOR	0Ω 1/16W J	
K456	NRSA63J-0R0X	MG RESISTOR	0Ω 1/16W J	
K501	NQR0502-001X	FERRITE BEADS		
K701	NQR0022-002X	FERRITE BEADS		
K702	NQR0022-002X	FERRITE BEADS		
K703	NQR0022-002X	FERRITE BEADS		
K704	NQR0022-002X	FERRITE BEADS		
K705	NQR0022-002X	FERRITE BEADS		
K706	NQR0022-005X	FERRITE BEADS		
K707	NQR0022-002X	FERRITE BEADS		
K708	NQR0022-002X	FERRITE BEADS		
K709	NQR0022-002X	FERRITE BEADS		
K710	NQR0022-002X	FERRITE BEADS		
K711	NQR0022-002X	FERRITE BEADS		
K720	NQR0022-002X	FERRITE BEADS		
K721	NRSA63J-0R0X	MG RESISTOR	0Ω 1/16W J	
K722	NRSA63J-0R0X	MG RESISTOR	0Ω 1/16W J	
K726	NRSA63J-0R0X	MG RESISTOR	0Ω 1/16W J	
K810	NQR0502-001X	FERRITE BEADS		
K811	NRSA63J-0R0X	MG RESISTOR	0Ω 1/16W J	
K812	NRSA63J-0R0X	MG RESISTOR	0Ω 1/16W J	
TH301	NAD0025-103X	N THERMISTOR	10kΩ	
X301	NAX0741-001X	CRYSTAL		
X302	NAX0376-002X	CRYSTAL		
X451	NAX0248-001X	C OSCILLATOR		

DVD loading board

Block No. [0][5]

Symbol No.	Part No.	Part Name	Description	Local
IC1	LB1641	IC		
IC2	LB1641	IC		
D1	MTZJ6.2A-T2	Z DIODE		
C1	QEKC1CM-107Z	E CAPACITOR	100uF 16V M	
C2	QCBB1HK-104Y	C CAPACITOR	0.1uF 50V K	
C3	QFLC1HJ-103Z	M CAPACITOR	0.01uF 50V J	
C5	QFLC1HJ-103Z	M CAPACITOR	0.01uF 50V J	
C6	QCBB1HK-104Y	C CAPACITOR	0.1uF 50V K	
C7	QCBB1HK-104Y	C CAPACITOR	0.1uF 50V K	
CN1	QGF1036F2-15	CONNECTOR	FFC/FPC (1-15)	
CN2	QGB2024K1-07S	CONNECTOR	B-B (1-7)	
CN3	QGB2024J1-07S	CONNECTOR	B-B (1-7)	
SW1	QSW0844-002	PUSH SWITCH		
SW2	QSW0844-002	PUSH SWITCH		
SW3	QSW0844-002	PUSH SWITCH		
SW4	QSW0844-002	PUSH SWITCH		
SW5	QSW0844-002	PUSH SWITCH		
SW6	QSW0854-002	PUSH SW		
SW7	QSW0886-002	DETECT SWITCH		
SW8	QSW0923-001	DETECT SWITCH		

< MEMEO >

Packing materials and accessories parts list

Block No. **M 3 M M**

No additional / supplemental order of WARRANTY CARDS are available.

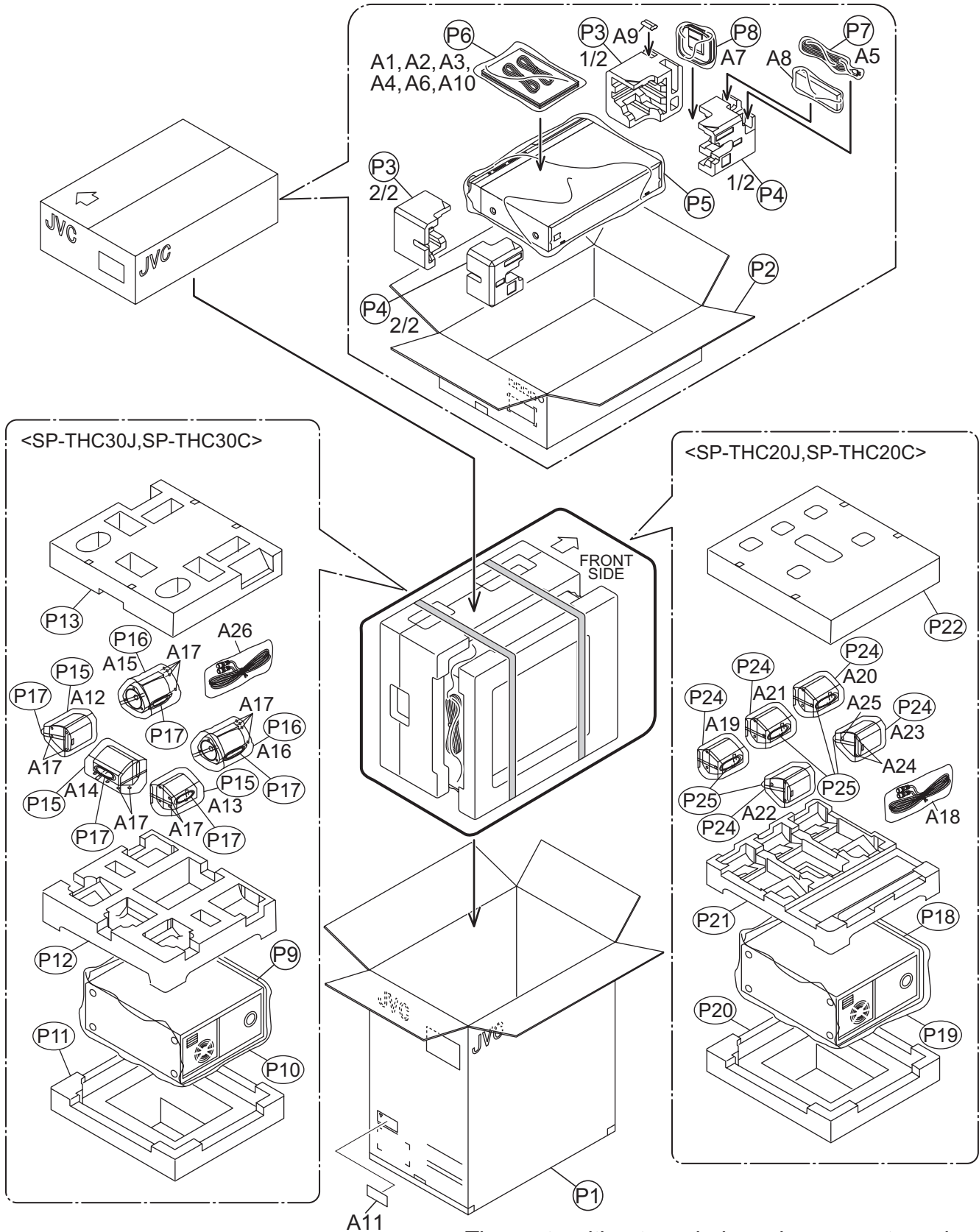

The parts without symbol number are not service.

Packing and Accessories

Block No. [M][3][M][M]

△	Symbol No.	Part No.	Part Name	Description	Local
	A 1	LVT1504-001A	INST BOOK	ENG	C30J,C20J
	A 1	LVT1504-002A	INST BOOK	ENG FRE	C30C,C20C
	A 2	YU20333	SAFETY INST.		
	A 3	BT-51034-2	REGISTRATION CARD		C30J,C20J
	A 4	QAM0216-001	SIGNAL CORD		
△	A 5	QMPE180-183-JN	POWER CORD(US/CA)	1.83m BLACK	
	A 6	QAL0457-001	ANT.WIRE		
	A 7	QAL0014-003	AM LOOP ANT		
	A 8	RM-STHC60J	REMOCON UNIT		
	A 9	-----	BATTERY	(x2)	
	A 10	-----	WARRANTY CARD	BT-52006-2	C30C,C20C
	A 11	LE40796-001A	VERANCE LABEL		
	A 12	AB080073-02	SPEAKER BOX	SPK WITH BOX-FL	C30J,C30C
	A 13	AB080073-01	SPEAKER BOX	SPK WITH BOX-FR	C30J,C30C
	A 14	AB080074-01	SPEAKER BOX	SPK WITH BOX-C	C30J,C30C
	A 15	AB080072-02	SPEAKER BOX	SPK WITH BOX-SL	C30J,C30C
	A 16	AB080072-01	SPEAKER BOX	SPK WITH BOX-SR	C30J,C30C
	A 17	9000008401	RUBBER CUSHION	(x20)	C30J,C30C
	A 18	6200044901	DIN CABLE		C20J,C20C
	A 19	AB080078-03	SPEAKER BOX	SPK WITH BOX-FL	C20J,C20C
	A 20	AB080078-02	SPEAKER BOX	SPK WITH BOX-FR	C20J,C20C
	A 21	AB080078-01	SPEAKER BOX	SPK WITH BOX-C	C20J,C20C
	A 22	AB080078-05	SPEAKER BOX	SPK WITH BOX-SL	C20J,C20C
	A 23	AB080078-04	SPEAKER BOX	SPK WITH BOX-SR	C20J,C20C
	A 24	9000008401	FOOT	(x10)	C20J,C20C
	A 25	9000009501	FOOT	(x5)	C20J,C20C
	A 26	6200044901	DIN CABLE		C30J,C30C
	P 1	LV36907-003A	MASTER CARTON		C30J,C30C
	P 1	LV36907-001A	MASTER CARTON		C20J,C20C
	P 2	LV36596-010A	CARTON BOX		C30J,C30C
	P 2	LV36596-008A	CARTON BOX		C20J,C20C
	P 3	LV22251-001A	CUSHION(F)		
	P 4	LV22252-001A	CUSHION(R)		
	P 5	QPC05006515P	POLY BAG	50cm x 65cm	
	P 6	QPA02503503P	POLY BAG	25cm x 35cm	
	P 7	QPA01003003	POLY BAG	10cm x 30cm	
	P 8	QPA01702503P	POLY BAG	17cm x 25cm	
	P 9	8500051881	MIRROR MAT		C30J,C30C
	P 10	8500051901	POLY BAG		C30J,C30C
	P 11	LV11261-001A	CUSHION A		C30J,C30C
	P 12	LV11261-002A	CUSHION B		C30J,C30C
	P 13	LV11261-003A	CUSHION C		C30J,C30C
	P 15	8500051961	POLY BAG	(x3)	C30J,C30C
	P 16	8500043421	POLY BAG	(x2)	C30J,C30C
	P 17	8500052241	POLY BAG	(x5)	C30J,C30C
	P 18	8500051881	MIRROR MAT		C20J,C20C
	P 19	8500051901	POLY BAG		C20J,C20C
	P 20	LV11255-001A	CUSHION A		C20J,C20C
	P 21	LV11255-002A	CUSHION B		C20J,C20C
	P 22	LV11255-003A	CUSHION C		C20J,C20C
	P 24	8500063111	MIRROR MAT SHEET	(x5)	C20J,C20C
	P 25	8500052241	POLY BAG	(x5)	C20J,C20C

JVC

SCHEMATIC DIAGRAMS

DVD DIGITAL THEATER SYSTEM

TH-C30J, TH-C30C TH-C20J, TH-C20C

CD-ROM No.SML200603

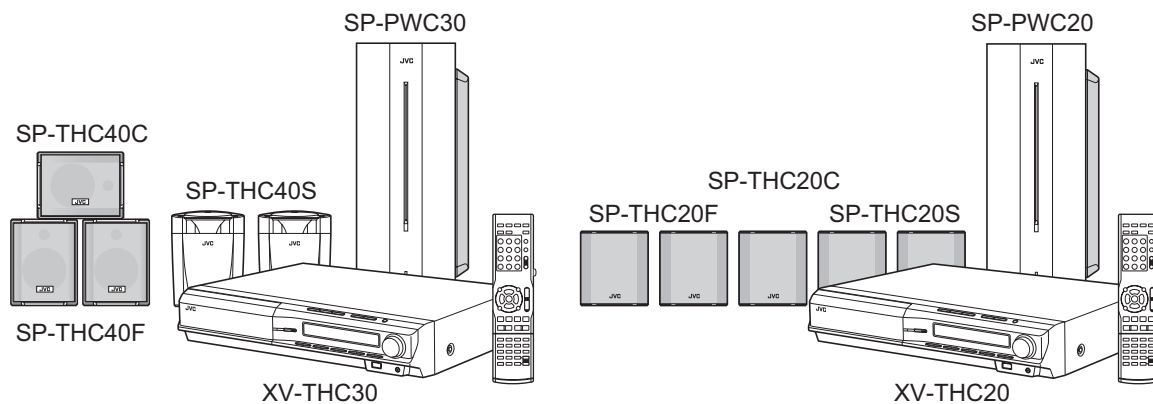

MPEG-4
ASF PLAYBACK

Digital Direct Progressive Scan
AV COMPU LINK

Lead free solder used in the board (material : Sn-Ag-Cu, melting point : 219 Centigrade)

Contents

Block diagrams	2-1
Standard schematic diagrams	2-3
Printed circuit boards	2-25 to 30

In regard with component parts appearing on the silk-screen printed side (parts side) of the PWB diagrams, the parts that are printed over with black such as the resistor (■), diode (▣) and ICP (●) or identified by the "⚠" mark nearby are critical for safety.

< MEMO >

Block diagram

<Main body section>

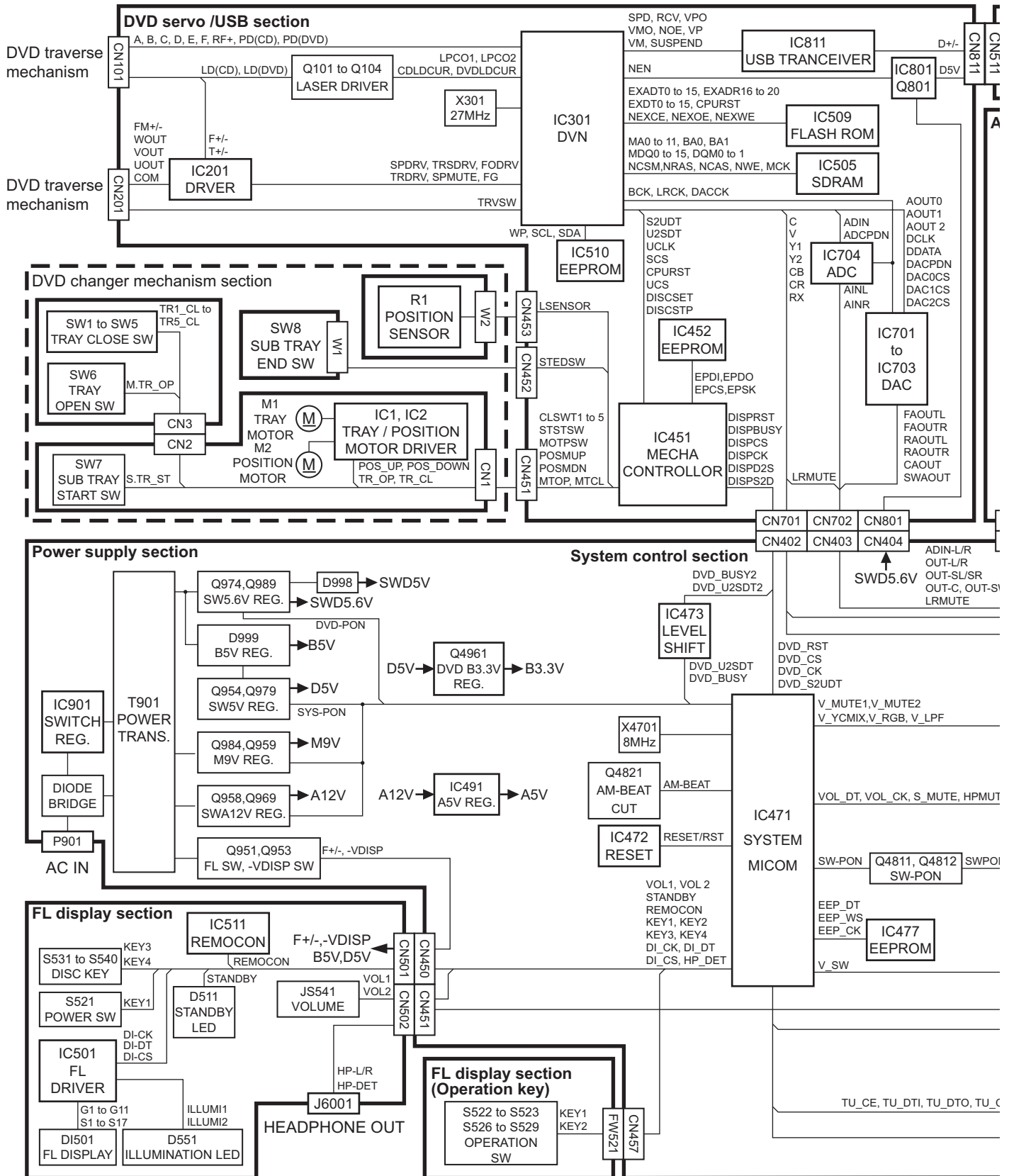

<Subwoofer section>

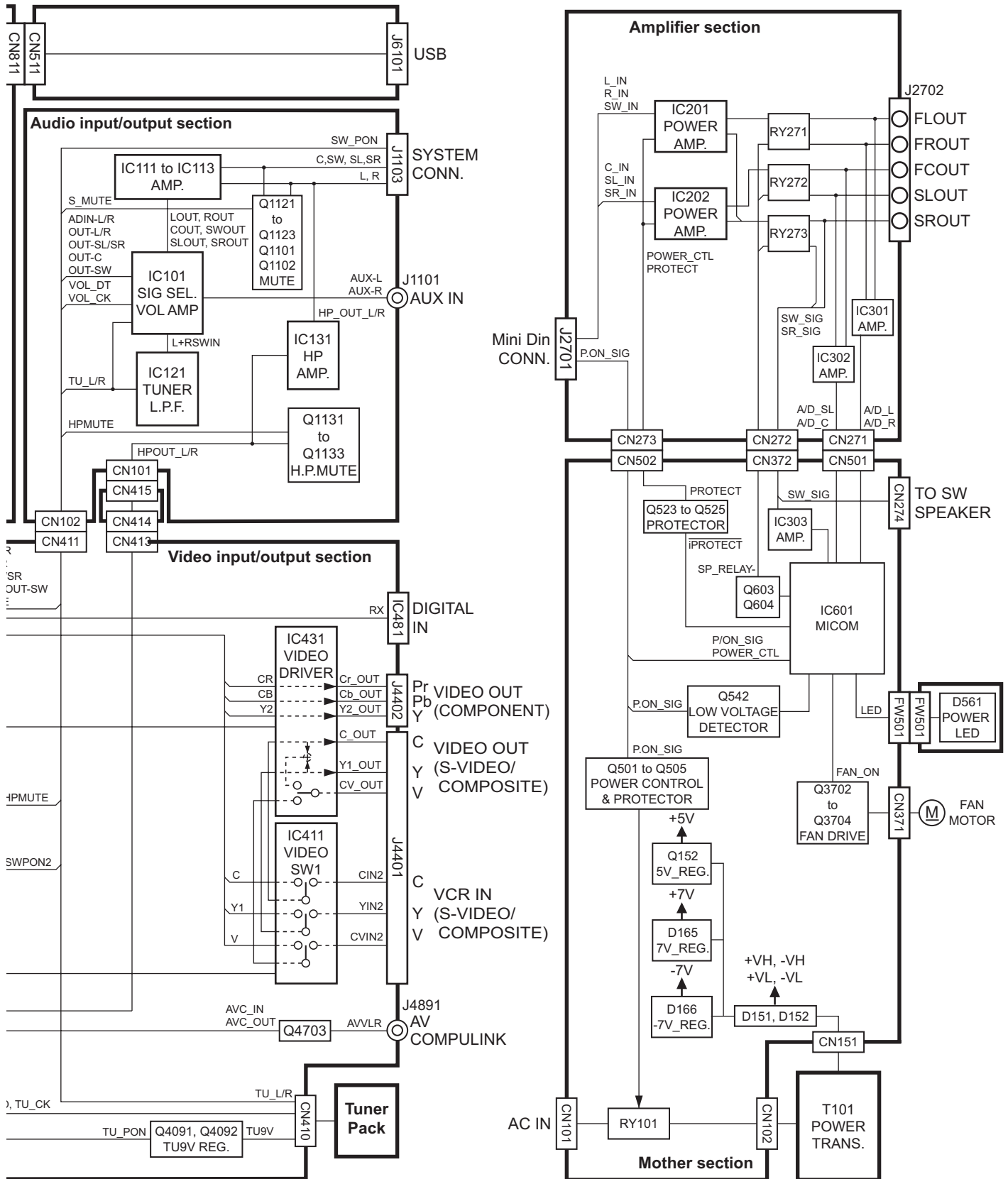

Standard schematic diagrams

Primary section

Ver.J/C
120V 60Hz

Ver.UW/UJ/UY/UP
US/UX/UG/UT
110-240V 50/60Hz

Ver.A
240V 50Hz

Ver.EE
230V 50Hz

Ver.UF
220V 50Hz

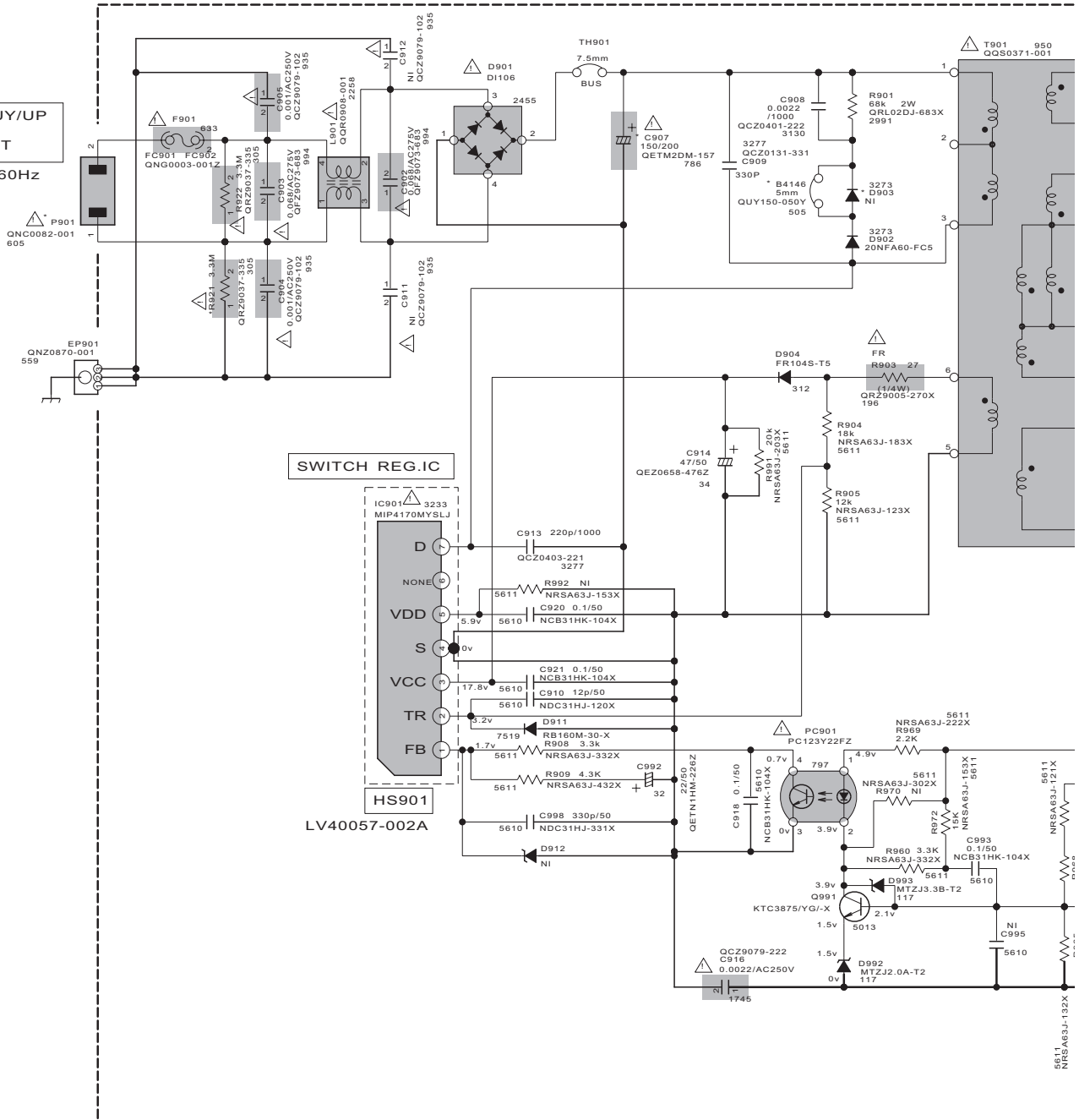

Ver.	ADDRESS	D	J/C	B	UY/UW/UJ/UP US/UX/UG/UT A/EE
*C907	(B-5)		QETM2DM-157		QETM2GM-107
*D903	(B-7)		QY150-050V BUS WIRE:5mm		20NFA60-FCS
*C952	(B-8)		QCZ0136-101Z		QCZ0136-102Z
*R957	(B-9)		NONE		NRSA63J-273X
*R955	(B-10)		NRSA63J-223X		NONE
*R921	(C-3)		QRZ9037-335		NONE
*P901	(B-2)		QNC0082-001		QNC0081-001
*B4146	(B-6)		QY150-050Y		NONE

VERSION CODES
J : U.S.A.
C : CANADA
B : GREAT BRITAIN
UW : BRAZIL/MEXICO/PERU
UY : ARGENTINE
UJ : USA MILITARY BASE
A : AUSTRALIA
US : SINGAPORE
UG : TURKEY/EGYPT/SOUTH AFRICA
UN : INDONESIA
UX : SAUDI ARABIA
UT : TAIWAN

▲ Parts are safety assurance parts.
When replacing those parts make
sure to use the specified one.

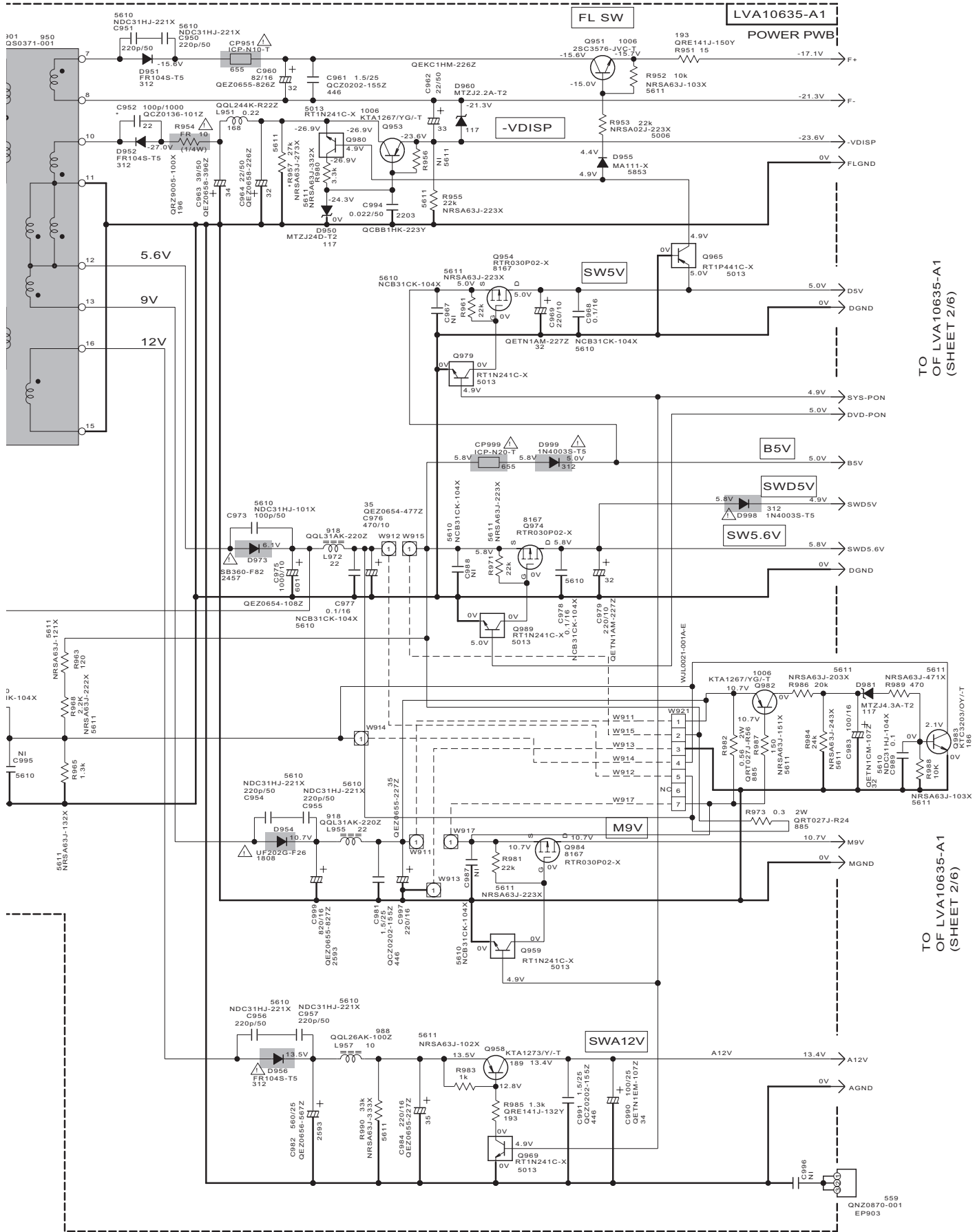

TO OF LVA10635-A1
(SHEET 2/6)

TO OF LVA10635-A1
(SHEET 2/6)

Audio section

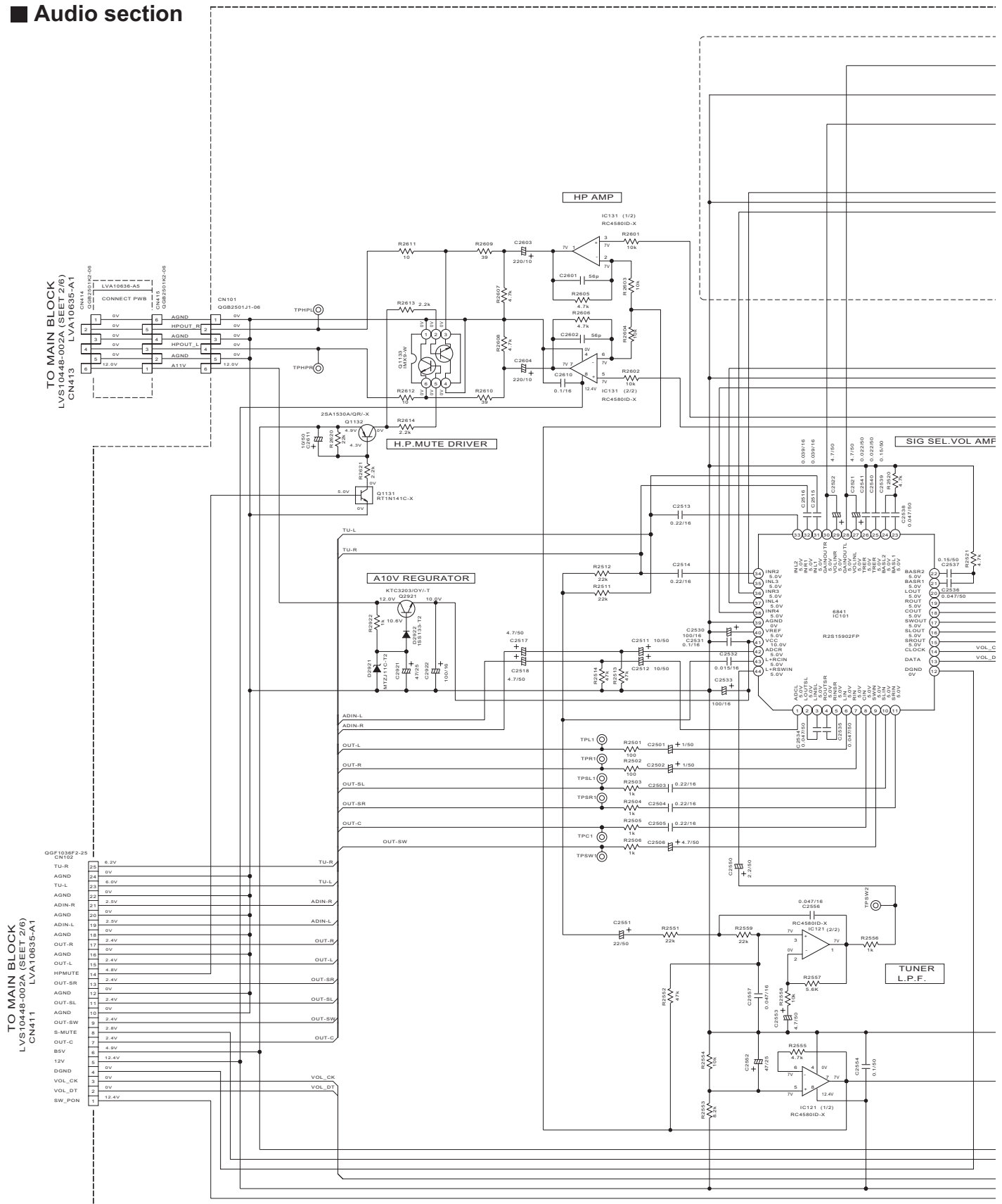

NOTES

- VOLTAGES ARE DC-MEASURED WITH A DIGITAL VOLT METER WITHOUT INPUT SIGNAL. CONDITION --- A CD disc in the Tray 1, and PLAY mode.
- UNLESS OTHERWISE SPECIFIED. ALL RESISTORS ARE 1/16W ±5% METAL GLAZE RESISTOR OR 0.5% METAL GLAZE RESISTOR. ALL CAPACITORS ARE 50V, 25V, 16V, 10V or 6.3V CERAMIC CAPACITOR. ALL RESISTANCE VALUES ARE IN OHM (Ω). ALL CAPACITANCE VALUES ARE IN µF (pF). ALL E-CAPACITORS ARE SHOWN IN THE FORM OF CAPACITANCE(µF)/RATED VOLTAGE (V). ALL INDUCTANCE VALUES ARE IN µH(m=mH).
- NI STANDS FOR NOT INSERTED PARTS.

*1	
R1158	F
R1159	F
XV-THC20	10K
XV-THC30/40	10K
XV-THC50	10K
XV-THC60	10K

*2 USE C90

LVA10636-A1
AUDIO PWB

*2 USE C90

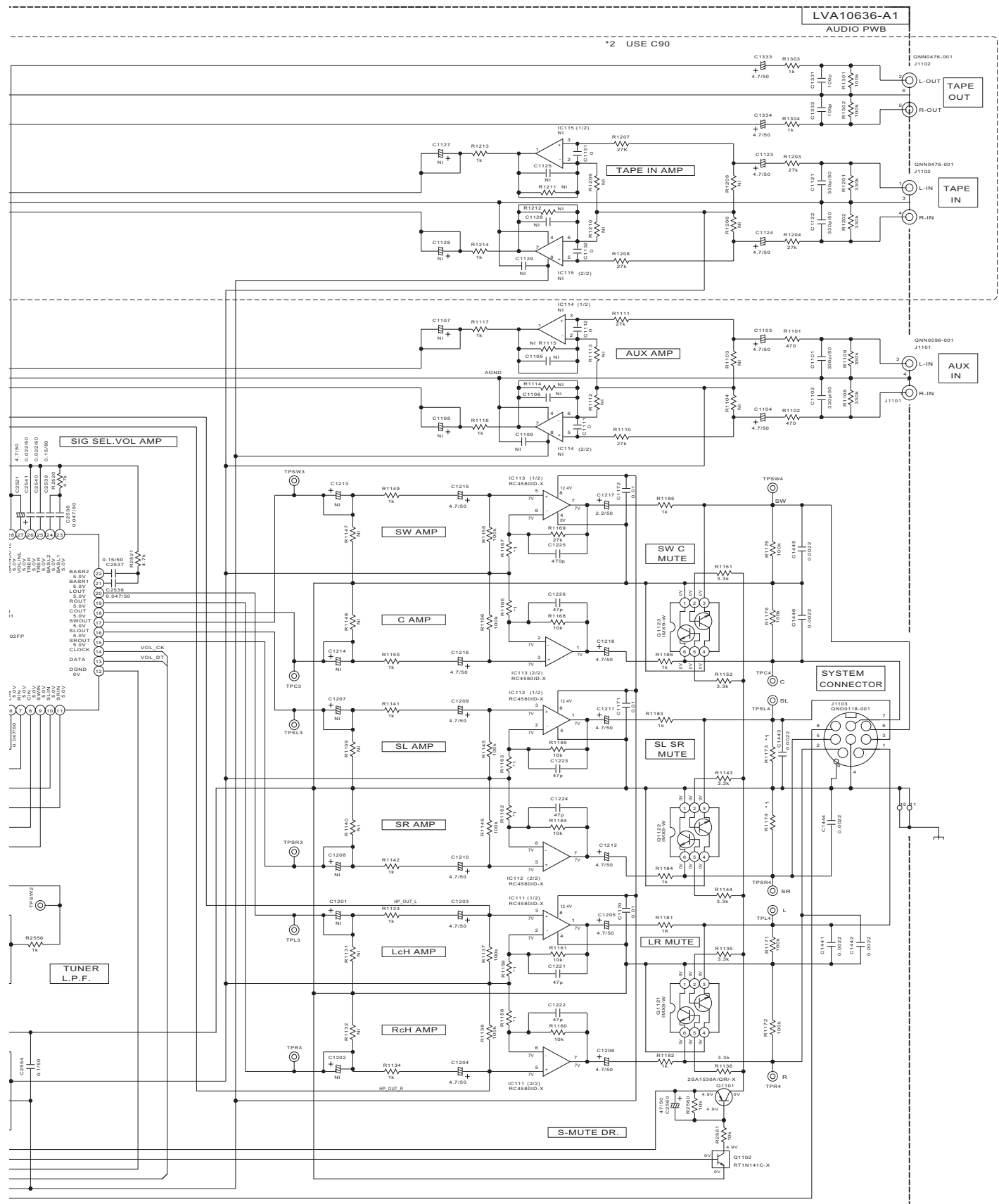

*1

	R1158 R1159	R1162 R1163	R1166	R1167	R1173 R1174
XV-THC20	10k	68k	10k	18k	100k
XV-THC30/40	10k	10k	10k	18k	100k
XV-THC50	10k	10k	13k	15k	100k
XV-THC60	10k	-	13k	12k	3.9k

*2 USE C90

Micon section

TO DVD BLOCK
FMU-SB1
LVS10494-001A or LVS104
LVA10655-101A LVA106

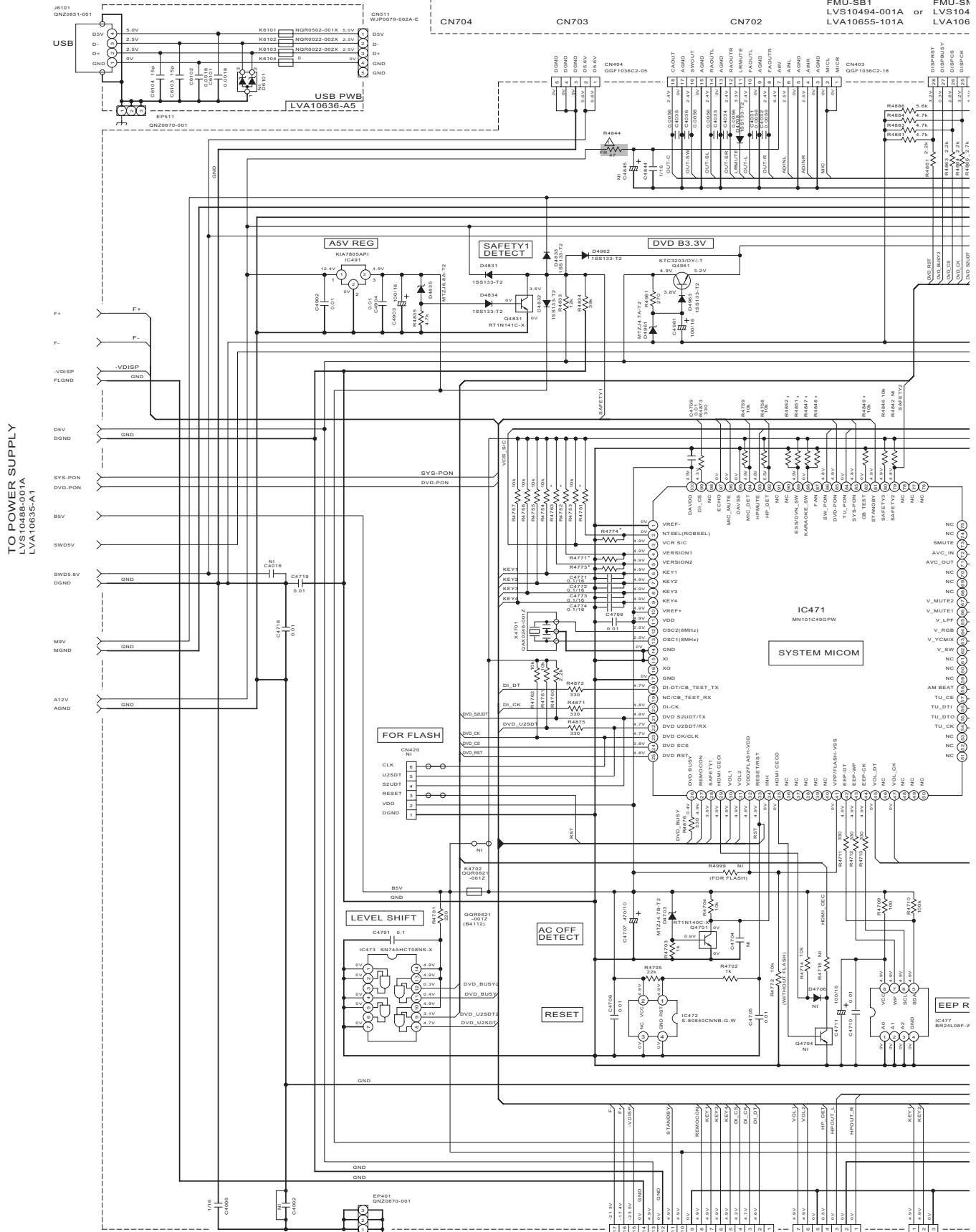

NOTES

1. VOLTAGES ARE DC-MEASURED WITH A DIGITAL VOLT METER WITHOUT INPUT SIGNAL.
CONDITION ... A DVD disc in the Tray 1, and STOP mode.
2. UNLESS OTHERWISE SPECIFIED.
ALL RESISTORS ARE 1/16W ± 5% METAL GLAZE RESISTOR. OR 0.5% METAL GLAZE RESISTOR.
ALL CAPACITORS ARE 50V, 25V, 10V or 6.3V CERAMIC CAPACITOR
ALL RESISTANCE VALUES ARE IN OHM (Ω). ALL CAPACITANCE VALUES ARE IN (μF)(pF).
ALL CAPACITORS ARE SHOWN IN THE FORM OF CAPACITANCE/(RATED VOLTAGE (V)).
ALL INDUCTANCE VALUES ARE IN nH(m=mmH).
3. NI STANDS FOR NOT INSERTED PARTS.

TO FRONT
LVS10488-005A
LVA10635-A2

TO TOP KE
FW521
LVS10488-005A
LVA10635-A2

) DVD BLOCK
 U-SB1
 310494-001A or LVS10483-001A
 310655-101A LVA10633-101A

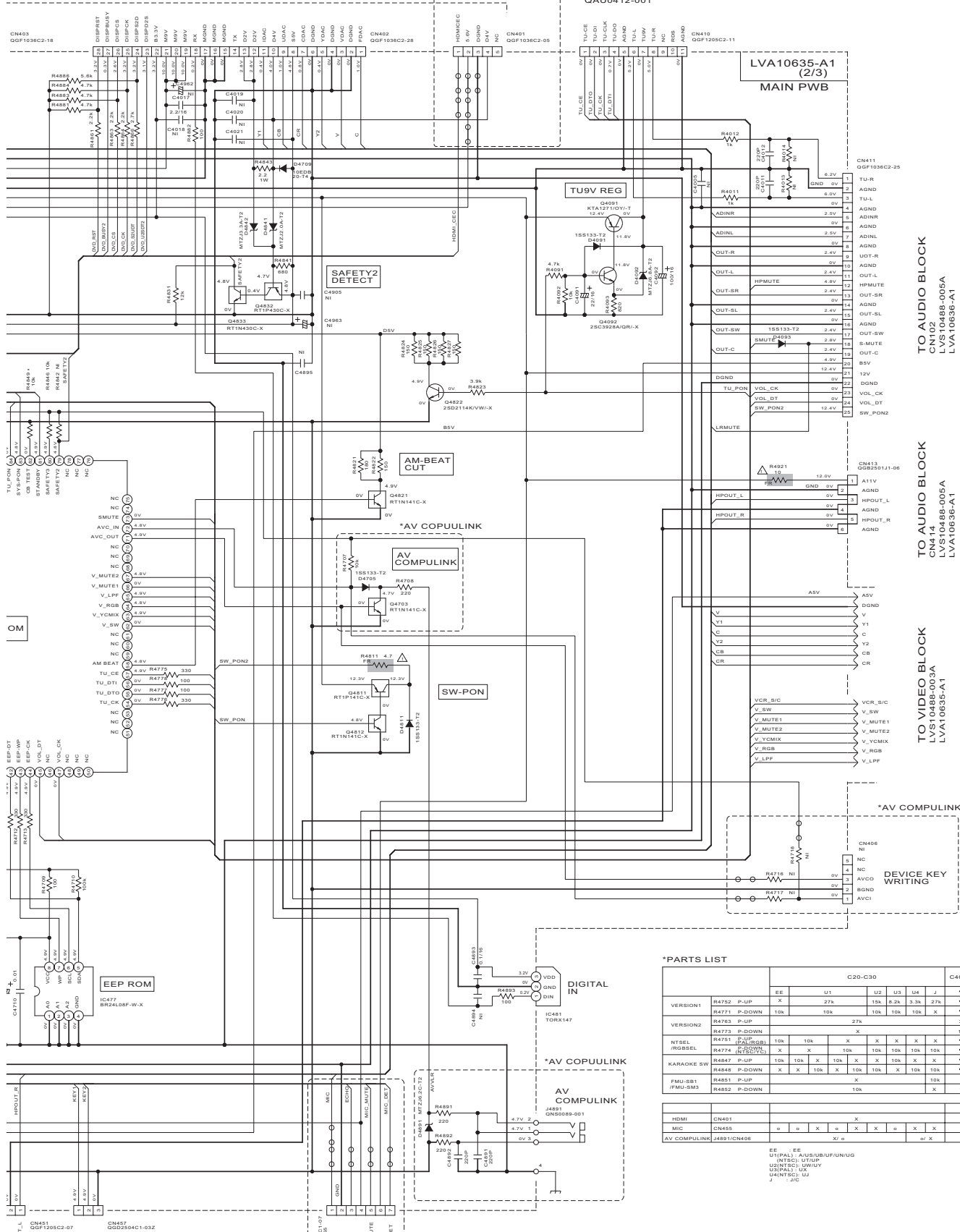

TO AUDIO BLOCK
 CN102
 LVS10488-005A
 LVA10636-A1

TO AUDIO BLOCK
 CN414
 LVS10488-005A
 LVA10636-A1

TO VIDEO BLOCK
 CN414
 LVS10488-003A
 LVA10635-A1

*AV COPULINK
 CN406
 NC
 AVCO
 BGRND
 AVCI

***PARTS LIST**

		EE	U1	U2	U3	U4	J	C40-C60	C90
VERSION1	R4752 P-UP	X	27k	15k	8.2k	3.3k	27k	←	←
	R4771 P-DOWN	10k		10k	10k	10k	X	←	←
VERSION2	R4763 P-UP		27k					27k	X
	R4773 P-DOWN							10k	10k
NTSEL /RGBSEL	R4751 P-UP (PAL/RGB)	10k	10k	X	X	X	X	←	←
	R4774 P-DOWN (PAL/RGB)	X	X	10k	10k	10k	10k	←	←
KARAOKE SW	R4841 P-UP	10k	10k	X	10k	X	X	←	←
	R4848 P-DOWN	X	X	10k	X	10k	10k	←	←
FMU-SB1 /FMU-SM3	R4851 P-UP		X					10k	X
	R4852 P-DOWN							X	10k
HDMI	CN403			X					3
	CN455	o	o	X	o	X	o	X	←
AV COPULINK	J4891CN406		X					o	X

EE U1PAL /AUS/UB/UP/UNIG
 U1NTSC/UTUP
 U2NTSC/UTUP
 U3PAL/UX
 U4NTSC/UX
 J JIC

⚠ Parts are safety assurance parts.
 When replacing those parts make
 sure to use the specified one.

TO TOP KEY
 FW521
 LVS10488-005A
 LVA10635-A2

TO MIC
 CN701
 LVS10488-006A
 LVA10636-A4

Front section

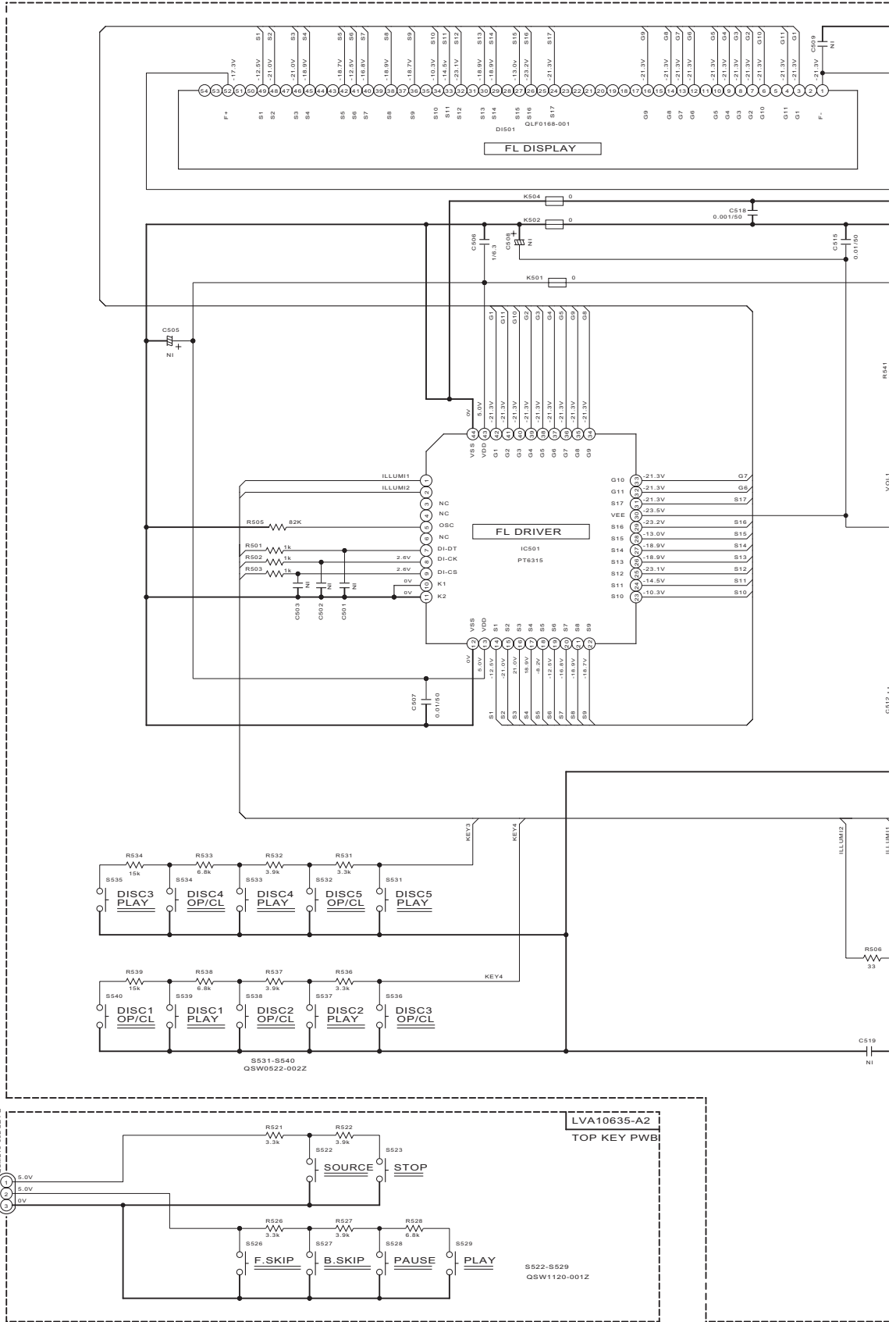

TO MAIN PWB
CN457 OF
LVS10488-002A
(SHEET 2/6)
LVA10635-A1

LVA10635-A2
TOP KEY PWB

S522-S529
QSW1120-001Z

NOTES

- VOLTAGES ARE DC-MEASURED WITH A CONDITION --- A CD disc in the 1
- UNLESS OTHERWISE SPECIFIED.
- ALL RESISTORS ARE 1/16W ±5% MET
- ALL CAPACITORS ARE 50V, 25V, 16V
- ALL RESISTANCE VALUES ARE IN OHM
- ALL CAPACITANCE VALUES ARE IN μ
- ALL E. CAPACITORS ARE SHOWN IN TH
- ALL INDUCTANCE VALUES ARE IN μH
- NI STANDS FOR NOT INSERTED PARTS.

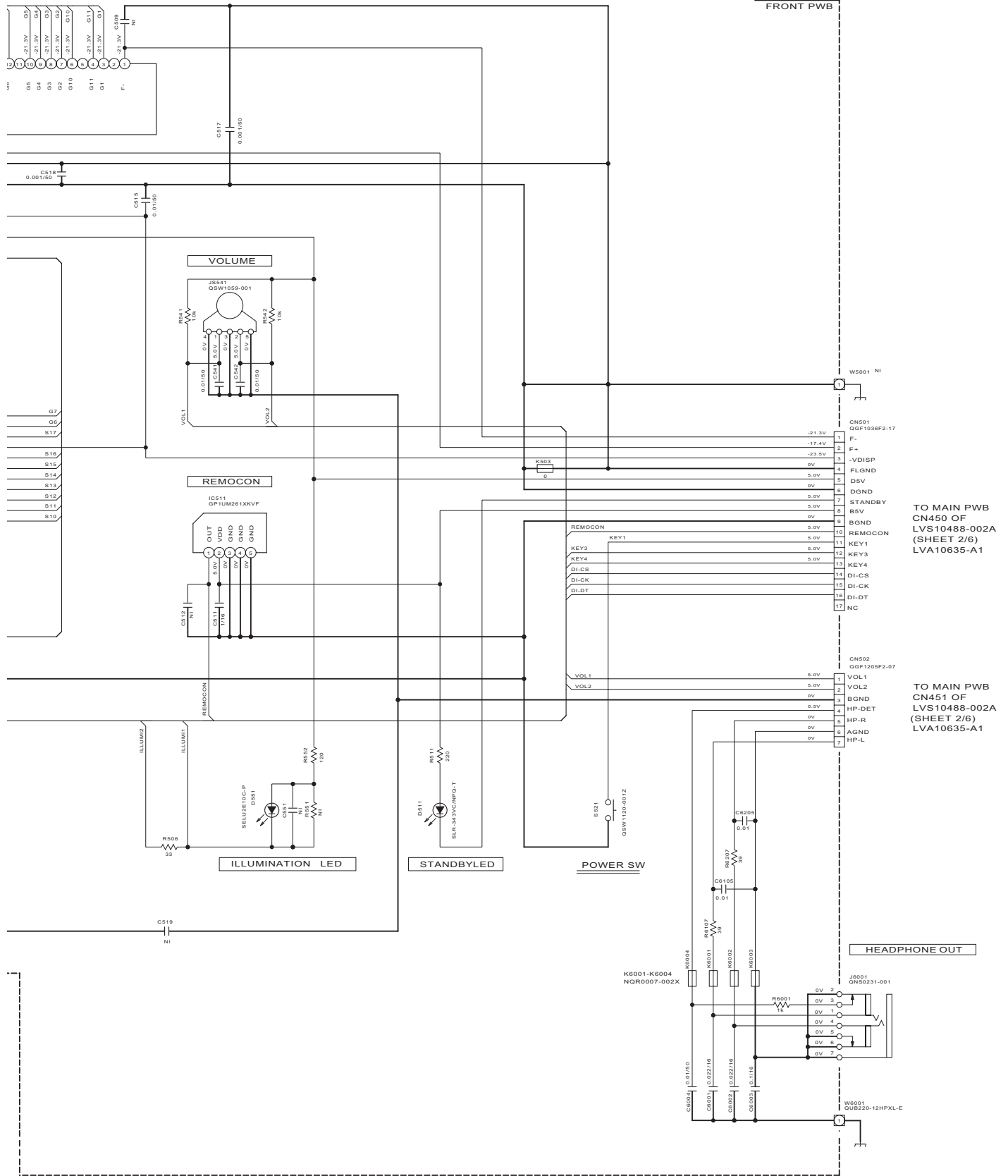

- NOTES
- VOLTAGES ARE DC-MEASURED WITH A DIGITAL VOLT METER WITHOUT INPUT SIGNAL.
CONDITION --- A CD disc in the Tray 1, and PLAY mode.
 - UNLESS OTHERWISE SPECIFIED.
ALL RESISTORS ARE 1/16W ±5% METAL GLAZE RESISTOR, OR 0.5% METAL GLAZE RESISTOR.
ALL CAPACITORS ARE 50V, 25V, 16V, 10V or 6.3V CERAMIC CAPACITOR
ALL RESISTANCE VALUES ARE IN OHM (Ω).
ALL CAPACITANCE VALUES ARE IN μF(p=pF).
ALL CAPACITORS ARE SHOWN IN THE FORM OF CAPACITANCE(μF)/RATED VOLTAGE (V).
ALL INDUCTANCE VALUES ARE IN μH(m=mH).
 - NI STANDS FOR NOT INSERTED PARTS.

TO MAIN PWB
CN450 OF
LVS10488-002A
(SHEET 2/6)
LVA10635-A1

TO MAIN PWB
CN451 OF
LVS10488-002A
(SHEET 2/6)
LVA10635-A1

Mother section

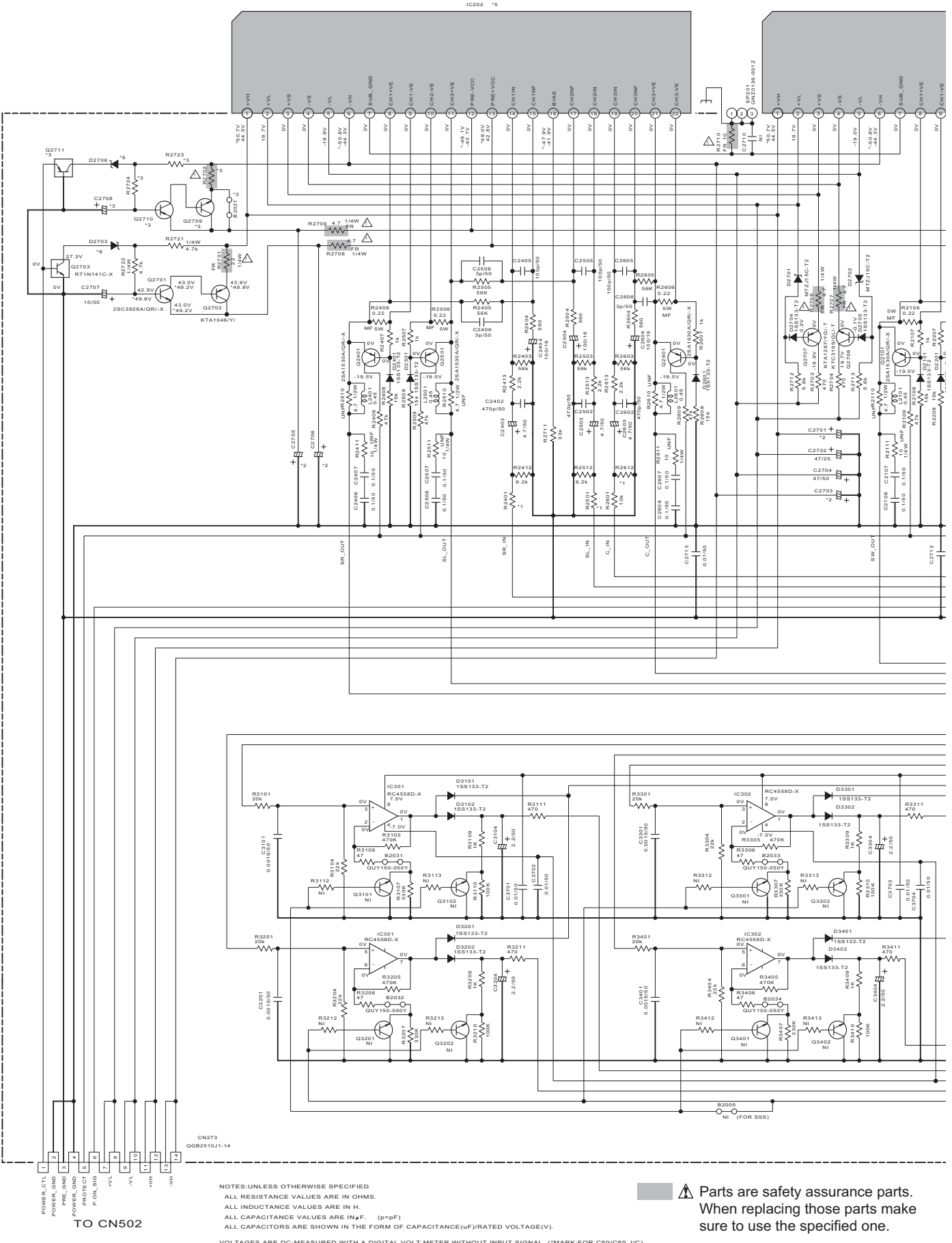

NOTES: UNLESS OTHERWISE SPECIFIED
 ALL RESISTANCE VALUES ARE IN OHMS.
 ALL INDUCTANCE VALUES ARE IN H.
 ALL CAPACITANCE VALUES ARE IN μ F. (p=PF)
 ALL CAPACITORS ARE SHOWN IN THE FORM OF CAPACITANCE (μ F)/RATED VOLTAGE(V).

VOLTAGES ARE DC-MEASURED WITH A DIGITAL VOLT METER WITHOUT INPUT SIGNAL. (*MARK-FOR C50/C60 J/C)

⚠ Parts are safety assurance parts.
 When replacing those parts make
 sure to use the specified one.

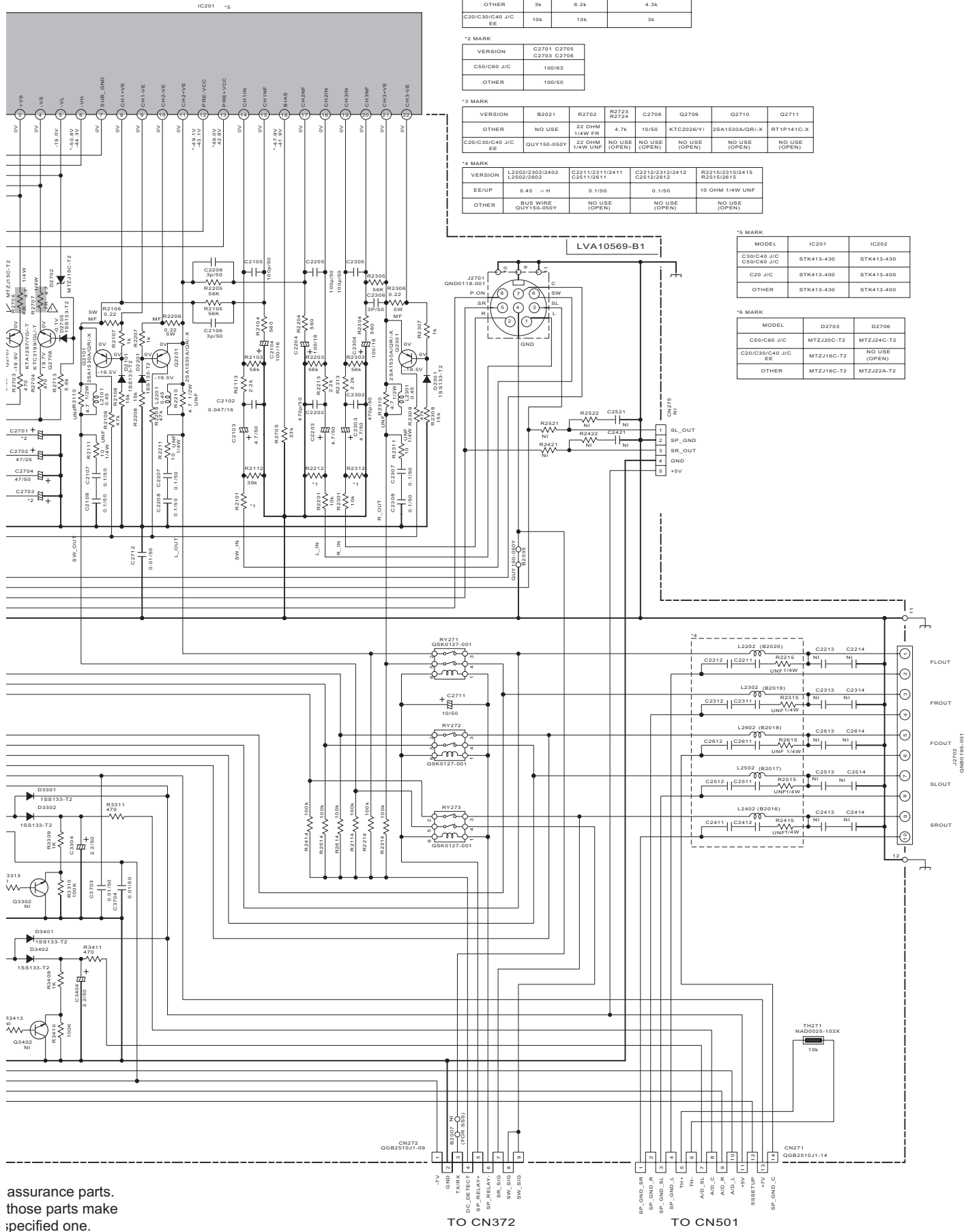

*1 MARK

VERSION	R2101 (SW)	R2401 (SR)	R2501 (SL)	R2212 (L)	R2312 (R)	R2612 (C)
OTHER	3k	6.2k			4.3k	
C20/C30/C40 J/C EE	10k	10k			3k	

*2 MARK

VERSION	C2701 C2705 C2703 C2708
C50/C60 J/C	100/63
OTHER	100/50

*3 MARK

VERSION	B2021	R2702	R2723 R2724	C2708	Q2709	Q2710	Q2711
OTHER	NO USE	22 OHM 1/4W FR	4.7k	10/50	KTC2026/Y/	2SA1530A/DR/-X	RT1P141C-X
C20/C30/C40 J/C EE	QUY150-050V	22 OHM 1/4W UNF	NO USE (OPEN)	NO USE (OPEN)	NO USE (OPEN)	NO USE (OPEN)	NO USE (OPEN)

*4 MARK

VERSION	L2202/2302/2402 L2502/2602	C2211/2311/2411 C2511/2611	C2212/2312/2412 C2512/2612	R2215/2315/2415 R2515/2615
EE/UP	0.45 μH	0.1/50	0.1/50	10 OHM 1/4W UNF
OTHER	BUS WIRE QUY150-050V	NO USE (OPEN)	NO USE (OPEN)	NO USE (OPEN)

*5 MARK

MODEL	IC201	IC202
C30/C40 J/C C50/C60 J/C	STK413-430	STK413-430
C20 J/C	STK413-400	STK413-400
OTHER	STK413-430	STK413-400

*6 MARK

MODEL	D2703	D2706
C50/C60 J/C	MTZJ20C-T2	MTZJ24C-T2
C20/C30/C40 J/C EE	MTZJ16C-T2	NO USE (OPEN)
OTHER	MTZJ16C-T2	MTZJ24A-T2

assurance parts.
those parts make
specified one.

TO CN372

TO CN501

Video section

LVA10635-A1 (3/3)
MAIN PWB

TO MICOM BLOCK
LVS10488-002A
LVA10635-A1

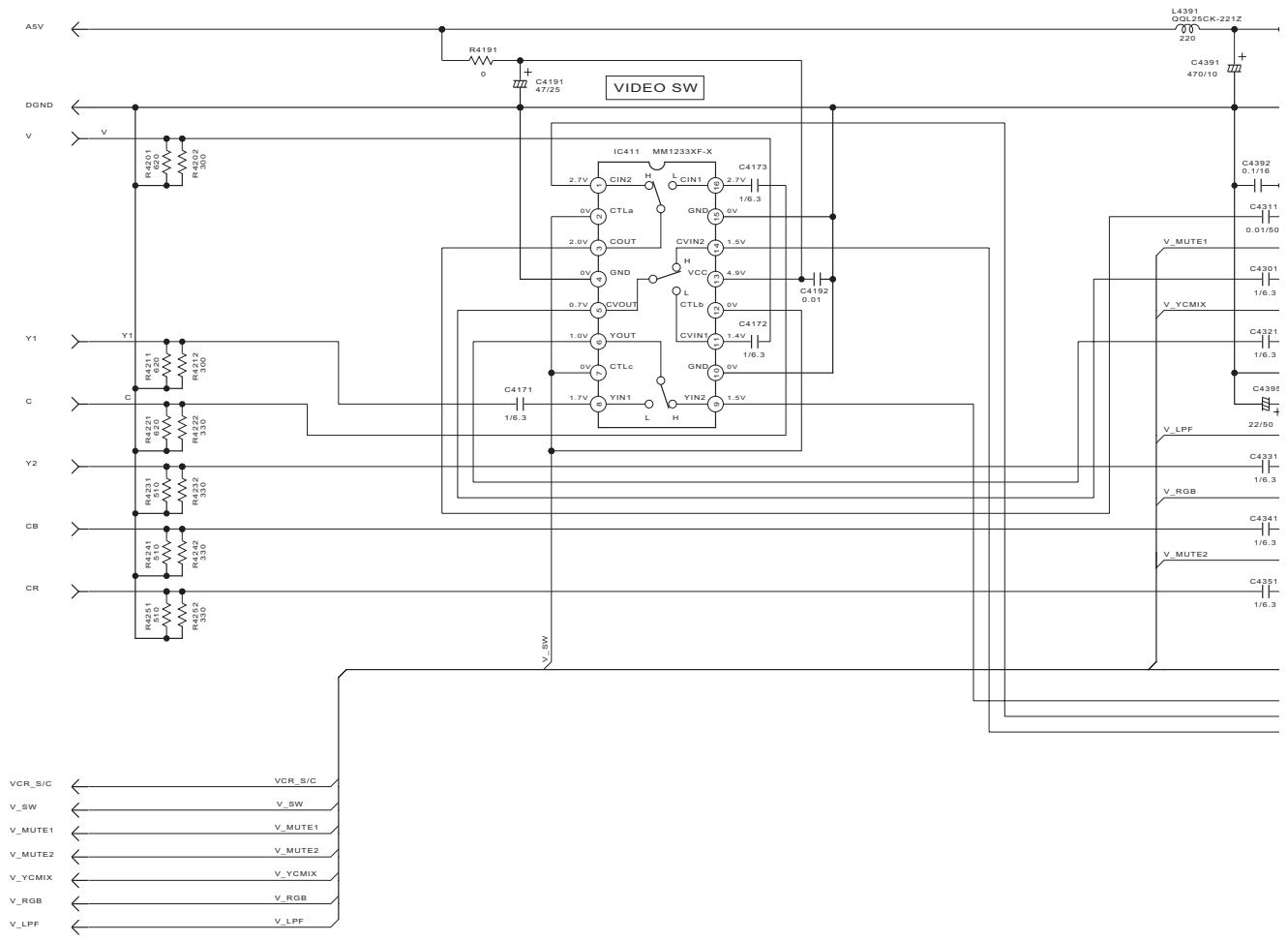

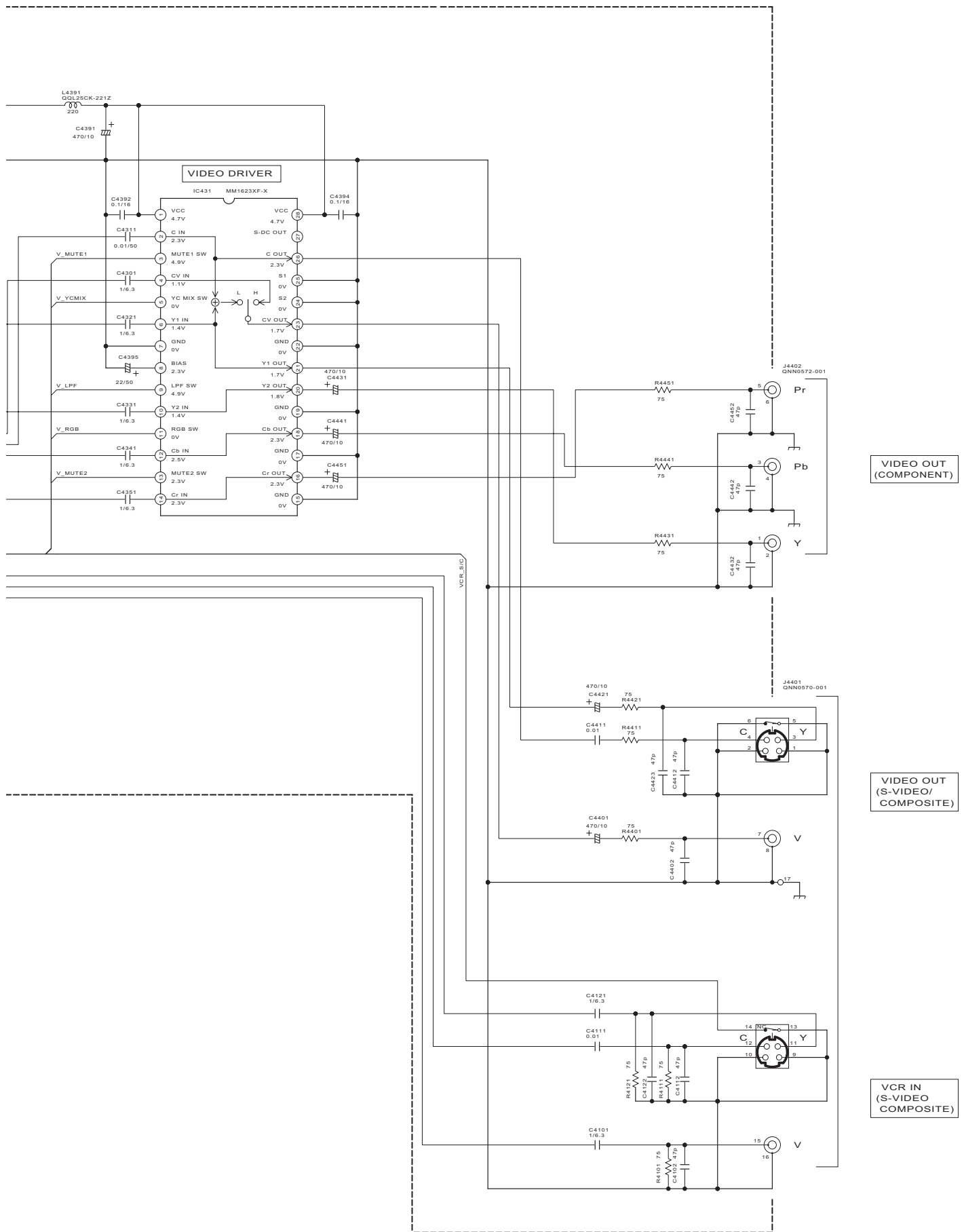

DVD servo control section (1/3)

PICKUP ASS'Y

QAL0786-***
(OPA-652PH*)

TRAMECHA ASS'Y
FXL-D20-1C

FEED MOTOR
QAR0165-001

SPINDLE MOTOR
QAR0387-001

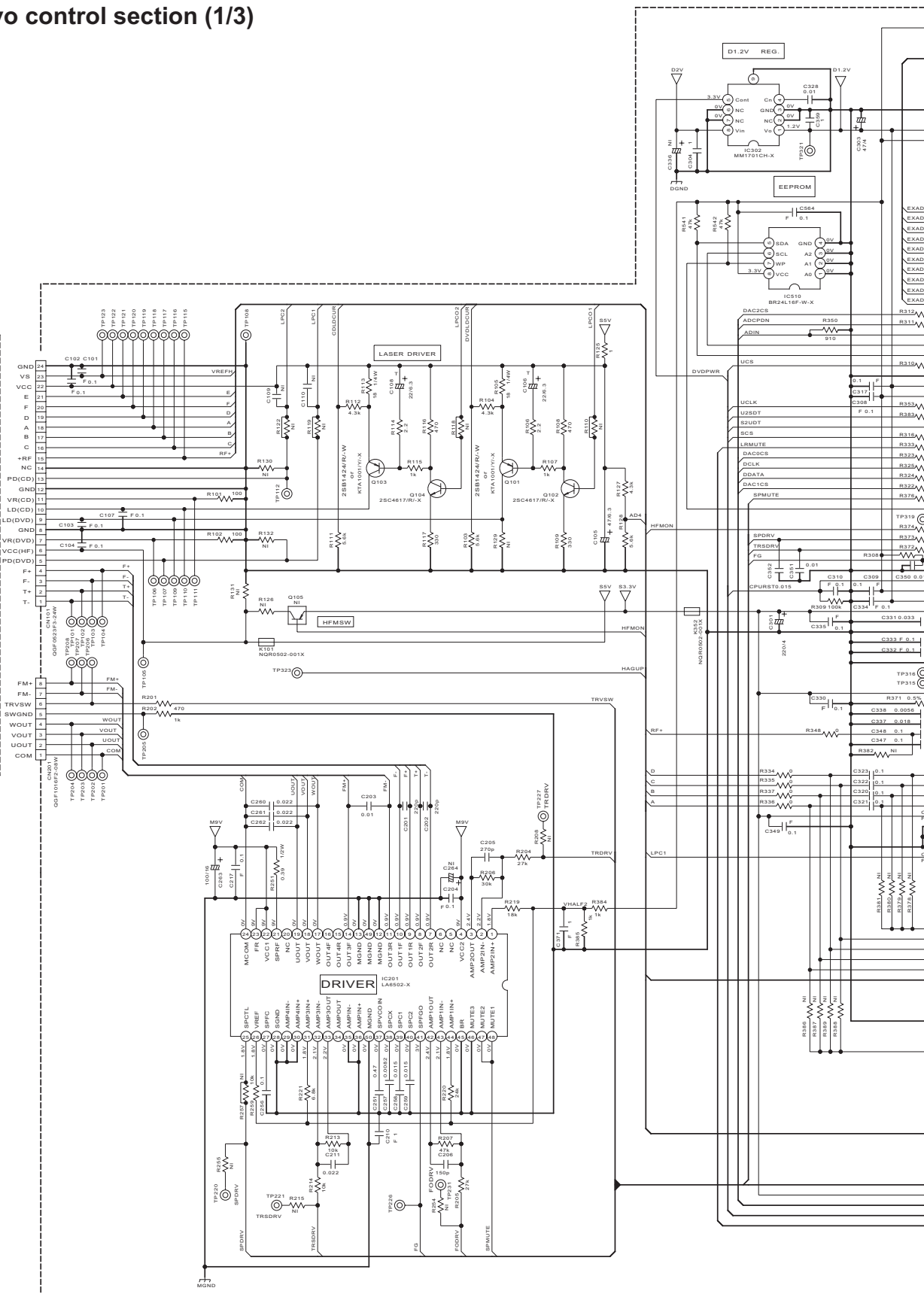

- NOTES**
1. VOLTAGES ARE DC-MEASURED WITH A D CONDITION ... A DVD disc in the T
 2. UNLESS OTHERWISE SPECIFIED.
ALL RESISTORS ARE 1/16W ± 5% META
ALL CAPACITORS ARE .50V, 25V, 16V, .
ALL RESISTANCE VALUES ARE IN OHM
ALL CAPACITANCE VALUES ARE IN μF
ALL E.CAPACITORS ARE SHOWN IN THE
ALL INDUCTANCE VALUES ARE IN μH(μ

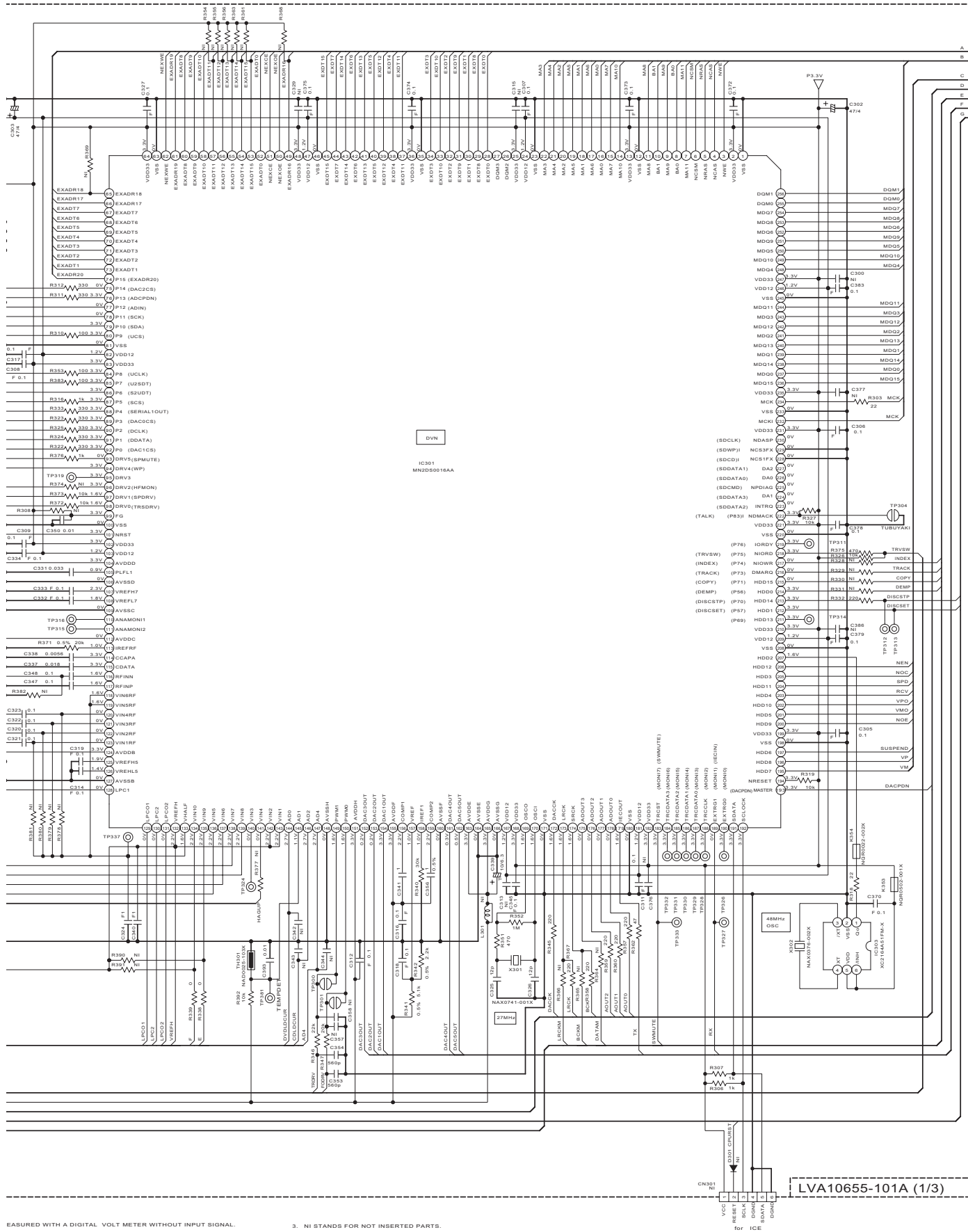

EASURED WITH A DIGITAL VOLT METER WITHOUT INPUT SIGNAL.
 V/D disc in the Tray 1, and STOP mode.

SPECIFIED:
 E 1/16W, 5% METAL GLAZE RESISTOR, OR 0.5% METAL GLAZE RESISTOR.
 RE 50V, 25V, 16V, 10V or 6.3V CERAMIC CAPACITOR
 LVALUES ARE IN OHM (Ω).
 VALUES ARE IN μF(p=pF).
 ARE SHOWN IN THE FORM OF CAPACITANCE(μF)/RATED VOLTAGE (V).
 ALUES ARE IN //H(m=mH).

3. NI STANDS FOR NOT INSERTED PARTS.

LVA10655-101A (1/3)

DVD servo control section (2/3)

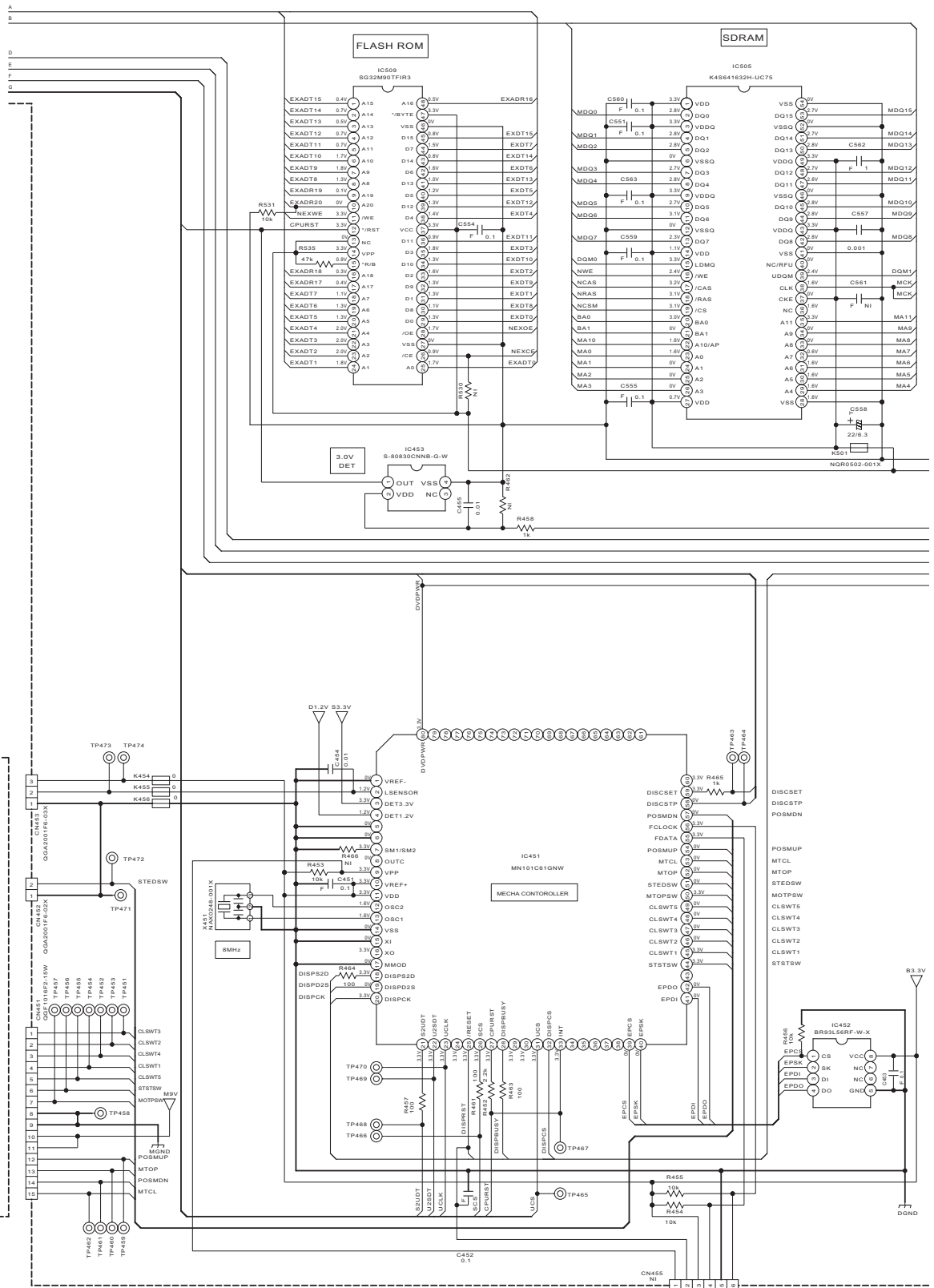

LOADER ASS'Y
CH6-BASE-1

See
LVS20135-002A

- NOTES**
1. VOLTAGES ARE DC-MEASURED WITH A DIGITAL VOLT METER WITHOUT INPUT SIGNAL.
CONDITION --- A DVD disc in the Tray 1, and STOP mode.
 2. UNLESS OTHERWISE SPECIFIED.
ALL RESISTORS ARE 1/16W ±5% METAL GLAZE RESISTOR, OR 0.5% METAL GLAZE RESISTOR.
ALL CAPACITORS ARE 50V, 25V, 16V, 10V OR 6.3V CERAMIC CAPACITOR
ALL RESISTANCE VALUES ARE IN OHM (Ω).
ALL CAPACITANCE VALUES ARE IN pF (p=F).
ALL ELECTROLYTIC CAPACITORS ARE SHOWN IN THE FORM OF CAPACITANCE (µF)/RATED VOLTAGE (V).
ALL INDUCTANCE VALUES ARE IN µH (m=MH).
 3. NI STANDS FOR NOT INSERTED PARTS.

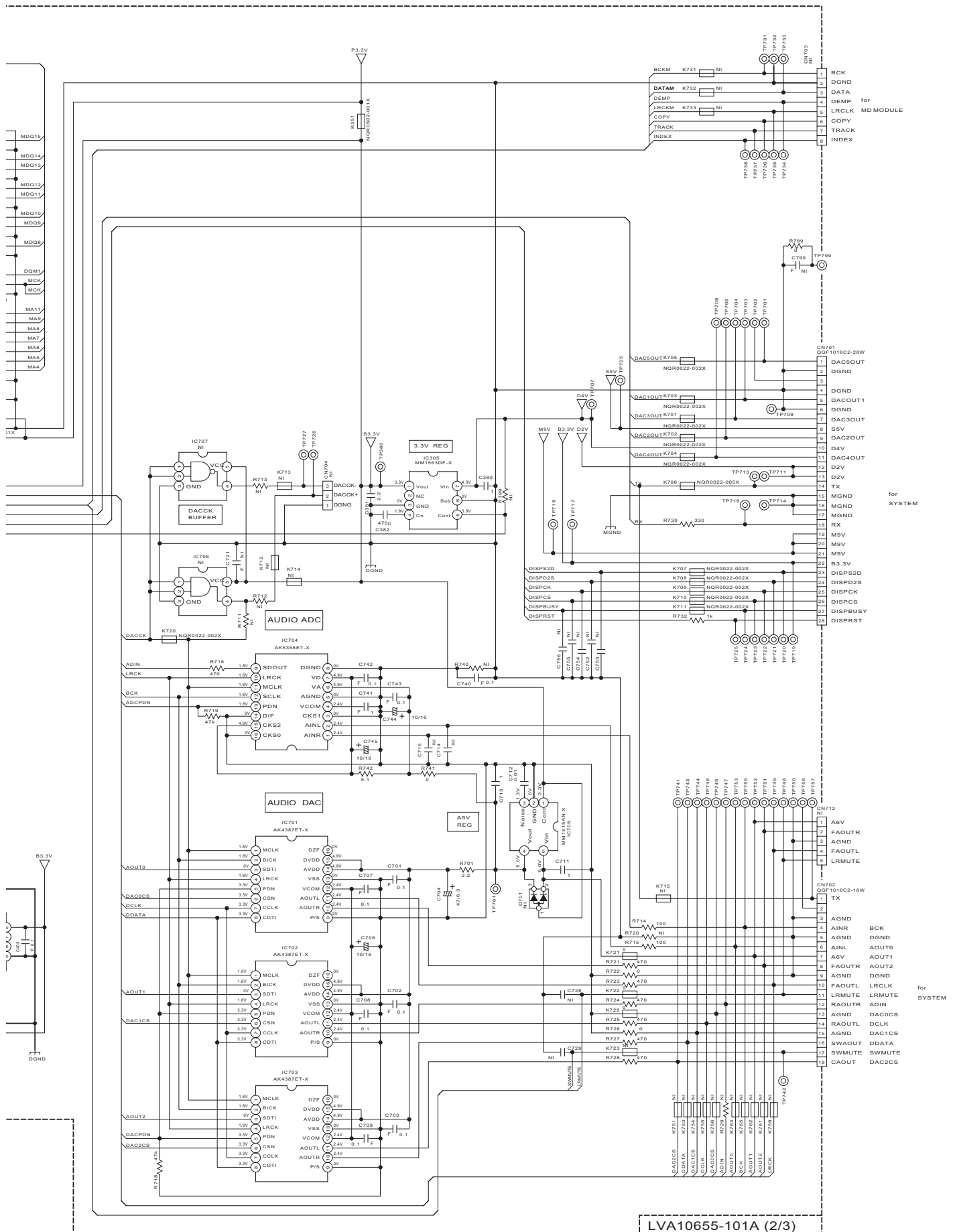

LVA10655-101A (2/3)

■ DVD servo control section (3/3)

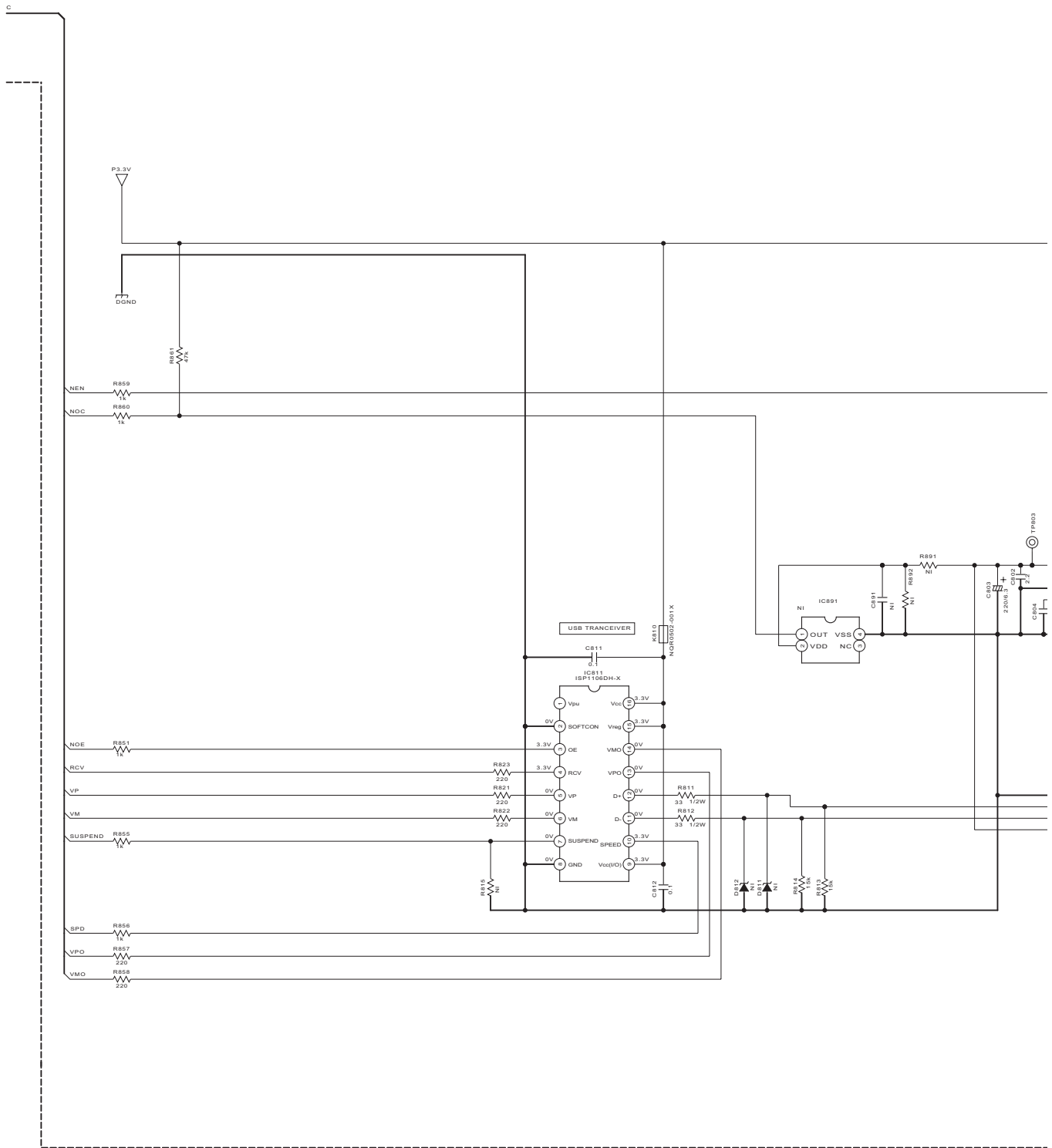

NOTES

1. VOLTAGES ARE DC-MEASURED WITH A DIGITAL VOLT METER WITHOUT INPUT SIGNAL. CONDITION --- A DVD disc in the Tray 1, and STOP mode.

2. UNLESS OTHERWISE SPECIFIED.

ALL RESISTORS ARE 1/16W ± 5% METAL GLAZE RESISTOR. OR 0.5% METAL GLAZE RESIS
ALL CAPACITORS ARE 50V, 25V, 16V, 10V or 6.3V CERAMIC CAPACITOR.

ALL RESISTANCE VALUES ARE IN OHM(Ω).

ALL CAPACITANCE VALUES ARE IN μF(p=pF).

ALL E,CAPACITORS ARE SHOWN IN THE FORM OF CAPACITANCE(μF)/RATED VOLTAGE (V)

ALL INDUCTANCE VALUES ARE IN μH(m=mH).

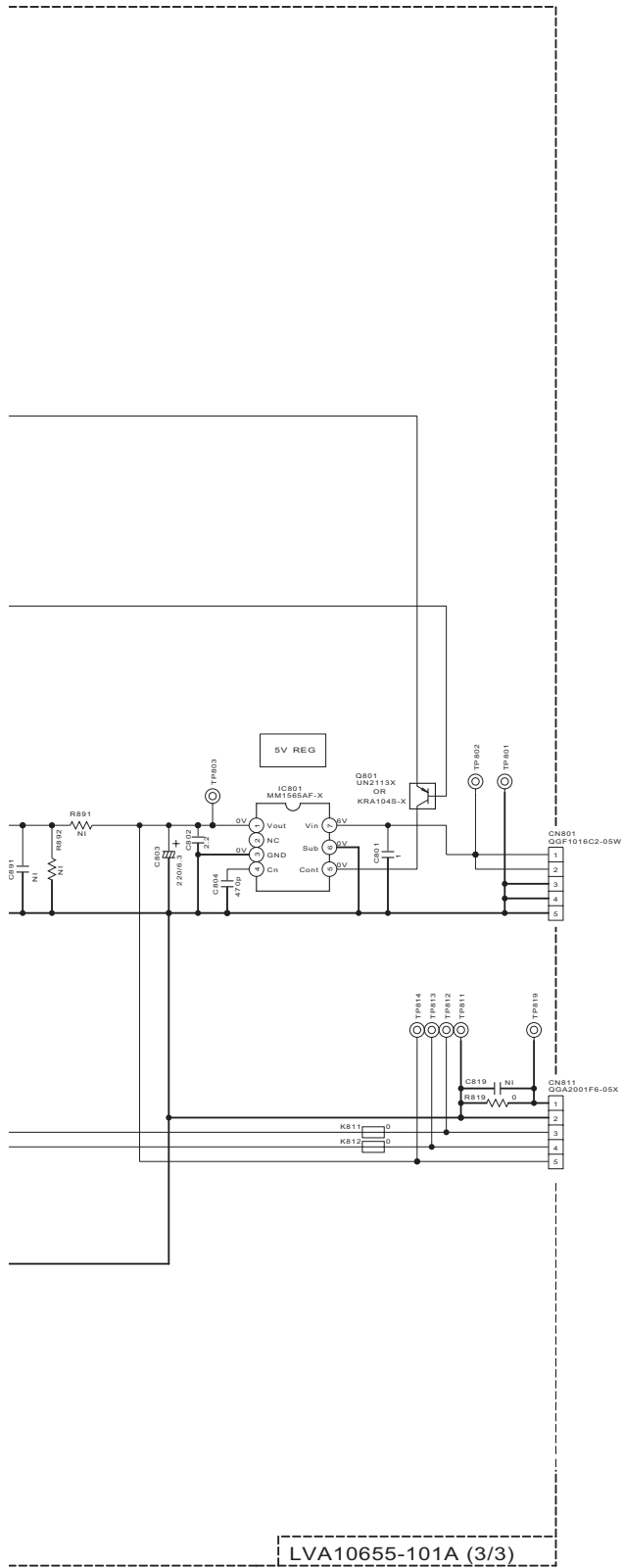

LVA10655-101A (3/3)

LT METER WITHOUT INPUT SIGNAL.
STOP mode.

3. NI STANDS FOR NOT INSERTED PARTS.

ESISTOR. OR 0.5% METAL GLAZE RESISTOR.
IV. CERAMIC CAPACITOR.

4. DIGITAL TRANSISTOR

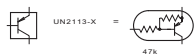

CAPACITANCE(#F)/RATED VOLTAGE (V).

Loader section

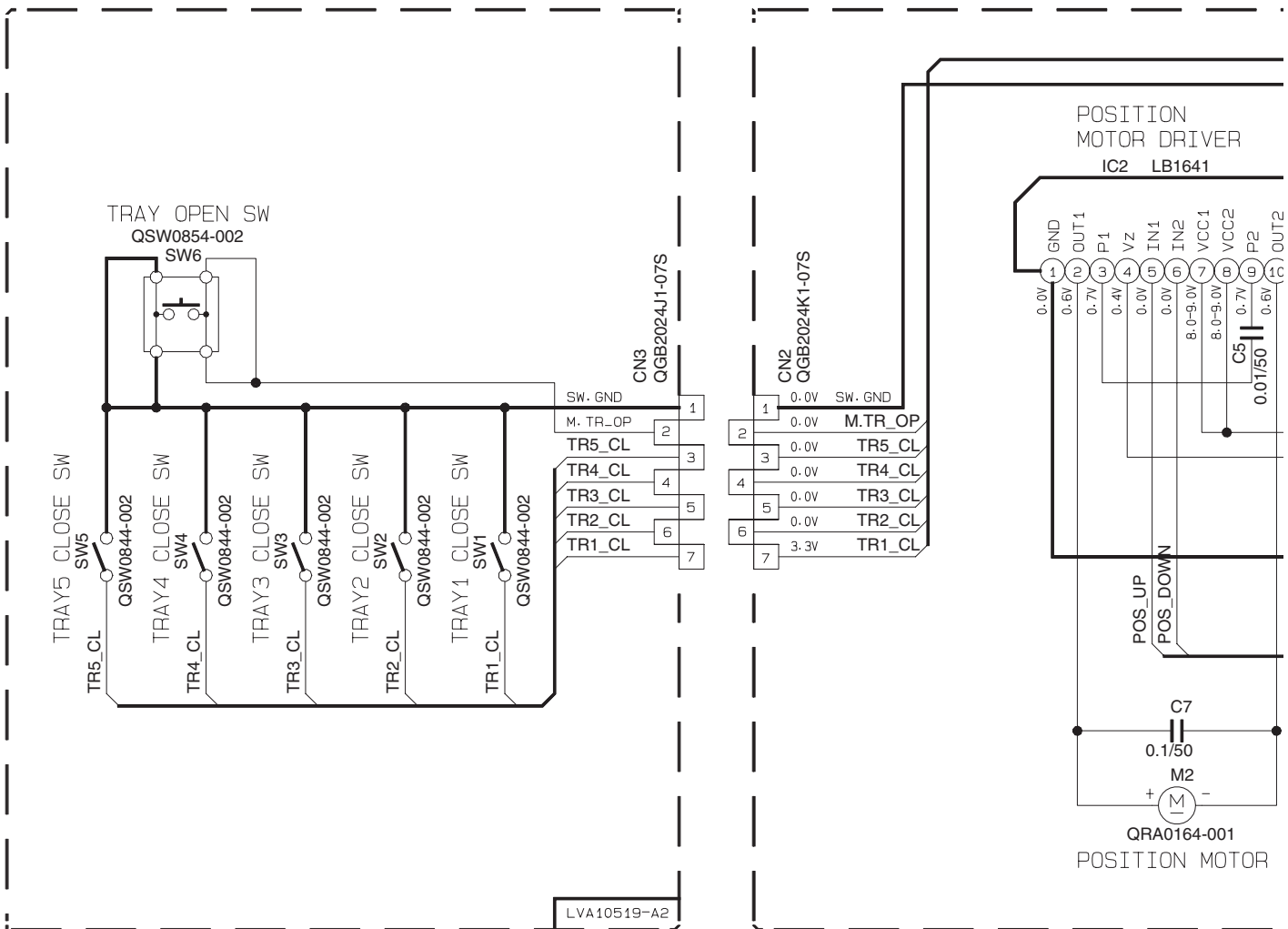

NOTES

- VOLTAGES ARE DC-MEASURED WITH A DIGITAL VOLT METER.
CONDITION: DISC1 STOP
- UNLESS OTHERWISE SPECIFIED.
ALL CAPACITORS ARE SHOWN IN THE FORM OF CAPACITANCE (μF)/RATED VOLTAGE (V).
- NI STANDS FOR NOT INSERTED PARTS.

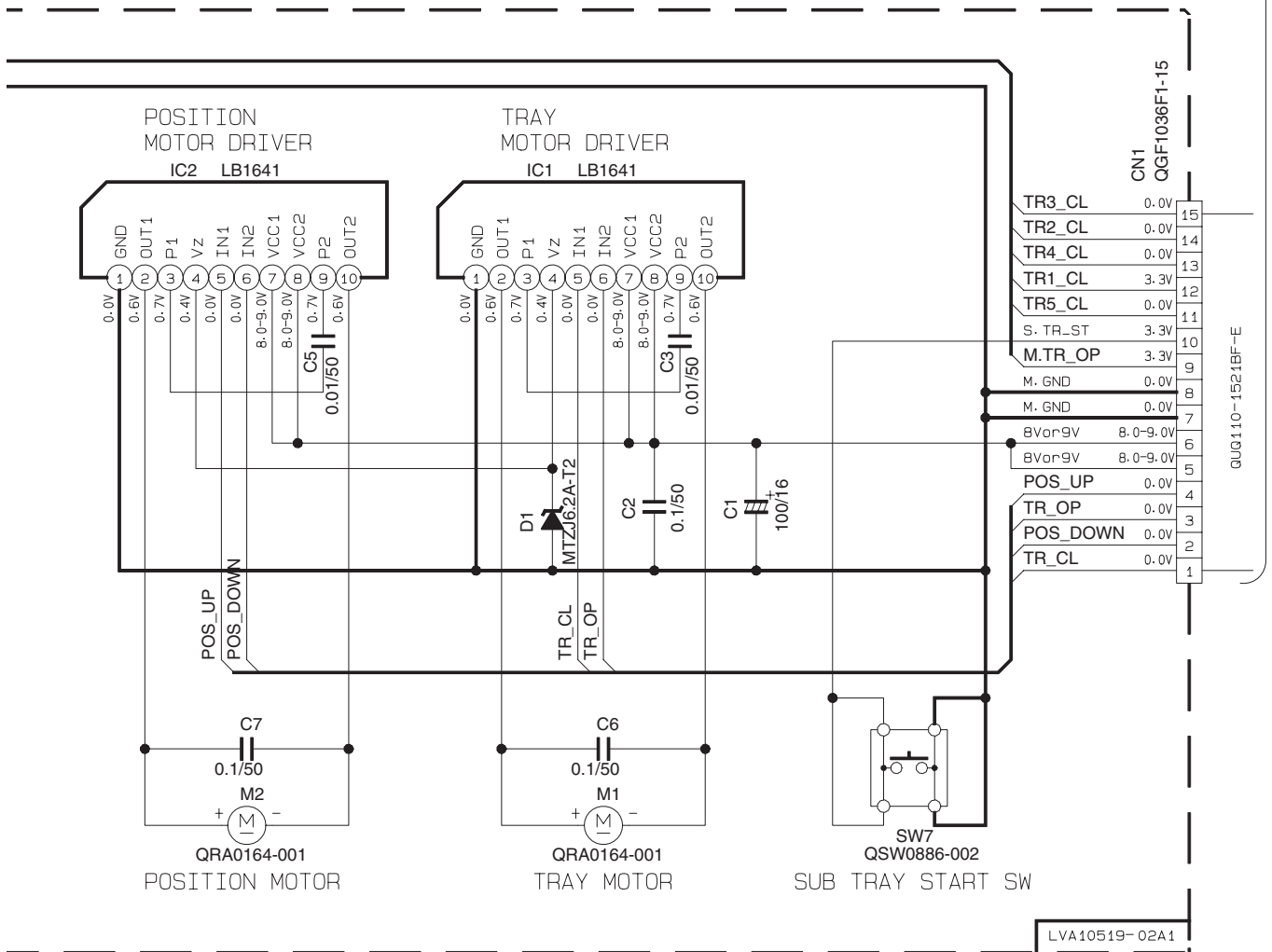
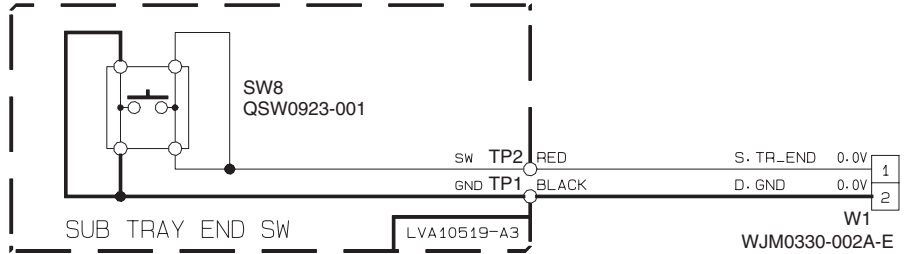
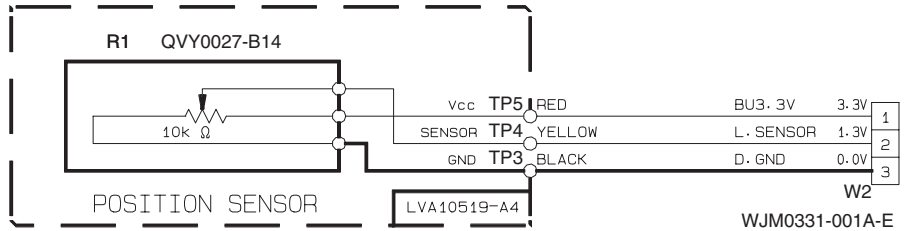

TO POWER AND MECHA CONTROL MICOM

(v).

Subwoofer primary section

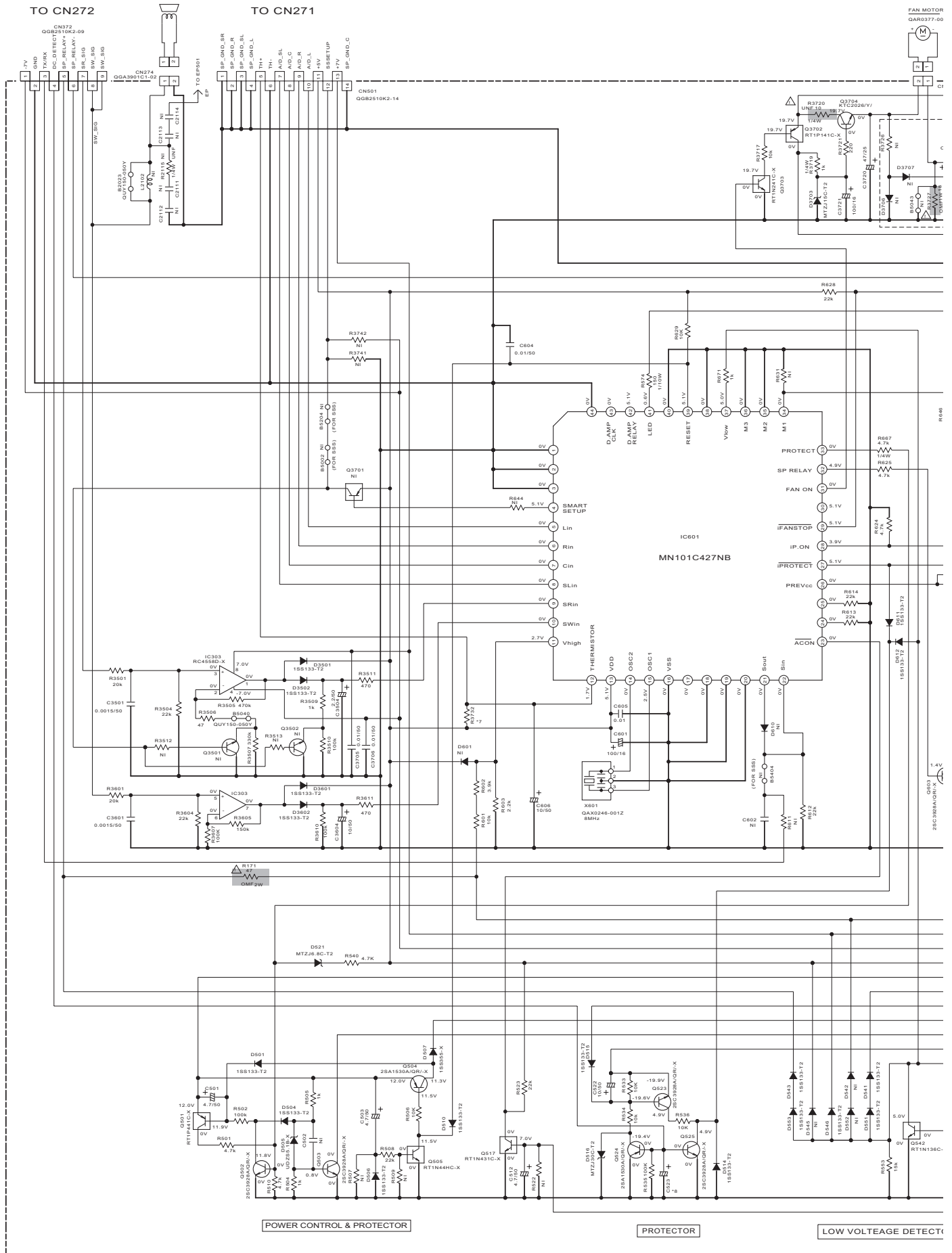

VERSION
 A : AUSTRALIA
 B : GREAT BRITAIN
 C : CANADA
 E : GERMANY/FRANCE/HOLLAND
 EN : SWEDEN/NORWAY/FINLAND/DENMARK
 EE : RUSSIA
 EV : EAST EUROPE
 J : U.S.A
 UT : TAIWAN

US : SINGAPOLE
 UB : HONG KONG
 UP : KOREA
 UF : CHINA
 UX : SAUDI ARABIA
 UW : BRAZIL/MEXICO/PERU
 UJ : USA MILITARY BASE
 UG : TURKY/EGYPT/SOUTH AFRICA
 UY : ARGENTIN

NOTES-UNLESS OTHERWISE SPECIFIED
 ALL RESISTANCE VALUES ARE IN OHMS.
 ALL INDUCTANCE VALUES ARE IN H.
 ALL CAPACITANCE VALUES ARE IN F_p (p+pF)
 ALL CAPACITORS ARE SHOWN IN THE FORM OF CAPACITANCE(μ F)/RATED VOLTAGE(V).
 VOLTAGES ARE DC-MEASURED WITH A DIGITAL VOLT METER WITHOUT INPUT SIGNAL. (*MARK:FOR C50/C60 J/C)

*7 MARK

VERSION	HS151	T101	F101	F102	F153/F154	S901	B5201	C161/C162	R3732	C157/C159	C158	B5408
C50/C60 J/C	G2W0115-001	QGT0522-001	8A-125V	NO USE	10A-125V	NO USE	QUY158-100Y	4700/63	15k	0.1/50	NO USE	NO USE
C30/C40 J/C	G2W0138-001	QGT0482-004	8A-125V	NO USE	10A-125V	NO USE	QUY158-100Y	4700/50	15k	0.022/50	NO USE	NO USE
C20 J/C	G2W0138-001	QGT0482-004	8A-125V	NO USE	10A-125V	NO USE	QUY158-100Y	3300/50	15k	0.022/50	NO USE	NO USE
A/EE/UP/UF	G2W0138-001	QGT0482-002	T3.15AL	NO USE	T8AL	NO USE	QUY158-100Y	3300/50	22k	0.022/50	NO USE	NO USE
US/UY	G2W0138-001	QGT0482-003	T8.3AL	T3.15AL	T8AL	QSW0924-001	NO USE	3300/50	22k	0.022/50	NO USE	QUY158-150Y

*8 MARK

VERSION	C523
C20/C30/C40 J/C	100/25
OTHER	47/25

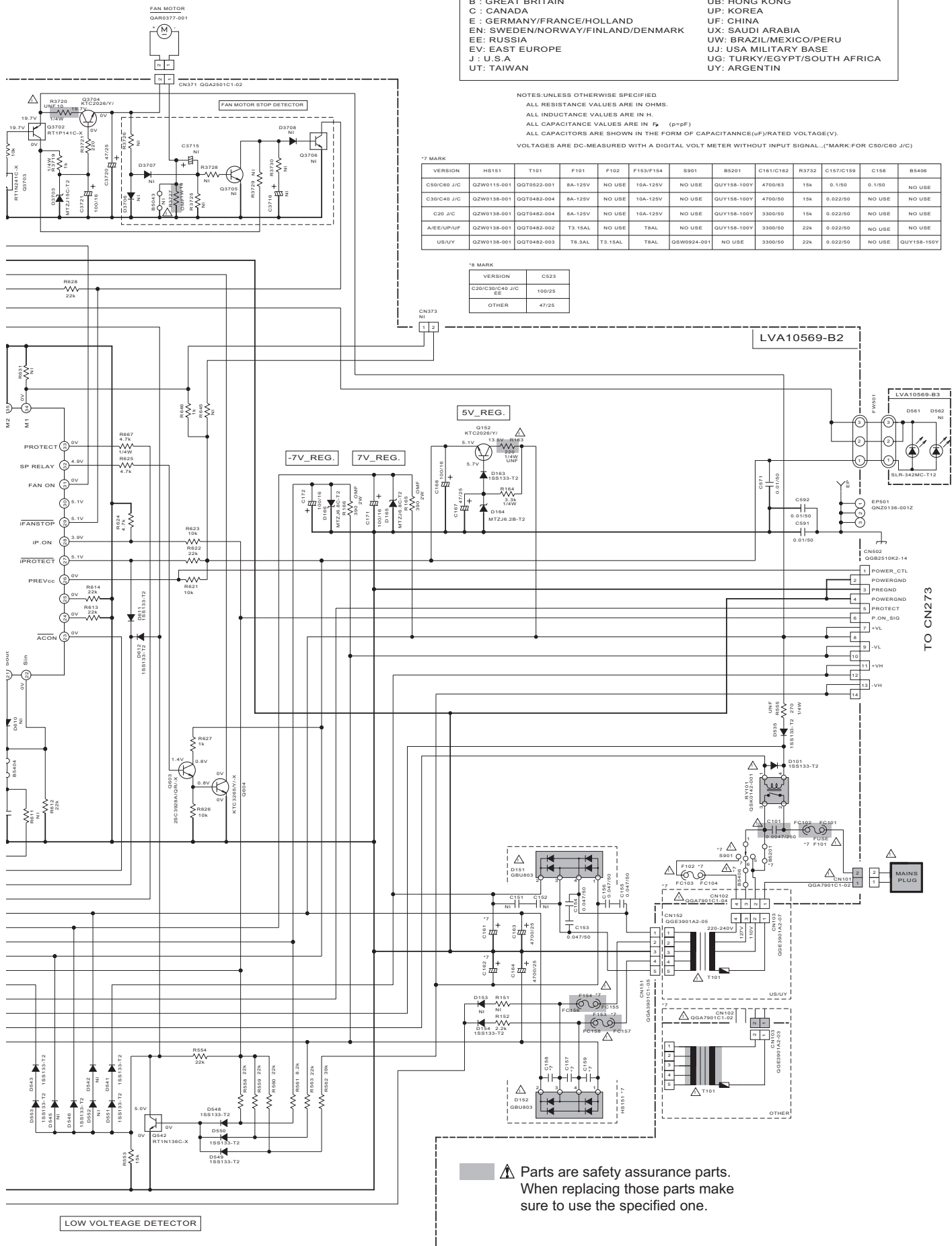

⚠ Parts are safety assurance parts.
 When replacing those parts make sure to use the specified one.

TO CN273

Printed circuit boards

■ Main board Lead free solder used in the board (material : Sn-Ag-Cu, melting point : 219 Centigrade)

(Operation board)

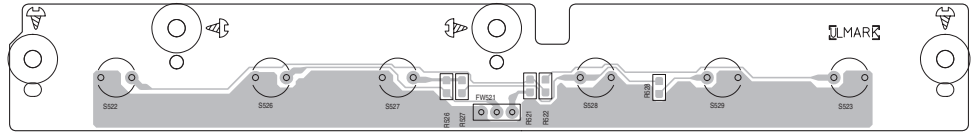

(Main board)

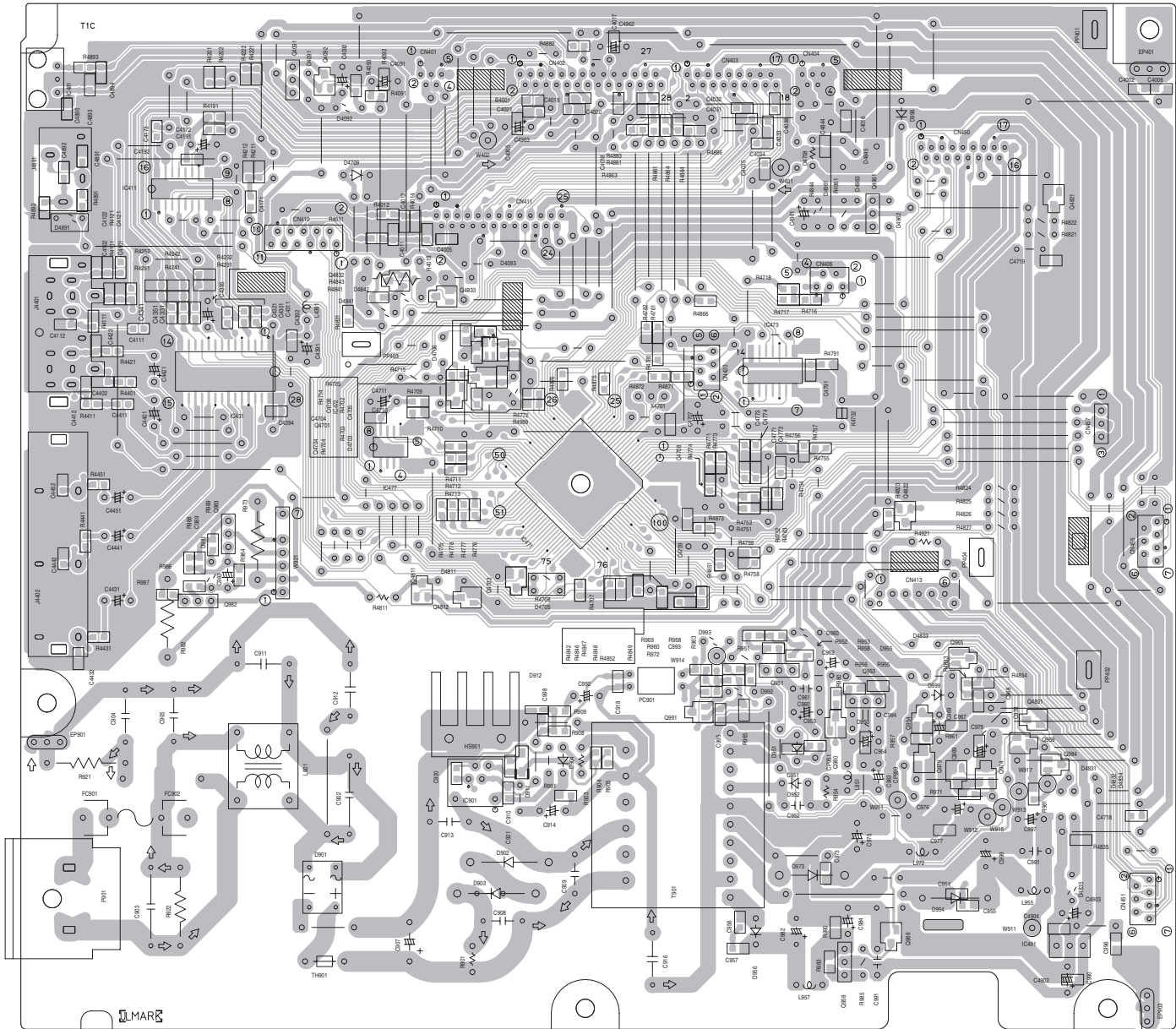

■ DVD servo control board

Lead free solder used in the board (material : Sn-Ag-Cu, melting point : 219 Centigrade)

Forward side

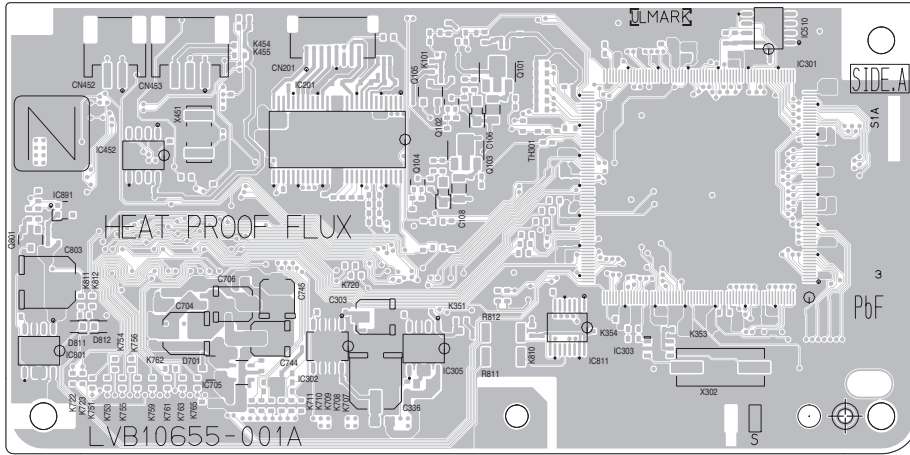

Reverse side

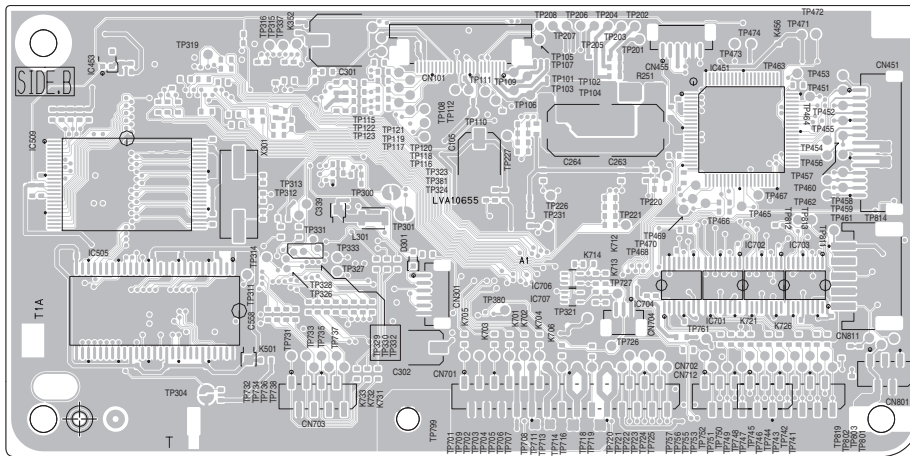

■ **Audio board** Lead free solder used in the board (material : Sn-Ag-Cu, melting point : 219 Centigrade)

(Audio & Digitalinput board)

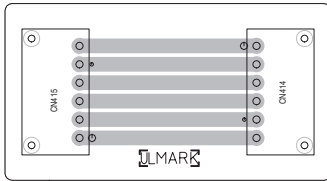
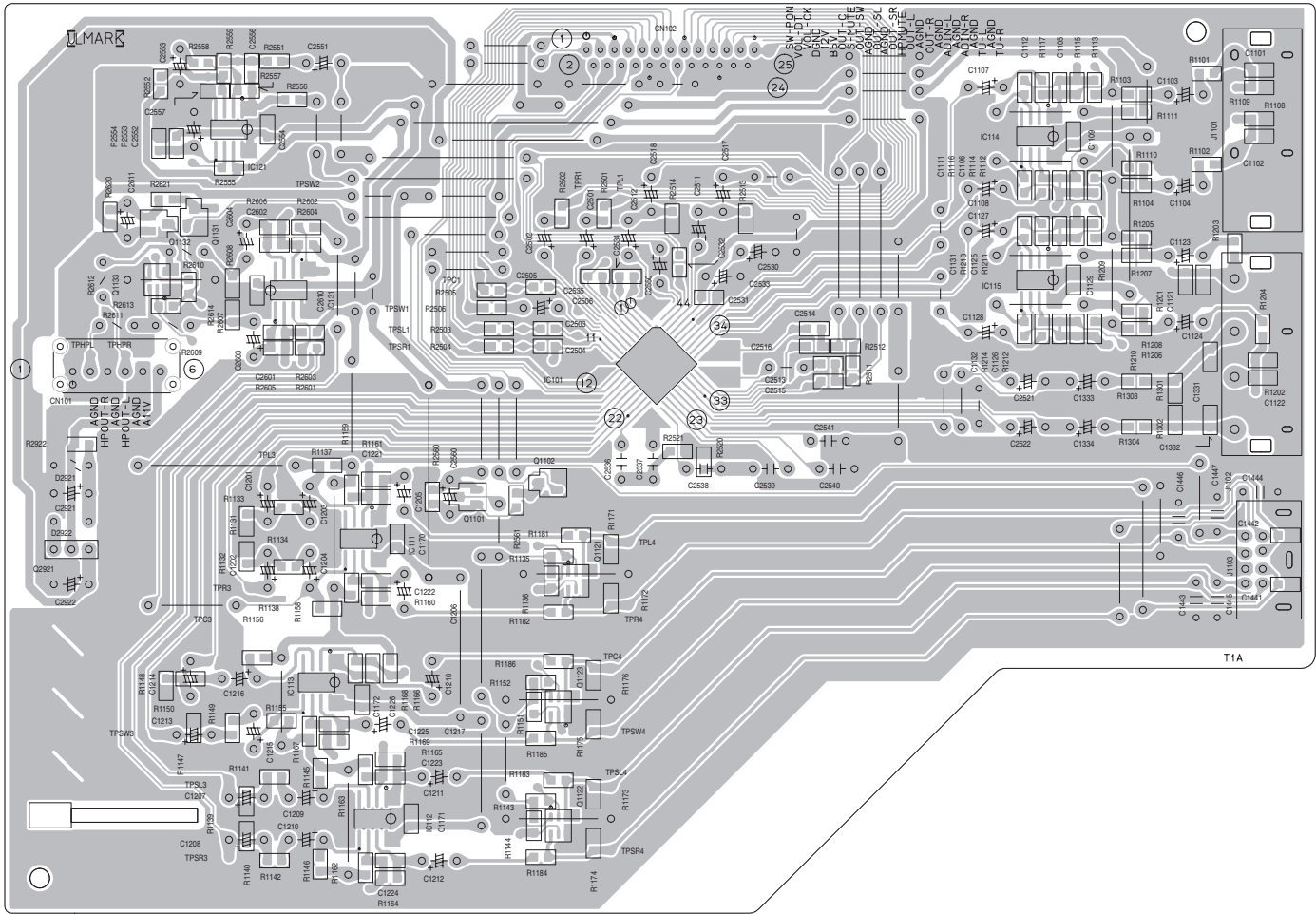

(Connection board)

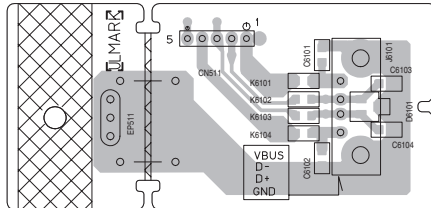

(USB jack board)

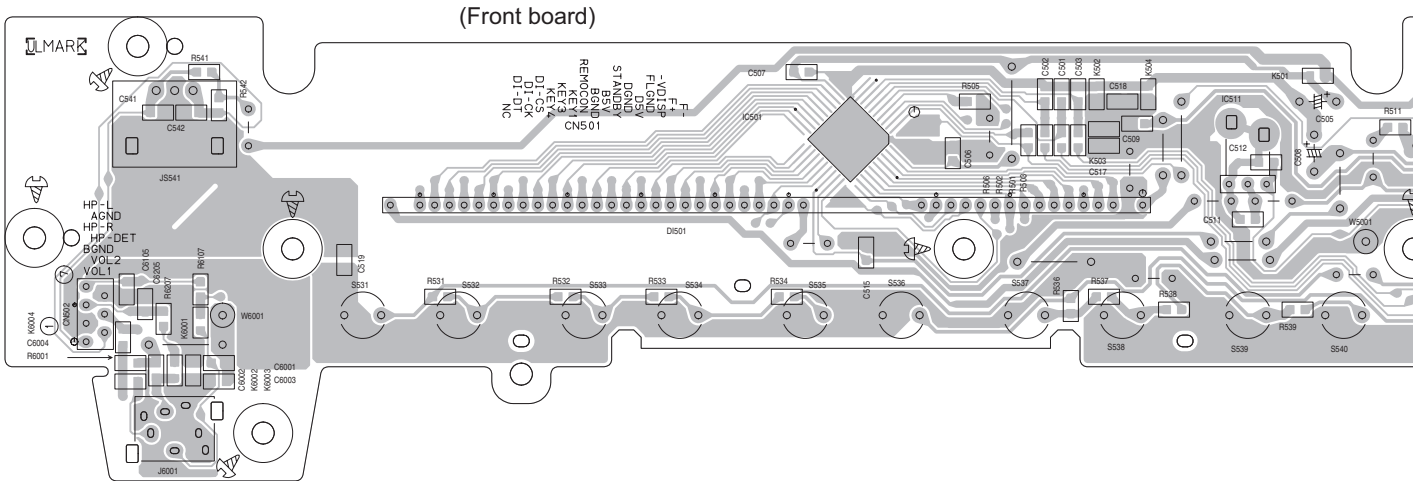

(Front board)

■ Loader board

Lead free solder used in the board (material : Sn-Ag-Cu, melting point : 219 Centigrade)

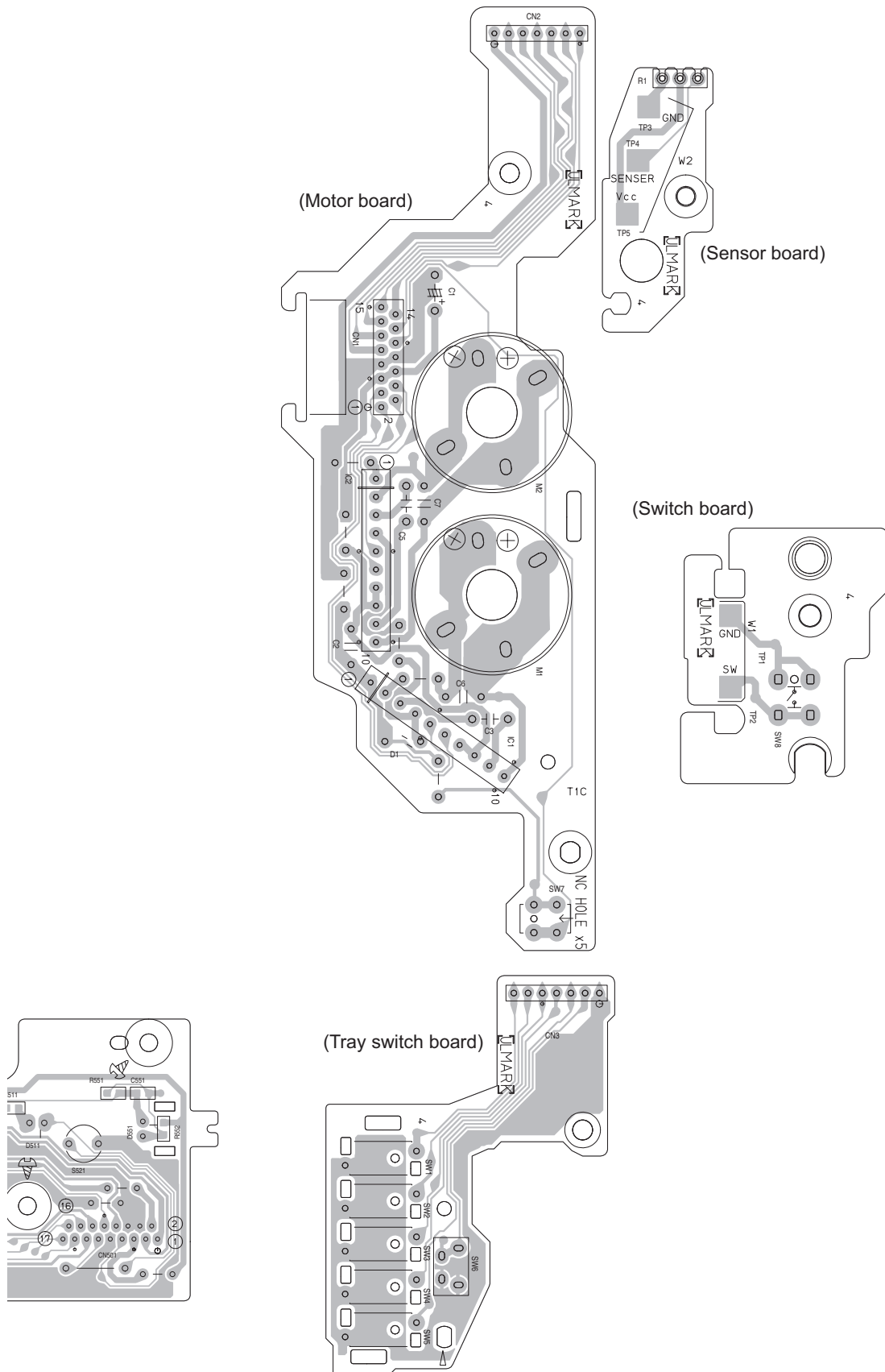

■ Speaker amp board Lead free solder used in the board (material : Sn-Ag-Cu, melting point : 219 Centigrade)

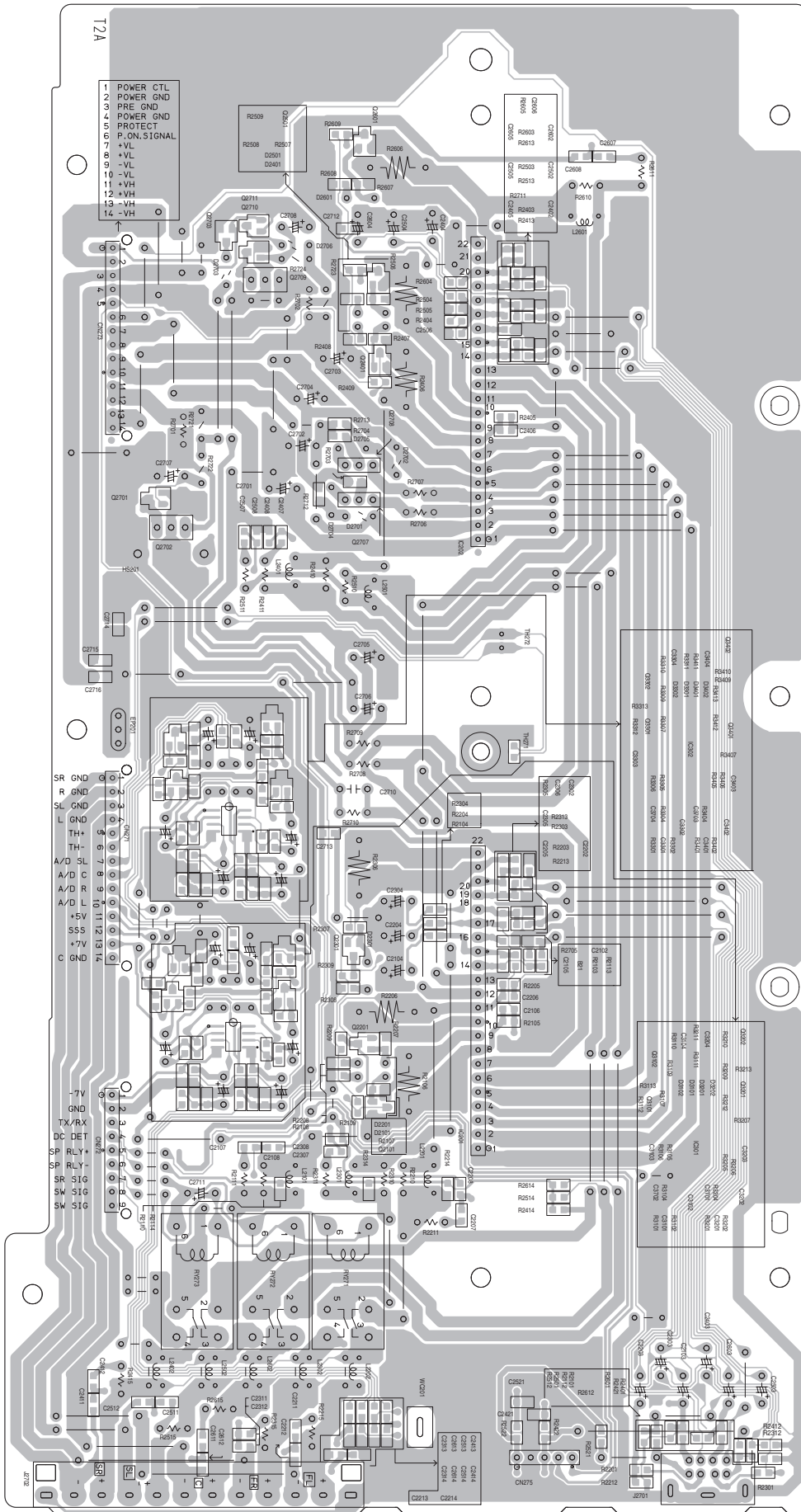

Speaker mother board

Lead free solder used in the board (material : Sn-Ag-Cu, melting point : 219 Centigrade)

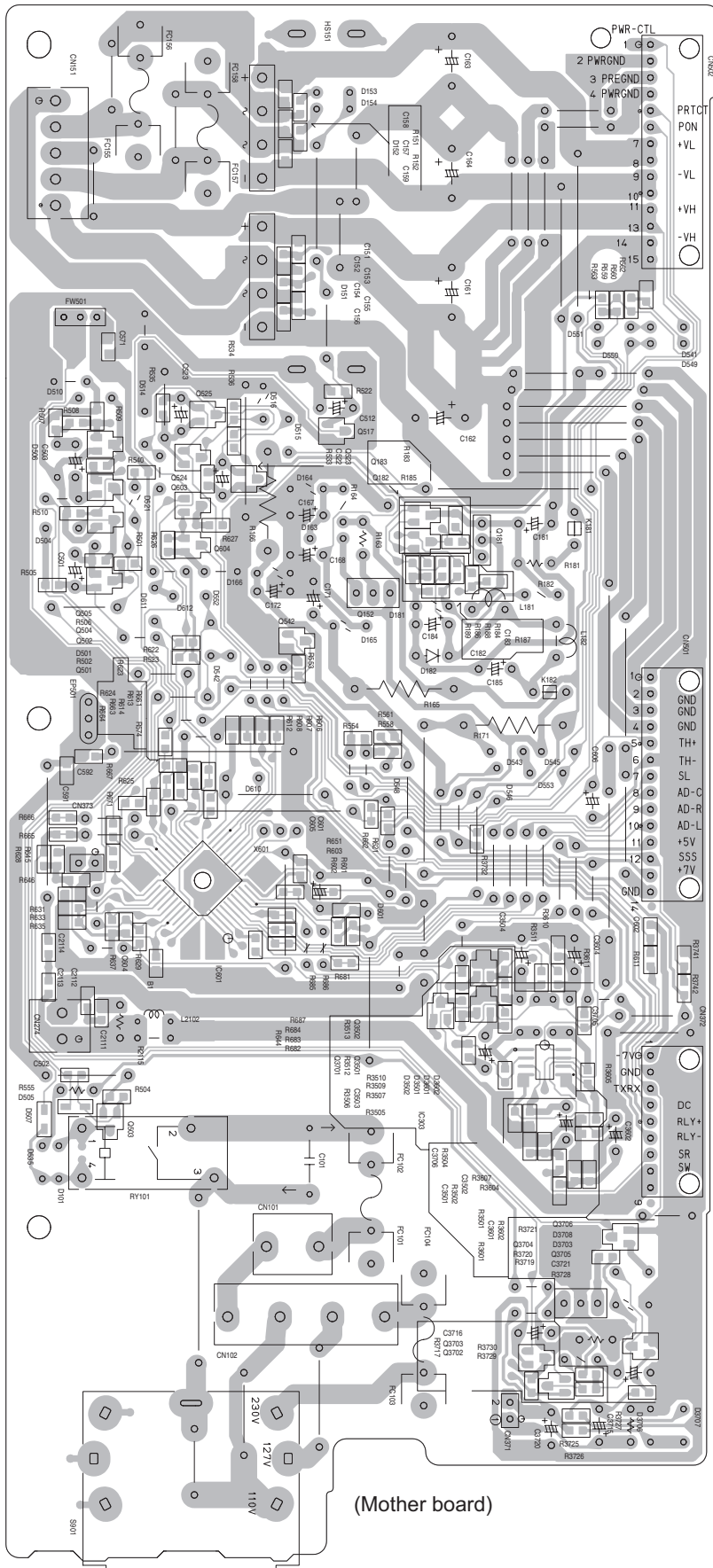

(Mother board)

(LED board)

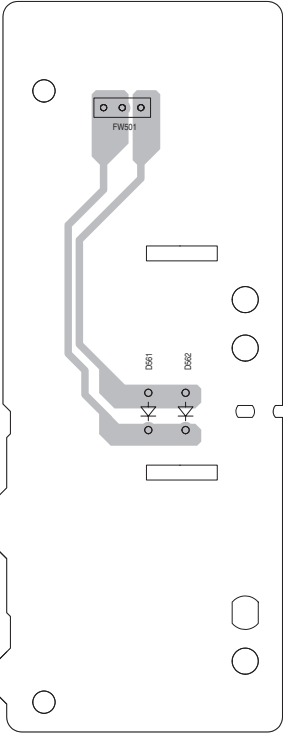

JVC

Victor Company of Japan, Limited

Audio/Video Systems Category 10-1,1chome,Ohwatari-machi,Maebashi-city,371-8543,Japan

(No.MB506SCH)



Printed in Japan
VPT