

JVC

SERVICE MANUAL

DVD DIGITAL CINEMA SYSTEM

TH-C6

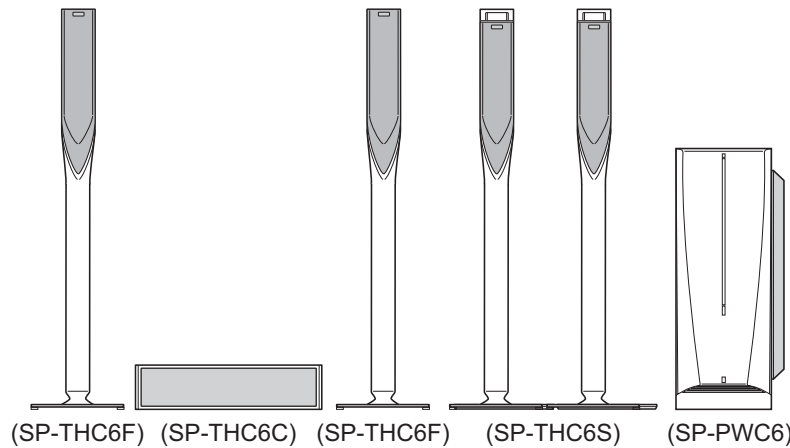

Area suffix

A	-----	Australia
UW	-----	Brazil, Mexico, Peru
UY	-----	Argentina
UJ	-----	U.S. Military
UG	---	Turkey, South Africa, Egypt

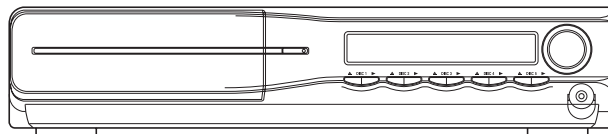
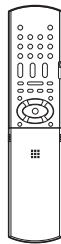

(XV-THC6)



Digital Direct Progressive Scan
AV COMPU LINK

Lead free solder used in the board (material : Sn-Ag-Cu, melting point : 219 Centigrade)

TABLE OF CONTENTS

1	PRECAUTION.....	1-4
2	SPECIFIC SERVICE INSTRUCTIONS.....	1-7
3	DISASSEMBLY	1-8
4	ADJUSTMENT	1-30
5	TROUBLESHOOTING	1-35

SPECIFICATION

Center unit (XV-THC9/XV-THC6/XV-THC3)

Audio section	Total Harmonic Distortion *1		0.02%
	Digital input*2	DIGITAL IN (DBS) (OPTICAL)	-21 dBm to -15 dBm (660 nm ± 30 nm)
Video section	Video System		PAL/NTSC
	Horizontal Resolution		500 lines
	Signal-to-Noise Ratio		64 dB
	Video output level		Composite: 1.0 V(p-p)/75 Ω S-video-Y: 1.0 V(p-p)/75 Ω S-video-C: For PAL: 0.3 V(p-p)/75 Ω S-video-C: For NTSC: 0.286 V(p-p)/75 Ω Component-Y: 1.0 V(p-p)/75 Ω Component-PB/PR: 0.7 V(p-p)/75 Ω
	Video input sensitivity/Impedance (VCR IN)		Composite: 1.0 V(p-p)/75 Ω S-video-Y: 1.0 V(p-p)/75 Ω S-video-C: For PAL: 0.3 V(p-p)/75 Ω S-video-C: For NTSC: 0.286 V(p-p)/75 Ω
Tuner section	Tuning Range	FM	87.5 MHz to 108.0 MHz
		AM (Except for Middle East)	531 kHz to 1 710 kHz (at 9 kHz channel spacing) 530 kHz to 1 710 kHz (at 10 kHz channel spacing)
		AM (For Middle East)	531 kHz to 1 602 kHz (at 9 kHz channel spacing) 530 kHz to 1 600 kHz (at 10 kHz channel spacing)
General	Power Requirements		AC 110-240 V , 50/60 Hz
	Power Consumption		19 W (at operation) 1.9 W (in standby mode)
	Dimensions (W × H × D)		400 mm × 85 mm × 399 mm
	Mass		4.2 kg

*1: This value is measured at System cord CONNECTOR for reference.

*2: Corresponding to Linear PCM, Dolby Digital, and DTS Digital Surround (with sampling frequency -32 kHz, 44.1 kHz, 48 kHz)

Subwoofer (SP-PWC6/SP-PWC3)

Amplifier section	Front		140W per channel, RMS at 4 Ω at 1 kHz, with 10% total harmonic distortion.
	Center/Surround		130W per channel, RMS at 4 Ω at 1 kHz, with 10% total harmonic distortion.
	Subwoofer		140 W, RMS at 4 Ω at 100 Hz, with 10% total harmonic distortion.
Speaker section	Speaker unit		16 cm Bass-reflex
	Power Handling Capacity		140 W
	Impedance		4 Ω
	Frequency Range		30 Hz to 200 Hz
General	Power Requirements	Except for Australia	AC 110 V/ AC 127 V/AC 220-240 V , 50/60 Hz
		For Australia only	AC 240 V , 50 Hz
	Power Consumption		135 W (at operation) 0 W (in standby mode)
	Dimensions (W × H × D)		169 mm × 411 mm × 459 mm
	Mass		11.3 kg

Satellite Speakers (SP-XTHC6)

Front speakers (SP-THC6F)	Speaker unit	5.5 cm × 2, 1.5 cm, Bass-reflex, Magnetically Shielded
	Power Handling Capacity	140 W
	Impedance	4 Ω
	Frequency Range	90 Hz to 20 kHz
	Dimensions (W × H × D)	250 mm × 110 mm × 250 mm
	Mass	2.6 kg each
Center speaker (SP-THC6C)	Speaker unit	5.5 cm × 2, 1.5 cm, Bass-reflex, Magnetically Shielded
	Power Handling Capacity	140 W
	Impedance	4 Ω
	Frequency Range	90 Hz to 20 kHz
	Dimensions (W × H × D)	320 mm × 75 mm × 92 mm
	Mass	0.9 kg
Surround speakers (SP-THC6S)	Speaker unit	5.5 cm × 2, 1.5 cm, Bass-reflex
	Power Handling Capacity	140 W
	Impedance	4 Ω
	Frequency Range	90 Hz to 20 kHz
	Dimensions (W × H × D)	250 mm × 114 mm × 250 mm
	Mass	2.6 kg each

Designs & specifications are subject to change without notice.

SECTION 1 PRECAUTION

1.1 Safety Precautions

- (1) This design of this product contains special hardware and many circuits and components specially for safety purposes. For continued protection, no changes should be made to the original design unless authorized in writing by the manufacturer. Replacement parts must be identical to those used in the original circuits. Services should be performed by qualified personnel only.
- (2) Alterations of the design or circuitry of the product should not be made. Any design alterations of the product should not be made. Any design alterations or additions will void the manufacturer's warranty and will further relieve the manufacturer of responsibility for personal injury or property damage resulting therefrom.
- (3) Many electrical and mechanical parts in the products have special safety-related characteristics. These characteristics are often not evident from visual inspection nor can the protection afforded by them necessarily be obtained by using replacement components rated for higher voltage, wattage, etc. Replacement parts which have these special safety characteristics are identified in the Parts List of Service Manual. Electrical components having such features are identified by shading on the schematics and by (Δ) on the Parts List in the Service Manual. The use of a substitute replacement which does not have the same safety characteristics as the recommended replacement parts shown in the Parts List of Service Manual may create shock, fire, or other hazards.
- (4) The leads in the products are routed and dressed with ties, clamps, tubings, barriers and the like to be separated from live parts, high temperature parts, moving parts and/or sharp edges for the prevention of electric shock and fire hazard. When service is required, the original lead routing and dress should be observed, and it should be confirmed that they have been returned to normal, after reassembling.

(5) Leakage shock hazard testing

After reassembling the product, always perform an isolation check on the exposed metal parts of the product (antenna terminals, knobs, metal cabinet, screw heads, headphone jack, control shafts, etc.) to be sure the product is safe to operate without danger of electrical shock. Do not use a line isolation transformer during this check.

- Plug the AC line cord directly into the AC outlet. Using a "Leakage Current Tester", measure the leakage current from each exposed metal part of the cabinet, particularly any exposed metal part having a return path to the chassis, to a known good earth ground. Any leakage current must not exceed 0.5mA AC (r.m.s.).
- Alternate check method
Plug the AC line cord directly into the AC outlet. Use an AC voltmeter having, 1,000 Ω per volt or more sensitivity in the following manner. Connect a 1,500 Ω 10W resistor paralleled by a 0.15 μ F AC-type capacitor between an exposed metal part and a known good earth ground. Measure the AC voltage across the resistor with the AC

voltmeter.

Move the resistor connection to each exposed metal part, particularly any exposed metal part having a return path to the chassis, and measure the AC voltage across the resistor. Now, reverse the plug in the AC outlet and repeat each measurement. Voltage measured any must not exceed 0.75 V AC (r.m.s.). This corresponds to 0.5 mA AC (r.m.s.).

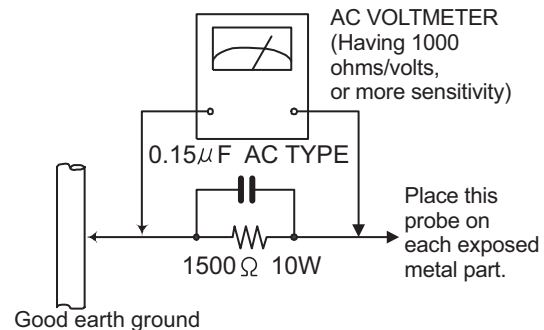

1.2 Warning

- (1) This equipment has been designed and manufactured to meet international safety standards.
- (2) It is the legal responsibility of the repairer to ensure that these safety standards are maintained.
- (3) Repairs must be made in accordance with the relevant safety standards.
- (4) It is essential that safety critical components are replaced by approved parts.
- (5) If mains voltage selector is provided, check setting for local voltage.

1.3 Caution

Burrs formed during molding may be left over on some parts of the chassis.

Therefore, pay attention to such burrs in the case of pre-forming repair of this system.

1.4 Critical parts for safety

In regard with component parts appearing on the silk-screen printed side (parts side) of the PWB diagrams, the parts that are printed over with black such as the resistor (■), diode (■) and ICP (●) or identified by the " Δ " mark nearby are critical for safety. When replacing them, be sure to use the parts of the same type and rating as specified by the manufacturer.

(This regulation does not Except the J and C version)

1.5 Preventing static electricity

Electrostatic discharge (ESD), which occurs when static electricity stored in the body, fabric, etc. is discharged, can destroy the laser diode in the traverse unit (optical pickup). Take care to prevent this when performing repairs.

1.5.1 Grounding to prevent damage by static electricity

Static electricity in the work area can destroy the optical pickup (laser diode) in devices such as laser products.

Be careful to use proper grounding in the area where repairs are being performed.

(1) Ground the workbench

Ground the workbench by laying conductive material (such as a conductive sheet) or an iron plate over it before placing the traverse unit (optical pickup) on it.

(2) Ground yourself

Use an anti-static wrist strap to release any static electricity built up in your body.

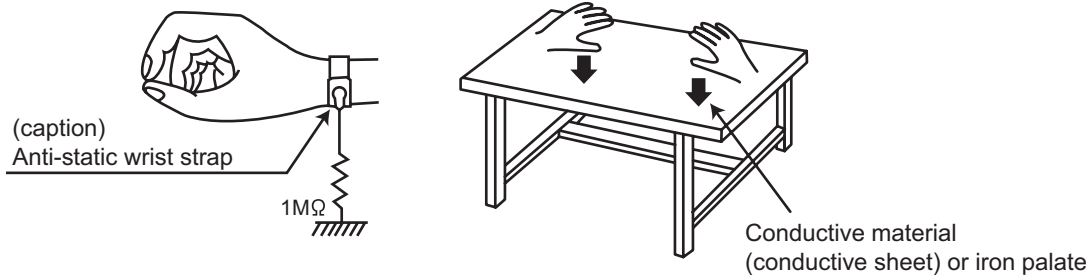

(3) Handling the optical pickup

- In order to maintain quality during transport and before installation, both sides of the laser diode on the replacement optical pickup are shorted. After replacement, return the shorted parts to their original condition. (Refer to the text.)
- Do not use a tester to check the condition of the laser diode in the optical pickup. The tester's internal power source can easily destroy the laser diode.

1.6 Handling the traverse unit (optical pickup)

- (1) Do not subject the traverse unit (optical pickup) to strong shocks, as it is a sensitive, complex unit.
- (2) Cut off the shorted part of the flexible cable using nippers, etc. after replacing the optical pickup. For specific details, refer to the replacement procedure in the text. Remove the anti-static pin when replacing the traverse unit. Be careful not to take too long a time when attaching it to the connector.
- (3) Handle the flexible cable carefully as it may break when subjected to strong force.
- (4) It is not possible to adjust the semi-fixed resistor that adjusts the laser power. Do not turn it.

1.7 Attention when traverse unit is decomposed

***Please refer to "Disassembly method" in the text for the pickup unit.**

- Apply solder to the short land sections before the flexible wire is disconnected from the connector on the servo board. (If the flexible wire is disconnected without applying solder, the pickup may be destroyed by static electricity.)
- In the assembly, be sure to remove solder from the short land sections after connecting the flexible wire.

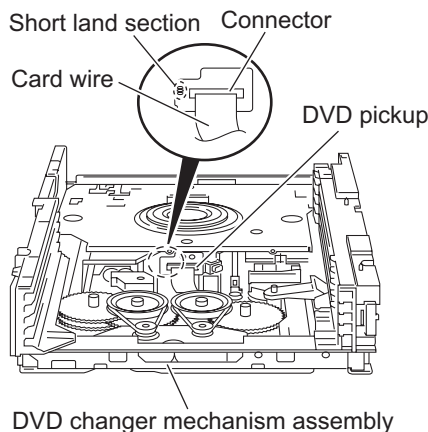

1.8 Important for laser products

1.CLASS 1 LASER PRODUCT

2.DANGER : Invisible laser radiation when open and interlock failed or defeated. Avoid direct exposure to beam.

3.CAUTION : There are no serviceable parts inside the Laser Unit. Do not disassemble the Laser Unit. Replace the complete Laser Unit if it malfunctions.

4.CAUTION : The CD,MD and DVD player uses invisible laser radiation and is equipped with safety switches which prevent emission of radiation when the drawer is open and the safety interlocks have failed or are defeated. It is dangerous to defeat the safety switches.

5.CAUTION : If safety switches malfunction, the laser is able to function.

6.CAUTION : Use of controls, adjustments or performance of procedures other than those specified here in may result in hazardous radiation exposure.



CAUTION Please use enough caution not to see the beam directly or touch it in case of an adjustment or operation check.

CAUTION : Visible and invisible laser radiation when open and interlock failed or defeated.

AVOID DIRECT EXPOSURE TO BEAM.

ADVARSEL : Synlig og usynlig laserstråling når maskinen er åben eller interlocken fejler. Undgå direkte eksponering til stråling.

VARNING : Synlig och osynlig laserstråling när den öppnas och spärren är urkopplad. Betrakta ej strålen.

VARO : Avattaessa ja suojalukitus ohitettuna tai viallisena olet alttiina näkyvälle ja näkymättömälle lasersäteilylle. Vältä säteen kohdistumista suoraan itseesi.

REPRODUCTION AND POSITION OF LABELS

WARNING LABEL

CAUTION : Visible and invisible laser radiation when open and interlock failed or defeated. AVOID DIRECT EXPOSURE TO BEAM. (e)	ADVARSEL : Synlig og usynlig laserstråling når maskinen er åben eller interlocken fejler. Undgå direkte eksponering til stråling. (d)	VARNING : Synlig och osynlig laserstråling när den öppnas och spärren är urkopplad. Betrakta ej strålen. (s)	VARO : Avattaessa ja suojalukitus ohitettuna tai viallisena olet alttiina näkyvälle ja näkymättömälle lasersäteilylle. Vältä säteen kohdistumista suoraan itseesi. (f)
---	--	---	---



CAUTION : Visible and invisible laser radiation when open and interlock failed or defeated. AVOID DIRECT EXPOSURE TO BEAM. (e)	VARO : Avattaessa ja suojalukitus ohitettuna tai viallisena olet alttiina näkyvälle ja näkymättömälle lasersäteilylle. Vältä säteen kohdistumista suoraan itseesi. (f)
VARNING : Synlig och osynlig laserstråling när den öppnas och spärren är urkopplad. Betrakta ej strålen. (s)	ADVARSEL : Synlig og usynlig laserstråling når maskinen er åben eller interlocken fejler. Undgå direkte eksponering til stråling. (d)

SECTION 2
SPECIFIC SERVICE INSTRUCTIONS

This service manual does not describe SPECIFIC SERVICE INSTRUCTIONS.

SECTION 3 DISASSEMBLY

3.1 Main body section

3.1.1 Removing the metal cover (See Figs. 1 to 4)

- (1) From the both sides of the main body, remove the four screws **A** attaching the metal cover. (See Figs. 1 and 2.)
- (2) From the back side of the main body, remove the three screws **B** attaching the metal cover. (See Fig. 3.)
- (3) Lift the rear section of the metal cover in the direction of the arrow while extending the lower sections of the metal cover, release the seven claws **a** using a longer screwdriver from the inside as required. (See Fig. 4.)

Note:

Do not damage any parts and boards inside the main body when releasing the claws **a** using a longer screwdriver.

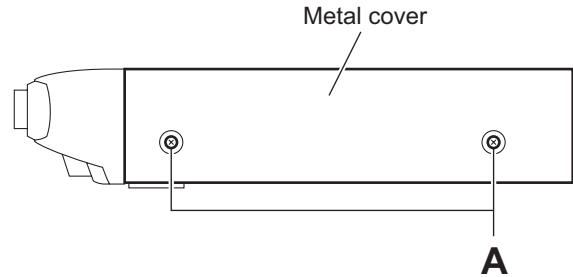

Fig.1

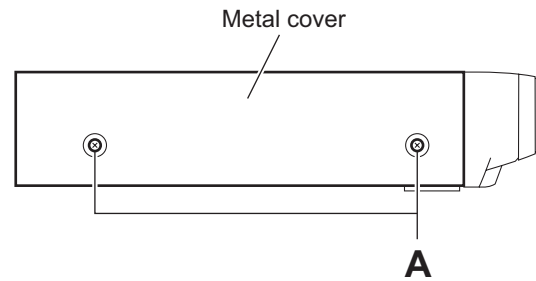

Fig.2

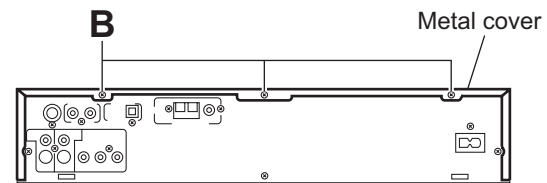

Fig.3

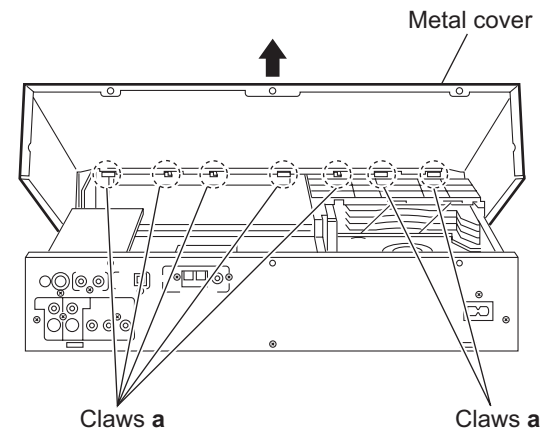

Fig.4

3.1.2 Removing the front panel assembly (See Figs. 5 and 6)

- Prior to performing the following procedures, remove the metal cover.

- (1) From the top side of the main body, disconnect the parallel wires from the connectors (CN456, CN457) on the main board. (See Fig. 5.)
- (2) Disconnect the card wires from the connectors (CN450, CN460) on the main board. (See Fig. 5.)
- (3) Remove the screw **C** attaching the earth wires to the main board. (See Fig. 5.)

Reference:

When attaching the screw **C**, attach the earth wires with it. (See Fig. 5.)

- (4) From the bottom side of the main body, remove the three screws **D** attaching the front panel assembly. (See Fig. 6.)
- (5) From the both and bottom sides of the main body, remove the front panel assembly in the direction of the arrow while releasing the joints **b** and **c**. (See Fig. 6.)

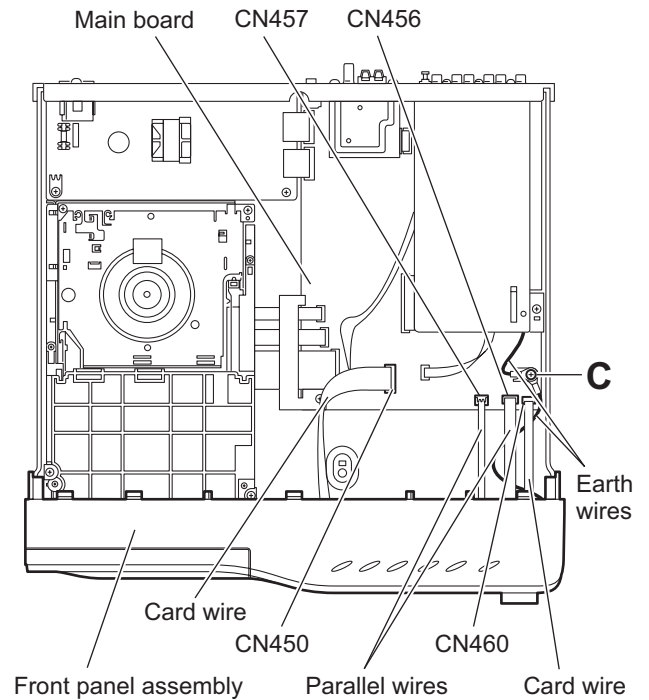

Fig.5

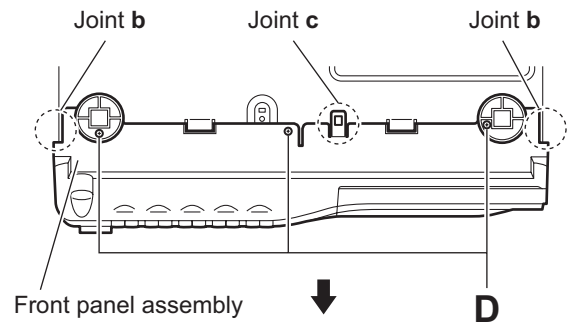

Fig.6

3.1.3 Removing the DVD changer mechanism assembly (See Fig. 7)

- Prior to performing the following procedures, remove metal cover and front panel assembly.

- (1) From the top side of the main body, remove the screw **E** attaching the wire protection board to the main board.
- (2) Take out the wire protection board, and disconnect the card wires from the connectors (CN401 to CN403) on the main board.

Reference:

When attaching the wire protection board, attach the wire protection board after connecting the card wires to the connectors (CN401 to CN403) on the main board.

- (3) Remove the four screws **F** attaching the DVD changer mechanism assembly on the bottom chassis.
- (4) Take out the DVD changer mechanism assembly in the upward direction.

Reference:

When attaching the DVD changer mechanism assembly, align the holes of the DVD changer mechanism assembly to the projections **d** on the bottom chassis.

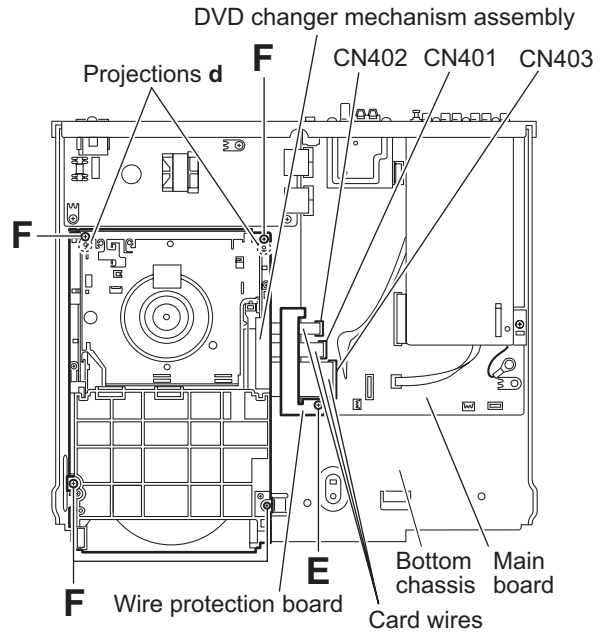

Fig.7

3.1.4 Removing the rear panel (See Fig. 8)

- Prior to performing the following procedures, remove the metal cover.

- (1) From the back side of the main body, remove the screw **G** and ten screws **H** attaching the rear panel. (For A, UW, UY and UG version)
- (2) From the back side of the main body, remove the screw **G** and eleven screws **H** attaching the rear panel. (For UJ version)

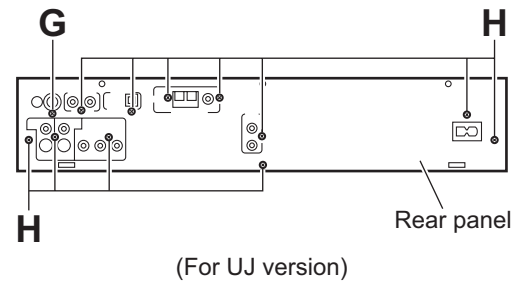
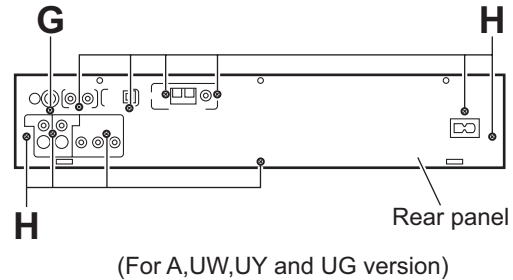

Fig.8

3.1.5 Removing the audio & digital input board (See Figs. 9 and 10)

- Prior to performing the following procedures, remove the metal cover.

- (1) From the top side of the main body, disconnect the card wires from the connectors (CN411, CN412) on the main board. (See Fig. 9.)
- (2) Remove the screw J attaching the earth wires to the main board. (See Fig. 9.)

Reference:

When attaching the screw J, attach the earth wires with it. (See Fig. 9.)

- (3) From the back side of the main body, remove the screw K and two screws M attaching the audio & digital input board to the rear panel. (See Fig. 10.)
- (4) Move the audio & digital input board in the direction of the arrow, and release the claw e of bracket board. (See Fig. 9.)
- (5) Take out the audio & digital input board from the main body.

3.1.6 Removing the tuner (See Figs. 9 and 10)

- Prior to performing the following procedures, remove the metal cover.

- (1) From the top side of the main body, disconnect the card wire from the connector CN1 on the tuner. (See Fig. 9.)
- (2) From the back side of the main body, remove the two screws Q attaching the tuner to the rear panel. (See Fig. 10.)
- (3) Take out the tuner from the main body.

3.1.7 Removing the power supply board (See Figs. 9 and 10)

- Prior to performing the following procedures, remove the metal cover.

- (1) From the top side of the main body, disconnect the parallel wires from the connectors (CN404 to CN407) on the main board. (See Fig. 9.)
- (2) Remove the three screws P attaching the power supply board. (See Fig. 9.)
- (3) From the back side of the main body, remove the screw R attaching the power supply board to the rear panel. (See Fig. 10.)
- (4) Take out the power supply board from the main body.

Reference:

Remove the rear panel as required. (See "3.1.4 Removing the rear panel")

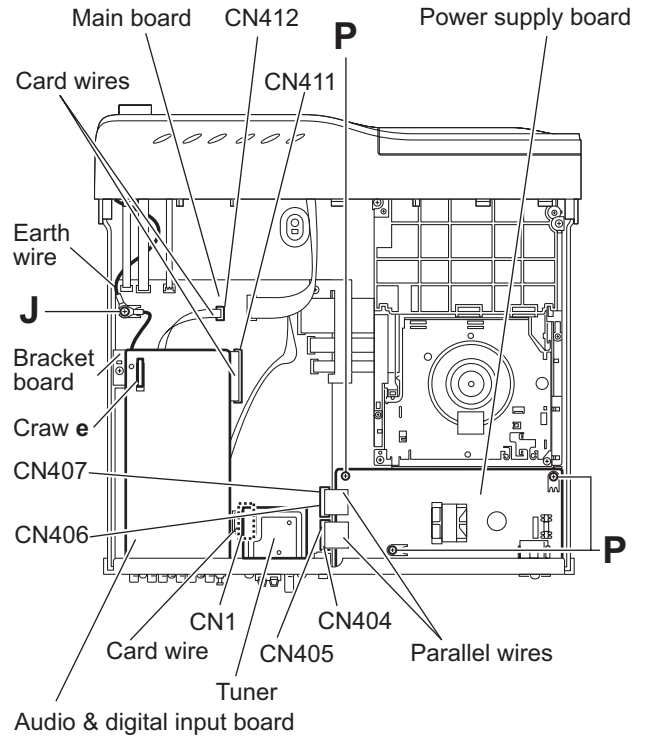

Fig.9

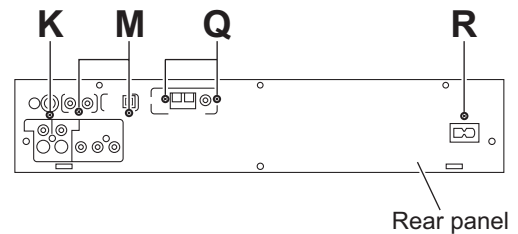

Fig.10

3.1.8 Removing the main board (See Fig. 11)

- Prior to performing the following procedures, remove the metal cover, rear panel, audio & digital input board and tuner.
 - (1) From the top side of the main body, remove the screw **S** attaching the bracket board and take the bracket board.
 - (2) Remove the screw **T** and screw **T'** attaching the main board on the bottom chassis.

Reference:

When attaching the screw **T'**, attach the wire protection board with it.

- (3) Take out the wire protection board, and disconnect the card wires from the connectors ([CN401](#) to [CN403](#)) on the main board.

Reference:

When attaching the wire protection board, attach the wire protection board after connecting the card wires to the connectors ([CN401](#) to [CN403](#)) on the main board.

- (4) Disconnect the card wires from the connectors ([CN450](#) and [CN460](#)) on the main board.
- (5) Disconnect the parallel wires from the connectors ([CN404](#) to [CN407](#), [CN456](#) and [CN457](#)) on the main board.
- (6) Take out the main board from the main body.

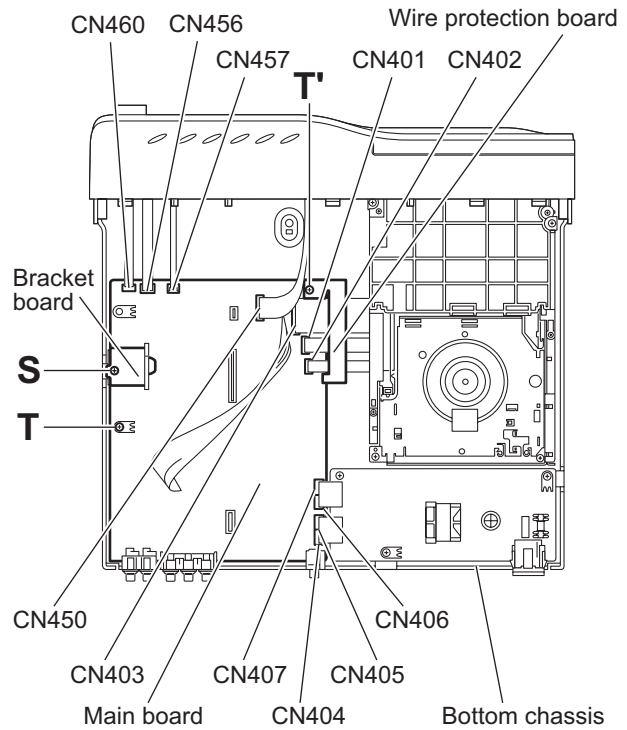

Fig.11

3.2 Front panel assembly section

- Prior to performing the following procedures, remove the front panel assembly from the main body.
(See "Removing the front panel assembly")

3.2.1 Removing the phone jack board (See Fig. 1)

- (1) From the inside of the front panel assembly, remove the screw **A** attaching the phone jack board.
- (2) Take out the phone jack board from the front panel assembly.

3.2.2 Removing the bracket board (See Fig. 1)

- (1) From the inside of the front panel assembly, remove the two screws **B** attaching the bracket board.

Reference:

When attaching the connect board, align the projections of the bracket board to the slots **a** and **b** of the front panel assembly.

- (2) Take out the bracket board from the front panel assembly.

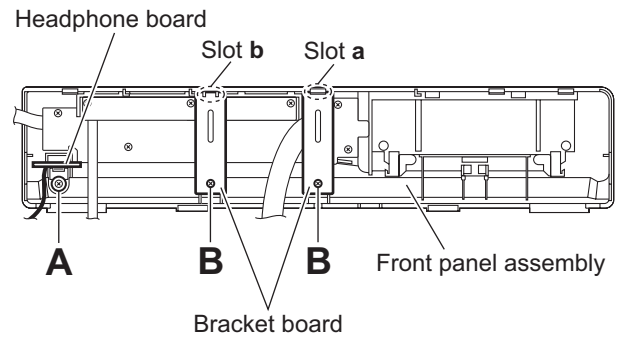

Fig.1

3.2.3 Removing the operation board (See Fig. 2)

- Prior to performing the following procedures, remove the bracket board.

- (1) From the inside of the front panel assembly, remove the three screws **C** attaching the operation board.

Reference:

When attaching the operation board, align the projections **c** of the front panel assembly to the holes of the operation board.

- (2) Take out the operation board.

3.2.4 Removing the power key board (See Fig. 2)

- Prior to performing the following procedures, remove the bracket board.

- (1) From the inside of the front panel assembly, remove the two screws **D** attaching the power key board.
- (2) Take out the power key board and remove the solder from the soldered point **d** to remove the parallel wire.

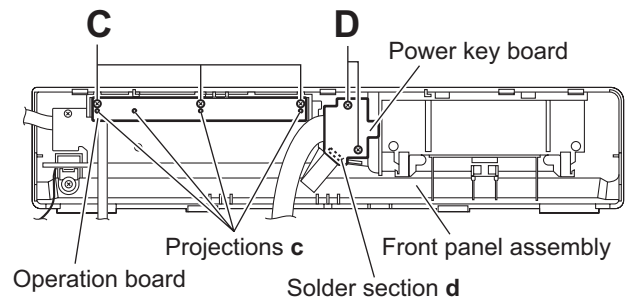

Fig.2

3.2.5 Removing the front board (See Figs. 3 and 4)

- Prior to performing the following procedures, remove the phone jack board, bracket board and operation board.
 - (1) From the front side of the front panel assembly, pull out the volume knob in the direction of the arrow. (See Fig. 3.)
 - (2) From the inside of the front panel assembly, remove the six screws **E** attaching the front board. (See Fig. 4.)
 - (3) Take out the front board and remove the solder from the soldered point **e** to remove the parallel wire. (See Fig. 4.)

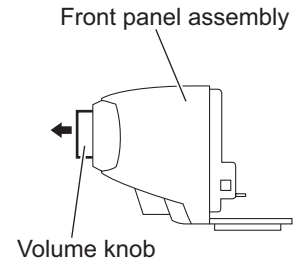

Fig.3

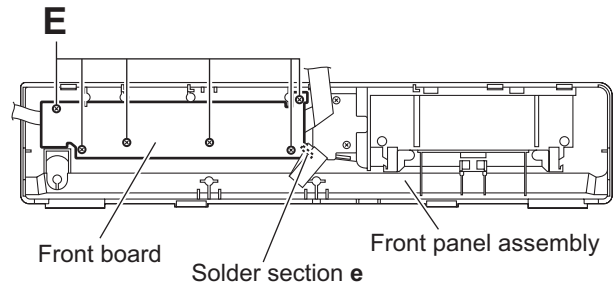

Fig.4

3.3 DVD changer mechanism assembly section

Remove the DVD changer mechanism assembly from the main body. (See "Removing the DVD changer mechanism assembly".)

3.3.1 Removing the tray assemblies

(See Figs.1 to 5)

- (1) From the top side of the main body, remove the two screws **A** from the top cover and release the two joints **a** on the both sides of the DVD changer mechanism assembly. (See Figs.1 and 2.)
- (2) Remove the two rods from the top cover and remove the top cover from the lifter assembly. (See Figs.1 and 2.)
- (3) Remove the open det. lever on the left side of the DVD changer mechanism assembly. (See Fig.3.)
- (4) From the right side of the DVD changer mechanism assembly, draw out the tray assemblies toward the front while pushing the part **b** of the side (R) assembly. (See Figs.4 and 5.)

Note:

The tray can be locked if all tray assemblies are attached.

- (5) From the topside of the DVD changer mechanism assembly, move the stopper tabs **c** in the direction of the arrow and release them. Pull out the tray assemblies from the DVD changer mechanism assembly. (See Fig. 5.)

Note:

Remove the tray assembly from top tray 5 in order.

Reference:

When reattaching the tray assembly, or when removing the disc remaining inside, refer to another section "3.3.15 Taking out the disc in the play mode".

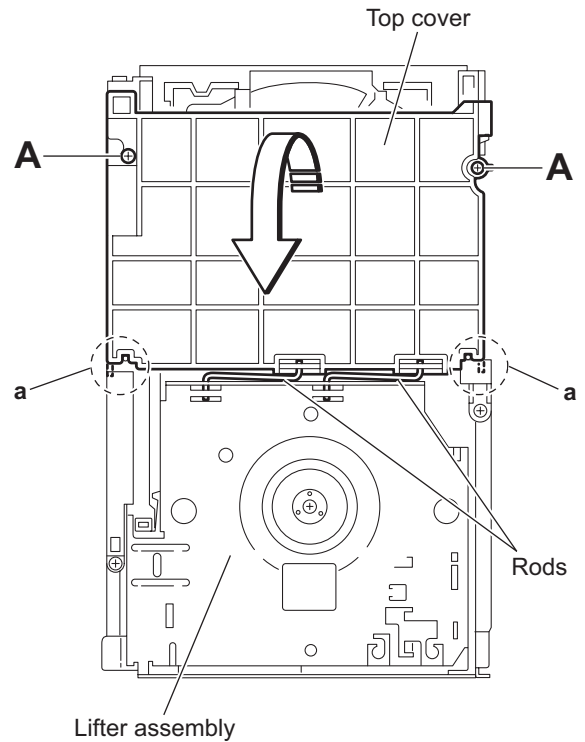

Fig.1

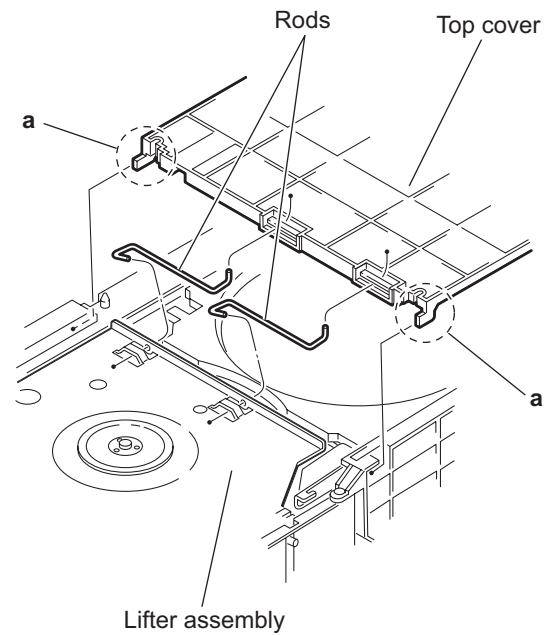

Fig.2

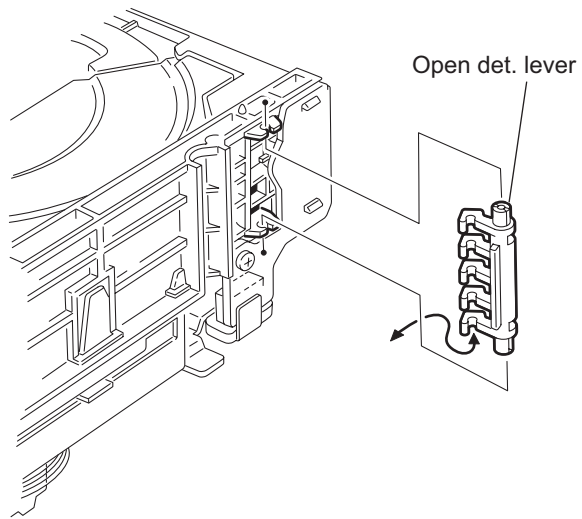

Fig.3

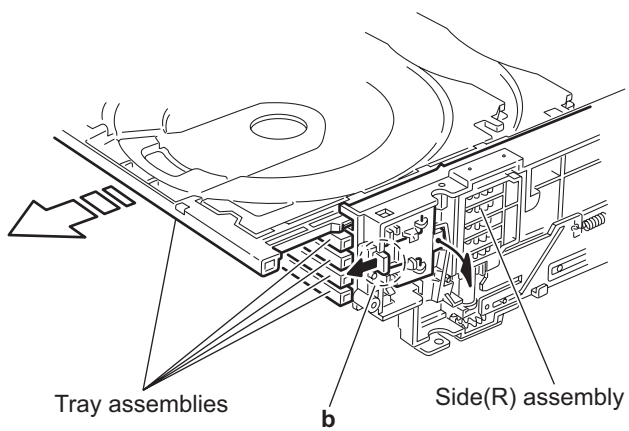

Fig.4

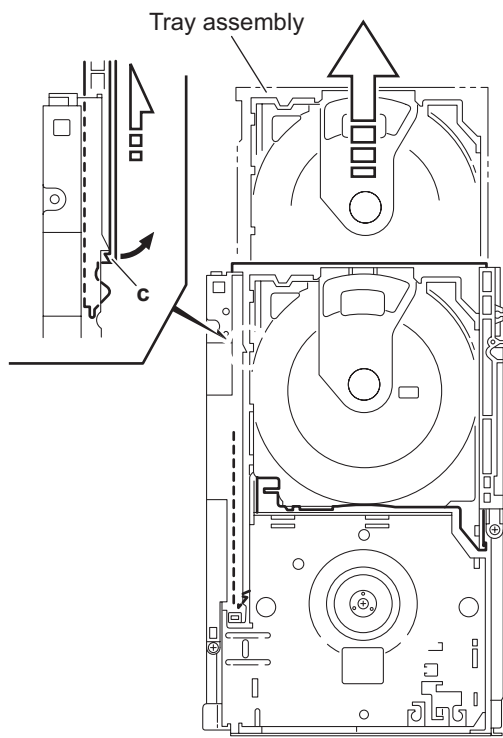

Fig.5

3.3.2 Removing the DVD servo board (See Figs.6 to 8)

Caution:

Solder the short land sections **d** on the DVD pickup before disconnecting the card wire extending from the DVD pickup. If you do not follow this instruction, the DVD pickup may be damaged.

- (1) From the topside of the DVD changer mechanism assembly, solder the short land sections **d** on the DVD pick up. (See Fig.6.)
- (2) From the bottom side of the DVD changer mechanism assembly, disconnect the card wire from the connectors (CN201, CN451) on the DVD servo board. (See Fig.7.)

Reference:

When connecting the card wire to the connector CN451, pass it through the sections **e** on the DVD traverse mechanism assembly. (See Fig.7.)

- (3) Disconnect the wires from the connectors (CN452, CN453) on the DVD servo board. (See Fig.7.)
- (4) Remove the two screws **B** attaching the DVD servo board. (See Fig.7.)
- (5) From the reverse side of the DVD servo board, release the lock of the connector CN101 in the direction of the arrow and disconnect the card wire. (See Fig.8.)

Caution:

Unsolder the solders from the short land sections **d** after reassembling. (See Fig.6.)

3.3.3 Removing the switch board (See Fig.7)

- (1) From the bottom side of the DVD changer mechanism assembly, remove the screw **C** attaching the switch board on the DVD changer mechanism assembly.
- (2) Disconnect the wires from the connectors (CN452, CN453) on the DVD servo board.
- (3) Release the wires from the section **f** and remove the switch board.
- (4) Release the wires from the sections **g** and remove the switch board.

Reference:

When reassembling, pass the wires through the sections (f, g) as before.

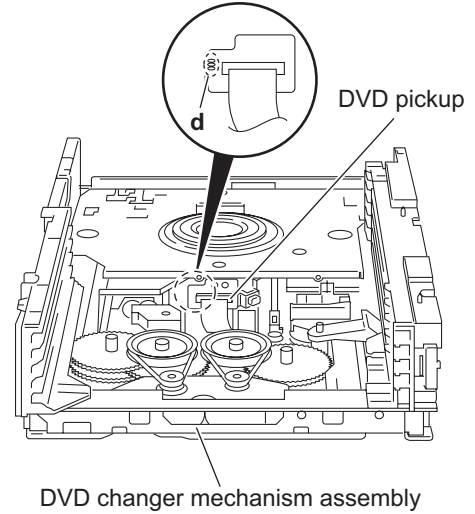

Fig.6

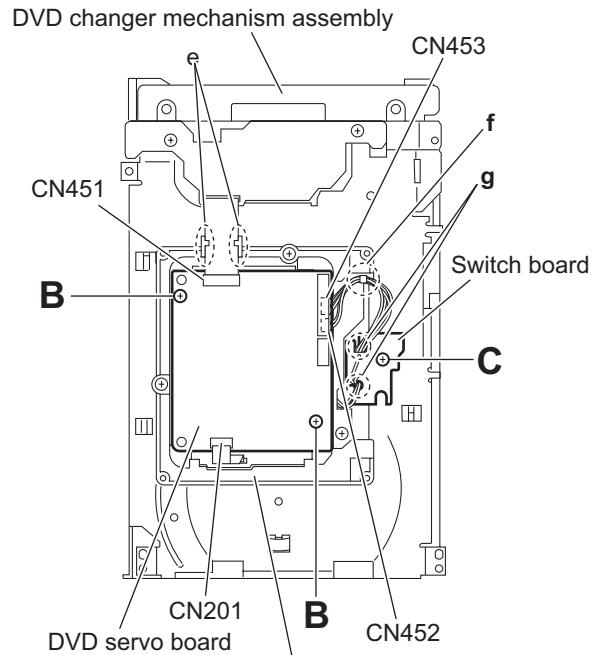

Fig.7

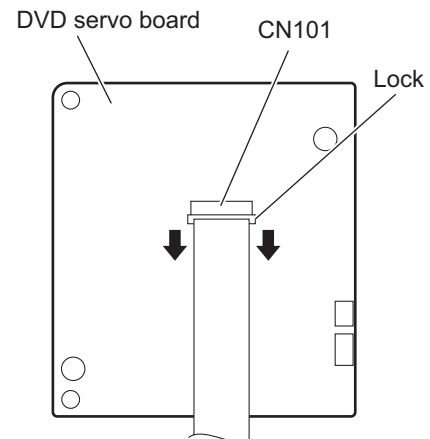

Fig.8

3.3.4 Removing the motor board (See Figs.9 and 10)

- (1) From the top side of the DVD changer mechanism assembly, remove the two belts from the motor pulleys. (See Fig.9.)

Note:

Take care not to attach grease on the belt.

- (2) Remove the two screws **D** attaching the motors to the loader assembly. (See Fig.9.)
- (3) From the bottom side of the DVD changer mechanism assembly, remove the two screws **E**. (See Fig.10.)
- (4) Disconnect the connector **CN2** on the motor board from the tray switch board and remove the motor board. (See Fig.10.)
- (5) Disconnect the card wire from the connector **CN1** on the forward side of the motor board. (See Fig.10.)

Note:

When connecting the card wire, let the card wire through the slots **h** of the motor board. (See Fig.10.)

Reference:

You need not to remove the tray assemblies, and in such case, move it.

3.3.5 Removing the motor (See Fig. 10)

- Remove the motor board.

- (1) From the reverse side of the motor board, unsolder the four soldered sections **i** on the motor board.
- (2) From the forward side of the motor board, remove the motors.

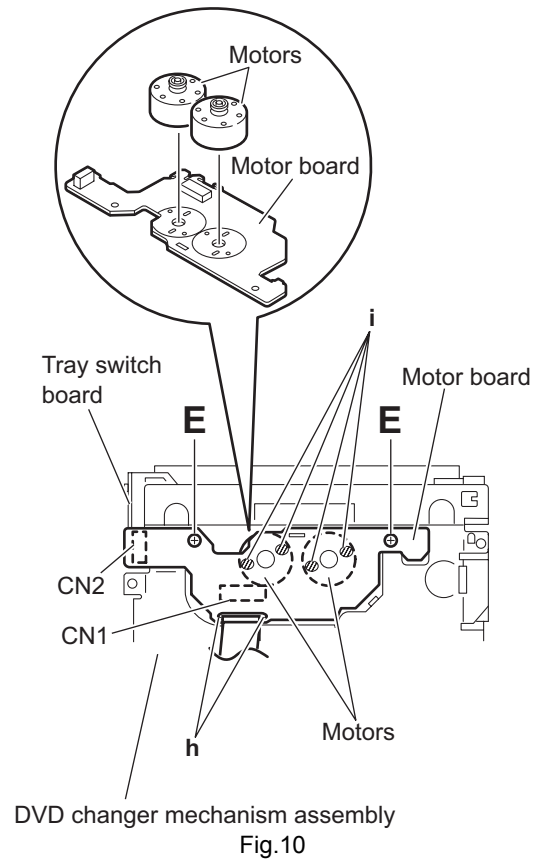
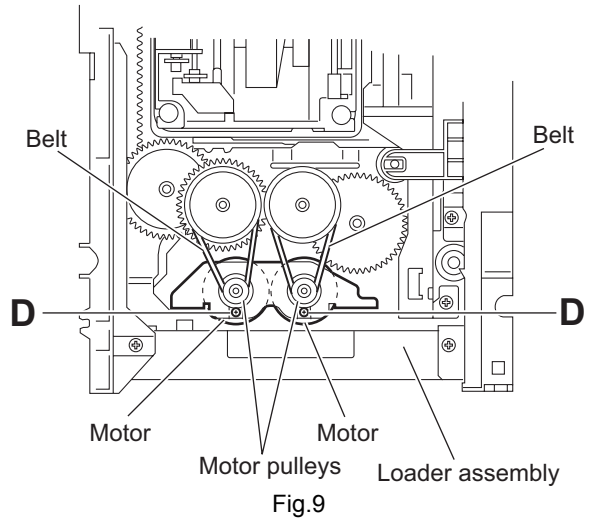

3.3.6 Removing the DVD traverse mechanism assembly (See Fig.11)

- Remove the tray assemblies and DVD servo board.
 - (1) From the bottom side of the DVD changer mechanism assembly, remove the three screws **F** attaching the DVD traverse mechanism assembly.
 - (2) Remove the wires from the section **j**.
 - (3) Take out the DVD traverse mechanism assembly from the DVD changer mechanism assembly.

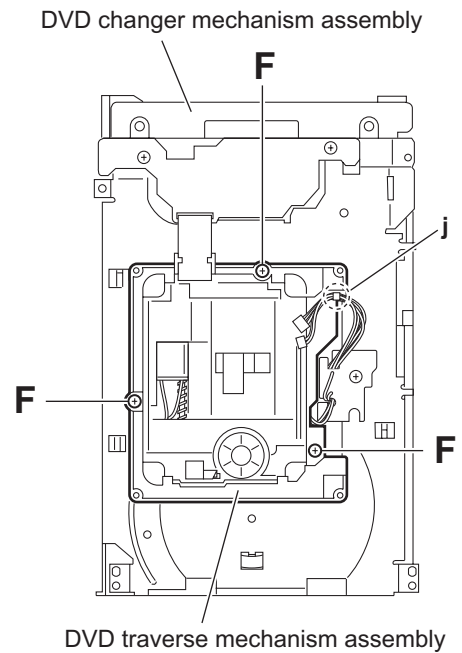

DVD traverse mechanism assembly
Fig.11

3.3.7 Removing the DVD pickup (See Figs.12 to 14)

- Remove the tray assemblies, DVD servo board and DVD traverse mechanism assembly.
 - (1) From the top side of the DVD traverse mechanism assembly, release the lock of the connector on the DVD pickup and disconnect the card wire in the direction of the arrow. (See Fig.12.)
 - (2) Turn the screw shaft gear in the direction of the arrow 1 to move the DVD pickup in the direction of the arrow 2. (See Fig.12.)
 - (3) Remove the screw **G** attaching the feed bracket and remove the feed bracket from the sections **k**. (See Fig.12.)
 - (4) Release the claw **m** of the thrust spring in the direction of the arrow and remove the thrust spring. (See Fig.12.)
 - (5) Remove the guide shaft from the sections (**n**, **p**) on the C.TM chassis. (See Fig.13.)
 - (6) Remove the section **q** of the DVD pickup. (See Fig.13.)
 - (7) Remove the two screws **H** attaching the rack arm spring and rack arm. (See Fig.14.)
 - (8) Pull the guide shaft from the DVD pickup in the direction of the arrow. (See Fig.14.)

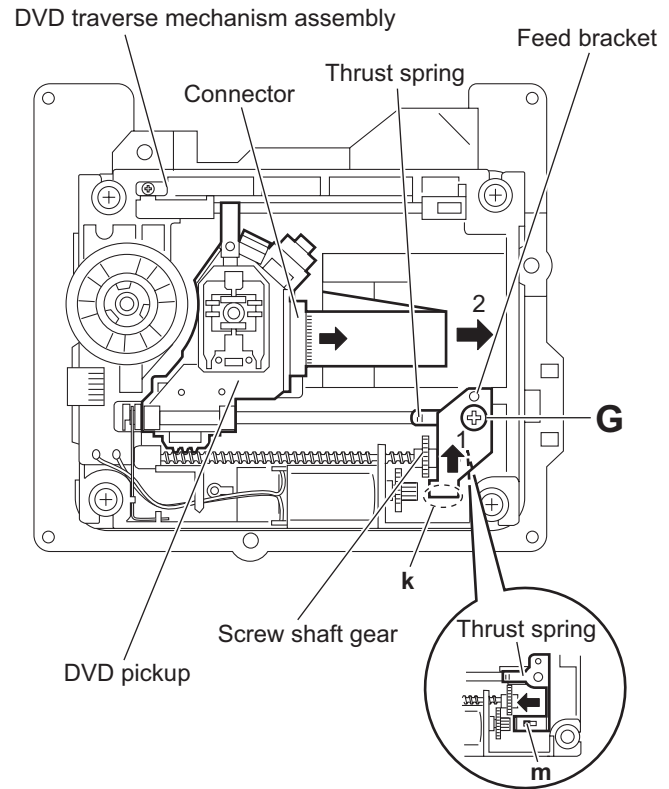

Fig.12

3.3.8 Attaching the DVD pickup (See Figs.12 to 14)

- (1) Attach the guide shaft to the DVD pickup and attach the rack arm spring and rack arm with the screws **H**. (See Fig.14.)
- (2) Attach the section **q** of the DVD pickup to the C.TM chassis first and attach the guide shaft to the sections (**n**, **p**). (See Fig.13.)

Reference:

When attaching the guide shaft to the section **p**, attach it under the rod spring. (See Fig.13.)

- (3) Attach the thrust spring and feed bracket with the screw **G**. (See Fig.12.)
- (4) Turn the screw shaft gear in the direction of the arrow 1 to move the DVD pickup in the direction of the arrow 2. (See Fig.15.)
- (5) Connect the card wire to the connector on the DVD pickup. (See Fig.15.)

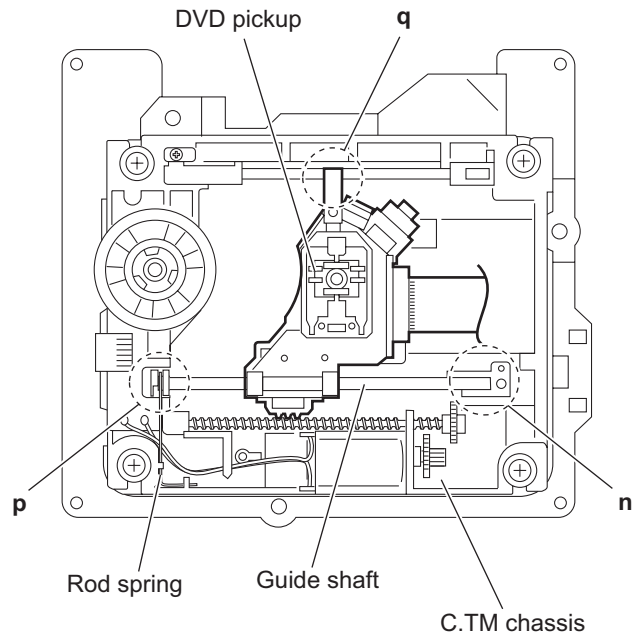

Fig.13

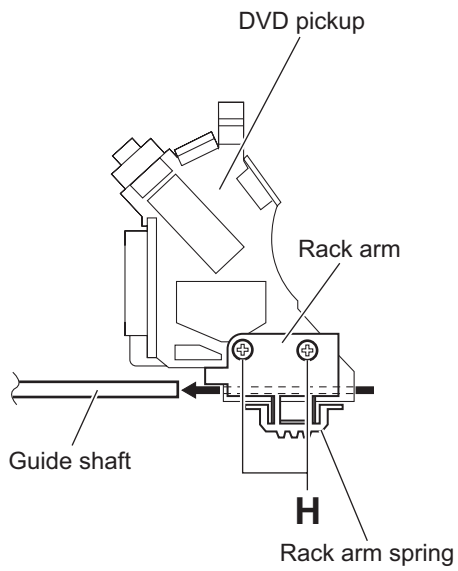

Fig.14

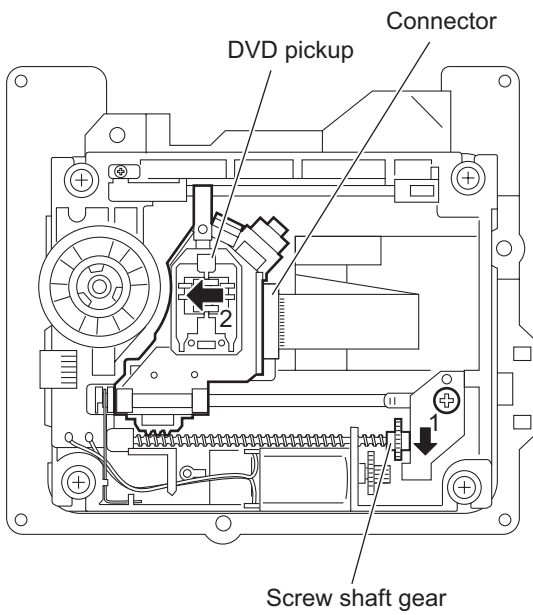

Fig.15

3.3.9 Removing the spindle motor board (See Figs.16 and 17)

- Remove the tray assemblies, DVD servo board and DVD traverse mechanism assembly.
 - From the top side of the DVD traverse mechanism assembly, remove the wires from the soldered sections **r** on the spindle motor board. (See Fig.16.)
 - From the bottom side of the DVD traverse mechanism assembly, remove the three screws **J** attaching the spindle motor board. (See Fig.17.)

Reference:

When attaching the spindle motor board, let the card wire through the hole **s** on the C.TM chassis. (See Fig.17.)

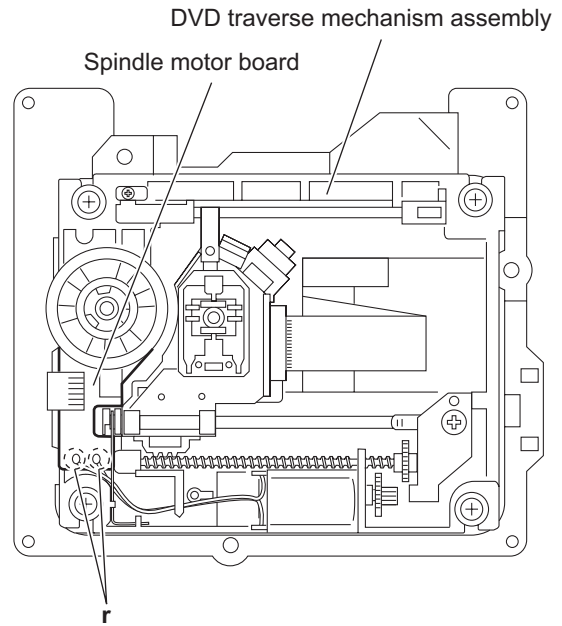

Fig.16

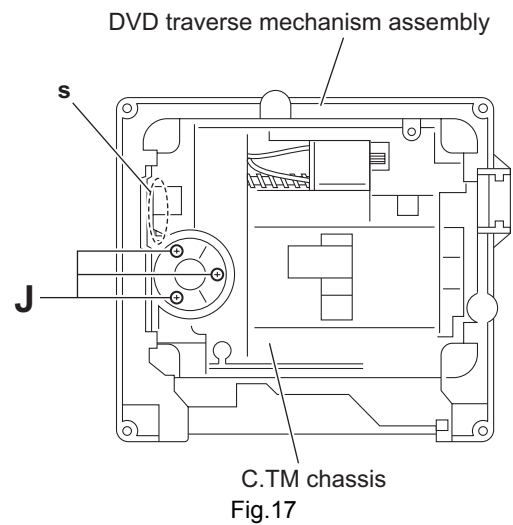

Fig.17

3.3.10 Removing the feed motor (See Figs.18 and 19)

- Remove the tray assemblies and DVD traverse mechanism assembly.
 - (1) From the top side of the DVD traverse mechanism assembly, remove the screw **K** attaching the feed bracket and remove the feed bracket from the sections **t**. (See Fig.18.)
 - (2) Release the claw **u** of the thrust spring in the direction of the arrow and remove the thrust spring. (See Fig.18.)
 - (3) Remove the screw shaft from the section **v** and remove it in the direction of the arrow. (See Fig.19.)
 - (4) Remove the middle gear. (See Fig.19.)
 - (5) Remove the screw **L** attaching the feed motor to the C.TM chassis. (See Fig.19.)
 - (6) Remove the wires from the soldered sections **w** on the spindle motor board. (See Fig.19.)
 - (7) Take out the feed motor from the motor base.

Reference:

After attaching the feed motor, pass the wires through the sections **x** on the C.TM chassis as before. (See Fig.19.)

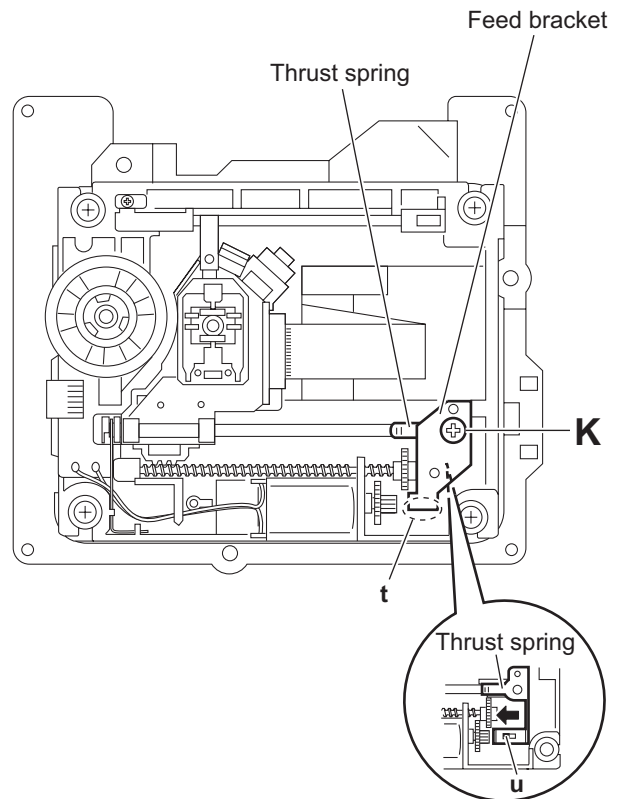

Fig.18

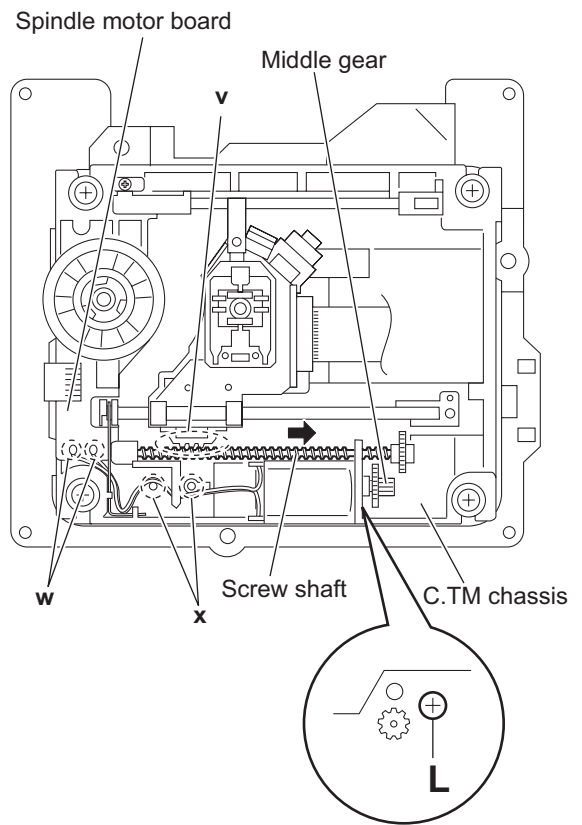
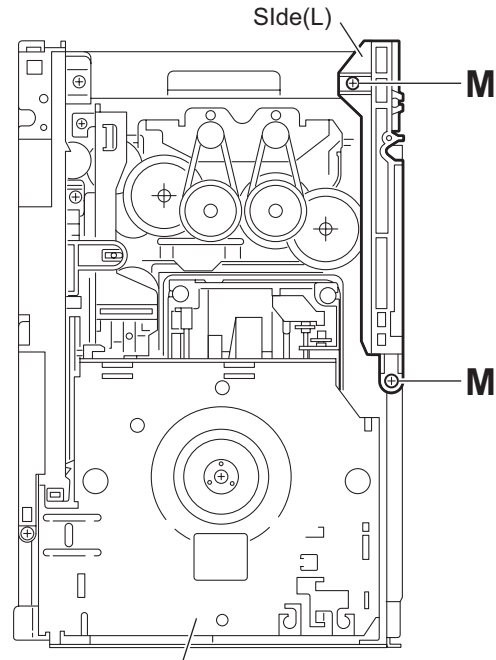

Fig.19

3.3.11 Removing the side (L) and tray switch board (See Figs.20 to 22)

- Remove the tray assemblies.
 - From the topside of the DVD changer mechanism assembly, remove the two screws **M** attaching the side (L). (See Fig.20.)
 - From the left side of the DVD changer mechanism assembly, disconnect the connector **CN3** on the tray switch board from the motor board and detach the side (L) in an upward direction. (See Fig.21.)
 - Remove the screw **N** attaching the tray switch board to the side (L). (See Fig.22.)
 - Release the joint tab **y** of the side (L) in the direction of the arrow 1 and release the joint tab **z** while removing the tray switch board in the direction of the arrow 2. (See Fig.22.)



DVD changer mechanism assembly
Fig.20

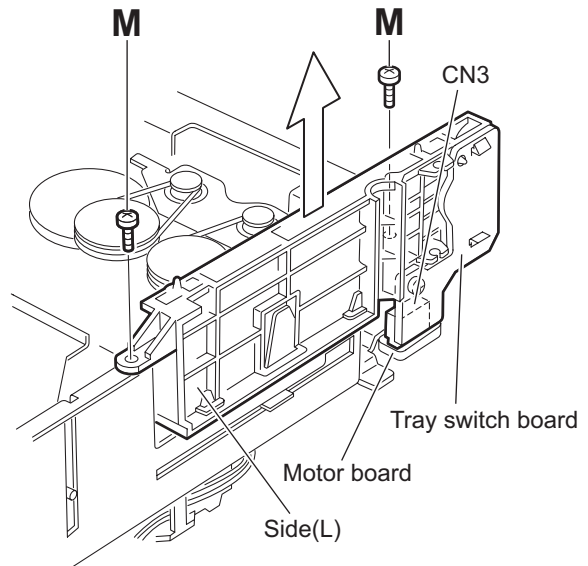

Fig.21

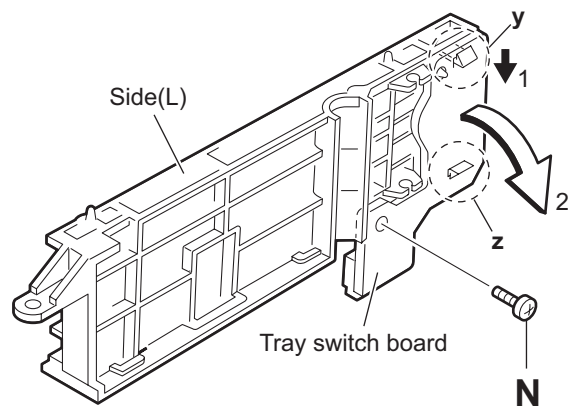

Fig.22

3.3.12 Removing the side (R) assembly (See Fig.23 to 27)

- Remove the tray assemblies and DVD servo board.
 - From the inside of the side (R) assembly, release the two tabs **aa** of the gear cover and remove the gear cover outward. (See Figs.23 and 24.)
 - From the right side of the DVD changer mechanism assembly, remove the elevator spring attached to the hook **ab** of the loader assembly. (See Figs.24 and 25.)
 - From the top side of the DVD changer mechanism assembly, turn the gear 1 clockwise to move the elevator cam rearward. (See Fig.25.)
 - Move the two slots **ac** and joint **ad** of the elevator cam and remove the elevator cam outward. (See Fig.25.)
 - Remove the three screws **P** and detaches the side (R) assembly upward. (See Figs.26 and 27.)

Note:

When reattaching the side (R) assembly, make sure to fit the shaft (part **ae**) into the slot of the select lever. (See Fig.26.)

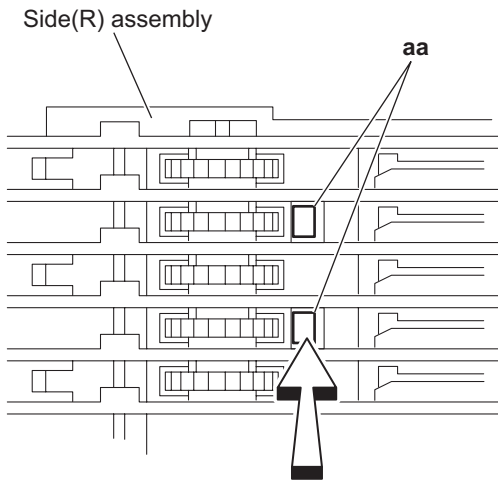
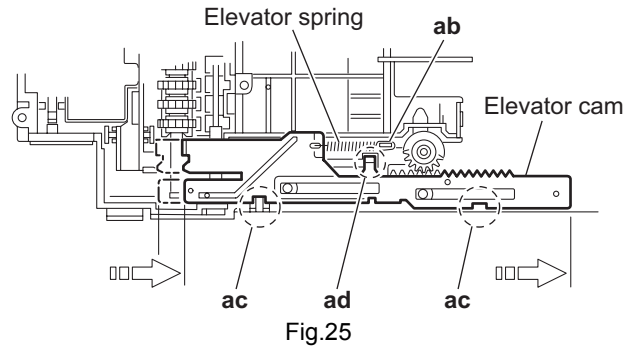

Fig.23

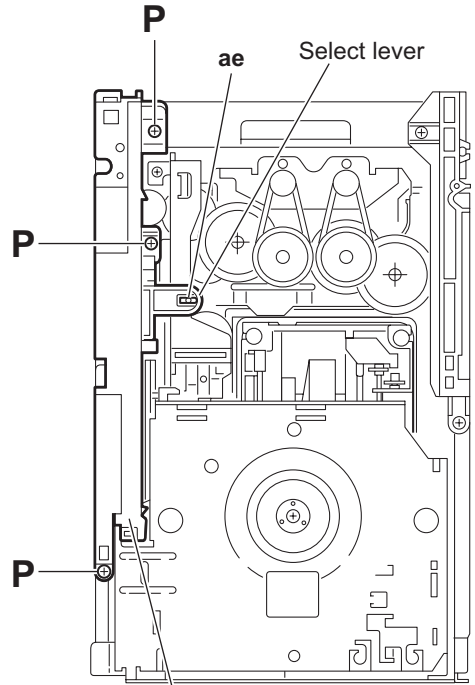

Fig.26

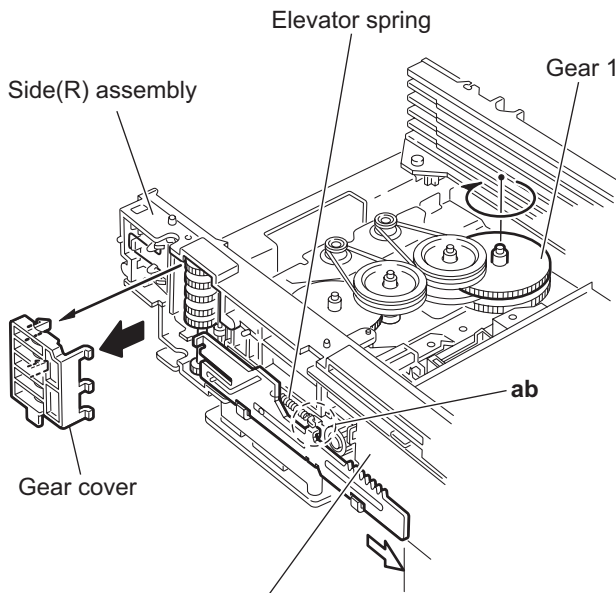

Fig.24

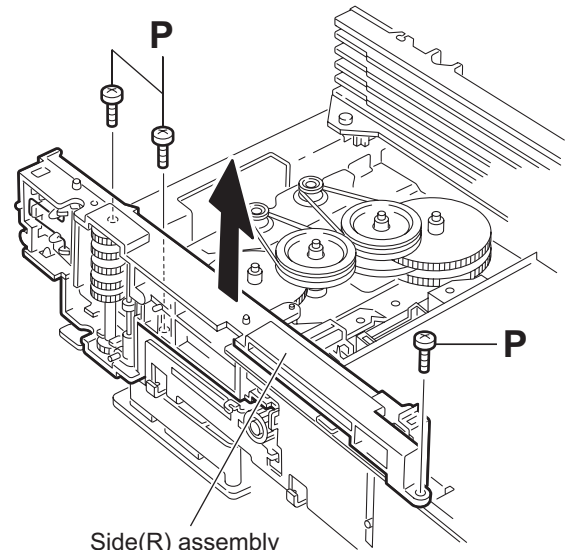

Fig.27

3.3.13 Removing the lifter assembly (See Figs.28 to 32)

- Remove the tray assemblies, DVD servo board, side (L) and side (R) assembly.
- (1) (1) From the top side of the DVD changer mechanism assembly, turn the gear 1 clockwise to move the lifter assembly upward. (See Figs.28 and 29.)
- (2) Turn the gear 2 clockwise to move the hook toward the front until it stops. (See Figs.28 and 29.)
- (3) Move the hook stopper in the direction of the arrow 2 while pushing the tab **af** of the hook stopper to unlock it in the direction of the arrow 1 and release four joints **ag** to detach from the rack holder. (See Fig.30.)
- (4) Release the rod (L) from part **ah**. (See Fig.30.)
- (5) Turn the gear 1 clockwise again to move the lifter assembly upward. (See Fig.31.)
- (6) Remove the lifter assembly from the DVD changer mechanism assembly upward at the positions **ai** where the four pins on the both sides of the lifter assembly fit to the notches of the loader assembly. (See Fig.31.)
- (7) Move the lifter assembly in the direction of the arrow and release it from the hook. (See Fig.32.)

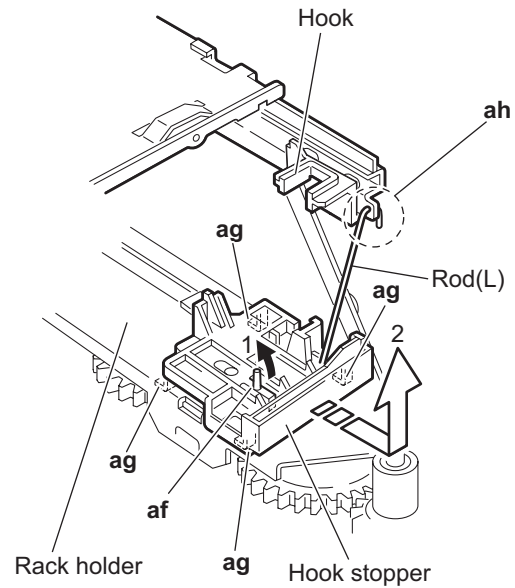
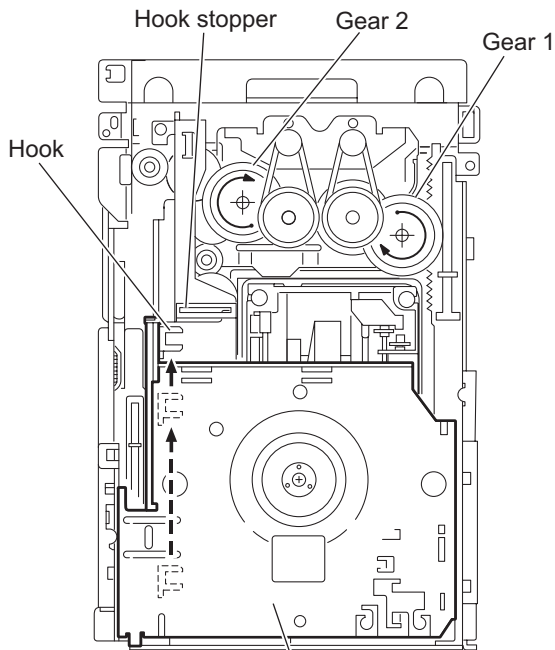
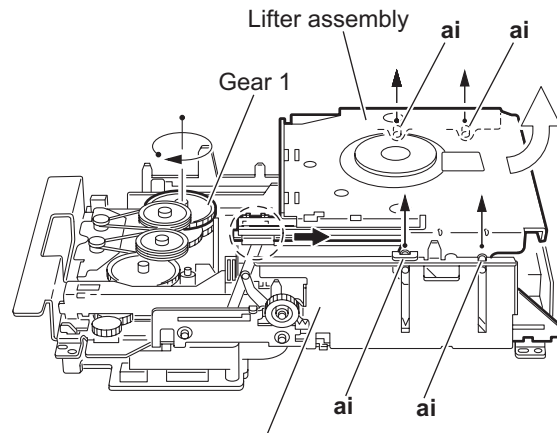

Fig.30



Lifter assembly
Fig.28



Lifter assembly
Loader assembly
Fig.31

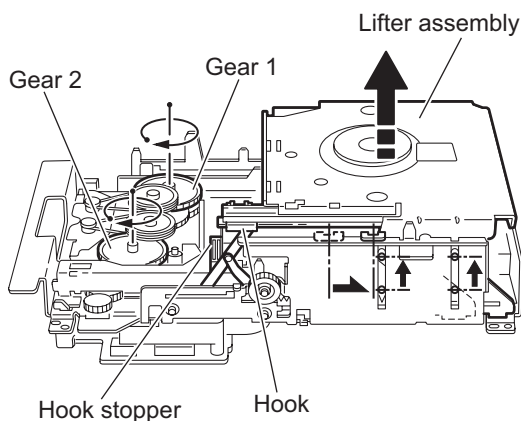

Lifter assembly
Hook stopper
Hook
Fig.29

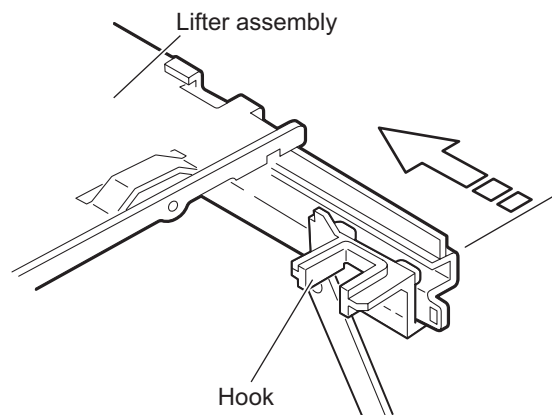

Lifter assembly
Hook
Fig.32

3.3.14 Removing the sensor board and SV resistor (See Fig.33)

- Remove the tray assemblies, side (L), side (R) assembly and lifter assembly.
 - Remove the solders from the soldered sections **aj** on the sensor board and remove the wires.
 - Remove the two screws **Q** and take out the sensor board with the SV resistor.

Reference:

- Remove the soldered section **ap** on the sensor board as required.
- When reassembling, pass the wires through the slot **ak** of the sensor board as before.

Note:

When reattaching the SV. resistor, fit the projection **am** on the bottom of the SV. resistor into slot **an** of the sensor slider.

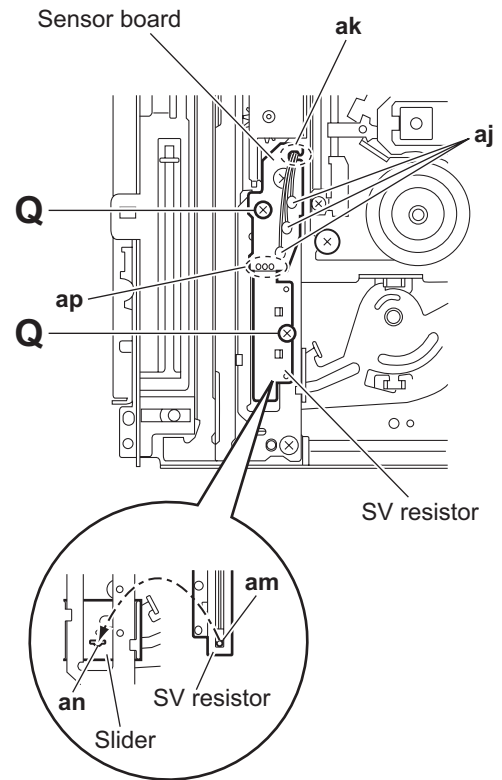

Fig.33

3.3.15 Taking out the disc in the play mode (See Fig.34 to 37)

Reference:

Refer to "3.3.1 Removing the tray assemblies".

- (1) From the top side of the DVD changer mechanism assembly, remove the top cover.
- (2) Unlock the tray assemblies and draw out the tray assemblies toward the front.
- (3) From the top side of the DVD changer mechanism assembly, turn the gear 1 clockwise to move the lifter assembly upward. (See Fig.34.)
- (4) Turn the gear 2 clockwise to move the sub tray remaining inside the lifter assembly toward the front, then pull out.
- (5) Take out the disc on the sub tray. (See Fig.35.)
- (6) After clearing away the disc, insert the sub tray into the main tray. (See Fig.36.)

Note:

When reattaching the sub tray, move the tray stopper on the bottom of the main tray in the direction of the arrow to lock the sub tray certainly. (See Figs.36 and 37.)

- (7) Push the tray assembly toward the DVD changer mechanism assembly and reattach.

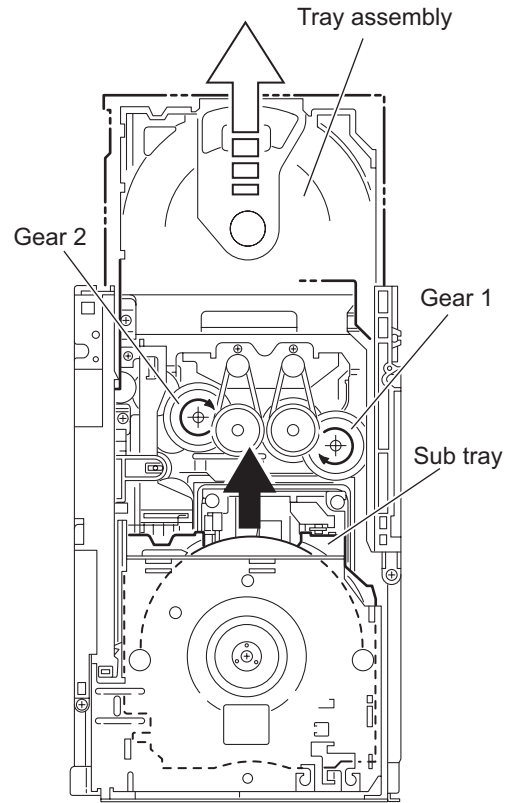

Fig.34

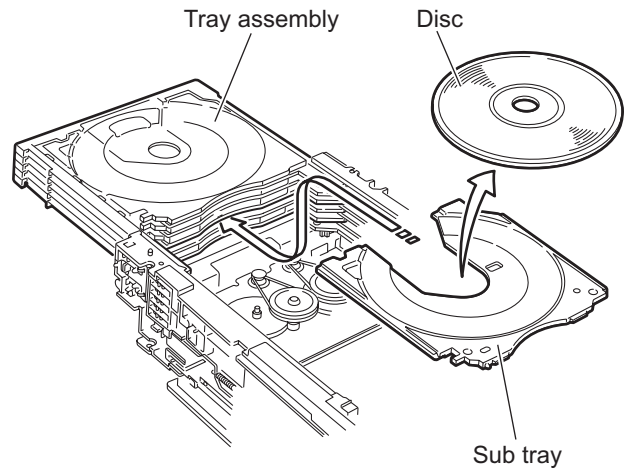

Fig.35

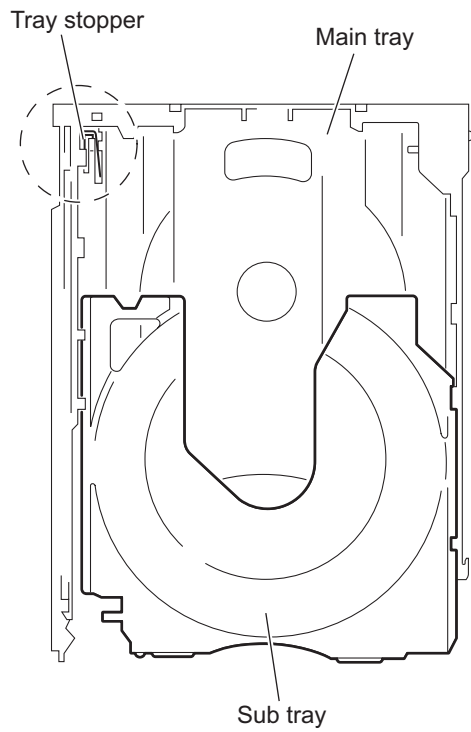

Fig.36

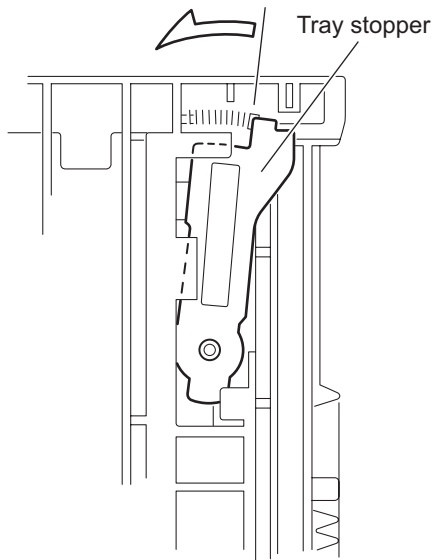

Fig.37

SECTION 4 ADJUSTMENT

4.1 Special mode

4.1.1 Outline

The contents in the special mode of operation, and the definition of a key (remote controller or main unit)

4.1.2 Special mode

1.DVD TEST MODE

It goes into the TEST mode of DVD.

DVD TEST mode is canceled by except DVD source, and POWER OFF.

It is referring to the "4.2 DVD test mode" for details.

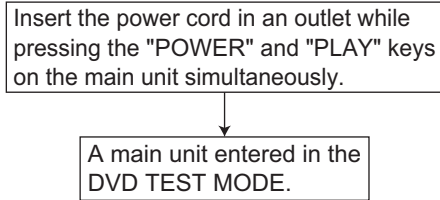

2.DVD NORMAL INITIALIZE

Initialize DVD backend memory.

<RDS> segment of FL will light up if successful.

It is referring to the "4.2 DVD test mode" for details.

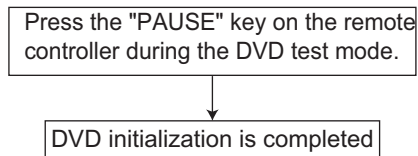

3.DVD FULL INITIALIZE

Initialize DVD memory including frontend.

<RDS> segment of FL will light up if successful.

It is referring to the "4.2 DVD test mode" for details.

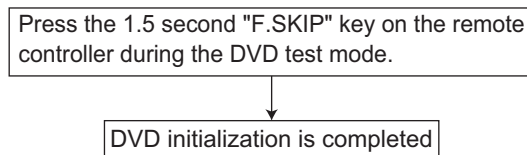

4.DVD REGION CHECK

FL display in DVD TEST MODE.

It is referring to the "4.2 DVD test mode" for details.

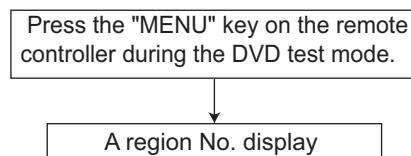

5.FORCED NTSC MODE

It is made compulsive NTSC mode.

From this, with regards to the input of NTSEL_SW, there is nothing only at the time of 1st power on, and it performs NTSC starting.

(Command specification is performed to a module.)

A mode clearance is performed by power off.

VIDEO FORMAT change is prohibited during Forced NTSC mode.

Insert the power cord in an outlet while pressing the "POWER" and "PAUSE" keys on the main unit simultaneously.

A main unit entered in the NTSC mode compulsively.

6.TRAY LOCK

A loader mechanism's tray lock is carried out. In the tray lock function ON state, EJECT processing is not performed to the EJECT key.

And , a LOCK display is performed at this time.

When it turns off a tray lock function, STOP and EJECT KEY are pushed simultaneously again.

Back up ON/OFF of a tray lock.

Press the "STOP" and "OPEN/CLOSE1" keys on the remote controller at standby.

A tray lock is completed.

7.TUNER AM 9k STEP SW (only U version)

AM frequency is changed with 9k STEP.

Press the "STOP" and "B.SKIP" keys on the main unit simultaneously.

A tuner unit entered in the 9k step mode.

8.TUNER AM 10k STEP SW (only U version)

AM frequency is changed with 10k STEP.

Press the "STOP" and "F.SKIP" keys on the main unit simultaneously.

A tuner unit entered in the 10k step mode.

4.1.3 Upgrading of firmware (DVD UPGRADE)

The latest firmware for upgrading is updated in "Optical disc CSG" page in JS-net. At the time of service, compare the version of the product and the latest version, and upgrade the old version into the latest version.

- (1) Press "STANDBY/ON" key of the main body to turn it on.
- (2) Push "OPEN/CLOSE" key of the main body, and insert the upgrade disc in the tray.
- (3) When reading the data of the disc, the OSD screen is displayed "VERSION UP DISC", "PROGRAM & DESTINATION MODE" and "READING..".
- (4) When the screen changes from "READING.." to "WRITING..", upgrading starts.
- (5) After writing the data of the disc, the screen is displayed "OPEN".
- (6) Take out the disc, and press "STANDBY/ON" key of the main body.
- (7) When the stand-by indicator is lighted, upgrading is completed.
- (8) Set the main body at test mode, and confirm the version of the firmware. (Refer to "4.2 Method of displaying version firmware".)

4.1.4 Upgrading of system microcomputer (ROM CORRECTION)

- (1) Press "STANDBY/ON" key of the main body to turn it on.
- (2) Push "OPEN/CLOSE" key of the main body, and insert the upgrade disc in the tray.
- (3) When reading the data of the disc, the OSD screen is displayed "VERSION UP DISC", "SYSCON UPG MODE" and "READING..".
- (4) When the screen changes from "READING.." to "WRITING..", system data is written.
- (5) After writing the data of the disc, the FL display of the main body is displayed "COMPLETE".
- (6) Take out the disc, and press "STANDBY/ON" key of the main body.
- (7) When the stand-by indicator is lighted, upgrading is completed.
- (8) Set the main body at test mode, and confirm the version of the system microcomputer. (Refer to "4.2 Method of displaying version firmware".)

4.2 DVD TEST MODE

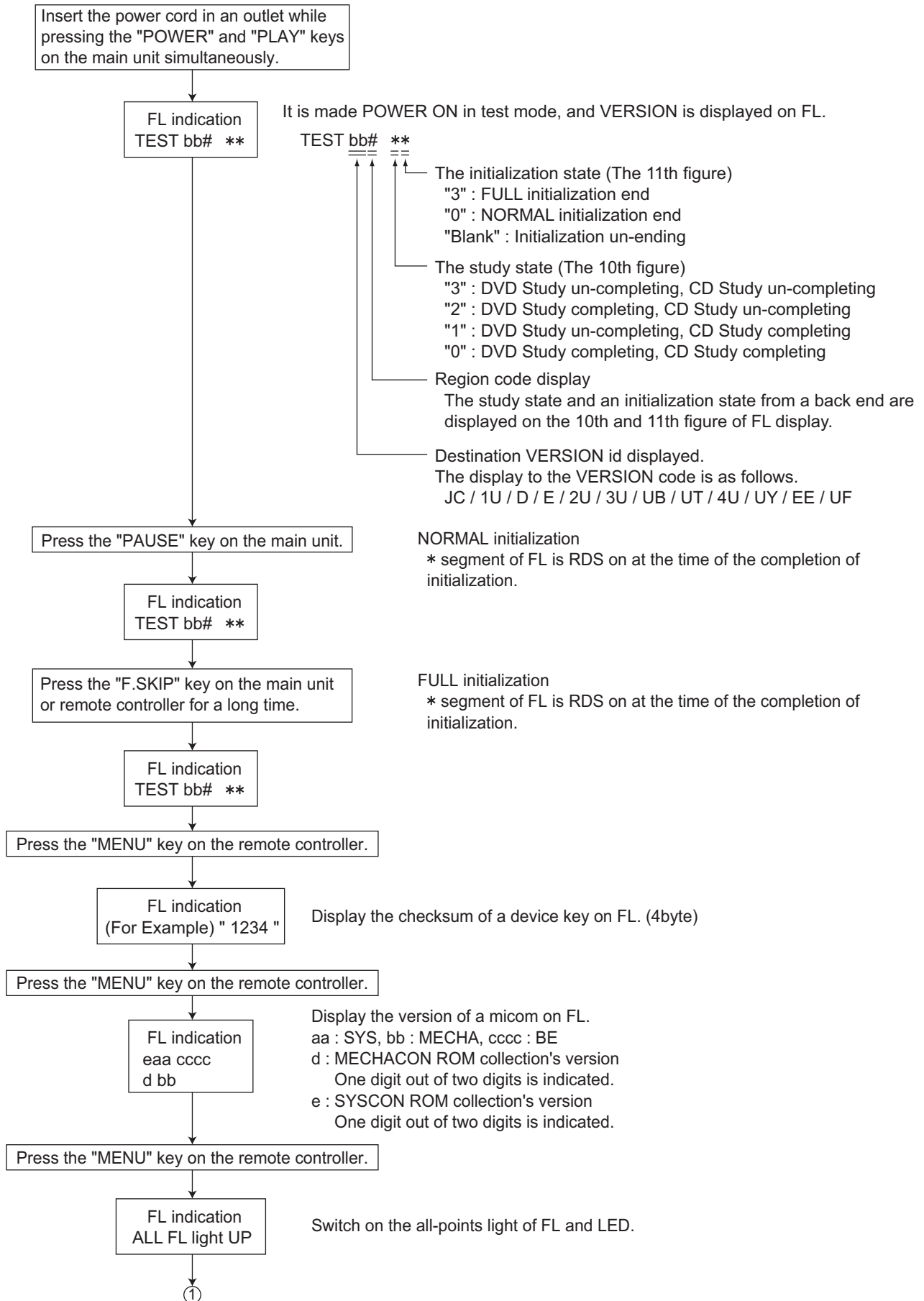

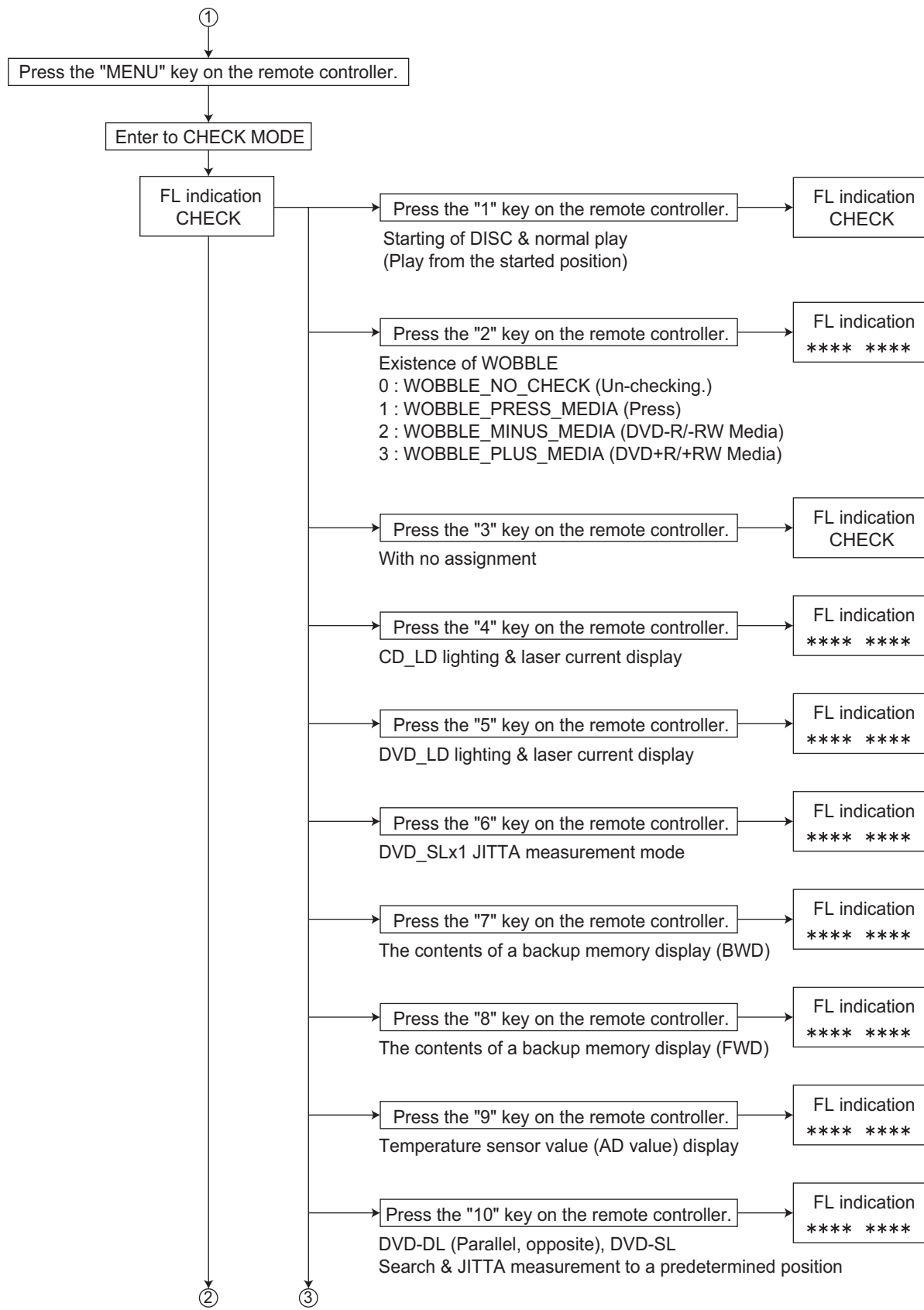

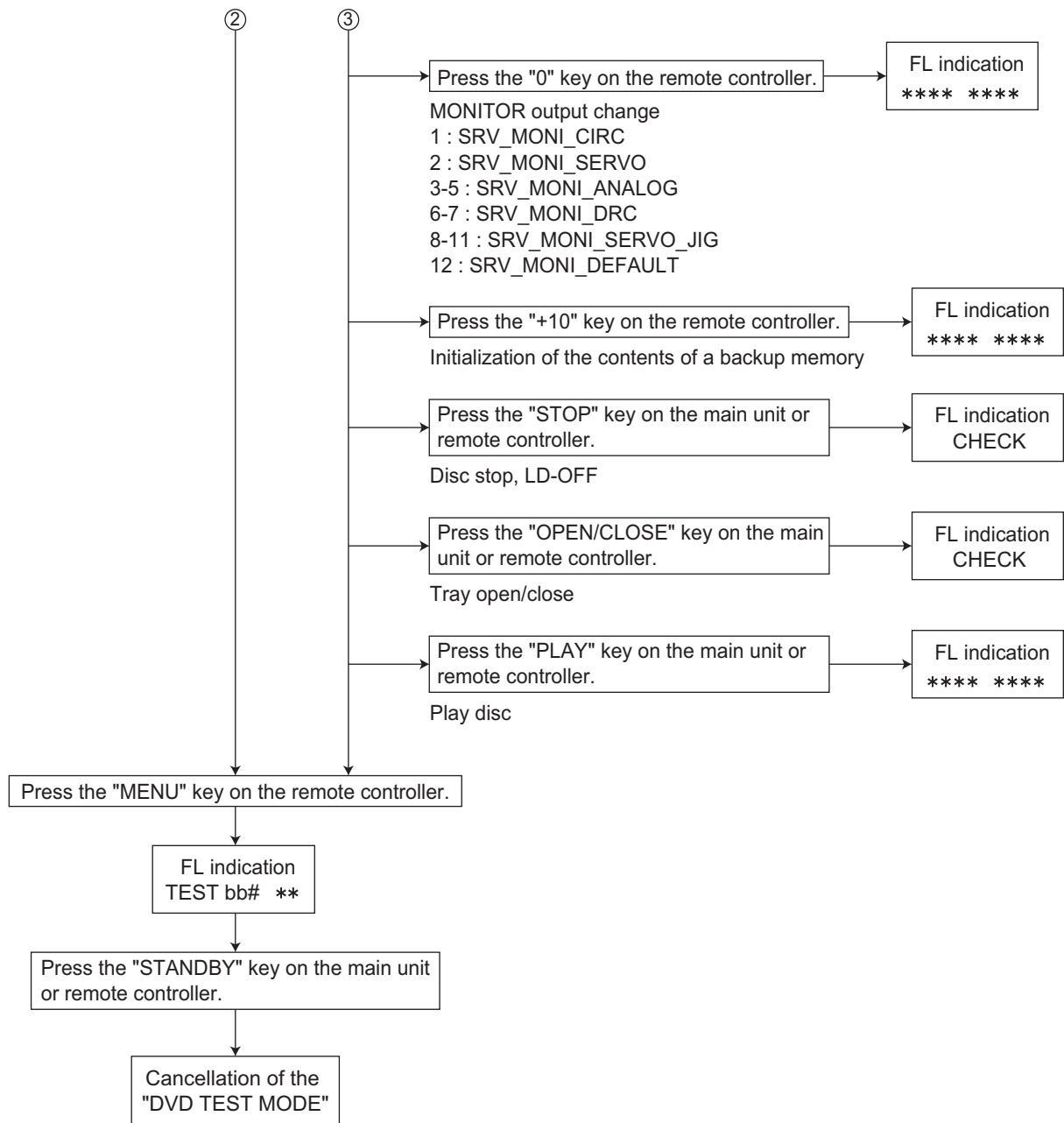

SECTION 5 TROUBLESHOOTING

This service manual does not describe TROUBLESHOOTING.



JVC

Victor Company of Japan, Limited

AV & MULTIMEDIA COMPANY AUDIO/VIDEO SYSTEMS CATEGORY 10-1,1chome,Ohwatari-machi,Maebashi-city,371-8543,Japan

(No.MB428)



Printed in Japan
VPT

JVC

SCHEMATIC DIAGRAMS

DVD DIGITAL CINEMA SYSTEM

TH-C6

CD-ROM No.SML200507

Area suffix

A ----- Australia
UW ----- Brazil, Mexico, Peru
UY ----- Argentina
UJ ----- U.S. Military
UG --- Turkey, South Africa, Egypt

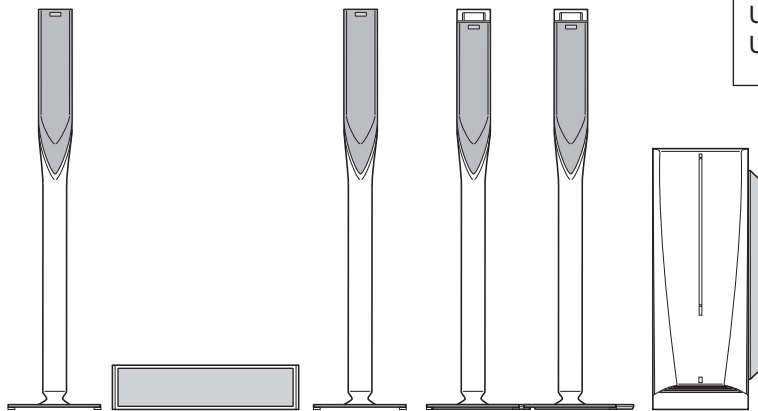

(SP-THC6F) (SP-THC6C) (SP-THC6F) (SP-THC6S) (SP-PWC6)

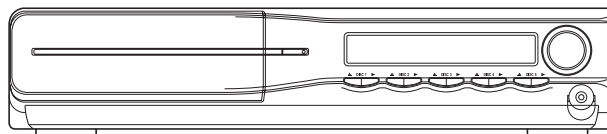
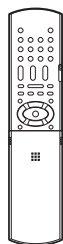

(XV-THC6)



Digital Direct Progressive Scan
AV COMPU LINK

Lead free solder used in the board (material : Sn-Ag-Cu, melting point : 219 Centigrade)

Contents

Block diagram	2-1
Standard schematic diagrams	2-2
Printed circuit boards	2-12 to 16

In regard with component parts appearing on the silk-screen printed side (parts side) of the PWB diagrams, the parts that are printed over with black such as the resistor (■), diode (⊣) and ICP (●) or identified by the "⚠" mark nearby are critical for safety.

Block diagram

<Main body section>

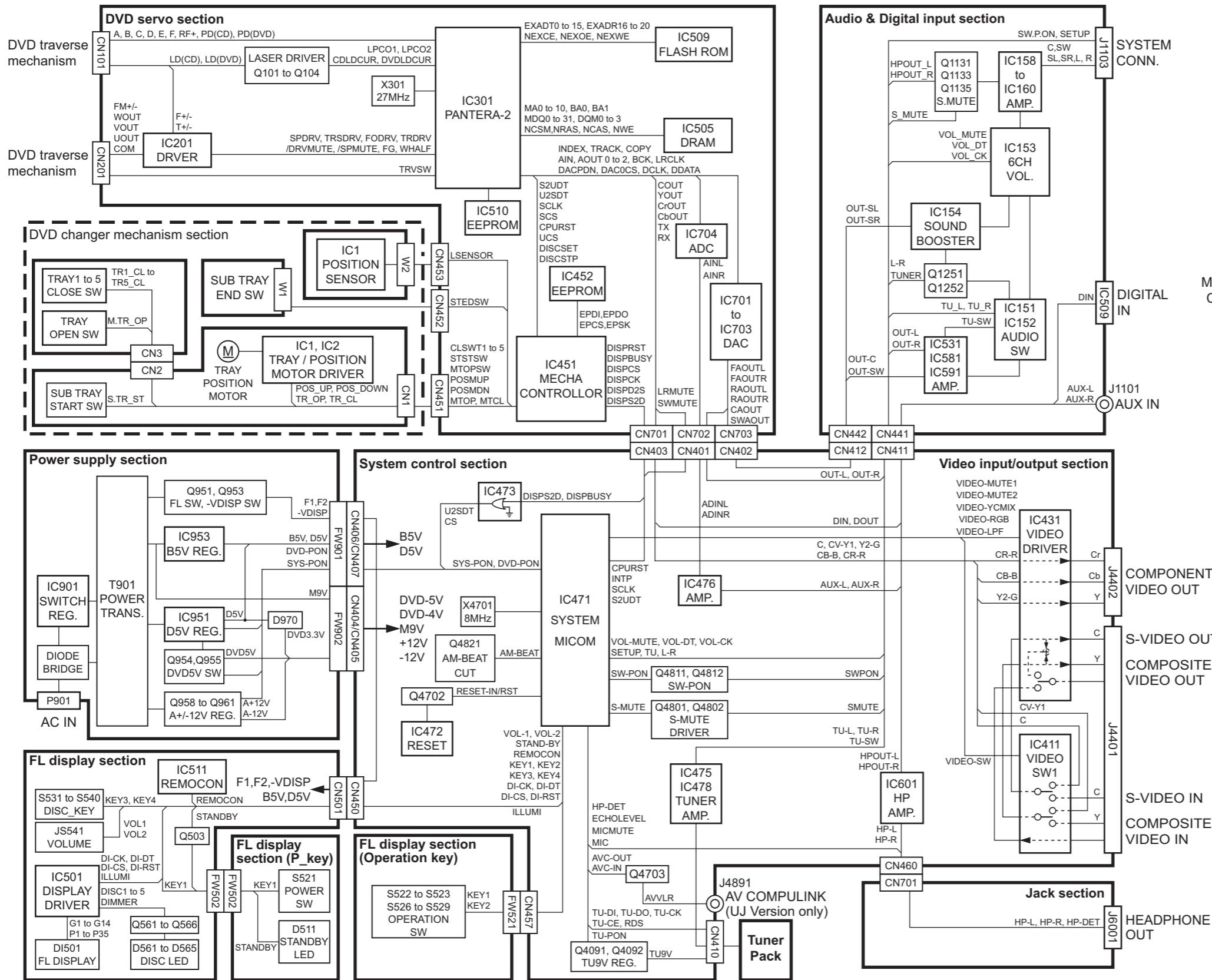

<Subwoofer section>

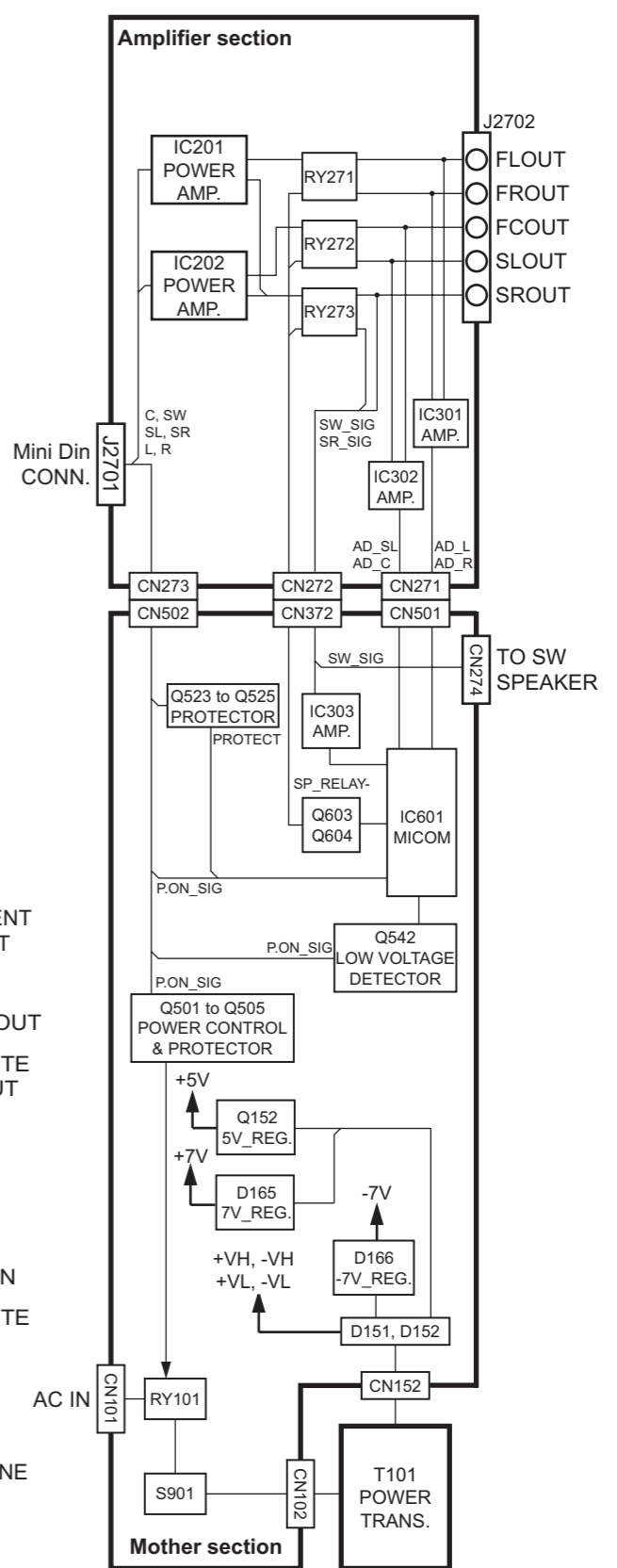

Standard schematic diagrams

<Main body section>

Power supply section

- Ver.J/C
- 120V 60Hz
- Ver.B
- 230V 50Hz
- Ver.UW/UJ/UJ/UN
- US/UX/UG/UT

110-240V 50/60Hz

- Ver.A
- 240V 50Hz

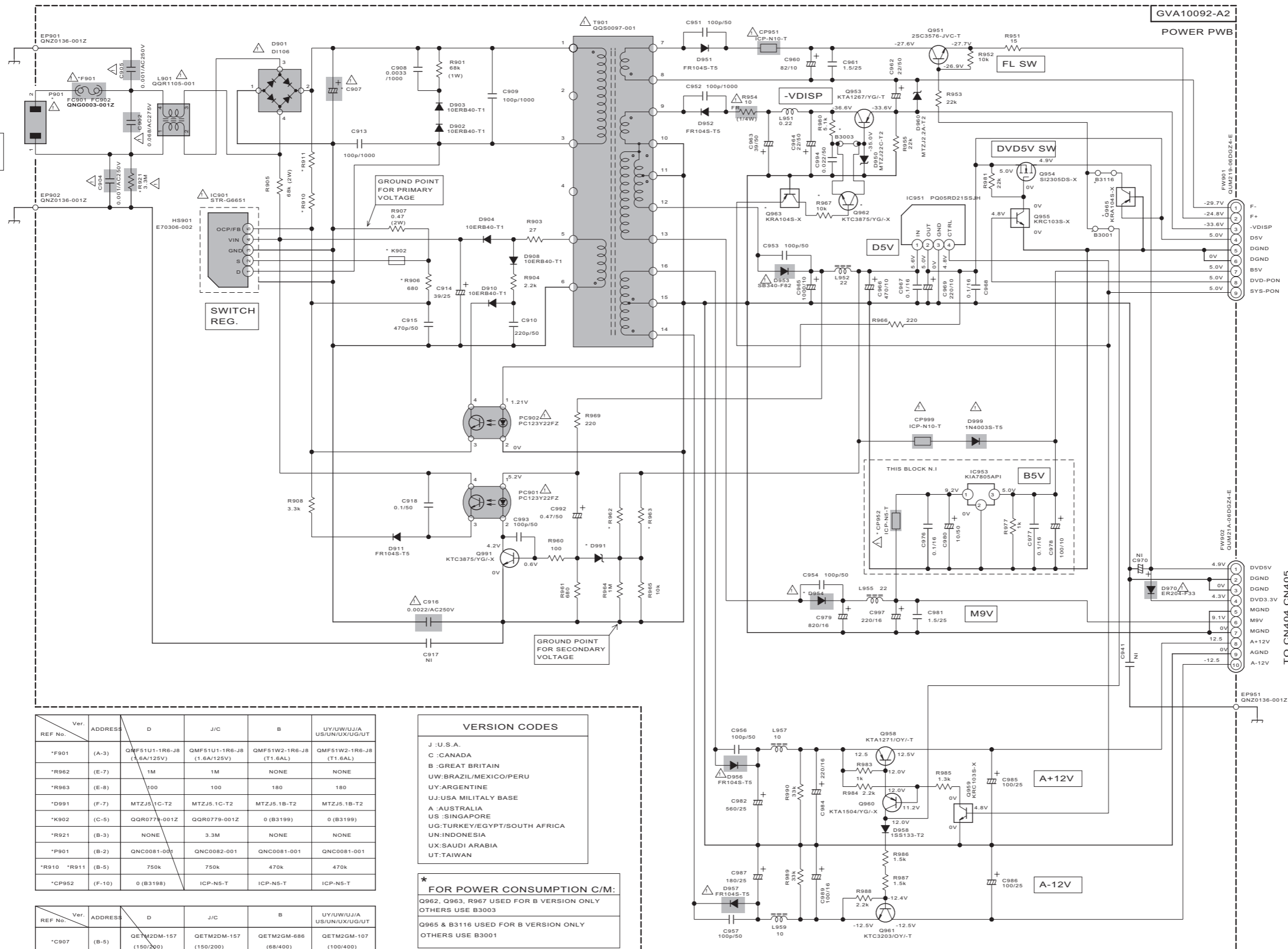

TO CN406, CN407 (SHEET 2)

TO CN404, CN405 (SHEET 2)

REF No.	Ver.	ADDRESS	D	J/C	B	UY/UW/UJ/UA US/UN/UX/UG/UT
*F901	(A-3)	QMF51U1-1R6-J8 (3.6A/125V)	QMF51U1-1R6-J8 (1.6A/125V)	QMF51W2-1R6-J8 (T1.6AL)	QMF51W2-1R6-J8 (T1.6AL)	
*R962	(E-7)	1M	1M	NONE	NONE	
*R963	(E-8)	100	100	180	180	
*D991	(F-7)	MTZJ5.1C-T2	MTZJ5.1C-T2	MTZJ5.1B-T2	MTZJ5.1B-T2	
*K902	(C-5)	QQR0779-001Z	QQR0779-001Z	0 (B3199)	0 (B3199)	
*R921	(B-3)	NONE	3.3M	NONE	NONE	
*P901	(B-2)	QNC0081-001	QNC0082-001	QNC0081-001	QNC0081-001	
*R910 *R911	(B-5)	750k	750k	470k	470k	
*CP952	(F-10)	0 (B3198)	ICP-N5-T	ICP-N5-T	ICP-N5-T	

REF No.	Ver.	ADDRESS	D	J/C	B	UY/UW/UJ/UA US/UN/UX/UG/UT
*C907	(B-5)	QETM2DM-157 (150/200)	QETM2DM-157 (150/200)	QETM2GM-686 (68/400)	QETM2GM-107 (100/400)	
*D954	(F-9)	FR104S-T5	10ERB40-T1	FR104S-T5	FR104S-T5	
*B3003	(B-10)		SHORT	OPEN	SHORT	

VERSION CODES

J : U.S.A.
 C : CANADA
 B : GREAT BRITAIN
 UW : BRAZIL/MEXICO/PERU
 UY : ARGENTINE
 UJ : USA MILITARY BASE
 A : AUSTRALIA
 US : SINGAPORE
 UG : TURKEY/EGYPT/SOUTH AFRICA
 UN : INDONESIA
 UX : SAUDI ARABIA
 UT : TAIWAN

*** FOR POWER CONSUMPTION C/M:**

Q962, Q963, R967 USED FOR B VERSION ONLY
 OTHERS USE B3003

Q965 & B3116 USED FOR B VERSION ONLY
 OTHERS USE B3001

▲ Parts are safety assurance parts.
 When replacing those parts make
 sure to use the specified one.

System control section

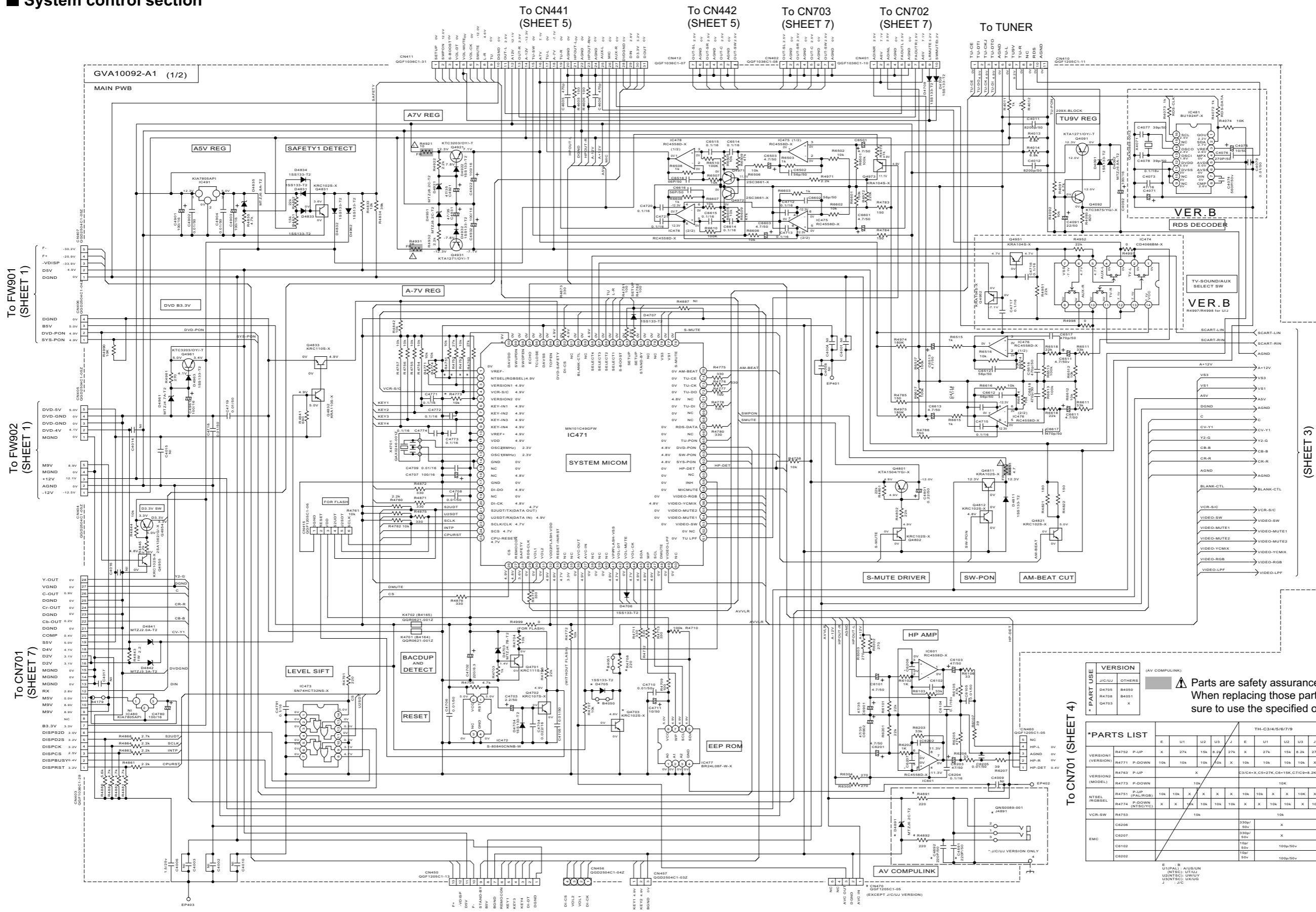

To FW901 (SHEET 1)

To FW902 (SHEET 1)

To CN701 (SHEET 7)

To CN501 (SHEET 4)
To FW561 (SHEET 4)
To FW521 (SHEET 4)

To CN701 (SHEET 4)

(SHEET 3)

VERSION (AV COMPULINK)
 * PART USE JIC/UJ OTHERS
 Q4705 B4050
 Q4706 B4051
 Q4703 X

⚠ Parts are safety assurance parts. When replacing those parts make sure to use the specified one.

VERSION (VERSION)	TH-C314/5/6/7/9											
	E	U1	U2	U3	J	E	U1	U2	U3	J		
R4752 P-UP	X	27k	10k	8.2k	27k	X	27k	10k	8.2k	27k		
R4771 P-DOWN	10k	10k	10k	10k	X	10k	10k	10k	10k	X		
R4783 P-UP					X						33k+X,CS-27k,CS-19k,C77C9+6.2k	
R4773 P-DOWN											10k	
R4751 P-UP (PAL/RGB)	10k	10k	X	X	X	10k	10k	X	X	10k	X	
R4774 P-DOWN (NTSC/YC)	X	X	X	X	X	10k	10k	10k	X	X	10k	X
R4783						10k					10k	
C8206											330p/50v	X
C8207											330p/50v	X
C8102											10p/50v	100p/50v
C8202											10p/50v	100p/50v

E U1/PALL AUSUN
 D1/INTC1 UJ/UJY
 U2/INTC1 UJ/UJY
 U3/INTC1 UJ/UJY
 J JIC

Video input / output section

GVA10092-A1

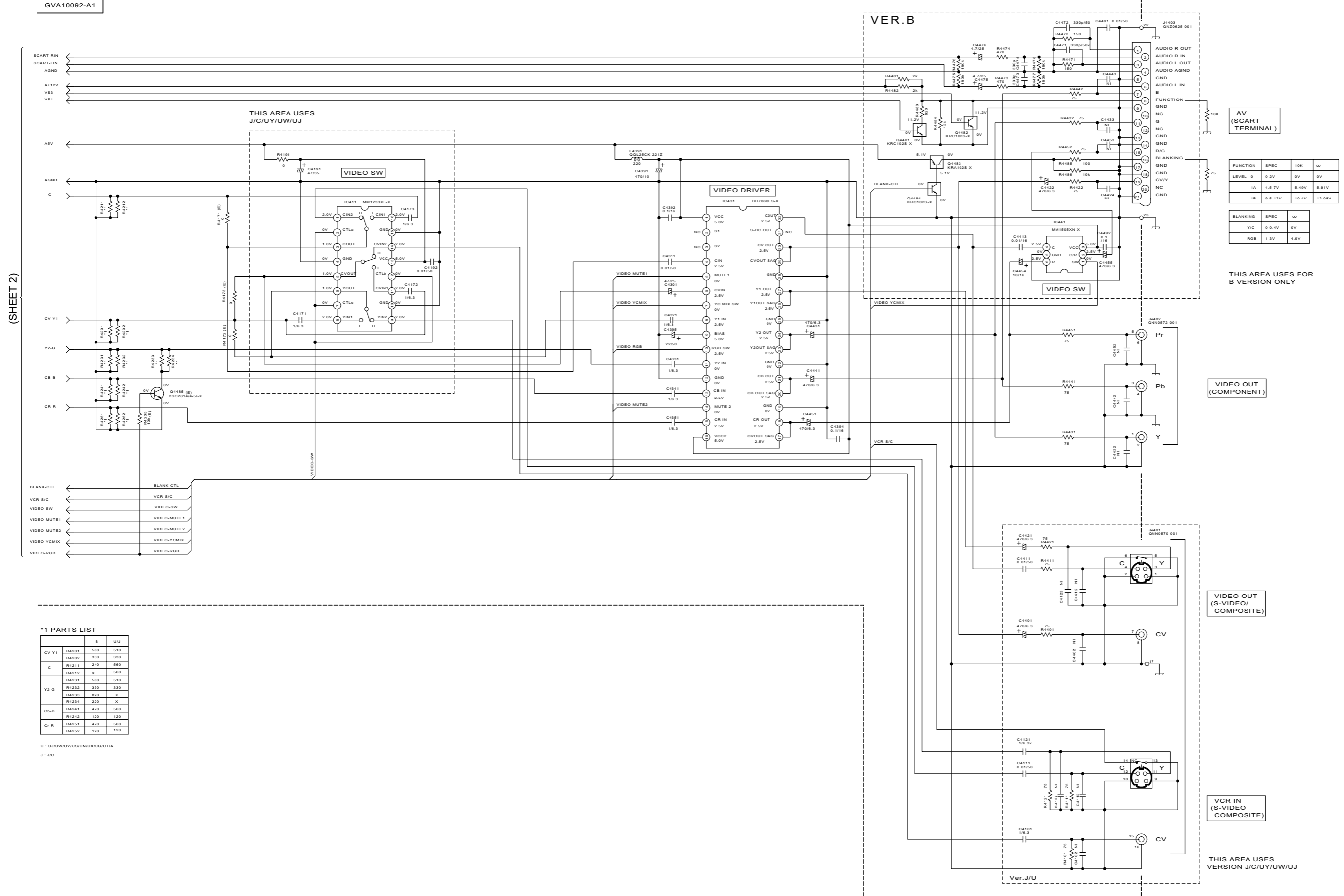

(SHEET 2)

*1 PARTS LIST

CV-Y1	R4201	560	510
	R4202	330	330
C	R4211	240	560
	R4212	X	560
	R4231	560	510
Y2-G	R4232	330	330
	R4233	820	X
	R4234	220	X
Cb-B	R4241	470	560
	R4242	120	120
Cr-R	R4251	470	560
	R4252	120	120

U : UJ/JU/WUY/UB/UN/UX/UG/UTA
J : J/C

FUNCTION	SPEC	10K	∞
LEVEL 0	0-2V	0V	0V
1A	4.5-7V	5.49V	5.91V
1B	9.5-12V	10.4V	12.08V

BLANKING	SPEC	∞
Y/C	0.8-4V	0V
RGB	1-3V	4.9V

THIS AREA USES FOR B VERSION ONLY

THIS AREA USES VERSION J/C/U/Y/U/W/U/J

FL display section

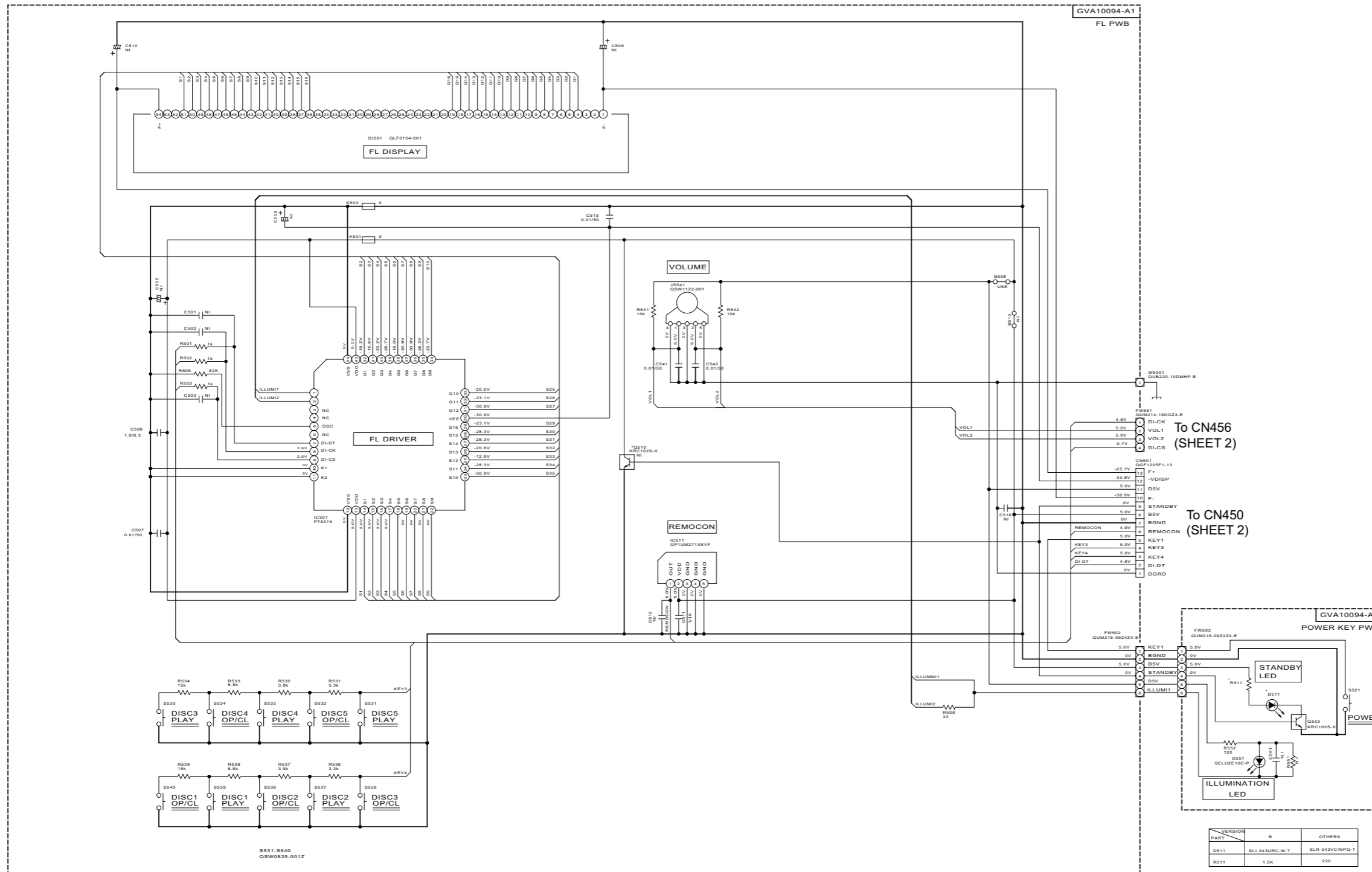

VERSION	B	OTHERS
PART		
D511	SL1-343URC-W-T	SLR-343VC/PG-T
R511	1.5K	220

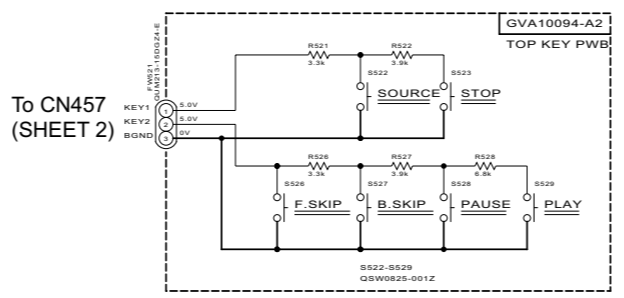
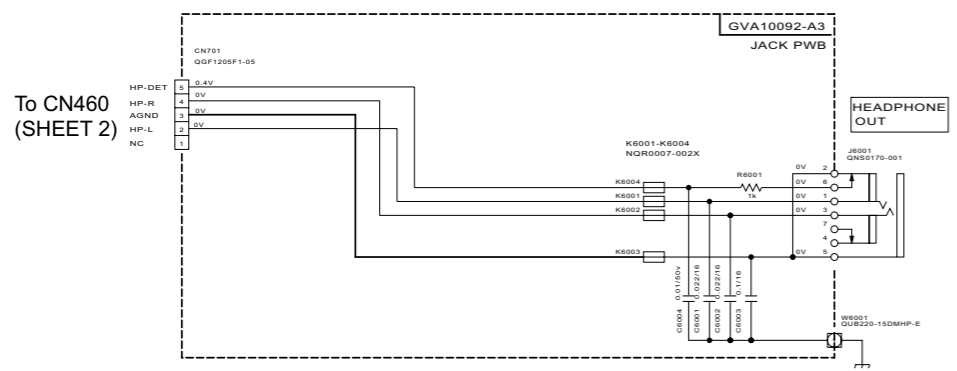

Audio & Digital input section

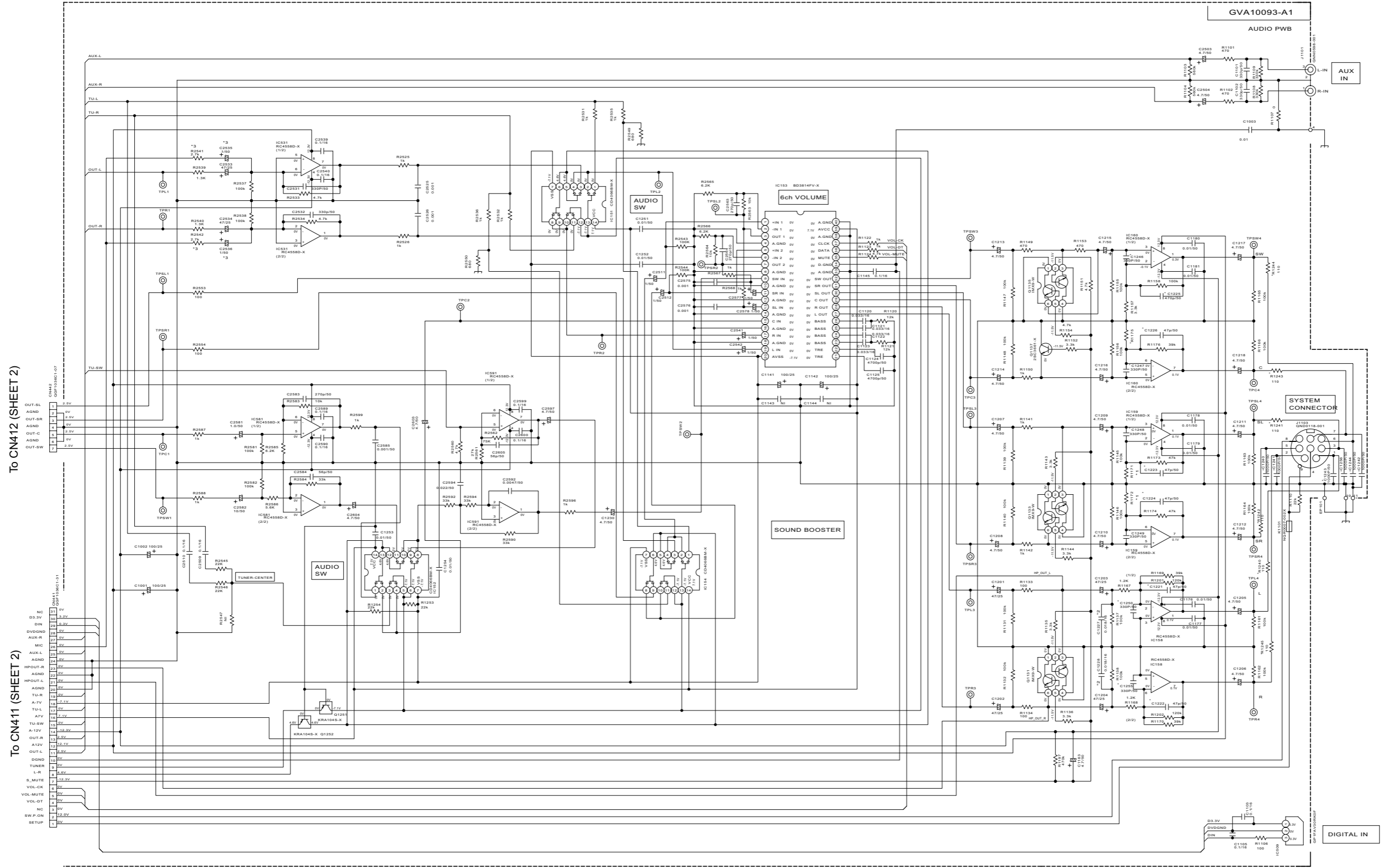

*3 USE U seri. With MIC.

VERSION	R1171	R1172	R1175
XV-THC3/4	1.5K	2K	
XV-THC5	2K	1.8K	
XV-THC6	2K	2K	
XV-THC7/9	1.8K	2K	

* EMC C/M			
PART	B	OTHERS	
C1246, C1248, C1247			NONE
C1249, C1250, C1255	330p		NONE
R1240, R1241, R1242			100 ohm 0 ohm
R1243, R1244, R1245			
C1240, C1241, C1242			NONE
C1243, C1244, C1256	1000p		NONE
C1221, C1222, C1223			NONE
C1224, C1225, C1226			USE

DVD servo section (1/2)

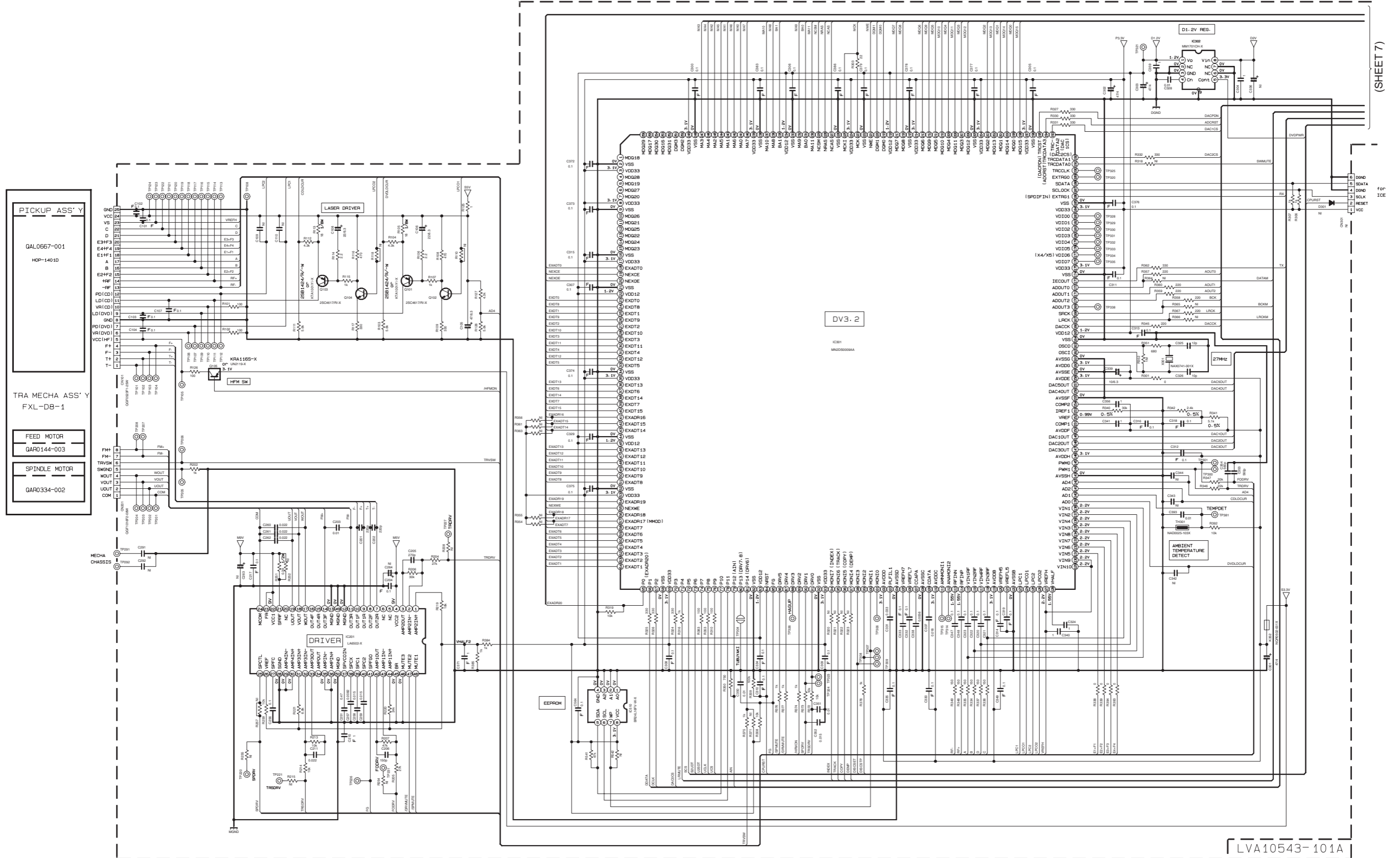

(SHEET 7)

LVA10543-101A

DVD servo section (2/2)

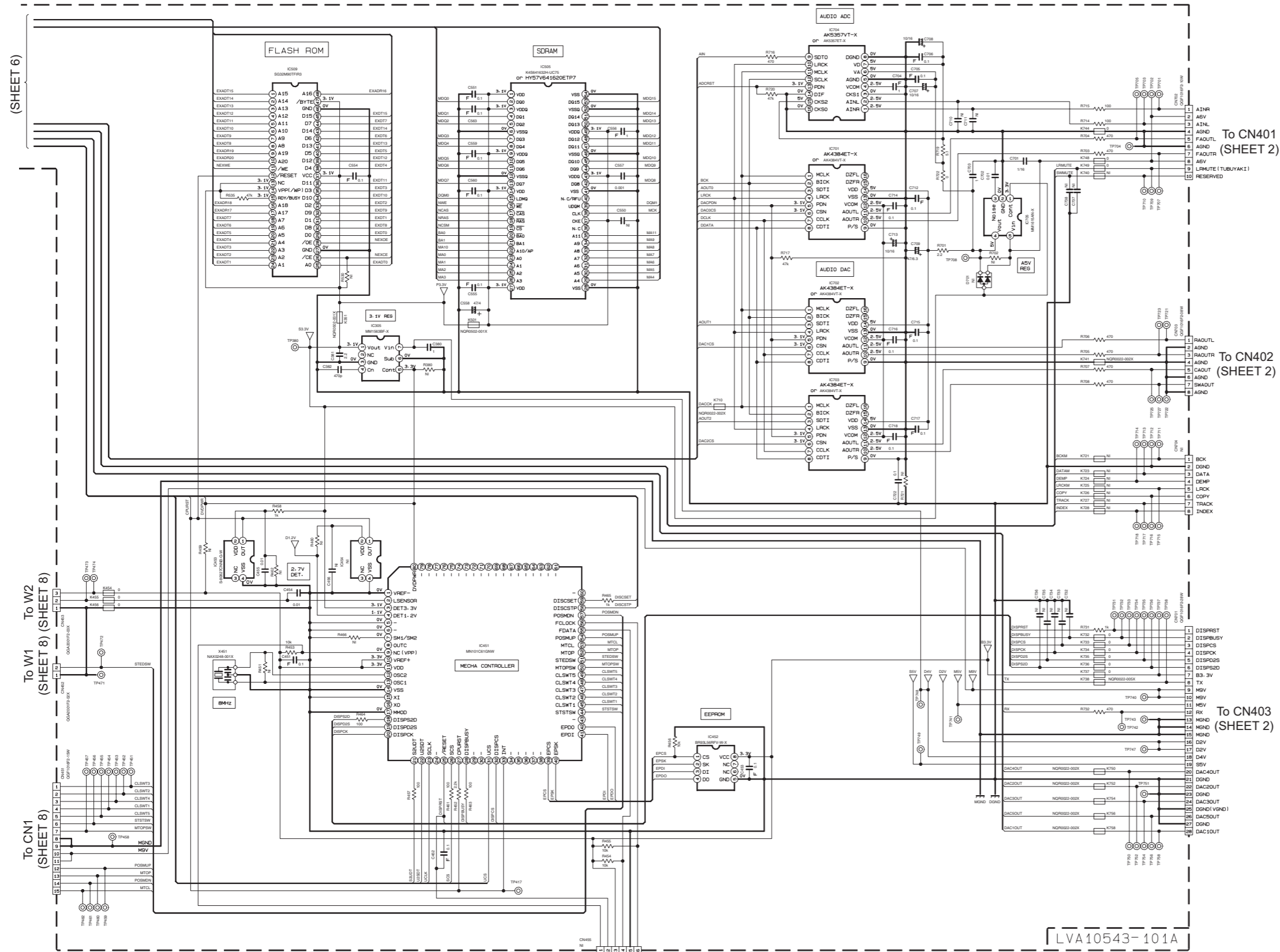

To W2 (SHEET 8)
To W1 (SHEET 8)
To CN1 (SHEET 8)

To CN401 (SHEET 2)

To CN402 (SHEET 2)

To CN403 (SHEET 2)

LVA10543-101A

- NOTES**
- VOLTAGES ARE DC-MEASURED WITH A DIGITAL VOLT METER WITHOUT INPUT SIGNAL. CONDITION --- A DVD disc in the Tray 1 and STOP mode.
 - UNLESS OTHERWISE SPECIFIED:
ALL RESISTORS ARE 1/16W ±5% METAL GLAZE RESISTOR, OR 0.5% METAL GLAZE RESISTOR.
ALL CAPACITORS ARE 50V, 25V, 16V, 10V OR 6.3V CERAMIC CAPACITOR.
ALL RESISTANCE VALUES ARE IN Ω(M), k(Ω), M(Ω).
ALL CAPACITANCE VALUES ARE IN p(F), n(F), μ(F).
ALL C CAPACITORS ARE SHOWN IN THE FORM OF CAPACITANCE(F) / RATED VOLTAGE (V).
ALL INDUCTANCE VALUES ARE IN μ(H), m(H).
 - NI STANDS FOR NOT INSERTED PARTS.

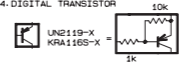

■ DVD changer mechanism section

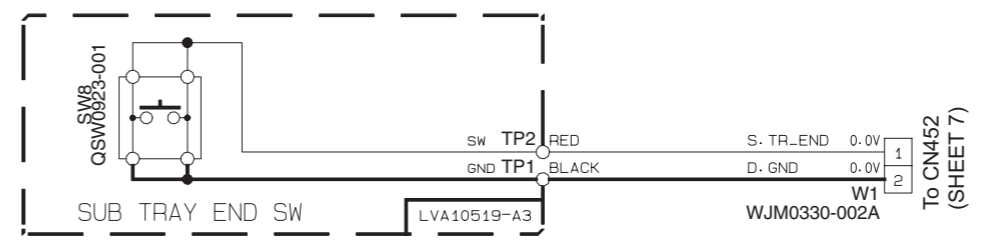
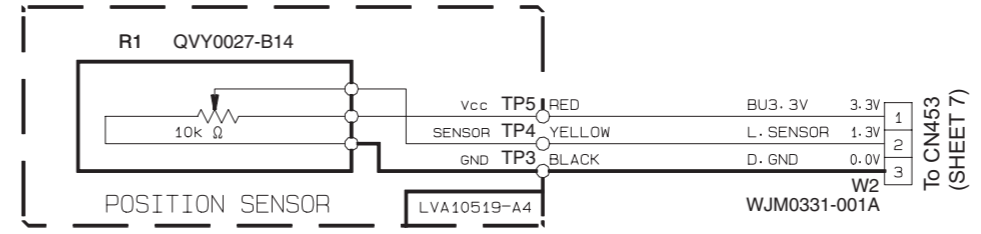
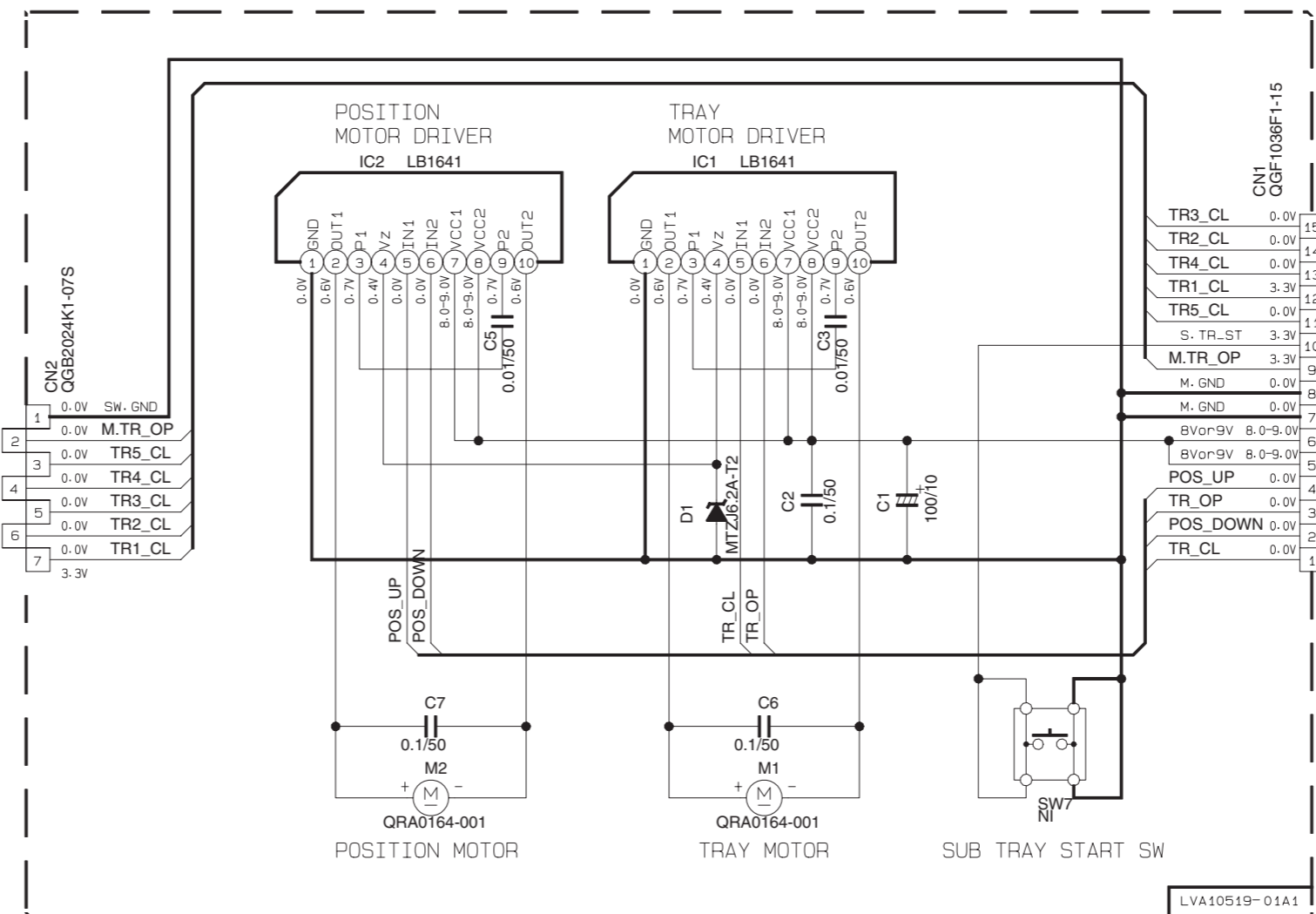
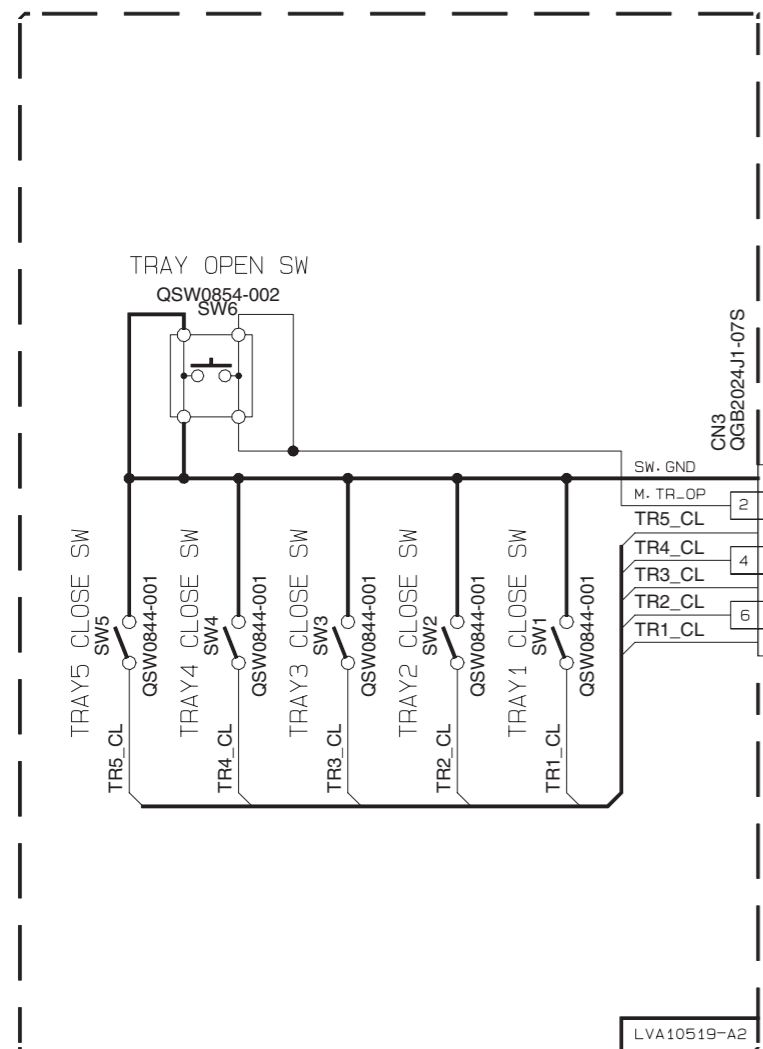

- NOTES
1. VOLTAGES ARE DC-MEASURED WITH A DIGITAL VOLT METER.
CONDITION: DISC1 STOP
 2. UNLESS OTHERWISE SPECIFIED.
ALL CAPACITORS ARE SHOWN IN THE FORM OF CAPACITANCE (μF)/RATED VOLTAGE (V).
 3. NI STANDS FOR NOT INSERTED PARTS.

<subwoofer section>

■ Amplifier section

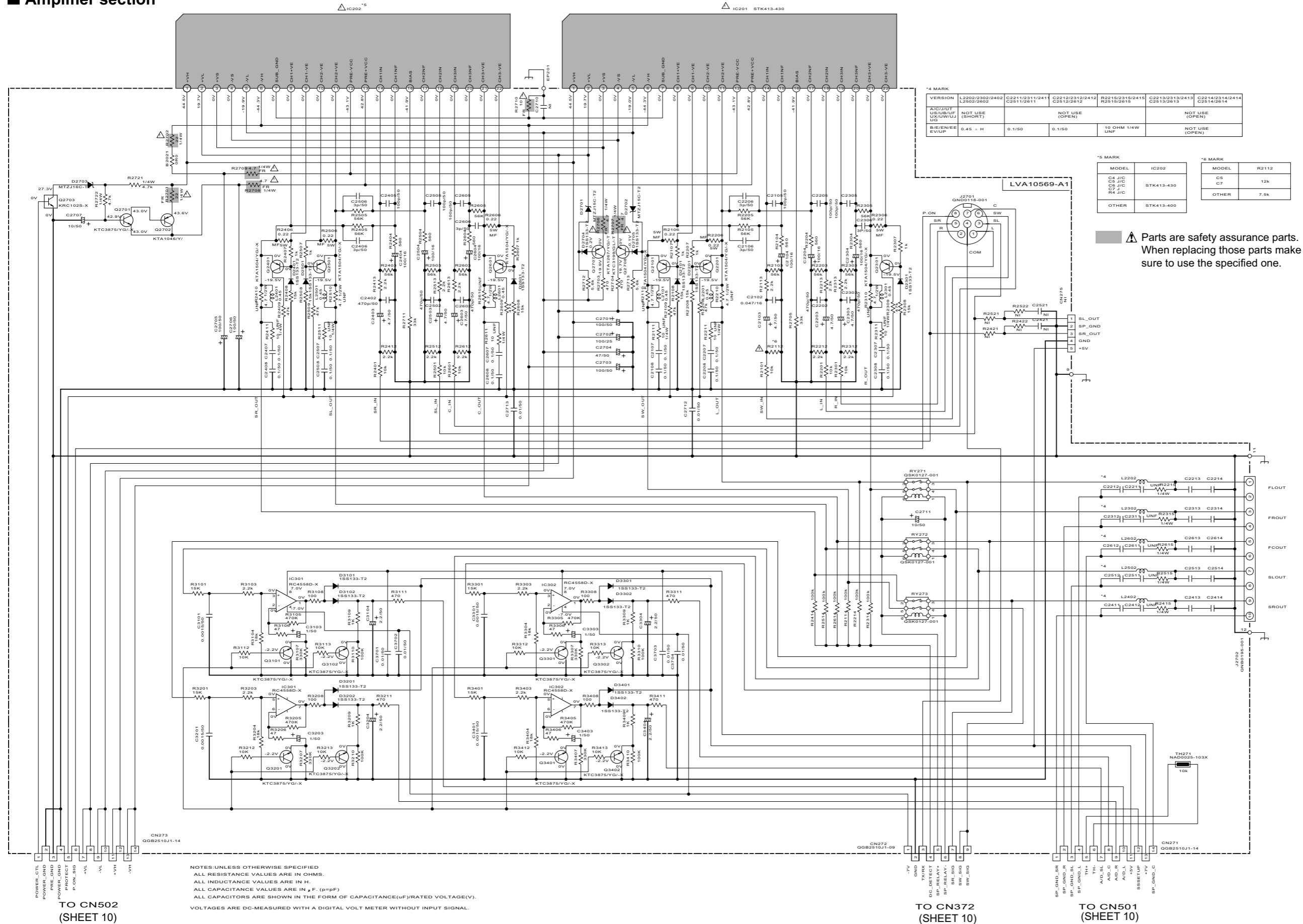

■ Mother section

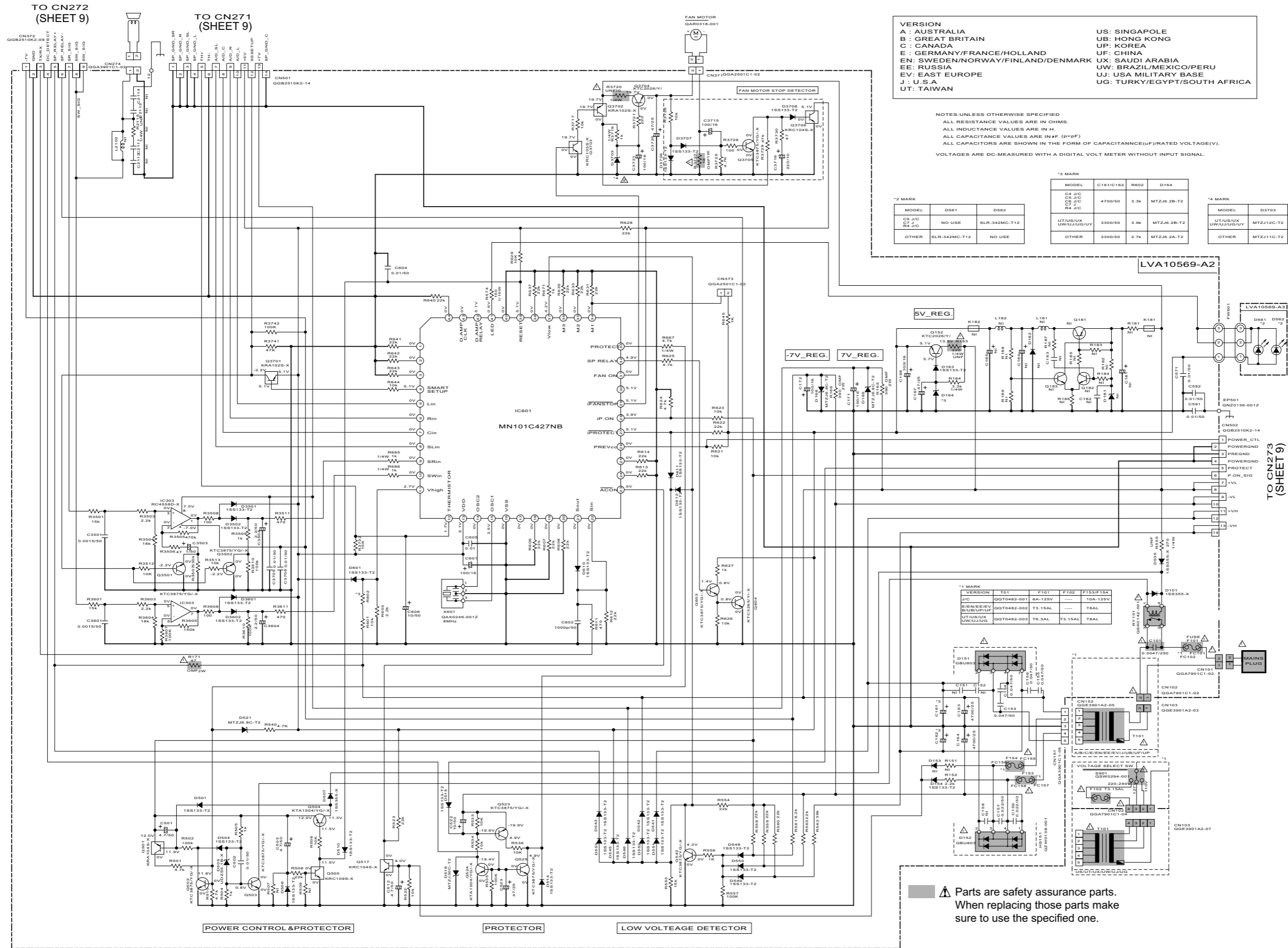

VERSION
 A : AUSTRALIA
 B : GREAT BRITAIN
 C : CANADA
 E : GERMANY/FRANCE/HOLLAND
 EN : SWEDEN/NORWAY/FINLAND/DENMARK
 EE : RUSSIA
 EV : EAST EUROPE
 J : U.S.A
 UT : TAIWAN

US: SINGAPOLE
 UB: HONG KONG
 UP: KOREA
 UF: CHINA
 UX: SAUDI ARABIA
 UW: BRAZIL/MEXICO/PERU
 UJ: USA MILITARY BASE
 UG: TURKEY/EGYPT/SOUTH AFRICA

NOTES: UNLESS OTHERWISE SPECIFIED
 ALL RESISTANCE VALUES ARE IN OHMS.
 ALL INDUCTANCE VALUES ARE IN H.
 ALL CAPACITANCE VALUES ARE IN P. (p=PF)
 ALL CAPACITORS ARE SHOWN IN THE FORM OF CAPACITANCE (uF)/RATED VOLTAGE (V).
 VOLTAGES ARE DC-MEASURED WITH A DIGITAL VOLT METER WITHOUT INPUT SIGNAL.

*2 MARK		*3 MARK			*4 MARK	
MODEL	D561	D561	D562			
C4 J/C				C4 J/C	4700/50	3.3k
C5 J/C				C5 J/C	3300/50	3.9k
R4 J/C	NO USE	SLR-342MC-T12		R4 J/C	3300/50	2.7k
OTHER	SLR-342MC-T12	NO USE		OTHER	MTZJ6.2B-T2	

VERSION	T01	F101	F102	F153/F154
E/EN/EE/EV	GGT0482-001	8A.15BV	---	10A.15BV
S/US/JP/UP	GGT0482-002	T3.15AL	---	TRAL
UW/UJ/UG/UY	GGT0482-003	T6.3AL	T3.15AL	TRAL

⚠ Parts are safety assurance parts.
 When replacing those parts make sure to use the specified one.

Printed circuit boards

<Main body section>

■ Main board Lead free solder used in the board (material : Sn-Ag-Cu, melting point : 219 Centigrade)

(Phone jack board)

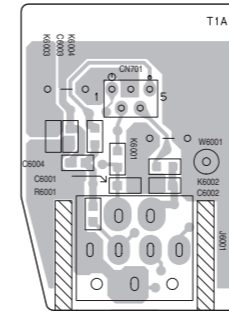

(Main board)

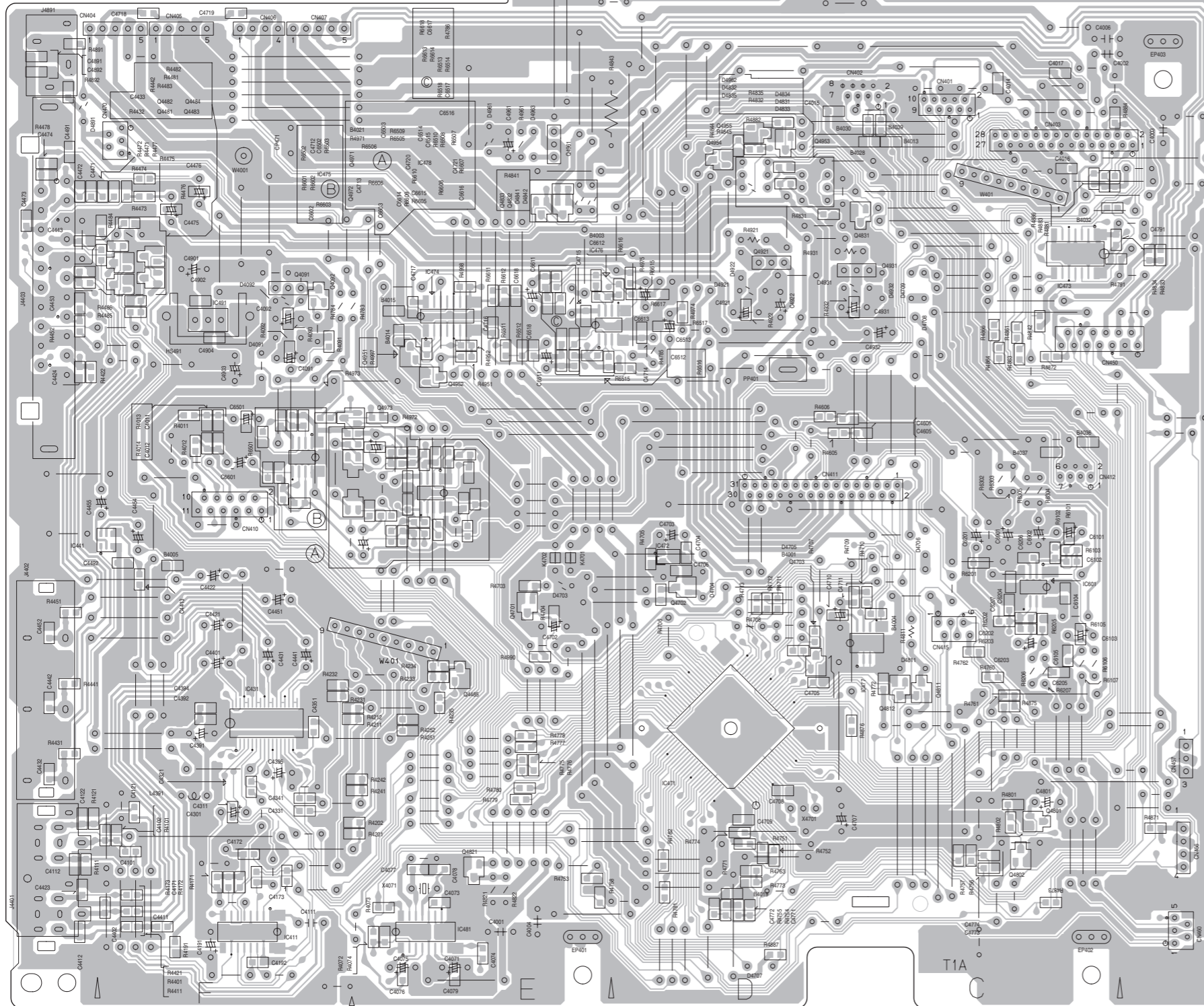

(Power supply board)

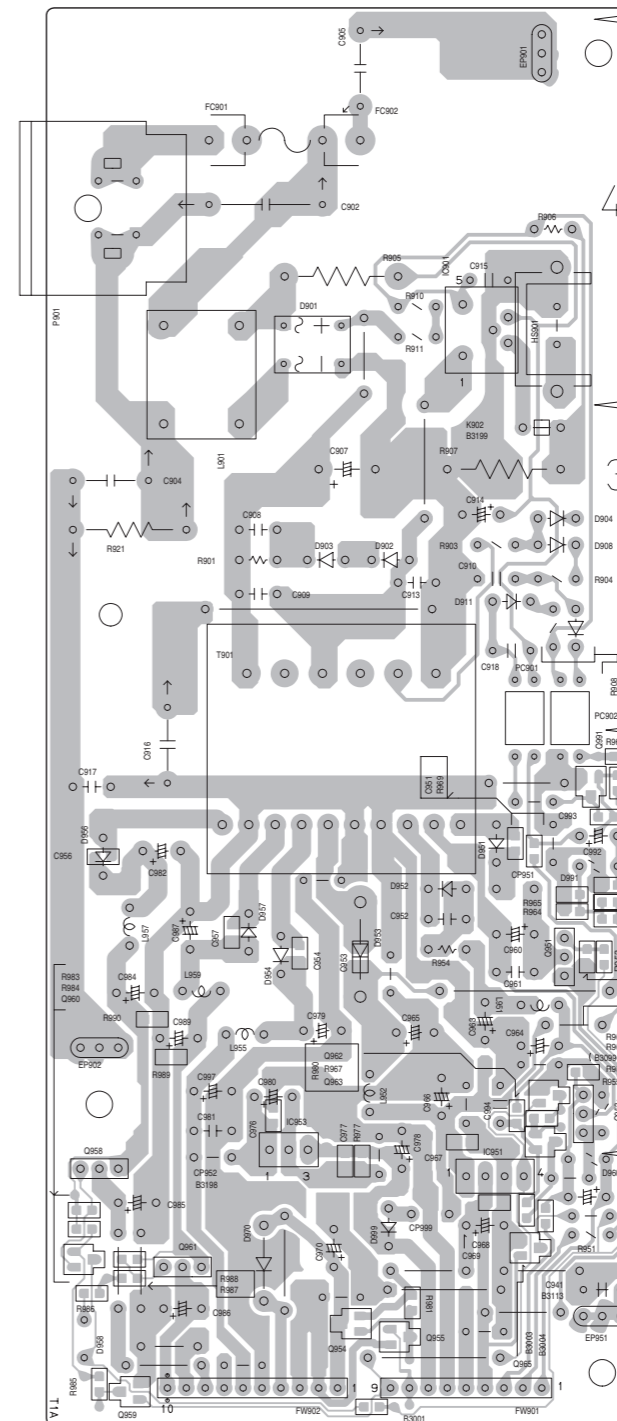

■ **Front board** Lead free solder used in the board (material : Sn-Ag-Cu, melting point : 219 Centigrade)

■ **Audio board** Lead free solder used in the board (material : Sn-Ag-Cu, melting point : 219 Centigrade)

(Front board)

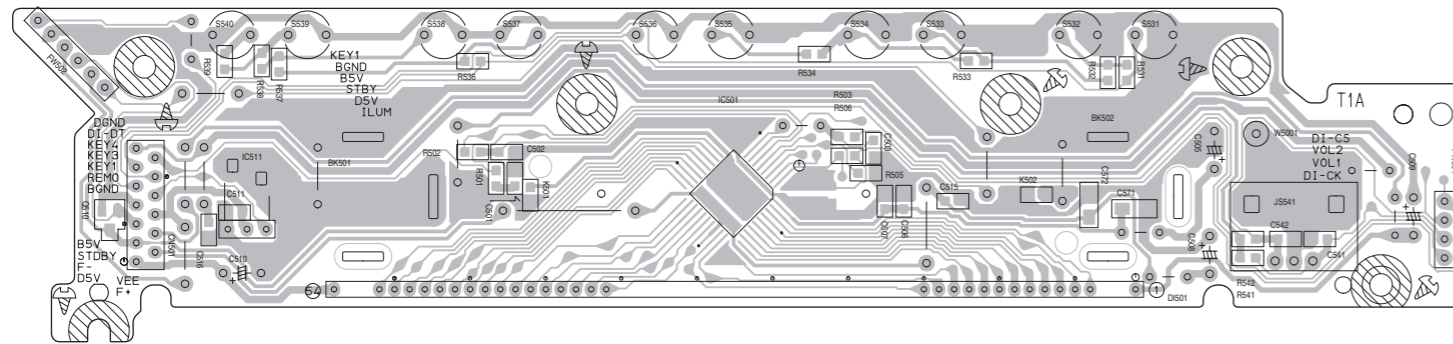

(Operation board)

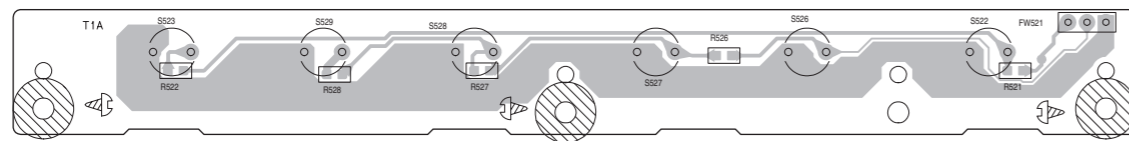

(Power key board)

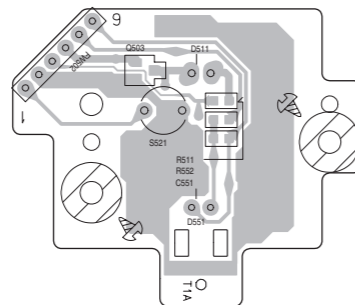

(Audio & Digital input board)

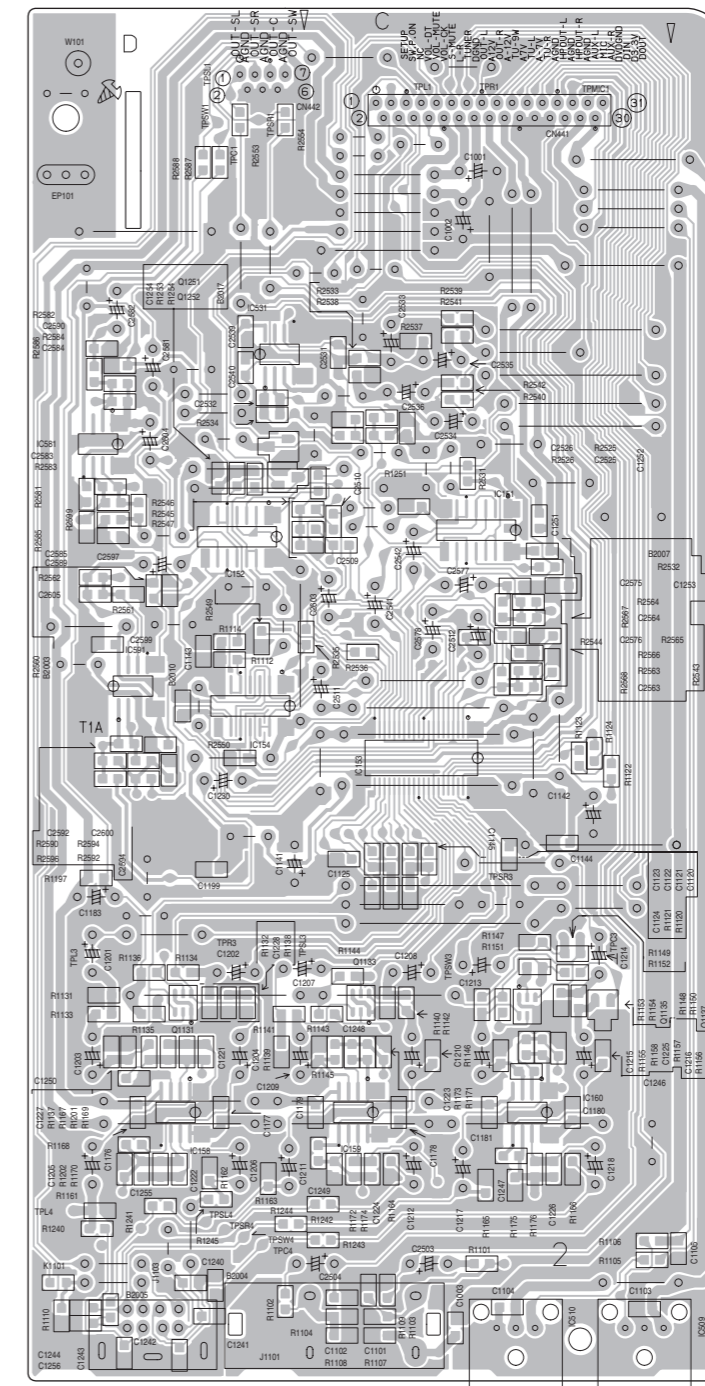

<Subwoofer section>

■ Amp board Lead free solder used in the board (material : Sn-Ag-Cu, melting point : 219 Centigrade)

(Amp board)

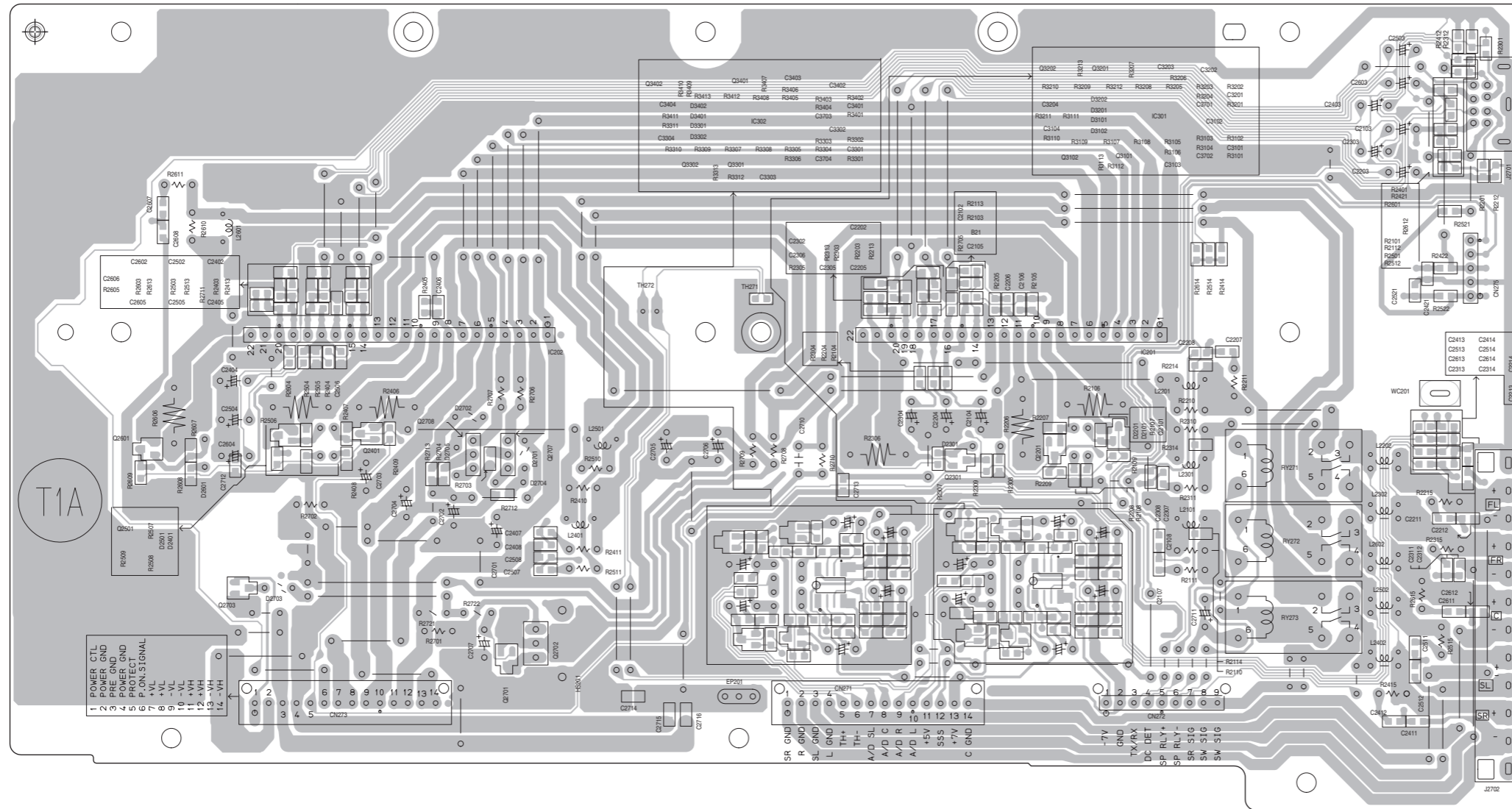

■ Mother board

Lead free solder used in the board (material : Sn-Ag-Cu, melting point : 219 Centigrade)

(Mother board)

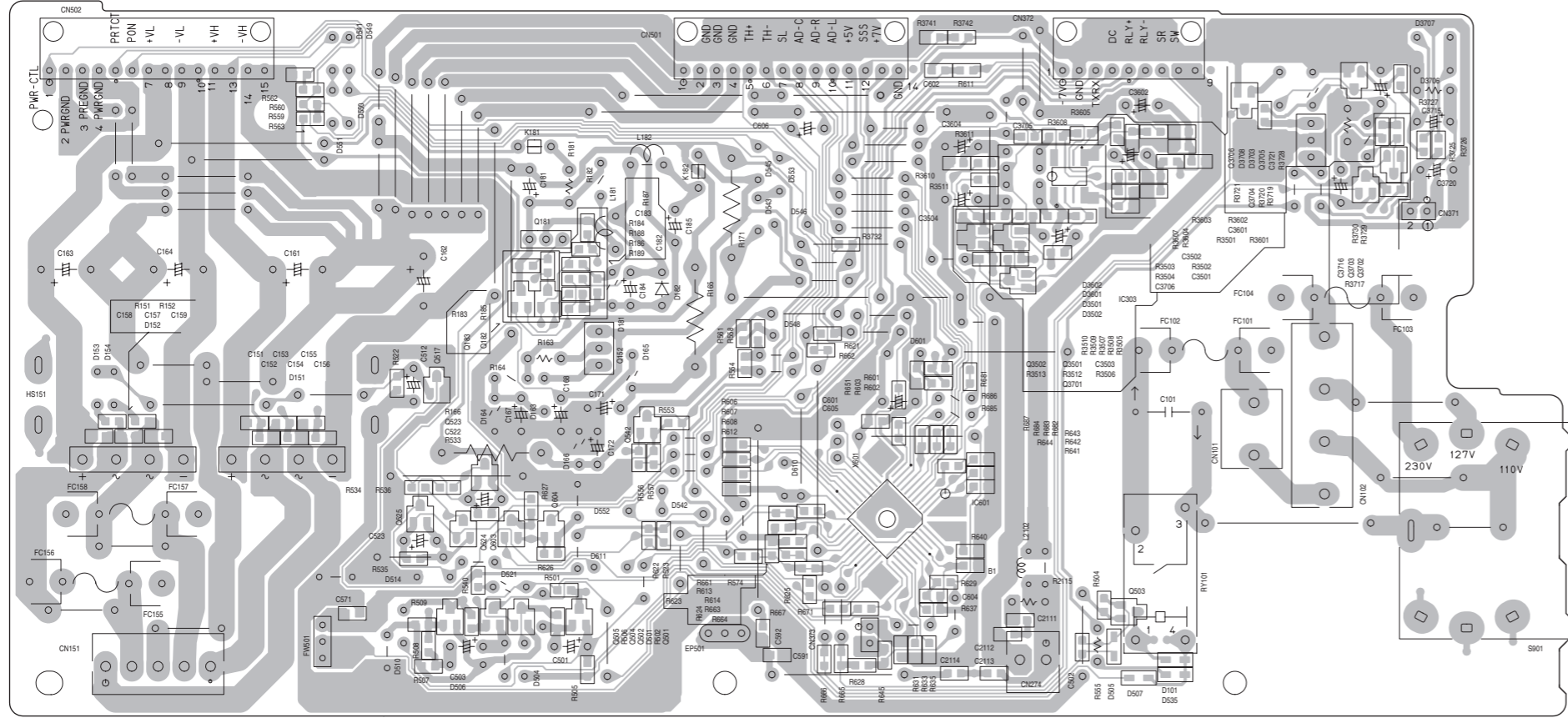

(LED board)

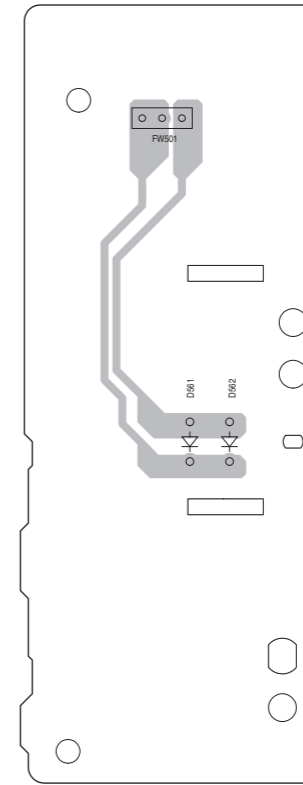

< MEMO >

JVC

Victor Company of Japan, Limited

AV & MULTIMEDIA COMPANY AUDIO/VIDEO SYSTEMS CATEGORY 10-1, 1chome, Ohwatari-machi, Maebashi-city, 371-8543, Japan

(No.MB428SCH)



Printed in Japan
VPT

PARTS LIST

[TH-C6]

* All printed circuit boards and its assemblies are not available as service parts.

Area suffix

A ----- Australia
UW ----- Brazil, Mexico, Peru
UY ----- Argentina
UJ ----- U.S. Military
UG - Turkey, South Africa, Egypt

- Contents -

Exploded view of general assembly and parts list (Block No.M1)	3- 2
Speaker assembly and parts list(Subwoofer) (Block No.M2)	3- 5
DVD mechanism assembly and parts list (Block No.MJ)	3- 7
DVD changer mechanism assembly and parts list (Block No.MK)	3- 9
Electrical parts list (Block No.01~06)	3-11
Packing materials and accessories parts list (Block No.M3) (A,UW,UY,UG)	3-22
Packing materials and accessories parts list (Block No.M4) (UJ)	3-24

Exploded view of general assembly and parts list

Block No. M 1 M M

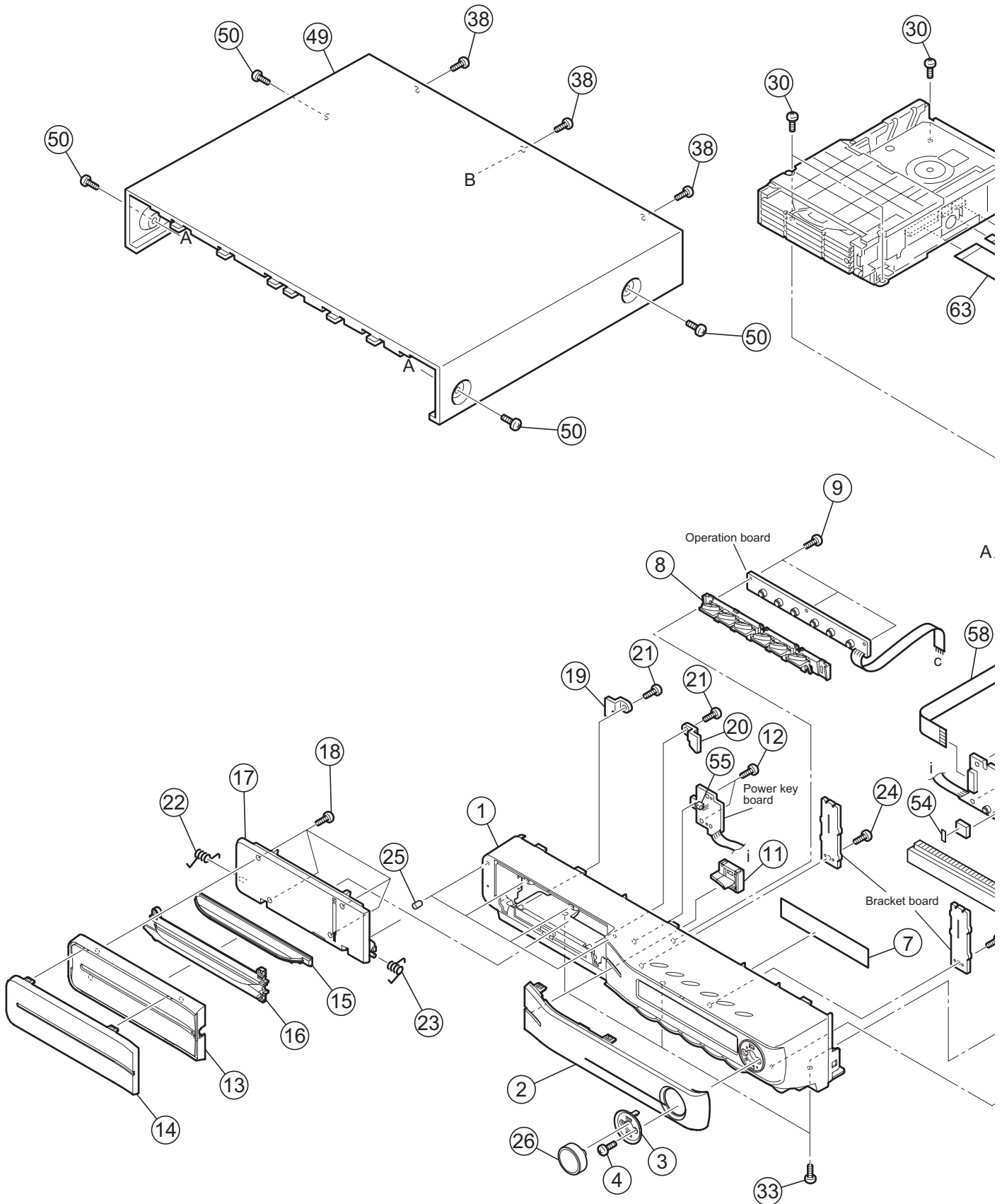

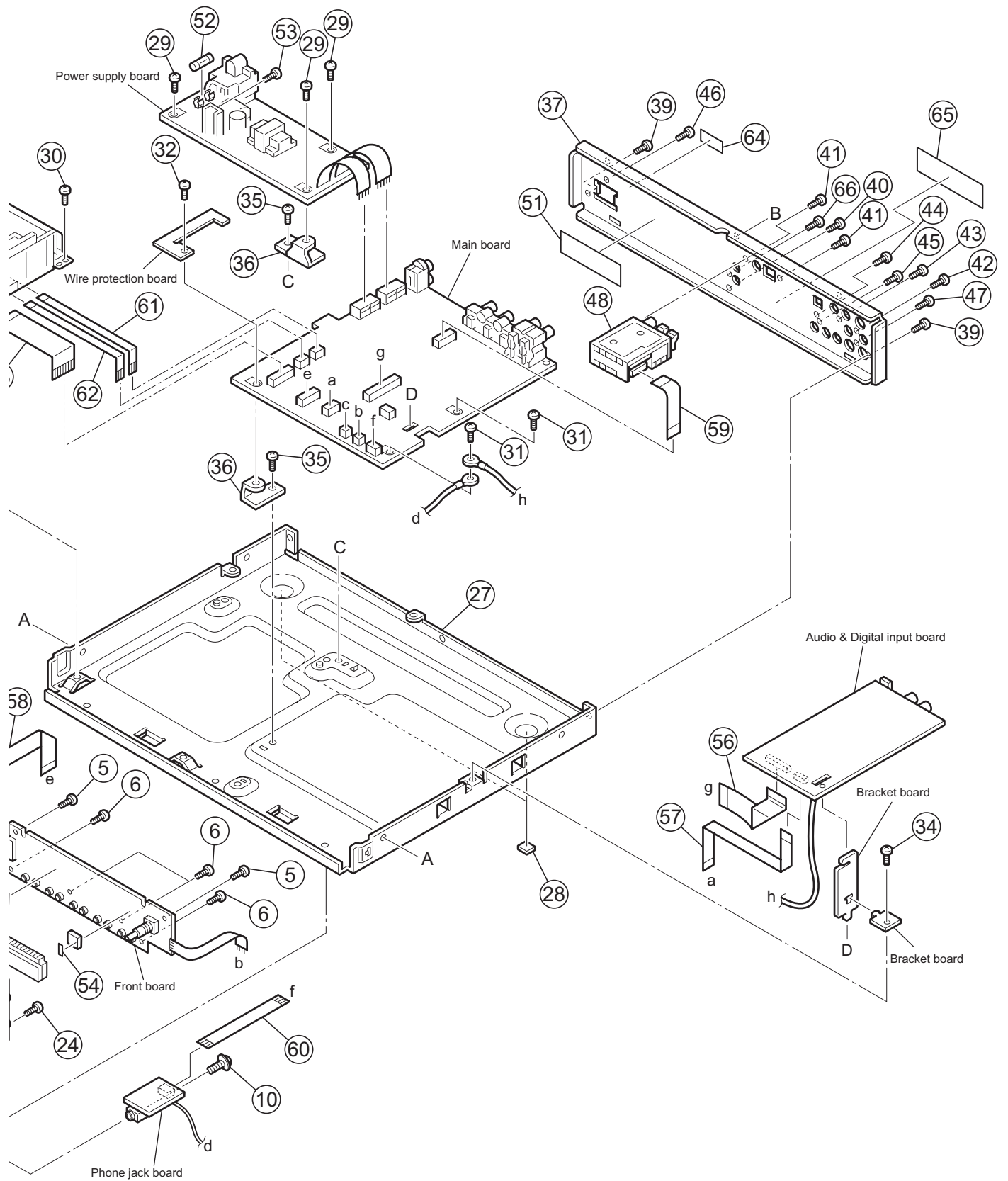

General Assembly

Block No. [M][1][M][M]

△	Symbol No.	Part No.	Part Name	Description	Local
	1	GV10233-007A	FRONT PANEL ASSY		UJ
	1	GV10233-002A	FRONT PANEL ASSY		A,UJ,UW,UY
	2	GV20310-001A	FRONT LENS		
	3	GV30641-002A	VOLUME RING		
	4	QYSDSF2608ZA	TAP SCREW	M2.6 x 8mm	
	5	QYSDSF2608ZA	TAP SCREW	M2.6 x 8mm(x2)	
	6	QYSDSF2608ZA	TAP SCREW	M2.6 x 8mm(x4)	
	7	LV42851-006A	FL SCREEN		
	8	GV20312-001A	BUTTON(TOP)		
	9	QYSDSF2612ZA	TAP SCREW	M2.6 x 12mm(x3)	
	10	GV40035-002A	SCREW		
	11	GV30643-002A	BTN(POWER)ASSY		
	12	QYSDSF2608ZA	TAP SCREW	M2.6 x 8mm(x2)	
	13	GV20313-001A	DVD DOOR		
	14	GV20314-004A	DOOR LENS		UJ
	14	GV20314-005A	DOOR LENS		A,UJ,UW,UY
	15	GV30646-001A	ILLUMI.LENS		
	16	GV30647-002A	ORNAMENT(DOOR)		
	17	GV20315-001A	DOOR HOLDER		
	18	QYSDSF2608ZA	TAP SCREW	M2.6 x 8mm(x4)	
	19	LV41694-001A	DOOR BKT(L)		
	20	LV41695-001A	DOOR BKT(R)		
	21	QYSDSF2608ZA	TAP SCREW	M2.6 x 8mm(x2)	
	22	GV40558-001A	DOOR SPRING(L)		
	23	GV40605-001A	DOOR SPRING(R)		
	24	QYSDSF2608ZA	TAP SCREW	M2.6 x 8mm(x2)	
	25	E69897-002	CUSHION	(x4)	
	26	GV30736-002A	VOL.KNOB ASSY		
	27	LV10770-004A	BOTTOM CHASSIS		
	28	LV40301-002A	FELT SPACER	(x2)	
	29	QYSDST3006ZA	TAP SCREW	M3 x 6mm(x3)	
	30	QYSDST3006ZA	TAP SCREW	M3 x 6mm(x4)	
	31	QYSBST3008ZA	TAP SCREW	M3 x 8mm(x2)	
	32	QYSBST3008ZA	TAP SCREW	M3 x 8mm	
	33	QYSDST3006ZA	TAP SCREW	M3 x 6mm(x3)	
	34	QYSDST3006ZA	TAP SCREW	M3 x 6mm	
	35	QYSDST3006ZA	TAP SCREW	M3 x 6mm(x2)	
	36	LV41548-001A-NK	C.B BKT	(x2)	
	37	GV20316-018A	REAR PANEL		A
	37	GV20316-019A	REAR PANEL		UG
	37	GV20316-024A	REAR PANEL		UJ
	37	GV20316-008A	REAR PANEL		UW
	37	GV20316-022A	REAR PANEL		UY
	38	QYSBSGY3008MA	TAP SCREW	M3 x 8mm(x3)	
	39	QYSBSGY3008MA	TAP SCREW	M3 x 8mm(x2)	
	40	QYSBSGY3008MA	TAP SCREW	M3 x 8mm	
	41	QYSBSGY3008MA	TAP SCREW	M3 x 8mm(x2)	
	42	QYSBST3006MA	TAP SCREW	M3 x 6mm	
	43	QYSBSGY3008MA	TAP SCREW	M3 x 8mm	
	44	QYSBSGY3008MA	TAP SCREW	M3 x 8mm	
	45	QYSBSGY3008MA	TAP SCREW	M3 x 8mm	
	46	QYSBSGY3008MA	TAP SCREW	M3 x 8mm	
	47	QYSBSGY3008MA	TAP SCREW	M3 x 8mm	
	48	QAU0346-001	TUNER	TU 1	
	49	GV10235-001A/S/	METAL COVER		
	50	QYSDSG3006NA	TAP SCREW	M3 x 6mm(x4)	
	51	LV41843-002A	LASER CAUTION		
△	52	QMF51W2-1R6-J8	FUSE	F 901 1.6A AC250V	
	53	QYSBSE3008ZA	TAP SCREW	M3 x 8mm	
	54	LV30225-0M9A	SPACER	(x2)	
	55	GV40557-001A	LED HOLDER		
	56	QUQH10-3112AJ-E	FFC WIRE	31pin 12cm	
	57	QUQH10-0714AJ-E	FFC WIRE	7pin 14cm	
	58	QUQH12-1320BJ-E	FFC WIRE	13pin 20cm	
	59	QUQH12-1107AJ-E	FFC WIRE	11pin 7cm	
	60	QUQH12-0512AJ-E	FFC WIRE	5pin 12cm	
	61	QUQH10-0817AJ-E	FFC WIRE	8pin 17cm	
	62	QUQH10-1017AJ-E	FFC WIRE	10pin 17cm	
	63	QUQH10-2817AJ-E	FFC WIRE	28pin 17cm	
	64	GV40641-001A	NOM LABEL		UW
	65	GV40642-001A	CAUTION LABEL		UW
	66	QYSBSGY3008MA	TAP SCREW	M3 x 8mm	UJ

Speaker assembly and parts list

Block No. M 2 M M

(Subwoofer)

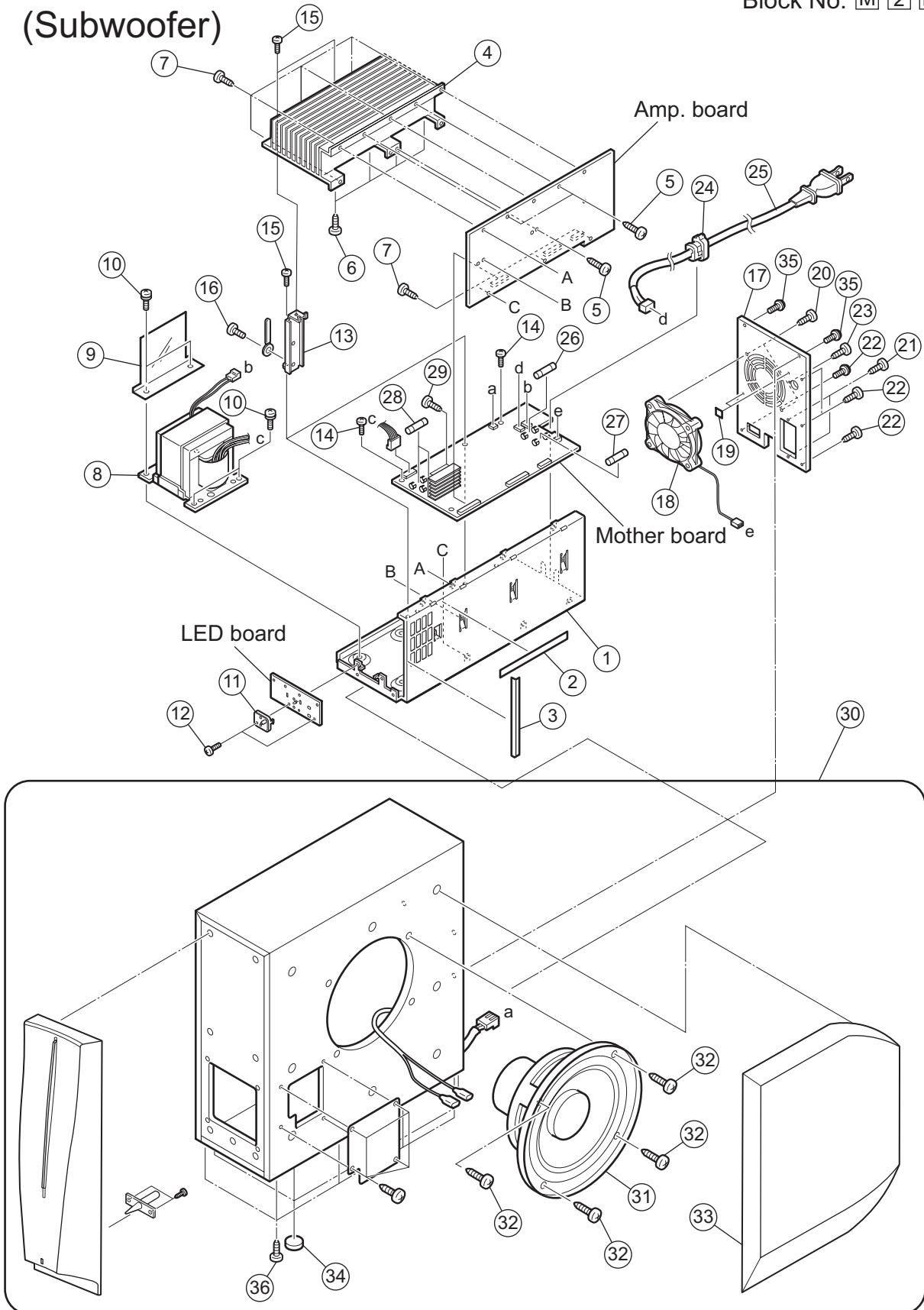

The parts without symbol number are not service.

Speaker(Subwoofer)

Block No. [M][2][M][M]

△	Symbol No.	Part No.	Part Name	Description	Local
	1	LV10875-002A	CHASSIS BASE		
	2	LV30225-0T5A	SPACER		
	3	LV30225-0T6A	SPACER		
	4	LV10951-001A	HEAT SINK		
	5	QYSBSG3010EA	TAP SCREW	M3 x 10mm(x3)	
	6	QYSBSG3016EA	TAP SCREW	M3 x 16mm(x4)	
	7	QYSBSG3010EA	TAP SCREW	M3 x 10mm(x9)	
△	8	QQT0482-002	POWER TRANSF		A
△	8	QQT0482-003	POWER TRANSF		UG,UJ,UW,UY
	9	LV44309-001A	BARRIER		
	10	QYSDSTL4008EA	TAP SCREW	M4 x 8mm(x4)	
	11	LV43692-002A	LED HOLDER		
	12	QYSBSG3010EA	TAP SCREW	M3 x 10mm(x2)	
	13	LV34712-001A	HEAT SINK BKT	(x2)	
	14	QYSBSG3010EA	TAP SCREW	M3 x 10mm(x2)	
	15	QYSBSG3010EA	TAP SCREW	M3 x 10mm(x4)	
	16	QYSBSG3006ZA	TAP SCREW	M3 x 6mm(x2)	
	17	LV21652-021A	REAR PANEL		A
	17	LV21652-022A	REAR PANEL		UG,UJ,UW,UY
	18	QAR0318-001	FAN MOTOR		
	19	LV30225-0D5A	SPACER	(x2)	
	20	QYSBSGY3008MA	TAP SCREW	M3 x 8mm(x2)	
	21	QYSBSGY3008MA	TAP SCREW	M3 x 8mm(x2)	
	22	QYSBSGY3008MA	TAP SCREW	M3 x 8mm(x4)	
	23	QYSBST3006MA	TAP SCREW	M3 x 6mm	
△	24	QZW0033-001	STRAIN RELIEF		
△	25	QMPG080-244-JD	POWER CORD(EU)	2.44m BLACK	A
△	25	QMPK200-200-JD	POWER CORD(EU)	2m BLACK	UG,UJ,UW
△	25	QMPR300-200-JC	POWER CORD(EU)	2m BLACK	UY
△	26	QMF51W2-3R15-J8	FUSE	F 101 3.15A AC250V	A
△	26	QMF51W2-6R3-J8	FUSE	F 101 6.3A AC250V	UG,UJ,UW,UY
△	27	QMF51W2-3R15-J8	FUSE	F 102 3.15A AC250V	UG,UJ,UW,UY
△	28	QMFZ051-8R0-J8	FUSE	F 153 F 154 8A(x2)	
	29	QYSPSPD3008ZA	SCREW	M3 x 8mm(x2)	
	30	QAS0301-002	SPEAKER BOX		A,UG,UW,UY
	30	QAS0301-001	SPEAKER BOX		UJ
	31	LE10016-063A	CONE SPK		
	32	7001541606	TAPPING SCREW	(x4)	
	33	9916013201	NET ASSY		
	34	9000007961	FOOT	(x4)	
	35	QYSDSA4016MA	TAP SCREW	M4 x 16mm(x2)	
	36	QYSDST4014MA	TAP SCREW	M4 x 14mm(x8)	

DVD mechanism assembly and parts list

Grease
 ★ = JVG-31N
 ■ = JVS-1003

FXL-D8-1M

Block No. M J M M

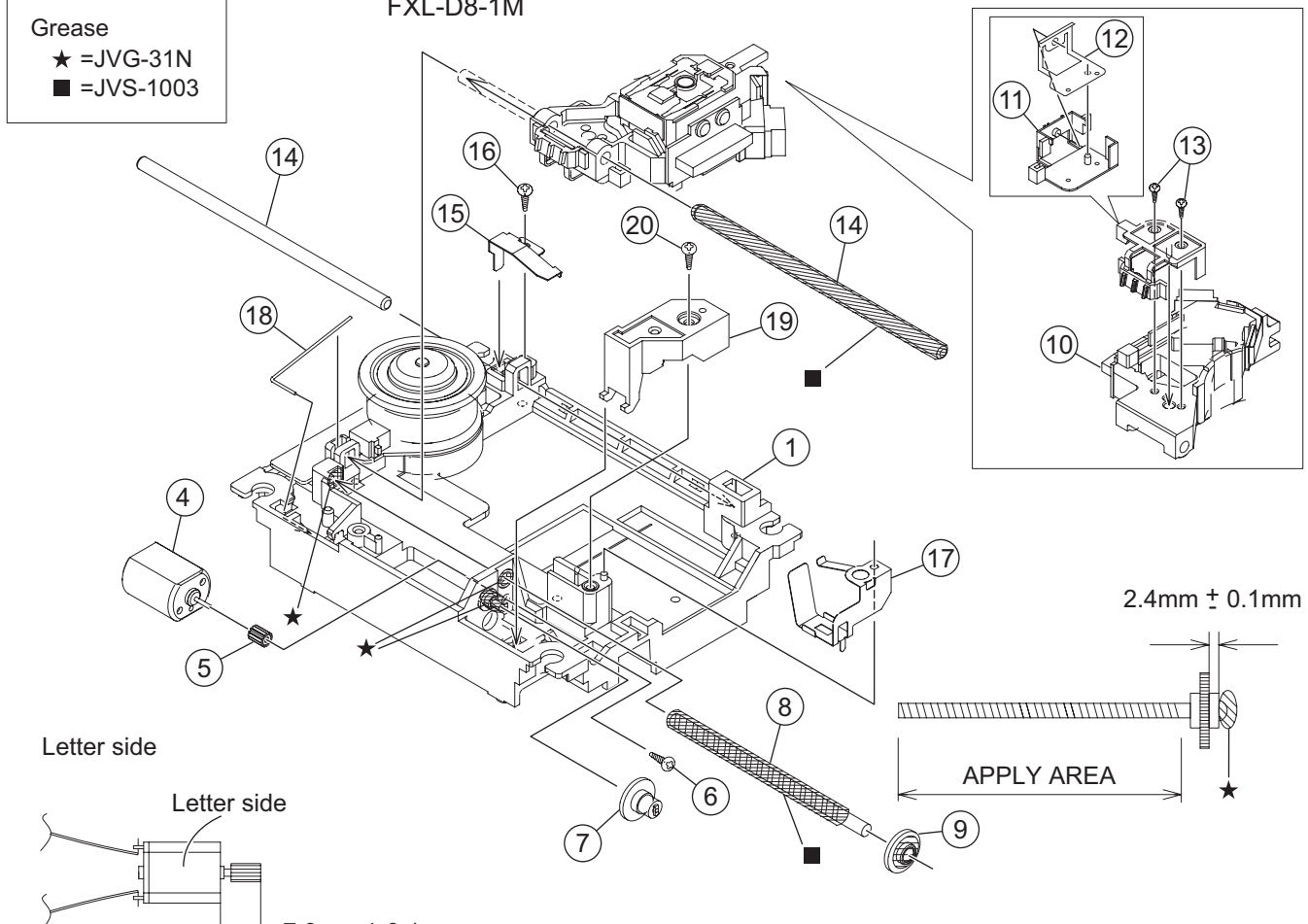

Letter side

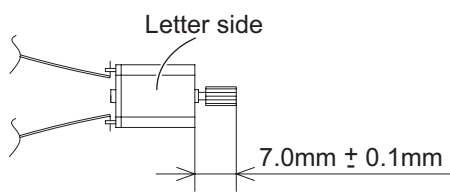

Reverse side

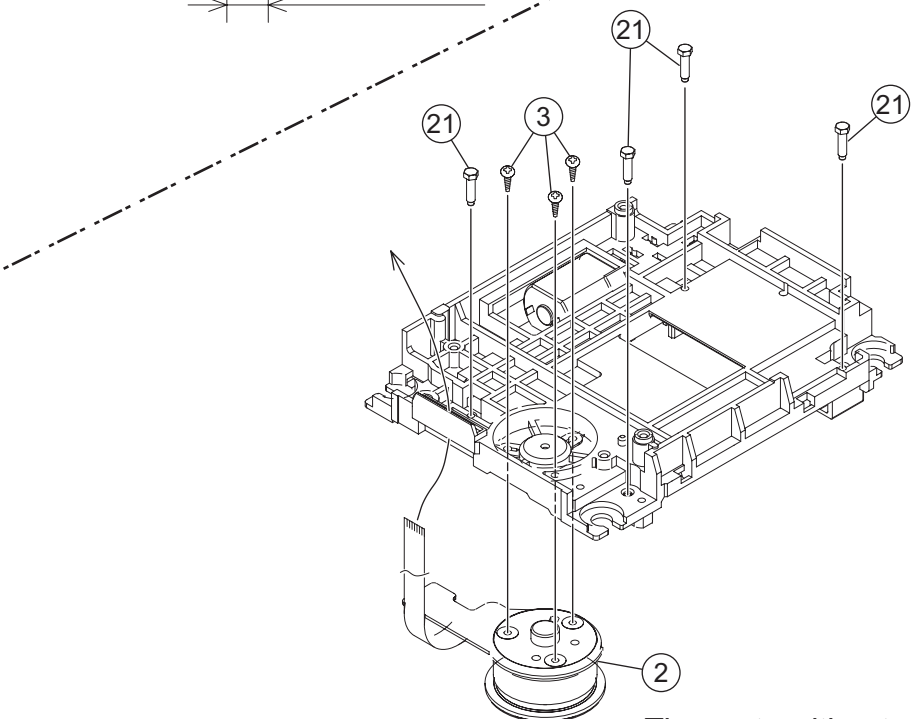

The parts without symbol number are not service.

DVD mechanism

Block No. [M][J][M][M]

△	Symbol No.	Part No.	Part Name	Description	Local
	1	LV10985-001A	C.TM CHASSIS		
	2	QAR0334-002	S.MOTOR		
	3	QYSPSPU1740ZA	SCREW	M1.7 x 4mm(x3)	
	4	QAR0144-003	MOTOR		
	5	VKS5557-001	F.M. GEAR		
	6	QYSPSPT2025ZA	SCREW	M2 x 2.5mm	
	7	LV35461-002A	MIDDLE GEAR		
	8	LV44040-001A	SCREW SHAFT		
	9	LV35462-001A	SCREW SHAFT GEA		
	10	QAL0667-001	DVD PICK		
	11	LV21869-001A	RACK ARM		
	12	LV35463-001A	RACK ARM SPRING		
	13	QYSPSFU1740ZA	TAP SCREW	M1.7 x 4mm(x2)	
	14	LV44041-001A	GUIDE SHAFT	(x2)	
	15	LV35464-001A	G.SHAFT ADJ.SP		
	16	QYSDSF2005ZA	TAP SCREW	M2 x 5mm	
	17	LV35465-001A	THRUST SPRING		
	18	LV44042-001A	ROD SPRING		
	19	LV35467-001A	FEED BRACKET		
	20	QYSDSF2005ZA	TAP SCREW	M2 x 5mm	
	21	LV44046-001A	ADJUST SCREW	(x4)	

DVD changer mechanism assembly and parts list

FMU-SM1-1M

Block No. M K M M

Grease

★=JVG-31N

▲=JVS-1003

CH5-BASE-1M

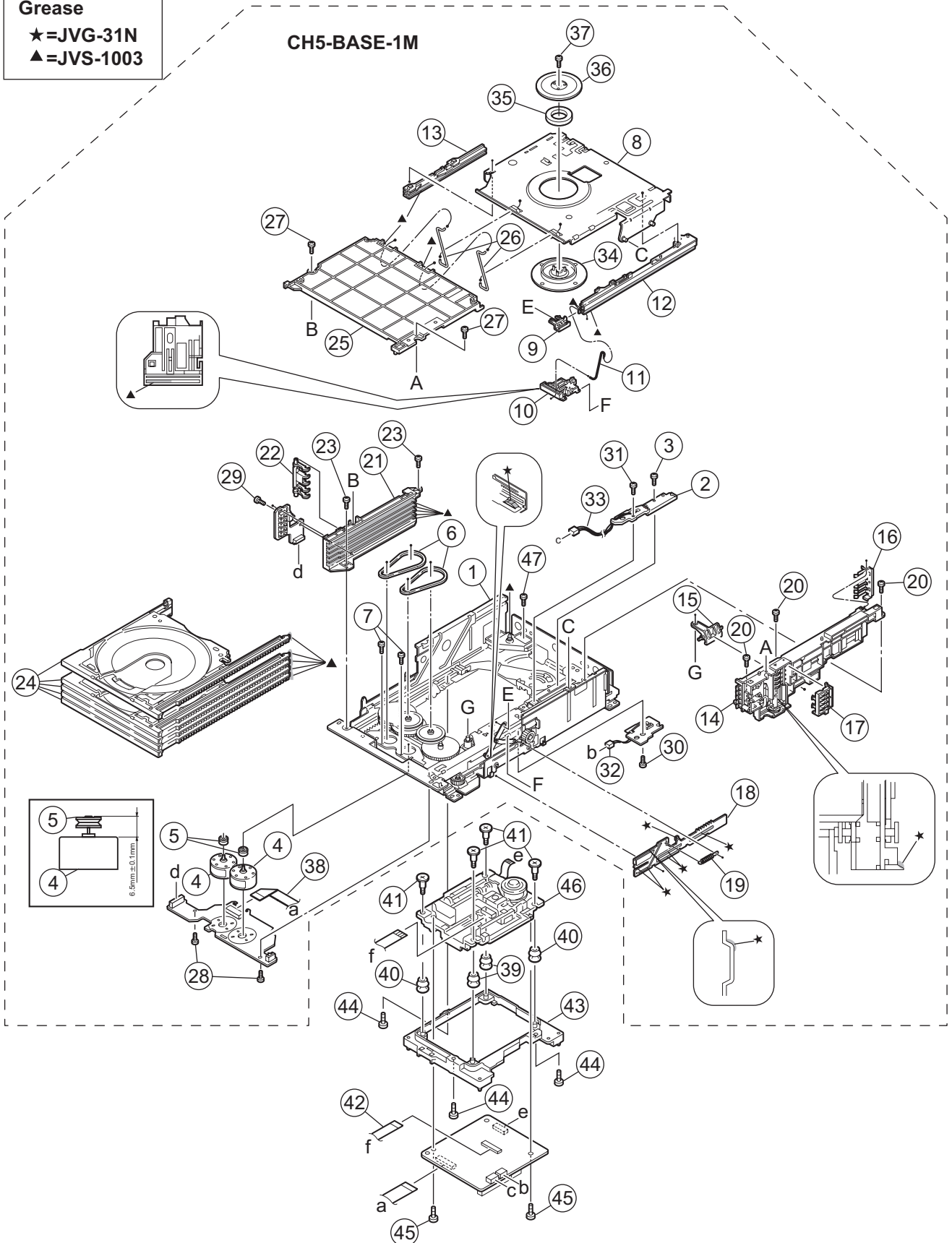

The parts without symbol number are not service.

DVD changer mechanism

Block No. [M][K][M][M]

△	Symbol No.	Part No.	Part Name	Description	Local
	1	LV10913-004A	LOADER ASSY		
	2	QVY0027-B14	S V RESISTOR		
	3	QYSDST2004ZA	TAP SCREW	M2 x 4mm	
	4	QAR0164-001	MOTOR	(x2)	
	5	LV42340-001A	MOTOR PULLEY	(x2)	
	6	LV41431-002A	BELT	(x2)	
	7	QYSPSPU1725NA	SCREW	M1.7 x 2.5mm(x2)	
	8	LV33965-004A	LIFTER ASSY		
	9	LV33963-001A	HOOK		
	10	LV33964-002A	HOOK STOPPER		
	11	LV43285-001A	ROD (L)		
	12	LV21408-002A	RAIL(R)		
	13	LV21409-002A	RAIL(L)		
	14	LV21520-004A	SIDE(R) ASSY		
	15	LV33974-002A	SELECT LEVER		
	16	LV33977-002A	CLICK SPRING		
	17	LV33975-001A	GEAR COVER		
	18	LV33976-002A	ELEVATOR CAM		
	19	LV43287-001A	ELEVATOR SPRING		
	20	QYSDST2605ZA	TAP SCREW	M2.6 x 5mm(x3)	
	21	LV10749-002A	SIDE(L)		
	22	LV33980-002A	OPEN DET.LEVER		
	23	QYSDST2605ZA	TAP SCREW	M2.6 x 5mm(x2)	
	24	LV10746-006A	TRAY ASSY	(x5)	
	25	LV10750-003A	TOP COVER		
	26	LV43289-003A	ROD	(x2)	
	27	QYSDSF2608ZA	TAP SCREW	M2.6 x 8mm(x2)	
	28	QYSDST2605ZA	TAP SCREW	M2.6 x 5mm(x2)	
	29	QYSDSF2608ZA	TAP SCREW	M2.6 x 8mm	
	30	QYSDST2605ZA	TAP SCREW	M2.6 x 5mm	
	31	QYSDST2004ZA	TAP SCREW	M2 x 4mm	
	32	WJM0330-002A-E	E-SI C WIRE C-F		
	33	WJM0331-001A-E	E-SI C WIRE C-F		
	34	LV32417-001A	CLAMPER		
	35	LV42930-003A	P.C.MAGNET		
	36	LV33992-001A	DVD YOKE		
	37	LV41741-003A	SPECIAL SCREW		
	38	QUQ110-1508BJ	FFC WIRE	15pin 8cm	
	39	LV44043-002A	INSULATOR	(x2)	
	40	LV44043-003A	INSULATOR	(x2)	
	41	LV44045-001A	SPECIAL SCREW	(x4)	
	42	LV44092-002A	PICK FFC		
	43	LV10986-001A	TRAMECHA HOLDER		
	44	QYSDST2605ZA	TAP SCREW	M2.6 x 5mm(x3)	
	45	LV44209-001A	WASHER SCREW	(x2)	
	46	-----	DVD TRAMECHA		
	47	QYSDST2605ZA	SCREW	M2.6 x 5 mm	

Electrical parts list

Main board

Block No. [0][1]

△ Symbol No.	Part No.	Part Name	Description	Local	△ Symbol No.	Part No.	Part Name	Description	Local
	IC411	MM1233XF-X	IC		D4709	1SS133-T2	SI DIODE		
	IC431	BH7868FS-X	IC		D4811	1SS133-T2	SI DIODE		
	IC471	MN101C49GFW	IC		D4831	1SS133-T2	SI DIODE		
	IC472	S-80840CNNB-G-W	IC		D4832	1SS133-T2	SI DIODE		
	IC473	SN74HCT32NS-X	IC(DIGITAL)		D4833	1SS133-T2	SI DIODE		
	IC475	RC4558D-X	IC		D4834	1SS133-T2	SI DIODE		
	IC476	RC4558D-X	IC		D4835	MTZJ6.8A-T2	Z DIODE		
	IC477	BR24L08F-W-X	IC(DIGITAL)		D4841	MTZJ2.0A-T2	Z DIODE		
	IC478	RC4558D-X	IC		D4842	MTZJ3.3A-T2	Z DIODE		
	IC491	KIA7805API	IC		D4891	MTZJ6.2C-T2	Z DIODE		
	IC601	RC4558D-X	IC		D4921	MTZJ8.2C-T2	Z DIODE		
△	IC901	STR-G6651	IC		D4922	1SS133-T2	SI DIODE		
	IC951	PQ05RD21SSJH	IC		D4931	MTZJ8.2C-T2	Z DIODE		
	Q951	2SC3576-JVC-T	TRANSISTOR		D4932	1SS133-T2	SI DIODE		
	Q953	KTA1267/YG/-T	TRANSISTOR		D4961	MTZJ4.7A-T2	Z DIODE		
	Q954	SI2305DS-X	TRANSISTOR		D4962	1SS133-T2	SI DIODE		
	Q955	KRC103S-X	DIGITAL TR		D4963	1SS133-T2	SI DIODE		
	Q958	KTA1271/OY/-T	TRANSISTOR		△ PC901	PC123Y22FZ	PHOTO COUPLER		
	Q959	KRC103S-X	DIGITAL TR		△ PC902	PC123Y22FZ	PHOTO COUPLER		
	Q960	KTA1504/YG/-X	SI TRANSISTOR		△ C902	QFZ9075-683	MPP CAPACITOR	0.068uF AC275V M	
	Q961	KTC3203/OY/-T	TRANSISTOR		△ C904	QCZ9079-102	C CAPACITOR	1000pF AC250V M	
	Q991	KTC3875/YG/-X	SI TRANSISTOR		△ C905	QCZ9079-102	C CAPACITOR	1000pF AC250V M	
	Q4091	KTA1271/OY/-T	TRANSISTOR		△ C907	QETM2GM-107	E CAPACITOR	100uF 400V M	
	Q4092	KTC3875/YG/-X	SI TRANSISTOR		C908	QCZ0136-332Z	C CAPACITOR	3300pF 1kV K	
	Q4701	KRC111S-X	TRANSISTOR		C909	QCZ0136-101Z	C CAPACITOR	100pF 1kV K	
	Q4702	KRC107S-X	DIGI TRANSISTOR		C910	QCB11HK-221Y	C CAPACITOR	220pF 50V K	
	Q4703	KRC102S-X	DIGI TRANSISTOR	UJ	C913	QCZ0136-101Z	C CAPACITOR	100pF 1kV K	
	Q4801	KTA1504/YG/-X	SI TRANSISTOR		C914	QEZO532-396Z	E CAPACITOR	39uF 25V M	
	Q4802	KRC102S-X	DIGI TRANSISTOR		C915	QCB11HK-471Y	C CAPACITOR	470pF 50V K	
	Q4811	KRA102S-X	DIGI TRANSISTOR		△ C916	QCZ9079-222	C CAPACITOR	2200pF AC250V M	
	Q4812	KRC102S-X	DIGI TRANSISTOR		C918	QCFB1HZ-104Y	C CAPACITOR	0.1uF 50V Z	
	Q4821	KRC102S-X	DIGI TRANSISTOR		C951	NDC31HJ-101X	C CAPACITOR	100pF 50V J	
	Q4831	KRC102S-X	DIGI TRANSISTOR		C952	QCZ0136-101Z	C CAPACITOR	100pF 1kV K	
	Q4832	KRA110S-X	TRANSISTOR		C953	NDC31HJ-101X	C CAPACITOR	100pF 50V J	
	Q4833	KRC110S-X	DIGI TRANSISTOR		C954	NDC31HJ-101X	C CAPACITOR	100pF 50V J	
	Q4921	KTC3203/OY/-T	TRANSISTOR		C956	NDC31HJ-101X	C CAPACITOR	100pF 50V J	
	Q4931	KTA1271/OY/-T	TRANSISTOR		C957	NDC31HJ-101X	C CAPACITOR	100pF 50V J	
	Q4954	2SA1362/G/-X	TRANSISTOR		C960	QEZO529-826Z	E CAPACITOR	82uF 10V M	
	Q4955	KRC102S-X	DIGI TRANSISTOR		C961	QCZ0202-155Z	C CAPACITOR	1.5uF 25V Z	
	Q4961	KTC3203/OY/-T	TRANSISTOR		C962	QEKC1HM-226Z	E CAPACITOR	22uF 50V M	
	Q4971	2SC3661-X	TRANSISTOR		C963	QEZO533-396Z	E CAPACITOR	39uF 50V M	
	Q4972	2SC3661-X	TRANSISTOR		C964	QETN1HM-226Z	E CAPACITOR	22uF 50V M	
	Q4973	KRA104S-X	DIGI TRANSISTOR		C965	QEZO528-108	E CAPACITOR	1000uF 10V M	
△	D901	DI106	BRIDGE DIODE		C966	QETN1AM-477Z	E CAPACITOR	470uF 10V M	
	D902	10ERB40-T1	FR DIODE		C967	NCB31CK-104X	C CAPACITOR	0.1uF 16V K	
	D903	10ERB40-T1	FR DIODE		C968	NCB31CK-104X	C CAPACITOR	0.1uF 16V K	
	D904	10ERB40-T1	FR DIODE		C969	QETN1AM-227Z	E CAPACITOR	220uF 10V M	
	D908	10ERB40-T1	FR DIODE		C979	QEZO530-827	E CAPACITOR	820uF 16V M	
	D910	10ERB40-T1	FR DIODE		C981	QCZ0202-155Z	C CAPACITOR	1.5uF 25V Z	
	D911	FR104S-T5	FR DIODE		C982	QEZO531-567	E CAPACITOR	560uF 25V M	
	D950	MTZJ22C-T2	Z DIODE		C984	QEKC1CM-227Z	E CAPACITOR	220uF 16V M	
	D951	FR104S-T5	FR DIODE		C985	QETN1EM-107Z	E CAPACITOR	100uF 25V M	
	D952	FR104S-T5	FR DIODE		C986	QETN1EM-107Z	E CAPACITOR	100uF 25V M	
△	D953	SB340-F82	FUSEIODE		C987	QEZO532-187Z	E CAPACITOR	180uF 25V M	
△	D954	FR104S-T5	FR DIODE		C989	QEKC1CM-107Z	E CAPACITOR	100uF 16V M	
△	D956	FR104S-T5	FR DIODE		C992	QETN1HM-474Z	E CAPACITOR	0.47uF 50V M	
△	D957	FR104S-T5	FR DIODE		C993	NDC31HJ-101X	C CAPACITOR	100pF 50V J	
	D958	1SS133-T2	SI DIODE		C994	QCB11HK-223Y	C CAPACITOR	0.022uF 50V K	
	D960	MTZJ2.2A-T2	S.B.DIODE		C997	QETN1CM-227Z	E CAPACITOR	220uF 16V M	
△	D970	ER204-F33	FR DIODE		C4006	QCZ0202-155Z	C CAPACITOR	1.5uF 25V Z	
	D991	MTZJ5.1B-T2	Z DIODE		C4011	NCB31HK-822X	C CAPACITOR	8200pF 50V K	
△	D999	1N4003S-T5	SI DIODE		C4012	NCB31HK-822X	C CAPACITOR	8200pF 50V K	
	D4091	1SS133-T2	SI DIODE		C4091	QETN1HM-226Z	E CAPACITOR	22uF 50V M	
	D4092	MTZJ6.8A-T2	Z DIODE		C4092	QETN1CM-107Z	E CAPACITOR	100uF 16V M	
	D4703	MTZJ4.7B-T2	Z DIODE		C4101	NCB30JK-105X	C CAPACITOR	1uF 6.3V K	
	D4704	1SS133-T2	SI DIODE		C4111	QFLC1HJ-103Z	M CAPACITOR	0.01uF 50V J	
	D4705	1SS133-T2	SI DIODE	UJ	C4121	NCB30JK-105X	C CAPACITOR	1uF 6.3V K	
	D4706	1SS133-T2	SI DIODE		C4171	NCB30JK-105X	C CAPACITOR	1uF 6.3V K	
	D4707	1SS133-T2	SI DIODE		C4172	NCB30JK-105X	C CAPACITOR	1uF 6.3V K	
	D4708	1SS133-T2	SI DIODE		C4173	NCB30JK-105X	C CAPACITOR	1uF 6.3V K	
					C4191	QETN1VM-476Z	E CAPACITOR	47uF 35V M	
					C4192	NCB31HK-103X	C CAPACITOR	0.01uF 50V K	
					C4301	QETN1EM-476Z	E CAPACITOR	47uF 25V M	
					C4311	NCB31HK-103X	C CAPACITOR	0.01uF 50V K	

△ Symbol No.	Part No.	Part Name	Description	Local	△ Symbol No.	Part No.	Part Name	Description	Local
C4321	NCB30JK-105X	C CAPACITOR	1uF 6.3V K		C6603	QETN1HM-475Z	E CAPACITOR	4.7uF 50V M	
C4331	NCB30JK-105X	C CAPACITOR	1uF 6.3V K		C6611	QETN1HM-475Z	E CAPACITOR	4.7uF 50V M	
C4341	NCB30JK-105X	C CAPACITOR	1uF 6.3V K		C6612	NDC31HJ-560X	C CAPACITOR	56pF 50V J	
C4351	NCB30JK-105X	C CAPACITOR	1uF 6.3V K		C6613	QETN1HM-475Z	E CAPACITOR	4.7uF 50V M	
C4391	QETN1AM-477Z	E CAPACITOR	470uF 10V M		C6614	NCB31CK-104X	C CAPACITOR	0.1uF 16V K	
C4392	NCB31CK-104X	C CAPACITOR	0.1uF 16V K		C6615	NCB31CK-104X	C CAPACITOR	0.1uF 16V K	
C4394	NCB31CK-104X	C CAPACITOR	0.1uF 16V K		C6616	NDC31HJ-560X	C CAPACITOR	56pF 50V J	
C4395	QETN1HM-226Z	E CAPACITOR	22uF 50V M		C6617	NCB31HK-471X	C CAPACITOR	470pF 50V K	
C4401	QETN0JM-477Z	E CAPACITOR	470uF 6.3V M		C6618	NCB31HK-471X	C CAPACITOR	470pF 50V K	
C4411	NCB31HK-103X	C CAPACITOR	0.01uF 50V K		C6901	QETN1VM-476Z	E CAPACITOR	47uF 35V M	
C4421	QETN0JM-477Z	E CAPACITOR	470uF 6.3V M		C6902	QETN1VM-476Z	E CAPACITOR	47uF 35V M	
C4431	QETN0JM-477Z	E CAPACITOR	470uF 6.3V M						
C4441	QETN0JM-477Z	E CAPACITOR	470uF 6.3V M		R901	QRL01DJ-683X	OMF RESISTOR	68kΩ 1W J	
C4451	QETN0JM-477Z	E CAPACITOR	470uF 6.3V M		R903	QRE141J-270Y	C RESISTOR	27Ω 1/4W J	
C4605	NCB31HK-471X	C CAPACITOR	470pF 50V K		R904	QRE141J-222Y	C RESISTOR	2.2kΩ 1/4W J	
C4606	NCB31HK-471X	C CAPACITOR	470pF 50V K		R905	QRL027J-683	OMF RESISTOR	68kΩ 2W J	
C4702	QETN0JM-227Z	E CAPACITOR	220uF 6.3V M		R906	QRJ146J-681X	UNF C RESISTOR	680Ω 1/4W J	
C4703	QETN1HM-225Z	E CAPACITOR	2.2uF 50V M		R907	QRT027J-R47	MF RESISTOR	0.47Ω 2W J	
C4704	NCB31CK-223X	C CAPACITOR	0.022uF 16V K		R908	QRE141J-332Y	C RESISTOR	3.3kΩ 1/4W J	
C4705	NCB31HK-103X	C CAPACITOR	0.01uF 50V K		R910	QRE141J-474Y	C RESISTOR	470kΩ 1/4W J	
C4706	NCB31HK-103X	C CAPACITOR	0.01uF 50V K		R911	QRE141J-474Y	C RESISTOR	470kΩ 1/4W J	
C4707	QETN1CM-107Z	E CAPACITOR	100uF 16V M		R951	QRE141J-150Y	C RESISTOR	15Ω 1/4W J	
C4708	NCB31HK-103X	C CAPACITOR	0.01uF 50V K		R952	NRSA63J-103X	MG RESISTOR	10kΩ 1/16W J	
C4709	NCB31HK-103X	C CAPACITOR	0.01uF 50V K		R953	NRSA02J-223X	MG RESISTOR	22kΩ 1/10W J	
C4710	NCB31HK-103X	C CAPACITOR	0.01uF 50V K		△R954	QRZ9005-100X	FUSI RESISTOR	10Ω	
C4711	QETN0JM-477Z	E CAPACITOR	470uF 6.3V M		R955	NRSA63J-223X	MG RESISTOR	22kΩ 1/16W J	
C4712	NCB31CK-104X	C CAPACITOR	0.1uF 16V K		R960	NRSA63J-101X	MG RESISTOR	100Ω 1/16W J	
C4713	NCB31CK-104X	C CAPACITOR	0.1uF 16V K		R961	NRSA63J-681X	MG RESISTOR	680Ω 1/16W J	
C4714	NCB31CK-104X	C CAPACITOR	0.1uF 16V K		R963	NRSA63J-181X	MG RESISTOR	180Ω 1/16W J	
C4715	NCB31CK-104X	C CAPACITOR	0.1uF 16V K		R964	NRSA63J-105X	MG RESISTOR	10kΩ 1/16W J	
C4718	NCB31HK-103X	C CAPACITOR	0.01uF 50V K		R965	NRSA63J-103X	MG RESISTOR	10kΩ 1/16W J	
C4719	NCB31HK-103X	C CAPACITOR	0.01uF 50V K		R966	NRSA02J-221X	MG RESISTOR	220Ω 1/10W J	
C4720	NCB31CK-104X	C CAPACITOR	0.1uF 16V K		R969	NRSA63J-221X	MG RESISTOR	220Ω 1/16W J	
C4721	NCB31CK-104X	C CAPACITOR	0.1uF 16V K		R980	NRSA63J-512X	MG RESISTOR	5.1kΩ 1/16W J	
C4771	NCB31CK-104X	C CAPACITOR	0.1uF 16V K		R981	NRSA63J-223X	MG RESISTOR	22kΩ 1/16W J	
C4772	NCB31CK-104X	C CAPACITOR	0.1uF 16V K		R983	NRSA63J-102X	MG RESISTOR	1kΩ 1/16W J	
C4773	NCB31CK-104X	C CAPACITOR	0.1uF 16V K		R984	NRSA63J-222X	MG RESISTOR	2.2kΩ 1/16W J	
C4774	NCB31CK-104X	C CAPACITOR	0.1uF 16V K		R985	NRSA02J-132X	MG RESISTOR	1.3kΩ 1/10W J	
C4791	NCB31CK-104X	C CAPACITOR	0.1uF 16V K		R986	NRSA02J-152X	MG RESISTOR	1.5kΩ 1/10W J	
C4801	QETN1HM-224Z	E CAPACITOR	0.22uF 50V M		R987	NRSA02J-152X	MG RESISTOR	1.5kΩ 1/10W J	
C4891	NCB31HK-221X	C CAPACITOR	220pF 50V K	UJ	R988	NRSA63J-222X	MG RESISTOR	2.2kΩ 1/16W J	
C4892	NCB31HK-221X	C CAPACITOR	220pF 50V K	UJ	R989	NRSA63J-333X	MG RESISTOR	33kΩ 1/16W J	
C4901	QETN1CM-107Z	E CAPACITOR	100uF 16V M		R990	NRSA63J-333X	MG RESISTOR	33kΩ 1/16W J	
C4902	NCB31HK-103X	C CAPACITOR	0.01uF 50V K		R4011	NRSA63J-102X	MG RESISTOR	1kΩ 1/16W J	
C4903	QETN1CM-107Z	E CAPACITOR	100uF 16V M		R4012	NRSA63J-102X	MG RESISTOR	1kΩ 1/16W J	
C4904	NCB31HK-103X	C CAPACITOR	0.01uF 50V K		R4013	NRSA63J-682X	MG RESISTOR	6.8kΩ 1/16W J	
C4921	QETN1VM-476Z	E CAPACITOR	47uF 35V M		R4014	NRSA63J-682X	MG RESISTOR	6.8kΩ 1/16W J	
C4922	QETN1CM-107Z	E CAPACITOR	100uF 16V M		R4091	NRSA63J-472X	MG RESISTOR	4.7kΩ 1/16W J	
C4931	QETN1VM-476Z	E CAPACITOR	47uF 35V M		R4092	NRSA63J-103X	MG RESISTOR	10kΩ 1/16W J	
C4932	QETN1CM-107Z	E CAPACITOR	100uF 16V M		R4093	NRSA63J-821X	MG RESISTOR	820Ω 1/16W J	
C4961	QETN1CM-107Z	E CAPACITOR	100uF 16V M		R4101	NRSA63J-750X	MG RESISTOR	75Ω 1/16W J	
C6001	NCB31CK-223X	C CAPACITOR	0.022uF 16V K		R4111	NRSA63J-750X	MG RESISTOR	75Ω 1/16W J	
C6002	NCB31CK-223X	C CAPACITOR	0.022uF 16V K		R4121	NRSA63J-750X	MG RESISTOR	75Ω 1/16W J	
C6003	NCB31CK-104X	C CAPACITOR	0.1uF 16V K		R4191	NRSA63J-0R0X	MG RESISTOR	0Ω 1/16W J	
C6004	NCB31HK-103X	C CAPACITOR	0.01uF 50V K		R4201	NRSA63J-511X	MG RESISTOR	510Ω 1/16W J	
C6101	QETN1HM-475Z	E CAPACITOR	4.7uF 50V M		R4202	NRSA63J-331X	MG RESISTOR	330Ω 1/16W J	
C6102	NDC31HJ-101X	C CAPACITOR	100pF 50V J		R4211	NRSA63J-561X	MG RESISTOR	560Ω 1/16W J	
C6103	QETN1HM-476Z	E CAPACITOR	47uF 50V M		R4212	NRSA63J-561X	MG RESISTOR	560Ω 1/16W J	
C6104	NCB31CK-104X	C CAPACITOR	0.1uF 16V K		R4231	NRSA63J-511X	MG RESISTOR	510Ω 1/16W J	
C6105	NCB31HK-103X	C CAPACITOR	0.01uF 50V K		R4232	NRSA63J-331X	MG RESISTOR	330Ω 1/16W J	
C6201	QETN1HM-475Z	E CAPACITOR	4.7uF 50V M		R4241	NRSA63J-561X	MG RESISTOR	560Ω 1/16W J	
C6202	NDC31HJ-101X	C CAPACITOR	100pF 50V J		R4242	NRSA63J-121X	MG RESISTOR	120Ω 1/16W J	
C6203	QETN1HM-476Z	E CAPACITOR	47uF 50V M		R4251	NRSA63J-561X	MG RESISTOR	560Ω 1/16W J	
C6204	NCB31CK-104X	C CAPACITOR	0.1uF 16V K		R4252	NRSA63J-121X	MG RESISTOR	120Ω 1/16W J	
C6205	NCB31HK-103X	C CAPACITOR	0.01uF 50V K		R4401	NRSA63J-750X	MG RESISTOR	75Ω 1/16W J	
C6501	QETN1HM-475Z	E CAPACITOR	4.7uF 50V M		R4411	NRSA63J-750X	MG RESISTOR	75Ω 1/16W J	
C6502	NCS31HJ-560X	C CAPACITOR	56pF 50V J		R4421	NRSA63J-750X	MG RESISTOR	75Ω 1/16W J	
C6503	QETN1HM-475Z	E CAPACITOR	4.7uF 50V M		R4431	NRSA63J-750X	MG RESISTOR	75Ω 1/16W J	
C6511	QETN1HM-475Z	E CAPACITOR	4.7uF 50V M		R4441	NRSA63J-750X	MG RESISTOR	75Ω 1/16W J	
C6512	NDC31HJ-560X	C CAPACITOR	56pF 50V J		R4451	NRSA63J-750X	MG RESISTOR	75Ω 1/16W J	
C6513	QETN1HM-475Z	E CAPACITOR	4.7uF 50V M		R4605	NRSA63J-101X	MG RESISTOR	100Ω 1/16W J	
C6514	NCB31CK-104X	C CAPACITOR	0.1uF 16V K		R4606	NRSA63J-101X	MG RESISTOR	100Ω 1/16W J	
C6515	NCB31CK-104X	C CAPACITOR	0.1uF 16V K		R4703	NRSA63J-102X	MG RESISTOR	1kΩ 1/16W J	
C6516	NDC31HJ-560X	C CAPACITOR	56pF 50V J		R4704	NRSA63J-103X	MG RESISTOR	10kΩ 1/16W J	
C6517	NCB31HK-471X	C CAPACITOR	470pF 50V K		R4705	NRSA63J-472X	MG RESISTOR	4.7kΩ 1/16W J	
C6518	NCB31HK-471X	C CAPACITOR	470pF 50V K		R4706	NRSA63J-223X	MG RESISTOR	22kΩ 1/16W J	
C6601	QETN1HM-475Z	E CAPACITOR	4.7uF 50V M		R4707	NRSA63J-103X	MG RESISTOR	10kΩ 1/16W J	
C6602	NDC31HJ-560X	C CAPACITOR	56pF 50V J		R4708	QRE141J-221Y	C RESISTOR	220Ω 1/4W J	UJ

△ Symbol No.	Part No.	Part Name	Description	Local	△ Symbol No.	Part No.	Part Name	Description	Local
R4709	NRSA63J-101X	MG RESISTOR	100Ω 1/16W J		R6101	NRSA63J-223X	MG RESISTOR	22kΩ 1/16W J	
R4710	NRSA63J-104X	MG RESISTOR	100kΩ 1/16W J		R6102	NRSA63J-102X	MG RESISTOR	1kΩ 1/16W J	
R4711	NRSA63J-331X	MG RESISTOR	330Ω 1/16W J		R6103	NRSA63J-333X	MG RESISTOR	33kΩ 1/16W J	
R4712	NRSA63J-331X	MG RESISTOR	330Ω 1/16W J		R6105	NRSA63J-473X	MG RESISTOR	47kΩ 1/16W J	
R4713	NRSA63J-331X	MG RESISTOR	330Ω 1/16W J		R6106	QRE141J-330Y	C RESISTOR	33Ω 1/4W J	
R4751	NRSA63J-103X	MG RESISTOR	10kΩ 1/16W J	A,UG	R6107	QRE141J-390Y	C RESISTOR	39Ω 1/4W J	
R4752	NRSA63J-822X	MG RESISTOR	8.2kΩ 1/16W J	UG	R6201	NRSA63J-223X	MG RESISTOR	22kΩ 1/16W J	
R4752	NRSA63J-273X	MG RESISTOR	27kΩ 1/16W J	A,UJ	R6202	NRSA63J-102X	MG RESISTOR	1kΩ 1/16W J	
R4752	NRSA63J-153X	MG RESISTOR	15kΩ 1/16W J	UW,UY	R6203	NRSA63J-333X	MG RESISTOR	33kΩ 1/16W J	
R4753	NRSA63J-103X	MG RESISTOR	10kΩ 1/16W J		R6205	NRSA63J-473X	MG RESISTOR	47kΩ 1/16W J	
R4754	NRSA63J-103X	MG RESISTOR	10kΩ 1/16W J		R6206	QRE141J-330Y	C RESISTOR	33Ω 1/4W J	
R4755	NRSA63J-103X	MG RESISTOR	10kΩ 1/16W J		R6207	QRE141J-390Y	C RESISTOR	39Ω 1/4W J	
R4756	NRSA63J-103X	MG RESISTOR	10kΩ 1/16W J		R6302	QRE141J-271Y	C RESISTOR	270Ω 1/4W J	
R4757	NRSA63J-103X	MG RESISTOR	10kΩ 1/16W J		R6303	QRE141J-271Y	C RESISTOR	270Ω 1/4W J	
R4758	NRSA63J-103X	MG RESISTOR	10kΩ 1/16W J		R6304	QRE141J-271Y	C RESISTOR	270Ω 1/4W J	
R4760	NRSA63J-222X	MG RESISTOR	2.2kΩ 1/16W J		R6305	QRE141J-271Y	C RESISTOR	270Ω 1/4W J	
R4761	NRSA63J-103X	MG RESISTOR	10kΩ 1/16W J		R6501	NRSA63J-104X	MG RESISTOR	100kΩ 1/16W J	
R4762	NRSA63J-103X	MG RESISTOR	10kΩ 1/16W J		R6502	NRSA63J-103X	MG RESISTOR	10kΩ 1/16W J	
R4763	NRSA63J-153X	MG RESISTOR	15kΩ 1/16W J		R6503	NRSA63J-102X	MG RESISTOR	1kΩ 1/16W J	
R4771	NRSA63J-103X	MG RESISTOR	10kΩ 1/16W J		R6505	NRSA63J-103X	MG RESISTOR	10kΩ 1/16W J	
R4772	NRSA63J-103X	MG RESISTOR	10kΩ 1/16W J	A,UG,UW,UY	R6506	NRSA63J-103X	MG RESISTOR	10kΩ 1/16W J	
R4773	NRSA63J-103X	MG RESISTOR	10kΩ 1/16W J		R6507	NRSA63J-103X	MG RESISTOR	10kΩ 1/16W J	
R4774	NRSA63J-103X	MG RESISTOR	10kΩ 1/16W J	UJ,UW,UY	R6508	NRSA63J-102X	MG RESISTOR	1kΩ 1/16W J	
R4775	NRSA63J-331X	MG RESISTOR	330Ω 1/16W J		R6509	NRSA63J-473X	MG RESISTOR	47kΩ 1/16W J	
R4776	NRSA63J-331X	MG RESISTOR	330Ω 1/16W J		R6510	NRSA63J-104X	MG RESISTOR	100kΩ 1/16W J	
R4777	NRSA63J-101X	MG RESISTOR	100Ω 1/16W J		R6511	NRSA63J-333X	MG RESISTOR	33kΩ 1/16W J	
R4778	NRSA63J-101X	MG RESISTOR	100Ω 1/16W J		R6512	NRSA63J-103X	MG RESISTOR	10kΩ 1/16W J	
R4781	NRSA63J-101X	MG RESISTOR	100Ω 1/16W J		R6513	NRSA63J-104X	MG RESISTOR	100kΩ 1/16W J	
R4782	NRSA63J-101X	MG RESISTOR	100Ω 1/16W J		R6514	NRSA63J-103X	MG RESISTOR	10kΩ 1/16W J	
R4783	QRE141J-151Y	C RESISTOR	150Ω 1/4W J		R6515	NRSA63J-102X	MG RESISTOR	1kΩ 1/16W J	
R4784	QRE141J-151Y	C RESISTOR	150Ω 1/4W J		R6516	NRSA63J-103X	MG RESISTOR	10kΩ 1/16W J	
R4785	QRE141J-151Y	C RESISTOR	150Ω 1/4W J		R6517	NRSA63J-104X	MG RESISTOR	100kΩ 1/16W J	
R4786	QRE141J-151Y	C RESISTOR	150Ω 1/4W J		R6518	NRSA63J-223X	MG RESISTOR	22kΩ 1/16W J	
R4791	NRSA02J-221X	MG RESISTOR	220Ω 1/10W J		R6601	NRSA63J-104X	MG RESISTOR	100kΩ 1/16W J	
R4801	NRSA63J-223X	MG RESISTOR	22kΩ 1/16W J		R6602	NRSA63J-103X	MG RESISTOR	10kΩ 1/16W J	
R4802	NRSA63J-223X	MG RESISTOR	22kΩ 1/16W J		R6603	NRSA63J-102X	MG RESISTOR	1kΩ 1/16W J	
△ R4811	QRZ9006-4R7X	F.RESISTOR	4.7Ω 1/4W J		R6605	NRSA63J-103X	MG RESISTOR	10kΩ 1/16W J	
R4821	QRE141J-181Y	C RESISTOR	180Ω 1/4W J		R6606	NRSA63J-103X	MG RESISTOR	10kΩ 1/16W J	
R4822	QRE141J-151Y	C RESISTOR	150Ω 1/4W J		R6607	NRSA63J-103X	MG RESISTOR	10kΩ 1/16W J	
R4831	NRSA63J-153X	MG RESISTOR	15kΩ 1/16W J		R6608	NRSA63J-102X	MG RESISTOR	1kΩ 1/16W J	
R4832	NRSA63J-223X	MG RESISTOR	22kΩ 1/16W J		R6609	NRSA63J-473X	MG RESISTOR	47kΩ 1/16W J	
R4833	NRSA63J-123X	MG RESISTOR	12kΩ 1/16W J		R6610	NRSA63J-104X	MG RESISTOR	100kΩ 1/16W J	
R4834	NRSA63J-393X	MG RESISTOR	39kΩ 1/16W J		R6611	NRSA63J-333X	MG RESISTOR	33kΩ 1/16W J	
R4835	NRSA63J-472X	MG RESISTOR	4.7kΩ 1/16W J		R6612	NRSA63J-103X	MG RESISTOR	10kΩ 1/16W J	
R4841	NRSA63J-681X	MG RESISTOR	680Ω 1/16W J		R6613	NRSA63J-104X	MG RESISTOR	100kΩ 1/16W J	
R4842	NRSA63J-103X	MG RESISTOR	10kΩ 1/16W J		R6614	NRSA63J-103X	MG RESISTOR	10kΩ 1/16W J	
R4843	QRT017J-2R2	MF RESISTOR	2.2Ω 1W J		R6615	NRSA63J-102X	MG RESISTOR	1kΩ 1/16W J	
R4844	NRSA63J-103X	MG RESISTOR	10kΩ 1/16W J		R6616	NRSA63J-103X	MG RESISTOR	10kΩ 1/16W J	
R4845	NRSA63J-222X	MG RESISTOR	2.2kΩ 1/16W J		R6617	NRSA63J-104X	MG RESISTOR	100kΩ 1/16W J	
R4861	NRSA63J-222X	MG RESISTOR	2.2kΩ 1/16W J		R6618	NRSA63J-223X	MG RESISTOR	22kΩ 1/16W J	
R4863	NRSA63J-222X	MG RESISTOR	2.2kΩ 1/16W J		△ L901	QQR1105-001	LINE FILTER		
R4864	NRSA63J-222X	MG RESISTOR	2.2kΩ 1/16W J		L951	QQL244K-R22Z	COIL	0.22uH K	
R4866	NRSA63J-272X	MG RESISTOR	2.7kΩ 1/16W J		L952	QQL44BK-220Z	COIL	22uH K	
R4871	NRSA63J-331X	MG RESISTOR	330Ω 1/16W J		L955	QQL26AK-220Z	COIL	22uH K	
R4872	NRSA63J-331X	MG RESISTOR	330Ω 1/16W J		L957	QQL244K-100Z	COIL	10uH K	
R4873	NRSA63J-331X	MG RESISTOR	330Ω 1/16W J		L959	QQL244K-100Z	COIL	10uH K	
R4875	NRSA63J-331X	MG RESISTOR	330Ω 1/16W J		L4391	QQL25CK-221Z	COIL	220uH K	
R4876	NRSA63J-331X	MG RESISTOR	330Ω 1/16W J		△ T901	QQS0097-001	SW TRANSF		
R4881	NRSA63J-472X	MG RESISTOR	4.7kΩ 1/16W J		CN401	QGF1036C1-10	CONNECTOR	FFC/FPC (1-10)	
R4883	NRSA63J-472X	MG RESISTOR	4.7kΩ 1/16W J		CN402	QGF1036C1-08	CONNECTOR	FFC/FPC (1-8)	
R4884	NRSA63J-472X	MG RESISTOR	4.7kΩ 1/16W J		CN403	QGF1036C1-28	CONNECTOR	FFC/FPC (1-28)	
R4886	NRSA63J-562X	MG RESISTOR	5.6kΩ 1/16W J		CN404	QGD2504C1-05Z	CONNECTOR	(1-5)	
R4891	NRSA63J-221X	MG RESISTOR	220Ω 1/16W J	UJ	CN405	QGD2504C1-05Z	CONNECTOR	(1-5)	
R4892	NRSA63J-221X	MG RESISTOR	220Ω 1/16W J	UJ	CN406	QGD2504C1-04Z	CONNECTOR	(1-4)	
△ R4921	QRZ9005-100X	FUSI RESISTOR	10Ω		CN407	QGD2504C1-05Z	CONNECTOR	(1-5)	
R4922	NRSA63J-222X	MG RESISTOR	2.2kΩ 1/16W J		CN410	QGF1205C1-11	CONNECTOR	FFC/FPC (1-11)	
△ R4931	QRZ9005-100X	FUSI RESISTOR	10Ω		CN411	QGF1036C1-31	CONNECTOR	FFC/FPC (1-31)	
R4932	NRSA63J-222X	MG RESISTOR	2.2kΩ 1/16W J		CN412	QGF1036C1-07	CONNECTOR	FFC/FPC (1-7)	
R4961	QRE141J-271Y	C RESISTOR	270Ω 1/4W J		CN450	QGF1205C1-13	CONNECTOR	FFC/FPC (1-13)	
R4971	NRSA63J-222X	MG RESISTOR	2.2kΩ 1/16W J		CN456	QGD2504C1-04Z	CONNECTOR	(1-4)	
R4972	NRSA63J-224X	MG RESISTOR	220kΩ 1/16W J		CN457	QGD2504C1-03Z	CONNECTOR	(1-3)	
R4973	NRSA63J-102X	MG RESISTOR	1kΩ 1/16W J		CN460	QGF1205C1-05	CONNECTOR	FFC/FPC (1-5)	
R4974	NRSA63J-184X	MG RESISTOR	180kΩ 1/16W J		CN470	QGF1205C1-05	CONNECTOR	FFC/FPC (1-5)	A,UG,UW,UY
R4975	NRSA63J-184X	MG RESISTOR	180kΩ 1/16W J		CN701	QGF1205F1-05	CONNECTOR	FFC/FPC (1-5)	
R4990	NRSA63J-103X	MG RESISTOR	10kΩ 1/16W J		△ CP951	ICP-N10-T	IC PROTECTOR	400mA	
R4997	NRSA63J-0R0X	MG RESISTOR	0Ω 1/16W J		△ CP999	ICP-N10-T	IC PROTECTOR	400mA	
R4998	NRSA63J-0R0X	MG RESISTOR	0Ω 1/16W J						
R6001	NRSA63J-102X	MG RESISTOR	1kΩ 1/16W J						

Symbol No.	Part No.	Part Name	Description	Local
EP401	QNZ0136-001Z	EARTH PLATE		
EP402	QNZ0136-001Z	EARTH PLATE		
EP403	QNZ0136-001Z	EARTH PLATE		
EP901	QNZ0136-001Z	EARTH PLATE		
EP902	QNZ0136-001Z	EARTH PLATE		
FC901	QNG0003-001Z	FUSE CLIP		
FC902	QNG0003-001Z	FUSE CLIP		
FW901	QUM219-06DGZ4-E	PARA RIBON WIR		
FW902	QUM21A-06DGZ4-E	PARA RIBON WIR		
HS901	GV40606-002A	HEAT SINK		
J4401	QNN0570-001	PIN JACK		
J4402	QNN0572-001	PIN JACK		
J4891	QNS0089-001	3.5 JACK		UJ
J6001	QNS0170-001	HEADPHONE JACK		
K4702	QQR0621-001Z	FERRITE BEADS		
K6001	NQR0007-002X	FERRITE BEADS		
K6002	NQR0007-002X	FERRITE BEADS		
K6003	NQR0007-002X	FERRITE BEADS		
K6004	NQR0007-002X	FERRITE BEADS		
P901	QNC0081-001	AC INLET		
X4701	QAX0246-001Z	C RESONATOR	8.00MHz	

Symbol No.	Part No.	Part Name	Description	Local
K501	NRSA02J-0R0X	MG RESISTOR	0Ω 1/10W J	
K502	NRSA02J-0R0X	MG RESISTOR	0Ω 1/10W J	
S521	QSW0825-001Z	TACT SW		
S522	QSW0825-001Z	TACT SW		
S523	QSW0825-001Z	TACT SW		
S526	QSW0825-001Z	TACT SW		
S527	QSW0825-001Z	TACT SW		
S528	QSW0825-001Z	TACT SW		
S529	QSW0825-001Z	TACT SW		
S531	QSW0825-001Z	TACT SW		
S532	QSW0825-001Z	TACT SW		
S533	QSW0825-001Z	TACT SW		
S534	QSW0825-001Z	TACT SW		
S535	QSW0825-001Z	TACT SW		
S536	QSW0825-001Z	TACT SW		
S537	QSW0825-001Z	TACT SW		
S538	QSW0825-001Z	TACT SW		
S539	QSW0825-001Z	TACT SW		
S540	QSW0825-001Z	TACT SW		

Audio board

Front board

Block No. [0][3]

Block No. [0][2]

Symbol No.	Part No.	Part Name	Description	Local
IC501	PT6315	IC		
IC511	GP1UM271XKVF	IR DETECT UNIT		
Q503	KRC102S-X	DIGI TRANSISTOR		
D511	SLR-343VC/NPQ-T	LED		
D551	SELU2E10C-P	LED		
C506	NCB30JK-105X	C CAPACITOR	1uF 6.3V K	
C507	NCB31HK-103X	C CAPACITOR	0.01uF 50V K	
C511	NCB21CK-105X	C CAPACITOR	1uF 16V K	
C515	NCB31HK-103X	C CAPACITOR	0.01uF 50V K	
C541	NCB31HK-103X	C CAPACITOR	0.01uF 50V K	
C542	NCB31HK-103X	C CAPACITOR	0.01uF 50V K	
R501	NRSA63J-102X	MG RESISTOR	1kΩ 1/16W J	
R502	NRSA63J-102X	MG RESISTOR	1kΩ 1/16W J	
R503	NRSA63J-102X	MG RESISTOR	1kΩ 1/16W J	
R505	NRSA63J-823X	MG RESISTOR	82kΩ 1/16W J	
R506	NRSA63J-330X	MG RESISTOR	33Ω 1/16W J	
R511	NRSA63J-221X	MG RESISTOR	220Ω 1/16W J	
R521	NRSA63J-332X	MG RESISTOR	3.3kΩ 1/16W J	
R522	NRSA63J-392X	MG RESISTOR	3.9kΩ 1/16W J	
R526	NRSA63J-332X	MG RESISTOR	3.3kΩ 1/16W J	
R527	NRSA63J-392X	MG RESISTOR	3.9kΩ 1/16W J	
R528	NRSA63J-682X	MG RESISTOR	6.8kΩ 1/16W J	
R531	NRSA63J-332X	MG RESISTOR	3.3kΩ 1/16W J	
R532	NRSA63J-392X	MG RESISTOR	3.9kΩ 1/16W J	
R533	NRSA63J-682X	MG RESISTOR	6.8kΩ 1/16W J	
R534	NRSA63J-153X	MG RESISTOR	15kΩ 1/16W J	
R536	NRSA63J-332X	MG RESISTOR	3.3kΩ 1/16W J	
R537	NRSA63J-392X	MG RESISTOR	3.9kΩ 1/16W J	
R538	NRSA63J-682X	MG RESISTOR	6.8kΩ 1/16W J	
R539	NRSA63J-153X	MG RESISTOR	15kΩ 1/16W J	
R541	NRSA63J-103X	MG RESISTOR	10kΩ 1/16W J	
R542	NRSA63J-103X	MG RESISTOR	10kΩ 1/16W J	
R552	NRSA63J-121X	MG RESISTOR	120Ω 1/16W J	
BK501	LV43659-001A	FL HOLDER		
BK502	LV43659-001A	FL HOLDER		
CN501	QGF1205F1-13	CONNECTOR	FFC/FPC (1-13)	
DI501	QLF0154-001	FL TUBE		
FW502	QUM216-09Z4Z4-E	PARA RIBON WIR		
FW521	QUM213-15DGZ4P1	PARA RIBON WIRE		UY
FW521	QUM213-15DGZ4-E	PARA RIBON WIRE		
FW561	QUM214-16DGZ4-E	PARA RIBON WIRE		
JS541	QSW1122-001	JOG VOLUME		

Symbol No.	Part No.	Part Name	Description	Local
IC151	CD4066BM-X	IC		
IC152	CD4066BM-X	IC		
IC153	BD3814FV-X	IC		
IC154	CD4066BM-X	IC		
IC158	RC4558D-X	IC		
IC159	RC4558D-X	IC		
IC160	RC4558D-X	IC		
IC509	GP1FAV30RK0F	OPT RECEIVER		
IC531	RC4558D-X	IC		
IC581	RC4558D-X	IC		
IC591	RC4558D-X	IC		
Q1131	IMX9-W	TRANSISTOR		
Q1133	IMX9-W	TRANSISTOR		
Q1135	IMX9-W	TRANSISTOR		
Q1137	2SC3661-X	TRANSISTOR		
Q1251	KRA104S-X	DIGI TRANSISTOR		
Q1252	KRA104S-X	DIGI TRANSISTOR		
C1001	QETN1EM-107Z	E CAPACITOR	100uF 25V M	
C1002	QETN1EM-107Z	E CAPACITOR	100uF 25V M	
C1003	NCB31HK-103X	C CAPACITOR	0.01uF 50V K	
C1101	NCB31HK-331X	C CAPACITOR	330pF 50V K	
C1102	NCB31HK-331X	C CAPACITOR	330pF 50V K	
C1103	NCB31CK-104X	C CAPACITOR	0.1uF 16V K	
C1120	NCB31CK-333X	C CAPACITOR	0.033uF 16V K	
C1121	NCB31CK-333X	C CAPACITOR	0.033uF 16V K	
C1122	NCB31CK-333X	C CAPACITOR	0.033uF 16V K	
C1123	NCB31CK-333X	C CAPACITOR	0.033uF 16V K	
C1124	NCB31HK-472X	C CAPACITOR	4700pF 50V K	
C1125	NCB31HK-472X	C CAPACITOR	4700pF 50V K	
C1141	QETN1EM-107Z	E CAPACITOR	100uF 25V M	
C1142	QETN1EM-107Z	E CAPACITOR	100uF 25V M	
C1145	NCB31CK-104X	C CAPACITOR	0.1uF 16V K	
C1176	NCB31HK-103X	C CAPACITOR	0.01uF 50V K	
C1177	NCB31HK-103X	C CAPACITOR	0.01uF 50V K	
C1178	NCB31HK-103X	C CAPACITOR	0.01uF 50V K	
C1179	NCB31HK-103X	C CAPACITOR	0.01uF 50V K	
C1180	NCB31HK-103X	C CAPACITOR	0.01uF 50V K	
C1181	NCB31HK-103X	C CAPACITOR	0.01uF 50V K	
C1183	QETN1HM-475Z	E CAPACITOR	4.7uF 50V M	
C1201	QETN1EM-476Z	E CAPACITOR	47uF 25V M	
C1202	QETN1EM-476Z	E CAPACITOR	47uF 25V M	
C1203	QETN1EM-476Z	E CAPACITOR	47uF 25V M	
C1204	QETN1EM-476Z	E CAPACITOR	47uF 25V M	
C1205	QETN1HM-475Z	E CAPACITOR	4.7uF 50V M	
C1206	QETN1HM-475Z	E CAPACITOR	4.7uF 50V M	
C1207	QETN1HM-475Z	E CAPACITOR	4.7uF 50V M	
C1208	QETN1HM-475Z	E CAPACITOR	4.7uF 50V M	

△ Symbol No.	Part No.	Part Name	Description	Local	△ Symbol No.	Part No.	Part Name	Description	Local
C1209	QETN1HM-475Z	E CAPACITOR	4.7uF 50V M		R1134	NRSA63J-101X	MG RESISTOR	100Ω 1/16W J	
C1210	QETN1HM-475Z	E CAPACITOR	4.7uF 50V M		R1135	NRSA63J-332X	MG RESISTOR	3.3kΩ 1/16W J	
C1211	QETN1HM-475Z	E CAPACITOR	4.7uF 50V M		R1136	NRSA63J-332X	MG RESISTOR	3.3kΩ 1/16W J	
C1212	QETN1HM-475Z	E CAPACITOR	4.7uF 50V M		R1137	NRSA63J-104X	MG RESISTOR	100kΩ 1/16W J	
C1213	QETN1HM-475Z	E CAPACITOR	4.7uF 50V M		R1138	NRSA63J-104X	MG RESISTOR	100kΩ 1/16W J	
C1214	QETN1HM-475Z	E CAPACITOR	4.7uF 50V M		R1139	NRSA63J-104X	MG RESISTOR	100kΩ 1/16W J	
C1215	QETN1HM-475Z	E CAPACITOR	4.7uF 50V M		R1140	NRSA63J-104X	MG RESISTOR	100kΩ 1/16W J	
C1216	QETN1HM-475Z	E CAPACITOR	4.7uF 50V M		R1141	NRSA63J-102X	MG RESISTOR	1kΩ 1/16W J	
C1217	QETN1HM-475Z	E CAPACITOR	4.7uF 50V M		R1142	NRSA63J-102X	MG RESISTOR	1kΩ 1/16W J	
C1218	QETN1HM-475Z	E CAPACITOR	4.7uF 50V M		R1143	NRSA63J-332X	MG RESISTOR	3.3kΩ 1/16W J	
C1221	NDC31HJ-470X	C CAPACITOR	47pF 50V J		R1144	NRSA63J-332X	MG RESISTOR	3.3kΩ 1/16W J	
C1222	NDC31HJ-470X	C CAPACITOR	47pF 50V J		R1145	NRSA63J-104X	MG RESISTOR	100kΩ 1/16W J	
C1223	NDC31HJ-470X	C CAPACITOR	47pF 50V J		R1146	NRSA63J-104X	MG RESISTOR	100kΩ 1/16W J	
C1224	NDC31HJ-470X	C CAPACITOR	47pF 50V J		R1147	NRSA63J-104X	MG RESISTOR	100kΩ 1/16W J	
C1225	NDC31HJ-471X	C CAPACITOR	470pF 50V J		R1148	NRSA63J-104X	MG RESISTOR	100kΩ 1/16W J	
C1226	NDC31HJ-470X	C CAPACITOR	47pF 50V J		R1149	NRSA63J-471X	MG RESISTOR	470Ω 1/16W J	
C1227	NCB31CK-183X	C CAPACITOR	0.018uF 16V K		R1150	NRSA63J-102X	MG RESISTOR	1kΩ 1/16W J	
C1228	NCB31CK-183X	C CAPACITOR	0.018uF 16V K		R1151	NRSA63J-472X	MG RESISTOR	4.7kΩ 1/16W J	
C1230	QETN1HM-475Z	E CAPACITOR	4.7uF 50V M		R1152	NRSA63J-332X	MG RESISTOR	3.3kΩ 1/16W J	
C1251	NCB31HK-103X	C CAPACITOR	0.01uF 50V K		R1153	NRSA63J-471X	MG RESISTOR	470Ω 1/16W J	
C1252	NCB31HK-103X	C CAPACITOR	0.01uF 50V K		R1154	NRSA63J-472X	MG RESISTOR	4.7kΩ 1/16W J	
C1253	NCB31HK-103X	C CAPACITOR	0.01uF 50V K		R1155	NRSA63J-104X	MG RESISTOR	100kΩ 1/16W J	
C1254	NCB31HK-103X	C CAPACITOR	0.01uF 50V K		R1156	NRSA63J-104X	MG RESISTOR	100kΩ 1/16W J	
C2503	QETN1HM-475Z	E CAPACITOR	4.7uF 50V M		R1157	NRSA63J-332X	MG RESISTOR	3.3kΩ 1/16W J	
C2504	QETN1HM-475Z	E CAPACITOR	4.7uF 50V M		R1158	NRSA63J-104X	MG RESISTOR	100kΩ 1/16W J	
C2509	NCB31CK-104X	C CAPACITOR	0.1uF 16V K		R1161	NRSA63J-104X	MG RESISTOR	100kΩ 1/16W J	
C2510	NCB31CK-104X	C CAPACITOR	0.1uF 16V K		R1162	NRSA63J-104X	MG RESISTOR	100kΩ 1/16W J	
C2511	QETN1HM-105Z	E CAPACITOR	1uF 50V M		R1163	NRSA63J-104X	MG RESISTOR	100kΩ 1/16W J	
C2512	QETN1HM-105Z	E CAPACITOR	1uF 50V M		R1164	NRSA63J-104X	MG RESISTOR	100kΩ 1/16W J	
C2525	NCB31HK-102X	C CAPACITOR	1000pF 50V K		R1165	NRSA63J-104X	MG RESISTOR	100kΩ 1/16W J	
C2526	NCB31HK-102X	C CAPACITOR	1000pF 50V K		R1166	NRSA63J-104X	MG RESISTOR	100kΩ 1/16W J	
C2531	NCB31HK-331X	C CAPACITOR	330pF 50V K		R1167	NRSA63J-122X	MG RESISTOR	1.2kΩ 1/16W J	
C2532	NCB31HK-331X	C CAPACITOR	330pF 50V K		R1168	NRSA63J-122X	MG RESISTOR	1.2kΩ 1/16W J	
C2533	QETN1EM-476Z	E CAPACITOR	47uF 25V M		R1169	NRSA63J-393X	MG RESISTOR	39kΩ 1/16W J	
C2534	QETN1EM-476Z	E CAPACITOR	47uF 25V M		R1170	NRSA63J-393X	MG RESISTOR	39kΩ 1/16W J	
C2539	NCB31CK-104X	C CAPACITOR	0.1uF 16V K		R1171	NRSA63J-202X	MG RESISTOR	2kΩ 1/16W J	
C2540	NCB31CK-104X	C CAPACITOR	0.1uF 16V K		R1172	NRSA63J-202X	MG RESISTOR	2kΩ 1/16W J	
C2541	QETN1HM-105Z	E CAPACITOR	1uF 50V M		R1173	NRSA63J-473X	MG RESISTOR	47kΩ 1/16W J	
C2542	QETN1HM-105Z	E CAPACITOR	1uF 50V M		R1174	NRSA63J-473X	MG RESISTOR	47kΩ 1/16W J	
C2563	NCB31HK-271X	C CAPACITOR	270pF 50V K		R1175	NRSA63J-202X	MG RESISTOR	2kΩ 1/16W J	
C2564	NCB31HK-271X	C CAPACITOR	270pF 50V K		R1176	NRSA63J-393X	MG RESISTOR	39kΩ 1/16W J	
C2575	NCB31HK-102X	C CAPACITOR	1000pF 50V K		R1197	NRSA63J-225X	MG RESISTOR	2.2MΩ 1/16W J	
C2576	NCB31HK-102X	C CAPACITOR	1000pF 50V K		R1201	NRSA63J-124X	MG RESISTOR	120kΩ 1/16W J	
C2577	QETN1HM-105Z	E CAPACITOR	1uF 50V M		R1202	NRSA63J-124X	MG RESISTOR	120kΩ 1/16W J	
C2578	QETN1HM-105Z	E CAPACITOR	1uF 50V M		R1240	NRSA63J-0R0X	MG RESISTOR	0Ω 1/16W J	
C2581	QETN1HM-105Z	E CAPACITOR	1uF 50V M		R1241	NRSA63J-0R0X	MG RESISTOR	0Ω 1/16W J	
C2582	QETN1HM-106Z	E CAPACITOR	10uF 50V M		R1242	NRSA63J-0R0X	MG RESISTOR	0Ω 1/16W J	
C2583	NCB31HK-271X	C CAPACITOR	270pF 50V K		R1243	NRSA63J-0R0X	MG RESISTOR	0Ω 1/16W J	
C2584	NDC31HJ-560X	C CAPACITOR	56pF 50V J		R1244	NRSA63J-0R0X	MG RESISTOR	0Ω 1/16W J	
C2585	NCB31HK-102X	C CAPACITOR	1000pF 50V K		R1245	NRSA63J-0R0X	MG RESISTOR	0Ω 1/16W J	
C2589	NCB31CK-104X	C CAPACITOR	0.1uF 16V K		R1253	NRSA63J-223X	MG RESISTOR	22kΩ 1/16W J	
C2590	NCB31CK-104X	C CAPACITOR	0.1uF 16V K		R1254	NRSA63J-223X	MG RESISTOR	22kΩ 1/16W J	
C2592	NCB31HK-472X	C CAPACITOR	4700pF 50V K		R2525	NRSA63J-102X	MG RESISTOR	1kΩ 1/16W J	
C2594	NCB31HK-223X	C CAPACITOR	0.022uF 50V K		R2526	NRSA63J-102X	MG RESISTOR	1kΩ 1/16W J	
C2597	QETN1HM-475Z	E CAPACITOR	4.7uF 50V M		R2531	NRSA63J-102X	MG RESISTOR	1kΩ 1/16W J	
C2599	NCB31CK-104X	C CAPACITOR	0.1uF 16V K		R2532	NRSA63J-102X	MG RESISTOR	1kΩ 1/16W J	
C2600	NCB31CK-104X	C CAPACITOR	0.1uF 16V K		R2533	NRSA63J-472X	MG RESISTOR	4.7kΩ 1/16W J	
C2603	QETN1HM-475Z	E CAPACITOR	4.7uF 50V M		R2534	NRSA63J-472X	MG RESISTOR	4.7kΩ 1/16W J	
C2604	QETN1HM-475Z	E CAPACITOR	4.7uF 50V M		R2535	NRSA63J-102X	MG RESISTOR	1kΩ 1/16W J	
C2605	NDC31HJ-560X	C CAPACITOR	56pF 50V J		R2536	NRSA63J-102X	MG RESISTOR	1kΩ 1/16W J	
					R2537	NRSA63J-104X	MG RESISTOR	100kΩ 1/16W J	
R1101	NRSA63J-471X	MG RESISTOR	470Ω 1/16W J		R2538	NRSA63J-104X	MG RESISTOR	100kΩ 1/16W J	
R1102	NRSA63J-471X	MG RESISTOR	470Ω 1/16W J		R2539	NRSA63J-132X	MG RESISTOR	1.3kΩ 1/16W J	
R1103	NRSA63J-564X	MG RESISTOR	560kΩ 1/16W J		R2540	NRSA63J-132X	MG RESISTOR	1.3kΩ 1/16W J	
R1104	NRSA63J-564X	MG RESISTOR	560kΩ 1/16W J		R2543	NRSA63J-104X	MG RESISTOR	100kΩ 1/16W J	
R1106	NRSA63J-101X	MG RESISTOR	100Ω 1/16W J		R2544	NRSA63J-104X	MG RESISTOR	100kΩ 1/16W J	
R1107	NRSA63J-0R0X	MG RESISTOR	0Ω 1/16W J		R2545	NRSA63J-223X	MG RESISTOR	22kΩ 1/16W J	
R1108	NRSA63J-334X	MG RESISTOR	330kΩ 1/16W J		R2546	NRSA63J-223X	MG RESISTOR	22kΩ 1/16W J	
R1109	NRSA63J-334X	MG RESISTOR	330kΩ 1/16W J		R2549	NRSA63J-681X	MG RESISTOR	680Ω 1/16W J	
R1110	NRSA63J-223X	MG RESISTOR	22kΩ 1/16W J		R2550	NRSA63J-681X	MG RESISTOR	680Ω 1/16W J	
R1120	NRSA63J-123X	MG RESISTOR	12kΩ 1/16W J		R2553	NRSA63J-101X	MG RESISTOR	100Ω 1/16W J	
R1121	NRSA63J-123X	MG RESISTOR	12kΩ 1/16W J		R2554	NRSA63J-101X	MG RESISTOR	100Ω 1/16W J	
R1122	NRSA63J-102X	MG RESISTOR	1kΩ 1/16W J		R2560	NRSA63J-472X	MG RESISTOR	4.7kΩ 1/16W J	
R1123	NRSA63J-102X	MG RESISTOR	1kΩ 1/16W J		R2561	NRSA63J-273X	MG RESISTOR	27kΩ 1/16W J	
R1124	NRSA63J-472X	MG RESISTOR	4.7kΩ 1/16W J		R2562	NRSA63J-753X	MG RESISTOR	75kΩ 1/16W J	
R1131	NRSA63J-104X	MG RESISTOR	100kΩ 1/16W J		R2563	NRSA63J-103X	MG RESISTOR	10kΩ 1/16W J	
R1132	NRSA63J-104X	MG RESISTOR	100kΩ 1/16W J		R2564	NRSA63J-103X	MG RESISTOR	10kΩ 1/16W J	
R1133	NRSA63J-101X	MG RESISTOR	100Ω 1/16W J		R2565	NRSA63J-622X	MG RESISTOR	6.2kΩ 1/16W J	

△ Symbol No.	Part No.	Part Name	Description	Local	△ Symbol No.	Part No.	Part Name	Description	Local
R2566	NRSA63J-622X	MG RESISTOR	6.2kΩ 1/16W J		Q3703	KRC103S-X	DIGITAL TR		
R2567	NRSA63J-102X	MG RESISTOR	1kΩ 1/16W J		Q3704	KTC2026/Y/	TRANSISTOR		
R2568	NRSA63J-102X	MG RESISTOR	1kΩ 1/16W J		Q3705	KTC3875/YG/-X	SI TRANSISTOR		
R2581	NRSA63J-104X	MG RESISTOR	100kΩ 1/16W J		Q3706	KRC104S-X	TRANSISTOR		
R2582	NRSA63J-104X	MG RESISTOR	100kΩ 1/16W J						
R2583	NRSA63J-103X	MG RESISTOR	10kΩ 1/16W J		D101	1SS355-X	SI DIODE		
R2584	NRSA63J-333X	MG RESISTOR	33kΩ 1/16W J		△ D151	GBU803	BRIDGE DIODE		
R2585	NRSA63J-622X	MG RESISTOR	6.2kΩ 1/16W J		△ D152	GBU803	BRIDGE DIODE		
R2586	NRSA63J-562X	MG RESISTOR	5.6kΩ 1/16W J		D154	1SS133-T2	SI DIODE		
R2587	NRSA63J-102X	MG RESISTOR	1kΩ 1/16W J		D163	1SS133-T2	SI DIODE		
R2588	NRSA63J-102X	MG RESISTOR	1kΩ 1/16W J		D164	MTZJ6.2B-T2	Z DIODE		
R2590	NRSA63J-333X	MG RESISTOR	33kΩ 1/16W J		D165	MTZJ6.8C-T2	Z DIODE		
R2592	NRSA63J-333X	MG RESISTOR	33kΩ 1/16W J		D166	MTZJ6.8C-T2	Z DIODE		
R2594	NRSA63J-333X	MG RESISTOR	33kΩ 1/16W J		D501	1SS133-T2	SI DIODE		
R2596	NRSA63J-102X	MG RESISTOR	1kΩ 1/16W J		D504	1SS133-T2	SI DIODE		
R2599	NRSA63J-102X	MG RESISTOR	1kΩ 1/16W J		D505	UDZS5.1B-X	Z DIODE		
CN441	QGF1036C1-31	CONNECTOR	FFC/FPC (1-31)		D506	1SS133-T2	SI DIODE		
CN442	QGF1036C1-07	CONNECTOR	FFC/FPC (1-7)		D507	1SS355-X	SI DIODE		
J1101	QNN0598-001	PIN JACK			D510	1SS133-T2	SI DIODE		
J1103	QND0118-001	DIN CONNECTOR			D514	1SS133-T2	SI DIODE		
K1101	NQR0007-002X	FERRITE BEADS			D515	1SS133-T2	SI DIODE		
					D516	MTZJ30C-T2	Z DIODE		
					D521	MTZJ6.8C-T2	Z DIODE		
					D535	1SS355-X	SI DIODE		
					D541	1SS133-T2	SI DIODE		
					D542	1SS133-T2	SI DIODE		
					D543	1SS133-T2	SI DIODE		
					D545	1SS133-T2	SI DIODE		
					D546	1SS133-T2	SI DIODE		
					D548	1SS133-T2	SI DIODE		
					D549	1SS133-T2	SI DIODE		
					D550	1SS133-T2	SI DIODE		
					D551	1SS133-T2	SI DIODE		
					D552	1SS133-T2	SI DIODE		
					D553	1SS133-T2	SI DIODE		
					D561	SLR-342MC-T12	LED		
					D601	1SS133-T2	SI DIODE		
					D610	1SS133-T2	SI DIODE		
					D611	1SS133-T2	SI DIODE		
					D612	1SS133-T2	SI DIODE		
					D2101	1SS133-T2	SI DIODE		
					D2201	1SS133-T2	SI DIODE		
					D2301	1SS133-T2	SI DIODE		
					D2401	1SS133-T2	SI DIODE		
					D2501	1SS133-T2	SI DIODE		
					D2601	1SS133-T2	SI DIODE		
					D2701	MTZJ15C-T2	Z DIODE		
					D2702	MTZJ15C-T2	Z DIODE		
					D2703	MTZJ16C-T2	Z DIODE		
					D2704	1SS133-T2	SI DIODE		
					D2705	1SS133-T2	SI DIODE		
					D2706	MTZJ22A-T2	Z DIODE		
					D3101	1SS133-T2	SI DIODE		
					D3102	1SS133-T2	SI DIODE		
					D3201	1SS133-T2	SI DIODE		
					D3202	1SS133-T2	SI DIODE		
					D3301	1SS133-T2	SI DIODE		
					D3302	1SS133-T2	SI DIODE		
					D3401	1SS133-T2	SI DIODE		
					D3402	1SS133-T2	SI DIODE		
					D3501	1SS133-T2	SI DIODE		
					D3502	1SS133-T2	SI DIODE		
					D3601	1SS133-T2	SI DIODE		
					D3602	1SS133-T2	SI DIODE		
					D3703	MTZJ15C-T2	Z DIODE		
					D3706	1SS133-T2	SI DIODE		
					D3707	1SS133-T2	SI DIODE		
					D3708	1SS133-T2	SI DIODE		

Mother board

Block No. [0][4]

△ Symbol No.	Part No.	Part Name	Description	Local
△ IC201	STK413-430	IC		
△ IC202	STK413-400	IC		
IC301	RC4558D-X	IC		
IC302	RC4558D-X	IC		
IC303	RC4558D-X	IC		
IC601	MN101C427NB	IC		
Q152	KTC2026/Y/	TRANSISTOR		
Q501	KRA104S-X	DIGI TRANSISTOR		
Q502	KTC3875/YG/-X	SI TRANSISTOR		
Q503	KTC3875/YG/-X	SI TRANSISTOR		
Q504	KTA1504/YG/-X	SI TRANSISTOR		
Q505	KRC109S-X	TRANSISTOR		
Q517	KRC104S-X	TRANSISTOR		
Q523	KTC3875/YG/-X	SI TRANSISTOR		
Q524	KTA1504/YG/-X	SI TRANSISTOR		
Q525	KTC3875/YG/-X	SI TRANSISTOR		
Q542	KTC3875/YG/-X	SI TRANSISTOR		
Q603	KTC3875/YG/-X	SI TRANSISTOR		
Q604	KTC3265/Y/-X	TRANSISTOR		
Q2101	KTA1504/YG/-X	SI TRANSISTOR		
Q2201	KTA1504/YG/-X	SI TRANSISTOR		
Q2301	KTA1504/YG/-X	SI TRANSISTOR		
Q2401	KTA1504/YG/-X	SI TRANSISTOR		
Q2501	KTA1504/YG/-X	SI TRANSISTOR		
Q2601	KTA1504/YG/-X	SI TRANSISTOR		
Q2701	KTC3875/YG/-X	SI TRANSISTOR		
Q2702	KTA1046/Y/	TRANSISTOR		
Q2703	KRC102S-X	DIGI TRANSISTOR		
Q2707	KTA1267/YG/-T	TRANSISTOR		
Q2708	KTC3199/GLJ-T	TRANSISTOR		
Q2709	KTC2026/Y/	TRANSISTOR		
Q2710	KTA1504/YG/-X	SI TRANSISTOR		
Q2711	KRA102S-X	DIGI TRANSISTOR		
Q3101	KTC3875/YG/-X	SI TRANSISTOR		
Q3102	KTC3875/YG/-X	SI TRANSISTOR		
Q3201	KTC3875/YG/-X	SI TRANSISTOR		
Q3202	KTC3875/YG/-X	SI TRANSISTOR		
Q3301	KTC3875/YG/-X	SI TRANSISTOR		
Q3302	KTC3875/YG/-X	SI TRANSISTOR		
Q3401	KTC3875/YG/-X	SI TRANSISTOR		
Q3402	KTC3875/YG/-X	SI TRANSISTOR		
Q3501	KTC3875/YG/-X	SI TRANSISTOR		
Q3502	KTC3875/YG/-X	SI TRANSISTOR		
Q3701	KRA102S-X	DIGI TRANSISTOR		
Q3702	KRA102S-X	DIGI TRANSISTOR		
△ C101	QCZ9105-472	C CAPACITOR	4700pF 250V M	
C153	NCF21HZ-473X	C CAPACITOR	0.047uF 50V Z	
C154	NCF21HZ-473X	C CAPACITOR	0.047uF 50V Z	
C155	NCF21HZ-473X	C CAPACITOR	0.047uF 50V Z	
C156	NCF21HZ-473X	C CAPACITOR	0.047uF 50V Z	
C157	NCF21HZ-223X	C CAPACITOR	0.022uF 50V Z	
C159	NCF21HZ-223X	C CAPACITOR	0.022uF 50V Z	
C161	QETM1HM-338	E CAPACITOR	3300uF 50V M	
C162	QETM1HM-338	E CAPACITOR	3300uF 50V M	

△ Symbol No.	Part No.	Part Name	Description	Local	△ Symbol No.	Part No.	Part Name	Description	Local
C163	QETM1EM-478	E CAPACITOR	4700uF 25V M		C3204	QETN1HM-225Z	E CAPACITOR	2.2uF 50V M	
C164	QETM1EM-478	E CAPACITOR	4700uF 25V M		C3301	NCB31HK-152X	C CAPACITOR	1500pF 50V K	
C167	QETN1EM-476Z	E CAPACITOR	47uF 25V M		C3303	QETN1HM-105Z	E CAPACITOR	1uF 50V M	
C168	QETN1CM-107Z	E CAPACITOR	100uF 16V M		C3304	QETN1HM-225Z	E CAPACITOR	2.2uF 50V M	
C171	QETN1CM-107Z	E CAPACITOR	100uF 16V M		C3401	NCB31HK-152X	C CAPACITOR	1500pF 50V K	
C172	QETN1CM-107Z	E CAPACITOR	100uF 16V M		C3403	QETN1HM-105Z	E CAPACITOR	1uF 50V M	
C501	QETN1HM-475Z	E CAPACITOR	4.7uF 50V M		C3404	QETN1HM-225Z	E CAPACITOR	2.2uF 50V M	
C502	NCF31HZ-103X	C CAPACITOR	0.01uF 50V Z		C3501	NCB31HK-152X	C CAPACITOR	1500pF 50V K	
C503	QETN1HM-475Z	E CAPACITOR	4.7uF 50V M		C3503	QETN1HM-105Z	E CAPACITOR	1uF 50V M	
C512	QETN1HM-475Z	E CAPACITOR	4.7uF 50V M		C3504	QETN1HM-225Z	E CAPACITOR	2.2uF 50V M	
C522	QETN1HM-106Z	E CAPACITOR	10uF 50V M		C3601	NCB31HK-152X	C CAPACITOR	1500pF 50V K	
C523	QETN1EM-476Z	E CAPACITOR	47uF 25V M		C3604	QETN1HM-225Z	E CAPACITOR	2.2uF 50V M	
C571	NCF31HZ-103X	C CAPACITOR	0.01uF 50V Z		C3701	NCF31HZ-103X	C CAPACITOR	0.01uF 50V Z	
C591	NCF31HZ-103X	C CAPACITOR	0.01uF 50V Z		C3702	NCF31HZ-103X	C CAPACITOR	0.01uF 50V Z	
C592	NCF31HZ-103X	C CAPACITOR	0.01uF 50V Z		C3703	NCF31HZ-103X	C CAPACITOR	0.01uF 50V Z	
C601	QETN1CM-107Z	E CAPACITOR	100uF 16V M		C3704	NCF31HZ-103X	C CAPACITOR	0.01uF 50V Z	
C602	NCB31HK-102X	C CAPACITOR	1000pF 50V K		C3705	NCF31HZ-103X	C CAPACITOR	0.01uF 50V Z	
C604	NCF31HZ-103X	C CAPACITOR	0.01uF 50V Z		C3706	NCF31HZ-103X	C CAPACITOR	0.01uF 50V Z	
C605	NCF31HZ-103X	C CAPACITOR	0.01uF 50V Z		C3715	QETN1CM-107Z	E CAPACITOR	100uF 16V M	
C606	QETN1HM-106Z	E CAPACITOR	10uF 50V M		C3716	QETN1AM-227Z	E CAPACITOR	220uF 10V M	
C2102	NCB31CK-473X	C CAPACITOR	0.047uF 16V K		C3720	QETN1EM-476Z	E CAPACITOR	47uF 25V M	
C2103	QETN1HM-475Z	E CAPACITOR	4.7uF 50V M		C3721	QEK1CM-107Z	E CAPACITOR	100uF 16V M	
C2104	QETN1CM-107Z	E CAPACITOR	100uF 16V M						
C2105	NDC31HJ-101X	C CAPACITOR	100pF 50V J		R152	NRSA63J-222X	MG RESISTOR	2.2kΩ 1/16W J	
C2106	NDC31HJ-3R0X	C CAPACITOR	3pF 50V J		△ R163	QRJ146J-221X	UNF C RESISTOR	220Ω 1/4W J	
C2107	NCB21HK-104X	C CAPACITOR	0.1uF 50V K		R164	QRE141J-332Y	C RESISTOR	3.3kΩ 1/4W J	
C2108	NCB21HK-104X	C CAPACITOR	0.1uF 50V K		R165	QRL027J-391	OMF RESISTOR	390Ω 2W J	
C2202	NCB31HK-471X	C CAPACITOR	470pF 50V K		R166	QRL027J-391	OMF RESISTOR	390Ω 2W J	
C2203	QETN1HM-475Z	E CAPACITOR	4.7uF 50V M		△ R171	QRL027J-470	OMF RESISTOR	47Ω 2W J	
C2204	QETN1CM-107Z	E CAPACITOR	100uF 16V M		R501	NRSA63J-472X	MG RESISTOR	4.7kΩ 1/16W J	
C2205	NDC31HJ-101X	C CAPACITOR	100pF 50V J		R502	NRSA63J-104X	MG RESISTOR	100kΩ 1/16W J	
C2206	NDC31HJ-3R0X	C CAPACITOR	3pF 50V J		R504	NRSA63J-102X	MG RESISTOR	1kΩ 1/16W J	
C2207	NCB21HK-104X	C CAPACITOR	0.1uF 50V K		R505	NRSA63J-102X	MG RESISTOR	1kΩ 1/16W J	
C2208	NCB21HK-104X	C CAPACITOR	0.1uF 50V K		R506	NRSA63J-103X	MG RESISTOR	10kΩ 1/16W J	
C2302	NCB31HK-471X	C CAPACITOR	470pF 50V K		R508	NRSA63J-223X	MG RESISTOR	22kΩ 1/16W J	
C2303	QETN1HM-475Z	E CAPACITOR	4.7uF 50V M		R510	NRSA63J-472X	MG RESISTOR	4.7kΩ 1/16W J	
C2304	QETN1CM-107Z	E CAPACITOR	100uF 16V M		R522	NRSA63J-103X	MG RESISTOR	10kΩ 1/16W J	
C2305	NDC31HJ-101X	C CAPACITOR	100pF 50V J		R523	NRSA63J-223X	MG RESISTOR	22kΩ 1/16W J	
C2306	NDC31HJ-3R0X	C CAPACITOR	3pF 50V J		R533	NRSA63J-103X	MG RESISTOR	10kΩ 1/16W J	
C2307	NCB21HK-104X	C CAPACITOR	0.1uF 50V K		R534	NRSA63J-103X	MG RESISTOR	10kΩ 1/16W J	
C2308	NCB21HK-104X	C CAPACITOR	0.1uF 50V K		R535	NRSA63J-104X	MG RESISTOR	100kΩ 1/16W J	
C2402	NCB31HK-471X	C CAPACITOR	470pF 50V K		R536	NRSA63J-103X	MG RESISTOR	10kΩ 1/16W J	
C2403	QETN1HM-475Z	E CAPACITOR	4.7uF 50V M		R540	NRSA63J-472X	MG RESISTOR	4.7kΩ 1/16W J	
C2404	QETN1CM-107Z	E CAPACITOR	100uF 16V M		R553	NRSA63J-153X	MG RESISTOR	15kΩ 1/16W J	
C2405	NDC31HJ-101X	C CAPACITOR	100pF 50V J		R554	NRSA63J-223X	MG RESISTOR	22kΩ 1/16W J	
C2406	NDC31HJ-3R0X	C CAPACITOR	3pF 50V J		R555	QRJ146J-271X	UNF C RESISTOR	270Ω 1/4W J	
C2407	NCB21HK-104X	C CAPACITOR	0.1uF 50V K		R556	NRSA63J-102X	MG RESISTOR	1kΩ 1/16W J	
C2408	NCB21HK-104X	C CAPACITOR	0.1uF 50V K		R557	NRSA63J-104X	MG RESISTOR	100kΩ 1/16W J	
C2502	NCB31HK-471X	C CAPACITOR	470pF 50V K		R558	NRSA63J-223X	MG RESISTOR	22kΩ 1/16W J	
C2503	QETN1HM-475Z	E CAPACITOR	4.7uF 50V M		R559	NRSA63J-223X	MG RESISTOR	22kΩ 1/16W J	
C2504	QETN1CM-107Z	E CAPACITOR	100uF 16V M		R560	NRSA63J-223X	MG RESISTOR	22kΩ 1/16W J	
C2505	NDC31HJ-101X	C CAPACITOR	100pF 50V J		R561	NRSA63J-822X	MG RESISTOR	8.2kΩ 1/16W J	
C2506	NDC31HJ-3R0X	C CAPACITOR	3pF 50V J		R562	NRSA63J-393X	MG RESISTOR	39kΩ 1/16W J	
C2507	NCB21HK-104X	C CAPACITOR	0.1uF 50V K		R563	NRSA63J-223X	MG RESISTOR	22kΩ 1/16W J	
C2508	NCB21HK-104X	C CAPACITOR	0.1uF 50V K		R574	NRSA02J-151X	MG RESISTOR	150Ω 1/10W J	
C2602	NCB31HK-471X	C CAPACITOR	470pF 50V K		R601	NRSA63J-103X	MG RESISTOR	10kΩ 1/16W J	
C2603	QETN1HM-475Z	E CAPACITOR	4.7uF 50V M		R602	NRSA63J-392X	MG RESISTOR	3.9kΩ 1/16W J	
C2604	QETN1CM-107Z	E CAPACITOR	100uF 16V M		R603	NRSA63J-222X	MG RESISTOR	2.2kΩ 1/16W J	
C2605	NDC31HJ-101X	C CAPACITOR	100pF 50V J		R606	NRSA63J-223X	MG RESISTOR	22kΩ 1/16W J	
C2606	NDC31HJ-3R0X	C CAPACITOR	3pF 50V J		R607	NRSA63J-223X	MG RESISTOR	22kΩ 1/16W J	
C2607	NCB21HK-104X	C CAPACITOR	0.1uF 50V K		R608	NRSA63J-223X	MG RESISTOR	22kΩ 1/16W J	
C2608	NCB21HK-104X	C CAPACITOR	0.1uF 50V K		R611	NRSA63J-471X	MG RESISTOR	470Ω 1/16W J	
C2701	QETN1HM-107Z	E CAPACITOR	100uF 50V M		R612	NRSA63J-223X	MG RESISTOR	22kΩ 1/16W J	
C2702	QETN1EM-107Z	E CAPACITOR	100uF 25V M		R613	NRSA63J-223X	MG RESISTOR	22kΩ 1/16W J	
C2703	QETN1HM-107Z	E CAPACITOR	100uF 50V M		R614	NRSA63J-223X	MG RESISTOR	22kΩ 1/16W J	
C2704	QETN1HM-476Z	E CAPACITOR	47uF 50V M		R621	NRSA63J-103X	MG RESISTOR	10kΩ 1/16W J	
C2705	QETN1HM-107Z	E CAPACITOR	100uF 50V M		R622	NRSA63J-223X	MG RESISTOR	22kΩ 1/16W J	
C2706	QETN1HM-107Z	E CAPACITOR	100uF 50V M		R623	NRSA63J-103X	MG RESISTOR	10kΩ 1/16W J	
C2707	QETN1HM-106Z	E CAPACITOR	10uF 50V M		R624	NRSA63J-472X	MG RESISTOR	4.7kΩ 1/16W J	
C2708	QETN1HM-106Z	E CAPACITOR	10uF 50V M		R625	NRSA63J-472X	MG RESISTOR	4.7kΩ 1/16W J	
C2711	QETN1HM-106Z	E CAPACITOR	10uF 50V M		R626	NRSA63J-103X	MG RESISTOR	10kΩ 1/16W J	
C2712	NCF31HZ-103X	C CAPACITOR	0.01uF 50V Z		R627	NRSA63J-102X	MG RESISTOR	1kΩ 1/16W J	
C2713	NCF31HZ-103X	C CAPACITOR	0.01uF 50V Z		R628	NRSA63J-223X	MG RESISTOR	22kΩ 1/16W J	
C3101	NCB31HK-152X	C CAPACITOR	1500pF 50V K		R629	NRSA63J-103X	MG RESISTOR	10kΩ 1/16W J	
C3103	QETN1HM-105Z	E CAPACITOR	1uF 50V M		R633	NRSA63J-223X	MG RESISTOR	22kΩ 1/16W J	
C3104	QETN1HM-225Z	E CAPACITOR	2.2uF 50V M		R635	NRSA63J-223X	MG RESISTOR	22kΩ 1/16W J	
C3201	NCB31HK-152X	C CAPACITOR	1500pF 50V K		R637	NRSA63J-223X	MG RESISTOR	22kΩ 1/16W J	
C3203	QETN1HM-105Z	E CAPACITOR	1uF 50V M		R640	NRSA63J-223X	MG RESISTOR	22kΩ 1/16W J	

△ Symbol No.	Part No.	Part Name	Description	Local	△ Symbol No.	Part No.	Part Name	Description	Local
R641	NRSA63J-223X	MG RESISTOR	22kΩ 1/16W J		R2606	QRZ0224-R22	EMIT RESISTOR	0.22Ω	
R642	NRSA63J-223X	MG RESISTOR	22kΩ 1/16W J		R2607	NRSA63J-102X	MG RESISTOR	1kΩ 1/16W J	
R643	NRSA63J-223X	MG RESISTOR	22kΩ 1/16W J		R2608	NRSA63J-153X	MG RESISTOR	15kΩ 1/16W J	
R644	NRSA63J-103X	MG RESISTOR	10kΩ 1/16W J		R2609	NRSA63J-473X	MG RESISTOR	47kΩ 1/16W J	
R646	NRSA63J-102X	MG RESISTOR	1kΩ 1/16W J		R2610	QRK126J-4R7X	UNF C RESISTOR	4.7Ω 1/2W J	
R667	NRSA63J-472X	MG RESISTOR	4.7kΩ 1/16W J		R2611	QRJ146J-100X	UNF C RESISTOR	10Ω 1/4W J	
R671	NRSA63J-102X	MG RESISTOR	1kΩ 1/16W J		R2612	NRSA63J-392X	MG RESISTOR	3.9kΩ 1/16W J	
R685	QRE141J-102Y	C RESISTOR	1kΩ 1/4W J		R2613	NRSA63J-222X	MG RESISTOR	2.2kΩ 1/16W J	
R686	QRE141J-102Y	C RESISTOR	1kΩ 1/4W J		R2614	NRSA63J-104X	MG RESISTOR	100kΩ 1/16W J	
R2101	NRSA63J-183X	MG RESISTOR	18kΩ 1/16W J		△ R2701	QRZ9005-220X	FUSI RESISTOR	22Ω	
R2103	NRSA63J-563X	MG RESISTOR	56kΩ 1/16W J		△ R2702	QRZ9005-220X	FUSI RESISTOR	22Ω	
R2104	NRSA63J-561X	MG RESISTOR	560Ω 1/16W J		R2703	NRSA63J-471X	MG RESISTOR	470Ω 1/16W J	
R2105	NRSA63J-563X	MG RESISTOR	56kΩ 1/16W J		R2704	NRSA63J-471X	MG RESISTOR	470Ω 1/16W J	
R2106	QRZ0224-R22	EMIT RESISTOR	0.22Ω		R2705	NRSA63J-333X	MG RESISTOR	33kΩ 1/16W J	
R2107	NRSA63J-102X	MG RESISTOR	1kΩ 1/16W J		△ R2706	QRZ9006-4R7X	F.RESISTOR	4.7Ω 1/4W J	
R2108	NRSA63J-153X	MG RESISTOR	15kΩ 1/16W J		△ R2707	QRZ9006-4R7X	F.RESISTOR	4.7Ω 1/4W J	
R2109	NRSA63J-473X	MG RESISTOR	47kΩ 1/16W J		△ R2708	QRZ9006-4R7X	F.RESISTOR	4.7Ω 1/4W J	
R2110	QRK126J-4R7X	UNF C RESISTOR	4.7Ω 1/2W J		△ R2709	QRZ9006-4R7X	F.RESISTOR	4.7Ω 1/4W J	
R2111	QRJ146J-100X	UNF C RESISTOR	10Ω 1/4W J		△ R2710	QRZ9005-100X	FUSI RESISTOR	10Ω	
R2112	NRSA63J-752X	MG RESISTOR	7.5kΩ 1/16W J		R2711	NRSA63J-333X	MG RESISTOR	33kΩ 1/16W J	
R2113	NRSA63J-222X	MG RESISTOR	2.2kΩ 1/16W J		R2712	NRSA63J-562X	MG RESISTOR	5.6kΩ 1/16W J	
R2114	NRSA63J-104X	MG RESISTOR	100kΩ 1/16W J		R2713	NRSA63J-562X	MG RESISTOR	5.6kΩ 1/16W J	
R2201	NRSA63J-273X	MG RESISTOR	27kΩ 1/16W J		R2721	QRE141J-472Y	C RESISTOR	4.7kΩ 1/4W J	
R2203	NRSA63J-563X	MG RESISTOR	56kΩ 1/16W J		R2722	QRE141J-472Y	C RESISTOR	4.7kΩ 1/4W J	
R2204	NRSA63J-561X	MG RESISTOR	560Ω 1/16W J		R2723	QRE141J-472Y	C RESISTOR	4.7kΩ 1/4W J	
R2205	NRSA63J-563X	MG RESISTOR	56kΩ 1/16W J		R2724	QRE141J-472Y	C RESISTOR	4.7kΩ 1/4W J	
R2206	QRZ0224-R22	EMIT RESISTOR	0.22Ω		R3101	NRSA63J-153X	MG RESISTOR	15kΩ 1/16W J	
R2207	NRSA63J-102X	MG RESISTOR	1kΩ 1/16W J		R3103	NRSA63J-222X	MG RESISTOR	2.2kΩ 1/16W J	
R2208	NRSA63J-153X	MG RESISTOR	15kΩ 1/16W J		R3104	NRSA63J-183X	MG RESISTOR	18kΩ 1/16W J	
R2209	NRSA63J-473X	MG RESISTOR	47kΩ 1/16W J		R3105	NRSA63J-474X	MG RESISTOR	470kΩ 1/16W J	
R2210	QRK126J-4R7X	UNF C RESISTOR	4.7Ω 1/2W J		R3106	NRSA63J-470X	MG RESISTOR	47Ω 1/16W J	
R2211	QRJ146J-100X	UNF C RESISTOR	10Ω 1/4W J		R3107	NRSA63J-334X	MG RESISTOR	330kΩ 1/16W J	
R2212	NRSA63J-392X	MG RESISTOR	3.9kΩ 1/16W J		R3108	NRSA63J-101X	MG RESISTOR	100Ω 1/16W J	
R2213	NRSA63J-222X	MG RESISTOR	2.2kΩ 1/16W J		R3109	NRSA63J-102X	MG RESISTOR	1kΩ 1/16W J	
R2214	NRSA63J-104X	MG RESISTOR	100kΩ 1/16W J		R3110	NRSA63J-104X	MG RESISTOR	100kΩ 1/16W J	
R2301	NRSA63J-273X	MG RESISTOR	27kΩ 1/16W J		R3111	NRSA63J-471X	MG RESISTOR	470Ω 1/16W J	
R2303	NRSA63J-563X	MG RESISTOR	56kΩ 1/16W J		R3112	NRSA63J-103X	MG RESISTOR	10kΩ 1/16W J	
R2304	NRSA63J-561X	MG RESISTOR	560Ω 1/16W J		R3113	NRSA63J-103X	MG RESISTOR	10kΩ 1/16W J	
R2305	NRSA63J-563X	MG RESISTOR	56kΩ 1/16W J		R3201	NRSA63J-153X	MG RESISTOR	15kΩ 1/16W J	
R2306	QRZ0224-R22	EMIT RESISTOR	0.22Ω		R3203	NRSA63J-222X	MG RESISTOR	2.2kΩ 1/16W J	
R2307	NRSA63J-102X	MG RESISTOR	1kΩ 1/16W J		R3204	NRSA63J-183X	MG RESISTOR	18kΩ 1/16W J	
R2308	NRSA63J-153X	MG RESISTOR	15kΩ 1/16W J		R3205	NRSA63J-474X	MG RESISTOR	470kΩ 1/16W J	
R2309	NRSA63J-473X	MG RESISTOR	47kΩ 1/16W J		R3206	NRSA63J-470X	MG RESISTOR	47Ω 1/16W J	
R2310	QRK126J-4R7X	UNF C RESISTOR	4.7Ω 1/2W J		R3207	NRSA63J-334X	MG RESISTOR	330kΩ 1/16W J	
R2311	QRJ146J-100X	UNF C RESISTOR	10Ω 1/4W J		R3208	NRSA63J-101X	MG RESISTOR	100Ω 1/16W J	
R2312	NRSA63J-392X	MG RESISTOR	3.9kΩ 1/16W J		R3209	NRSA63J-102X	MG RESISTOR	1kΩ 1/16W J	
R2313	NRSA63J-222X	MG RESISTOR	2.2kΩ 1/16W J		R3210	NRSA63J-104X	MG RESISTOR	100kΩ 1/16W J	
R2314	NRSA63J-104X	MG RESISTOR	100kΩ 1/16W J		R3211	NRSA63J-471X	MG RESISTOR	470Ω 1/16W J	
R2401	NRSA63J-273X	MG RESISTOR	27kΩ 1/16W J		R3212	NRSA63J-103X	MG RESISTOR	10kΩ 1/16W J	
R2403	NRSA63J-563X	MG RESISTOR	56kΩ 1/16W J		R3213	NRSA63J-103X	MG RESISTOR	10kΩ 1/16W J	
R2404	NRSA63J-561X	MG RESISTOR	560Ω 1/16W J		R3301	NRSA63J-153X	MG RESISTOR	15kΩ 1/16W J	
R2405	NRSA63J-563X	MG RESISTOR	56kΩ 1/16W J		R3303	NRSA63J-222X	MG RESISTOR	2.2kΩ 1/16W J	
R2406	QRZ0224-R22	EMIT RESISTOR	0.22Ω		R3304	NRSA63J-183X	MG RESISTOR	18kΩ 1/16W J	
R2407	NRSA63J-102X	MG RESISTOR	1kΩ 1/16W J		R3305	NRSA63J-474X	MG RESISTOR	470kΩ 1/16W J	
R2408	NRSA63J-153X	MG RESISTOR	15kΩ 1/16W J		R3306	NRSA63J-470X	MG RESISTOR	47Ω 1/16W J	
R2409	NRSA63J-473X	MG RESISTOR	47kΩ 1/16W J		R3307	NRSA63J-334X	MG RESISTOR	330kΩ 1/16W J	
R2410	QRK126J-4R7X	UNF C RESISTOR	4.7Ω 1/2W J		R3308	NRSA63J-101X	MG RESISTOR	100Ω 1/16W J	
R2411	QRJ146J-100X	UNF C RESISTOR	10Ω 1/4W J		R3309	NRSA63J-102X	MG RESISTOR	1kΩ 1/16W J	
R2412	NRSA63J-392X	MG RESISTOR	3.9kΩ 1/16W J		R3310	NRSA63J-104X	MG RESISTOR	100kΩ 1/16W J	
R2413	NRSA63J-222X	MG RESISTOR	2.2kΩ 1/16W J		R3311	NRSA63J-471X	MG RESISTOR	470Ω 1/16W J	
R2414	NRSA63J-104X	MG RESISTOR	100kΩ 1/16W J		R3312	NRSA63J-103X	MG RESISTOR	10kΩ 1/16W J	
R2501	NRSA63J-273X	MG RESISTOR	27kΩ 1/16W J		R3313	NRSA63J-103X	MG RESISTOR	10kΩ 1/16W J	
R2503	NRSA63J-563X	MG RESISTOR	56kΩ 1/16W J		R3401	NRSA63J-153X	MG RESISTOR	15kΩ 1/16W J	
R2504	NRSA63J-561X	MG RESISTOR	560Ω 1/16W J		R3403	NRSA63J-222X	MG RESISTOR	2.2kΩ 1/16W J	
R2505	NRSA63J-563X	MG RESISTOR	56kΩ 1/16W J		R3404	NRSA63J-183X	MG RESISTOR	18kΩ 1/16W J	
R2506	QRZ0224-R22	EMIT RESISTOR	0.22Ω		R3405	NRSA63J-474X	MG RESISTOR	470kΩ 1/16W J	
R2507	NRSA63J-102X	MG RESISTOR	1kΩ 1/16W J		R3406	NRSA63J-470X	MG RESISTOR	47Ω 1/16W J	
R2508	NRSA63J-153X	MG RESISTOR	15kΩ 1/16W J		R3407	NRSA63J-334X	MG RESISTOR	330kΩ 1/16W J	
R2509	NRSA63J-473X	MG RESISTOR	47kΩ 1/16W J		R3408	NRSA63J-101X	MG RESISTOR	100Ω 1/16W J	
R2510	QRK126J-4R7X	UNF C RESISTOR	4.7Ω 1/2W J		R3409	NRSA63J-102X	MG RESISTOR	1kΩ 1/16W J	
R2511	QRJ146J-100X	UNF C RESISTOR	10Ω 1/4W J		R3410	NRSA63J-104X	MG RESISTOR	100kΩ 1/16W J	
R2512	NRSA63J-392X	MG RESISTOR	3.9kΩ 1/16W J		R3411	NRSA63J-471X	MG RESISTOR	470Ω 1/16W J	
R2513	NRSA63J-222X	MG RESISTOR	2.2kΩ 1/16W J		R3412	NRSA63J-103X	MG RESISTOR	10kΩ 1/16W J	
R2514	NRSA63J-104X	MG RESISTOR	100kΩ 1/16W J		R3413	NRSA63J-103X	MG RESISTOR	10kΩ 1/16W J	
R2601	NRSA63J-273X	MG RESISTOR	27kΩ 1/16W J		R3501	NRSA63J-153X	MG RESISTOR	15kΩ 1/16W J	
R2603	NRSA63J-563X	MG RESISTOR	56kΩ 1/16W J		R3503	NRSA63J-222X	MG RESISTOR	2.2kΩ 1/16W J	
R2604	NRSA63J-561X	MG RESISTOR	560Ω 1/16W J		R3504	NRSA63J-183X	MG RESISTOR	18kΩ 1/16W J	
R2605	NRSA63J-563X	MG RESISTOR	56kΩ 1/16W J		R3505	NRSA63J-474X	MG RESISTOR	470kΩ 1/16W J	

Symbol No.	Part No.	Part Name	Description	Local
R3506	NRSA63J-470X	MG RESISTOR	47Ω 1/16W J	
R3507	NRSA63J-334X	MG RESISTOR	330kΩ 1/16W J	
R3508	NRSA63J-101X	MG RESISTOR	100Ω 1/16W J	
R3509	NRSA63J-102X	MG RESISTOR	1kΩ 1/16W J	
R3510	NRSA63J-104X	MG RESISTOR	100kΩ 1/16W J	
R3511	NRSA63J-471X	MG RESISTOR	470Ω 1/16W J	
R3512	NRSA63J-103X	MG RESISTOR	10kΩ 1/16W J	
R3513	NRSA63J-103X	MG RESISTOR	10kΩ 1/16W J	
R3601	NRSA63J-153X	MG RESISTOR	15kΩ 1/16W J	
R3603	NRSA63J-222X	MG RESISTOR	2.2kΩ 1/16W J	
R3604	NRSA63J-183X	MG RESISTOR	18kΩ 1/16W J	
R3605	NRSA63J-154X	MG RESISTOR	150kΩ 1/16W J	
R3607	NRSA63J-104X	MG RESISTOR	100kΩ 1/16W J	
R3608	NRSA63J-101X	MG RESISTOR	100Ω 1/16W J	
R3610	NRSA63J-104X	MG RESISTOR	100kΩ 1/16W J	
R3611	NRSA63J-471X	MG RESISTOR	470Ω 1/16W J	
R3717	NRSA63J-103X	MG RESISTOR	10kΩ 1/16W J	
R3719	QRE141J-102Y	C RESISTOR	1kΩ 1/4W J	
△ R3720	QRJ146J-100X	UNF C RESISTOR	10Ω 1/4W J	
R3721	NRSA63J-221X	MG RESISTOR	220Ω 1/16W J	
R3725	NRSA63J-472X	MG RESISTOR	4.7kΩ 1/16W J	
R3726	NRSA63J-103X	MG RESISTOR	10kΩ 1/16W J	
△ R3727	QRL01DJ-180X	OMF RESISTOR	18Ω 1W J	
R3728	NRSA63J-101X	MG RESISTOR	100Ω 1/16W J	
R3729	NRSA63J-473X	MG RESISTOR	47kΩ 1/16W J	
R3730	NRSA63J-470X	MG RESISTOR	47Ω 1/16W J	
R3732	NRSA63J-153X	MG RESISTOR	15kΩ 1/16W J	
R3741	NRSA63J-473X	MG RESISTOR	47kΩ 1/16W J	
R3742	NRSA63J-104X	MG RESISTOR	100kΩ 1/16W J	
L2101	QQLZ005-R45	COIL	0.45uH	
L2201	QQLZ005-R45	COIL	0.45uH	
L2301	QQLZ005-R45	COIL	0.45uH	
L2401	QQLZ005-R45	COIL	0.45uH	
L2501	QQLZ005-R45	COIL	0.45uH	
L2601	QQLZ005-R45	COIL	0.45uH	
B1	NRSA63J-0R0X	MG RESISTOR	0Ω 1/16W J	
B21	NRSA63J-0R0X	MG RESISTOR	0Ω 1/16W J	
△ CN101	QGA7901C1-02	CONNECTOR	W-B (1-2)	
△ CN102	QGA7901C1-02	CONNECTOR	W-B (1-2)	A
CN102	QGA7901C1-04	CONNECTOR	W-B (1-4)	UG,UJ,UW,UY
CN151	QGA3901C1-05	CONNECTOR	W-B (1-5)	
CN271	QGB2510J1-14	CONNECTOR	B-B (1-14)	
CN272	QGB2510J1-09	CONNECTOR	B-B (1-9)	
CN273	QGB2510J1-14	CONNECTOR	B-B (1-14)	
CN274	QGA3901C1-02	CONNECTOR	W-B (1-2)	
CN371	QGA2501C1-02	CONNECTOR	W-B (1-2)	
CN372	QGB2510K2-09	CONNECTOR	B-B (1-9)	
CN501	QGB2510K2-14	CONNECTOR	B-B (1-14)	
CN502	QGB2510K2-14	CONNECTOR	B-B (1-14)	
EP201	QNZ0136-001Z	EARTH PLATE		
EP501	QNZ0136-001Z	EARTH PLATE		
FC101	QNG0019-001Z	FUSE CLIP		
FC102	QNG0019-001Z	FUSE CLIP		
FC103	QNG0019-001Z	FUSE CLIP		UG,UJ,UW,UY
FC104	QNG0019-001Z	FUSE CLIP		UG,UJ,UW,UY
FC155	QNG0019-001Z	FUSE CLIP		
FC156	QNG0019-001Z	FUSE CLIP		
FC157	QNG0019-001Z	FUSE CLIP		
FC158	QNG0019-001Z	FUSE CLIP		
FW501	QUM213-28Z4Z4-E	RIBBON WIRE		
HS151	QZW0138-001	HEAT SINK		
J2701	QND0118-001	DIN CONNECTOR		
J2702	QNB0195-001	SPEAKER TERMINA		
△ RY101	QSK0142-001	RELAY		
RY271	QSK0127-001	RELAY		
RY272	QSK0127-001	RELAY		
RY273	QSK0127-001	RELAY		
△ S901	QSW0924-001	VOLTAGE SWITCH		UG,UJ,UW,UY
TH271	NAD0025-103X	N THERMISTOR	10kΩ	
WC201	QZW0112-001	WIRE CLAMP		
X601	QAX0246-001Z	C RESONATOR	8.00MHz	

DVD servo board

Block No. [0][5]

Symbol No.	Part No.	Part Name	Description	Local
IC201	LA6502-X	IC		
IC301	MN2DS0009AA	IC		
IC302	MM1701CH-X	IC		
IC305	MM1563BF-X	IC	3.1V Regulator	
IC451	MN101C61GNW	IC		
IC452	BR93L56RFV-W-X	IC		
IC453	S-80827CNNB-G-W	IC		
IC505	K4S641632H-UC75	IC		
IC505	or HY57V641620ETP7	IC(DIGITAL)		
IC509	-----	IC(MICRO C ROM)		
IC510	BR24L16FV-W-X	IC		
IC701	AK4384VT-X	IC		
IC701	or AK4384ET-X	IC		
IC702	AK4384VT-X	IC		
IC702	or AK4384ET-X	IC		
IC703	AK4384VT-X	IC		
IC703	or AK4384ET-X	IC		
IC704	AK5357VT-X	IC		
IC704	or AK5357ET-X	IC		
IC705	MM1615AN-X	IC		
Q101	KTA1001/Y/-X	TRANSISTOR		
Q101	or 2SB1424/R/-W	TRANSISTOR		
Q102	2SC4617/R/-X	TRANSISTOR		
Q103	KTA1001/Y/-X	TRANSISTOR		
Q103	or 2SB1424/R/-W	TRANSISTOR		
Q104	2SC4617/R/-X	TRANSISTOR		
Q105	UN2119-X	TRANSISTOR		
Q105	or KRA116S-X	TRANSISTOR		
C101	NCF31EZ-104X	C CAPACITOR	0.1uF 25V Z	
C102	NCF31EZ-104X	C CAPACITOR	0.1uF 25V Z	
C103	NCF31EZ-104X	C CAPACITOR	0.1uF 25V Z	
C104	NCF31EZ-104X	C CAPACITOR	0.1uF 25V Z	
C105	NEAF0JM-476X	E CAPACITOR	47uF 6.3V M	
C106	NBE20JM-226X	TA E CAPACITOR	22uF 6.3V M	
C107	NCF31EZ-104X	C CAPACITOR	0.1uF 25V Z	
C108	NBE20JM-226X	TA E CAPACITOR	22uF 6.3V M	
C201	NDC31HJ-221X	C CAPACITOR	220pF 50V J	
C202	NDC31HJ-221X	C CAPACITOR	220pF 50V J	
C203	NCB31HK-103X	C CAPACITOR	0.01uF 50V K	
C204	NCF31EZ-104X	C CAPACITOR	0.1uF 25V Z	
C205	NCB31HK-271X	C CAPACITOR	270pF 50V K	
C206	NDC31HJ-151X	C CAPACITOR	150pF 50V J	
C210	NCF31AZ-105X	C CAPACITOR	1uF 10V Z	
C211	NCB31EK-223X	C CAPACITOR	0.022uF 25V K	
C217	NCF31EZ-104X	C CAPACITOR	0.1uF 25V Z	
C251	NCB31AK-474X	C CAPACITOR	0.47uF 10V K	
C256	NCB31CK-104X	C CAPACITOR	0.1uF 16V K	
C257	NCB31HK-822X	C CAPACITOR	8200pF 50V K	
C258	NCB31CK-153X	C CAPACITOR	0.015uF 16V K	
C259	NCB31CK-153X	C CAPACITOR	0.015uF 16V K	
C260	NCB31HK-223X	C CAPACITOR	0.022uF 50V K	
C261	NCB31HK-223X	C CAPACITOR	0.022uF 50V K	
C262	NCB31HK-223X	C CAPACITOR	0.022uF 50V K	
C300	NCF31EZ-104X	C CAPACITOR	0.1uF 25V Z	
C301	NEAF0GM-476X	E CAPACITOR	47uF 4V M	
C302	NEAF0GM-476X	E CAPACITOR	47uF 4V M	
C303	NEAF0GM-476X	E CAPACITOR	47uF 4V M	
C304	NCB30JK-105X	C CAPACITOR	1uF 6.3V K	
C305	NCF31EZ-104X	C CAPACITOR	0.1uF 25V Z	
C306	NCF31EZ-104X	C CAPACITOR	0.1uF 25V Z	
C307	NCF31EZ-104X	C CAPACITOR	0.1uF 25V Z	
C308	NCF31EZ-104X	C CAPACITOR	0.1uF 25V Z	
C309	NCF31EZ-104X	C CAPACITOR	0.1uF 25V Z	
C310	NCB31CK-104X	C CAPACITOR	0.1uF 16V K	
C311	NCF31EZ-104X	C CAPACITOR	0.1uF 25V Z	
C312	NCF31EZ-104X	C CAPACITOR	0.1uF 25V Z	
C313	NCF31EZ-104X	C CAPACITOR	0.1uF 25V Z	
C314	NCF31EZ-104X	C CAPACITOR	0.1uF 25V Z	
C315	NCF31EZ-104X	C CAPACITOR	0.1uF 25V Z	
C316	NCF31EZ-104X	C CAPACITOR	0.1uF 25V Z	
C318	NCF31EZ-104X	C CAPACITOR	0.1uF 25V Z	
C319	NCF31EZ-104X	C CAPACITOR	0.1uF 25V Z	

△ Symbol No.	Part No.	Part Name	Description	Local	△ Symbol No.	Part No.	Part Name	Description	Local
C320	NCB31CK-104X	C CAPACITOR	0.1uF 16V K		R101	NRSA63J-101X	MG RESISTOR	100Ω 1/16W J	
C321	NCB31CK-104X	C CAPACITOR	0.1uF 16V K		R102	NRSA63J-101X	MG RESISTOR	100Ω 1/16W J	
C322	NCB31CK-104X	C CAPACITOR	0.1uF 16V K		R103	NRSA63J-562X	MG RESISTOR	5.6kΩ 1/16W J	
C323	NCB31CK-104X	C CAPACITOR	0.1uF 16V K		R104	NRSA63J-432X	MG RESISTOR	4.3kΩ 1/16W J	
C324	NCB30JK-105X	C CAPACITOR	1uF 6.3V K		R105	NRS181J-180X	MG RESISTOR	18Ω 1/8W J	
C325	NDC31HJ-120X	C CAPACITOR	12pF 50V J		R106	NRSA63J-2R2X	MG RESISTOR	2.2Ω 1/16W J	
C326	NDC31HJ-100X	C CAPACITOR	10pF 50V J		R107	NRSA63J-102X	MG RESISTOR	1kΩ 1/16W J	
C328	NCB31HK-103X	C CAPACITOR	0.01uF 50V K		R108	NRSA63J-471X	MG RESISTOR	470Ω 1/16W J	
C329	NCF31EZ-104X	C CAPACITOR	0.1uF 25V Z		R109	NRSA63J-331X	MG RESISTOR	330Ω 1/16W J	
C330	NCF31EZ-104X	C CAPACITOR	0.1uF 25V Z		R111	NRSA63J-562X	MG RESISTOR	5.6kΩ 1/16W J	
C331	NCB31CK-333X	C CAPACITOR	0.033uF 16V K		R112	NRSA63J-432X	MG RESISTOR	4.3kΩ 1/16W J	
C332	NCF31EZ-104X	C CAPACITOR	0.1uF 25V Z		R113	NRS181J-180X	MG RESISTOR	18Ω 1/8W J	
C333	NCF31EZ-104X	C CAPACITOR	0.1uF 25V Z		R114	NRSA63J-2R2X	MG RESISTOR	2.2Ω 1/16W J	
C334	NCF31EZ-104X	C CAPACITOR	0.1uF 25V Z		R115	NRSA63J-102X	MG RESISTOR	1kΩ 1/16W J	
C335	NCF31EZ-104X	C CAPACITOR	0.1uF 25V Z		R116	NRSA63J-471X	MG RESISTOR	470Ω 1/16W J	
C337	NCB31CK-183X	C CAPACITOR	0.018uF 16V K		R117	NRSA63J-331X	MG RESISTOR	330Ω 1/16W J	
C338	NCB31HK-562X	C CAPACITOR	5600pF 50V K		R125	NRSA63J-1R0X	MG RESISTOR	1Ω 1/16W J	
C339	NBE20JM-106X	TA E CAPACITOR	10uF 6.3V M		R126	NRSA63J-101X	MG RESISTOR	100Ω 1/16W J	
C340	NCB30JK-105X	C CAPACITOR	1uF 6.3V K		R127	NRSA63J-432X	MG RESISTOR	4.3kΩ 1/16W J	
C341	NCB30JK-105X	C CAPACITOR	1uF 6.3V K		R128	NRSA63J-562X	MG RESISTOR	5.6kΩ 1/16W J	
C347	NCB31CK-104X	C CAPACITOR	0.1uF 16V K		R202	NRSA63J-102X	MG RESISTOR	1kΩ 1/16W J	
C348	NCB31CK-104X	C CAPACITOR	0.1uF 16V K		R204	NRSA63J-273X	MG RESISTOR	27kΩ 1/16W J	
C349	NCF31EZ-104X	C CAPACITOR	0.1uF 25V Z		R205	NRSA63J-273X	MG RESISTOR	27kΩ 1/16W J	
C350	NCB31HK-103X	C CAPACITOR	0.01uF 50V K		R206	NRSA63J-303X	MG RESISTOR	30kΩ 1/16W J	
C351	NCB31HK-103X	C CAPACITOR	0.01uF 50V K		R207	NRSA63J-473X	MG RESISTOR	47kΩ 1/16W J	
C352	NCB31CK-153X	C CAPACITOR	0.015uF 16V K		R213	NRSA63J-103X	MG RESISTOR	10kΩ 1/16W J	
C353	NCB31HK-561X	C CAPACITOR	560pF 50V K		R214	NRSA63J-103X	MG RESISTOR	10kΩ 1/16W J	
C354	NCB31HK-561X	C CAPACITOR	560pF 50V K		R219	NRSA63J-183X	MG RESISTOR	18kΩ 1/16W J	
C356	NCB30JK-105X	C CAPACITOR	1uF 6.3V K		R220	NRSA63J-243X	MG RESISTOR	24kΩ 1/16W J	
C359	NCB30JK-105X	C CAPACITOR	1uF 6.3V K		R221	NRSA63J-682X	MG RESISTOR	6.8kΩ 1/16W J	
C371	NCF31AZ-105X	C CAPACITOR	1uF 10V Z		R251	NRS125J-R39X	MG RESISTOR	0.39Ω 1/2W J	
C372	NCF31EZ-104X	C CAPACITOR	0.1uF 25V Z		R259	NRSA63J-103X	MG RESISTOR	10kΩ 1/16W J	
C373	NCF31EZ-104X	C CAPACITOR	0.1uF 25V Z		R301	NRS181J-0R0X	MG RESISTOR	0Ω 1/8W J	
C374	NCF31EZ-104X	C CAPACITOR	0.1uF 25V Z		R303	NRSA63J-220X	MG RESISTOR	22Ω 1/16W J	
C375	NCF31EZ-104X	C CAPACITOR	0.1uF 25V Z		R306	NRSA63J-102X	MG RESISTOR	1kΩ 1/16W J	
C376	NCF31EZ-104X	C CAPACITOR	0.1uF 25V Z		R307	NRSA63J-102X	MG RESISTOR	1kΩ 1/16W J	
C377	NCF31EZ-104X	C CAPACITOR	0.1uF 25V Z		R308	NRSA63J-103X	MG RESISTOR	10kΩ 1/16W J	
C378	NCF31EZ-104X	C CAPACITOR	0.1uF 25V Z		R309	NRSA63J-104X	MG RESISTOR	100kΩ 1/16W J	
C379	NCF31EZ-104X	C CAPACITOR	0.1uF 25V Z		R310	NRSA63J-101X	MG RESISTOR	100Ω 1/16W J	
C380	NCB21CK-105X	C CAPACITOR	1uF 16V K		R316	NRSA63J-102X	MG RESISTOR	1kΩ 1/16W J	
C381	NCB21AK-225X	C CAPACITOR	2.2uF 10V K		R319	NRSA63J-103X	MG RESISTOR	10kΩ 1/16W J	
C382	NCB31HK-471X	C CAPACITOR	470pF 50V K		R324	NRSA63J-331X	MG RESISTOR	330Ω 1/16W J	
C383	NCF31EZ-104X	C CAPACITOR	0.1uF 25V Z		R325	NRSA63J-331X	MG RESISTOR	330Ω 1/16W J	
C386	NCF31EZ-104X	C CAPACITOR	0.1uF 25V Z		R326	NRSA63J-331X	MG RESISTOR	330Ω 1/16W J	
C393	NCB31HK-103X	C CAPACITOR	0.01uF 50V K		R327	NRSA63J-331X	MG RESISTOR	330Ω 1/16W J	
C451	NCF31EZ-104X	C CAPACITOR	0.1uF 25V Z		R330	NRSA63J-331X	MG RESISTOR	330Ω 1/16W J	
C452	NCB31CK-104X	C CAPACITOR	0.1uF 16V K		R331	NRSA63J-331X	MG RESISTOR	330Ω 1/16W J	
C453	NCF31EZ-104X	C CAPACITOR	0.1uF 25V Z		R332	NRSA63J-331X	MG RESISTOR	330Ω 1/16W J	
C454	NCB31HK-103X	C CAPACITOR	0.01uF 50V K		R334	NRSA63J-151X	MG RESISTOR	150Ω 1/16W J	
C455	NCB31HK-103X	C CAPACITOR	0.01uF 50V K		R335	NRSA63J-151X	MG RESISTOR	150Ω 1/16W J	
C551	NCF31EZ-104X	C CAPACITOR	0.1uF 25V Z		R336	NRSA63J-151X	MG RESISTOR	150Ω 1/16W J	
C554	NCF31EZ-104X	C CAPACITOR	0.1uF 25V Z		R337	NRSA63J-151X	MG RESISTOR	150Ω 1/16W J	
C555	NCF31EZ-104X	C CAPACITOR	0.1uF 25V Z		R338	NRSA63J-0R0X	MG RESISTOR	0Ω 1/16W J	
C556	NCF31AZ-105X	C CAPACITOR	1uF 10V Z		R339	NRSA63J-0R0X	MG RESISTOR	0Ω 1/16W J	
C557	NCB31HK-102X	C CAPACITOR	1000pF 50V K		R340	NRSA63D-303X	MG RESISTOR	30kΩ 1/16W D	
C558	NEAF0GM-476X	E CAPACITOR	47uF 4V M		R341	NRSA63D-512X	MG RESISTOR	5.1kΩ 1/16W D	
C559	NCF31EZ-104X	C CAPACITOR	0.1uF 25V Z		R342	NRSA63D-242X	MG RESISTOR	2.4kΩ 1/16W D	
C560	NCF31EZ-104X	C CAPACITOR	0.1uF 25V Z		R345	NRSA63J-221X	MG RESISTOR	220Ω 1/16W J	
C563	NCF31EZ-104X	C CAPACITOR	0.1uF 25V Z		R346	NRSA63J-223X	MG RESISTOR	22kΩ 1/16W J	
C564	NCF31EZ-104X	C CAPACITOR	0.1uF 25V Z		R347	NRSA63J-203X	MG RESISTOR	20kΩ 1/16W J	
C701	NCB21CK-105X	C CAPACITOR	1uF 16V K		R348	NRSA63J-151X	MG RESISTOR	150Ω 1/16W J	
C702	NCB31HK-103X	C CAPACITOR	0.01uF 50V K		R349	NRSA63J-151X	MG RESISTOR	150Ω 1/16W J	
C703	NCB30JK-105X	C CAPACITOR	1uF 6.3V K		R350	NRSA63J-751X	MG RESISTOR	750Ω 1/16W J	
C704	NCF31AZ-105X	C CAPACITOR	1uF 10V Z		R351	NRSA63J-681X	MG RESISTOR	680Ω 1/16W J	
C705	NCF31EZ-104X	C CAPACITOR	0.1uF 25V Z		R352	NRSA63J-105X	MG RESISTOR	1MΩ 1/16W J	
C706	NCF31EZ-104X	C CAPACITOR	0.1uF 25V Z		R353	NRSA63J-101X	MG RESISTOR	100Ω 1/16W J	
C707	NEAF1CM-106X	E CAPACITOR	10uF 16V M		R357	NRSA63J-221X	MG RESISTOR	220Ω 1/16W J	
C708	NEAF1CM-106X	E CAPACITOR	10uF 16V M		R358	NRSA63J-221X	MG RESISTOR	220Ω 1/16W J	
C709	NEAF0JM-476X	E CAPACITOR	47uF 6.3V M		R359	NRSA63J-221X	MG RESISTOR	220Ω 1/16W J	
C712	NCF31EZ-104X	C CAPACITOR	0.1uF 25V Z		R360	NRSA63J-221X	MG RESISTOR	220Ω 1/16W J	
C713	NEAF1CM-106X	E CAPACITOR	10uF 16V M		R362	NRSA63J-331X	MG RESISTOR	330Ω 1/16W J	
C714	NCF31EZ-104X	C CAPACITOR	0.1uF 25V Z		R367	NRSA63J-221X	MG RESISTOR	220Ω 1/16W J	
C715	NCF31EZ-104X	C CAPACITOR	0.1uF 25V Z		R372	NRSA63J-103X	MG RESISTOR	10kΩ 1/16W J	
C716	NCF31EZ-104X	C CAPACITOR	0.1uF 25V Z		R373	NRSA63J-103X	MG RESISTOR	10kΩ 1/16W J	
C717	NCF31EZ-104X	C CAPACITOR	0.1uF 25V Z		R374	NRSA63J-102X	MG RESISTOR	1kΩ 1/16W J	
C718	NCF31EZ-104X	C CAPACITOR	0.1uF 25V Z		R375	NRSA63J-102X	MG RESISTOR	1kΩ 1/16W J	
C722	NCF31EZ-104X	C CAPACITOR	0.1uF 25V Z		R376	NRSA63J-102X	MG RESISTOR	1kΩ 1/16W J	
					R377	NRSA63J-102X	MG RESISTOR	1kΩ 1/16W J	

Symbol No.	Part No.	Part Name	Description	Local
R378	NRSA63J-102X	MG RESISTOR	1kΩ 1/16W J	
R383	NRSA63J-101X	MG RESISTOR	100Ω 1/16W J	
R384	NRSA63J-102X	MG RESISTOR	1kΩ 1/16W J	
R385	NRSA63J-102X	MG RESISTOR	1kΩ 1/16W J	
R392	NRSA63J-103X	MG RESISTOR	10kΩ 1/16W J	
R393	NRSA63J-0R0X	MG RESISTOR	0Ω 1/16W J	
R394	NRSA63J-0R0X	MG RESISTOR	0Ω 1/16W J	
R452	NRSA63J-222X	MG RESISTOR	2.2kΩ 1/16W J	
R453	NRSA63J-103X	MG RESISTOR	10kΩ 1/16W J	
R454	NRSA63J-103X	MG RESISTOR	10kΩ 1/16W J	
R455	NRSA63J-103X	MG RESISTOR	10kΩ 1/16W J	
R456	NRSA63J-103X	MG RESISTOR	10kΩ 1/16W J	
R457	NRSA63J-101X	MG RESISTOR	100Ω 1/16W J	
R458	NRSA63J-102X	MG RESISTOR	1kΩ 1/16W J	
R461	NRSA63J-101X	MG RESISTOR	100Ω 1/16W J	
R463	NRSA63J-101X	MG RESISTOR	100Ω 1/16W J	
R464	NRSA63J-101X	MG RESISTOR	100Ω 1/16W J	
R465	NRSA63J-102X	MG RESISTOR	1kΩ 1/16W J	
R535	NRSA63J-473X	MG RESISTOR	47kΩ 1/16W J	
R541	NRSA63J-473X	MG RESISTOR	47kΩ 1/16W J	
R701	NRSA63J-2R2X	MG RESISTOR	2.2Ω 1/16W J	
R703	NRSA63J-471X	MG RESISTOR	470Ω 1/16W J	
R704	NRSA63J-471X	MG RESISTOR	470Ω 1/16W J	
R705	NRSA63J-471X	MG RESISTOR	470Ω 1/16W J	
R706	NRSA63J-471X	MG RESISTOR	470Ω 1/16W J	
R707	NRSA63J-471X	MG RESISTOR	470Ω 1/16W J	
R708	NRSA63J-471X	MG RESISTOR	470Ω 1/16W J	
R714	NRSA63J-101X	MG RESISTOR	100Ω 1/16W J	
R715	NRSA63J-101X	MG RESISTOR	100Ω 1/16W J	
R716	NRSA63J-471X	MG RESISTOR	470Ω 1/16W J	
R717	NRSA63J-473X	MG RESISTOR	47kΩ 1/16W J	
R719	NRSA63J-5R1X	MG RESISTOR	5.1Ω 1/16W J	
R720	NRSA63J-473X	MG RESISTOR	47kΩ 1/16W J	
R722	NRSA63J-0R0X	MG RESISTOR	0Ω 1/16W J	
R731	NRSA63J-102X	MG RESISTOR	1kΩ 1/16W J	
R732	NRSA63J-471X	MG RESISTOR	470Ω 1/16W J	
CN101	QGF0523F1-25W	CONNECTOR	FFC/FPC (1-25)	
CN201	QGF1016F2-08W	CONNECTOR	FFC/FPC (1-8)	
CN451	QGF1016F2-15W	CONNECTOR	FFC/FPC (1-15)	
CN452	QGA2001F2-02X	CONNECTOR	W-B (1-2)	
CN453	QGA2001F2-03X	CONNECTOR	W-B (1-3)	
CN701	QGF1016F2-28W	CONNECTOR	FFC/FPC (1-28)	
CN702	QGF1016F2-10W	CONNECTOR	FFC/FPC (1-10)	
CN703	QGF1016F2-08W	CONNECTOR	FFC/FPC (1-8)	
K351	NQR0502-001X	FERRITE BEADS		
K352	NQR0502-001X	FERRITE BEADS		
K454	NRSA63J-0R0X	MG RESISTOR	0Ω 1/16W J	
K455	NRSA63J-0R0X	MG RESISTOR	0Ω 1/16W J	
K456	NRSA63J-0R0X	MG RESISTOR	0Ω 1/16W J	
K501	NQR0502-001X	FERRITE BEADS		
K710	NQR0022-002X	FERRITE BEADS		
K732	NRSA63J-0R0X	MG RESISTOR	0Ω 1/16W J	
K733	NRSA63J-0R0X	MG RESISTOR	0Ω 1/16W J	
K734	NRSA63J-0R0X	MG RESISTOR	0Ω 1/16W J	
K735	NRSA63J-0R0X	MG RESISTOR	0Ω 1/16W J	
K736	NRSA63J-0R0X	MG RESISTOR	0Ω 1/16W J	
K737	NRSA63J-0R0X	MG RESISTOR	0Ω 1/16W J	
K738	NQR0022-005X	FERRITE BEADS		
K741	NQR0022-002X	FERRITE BEADS		
K744	NRSA63J-0R0X	MG RESISTOR	0Ω 1/16W J	
K748	NRSA63J-0R0X	MG RESISTOR	0Ω 1/16W J	
K749	NRSA63J-0R0X	MG RESISTOR	0Ω 1/16W J	
K750	NQR0022-002X	FERRITE BEADS		
K752	NQR0022-002X	FERRITE BEADS		
K754	NQR0022-002X	FERRITE BEADS		
K756	NQR0022-002X	FERRITE BEADS		
K758	NQR0022-002X	FERRITE BEADS		
TH301	NAD0025-103X	N THERMISTOR	10kΩ	
X301	NAX0741-001X	CRYSTAL		
X451	NAX0248-001X	C OSCILLATOR	8.000MHz	

Loading board

Block No. [0][6]

Symbol No.	Part No.	Part Name	Description	Local
IC1	LB1641	IC		
IC2	LB1641	IC		
D1	MTZJ6.2A-T2	Z DIODE		
C1	QEKC1AM-107Z	E CAPACITOR	100uF 10V M	
C2	QCBB1HK-104Y	C CAPACITOR	0.1uF 50V K	
C3	QFLC1HJ-103Z	M CAPACITOR	0.01uF 50V J	
C5	QFLC1HJ-103Z	M CAPACITOR	0.01uF 50V J	
C6	QCBB1HK-104Y	C CAPACITOR	0.1uF 50V K	
C7	QCBB1HK-104Y	C CAPACITOR	0.1uF 50V K	
CN1	QGF1036F1-15	CONNECTOR	FFC/FPC (1-15)	
CN2	QGB2024K1-07S	CONNECTOR	B-B (1-7)	
CN3	QGB2024J1-07S	CONNECTOR	B-B (1-7)	
SW1	QSW0844-001	PUSH SWITCH		
SW2	QSW0844-001	PUSH SWITCH		
SW3	QSW0844-001	PUSH SWITCH		
SW4	QSW0844-001	PUSH SWITCH		
SW5	QSW0844-001	PUSH SWITCH		
SW6	QSW0854-002	PUSH SW		
SW8	QSW0923-001	DETECT SWITCH		

Packing materials and accessories parts list

Block No. **M 3 M M**

(A,UW,UY,UG)

No additional / supplemental order of WARRANTY CARDS are available

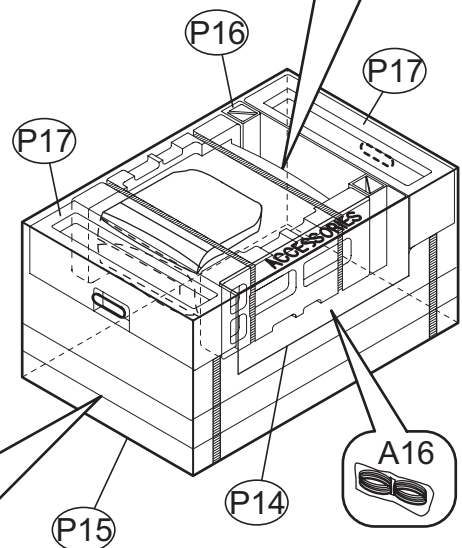
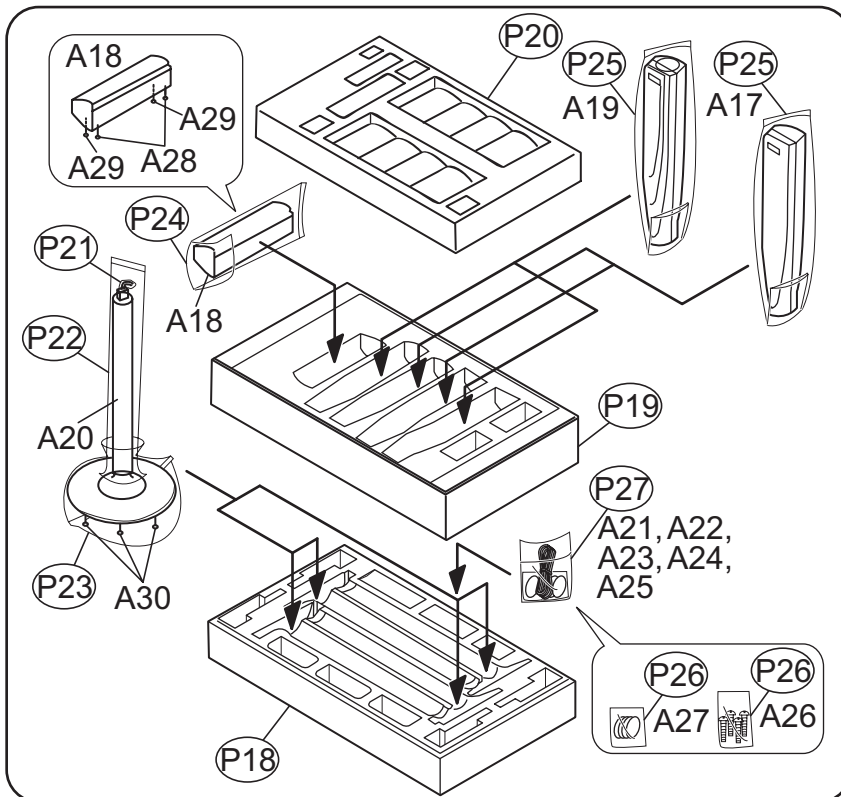
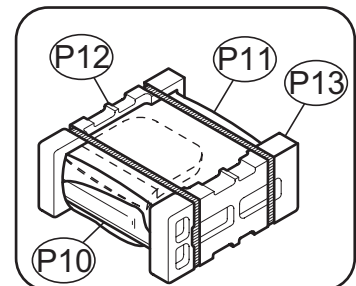
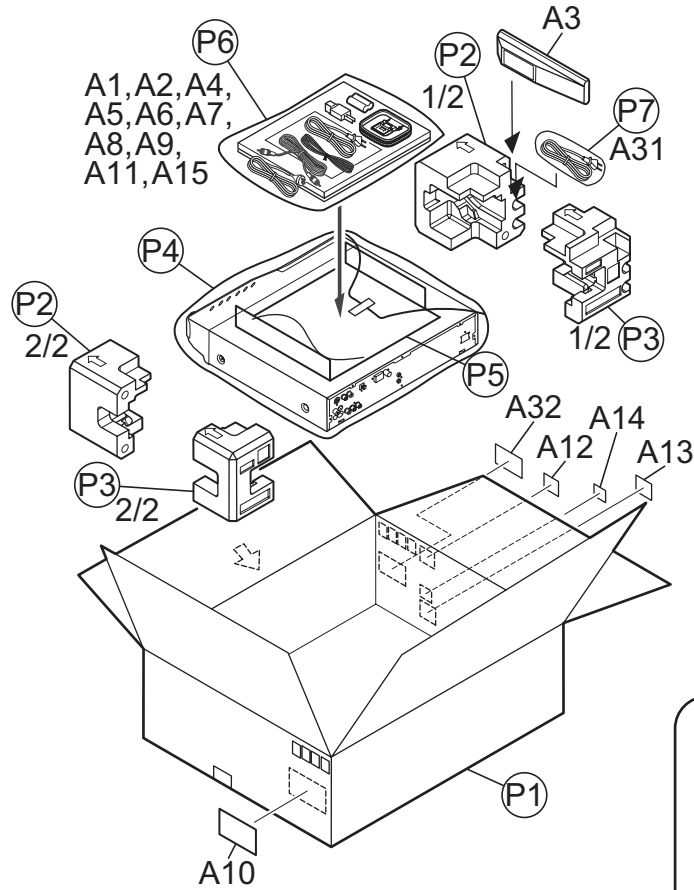

Packing and Accessories (A,UW,UY,UG)

Block No. [M][3][M][M]

△	Symbol No.	Part No.	Part Name	Description	Local
	A 1	GVT0150-008A	INSTRUC.BOOK	ENG	A,UG,UW
	A 2	GVT0150-006A	INSTRUC.BOOK	ARA PER	UG
	A 2	GVT0150-004A	INSTRUC.BOOK	SPA POR	UW,UY
	A 3	RM-STHC7U	REMOTE CON.		
△	A 4	QMPL060-183-JD	POWER CORD(EU)	1.83m BLACK	UG,UW
	A 5	-----	BATTERY	(x2)	
	A 6	QAM0216-001	SIGNAL CORD		
	A 7	QAL0014-001	AM LOOP ANT		
	A 8	QAL0457-001	ANT.WIRE		
△	A 9	QAM0112-002	PLUG ADAPTOR	(x2)	UG,UW
	A 10	CL0020-001	COMPUTER LABEL		
	A 11	-----	WARRANTY CARD	BT-56012-1	A
	A 12	GV40641-002A	NOM LABEL		UW
	A 13	LV30259-018A	UY LABEL		UY
	A 14	GV30824-002A	IRAM LABEL		UY
△	A 15	QMPH050-183-JC	POWER CORD(EU)	1.83m BLACK	A
	A 16	6200044901	DIN CABLE		
	A 17	AB050036-01	SPEAKER BOX	FRONT(x2)	
	A 18	AB050038-01	SPEAKER BOX	CENTER	
	A 19	AB050037-01	SPEAKER BOX	SURROUND(x2)	
	A 20	9900033801	STAND BASE ASSY	(x4)	
	A 21	6200045901	SPK CORD-C	CENTER	
	A 22	6200045911	SPK CORD-FR	FRONT RIGHT	
	A 23	6200045921	SPK CORD-FL	FRONT LEFT	
	A 24	6200045931	SPK CORD-SR	SURROUND RIGHT	
	A 25	6200045941	SPK CORD-SL	SURROUND LEFT	
	A 26	7001652506	SCREW	(x4)	
	A 27	9000011101	COVER	(x4)	
	A 28	9000008401	RUBBER CUSHION	CENTER SPK(x2)	
	A 29	9000009501	RUBBER CUSHION	CENTER SPK(x2)	
	A 30	9000005371	FOOT	STAND BASE(x24)	
△	A 31	QMPS190-183-JC	POWER CORD(EU)	1.83m BLACK	UY
	A 32	LE40796-001A	VERANCE LABEL		
	P 1	GV20328-002A	CARTON ASSY		UG
	P 1	GV20328-001A	CARTON ASSY		A,UW,UY
	P 2	GV20325-001A	CUSHION(FRONT)		
	P 3	GV20326-001A	CUSHION(REAR)		
	P 4	QPC05006515P	POLY BAG	50cm x 65cm	
	P 5	GV30779-001A	CARTON SPACER		
	P 6	QPA02503505P	POLY BAG	25cm x 35cm	
	P 7	QPA01503503	POLY BAG	15cm x 35cm	UY
	P 10	8500051881	MIRROR MAT		
	P 11	8500051901	POLY BAG		
	P 12	LV22000-001A	TOP CUSHION		
	P 13	LV22000-002A	BOTTOM CUSHION		
	P 14	LV35852-001A	ACCESSORY BOX		
	P 15	LV35831-014A	PACKING CASE		UG,UW,UY
	P 15	LV35831-040A	PACKING CASE		A
	P 16	LV35833-002A	PARTITION		
	P 17	LV35994-001A	CUSHION	(x2)	
	P 18	LV22009-001A	CUSHION A		
	P 19	LV22009-002A	CUSHION B		
	P 20	LV22009-003A	CUSHION C		
	P 21	8500047111	POLY BAG	(x4)	
	P 22	8500059101	POLY BAG	(x4)	
	P 23	8500055761	POLY BAG	(x4)	
	P 24	8500055781	POLY BAG		
	P 25	8500055771	POLY BAG	(x4)	
	P 26	8500047101	POLY BAG	(x2)	
	P 27	8500032771	POLY BAG		

Packing materials and accessories parts list

Block No. M 4 M M

(UJ)

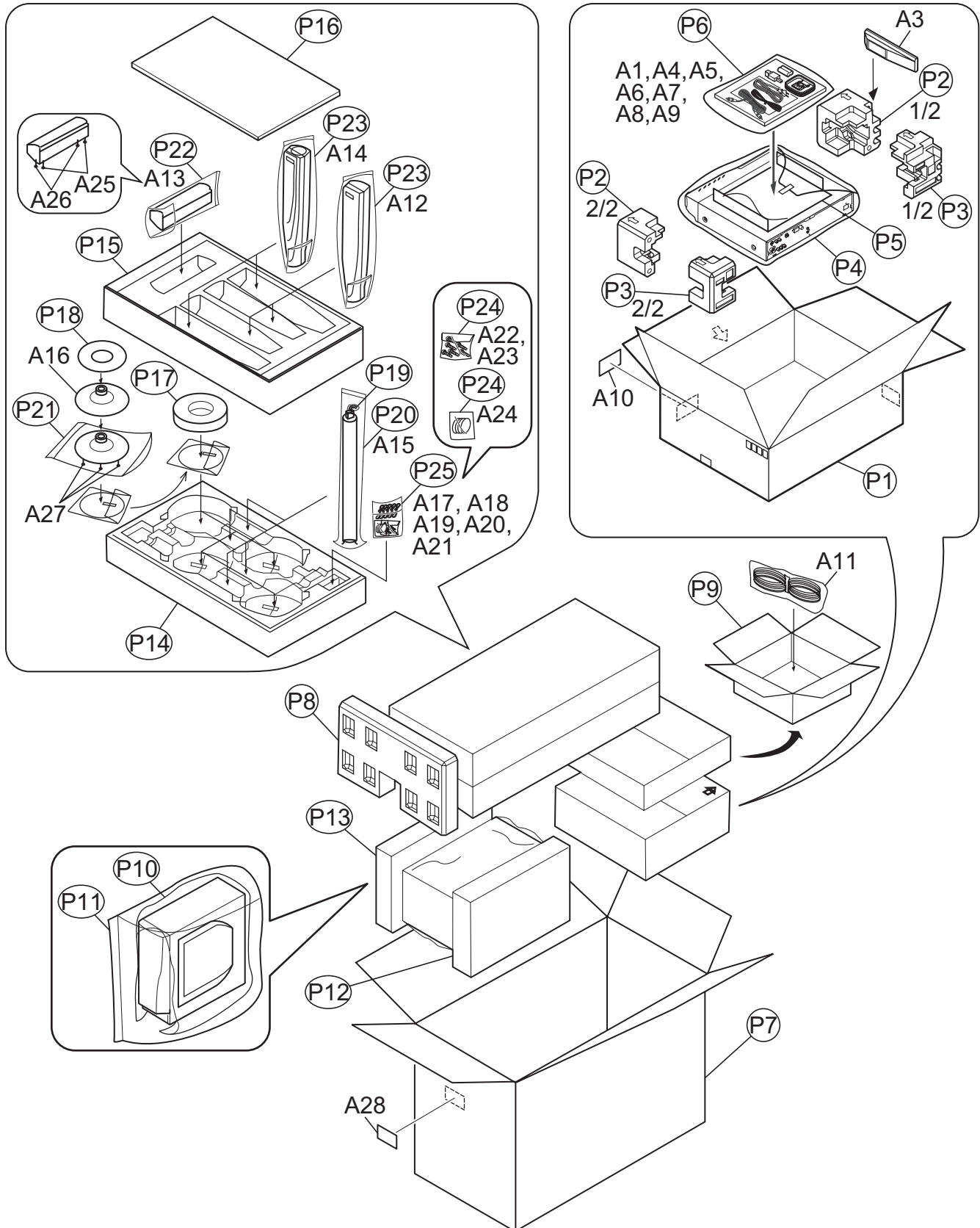

Packing and Accessories (UJ)

Block No. [M][4][M][M]

△	Symbol No.	Part No.	Part Name	Description	Local
	A 1	GVT0150-009A	INSTRUC.BOOK	ENG	
	A 3	RM-STHC8J	REMOTE CON.		
△	A 4	QMPL060-183-JD	POWER CORD(EU)	1.83m BLACK	
	A 5	-----	BATTERY	(x2)	
	A 6	QAM0216-001	SIGNAL CORD		
	A 7	QAL0014-001	AM LOOP ANT		
	A 8	QAL0457-001	ANT.WIRE		
△	A 9	QAM0112-002	PLUG ADAPTOR	(x2)	
	A 10	CL0020-001	COMPUTER LABEL		
	A 11	QAM0588-001	DIN CABLE		
	A 12	AB050036-01	SPEAKER BOX	FRONT(x2)	
	A 13	AB050038-01	SPEAKER BOX	CENTER	
	A 14	AB050037-01	SPEAKER BOX	SURROUND(x2)	
	A 15	9900033701	STAND ASSY	(x4)	
	A 16	9900033711	BASE ASSY	(x4)	
	A 17	6200045901	SPK CORD-C	CENTER	
	A 18	6200045911	SPK CORD-FR	FRONT RIGHT	
	A 19	6200045921	SPK CORD-FL	FRONT LEFT	
	A 20	6200045931	SPK CORD-SR	SURROUND RIGHT	
	A 21	6200045941	SPK CORD-SL	SURROUND LEFT	
	A 22	7004445506	SCREW	(x12)	
	A 23	7001652506	SCREW	(x4)	
	A 24	9000011101	COVER	(x4)	
	A 25	9000008401	RUBBER CUSHION	(x2)	
	A 26	9000009501	RUBBER CUSHION	(x2)	
	A 27	9000005371	FOOT	(x24)	
	A 28	LE40796-001A	VERANCE LABEL		
	P 1	GV30768-003A	CARTON ASSY		
	P 2	GV20325-001A	CUSHION(FRONT)		
	P 3	GV20326-001A	CUSHION(REAR)		
	P 4	QPC05006515P	POLY BAG	50cm x 65cm	
	P 5	GV30779-001A	CARTON SPACER		
	P 6	QPA02503505P	POLY BAG	25cm x 35cm	
	P 7	GV20321-004A	MASTER CARTON		
	P 8	GV30657-001A	CUSHION PAD		
	P 9	GV30658-001A	ACC. BOX		
	P 10	8500051881	MIRROR MAT		
	P 11	8500051901	POLY BAG		
	P 12	LV22000-001A	TOP CUSHION		
	P 13	LV22000-002A	BOTTOM CUSHION		
	P 14	LV21999-001A	CUSHION A		
	P 15	LV21999-002A	CUSHION B		
	P 16	LV21999-003A	CUSHION C		
	P 17	LV35854-001A	CUSHION	(x4)	
	P 18	8500059001	MIRROR MAT	(x4)	
	P 19	8500047111	POLY BAG	(x4)	
	P 20	8500059101	POLY BAG	(x4)	
	P 21	8500059141	POLY BAG	(x4)	
	P 22	8500055781	POLY BAG		
	P 23	8500055771	POLY BAG	(x4)	
	P 24	8500047101	POLY BAG	(x2)	
	P 25	8500032771	POLY BAG		