

JVC

SERVICE MANUAL

DVD DIGITAL CINEMA SYSTEM

TH-C90A, TH-C90US, TH-C90UX, TH-C90UG, TH-C60US, TH-C60UP, TH-C60UW, TH-C60UX, TH-C60UY, TH-C60UG

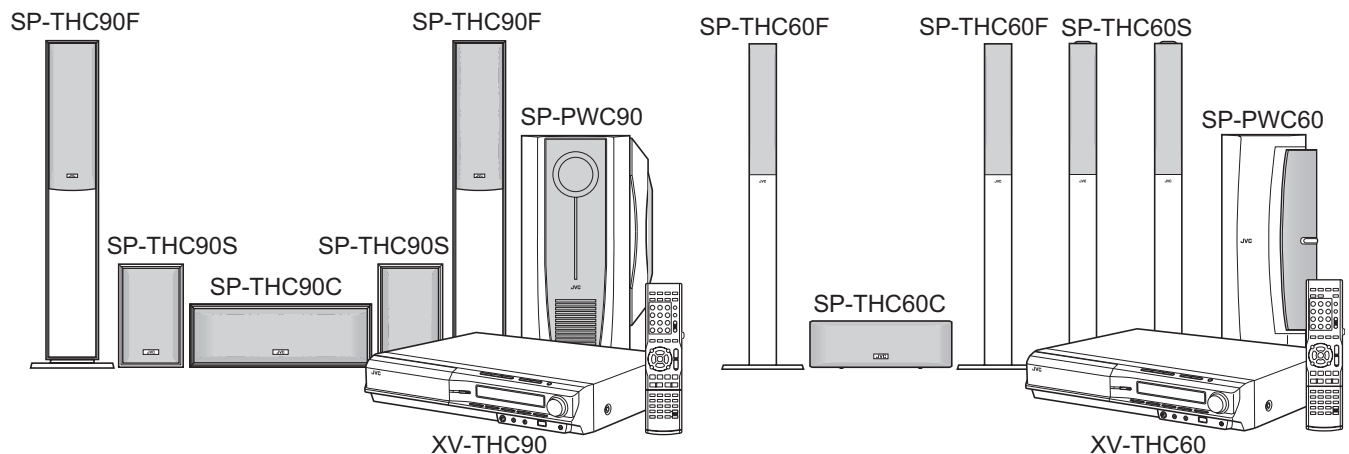

Lead free solder used in the board (material : Sn-Ag-Cu, melting point : 219 Centigrade)

TABLE OF CONTENTS

1	PRECAUTION.....	1-4
2	SPECIFIC SERVICE INSTRUCTIONS.....	1-7
3	DISASSEMBLY.....	1-8
4	ADJUSTMENT.....	1-39
5	TROUBLESHOOTING.....	1-43

SPECIFICATION

Center unit (XV-THC90/XV-THC60)

Audio section	Digital input*1	DIGITAL IN (DBS) (OPTICAL)	-21 dBm to -15 dBm (660 nm ±30 nm)	
	Analog input		AUX IN (VCR) TAPE IN (Only for XV-THC90)	
	Analog output		TAPE OUT (Only for XV-THC90)	
Video section	Video System		PAL/NTSC	
	Horizontal Resolution		500 lines	
	Signal-to-Noise Ratio		64 dB	
	Video output level	Composite		1.0 V(p-p)/75 Ω
		S-video-Y		1.0 V(p-p)/75 Ω
		S-video-C		For PAL: 0.3 V(p-p)/75 Ω For NTSC: 0.286 V(p-p)/75 Ω
		Component-Y		1.0 V(p-p)/75 Ω
Component-PB/PR			0.7 V(p-p)/75 Ω	
Video input sensitivity/ Impedance (VCR IN)	Composite		1.0 V(p-p)/75 Ω	
	S-video-Y		1.0 V(p-p)/75 Ω	
	S-video-C		For PAL: 0.3 V(p-p)/75 Ω For NTSC: 0.286 V(p-p)/75 Ω	
USB storage	USB specification		Compatible with the USB 2.0 Full-Speed	
	Compatible device		Mass Storage Class	
	Compatible file system		FAT16, FAT32	
	Bus power supply		Max. 500 mA	
Tuner section	Tuning Range	FM	87.50 MHz to 108.00 MHz	
		AM	At 10 kHz intervals : 530 kHz to 1 710 kHz (1 600 kHz)*2 At 9 kHz intervals : 531 kHz to 1 710 kHz (1 602 kHz)*2	
General	Power Requirements		AC 110 - 240 V , 50/60 Hz (For US, UG, UX) AC 240 V , 50 Hz (For A) AC 110-240 V , 50/60 Hz (For UW)	
	Power Consumption		25 W (at operation), 1.2 W (in standby mode)	
	Dimensions (W × H × D)		400 mm × 85 mm × 316 mm	
	Mass		3.8 kg	

*1: Corresponding to Linear PCM, Dolby Digital, and DTS Digital Surround (with sampling frequency -32 kHz, 44.1 kHz, 48 kHz)

*2: For the countries of the Middle East

Subwoofer (SP-PWC90)

Amplifier section	Front/Center/Surround	140 W per channel, RMS at 4 Ω at 1 kHz, with 10 % total harmonic distortion.
	Subwoofer	300 W, RMS at 4 Ω at 40 Hz, with 10 % total harmonic distortion.
Speaker section	Speaker unit	25 cm Bass-reflex
	Power Handling Capacity	300 W
	Impedance	4 Ω
	Frequency Range	25 Hz to 200 Hz
	Sound Pressure Level	74 dB/W·m
General	Power Requirements	AC 110 V/ AC 127 V/ AC 220 - 240 V , 50/60 Hz
	Power Consumption	110 W (at operation), 0 W (in standby mode)
	Dimensions (W × H × D)	264 mm × 481 mm × 459 mm
	Mass	17.6 kg

Subwoofer (SP-PWC60)

Amplifier section	Front/Center/Surround	135 W per channel, RMS at 4 Ω at 1 kHz, with 10 % total harmonic distortion.
	Subwoofer	135 W, RMS at 4 Ω at 100 Hz, with 10 % total harmonic distortion.
Speaker section	Speaker unit	16 cm Bass-reflex
	Power Handling Capacity	140 W
	Impedance	4 Ω
	Frequency Range	30 Hz to 200 Hz
	Sound Pressure Level	75 dB/W·m
General	Power Requirements	AC 110 V/ AC 127 V/ AC 220 - 240 V , 50/60 Hz
	Power Consumption	135 W (at operation), 0 W (in standby mode)
	Dimensions (W × H × D)	171 mm × 411 mm × 458 mm
	Mass	12.3 kg

Satellite Speakers (SP-XTHC90)

Front speakers (SP-THC90F)	Type	2-way 3-speaker Bass reflex type (Magnetically shielded Type)
	Speaker	13.5 cm cone × 2, 6.0 cm cone × 1
	Power Handling Capacity	140 W
	Impedance	4 Ω
	Frequency Range	60 Hz to 20 000 Hz
	Sound Pressure Level	89 dB/W·m
	Dimensions (W × H × D)	270 mm × 1 027.5 mm × 320 mm
	Mass	8.8 kg each
Center speaker (SP-THC90C)	Type	2-way 3-speaker Bass reflex type (Magnetically shielded Type)
	Speaker	10.5 cm cone × 2, 4.0 cm cone × 1
	Power Handling Capacity	140 W
	Impedance	4 Ω
	Frequency Range	65 Hz to 20 000 Hz
	Sound Pressure Level	89 dB/W·m
	Dimensions (W × H × D)	400 mm × 141 mm × 171.5 mm
	Mass	3.8 kg
Surround speakers (SP-THC90S)	Type	2-way Bass reflex type
	Speaker	10.5 cm cone × 1, 4.0 cm cone × 1
	Power Handling Capacity	140 W
	Impedance	4 Ω
	Frequency Range	75 Hz to 20 000 Hz
	Sound Pressure Level	81 dB/W·m
	Dimensions (W × H × D)	140 mm × 228.5 mm × 174 mm
	Mass	1.7 kg each

Satellite Speakers (SP-XTHC60)

Front speakers (SP-THC60F)	Type	1-way 2-speaker Bass reflex type (Magnetically shielded Type)
	Speaker	5.5 cm cone × 2
	Power Handling Capacity	140 W
	Impedance	4 Ω
	Frequency Range	100 Hz to 20 000 Hz
	Sound Pressure Level	79 dB/W·m
	Dimensions (W × H × D)	280 mm × 1 106 mm × 280 mm
	Mass	3.3 kg each
Center speaker (SP-THC60C)	Type	1-way 2-speaker Bass reflex type (Magnetically shielded Type)
	Speaker	6.5 cm cone × 2
	Power Handling Capacity	140 W
	Impedance	4 Ω
	Frequency Range	90 Hz to 20 000 Hz
	Sound Pressure Level	82 dB/W·m
	Dimensions (W × H × D)	250 mm × 85 mm × 91 mm
	Mass	0.8 kg
Surround speakers (SP-THC60S)	Type	2-way 3-speaker Bass reflex type
	Speaker	5.5 cm cone × 2, 3.0 cm dome × 1
	Power Handling Capacity	140 W
	Impedance	4 Ω
	Frequency Range	100 Hz to 20 000 Hz
	Sound Pressure Level	79 dB/W·m
	Dimensions (W × H × D)	280 mm × 1 114 mm × 280 mm
	Mass	3.4 kg each

Designs & specifications are subject to change without notice.

SECTION 1 PRECAUTION

1.1 Safety Precautions

- (1) This design of this product contains special hardware and many circuits and components specially for safety purposes. For continued protection, no changes should be made to the original design unless authorized in writing by the manufacturer. Replacement parts must be identical to those used in the original circuits. Services should be performed by qualified personnel only.
- (2) Alterations of the design or circuitry of the product should not be made. Any design alterations of the product should not be made. Any design alterations or additions will void the manufacturer's warranty and will further relieve the manufacturer of responsibility for personal injury or property damage resulting therefrom.
- (3) Many electrical and mechanical parts in the products have special safety-related characteristics. These characteristics are often not evident from visual inspection nor can the protection afforded by them necessarily be obtained by using replacement components rated for higher voltage, wattage, etc. Replacement parts which have these special safety characteristics are identified in the Parts List of Service Manual. Electrical components having such features are identified by shading on the schematics and by (Δ) on the Parts List in the Service Manual. The use of a substitute replacement which does not have the same safety characteristics as the recommended replacement parts shown in the Parts List of Service Manual may create shock, fire, or other hazards.
- (4) The leads in the products are routed and dressed with ties, clamps, tubings, barriers and the like to be separated from live parts, high temperature parts, moving parts and/or sharp edges for the prevention of electric shock and fire hazard. When service is required, the original lead routing and dress should be observed, and it should be confirmed that they have been returned to normal, after reassembling.

(5) Leakage shock hazard testing

After reassembling the product, always perform an isolation check on the exposed metal parts of the product (antenna terminals, knobs, metal cabinet, screw heads, headphone jack, control shafts, etc.) to be sure the product is safe to operate without danger of electrical shock. Do not use a line isolation transformer during this check.

- Plug the AC line cord directly into the AC outlet. Using a "Leakage Current Tester", measure the leakage current from each exposed metal part of the cabinet, particularly any exposed metal part having a return path to the chassis, to a known good earth ground. Any leakage current must not exceed 0.5mA AC (r.m.s.).
- Alternate check method
Plug the AC line cord directly into the AC outlet. Use an AC voltmeter having, 1,000 Ω per volt or more sensitivity in the following manner. Connect a 1,500 Ω 10W resistor paralleled by a 0.15 μ F AC-type capacitor between an exposed metal part and a known good earth ground. Measure the AC voltage across the resistor with the AC

voltmeter.

Move the resistor connection to each exposed metal part, particularly any exposed metal part having a return path to the chassis, and measure the AC voltage across the resistor. Now, reverse the plug in the AC outlet and repeat each measurement. Voltage measured any must not exceed 0.75 V AC (r.m.s.). This corresponds to 0.5 mA AC (r.m.s.).

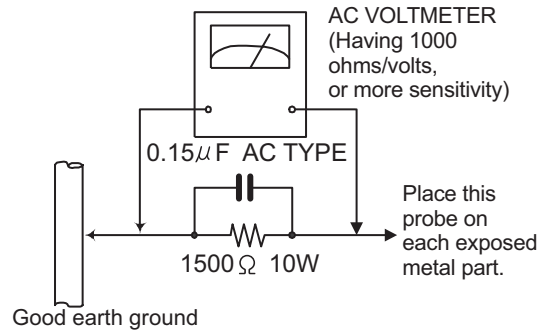

1.2 Warning

- (1) This equipment has been designed and manufactured to meet international safety standards.
- (2) It is the legal responsibility of the repairer to ensure that these safety standards are maintained.
- (3) Repairs must be made in accordance with the relevant safety standards.
- (4) It is essential that safety critical components are replaced by approved parts.
- (5) If mains voltage selector is provided, check setting for local voltage.

1.3 Caution

Burrs formed during molding may be left over on some parts of the chassis.

Therefore, pay attention to such burrs in the case of pre-forming repair of this system.

1.4 Critical parts for safety

In regard with component parts appearing on the silk-screen printed side (parts side) of the PWB diagrams, the parts that are printed over with black such as the resistor (■), diode (■) and ICP (●) or identified by the " Δ " mark nearby are critical for safety. When replacing them, be sure to use the parts of the same type and rating as specified by the manufacturer. (This regulation does not Except the J and C version)

1.5 Preventing static electricity

Electrostatic discharge (ESD), which occurs when static electricity stored in the body, fabric, etc. is discharged, can destroy the laser diode in the traverse unit (optical pickup). Take care to prevent this when performing repairs.

1.5.1 Grounding to prevent damage by static electricity

Static electricity in the work area can destroy the optical pickup (laser diode) in devices such as laser products. Be careful to use proper grounding in the area where repairs are being performed.

(1) Ground the workbench

Ground the workbench by laying conductive material (such as a conductive sheet) or an iron plate over it before placing the traverse unit (optical pickup) on it.

(2) Ground yourself

Use an anti-static wrist strap to release any static electricity built up in your body.

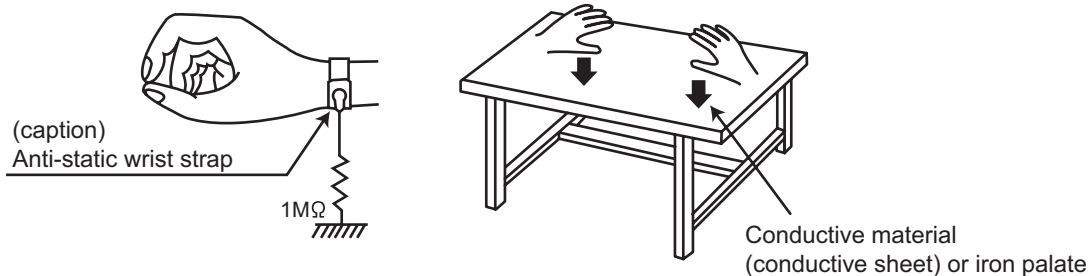

(3) Handling the optical pickup

- In order to maintain quality during transport and before installation, both sides of the laser diode on the replacement optical pickup are shorted. After replacement, return the shorted parts to their original condition. (Refer to the text.)
- Do not use a tester to check the condition of the laser diode in the optical pickup. The tester's internal power source can easily destroy the laser diode.

1.6 Handling the traverse unit (optical pickup)

- (1) Do not subject the traverse unit (optical pickup) to strong shocks, as it is a sensitive, complex unit.
- (2) Cut off the shorted part of the flexible cable using nippers, etc. after replacing the optical pickup. For specific details, refer to the replacement procedure in the text. Remove the anti-static pin when replacing the traverse unit. Be careful not to take too long a time when attaching it to the connector.
- (3) Handle the flexible cable carefully as it may break when subjected to strong force.
- (4) It is not possible to adjust the semi-fixed resistor that adjusts the laser power. Do not turn it.

1.7 Attention when traverse unit is decomposed

***Please refer to "Disassembly method" in the text for the pickup unit.**

- Apply solder to the short land sections before the card wire is disconnected from the connector on the servo board. (If the card wire is disconnected without applying solder, the pickup may be destroyed by static electricity.)
- In the assembly, be sure to remove solder from the short land sections after connecting the card wire.

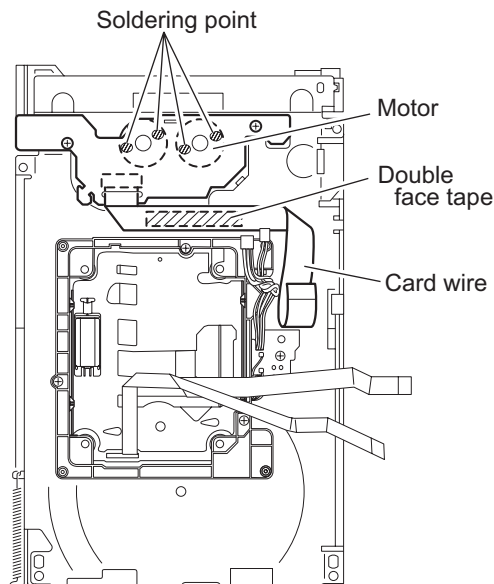

1.8 Important for laser products

1.CLASS 1 LASER PRODUCT

2.CAUTION :

(For U.S.A.) Visible and/or invisible class II laser radiation when open. Do not stare into beam.

(Others) Visible and/or invisible class 1M laser radiation when open. Do not view directly with optical instruments.

3.CAUTION : Visible and/or invisible laser radiation when open and inter lock failed or defeated. Avoid direct exposure to beam.

4.CAUTION : This laser product uses visible and/or invisible laser radiation and is equipped with safety switches which prevent emission of radiation when the drawer is open and the safety interlocks have failed or are defeated. It is dangerous to defeat the safety switches.

(For U.S.A.)

CAUTION : Visible and/or invisible class II laser radiation when open. Do not stare into beam.

(Others)

CAUTION : Visible and/or invisible class 1M laser radiation when open. Do not view directly with optical instruments

ACHTUNG: Sichtbare und/oder unsichtbare Laserstrahlung der Klasse 1M bei offenen Abdeckungen. Nicht direkt mit optischen Instrumenten betrachten.

ATTENTION: Rayonnement laser visible et/ou invisible de classe 1M une fois ouvert. Ne pas regarder directement avec des instruments optiques.

VOORZICHTIG: Zichtbare en/of onzichtbare klasse 1M laserstralen indien geopend. Bekijk niet direct met optische instrumenten.

ATTENZIONE: Radiazione laser in classe 1M visibile e/o invisibile quando aperto. Non osservare direttamente con strumenti ottici.

WARNING: Synlig och/eller osynlig laserstrålning, klass 1M, när denna del är öppnad. Betrakta ej strålen med optiska instrument.

VARO! Avattaessa olet alttiina nakyyvalle ja/tai näkymättömälle luokan 1M lasersäteilylle. Älä tarkastele sitä optisen laitteen läpi.

ADVASEL: Synlig og/eller usynlig klasse 1M-laserstråling ved åbning. Se ikke direkte med optiske instrumenter.

AVISO: Radiación láser de clase 1M visible y/o invisible cuando está abierto. No mirar directamente con instrumental óptico.

PRECAUÇÃO: Radiação laser de classe 1M visível e/ou invisível quando aberto. Não olhe diretamente com instrumentos ópticos.

5.CAUTION : If safety switches malfunction, the laser is able to function.

6.CAUTION : Use of controls, adjustments or performance of procedures other than those specified here in may result in hazardous radiation exposure.



CAUTION Please use enough caution not to see the beam directly or touch it in case of an adjustment or operation check.

PRECAUÇÃO: Radiação laser de classe 1M visível e/ou invisível quando aberto. Não olhe diretamente com instrumentos ópticos.

ПРЕДУПРЕЖДЕНИЕ: В открытом состоянии происходит видимое и/или невидимое излучение лазера класса 1M. Не смотрите непосредственно в оптические инструменты.

UWAGA: Otwarcie spowoduje narażenie na widzialne i/lub niewidzialne promieniowanie lasera klasy 1M. Nie patrzeć bezpośrednio w przyrządy optyczne.

UPOZORNĚNÍ: Při otevření vydává viditelné popř. neviditelné laserové ozáření třídy 1M. Nedívejte se do otvoru přímo s optickými nástroji.

FIGYELMEZTETÉS: Látható és/vagy láthatatlan 1M osztályú sugárzás nyitott állapotban. Ne nézze közvetlenül optikai műszerekkel.

注意: 打開蓋板可能會產生可見或不可見的 1M 級鐳射。不要使用光學儀器直接進行窺視。

注意: 打开蓋板可能会产生可见或不可见的 1M 级辐射。不要使用光学仪器直接进行窥视。

تنبيه: يوجد إشعاع ليزري مرئي و/أو غير مرئي من الفئة 1M عندما يكون الجهاز مفتوحاً. تجنب النظر مباشرة داخل الجهاز باستخدام أدوات بصرية.

احتياط: هنگامی که باز گردد، تشعشع مرئی و یا نامرئی کلاس 1M لیزر وجود دارد. با لوازم چشمی مستقیماً به آن نگاه نکنید.

주의: 개방하면 가시 및/또는 비가시 클래스 1M 레이저 방사선이 나옵니다. 광학 기구로 직접 들여다보지 마십시오.

REPRODUCTION AND POSITION OF LABELS and PRINT WARNING LABEL and PRINT

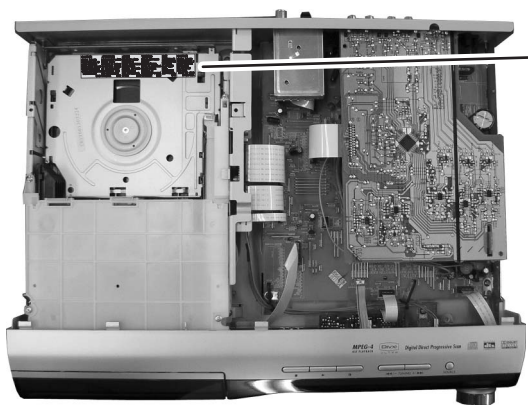

CAUTION VISIBLE AND/OR INVISIBLE CLASS 1M LASER RADIATION WHEN OPEN. DO NOT VIEW DIRECTLY WITH OPTICAL INSTRUMENTS. IEC60825-1:2001 (ENG)	ATTENTION RAYONNEMENT LASER VISIBLE ET/OU INVISIBLE DE CLASSE 1M UNE FOIS OUVERT. NE PAS REGARDER DIRECTEMENT AVEC DES INSTRUMENTS OPTIQUES. (FRA)	AVISO RADIACIÓN LASER DE CLASE 1M VISIBLE Y/O INVISIBLE CUANDO ESTA ABIERTO. NO MIRAR DIRECTAMENTE CON INSTRUMENTAL OPTICO. (ESP)	WARNING SYNLIG OCH/ELLER OSYNLIG LASERSTRÅLNING, KLASS 1M, NÄR DENNA DEL ÄR ÖPPNAD. BETRAKTA EJ STRÅLEN MED OPTISKA INSTRUMENT. (SWE)	注意 ニニニニニニニニニ 及び/または不可視 のクラス1M レーザー放射が 出ます。 光学装置で直接 見ないでください。 (JPN)	CAUTION VISIBLE AND/OR INVISIBLE CLASS II LASER RADIATION WHEN OPEN. DO NOT STARE INTO BEAM. FDA 21 CFR (ENG) LV44603-003A
--	--	---	---	---	---

CLASS 1
LASER PRODUCT



SECTION 2 SPECIFIC SERVICE INSTRUCTIONS

2.1 Extension cable for subwoofer

Please use the extension cable described to Service Bulletin (No. MB-SB-00018-2) when you service. It is an extension cable for the subwoofer.

Parts No.	Parts name	Amount used
EXTPWC5-14P	Extension cable	2
EXTPWM505-09P	Extension cable	1

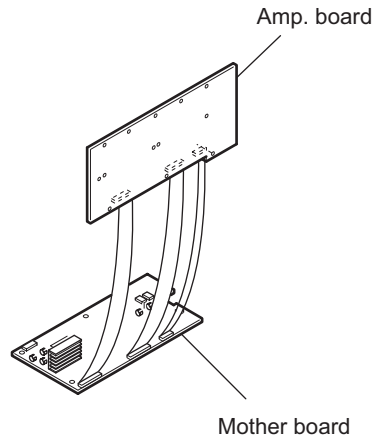

3.1.2 Removing the Front panel assembly (See Fig. 3 to 5)

- (1) Disconnect the card wires from Front panel assembly connected to connectors [CN450](#), [CN457](#), [CN455](#) and [CN451](#) of the main board assembly. (See Fig. 3)
- (2) Remove the one screw **C** attaching the earth wire to Main board assembly. (See Fig. 3)
- (3) Remove the two screws **D** attaching the Front panel assembly from bottom side. (See Fig. 4)
- (4) Disengage the hook **a** from the bottom chassis. (See Fig. 4)
- (5) Disengage the hook **b** and **c** from the both side of the bottom chassis. (See Fig. 5)

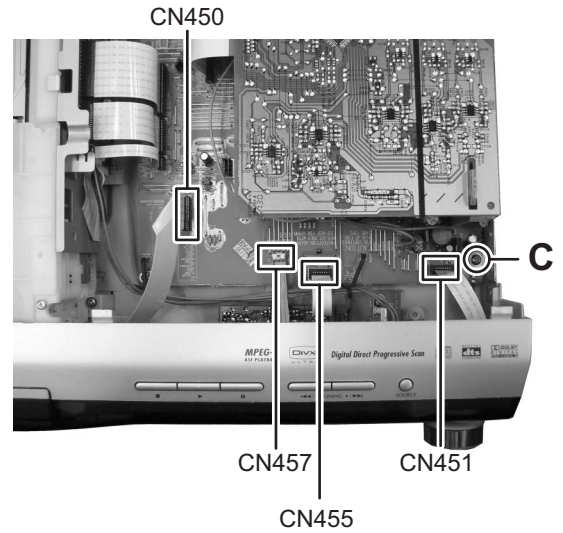

Fig.3

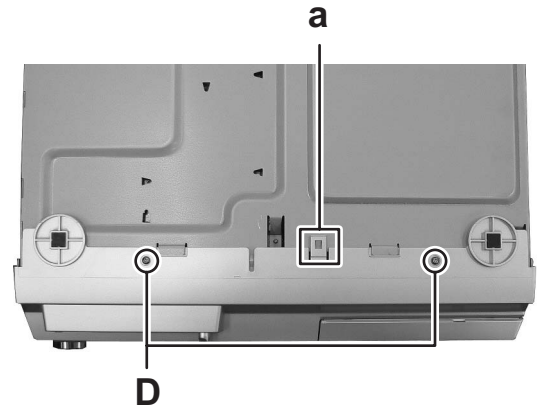

Fig.4

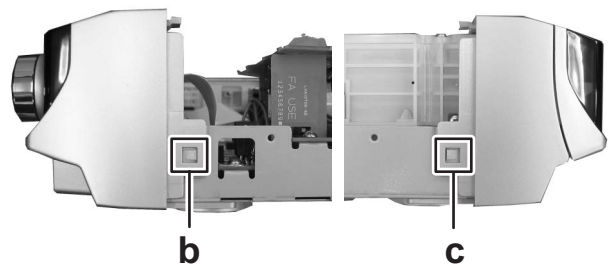

Fig.5

3.1.3 Removing the Audio & Digital input board assembly (See Fig. 6 to 8)

- (1) Disconnect the card wire from Main board connected to connector **CN102** of the Audio & Digital input board assembly. (See Fig. 6)
- (2) For TH-C90, remove the one screw **E** and two screws **F** attaching the Audio & Digital input board assembly. (See Fig. 7)
- (3) For TH-C60, remove the one screw **G** and one screw **H** attaching the Audio & Digital input board assembly. (See Fig. 8)
- (4) Disconnect the board to board connector **CN101** connected to connection board and then pull and lift up to direction of the arrow then take out the Audio & Digital input board assembly. (See Fig. 6)

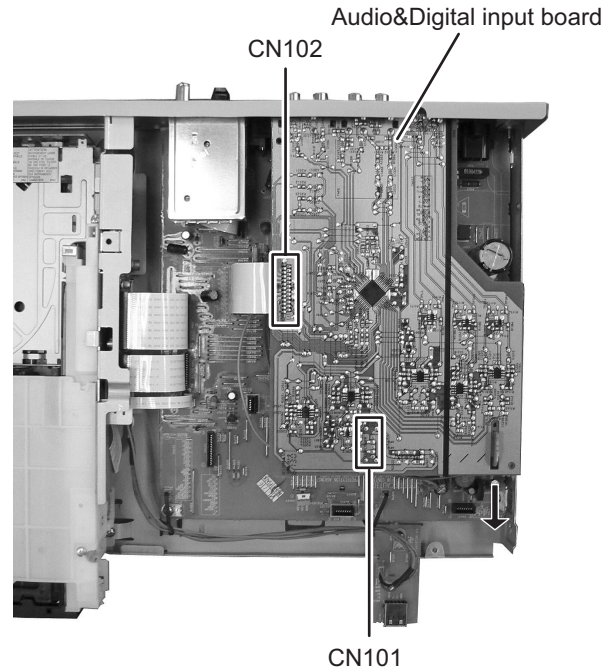

Fig.6

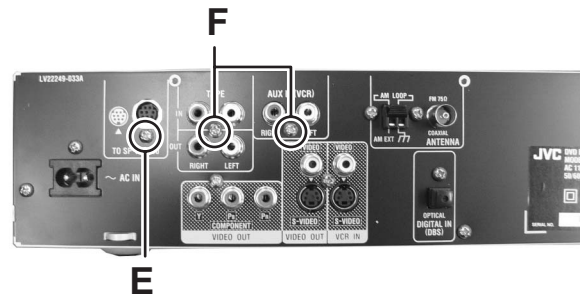

Fig.7

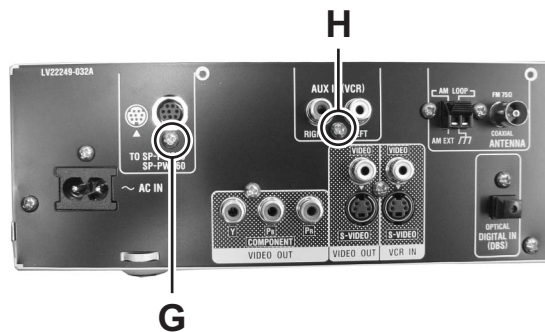
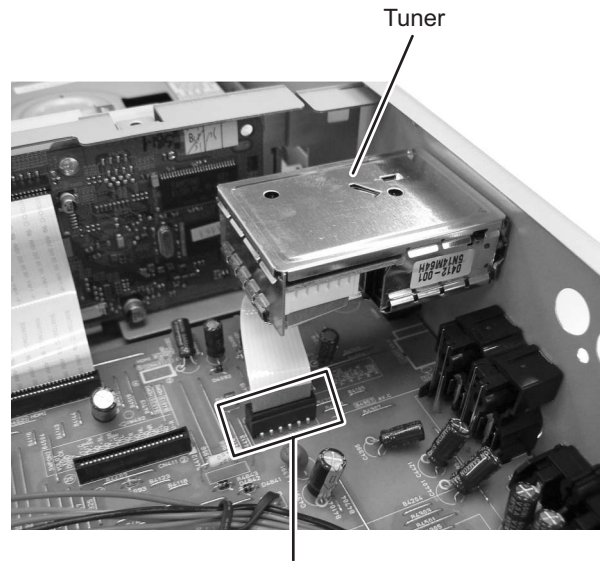

Fig.8

3.1.4 Removing the Tuner pack (See Fig. 9, 10)

- (1) Disconnect the card wire from Tuner pack connected to connector [CN410](#) of the Main board assembly. (See Fig. 9)
- (2) Remove the two screws **J** attaching the Tuner pack. (See Fig. 10)



CN410

Fig.9

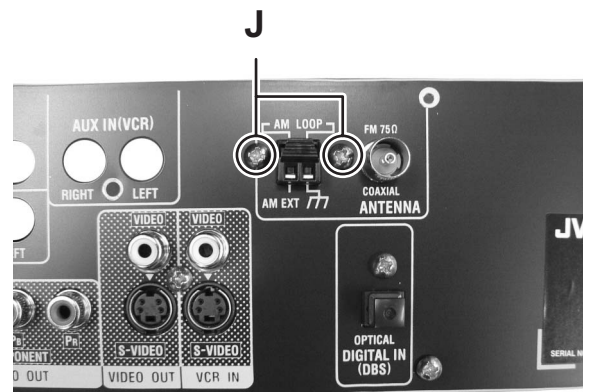

Fig.10

3.1.5 Removing the Main board assembly (See Fig. 11, 12)

- (1) Disconnect the card wires from DVD servo board assembly connected to connector [CN402](#), [CN403](#) and [CN404](#) of the Main board assembly. (See Fig. 11)
- (2) Remove the four screws **K** attaching the Main board assembly. (See Fig. 11)
- (3) Remove the four screws **L** attaching the Main board assembly from back side. (See Fig. 12)

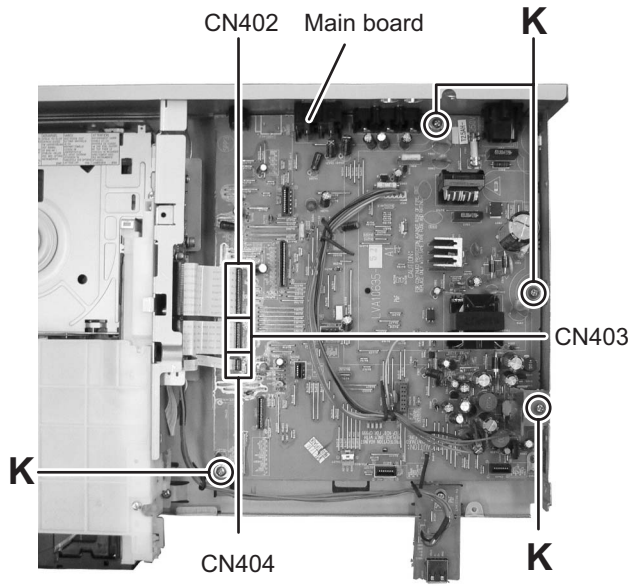

Fig.11

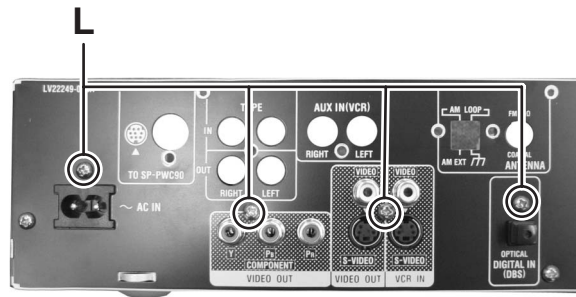

Fig.12

3.1.6 Removing the USB jack board assembly (See Fig. 13)

- (1) Disconnect the connector wire from USB jack board assembly connected to connector [CN811](#) of the DVD servo board assembly.
- (2) Remove the one screw **M** attaching the USB jack board assembly.

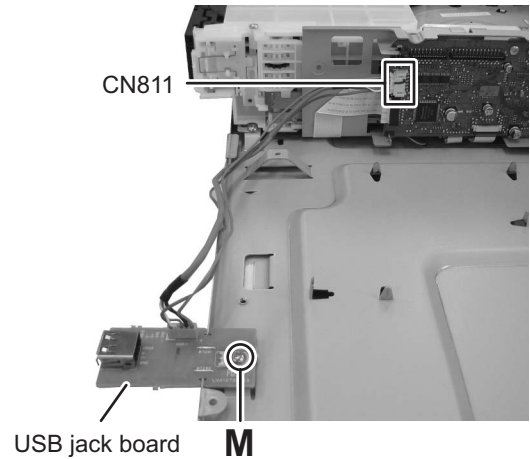

Fig.13

3.1.7 Removing the DVD changer mechanism assembly (See Fig. 14)

- (1) Remove the four screws **N** attaching the DVD changer mechanism assembly.

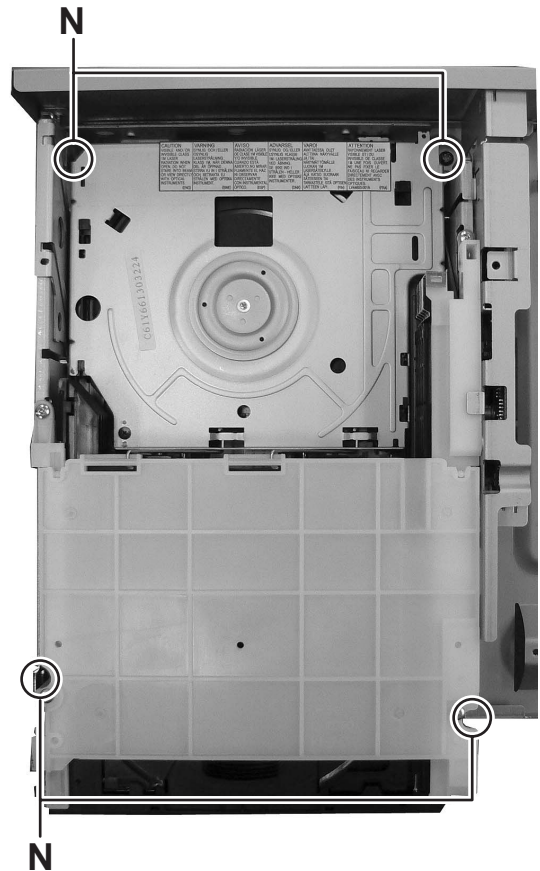

Fig.14

**3.1.8 Removing the Operation board assembly
(See Fig. 15)**

- (1) Remove the one screw **P** attaching the bracket board.
- (2) Remove the four screws **Q** attaching the Operation board.

**3.1.9 Removing the Front board assembly
(See Fig. 15, 16)**

- (1) Remove the bracket board.
- (2) Remove the Operation board assembly.
- (3) Remove the volume knob.
- (4) Remove the one screw **R** attaching the Front board assembly. (See Fig.16)
- (5) Remove the eight screws **S** attaching the Front board assembly.

**3.1.10 Removing the Mic jack board assembly
(See Fig. 15)**

- (1) Remove the mic volume knob.
- (2) Remove the two screws **T** attaching the Mic jack assembly.

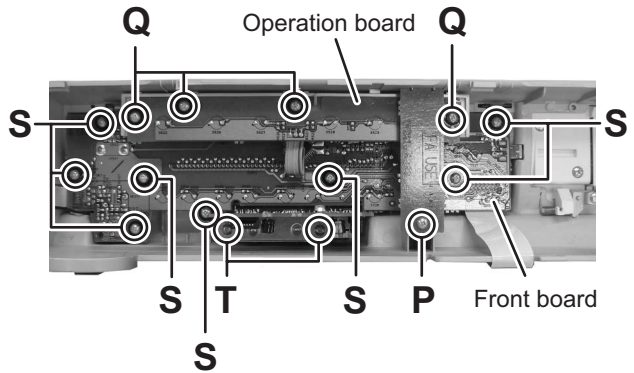

Fig.15



Fig.16

3.2 DVD mechanism section

3.2.1 Removing the DVD module board

(See Fig.1)

- (1) Disconnect the card wire connected to [CN451](#), [CN452](#), [CN453](#), [CN101](#) and [CN102](#) of DVD module board. (See Fig.1)
- (2) Remove the two screws **A** attaching the DVD module board. (See Fig.1)

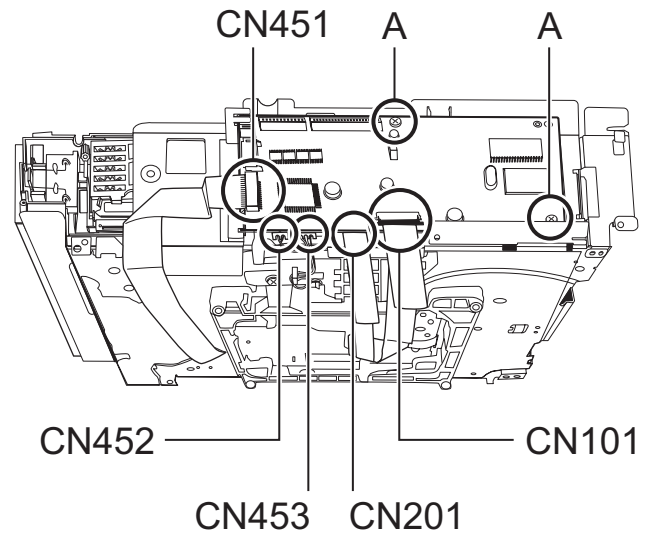

Fig.1

3.2.2 Removing the PWB bracket and wire holder

(See Fig.2)

- (1) Remove the two screws **B** attaching the wire holder.
- (2) Remove the one screw **C** attaching the PWB bracket.

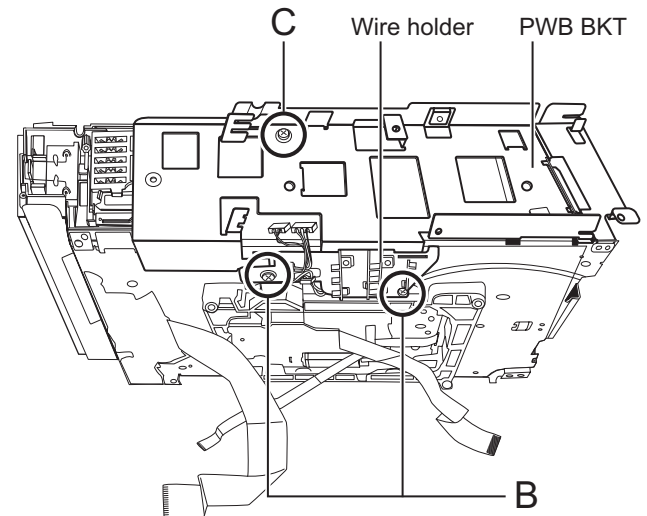

Fig.2

3.2.3 Removing the tray assembly (See Fig.3 to 7)

- (1) Remove the two screws **D** from the top cover and release the two joints **a** on both sides of the body. (See Fig.3)
- (2) Remove the top cover with the two rods attached to the top cover and lifter assembly respectively. (See Fig.4)
- (3) Remove the open detect lever on the left side of the body. (See Fig.5)
- (4) Push part **b** of the slide (R) assembly on the right side of the body to unlock the tray assembly. Draw out the trays toward the front. (See Fig.6)

Attention:

The tray can be locked if all tray assemblies are attached.

- (5) From top of the body, move the stopper tab **c** in the direction of the arrow and release. Pull out the tray assemblies from the body. (See Fig.6 and 7)

Caution:

Remove the tray assembly from top tray 5 in order.

Attention:

When reattaching the sub tray of the tray assembly, or when removing the DVD mechanism inside, refer to another section.

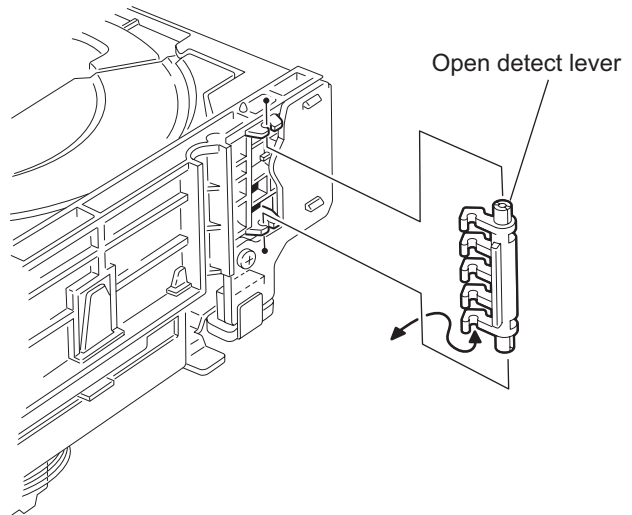

Fig.5

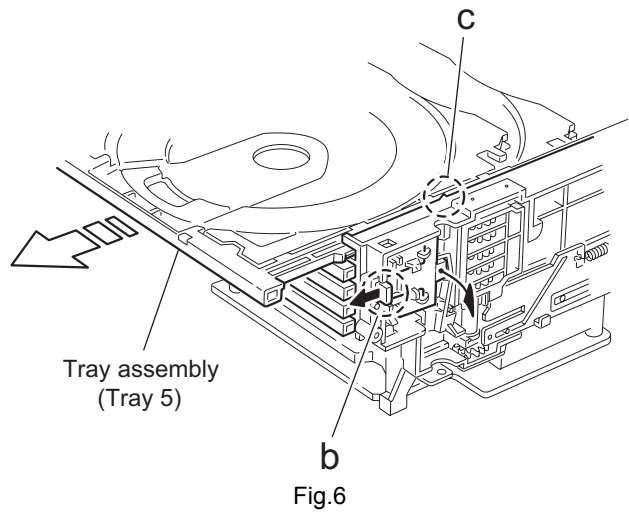

Fig.6

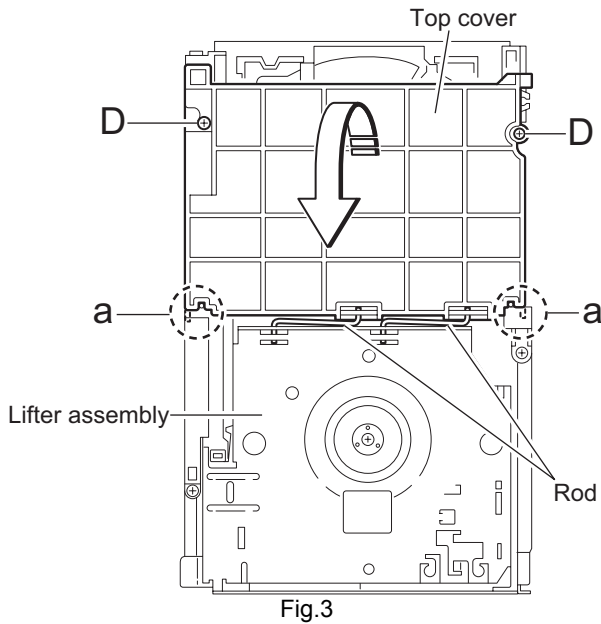

Fig.3

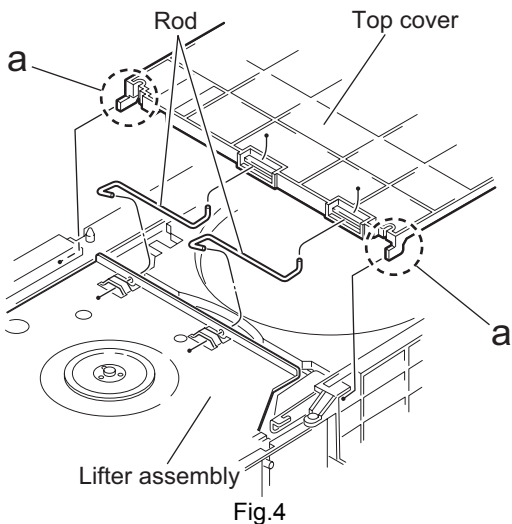

Fig.4

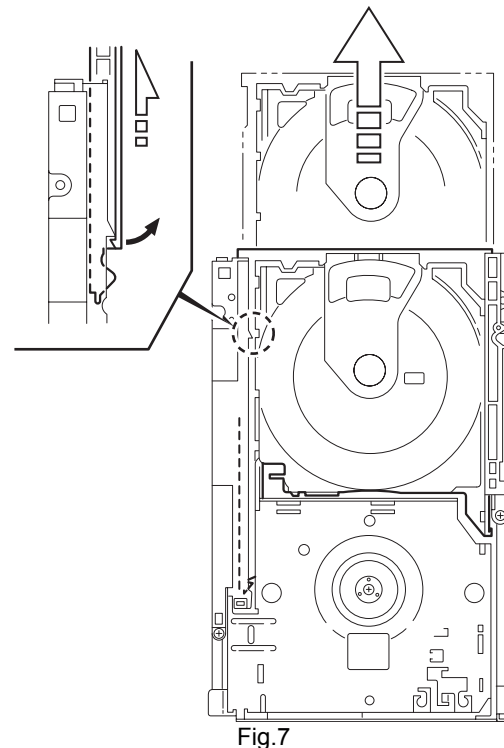

Fig.7

3.2.4 Removing the motor board

(See Fig.8)

- (1) Remove the two screws **D** attaching the motor board.
- (2) Remove the spacer fixing the motor board and tray switch-board, and disconnect the connector **CN2** on the motor board.
- (3) Disconnect the card wire from connector **CN1** on the motor board.

Caution:

When reconnection the card wire, let the card wire through the slot **d** of the motor board and attach it to bottom of the body using a double face tape.

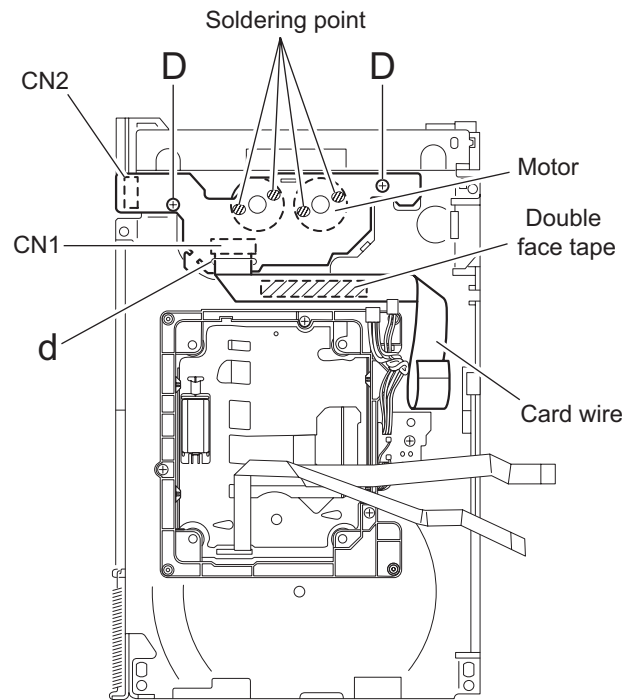
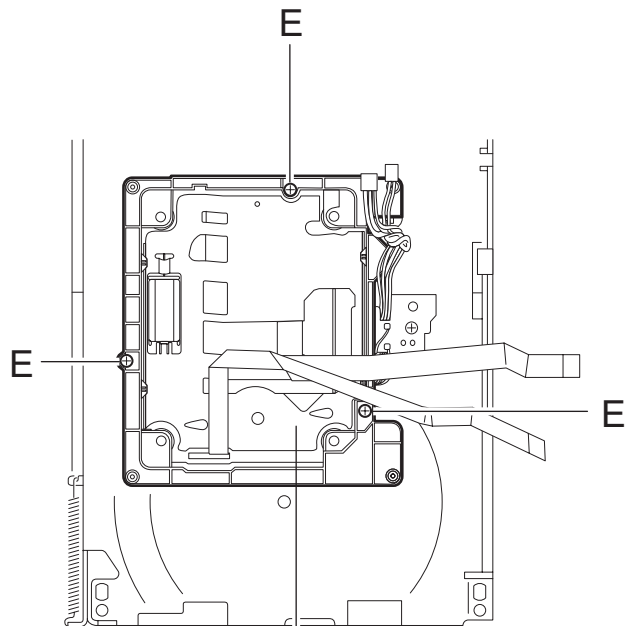

Fig.8

3.2.5 Removing the DVD tramecha assembly

(See Fig.9)

- (1) Remove the three screws **E** attaching the DVD tramecha assembly.



DVD Tramecha assembly
Fig.9

3.2.6 Removing the pickup (See Fig.10 and 11)

- (1) Remove the one screw **F** and **G** attaching the spring holder. (See Fig.10)
- (2) Lift up the shaft from the tramecha assembly. (See Fig.10)
- (3) Remove the two screws **H** attaching the lack. (See Fig.11)

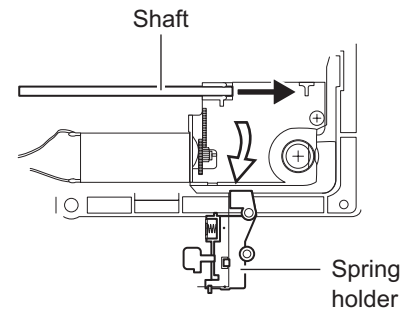
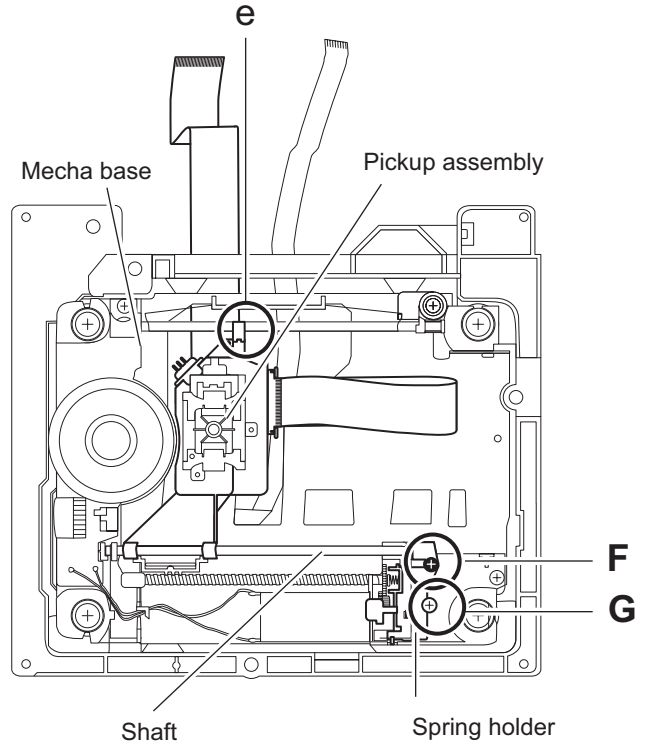

Fig.10

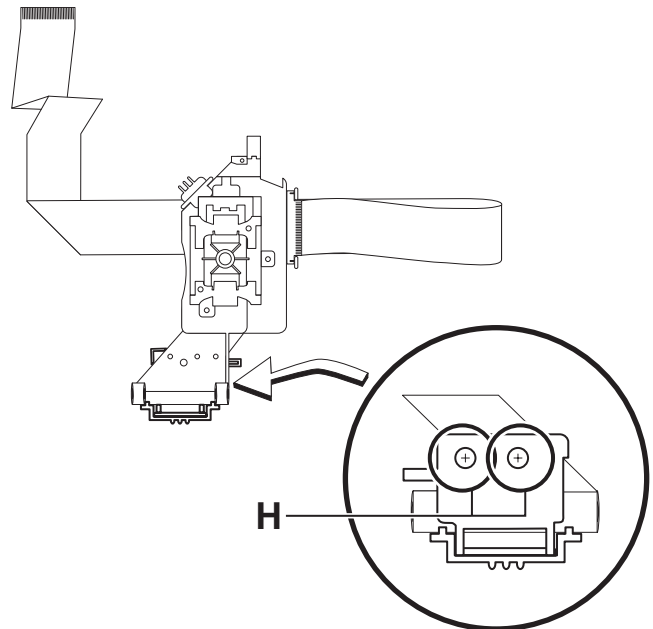

Fig.11

3.2.7 Removing the side (L) (See Fig.12 to 14)

- (1) Remove the two screws **J** attaching the side (L). (See Fig.12)
- (2) From the side of body, remove the spacer fixing the tray switch board and motor board. Disconnect connector **CN3** on the tray switch board and detach the side (L) upward. (See Fig.13)
- (3) Remove the one screw **K** attaching the tray switch board. (See Fig.14)
- (4) Push the joint tab **d** of the side (L) in the direction of the arrow and remove the tray switch board outward, then release joint **f**. (See Fig.14)

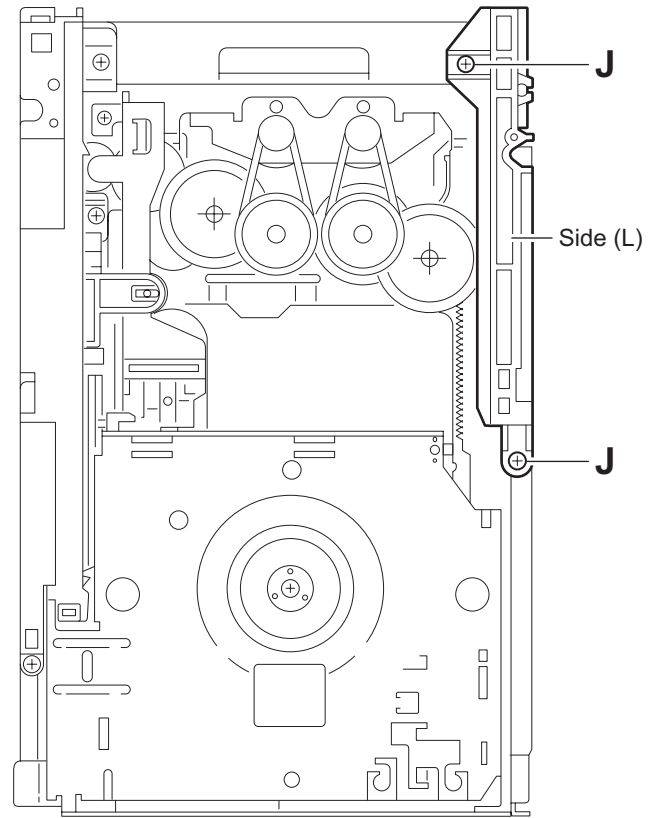

Fig.12

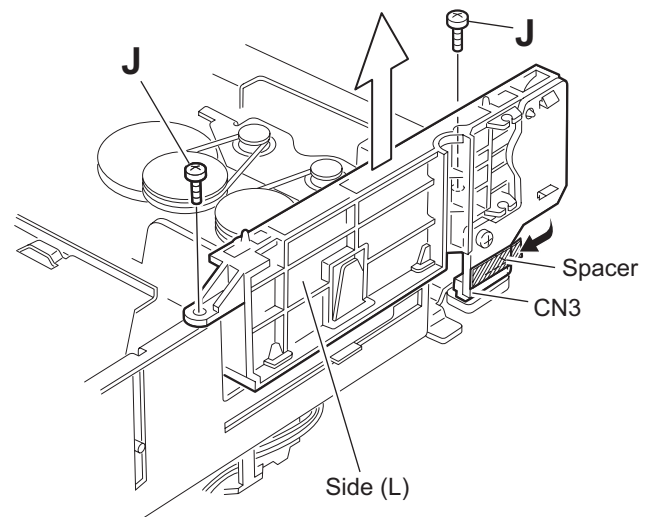

Fig.13

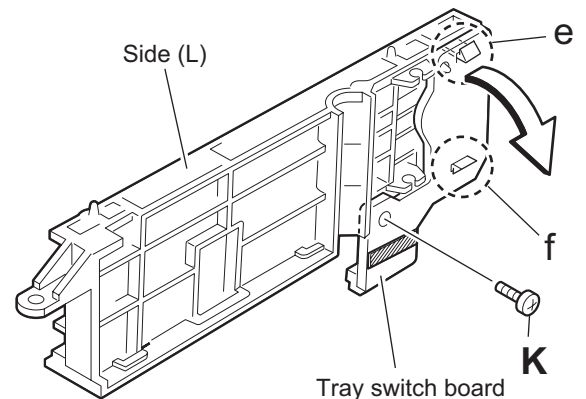

Fig.14

3.2.8 Removing the side (R) assembly (See Fig.15 to 19)

- (1) Remove the three screws **L** attaching the side (R) assembly. (See Fig.15)
- (2) Remove the spring attached to part **g** of the hook on the right side of the body. (See Fig.16)
- (3) Push and release the two tabs **h** of the gear cover through the notches inside the side (R) assembly. Remove the gear cover outward. (See Fig.17)
- (4) From top of the body, turn the 1 gear clockwise to move the elevator cam rearward. Move the two slots **k** and joint **m** of the elevator cam as shown Fig.18 and remove the elevator cam outward.
- (5) Remove the three screws **M** and detach the side (R) upward. (See Fig.19)

Caution:

When reattaching the side (R) assembly, make sure to fit the shaft into the slot of the select lever.

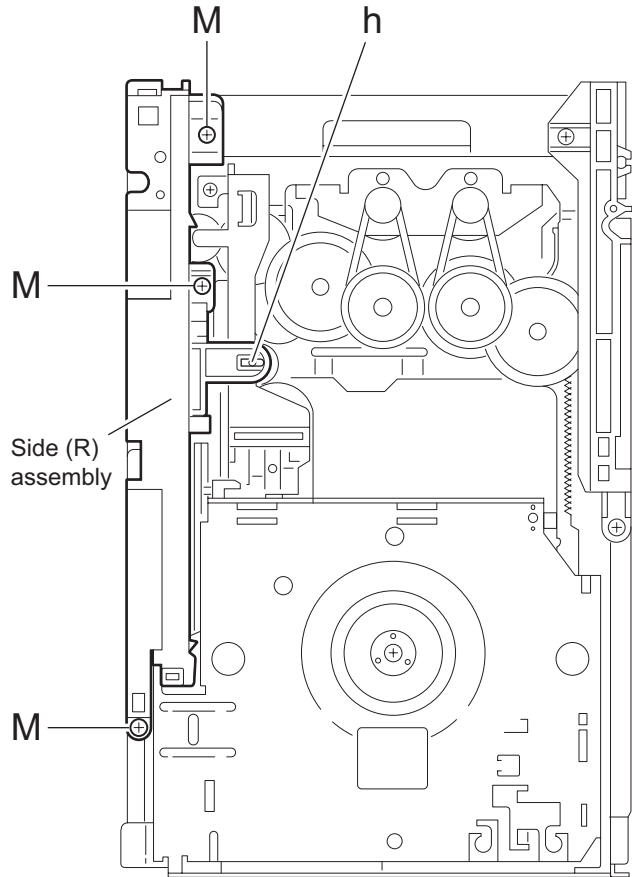
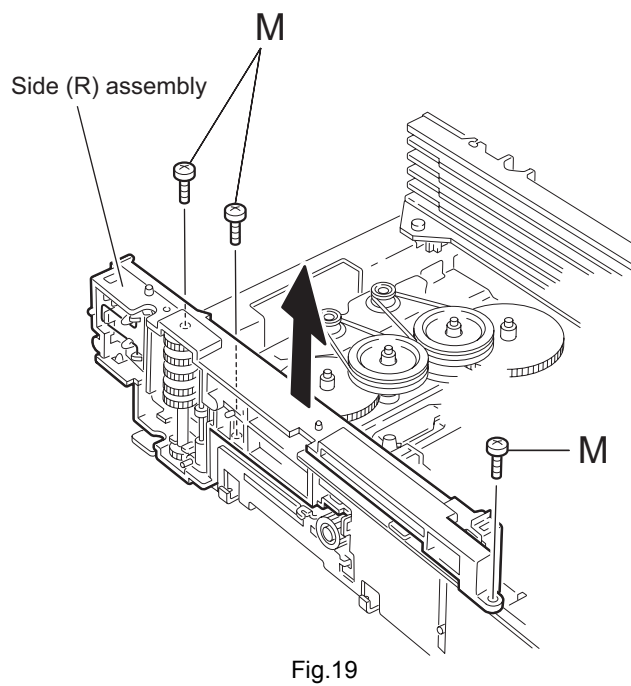
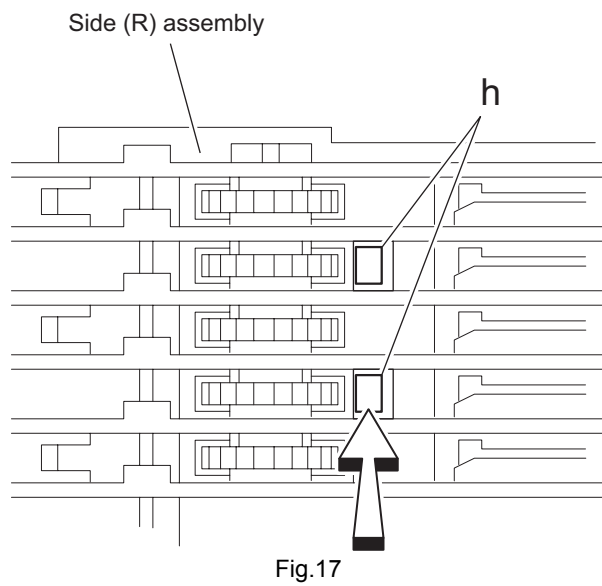
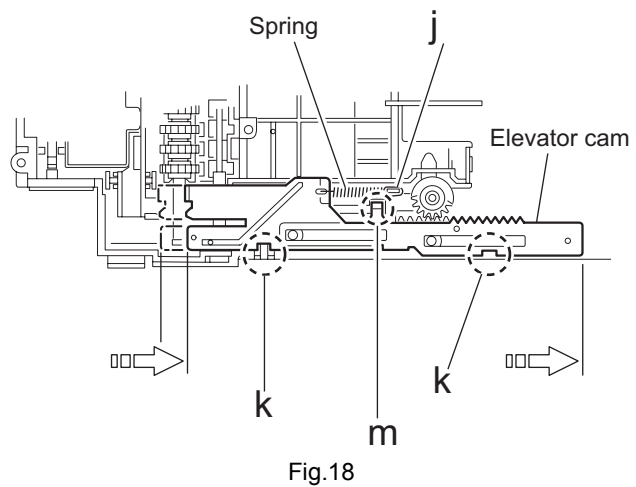
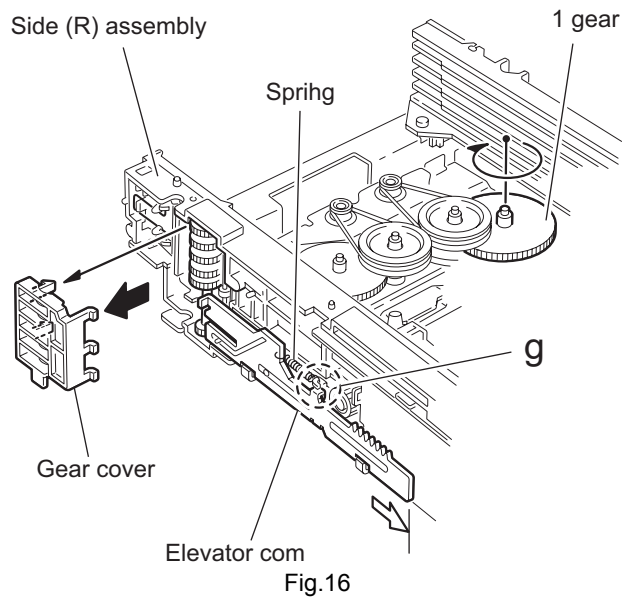

Fig.15



3.2.9 Removing the lifter assembly (See Fig.20 to 24)

- (1) From top of the body, turn the 1 gear clockwise to move the lifter assembly upward. (See Fig.20)
- (2) From top of the body, turn 2 gear clockwise to move the hook toward the front until it stops. (See Fig.20)
- (3) Move the hook stopper in the direction of the arrow while pushing the tab **n** of the hook stopper to unlock it. Release four joints **p** to detach from rack holder. Release the rod from part **q**. (See Fig.21 and 22)
- (4) Turn 1 gear clockwise again to move the lifter assembly upward. (See Fig.23)
- (5) Remove the lifter assembly from the body upward at position **r** where the four pins on the right and left sides of the lifter assembly fit to the notches of the **s**. Move the lifter assembly toward the front and release from the hook. (See Fig.23 and 24)

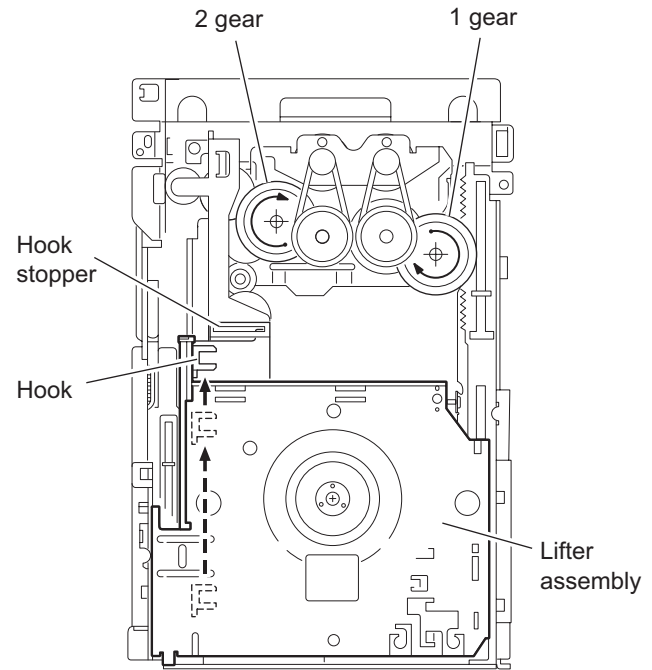

Fig.20

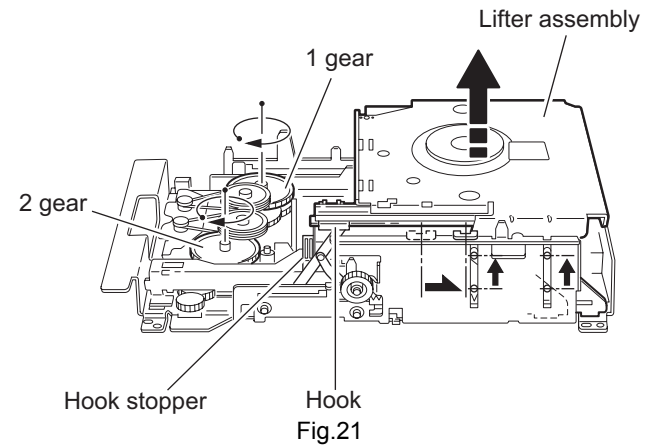

Fig.21

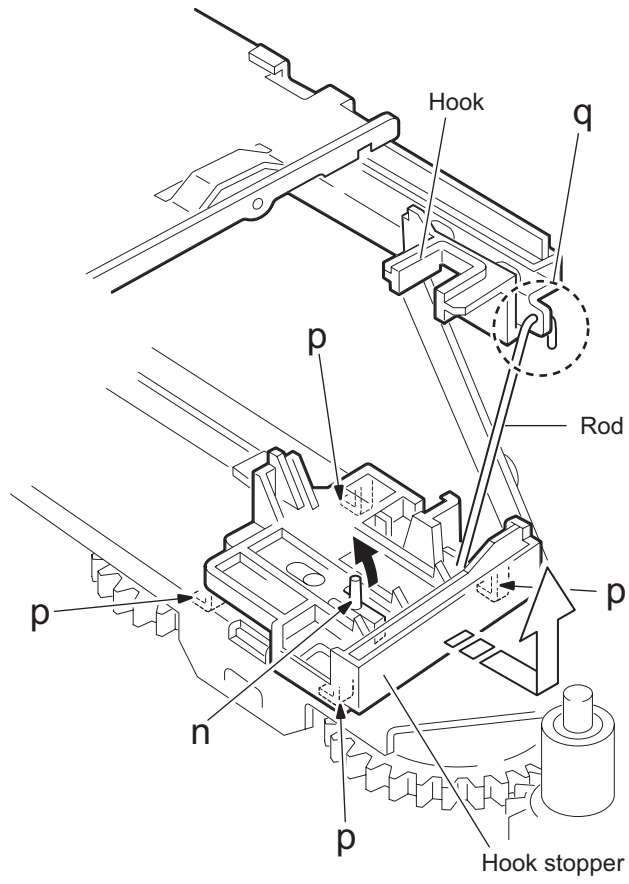

Fig.22

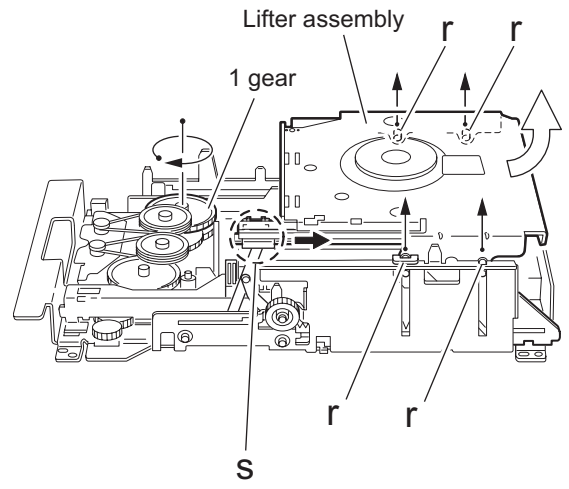

Fig.23

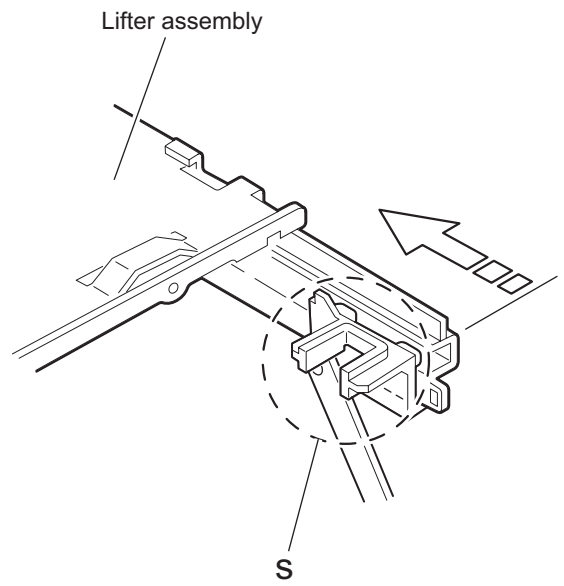

Fig.24

3.2.10 Removing the rack holder assembly / sensor assembly (See Fig.25 to 30)

Attention:

If the slide gear of the body places at joint **u** of the rack holder assembly, turn the 1 gear counterclockwise to move the slide gear toward the front. Remove the rack holder assembly.

- (1) Remove the three screws **N** attaching the rack holder assembly. Release joint **u** from the notch.

Caution:

When reattaching the rack holder assembly, do not nip the wire **v** extending from the sensor assembly.

- (2) Move the sensor assembly in the direction of the arrow to release from slot at joint **y**.
- (3) Remove the spring attached to the bottom of the sensor assembly from the boss **z** on the sensor slider.
- (4) Remove the screw **P** and **Q** attaching the sensor board and SV resistor respectively. If necessary, unsolder the sensor board.

Caution:

When reattaching the SV resistor, attach the sensor slider to the sensor bracket and fit the lever on the bottom of the SC resistor into slot **a'** of the sensor slider.

Caution:

When reattaching the rack holder assembly, turn the 1 gear clockwise to move the slide gear and slide lever inside the body rearward.

- Let the wire extending from the sensor assembly through notch **x** to the bottom of the body.
- Fix pin **c'** of the slide lever into hole **b'** on the sensor slider on the bottom of the sensor assembly while attaching the spring to the boss **z** of the sensor slider.
- Engage joint **y** of the sensor assembly to the notch of the body.

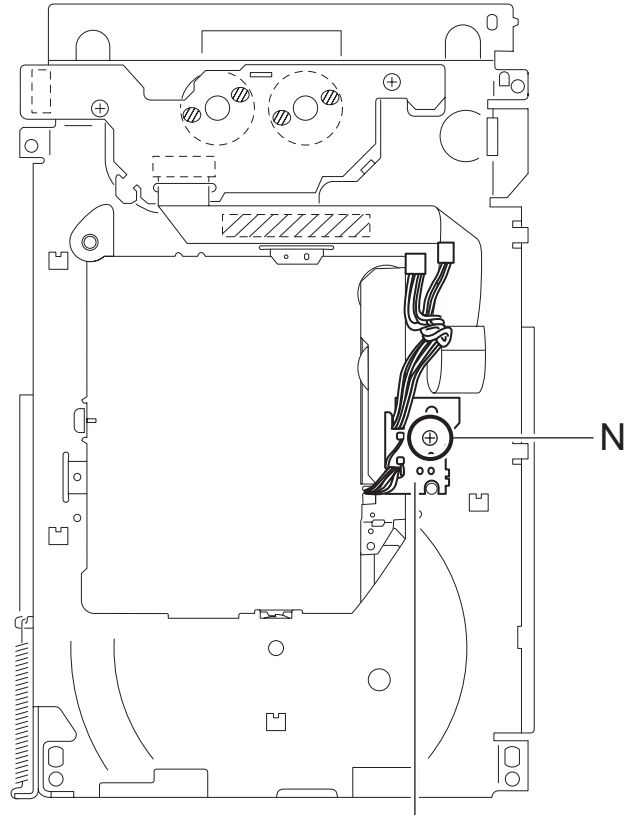

Switch board

Fig.25

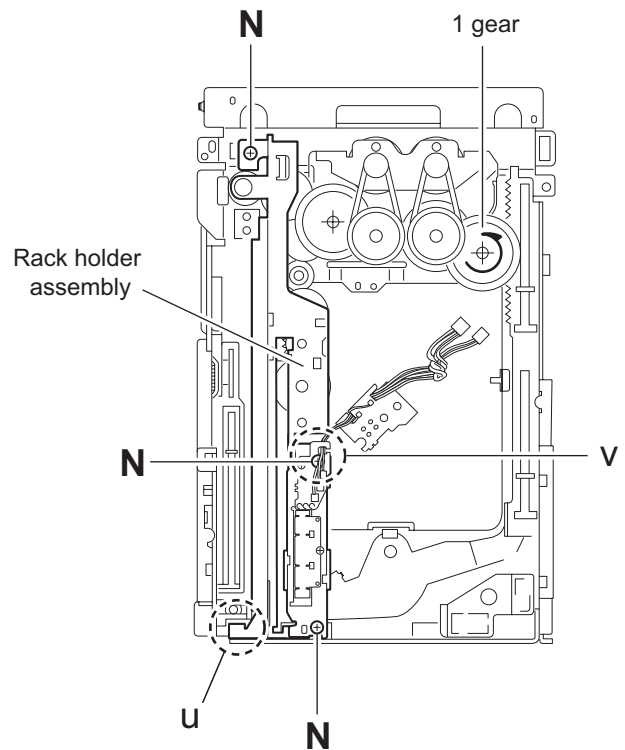

Fig.26

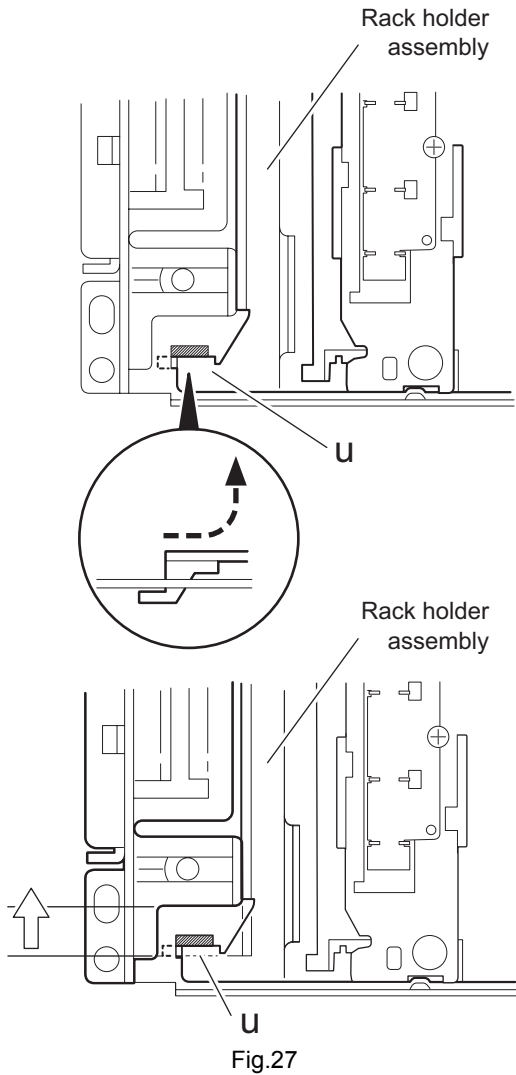

Fig.27

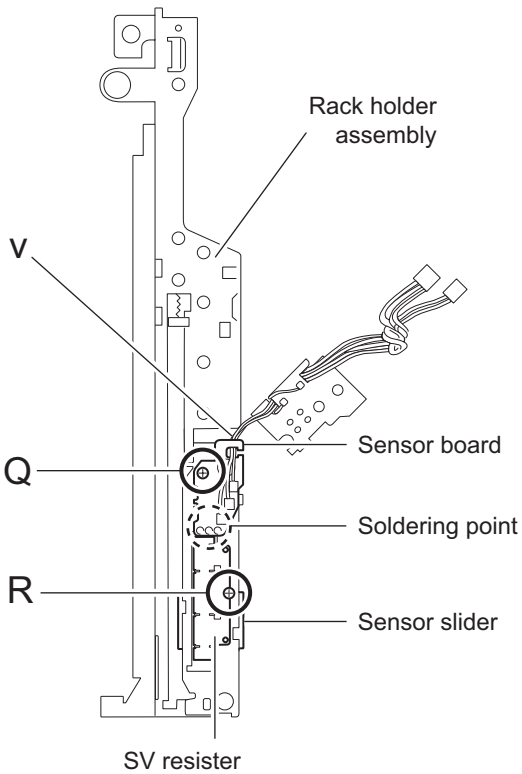

Fig.28

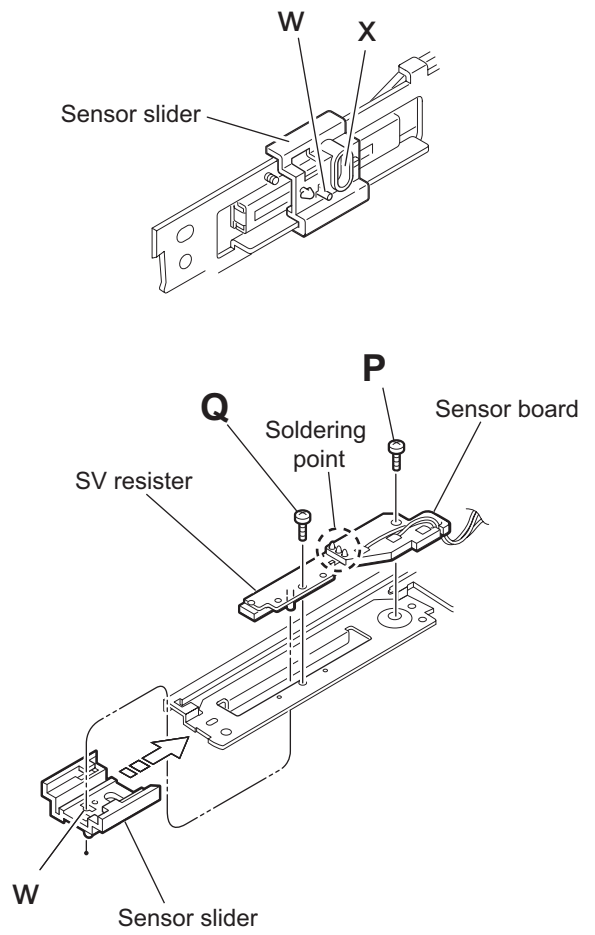

Fig.29

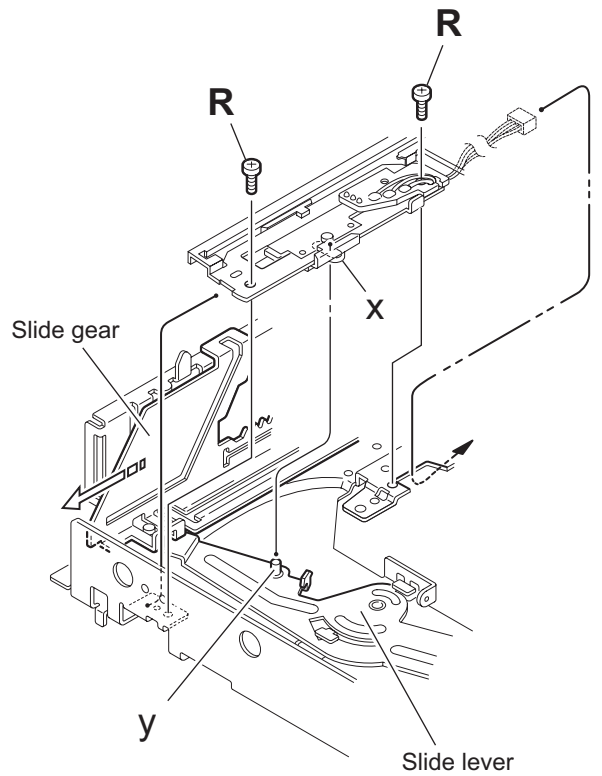

Fig.30

3.2.11 Removing the motor (See Fig.31 and 32)

Attention:

You need not to remove the tray assembly, and in such case, move it.

- (1) Remove the two belts on top of the body.
- (2) Remove the two screws **S** attaching the motor.
- (3) Remove the motor from the bottom of the body.

Attention:

When removing the motor board with the motor, you need not to unsolder four solder parts.

Caution:

When reattaching the motor, turn the side where the label should be put to the front side.

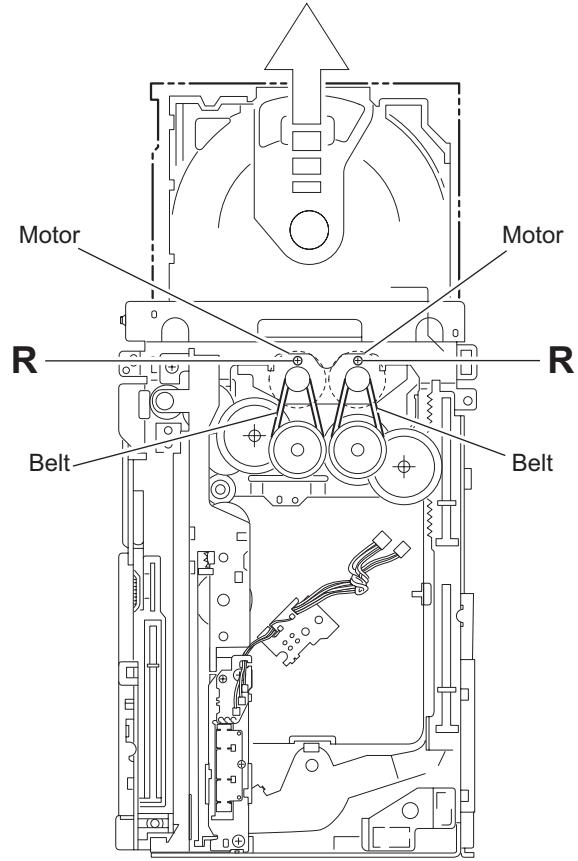

Fig.31

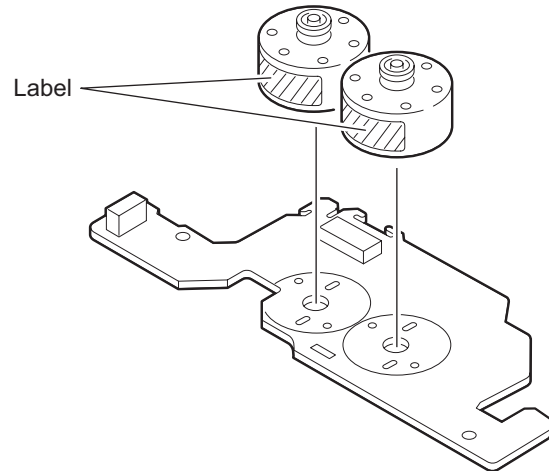

Fig.32

3.2.12 Taking out the disc in play mode (See Fig.33 to 36)

Attention:

Refer to "Removing the tray assembly".

- (1) Remove the top cover upward.
- (2) Unlock the tray assembly and draw out the tray assembly toward the front.
- (3) From top of the body, turn the 1 gear clockwise to move the lifter assembly upward.
- (4) From top of the body, turn 2 gear clockwise to move the sub tray remaining inside the lifter assembly toward the front, then pull out.
- (5) Take out the disc on the sub tray.
- (6) After clearing away the disc, insert the sub tray into the main tray.

Caution:

When reattaching the sub tray, move the tray stopper on the bottom of the tray in the direction of the arrow to lock the sub tray certainly.

- (7) Push the tray assembly toward to body and reattach.

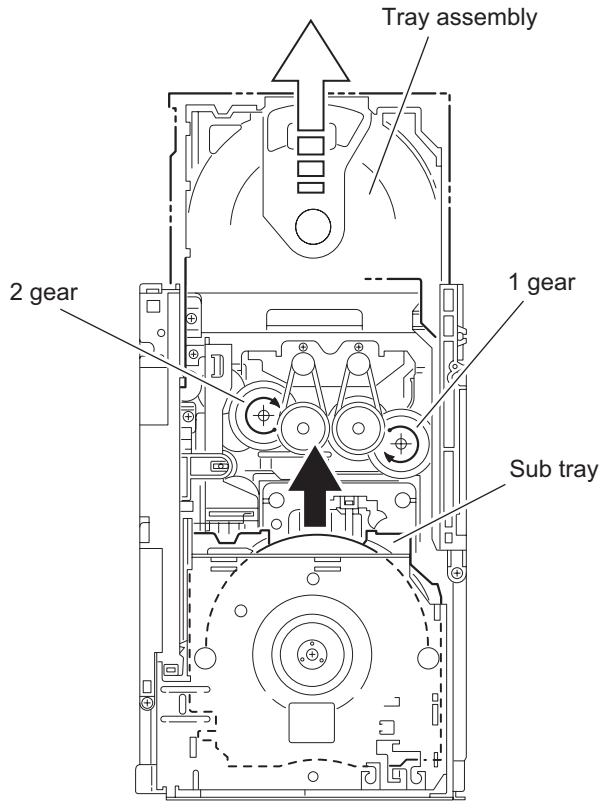

Fig.33

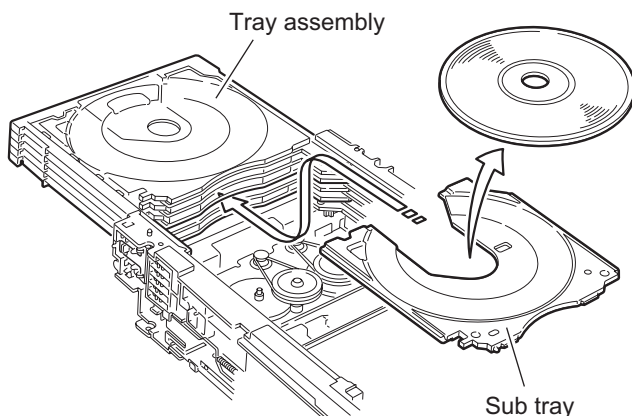
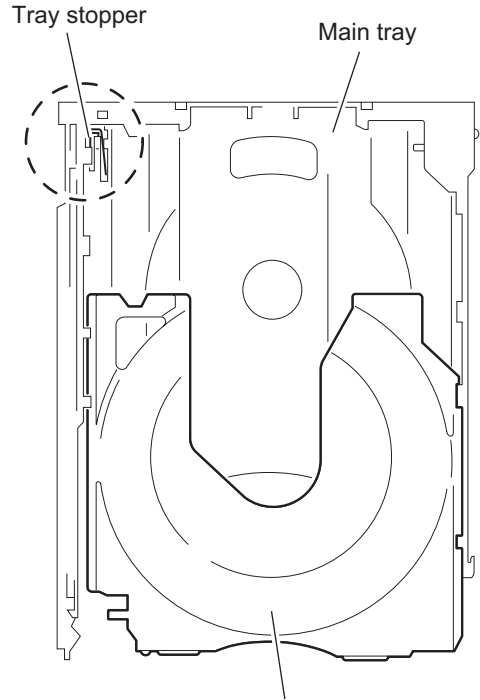

Fig.34



Sub tray
Fig.35

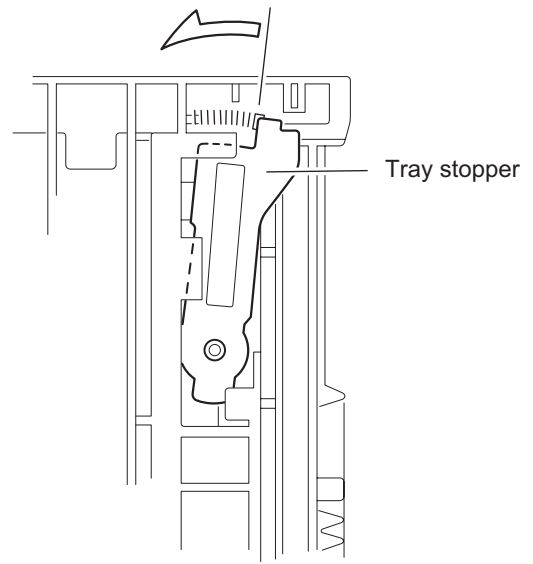

Fig.36

3.3 Subwoofer (SP-PWC90)

3.3.1 Removing the amplifier assembly (See Figs.1 to 3)

- (1) From the back side of the speaker main body, remove three screws **A** attaching the amplifier assembly. (See Fig.1.)
- (2) From the bottom side of the speaker main body, remove the eight screws **B** attaching amplifier assembly. (See Fig.2.)
- (3) From the top side of the speaker main body, move the amplifier assembly backward and disconnect the wire from the connector [CN352](#) on the relay board. (See Fig.3)
- (4) Take out the amplifier assembly.

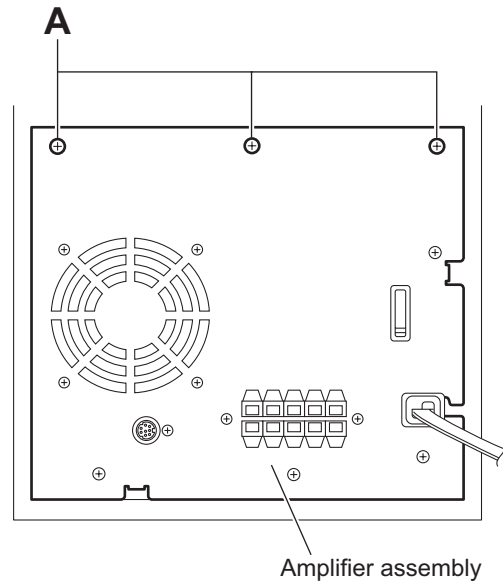

Fig.1

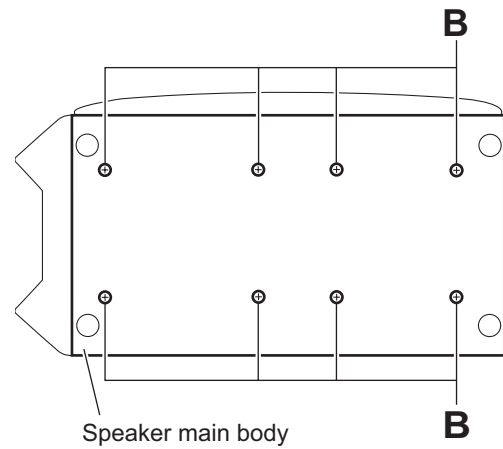

Fig.2

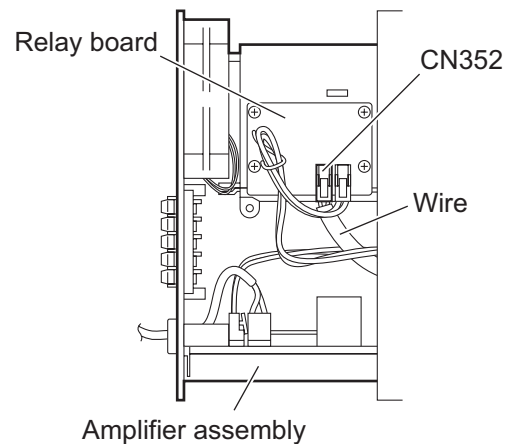

Fig.3

3.3.2 Removing the rear panel (See Figs.4 and 5)

- Prior to performing the following procedure, remove the amplifier assembly.
 - (1) From the back side of the amplifier assembly, remove the six screws **C** and screw **D** attaching the rear panel. (See Fig.4.)
 - (2) Take out the rear panel with fan motor backward from the amplifier assembly.
 - (3) From the top side of the amplifier assembly, disconnect the fan wire from the connector **CN308** on the main board. (See Fig.5.)
 - (4) Take out the rear panel.

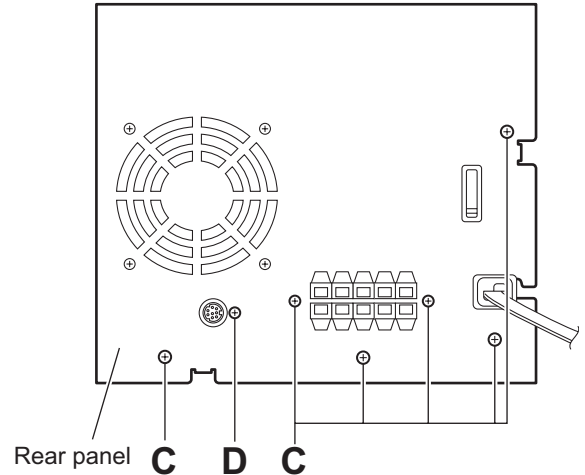

Fig.4

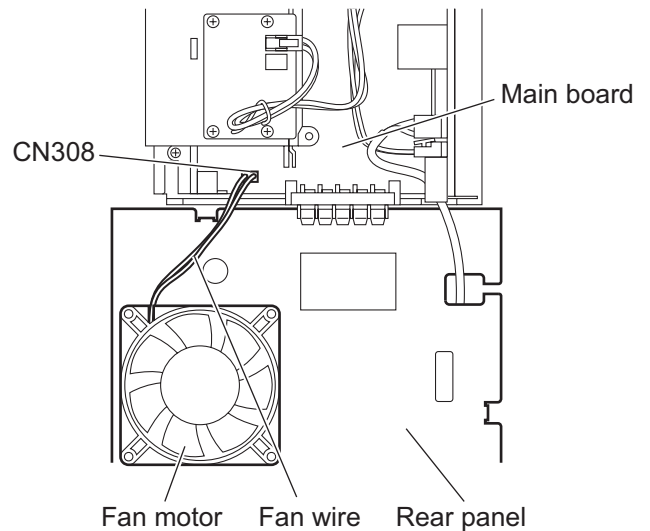

Fig.5

3.3.3 Removing the fan motor (See Fig.6)

- Prior to performing the following procedures, remove the amplifier assembly and rear panel.
 - (1) From the front side of the rear panel, remove the four screws **E** attaching the fan motor.
 - (2) Take out the fan motor.

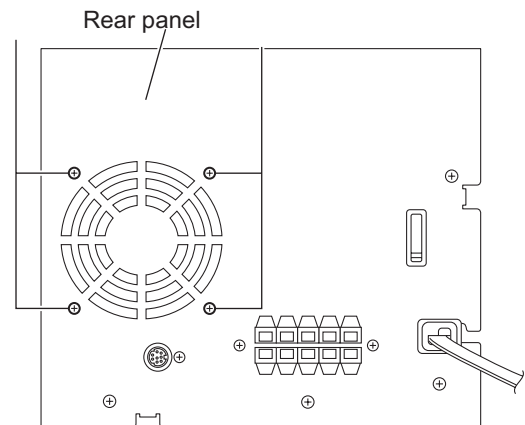

Fig.6

3.3.4 Removing the power board (See Figs.7 to 9)

- Prior to performing the following procedures, remove the amplifier assembly and rear panel.

- (1) From the top side of the amplifier assembly, disconnect the wires from the connectors (CN103, CN151) on the power board. (See Fig.7)
- (2) Disconnect the power cord from the connector CN101 on the power board, and take out the power cord. (See Fig.7)
- (3) Remove the five screws F, screw F' and two screws G attaching the power board. (See Figs.7 and 8.)

Reference:

When attaching the screw F', attach it with the earth wire.
(See Fig.8.)

- (4) From the right side of the amplifier assembly, remove the two screws H attaching the power board. (See Fig.9)
- (5) From top side of the amplifier assembly, disconnect the power board from the connectors (CN301, CN302 and CN304) on the main board, and take out the power board from the amplifier assembly. (See Fig.8)

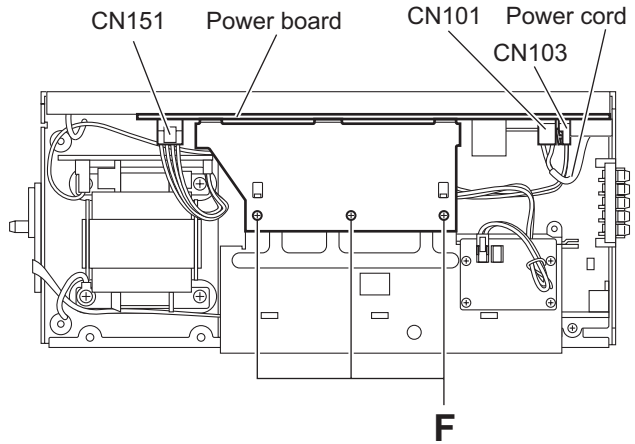

Fig.7

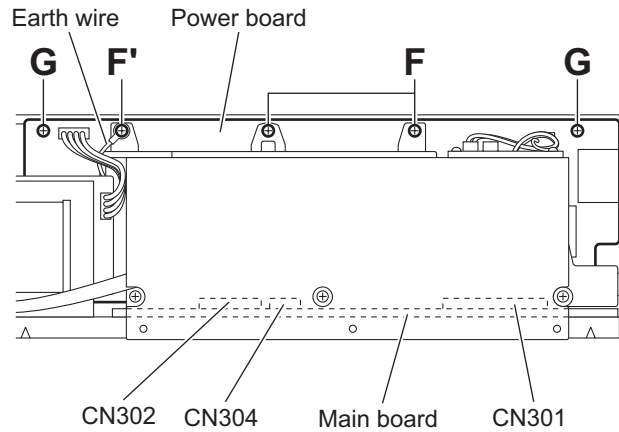

Fig.8

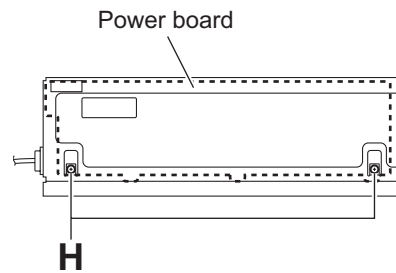

Fig.9

3.3.5 Removing the relay board (See Fig.10)

- Prior to performing the following procedure, remove the amplifier assembly.
 - (1) From the top side of the amplifier assembly, disconnect the parallel wire from the connector [CN352](#) on the relay board.
 - (2) Remove the four screws **J** attaching the relay board to the heat sink.
 - (3) Take out the relay board.

Reference:

After attaching the relay board, bundles the parallel wire by wire clamp.

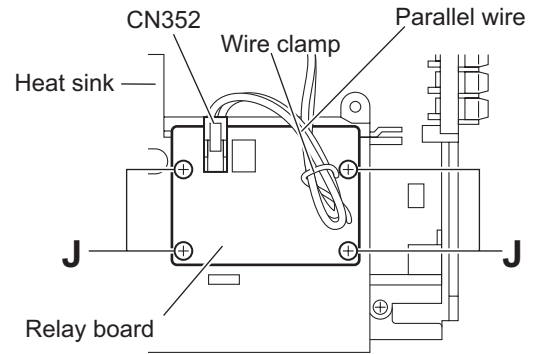

Fig.10

3.3.6 Removing the heat sink (See Figs.11 and 13)

- Prior to performing the following procedures, remove the amplifier assembly, rear panel, power board and relay board.
 - (1) From left side of the amplifier assembly, remove the three screws **K** attaching the IC bracket to the heat sink. (See Fig.11)
 - (2) Remove the three screws **M** attaching the heat sink to the main board. (See Fig.12)
 - (3) From left side of the amplifier assembly, remove the three screws **N** attaching the heat sink. (See Fig.13)
 - (4) Take out the heat sink.

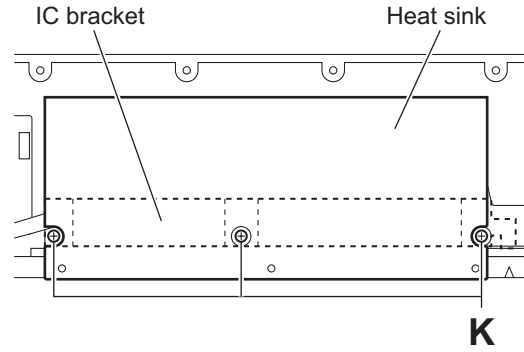

Fig.11

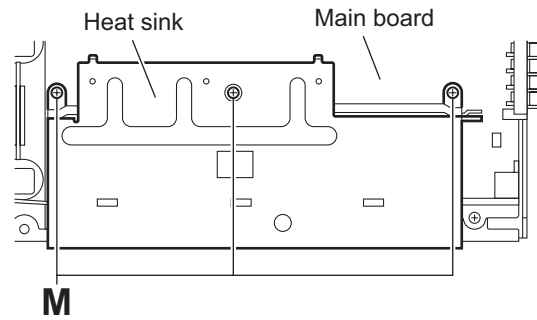

Fig.12

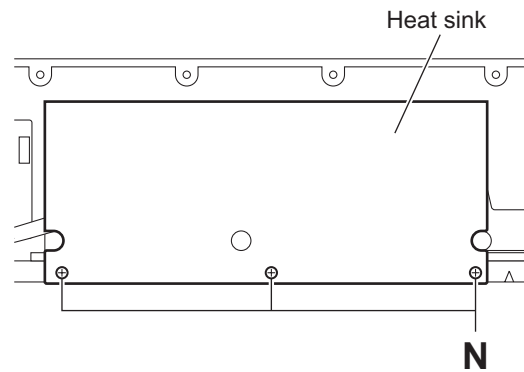

Fig.13

3.3.7 Removing the amplifier board (See Fig.14)

- Prior to performing the following procedures, remove the amplifier assembly, rear panel, power board, relay board and heat sink.
 - (1) From the top side of the amplifier assembly, disconnect the amplifier board from the connectors (CN311, CN312) on the main board.
 - (2) Take out the amplifier board.

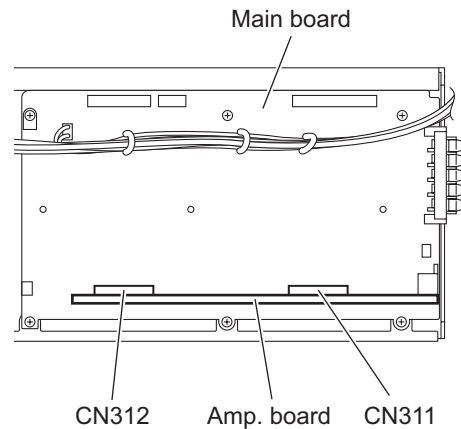

Fig.14

3.3.8 Removing the main board (See Fig.15)

- Prior to performing the following procedures, remove the amplifier assembly, rear panel, power board, relay board, heat sink and amplifier board.
 - (1) From the top side of the amplifier assembly, remove the wires from the wire clamps on the main board.
 - (2) Remove the six screws **P** attaching the main board to the amplifier assembly.
 - (3) Take out the main board.

Reference:

After attaching the main board, bundle the wires by the wire clamps.

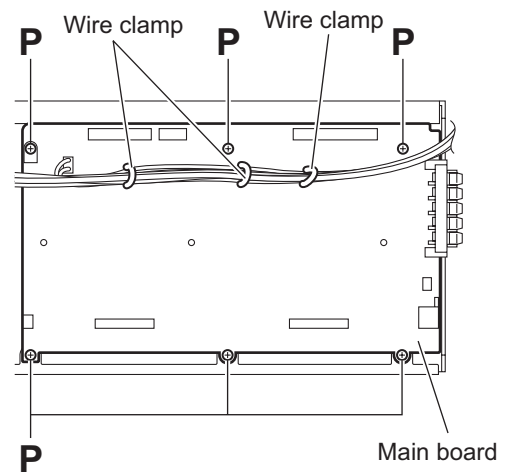

Fig.15

3.3.9 Removing the power transformer (See Fig.16)

- Prior to performing the following procedure, remove the amplifier assembly.
 - (1) From the top side of the amplifier assembly, disconnect the wire from the connector [CN102](#) on the trans board.
 - (2) Remove the parallel wire from the wire clamp.
 - (3) Remove the three screws **R** and screw **R'** attaching the power transformer, and take out the power transformer with the trans board.

Reference:

- When attaching the power transformer, attach the screw **R'** with wire clamp.
- After attaching the power transformer, bundle the wires by the wire clamps.

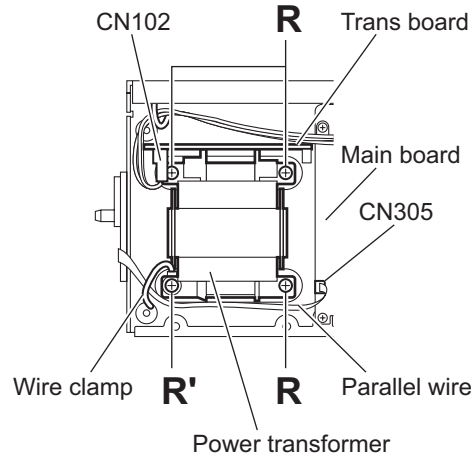

Fig.16

3.3.10 Removing the trans board (See Fig.17)

- Prior to performing the following procedures, remove the amplifier assembly and power transformer.
 - (1) From the reverse side of the trans board, remove the solder from the solder sections **a** on the trans board.
 - (2) Take out the trans board from the power transformer.

3.3.11 Removing the LED board (See Fig.16 and 18)

- Prior to performing the following procedure, remove the amplifier assembly.
 - (1) From the top side of the amplifier assembly, disconnect the wire from the connector [CN305](#) on the main board. (See Fig.16.)
 - (2) Remove the parallel wire from the wire clamp. (See Fig.16.)
 - (3) Remove the two screws **S** attaching the LED board, and take out the LED board. (See Fig.18)

Reference:

- After attaching the LED board, bundle the parallel wire by the wire clamp. (See Fig.16)

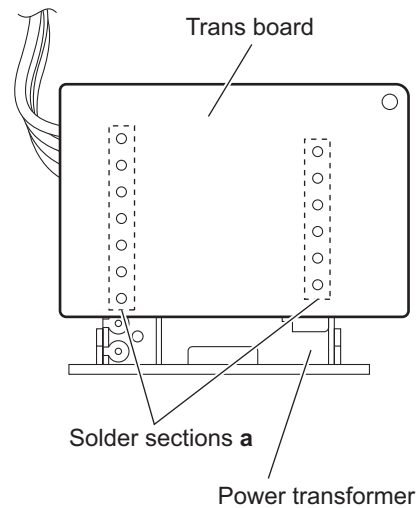

Fig.17

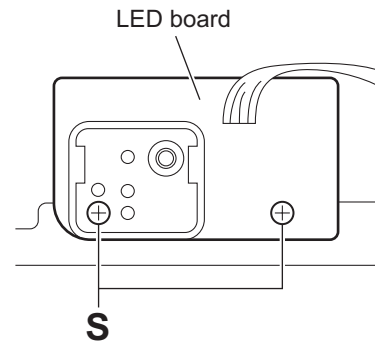

Fig.18

3.4 Subwoofer (SP-PWC60)

3.4.1 Removing the amplifier assembly

(See Figs.1 to 3)

- (1) From the back side of the speaker main body, remove two screws **A** attaching the amplifier assembly. (See Fig.1.)
- (2) From the bottom side of the speaker main body, remove the eight screws **B** attaching amplifier assembly. (See Fig.2.)
- (3) From the top side of the speaker main body, move the amplifier assembly backward and disconnect the wire from the connector **CN274** on the relay board. (See Fig.3)
- (4) Take out the amplifier assembly.

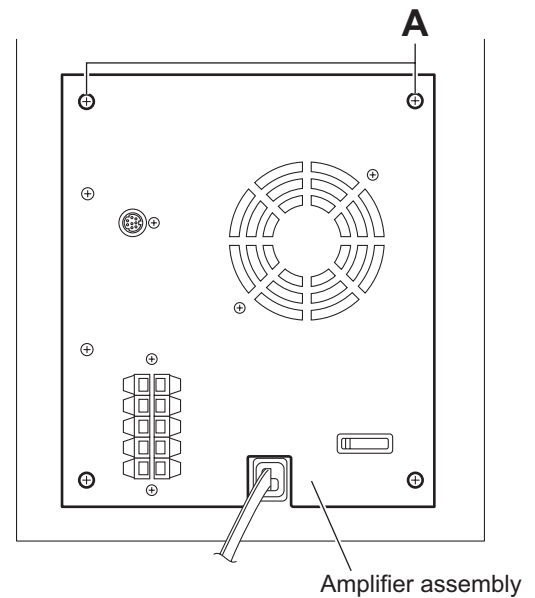

Fig.1

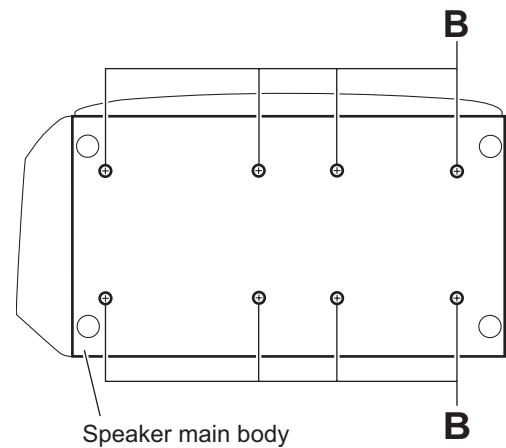

Fig.2

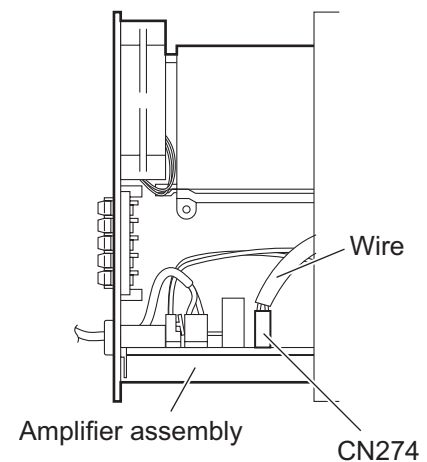

Fig.3

3.4.2 Removing the rear panel (See Figs.4 and 5)

- Prior to performing the following procedure, remove the amplifier assembly.
 - (1) From the back side of the amplifier assembly, remove the six screws **C** and screw **D** attaching the rear panel. (See Fig.4.)
 - (2) Take out the rear panel with fan motor backward from the amplifier assembly.
 - (3) From the top side of the amplifier assembly, disconnect the fan wire from the connector [CN371](#) on the main board. (See Fig.5.)
 - (4) Take out the rear panel.

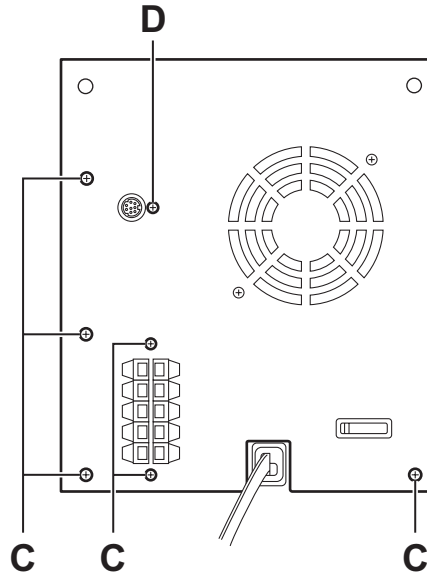

Fig.4

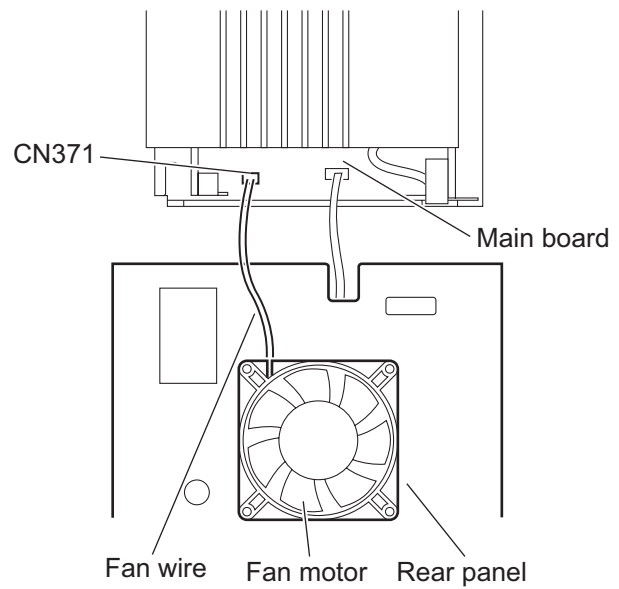

Fig.5

3.4.3 Removing the fan motor (See Fig.6)

- Prior to performing the following procedures, remove the amplifier assembly and rear panel.
 - (1) From the front side of the rear panel, remove the two screws **E** attaching the fan motor.
 - (2) Take out the fan motor.

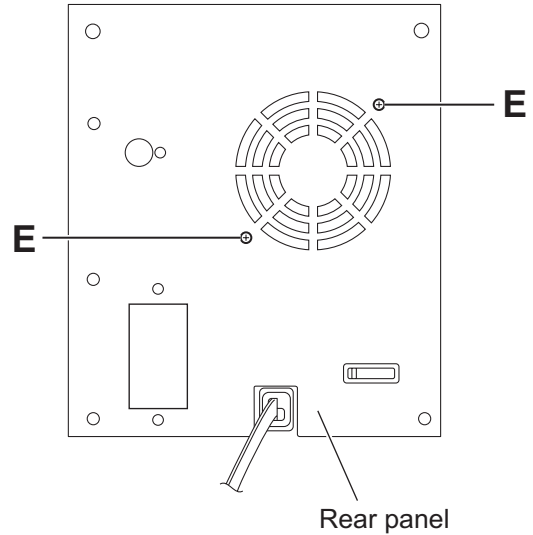

Fig.6

3.4.4 Removing the mother board (See Figs.7 to 8)

- Prior to performing the following procedures, remove the amplifier assembly and rear panel.
 - (1) From the top side of the amplifier assembly, disconnect the wires from the connectors (CN102, CN151) on the mother board. (See Fig.7)
 - (2) Disconnect the power cord from the connector CN101 on the mother board, and take out the power cord. (See Fig.7)
 - (3) Remove the two screws **F** attaching the heat sink bracket. (See Fig. 8)
 - (4) Remove the two screws **G** attaching the mother board. (See Fig. 8.)
 - (5) Disconnect the mother board from the connectors (CN271, CN272 and CN273) on the amp board, and take out the mother board from the amplifier assembly. (See Fig.8)

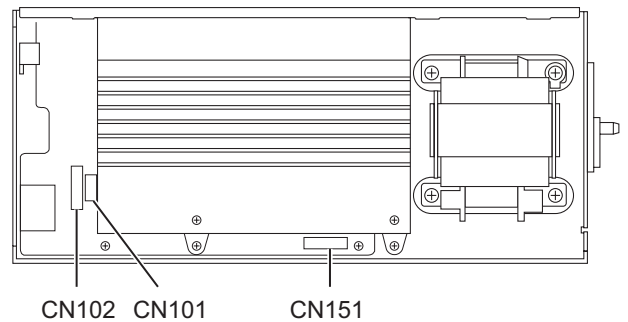

Fig.7

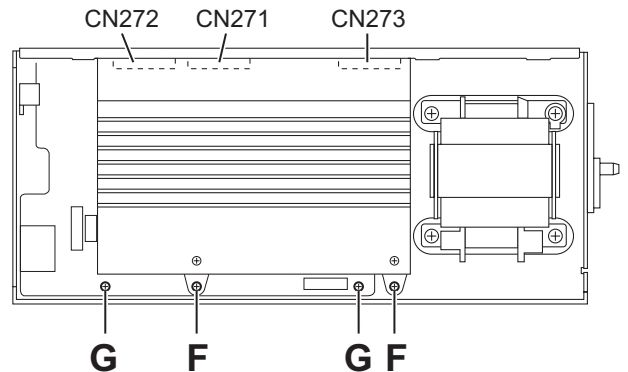

Fig.8

3.4.5 Removing the amplifier board (See Fig.9)

- (1) Remove the three screws **H** attaching the amp board.
- (2) Remove the six screws **J** attaching the amp board with heat sink.

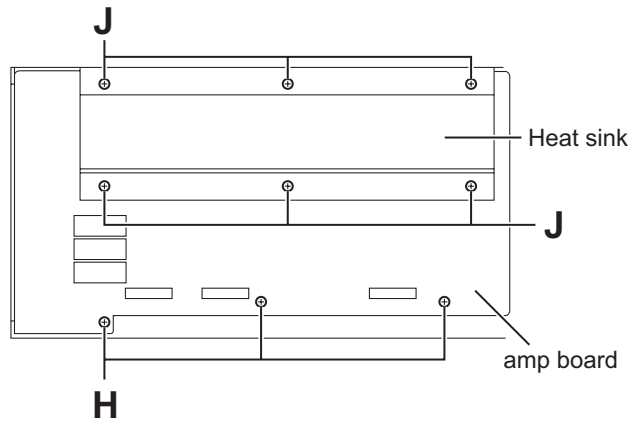

Fig.9

3.4.6 Removing the power transformer (See Fig.10)

- (1) Remove the four screws **K** attaching the power transformer.

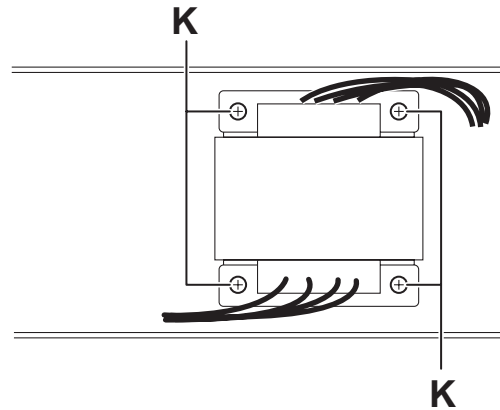

Fig.10

3.4.7 Removing the LED board (See Fig.11)

- Prior to performing the following procedure, remove the amplifier assembly.
- (1) Remove the two screws **L** attaching the LED board, and take out the LED board. (See Fig.11)

Reference:

After attaching the LED board, bundle the parallel wire by the wire clamp.

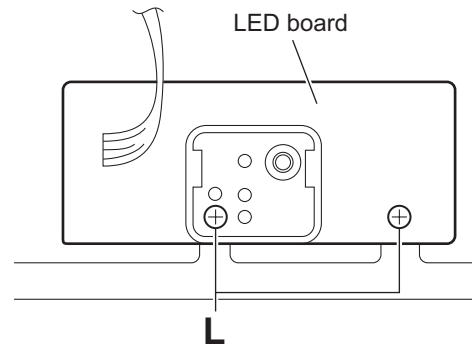

Fig.11

SECTION 4 ADJUSTMENT

4.1 ATTENTION IN SERVICE OF DVD SECTION

- (1) When pickup, Flash ROM ,DVD module board were changed, initialize EEPROM by all means.
- (2) When full initialization was excuted, excute learning with a DVD test disc by all means.
 Test disc : VT-501, VT-502
 Learning method : It is adjusted automatically by normal playback of a DVD disc.

4.2 TEST MODE

4.2.1 OUTLINE

To the set which is using the DVD module, in order to perform common correspondence in production, TEST mode is prepared. Table 1 is corresponded in TEST mode.

MODE	CONTENTS
The destination, a region, study state check mode	Indication the distination code, region number and study state fo DVD micon.
NORMAL initialize, FULL initialize	Mode of DVD micon initialize. Initialize has NORMAL initialize and FULL initialize. NORMAL initialize : Initialize the value of user setting item, like a indication contents of SETUP OSD. FULL initialize : Plus the contents of study which are carrying out the memory by FRONT END for lead shortening are initialized for NORMAL initialize contents.
Device key write (CPPM, CPRM)	For device key writing mode. Device key have CPPM(DVD Audio) and CPRM(VR).
Device key check sum indication mode	Indication the wrote device key check sum. Indication this value, it can check the device key was wrote or not.
Micon version indication mode	Indication System micon, DVD micon, other ROM version. With a set, correspondence and the contents of correspondence shall be individual, and shall be decided.
FL all on mode	Mode of FL (LCD) all on. With a set, correspondence and the contents of correspondence shall be individual, and shall be decided.
FRONT END check mode	Mode of relation of FRONT END.

Table 1. Contents corresponding to TEST mode.

4.2.2 SET OPERATE

TEST mode performs correspondence by operation specially so that a user cannot enter.

- * TEST MODE start should be press PLAY key & POWER key of main unit together and keep condition, connect AC.
- * After set up TEST MODE, mode select by MENU key.

The changes to the key in TEST mode are shown in Fig. 1.

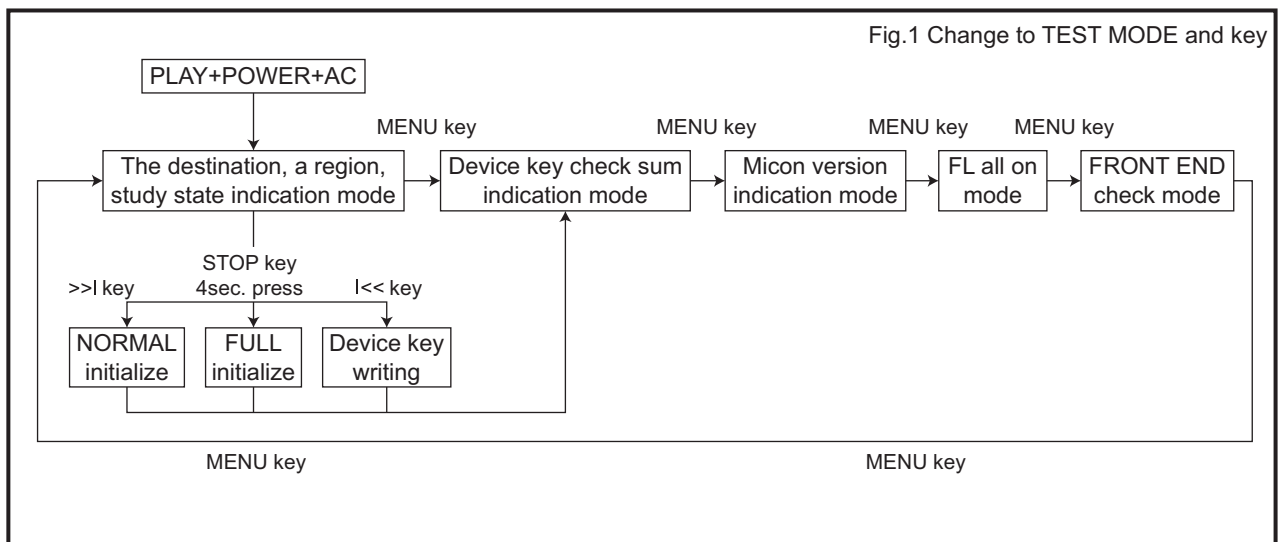

Fig.1 Change to TEST MODE and key

(*1) : Shift from destination, region and study state indication mode to NORMAL initialize, FULL initialize and device writing mode should only can main unit key.

4.3.4 ROM correction (Mecha micon)

Processing	FL indication	Display (OSD) indication	Remarks
TOC READ	"READING_"	NOW READING	TOC reading
DATA READ	"READING_" "READING_"	VERSION UP DISC SYSCON UPG MODE CURRENT VERSION **** READING.. SECTOR 1	Disc data reading Indicate firm current versin. Only [POWER] [OPEN/CLOSE] key of a main unit is validated.
WRITING	"REDING_"	VERSION UP DISC SYSCON UPG MODE CURRENT VERSION **** WRITING..	Writing the data to EEPROM. Input a main unit and all the key of remote control are forbidden.
END	"MECH_OK_"	VERSION UP DISC SYSCON UP MODE CURRENT VERSION **** WRITING..	ROM CORRECTION completed. Prohibition of a key input is canceled as without disc type is UPGRADE status.

4.4 Key special mode

Mode name	Operation	Function
Tuner 9k/10k select (U*version)	Press STOP key & PLAY key together at TUNER AM then 9kHz step.	9kHz/10kHz step select of TUNER AM band. Indication "9k STEP" , "10k STEP"
	Press STOP key & PAUSE key together at TUNER AM then 10kHz step.	
TRAY LOCK	Press STOP key & EJECT1 key together at P.OFF.	Do the TRAY LOCK mode select. Temporaly P.ON operation, select "LOCKED", "UNLOCKED". (Not done P.ON operation). Transience (2sec.) indication end, and then return to P.OFF mode. When press the EJECT key at LOCK mode, at P.OFF condition tempraly P.ON operation and then transience (2sec.) indication "LOCKED". At P.ON condition, transience (2sec.) indication "LOCKED".
DVD TEST MODE	At AC off line condition, press PLAY+POWER together and keep condition, connect AC.	"Operation to TEST mode to on of DVD backend. Operation of internal TEST MODE is refer the TEST mode."

4.5 Remocon special mode

Mode name	Operation	Function
COLD START	2-times input at P.OFF.	"Fix by 2 time input, operation temporaly P.ON and then transience(3sec.) indication "COLD SET". Indication end, done the P.OFF mode. AC to off line, operation the COLD START.B330 : remote controller press POWER + STOP + 0 key together."
FL all on Preset frequency writeing	Input at P.ON.	"Rewrite preset frequency, LED on chek(each 300ms), FL all on. LED on turn: STANDBY - ILLUMI - REMOCON<VOL+> - <VOL->Volume control of key input, keep high-speed mode until POWER OFF. B331 : Remocon POWER + STOP + 1 key together"
Version indication	Input at P.ON.	"Indication turn Syscon version - Unit version - Distination, Chip select by transience(5 sec.). Syscon version : "SC ## \$\$" (## : Sys version,\$: Sys ROM-corr) Unit version : "BE %%%%"(%%%% : Unit version) Distination, Chip select 1 : "\$\$K%H%"(\$\$: sys distination, K% : KARAOKE H% : HDMI CS, S% : SOURCE CS % are each select status 0 or 1) B33E : Press remocon POWER + STOP + 10 key together."

SECTION 5 TROUBLESHOOTING

This service manual does not describe TROUBLESHOOTING.



JVC

Victor Company of Japan, Limited
Audio/Video Systems Category 10-1, 1chome, Ohwatari-machi, Maebashi-city, 371-8543, Japan

(No.MB570)

JVC

SCHEMATIC DIAGRAMS

DVD DIGITAL CINEMA SYSTEM

TH-C90A, TH-C90US, TH-C90UX, TH-C90UG
TH-C60US, TH-C60UP, TH-C60UW
TH-C60UX, TH-C60UY, TH-C60UG

CD-ROM No.SML200609

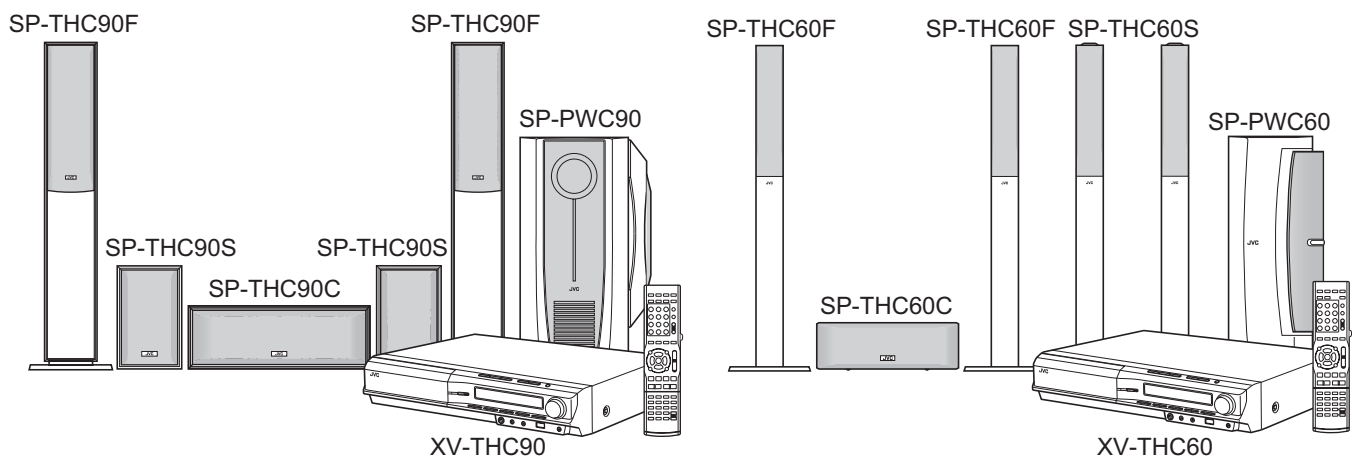

Lead free solder used in the board (material : Sn-Ag-Cu, melting point : 219 Centigrade)

Contents

Block diagrams	2-1
Standard schematic diagrams	2-3
Printed circuit boards	2-18 to 22

In regard with component parts appearing on the silk-screen printed side (parts side) of the PWB diagrams, the parts that are printed over with black such as the resistor (■), diode (▣) and ICP (●) or identified by the "▲" mark nearby are critical for safety.

Block diagram

<Main body section>

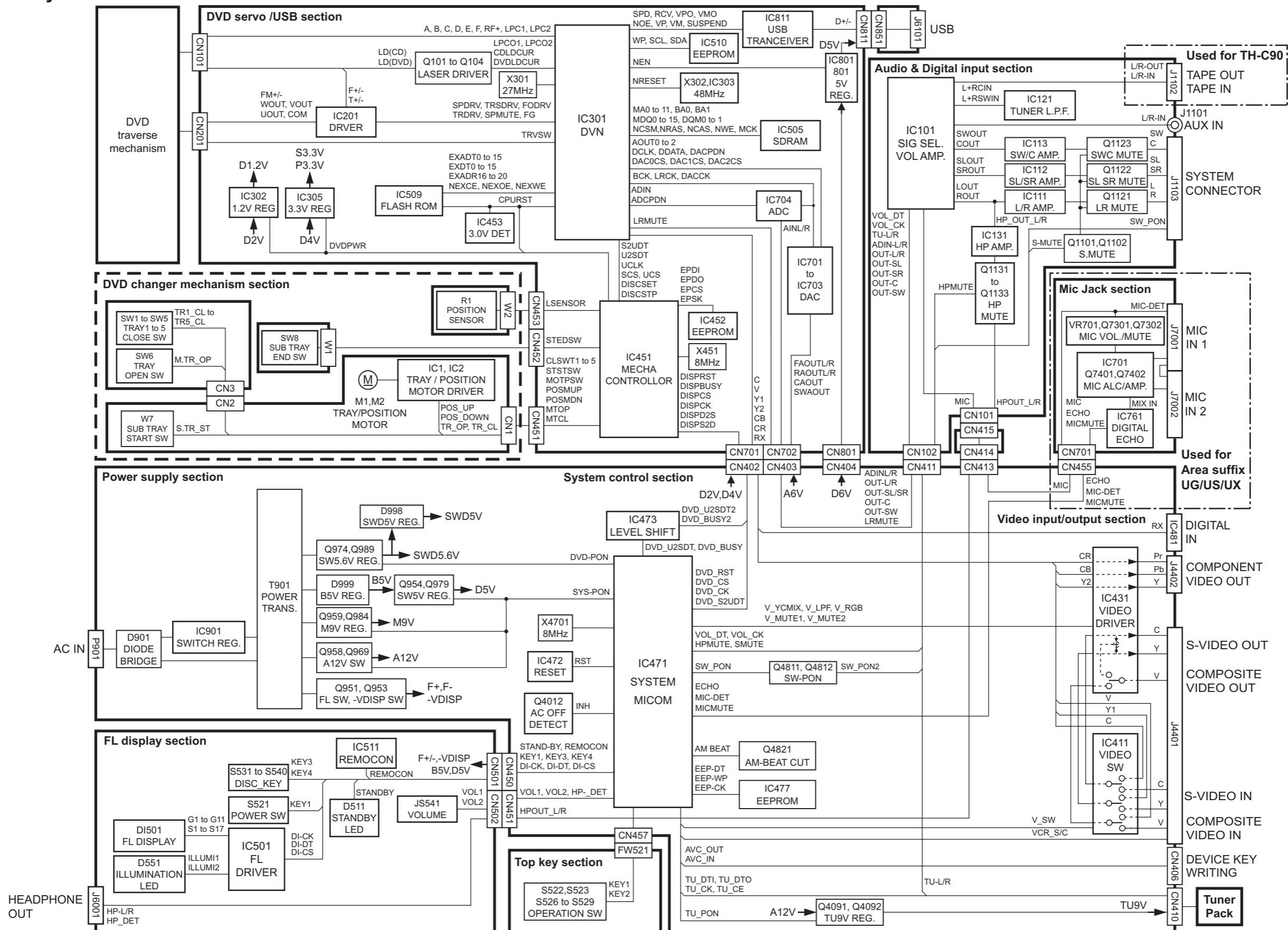

<Subwoofer section> (For TH-C60)

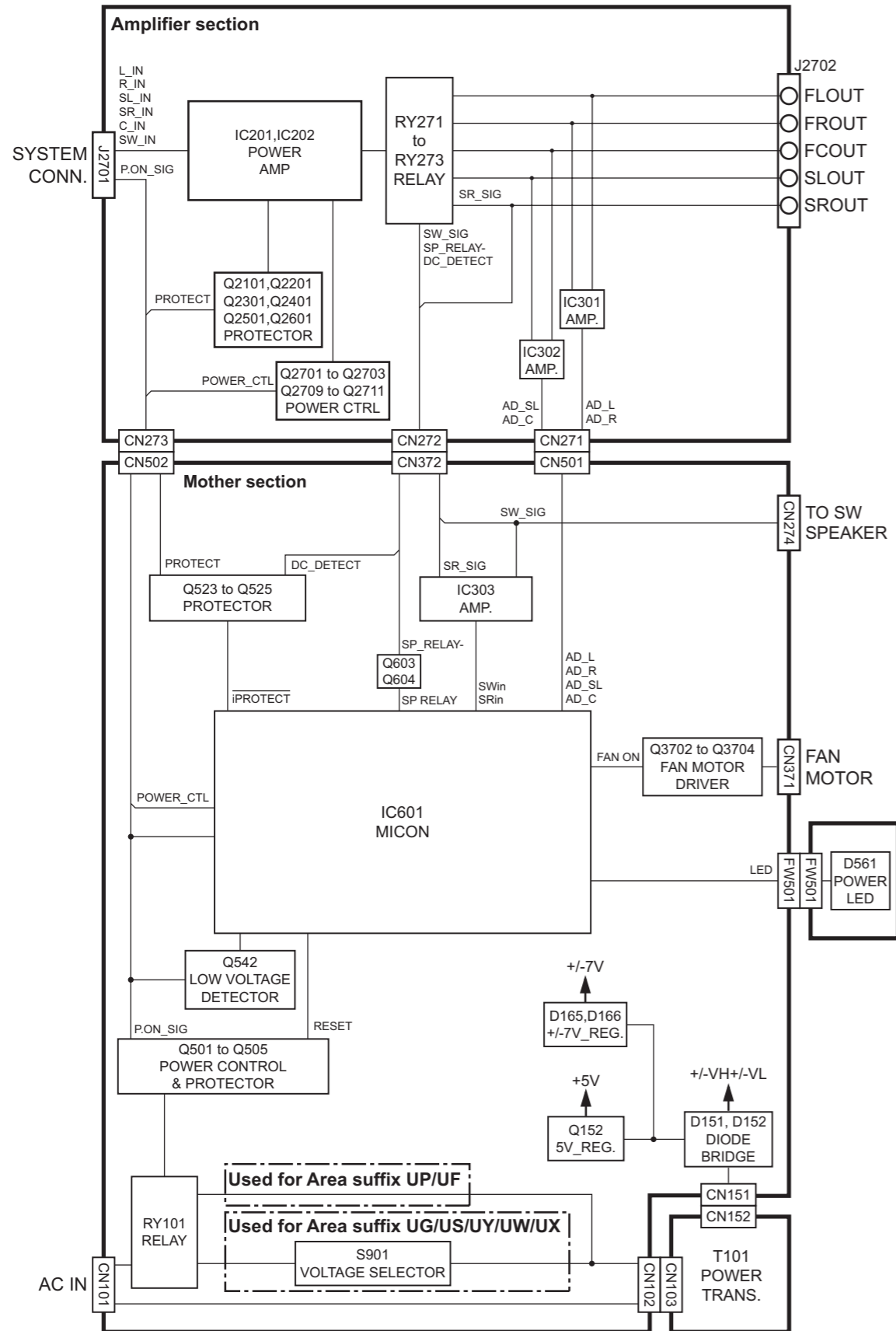

<Subwoofer section> (For TH-C90)

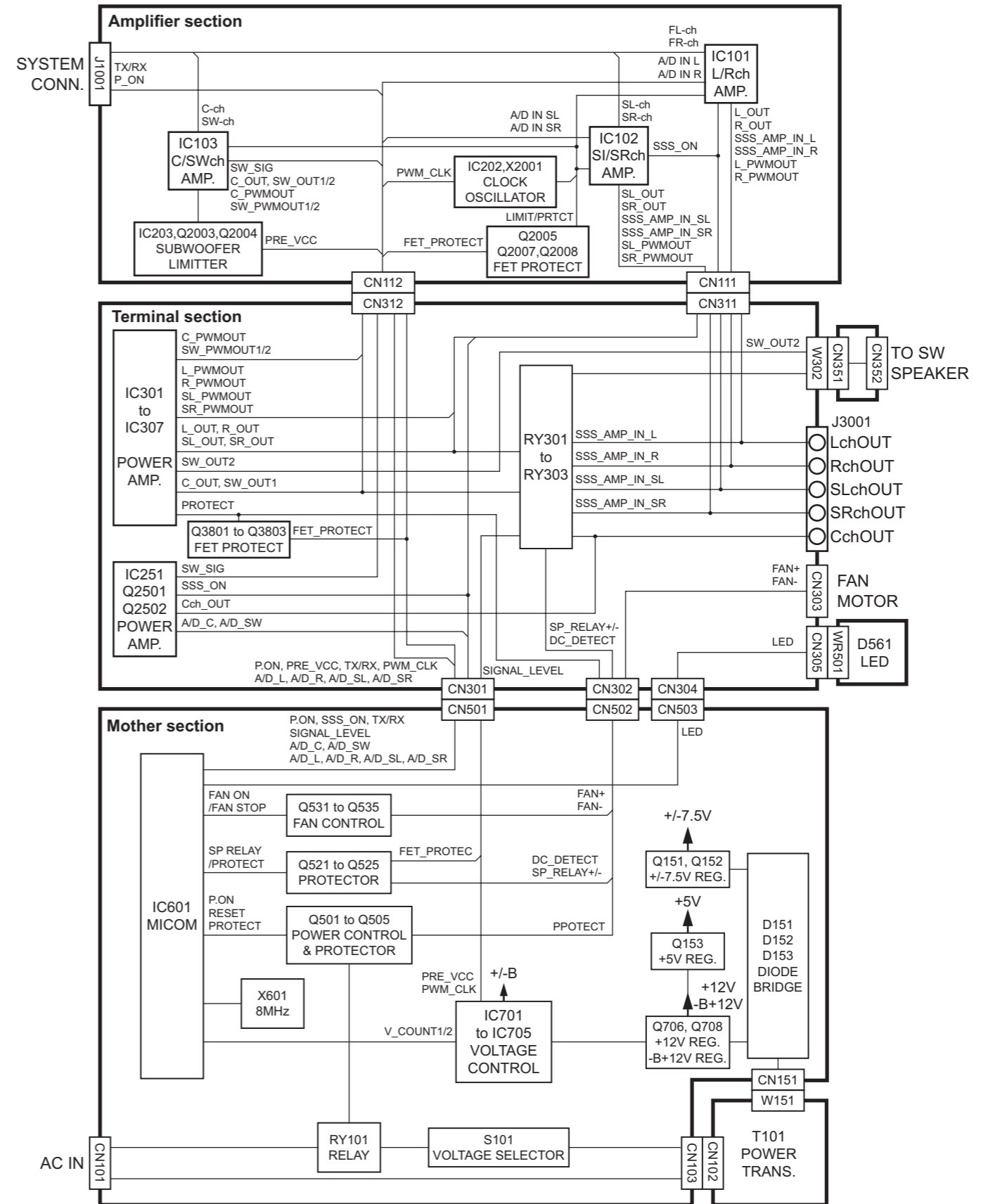

■ Micon section

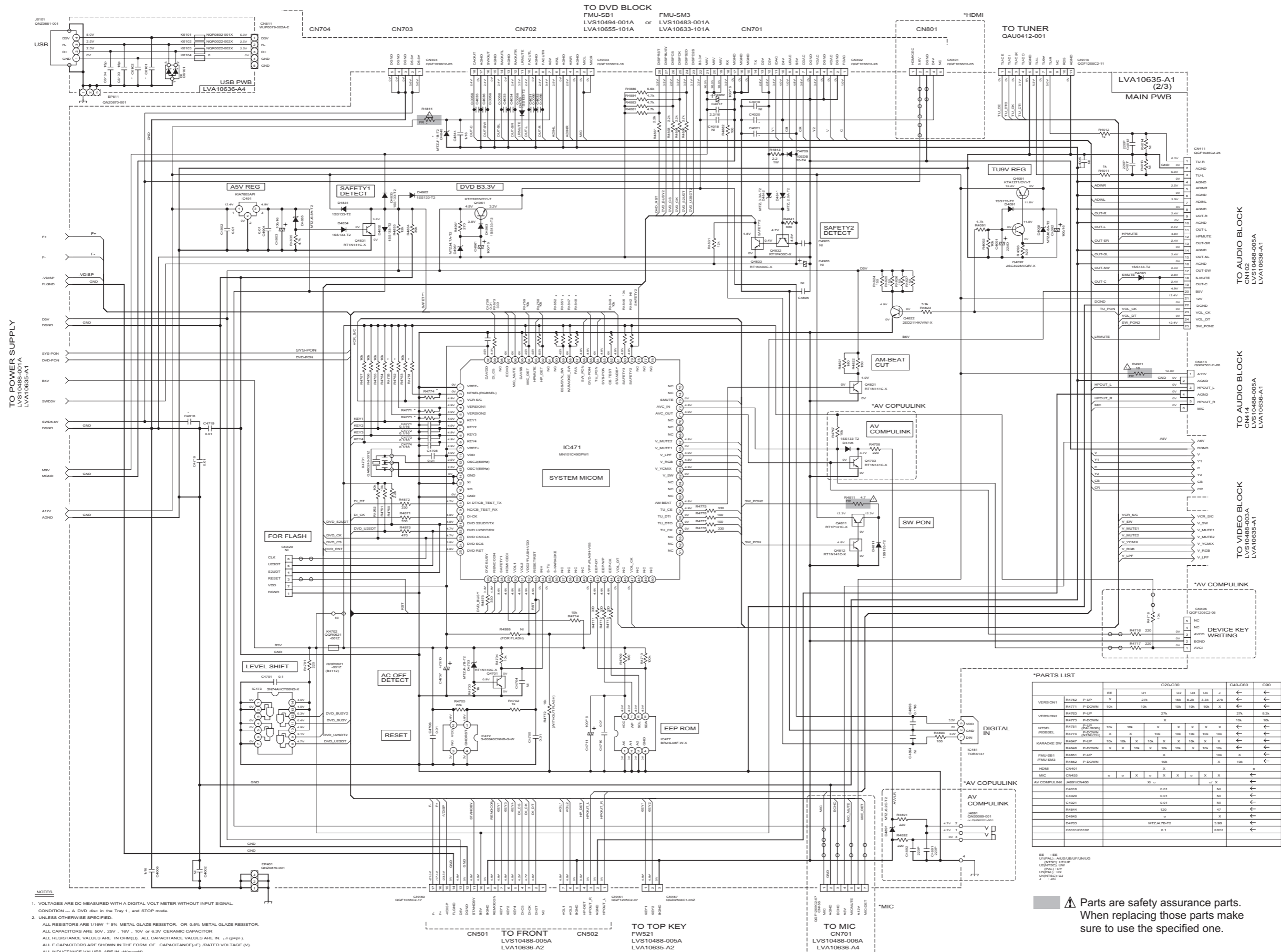

***PARTS LIST**

VERSION1	R4752	P-UP	C20-C30					C40-C50	C90	
			EE	UT	U2	U3	U4			J
VERSION1	R4752	P-UP	X	27k	10k	8.2k	3.3k	27k	X	
VERSION2	R4773	P-DOWN	10k	10k	10k	10k	10k	X		
VERSION3	R4773	P-DOWN		27k				27k	8.2k	
VERSION4	R4773	P-DOWN							10k	
VERSION5	R4773	P-DOWN							10k	
VERSION6	R4773	P-DOWN							10k	
VERSION7	R4773	P-DOWN							10k	
VERSION8	R4773	P-DOWN							10k	
VERSION9	R4773	P-DOWN							10k	
VERSION10	R4773	P-DOWN							10k	
VERSION11	R4773	P-DOWN							10k	
VERSION12	R4773	P-DOWN							10k	
VERSION13	R4773	P-DOWN							10k	
VERSION14	R4773	P-DOWN							10k	
VERSION15	R4773	P-DOWN							10k	
VERSION16	R4773	P-DOWN							10k	
VERSION17	R4773	P-DOWN							10k	
VERSION18	R4773	P-DOWN							10k	
VERSION19	R4773	P-DOWN							10k	
VERSION20	R4773	P-DOWN							10k	
VERSION21	R4773	P-DOWN							10k	
VERSION22	R4773	P-DOWN							10k	
VERSION23	R4773	P-DOWN							10k	
VERSION24	R4773	P-DOWN							10k	
VERSION25	R4773	P-DOWN							10k	
VERSION26	R4773	P-DOWN							10k	
VERSION27	R4773	P-DOWN							10k	
VERSION28	R4773	P-DOWN							10k	
VERSION29	R4773	P-DOWN							10k	
VERSION30	R4773	P-DOWN							10k	
VERSION31	R4773	P-DOWN							10k	
VERSION32	R4773	P-DOWN							10k	
VERSION33	R4773	P-DOWN							10k	
VERSION34	R4773	P-DOWN							10k	
VERSION35	R4773	P-DOWN							10k	
VERSION36	R4773	P-DOWN							10k	
VERSION37	R4773	P-DOWN							10k	
VERSION38	R4773	P-DOWN							10k	
VERSION39	R4773	P-DOWN							10k	
VERSION40	R4773	P-DOWN							10k	
VERSION41	R4773	P-DOWN							10k	
VERSION42	R4773	P-DOWN							10k	
VERSION43	R4773	P-DOWN							10k	
VERSION44	R4773	P-DOWN							10k	
VERSION45	R4773	P-DOWN							10k	
VERSION46	R4773	P-DOWN							10k	
VERSION47	R4773	P-DOWN							10k	
VERSION48	R4773	P-DOWN							10k	
VERSION49	R4773	P-DOWN							10k	
VERSION50	R4773	P-DOWN							10k	
VERSION51	R4773	P-DOWN							10k	
VERSION52	R4773	P-DOWN							10k	
VERSION53	R4773	P-DOWN							10k	
VERSION54	R4773	P-DOWN							10k	
VERSION55	R4773	P-DOWN							10k	
VERSION56	R4773	P-DOWN							10k	
VERSION57	R4773	P-DOWN							10k	
VERSION58	R4773	P-DOWN							10k	
VERSION59	R4773	P-DOWN							10k	
VERSION60	R4773	P-DOWN							10k	
VERSION61	R4773	P-DOWN							10k	
VERSION62	R4773	P-DOWN							10k	
VERSION63	R4773	P-DOWN							10k	
VERSION64	R4773	P-DOWN							10k	
VERSION65	R4773	P-DOWN							10k	
VERSION66	R4773	P-DOWN							10k	
VERSION67	R4773	P-DOWN							10k	
VERSION68	R4773	P-DOWN							10k	
VERSION69	R4773	P-DOWN							10k	
VERSION70	R4773	P-DOWN							10k	
VERSION71	R4773	P-DOWN							10k	
VERSION72	R4773	P-DOWN							10k	
VERSION73	R4773	P-DOWN							10k	
VERSION74	R4773	P-DOWN							10k	
VERSION75	R4773	P-DOWN							10k	
VERSION76	R4773	P-DOWN							10k	
VERSION77	R4773	P-DOWN							10k	
VERSION78	R4773	P-DOWN							10k	
VERSION79	R4773	P-DOWN							10k	
VERSION80	R4773	P-DOWN							10k	
VERSION81	R4773	P-DOWN							10k	
VERSION82	R4773	P-DOWN							10k	
VERSION83	R4773	P-DOWN							10k	
VERSION84	R4773	P-DOWN							10k	
VERSION85	R4773	P-DOWN							10k	
VERSION86	R4773	P-DOWN							10k	
VERSION87	R4773	P-DOWN							10k	
VERSION88	R4773	P-DOWN							10k	
VERSION89	R4773	P-DOWN							10k	
VERSION90	R4773	P-DOWN							10k	
VERSION91	R4773	P-DOWN							10k	
VERSION92	R4773	P-DOWN							10k	
VERSION93	R4773	P-DOWN							10k	
VERSION94	R4773	P-DOWN							10k	
VERSION95	R4773	P-DOWN							10k	
VERSION96	R4773	P-DOWN							10k	
VERSION97	R4773	P-DOWN							10k	
VERSION98	R4773	P-DOWN							10k	
VERSION99	R4773	P-DOWN							10k	
VERSION100	R4773	P-DOWN							10k	

⚠ Parts are safety assurance parts. When replacing those parts make sure to use the specified one.

Video section

LVA10635-A1 (3/3)
MAIN PWB

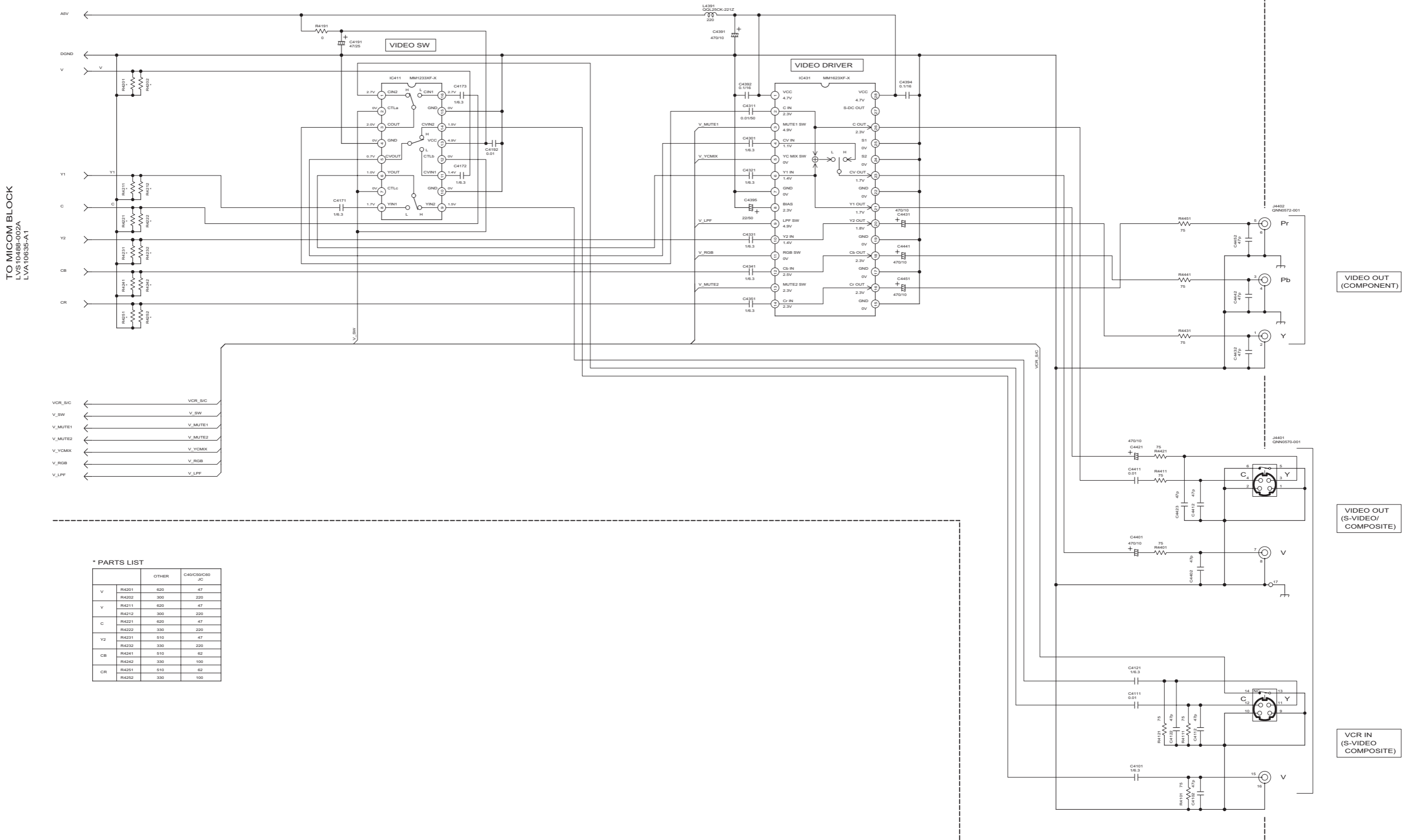

TO MICOM BLOCK
LVS10485-002A
LVA10635-A1

* PARTS LIST

	OTHER	C40/C50/C60	JC
V	R4201	620	47
	R4202	300	220
Y	R4211	620	47
	R4212	300	220
C	R4221	620	47
	R4222	330	220
Y2	R4231	510	47
	R4232	330	220
CB	R4241	510	62
	R4242	330	100
CR	R4251	510	62
	R4252	330	100

■ Audio section

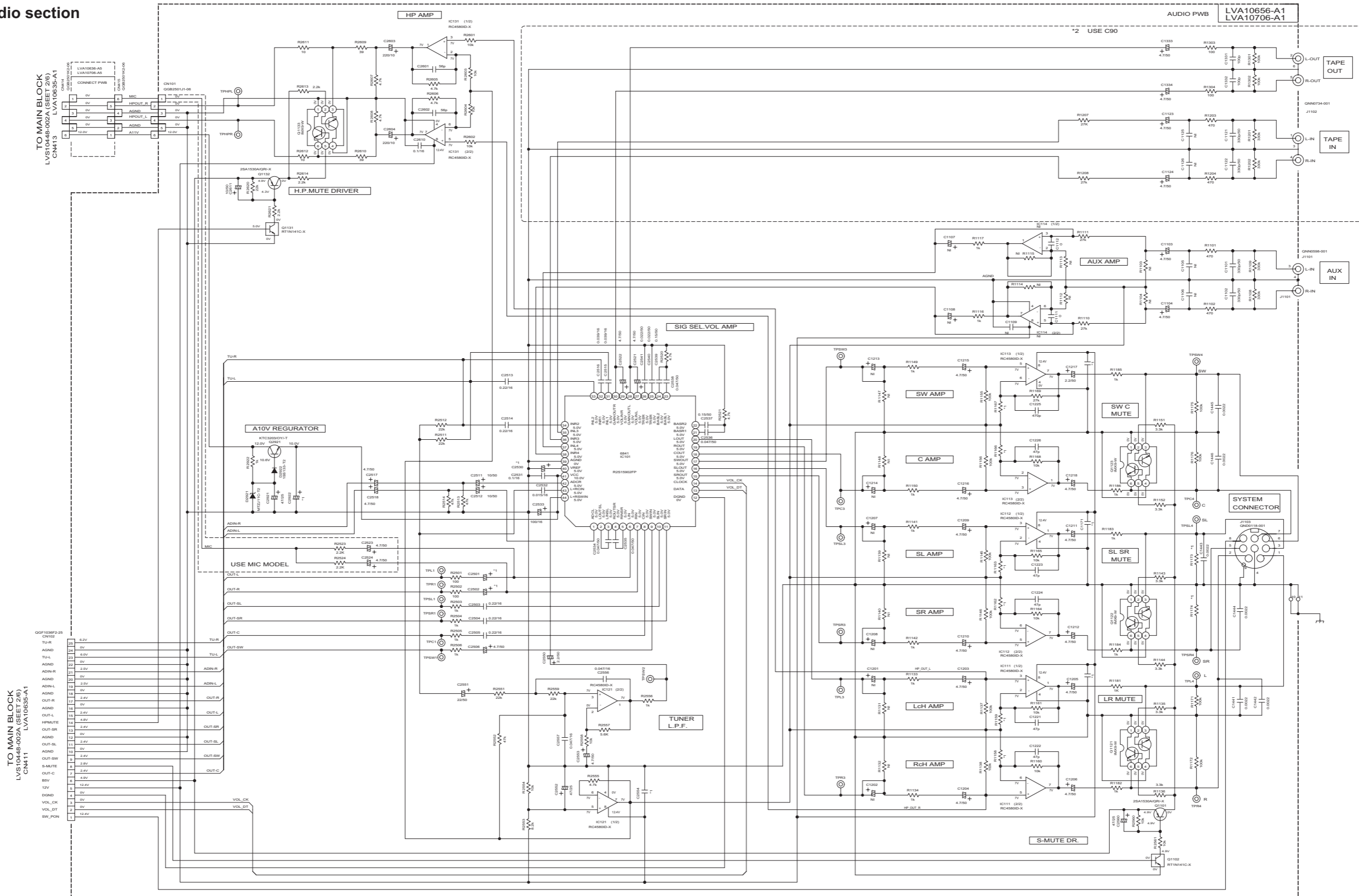

TO MAIN BLOCK
LVS1048-002A (SEE T.26)
CNM11
LVA10635-A1

TO MAIN BLOCK
LVS1048-002A (SEE T.26)
CNM11
LVA10635-A1

CONNECT PWB
LVA10656-A1
LVA10706-A1
CNM14
CNM15
CNM16
CNM17
CNM18
CNM19
CNM20
CNM21
CNM22
CNM23
CNM24
CNM25
CNM26
CNM27
CNM28
CNM29
CNM30
CNM31
CNM32
CNM33
CNM34
CNM35
CNM36
CNM37
CNM38
CNM39
CNM40
CNM41
CNM42
CNM43
CNM44
CNM45
CNM46
CNM47
CNM48
CNM49
CNM50
CNM51
CNM52
CNM53
CNM54
CNM55
CNM56
CNM57
CNM58
CNM59
CNM60
CNM61
CNM62
CNM63
CNM64
CNM65
CNM66
CNM67
CNM68
CNM69
CNM70
CNM71
CNM72
CNM73
CNM74
CNM75
CNM76
CNM77
CNM78
CNM79
CNM80
CNM81
CNM82
CNM83
CNM84
CNM85
CNM86
CNM87
CNM88
CNM89
CNM90
CNM91
CNM92
CNM93
CNM94
CNM95
CNM96
CNM97
CNM98
CNM99
CNM100

NOTES

1. VOLTAGES ARE DC-MEASURED WITH A DIGITAL VOLT METER WITHOUT INPUT SIGNAL.
CONDITION - A CD disc in the Tray 1, and PLAY mode.

2. UNLESS OTHERWISE SPECIFIED:
ALL RESISTORS ARE 1/16W ± 5% METAL GLAZE RESISTOR. OR 0.5% METAL GLAZE RESISTOR.
ALL CAPACITORS ARE 50V, 25V, 16V, 10V or 6.3V CERAMIC CAPACITOR.
ALL RESISTANCE VALUES ARE IN OHM (Ω).
ALL CAPACITANCE VALUES ARE IN pF (pF).
ALL L-CAPACITORS ARE SHOWN IN THE FORM OF CAPACITANCE (pF) / RATED VOLTAGE (V).
ALL INDUCTANCE VALUES ARE IN nH (nH).

3. NI STANDS FOR NOT INSERTED PARTS.

*1 PARTS LIST

	R1158 R1159	R1162 R1163	R1166	R1167	R1173 R1174 R1174	C1170 C1171 C1172	C1446	C2554	C2501 C2502	C2530	C2922	
XV-THC20/26	10k	6.8k	68k	10k	18k	100k	0.01/50	0.0022	0.1/50	1/50	100/16	100/16
XV-THC30/40	10k	-	10k	10k	18k	100k	0.01/50	0.0022	0.1/50	1/50	100/16	100/16
XV-THC50/43	10k	-	10k	15k	10k	100k	1/16	0.001	1/16	4.7/50	47/25	100/25
XV-THC60/67	10k	6.8k	-	15k	9.1k	3.9k	1/16	0.001	1/16	4.7/50	47/25	100/25
XV-THC90	18k	10k	33k	18k	1.8k	100k	1/16	0.001	1/16	4.7/50	47/25	100/25

*2 USE C90

■ Mic input section

TO MAIN PWB
CN455 OF
LVS10488-002A (SHEET 2/6)
LVA10635-A1

FOR U Seri.With MIC.

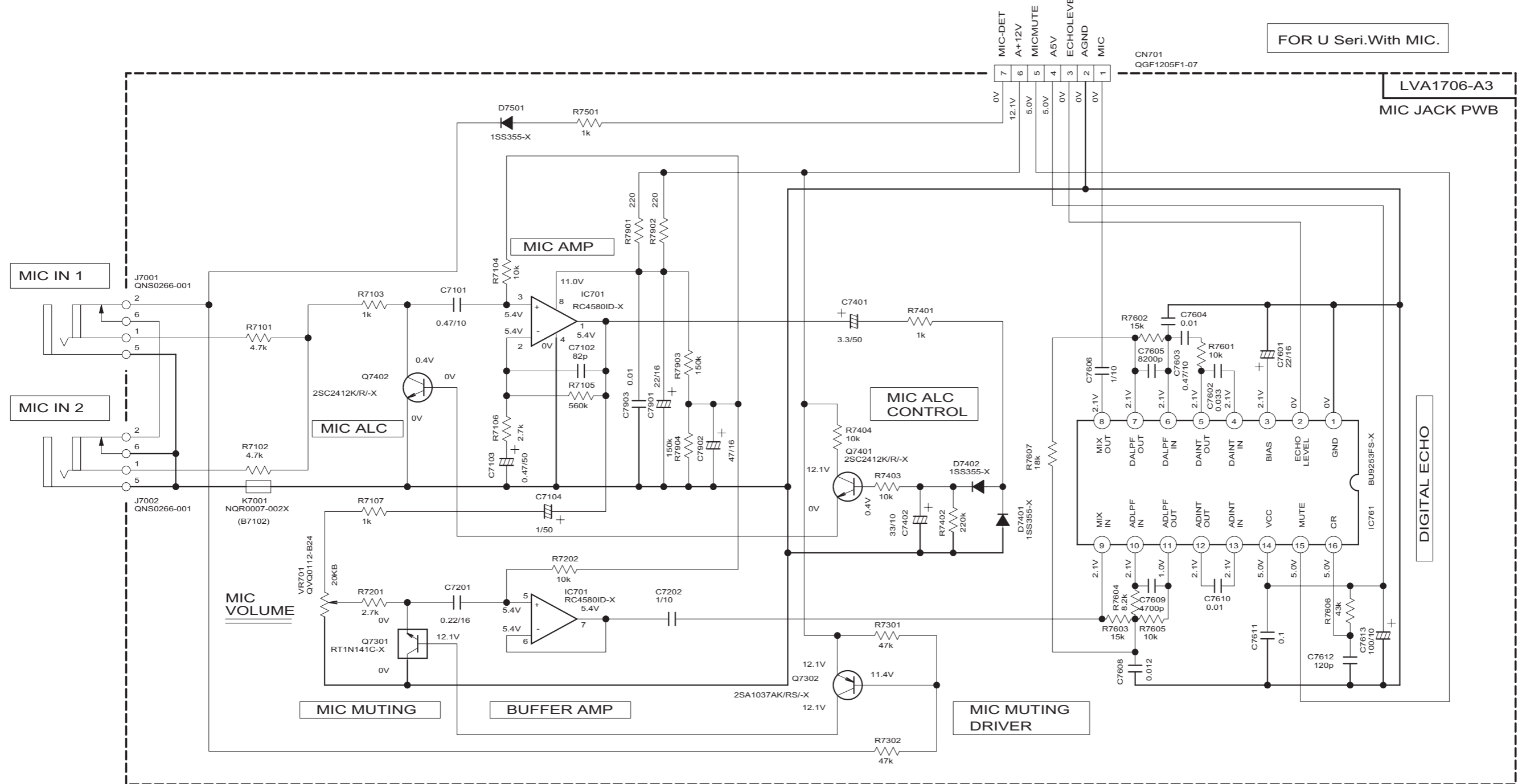

NOTES

- VOLTAGES ARE DC-MEASURED WITH A DIGITAL VOLT METER WITHOUT INPUT SIGNAL.
CONDITION --- A CD disc in the Tray 1, and PLAY mode.
- UNLESS OTHERWISE SPECIFIED.
ALL RESISTORS ARE 1/16W ±5% METAL GLAZE RESISTOR. OR 0.5% METAL GLAZE RESISTOR.
ALL CAPACITORS ARE 50V, 25V, 16V, 10V or 6.3V CERAMIC CAPACITOR.
ALL RESISTANCE VALUES ARE IN OHM(Ω).
ALL CAPACITANCE VALUES ARE IN μF(p=pF).
ALL E.CAPACITORS ARE SHOWN IN THE FORM OF CAPACITANCE(μF) /RATED VOLTAGE (V).
ALL INDUCTANCE VALUES ARE IN μH(m=mH).
- NI STANDS FOR NOT INSERTED PARTS.

■ Speaker amplifier section for TH-C90

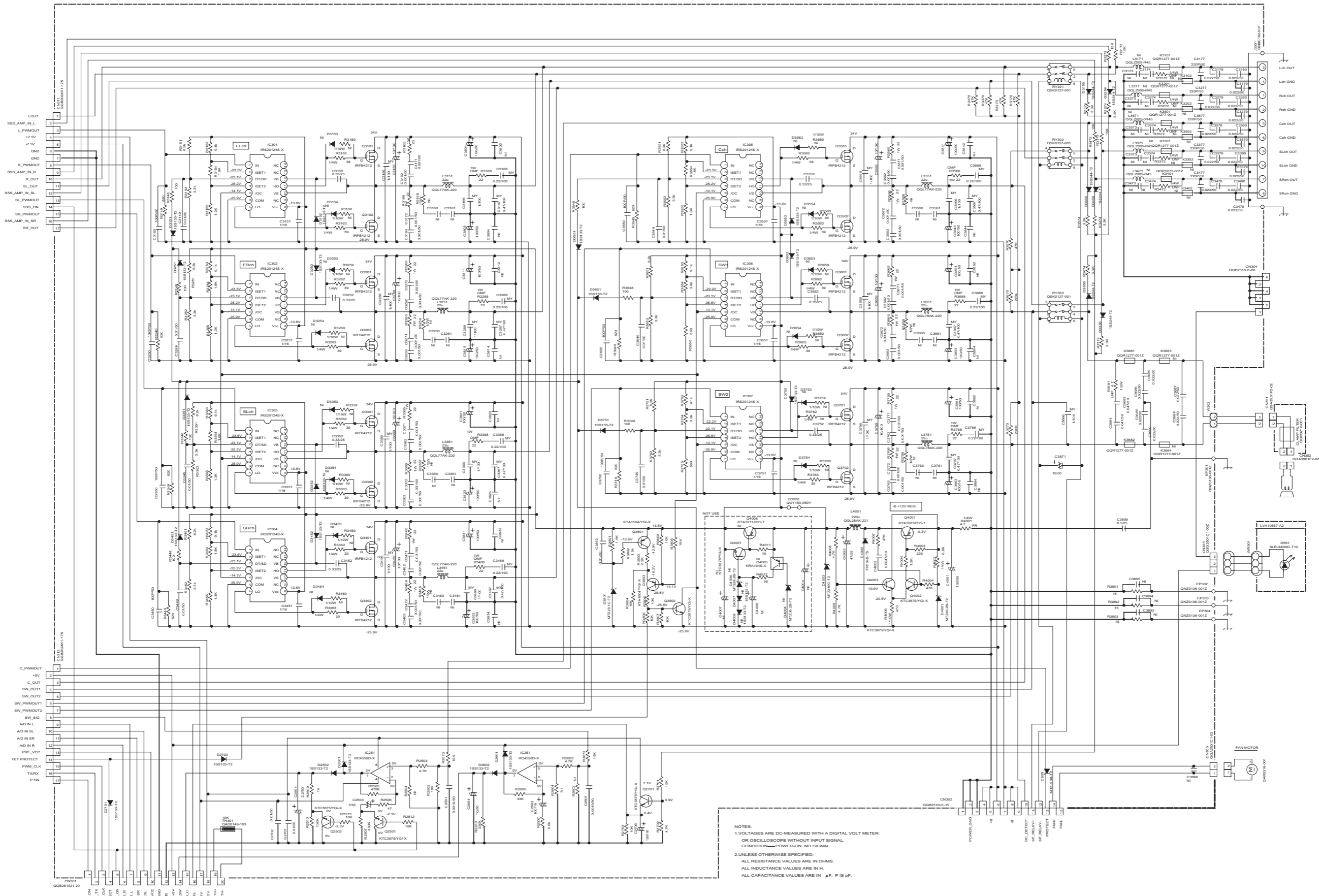

NOTES:
 1. VOLTAGES ARE DC-MEASURED WITH A DIGITAL VOLT METER OR OSCILLOSCOPE WITHOUT INPUT SIGNAL. CONDITION—POWER ON, NO SIGNAL.
 2. UNLESS OTHERWISE SPECIFIED, ALL RESISTANCE VALUES ARE IN OHMS. ALL INDUCTANCE VALUES ARE IN H. ALL CAPACITANCE VALUES ARE IN μ F. P IS PF.

■ Speaker input section for TH-C90

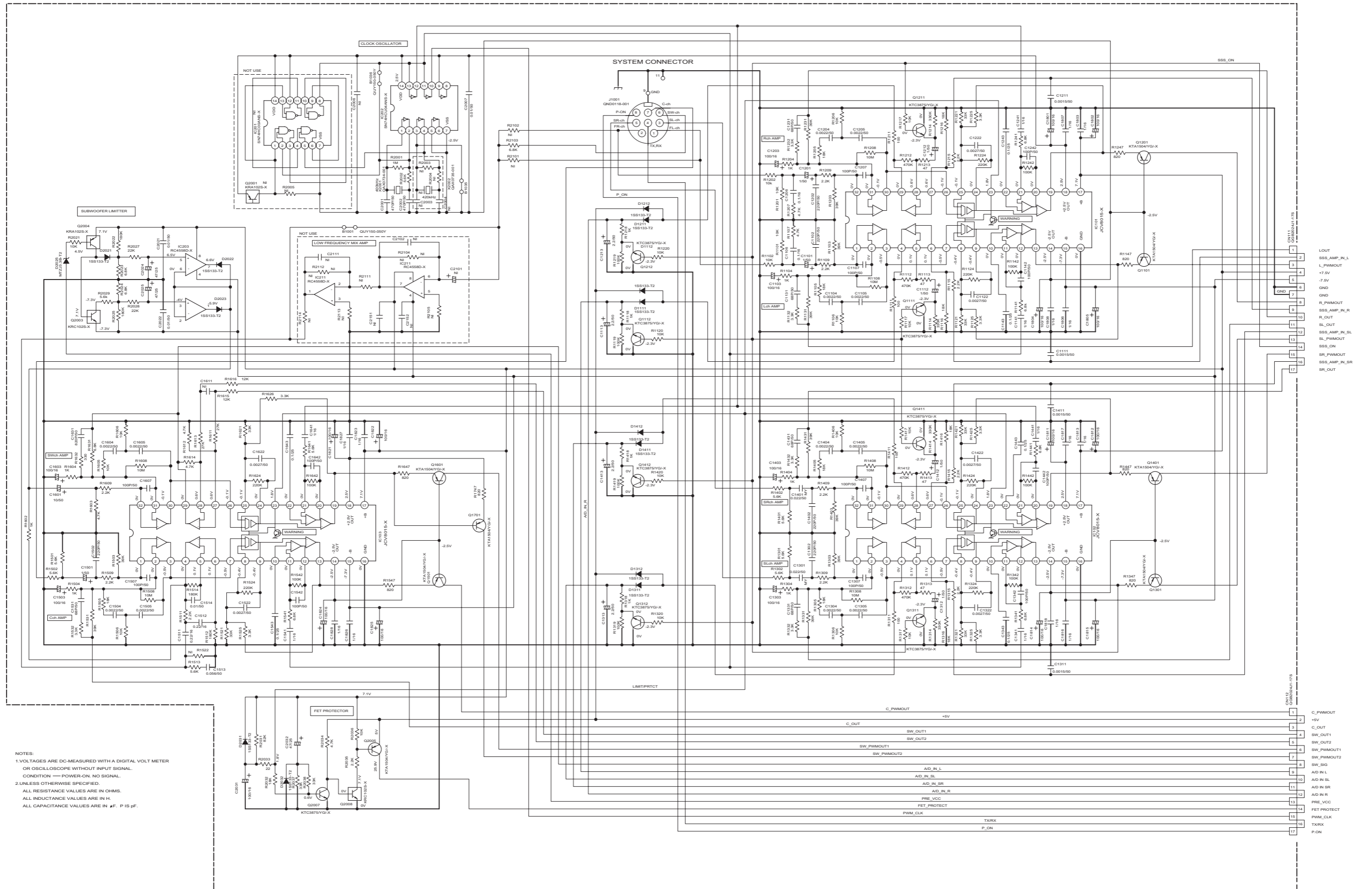

NOTES:
 1. VOLTAGES ARE DC-MEASURED WITH A DIGITAL VOLT METER OR OSCILLOSCOPE WITHOUT INPUT SIGNAL. CONDITION — POWER-ON, NO SIGNAL.
 2. UNLESS OTHERWISE SPECIFIED, ALL RESISTANCE VALUES ARE IN OHMS. ALL INDUCTANCE VALUES ARE IN H. ALL CAPACITANCE VALUES ARE IN #F. P IS pF.

■ Speaker primary section for TH-C60

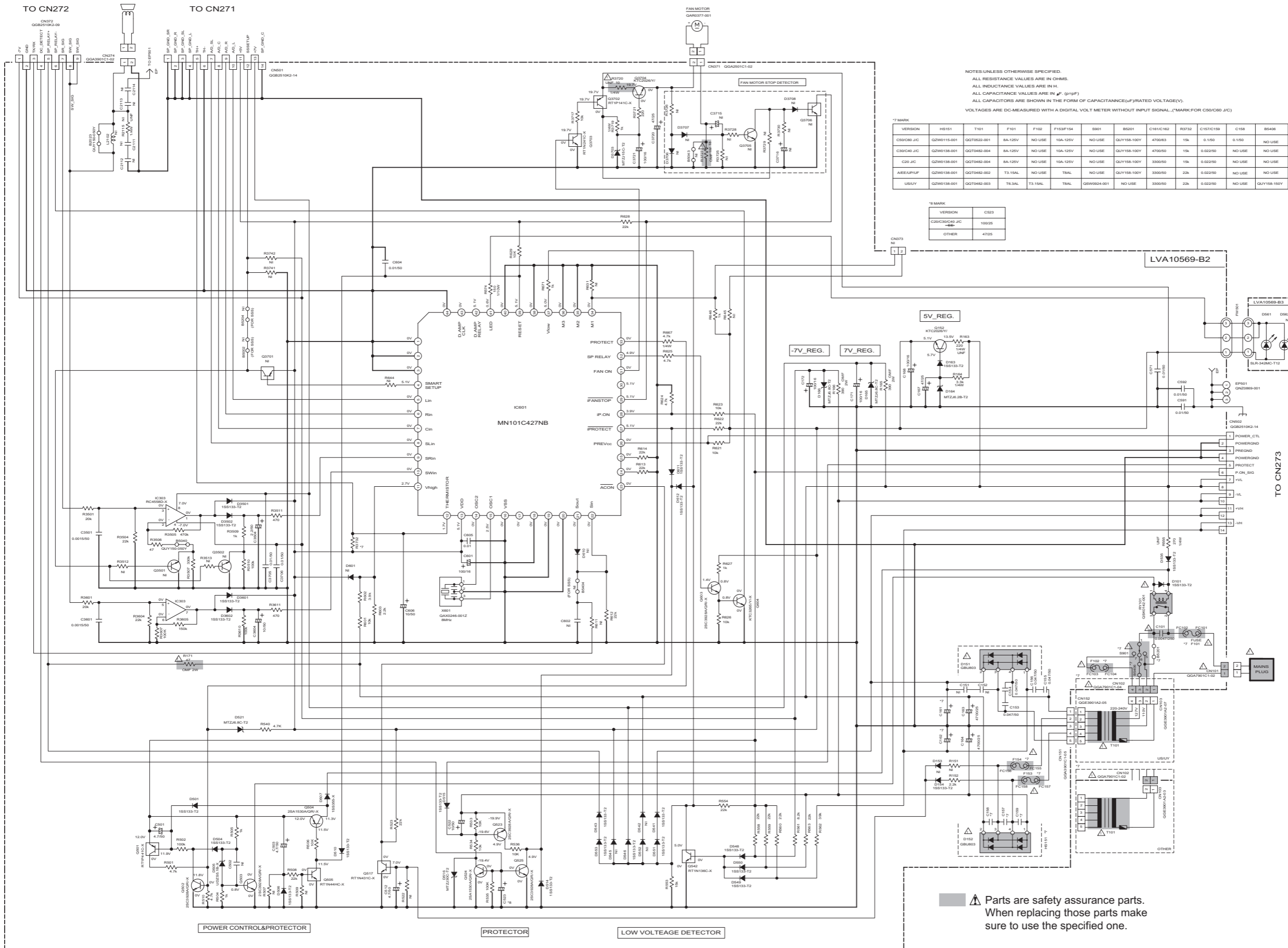

NOTES UNLESS OTHERWISE SPECIFIED.
 ALL RESISTANCE VALUES ARE IN OHMS.
 ALL INDUCTANCE VALUES ARE IN H.
 ALL CAPACITANCE VALUES ARE IN μF (p=PF)
 VOLTAGES ARE DC-MEASURED WITH A DIGITAL VOLT METER WITHOUT INPUT SIGNAL. (*MARK FOR C50/C60 J/C)

7 MARK	VERSION	H5151	T101	F101	F102	F153F154	S901	S9201	C181C182	R3732	C187C189	C188	B5406
C50/C60 J/C	QZW615-001	QGT052-001	8A-125V	NO USE	10A-125V	NO USE	QUY158-100Y	470083	15k	0.150	0.150	NO USE	
C30/C40 J/C	QZW6138-001	QGT0482-004	8A-125V	NO USE	10A-125V	NO USE	QUY158-100Y	470050	15k	0.02250	NO USE	NO USE	
C20 J/C	QZW6138-001	QGT0482-004	8A-125V	NO USE	10A-125V	NO USE	QUY158-100Y	330050	15k	0.02250	NO USE	NO USE	
A8E/AP/UP	QZW6138-001	QGT0482-002	T3.15AL	NO USE	T8AL	NO USE	QUY158-100Y	330050	22k	0.02250	NO USE	NO USE	
USU/Y	QZW6138-001	QGT0482-003	T8.3AL	T3.15AL	T8AL	NO USE	QSW0924-001	NO USE	330050	22k	0.02250	NO USE	QUY158-100Y

8 MARK	VERSION	C523
C20/C30/C40 J/C	8E8	100225
OTHER		4725

▲ Parts are safety assurance parts.
 When replacing those parts make
 sure to use the specified one.

■ Speaker amplifier section for TH-C60

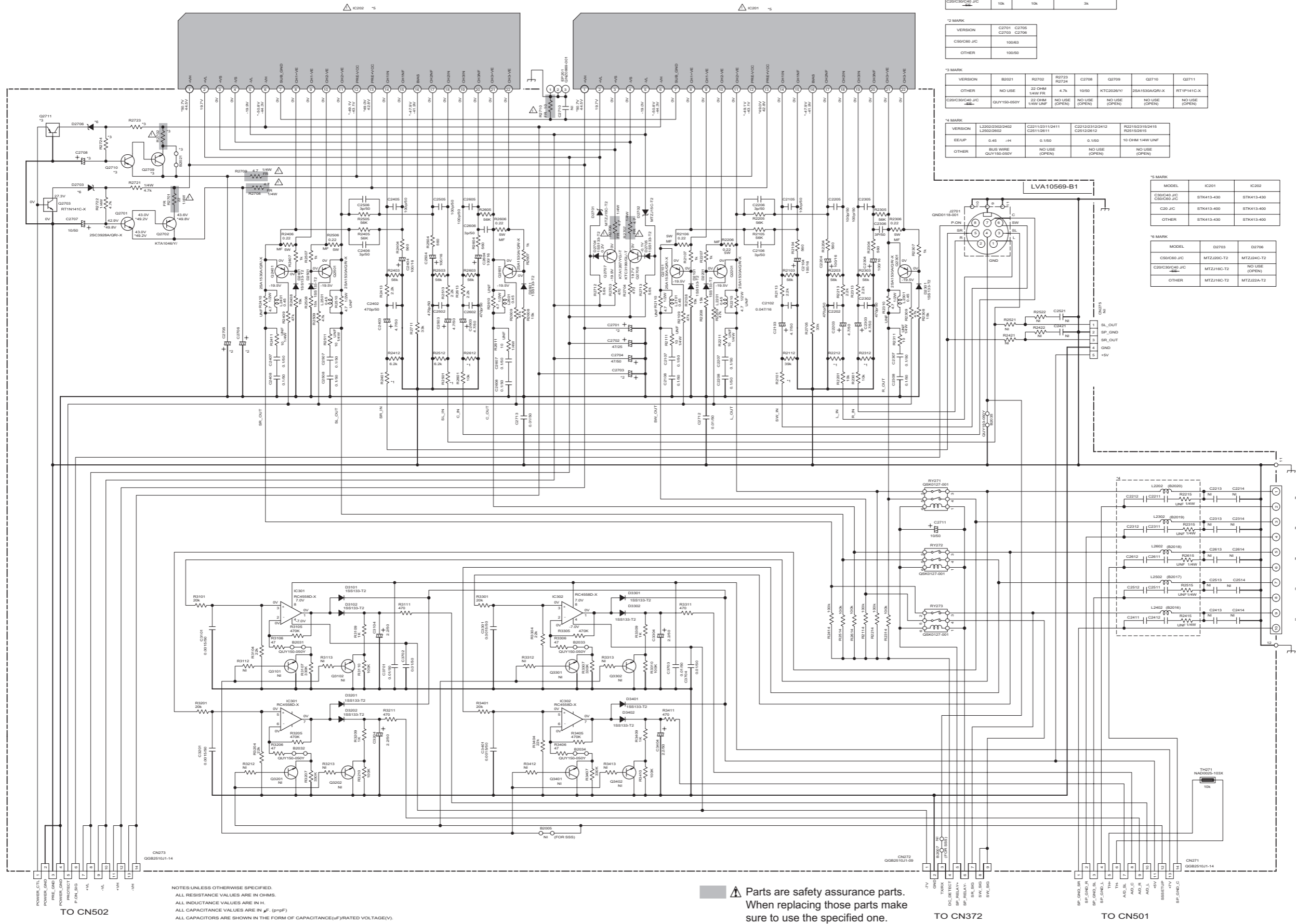

*1 MARK

VERSION	R2101 (R1)	R2401 (R2)	R2601 (R3)	R2112 (R4)	R2312 (R5)	R2612 (R6)
OTHER	3k	6.2k			4.3k	
C20/C30/C40 J/C	10k	10k			3k	

*2 MARK

VERSION	C2701	C2706
OTHER	C2703	C2706
C50/C60 J/C	100k3	
OTHER	10050	

*3 MARK

VERSION	R2021	R2702	R2723	R2724	C2708	Q2709	Q2710	Q2711
OTHER	NO USE	22 OHM 1/4W FR	4.7k	1050	KTC2026(Y)	2SA1553AQR(X)	RT1P141C(X)	
C20/C30/C40 J/C	QUY150-050Y	22 OHM 1/4W UNF (OPEN)	NO USE (OPEN)	NO USE (OPEN)	NO USE (OPEN)	NO USE (OPEN)	NO USE (OPEN)	NO USE (OPEN)

*4 MARK

VERSION	L2202	C2211	C2212	R2215	R2216	R2217
EE/UP	0.45	10H	0.150	0.150	10 OHM 1/4W UNF	
OTHER	BUS WIRE	QUY150-050Y	NO USE (OPEN)	NO USE (OPEN)	NO USE (OPEN)	NO USE (OPEN)

*5 MARK

MODEL	IC201	IC202
C30/C40 J/C	STK413-430	STK413-430
C50 J/C	STK413-400	STK413-400
OTHER	STK413-430	STK413-400

*6 MARK

MODEL	D2703	D2706
C50/C60 J/C	MTZJ00C-T2	MTZJ04C-T2
C20/C30/C40 J/C	MTZJ18C-T2	NO USE (OPEN)
OTHER	MTZJ18C-T2	MTZJ22A-T2

NOTES: UNLESS OTHERWISE SPECIFIED,
 ALL RESISTANCE VALUES ARE IN OHMS.
 ALL INDUCTANCE VALUES ARE IN H.
 ALL CAPACITANCE VALUES ARE IN μ F. (p=pF)
 ALL CAPACITORS ARE SHOWN IN THE FORM OF CAPACITANCE(μ F)/RATED VOLTAGE(V).
 VOLTAGES ARE DC-MEASURED WITH A DIGITAL VOLT METER WITHOUT INPUT SIGNAL. (*MARK-FOR C50/C60 J/C)

⚠ Parts are safety assurance parts.
 When replacing those parts make
 sure to use the specified one.

TO CN502

TO CN372

TO CN501

■ DVD section (1/3)

PICKUP ASSY
QAL0786-***
(OPA-652PH*)

TRA MECHASSY
FXL-D20-1C

FEED MOTOR
QAR0165-001

SPINDLE MOTOR
QAR0387-001

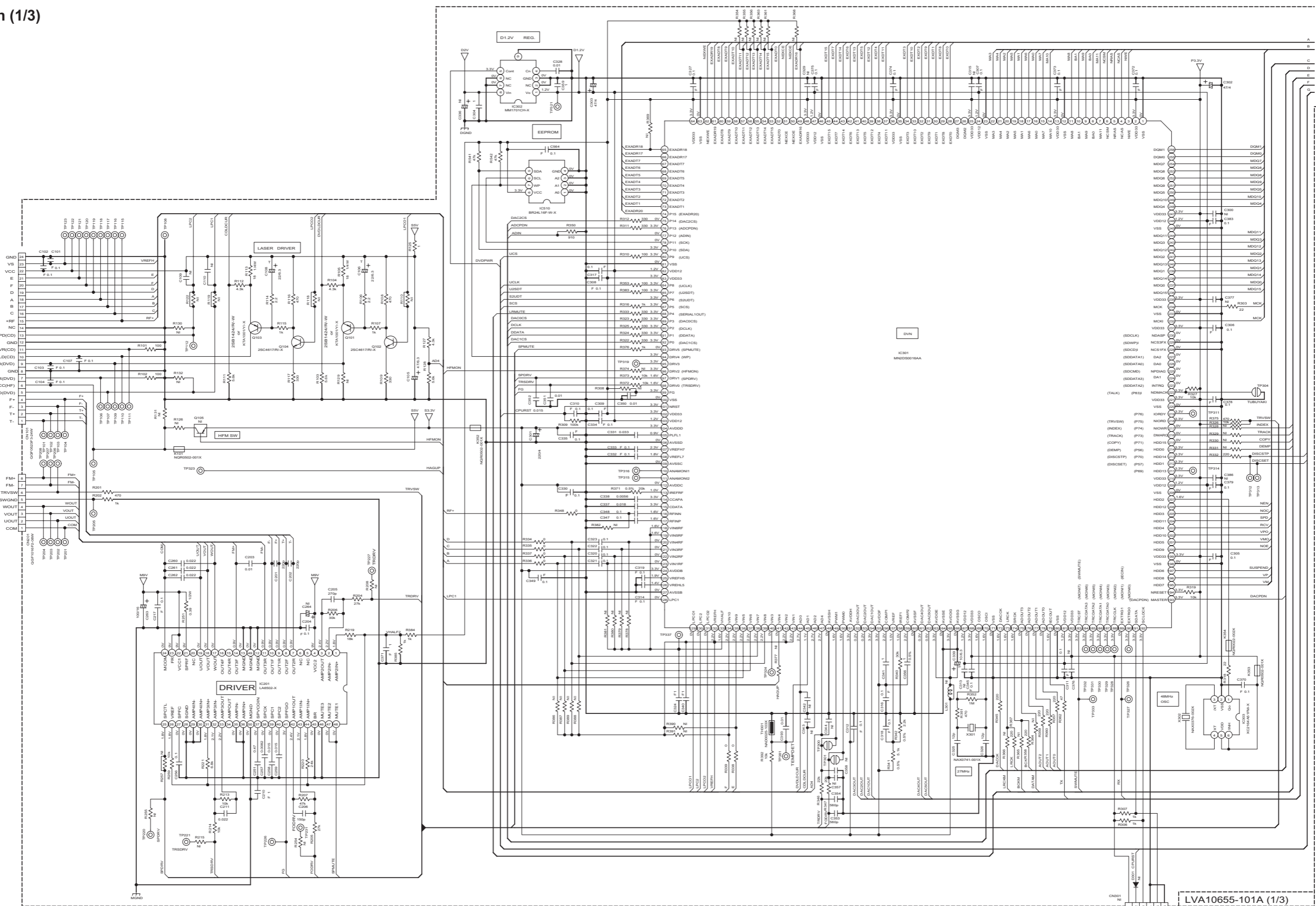

NOTES

- VOLTAGES ARE DC-MEASURED WITH A DIGITAL VOLT METER WITHOUT INPUT SIGNAL. CONDITION—A DVD disk in the Tray 1, and STOP mode.
- UNLESS OTHERWISE SPECIFIED:
ALL RESISTORS ARE 1/16W ±5% METAL GLAZE RESISTOR, OR 0.5% METAL GLAZE RESISTOR.
ALL CAPACITORS ARE 50V, .25V, .16V, .10V or 6.3V CERAMIC CAPACITOR.
ALL RESISTANCE VALUES ARE IN OHM(Ω).
ALL CAPACITANCE VALUES ARE IN pF(pF).
ALL E-CAPACITORS ARE SHOWN IN THE FORM OF CAPACITANCE(μF) / RATED VOLTAGE (V).
ALL INDUCTANCE VALUES ARE IN mH(mH).

3. NI STANDS FOR NOT INSERTED PARTS.

LVA10655-101A (1/3)

DVD section (2/3)

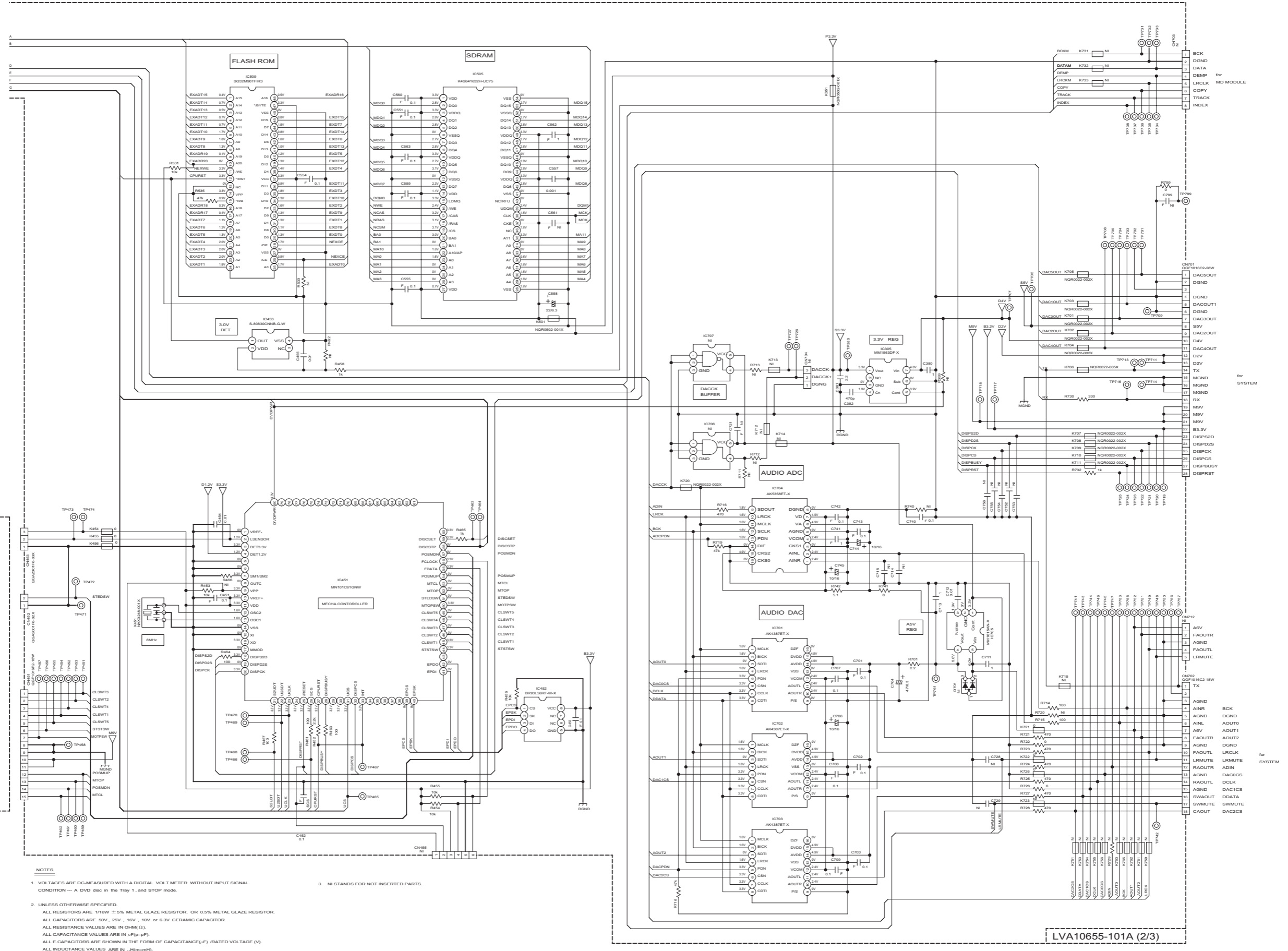

LOADER ASS'Y
CH6-BASE-1

See
LVS20135-002A

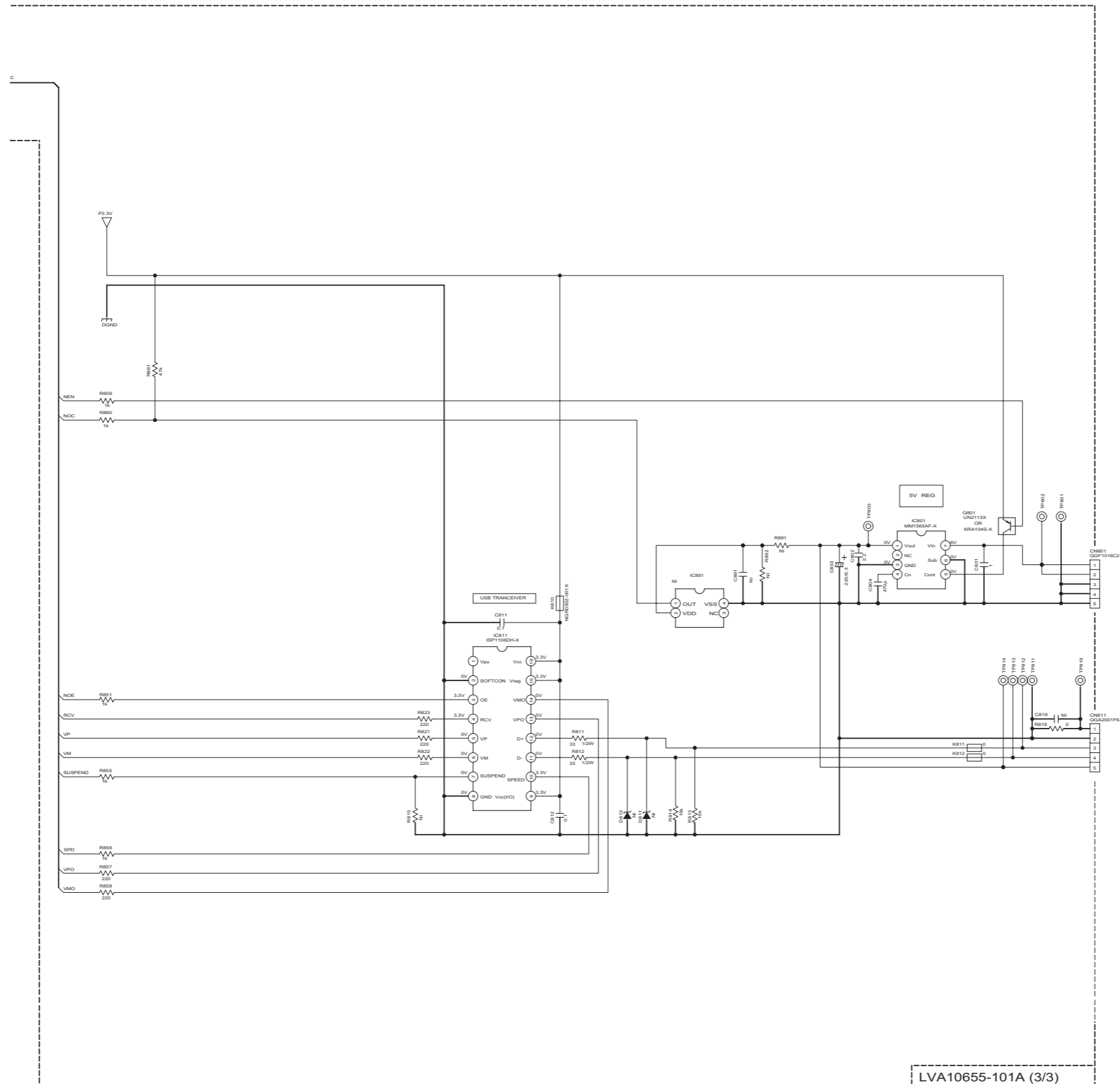

LVA10655-101A (3/3)

- NOTES**
1. VOLTAGES ARE DC-MEASURED WITH A DIGITAL VOLT METER. WITHOUT INPUT SIGNAL. CONDITION --- A DVD disc in the Tray 1, and STOP mode.
 2. UNLESS OTHERWISE SPECIFIED:
ALL RESISTORS ARE 1/16W ± 5% METAL GLAZE RESISTOR. OR 0.5% METAL GLAZE RESISTOR.
ALL CAPACITORS ARE 50V, 25V, 16V, 10V or 6.3V CERAMIC CAPACITOR.
ALL RESISTANCE VALUES ARE IN OHM (Ω).
ALL CAPACITANCE VALUES ARE IN μF (PF).
ALL E-CAPACITORS ARE SHOWN IN THE FORM OF CAPACITANCE(μF) / RATED VOLTAGE (V).
ALL INDUCTANCE VALUES ARE IN μH (mH).
 3. NI STANDS FOR NOT INSERTED PARTS.
 4. DIGITAL TRANSISTOR
UN2113-X =  47k

■ Loader section

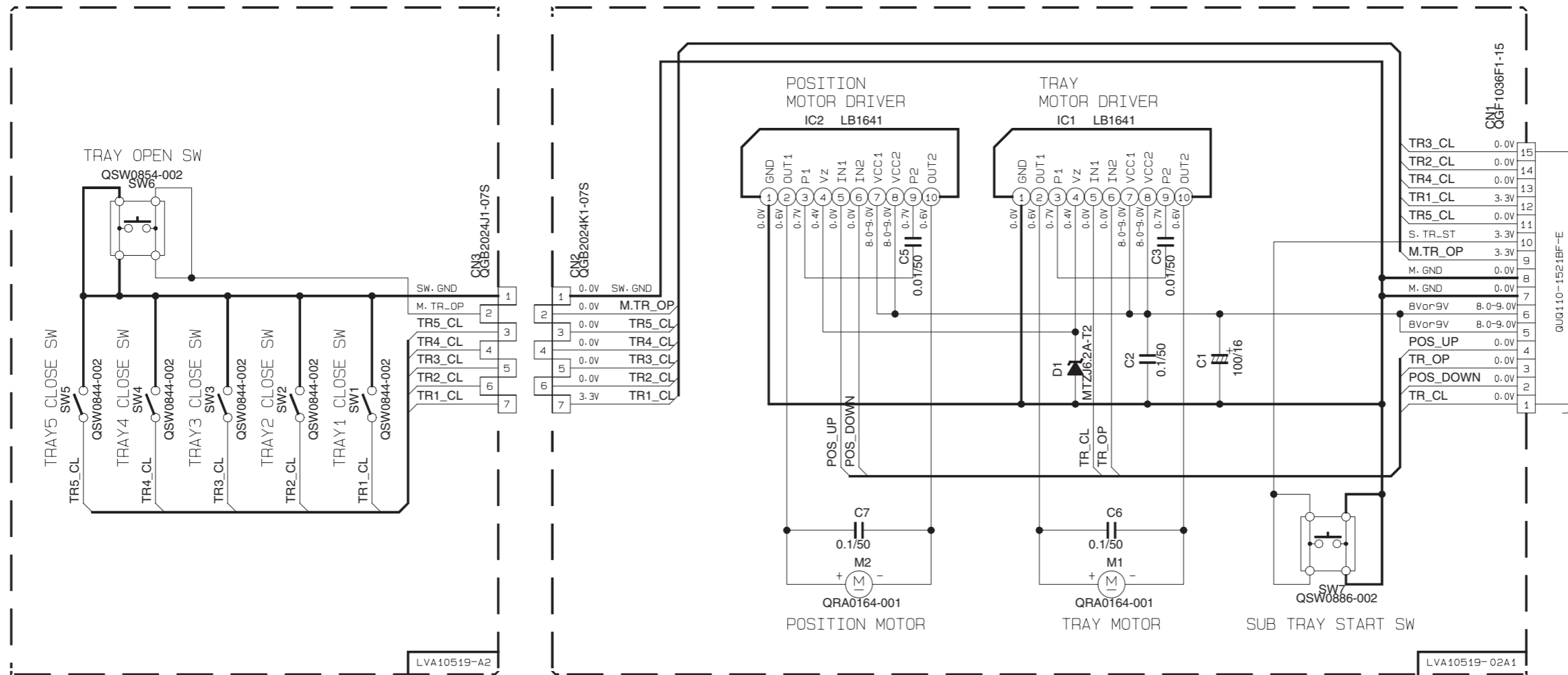

NOTES

1. VOLTAGES ARE DC-MEASURED WITH A DIGITAL VOLT METER.
CONDITION:DISC1 STOP
2. UNLESS OTHERWISE SPECIFIED.
ALL CAPACITORS ARE SHOWN IN THE FORM OF CAPACITANCE(μF)/RATED VOLTAGE(V).
3. NI STANDS FOR NOT INSERTED PARTS.

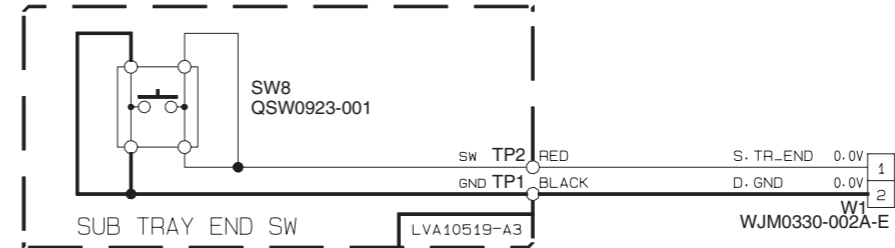
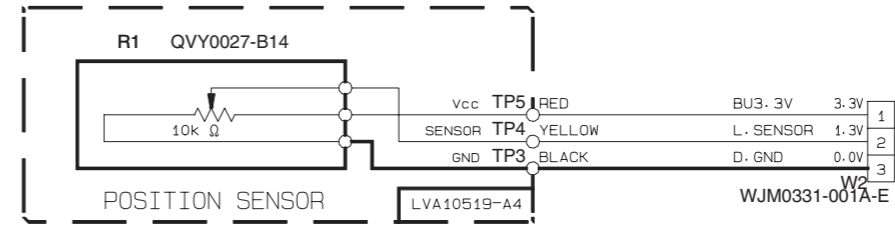

TO POWER AND MECHA CONTROL MICOM

Printed circuit boards

■ Main board Lead free solder used in the board (material : Sn-Ag-Cu, melting point : 219 Centigrade)

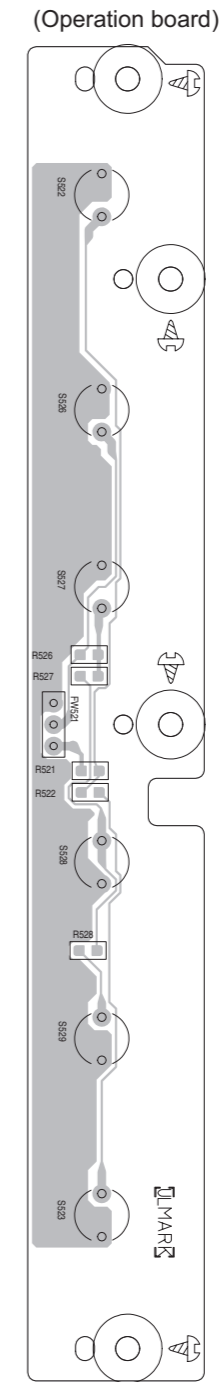
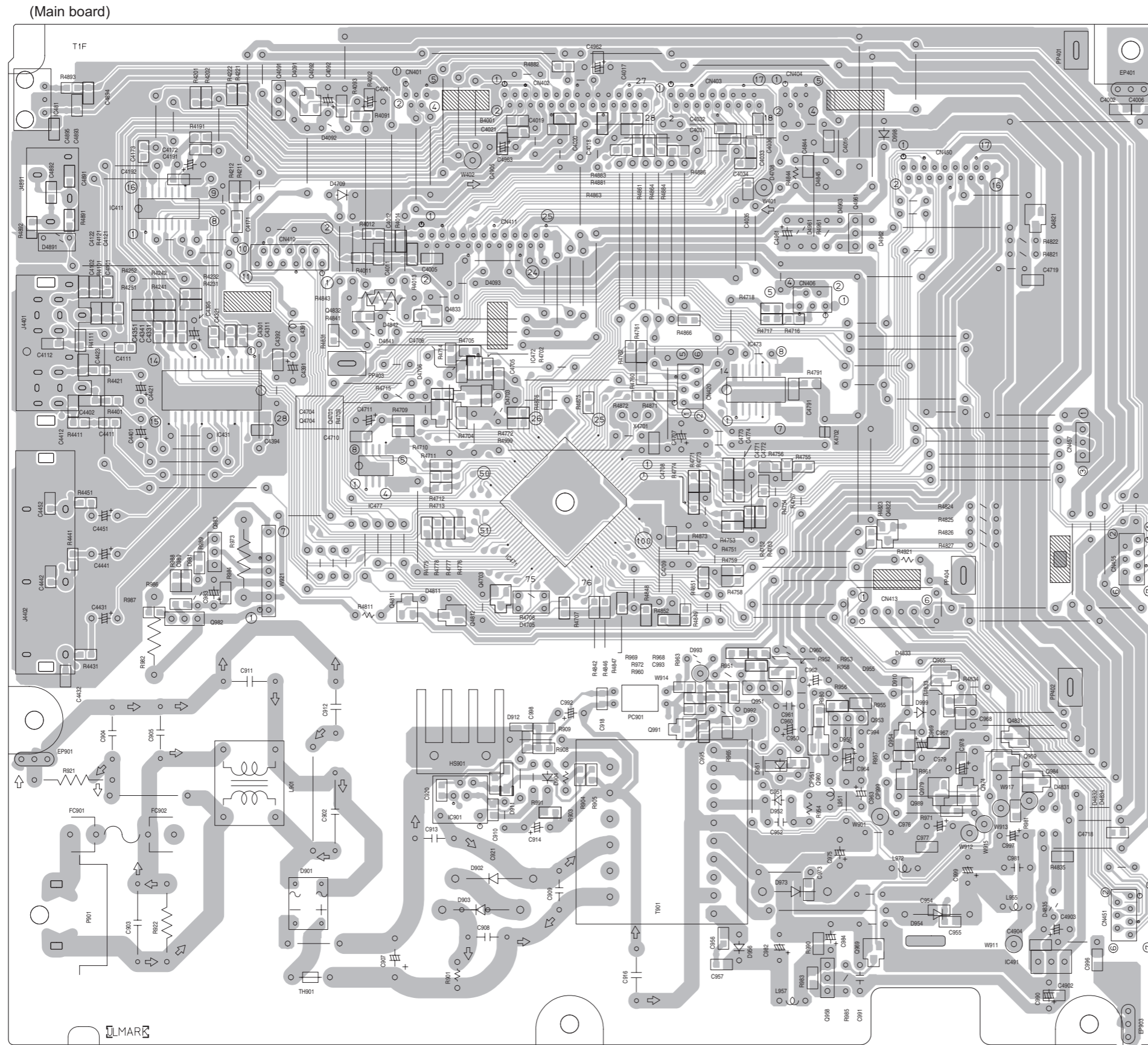

■ Speaker board for TH-C90 Lead free solder used in the board (material : Sn-Ag-Cu, melting point : 219 Centigrade)

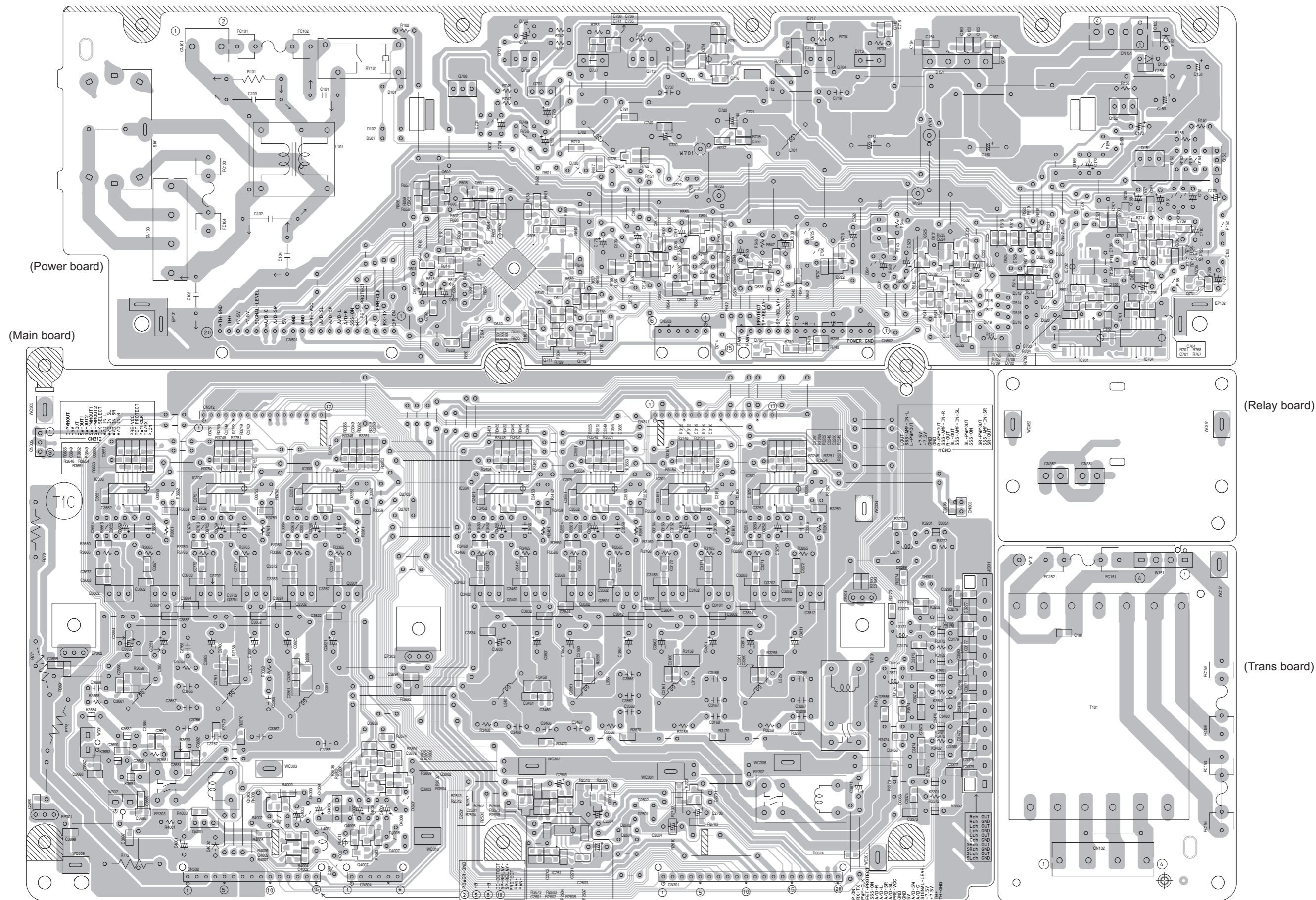

■ Speaker board for TH-C60 Lead free solder used in the board (material : Sn-Ag-Cu, melting point : 219 Centigrade)

(Amp. board)

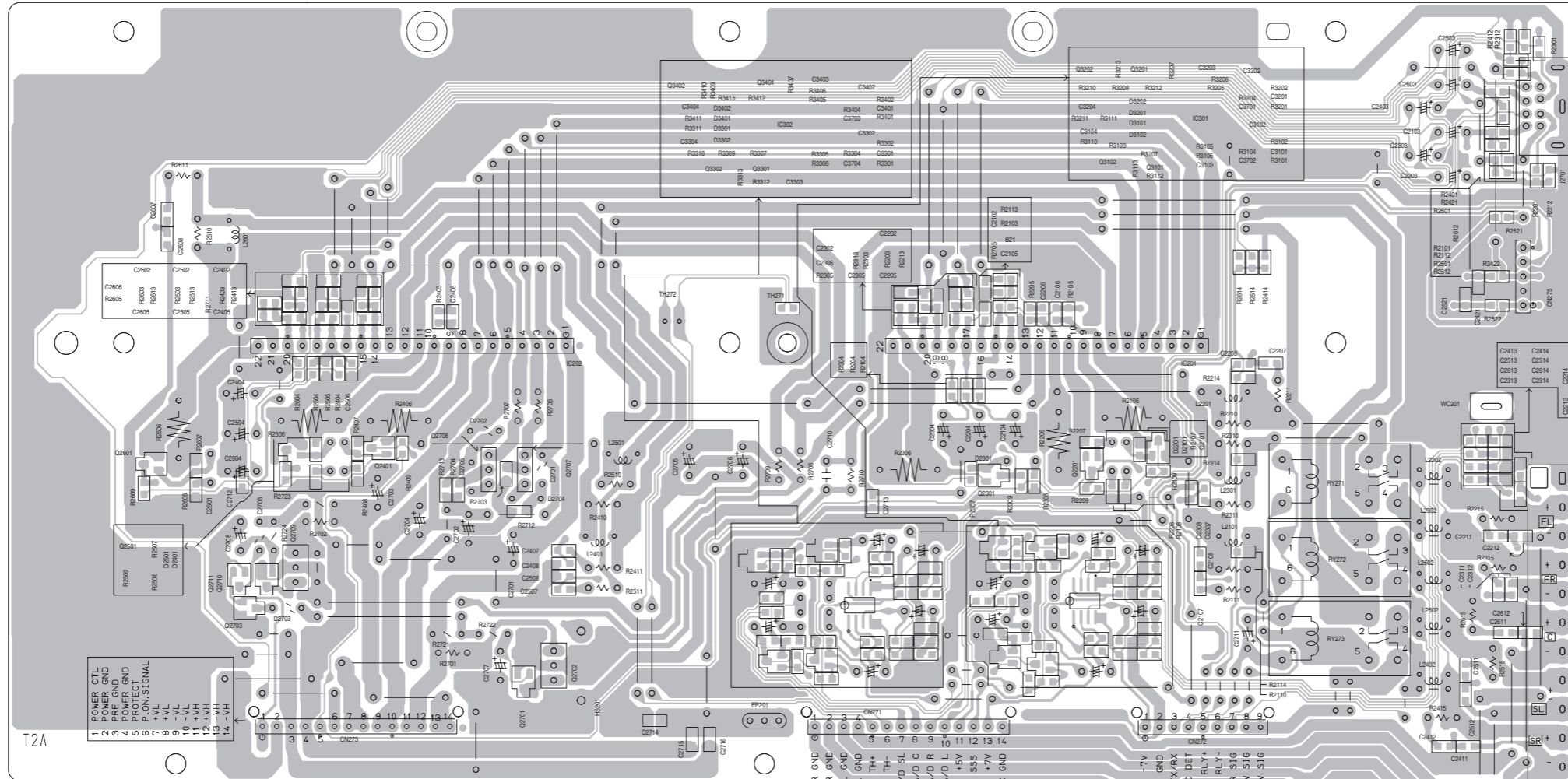

(Mother board)

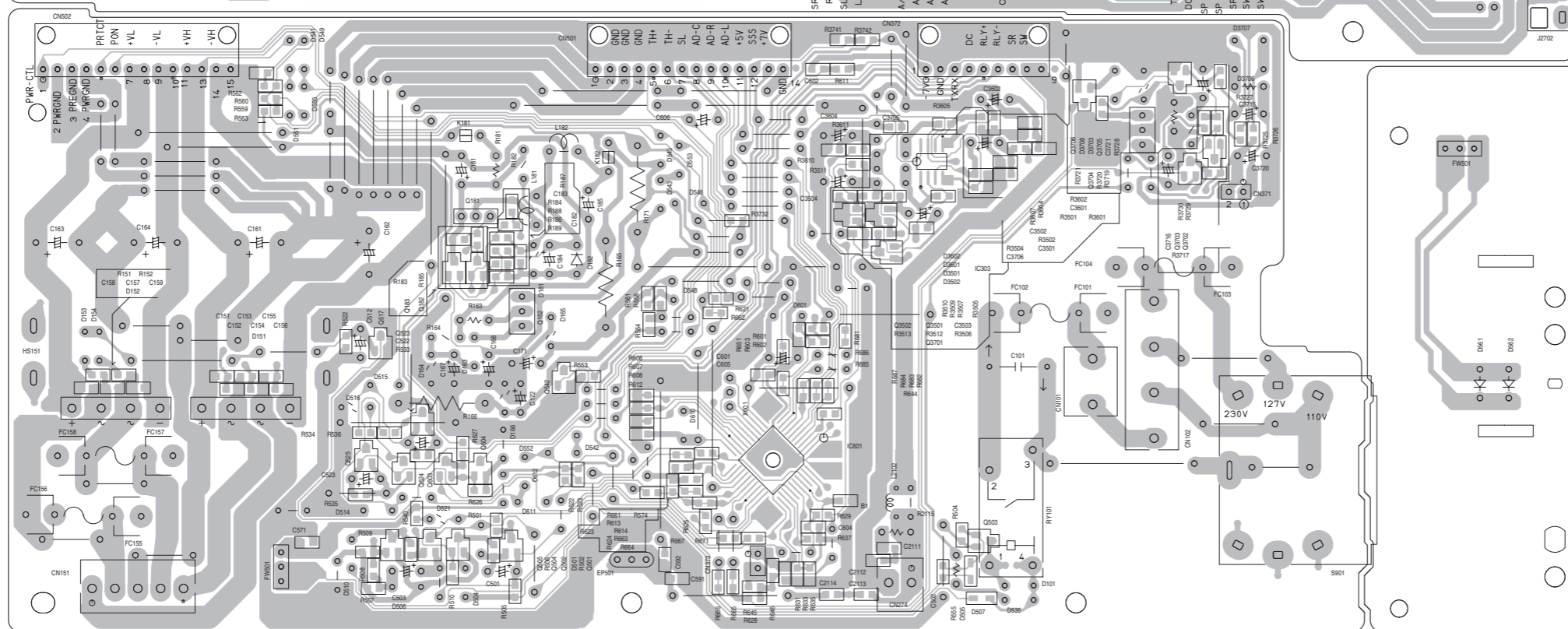

(LED board)

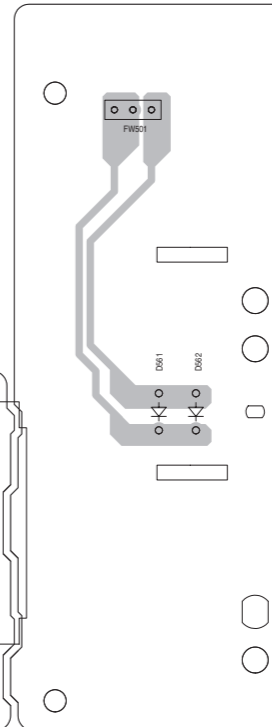

< MEMO >

JVC

Victor Company of Japan, Limited

Audio/Video Systems Category 10-1, 1chome, Ohwatari-machi, Maebashi-city, 371-8543, Japan

(No.MB570SCH)



Printed in Japan
VPT

PARTS LIST

TH-C90A, TH-C90US, TH-C90UX, TH-C90UG
TH-C60US, TH-C60UP, TH-C60UW
TH-C60UX, TH-C60UY, TH-C60UG

* All printed circuit boards and its assemblies are not available as service parts.

- Contents -

Exploded view of general assembly and parts list (Block No.M1)	3- 2
Speaker assembly and parts list(Subwoofer) (Block No.M2) (TH-C90)	3- 6
Speaker assembly and parts list(Subwoofer) (Block No.M3) (TH-C60)	3- 8
DVD mechanism assembly and parts list (Block No.MJ)	3-10
DVD changer mechanism assembly and parts list (Block No.MK)	3-12
Electrical parts list (Block No.01~07)	3-14
Packing materials and accessories parts list (Block No.M4) (TH-C90)	3-34
Packing materials and accessories parts list (Block No.M5) (TH-C60 (Except TH-C60UP))	3-36
Packing materials and accessories parts list (Block No.M6) (TH-C60UP)	3-38

Exploded view of general assembly and parts list

Block No. **M 1 M M**

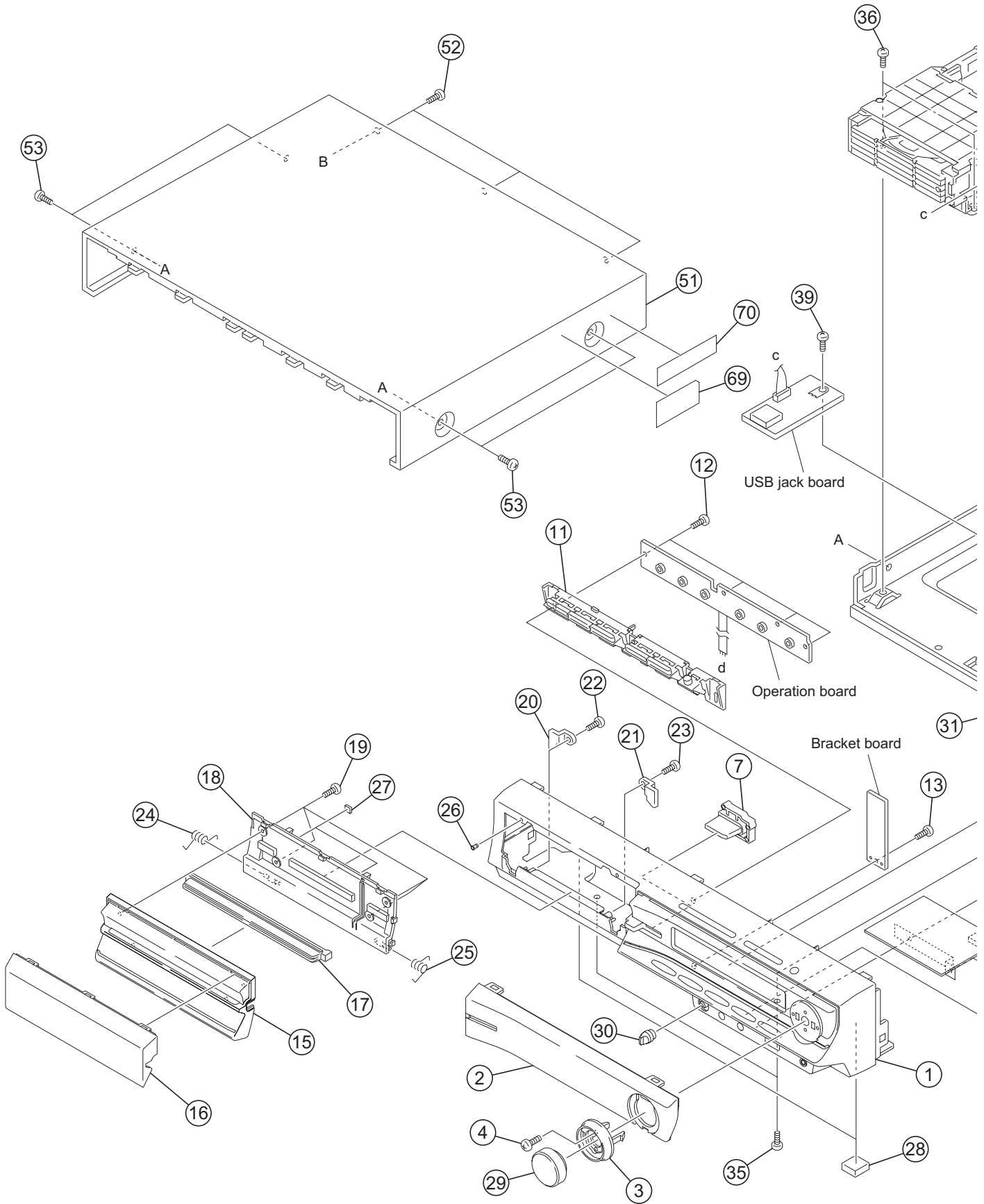

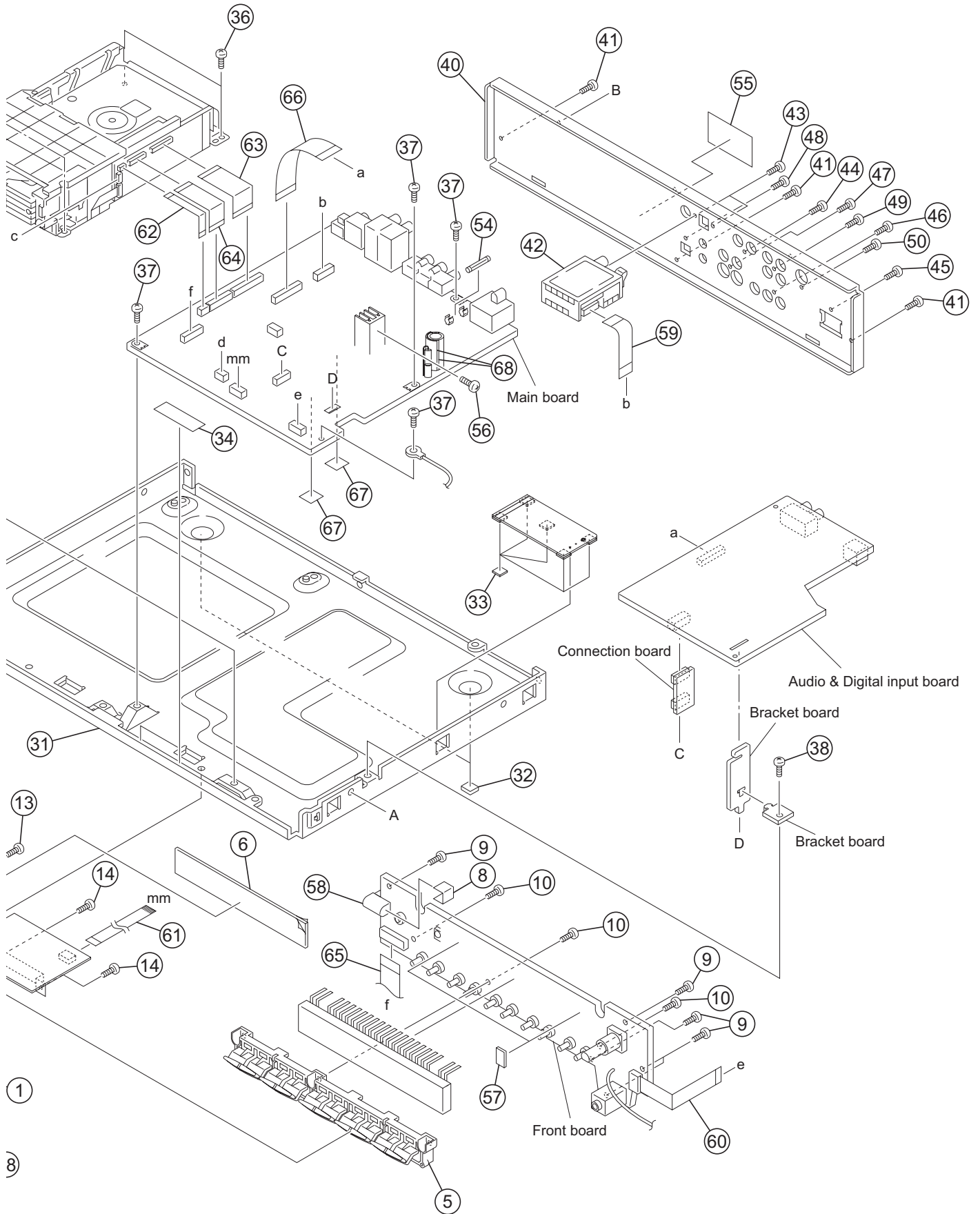

General Assembly

Block No. [M][1][M][M]

△	Symbol No.	Part No.	Part Name	Description	Local
	1	LV11209-005A	FRONT PANEL		C90A,C60UP,C60UW,C60UY
	1	LV11209-004A	FRONT PANEL		C90US,C90UX,C90UG,C60US,C60UX,C60UG
	2	LV22243-001A	FRONT LENS		
	3	LV34588-001A	VOL RING		
	4	QYSDSF2608ZA	TAP SCREW	M2.6 x 8mm	
	5	LV22242-001A	BUTTON(DISC)		
	6	LV42851-006A	FL SCREEN		
	7	LV36581-001A	POWER BTN ASSY		
	8	LV30227-045A	SPACER		
	9	QYSBSF2610ZA	TAP SCREW	M2.6 x 10mm(x5)	
	10	QYSBSF2610ZA	TAP SCREW	M2.6 x 10mm(x3)	
	11	LV22244-001A	BUTTON(TOP)		
	12	QYSBSF2610ZA	TAP SCREW	M2.6 x 10mm(x4)	
	13	QYSBSF2610ZA	TAP SCREW	M2.6 x 10mm	
	14	QYSBSF2610ZA	TAP SCREW	M2.6 x 10mm(x2)	C90US,C90UX,C90UG,C60US,C60UX,C60UG
	15	LV22246-002A	DOOR COVER		
	16	LV22247-010A	DOOR LENS		C90A,C90US,C90UX,C90UG
	16	LV22247-009A	DOOR LENS		C60US,C60UP,C60UW,C60UX,C60UY,C60UG
	17	LV36583-001A	ILLUMI LENS		
	18	LV22245-001A	DOOR BASE		
	19	QYSDSF2608ZA	TAP SCREW	M2.6 x 8mm(x4)	
	20	LV41694-201A	DOOR BKT(L)		
	21	LV41695-201A	DOOR BKT(R)		
	22	QYSDSF2608ZA	TAP SCREW	M2.6 x 8mm	
	23	QYSDSF2608ZA	TAP SCREW	M2.6 x 8mm	
	24	LV44491-002A	DOOR SPRING (L)		
	25	LV44492-002A	DOOR SPRING (R)		
	26	E69897-002	CUSHION		
	27	LV30227-050A	SPACER	(x2)	
	28	LV40301-002A	FELT SPACER	(x2)	
	29	LV34594-002A	VOLUME KNOB		
	30	VXL4431-005	MIC VOL KNOB		C90US,C90UX,C90UG,C60US,C60UX,C60UG
	31	LV11210-001A	CHASSIS BASE		
	32	LV40301-002A	FELT SPACER	(x2)	
	33	VYSH101-009	SPACER	(x5)	
	34	LV30225-0M7A	SPACER	(x2)	C90US,C90UX,C90UG,C60US,C60UX,C60UG
	35	QYSBST3006EA	TAP SCREW	M3 x 6mm(x2)	
	36	QYSBST3006EA	TAP SCREW	M3 x 6mm(x4)	
	37	QYSBST3006EA	TAP SCREW	M3 x 6mm(x4)	
	38	QYSBST3006EA	TAP SCREW	M3 x 6mm	
	39	QYSBST3006EA	TAP SCREW	M3 x 6mm	
	40	LV22249-033A	REAR PANEL		C90A,C90US,C90UX,C90UG
	40	LV22249-032A	REAR PANEL		C60US,C60UP,C60UW,C60UX,C60UY,C60UG
	41	QYSBSGY3008EA	TAP SCREW	M3 x 8mm(x3)	
	42	QAU0412-001	TUNER	FM/AM	C90A,C90US,C90UX,C90UG,C60US,C60UW,C60UX,C60UY,C60UG
	42	QAU0413-001	TUNER	FM/AM	C60UP
	43	QYSBSGY3008EA	TAP SCREW	M3 x 8mm(x2)	
	44	QYSBSGY3008EA	TAP SCREW	M3 x 8mm	
	45	QYSBSGY3008EA	TAP SCREW	M3 x 8mm	
	46	QYSBSGY3008EA	TAP SCREW	M3 x 8mm	
	47	QYSBSGY3008EA	TAP SCREW	M3 x 8mm	
	48	QYSBSGY3008EA	TAP SCREW	M3 x 8mm	
	49	QYSBSGY3008EA	TAP SCREW	M3 x 8mm	C90A,C90US,C90UX,C90UG
	50	QYSBST3006EA	TAP SCREW	M3 x 6mm	
	51	LV22248-001A/S/	METAL COVER		
	52	QYSBSGY3008EA	TAP SCREW	M3 x 8mm(x3)	
	53	E406308-007	SPECIAL SCREW	(x4)	
△	54	QMFZ059-2R5-E	FUSE	F901	2.5A
	55	LV36586-048A	RATING LABEL		C90A
	55	LV36586-045A	RATING LABEL		C90US
	55	LV36586-047A	RATING LABEL		C90UX
	55	LV36586-046A	RATING LABEL		C90UG
	55	LV36586-040A	RATING LABEL		C60US
	55	LV36586-044A	RATING LABEL		C60UP
	55	LV36586-038A	RATING LABEL		C60UW
	55	LV36586-042A	RATING LABEL		C60UX
	55	LV36586-039A	RATING LABEL		C60UY
	55	LV36586-041A	RATING LABEL		C60UG
	56	QYSBSE3008ZA	TAP SCREW	M3 x 8mm	
	57	LV30227-051A	SPACER	(x2)	
	58	LV36587-001A	LED HOLDER		
	59	QUQQ12-1107CJ-E	FFC WIRE	11pin 7cm	
	60	QUQQ12-0712CJ-E	FFC WIRE	7pin 12cm	
	61	QUQQ12-0707DJ-E	FFC WIRE	7pin 7cm	C90US,C90UX,C90UG,C60US,C60UX,C60UG

△	Symbol No.	Part No.	Part Name	Description	Local
	62	QUQV10-0507CJ-E	FFC WIRE	5pin 7cm	
	63	QUQV10-2807CJ-E	FFC WIRE	28pin 7cm	
	64	QUQV10-1807CJ-E	FFC WIRE	18pin 7cm	
	65	QUQV10-1715CJ-E	FFC WIRE	17pin 15cm	
	66	QUQV10-2507CJ-E	FFC WIRE	25pin 7cm	
	67	VYSH101-009	SPACER	(x2)	
△	68	QWTJA09-030	GLASS TUBE	WHITE(x2)	
	69	LV30271-006A	UP LABEL		C60UP
	70	LV44281-001A	NOM MARK LABEL		C60UW

Speaker assembly and parts list

Block No. **M 2 M M**

TH-C90 (Subwoofer)

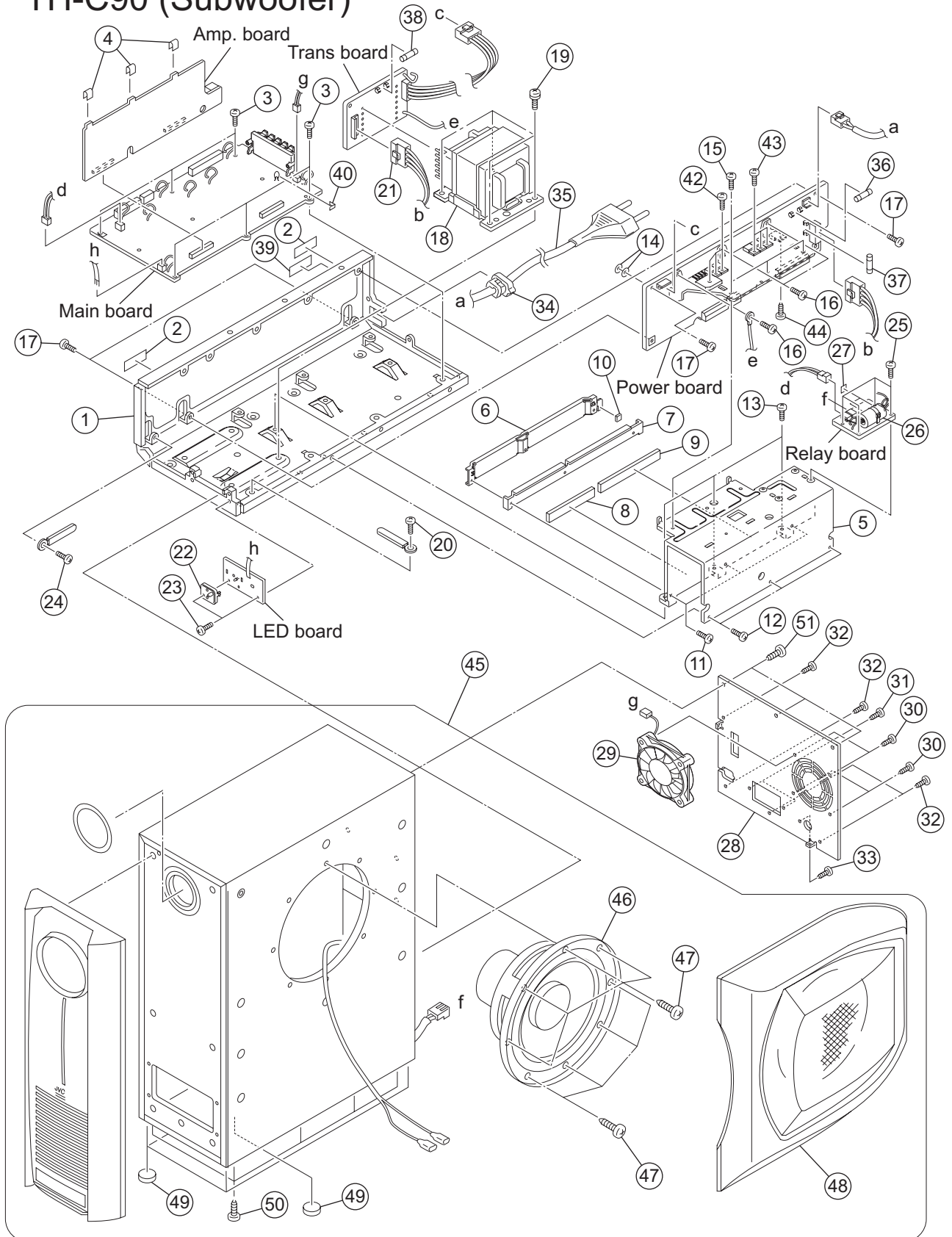

The parts without symbol number are not service.

Speaker(Subwoofer) (TH-C90)

Block No. [M][2][M][M]

△	Symbol No.	Part No.	Part Name	Description	Local
	1	LV11059-001A	CHASSIS BASE		
	2	LV30225-0T9A	SPACER	(x2)	
	3	QYSBSG3008EA	TAP SCREW	M3 x 8mm(x6)	
	4	LV30225-0U9A	SPACER	(x3)	
	5	LV21942-002A	HIAT SINK		
	6	LV35739-002A	IC BRACKET		
	7	LV36234-001A	H/S BRACKET		
	8	LV44170-001A	COOLING RUBBER		
	9	LV44170-002A	COOLING RUBBER		
	10	LV30227-004A	SPACER		
	11	QYSBSGY3008EA	TAP SCREW	M3 x 8mm(x3)	
	12	QYSBSGY3008EA	TAP SCREW	M3 x 8mm(x3)	
	13	QYSBSGY3008EA	TAP SCREW	M3 x 8mm(x3)	
	14	LV30226-034A	SPACER	(x2)	C90US,C90UX,C90UG
	15	QYSBSGY3008EA	TAP SCREW	M3 x 8mm(x3)	
	16	QYSBSGY3008EA	TAP SCREW	M3 x 8mm(x3)	
	17	QYSBSG3008EA	TAP SCREW	M3 x 8mm(x4)	
△	18	QQT0483-002	POWER TRANSF	T101	
	19	QYSDSTL4010EA	TAP SCREW	M4 x 10mm(x4)	
	20	QYSBST3008ZA	TAP SCREW	M3 x 8mm	
	21	WJJ0582-001A-E	E-SI C WIRE		
	22	LV43692-002A	LED HOLDER		
	23	QYSBSG3008ZA	TAP SCREW	M3 x 8mm(x2)	
	24	QYSBST3008ZA	TAP SCREW	M3 x 8mm	
	25	QYSBSG3008ZA	TAP SCREW	M3 x 8mm(x4)	
	26	QQR0216-001	NOISE FILTER		
	27	VYSH101-009	SPACER	(x2)	
	28	LV21943-004A	REAR PANEL		
	29	QAR0318-001	FAN MOTOR	12V DC	
	30	QYSBSGY3008MA	TAP SCREW	M3 x 8mm(x4)	
	31	QYSBSGY3008MA	TAP SCREW	M3 x 8mm(x2)	
	32	QYSBSGY3008MA	TAP SCREW	M3 x 8mm(x4)	
	33	QYSBST3006MA	TAP SCREW	M3 x 6mm	
△	34	QZIW0033-001	STRAIN RELIEF		
△	35	QMPG080-244-JD	POWER CORD(EU)	2.44m BLACK	C90A
△	35	QMPK200-200-JD	POWER CORD(EU)	2m BLACK	C90US,C90UX,C90UG
△	36	QMFZ051-8R0-J8	FUSE	F101 8A	
△	37	QMF51W2-4R0-J8	FUSE	F102 4A AC250V	
△	38	QMF51W2-1R0-J8	FUSE	F153 1A AC250V	
	39	LV43583-001A	LABEL		
	40	LV30227-005A	SPACER		
	42	QYSBSG3008ZA	TAP SCREW	M3 x 8mm(x3)	
	43	QYSBSG3008ZA	TAP SCREW	M3 x 8mm(x3)	
	44	QYSBSG3008ZA	TAP SCREW	M3 x 8mm	
	45	QAS0303-003	SPEAKER WITH BOX		
	46	LE10025-011A	CONE SPK		
	47	7001541606	TAPPING SCREW	(x8)	
	48	LV35797-001A	SIDE PANEL ASSY		
	49	9000007961	FOOT	(x5)	
	50	7014341401	SCREW	(x8)	
	51	7001541605	SCREW	(x3)	

Speaker assembly and parts list

TH-C60 (Subwoofer)

Block No. **M** **3** **M** **M**

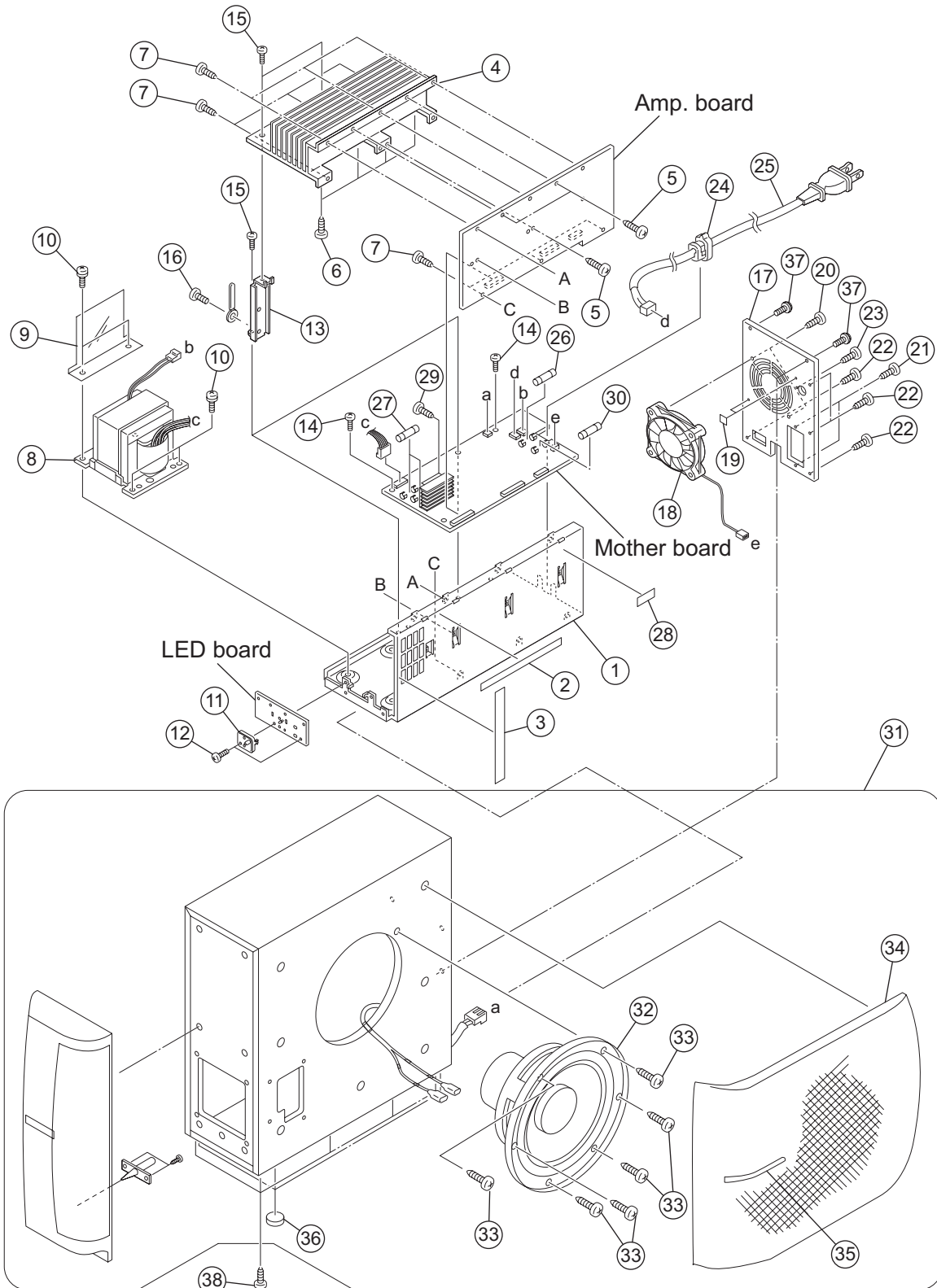

The parts without symbol number are not service.

Speaker(Subwoofer) (TH-C60)

Block No. [M][3][M][M]

△	Symbol No.	Part No.	Part Name	Description	Local
	1	LV10875-002A	CHASSIS BASE		
	2	LV30225-0T5A	SPACER		
	3	LV30225-0T6A	SPACER		
	4	LV10951-201A	HEAT SINK		
	5	QYSBSG3010EA	TAP SCREW	M3 x 10mm(x3)	
	6	QYSBSG3016EA	TAP SCREW	M3 x 16mm(x4)	
	7	QYSBSG3010EA	TAP SCREW	M3 x 10mm(x9)	
△	8	QQT0482-003	POWER TRANSF		C60US,C60UW,C60UX,C60UY,C60UG
△	8	QQT0482-002	POWER TRANSF		C60UP
	9	LV44309-201A	BARRIER		
	10	QYSDSTL4008EA	TAP SCREW	M4 x 8mm(x4)	
	11	LV43692-002A	LED HOLDER		
	12	QYSBSG3010EA	TAP SCREW	M3 x 10mm(x2)	
	13	LV34712-001A	HEAT SINK BKT	(x2)	
	14	QYSBSG3010EA	TAP SCREW	M3 x 10mm(x2)	
	15	QYSBSG3010EA	TAP SCREW	M3 x 10mm(x4)	
	16	QYSBSG3006ZA	TAP SCREW	M3 x 6mm(x2)	
	17	LV21652-026A	REAR PANEL		C60US,C60UW,C60UX,C60UY,C60UG
	17	LV21652-030A	REAR PANEL		C60UP
	18	QAR0377-001	COOLING FAN		
	19	LV30225-0D5A	SPACER	(x2)	
	20	QYSBSGY3008MA	TAP SCREW	M3 x 8mm(x2)	
	21	QYSBSGY3008MA	TAP SCREW	M3 x 8mm(x2)	
	22	QYSBSGY3008MA	TAP SCREW	M3 x 8mm(x4)	
	23	QYSBST3006EA	TAP SCREW	M3 x 6mm	
△	24	QZW0033-001	STRAIN RELIEF		
△	25	QMPK200-200-JD	POWER CORD(EU)	2m BLACK	C60US,C60UW,C60UX,C60UG
△	25	QMPR310-200-JC	POWER CORD(EU)	2m BLACK	C60UP
△	25	QMPR300-200-JC	POWER CORD(EU)	2m BLACK	C60UY
△	26	QMF51W2-6R3-J8	FUSE	F101 6.3A AC250V	C60US,C60UW,C60UX,C60UY,C60UG
△	26	QMF51W2-3R15-J8	FUSE	F101 3.15A AC250V	C60UP
△	27	QMFZ051-8R0-J8	FUSE	F153 F154 8A(x2)	
	28	LV43583-001A	LABEL		
	29	QYSPSPD3008ZA	SCREW	M3 x 8mm(x2)	
△	30	QMF51W2-3R15-J8	FUSE	F102 3.15A AC250V	C60US,C60UW,C60UX,C60UY,C60UG
	31	QAS0419-002	SPEAKER WITH BOX		
	32	LE10016-069A	CONE SPK		
	33	7001541606	TAPPING SCREW	(x6)	
	34	LV11246-001A	SIDE PANEL ASSY		
	35	LV36781-001A	BADGE		
	36	9000007961	FOOT	(x4)	
	37	7001541605	SCREW	(x2)	
	38	7014341401	SCREW	(x8)	

DVD mechanism assembly and parts list

Block No. M J M M

Grease
 ★ =JVG-31N
 ● =JVS-1003
 ■ =1401C

FXL-D20-1C

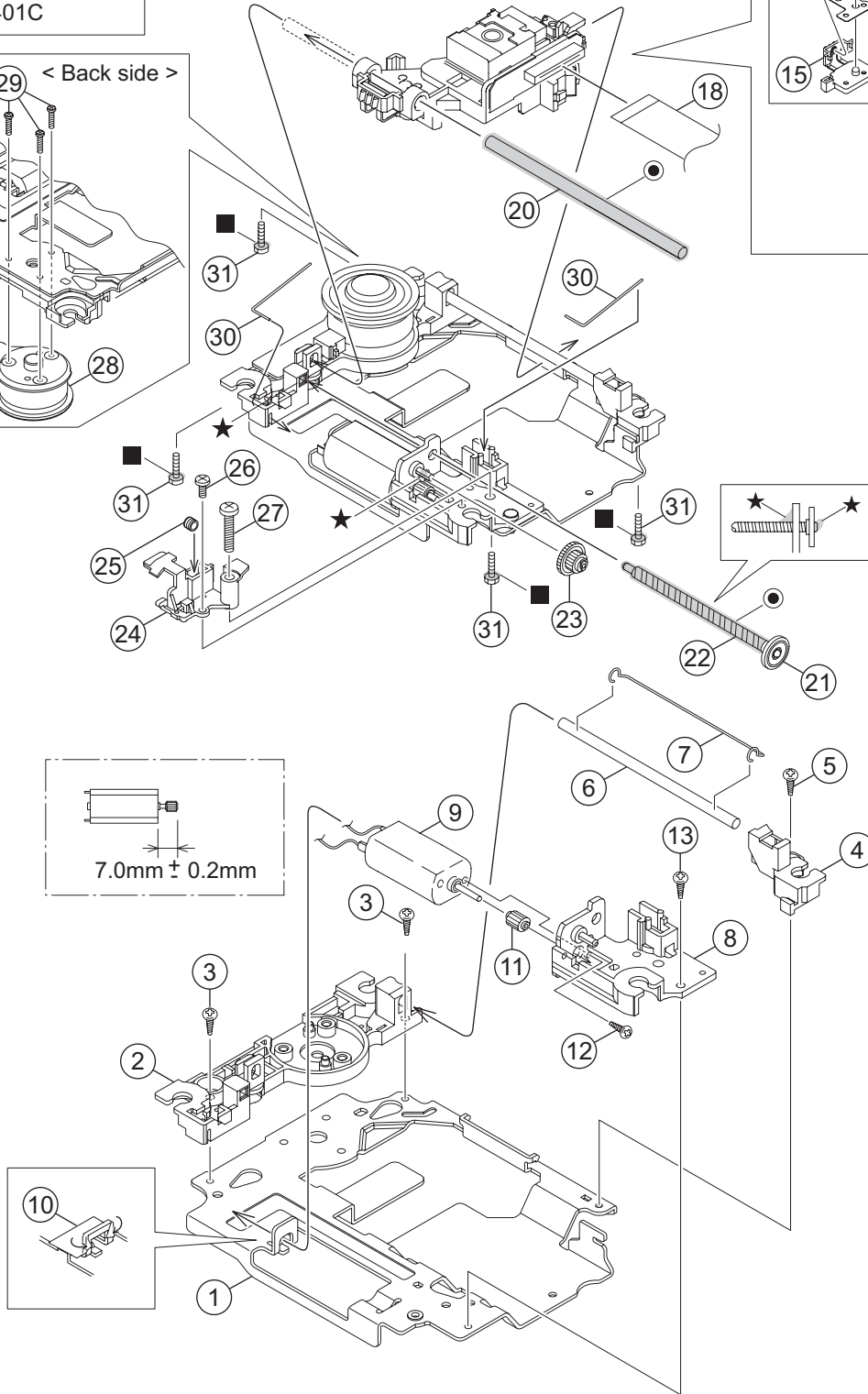
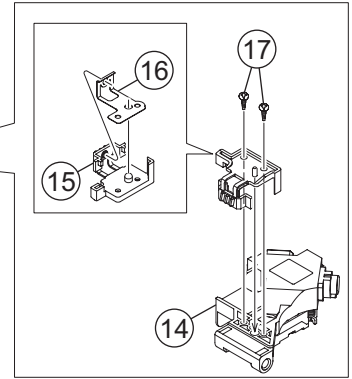
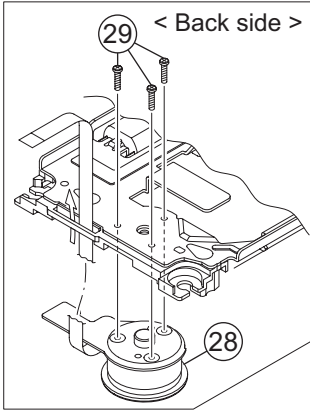

The parts without symbol number are not service.

DVD mechanism

Block No. [M][J][M][M]

△	Symbol No.	Part No.	Part Name	Description	Local
	1	LV22234-001A	TM.CHASSIS		
	2	LV22294-001A	C.SPINDLE BASE		
	3	QYSDST2005ZA	TAP SCREW	M2 x 5mm(x2)	
	4	LV36791-001A	C.G.S.HOLDER		
	5	QYSDST2005ZA	TAP SCREW	M2 x 5mm	
	6	LV44041-002A	GUIDE SHAFT		
	7	LV44479-001A	BAR SPRING		
	8	LV22236-001A	FEED HOLDER		
	9	QAR0165-001	FEED MOTOR		
	10	LV30225-0X5A	SPACER		
	11	LV36557-001A	F.M.GEAR		
	12	QYSPSPT2030MA	SCREW	M2 x 3mm	
	13	QYSDST2005ZA	TAP SCREW	M2 x 5mm	
	14	QAL0786-002	P.UP		
	15	LV22237-001A	RACK ARM		
	16	LV36560-001A	RACK ARM SPRING		
	17	QYSPSFU1740ZA	TAP SCREW	M1.7 x 4mm(x2)	
	18	QUQK05-2424AC-E	FFC WIRE	24pin 24cm	
	20	LV44041-002A	GUIDE SHAFT		
	21	LV36559-001A	L.S.GEAR		
	22	LV41517-003A	LEAD SCREW		
	23	LV36558-001A	MIDDLE GEAR		
	24	LV36556-001A	SPRING HOLDER		
	25	LV44623-001A	COMP.SPRING		
	26	QYSDST2005ZA	TAP SCREW	M2 x 5mm	
	27	QYSDST2616MA	TAP SCREW	M2.6 x 16mm	
	28	QAR0387-001	S.MOTOR		
	29	QYSPSPU1775ZA	SCREW	M1.7 x 7.5mm(x3)	
	30	LV44042-001A	ROD SPRING	(x2)	
	31	LE40858-002A	SPECIAL SCREW	(x4)	

DVD changer mechanism assembly and parts list

Block No. M K M M

FMU-SB1-1C

Grease

★=JVG-31N
▲=JVS-1003

CH6-BASE-1M

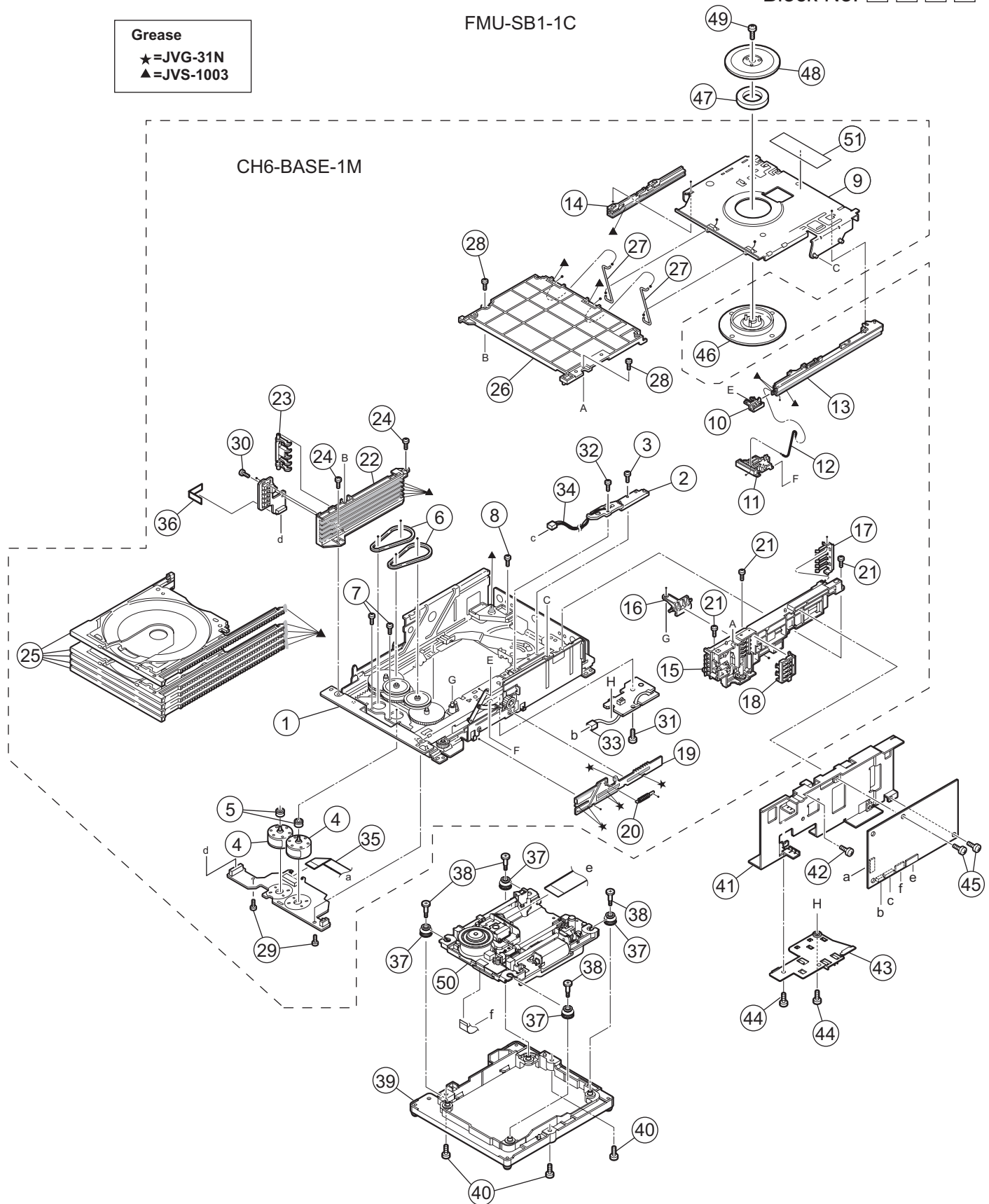

The parts without symbol number are not service.

DVD changer mechanism

Block No. [M][K][M][M]

△	Symbol No.	Part No.	Part Name	Description	Local
	1	LV10913-007A	LOADER ASSY		
	2	QVY0027-B14	S V RESISTOR		
	3	QYSDST2004ZA	TAP SCREW	M2 x 4mm	
	4	QAR0164-001	MOTOR	(x2)	
	5	LV42340-001A	MOTOR PULLEY	(x2)	
	6	LV41431-002A	BELT	(x2)	
	7	QYSPSPU1725NA	SCREW	M1.7 x 2.5mm(x2)	
	8	QYSDST2605ZA	TAP SCREW	M2.6 x 5mm	
	9	LV33965-008A	LIFTER ASSY		
	10	LV33963-001A	HOOK		
	11	LV33964-002A	HOOK STOPPER		
	12	LV43285-001A	ROD (L)		
	13	LV21408-002A	RAIL(R)		
	14	LV21409-002A	RAIL(L)		
	15	LV21520-005A	SIDE(R) ASSY		
	16	LV33974-002A	SELECT LEVER		
	17	LV33977-002A	CLICK SPRING		
	18	LV33975-001A	GEAR COVER		
	19	LV33976-002A	ELEVATOR CAM		
	20	LV43287-001A	ELEVATOR SPRING		
	21	QYSDST2605ZA	TAP SCREW	M2.6 x 5mm(x3)	
	22	LV10749-003A	SIDE(L)		
	23	LV33980-002A	OPEN DET.LEVER		
	24	QYSDST2605ZA	TAP SCREW	M2.6 x 5mm(x2)	
	25	LV10746-007A	TRAY ASSY	(x5)	
	26	LV10750-003A	TOP COVER		
	27	LV43289-003A	ROD	(x2)	
	28	QYSDSF2608ZA	TAP SCREW	M2.6 x 8mm(x2)	
	29	QYSDST2605ZA	TAP SCREW	M2.6 x 5mm(x2)	
	30	QYSDSF2608ZA	TAP SCREW	M2.6 x 8mm	
	31	QYSDST2605ZA	TAP SCREW	M2.6 x 5mm	
	32	QYSDST2004ZA	TAP SCREW	M2 x 4mm	
	33	WJM0330-002A-E	E-SI C WIRE C-F		
	34	WJM0331-001A-E	E-SI C WIRE C-F		
	35	QUQW10-1521BF-E	FFC WIRE	15pin 21cm	
	36	LV30227-044A	SPACER		
	37	LE40900-003A	INSULATOR	(x4)	
	38	LV44045-001A	SPECIAL SCREW	(x4)	
	39	LV11252-002A	C.TM.HOLDER		
	40	QYSDST2605ZA	TAP SCREW	M2.6 x 5mm(x3)	
	41	LV22274-001A	PWB BKT		
	42	QYSDSF2608ZA	TAP SCREW	M2.6 x 8mm	
	43	LV22275-001A	WIRE HOLDER		
	44	QYSDST2605ZA	TAP SCREW	M2.6 x 5mm(x2)	
	45	QYSDST2605ZA	TAP SCREW	M2.6 x 5mm(x2)	
	46	LV32417-001A	CLAMPER		
	47	LV42930-003A	P.C.MAGNET		
	48	LV33992-001A	DVD YOKE		
	49	LE40906-002A	SPECIAL SCREW		
	50	-----	DVD TRAMECHA		
	51	LV44603-003A	LASER CATION		

Electrical parts list

Main board

Block No. [0][1]

△ Symbol No.	Part No.	Part Name	Description	Local
IC411	MM1233XF-X	IC C/M		
IC431	MM1623XF-X	IC		
IC471	MN101C49GPW1	IC MASK		
IC472	S-80840CNNB-G-W	IC		
IC473	SN74AHC08NS-X	IC		
IC477	BR24L08F-W-X	IC(DIGITAL)		
IC481	TORX147	OPT RECEIVER		
IC491	KIA7805API	IC		
△ IC901	MIP4170MDSLJ	SW-IC		
Q951	2SC3576-JVC-T	TRANSISTOR		
Q953	KTA1267/YG/-T	TRANSISTOR		
Q954	RTR030P02-X	MOS FET		
Q958	KTA1273/Y/-T	TRANSISTOR		
Q959	RT1N241C-X	DIGI TRANSISTOR		
Q965	RT1P441C-X	DIGI TRANSISTOR		
Q969	RT1N241C-X	DIGI TRANSISTOR		
Q974	RTR030P02-X	MOS FET		
Q979	RT1N241C-X	DIGI TRANSISTOR		
Q980	RT1N241C-X	DIGI TRANSISTOR		
Q982	KTA1267/YG/-T	TRANSISTOR		
Q983	KTC3203/OY/-T	TRANSISTOR		
Q984	RTR030P02-X	MOS FET		
Q989	RT1N241C-X	DIGI TRANSISTOR		
Q991	KTC3875/YG/-X	TRANSISTOR		
Q4091	KTA1271/OY/-T	TRANSISTOR		
Q4092	2SC3928A/QR/-X	TRANSISTOR		
Q4701	RT1N140C-X	DIGI TRANSISTOR		
Q4811	RT1P141C-X	DIGI TRANSISTOR		
Q4812	RT1N141C-X	DIGI TRANSISTOR		
Q4821	RT1N141C-X	DIGI TRANSISTOR		
Q4822	2SD2114K/VV/-X	TRANSISTOR		
Q4831	RT1N141C-X	DIGI TRANSISTOR		
Q4832	RT1P430C-X	TRANSISTOR		
Q4833	RT1N430C-X	TRANSISTOR		
Q4961	KTC3203/OY/-T	TRANSISTOR		
△ D901	DI106	BRIDGE DIODE		
D902	20NFA60-FC5	FR DIODE		
D903	20NFA60-FC5	FR DIODE		
D904	FR104S-T5	FR DIODE		
△ D910	MA111-X	SI DIODE		
D911	RB160M-30-X	SB DIODE		
D950	MTZJ24D-T2	Z DIODE I/M		
D951	FR104S-T5	FR DIODE		
D952	FR104S-T5	FR DIODE		
△ D954	UF202G-F26	FR EIODE		
D955	MA111-X	SI DIODE		
△ D956	FR104S-T5	FR DIODE		
D960	MTZJ2.2A-T2	S.B.DIODE		
△ D973	SB360-F82	FUSEIODE		
D981	MTZJ4.3B-T2	Z DIODE		
D992	MTZJ2.0A-T2	Z DIODE		
D993	MTZJ3.3B-T2	Z DIODE		
△ D998	1N4003S-T5	SI DIODE		
△ D999	1N4003S-T5	SI DIODE		
D4091	1SS133-T2	SI DIODE		
D4092	MTZJ6.8A-T2	Z DIODE		
D4093	1SS133-T2	SI DIODE		
D4703	MTZJ3.9B-T2	Z DIODE		
D4708	1SS133-T2	SI DIODE		
D4709	10EDB20-T4	DIODE		
D4811	1SS133-T2	SI DIODE		
D4831	1SS133-T2	SI DIODE		
D4832	1SS133-T2	SI DIODE		
D4833	1SS133-T2	SI DIODE		
D4834	1SS133-T2	SI DIODE		
D4835	MTZJ6.8A-T2	Z DIODE		
D4841	MTZJ2.0A-T2	Z DIODE		
D4842	MTZJ3.3A-T2	Z DIODE		
D4845	MTZJ11B-T2	Z DIODE		
D4961	MTZJ4.7A-T2	Z DIODE		

△ Symbol No.	Part No.	Part Name	Description	Local
D4962	1SS133-T2	SI DIODE		
D4963	1SS133-T2	SI DIODE		
△ PC901	PC123Y22FZ	PHOTO COUPLER		
△ C902	QFZ9073-683	MM CAPACITOR	0.068uF AC250V M	
△ C903	QFZ9073-683	MM CAPACITOR	0.068uF AC250V M	
△ C904	QCZ9079-102	C CAPACITOR	1000pF AC250V M	
△ C905	QCZ9079-102	C CAPACITOR	1000pF AC250V M	
C906	QCZ0213-472	C CAPACITOR	4700pF 1kV K	
△ C907	QEZ0790-107	E CAPACITOR	100uF	
C908	QCZ0213-472	C CAPACITOR	4700pF 1kV K	
C909	QCZ0131-331	C CAPACITOR	330pF 2kV K	
C910	NDC31HJ-120X	C CAPACITOR	12pF 50V J	
C913	QCZ0403-221	C CAPACITOR	220pF 2kV K	
C914	QEZ0658-476Z	E CAPACITOR	47uF 50V M	
△ C916	QCZ9079-222	C CAPACITOR	2200pF AC250V M	
C918	NCB31HK-104X	C CAPACITOR	0.1uF 50V K	
C920	NCB31HK-104X	C CAPACITOR	0.1uF 50V K	
C921	NCB31HK-104X	C CAPACITOR	0.1uF 50V K	
C950	NDC31HJ-221X	C CAPACITOR	220pF 50V J	
C951	NDC31HJ-221X	C CAPACITOR	220pF 50V J	
C952	QCZ0136-102Z	C CAPACITOR	1000pF 1kV K	
C954	NDC31HJ-221X	C CAPACITOR	220pF 50V J	
C955	NDC31HJ-221X	C CAPACITOR	220pF 50V J	
C956	NDC31HJ-221X	C CAPACITOR	220pF 50V J	
C957	NDC31HJ-221X	C CAPACITOR	220pF 50V J	
C960	QEZ0655-826Z	E CAPACITOR	82uF 16V M	
C961	QCZ0202-155Z	C CAPACITOR	1.5uF 25V Z	
C962	QETN1HM-226Z	E CAPACITOR	22uF 50V M	
C963	QEZ0658-396Z	E CAPACITOR	39uF 50V M	
C964	QEZ0658-226Z	E CAPACITOR	22uF 50V M	
C968	NCB31CK-104X	C CAPACITOR	0.1uF 16V K	
C969	QETN1HM-106Z	E CAPACITOR	10uF 50V M	
C973	NDC31HJ-101X	C CAPACITOR	100pF 50V J	
C975	QEZ0654-108Z	E CAPACITOR	1000uF 10V M	
C976	QEZ0654-108Z	E CAPACITOR	1000uF 10V M	
C977	NCB31CK-104X	C CAPACITOR	0.1uF 16V K	
C978	NCB31CK-104X	C CAPACITOR	0.1uF 16V K	
C979	QETN1HM-106Z	E CAPACITOR	10uF 50V M	
C981	QCZ0202-155Z	C CAPACITOR	1.5uF 25V Z	
C982	QEZ0656-567Z	E CAPACITOR	560uF	
C983	QETN1CM-107Z	E CAPACITOR	100uF 16V M	
C984	QEZ0655-227Z	E CAPACITOR	220uF 16V M	
C989	NCB31HK-104X	C CAPACITOR	0.1uF 50V K	
C990	QETN1EM-107Z	E CAPACITOR	100uF 25V M	
C991	QCZ0202-155Z	C CAPACITOR	1.5uF 25V Z	
C992	QETN1HM-226Z	E CAPACITOR	22uF 50V M	
C993	NCB31HK-104X	C CAPACITOR	0.1uF 50V K	
C994	QCB11HK-223Y	C CAPACITOR	0.022uF 50V K	
C996	NRSA63J-0R0X	MG RESISTOR	0Ω 1/16W J	
C997	QEZ0655-227Z	E CAPACITOR	220uF 16V M	
C998	NDC31HJ-331X	C CAPACITOR	330pF 50V J	
C999	QEZ0655-827Z	E CAPACITOR	820uF	
C4002	NRSA63J-0R0X	MG RESISTOR	0Ω 1/16W J	
C4006	NCF21CZ-105X	C CAPACITOR	1uF 16V Z	
C4011	NDC31HJ-221X	C CAPACITOR	220pF 50V J	
C4012	NDC31HJ-221X	C CAPACITOR	220pF 50V J	
C4016	NCB31HK-103X	C CAPACITOR	0.01uF 50V K	
C4017	NCF21CZ-225X	C CAPACITOR	2.2uF 16V Z	
C4020	NCB31HK-103X	C CAPACITOR	0.01uF 50V K	
C4021	NCB31HK-103X	C CAPACITOR	0.01uF 50V K	
C4031	NCB31HK-562X	C CAPACITOR	5600pF 50V K	
C4032	NCB31HK-562X	C CAPACITOR	5600pF 50V K	
C4033	NCB31HK-562X	C CAPACITOR	5600pF 50V K	
C4034	NCB31HK-562X	C CAPACITOR	5600pF 50V K	
C4035	NCB31HK-472X	C CAPACITOR	4700pF 50V K	
C4036	NCB31HK-562X	C CAPACITOR	5600pF 50V K	
C4091	QETN1HM-226Z	E CAPACITOR	22uF 50V M	
C4092	QETN1CM-107Z	E CAPACITOR	100uF 16V M	
C4101	NCB30JK-105X	C CAPACITOR	1uF 6.3V K	
C4102	NDC31HJ-470X	C CAPACITOR	47pF 50V J	
C4111	NCB31HK-103X	C CAPACITOR	0.01uF 50V K	
C4112	NDC31HJ-470X	C CAPACITOR	47pF 50V J	
C4121	NCB30JK-105X	C CAPACITOR	1uF 6.3V K	
C4122	NDC31HJ-470X	C CAPACITOR	47pF 50V J	

△ Symbol No.	Part No.	Part Name	Description	Local	△ Symbol No.	Part No.	Part Name	Description	Local
C4171	NCB30JK-105X	C CAPACITOR	1uF 6.3V K		R983	NRSA63J-102X	MG RESISTOR	1kΩ 1/16W J	
C4172	NCB30JK-105X	C CAPACITOR	1uF 6.3V K		R984	NRSA63J-243X	MG RESISTOR	24kΩ 1/16W J	
C4173	NCB30JK-105X	C CAPACITOR	1uF 6.3V K		R985	QRE141J-132Y	C RESISTOR	1.3kΩ 1/4W J	
C4191	QETN1EM-476Z	E CAPACITOR	47uF 25V M		R986	NRSA63J-203X	MG RESISTOR	20kΩ 1/16W J	
C4192	NCB31HK-103X	C CAPACITOR	0.01uF 50V K		R987	NRSA63J-151X	MG RESISTOR	150Ω 1/16W J	
C4301	NCB30JK-105X	C CAPACITOR	1uF 6.3V K		R988	NRSA63J-103X	MG RESISTOR	10kΩ 1/16W J	
C4311	NCB31HK-103X	C CAPACITOR	0.01uF 50V K		R989	NRSA63J-471X	MG RESISTOR	470Ω 1/16W J	
C4321	NCB30JK-105X	C CAPACITOR	1uF 6.3V K		R990	NRSA63J-333X	MG RESISTOR	33kΩ 1/16W J	
C4331	NCB30JK-105X	C CAPACITOR	1uF 6.3V K		R4011	NRSA63J-102X	MG RESISTOR	1kΩ 1/16W J	
C4341	NCB30JK-105X	C CAPACITOR	1uF 6.3V K		R4012	NRSA63J-102X	MG RESISTOR	1kΩ 1/16W J	
C4351	NCB30JK-105X	C CAPACITOR	1uF 6.3V K		R4091	NRSA63J-472X	MG RESISTOR	4.7kΩ 1/16W J	
C4391	QETN1AM-477Z	E CAPACITOR	470uF 10V M		R4092	NRSA63J-103X	MG RESISTOR	10kΩ 1/16W J	
C4392	NCB31CK-104X	C CAPACITOR	0.1uF 16V K		R4093	NRSA63J-821X	MG RESISTOR	820Ω 1/16W J	
C4394	NCB31CK-104X	C CAPACITOR	0.1uF 16V K		R4101	NRSA63J-750X	MG RESISTOR	75Ω 1/16W J	
C4395	QETN1HM-226Z	E CAPACITOR	22uF 50V M		R4111	NRSA63J-750X	MG RESISTOR	75Ω 1/16W J	
C4401	QETN1AM-477Z	E CAPACITOR	470uF 10V M		R4121	NRSA63J-750X	MG RESISTOR	75Ω 1/16W J	
C4402	NDC31HJ-470X	C CAPACITOR	47pF 50V J		R4191	NRSA63J-0R0X	MG RESISTOR	0Ω 1/16W J	
C4411	NCB31HK-103X	C CAPACITOR	0.01uF 50V K		R4201	NRSA63J-621X	MG RESISTOR	620Ω 1/16W J	
C4412	NDC31HJ-470X	C CAPACITOR	47pF 50V J		R4202	NRSA63J-301X	MG RESISTOR	300Ω 1/16W J	
C4421	QETN1AM-477Z	E CAPACITOR	470uF 10V M		R4211	NRSA63J-621X	MG RESISTOR	620Ω 1/16W J	
C4423	NDC31HJ-470X	C CAPACITOR	47pF 50V J		R4212	NRSA63J-301X	MG RESISTOR	300Ω 1/16W J	
C4431	QETN1AM-477Z	E CAPACITOR	470uF 10V M		R4221	NRSA63J-621X	MG RESISTOR	620Ω 1/16W J	
C4432	NDC31HJ-470X	C CAPACITOR	47pF 50V J		R4222	NRSA63J-331X	MG RESISTOR	330Ω 1/16W J	
C4441	QETN1AM-477Z	E CAPACITOR	470uF 10V M		R4231	NRSA63J-511X	MG RESISTOR	510Ω 1/16W J	
C4442	NDC31HJ-470X	C CAPACITOR	47pF 50V J		R4232	NRSA63J-331X	MG RESISTOR	330Ω 1/16W J	
C4451	QETN1AM-477Z	E CAPACITOR	470uF 10V M		R4241	NRSA63J-511X	MG RESISTOR	510Ω 1/16W J	
C4452	NDC31HJ-470X	C CAPACITOR	47pF 50V J		R4242	NRSA63J-331X	MG RESISTOR	330Ω 1/16W J	
C4705	NCB31HK-103X	C CAPACITOR	0.01uF 50V K		R4251	NRSA63J-511X	MG RESISTOR	510Ω 1/16W J	
C4706	NCB31HK-103X	C CAPACITOR	0.01uF 50V K		R4252	NRSA63J-331X	MG RESISTOR	330Ω 1/16W J	
C4707	QETN1AM-477Z	E CAPACITOR	470uF 10V M		R4401	NRSA63J-750X	MG RESISTOR	75Ω 1/16W J	
C4708	NCB31HK-103X	C CAPACITOR	0.01uF 50V K		R4411	NRSA63J-750X	MG RESISTOR	75Ω 1/16W J	
C4709	NCB31HK-103X	C CAPACITOR	0.01uF 50V K		R4421	NRSA63J-750X	MG RESISTOR	75Ω 1/16W J	
C4710	NCB31HK-103X	C CAPACITOR	0.01uF 50V K		R4431	NRSA63J-750X	MG RESISTOR	75Ω 1/16W J	
C4711	QETN1CM-107Z	E CAPACITOR	100uF 16V M		R4441	NRSA63J-750X	MG RESISTOR	75Ω 1/16W J	
C4718	NCB31HK-103X	C CAPACITOR	0.01uF 50V K		R4451	NRSA63J-750X	MG RESISTOR	75Ω 1/16W J	
C4719	NCB31HK-103X	C CAPACITOR	0.01uF 50V K		R4702	NRSA63J-102X	MG RESISTOR	1kΩ 1/16W J	
C4771	NCB31CK-104X	C CAPACITOR	0.1uF 16V K		R4703	NRSA63J-102X	MG RESISTOR	1kΩ 1/16W J	
C4772	NCB31CK-104X	C CAPACITOR	0.1uF 16V K		R4704	NRSA63J-103X	MG RESISTOR	10kΩ 1/16W J	
C4773	NCB31CK-104X	C CAPACITOR	0.1uF 16V K		R4705	NRSA63J-223X	MG RESISTOR	22kΩ 1/16W J	
C4774	NCB31CK-104X	C CAPACITOR	0.1uF 16V K		R4709	NRSA63J-101X	MG RESISTOR	100Ω 1/16W J	
C4791	NCB31CK-104X	C CAPACITOR	0.1uF 16V K		R4710	NRSA63J-104X	MG RESISTOR	100kΩ 1/16W J	
C4844	NCF21CZ-105X	C CAPACITOR	1uF 16V Z		R4711	NRSA63J-331X	MG RESISTOR	330Ω 1/16W J	
C4893	NCB31CK-104X	C CAPACITOR	0.1uF 16V K		R4712	NRSA63J-331X	MG RESISTOR	330Ω 1/16W J	
C4902	NCB31HK-103X	C CAPACITOR	0.01uF 50V K		R4713	NRSA63J-331X	MG RESISTOR	330Ω 1/16W J	
C4903	QETN1CM-107Z	E CAPACITOR	100uF 16V M		R4714	NRSA63J-103X	MG RESISTOR	10kΩ 1/16W J	
C4904	NCB31HK-103X	C CAPACITOR	0.01uF 50V K		R4716	NRSA63J-221X	MG RESISTOR	220Ω 1/16W J	
C4961	QETN1CM-107Z	E CAPACITOR	100uF 16V M		R4717	NRSA63J-221X	MG RESISTOR	220Ω 1/16W J	
C4962	QETN1CM-107Z	E CAPACITOR	100uF 16V M		R4718	NRSA63J-103X	MG RESISTOR	10kΩ 1/16W J	
R521	NRSA63J-332X	MG RESISTOR	3.3kΩ 1/16W J						C90A, C90US, C90UX, C90UG, C60US, C60UX, C60UY, C60UG
R522	NRSA63J-392X	MG RESISTOR	3.9kΩ 1/16W J						C90A, C90US, C90UG, C60US, C60UP, C60UG
R526	NRSA63J-332X	MG RESISTOR	3.3kΩ 1/16W J		R4751	NRSA63J-103X	MG RESISTOR	10kΩ 1/16W J	
R527	NRSA63J-392X	MG RESISTOR	3.9kΩ 1/16W J						
R528	NRSA63J-682X	MG RESISTOR	6.8kΩ 1/16W J						
R901	QRL036J-103	OMF RESISTOR	10kΩ 3W J						
△ R903	QRZ9005-270X	FUSI RESISTOR	27Ω						
R904	NRSA63J-183X	MG RESISTOR	18kΩ 1/16W J						
R905	NRSA63J-123X	MG RESISTOR	12kΩ 1/16W J		R4752	NRSA63J-273X	MG RESISTOR	27kΩ 1/16W J	
R908	NRSA63J-332X	MG RESISTOR	3.3kΩ 1/16W J						
R909	NRSA63J-432X	MG RESISTOR	4.3kΩ 1/16W J						
△ R922	QRZ9037-335	COMP RESISTOR	3.3MΩ 1/2W K		R4752	NRSA63J-822X	MG RESISTOR	8.2kΩ 1/16W J	
R951	QRE141J-150Y	C RESISTOR	15Ω 1/4W J		R4752	NRSA63J-153X	MG RESISTOR	15kΩ 1/16W J	
R952	NRSA63J-103X	MG RESISTOR	10kΩ 1/16W J		R4753	NRSA63J-103X	MG RESISTOR	10kΩ 1/16W J	
R953	NRSA02J-223X	MG RESISTOR	22kΩ 1/10W J		R4754	NRSA63J-103X	MG RESISTOR	10kΩ 1/16W J	
△ R954	QRZ9005-100X	FUSI RESISTOR	10Ω		R4755	NRSA63J-103X	MG RESISTOR	10kΩ 1/16W J	
R955	NRSA63J-223X	MG RESISTOR	22kΩ 1/16W J		R4756	NRSA63J-103X	MG RESISTOR	10kΩ 1/16W J	
R957	NRSA63J-273X	MG RESISTOR	27kΩ 1/16W J		R4757	NRSA63J-103X	MG RESISTOR	10kΩ 1/16W J	
R960	NRSA63J-332X	MG RESISTOR	3.3kΩ 1/16W J		R4758	NRSA63J-103X	MG RESISTOR	10kΩ 1/16W J	
R961	NRSA63J-223X	MG RESISTOR	22kΩ 1/16W J		R4759	NRSA63J-103X	MG RESISTOR	10kΩ 1/16W J	
R963	NRSA63D-151X	MG RESISTOR	150Ω 1/16W D		R4760	NRSA63J-222X	MG RESISTOR	2.2kΩ 1/16W J	
R965	NRSA63J-132X	MG RESISTOR	1.3kΩ 1/16W J		R4761	NRSA63J-103X	MG RESISTOR	10kΩ 1/16W J	
R968	NRSA63D-222X	MG RESISTOR	2.2kΩ 1/16W D		R4762	NRSA63J-103X	MG RESISTOR	10kΩ 1/16W J	
R969	NRSA63J-222X	MG RESISTOR	2.2kΩ 1/16W J						
R971	NRSA63J-223X	MG RESISTOR	22kΩ 1/16W J		R4763	NRSA63J-822X	MG RESISTOR	8.2kΩ 1/16W J	
R972	NRSA63J-153X	MG RESISTOR	15kΩ 1/16W J						
R980	NRSA63J-332X	MG RESISTOR	3.3kΩ 1/16W J						C90A, C90US, C90UX, C90UG
R981	NRSA63J-223X	MG RESISTOR	22kΩ 1/16W J						
R982	QRT027J-R56	MF RESISTOR	0.56Ω 2W J						

△ Symbol No.	Part No.	Part Name	Description	Local
R4763	NRSA63J-273X	MG RESISTOR	27kΩ 1/16W J	C60US, C60UP, C60UW, C60UX, C60UY, C60UG
R4771	NRSA63J-103X	MG RESISTOR	10kΩ 1/16W J	
R4772	NRSA63J-103X	MG RESISTOR	10kΩ 1/16W J	
R4773	NRSA63J-103X	MG RESISTOR	10kΩ 1/16W J	C90A, C90US, C90UX, C90UG, C60UP, C60UW
R4774	NRSA63J-103X	MG RESISTOR	10kΩ 1/16W J	
R4775	NRSA63J-331X	MG RESISTOR	330Ω 1/16W J	
R4776	NRSA63J-331X	MG RESISTOR	330Ω 1/16W J	
R4777	NRSA63J-101X	MG RESISTOR	100Ω 1/16W J	
R4778	NRSA63J-101X	MG RESISTOR	100Ω 1/16W J	
R4791	NRSA02J-221X	MG RESISTOR	220Ω 1/10W J	
△ R4811	QRZ9006-4R7X	FUSI RESISTOR	4.7Ω	
R4821	QRE141J-181Y	C RESISTOR	180Ω 1/4W J	
R4822	QRE141J-151Y	C RESISTOR	150Ω 1/4W J	
R4823	NRSA63J-392X	MG RESISTOR	3.9kΩ 1/16W J	
R4824	QRE141J-151Y	C RESISTOR	150Ω 1/4W J	
R4825	QRE141J-151Y	C RESISTOR	150Ω 1/4W J	
R4826	QRE141J-151Y	C RESISTOR	150Ω 1/4W J	
R4827	QRE141J-151Y	C RESISTOR	150Ω 1/4W J	
R4831	NRSA63J-123X	MG RESISTOR	12kΩ 1/16W J	
R4833	NRSA63J-123X	MG RESISTOR	12kΩ 1/16W J	
R4834	NRSA63J-393X	MG RESISTOR	39kΩ 1/16W J	
R4835	NRSA63J-472X	MG RESISTOR	4.7kΩ 1/16W J	
R4841	NRSA63J-681X	MG RESISTOR	680Ω 1/16W J	
R4843	QRT017J-2R2	MF RESISTOR	2.2Ω 1W J	
△ R4844	QRL02DJ-121X	OMF RESISTOR	120Ω 2W J	
R4846	NRSA63J-103X	MG RESISTOR	10kΩ 1/16W J	
R4847	NRSA63J-103X	MG RESISTOR	10kΩ 1/16W J	C90US, C90UX, C90UG, C60US, C60UX, C60UG
R4848	NRSA63J-103X	MG RESISTOR	10kΩ 1/16W J	C90A, C60UP, C60UW, C60UY
R4849	NRSA63J-103X	MG RESISTOR	10kΩ 1/16W J	
R4851	NRSA63J-103X	MG RESISTOR	10kΩ 1/16W J	
R4861	NRSA63J-222X	MG RESISTOR	2.2kΩ 1/16W J	
R4863	NRSA63J-222X	MG RESISTOR	2.2kΩ 1/16W J	
R4864	NRSA63J-222X	MG RESISTOR	2.2kΩ 1/16W J	
R4866	NRSA63J-272X	MG RESISTOR	2.7kΩ 1/16W J	
R4871	NRSA63J-331X	MG RESISTOR	330Ω 1/16W J	
R4872	NRSA63J-331X	MG RESISTOR	330Ω 1/16W J	
R4873	NRSA63J-331X	MG RESISTOR	330Ω 1/16W J	
R4875	NRSA63J-471X	MG RESISTOR	470Ω 1/16W J	
R4876	NRSA63J-331X	MG RESISTOR	330Ω 1/16W J	
R4881	NRSA63J-472X	MG RESISTOR	4.7kΩ 1/16W J	
R4882	NRSA63J-101X	MG RESISTOR	100Ω 1/16W J	
R4883	NRSA63J-472X	MG RESISTOR	4.7kΩ 1/16W J	
R4884	NRSA63J-472X	MG RESISTOR	4.7kΩ 1/16W J	
R4886	NRSA63J-562X	MG RESISTOR	5.6kΩ 1/16W J	
R4893	NRSA63J-101X	MG RESISTOR	100Ω 1/16W J	
△ R4921	QRZ9005-100X	FUSI RESISTOR	10Ω	
R4961	QRE141J-271Y	C RESISTOR	270Ω 1/4W J	
△ L901	QQR0908-001	LINE FILTER		
L951	QQL244K-R22Z	COIL	0.22uH K	
L955	QQL31AK-220Z	COIL	22uH K	
L957	QQL26AK-100Z	COIL	10uH K	
L972	QQL31AK-220Z	COIL	22uH K	
L4391	QQL25CK-221Z	COIL	220uH K	
△ T901	QQS0371-001	SW TRANSF		
CN402	QGF1036C2-28	CONNECTOR	FFC/FPC (1-28)	
CN403	QGF1036C2-18	CONNECTOR	FFC/FPC (1-18)	
CN404	QGF1036C2-05	CONNECTOR	FFC/FPC (1-5)	
CN406	QGF1205C2-05	CONNECTOR	FFC/FPC (1-5)	
CN410	QGF1205C2-11	CONNECTOR	FFC/FPC (1-11)	
CN411	QGF1036C2-25	CONNECTOR	FFC/FPC (1-25)	
CN413	QGB2501J1-06	CONNECTOR	B-B (1-6)	

△ Symbol No.	Part No.	Part Name	Description	Local
CN450	QGF1036C2-17	CONNECTOR	FFC/FPC (1-17)	
CN451	QGF1205C2-07	CONNECTOR	FFC/FPC (1-7)	C90US, C90UX, C90UG, C60US, C60UX, C60UG
CN455	QGF1205C2-07	CONNECTOR	FFC/FPC (1-7)	
CN457	QGD2504C1-03Z	CONNECTOR	(1-3)	
△ CP951	ICP-N10-T	IC PROTECTOR	400mA	
△ CP999	ICP-N20-T	IC PROTECTOR	800mA	
EP401	QNZ0870-001	EARTH PLATE		
EP901	QNZ0870-001	EARTH PLATE		
EP903	QNZ0870-001	EARTH PLATE		
FC901	QNG0003-001Z	FUSE CLIP		
FC902	QNG0003-001Z	FUSE CLIP		
FW521	QUM213-08DGZ4-E	PARA RIBON WIRE		
HS901	LV40057-002A	HEAT SINK		
J4401	QNN0570-001	PIN JACK		
J4402	QNN0572-001	PIN JACK		
K901	QQR1769-001	FERRITE CORE		
K4702	QQR0621-001Z	COIL		
△ P901	QNC0081-001	AC INLET		
PP401	QZW0112-001	WIRE CLAMP		
PP402	QZW0112-001	WIRE CLAMP		
PP403	QZW0112-001	WIRE CLAMP		
PP404	QZW0112-001	WIRE CLAMP		
S522	QSW1120-001Z	PUSH SW		
S523	QSW1120-001Z	PUSH SW		
S526	QSW1120-001Z	PUSH SW		
S527	QSW1120-001Z	PUSH SW		
S528	QSW1120-001Z	PUSH SW		
S529	QSW1120-001Z	PUSH SW		
X4701	QAX0246-001Z	C RESONATOR	8.00MHz	

Audio board

Block No. [0][2]

△ Symbol No.	Part No.	Part Name	Description	Local
IC101	R2S15902FP	IC		
IC111	RC4580ID-X	IC		
IC112	RC4580ID-X	IC		
IC113	RC4580ID-X	IC		
IC121	RC4580ID-X	IC		
IC131	RC4580ID-X	IC		
IC501	PT6315	IC		
IC511	GP1UM261XKVF	IR DETECT UNIT		
IC701	RC4580ID-X	IC		C90US,C90UX, C90UG,C60US, C60UX,C60UG
IC761	BU9253FS-X	IC		C90US,C90UX, C90UG,C60US, C60UX,C60UG
Q1101	2SA1530A/QR/-X	TRANSISTOR		
Q1102	RT1N141C-X	DIGI TRANSISTOR		
Q1121	IMX9-W	TRANSISTOR		
Q1122	IMX9-W	TRANSISTOR		
Q1123	IMX9-W	TRANSISTOR		
Q1131	RT1N141C-X	DIGI TRANSISTOR		
Q1132	2SA1530A/QR/-X	TRANSISTOR		
Q1133	IMX9-W	TRANSISTOR		
Q2921	KTC3203/OY/-T	TRANSISTOR		
Q7301	RT1N141C-X	DIGI TRANSISTOR		C90US,C90UX, C90UG,C60US, C60UX,C60UG
Q7302	2SA1037AK/RS/-X	TRANSISTOR		C90US,C90UX, C90UG,C60US, C60UX,C60UG
Q7401	2SC2412K/R/-X	TRANSISTOR		C90US,C90UX, C90UG,C60US, C60UX,C60UG
Q7402	2SC2412K/R/-X	TRANSISTOR		C90US,C90UX, C90UG,C60US, C60UX,C60UG

△ Symbol No.	Part No.	Part Name	Description	Local	△ Symbol No.	Part No.	Part Name	Description	Local
D511	SLR-343VC/NPQ-T	LED			C2514	NCB21CK-224X	C CAPACITOR	0.22uF 16V K	
D551	SELU2E10C-P	LED			C2515	NCB31CK-393X	C CAPACITOR	0.039uF 16V K	
D2921	MTZJ11C-T2	Z DIODE			C2516	NCB31CK-393X	C CAPACITOR	0.039uF 16V K	
D2922	1SS133-T2	SI DIODE			C2517	QETN1HM-475Z	E CAPACITOR	4.7uF 50V M	
D7401	1SS355-X	SI DIODE		C90US,C90UX, C90UG,C60US, C60UX,C60UG	C2518	QETN1HM-475Z	E CAPACITOR	4.7uF 50V M	
D7402	1SS355-X	SI DIODE		C90US,C90UX, C90UG,C60US, C60UX,C60UG	C2521	QETN1HM-475Z	E CAPACITOR	4.7uF 50V M	
D7501	1SS355-X	SI DIODE		C90US,C90UX, C90UG,C60US, C60UX,C60UG	C2522	QETN1HM-475Z	E CAPACITOR	4.7uF 50V M	
C506	NCB30JK-105X	C CAPACITOR	1uF 6.3V K		C2523	QETN1HM-475Z	E CAPACITOR	4.7uF 50V M	C90US,C90UX, C90UG,C60US, C60UX,C60UG
C507	NCB31HK-103X	C CAPACITOR	0.01uF 50V K		C2524	QETN1HM-475Z	E CAPACITOR	4.7uF 50V M	C90US,C90UX, C90UG,C60US, C60UX,C60UG
C511	NCB21CK-105X	C CAPACITOR	1uF 16V K		C2530	QTE1E46-476Z	E CAPACITOR	47uF 25V	
C515	NCB31HK-103X	C CAPACITOR	0.01uF 50V K		C2531	NCB31CK-104X	C CAPACITOR	0.1uF 16V K	
C541	NCB31HK-103X	C CAPACITOR	0.01uF 50V K		C2532	NCB31CK-153X	C CAPACITOR	0.015uF 16V K	
C542	NCB31HK-103X	C CAPACITOR	0.01uF 50V K		C2533	QETN1CM-107Z	E CAPACITOR	100uF 16V M	
C1101	NDC31HJ-331X	C CAPACITOR	330pF 50V J		C2534	NCB31HK-473X	C CAPACITOR	0.047uF 50V K	
C1102	NDC31HJ-331X	C CAPACITOR	330pF 50V J		C2535	NCB31HK-473X	C CAPACITOR	0.047uF 50V K	
C1103	QETN1HM-475Z	E CAPACITOR	4.7uF 50V M		C2536	QFV61HJ-473Z	MF CAPACITOR	0.047uF 50V J	
C1104	QETN1HM-475Z	E CAPACITOR	4.7uF 50V M		C2537	QFV61HJ-154Z	MF CAPACITOR	0.15uF 50V J	
C1121	NCS31HJ-331X	C CAPACITOR	330pF 50V J	C90A,C90US, C90UX,C90UG	C2538	QFV61HJ-473Z	MF CAPACITOR	0.047uF 50V J	
C1122	NCS31HJ-331X	C CAPACITOR	330pF 50V J	C90A,C90US, C90UX,C90UG	C2539	QFV61HJ-154Z	MF CAPACITOR	0.15uF 50V J	
C1123	QETN1HM-475Z	E CAPACITOR	4.7uF 50V M	C90A,C90US, C90UX,C90UG	C2540	QFV61HJ-223Z	MF CAPACITOR	0.022uF 50V J	
C1124	QETN1HM-475Z	E CAPACITOR	4.7uF 50V M	C90A,C90US, C90UX,C90UG	C2541	QFV61HJ-223Z	MF CAPACITOR	0.022uF 50V J	
C1170	NCF21CZ-105X	C CAPACITOR	1uF 16V Z		C2542	QETN1HM-225Z	E CAPACITOR	2.2uF 50V M	
C1171	NCF21CZ-105X	C CAPACITOR	1uF 16V Z		C2551	QETN1HM-226Z	E CAPACITOR	22uF 50V M	
C1172	NCF21CZ-105X	C CAPACITOR	1uF 16V Z		C2552	QTE1C46-107Z	E CAPACITOR	100uF 16V	
C1203	QETN1HM-475Z	E CAPACITOR	4.7uF 50V M		C2553	QETN1HM-475Z	E CAPACITOR	4.7uF 50V M	
C1204	QETN1HM-475Z	E CAPACITOR	4.7uF 50V M		C2554	NCF21CZ-105X	C CAPACITOR	1uF 16V Z	
C1205	QETN1HM-475Z	E CAPACITOR	4.7uF 50V M		C2555	NCB31CK-473X	C CAPACITOR	0.047uF 16V K	
C1206	QETN1HM-475Z	E CAPACITOR	4.7uF 50V M		C2556	NCB31CK-473X	C CAPACITOR	0.047uF 16V K	
C1209	QETN1HM-475Z	E CAPACITOR	4.7uF 50V M		C2557	QETN1EM-476Z	E CAPACITOR	47uF 25V M	
C1210	QETN1HM-475Z	E CAPACITOR	4.7uF 50V M		C2601	NDC31HJ-560X	C CAPACITOR	56pF 50V J	
C1211	QER61EM-475Z	E CAPACITOR	4.7uF 25V M		C2602	NDC31HJ-560X	C CAPACITOR	56pF 50V J	
C1212	QER61EM-475Z	E CAPACITOR	4.7uF 25V M		C2603	QETN1AM-227Z	E CAPACITOR	220uF 10V M	
C1215	QETN1HM-475Z	E CAPACITOR	4.7uF 50V M		C2604	QETN1AM-227Z	E CAPACITOR	220uF 10V M	
C1216	QTE1H46-475Z	E CAPACITOR	4.7uF 50V		C2610	NCB31CK-104X	C CAPACITOR	0.1uF 16V K	
C1217	QETN1HM-225Z	E CAPACITOR	2.2uF 50V M		C2611	QETN1HM-106Z	E CAPACITOR	10uF 50V M	
C1218	QTE1H46-475Z	E CAPACITOR	4.7uF 50V		C2921	QETN1EM-476Z	E CAPACITOR	47uF 25V M	
C1221	NDC31HJ-470X	C CAPACITOR	47pF 50V J		C2922	QEZO807-107Z	E CAPACITOR	100uF 25V M	
C1222	NDC31HJ-470X	C CAPACITOR	47pF 50V J		C6001	NCB31CK-223X	C CAPACITOR	0.022uF 16V K	
C1223	NDC31HJ-470X	C CAPACITOR	47pF 50V J		C6002	NCB31CK-223X	C CAPACITOR	0.022uF 16V K	
C1224	NDC31HJ-470X	C CAPACITOR	47pF 50V J		C6003	NCB31CK-104X	C CAPACITOR	0.1uF 16V K	
C1225	NDC31HJ-471X	C CAPACITOR	470pF 50V J		C6004	NCB31HK-103X	C CAPACITOR	0.01uF 50V K	
C1226	NDC31HJ-470X	C CAPACITOR	47pF 50V J		C6101	NCB31HK-182X	C CAPACITOR	1800pF 50V K	C90A,C60UP, C60UW,C60UY C90US,C90UX, C90UG,C60US, C60UX,C60UG
C1331	NCS31HJ-101X	C CAPACITOR	100pF 50V J	C90A,C90US, C90UX,C90UG	C6101	NCB31HK-104X	C CAPACITOR	0.1uF 50V K	
C1332	NCS31HJ-101X	C CAPACITOR	100pF 50V J	C90A,C90US, C90UX,C90UG	C6102	NCB31HK-182X	C CAPACITOR	1800pF 50V K	C90A,C60UP, C60UW,C60UY C90US,C90UX, C90UG,C60US, C60UX,C60UG
C1333	QETN1HM-475Z	E CAPACITOR	4.7uF 50V M	C90A,C90US, C90UX,C90UG	C6102	NCB31HK-104X	C CAPACITOR	0.1uF 50V K	
C1334	QETN1HM-475Z	E CAPACITOR	4.7uF 50V M	C90A,C90US, C90UX,C90UG	C6103	NDC31HJ-150X	C CAPACITOR	15pF 50V J	
C1441	NCB31HK-222X	C CAPACITOR	2200pF 50V K		C6104	NDC31HJ-150X	C CAPACITOR	15pF 50V J	
C1442	NCB31HK-222X	C CAPACITOR	2200pF 50V K		C6105	NCB31HK-103X	C CAPACITOR	0.01uF 50V K	
C1443	QCBB1HK-222Y	C CAPACITOR	2200pF 50V K		C6205	NCB31HK-103X	C CAPACITOR	0.01uF 50V K	
C1443 or	QDXB1CM-222Y	C CAPACITOR	2200pF 16V M		C7101	NCB31AK-474X	C CAPACITOR	0.47uF 10V K	C90US,C90UX, C90UG,C60US, C60UX,C60UG
C1444	QCBB1HK-222Y	C CAPACITOR	2200pF 50V K		C7102	NDC31HJ-820X	C CAPACITOR	82pF 50V J	C90US,C90UX, C90UG,C60US, C60UX,C60UG
C1444 or	QDXB1CM-222Y	C CAPACITOR	2200pF 16V M		C7103	QER61HM-474Z	E CAPACITOR	0.47uF 50V M	C90US,C90UX, C90UG,C60US, C60UX,C60UG
C1445	QCBB1HK-222Y	C CAPACITOR	2200pF 50V K		C7104	QER61HM-105Z	E CAPACITOR	1uF 50V M	C90US,C90UX, C90UG,C60US, C60UX,C60UG
C1445 or	QDXB1CM-222Y	C CAPACITOR	2200pF 16V M		C7201	NCB31CK-224X	C CAPACITOR	0.22uF 16V K	C90US,C90UX, C90UG,C60US, C60UX,C60UG
C1446	QDGB1HK-102Y	C CAPACITOR	1000pF 50V K		C7202	NCB31AK-105X	C CAPACITOR	1uF 10V K	C90US,C90UX, C90UG,C60US, C60UX,C60UG
C2501	QTE1H46-475Z	E CAPACITOR	4.7uF 50V		C7401	QER61HM-335Z	E CAPACITOR	3.3uF 50V M	C90US,C90UX, C90UG,C60US, C60UX,C60UG
C2502	QTE1H46-475Z	E CAPACITOR	4.7uF 50V						
C2503	NCB21CK-224X	C CAPACITOR	0.22uF 16V K						
C2504	NCB21CK-224X	C CAPACITOR	0.22uF 16V K						
C2505	NCB21CK-224X	C CAPACITOR	0.22uF 16V K						
C2506	QTE1H46-475Z	E CAPACITOR	4.7uF 50V						
C2511	QETN1HM-106Z	E CAPACITOR	10uF 50V M						
C2512	QETN1HM-106Z	E CAPACITOR	10uF 50V M						
C2513	NCB21CK-224X	C CAPACITOR	0.22uF 16V K						

△ Symbol No.	Part No.	Part Name	Description	Local	△ Symbol No.	Part No.	Part Name	Description	Local
C7402	QER61AM-336Z	E CAPACITOR	33uF 10V M	C90US,C90UX, C90UG,C60US, C60UX,C60UG	R1145	NRSA63J-104X	MG RESISTOR	100kΩ 1/16W J	
C7601	QER61CM-226Z	E CAPACITOR	22uF 16V M	C90US,C90UX, C90UG,C60US, C60UX,C60UG	R1146	NRSA63J-104X	MG RESISTOR	100kΩ 1/16W J	
C7602	NCB31CK-333X	C CAPACITOR	0.033uF 16V K	C90US,C90UX, C90UG,C60US, C60UX,C60UG	R1149	NRSA63J-102X	MG RESISTOR	1kΩ 1/16W J	
C7603	NCB31AK-474X	C CAPACITOR	0.47uF 10V K	C90US,C90UX, C90UG,C60US, C60UX,C60UG	R1150	NRSA63J-102X	MG RESISTOR	1kΩ 1/16W J	
C7604	NCB31HK-103X	C CAPACITOR	0.01uF 50V K	C90US,C90UX, C90UG,C60US, C60UX,C60UG	R1151	NRSA63J-332X	MG RESISTOR	3.3kΩ 1/16W J	
C7605	NCB31HK-822X	C CAPACITOR	8200pF 50V K	C90US,C90UX, C90UG,C60US, C60UX,C60UG	R1152	NRSA63J-332X	MG RESISTOR	3.3kΩ 1/16W J	
C7606	NCB31AK-105X	C CAPACITOR	1uF 10V K	C90US,C90UX, C90UG,C60US, C60UX,C60UG	R1155	NRSA63J-104X	MG RESISTOR	100kΩ 1/16W J	
C7608	NCB31HK-123X	C CAPACITOR	0.012uF 50V K	C90US,C90UX, C90UG,C60US, C60UX,C60UG	R1156	NRSA63J-104X	MG RESISTOR	100kΩ 1/16W J	
C7609	NCB31HK-472X	C CAPACITOR	4700pF 50V K	C90US,C90UX, C90UG,C60US, C60UX,C60UG	R1158	NRSA63J-183X	MG RESISTOR	18kΩ 1/16W J	C90A
C7610	NCB31HK-103X	C CAPACITOR	0.01uF 50V K	C90US,C90UX, C90UG,C60US, C60UX,C60UG	R1158	NRSA63J-103X	MG RESISTOR	10kΩ 1/16W J	C90US,C90UX, C90UG,C60UP, C60UW,C60UY, C60US,C60UX, C60UG
C7611	NCB31CK-104X	C CAPACITOR	0.1uF 16V K	C90US,C90UX, C90UG,C60US, C60UX,C60UG	R1159	NRSA63J-183X	MG RESISTOR	18kΩ 1/16W J	C90A
C7612	NCS31HJ-121X	C CAPACITOR	120pF 50V J	C90US,C90UX, C90UG,C60US, C60UX,C60UG	R1159	NRSA63J-103X	MG RESISTOR	10kΩ 1/16W J	C90US,C90UX, C90UG,C60UP, C60UW,C60UY, C60US,C60UX, C60UG
C7613	QER61AM-107Z	E CAPACITOR	100uF 10V M	C90US,C90UX, C90UG,C60US, C60UX,C60UG	R1159	NRSA63J-682X	MG RESISTOR	6.8kΩ 1/16W J	
C7901	QER61CM-226Z	E CAPACITOR	22uF 16V M	C90US,C90UX, C90UG,C60US, C60UX,C60UG	R1160	NRSA63J-103X	MG RESISTOR	10kΩ 1/16W J	
C7902	QER61CM-476Z	E CAPACITOR	47uF 16V M	C90US,C90UX, C90UG,C60US, C60UX,C60UG	R1161	NRSA63J-103X	MG RESISTOR	10kΩ 1/16W J	
C7903	NCB31HK-103X	C CAPACITOR	0.01uF 50V K	C90US,C90UX, C90UG,C60US, C60UX,C60UG	R1162	NRSA63J-333X	MG RESISTOR	33kΩ 1/16W J	C90A,C90US, C90UX,C90UG
R501	NRSA63J-102X	MG RESISTOR	1kΩ 1/16W J		R1163	NRSA63J-333X	MG RESISTOR	33kΩ 1/16W J	C90A,C90US, C90UX,C90UG
R502	NRSA63J-102X	MG RESISTOR	1kΩ 1/16W J		R1164	NRSA63J-103X	MG RESISTOR	10kΩ 1/16W J	
R503	NRSA63J-102X	MG RESISTOR	1kΩ 1/16W J		R1165	NRSA63J-103X	MG RESISTOR	10kΩ 1/16W J	
R505	NRSA63J-823X	MG RESISTOR	82kΩ 1/16W J		R1166	NRSA63J-183X	MG RESISTOR	18kΩ 1/16W J	C90A,C90US, C90UX,C90UG
R506	NRSA63J-330X	MG RESISTOR	33Ω 1/16W J		R1166	NRSA63J-153X	MG RESISTOR	15kΩ 1/16W J	C60US,C60UP, C60UW,C60UX, C60UY,C60UG
R511	NRSA63J-221X	MG RESISTOR	220Ω 1/16W J		R1167	NRSA63J-182X	MG RESISTOR	1.8kΩ 1/16W J	C90A,C90US, C90UX,C90UG
R531	NRSA63J-332X	MG RESISTOR	3.3kΩ 1/16W J		R1167	NRSA63J-123X	MG RESISTOR	12kΩ 1/16W J	C60US,C60UP, C60UW,C60UX, C60UY,C60UG
R532	NRSA63J-392X	MG RESISTOR	3.9kΩ 1/16W J		R1168	NRSA63J-103X	MG RESISTOR	10kΩ 1/16W J	
R533	NRSA63J-682X	MG RESISTOR	6.8kΩ 1/16W J		R1169	NRSA63J-273X	MG RESISTOR	27kΩ 1/16W J	
R534	NRSA63J-153X	MG RESISTOR	15kΩ 1/16W J		R1171	NRSA63J-104X	MG RESISTOR	100kΩ 1/16W J	
R536	NRSA63J-332X	MG RESISTOR	3.3kΩ 1/16W J		R1172	NRSA63J-104X	MG RESISTOR	100kΩ 1/16W J	
R537	NRSA63J-392X	MG RESISTOR	3.9kΩ 1/16W J		R1173	NRSA63J-104X	MG RESISTOR	100kΩ 1/16W J	C90A,C90US, C90UX,C90UG
R538	NRSA63J-682X	MG RESISTOR	6.8kΩ 1/16W J		R1173	NRSA63J-392X	MG RESISTOR	3.9kΩ 1/16W J	C60US,C60UP, C60UW,C60UX, C60UY,C60UG
R539	NRSA63J-153X	MG RESISTOR	15kΩ 1/16W J		R1174	NRSA63J-104X	MG RESISTOR	100kΩ 1/16W J	C90A,C90US, C90UX,C90UG
R541	NRSA63J-103X	MG RESISTOR	10kΩ 1/16W J		R1174	NRSA63J-392X	MG RESISTOR	3.9kΩ 1/16W J	C60US,C60UP, C60UW,C60UX, C60UY,C60UG
R542	NRSA63J-103X	MG RESISTOR	10kΩ 1/16W J		R1175	NRSA63J-104X	MG RESISTOR	100kΩ 1/16W J	
R552	NRSA63J-121X	MG RESISTOR	120Ω 1/16W J		R1176	NRSA63J-104X	MG RESISTOR	100kΩ 1/16W J	
R1101	NRSA63J-471X	MG RESISTOR	470Ω 1/16W J		R1181	NRSA63J-102X	MG RESISTOR	1kΩ 1/16W J	
R1102	NRSA63J-471X	MG RESISTOR	470Ω 1/16W J		R1182	NRSA63J-102X	MG RESISTOR	1kΩ 1/16W J	
R1108	NRSA63J-334X	MG RESISTOR	330kΩ 1/16W J		R1183	NRSA63J-102X	MG RESISTOR	1kΩ 1/16W J	
R1109	NRSA63J-334X	MG RESISTOR	330kΩ 1/16W J		R1184	NRSA63J-102X	MG RESISTOR	1kΩ 1/16W J	
R1110	NRSA63J-273X	MG RESISTOR	27kΩ 1/16W J		R1185	NRSA63J-102X	MG RESISTOR	1kΩ 1/16W J	
R1111	NRSA63J-273X	MG RESISTOR	27kΩ 1/16W J		R1186	NRSA63J-102X	MG RESISTOR	1kΩ 1/16W J	
R1133	NRSA63J-102X	MG RESISTOR	1kΩ 1/16W J		R1201	NRSA63J-334X	MG RESISTOR	330kΩ 1/16W J	C90A,C90US, C90UX,C90UG
R1134	NRSA63J-102X	MG RESISTOR	1kΩ 1/16W J		R1202	NRSA63J-334X	MG RESISTOR	330kΩ 1/16W J	C90A,C90US, C90UX,C90UG
R1135	NRSA63J-332X	MG RESISTOR	3.3kΩ 1/16W J		R1203	NRSA63J-471X	MG RESISTOR	470Ω 1/16W J	C90A,C90US, C90UX,C90UG
R1136	NRSA63J-332X	MG RESISTOR	3.3kΩ 1/16W J		R1204	NRSA63J-471X	MG RESISTOR	470Ω 1/16W J	C90A,C90US, C90UX,C90UG
R1137	NRSA63J-104X	MG RESISTOR	100kΩ 1/16W J		R1207	NRSA63J-273X	MG RESISTOR	27kΩ 1/16W J	C90A,C90US, C90UX,C90UG
R1138	NRSA63J-104X	MG RESISTOR	100kΩ 1/16W J		R1208	NRSA63J-273X	MG RESISTOR	27kΩ 1/16W J	C90A,C90US, C90UX,C90UG
R1141	NRSA63J-102X	MG RESISTOR	1kΩ 1/16W J		R1301	NRSA63J-104X	MG RESISTOR	100kΩ 1/16W J	C90A,C90US, C90UX,C90UG
R1142	NRSA63J-102X	MG RESISTOR	1kΩ 1/16W J		R1302	NRSA63J-104X	MG RESISTOR	100kΩ 1/16W J	C90A,C90US, C90UX,C90UG
R1143	NRSA63J-332X	MG RESISTOR	3.3kΩ 1/16W J		R1303	NRSA63J-101X	MG RESISTOR	100Ω 1/16W J	C90A,C90US, C90UX,C90UG
R1144	NRSA63J-332X	MG RESISTOR	3.3kΩ 1/16W J		R1304	NRSA63J-101X	MG RESISTOR	100Ω 1/16W J	C90A,C90US, C90UX,C90UG
R2501	NRSA63J-101X	MG RESISTOR	100Ω 1/16W J		R2501	NRSA63J-101X	MG RESISTOR	100Ω 1/16W J	
R2502	NRSA63J-101X	MG RESISTOR	100Ω 1/16W J		R2502	NRSA63J-101X	MG RESISTOR	100Ω 1/16W J	

△ Symbol No.	Part No.	Part Name	Description	Local	△ Symbol No.	Part No.	Part Name	Description	Local
R2503	NRSA63J-102X	MG RESISTOR	1kΩ 1/16W J		R7401	NRSA63J-102X	MG RESISTOR	1kΩ 1/16W J	C90US,C90UX, C90UG,C60US, C60UX,C60UG
R2504	NRSA63J-102X	MG RESISTOR	1kΩ 1/16W J		R7402	NRSA63J-224X	MG RESISTOR	220kΩ 1/16W J	C90US,C90UX, C90UG,C60US, C60UX,C60UG
R2505	NRSA63J-102X	MG RESISTOR	1kΩ 1/16W J		R7403	NRSA63J-103X	MG RESISTOR	10kΩ 1/16W J	C90US,C90UX, C90UG,C60US, C60UX,C60UG
R2506	NRSA63J-102X	MG RESISTOR	1kΩ 1/16W J		R7404	NRSA63J-103X	MG RESISTOR	10kΩ 1/16W J	C90US,C90UX, C90UG,C60US, C60UX,C60UG
R2511	NRSA63J-223X	MG RESISTOR	22kΩ 1/16W J		R7501	NRSA63J-102X	MG RESISTOR	1kΩ 1/16W J	C90US,C90UX, C90UG,C60US, C60UX,C60UG
R2512	NRSA63J-223X	MG RESISTOR	22kΩ 1/16W J		R7601	NRSA63J-103X	MG RESISTOR	10kΩ 1/16W J	C90US,C90UX, C90UG,C60US, C60UX,C60UG
R2513	NRSA63J-473X	MG RESISTOR	47kΩ 1/16W J		R7602	NRSA63J-153X	MG RESISTOR	15kΩ 1/16W J	C90US,C90UX, C90UG,C60US, C60UX,C60UG
R2514	NRSA63J-473X	MG RESISTOR	47kΩ 1/16W J		R7603	NRSA63J-153X	MG RESISTOR	15kΩ 1/16W J	C90US,C90UX, C90UG,C60US, C60UX,C60UG
R2520	NRSA63J-472X	MG RESISTOR	4.7kΩ 1/16W J		R7604	NRSA63J-822X	MG RESISTOR	8.2kΩ 1/16W J	C90US,C90UX, C90UG,C60US, C60UX,C60UG
R2521	NRSA63J-472X	MG RESISTOR	4.7kΩ 1/16W J		R7605	NRSA63J-103X	MG RESISTOR	10kΩ 1/16W J	C90US,C90UX, C90UG,C60US, C60UX,C60UG
R2523	NRSA63J-222X	MG RESISTOR	2.2kΩ 1/16W J	C90US,C90UX, C90UG,C60US, C60UX,C60UG	R7606	NRSA63J-433X	MG RESISTOR	43kΩ 1/16W J	C90US,C90UX, C90UG,C60US, C60UX,C60UG
R2524	NRSA63J-222X	MG RESISTOR	2.2kΩ 1/16W J	C90US,C90UX, C90UG,C60US, C60UX,C60UG	R7607	NRSA63J-183X	MG RESISTOR	18kΩ 1/16W J	C90US,C90UX, C90UG,C60US, C60UX,C60UG
R2551	NRSA63J-223X	MG RESISTOR	22kΩ 1/16W J		R7901	QRE141J-221Y	C RESISTOR	220Ω 1/4W J	C90US,C90UX, C90UG,C60US, C60UX,C60UG
R2552	NRSA63J-473X	MG RESISTOR	47kΩ 1/16W J		R7902	QRE141J-221Y	C RESISTOR	220Ω 1/4W J	C90US,C90UX, C90UG,C60US, C60UX,C60UG
R2553	NRSA63J-822X	MG RESISTOR	8.2kΩ 1/16W J		R7903	NRSA63J-154X	MG RESISTOR	150kΩ 1/16W J	C90US,C90UX, C90UG,C60US, C60UX,C60UG
R2554	NRSA63J-103X	MG RESISTOR	10kΩ 1/16W J		R7904	NRSA63J-154X	MG RESISTOR	150kΩ 1/16W J	C90US,C90UX, C90UG,C60US, C60UX,C60UG
R2555	NRSA63J-472X	MG RESISTOR	4.7kΩ 1/16W J		VR701	QVQ0112-B24	V RESISTOR		C90US,C90UX, C90UG,C60US, C60UX,C60UG
R2556	NRSA63J-102X	MG RESISTOR	1kΩ 1/16W J		57	LV30227-051A	SPACER	(x2)	C60US,C60UP, C60UW,C60UX, C60UY,C60UG
R2557	NRSA63J-562X	MG RESISTOR	5.6kΩ 1/16W J		58	LV36587-001A	LED HOLDER		C60US,C60UP, C60UW,C60UX, C60UY,C60UG
R2558	NRSA63J-103X	MG RESISTOR	10kΩ 1/16W J		BK701	LV36588-001A	MIC BRACKET		C90US,C90UX, C90UG,C60US, C60UX,C60UG
R2559	NRSA63J-223X	MG RESISTOR	22kΩ 1/16W J		CN101	QGB2501J1-06	CONNECTOR	B-B (1-6)	
R2560	NRSA63J-103X	MG RESISTOR	10kΩ 1/16W J		CN102	QGF1036F2-25	CONNECTOR	FFC/FPC (1-25)	
R2561	NRSA63J-103X	MG RESISTOR	10kΩ 1/16W J		CN414	QGB2501K2-06	CONNECTOR	B-B (1-6)	
R2601	NRSA63J-103X	MG RESISTOR	10kΩ 1/16W J		CN415	QGB2501K2-06	CONNECTOR	B-B (1-6)	
R2602	NRSA63J-103X	MG RESISTOR	10kΩ 1/16W J		CN501	QGF1036F2-17	CONNECTOR	FFC/FPC (1-17)	
R2603	NRSA63J-103X	MG RESISTOR	10kΩ 1/16W J		CN502	QGF1205F2-07	CONNECTOR	FFC/FPC (1-7)	
R2604	NRSA63J-103X	MG RESISTOR	10kΩ 1/16W J		CN511	WJP0079-002A-E	E-SH C WIRE C-B		
R2605	NRSA63J-472X	MG RESISTOR	4.7kΩ 1/16W J		CN701	QGF1205F2-07	CONNECTOR	FFC/FPC (1-7)	C90US,C90UX, C90UG,C60US, C60UX,C60UG
R2606	NRSA63J-472X	MG RESISTOR	4.7kΩ 1/16W J		DI501	QLF0168-001	FL TUBE		
R2607	NRSA63J-472X	MG RESISTOR	4.7kΩ 1/16W J		EP511	QNZ0870-001	EARTH PLATE		
R2608	NRSA63J-472X	MG RESISTOR	4.7kΩ 1/16W J		J1101	QNN0598-001	PIN JACK		
R2609	QRE141J-390Y	C RESISTOR	39Ω 1/4W J		J1102	QNN0734-001	PIN JACK		C90A,C90US, C90UX,C90UG
R2610	QRE141J-390Y	C RESISTOR	39Ω 1/4W J		J1103	QND0118-001	DIN CONNECTOR		
R2611	QRE141J-100Y	C RESISTOR	10Ω 1/4W J		J6001	QNS0231-001	JACK		
R2612	QRE141J-100Y	C RESISTOR	10Ω 1/4W J		J6101	QNZ0851-001	USB CONNECTOR		
R2613	NRSA63J-222X	MG RESISTOR	2.2kΩ 1/16W J		J7001	QNS0266-001	JACK		C90US,C90UX, C90UG,C60US, C60UX,C60UG
R2614	NRSA63J-222X	MG RESISTOR	2.2kΩ 1/16W J						
R2620	NRSA63J-223X	MG RESISTOR	22kΩ 1/16W J						
R2621	NRSA63J-222X	MG RESISTOR	2.2kΩ 1/16W J						
R2922	NRSA63J-102X	MG RESISTOR	1kΩ 1/16W J						
R6001	NRSA63J-102X	MG RESISTOR	1kΩ 1/16W J						
R6107	NRSA63J-390X	MG RESISTOR	39Ω 1/16W J						
R6207	NRSA63J-390X	MG RESISTOR	39Ω 1/16W J						
R7101	NRSA63J-472X	MG RESISTOR	4.7kΩ 1/16W J	C90US,C90UX, C90UG,C60US, C60UX,C60UG					
R7102	NRSA63J-472X	MG RESISTOR	4.7kΩ 1/16W J	C90US,C90UX, C90UG,C60US, C60UX,C60UG					
R7103	NRSA63J-102X	MG RESISTOR	1kΩ 1/16W J	C90US,C90UX, C90UG,C60US, C60UX,C60UG					
R7104	NRSA63J-103X	MG RESISTOR	10kΩ 1/16W J	C90US,C90UX, C90UG,C60US, C60UX,C60UG					
R7105	NRSA63J-564X	MG RESISTOR	560kΩ 1/16W J	C90US,C90UX, C90UG,C60US, C60UX,C60UG					
R7106	NRSA63J-272X	MG RESISTOR	2.7kΩ 1/16W J	C90US,C90UX, C90UG,C60US, C60UX,C60UG					
R7107	NRSA63J-102X	MG RESISTOR	1kΩ 1/16W J	C90US,C90UX, C90UG,C60US, C60UX,C60UG					
R7201	NRSA63J-272X	MG RESISTOR	2.7kΩ 1/16W J	C90US,C90UX, C90UG,C60US, C60UX,C60UG					
R7202	NRSA63J-103X	MG RESISTOR	10kΩ 1/16W J	C90US,C90UX, C90UG,C60US, C60UX,C60UG					
R7301	NRSA63J-473X	MG RESISTOR	47kΩ 1/16W J	C90US,C90UX, C90UG,C60US, C60UX,C60UG					
R7302	NRSA63J-473X	MG RESISTOR	47kΩ 1/16W J	C90US,C90UX, C90UG,C60US, C60UX,C60UG					

Symbol No.	Part No.	Part Name	Description	Local
J7002	QNS0266-001	JACK		C90US,C90UX, C90UG,C60US, C60UX,C60UG
JS541	QSW1059-001	JOG VOLUME		
K6001	NQR0007-002X	FERRITE BEADS		
K6002	NQR0007-002X	FERRITE BEADS		
K6003	NQR0007-002X	FERRITE BEADS		
K6004	NQR0007-002X	FERRITE BEADS		
K6101	NQR0502-001X	FERRITE BEADS		
K6102	NQR0022-002X	FERRITE BEADS		
K6103	NQR0022-002X	FERRITE BEADS		
K6104	NRSA63J-0R0X	MG RESISTOR	0Ω 1/16W J	
K7001	NQR0007-002X	FERRITE BEADS		C90US,C90UX, C90UG,C60US, C60UX,C60UG
S521	QSW1120-001Z	PUSH SW		
S531	QSW0522-002Z	PUSH SW I.M		
S532	QSW0522-002Z	PUSH SW I.M		
S533	QSW0522-002Z	PUSH SW I.M		
S534	QSW0522-002Z	PUSH SW I.M		
S535	QSW0522-002Z	PUSH SW I.M		
S536	QSW0522-002Z	PUSH SW I.M		
S537	QSW0522-002Z	PUSH SW I.M		
S538	QSW0522-002Z	PUSH SW I.M		
S539	QSW0522-002Z	PUSH SW I.M		
S540	QSW0522-002Z	PUSH SW I.M		

Symbol No.	Part No.	Part Name	Description	Local
Q705	KTA1504/YG/-X	TRANSISTOR		
Q706	KTC2028/Y/	TRANSISTOR		
Q708	KTC2028/Y/	TRANSISTOR		
Q710	KRC102S-X	DIGI TRANSISTOR		
Q711	KRC102S-X	DIGI TRANSISTOR		
Q712	KRC102S-X	DIGI TRANSISTOR		
Q713	2SK3599-01MR	POWER MOS FET		
Q722	KRC102S-X	DIGI TRANSISTOR		
Q726	KRC102S-X	DIGI TRANSISTOR		
Q731	KTC3875/YG/-X	TRANSISTOR		
Q2501	KTC3875/YG/-X	TRANSISTOR		
Q2502	KTC3875/YG/-X	TRANSISTOR		
Q2701	KTC3875/YG/-X	TRANSISTOR		
Q3101	IRFB4212	FET		
Q3102	IRFB4212	FET		
Q3201	IRFB4212	FET		
Q3202	IRFB4212	FET		
Q3301	IRFB4212	FET		
Q3302	IRFB4212	FET		
Q3401	IRFB4212	FET		
Q3402	IRFB4212	FET		
Q3501	IRFB4212	FET		
Q3502	IRFB4212	FET		
Q3601	IRFB4212	FET		
Q3602	IRFB4212	FET		
Q3701	IRFB4212	FET		
Q3702	IRFB4212	FET		
Q3801	KTA1504/YG/-X	TRANSISTOR		
Q3802	KTC3875/YG/-X	TRANSISTOR		
Q3803	KTA1504/YG/-X	TRANSISTOR		
Q4001	KTA1023/OY/-T	TRANSISTOR		
Q4002	KTC3875/YG/-X	TRANSISTOR		
Q4003	KTC3875/YG/-X	TRANSISTOR		

Mother board (TH-C90)

Block No. [0][3]

Symbol No.	Part No.	Part Name	Description	Local
IC251	RC4558D-X	IC		
IC301	IRS20124S-X	IC		
IC302	IRS20124S-X	IC		
IC303	IRS20124S-X	IC		
IC304	IRS20124S-X	IC		
IC305	IRS20124S-X	IC		
IC306	IRS20124S-X	IC		
IC307	IRS20124S-X	IC		
IC601	MN101C427NY	IC		
IC701	SN74HC00ANS-X	IC		
IC702	NJM2403M-X	IC		
IC703	IRS2011S-X	IC		
IC704	SN74HC74ANS-X	IC		
IC705	NJM2125F-X	IC		
Q151	KTC2026/Y/	TRANSISTOR		
Q152	KTA1046/Y/	TRANSISTOR		
Q153	KTC3203/OY/-T	TRANSISTOR		
Q156	KRC104S-X	TRANSISTOR		
Q157	KTC3875/YG/-X	TRANSISTOR		
Q501	KRA109S-X	D.TRANSISTOR		
Q502	KTC3875/YG/-X	TRANSISTOR		
Q503	KTC3875/YG/-X	TRANSISTOR		
Q504	KTA1504/YG/-X	TRANSISTOR		
Q505	KRC102S-X	DIGI TRANSISTOR		
Q511	KTC3875/YG/-X	TRANSISTOR		
Q521	KTC3875/YG/-X	TRANSISTOR		
Q522	KTC3265/Y/-X	TRANSISTOR		
Q523	KTC3875/YG/-X	TRANSISTOR		
Q524	KTA1504/YG/-X	TRANSISTOR		
Q525	KTC3875/YG/-X	TRANSISTOR		
Q531	KRC103S-X	DIGITAL TR		
Q532	KRA102S-X	DIGI TRANSISTOR		
Q533	KTC2026/Y/	TRANSISTOR		
Q534	KTC3875/YG/-X	TRANSISTOR		
Q535	KRC104S-X	TRANSISTOR		
Q601	KRA102S-X	DIGI TRANSISTOR		
Q602	KTC3875/YG/-X	TRANSISTOR		
Q603	KTC3875/YG/-X	TRANSISTOR		
Q701	KTA1268/GL/-T	TRANSISTOR		
Q702	KTA1504/YG/-X	TRANSISTOR		
Q703	KRC102S-X	DIGI TRANSISTOR		
Q704	2SK3599-01MR	POWER MOS FET		

D101	1SS133-T2	SI DIODE
D102	1SS133-T2	SI DIODE
△D151	GBU803	BRIDGE DIODE
△D152	10EDB20-T4	DIODE
△D153	10EDB20-T4	DIODE
D154	1SS133-T2	SI DIODE
D155	1SS133-T2	SI DIODE
D156	1SS133-T2	SI DIODE
D161	MTZJ8.2C-T2	Z DIODE
D162	1SS133-T2	SI DIODE
D163	MTZJ6.2B-T2	Z DIODE
D164	1SS133-T2	SI DIODE
D165	MTZJ8.2C-T2	Z DIODE
D166	1SS133-T2	SI DIODE
D501	1SS133-T2	SI DIODE
D502	MTZJ8.2C-T2	Z DIODE
D503	MTZJ6.8C-T2	Z DIODE
D504	1SS133-T2	SI DIODE
D505	MTZJ5.1C-T2	Z DIODE
D506	1SS133-T2	SI DIODE
D507	1SS133-T2	SI DIODE
D508	1SS133-T2	SI DIODE
D509	MTZJ20B-T2	Z DIODE
D511	1SS133-T2	SI DIODE
D512	1SS133-T2	SI DIODE
D513	1SS133-T2	SI DIODE
D514	1SS133-T2	SI DIODE
D515	1SS133-T2	SI DIODE
D516	1SS133-T2	SI DIODE
D517	1SS133-T2	SI DIODE
D518	1SS133-T2	SI DIODE
D519	1SS133-T2	SI DIODE
D523	1SS133-T2	SI DIODE
D524	1SS133-T2	SI DIODE
D525	1SS133-T2	SI DIODE
D526	1SS133-T2	SI DIODE
D531	1SS133-T2	SI DIODE
D541	MTZJ11C-T2	Z DIODE
D542	1SS133-T2	SI DIODE
D543	MA700A-T2	SB DIODE
D544	1SS133-T2	SI DIODE
D610	1SS133-T2	SI DIODE
D611	1SS133-T2	SI DIODE
D701	1SS133-T2	SI DIODE

△ Symbol No.	Part No.	Part Name	Description	Local	△ Symbol No.	Part No.	Part Name	Description	Local
D702	1SS133-T2	SI DIODE			C503	QETN1HM-106Z	E CAPACITOR	10uF 50V M	
D704	1SS133-T2	SI DIODE			C504	NCB31HK-102X	C CAPACITOR	1000pF 50V K	
D705	1SS133-T2	SI DIODE			C522	QETN1HM-106Z	E CAPACITOR	10uF 50V M	
D707	1SS133-T2	SI DIODE			C523	QETN1EM-476Z	E CAPACITOR	47uF 25V M	
D711	1SS244-T2	SI DIODE			C531	QETN1CM-107Z	E CAPACITOR	100uF 16V M	
D712	1SS133-T2	SI DIODE			C532	QETN1EM-476Z	E CAPACITOR	47uF 25V M	
D713	FMB-G19L	SB DIODE			C533	QETN1CM-107Z	E CAPACITOR	100uF 16V M	
D714	1SS133-T2	SI DIODE			C534	QETN1AM-227Z	E CAPACITOR	220uF 10V M	
D721	1SS133-T2	SI DIODE			C601	QETN1HM-106Z	E CAPACITOR	10uF 50V M	
D722	MTZJ13C-T2	Z DIODE			C602	QETN1CM-107Z	E CAPACITOR	100uF 16V M	
D725	MTZJ30C-T2	Z DIODE			C603	NCF31HZ-103X	C CAPACITOR	0.01uF 50V Z	
D726	MTZJ20B-T2	Z DIODE			C604	NCB31HK-102X	C CAPACITOR	1000pF 50V K	
D728	MTZJ30C-T2	Z DIODE			C605	NCF31HZ-103X	C CAPACITOR	0.01uF 50V Z	
D729	MTZJ20B-T2	Z DIODE			C701	NCF31HZ-103X	C CAPACITOR	0.01uF 50V Z	
D730	MTZJ20B-T2	Z DIODE			C702	NDC31HJ-101X	C CAPACITOR	100pF 50V J	
D734	1SS133-T2	SI DIODE			C703	NDC31HJ-101X	C CAPACITOR	100pF 50V J	
D735	MTZJ13C-T2	Z DIODE			C704	NDC31HJ-470X	C CAPACITOR	47pF 50V J	
D737	FMB-G19L	SB DIODE			C706	QETN1CM-107Z	E CAPACITOR	100uF 16V M	
D2501	1SS133-T2	SI DIODE			C707	NCB31CK-105X	C CAPACITOR	1uF 16V K	
D2502	1SS133-T2	SI DIODE			C708	NCF31HZ-103X	C CAPACITOR	0.01uF 50V Z	
D2601	1SS133-T2	SI DIODE			C709	NCB31CK-105X	C CAPACITOR	1uF 16V K	
D2602	1SS133-T2	SI DIODE			C710	QETN1EM-476Z	E CAPACITOR	47uF 25V M	
D2701	1SS133-T2	SI DIODE			C711	NCB31HK-821X	C CAPACITOR	820pF 50V K	
D2703	1SS133-T2	SI DIODE			C714	NCB31HK-102X	C CAPACITOR	1000pF 50V K	
D3151	1SS133-T2	SI DIODE			C715	NCB31HK-102X	C CAPACITOR	1000pF 50V K	
D3152	1SS244-T2	SI DIODE			C716	NCB31CK-105X	C CAPACITOR	1uF 16V K	
D3156	1SS244-T2	SI DIODE			C717	NCB31HK-102X	C CAPACITOR	1000pF 50V K	
D3251	1SS133-T2	SI DIODE			C718	NCB31HK-102X	C CAPACITOR	1000pF 50V K	
D3252	1SS244-T2	SI DIODE			C719	QFZ0212-105Z	MM CAPACITOR	1uF 100V J	
D3256	1SS244-T2	SI DIODE			C720	NCF31HZ-103X	C CAPACITOR	0.01uF 50V Z	
D3351	1SS133-T2	SI DIODE			C721	QETM1HM-228	E CAPACITOR	2200uF 50V M	
D3352	1SS244-T2	SI DIODE			C726	QETN2AM-106Z	E CAPACITOR	10uF 100V M	
D3356	1SS244-T2	SI DIODE			C727	QETN1HM-106Z	E CAPACITOR	10uF 50V M	
D3451	1SS133-T2	SI DIODE			C731	QETN1HM-106Z	E CAPACITOR	10uF 50V M	
D3452	1SS244-T2	SI DIODE			C732	QETN2AM-106Z	E CAPACITOR	10uF 100V M	
D3456	1SS244-T2	SI DIODE			C733	NDC31HJ-100X	C CAPACITOR	10pF 50V J	
D3551	1SS133-T2	SI DIODE			C734	NCB21HK-104X	C CAPACITOR	0.1uF 50V K	
D3552	1SS244-T2	SI DIODE			C735	NCB31HK-102X	C CAPACITOR	1000pF 50V K	
D3556	1SS244-T2	SI DIODE			C736	NCB31HK-102X	C CAPACITOR	1000pF 50V K	
D3651	1SS133-T2	SI DIODE			C737	QFZ0212-105Z	MM CAPACITOR	1uF 100V J	
D3652	1SS244-T2	SI DIODE			C738	NCB31HK-102X	C CAPACITOR	1000pF 50V K	
D3656	1SS244-T2	SI DIODE			C739	QETM1HM-228	E CAPACITOR	2200uF 50V M	
D3751	1SS133-T2	SI DIODE			C740	NCF31HZ-103X	C CAPACITOR	0.01uF 50V Z	
D3752	1SS244-T2	SI DIODE			C741	NCB31HK-102X	C CAPACITOR	1000pF 50V K	
D3801	MTZJ9.1C-T2	Z DIODE			C792	NCF31HZ-103X	C CAPACITOR	0.01uF 50V Z	
D4001	MTZJ6.2B-T2	Z DIODE			C2501	NCB31HK-152X	C CAPACITOR	1500pF 50V K	
D4002	FR104S-T5	FR DIODE			C2503	QETN1HM-105Z	E CAPACITOR	1uF 50V M	
D4003	MTZJ16C-T2	Z DIODE			C2504	QETN1HM-225Z	E CAPACITOR	2.2uF 50V M	
△ C101	QCZ9104-472	C CAPACITOR	4700pF M		C2601	NCB31HK-152X	C CAPACITOR	1500pF 50V K	
△ C102	QFZ9075-154	MPP CAPACITOR	0.15uF AC275V M		C2603	QETN1CM-107Z	E CAPACITOR	100uF 16V M	
△ C103	QFZ9075-154	MPP CAPACITOR	0.15uF AC275V M		C2604	QETN1HM-106Z	E CAPACITOR	10uF 50V M	
△ C104	QCZ9079-102	C CAPACITOR	1000pF AC250V M		C2701	NCF31HZ-103X	C CAPACITOR	0.01uF 50V Z	
△ C105	QCZ9079-102	C CAPACITOR	1000pF AC250V M		C2702	NCF31HZ-103X	C CAPACITOR	0.01uF 50V Z	
C151	NCB21HK-104X	C CAPACITOR	0.1uF 50V K		C2706	QETN1CM-107Z	E CAPACITOR	100uF 16V M	
C152	NCB21HK-104X	C CAPACITOR	0.1uF 50V K		C3149	NCB31HK-103X	C CAPACITOR	0.01uF 50V K	
C153	NCB21HK-104X	C CAPACITOR	0.1uF 50V K		C3150	NDC31HJ-101X	C CAPACITOR	100pF 50V J	
C154	NCB21HK-104X	C CAPACITOR	0.1uF 50V K		C3151	NCB31CK-105X	C CAPACITOR	1uF 16V K	
C155	NCF31HZ-223X	C CAPACITOR	0.022uF 50V Z		C3152	NCB21EK-334X	C CAPACITOR	0.33uF 25V K	
C156	NCF31HZ-223X	C CAPACITOR	0.022uF 50V Z		C3156	QFZ0212-105Z	MM CAPACITOR	1uF 100V J	
C158	QETM1EM-228	E CAPACITOR	2200uF 25V M		C3159	QETN2AM-106Z	E CAPACITOR	10uF 100V M	
C159	QETM1EM-108	E CAPACITOR	1000uF 25V M		C3162	NCB31HK-102X	C CAPACITOR	1000pF 50V K	
C160	QEZO613-338	E CAPACITOR	3300uF M		C3163	NCB31HK-102X	C CAPACITOR	1000pF 50V K	
C161	QEZO613-338	E CAPACITOR	3300uF M		C3166	QFZ0212-105Z	MM CAPACITOR	1uF 100V J	
C162	NCB21HK-104X	C CAPACITOR	0.1uF 50V K		C3167	QFZ0212-474Z	MF CAPACITOR	0.47uF 100V J	
C163	NCB21HK-104X	C CAPACITOR	0.1uF 50V K		C3168	QFZ0212-224Z	MM CAPACITOR	0.22uF 100V J	
C164	NCB21HK-104X	C CAPACITOR	0.1uF 50V K		C3171	NCB31HK-102X	C CAPACITOR	1000pF 50V K	
C167	QETN1HM-106Z	E CAPACITOR	10uF 50V M		C3172	NCB31HK-102X	C CAPACITOR	1000pF 50V K	
C168	QETN1EM-476Z	E CAPACITOR	47uF 25V M		C3177	NCB31HK-221X	C CAPACITOR	220pF 50V K	
C169	QETN1HM-104Z	E CAPACITOR	0.1uF 50V M		C3178	NCB31HK-223X	C CAPACITOR	0.022uF 50V K	
C170	QETN1CM-107Z	E CAPACITOR	100uF 16V M		C3179	NCB31HK-223X	C CAPACITOR	0.022uF 50V K	
C172	QETN1HM-106Z	E CAPACITOR	10uF 50V M		C3180	NCB31HK-223X	C CAPACITOR	0.022uF 50V K	
C173	QETN1EM-476Z	E CAPACITOR	47uF 25V M		C3249	NCB31HK-103X	C CAPACITOR	0.01uF 50V K	
C176	QETN1HM-106Z	E CAPACITOR	10uF 50V M		C3250	NDC31HJ-101X	C CAPACITOR	100pF 50V J	
C177	QETN2AM-475Z	E CAPACITOR	4.7uF 100V M		C3251	NCB31CK-105X	C CAPACITOR	1uF 16V K	
C191	NCB31EK-104X	C CAPACITOR	0.1uF 25V K		C3252	NCB21EK-334X	C CAPACITOR	0.33uF 25V K	
C501	QETN1HM-335Z	E CAPACITOR	3.3uF 50V M		C3256	QFZ0212-105Z	MM CAPACITOR	1uF 100V J	
C502	NCF31HZ-103X	C CAPACITOR	0.01uF 50V Z		C3259	QETN2AM-106Z	E CAPACITOR	10uF 100V M	
					C3262	NCB31HK-102X	C CAPACITOR	1000pF 50V K	

△ Symbol No.	Part No.	Part Name	Description	Local	△ Symbol No.	Part No.	Part Name	Description	Local
C3263	NCB31HK-102X	C CAPACITOR	1000pF 50V K		C3687	NCB31HK-223X	C CAPACITOR	0.022uF 50V K	
C3266	QFZ0212-105Z	MM CAPACITOR	1uF 100V J		C3688	NCB31HK-223X	C CAPACITOR	0.022uF 50V K	
C3267	QFZ0212-474Z	MF CAPACITOR	0.47uF 100V J		C3689	NCB31HK-223X	C CAPACITOR	0.022uF 50V K	
C3268	QFZ0212-224Z	MM CAPACITOR	0.22uF 100V J		C3690	NCB31HK-223X	C CAPACITOR	0.022uF 50V K	
C3271	NCB31HK-102X	C CAPACITOR	1000pF 50V K		C3749	NCB31HK-103X	C CAPACITOR	0.01uF 50V K	
C3272	NCB31HK-102X	C CAPACITOR	1000pF 50V K		C3750	NDC31HJ-101X	C CAPACITOR	100pF 50V J	
C3277	NCB31HK-221X	C CAPACITOR	220pF 50V K		C3751	NCB31CK-105X	C CAPACITOR	1uF 16V K	
C3278	NCB31HK-223X	C CAPACITOR	0.022uF 50V K		C3752	NCB21EK-334X	C CAPACITOR	0.33uF 25V K	
C3279	NCB31HK-223X	C CAPACITOR	0.022uF 50V K		C3756	QFZ0212-105Z	MM CAPACITOR	1uF 100V J	
C3280	NCB31HK-223X	C CAPACITOR	0.022uF 50V K		C3759	QETN2AM-106Z	E CAPACITOR	10uF 100V M	
C3349	NCB31HK-103X	C CAPACITOR	0.01uF 50V K		C3762	NCB31HK-102X	C CAPACITOR	1000pF 50V K	
C3350	NDC31HJ-101X	C CAPACITOR	100pF 50V J		C3763	NCB31HK-102X	C CAPACITOR	1000pF 50V K	
C3351	NCB31CK-105X	C CAPACITOR	1uF 16V K		C3767	QFZ0212-474Z	MF CAPACITOR	0.47uF 100V J	
C3352	NCB21EK-334X	C CAPACITOR	0.33uF 25V K		C3768	QFZ0212-224Z	MM CAPACITOR	0.22uF 100V J	
C3356	QFZ0212-105Z	MM CAPACITOR	1uF 100V J		C3771	NCB31HK-102X	C CAPACITOR	1000pF 50V K	
C3359	QETN2AM-106Z	E CAPACITOR	10uF 100V M		C3772	NCB31HK-102X	C CAPACITOR	1000pF 50V K	
C3362	NCB31HK-102X	C CAPACITOR	1000pF 50V K		C3801	QETN1HM-107Z	E CAPACITOR	100uF 50V M	
C3363	NCB31HK-102X	C CAPACITOR	1000pF 50V K		C3803	QETN1HM-107Z	E CAPACITOR	100uF 50V M	
C3366	QFZ0212-105Z	MM CAPACITOR	1uF 100V J		C3811	QETN1HM-107Z	E CAPACITOR	100uF 50V M	
C3367	QFZ0212-474Z	MF CAPACITOR	0.47uF 100V J		C3813	QETN1HM-107Z	E CAPACITOR	100uF 50V M	
C3368	QFZ0212-224Z	MM CAPACITOR	0.22uF 100V J		C3821	QETN1HM-107Z	E CAPACITOR	100uF 50V M	
C3371	NCB31HK-102X	C CAPACITOR	1000pF 50V K		C3823	QETN1HM-107Z	E CAPACITOR	100uF 50V M	
C3372	NCB31HK-102X	C CAPACITOR	1000pF 50V K		C3831	QETN1HM-107Z	E CAPACITOR	100uF 50V M	
C3377	NCB31HK-221X	C CAPACITOR	220pF 50V K		C3833	QETN1HM-107Z	E CAPACITOR	100uF 50V M	
C3378	NCB31HK-223X	C CAPACITOR	0.022uF 50V K		C3841	QETN1HM-107Z	E CAPACITOR	100uF 50V M	
C3379	NCB31HK-223X	C CAPACITOR	0.022uF 50V K		C3843	QETN1HM-107Z	E CAPACITOR	100uF 50V M	
C3380	NCB31HK-223X	C CAPACITOR	0.022uF 50V K		C3851	QETN1HM-107Z	E CAPACITOR	100uF 50V M	
C3449	NCB31HK-103X	C CAPACITOR	0.01uF 50V K		C3853	QETN1HM-107Z	E CAPACITOR	100uF 50V M	
C3450	NDC31HJ-101X	C CAPACITOR	100pF 50V J		C3861	QETN1HM-107Z	E CAPACITOR	100uF 50V M	
C3451	NCB31CK-105X	C CAPACITOR	1uF 16V K		C3863	QETN1HM-107Z	E CAPACITOR	100uF 50V M	
C3452	NCB21EK-334X	C CAPACITOR	0.33uF 25V K		C3871	QETN1HM-106Z	E CAPACITOR	10uF 50V M	
C3456	QFZ0212-105Z	MM CAPACITOR	1uF 100V J		C3872	NCB31HK-103X	C CAPACITOR	0.01uF 50V K	
C3459	QETN2AM-106Z	E CAPACITOR	10uF 100V M		C3899	NCB31EK-104X	C CAPACITOR	0.1uF 25V K	
C3462	NCB31HK-102X	C CAPACITOR	1000pF 50V K		C4001	QETN1HM-107Z	E CAPACITOR	100uF 50V M	
C3463	NCB31HK-102X	C CAPACITOR	1000pF 50V K		C4002	NCB31HK-472X	C CAPACITOR	4700pF 50V K	
C3466	QFZ0212-105Z	MM CAPACITOR	1uF 100V J		C4003	QETN1EM-476Z	E CAPACITOR	47uF 25V M	
C3467	QFZ0212-474Z	MF CAPACITOR	0.47uF 100V J						
C3468	QFZ0212-224Z	MM CAPACITOR	0.22uF 100V J		△ R101	QRZ9037-335	COMP RESISTOR	3.3MΩ 1/2W K	
C3471	NCB31HK-102X	C CAPACITOR	1000pF 50V K		R102	QRJ146J-121X	UNF C RESISTOR	120Ω 1/4W J	
C3472	NCB31HK-102X	C CAPACITOR	1000pF 50V K		R151	QRE141J-152Y	C RESISTOR	1.5kΩ 1/4W J	
C3477	NCB31HK-221X	C CAPACITOR	220pF 50V K		R152	QRE141J-332Y	C RESISTOR	3.3kΩ 1/4W J	
C3478	NCB31HK-223X	C CAPACITOR	0.022uF 50V K		R156	QRJ146J-220X	UNF C RESISTOR	22Ω 1/4W J	
C3479	NCB31HK-223X	C CAPACITOR	0.022uF 50V K		R157	QRE141J-152Y	C RESISTOR	1.5kΩ 1/4W J	
C3480	NCB31HK-223X	C CAPACITOR	0.022uF 50V K		R158	QRK126J-470X	UNF C RESISTOR	47Ω 1/2W J	
C3549	NCB31HK-103X	C CAPACITOR	0.01uF 50V K		R159	QRE141J-152Y	C RESISTOR	1.5kΩ 1/4W J	
C3550	NDC31HJ-101X	C CAPACITOR	100pF 50V J		R161	QRJ146J-100X	UNF C RESISTOR	10Ω 1/4W J	
C3551	NCB31CK-105X	C CAPACITOR	1uF 16V K		R162	QRE141J-182Y	C RESISTOR	1.8kΩ 1/4W J	
C3552	NCB21EK-334X	C CAPACITOR	0.33uF 25V K		R166	NRSA63J-103X	MG RESISTOR	10kΩ 1/16W J	
C3556	QFZ0212-105Z	MM CAPACITOR	1uF 100V J		R167	NRSA63J-223X	MG RESISTOR	22kΩ 1/16W J	
C3559	QETN2AM-106Z	E CAPACITOR	10uF 100V M		R168	QRE141J-103Y	C RESISTOR	10kΩ 1/4W J	
C3562	NCB31HK-102X	C CAPACITOR	1000pF 50V K		R169	NRSA63J-103X	MG RESISTOR	10kΩ 1/16W J	
C3563	NCB31HK-102X	C CAPACITOR	1000pF 50V K		△ R171	QRL01DJ-180X	OMF RESISTOR	18Ω 1W J	
C3566	QFZ0212-105Z	MM CAPACITOR	1uF 100V J		R501	NRSA63J-103X	MG RESISTOR	10kΩ 1/16W J	
C3567	QFZ0212-474Z	MF CAPACITOR	0.47uF 100V J		R502	NRSA63J-104X	MG RESISTOR	100kΩ 1/16W J	
C3568	QFZ0212-224Z	MM CAPACITOR	0.22uF 100V J		R503	NRSA63J-472X	MG RESISTOR	4.7kΩ 1/16W J	
C3571	NCB31HK-102X	C CAPACITOR	1000pF 50V K		R504	NRSA63J-102X	MG RESISTOR	1kΩ 1/16W J	
C3572	NCB31HK-102X	C CAPACITOR	1000pF 50V K		R505	NRSA63J-102X	MG RESISTOR	1kΩ 1/16W J	
C3577	NCB31HK-221X	C CAPACITOR	220pF 50V K		R506	NRSA63J-103X	MG RESISTOR	10kΩ 1/16W J	
C3578	NCB31HK-223X	C CAPACITOR	0.022uF 50V K		R507	NRSA63J-223X	MG RESISTOR	22kΩ 1/16W J	
C3579	NCB31HK-223X	C CAPACITOR	0.022uF 50V K		R508	NRSA63J-103X	MG RESISTOR	10kΩ 1/16W J	
C3580	NCB31HK-223X	C CAPACITOR	0.022uF 50V K		R511	NRSA63J-153X	MG RESISTOR	15kΩ 1/16W J	
C3649	NCB31HK-103X	C CAPACITOR	0.01uF 50V K		R512	NRSA63J-223X	MG RESISTOR	22kΩ 1/16W J	
C3650	NDC31HJ-101X	C CAPACITOR	100pF 50V J		R513	NRSA63J-102X	MG RESISTOR	1kΩ 1/16W J	
C3651	NCB31CK-105X	C CAPACITOR	1uF 16V K		R514	NRSA63J-104X	MG RESISTOR	100kΩ 1/16W J	
C3652	NCB21EK-334X	C CAPACITOR	0.33uF 25V K		R515	NRSA63J-223X	MG RESISTOR	22kΩ 1/16W J	
C3656	QFZ0212-105Z	MM CAPACITOR	1uF 100V J		R516	NRSA63J-223X	MG RESISTOR	22kΩ 1/16W J	
C3659	QETN2AM-106Z	E CAPACITOR	10uF 100V M		R517	NRSA63J-223X	MG RESISTOR	22kΩ 1/16W J	
C3662	NCB31HK-102X	C CAPACITOR	1000pF 50V K		R518	NRSA63J-223X	MG RESISTOR	22kΩ 1/16W J	
C3663	NCB31HK-102X	C CAPACITOR	1000pF 50V K		R519	NRSA63J-822X	MG RESISTOR	8.2kΩ 1/16W J	
C3666	QFZ0212-105Z	MM CAPACITOR	1uF 100V J		R520	NRSA63J-153X	MG RESISTOR	15kΩ 1/16W J	
C3667	QFZ0212-474Z	MF CAPACITOR	0.47uF 100V J		R521	NRSA63J-273X	MG RESISTOR	27kΩ 1/16W J	
C3668	QFZ0212-224Z	MM CAPACITOR	0.22uF 100V J		R522	NRSA63J-153X	MG RESISTOR	15kΩ 1/16W J	
C3671	NCB31HK-102X	C CAPACITOR	1000pF 50V K		R526	NRSA63J-472X	MG RESISTOR	4.7kΩ 1/16W J	
C3672	NCB31HK-102X	C CAPACITOR	1000pF 50V K		R527	NRSA63J-103X	MG RESISTOR	10kΩ 1/16W J	
C3683	NCB21HK-473X	C CAPACITOR	0.047uF 50V K		R532	NRSA63J-103X	MG RESISTOR	10kΩ 1/16W J	
C3684	NCB21HK-473X	C CAPACITOR	0.047uF 50V K		R533	NRSA63J-103X	MG RESISTOR	10kΩ 1/16W J	
C3685	NCB31HK-223X	C CAPACITOR	0.022uF 50V K		R534	NRSA63J-103X	MG RESISTOR	10kΩ 1/16W J	
C3686	NCB31HK-223X	C CAPACITOR	0.022uF 50V K		R535	NRSA63J-104X	MG RESISTOR	100kΩ 1/16W J	

△ Symbol No.	Part No.	Part Name	Description	Local	△ Symbol No.	Part No.	Part Name	Description	Local
R536	NRSA63J-103X	MG RESISTOR	10kΩ 1/16W J		R730	NRSA63J-223X	MG RESISTOR	22kΩ 1/16W J	
R541	NRSA63J-103X	MG RESISTOR	10kΩ 1/16W J		R731	NRS125J-4R7X	MG RESISTOR	4.7Ω 1/2W J	
R542	QRE141J-102Y	C RESISTOR	1kΩ 1/4W J		R732	NRS125J-330X	MG RESISTOR	33Ω 1/2W J	
R543	NRSA63J-221X	MG RESISTOR	220Ω 1/16W J		R733	QRL01DJ-100X	OMF RESISTOR	10Ω 1W J	
R544	QRJ146J-100X	UNF C RESISTOR	10Ω 1/4W J		R734	QRL01DJ-100X	OMF RESISTOR	10Ω 1W J	
R545	NRSA63J-103X	MG RESISTOR	10kΩ 1/16W J		R736	NRSA63F-561X	MG RESISTOR	560Ω 1/16W F	
△ R546	QRL01DJ-180X	OMF RESISTOR	18Ω 1W J		R738	NRSA63F-272X	MG RESISTOR	2.7kΩ 1/16W F	
R547	NRSA63J-223X	MG RESISTOR	22kΩ 1/16W J		R739	NRSA63F-333X	MG RESISTOR	33kΩ 1/16W F	
R548	NRSA63J-101X	MG RESISTOR	100Ω 1/16W J		R740	NRSA63F-273X	MG RESISTOR	27kΩ 1/16W F	
R549	NRSA63J-473X	MG RESISTOR	47kΩ 1/16W J		R741	QRJ146J-470X	UNF C RESISTOR	47Ω 1/4W J	
R550	NRSA63J-0R0X	MG RESISTOR	0Ω 1/16W J		R742	QRK126J-103X	UNF C RESISTOR	10kΩ 1/2W J	
R556	NRSA63J-103X	MG RESISTOR	10kΩ 1/16W J		R743	NRSA63F-561X	MG RESISTOR	560Ω 1/16W F	
R557	NRSA63J-104X	MG RESISTOR	100kΩ 1/16W J		R746	QRZ9005-101X	F RESISTOR	100Ω	
R558	NRSA63J-223X	MG RESISTOR	22kΩ 1/16W J		R747	QRK126J-103X	UNF C RESISTOR	10kΩ 1/2W J	
R559	NRSA63J-103X	MG RESISTOR	10kΩ 1/16W J		R749	QRE141J-561Y	C RESISTOR	560Ω 1/4W J	
R602	NRSA63J-223X	MG RESISTOR	22kΩ 1/16W J		R750	QRE141J-561Y	C RESISTOR	560Ω 1/4W J	
R603	NRSA63J-223X	MG RESISTOR	22kΩ 1/16W J		R751	NRSA63J-102X	MG RESISTOR	1kΩ 1/16W J	
R604	NRSA63J-103X	MG RESISTOR	10kΩ 1/16W J		R752	NRS125J-330X	MG RESISTOR	33Ω 1/2W J	
R605	NRSA63J-473X	MG RESISTOR	47kΩ 1/16W J		R753	QRL01DJ-100X	OMF RESISTOR	10Ω 1W J	
R606	NRSA63J-104X	MG RESISTOR	100kΩ 1/16W J		R754	QRL01DJ-100X	OMF RESISTOR	10Ω 1W J	
R607	NRSA63J-102X	MG RESISTOR	1kΩ 1/16W J		R756	NRSA63J-103X	MG RESISTOR	10kΩ 1/16W J	
R608	NRSA63J-102X	MG RESISTOR	1kΩ 1/16W J		R757	NRSA63J-222X	MG RESISTOR	2.2kΩ 1/16W J	
R609	NRSA63J-102X	MG RESISTOR	1kΩ 1/16W J		R762	NRSA63J-222X	MG RESISTOR	2.2kΩ 1/16W J	
R610	NRSA63J-102X	MG RESISTOR	1kΩ 1/16W J		R766	NRSA63J-681X	MG RESISTOR	680Ω 1/16W J	
R611	NRSA63J-102X	MG RESISTOR	1kΩ 1/16W J		R767	NRSA63J-222X	MG RESISTOR	2.2kΩ 1/16W J	
R612	NRSA63J-102X	MG RESISTOR	1kΩ 1/16W J		R768	NRSA63J-271X	MG RESISTOR	270Ω 1/16W J	
R613	NRSA63J-222X	MG RESISTOR	2.2kΩ 1/16W J		R2502	NRSA63J-183X	MG RESISTOR	18kΩ 1/16W J	
R614	NRSA63J-821X	MG RESISTOR	820Ω 1/16W J		R2503	NRSA63J-472X	MG RESISTOR	4.7kΩ 1/16W J	
R615	NRSA63J-103X	MG RESISTOR	10kΩ 1/16W J		R2505	NRSA63J-474X	MG RESISTOR	470kΩ 1/16W J	
R616	NRSA63J-153X	MG RESISTOR	15kΩ 1/16W J		R2506	NRSA63J-470X	MG RESISTOR	47Ω 1/16W J	
R617	NRSA63J-102X	MG RESISTOR	1kΩ 1/16W J		R2507	NRSA63J-334X	MG RESISTOR	330kΩ 1/16W J	
R625	NRSA63J-104X	MG RESISTOR	100kΩ 1/16W J		R2509	NRSA63J-102X	MG RESISTOR	1kΩ 1/16W J	
R629	NRSA63J-471X	MG RESISTOR	470Ω 1/16W J		R2510	NRSA63J-104X	MG RESISTOR	100kΩ 1/16W J	
R630	NRSA63J-223X	MG RESISTOR	22kΩ 1/16W J		R2512	NRSA63J-103X	MG RESISTOR	10kΩ 1/16W J	
R631	NRSA63J-102X	MG RESISTOR	1kΩ 1/16W J		R2513	NRSA63J-103X	MG RESISTOR	10kΩ 1/16W J	
R632	NRSA63J-102X	MG RESISTOR	1kΩ 1/16W J		R2603	NRSA63J-472X	MG RESISTOR	4.7kΩ 1/16W J	
R633	NRSA63J-102X	MG RESISTOR	1kΩ 1/16W J		R2605	NRSA63J-333X	MG RESISTOR	33kΩ 1/16W J	
R634	NRSA63J-102X	MG RESISTOR	1kΩ 1/16W J		R2607	NRSA63J-562X	MG RESISTOR	5.6kΩ 1/16W J	
R635	NRSA63J-103X	MG RESISTOR	10kΩ 1/16W J		R2610	NRSA63J-224X	MG RESISTOR	220kΩ 1/16W J	
R636	NRSA63J-223X	MG RESISTOR	22kΩ 1/16W J		R2701	NRSA63J-153X	MG RESISTOR	15kΩ 1/16W J	
R637	NRSA63J-103X	MG RESISTOR	10kΩ 1/16W J		R2702	NRSA63J-472X	MG RESISTOR	4.7kΩ 1/16W J	
R638	NRSA63J-472X	MG RESISTOR	4.7kΩ 1/16W J		R2703	NRSA63J-103X	MG RESISTOR	10kΩ 1/16W J	
R639	NRSA63J-102X	MG RESISTOR	1kΩ 1/16W J		R3148	NRSA63J-101X	MG RESISTOR	100Ω 1/16W J	
R640	NRSA63J-102X	MG RESISTOR	1kΩ 1/16W J		R3149	NRSA63J-821X	MG RESISTOR	820Ω 1/16W J	
R641	NRSA63J-472X	MG RESISTOR	4.7kΩ 1/16W J		R3151	NRSA63J-822X	MG RESISTOR	8.2kΩ 1/16W J	
R642	NRSA63J-103X	MG RESISTOR	10kΩ 1/16W J		R3152	NRSA63J-332X	MG RESISTOR	3.3kΩ 1/16W J	
R643	NRSA63J-103X	MG RESISTOR	10kΩ 1/16W J		R3153	NRSA63J-912X	MG RESISTOR	9.1kΩ 1/16W J	
R646	NRSA63J-223X	MG RESISTOR	22kΩ 1/16W J		R3154	NRSA63J-182X	MG RESISTOR	1.8kΩ 1/16W J	
R649	NRSA63J-102X	MG RESISTOR	1kΩ 1/16W J		R3155	NRSA63J-132X	MG RESISTOR	1.3kΩ 1/16W J	
R650	NRSA63J-223X	MG RESISTOR	22kΩ 1/16W J		R3162	QRE141J-390Y	C RESISTOR	39Ω 1/4W J	
R651	NRSA63J-102X	MG RESISTOR	1kΩ 1/16W J		R3163	QRE141J-390Y	C RESISTOR	39Ω 1/4W J	
R652	NRSA63J-103X	MG RESISTOR	10kΩ 1/16W J		R3165	QRL01DJ-220X	OMF RESISTOR	22Ω 1W J	
R653	NRSA02J-151X	MG RESISTOR	150Ω 1/10W J		R3166	QRL01DJ-220X	OMF RESISTOR	22Ω 1W J	
R656	NRSA63J-223X	MG RESISTOR	22kΩ 1/16W J		R3168	QRL01DJ-220X	OMF RESISTOR	22Ω 1W J	
R657	NRSA63J-153X	MG RESISTOR	15kΩ 1/16W J		R3170	NRSA63J-473X	MG RESISTOR	47kΩ 1/16W J	
R658	NRSA63J-223X	MG RESISTOR	22kΩ 1/16W J		R3173	NRSA63J-153X	MG RESISTOR	15kΩ 1/16W J	
R659	NRSA63J-472X	MG RESISTOR	4.7kΩ 1/16W J		R3174	NRSA63J-332X	MG RESISTOR	3.3kΩ 1/16W J	
R701	NRSA63J-103X	MG RESISTOR	10kΩ 1/16W J		R3248	NRSA63J-101X	MG RESISTOR	100Ω 1/16W J	
R703	NRSA63J-332X	MG RESISTOR	3.3kΩ 1/16W J		R3249	NRSA63J-821X	MG RESISTOR	820Ω 1/16W J	
R704	NRSA63J-681X	MG RESISTOR	680Ω 1/16W J		R3251	NRSA63J-822X	MG RESISTOR	8.2kΩ 1/16W J	
R705	NRSA63J-513X	MG RESISTOR	51kΩ 1/16W J		R3252	NRSA63J-332X	MG RESISTOR	3.3kΩ 1/16W J	
R706	NRSA63J-103X	MG RESISTOR	10kΩ 1/16W J		R3253	NRSA63J-912X	MG RESISTOR	9.1kΩ 1/16W J	
R707	NRSA63J-102X	MG RESISTOR	1kΩ 1/16W J		R3254	NRSA63J-182X	MG RESISTOR	1.8kΩ 1/16W J	
R708	NRSA63J-105X	MG RESISTOR	1MΩ 1/16W J		R3255	NRSA63J-132X	MG RESISTOR	1.3kΩ 1/16W J	
R709	NRSA63J-102X	MG RESISTOR	1kΩ 1/16W J		R3262	QRE141J-390Y	C RESISTOR	39Ω 1/4W J	
R710	NRSA63J-102X	MG RESISTOR	1kΩ 1/16W J		R3263	QRE141J-390Y	C RESISTOR	39Ω 1/4W J	
R711	NRSA63J-153X	MG RESISTOR	15kΩ 1/16W J		R3265	QRL01DJ-220X	OMF RESISTOR	22Ω 1W J	
R714	QRE141J-101Y	C RESISTOR	100Ω 1/4W J		R3266	QRL01DJ-220X	OMF RESISTOR	22Ω 1W J	
R716	NRSA63J-151X	MG RESISTOR	150Ω 1/16W J		R3268	QRL01DJ-220X	OMF RESISTOR	22Ω 1W J	
R717	NRSA63J-473X	MG RESISTOR	47kΩ 1/16W J		R3270	NRSA63J-473X	MG RESISTOR	47kΩ 1/16W J	
R718	NRSA63J-183X	MG RESISTOR	18kΩ 1/16W J		R3273	NRSA63J-153X	MG RESISTOR	15kΩ 1/16W J	
R721	NRSA63J-222X	MG RESISTOR	2.2kΩ 1/16W J		R3274	NRSA63J-332X	MG RESISTOR	3.3kΩ 1/16W J	
R724	NRSA63J-124X	MG RESISTOR	120kΩ 1/16W J		R3348	NRSA63J-101X	MG RESISTOR	100Ω 1/16W J	
R725	NRSA63J-103X	MG RESISTOR	10kΩ 1/16W J		R3349	NRSA63J-821X	MG RESISTOR	820Ω 1/16W J	
R726	NRSA63F-223X	MG RESISTOR	22kΩ 1/16W F		R3351	NRSA63J-822X	MG RESISTOR	8.2kΩ 1/16W J	
R727	NRSA63F-273X	MG RESISTOR	27kΩ 1/16W F		R3352	NRSA63J-332X	MG RESISTOR	3.3kΩ 1/16W J	
R728	NRSA63J-433X	MG RESISTOR	43kΩ 1/16W J		R3353	NRSA63J-912X	MG RESISTOR	9.1kΩ 1/16W J	
R729	NRSA63J-273X	MG RESISTOR	27kΩ 1/16W J		R3354	NRSA63J-182X	MG RESISTOR	1.8kΩ 1/16W J	

△ Symbol No.	Part No.	Part Name	Description	Local	△ Symbol No.	Part No.	Part Name	Description	Local
R3355	NRSA63J-132X	MG RESISTOR	1.3kΩ 1/16W J		R3892	NRSA63J-150X	MG RESISTOR	15Ω 1/16W J	
R3362	QRE141J-390Y	C RESISTOR	39Ω 1/4W J		R3893	NRSA63J-150X	MG RESISTOR	15Ω 1/16W J	
R3363	QRE141J-390Y	C RESISTOR	39Ω 1/4W J		R4001	QRZ9006-4R7X	FUSI RESISTOR	4.7Ω	
R3365	QRL01DJ-220X	OMF RESISTOR	22Ω 1W J		R4002	QRE141J-682Y	C RESISTOR	6.8kΩ 1/4W J	
R3366	QRL01DJ-220X	OMF RESISTOR	22Ω 1W J		R4003	NRSA63J-221X	MG RESISTOR	220Ω 1/16W J	
R3368	QRL01DJ-220X	OMF RESISTOR	22Ω 1W J		R4004	NRSA63J-471X	MG RESISTOR	470Ω 1/16W J	
R3370	NRSA63J-473X	MG RESISTOR	47kΩ 1/16W J		R4005	NRSA63J-122X	MG RESISTOR	1.2kΩ 1/16W J	
R3373	NRSA63J-153X	MG RESISTOR	15kΩ 1/16W J		R4006	NRSA02J-471X	MG RESISTOR	470Ω 1/10W J	
R3374	NRSA63J-332X	MG RESISTOR	3.3kΩ 1/16W J		R4007	NRSA63J-473X	MG RESISTOR	47kΩ 1/16W J	
R3448	NRSA63J-101X	MG RESISTOR	100Ω 1/16W J		R4008	NRSA63J-472X	MG RESISTOR	4.7kΩ 1/16W J	
R3449	NRSA63J-821X	MG RESISTOR	820Ω 1/16W J		R4009	NRSA63J-472X	MG RESISTOR	4.7kΩ 1/16W J	
R3451	NRSA63J-822X	MG RESISTOR	8.2kΩ 1/16W J		△ L101	QQR1676-001	LINE FILTER		
R3452	NRSA63J-332X	MG RESISTOR	3.3kΩ 1/16W J		L701	QQL78AK-100	COIL	10uH K	
R3453	NRSA63J-912X	MG RESISTOR	9.1kΩ 1/16W J		L702	QQL78AK-100	COIL	10uH K	
R3454	NRSA63J-182X	MG RESISTOR	1.8kΩ 1/16W J		L3151	QQL77AK-220	COIL	22uH K	
R3455	NRSA63J-132X	MG RESISTOR	1.3kΩ 1/16W J		L3251	QQL77AK-220	COIL	22uH K	
R3462	QRE141J-390Y	C RESISTOR	39Ω 1/4W J		L3351	QQL77AK-220	COIL	22uH K	
R3463	QRE141J-390Y	C RESISTOR	39Ω 1/4W J		L3451	QQL77AK-220	COIL	22uH K	
R3465	QRL01DJ-220X	OMF RESISTOR	22Ω 1W J		L3551	QQL77AK-220	COIL	22uH K	
R3466	QRL01DJ-220X	OMF RESISTOR	22Ω 1W J		L3651	QQL78AK-220	COIL	22uH K	
R3468	QRL01DJ-220X	OMF RESISTOR	22Ω 1W J		L3751	QQL78AK-220	COIL	22uH K	
R3470	NRSA63J-473X	MG RESISTOR	47kΩ 1/16W J		L4001	QQL28AK-221	CHOKO COIL	220uH K	
R3473	NRSA63J-153X	MG RESISTOR	15kΩ 1/16W J		△ CN101	QGA7901C1-02	CONNECTOR	W-B (1-2)	
R3474	NRSA63J-332X	MG RESISTOR	3.3kΩ 1/16W J		△ CN102	QGA7901C1-04	CONNECTOR	W-B (1-4)	
R3548	NRSA63J-101X	MG RESISTOR	100Ω 1/16W J		△ CN103	QGA7901C1-04	CONNECTOR	W-B (1-4)	
R3549	NRSA63J-821X	MG RESISTOR	820Ω 1/16W J		CN151	QGA3901C1-04	CONNECTOR	W-B (1-4)	
R3551	NRSA63J-822X	MG RESISTOR	8.2kΩ 1/16W J		CN301	QGB2510J1-20	CONNECTOR	B-B (1-20)	
R3552	NRSA63J-332X	MG RESISTOR	3.3kΩ 1/16W J		CN302	QGB2510J1-15	CONNECTOR	B-B (1-15)	
R3553	NRSA63J-912X	MG RESISTOR	9.1kΩ 1/16W J		CN303	QGA2501C1-02	CONNECTOR	W-B (1-2)	
R3554	NRSA63J-182X	MG RESISTOR	1.8kΩ 1/16W J		CN304	QGB2510J1-06	CONNECTOR	B-B (1-6)	
R3555	NRSA63J-132X	MG RESISTOR	1.3kΩ 1/16W J		CN305	QGD2501C1-03Z	CONNECTOR	(1-3)	
R3562	QRE141J-390Y	C RESISTOR	39Ω 1/4W J		CN311	QGB2024K1-17S	CONNECTOR	B-B (1-17)	
R3563	QRE141J-390Y	C RESISTOR	39Ω 1/4W J		CN312	QGB2024K1-17S	CONNECTOR	B-B (1-17)	
R3565	QRL01DJ-220X	OMF RESISTOR	22Ω 1W J		CN351	QGA3901F2-02	CONNECTOR	W-B (1-2)	
R3566	QRL01DJ-220X	OMF RESISTOR	22Ω 1W J		CN352	QGA3901F2-02	CONNECTOR	W-B (1-2)	
R3568	QRL01DJ-220X	OMF RESISTOR	22Ω 1W J		CN501	QGB2510K2-20	CONNECTOR	B-B (1-20)	
R3570	NRSA63J-473X	MG RESISTOR	47kΩ 1/16W J		CN502	QGB2510K2-15	CONNECTOR	B-B (1-15)	
R3573	NRSA63J-153X	MG RESISTOR	15kΩ 1/16W J		CN503	QGB2510K2-06	CONNECTOR	B-B (1-6)	
R3574	NRSA63J-332X	MG RESISTOR	3.3kΩ 1/16W J		EP101	LV43391-001A	BLACKET		
R3648	NRSA63J-101X	MG RESISTOR	100Ω 1/16W J		EP102	LV43391-001A	BLACKET		
R3649	NRSA63J-821X	MG RESISTOR	820Ω 1/16W J		EP301	QNZ0136-001Z	EARTH PLATE		
R3651	NRSA63J-822X	MG RESISTOR	8.2kΩ 1/16W J		EP302	QNZ0136-001Z	EARTH PLATE		
R3652	NRSA63J-332X	MG RESISTOR	3.3kΩ 1/16W J		EP303	QNZ0136-001Z	EARTH PLATE		
R3653	NRSA63J-912X	MG RESISTOR	9.1kΩ 1/16W J		EP304	QNZ0136-001Z	EARTH PLATE		
R3654	NRSA63J-392X	MG RESISTOR	3.9kΩ 1/16W J		FC101	QNG0019-001Z	FUSE CLIP		
R3655	NRSA63J-561X	MG RESISTOR	560Ω 1/16W J		FC102	QNG0019-001Z	FUSE CLIP		
R3662	QRE141J-390Y	C RESISTOR	39Ω 1/4W J		FC103	QNG0019-001Z	FUSE CLIP		
R3663	QRE141J-390Y	C RESISTOR	39Ω 1/4W J		FC104	QNG0019-001Z	FUSE CLIP		
R3665	QRL01DJ-220X	OMF RESISTOR	22Ω 1W J		FC155	QNG0019-001Z	FUSE CLIP		
R3666	QRL01DJ-220X	OMF RESISTOR	22Ω 1W J		FC156	QNG0019-001Z	FUSE CLIP		
R3668	QRL01DJ-220X	OMF RESISTOR	22Ω 1W J		HS151	LV35740-003A	IC HOLDER		
R3670	NRSA63J-224X	MG RESISTOR	220kΩ 1/16W J		J3001	QNB0192-001	SPEAKER TERMINA		
R3673	NRSA63J-153X	MG RESISTOR	15kΩ 1/16W J		K3101	QQR1277-001Z	COIL		
R3674	NRSA63J-332X	MG RESISTOR	3.3kΩ 1/16W J		K3201	QQR1277-001Z	COIL		
R3681	QRK126J-4R7X	UNF C RESISTOR	4.7Ω 1/2W J		K3301	QQR1277-001Z	COIL		
R3748	NRSA63J-101X	MG RESISTOR	100Ω 1/16W J		K3401	QQR1277-001Z	COIL		
R3749	NRSA63J-821X	MG RESISTOR	820Ω 1/16W J		K3501	QQR1277-001Z	COIL		
R3751	NRSA63J-822X	MG RESISTOR	8.2kΩ 1/16W J		K3681	QQR1277-001Z	COIL		
R3752	NRSA63J-332X	MG RESISTOR	3.3kΩ 1/16W J		K3682	QQR1277-001Z	COIL		
R3753	NRSA63J-912X	MG RESISTOR	9.1kΩ 1/16W J		△ RY101	QSK0142-001	RELAY		
R3754	NRSA63J-392X	MG RESISTOR	3.9kΩ 1/16W J		RY301	QSK0127-001	RELAY		
R3755	NRSA63J-561X	MG RESISTOR	560Ω 1/16W J		RY302	QSK0127-001	RELAY		
R3762	QRE141J-390Y	C RESISTOR	39Ω 1/4W J		RY303	QSK0127-001	RELAY		
R3763	QRE141J-390Y	C RESISTOR	39Ω 1/4W J		△ S101	QSW0924-001	VOLTAGE SWITCH		
R3765	QRL01DJ-220X	OMF RESISTOR	22Ω 1W J		TH301	QAD0146-103	N THERMISTOR	10kΩ	
R3766	QRL01DJ-220X	OMF RESISTOR	22Ω 1W J		W711	QUB220-07A2A2-E	SIN TWIST WIRE		
R3768	QRL01DJ-220X	OMF RESISTOR	22Ω 1W J		WC151	QZW0112-001	WIRE CLAMP		
R3770	NRSA63J-224X	MG RESISTOR	220kΩ 1/16W J		WC301	QZW0112-001	WIRE CLAMP		
R3801	NRSA63J-152X	MG RESISTOR	1.5kΩ 1/16W J		WC302	QZW0112-001	WIRE CLAMP		
R3802	NRSA63J-152X	MG RESISTOR	1.5kΩ 1/16W J		WC303	QZW0112-001	WIRE CLAMP		
R3803	NRSA63J-222X	MG RESISTOR	2.2kΩ 1/16W J		WC304	QZW0112-001	WIRE CLAMP		
R3804	NRSA63J-103X	MG RESISTOR	10kΩ 1/16W J		WC305	QZW0112-001	WIRE CLAMP		
R3805	NRSA63J-103X	MG RESISTOR	10kΩ 1/16W J		WC307	QZW0112-001	WIRE CLAMP		
R3806	NRSA63J-103X	MG RESISTOR	10kΩ 1/16W J		WC309	QZW0112-001	WIRE CLAMP		
R3807	NRSA63J-103X	MG RESISTOR	10kΩ 1/16W J						
R3808	NRSA63J-103X	MG RESISTOR	10kΩ 1/16W J						
R3809	NRSA63J-103X	MG RESISTOR	10kΩ 1/16W J						
R3891	NRSA63J-150X	MG RESISTOR	15Ω 1/16W J						

C90US,
C90UX,
C90UG

△ Symbol No.	Part No.	Part Name	Description	Local	△ Symbol No.	Part No.	Part Name	Description	Local
WC310	QZW0112-001	WIRE CLAMP			C1211	NCB31HK-152X	C CAPACITOR	1500pF 50V K	
WC351	QZW0112-001	WIRE CLAMP			C1212	QETN1HM-105Z	E CAPACITOR	1uF 50V M	
X601	QAX0246-001Z	C RESONATOR	8.00MHz		C1213	QETN1HM-225Z	E CAPACITOR	2.2uF 50V M	

Amplifier board (TH-C90)

Block No. [0][4]

△ Symbol No.	Part No.	Part Name	Description	Local
IC101	JCV8015-X	IC		
IC102	JCV8015-X	IC		
IC103	JCV8015-X	IC		
IC202	SN74HCU04ANS-X	IC		
IC203	RC4558D-X	IC		
Q1101	KTA1504/YG/-X	TRANSISTOR		
Q1111	KTC3875/YG/-X	TRANSISTOR		
Q1112	KTC3875/YG/-X	TRANSISTOR		
Q1201	KTA1504/YG/-X	TRANSISTOR		
Q1211	KTC3875/YG/-X	TRANSISTOR		
Q1212	KTC3875/YG/-X	TRANSISTOR		
Q1301	KTA1504/YG/-X	TRANSISTOR		
Q1311	KTC3875/YG/-X	TRANSISTOR		
Q1312	KTC3875/YG/-X	TRANSISTOR		
Q1401	KTA1504/YG/-X	TRANSISTOR		
Q1411	KTC3875/YG/-X	TRANSISTOR		
Q1412	KTC3875/YG/-X	TRANSISTOR		
Q1501	KTA1504/YG/-X	TRANSISTOR		
Q1601	KTA1504/YG/-X	TRANSISTOR		
Q1701	KTA1504/YG/-X	TRANSISTOR		
Q2003	KRC102S-X	DIGI TRANSISTOR		
Q2004	KRA102S-X	DIGI TRANSISTOR		
Q2005	KTA1504/YG/-X	TRANSISTOR		
Q2007	KTC3875/YG/-X	TRANSISTOR		
Q2008	KRC102S-X	DIGI TRANSISTOR		
D561	SLR-342MC-T12	LED		
D1111	1SS133-T2	SI DIODE		
D1112	1SS133-T2	SI DIODE		
D1211	1SS133-T2	SI DIODE		
D1212	1SS133-T2	SI DIODE		
D1311	1SS133-T2	SI DIODE		
D1312	1SS133-T2	SI DIODE		
D1411	1SS133-T2	SI DIODE		
D1412	1SS133-T2	SI DIODE		
D2021	1SS133-T2	SI DIODE		
D2022	1SS133-T2	SI DIODE		
D2023	1SS133-T2	SI DIODE		
D2025	MTZJ3.3B-T2	Z DIODE		
D2031	1SS133-T2	SI DIODE		
D2032	1SS133-T2	SI DIODE		
C1101	QETN1HM-105Z	E CAPACITOR	1uF 50V M	
C1102	NCB31HK-221X	C CAPACITOR	220pF 50V K	
C1103	QETN1CM-107Z	E CAPACITOR	100uF 16V M	
C1104	NCB31HK-222X	C CAPACITOR	2200pF 50V K	
C1105	NCB31HK-222X	C CAPACITOR	2200pF 50V K	
C1106	NCB31CK-104X	C CAPACITOR	0.1uF 16V K	
C1107	NDC31HJ-101X	C CAPACITOR	100pF 50V J	
C1111	NCB31HK-152X	C CAPACITOR	1500pF 50V K	
C1112	QETN1HM-105Z	E CAPACITOR	1uF 50V M	
C1113	QETN1HM-225Z	E CAPACITOR	2.2uF 50V M	
C1122	NCB31HK-272X	C CAPACITOR	2700pF 50V K	
C1131	NDC31HJ-680X	C CAPACITOR	68pF 50V J	
C1141	NCB31CK-105X	C CAPACITOR	1uF 16V K	
C1142	NDC31HG-101X	C CAPACITOR	100pF 50V G	
C1143	NCF31EZ-104X	C CAPACITOR	0.1uF 25V Z	
C1201	QETN1HM-105Z	E CAPACITOR	1uF 50V M	
C1202	NCB31HK-221X	C CAPACITOR	220pF 50V K	
C1203	QETN1CM-107Z	E CAPACITOR	100uF 16V M	
C1204	NCB31HK-222X	C CAPACITOR	2200pF 50V K	
C1205	NCB31HK-222X	C CAPACITOR	2200pF 50V K	
C1206	NCB31CK-104X	C CAPACITOR	0.1uF 16V K	
C1207	NDC31HJ-101X	C CAPACITOR	100pF 50V J	
C1211	NCB31HK-152X	C CAPACITOR	1500pF 50V K	
C1212	QETN1HM-105Z	E CAPACITOR	1uF 50V M	
C1213	QETN1HM-225Z	E CAPACITOR	2.2uF 50V M	
C1222	NCB31HK-272X	C CAPACITOR	2700pF 50V K	
C1231	NDC31HJ-680X	C CAPACITOR	68pF 50V J	
C1241	NCB31CK-105X	C CAPACITOR	1uF 16V K	
C1242	NDC31HG-101X	C CAPACITOR	100pF 50V G	
C1243	NCF31EZ-104X	C CAPACITOR	0.1uF 25V Z	
C1301	QFLC1HJ-223Z	M CAPACITOR	0.022uF 50V J	
C1302	NCB31HK-221X	C CAPACITOR	220pF 50V K	
C1303	QETN1CM-107Z	E CAPACITOR	100uF 16V M	
C1304	NCB31HK-222X	C CAPACITOR	2200pF 50V K	
C1305	NCB31HK-222X	C CAPACITOR	2200pF 50V K	
C1307	NDC31HJ-101X	C CAPACITOR	100pF 50V J	
C1311	NCB31HK-152X	C CAPACITOR	1500pF 50V K	
C1312	QETN1HM-105Z	E CAPACITOR	1uF 50V M	
C1313	QETN1HM-225Z	E CAPACITOR	2.2uF 50V M	
C1322	NCB31HK-272X	C CAPACITOR	2700pF 50V K	
C1331	NDC31HJ-680X	C CAPACITOR	68pF 50V J	
C1341	NCB31CK-105X	C CAPACITOR	1uF 16V K	
C1342	NDC31HG-101X	C CAPACITOR	100pF 50V G	
C1343	NCF31EZ-104X	C CAPACITOR	0.1uF 25V Z	
C1401	QFLC1HJ-223Z	M CAPACITOR	0.022uF 50V J	
C1402	NCB31HK-221X	C CAPACITOR	220pF 50V K	
C1403	QETN1CM-107Z	E CAPACITOR	100uF 16V M	
C1404	NCB31HK-222X	C CAPACITOR	2200pF 50V K	
C1405	NCB31HK-222X	C CAPACITOR	2200pF 50V K	
C1407	NDC31HJ-101X	C CAPACITOR	100pF 50V J	
C1411	NCB31HK-152X	C CAPACITOR	1500pF 50V K	
C1412	QETN1HM-105Z	E CAPACITOR	1uF 50V M	
C1413	QETN1HM-225Z	E CAPACITOR	2.2uF 50V M	
C1422	NCB31HK-272X	C CAPACITOR	2700pF 50V K	
C1431	NDC31HJ-680X	C CAPACITOR	68pF 50V J	
C1441	NCB31CK-105X	C CAPACITOR	1uF 16V K	
C1442	NCS31HJ-101X	C CAPACITOR	100pF 50V J	
C1443	NCF31EZ-104X	C CAPACITOR	0.1uF 25V Z	
C1501	QETN1HM-105Z	E CAPACITOR	1uF 50V M	
C1502	NCB31HK-221X	C CAPACITOR	220pF 50V K	
C1503	QETN1CM-107Z	E CAPACITOR	100uF 16V M	
C1504	NCB31HK-222X	C CAPACITOR	2200pF 50V K	
C1505	NCB31HK-222X	C CAPACITOR	2200pF 50V K	
C1507	NDC31HJ-101X	C CAPACITOR	100pF 50V J	
C1511	NCB21CK-224X	C CAPACITOR	0.22uF 16V K	
C1512	NCB21CK-224X	C CAPACITOR	0.22uF 16V K	
C1513	NCB21HK-563X	C CAPACITOR	0.056uF 50V K	
C1514	NCB31HK-103X	C CAPACITOR	0.01uF 50V K	
C1522	NCB31HK-272X	C CAPACITOR	2700pF 50V K	
C1531	NDC31HJ-680X	C CAPACITOR	68pF 50V J	
C1541	NCB31CK-105X	C CAPACITOR	1uF 16V K	
C1542	NDC31HG-101X	C CAPACITOR	100pF 50V G	
C1543	NCF31EZ-104X	C CAPACITOR	0.1uF 25V Z	
C1601	QETN1HM-106Z	E CAPACITOR	10uF 50V M	
C1603	QETN1CM-107Z	E CAPACITOR	100uF 16V M	
C1604	NCB31HK-222X	C CAPACITOR	2200pF 50V K	
C1605	NCB31HK-222X	C CAPACITOR	2200pF 50V K	
C1607	NDC31HJ-101X	C CAPACITOR	100pF 50V J	
C1622	NCB31HK-272X	C CAPACITOR	2700pF 50V K	
C1631	NCB31HK-821X	C CAPACITOR	820pF 50V K	
C1641	NCB31CK-105X	C CAPACITOR	1uF 16V K	
C1642	NDC31HG-101X	C CAPACITOR	100pF 50V G	
C1643	NCF31EZ-104X	C CAPACITOR	0.1uF 25V Z	
C1801	QETN1CM-107Z	E CAPACITOR	100uF 16V M	
C1802	QETN1CM-107Z	E CAPACITOR	100uF 16V M	
C1803	NCB31CK-105X	C CAPACITOR	1uF 16V K	
C1804	QETN1CM-107Z	E CAPACITOR	100uF 16V M	
C1805	QETN1CM-107Z	E CAPACITOR	100uF 16V M	
C1806	NCB31CK-105X	C CAPACITOR	1uF 16V K	
C1807	NCB31CK-105X	C CAPACITOR	1uF 16V K	
C1808	NCB31CK-105X	C CAPACITOR	1uF 16V K	
C1811	QETN1CM-107Z	E CAPACITOR	100uF 16V M	
C1812	QETN1CM-107Z	E CAPACITOR	100uF 16V M	
C1813	NCB31CK-105X	C CAPACITOR	1uF 16V K	
C1814	QETN1CM-107Z	E CAPACITOR	100uF 16V M	
C1815	QETN1CM-107Z	E CAPACITOR	100uF 16V M	
C1816	NCB31CK-105X	C CAPACITOR	1uF 16V K	
C1817	NCB31CK-105X	C CAPACITOR	1uF 16V K	
C1818	NCB31CK-105X	C CAPACITOR	1uF 16V K	
C1821	QETN1CM-107Z	E CAPACITOR	100uF 16V M	

△ Symbol No.	Part No.	Part Name	Description	Local	△ Symbol No.	Part No.	Part Name	Description	Local
C1822	QETN1CM-107Z	E CAPACITOR	100uF 16V M		R1309	NRSA63J-222X	MG RESISTOR	2.2kΩ 1/16W J	
C1823	NCB31CK-105X	C CAPACITOR	1uF 16V K		R1311	NRSA63J-101X	MG RESISTOR	100Ω 1/16W J	
C1824	QETN1CM-107Z	E CAPACITOR	100uF 16V M		R1312	NRSA63J-474X	MG RESISTOR	470kΩ 1/16W J	
C1825	QETN1CM-107Z	E CAPACITOR	100uF 16V M		R1313	NRSA63J-470X	MG RESISTOR	47Ω 1/16W J	
C1826	NCB31CK-105X	C CAPACITOR	1uF 16V K		R1314	NRSA63J-334X	MG RESISTOR	330kΩ 1/16W J	
C1827	NCB31CK-105X	C CAPACITOR	1uF 16V K		R1315	NRSA63J-222X	MG RESISTOR	2.2kΩ 1/16W J	
C1828	NCB31CK-105X	C CAPACITOR	1uF 16V K		R1316	NRSA63J-183X	MG RESISTOR	18kΩ 1/16W J	
C2001	NCB31HK-471X	C CAPACITOR	470pF 50V K		R1317	NRSA63J-103X	MG RESISTOR	10kΩ 1/16W J	
C2002	NCB31HK-471X	C CAPACITOR	470pF 50V K		R1318	NRSA63J-102X	MG RESISTOR	1kΩ 1/16W J	
C2007	NCF31HZ-103X	C CAPACITOR	0.01uF 50V Z		R1319	NRSA63J-104X	MG RESISTOR	100kΩ 1/16W J	
C2021	NCF31HZ-103X	C CAPACITOR	0.01uF 50V Z		R1320	NRSA63J-103X	MG RESISTOR	10kΩ 1/16W J	
C2022	NCF31HZ-103X	C CAPACITOR	0.01uF 50V Z		R1321	NRSA63J-333X	MG RESISTOR	33kΩ 1/16W J	
C2024	QETN1EM-476Z	E CAPACITOR	47uF 25V M		R1322	NRSA63J-224X	MG RESISTOR	220kΩ 1/16W J	
C2025	QETN1EM-476Z	E CAPACITOR	47uF 25V M		R1325	NRSA63J-332X	MG RESISTOR	3.3kΩ 1/16W J	
C2031	QETN1CM-107Z	E CAPACITOR	100uF 16V M		R1331	NRSA63J-393X	MG RESISTOR	39kΩ 1/16W J	
C2032	QETN1EM-476Z	E CAPACITOR	47uF 25V M		R1332	NRSA63J-332X	MG RESISTOR	3.3kΩ 1/16W J	
					R1341	NRSA63F-682X	MG RESISTOR	6.8kΩ 1/16W F	
R1101	NRSA63J-103X	MG RESISTOR	10kΩ 1/16W J		R1342	NRSA63J-104X	MG RESISTOR	100kΩ 1/16W J	
R1102	NRSA63J-103X	MG RESISTOR	10kΩ 1/16W J		R1347	NRSA63J-821X	MG RESISTOR	820Ω 1/16W J	
R1103	NRSA63J-393X	MG RESISTOR	39kΩ 1/16W J		R1401	NRSA63J-562X	MG RESISTOR	5.6kΩ 1/16W J	
R1104	NRSA63J-102X	MG RESISTOR	1kΩ 1/16W J		R1402	NRSA63J-562X	MG RESISTOR	5.6kΩ 1/16W J	
R1105	NRSA63J-183X	MG RESISTOR	18kΩ 1/16W J		R1403	NRSA63J-393X	MG RESISTOR	39kΩ 1/16W J	
R1106	NRSA63J-103X	MG RESISTOR	10kΩ 1/16W J		R1404	NRSA63J-102X	MG RESISTOR	1kΩ 1/16W J	
R1107	NRSA63J-472X	MG RESISTOR	4.7kΩ 1/16W J		R1405	NRSA63J-183X	MG RESISTOR	18kΩ 1/16W J	
R1108	NRSA63J-106X	MG RESISTOR	10MΩ 1/16W J		R1406	NRSA63J-103X	MG RESISTOR	10kΩ 1/16W J	
R1109	NRSA63J-222X	MG RESISTOR	2.2kΩ 1/16W J		R1408	NRSA63J-106X	MG RESISTOR	10MΩ 1/16W J	
R1111	NRSA63J-101X	MG RESISTOR	100Ω 1/16W J		R1409	NRSA63J-222X	MG RESISTOR	2.2kΩ 1/16W J	
R1112	NRSA63J-474X	MG RESISTOR	470kΩ 1/16W J		R1411	NRSA63J-101X	MG RESISTOR	100Ω 1/16W J	
R1113	NRSA63J-470X	MG RESISTOR	47Ω 1/16W J		R1412	NRSA63J-474X	MG RESISTOR	470kΩ 1/16W J	
R1114	NRSA63J-334X	MG RESISTOR	330kΩ 1/16W J		R1413	NRSA63J-470X	MG RESISTOR	47Ω 1/16W J	
R1115	NRSA63J-222X	MG RESISTOR	2.2kΩ 1/16W J		R1414	NRSA63J-334X	MG RESISTOR	330kΩ 1/16W J	
R1116	NRSA63J-183X	MG RESISTOR	18kΩ 1/16W J		R1415	NRSA63J-222X	MG RESISTOR	2.2kΩ 1/16W J	
R1117	NRSA63J-103X	MG RESISTOR	10kΩ 1/16W J		R1416	NRSA63J-183X	MG RESISTOR	18kΩ 1/16W J	
R1118	NRSA63J-102X	MG RESISTOR	1kΩ 1/16W J		R1417	NRSA63J-103X	MG RESISTOR	10kΩ 1/16W J	
R1119	NRSA63J-104X	MG RESISTOR	100kΩ 1/16W J		R1418	NRSA63J-102X	MG RESISTOR	1kΩ 1/16W J	
R1120	NRSA63J-103X	MG RESISTOR	10kΩ 1/16W J		R1419	NRSA63J-104X	MG RESISTOR	100kΩ 1/16W J	
R1121	NRSA63J-333X	MG RESISTOR	33kΩ 1/16W J		R1420	NRSA63J-103X	MG RESISTOR	10kΩ 1/16W J	
R1124	NRSA63J-224X	MG RESISTOR	220kΩ 1/16W J		R1421	NRSA63J-333X	MG RESISTOR	33kΩ 1/16W J	
R1125	NRSA63J-332X	MG RESISTOR	3.3kΩ 1/16W J		R1424	NRSA63J-224X	MG RESISTOR	220kΩ 1/16W J	
R1131	NRSA63J-393X	MG RESISTOR	39kΩ 1/16W J		R1425	NRSA63J-332X	MG RESISTOR	3.3kΩ 1/16W J	
R1132	NRSA63J-332X	MG RESISTOR	3.3kΩ 1/16W J		R1431	NRSA63J-393X	MG RESISTOR	39kΩ 1/16W J	
R1141	NRSA63F-682X	MG RESISTOR	6.8kΩ 1/16W F		R1432	NRSA63J-332X	MG RESISTOR	3.3kΩ 1/16W J	
R1142	NRSA63J-104X	MG RESISTOR	100kΩ 1/16W J		R1441	NRSA63F-682X	MG RESISTOR	6.8kΩ 1/16W F	
R1147	NRSA63J-821X	MG RESISTOR	820Ω 1/16W J		R1442	NRSA63J-104X	MG RESISTOR	100kΩ 1/16W J	
R1201	NRSA63J-103X	MG RESISTOR	10kΩ 1/16W J		R1447	NRSA63J-821X	MG RESISTOR	820Ω 1/16W J	
R1202	NRSA63J-103X	MG RESISTOR	10kΩ 1/16W J		R1501	NRSA63J-562X	MG RESISTOR	5.6kΩ 1/16W J	
R1203	NRSA63J-393X	MG RESISTOR	39kΩ 1/16W J		R1502	NRSA63J-562X	MG RESISTOR	5.6kΩ 1/16W J	
R1204	NRSA63J-102X	MG RESISTOR	1kΩ 1/16W J		R1503	NRSA63J-393X	MG RESISTOR	39kΩ 1/16W J	
R1205	NRSA63J-183X	MG RESISTOR	18kΩ 1/16W J		R1504	NRSA63J-102X	MG RESISTOR	1kΩ 1/16W J	
R1206	NRSA63J-103X	MG RESISTOR	10kΩ 1/16W J		R1505	NRSA63J-183X	MG RESISTOR	18kΩ 1/16W J	
R1207	NRSA63J-472X	MG RESISTOR	4.7kΩ 1/16W J		R1506	NRSA63J-103X	MG RESISTOR	10kΩ 1/16W J	
R1208	NRSA63J-106X	MG RESISTOR	10MΩ 1/16W J		R1508	NRSA63J-106X	MG RESISTOR	10MΩ 1/16W J	
R1209	NRSA63J-222X	MG RESISTOR	2.2kΩ 1/16W J		R1509	NRSA63J-222X	MG RESISTOR	2.2kΩ 1/16W J	
R1211	NRSA63J-101X	MG RESISTOR	100Ω 1/16W J		R1511	NRSA63J-222X	MG RESISTOR	2.2kΩ 1/16W J	
R1212	NRSA63J-474X	MG RESISTOR	470kΩ 1/16W J		R1512	NRSA63J-184X	MG RESISTOR	180kΩ 1/16W J	
R1213	NRSA63J-470X	MG RESISTOR	47Ω 1/16W J		R1513	NRSA63J-562X	MG RESISTOR	5.6kΩ 1/16W J	
R1214	NRSA63J-334X	MG RESISTOR	330kΩ 1/16W J		R1514	NRSA63J-184X	MG RESISTOR	180kΩ 1/16W J	
R1215	NRSA63J-222X	MG RESISTOR	2.2kΩ 1/16W J		R1521	NRSA63J-333X	MG RESISTOR	33kΩ 1/16W J	
R1216	NRSA63J-183X	MG RESISTOR	18kΩ 1/16W J		R1524	NRSA63J-224X	MG RESISTOR	220kΩ 1/16W J	
R1217	NRSA63J-103X	MG RESISTOR	10kΩ 1/16W J		R1525	NRSA63J-332X	MG RESISTOR	3.3kΩ 1/16W J	
R1218	NRSA63J-102X	MG RESISTOR	1kΩ 1/16W J		R1531	NRSA63J-393X	MG RESISTOR	39kΩ 1/16W J	
R1219	NRSA63J-104X	MG RESISTOR	100kΩ 1/16W J		R1532	NRSA63J-332X	MG RESISTOR	3.3kΩ 1/16W J	
R1220	NRSA63J-103X	MG RESISTOR	10kΩ 1/16W J		R1541	NRSA63F-682X	MG RESISTOR	6.8kΩ 1/16W F	
R1221	NRSA63J-333X	MG RESISTOR	33kΩ 1/16W J		R1542	NRSA63J-104X	MG RESISTOR	100kΩ 1/16W J	
R1224	NRSA63J-224X	MG RESISTOR	220kΩ 1/16W J		R1547	NRSA63J-821X	MG RESISTOR	820Ω 1/16W J	
R1225	NRSA63J-332X	MG RESISTOR	3.3kΩ 1/16W J		R1602	NRSA63J-102X	MG RESISTOR	1kΩ 1/16W J	
R1231	NRSA63J-393X	MG RESISTOR	39kΩ 1/16W J		R1603	NRSA63J-472X	MG RESISTOR	4.7kΩ 1/16W J	
R1232	NRSA63J-332X	MG RESISTOR	3.3kΩ 1/16W J		R1604	NRSA63J-102X	MG RESISTOR	1kΩ 1/16W J	
R1241	NRSA63F-682X	MG RESISTOR	6.8kΩ 1/16W F		R1605	NRSA63J-103X	MG RESISTOR	10kΩ 1/16W J	
R1242	NRSA63J-104X	MG RESISTOR	100kΩ 1/16W J		R1606	NRSA63J-103X	MG RESISTOR	10kΩ 1/16W J	
R1247	NRSA63J-821X	MG RESISTOR	820Ω 1/16W J		R1608	NRSA63J-106X	MG RESISTOR	10MΩ 1/16W J	
R1301	NRSA63J-562X	MG RESISTOR	5.6kΩ 1/16W J		R1609	NRSA63J-222X	MG RESISTOR	2.2kΩ 1/16W J	
R1302	NRSA63J-562X	MG RESISTOR	5.6kΩ 1/16W J		R1611	NRSA63J-273X	MG RESISTOR	27kΩ 1/16W J	
R1303	NRSA63J-393X	MG RESISTOR	39kΩ 1/16W J		R1612	NRSA63J-472X	MG RESISTOR	4.7kΩ 1/16W J	
R1304	NRSA63J-102X	MG RESISTOR	1kΩ 1/16W J		R1613	NRSA63J-273X	MG RESISTOR	27kΩ 1/16W J	
R1305	NRSA63J-183X	MG RESISTOR	18kΩ 1/16W J		R1614	NRSA63J-472X	MG RESISTOR	4.7kΩ 1/16W J	
R1306	NRSA63J-103X	MG RESISTOR	10kΩ 1/16W J		R1615	NRSA63J-123X	MG RESISTOR	12kΩ 1/16W J	
R1308	NRSA63J-106X	MG RESISTOR	10MΩ 1/16W J		R1616	NRSA63J-123X	MG RESISTOR	12kΩ 1/16W J	

△ Symbol No.	Part No.	Part Name	Description	Local	△ Symbol No.	Part No.	Part Name	Description	Local
R1621	NRSA63J-333X	MG RESISTOR	33kΩ 1/16W J		Q3702	RT1P141C-X	DIGI TRANSISTOR		
R1624	NRSA63J-224X	MG RESISTOR	220kΩ 1/16W J		Q3703	RT1N241C-X	DIGI TRANSISTOR		
R1626	NRSA63J-332X	MG RESISTOR	3.3kΩ 1/16W J		Q3704	KTC2026/Y/	TRANSISTOR		
R1631	NRSA63J-682X	MG RESISTOR	6.8kΩ 1/16W J						
R1632	NRSA63J-331X	MG RESISTOR	330Ω 1/16W J		D101	1SS133-T2	SI DIODE		
R1641	NRSA63F-562X	MG RESISTOR	5.6kΩ 1/16W F		△ D151	GBU803	BRIDGE DIODE		
R1642	NRSA63J-104X	MG RESISTOR	100kΩ 1/16W J		△ D152	GBU803	BRIDGE DIODE		
R1647	NRSA63J-821X	MG RESISTOR	820Ω 1/16W J		D154	1SS133-T2	SI DIODE		
R1747	NRSA63J-821X	MG RESISTOR	820Ω 1/16W J		D163	1SS133-T2	SI DIODE		
R2001	NRSA63J-105X	MG RESISTOR	1MΩ 1/16W J		D164	MTZJ6.2B-T2	Z DIODE		
R2002	NRSA63J-562X	MG RESISTOR	5.6kΩ 1/16W J		D165	MTZJ6.8C-T2	Z DIODE		
R2021	NRSA63J-103X	MG RESISTOR	10kΩ 1/16W J		D166	MTZJ6.8C-T2	Z DIODE		
R2022	NRSA63J-184X	MG RESISTOR	180kΩ 1/16W J		D501	1SS133-T2	SI DIODE		
R2023	NRSA63J-682X	MG RESISTOR	6.8kΩ 1/16W J		D504	1SS133-T2	SI DIODE		
R2024	NRSA63J-682X	MG RESISTOR	6.8kΩ 1/16W J		D505	UDZS5.1B-X	Z DIODE		
R2025	NRSA63J-184X	MG RESISTOR	180kΩ 1/16W J		D506	1SS133-T2	SI DIODE		
R2027	NRSA63J-223X	MG RESISTOR	22kΩ 1/16W J		D507	1SS355-X	SI DIODE		
R2028	NRSA63J-223X	MG RESISTOR	22kΩ 1/16W J		D510	1SS133-T2	SI DIODE		
R2029	QRE141J-562Y	C RESISTOR	5.6kΩ 1/4W J		D514	1SS133-T2	SI DIODE		
R2031	NRSA63J-823X	MG RESISTOR	82kΩ 1/16W J		D515	1SS133-T2	SI DIODE		
R2032	NRSA63J-183X	MG RESISTOR	18kΩ 1/16W J		D516	MTZJ30C-T2	Z DIODE		
R2033	NRSA63J-220X	MG RESISTOR	22Ω 1/16W J		D521	MTZJ6.8C-T2	Z DIODE		
R2034	NRSA63J-472X	MG RESISTOR	4.7kΩ 1/16W J		D535	1SS133-T2	SI DIODE		
R2035	NRSA63J-222X	MG RESISTOR	2.2kΩ 1/16W J		D541	1SS133-T2	SI DIODE		
R2036	NRSA63J-103X	MG RESISTOR	10kΩ 1/16W J		D543	1SS133-T2	SI DIODE		
R2037	NRSA63J-333X	MG RESISTOR	33kΩ 1/16W J		D546	1SS133-T2	SI DIODE		
R2038	NRSA63J-333X	MG RESISTOR	33kΩ 1/16W J		D548	1SS133-T2	SI DIODE		
R2103	NRSA63J-682X	MG RESISTOR	6.8kΩ 1/16W J		D549	1SS133-T2	SI DIODE		
CN111	QGB2024J1-17S	CONNECTOR	B-B (1-17)		D550	1SS133-T2	SI DIODE		
CN112	QGB2024J1-17S	CONNECTOR	B-B (1-17)		D551	1SS133-T2	SI DIODE		
J1001	QND0118-001	DIN CONNECTOR			D553	1SS133-T2	SI DIODE		
WR501	QUM213-22DGZ4-E	PARA RIBON WIRE			D561	SLR-342MC-T12	LED		
X2001	QAX0734-001	C RESONATOR	400.00kHz		D611	1SS133-T2	SI DIODE		

Mother board (TH-C60)

Block No. [0][5]

△ Symbol No.	Part No.	Part Name	Description	Local	△ Symbol No.	Part No.	Part Name	Description	Local
△ IC201	STK413-430	IC			D2101	1SS133-T2	SI DIODE		
△ IC202	STK413-400	IC			D2201	1SS133-T2	SI DIODE		
IC301	RC4558D-X	IC			D2301	1SS133-T2	SI DIODE		
IC302	RC4558D-X	IC			D2401	1SS133-T2	SI DIODE		
IC303	RC4558D-X	IC			D2501	1SS133-T2	SI DIODE		
IC601	MN101C427NB	IC			D2601	1SS133-T2	SI DIODE		
Q152	KTC2026/Y/	TRANSISTOR			D2701	MTZJ15C-T2	Z DIODE		
Q501	RT1P441C-X	DIGI TRANSISTOR			D2702	MTZJ15C-T2	Z DIODE		
Q502	2SC3928A/QR/-X	TRANSISTOR			D2703	MTZJ16C-T2	Z DIODE		
Q503	2SC3928A/QR/-X	TRANSISTOR			D2704	1SS133-T2	SI DIODE		
Q504	2SA1530A/QR/-X	TRANSISTOR			D2705	1SS133-T2	SI DIODE		
Q505	RT1N44HC-X	DIGI TRANSISTOR			D2706	MTZJ22A-T2	Z DIODE		
Q517	RT1N431C-X	TRANSISTOR			D3101	1SS133-T2	SI DIODE		
Q523	2SC3928A/QR/-X	TRANSISTOR			D3102	1SS133-T2	SI DIODE		
Q524	2SA1530A/QR/-X	TRANSISTOR			D3201	1SS133-T2	SI DIODE		
Q525	2SC3928A/QR/-X	TRANSISTOR			D3202	1SS133-T2	SI DIODE		
Q542	RT1N136C-X	DIGI TRANSISTOR			D3301	1SS133-T2	SI DIODE		
Q603	2SC3928A/QR/-X	TRANSISTOR			D3302	1SS133-T2	SI DIODE		
Q604	KTC3265/Y/-X	TRANSISTOR			D3401	1SS133-T2	SI DIODE		
Q2101	2SA1530A/QR/-X	TRANSISTOR			D3402	1SS133-T2	SI DIODE		
Q2201	2SA1530A/QR/-X	TRANSISTOR			D3501	1SS133-T2	SI DIODE		
Q2301	2SA1530A/QR/-X	TRANSISTOR			D3502	1SS133-T2	SI DIODE		
Q2401	2SA1530A/QR/-X	TRANSISTOR			D3601	1SS133-T2	SI DIODE		
Q2501	2SA1530A/QR/-X	TRANSISTOR			D3602	1SS133-T2	SI DIODE		
Q2601	2SA1530A/QR/-X	TRANSISTOR			D3703	MTZJ15C-T2	Z DIODE		
Q2701	2SC3928A/QR/-X	TRANSISTOR			△ C101	QCZ9105-472	C CAPACITOR	4700pF 250V M	
Q2702	KTA1046/Y/	TRANSISTOR			C153	NCF21HZ-473X	C CAPACITOR	0.047uF 50V Z	
Q2703	RT1N141C-X	DIGI TRANSISTOR			C154	NCF21HZ-473X	C CAPACITOR	0.047uF 50V Z	
Q2707	KTA1267/YG-T	TRANSISTOR			C155	NCF21HZ-473X	C CAPACITOR	0.047uF 50V Z	
Q2708	KTC3199/GL-T	TRANSISTOR			C156	NCF21HZ-473X	C CAPACITOR	0.047uF 50V Z	
Q2709	KTC2026/Y/	TRANSISTOR			C157	NCF21HZ-223X	C CAPACITOR	0.022uF 50V Z	
Q2710	2SA1530A/QR/-X	TRANSISTOR			C159	NCF21HZ-223X	C CAPACITOR	0.022uF 50V Z	
Q2711	RT1P141C-X	DIGI TRANSISTOR			C161	QETM1HM-338	E CAPACITOR	3300uF 50V M	
					C162	QETM1HM-338	E CAPACITOR	3300uF 50V M	
					C163	QETM1EM-478	E CAPACITOR	4700uF 25V M	
					C164	QETM1EM-478	E CAPACITOR	4700uF 25V M	
					C167	QETN1EM-476Z	E CAPACITOR	47uF 25V M	
					C168	QETN1CM-107Z	E CAPACITOR	100uF 16V M	
					C171	QETN1CM-107Z	E CAPACITOR	100uF 16V M	
					C172	QETN1CM-107Z	E CAPACITOR	100uF 16V M	
					C501	QETN1HM-475Z	E CAPACITOR	4.7uF 50V M	
					C503	QETN1HM-475Z	E CAPACITOR	4.7uF 50V M	
					C512	QETN1HM-475Z	E CAPACITOR	4.7uF 50V M	

△ Symbol No.	Part No.	Part Name	Description	Local	△ Symbol No.	Part No.	Part Name	Description	Local
C522	QETN1HM-106Z	E CAPACITOR	10uF 50V M		C3401	NCB31HK-152X	C CAPACITOR	1500pF 50V K	
C523	QETN1EM-476Z	E CAPACITOR	47uF 25V M		C3404	QETN1HM-225Z	E CAPACITOR	2.2uF 50V M	
C571	NCF31HZ-103X	C CAPACITOR	0.01uF 50V Z		C3501	NCB31HK-152X	C CAPACITOR	1500pF 50V K	
C591	NCF31HZ-103X	C CAPACITOR	0.01uF 50V Z		C3504	QETN1HM-225Z	E CAPACITOR	2.2uF 50V M	
C592	NCF31HZ-103X	C CAPACITOR	0.01uF 50V Z		C3601	NCB31HK-152X	C CAPACITOR	1500pF 50V K	
C601	QETN1CM-107Z	E CAPACITOR	100uF 16V M		C3604	QETN1HM-106Z	E CAPACITOR	100uF 50V M	
C604	NCF31HZ-103X	C CAPACITOR	0.01uF 50V Z		C3701	NCF31HZ-103X	C CAPACITOR	0.01uF 50V Z	
C605	NCF31HZ-103X	C CAPACITOR	0.01uF 50V Z		C3702	NCF31HZ-103X	C CAPACITOR	0.01uF 50V Z	
C606	QETN1HM-106Z	E CAPACITOR	10uF 50V M		C3703	NCF31HZ-103X	C CAPACITOR	0.01uF 50V Z	
C2102	NCB31CK-473X	C CAPACITOR	0.047uF 16V K		C3704	NCF31HZ-103X	C CAPACITOR	0.01uF 50V Z	
C2103	QETN1HM-475Z	E CAPACITOR	4.7uF 50V M		C3705	NCF31HZ-103X	C CAPACITOR	0.01uF 50V Z	
C2104	QETN1CM-107Z	E CAPACITOR	100uF 16V M		C3706	NCF31HZ-103X	C CAPACITOR	0.01uF 50V Z	
C2105	NDC31HJ-101X	C CAPACITOR	100pF 50V J		C3720	QETN1EM-476Z	E CAPACITOR	47uF 25V M	
C2106	NDC31HJ-3R0X	C CAPACITOR	3pF 50V J		C3721	QEK1CM-107Z	E CAPACITOR	100uF 16V M	
C2107	NCB21HK-104X	C CAPACITOR	0.1uF 50V K						
C2108	NCB21HK-104X	C CAPACITOR	0.1uF 50V K		R152	NRSA63J-222X	MG RESISTOR	2.2kΩ 1/16W J	
C2202	NCB31HK-471X	C CAPACITOR	470pF 50V K		△ R163	QRJ146J-221X	UNF C RESISTOR	220Ω 1/4W J	
C2203	QETN1HM-475Z	E CAPACITOR	4.7uF 50V M		R164	QRE141J-332Y	C RESISTOR	3.3kΩ 1/4W J	
C2204	QETN1CM-107Z	E CAPACITOR	100uF 16V M		R165	QRL027J-391	OMF RESISTOR	390Ω 2W J	
C2205	NDC31HJ-101X	C CAPACITOR	100pF 50V J		R166	QRL027J-391	OMF RESISTOR	390Ω 2W J	
C2206	NDC31HJ-3R0X	C CAPACITOR	3pF 50V J		△ R171	QRL027J-470	OMF RESISTOR	47Ω 2W J	
C2207	NCB21HK-104X	C CAPACITOR	0.1uF 50V K		R501	NRSA63J-472X	MG RESISTOR	4.7kΩ 1/16W J	
C2208	NCB21HK-104X	C CAPACITOR	0.1uF 50V K		R502	NRSA63J-104X	MG RESISTOR	100kΩ 1/16W J	
C2211	NCB21HK-104X	C CAPACITOR	0.1uF 50V K	C60UP	R504	NRSA63J-102X	MG RESISTOR	1kΩ 1/16W J	
C2212	NCB21HK-104X	C CAPACITOR	0.1uF 50V K	C60UP	R505	NRSA63J-102X	MG RESISTOR	1kΩ 1/16W J	
C2302	NCB31HK-471X	C CAPACITOR	470pF 50V K		R506	NRSA63J-103X	MG RESISTOR	10kΩ 1/16W J	
C2303	QETN1HM-475Z	E CAPACITOR	4.7uF 50V M		R508	NRSA63J-223X	MG RESISTOR	22kΩ 1/16W J	
C2304	QETN1CM-107Z	E CAPACITOR	100uF 16V M		R510	NRSA63J-472X	MG RESISTOR	4.7kΩ 1/16W J	
C2305	NDC31HJ-101X	C CAPACITOR	100pF 50V J		R523	NRSA63J-223X	MG RESISTOR	22kΩ 1/16W J	
C2306	NDC31HJ-3R0X	C CAPACITOR	3pF 50V J		R533	NRSA63J-103X	MG RESISTOR	10kΩ 1/16W J	
C2307	NCB21HK-104X	C CAPACITOR	0.1uF 50V K		R534	NRSA63J-103X	MG RESISTOR	10kΩ 1/16W J	
C2308	NCB21HK-104X	C CAPACITOR	0.1uF 50V K		R535	NRSA63J-104X	MG RESISTOR	100kΩ 1/16W J	
C2311	NCB21HK-104X	C CAPACITOR	0.1uF 50V K	C60UP	R536	NRSA63J-103X	MG RESISTOR	10kΩ 1/16W J	
C2312	NCB21HK-104X	C CAPACITOR	0.1uF 50V K	C60UP	R540	NRSA63J-472X	MG RESISTOR	4.7kΩ 1/16W J	
C2402	NCB31HK-471X	C CAPACITOR	470pF 50V K		R553	NRSA63J-153X	MG RESISTOR	15kΩ 1/16W J	
C2403	QETN1HM-475Z	E CAPACITOR	4.7uF 50V M		R554	NRSA63J-223X	MG RESISTOR	22kΩ 1/16W J	
C2404	QETN1CM-107Z	E CAPACITOR	100uF 16V M		R555	QRJ146J-271X	UNF C RESISTOR	270Ω 1/4W J	
C2405	NDC31HJ-101X	C CAPACITOR	100pF 50V J		R558	NRSA63J-223X	MG RESISTOR	22kΩ 1/16W J	
C2406	NDC31HJ-3R0X	C CAPACITOR	3pF 50V J		R559	NRSA63J-223X	MG RESISTOR	22kΩ 1/16W J	
C2407	NCB21HK-104X	C CAPACITOR	0.1uF 50V K		R560	NRSA63J-223X	MG RESISTOR	22kΩ 1/16W J	
C2408	NCB21HK-104X	C CAPACITOR	0.1uF 50V K		R561	NRSA63J-822X	MG RESISTOR	8.2kΩ 1/16W J	
C2411	NCB21HK-104X	C CAPACITOR	0.1uF 50V K	C60UP	R562	NRSA63J-393X	MG RESISTOR	39kΩ 1/16W J	
C2412	NCB21HK-104X	C CAPACITOR	0.1uF 50V K	C60UP	R563	NRSA63J-223X	MG RESISTOR	22kΩ 1/16W J	
C2502	NCB31HK-471X	C CAPACITOR	470pF 50V K		R574	NRSA02J-151X	MG RESISTOR	150Ω 1/10W J	
C2503	QETN1HM-475Z	E CAPACITOR	4.7uF 50V M		R601	NRSA63J-103X	MG RESISTOR	10kΩ 1/16W J	
C2504	QETN1CM-107Z	E CAPACITOR	100uF 16V M		R602	NRSA63J-392X	MG RESISTOR	3.9kΩ 1/16W J	
C2505	NDC31HJ-101X	C CAPACITOR	100pF 50V J		R603	NRSA63J-222X	MG RESISTOR	2.2kΩ 1/16W J	
C2506	NDC31HJ-3R0X	C CAPACITOR	3pF 50V J		R612	NRSA63J-223X	MG RESISTOR	22kΩ 1/16W J	
C2507	NCB21HK-104X	C CAPACITOR	0.1uF 50V K		R613	NRSA63J-223X	MG RESISTOR	22kΩ 1/16W J	
C2508	NCB21HK-104X	C CAPACITOR	0.1uF 50V K		R614	NRSA63J-223X	MG RESISTOR	22kΩ 1/16W J	
C2511	NCB21HK-104X	C CAPACITOR	0.1uF 50V K	C60UP	R621	NRSA63J-103X	MG RESISTOR	10kΩ 1/16W J	
C2512	NCB21HK-104X	C CAPACITOR	0.1uF 50V K	C60UP	R622	NRSA63J-223X	MG RESISTOR	22kΩ 1/16W J	
C2602	NCB31HK-471X	C CAPACITOR	470pF 50V K		R623	NRSA63J-103X	MG RESISTOR	10kΩ 1/16W J	
C2603	QETN1HM-475Z	E CAPACITOR	4.7uF 50V M		R624	NRSA63J-472X	MG RESISTOR	4.7kΩ 1/16W J	
C2604	QETN1CM-107Z	E CAPACITOR	100uF 16V M		R625	NRSA63J-472X	MG RESISTOR	4.7kΩ 1/16W J	
C2605	NDC31HJ-101X	C CAPACITOR	100pF 50V J		R626	NRSA63J-103X	MG RESISTOR	10kΩ 1/16W J	
C2606	NDC31HJ-3R0X	C CAPACITOR	3pF 50V J		R627	NRSA63J-102X	MG RESISTOR	1kΩ 1/16W J	
C2607	NCB21HK-104X	C CAPACITOR	0.1uF 50V K		R628	NRSA63J-223X	MG RESISTOR	22kΩ 1/16W J	
C2608	NCB21HK-104X	C CAPACITOR	0.1uF 50V K		R629	NRSA63J-103X	MG RESISTOR	10kΩ 1/16W J	
C2611	NCB21HK-104X	C CAPACITOR	0.1uF 50V K	C60UP	R646	NRSA63J-102X	MG RESISTOR	1kΩ 1/16W J	
C2612	NCB21HK-104X	C CAPACITOR	0.1uF 50V K	C60UP	R667	NRSA63J-472X	MG RESISTOR	4.7kΩ 1/16W J	
C2701	QETN1HM-107Z	E CAPACITOR	100uF 50V M		R671	NRSA63J-102X	MG RESISTOR	1kΩ 1/16W J	
C2702	QETN1EM-476Z	E CAPACITOR	47uF 25V M		R2101	NRSA63J-302X	MG RESISTOR	3kΩ 1/16W J	
C2703	QETN1HM-107Z	E CAPACITOR	100uF 50V M		R2103	NRSA63J-563X	MG RESISTOR	56kΩ 1/16W J	
C2704	QETN1HM-476Z	E CAPACITOR	47uF 50V M		R2104	NRSA63J-561X	MG RESISTOR	560Ω 1/16W J	
C2705	QETN1HM-107Z	E CAPACITOR	100uF 50V M		R2105	NRSA63J-563X	MG RESISTOR	56kΩ 1/16W J	
C2706	QETN1HM-107Z	E CAPACITOR	100uF 50V M		R2106	QRZ0224-R22	EMIT RESISTOR	0.22Ω	
C2707	QETN1HM-106Z	E CAPACITOR	10uF 50V M		R2107	NRSA63J-102X	MG RESISTOR	1kΩ 1/16W J	
C2708	QETN1HM-106Z	E CAPACITOR	10uF 50V M		R2108	NRSA63J-153X	MG RESISTOR	15kΩ 1/16W J	
C2711	QETN1HM-106Z	E CAPACITOR	10uF 50V M		R2109	NRSA63J-473X	MG RESISTOR	47kΩ 1/16W J	
C2712	NCF31HZ-103X	C CAPACITOR	0.01uF 50V Z		R2110	QRK126J-4R7X	UNF C RESISTOR	4.7Ω 1/2W J	
C2713	NCF31HZ-103X	C CAPACITOR	0.01uF 50V Z		R2111	QRJ146J-100X	UNF C RESISTOR	10Ω 1/4W J	
C3101	NCB31HK-152X	C CAPACITOR	1500pF 50V K		R2112	NRSA63J-393X	MG RESISTOR	39kΩ 1/16W J	
C3104	QETN1HM-225Z	E CAPACITOR	2.2uF 50V M		R2113	NRSA63J-222X	MG RESISTOR	2.2kΩ 1/16W J	
C3201	NCB31HK-152X	C CAPACITOR	1500pF 50V K		R2114	NRSA63J-104X	MG RESISTOR	100kΩ 1/16W J	
C3204	QETN1HM-225Z	E CAPACITOR	2.2uF 50V M		R2201	NRSA63J-103X	MG RESISTOR	10kΩ 1/16W J	
C3301	NCB31HK-152X	C CAPACITOR	1500pF 50V K		R2203	NRSA63J-563X	MG RESISTOR	56kΩ 1/16W J	
C3304	QETN1HM-225Z	E CAPACITOR	2.2uF 50V M		R2204	NRSA63J-561X	MG RESISTOR	560Ω 1/16W J	

△ Symbol No.	Part No.	Part Name	Description	Local	△ Symbol No.	Part No.	Part Name	Description	Local
R2205	NRSA63J-563X	MG RESISTOR	56kΩ 1/16W J		R2712	NRSA63J-562X	MG RESISTOR	5.6kΩ 1/16W J	
R2206	QRZ0224-R22	EMIT RESISTOR	0.22Ω		R2713	NRSA63J-562X	MG RESISTOR	5.6kΩ 1/16W J	
R2207	NRSA63J-102X	MG RESISTOR	1kΩ 1/16W J		R2721	QRE141J-472Y	C RESISTOR	4.7kΩ 1/4W J	
R2208	NRSA63J-153X	MG RESISTOR	15kΩ 1/16W J		R2722	QRE141J-472Y	C RESISTOR	4.7kΩ 1/4W J	
R2209	NRSA63J-473X	MG RESISTOR	47kΩ 1/16W J		R2723	QRE141J-472Y	C RESISTOR	4.7kΩ 1/4W J	
R2210	QRK126J-4R7X	UNF C RESISTOR	4.7Ω 1/2W J		R2724	QRE141J-472Y	C RESISTOR	4.7kΩ 1/4W J	
R2211	QRJ146J-100X	UNF C RESISTOR	10Ω 1/4W J		R3101	NRSA63J-203X	MG RESISTOR	20kΩ 1/16W J	
R2212	NRSA63J-432X	MG RESISTOR	4.3kΩ 1/16W J		R3104	NRSA63J-223X	MG RESISTOR	22kΩ 1/16W J	
R2213	NRSA63J-222X	MG RESISTOR	2.2kΩ 1/16W J		R3105	NRSA63J-474X	MG RESISTOR	470kΩ 1/16W J	
R2214	NRSA63J-104X	MG RESISTOR	100kΩ 1/16W J		R3106	NRSA63J-470X	MG RESISTOR	47Ω 1/16W J	
R2215	QRJ146J-100X	UNF C RESISTOR	10Ω 1/4W J	C60UP	R3107	NRSA63J-334X	MG RESISTOR	330kΩ 1/16W J	
R2301	NRSA63J-103X	MG RESISTOR	10kΩ 1/16W J		R3109	NRSA63J-102X	MG RESISTOR	1kΩ 1/16W J	
R2303	NRSA63J-563X	MG RESISTOR	56kΩ 1/16W J		R3110	NRSA63J-104X	MG RESISTOR	100kΩ 1/16W J	
R2304	NRSA63J-561X	MG RESISTOR	560Ω 1/16W J		R3111	NRSA63J-471X	MG RESISTOR	470Ω 1/16W J	
R2305	NRSA63J-563X	MG RESISTOR	56kΩ 1/16W J		R3201	NRSA63J-203X	MG RESISTOR	20kΩ 1/16W J	
R2306	QRZ0224-R22	EMIT RESISTOR	0.22Ω		R3204	NRSA63J-223X	MG RESISTOR	22kΩ 1/16W J	
R2307	NRSA63J-102X	MG RESISTOR	1kΩ 1/16W J		R3205	NRSA63J-474X	MG RESISTOR	470kΩ 1/16W J	
R2308	NRSA63J-153X	MG RESISTOR	15kΩ 1/16W J		R3206	NRSA63J-470X	MG RESISTOR	47Ω 1/16W J	
R2309	NRSA63J-473X	MG RESISTOR	47kΩ 1/16W J		R3207	NRSA63J-334X	MG RESISTOR	330kΩ 1/16W J	
R2310	QRK126J-4R7X	UNF C RESISTOR	4.7Ω 1/2W J		R3209	NRSA63J-102X	MG RESISTOR	1kΩ 1/16W J	
R2311	QRJ146J-100X	UNF C RESISTOR	10Ω 1/4W J		R3210	NRSA63J-104X	MG RESISTOR	100kΩ 1/16W J	
R2312	NRSA63J-432X	MG RESISTOR	4.3kΩ 1/16W J		R3211	NRSA63J-471X	MG RESISTOR	470Ω 1/16W J	
R2313	NRSA63J-222X	MG RESISTOR	2.2kΩ 1/16W J		R3301	NRSA63J-203X	MG RESISTOR	20kΩ 1/16W J	
R2314	NRSA63J-104X	MG RESISTOR	100kΩ 1/16W J		R3304	NRSA63J-223X	MG RESISTOR	22kΩ 1/16W J	
R2315	QRJ146J-100X	UNF C RESISTOR	10Ω 1/4W J	C60UP	R3305	NRSA63J-474X	MG RESISTOR	470kΩ 1/16W J	
R2401	NRSA63J-622X	MG RESISTOR	6.2kΩ 1/16W J		R3306	NRSA63J-470X	MG RESISTOR	47Ω 1/16W J	
R2403	NRSA63J-563X	MG RESISTOR	56kΩ 1/16W J		R3307	NRSA63J-334X	MG RESISTOR	330kΩ 1/16W J	
R2404	NRSA63J-561X	MG RESISTOR	560Ω 1/16W J		R3309	NRSA63J-102X	MG RESISTOR	1kΩ 1/16W J	
R2405	NRSA63J-563X	MG RESISTOR	56kΩ 1/16W J		R3310	NRSA63J-104X	MG RESISTOR	100kΩ 1/16W J	
R2406	QRZ0224-R22	EMIT RESISTOR	0.22Ω		R3311	NRSA63J-471X	MG RESISTOR	470Ω 1/16W J	
R2407	NRSA63J-102X	MG RESISTOR	1kΩ 1/16W J		R3401	NRSA63J-203X	MG RESISTOR	20kΩ 1/16W J	
R2408	NRSA63J-153X	MG RESISTOR	15kΩ 1/16W J		R3404	NRSA63J-223X	MG RESISTOR	22kΩ 1/16W J	
R2409	NRSA63J-473X	MG RESISTOR	47kΩ 1/16W J		R3405	NRSA63J-474X	MG RESISTOR	470kΩ 1/16W J	
R2410	QRK126J-4R7X	UNF C RESISTOR	4.7Ω 1/2W J		R3406	NRSA63J-470X	MG RESISTOR	47Ω 1/16W J	
R2411	QRJ146J-100X	UNF C RESISTOR	10Ω 1/4W J		R3407	NRSA63J-334X	MG RESISTOR	330kΩ 1/16W J	
R2412	NRSA63J-622X	MG RESISTOR	6.2kΩ 1/16W J		R3409	NRSA63J-102X	MG RESISTOR	1kΩ 1/16W J	
R2413	NRSA63J-222X	MG RESISTOR	2.2kΩ 1/16W J		R3410	NRSA63J-104X	MG RESISTOR	100kΩ 1/16W J	
R2414	NRSA63J-104X	MG RESISTOR	100kΩ 1/16W J		R3411	NRSA63J-471X	MG RESISTOR	470Ω 1/16W J	
R2415	QRJ146J-100X	UNF C RESISTOR	10Ω 1/4W J	C60UP	R3501	NRSA63J-203X	MG RESISTOR	20kΩ 1/16W J	
R2501	NRSA63J-622X	MG RESISTOR	6.2kΩ 1/16W J		R3504	NRSA63J-223X	MG RESISTOR	22kΩ 1/16W J	
R2503	NRSA63J-563X	MG RESISTOR	56kΩ 1/16W J		R3505	NRSA63J-474X	MG RESISTOR	470kΩ 1/16W J	
R2504	NRSA63J-561X	MG RESISTOR	560Ω 1/16W J		R3506	NRSA63J-470X	MG RESISTOR	47Ω 1/16W J	
R2505	NRSA63J-563X	MG RESISTOR	56kΩ 1/16W J		R3507	NRSA63J-334X	MG RESISTOR	330kΩ 1/16W J	
R2506	QRZ0224-R22	EMIT RESISTOR	0.22Ω		R3509	NRSA63J-102X	MG RESISTOR	1kΩ 1/16W J	
R2507	NRSA63J-102X	MG RESISTOR	1kΩ 1/16W J		R3510	NRSA63J-104X	MG RESISTOR	100kΩ 1/16W J	
R2508	NRSA63J-153X	MG RESISTOR	15kΩ 1/16W J		R3511	NRSA63J-471X	MG RESISTOR	470Ω 1/16W J	
R2509	NRSA63J-473X	MG RESISTOR	47kΩ 1/16W J		R3601	NRSA63J-203X	MG RESISTOR	20kΩ 1/16W J	
R2510	QRK126J-4R7X	UNF C RESISTOR	4.7Ω 1/2W J		R3604	NRSA63J-223X	MG RESISTOR	22kΩ 1/16W J	
R2511	QRJ146J-100X	UNF C RESISTOR	10Ω 1/4W J		R3605	NRSA63J-154X	MG RESISTOR	150kΩ 1/16W J	
R2512	NRSA63J-622X	MG RESISTOR	6.2kΩ 1/16W J		R3607	NRSA63J-104X	MG RESISTOR	100kΩ 1/16W J	
R2513	NRSA63J-222X	MG RESISTOR	2.2kΩ 1/16W J		R3610	NRSA63J-104X	MG RESISTOR	100kΩ 1/16W J	
R2514	NRSA63J-104X	MG RESISTOR	100kΩ 1/16W J		R3611	NRSA63J-471X	MG RESISTOR	470Ω 1/16W J	
R2515	QRJ146J-100X	UNF C RESISTOR	10Ω 1/4W J	C60UP	R3717	NRSA63J-103X	MG RESISTOR	10kΩ 1/16W J	
R2601	NRSA63J-103X	MG RESISTOR	10kΩ 1/16W J		R3719	QRE141J-102Y	C RESISTOR	1kΩ 1/4W J	
R2603	NRSA63J-563X	MG RESISTOR	56kΩ 1/16W J		△ R3720	QRJ146J-100X	UNF C RESISTOR	10Ω 1/4W J	
R2604	NRSA63J-561X	MG RESISTOR	560Ω 1/16W J		R3721	NRSA63J-221X	MG RESISTOR	220Ω 1/16W J	
R2605	NRSA63J-563X	MG RESISTOR	56kΩ 1/16W J		△ R3727	QRL01DJ-180X	OMF RESISTOR	18Ω 1W J	
R2606	QRZ0224-R22	EMIT RESISTOR	0.22Ω		R3732	NRSA63J-223X	MG RESISTOR	22kΩ 1/16W J	
R2607	NRSA63J-102X	MG RESISTOR	1kΩ 1/16W J		L2101	QLLZ005-R45	COIL	0.45uH	
R2608	NRSA63J-153X	MG RESISTOR	15kΩ 1/16W J		L2201	QLLZ005-R45	COIL	0.45uH	
R2609	NRSA63J-473X	MG RESISTOR	47kΩ 1/16W J		L2202	QLLZ005-R45	COIL	0.45uH	C60UP
R2610	QRK126J-4R7X	UNF C RESISTOR	4.7Ω 1/2W J		L2301	QLLZ005-R45	COIL	0.45uH	
R2611	QRJ146J-100X	UNF C RESISTOR	10Ω 1/4W J		L2302	QLLZ005-R45	COIL	0.45uH	C60UP
R2612	NRSA63J-432X	MG RESISTOR	4.3kΩ 1/16W J		L2401	QLLZ005-R45	COIL	0.45uH	
R2613	NRSA63J-222X	MG RESISTOR	2.2kΩ 1/16W J		L2402	QLLZ005-R45	COIL	0.45uH	C60UP
R2614	NRSA63J-104X	MG RESISTOR	100kΩ 1/16W J		L2501	QLLZ005-R45	COIL	0.45uH	
R2615	QRJ146J-100X	UNF C RESISTOR	10Ω 1/4W J	C60UP	L2502	QLLZ005-R45	COIL	0.45uH	C60UP
△ R2701	QRZ9005-220X	FUSI RESISTOR	22Ω		L2601	QLLZ005-R45	COIL	0.45uH	
△ R2702	QRZ9005-220X	FUSI RESISTOR	22Ω		L2602	QLLZ005-R45	COIL	0.45uH	C60UP
R2703	NRSA63J-471X	MG RESISTOR	470Ω 1/16W J		△ CN101	QGA7901C1-02	CONNECTOR	W-B (1-2)	
R2704	NRSA63J-471X	MG RESISTOR	470Ω 1/16W J		△ CN102	QGA7901C1-04	CONNECTOR	W-B (1-4)	C60US,C60UW, C60UX,C60UY, C60UG
R2705	NRSA63J-333X	MG RESISTOR	33kΩ 1/16W J		△ CN102	QGA7901C1-02	CONNECTOR	W-B (1-2)	C60UP
△ R2706	QRZ9006-4R7X	FUSI RESISTOR	4.7Ω		△ CN151	QGA3901C1-05	CONNECTOR	W-B (1-5)	
△ R2707	QRZ9006-4R7X	FUSI RESISTOR	4.7Ω		CN271	QGB2510J1-14	CONNECTOR	B-B (1-14)	
△ R2708	QRZ9006-4R7X	FUSI RESISTOR	4.7Ω						
△ R2709	QRZ9006-4R7X	FUSI RESISTOR	4.7Ω						
△ R2710	QRZ9005-100X	FUSI RESISTOR	10Ω						
R2711	NRSA63J-333X	MG RESISTOR	33kΩ 1/16W J						

△ Symbol No.	Part No.	Part Name	Description	Local
CN272	QGB2510J1-09	CONNECTOR	B-B (1-9)	
CN273	QGB2510J1-14	CONNECTOR	B-B (1-14)	
CN274	QGA3901C1-02	CONNECTOR	W-B (1-2)	
CN371	QGA2501C1-02	CONNECTOR	W-B (1-2)	
CN372	QGB2510K2-09	CONNECTOR	B-B (1-9)	
CN501	QGB2510K2-14	CONNECTOR	B-B (1-14)	
CN502	QGB2510K2-14	CONNECTOR	B-B (1-14)	
EP201	QNZ0869-001	EARTH PLATE		
EP501	QNZ0869-001	EARTH PLATE		
FC101	QNG0019-001Z	FUSE CLIP		
FC102	QNG0019-001Z	FUSE CLIP		
FC103	QNG0019-001Z	FUSE CLIP		C60US,C60UW, C60UX,C60UY, C60UG
FC104	QNG0019-001Z	FUSE CLIP		C60US,C60UW, C60UX,C60UY, C60UG
FC155	QNG0019-001Z	FUSE CLIP		
FC156	QNG0019-001Z	FUSE CLIP		
FC157	QNG0019-001Z	FUSE CLIP		
FC158	QNG0019-001Z	FUSE CLIP		
FW501	QUM213-28Z4Z4-E	RIBBON WIRE		
HS151	QZW0138-001	HEAT SINK		
J2701	QND0118-001	DIN CONNECTOR		
J2702	QNB0195-001	SPEAKER TERMINA		
K191	QQR0621-001Z	COIL		C60UP
K192	QQR0621-001Z	COIL		
K193	QQR0621-001Z	COIL		
K194	QQR0621-001Z	COIL		
△ RY101	QSK0142-001	RELAY		
RY271	QSK0127-001	RELAY		
RY272	QSK0127-001	RELAY		
RY273	QSK0127-001	RELAY		
△ S901	QSW0924-001	VOLTAGE SWITCH		C60US,C60UW, C60UX,C60UY, C60UG
TH271	NAD0025-103X	N THERMISTOR	10kΩ	
WC201	QZW0112-001	WIRE CLAMP		
X601	QAX0246-001Z	C RESONATOR	8.00MHz	

△ Symbol No.	Part No.	Part Name	Description	Local
C101	NCF31EZ-104X	C CAPACITOR	0.1uF 25V Z	
C102	NCF31EZ-104X	C CAPACITOR	0.1uF 25V Z	
C103	NCF31EZ-104X	C CAPACITOR	0.1uF 25V Z	
C104	NCF31EZ-104X	C CAPACITOR	0.1uF 25V Z	
C105	NEAF0JM-476X	E CAPACITOR	47uF 6.3V M	
C106	NBE20JM-226X	TA E CAPACITOR	22uF 6.3V M	
C107	NCF31EZ-104X	C CAPACITOR	0.1uF 25V Z	
C108	NBE20JM-226X	TA E CAPACITOR	22uF 6.3V M	
C201	NDC31HJ-221X	C CAPACITOR	220pF 50V J	
C202	NDC31HJ-221X	C CAPACITOR	220pF 50V J	
C203	NCB31HK-103X	C CAPACITOR	0.01uF 50V K	
C204	NCF31EZ-104X	C CAPACITOR	0.1uF 25V Z	
C205	NCB31HK-271X	C CAPACITOR	270pF 50V K	
C206	NDC31HJ-151X	C CAPACITOR	150pF 50V J	
C210	NCF31AZ-105X	C CAPACITOR	1uF 10V Z	
C211	NCB31HK-223X	C CAPACITOR	0.022uF 50V K	
C217	NCF31EZ-104X	C CAPACITOR	0.1uF 25V Z	
C251	NCB31AK-474X	C CAPACITOR	0.47uF 10V K	
C256	NCB31CK-104X	C CAPACITOR	0.1uF 16V K	
C257	NCB31HK-822X	C CAPACITOR	8200pF 50V K	
C258	NCB31CK-153X	C CAPACITOR	0.015uF 16V K	
C259	NCB31CK-153X	C CAPACITOR	0.015uF 16V K	
C260	NCB31HK-223X	C CAPACITOR	0.022uF 50V K	
C261	NCB31HK-223X	C CAPACITOR	0.022uF 50V K	
C262	NCB31HK-223X	C CAPACITOR	0.022uF 50V K	
C263	NEAF1CM-107X	E CAPACITOR	100uF 16V M	
C301	NEAF0GM-227X	E CAPACITOR	220uF 4V M	
C302	NEAF0GM-476X	E CAPACITOR	47uF 4V M	
C303	NEAF0GM-476X	E CAPACITOR	47uF 4V M	
C304	NCB30JK-105X	C CAPACITOR	1uF 6.3V K	
C305	NCF31EZ-104X	C CAPACITOR	0.1uF 25V Z	
C306	NCF31EZ-104X	C CAPACITOR	0.1uF 25V Z	
C307	NCF31EZ-104X	C CAPACITOR	0.1uF 25V Z	
C308	NCF31EZ-104X	C CAPACITOR	0.1uF 25V Z	
C309	NCF31EZ-104X	C CAPACITOR	0.1uF 25V Z	
C310	NCF31EZ-104X	C CAPACITOR	0.1uF 25V Z	
C311	NCF31EZ-104X	C CAPACITOR	0.1uF 25V Z	
C312	NCF31EZ-104X	C CAPACITOR	0.1uF 25V Z	
C314	NCF31EZ-104X	C CAPACITOR	0.1uF 25V Z	
C316	NCF31EZ-104X	C CAPACITOR	0.1uF 25V Z	
C317	NCF31EZ-104X	C CAPACITOR	0.1uF 25V Z	
C318	NCF31EZ-104X	C CAPACITOR	0.1uF 25V Z	
C319	NCF31EZ-104X	C CAPACITOR	0.1uF 25V Z	
C320	NCB31CK-104X	C CAPACITOR	0.1uF 16V K	
C321	NCB31CK-104X	C CAPACITOR	0.1uF 16V K	
C322	NCB31CK-104X	C CAPACITOR	0.1uF 16V K	
C323	NCB31CK-104X	C CAPACITOR	0.1uF 16V K	
C324	NCB30JK-105X	C CAPACITOR	1uF 6.3V K	
C325	NDC31HJ-120X	C CAPACITOR	12pF 50V J	
C326	NDC31HJ-120X	C CAPACITOR	12pF 50V J	
C327	NCF31EZ-104X	C CAPACITOR	0.1uF 25V Z	
C328	NCB31HK-103X	C CAPACITOR	0.01uF 50V K	
C330	NCF31EZ-104X	C CAPACITOR	0.1uF 25V Z	
C331	NCB31CK-333X	C CAPACITOR	0.033uF 16V K	
C332	NCF31EZ-104X	C CAPACITOR	0.1uF 25V Z	
C333	NCF31EZ-104X	C CAPACITOR	0.1uF 25V Z	
C334	NCF31EZ-104X	C CAPACITOR	0.1uF 25V Z	
C335	NCF31EZ-104X	C CAPACITOR	0.1uF 25V Z	
C337	NCB31CK-183X	C CAPACITOR	0.018uF 16V K	
C338	NCB31HK-562X	C CAPACITOR	5600pF 50V K	
C339	NBE20JM-106X	TA E CAPACITOR	10uF 6.3V M	
C340	NCB30JK-105X	C CAPACITOR	1uF 6.3V K	
C341	NCB30JK-105X	C CAPACITOR	1uF 6.3V K	
C345	NCF31EZ-104X	C CAPACITOR	0.1uF 25V Z	
C347	NCB31CK-104X	C CAPACITOR	0.1uF 16V K	
C348	NCB31CK-104X	C CAPACITOR	0.1uF 16V K	
C349	NCF31EZ-104X	C CAPACITOR	0.1uF 25V Z	
C350	NCB31HK-103X	C CAPACITOR	0.01uF 50V K	
C351	NCB31HK-103X	C CAPACITOR	0.01uF 50V K	
C352	NCB31CK-153X	C CAPACITOR	0.015uF 16V K	
C353	NCB31HK-561X	C CAPACITOR	560pF 50V K	
C354	NCB31HK-561X	C CAPACITOR	560pF 50V K	
C356	NCB30JK-105X	C CAPACITOR	1uF 6.3V K	
C359	NCB30JK-105X	C CAPACITOR	1uF 6.3V K	
C370	NCF31EZ-104X	C CAPACITOR	0.1uF 25V Z	
C371	NCF31AZ-105X	C CAPACITOR	1uF 10V Z	
C372	NCF31EZ-104X	C CAPACITOR	0.1uF 25V Z	
C373	NCF31EZ-104X	C CAPACITOR	0.1uF 25V Z	

DVD servo board

Block No. [0][6]

△ Symbol No.	Part No.	Part Name	Description	Local
IC201	LA6502-X	IC		
IC301	MN2DS0016AA	IC		
IC302	MM1701CH-X	IC		
IC303	XC2164A51FM-X	IC		
IC305	MM1563DF-X	IC		
IC451	MN101C61GNW	IC		
IC452	BR93L56RF-W-X	IC		
IC453	S-80830CNNB-G-W	IC		
IC505	K4S641632H-UC75	IC		
IC505	or K4S641632K-UC75	IC		
IC509	-----	IC(MICRO C ROM)		
IC509	or -----	IC(MICRO C ROM)		
IC510	BR24L16F-W-X	IC		
IC701	AK4387ET-X	IC		
IC702	AK4387ET-X	IC		
IC703	AK4387ET-X	IC		
IC704	AK5358ET-X	IC		
IC705	MM1615AN-X	IC		
IC801	MM1565AF-X	IC		
IC811	ISP1106DH-X	IC		
Q101	KTA1001Y/-X	TRANSISTOR		
Q101	or 2SB1424/R/-W	TRANSISTOR		
Q102	2SC4617/R/-X	TRANSISTOR		
Q103	KTA1001Y/-X	TRANSISTOR		
Q103	or 2SB1424/R/-W	TRANSISTOR		
Q104	2SC4617/R/-X	TRANSISTOR		
Q801	KRA104S-X	DIGI TRANSISTOR		
Q801	or UN2113-X	DIGI TRANSISTOR		

△ Symbol No.	Part No.	Part Name	Description	Local	△ Symbol No.	Part No.	Part Name	Description	Local
C374	NCF31EZ-104X	C CAPACITOR	0.1uF 25V Z		R251	NRSA125J-R39X	MG RESISTOR	0.39Ω 1/2W J	
C375	NCF31EZ-104X	C CAPACITOR	0.1uF 25V Z		R259	NRSA63J-103X	MG RESISTOR	10kΩ 1/16W J	
C378	NCF31EZ-104X	C CAPACITOR	0.1uF 25V Z		R303	NRSA63J-220X	MG RESISTOR	22Ω 1/16W J	
C379	NCF31EZ-104X	C CAPACITOR	0.1uF 25V Z		R306	NRSA63J-102X	MG RESISTOR	1kΩ 1/16W J	
C380	NCB21CK-105X	C CAPACITOR	1uF 16V K		R307	NRSA63J-102X	MG RESISTOR	1kΩ 1/16W J	
C381	NCB21AK-225X	C CAPACITOR	2.2uF 10V K		R309	NRSA63J-104X	MG RESISTOR	100kΩ 1/16W J	
C382	NCB31HK-471X	C CAPACITOR	470pF 50V K		R310	NRSA63J-101X	MG RESISTOR	100Ω 1/16W J	
C383	NCF31EZ-104X	C CAPACITOR	0.1uF 25V Z		R311	NRSA63J-331X	MG RESISTOR	330Ω 1/16W J	
C393	NCB31HK-103X	C CAPACITOR	0.01uF 50V K		R312	NRSA63J-331X	MG RESISTOR	330Ω 1/16W J	
C451	NCF31EZ-104X	C CAPACITOR	0.1uF 25V Z		R316	NRSA63J-102X	MG RESISTOR	1kΩ 1/16W J	
C452	NCF31EZ-104X	C CAPACITOR	0.1uF 25V Z		R318	NRSA63J-220X	MG RESISTOR	22Ω 1/16W J	
C453	NCF31EZ-104X	C CAPACITOR	0.1uF 25V Z		R319	NRSA63J-103X	MG RESISTOR	10kΩ 1/16W J	
C454	NCB31HK-103X	C CAPACITOR	0.01uF 50V K		R322	NRSA63J-331X	MG RESISTOR	330Ω 1/16W J	
C455	NCB31HK-103X	C CAPACITOR	0.01uF 50V K		R323	NRSA63J-331X	MG RESISTOR	330Ω 1/16W J	
C551	NCF31EZ-104X	C CAPACITOR	0.1uF 25V Z		R324	NRSA63J-331X	MG RESISTOR	330Ω 1/16W J	
C554	NCF31EZ-104X	C CAPACITOR	0.1uF 25V Z		R325	NRSA63J-331X	MG RESISTOR	330Ω 1/16W J	
C555	NCF31EZ-104X	C CAPACITOR	0.1uF 25V Z		R326	NRSA63J-103X	MG RESISTOR	10kΩ 1/16W J	
C557	NCB31HK-102X	C CAPACITOR	1000pF 50V K		R327	NRSA63J-103X	MG RESISTOR	10kΩ 1/16W J	
C558	NBE20JM-226X	TA E CAPACITOR	22uF 6.3V M		R332	NRSA63J-221X	MG RESISTOR	220Ω 1/16W J	
C559	NCF31EZ-104X	C CAPACITOR	0.1uF 25V Z		R333	NRSA63J-331X	MG RESISTOR	330Ω 1/16W J	
C560	NCF31EZ-104X	C CAPACITOR	0.1uF 25V Z		R334	NRSA63J-0R0X	MG RESISTOR	0Ω 1/16W J	
C562	NCF31AZ-105X	C CAPACITOR	1uF 10V Z		R335	NRSA63J-0R0X	MG RESISTOR	0Ω 1/16W J	
C563	NCF31EZ-104X	C CAPACITOR	0.1uF 25V Z		R336	NRSA63J-0R0X	MG RESISTOR	0Ω 1/16W J	
C564	NCF31EZ-104X	C CAPACITOR	0.1uF 25V Z		R337	NRSA63J-0R0X	MG RESISTOR	0Ω 1/16W J	
C701	NCF31EZ-104X	C CAPACITOR	0.1uF 25V Z		R338	NRSA63J-0R0X	MG RESISTOR	0Ω 1/16W J	
C702	NCF31EZ-104X	C CAPACITOR	0.1uF 25V Z		R339	NRSA63J-0R0X	MG RESISTOR	0Ω 1/16W J	
C703	NCF31EZ-104X	C CAPACITOR	0.1uF 25V Z		R340	NRSA63D-303X	MG RESISTOR	30kΩ 1/16W D	
C704	NEAF0JM-476X	E CAPACITOR	47uF 6.3V M		R341	NRSA63D-512X	MG RESISTOR	5.1kΩ 1/16W D	
C706	NEAF1CM-106X	E CAPACITOR	10uF 16V M		R342	NRSA63D-222X	MG RESISTOR	2.2kΩ 1/16W D	
C707	NCF31EZ-104X	C CAPACITOR	0.1uF 25V Z		R345	NRSA63J-221X	MG RESISTOR	220Ω 1/16W J	
C708	NCF31EZ-104X	C CAPACITOR	0.1uF 25V Z		R346	NRSA63J-223X	MG RESISTOR	22kΩ 1/16W J	
C709	NCF31EZ-104X	C CAPACITOR	0.1uF 25V Z		R347	NRSA63J-203X	MG RESISTOR	20kΩ 1/16W J	
C711	NCB21CK-105X	C CAPACITOR	1uF 16V K		R348	NRSA63J-0R0X	MG RESISTOR	0Ω 1/16W J	
C712	NCB31HK-103X	C CAPACITOR	0.01uF 50V K		R350	NRSA63J-911X	MG RESISTOR	910Ω 1/16W J	
C713	NCB21CK-105X	C CAPACITOR	1uF 16V K		R351	NRSA63J-471X	MG RESISTOR	470Ω 1/16W J	
C740	NCB31CK-104X	C CAPACITOR	0.1uF 16V K		R352	NRSA63J-105X	MG RESISTOR	1MΩ 1/16W J	
C741	NCF31AZ-105X	C CAPACITOR	1uF 10V Z		R353	NRSA63J-101X	MG RESISTOR	100Ω 1/16W J	
C742	NCF31EZ-104X	C CAPACITOR	0.1uF 25V Z		R357	NRSA63J-221X	MG RESISTOR	220Ω 1/16W J	
C743	NCF31EZ-104X	C CAPACITOR	0.1uF 25V Z		R358	NRSA63J-221X	MG RESISTOR	220Ω 1/16W J	
C744	NEAF1CM-106X	E CAPACITOR	10uF 16V M		R359	NRSA63J-221X	MG RESISTOR	220Ω 1/16W J	
C745	NEAF1CM-106X	E CAPACITOR	10uF 16V M		R360	NRSA63J-221X	MG RESISTOR	220Ω 1/16W J	
C801	NCB21CK-105X	C CAPACITOR	1uF 16V K		R362	NRSA63J-470X	MG RESISTOR	47Ω 1/16W J	
C802	NCB21AK-225X	C CAPACITOR	2.2uF 10V K		R367	NRSA63J-221X	MG RESISTOR	220Ω 1/16W J	
C803	NEAF0JM-227X	E CAPACITOR	220uF 6.3V M		R371	NRSA63D-203X	MG RESISTOR	20kΩ 1/16W D	
C804	NCB31HK-471X	C CAPACITOR	470pF 50V K		R372	NRSA63J-103X	MG RESISTOR	10kΩ 1/16W J	
C811	NCF31EZ-104X	C CAPACITOR	0.1uF 25V Z		R373	NRSA63J-103X	MG RESISTOR	10kΩ 1/16W J	
C812	NCF31EZ-104X	C CAPACITOR	0.1uF 25V Z		R375	NRSA63J-471X	MG RESISTOR	470Ω 1/16W J	
					R376	NRSA63J-102X	MG RESISTOR	1kΩ 1/16W J	
R101	NRSA63J-101X	MG RESISTOR	100Ω 1/16W J		R383	NRSA63J-101X	MG RESISTOR	100Ω 1/16W J	
R102	NRSA63J-101X	MG RESISTOR	100Ω 1/16W J		R384	NRSA63J-102X	MG RESISTOR	1kΩ 1/16W J	
R103	NRSA63J-562X	MG RESISTOR	5.6kΩ 1/16W J		R385	NRSA63J-102X	MG RESISTOR	1kΩ 1/16W J	
R104	NRSA63J-432X	MG RESISTOR	4.3kΩ 1/16W J		R392	NRSA63J-103X	MG RESISTOR	10kΩ 1/16W J	
R105	NRS181J-180X	MG RESISTOR	18Ω 1/8W J		R452	NRSA63J-222X	MG RESISTOR	2.2kΩ 1/16W J	
R106	NRSA63J-2R2X	MG RESISTOR	2.2Ω 1/16W J		R453	NRSA63J-103X	MG RESISTOR	10kΩ 1/16W J	
R107	NRSA63J-102X	MG RESISTOR	1kΩ 1/16W J		R454	NRSA63J-103X	MG RESISTOR	10kΩ 1/16W J	
R108	NRSA63J-471X	MG RESISTOR	470Ω 1/16W J		R455	NRSA63J-103X	MG RESISTOR	10kΩ 1/16W J	
R109	NRSA63J-331X	MG RESISTOR	330Ω 1/16W J		R456	NRSA63J-103X	MG RESISTOR	10kΩ 1/16W J	
R111	NRSA63J-562X	MG RESISTOR	5.6kΩ 1/16W J		R457	NRSA63J-101X	MG RESISTOR	100Ω 1/16W J	
R112	NRSA63J-432X	MG RESISTOR	4.3kΩ 1/16W J		R458	NRSA63J-102X	MG RESISTOR	1kΩ 1/16W J	
R113	NRS181J-180X	MG RESISTOR	18Ω 1/8W J		R461	NRSA63J-101X	MG RESISTOR	100Ω 1/16W J	
R114	NRSA63J-2R2X	MG RESISTOR	2.2Ω 1/16W J		R463	NRSA63J-101X	MG RESISTOR	100Ω 1/16W J	
R115	NRSA63J-102X	MG RESISTOR	1kΩ 1/16W J		R464	NRSA63J-101X	MG RESISTOR	100Ω 1/16W J	
R116	NRSA63J-471X	MG RESISTOR	470Ω 1/16W J		R465	NRSA63J-102X	MG RESISTOR	1kΩ 1/16W J	
R117	NRSA63J-331X	MG RESISTOR	330Ω 1/16W J		R531	NRSA63J-103X	MG RESISTOR	10kΩ 1/16W J	
R125	NRSA63J-1R0X	MG RESISTOR	1Ω 1/16W J		R535	NRSA63J-473X	MG RESISTOR	47kΩ 1/16W J	
R127	NRSA63J-432X	MG RESISTOR	4.3kΩ 1/16W J		R541	NRSA63J-473X	MG RESISTOR	47kΩ 1/16W J	
R128	NRSA63J-562X	MG RESISTOR	5.6kΩ 1/16W J		R542	NRSA63J-473X	MG RESISTOR	47kΩ 1/16W J	
R201	NRSA63J-471X	MG RESISTOR	470Ω 1/16W J		R701	NRSA63J-2R2X	MG RESISTOR	2.2Ω 1/16W J	
R202	NRSA63J-102X	MG RESISTOR	1kΩ 1/16W J		R714	NRSA63J-101X	MG RESISTOR	100Ω 1/16W J	
R204	NRSA63J-273X	MG RESISTOR	27kΩ 1/16W J		R715	NRSA63J-101X	MG RESISTOR	100Ω 1/16W J	
R205	NRSA63J-273X	MG RESISTOR	27kΩ 1/16W J		R716	NRSA63J-471X	MG RESISTOR	470Ω 1/16W J	
R206	NRSA63J-303X	MG RESISTOR	30kΩ 1/16W J		R718	NRSA63J-473X	MG RESISTOR	47kΩ 1/16W J	
R207	NRSA63J-473X	MG RESISTOR	47kΩ 1/16W J		R719	NRSA63J-473X	MG RESISTOR	47kΩ 1/16W J	
R213	NRSA63J-103X	MG RESISTOR	10kΩ 1/16W J		R721	NRSA63J-471X	MG RESISTOR	470Ω 1/16W J	
R214	NRSA63J-103X	MG RESISTOR	10kΩ 1/16W J		R722	NRSA63J-0R0X	MG RESISTOR	0Ω 1/16W J	
R219	NRSA63J-183X	MG RESISTOR	18kΩ 1/16W J		R723	NRSA63J-471X	MG RESISTOR	470Ω 1/16W J	
R220	NRSA63J-243X	MG RESISTOR	24kΩ 1/16W J		R724	NRSA63J-471X	MG RESISTOR	470Ω 1/16W J	
R221	NRSA63J-682X	MG RESISTOR	6.8kΩ 1/16W J		R725	NRSA63J-471X	MG RESISTOR	470Ω 1/16W J	

Symbol No.	Part No.	Part Name	Description	Local
R726	NRSA63J-0R0X	MG RESISTOR	0Ω 1/16W J	
R727	NRSA63J-471X	MG RESISTOR	470Ω 1/16W J	
R728	NRSA63J-471X	MG RESISTOR	470Ω 1/16W J	
R730	NRSA63J-331X	MG RESISTOR	330Ω 1/16W J	
R732	NRSA63J-102X	MG RESISTOR	1kΩ 1/16W J	
R741	NRSA63J-0R0X	MG RESISTOR	0Ω 1/16W J	
R742	NRSA63J-5R1X	MG RESISTOR	5.1Ω 1/16W J	
R799	NRSA63J-0R0X	MG RESISTOR	0Ω 1/16W J	
R811	NRS125J-330X	MG RESISTOR	33Ω 1/2W J	
R812	NRS125J-330X	MG RESISTOR	33Ω 1/2W J	
R813	NRSA63J-153X	MG RESISTOR	15kΩ 1/16W J	
R814	NRSA63J-153X	MG RESISTOR	15kΩ 1/16W J	
R819	NRSA63J-0R0X	MG RESISTOR	0Ω 1/16W J	
R821	NRSA63J-221X	MG RESISTOR	220Ω 1/16W J	
R822	NRSA63J-221X	MG RESISTOR	220Ω 1/16W J	
R823	NRSA63J-221X	MG RESISTOR	220Ω 1/16W J	
R851	NRSA63J-102X	MG RESISTOR	1kΩ 1/16W J	
R855	NRSA63J-102X	MG RESISTOR	1kΩ 1/16W J	
R856	NRSA63J-102X	MG RESISTOR	1kΩ 1/16W J	
R857	NRSA63J-221X	MG RESISTOR	220Ω 1/16W J	
R858	NRSA63J-221X	MG RESISTOR	220Ω 1/16W J	
R859	NRSA63J-102X	MG RESISTOR	1kΩ 1/16W J	
R860	NRSA63J-102X	MG RESISTOR	1kΩ 1/16W J	
R861	NRSA63J-473X	MG RESISTOR	47kΩ 1/16W J	
CN101	QGF0523F3-24W	CONNECTOR	FFC/FPC (1-24)	
CN201	QGF1016F8-08W	CONNECTOR	FFC/FPC (1-8)	
CN451	QGF1016F8-15W	CONNECTOR	FFC/FPC (1-15)	
CN452	QGA2001F6-02X	CONNECTOR	W-B (1-2)	
CN453	QGA2001F6-03X	CONNECTOR	W-B (1-3)	
CN701	QGF1016C6-28W	CONNECTOR	FFC/FPC (1-28)	
CN702	QGF1016C6-18W	CONNECTOR	FFC/FPC (1-18)	
CN801	QGF1016C6-05W	CONNECTOR	FFC/FPC (1-5)	
CN811	QGA2001F6-05X	CONNECTOR	W-B (1-5)	
K101	NQR0502-001X	FERRITE BEADS		
K351	NQR0502-001X	FERRITE BEADS		
K352	NQR0502-001X	FERRITE BEADS		
K353	NQR0502-001X	FERRITE BEADS		
K354	NQR0022-002X	FERRITE BEADS		
K454	NRSA63J-0R0X	MG RESISTOR	0Ω 1/16W J	
K455	NRSA63J-0R0X	MG RESISTOR	0Ω 1/16W J	
K456	NRSA63J-0R0X	MG RESISTOR	0Ω 1/16W J	
K501	NQR0502-001X	FERRITE BEADS		
K701	NQR0022-002X	FERRITE BEADS		
K702	NQR0022-002X	FERRITE BEADS		
K703	NQR0022-002X	FERRITE BEADS		
K704	NQR0022-002X	FERRITE BEADS		
K705	NQR0022-002X	FERRITE BEADS		
K706	NQR0022-005X	FERRITE BEADS		
K707	NQR0022-002X	FERRITE BEADS		
K708	NQR0022-002X	FERRITE BEADS		
K709	NQR0022-002X	FERRITE BEADS		
K710	NQR0022-002X	FERRITE BEADS		
K711	NQR0022-002X	FERRITE BEADS		
K720	NQR0022-002X	FERRITE BEADS		
K721	NRSA63J-0R0X	MG RESISTOR	0Ω 1/16W J	
K722	NRSA63J-0R0X	MG RESISTOR	0Ω 1/16W J	
K726	NRSA63J-0R0X	MG RESISTOR	0Ω 1/16W J	
K810	NQR0502-001X	FERRITE BEADS		
K811	NRSA63J-0R0X	MG RESISTOR	0Ω 1/16W J	
K812	NRSA63J-0R0X	MG RESISTOR	0Ω 1/16W J	
TH301	NAD0025-103X	N THERMISTOR	10kΩ	
X301	NAX0741-001X	CRYSTAL		
X302	NAX0376-002X	CRYSTAL		
X451	NAX0248-001X	C OSCILLATOR		

DVD loading board

Block No. [0][7]

Symbol No.	Part No.	Part Name	Description	Local
IC1	LB1641	IC		
IC2	LB1641	IC		
D1	MTZJ6.2A-T2	Z DIODE		
C1	QKCC1CM-107Z	E CAPACITOR	100uF 16V M	
C2	QCB1HK-104Y	C CAPACITOR	0.1uF 50V K	
C3	QFLC1HJ-103Z	M CAPACITOR	0.01uF 50V J	
C5	QFLC1HJ-103Z	M CAPACITOR	0.01uF 50V J	
C6	QCB1HK-104Y	C CAPACITOR	0.1uF 50V K	
C7	QCB1HK-104Y	C CAPACITOR	0.1uF 50V K	
CN1	QGF1036F2-15	CONNECTOR	FFC/FPC (1-15)	
CN2	QGB2024K1-07S	CONNECTOR	B-B (1-7)	
CN3	QGB2024J1-07S	CONNECTOR	B-B (1-7)	
SW1	QSW0844-002	PUSH SWITCH		
SW2	QSW0844-002	PUSH SWITCH		
SW3	QSW0844-002	PUSH SWITCH		
SW4	QSW0844-002	PUSH SWITCH		
SW5	QSW0844-002	PUSH SWITCH		
SW6	QSW0854-002	PUSH SW		
SW7	QSW0886-002	DETECT SWITCH		
SW8	QSW0923-001	DETECT SWITCH		

< MEMO >

Packing materials and accessories parts list

Block No. M 4 M M

(TH-C90)

No additional / supplemental order of WARRANTY CARDS are available.

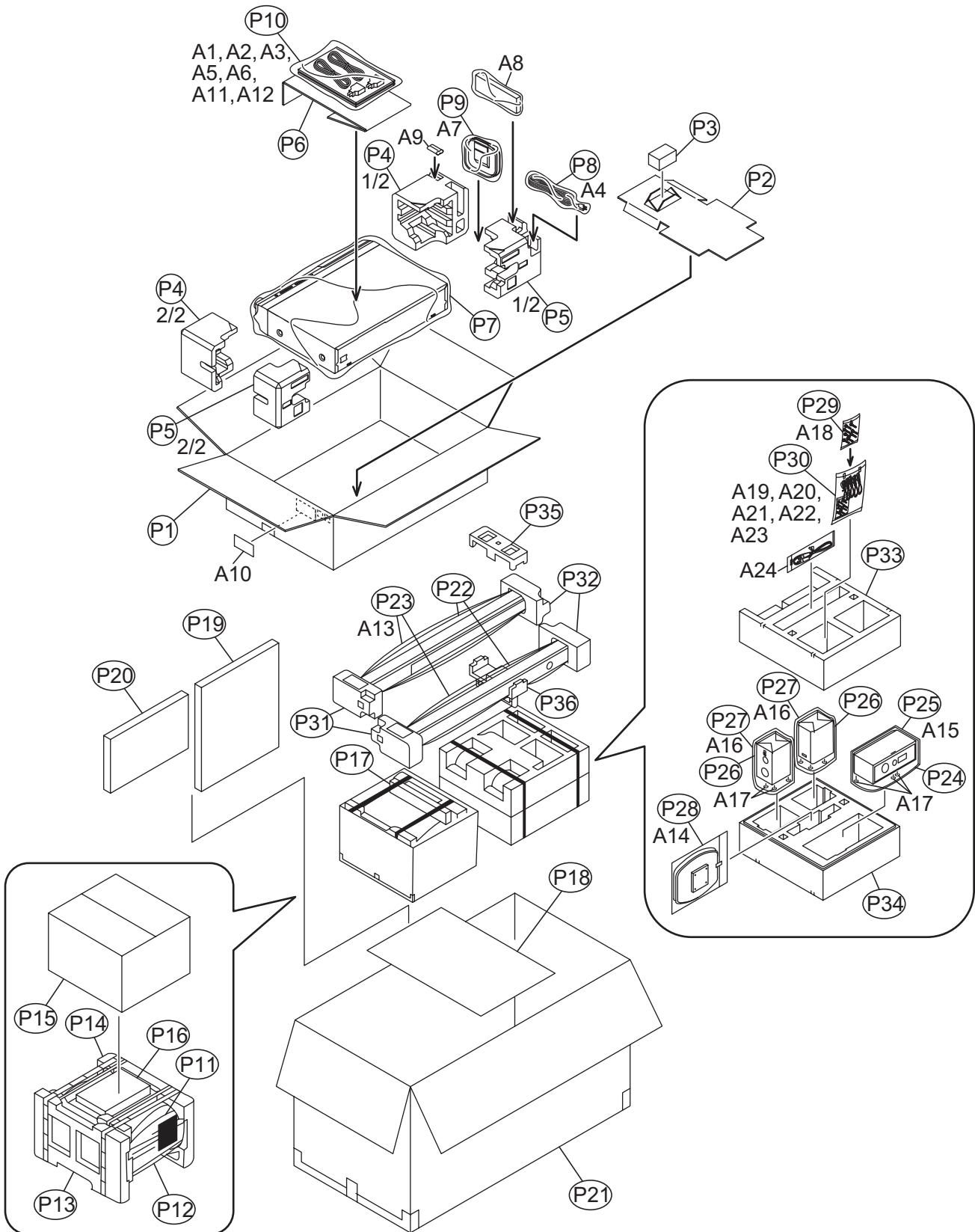

Packing and Accessories (TH-C90)

Block No. [M][4][M][M]

△	Symbol No.	Part No.	Part Name	Description	Local
	A 1	LVT1504-010A	INST BOOK	ENG	C90A
	A 1	LVT1504-005B	INST BOOK	ENG	C90US,C90UX,C90UG
	A 2	LVT1504-006A	INST BOOK	CHI(PEKIN)	C90US
	A 2	LVT1504-007B	INST BOOK	ARA PER	C90UX,C90UG
	A 3	QAM0216-001	VIDEO CABLE		
△	A 4	QMPH010-183-JD	POWER CORD(EU)	1.83m BLACK	C90A
△	A 4	QMPL150-183-JC	POWER CORD(EU)	1.83m BLACK	C90US,C90UX,C90UG
△	A 5	QAM0112-002	CONVERSION PLUG	(x2)	C90US
	A 6	QAL0457-001	ANT.WIRE		
	A 7	QAL0014-003	AM LOOP ANT		
	A 8	RM-STHC91U	REMOTE CONTROL UNIT		C90A
	A 8	RM-STHC90U	REMOTE CONTROL UNIT		C90US,C90UX,C90UG
	A 9	-----	BATTERY	(x2)	
	A 10	LE40796-001A	VERANCE LABEL		
	A 11	-----	WARRANTY CARD	BT-56017-1	C90A
	A 12	-----	WARRANTY CARD	BT-56016-1	C90A
	A 13	AB130048-01	SPEAKER BOX	SPK WITH BOX-F(x2)	
	A 14	9913008801	STAND BASE ASSY	(x2)	
	A 15	AB100072-01	SPEAKER BOX	SPK WITH BOX-C	
	A 16	AB100073-01	SPEAKER BOX	SPK WITH BOX-S(x2)	
	A 17	9000005311	FOOT	(x9)	
	A 18	7000743006	SCREW	(x8)	
	A 19	6200044701	CORD SET		
	A 20	6200044711	CORD SET		
	A 21	6200044721	CORD SET		
	A 22	6200044731	SPK CORD-SR		
	A 23	6200044741	SPK CORD-SL		
	A 24	6200044901	DIN CABLE		
	P 1	LV36670-028A	CARTON BOX		C90A
	P 1	LV36670-026A	CARTON BOX		C90US
	P 1	LV36670-027A	CARTON BOX		C90UX,C90UG
	P 2	LV37060-001A	CARTON SPACER		
	P 3	LV44678-001A	CUSHION SPACER		
	P 4	LV22251-001A	CUSHION(F)		
	P 5	LV22252-001A	CUSHION(R)		
	P 6	LV36905-001A	CARTON SPACER		
	P 7	QPC05006515PB	POLY BAG	50cm x 65cm	
	P 8	LV30245-006A	POLY BAG		C90A
	P 8	QPA01003003	POLY BAG	10cm x 30cm	C90US,C90UX,C90UG
	P 9	QPA01702503PB	POLY BAG	17cm x 25cm	
	P 10	QPA02503503PB	POLY BAG	25cm x 35cm	
	P 11	8500051891	MIRROR MAT		
	P 12	8500051991	POLY BAG		
	P 13	LV22214-001A	TOP CUSHION		C90A
	P 13	LV22024-001A	TOP CUSHION		C90US,C90UX,C90UG
	P 14	LV22214-002A	BOTTOM CUSHION		C90A
	P 14	LV22024-002A	BOTTOM CUSHION		C90US,C90UX,C90UG
	P 15	LV36099-002A	PACKING CASE		C90A
	P 15	LV36099-001A	PACKING CASE		C90US,C90UX,C90UG
	P 16	LV44368-001A	CUSHION		
	P 17	LV44369-001A	CUSHION		
	P 18	LV44370-001A	PARTITION		
	P 19	LV44635-001A	CUSHION		C90A
	P 20	LV44636-001A	CUSHION		C90A
	P 21	LV35831-0A7A	PACKING CASE		C90A
	P 21	LV35831-0A5A	PACKING CASE		C90US,C90UG
	P 21	LV35831-0A6A	PACKING CASE		C90UX
	P 22	8500055511	MIRROR MAT	(x2)	
	P 23	8500062711	POLY BAG	(x2)	
	P 24	8500063701	MIRROR MAT SHEET		
	P 25	8500062721	POLY BAG		
	P 26	8500063711	MIRROR MAT	(x2)	
	P 27	8500062731	POLY BAG	(x2)	
	P 28	8500061331	MIRROR MAT BAG		
	P 29	8500047101	POLY BAG		
	P 30	8500032771	POLY BAG		
	P 31	LV37011-001A	TOP CUSHION	(x2)	
	P 32	LV37011-002A	BOTTOM CUSHION	(x2)	
	P 33	LV22361-001A	TOP CUSHION		
	P 34	LV22361-002A	BOTTOM CUSHION		
	P 35	LV22362-001A	TOP CUSHION		
	P 36	LV22362-002A	BOTTOM CUSHION		

Packing materials and accessories parts list

(TH-C60 (Except TH-C60UP))

Block No. M 5 M M

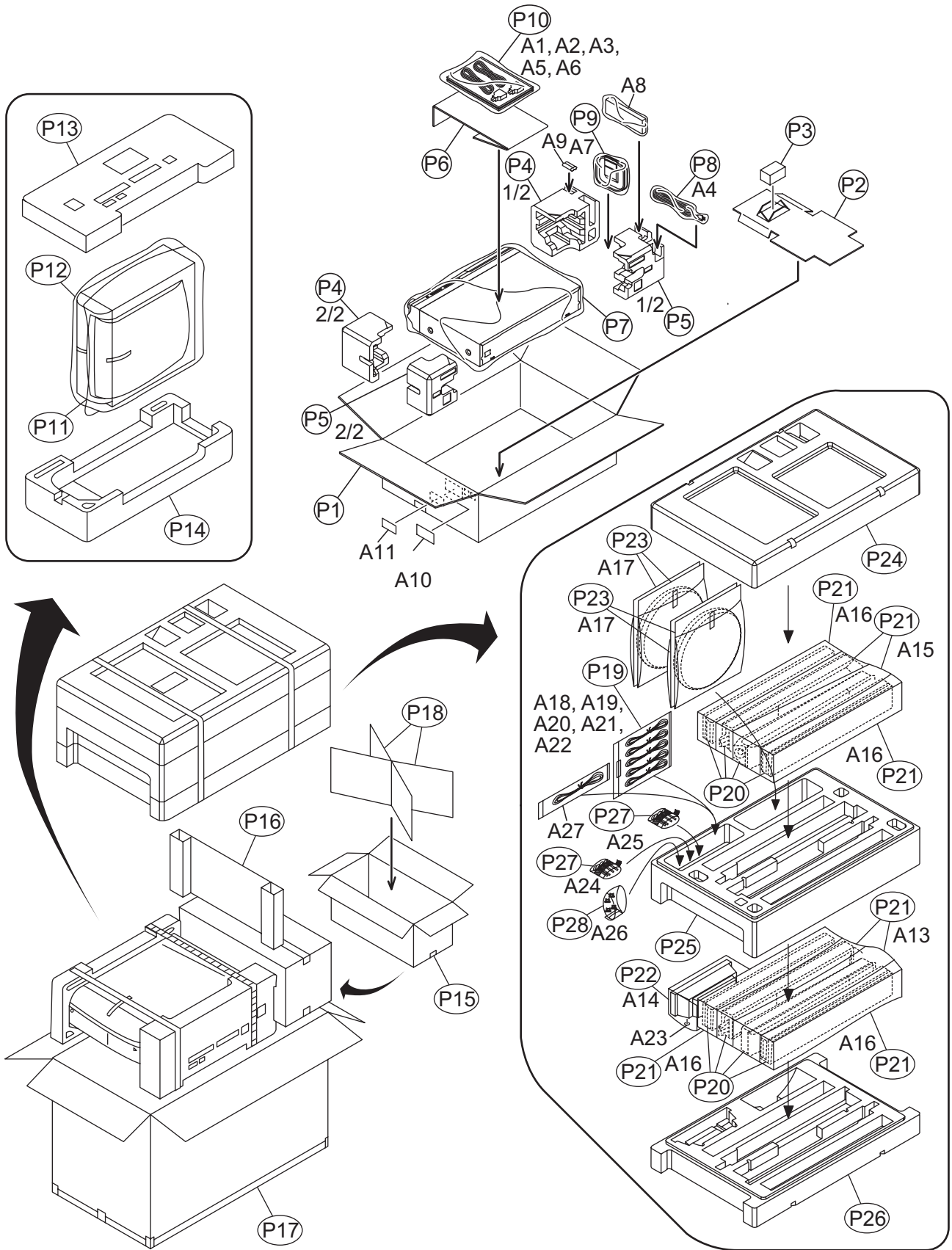

Packing and Accessories (TH-C60 (Except TH-C60UP))

Block No. [M][5][M][M]

△	Symbol No.	Part No.	Part Name	Description	Local
	A 1	LVT1504-005B	INST BOOK	ENG	C60US,C60UX,C60UG
	A 1	LVT1504-008A	INST BOOK	ENG POR	C60UW
	A 1	LVT1504-009A	INST BOOK	SPA	C60UY
	A 2	LVT1504-006A	INST BOOK	CHI(PEKIN)	C60US
	A 2	LVT1504-009A	INST BOOK	SPA	C60UW
	A 2	LVT1504-007B	INST BOOK	ARA PER	C60UX,C60UG
	A 3	QAM0216-001	VIDEO CABLE		
△	A 4	QMPL150-183-JC	POWER CORD(EU)	1.83m BLACK	C60US,C60UW,C60UX,C60UG
△	A 4	QMPS190-183-JC	POWER CORD(EU)	1.83m BLACK	C60UY
△	A 5	QAM0112-002	CONVERSION PLUG	(x2)	C60US,C60UW
	A 6	QAL0457-001	ANT.WIRE		
	A 7	QAL0014-003	AM LOOP ANT		
	A 8	RM-STHC60U	REMOTE CONTROL UNIT		C60US,C60UX,C60UG
	A 8	RM-STHC60J	REMOTE CONTROL UNIT		C60UW,C60UY
	A 9	-----	BATTERY	(x2)	
	A 10	LE40796-001A	VERANCE LABEL		
	A 11	LV44410-001A	NOM LABEL		C60UW
	A 13	AB050049-01	SPEAKER BOX	SPK WITH BOX-F(x2)	
	A 14	AB066004-01	SPEAKER BOX	SPK WITH BOX-C	
	A 15	AB050050-01	SPEAKER BOX	SPK WITH BOX-S(x2)	
	A 16	9906600501	STAND ASSY	(x4)	
	A 17	9900035301	BASE ASSY	(x4)	
	A 18	6200045901	SPK CORD-C		
	A 19	6200045911	SPK CORD-FR		
	A 20	6200045921	SPK CORD-FL		
	A 21	6200045931	SPK CORD-SR		
	A 22	6200045941	SPK CORD-SL		
	A 23	9000008411	FOOT	(x3)	
	A 24	7010954004	SCREW	(x4)	
	A 25	7010942006	SCREW	(x8)	
	A 26	6400018701	CORD CLAMP	(x4)	
	A 27	6200044901	DIN CABLE		
	P 1	LV36670-023A	CARTON BOX		C60US
	P 1	LV36670-022A	CARTON BOX		C60UW,C60UY
	P 1	LV36670-024A	CARTON BOX		C60UX,C60UG
	P 2	LV37060-001A	CARTON SPACER		
	P 3	LV44678-001A	CUSHION SPACER		
	P 4	LV22251-001A	CUSHION(F)		
	P 5	LV22252-001A	CUSHION(R)		
	P 6	LV36905-001A	CARTON SPACER		
	P 7	QPC05006515PB	POLY BAG	50cm x 65cm	
	P 8	QPA01003003	POLY BAG	10cm x 30cm	C60US,C60UW,C60UX,C60UG
	P 8	LV30245-006A	POLY BAG		C60UY
	P 9	QPA01702503PB	POLY BAG	17cm x 25cm	
	P 10	QPA02503503PB	POLY BAG	25cm x 35cm	
	P 11	8500051881	MIRROR MAT		
	P 12	8500051901	POLY BAG		
	P 13	LV22292-001A	TOP CUSHION		
	P 14	LV22293-001A	BOTTOM CUSHION		
	P 15	LV36825-001A	ACCESSORY BOX		C60US,C60UW,C60UX,C60UG
	P 15	LV36825-002A	ACCESSORY BOX		C60UY
	P 16	LV36093-003A	PARTITION		C60UY
	P 17	LV35831-086A	PACKING CASE		C60US,C60UW,C60UY,C60UG
	P 17	LV35831-087A	PACKING CASE		C60UX
	P 18	LV37055-001A	PARTITION PAPER	(x2)	
	P 19	8500032771	POLY BAG		
	P 20	8500062251	MIRROR MAT SHEET	(x8)	
	P 21	8500061661	POLY BAG	(x8)	
	P 22	8500061671	POLY BAG		
	P 23	8500062401	MIRROR MAT BAG	(x4)	
	P 24	LV11254-001A	CUSHION A		
	P 25	LV11254-002A	CUSHION B		
	P 26	LV11254-003A	CUSHION C		
	P 27	8500047141	POLY BAG	(x2)	
	P 28	8500035721	POLY BAG		

Packing materials and accessories parts list

Block No. M 6 M M

(TH-C60UP)

No additional / supplemental order of WARRANTY CARDS are available.

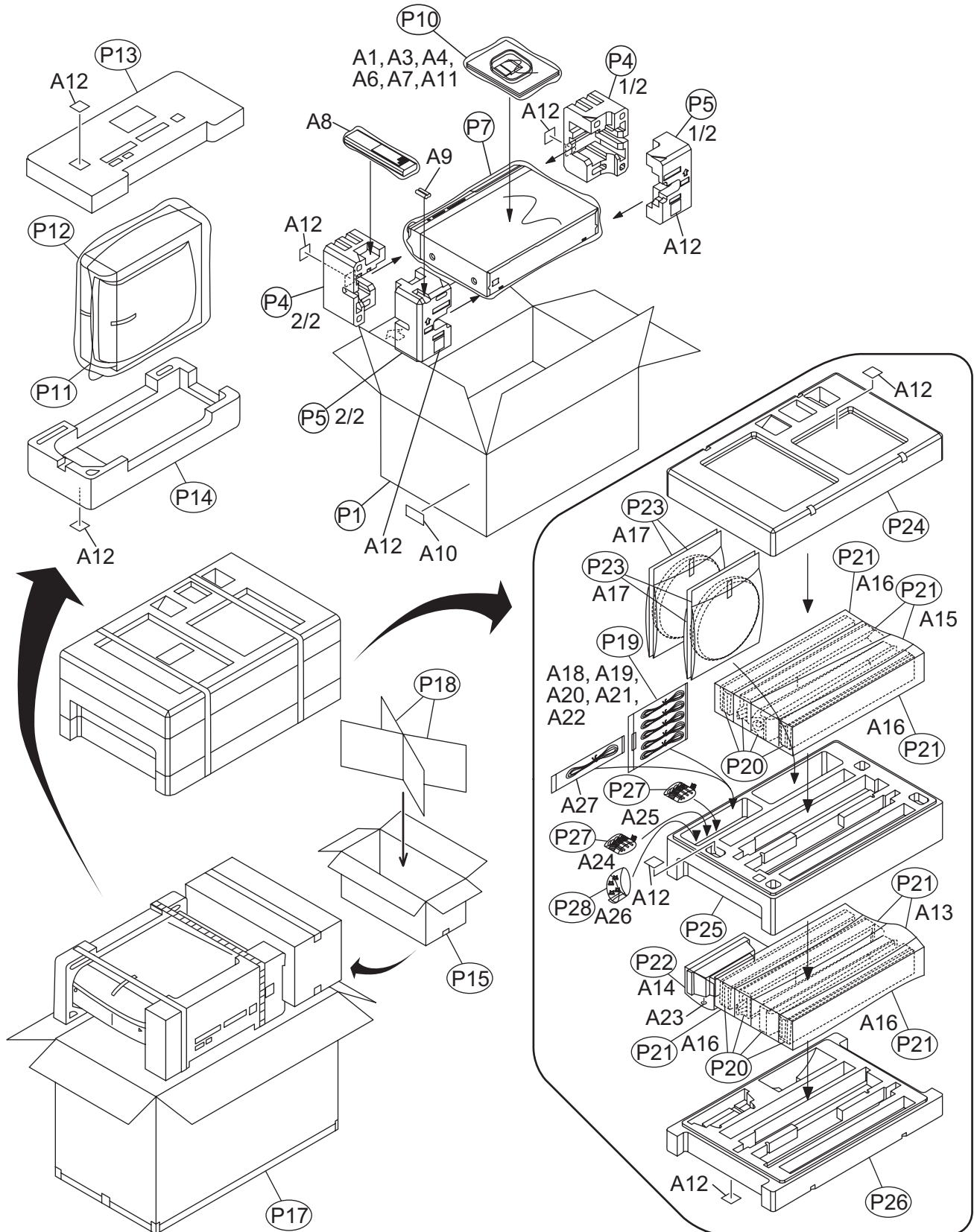

Packing and Accessories (TH-C60UP)

Block No. [M][6][M][M]

△	Symbol No.	Part No.	Part Name	Description	Local
	A 1	LVT1504-012A	INST BOOK	KOR	
	A 3	QAM0216-001	VIDEO CABLE		
△	A 4	QMPS200-190-JC	POWER CORD(EU)	1.9m BLACK	
	A 6	QAL0457-001	ANT.WIRE		
	A 7	QAL0014-003	AM LOOP ANT		
	A 8	RM-STHC60J	REMOTE CONTROL UNIT		
	A 9	-----	BATTERY	(x2)	
	A 10	LE40796-001A	VERANCE LABEL		
	A 11	-----	WARRANTY CARD	BT-56013-1	
	A 12	LV43644-001A	LABEL	(x9)	
	A 13	AB050049-01	SPEAKER BOX	SPK WITH BOX-F(x2)	
	A 14	AB066004-01	SPEAKER BOX	SPK WITH BOX-C	
	A 15	AB050050-01	SPEAKER BOX	SPK WITH BOX-S(x2)	
	A 16	9906600501	STAND ASSY	(x4)	
	A 17	9900035301	BASE ASSY	(x4)	
	A 18	6200045901	SPK CORD-C		
	A 19	6200045911	SPK CORD-FR		
	A 20	6200045921	SPK CORD-FL		
	A 21	6200045931	SPK CORD-SR		
	A 22	6200045941	SPK CORD-SL		
	A 23	9000008411	FOOT	(x3)	
	A 24	7010954004	SCREW	(x4)	
	A 25	7010942006	SCREW	(x8)	
	A 26	6400018701	CORD CLAMP	(x4)	
	A 27	6200044901	DIN CABLE		
	P 1	LV36670-025A	CARTON BOX		
	P 4	LV22308-001A	CUSHION (F)		
	P 5	LV22309-001A	CUSHION (R)		
	P 7	QPC05006515PB	POLY BAG	50cm x 65cm	
	P 10	QPA02503503PB	POLY BAG	25cm x 35cm	
	P 11	8500051881	MIRROR MAT		
	P 12	8500051901	POLY BAG		
	P 13	LV22292-001A	TOP CUSHION		
	P 14	LV22293-001A	BOTTOM CUSHION		
	P 15	LV36825-001A	ACCESSORY BOX		
	P 17	LV35831-086A	PACKING CASE		
	P 18	LV37055-001A	PARTITION PAPER	(x2)	
	P 19	8500032771	POLY BAG		
	P 20	8500062251	MIRROR MAT SHEET	(x8)	
	P 21	8500061661	POLY BAG	(x8)	
	P 22	8500061671	POLY BAG		
	P 23	8500062401	MIRROR MAT BAG	(x4)	
	P 24	LV11254-001A	CUSHION A		
	P 25	LV11254-002A	CUSHION B		
	P 26	LV11254-003A	CUSHION C		
	P 27	8500047141	POLY BAG	(x2)	
	P 28	8500035721	POLY BAG		