

# JVC

## SCHEMATIC DIAGRAMS

### DVD DIGITAL THEATER SYSTEM

# TH-G40J, TH-G40C, TH-G40UJ TH-G30J, TH-G30C

DVD-ROM No.SML2008Q2

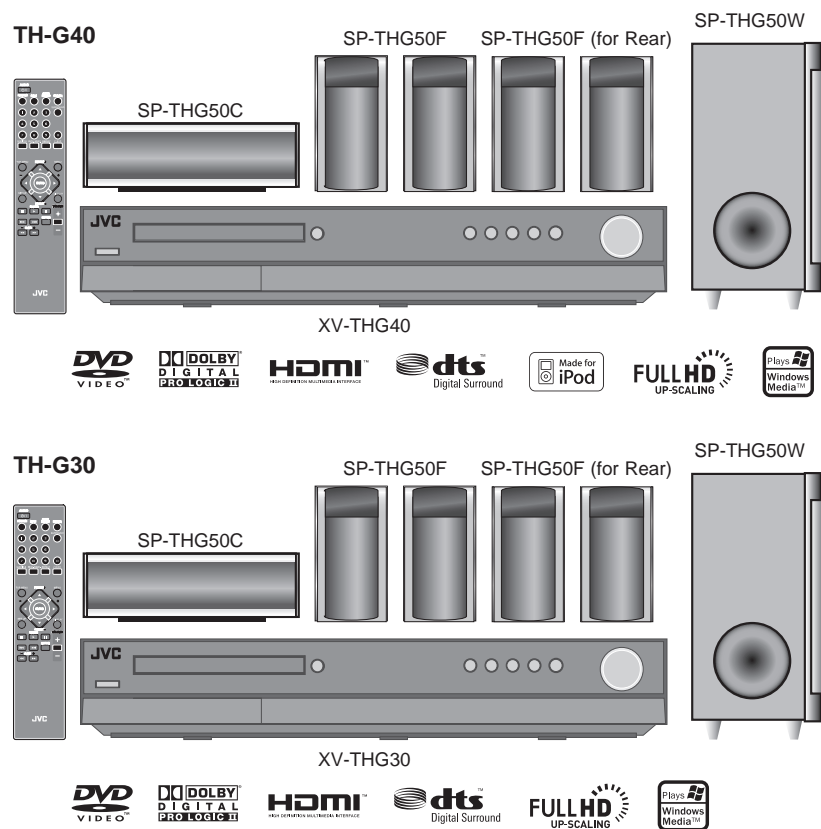

Lead free solder used in the board (material : Sn-Ag-Cu, melting point : 219 Centigrade)

### Contents

Block diagrams .....	2-1
Standard schematic diagrams .....	2-2
Printed circuit boards .....	2-24 to 34

In regard with component parts appearing on the silk-screen printed side (parts side) of the PWB diagrams, the parts that are printed over with black such as the resistor (■), diode (▣) and ICP (●) or identified by the "⚠" mark nearby are critical for safety.

# Block diagram

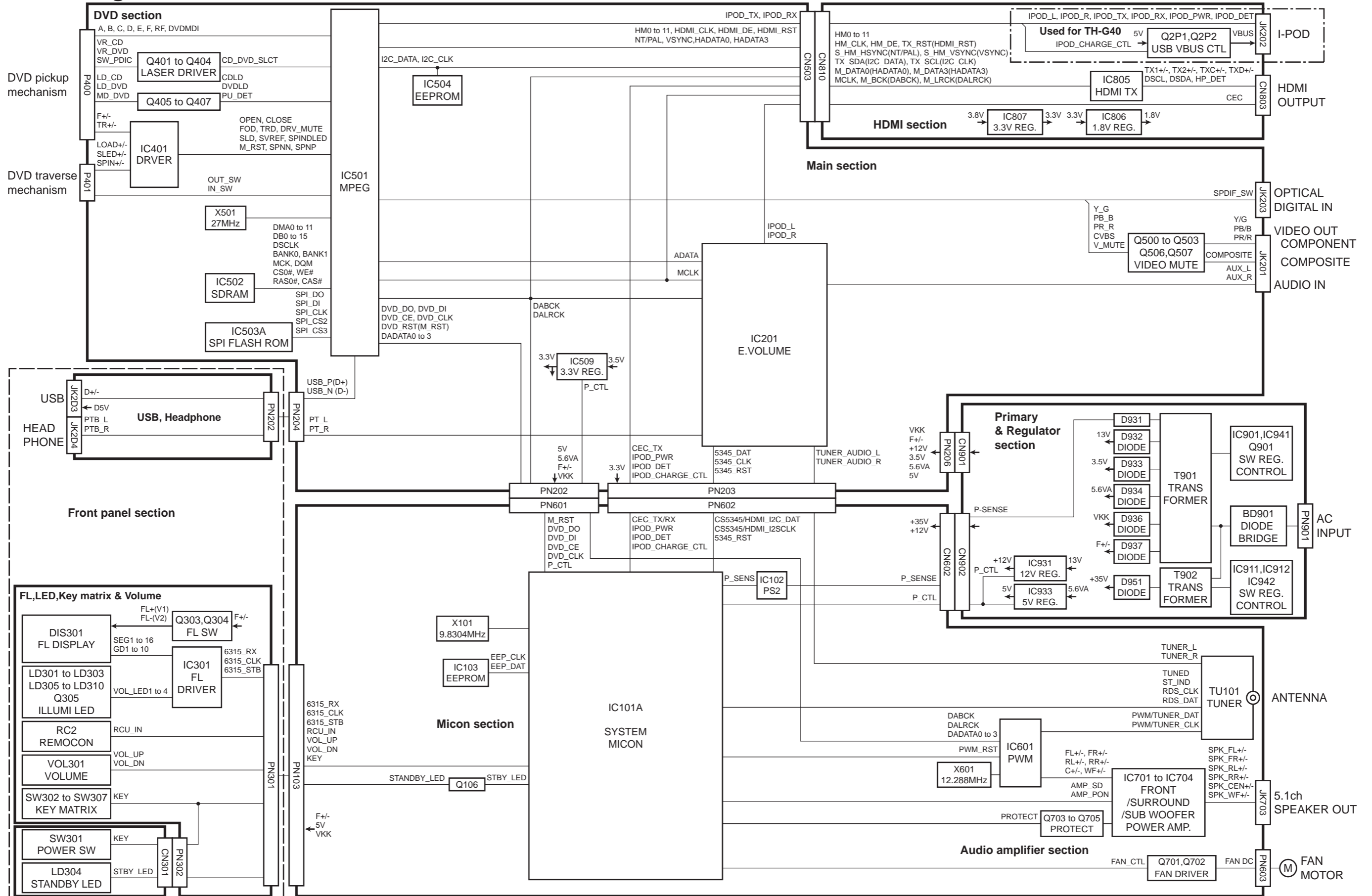

# Standard schematic diagrams

## SMPS section

### IMPORTANT SAFETY NOTICE

WHEN SERVICING THIS CHASSIS, UNDER NO CIRCUMSTANCES SHOULD THE ORIGINAL DESIGN BE MODIFIED OR ALTERED WITHOUT PERMISSION FROM THE JVC CORPORATION. ALL COMPONENTS SHOULD BE REPLACED ONLY WITH TYPES IDENTICAL TO THOSE IN THE ORIGINAL CIRCUIT. SPECIAL

COMPONENTS ARE SHADED ON THE SCHEMATIC FOR EASY IDENTIFICATION. THIS CIRCUIT DIAGRAM MAY OCCASIONALLY DIFFER FROM THE ACTUAL CIRCUIT USED. THIS WAY, IMPLEMENTATION OF THE LATEST SAFETY AND PERFORMANCE IMPROVEMENT CHANGES INTO THE SET IS NOT DELAYED UNTIL THE NEW SERVICE LITERATURE IS PRINTED.

### NOTE :

1. Shaded (■) parts are critical for safety. Replace only with specified part number.
2. Voltages are DC-measured with a digital voltmeter during Play mode.

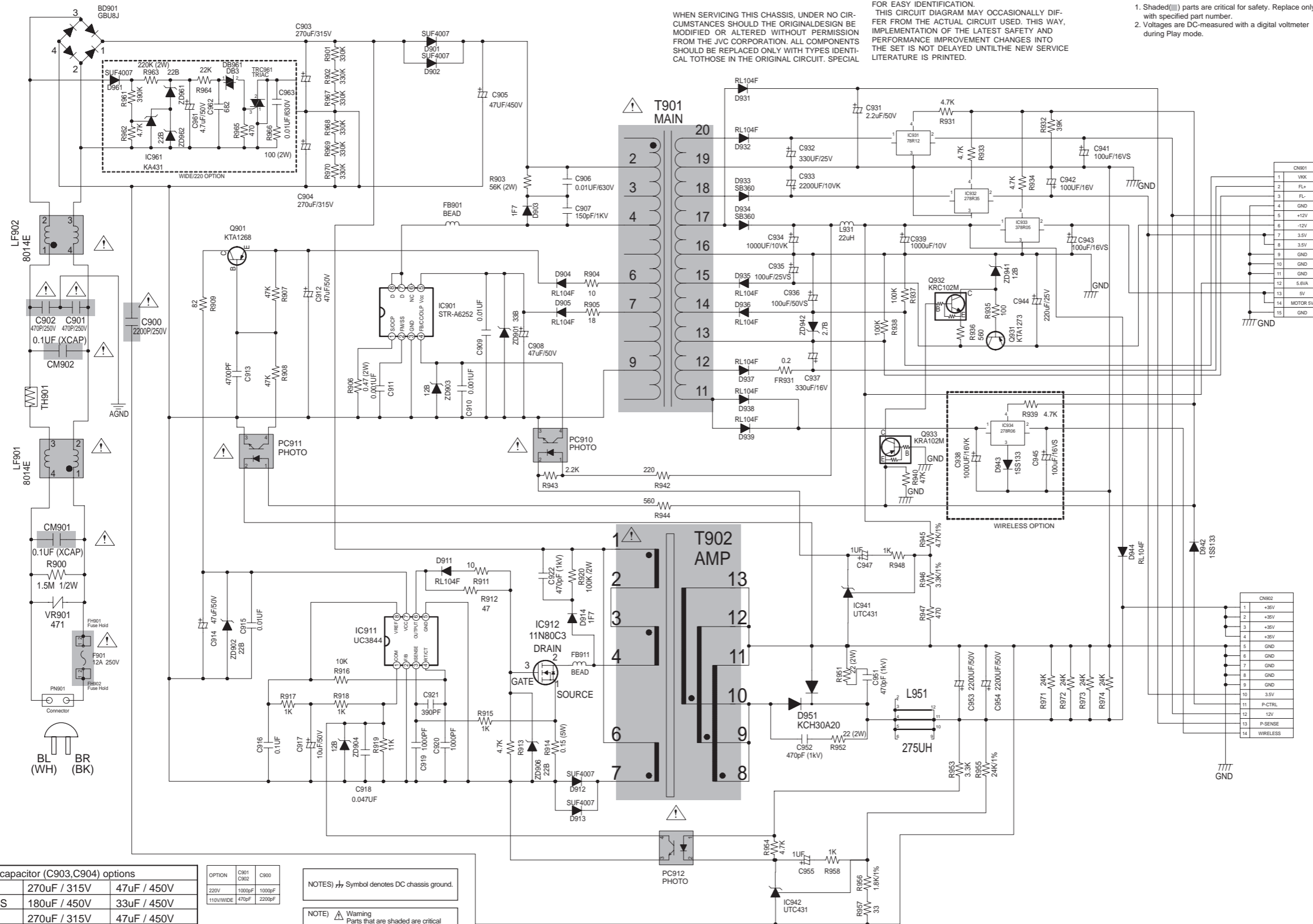

\*Primary capacitor (C903,C904) options

110V	270uF / 315V	47uF / 450V
220V/CIS	180uF / 450V	33uF / 450V
WIDE	270uF / 315V	47uF / 450V

OPTION	C901	C900
220V	1000pF	1000pF
110V/WIDE	470pF	2200pF

NOTES  $\perp$  Symbol denotes DC chassis ground.

NOTE  $\triangle$  Warning Parts that are shaded are critical With respect to risk of fire or electrical shock.

■ MPEG section

SERVO&DECK

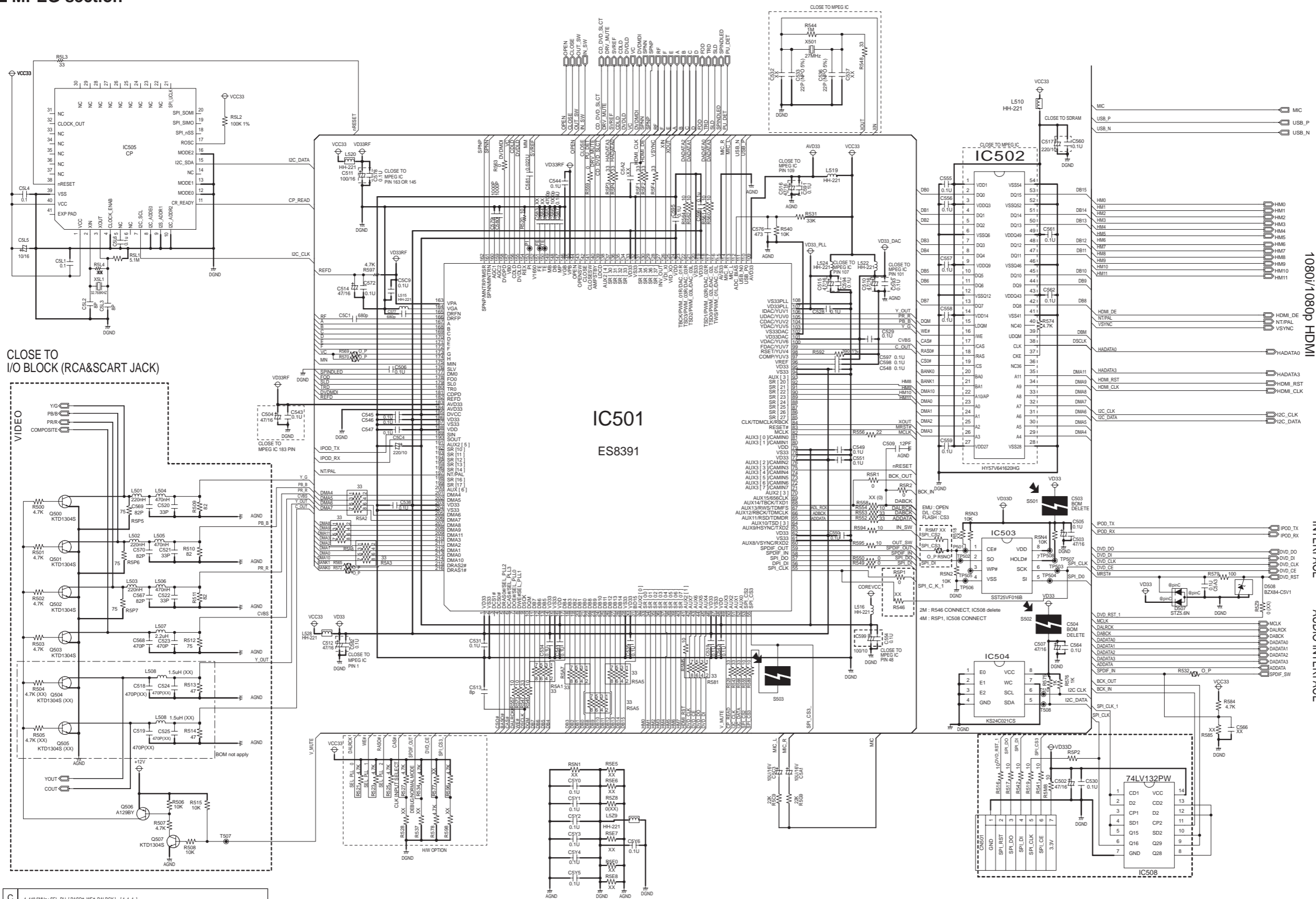

- CHANGES**
1. 148.5MHz - SEL\_PLL [ RASON, WEAR, DALROK ] = [ 1, 1, 1, ]
  2. CLK INPUT SELECT [ CAS# ] : HIGH = X-TAL INPUT, LOW = SYSTEM CLK INPUT
  3. DEBUG MODE ( #40, #159, #160 ) : 0XX = NORMAL MODE, 111 = SCAN, 110 = PLL TEST, 101 = CTAG BIST, 100 = FULL BIST
  4. SPI BOOT SELECT ( #33 ) : 1=PARALLEL FLASH, 0 = SPI FLASH
  5. SPI BANK-SWAP SELECT ( #44 ) : 1=DONT SWAP BANK 2, 3 0 = SWAP BANK2,3

■ Power interface section

[ CONNECT WITH AMP ]

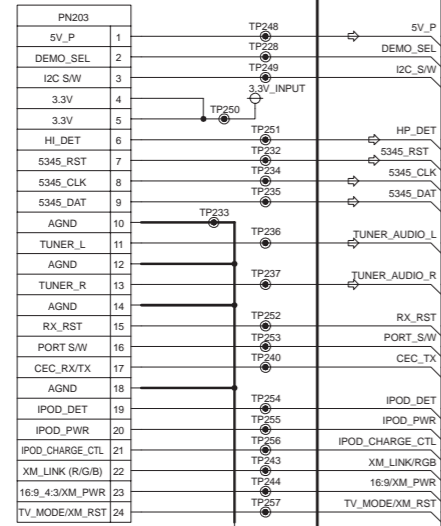
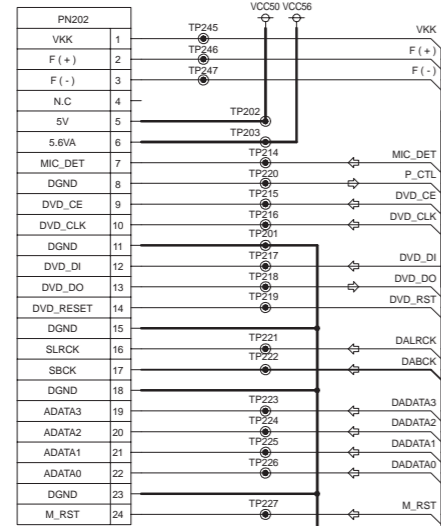

[ CONNECT WITH MIC/USB ]

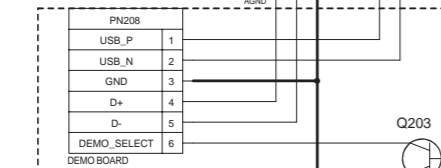
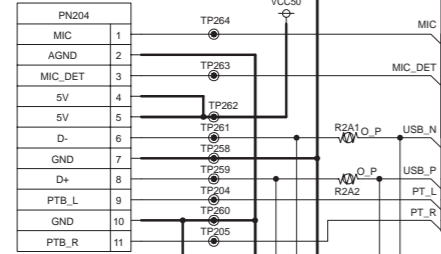

[ CONNECT WITH HDMI BOARD ]

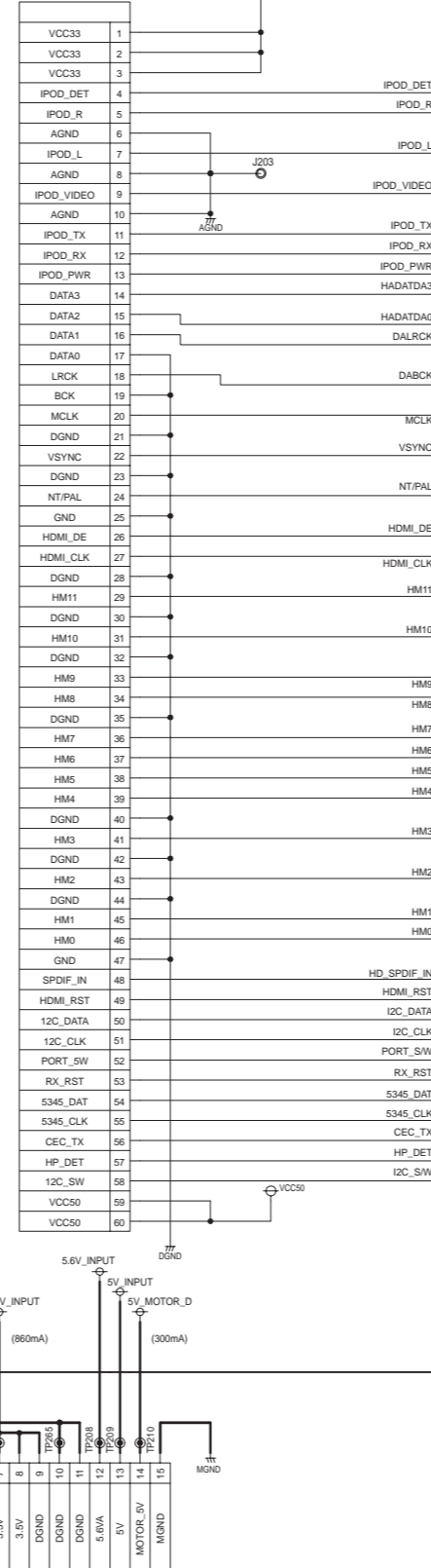
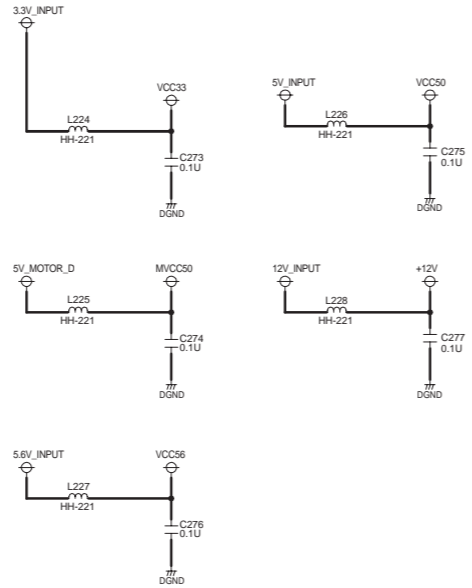

[ FROM SMPS ]

For JIG Test Point

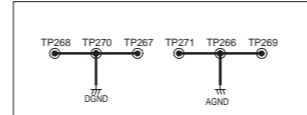

PCB ADD DEMO SILK  
< DEMO OPTION >

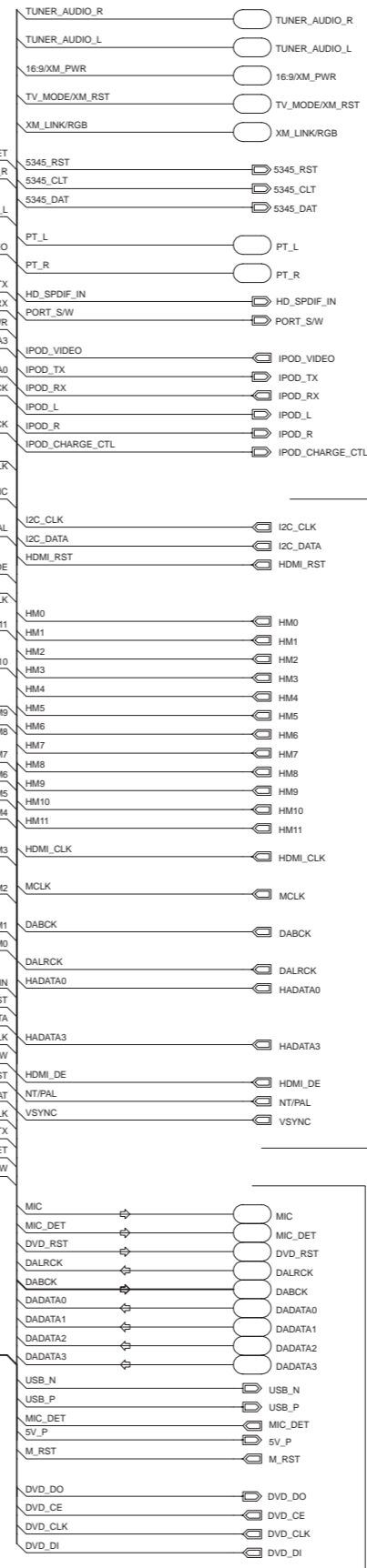

I/O SECTION

MPEG SECTION

MPEG SECTION



■ Servo section

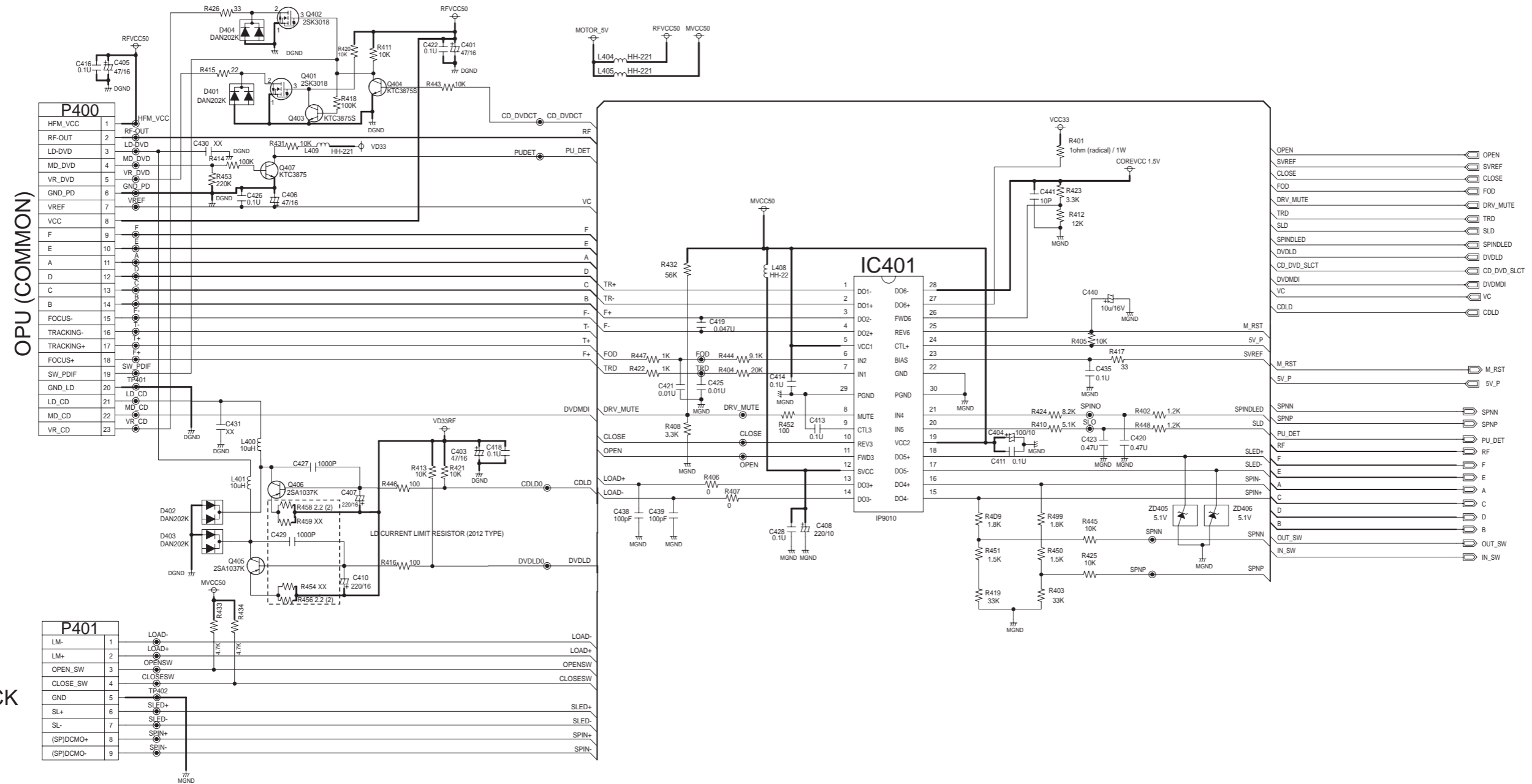



# Amp section

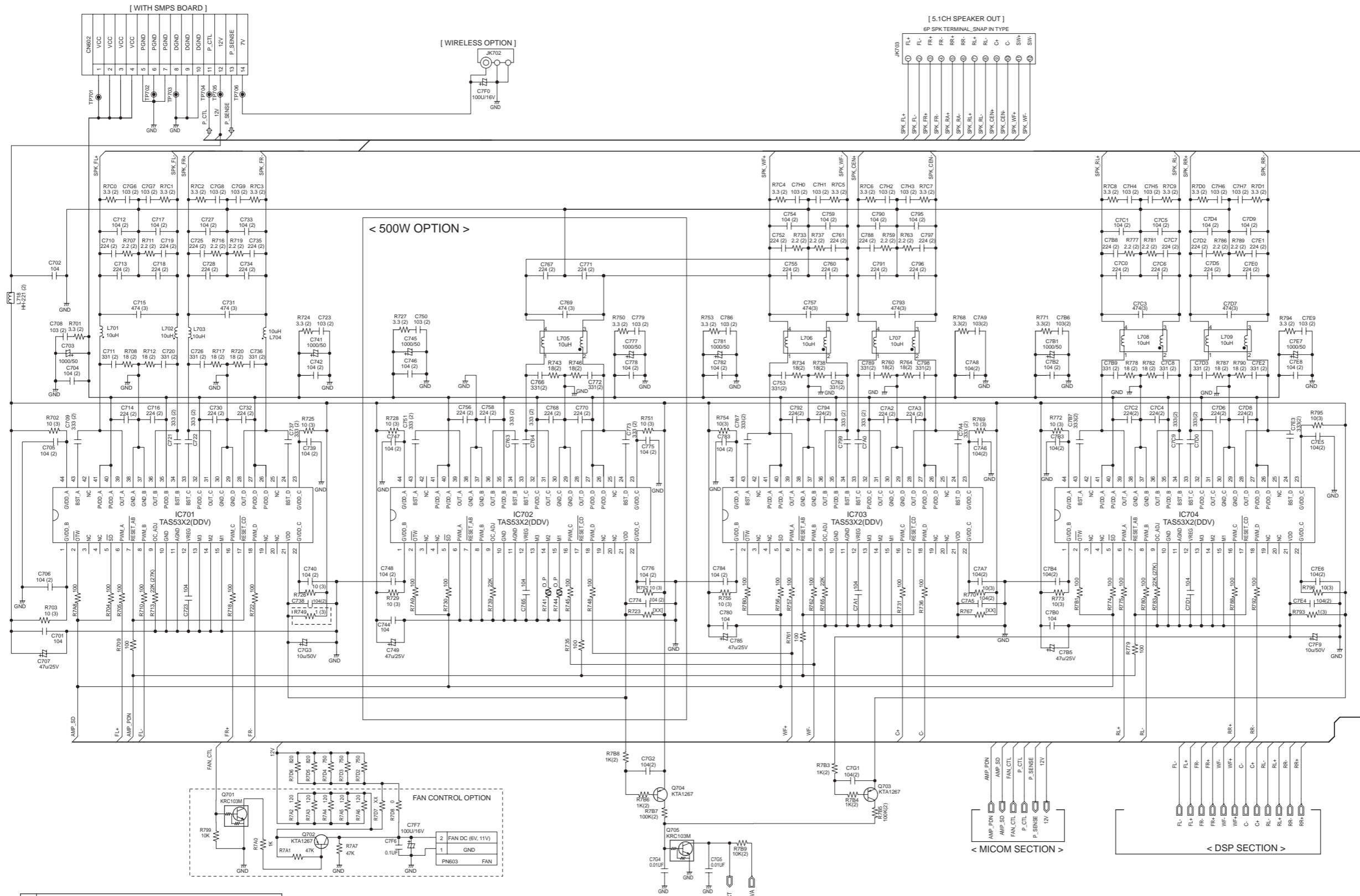

1. \*\*\* (3) : SMD 3225 TYPE  
2. AMP IC OPTION

MODEL	IC NAME
HT903 SERIES	TAS5352 4EA
HT503 SERIES	TAS5352 2EA, TAS5352 1EA(woofer)

OC\_ADJ resistor : TAS5342 (27K), TAS5352 (22K)

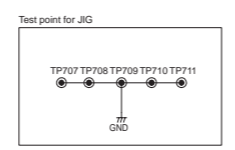

■ DSP section

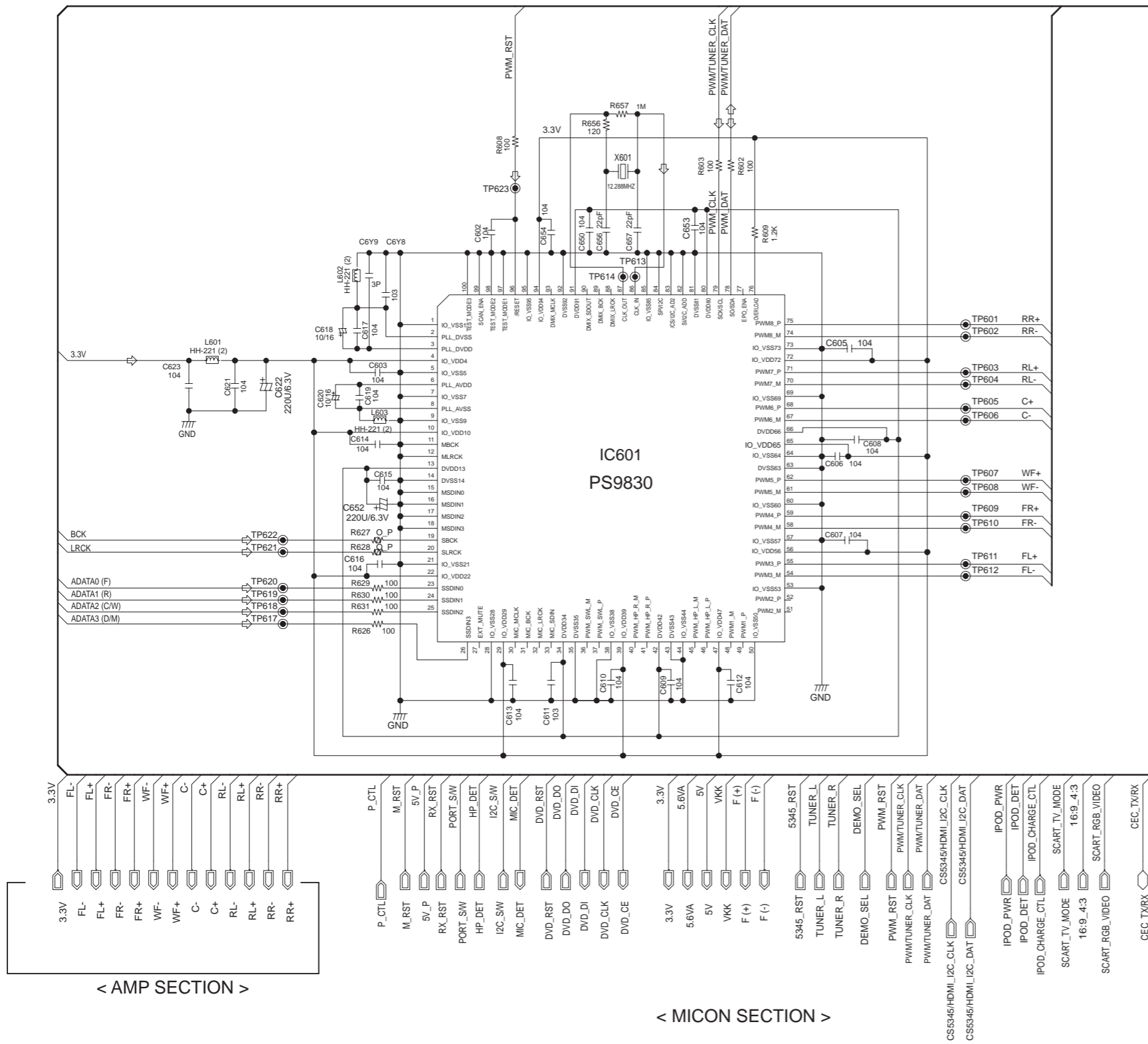

[ WITH MAIN BOARD ]

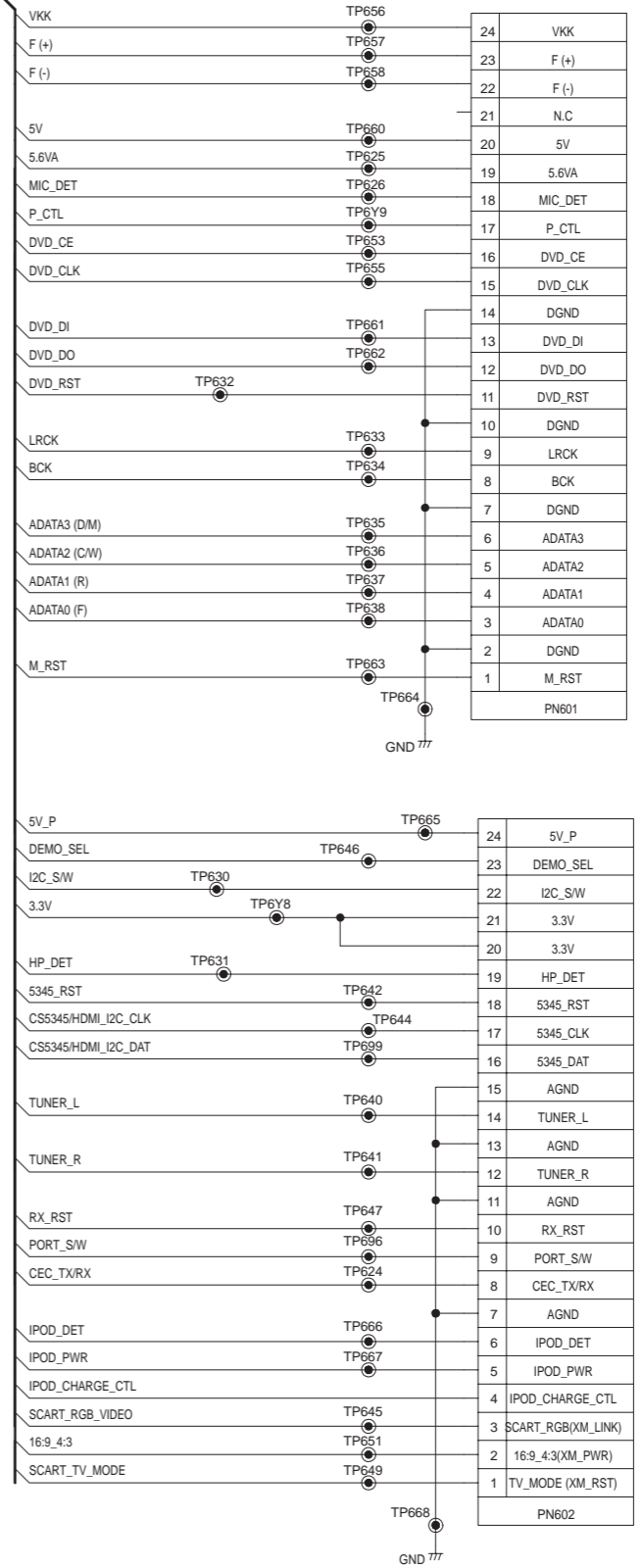

■ Micom section

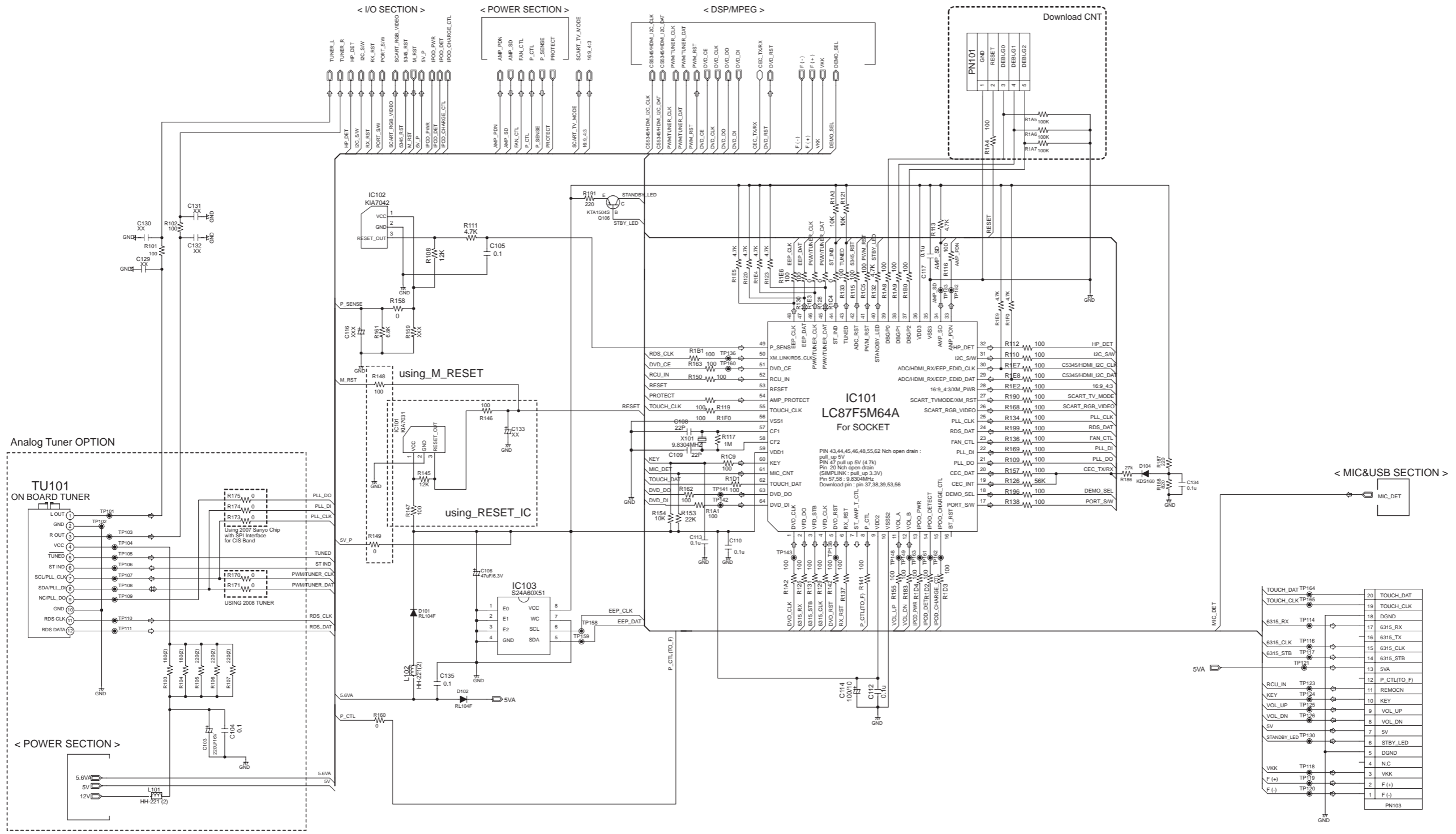

CHANGES  
1. \*\*\*(2) : SMD 2012 TYPE

■ HDMI section 1 (for TH-G40J, TH-G30J)

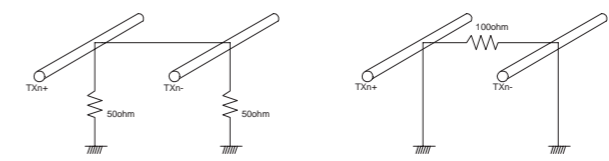
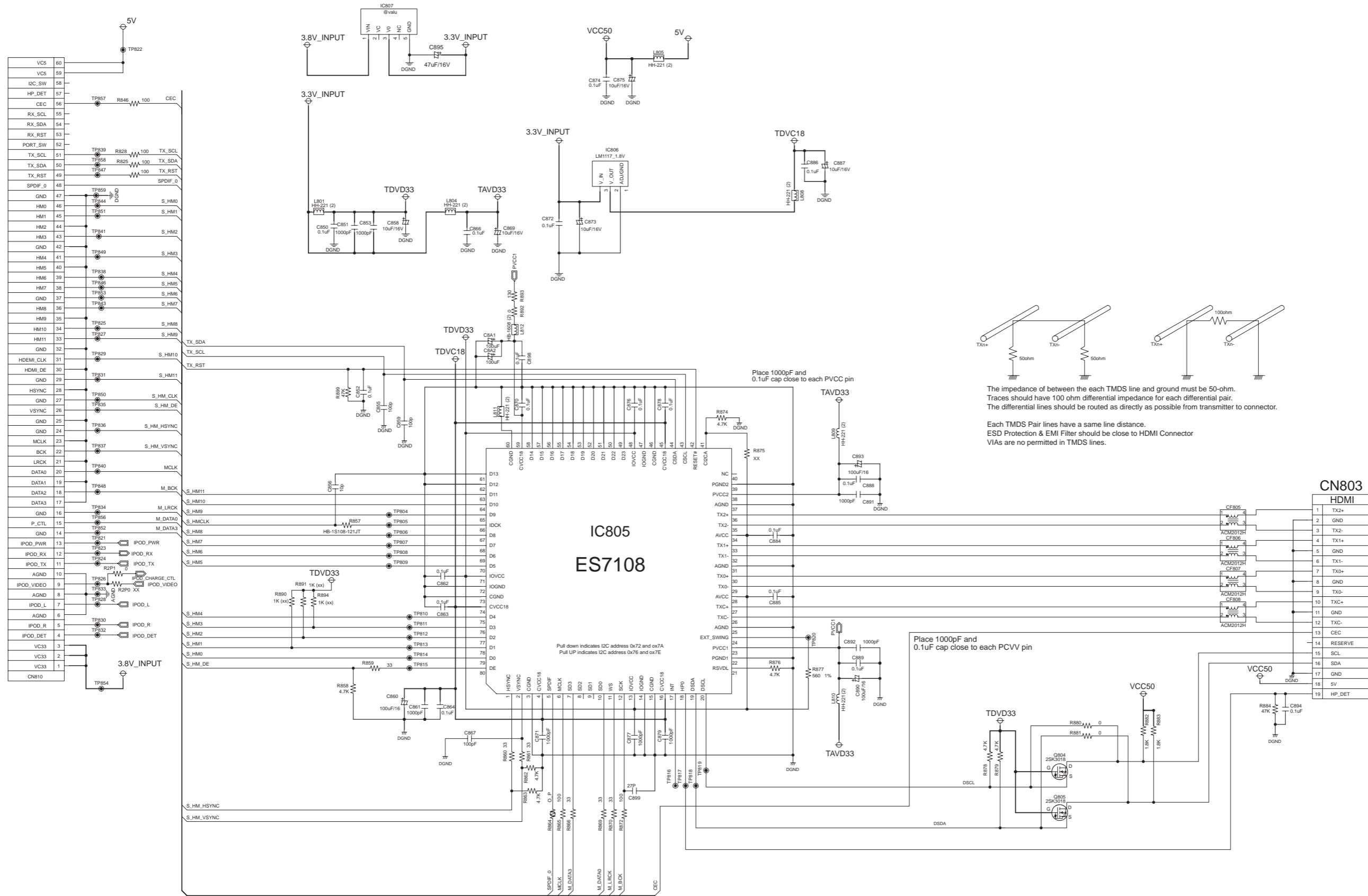

The impedance of between the each TMDS line and ground must be 50-ohm. Traces should have 100 ohm differential impedance for each differential pair. The differential lines should be routed as directly as possible from transmitter to connector.

Each TMDS Pair lines have a same line distance. ESD Protection & EMI Filter should be close to HDMI Connector VIAs are not permitted in TMDS lines.

■ HDMI section 2 (for TH-G40J)

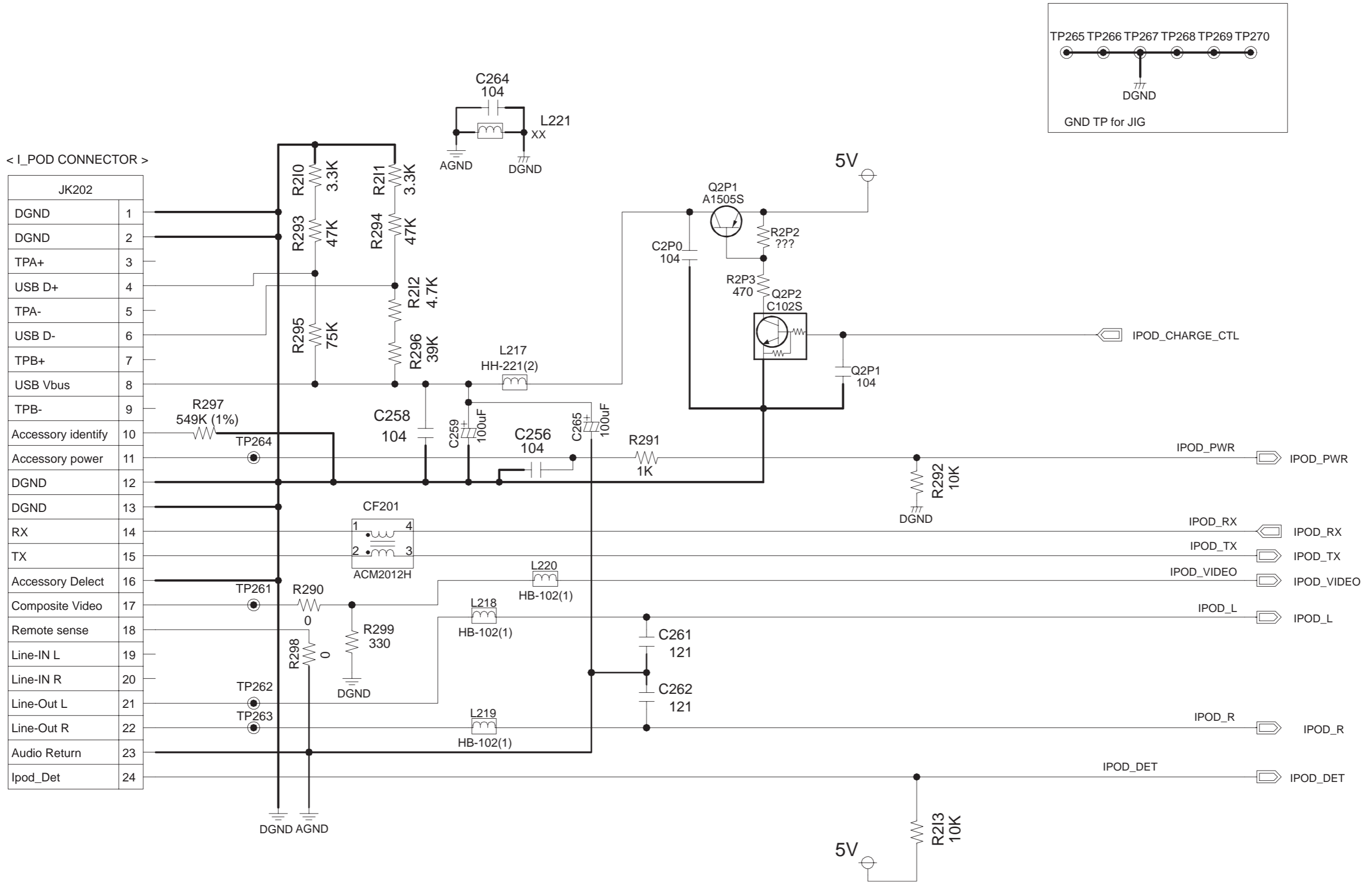



■ HDMI section 2 (for TH-G40C, TH-G40UJ)

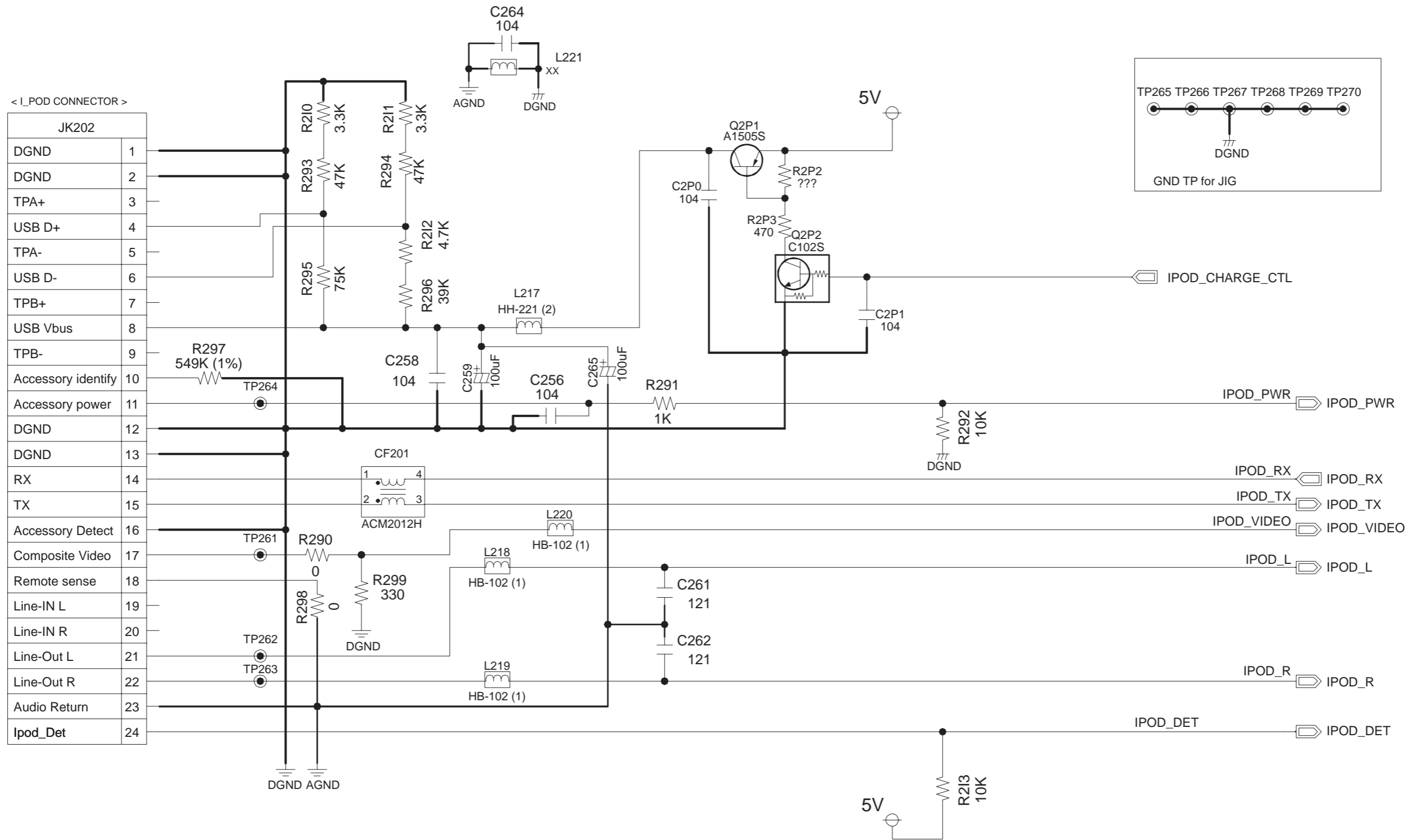

■ Front key & Timer section

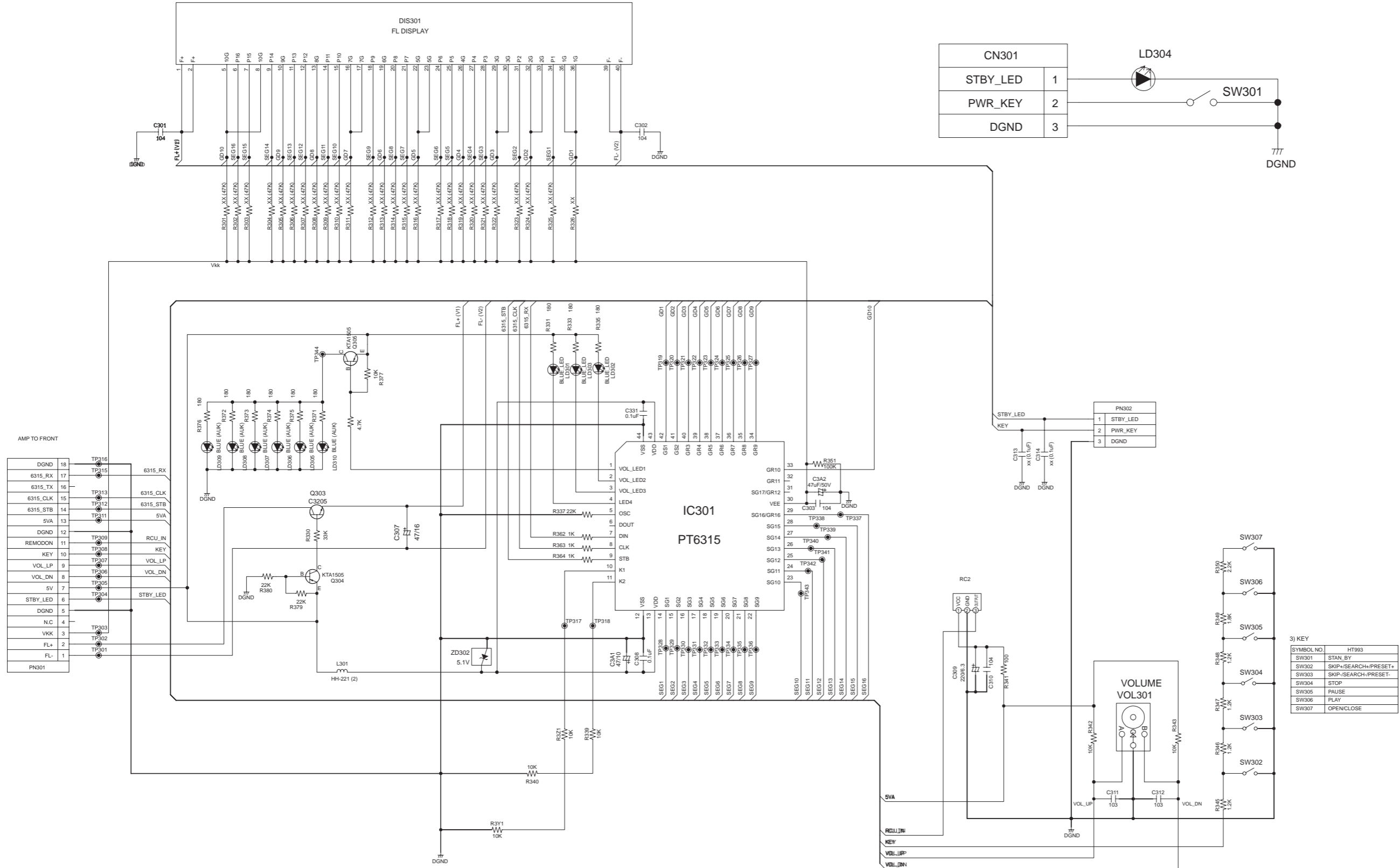



■ USB section

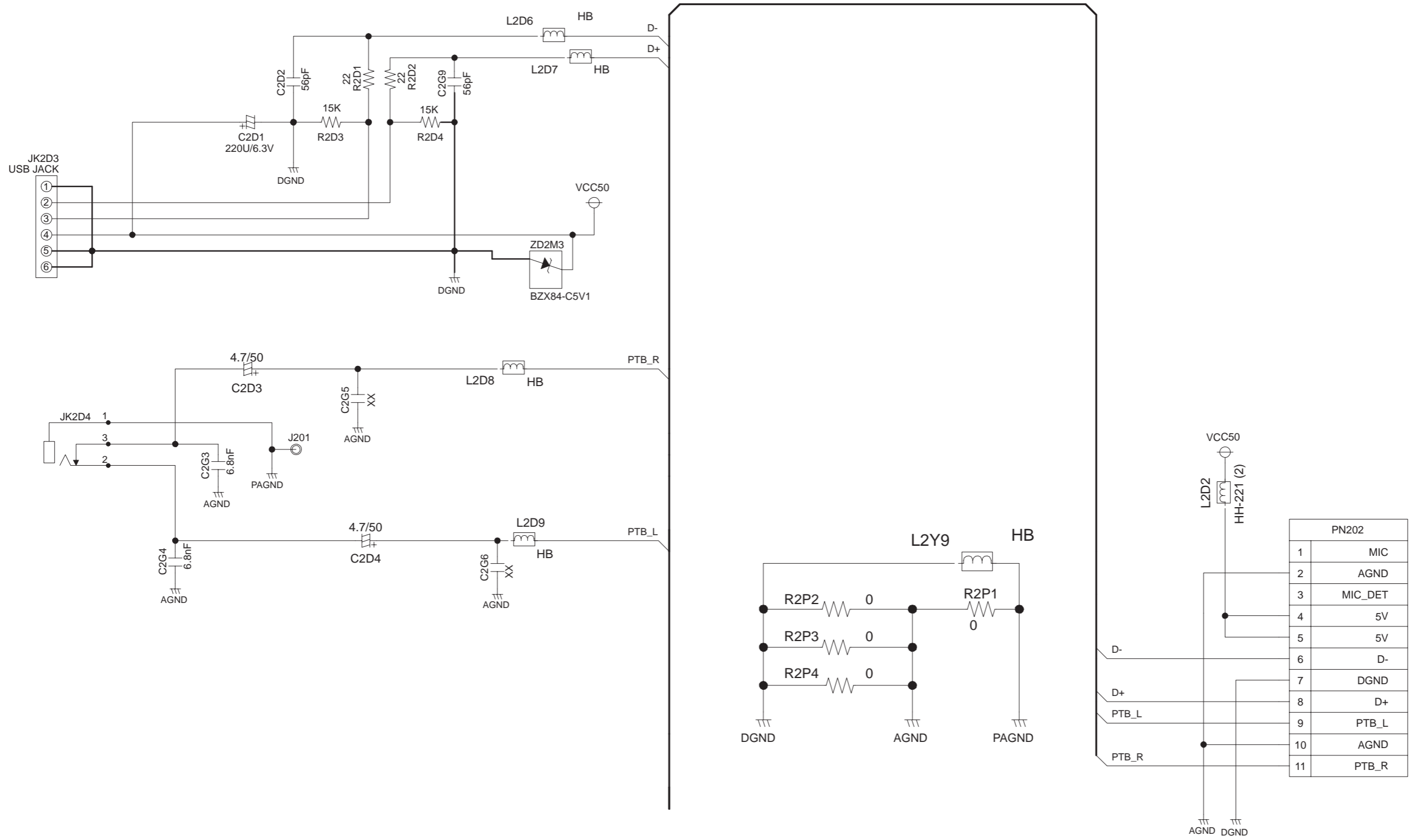

PN202	
1	MIC
2	AGND
3	MIC_DET
4	5V
5	5V
6	D-
7	DGND
8	D+
9	PTB_L
10	AGND
11	PTB_R

## CIRCUIT VOLTAGE CHART

MPEG (IC501)		
Names	Pin Numbers	Voltage
COREVCC 1.5	16, 48, 79, 124, 185, 188	1.51 V
VD33_DAC	97, 101	3.47 V
VD33_PLL	107	3.47V
AVD33	109	3.47V
VD33RF	145,163,183	3.47V
VD33	1, 14, 30, 46, 62, 77, 95, 119, 133, 186, 203	3.47V
SDRAM (IC502)		
Names	Pin Numbers	Voltage
VCC33	1, 3, 9, 14, 27, 43, 49	3.47 V
FLASH (IC503)		
Names	Pin Numbers	Voltage
VD33	1, 3, 8	3.47 V
EEPROM (IC504)		
Names	Pin Numbers	Voltage
VD33	8	3.47 V
IPOD (IC507)		
Names	Pin Numbers	Voltage
VCC33	1, 40	3.47 V
ADC (IC201)		
Names	Pin Numbers	Voltage
VCC50	5, 14, 30	4.87 V
VCC33	36, 46	3.47 V
SERVO (IC401)		
Names	Pin Numbers	Voltage
12V_INPUT	12	12.04V
MVCC50	5, 19	4.86 V
COREVCC1.5	28	1.56V

ADG884 (IC804)		
Names	Pin Numbers	Voltage
EEP_VCC(VCC50)	1	4.32V
HDMI TX (IC805)		
Names	Pin Numbers	Voltage
TDVD33	13, 28, 34, 48, 70	3.23 V
TAVD33	23, 38	3.29 V
TDVC18	4, 16, 45, 59, 74	1.8 V
LC87F5R64A (IC101)		
Names	Pin Numbers	Voltage
5V_P	9, 36, 59	5.04 V
TS5A2053 (IC202)		
Names	Pin Numbers	Voltage
VCC50	8	4.87V

■ MPEG section (TH-G40UJ)

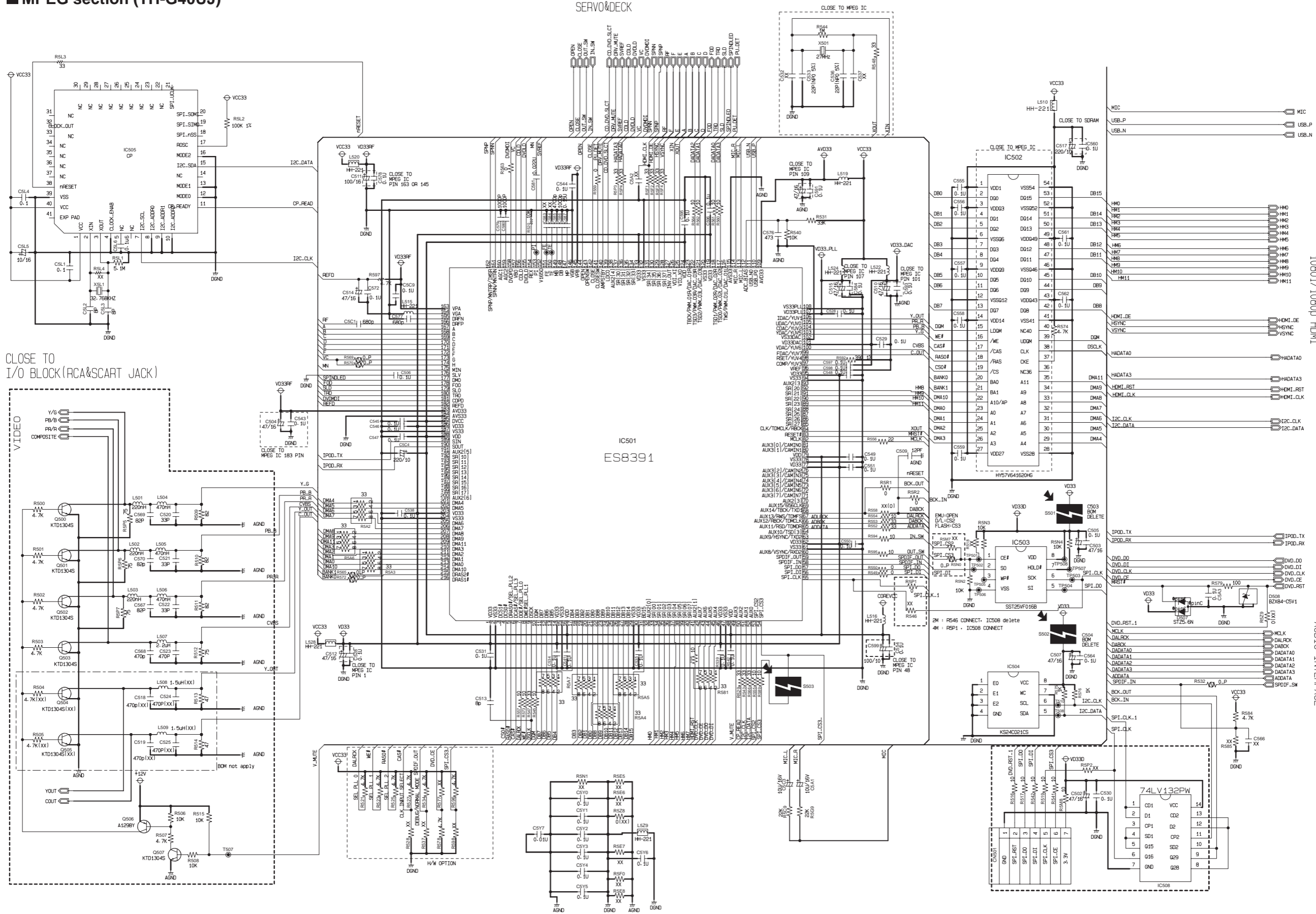

1080i/1080p HDMI  
MAIN INTERFACE  
AUDIO INTERFACE

■ Power interface section (TH-G40UJ)

[CONNECT WITH AMP]

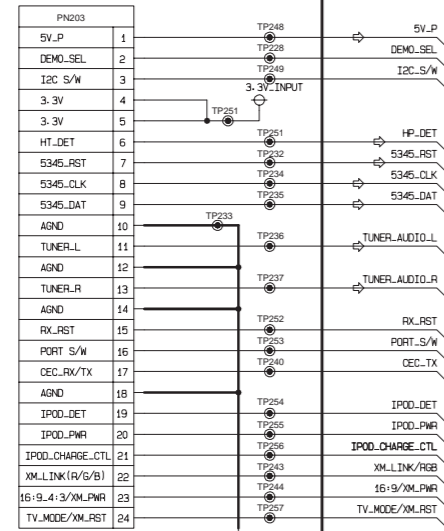
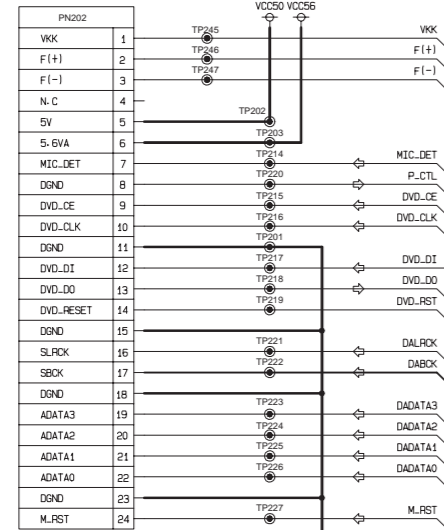

[CONNECT WITH MIC/USB]

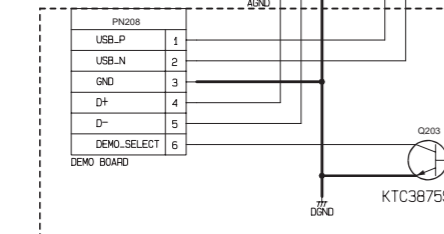
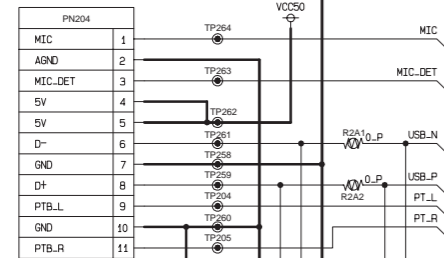

[CONNECT WITH HDMI BOARD]

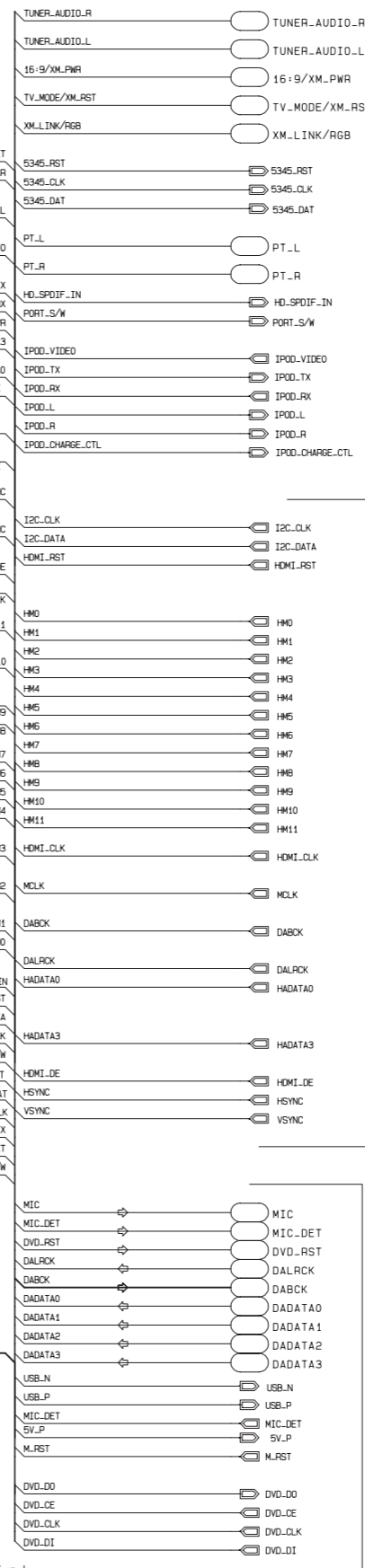
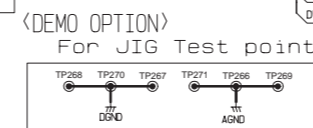
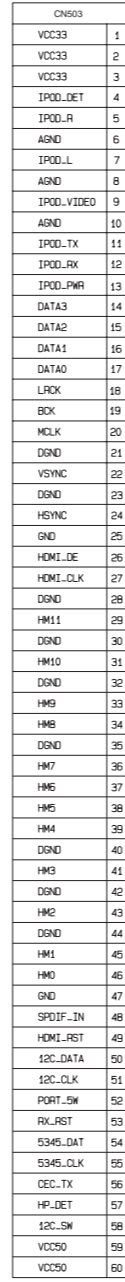
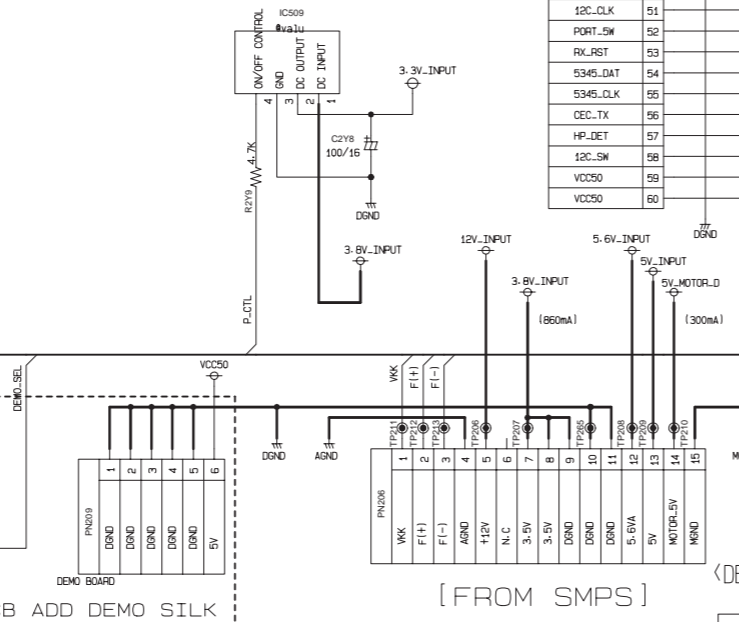
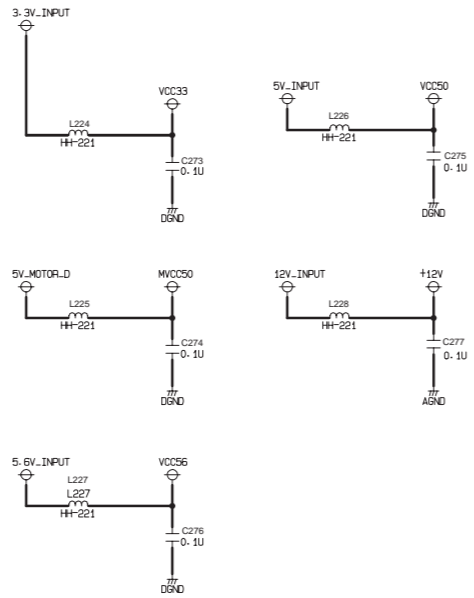

I/O SECTION

MPEG SECTION

MPEG SECTION

PCB ADD DEMO SILK

[FROM SMPS] <DEMO OPTION> For JIG Test point



■ Servo section (TH-G40UJ)

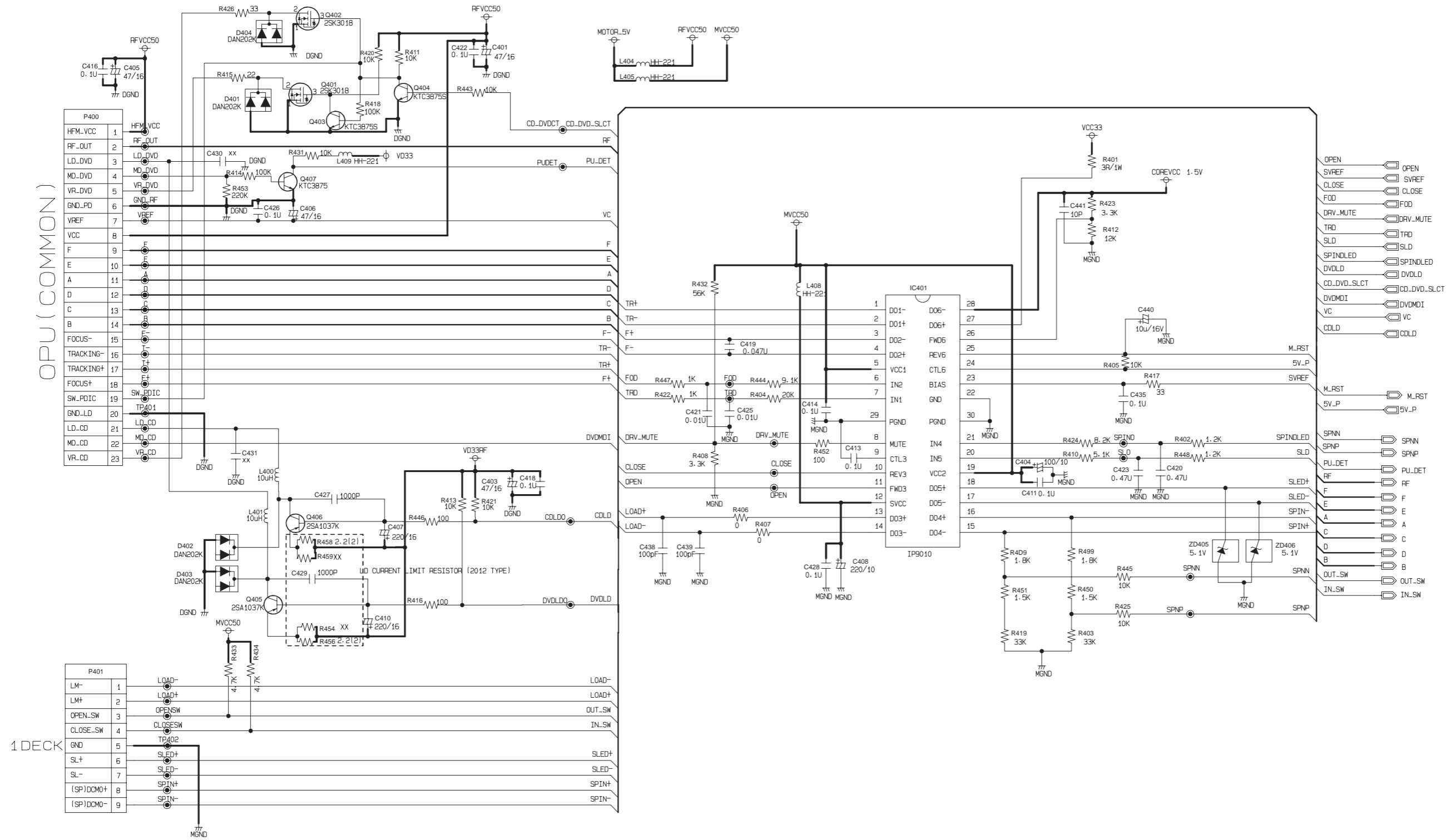

# ■ Amp section (TH-G40UJ)

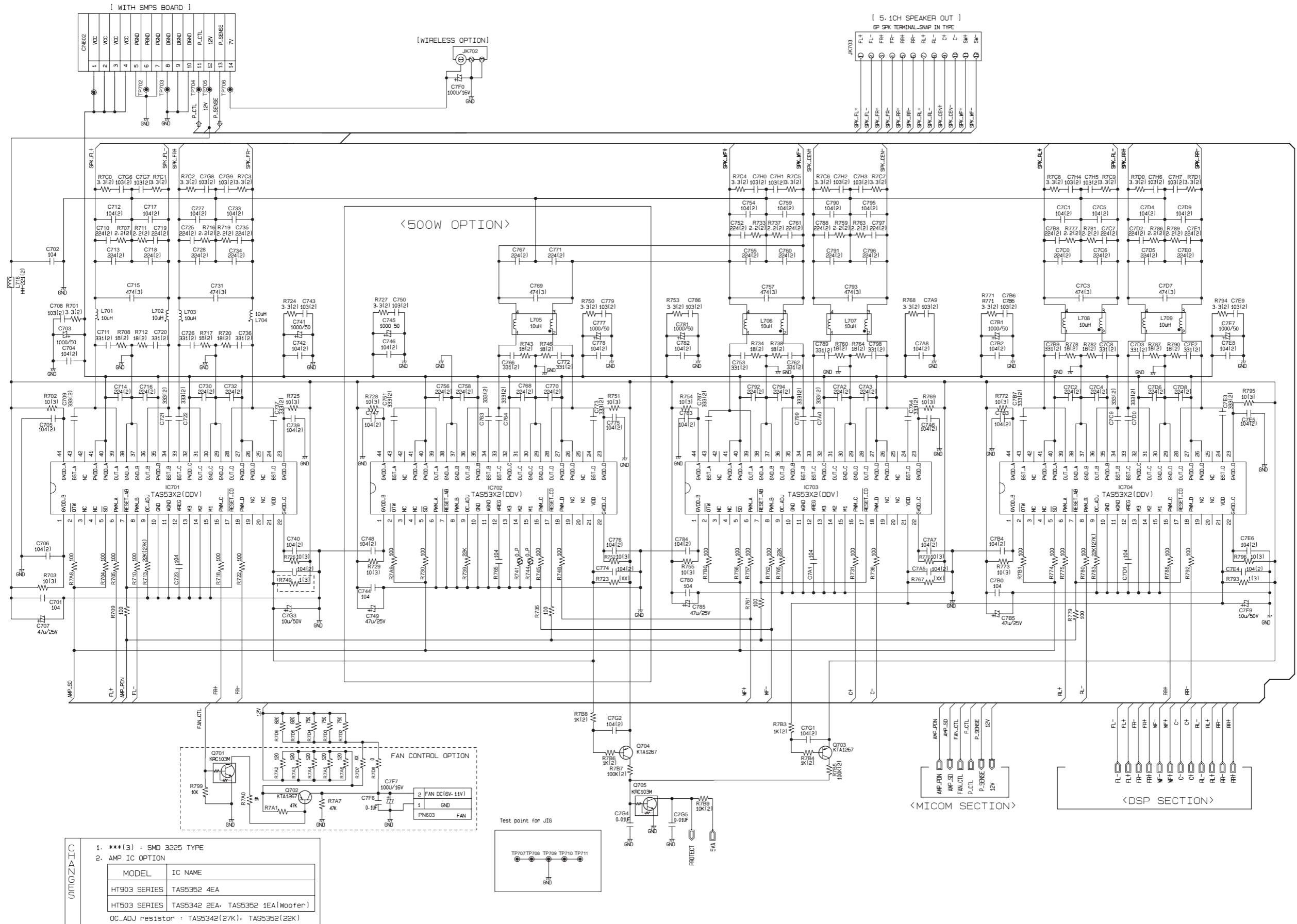

[ WITH SMPS BOARD ]

[ WIRELESS OPTION ]

[ 5.1CH SPEAKER OUT ]

GP SPK TERMINAL\_SMP IN TYPE

<500W OPTION>

<MICOM SECTION>

<DSP SECTION>

1. \*\*\*(3) : SMD 3225 TYPE  
2. AMP IC OPTION

MODEL	IC NAME
HT903 SERIES	TAS5352 4EA
HT503 SERIES	TAS5342 2EA, TAS5352 1EA(Woofers)

OC\_ADJ resistor : TAS5342(27K), TAS5352(22K)

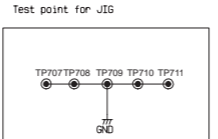

■ DSP section (TH-G40UJ)

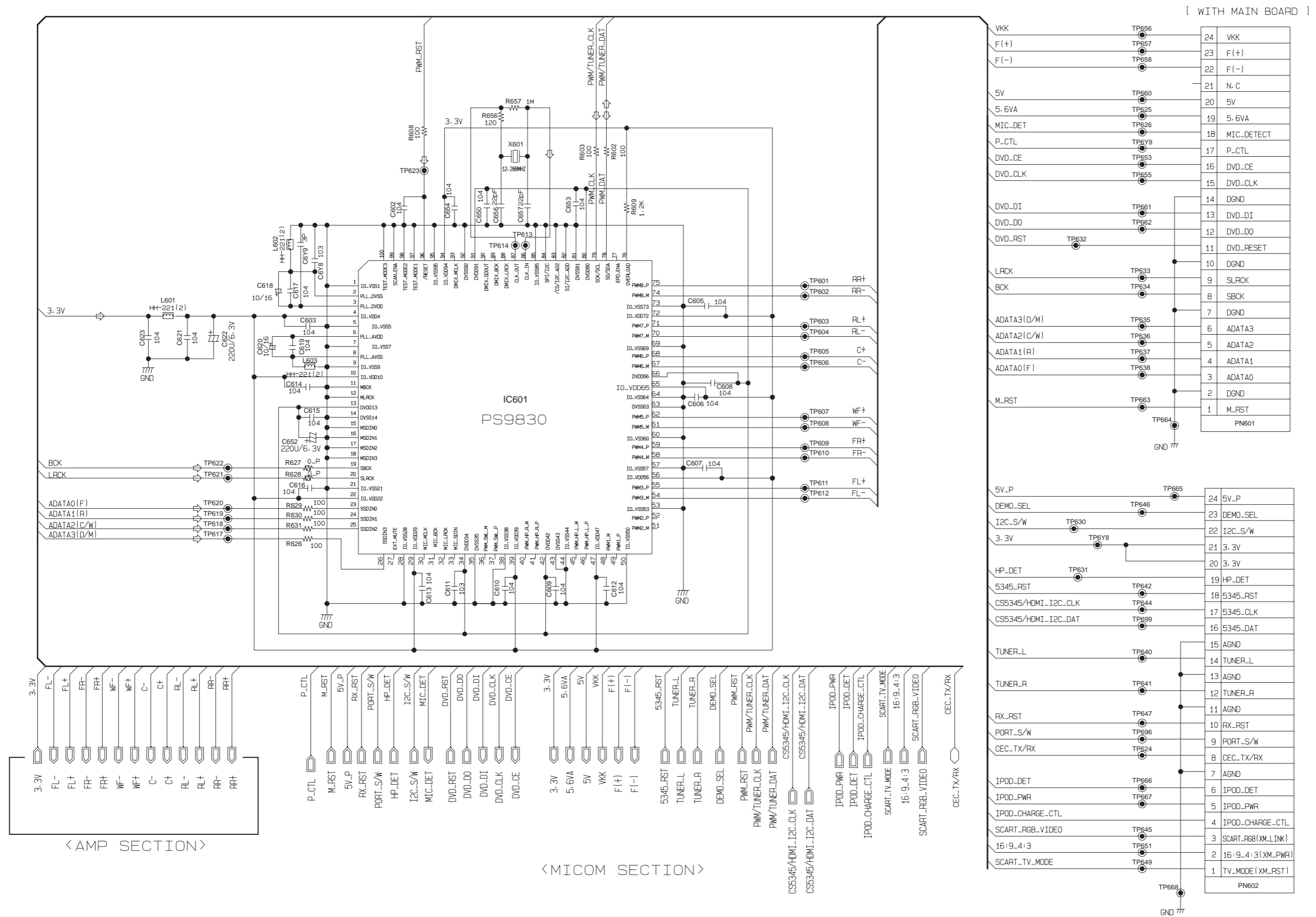



■ Micom section (TH-G40UJ)

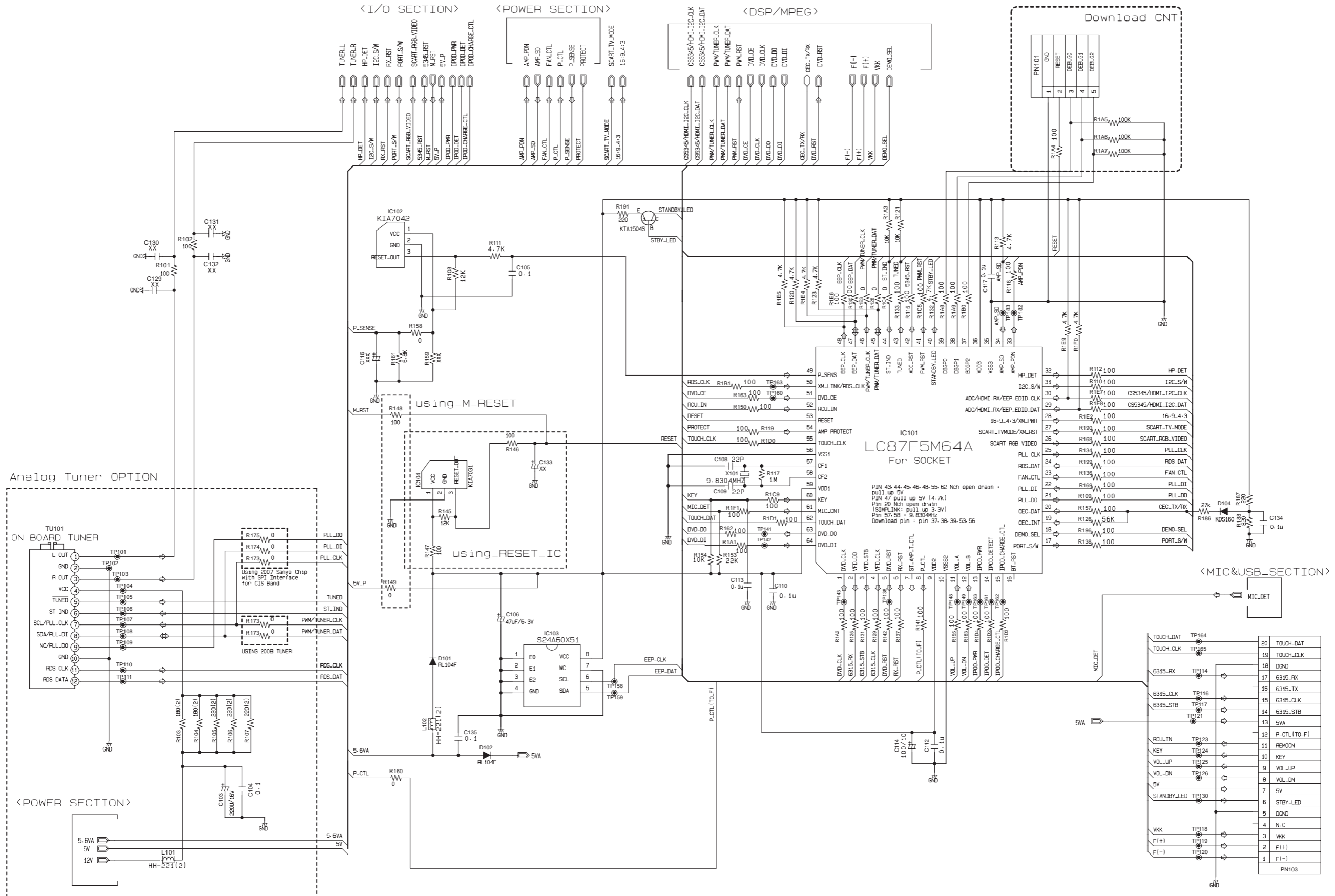



**Main board**  
reverse side

Lead free solder used in the board (material : Sn-Ag-Cu, melting point : 219 Centigrade)

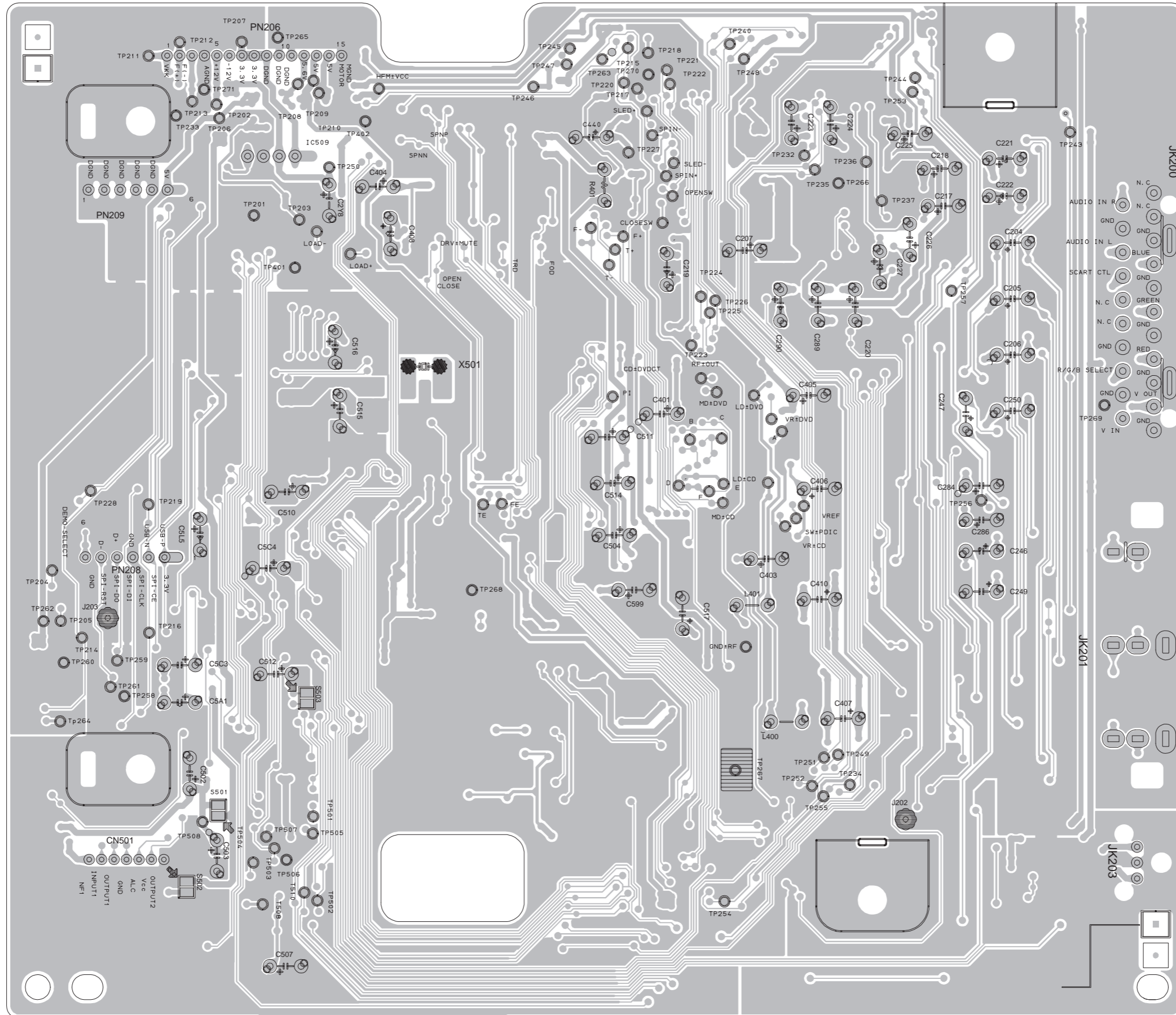

■ Amp board  
forward side

Lead free solder used in the board (material : Sn-Ag-Cu, melting point : 219 Centigrade)

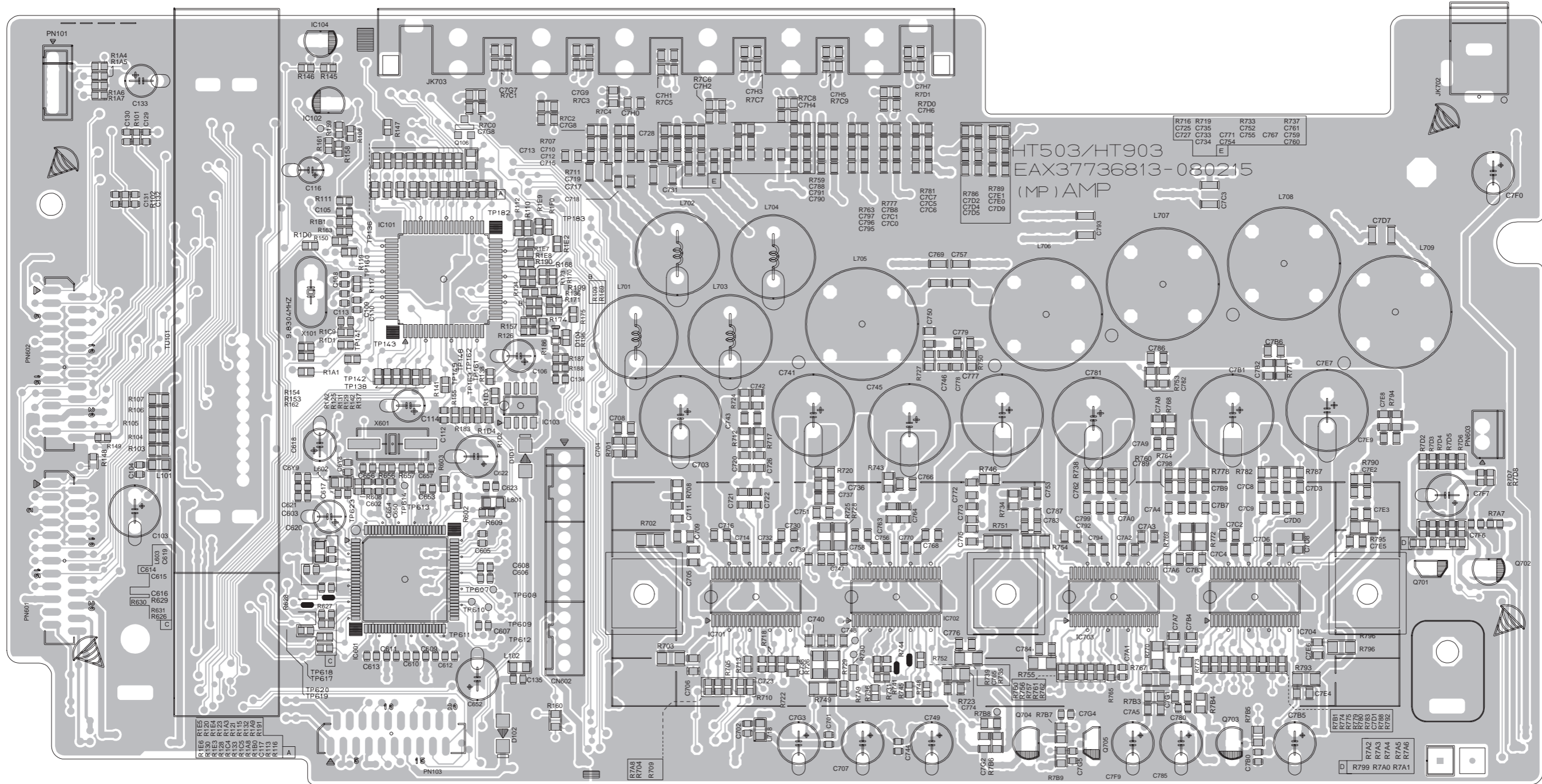

■ Amp board  
reverse side

Lead free solder used in the board (material : Sn-Ag-Cu, melting point : 219 Centigrade)

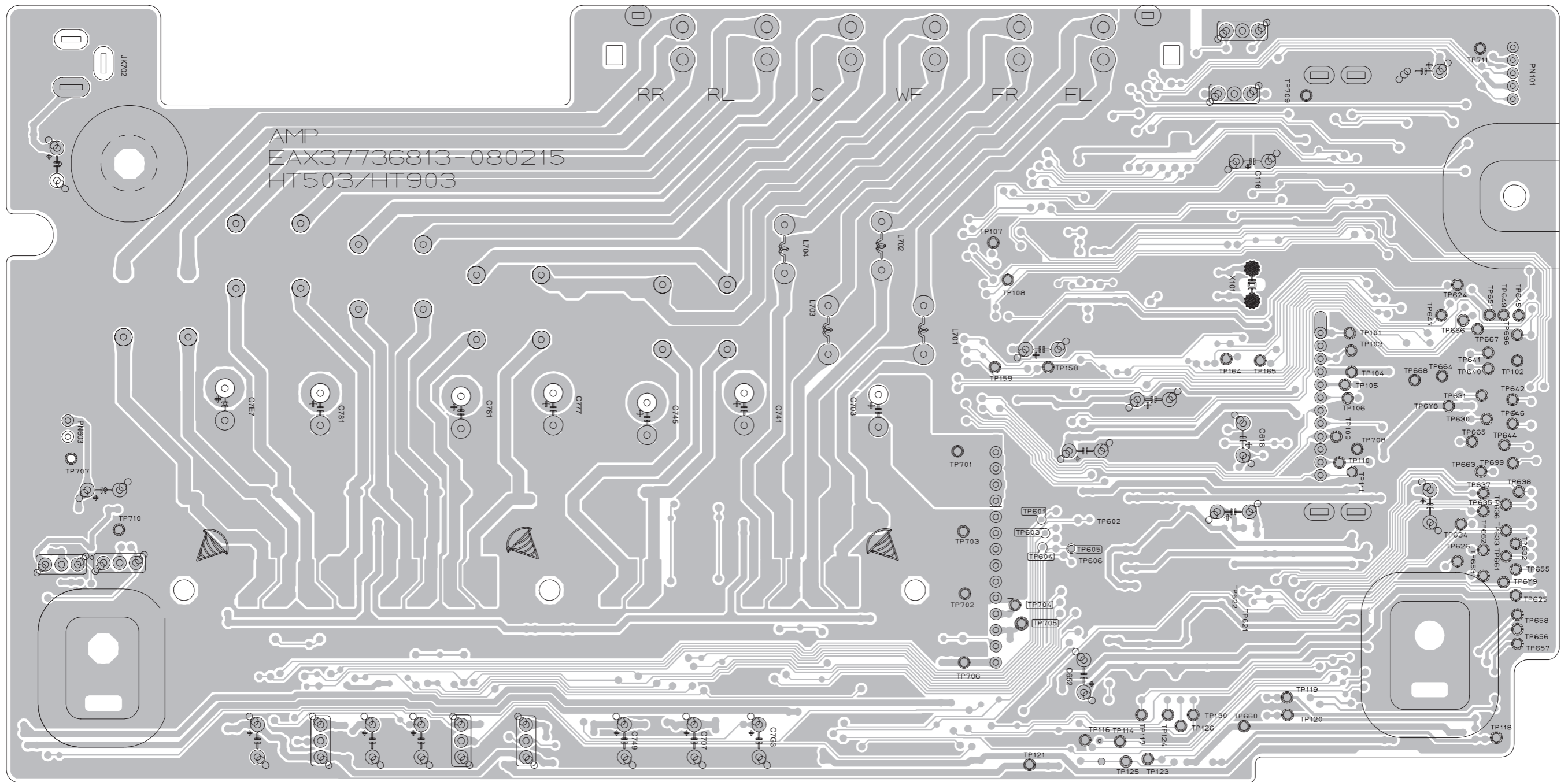

■ Main board (TH-G40UJ) Lead free solder used in the board (material : Sn-Ag-Cu, melting point : 219 Centigrade)

forward side

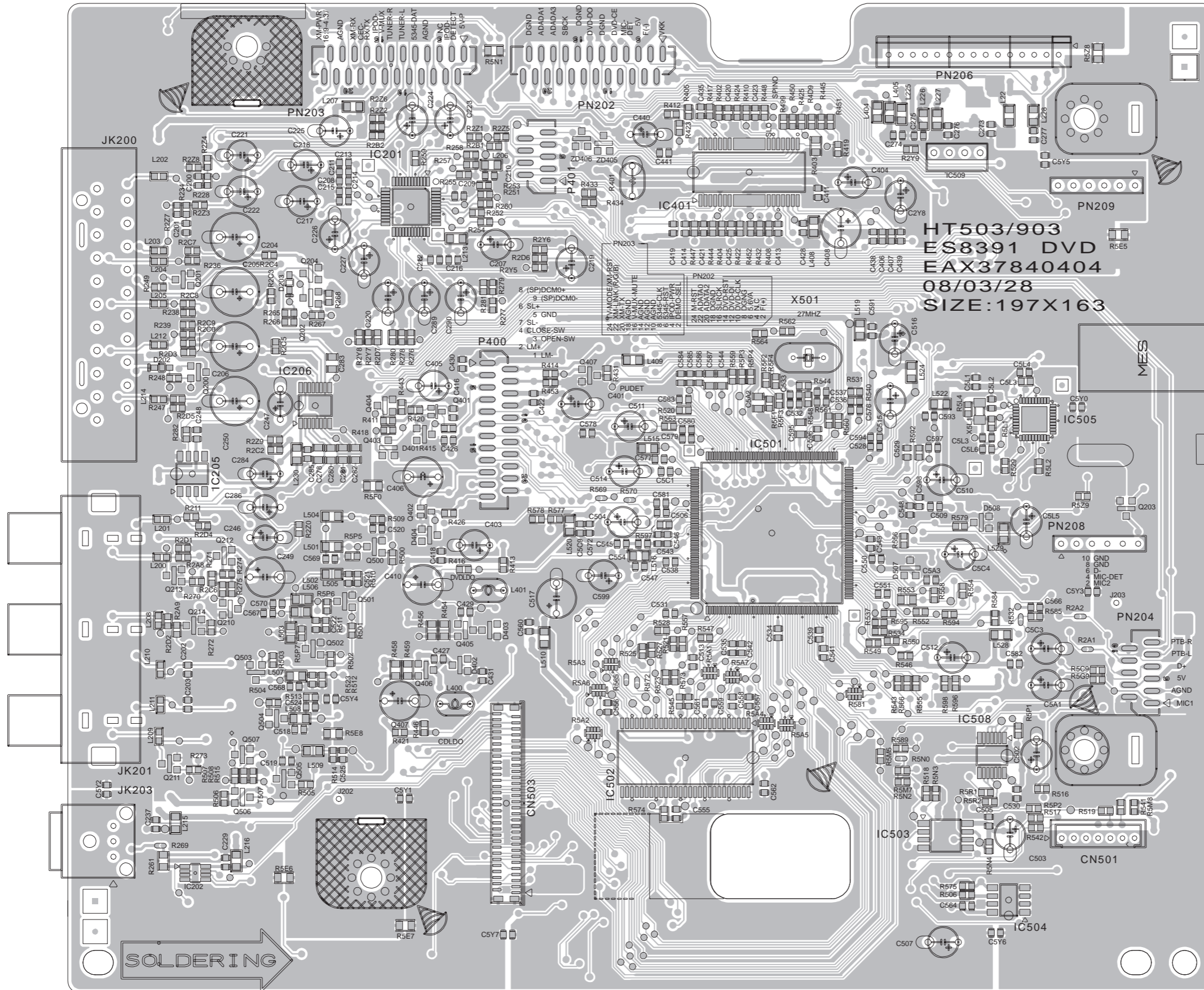

■ Main board (TH-G40UJ) Lead free solder used in the board (material : Sn-Ag-Cu, melting point : 219 Centigrade)

reverse side

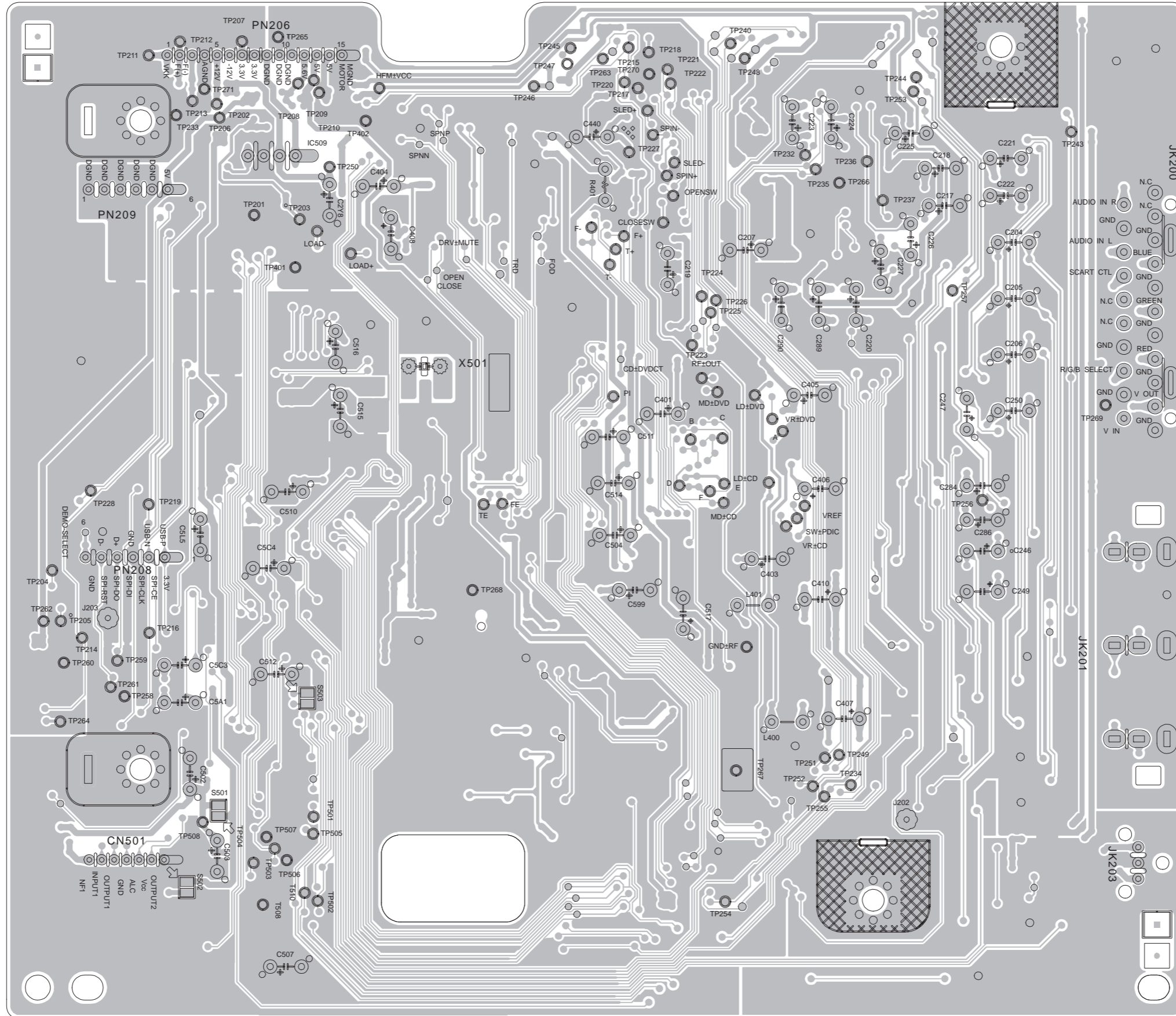

■ Amp board (TH-G40UJ) Lead free solder used in the board (material : Sn-Ag-Cu, melting point : 219 Centigrade)

forward side

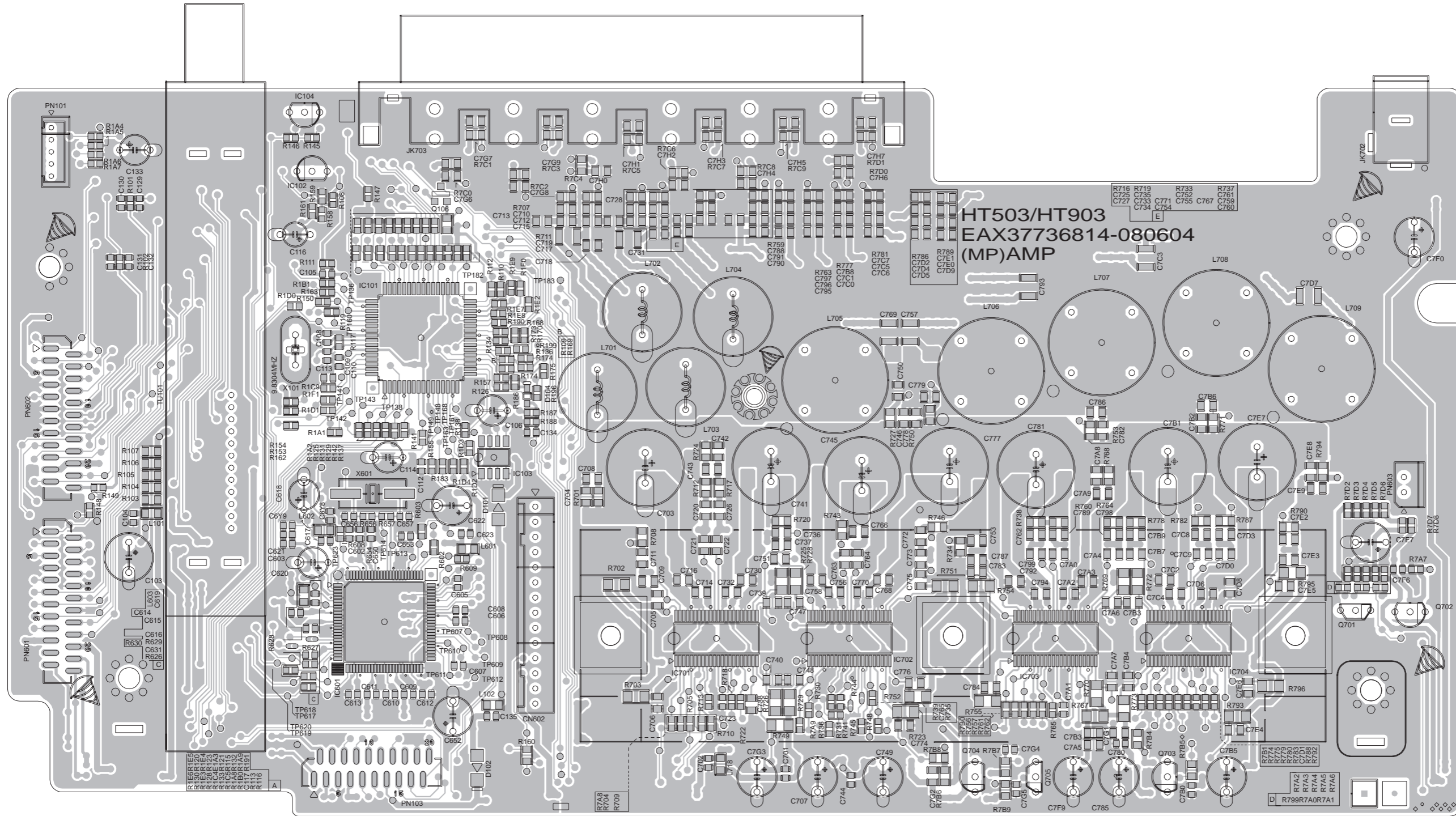



■ Amp board (TH-G40UJ) Lead free solder used in the board (material : Sn-Ag-Cu, melting point : 219 Centigrade)

reverse side

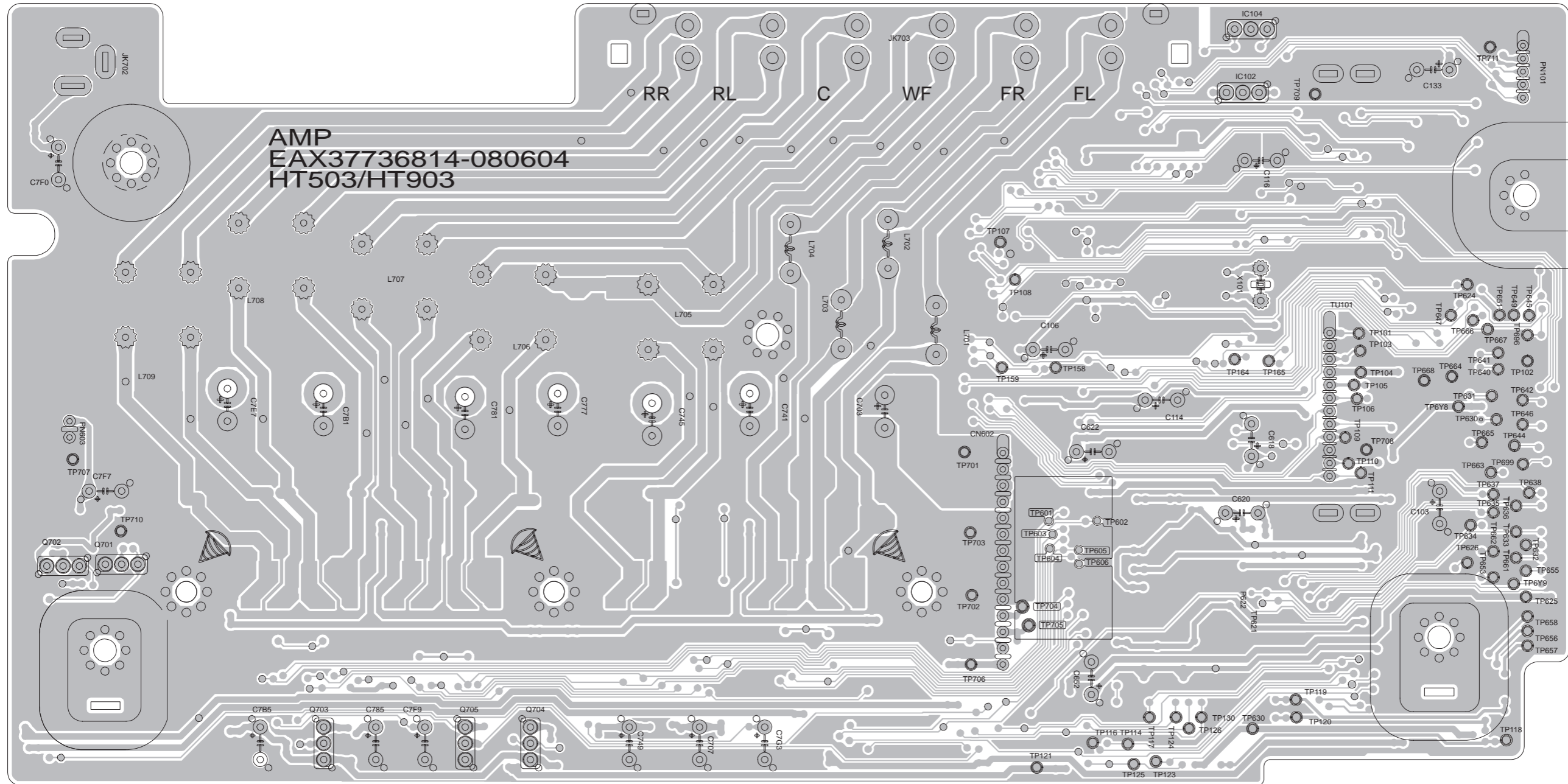

■ Front board

Lead free solder used in the board (material : Sn-Ag-Cu, melting point : 219 Centigrade)

forward side

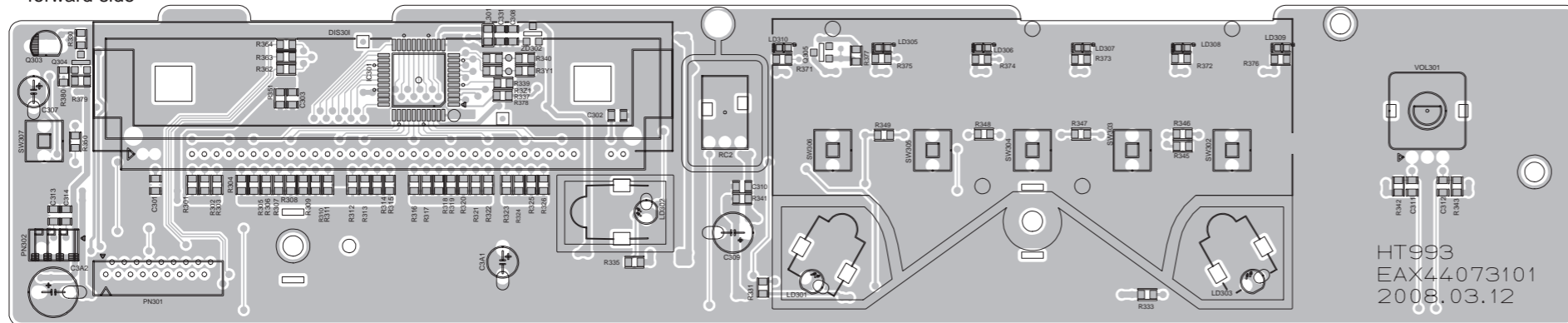

reverse side

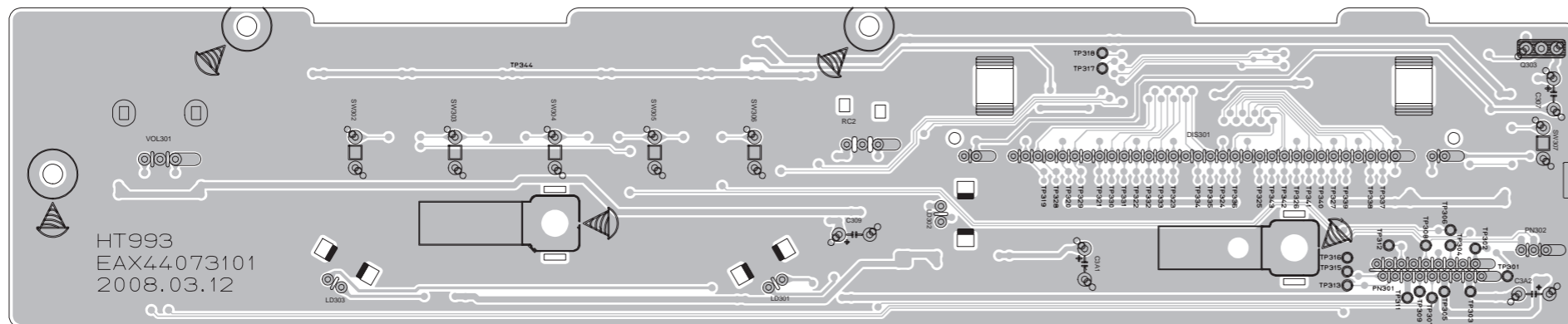

■ HDMI board (for TH-G40J, TH-G30J)

Lead free solder used in the board (material : Sn-Ag-Cu, melting point : 219 Centigrade)

forward side

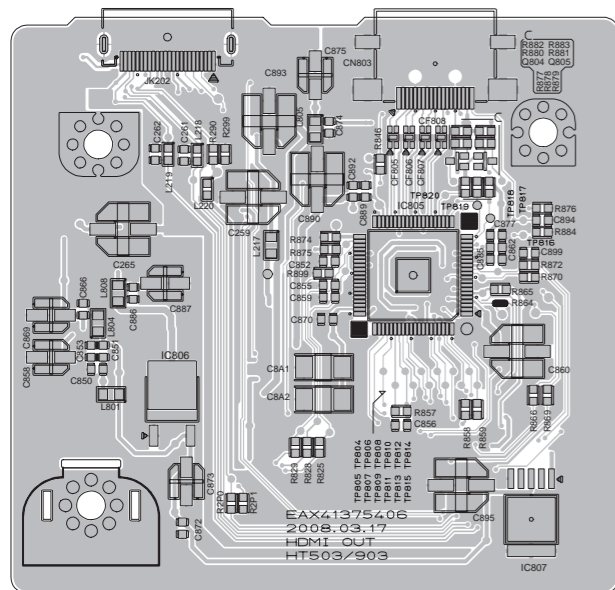

reverse side

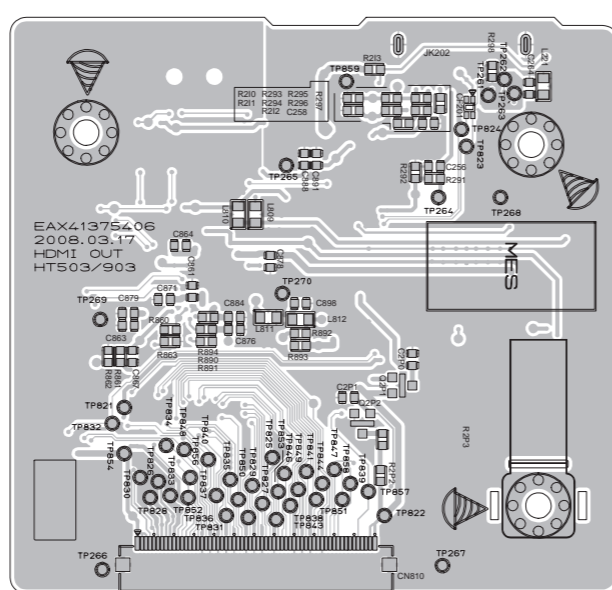

■ HDMI board (for TH-G40C, TH-G40UJ, TH-G30C)

Lead free solder used in the board (material : Sn-Ag-Cu, melting point : 219 Centigrade)

forward side

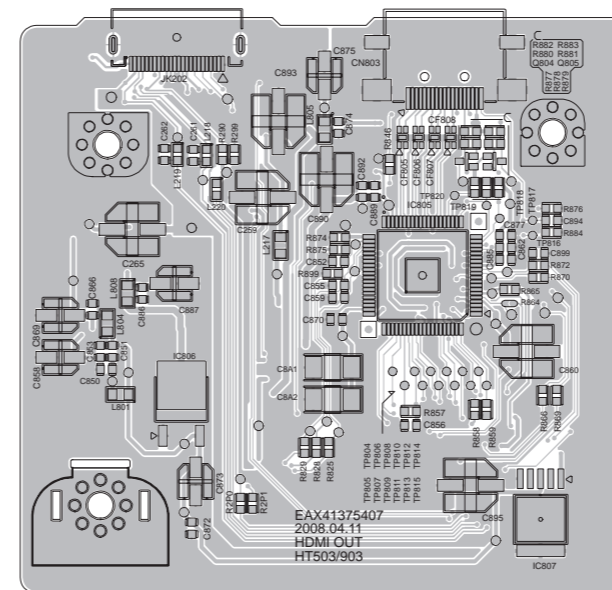

reverse side

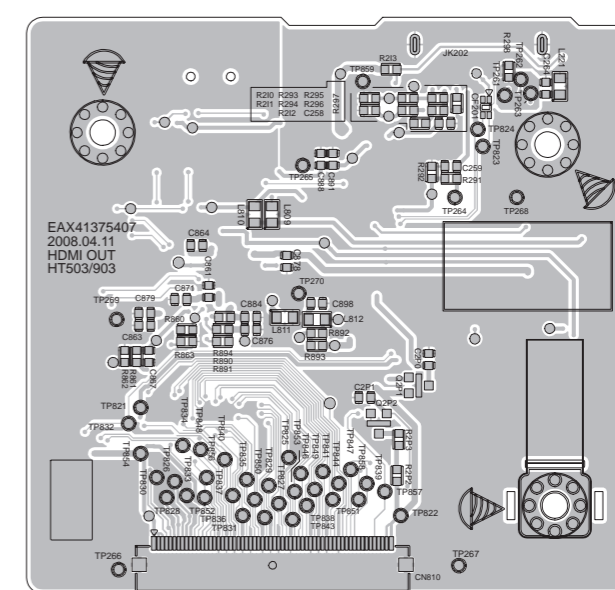

■ **SMPS board** Lead free solder used in the board (material : Sn-Ag-Cu, melting point : 219 Centigrade)

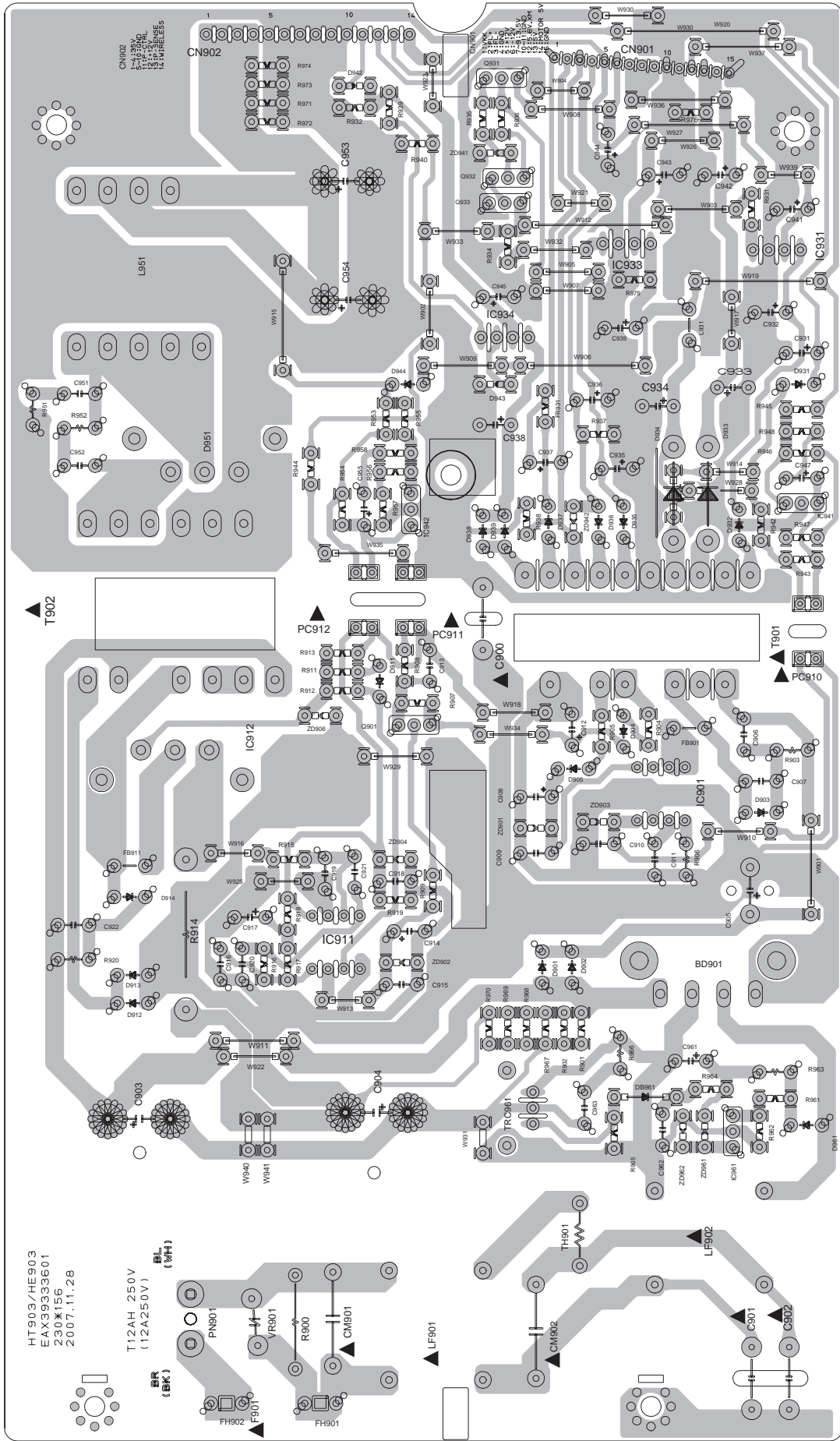

■ **Front jack board** Lead free solder used in the board (material : Sn-Ag-Cu, melting point : 219 Centigrade)

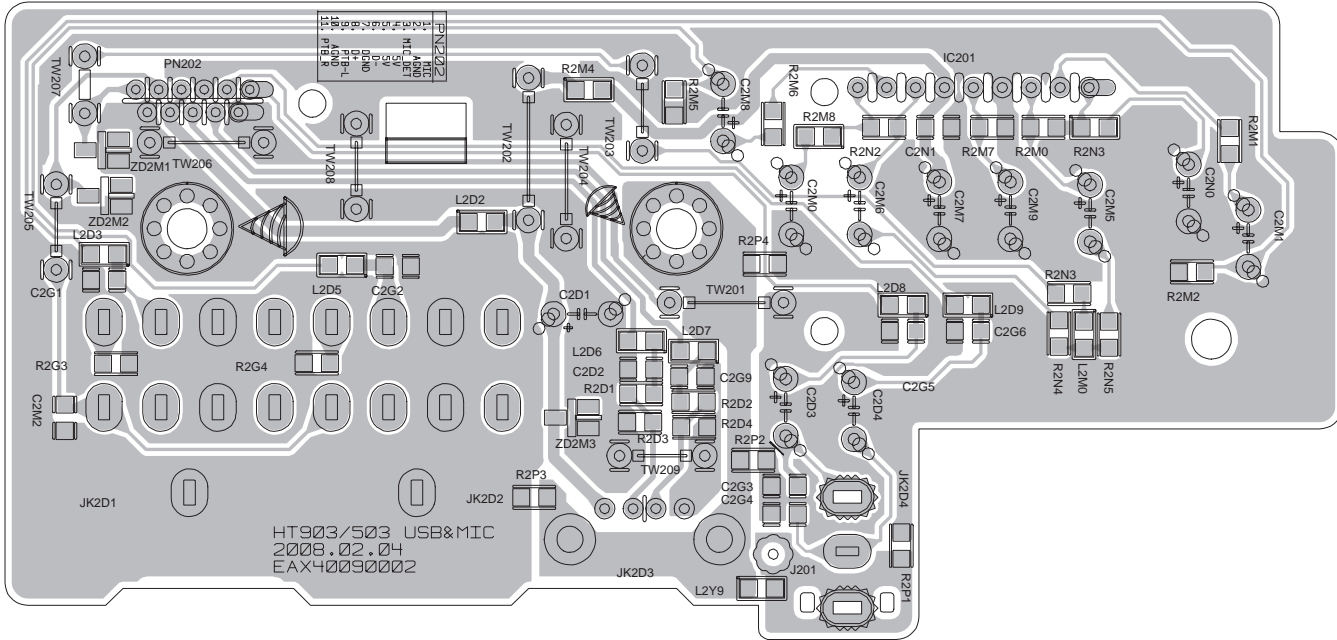

■ **Front key board** Lead free solder used in the board (material : Sn-Ag-Cu, melting point : 219 Centigrade)

forward side

reverse side

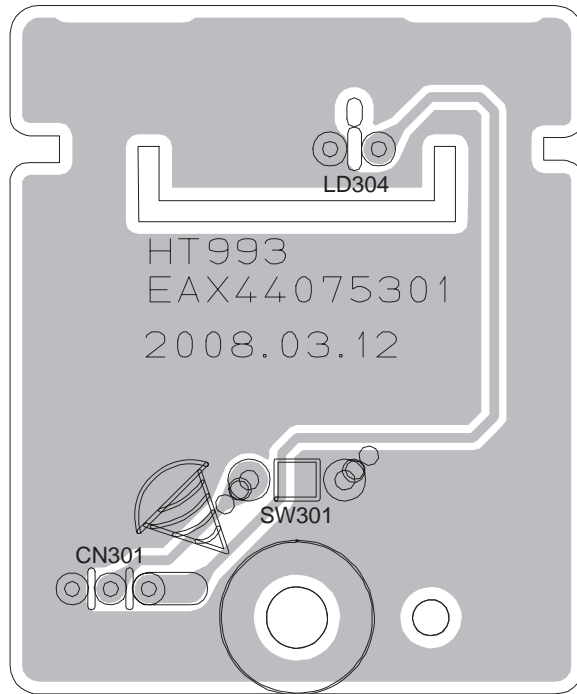
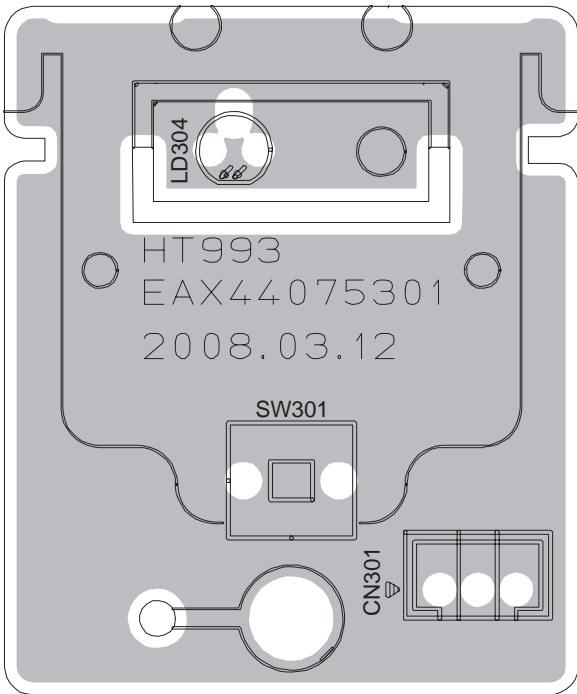

< MEMO >



Victor Company of Japan, Limited

Audio/Video Systems Division 10-1, 1chome, Ohwatari-machi, Maebashi-city, 371-8543, Japan