



REVISION INFORMATION

DVD DIGITAL CINEMA SYSTEM

**TH-G31A, TH-G31B, TH-G31E, TH-G31EN,
TH-G31UG, TH-G31UH, TH-G31UN, TH-G31UX,
TH-G41A, TH-G41UX, TH-G61A, TH-G61E,
TH-G61EN, TH-G61UH, TH-G61UN, TH-G61UX**

■ OVERVIEW

Add TH-G31UG.

■ DETAILS

COVER SECTION

Title	Line	No.MB713<Rev.002>	No.MB713<Rev.003>	Description
Revision		Rev.002	Rev.003	
Issue Date		2010/01	2010/06	
Model No.		TH-G31A, TH-G31B, TH-G31E, TH-G31EN, TH-G31UH, TH-G31UN, TH-G31UX, TH-G41A, TH-G41UX, TH-G61A, TH-G61E, TH-G61EN, TH-G61UH, TH-G61UN, TH-G61UX	TH-G31A, TH-G31B, TH-G31E, TH-G31EN, TH-G31UG, TH-G31UH, TH-G31UN, TH-G31UX, TH-G41A, TH-G41UX, TH-G61A, TH-G61E, TH-G61EN, TH-G61UH, TH-G61UN, TH-G61UX	

STANDARD SCHEMATIC DIAGRAMS

Schematic Diagram

Diagram Name	No.MB713<Rev.002>	No.MB713<Rev.003>	Description
Menu	FRONT JACK CIRCUIT DAI AGRAM	FRONT JACK CIRCUIT DI AGRAM	

Exploded View

Diagram Name	No.MB713<Rev.002>	No.MB713<Rev.003>	Description
Menu	Packing materials and accessories(TH-G41/G31)	Packing materials and accessories(TH-G31/G41)	

PARTS LIST

MODEL No. LIST

Model No.	No.MB713<Rev.003>
TH-G31A	01
TH-G31B	02
TH-G31E	03
TH-G31EN	04
TH-G31UG	05
TH-G31UH	06

Model No.	No.MB713<Rev.003>
TH-G31UN	07
TH-G31UX	08
TH-G41A	09
TH-G41UX	0A
TH-G61A	0B
TH-G61E	0C

Model No.	No.MB713<Rev.003>
TH-G61EN	0D
TH-G61UH	0E
TH-G61UN	0F
TH-G61UX	10

General assembly [M1MM]

△	Symbol	or	Part No.		Part Name	Description	Qty	Models
			<Rev.002>	<Rev.003>				
	M1MM	9	LG-5900R-D004K	LG-5900R-D004G	FAN		1	01, 02, 03, 04, 05, 06, 07, 08, 09, 0A, 0B, 0C, 0D, 0E, 0F, 10
	M1MM	9	or LG-5900R-D004G	LG-5900R-D004K	FAN		1	01, 02, 03, 04, 05, 06, 07, 08, 09, 0A, 0B, 0C, 0D, 0E, 0F, 10
	M1MM	33	-----	LG-EBR63693207	MAIN BOARD ASSY	(Addition)	1	0F
	M1MM	33	-----	LG-EBR63693228	MAIN BOARD ASSY	(Addition)	1	10

Electrical parts list Main board [01]

△	Symbol	or	Part No.		Part Name	Description	Qty	Models
			<Rev.002>	<Rev.003>				
	01	IC104	-----	LG-0IPMGKE022B	IC	(Addition)	1	01, 02, 03, 04, 05, 06, 07, 08, 09, 0A, 0B, 0C, 0D, 0E, 0F, 10
	01	IC104	LG-0IPMGKE022B	-----	IC	(Deletion)	1	0B, 10, 0F, 09, 0A, 01, 08, 07, 0E, 06
	01	IC104	LG-EAN60658301	-----	IC	(Deletion)	1	0C, 0D, 02, 03, 04
	01	IC104	or LG-0IPMGKE022B	LG-EAN60658301	IC		1	02, 03, 04, 0C, 0D
	01	IC106	-----	LG-0IPMGKE047A	IC	(Addition)	1	01, 02, 03, 04, 05, 06, 07, 08, 09, 0A, 0B, 0C, 0D, 0E, 0F, 10
	01	IC106	LG-0IPMGKE047A	-----	IC	(Deletion)	1	0B, 10, 0F, 09, 0A, 01, 08, 07, 0E, 06
	01	IC106	LG-EAN42369201	-----	IC	(Deletion)	1	0C, 0D, 02, 03, 04
	01	IC106	or LG-0IPMGKE047A	LG-EAN42369201	IC		1	02, 03, 04, 0C, 0D
	01	Q403	LG-0TRAU80008A	KTA1504/G/-X	BIPOLAR TR		1	01, 02, 03, 04, 05, 06, 07, 08, 09, 0A, 0B, 0C, 0D, 0E, 0F, 10
	01	Q403	or KTA1504/G/-X	LG-0TRAU80008A	BIPOLAR TR		1	01, 02, 03, 04, 05, 06, 07, 08, 09, 0A, 0B, 0C, 0D, 0E, 0F, 10
	01	Q405	LG-0TRAU80008A	KTA1504/G/-X	BIPOLAR TR		1	01, 02, 03, 04, 05, 06, 07, 08, 09, 0A, 0B, 0C, 0D, 0E, 0F, 10
	01	Q405	or KTA1504/G/-X	LG-0TRAU80008A	BIPOLAR TR		1	01, 02, 03, 04, 05, 06, 07, 08, 09, 0A, 0B, 0C, 0D, 0E, 0F, 10

PTB board [03]

△	Symbol	or	Part No.		Part Name	Description	Qty	Models
			<Rev.002>	<Rev.003>				
	03	C2D6	-----	LG-0CH1104H946	C CAPACITOR	(Addition)	1	01, 02, 03, 04, 05, 06, 07, 08, 09, 0A, 0B, 0C, 0D, 0E, 0F, 10
	03	C2D6	LG-0CH1104H946	-----	C CAPACITOR	(Deletion)	1	0C, 0D, 0B, 10, 0F, 09, 0A, 02, 03, 04, 01, 08, 07
	03	C2D6	LG-0RH0000D622	-----	CHIP RESISTOR	(Deletion)	1	0E, 06
	03	C2D6	or LG-0CH1104H946	LG-0RH0000D622	CHIP RESISTOR		1	05, 06, 0E

Packing and accessories G61 [M3MM]

△	Symbol	or	Part No.		Part Name	Description	Qty	Models
			<Rev.002>	<Rev.003>				
	M3MM	A19	LG-EAA56672101	LG-5010R-L004C	AM ANTENNA		1	0B, 0E, 0F, 10
	M3MM	A19	or LG-5010R-L004C	LG-EAA56672101	AM ANTENNA		1	0B, 0E, 0F, 10

Packing and accessories G31/G41 [M4MM]

△	Symbol	or	Part No.		Part Name	Description	Qty	Models
			<Rev.002>	<Rev.003>				
	M4MM	A1	-----	LG-AFN73972701	INST ASSY	(Addition)	1	05
	M4MM	A19	LG-EAA56672101	LG-5010R-L004C	AM ANTENNA		1	01, 05, 06, 07, 08, 09, 0A
	M4MM	A19	or LG-5010R-L004C	LG-EAA56672101	AM ANTENNA		1	01, 05, 06, 07, 08, 09, 0A



Victor Company of Japan, Limited

Home Entertainment Business Division Personal AV Operation 10-1, 1chome, Ohwatari-machi, Maebashi-city, 371-8543, Japan



REVISION INFORMATION

DVD DIGITAL THEATER SYSTEM

TH-G51J, TH-G41J, TH-G41C, TH-G31J, TH-G31C, TH-G61C

■ OVERVIEW

Add TH-G61C.

■ DETAILS

COVER SECTION

Title	Line	No.MB712<Rev.001>	No.MB712<Rev.002>	Description
Revision		Rev.001	Rev.002	
Issue Date		2009/09	2010/02	
Model No.		TH-G31C, TH-G31J, TH-G41C, TH-G41J, H-G51J	TH-G31C, TH-G31J, TH-G41C, TH-G41J, TH-G51J, TH-G61C	
Cover Illustration		ILLUSTRATION(mb712_0001.png)	ILLUSTRATION(mb712_0001.png)	
Category		Audio/Video Systems Division	Home Entertainment Business Division Personal AV Operation	
Copyright		COPYRIGHT (C) 2009 Victor Company of Japan, Limited	COPYRIGHT (C) 2010 Victor Company of Japan, Limited	
SPECIFICATION	192	-	TH-G61	
	193	-	General	
	194	-	Power supply 120 V ~ 60 Hz	
	195	-	Power consumption 130 W	
	196	-	Net Weight 3.6 kg	
	197	-	External dimensions (W × H × D) 430 × 76 × 317 mm	
	198	-	Operating conditions Temperature: 5°C to 35°C, Operation status: Horizontal	

Title	Line	No.MB712<Rev.001>	No.MB712<Rev.002>	Description
	199	-	Operating humidity 5% to 85%	
	200	-	Laser Semiconductor laser, wavelength 650 nm	
	201	-	CD/DVD	
	202	-	Video system NTSC	
	203	-	Frequency response (audio) 140 Hz to 20 kHz *	
	204	-	Signal-to-noise ratio (audio) More than 75 dB (1 kHz, 20 kHz LPF/A-Filter) *	
	205	-	Dynamic range (audio) More than 75 dB *	
	206	-	Harmonic distortion (audio) 0.5 % (1 kHz, at 1W position) (20 kHz LPF) *	
	207	-	Video	
	208	-	Video output 1.0 V (p-p), 75 Ω, negative sync., RCA jack × 1	
	209	-	COMPONENT VIDEO OUT (Y) 1.0 V (p-p), 75 ohms, negative sync, RCA jack × 1	
	210	-	(PB)/(PR) 0.7 V (p-p), 75 ohms, RCA jack × 1	
	211	-	HDMI OUT 480i/480p/720p/1080i/1080p	
	212	-	Tuner	
	213	-	FM Tuning Range 87.5 - 108.0 MHz	
	214	-	Intermediate Frequency 10.7 MHz	
	215	-	Signal-to Noise Ratio 60 dB (Mono) *	
	216	-	Frequency Response 140 - 10,000 Hz *	
	217	-	Amplifier	
	218	-	Stereo mode 155 W + 155 W (4Ω at 1 kHz, THD 10 %)	
	219	-	Surround mode(* Depending on the sound mode settings and the source, there may be no sound output.) Front 155 W + 155 W (THD 10 %)	
	220	-	center* 155 W	
	221	-	Surround* 155 W + 155 W (4Ω at 1 kHz, THD 10 %)	
	222	-	Subwoofer* 225 W (3Ω at 70 Hz, THD 10 %)	
	223	-	Inputs AUDIO IN, OPTICAL IN, AUX IN, iPod	

Title	Line	No.MB712<Rev.001>	No.MB712<Rev.002>	Description
	224	-	Outputs MONITOR OUT, HDMI OUT, COMPONENT VIDEO OUT	
	225	-	Speakers	
	226	-	Front Speaker Type 2 Way 3 Speaker	
	227	-	Impedance 4 Ω	
	228	-	Frequency Response 80 - 18000 Hz	
	229	-	Sound Pressure Level 83 dB/W (1m)	
	230	-	Rated Input Power 155 W	
	231	-	Max. Input Power 310 W	
	232	-	Net Dimensions (W × H × D) 280 × 1201 × 280 mm	
	233	-	Net Weight 4.4 kg	
	234	-	Center speaker Type 1 Way 1 Speaker	
	235	-	Impedance 4 Ω	
	236	-	Frequency Response 120 -18000 Hz	
	237	-	Sound Pressure Level 83 dB/W (1m)	
	238	-	Rated Input Power 155 W	
	239	-	Max. Input Power 310 W	
	240	-	Net Dimensions (W × H × D) 301 × 118 × 83 mm	
	241	-	Net Weight 0.9 kg	
	242	-	Rear Speaker Type 1 Way 1 Speaker	
	243	-	Impedance 4 Ω	
	244	-	Frequency Response 120 -18000 Hz	
	245	-	Sound Pressure Level 83 dB/W (1m)	
	246	-	Rated Input Power 155 W	
	247	-	Max. Input Power 310 W	

Title	Line	No.MB712<Rev.001>	No.MB712<Rev.002>	Description
	248	-	Net Dimensions (W × H × D) 311 × 209 × 83 mm	
	249	-	Net Weight 0.78 kg	
	250	-	Passive Subwoofer Type 1 Way 1 Speaker	
	251	-	Impedance 3 Ω	
	252	-	Frequency Response 40 - 1500 Hz	
	253	-	Sound Pressure Level 82 dB/W (1m)	
	254	-	Rated Input Power 225 W	
	255	-	Max. Input Power 450 W	
	256	-	Net Dimensions (W × H × D) 236 × 435 × 391 mm	
	257	-	Net Weight 5.7 kg	
	259	-	Items with * are measured at Front Speaker Terminals in STEREO mode	
	260	-	Designs and specifications are subject to change without notice.	

STANDARD SCHEMATIC DIAGRAMS

Exploded View

Diagram Name	No.MB712<Rev.001>	No.MB712<Rev.002>	Description
Menu	Packing materials and accessories	Packing materials and accessories 1	
Menu	-	Packing materials and accessories 2 mb712_m401.svgz	

PARTS LIST

MODEL No. LIST

Model No.	No.MB712<Rev.002>
TH-G31C	05
TH-G31J	04
TH-G41C	03
TH-G41J	02
TH-G51J	01
TH-G61C	06

General assembly [M1MM]

△	Symbol	or	Part No.		Part Name	Description	Qty	Models	
			<Rev.001>	<Rev.002>					
	M1MM	1	-----	LG-AGL72919608	FRONT PANEL ASSY	(Addition)	1	06	
	M1MM	2	-----	LG-ADV72931908	FRAME ASSY	(Addition)	1	06	
	M1MM	12	-----	LG-3300RCH001B	PLATE	(Addition)	1	06	
	M1MM	12	or	-----	LG-3300R-V127A	PLATE	(Addition)	2	06
△	M1MM	16	-----	LG-MGC58116629	REAR PANEL	(Addition)	1	06	

Electrical parts list Main board [01]

△	Symbol	or	Part No.		Part Name	Description	Qty	Models
			<Rev.001>	<Rev.002>				
	01 C3C6		-----	LG-0CK104CKG6A	C CAPACITOR	(Addition)	1	06
	01 L3D2		-----	LG-0LCCE00042A	BEAD FILTER	(Addition)	1	06
	01 L3D3		-----	LG-0LCCE00042A	BEAD FILTER	(Addition)	1	06

Packing and accessories TH-G61 [M4MM]

△	Symbol	or	Part No.		Part Name	Description	Qty	Models
			<Rev.001>	<Rev.002>				
	M4MM A1		-----	LG-AFN73077614	INST ASSY	(Addition)	1	06
	M4MM A2		-----	-----	BATTERY	(Addition)	1	06
	M4MM A3		-----	LG-AKB37006111	REMOCON UNIT	(Addition)	1	06
	M4MM A4		-----	LG-6850R-PAA5F	RCA CABLE	(Addition)	1	06
	M4MM A5		-----	LG-EAD60793901	iPod DOC STATION	(Addition)	1	06
	M4MM A6		-----	LG-5010R-T001D	FM ANTENA	(Addition)	1	06
	M4MM A7		-----	LG-EBR61173101	SPK CORD(L)	(Addition)	1	06
	M4MM A8		-----	LG-EBR61173102	SPK CORD(R)	(Addition)	1	06
	M4MM A9		-----	LG-EBR61173103	SPK CORD	(Addition)	1	06
	M4MM A10		-----	LG-EBR61173104	SPK CORD(W)	(Addition)	1	06
	M4MM A11		-----	LG-EBR61173105	SPK CORD(RL)	(Addition)	1	06
	M4MM A12		-----	LG-EBR61173106	SPK CORD(RR)	(Addition)	1	06
	M4MM A13		-----	LG-EAB60819601	CENTER SPK	(Addition)	1	06
	M4MM A14		-----	LG-EAB60799901	FRONT SPK	(Addition)	2	06
	M4MM A15		-----	LG-EAB60818401	FRONT SPK STAND	(Addition)	2	06
	M4MM A16		-----	LG-EAB60799601	FRONT/REAR SPK	(Addition)	2	06
	M4MM A17		-----	LG-EAB51655701	SUBWOOFER	(Addition)	1	06
	M4MM P1		-----	LG-MAY62017558	CARTON	(Addition)	1	06
	M4MM P2		-----	LG-MFZ47047382	CUSHION	(Addition)	1	06
	M4MM P3		-----	LG-MFZ61796853	SPK CUSHION A	(Addition)	1	06
	M4MM P4		-----	LG-MFZ61796854	SPK CUSHION B	(Addition)	1	06
	M4MM P7		-----	LG-MFZ61796850	SPK CUSHION(BTM)	(Addition)	1	06
	M4MM P8		-----	LG-MFZ61796851	SPK CUSHION(MDL)	(Addition)	1	06
	M4MM P9		-----	LG-MFZ61796852	SPK CUSHION(TOP)	(Addition)	1	06



Victor Company of Japan, Limited

Home Entertainment Business Division Personal AV Operation 10-1, 1chome, Ohwatari-machi, Maebashi-city, 371-8543, Japan

JVC

SERVICE MANUAL

DVD DIGITAL CINEMA SYSTEM

**TH-G61E, TH-G61EN, TH-G61A, TH-G61UX,
TH-G61UN, TH-G41A, TH-G41UX, TH-G31B,
TH-G31E, TH-G31EN, TH-G31A, TH-G31UX,
TH-G31UN, TH-G61UH, TH-G31UH**

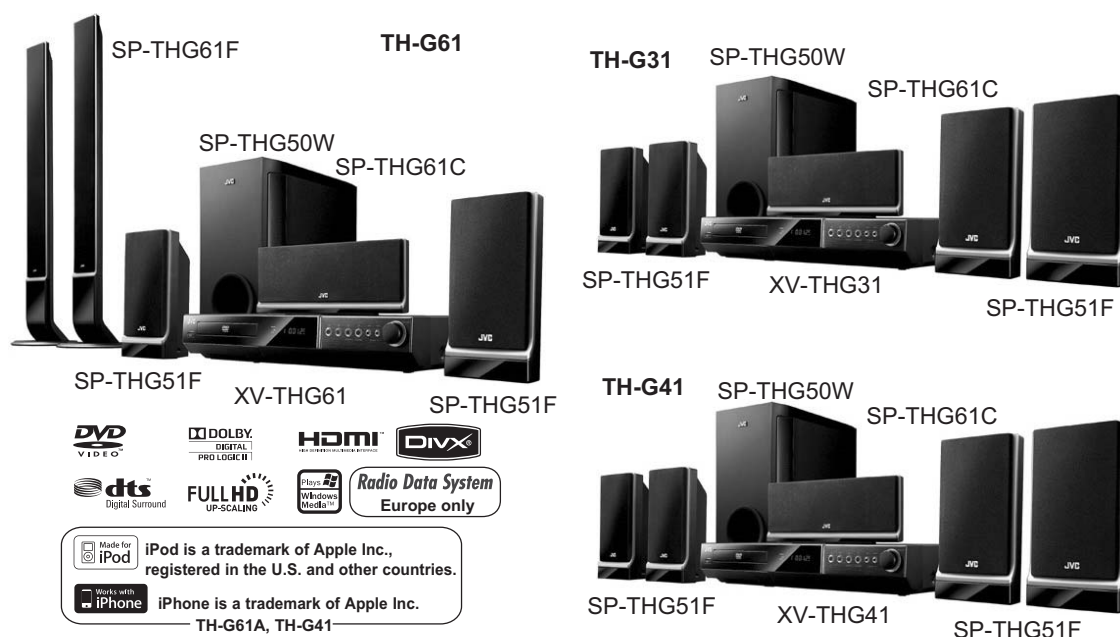

Lead free solder used in the board (material : Sn-Ag-Cu, melting point : 219 Centigrade)

TABLE OF CONTENTS

1	PRECAUTION	1-14
2	SPECIFIC SERVICE INSTRUCTIONS	1-16
3	DISASSEMBLY	1-17
4	ADJUSTMENT	1-20
5	TROUBLESHOOTING	1-21

SPECIFICATION

TH-G61 Europe and Oceania

TH-G61 Europe and Oceania		
General		
Power supply	220 - 240 V ~ 50/60 Hz	
Power consumption	130 W	
Net Weight	3.6 kg	
External dimensions (W × H × D)	430 × 76 × 317 mm	
Operating conditions	Temperature: 5°C to 35°C, Operation status: Horizontal	
Operating humidity	5% to 85%	
Laser	Semiconductor laser, wavelength 650 nm	
CD/DVD		
Video system	PAL/NTSC	
Frequency response (audio)	140 Hz to 20 kHz*	
Signal-to-noise ratio (audio)	More than 75 dB (1 kHz, 20 kHz LPF/A-Filter)*	
Dynamic range (audio)	More than 75 dB*	
Harmonic distortion (audio)	0.5 % (1 kHz, at 1W position) (20 kHz LPF)*	
Video		
Video output	1.0 V (p-p), 75 Ω, negative sync., RCA jack × 1/ SCART (TO TV)	
COMPONENT VIDEO OUT	(Y) 1.0 V (p-p), 75 ohms, negative sync, RCA jack × 1	
	(PB)/(PR) 0.7 V (p-p), 75 ohms, RCA jack × 1	
HDMI OUT	480i (or 576i)/480p (or 576p)/720p/1080i/1080p	
Tuner		
FM	Tuning Range	87.5 - 108.0 MHz
	Intermediate Frequency	128 kHz
	Signal-to Noise Ratio	60 dB (Mono) *
	Frequency Response	140 - 10,000 Hz *
AM (for Australia and Asia)	Tuning Range	522 - 1,710 MHz
	Intermediate Frequency	128 kHz
Amplifier		
Stereo mode	155 W + 155 W (4Ω at 1 kHz, THD 10 %)	
Surround mode (* Depending on the sound mode settings and the source, there may be no sound output.)	Front	155 W
	Center*	155 W + 155 W (4Ω at 1 kHz, THD 10 %)
	Surround*	225 W (3Ω at 70 Hz, THD 10 %)
	Subwoofer*	
Inputs	AUDIO IN, OPTICAL IN, AUX IN, USB, TV-AUDIO (SCART)	
Outputs	MONITOR OUT, HDMI OUT, SCART (for Europe), COMPONENT VIDEO OUT	
Speakers		
Front Speaker	Type	2 Way 3 Speaker
	Impedance	4 Ω
	Frequency Response	80 - 18000 Hz
	Sound Pressure Level	83 dB/W (1m)
	Rated Input Power	155 W
	Max. Input Power	310 W
	Net Dimensions (W × H × D)	280 × 1201 × 280 mm
	Net Weight	4.4 kg

Center speaker	Type	1 Way 1 Speaker
	Impedance	4 Ω
	Frequency Response	120 - 18000 Hz
	Sound Pressure Level	83 dB/W (1m)
	Rated Input Power	155 W
	Max. Input Power	310 W
	Net Dimensions (W \times H \times D)	301 \times 118 \times 83 mm
	Net Weight	0.9 kg
Rear Speaker	Type	1 Way 1 Speaker
	Impedance	4 Ω
	Frequency Response	120 - 18000 Hz
	Sound Pressure Level	83 dB/W (1m)
	Rated Input Power	155 W
	Max. Input Power	310 W
	Net Dimensions (W \times H \times D)	113 \times 209 \times 83 mm
	Net Weight	0.78 kg
Passive Subwoofer	Type	1 Way 1 Speaker
	Impedance	3 Ω
	Frequency Response	40 - 1500 Hz
	Sound Pressure Level	82 dB/W (1m)
	Rated Input Power	255 W
	Max. Input Power	450 W
	Net Dimensions (W \times H \times D)	236 \times 435 \times 391 mm
	Net Weight	5.7 kg
USB		
Output power	DC 5V 500mA	

Items with * are measured at Front Speaker Terminals in STEREO mode
 Designs and specifications are subject to change without notice.

TH-G61 Asia

General

Power supply	110 - 240 V ~ 50/60 Hz
Power consumption	130 W
Net Weight	3.6 kg
External dimensions (W × H × D)	430 × 76 × 317 mm
Operating conditions	Temperature: 5°C to 35°C, Operation status: Horizontal
Operating humidity	5% to 85%
Laser	Semiconductor laser, wavelength 650 nm

CD/DVD

Video system	PAL/NTSC
Frequency response (audio)	140 Hz to 20 kHz*
Signal-to-noise ratio (audio)	More than 75 dB (1 kHz, 20 kHz LPF/A-Filter)*
Dynamic range (audio)	More than 75 dB*
Harmonic distortion (audio)	0.5 % (1 kHz, at 1W position) (20 kHz LPF)*

Video

Video output	1.0 V (p-p), 75 Ω, negative sync., RCA jack × 1
COMPONENT VIDEO OUT	(Y) 1.0 V (p-p), 75 ohms, negative sync, RCA jack × 1 (PB)/(PR) 0.7 V (p-p), 75 ohms, RCA jack × 1
HDMI OUT	480i (or 576i)/480p (or 576p)/720p/1080i/1080p

Tuner

FM	Tuning Range	87.5 - 108.0 MHz
	Intermediate Frequency	128 kHz
	Signal-to Noise Ratio	60 dB (Mono) *
	Frequency Response	140 - 10,000 Hz *
AM (for Australia and Asia)	Tuning Range	522 - 1,710 MHz
	Intermediate Frequency	128 kHz

Amplifier

Stereo mode	155 W + 155 W (4Ω at 1 kHz, THD 10 %)	
Surround mode (* Depending on the sound mode settings and the source, there may be no sound output.)	Front	155 W
	Center*	155 W + 155 W (4Ω at 1 kHz, THD 10 %)
	Surround*	225 W (3Ω at 70 Hz, THD 10 %)
	Subwoofer*	
Inputs	AUDIO IN, OPTICAL IN, AUX IN, USB, TV-AUDIO (SCART)	
Outputs	MONITOR OUT, HDMI OUT, COMPONENT VIDEO OUT	

Speakers

Front Speaker	Type	2 Way 3 Speaker
	Impedance	4 Ω
	Frequency Response	80 - 18000 Hz
	Sound Pressure Level	83 dB/W (1m)
	Rated Input Power	155 W
	Max. Input Power	310 W
	Net Dimensions (W × H × D)	280 × 1201 × 280 mm
	Net Weight	4.4 kg

Center speaker	Type	1 Way 1 Speaker
	Impedance	4 Ω
	Frequency Response	120 - 18000 Hz
	Sound Pressure Level	83 dB/W (1m)
	Rated Input Power	155 W
	Max. Input Power	310 W
	Net Dimensions (W \times H \times D)	301 \times 118 \times 83 mm
	Net Weight	0.9 kg
Rear Speaker	Type	1 Way 1 Speaker
	Impedance	4 Ω
	Frequency Response	120 - 18000 Hz
	Sound Pressure Level	83 dB/W (1m)
	Rated Input Power	155 W
	Max. Input Power	310 W
	Net Dimensions (W \times H \times D)	113 \times 209 \times 83 mm
	Net Weight	0.78 kg
Passive Subwoofer	Type	1 Way 1 Speaker
	Impedance	3 Ω
	Frequency Response	40 - 1500 Hz
	Sound Pressure Level	82 dB/W (1m)
	Rated Input Power	255 W
	Max. Input Power	450 W
	Net Dimensions (W \times H \times D)	236 \times 435 \times 391 mm
	Net Weight	5.7 kg
USB		
Output power	DC 5V 500mA	

Items with * are measured at Front Speaker Terminals in STEREO mode
 Designs and specifications are subject to change without notice.

TH-G41 Oceania

General

Power supply	220 - 240 V ~ 50/60 Hz
Power consumption	130 W
Net Weight	3.6 kg
External dimensions (W × H × D)	430 × 76 × 317 mm
Operating conditions	Temperature: 5°C to 35°C, Operation status: Horizontal
Operating humidity	5% to 85%
Laser	Semiconductor laser, wavelength 650 nm

CD/DVD

Video system	PAL/NTSC
Frequency response (audio)	140 Hz to 20 kHz*
Signal-to-noise ratio (audio)	More than 75 dB (1 kHz, 20 kHz LPF/A-Filter)*
Dynamic range (audio)	More than 75 dB*
Harmonic distortion (audio)	0.5 % (1 kHz, at 1W position) (20 kHz LPF)*

Video

Video output	1.0 V (p-p), 75 Ω, negative sync., RCA jack × 1
COMPONENT VIDEO OUT	(Y) 1.0 V (p-p), 75 ohms, negative sync, RCA jack × 1 (PB)/(PR) 0.7 V (p-p), 75 ohms, RCA jack × 1
HDMI OUT	480i (or 576i)/480p (or 576p)/720p/1080i/1080p

Tuner

FM	Tuning Range	87.50 - 108.00 MHz
	Intermediate Frequency	128 kHz
	Signal-to Noise Ratio	60 dB (Mono) *
	Frequency Response	140 - 10,000 Hz *
AM (for Australia and Asia)	Tuning Range	522 - 1,710 MHz
	Intermediate Frequency	128 kHz

Amplifier

Stereo mode	155 W + 155 W (4Ω at 1 kHz, THD 10 %)	
Surround mode (* Depending on the sound mode settings and the source, there may be no sound output.)	Front	155 W + 155 W (THD 10 %)
	Center*	155 W
	Surround*	155 W + 155 W (4Ω at 1 kHz, THD 10 %)
	Subwoofer*	225 W (3Ω at 70 Hz, THD 10 %)
Inputs	AUDIO IN, OPTICAL IN, AUX IN, iPod, HDMI IN, USB	
Outputs	MONITOR OUT, HDMI OUT, COMPONENT VIDEO OUT	

Speakers

Front/Rear Speaker	Type	1 Way 1 Speaker
	Impedance	4 Ω
	Frequency Response	120 - 18000 Hz
	Sound Pressure Level	83 dB/W (1m)
	Rated Input Power	155 W
	Max. Input Power	310 W
	Net Dimensions (W × H × D)	113 × 209 × 83 mm
	Net Weight	0.78 kg

Center speaker	Type	1 Way 1 Speaker
	Impedance	4 Ω
	Frequency Response	120 - 18000 Hz
	Sound Pressure Level	83 dB/W (1m)
	Rated Input Power	155 W
	Max. Input Power	310 W
	Net Dimensions (W \times H \times D)	301 \times 118 \times 83 mm
	Net Weight	0.9 kg
Passive Subwoofer	Type	1 Way 1 Speaker
	Impedance	3 Ω
	Frequency Response	40 - 1500 Hz
	Sound Pressure Level	82 dB/W (1m)
	Rated Input Power	255 W
	Max. Input Power	450 W
	Net Dimensions (W \times H \times D)	236 \times 435 \times 391 mm
	Net Weight	5.7 kg
USB		
Output power	DC 5V 500mA	

Items with * are measured at Front Speaker Terminals in STEREO mode
 Designs and specifications are subject to change without notice.

TH-G41 Asia

General

Power supply	110 - 240 V ~ 50/60 Hz
Power consumption	130 W
Net Weight	3.6 kg
External dimensions (W × H × D)	430 × 76 × 317 mm
Operating conditions	Temperature: 5°C to 35°C, Operation status: Horizontal
Operating humidity	5% to 85%
Laser	Semiconductor laser, wavelength 650 nm

CD/DVD

Video system	PAL/NTSC
Frequency response (audio)	140 Hz to 20 kHz*
Signal-to-noise ratio (audio)	More than 75 dB (1 kHz, 20 kHz LPF/A-Filter)*
Dynamic range (audio)	More than 75 dB*
Harmonic distortion (audio)	0.5 % (1 kHz, at 1W position) (20 kHz LPF)*

Video

Video output	1.0 V (p-p), 75 Ω, negative sync., RCA jack × 1
COMPONENT VIDEO OUT	(Y) 1.0 V (p-p), 75 ohms, negative sync, RCA jack × 1 (PB)/(PR) 0.7 V (p-p), 75 ohms, RCA jack × 1
HDMI OUT	480i (or 576i)/480p (or 576p)/720p/1080i/1080p

Tuner

FM	Tuning Range	87.50 - 108.00 MHz (or 87.5 - 108.0 MHz)
	Intermediate Frequency	128 kHz
	Signal-to Noise Ratio	60 dB (Mono) *
	Frequency Response	140 - 10,000 Hz *
AM (for Australia and Asia)	Tuning Range	522 - 1,710 MHz
	Intermediate Frequency	128 kHz

Amplifier

Stereo mode	155 W + 155 W (4Ω at 1 kHz, THD 10 %)	
Surround mode (* Depending on the sound mode settings and the source, there may be no sound output.)	Front	155 W + 155 W (THD 10 %)
	Center*	155 W
	Surround*	155 W + 155 W (4Ω at 1 kHz, THD 10 %)
	Subwoofer*	225 W (3Ω at 70 Hz, THD 10 %)
Inputs	AUDIO IN, OPTICAL IN, AUX IN, iPod, HDMI IN, USB	
Outputs	MONITOR OUT, HDMI OUT, COMPONENT VIDEO OUT	

Speakers

Front/Rear Speaker	Type	1 Way 1 Speaker
	Impedance	4 Ω
	Frequency Response	120 - 18000 Hz
	Sound Pressure Level	83 dB/W (1m)
	Rated Input Power	155 W
	Max. Input Power	310 W
	Net Dimensions (W × H × D)	113 × 209 × 83 mm
	Net Weight	0.78 kg

Center speaker	Type	1 Way 1 Speaker
	Impedance	4 Ω
	Frequency Response	120 - 18000 Hz
	Sound Pressure Level	83 dB/W (1m)
	Rated Input Power	155 W
	Max. Input Power	310 W
	Net Dimensions (W \times H \times D)	301 \times 118 \times 83 mm
	Net Weight	0.9 kg
Passive Subwoofer	Type	1 Way 1 Speaker
	Impedance	3 Ω
	Frequency Response	40 - 1500 Hz
	Sound Pressure Level	82 dB/W (1m)
	Rated Input Power	255 W
	Max. Input Power	450 W
	Net Dimensions (W \times H \times D)	236 \times 435 \times 391 mm
	Net Weight	5.7 kg
USB		
Output power	DC 5V 500mA	

Items with * are measured at Front Speaker Terminals in STEREO mode
 Designs and specifications are subject to change without notice.

TH-G31 Europe and Oceania		
General		
Power supply	220 - 240 V ~ 50/60 Hz	
Power consumption	130 W	
Net Weight	3.6 kg	
External dimensions (W × H × D)	430 × 76 × 317 mm	
Operating conditions	Temperature: 5°C to 35°C, Operation status: Horizontal	
Operating humidity	5% to 85%	
Laser	Semiconductor laser, wavelength 650 nm	
CD/DVD		
Video system	PAL/NTSC	
Frequency response (audio)	140 Hz to 20 kHz*	
Signal-to-noise ratio (audio)	More than 75 dB (1 kHz, 20 kHz LPF/A-Filter)*	
Dynamic range (audio)	More than 75 dB*	
Harmonic distortion (audio)	0.5 % (1 kHz, at 1W position) (20 kHz LPF)*	
Video		
Video output	1.0 V (p-p), 75 Ω, negative sync., RCA jack × 1	
COMPONENT VIDEO OUT	(Y) 1.0 V (p-p), 75 ohms, negative sync, RCA jack × 1 (PB)/(PR) 0.7 V (p-p), 75 ohms, RCA jack × 1	
HDMI OUT	480i (or 576i)/480p (or 576p)/720p/1080i/1080p	
Tuner		
FM	Tuning Range	87.50 - 108.00 MHz
	Intermediate Frequency	128 kHz
	Signal-to Noise Ratio	60 dB (Mono) *
	Frequency Response	140 - 10,000 Hz *
AM (for Australia and Asia)	Tuning Range	522 - 1,710 MHz
	Intermediate Frequency	128 kHz
Amplifier		
Stereo mode	155 W + 155 W (4Ω at 1 kHz, THD 10 %)	
Surround mode (* Depending on the sound mode settings and the source, there may be no sound output.)	Front	155 W + 155 W (THD 10 %)
	Center*	155 W
	Surround*	155 W + 155 W (4Ω at 1 kHz, THD 10 %)
	Subwoofer*	225 W (3Ω at 70 Hz, THD 10 %)
Inputs	AUDIO IN, OPTICAL IN, AUX IN, iPod, HDMI IN, USB	
Outputs	MONITOR OUT, HDMI OUT, COMPONENT VIDEO OUT, SCART (for Europe)	
Speakers		
Front/Rear Speaker	Type	1 Way 1 Speaker
	Impedance	4 Ω
	Frequency Response	120 - 18000 Hz
	Sound Pressure Level	83 dB/W (1m)
	Rated Input Power	155 W
	Max. Input Power	310 W
	Net Dimensions (W × H × D)	113 × 209 × 83 mm
	Net Weight	0.78 kg

Center speaker	Type	1 Way 1 Speaker
	Impedance	4 Ω
	Frequency Response	120 - 18000 Hz
	Sound Pressure Level	83 dB/W (1m)
	Rated Input Power	155 W
	Max. Input Power	310 W
	Net Dimensions (W \times H \times D)	301 \times 118 \times 83 mm
	Net Weight	0.9 kg
Passive Subwoofer	Type	1 Way 1 Speaker
	Impedance	3 Ω
	Frequency Response	40 - 1500 Hz
	Sound Pressure Level	82 dB/W (1m)
	Rated Input Power	255 W
	Max. Input Power	450 W
	Net Dimensions (W \times H \times D)	236 \times 435 \times 391 mm
	Net Weight	5.7 kg

Items with * are measured at Front Speaker Terminals in STEREO mode
 Designs and specifications are subject to change without notice.

TH-G31 Asia

General

Power supply	110 - 240 V ~ 50/60 Hz
Power consumption	130 W
Net Weight	3.6 kg
External dimensions (W × H × D)	430 × 76 × 317 mm
Operating conditions	Temperature: 5°C to 35°C, Operation status: Horizontal
Operating humidity	5% to 85%
Laser	Semiconductor laser, wavelength 650 nm

CD/DVD

Video system	PAL/NTSC
Frequency response (audio)	140 Hz to 20 kHz*
Signal-to-noise ratio (audio)	More than 75 dB (1 kHz, 20 kHz LPF/A-Filter)*
Dynamic range (audio)	More than 75 dB*
Harmonic distortion (audio)	0.5 % (1 kHz, at 1W position) (20 kHz LPF)*

Video

Video output	1.0 V (p-p), 75 Ω, negative sync., RCA jack × 1
COMPONENT VIDEO OUT	(Y) 1.0 V (p-p), 75 ohms, negative sync, RCA jack × 1 (PB)/(PR) 0.7 V (p-p), 75 ohms, RCA jack × 1
HDMI OUT	480i (or 576i)/480p (or 576p)/720p/1080i/1080p

Tuner

FM	Tuning Range	87.50 - 108.00 MHz
	Intermediate Frequency	128 kHz
	Signal-to Noise Ratio	60 dB (Mono) *
	Frequency Response	140 - 10,000 Hz *
AM (for Australia and Asia)	Tuning Range	522 - 1,710 MHz
	Intermediate Frequency	128 kHz

Amplifier

Stereo mode	155 W + 155 W (4Ω at 1 kHz, THD 10 %)	
Surround mode (* Depending on the sound mode settings and the source, there may be no sound output.)	Front	155 W + 155 W (THD 10 %)
	Center*	155 W
	Surround*	155 W + 155 W (4Ω at 1 kHz, THD 10 %)
	Subwoofer*	225 W (3Ω at 70 Hz, THD 10 %)
Inputs	AUDIO IN, OPTICAL IN, AUX IN, iPod, HDMI IN, USB	
Outputs	MONITOR OUT, HDMI OUT, COMPONENT VIDEO OUT	

Speakers

Front/Rear Speaker	Type	1 Way 1 Speaker
	Impedance	4 Ω
	Frequency Response	120 - 18000 Hz
	Sound Pressure Level	83 dB/W (1m)
	Rated Input Power	155 W
	Max. Input Power	310 W
	Net Dimensions (W × H × D)	113 × 209 × 83 mm
	Net Weight	0.78 kg

Center speaker	Type	1 Way 1 Speaker
	Impedance	4 Ω
	Frequency Response	120 - 18000 Hz
	Sound Pressure Level	83 dB/W (1m)
	Rated Input Power	155 W
	Max. Input Power	310 W
	Net Dimensions (W \times H \times D)	301 \times 118 \times 83 mm
	Net Weight	0.9 kg
Passive Subwoofer	Type	1 Way 1 Speaker
	Impedance	3 Ω
	Frequency Response	40 - 1500 Hz
	Sound Pressure Level	82 dB/W (1m)
	Rated Input Power	255 W
	Max. Input Power	450 W
	Net Dimensions (W \times H \times D)	236 \times 435 \times 391 mm
	Net Weight	5.7 kg

Items with * are measured at Front Speaker Terminals in STEREO mode
 Designs and specifications are subject to change without notice.

SECTION 1 PRECAUTION

1.1 Safety Precautions

- (1) This design of this product contains special hardware and many circuits and components specially for safety purposes. For continued protection, no changes should be made to the original design unless authorized in writing by the manufacturer. Replacement parts must be identical to those used in the original circuits. Services should be performed by qualified personnel only.
- (2) Alterations of the design or circuitry of the product should not be made. Any design alterations of the product should not be made. Any design alterations or additions will void the manufacturer's warranty and will further relieve the manufacturer of responsibility for personal injury or property damage resulting therefrom.
- (3) Many electrical and mechanical parts in the products have special safety-related characteristics. These characteristics are often not evident from visual inspection nor can the protection afforded by them necessarily be obtained by using replacement components rated for higher voltage, wattage, etc. Replacement parts which have these special safety characteristics are identified in the Parts List of Service Manual. Electrical components having such features are identified by shading on the schematics and by () on the Parts List in the Service Manual. The use of a substitute replacement which does not have the same safety characteristics as the recommended replacement parts shown in the Parts List of Service Manual may create shock, fire, or other hazards.
- (4) The leads in the products are routed and dressed with ties, clamps, tubings, barriers and the like to be separated from live parts, high temperature parts, moving parts and/or sharp edges for the prevention of electric shock and fire hazard. When service is required, the original lead routing and dress should be observed, and it should be confirmed that they have been returned to normal, after reassembling.

(5) Leakage shock hazard testing

After reassembling the product, always perform an isolation check on the exposed metal parts of the product (antenna terminals, knobs, metal cabinet, screw heads, headphone jack, control shafts, etc.) to be sure the product is safe to operate without danger of electrical shock. Do not use a line isolation transformer during this check.

- Plug the AC line cord directly into the AC outlet. Using a "Leakage Current Tester", measure the leakage current from each exposed metal part of the cabinet, particularly any exposed metal part having a return path to the chassis, to a known good earth ground. Any leakage current must not exceed 0.5mA AC (r.m.s.).
- Alternate check method
Plug the AC line cord directly into the AC outlet. Use an AC voltmeter having, 1,000Ω per volt or more sensitivity in the following manner. Connect a 1,500Ω 10W resistor paralleled by a 0.15μF AC-type capacitor between an exposed metal part and a known good earth ground. Measure the AC voltage across the resistor with the AC

voltmeter.

Move the resistor connection to each exposed metal part, particularly any exposed metal part having a return path to the chassis, and measure the AC voltage across the resistor. Now, reverse the plug in the AC outlet and repeat each measurement. Voltage measured any must not exceed 0.75 V AC (r.m.s.). This corresponds to 0.5 mA AC (r.m.s.).

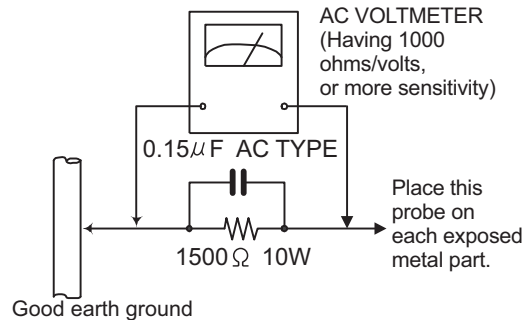

1.2 Warning

- (1) This equipment has been designed and manufactured to meet international safety standards.
- (2) It is the legal responsibility of the repairer to ensure that these safety standards are maintained.
- (3) Repairs must be made in accordance with the relevant safety standards.
- (4) It is essential that safety critical components are replaced by approved parts.
- (5) If mains voltage selector is provided, check setting for local voltage.

1.3 Caution

Burrs formed during molding may be left over on some parts of the chassis.

Therefore, pay attention to such burrs in the case of performing repair of this system.

1.4 Critical parts for safety

In regard with component parts appearing on the silk-screen printed side (parts side) of the PWB diagrams, the parts that are printed over with black such as the resistor (■), diode (■) and ICP (●) or identified by the "▲" mark nearby are critical for safety. When replacing them, be sure to use the parts of the same type and rating as specified by the manufacturer. (This regulation does not Except the J and C version)

1.5 Preventing static electricity

Electrostatic discharge (ESD), which occurs when static electricity stored in the body, fabric, etc. is discharged, can destroy the laser diode in the traverse unit (optical pickup). Take care to prevent this when performing repairs.

1.5.1 Grounding to prevent damage by static electricity

Static electricity in the work area can destroy the optical pickup (laser diode) in devices such as laser products.

Be careful to use proper grounding in the area where repairs are being performed.

(1) Ground the workbench

Ground the workbench by laying conductive material (such as a conductive sheet) or an iron plate over it before placing the traverse unit (optical pickup) on it.

(2) Ground yourself

Use an anti-static wrist strap to release any static electricity built up in your body.

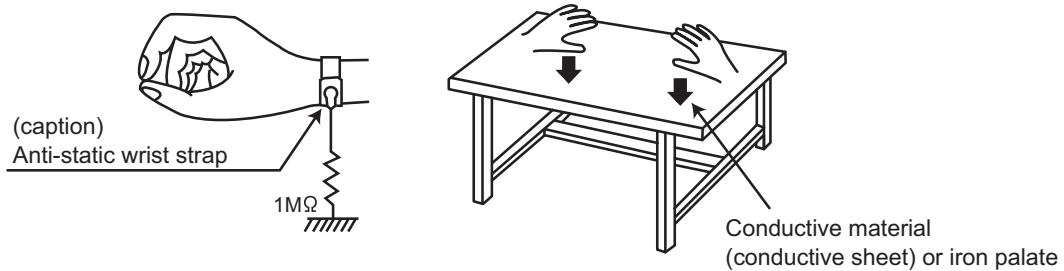

(3) Handling the optical pickup

- In order to maintain quality during transport and before installation, both sides of the laser diode on the replacement optical pickup are shorted. After replacement, return the shorted parts to their original condition. (Refer to the text.)
- Do not use a tester to check the condition of the laser diode in the optical pickup. The tester's internal power source can easily destroy the laser diode.

1.6 Handling the traverse unit (optical pickup)

- (1) Do not subject the traverse unit (optical pickup) to strong shocks, as it is a sensitive, complex unit.
- (2) Cut off the shorted part of the flexible cable using nippers, etc. after replacing the optical pickup. For specific details, refer to the replacement procedure in the text. Remove the anti-static pin when replacing the traverse unit. Be careful not to take too long a time when attaching it to the connector.
- (3) Handle the flexible cable carefully as it may break when subjected to strong force.
- (4) It is not possible to adjust the semi-fixed resistor that adjusts the laser power. Do not turn it.

1.7 Important for laser products

1.CLASS 1 LASER PRODUCT

2.CAUTION :

(For U.S.A.) Visible and/or invisible class II laser radiation when open. Do not stare into beam.
(Others) Visible and/or invisible class 1M laser radiation when open. Do not view directly with optical instruments.

3.CAUTION : Visible and/or invisible laser radiation when open and inter lock failed or defeated. Avoid direct exposure to beam.

4.CAUTION : This laser product uses visible and/or invisible laser radiation and is equipped with safety switches which prevent emission of radiation when the drawer is open and the safety interlocks have failed or are defeated. It is dangerous to defeat the safety switches.

5.CAUTION : If safety switches malfunction, the laser is able to function.

6.CAUTION : Use of controls, adjustments or performance of procedures other than those specified here in may result in hazardous radiation exposure.



CAUTION Please use enough caution not to see the beam directly or touch it in case of an adjustment or operation check.

(For U.S.A.)

CAUTION : Visible and/or invisible class II laser radiation when open. Do not stare into beam.
(Others)

CAUTION : Visible and/or invisible class 1M laser radiation when open. Do not view directly with optical instruments

ACHTUNG: Sichtbare und/oder unsichtbare Laserstrahlung der Klasse 1M bei offenen Abdeckungen. Nicht direkt mit optischen Instrumenten betrachten.

ATTENTION: Rayonnement laser visible et/ou invisible de classe 1M une fois ouvert. Ne pas regarder directement avec des instruments optiques.

VOORZICHTIG: Zichtbare en/of onzichtbare klasse 1M laserstralen indien geopend. Bekijk niet direct met optische instrumenten.

ATTENZIONE: Radiazione laser in classe 1M visibile e/o invisibile quando aperto. Non osservare direttamente con strumenti ottici.

WARNING: Synlig och/eller osynlig laserstrålning, klass 1M, når denna del är öppen. Betrakta ej strålen med optiska instrument.

VARO! Avattaessa olet alttiina näkyvalle ja/tai näkymättömälle luokan 1M lasersäteilylle. Älä tarkastele sitä optisen laitteen läpi.

ADVARSEL: Synlig og/eller usynlig klasse 1M-laserstråling ved åbning. Se ikke direkte med optiske instrumenter.

AVISO: Radiación láser de clase 1M visible y/o invisible cuando está abierto. No mirar directamente con instrumental óptico.

PRECAUÇÃO: Radiação laser de classe 1M visível e/ou invisível quando aberto. Não olhe diretamente com instrumentos ópticos.

PRECAUÇÃO: Radiação laser de classe 1M visível e/ou invisível quando aberto. Não olhe diretamente com instrumentos ópticos.

ПРЕДУПРЕЖДЕНИЕ: В открытом состоянии происходит видимое и/или невидимое излучение лазера класса 1M. Не смотрите непосредственно в оптические инструменты.

UWAGA: Otwarcie spowoduje narażenie na widzialne i/lub niewidzialne promieniowanie lasera klasy 1M. Nie patrzeć bezpośrednio w przyrządy optyczne.

UPOZORNĚNÍ: Při otevření vydává viditelné popř. neviditelné laserové ozáření třídy 1M. Nedívejte se do otvoru přímo s optickými nástroji.

FIGYELMEZTETÉS: Látható és/vagy láthatatlan 1M osztályú sugárzás nyitott állapotban. Ne nézze közvetlenül optikai műszerekkel.

注意: 打開蓋板可能會產生可見或不可見的 1M 級鐳射。不要使用光學儀器直接進行窺視。

注意: 打开盖板可能会产生可见或不可见的 1M 级辐射。不要使用光学仪器直接进行窥视。

تنبيه: يوجد إشعاع ليزري مرئي و/أو غير مرئي من الفئة 1M عندما يكون الجهاز مفتوحاً. تجنب النظر مباشرة داخل الجهاز باستخدام أدوات بصرية.

احتياط: هنگامی که باز گردد، تشعشع مرئی و یا نامرئی کلاس 1M لیزر وجود دارد. با لوازم چشمی مستقیماً به آن نگاه نکنید.

주의: 개방하면 가시 및/또는 비가시 클래스 1M 레이저 방사선이 나옵니다. 광학 기구로 직접 들여다보지 마십시오.

SECTION 2 SPECIFIC SERVICE INSTRUCTIONS

This service manual does not describe SPECIFIC SERVICE INSTRUCTIONS.

SECTION 3 DISASSEMBLY

3.1 Main body (Used figure are TH-G61E)

3.1.1 Removing the Top cover (See Fig.1)

- (1) Remove the three screws **A** attaching the Top cover.

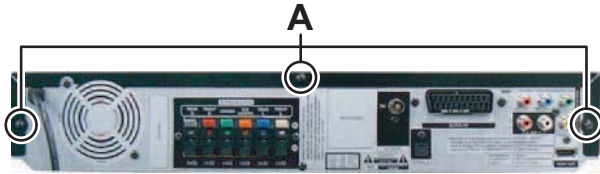

Fig.1

3.1.2 Removing the Front panel (See Fig.2, 3 and 4)

- (1) Disconnect the card wire from Front panel connected to connector **CN102** of the Main boards. (See Fig.2)
- (2) Disengage three hooks **a** engaged the Front panel. (See Fig.2)

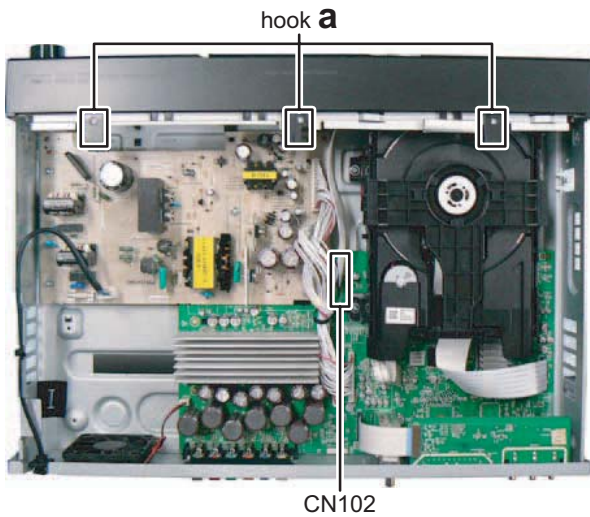

Fig.2

- (3) Disengage two hooks **b** engaged both side of the Front panel. (See Fig.3)

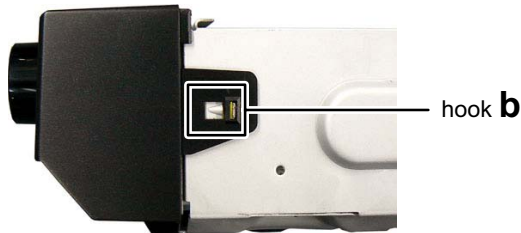

Fig.3

- (4) Disengaged three hooks **c** engaged the Front panel. (See Fig.4)

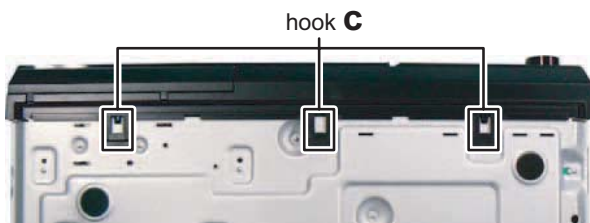

Fig.4

3.1.3 Removing the DVD mechanism (See Fig.5)

- (1) Disconnect the card wires from DVD mechanism connected to connectors **CN401** and **CN402** of the Main board
- (2) Remove the four screws **B** attaching the DVD mechanism.

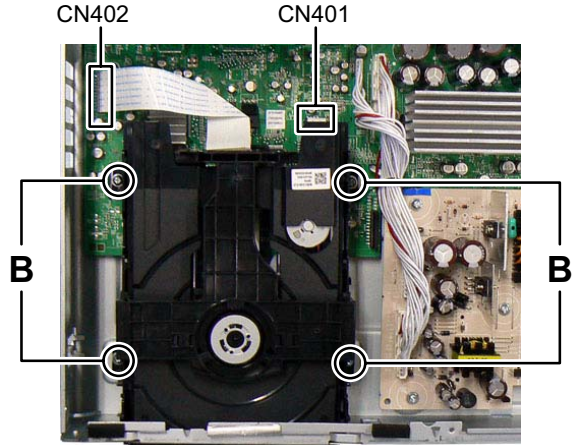

Fig.5

3.1.4 Removing the SMPC board (See Fig.6)

- (1) Disconnect the connector wire from SMPC board connected to connector **CN602** of the Main board.
- (2) Disconnect the connector wire from Main board connected to connector **CN903** of the SMPC board
- (3) Disconnect the Power cord connected to connector **PN901** of the SMPC board.
- (4) Remove the five screws **C** attaching the SMPC board.

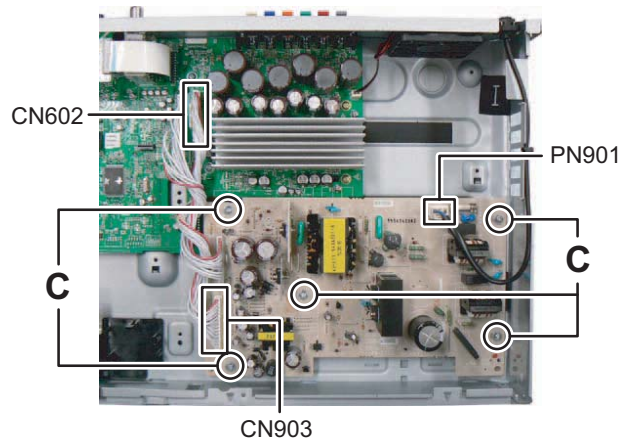

Fig.6

3.1.5 Removing the SCART board (See Fig.7, 8)

- (1) Disconnect the card wire from Main board connected to connector [CN250](#) of the SCART board. (See Fig.7)

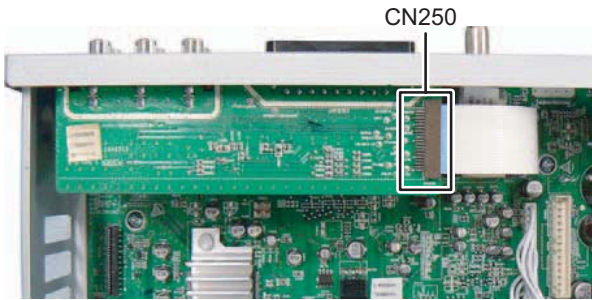

Fig.7

- (2) Remove the three screws [D](#) attaching the SCART board. (See Fig.8)

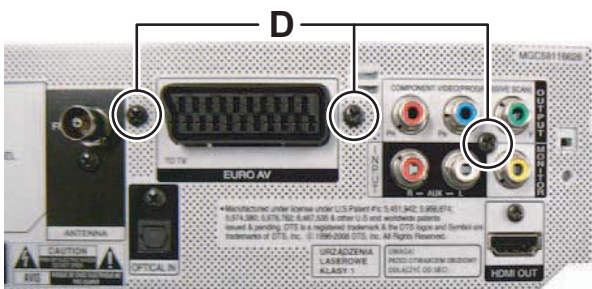

Fig.8

3.1.6 Removing the USB board (See Fig.9)

- (1) Disconnect the card wire from Main board connected to connector [CN202](#) of the USB board.
- (2) Remove the two screws [E](#) attaching the USB board.

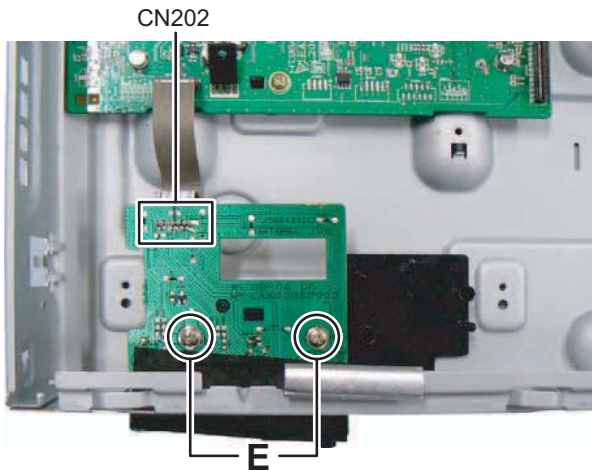

Fig.9

3.1.7 Removing the Main board (See Fig.10, 11)

- (1) Remove the two screws [F](#) attaching the Speaker terminal. (See Fig.10)
- (2) Remove the one screw [G](#) attaching the Tuner pack. (See Fig.10)
- (3) Remove the one screw [H](#) attaching the Optical jack. (See Fig.10)
- (4) Remove the one screw [J](#) attaching the HDMI jack, (See Fig.10)

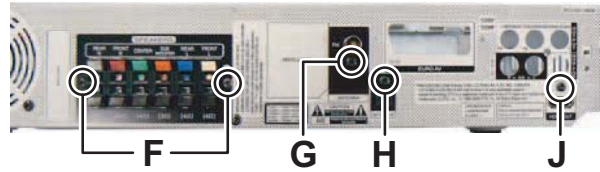

Fig.10

- (5) Disconnect the connector wire from FAN connected to connector [CN603](#) of the Mainboard. (See Fig.11)
- (6) Remove the three screws [K](#) and three screws [L](#) attaching the Main board. (See Fig.11)

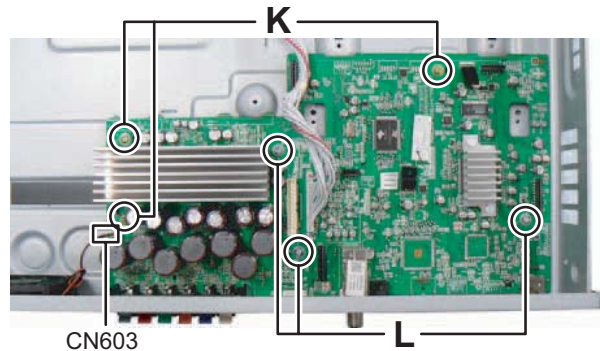

Fig.11

3.1.8 Removing the Front key board (See Fig.12)

- (1) Remove the one screw [M](#) attaching the Front key board.
- (2) Disconnect the connector wire from Front timer board connected to connector [CN301](#) of the Front key board.

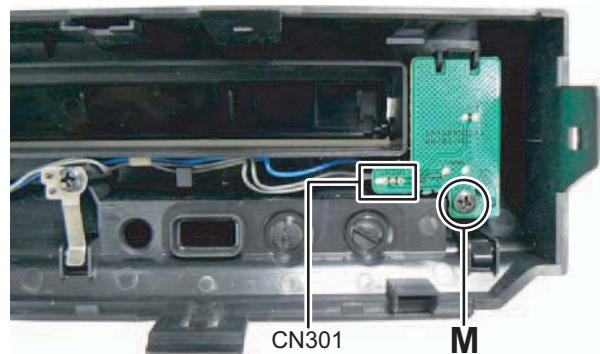

Fig.12

3.1.9 Removing the Front timer board (See Fig.13)

- (1) Remove the volume knob.
- (2) Remove the six screws [N](#) attaching the Front timer board.

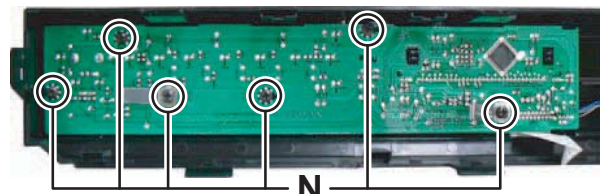

Fig.13

3.2 DVD mechanism

3.2.1 Main base (See Fig.1)

- (1) Place the disc clamp assembly as Fig.1.
- (2) Lift up the disc clamp assembly in direction of the arrow (A).
- (3) Separate the disc clamp assembly from the Clamp holder.
- (4) Turn the Clamper plate to counterclockwise direction and then lift up the clamper plate.

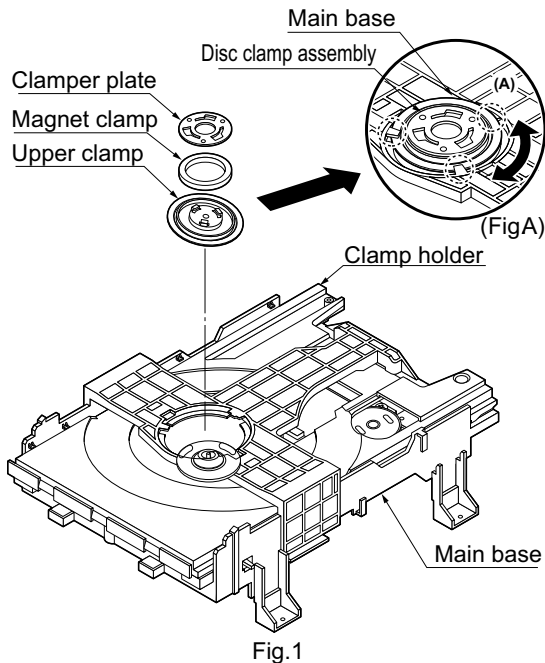

Fig.1

3.2.2 Disc tray (See Fig.2)

- (1) Insert and push a screwdriver in the emergency eject hole (A) at the right side, or put the screwdriver on the lever (B) of the emergency gear and pull the lever (B) in direction of arrow so that the Disc tray is ejected about 15 ~ 20 mm.
- (2) Pull the Disc tray until it is separated from the Main base completely.

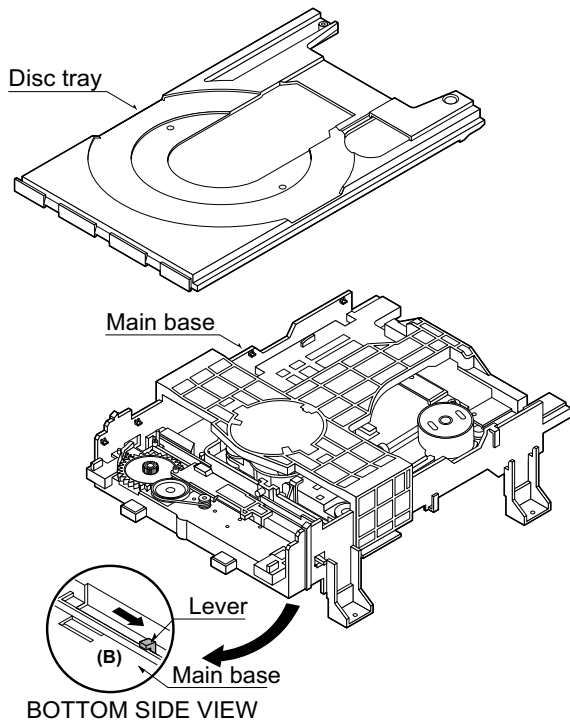

Fig.2

3.2.3 Slide base assembly (See Fig.3)

- (1) Release the four screws (S2).
- (2) Disconnect the FFC connector (C1).
- (3) Release the screw (S3).

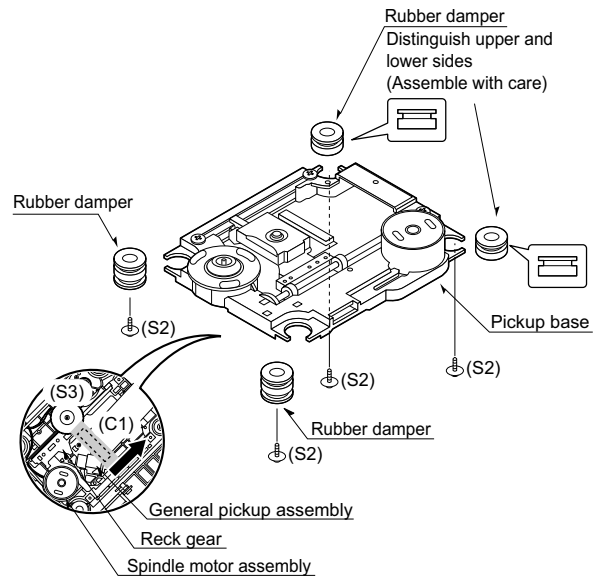

Fig.3

3.2.4 Up/Down frame assembly (See Fig.4)

NOTE:

Put the Main base face down (Bottom side)

- (1) Release the screw (S4).
- (2) Unlock the Locking tab (L3) in direction of arrow and then lift up the Up/down frame assembly to separate it from the Main base.

NOTE:

When reassembling move the Up/Down guide in direction of arrow (C) until it is positioned as Fig (C).
When reassembling insert (A) position of the Up/down frame assembly in the (B) position of the Up/down frame assembly as Fig (B).

3.2.5 Pulley gear (See Fig.4)

- (1) Unlock the locking tab (L4) in direction of arrow (B) and then separate the pulley gear from the main base.

3.2.6 Up/down guide (See Fig.4)

- (1) Move the Up/down guide in direction of arrow (A) as Fig (A).
- (2) Push the locking tab (L5) down and then lift up the Up/down guide to separate it from the main base.

NOTE:

When reassembling place the Up/down guide as Fig (C) and move it direction arrow (B) until it is locked by the locking tab (L5). And confirm the Up/down guide as Fig (A).

3.2.7 Loading board assembly (See Fig.4)

- (1) Release one screw (S5).
- (2) Unlock the loading motor (C2) from the hook (H1) on the main base.
- (3) Unlock two locking tabs (L6) and separate the loading board assembly from the main base.

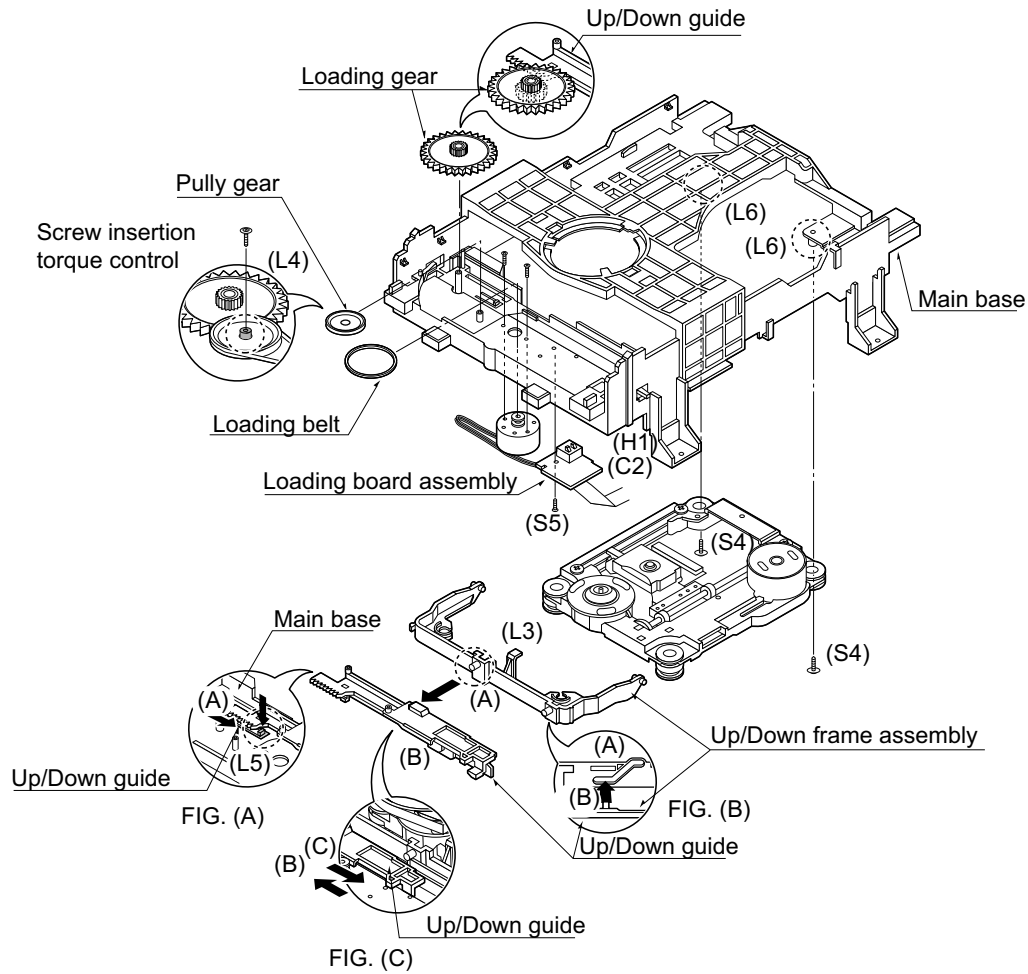

Fig.4

SECTION 4 ADJUSTMENT

This service manual dose not describe ADJUSTMENT.

SECTION 5 TROUBLESHOOTING

5.1 Power supply circuit

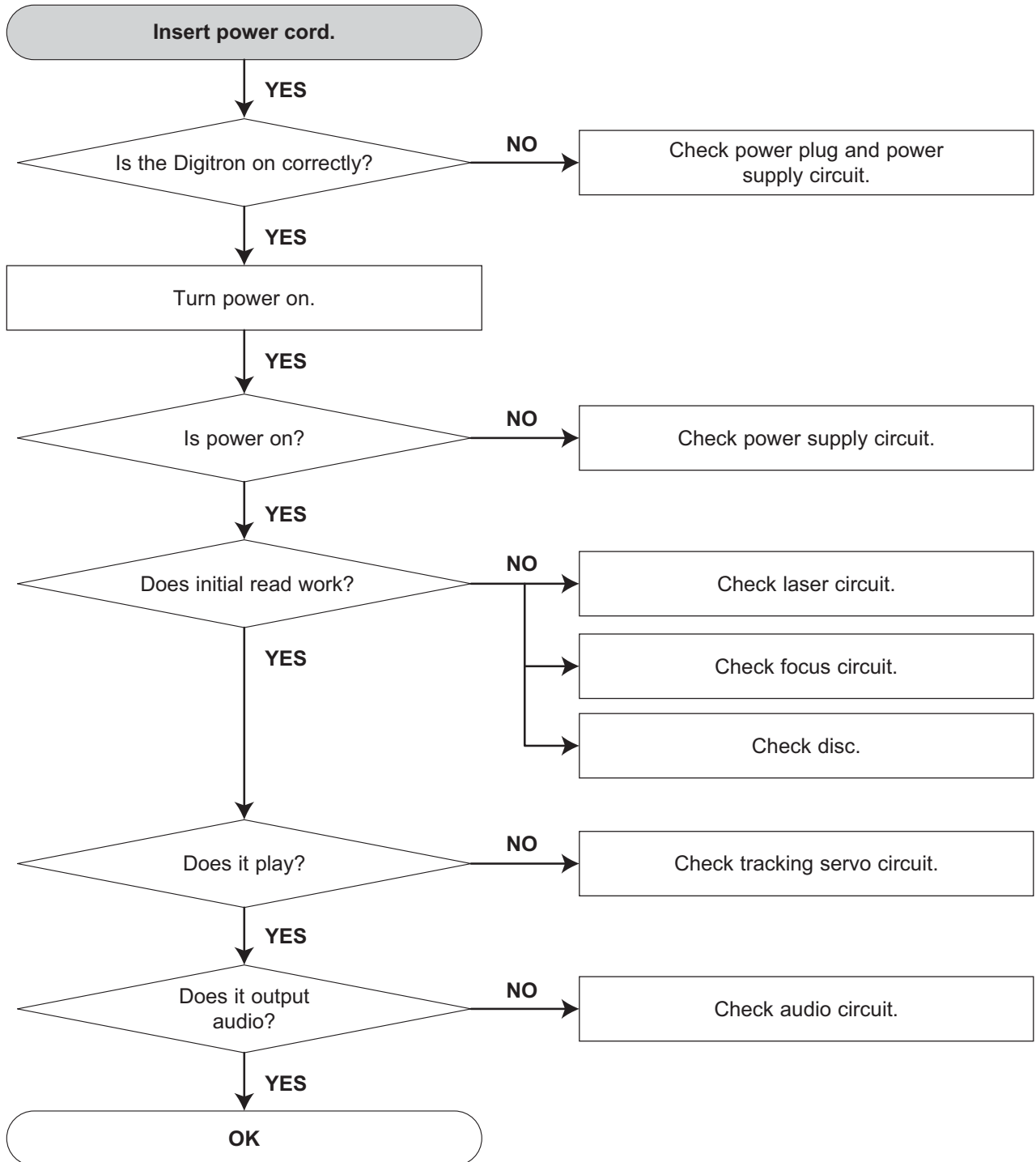

5.2 Front circuit

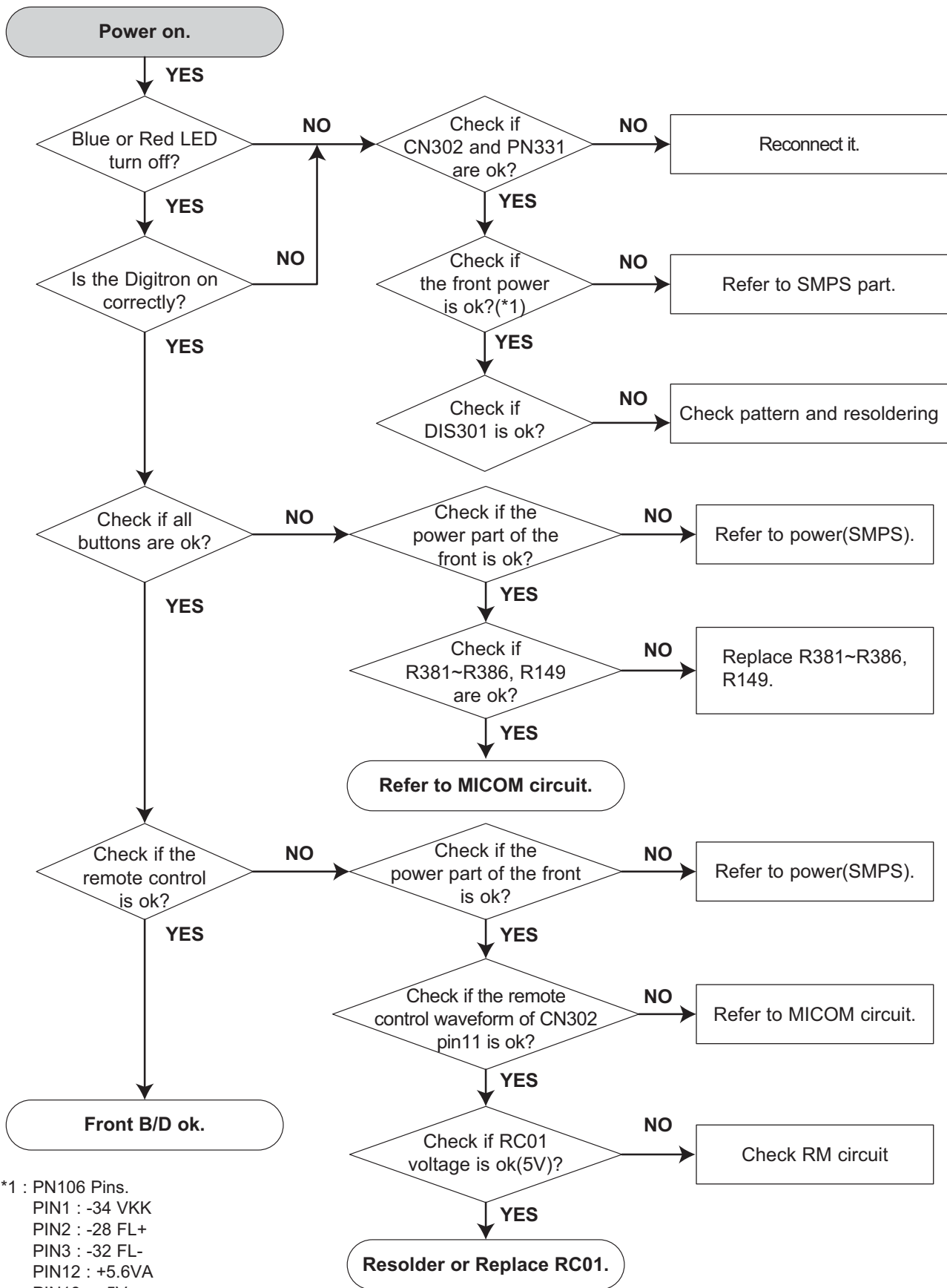

5.3 System operation flow

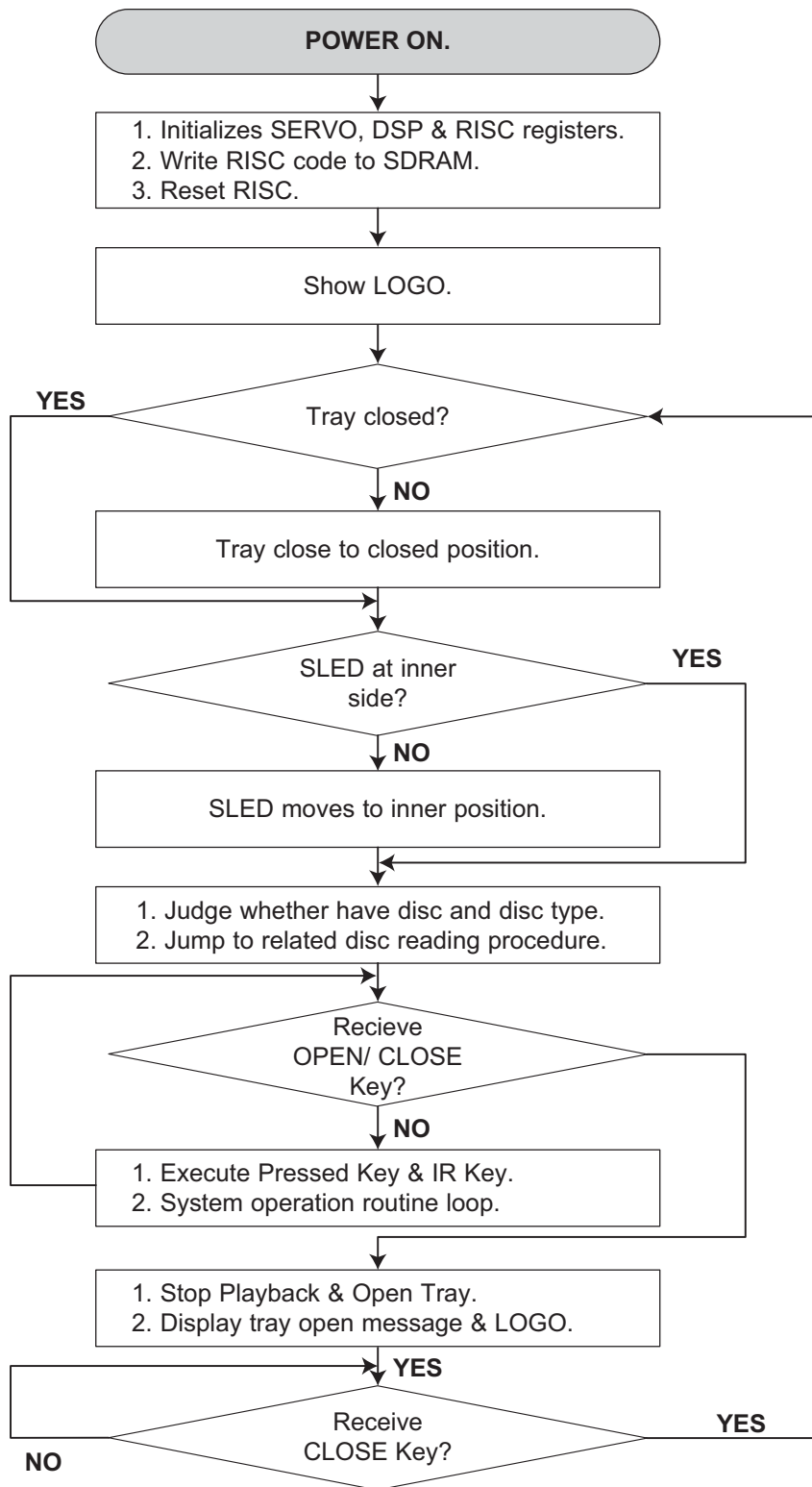

5.4 Amp protection

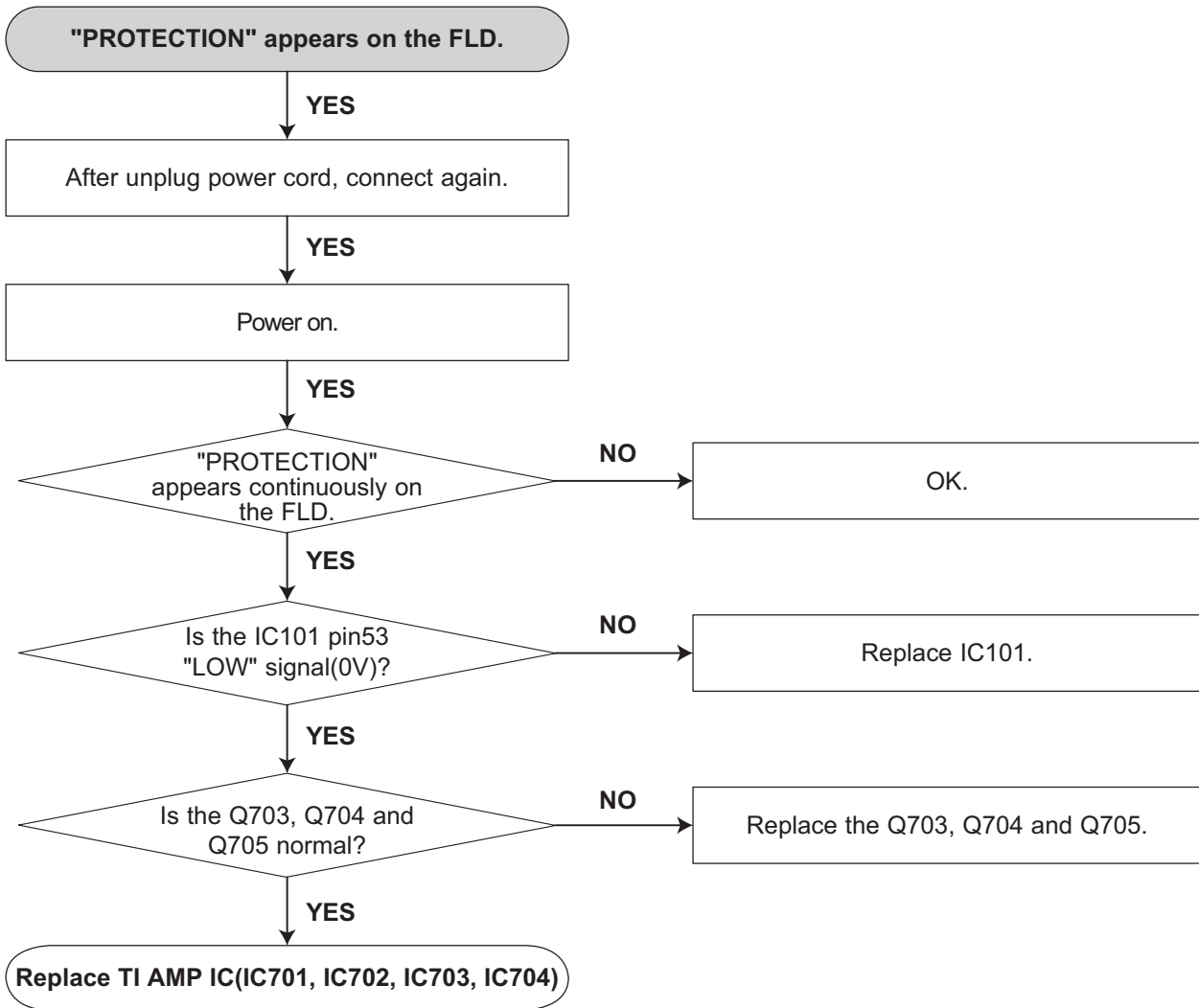

5.5 AUDIO u-COM circuit (DVD & AMP)

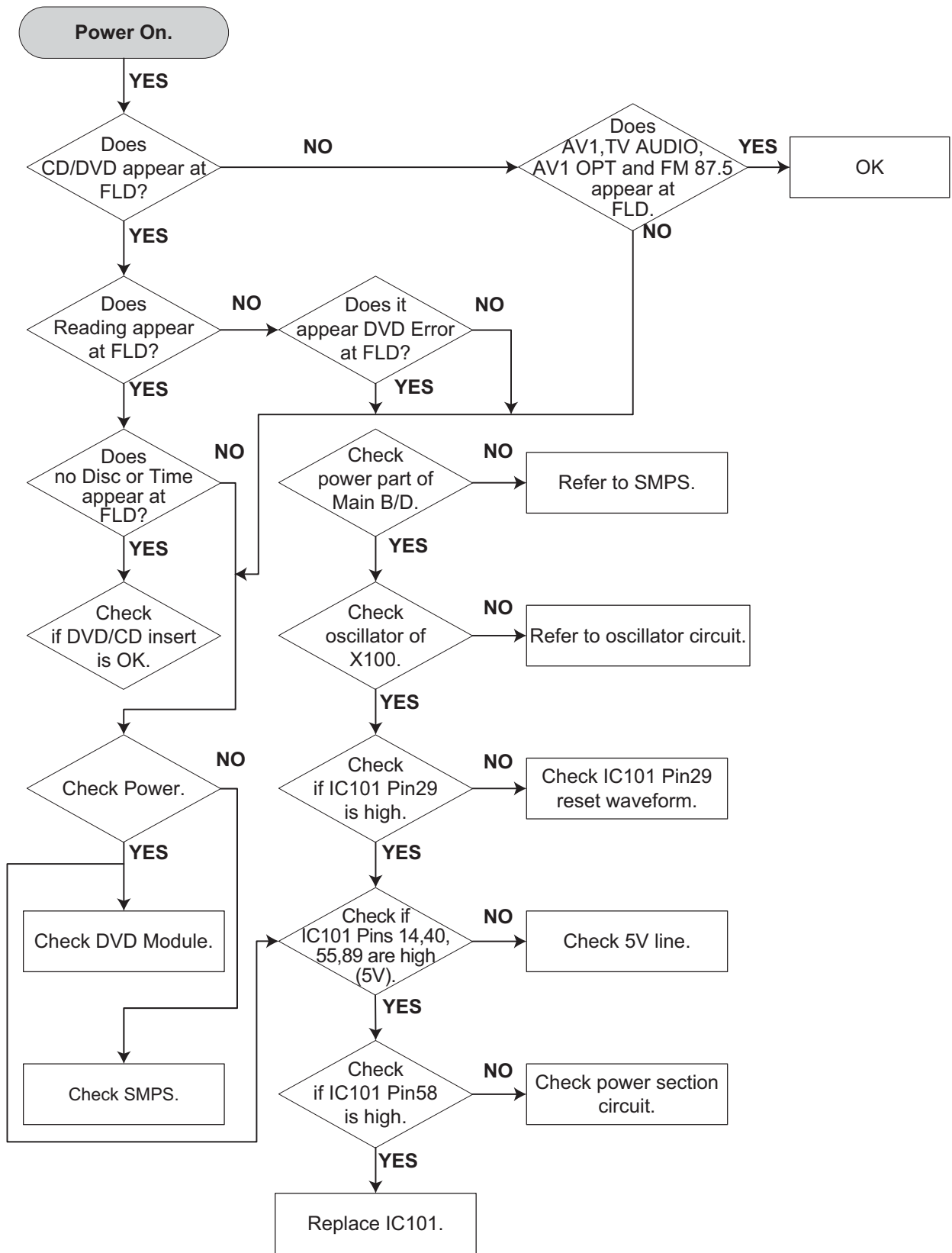

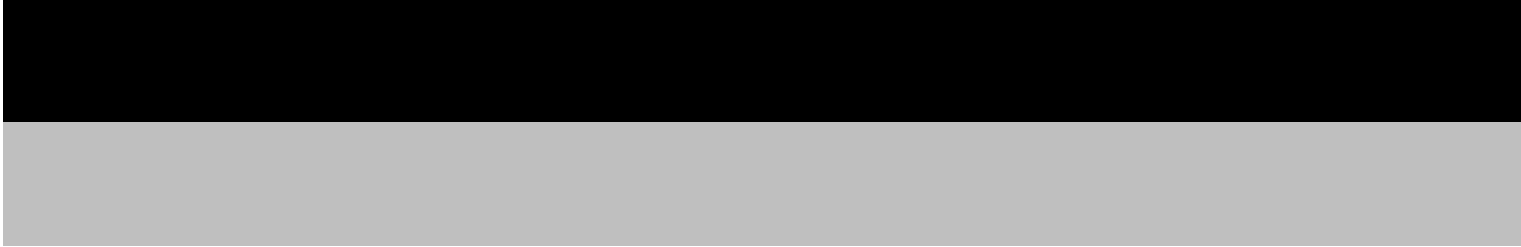

JVC

Victor Company of Japan, Limited
Home Entertainment Business Division Personal AV Operation 10-1,1chome,Ohwatari-machi,Maebashi-city,371-8543,Japan

(No.MB713<Rev.002>)

Printed in Japan
VSE

JVC

SCHEMATIC DIAGRAMS

DVD DIGITAL CINEMA SYSTEM

**TH-G61E, TH-G61EN, TH-G61A,
TH-G61UX, TH-G61UN, TH-G41A,
TH-G41UX, TH-G31B, TH-G31E,
TH-G31EN, TH-G31A, TH-G31UX,
TH-G31UN, TH-G61UH, TH-G31UH**

DVD-ROM No.SML2009S2

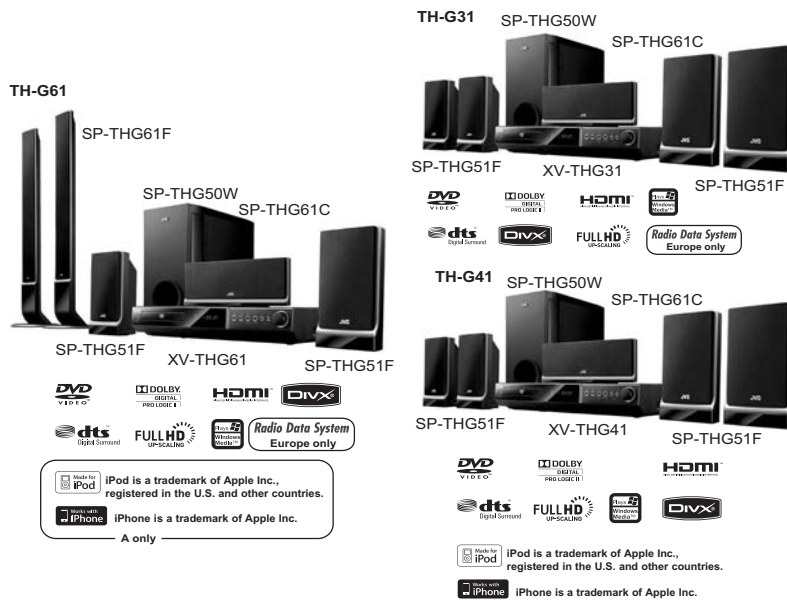

Lead free solder used in the board (material : Sn-Ag-Cu, melting point : 219 Centigrade)

Contents

Block diagrams	2-1
Standard schematic diagrams	2-2
Printed circuit boards	2-17 to 20

In regard with component parts appearing on the silk-screen printed side (parts side) of the PWB diagrams, the parts that are printed over with black such as the resistor (■), diode (▬) and ICP (●) or identified by the "⚠" mark nearby are critical for safety.

Block diagram

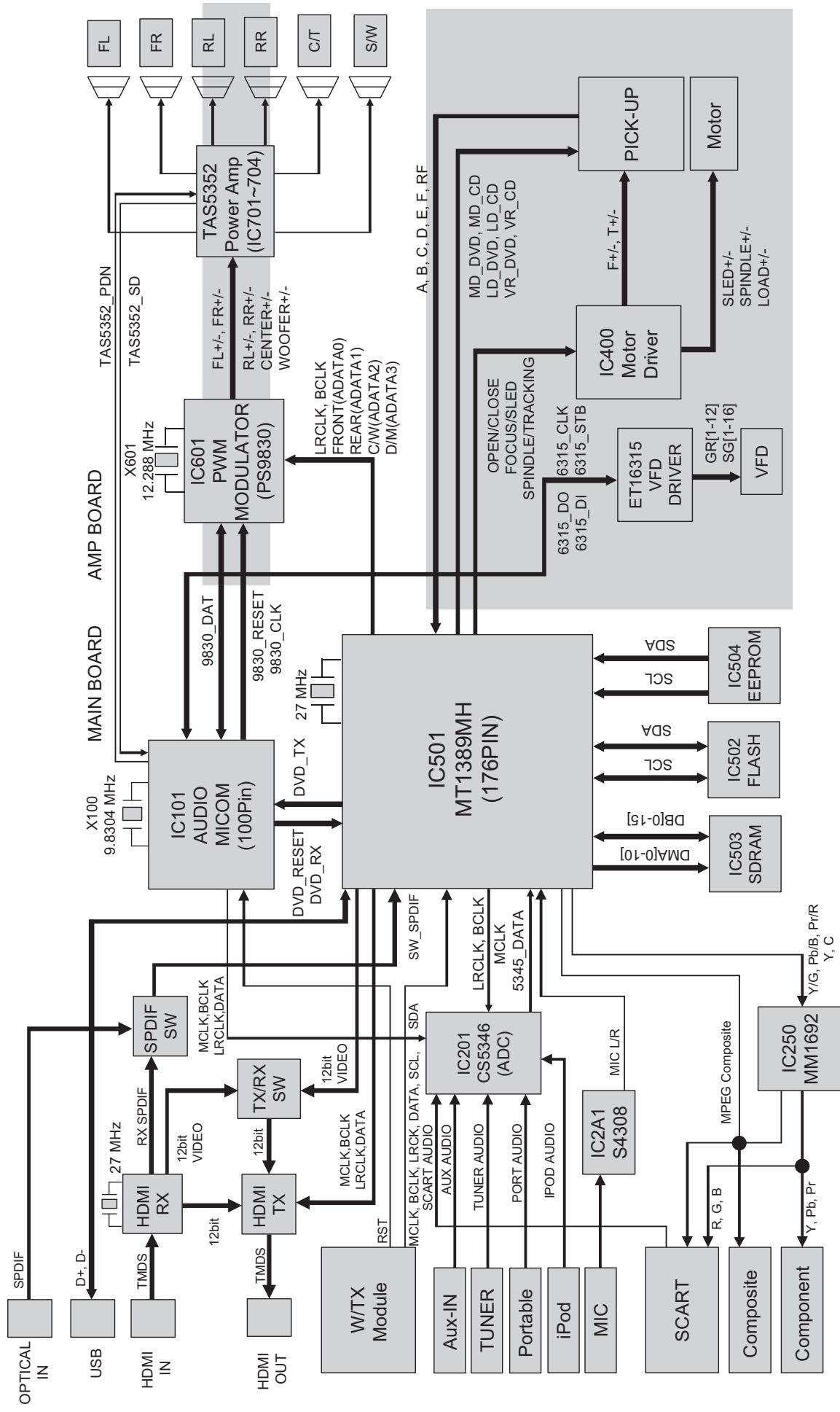

Standard schematic diagrams

■ SMPS CIRCUIT DIAGRAM

IMPORTANT SAFETY NOTICE

WHEN SERVICING THIS CHASSIS, UNDER NO CIRCUMSTANCES SHOULD THE ORIGINAL DESIGN BE MODIFIED OR ALTERED WITHOUT PERMISSION FROM THE JVC CORPORATION. ALL COMPONENTS SHOULD BE REPLACED ONLY WITH TYPES IDENTICAL TO THOSE IN THE ORIGINAL CIRCUIT.

SPECIAL COMPONENTS ARE SHADED ON THE SCHEMATIC FOR EASIER IDENTIFICATION.

THIS CIRCUIT DIAGRAM MAY OCCASIONALLY DIFFER FROM THE ACTUAL CIRCUIT USED. THIS WAY, IMPLEMENTATION OF THE LATEST SAFETY AND PERFORMANCE IMPROVEMENT CHANGES INTO THE SET IS NOT DELAYED UNTIL THE NEW SERVICE LITERATURE IS PRINTED.

NOTE :

1. Voltages are DC-measured with a digital voltmeter during Play mode.

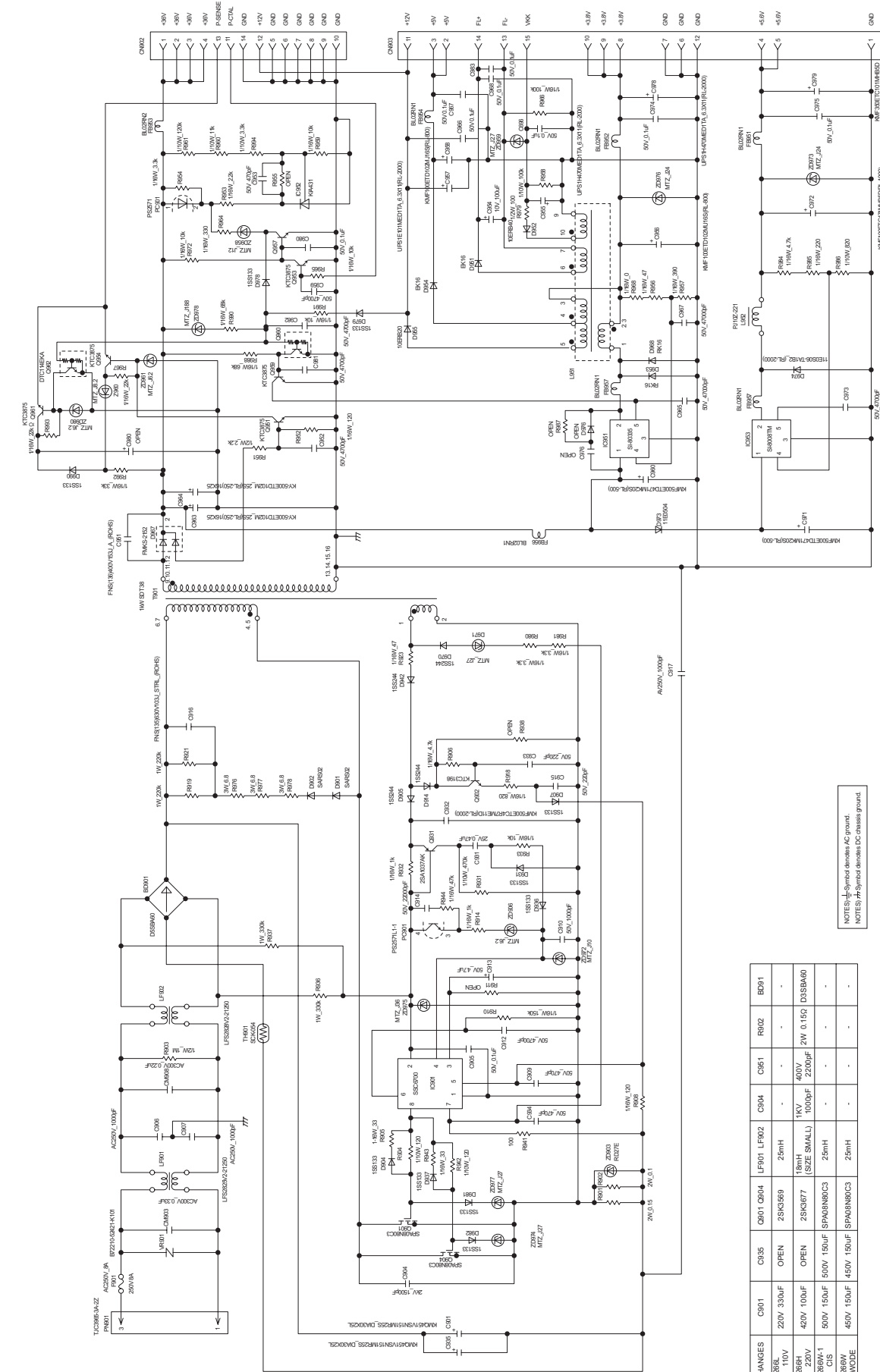

NOTE: - Symbol denotes AC ground.
 NOTES: - Symbol denotes DC chassis ground.

CHANGES	C001	C035	C007	C004	C004	C051	R002	BD91
3H26BL	110V	220V 330uF	OPEN	OPEN	LF501	LF502	-	-
3H26BR	220V	420V 100uF	OPEN	25K3569	25mH	-	-	-
3H26CS	110V	500V 150uF	OPEN	25K3977	25mH	1KV 1000uF	2W 0.15Q	D3SBA60
3H26RW	220V	450V 150uF	OPEN	SFA0NB0C3	25mH	-	-	-
3H26RW	220V	450V 150uF	OPEN	SFA0NB0C3	25mH	-	-	-

MPEG CIRCUIT DIAGRAM

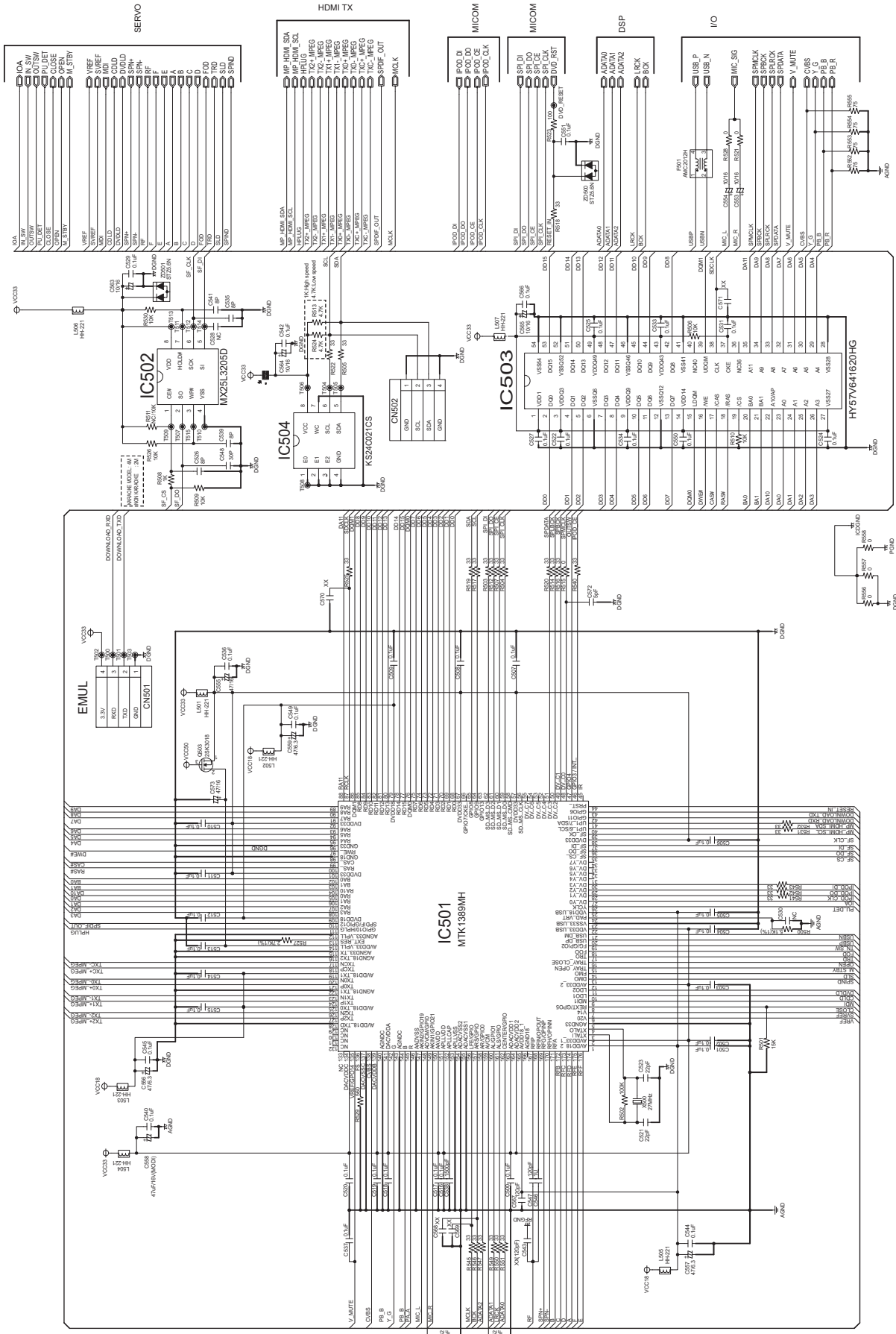

SERVO CIRCUIT DIAGRAM

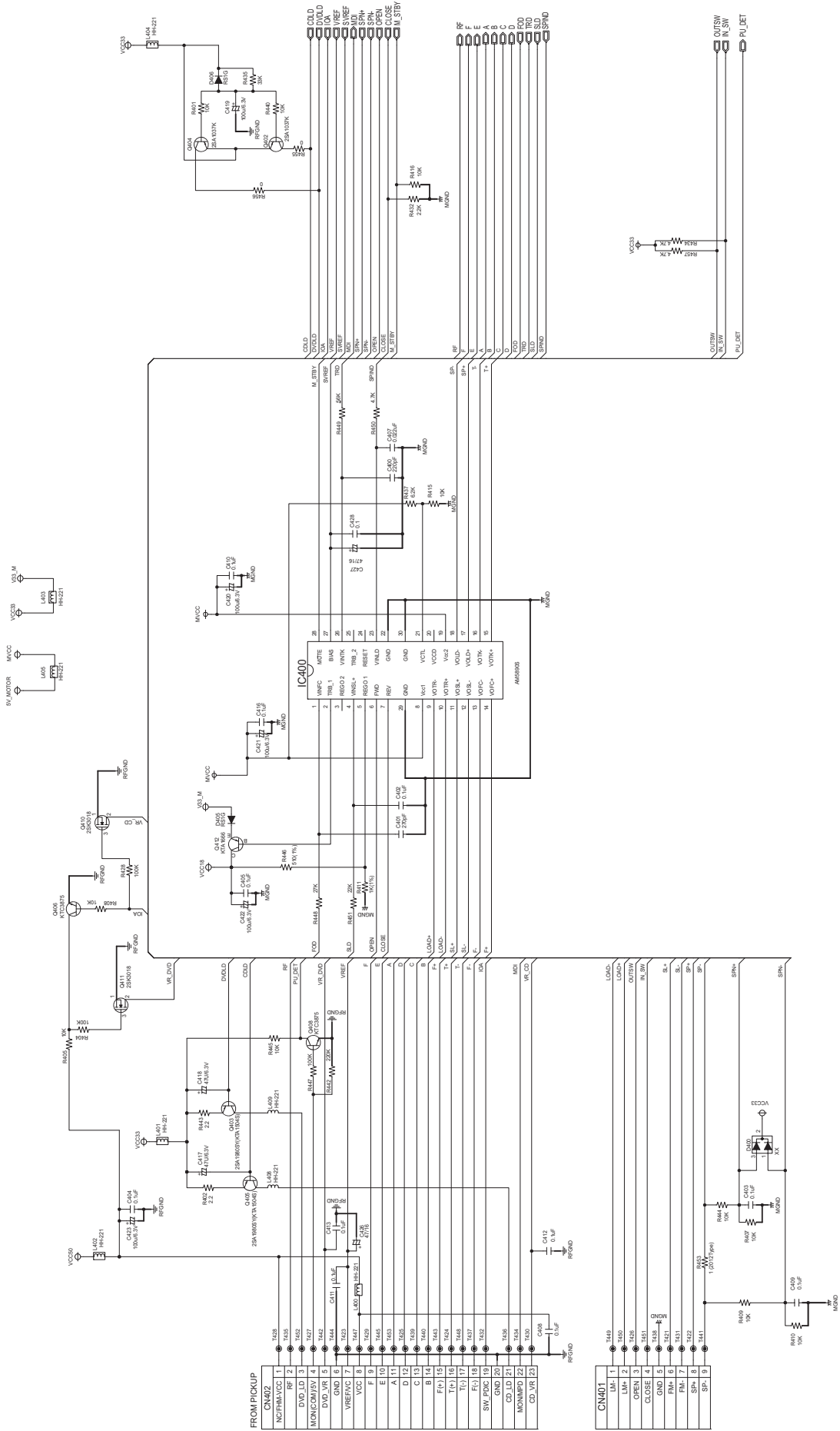

I/O CIRCUIT DIAGRAM

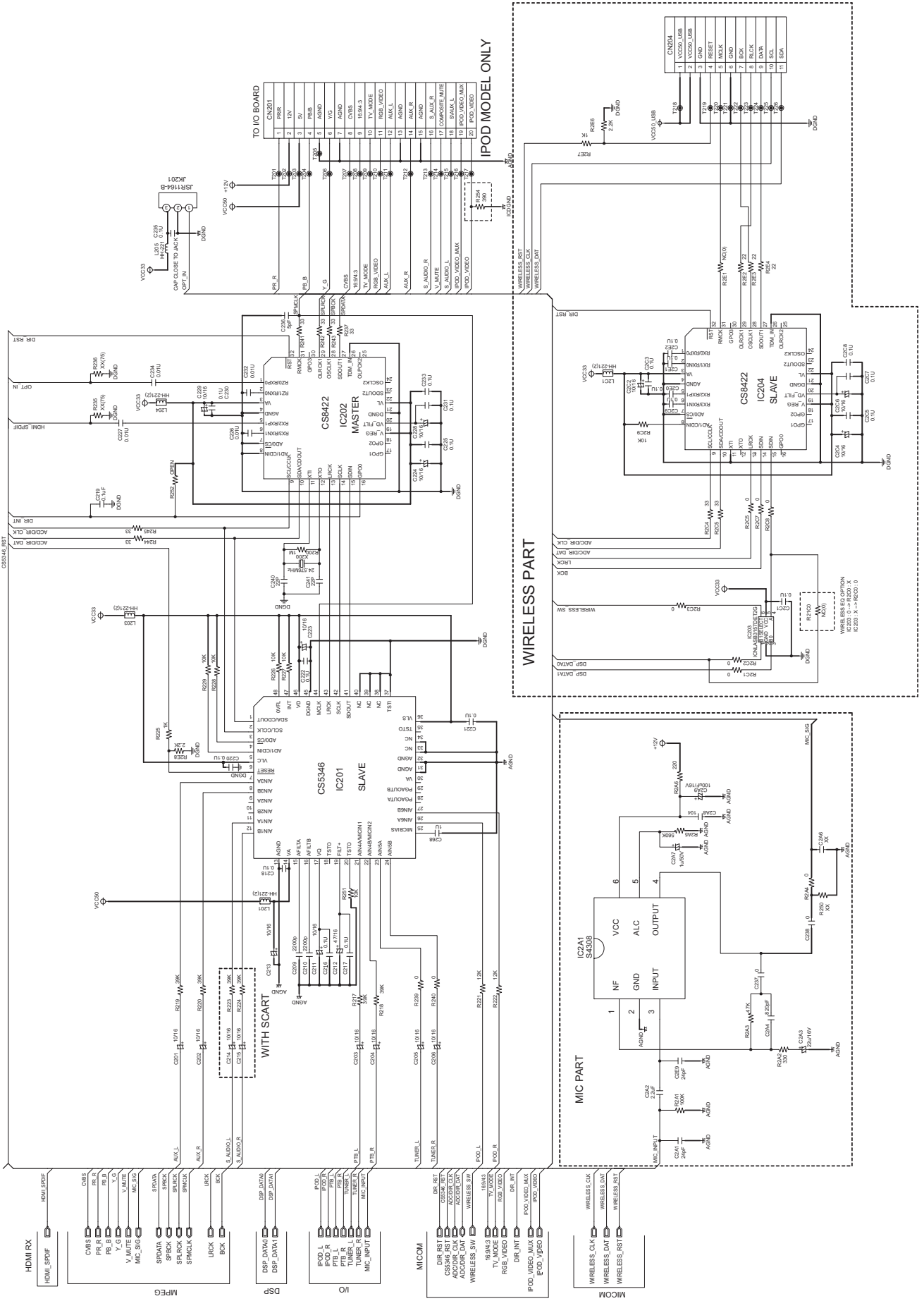

MICOM CIRCUIT DIAGRAM

RT161	100
RT162	100
RT1A7	NC
RT1A8	NC
RT1B3	NC
RT1G3	NC
RT1G4	0
RT1G5	0
RT1E1	NC
RT1E2	NC
RT1Z7	150

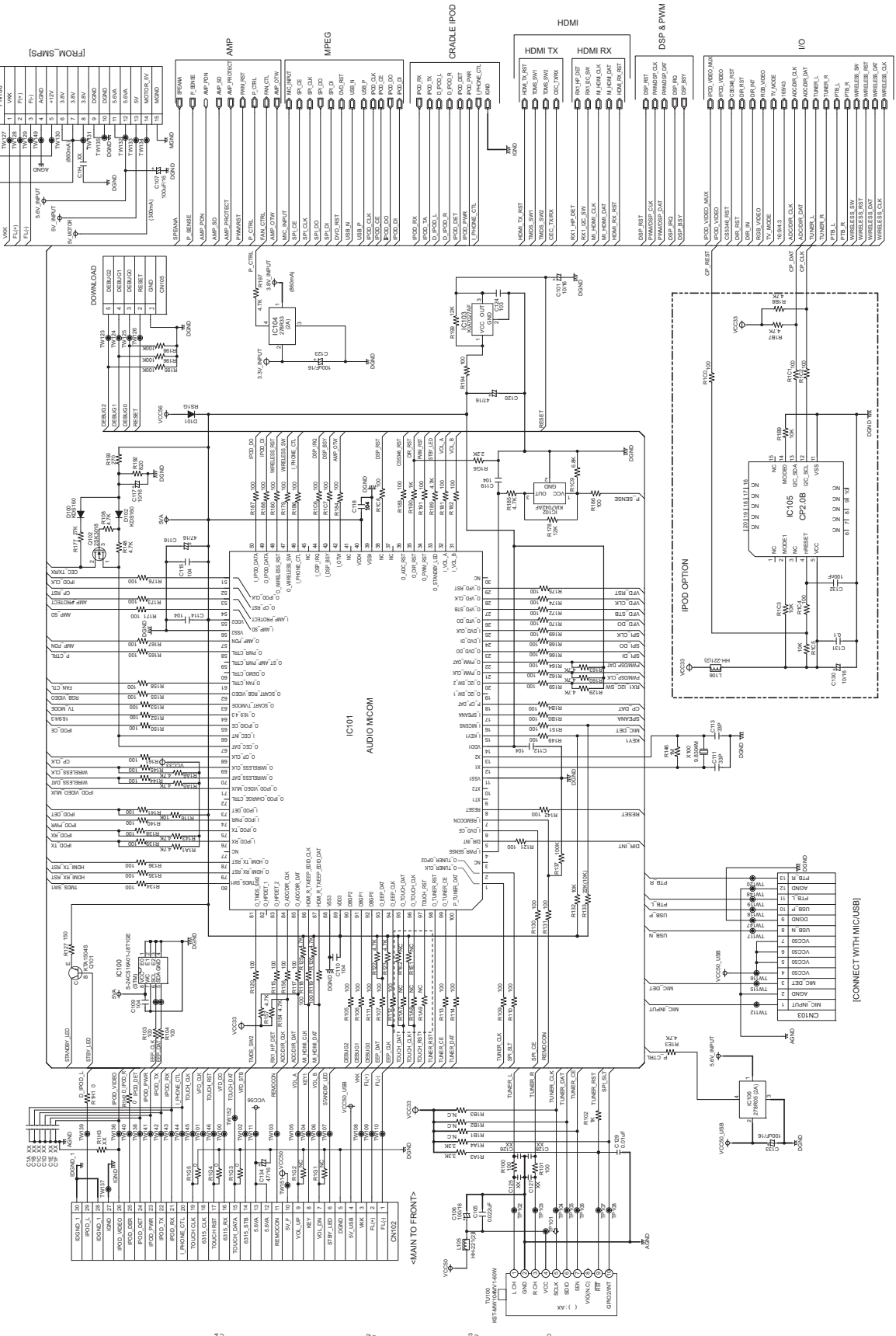

RT161	100
RT162	100
RT1A7	NC
RT1A8	NC
RT1B3	NC
RT1G3	NC
RT1G4	0
RT1G5	0
RT1E1	NC
RT1E2	NC
RT1Z7	150

HDMI RX CIRCUIT DIAGRAM

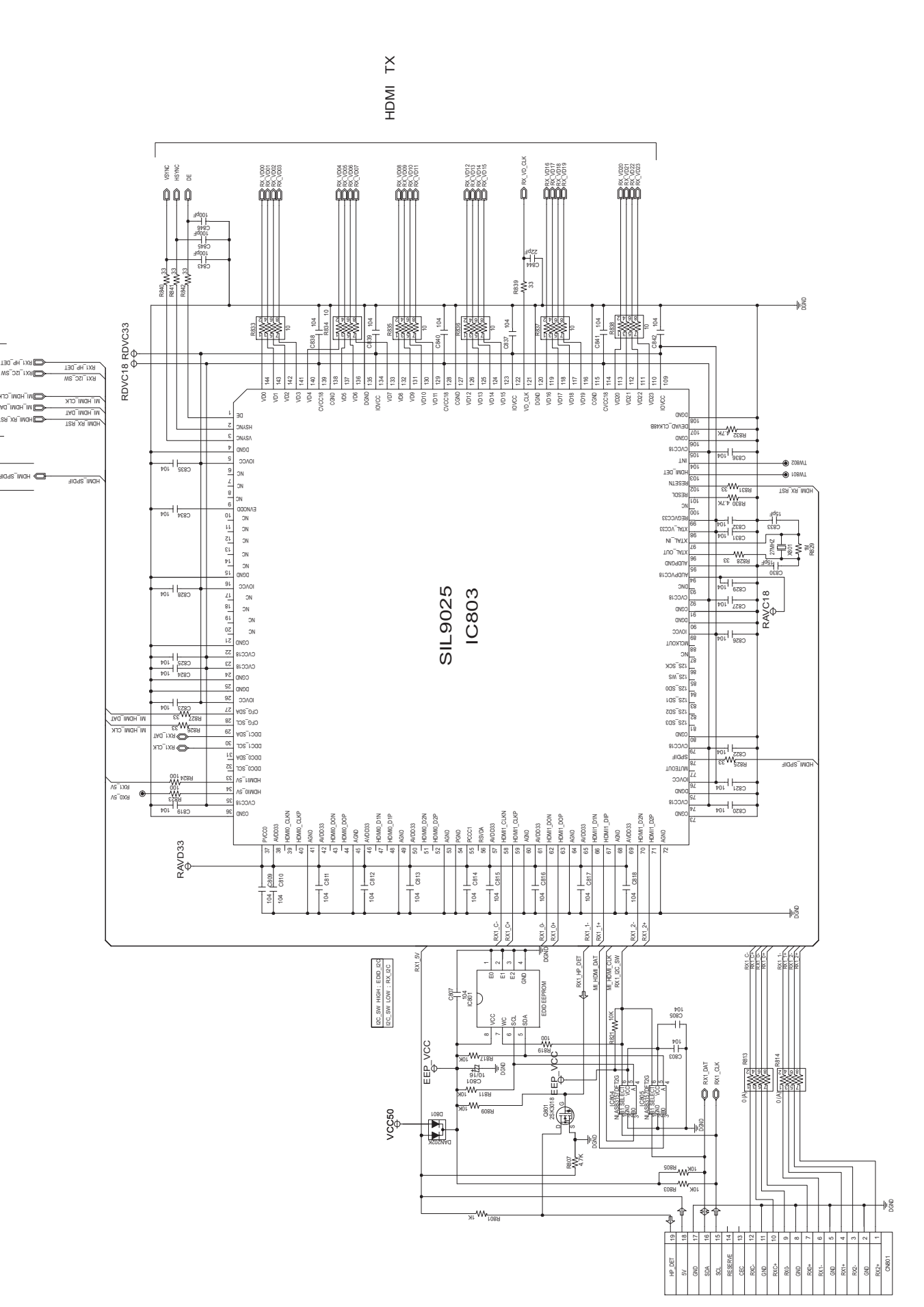

HDMI TX CIRCUIT DIAGRAM

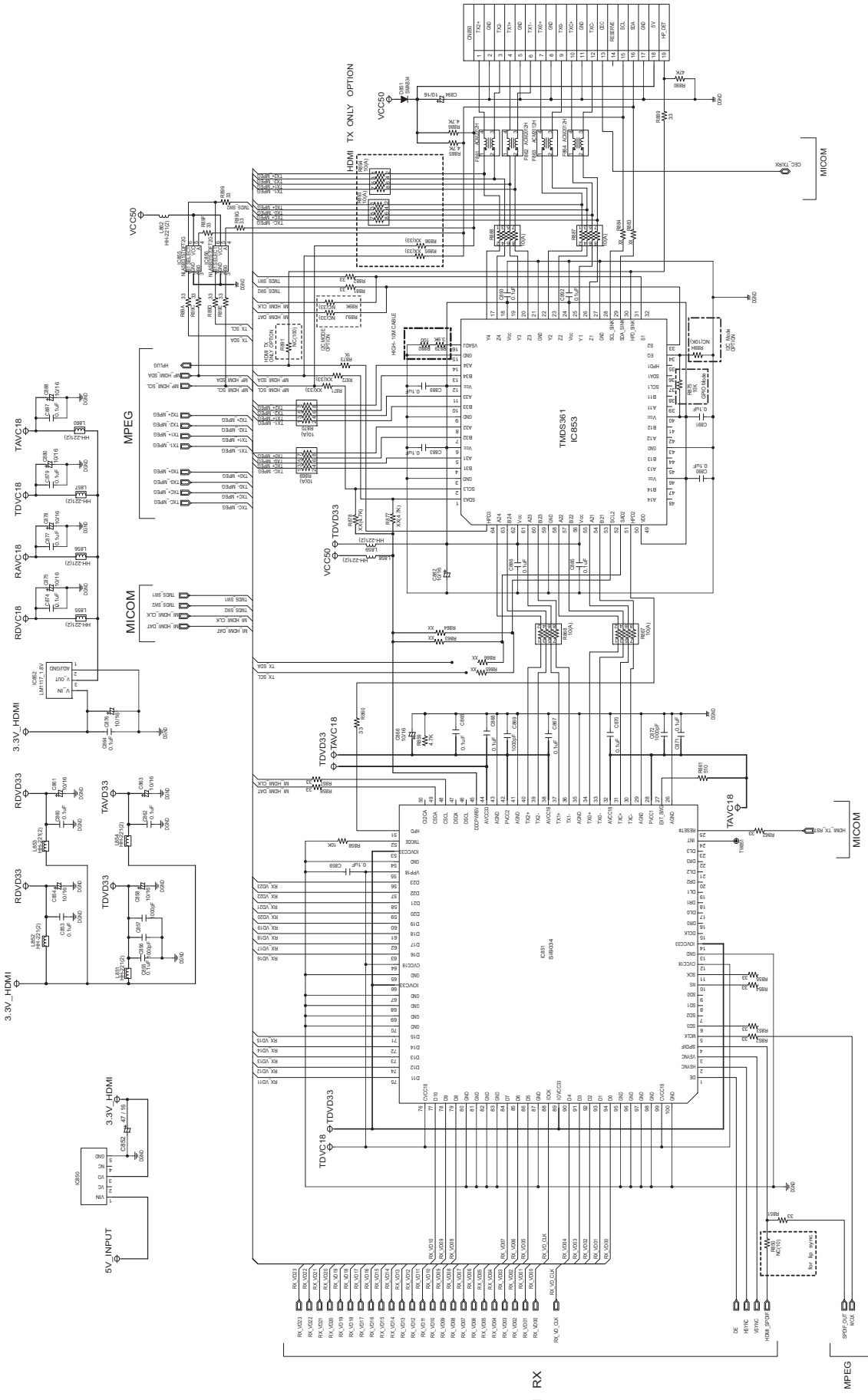

iPod CIRCUIT DIAGRAM

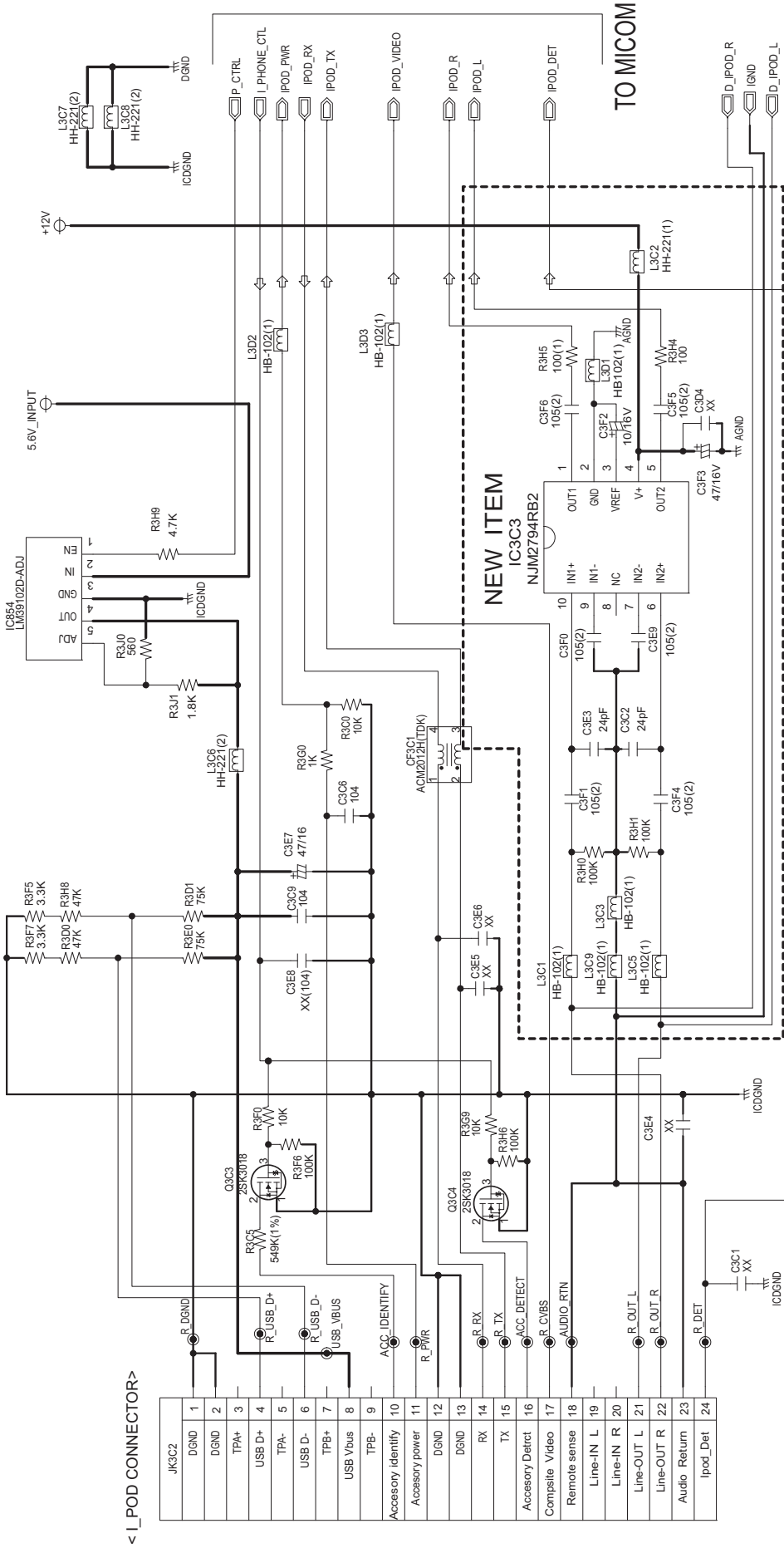

< I_POD CONNECTOR >

JK3C2	1
DGND	2
TPA+	3
USB D+	4
TPA-	5
USB D-	6
TPB+	7
USB Vbus	8
TPB-	9
Accessory Identify	10
Accessory power	11
DGND	12
DGND	13
RX	14
TX	15
ACC_DETECT	16
Accessory Video	17
Remote sense	18
Line-IN L	19
Line-IN R	20
Line-OUT L	21
Line-OUT R	22
Audio Return	23
Ipod_Det	24

Close to ADC

TO MICOM

AMP CIRCUIT DIAGRAM

[BOARD]

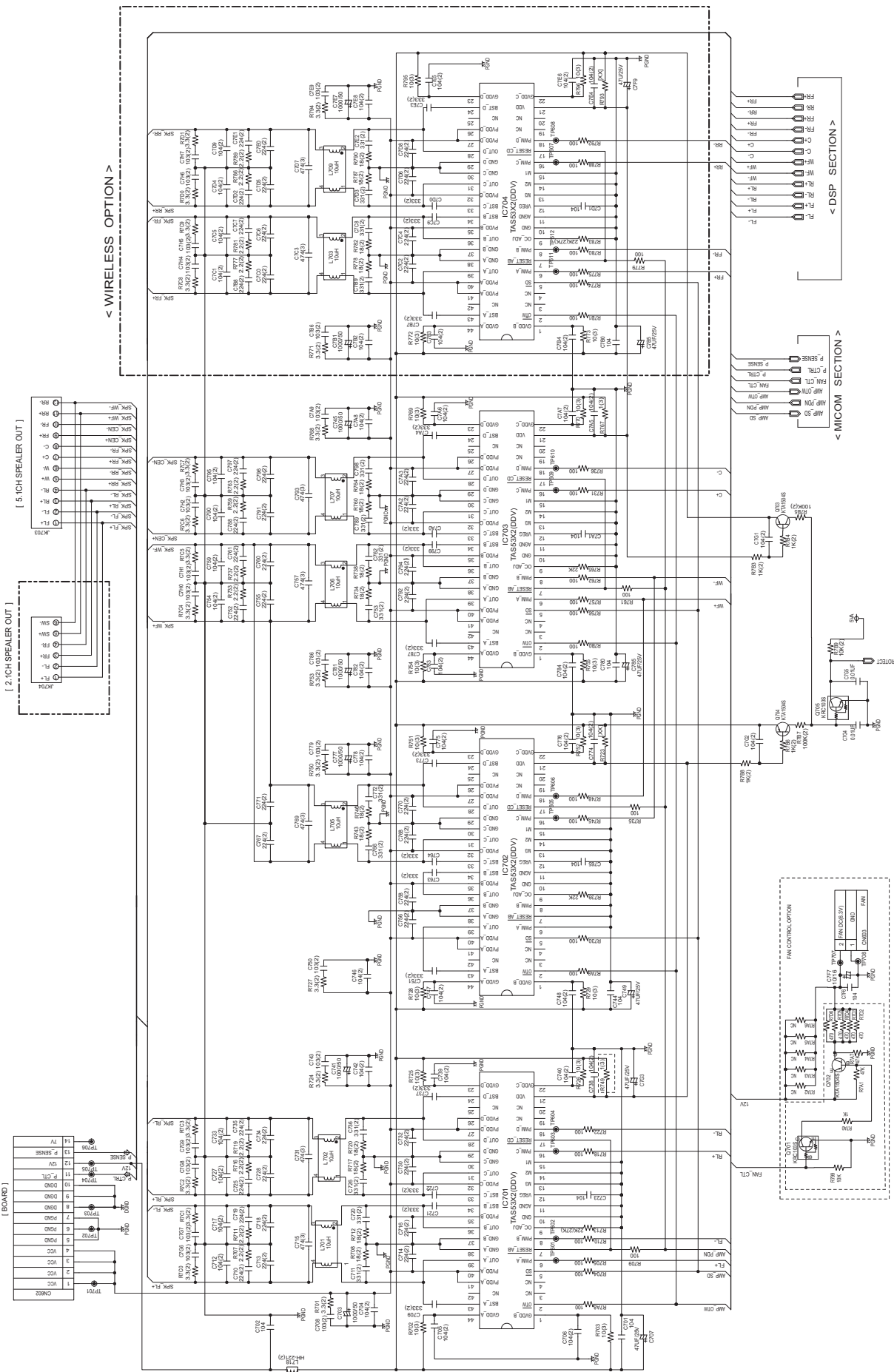

■ DSP & PWM CIRCUIT DIAGRAM

<< DSP & PWM SECTION >>

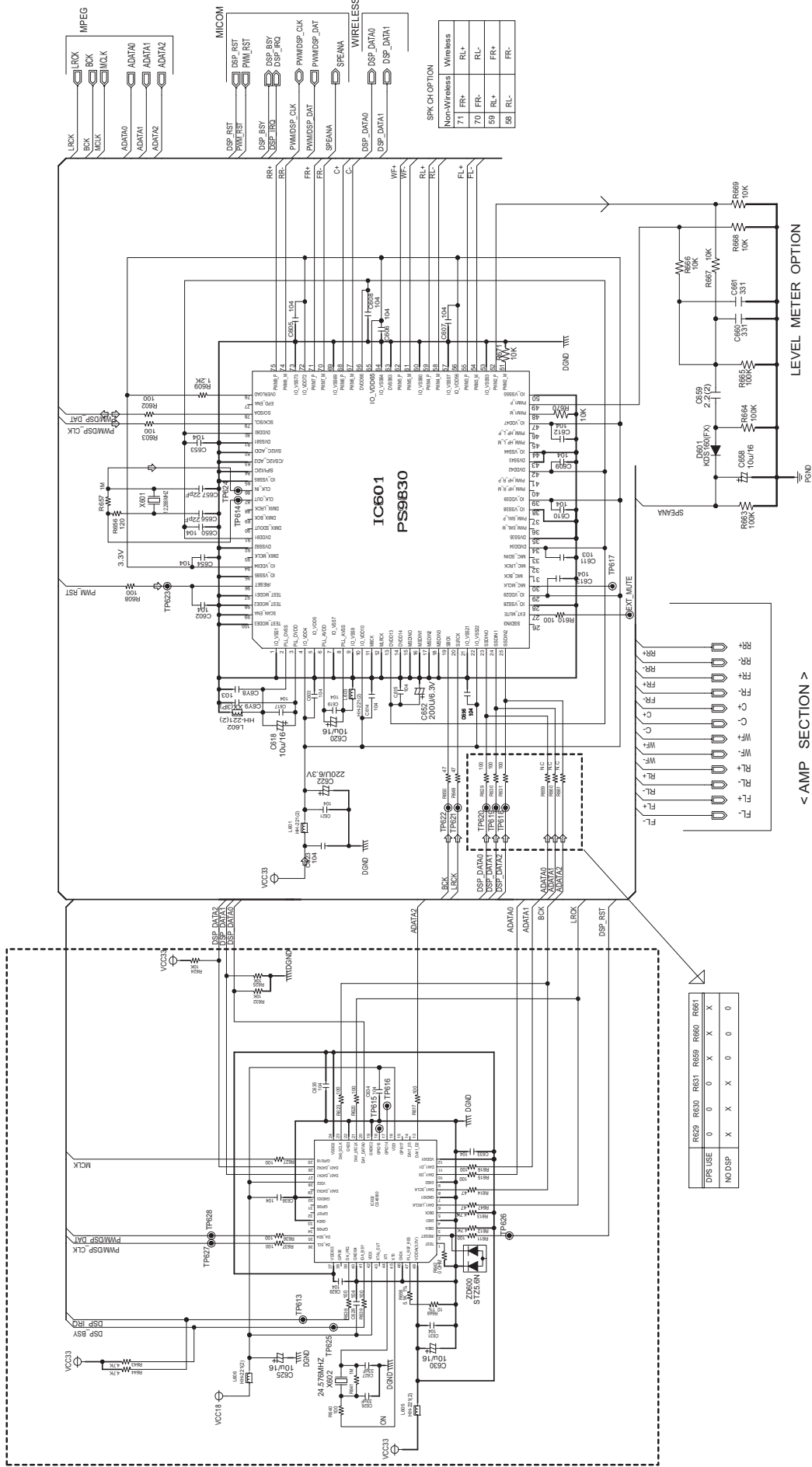

DPS USE	R629	R630	R631	R659	R660	R661
NO DSP	X	X	X	0	0	0

< AMP SECTION >

LEVEL METER OPTION

SPK CH OPTION

Non-Wireless	Wireless
71 FR+	RL+
70 FR-	RL-
59 RL+	FR+
58 RL-	FR-

■ I/O JACK CIRCUIT DIAGRAM

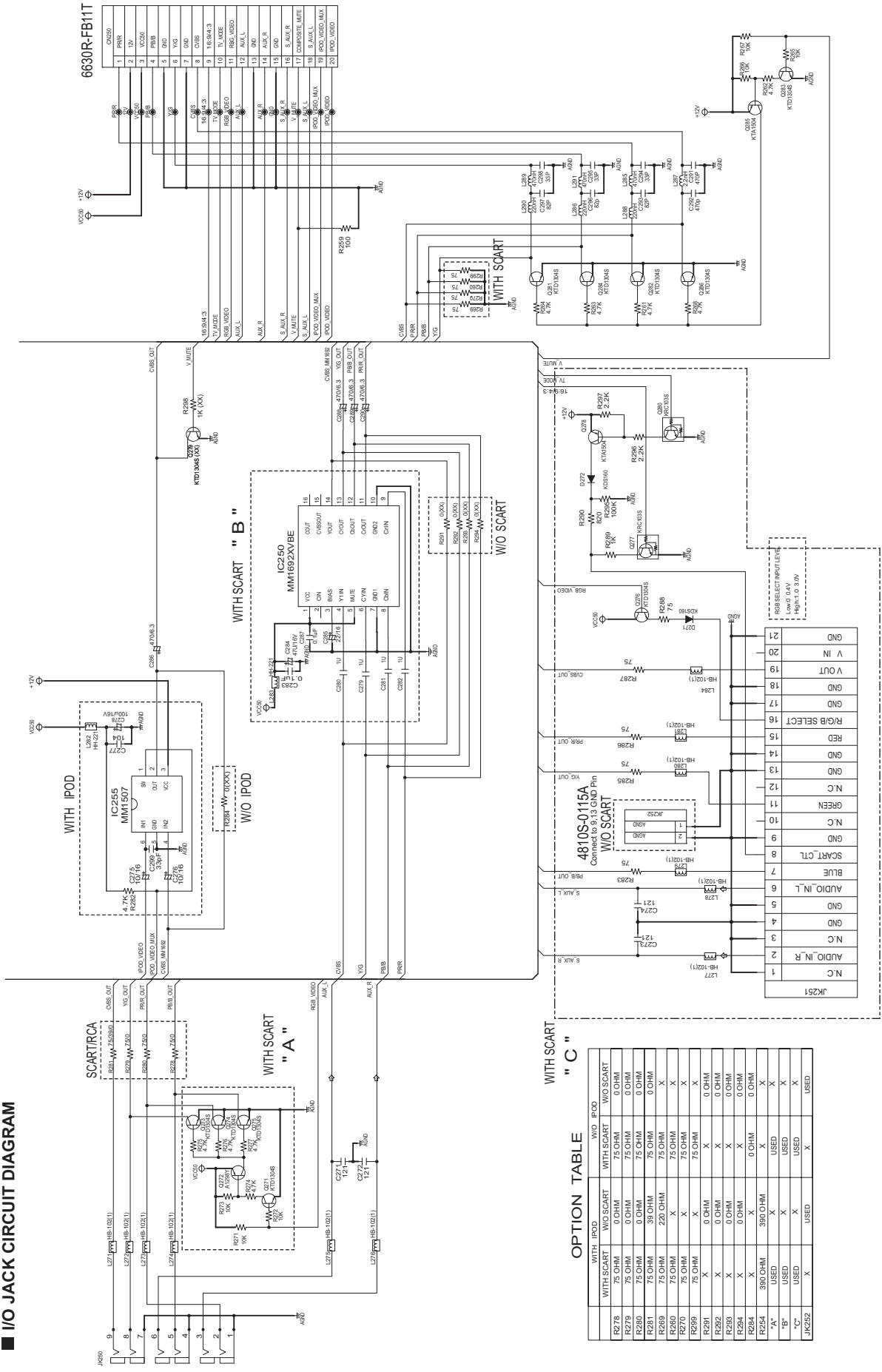

6630R-FB11T

1	CVBS
2	PRKR
3	Y
4	UV
5	CS
6	VID
7	Y
8	CS
9	16.9A.3
10	TV.MDE
11	RGB.VIDEO
12	AUX.L
13	Y
14	AUX.R
15	Y
16	S.AUX.R
17	COMPOSITE.MUTE
18	S.AUX.L
19	POD.VIDEO.MIX
20	POD.VIDEO

WITH SCART "B"

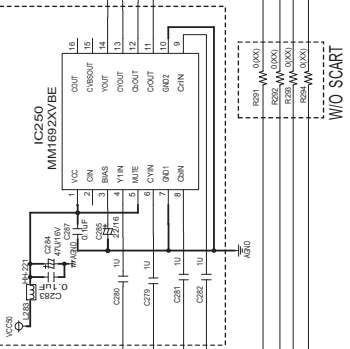

WITH SCART "A"

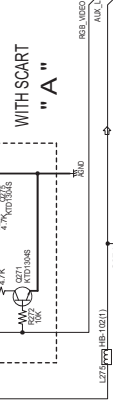

WITH SCART "C"

OPTION TABLE

	WITH IPOD	W/O IPOD	WITH SCART	W/O SCART
R278	75 OHM	0 OHM	75 OHM	0 OHM
R279	75 OHM	0 OHM	75 OHM	0 OHM
R280	75 OHM	0 OHM	75 OHM	0 OHM
R281	75 OHM	220 OHM	75 OHM	0 OHM
R289	75 OHM	X	75 OHM	X
R290	75 OHM	X	75 OHM	X
R291	X	0 OHM	75 OHM	X
R292	X	0 OHM	75 OHM	X
R294	X	0 OHM	0 OHM	0 OHM
R295	X	390 OHM	X	X
"A"	USED	X	USED	X
"B"	USED	X	USED	X
"C"	USED	X	USED	X
JK252	X	USED	X	USED

JK251

1	N.C
2	AUDIO_IN_R
3	GND
4	GND
5	AUX_IN_L
6	AUX_L
7	BLUE
8	SCART_CTL
9	GND
10	N.C
11	N.C
12	GND
13	YG_OUT
14	GND
15	RGB_SELECT
16	RED
17	GND
18	V_OUT
19	V_IN
20	GND
21	GND

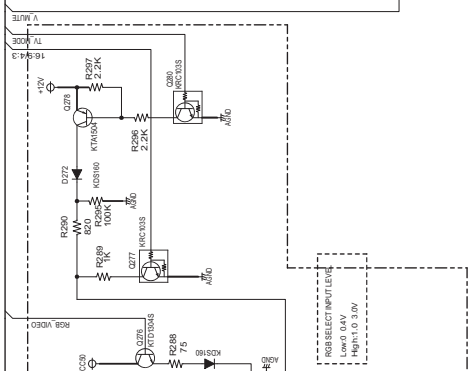

■ MIC & USB & PTB CIRCUIT DIAGRAM

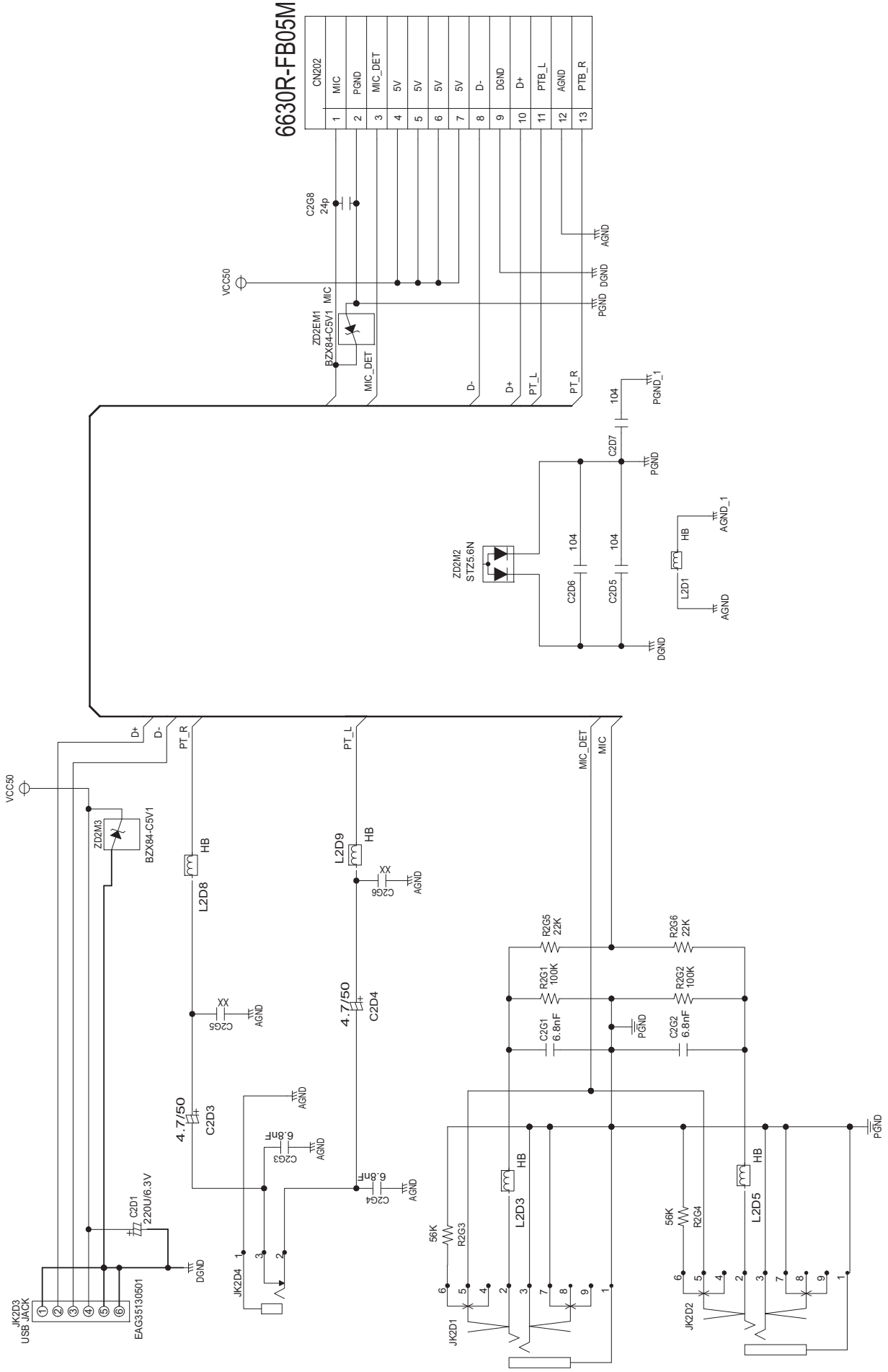

6630R-FB05M

CN202	
1	MIC
2	PGND
3	MIC_DET
4	5V
5	5V
6	5V
7	5V
8	D-
9	DGND
10	D+
11	PTB_L
12	AGND
13	PTB_R

FRONT JACK CIRCUIT DAIIAGRAM

TIMER PART

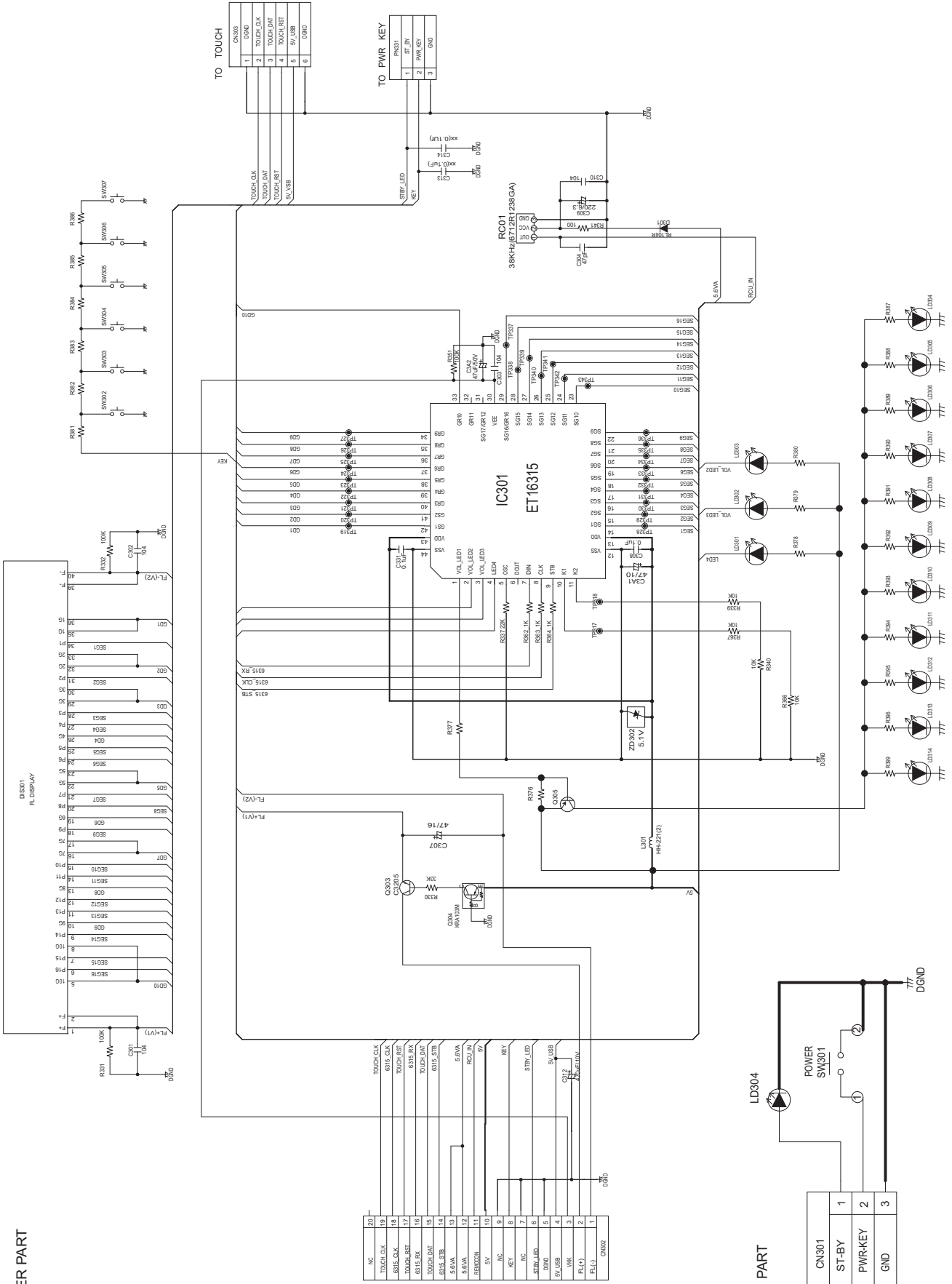

CIRCUIT VOLTAGE CHART

■ ICs on BOARD

MAIN			
IC100 (EEPROM)			
Pin No.	SPEC	DVD PB (V)	VOLT
8	5	4.94	
IC101 (A-Micom)			
Pin No.	SPEC	VOLT	
14	5.0	4.94	
40	5.0	4.94	
55	5.0	4.94	
89	5.0	4.94	
IC104			
Pin No.	SPEC	VOLT	
1	5.0	5.0	
3	3.3	3.3	
IC105			
Pin No.	SPEC	DVD PB (V)	
5	3.3	3.23	
IC106			
Pin No.	SPEC	VOLT	
1	5.6	5.6	
2	5	5	
IC201 (ADC)			
Pin No.	SPEC	VOLT	
5	3.3	3.24	
14	5	5.05	
36	3.3	3.26	
46	3.3	3.24	
IC202 (DIR)			
Pin No.	SPEC	DVD PB (V)	
3	3.3	3.24	
19	3.3	3.24	
22	3.3	3.24	
IC203 (SW)			
Pin No.	SPEC	DVD PB (V)	
5	3.3	3.22	
IC204 (DIR)			
Pin No.	SPEC	DVD PB (V)	
3	3.3	3.22	
19	3.3	3.22	
22	3.3	3.22	
IC250 (SCART)			
Pin No.	SPEC	VOLT	
1	5.0	5.06	
5	5.0	5.06	

IC255 (IPOD)			
Pin No.	SPEC	VOLT	
6	5.0	5.06	
IC2A1 (MIC)			
Pin No.	SPEC	VOLT	
6	12.0	11.4	
IC400 (MOTOR)			
Pin No.	SPEC	VOLT	
8	5.0	5.05	
19	5.0	5.05	
IC501 (MPEG)			
Pin No.	SPEC	DVD PB (V)	
1	1.8	1.88	
2	3.3	3.22	
12	3.3	3.22	
22	3.3	3.22	
25	1.8	1.88	
38	3.3	3.24	
57	3.3	3.24	
67	3.3	3.24	
79	1.8	1.87	
92	3.3	3.24	
101	3.3	3.24	
109	1.8	1.87	
114	3.3	3.24	
119	1.8	1.87	
125	3.3	1.88	
134	3.3	3.22	
139	3.3	3.22	
141	3.3	3.22	
150	3.3	3.22	
151	3.3	3.22	
163	3.3	3.22	
164	3.3	3.22	
165	1.8	1.88	
IC502 (FLASH)			
Pin No.	SPEC	DVD PB (V)	
8	3.3	3.22	
IC503 (SDRAM)			
Pin No.	SPEC	DVD PB (V)	
1	3.3	3.22	
3	3.3	3.25	
9	3.3	3.24	
14	3.3	3.25	

Pin No.	SPEC	DVD PB (V)
27	3.3	3.24
43	3.3	3.24
49	3.3	3.24
IC504 (EEPROM)		
Pin No.	SPEC	DVD PB (V)
8	3.3	3.24
IC542		
Pin No.	SPEC	DVD PB (V)
8	3.3	3.25
IC601 (PWM)		
Pin No.	SPEC	DVD PB (V)
4	3.3	3.21
10	3.3	3.21
22	3.3	3.21
29	3.3	3.21
39	3.3	3.21
47	3.3	3.21
56	3.3	3.21
65	3.3	3.21
72	3.3	3.21
91	3.3	3.21
94	3.3	3.21
IC701 (AMP)		
Pin No.	SPEC	DVD PB (V)
26	35	35.44
27	35	35.43
32	35	35.43
35	35	35.44
40	35	35.43
41	35	35.43
IC702 (AMP)		
Pin No.	SPEC	DVD PB (V)
26	35	35.44
27	35	35.43
32	35	35.43
35	35	35.44
40	35	35.43
41	35	35.43
IC703 (AMP)		
Pin No.	SPEC	DVD PB (V)
26	35	35.44
27	35	35.43
32	35	35.43

35	35	35.44
40	35	35.43
41	35	35.43
IC704 (AMP)		
Pin No.	SPEC	DVD PB (V)
26	35	35.44
27	35	35.43
32	35	35.43
35	35	35.44
40	35	35.43
41	35	35.43
IC801 (EEPROM)		
Pin No.	SPEC	DVD PB (V)
8	5	4.93
IC803 (HDMI Rx)		
Pin No.	SPEC	DVD PB (V)
5	3.3	3.31
16	3.3	3.31
22	1.8	1.77
23	1.8	1.77
26	1.8	1.78
35	1.8	1.77
37	3.3	3.31
38	1.8	1.78
42	3.3	3.31
46	3.3	3.3
50	3.3	3.3
55	3.3	3.3
57	3.3	3.3
61	3.3	3.3
65	3.3	3.3
69	3.3	3.3
74	1.8	1.77
76	1.8	1.77
79	1.8	1.77
89	3.3	3.3
92	1.8	1.77
94	1.8	1.77
98	1.8	1.77
99	3.3	3.3
105	1.8	1.77
109	1.8	1.77
114	1.8	1.77
122	3.3	3.3

128	1.8	1.77
134	3.3	3.3
139	1.8	1.77
IC850		
Pin No.	SPEC	VOLT
1	5.0	4.99
3	3.3	3.29
IC851 (HDMI SW)		
Pin No.	SPEC	DVD PB (V)
12	1.8	1.77
14	3.3	3.3
28	1.8	1.77
32	1.8	1.77
38	1.8	1.77
42	1.8	1.77
44	3.3	3.3
45	5	5.06
53	3.3	3.3
55	1.8	1.77
64	1.8	1.77
66	3.3	3.3
76	1.8	1.77
89	3.3	3.29
99	1.8	1.77
IC852		
Pin No.	SPEC	VOLT
2	1.8	1.77
3	3.3	3.3
IC853		
Pin No.	SPEC	DVD PB (V)
6	3.3	3.3
12	3.3	3.3
19	3.3	3.3
25	3.3	3.3
40	3.3	3.3
46	3.3	3.3
49	3.3	3.3
55	3.3	3.3
61	3.3	3.3
FRONT		
IC301 (VFD)		
Pin No.	SPEC	VOLT
13	5.0	5.08
43	5.0	4.99

■ CAPACITORS on BOARD

No	Value (uF)	Voltage_Spec	positive (+)	negative (-)	voltage
C101	10uF	16	4.94	0.00	4.94
C106	100uF	16	5.00	0.00	5.00
C116	47uF	16	4.95	0.00	4.95
C117	10uF	16	3.90	0.00	3.90
C120	47uF	16	4.95	0.00	4.95
C123	100uF	16	3.30	0.00	3.30
C133	100uF	16	5.04	0.00	5.04
C201	10uF	16	2.50	2.16	0.34
C202	10uF	16	2.51	2.24	0.27
C203	10uF	16	2.50	2.22	0.28
C204	10uF	16	2.10	2.10	0.00
C205	10uF	16	2.51	2.23	0.28
C206	10uF	16	2.50	2.22	0.28
C207	10uF	16	2.51	2.24	0.27
C208	10uF	16	2.51	2.19	0.32
C211	10uF	16	2.41	0.00	2.41
C212	47uF	16	4.83	0.00	4.83
C213	10uF	16	5.05	0.00	5.05
C214	10uF	16	0.52	0.00	0.01
C215	10uF	16	0.52	0.42	0.10
C223	10uF	16	3.24	0.00	3.24
C224	10uF	16	3.24	0.00	3.24
C228	10uF	16	2.47	0.00	2.47
C229	10uF	16	3.24	0.00	3.24
C275	10uF	16	2.99	2.63	0.36
C276	10uF	16	2.38	2.21	0.17
C278	100uF	16	5.04	0.00	5.04
C284	47uF	16	5.03	0.00	5.03
C285	22uF	16	2.51	0.00	2.51
C286	470uF	6.30	2.41	1.44	0.97
C288	470uF	6.30	1.70	0.00	1.70
C289	470uF	6.30	2.34	0.00	2.34
C290	470uF	6.30	2.34	0.00	2.34
C2A3	22uF	16	1.95	0.00	1.95
C2A5	100uF	16	1.99	0.84	1.15
C2A7	1uF	50	0.00	0.00	0.00
C2A9	100uF	16	11.07	0.00	11.07
C2C2	10uF	16	3.25	0.00	3.25
C2C4	10uF	16	3.22	0.00	3.22
C2C6	10uF	16	2.48	0.00	2.48
C3D2	47uF	16	4.95	0.00	4.95
C417	47uF	6.30	3.19	0.84	0.92

No	Value (uF)	Voltage_Spec	positive (+)	negative (-)	voltage
C418	47uF	6.30	3.19	3.04	0.15
C419	100uF	6.30	3.19	0.00	3.19
C420	100uF	6.30	5.03	0.00	5.03
C421	100uF	6.30	5.03	0.00	5.03
C422	100uF	6.30	1.89	0.00	1.89
C423	100uF	6.30	5.04	0.00	5.04
C426	47uF	16	2.05	0.00	2.05
C427	47uF	16	1.43	0.00	1.43
C553	10uF	25	1.31	1.04	0.27
C554	10uF	25	1.29	1.06	0.23
C555	47uF	16	3.24	0.00	3.24
C556	47uF	6.30	1.88	0.00	1.88
C557	47uF	6.30	1.88	0.00	1.88
C558	47uF	16	3.22	0.00	3.22
C559	47uF	6.30	1.87	0.00	1.87
C560	47uF	6.30	1.57	0.00	1.57
C561	47uF	6.30	1.36	0.00	1.36
C563	10uF	25	3.21	0.00	3.21
C564	10uF	25	3.25	0.00	3.25
C565	10uF	25	3.25	0.00	3.25
C618	10uF	16	1.92	0.00	1.92
C620	10uF	16	1.93	0.00	1.93
C622	220uF	6.30	3.21	0.00	3.21
C625	10uF	16	1.85	0.00	1.85
C630	10uF	16	3.22	0.00	3.22
C652	220uF	6.30	1.93	0.00	1.93
C707	47uF	25	11.79	0.00	11.79
C749	47uF	25	11.79	0.00	11.79
C785	47uF	25	11.79	0.00	11.79
C7B5	47uF	25	11.78	0.00	11.78
C7F7	10uF	16	11.77	0.00	11.77
C7F9	47uF	25	11.76	0.00	11.76
C7G3	47uF	25	11.77	0.00	11.77
C801	10uF	25	4.94	0.00	4.94
C852	47uF	16	3.31	0.00	3.31
C854	10uF	25	3.31	0.00	3.31
C858	10uF	25	3.31	0.00	3.31
C861	10uF	25	3.31	0.00	3.31
C863	10uF	25	3.31	0.00	3.31
C866	10uF	25	1.87	0.00	1.87
C875	10uF	25	1.78	0.00	1.78
C876	10uF	25	3.31	0.00	3.31

■ DIODES on BOARD

ZD2M1 (BZX84-C5V1)		VOLT
Pin No.		
1		-0.01 V
2		-0.28 V
3		0.02 V
ZD2M2 (BZX84-C5V1)		VOLT
Pin No.		
1		-0.01 V
2		-0.13 V
3		-0.01 V
ZD302 (BZX84-C5V1)		VOLT
Pin No.		
1		0 V
2		0 V
3		5.07 V
ZD500 (BZX84-C5V1)		VOLT
Pin No.		
1		-0.01 V
2		-0.23 V
3		0 V
D801 (DAN202K)		VOLT
Pin No.		
1		-0.01 V
2		-0.23 V
3		0 V

Printed circuit boards

- **Main board (forward side)**
(Lead free solder used in the board (material : Sn-Ag-Cu, melting point : 219 Centigrade))

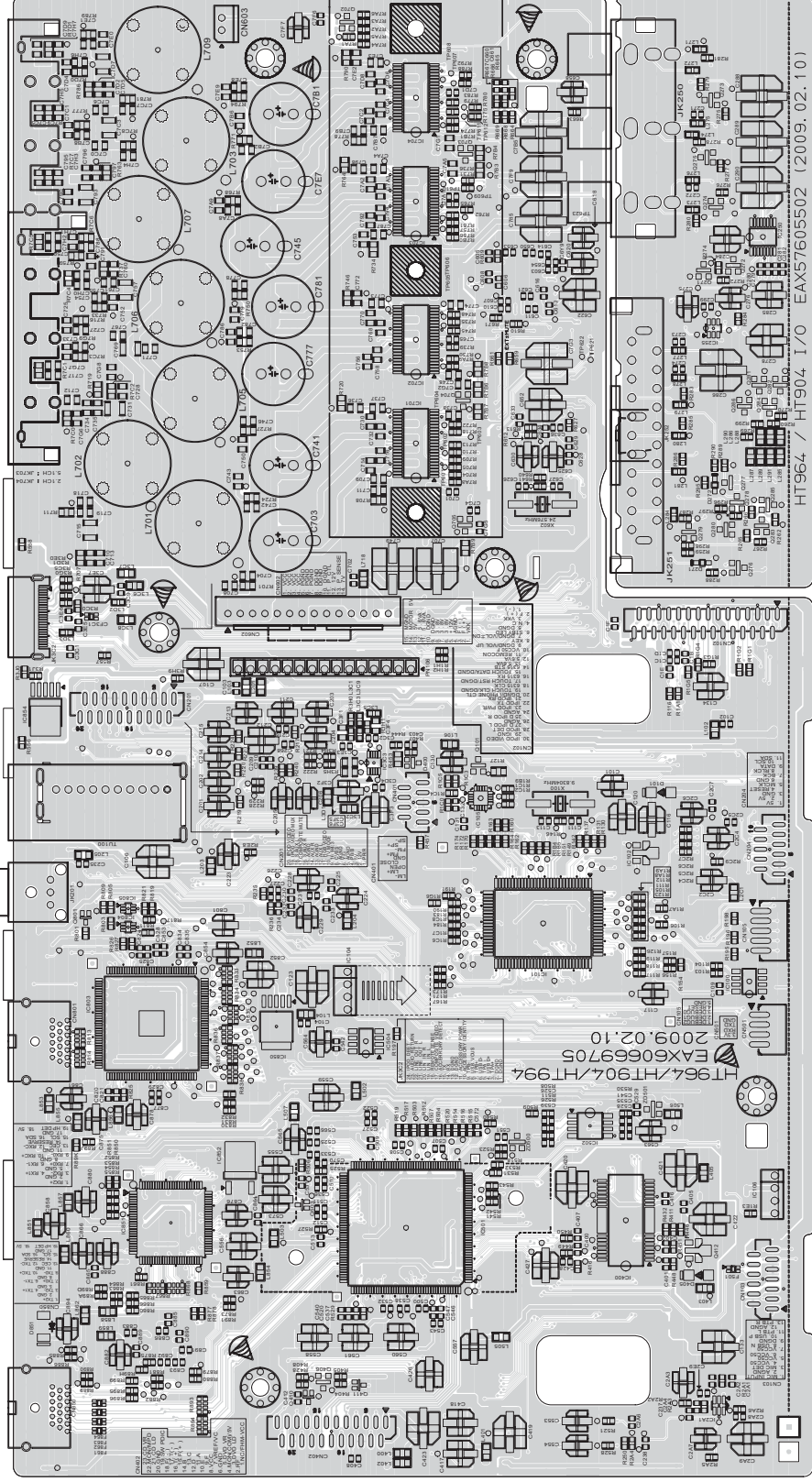

- **Timer board**
(Lead free solder used in the board (material : Sn-Ag-Cu, melting point : 219 Centigrade))

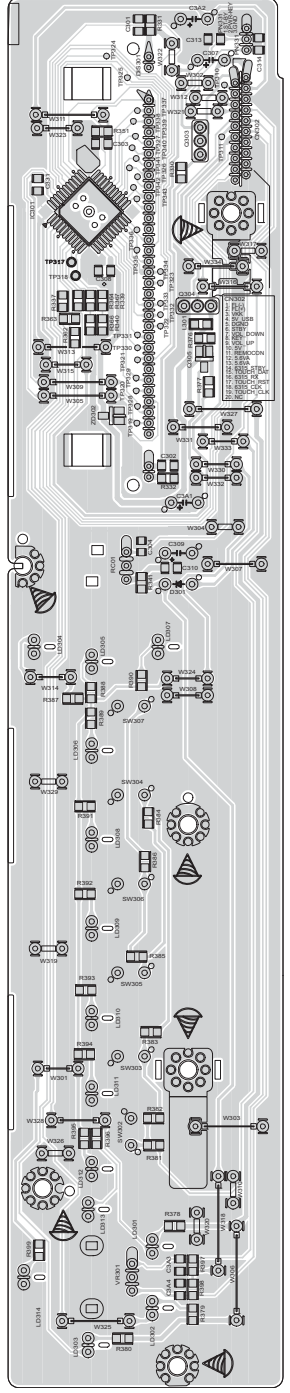

■ **Main board (reverse side)**
 (Lead free solder used in the board (material : Sn-Ag-Cu, melting point : 219 Centigrade))

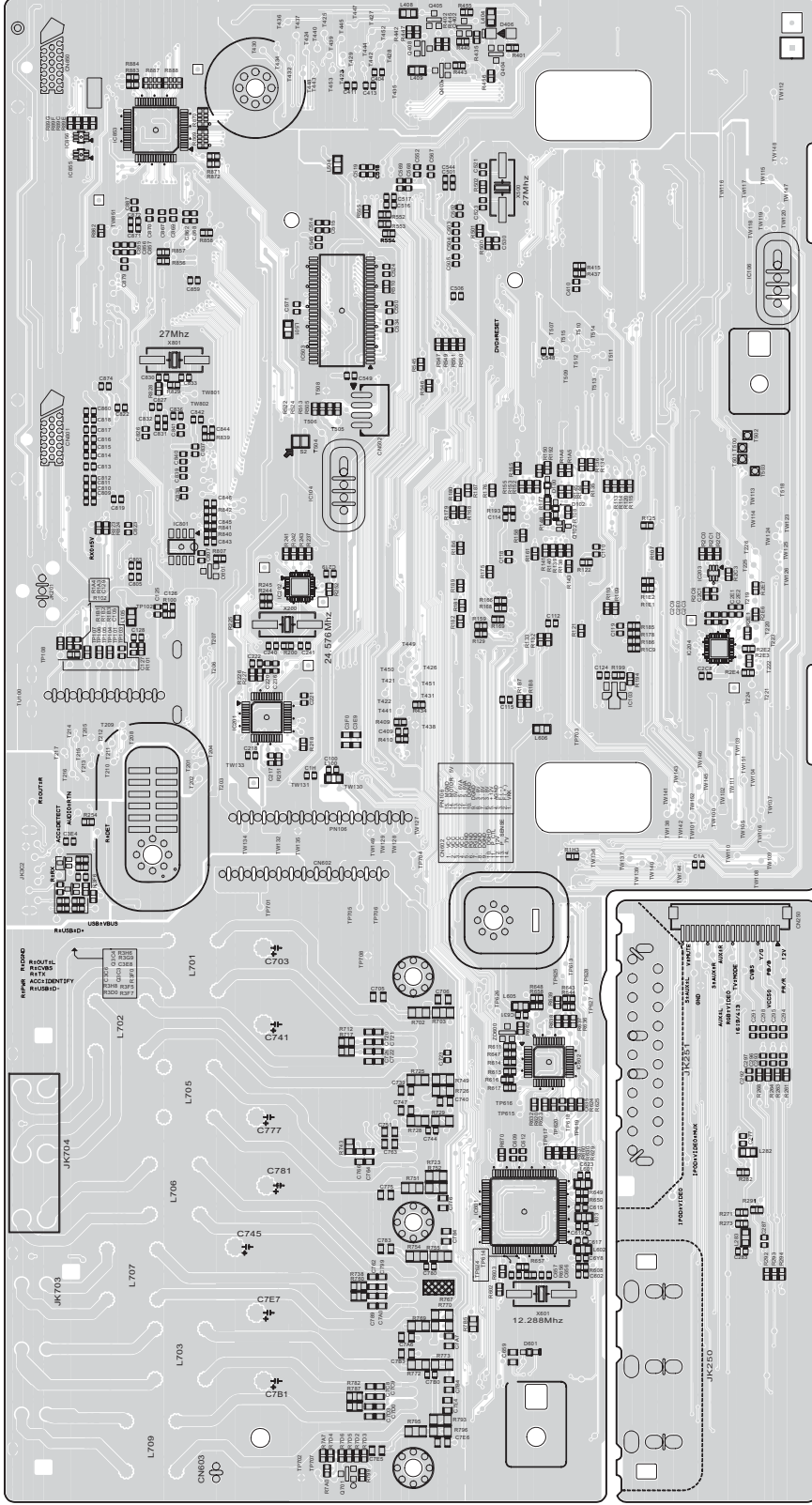

■ **MIC board**
 (Lead free solder used in the board (material : Sn-Ag-Cu, melting point : 219 Centigrade))

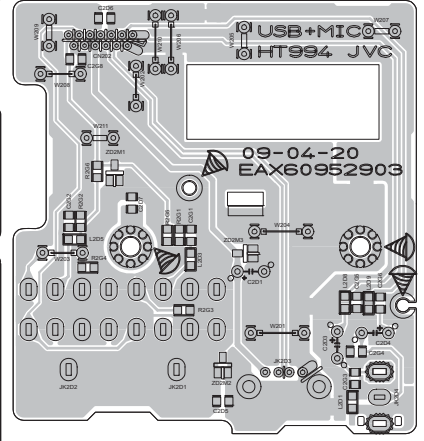

■ **Key board**
 (Lead free solder used in the board (material : Sn-Ag-Cu, melting point : 219 Centigrade))

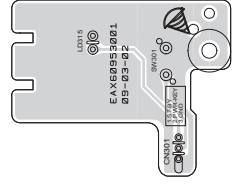

SMPS board (forward side)

(Lead free solder used in the board (material : Sn-Ag-Cu, melting point : 219 Centigrade))

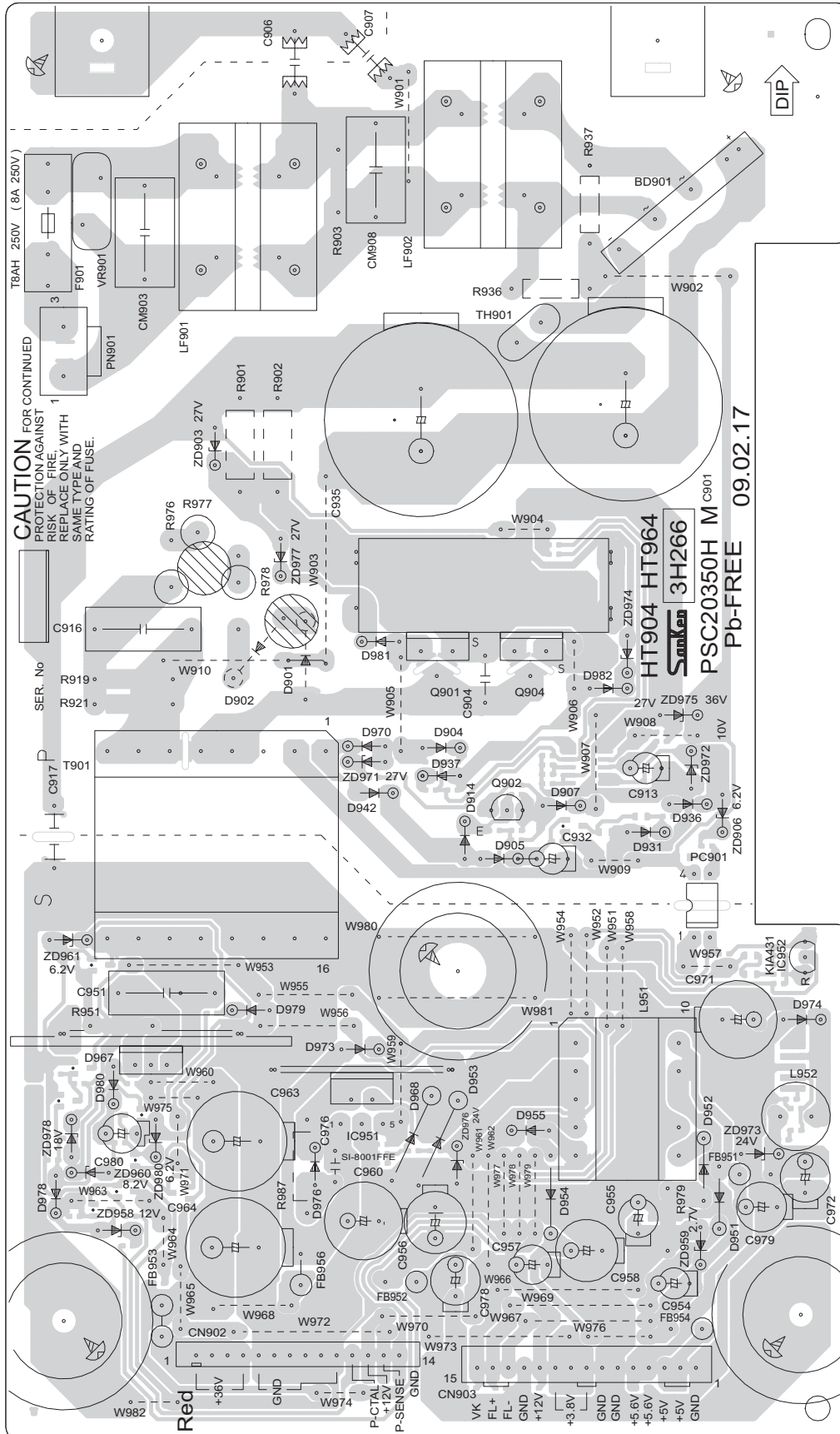

SMPS board (reverse side)
 (Lead free solder used in the board (material : Sn-Ag-Cu, melting point : 219 Centigrade))

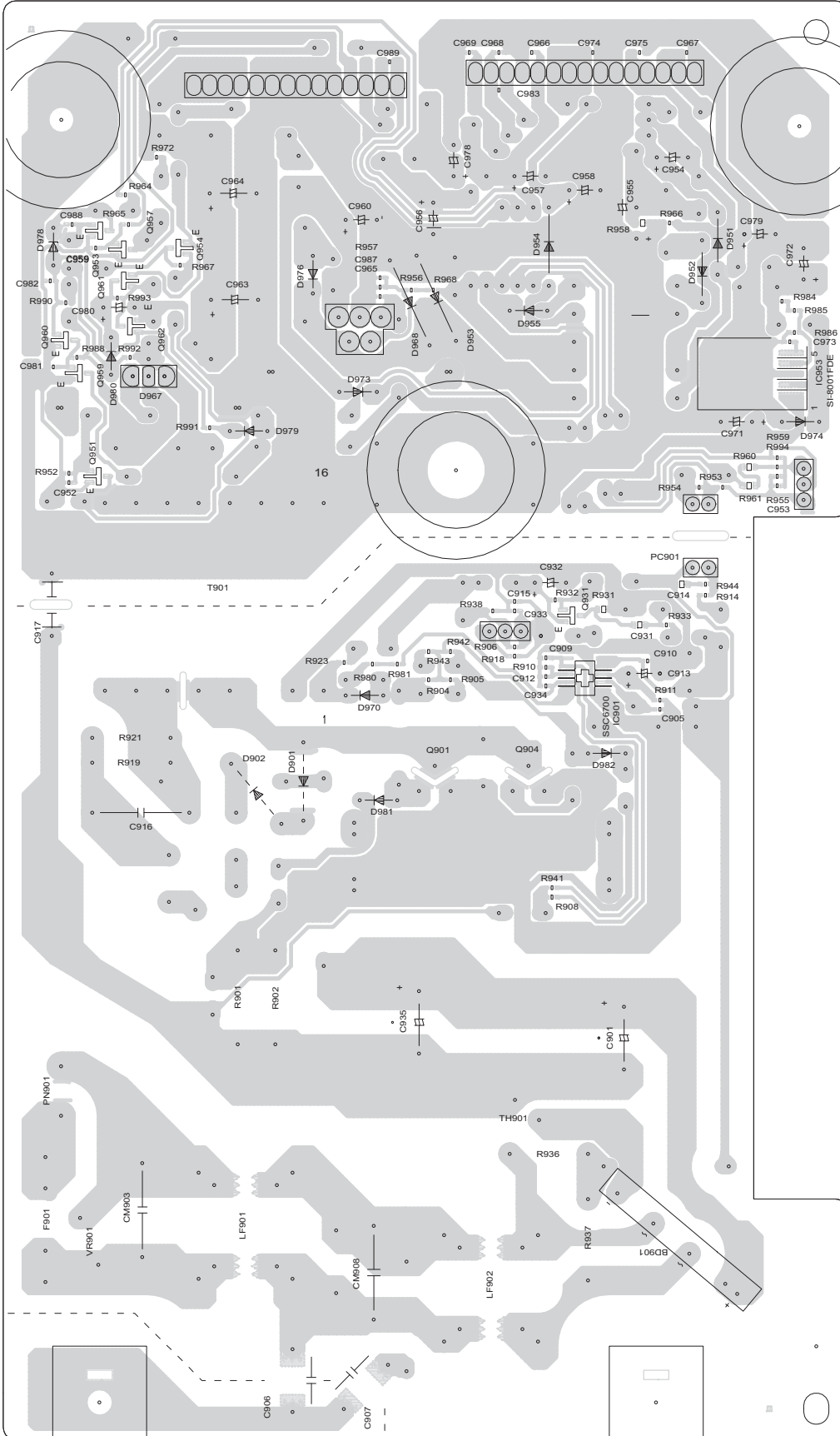

< MEMO >



Victor Company of Japan, Limited

Home Entertainment Business Division Personal AV Operation

(No.MB713SCH<Rev.002>)

Printed in Japan
VSE

PARTS LIST

TH-G61E, TH-G61EN, TH-G61A, TH-G61UX,
 TH-G61UN, TH-G41A, TH-G41UX, TH-G31B,
 TH-G31E, TH-G31EN, TH-G31A, TH-G31UX,
 TH-G31UN, TH-G61UH, TH-G31UH

MODEL	MARK	MODEL	MARK	MODEL	MARK
TH-G61E	A	TH-G41A	F	TH-G31A	K
TH-G61EN	B	TH-G41UX	G	TH-G31UX	L
TH-G61A	C	TH-G31B	H	TH-G31UN	M
TH-G61UX	D	TH-G31E	I	TH-G61UH	N
TH-G61UN	E	TH-G31EN	J	TH-G31UH	O

* All printed circuit boards and its assemblies are not available as service parts.

- Contents -

Exploded view of general assembly and parts list (Block No.M1) 3- 2
 DVD mechanism assembly and parts list (Block No.MJ) 3- 6
 Electrical parts list s list (Block No.01~03) 3- 8
 Packing materials and accessories parts list (Block No.M3) 3-18
 Packing materials and accessories parts list (Block No.M4) 3-20

Exploded view of general assembly and parts list

Block No. M 1 M M

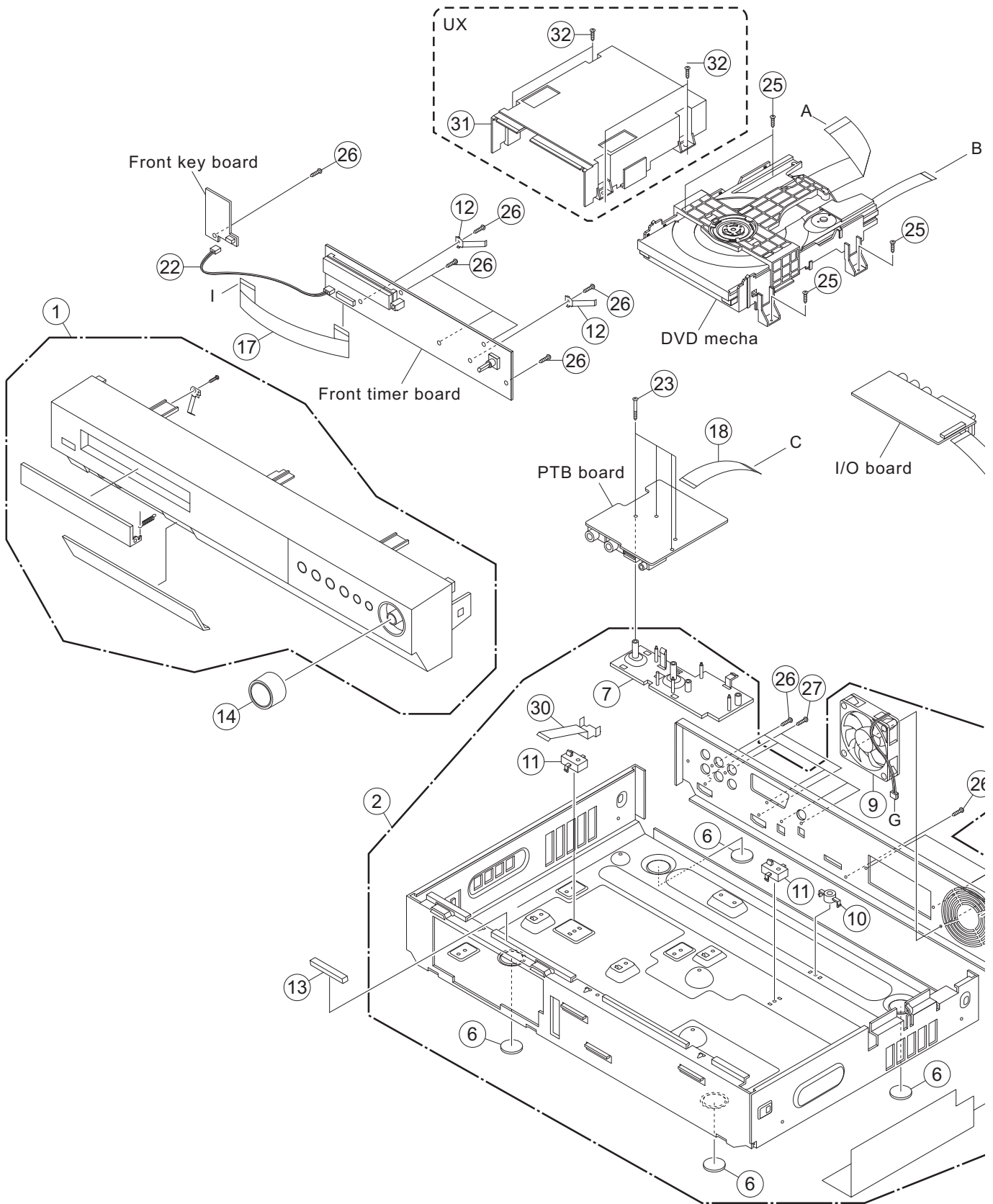

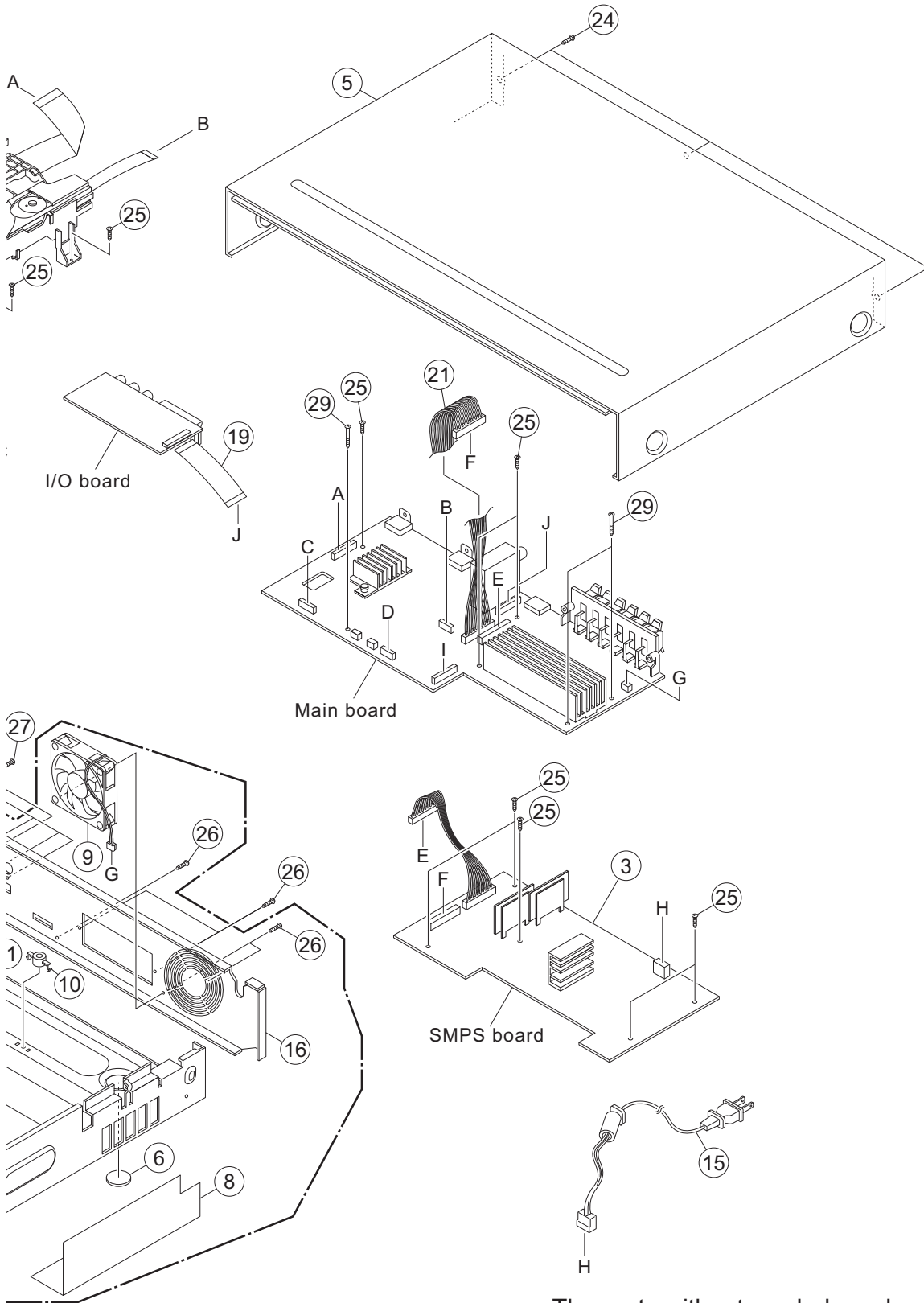

The parts without symbol number are not service.

General Assembly

Block No. [M][1][M][M]

△	Symbol No.	Part No.	Part Name	Description	Local
	1	LG-AGL72919617	FRONT PANEL ASSY		A,B
	1	LG-AGL72919618	FRONT PANEL ASSY		C,D,E,N
	1	LG-AGL72919616	FRONT PANEL ASSY		F,G
	1	LG-AGL72919614	FRONT PANEL ASSY		H,I,J
	1	LG-AGL72919615	FRONT PANEL ASSY		K,L,M,O
	2	LG-ADV72931903	FRAME ASSY		A,B,H,I,J
	2	LG-ADV72931906	FRAME ASSY		C,F,G
	2	LG-ADV72931904	FRAME ASSY		D,E,K,L,M,N,O
	3	LG-EAY60568702	SMPS BOARD ASSY		A,B,C,F,H,I,J,K
	3	LG-EAY60568701	SMPS BOARD ASSY		D,E,G,L,M,N,O
△	5	LG-MCK58117803	TOP COVER		
	6	LG-5040R-5040D	DAMPER	(x4)	
	7	LG-MEG58109901	HOLDER		
	8	LG-MHK34309301	SHEET		
	9	LG-5900R-D004K	FAN		
	9	or LG-5900R-D004G	FAN		
	10	LG-MEG51770501	HOLDER		
	11	LG-MEG58109801	HOLDER	(x2)	
	12	LG-3300RCH001B	PLATE	(x2)	
	13	LG-4850RL0002J	DAMPER		
	14	LG-MEY61843701	KNOB		
△	15	LG-EAD57556404	POWER CORD		A,B,D,E,G,I,J,L,M
△	15	LG-EAD51247902	POWER CORD		C,F,K
△	15	LG-6410RBHV05B	POWER CORD		H
△	15	LG-EAD41652903	POWER CORD		N,O
△	16	LG-MGC58116626	REAR PANEL		A,B,H,I,J
△	16	LG-MGC58116628	REAR PANEL		C,F,G
△	16	LG-MGC58116627	REAR PANEL		D,E,K,L,M,N,O
	17	LG-EAD43284006	FFC WIRE	20P 200mm	
	18	LG-EAD39304203	FFC WIRE	13P 90mm	
	19	LG-EAD43284002	FFC WIRE	20P 80mm	
	21	LG-EAD42218204	HARNESS	15P 220mm	
	22	LG-EAD35219502	HARNESS	3P 160mm	
	23	LG-1SZZR-0081B	SCREW	25mm(x4)	
	24	LG-1SZZR-0098H	SCREW	3mm 8mm(x3)	
	25	LG-1SZZR-0098G	SCREW	3mm 8mm(x12)	
	26	LG-1SZZR-0097K	SCREW	3mm 10mm(x17)	
	27	LG-353-022S	SCREW	3mm(x2)	
	29	LG-1SZZR-0098D	SCREW	3mm 14mm(x3)	
	30	LG-MGJ61898401	GROUND PLATE		
	31	LG-MCK61869301	MECHA COVER		D,G,L
	32	LG-1SZZR-0098A	SCREW	3mm 10mm(x4)	D,G,L

<MEMO>

DVD mechanism assembly and parts list

Block No. M J M M

DP-12AV

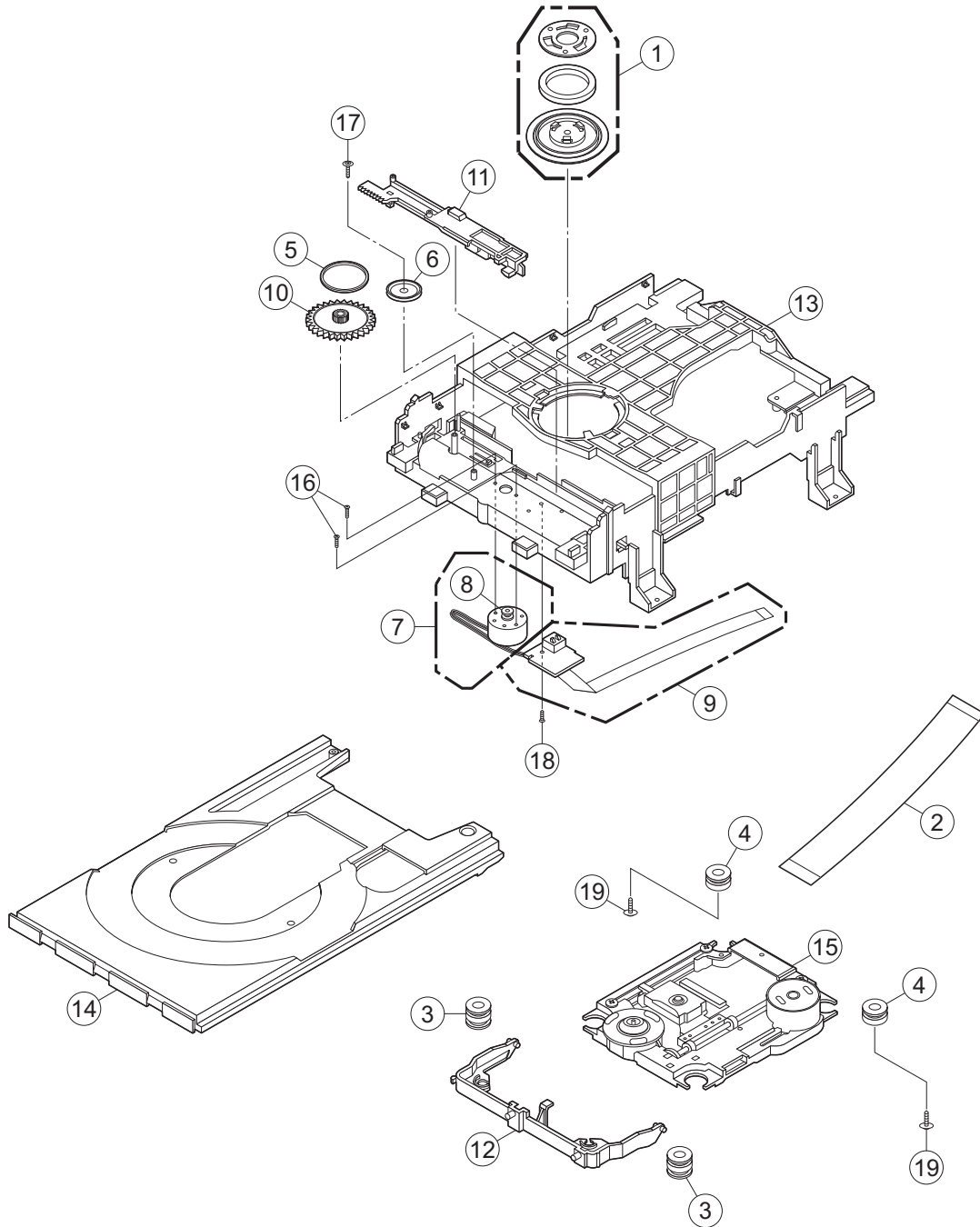

The parts without symbol number are not service.

DVD mechanism

Block No. [M][J][M][M]

△	Symbol No.	Part No.	Part Name	Description	Local
	1	LG-ACA34280801	CLAMP ASSY		
	2	LG-EAD39264010	FFC WIRE	240mm 23P	
	3	LG-MCQ41263801	DAMPER	(x2)	
	4	LG-MCQ38556901	DAMPER	(x2)	
	5	LG-4400R-0006B	BELT		
	6	LG-4470R-0154A	GEAR		
	7	LG-EAU32164911	DC MOTOR ASSY		
	8	LG-4560R-0008A	PULLEY		
	9	LG-6871R-9297M	LOADING SW BOARD ASSY		
	10	LG-4470R-0176A	GEAR		
	11	LG-4974R-0067A	GUIDE		
	12	LG-MDQ39573201	FRAME		
	13	LG-MAM39572801	BASE		
	14	LG-MJS57268001	TRAY		
	15	LG-EAZ40060202	PICK UP ASSY		
	16	LG-1SZZR-0011A	SCREW	(x2)	
	17	LG-1SZZR-0075A	SCREW	1.7mm 10mm	
	18	LG-1SZZH-1007B	SCREW		
	19	LG-FAB30124101	TAP SCREW	2.6mm 7mm(x2)	

Electrical parts list

Main board

△ Symbol No.	Part No.	Part Name	Description	Local
Block No. [0][1]				
IC100	LG-EAN57037601	IC	M24C16-RMN6TP	
IC102	LG-0IKE704200J	IC	KIA7042AF	
IC103	LG-0IKE702700D	IC	KIA7027AF	
IC104	LG-EAN60658301	IC	A278R33PIC	A,B,H,I
IC104	LG-0IPMGKE022B	IC	KIA278R33PI-CU	,J C,D,E, F,G,K,L ,M,N,O
IC104	or LG-0IPMGKE022B	IC(REGULATOR)	KIA278R33PI-CU	A,B,H,I ,J
IC105	LG-EAN42565602	IC	341S2164	C,F,G
IC106	LG-EAN42369201	IC	G9205ATF1T	A,B,H,I ,J
IC106	LG-0IPMGKE047A	IC	KIA278R05PI-CU	C,D,E, F,G,K,L ,M,N,O
IC106	or LG-0IPMGKE047A	IC(REGULATOR)	KIA278R05PI-CU	A,B,H,I ,J
IC201	LG-EAN58772001	IC	CS5346-CQZR	
IC202	LG-EAN57065701	IC(I/O)	CS8422-CNZR	
IC250	LG-0ILNR00048A	IC	MM1692XVBE	A,B,H,I ,J
IC255	LG-0ILNRM003A	IC	MM1507XNRE	C,F,G
IC2A1	LG-EAN57059401	IC	S4308	C,D,E, F,G,K,L ,M,N,O
IC3C3	LG-EAN60153201	IC	NJM2794RB2	C,F,G
IC400	LG-EAN33860001	IC	AM5890	
IC501	LG-EAN57120601	IC	MT1389MH	
IC503	LG-EAN56306901	IC(SDRAM)	V54C3128164VBI6	
IC503	or LG-0IMMREB008C	IC	M12L128168A-6TG	C,N,O
IC504	LG-EAN57037601	IC	M24C16-RMN6TP	
IC601	LG-EAN39871601	IC(PWM)	PS9830B	
IC701	LG-EAN41746102	IC(POWER AMP)	TAS5352ADDV	
IC702	LG-EAN41746102	IC(POWER AMP)	TAS5352ADDV	
IC703	LG-EAN41746102	IC(POWER AMP)	TAS5352ADDV	
IC704	LG-EAN41746102	IC(POWER AMP)	TAS5352ADDV	
IC801	LG-0IMMR00014A	IC	M24C02-RMN6TP	C,F,G
IC803	LG-0IPRPS5006C	IC	SIL9025CTU	C,F,G
IC804	LG-EAN38256201	IC	NLASB3157DFT2 G	C,F,G
IC805	LG-EAN38256201	IC	NLASB3157DFT2 G	C,F,G
IC850	LG-0IPMGKE031A	IC	KIA78R33F	C,F,G
IC851	LG-EAN57008001	IC	Sil9034	C,F,G
IC852	LG-0IPMGUC006A	IC	LD1117A-1.8-AA3-AR	C,F,G
IC853	LG-EAN41347203	IC	TMDS361APAGR	C,F,G
IC854	LG-EAN40228201	IC	LM39102-ADJ	C,F,G
IC855	LG-EAN38256201	IC	NLASB3157DFT2 G	C,F,G
IC856	LG-EAN38256201	IC	NLASB3157DFT2 G	C,F,G
IC101A	LG-SAA34054602	MICOM	HW994	
IC502A	LG-SAA34054505	MICOM	JVC/MT1389MH	A,B,C, D,F,G, H,I,J,K, L
IC502A	LG-SAA34054506	MICOM	JVC/ASIA/MT1389MH	E,M,N, O
Q101	KTA1504/G/-X	BIPOLAR TR		
Q271	LG-0TR130409BA	BIPOLAR TR	KTD1304S	A,B,H,I ,J
Q272	LG-0TR129809BB	BIPOLAR TR	KTA1298Y	A,B,H,I ,J
Q273	LG-0TR130409BA	BIPOLAR TR	KTD1304S	A,B,H,I ,J
Q274	LG-0TR130409BA	BIPOLAR TR	KTD1304S	A,B,H,I ,J
Q275	LG-0TR130409BA	BIPOLAR TR	KTD1304S	A,B,H,I ,J
Q276	LG-0TR130409BA	BIPOLAR TR	KTD1304S	A,B,H,I ,J

△ Symbol No.	Part No.	Part Name	Description	Local
Q277	KRC103S-X	DIGITAL TR		A,B,H,I ,J
Q278	KTA1504/G/-X	BIPOLAR TR		A,B,H,I ,J
Q280	KRC103S-X	DIGITAL TR		A,B,H,I ,J
Q281	LG-0TR130409BA	BIPOLAR TR	KTD1304S	
Q282	LG-0TR130409BA	BIPOLAR TR	KTD1304S	
Q283	LG-0TR130409BA	BIPOLAR TR	KTD1304S	
Q284	LG-0TR130409BA	BIPOLAR TR	KTD1304S	
Q285	KTA1504/G/-X	BIPOLAR TR		
Q286	LG-0TR130409BA	BIPOLAR TR	KTD1304S	
Q3C3	LG-0TRRH80042A	FET	2SK3018-T106	C,F,G
Q3C4	LG-0TRRH80042A	FET	2SK3018-T106	C,F,G
Q402	2SA1037K/QR/-X	TRANSISTOR		
Q403	LG-0TRAU80008A	BIPOLAR TR	2SA1980SY	
Q403	or KTA1504/G/-X	BIPOLAR TR		
Q404	2SA1037K/QR/-X	TRANSISTOR		
Q405	LG-0TRAU80008A	BIPOLAR TR	2SA1980SY	
Q405	or KTA1504/G/-X	BIPOLAR TR		
Q406	LG-0TR387509AC	BIPOLAR TR	KTC3875S-GR(ALG)	
Q408	LG-0TR387509AC	BIPOLAR TR	KTC3875S-GR(ALG)	
Q410	LG-0TRRH80042A	FET	2SK3018-T106	
Q411	LG-0TRRH80042A	FET	2SK3018-T106	
Q412	LG-0TR166608AA	BIPOLAR TR	KTA1666-Y	
Q503	LG-0TRRH80042A	FET	2SK3018-T106	
Q701	KRC103S-X	DIGITAL TR		
Q702	KTA1504/G/-X	BIPOLAR TR		
Q703	KTA1504/G/-X	BIPOLAR TR		
Q704	KTA1504/G/-X	BIPOLAR TR		
Q705	KRC103S-X	DIGITAL TR		
Q801	LG-0TRRH80042A	FET	2SK3018-T106	C,F,G
D101	LG-0DRTW00268A	RECTIFIER DIODE	400V 1.3V 5uA 30A	
D271	LG-0DD160009AB	SW DIODE	1.2V 85V	A,B,H,I ,J
D272	LG-0DD160009AB	SW DIODE	1.2V 85V	A,B,H,I ,J
D405	LG-0DRTW00268A	RECTIFIER DIODE	400V 1.3V 5uA 30A	
D406	LG-0DRTW00268A	RECTIFIER DIODE	400V 1.3V 5uA 30A	
D601	LG-0DD160009AB	SW DIODE	1.2V 85V	
D801	LG-0DS202009CA	SW DIODE	1.2V 80V	C,F,G
D851	LG-0DSKE00048A	SCHOTTKY DIODE	520mV 40V 3A	
C100	LG-0CK104CKG6A	C CAPACITOR	100nF 10% 50V	
C101	LG-0CH8106F611	AL CAPACITOR	10uF 20% 16V	
C102	LG-0CK104CKG6A	C CAPACITOR	100nF 10% 50V	
C103	LG-0CK104CKG6A	C CAPACITOR	100nF 10% 50V	
C104	LG-0CK104CKG6A	C CAPACITOR	100nF 10% 50V	
C105	LG-0CH1223K562	C CAPACITOR	22nF 10% 50V	
C106	LG-0CH8107F611	AL CAPACITOR	100uF 20% 16V	
C107	LG-0CH8107F611	AL CAPACITOR	100uF 20% 16V	
C109	LG-0CK104CKG6A	C CAPACITOR	100nF 10% 50V	
C110	LG-0CK104CKG6A	C CAPACITOR	100nF 10% 50V	
C111	LG-0CH4330K412	C CAPACITOR	33pF 5% 50V	
C112	LG-0CK104CKG6A	C CAPACITOR	100nF 10% 50V	
C113	LG-0CH4330K412	C CAPACITOR	33pF 5% 50V	
C114	LG-0CK104CKG6A	C CAPACITOR	100nF 10% 50V	
C115	LG-0CK104CKG6A	C CAPACITOR	100nF 10% 50V	
C116	LG-EAE60659001	AL CAPACITOR	47uF	
C118	LG-0CK104CKG6A	C CAPACITOR	100nF 10% 50V	
C119	LG-0CK104CKG6A	C CAPACITOR	100nF 10% 50V	
C120	LG-EAE60659001	AL CAPACITOR	47uF	
C123	LG-0CH8107F611	AL CAPACITOR	100uF 20% 16V	
C124	LG-0CH1103K562	C CAPACITOR	10nF 10% 50V	
C129	LG-0CH1103K562	C CAPACITOR	10nF 10% 50V	
C130	LG-0CH8106F611	AL CAPACITOR	10uF 20% 16V	C,F,G
C131	LG-0CK104CKG6A	C CAPACITOR	100nF 10% 50V	C,F,G
C132	LG-0CK104CKG6A	C CAPACITOR	100nF 10% 50V	C,F,G
C133	LG-0CH8107F611	AL CAPACITOR	100uF 20% 16V	
C134	LG-EAE60659001	AL CAPACITOR	47uF	
C201	LG-0CH8106F611	AL CAPACITOR	10uF 20% 16V	
C202	LG-0CH8106F611	AL CAPACITOR	10uF 20% 16V	
C203	LG-0CH8106F611	AL CAPACITOR	10uF 20% 16V	
C204	LG-0CH8106F611	AL CAPACITOR	10uF 20% 16V	

△ Symbol No.	Part No.	Part Name	Description	Local	△ Symbol No.	Part No.	Part Name	Description	Local
C205	LG-0CH8106F611	AL CAPACITOR	10uF 20% 16V		C2A1	LG-0CH4240K412	C CAPACITOR	24pF 5% 50V	C,D,E, F,G,K,L ,M,N,O
C206	LG-0CH8106F611	AL CAPACITOR	10uF 20% 16V		C2A2	LG-0CK225CD94A	C CAPACITOR	2.2uF	C,D,E, F,G,K,L ,M,N,O
C209	LG-0CH1222K562	C CAPACITOR	2.2nF 10% 50V		C2A3	LG-0CE226SF6DC	AL CAPACITOR	22uF 20%	C,D,E, F,G,K,L ,M,N,O
C210	LG-0CH1222K562	C CAPACITOR	2.2nF 10% 50V		C2A4	LG-0CH1821K562	C CAPACITOR	820pF 10% 50V	C,D,E, F,G,K,L ,M,N,O
C211	LG-0CH8106F611	AL CAPACITOR	10uF 20% 16V		C2A6	LG-0CH1333K562	C CAPACITOR	33nF 10% 50V	C,D,G, L,N,O
C212	LG-EAE60659001	AL CAPACITOR	47uF		C2A7	LG-0CE105WK6DC	AL CAPACITOR	1uF 20% 50V	C,D,E, F,G,K,L ,M,N,O
C213	LG-0CH8106F611	AL CAPACITOR	10uF 20% 16V		C2A8	LG-0CK104CKG6A	C CAPACITOR	100nF 10% 50V	C,D,E, F,G,K,L ,M,N,O
C214	LG-0CH8106F611	AL CAPACITOR	10uF 20% 16V	A,B,H,I ,J	C2A9	LG-0CH8107F611	AL CAPACITOR	100uF 20% 16V	C,D,E, F,G,K,L ,M,N,O
C215	LG-0CH8106F611	AL CAPACITOR	10uF 20% 16V	A,B,H,I ,J	C2E9	LG-0CH4240K412	C CAPACITOR	24pF 5% 50V	C,D,E, F,G,K,L ,M,N,O
C216	LG-0CK104CKG6A	C CAPACITOR	100nF 10% 50V		C3C2	LG-0CH4240K412	C CAPACITOR	24pF 5% 50V	C,F,G
C217	LG-0CK104CKG6A	C CAPACITOR	100nF 10% 50V		C3E3	LG-0CH4240K412	C CAPACITOR	24pF 5% 50V	C,F,G
C218	LG-0CK104CKG6A	C CAPACITOR	100nF 10% 50V		C3E7	LG-EAE60659001	AL CAPACITOR	47uF	C,F,G
C219	LG-0CK104CKG6A	C CAPACITOR	100nF 10% 50V		C3E9	LG-EAE35701401	C CAPACITOR	1uF 10% 25V	C,F,G
C220	LG-0CK104CKG6A	C CAPACITOR	100nF 10% 50V		C3F0	LG-EAE35701401	C CAPACITOR	1uF 10% 25V	C,F,G
C221	LG-0CK104CKG6A	C CAPACITOR	100nF 10% 50V		C3F1	LG-EAE35701401	C CAPACITOR	1uF 10% 25V	C,F,G
C222	LG-0CK104CKG6A	C CAPACITOR	100nF 10% 50V		C3F2	LG-0CH8106F611	AL CAPACITOR	10uF 20% 16V	C,F,G
C223	LG-0CH8106F611	AL CAPACITOR	10uF 20% 16V		C3F3	LG-EAE60659001	AL CAPACITOR	47uF	C,F,G
C224	LG-0CH8106F611	AL CAPACITOR	10uF 20% 16V		C3F4	LG-EAE35701401	C CAPACITOR	1uF 10% 25V	C,F,G
C225	LG-0CK104CKG6A	C CAPACITOR	100nF 10% 50V		C3F5	LG-EAE35701401	C CAPACITOR	1uF 10% 25V	C,F,G
C226	LG-0CH1103K562	C CAPACITOR	10nF 10% 50V		C3F6	LG-EAE35701401	C CAPACITOR	1uF 10% 25V	C,F,G
C227	LG-0CH1103K562	C CAPACITOR	10nF 10% 50V		C400	NDC31HJ-221X	C CAPACITOR	220pF 50V J	
C228	LG-0CH8106F611	AL CAPACITOR	10uF 20% 16V		C401	LG-0CH4271K412	C CAPACITOR	270pF 5% 50V	
C229	LG-0CH8106F611	AL CAPACITOR	10uF 20% 16V		C402	LG-0CK104CKG6A	C CAPACITOR	100nF 10% 50V	
C230	LG-0CK104CKG6A	C CAPACITOR	100nF 10% 50V		C403	LG-0CK104CKG6A	C CAPACITOR	100nF 10% 50V	
C231	LG-0CK104CKG6A	C CAPACITOR	100nF 10% 50V		C404	LG-0CK104CKG6A	C CAPACITOR	100nF 10% 50V	
C232	LG-0CH1103K562	C CAPACITOR	10nF 10% 50V		C405	LG-0CK104CKG6A	C CAPACITOR	100nF 10% 50V	
C233	LG-0CK104CKG6A	C CAPACITOR	100nF 10% 50V		C407	LG-0CH1223K562	C CAPACITOR	22nF 10% 50V	
C234	LG-0CH1103K562	C CAPACITOR	10nF 10% 50V		C408	LG-0CK104CKG6A	C CAPACITOR	100nF 10% 50V	
C235	LG-0CK104CKG6A	C CAPACITOR	100nF 10% 50V		C409	LG-0CK104CKG6A	C CAPACITOR	100nF 10% 50V	
C236	LG-0CH4050K012	C CAPACITOR	5pF 0.25PF 50V		C410	LG-0CK104CKG6A	C CAPACITOR	100nF 10% 50V	
C237	NRSA63J-0R0X	MG RESISTOR	LG-0RH0000C622	C,D,E, F,G,K,L ,M,N,O	C411	LG-0CK104CKG6A	C CAPACITOR	100nF 10% 50V	
C238	NRSA63J-0R0X	MG RESISTOR	LG-0RH0000C622	C,D,E, F,G,K,L ,M,N,O	C412	LG-0CK104CKG6A	C CAPACITOR	100nF 10% 50V	
C240	LG-0CH4220K412	C CAPACITOR	22pF 5% 50V		C413	LG-0CK104CKG6A	C CAPACITOR	100nF 10% 50V	
C241	LG-0CH4220K412	C CAPACITOR	22pF 5% 50V		C416	LG-0CK104CKG6A	C CAPACITOR	100nF 10% 50V	
C268	LG-0CH1105F942	C CAPACITOR	1uF		C417	LG-0CH8476C611	AL CAPACITOR	47uF 20% 6.3V	
C271	LG-0CH4121K412	C CAPACITOR	120pF 5% 50V		C418	LG-0CH8476C611	AL CAPACITOR	47uF 20% 6.3V	
C272	LG-0CH4121K412	C CAPACITOR	120pF 5% 50V		C419	LG-0CH8107C621	AL CAPACITOR	100uF 20%	
C273	LG-0CH4121K412	C CAPACITOR	120pF 5% 50V	A,B,H,I ,J	C420	LG-0CH8107C621	AL CAPACITOR	100uF 20%	
C274	LG-0CH4121K412	C CAPACITOR	120pF 5% 50V	A,B,H,I ,J	C421	LG-0CH8107C621	AL CAPACITOR	100uF 20%	
C275	LG-0CH8106F611	AL CAPACITOR	10uF 20% 16V	C,F,G	C422	LG-0CH8107C621	AL CAPACITOR	100uF 20%	
C276	LG-0CH8106F611	AL CAPACITOR	10uF 20% 16V	C,F,G	C423	LG-0CH8107C621	AL CAPACITOR	100uF 20%	
C277	LG-0CK104CKG6A	C CAPACITOR	100nF 10% 50V	C,F,G	C426	LG-EAE60659001	AL CAPACITOR	47uF	
C278	LG-0CH8107F611	AL CAPACITOR	100uF 20% 16V	C,F,G	C427	LG-EAE60659001	AL CAPACITOR	47uF	
C279	LG-0CH1105F942	C CAPACITOR	1uF	A,B,H,I ,J	C428	LG-0CK104CKG6A	C CAPACITOR	100nF 10% 50V	
C280	LG-0CH1105F942	C CAPACITOR	1uF	A,B,H,I ,J	C500	LG-0CK104CKG6A	C CAPACITOR	100nF 10% 50V	
C281	LG-0CH1105F942	C CAPACITOR	1uF	A,B,H,I ,J	C501	LG-0CK104CKG6A	C CAPACITOR	100nF 10% 50V	
C282	LG-0CH1105F942	C CAPACITOR	1uF	A,B,H,I ,J	C502	LG-0CK104CKG6A	C CAPACITOR	100nF 10% 50V	
C283	LG-0CK104CKG6A	C CAPACITOR	100nF 10% 50V	A,B,H,I ,J	C503	LG-0CK104CKG6A	C CAPACITOR	100nF 10% 50V	
C284	LG-EAE60659001	AL CAPACITOR	47uF	A,B,H,I ,J	C504	LG-0CK104CKG6A	C CAPACITOR	100nF 10% 50V	
C285	LG-0CE226SF6DC	AL CAPACITOR	22uF 20% 16V	A,B,H,I ,J	C505	LG-0CK104CKG6A	C CAPACITOR	100nF 10% 50V	
C286	LG-0CH8477C611	AL CAPACITOR	470uF 20% 6.3V		C506	LG-0CK104CKG6A	C CAPACITOR	100nF 10% 50V	
C287	LG-0CK104CKG6A	C CAPACITOR	100nF 10% 50V	A,B,H,I ,J	C507	LG-0CK104CKG6A	C CAPACITOR	100nF 10% 50V	
C288	LG-0CH8477C611	AL CAPACITOR	470uF 20% 6.3V		C508	LG-0CK104CKG6A	C CAPACITOR	100nF 10% 50V	
C289	LG-0CH8477C611	AL CAPACITOR	470uF 20% 6.3V		C509	LG-0CK104CKG6A	C CAPACITOR	100nF 10% 50V	
C291	LG-0CH1471K562	C CAPACITOR	470pF 10% 50V		C510	LG-0CK104CKG6A	C CAPACITOR	100nF 10% 50V	
C292	LG-0CH1471K562	C CAPACITOR	470pF 10% 50V		C511	LG-0CK104CKG6A	C CAPACITOR	100nF 10% 50V	
C293	LG-0CH4820K412	C CAPACITOR	82pF 5% 50V		C512	LG-0CK104CKG6A	C CAPACITOR	100nF 10% 50V	
C294	LG-0CH4330K412	C CAPACITOR	33pF 5% 50V		C513	LG-0CK104CKG6A	C CAPACITOR	100nF 10% 50V	
C295	LG-0CH4330K412	C CAPACITOR	33pF 5% 50V		C514	LG-0CK104CKG6A	C CAPACITOR	100nF 10% 50V	
C296	LG-0CH4820K412	C CAPACITOR	82pF 5% 50V		C515	LG-0CK104CKG6A	C CAPACITOR	100nF 10% 50V	
C297	LG-0CH4820K412	C CAPACITOR	82pF 5% 50V		C516	LG-0CK104CKG6A	C CAPACITOR	100nF 10% 50V	
C298	LG-0CH4330K412	C CAPACITOR	33pF 5% 50V		C517	LG-0CK104CKG6A	C CAPACITOR	100nF 10% 50V	
C299	LG-0CH4330K412	C CAPACITOR	33pF 5% 50V	C,F,G	C518	LG-0CK104CKG6A	C CAPACITOR	100nF 10% 50V	

Symbol No.	Part No.	Part Name	Description	Local	Symbol No.	Part No.	Part Name	Description	Local
C519	LG-0CK104CKG6A	C CAPACITOR	100nF 10% 50V		C6Y8	LG-0CH1103K562	C CAPACITOR	10nF 10% 50V	
C520	LG-0CK104CKG6A	C CAPACITOR	100nF 10% 50V		C701	LG-0CK104CKG6A	C CAPACITOR	100nF 10% 50V	
C521	LG-0CH4220K412	C CAPACITOR	22pF 5% 50V		C702	LG-0CK104CKG6A	C CAPACITOR	100nF 10% 50V	
C522	LG-0CK104CKG6A	C CAPACITOR	100nF 10% 50V		C703	LG-OCE108AK610	AL CAPACITOR	1000uF 20%	
C523	LG-0CH4220K412	C CAPACITOR	22pF 5% 50V		C704	LG-0CH1104K566	C CAPACITOR	100nF 10% 50V	
C524	LG-0CK104CKG6A	C CAPACITOR	100nF 10% 50V		C705	LG-0CH1104K566	C CAPACITOR	100nF 10% 50V	
C525	LG-0CK104CKG6A	C CAPACITOR	100nF 10% 50V		C706	LG-0CH1104K566	C CAPACITOR	100nF 10% 50V	
C526	LG-0CH4080K112	C CAPACITOR	8pF 0.5PF 50V		C707	LG-0CH8476H691	AL CAPACITOR	47uF 20% 25V	
C527	LG-0CK104CKG6A	C CAPACITOR	100nF 10% 50V		C708	LG-0CH1103K566	C CAPACITOR	10nF 10% 50V	
C529	LG-0CK104CKG6A	C CAPACITOR	100nF 10% 50V		C709	LG-0CH1333K566	C CAPACITOR	33nF 10% 50V	
C531	LG-0CK104CKG6A	C CAPACITOR	100nF 10% 50V		C710	LG-0CH1224K946	C CAPACITOR	220nF	
C532	LG-0CK104CKG6A	C CAPACITOR	100nF 10% 50V		C711	LG-0CH4331K416	C CAPACITOR	330pF 5% 50V	
C533	LG-0CK104CKG6A	C CAPACITOR	100nF 10% 50V		C712	LG-0CH1104K566	C CAPACITOR	100nF 10% 50V	
C534	LG-0CK104CKG6A	C CAPACITOR	100nF 10% 50V		C713	LG-0CH1224K946	C CAPACITOR	220nF	
C535	LG-0CH4080K112	C CAPACITOR	8pF 0.5PF 50V		C714	LG-0CH1224K946	C CAPACITOR	220nF	
C536	LG-0CK104CKG6A	C CAPACITOR	100nF 10% 50V		C715	LG-EAE37475001	C CAPACITOR	470nF 10%	
C537	LG-0CK104CKG6A	C CAPACITOR	100nF 10% 50V		C716	LG-0CH1224K946	C CAPACITOR	220nF	
C538	LG-0CH1152K562	C CAPACITOR	1.5nF 10% 50V		C717	LG-0CH1104K566	C CAPACITOR	100nF 10% 50V	
C539	LG-0CH4080K112	C CAPACITOR	8pF 0.5PF 50V		C718	LG-0CH1224K946	C CAPACITOR	220nF	
C540	LG-0CK104CKG6A	C CAPACITOR	100nF 10% 50V		C719	LG-0CH1224K946	C CAPACITOR	220nF	
C541	LG-0CH4080K112	C CAPACITOR	8pF 0.5PF 50V		C720	LG-0CH4331K416	C CAPACITOR	330pF 5% 50V	
C542	LG-0CK104CKG6A	C CAPACITOR	100nF 10% 50V		C721	LG-0CH1333K566	C CAPACITOR	33nF 10% 50V	
C544	LG-0CK104CKG6A	C CAPACITOR	100nF 10% 50V		C722	LG-0CH1333K566	C CAPACITOR	33nF 10% 50V	
C545	LG-0CK104CKG6A	C CAPACITOR	100nF 10% 50V		C723	LG-0CK104CKG6A	C CAPACITOR	100nF 10% 50V	
C546	LG-0CH1105F942	C CAPACITOR	1uF		C725	LG-0CH1224K946	C CAPACITOR	220nF	
C547	LG-0CH4121K412	C CAPACITOR	120pF 5% 50V		C726	LG-0CH4331K416	C CAPACITOR	330pF 5% 50V	
C548	LG-0CH4300K412	C CAPACITOR	30pF 5% 50V		C727	LG-0CH1104K566	C CAPACITOR	100nF 10% 50V	
C549	LG-0CK104CKG6A	C CAPACITOR	100nF 10% 50V		C728	LG-0CH1224K946	C CAPACITOR	220nF	
C550	LG-0CK104CKG6A	C CAPACITOR	100nF 10% 50V		C730	LG-0CH1224K946	C CAPACITOR	220nF	
C551	LG-0CK104CKG6A	C CAPACITOR	100nF 10% 50V		C731	LG-EAE37475001	C CAPACITOR	470nF 10%	
C552	LG-0CK104CKG6A	C CAPACITOR	100nF 10% 50V		C732	LG-0CH1224K946	C CAPACITOR	220nF	
C553	LG-0CH8106F611	AL CAPACITOR	10uF 20% 16V		C733	LG-0CH1104K566	C CAPACITOR	100nF 10% 50V	
C554	LG-0CH8106F611	AL CAPACITOR	10uF 20% 16V		C734	LG-0CH1224K946	C CAPACITOR	220nF	
C555	LG-EAE60659001	AL CAPACITOR	47uF		C735	LG-0CH1224K946	C CAPACITOR	220nF	
C556	LG-0CH8476C611	AL CAPACITOR	47uF 20% 6.3V		C736	LG-0CH4331K416	C CAPACITOR	330pF 5% 50V	
C557	LG-0CH8476C611	AL CAPACITOR	47uF 20% 6.3V		C737	LG-0CH1333K566	C CAPACITOR	33nF 10% 50V	
C558	LG-EAE60659001	AL CAPACITOR	47uF		C738	LG-0CH1104K566	C CAPACITOR	100nF 10% 50V	
C559	LG-0CH8476C611	AL CAPACITOR	47uF 20% 6.3V		C739	LG-0CH1104K566	C CAPACITOR	100nF 10% 50V	
C560	LG-0CH8476C611	AL CAPACITOR	47uF 20% 6.3V		C740	LG-0CH1104K566	C CAPACITOR	100nF 10% 50V	
C561	LG-0CH8476C611	AL CAPACITOR	47uF 20% 6.3V		C741	LG-OCE108AK610	AL CAPACITOR	1000uF 20%	
C563	LG-0CH8106F611	AL CAPACITOR	10uF 20% 16V		C742	LG-0CH1104K566	C CAPACITOR	100nF 10% 50V	
C564	LG-0CH8106F611	AL CAPACITOR	10uF 20% 16V		C743	LG-0CH1103K566	C CAPACITOR	10nF 10% 50V	
C565	LG-0CH8106F611	AL CAPACITOR	10uF 20% 16V		C744	LG-0CK104CKG6A	C CAPACITOR	100nF 10% 50V	
C566	LG-0CK104CKG6A	C CAPACITOR	100nF 10% 50V		C745	LG-OCE108AK610	AL CAPACITOR	1000uF 20%	
C567	LG-0CH4121K412	C CAPACITOR	120pF 5% 50V		C746	LG-0CH1104K566	C CAPACITOR	100nF 10% 50V	
C572	LG-0CH4050K012	C CAPACITOR	5pF 0.25PF 50V		C747	LG-0CH1104K566	C CAPACITOR	100nF 10% 50V	
C573	LG-EAE60659001	AL CAPACITOR	47uF		C748	LG-0CH1104K566	C CAPACITOR	100nF 10% 50V	
C602	LG-0CK104CKG6A	C CAPACITOR	100nF 10% 50V		C749	LG-0CH8476H691	AL CAPACITOR	47uF 20% 25V	
C603	LG-0CK104CKG6A	C CAPACITOR	100nF 10% 50V		C750	LG-0CH1103K566	C CAPACITOR	10nF 10% 50V	
C605	LG-0CK104CKG6A	C CAPACITOR	100nF 10% 50V		C751	LG-0CH1333K566	C CAPACITOR	33nF 10% 50V	
C606	LG-0CK104CKG6A	C CAPACITOR	100nF 10% 50V		C752	LG-0CH1224K946	C CAPACITOR	220nF	
C607	LG-0CK104CKG6A	C CAPACITOR	100nF 10% 50V		C753	LG-0CH4331K416	C CAPACITOR	330pF 5% 50V	
C608	LG-0CK104CKG6A	C CAPACITOR	100nF 10% 50V		C754	LG-0CH1104K566	C CAPACITOR	100nF 10% 50V	
C609	LG-0CK104CKG6A	C CAPACITOR	100nF 10% 50V		C755	LG-0CH1224K946	C CAPACITOR	220nF	
C610	LG-0CK104CKG6A	C CAPACITOR	100nF 10% 50V		C756	LG-0CH1224K946	C CAPACITOR	220nF	
C611	LG-0CH1103K562	C CAPACITOR	10nF 10% 50V		C757	LG-EAE37475001	C CAPACITOR	470nF 10%	
C612	LG-0CK104CKG6A	C CAPACITOR	100nF 10% 50V		C758	LG-0CH1224K946	C CAPACITOR	220nF	
C613	LG-0CK104CKG6A	C CAPACITOR	100nF 10% 50V		C759	LG-0CH1104K566	C CAPACITOR	100nF 10% 50V	
C614	LG-0CK104CKG6A	C CAPACITOR	100nF 10% 50V		C760	LG-0CH1224K946	C CAPACITOR	220nF	
C615	LG-0CK104CKG6A	C CAPACITOR	100nF 10% 50V		C761	LG-0CH1224K946	C CAPACITOR	220nF	
C616	LG-0CK104CKG6A	C CAPACITOR	100nF 10% 50V		C762	LG-0CH4331K416	C CAPACITOR	330pF 5% 50V	
C617	LG-0CK104CKG6A	C CAPACITOR	100nF 10% 50V		C763	LG-0CH1333K566	C CAPACITOR	33nF 10% 50V	
C618	LG-EAE56703201	AL CAPACITOR	10uF		C764	LG-0CH1333K566	C CAPACITOR	33nF 10% 50V	
C619	LG-0CK104CKG6A	C CAPACITOR	100nF 10% 50V		C765	LG-0CK104CKG6A	C CAPACITOR	100nF 10% 50V	
C620	LG-EAE56703201	AL CAPACITOR	10uF		C766	LG-0CH4331K416	C CAPACITOR	330pF 5% 50V	
C621	LG-0CK104CKG6A	C CAPACITOR	100nF 10% 50V		C767	LG-0CH1224K946	C CAPACITOR	220nF	
C622	LG-EAE36144701	AL CAPACITOR	220uF		C768	LG-0CH1224K946	C CAPACITOR	220nF	
C623	LG-0CK104CKG6A	C CAPACITOR	100nF 10% 50V		C769	LG-EAE37475001	C CAPACITOR	470nF 10%	
C650	LG-0CK104CKG6A	C CAPACITOR	100nF 10% 50V		C770	LG-0CH1224K946	C CAPACITOR	220nF	
C652	LG-EAE36144701	AL CAPACITOR	220uF		C771	LG-0CH1224K946	C CAPACITOR	220nF	
C653	LG-0CK104CKG6A	C CAPACITOR	100nF 10% 50V		C772	LG-0CH4331K416	C CAPACITOR	330pF 5% 50V	
C654	LG-0CK104CKG6A	C CAPACITOR	100nF 10% 50V		C773	LG-0CH1333K566	C CAPACITOR	33nF 10% 50V	
C656	LG-0CH4220K412	C CAPACITOR	22pF 5% 50V		C774	LG-0CH1104K566	C CAPACITOR	100nF 10% 50V	
C657	LG-0CH4220K412	C CAPACITOR	22pF 5% 50V		C775	LG-0CH1104K566	C CAPACITOR	100nF 10% 50V	
C658	LG-EAE56703201	AL CAPACITOR	10uF		C776	LG-0CH1104K566	C CAPACITOR	100nF 10% 50V	
C659	LG-0CH1225F946	C CAPACITOR	2.2uF		C777	LG-OCE108AK610	AL CAPACITOR	1000uF 20%	
C660	LG-0CH4331K412	C CAPACITOR	330pF 5% 50V		C778	LG-0CH1104K566	C CAPACITOR	100nF 10% 50V	
C661	LG-0CH4331K412	C CAPACITOR	330pF 5% 50V		C779	LG-0CH1103K566	C CAPACITOR	10nF 10% 50V	

△ Symbol No.	Part No.	Part Name	Description	Local	△ Symbol No.	Part No.	Part Name	Description	Local
C780	LG-0CK104CKG6A	C CAPACITOR	100nF 10% 50V		C766	LG-0CH1103K566	C CAPACITOR	10nF 10% 50V	
C781	LG-0CE108AK610	AL CAPACITOR	1000uF 20%		C767	LG-0CH1103K566	C CAPACITOR	10nF 10% 50V	
C782	LG-0CH1104K566	C CAPACITOR	100nF 10% 50V		C768	LG-0CH1103K566	C CAPACITOR	10nF 10% 50V	
C783	LG-0CH1104K566	C CAPACITOR	100nF 10% 50V		C769	LG-0CH1103K566	C CAPACITOR	10nF 10% 50V	
C784	LG-0CH1104K566	C CAPACITOR	100nF 10% 50V		C770	LG-0CH1103K566	C CAPACITOR	10nF 10% 50V	
C785	LG-0CH8476H691	AL CAPACITOR	47uF 20% 25V		C771	LG-0CH1103K566	C CAPACITOR	10nF 10% 50V	
C786	LG-0CH1103K566	C CAPACITOR	10nF 10% 50V		C772	LG-0CH1103K566	C CAPACITOR	10nF 10% 50V	
C787	LG-0CH1333K566	C CAPACITOR	33nF 10% 50V		C773	LG-0CH1103K566	C CAPACITOR	10nF 10% 50V	
C788	LG-0CH1224K946	C CAPACITOR	220nF		C774	LG-0CH1103K566	C CAPACITOR	10nF 10% 50V	
C789	LG-0CH4331K416	C CAPACITOR	330pF 5% 50V		C775	LG-0CH1103K566	C CAPACITOR	10nF 10% 50V	
C790	LG-0CH1104K566	C CAPACITOR	100nF 10% 50V		C776	LG-0CH1103K566	C CAPACITOR	10nF 10% 50V	
C791	LG-0CH1224K946	C CAPACITOR	220nF		C777	LG-0CH1103K566	C CAPACITOR	10nF 10% 50V	
C792	LG-0CH1224K946	C CAPACITOR	220nF		C801	LG-0CH8106F611	AL CAPACITOR	10uF 20% 16V	C,F,G
C793	LG-EAE37475001	C CAPACITOR	470nF 10%		C803	LG-0CK104CKG6A	C CAPACITOR	100nF 10% 50V	C,F,G
C794	LG-0CH1224K946	C CAPACITOR	220nF		C805	LG-0CK104CKG6A	C CAPACITOR	100nF 10% 50V	C,F,G
C795	LG-0CH1104K566	C CAPACITOR	100nF 10% 50V		C807	LG-0CK104CKG6A	C CAPACITOR	100nF 10% 50V	C,F,G
C796	LG-0CH1224K946	C CAPACITOR	220nF		C809	LG-0CK104CKG6A	C CAPACITOR	100nF 10% 50V	C,F,G
C797	LG-0CH1224K946	C CAPACITOR	220nF		C810	LG-0CK104CKG6A	C CAPACITOR	100nF 10% 50V	C,F,G
C798	LG-0CH4331K416	C CAPACITOR	330pF 5% 50V		C811	LG-0CK104CKG6A	C CAPACITOR	100nF 10% 50V	C,F,G
C799	LG-0CH1333K566	C CAPACITOR	33nF 10% 50V		C812	LG-0CK104CKG6A	C CAPACITOR	100nF 10% 50V	C,F,G
C7A0	LG-0CH1333K566	C CAPACITOR	33nF 10% 50V		C813	LG-0CK104CKG6A	C CAPACITOR	100nF 10% 50V	C,F,G
C7A1	LG-0CK104CKG6A	C CAPACITOR	100nF 10% 50V		C814	LG-0CK104CKG6A	C CAPACITOR	100nF 10% 50V	C,F,G
C7A2	LG-0CH1224K946	C CAPACITOR	220nF		C815	LG-0CK104CKG6A	C CAPACITOR	100nF 10% 50V	C,F,G
C7A3	LG-0CH1224K946	C CAPACITOR	220nF		C816	LG-0CK104CKG6A	C CAPACITOR	100nF 10% 50V	C,F,G
C7A4	LG-0CH1333K566	C CAPACITOR	33nF 10% 50V		C817	LG-0CK104CKG6A	C CAPACITOR	100nF 10% 50V	C,F,G
C7A5	LG-0CH1104K566	C CAPACITOR	100nF 10% 50V		C818	LG-0CK104CKG6A	C CAPACITOR	100nF 10% 50V	C,F,G
C7A6	LG-0CH1104K566	C CAPACITOR	100nF 10% 50V		C819	LG-0CK104CKG6A	C CAPACITOR	100nF 10% 50V	C,F,G
C7A7	LG-0CH1104K566	C CAPACITOR	100nF 10% 50V		C820	LG-0CK104CKG6A	C CAPACITOR	100nF 10% 50V	C,F,G
C7A8	LG-0CH1104K566	C CAPACITOR	100nF 10% 50V		C821	LG-0CK104CKG6A	C CAPACITOR	100nF 10% 50V	C,F,G
C7A9	LG-0CH1103K566	C CAPACITOR	10nF 10% 50V		C822	LG-0CK104CKG6A	C CAPACITOR	100nF 10% 50V	C,F,G
C7B0	LG-0CK104CKG6A	C CAPACITOR	100nF 10% 50V		C823	LG-0CK104CKG6A	C CAPACITOR	100nF 10% 50V	C,F,G
C7B1	LG-0CE108AK610	AL CAPACITOR	1000uF 20%		C824	LG-0CK104CKG6A	C CAPACITOR	100nF 10% 50V	C,F,G
C7B2	LG-0CH1104K566	C CAPACITOR	100nF 10% 50V		C825	LG-0CK104CKG6A	C CAPACITOR	100nF 10% 50V	C,F,G
C7B3	LG-0CH1104K566	C CAPACITOR	100nF 10% 50V		C826	LG-0CK104CKG6A	C CAPACITOR	100nF 10% 50V	C,F,G
C7B4	LG-0CH1104K566	C CAPACITOR	100nF 10% 50V		C827	LG-0CK104CKG6A	C CAPACITOR	100nF 10% 50V	C,F,G
C7B5	LG-0CH8476H691	AL CAPACITOR	47uF 20% 25V		C828	LG-0CK104CKG6A	C CAPACITOR	100nF 10% 50V	C,F,G
C7B6	LG-0CH1103K566	C CAPACITOR	10nF 10% 50V		C829	LG-0CK104CKG6A	C CAPACITOR	100nF 10% 50V	C,F,G
C7B7	LG-0CH1333K566	C CAPACITOR	33nF 10% 50V		C830	LG-0CH4150K412	C CAPACITOR	15pF 5% 50V	C,F,G
C7B8	LG-0CH1224K946	C CAPACITOR	220nF		C831	LG-0CK104CKG6A	C CAPACITOR	100nF 10% 50V	C,F,G
C7B9	LG-0CH4331K416	C CAPACITOR	330pF 5% 50V		C832	LG-0CK104CKG6A	C CAPACITOR	100nF 10% 50V	C,F,G
C7C0	LG-0CH1224K946	C CAPACITOR	220nF		C833	LG-0CH4150K412	C CAPACITOR	15pF 5% 50V	C,F,G
C7C1	LG-0CH1104K566	C CAPACITOR	100nF 10% 50V		C834	LG-0CK104CKG6A	C CAPACITOR	100nF 10% 50V	C,F,G
C7C2	LG-0CH1224K946	C CAPACITOR	220nF		C835	LG-0CK104CKG6A	C CAPACITOR	100nF 10% 50V	C,F,G
C7C3	LG-EAE37475001	C CAPACITOR	470nF 10%		C836	LG-0CK104CKG6A	C CAPACITOR	100nF 10% 50V	C,F,G
C7C4	LG-0CH1224K946	C CAPACITOR	220nF		C837	LG-0CK104CKG6A	C CAPACITOR	100nF 10% 50V	C,F,G
C7C5	LG-0CH1104K566	C CAPACITOR	100nF 10% 50V		C838	LG-0CK104CKG6A	C CAPACITOR	100nF 10% 50V	C,F,G
C7C6	LG-0CH1224K946	C CAPACITOR	220nF		C839	LG-0CK104CKG6A	C CAPACITOR	100nF 10% 50V	C,F,G
C7C7	LG-0CH1224K946	C CAPACITOR	220nF		C840	LG-0CK104CKG6A	C CAPACITOR	100nF 10% 50V	C,F,G
C7C8	LG-0CH4331K416	C CAPACITOR	330pF 5% 50V		C841	LG-0CK104CKG6A	C CAPACITOR	100nF 10% 50V	C,F,G
C7C9	LG-0CH1333K566	C CAPACITOR	33nF 10% 50V		C842	LG-0CK104CKG6A	C CAPACITOR	100nF 10% 50V	C,F,G
C7D0	LG-0CH1333K566	C CAPACITOR	33nF 10% 50V		C843	NDC31HJ-101X	C CAPACITOR	LG-0CH4101K412	C,F,G
C7D1	LG-0CK104CKG6A	C CAPACITOR	100nF 10% 50V		C844	LG-0CH4220K412	C CAPACITOR	22pF 5% 50V	C,F,G
C7D2	LG-0CH1224K946	C CAPACITOR	220nF		C845	NDC31HJ-101X	C CAPACITOR	LG-0CH4101K412	C,F,G
C7D3	LG-0CH4331K416	C CAPACITOR	330pF 5% 50V		C846	NDC31HJ-101X	C CAPACITOR	LG-0CH4101K412	C,F,G
C7D4	LG-0CH1104K566	C CAPACITOR	100nF 10% 50V		C852	LG-EAE60659001	AL CAPACITOR	47uF	C,F,G
C7D5	LG-0CH1224K946	C CAPACITOR	220nF		C853	LG-0CK104CKG6A	C CAPACITOR	100nF 10% 50V	C,F,G
C7D6	LG-0CH1224K946	C CAPACITOR	220nF		C854	LG-0CH8106F611	AL CAPACITOR	10uF 20% 16V	C,F,G
C7D7	LG-EAE37475001	C CAPACITOR	470nF 10%		C855	LG-0CK104CKG6A	C CAPACITOR	100nF 10% 50V	C,F,G
C7D8	LG-0CH1224K946	C CAPACITOR	220nF		C856	LG-0CH1102K562	C CAPACITOR	1nF 10% 50V	C,F,G
C7D9	LG-0CH1104K566	C CAPACITOR	100nF 10% 50V		C857	LG-0CH1102K562	C CAPACITOR	1nF 10% 50V	C,F,G
C7E0	LG-0CH1224K946	C CAPACITOR	220nF		C858	LG-0CH8106F611	AL CAPACITOR	10uF 20% 16V	C,F,G
C7E1	LG-0CH1224K946	C CAPACITOR	220nF		C859	LG-0CK104CKG6A	C CAPACITOR	100nF 10% 50V	C,F,G
C7E2	LG-0CH4331K416	C CAPACITOR	330pF 5% 50V		C860	LG-0CK104CKG6A	C CAPACITOR	100nF 10% 50V	C,F,G
C7E3	LG-0CH1333K566	C CAPACITOR	33nF 10% 50V		C861	LG-0CH8106F611	AL CAPACITOR	10uF 20% 16V	C,F,G
C7E4	LG-0CH1104K566	C CAPACITOR	100nF 10% 50V		C862	LG-0CK104CKG6A	C CAPACITOR	100nF 10% 50V	C,F,G
C7E5	LG-0CH1104K566	C CAPACITOR	100nF 10% 50V		C863	LG-0CH8106F611	AL CAPACITOR	10uF 20% 16V	C,F,G
C7E6	LG-0CH1104K566	C CAPACITOR	100nF 10% 50V		C864	LG-0CK104CKG6A	C CAPACITOR	100nF 10% 50V	C,F,G
C7E7	LG-0CE108AK610	AL CAPACITOR	1000uF 20%		C865	LG-0CK104CKG6A	C CAPACITOR	100nF 10% 50V	C,F,G
C7E8	LG-0CH1104K566	C CAPACITOR	100nF 10% 50V		C866	LG-0CH8106F611	AL CAPACITOR	10uF 20% 16V	C,F,G
C7E9	LG-0CH1103K566	C CAPACITOR	10nF 10% 50V		C867	LG-0CK104CKG6A	C CAPACITOR	100nF 10% 50V	C,F,G
C7F6	LG-0CK104CKG6A	C CAPACITOR	100nF 10% 50V		C868	LG-0CK104CKG6A	C CAPACITOR	100nF 10% 50V	C,F,G
C7F7	LG-EAE56703201	AL CAPACITOR	10uF		C869	LG-0CH1102K562	C CAPACITOR	1nF 10% 50V	C,F,G
C7F9	LG-0CH8476H691	AL CAPACITOR	47uF 20% 25V		C870	LG-0CK104CKG6A	C CAPACITOR	100nF 10% 50V	C,F,G
C7G1	LG-0CH1104K566	C CAPACITOR	100nF 10% 50V		C871	LG-0CK104CKG6A	C CAPACITOR	100nF 10% 50V	C,F,G
C7G2	LG-0CH1104K566	C CAPACITOR	100nF 10% 50V		C872	LG-0CH1102K562	C CAPACITOR	1nF 10% 50V	C,F,G
C7G3	LG-0CH8476H691	AL CAPACITOR	47uF 20% 25V		C874	LG-0CK104CKG6A	C CAPACITOR	100nF 10% 50V	C,F,G
C7G4	LG-0CH1103K562	C CAPACITOR	10nF 10% 50V		C875	LG-0CH8106F611	AL CAPACITOR	10uF 20% 16V	C,F,G
C7G5	LG-0CH1103K562	C CAPACITOR	10nF 10% 50V		C876	LG-0CH8106F611	AL CAPACITOR	10uF 20% 16V	C,F,G

Symbol No.	Part No.	Part Name	Description	Local	Symbol No.	Part No.	Part Name	Description	Local
C877	LG-0CK104CKG6A	C CAPACITOR	100nF 10% 50V	C,F,G	R166	NRSA63J-101X	MG RESISTOR	100Ω 1/16W J	
C878	LG-0CH8106F611	AL CAPACITOR	10uF 20% 16V	C,F,G	R167	NRSA63J-101X	MG RESISTOR	100Ω 1/16W J	
C879	LG-0CK104CKG6A	C CAPACITOR	100nF 10% 50V	C,F,G	R168	NRSA63J-101X	MG RESISTOR	100Ω 1/16W J	
C880	LG-0CH8106F611	AL CAPACITOR	10uF 20% 16V	C,F,G	R169	NRSA63J-101X	MG RESISTOR	100Ω 1/16W J	
C882	LG-0CH8106F611	AL CAPACITOR	10uF 20% 16V	C,F,G	R170	NRSA63J-101X	MG RESISTOR	100Ω 1/16W J	
C883	LG-0CK104CKG6A	C CAPACITOR	100nF 10% 50V	C,F,G	R171	NRSA63J-101X	MG RESISTOR	100Ω 1/16W J	
C885	LG-0CK104CKG6A	C CAPACITOR	100nF 10% 50V	C,F,G	R172	NRSA63J-101X	MG RESISTOR	100Ω 1/16W J	
C886	LG-0CK104CKG6A	C CAPACITOR	100nF 10% 50V	C,F,G	R173	NRSA63J-101X	MG RESISTOR	100Ω 1/16W J	
C887	LG-0CK104CKG6A	C CAPACITOR	100nF 10% 50V	C,F,G	R174	NRSA63J-101X	MG RESISTOR	100Ω 1/16W J	
C888	LG-0CH8106F611	AL CAPACITOR	10uF 20% 16V	C,F,G	R175	NRSA63J-101X	MG RESISTOR	100Ω 1/16W J	
C889	LG-0CK104CKG6A	C CAPACITOR	100nF 10% 50V	C,F,G	R176	NRSA63J-101X	MG RESISTOR	100Ω 1/16W J	
C890	LG-0CK104CKG6A	C CAPACITOR	100nF 10% 50V	C,F,G	R178	NRSA63J-123X	MG RESISTOR	12kΩ 1/16W J	
C891	LG-0CK104CKG6A	C CAPACITOR	100nF 10% 50V	C,F,G	R179	NRSA63J-101X	MG RESISTOR	100Ω 1/16W J	
C892	LG-0CK104CKG6A	C CAPACITOR	100nF 10% 50V	C,F,G	R180	NRSA63J-101X	MG RESISTOR	100Ω 1/16W J	
C893	LG-0CK104CKG6A	C CAPACITOR	100nF 10% 50V	C,F,G	R181	NRSA63J-101X	MG RESISTOR	100Ω 1/16W J	
C894	LG-0CH8106F611	AL CAPACITOR	10uF 20% 16V	C,F,G	R182	NRSA63J-101X	MG RESISTOR	100Ω 1/16W J	
R100	NRSA63J-101X	MG RESISTOR	100Ω 1/16W J		R183	NRSA63J-101X	MG RESISTOR	100Ω 1/16W J	
R101	NRSA63J-101X	MG RESISTOR	100Ω 1/16W J		R184	NRSA63J-101X	MG RESISTOR	100Ω 1/16W J	
R102	NRSA63J-102X	MG RESISTOR	1kΩ 1/16W J		R185	NRSA63J-472X	MG RESISTOR	4.7kΩ 1/16W J	
R103	NRSA63J-101X	MG RESISTOR	100Ω 1/16W J		R186	NRSA63J-101X	MG RESISTOR	100Ω 1/16W J	
R104	NRSA63J-101X	MG RESISTOR	100Ω 1/16W J		R187	NRSA63J-101X	MG RESISTOR	100Ω 1/16W J	
R105	NRSA63J-101X	MG RESISTOR	100Ω 1/16W J		R188	NRSA63J-101X	MG RESISTOR	100Ω 1/16W J	
R106	NRSA63J-101X	MG RESISTOR	100Ω 1/16W J		R189	NRSA63J-472X	MG RESISTOR	4.7kΩ 1/16W J	
R107	NRSA63J-101X	MG RESISTOR	100Ω 1/16W J		R190	NRSA63J-102X	MG RESISTOR	1kΩ 1/16W J	
R109	NRSA63J-101X	MG RESISTOR	100Ω 1/16W J		R191	NRSA63J-101X	MG RESISTOR	100Ω 1/16W J	
R110	NRSA63J-101X	MG RESISTOR	100Ω 1/16W J		R192	NRSA6AD-821W	MG RESISTOR	820Ω 1/16W D	
R111	NRSA63J-101X	MG RESISTOR	100Ω 1/16W J		R194	NRSA63J-101X	MG RESISTOR	100Ω 1/16W J	
R112	NRSA63J-101X	MG RESISTOR	100Ω 1/16W J		R195	NRSA63J-104X	MG RESISTOR	100kΩ 1/16W J	
R113	NRSA63J-101X	MG RESISTOR	100Ω 1/16W J		R196	NRSA63J-104X	MG RESISTOR	100kΩ 1/16W J	
R114	NRSA63J-101X	MG RESISTOR	100Ω 1/16W J		R197	NRSA63J-472X	MG RESISTOR	4.7kΩ 1/16W J	
R115	NRSA63J-101X	MG RESISTOR	100Ω 1/16W J		R198	NRSA63J-104X	MG RESISTOR	100kΩ 1/16W J	
R116	NRSA63J-103X	MG RESISTOR	10kΩ 1/16W J		R199	NRSA63J-123X	MG RESISTOR	12kΩ 1/16W J	
R117	NRSA63J-101X	MG RESISTOR	100Ω 1/16W J		R1A1	NRSA63J-472X	MG RESISTOR	4.7kΩ 1/16W J	
R118	NRSA63J-101X	MG RESISTOR	100Ω 1/16W J		R1A3	NRSA63J-332X	MG RESISTOR	3.3kΩ 1/16W J	
R119	NRSA63J-101X	MG RESISTOR	100Ω 1/16W J		R1A4	NRSA63J-332X	MG RESISTOR	3.3kΩ 1/16W J	
R120	NRSA63J-101X	MG RESISTOR	100Ω 1/16W J		R1A5	NRSA63J-472X	MG RESISTOR	4.7kΩ 1/16W J	
R121	NRSA63J-101X	MG RESISTOR	100Ω 1/16W J		R1A6	NRSA63J-472X	MG RESISTOR	4.7kΩ 1/16W J	
R122	NRSA63J-472X	MG RESISTOR	4.7kΩ 1/16W J		R1B4	NRSA63J-101X	MG RESISTOR	100Ω 1/16W J	
R123	NRSA63J-472X	MG RESISTOR	4.7kΩ 1/16W J		R1B5	NRSA63J-101X	MG RESISTOR	100Ω 1/16W J	
R125	NRSA63J-472X	MG RESISTOR	4.7kΩ 1/16W J		R1B6	NRSA63J-101X	MG RESISTOR	100Ω 1/16W J	
R126	NRSA63J-472X	MG RESISTOR	4.7kΩ 1/16W J		R1B7	NRSA63J-472X	MG RESISTOR	LG-0RH4701C622 C,F,G	
R127	LG-0RH1500D622	CHIP RESISTOR	150Ω 5% 1/8W		R1B8	NRSA63J-472X	MG RESISTOR	LG-0RH4701C622 C,F,G	
R129	NRSA63J-472X	MG RESISTOR	4.7kΩ 1/16W J		R1B9	NRSA63J-103X	MG RESISTOR	LG-0RH1002C622 C,F,G	
R130	NRSA63J-101X	MG RESISTOR	100Ω 1/16W J		R1C0	NRSA63J-101X	MG RESISTOR	LG-0RH1000C622 C,F,G	
R131	NRSA63J-101X	MG RESISTOR	100Ω 1/16W J		R1C1	NRSA63J-101X	MG RESISTOR	LG-0RH1000C622 C,F,G	
R132	NRSA63J-103X	MG RESISTOR	10kΩ 1/16W J		R1C2	NRSA63J-101X	MG RESISTOR	LG-0RH1000C622 C,F,G	
R133	NRSA63J-223X	MG RESISTOR	22kΩ 1/16W J		R1C3	NRSA63J-103X	MG RESISTOR	LG-0RH1002C622 C,F,G	
R134	NRSA63J-101X	MG RESISTOR	100Ω 1/16W J		R1C4	NRSA63J-101X	MG RESISTOR	LG-0RH1000C622 C,F,G	
R135	NRSA63J-101X	MG RESISTOR	100Ω 1/16W J		R1C5	NRSA63J-103X	MG RESISTOR	LG-0RH1002C622 C,F,G	
R136	NRSA63J-101X	MG RESISTOR	100Ω 1/16W J		R1C6	NRSA63J-101X	MG RESISTOR	100Ω 1/16W J	
R137	NRSA63J-104X	MG RESISTOR	100kΩ 1/16W J		R1C7	NRSA63J-101X	MG RESISTOR	100Ω 1/16W J	
R138	NRSA63J-101X	MG RESISTOR	100Ω 1/16W J		R1C8	NRSA63J-101X	MG RESISTOR	100Ω 1/16W J	
R139	NRSA63J-101X	MG RESISTOR	100Ω 1/16W J		R1C9	NRSA63J-682X	MG RESISTOR	6.8kΩ 1/16W J	
R140	NRSA63J-101X	MG RESISTOR	100Ω 1/16W J		R1E3	NRSA63J-472X	MG RESISTOR	4.7kΩ 1/16W J	
R141	NRSA63J-101X	MG RESISTOR	100Ω 1/16W J		R1G3	NRSA63J-0R0X	MG RESISTOR	0Ω 1/10W J	
R142	NRSA63J-101X	MG RESISTOR	100Ω 1/16W J		R1G4	NRSA63J-0R0X	MG RESISTOR	0Ω 1/10W J	
R143	NRSA63J-472X	MG RESISTOR	4.7kΩ 1/16W J		R1G5	NRSA63J-0R0X	MG RESISTOR	0Ω 1/10W J	
R144	NRSA63J-101X	MG RESISTOR	100Ω 1/16W J		R1G6	NRSA63J-222X	MG RESISTOR	2.2kΩ 1/16W J	
R145	NRSA63J-101X	MG RESISTOR	100Ω 1/16W J		R200	NRSA63J-105X	MG RESISTOR	1MΩ 1/16W J	
R146	NRSA63J-105X	MG RESISTOR	1MΩ 1/16W J		R217	NRSA6AD-393W	MG RESISTOR	39kΩ 1/16W D	
R149	NRSA63J-101X	MG RESISTOR	100Ω 1/16W J		R218	NRSA6AD-393W	MG RESISTOR	39kΩ 1/16W D	
R150	NRSA63J-101X	MG RESISTOR	100Ω 1/16W J		R219	NRSA6AD-393W	MG RESISTOR	39kΩ 1/16W D	
R151	NRSA63J-101X	MG RESISTOR	100Ω 1/16W J		R220	NRSA6AD-393W	MG RESISTOR	39kΩ 1/16W D	
R152	NRSA63J-101X	MG RESISTOR	100Ω 1/16W J		R221	NRSA63J-123X	MG RESISTOR	12kΩ 1/16W J	
R153	NRSA63J-101X	MG RESISTOR	100Ω 1/16W J		R222	NRSA63J-123X	MG RESISTOR	12kΩ 1/16W J	
R154	NRSA63J-472X	MG RESISTOR	4.7kΩ 1/16W J		R223	NRSA6AD-393W	MG RESISTOR	39kΩ 1/16W D	A,B,H,I
R155	NRSA63J-101X	MG RESISTOR	100Ω 1/16W J		R224	NRSA6AD-393W	MG RESISTOR	39kΩ 1/16W D	J
R156	NRSA63J-101X	MG RESISTOR	100Ω 1/16W J						A,B,H,I
R157	NRSA63J-472X	MG RESISTOR	4.7kΩ 1/16W J						J
R158	NRSA63J-101X	MG RESISTOR	100Ω 1/16W J		R225	NRSA63J-102X	MG RESISTOR	1kΩ 1/16W J	
R159	NRSA63J-101X	MG RESISTOR	100Ω 1/16W J		R226	NRSA63J-103X	MG RESISTOR	10kΩ 1/16W J	
R160	NRSA63J-472X	MG RESISTOR	4.7kΩ 1/16W J		R227	NRSA63J-103X	MG RESISTOR	10kΩ 1/16W J	
R161	NRSA63J-101X	MG RESISTOR	100Ω 1/16W J		R228	NRSA63J-103X	MG RESISTOR	10kΩ 1/16W J	
R162	NRSA63J-101X	MG RESISTOR	100Ω 1/16W J		R229	NRSA63J-103X	MG RESISTOR	10kΩ 1/16W J	
R163	NRSA63J-472X	MG RESISTOR	4.7kΩ 1/16W J		R237	LG-0RH0332C622	CHIP RESISTOR	3Ω 5% 1/10W	
R164	NRSA63J-101X	MG RESISTOR	100Ω 1/16W J		R239	NRSA63J-0R0X	MG RESISTOR	0Ω 1/10W J	
R165	NRSA63J-101X	MG RESISTOR	100Ω 1/16W J		R240	NRSA63J-0R0X	MG RESISTOR	0Ω 1/10W J	
					R241	LG-0RH0332C622	CHIP RESISTOR	3Ω 5% 1/10W	

△ Symbol No.	Part No.	Part Name	Description	Local	△ Symbol No.	Part No.	Part Name	Description	Local
R242	LG-0RH0332C622	CHIP RESISTOR	3Ω 5% 1/10W		R292	NRSA63J-0R0X	MG RESISTOR	LG-0RH0000C622	C,D,E, F,G,K,L ,M,N,O
R243	LG-0RH0332C622	CHIP RESISTOR	3Ω 5% 1/10W						
R244	LG-0RH0332C622	CHIP RESISTOR	3Ω 5% 1/10W		R293	NRSA63J-0R0X	MG RESISTOR	LG-0RH0000C622	C,D,E, F,G,K,L ,M,N,O
R245	LG-0RH0332C622	CHIP RESISTOR	3Ω 5% 1/10W						
R251	NRSA63J-103X	MG RESISTOR	10kΩ 1/16W J		R294	NRSA63J-0R0X	MG RESISTOR	LG-0RH0000C622	C,D,E, F,G,K,L ,M,N,O
R252	NRSA63J-472X	MG RESISTOR	4.7kΩ 1/16W J						
R254	LG-0RH3900C622	CHIP RESISTOR	390Ω 5% 1/10W	C,F,G	R295	NRSA63J-104X	MG RESISTOR	100kΩ 1/16W J	A,B,H,I ,J
R259	NRSA63J-101X	MG RESISTOR	100kΩ 1/16W J						
R260	NRSA63J-750X	MG RESISTOR	75Ω 1/16W J	A,B,H,I ,J	R296	NRSA63J-222X	MG RESISTOR	2.2kΩ 1/16W J	A,B,H,I ,J
R261	NRSA63J-472X	MG RESISTOR	4.7kΩ 1/16W J		R297	NRSA63J-222X	MG RESISTOR	2.2kΩ 1/16W J	A,B,H,I ,J
R262	NRSA63J-472X	MG RESISTOR	4.7kΩ 1/16W J						
R263	NRSA63J-472X	MG RESISTOR	4.7kΩ 1/16W J		R299	NRSA63J-750X	MG RESISTOR	75Ω 1/16W J	A,B,H,I ,J
R264	NRSA63J-472X	MG RESISTOR	4.7kΩ 1/16W J						
R265	NRSA63J-103X	MG RESISTOR	10kΩ 1/16W J		R2A1	NRSA63J-104X	MG RESISTOR	LG-0RH1003C622	C,D,E, F,G,K,L ,M,N,O
R266	NRSA63J-103X	MG RESISTOR	10kΩ 1/16W J						
R267	NRSA63J-103X	MG RESISTOR	10kΩ 1/16W J		R2A2	NRSA63J-331X	MG RESISTOR	LG-0RH3300C622	C,D,E, F,G,K,L ,M,N,O
R268	NRSA63J-472X	MG RESISTOR	4.7kΩ 1/16W J						
R269	NRSA63J-750X	MG RESISTOR	75Ω 1/16W J	A,B,H,I ,J	R2A3	NRSA6AD-473W	MG RESISTOR	LG-0RH4702C622	C,D,E, F,G,K,L ,M,N,O
R269	NRSA63J-221X	MG RESISTOR	LG-0RH2200C622	C,F,G					
R270	NRSA63J-750X	MG RESISTOR	75Ω 1/16W J	A,B,H,I ,J	R2A4	NRSA63J-0R0X	MG RESISTOR	LG-0RH0000C622	C,D,E, F,G,K,L ,M,N,O
R271	NRSA63J-103X	MG RESISTOR	10kΩ 1/16W J	A,B,H,I ,J	R2A5	LG-0RH5603C622	CHIP RESISTOR	560kΩ 5% 1/10W	C,D,E, F,G,K,L ,M,N,O
R272	NRSA63J-103X	MG RESISTOR	10kΩ 1/16W J	A,B,H,I ,J	R2A6	NRSA63J-221X	MG RESISTOR	LG-0RH2200C622	C,D,E, F,G,K,L ,M,N,O
R273	NRSA63J-103X	MG RESISTOR	10kΩ 1/16W J	A,B,H,I ,J	R2E8	NRSA63J-222X	MG RESISTOR	2.2kΩ 1/16W J	
					R3C0	NRSA63J-103X	MG RESISTOR	LG-0RH1002C622	C,F,G
R274	NRSA63J-472X	MG RESISTOR	4.7kΩ 1/16W J	A,B,H,I ,J	R3C5	LG-EBC36543501	CHIP RESISTOR	549kΩ 1% 1/10W	C,F,G
					R3D0	NRSA6AD-473W	MG RESISTOR	LG-0RH4702C622	C,F,G
R275	NRSA63J-472X	MG RESISTOR	4.7kΩ 1/16W J	A,B,H,I ,J	R3D1	LG-0RH7502C622	CHIP RESISTOR	75CαΩ 5% 1/10W	C,F,G
					R3E0	LG-0RH7502C622	CHIP RESISTOR	75CαΩ 5% 1/10W	C,F,G
R276	NRSA63J-472X	MG RESISTOR	4.7kΩ 1/16W J	A,B,H,I ,J	R3F0	NRSA63J-103X	MG RESISTOR	LG-0RH1002C622	C,F,G
					R3F5	NRSA63J-332X	MG RESISTOR	LG-0RH3301C622	C,F,G
R277	NRSA63J-472X	MG RESISTOR	4.7kΩ 1/16W J	A,B,H,I ,J	R3F6	NRSA63J-104X	MG RESISTOR	LG-0RH1003C622	C,F,G
					R3F7	NRSA63J-332X	MG RESISTOR	LG-0RH3301C622	C,F,G
R278	NRSA63J-750X	MG RESISTOR	75Ω 1/16W J	A,B,H,I ,J	R3G0	NRSA63J-102X	MG RESISTOR	LG-0RH1001C622	C,F,G
					R3G9	NRSA63J-103X	MG RESISTOR	LG-0RH1002C622	C,F,G
R278	NRSA63J-0R0X	MG RESISTOR	LG-0RH0000C622	C,D,E, F,G,K,L ,M,N,O	R3H0	NRSA63J-104X	MG RESISTOR	LG-0RH1003C622	C,F,G
					R3H1	NRSA63J-104X	MG RESISTOR	LG-0RH1003C622	C,F,G
R279	NRSA63J-750X	MG RESISTOR	75Ω 1/16W J	A,B,H,I ,J	R3H4	NRSA63J-101X	MG RESISTOR	LG-0RH1000C622	C,F,G
					R3H5	NRSA63J-101X	MG RESISTOR	LG-0RH1000C622	C,F,G
R279	NRSA63J-0R0X	MG RESISTOR	LG-0RH0000C622	C,D,E, F,G,K,L ,M,N,O	R3H6	NRSA63J-104X	MG RESISTOR	LG-0RH1003C622	C,F,G
					R3H8	NRSA6AD-473W	MG RESISTOR	LG-0RH4702C622	C,F,G
R280	NRSA63J-750X	MG RESISTOR	75Ω 1/16W J	A,B,H,I ,J	R3H9	NRSA63J-472X	MG RESISTOR	LG-0RH4701C622	C,F,G
					R3J0	NRSA63J-561X	MG RESISTOR	LG-0RH5600C622	C,F,G
R280	NRSA63J-0R0X	MG RESISTOR	LG-0RH0000C622	C,D,E, F,G,K,L ,M,N,O	R3J1	NRSA63J-182X	MG RESISTOR	LG-0RH1801C622	C,F,G
					R401	NRSA63J-103X	MG RESISTOR	10kΩ 1/16W J	
R281	NRSA63J-750X	MG RESISTOR	75Ω 1/16W J	A,B,H,I ,J	R402	LG-0RH0221C622	CHIP RESISTOR	2.2Ω 5% 1/10W	
					R404	NRSA63J-104X	MG RESISTOR	100kΩ 1/16W J	
R281	LG-0RH0392C622	CHIP RESISTOR	39Ω 5% 1/10W	C,F,G	R405	NRSA63J-103X	MG RESISTOR	10kΩ 1/16W J	
					R407	NRSA63J-103X	MG RESISTOR	10kΩ 1/16W J	
R281	NRSA63J-0R0X	MG RESISTOR	LG-0RH0000C622	D,E,K, L,M,N, O	R408	NRSA63J-103X	MG RESISTOR	10kΩ 1/16W J	
					R409	NRSA63J-103X	MG RESISTOR	10kΩ 1/16W J	
R282	NRSA63J-472X	MG RESISTOR	4.7kΩ 1/16W J	A,B,D, E,H,I,J, K,L,M, N,O	R410	NRSA63J-103X	MG RESISTOR	10kΩ 1/16W J	
					R411	LG-0RH1001C422	CHIP RESISTOR	1kΩ 1% 1/10W	
R284	NRSA63J-0R0X	MG RESISTOR	0Ω 1/10W J	A,B,H,I ,J	R415	NRSA63J-103X	MG RESISTOR	10kΩ 1/16W J	
					R416	NRSA63J-103X	MG RESISTOR	10kΩ 1/16W J	
R285	NRSA63J-750X	MG RESISTOR	75Ω 1/16W J	A,B,H,I ,J	R428	NRSA63J-104X	MG RESISTOR	100kΩ 1/16W J	
					R432	NRSA63J-222X	MG RESISTOR	2.2kΩ 1/16W J	
R286	NRSA63J-750X	MG RESISTOR	75Ω 1/16W J	A,B,H,I ,J	R434	NRSA63J-472X	MG RESISTOR	4.7kΩ 1/16W J	
					R435	LG-0RH3302C622	CHIP RESISTOR	33kΩ 5% 1/10W	
R287	NRSA63J-750X	MG RESISTOR	75Ω 1/16W J	A,B,H,I ,J	R437	LG-0RH6201C622	CHIP RESISTOR	6.2kΩ 5% 1/10W	
					R440	NRSA63J-103X	MG RESISTOR	10kΩ 1/16W J	
R288	NRSA63J-750X	MG RESISTOR	75Ω 1/16W J	A,B,H,I ,J	R442	LG-0RH2203C622	CHIP RESISTOR	220kΩ 5% 1/10W	
					R443	LG-0RH0221C622	CHIP RESISTOR	2.2Ω 5% 1/10W	
R289	NRSA63J-102X	MG RESISTOR	1kΩ 1/16W J	A,B,H,I ,J	R444	NRSA63J-103X	MG RESISTOR	10kΩ 1/16W J	
					R445	NRSA63J-103X	MG RESISTOR	10kΩ 1/16W J	
R290	NRSA6AD-821W	MG RESISTOR	820Ω 1/16W D	A,B,H,I ,J	R446	LG-0RH5100C422	CHIP RESISTOR	510Ω 1% 1/10W	
					R447	NRSA63J-104X	MG RESISTOR	100kΩ 1/16W J	
R291	NRSA63J-0R0X	MG RESISTOR	LG-0RH0000C622	C,D,E, F,G,K,L ,M,N,O	R448	NRSA6AD-273W	MG RESISTOR	27kΩ 1/16W D	
					R449	NRSA63J-563X	MG RESISTOR	56kΩ 1/16W J	

△ Symbol No.	Part No.	Part Name	Description	Local	△ Symbol No.	Part No.	Part Name	Description	Local
R450	NRSA63J-472X	MG RESISTOR	4.7kΩ 1/16W J		R668	NRSA63J-103X	MG RESISTOR	10kΩ 1/16W J	
R451	NRSA63J-223X	MG RESISTOR	22kΩ 1/16W J		R669	NRSA63J-103X	MG RESISTOR	10kΩ 1/16W J	
R453	LG-0RH0101D622	CHIP RESISTOR	1Ω 5% 1/8W		R670	NRSA63J-103X	MG RESISTOR	10kΩ 1/16W J	
R455	NRSA63J-0R0X	MG RESISTOR	0Ω 1/10W J		R671	NRSA63J-103X	MG RESISTOR	10kΩ 1/16W J	
R456	NRSA63J-0R0X	MG RESISTOR	0Ω 1/10W J		R701	LG-0RH0331D622	CHIP RESISTOR	3.3Ω 5% 1/8W	
R457	NRSA63J-472X	MG RESISTOR	4.7kΩ 1/16W J		R702	LG-0RH0102G622	CHIP RESISTOR	10Ω 5% 1/4W	
R500	LG-0RH5101C422	CHIP RESISTOR	5.1kΩ 1% 1/10W		R703	LG-0RH0102G622	CHIP RESISTOR	10Ω 5% 1/4W	
R501	NRSA63J-153X	MG RESISTOR	15kΩ 1/16W J		R704	NRSA63J-101X	MG RESISTOR	100Ω 1/16W J	
R502	NRSA63J-104X	MG RESISTOR	100kΩ 1/16W J		R705	NRSA63J-101X	MG RESISTOR	100Ω 1/16W J	
R503	LG-0RH0332C622	CHIP RESISTOR	3Ω 5% 1/10W		R707	LG-0RH0221D622	CHIP RESISTOR	2.2Ω 5% 1/8W	
R504	LG-0RH0332C622	CHIP RESISTOR	3Ω 5% 1/10W		R708	LG-0RH0182D622	CHIP RESISTOR	2.2Ω 5% 1/8W	
R505	LG-0RH0332C622	CHIP RESISTOR	3Ω 5% 1/10W		R709	NRSA63J-101X	MG RESISTOR	100Ω 1/16W J	
R506	NRSA63J-103X	MG RESISTOR	10kΩ 1/16W J		R710	NRSA63J-101X	MG RESISTOR	100Ω 1/16W J	
R507	LG-0RH0332C622	CHIP RESISTOR	3Ω 5% 1/10W		R711	LG-0RH0221D622	CHIP RESISTOR	2.2Ω 5% 1/8W	
R508	NRSA63J-102X	MG RESISTOR	1kΩ 1/16W J		R712	LG-0RH0182D622	CHIP RESISTOR	18Ω 5% 1/8W	
R509	NRSA63J-103X	MG RESISTOR	10kΩ 1/16W J		R713	NRSA63J-223X	MG RESISTOR	22kΩ 1/16W J	
R510	NRSA63J-103X	MG RESISTOR	10kΩ 1/16W J		R716	LG-0RH0221D622	CHIP RESISTOR	2.2Ω 5% 1/8W	
R512	LG-0RH0332C622	CHIP RESISTOR	3Ω 5% 1/10W		R717	LG-0RH0182D622	CHIP RESISTOR	18Ω 5% 1/8W	
R513	NRSA63J-472X	MG RESISTOR	4.7kΩ 1/16W J		R718	NRSA63J-101X	MG RESISTOR	100Ω 1/16W J	
R514	LG-0RH0332C622	CHIP RESISTOR	3Ω 5% 1/10W		R719	LG-0RH0221D622	CHIP RESISTOR	2.2Ω 5% 1/8W	
R515	NRSA63J-0R0X	MG RESISTOR	0Ω 1/10W J		R720	LG-0RH0182D622	CHIP RESISTOR	18Ω 5% 1/8W	
R516	LG-0RH0332C622	CHIP RESISTOR	3Ω 5% 1/10W		R722	NRSA63J-101X	MG RESISTOR	100Ω 1/16W J	
R517	LG-0RH0332C622	CHIP RESISTOR	3Ω 5% 1/10W		R724	LG-0RH0331D622	CHIP RESISTOR	3.3Ω 5% 1/8W	
R518	LG-0RH0332C622	CHIP RESISTOR	3Ω 5% 1/10W		R725	LG-0RH0102G622	CHIP RESISTOR	10Ω 5% 1/4W	
R519	LG-0RH0332C622	CHIP RESISTOR	3Ω 5% 1/10W		R726	LG-0RH0102G622	CHIP RESISTOR	10Ω 5% 1/4W	
R520	LG-0RH0332C622	CHIP RESISTOR	3Ω 5% 1/10W		R727	LG-0RH0331D622	CHIP RESISTOR	3.3Ω 5% 1/8W	
R521	NRSA63J-0R0X	MG RESISTOR	0Ω 1/10W J	A,B,F,H .J,J,K C,D,E, G,L,M, N,O	R728	LG-0RH0102G622	CHIP RESISTOR	10Ω 5% 1/4W	
R521	NRSA6AD-392W	MG RESISTOR	LG-0RH3901C622		R729	LG-0RH0102G622	CHIP RESISTOR	10Ω 5% 1/4W	
R522	LG-0RH0332C622	CHIP RESISTOR	3Ω 5% 1/10W		R730	NRSA63J-101X	MG RESISTOR	100Ω 1/16W J	
R523	NRSA63J-101X	MG RESISTOR	100Ω 1/16W J		R731	NRSA63J-101X	MG RESISTOR	100Ω 1/16W J	
R524	NRSA63J-472X	MG RESISTOR	4.7kΩ 1/16W J		R733	LG-0RH0221D622	CHIP RESISTOR	2.2Ω 5% 1/8W	
R525	LG-0RH0332C622	CHIP RESISTOR	3Ω 5% 1/10W		R734	LG-0RH0182D622	CHIP RESISTOR	18Ω 5% 1/8W	
R526	NRSA63J-103X	MG RESISTOR	10kΩ 1/16W J		R735	NRSA63J-101X	MG RESISTOR	100Ω 1/16W J	
R527	LG-0RH2701C422	CHIP RESISTOR	2.7kΩ 1% 1/10W		R736	NRSA63J-101X	MG RESISTOR	100Ω 1/16W J	
R528	NRSA63J-0R0X	MG RESISTOR	0Ω 1/10W J	A,B,F,H .J,J,K C,D,E, G,L,M, N,O	R737	LG-0RH0221D622	CHIP RESISTOR	2.2Ω 5% 1/8W	
R528	NRSA6AD-392W	MG RESISTOR	LG-0RH3901C622		R738	LG-0RH0182D622	CHIP RESISTOR	18Ω 5% 1/8W	
R529	NRSA63J-561X	MG RESISTOR	560Ω 1/16W J		R739	NRSA63J-223X	MG RESISTOR	22kΩ 1/16W J	
R530	NRSA63J-103X	MG RESISTOR	10kΩ 1/16W J		R743	LG-0RH0182D622	CHIP RESISTOR	18Ω 5% 1/8W	
R531	LG-0RH0332C622	CHIP RESISTOR	3Ω 5% 1/10W		R745	NRSA63J-101X	MG RESISTOR	100Ω 1/16W J	
R532	LG-0RH0332C622	CHIP RESISTOR	3Ω 5% 1/10W		R746	LG-0RH0182D622	CHIP RESISTOR	18Ω 5% 1/8W	
R540	LG-0RH0332C622	CHIP RESISTOR	3Ω 5% 1/10W		R748	NRSA63J-101X	MG RESISTOR	100Ω 1/16W J	
R541	LG-0RH0332C622	CHIP RESISTOR	3Ω 5% 1/10W		R749	LG-0RH0101G622	CHIP RESISTOR	1Ω 5% 1/4W	
R542	LG-0RH0332C622	CHIP RESISTOR	3Ω 5% 1/10W		R750	LG-0RH0331D622	CHIP RESISTOR	3.3Ω 5% 1/8W	
R543	LG-0RH0332C622	CHIP RESISTOR	3Ω 5% 1/10W		R751	LG-0RH0102G622	CHIP RESISTOR	10Ω 5% 1/4W	
R544	LG-0RH0332C622	CHIP RESISTOR	3Ω 5% 1/10W		R752	LG-0RH0102G622	CHIP RESISTOR	10Ω 5% 1/4W	
R545	LG-0RH0332C622	CHIP RESISTOR	3Ω 5% 1/10W		R753	LG-0RH0331D622	CHIP RESISTOR	3.3Ω 5% 1/8W	
R546	LG-0RH0332C622	CHIP RESISTOR	3Ω 5% 1/10W		R754	LG-0RH0102G622	CHIP RESISTOR	10Ω 5% 1/4W	
R547	LG-0RH0332C622	CHIP RESISTOR	3Ω 5% 1/10W		R755	LG-0RH0102G622	CHIP RESISTOR	10Ω 5% 1/4W	
R549	LG-0RH0332C622	CHIP RESISTOR	3Ω 5% 1/10W		R756	NRSA63J-101X	MG RESISTOR	100Ω 1/16W J	
R550	LG-0RH0332C622	CHIP RESISTOR	3Ω 5% 1/10W		R757	NRSA63J-101X	MG RESISTOR	100Ω 1/16W J	
R551	LG-0RH0332C622	CHIP RESISTOR	3Ω 5% 1/10W		R759	LG-0RH0221D622	CHIP RESISTOR	2.2Ω 5% 1/8W	
R552	NRSA63J-750X	MG RESISTOR	75Ω 1/16W J		R760	LG-0RH0182D622	CHIP RESISTOR	18Ω 5% 1/8W	
R553	NRSA63J-750X	MG RESISTOR	75Ω 1/16W J		R761	NRSA63J-101X	MG RESISTOR	100Ω 1/16W J	
R554	NRSA63J-750X	MG RESISTOR	75Ω 1/16W J		R762	NRSA63J-101X	MG RESISTOR	100Ω 1/16W J	
R555	NRSA63J-750X	MG RESISTOR	75Ω 1/16W J		R763	LG-0RH0221D622	CHIP RESISTOR	2.2Ω 5% 1/8W	
R602	NRSA63J-101X	MG RESISTOR	100Ω 1/16W J		R764	LG-0RH0182D622	CHIP RESISTOR	18Ω 5% 1/8W	
R603	NRSA63J-101X	MG RESISTOR	100Ω 1/16W J		R765	NRSA63J-223X	MG RESISTOR	22kΩ 1/16W J	
R608	NRSA63J-101X	MG RESISTOR	100Ω 1/16W J		R767	LG-0RH0101G622	CHIP RESISTOR	1Ω 5% 1/4W	
R609	NRSA63J-122X	MG RESISTOR	1.2kΩ 1/16W J		R768	LG-0RH0331D622	CHIP RESISTOR	3.3Ω 5% 1/8W	
R610	NRSA63J-101X	MG RESISTOR	100Ω 1/16W J		R769	LG-0RH0102G622	CHIP RESISTOR	10Ω 5% 1/4W	
R629	NRSA63J-101X	MG RESISTOR	100Ω 1/16W J		R770	LG-0RH0102G622	CHIP RESISTOR	10Ω 5% 1/4W	
R630	NRSA63J-101X	MG RESISTOR	100Ω 1/16W J		R771	LG-0RH0331D622	CHIP RESISTOR	3.3Ω 5% 1/8W	
R649	NRSA6AD-470W	MG RESISTOR	47Ω 1/16W D		R772	LG-0RH0102G622	CHIP RESISTOR	10Ω 5% 1/4W	
R650	NRSA6AD-470W	MG RESISTOR	47Ω 1/16W D		R773	LG-0RH0102G622	CHIP RESISTOR	10Ω 5% 1/4W	
R656	LG-0RH1200C622	CHIP RESISTOR	120Ω 5% 1/10W		R774	NRSA63J-101X	MG RESISTOR	100Ω 1/16W J	
R657	NRSA63J-105X	MG RESISTOR	1MΩ 1/16W J		R775	NRSA63J-101X	MG RESISTOR	100Ω 1/16W J	
R659	NRSA63J-101X	MG RESISTOR	100Ω 1/16W J		R777	LG-0RH0221D622	CHIP RESISTOR	2.2Ω 5% 1/8W	
R660	NRSA63J-101X	MG RESISTOR	100Ω 1/16W J		R778	LG-0RH0182D622	CHIP RESISTOR	18Ω 5% 1/8W	
R661	NRSA63J-101X	MG RESISTOR	100Ω 1/16W J		R779	NRSA63J-101X	MG RESISTOR	100Ω 1/16W J	
R663	NRSA63J-104X	MG RESISTOR	100kΩ 1/16W J		R780	NRSA63J-101X	MG RESISTOR	100Ω 1/16W J	
R664	NRSA63J-104X	MG RESISTOR	100kΩ 1/16W J		R781	LG-0RH0221D622	CHIP RESISTOR	2.2Ω 5% 1/8W	
R665	NRSA63J-104X	MG RESISTOR	100kΩ 1/16W J		R782	LG-0RH0182D622	CHIP RESISTOR	18Ω 5% 1/8W	
R666	NRSA63J-103X	MG RESISTOR	10kΩ 1/16W J		R783	NRSA63J-223X	MG RESISTOR	22kΩ 1/16W J	
R667	NRSA63J-103X	MG RESISTOR	10kΩ 1/16W J		R786	LG-0RH0221D622	CHIP RESISTOR	2.2Ω 5% 1/8W	
					R787	LG-0RH0182D622	CHIP RESISTOR	18Ω 5% 1/8W	
					R788	NRSA63J-101X	MG RESISTOR	100Ω 1/16W J	
					R789	LG-0RH0221D622	CHIP RESISTOR	2.2Ω 5% 1/8W	
					R790	LG-0RH0182D622	CHIP RESISTOR	18Ω 5% 1/8W	

△ Symbol No.	Part No.	Part Name	Description	Local	△ Symbol No.	Part No.	Part Name	Description	Local
R792	NRSA63J-101X	MG RESISTOR	100Ω 1/16W J		R862	LG-0RH0332C622	CHIP RESISTOR	33Ω 5% 1/10W	C,F,G
R794	LG-0RH0331D622	CHIP RESISTOR	3.3Ω 5% 1/8W		R867	LG-0RRZVTA0011	ARRAY RESISTOR	10Ω 5% 1/16W	C,F,G
R795	LG-0RH0102G622	CHIP RESISTOR	10Ω 5% 1/4W		R868	LG-0RRZVTA0011	ARRAY RESISTOR	10Ω 5% 1/16W	C,F,G
R796	LG-0RH0102G622	CHIP RESISTOR	10Ω 5% 1/4W		R869	LG-0RRZVTA0011	ARRAY RESISTOR	10Ω 5% 1/16W	C,F,G
R799	NRSA63J-103X	MG RESISTOR	10kΩ 1/16W J		R870	LG-0RRZVTA0011	ARRAY RESISTOR	10Ω 5% 1/16W	C,F,G
R7A0	NRSA63J-102X	MG RESISTOR	1kΩ 1/16W J		R873	NRSA63J-102X	MG RESISTOR	LG-0RH1001C622	C,F,G
R7A1	NRSA6AD-473W	MG RESISTOR	47kΩ 1/16W D		R875	NRSA63J-103X	MG RESISTOR	LG-0RH1002C622	C,F,G
R7A7	NRSA6AD-473W	MG RESISTOR	47kΩ 1/16W D		R879	NRSA6AD-392W	MG RESISTOR	LG-0RH3901C622	C,F,G
R7A8	NRSA63J-101X	MG RESISTOR	100Ω 1/16W J		R880	NRSA63J-101X	MG RESISTOR	LG-0RH1000C622	C,F,G
R7A9	NRSA63J-101X	MG RESISTOR	100Ω 1/16W J		R881	LG-0RH0332C622	CHIP RESISTOR	33Ω 5% 1/10W	C,F,G
R7B0	NRSA63J-101X	MG RESISTOR	100Ω 1/16W J		R882	LG-0RH0332C622	CHIP RESISTOR	33Ω 5% 1/10W	C,F,G
R7B1	NRSA63J-101X	MG RESISTOR	100Ω 1/16W J		R885	NRSA63J-472X	MG RESISTOR	4.7kΩ 1/16W J	
R7B3	LG-0RH1001D622	CHIP RESISTOR	1kΩ 5% 1/8W		R886	NRSA63J-472X	MG RESISTOR	4.7kΩ 1/16W J	
R7B4	LG-0RH1001D622	CHIP RESISTOR	1kΩ 5% 1/8W		R887	LG-0RRZVTA0011	ARRAY RESISTOR	10Ω 5% 1/16W	C,F,G
R7B5	LG-0RH1003D622	CHIP RESISTOR	100kΩ 5% 1/8W		R888	LG-0RRZVTA0011	ARRAY RESISTOR	10Ω 5% 1/16W	C,F,G
R7B6	LG-0RH1001D622	CHIP RESISTOR	1kΩ 5% 1/8W		R889	LG-0RH0332C622	CHIP RESISTOR	3Ω 5% 1/10W	
R7B7	LG-0RH1003D622	CHIP RESISTOR	100kΩ 5% 1/8W		R890	NRSA6AD-473W	MG RESISTOR	47kΩ 1/16W D	
R7B8	LG-0RH1001D622	CHIP RESISTOR	1kΩ 5% 1/8W		R891	NRSA63J-101X	MG RESISTOR	100Ω 1/16W J	A,B,D, E,H,I,J, K,L,M, N,O
R7B9	LG-0RH1002D622	CHIP RESISTOR	10kΩ 5% 1/8W						
R7C0	LG-0RH0331D622	CHIP RESISTOR	3.3Ω 5% 1/8W		R893	LG-0RRZVTA0011	ARRAY RESISTOR	10Ω 5% 1/16W	A,B,D, E,H,I,J, K,L,M, N,O
R7C1	LG-0RH0331D622	CHIP RESISTOR	3.3Ω 5% 1/8W						
R7C2	LG-0RH0331D622	CHIP RESISTOR	3.3Ω 5% 1/8W						
R7C3	LG-0RH0331D622	CHIP RESISTOR	3.3Ω 5% 1/8W		R894	LG-0RRZVTA0011	ARRAY RESISTOR	10Ω 5% 1/16W	A,B,D, E,H,I,J, K,L,M, N,O
R7C4	LG-0RH0331D622	CHIP RESISTOR	3.3Ω 5% 1/8W						
R7C5	LG-0RH0331D622	CHIP RESISTOR	3.3Ω 5% 1/8W						
R7C6	LG-0RH0331D622	CHIP RESISTOR	3.3Ω 5% 1/8W		R895	NRSA63J-0R0X	MG RESISTOR	0Ω 1/10W J	A,B,D, E,H,I,J, K,L,M, N,O
R7C7	LG-0RH0331D622	CHIP RESISTOR	3.3Ω 5% 1/8W						
R7C8	LG-0RH0331D622	CHIP RESISTOR	3.3Ω 5% 1/8W						
R7C9	LG-0RH0331D622	CHIP RESISTOR	3.3Ω 5% 1/8W		R896	NRSA63J-0R0X	MG RESISTOR	0Ω 1/10W J	A,B,D, E,H,I,J, K,L,M, N,O
R7D0	LG-0RH0331D622	CHIP RESISTOR	3.3Ω 5% 1/8W						
R7D1	LG-0RH0331D622	CHIP RESISTOR	3.3Ω 5% 1/8W						
R7D2	NRSA63J-471X	MG RESISTOR	470Ω 1/16W J						
R7D3	NRSA63J-471X	MG RESISTOR	470Ω 1/16W J		R899	LG-0RH0332C622	CHIP RESISTOR	33Ω 5% 1/10W	C,F,G
R7D4	NRSA63J-471X	MG RESISTOR	470Ω 1/16W J		R89A	LG-0RH0332C622	CHIP RESISTOR	33Ω 5% 1/10W	C,F,G
R7D5	NRSA63J-471X	MG RESISTOR	470Ω 1/16W J		R89C	LG-0RH0332C622	CHIP RESISTOR	33Ω 5% 1/10W	C,F,G
R7D6	NRSA63J-471X	MG RESISTOR	470Ω 1/16W J		R89D	LG-0RH0332C622	CHIP RESISTOR	33Ω 5% 1/10W	C,F,G
R801	NRSA63J-102X	MG RESISTOR	LG-0RH1001C622	C,F,G	R89E	LG-0RH0332C622	CHIP RESISTOR	33Ω 5% 1/10W	C,F,G
R803	NRSA63J-103X	MG RESISTOR	LG-0RH1002C622	C,F,G	R89F	LG-0RH0332C622	CHIP RESISTOR	33Ω 5% 1/10W	C,F,G
R805	NRSA63J-103X	MG RESISTOR	LG-0RH1002C622	C,F,G	R89G	LG-0RH0332C622	CHIP RESISTOR	33Ω 5% 1/10W	C,F,G
R807	NRSA63J-472X	MG RESISTOR	LG-0RH4701C622	C,F,G					
R809	NRSA63J-103X	MG RESISTOR	LG-0RH1002C622	C,F,G					
R811	NRSA63J-103X	MG RESISTOR	LG-0RH1002C622	C,F,G					
R813	LG-0RRZVTA001T	ARRAY RESISTOR	0Ω 5% 1/16W	C,F,G	L100	LG-0LCCE00005N	BEAD FILTER	220Ω	
R814	LG-0RRZVTA001T	ARRAY RESISTOR	0Ω 5% 1/16W	C,F,G	L102	LG-0LCCE00005N	BEAD FILTER	220Ω	
R817	NRSA63J-103X	MG RESISTOR	LG-0RH1002C622	C,F,G	L103	LG-0LCCE00005N	BEAD FILTER	220Ω	
R819	NRSA63J-101X	MG RESISTOR	LG-0RH1000C622	C,F,G	L104	LG-0LCCE00005N	BEAD FILTER	220Ω	
R821	NRSA63J-103X	MG RESISTOR	LG-0RH1002C622	C,F,G	L105	LG-0LCCE00005N	BEAD FILTER	220Ω	
R823	NRSA63J-101X	MG RESISTOR	LG-0RH1000C622	C,F,G	L106	LG-0LCCE00005N	BEAD FILTER	220Ω	C,F,G
R824	NRSA63J-101X	MG RESISTOR	LG-0RH1000C622	C,F,G	L201	LG-0LCCE00005N	BEAD FILTER	220Ω	
R825	LG-0RH0332C622	CHIP RESISTOR	33Ω 5% 1/10W	C,F,G	L203	LG-0LCCE00005N	BEAD FILTER	220Ω	
R826	LG-0RH0332C622	CHIP RESISTOR	33Ω 5% 1/10W	C,F,G	L204	LG-0LCCE00005N	BEAD FILTER	220Ω	
R827	LG-0RH0332C622	CHIP RESISTOR	33Ω 5% 1/10W	C,F,G	L205	LG-0LCCE00005N	BEAD FILTER	220Ω	
R828	LG-0RH0332C622	CHIP RESISTOR	33Ω 5% 1/10W	C,F,G	L271	LG-0LC11608C01	BEAD FILTER	1000Ω	
R829	NRSA63J-105X	MG RESISTOR	LG-0RH1004C622	C,F,G	L272	LG-0LC11608C01	BEAD FILTER	1000Ω	
R830	NRSA63J-472X	MG RESISTOR	LG-0RH4701C622	C,F,G	L273	LG-0LC11608C01	BEAD FILTER	1000Ω	
R831	LG-0RH0332C622	CHIP RESISTOR	33Ω 5% 1/10W	C,F,G	L274	LG-0LC11608C01	BEAD FILTER	1000Ω	
R832	NRSA63J-472X	MG RESISTOR	LG-0RH4701C622	C,F,G	L275	LG-0LC11608C01	BEAD FILTER	1000Ω	
R833	LG-0RRZVTA0011	ARRAY RESISTOR	10Ω 5% 1/16W	C,F,G	L276	LG-0LC11608C01	BEAD FILTER	1000Ω	
R834	LG-0RRZVTA0011	ARRAY RESISTOR	10Ω 5% 1/16W	C,F,G	L277	LG-0LC11608C01	BEAD FILTER	1000Ω	A,B,H,I, J
R835	LG-0RRZVTA0011	ARRAY RESISTOR	10Ω 5% 1/16W	C,F,G	L278	LG-0LC11608C01	BEAD FILTER	1000Ω	A,B,H,I, J
R836	LG-0RRZVTA0011	ARRAY RESISTOR	10Ω 5% 1/16W	C,F,G					
R837	LG-0RRZVTA0011	ARRAY RESISTOR	10Ω 5% 1/16W	C,F,G	L279	LG-0LC11608C01	BEAD FILTER	1000Ω	A,B,H,I, J
R838	LG-0RRZVTA0011	ARRAY RESISTOR	10Ω 5% 1/16W	C,F,G					
R839	LG-0RH0332C622	CHIP RESISTOR	33Ω 5% 1/10W	C,F,G	L280	LG-0LC11608C01	BEAD FILTER	1000Ω	A,B,H,I, J
R840	LG-0RH0332C622	CHIP RESISTOR	33Ω 5% 1/10W	C,F,G					
R841	LG-0RH0332C622	CHIP RESISTOR	33Ω 5% 1/10W	C,F,G	L281	LG-0LC11608C01	BEAD FILTER	1000Ω	A,B,H,I, J
R842	LG-0RH0332C622	CHIP RESISTOR	33Ω 5% 1/10W	C,F,G					
R851	LG-0RH0332C622	CHIP RESISTOR	33Ω 5% 1/10W	C,F,G	L282	LG-0LCCE00005N	BEAD FILTER	220Ω	C,F,G
R852	LG-0RH0332C622	CHIP RESISTOR	33Ω 5% 1/10W	C,F,G	L283	LG-0LCCE00005N	BEAD FILTER	220Ω	A,B,H,I, J
R853	LG-0RH0332C622	CHIP RESISTOR	33Ω 5% 1/10W	C,F,G					
R854	LG-0RH0332C622	CHIP RESISTOR	33Ω 5% 1/10W	C,F,G	L284	LG-0LC11608C01	BEAD FILTER	1000Ω	A,B,H,I, J
R855	LG-0RH0332C622	CHIP RESISTOR	33Ω 5% 1/10W	C,F,G					
R856	LG-0RH0332C622	CHIP RESISTOR	33Ω 5% 1/10W	C,F,G					
R857	LG-0RH0332C622	CHIP RESISTOR	33Ω 5% 1/10W	C,F,G	L285	LG-0LCCE00016A	INDUCTOR	470nH 10% 0V	
R858	NRSA63J-103X	MG RESISTOR	LG-0RH1002C622	C,F,G	L286	LG-0LC2000005B	INDUCTOR	220nH 10% 0V	
R859	NRSA63J-472X	MG RESISTOR	LG-0RH4701C622	C,F,G	L287	LG-0LCCE00004N	INDUCTOR	2.2uH 10% 50V	
R860	LG-0RH0332C622	CHIP RESISTOR	33Ω 5% 1/10W	C,F,G	L288	LG-0LC2000005B	INDUCTOR	220nH 10% 0V	
R861	LG-0RH5100C422	CHIP RESISTOR	510Ω 1% 1/10W	C,F,G	L289	LG-0LCCE00016A	INDUCTOR	470nH 10% 0V	

△ Symbol No.	Part No.	Part Name	Description	Local
L290	LG-0LC2000005B	INDUCTOR	220nH 10% 0V	
L291	LG-0LCCE00016A	INDUCTOR	470nH 10% 0V	
L3C1	LG-0LCCE00042A	BEAD FILTER	1000Ω	C,F,G
L3C2	LG-0LCCE00005N	BEAD FILTER	220Ω	C,F,G
L3C3	LG-0LCCE00042A	BEAD FILTER	1000Ω	C,F,G
L3C5	LG-0LCCE00042A	BEAD FILTER	1000Ω	C,F,G
L3C6	LG-0LCCE00005N	BEAD FILTER	220Ω	C,F,G
L3C7	LG-0LCCE00005N	BEAD FILTER	220Ω	
L3C8	LG-0RH0000D622	CHIP RESISTOR	0Ω 5% 1/8W	
L3C9	LG-0LCCE00042A	BEAD FILTER	1000Ω	C,F,G
L3D1	LG-0LCCE00005N	BEAD FILTER	220Ω	C,F,G
L3D2	NRSA63J-0R0X	MG RESISTOR	LG-0RH0000C622	C,F,G
L3D3	NRSA63J-0R0X	MG RESISTOR	LG-0RH0000C622	C,F,G
L400	LG-0LCCE00005N	BEAD FILTER	220Ω	
L401	LG-0LCCE00005N	BEAD FILTER	220Ω	
L402	LG-0LCCE00005N	BEAD FILTER	220Ω	
L403	LG-0LCCE00005N	BEAD FILTER	220Ω	
L404	LG-0LCCE00005N	BEAD FILTER	220Ω	
L405	LG-0LCCE00005N	BEAD FILTER	220Ω	
L408	LG-0LCCE00005N	BEAD FILTER	220Ω	
L409	LG-0LCCE00005N	BEAD FILTER	220Ω	
L501	LG-0LCCE00005N	BEAD FILTER	220Ω	
L502	LG-0LCCE00005N	BEAD FILTER	220Ω	
L503	LG-0LCCE00005N	BEAD FILTER	220Ω	
L504	LG-0LCCE00005N	BEAD FILTER	220Ω	
L505	LG-0LCCE00005N	BEAD FILTER	220Ω	
L506	LG-0LCCE00005N	BEAD FILTER	220Ω	
L507	LG-0LCCE00005N	BEAD FILTER	220Ω	
L601	LG-0LCCE00005N	BEAD FILTER	220Ω	
L602	LG-0LCCE00005N	BEAD FILTER	220Ω	
L603	LG-0LCCE00005N	BEAD FILTER	220Ω	
L701	LG-6140RCC012C	CHOKE COIL	10uH 7A	
L702	LG-6140RCC012C	CHOKE COIL	10uH 7A	
L703	LG-6140RCC012C	CHOKE COIL	10uH 7A	
L705	LG-6140RCC012C	CHOKE COIL	10uH 7A	
L706	LG-6140RCC012C	CHOKE COIL	10uH 7A	
L707	LG-6140RCC012C	CHOKE COIL	10uH 7A	
L709	LG-6140RCC012C	CHOKE COIL	10uH 7A	
L718	LG-0LCCE00005N	BEAD FILTER	220Ω	
L851	LG-0LCCE00005N	BEAD FILTER	220Ω	C,F,G
L852	LG-0LCCE00005N	BEAD FILTER	220Ω	C,F,G
L853	LG-0LCCE00005N	BEAD FILTER	220Ω	C,F,G
L854	LG-0LCCE00005N	BEAD FILTER	220Ω	C,F,G
L855	LG-0LCCE00005N	BEAD FILTER	220Ω	C,F,G
L856	LG-0LCCE00005N	BEAD FILTER	220Ω	C,F,G
L857	LG-0LCCE00005N	BEAD FILTER	220Ω	C,F,G
L858	LG-0LCCE00005N	BEAD FILTER	220Ω	C,F,G
L859	LG-0LCCE00005N	BEAD FILTER	220Ω	C,F,G
L860	LG-0LCCE00005N	BEAD FILTER	220Ω	C,F,G
L862	LG-0LCCE00005N	BEAD FILTER	220Ω	C,F,G
CF3C1	LG-6200J000039	NOISE FILTER	90H	C,F,G
CN102	LG-6630XE00120	CONNECTOR	20P	
CN103	LG-6630XE00313	CONNECTOR	13P	
CN201	LG-6630XE00120	CONNECTOR	20P	
CN250	LG-6630R-FB11T	CONNECTOR	20P	
CN401	LG-6630XE00109	CONNECTOR	9P	
CN402	LG-6630XE00123	CONNECTOR	23P	
CN602	LG-6602T25008N	CONNECTOR	14P	
CN603	LG-561-661B	CONNECTOR	2P	
CN801	LG-EAG40562101	DSUB CONNE	19P	C,F,G
CN850	LG-EAG40562101	CONNECTOR	19P	
F501	LG-6200JB8014A	NOISE FILTER	90H	
F861	LG-6200J000039	NOISE FILTER	90H	
F862	LG-6200J000039	NOISE FILTER	90H	
F863	LG-6200J000039	NOISE FILTER	90H	
F864	LG-6200J000039	NOISE FILTER	90H	
JK201	LG-6612K00010B	FIBER OPT JACK	JSR1164-B	
JK250	LG-6612JH002XG	RCA JACK		
JK251	LG-EAG60700901	SCART JACK		A,B,H,I ,J
JK252	LG-MAZ37689001	BRACKET		C,D,E, F,G,K,L ,M,N,O
JK3C2	LG-EAG57068001	CONNECTOR	24P	C,F,G
JK703	LG-6640000070D	CONNECTOR	12P	
PN106	LG-EAD42218204	HARNESS	15P 220mm	N,O
TU100	LG-EBL57006602	ANALOG TUNER	KST-MW104FV1-S60	A,B,H,I ,J

△ Symbol No.	Part No.	Part Name	Description	Local
TU100	LG-EBL57006801	ANALOG TUNER	KST-MW004MV0-S60W	C,D,E, F,G,K,L ,M,N,O
X100	LG-EAW32918901	CRYSTAL	9.8304MHz	
X200	LG-6212AB2246C	CRYSTAL	24.576MHz	
X500	LG-EAW32919201	CRYSTAL	27MHz 15pF	
X601	LG-EAW32919901	CRYSTAL	12.288MHz	
X801	LG-EAW32919201	CRYSTAL	27MHz 15pF	C,F,G
ZD500	LG-0DZRM00338A	Z DIODE	5.6V 60Ω	
ZD501	LG-0DZRM00338A	Z DIODE	5.6V 60Ω	

Front board

Block No. [0][2]

△ Symbol No.	Part No.	Part Name	Description	Local
IC301	LG-EAN41678501	IC	ET16315	
Q303	LG-0TR320509AB	TRANSISTOR	KTC3205-Y(KTC2236A) KTC3205-TP	
Q304	LG-0TR220309AF	BIPOLAR TR	SRA2203	
Q305	LG-0TR129809BB	BIPOLAR TR	KTA1298Y	
D301	LG-0DR104009AB	RECTIFIER DIODE	400V 1.1V 5uA 30A	
C301	LG-0CH1104K566	C CAPACITOR	100nF 10% 50V	
C302	LG-0CH1104K566	C CAPACITOR	100nF 10% 50V	
C303	LG-0CH1104K566	C CAPACITOR	100nF 10% 50V	
C304	LG-0CH4470K416	C CAPACITOR	47pF 5% 50V	
C307	QET61CM-476	E CAPACITOR	47uF 16V M	
C308	LG-0CH1104K566	C CAPACITOR	100nF 10% 50V	
C309	LG-0CE2274C638	AL CAPACITOR	220uF 20%	
C310	LG-0CH1104K566	C CAPACITOR	100nF 10% 50V	
C331	LG-0CH1104K566	C CAPACITOR	100nF 10% 50V	
C3A1	QET61CM-476	E CAPACITOR	47uF 16V M	
C3A2	LG-0CE4765K618	AL CAPACITOR	47uF 20%	
C3A3	LG-0CH1103K566	C CAPACITOR	10nF 10% 50V	
C3A4	LG-0CH1103K566	C CAPACITOR	10nF 10% 50V	
R330	LG-0RH3302D622	CHIP RESISTOR	33kΩ 5% 1/8W	
R331	LG-0RH1003D622	CHIP RESISTOR	100kΩ 5% 1/8W	
R332	LG-0RH1003D622	CHIP RESISTOR	100kΩ 5% 1/8W	
R337	LG-0RH2202D622	CHIP RESISTOR	22kΩ 5% 1/8W	
R339	LG-0RH1002D622	CHIP RESISTOR	10kΩ 5% 1/8W	
R340	LG-0RH1002D622	CHIP RESISTOR	10kΩ 5% 1/8W	
R341	LG-0RH1000D622	CHIP RESISTOR	100Ω 5% 1/8W	
R351	LG-0RH1003D622	CHIP RESISTOR	100kΩ 5% 1/8W	
R362	LG-0RH1001D622	CHIP RESISTOR	1kΩ 5% 1/8W	
R363	LG-0RH1001D622	CHIP RESISTOR	1kΩ 5% 1/8W	
R364	LG-0RH1001D622	CHIP RESISTOR	1kΩ 5% 1/8W	
R366	LG-0RH1002D622	CHIP RESISTOR	10kΩ 5% 1/8W	
R367	LG-0RH1002D622	CHIP RESISTOR	10kΩ 5% 1/8W	
R376	LG-0RH1002D622	CHIP RESISTOR	10kΩ 5% 1/8W	
R377	LG-0RH4701D622	CHIP RESISTOR	4.7kΩ 5% 1/8W	
R378	LG-0RH1200D622	CHIP RESISTOR	120Ω 5% 1/8W	
R379	LG-0RH1200D622	CHIP RESISTOR	120Ω 5% 1/8W	
R380	LG-0RH1200D622	CHIP RESISTOR	120Ω 5% 1/8W	
R381	LG-0RH1201D622	CHIP RESISTOR	1.2kΩ 5% 1/8W	
R382	LG-0RH1001D622	CHIP RESISTOR	1kΩ 5% 1/8W	
R383	LG-0RH1201D622	CHIP RESISTOR	1.2kΩ 5% 1/8W	
R384	LG-0RH1201D622	CHIP RESISTOR	1.2kΩ 5% 1/8W	
R385	LG-0RH1801D622	CHIP RESISTOR	1.8kΩ 5% 1/8W	
R386	LG-0RH2201D622	CHIP RESISTOR	2.2kΩ 5% 1/8W	
R387	LG-0RH1200D622	CHIP RESISTOR	120Ω 5% 1/8W	
R388	LG-0RH1200D622	CHIP RESISTOR	120Ω 5% 1/8W	
R389	LG-0RH1200D622	CHIP RESISTOR	120Ω 5% 1/8W	
R390	LG-0RH1200D622	CHIP RESISTOR	120Ω 5% 1/8W	
R391	LG-0RH1200D622	CHIP RESISTOR	120Ω 5% 1/8W	
R392	LG-0RH1200D622	CHIP RESISTOR	120Ω 5% 1/8W	
R393	LG-0RH1200D622	CHIP RESISTOR	120Ω 5% 1/8W	
R394	LG-0RH1200D622	CHIP RESISTOR	120Ω 5% 1/8W	
R395	LG-0RH1200D622	CHIP RESISTOR	120Ω 5% 1/8W	
R396	LG-0RH1200D622	CHIP RESISTOR	120Ω 5% 1/8W	
R397	LG-0RH1002D622	CHIP RESISTOR	10kΩ 5% 1/8W	

△ Symbol No.	Part No.	Part Name	Description	Local	△ Symbol No.	Part No.	Part Name	Description	Local
R398	LG-0RH1002D622	CHIP RESISTOR	10kΩ 5% 1/8W		R2G6	LG-0RH2202D622	CHIP RESISTOR	22ÇäΩ 5% 1/8W	C,D,E, F,G,K,L, M,N,O
R399	LG-0RH1200D622	CHIP RESISTOR	120Ω 5% 1/8W						
VR301	LG-6110E00019C	ENCODER SWITCH							
L301	LG-0LCCE00005N	BEAD FILTER	220Ω		L2D1	LG-6200HJC102A	BEAD FILTER	1000Ω	
CN301	LG-561-711C	CONNECTOR	3P		L2D3	LG-6200HJC102A	BEAD FILTER	1000Ω	C,D,E, F,G,K,L, M,N,O
CN302	LG-6630R-FB05T	CONNECTOR	20P						
DIS301	LG-EAJ35072601	VFD			L2D5	LG-6200HJC102A	BEAD FILTER	1000Ω	C,D,E, F,G,K,L, M,N,O
LD301	LG-0DLBE0175AA	LED							
LD302	LG-0DLBE0175AA	LED			L2D8	LG-6200HJC102A	BEAD FILTER	1000Ω	
LD303	LG-0DLBE0175AA	LED			L2D9	LG-6200HJC102A	BEAD FILTER	1000Ω	
LD304	LG-0DLBE0175AA	LED							
LD305	LG-0DLBE0175AA	LED			CN202	LG-6630R-FB05M	CONNECTOR	13P	
LD306	LG-0DLBE0175AA	LED			JK2D1	LG-6612F00022C	PHONE JACK		C,D,E, F,G,K,L, M,N,O
LD307	LG-0DLBE0175AA	LED							
LD308	LG-0DLBE0175AA	LED			JK2D2	LG-6612F00022C	PHONE JACK		C,D,E, F,G,K,L, M,N,O
LD309	LG-0DLBE0175AA	LED							
LD310	LG-0DLBE0175AA	LED			JK2D3	LG-EAG35130501	USB CONNECTOR	1P	
LD311	LG-0DLBE0175AA	LED			JK2D4	LG-6612F00086A	PHONE JACK		
LD312	LG-0DLBE0175AA	LED			ZD2M1	LG-0DZPH00048A	Z DIODE	5.1V +5% 60Ω	
LD313	LG-0DLBE0175AA	LED			ZD2M2	LG-0DZRM00338A	Z DIODE	5.6V 60Ω	C,D,E, F,G,K,L, M,N,O
LD314	LG-0DLBE0175AA	LED							
LD315	LG-0DLRH0049AA	LED			ZD2M3	LG-0DZPH00048A	Z DIODE	5.1V +5% 60Ω	
PN331	LG-EAD35219502	HARNES	3P 160mm	N,O					
RC01	LG-6712R2038GJ	RECEIVER MODULE	TSOP4438QJ1						
SW301	LG-EBF40098801	TACT SWITCH							
SW302	LG-EBF40098801	TACT SWITCH							
SW303	LG-EBF40098801	TACT SWITCH							
SW304	LG-EBF40098801	TACT SWITCH							
SW305	LG-EBF40098801	TACT SWITCH							
SW306	LG-EBF40098801	TACT SWITCH							
SW307	LG-EBF40098801	TACT SWITCH							
ZD302	LG-0DZPH00048A	Z DIODE	5.1V +-5% 60Ω						

PTB board

Block No. [0][3]

△ Symbol No.	Part No.	Part Name	Description	Local
C2D1	LG-0CE2274C638	AL CAPACITOR	220uF 20%	
C2D3	LG-0CE4754K638	AL CAPACITOR	4.7uF 20%	
C2D4	LG-0CE4754K638	AL CAPACITOR	4.7uF 20%	
C2D5	LG-0CH1104H946	C CAPACITOR	100nF	
C2D6	LG-0CH1104H946	C CAPACITOR	100nF	A,B,C, D,E,F,G ,H,I,J,K ,L,M N,O
C2D6	LG-0RH0000D622	CHIP RESISTOR	0Ω 5% 1/8W	N,O
C2D6	or LG-0CH1104H946	C CAPACITOR	100nF	N,O
C2D7	LG-0CH1104H946	C CAPACITOR	100nF	
C2G1	LG-0CH1682K566	C CAPACITOR	6.8nF 10% 50V	C,D,E, F,G,K,L, M,N,O
C2G2	LG-0CH1682K566	C CAPACITOR	6.8nF 10% 50V	C,D,E, F,G,K,L, M,N,O
C2G3	LG-0CH1682K566	C CAPACITOR	6.8nF 10% 50V	
C2G4	LG-0CH1682K566	C CAPACITOR	6.8nF 10% 50V	
R2G1	LG-0RH1003D622	CHIP RESISTOR	100ÇäΩ 5% 1/8W	C,D,E, F,G,K,L, M,N,O
R2G2	LG-0RH1003D622	CHIP RESISTOR	100ÇäΩ 5% 1/8W	C,D,E, F,G,K,L, M,N,O
R2G3	LG-0RH5602D622	CHIP RESISTOR	56kΩ 5% 1/8W	C,D,E, F,G,K,L, M,N,O
R2G4	LG-0RH5602D622	CHIP RESISTOR	56kΩ 5% 1/8W	C,D,E, F,G,K,L, M,N,O
R2G5	LG-0RH2202D622	CHIP RESISTOR	22ÇäΩ 5% 1/8W	C,D,E, F,G,K,L, M,N,O

Packing materials and accessories parts list (TH-G61)

Block No. M 3 M M

No additional / supplemental order of WARRANTY CARDS are available.

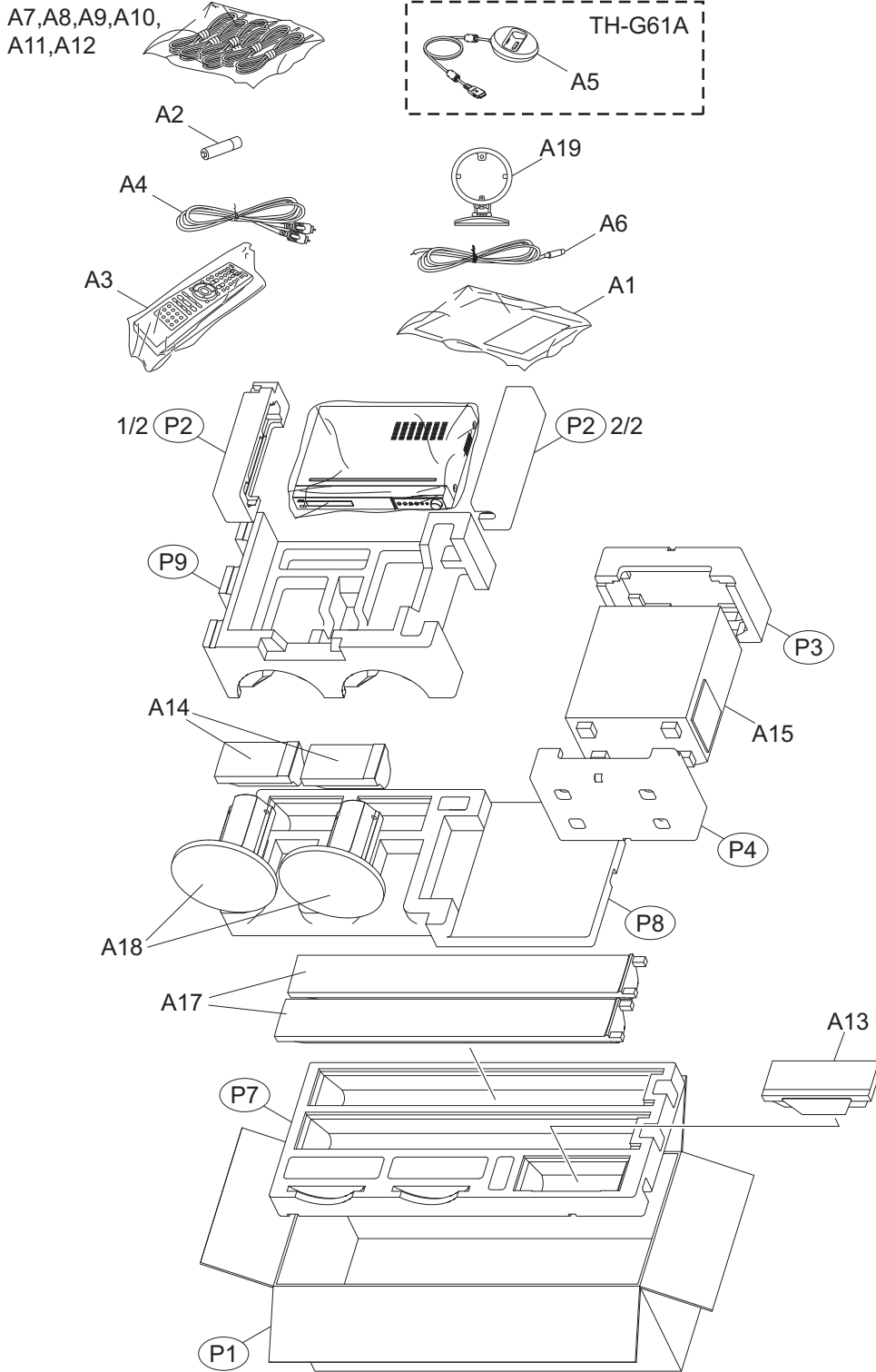

The parts without symbol number are not service.

Packing and Accessories (TH-G61)

Block No. [M][3][M][M]

△ Symbol No.	Part No.	Part Name	Description	Local
A 1	LG-AFN73077659	INST ASSY		A
A 1	LG-AFN73077672	INST ASSY		B
A 1	LG-AFN73273245	INST ASSY		C
A 1	LG-AFN73363503	INST ASSY		D
A 1	LG-AFN73273212	INST ASSY		E
A 1	LG-AFN73363560	INST ASSY		N
A 2	-----	BATTERY	1.5V	
A 3	LG-AKB37006112	REMOCON UNIT		A,B
A 3	LG-AKB37006113	REMOCON UNIT		C,D,E,N
A 4	LG-6850R-PAA5F	RCA CABLE		
A 5	LG-EBR36932307	DOCKING STATION		C
A 6	LG-5010R-T001D	FM ANTENA		
A 7	LG-EBR61173101	SPK CABLE	FRONT L	
A 8	LG-EBR61173102	SPK CABLE	FRONT R	
A 9	LG-EBR61173103	SPK CABLE	CENTER	
A 10	LG-EBR61173104	SPK CABLE	WOOFER	
A 11	LG-EBR61173105	SPK CABLE	REAR L	
A 12	LG-EBR61173106	SPK CABLE	REAR R	
A 13	LG-EAB60819601	CENTER SPK	SP-THG61C	
A 14	LG-EAB60799601	FRONT/REAR SPK	SP-THG51F(x2)	
A 15	LG-EAB51655701	SUBWOOFER	SP-THG50W	
A 17	LG-EAB60799901	FRONT SPK	SP-THG61F(x2)	
A 18	LG-EAB60818401	FRONT SPK STAND	(x2)	
A 19	LG-EAA56672101	AM ANTENNA		C,D,E,N
A 19	or LG-5010R-L004C	AM ANTENNA		C,D,E,N
P 1	LG-MAY62017571	CARTON		A,B
P 1	LG-MAY62213127	CARTON		C
P 1	LG-MAY61911483	CARTON		D,E,N
P 2	LG-MFZ47047382	CUSHION	UNIT	
P 3	LG-MFZ61796853	SPK CUSHION A	WOOFER	
P 4	LG-MFZ61796854	SPK CUSHION B	WOOFER	
P 7	LG-MFZ61796850	SPK CUSHION	BTM	
P 8	LG-MFZ61796851	SPK CUSHION	MIDL	
P 9	LG-MFZ61796852	SPK CUSHION	TOP	

Packing materials and accessories parts list (TH-G41/G31)

Block No. M 4 M M

No additional / supplemental order of WARRANTY CARDS are available.

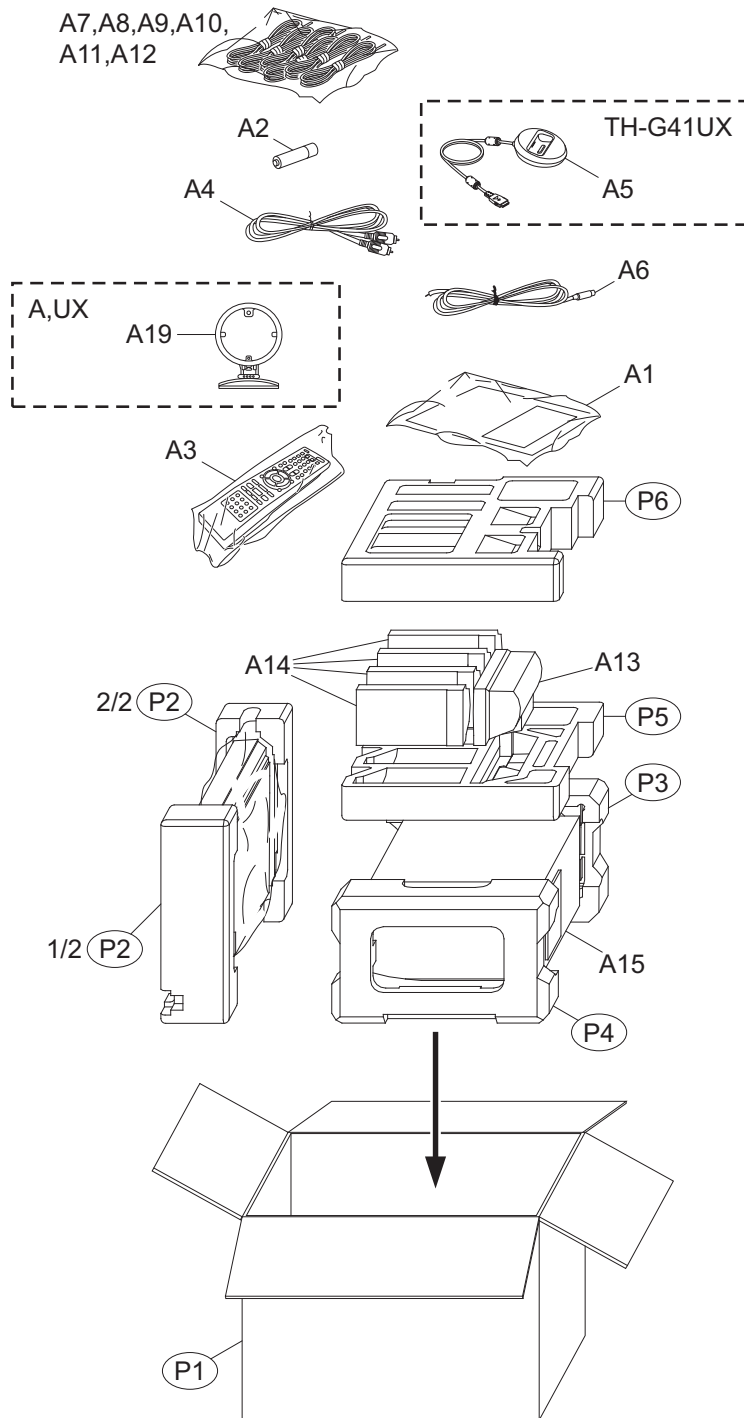

The parts without symbol number are not service.

Packing and Accessories (TH-G41/G31)

Block No. [M][4][M][M]

△ Symbol No.	Part No.	Part Name	Description	Local
A 1	LG-AFN73077658	INST ASSY		F
A 1	LG-AFN73273270	INST ASSY		G
A 1	LG-AFN73273297	INST ASSY		H
A 1	LG-AFN73077663	INST ASSY		I
A 1	LG-AFN73077677	INST ASSY		J
A 1	LG-AFN73077657	INST ASSY		K
A 1	LG-AFN73273298	INST ASSY		L
A 1	LG-AFN73273214	INST ASSY		M
A 1	LG-AFN73273295	INST ASSY		O
A 2	-----	BATTERY	1.5V	
A 3	LG-AKB37006113	REMOCON UNIT		F,G,K,L,M,O
A 3	LG-AKB37006112	REMOCON UNIT		H,I,J
A 4	LG-6850R-PAA5F	RCA CABLE		
A 5	LG-EAD60793901	DOCKING STATION		F
A 5	LG-EBR36932307	DOCKING STATION		G
A 6	LG-5010R-T001D	FM ANTENNA		
A 7	LG-EBR61173101	SPK CABLE	FRONT L	
A 8	LG-EBR61173102	SPK CABLE	FRONT R	
A 9	LG-EBR61173103	SPK CABLE	CENTER	
A 10	LG-EBR61173104	SPK CABLE	SUBWOOFER	
A 11	LG-EBR61173105	SPK CABLE	REAR L	
A 12	LG-EBR61173106	SPK CABLE	REAR R	
A 13	LG-EAB60819601	CENTER SPK	SP-THG61C	
A 14	LG-EAB60799601	FRONT/REAR SPK	SP-THG51F(x4)	
A 15	LG-EAB51655701	SUB WOOFER	SP-THG50W	
A 19	LG-EAA56672101	AM ANTENNA		F,G,K,L,M,O
A 19	or LG-5010R-L004C	AM ANTENNA		F,G,K,L,M,O
P 1	LG-MAY62017573	CARTON		F
P 1	LG-MAY61911488	CARTON		G
P 1	LG-MAY62017570	CARTON		H,I,J
P 1	LG-MAY62017572	CARTON		K
P 1	LG-MAY61911482	CARTON		L,M,O
P 2	LG-MFZ47047381	CUSHION	UNIT	
P 3	LG-MFZ41605475	SPK CUSHION	WOOFER	
P 4	LG-MFZ41605476	SPK CUSHION	WOOFER	
P 5	LG-MFZ61796848	SPK CUSHION	FRONT/CENTER SPK	
P 6	LG-MFZ61796849	SPK CUSHION	FRONT/CENTER SPK	



REVISION INFORMATION

DVD DIGITAL CINEMA SYSTEM

**TH-G61E, TH-G61EN, TH-G61A, TH-G61UX,
TH-G61UN, TH-G41A, TH-G41UX, TH-G31B,
TH-G31E, TH-G31EN, TH-G31A, TH-G31UX,
TH-G31UN, TH-G61UH, TH-G31UH**

■ OVERVIEW

Add TH-G61UH and TH-G31UH.

■ DETAILS

COVER SECTION

Title	Line	No.MB713<Rev.001>	No.MB713<Rev.002>	Description
Revision		Rev.001	Rev.002	
Issue Date		2009/10	2010/01	
Model No.		TH-G31A, TH-G31B, TH-G31E, TH-G31EN, TH-G31UN, TH-G31UX, TH-G41A, TH-G41UX, TH-G61A, TH-G61E, TH-G61EN, TH-G61UN, TH-G61UX	TH-G31A, TH-G31B, TH-G31E, TH-G31EN, TH-G31UH, TH-G31UN, TH-G31UX, TH-G41A, TH-G41UX, TH-G61A, TH-G61E, TH-G61EN, TH-G61UH, TH-G61UN, TH-G61UX	
Cover Illustration		ILLUSTRATION(mb713_0001.png)	ILLUSTRATION(mb713_0001.png)	
Copyright		COPYRIGHT (C) 2009 Victor Company of Japan, Limited	COPYRIGHT (C) 2010 Victor Company of Japan, Limited	
SPECIFICATION	T	-	SPECIFICATION	
	2	-	TH-G61 Europe and Oceania	
	3	-	General	
	4	-	Power supply 220 - 240 V ~ 50/60 Hz	
	5	-	Power consumption 130 W	
	6	-	Net Weight 3.6 kg	
	7	-	External dimensions (W × H × D) 430 × 76 × 317 mm	

Title	Line	No.MB713<Rev.001>	No.MB713<Rev.002>	Description
	8	-	Operating conditions Temperature: 5°C to 35°C, Operation status: Horizontal	
	9	-	Operating humidity 5% to 85%	
	10	-	Laser Semiconductor laser, wavelength 650 nm	
	11	-	CD/DVD	
	12	-	Video system PAL/NTSC	
	13	-	Frequency response (audio) 140 Hz to 20 kHz*	
	14	-	Signal-to-noise ratio (audio) More than 75 dB (1 kHz, 20 kHz LPF/A-Filter)*	
	15	-	Dynamic range (audio) More than 75 dB*	
	16	-	Harmonic distortion (audio) 0.5 % (1 kHz, at 1W position) (20 kHz LPF)*	
	17	-	Video	
	18	-	Video output 1.0 V (p-p), 75 Ω, negative sync., RCA jack × 1/ SCART (TO TV)	
	19	-	COMPONENT VIDEO OUT (Y) 1.0 V (p-p), 75 ohms, negative sync, RCA jack × 1	
	20	-	(PB)/(PR) 0.7 V (p-p), 75 ohms, RCA jack × 1	
	21	-	HDMI OUT 480i (or 576i)/480p (or 576p)/720p/1080i/1080p	
	22	-	Tuner	
	23	-	FM Tuning Range 87.5 - 108.0 MHz	
	24	-	Intermediate Frequency 128 kHz	
	25	-	Signal-to Noise Ratio 60 dB (Mono) *	
	26	-	Frequency Response 140 - 10,000 Hz *	
	27	-	AM (for Australia and Asia) Tuning Range 522 - 1,710 MHz	
	28	-	Intermediate Frequency 128 kHz	
	29	-	Amplifier	
	30	-	Stereo mode 155 W + 155 W (4Ω at 1 kHz, THD 10 %)	
	31	-	Surround mode(* Depending on the sound mode settings and the source, there may be no sound output.) Front 155 W	
	32	-	Center* 155 W + 155 W (4Ω at 1 kHz, THD 10 %)	
	33	-	Surround* 225 W (3Ω at 70 Hz, THD 10 %)	

Title	Line	No.MB713<Rev.001>	No.MB713<Rev.002>	Description
	34	-	Subwoofer*	
	35	-	Inputs AUDIO IN, OPTICAL IN, AUX IN, USB, TV-AUDIO (SCART)	
	36	-	Outputs MONITOR OUT, HDMI OUT, SCART (for Europe), COMPONENT VIDEO OUT	
	37	-	Speakers	
	38	-	Front Speaker Type 2 Way 3 Speaker	
	39	-	Impedance 4 Ω	
	40	-	Frequency Response 80 - 18000 Hz	
	41	-	Sound Pressure Level 83 dB/W (1m)	
	42	-	Rated Input Power 155 W	
	43	-	Max. Input Power 310 W	
	44	-	Net Dimensions (W × H × D) 280 × 1201 × 280 mm	
	45	-	Net Weight 4.4 kg	
	46	-	Center speaker Type 1 Way 1 Speaker	
	47	-	Impedance 4 Ω	
	48	-	Frequency Response 120 - 18000 Hz	
	49	-	Sound Pressure Level 83 dB/W (1m)	
	50	-	Rated Input Power 155 W	
	51	-	Max. Input Power 310 W	
	52	-	Net Dimensions (W × H × D) 301 × 118 × 83 mm	
	53	-	Net Weight 0.9 kg	
	54	-	Rear Speaker Type 1 Way 1 Speaker	
	55	-	Impedance 4 Ω	
	56	-	Frequency Response 120 - 18000 Hz	
	57	-	Sound Pressure Level 83 dB/W (1m)	
	58	-	Rated Input Power 155 W	

Title	Line	No.MB713<Rev.001>	No.MB713<Rev.002>	Description
	59	-	Max. Input Power 310 W	
	60	-	Net Dimensions (W × H × D) 113 × 209 × 83 mm	
	61	-	Net Weight 0.78 kg	
	62	-	Passive Subwoofer Type 1 Way 1 Speaker	
	63	-	Impedance 3 Ω	
	64	-	Frequency Response 40 - 1500 Hz	
	65	-	Sound Pressure Level 82 dB/W (1m)	
	66	-	Rated Input Power 255 W	
	67	-	Max. Input Power 450 W	
	68	-	Net Dimensions (W × H × D) 236 × 435 × 391 mm	
	69	-	Net Weight 5.7 kg	
	70	-	USB	
	71	-	Output power DC 5V 500mA	
	73	-	Items with * are measured at Front Speaker Terminals in STEREO mode	
	74	-	Designs and specifications are subject to change without notice.	
	76	-	TH-G61 Asia	
	77	-	General	
	78	-	Power supply 110 - 240 V ~ 50/60 Hz	
	79	-	Power consumption 130 W	
	80	-	Net Weight 3.6 kg	
	81	-	External dimensions (W × H × D) 430 × 76 × 317 mm	
	82	-	Operating conditions Temperature: 5°C to 35°C, Operation status: Horizontal	
	83	-	Operating humidity 5% to 85%	
	84	-	Laser Semiconductor laser, wavelength 650 nm	
	85	-	CD/DVD	
	86	-	Video system PAL/NTSC	
	87	-	Frequency response (audio) 140 Hz to 20 kHz*	

Title	Line	No.MB713<Rev.001>	No.MB713<Rev.002>	Description
	88	-	Signal-to-noise ratio (audio) More than 75 dB (1 kHz, 20 kHz LPF/A-Filter)*	
	89	-	Dynamic range (audio) More than 75 dB*	
	90	-	Harmonic distortion (audio) 0.5 % (1 kHz, at 1W position) (20 kHz LPF)*	
	91	-	Video	
	92	-	Video output 1.0 V (p-p), 75 Ω, negative sync., RCA jack × 1	
	93	-	COMPONENT VIDEO OUT (Y) 1.0 V (p-p), 75 ohms, negative sync, RCA jack × 1	
	94	-	(PB)/(PR) 0.7 V (p-p), 75 ohms, RCA jack × 1	
	95	-	HDMI OUT 480i (or 576i)/480p (or 576p)/720p/1080i/1080p	
	96	-	Tuner	
	97	-	FM Tuning Range 87.5 - 108.0 MHz	
	98	-	Intermediate Frequency 128 kHz	
	99	-	Signal-to Noise Ratio 60 dB (Mono) *	
	100	-	Frequency Response 140 - 10,000 Hz *	
	101	-	AM (for Australia and Asia) Tuning Range 522 - 1,710 MHz	
	102	-	Intermediate Frequency 128 kHz	
	103	-	Amplifier	
	104	-	Stereo mode 155 W + 155 W (4Ω at 1 kHz, THD 10 %)	
	105	-	Surround mode (* Depending on the sound mode settings and the source, there may be no sound output.) Front 155 W	
	106	-	Center* 155 W + 155 W (4Ω at 1 kHz, THD 10 %)	
	107	-	Surround* 225 W (3Ω at 70 Hz, THD 10 %)	
	108	-	Subwoofer*	
	109	-	Inputs AUDIO IN, OPTICAL IN, AUX IN, USB, TV-AUDIO (SCART)	
	110	-	Outputs MONITOR OUT, HDMI OUT, COMPONENT VIDEO OUT	
	111	-	Speakers	
	112	-	Front Speaker Type 2 Way 3 Speaker	
	113	-	Impedance 4 Ω	

Title	Line	No.MB713<Rev.001>	No.MB713<Rev.002>	Description
	114	-	Frequency Response 80 - 18000 Hz	
	115	-	Sound Pressure Level 83 dB/W (1m)	
	116	-	Rated Input Power 155 W	
	117	-	Max. Input Power 310 W	
	118	-	Net Dimensions (W × H × D) 280 × 1201 × 280 mm	
	119	-	Net Weight 4.4 kg	
	120	-	Center speaker Type 1 Way 1 Speaker	
	121	-	Impedance 4 Ω	
	122	-	Frequency Response 120 - 18000 Hz	
	123	-	Sound Pressure Level 83 dB/W (1m)	
	124	-	Rated Input Power 155 W	
	125	-	Max. Input Power 310 W	
	126	-	Net Dimensions (W × H × D) 301 × 118 × 83 mm	
	127	-	Net Weight 0.9 kg	
	128	-	Rear Speaker Type 1 Way 1 Speaker	
	129	-	Impedance 4 Ω	
	130	-	Frequency Response 120 - 18000 Hz	
	131	-	Sound Pressure Level 83 dB/W (1m)	
	132	-	Rated Input Power 155 W	
	133	-	Max. Input Power 310 W	
	134	-	Net Dimensions (W × H × D) 113 × 209 × 83 mm	
	135	-	Net Weight 0.78 kg	
	136	-	Passive Subwoofer Type 1 Way 1 Speaker	
	137	-	Impedance 3 Ω	
	138	-	Frequency Response 40 - 1500 Hz	

Title	Line	No.MB713<Rev.001>	No.MB713<Rev.002>	Description
	139	-	Sound Pressure Level 82 dB/W (1m)	
	140	-	Rated Input Power 255 W	
	141	-	Max. Input Power 450 W	
	142	-	Net Dimensions (W × H × D) 236 × 435 × 391 mm	
	143	-	Net Weight 5.7 kg	
	144	-	USB	
	145	-	Output power DC 5V 500mA	
	147	-	Items with * are measured at Front Speaker Terminals in STEREO mode	
	148	-	Designs and specifications are subject to change without notice.	
	150	-	TH-G41 Oceania	
	151	-	General	
	152	-	Power supply 220 - 240 V ~ 50/60 Hz	
	153	-	Power consumption 130 W	
	154	-	Net Weight 3.6 kg	
	155	-	External dimensions (W × H × D) 430 × 76 × 317 mm	
	156	-	Operating conditions Temperature: 5°C to 35°C, Operation status: Horizontal	
	157	-	Operating humidity 5% to 85%	
	158	-	Laser Semiconductor laser, wavelength 650 nm	
	159	-	CD/DVD	
	160	-	Video system PAL/NTSC	
	161	-	Frequency response (audio) 140 Hz to 20 kHz*	
	162	-	Signal-to-noise ratio (audio) More than 75 dB (1 kHz, 20 kHz LPF/A-Filter)*	
	163	-	Dynamic range (audio) More than 75 dB*	
	164	-	Harmonic distortion (audio) 0.5 % (1 kHz, at 1W position) (20 kHz LPF)*	
	165	-	Video	
	166	-	Video output 1.0 V (p-p), 75 Ω, negative sync., RCA jack × 1	
	167	-	COMPONENT VIDEO OUT (Y) 1.0 V (p-p), 75 ohms, negative sync, RCA jack × 1	
	168	-	(PB)/(PR) 0.7 V (p-p), 75 ohms, RCA jack × 1	
	169	-	HDMI OUT 480i (or 576i)/480p (or 576p)/720p/1080i/1080p	

Title	Line	No.MB713<Rev.001>	No.MB713<Rev.002>	Description
	170	-	Tuner	
	171	-	FM Tuning Range 87.50 - 108.00 MHz	
	172	-	Intermediate Frequency 128 kHz	
	173	-	Signal-to Noise Ratio 60 dB (Mono) *	
	174	-	Frequency Response 140 - 10,000 Hz *	
	175	-	AM (for Australia and Asia) Tuning Range 522 - 1,710 MHz	
	176	-	Intermediate Frequency 128 kHz	
	177	-	Amplifier	
	178	-	Stereo mode 155 W + 155 W (4Ω at 1 kHz, THD 10 %)	
	179	-	Surround mode (* Depending on the sound mode settings and the source, there may be no sound output.) Front 155 W + 155 W (THD 10 %)	
	180	-	Center* 155 W	
	181	-	Surround* 155 W + 155 W (4Ω at 1 kHz, THD 10 %)	
	182	-	Subwoofer* 225 W (3Ω at 70 Hz, THD 10 %)	
	183	-	Inputs AUDIO IN, OPTICAL IN, AUX IN, iPod, HDMI IN, USB	
	184	-	Outputs MONITOR OUT, HDMI OUT, COMPONENT VIDEO OUT	
	185	-	Speakers	
	186	-	Front/Rear Speaker Type 1 Way 1 Speaker	
	187	-	Impedance 4 Ω	
	188	-	Frequency Response 120 - 18000 Hz	
	189	-	Sound Pressure Level 83 dB/W (1m)	
	190	-	Rated Input Power 155 W	
	191	-	Max. Input Power 310 W	
	192	-	Net Dimensions (W × H × D) 113 × 209 × 83 mm	
	193	-	Net Weight 0.78 kg	

Title	Line	No.MB713<Rev.001>	No.MB713<Rev.002>	Description
	194	-	Center speaker Type 1 Way 1 Speaker	
	195	-	Impedance 4 Ω	
	196	-	Frequency Response 120 - 18000 Hz	
	197	-	Sound Pressure Level 83 dB/W (1m)	
	198	-	Rated Input Power 155 W	
	199	-	Max. Input Power 310 W	
	200	-	Net Dimensions (W × H × D) 301 × 118 × 83 mm	
	201	-	Net Weight 0.9 kg	
	202	-	Passive Subwoofer Type 1 Way 1 Speaker	
	203	-	Impedance 3 Ω	
	204	-	Frequency Response 40 - 1500 Hz	
	205	-	Sound Pressure Level 82 dB/W (1m)	
	206	-	Rated Input Power 255 W	
	207	-	Max. Input Power 450 W	
	208	-	Net Dimensions (W × H × D) 236 × 435 × 391 mm	
	209	-	Net Weight 5.7 kg	
	210	-	USB	
	211	-	Output power DC 5V 500mA	
	213	-	Items with * are measured at Front Speaker Terminals in STEREO mode	
	214	-	Designs and specifications are subject to change without notice.	
	216	-	TH-G41 Asia	
	217	-	General	
	218	-	Power supply 110 - 240 V ~ 50/60 Hz	
	219	-	Power consumption 130 W	
	220	-	Net Weight 3.6 kg	
	221	-	External dimensions (W × H × D) 430 × 76 × 317 mm	
	222	-	Operating conditions Temperature: 5°C to 35°C, Operation status: Horizontal	

Title	Line	No.MB713<Rev.001>	No.MB713<Rev.002>	Description
	223	-	Operating humidity 5% to 85%	
	224	-	Laser Semiconductor laser, wavelength 650 nm	
	225	-	CD/DVD	
	226	-	Video system PAL/NTSC	
	227	-	Frequency response (audio) 140 Hz to 20 kHz*	
	228	-	Signal-to-noise ratio (audio) More than 75 dB (1 kHz, 20 kHz LPF/A-Filter)*	
	229	-	Dynamic range (audio) More than 75 dB*	
	230	-	Harmonic distortion (audio) 0.5 % (1 kHz, at 1W position) (20 kHz LPF)*	
	231	-	Video	
	232	-	Video output 1.0 V (p-p), 75 Ω, negative sync., RCA jack × 1	
	233	-	COMPONENT VIDEO OUT (Y) 1.0 V (p-p), 75 ohms, negative sync, RCA jack × 1	
	234	-	(PB)/(PR) 0.7 V (p-p), 75 ohms, RCA jack × 1	
	235	-	HDMI OUT 480i (or 576i)/480p (or 576p)/720p/1080i/1080p	
	236	-	Tuner	
	237	-	FM Tuning Range 87.50 - 108.00 MHz (or 87.5 - 108.0 MHz)	
	238	-	Intermediate Frequency 128 kHz	
	239	-	Signal-to Noise Ratio 60 dB (Mono) *	
	240	-	Frequency Response 140 - 10,000 Hz *	
	241	-	AM (for Australia and Asia) Tuning Range 522 - 1,710 MHz	
	242	-	Intermediate Frequency 128 kHz	
	243	-	Amplifier	
	244	-	Stereo mode 155 W + 155 W (4Ω at 1 kHz, THD 10 %)	
	245	-	Surround mode(* Depending on the sound mode settings and the source, there may be no sound output.) Front 155 W + 155 W (THD 10 %)	
	246	-	Center* 155 W	
	247	-	Surround* 155 W + 155 W (4Ω at 1 kHz, THD 10 %)	
	248	-	Subwoofer* 225 W (3Ω at 70 Hz, THD 10 %)	
	249	-	Inputs AUDIO IN, OPTICAL IN, AUX IN, iPod, HDMI IN, USB	

Title	Line	No.MB713<Rev.001>	No.MB713<Rev.002>	Description
	250	-	Outputs MONITOR OUT, HDMI OUT, COMPONENT VIDEO OUT	
	251	-	Speakers	
	252	-	Front/Rear Speaker Type 1 Way 1 Speaker	
	253	-	Impedance 4 Ω	
	254	-	Frequency Response 120 - 18000 Hz	
	255	-	Sound Pressure Level 83 dB/W (1m)	
	256	-	Rated Input Power 155 W	
	257	-	Max. Input Power 310 W	
	258	-	Net Dimensions (W × H × D) 113 × 209 × 83 mm	
	259	-	Net Weight 0.78 kg	
	260	-	Center speaker Type 1 Way 1 Speaker	
	261	-	Impedance 4 Ω	
	262	-	Frequency Response 120 - 18000 Hz	
	263	-	Sound Pressure Level 83 dB/W (1m)	
	264	-	Rated Input Power 155 W	
	265	-	Max. Input Power 310 W	
	266	-	Net Dimensions (W × H × D) 301 × 118 × 83 mm	
	267	-	Net Weight 0.9 kg	
	268	-	Passive Subwoofer Type 1 Way 1 Speaker	
	269	-	Impedance 3 Ω	
	270	-	Frequency Response 40 - 1500 Hz	
	271	-	Sound Pressure Level 82 dB/W (1m)	
	272	-	Rated Input Power 255 W	
	273	-	Max. Input Power 450 W	
	274	-	Net Dimensions (W × H × D) 236 × 435 × 391 mm	

Title	Line	No.MB713<Rev.001>	No.MB713<Rev.002>	Description
	275	-	Net Weight 5.7 kg	
	276	-	USB	
	277	-	Output power DC 5V 500mA	
	279	-	Items with * are measured at Front Speaker Terminals in STEREO mode	
	280	-	Designs and specifications are subject to change without notice.	
	282	-	TH-G31 Europe and Oceania	
	283	-	General	
	284	-	Power supply 220 - 240 V ~ 50/60 Hz	
	285	-	Power consumption 130 W	
	286	-	Net Weight 3.6 kg	
	287	-	External dimensions (W × H × D) 430 × 76 × 317 mm	
	288	-	Operating conditions Temperature: 5°C to 35°C, Operation status: Horizontal	
	289	-	Operating humidity 5% to 85%	
	290	-	Laser Semiconductor laser, wavelength 650 nm	
	291	-	CD/DVD	
	292	-	Video system PAL/NTSC	
	293	-	Frequency response (audio) 140 Hz to 20 kHz*	
	294	-	Signal-to-noise ratio (audio) More than 75 dB (1 kHz, 20 kHz LPF/A-Filter)*	
	295	-	Dynamic range (audio) More than 75 dB*	
	296	-	Harmonic distortion (audio) 0.5 % (1 kHz, at 1W position) (20 kHz LPF)*	
	297	-	Video	
	298	-	Video output 1.0 V (p-p), 75 Ω, negative sync., RCA jack × 1	
	299	-	COMPONENT VIDEO OUT (Y) 1.0 V (p-p), 75 ohms, negative sync, RCA jack × 1	
	300	-	(PB)/(PR) 0.7 V (p-p), 75 ohms, RCA jack × 1	
	301	-	HDMI OUT 480i (or 576i)/480p (or 576p)/720p/1080i/1080p	
	302	-	Tuner	
	303	-	FM Tuning Range 87.50 - 108.00 MHz	
	304	-	Intermediate Frequency 128 kHz	
	305	-	Signal-to Noise Ratio 60 dB (Mono) *	

Title	Line	No.MB713<Rev.001>	No.MB713<Rev.002>	Description
	306	-	Frequency Response 140 - 10,000 Hz *	
	307	-	AM (for Australia and Asia) Tuning Range 522 - 1,710 MHz	
	308	-	Intermediate Frequency 128 kHz	
	309	-	Amplifier	
	310	-	Stereo mode 155 W + 155 W (4Ω at 1 kHz, THD 10 %)	
	311	-	Surround mode(* Depending on the sound mode settings and the source, there may be no sound output.) Front 155 W + 155 W (THD 10 %)	
	312	-	Center* 155 W	
	313	-	Surround* 155 W + 155 W (4Ω at 1 kHz, THD 10 %)	
	314	-	Subwoofer* 225 W (3Ω at 70 Hz, THD 10 %)	
	315	-	Inputs AUDIO IN, OPTICAL IN, AUX IN, iPod, HDMI IN, USB	
	316	-	Outputs MONITOR OUT, HDMI OUT, COMPONENT VIDEO OUT, SCART (for Europe)	
	317	-	Speakers	
	318	-	Front/Rear Speaker Type 1 Way 1 Speaker	
	319	-	Impedance 4 Ω	
	320	-	Frequency Response 120 - 18000 Hz	
	321	-	Sound Pressure Level 83 dB/W (1m)	
	322	-	Rated Input Power 155 W	
	323	-	Max. Input Power 310 W	
	324	-	Net Dimensions (W × H × D) 113 × 209 × 83 mm	
	325	-	Net Weight 0.78 kg	
	326	-	Center speaker Type 1 Way 1 Speaker	
	327	-	Impedance 4 Ω	
	328	-	Frequency Response 120 - 18000 Hz	
	329	-	Sound Pressure Level 83 dB/W (1m)	
	330	-	Rated Input Power 155 W	

Title	Line	No.MB713<Rev.001>	No.MB713<Rev.002>	Description
	331	-	Max. Input Power 310 W	
	332	-	Net Dimensions (W × H × D) 301 × 118 × 83 mm	
	333	-	Net Weight 0.9 kg	
	334	-	Passive Subwoofer Type 1 Way 1 Speaker	
	335	-	Impedance 3 Ω	
	336	-	Frequency Response 40 - 1500 Hz	
	337	-	Sound Pressure Level 82 dB/W (1m)	
	338	-	Rated Input Power 255 W	
	339	-	Max. Input Power 450 W	
	340	-	Net Dimensions (W × H × D) 236 × 435 × 391 mm	
	341	-	Net Weight 5.7 kg	
	343	-	Items with * are measured at Front Speaker Terminals in STEREO mode	
	344	-	Designs and specifications are subject to change without notice.	
	346	-	TH-G31 Asia	
	347	-	General	
	348	-	Power supply 110 - 240 V ~ 50/60 Hz	
	349	-	Power consumption 130 W	
	350	-	Net Weight 3.6 kg	
	351	-	External dimensions (W × H × D) 430 × 76 × 317 mm	
	352	-	Operating conditions Temperature: 5°C to 35°C, Operation status: Horizontal	
	353	-	Operating humidity 5% to 85%	
	354	-	Laser Semiconductor laser, wavelength 650 nm	
	355	-	CD/DVD	
	356	-	Video system PAL/NTSC	
	357	-	Frequency response (audio) 140 Hz to 20 kHz*	
	358	-	Signal-to-noise ratio (audio) More than 75 dB (1 kHz, 20 kHz LPF/A-Filter)*	
	359	-	Dynamic range (audio) More than 75 dB*	

Title	Line	No.MB713<Rev.001>	No.MB713<Rev.002>	Description
	360	-	Harmonic distortion (audio) 0.5 % (1 kHz, at 1W position) (20 kHz LPF)*	
	361	-	Video	
	362	-	Video output 1.0 V (p-p), 75 Ω, negative sync., RCA jack × 1	
	363	-	COMPONENT VIDEO OUT (Y) 1.0 V (p-p), 75 ohms, negative sync, RCA jack × 1	
	364	-	(PB)/(PR) 0.7 V (p-p), 75 ohms, RCA jack × 1	
	365	-	HDMI OUT 480i (or 576i)/480p (or 576p)/720p/1080i/1080p	
	366	-	Tuner	
	367	-	FM Tuning Range 87.50 - 108.00 MHz	
	368	-	Intermediate Frequency 128 kHz	
	369	-	Signal-to Noise Ratio 60 dB (Mono) *	
	370	-	Frequency Response 140 - 10,000 Hz *	
	371	-	AM (for Australia and Asia) Tuning Range 522 - 1,710 MHz	
	372	-	Intermediate Frequency 128 kHz	
	373	-	Amplifier	
	374	-	Stereo mode 155 W + 155 W (4Ω at 1 kHz, THD 10 %)	
	375	-	Surround mode(* Depending on the sound mode settings and the source, there may be no sound output.) Front 155 W + 155 W (THD 10 %)	
	376	-	Center* 155 W	
	377	-	Surround* 155 W + 155 W (4Ω at 1 kHz, THD 10 %)	
	378	-	Subwoofer* 225 W (3Ω at 70 Hz, THD 10 %)	
	379	-	Inputs AUDIO IN, OPTICAL IN, AUX IN, iPod, HDMI IN, USB	
	380	-	Outputs MONITOR OUT, HDMI OUT, COMPONENT VIDEO OUT	
	381	-	Speakers	
	382	-	Front/Rear Speaker Type 1 Way 1 Speaker	
	383	-	Impedance 4 Ω	
	384	-	Frequency Response 120 - 18000 Hz	

Title	Line	No.MB713<Rev.001>	No.MB713<Rev.002>	Description
	385	-	Sound Pressure Level 83 dB/W (1m)	
	386	-	Rated Input Power 155 W	
	387	-	Max. Input Power 310 W	
	388	-	Net Dimensions (W × H × D) 113 × 209 × 83 mm	
	389	-	Net Weight 0.78 kg	
	390	-	Center speaker Type 1 Way 1 Speaker	
	391	-	Impedance 4 Ω	
	392	-	Frequency Response 120 - 18000 Hz	
	393	-	Sound Pressure Level 83 dB/W (1m)	
	394	-	Rated Input Power 155 W	
	395	-	Max. Input Power 310 W	
	396	-	Net Dimensions (W × H × D) 301 × 118 × 83 mm	
	397	-	Net Weight 0.9 kg	
	398	-	Passive Subwoofer Type 1 Way 1 Speaker	
	399	-	Impedance 3 Ω	
	400	-	Frequency Response 40 - 1500 Hz	
	401	-	Sound Pressure Level 82 dB/W (1m)	
	402	-	Rated Input Power 255 W	
	403	-	Max. Input Power 450 W	
	404	-	Net Dimensions (W × H × D) 236 × 435 × 391 mm	
	405	-	Net Weight 5.7 kg	
	407	-	Items with * are measured at Front Speaker Terminals in STEREO mode	
	408	-	Designs and specifications are subject to change without notice.	
UNDER SPEC	T	-	UNDER SPEC	

PARTS LIST

MODEL No. LIST

Model No.	No.MB713<Rev.002>
TH-G31A	0B
TH-G31B	08
TH-G31E	09
TH-G31EN	0A
TH-G31UH	0F

Model No.	No.MB713<Rev.002>
TH-G31UN	0D
TH-G31UX	0C
TH-G41A	06
TH-G41UX	07
TH-G61A	03

Model No.	No.MB713<Rev.002>
TH-G61E	01
TH-G61EN	02
TH-G61UH	0E
TH-G61UN	05
TH-G61UX	04

General assembly [M1MM]

△	Symbol	or	Part No.		Part Name	Description	Qty	Models
			<Rev.001>	<Rev.002>				
M1MM	15		----- ----	LG-EAD41652903	POWER CORD	(Addition)	1	0E,0F
M1MM	23		LG-1SZZR-0081B	LG-1SZZR-0081B	SCREW		1	01,02,03,04,05,06,07,08,09,0A,0B,0C,0D,0E,0F

Electrical parts list Main board [01]

△	Symbol	or	Part No.		Part Name	Description	Qty	Models
			<Rev.001>	<Rev.002>				
	01	PN106	-----	LG-EAD42218204	HARNESS	(Addition)	1	0E,0F

Front board [02]

△	Symbol	or	Part No.		Part Name	Description	Qty	Models
			<Rev.001>	<Rev.002>				
	02	PN331	-----	LG-EAD35219502	HARNESS	(Addition)	1	0E,0F

PTB board [03]

△	Symbol	or	Part No.		Part Name	Description	Qty	Models	
			<Rev.001>	<Rev.002>					
	03	C2D6	-----	LG-ORH0000D622	CHIP RESISTOR	(Addition)	1	0E,0F	
	03	C2D6	or	-----	LG-0CH1104H946	C CAPACITOR	(Addition)	1	0E,0F

Packing and accessories G61 [M3MM]

△	Symbol	or	Part No.		Part Name	Description	Qty	Models
			<Rev.001>	<Rev.002>				
	M3MM	A1	-----	LG-AFN73363560	INST ASSY	(Addition)	1	0E
	M3MM	A2	LG-534-008C	-----	BATTERY		1	01,02,03,04,05,0E

Packing and accessories G41/G31 [M4MM]

△	Symbol	or	Part No.		Part Name	Description	Qty	Models
			<Rev.001>	<Rev.002>				
	M4MM	A1	-----	LG-AFN73273295	INST ASSY	(Addition)	1	0F



Victor Company of Japan, Limited

Home Entertainment Business Division Personal AV Operation 10-1,1chome,Ohwatari-machi,Maebashi-city,371-8543,Japan



REVISION INFORMATION

DVD DIGITAL THEATER SYSTEM

TH-G51J, TH-G41J, TH-G41C, TH-G31J, TH-G31C, TH-G61C

■ OVERVIEW

Add TH-G61C.

■ DETAILS

COVER SECTION

Title	Line	No.MB712<Rev.001>	No.MB712<Rev.002>	Description
Revision		Rev.001	Rev.002	
Issue Date		2009/09	2010/02	
Model No.		TH-G31C, TH-G31J, TH-G41C, TH-G41J, H-G51J	TH-G31C, TH-G31J, TH-G41C, TH-G41J, TH-G51J, TH-G61C	
Cover Illustration		ILLUSTRATION(mb712_0001.png)	ILLUSTRATION(mb712_0001.png)	
Category		Audio/Video Systems Division	Home Entertainment Business Division Personal AV Operation	
Copyright		COPYRIGHT (C) 2009 Victor Company of Japan, Limited	COPYRIGHT (C) 2010 Victor Company of Japan, Limited	
SPECIFICATION	192	-	TH-G61	
	193	-	General	
	194	-	Power supply 120 V ~ 60 Hz	
	195	-	Power consumption 130 W	
	196	-	Net Weight 3.6 kg	
	197	-	External dimensions (W × H × D) 430 × 76 × 317 mm	
	198	-	Operating conditions Temperature: 5°C to 35°C, Operation status: Horizontal	

Title	Line	No.MB712<Rev.001>	No.MB712<Rev.002>	Description
	199	-	Operating humidity 5% to 85%	
	200	-	Laser Semiconductor laser, wavelength 650 nm	
	201	-	CD/DVD	
	202	-	Video system NTSC	
	203	-	Frequency response (audio) 140 Hz to 20 kHz *	
	204	-	Signal-to-noise ratio (audio) More than 75 dB (1 kHz, 20 kHz LPF/A-Filter) *	
	205	-	Dynamic range (audio) More than 75 dB *	
	206	-	Harmonic distortion (audio) 0.5 % (1 kHz, at 1W position) (20 kHz LPF) *	
	207	-	Video	
	208	-	Video output 1.0 V (p-p), 75 Ω, negative sync., RCA jack × 1	
	209	-	COMPONENT VIDEO OUT (Y) 1.0 V (p-p), 75 ohms, negative sync, RCA jack × 1	
	210	-	(PB)/(PR) 0.7 V (p-p), 75 ohms, RCA jack × 1	
	211	-	HDMI OUT 480i/480p/720p/1080i/1080p	
	212	-	Tuner	
	213	-	FM Tuning Range 87.5 - 108.0 MHz	
	214	-	Intermediate Frequency 10.7 MHz	
	215	-	Signal-to Noise Ratio 60 dB (Mono) *	
	216	-	Frequency Response 140 - 10,000 Hz *	
	217	-	Amplifier	
	218	-	Stereo mode 155 W + 155 W (4Ω at 1 kHz, THD 10 %)	
	219	-	Surround mode(* Depending on the sound mode settings and the source, there may be no sound output.) Front 155 W + 155 W (THD 10 %)	
	220	-	center* 155 W	
	221	-	Surround* 155 W + 155 W (4Ω at 1 kHz, THD 10 %)	
	222	-	Subwoofer* 225 W (3Ω at 70 Hz, THD 10 %)	
	223	-	Inputs AUDIO IN, OPTICAL IN, AUX IN, iPod	

Title	Line	No.MB712<Rev.001>	No.MB712<Rev.002>	Description
	224	-	Outputs MONITOR OUT, HDMI OUT, COMPONENT VIDEO OUT	
	225	-	Speakers	
	226	-	Front Speaker Type 2 Way 3 Speaker	
	227	-	Impedance 4 Ω	
	228	-	Frequency Response 80 - 18000 Hz	
	229	-	Sound Pressure Level 83 dB/W (1m)	
	230	-	Rated Input Power 155 W	
	231	-	Max. Input Power 310 W	
	232	-	Net Dimensions (W × H × D) 280 × 1201 × 280 mm	
	233	-	Net Weight 4.4 kg	
	234	-	Center speaker Type 1 Way 1 Speaker	
	235	-	Impedance 4 Ω	
	236	-	Frequency Response 120 -18000 Hz	
	237	-	Sound Pressure Level 83 dB/W (1m)	
	238	-	Rated Input Power 155 W	
	239	-	Max. Input Power 310 W	
	240	-	Net Dimensions (W × H × D) 301 × 118 × 83 mm	
	241	-	Net Weight 0.9 kg	
	242	-	Rear Speaker Type 1 Way 1 Speaker	
	243	-	Impedance 4 Ω	
	244	-	Frequency Response 120 -18000 Hz	
	245	-	Sound Pressure Level 83 dB/W (1m)	
	246	-	Rated Input Power 155 W	
	247	-	Max. Input Power 310 W	

Title	Line	No.MB712<Rev.001>	No.MB712<Rev.002>	Description
	248	-	Net Dimensions (W × H × D) 311 × 209 × 83 mm	
	249	-	Net Weight 0.78 kg	
	250	-	Passive Subwoofer Type 1 Way 1 Speaker	
	251	-	Impedance 3 Ω	
	252	-	Frequency Response 40 - 1500 Hz	
	253	-	Sound Pressure Level 82 dB/W (1m)	
	254	-	Rated Input Power 225 W	
	255	-	Max. Input Power 450 W	
	256	-	Net Dimensions (W × H × D) 236 × 435 × 391 mm	
	257	-	Net Weight 5.7 kg	
	259	-	Items with * are measured at Front Speaker Terminals in STEREO mode	
	260	-	Designs and specifications are subject to change without notice.	

STANDARD SCHEMATIC DIAGRAMS

Exploded View

Diagram Name	No.MB712<Rev.001>	No.MB712<Rev.002>	Description
Menu	Packing materials and accessories	Packing materials and accessories 1	
Menu	-	Packing materials and accessories 2 mb712_m401.svgz	

PARTS LIST

MODEL No. LIST

Model No.	No.MB712<Rev.002>
TH-G31C	05
TH-G31J	04
TH-G41C	03
TH-G41J	02
TH-G51J	01
TH-G61C	06

General assembly [M1MM]

△	Symbol	or	Part No.		Part Name	Description	Qty	Models	
			<Rev.001>	<Rev.002>					
	M1MM	1	-----	LG-AGL72919608	FRONT PANEL ASSY	(Addition)	1	06	
	M1MM	2	-----	LG-ADV72931908	FRAME ASSY	(Addition)	1	06	
	M1MM	12	-----	LG-3300RCH001B	PLATE	(Addition)	1	06	
	M1MM	12	or	-----	LG-3300R-V127A	PLATE	(Addition)	2	06
△	M1MM	16	-----	LG-MGC58116629	REAR PANEL	(Addition)	1	06	

Electrical parts list Main board [01]

△	Symbol	or	Part No.		Part Name	Description	Qty	Models
			<Rev.001>	<Rev.002>				
	01 C3C6		-----	LG-0CK104CKG6A	C CAPACITOR	(Addition)	1	06
	01 L3D2		-----	LG-0LCCE00042A	BEAD FILTER	(Addition)	1	06
	01 L3D3		-----	LG-0LCCE00042A	BEAD FILTER	(Addition)	1	06

Packing and accessories TH-G61 [M4MM]

△	Symbol	or	Part No.		Part Name	Description	Qty	Models
			<Rev.001>	<Rev.002>				
	M4MM A1		-----	LG-AFN73077614	INST ASSY	(Addition)	1	06
	M4MM A2		-----	-----	BATTERY	(Addition)	1	06
	M4MM A3		-----	LG-AKB37006111	REMOCON UNIT	(Addition)	1	06
	M4MM A4		-----	LG-6850R-PAA5F	RCA CABLE	(Addition)	1	06
	M4MM A5		-----	LG-EAD60793901	iPod DOC STATION	(Addition)	1	06
	M4MM A6		-----	LG-5010R-T001D	FM ANTENA	(Addition)	1	06
	M4MM A7		-----	LG-EBR61173101	SPK CORD(L)	(Addition)	1	06
	M4MM A8		-----	LG-EBR61173102	SPK CORD(R)	(Addition)	1	06
	M4MM A9		-----	LG-EBR61173103	SPK CORD	(Addition)	1	06
	M4MM A10		-----	LG-EBR61173104	SPK CORD(W)	(Addition)	1	06
	M4MM A11		-----	LG-EBR61173105	SPK CORD(RL)	(Addition)	1	06
	M4MM A12		-----	LG-EBR61173106	SPK CORD(RR)	(Addition)	1	06
	M4MM A13		-----	LG-EAB60819601	CENTER SPK	(Addition)	1	06
	M4MM A14		-----	LG-EAB60799901	FRONT SPK	(Addition)	2	06
	M4MM A15		-----	LG-EAB60818401	FRONT SPK STAND	(Addition)	2	06
	M4MM A16		-----	LG-EAB60799601	FRONT/REAR SPK	(Addition)	2	06
	M4MM A17		-----	LG-EAB51655701	SUBWOOFER	(Addition)	1	06
	M4MM P1		-----	LG-MAY62017558	CARTON	(Addition)	1	06
	M4MM P2		-----	LG-MFZ47047382	CUSHION	(Addition)	1	06
	M4MM P3		-----	LG-MFZ61796853	SPK CUSHION A	(Addition)	1	06
	M4MM P4		-----	LG-MFZ61796854	SPK CUSHION B	(Addition)	1	06
	M4MM P7		-----	LG-MFZ61796850	SPK CUSHION(BTM)	(Addition)	1	06
	M4MM P8		-----	LG-MFZ61796851	SPK CUSHION(MDL)	(Addition)	1	06
	M4MM P9		-----	LG-MFZ61796852	SPK CUSHION(TOP)	(Addition)	1	06



Victor Company of Japan, Limited

Home Entertainment Business Division Personal AV Operation 10-1, 1chome, Ohwatari-machi, Maebashi-city, 371-8543, Japan