

JVC

SERVICE MANUAL

DVD DIGITAL CINEMA SYSTEM

TH-M45

Area suffix

B ----- U.K.
E ----- Continental Europe
EN ----- Northern Europe

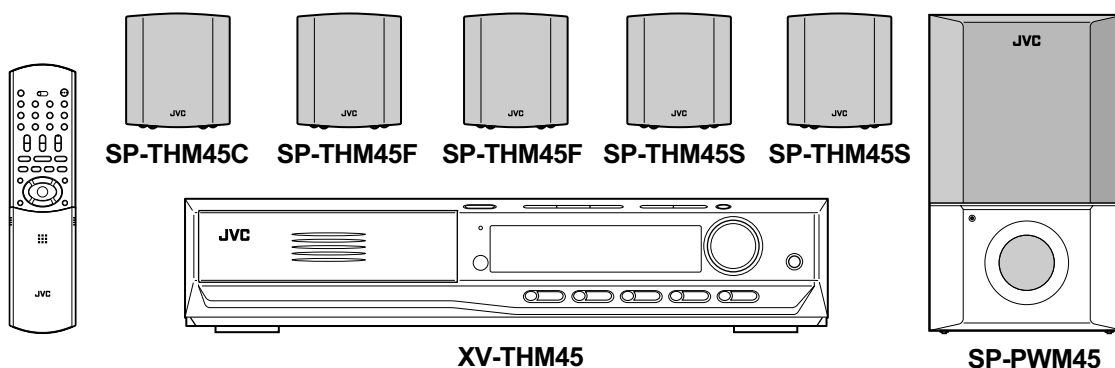

TABLE OF CONTENTS

1	PRECAUTION.....	1-3
2	SPECIFIC SERVICE INSTRUCTIONS.....	1-7
3	DISASSEMBLY.....	1-8
4	ADJUSTMENT.....	1-34
5	TROUBLESHOOTING.....	1-39

SPECIFICATION

Center unit			
Audio section			
Total Harmonic Distortion	0.02% NOTE : This value is measured at System cord CONNECTOR for reference.		
Audio input sensitivity/ Impedance (at 1 kHz)	Analog input	AUX IN	290 mV/47 k Ω
	Digital input*	DIGITAL IN (OPTICAL)	-21 dBm to -15 dBm (660 nm \pm 30 nm)
	* Corresponding to Linear PCM, Dolby Digital, and DTS Digital Surround (with sampling frequency - 32 kHz, 44.1 kHz, 48 kHz)		
Video section			
Color System	PAL		
Horizontal Resolution	500 lines		
Signal-to-Noise Ratio (Composite signal when "RGB" is selected)	64 dB		
Video output level	Composite	1.0 V(p-p)/75 Ω	
	S-video-Y	1.0 V(p-p)/75 Ω	
	S-video-C	0.286 V(p-p)/75 Ω	
Tuner section			
Tuning Range	FM	87.5 MHz to 108.0 MHz	
	AM (MW)	522 kHz to 1629 kHz	
General			
Power Requirements	AC 230 V, 50 Hz		
Power Consumption	20 W (at operation), 1.6 W (in standby mode)		
Dimensions (W \times H \times D)	400 mm \times 85 mm \times 386 mm		
Mass	4.6 kg		
Subwoofer			
Amplifier section			
Front/Center/Surround	80 W per channel, RMS at 6 Ω at 1 kHz, with 10 % total harmonic distortion.		
Subwoofer	120 W, RMS at 4 Ω at 100 Hz, with 10 % total harmonic distortion.		
Speaker section			
Speaker unit	16 cm Bass-reflex, Magnetically Shielded		
Frequency Range	30 Hz to 200 Hz		
General			
Power Requirements	AC 230 V, 50 Hz		
Power Consumption	150 W (at operation), 0 W (in standby mode)		
Dimensions (W \times H \times D)	216 mm \times 353 mm \times 485 mm		
Mass	12.0 kg		
Satellite Speakers			
Front speakers (SP-THM45F)			
Speakers	8.0 cm Bass-reflex, Magnetically Shielded		
Power Handling Capacity	80 W		
Impedance	6 Ω		
Frequency Range	90 Hz to 20 kHz		
Dimensions (W \times H \times D)	103 mm \times 115 mm \times 100 mm		
Mass	0.64 kg		
Surround speakers (SP-THM45S)			
Speakers	8.0 cm Bass-reflex, Magnetically Shielded		
Power Handling Capacity	80 W		
Impedance	6 Ω		
Frequency Range	90 Hz to 20 kHz		
Dimensions (W \times H \times D)	103 mm \times 115 mm \times 100 mm		
Mass	0.52 kg		
Center speaker			
Speakers	8.0 cm Bass-reflex, Magnetically Shielded		
Power Handling Capacity	80 W		
Impedance	6 Ω		
Frequency Range	90 Hz to 20 kHz		
Dimensions (W \times H \times D)	103 mm \times 115 mm \times 100 mm		
Mass	0.64 kg		
Accessories			
Remote control (1), Batteries (2), FM antenna (1), AM (MW) loop antenna (1), Power cord (1), System cord (1)			
Speaker codes			
5 m	For satellite (front left/right) and center speakers (3)		
10 m	For satellite speakers (surround left/right) (2) (The length of the above speaker cords are approximate.)		

Design and specifications are subject to change without notice.

SECTION 1 PRECAUTION

1.1 Safety Precautions

- (1) This design of this product contains special hardware and many circuits and components specially for safety purposes. For continued protection, no changes should be made to the original design unless authorized in writing by the manufacturer. Replacement parts must be identical to those used in the original circuits. Services should be performed by qualified personnel only.
- (2) Alterations of the design or circuitry of the product should not be made. Any design alterations of the product should not be made. Any design alterations or additions will void the manufacturer's warranty and will further relieve the manufacturer of responsibility for personal injury or property damage resulting therefrom.
- (3) Many electrical and mechanical parts in the products have special safety-related characteristics. These characteristics are often not evident from visual inspection nor can the protection afforded by them necessarily be obtained by using replacement components rated for higher voltage, wattage, etc. Replacement parts which have these special safety characteristics are identified in the Parts List of Service Manual. Electrical components having such features are identified by shading on the schematics and by (Δ) on the Parts List in the Service Manual. The use of a substitute replacement which does not have the same safety characteristics as the recommended replacement parts shown in the Parts List of Service Manual may create shock, fire, or other hazards.
- (4) The leads in the products are routed and dressed with ties, clamps, tubings, barriers and the like to be separated from live parts, high temperature parts, moving parts and/or sharp edges for the prevention of electric shock and fire hazard. When service is required, the original lead routing and dress should be observed, and it should be confirmed that they have been returned to normal, after reassembling.

(5) Leakage shock hazard testing

After reassembling the product, always perform an isolation check on the exposed metal parts of the product (antenna terminals, knobs, metal cabinet, screw heads, headphone jack, control shafts, etc.) to be sure the product is safe to operate without danger of electrical shock. Do not use a line isolation transformer during this check.

- Plug the AC line cord directly into the AC outlet. Using a "Leakage Current Tester", measure the leakage current from each exposed metal part of the cabinet, particularly any exposed metal part having a return path to the chassis, to a known good earth ground. Any leakage current must not exceed 0.5mA AC (r.m.s.).
- Alternate check method
Plug the AC line cord directly into the AC outlet. Use an AC voltmeter having, 1,000 Ω per volt or more sensitivity in the following manner. Connect a 1,500 Ω 10W resistor paralleled by a 0.15 μ F AC-type capacitor between an exposed metal part and a known good earth ground. Measure the AC voltage across the resistor with the AC

voltmeter.

Move the resistor connection to each exposed metal part, particularly any exposed metal part having a return path to the chassis, and measure the AC voltage across the resistor. Now, reverse the plug in the AC outlet and repeat each measurement. Voltage measured any must not exceed 0.75 V AC (r.m.s.). This corresponds to 0.5 mA AC (r.m.s.).

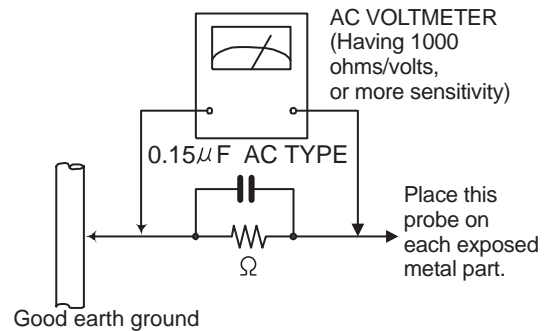

1.2 Warning

- (1) This equipment has been designed and manufactured to meet international safety standards.
- (2) It is the legal responsibility of the repairer to ensure that these safety standards are maintained.
- (3) Repairs must be made in accordance with the relevant safety standards.
- (4) It is essential that safety critical components are replaced by approved parts.
- (5) If mains voltage selector is provided, check setting for local voltage.

1.3 Caution

Burrs formed during molding may be left over on some parts of the chassis.

Therefore, pay attention to such burrs in the case of pre-forming repair of this system.

1.4 Critical parts for safety

In regard with component parts appearing on the silk-screen printed side (parts side) of the PWB diagrams, the parts that are printed over with black such as the resistor (---), diode (---) and ICP (\bullet) or identified by the " Δ " mark nearby are critical for safety. When replacing them, be sure to use the parts of the same type and rating as specified by the manufacturer. (This regulation does not Except the J and C version)

1.5 Safety Precautions (U.K only)

- (1) This design of this product contains special hardware and many circuits and components specially for safety purposes. For continued protection, no changes should be made to the original design unless authorized in writing by the manufacturer. Replacement parts must be identical to those used in the original circuits.
- (2) Any unauthorised design alterations or additions will void the manufacturer's guarantee; furthermore the manufacturer cannot accept responsibility for personal injury or property damage resulting therefrom.
- (3) Essential safety critical components are identified by () on the Parts List and by shading on the schematics, and must never be replaced by parts other than those listed in the manual. Please note however that many electrical and mechanical parts in the product have special safety related characteristics. These characteristics are often not evident from visual inspection. Parts other than specified by the manufacturer may not have the same safety characteristics as the recommended replacement parts shown in the Parts List of the Service Manual and may create shock, fire, or other hazards.
- (4) The leads in the products are routed and dressed with ties, clamps, tubings, barriers and the like to be separated from live parts, high temperature parts, moving parts and/or sharp edges for the prevention of electric shock and fire hazard. When service is required, the original lead routing and dress should be observed, and it should be confirmed that they have been returned to normal, after re-assembling.

1.5.1 Warning

- (1) Service should be performed by qualified personnel only.
- (2) This equipment has been designed and manufactured to meet international safety standards.
- (3) It is the legal responsibility of the repairer to ensure that these safety standards are maintained.
- (4) Repairs must be made in accordance with the relevant safety standards.
- (5) It is essential that safety critical components are replaced by approved parts.
- (6) If mains voltage selector is provided, check setting for local voltage.



CAUTION Burrs formed during molding may be left over on some parts of the chassis. Therefore, pay attention to such burrs in the case of preforming repair of this system.

1.6 Preventing static electricity

Electrostatic discharge (ESD), which occurs when static electricity stored in the body, fabric, etc. is discharged, can destroy the laser diode in the traverse unit (optical pickup). Take care to prevent this when performing repairs.

1.6.1 Grounding to prevent damage by static electricity

Static electricity in the work area can destroy the optical pickup (laser diode) in devices such as DVD players.

Be careful to use proper grounding in the area where repairs are being performed.

(1) Ground the workbench

Ground the workbench by laying conductive material (such as a conductive sheet) or an iron plate over it before placing the traverse unit (optical pickup) on it.

(2) Ground yourself

Use an anti-static wrist strap to release any static electricity built up in your body.

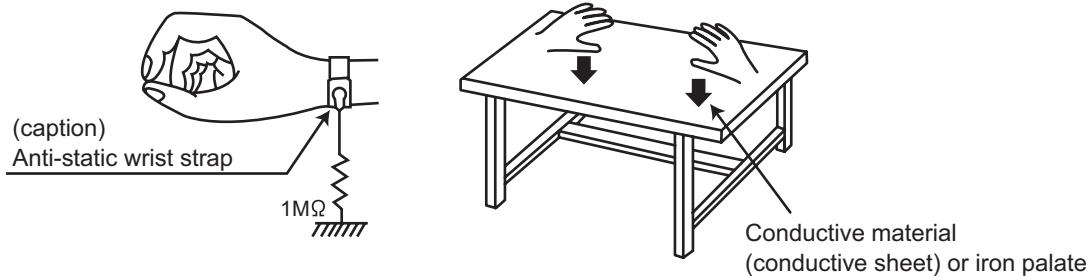

(3) Handling the optical pickup

- In order to maintain quality during transport and before installation, both sides of the laser diode on the replacement optical pickup are shorted. After replacement, return the shorted parts to their original condition. (Refer to the text.)
- Do not use a tester to check the condition of the laser diode in the optical pickup. The tester's internal power source can easily destroy the laser diode.

1.7 Handling the traverse unit (optical pickup)

- (1) Do not subject the traverse unit (optical pickup) to strong shocks, as it is a sensitive, complex unit.
- (2) Cut off the shorted part of the flexible cable using nippers, etc. after replacing the optical pickup. For specific details, refer to the replacement procedure in the text. Remove the anti-static pin when replacing the traverse unit. Be careful not to take too long a time when attaching it to the connector.
- (3) Handle the flexible cable carefully as it may break when subjected to strong force.
- (4) It is not possible to adjust the semi-fixed resistor that adjusts the laser power. Do not turn it.

1.8 Attention when traverse unit is decomposed

***Please refer to "Disassembly method" in the text for the DVD pickup unit.**

- Apply solder to the short circuit points before the flexible wire is disconnected from the connector on the DVD pickup. (If the flexible wire is disconnected without applying solder, the DVD pickup may be destroyed by static electricity.)
- In the assembly, be sure to remove solder from the short land sections after connecting the flexible wire.

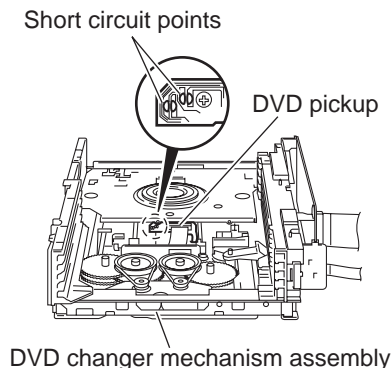

1.9 Important for laser products

1.CLASS 1 LASER PRODUCT

2.DANGER : Invisible laser radiation when open and interlock failed or defeated. Avoid direct exposure to beam.

3.CAUTION : There are no serviceable parts inside the Laser Unit. Do not disassemble the Laser Unit. Replace the complete Laser Unit if it malfunctions.

4.CAUTION : The compact disc player uses invisible laser radiation and is equipped with safety switches which prevent emission of radiation when the drawer is open and the safety interlocks have failed or are defeated. It is dangerous to defeat the safety switches.

5.CAUTION : If safety switches malfunction, the laser is able to function.

6.CAUTION : Use of controls, adjustments or performance of procedures other than those specified herein may result in hazardous radiation exposure.



CAUTION Please use enough caution not to see the beam directly or touch it in case of an adjustment or operation check.

VARNING : Osynlig laserstrålning är denna del är öppnad och spårren är urkopplad. Betrakta ej strålen.

VARO : Avattaessa ja suojalukitus ohitettaessa olet alttiina näkymättömälle lasersäteilylle. Älä katso säteeseen.

ADVARSEL : Usynlig laserstrålning ved åbning , når sikkerhedsafbrydere er ude af funktion. Undgå udsættelse for stråling.

ADVARSEL : Usynlig laserstrålning ved åbning,når sikkerhetsbryteren er avslott. unngå utsettelse for stråling.

SECTION 2
SPECIFIC SERVICE INSTRUCTIONS

This service manual does not describe SPECIFIC SERVICE INSTRUCTIONS.

SECTION 3 DISASSEMBLY

3.1 Main body section

3.1.1 Removing the metal cover (See Figs.1 to 4)

- (1) From the right and left sides of the main body, remove the four screws **A** attaching the metal cover. (See Figs.1 and 2.)
- (2) From the back side of the main body, remove the three screws **B** attaching the metal cover. (See Fig.3.)
- (3) Lift the rear section of the metal cover in the direction of the arrow while extending the lower sections of the metal cover, release the claws **a** using a longer screwdriver from the inside as required. (See Fig.4.)

Note:

Do not damage any parts and boards inside the main body when releasing the joints **a** using a longer screwdriver.

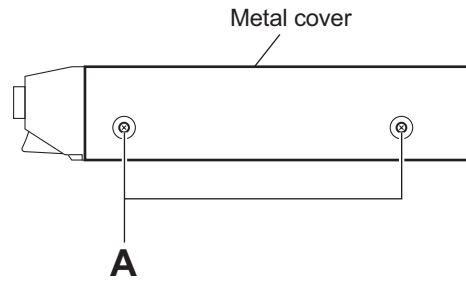

Fig.1

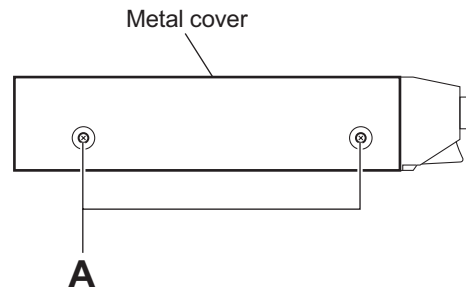

Fig.2

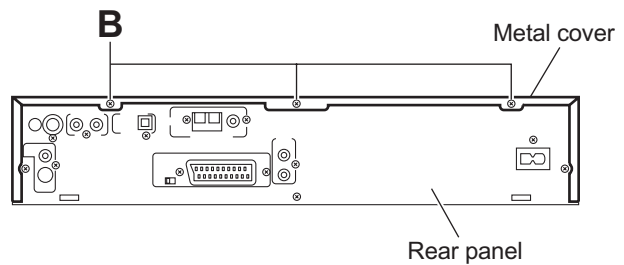

Fig.3

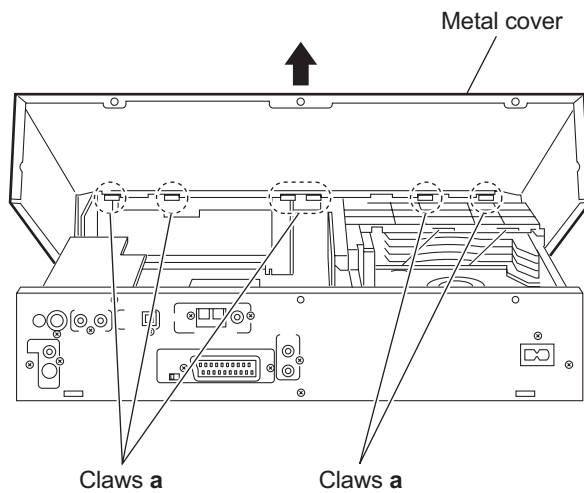

Fig.4

3.1.2 Removing the front panel assembly (See Figs.5 and 6)

- Remove the metal cover.
 - From the top side of the main body, disconnect the parallel wires from the connectors (CN408, CN409) on the main board. (See Fig.5.)
 - Disconnect the card wires from the connectors (CN407, CN412) on the main board. (See Fig.5.)
 - Remove the screw **C** attaching the earth wire to the main board. (See Fig.5.)
 - From the bottom side of the main body, remove the three screws **D** attaching the front panel assembly. (See Fig.6.)
 - Release the two hooks **b** and hook **c** from the both and bottom sides of the main body, and remove the front panel assembly in the direction of the arrow. (See Figs.5 and 6.)

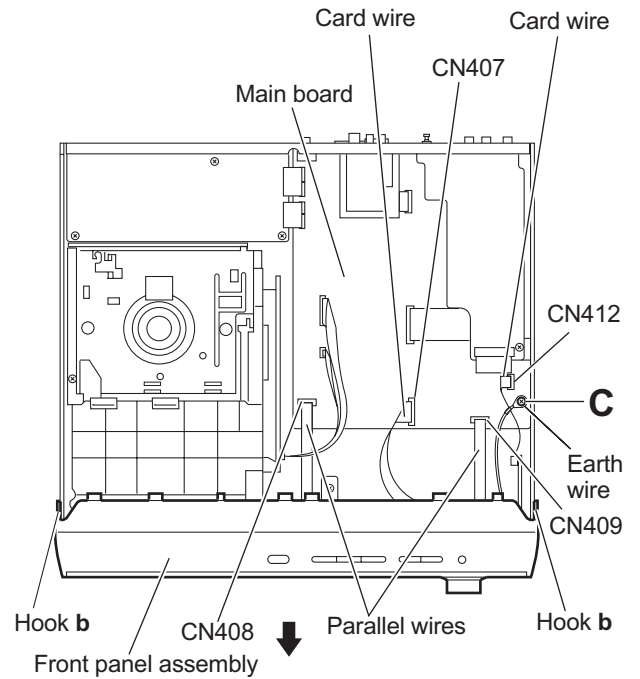

Fig.5

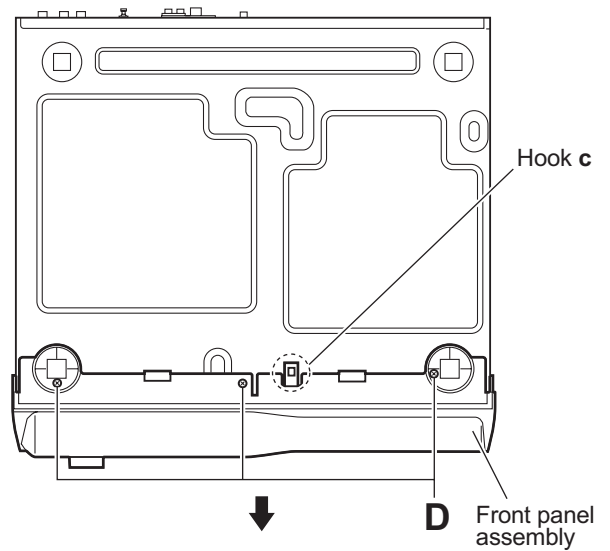

Fig.6

3.1.3 Removing the DVD changer mechanism assembly (See Fig.7)

- Remove the metal cover.
- Remove the front panel assembly.
 - (1) From the top side of the main body, disconnect the card wires from the connectors (CN405, CN415) on the main board.
 - (2) Remove the four screws **E** attaching the DVD changer mechanism assembly to the chassis base.
 - (3) Take out the DVD changer mechanism assembly in an upward direction.

Note:

When attaching the screw **E**, fit the hole of the DVD changer mechanism assembly to the bosses **d** on the chassis base.

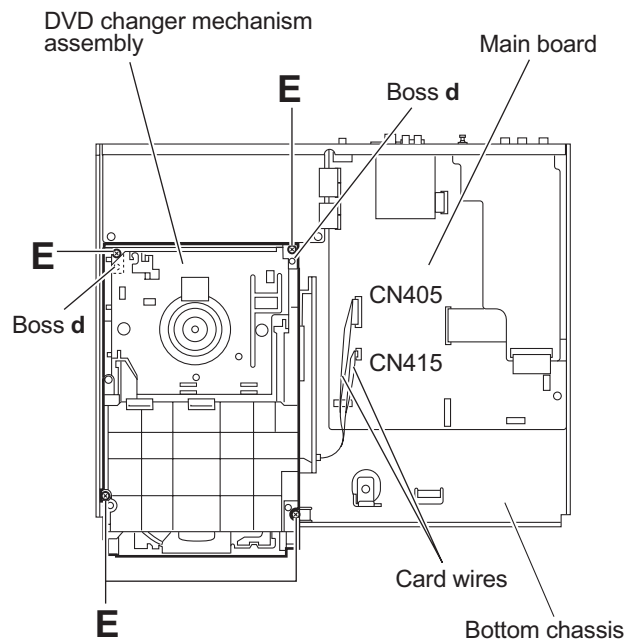

Fig.7

3.1.4 Removing the rear panel (See Fig.8)

- Remove the metal cover.
 - (1) From the back side of the main body, remove the screw **F**, nine screws **G** and three screws **H** attaching the rear panel.

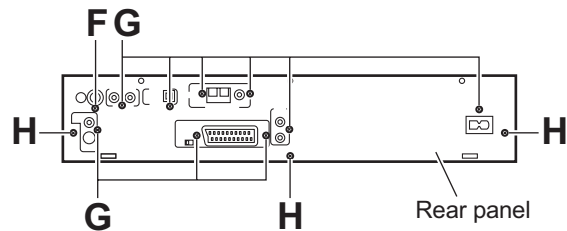

Fig.8

3.1.5 Removing the audio & digital input board (See Figs.9 and 10)

- Remove the metal cover.
 - (1) From the top side of the main body, disconnect the card wire from the connector **CN401** on the audio & digital input board. (See Fig.9.)
 - (2) Remove the screw **J** attaching the audio & digital input board. (See Fig.9.)
 - (3) From the back side of the main body, remove the screw **K** and two screws **L** attaching the audio & digital input board to the rear panel. (See Fig.10.)
 - (4) Take out the audio & digital input board from the main body.

3.1.6 Removing the tuner (See Figs.9 and 10)

- Remove the metal cover.
 - (1) From the top side of the main body, disconnect the card wire from the connector **CN1** on the tuner. (See Fig.9.)
 - (2) From the back side of the main body, remove the two screws **M** attaching the tuner to the rear panel. (See Fig.10.)
 - (3) Take out the tuner from the main body.

3.1.7 Removing the power supply board (See Figs.9 and 10)

- Remove the metal cover.
 - (1) From the top side of the main body, disconnect the parallel wires from the connectors (**CN401** to **CN404**) on the main board. (See Fig.9.)
 - (2) Remove the three screws **N** attaching the power supply board. (See Fig.9.)
 - (3) From the back side of the main body, remove the screw **P** attaching the power supply board to the rear panel. (See Fig.10.)
 - (4) Take out the power supply board from the main body.

Reference:

Remove the rear panel as required. (See Fig.8.)

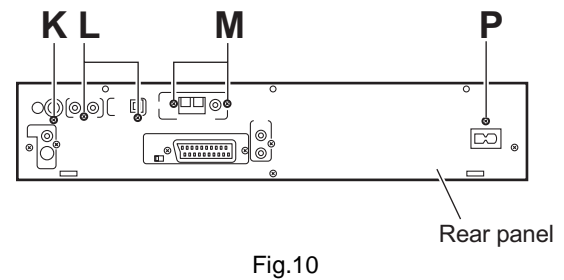
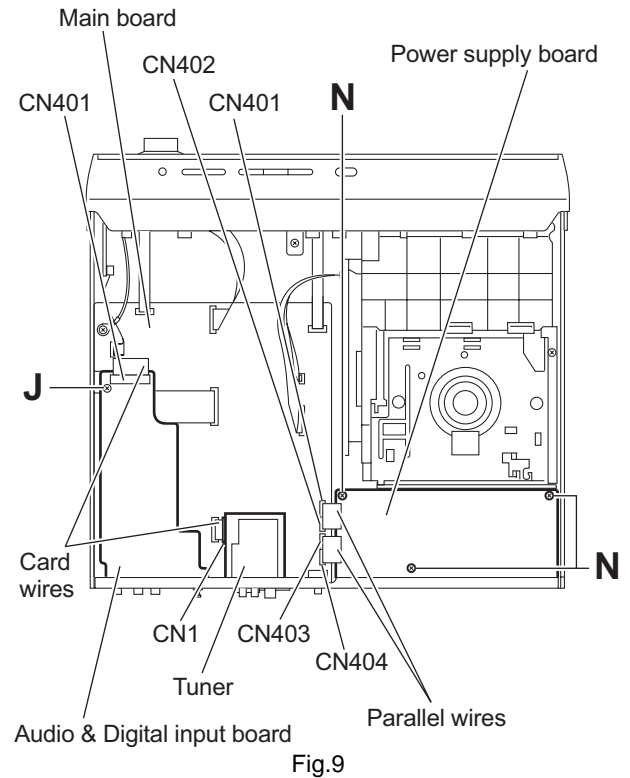

3.1.8 Removing the main board (See Figs.11 to 13)

- Remove the metal cover.
 - (1) From the top side of the main body, disconnect the card wires from the connectors (CN405, CN407, CN410 to CN412, CN415) on the main board (See Fig.11.)
 - (2) Disconnect the parallel wires from the connectors (CN401 to CN404, CN408, CN409) on the main board. (See Fig.11.)
 - (3) Remove the screw Q attaching the audio & digital input board. (See Fig.11.)
 - (4) From the back side of the main body, remove the five screws R and three screws S attaching the rear panel. (See Fig.12.)
 - (5) Take out the rear panel together the audio & digital input board and tuner.
 - (6) From the top side of the main body, remove the screw T and two screws U attaching the main board to the chassis base. (See Fig.13.)

Note:

When attaching the screw T, attach the earth wire of the front panel assembly at the same time.

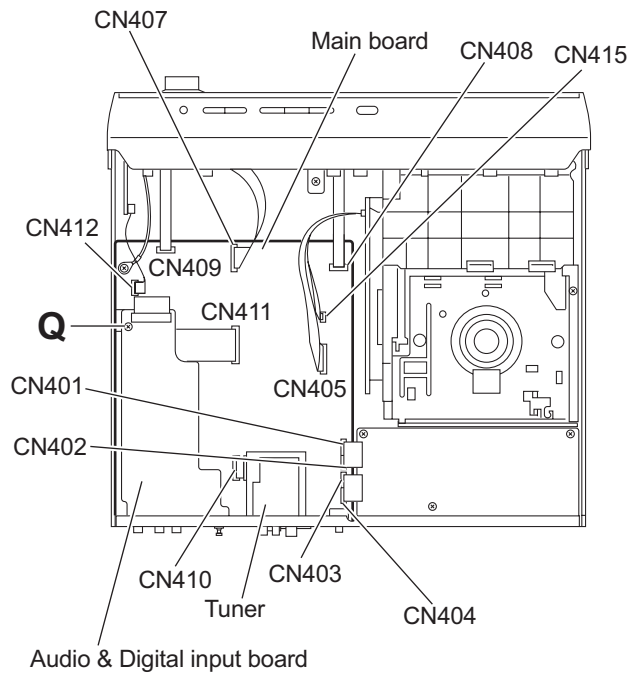

Fig.11

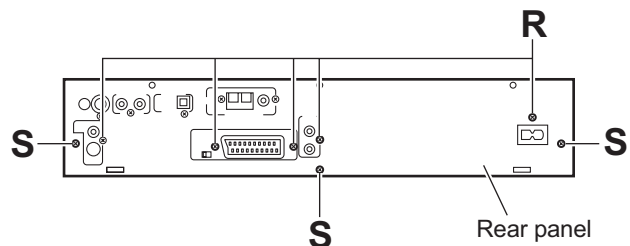

Fig.12

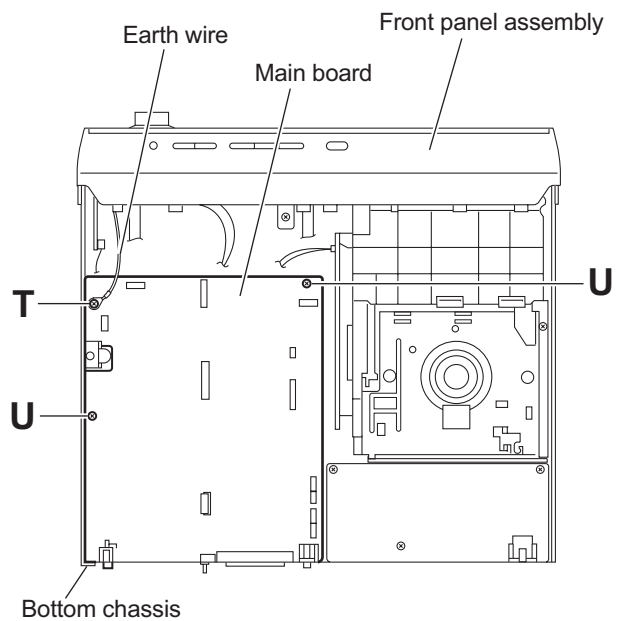

Fig.13

3.1.9 Removing the connect board (See Fig.14)

- Remove the metal cover.
- Remove the front panel assembly.
 - (1) From the inside of the front panel assembly, disconnect the card wire from the connector **CN561** on the connect board.
 - (2) Remove the screw **V** attaching the support board.
 - (3) Take out the connect board.

3.1.10 Removing the phone jack board (See Fig.14)

- Remove the metal cover.
- Remove the front panel assembly.
 - (1) From the inside of the front panel assembly, remove the two screws **W** attaching the phone jack board.
 - (2) Take out the phone jack board.

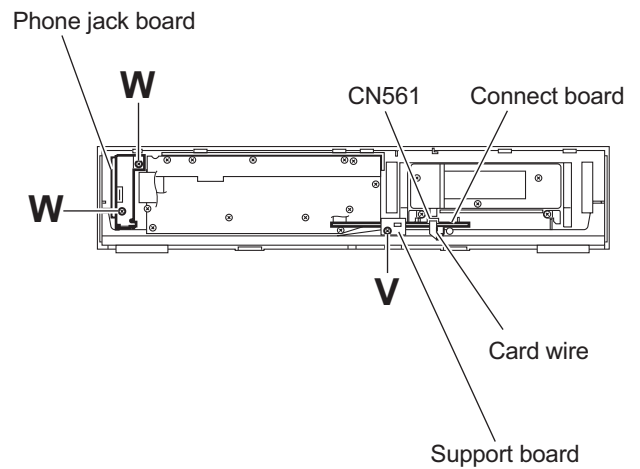

Fig.14

3.1.11 Removing the operation board (See Fig.15)

- Remove the metal cover.
- Remove the front panel assembly.
- Remove the support board.
 - (1) Remove the two screws **X** attaching the operation board.
 - (2) Take out the operation board together the Button(top).

Reference:

Remove the Button(top) from the front board as required.

3.1.12 Removing the front board (See Figs.15 and 16)

- Remove the metal cover.
- Remove the front panel assembly.
- Remove the connect board.
- Remove the operation board.
 - (1) From the front side of the front panel assembly, pull out the volume knob. (See Fig.16.)
 - (2) Remove the screw **Y** attaching the front board. (See Fig.16.)
 - (3) From the inside of the front panel assembly, remove the eight screws **Z** attaching the front board. (See Fig.15.)
 - (4) Take out the front board while releasing the claws **e** in the direction of the arrow. (See Fig.15.)

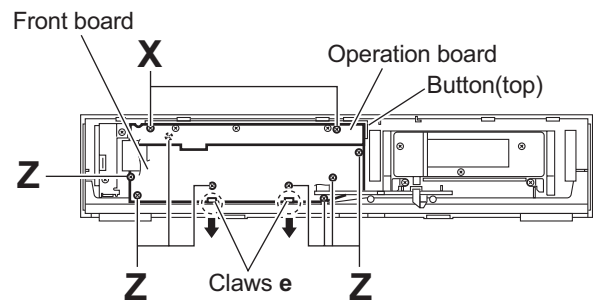

Fig.15

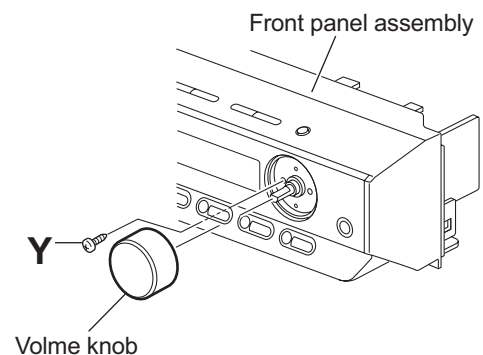

Fig.16

3.1.13 Removing the illumination board (See Figs.17 and 18)

- (1) Open the door assembly of the front panel assembly and remove the three screws **AA** attaching the door cover to the door assembly. (See Fig.17.)
- (2) Disconnect the card wire from the connector **CN551** on the illumination board. (See Fig.18.)
- (3) Take out the illumination board from the door assembly.

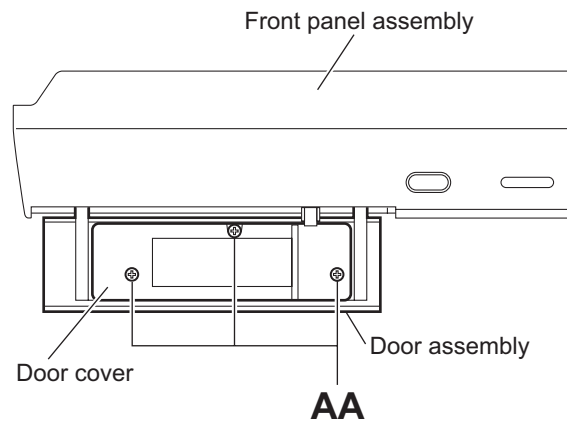

Fig.17

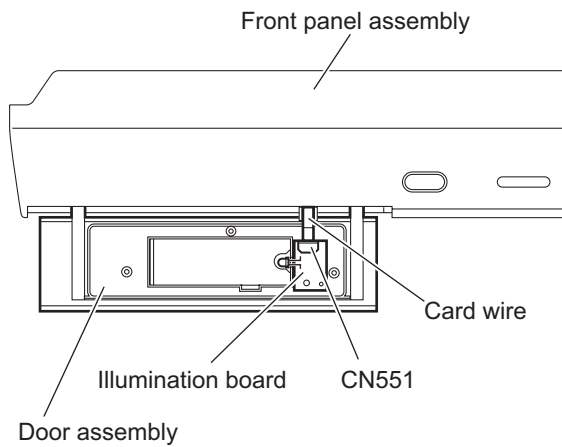

Fig.18

3.2 DVD changer mechanism assembly section

3.2.1 Removing the tray assemblies

(See Figs.1 to 5)

- (1) Remove the two screws **A** from the top cover and release the two joints **a** on the both sides of the DVD changer mechanism assembly. (See Figs.1 and 2.)
- (2) Remove the two rods from the top cover and remove the top cover from the lifter assembly. (See Figs.1 and 2.)
- (3) Remove the open det lever on the left side of the DVD changer mechanism assembly. (See Fig.3.)
- (4) From the right side of the DVD changer mechanism assembly, draw out the tray assemblies toward the front while pushing the part **b** of the side (R) assembly. (See Fig.4.)

Attention:

The tray can be locked if all tray assemblies are attached.

- (5) From the topside of the DVD changer mechanism assembly, move the stopper tabs **c** in the direction of the arrow and release them. Pull out the tray assemblies from the DVD changer mechanism assembly. (See Figs.4 and 5.)

Caution:

Remove the tray assembly from top tray 5 in order.

Attention:

When reattaching the tray assembly, or when removing the disc remaining inside, refer to another section "3.2.15 Taking out the disc in the play mode (See Fig.39 to 42)".

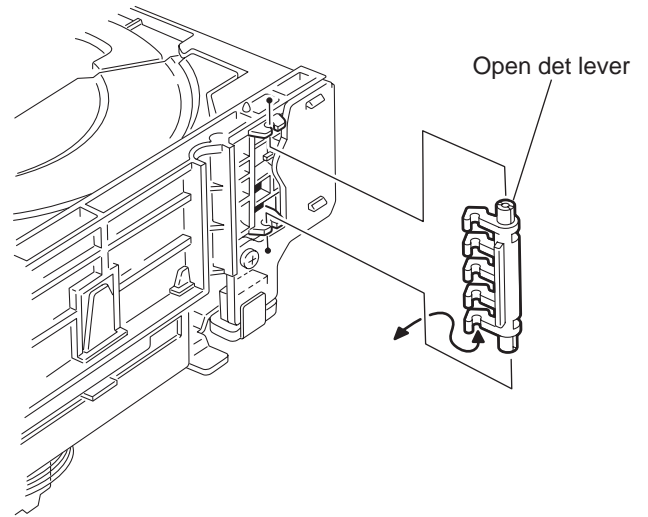

Fig.3

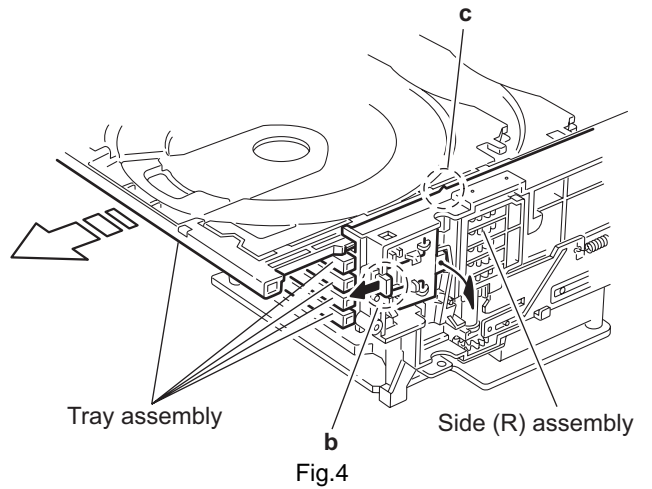

Fig.4

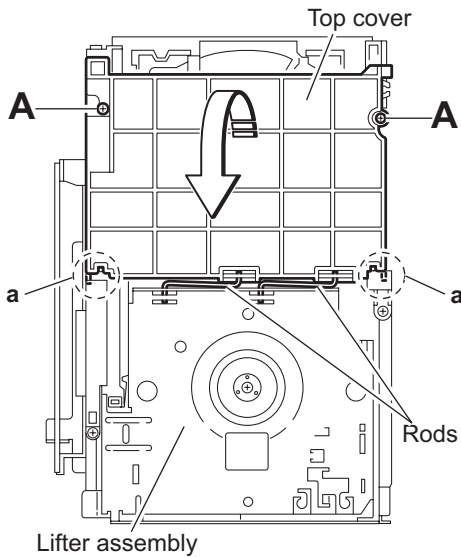

Fig.1

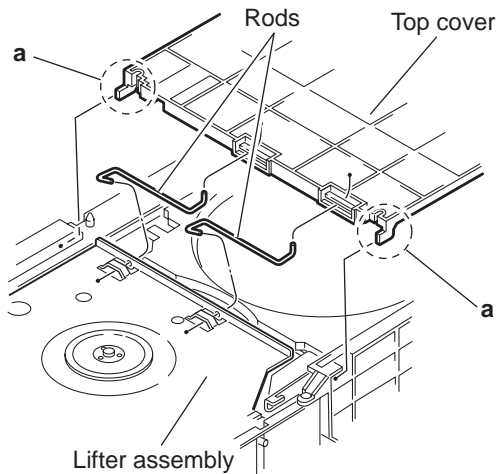

Fig.2

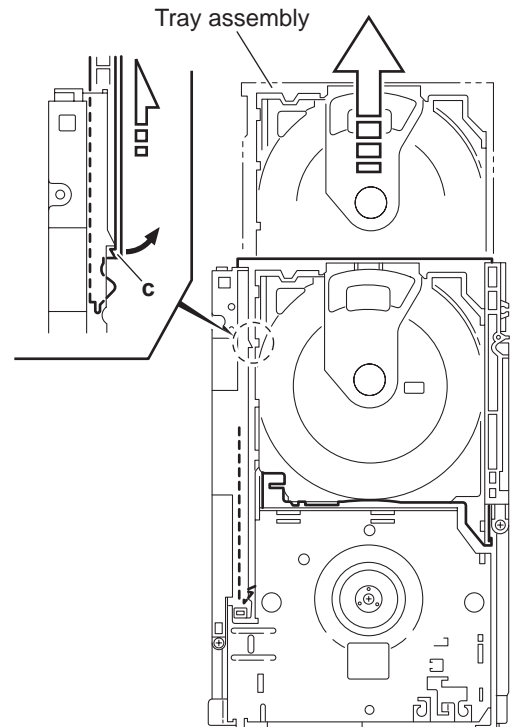

Fig.5

3.2.2 Removing the DVD servo board (See Figs.6 and 7)

- Prior to performing the following procedures, remove the tray assemblies.

(1) From the topside of the DVD changer mechanism assembly, solder the short-circuit points **d** on the DVD pickup. (See Fig.6.)

Caution:

Solder the short-circuit points **d** on the DVD pickup before disconnecting the flexible wire extending from the DVD pickup. If you do not follow this instruction, the DVD pickup may be damaged.

- (2) From the right side of the DVD changer mechanism assembly, disconnect the card wires from the connectors (CN103, CN201) and the wires from the connectors (CN104, CN205) and the flexible wire from the connector CN101 on the DVD servo board. (See Fig.7.)
- (3) Remove the screw **B** attaching the bracket to the DVD changer mechanism assembly. (See Fig.7.)
- (4) Release the two sections **e** of the bracket from the DVD changer mechanism assembly and remove the DVD servo board with the bracket. (See Fig.7.)
- (5) Remove the two screws **C** attaching the DVD servo board to the bracket. (See Fig.7.)
- (6) Release the three sections **f** of the bracket and remove the DVD servo board. (See Fig.7.)

Caution:

Unsolder the solders from the short-circuit points **d** after reassembling.

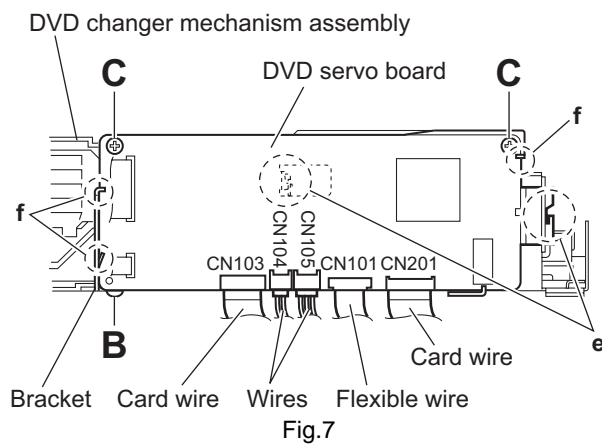
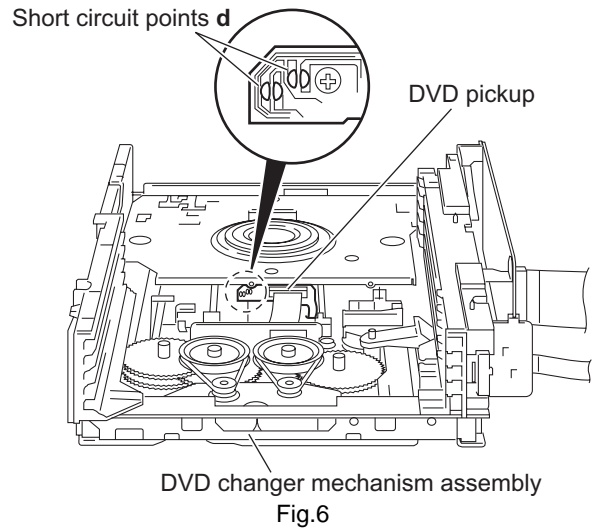

3.2.3 Removing the switch board (See Fig.8)

- (1) From the bottom side of the DVD changer mechanism assembly, disconnect the wires from connectors CN104 and CN105 on the DVD servo board.
- (2) Remove the screw **D** attaching the switch board to the DVD changer mechanism assembly.
- (3) Release the wires from the slots **g** of the switch board.

Caution:

When reassembling, let the wires through the slots **g** of the switch board.

Reference:

When connecting the wires to the connectors on the DVD servo board, fix the wires with spacer.

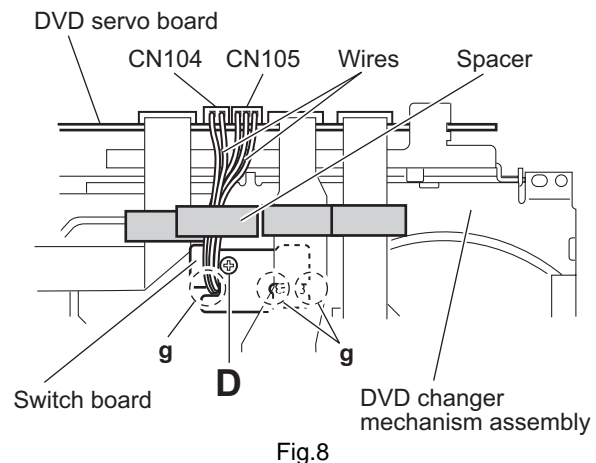

3.2.4 Removing the motor board (See Figs.9 and 10)

- (1) From the top side of the DVD changer mechanism assembly, remove the two belts from the motor pulleys. (See Fig.9.)

Caution:

Take care not to attach grease on the belt.

- (2) Remove the four screws **E** attaching the motors to the chassis assembly. (See Fig.9.)
- (3) From the bottom side of the DVD changer mechanism assembly, remove the two screws **F**. (See Fig.10.)
- (4) Disconnect the connector **CN2** on the motor board from the tray switch board and remove the motor board. (See Fig.10.)
- (5) Disconnect the card wire from the connector **CN1** on the motor board. (See Fig.10.)

Caution:

- When connecting the card wire, let the card wire through the slots **h** of the motor board. (See Fig.10.)
- When reattaching the motor, turn the side where the label should be put to the front side. (See Fig.10.)

Reference:

- You need not to remove the tray assemblies, and in such case, move it.
- After connecting the motor board, attach the spacer on the motor board. (See Fig.10.)

3.2.5 Removing the motor (See Fig. 10)

- Prior to performing the following procedures, remove the motor board.
 - (1) From the reverse side of the motor board, unsolder the four soldered sections **i** on the motor board.
 - (2) From the forward side of the motor board, remove the motors.

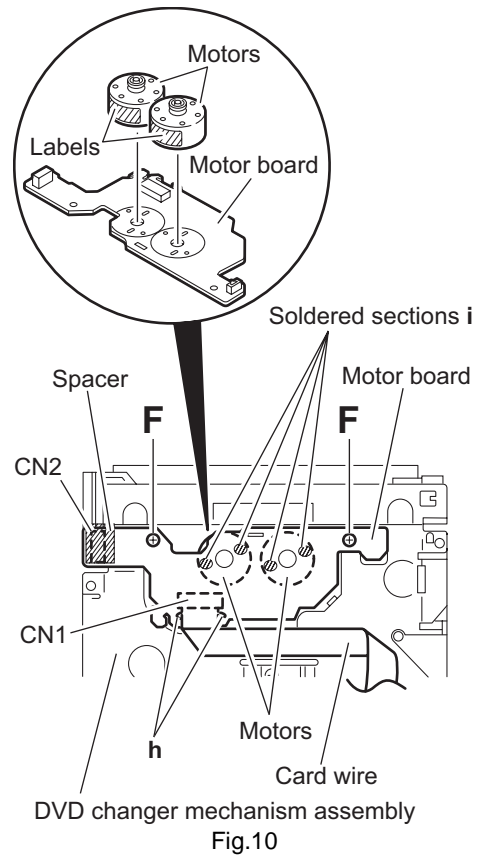
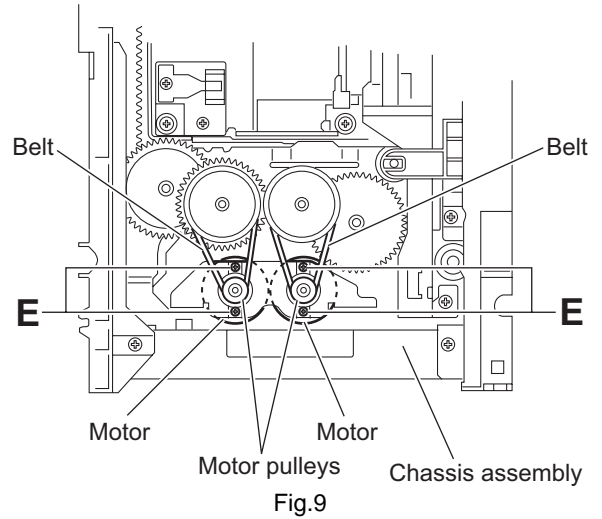

3.2.6 Removing the DVD traverse mechanism assembly (See Figs.6 and 11)

- Prior to performing the following procedures, remove the tray assemblies.

(1) From the topside of the DVD changer mechanism assembly, solder the short-circuit points **d** on the DVD pickup. (See Fig.6.)

Caution:

Solder the short-circuit points **d** on the DVD pickup before disconnecting the flexible wire extending from the DVD pickup. If you do not follow this instruction, the DVD pickup may be damaged.

(2) From the bottom side of the DVD changer mechanism assembly, disconnect the flexible wire from the connector **CN101** on the DVD servo board. (See Fig.11.)

(3) Disconnect the card wire from the connector **CN201** on the DVD servo board. (See Fig.11.)

(4) Remove the three screws **G** attaching the DVD traverse mechanism assembly. (See Fig.11.)

(5) Take out the DVD traverse mechanism assembly from the DVD changer mechanism assembly.

Caution:

Unsolder the solders from the short-circuit points **d** after reassembling.

Reference:

When connecting the each wire to the connectors on the DVD servo board, fix the each wire with spacers.

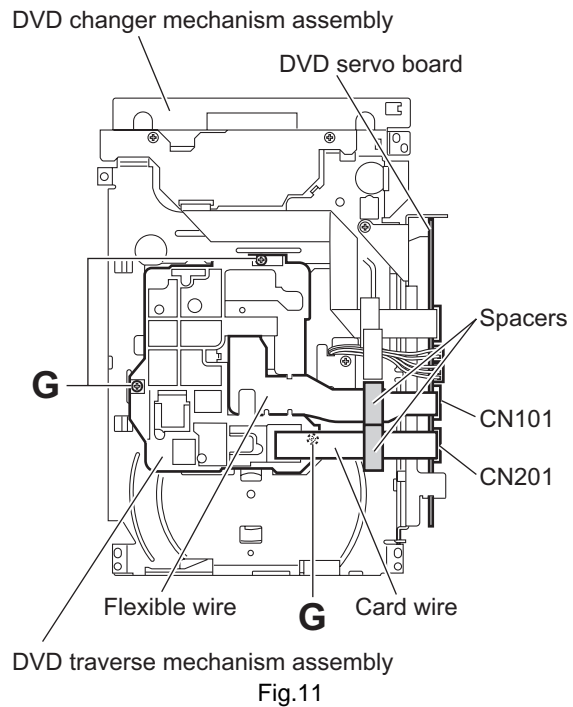

3.2.7 Removing the DVD pickup (See Figs.12 to 14)

- Prior to performing the following procedures, remove the tray assemblies and DVD traverse mechanism assembly.
 - (1) From topside of the DVD traverse mechanism assembly, disconnect the flexible wire from the connector on the DVD pickup. (See Fig.12.)
 - (2) Turn the screw shaft gear in the direction of the arrow 1 to move the DVD pickup in the direction of the arrow 2. (See Fig.12.)
 - (3) Remove the screw **H** attaching the gear holder. (See Fig.12.)
 - (4) Remove the screw **J** attaching the SS adj. spring. (See Fig.12.)
 - (5) Move the DVD pickup in the direction of the arrow and remove the screw shaft from the section **j** on the screw shaft holder. (See Fig.13.)
 - (6) Remove the section **k** of the DVD pickup from the guide shaft. (See Fig.13.)
 - (7) Remove the two screws **K** attaching the rack arm to the DVD pickup. (See Fig.14.)
 - (8) Pull the screw shaft from the DVD pickup in the direction of the arrow. (See Fig.14.)

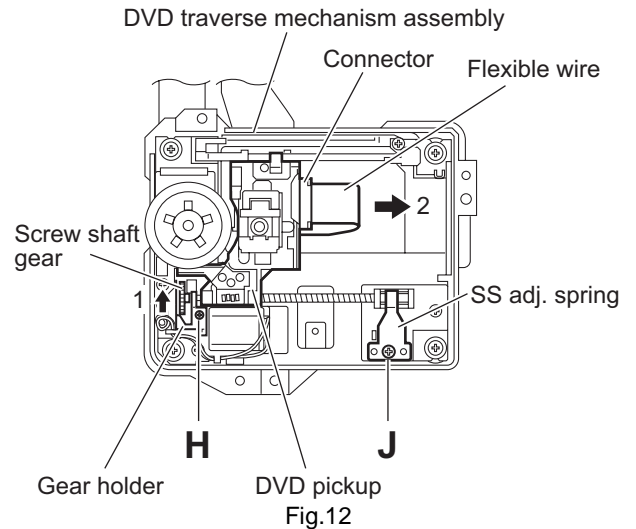

3.2.8 Attaching the DVD pickup (See Figs.12 to 14)

- (1) Attach the screw shaft to the DVD pickup and attach the rack arm with the screws **K**. (See Fig.14.)

Reference:

- After attaching the screw shaft to the DVD pickup, attach the screw shaft collar to the screw shaft. (See Fig.14.)
- (2) Attach the section **k** of the DVD pickup to the guide shaft first and attach the screw shaft to the section **j** on the screw shaft holder. (See Fig.14.)
- (3) Attach the SS adj. spring and gear holder with the screws **H** and **J**. (See Fig.12.)
- (4) Turn the screw shaft gear to move the DVD pickup toward the left. (See Fig.12.)
- (5) Connect the flexible wire to the connector on the DVD pickup. (See Fig.12.)

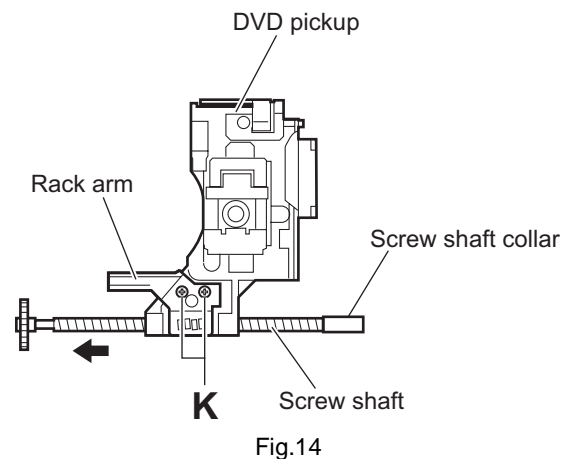
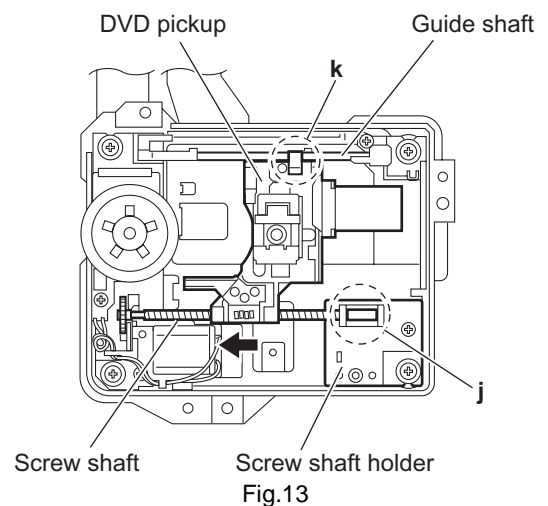

3.2.9 Removing the spindle motor board (See Figs.15 and 16)

- Prior to performing the following procedures, remove the tray assemblies and DVD traverse mechanism assembly.
 - (1) From the topside of the DVD traverse mechanism assembly, remove the four screws **L** attaching the DVD traverse mechanism assembly to the DVD traverse mechanism base. (See Fig.15.)
 - (2) Remove the wires from the soldered section **m** on the spindle motor board. (See Fig.15.)
 - (3) Remove the screw **M** attaching the spindle motor board. (See Fig.15.)
 - (4) From the bottom side of the DVD traverse mechanism assembly, remove the three screws **N** attaching the spindle motor board. (See Fig.16.)

Reference:

When attaching the spindle motor board, let the card wire through the hole **n** on the motor base. (See Fig.15.)

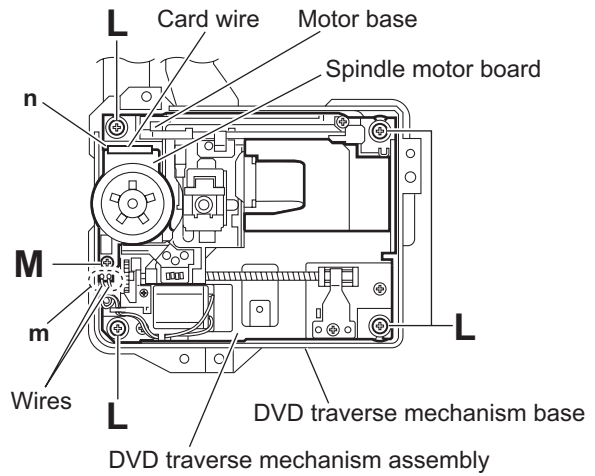

Fig.15

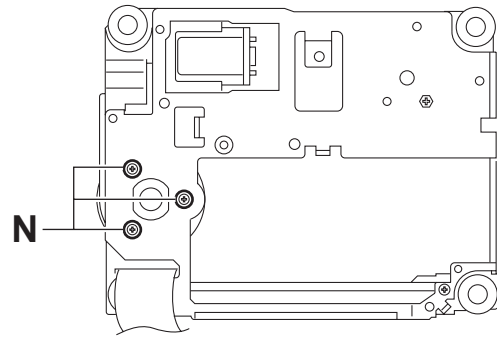

Fig.16

3.2.10 Removing the feed motor (See Figs.17 and 18)

- Prior to performing the following procedures, remove the tray assemblies, DVD traverse mechanism assembly, DVD pickup board and spindle motor board.
- Remove the wires of the feed motor as required.
 - (1) Remove the middle gear in the direction of the arrow. (See Fig.17.)
 - (2) Remove the screw **P** and screw **Q** attaching the motor base.
 - (3) Remove the screw **R** attaching the feed motor to the motor base. (See Fig.18.)
 - (4) Take out the feed motor from the motor base.

Reference:

After attaching the feed motor, let the wires through the sections **p** and **q** on the motor base. (See Fig.17.)

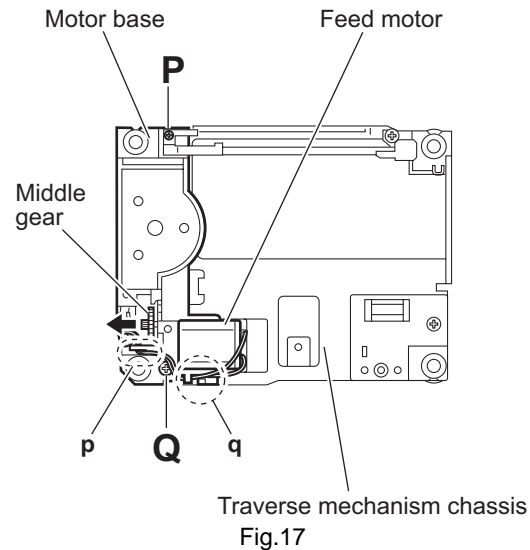

Fig.17

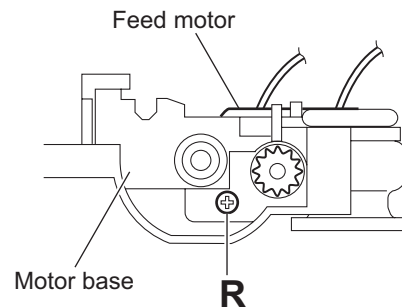

Fig.18

3.2.11 Removing the side (L) assembly and tray switch board (See Figs.19 to 21)

- Prior to performing the following procedures, remove the tray assemblies.
 - (1) From the topside of the DVD changer mechanism assembly, remove the two screws **S** attaching the side (L) assembly. (See Fig.19.)
 - (2) From the left side of the DVD changer mechanism assembly, removing the spacer fixing the tray switch board and motor board. (See Fig.20.)
 - (3) Disconnect the connector **CN3** on the tray switch board from the motor board and detach the side (L) assembly in an upward direction. (See Fig.20.)
 - (4) Remove the screw **T** attaching the tray switch board to the side (L) assembly. (See Fig.21.)
 - (5) Release the joint tab **r** of the side (L) assembly in the direction of the arrow 1 and release the joint tab **s** while removing the tray switch board in the direction of the arrow 2. (See Fig.21.)

Reference:

After attaching the tray switch board to the motor board, fix them with spacers.

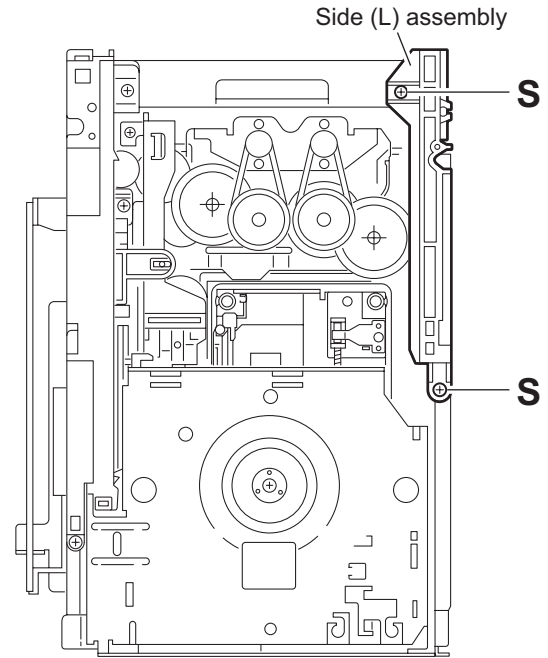

Fig.19

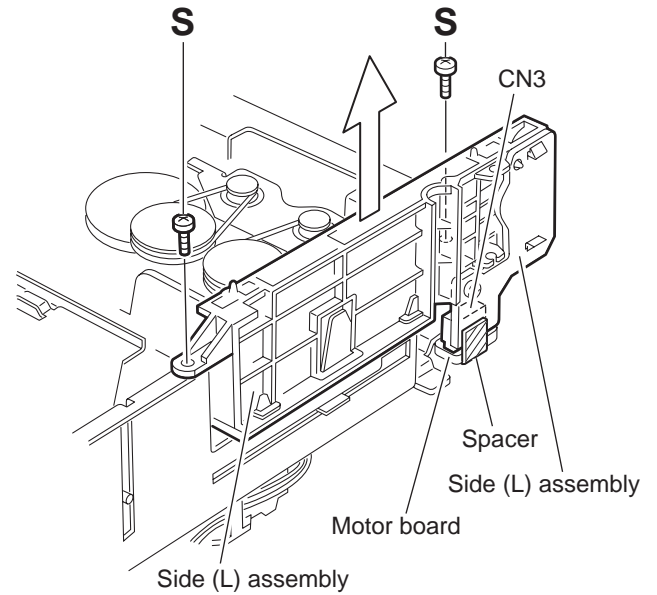

Fig.20

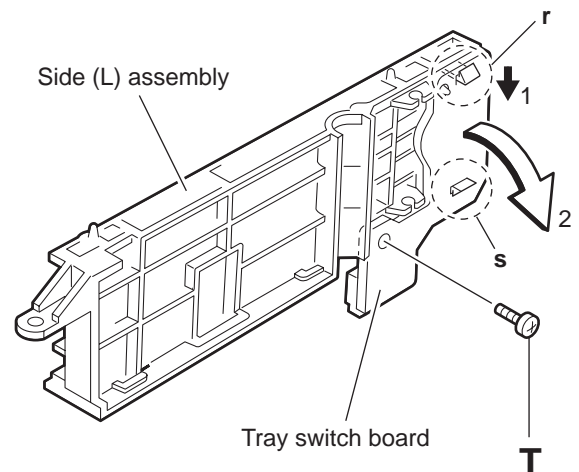

Fig.21

3.2.12 Removing the side (R) assembly (See Fig.22 to 26)

- Prior to performing the following procedures, remove the tray assemblies and DVD servo board.
- When removing the DVD servo board, it is not necessary to remove the DVD servo board from the bracket.
 - (1) From the inside of the side (R) assembly, release the two tabs **t** of the gear cover and remove the gear cover outward. (See Figs.22 and 23.)
 - (2) From the right side of the DVD changer mechanism assembly, remove the elevator spring attached to the hook **u** of the chassis assembly. (See Figs.23 and 24.)
 - (3) From the topside of the DVD changer mechanism assembly, turn the gear 1 clockwise to move the elevator cam rearward. (See Fig.24.)
 - (4) Move the two slots **v** and joint **w** of the elevator cam and remove the elevator cam outward. (See Fig.24.)
 - (5) Remove the three screws **U** and detach the side (R) assembly upward. (See Figs.25 and 26.)

Caution:

When reattaching the side (R) assembly, make sure to fit the shaft (part **x**) into the slot of the select lever. (See Fig.25.)

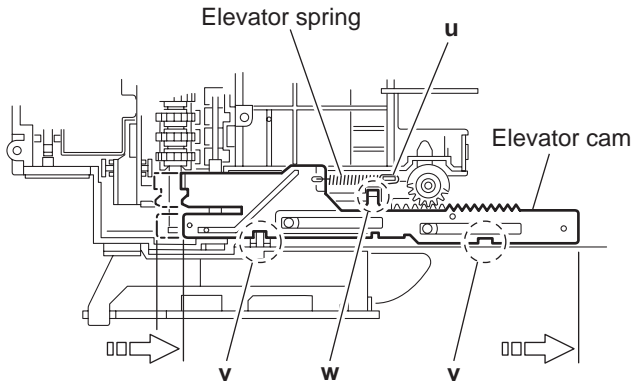
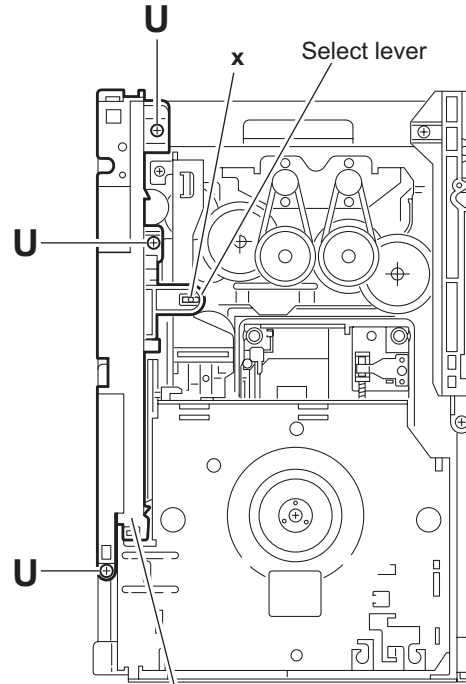

Fig.24



Side (R) assembly
Fig.25

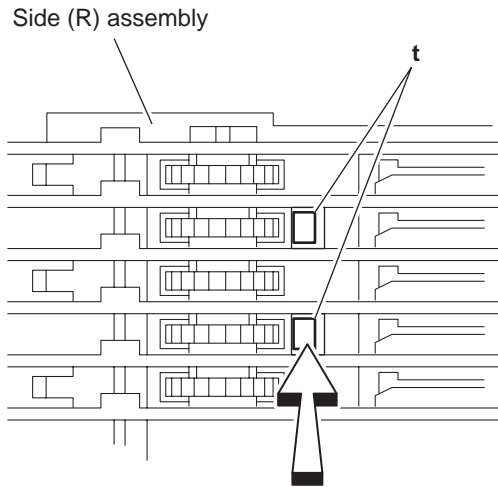
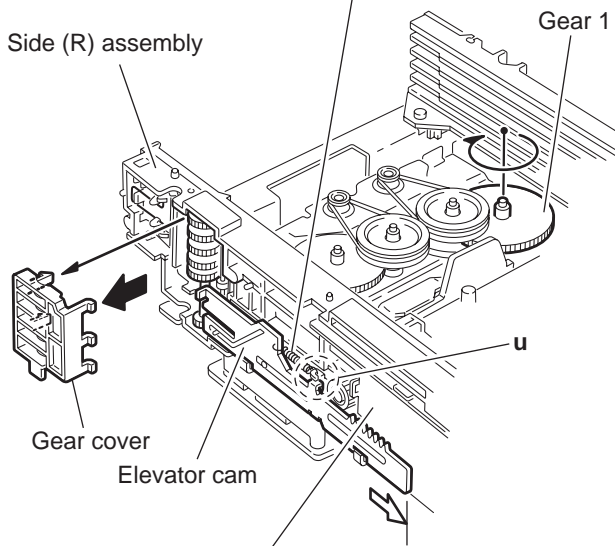
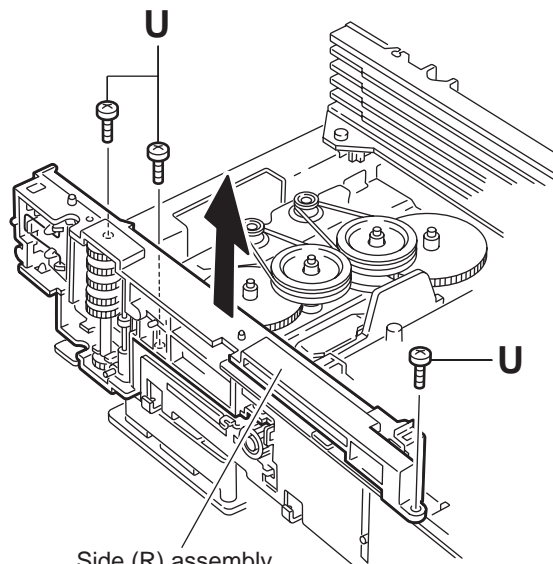

Fig.22



Chassis assembly
Fig.23



Side (R) assembly
Fig.26

3.2.13 Removing the lifter assembly (See Figs.27 to 31)

- Prior to performing the following procedures, remove the tray assemblies, DVD servo board, side (L) assembly and side (R) assembly.
- When removing the DVD servo board, it is not necessary to remove the DVD servo board from the bracket.

- (1) From the topside of the DVD changer mechanism assembly, turn the gear 1 clockwise to move the lifter assembly upward. (See Figs.27 and 28.)
- (2) Turn the gear 2 clockwise to move the hook toward the front until it stops. (See Figs.27 and 28.)
- (3) Move the hook stopper in the direction of the arrow 2 while pushing the tab y of the hook stopper to unlock it in the direction of the arrow 1 and release four joints z to detach from the rack holder. (See Fig.29.)
- (4) Release the rod from part aa. (See Fig.29.)
- (5) Turn the gear 1 clockwise again to move the lifter assembly upward. (See Fig.30.)
- (6) Remove the lifter assembly from the DVD changer mechanism assembly upward at the positions ab where the four pins on the both sides of the lifter assembly fit to the notches of the chassis assembly. (See Fig.30.)
- (7) Move the lifter assembly in the direction of the arrow and release it from the hook. (See Fig.31.)

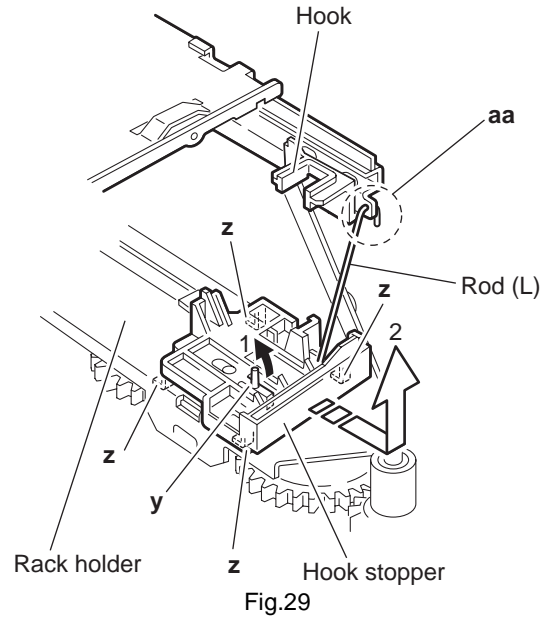

Fig.29

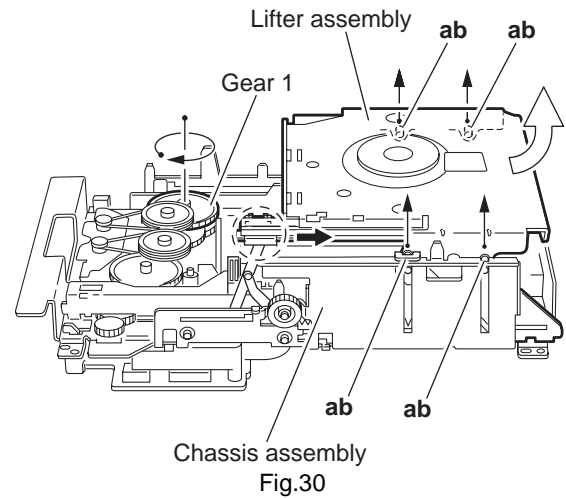
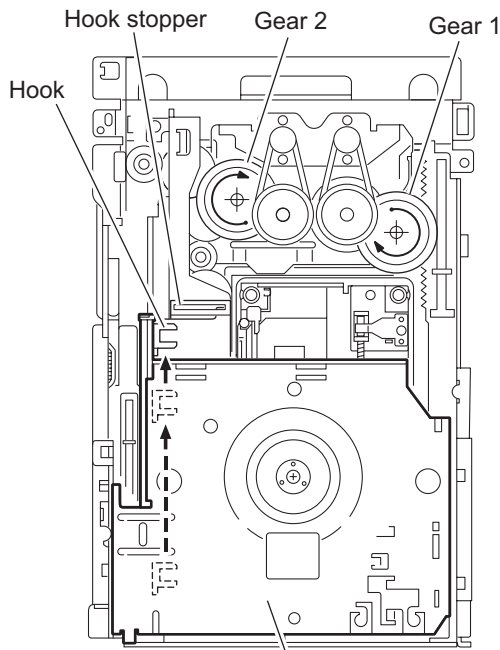

Fig.30



Lifter assembly
Fig.27

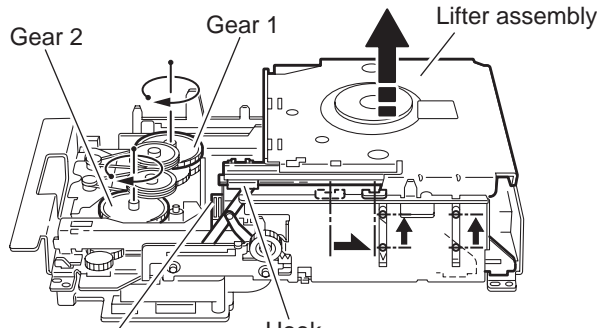

Fig.28

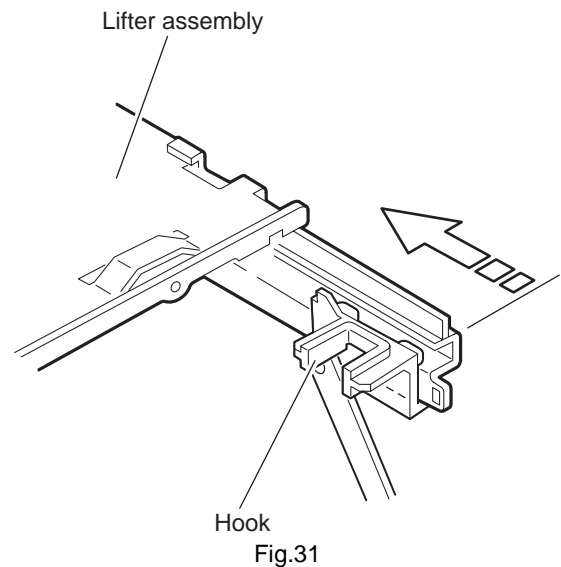

Fig.31

3.2.14 Removing the rack holder assembly and sensor assembly (See Figs.32 to 38)

- Prior to performing the following procedures, remove the tray assemblies, side (L) assembly, side (R) assembly and lifter assembly.

Reference:

If the slide gear of the DVD changer mechanism assembly places at joint **ac** of the rack holder assembly, turn the gear 1 counterclockwise to move the slide gear in the direction of the arrow. Then Remove the rack holder assembly. (See Figs.32 and 33.)

- (1) Remove the three screws **V** attaching the rack holder assembly and release joint **ac** from the notch **ad**. (See Figs.32 and 34.)

Caution:

When reattaching the rack holder assembly, do not nip the wires extending from the sensor assembly. (See Fig.32.)

- (2) Remove the two screws **W** attaching the sensor assembly. (See Figs.35 and 38.)
- (3) Move the sensor assembly in the direction of the arrow to release from the joint section **ae**. (See Figs.35 and 38.)
- (4) Remove the sensor spring attached to the bottom of the sensor assembly from the boss **af** on the sensor slider. (See Figs.35 and 36.)
- (5) Remove the screw **X** and **Y** attaching the sensor board and SV. resister respectively. (See Fig.37.)

Reference:

Remove the soldered section **ai** on the sensor board as required. (See Fig.37.)

Caution:

- When reattaching the SV. resister, attach the sensor slider to the sensor bracket and fit the lever on the bottom of the SV. resister into slot **aj** of the sensor slider. (See Figs.36 and 37.)
- When reattaching the rack holder assembly, turn the gear 1 clockwise to move the slide gear and slide lever inside the body in the direction of the arrow. (See Figs.32 and 38.)
- Let the wire extending from the sensor assembly through notch **ag** to the bottom of the DVD changer mechanism assembly. (See Figs.35 and 38.)
- Fit pin **ak** of the slide lever into hole **ah** of the sensor slider on the bottom of the sensor assembly while attaching the sensor spring to the boss **af** of the sensor slider. (See Figs.36 and 38.)
- Joint section **ae** of the sensor assembly to the notch **am** of the DVD changer mechanism assembly. (See Figs.35 and 38.)

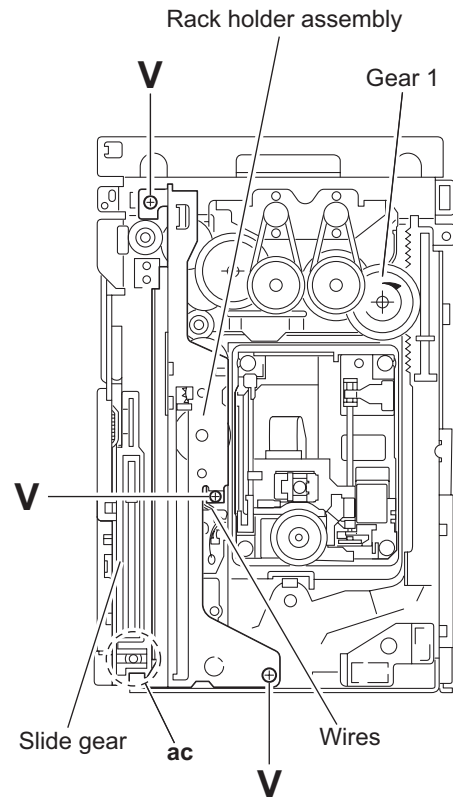

Fig.32

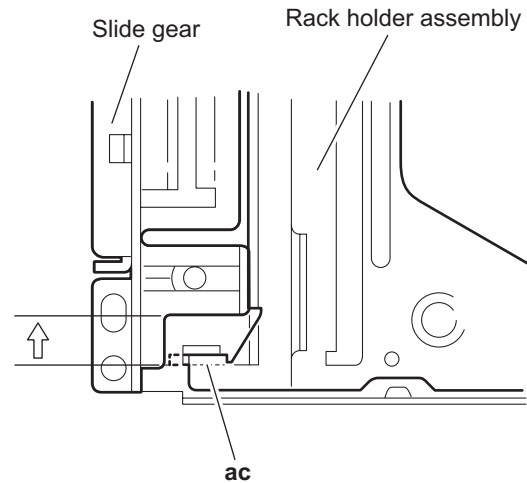

Fig.33

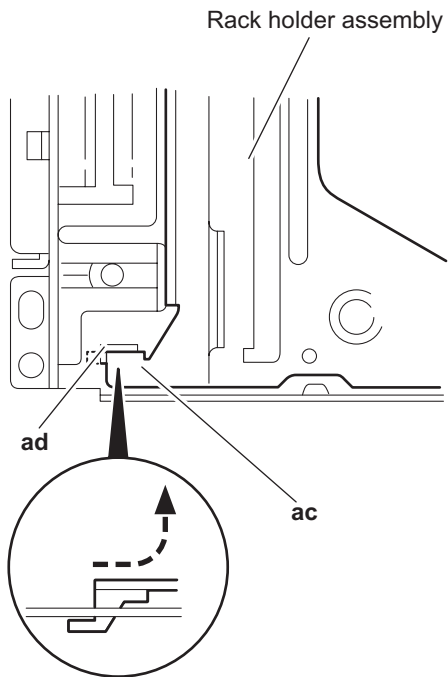

Fig.34

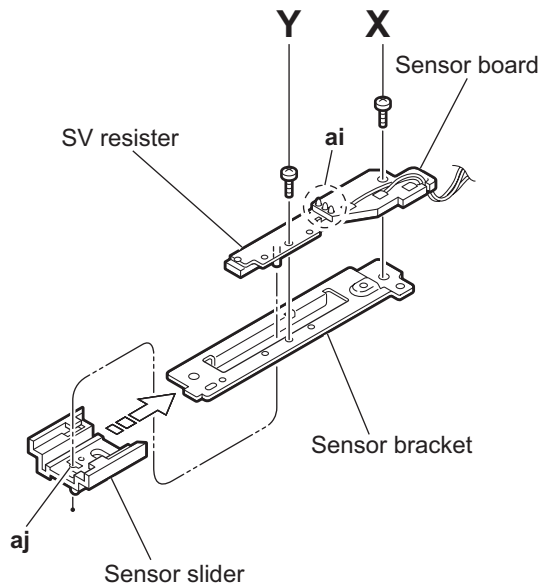

Fig.37

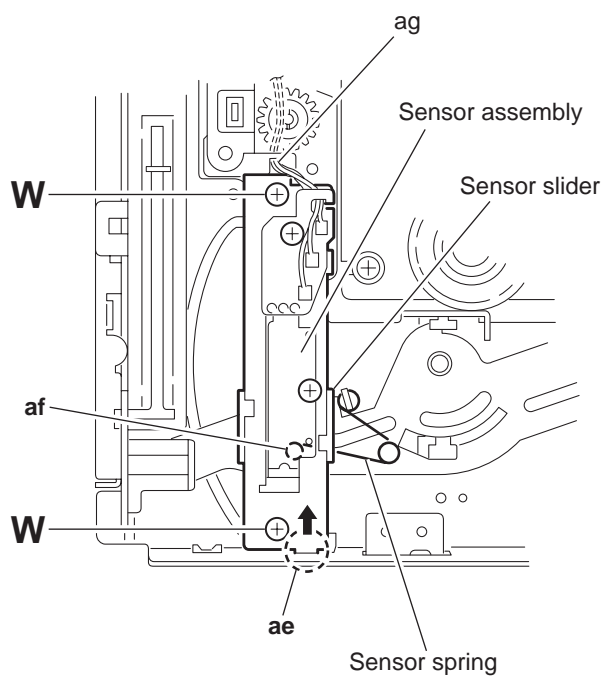

Fig.35

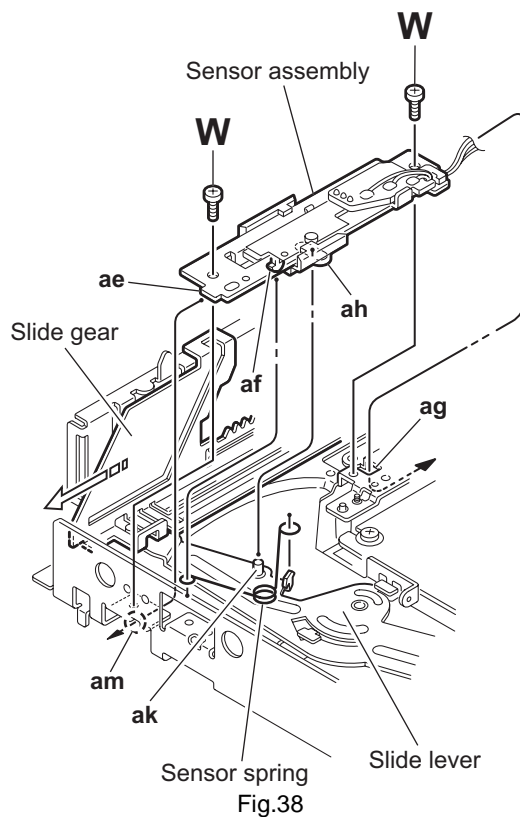

Fig.38

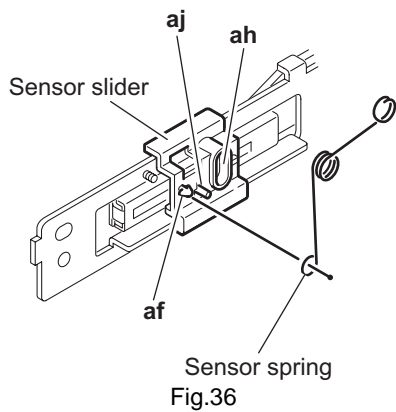

Fig.36

3.2.15 Taking out the disc in the play mode (See Fig.39 to 42)

Reference:

Refer to "Removing the tray assemblies".

- (1) From the topside of the DVD mechanism assembly, remove the top cover.
- (2) Unlock the tray assemblies and draw out the tray assemblies toward the front.
- (3) From the top side of the DVD mechanism assembly, turn the gear 1 clockwise to move the lifter assembly upward. (See Fig.39.)
- (4) Turn the gear 2 clockwise to move the sub tray remaining inside the lifter assembly toward the front, then pull out.
- (5) Take out the disc on the sub tray. (See Fig.40.)
- (6) After clearing away the disc, insert the sub tray into the main tray. (See Fig.41.)
- (7) Push the tray assembly toward the body and reattach.

Caution:

When reattaching the sub tray, move the tray stopper on the bottom of the main tray in the direction of the arrow to lock the sub tray certainly. (See Figs.41 and 42.)

- (7) Push the tray assembly toward the body and reattach.

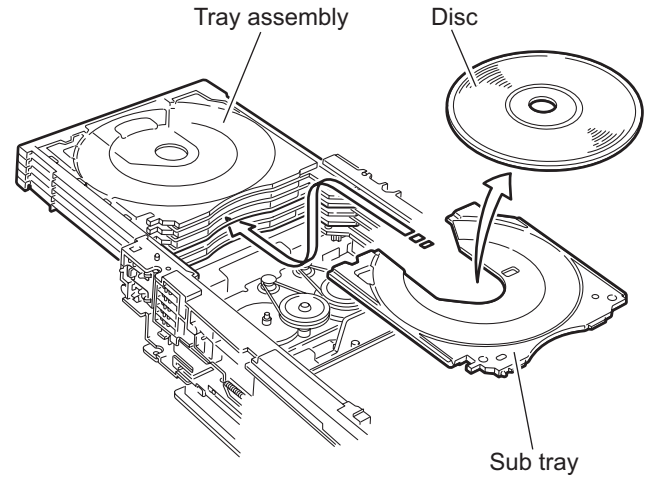

Fig.40

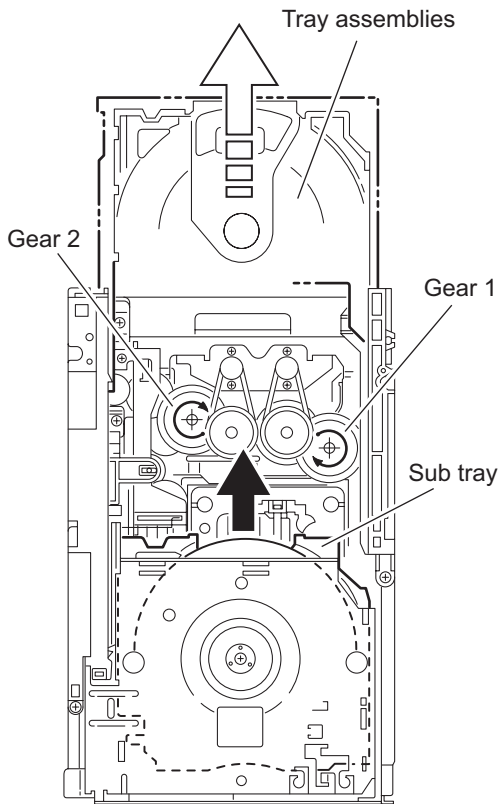

Fig.39

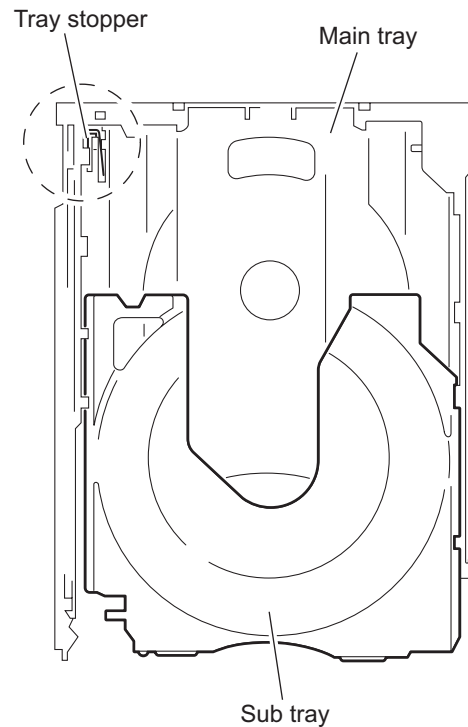

Fig.41

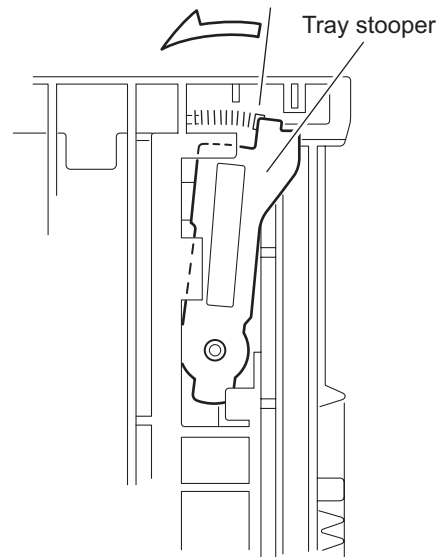

Fig.42

3.3 Speaker section

3.3.1 Removing the amplifier assembly (See Figs.3 and 4)

- (1) From the back side of the speaker main body, remove the four screws **A** attaching the heat sink cover and then remove the heat sink cover. (See Fig.1.)
- (2) Remove the nine screws **B** attaching the amplifier assembly. (See Fig.2.)
- (3) Move the amplifier assembly backward and disconnect the wire from the connector **CN402** on the speaker terminal board. (See Fig.3.)

3.3.2 Removing the rear panel (See Figs.1 and 4)

- (1) From the back side of the speaker main body, remove the four screws **A** attaching the heat sink cover and then remove the heat sink cover. (See Fig.1.)

Reference:

If the amplifier assembly was removed from the main body, this step (1) is unnecessary.

- (2) Remove the four screws **C**, twelve screws **D** and screw **E** attaching the rear panel. (See Fig.4.)

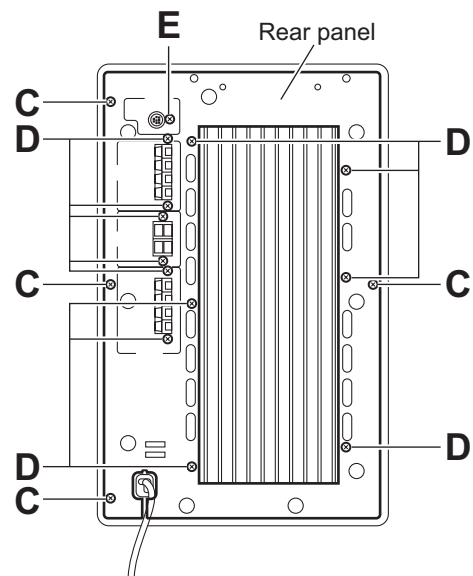
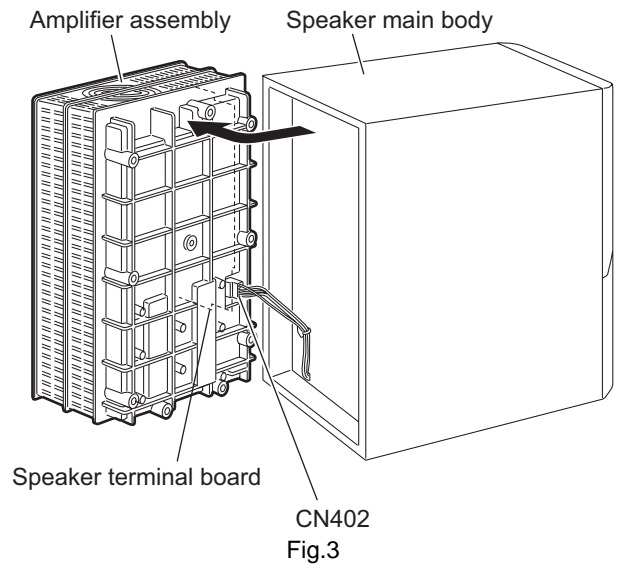
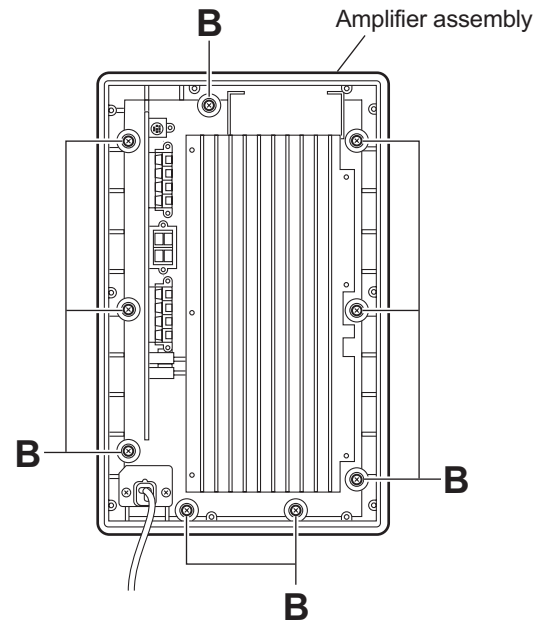
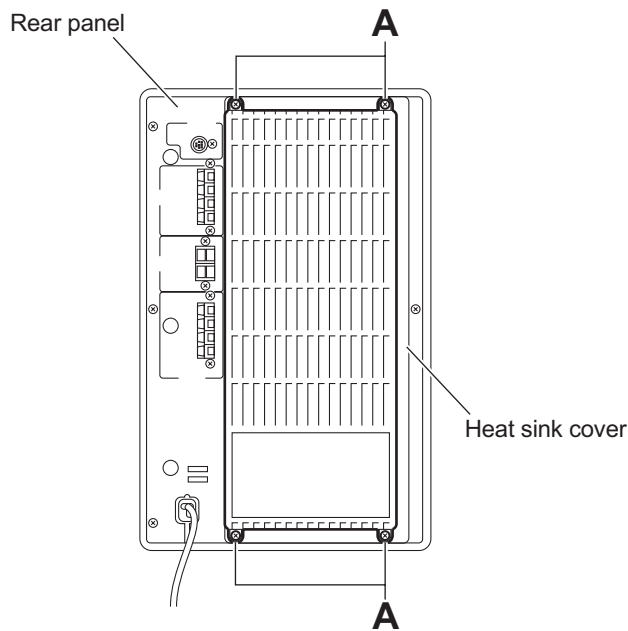

3.3.3 Removing the speaker terminal board (See Figs.5 and 6)

- Remove the amplifier assembly.
- Remove the rear panel.
 - (1) From the back side of the amplifier assembly, remove the two screws **F** attaching the AC bracket. (See Fig.5.)
 - (2) Disconnect the wires from the connectors **CN101** and **CN102** on the speaker terminal board. (See Figs.5 and 6.)
 - (3) Disconnect the speaker terminal board from the connectors (**CN501**, **CN503**, **CN504**) on the mother board. (See Fig.6.)

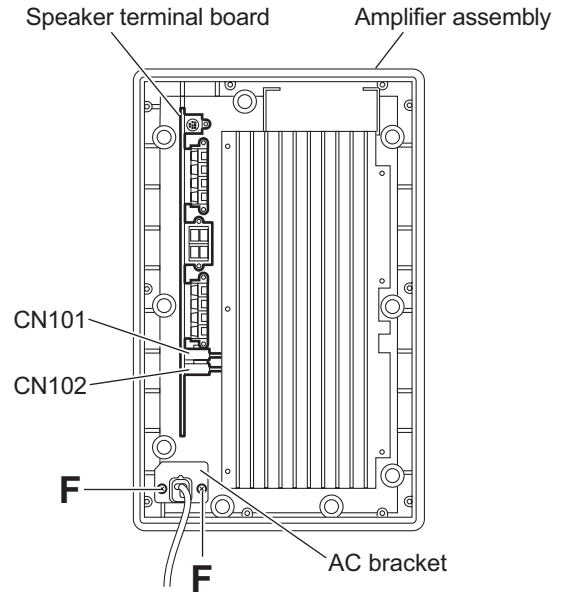

Fig.5

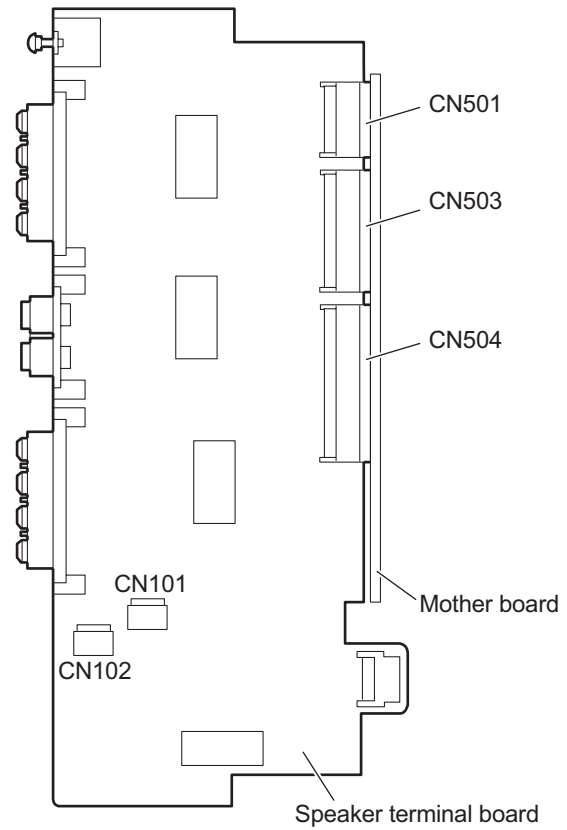

Fig.6

3.3.4 Removing the mother board (See Figs.7 to 9)

- Remove the rear panel.
- Remove the amplifier assembly.
- Remove the speaker terminal board.
 - (1) From the inside of the amplifier assembly, disconnect the wire from the connector [CN151](#) on the mother board. (See Fig.7.)
 - (2) Remove the five screws **G** attaching the mother board. (See Fig.7.)
 - (3) Take out the mother board together the amplifier boards (A,B) and heat sink.
 - (4) Remove the four screws **H** attaching the mother board. (See Fig.8.)
 - (5) Release the claws **a** and **b** of the connectors ([CN521](#), [CN522](#), [CN531](#), [CN532](#)) on the mother board using the flat-bladed screwdriver or a similar tool, disconnect the mother board from the connectors ([CN251](#), [CN252](#), [CN351](#), [CN352](#)) on the amplifier boards (A,B). (See Fig.9.)

Note:

When releasing the claws **a** and **b** of the connectors ([CN521](#), [CN522](#), [CN531](#), [CN532](#)) on the mother board, be careful not to break the claws of the connectors.

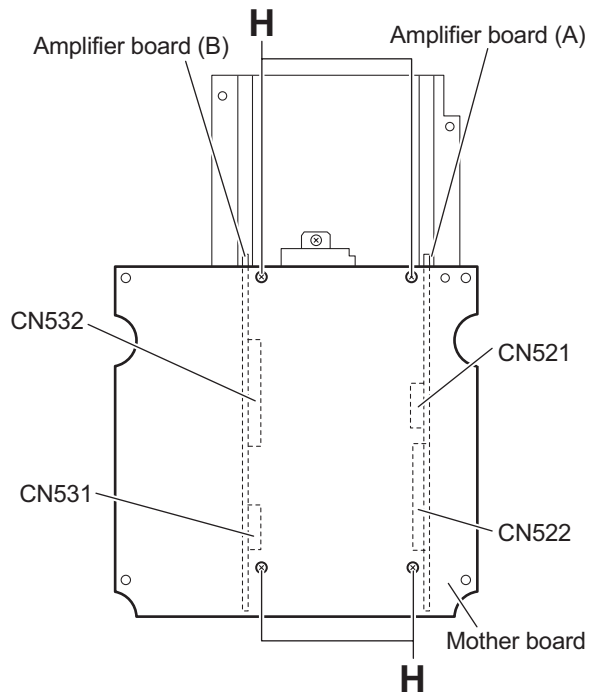

Fig.8

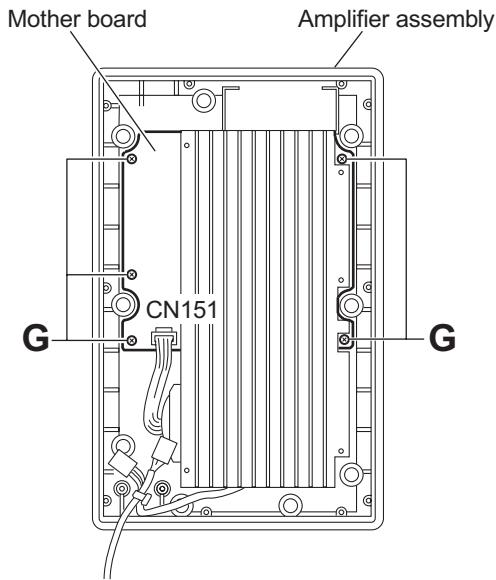

Fig.7

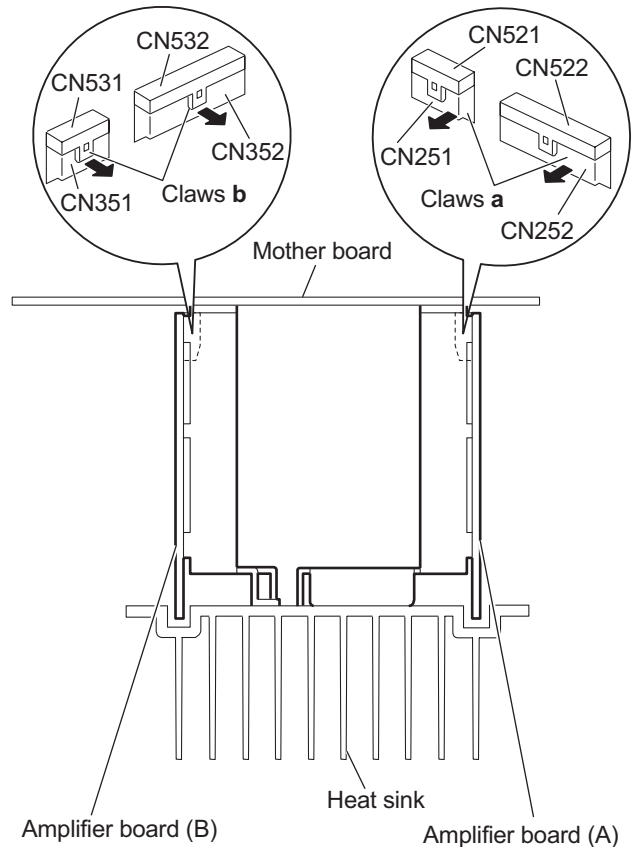

Fig.9

3.3.5 Removing the amplifier board (A)
(See Figs.10 and 11)

- Remove the rear panel.
- Remove the amplifier assembly.
- Remove the speaker terminal board.
- Remove the mother board.
 - (1) Remove the three screws **J** attaching the IC bracket. (See Fig.10.)
 - (2) Remove the amplifier board (A) from the heat sink together the IC bracket.
 - (3) Disengage the engagement sections **c**. (See Fig.11.)
 - (4) Slide the amplifier board (A) in the direction of the arrow and then disengage the amplifier board (A) from the engagement sections **d** and **e** of the IC bracket. (See Fig.11.)

Reference:

After attaching the IC bracket to the amplifier board (A), apply the bond to the engagement sections **c** and **d**. (See Fig.11.)

3.3.6 Removing the amplifier board (B)
(See Figs.10 and 12)

- Remove the mother board.
 - (1) Remove the three screws **K** attaching the IC bracket. (See Fig.10.)
 - (2) Remove the amplifier board (B) from the heat sink together the IC bracket.
 - (3) Disengage the engagement sections **f**. (See Fig.11.)
 - (4) Slide the amplifier board (B) in the direction of the arrow and then disengage the amplifier board (B) from the engagement sections **g** and **h** of the IC bracket. (See Fig.12.)

Reference:

After attaching the IC bracket to the amplifier board (B), apply the bond to the engagement sections **f** and **g**. (See Fig.12.)

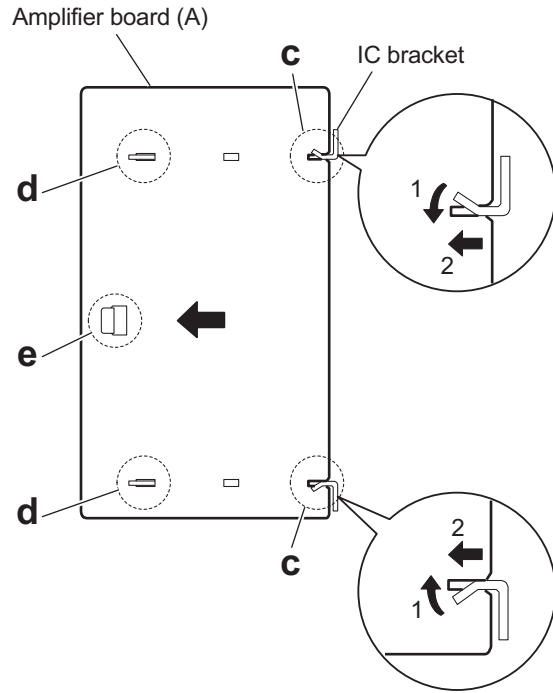

Fig.11

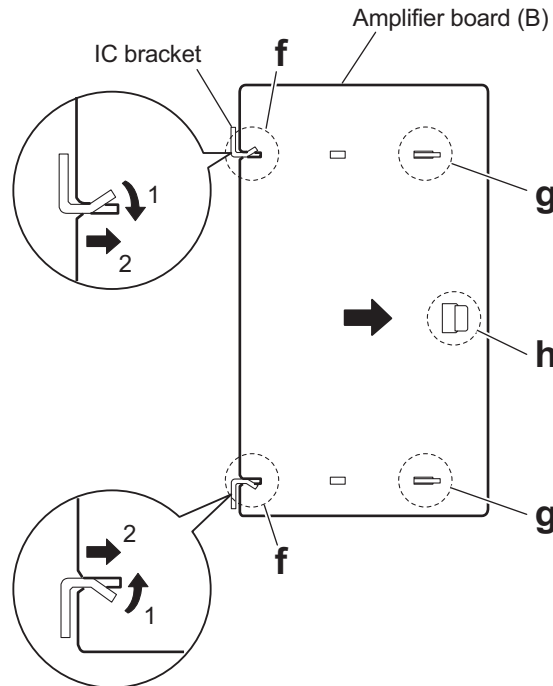

Fig.12

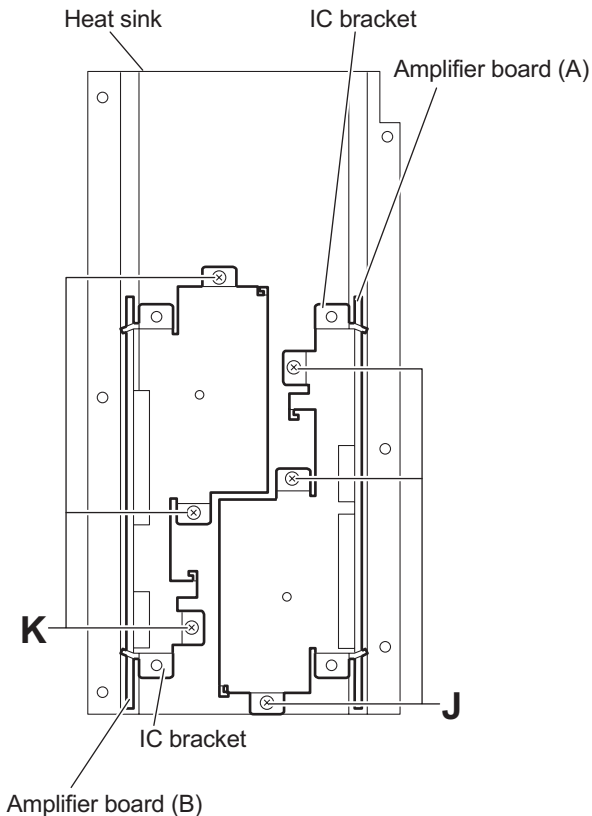

Fig.10

3.3.7 Removing the power transformer (See Figs.13 and 14)

- Remove the rear panel.
- Remove the amplifier assembly.
- Remove the speaker terminal board.
 - (1) Remove the tie bands bundling the power cord and power transformer wire. (See Fig.13.)
 - (2) Disconnect the wire from the connector **CN151** on the mother board. (See Fig.13.)
 - (3) Remove the five screws **L** attaching the mother board. (See Fig.13.)
 - (4) Take out the mother board together the heat sink.
 - (5) Remove the four screws **M** attaching the power transformer. (See Fig.14.)
 - (6) Take out the power transformer from the rear chassis.

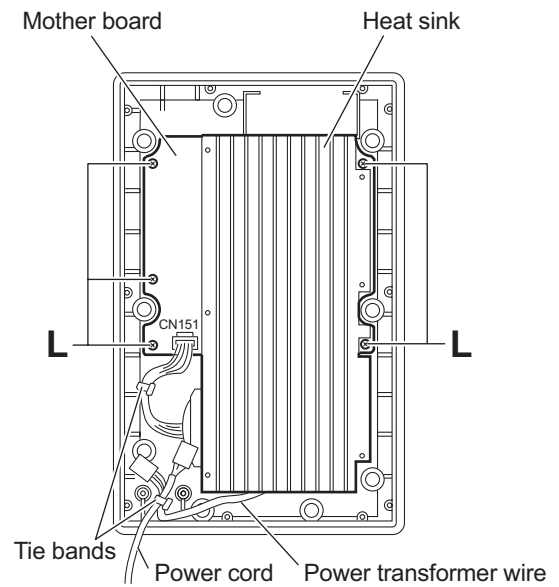

Fig.13

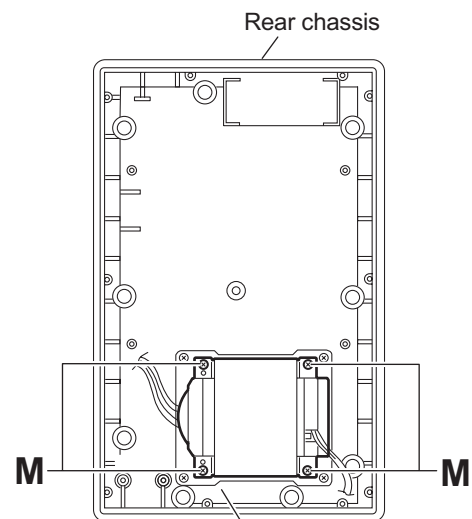

Fig.14

3.3.8 Removing the indicator board (See Fig.15 to 17)

- (1) Insert the tip of a flat-bladed screwdriver or a similar tool into the space between the speaker main body and baffle assembly (the section indicated by the arrows), and lift the baffle assembly little by little to move. (See Fig.15.)

Note:

To prevent damaging the baffle assembly and speaker main body, insert cushioning plates etc. above and below the tip of the flat-bladed screwdriver or a similar tool. (See Fig.16.)

- (2) From the inside of the baffle assembly, remove the two screws **N** attaching the indicator board. (See Fig.17.)
- (3) Disconnect the wire from the connector [CN109](#) on the indicator board. (See Fig.17.)

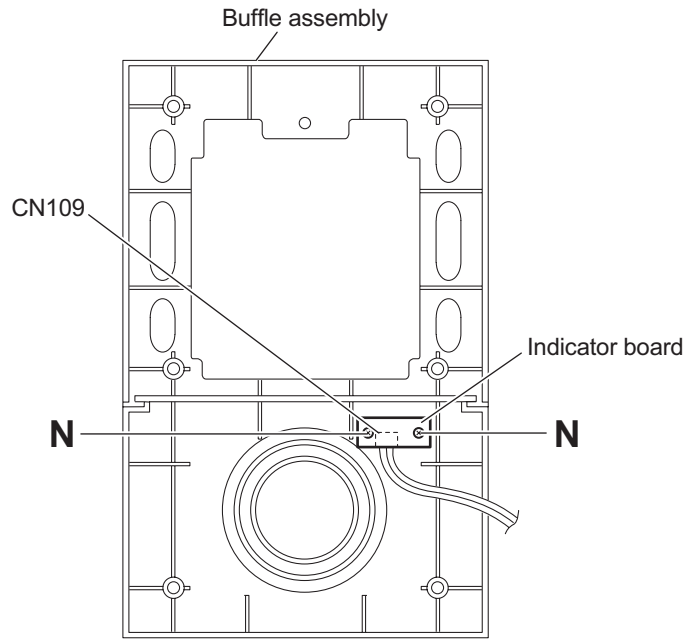
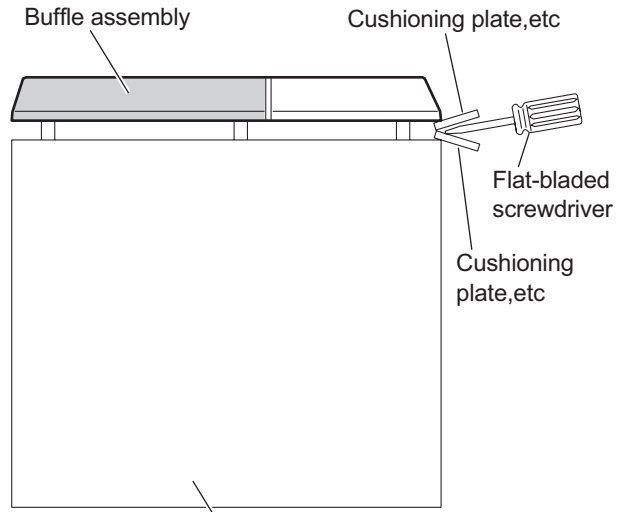
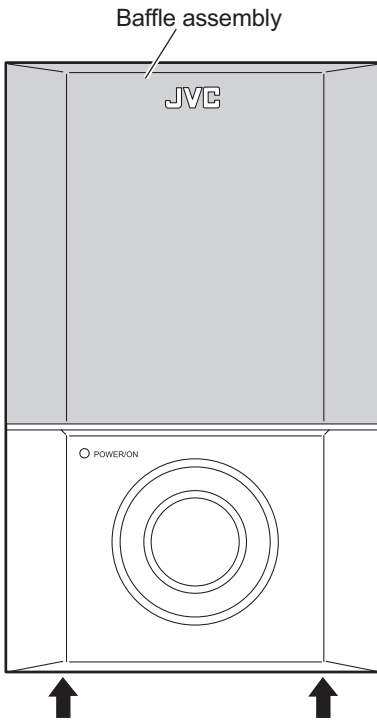

3.3.9 Removing the speaker (See Figs.18 and 19)

- (1) Remove the four screws **P** attaching the speaker. (See Fig.18.)
- (2) Take out the speaker.
- (3) Disconnect the wires from the terminal of the speaker. (See Fig.19.)

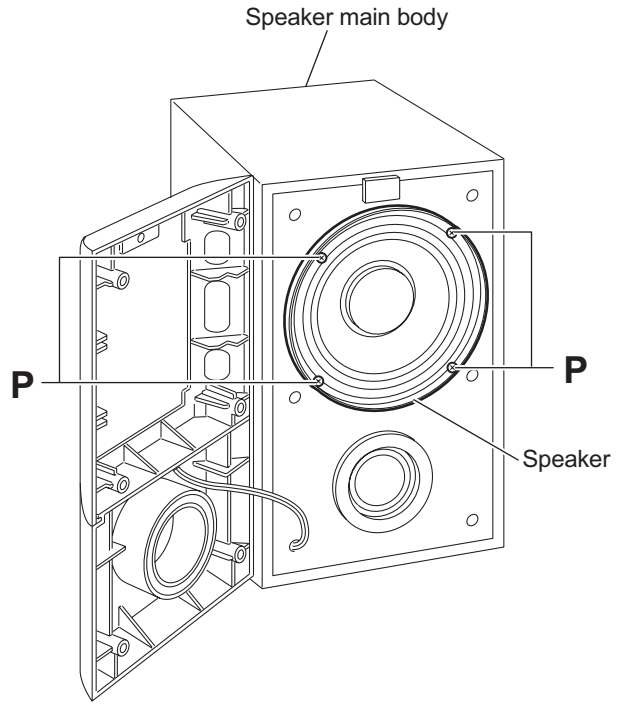

Fig.18

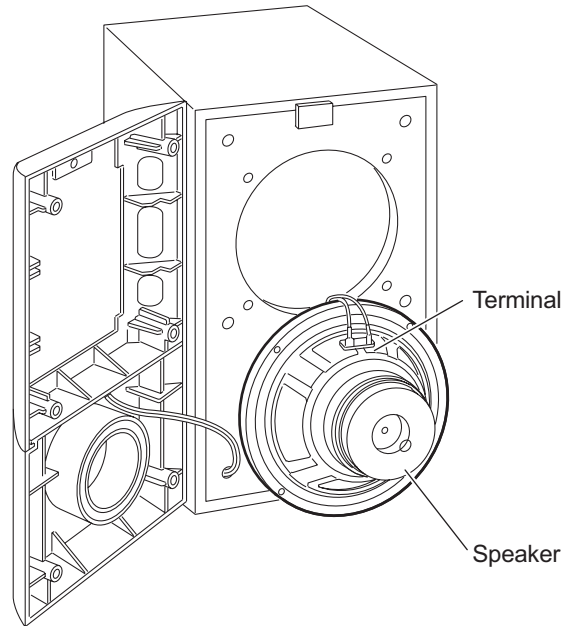

Fig.19

SECTION 4 ADJUSTMENT

4.1 Test mode setting method

- (1) Unplug the power plug.
- (2) Insert power plug into outlet while pressing both "STOP" key and "OPEN/CLOSE" key (for DISC 1) of the main body.
- (3) "Area code" is indicated at the upper left of display.
- (4) To release test mode, press "STANDBY/ON" key of the main body.

NOTE:

Each pressing of "CHOICE" key of the remote controller in test mode changes the mode as follows.

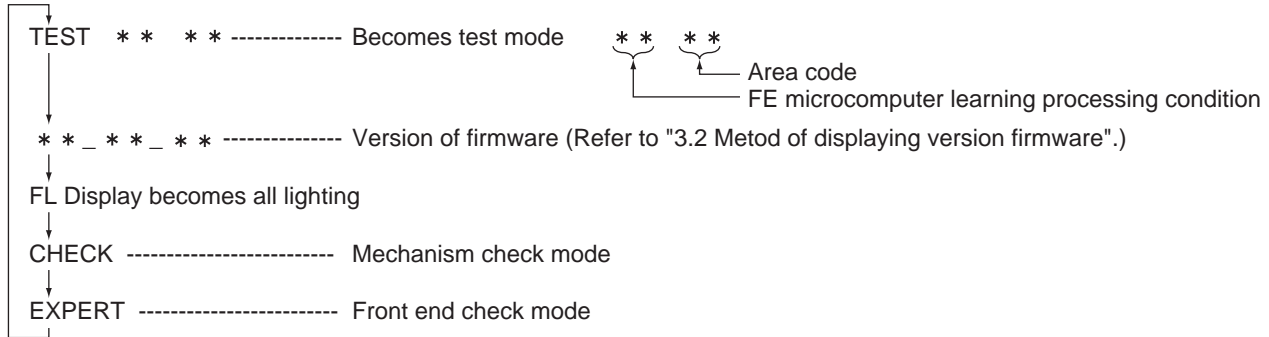

4.2 Method of displaying version of firmware

- (1) Set the main body at test mode.
- (2) Press "CHOICE" key of the remote controller once. Then, version number and alphabetical letter of the system controller and the back end are displayed in the FL display as follows.

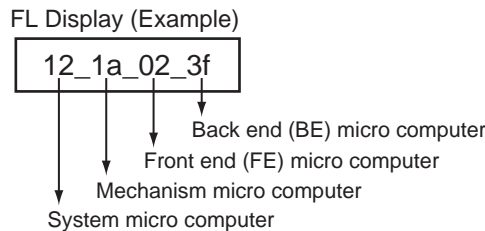

4.3 Initialization method

Please initialize according to the following procedures in the following case:

- Just after you upgrade the firmware.
- After you confirm the symptoms that a customer points out. First Initialize, and then confirm whether the symptoms are improved or not.
- After servicing, before returning the main body to a customer. (Initialized main body should be returned to a customer.)

- (1) Set the main body at test mode.
- (2) Press "PAUSE" key of the main body.
- (3) When initialization is completed, "00" and "RDS" is displayed in the FL display

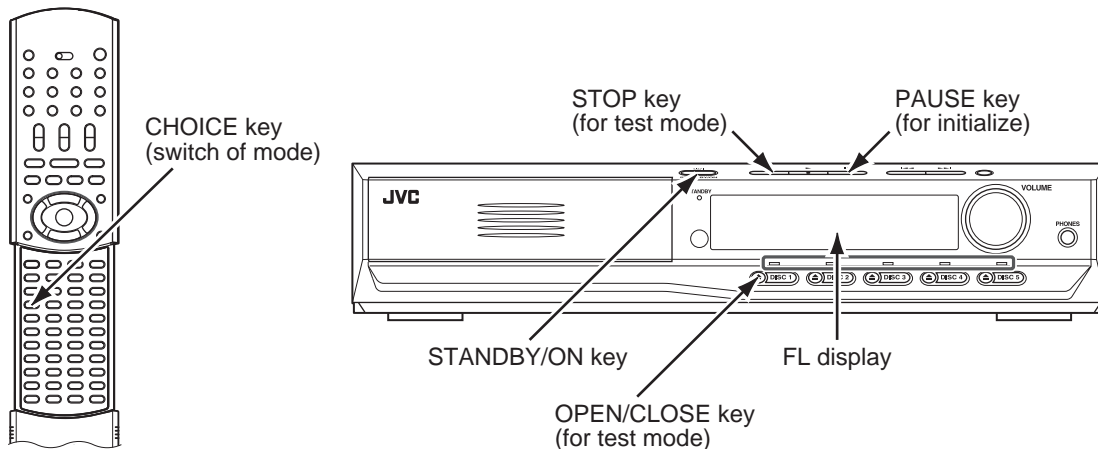

4.4 All-initialization method

Please perform all-initialization according to the following procedures in the following case:

- Just after you exchange the pick-up.
- Just after you exchange the spindle motor.
- Just after you exchange the traverse mechanism base.

NOTE:

Please perform all-initialization when you exchange the parts above and also when you remove the parts above.

- Just after the flap adjustment of the pick-up guide shaft.
 - (1) Set the main body at test mode.
 - (2) Press and hold "REVERSE SKIP" key of the main body for more than 1.5 seconds.
 - (3) When all-initialization is completed, "33" and "RDS" is displayed in the FL display.
 - (4) To release test mode, press "STANDBY/ON" key of the main body

NOTE:

After all-initialization, be sure to perform optimization adjustment of Front End parameter.

4.5 Optimization adjustment of Front End parameter

Adjustment to optimize Front End parameter must be performed in each mechanism assembly of this model for high-speed starting. Please perform optimization according to the following procedures just after all-initialization is completed and when FL display shows anything except "0" (For example when FL display shows "1", "2", and "3") at test mode

- (1) Press "STANDBY/ON" key of the main body to turn the main body on (not to set the main body at test mode).
- (2) Insert the test disc VT-501 or commercial dual-layer DVD software.
- (3) Remove the disc when the FL display changes from "READING" to disc information.
- (4) Perform the same procedures as in (2) and (3) above by using the test disc CTS-1000 or commercial CD-DA software.
- (5) Set the main body at test mode, and check that the FL display shows "0".

NOTE:

Status of this adjustment can be judged by the number displayed at test mode as follows:

DVD adjustment	CD adjustment	FL display at test mode
Adjusted	Adjusted	0
Not adjusted	Adjusted	1
Adjusted	Not adjusted	2
Not adjusted	Not adjusted	3

NOTE:

As for a disc used for adjustment,

- Disc should be mounted. ("Mounting" means to display "READING" after the disc is inserted and then display the disc information.) Disc need not be played.
- If you do not have test disc either VT-501 (DVD) or CTS-1000 (CD-DA), use a commercial disc (for DVD, dual-layer software) after seeing and checking that the disc is neither curved nor foreseen that it may shake at the time of playback. If you use a disc with bad features, starting time may be slow or disc may not be read.

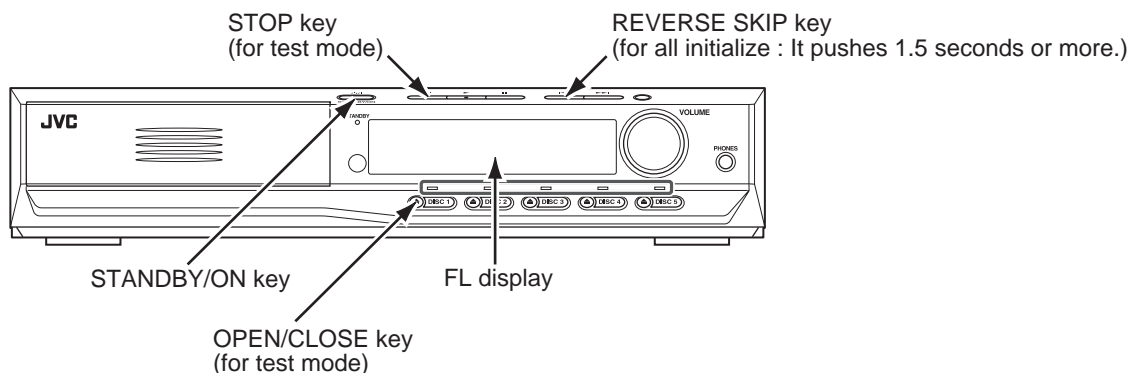

4.6 Display of current value of laser

- (1) Set the main body at test mode.
- (2) Press "CHOICE" key of the remote controller three times. Then, FL display is displayed "CHECK".
- (3) The laser current value can be switched between the value of CD and that of DVD by pressing the following key of the remote controller.

FL Display (Example)

1419 0000	Remote controller "4" key --- Laser of CD Remote controller "5" key --- Laser of DVD
-----------	---

- The number shown in the FL display shows mA of current value of laser.
- The first two numbers ("14" in "1419") shows current value of laser at the time of adjustment after the latest all-initialization, 14mA in this example.
- The last two numbers ("19" in "1419") shows the present current value of laser, 19mA in this example.
- The first two numbers ("14" in "1419") usually shows current value of laser at the time of shipment, so you can see how the product has been deteriorated by comparing the first two numbers ("14" in "1419") and the last two numbers ("19" in "1419").

CD and DVD:

The laser current value of 80mA or less in normal. The laser current value of over 81mA is not normal. Laser diode of the pickup has been deteriorated.

- To return to test mode, press "STOP" key of the main body.

4.7 Flap adjustment of the pick-up guide shaft

Please perform flap adjustment of the pick-up guide shaft in the following case:

- Just after you exchange the pick-up.
- Just after you exchange the spindle motor.
- Just after you exchange the traverse mechanism base.

NOTE:

Please perform flap adjustment of the pick-up guide shaft when you exchange the parts above and also when you remove the parts above.

- When the reading accuracy of the signal is bad (There is a block noise in the screen, Screen stops in the outer circumference of a disc, etc.)

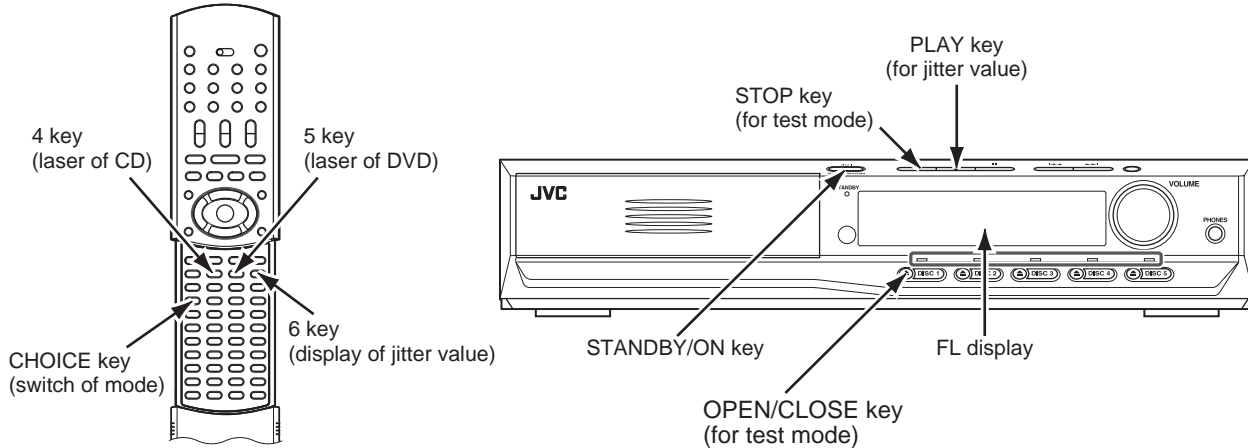

4.7.1 Tool for adjustment

*Stud: One set (four studs), Part number: JIGXVS40



4.7.2 Preparation for adjustment

- (1) Set the disassembly procedure, and remove the changer mechanism assembly from the main body.
- (2) Disconnect the card wires from the connectors [CN501](#) and [CN502](#) on the DVD servo board.
- (3) Attach the four studs to the changer mechanism assembly.
- (4) Put the changer mechanism assembly in the main body, and connect the card wires to the connector [CN501](#) and [CN502](#) on the DVD servo board.

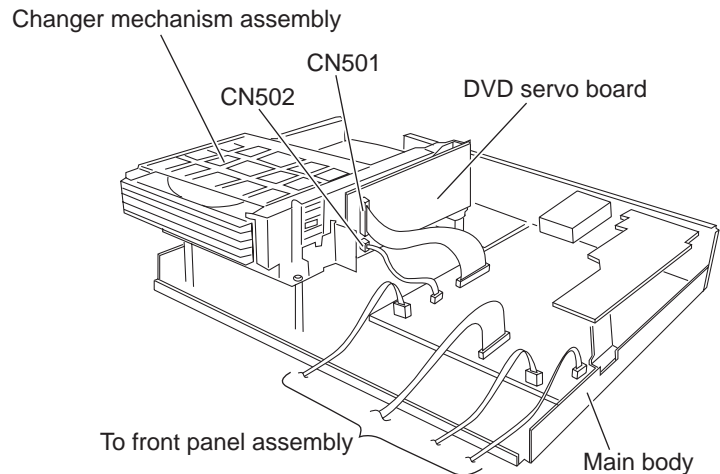
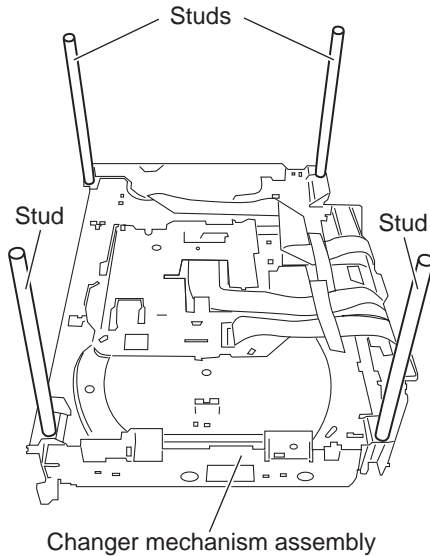

4.7.3 Adjustment

- (1) Set the unit to test mode.
- (2) Press the "CHOICE" key of the remote controller three times, and the FL display is displayed "CHECK".
- (3) A "PLAY" key is pushed after insert a test disc (VT-501), and press the numeric key "1" of the remote controller for automatic adjustment.
- (4) After a few seconds, press the numeric key "6" of the remote controller. Then, the FL display displays a jitter value.
- (5) Turn the adjustment screws on the underside of the traverse mechanism with Phillips screw driver until the maximum jitter value is displayed on the FL display. (In this model, a bigger jitter value means a better result.)

NOTE:

Reference values to judge whether the jitter is allowable or not are displayed, instead of actual jitter values.

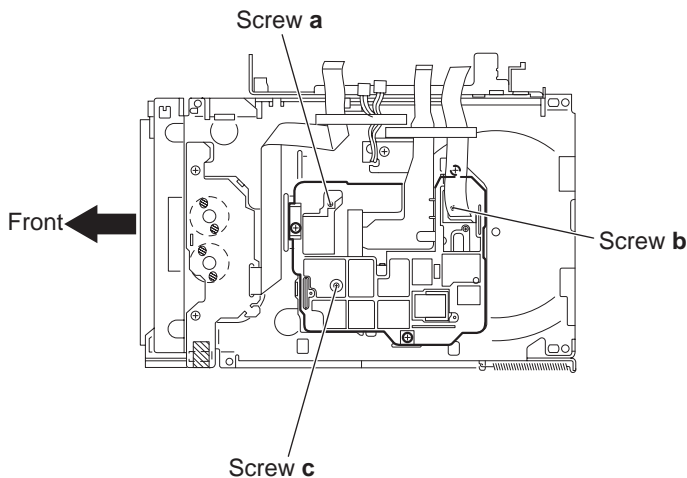

POINT:

Turn the adjustment screws **a** and **b** to the same angle in the right direction. And turn the adjustment screws **a** and **b** to the same angle in the left direction. Then, turn the screws **a** and **b** in either the right or the left direction to increase the number of jitter. Don't turn the adjustment screw **c**.

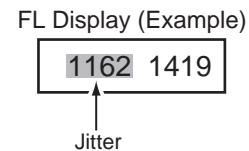

4.8 Confirmation of region

- (1) Unplug the power plug.
- (2) Insert power plug into outlet while pressing both "PAUSE" key and "FORWARD SKIP" key of the main body.
About 3 seconds later, FL display indicates "REGION".
- (3) Push the "OPEN/CLOSE" key (for DISC 1) and confirm the tray of DISC 1 is ejected.
- (4) To release test mode, press "STANDBY/ON" key of the main body.

NOTE:

Until the tray is completely close up and the sound of mechanism movement disappears, do not pull the power plug from the outlet.

4.9 Upgrading of firmware

The latest firmware for upgrading is updated in "Optical disc CSG" page in JS-net. At the time of service, compare the version of the product and the latest version, and upgrade the old version into the latest version.

- (1) Press the "STANDBY/ON" key of the main body to turn the main body on.
- (2) A disc button is pushed after inserting an upgrade disc in a tray 1.
- (3) When FL display of the main body changes from "READING" to "UPGRADE", press "cursor UP" key () of the remote controller.
- (4) The entire screen becomes blue, and upgrading starts.
- (5) The tray opens automatically. Remove the upgrade disc.
- (6) The screen returns to the normal screen. Then, press the "STANDBY/ON" key of the main body. When the stand-by indicator is lighted, upgrading is completed.
- (7) Set the main body at test mode, and perform initialization. Then, confirm the version of the firmware.

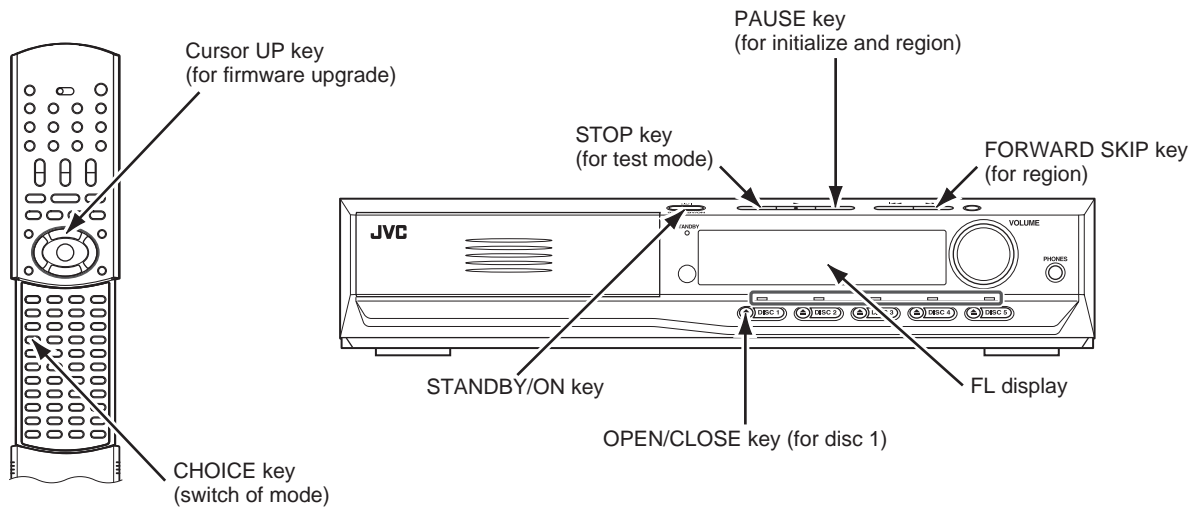
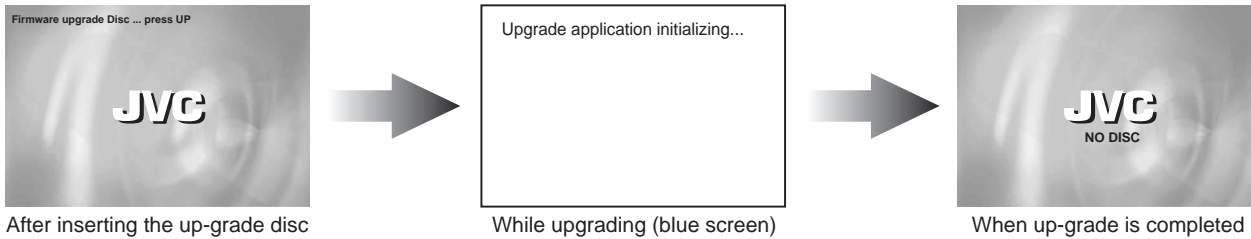

SECTION 5 TROUBLESHOOTING

This service manual does not describe TROUBLESHOOTING.



JVC

VICTOR COMPANY OF JAPAN, LIMITED

AV & MULTIMEDIA COMPANY AUDIO/VIDEO SYSTEMS CATEGORY 10-1,1chome,Ohwatari-machi,Maebashi-city,371-8543,Japan

(No.MB033)



Printed in Japan
WPC

PARTS LIST

[TH-M45]

* All printed circuit boards and its assemblies are not available as service parts.

Area suffix

B ----- U.K.
E ----- Continental Europe
EN ----- Northern Europe

- Contents -

Exploded view of general assembly and parts list (Block No.M1)	3- 2
Speaker assembly and parts list (Subwoofer) (Block No.M2)	3- 5
Speaker assembly and parts list (Front speaker,Center speaker,Surround speaker) (Block No.M6)	3- 7
DVD changer mechanism assembly and parts list (Block No.MK)	3- 8
Electrical parts list (Block No.01~07)	3-10
Packing materials and accessories parts list (Block No.M3)	3-22

Exploded view of general assembly and parts list

Block No. **M 1 M M**

Power

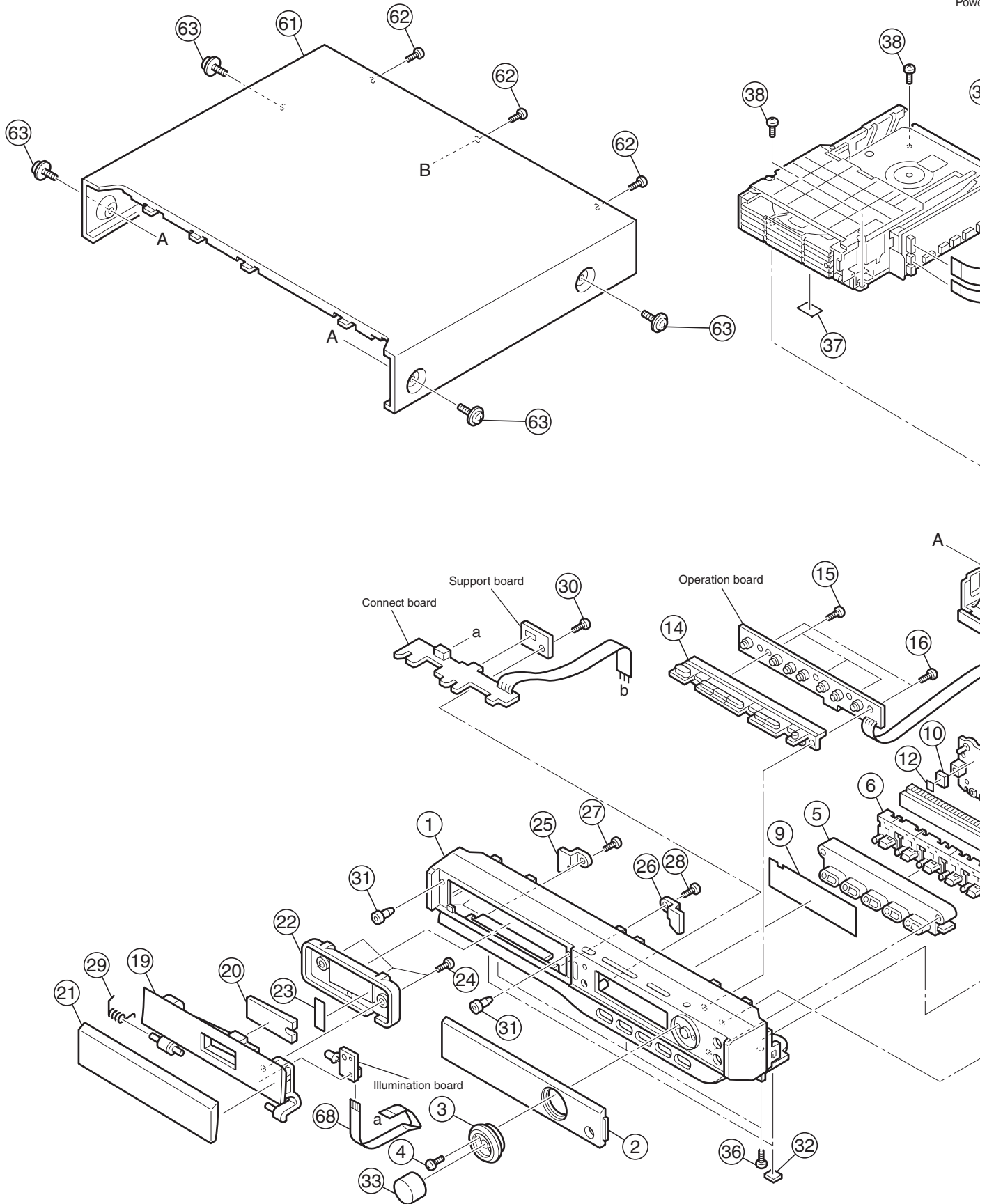

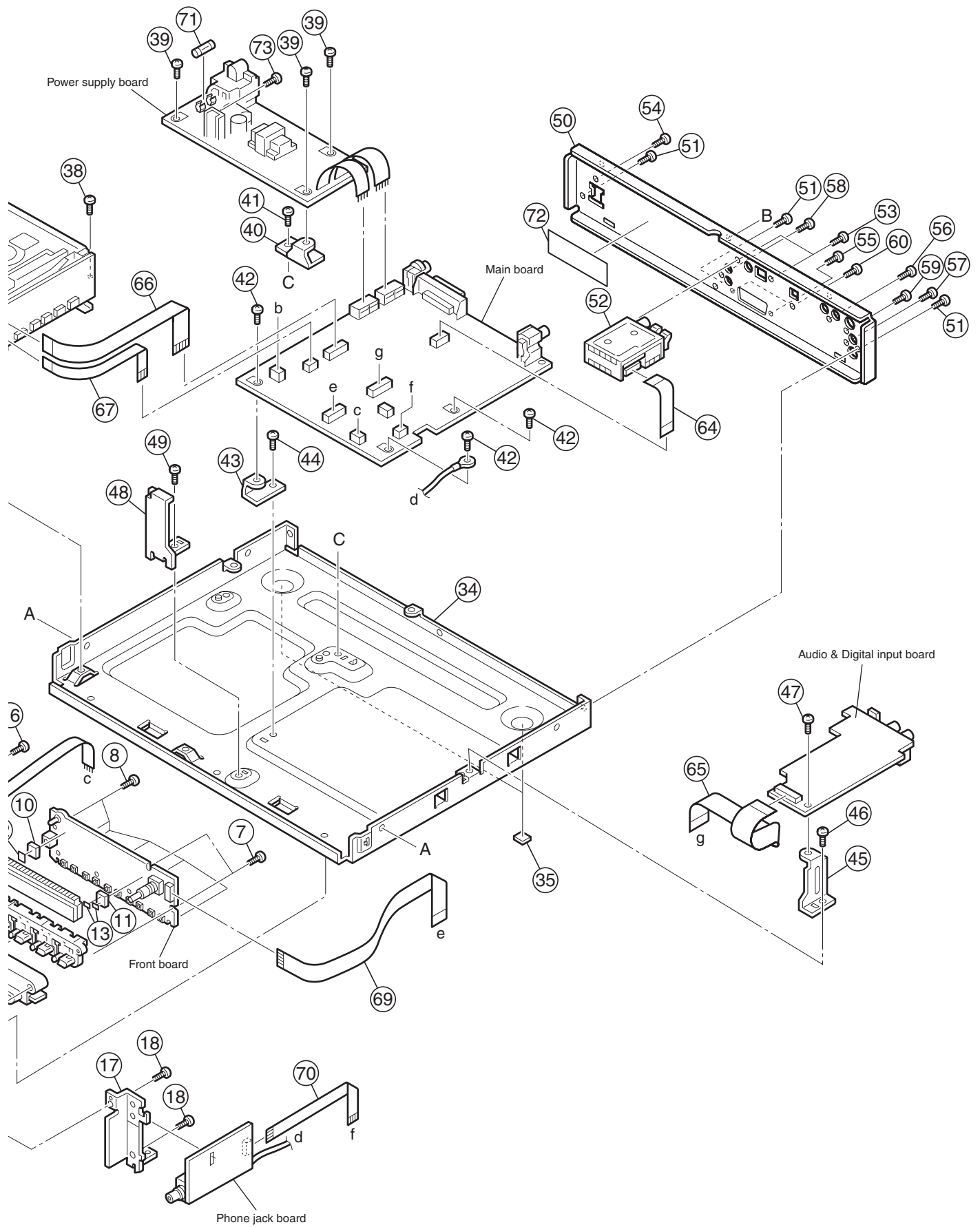

General assembly

Block No. [M][1][M][M]

Symbol No.	Part No.	Part Name	Description	Local
1	LV10769-005A	FRONT PANEL		
2	LV34038-004A	FL LENS		
3	LV43327-002A	VOL RING		
4	QYSDSF2608Z	SCREW	2.6mm x 8mm	
5	LV21451-002A	BUTTON ORNAMENT		
6	LV21448-001A	BUTTON(DISC)		
7	QYSDSF2608Z	SCREW	2.6mm x 8mm(x2)	
8	QYSDSF2608Z	SCREW	2.6mm x 8mm(x6)	
9	LV43329-001A	FL SCREEN		
10	LV43330-001A	FL HOLDER(L)		
11	LV43331-001A	FL HOLDER(R)		
12	VYSH101-009	SPACER		
13	LV30225-0M9A	SPACER	(x2)	
14	LV21460-001A	BUTTON(TOP)		
15	QYSDSF2608Z	SCREW	2.6mm x 8mm(x3)	
16	QYSDSF2612Z	TAP SCREW	M2.6 x 12mm(x2)	
17	LV43332-002A	BKT(H.PHONE)		
18	QYSDSF2608Z	SCREW	2.6mm x 8mm(x2)	
19	LV21447-002A	DOOR		
20	LV43326-001A	LED LENS		
21	LV34036-005A	DOOR LENS		
22	LV34037-001A	DOOR COVER		
23	LV30225-011A	SPACER		
24	QYSDSF2608Z	SCREW	2.6mm x 8mm(x3)	
25	LV41694-001A	DOOR BKT(L)		
26	LV41695-001A	DOOR BKT(R)		
27	QYSDSF2608Z	SCREW	2.6mm x 8mm	
28	QYSDSF2608Z	SCREW	2.6mm x 8mm	
29	LV43334-001A	DOOR SPRING		
30	QYSDSF2608Z	SCREW	2.6mm x 8mm	
31	E69897-002	CUSHION	(x2)	
32	LV40301-001A	FELT SPACER	(x2)	
33	LV34039-001A	VOLUME KNOB		
34	LV10770-002A	BOTTOM CHASSIS		
35	LV40301-002A	FELT SPACER	(x2)	
36	QYSBSG3006Z	TAPPING SCREW	3mm x 6mm(x3)	
37	LV30225-0Q2A	SPACER		
38	QYSBSG3006Z	TAPPING SCREW	3mm x 6mm(x4)	
39	QYSBSG3006Z	TAPPING SCREW	3mm x 6mm(x3)	
40	LV41548-001A-NK	C.B BKT		
41	QYSBSG3006Z	TAPPING SCREW	3mm x 6mm	
42	QYSBSG3006Z	TAPPING SCREW	3mm x 6mm(x3)	
43	LV41548-001A-NK	C.B BKT		
44	QYSBSG3006Z	TAPPING SCREW	3mm x 6mm	
45	LV43333-001A	BKT(DSP)		
46	QYSBSG3006Z	TAPPING SCREW	3mm x 6mm	
47	QYSBSG3006Z	TAPPING SCREW	3mm x 6mm	
48	LV43429-001A	STAY BKT		
49	QYSBSG3006Z	TAPPING SCREW	3mm x 6mm	
50	LV21450-018A	REAR PANEL		
51	QYSBSGY3008M	SPECIAL SCREW	3mm x 8mm(x3)	
52	QAU0278-003	TUNER		
53	QYSBSGY3008M	SPECIAL SCREW	3mm x 8mm(x2)	
54	QYSBSGY3008M	SPECIAL SCREW	3mm x 8mm	
55	QYSBSGY3008M	SPECIAL SCREW	3mm x 8mm(x2)	
56	QYSBSGY3008M	SPECIAL SCREW	3mm x 8mm	
57	QYSBSGY3008M	SPECIAL SCREW	3mm x 8mm	
58	QYSBSGY3008M	SPECIAL SCREW	3mm x 8mm	
59	QYSBST3006M	TAPPING SCREW	3mm x 6mm	
60	QYSBSGY3008M	SPECIAL SCREW	3mm x 8mm	
61	LV21449-002A/S/	METAL COVER		
62	QYSBSGY3008M	SPECIAL SCREW	3mm x 8mm(x3)	
63	E406308-004	SPECIAL SCREW	(x4)	
64	QUQ412-1107CJ	FFC WIRE		
65	QUQ410-3115CJ	FFC WIRE		
66	QUQ410-2317CJ	FFC WIRE		
67	QUQ410-0712CJ	FFC WIRE		
68	QUQ610-0407BJ	FFC WIRE		
69	QUQM10-2124AJ	FFC WIRE		
70	QUQ412-0610CJ	FFC WIRE		
△ 71	QMF51W2-1R6-J8	FUSE	F 901 1.6A AC250V	
72	LV41843-002A	LASER CAUTION		
73	QYSBSE3008Z	SCREW	3mm x 8mm	

Speaker assembly and parts list

(Subwoofer)

Block No. M 2 M M

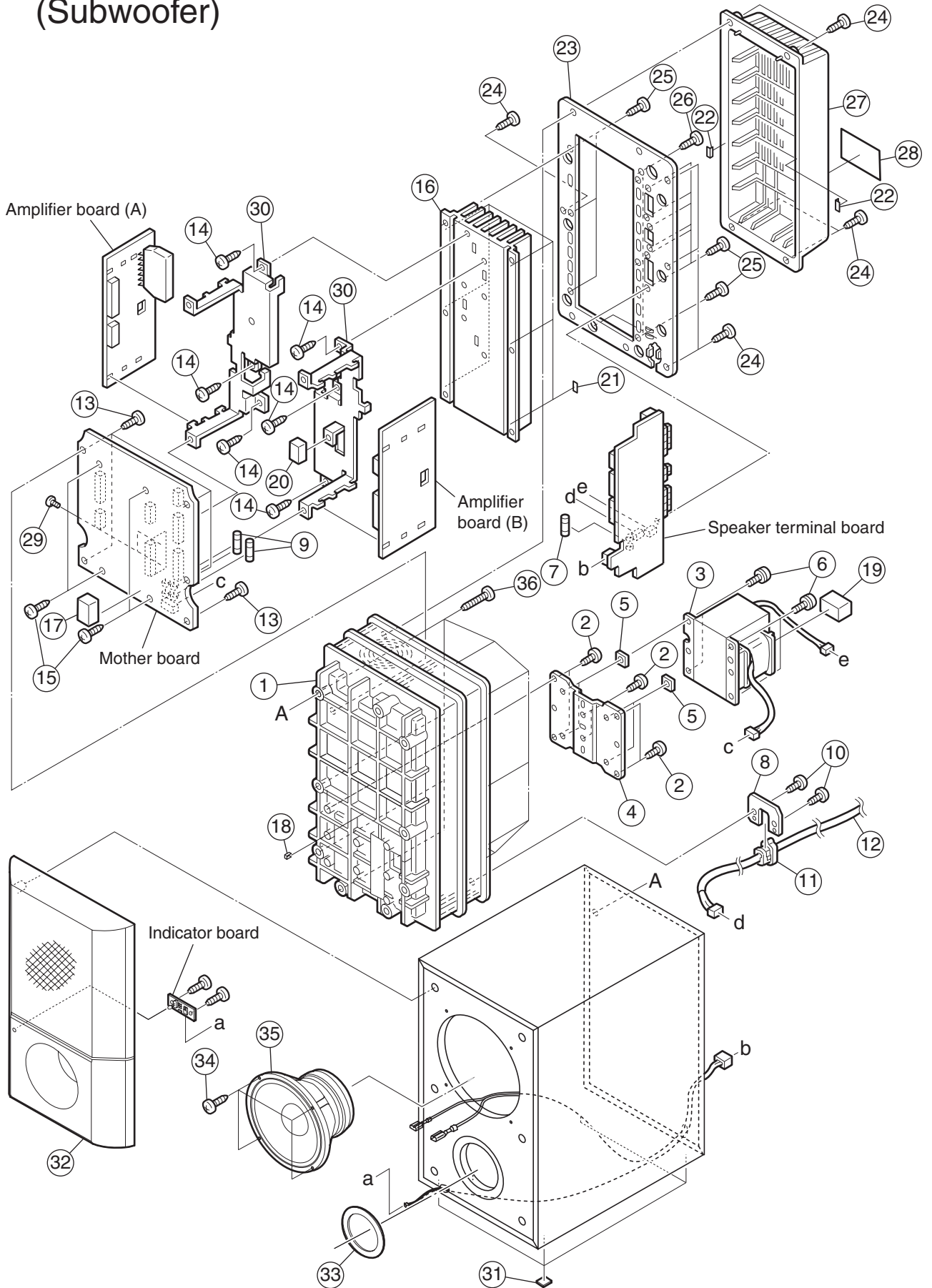

Speaker (Subwoofer)

Block No. [M][2][M][M]

Symbol No.	Part No.	Part Name	Description	Local
△ 1	LV10784-010A	REAR CHASSIS		
2	QYSBSF4010Z	TAP SCREW	M4 x 10mm(x6)	
△ 3	QQT0417-002	POWER TRANSF		
4	LV31723-001A	TRANS BRACKET		
5	E406309-002	SPACER	(x4)	
6	QYSDSTL4010E	TAP SCREW	M4 x 10mm(x4)	
△ 7	QMF51W2-3R15-J8	FUSE	F 101 3.15A AC250V	
8	LV42032-001A	AC BRACKET		
△ 9	QMFZ051-8R0-J8	FUSE	F 153 F 154 8A(x2)	
10	QYSBSF3010Z	TAP SCREW	3mm x 10mm(x2)	
△ 11	QHS3771-108	CORD STOPPER		
△ 12	QMPK210-205-JN	POWER CORD(EU)	2.05m BLACK	THM4 5E.TH M45E N
△ 12	QMPN150-200-JC	POWER CORD		THM4 5B
13	QYSBSF3010Z	TAP SCREW	3mm x 10mm(x5)	
14	QYSBSG3008E	TAPPING SCREW	3mm x 8mm(x6)	
15	QYSBSG3008E	TAPPING SCREW	3mm x 8mm(x4)	
△ 16	LV21474-001A	HEAT SINK		
17	LV30225-078A	SPACER		
18	LV30225-0N4A	SPACER		
19	LV30225-0N5A	SPACER		
20	LV30225-0N6A	SPACER		
21	LV30225-0N7A	SPACER	(x6)	
22	LV30225-0N7A	SPACER	(x2)	
23	LV21475-013A	REAR PANEL		
24	QYSDSF3012M	TAP SCREW	M3 x 12mm(x8)	
25	QYSBSGY3008E	SPECIAL SCREW	3mm x 8mm(x12)	
26	QYSBSP3006M	SCREW	M3 x 6mm	
27	LV10785-002A	H.S.COVER		
28	LV34201-011A	RATING LABEL		
29	QYSPSPD3008Z	SCREW	3mm x 8mm(x2)	
30	LV34197-003A	IC BRACKET	(x2)	
31	5600006901	RUBBER FOOT	(x4)	
32	9916011101	BAFFLE ASSY		
33	2910008601	PACKING		
34	7005942002	SCREW	(x4)	
35	CR16006601	SPEAKER		
36	7001542506	SCREW	(x9)	

Speaker assembly and parts list

Block No. [M][6][M][M]

(Front speaker,Center speaker,Surround speaker)

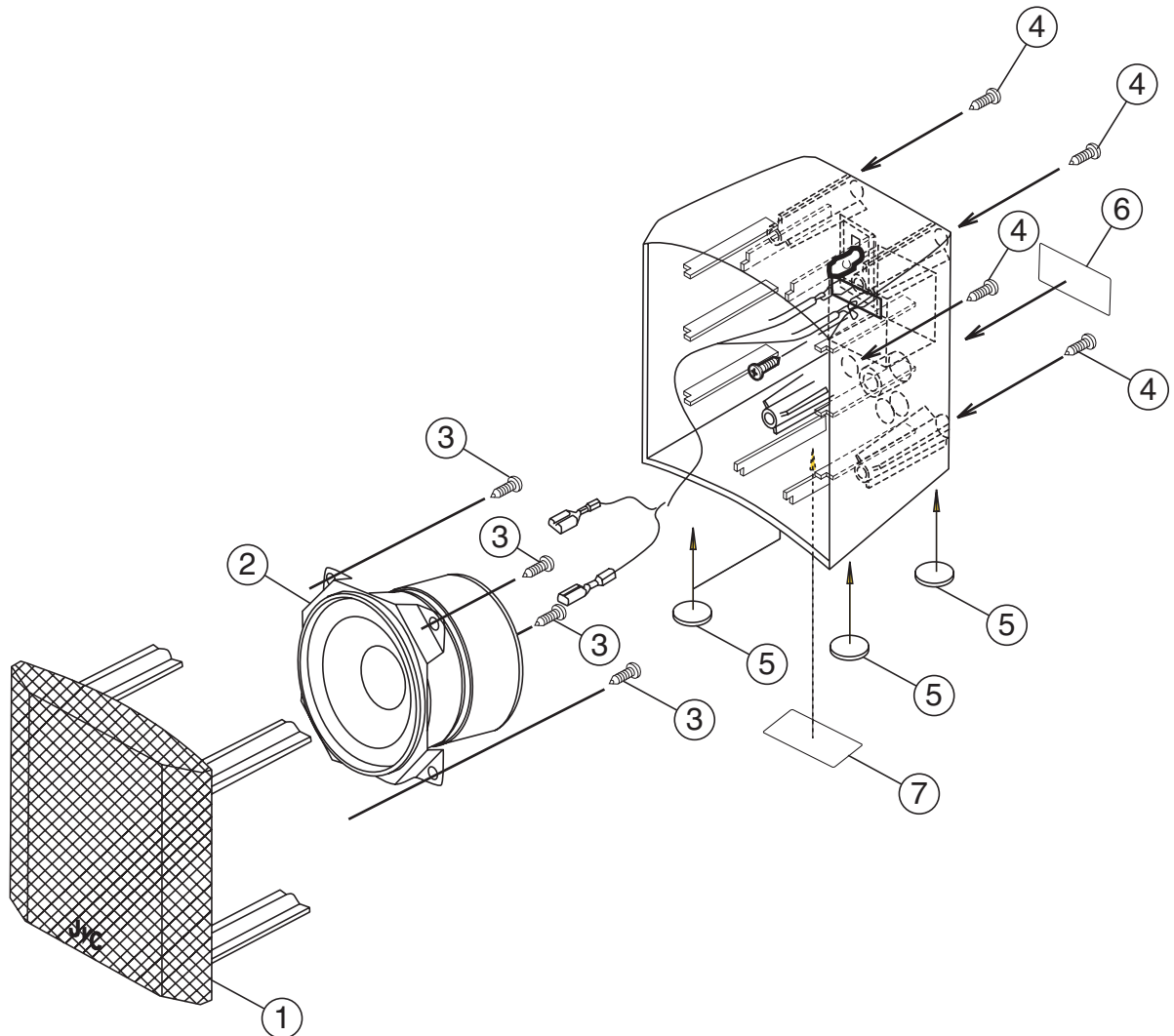

Speaker (Front speaker,Center speaker,Surround speaker)

Block No. [M][6][M][M]

△ Symbol No.	Part No.	Part Name	Description	Local
1	9907701001	NET ASSY	(x5)	
2	KK07701001	SPEAKER(FRONT/ CENTRE)	(x3)	
2	KK07701101	SPEAKER(SURROU ND)	(x2)	
3	7001040801	SCREW	(x20)	
4	7001741201	SCREW	(x20)	
5	9000005361	FOOT	(x20)	
6	6000197701	LABEL(FRONT)	(x2)	
6	6000197501	LABEL(CENTRE)		
6	6000197601	LABEL(SURROUND)	(x2)	
7	6000196301	RATING LABEL(FRONT)	(x2)	
7	6000197801	RATING LABEL(CENTRE)		
7	6000197901	RATING LABEL(SURROUND)	(x2)	

DVD changer mechanism assembly and parts list

Block No. M K M M

Grease
 ★ = JVG-31N
 ▲ = JVS-1003

EMU-SD1-1

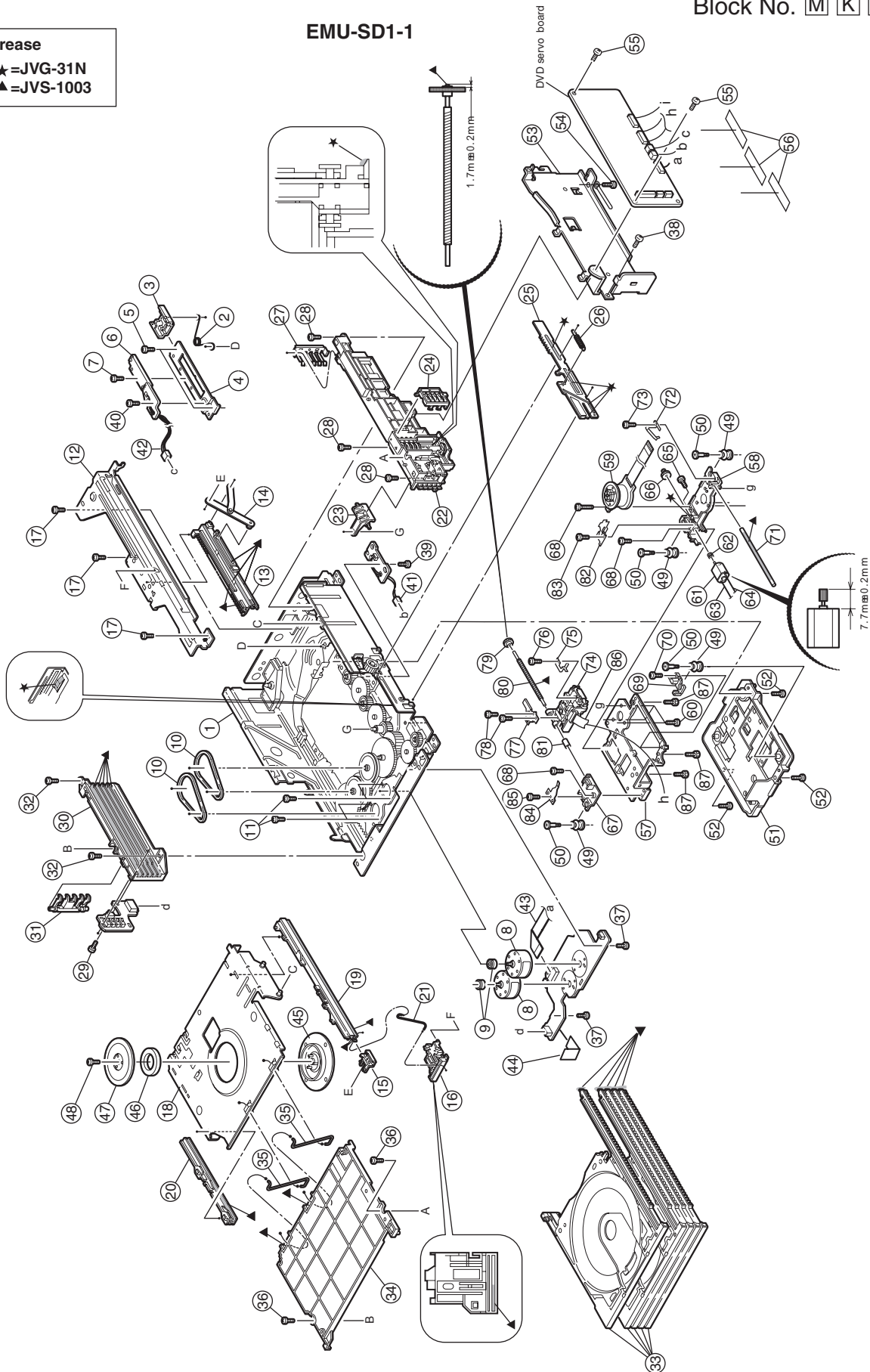

DVD changer mechanism

Block No. [M][K][M][M]

△ Symbol No.	Part No.	Part Name	Description	Local
1	LV10743-003A	CHASSIS ASSY		
2	LV43278-001A	SENSOR SPRING		
3	LV33961-001A	SENSOR SLIDER		
4	LV33962-001A	SENSOR BRACKET		
5	QYSDST2605Z	SCREW	2.6mm x 5mm(x2)	
6	QVY0027-B14	S V RESISTOR		
7	QYSDST2004Z	SCREW	2mm x 4mm	
8	QAR0164-001	MOTOR	(x2)	
9	LV42340-001A	MOTOR PULLEY	(x2)	
10	LV41431-001A	BELT	(x2)	
11	QYSPSPU1725N	SCREW	1.7mm x 2.5mm(x4)	
12	LV10744-002A	RACK HOLDER		
13	LV21406-002A	LOADING RACK		
14	LV43279-001A	LIFT ARM ASSY		
15	LV33963-001A	HOOK		
16	LV33964-001A	HOOK STOPPER		
17	QYSDST2605Z	SCREW	2.6mm x 5mm(x3)	
18	LV33965-005A	LIFTER ASSY		
19	LV21408-002A	RAIL(R)		
20	LV21409-002A	RAIL(L)		
21	LV43285-001A	ROD (L)		
22	LV21520-002A	SIDE(R) ASSY		
23	LV33974-001A	SELECT LEVER		
24	LV33975-001A	GEAR COVER		
25	LV33976-001A	ELEVATOR CAM		
26	LV43287-001A	ELEVATOR SPRING		
27	LV33977-002A	CLICK SPRING		
28	QYSDST2605Z	SCREW	2.6mm x 5mm(x3)	
29	QYSDSF2608Z	SCREW	2.6mm x 8mm	
30	LV10749-001A	SIDE(L)		
31	LV33980-001A	OPEN DET.LEVER		
32	QYSDST2605Z	SCREW	2.6mm x 5mm(x2)	
33	LV10746-002A	TRAY ASSY	(x5)	
34	LV10750-002A	TOP COVER		
35	LV43289-001A	ROD	(x2)	
36	QYSDSF2608Z	SCREW	2.6mm x 8mm(x2)	
37	QYSDST2605Z	SCREW	2.6mm x 5mm(x2)	
38	QYSDSF2608Z	SCREW	2.6mm x 8mm	
39	QYSDST2605Z	SCREW	2.6mm x 5mm	
40	QYSDST2004Z	SCREW	2mm x 4mm	
41	WJM0330-001A	E-SI C WIRE C-F		
42	WJM0331-001A	E-SI C WIRE C-F		
43	QUQ110-1521BF	FFC WIRE		
44	VYSA1R4-056	SPACER		
45	LV32417-001A	CLAMPER		
46	LV42930-003A	P.C.MAGNET		
47	LV33992-001A	DVD YOKE		
48	LV41741-001A	SPECIAL SCREW		
49	LV41659-002A	INSULATOR	(x4)	
50	LV43245-001A	SPECIAL SCREW	(x4)	
51	LV10753-001A	DVD TM BASE		
52	QYSDST2605Z	SCREW	2.6mm x 5mm(x3)	
53	LV21414-001A	DVD MOD BKT.		
54	QYSDST2605Z	SCREW	2.6mm x 5mm	
55	QYSDST2605Z	SCREW	2.6mm x 5mm(x2)	
56	VYSA1R4-057	SPACER	(x3)	
57	LV10751-001A	TM CHASSIS		
58	LV10752-001A	SF MOTOR BASE		
59	QAR0270-001	SPINDLE MOTOR		
60	LV43461-001A	SPECIAL SCREW	(x3)	
61	QAR0251-002	MOTOR		
62	VKS5557-001	F.M. GEAR		
63	QUB549-08A1A1	SIN TWIST WIRE		
64	QUB544-08A1A1	SIN TWIST WIRE		
65	QYSPSPT2030M	SCREW	M2 x 3mm	
66	LV33985-001A	MIDDLE GEAR		
67	LV33989-001A	S.SHAFT HOLDER		
68	QYSDST2008Z	TAP SCREW	M2 x 8mm(x3)	
69	LV33990-001A	G.SHAFT HOLDER		
70	QYSDST2008Z	TAP SCREW	M2 x 8mm	
71	LV43291-002A	GUIDE SHAFT		
72	LV33991-001A	ADJUST SPRING		
73	QYSPST2008Z	TAP SCREW	M2 x 8mm	

△ Symbol No.	Part No.	Part Name	Description	Local
74	QAL0478-001	PICK UP		
75	LV33983-001A	PS SPRING		
76	QYSPSFT1730Z	TAP SCREW	M1.7 x 3mm	
77	LV33984-001A	RACK ARM		
78	QYSPSFT1730Z	TAP SCREW	M1.7 x 3mm(x2)	
79	LV33986-001A	S.SHAFT GEAR		
80	LV43293-001A	SCREW SHAFT		
81	LV43290-001A	S.SHAFT COLLOR		
82	LV33987-001A	GEAR HOLDER		
83	QYSPSFT2040Z	TAP SCREW	M2 x 4mm	
84	LV33988-001A	SS ADJ SPRING		
85	QYSDST2008Z	TAP SCREW	M2 x 8mm	
86	LVB30013-001A	FPC		
87	LV43292-002A	ADJUST SCREW	(x3)	

Electrical parts list

Main board

Block No. [0][1][0][0]

Symbol No.	Part No.	Part Name	Description	Local	Symbol No.	Part No.	Part Name	Description	Local
					D4703	MTZJ4.7B-T2	Z DIODE		
					D4704	1SS133-T2	DIODE		
					D4705	1SS133-T2	DIODE		
					D4811	1SS133-T2	DIODE		
					D4831	1SS133-T2	DIODE		
					D4832	1SS133-T2	DIODE		
					D4833	1SS133-T2	DIODE		
					D4834	1SS133-T2	DIODE		
					D4835	MTZJ6.8A-T2	Z DIODE		
					D4841	1SS133-T2	DIODE		
					D4891	MTZJ6.2C-T2	Z DIODE		
					D4921	MTZJ8.2C-T2	Z DIODE		
					D4922	1SS355-X	SI DIODE		
					D4931	MTZJ8.2C-T2	Z DIODE		
					D4932	1SS355-X	SI DIODE		
					D4961	MTZJ4.7A-T2	Z DIODE		
					D4962	1SS133-T2	DIODE		
					D4963	1SS133-T2	DIODE		
					△ PC901	PC123Y22FZ	PHOTO COUPLER	Photo coupler	
					△ PC902	PC123Y22FZ	PHOTO COUPLER	Photo coupler	
					△ C902	QFZ9075-683	MPP CAPACITOR	0.068uF AC275V M	
					△ C904	QCZ9079-102	C CAPACITOR	1000pF AC250V M	
					△ C905	QCZ9079-102	C CAPACITOR	1000pF AC250V M	
					△ C907	QEZ0522-826	E CAPACITOR	82uF	
					C908	QCZ0136-332Z	C CAPACITOR	3300pF 1kV K	
					C909	QCZ0136-101Z	C CAPACITOR	100pF 1kV K	
					C910	QCB1HK-221Y	C CAPACITOR	220pF 50V K	
					C913	QCZ0136-101Z	C CAPACITOR	100pF 1kV K	
					C914	QEZ0532-396Z	E CAPACITOR	39uF 25V M	
					C915	QCB1HK-471Y	C CAPACITOR	470pF 50V K	
					△ C916	QCZ9079-222	C CAPACITOR	2200pF AC250V M	
					C918	QCFB1HZ-104Y	C CAPACITOR	0.1uF 50V Z	
					C951	NDC31HJ-101X	C CAPACITOR	100pF 50V J	
					C952	QCZ0136-101Z	C CAPACITOR	100pF 1kV K	
					C953	NDC31HJ-101X	C CAPACITOR	100pF 50V J	
					C954	NDC31HJ-101X	C CAPACITOR	100pF 50V J	
					C956	NDC31HJ-101X	C CAPACITOR	100pF 50V J	
					C957	NDC31HJ-101X	C CAPACITOR	100pF 50V J	
					C960	QEZ0529-826Z	E CAPACITOR	82uF 10V M	
					C961	QCZ0202-155Z	C CAPACITOR	1.5uF 25V Z	
					C962	QK1HM-226Z	E CAPACITOR	22uF 50V M	
					C963	QEZ0533-396Z	E CAPACITOR	39uF 50V M	
					C964	QETN1HM-226Z	E CAPACITOR	22uF 50V M	
					C965	QTMN1AM-108Z	E CAPACITOR	1000uF 10V M	
					C966	QETN1AM-477Z	E CAPACITOR	470uF 10V M	
					C967	NCB31CK-104X	C CAPACITOR	0.1uF 16V K	
					C968	NCB31CK-104X	C CAPACITOR	0.1uF 16V K	
					C969	QETN1AM-227Z	E CAPACITOR	220uF 10V M	
					C970	NCB31CK-104X	C CAPACITOR	0.1uF 16V K	
					C973	QETN1CM-107Z	E CAPACITOR	100uF 16V M	
					C976	NCB31CK-104X	C CAPACITOR	0.1uF 16V K	
					C977	NCB31CK-104X	C CAPACITOR	0.1uF 16V K	
					C978	QK1CM-107Z	E CAPACITOR	100uF 10V M	
					C979	QEZ0530-827	E CAPACITOR	820uF 16V M	
					C980	QK1HM-106Z	E CAPACITOR	10uF 50V M	
					C981	QCZ0202-155Z	C CAPACITOR	1.5uF 25V Z	
					C982	QEZ0531-567	E CAPACITOR	560uF 25V M	
					C984	QK1CM-227Z	E CAPACITOR	220uF 16V M	
					C985	QETN1EM-107Z	E CAPACITOR	100uF 25V M	
					C986	QETN1EM-107Z	E CAPACITOR	100uF 25V M	
					C987	QEZ0532-187Z	E CAPACITOR	180uF 25V M	
					C989	QK1CM-107Z	E CAPACITOR	100uF 16V M	
					C992	QETN1HM-474Z	E CAPACITOR	0.47uF 50V M	
					C993	NDC31HJ-101X	C CAPACITOR	100pF 50V J	
					C994	QCB1HK-223Y	C CAPACITOR	0.022uF 50V K	
					C997	QETN1CM-227Z	E CAPACITOR	220uF 16V M	
					C4003	QCZ0202-155Z	C CAPACITOR	1.5uF 25V Z	
					C4006	QCZ0202-155Z	C CAPACITOR	1.5uF 25V Z	
					C4011	NCB31HK-822X	C CAPACITOR	8200pF 50V K	
					C4012	NCB31HK-822X	C CAPACITOR	8200pF 50V K	
					C4071	QETN1HM-106Z	E CAPACITOR	10uF 50V M	
					C4072	NCB31CK-473X	C CAPACITOR	0.047uF 16V K	
IC431	LA73054-X	IC	Video driver						
IC471	MN101C49GMN1	IC							
IC472	BD4740G-W	IC	Reset						
IC473	SN74HCT32NS-X	IC(DIGITAL)							
IC481	SAA6588T/V2-X	IC	RDS decoder						
IC491	KIA7805API	IC	Regulator						
IC492	CD4066BM-X	IC							
IC601	HA17558AF-X	IC	Dual Operational Amp						
△ IC901	STR-G6651	IC	Switching regulator						
IC951	PQ05RD21	IC	Regulator						
IC953	KIA7805API	IC	Regulator						
Q951	2SC3576-JVC-T	TRANSISTOR							
Q953	KTA1267/YG/-T	TRANSISTOR							
Q954	SI2305DS-X	TRANSISTOR							
Q955	KRC103S-X	DIGITAL TR							
Q958	KTA1271/OY/-T	TRANSISTOR							
Q959	KRC103S-X	DIGITAL TR							
Q960	KTA1504/YG/-X	SI.TRANSISTOR							
Q961	KTC3203/OY/-T	TRANSISTOR							
Q964	KTA1046/Y/	TRANSISTOR	Q 51 Q 52						
Q965	KTC3875/YG/-X	SI.TRANSISTOR							
Q991	KTC3875/YG/-X	SI.TRANSISTOR							
Q4091	KTA1271/OY/-T	TRANSISTOR							
Q4092	KTC3875/YG/-X	SI.TRANSISTOR							
Q4481	KRC102S-X	DIGI TRANSISTOR							
Q4482	KRC102S-X	DIGI TRANSISTOR							
Q4483	KRA102S-X	DIGI TRANSISTOR							
Q4484	KRC102S-X	DIGI TRANSISTOR							
Q4701	KRC111S-X	TRANSISTOR							
Q4702	KRC107S-X	DIGI TRANSISTOR							
Q4703	KRC102S-X	DIGI TRANSISTOR							
Q4801	KTA1504/YG/-X	SI.TRANSISTOR							
Q4802	KRC102S-X	DIGI TRANSISTOR							
Q4811	KRA102S-X	DIGI TRANSISTOR							
Q4812	KRC102S-X	DIGI TRANSISTOR							
Q4821	KRC102S-X	DIGI TRANSISTOR							
Q4831	KRC102S-X	DIGI TRANSISTOR							
Q4851	KRC102S-X	DIGI TRANSISTOR							
Q4852	KRC111S-X	TRANSISTOR							
Q4921	KTC3203/OY/-T	TRANSISTOR							
Q4931	KTA1271/OY/-T	TRANSISTOR							
Q4951	KRA104S-X	DIGI TRANSISTOR							
Q4952	KRA104S-X	DIGI TRANSISTOR							
Q4961	KTC3203/OY/-T	TRANSISTOR							
△ D901	S1WB/A/60-4101	BRIDGE DIODE							
D902	ERA18-04-T1	FR DIODE							
D903	ERA18-04-T1	FR DIODE							
D904	ERA18-04-T1	FR DIODE							
D908	ERA18-04-T1	FR DIODE							
D910	ERA18-04-T1	FR DIODE							
D911	ERA18-04-T1	FR DIODE							
D950	MTZJ36C-T2	Z DIODE							
D951	ERA18-04-T1	FR DIODE							
D951	or AU02-T1	FR DIODE							
D952	ERA18-04-T1	FR DIODE							
D952	or AU02-T1	FR DIODE							
△ D953	FMB-24	FUSEIODE							
△ D954	EU2YX-LFH6K	FR DIODE							
△ D956	EU2YX-LFH6K	FR DIODE							
△ D957	EU2YX-LFH6K	FR DIODE							
D958	1SS133-T2	DIODE							
D960	MTZJ3.6B-T2	Z DIODE							
D970	1SS133-T2	DIODE							
D975	1SS133-T2	DIODE							
D991	MTZJ5.1B-T2	Z DIODE							
D4091	1SS133-T2	DIODE							
D4092	MTZJ6.8A-T2	Z DIODE							
D4701	1SS133-T2	DIODE							
D4702	1SS133-T2	DIODE							

△ Symbol No.	Part No.	Part Name	Description	Local	△ Symbol No.	Part No.	Part Name	Description	Local
C4073	NCB31CK-104X	C CAPACITOR	0.1uF 16V K		C6201	QETN1HM-475Z	E CAPACITOR	4.7uF 50V M	
C4074	NCB31HK-561X	C CAPACITOR	560pF 50V K		C6202	NDC31HJ-180X	C CAPACITOR	18pF 50V J	
C4075	QETN1HM-225Z	E CAPACITOR	2.2uF 50V M		C6203	QETN1VM-476Z	E CAPACITOR	47uF 35V M	
C4076	NCB31HK-331X	C CAPACITOR	330pF 50V K		C6204	NCB31HK-103X	C CAPACITOR	0.01uF 50V K	
C4077	NCS31HJ-820X	C CAPACITOR	82pF 50V J		C6901	QETN1VM-476Z	E CAPACITOR	47uF 35V M	
C4078	NCS31HJ-470X	C CAPACITOR	47pF 50V J		C6902	QETN1VM-476Z	E CAPACITOR	47uF 35V M	
C4091	QETN1HM-106Z	E CAPACITOR	10uF 50V M		R901	QRL01DJ-683X	OMF RESISTOR	68kΩ 1W J	
C4092	QETN1CM-107Z	E CAPACITOR	100uF 16V M		R903	QRE141J-270Y	C RESISTOR	27Ω 1/4W J	
C4111	QFN31HJ-103Z	M CAPACITOR	0.01uF 50V J		R904	QRE141J-222Y	C RESISTOR	2.2kΩ 1/4W J	
C4301	QETN1VM-476Z	E CAPACITOR	47uF 35V M		R905	QRL027J-683	OMF RESISTOR	68kΩ 2W J	
C4311	NCB31CK-103X	C CAPACITOR	0.01uF 16V K		R906	QRJ146J-681X	UNF C RESISTOR	680Ω 1/4W J	
C4321	NCB30JK-105X	C CAPACITOR	1uF 6.3V K		R907	QRT027J-R47	MF RESISTOR	0.47Ω 2W J	
C4331	NCB30JK-105X	C CAPACITOR	1uF 6.3V K		R908	QRE141J-332Y	C RESISTOR	3.3kΩ 1/4W J	
C4341	NCB30JK-105X	C CAPACITOR	1uF 6.3V K		R910	QRE141J-474Y	C RESISTOR	470kΩ 1/4W J	
C4351	NCB30JK-105X	C CAPACITOR	1uF 6.3V K		R911	QRE141J-474Y	C RESISTOR	470kΩ 1/4W J	
C4391	QETN1AM-477Z	E CAPACITOR	470uF 10V M		R952	NRSA63J-103X	MG RESISTOR	10kΩ 1/16W J	
C4392	NCB31CK-104X	C CAPACITOR	0.1uF 16V K		R953	NRSA02J-223X	MG RESISTOR	22kΩ 1/10W J	
C4393	QETN1AM-477Z	E CAPACITOR	470uF 10V M		△ R954	QRZ9005-100X	FUSI RESISTOR	10Ω	
C4394	NCB31CK-104X	C CAPACITOR	0.1uF 16V K		R955	NRSA63J-223X	MG RESISTOR	22kΩ 1/16W J	
C4395	NCB31CK-104X	C CAPACITOR	0.1uF 16V K		R960	NRSA63J-101X	MG RESISTOR	100Ω 1/16W J	
C4401	QETN0JM-477Z	E CAPACITOR	470uF 6.3V M		R961	NRSA63J-681X	MG RESISTOR	680Ω 1/16W J	
C4402	NDC31HJ-470X	C CAPACITOR	47pF 50V J		R964	NRSA63J-105X	MG RESISTOR	1MΩ 1/16W J	
C4411	NCB31CK-103X	C CAPACITOR	0.01uF 16V K		R965	NRSA63J-103X	MG RESISTOR	10kΩ 1/16W J	
C4412	NDC31HJ-470X	C CAPACITOR	47pF 50V J		R966	NRSA63J-221X	MG RESISTOR	220Ω 1/16W J	
C4421	QETN0JM-477Z	E CAPACITOR	470uF 6.3V M		R969	NRSA63J-221X	MG RESISTOR	220Ω 1/16W J	
C4422	QETN0JM-477Z	E CAPACITOR	470uF 6.3V M		R971	NRSA63J-472X	MG RESISTOR	4.7kΩ 1/16W J	
C4423	NDC31HJ-470X	C CAPACITOR	47pF 50V J		R972	NRSA63J-122X	MG RESISTOR	1.2kΩ 1/16W J	
C4424	NDC31HJ-470X	C CAPACITOR	47pF 50V J		R977	NRSA63J-102X	MG RESISTOR	1kΩ 1/16W J	
C4431	QETN0JM-477Z	E CAPACITOR	470uF 6.3V M		R980	NRSA63J-272X	MG RESISTOR	2.7kΩ 1/16W J	
C4433	NDC31HJ-470X	C CAPACITOR	47pF 50V J		R981	NRSA63J-223X	MG RESISTOR	22kΩ 1/16W J	
C4441	QETN0JM-477Z	E CAPACITOR	470uF 6.3V M		R983	NRSA63J-102X	MG RESISTOR	1kΩ 1/16W J	
C4443	NDC31HJ-470X	C CAPACITOR	47pF 50V J		R984	NRSA63J-222X	MG RESISTOR	2.2kΩ 1/16W J	
C4444	NDC31HJ-470X	C CAPACITOR	47pF 50V J		R985	NRSA02J-132X	MG RESISTOR	1.3kΩ 1/10W J	
C4451	QETN0JM-477Z	E CAPACITOR	470uF 6.3V M		R986	NRSA02J-152X	MG RESISTOR	1.5kΩ 1/10W J	
C4453	NDC31HJ-470X	C CAPACITOR	47pF 50V J		R987	NRSA02J-152X	MG RESISTOR	1.5kΩ 1/10W J	
C4471	NCB31HK-331X	C CAPACITOR	330pF 50V K		R988	NRSA63J-222X	MG RESISTOR	2.2kΩ 1/16W J	
C4472	NCB31HK-331X	C CAPACITOR	330pF 50V K		R989	NRSA63J-333X	MG RESISTOR	33kΩ 1/16W J	
C4473	NCB31HK-331X	C CAPACITOR	330pF 50V K		R990	NRSA63J-333X	MG RESISTOR	33kΩ 1/16W J	
C4474	NCB31HK-331X	C CAPACITOR	330pF 50V K		R4011	NRSA63J-102X	MG RESISTOR	1kΩ 1/16W J	
C4475	QETN1HM-475Z	E CAPACITOR	4.7uF 50V M		R4012	NRSA63J-102X	MG RESISTOR	1kΩ 1/16W J	
C4476	QETN1HM-475Z	E CAPACITOR	4.7uF 50V M		R4013	NRSA63J-682X	MG RESISTOR	6.8kΩ 1/16W J	
C4491	NCB31HK-103X	C CAPACITOR	0.01uF 50V K		R4014	NRSA63J-682X	MG RESISTOR	6.8kΩ 1/16W J	
C4605	NDC31HJ-471X	C CAPACITOR	470pF 50V J		R4017	NRSA63J-474X	MG RESISTOR	470kΩ 1/16W J	
C4606	NDC31HJ-471X	C CAPACITOR	470pF 50V J		R4072	NRSA63J-102X	MG RESISTOR	1kΩ 1/16W J	
C4701	QEZO554-479	EDL CAPACITOR	0.047F		R4073	NRSA63J-103X	MG RESISTOR	10kΩ 1/16W J	
C4702	QETN0JM-227Z	E CAPACITOR	220uF 6.3V M		R4074	NRSA63J-103X	MG RESISTOR	10kΩ 1/16W J	
C4703	QETN1HM-225Z	E CAPACITOR	2.2uF 50V M		R4091	NRSA63J-472X	MG RESISTOR	4.7kΩ 1/16W J	
C4704	NCB31HK-223X	C CAPACITOR	0.022uF 50V K		R4092	NRSA63J-103X	MG RESISTOR	10kΩ 1/16W J	
C4705	NCB31HK-102X	C CAPACITOR	1000pF 50V K		R4093	NRSA63J-821X	MG RESISTOR	820Ω 1/16W J	
C4706	NCB31HK-103X	C CAPACITOR	0.01uF 50V K		R4201	NRSA63J-360X	MG RESISTOR	36Ω 1/16W J	
C4707	QETN1CM-107Z	E CAPACITOR	100uF 16V M		R4231	NRSA63J-750X	MG RESISTOR	75Ω 1/16W J	
C4708	NCB31HK-103X	C CAPACITOR	0.01uF 50V K		R4232	NRSA63J-750X	MG RESISTOR	75Ω 1/16W J	
C4709	QCF31HZ-103Z	C CAPACITOR	0.01uF 50V Z		R4241	NRSA63J-750X	MG RESISTOR	75Ω 1/16W J	
C4771	NCB31CK-104X	C CAPACITOR	0.1uF 16V K		R4242	NRSA63J-750X	MG RESISTOR	75Ω 1/16W J	
C4772	NCB31CK-104X	C CAPACITOR	0.1uF 16V K		R4251	NRSA63J-750X	MG RESISTOR	75Ω 1/16W J	
C4773	NCB31CK-104X	C CAPACITOR	0.1uF 16V K		R4252	NRSA63J-750X	MG RESISTOR	75Ω 1/16W J	
C4774	NCB31CK-104X	C CAPACITOR	0.1uF 16V K		R4381	NRSA63J-103X	MG RESISTOR	10kΩ 1/16W J	
C4791	NCB31CK-104X	C CAPACITOR	0.1uF 16V K		R4382	NRSA63J-103X	MG RESISTOR	10kΩ 1/16W J	
C4801	QETN1HM-224Z	E CAPACITOR	0.22uF 50V M		R4383	NRSA63J-0R0X	MG RESISTOR	0Ω 1/16W J	
C4891	NCB31HK-221X	C CAPACITOR	220pF 50V K		R4385	NRSA63J-103X	MG RESISTOR	10kΩ 1/16W J	
C4892	NCB31HK-221X	C CAPACITOR	220pF 50V K		R4401	NRSA63J-750X	MG RESISTOR	75Ω 1/16W J	
C4901	QETN1CM-107Z	E CAPACITOR	100uF 16V M		R4411	NRSA63J-750X	MG RESISTOR	75Ω 1/16W J	
C4902	NCB31CK-103X	C CAPACITOR	0.01uF 16V K		R4421	NRSA63J-750X	MG RESISTOR	75Ω 1/16W J	
C4903	QETN1CM-107Z	E CAPACITOR	100uF 16V M		R4422	NRSA63J-750X	MG RESISTOR	75Ω 1/16W J	
C4904	NCB31CK-103X	C CAPACITOR	0.01uF 16V K		R4432	NRSA63J-750X	MG RESISTOR	75Ω 1/16W J	
C4921	QETN1VM-476Z	E CAPACITOR	47uF 35V M		R4442	NRSA63J-750X	MG RESISTOR	75Ω 1/16W J	
C4922	QETN1CM-107Z	E CAPACITOR	100uF 16V M		R4452	NRSA63J-750X	MG RESISTOR	75Ω 1/16W J	
C4931	QETN1VM-476Z	E CAPACITOR	47uF 35V M		R4471	NRSA63J-151X	MG RESISTOR	150Ω 1/16W J	
C4932	QETN1CM-107Z	E CAPACITOR	100uF 16V M		R4472	NRSA63J-151X	MG RESISTOR	150Ω 1/16W J	
C4941	NCB31CK-103X	C CAPACITOR	0.01uF 16V K		R4473	NRSA63J-471X	MG RESISTOR	470Ω 1/16W J	
C4961	QETN1CM-107Z	E CAPACITOR	100uF 16V M		R4474	NRSA63J-471X	MG RESISTOR	470Ω 1/16W J	
C4971	NCB31CK-103X	C CAPACITOR	0.01uF 16V K		R4475	NRSA63J-184X	MG RESISTOR	180kΩ 1/16W J	
C6001	NCB31CK-473X	C CAPACITOR	0.047uF 16V K		R4476	NRSA63J-184X	MG RESISTOR	180kΩ 1/16W J	
C6002	NCB31CK-473X	C CAPACITOR	0.047uF 16V K		R4477	NRSA63J-184X	MG RESISTOR	180kΩ 1/16W J	
C6003	NCB31CK-473X	C CAPACITOR	0.047uF 16V K		R4478	NRSA63J-184X	MG RESISTOR	180kΩ 1/16W J	
C6101	QETN1HM-475Z	E CAPACITOR	4.7uF 50V M		R4481	QRE141J-102Y	C RESISTOR	1kΩ 1/4W J	
C6102	NDC31HJ-180X	C CAPACITOR	18pF 50V J		R4483	NRSA63J-821X	MG RESISTOR	820Ω 1/16W J	
C6103	QETN1VM-476Z	E CAPACITOR	47uF 35V M						
C6104	NCB31HK-103X	C CAPACITOR	0.01uF 50V K						

△ Symbol No.	Part No.	Part Name	Description	Local	△ Symbol No.	Part No.	Part Name	Description	Local
R4484	NRSA63J-123X	MG RESISTOR	12kΩ 1/16W J		R6206	NRSA63J-330X	MG RESISTOR	33Ω 1/16W J	
R4485	NRSA63J-101X	MG RESISTOR	100Ω 1/16W J		R6207	NRSA63J-390X	MG RESISTOR	39Ω 1/16W J	
R4486	NRSA63J-103X	MG RESISTOR	10kΩ 1/16W J		R6301	NRSA63J-102X	MG RESISTOR	1kΩ 1/16W J	
R4605	NRSA63J-102X	MG RESISTOR	1kΩ 1/16W J		△ L901	QQR1105-001	LINE FILTER		
R4606	NRSA63J-102X	MG RESISTOR	1kΩ 1/16W J		L951	QQL244K-R22Z	COIL	0.22uH K	
R4701	NRSA02J-681X	MG RESISTOR	680Ω 1/10W J		L952	QQL44BK-220Z	COIL	22uH K	
R4702	NRSA02J-681X	MG RESISTOR	680Ω 1/10W J		L955	QQL26AK-220Z	COIL	22uH K	
R4703	NRSA63J-102X	MG RESISTOR	1kΩ 1/16W J		L957	QQL244K-100Z	COIL	10uH K	
R4704	NRSA63J-103X	MG RESISTOR	10kΩ 1/16W J		L959	QQL244K-100Z	COIL	10uH K	
R4705	NRSA63J-472X	MG RESISTOR	4.7kΩ 1/16W J		L4391	QQL25CK-221Z	COIL	220uH K	
R4706	NRSA63J-223X	MG RESISTOR	22kΩ 1/16W J		△ T901	QQS0097-001	SW TRANSF		
R4707	NRSA63J-103X	MG RESISTOR	10kΩ 1/16W J		CN402	QGD2504C1-04Z	CONNECTOR	(1-4)	
R4708	QRE141J-221Y	C RESISTOR	220Ω 1/4W J		CN403	QGD2504C1-05Z	CONNECTOR	(1-5)	
R4751	NRSA63J-103X	MG RESISTOR	10kΩ 1/16W J		CN404	QGD2504C1-05Z	CONNECTOR	(1-5)	
R4754	NRSA63J-103X	MG RESISTOR	10kΩ 1/16W J		CN405	QGF1016C1-23	CONNECTOR	FFC/FPC (1-23)	
R4755	NRSA63J-103X	MG RESISTOR	10kΩ 1/16W J		CN407	QGF1016C1-21	CONNECTOR	FFC/FPC (1-21)	
R4756	NRSA63J-103X	MG RESISTOR	10kΩ 1/16W J		CN408	QGD2504C1-04Z	CONNECTOR	(1-4)	
R4757	NRSA63J-103X	MG RESISTOR	10kΩ 1/16W J		CN409	QGD2504C1-04Z	CONNECTOR	(1-4)	
R4758	NRSA63J-103X	MG RESISTOR	10kΩ 1/16W J		CN410	QGF1205C1-11	CONNECTOR	FFC/FPC (1-11)	
R4759	NRSA63J-103X	MG RESISTOR	10kΩ 1/16W J		CN411	QGF1016C1-31	CONNECTOR	FFC/FPC (1-31)	
R4760	NRSA63J-103X	MG RESISTOR	10kΩ 1/16W J		CN412	QGF1205C1-06	CONNECTOR	FFC/FPC (1-6)	
R4761	NRSA63J-103X	MG RESISTOR	10kΩ 1/16W J		CN414	QGF1205C1-06	CONNECTOR	FFC/FPC (1-6)	
R4762	NRSA63J-103X	MG RESISTOR	10kΩ 1/16W J		CN415	QGF1016C1-07	CONNECTOR	FFC/FPC (1-7)	
R4771	NRSA63J-103X	MG RESISTOR	10kΩ 1/16W J		CN416	QGD2504C1-05Z	CONNECTOR	(1-5)	
R4772	NRSA63J-103X	MG RESISTOR	10kΩ 1/16W J		CN601	QGF1201F3-06	CONNECTOR	FFC/FPC (1-6)	
R4773	NRSA63J-103X	MG RESISTOR	10kΩ 1/16W J		△ CP471	ICP-N5-T	IC PROTECTOR	250mA	
R4791	NRSA02J-221X	MG RESISTOR	220Ω 1/10W J		△ CP951	ICP-N10-T	IC PROTECTOR	400mA	
R4801	NRSA63J-223X	MG RESISTOR	22kΩ 1/16W J		△ CP952	ICP-N5-T	IC PROTECTOR	250mA	
R4802	NRSA63J-223X	MG RESISTOR	22kΩ 1/16W J		EP401	QNZ0136-001Z	EARTH PLATE		
△ R4811	QRZ9006-4R7X	F.RESISTOR	4.7Ω 1/4W J		EP402	QNZ0136-001Z	EARTH PLATE		
R4821	QRE141J-181Y	C RESISTOR	180Ω 1/4W J		EP403	QNZ0136-001Z	EARTH PLATE		
R4822	QRE141J-151Y	C RESISTOR	150Ω 1/4W J		EP901	QNZ0136-001Z	EARTH PLATE		
R4831	NRSA63J-153X	MG RESISTOR	15kΩ 1/16W J		EP902	QNZ0136-001Z	EARTH PLATE		
R4832	NRSA63J-223X	MG RESISTOR	22kΩ 1/16W J		EP951	QNZ0136-001Z	EARTH PLATE		
R4833	NRSA63J-123X	MG RESISTOR	12kΩ 1/16W J		FC901	QNG0003-001Z	FUSE CLIP		
R4834	NRSA63J-393X	MG RESISTOR	39kΩ 1/16W J		FC902	QNG0003-001Z	FUSE CLIP		
R4835	NRSA63J-472X	MG RESISTOR	4.7kΩ 1/16W J		FW401	QUM213-11Z4Z4	PARA RIBON WIR		
R4841	NRSA63J-123X	MG RESISTOR	12kΩ 1/16W J		FW901	QUM219-06DGZ4	PARA RIBON WIR		
R4842	NRSA63J-393X	MG RESISTOR	39kΩ 1/16W J		FW902	QUM21A-06DGZ4	PARA RIBON WIR		
R4851	NRSA63J-151X	MG RESISTOR	150Ω 1/16W J		HS491	LE40505-001A	HEAT SINK		
R4852	NRSA63J-331X	MG RESISTOR	330Ω 1/16W J		HS901	E70306-002	HEAT SINK		
R4861	NRSA63J-222X	MG RESISTOR	2.2kΩ 1/16W J		HS964	LE40505-001A	HEAT SINK		
R4863	NRSA63J-222X	MG RESISTOR	2.2kΩ 1/16W J		J4401	QNN0557-002	PIN JACK		
R4864	NRSA63J-222X	MG RESISTOR	2.2kΩ 1/16W J		J4403	QNZ0625-001	RGB CONNECTOR		
R4866	NRSA63J-222X	MG RESISTOR	2.2kΩ 1/16W J		J4891	QNS0089-001	3.5 JACK		
R4871	NRSA63J-102X	MG RESISTOR	1kΩ 1/16W J		J6001	QNS0218-002	6.3 JACK		
R4872	NRSA63J-102X	MG RESISTOR	1kΩ 1/16W J		K6001	NQR0007-002X	FERRITE BEADS		
R4873	NRSA63J-102X	MG RESISTOR	1kΩ 1/16W J		K6002	NQR0007-002X	FERRITE BEADS		
R4874	NRSA63J-102X	MG RESISTOR	1kΩ 1/16W J		K6003	NQR0007-002X	FERRITE BEADS		
R4881	NRSA63J-472X	MG RESISTOR	4.7kΩ 1/16W J		△ P901	QNC0081-001	AC INLET		
R4883	NRSA63J-472X	MG RESISTOR	4.7kΩ 1/16W J		S4401	QSW0454-001	SW		
R4884	NRSA63J-472X	MG RESISTOR	4.7kΩ 1/16W J		SP471	VYH7653-001	IC HOLDER		
R4886	NRSA63J-472X	MG RESISTOR	4.7kΩ 1/16W J		X4071	QAX0263-001Z	CRYSTAL	4.332MHz	
R4891	NRSA63J-221X	MG RESISTOR	220Ω 1/16W J		X4701	QAX0246-001Z	C RESONATOR	8.00MHz	
R4892	NRSA63J-221X	MG RESISTOR	220Ω 1/16W J						
△ R4921	QRZ9005-100X	FUSI RESISTOR	10Ω						
R4922	NRSA63J-222X	MG RESISTOR	2.2kΩ 1/16W J						
△ R4931	QRZ9005-100X	FUSI RESISTOR	10Ω						
R4932	NRSA63J-222X	MG RESISTOR	2.2kΩ 1/16W J						
R4941	QRE141J-271Y	C RESISTOR	270Ω 1/4W J						
R4942	QRE141J-271Y	C RESISTOR	270Ω 1/4W J						
R4951	NRSA63J-223X	MG RESISTOR	22kΩ 1/16W J						
R4952	NRSA63J-223X	MG RESISTOR	22kΩ 1/16W J						
R4961	QRE141J-271Y	C RESISTOR	270Ω 1/4W J						
R4971	QRE141J-271Y	C RESISTOR	270Ω 1/4W J						
R4972	QRE141J-271Y	C RESISTOR	270Ω 1/4W J						
R6101	NRSA63J-104X	MG RESISTOR	100kΩ 1/16W J						
R6102	NRSA63J-103X	MG RESISTOR	10kΩ 1/16W J		IC501	MN101C35DKW	IC(MPU)	FL driver	
R6103	NRSA63J-154X	MG RESISTOR	150kΩ 1/16W J		IC502	GP1UM271XK	IR DETECT UNIT	microcomputer	
R6104	NRSA63J-103X	MG RESISTOR	10kΩ 1/16W J					Receiver for remote	
R6105	NRSA63J-473X	MG RESISTOR	47kΩ 1/16W J		Q501	KRC102S-X	DIGI TRANSISTOR		
R6106	NRSA63J-330X	MG RESISTOR	33Ω 1/16W J		Q502	KRC102S-X	DIGI TRANSISTOR		
R6107	NRSA63J-390X	MG RESISTOR	39Ω 1/16W J		Q503	KRC102S-X	DIGI TRANSISTOR		
R6201	NRSA63J-104X	MG RESISTOR	100kΩ 1/16W J						
R6202	NRSA63J-103X	MG RESISTOR	10kΩ 1/16W J		D501	SLR-342VC-T	LED		
R6203	NRSA63J-154X	MG RESISTOR	150kΩ 1/16W J		D551	SELU2E10C-P-T10	LED		
R6204	NRSA63J-103X	MG RESISTOR	10kΩ 1/16W J						
R6205	NRSA63J-473X	MG RESISTOR	47kΩ 1/16W J		C501	NCB31HK-471X	C CAPACITOR	470pF 50V K	

Front board

Block No. [0][2][0][0]

△ Symbol No.	Part No.	Part Name	Description	Local
IC501	MN101C35DKW	IC(MPU)	FL driver	
IC502	GP1UM271XK	IR DETECT UNIT	microcomputer	
Q501	KRC102S-X	DIGI TRANSISTOR	Receiver for remote	
Q502	KRC102S-X	DIGI TRANSISTOR		
Q503	KRC102S-X	DIGI TRANSISTOR		
D501	SLR-342VC-T	LED		
D551	SELU2E10C-P-T10	LED		
C501	NCB31HK-471X	C CAPACITOR	470pF 50V K	

△ Symbol No.	Part No.	Part Name	Description	Local	△ Symbol No.	Part No.	Part Name	Description	Local
C502	NCB31HK-471X	C CAPACITOR	470pF 50V K		IC406	UPD784215AGC167	IC(MICRO C ROM)	Digital signal controller	
C503	NCB31CK-103X	C CAPACITOR	0.01uF 16V K		IC407	MM1563DF-X	IC	Regulator	
C504	NCB31CK-103X	C CAPACITOR	0.01uF 16V K		IC408	74VHC00SJ-X	IC		
C505	QEKCOJM-107Z	E CAPACITOR	100uF 6.3V M		IC409	GP1FA352RZ	OPT RECEIVER		
C506	NCB31CK-103X	C CAPACITOR	0.01uF 16V K		IC510	BA15218F-XE	IC	Dual operational amplifier	
C507	NCB30JK-105X	C CAPACITOR	1uF 6.3V K		IC511	BA15218F-XE	IC	Dual operational amplifier	
C541	NCB31CK-103X	C CAPACITOR	0.01uF 16V K		IC531	BA15218F-XE	IC	Dual operational amplifier	
C542	NCB31CK-103X	C CAPACITOR	0.01uF 16V K		IC561	BA15218F-XE	IC	Dual operational amplifier	
C551	NCB31CK-103X	C CAPACITOR	0.01uF 16V K		IC581	BA15218F-XE	IC	Dual operational amplifier	
R501	NRSA63J-102X	MG RESISTOR	1kΩ 1/16W J		IC591	BA15218F-XE	IC	Dual operational amplifier	
R502	NRSA63J-102X	MG RESISTOR	1kΩ 1/16W J		Q401	KRA104S-X	DIGI TRANSISTOR		
R503	NRSA63J-102X	MG RESISTOR	1kΩ 1/16W J		Q402	KRC107S-X	DIGI TRANSISTOR		
R504	NRSA63J-102X	MG RESISTOR	1kΩ 1/16W J		Q403	KRC107S-X	DIGI TRANSISTOR		
R505	NRSA63J-221X	MG RESISTOR	220Ω 1/16W J		Q1131	IMX9-W	TRANSISTOR	Driver	
R531	NRSA63J-332X	MG RESISTOR	3.3kΩ 1/16W J		Q1133	IMX9-W	TRANSISTOR	Driver	
R532	NRSA63J-392X	MG RESISTOR	3.9kΩ 1/16W J		Q1135	IMX9-W	TRANSISTOR	Driver	
R533	NRSA63J-682X	MG RESISTOR	6.8kΩ 1/16W J		Q1137	2SC3661-X	TRANSISTOR		
R534	NRSA63J-153X	MG RESISTOR	15kΩ 1/16W J		Q1251	KRA104S-X	DIGI TRANSISTOR		
R535	NRSA63J-332X	MG RESISTOR	3.3kΩ 1/16W J		Q1252	KRA104S-X	DIGI TRANSISTOR		
R536	NRSA63J-392X	MG RESISTOR	3.9kΩ 1/16W J		Q2501	KRA104S-X	DIGI TRANSISTOR		
R537	NRSA63J-682X	MG RESISTOR	6.8kΩ 1/16W J		Q2502	KRC107S-X	DIGI TRANSISTOR		
R538	NRSA63J-153X	MG RESISTOR	15kΩ 1/16W J		Q2521	IMX9-W	TRANSISTOR	Driver	
R541	NRSA63J-103X	MG RESISTOR	10kΩ 1/16W J		Q2561	IMX9-W	TRANSISTOR	Driver	
R542	NRSA63J-103X	MG RESISTOR	10kΩ 1/16W J		Q2581	IMX9-W	TRANSISTOR	Driver	
R551	NRSA63J-104X	MG RESISTOR	100kΩ 1/16W J		D401	MA152WK-X	SI DIODE		
R571	NRSA63J-332X	MG RESISTOR	3.3kΩ 1/16W J		D403	MA152WK-X	SI DIODE		
R572	NRSA63J-392X	MG RESISTOR	3.9kΩ 1/16W J		D405	MA152WK-X	SI DIODE		
R573	NRSA63J-682X	MG RESISTOR	6.8kΩ 1/16W J		D406	DAP202K-X	D.TRANSISTOR		
R574	NRSA63J-332X	MG RESISTOR	3.3kΩ 1/16W J		C401	NCB31HK-102X	C CAPACITOR	1000pF 50V K	
R575	NRSA63J-392X	MG RESISTOR	3.9kΩ 1/16W J		C402	NCB31HK-102X	C CAPACITOR	1000pF 50V K	
CN501	QGF1016F2-21W	CONNECTOR	FFC/FPC (1-21)		C403	NEA70JM-476X	E CAPACITOR	47uF 6.3V M	
CN551	QGF1006F1-04W	CONNECTOR	FFC/FPC (1-4)		C404	NEA70JM-476X	E CAPACITOR	47uF 6.3V M	
CN561	QGF1006F1-04W	CONNECTOR	FFC/FPC (1-4)		C405	NCB31CK-104X	C CAPACITOR	0.1uF 16V K	
DI501	QLF0119-001	FL TUBE			C406	NCB31CK-104X	C CAPACITOR	0.1uF 16V K	
FW561	QUM214-16DGZ4	PARA RIBON WIRE			C407	NCB31CK-104X	C CAPACITOR	0.1uF 16V K	
FW571	QUM214-16DGZ4	PARA RIBON WIRE			C408	NEA70JM-476X	E CAPACITOR	47uF 6.3V M	
JS501	QSW0898-001	JOG VOLUME			C411	NCB31CK-104X	C CAPACITOR	0.1uF 16V K	
S501	QSW0683-001Z	PUSH SW			C413	NCB31CK-104X	C CAPACITOR	0.1uF 16V K	
S502	QSW0683-001Z	PUSH SW			C421	NEA70JM-107X	E CAPACITOR	100uF 6.3V M	
S503	QSW0683-001Z	PUSH SW			C422	NCB31CK-103X	C CAPACITOR	0.01uF 16V K	
S504	QSW0683-001Z	PUSH SW			C423	NDC31HJ-101X	C CAPACITOR	100pF 50V J	
S505	QSW0683-001Z	PUSH SW			C424	NCS31HJ-121X	C CAPACITOR	120pF 50V J	
S506	QSW0683-001Z	PUSH SW			C425	NCB31AK-474X	C CAPACITOR	0.47uF 10V K	
S507	QSW0683-001Z	PUSH SW			C426	NCB31CK-103X	C CAPACITOR	0.01uF 16V K	
S508	QSW0683-001Z	PUSH SW			C427	NCB31CK-104X	C CAPACITOR	0.1uF 16V K	
S509	QSW0683-001Z	PUSH SW			C428	NCB31CK-104X	C CAPACITOR	0.1uF 16V K	
S510	QSW0683-001Z	PUSH SW			C429	NCB31CK-104X	C CAPACITOR	0.1uF 16V K	
S571	QSW0683-001Z	PUSH SW			C430	NCB31CK-473X	C CAPACITOR	0.047uF 16V K	
S572	QSW0683-001Z	PUSH SW			C431	NDC31HJ-180X	C CAPACITOR	18pF 50V J	
S573	QSW0683-001Z	PUSH SW			C432	NDC31HJ-220X	C CAPACITOR	22pF 50V J	
S574	QSW0683-001Z	PUSH SW			C433	NCB31CK-103X	C CAPACITOR	0.01uF 16V K	
S575	QSW0683-001Z	PUSH SW			C434	NEA70JM-107X	E CAPACITOR	100uF 6.3V M	
S576	QSW0683-001Z	PUSH SW			C435	NCB31CK-103X	C CAPACITOR	0.01uF 16V K	
S577	QSW0683-001Z	PUSH SW			C436	NEA70JM-476X	E CAPACITOR	47uF 6.3V M	
X501	NAX0623-001X	C RESONATOR			C437	NCB31CK-103X	C CAPACITOR	0.01uF 16V K	

DSP board

Block No. [0][3][0][0]

△ Symbol No.	Part No.	Part Name	Description	Local
IC151	BU4066BCF-X	IC	Source selector	
IC153	M62446AFP-X	IC	6 channel electronic volume	
IC158	NJM4565M-WE	IC	CD L.P.F	
IC159	NJM4565M-WE	IC	CD L.P.F	
IC160	NJM4565M-WE	IC	CD L.P.F	
IC401	AK4527BVQP	IC	A/D D/A converter	
IC402	MM1613DN-X	IC	Regulator	
IC403	TC9446F-025	IC	Audio digital processor	
IC404	LP61L1024S-12-X	IC	SRAM	

△ Symbol No.	Part No.	Part Name	Description	Local	△ Symbol No.	Part No.	Part Name	Description	Local
C461	NEA71CM-476X	E CAPACITOR	47uF 16V M		C2531	NDC31HJ-560X	C CAPACITOR	56pF 50V J	
C462	NCB31CK-103X	C CAPACITOR	0.01uF 16V K		C2532	NDC31HJ-560X	C CAPACITOR	56pF 50V J	
C463	NEA70JM-107X	E CAPACITOR	100uF 6.3V M		C2533	NEA71HM-105X	E CAPACITOR	1uF 50V M	
C466	NEA71CM-476X	E CAPACITOR	47uF 16V M		C2534	NEA71HM-105X	E CAPACITOR	1uF 50V M	
C467	NCF31CZ-104X	C CAPACITOR	0.1uF 16V Z		C2539	NCF31CZ-104X	C CAPACITOR	0.1uF 16V Z	
C493	NCB30JK-105X	C CAPACITOR	1uF 6.3V K		C2540	NCF31CZ-104X	C CAPACITOR	0.1uF 16V Z	
C494	NCB31CK-103X	C CAPACITOR	0.01uF 16V K		C2541	NEA71EM-475X	E CAPACITOR	4.7uF 25V M	
C495	NCB31CK-103X	C CAPACITOR	0.01uF 16V K		C2542	NEA71EM-475X	E CAPACITOR	4.7uF 25V M	
C1101	NCB31HK-331X	C CAPACITOR	330pF 50V K		C2553	NCB31HK-562X	C CAPACITOR	5600pF 50V K	
C1102	NCB31HK-331X	C CAPACITOR	330pF 50V K		C2554	NCB31HK-562X	C CAPACITOR	5600pF 50V K	
C1103	NEA71EM-475X	E CAPACITOR	4.7uF 25V M		C2555	NCF31CZ-104X	C CAPACITOR	0.1uF 16V Z	
C1104	NEA71EM-475X	E CAPACITOR	4.7uF 25V M		C2556	NCF31CZ-104X	C CAPACITOR	0.1uF 16V Z	
C1121	NCB31CK-223X	C CAPACITOR	0.022uF 16V K		C2561	NEA71HM-105X	E CAPACITOR	1uF 50V M	
C1122	NCB31HK-822X	C CAPACITOR	8200pF 50V K		C2562	NEA71HM-105X	E CAPACITOR	1uF 50V M	
C1123	NCB31HK-103X	C CAPACITOR	0.01uF 50V K		C2563	NDC31HJ-220X	C CAPACITOR	22pF 50V J	
C1124	NCB21CK-224X	C CAPACITOR	0.22uF 16V K		C2564	NDC31HJ-220X	C CAPACITOR	22pF 50V J	
C1125	NCB31CK-223X	C CAPACITOR	0.022uF 16V K		C2569	NCF31CZ-104X	C CAPACITOR	0.1uF 16V Z	
C1126	NCB31CK-223X	C CAPACITOR	0.022uF 16V K		C2570	NCF31CZ-104X	C CAPACITOR	0.1uF 16V Z	
C1127	NEA71EM-475X	E CAPACITOR	4.7uF 25V M		C2575	NCB31HK-102X	C CAPACITOR	1000pF 50V K	
C1128	NEA71EM-475X	E CAPACITOR	4.7uF 25V M		C2576	NCB31HK-102X	C CAPACITOR	1000pF 50V K	
C1129	NCB31HK-822X	C CAPACITOR	8200pF 50V K		C2577	NEA71EM-475X	E CAPACITOR	4.7uF 25V M	
C1130	NCB21CK-224X	C CAPACITOR	0.22uF 16V K		C2578	NEA71EM-475X	E CAPACITOR	4.7uF 25V M	
C1131	NCB31HK-103X	C CAPACITOR	0.01uF 50V K		C2581	NEA71HM-105X	E CAPACITOR	1uF 50V M	
C1141	NEA71CM-476X	E CAPACITOR	47uF 16V M		C2582	NEA71CM-106X	E CAPACITOR	10uF 16V M	
C1142	NEA71CM-476X	E CAPACITOR	47uF 16V M		C2583	NDC31HJ-220X	C CAPACITOR	22pF 50V J	
C1176	NCB31CK-103X	C CAPACITOR	0.01uF 16V K		C2584	NDC31HJ-560X	C CAPACITOR	56pF 50V J	
C1177	NCB31CK-103X	C CAPACITOR	0.01uF 16V K		C2589	NCF31CZ-104X	C CAPACITOR	0.1uF 16V Z	
C1178	NCB31CK-103X	C CAPACITOR	0.01uF 16V K		C2590	NCF31CZ-104X	C CAPACITOR	0.1uF 16V Z	
C1179	NCB31CK-103X	C CAPACITOR	0.01uF 16V K		C2592	NCB31HK-472X	C CAPACITOR	4700pF 50V K	
C1180	NCB31CK-103X	C CAPACITOR	0.01uF 16V K		C2594	NCB31HK-223X	C CAPACITOR	0.022uF 50V K	
C1181	NCB31CK-103X	C CAPACITOR	0.01uF 16V K		C2595	NCB31HK-102X	C CAPACITOR	1000pF 50V K	
C1183	NEA71EM-475X	E CAPACITOR	4.7uF 25V M		C2597	NEA71EM-475X	E CAPACITOR	4.7uF 25V M	
C1201	NEA71EM-475X	E CAPACITOR	4.7uF 25V M		C2598	NEA71EM-475X	E CAPACITOR	4.7uF 25V M	
C1202	NEA71EM-475X	E CAPACITOR	4.7uF 25V M		C2599	NCF31CZ-104X	C CAPACITOR	0.1uF 16V Z	
C1203	NEA71EM-475X	E CAPACITOR	4.7uF 25V M		C2600	NCF31CZ-104X	C CAPACITOR	0.1uF 16V Z	
C1204	NEA71EM-475X	E CAPACITOR	4.7uF 25V M		C2601	NEA71EM-475X	E CAPACITOR	4.7uF 25V M	
C1205	NEA71EM-475X	E CAPACITOR	4.7uF 25V M		C2602	NEA71EM-475X	E CAPACITOR	4.7uF 25V M	
C1206	NEA71EM-475X	E CAPACITOR	4.7uF 25V M		C2603	NEA71EM-475X	E CAPACITOR	4.7uF 25V M	
C1207	NEA71EM-475X	E CAPACITOR	4.7uF 25V M		C2604	NEA71EM-475X	E CAPACITOR	4.7uF 25V M	
C1208	NEA71EM-475X	E CAPACITOR	4.7uF 25V M						
C1209	NEA71EM-475X	E CAPACITOR	4.7uF 25V M		R403	NRSA63J-221X	MG RESISTOR	220Ω 1/16W J	
C1210	NEA71EM-475X	E CAPACITOR	4.7uF 25V M		R404	NRSA63J-221X	MG RESISTOR	220Ω 1/16W J	
C1211	NEA71EM-475X	E CAPACITOR	4.7uF 25V M		R405	NRSA63J-221X	MG RESISTOR	220Ω 1/16W J	
C1212	NEA71EM-475X	E CAPACITOR	4.7uF 25V M		R406	NRSA63J-221X	MG RESISTOR	220Ω 1/16W J	
C1213	NEA71EM-475X	E CAPACITOR	4.7uF 25V M		R407	NRSA63J-221X	MG RESISTOR	220Ω 1/16W J	
C1214	NEA71EM-475X	E CAPACITOR	4.7uF 25V M		R408	NRSA63J-221X	MG RESISTOR	220Ω 1/16W J	
C1215	NEA71EM-475X	E CAPACITOR	4.7uF 25V M		R415	NRSA63J-221X	MG RESISTOR	220Ω 1/16W J	
C1216	NEA71EM-475X	E CAPACITOR	4.7uF 25V M		R418	NRSA63J-101X	MG RESISTOR	100Ω 1/16W J	
C1217	NEA71EM-475X	E CAPACITOR	4.7uF 25V M		R419	NRSA63J-103X	MG RESISTOR	10kΩ 1/16W J	
C1218	NEA71EM-475X	E CAPACITOR	4.7uF 25V M		R420	NRSA63J-221X	MG RESISTOR	220Ω 1/16W J	
C1221	NDC31HJ-470X	C CAPACITOR	47pF 50V J		R423	NRSA63F-102X	MG RESISTOR	1kΩ 1/16W F	
C1222	NDC31HJ-470X	C CAPACITOR	47pF 50V J		R424	NRSA63J-153X	MG RESISTOR	15kΩ 1/16W J	
C1223	NDC31HJ-470X	C CAPACITOR	47pF 50V J		R425	NRSA63F-102X	MG RESISTOR	1kΩ 1/16W F	
C1224	NDC31HJ-470X	C CAPACITOR	47pF 50V J		R426	NRSA63J-103X	MG RESISTOR	10kΩ 1/16W J	
C1225	NCS31HJ-471X	C CAPACITOR	470pF 50V J		R427	NRSA63J-103X	MG RESISTOR	10kΩ 1/16W J	
C1226	NDC31HJ-470X	C CAPACITOR	47pF 50V J		R428	NRSA63J-472X	MG RESISTOR	4.7kΩ 1/16W J	
C1227	NCB31HK-471X	C CAPACITOR	470pF 50V K		R429	NRSA63J-101X	MG RESISTOR	100Ω 1/16W J	
C1228	NCB31HK-471X	C CAPACITOR	470pF 50V K		R430	NRSA63J-103X	MG RESISTOR	10kΩ 1/16W J	
C1251	NCB31CK-103X	C CAPACITOR	0.01uF 16V K		R431	NRSA63J-225X	MG RESISTOR	2.2MΩ 1/16W J	
C1252	NCB31CK-103X	C CAPACITOR	0.01uF 16V K		R432	NRSA63J-472X	MG RESISTOR	4.7kΩ 1/16W J	
C2503	NEA71EM-475X	E CAPACITOR	4.7uF 25V M		R435	NRSA63J-103X	MG RESISTOR	10kΩ 1/16W J	
C2504	NEA71EM-475X	E CAPACITOR	4.7uF 25V M		R438	NRSA63J-0R0X	MG RESISTOR	0Ω 1/16W J	
C2507	NDC31HJ-560X	C CAPACITOR	56pF 50V J		R441	NRSA63J-221X	MG RESISTOR	220Ω 1/16W J	
C2508	NDC31HJ-560X	C CAPACITOR	56pF 50V J		R443	NRSA63J-221X	MG RESISTOR	220Ω 1/16W J	
C2511	NCB31AK-474X	C CAPACITOR	0.47uF 10V K		R444	NRSA63J-221X	MG RESISTOR	220Ω 1/16W J	
C2512	NCB31AK-474X	C CAPACITOR	0.47uF 10V K		R445	NRSA63J-221X	MG RESISTOR	220Ω 1/16W J	
C2513	NCB31HK-182X	C CAPACITOR	1800pF 50V K		R446	NRSA63J-221X	MG RESISTOR	220Ω 1/16W J	
C2514	NCB31HK-182X	C CAPACITOR	1800pF 50V K		R447	NRSA63J-221X	MG RESISTOR	220Ω 1/16W J	
C2515	NDC31HJ-181X	C CAPACITOR	180pF 50V J		R448	NRSA63J-221X	MG RESISTOR	220Ω 1/16W J	
C2516	NDC31HJ-181X	C CAPACITOR	180pF 50V J		R449	NRSA63J-221X	MG RESISTOR	220Ω 1/16W J	
C2517	NCB31HK-562X	C CAPACITOR	5600pF 50V K		R450	NRSA63J-221X	MG RESISTOR	220Ω 1/16W J	
C2518	NCB31HK-562X	C CAPACITOR	5600pF 50V K		R451	NRSA63J-103X	MG RESISTOR	10kΩ 1/16W J	
C2519	NCF31CZ-104X	C CAPACITOR	0.1uF 16V Z		R452	NRSA63J-432X	MG RESISTOR	4.3kΩ 1/16W J	
C2520	NCF31CZ-104X	C CAPACITOR	0.1uF 16V Z		R453	NRSA63J-432X	MG RESISTOR	4.3kΩ 1/16W J	
C2525	NCB31HK-102X	C CAPACITOR	1000pF 50V K		R454	NRSA63J-432X	MG RESISTOR	4.3kΩ 1/16W J	
C2526	NCB31HK-102X	C CAPACITOR	1000pF 50V K		R455	NRSA63J-822X	MG RESISTOR	8.2kΩ 1/16W J	
C2527	NEA71EM-475X	E CAPACITOR	4.7uF 25V M		R456	NRSA63J-822X	MG RESISTOR	8.2kΩ 1/16W J	
C2528	NEA71EM-475X	E CAPACITOR	4.7uF 25V M		R457	NRSA63J-822X	MG RESISTOR	8.2kΩ 1/16W J	

△ Symbol No.	Part No.	Part Name	Description	Local	△ Symbol No.	Part No.	Part Name	Description	Local
R458	NRSA63J-103X	MG RESISTOR	10kΩ 1/16W J		R2502	NRSA63J-103X	MG RESISTOR	10kΩ 1/16W J	
R459	NRSA63J-102X	MG RESISTOR	1kΩ 1/16W J		R2503	NRSA63J-513X	MG RESISTOR	51kΩ 1/16W J	
R461	NRSA63J-432X	MG RESISTOR	4.3kΩ 1/16W J		R2504	NRSA63J-513X	MG RESISTOR	51kΩ 1/16W J	
R462	NRSA63J-822X	MG RESISTOR	8.2kΩ 1/16W J		R2507	NRSA63J-103X	MG RESISTOR	10kΩ 1/16W J	
R463	NRSA63J-0R0X	MG RESISTOR	0Ω 1/16W J		R2508	NRSA63J-103X	MG RESISTOR	10kΩ 1/16W J	
R464	NRSA63J-103X	MG RESISTOR	10kΩ 1/16W J		R2509	NRSA63J-103X	MG RESISTOR	10kΩ 1/16W J	
R465	NRSA63J-0R0X	MG RESISTOR	0Ω 1/16W J		R2510	NRSA63J-103X	MG RESISTOR	10kΩ 1/16W J	
R466	NRSA63J-103X	MG RESISTOR	10kΩ 1/16W J		R2513	NRSA63J-103X	MG RESISTOR	10kΩ 1/16W J	
R467	NRSA63J-103X	MG RESISTOR	10kΩ 1/16W J		R2514	NRSA63J-103X	MG RESISTOR	10kΩ 1/16W J	
R468	NRSA63J-103X	MG RESISTOR	10kΩ 1/16W J		R2515	NRSA63J-103X	MG RESISTOR	10kΩ 1/16W J	
R471	NRSA63J-102X	MG RESISTOR	1kΩ 1/16W J		R2516	NRSA63J-103X	MG RESISTOR	10kΩ 1/16W J	
R472	NRSA63J-102X	MG RESISTOR	1kΩ 1/16W J		R2517	NRSA63J-102X	MG RESISTOR	1kΩ 1/16W J	
R473	NRSA63J-102X	MG RESISTOR	1kΩ 1/16W J		R2518	NRSA63J-102X	MG RESISTOR	1kΩ 1/16W J	
R474	NRSA63J-102X	MG RESISTOR	1kΩ 1/16W J		R2519	NRSA63J-102X	MG RESISTOR	1kΩ 1/16W J	
R475	NRSA63J-102X	MG RESISTOR	1kΩ 1/16W J		R2520	NRSA63J-102X	MG RESISTOR	1kΩ 1/16W J	
R476	NRSA63J-102X	MG RESISTOR	1kΩ 1/16W J		R2525	NRSA63J-102X	MG RESISTOR	1kΩ 1/16W J	
R481	NRSA63J-222X	MG RESISTOR	2.2kΩ 1/16W J		R2526	NRSA63J-102X	MG RESISTOR	1kΩ 1/16W J	
R482	NRSA63J-103X	MG RESISTOR	10kΩ 1/16W J		R2527	NRSA63J-104X	MG RESISTOR	100kΩ 1/16W J	
R483	NRSA63J-105X	MG RESISTOR	1MΩ 1/16W J		R2528	NRSA63J-104X	MG RESISTOR	100kΩ 1/16W J	
R491	NRSA63J-0R0X	MG RESISTOR	0Ω 1/16W J		R2529	NRSA63J-103X	MG RESISTOR	10kΩ 1/16W J	
R492	NRSA63J-0R0X	MG RESISTOR	0Ω 1/16W J		R2530	NRSA63J-103X	MG RESISTOR	10kΩ 1/16W J	
R1101	NRSA63J-471X	MG RESISTOR	470Ω 1/16W J		R2531	NRSA63J-104X	MG RESISTOR	100kΩ 1/16W J	
R1102	NRSA63J-471X	MG RESISTOR	470Ω 1/16W J		R2532	NRSA63J-104X	MG RESISTOR	100kΩ 1/16W J	
R1103	NRSA63J-564X	MG RESISTOR	560kΩ 1/16W J		R2533	NRSA63J-223X	MG RESISTOR	22kΩ 1/16W J	
R1104	NRSA63J-564X	MG RESISTOR	560kΩ 1/16W J		R2534	NRSA63J-223X	MG RESISTOR	22kΩ 1/16W J	
R1121	NRSA63J-103X	MG RESISTOR	10kΩ 1/16W J		R2535	NRSA63J-563X	MG RESISTOR	56kΩ 1/16W J	
R1122	NRSA63J-103X	MG RESISTOR	10kΩ 1/16W J		R2536	NRSA63J-563X	MG RESISTOR	56kΩ 1/16W J	
R1123	NRSA63J-103X	MG RESISTOR	10kΩ 1/16W J		R2537	NRSA63J-104X	MG RESISTOR	100kΩ 1/16W J	
R1131	NRSA63J-104X	MG RESISTOR	100kΩ 1/16W J		R2538	NRSA63J-104X	MG RESISTOR	100kΩ 1/16W J	
R1132	NRSA63J-104X	MG RESISTOR	100kΩ 1/16W J		R2561	NRSA63J-104X	MG RESISTOR	100kΩ 1/16W J	
R1133	NRSA63J-102X	MG RESISTOR	1kΩ 1/16W J		R2562	NRSA63J-104X	MG RESISTOR	100kΩ 1/16W J	
R1134	NRSA63J-102X	MG RESISTOR	1kΩ 1/16W J		R2563	NRSA63J-103X	MG RESISTOR	10kΩ 1/16W J	
R1135	NRSA63J-332X	MG RESISTOR	3.3kΩ 1/16W J		R2564	NRSA63J-103X	MG RESISTOR	10kΩ 1/16W J	
R1136	NRSA63J-332X	MG RESISTOR	3.3kΩ 1/16W J		R2565	NRSA63J-392X	MG RESISTOR	3.9kΩ 1/16W J	
R1137	NRSA63J-104X	MG RESISTOR	100kΩ 1/16W J		R2566	NRSA63J-392X	MG RESISTOR	3.9kΩ 1/16W J	
R1138	NRSA63J-104X	MG RESISTOR	100kΩ 1/16W J		R2567	NRSA63J-103X	MG RESISTOR	10kΩ 1/16W J	
R1139	NRSA63J-104X	MG RESISTOR	100kΩ 1/16W J		R2568	NRSA63J-103X	MG RESISTOR	10kΩ 1/16W J	
R1140	NRSA63J-104X	MG RESISTOR	100kΩ 1/16W J		R2575	NRSA63J-102X	MG RESISTOR	1kΩ 1/16W J	
R1141	NRSA63J-102X	MG RESISTOR	1kΩ 1/16W J		R2576	NRSA63J-102X	MG RESISTOR	1kΩ 1/16W J	
R1142	NRSA63J-102X	MG RESISTOR	1kΩ 1/16W J		R2577	NRSA63J-104X	MG RESISTOR	100kΩ 1/16W J	
R1143	NRSA63J-332X	MG RESISTOR	3.3kΩ 1/16W J		R2578	NRSA63J-104X	MG RESISTOR	100kΩ 1/16W J	
R1144	NRSA63J-332X	MG RESISTOR	3.3kΩ 1/16W J		R2579	NRSA63J-104X	MG RESISTOR	100kΩ 1/16W J	
R1145	NRSA63J-104X	MG RESISTOR	100kΩ 1/16W J		R2580	NRSA63J-104X	MG RESISTOR	100kΩ 1/16W J	
R1146	NRSA63J-104X	MG RESISTOR	100kΩ 1/16W J		R2581	NRSA63J-104X	MG RESISTOR	100kΩ 1/16W J	
R1147	NRSA63J-104X	MG RESISTOR	100kΩ 1/16W J		R2582	NRSA63J-104X	MG RESISTOR	100kΩ 1/16W J	
R1148	NRSA63J-104X	MG RESISTOR	100kΩ 1/16W J		R2583	NRSA63J-103X	MG RESISTOR	10kΩ 1/16W J	
R1149	NRSA63J-471X	MG RESISTOR	470Ω 1/16W J		R2584	NRSA63J-124X	MG RESISTOR	120kΩ 1/16W J	
R1150	NRSA63J-102X	MG RESISTOR	1kΩ 1/16W J		R2585	NRSA63J-392X	MG RESISTOR	3.9kΩ 1/16W J	
R1151	NRSA63J-472X	MG RESISTOR	4.7kΩ 1/16W J		R2586	NRSA63J-123X	MG RESISTOR	12kΩ 1/16W J	
R1152	NRSA63J-332X	MG RESISTOR	3.3kΩ 1/16W J		R2587	NRSA63J-103X	MG RESISTOR	10kΩ 1/16W J	
R1153	NRSA63J-471X	MG RESISTOR	470Ω 1/16W J		R2588	NRSA63J-103X	MG RESISTOR	10kΩ 1/16W J	
R1154	NRSA63J-472X	MG RESISTOR	4.7kΩ 1/16W J		R2590	NRSA63J-333X	MG RESISTOR	33kΩ 1/16W J	
R1155	NRSA63J-104X	MG RESISTOR	100kΩ 1/16W J		R2592	NRSA63J-333X	MG RESISTOR	33kΩ 1/16W J	
R1156	NRSA63J-104X	MG RESISTOR	100kΩ 1/16W J		R2594	NRSA63J-333X	MG RESISTOR	33kΩ 1/16W J	
R1157	NRSA63J-332X	MG RESISTOR	3.3kΩ 1/16W J		R2595	NRSA63J-102X	MG RESISTOR	1kΩ 1/16W J	
R1158	NRSA63J-104X	MG RESISTOR	100kΩ 1/16W J		R2596	NRSA63J-102X	MG RESISTOR	1kΩ 1/16W J	
R1161	NRSA63J-104X	MG RESISTOR	100kΩ 1/16W J		R2597	NRSA63J-104X	MG RESISTOR	100kΩ 1/16W J	
R1162	NRSA63J-104X	MG RESISTOR	100kΩ 1/16W J		R2598	NRSA63J-104X	MG RESISTOR	100kΩ 1/16W J	
R1163	NRSA63J-104X	MG RESISTOR	100kΩ 1/16W J		R2599	NRSA63J-104X	MG RESISTOR	100kΩ 1/16W J	
R1164	NRSA63J-104X	MG RESISTOR	100kΩ 1/16W J		R2600	NRSA63J-104X	MG RESISTOR	100kΩ 1/16W J	
R1165	NRSA63J-104X	MG RESISTOR	100kΩ 1/16W J						
R1166	NRSA63J-104X	MG RESISTOR	100kΩ 1/16W J		CN401	QGF1016F2-31W	CONNECTOR	FFC/FPC (1-31)	
R1167	NRSA63J-332X	MG RESISTOR	3.3kΩ 1/16W J		J1101	QNN0598-001	PIN JACK		
R1168	NRSA63J-332X	MG RESISTOR	3.3kΩ 1/16W J		J1103	QND0118-001	DIN CONNECTOR		
R1169	NRSA63J-393X	MG RESISTOR	39kΩ 1/16W J		K401	NQR0319-001X	FERRITE BEADS		
R1170	NRSA63J-393X	MG RESISTOR	39kΩ 1/16W J		LC401	NQR0321-001X	EMI FILTER		
R1171	NRSA63J-332X	MG RESISTOR	3.3kΩ 1/16W J		X401	NAX0385-001X	CRYSTAL	24.576MHz	
R1172	NRSA63J-332X	MG RESISTOR	3.3kΩ 1/16W J		X402	NAX0275-001X	C OSCILLATOR	6.144MHz	
R1173	NRSA63J-473X	MG RESISTOR	47kΩ 1/16W J						
R1174	NRSA63J-473X	MG RESISTOR	47kΩ 1/16W J						
R1175	NRSA63J-332X	MG RESISTOR	3.3kΩ 1/16W J						
R1176	NRSA63J-393X	MG RESISTOR	39kΩ 1/16W J						
R1197	NRSA63J-474X	MG RESISTOR	470kΩ 1/16W J						
R1201	NRSA63J-124X	MG RESISTOR	120kΩ 1/16W J						
R1202	NRSA63J-124X	MG RESISTOR	120kΩ 1/16W J						
R1251	NRSA63J-223X	MG RESISTOR	22kΩ 1/16W J						
R1252	NRSA63J-223X	MG RESISTOR	22kΩ 1/16W J						
R2501	NRSA63J-103X	MG RESISTOR	10kΩ 1/16W J						

Mother board

Block No. [0][4][0][0]

Symbol No.	Part No.	Part Name	Description	Local
△ Q151	KTC3203/OY/-T	TRANSISTOR		
Q501	KRA104M-T	DIGI TRANSISTOR		
Q502	KRC102M-T	DIGI TRANSISTOR		
Q503	KTC3199/GL/-T	TRANSISTOR		
Q504	KTA1267/YG/-T	TRANSISTOR		
Q505	KRC102M-T	DIGI TRANSISTOR		
Q511	KRC104M-T	TRANSISTOR		
Q512	KTC3199/GL/-T	TRANSISTOR		
Q513	KTC3199/GL/-T	TRANSISTOR		
Q514	KRA102M-T	DIGI TRANSISTOR		
Q515	KTC3203/OY/-T	TRANSISTOR		
Q516	KTC3199/GL/-T	TRANSISTOR		
Q517	KRC104M-T	TRANSISTOR		
Q521	KRA104M-T	DIGI TRANSISTOR		
Q522	KTC3199/GL/-T	TRANSISTOR		
Q523	KTC3199/GL/-T	TRANSISTOR		
Q524	KTA1267/YG/-T	TRANSISTOR		
Q525	KTC3199/GL/-T	TRANSISTOR		
Q531	KTC3199/GL/-T	TRANSISTOR		
Q532	KTC3199/GL/-T	TRANSISTOR		
Q545	KRC102M-T	DIGI TRANSISTOR		
D101	1SS133-T2	DIODE		
△ D151	GBU803	BRIDGE DIODE		
△ D152	GBU803	BRIDGE DIODE		
D153	1SS133-T2	DIODE		
D154	1SS133-T2	DIODE		
D161	1SS133-T2	DIODE		
D162	MTZJ13C-T2	Z DIODE		
D401	11ES2-T4	DIODE		
D402	1SS133-T2	DIODE		
D403	MTZJ6.2B-T2	Z DIODE		
D501	1SS133-T2	DIODE		
D502	1SS133-T2	DIODE		
D503	MTZJ5.1C-T2	Z DIODE		
D504	1SS133-T2	DIODE		
D505	1SS133-T2	DIODE		
D511	1SS133-T2	DIODE		
D512	1SS133-T2	DIODE		
D513	1SS133-T2	DIODE		
D514	1SS133-T2	DIODE		
D515	MTZJ15C-T2	Z DIODE		
D516	1SS133-T2	DIODE		
D517	MTZJ27B-T2	Z DIODE		
D518	MTZJ27B-T2	Z DIODE		
D519	1SS133-T2	DIODE		
D520	MTZJ3.6A-T2	ZENER DIODE		
D521	1SS133-T2	DIODE		
D522	1SS133-T2	DIODE		
D523	1SS133-T2	DIODE		
D524	1SS133-T2	DIODE		
D525	MTZJ15C-T2	Z DIODE		
D526	MTZJ6.2B-T2	Z DIODE		
D535	1SS133-T2	DIODE		
△ C101	QCZ9105-472	C CAPACITOR	4700pF 250V M	
C151	QFLC2AJ-104Z	M CAPACITOR	0.1uF 100V J	
C152	QFLC2AJ-104Z	M CAPACITOR	0.1uF 100V J	
C153	QFLC2AJ-104Z	M CAPACITOR	0.1uF 100V J	
C154	QFLC2AJ-104Z	M CAPACITOR	0.1uF 100V J	
C155	QFLC2AJ-104Z	M CAPACITOR	0.1uF 100V J	
C156	QFLC2AJ-104Z	M CAPACITOR	0.1uF 100V J	
C161	QEZO223-478	E CAPACITER	4700uF	
C162	QEZO223-478	E CAPACITER	4700uF	
C163	QETM1EM-688	E CAPACITOR	6800uF 25V M	
C164	QETM1EM-688	E CAPACITOR	6800uF 25V M	
C165	QETN1EM-476Z	E CAPACITOR	47uF 25V M	
C166	QETN1EM-107Z	E CAPACITOR	100uF 25V M	
C411	QFVF1HJ-104Z	MF CAPACITOR	0.1uF 50V J	
C412	QFVF1HJ-104Z	MF CAPACITOR	0.1uF 50V J	
C421	QFVF1HJ-104Z	MF CAPACITOR	0.1uF 50V J	
C422	QFVF1HJ-104Z	MF CAPACITOR	0.1uF 50V J	
C431	QFVF1HJ-104Z	MF CAPACITOR	0.1uF 50V J	
C432	QFVF1HJ-104Z	MF CAPACITOR	0.1uF 50V J	

Symbol No.	Part No.	Part Name	Description	Local
C441	QFVF1HJ-104Z	MF CAPACITOR	0.1uF 50V J	
C442	QFVF1HJ-104Z	MF CAPACITOR	0.1uF 50V J	
C451	QFVF1HJ-104Z	MF CAPACITOR	0.1uF 50V J	
C452	QFVF1HJ-104Z	MF CAPACITOR	0.1uF 50V J	
C501	QETN1HM-335Z	E CAPACITOR	3.3uF 50V M	
C502	QFN31HJ-103Z	M CAPACITOR	0.01uF 50V J	
C503	QETN1HM-475Z	E CAPACITOR	4.7uF 50V M	
C511	QETN1CM-227Z	E CAPACITOR	220uF 16V M	
C512	QETN1HM-475Z	E CAPACITOR	4.7uF 50V M	
C521	QETN1HM-226Z	E CAPACITOR	22uF 50V M	
C522	QETN1HM-106Z	E CAPACITOR	10uF 50V M	
C523	QETN1EM-476Z	E CAPACITOR	47uF 25V M	
C531	QETN1HM-106Z	E CAPACITOR	10uF 50V M	
C532	QCF31HZ-103Z	C CAPACITOR	0.01uF 50V Z	
C533	QCF31HZ-103Z	C CAPACITOR	0.01uF 50V Z	
R151	QRE141J-222Y	C RESISTOR	2.2kΩ 1/4W J	
R152	QRE141J-222Y	C RESISTOR	2.2kΩ 1/4W J	
R153	QRL027J-391	OMF RESISTOR	390Ω 2W J	
△ R161	QRZ9005-100X	FUSI RESISTOR	10Ω	
R162	QRE141J-102Y	C RESISTOR	1kΩ 1/4W J	
R411	QRJ146J-100X	UNF C RESISTOR	10Ω 1/4W J	
R421	QRJ146J-100X	UNF C RESISTOR	10Ω 1/4W J	
R431	QRJ146J-100X	UNF C RESISTOR	10Ω 1/4W J	
R441	QRJ146J-100X	UNF C RESISTOR	10Ω 1/4W J	
R451	QRJ146J-100X	UNF C RESISTOR	10Ω 1/4W J	
△ R491	QRL027J-470	OMF RESISTOR	47Ω 2W J	
R492	QRE141J-472Y	C RESISTOR	4.7kΩ 1/4W J	
R501	QRE141J-102Y	C RESISTOR	1kΩ 1/4W J	
R502	QRE141J-104Y	C RESISTOR	100kΩ 1/4W J	
R503	QRE141J-104Y	C RESISTOR	100kΩ 1/4W J	
R504	QRE141J-102Y	C RESISTOR	1kΩ 1/4W J	
R505	QRE141J-102Y	C RESISTOR	1kΩ 1/4W J	
R506	QRE141J-103Y	C RESISTOR	10kΩ 1/4W J	
R510	QRE141J-102Y	C RESISTOR	1kΩ 1/4W J	
R511	QRE141J-753Y	C RESISTOR	75kΩ 1/4W J	
R512	QRE141J-223Y	C RESISTOR	22kΩ 1/4W J	
R513	QRE141J-101Y	C RESISTOR	100Ω 1/4W J	
R514	QRE141J-753Y	C RESISTOR	75kΩ 1/4W J	
R515	QRE141J-223Y	C RESISTOR	22kΩ 1/4W J	
R516	QRE141J-102Y	C RESISTOR	1kΩ 1/4W J	
R517	QRE141J-224Y	C RESISTOR	220kΩ 1/4W J	
R518	QRE141J-222Y	C RESISTOR	2.2kΩ 1/4W J	
R519	QRE141J-332Y	C RESISTOR	3.3kΩ 1/4W J	
R520	QRE141J-332Y	C RESISTOR	3.3kΩ 1/4W J	
R521	QRE141J-223Y	C RESISTOR	22kΩ 1/4W J	
R522	QRE141J-103Y	C RESISTOR	10kΩ 1/4W J	
R531	QRE141J-104Y	C RESISTOR	100kΩ 1/4W J	
R532	QRE141J-101Y	C RESISTOR	100Ω 1/4W J	
R533	QRE141J-103Y	C RESISTOR	10kΩ 1/4W J	
R534	QRE141J-104Y	C RESISTOR	100kΩ 1/4W J	
R535	QRE141J-104Y	C RESISTOR	100kΩ 1/4W J	
R536	QRE141J-103Y	C RESISTOR	10kΩ 1/4W J	
R537	QRE141J-472Y	C RESISTOR	4.7kΩ 1/4W J	
R538	QRE141J-472Y	C RESISTOR	4.7kΩ 1/4W J	
R539	QRE141J-472Y	C RESISTOR	4.7kΩ 1/4W J	
R541	QRE141J-472Y	C RESISTOR	4.7kΩ 1/4W J	
R543	QRE141J-472Y	C RESISTOR	4.7kΩ 1/4W J	
R544	QRE141J-222Y	C RESISTOR	2.2kΩ 1/4W J	
R545	QRE141J-123Y	C RESISTOR	12kΩ 1/4W J	
R546	QRE141J-222Y	C RESISTOR	2.2kΩ 1/4W J	
R547	QRE141J-104Y	C RESISTOR	100kΩ 1/4W J	
R548	QRE141J-223Y	C RESISTOR	22kΩ 1/4W J	
R549	QRE141J-223Y	C RESISTOR	22kΩ 1/4W J	
R550	QRE141J-102Y	C RESISTOR	1kΩ 1/4W J	
△ R555	QRZ9005-271X	FUSI RESISTOR	270Ω	
R556	QRE141J-102Y	C RESISTOR	1kΩ 1/4W J	
R557	QRE141J-102Y	C RESISTOR	1kΩ 1/4W J	
R561	QRE141J-104Y	C RESISTOR	100kΩ 1/4W J	
R562	QRE141J-104Y	C RESISTOR	100kΩ 1/4W J	
R563	QRE141J-104Y	C RESISTOR	100kΩ 1/4W J	
R564	QRE141J-104Y	C RESISTOR	100kΩ 1/4W J	
R565	QRE141J-104Y	C RESISTOR	100kΩ 1/4W J	
R566	QRE141J-104Y	C RESISTOR	100kΩ 1/4W J	
L411	QQLZ038-R45	COIL	0.45uH	
L421	QQLZ038-R45	COIL	0.45uH	
L431	QQLZ038-R45	COIL	0.45uH	

△ Symbol No.	Part No.	Part Name	Description	Local	△ Symbol No.	Part No.	Part Name	Description	Local
L441	QLLZ038-R45	COIL	0.45uH		C2208	QFVF1HJ-104Z	MF CAPACITOR	0.1uF 50V J	
L451	QLLZ038-R45	COIL	0.45uH		C2302	QCBB1HK-471Y	C CAPACITOR	470pF 50V K	
△ CN101	QGA7901C1-02	CONNECTOR	W-B (1-2)		C2303	QETN1HM-475Z	E CAPACITOR	4.7uF 50V M	
△ CN102	QGA7901C1-02	CONNECTOR	W-B (1-2)		C2304	QETN1AM-107Z	E CAPACITOR	100uF 10V M	
△ CN151	QGA3901C1-05	CONNECTOR	W-B (1-5)		C2305	QCBB1HK-101Y	C CAPACITOR	100pF 50V K	
CN401	QGB2510K2-08	CONNECTOR	B-B (1-8)		C2306	QCSB1HK-3R3Y	C CAPACITOR	3.3pF 50V K	
CN402	QGA3901F2-04	CONNECTOR	W-B (1-4)		C2307	QFVF1HJ-104Z	MF CAPACITOR	0.1uF 50V J	
CN403	QGB2510K2-14	CONNECTOR	B-B (1-14)		C2308	QFVF1HJ-104Z	MF CAPACITOR	0.1uF 50V J	
CN404	QGB2510K2-18	CONNECTOR	B-B (1-18)		C2501	QETN1HM-107Z	E CAPACITOR	100uF 50V M	
CN501	QGB2510J1-08	CONNECTOR	B-B (1-8)		C2502	QTE1E06-476Z	E CAPACITOR	47uF 25V	
CN503	QGB2510J1-14	CONNECTOR	B-B (1-14)		C2503	QETN1HM-107Z	E CAPACITOR	100uF 50V M	
CN504	QGB2510J1-18	CONNECTOR	B-B (1-18)		C2504	QTE1E06-476Z	E CAPACITOR	47uF 25V	
CN521	QGB2510J1-07	CONNECTOR	B-B (1-7)		C2505	QETN1HM-107Z	E CAPACITOR	100uF 50V M	
CN522	QGB2510J1-18	CONNECTOR	B-B (1-18)		C2506	QETN1HM-107Z	E CAPACITOR	100uF 50V M	
CN531	QGB2510J1-07	CONNECTOR	B-B (1-7)		C2507	QCBB1HK-103Y	C CAPACITOR	0.01uF 50V K	
CN532	QGB2510J1-18	CONNECTOR	B-B (1-18)		C3102	QFVJ1HJ-473Z	MF CAPACITOR	0.047uF 50V J	
FC101	QNG0003-001Z	FUSE CLIP			C3103	QETN1HM-475Z	E CAPACITOR	4.7uF 50V M	
FC102	QNG0003-001Z	FUSE CLIP			C3104	QETN1AM-107Z	E CAPACITOR	100uF 10V M	
FC155	QNG0003-001Z	FUSE CLIP			C3105	QCBB1HK-101Y	C CAPACITOR	100pF 50V K	
FC156	QNG0003-001Z	FUSE CLIP			C3106	QCSB1HK-3R3Y	C CAPACITOR	3.3pF 50V K	
FC157	QNG0003-001Z	FUSE CLIP			C3107	QFVF1HJ-104Z	MF CAPACITOR	0.1uF 50V J	
FC158	QNG0003-001Z	FUSE CLIP			C3108	QFVF1HJ-104Z	MF CAPACITOR	0.1uF 50V J	
HS151	QZW0115-001	HEATSINK			C3202	QCBB1HK-471Y	C CAPACITOR	470pF 50V K	
J401	QND0118-001	DIN CONNECTOR			C3203	QETN1HM-475Z	E CAPACITOR	4.7uF 50V M	
J402	QNB0162-002	SPK TERMINAL			C3204	QETN1AM-107Z	E CAPACITOR	100uF 10V M	
J403	QNB0161-002	SPK TERMINAL			C3205	QCBB1HK-101Y	C CAPACITOR	100pF 50V K	
J404	QNB0162-002	SPK TERMINAL			C3206	QCSB1HK-3R3Y	C CAPACITOR	3.3pF 50V K	
K401	QQR1277-001Z	COIL			C3207	QFVF1HJ-104Z	MF CAPACITOR	0.1uF 50V J	
K402	QQR1277-001Z	COIL			C3208	QFVF1HJ-104Z	MF CAPACITOR	0.1uF 50V J	
△ RY101	QSK0142-001	RELAY			C3302	QCBB1HK-471Y	C CAPACITOR	470pF 50V K	
RY401	QSK0127-001	RELAY			C3303	QETN1HM-475Z	E CAPACITOR	4.7uF 50V M	
RY402	QSK0127-001	RELAY			C3304	QETN1AM-107Z	E CAPACITOR	100uF 10V M	
RY403	QSK0127-001	RELAY			C3305	QCBB1HK-101Y	C CAPACITOR	100pF 50V K	

Amplifier board

Block No. [0][5][0][0]

△ Symbol No.	Part No.	Part Name	Description	Local	△ Symbol No.	Part No.	Part Name	Description	Local
△ IC201	STK413-490	IC(HYBRID)			R2101	QRE141J-103Y	C RESISTOR	10kΩ 1/4W J	
△ IC301	STK413-420	IC(HYBRID)			R2102	QRE141J-471Y	C RESISTOR	470Ω 1/4W J	
Q2101	KTA1267/YG/-T	TRANSISTOR			R2103	QRE141J-563Y	C RESISTOR	56kΩ 1/4W J	
Q2201	KTA1267/YG/-T	TRANSISTOR			R2104	QRE141J-561Y	C RESISTOR	560Ω 1/4W J	
Q2301	KTA1267/YG/-T	TRANSISTOR			R2105	QRE141J-563Y	C RESISTOR	56kΩ 1/4W J	
Q3101	KTA1267/YG/-T	TRANSISTOR			△ R2106	QRZ0224-R22	EMIT RESISTOR	0.22Ω	
Q3201	KTA1267/YG/-T	TRANSISTOR			R2107	QRE141J-102Y	C RESISTOR	1kΩ 1/4W J	
Q3301	KTA1267/YG/-T	TRANSISTOR			R2108	QRE141J-153Y	C RESISTOR	15kΩ 1/4W J	
D2101	1SS133-T2	DIODE			R2109	QRE141J-473Y	C RESISTOR	47kΩ 1/4W J	
D2201	1SS133-T2	DIODE			R2110	QRK126J-4R7X	UNF C RESISTOR	4.7Ω 1/2W J	
D2301	1SS133-T2	DIODE			R2111	QRJ146J-100X	UNF C RESISTOR	10Ω 1/4W J	
D2501	MTZJ13C-T2	Z DIODE			R2112	QRE141J-222Y	C RESISTOR	2.2kΩ 1/4W J	
D2502	MTZJ13C-T2	Z DIODE			R2113	QRE141J-222Y	C RESISTOR	2.2kΩ 1/4W J	
D3101	1SS133-T2	DIODE			R2201	QRE141J-103Y	C RESISTOR	10kΩ 1/4W J	
D3201	1SS133-T2	DIODE			R2202	QRE141J-471Y	C RESISTOR	470Ω 1/4W J	
D3301	1SS133-T2	DIODE			R2203	QRE141J-563Y	C RESISTOR	56kΩ 1/4W J	
D3501	MTZJ13C-T2	Z DIODE			R2204	QRE141J-561Y	C RESISTOR	560Ω 1/4W J	
D3502	MTZJ13C-T2	Z DIODE			R2205	QRE141J-563Y	C RESISTOR	56kΩ 1/4W J	
C2102	QCBB1HK-471Y	C CAPACITOR	470pF 50V K		△ R2206	QRZ0224-R22	EMIT RESISTOR	0.22Ω	
C2103	QETN1HM-475Z	E CAPACITOR	4.7uF 50V M		R2207	QRE141J-102Y	C RESISTOR	1kΩ 1/4W J	
C2104	QETN1AM-107Z	E CAPACITOR	100uF 10V M		R2208	QRE141J-153Y	C RESISTOR	15kΩ 1/4W J	
C2105	QCBB1HK-101Y	C CAPACITOR	100pF 50V K		R2209	QRE141J-473Y	C RESISTOR	47kΩ 1/4W J	
C2106	QCSB1HK-3R3Y	C CAPACITOR	3.3pF 50V K		R2210	QRK126J-4R7X	UNF C RESISTOR	4.7Ω 1/2W J	
C2107	QFVF1HJ-104Z	MF CAPACITOR	0.1uF 50V J		R2211	QRJ146J-100X	UNF C RESISTOR	10Ω 1/4W J	
C2108	QFVF1HJ-104Z	MF CAPACITOR	0.1uF 50V J		R2212	QRE141J-222Y	C RESISTOR	2.2kΩ 1/4W J	
C2202	QCBB1HK-471Y	C CAPACITOR	470pF 50V K		R2213	QRE141J-222Y	C RESISTOR	2.2kΩ 1/4W J	
C2203	QETN1HM-475Z	E CAPACITOR	4.7uF 50V M		R2214	QRE141J-103Y	C RESISTOR	10kΩ 1/4W J	
C2204	QETN1AM-107Z	E CAPACITOR	100uF 10V M		R2301	QRE141J-103Y	C RESISTOR	10kΩ 1/4W J	
C2205	QCBB1HK-101Y	C CAPACITOR	100pF 50V K		R2302	QRE141J-471Y	C RESISTOR	470Ω 1/4W J	
C2206	QCSB1HK-3R3Y	C CAPACITOR	3.3pF 50V K		R2303	QRE141J-563Y	C RESISTOR	56kΩ 1/4W J	
C2207	QFVF1HJ-104Z	MF CAPACITOR	0.1uF 50V J		R2304	QRE141J-561Y	C RESISTOR	560Ω 1/4W J	
					R2305	QRE141J-563Y	C RESISTOR	56kΩ 1/4W J	
					△ R2306	QRZ0224-R22	EMIT RESISTOR	0.22Ω	
					R2307	QRE141J-102Y	C RESISTOR	1kΩ 1/4W J	
					R2308	QRE141J-153Y	C RESISTOR	15kΩ 1/4W J	

Symbol No.	Part No.	Part Name	Description	Local
R2309	QRE141J-473Y	C RESISTOR	47kΩ 1/4W J	
R2310	QRK126J-4R7X	UNF C RESISTOR	4.7Ω 1/2W J	
R2311	QRJ146J-100X	UNF C RESISTOR	10Ω 1/4W J	
R2312	QRE141J-222Y	C RESISTOR	2.2kΩ 1/4W J	
R2313	QRE141J-222Y	C RESISTOR	2.2kΩ 1/4W J	
△ R2501	QRZ9005-101X	F.RES. I.M	100Ω	
△ R2502	QRZ9005-101X	F.RES. I.M	100Ω	
R2503	QRK126J-222X	UNF C RESISTOR	2.2kΩ 1/2W J	
R2504	QRK126J-222X	UNF C RESISTOR	2.2kΩ 1/2W J	
R2505	QRE141J-333Y	C RESISTOR	33kΩ 1/4W J	
R2506	QRZ9006-4R7X	F.RESISTOR	4.7Ω 1/4W J	
R2507	QRZ9006-4R7X	F.RESISTOR	4.7Ω 1/4W J	
R2508	QRZ9006-4R7X	F.RESISTOR	4.7Ω 1/4W J	
R2509	QRZ9006-4R7X	F.RESISTOR	4.7Ω 1/4W J	
△ R2510	QRZ9005-101X	F.RES. I.M	100Ω	
R3101	QRE141J-103Y	C RESISTOR	10kΩ 1/4W J	
R3102	QRE141J-471Y	C RESISTOR	470Ω 1/4W J	
R3103	QRE141J-563Y	C RESISTOR	56kΩ 1/4W J	
R3104	QRE141J-561Y	C RESISTOR	560Ω 1/4W J	
R3105	QRE141J-563Y	C RESISTOR	56kΩ 1/4W J	
△ R3106	QRZ0224-R22	EMIT RESISTOR	0.22Ω	
R3107	QRE141J-102Y	C RESISTOR	1kΩ 1/4W J	
R3108	QRE141J-153Y	C RESISTOR	15kΩ 1/4W J	
R3109	QRE141J-473Y	C RESISTOR	47kΩ 1/4W J	
R3110	QRK126J-4R7X	UNF C RESISTOR	4.7Ω 1/2W J	
R3111	QRJ146J-4R7X	UNF C RESISTOR	4.7Ω 1/4W J	
R3112	QRE141J-512Y	C RESISTOR	5.1kΩ 1/4W J	
R3113	QRE141J-222Y	C RESISTOR	2.2kΩ 1/4W J	
R3201	QRE141J-103Y	C RESISTOR	10kΩ 1/4W J	
R3202	QRE141J-471Y	C RESISTOR	470Ω 1/4W J	
R3203	QRE141J-563Y	C RESISTOR	56kΩ 1/4W J	
R3204	QRE141J-561Y	C RESISTOR	560Ω 1/4W J	
R3205	QRE141J-563Y	C RESISTOR	56kΩ 1/4W J	
△ R3206	QRZ0224-R22	EMIT RESISTOR	0.22Ω	
R3207	QRE141J-102Y	C RESISTOR	1kΩ 1/4W J	
R3208	QRE141J-153Y	C RESISTOR	15kΩ 1/4W J	
R3209	QRE141J-473Y	C RESISTOR	47kΩ 1/4W J	
R3210	QRK126J-4R7X	UNF C RESISTOR	4.7Ω 1/2W J	
R3211	QRJ146J-100X	UNF C RESISTOR	10Ω 1/4W J	
R3212	QRE141J-222Y	C RESISTOR	2.2kΩ 1/4W J	
R3213	QRE141J-222Y	C RESISTOR	2.2kΩ 1/4W J	
R3301	QRE141J-103Y	C RESISTOR	10kΩ 1/4W J	
R3302	QRE141J-471Y	C RESISTOR	470Ω 1/4W J	
R3303	QRE141J-563Y	C RESISTOR	56kΩ 1/4W J	
R3304	QRE141J-561Y	C RESISTOR	560Ω 1/4W J	
R3305	QRE141J-563Y	C RESISTOR	56kΩ 1/4W J	
△ R3306	QRZ0224-R22	EMIT RESISTOR	0.22Ω	
R3307	QRE141J-102Y	C RESISTOR	1kΩ 1/4W J	
R3308	QRE141J-153Y	C RESISTOR	15kΩ 1/4W J	
R3309	QRE141J-473Y	C RESISTOR	47kΩ 1/4W J	
R3310	QRK126J-4R7X	UNF C RESISTOR	4.7Ω 1/2W J	
R3311	QRJ146J-100X	UNF C RESISTOR	10Ω 1/4W J	
R3312	QRE141J-222Y	C RESISTOR	2.2kΩ 1/4W J	
R3313	QRE141J-222Y	C RESISTOR	2.2kΩ 1/4W J	
△ R3501	QRZ9005-101X	F.RES. I.M	100Ω	
△ R3502	QRZ9005-101X	F.RES. I.M	100Ω	
R3503	QRK126J-222X	UNF C RESISTOR	2.2kΩ 1/2W J	
R3504	QRK126J-222X	UNF C RESISTOR	2.2kΩ 1/2W J	
R3505	QRE141J-333Y	C RESISTOR	33kΩ 1/4W J	
R3506	QRZ9006-4R7X	F.RESISTOR	4.7Ω 1/4W J	
R3507	QRZ9006-4R7X	F.RESISTOR	4.7Ω 1/4W J	
R3508	QRZ9006-4R7X	F.RESISTOR	4.7Ω 1/4W J	
R3509	QRZ9006-4R7X	F.RESISTOR	4.7Ω 1/4W J	
△ R3510	QRZ9005-101X	F.RES. I.M	100Ω	
L2101	QQLZ038-R45	COIL	0.45uH	
L2201	QQLZ038-R45	COIL	0.45uH	
L2301	QQLZ038-R45	COIL	0.45uH	
L3101	QQLZ038-R45	COIL	0.45uH	
L3201	QQLZ038-R45	COIL	0.45uH	
L3301	QQLZ038-R45	COIL	0.45uH	
CN251	QGB2510K2-07	CONNECTOR	B-B (1-7)	
CN252	QGB2510K2-18	CONNECTOR	B-B (1-18)	
CN351	QGB2510K2-07	CONNECTOR	B-B (1-7)	
CN352	QGB2510K2-18	CONNECTOR	B-B (1-18)	

DVD loading board

Block No. [0][6][0][0]

Symbol No.	Part No.	Part Name	Description	Local
IC1	LB1641	IC	DC Motor driver	
IC2	LB1641	IC	DC Motor driver	
D1	MTZJ6.2A-T2	Z DIODE		
C1	QKFC1AM-107Z	E CAPACITOR	100uF 10V M	
C2	QCFB1HZ-104Y	C CAPACITOR	0.1uF 50V Z	
C3	QFLC1HJ-103Z	M CAPACITOR	0.01uF 50V J	
C5	QFLC1HJ-103Z	M CAPACITOR	0.01uF 50V J	
C6	QCFB1HZ-104Y	C CAPACITOR	0.1uF 50V Z	
C7	QCFB1HZ-104Y	C CAPACITOR	0.1uF 50V Z	
CN1	QGF1036F1-15	CONNECTOR	FFC/FPC (1-15)	
CN2	QGB1214J1-08S	CONNECTOR	B-B (1-8)	
CN3	QGB1214K1-08S	CONNECTOR	B-B (1-8)	
SW1	QSW0844-001	PUSH SWITCH		
SW2	QSW0844-001	PUSH SWITCH		
SW3	QSW0844-001	PUSH SWITCH		
SW4	QSW0844-001	PUSH SWITCH		
SW5	QSW0844-001	PUSH SWITCH		
SW6	QSW0854-002	PUSH SW		
SW7	QSW0886-002	DETECT SWITCH		
SW8	QSW0886-002	DETECT SWITCH		

DVD servo board

Block No. [0][7][0][0]

Symbol No.	Part No.	Part Name	Description	Local
IC101	AN8703FH-V	IC	Frontend processor for DVD	
IC201	BA5983FM-X	IC	4-channel driver	
IC251	BA6664FM-X	IC	Motor driver	
IC301	MN103S26EDC-H	IC		
IC301	or MN103S26EGB-H	IC	Super optical disc controller	
IC403	MN101C28DMJ	IC		
IC404	BR93L46F-W-X	IC		
IC405	SST39VF160-M45	IC		
IC406	74LCX373MTC-X	IC(DIGITAL)	Octal D-type latch	
IC406	or 74LVC373APW-X	IC(DIGITAL)	Octal D-type transparent latch	
IC407	74LCX373MTC-X	IC(DIGITAL)	Octal D-type latch	
IC407	or 74LVC373APW-X	IC(DIGITAL)	Octal D-type transparent latch	
IC501	JCE8045	IC		
IC501	or NDV8601VWA-BE	IC	DVD on a chip processor	
IC505	K4S643232F-TC60	IC		
IC505	or HY57643220CT7	IC		
IC505	or HY57643220CT55	IC		
IC505	or K4S643232F-TC70	IC		
IC505	or W986432DH-7	IC	Bits SDRAM	
IC511	LM1117MP1.8-X	IC	Regulator	
Q101	KTA1001/Y/-X	TRANSISTOR		
Q101	or 2SB1424/R/-W	TRANSISTOR		
Q102	KTA1001/Y/-X	TRANSISTOR		
Q102	or 2SB1424/R/-W	TRANSISTOR		
Q103	DTA144EE-X	DIGI TRANSISTOR		
D101	RB521S-30-X	SB DIODE		
D301	RB521S-30-X	SB DIODE		
C105	NEA70JM-476X	E CAPACITOR	47uF 6.3V M	
C106	NEA70JM-476X	E CAPACITOR	47uF 6.3V M	
C109	NCB31CK-104X	C CAPACITOR	0.1uF 16V K	
C110	NCS31HJ-221X	C CAPACITOR	220pF 50V J	
C111	NCF31CZ-104X	C CAPACITOR	0.1uF 16V Z	
C112	NCF31CZ-104X	C CAPACITOR	0.1uF 16V Z	
C116	NCB31CK-104X	C CAPACITOR	0.1uF 16V K	

△ Symbol No.	Part No.	Part Name	Description	Local	△ Symbol No.	Part No.	Part Name	Description	Local
C117	NCB31CK-473X	C CAPACITOR	0.047uF 16V K		C346	NCF31CZ-104X	C CAPACITOR	0.1uF 16V Z	
C118	NCB31CK-273X	C CAPACITOR	0.027uF 16V K		C347	NCF31CZ-104X	C CAPACITOR	0.1uF 16V Z	
C119	NCB31HK-561X	C CAPACITOR	560pF 50V K		C348	NCB31CK-104X	C CAPACITOR	0.1uF 16V K	
C120	NCB31HK-561X	C CAPACITOR	560pF 50V K		C349	NCF31CZ-104X	C CAPACITOR	0.1uF 16V Z	
C121	NCB31CK-104X	C CAPACITOR	0.1uF 16V K		C350	NCF31CZ-104X	C CAPACITOR	0.1uF 16V Z	
C122	NCS31HJ-120X	C CAPACITOR	12pF 50V J		C351	NCB31HK-471X	C CAPACITOR	470pF 50V K	
C123	NCF31CZ-104X	C CAPACITOR	0.1uF 16V Z		C360	NEA70GM-476X	E CAPACITOR	47uF 4V M	
C124	NCS31HJ-470X	C CAPACITOR	47pF 50V J		C410	NCF31CZ-104X	C CAPACITOR	0.1uF 16V Z	
C125	NCB31HK-271X	C CAPACITOR	270pF 50V K		C411	NCB31CK-104X	C CAPACITOR	0.1uF 16V K	
C126	NCF31CZ-104X	C CAPACITOR	0.1uF 16V Z		C412	NCF31CZ-104X	C CAPACITOR	0.1uF 16V Z	
C127	NCF31CZ-104X	C CAPACITOR	0.1uF 16V Z		C413	NCF31CZ-104X	C CAPACITOR	0.1uF 16V Z	
C128	NCF31CZ-104X	C CAPACITOR	0.1uF 16V Z		C414	NCF31CZ-104X	C CAPACITOR	0.1uF 16V Z	
C129	NCB31HK-472X	C CAPACITOR	4700pF 50V K		C415	NCF31CZ-104X	C CAPACITOR	0.1uF 16V Z	
C135	NEA70JM-476X	E CAPACITOR	47uF 6.3V M		C416	NCF31CZ-104X	C CAPACITOR	0.1uF 16V Z	
C137	NEA70GM-476X	E CAPACITOR	47uF 4V M		C417	NCF31CZ-104X	C CAPACITOR	0.1uF 16V Z	
C138	NCF31CZ-104X	C CAPACITOR	0.1uF 16V Z		C419	NCF31CZ-104X	C CAPACITOR	0.1uF 16V Z	
C141	NCF31CZ-104X	C CAPACITOR	0.1uF 16V Z		C421	NCF31CZ-104X	C CAPACITOR	0.1uF 16V Z	
C142	NCF31CZ-104X	C CAPACITOR	0.1uF 16V Z		C422	NCF31CZ-104X	C CAPACITOR	0.1uF 16V Z	
C144	NCB31CK-103X	C CAPACITOR	0.01uF 16V K		C423	NCF31CZ-104X	C CAPACITOR	0.1uF 16V Z	
C204	NCF31CZ-104X	C CAPACITOR	0.1uF 16V Z		C424	NCB31CK-103X	C CAPACITOR	0.01uF 16V K	
C205	NCS31HJ-121X	C CAPACITOR	120pF 50V J		C432	NCB31CK-223X	C CAPACITOR	0.022uF 16V K	
C207	NCB31HK-391X	C CAPACITOR	390pF 50V K		C440	NCB31CK-223X	C CAPACITOR	0.022uF 16V K	
C208	NCB31HK-391X	C CAPACITOR	390pF 50V K		C501	NCF31CZ-104X	C CAPACITOR	0.1uF 16V Z	
C211	NCB31HK-223X	C CAPACITOR	0.022uF 50V K		C506	NDC31HJ-150X	C CAPACITOR	15pF 50V J	
C212	NCB31CK-103X	C CAPACITOR	0.01uF 16V K		C507	NDC31HJ-180X	C CAPACITOR	18pF 50V J	
C217	NCF31CZ-104X	C CAPACITOR	0.1uF 16V Z		C510	NCB31HK-471X	C CAPACITOR	470pF 50V K	
C251	NCF31CZ-104X	C CAPACITOR	0.1uF 16V Z		C512	NCF31CZ-104X	C CAPACITOR	0.1uF 16V Z	
C253	NCF31CZ-104X	C CAPACITOR	0.1uF 16V Z		C513	NCB31HK-471X	C CAPACITOR	470pF 50V K	
C255	NCB31CK-153X	C CAPACITOR	0.015uF 16V K		C514	NCB31HK-471X	C CAPACITOR	470pF 50V K	
C256	NCB31CK-104X	C CAPACITOR	0.1uF 16V K		C515	NCB31HK-471X	C CAPACITOR	470pF 50V K	
C257	NCF31CZ-104X	C CAPACITOR	0.1uF 16V Z		C516	NCB31HK-471X	C CAPACITOR	470pF 50V K	
C258	NCF31CZ-104X	C CAPACITOR	0.1uF 16V Z		C517	NCF31CZ-104X	C CAPACITOR	0.1uF 16V Z	
C259	NCF31CZ-104X	C CAPACITOR	0.1uF 16V Z		C518	NCF31CZ-104X	C CAPACITOR	0.1uF 16V Z	
C260	NCF31CZ-104X	C CAPACITOR	0.1uF 16V Z		C519	NCF31CZ-104X	C CAPACITOR	0.1uF 16V Z	
C261	NCF31CZ-104X	C CAPACITOR	0.1uF 16V Z		C520	NCB31HK-471X	C CAPACITOR	470pF 50V K	
C262	NCF31CZ-104X	C CAPACITOR	0.1uF 16V Z		C521	NCF31CZ-104X	C CAPACITOR	0.1uF 16V Z	
C263	NCF31CZ-104X	C CAPACITOR	0.1uF 16V Z		C522	NCB31HK-471X	C CAPACITOR	470pF 50V K	
C264	NCB31CK-103X	C CAPACITOR	0.01uF 16V K		C523	NCF31CZ-104X	C CAPACITOR	0.1uF 16V Z	
C301	NCF31CZ-104X	C CAPACITOR	0.1uF 16V Z		C524	NEA70GM-476X	E CAPACITOR	47uF 4V M	
C302	NCF31CZ-104X	C CAPACITOR	0.1uF 16V Z		C525	NCB31HK-471X	C CAPACITOR	470pF 50V K	
C303	NCF31CZ-104X	C CAPACITOR	0.1uF 16V Z		C527	NEA70GM-476X	E CAPACITOR	47uF 4V M	
C304	NEA70GM-476X	E CAPACITOR	47uF 4V M		C528	NCB31HK-471X	C CAPACITOR	470pF 50V K	
C306	NEA70GM-476X	E CAPACITOR	47uF 4V M		C529	NCB31HK-471X	C CAPACITOR	470pF 50V K	
C308	NEA70GM-476X	E CAPACITOR	47uF 4V M		C530	NCB31HK-471X	C CAPACITOR	470pF 50V K	
C310	NCF31CZ-104X	C CAPACITOR	0.1uF 16V Z		C531	NCF31CZ-104X	C CAPACITOR	0.1uF 16V Z	
C311	NCB31HK-561X	C CAPACITOR	560pF 50V K		C532	NCF31CZ-104X	C CAPACITOR	0.1uF 16V Z	
C312	NCB31HK-561X	C CAPACITOR	560pF 50V K		C533	NCF31CZ-104X	C CAPACITOR	0.1uF 16V Z	
C313	NCB31HK-561X	C CAPACITOR	560pF 50V K		C534	NCF31CZ-104X	C CAPACITOR	0.1uF 16V Z	
C314	NCB31HK-331X	C CAPACITOR	330pF 50V K		C535	NCB31HK-471X	C CAPACITOR	470pF 50V K	
C315	NCB31HK-471X	C CAPACITOR	470pF 50V K		C536	NCB31HK-471X	C CAPACITOR	470pF 50V K	
C316	NCB31HK-271X	C CAPACITOR	270pF 50V K		C537	NCB31HK-471X	C CAPACITOR	470pF 50V K	
C317	NCS31HJ-121X	C CAPACITOR	120pF 50V J		C538	NCB31HK-471X	C CAPACITOR	470pF 50V K	
C318	NCF31CZ-104X	C CAPACITOR	0.1uF 16V Z		C539	NCB31HK-471X	C CAPACITOR	470pF 50V K	
C319	NCB31HK-102X	C CAPACITOR	1000pF 50V K		C540	NCF31CZ-104X	C CAPACITOR	0.1uF 16V Z	
C320	NCB31HK-102X	C CAPACITOR	1000pF 50V K		C541	NCF31CZ-104X	C CAPACITOR	0.1uF 16V Z	
C321	NCB31HK-102X	C CAPACITOR	1000pF 50V K		C542	NCB31CK-104X	C CAPACITOR	0.1uF 16V K	
C322	NCB31HK-562X	C CAPACITOR	5600pF 50V K		C543	NCF31CZ-104X	C CAPACITOR	0.1uF 16V Z	
C323	NCB31HK-102X	C CAPACITOR	1000pF 50V K		C544	NCF31CZ-104X	C CAPACITOR	0.1uF 16V Z	
C324	NCF31CZ-104X	C CAPACITOR	0.1uF 16V Z		C545	NCF31CZ-104X	C CAPACITOR	0.1uF 16V Z	
C325	NCS31HJ-470X	C CAPACITOR	47pF 50V J		C546	NCB31HK-471X	C CAPACITOR	470pF 50V K	
C326	NCB31CK-183X	C CAPACITOR	0.018uF 16V K		C547	NCB31HK-471X	C CAPACITOR	470pF 50V K	
C327	NCB31HK-102X	C CAPACITOR	1000pF 50V K		C548	NCF31CZ-104X	C CAPACITOR	0.1uF 16V Z	
C328	NCF31CZ-104X	C CAPACITOR	0.1uF 16V Z		C549	NEA70GM-476X	E CAPACITOR	47uF 4V M	
C329	NCB31CK-103X	C CAPACITOR	0.01uF 16V K		C550	NCF31CZ-104X	C CAPACITOR	0.1uF 16V Z	
C330	NCB31CK-104X	C CAPACITOR	0.1uF 16V K		C551	NCB31HK-471X	C CAPACITOR	470pF 50V K	
C331	NCB31CK-103X	C CAPACITOR	0.01uF 16V K		C557	NCF31CZ-104X	C CAPACITOR	0.1uF 16V Z	
C332	NCF31CZ-104X	C CAPACITOR	0.1uF 16V Z		C558	NCF31CZ-104X	C CAPACITOR	0.1uF 16V Z	
C333	NCB31CK-104X	C CAPACITOR	0.1uF 16V K		C559	NCB31HK-471X	C CAPACITOR	470pF 50V K	
C334	NCB31CK-104X	C CAPACITOR	0.1uF 16V K		C560	NCB31HK-471X	C CAPACITOR	470pF 50V K	
C337	NCF31CZ-104X	C CAPACITOR	0.1uF 16V Z		C561	NCB31HK-471X	C CAPACITOR	470pF 50V K	
C338	NCF31CZ-104X	C CAPACITOR	0.1uF 16V Z		C562	NCF31CZ-104X	C CAPACITOR	0.1uF 16V Z	
C339	NCB31CK-104X	C CAPACITOR	0.1uF 16V K		C563	NCB31HK-471X	C CAPACITOR	470pF 50V K	
C340	NCB31CK-104X	C CAPACITOR	0.1uF 16V K		C565	NEA70GM-476X	E CAPACITOR	47uF 4V M	
C341	NCF31CZ-104X	C CAPACITOR	0.1uF 16V Z		C571	NEA70GM-476X	E CAPACITOR	47uF 4V M	
C342	NCB31HK-471X	C CAPACITOR	470pF 50V K		C572	NCF31CZ-104X	C CAPACITOR	0.1uF 16V Z	
C343	NCF31CZ-104X	C CAPACITOR	0.1uF 16V Z		C573	NEA70GM-476X	E CAPACITOR	47uF 4V M	
C344	NCB31HK-471X	C CAPACITOR	470pF 50V K		C578	NCF31CZ-104X	C CAPACITOR	0.1uF 16V Z	
C345	NCF31CZ-104X	C CAPACITOR	0.1uF 16V Z		C581	NEA70GM-227X	E CAPACITOR	220uF 4V M	

△ Symbol No.	Part No.	Part Name	Description	Local	△ Symbol No.	Part No.	Part Name	Description	Local
R101	NRSA63J-333X	MG RESISTOR	33kΩ	1/16W J	R342	NRSA63J-0R0X	MG RESISTOR	0Ω	1/16W J
R102	NRSA63J-223X	MG RESISTOR	22kΩ	1/16W J	R343	NRSA63J-103X	MG RESISTOR	10kΩ	1/16W J
R103	NRSA63J-223X	MG RESISTOR	22kΩ	1/16W J	R344	NRSA63J-103X	MG RESISTOR	10kΩ	1/16W J
R104	NRS125J-270X	MG RESISTOR	27Ω	1/2W J	R345	NRSA63J-681X	MG RESISTOR	680Ω	1/16W J
R105	NRS125J-270X	MG RESISTOR	27Ω	1/2W J	R409	NRSA63J-0R0X	MG RESISTOR	0Ω	1/16W J
R106	NRSA63J-273X	MG RESISTOR	27kΩ	1/16W J	R413	NRSA63J-103X	MG RESISTOR	10kΩ	1/16W J
R107	NRSA63J-273X	MG RESISTOR	27kΩ	1/16W J	R414	NRSA63J-103X	MG RESISTOR	10kΩ	1/16W J
R108	NRSA63J-222X	MG RESISTOR	2.2kΩ	1/16W J	R415	NRSA63J-103X	MG RESISTOR	10kΩ	1/16W J
R109	NRSA63J-182X	MG RESISTOR	1.8kΩ	1/16W J	R416	NRSA63J-103X	MG RESISTOR	10kΩ	1/16W J
R110	NRSA63J-333X	MG RESISTOR	33kΩ	1/16W J	R501	NRSA63J-470X	MG RESISTOR	47Ω	1/16W J
R111	NRVA63D-243X	CMF RESISTOR	24kΩ	1/16W D	R513	NRSA63J-0R0X	MG RESISTOR	0Ω	1/16W J
R112	NRSA63J-822X	MG RESISTOR	8.2kΩ	1/16W J	R514	NRSA63J-220X	MG RESISTOR	22Ω	1/16W J
R113	NRSA63J-103X	MG RESISTOR	10kΩ	1/16W J	R550	NRSA63J-471X	MG RESISTOR	470Ω	1/16W J
R115	NRSA63J-0R0X	MG RESISTOR	0Ω	1/16W J	R565	NRSA63J-103X	MG RESISTOR	10kΩ	1/16W J
R116	NRSA63J-101X	MG RESISTOR	100Ω	1/16W J	R566	NRVA63D-122X	CMF RESISTOR	1.2kΩ	1/16W D
R117	NRSA63J-101X	MG RESISTOR	100Ω	1/16W J	R567	NRSA63J-102X	MG RESISTOR	1kΩ	1/16W J
R119	NRSA63J-2R2X	MG RESISTOR	2.2Ω	1/16W J	R568	NRSA63J-102X	MG RESISTOR	1kΩ	1/16W J
R120	NRSA63J-2R2X	MG RESISTOR	2.2Ω	1/16W J	R569	NRSA63J-102X	MG RESISTOR	1kΩ	1/16W J
R125	NRSA63J-105X	MG RESISTOR	1MΩ	1/16W J	R570	NRSA63J-100X	MG RESISTOR	10Ω	1/16W J
R126	NRSA63J-105X	MG RESISTOR	1MΩ	1/16W J	R572	NRSA63J-102X	MG RESISTOR	1kΩ	1/16W J
R127	NRSA63J-222X	MG RESISTOR	2.2kΩ	1/16W J	R573	NRSA63J-162X	MG RESISTOR	1.6kΩ	1/16W J
R128	NRS125J-1R0X	MG RESISTOR	1Ω	1/2W J	R574	NRSA63J-162X	MG RESISTOR	1.6kΩ	1/16W J
R129	NRS125J-1R0X	MG RESISTOR	1Ω	1/2W J	R575	NRSA63J-151X	MG RESISTOR	150Ω	1/16W J
R130	NRSA63J-182X	MG RESISTOR	1.8kΩ	1/16W J	R576	NRSA63J-151X	MG RESISTOR	150Ω	1/16W J
R201	NRSA63J-470X	MG RESISTOR	47Ω	1/16W J	R578	NRSA63J-151X	MG RESISTOR	150Ω	1/16W J
R202	NRS125J-1R0X	MG RESISTOR	1Ω	1/2W J	R583	NRSA63J-101X	MG RESISTOR	100Ω	1/16W J
R204	NRSA63J-273X	MG RESISTOR	27kΩ	1/16W J	R584	NRSA63J-332X	MG RESISTOR	3.3kΩ	1/16W J
R205	NRSA63J-273X	MG RESISTOR	27kΩ	1/16W J	R589	NRSA63J-0R0X	MG RESISTOR	0Ω	1/16W J
R206	NRSA63J-303X	MG RESISTOR	30kΩ	1/16W J	L501	NQL044K-100X	COIL	10uH K	
R207	NRSA63J-473X	MG RESISTOR	47kΩ	1/16W J	CN101	QGF0501F2-24X	CONNECTOR	FFC/FPC (1-24)	
R208	NRSA63J-223X	MG RESISTOR	22kΩ	1/16W J	CN103	QGF1037F1-15W	CONNECTOR	FFC/FPC (1-15)	
R209	NRSA63J-223X	MG RESISTOR	22kΩ	1/16W J	CN104	QGA2001F2-02X	CONNECTOR	W-B (1-2)	
R213	NRSA63J-103X	MG RESISTOR	10kΩ	1/16W J	CN105	QGA2001F2-03X	CONNECTOR	W-B (1-3)	
R214	NRSA63J-103X	MG RESISTOR	10kΩ	1/16W J	CN201	QGF1037F1-15W	CONNECTOR	FFC/FPC (1-15)	
R215	NRSA63J-103X	MG RESISTOR	10kΩ	1/16W J	CN501	QGF1016C2-07W	CONNECTOR	FFC/FPC (1-7)	
R219	NRSA63J-183X	MG RESISTOR	18kΩ	1/16W J	CN502	QGF1016C2-23W	CONNECTOR	FFC/FPC (1-23)	
R220	NRSA63J-243X	MG RESISTOR	24kΩ	1/16W J	K101	NQR0007-002X	FERRITE BEADS		
R221	NRSA63J-682X	MG RESISTOR	6.8kΩ	1/16W J	K501	NQR0007-002X	FERRITE BEADS		
R230	NRSA63J-332X	MG RESISTOR	3.3kΩ	1/16W J	K508	NQR0007-002X	FERRITE BEADS		
R251	NRS125J-R47X	MG RESISTOR	0.47Ω	1/2W J	K509	NQR0007-002X	FERRITE BEADS		
R252	NRSA63J-2R2X	MG RESISTOR	2.2Ω	1/16W J	K556	NQR0129-002X	FERRITE BEADS		
R254	NRSA63J-203X	MG RESISTOR	20kΩ	1/16W J	K557	NQR0129-002X	FERRITE BEADS		
R255	NRSA63J-103X	MG RESISTOR	10kΩ	1/16W J	K558	NQR0129-002X	FERRITE BEADS		
R256	NRSA63J-470X	MG RESISTOR	47Ω	1/16W J	K559	NQR0129-002X	FERRITE BEADS		
R259	NRSA63J-103X	MG RESISTOR	10kΩ	1/16W J	K560	NQR0007-002X	FERRITE BEADS		
R280	NRSA63J-332X	MG RESISTOR	3.3kΩ	1/16W J	X301	NAX0566-001X	C RESONATOR	16.934MHz	
R301	NRSA63J-473X	MG RESISTOR	47kΩ	1/16W J	X401	NAX0248-001X	C OSCILLATOR		
R302	NRSA63J-473X	MG RESISTOR	47kΩ	1/16W J	X571	NAX0550-001X	CRYSTAL	27.000MHz	
R303	NRSA63J-473X	MG RESISTOR	47kΩ	1/16W J					
R304	NRSA63J-473X	MG RESISTOR	47kΩ	1/16W J					
R305	NRSA63J-473X	MG RESISTOR	47kΩ	1/16W J					
R306	NRSA63J-473X	MG RESISTOR	47kΩ	1/16W J					
R307	NRSA63J-473X	MG RESISTOR	47kΩ	1/16W J					
R308	NRSA63J-0R0X	MG RESISTOR	0Ω	1/16W J					
R309	NRSA63J-473X	MG RESISTOR	47kΩ	1/16W J					
R313	NRSA63J-473X	MG RESISTOR	47kΩ	1/16W J					
R317	NRSA63J-473X	MG RESISTOR	47kΩ	1/16W J					
R320	NRSA63J-105X	MG RESISTOR	1MΩ	1/16W J					
R321	NRSA63J-473X	MG RESISTOR	47kΩ	1/16W J					
R323	NRSA63J-473X	MG RESISTOR	47kΩ	1/16W J					
R324	NRSA63J-473X	MG RESISTOR	47kΩ	1/16W J					
R325	NRSA63J-123X	MG RESISTOR	12kΩ	1/16W J					
R326	NRSA63J-473X	MG RESISTOR	47kΩ	1/16W J					
R327	NRSA63J-105X	MG RESISTOR	1MΩ	1/16W J					
R328	NRSA63J-153X	MG RESISTOR	15kΩ	1/16W J					
R329	NRSA63J-473X	MG RESISTOR	47kΩ	1/16W J					
R330	NRSA63J-473X	MG RESISTOR	47kΩ	1/16W J					
R331	NRSA63J-473X	MG RESISTOR	47kΩ	1/16W J					
R332	NRSA63J-102X	MG RESISTOR	1kΩ	1/16W J					
R333	NRSA63J-183X	MG RESISTOR	18kΩ	1/16W J					
R334	NRSA63J-102X	MG RESISTOR	1kΩ	1/16W J					
R336	NRSA63J-273X	MG RESISTOR	27kΩ	1/16W J					
R337	NRSA63J-273X	MG RESISTOR	27kΩ	1/16W J					
R338	NRSA63J-472X	MG RESISTOR	4.7kΩ	1/16W J					
R339	NRSA63J-472X	MG RESISTOR	4.7kΩ	1/16W J					
R340	NRSA63J-103X	MG RESISTOR	10kΩ	1/16W J					
R341	NRSA63J-562X	MG RESISTOR	5.6kΩ	1/16W J					

< MEMO >

Packing materials and accessories parts list

Block No. **M** **3** **M** **M**

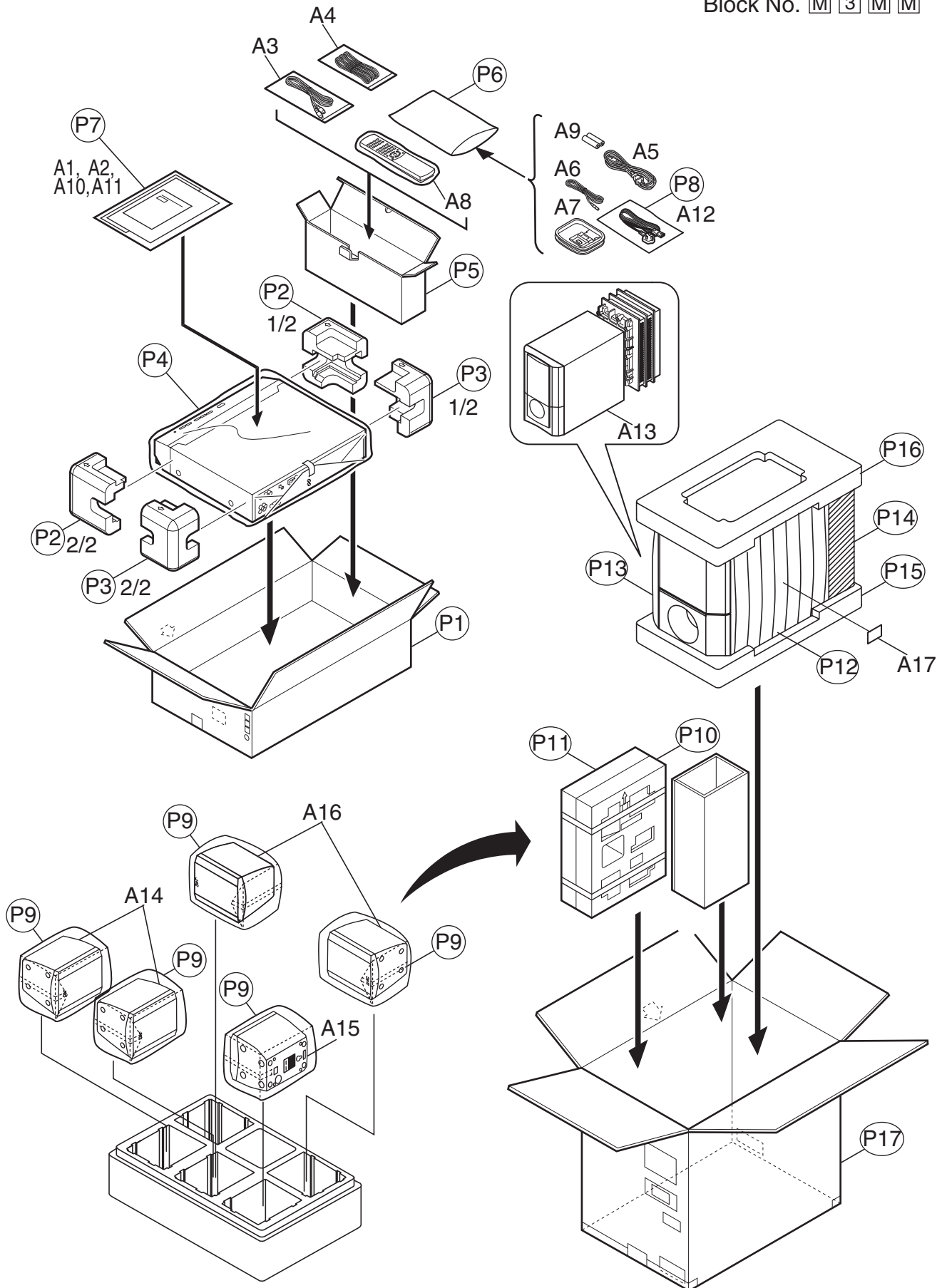

Packing and accessories

Block No. [M][3][M][M]

△ Symbol No.	Part No.	Part Name	Description	Local
A 1	LVT1024-003B	INST BOOK	ENG	THM45B
A 1	LVT1024-004B	INST BOOK	GER,FRE,DUT	THM45E
A 1	LVT1024-005B	INST BOOK	SWE,FIN,DAN	THM45EN
A 2	BT-54013-6	WARRANTY CARD		
A 3	QAM0381-001	SYSTEM CABLE		
A 4	LV43454-001A	SPK CORD ASSY		
△ A 5	QMPL060-183-JD	POWER CORD(EU)	1.83m BLACK	THM45E, THM45EN
A 6	QAL0457-001	ANT.WIRE		
A 7	QAL0014-001	AM LOOP ANT		
A 8	RM-STHM45R	REMOCON UNIT		
A 9	-----	BATTERY	(x2)	
A 10	VNA3000-204	REGISTER CARD		THM45B
A 11	LVT1024-006B	INST BOOK	GER FRE SPA ITA	THM45EN
△ A 12	QMPP060-183-JD	POWER CORD(EK)	1.83m BLACK	THM45B
A 13	SPPWM45E-SPBOX	SPEAKER BOX		THM45E
A 14	SPTHM45FE-SPBOX	SPEAKER BOX	(x2)	
A 15	SPTHM45CE-SPBOX	SPEAKER BOX		
A 16	SPTHM45SE-SPBOX	SPEAKER BOX	(x2)	
A 17	6000200621	LABEL		THM45B
A 17	6000200631	LABEL		THM45EN
A 17	6000200611	LABEL		THM45E
P 1	LV34043-001A	CARTON BOX		
P 2	LV21452-001A	CUSHION FRONT		
P 3	LV21453-001A	CUSHION REAR		
P 4	QPC06006015P	ENVELOPE	60cm x 60cm	
P 5	LV34231-002A	ACCESSORY BOX		
P 6	QPA02503503P	POLY BAG	25cm x 35cm	
P 7	QPA02503505P	POLY BAG	25cm x 35cm	THM45B, THM45E
P 7	QPA03004503P	POLY BAG	30cm x 45cm	THM45EN
P 8	QPA01503503	POLY BAG	15cm x 35cm	THM45B
P 9	8500048151	POLY BAG	(x5)	
P 10	8000051401	CUSHION		
P 11	8000051501	CUSHION		
P 12	8500051801	MIRROR MAT		
P 13	8500051901	POLY BAG		
P 14	8100117501	PARTITION		
P 15	8000053011	CUSHION(BTTM)		
P 16	8000053001	CUSHION(TOP)		
P 17	8300047731	INDI.CARTON		

JVC

SCHEMATIC DIAGRAMS

DVD DIGITAL CINEMA SYSTEM

TH-M45

CD-ROM No.SML200311

Area suffix

B ----- U.K.
E ----- Continental Europe
EN ----- Northern Europe

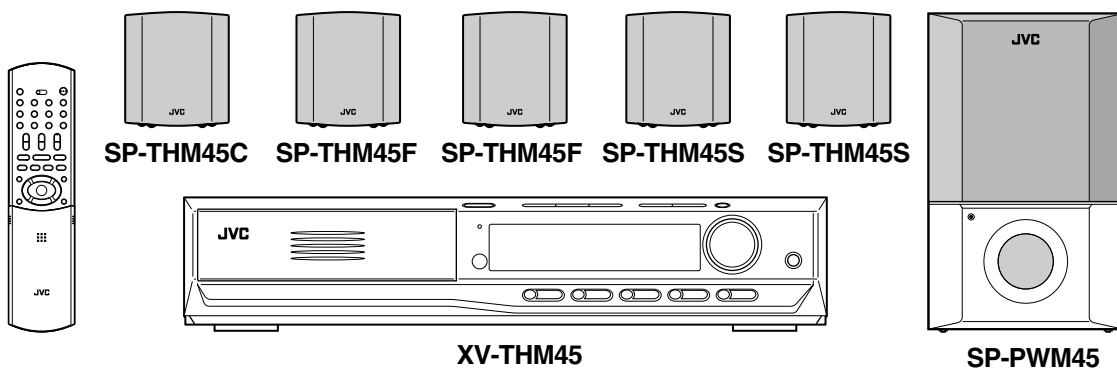

Contents

Block diagrams	2-1
Standard schematic diagrams	2-2
Printed circuit boards	2-14 to 19

In regard with component parts appearing on the silk-screen printed side (parts side) of the PWB diagrams, the parts that are printed over with black such as the resistor (■), diode (⬤) and ICP (●) or identified by the "⚠" mark nearby are critical for safety.

(This regulation does not correspond to J and C version.)

Block diagrams

<Main body section>

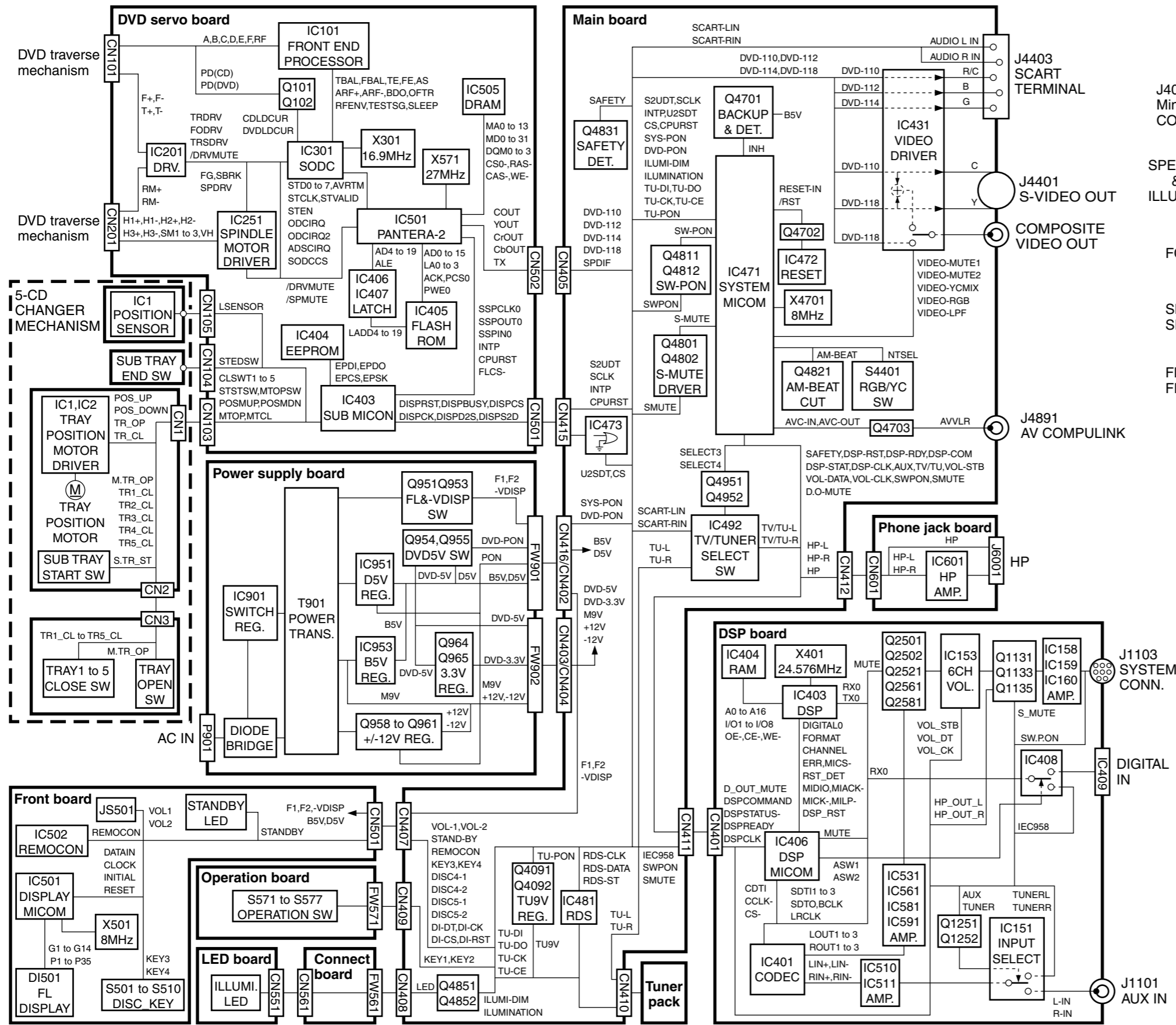

<Subwoofer section>

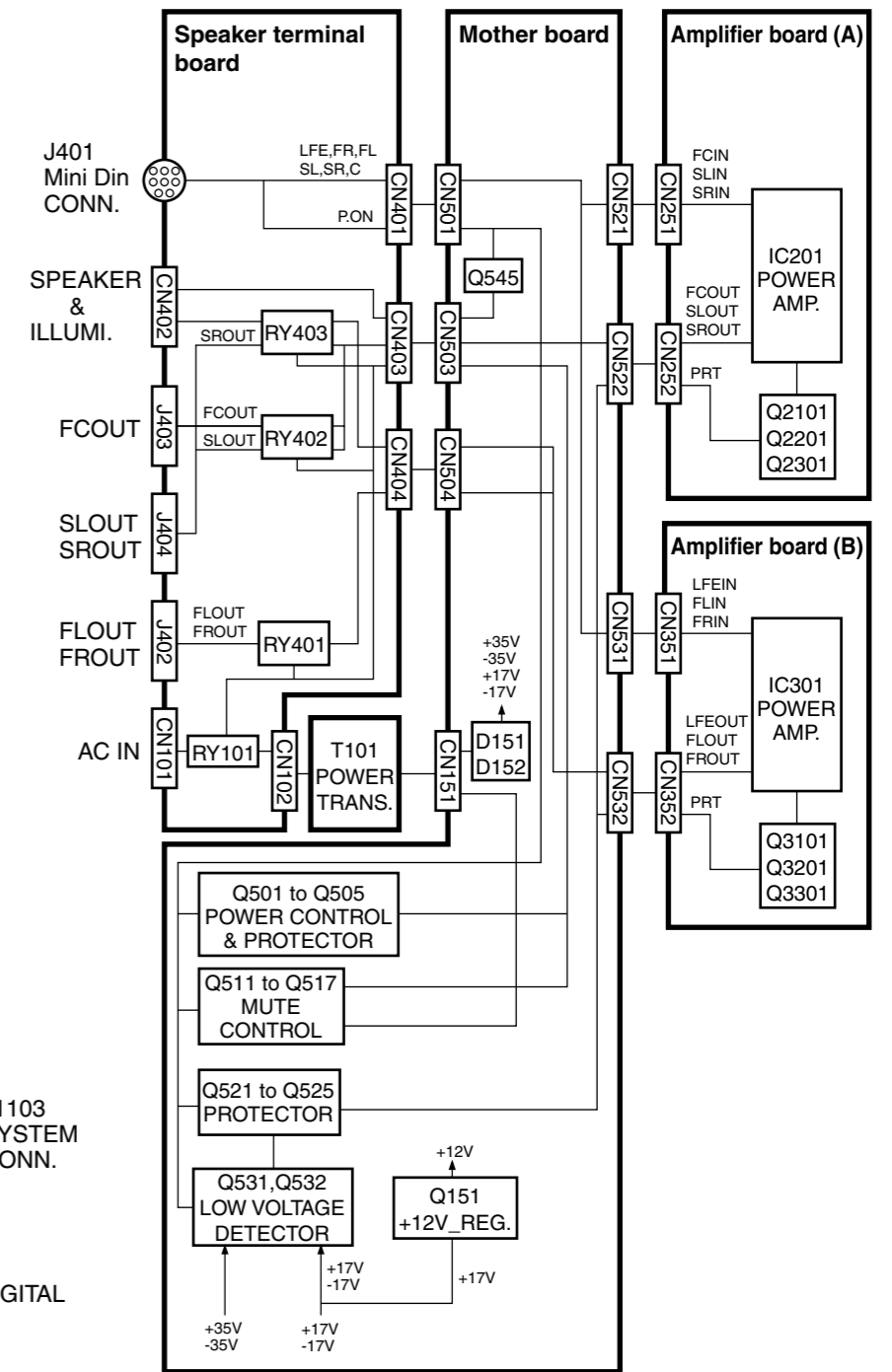

Standard schematic diagrams

<Main body section>

■ Power supply section

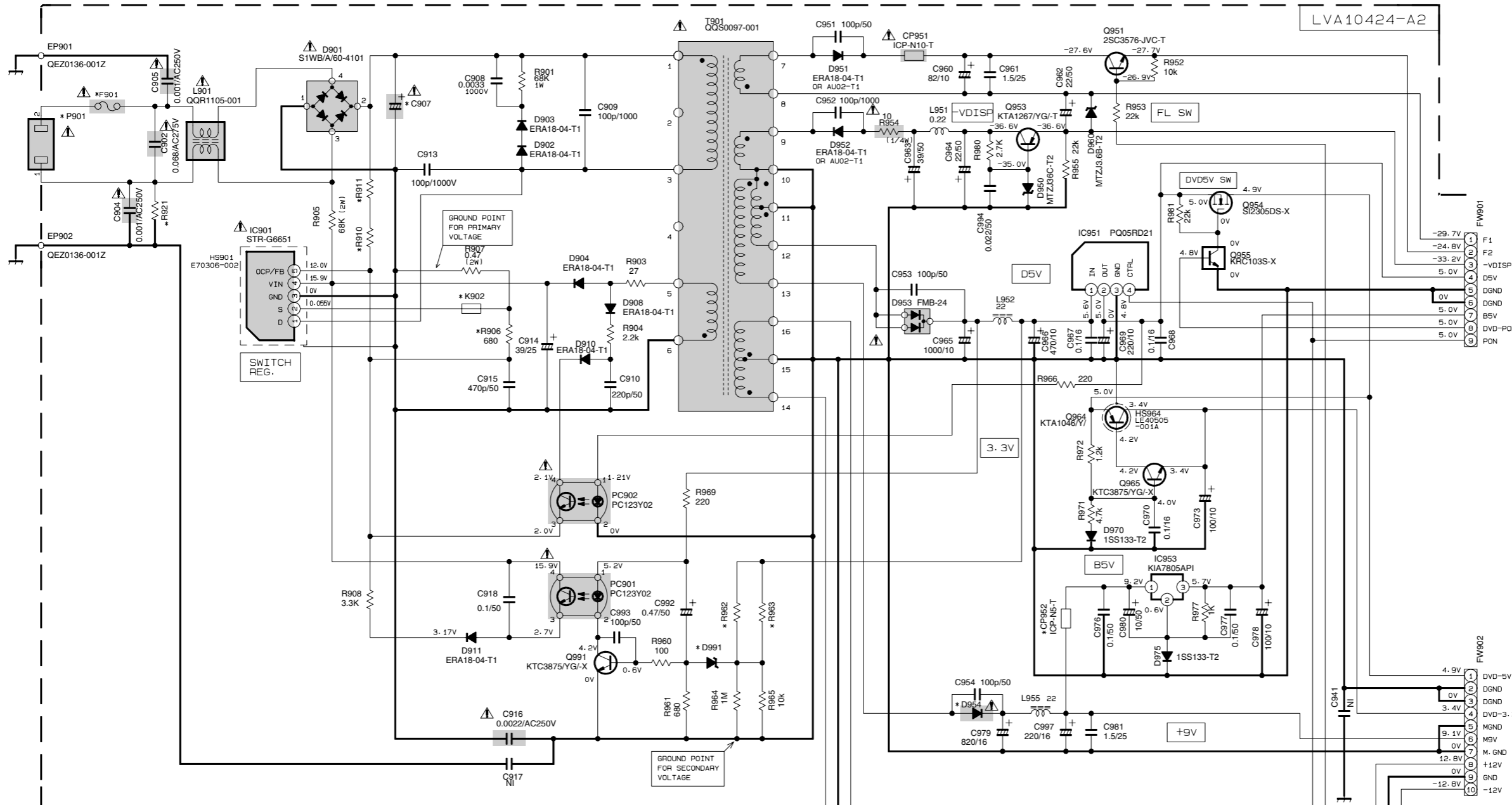

TO CN401, CN402
OF LVA10424-A1
(SHEET 2/10)

TO CN403, CN404
OF LVA10424-A1
(SHEET 2/10)

REF NO	Ver	ADDRESS	D	J/C	B/E/EN/EE/EV	UG/US/UW/UJ /UP/UF/A/UB/UY /UX/UT
*F901	(A-3)	QMF51U1-1R6-JB (1.6A/125V)	QMF51U1-1R6-JB (1.6A/125V)	QMF51W2-1R6-JB (1.6A)	QMF51W2-1R6-JB (1.6A)	QMF51W2-1R6-JB (1.6A)
*R962	(E-7)	1M	1M	0 (B3099)	0 (B3099)	
*R963	(E-8)	100	100	NONE	NONE	
*D991	(F-7)	MTZJ5.1C-T2	MTZJ5.1C-T2	MTZJ5.1B-T2	MTZJ5.1B-T2	
*K902	(C-5)	QGRO779-001Z	QGRO779-001Z	0 (B3199)	0 (B3199)	
*R921	(B-3)	NONE	3.3M	NONE	NONE	
*P901	(B-2)	QNC00B1-001	QNC00B2-001	QNC00B1-001	QNC00B1-001	
*R910 *R911	(B-5)	750K	750K	470K	470K	
*CP952	(F-10)	0 (B3198)	0 (B3198)	ICP-N5-T	ICP-N5-T	

VERSION CODES	
J	U.S.A.
C	CANADA
E	GERMANY/FRANCE/HOLLAND
B	GREAT BRITAIN
EE	RUSSIA
EN	SWEDEN/NORWAY/FINLAND/DENMARK
EV	EAST EUROPE
A	AUSTRALIA
UW	BRAZIL/MEXICO/PERU
US	SINGAPOLE
UJ	USA MILITARY BASE
UG	TURKEY/EGYPT/SOUTHAFRICA

- Ver. J/C
120V 60Hz
- Ver. B/E/EN/EE/EV
230V 50Hz
- Ver. US/UW/UJ/UG
110-230V 50/60Hz
- Ver. A
240V 50Hz

REF NO	Ver	ADDRESS	D	J/C	B/E/EN/EE/EV A/UB/UP/UF/UY	US/UW/UJ/UG /UX/UT
*C907	(B-5)	QETM2DM-157 (150/200)	QETM2DM-157 (150/200)	QE20522-B26 QE20374-B26 (82/400)	QE20522-127 QE20445-127 (120/400)	
*D954	(F-9)	EU2YX-LFH6K	ERA18-04-T1	EU2YX-LFH6K	EU2YX-LFH6K	

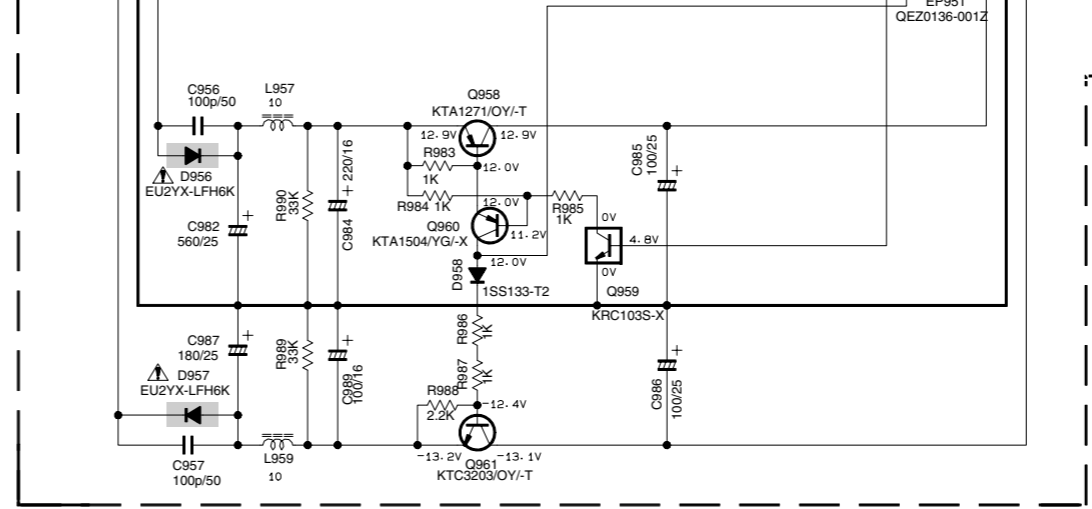

▲ Parts are safety assurance parts.
When replacing those parts make
sure to use the specified one.

System control section

TO CN401 OF LVA10309-A1
(SHEET 5/10)

TO FW901 OF LVA10424-A2
(SHEET 1/10)

TO FW902 OF LVA10424-A2
(SHEET 1/10)

TO CN502 OF LEA10077
(SHEET 9/10)

TO CN501 OF LEA10077
(SHEET 9/10)

LVA10424-A1 (1/2)

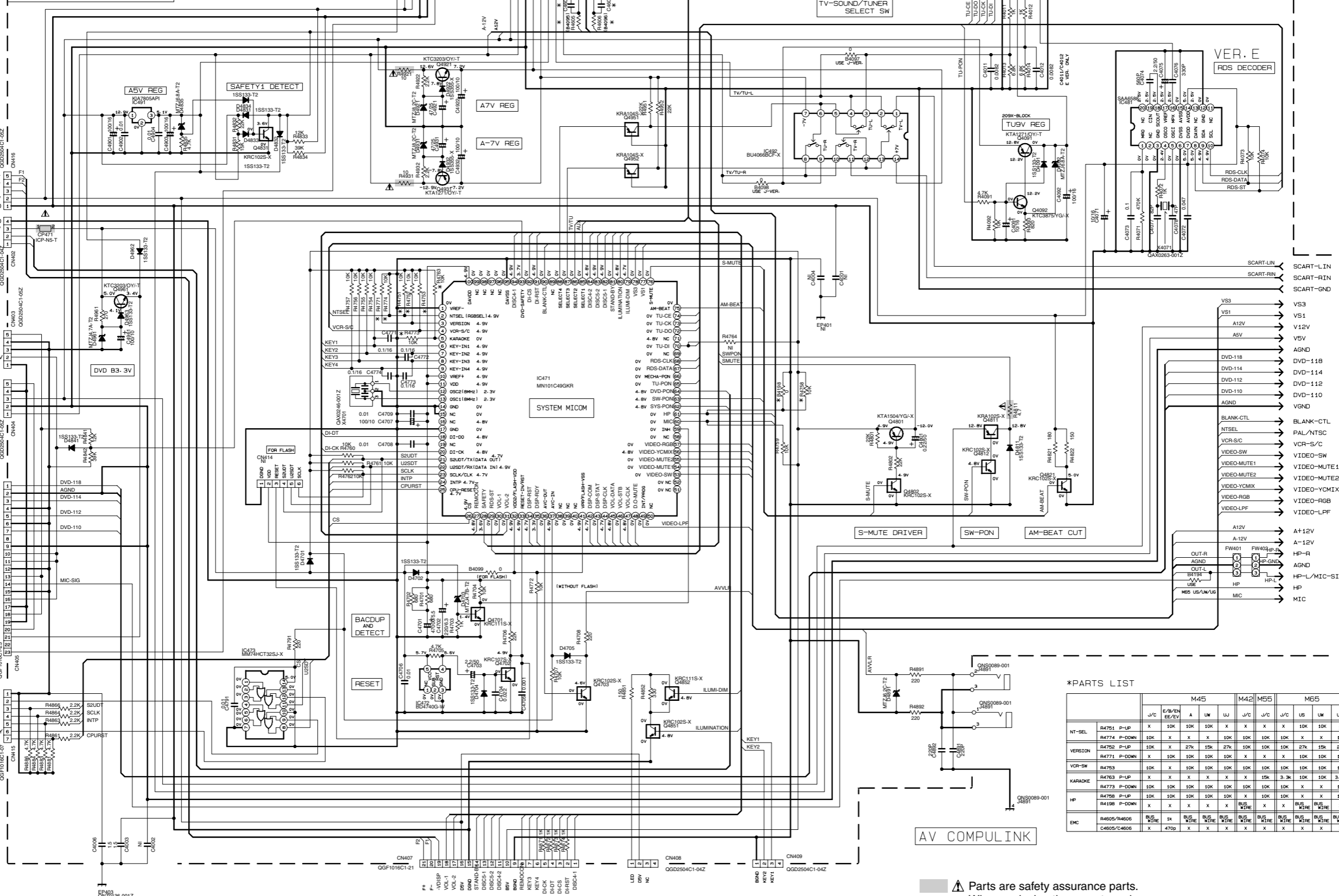

TO CN501 OF LVA10425-A1
(SHEET 4/10)

TO FW561 OF LVA10425-A3
(SHEET 4/10)

TO FW571 OF LVA10425-A5
(SHEET 4/10)

*PARTS LIST

	QTY	M45				M42		M55		M65			
		J/C	E/B/EN/EE/EN	A	UW	UJ	J/C	J/C	J/C	US	UW	UJ	US
NT-SEL	R4751 P-UP	X	10K	10K	10K	X	X	X	X	10K	10K	X	10K
	R4774 P-DOWN	10K	X	X	X	10K	10K	10K	X	X	X	10K	
VERSION	R4752 P-UP	10K	X	27K	15K	27K	10K	10K	27K	15K	27K	27K	
	R4771 P-DOWN	X	10K	10K	10K	10K	X	X	10K	10K	X	10K	
VCR-SW	R4753	10K	X	10K	10K	10K	10K	10K	10K	10K	10K	10K	
KARAOKE	R4763 P-UP	X	X	X	X	X	X	15K	3.3K	10K	10K	3.3K	
	R4773 P-DOWN	10K	10K	10K	10K	10K	10K	10K	10K	X	X	10K	
HP	R4756 P-UP	10K	10K	10K	10K	10K	X	10K	10K	X	X	10K	
	R4198 P-DOWN	X	X	X	X	X	X	X	BUS WIRE	BUS WIRE	BUS WIRE	BUS WIRE	
EMC	R4605/R4606	BUS WIRE	1K	BUS WIRE	BUS WIRE	BUS WIRE	BUS WIRE	BUS WIRE	BUS WIRE	BUS WIRE	BUS WIRE	BUS WIRE	
	C4605/C4606	X	470p	X	X	X	X	X	X	X	X	X	

Parts are safety assurance parts. When replacing those parts make sure to use the specified one.

TO VIDEO BLOCK (SHEET 3/10)

Video input / output section

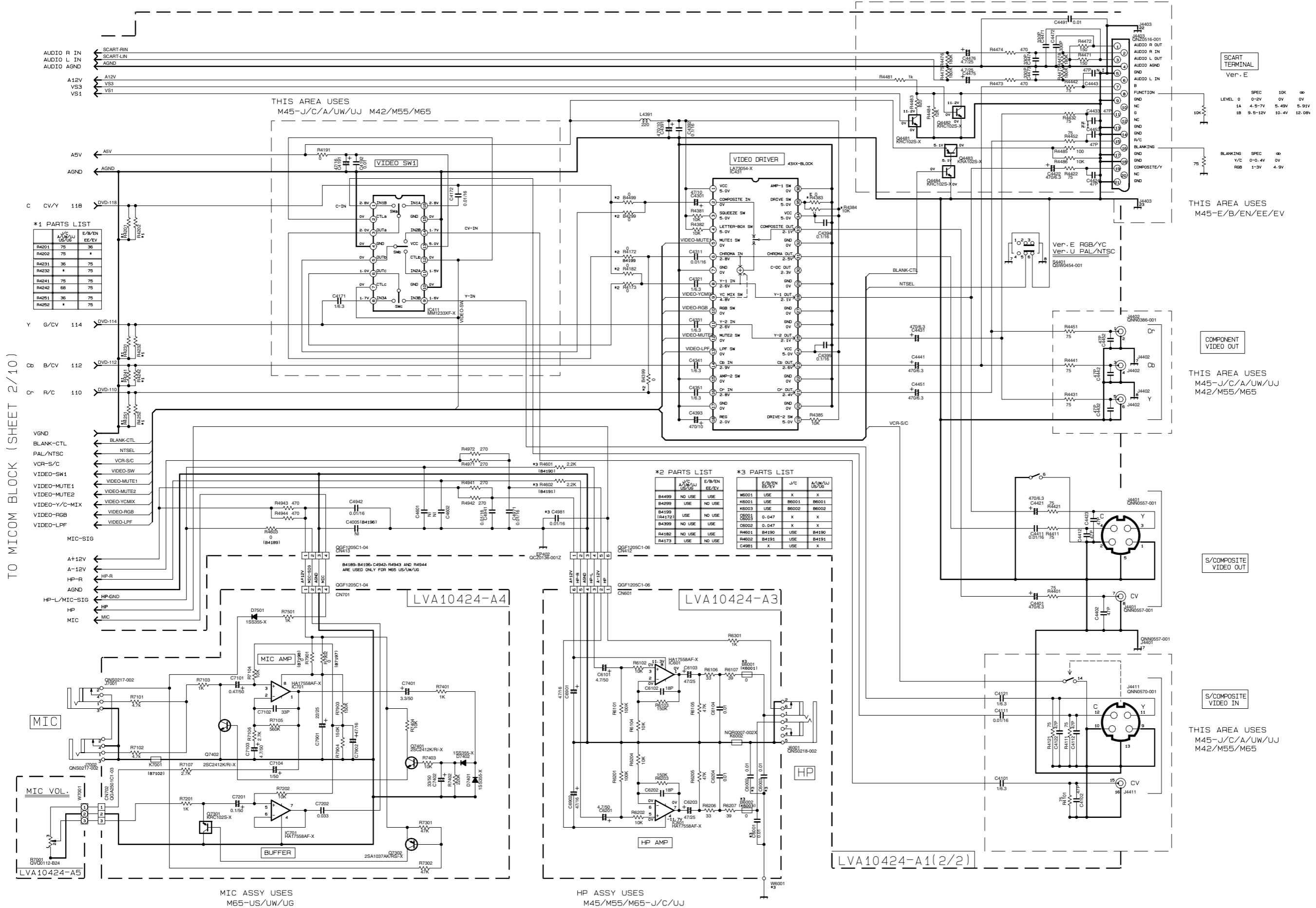

FL display section

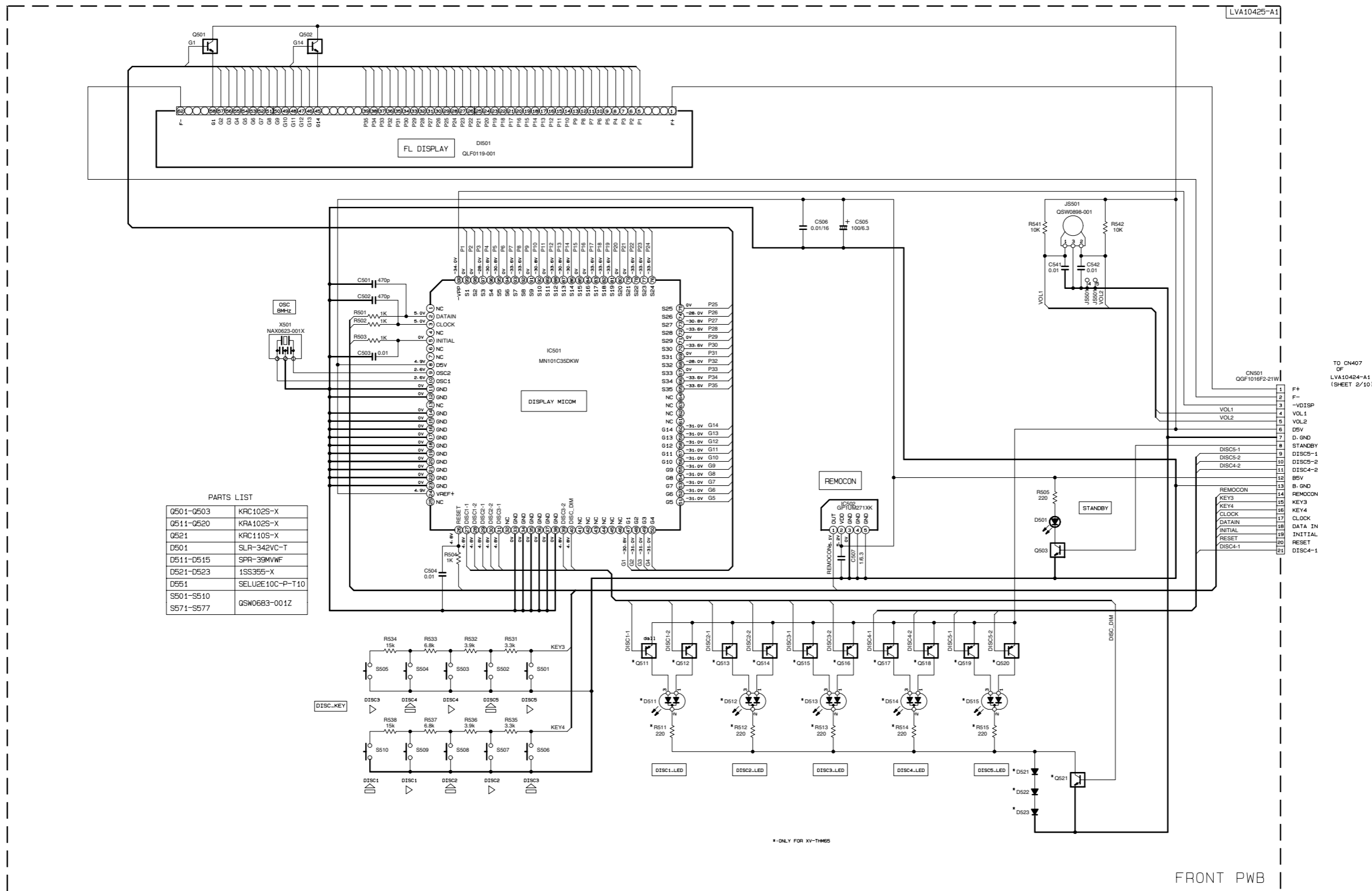

PARTS LIST

Q501-Q503	KRC102S-X
Q511-Q520	KRA102S-X
Q521	KRC110S-X
D501	SLR-342VC-T
D511-D515	SPR-39MWWF
D521-D523	1SS355-X
D551	SELU2E10C-P-T10
S501-S510	
S571-S577	QSW0683-001Z

FRONT PWB

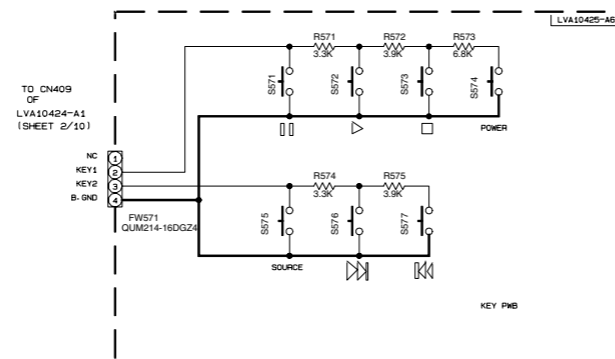
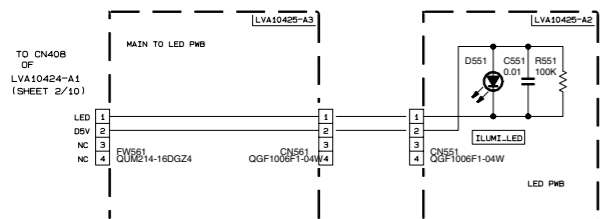

■ Audio input / output section

LVA10309-A1

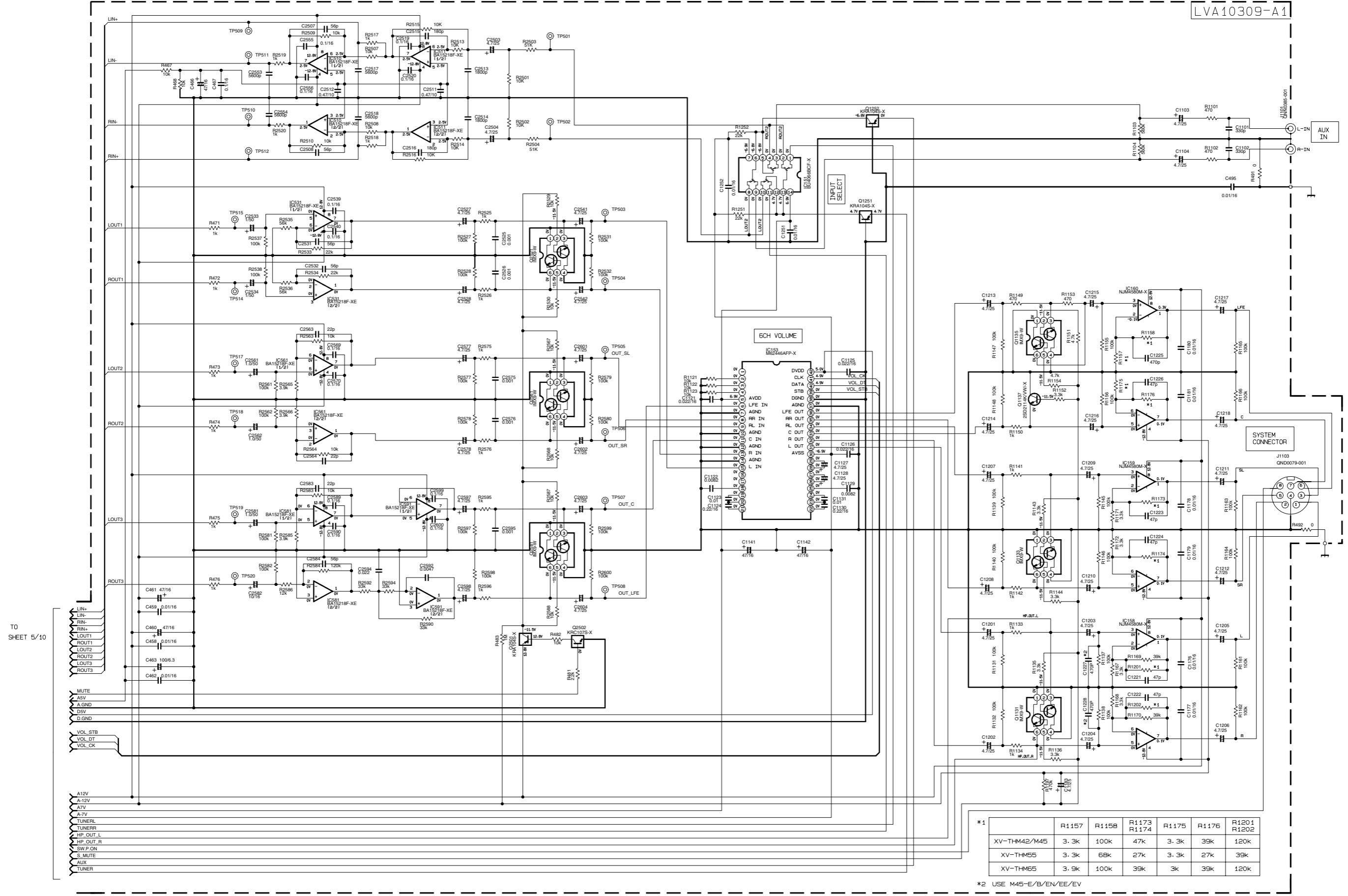

TO SHEET 5/10

*1

	R1157	R1158	R1173 R1174	R1175	R1176	R1201 R1202
XV-THM42/M45	3.3k	100k	47k	3.3k	39k	120k
XV-THM55	3.3k	68k	27k	3.3k	27k	39k
XV-THM65	3.9k	100k	39k	3k	39k	120k

*2 USE M45-E/B/EN/EE/EV

DVD servo section 2/4

FROM SHEET1
OCC1PQ2
OCC1PQ
ADSC1PQ
SOCCCS

FROM SHEET1
AVSTM
STCLK
STVALD
STEN
STD0-STD7

/SPMUTE FROM SHEET1

DAC0CS
DAC1CS
DAC2CS
X6
DAC2ENA
CLMST
SPST
INTP
DOUTCNT
ADSC1PQ
SOCCCS
/SPMUTE
FLCS-

TO SHEET3

PCSO
LHLD
LHLDLDA
LAO-LA3
ALE
RD-
ACK
SCLK
PWE0-PWE3
ADD-AD31

TO SHEET3

SSPCLK0
SSPINO
SSPOUT0
AMUTE
S1OUT
SSPCLK1
SSPOUT1
LRELK
SCK
ADUTO
TX
POMLK
ATN
VBI0
DOUT
DOUT
YOUT
DOUT

TO SHEET3

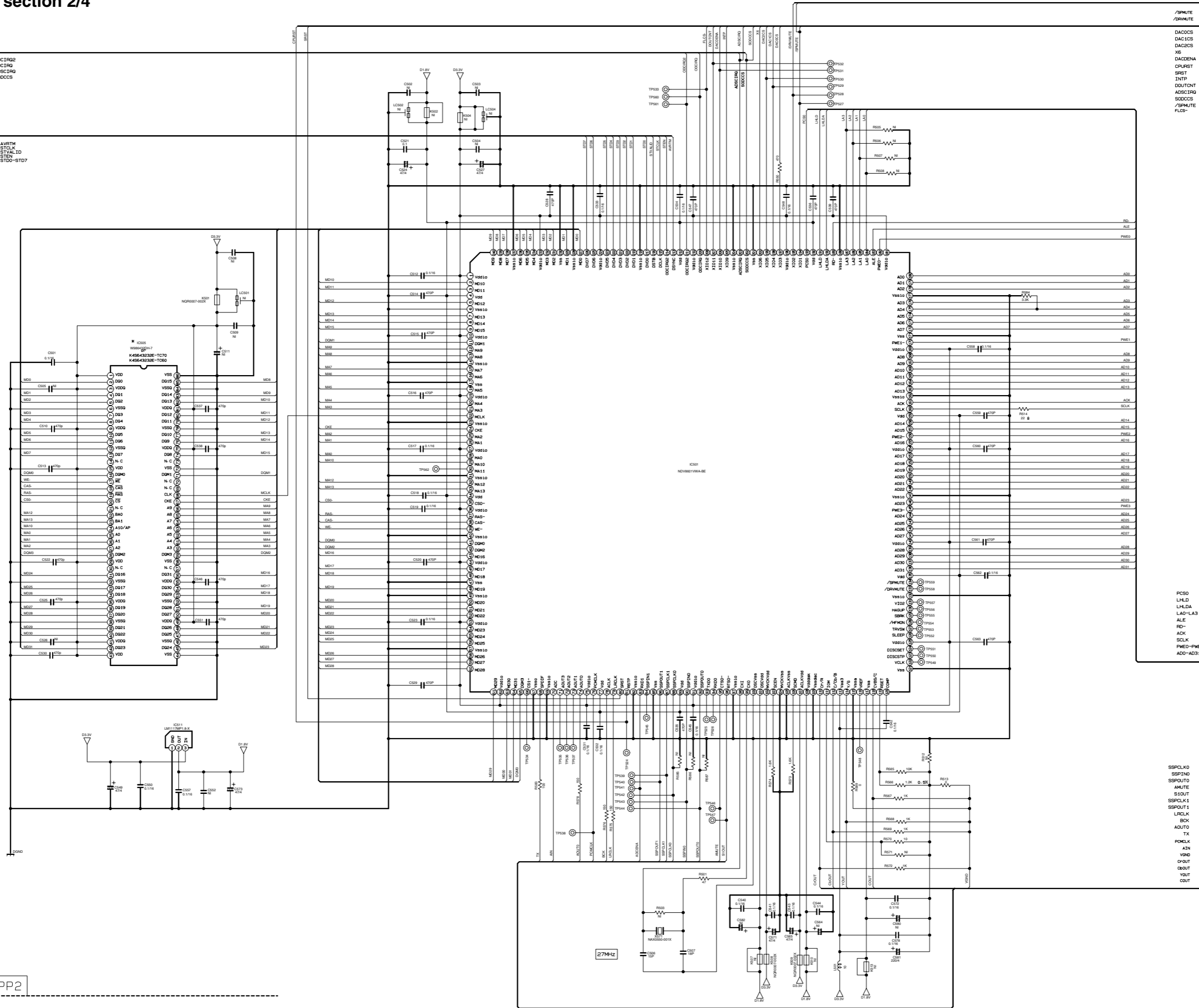

LEA10077-PP2

DVD servo section 3/4

FLCS- DAC1CS SRST
 DAC2CS INTPT
 FROM X6 DOUTONT
 SHEET 2 DAC2ENA ADSC1NG
 CPURST SDCCS
 /SPKTE

FROM LADD4-LADD17
 SHEET 1

FROM SHEET 2

FROM SHEET 1

FROM SHEET 2

FROM SHEET 2

FROM SHEET 2

FROM SHEET 2

FROM SHEET 2

FROM SHEET 2

FROM SHEET 2

FROM SHEET 2

FROM SHEET 2

FROM SHEET 2

FROM SHEET 2

FROM SHEET 2

FROM SHEET 2

FROM SHEET 2

FROM SHEET 2

FROM SHEET 2

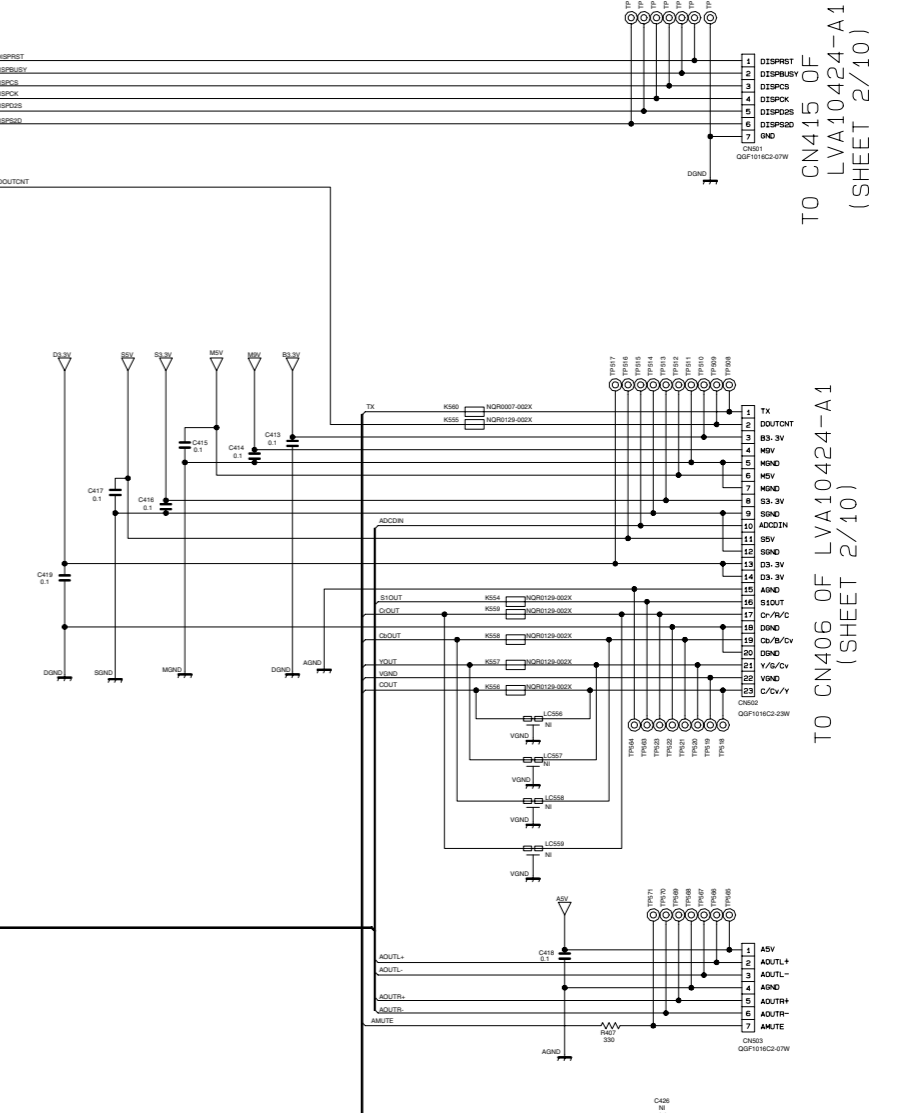
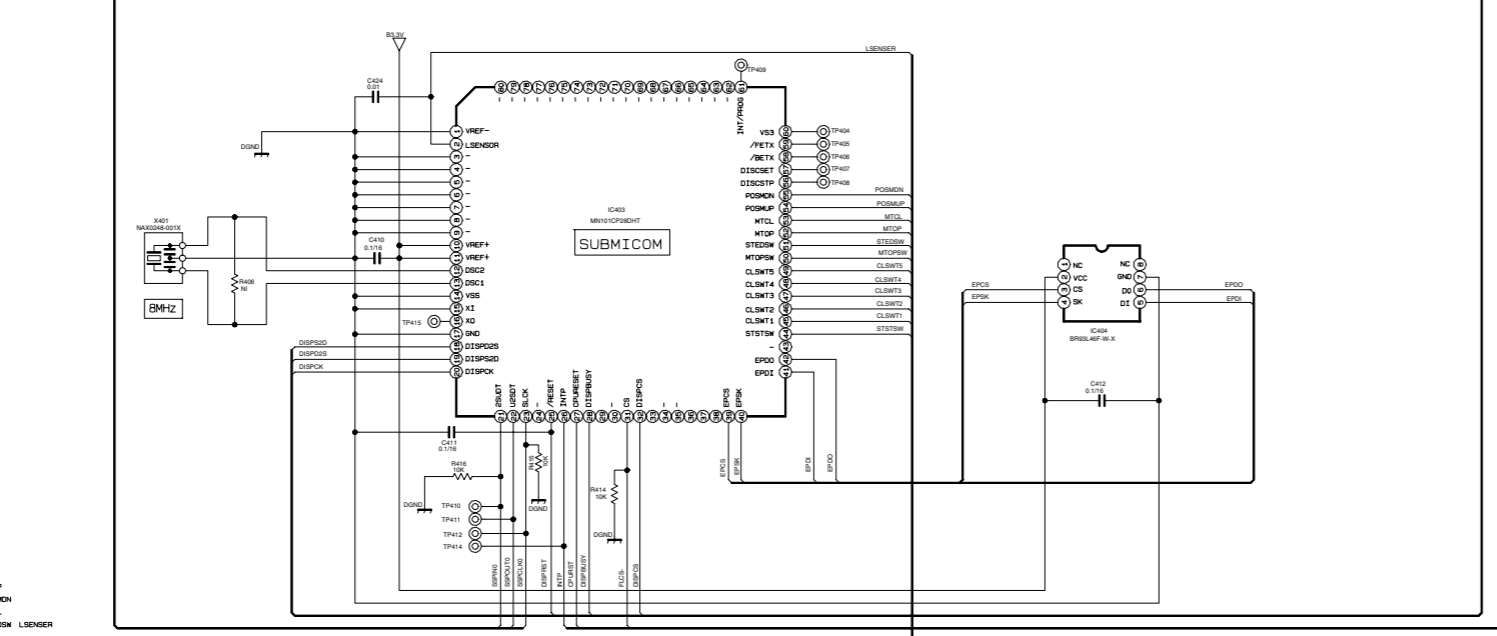
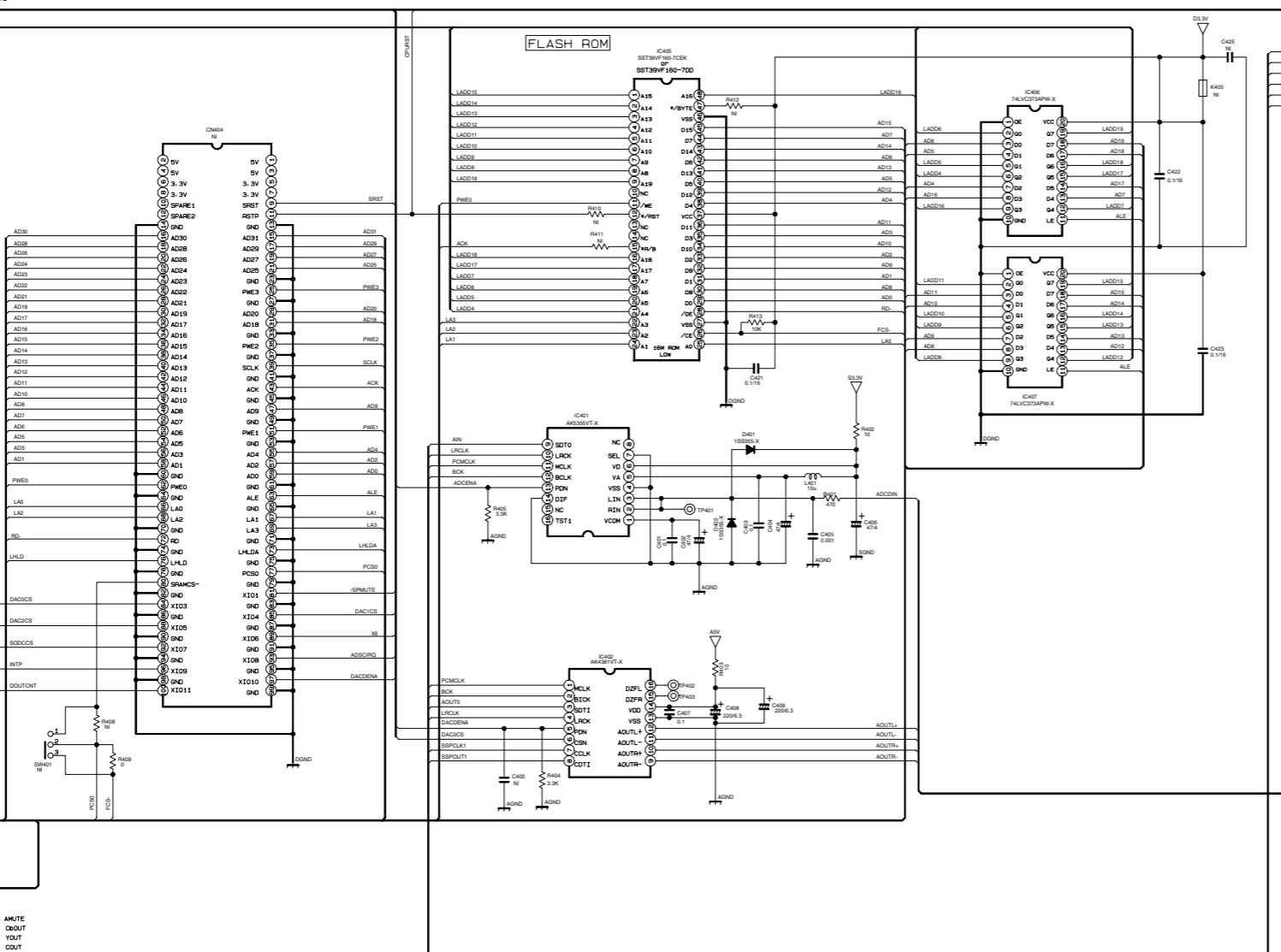

	EMU-SD1-1	EMU-SD1-11	EMU-SD2-1	EMU-SD2-11
IC402	NO INSERT	NO INSERT	INSERT	INSERT
C400	NO INSERT	NO INSERT	INSERT	INSERT
C407	NO INSERT	NO INSERT	INSERT	INSERT
C408	NO INSERT	NO INSERT	INSERT	INSERT
C409	NO INSERT	NO INSERT	INSERT	INSERT
R403	NO INSERT	NO INSERT	INSERT	INSERT
R404	NO INSERT	NO INSERT	INSERT	INSERT
R407	NO INSERT	NO INSERT	INSERT	INSERT
C410	NO INSERT	NO INSERT	INSERT	INSERT
CN503	NO INSERT	INSERT	NO INSERT	INSERT
IC401	NO INSERT	INSERT	NO INSERT	INSERT
C401	NO INSERT	INSERT	NO INSERT	INSERT
C402	NO INSERT	INSERT	NO INSERT	INSERT
C403	NO INSERT	INSERT	NO INSERT	INSERT
C404	NO INSERT	INSERT	NO INSERT	INSERT
C405	NO INSERT	INSERT	NO INSERT	INSERT
C406	NO INSERT	INSERT	NO INSERT	INSERT
R401	NO INSERT	INSERT	NO INSERT	INSERT
R402	NO INSERT	INSERT	NO INSERT	INSERT
R405	NO INSERT	INSERT	NO INSERT	INSERT
D401	NO INSERT	INSERT	NO INSERT	INSERT
D402	NO INSERT	INSERT	NO INSERT	INSERT
L401	NO INSERT	INSERT	NO INSERT	INSERT
K554	NO INSERT	NO INSERT	INSERT	INSERT
K555	NO INSERT	NO INSERT	INSERT	INSERT

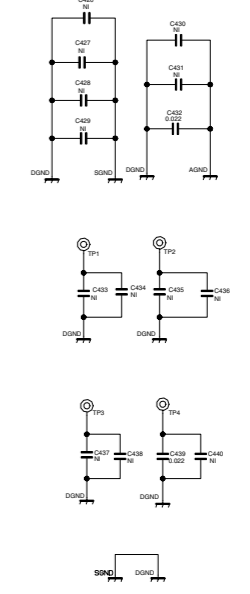

TO CN415 OF LVA10424-A1 (SHEET 2/10)

TO CN406 OF LVA10424-A1 (SHEET 2/10)

■ DVD mechanism control section

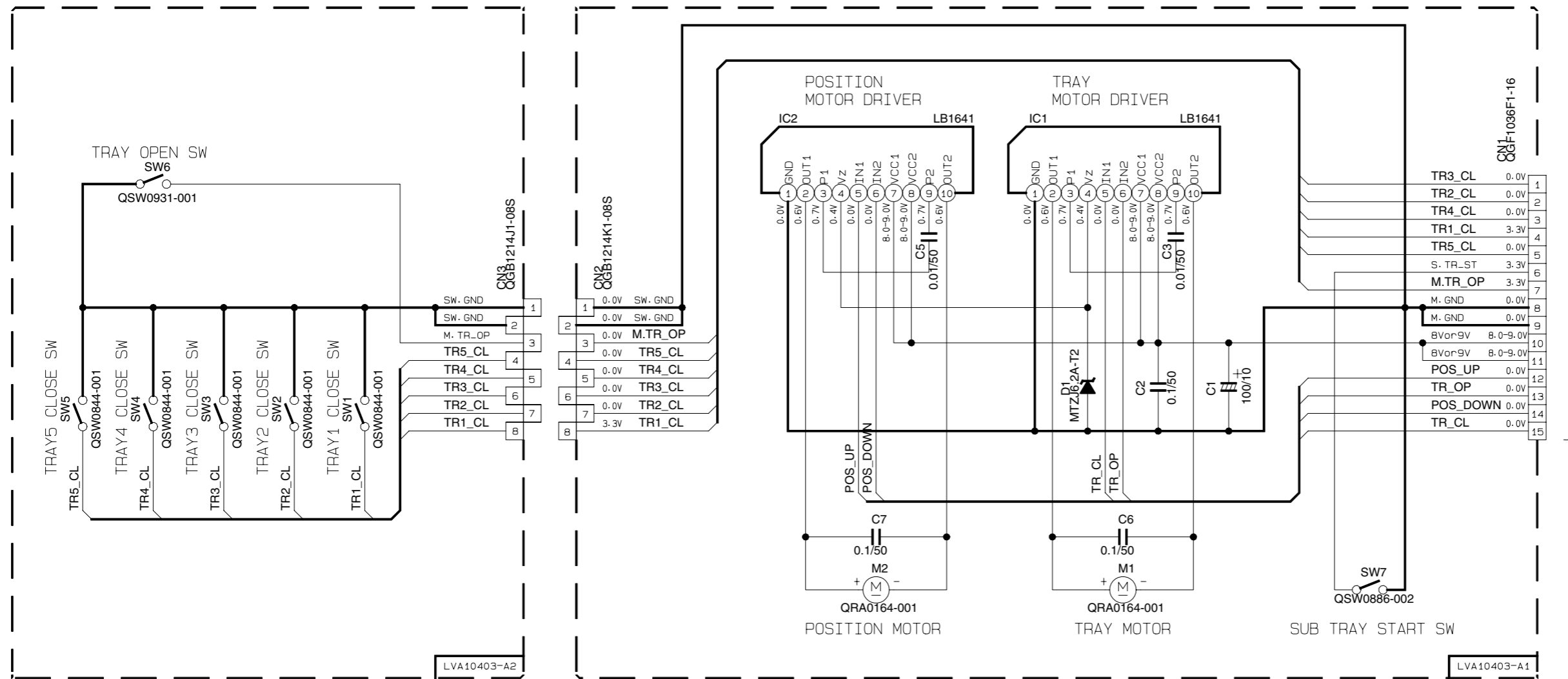

TO POWER AND MECHA CONTROL MICOM

NOTES

- VOLTAGES ARE DC-MEASURED WITH A DIGITAL VOLT METER. CONDITION: DISC1 STOP
- UNLESS OTHERWISE SPECIFIED. ALL CAPACITORS ARE SHOWN IN THE FORM OF CAPACITANCE (μF)/RATED VOLTAGE (V).

Printed circuit boards

<Main body section>

■ Main board

(Phone jack board)

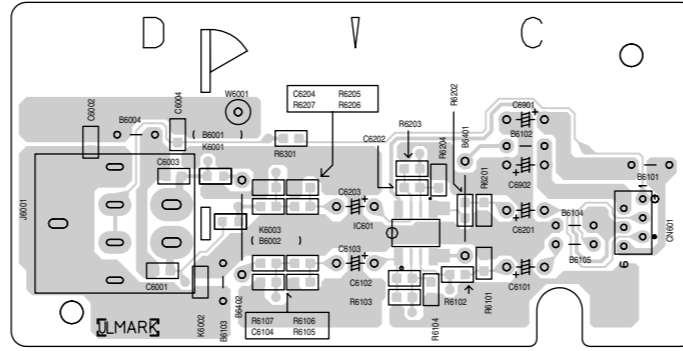

(Main board)

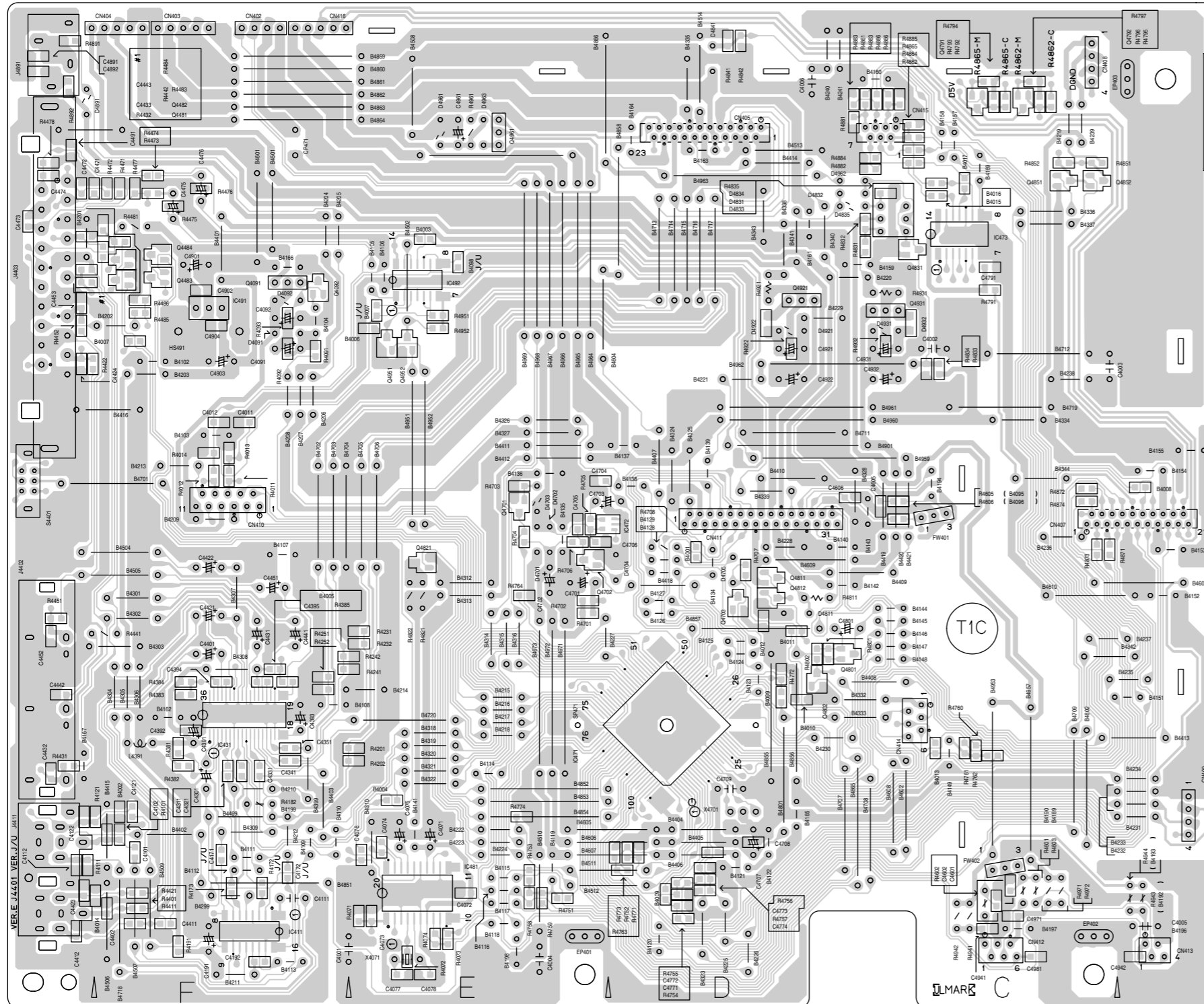

(Power supply board)

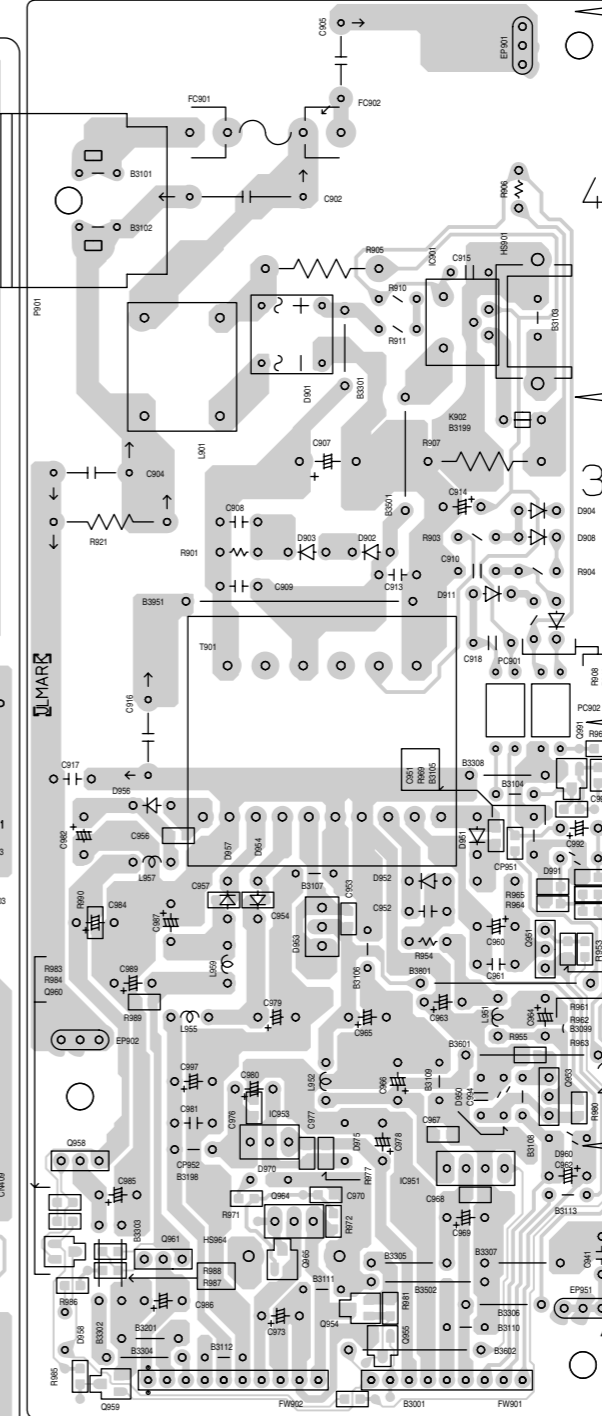

■ DSP board

Forward side

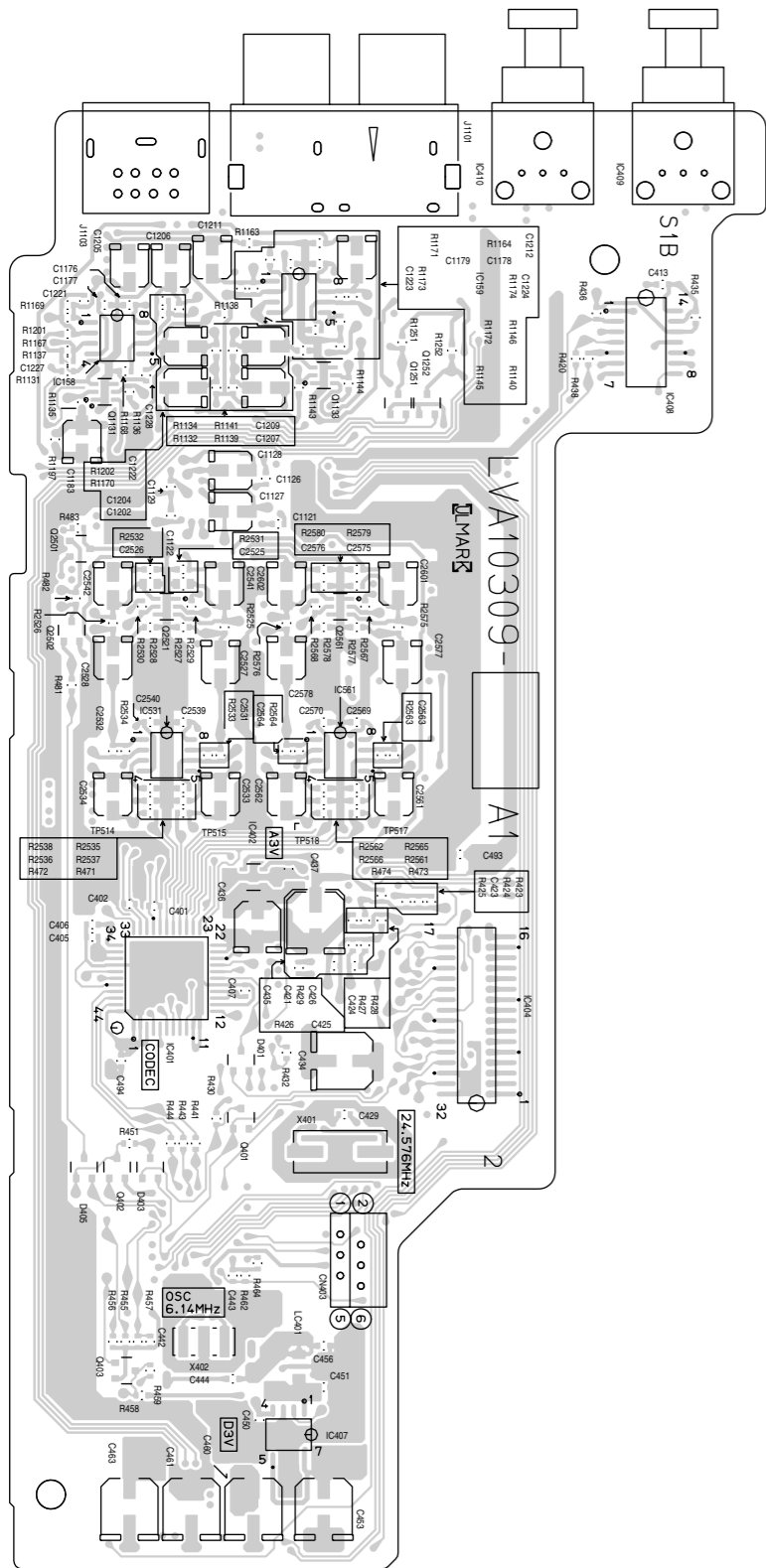

Reverse side

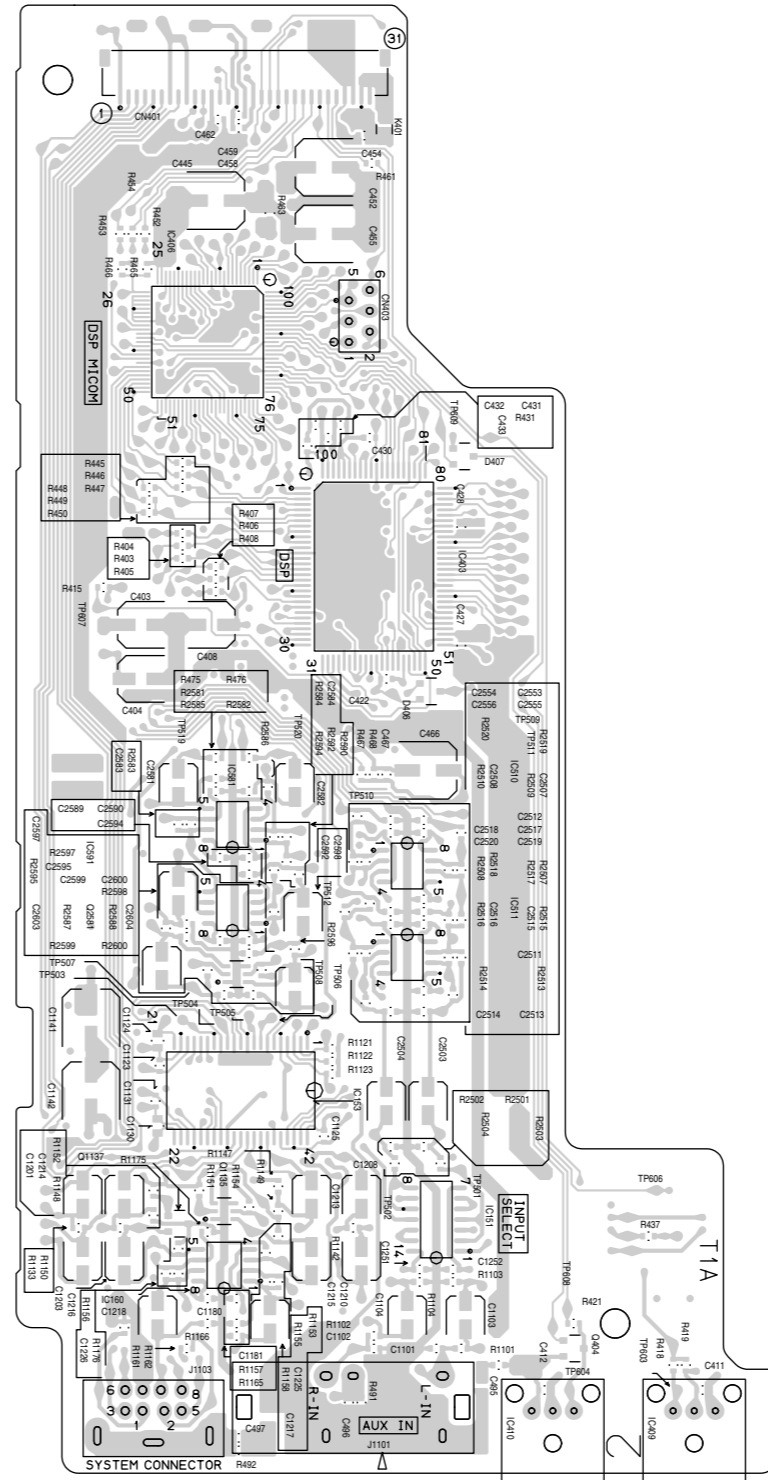

■ DVD servo board

Forward side

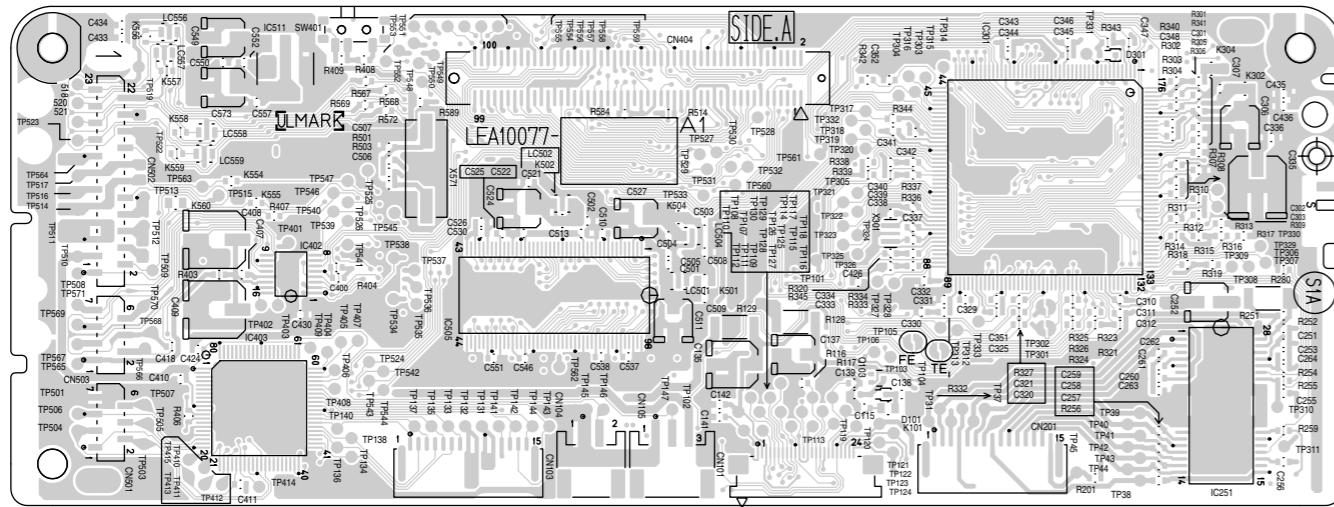

Reverse side

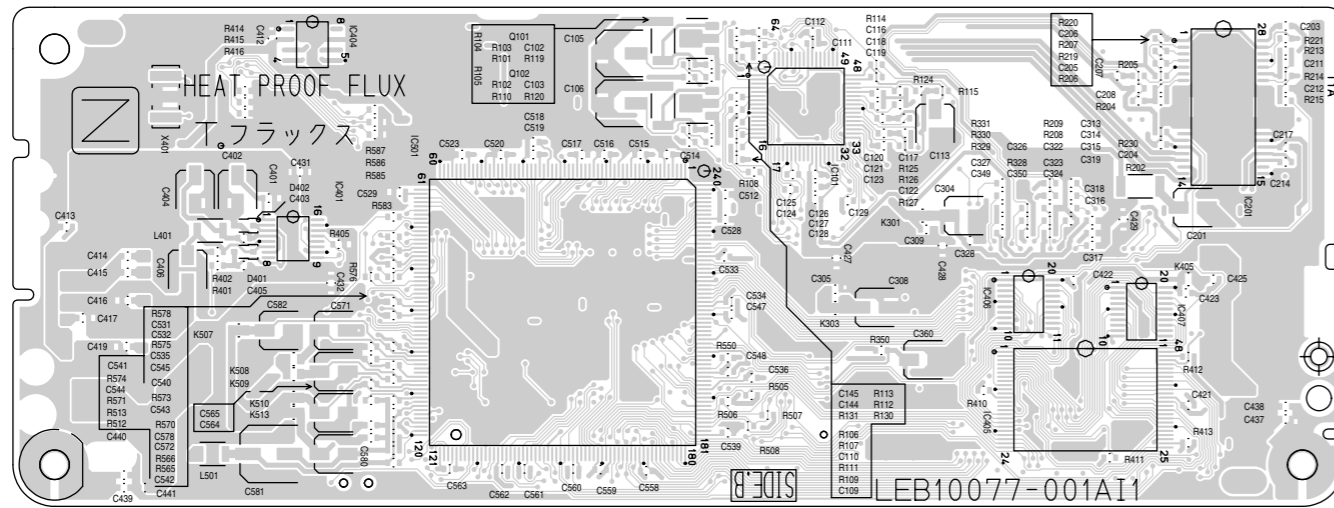

■ DVD loading board

(Motor board)

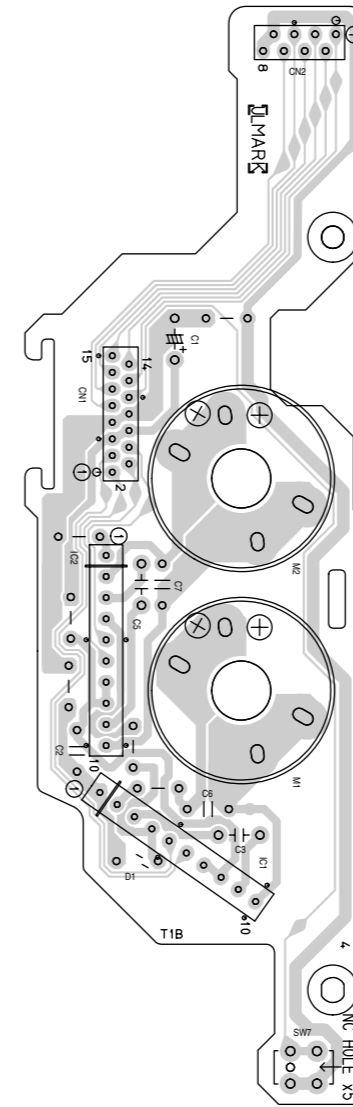

(Sensor board)

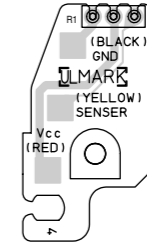

(Switch board)

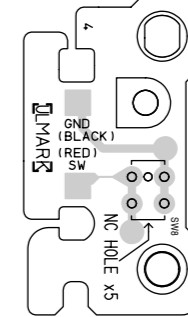

(Tray switch board)

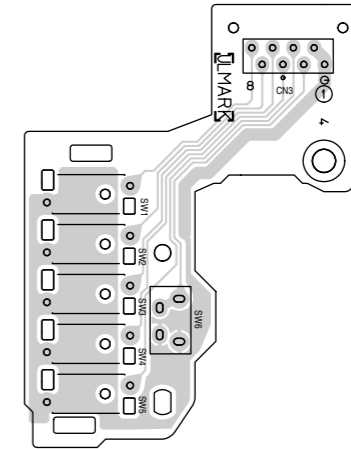

<Subwoofer section>

■ Mother board

(Mother board)

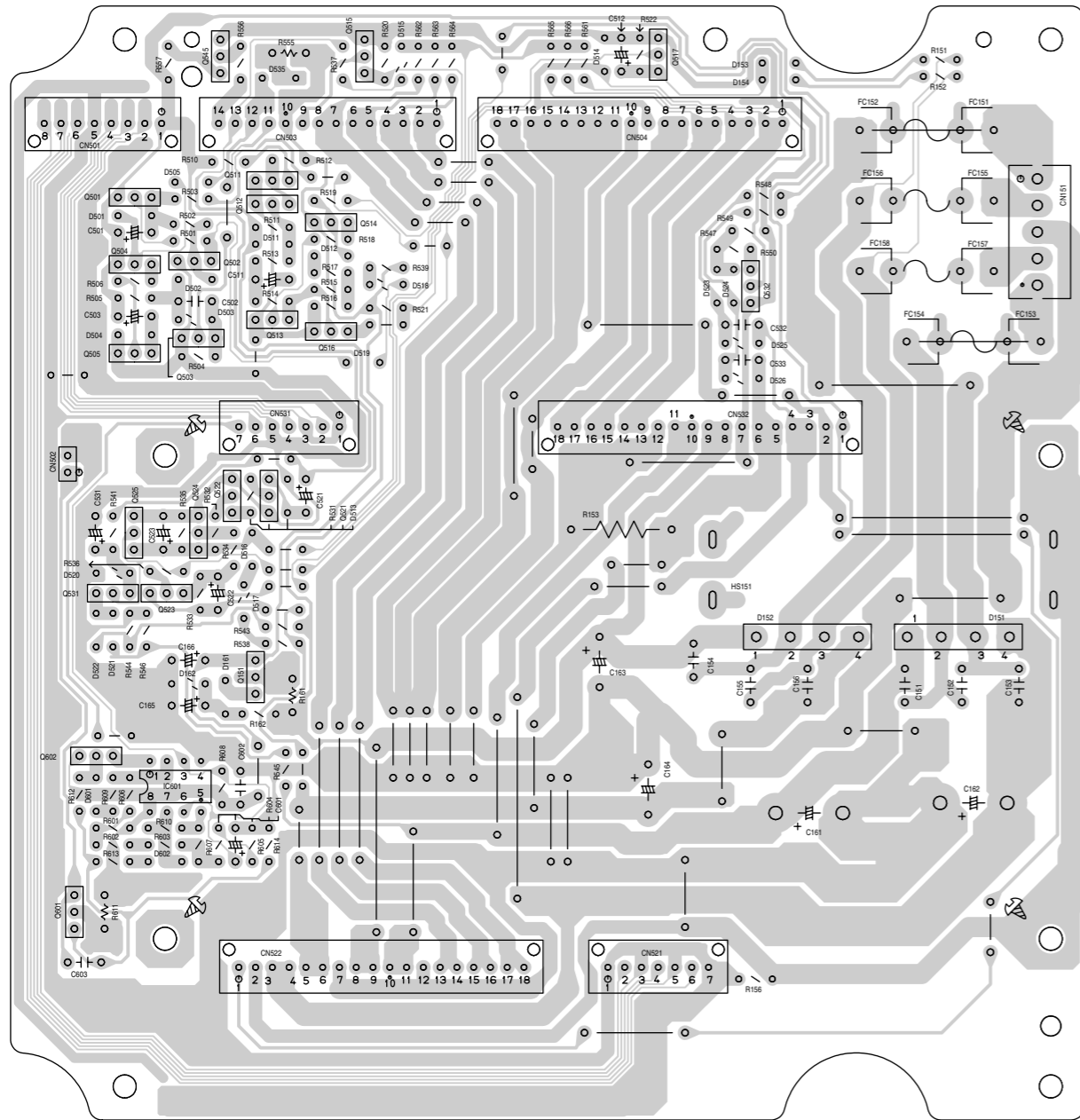

(Speaker terminal board)

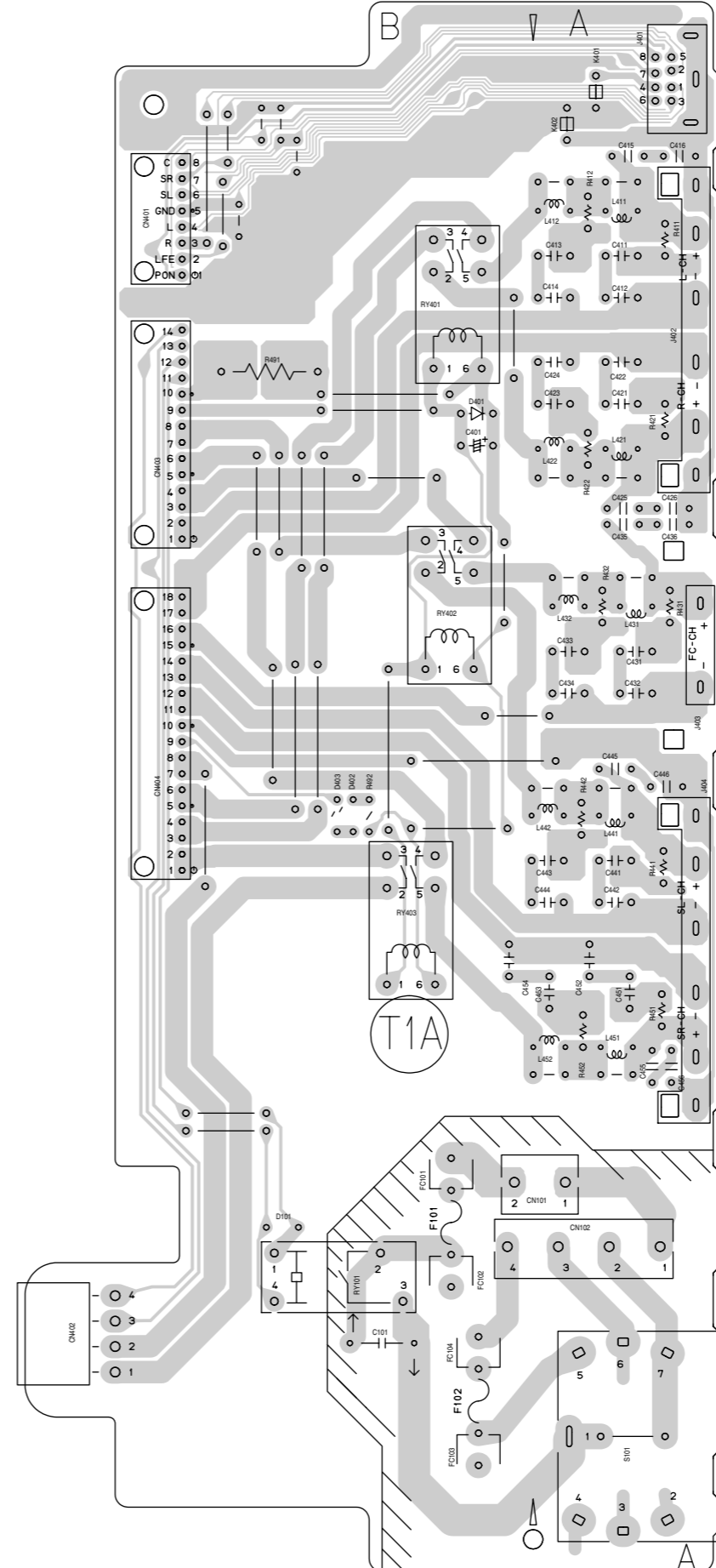

JVC

VICTOR COMPANY OF JAPAN, LIMITED

AV & MULTIMEDIA COMPANY AUDIO/VIDEO SYSTEMS CATEGORY 10-1, 1chome, Ohwatari-machi, Maebashi-city, 371-8543, Japan

(No.MB033SCH)



Printed in Japan
WPC