

# JVC

## SERVICE MANUAL

### DVD DIGITAL CINEMA SYSTEM

## TH-S5, TH-S51

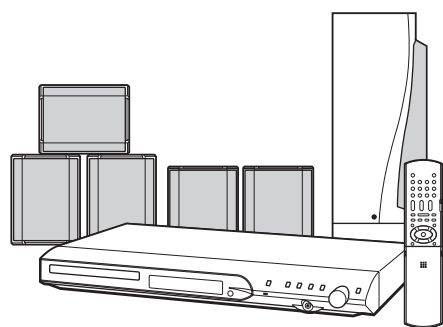

TH-S5

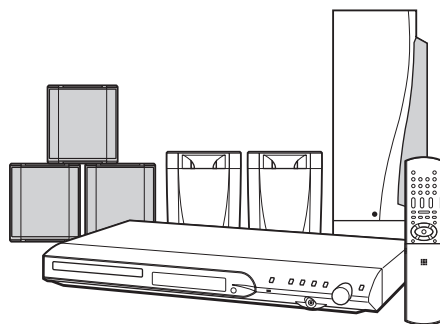

TH-S51

TH-S5	
Area suffix	
B .....	U.K.
E .....	Continental Europe
EN .....	Northern Europe
EV .....	Eastern Europe

TH-S51	
Area suffix	
B .....	U.K.



*Digital Direct Progressive Scan*

### TABLE OF CONTENTS

1	PRECAUTIONS .....	1-3
2	SPECIFIC SERVICE INSTRUCTIONS .....	1-7
3	DISASSEMBLY .....	1-8
4	ADJUSTMENT .....	1-25
5	TROUBLESHOOTING .....	1-29

# SPECIFICATION

## Center unit (XV-THS5/XV-THS51)

Audio section	Total Harmonic Distortion	0.02%*1	
	Digital input*2	DIGITAL IN (OPTICAL):-21 dBm to -15 dBm(660 nm E30 nm)	
Video section	Video System	PAL	
	Horizontal Resolution	500 lines	
	Signal-to-Noise Ratio	64 dB (Composite signal when "RGB" is selected)	
	Video output level	Composite	1.0 V(p-p)/75 Ω
		S-video-Y	1.0 V(p-p)/75 Ω
		S-video-C	0.3 V(p-p)/75 Ω
		Component-Y	1.0 V(p-p)/75 Ω
Component-PB/PR		0.7 V(p-p)/75 Ω	
RGB	0.7 V(p-p)/75 Ω		
Tuner section	Tuning Range	FM:87.50 MHz to 108.00 MHz	
		AM (MW):522 kHz to 1 629 kHz	
General	Power Requirements	AC 230 V , 50 Hz	
	Power Consumption	18 W (at operation)	
		2.0 W (in standby mode)	
	Dimensions (W × H × D)	435 mm × 57 mm × 319 mm	
Mass	3.0 kg		

\*1 : This value is measured at System cord CONNECTOR for reference.

\*2 : Corresponding to Linear PCM, Dolby Digital, and DTS Digital Surround (with sampling frequency - 32 kHz, 44.1 kHz, 48 kHz)

## Subwoofer (SP-PWS5/SP-PWS51)

Amplifier section	Front/Center/Surround	80 W per channel, RMS at 6 Ω (Center/Surround)/120 W per channel, RMS at 4 Ω (Front) at 1 kHz, with 10 % total harmonic distortion.
	Subwoofer	120 W, RMS at 4 Ω at 100 Hz, with 10 % total harmonic distortion.
Speaker section	Speaker unit	16 cm Bass-reflex, Magnetically Shielded
	Frequency Range	30 Hz to 200 Hz
General	Power Requirements	AC 230 V , 50 Hz
	Power Consumption	110 W (at operation)
		0 W (in standby mode)
	Dimensions (W × H × D)	170 mm × 412 mm × 444 mm
Mass	12.0 kg	

## Satellite Speakers

Front speakers (SP-THS5F)	Speakers	Woofer:8.0 cm
		Tweeter:1.5 cm Bass-reflex, Magnetically Shielded
	Power Handling Capacity	120 W
	Impedance	4 Ω
	Frequency Range	90 Hz to 20 kHz
	Dimensions (W × H × D)	106 mm × 139.5 mm × 102 mm
	Mass	0.67 kg
Surround speakers (SP-THS5S)	Speakers	8.0 cm
		Bass-reflex, Magnetically Shielded
	Power Handling Capacity	80 W
	Impedance	6 Ω
	Frequency Range	90 Hz to 20 kHz
	Dimensions (W × H × D)	106 mm × 119.5 mm × 102 mm
Center Speaker (SP-THS5C)	Speakers	Woofer:8.0 cm
		Tweeter:1.5 cm Bass-reflex, Magnetically Shielded
	Power Handling Capacity	80 W
	Impedance	6 Ω
	Frequency Range	90 Hz to 20 kHz
	Dimensions (W × H × D)	137.5 mm × 105 mm × 108 mm
	Mass	0.67 kg

Designs & specifications are subject to change without notice.

# SECTION 1 PRECAUTIONS

## 1.1 Safety Precautions

- (1) This design of this product contains special hardware and many circuits and components specially for safety purposes. For continued protection, no changes should be made to the original design unless authorized in writing by the manufacturer. Replacement parts must be identical to those used in the original circuits. Services should be performed by qualified personnel only.
- (2) Alterations of the design or circuitry of the product should not be made. Any design alterations of the product should not be made. Any design alterations or additions will void the manufacturer's warranty and will further relieve the manufacturer of responsibility for personal injury or property damage resulting therefrom.
- (3) Many electrical and mechanical parts in the products have special safety-related characteristics. These characteristics are often not evident from visual inspection nor can the protection afforded by them necessarily be obtained by using replacement components rated for higher voltage, wattage, etc. Replacement parts which have these special safety characteristics are identified in the Parts List of Service Manual. Electrical components having such features are identified by shading on the schematics and by ( $\Delta$ ) on the Parts List in the Service Manual. The use of a substitute replacement which does not have the same safety characteristics as the recommended replacement parts shown in the Parts List of Service Manual may create shock, fire, or other hazards.
- (4) The leads in the products are routed and dressed with ties, clamps, tubings, barriers and the like to be separated from live parts, high temperature parts, moving parts and/or sharp edges for the prevention of electric shock and fire hazard. When service is required, the original lead routing and dress should be observed, and it should be confirmed that they have been returned to normal, after reassembling.

### (5) Leakage shock hazard testing

After reassembling the product, always perform an isolation check on the exposed metal parts of the product (antenna terminals, knobs, metal cabinet, screw heads, headphone jack, control shafts, etc.) to be sure the product is safe to operate without danger of electrical shock. Do not use a line isolation transformer during this check.

- Plug the AC line cord directly into the AC outlet. Using a "Leakage Current Tester", measure the leakage current from each exposed metal part of the cabinet, particularly any exposed metal part having a return path to the chassis, to a known good earth ground. Any leakage current must not exceed 0.5mA AC (r.m.s.).
- Alternate check method  
Plug the AC line cord directly into the AC outlet. Use an AC voltmeter having, 1,000 $\Omega$  per volt or more sensitivity in the following manner. Connect a 1,500 $\Omega$  10W resistor paralleled by a 0.15 $\mu$ F AC-type capacitor between an exposed metal part and a known good earth ground. Measure the AC voltage across the resistor with the AC

voltmeter.

Move the resistor connection to each exposed metal part, particularly any exposed metal part having a return path to the chassis, and measure the AC voltage across the resistor. Now, reverse the plug in the AC outlet and repeat each measurement. Voltage measured any must not exceed 0.75 V AC (r.m.s.). This corresponds to 0.5 mA AC (r.m.s.).

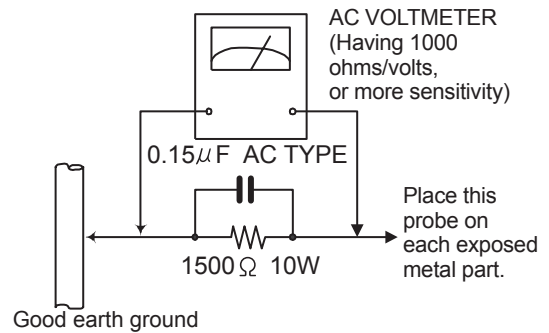

## 1.2 Warning

- (1) This equipment has been designed and manufactured to meet international safety standards.
- (2) It is the legal responsibility of the repairer to ensure that these safety standards are maintained.
- (3) Repairs must be made in accordance with the relevant safety standards.
- (4) It is essential that safety critical components are replaced by approved parts.
- (5) If mains voltage selector is provided, check setting for local voltage.

## 1.3 Caution

**Burrs formed during molding may be left over on some parts of the chassis.**

**Therefore, pay attention to such burrs in the case of pre-forming repair of this system.**

## 1.4 Critical parts for safety

In regard with component parts appearing on the silk-screen printed side (parts side) of the PWB diagrams, the parts that are printed over with black such as the resistor (■), diode (■) and ICP (●) or identified by the " $\Delta$ " mark nearby are critical for safety. When replacing them, be sure to use the parts of the same type and rating as specified by the manufacturer. (This regulation does not Except the J and C version)

## 1.5 Safety Precautions (U.K only)

- (1) This design of this product contains special hardware and many circuits and components specially for safety purposes. For continued protection, no changes should be made to the original design unless authorized in writing by the manufacturer. Replacement parts must be identical to those used in the original circuits.
- (2) Any unauthorised design alterations or additions will void the manufacturer's guarantee; furthermore the manufacturer cannot accept responsibility for personal injury or property damage resulting therefrom.
- (3) Essential safety critical components are identified by (  ) on the Parts List and by shading on the schematics, and must never be replaced by parts other than those listed in the manual. Please note however that many electrical and mechanical parts in the product have special safety related characteristics. These characteristics are often not evident from visual inspection. Parts other than specified by the manufacturer may not have the same safety characteristics as the recommended replacement parts shown in the Parts List of the Service Manual and may create shock, fire, or other hazards.
- (4) The leads in the products are routed and dressed with ties, clamps, tubings, barriers and the like to be separated from live parts, high temperature parts, moving parts and/or sharp edges for the prevention of electric shock and fire hazard. When service is required, the original lead routing and dress should be observed, and it should be confirmed that they have been returned to normal, after re-assembling.

### 1.5.1 Warning

- (1) Service should be performed by qualified personnel only.
- (2) This equipment has been designed and manufactured to meet international safety standards.
- (3) It is the legal responsibility of the repairer to ensure that these safety standards are maintained.
- (4) Repairs must be made in accordance with the relevant safety standards.
- (5) It is essential that safety critical components are replaced by approved parts.
- (6) If mains voltage selector is provided, check setting for local voltage.



**CAUTION** Burrs formed during molding may be left over on some parts of the chassis. Therefore, pay attention to such burrs in the case of preforming repair of this system.

## 1.6 Preventing static electricity

Electrostatic discharge (ESD), which occurs when static electricity stored in the body, fabric, etc. is discharged, can destroy the laser diode in the traverse unit (optical pickup). Take care to prevent this when performing repairs.

### 1.6.1 Grounding to prevent damage by static electricity

Static electricity in the work area can destroy the optical pickup (laser diode) in devices such as laser products.

Be careful to use proper grounding in the area where repairs are being performed.

(1) Ground the workbench

Ground the workbench by laying conductive material (such as a conductive sheet) or an iron plate over it before placing the traverse unit (optical pickup) on it.

(2) Ground yourself

Use an anti-static wrist strap to release any static electricity built up in your body.

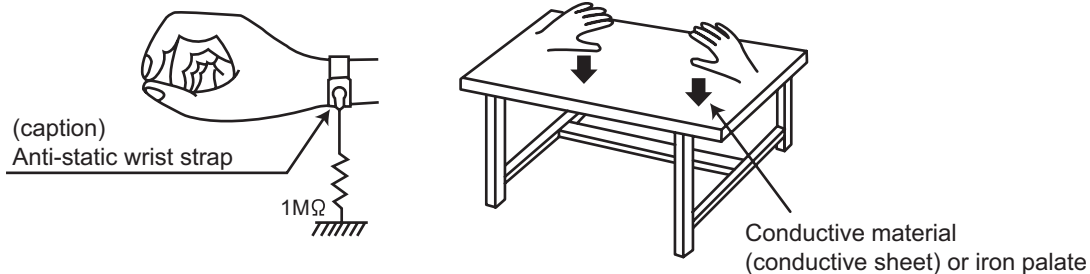

(3) Handling the optical pickup

- In order to maintain quality during transport and before installation, both sides of the laser diode on the replacement optical pickup are shorted. After replacement, return the shorted parts to their original condition. (Refer to the text.)
- Do not use a tester to check the condition of the laser diode in the optical pickup. The tester's internal power source can easily destroy the laser diode.

## 1.7 Handling the traverse unit (optical pickup)

- (1) Do not subject the traverse unit (optical pickup) to strong shocks, as it is a sensitive, complex unit.
- (2) Cut off the shorted part of the flexible cable using nippers, etc. after replacing the optical pickup. For specific details, refer to the replacement procedure in the text. Remove the anti-static pin when replacing the traverse unit. Be careful not to take too long a time when attaching it to the connector.
- (3) Handle the flexible cable carefully as it may break when subjected to strong force.
- (4) It is not possible to adjust the semi-fixed resistor that adjusts the laser power. Do not turn it.

## 1.8 Attention when traverse unit is decomposed

**\*Please refer to "Disassembly method" in the text for the pickup unit.**

- Apply solder to the short land sections before the flexible wire is disconnected from the connector on the servo board. (If the flexible wire is disconnected without applying solder, the pickup may be destroyed by static electricity.)
- In the assembly, be sure to remove solder from the short land sections after connecting the flexible wire.

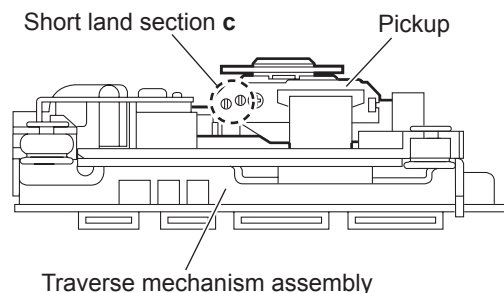

## 1.9 Important for laser products

### 1.CLASS 1 LASER PRODUCT

**2.DANGER** : Invisible laser radiation when open and interlock failed or defeated. Avoid direct exposure to beam.

**3.CAUTION** : There are no serviceable parts inside the Laser Unit. Do not disassemble the Laser Unit. Replace the complete Laser Unit if it malfunctions.

**4.CAUTION** : The CD,MD and DVD player uses invisible laser radiation and is equipped with safety switches which prevent emission of radiation when the drawer is open and the safety interlocks have failed or are defeated. It is dangerous to defeat the safety switches.

**5.CAUTION** : If safety switches malfunction, the laser is able to function.

**6.CAUTION** : Use of controls, adjustments or performance of procedures other than those specified here in may result in hazardous radiation exposure.



**CAUTION** Please use enough caution not to see the beam directly or touch it in case of an adjustment or operation check.

**CAUTION** : Visible and invisible laser radiation when open and interlock failed or defeated.

AVOID DIRECT EXPOSURE TO BEAM.

**ADVARSEL** : Synlig og usynlig laserstråling når maskinen er åben eller interlocken fejler. Undgå direkte eksponering til stråling.

**VARNING** : Synlig och osynlig laserstråling när den öppnas och spärren är urkopplad. Betrakta ej strålen.

**VARO** : Avattaessa ja suojalukitus ohitettuna tai viallisena olet alttiina näkyvälle ja näkymättömälle lasersäteilylle. Vältä säteen kohdistumista suoraan itseesi.

## REPRODUCTION AND POSITION OF LABELS

### WARNING LABEL

<b>CAUTION</b> : Visible and invisible laser radiation when open and interlock failed or defeated. AVOID DIRECT EXPOSURE TO BEAM. (e)	<b>ADVARSEL</b> : Synlig og usynlig laserstråling når maskinen er åben eller interlocken fejler. Undgå direkte eksponering til stråling. (d)	<b>VARNING</b> : Synlig och osynlig laserstråling när den öppnas och spärren är urkopplad. Betrakta ej strålen. (s)	<b>VARO</b> : Avattaessa ja suojalukitus ohitettuna tai viallisena olet alttiina näkyvälle ja näkymättömälle lasersäteilylle. Vältä säteen kohdistumista suoraan itseesi. (f)
---	--	---	---

**CLASS 1  
LASER PRODUCT**

<b>CAUTION</b> : Visible and invisible laser radiation when open and interlock failed or defeated. AVOID DIRECT EXPOSURE TO BEAM. (e)	<b>VARO</b> : Avattaessa ja suojalukitus ohitettuna tai viallisena olet alttiina näkyvälle ja näkymättömälle lasersäteilylle. Vältä säteen kohdistumista suoraan itseesi. (f)
<b>VARNING</b> : Synlig och osynlig laserstråling när den öppnas och spärren är urkopplad. Betrakta ej strålen. (s)	<b>ADVARSEL</b> : Synlig og usynlig laserstråling når maskinen er åben eller interlocken fejler. Undgå direkte eksponering til stråling. (d)

**SECTION 2**  
**SPECIFIC SERVICE INSTRUCTIONS**

This service manual does not describe SPECIFIC SERVICE INSTRUCTIONS.

## SECTION 3 DISASSEMBLY

### 3.1 Main body section

#### 3.1.1 Removing the top cover

(See Figs.1 to 3)

- (1) From the both sides of the main body, remove the four screws **A** attaching the top cover. (See Figs.1 and 2)
- (2) From the back side of the main body, remove the three screws **B** attaching the top cover. (See Fig.3)
- (3) Lift the rear section of the top cover upward while extending the lower sections of the top cover. (See Fig.3)

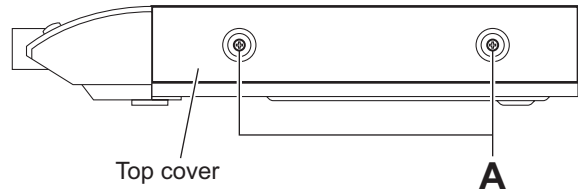

Fig.1

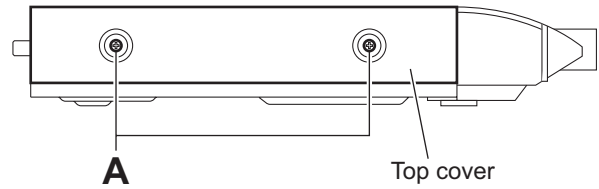

Fig.2

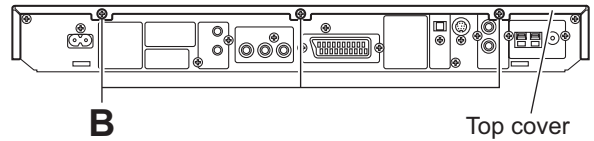

Fig.3



### 3.1.2 Removing the front panel assembly (See Figs.4 and 5)

- Prior to performing the following procedures, remove the top cover.

- (1) From the top side of the main body, disconnect the parallel wires from the connectors [CN451](#) and [CN452](#) on the main board. (See Fig.4)
- (2) Remove the screw **C** attaching the earth wire to the main board. (See Fig.4)

**Reference:**

When attaching the screw **C**, attach the earth wire with it. (See Fig.4)

- (3) From the bottom side of the main body, remove the four screws **D** attaching the front panel assembly. (See Fig.5)
- (4) Remove the front panel assembly in the direction of the arrow while releasing the joint **a**. (See Fig.5)

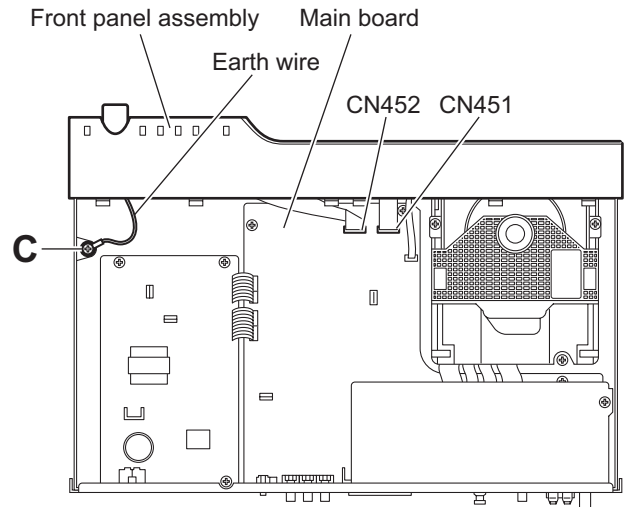

Fig.4

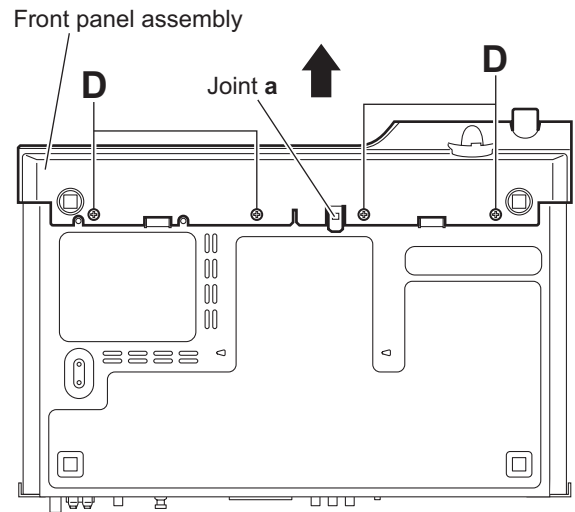

Fig.5

### 3.1.3 Removing the rear panel (See Fig.6)

- Prior to performing the following procedures, remove the top cover.

- (1) From the back side of the main body, remove the four screws **E**, screw **F** and ten screws **G** attaching the rear panel.

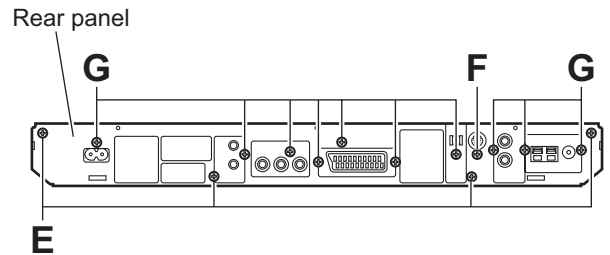

Fig.6

### 3.1.4 Removing the DSP board (See Figs.7 and 8)

- Prior to performing the following procedures, remove the top cover.
  - (1) From the back side of the main body, remove the screw **F** and three screws **H** attaching the DSP board to the rear panel. (See Fig.7)
  - (2) From the top side of the main body, remove the screw **J** attaching the DSP board to the main body. (See Fig.8)
  - (3) Take out the DSP board, and disconnect the card wires from the connectors [CN441](#) and [CN442](#) on the DSP board. (See Fig.8)

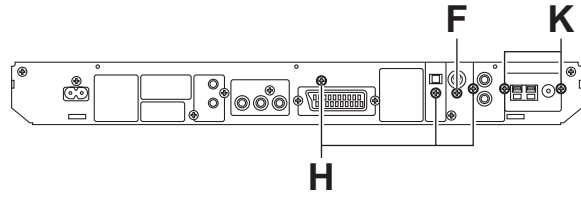

Fig.7

### 3.1.5 Removing the tuner (See Figs.7 and 9)

- Prior to performing the following procedures, remove the top cover and DSP board.
  - (1) From the back side of the main body, remove the two screws **K** attaching the tuner to the rear panel. (See Fig.7)
  - (2) From the top side of the main body, disconnect the card wire from the connector [CN410](#) on the main board. (See Fig.9)
  - (3) Take out the tuner from the main body.

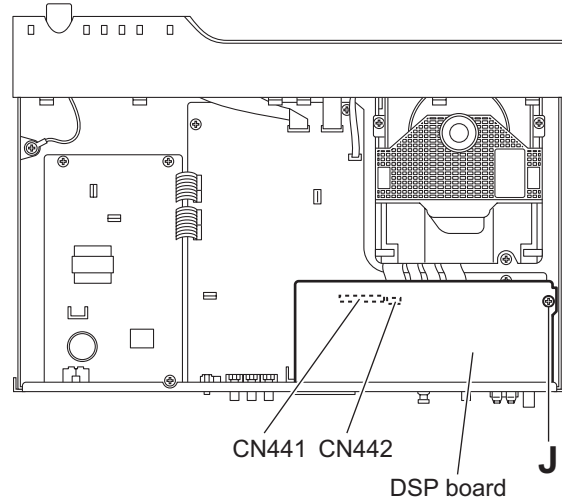

Fig.8

### 3.1.6 Removing the DVD mechanism assembly (See Fig.9)

- Prior to performing the following procedures, remove top cover and DSP board.
  - (1) From the top side of the main body, disconnect the card wires from the connectors [CN401](#) to [CN403](#), [CN408](#) and [CN409](#) on the main board.
  - (2) Remove the three screws **L** attaching the DVD mechanism assembly on the main body.
  - (3) Take out the DVD mechanism assembly to the upward direction.

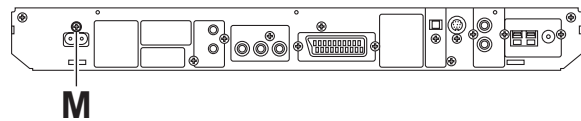

Fig.9

#### Note:

When attaching the DVD mechanism assembly, connect the card wires to the connectors at first.

### 3.1.7 Removing the power board (See Figs.10 and 11)

- Prior to performing the following procedures, remove the top cover.
  - (1) From the back side of the main body, remove the screw **M** attaching the power board to the rear panel. (See Fig.10)
  - (2) From the top side of the main body, disconnect the parallel wires from the connectors [CN404](#) to [CN407](#) on the main board. (See Fig.11)
  - (3) Remove the three screws **N** attaching the power board. (See Fig.11)
  - (4) Take out the power board from the main body.

#### Reference:

Remove the rear panel as required. (See "3.1.3 Removing the rear panel")

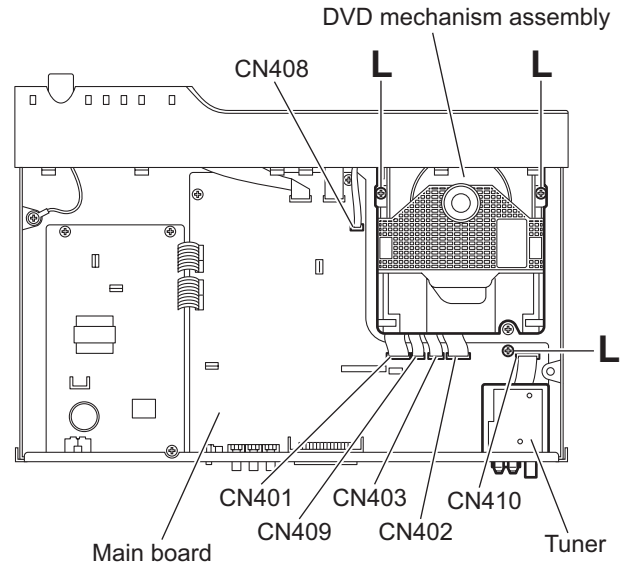

Fig.10

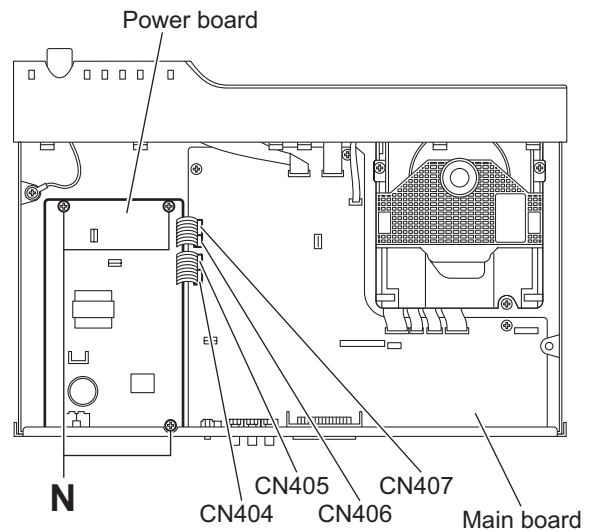

Fig.11

### 3.1.8 Removing the main board (See Fig.12)

- Prior to performing the following procedures, remove the top cover, rear panel, DSP board and tuner.
  - (1) From the top side of the main body, disconnect the card wires from the connectors [CN401](#) to [CN403](#), [CN408](#), [CN409](#), [CN451](#) and [CN452](#) on the main board.
  - (2) Disconnect the parallel wires from the connectors [CN404](#) to [CN407](#) on the main board.
  - (3) From the top side of the main body, remove the three screws **P** attaching the main board on the main body.
  - (4) Take out the main board from the main body.

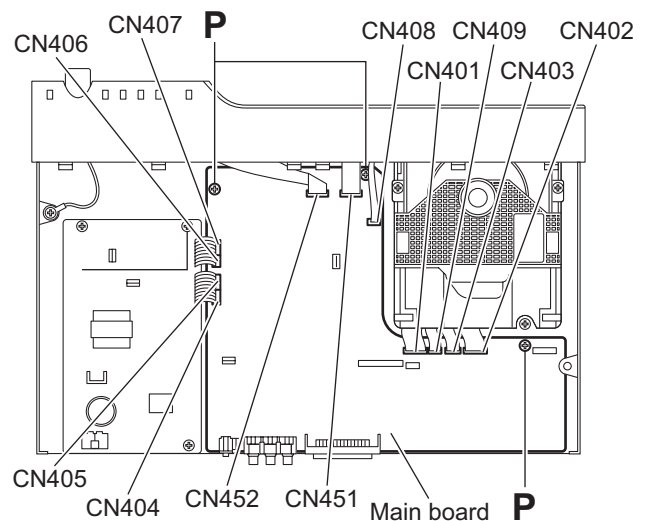

Fig.12

### 3.2 Front panel assembly section

- Prior to performing the following procedures, remove the top cover and front panel assembly.

#### 3.2.1 Removing the FL board (See Fig.1)

- (1) From the inside of the front panel assembly, remove the screw **A** attaching the FL board.
- (2) Take out the FL board from the front panel assembly.

#### Reference:

- When attaching the FL board, align the section a of the front panel assembly to the right side of the FL board.
- After attaching the FL board, passing the card wire through the Hook b.

#### 3.2.2 Removing the SW board (See Figs.2 to 3)

- (1) From the front side of the front panel assembly, remove the volume jog from the front panel assembly forward.
- (2) From the inside of the front panel assembly, release the seven claws **c** attaching the front cover.
- (3) Remove the front cover to the direction of the arrow.
- (4) Remove the three screws **B** attaching the SW board, and take out the SW board.

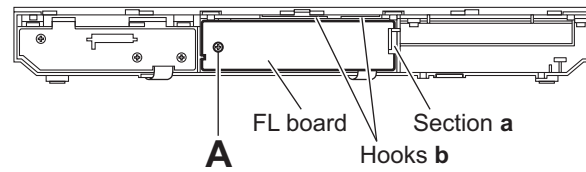

Fig.1

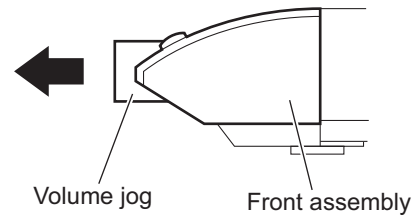

Fig.2

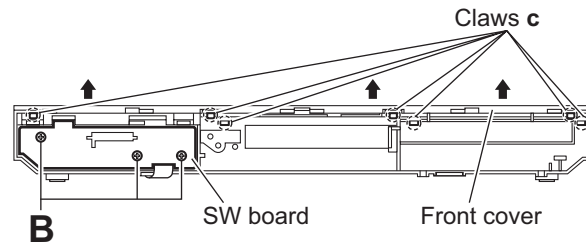

Fig.3

### 3.3 DVD mechanism section

- Remove the DVD mechanism assembly from the main body.  
(See "3.1.6 Removing the DVD mechanism assembly".)

#### 3.3.1 Removing the tray assembly (See Figs.1 to 3)

- (1) From the right side of the DVD mechanism assembly, push the slide cam and pull the tray assembly out of the DVD mechanism assembly in the direction of the arrow. (See Fig.1.)
- (2) From the top side of the DVD mechanism assembly, remove the two screws **A** attaching the leaf spring to the bushing and remove the leaf spring. (See Fig.2.)
- (3) Remove the bushing of the tray assembly from the projection **a** on the DVD mechanism assembly and move the tray assembly in the direction of the arrow. (See Fig.3.)
- (4) Remove the claw **b** of the tray assembly from the DVD mechanism assembly and take out the tray assembly. (See Fig.3.)

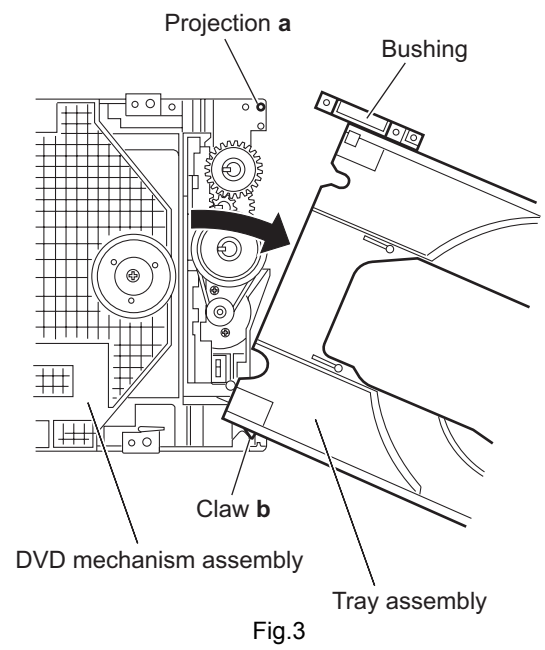
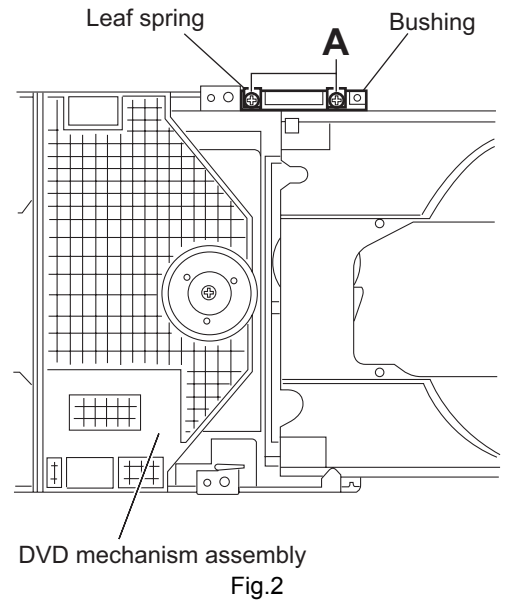
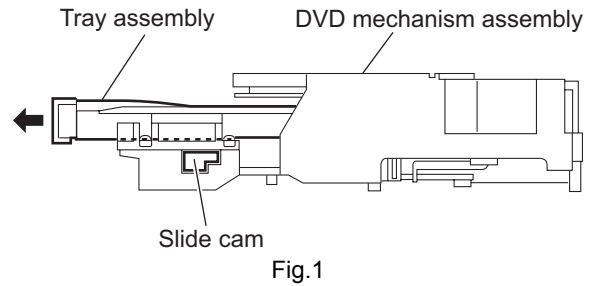

### 3.3.2 Removing the traverse mechanism assembly (See Figs.4)

- (1) From the bottom side of the DVD mechanism assembly, remove the four screws **B** attaching the traverse mechanism assembly and take out the DVD traverse mechanism assembly with the DVD servo board.

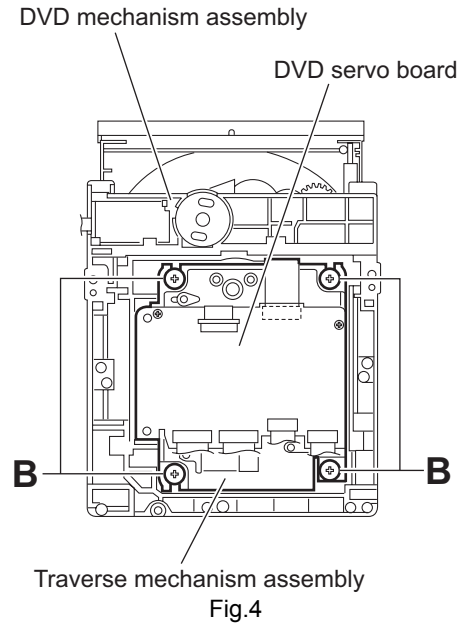

### 3.3.3 Removing the DVD servo board (See Figs.5 and 6)

- Remove the traverse mechanism assembly.
  - (1) From the side of the traverse mechanism assembly, solder the short land sections **c** on the pickup. (See Fig.5.)
  - (2) From the bottom side of the traverse mechanism assembly, release the lock of the connector **CN101** on the DVD servo board in the direction of the arrow 1 and disconnect the card wire. (See Fig.6.)

**Caution:**

- Solder the short land sections **c** on the pickup before disconnecting the card wire from the connector **CN101** on the DVD servo board. If the card wire is disconnected without attaching solder, the pickup may be destroyed by static electricity. (See Figs.5 and 6.)
  - When attaching the DVD servo board, be sure to remove solders from the short land sections **c** after connecting the card wire to the connector **CN101** on the DVD servo board. (See Figs.5 and 6.)
- (3) Disconnect the card wire from the connector **CN201** on the DVD servo board. (See Fig.6.)
  - (4) Remove the two screws **C** attaching the DVD servo board. (See Fig.6.)
  - (5) Remove the DVD servo board from the engagement section **d** in an upward and remove the engagement section **f** in the direction 3 while removing the engagement section **e** in the direction of the arrow 2. (See Fig.6.)

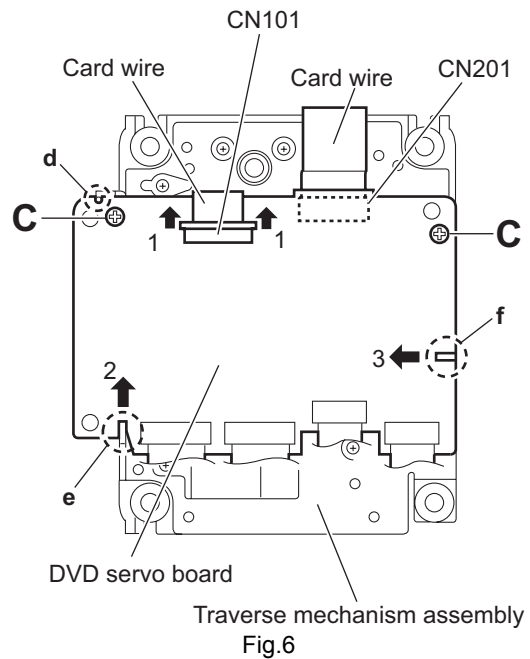
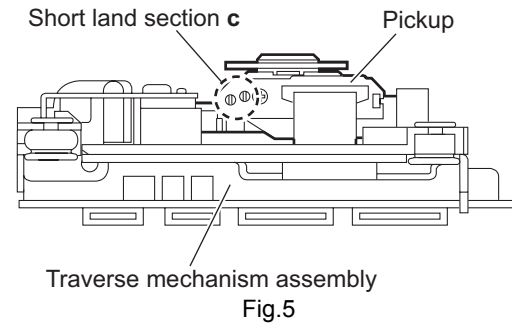

### 3.3.4 Removing the pickup (See Figs.5,7 to 9)

- Remove the traverse mechanism assembly.

- (1) From the side of the traverse mechanism assembly, solder the short land sections **c** on the pickup. (See Fig.5.)
- (2) Release the lock of the connector on the pickup in the direction of the arrow and disconnect the card wire. (See Fig.7.)

**Caution:**

- Solder the short land sections **c** on the pickup before disconnecting the card wire from the connector on the pickup. If the card wire is disconnected without attaching solder, the pickup may be destroyed by static electricity. (See Figs.5 and 7.)
- When attaching the pickup, be sure to remove solders from the short land sections **c** after connecting the card wire to the connector on the pickup. (See Figs.5 and 7.)

- (3) Remove the screw **D** attaching the plate and thrust spring. (See Fig.7.)
- (4) Remove the engagement section **g** attaching the plate to the feed holder and remove the plate with the thrust spring. (See Fig.7.)
- (5) Remove the shaft of the pickup from the section **h** on the traverse mechanism assembly and remove the shaft from the section **i** while moving it in the direction of the arrow. (See Fig.8.)
- (6) Remove the pickup from the section **j** of the traverse mechanism assembly and take out the pickup with the shaft. (See fig.8.)
- (7) From the bottom side of the pickup, remove the two screws **E** attaching the SW actuator and LEAD spring. (See Fig.9.)
- (8) Pull the shaft out of the pickup. (See Fig.9.)

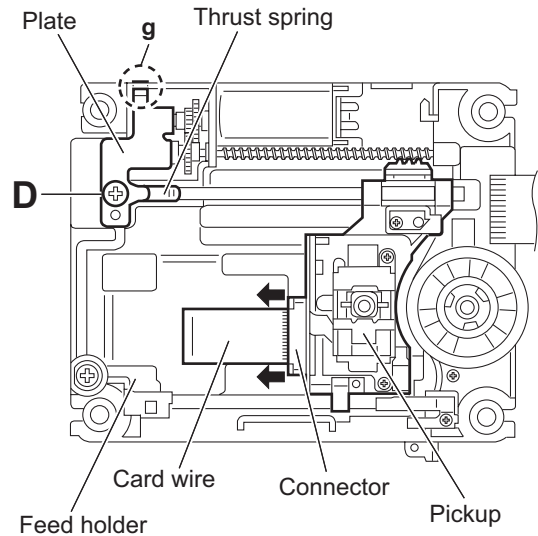

Fig.7

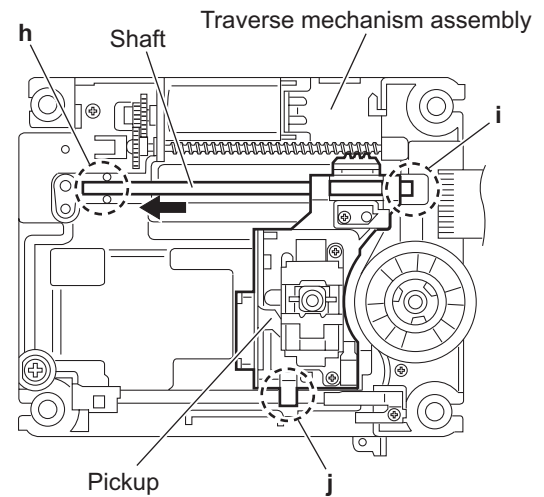

Fig.8

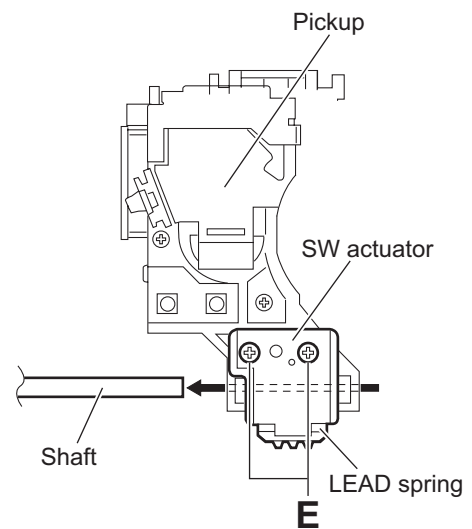

Fig.9

### 3.3.5 Attaching the pickup (See Figs.5,7 to 10)

- See "3.3.4 Removing the pickup".
  - (1) Attach the shaft, SW actuator and LEAD spring to the pickup. (See Fig.9.)
  - (2) Align the pickup to the section **j** of the traverse mechanism assembly first, and set the both ends of the shaft of the pickup in the sections **g** and **i** of the traverse mechanism assembly. (See Fig.8.)
  - (3) Attach the plate and thrust spring. (See Fig.7.)
  - (4) Remove solders from the short land sections **c** after connecting the card wire to the connector on the pickup. (See Figs.5 and 7.)
  - (5) Turn the feed gear M in the direction of the arrow 1 to move the pickup in the direction of the arrow 2. (See Fig.10.)

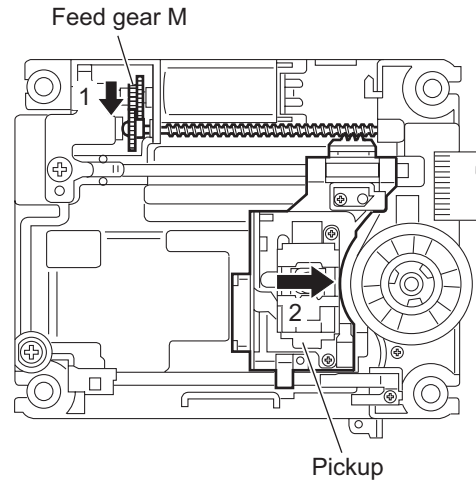

Fig.10

### 3.3.6 Removing the feed motor (See Figs.7,11 and 12)

- Remove the traverse mechanism assembly.
  - (1) From the top side of the traverse mechanism assembly, remove the screw **D** attaching the plate and thrust spring. (See Fig.7.)
  - (2) Remove the engagement section **g** attaching the plate to the feed holder and remove the plate with the thrust spring. (See Fig.7.)
  - (3) Remove the wires from the soldered section **k** on the spindle motor board. (See Fig.11.)

**Reference:**

When attaching the feed motor, pass the wire through the section **m** on the spindle base. (See Fig.11.)

- (4) Remove the feed holder, feed motor, lead screw, feed gear E and feed gear M at the same time after removing the two screws **F** attaching the feed holder. (See Fig.11.)
- (5) From the side of the feed holder, remove the two screws **G** attaching the feed motor. (See Fig.12.)

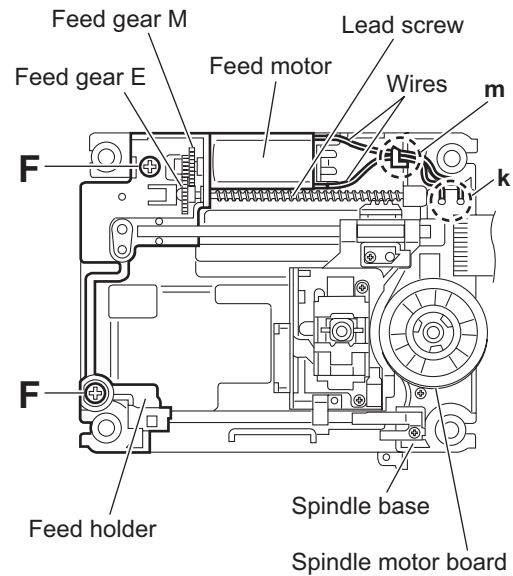

Fig.11

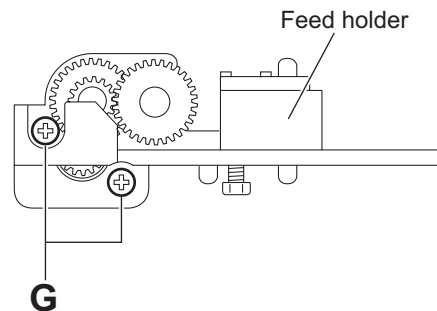

Fig.12



### 3.3.7 Removing the spindle motor board (See Figs.11 and 13)

- Remove the traverse mechanism assembly.
- Remove the DVD servo board.
  - (1) From the top side of the traverse mechanism assembly, remove the wires from the soldered section **k** on the spindle motor board. (See Fig.11.)
  - (2) From the bottom side of the traverse mechanism assembly, remove the three screws **H** attaching the spindle motor board. (See Fig.13.)

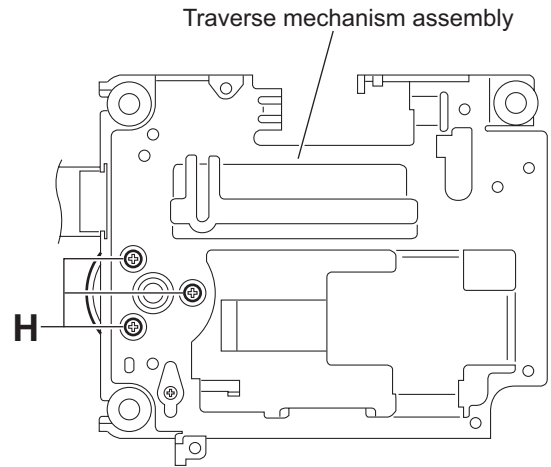

Fig.13

### 3.3.8 Removing the switch board (See Fig.14.)

- (1) From the bottom side of the DVD mechanism assembly, remove the wires from the soldered section **n** on the switch board.
- (2) Lift the switch board while pressing the claw **p** of the DVD mechanism assembly in the direction of the arrow and remove it from the section **q**.

**Reference:**

- Put the wires on the section **r** after attaching the switch board to the DVD mechanism assembly.
- Fix the claw **p** on the DVD mechanism assembly with bonds after attaching the switch board.

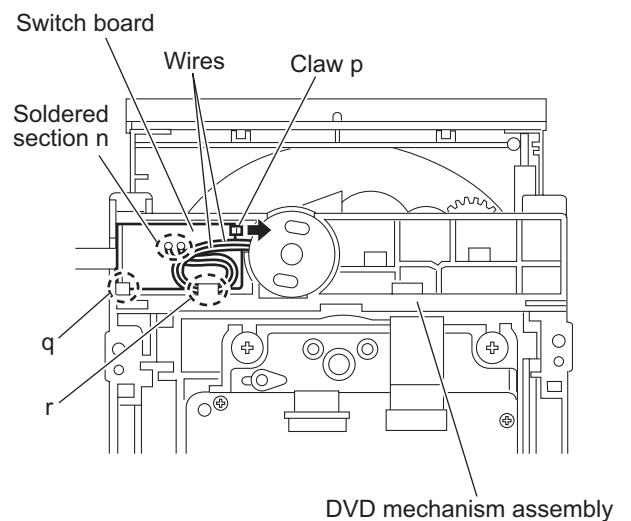

Fig.14

### 3.3.9 Removing the motor (See Figs.14 and 15)

- Remove the tray assembly.
  - (1) From the bottom side of the DVD mechanism assembly, remove the wires from the soldered section **n** on the switch board. (See Fig.14.)
  - (2) From the top side of the DVD mechanism assembly, remove the belt from the motor pulley. (See Fig.15.)

**Note:**

Take care not to attach grease on the belt.

- (3) Remove the two screws **J** attaching the motor to the DVD mechanism assembly and take out the motor from the bottom side of the DVD mechanism assembly. (See Fig.15.)

**Reference:**

Put the wires on the section **r** after attaching the motor to the DVD mechanism assembly. (See Fig.14.)

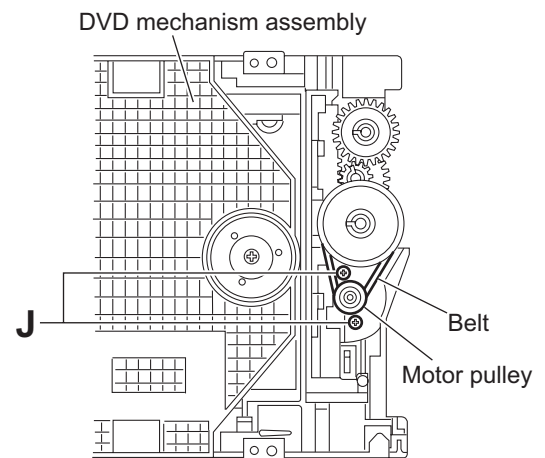

Fig.15

### 3.4 Speaker section

#### 3.4.1 Removing the amplifier assembly

(See Figs.1 to 3)

- (1) From the back side of the speaker main body, remove two screws **A** attaching the amplifier assembly. (See Fig.1)
- (2) From the bottom side of the speaker main body, remove the eight screws **B** attaching amplifier assembly. (See Fig.2)
- (3) From the left side of the speaker main body, move the amplifier assembly backward and disconnect the wire from the connector **CN274** on the mother board. (See Fig.3)

#### Reference:

After connecting the wire to the connector **CN274** on the mother board, bundle the wire by the wire clamp. (See Fig.3)

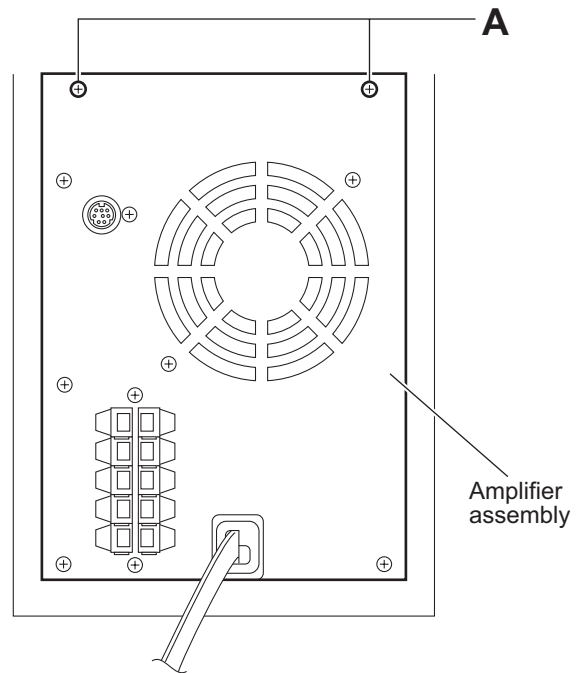

Fig.1

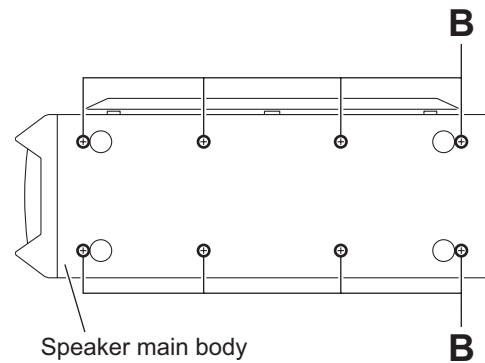

Fig.2

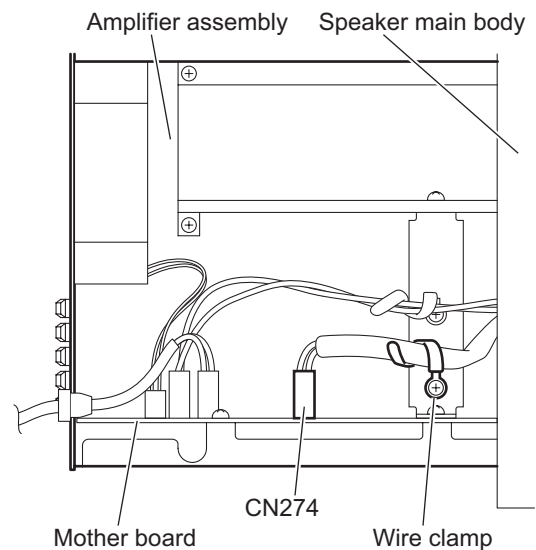

Fig.3

### 3.4.2 Removing the rear panel (See Figs.4 and 5)

- Prior to performing the following procedures, remove the amplifier assembly.
  - (1) From the back side of the amplifier assembly, remove the four screws **C**, two screws **D** and screw **E** attaching the rear panel. (See Fig.4)
  - (2) From the top side of the amplifier assembly, take out the rear panel with fan motor, and disconnect the wire from the connector [CN371](#) on the mother board. (See Fig.5)

### 3.4.3 Removing the fan motor (See Figs.4 and 5)

- Prior to performing the following procedures, remove the amplifier assembly.
  - (1) From the back side of the rear panel, remove the two screws **F** attaching the fan motor. (See Fig.4)
  - (2) From the top side of the amplifier assembly, take out the fan motor and disconnect the wire from the connector [CN371](#) on the mother board. (See Fig.5)

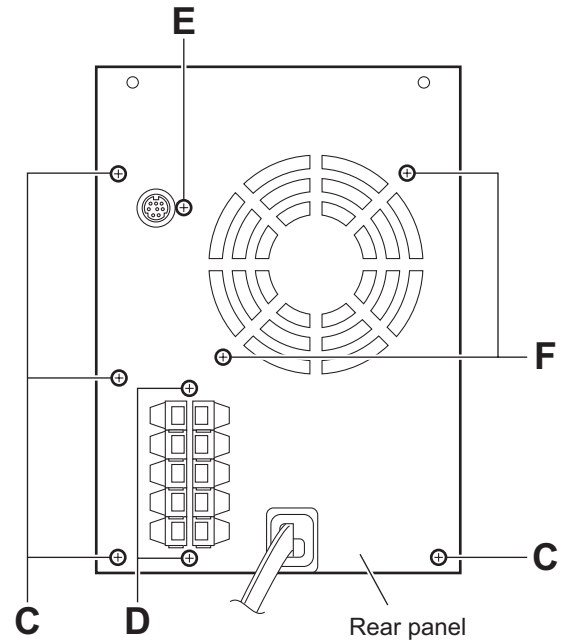

Fig.4

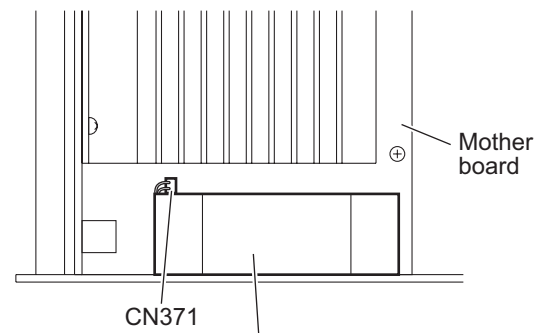

Fig.5

### 3.4.4 Removing the heat sink BKT (See Figs.6 and 7)

- Prior to performing the following procedures, remove the amplifier assembly and rear panel.
  - (1) From the left side of the amplifier assembly, remove the wires from the wire clamp on the heat sink BKT. (See Fig.6)
  - (2) From the left side of the amplifier assembly, remove the four screws **G** attaching the heat sink BKT. (See Fig.7)
  - (3) Take out the two heat sink BKT.

#### Reference:

After attaching the heat sink BKT, bundle the wire by the wire clamp. (See Fig.6)

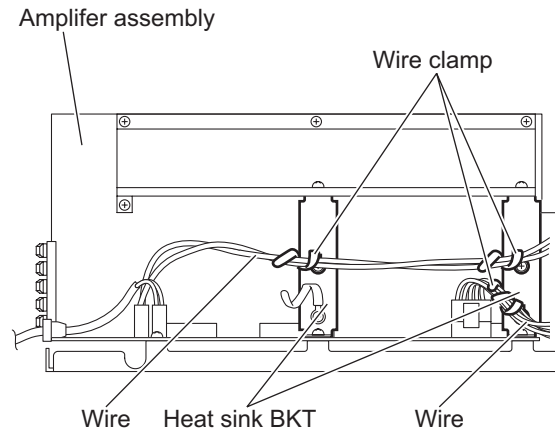

Fig.6

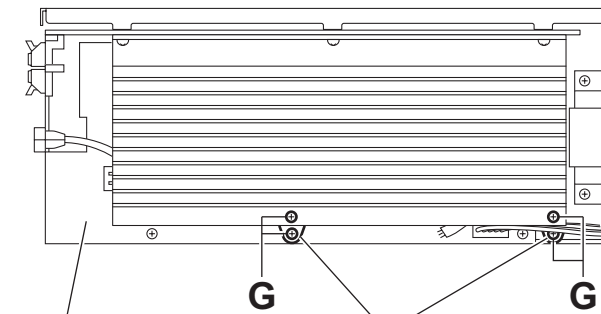

Fig.7

### 3.4.5 Removing the mother board (See Figs.8 and 9)

- Prior to performing the following procedures, remove the amplifier assembly, rear panel and heat sink BKT.
  - (1) From the top side of the amplifier assembly, remove the two screws **H** attaching the mother board. (See Fig.8)
  - (2) From the left side of the amplifier assembly, disconnect the wires from the connectors [CN102](#) and [CN151](#) on the mother board. (See Fig.9)
  - (3) Disconnect the power cord from the connector [CN101](#) on the mother board, and take out the power cord. (See Fig.9)
  - (4) Disconnect the mother board from the connector [CN271](#), [CN272](#) and [CN273](#) on the amp. board, and take out the mother board assembly from the amplifier assembly. (See Fig.9)

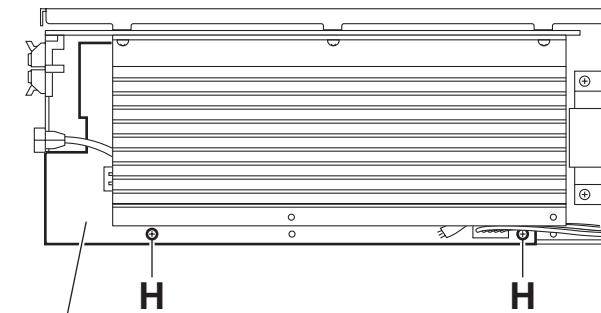

Fig.8

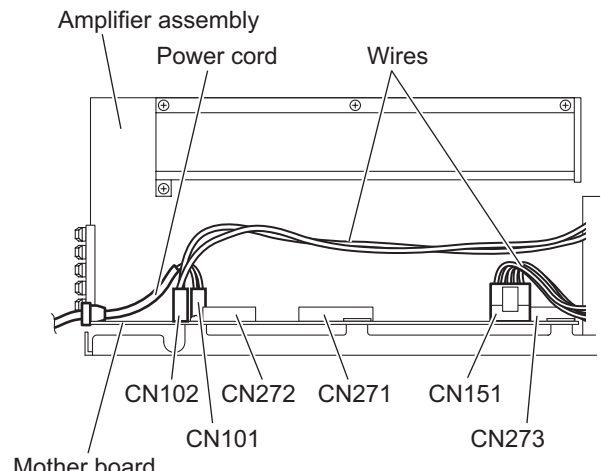

Fig.9

**3.4.6 Removing the amp. board**  
(See Fig.10)

- Prior to performing the following procedures, remove the amplifier assembly, rear panel, heat sink BKT and mother board.
- (1) From the left side of the amplifier assembly, remove the nine screws **J** attaching the amp. board.
- (2) Take out the amp. board with the heat sink.

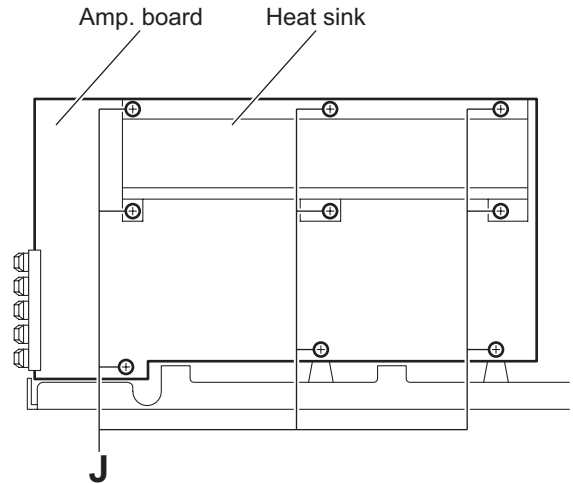

Fig.10

**3.4.7 Removing the heat sink**  
(See Figs.11 and 12)

- Prior to performing the following procedures, remove the amplifier assembly, rear panel, heat sink BKT, mother board and amp. board.
- (1) From left side of the amp. board, remove the screw **K** attaching the hold spring to the heat sink. (See Fig.11)
- (2) Remove the four screws **L** attaching the power IC to the heat sink. (See Fig.11)
- (3) From the reverse side of the amp. board, remove the three screws **M** attaching the heat sink to the amp. board. (See Fig.12)
- (4) Take out the heat sink.

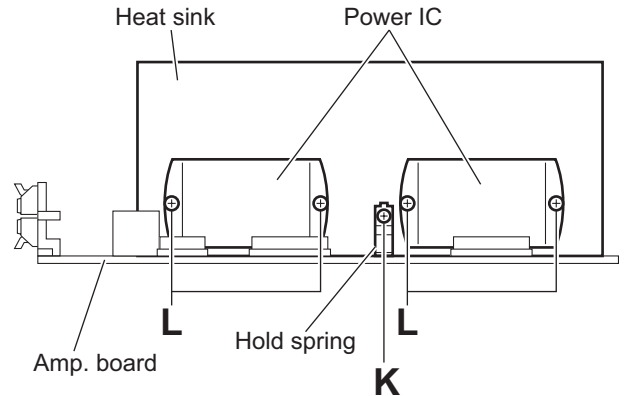

Fig.11

**3.4.8 Removing the power IC**  
(See Fig. 12)

- Prior to performing the following procedures, remove the amplifier assembly, rear panel, heat sink BKT, mother board, amp. board and heat sink.
- (1) From the reverse side of the amp. board, remove the solders from the solder points **a** on the amp. board.
- (2) Take out the power IC.

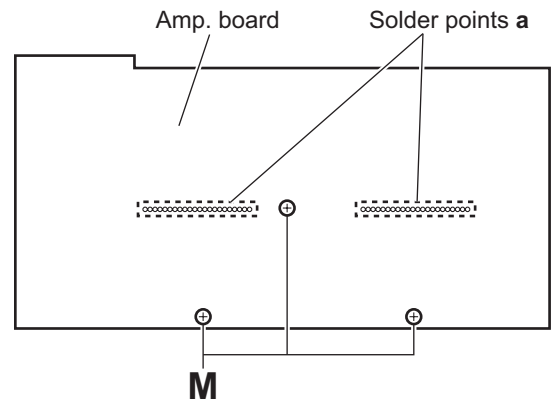

Fig.12

### 3.4.9 Removing the LED board (See Fig.13)

- Prior to performing the following procedures, remove the amplifier assembly and rear panel.
  - (1) From the front side of the amplifier assembly, cut off the tie bands.
  - (2) Remove the screw **N** attaching the LED board.
  - (3) From the reverse side of the LED board, remove the solder from the solder point **b** on the LED board.

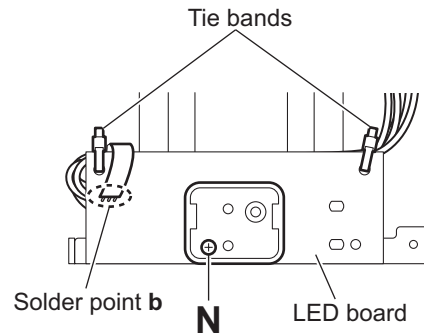

Fig.13

### 3.4.10 Removing the power transformer (See Figs.14 and 15)

- Prior to performing the following procedures, remove the amplifier assembly and rear panel.
  - (1) From the top side of the amplifier assembly, disconnect the wires from the connectors [CN102](#) and [CN151](#) on the mother board. (See fig.14)
  - (2) Remove the four screws **P** attaching the power transformer, and take out the power transformer from the amplifier assembly. (See fig.15)

#### Reference:

- When attaching the power transformer, attach the screws **P** with the barrier. (See fig.15)
- After connect the wires from the connectors [CN102](#) and [CN151](#), bundle the wire by the wire clamp. (See Fig.14)

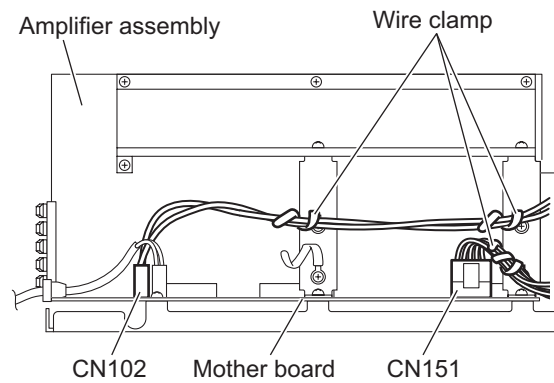

Fig.14

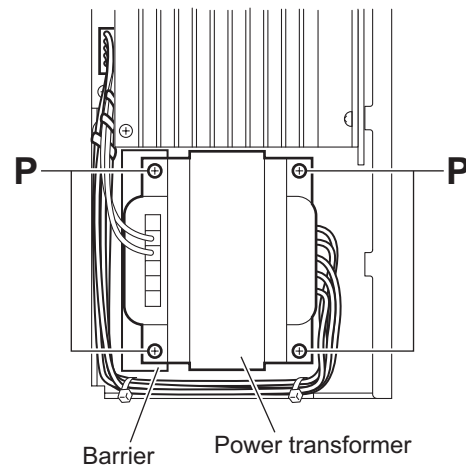

Fig.15

### 3.4.11 Removing the speaker net (See Figs.16 and 17)

- (1) From side of the speaker main body, insert the tip of the flat-bladed screwdriver or similar tool into the space between the speaker main body and speaker net, and lift the speaker net little by little to remove. (See Fig.16)

**Note:**

To prevent damaging the speaker net and speaker main body, insert cushioning plates etc. and below the tip of the flat-bladed screwdriver or similar tool.

- (2) From right side of the speaker main body, release the eight joint **c**, and take out the speaker net from the speaker main body. (See Fig.17)

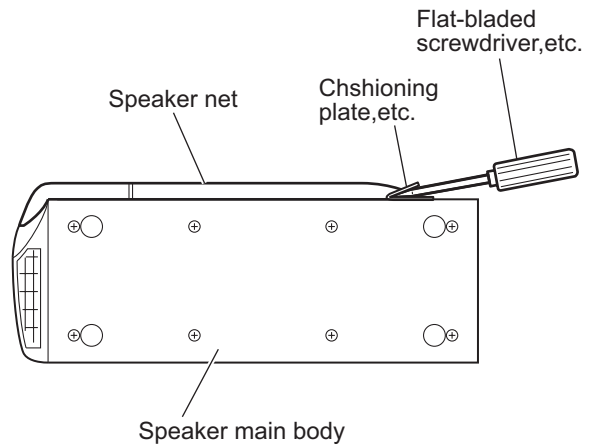

Fig.16

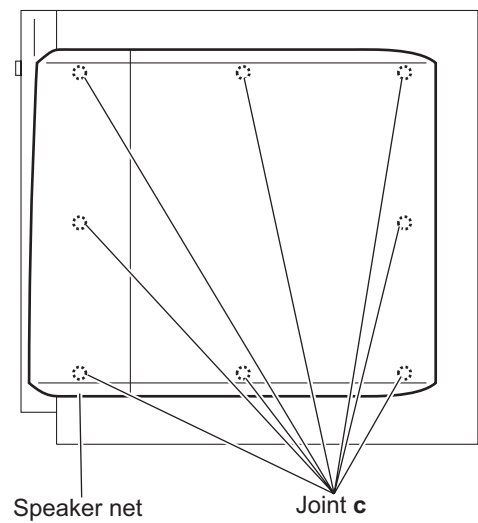

Fig.17

### 3.4.12 Removing the speaker (See Figs.18 and 19)

- Prior to performing the following procedures, remove the speaker net.
  - (1) From right side of the speaker main body, remove the four screws **Q** attaching the speaker. (See Fig.18)
  - (2) Take out the speaker from the speaker main body. (See Fig.19)
  - (3) Disconnect the wires from the terminal of the speaker. (See Fig.19)

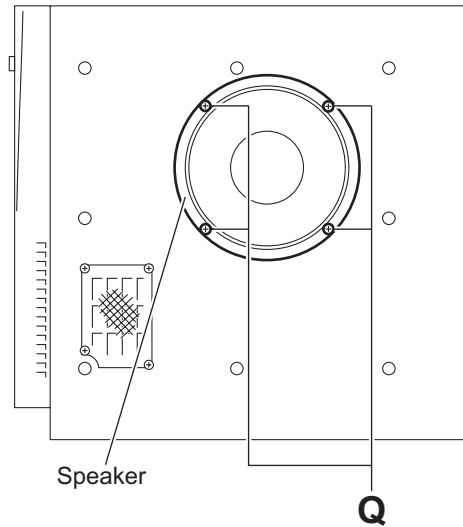

Fig.18

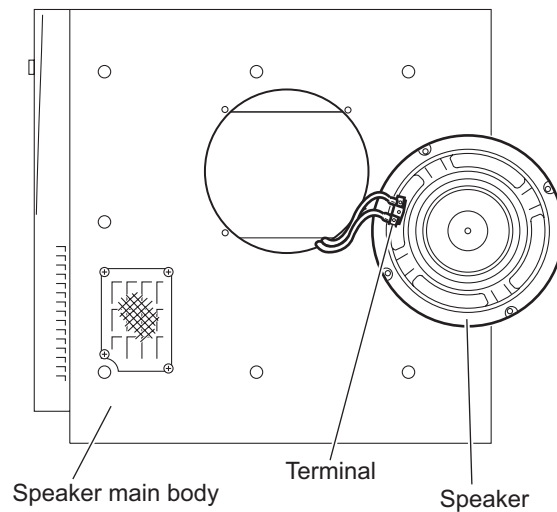

Fig.19



# SECTION 4 ADJUSTMENT

## 4.1 Test mode setting method

- (1) Unplug the power plug.
- (2) Insert power plug into outlet while pressing both "PLAY" key and "STANDBY/ON" key of the main body.
- "Area code" is indicated at the upper left of display.
- (3) To release test mode, press "STANDBY/ON" key of the main body.

**NOTE:**

Each pressing of "MENU" key of the remote controller in test mode changes the mode as follows.

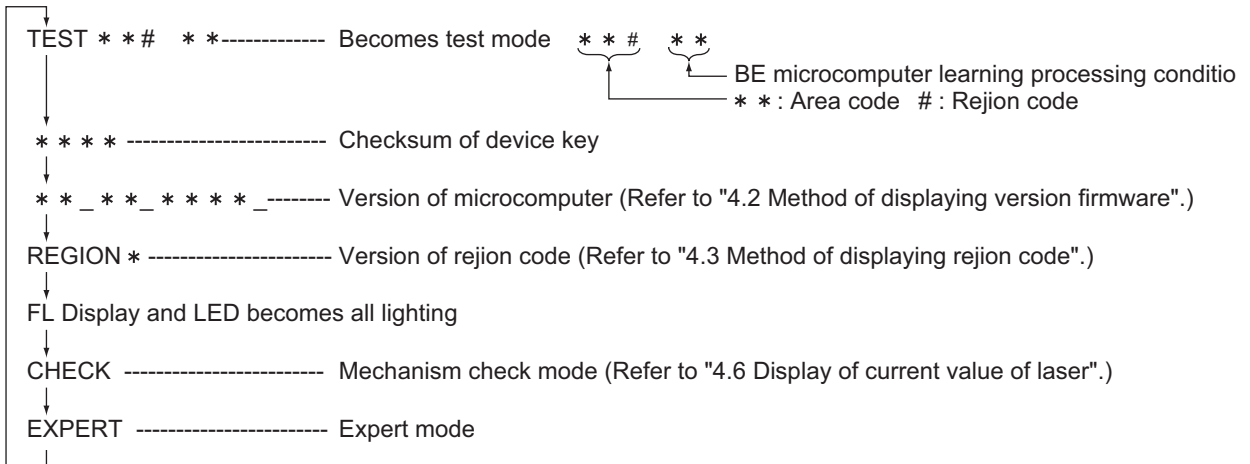

## 4.2 Method of displaying version of firmware

- (1) Set the main body at test mode.
- (2) Press "MENU" key of the remote controller twice. Then, version number and alphabetical letter of the system controller and the back end are displayed in the FL display as follows.
- (3) Each pressing of "ON SCREEN" key of the remote controller at the displaying version of firmware, changes the display as follows.

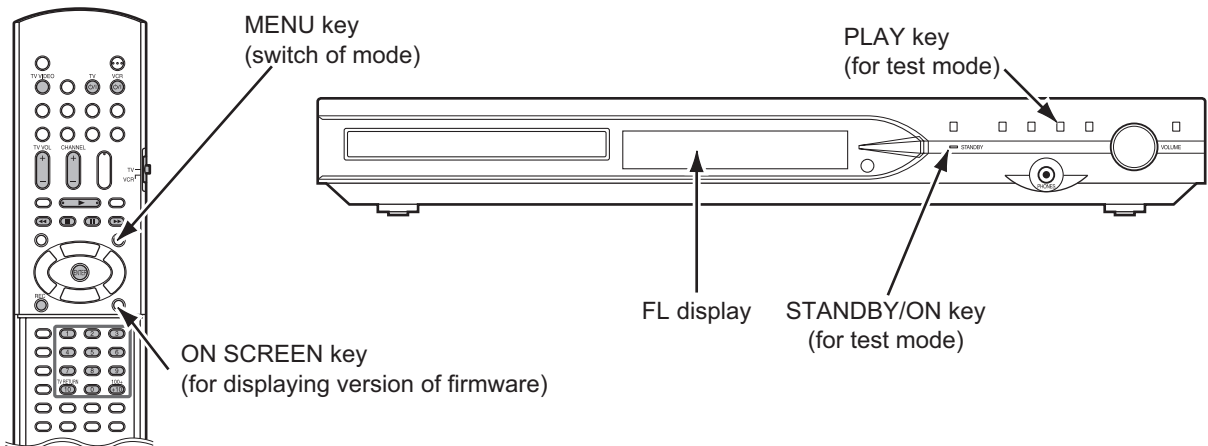
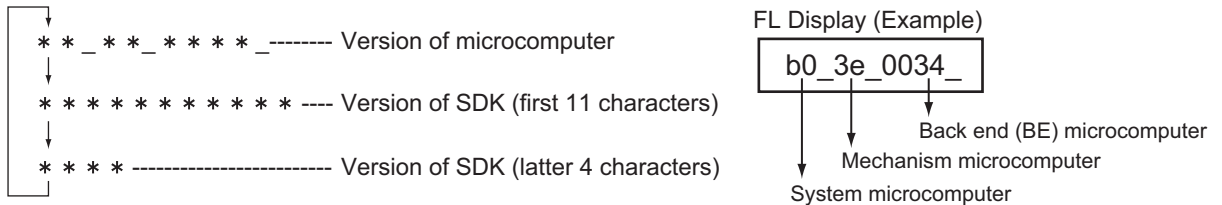

### 4.3 Method of displaying region code

- (1) Set the main body at test mode.
- (2) Press "MENU" key of the remote controller three times. Then, region code are displayed in the FL display.

### 4.4 Initialization method

Please initialize according to the following procedures in the following case:

- Just after you upgrade the firmware.
- After you confirm the symptoms that a customer points out. First Initialize, and then confirm whether the symptoms are improved or not.
- After servicing, before returning the main body to a customer. (Initialized main body should be returned to a customer.)
  - (1) Set the main body at test mode.
  - (2) Press "PAUSE" key of the main body.
  - (3) When initialization is completed, "00" and "RDS" is displayed in the FL display.

### 4.5 Display of current value of laser

- (1) Set the main body at test mode.
- (2) Press "MENU" key of the remote controller five times. Then, FL display is displayed "CHECK".
- (3) The laser current value can be switched between the value of CD and that of DVD by pressing the following key of the remote controller.

FL Display (Example)

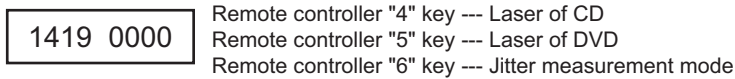

- The number shown in the FL display shows mA of current value of laser.
- The first two numbers ("14" in "1419") shows current value of laser at the time of adjustment after the latest all-initialization, 14mA in this example.
- The last two numbers ("19" in "1419") shows the present current value of laser, 19mA in this example.
- The first two numbers ("14" in "1419") usually shows current value of laser at the time of shipment, so you can see how the product has been deteriorated by comparing the first two numbers ("14" in "1419") and the last two numbers ("19" in "1419").

#### CD and DVD:

The laser current value of 80mA or less in normal. The laser current value of over 81mA is not normal. Laser diode of the pickup has been deteriorated.

- To return to test mode, press "STOP" key of the main body.

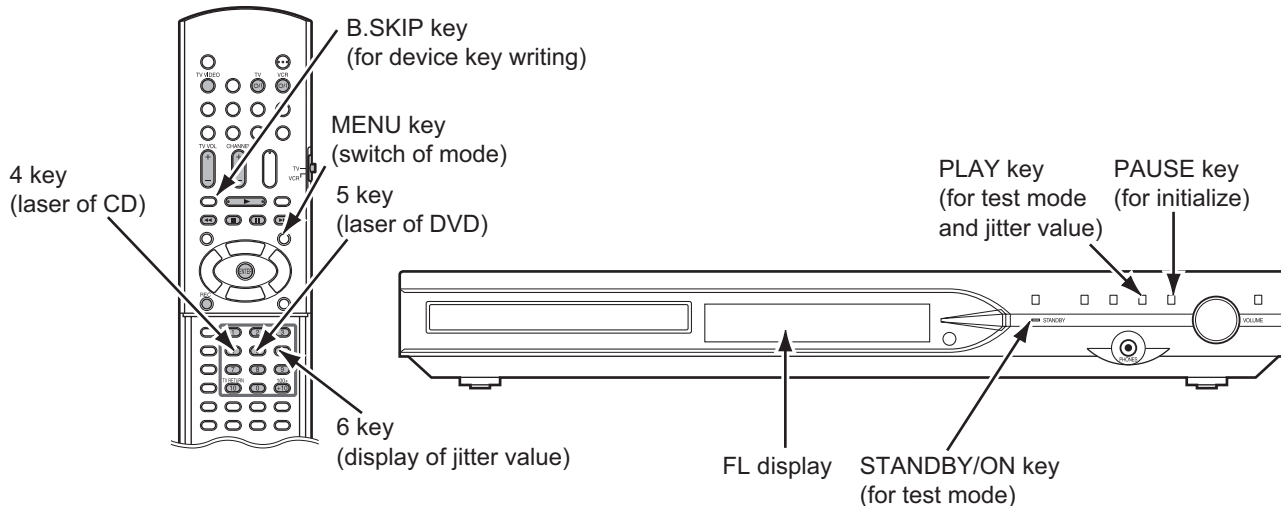

#### 4.6 Upgrading of firmware (DVD UPGRADE)

The latest firmware for upgrading is updated in "Optical disc CSG" page in JS-net. At the time of service, compare the version of the product and the latest version, and upgrade the old version into the latest version.

- (1) Press "STANDBY/ON" key of the main body to turn it on.
- (2) Push "OPEN/CLOSE" key of the main body, and insert the upgrade disc in the tray.
- (3) When reading the data of the disc, the OSD screen is displayed "VERSION UP DISC", "PROGRAM & DESTINATION MODE" and "READING..".
- (4) When the screen changes from "READING.." to "WRITING..", upgrading starts.
- (5) After writing the data of the disc, the screen is displayed "OPEN".
- (6) Take out the disc, and press "STANDBY/ON" key of the main body.
- (7) When the stand-by indicator is lighted, upgrading is completed.
- (8) Set the main body at test mode, and confirm the version of the firmware. (Refer to "4.2 Method of displaying version firmware".)

#### 4.7 Upgrading of system microcomputer (ROM CORRECTION)

- (1) Press "STANDBY/ON" key of the main body to turn it on.
- (2) Push "OPEN/CLOSE" key of the main body, and insert the upgrade disc in the tray.
- (3) When reading the data of the disc, the OSD screen is displayed "VERSION UP DISC", "SYSCON UPG MODE" and "READING..".
- (4) When the screen changes from "READING.." to "WRITING..", system data is written.
- (5) After writing the data of the disc, the FL display of the main body is displayed "COMPLETE".
- (6) Take out the disc, and press "STANDBY/ON" key of the main body.
- (7) When the stand-by indicator is lighted, upgrading is completed.
- (8) Set the main body at test mode, and confirm the version of the system microcomputer. (Refer to "4.2 Method of displaying version firmware".)

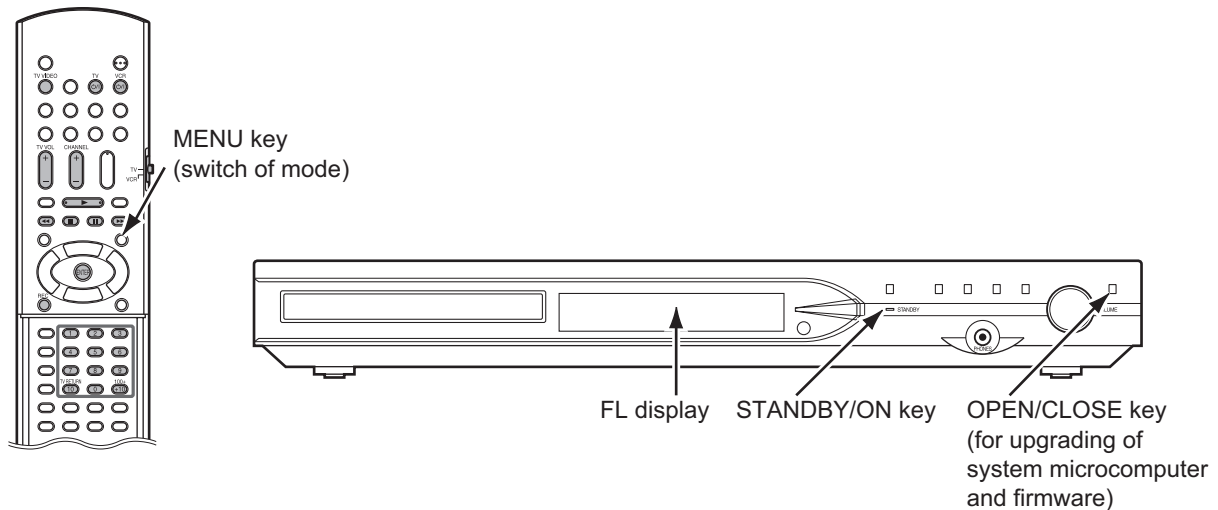

#### 4.8 Compulsive NTSC mode

- (1) Unplug the power plug.
- (2) Insert power plug into outlet while pressing both "PAUSE" key and "STANDBY/ON" key of the main body.
- (3) The compulsive NTSC mode is set up.

**NOTE:**

In E version, Y/C mode is set up.

- (4) Unless the mode is canceled, regardless of input of "NTSEL" switch, it starts only at the time of the first power-on.
- (5) When power-off is carried out, the mode is canceled.

#### 4.9 Locking disc tray

- (1) Unplug the power plug.
- (2) Insert power plug into outlet while pressing both "STOP" key and "OPEN/CLOSE" key of the main body.
- (3) Then, the FL display of main body is displayed "LOCKED" and the disc tray is locked.
- (4) For unlock the tray, press both "STOP" key and "OPEN/CLOSE" key.
- (5) Then, the FL display of main body is displayed "UNLOCKED" and the tray is unlocked.

**NOTE:**

Unless unlocking disc tray, it does not process to input "OPEN/CLOSE" key.

#### 4.10 Switching tuner AM step (U version only)

- Switching 9kHz  
(1) Press both "STOP" key and "PLAY" key of the main body.
- Switching 10kHz  
(1) Press both "STOP" key and "PAUSE" key of main body.

**NOTE:**

Switching tuner AM step is effective only when source is AM.

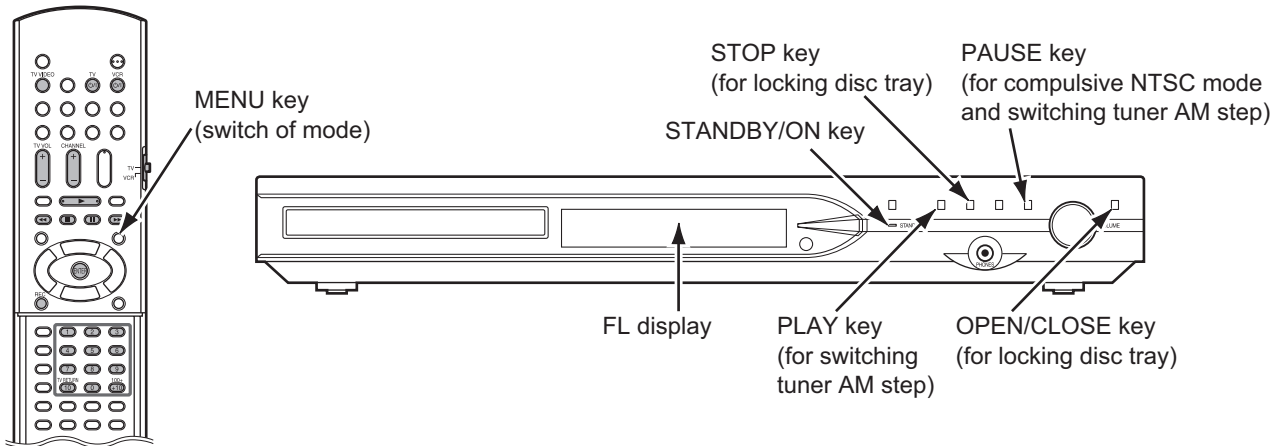

## **SECTION 5 TROUBLESHOOTING**

This service manual does not describe TROUBLESHOOTING.



**JVC**

VICTOR COMPANY OF JAPAN, LIMITED  
AV & MULTIMEDIA COMPANY AUDIO/VIDEO SYSTEMS CATEGORY 10-1,1chome,Ohwatari-machi,Maebashi-city,371-8543,Japan

(No.MB180)