

JVC

SERVICE MANUAL

DVD DIGITAL CINEMA SYSTEM

TH-SW9, TH-SW8

Area suffix

B ----- U.K.
E ----- Continental Europe
EN ----- Northern Europe
EV ----- Eastern Europe

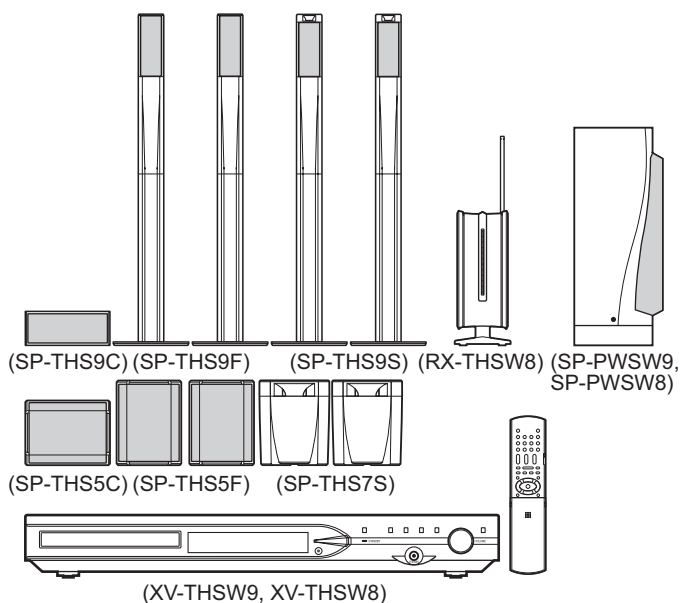

Digital Direct Progressive Scan

TABLE OF CONTENTS

1	PRECAUTION	1-4
2	SPECIFIC SERVICE INSTRUCTIONS	1-8
3	DISASSEMBLY	1-9
4	ADJUSTMENT	1-31
5	TROUBLESHOOTING	1-35

SPECIFICATION

Center unit (XV-THSW9/XV-THSW8)

Wireless section	CH1		863.3 MHz
	CH2		863.7 MHz
	CH3		864.1 MHz
	CH4		864.5 MHz
Audio section	Total Harmonic Distortion*1		0.02%
	Digital input*2		DIGITAL IN (OPTICAL):-21 dBm to -15 dBm (660 nm ± 30 nm)
Video section	Video System		PAL
	Horizontal Resolution		500 lines
	Signal-to-Noise Ratio (Composite signal when "RGB" is selected)		64 dB
	Video output level	Composite	1.0 V(p-p)/75 Ω
		S-video-Y	1.0 V(p-p)/75 Ω
		S-video-C	0.3 V(p-p)/75 Ω
		Component-Y	1.0 V(p-p)/75 Ω
Component-PB/PR		0.7 V(p-p)/75 Ω	
Tuner section	Tuning Range	FM	87.50 MHz to 108.00 MHz
		AM (MW)	522 kHz to 1 629 kHz
General	Power Requirements		AC 230 V , 50 Hz
	Power Consumption		20 W (at operation) 2.0 W (in standby mode)
	Dimensions (W × H × D)		435 mm × 57 mm × 319 mm
	Mass		3.0 kg

*1 : This value is measured at System cord CONNECTOR for reference.

*2 :Corresponding to Linear PCM, Dolby Digital, and DTS Digital Surround (with sampling frequency - 32 kHz, 44.1 kHz, 48 kHz)

Wireless receiver unit (RX-THSW8)

Wireless section	Reception frequency	CH1	863.3 MHz
		CH2	863.7 MHz
		CH3	864.1 MHz
		CH4	864.5 MHz
Amplifier section	Surround		50 W per Ωchannel, RMS at 6 Ω at 1 kHz, with 10 % total harmonic distortion.
	General	Power Requirements	AC 230 V , 50 Hz
		Power Consumption	25 W (at operation) 2.0 W (in standby mode)
		Dimensions (W × H × D)	80 mm × 191 mm × 150 mm
		Mass	0.93 kg

Subwoofer (SP-PWSW9/SP-PWSW8)

Amplifier section	Front/Center/Surround	80 W per Ωchannel, RMS at 6 Ω (Center/Surround)/120 W per Ωchannel, RMS at 4 Ω (Front) at 1 kHz, with 10 % total harmonic distortion.
	Subwoofer	120 W, RMS at 4 Ω at 100 Hz, with 10 % total harmonic distortion.
Speaker section	Speaker unit	16 cm Bass-reflex, Magnetically Shielded
	Frequency Range	30 Hz to 200 Hz
General	Power Requirements	AC 230 V , 50 Hz
	Power Consumption	110 W (at operation) 0 W (in standby mode)
	Dimensions (W × H × D)	170 mm × 412 mm × 444 mm
	Mass	12.0 kg

Satellite Speakers

Front speakers (SP-THS9F)	Speakers	5.5 cm × 2, 3.0 cm Bass-reflex, Magnetically Shielded
	Power Handling Capacity	120 W
	Impedance	4 Ω
	Frequency Range	95 Hz to 40 kHz
	Dimensions (W × H × D)	250 mm × 103 mm × 250 mm
	Mass	3.67 kg
Surround speakers (SP-THS9S)	Speakers	5.5 cm × 2 Bass-reflex, Magnetically Shielded
	Power Handling Capacity	80 W
	Impedance	6 Ω
	Frequency Range	90 Hz to 30 kHz
	Dimensions (W × H × D)	250 mm × 103 mm × 250 mm
	Mass	3.77 kg
Center speaker (SP-THS9C)	Speakers	5.5 cm × 2, 3.0 cm Bass-reflex, Magnetically Shielded
	Power Handling Capacity	80 W
	Impedance	6 Ω
	Frequency Range	90 Hz to 40 kHz
	Dimensions (W × H × D)	209 mm × 85 mm × 92 mm
	Mass	0.87 kg

Designs & specifications are subject to change without notice.

SECTION 1 PRECAUTION

1.1 Safety Precautions

- (1) This design of this product contains special hardware and many circuits and components specially for safety purposes. For continued protection, no changes should be made to the original design unless authorized in writing by the manufacturer. Replacement parts must be identical to those used in the original circuits. Services should be performed by qualified personnel only.
- (2) Alterations of the design or circuitry of the product should not be made. Any design alterations of the product should not be made. Any design alterations or additions will void the manufacturer's warranty and will further relieve the manufacturer of responsibility for personal injury or property damage resulting therefrom.
- (3) Many electrical and mechanical parts in the products have special safety-related characteristics. These characteristics are often not evident from visual inspection nor can the protection afforded by them necessarily be obtained by using replacement components rated for higher voltage, wattage, etc. Replacement parts which have these special safety characteristics are identified in the Parts List of Service Manual. Electrical components having such features are identified by shading on the schematics and by (Δ) on the Parts List in the Service Manual. The use of a substitute replacement which does not have the same safety characteristics as the recommended replacement parts shown in the Parts List of Service Manual may create shock, fire, or other hazards.
- (4) The leads in the products are routed and dressed with ties, clamps, tubings, barriers and the like to be separated from live parts, high temperature parts, moving parts and/or sharp edges for the prevention of electric shock and fire hazard. When service is required, the original lead routing and dress should be observed, and it should be confirmed that they have been returned to normal, after reassembling.

(5) Leakage shock hazard testing

After reassembling the product, always perform an isolation check on the exposed metal parts of the product (antenna terminals, knobs, metal cabinet, screw heads, headphone jack, control shafts, etc.) to be sure the product is safe to operate without danger of electrical shock. Do not use a line isolation transformer during this check.

- Plug the AC line cord directly into the AC outlet. Using a "Leakage Current Tester", measure the leakage current from each exposed metal part of the cabinet, particularly any exposed metal part having a return path to the chassis, to a known good earth ground. Any leakage current must not exceed 0.5mA AC (r.m.s.).
- Alternate check method
Plug the AC line cord directly into the AC outlet. Use an AC voltmeter having, 1,000 Ω per volt or more sensitivity in the following manner. Connect a 1,500 Ω 10W resistor paralleled by a 0.15 μ F AC-type capacitor between an exposed metal part and a known good earth ground. Measure the AC voltage across the resistor with the AC

voltmeter.

Move the resistor connection to each exposed metal part, particularly any exposed metal part having a return path to the chassis, and measure the AC voltage across the resistor. Now, reverse the plug in the AC outlet and repeat each measurement. Voltage measured any must not exceed 0.75 V AC (r.m.s.). This corresponds to 0.5 mA AC (r.m.s.).

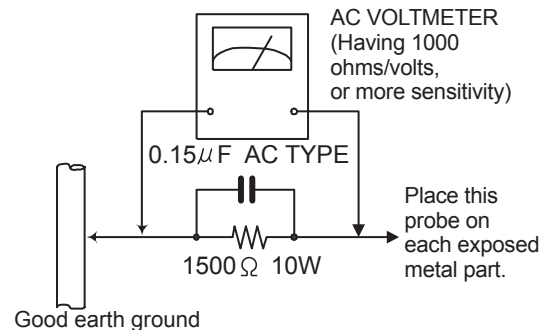

1.2 Warning

- (1) This equipment has been designed and manufactured to meet international safety standards.
- (2) It is the legal responsibility of the repairer to ensure that these safety standards are maintained.
- (3) Repairs must be made in accordance with the relevant safety standards.
- (4) It is essential that safety critical components are replaced by approved parts.
- (5) If mains voltage selector is provided, check setting for local voltage.

1.3 Caution

Burrs formed during molding may be left over on some parts of the chassis.

Therefore, pay attention to such burrs in the case of pre-forming repair of this system.

1.4 Critical parts for safety

In regard with component parts appearing on the silk-screen printed side (parts side) of the PWB diagrams, the parts that are printed over with black such as the resistor (■), diode (■) and ICP (●) or identified by the " Δ " mark nearby are critical for safety. When replacing them, be sure to use the parts of the same type and rating as specified by the manufacturer. (This regulation does not Except the J and C version)

1.5 Safety Precautions (U.K only)

- (1) This design of this product contains special hardware and many circuits and components specially for safety purposes. For continued protection, no changes should be made to the original design unless authorized in writing by the manufacturer. Replacement parts must be identical to those used in the original circuits.
- (2) Any unauthorised design alterations or additions will void the manufacturer's guarantee; furthermore the manufacturer cannot accept responsibility for personal injury or property damage resulting therefrom.
- (3) Essential safety critical components are identified by () on the Parts List and by shading on the schematics, and must never be replaced by parts other than those listed in the manual. Please note however that many electrical and mechanical parts in the product have special safety related characteristics. These characteristics are often not evident from visual inspection. Parts other than specified by the manufacturer may not have the same safety characteristics as the recommended replacement parts shown in the Parts List of the Service Manual and may create shock, fire, or other hazards.
- (4) The leads in the products are routed and dressed with ties, clamps, tubings, barriers and the like to be separated from live parts, high temperature parts, moving parts and/or sharp edges for the prevention of electric shock and fire hazard. When service is required, the original lead routing and dress should be observed, and it should be confirmed that they have been returned to normal, after re-assembling.

1.5.1 Warning

- (1) Service should be performed by qualified personnel only.
- (2) This equipment has been designed and manufactured to meet international safety standards.
- (3) It is the legal responsibility of the repairer to ensure that these safety standards are maintained.
- (4) Repairs must be made in accordance with the relevant safety standards.
- (5) It is essential that safety critical components are replaced by approved parts.
- (6) If mains voltage selector is provided, check setting for local voltage.



CAUTION Burrs formed during molding may be left over on some parts of the chassis. Therefore, pay attention to such burrs in the case of performing repair of this system.

1.6 Preventing static electricity

Electrostatic discharge (ESD), which occurs when static electricity stored in the body, fabric, etc. is discharged, can destroy the laser diode in the traverse unit (optical pickup). Take care to prevent this when performing repairs.

1.6.1 Grounding to prevent damage by static electricity

Static electricity in the work area can destroy the optical pickup (laser diode) in devices such as laser products. Be careful to use proper grounding in the area where repairs are being performed.

(1) Ground the workbench

Ground the workbench by laying conductive material (such as a conductive sheet) or an iron plate over it before placing the traverse unit (optical pickup) on it.

(2) Ground yourself

Use an anti-static wrist strap to release any static electricity built up in your body.

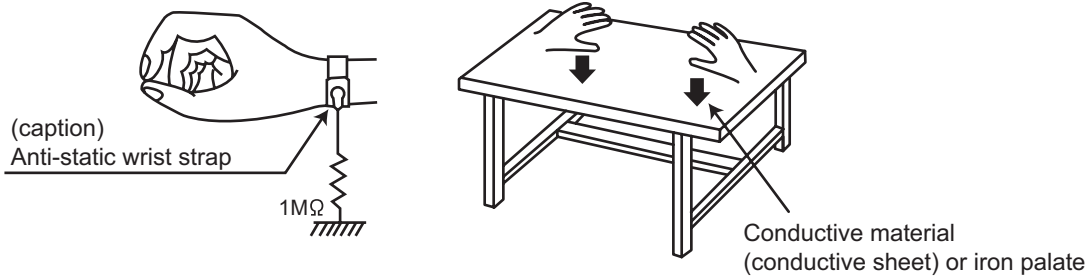

(3) Handling the optical pickup

- In order to maintain quality during transport and before installation, both sides of the laser diode on the replacement optical pickup are shorted. After replacement, return the shorted parts to their original condition. (Refer to the text.)
- Do not use a tester to check the condition of the laser diode in the optical pickup. The tester's internal power source can easily destroy the laser diode.

1.7 Handling the traverse unit (optical pickup)

- (1) Do not subject the traverse unit (optical pickup) to strong shocks, as it is a sensitive, complex unit.
- (2) Cut off the shorted part of the flexible cable using nippers, etc. after replacing the optical pickup. For specific details, refer to the replacement procedure in the text. Remove the anti-static pin when replacing the traverse unit. Be careful not to take too long a time when attaching it to the connector.
- (3) Handle the flexible cable carefully as it may break when subjected to strong force.
- (4) It is not possible to adjust the semi-fixed resistor that adjusts the laser power. Do not turn it.

1.8 Attention when traverse unit is decomposed

***Please refer to "Disassembly method" in the text for the pickup unit.**

- Apply solder to the short land sections before the flexible wire is disconnected from the connector on the servo board. (If the flexible wire is disconnected without applying solder, the pickup may be destroyed by static electricity.)
- In the assembly, be sure to remove solder from the short land sections after connecting the flexible wire.

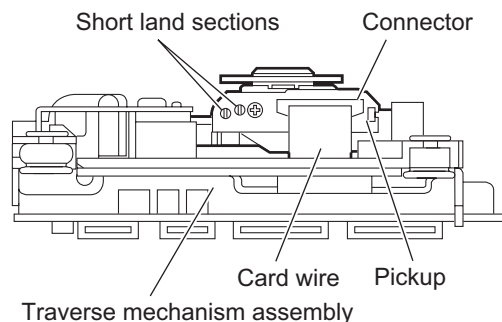

1.9 Important for laser products

1.CLASS 1 LASER PRODUCT

2.DANGER : Invisible laser radiation when open and interlock failed or defeated. Avoid direct exposure to beam.

3.CAUTION : There are no serviceable parts inside the Laser Unit. Do not disassemble the Laser Unit. Replace the complete Laser Unit if it malfunctions.

4.CAUTION : The CD,MD and DVD player uses invisible laser radiation and is equipped with safety switches which prevent emission of radiation when the drawer is open and the safety interlocks have failed or are defeated. It is dangerous to defeat the safety switches.

5.CAUTION : If safety switches malfunction, the laser is able to function.

6.CAUTION : Use of controls, adjustments or performance of procedures other than those specified here in may result in hazardous radiation exposure.

 **CAUTION** Please use enough caution not to see the beam directly or touch it in case of an adjustment or operation check.

CAUTION : Visible and invisible laser radiation when open and interlock failed or defeated.

AVOID DIRECT EXPOSURE TO BEAM.

ADVARSEL : Synlig og usynlig laserstråling når maskinen er åben eller interlocken fejler. Undgå direkte eksponering til stråling.

VARNING : Synlig och osynlig laserstråling när den öppnas och spärren är urkopplad. Betrakta ej strålen.

VARO : Avattaessa ja suojalukitus ohitettuna tai viallisena olet alltiina näkyvälle ja näkymättömälle lasersäteilylle. Vältä säteen kohdistumista suoraan itseesi.

REPRODUCTION AND POSITION OF LABELS

WARNING LABEL

CAUTION : Visible and invisible laser radiation when open and interlock failed or defeated. AVOID DIRECT EXPOSURE TO BEAM. (e)	ADVARSEL : Synlig og usynlig laserstråling når maskinen er åben eller interlocken fejler. Undgå direkte eksponering til stråling. (d)	VARNING : Synlig och osynlig laserstråling när den öppnas och spärren är urkopplad. Betrakta ej strålen. (s)	VARO : Avattaessa ja suojalukitus ohitettuna tai viallisena olet alltiina näkyvälle ja näkymättömälle lasersäteilylle. Vältä säteen kohdistumista suoraan itseesi. (f)
---	--	---	---

CLASS 1
LASER PRODUCT

CAUTION : Visible and invisible laser radiation when open and interlock failed or defeated. AVOID DIRECT EXPOSURE TO BEAM. (e)	VARO : Avattaessa ja suojalukitus ohitettuna tai viallisena olet alltiina näkyvälle ja näkymättömälle lasersäteilylle. Vältä säteen kohdistumista suoraan itseesi. (f)
VARNING : Synlig och osynlig laserstråling när den öppnas och spärren är urkopplad. Betrakta ej strålen. (s)	ADVARSEL : Synlig og usynlig laserstråling når maskinen er åben eller interlocken fejler. Undgå direkte eksponering til stråling. (d)

SECTION 2 SPECIFIC SERVICE INSTRUCTIONS

This service manual does not describe SPECIFIC SERVICE INSTRUCTIONS.

SECTION 3 DISASSEMBLY

3.1 Main body section

3.1.1 Removing the top cover

(See Figs.1 to 3)

- (1) From the both sides of the main body, remove the four screws **A** attaching the top cover. (See Figs.1 and 2)
- (2) From the back side of the main body, remove the three screws **B** attaching the top cover. (See Fig.3)
- (3) Lift the rear section of the top cover upward while extending the lower sections of the top cover. (See Fig.3)

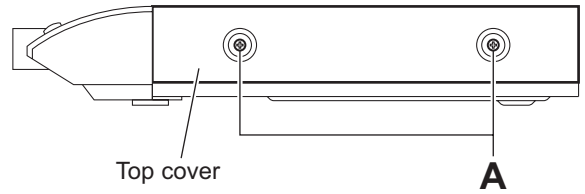

Fig.1

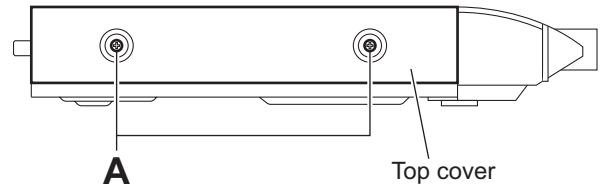

Fig.2

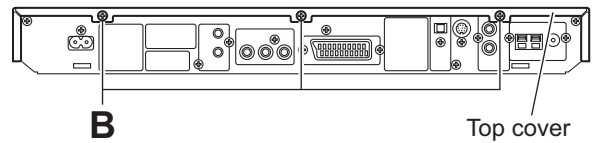

Fig.3

3.1.2 Removing the front panel assembly (See Figs.4 to 6)

- Prior to performing the following procedure, remove the top cover.

- (1) From the top side of the main body, disconnect the parallel wires from the connectors [CN451](#) and [CN452](#) on the main board. (See Fig.4)
- (2) Remove the screw **C** attaching the earth wire to the RF module. (See Fig.4)

Reference:

When attaching the screw **C**, attach the earth wire with it. (See Fig.4)

- (3) Disconnect the earth wire from the [TP701](#) on the TX ant board. (See Figs.4 and 5)
- (4) From the bottom side of the main body, remove the four screws **D** attaching the front panel assembly. (See Fig.6)
- (5) Remove the front panel assembly in the direction of the arrow while releasing the joint **a**. (See Fig.6)

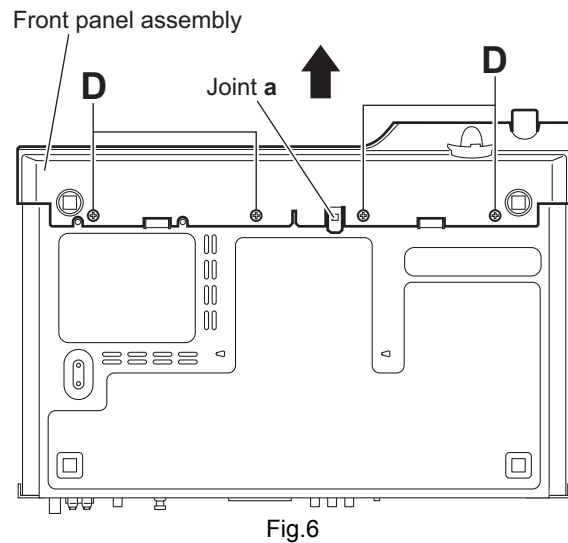
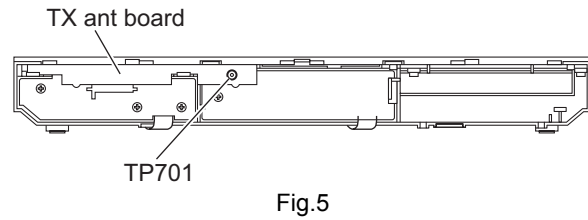
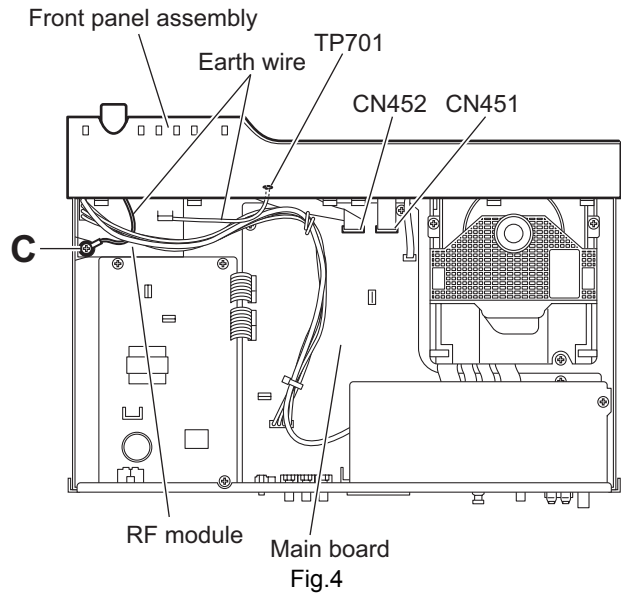

3.1.3 Removing the rear panel (See Fig.7)

- Prior to performing the following procedure, remove the top cover.

- (1) From the back side of the main body, remove the four screws **E**, screw **F** and ten screws **G** attaching the rear panel.

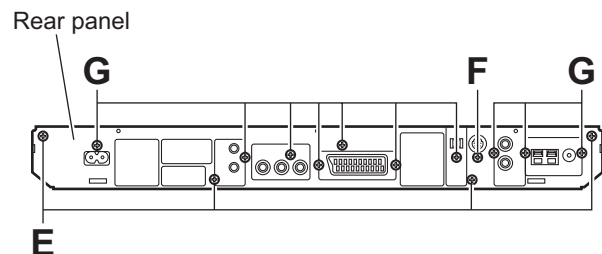

3.1.4 Removing the DSP board (See Figs.8 and 9)

- Prior to performing the following procedure, remove the top cover.
- (1) From the back side of the main body, remove the screw **F** and three screws **H** attaching the DSP board to the rear panel. (See Fig.8)
- (2) From the top side of the main body, remove the screw **J** attaching the DSP board to the main body. (See Fig.9)
- (3) Take out the DSP board, and disconnect the card wires from the connectors **CN441** and **CN442** on the DSP board. (See Fig.9)
- (4) Disconnect the parallel wire from the connector **CN443** on the DSP board. (See Fig.9)

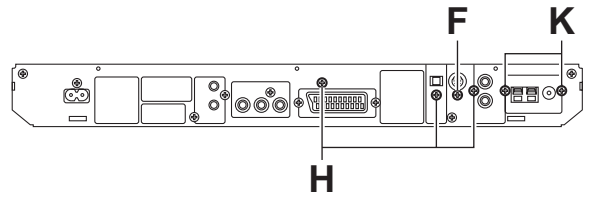

Fig.8

3.1.5 Removing the tuner (See Figs.8 and 10)

- Prior to performing the following procedures, remove the top cover and DSP board.
- (1) From the back side of the main body, remove the two screws **K** attaching the tuner to the rear panel. (See Fig.8)
- (2) From the top side of the main body, disconnect the card wire from the connector **CN410** on the main board. (See Fig.10)
- (3) Take out the tuner from the main body.

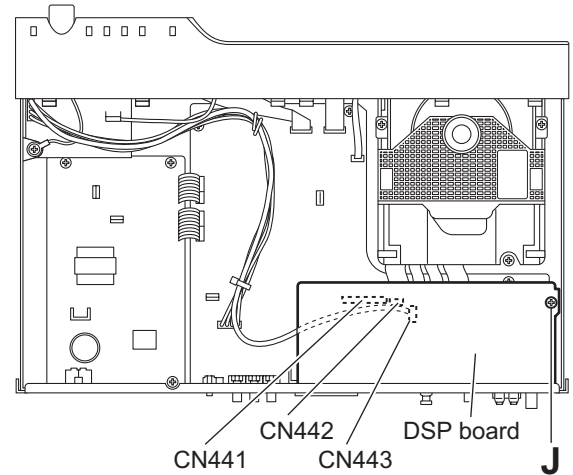

Fig.9

3.1.6 Removing the DVD mechanism assembly (See Fig.10)

- Prior to performing the following procedures, remove top cover and DSP board.
- (1) From the top side of the main body, disconnect the card wires from the connectors **CN401**, **CN402**, **CN403**, **CN408** and **CN409** on the main board.
- (2) Remove the three screws **L** attaching the DVD mechanism assembly to the main body.
- (3) Take out the DVD mechanism assembly to the upward direction.

Note:

When attaching the DVD mechanism assembly, connect the card wires to the connectors at first.

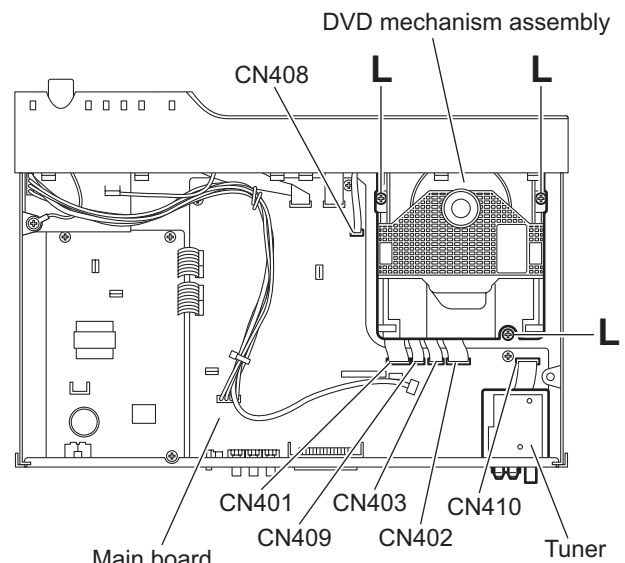

Fig.10

3.1.7 Removing the power board (See Figs.11 and 12)

- Prior to performing the following procedure, remove the top cover.
 - (1) From the back side of the main body, remove the screw **M** attaching the power board to the rear panel. (See Fig.11)
 - (2) From the top side of the main body, disconnect the parallel wires from the connectors [CN404](#), [CN405](#), [CN406](#) and [CN407](#) on the main board. (See Fig.12)
 - (3) Remove the three screws **N** attaching the power board. (See Fig.12)
 - (4) Take out the power board from the main body.

Reference:

Remove the rear panel as required. (See “3.1.3 Removing the rear panel”)

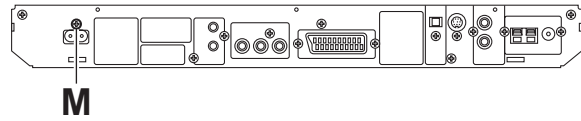

Fig.11

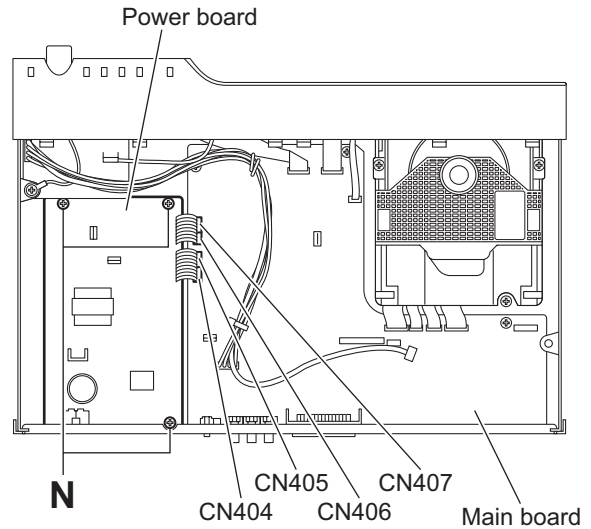

Fig.12

3.1.8 Removing the main board (See Fig.13)

- Prior to performing the following procedures, remove the top cover, rear panel, DSP board and tuner.
 - (1) From the top side of the main body, disconnect the card wires from the connectors [CN401](#), [CN402](#), [CN403](#), [CN408](#), [CN409](#), [CN451](#) and [CN452](#) on the main board.
 - (2) Disconnect the parallel wires from the connectors [CN404](#), [CN405](#), [CN406](#), [CN407](#) and [CN416](#) on the main board.
 - (3) From the top side of the main body, remove the three screws **P** attaching the main board on the main body.
 - (4) Take out the main board from the main body.

Reference:

After connecting the wire to the connector [CN416](#) on the main board, bundle the wire by the wire clamp.

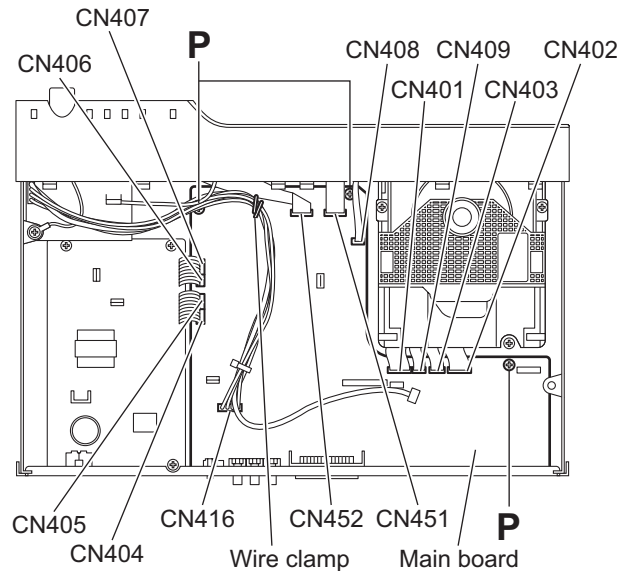

Fig.13

3.1.9 Removing the RF module (See Fig.14)

- Prior to performing the following procedures, remove the top cover and front panel assembly.
 - (1) From the top side of the main body, disconnect the wire from the connector on the RF module.
 - (2) Remove the screw **Q** attaching the RF module to the main body, and take out the RF module.

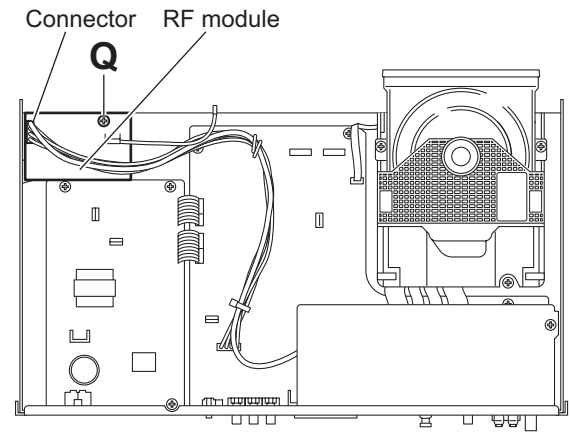

Fig.14

3.2 Front panel assembly section

- Prior to performing the following procedures, remove the top cover and front panel assembly.

3.2.1 Removing the TX ant board (See Fig.1)

- (1) From the inside of the front panel assembly, release the two claws **a** attaching the TX ant board.
- (2) Take out the TX ant board from the front panel assembly.

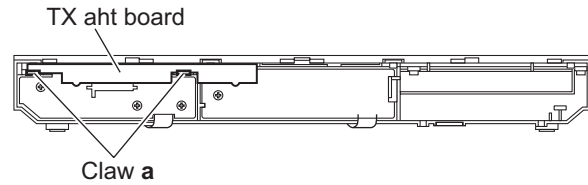

Fig.1

3.2.2 Removing the FL board (See Fig.2)

- Prior to performing the following procedure, remove the TX ant board.
- (1) From the inside of the front panel assembly, remove the screw **A** attaching the FL board.
 - (2) Take out the FL board from the front panel assembly.

- After attaching the FL board, passing the card wire through the Hook **c**.

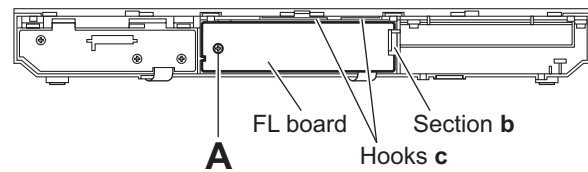

Fig.2

Reference:

- When attaching the FL board, align the section **b** of the front panel assembly to the right side of the FL board.

3.2.3 Removing the front cover and SW board (See Figs.3 and 4)

- Prior to performing the following procedure, remove the TX ant board.
- (1) From the front side of the front panel assembly, remove the volume jog from the front panel assembly forward. (See Fig.3)
 - (2) From the inside of the front panel assembly, release the seven claws **d** attaching the front cover. (See Fig.4)
 - (3) Remove the front cover to the direction of the arrow. (See Fig.4)
 - (4) Remove the three screws **B** attaching the SW board, and take out the SW board. (See Fig.4)

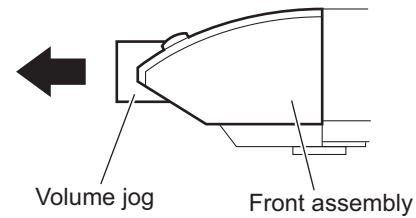

Fig.3

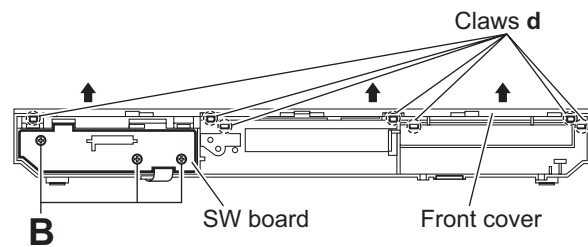

Fig.4

3.3 DVD mechanism section

- Prior to performing the following procedures, remove the DVD mechanism assembly from the main body.
(See “3.1.6 Removing the DVD mechanism assembly”.)

3.3.1 Removing the tray assembly (See Figs.1 to 3)

- (1) From the right side of the DVD mechanism assembly, push the slide cam and pull the tray assembly out of the DVD mechanism assembly in the direction of the arrow. (See Fig.1.)
- (2) From the top side of the DVD mechanism assembly, remove the two screws **A** attaching the leaf spring to the bushing and remove the leaf spring. (See Fig.2.)
- (3) Remove the bushing of the tray assembly from the projection **a** on the DVD mechanism assembly and move the tray assembly in the direction of the arrow. (See Fig.3.)
- (4) Remove the claw **b** of the tray assembly from the DVD mechanism assembly and take out the tray assembly. (See Fig.3.)

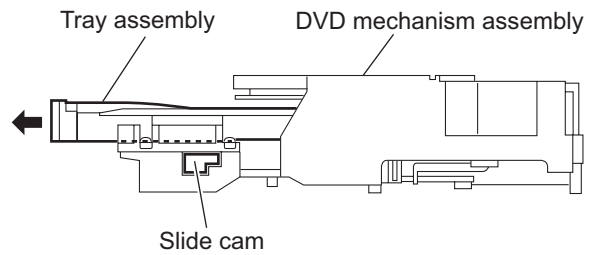

Fig.1

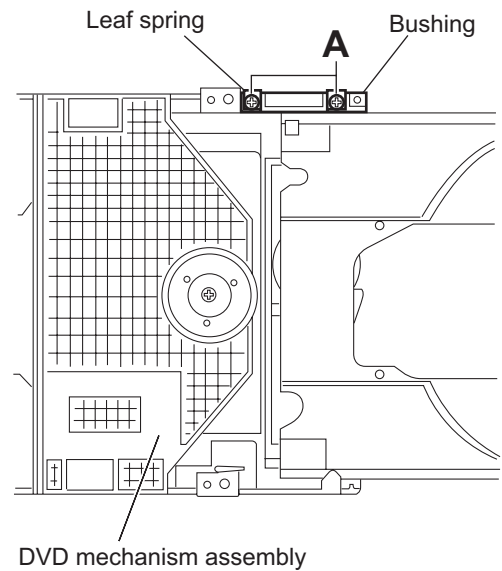

Fig.2

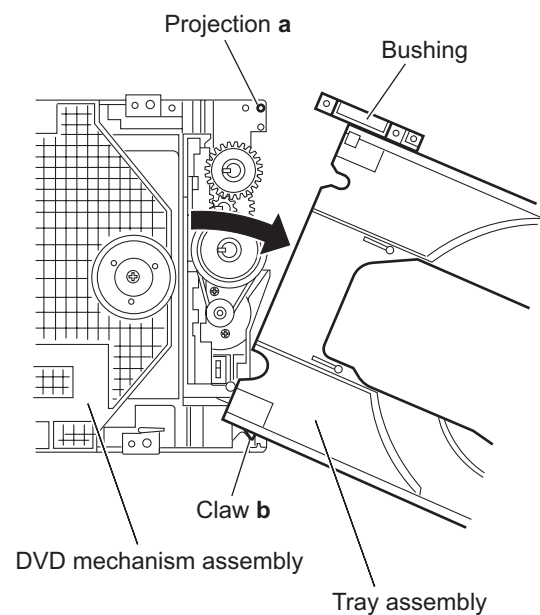

Fig.3

3.3.2 Removing the traverse mechanism assembly (See Figs.4)

From the bottom side of the DVD mechanism assembly, remove the three screws **B** and screw **B'** attaching the traverse mechanism assembly and take out the DVD traverse mechanism assembly with the DVD servo board.

Reference:

When attaching the screw **B'**, attach the washer with it.

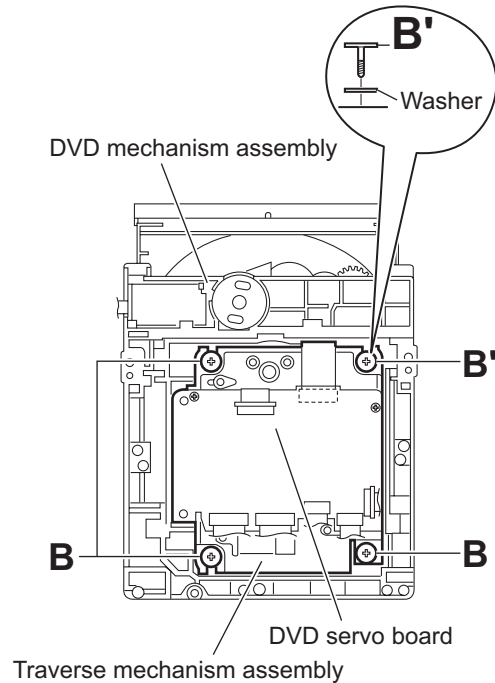

Fig.4

3.3.3 Removing the DVD servo board (See Figs.5 and 6)

- Prior to performing the following procedures, remove the traverse mechanism assembly.
 - (1) From the side of the traverse mechanism assembly, solder the short land sections **c** on the pickup. (See Fig.5.)
 - (2) From the bottom side of the traverse mechanism assembly, release the lock of the connector **CN101** on the DVD servo board in the direction of the arrow 1 and disconnect the card wire. (See Fig.6.)

Caution:

- Solder the short land sections **c** on the pickup before disconnecting the card wire from the connector **CN101** on the DVD servo board. If the card wire is disconnected without attaching solder, the pickup may be destroyed by static electricity. (See Figs.5 and 6.)
 - When attaching the DVD servo board, be sure to remove solders from the short land sections **c** after connecting the card wire to the connector **CN101** on the DVD servo board. (See Figs.5 and 6.)
- (3) Disconnect the card wire from the connector **CN201** on the DVD servo board. (See Fig.6.)
 - (4) Remove the two screws **C** attaching the DVD servo board. (See Fig.6.)
 - (5) Remove the DVD servo board from the engagement section **d** in an upward and remove the engagement section **f** in the direction 3 while removing the engagement section **e** in the direction of the arrow 2. (See Fig.6.)

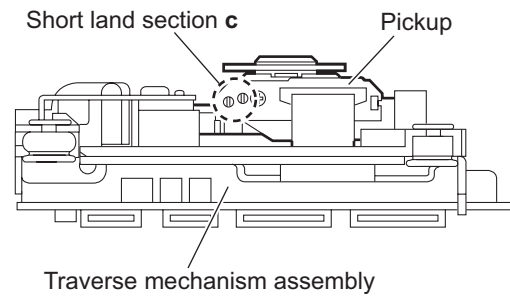

Fig.5

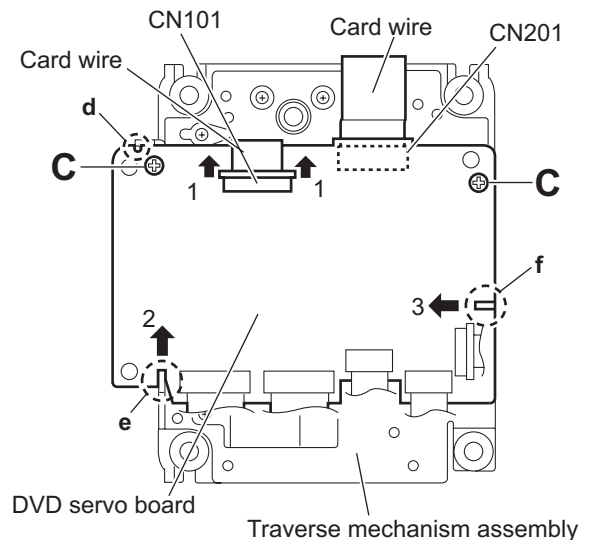

Fig.6

3.3.4 Removing the pickup (See Figs.5, 7 to 9)

- Prior to performing the following procedures, remove the traverse mechanism assembly.

- (1) From the side of the traverse mechanism assembly, solder the short land sections **c** on the pickup. (See Fig.5.)
- (2) Release the lock of the connector on the pickup in the direction of the arrow and disconnect the card wire. (See Fig.7.)

Caution:

- Solder the short land sections **c** on the pickup before disconnecting the card wire from the connector on the pickup. If the card wire is disconnected without attaching solder, the pickup may be destroyed by static electricity. (See Figs.5 and 7.)
 - When attaching the pickup, be sure to remove solders from the short land sections **c** after connecting the card wire to the connector on the pickup. (See Figs.5 and 7.)
- (3) Remove the screw **D** attaching the plate and thrust spring. (See Fig.7.)
 - (4) Remove the engagement section **g** attaching the plate to the feed holder and remove the plate with the thrust spring. (See Fig.7.)
 - (5) Remove the shaft of the pickup from the section **h** on the traverse mechanism assembly and remove the shaft from the section **i** while moving it in the direction of the arrow. (See Fig.8.)
 - (6) Remove the pickup from the section **j** of the traverse mechanism assembly and take out the pickup with the shaft. (See fig.8.)
 - (7) From the bottom side of the pickup, remove the two screws **E** attaching the SW actuator and LEAD spring. (See Fig.9.)
 - (8) Pull the shaft out of the pickup. (See Fig.9.)

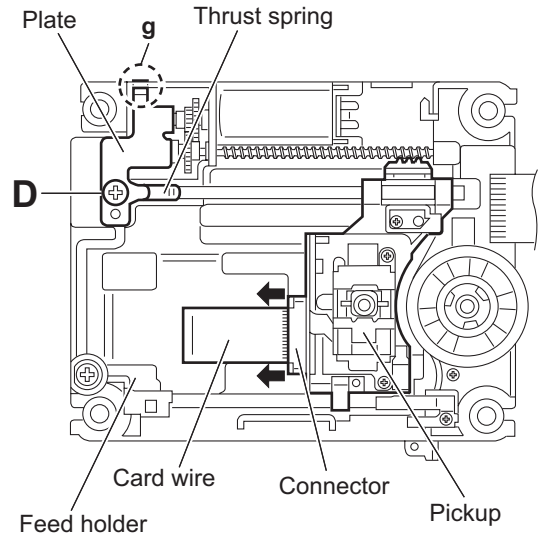

Fig.7

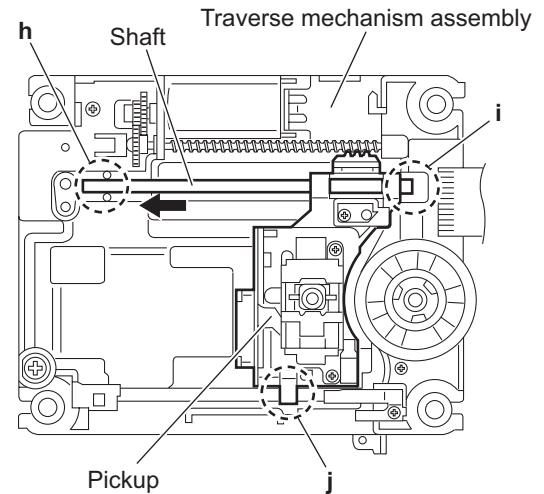

Fig.8

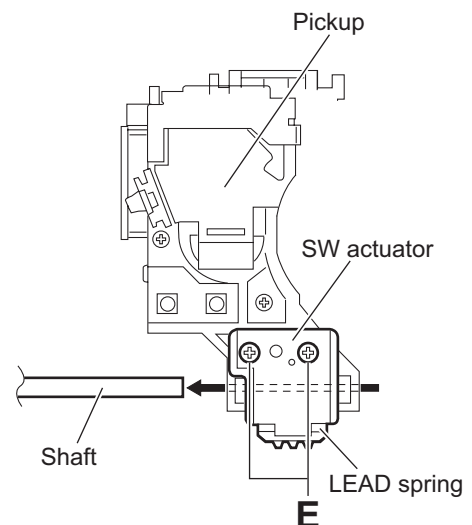

Fig.9

3.3.5 Attaching the pickup (See Figs.5, 7 to 10)

- See “3.2.4 Removing the pickup”.
 - (1) Attach the shaft, SW actuator and LEAD spring to the pickup. (See Fig.9.)
 - (2) Align the pickup to the section **j** of the traverse mechanism assembly first, and set the both ends of the shaft of the pickup in the sections **g** and **i** of the traverse mechanism assembly. (See Fig.8.)
 - (3) Attach the plate and thrust spring. (See Fig.7.)
 - (4) Remove solders from the short land sections **c** after connecting the card wire to the connector on the pickup. (See Figs.5 and 7.)
 - (5) Turn the feed gear M in the direction of the arrow 1 to move the pickup in the direction of the arrow 2. (See Fig.10.)

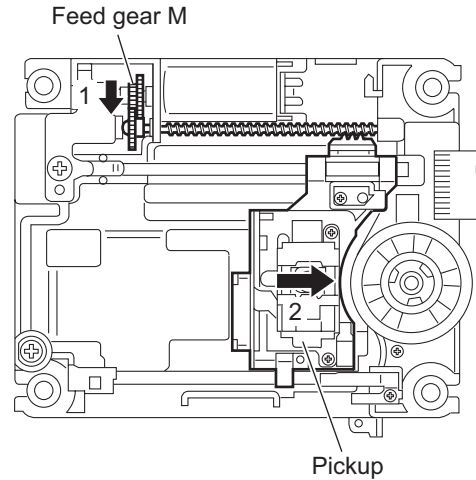

Fig.10

3.3.6 Removing the feed motor (See Figs.7, 11 and 12)

- Prior to performing the following procedures, remove the traverse mechanism assembly.
 - (1) From the top side of the traverse mechanism assembly, remove the screw **D** attaching the plate and thrust spring. (See Fig.7.)
 - (2) Remove the engagement section **g** attaching the plate to the feed holder and remove the plate with the thrust spring. (See Fig.7.)
 - (3) Remove the wires from the soldered section **k** on the spindle motor board. (See Fig.11.)

Reference:

When attaching the feed motor, pass the wire through the section **m** on the spindle base. (See Fig.11.)

- (4) Remove the feed holder, feed motor, lead screw, feed gear E and feed gear M at the same time after removing the two screws **F** attaching the feed holder. (See Fig.11.)
- (5) From the side of the feed holder, remove the two screws **G** attaching the feed motor. (See Fig.12.)

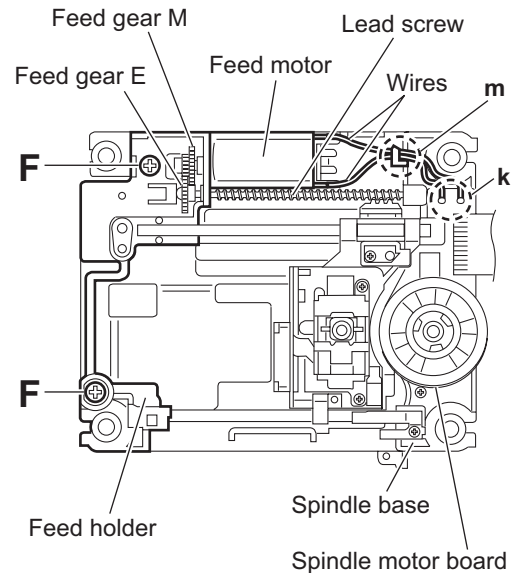

Fig.11

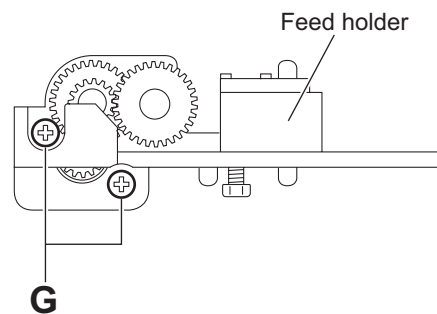

Fig.12

3.3.7 Removing the spindle motor board (See Figs.11 and 13)

- Prior to performing the following procedures, remove the traverse mechanism assembly and DVD servo board.
 - (1) From the top side of the traverse mechanism assembly, remove the wires from the soldered section **k** on the spindle motor board. (See Fig.11.)
 - (2) From the bottom side of the traverse mechanism assembly, remove the three screws **H** attaching the spindle motor board. (See Fig.13.)

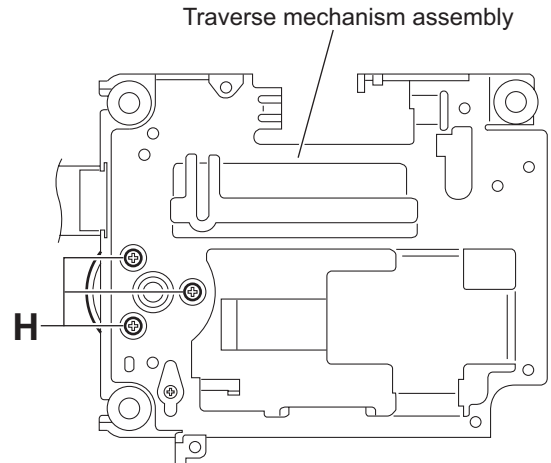

Fig.13

3.3.8 Removing the switch board (See Fig.14.)

- (1) From the bottom side of the DVD mechanism assembly, remove the wires from the soldered section **n** on the switch board.
- (2) Lift the switch board while pressing the claw **p** of the DVD mechanism assembly in the direction of the arrow and remove it from the section **q**.

Reference:

- Put the wires on the section **r** after attaching the switch board to the DVD mechanism assembly.
- Fix the claw **p** on the DVD mechanism assembly with bonds after attaching the switch board.

3.3.9 Removing the motor (See Figs.14 and 15)

- Prior to performing the following procedures, remove the tray assembly.
 - (1) From the bottom side of the DVD mechanism assembly, remove the wires from the soldered section **n** on the switch board. (See Fig.14.)
 - (2) From the top side of the DVD mechanism assembly, remove the belt from the motor pulley. (See Fig.15.)

Note:

Take care not to attach grease on the belt.

- (3) Remove the two screws **J** attaching the motor to the DVD mechanism assembly and take out the motor from the bottom side of the DVD mechanism assembly. (See Fig.15.)

Reference:

Put the wires on the section **r** after attaching the motor to the DVD mechanism assembly. (See Fig.14.)

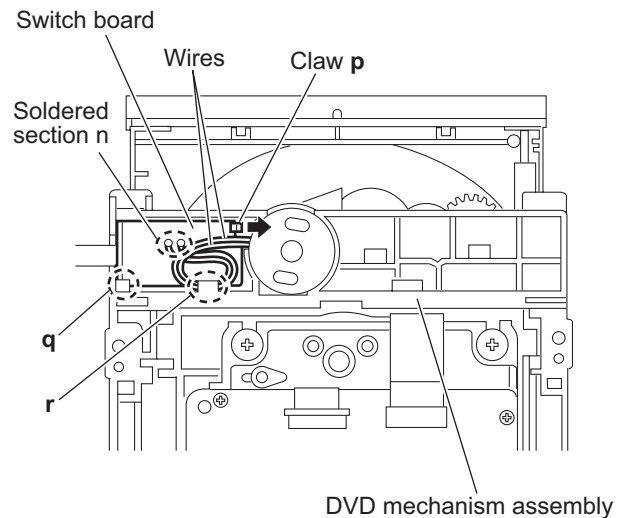

Fig.14

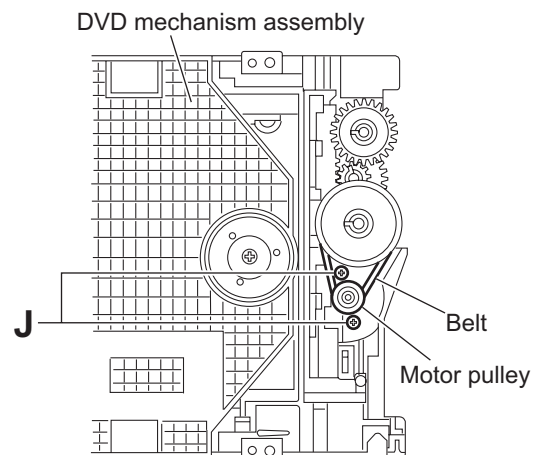

Fig.15

3.4 Subwoofer section

3.4.1 Removing the amplifier assembly

(See Figs.1 to 3)

- (1) From the back side of the speaker main body, remove two screws **A** attaching the amplifier assembly. (See Fig.1)
- (2) From the bottom side of the speaker main body, remove the eight screws **B** attaching amplifier assembly. (See Fig.2)
- (3) From the left side of the speaker main body, move the amplifier assembly backward and disconnect the wire from the connector **CN274** on the mother board. (See Fig.3)

Reference:

After connecting the wire to the connector **CN274** on the mother board, bundles the wire by the wire clamp. (See Fig.3)

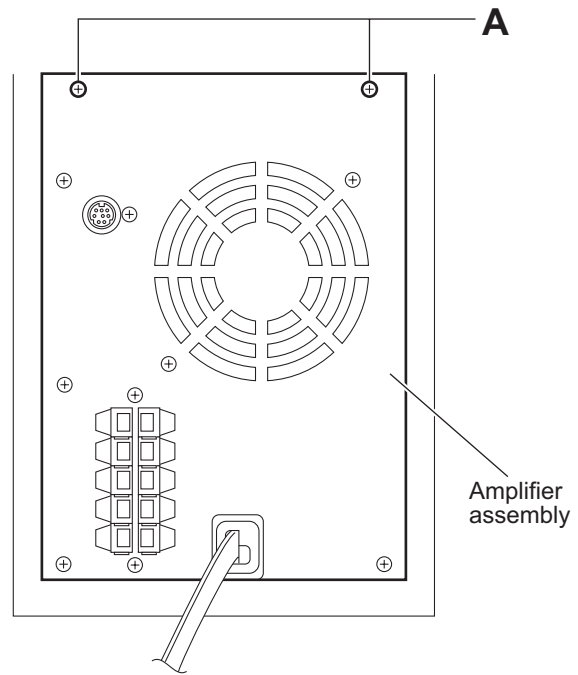

Fig.1

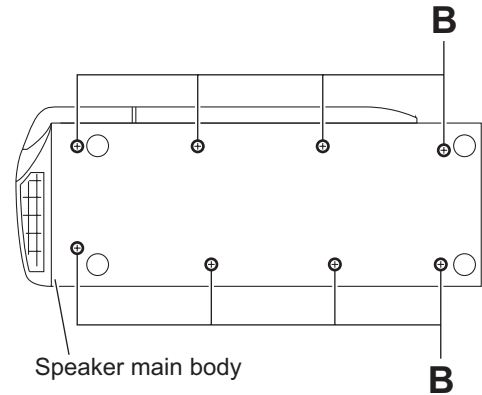

Fig.2

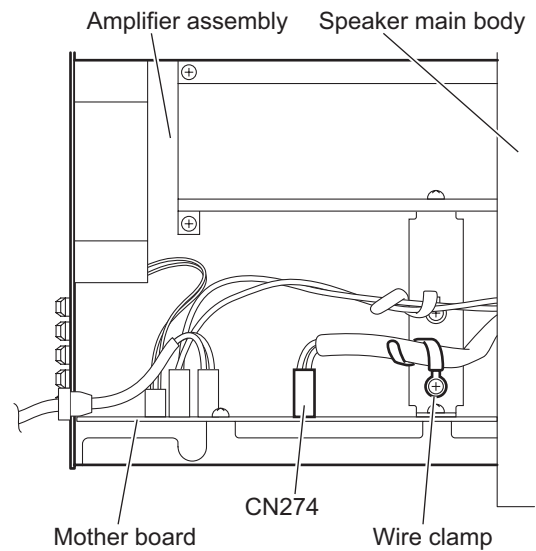

Fig.3

3.4.2 Removing the rear panel (See Figs.4 and 5)

- Prior to performing the following procedure, remove the amplifier assembly.
 - (1) From the back side of the amplifier assembly, remove the four screws **C**, two screws **D** and screw **E** attaching the rear panel. (See Fig.4)
 - (2) From the top side of the amplifier assembly, take out the rear panel with fan motor, and disconnect the wire from the connector [CN371](#) on the mother board. (See Fig.5)

3.4.3 Removing the fan motor (See Figs.4 and 5)

- Prior to performing the following procedure, remove the amplifier assembly.
 - (1) From the back side of the rear panel, remove the two screws **F** attaching the fan motor. (See Fig.4)
 - (2) From the top side of the amplifier assembly, take out the fan motor and disconnect the wire from the connector [CN371](#) on the mother board. (See Fig.5)

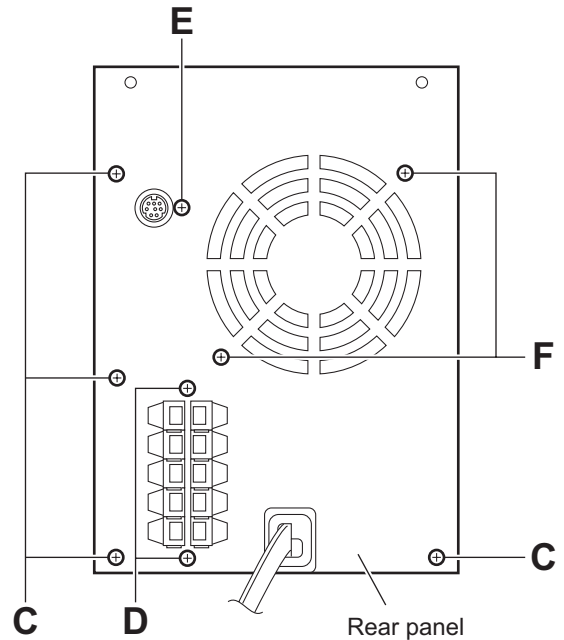
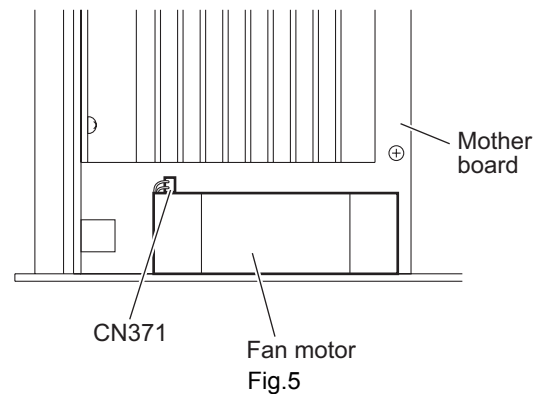

Fig.4



3.4.4 Removing the heat sink BKT (See Figs.6 and 7)

- Prior to performing the following procedures, remove the amplifier assembly and rear panel.
 - (1) From the left side of the amplifier assembly, remove the wires from the wire clamp on the heat sink BKT. (See Fig.6)
 - (2) From the left side of the amplifier assembly, remove the four screws **G** attaching the heat sink BKT. (See Fig.7)
 - (3) Take out the two heat sink BKT.

Reference:

After attaching the heat sink BKT, bundle the wires by the wire clamp. (See Fig.6)

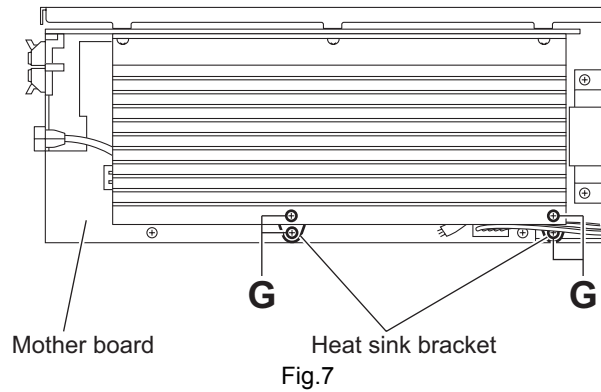
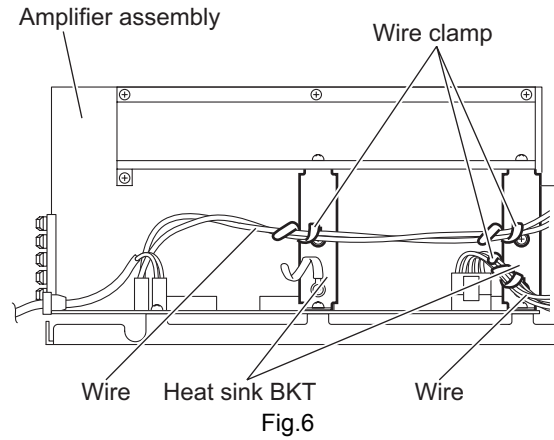

3.4.5 Removing the mother board (See Figs.8 and 9)

- Prior to performing the following procedures, remove the amplifier assembly, rear panel and heat sink BKT.
 - (1) From the top side of the amplifier assembly, remove the two screws **H** attaching the mother board. (See Fig.8)
 - (2) From the left side of the amplifier assembly, disconnect the wires from the connectors [CN102](#) and [CN151](#) on the mother board. (See Fig.9)
 - (3) Disconnect the power cord from the connector [CN101](#) on the mother board, and take out the power cord. (See Fig.9)
 - (4) Disconnect the mother board from the connector [CN271](#), [CN272](#) and [CN273](#) on the amp. board, and take out the mother board assembly from the amplifier assembly. (See Fig.9)

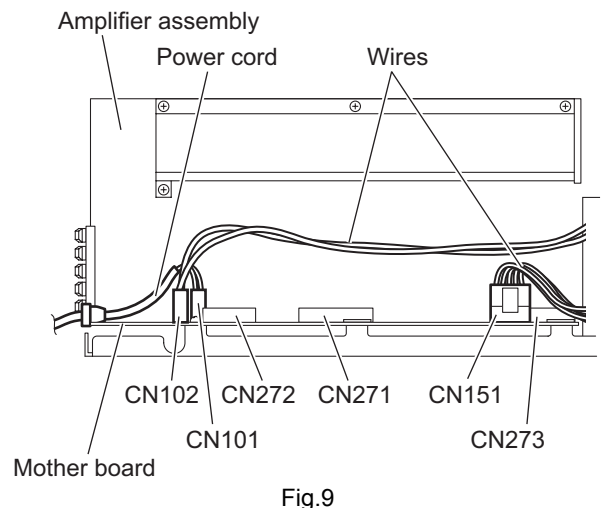
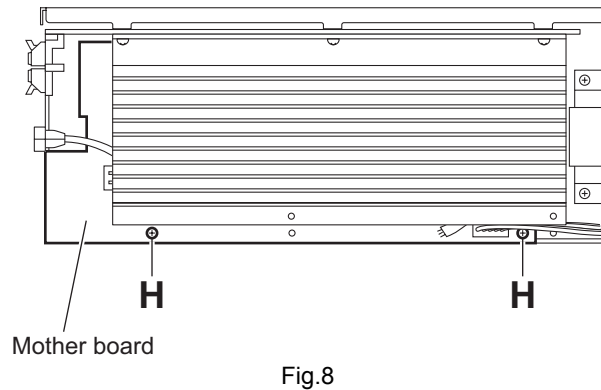

3.4.6 Removing the amp. board (See Fig.10)

- Prior to performing the following procedures, remove the amplifier assembly, rear panel, heat sink BKT and mother board.
 - (1) From the left side of the amplifier assembly, remove the nine screws **J** attaching the amp. board.
 - (2) Take out the amp. board with the heat sink.

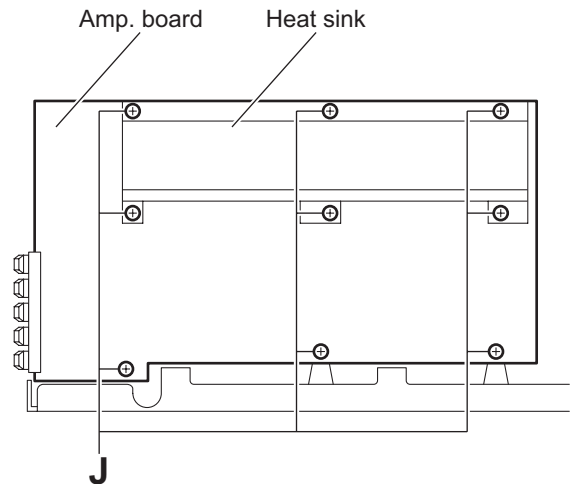

Fig.10

3.4.7 Removing the heat sink (See Figs.11 and 12)

- Prior to performing the following procedures, remove the amplifier assembly, rear panel, heat sink BKT, mother board and amp. board.
 - (1) From left side of the amp. board, remove the screw **K** attaching the hold spring to the heat sink. (See Fig.11)
 - (2) Remove the four screws **L** attaching the power IC to the heat sink. (See Fig.11)
 - (3) From the reverse side of the amp. board, remove the three screws **M** attaching the heat sink to the amp. board. (See Fig.12)
 - (4) Take out the heat sink.

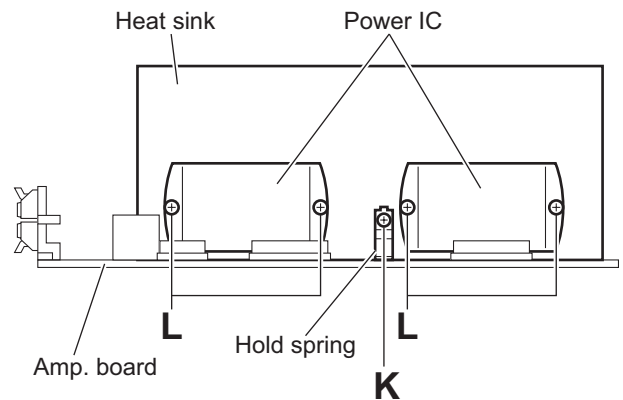

Fig.11

3.4.8 Removing the power IC (See Fig. 12)

- Prior to performing the following procedures, remove the amplifier assembly, rear panel, heat sink BKT, mother board, amp. board and heat sink.
 - (1) From the reverse side of the amp. board, remove the solders from the solder points **a** on the amp. board.
 - (2) Take out the power IC.

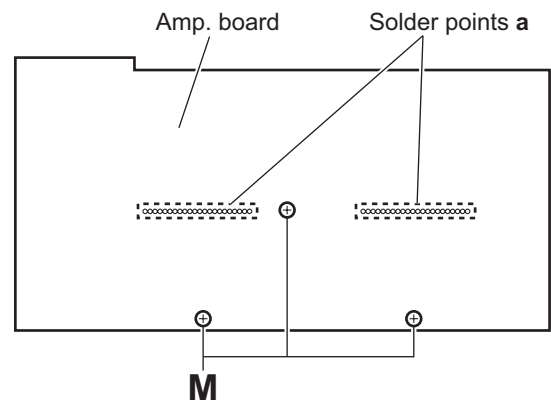

Fig.12

3.4.9 Removing the LED board (See Fig.13)

- Prior to performing the following procedures, remove the amplifier assembly and rear panel.
 - (1) From the front side of the amplifier assembly, cut off the tie bands.
 - (2) Remove the screw **N** attaching the LED board.
 - (3) From the reverse side of the LED board, remove the solder from the solder point **b** on the LED board.

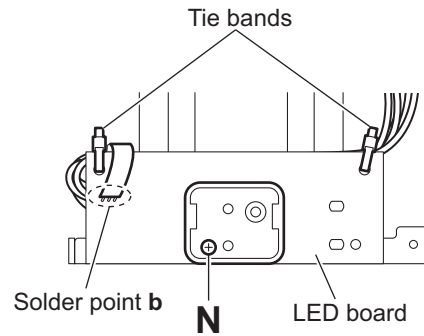

Fig.13

3.4.10 Removing the power transformer (See Figs.14 and 15)

- Prior to performing the following procedures, remove the amplifier assembly and rear panel.
 - (1) From the top side of the amplifier assembly, disconnect the wires from the connectors [CN102](#) and [CN151](#) on the mother board. (See Fig.14)
 - (2) Remove the four screws **P** attaching the power transformer, and take out the power transformer from the amplifier assembly. (See Fig.15)

Reference:

- When attaching the power transformer, attach the screws **P** with the barrier. (See Fig.15)
- After connect the wires from the connectors [CN102](#) and [CN151](#), bundle the wire by the wire clamp. (See Fig.14)

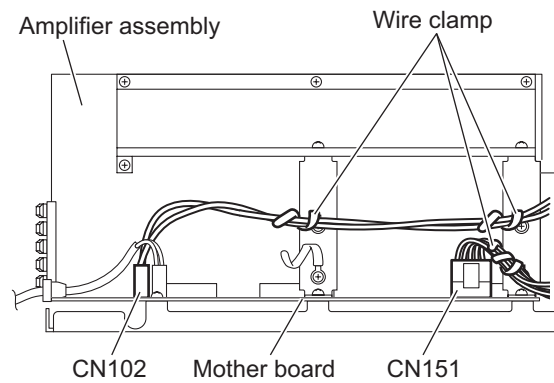

Fig.14

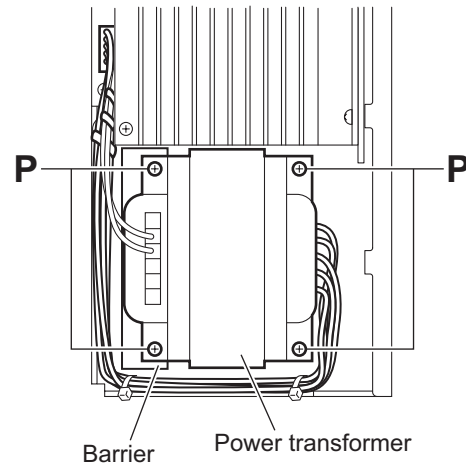

Fig.15

3.4.11 Removing the net assembly (See Figs.16 and 17)

- (1) From side of the speaker main body, insert the tip of the flat-bladed screwdriver or similar tool into the space between the speaker main body and net assembly, and lift the net assembly little by little to remove. (See Fig.16)

Note:

To prevent damaging the net assembly and speaker main body, insert cushioning plates etc. and below the tip of the flat-bladed screwdriver or similar tool.

- (2) From right side of the speaker main body, release the eight joint **c**, and take out the net assembly from the speaker main body. (See Fig.17)

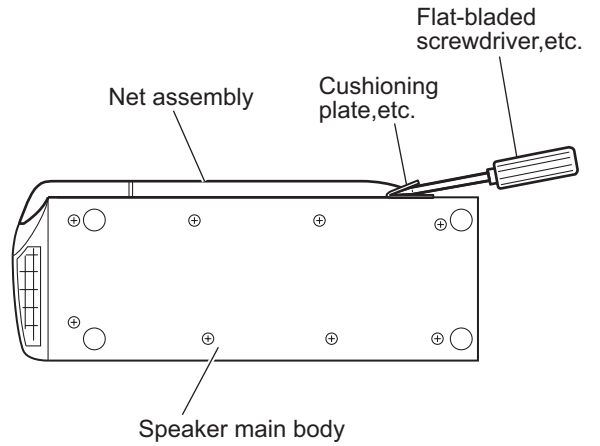

Fig.16

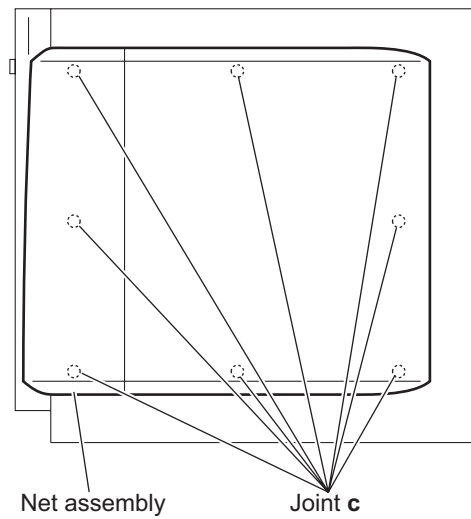

Fig.17

3.4.12 Removing the cone speaker (See Figs.18 and 19)

- Prior to performing the following procedure, remove the net assembly.
 - (1) From right side of the speaker main body, remove the four screws **Q** attaching the cone speaker. (See Fig.18)
 - (2) Take out the cone speaker from the speaker main body. (See Fig.19)
 - (3) Disconnect the wires from the terminal of the cone speaker. (See Fig.19)

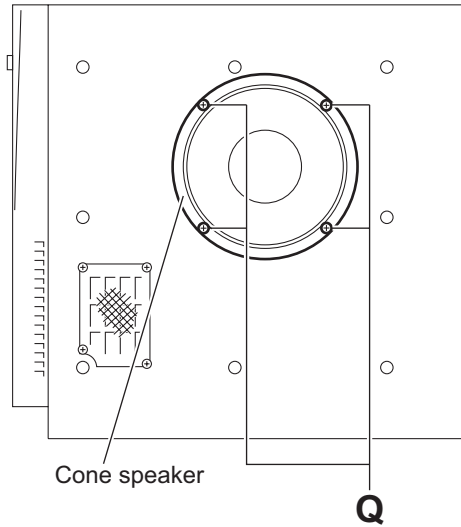

Fig.18

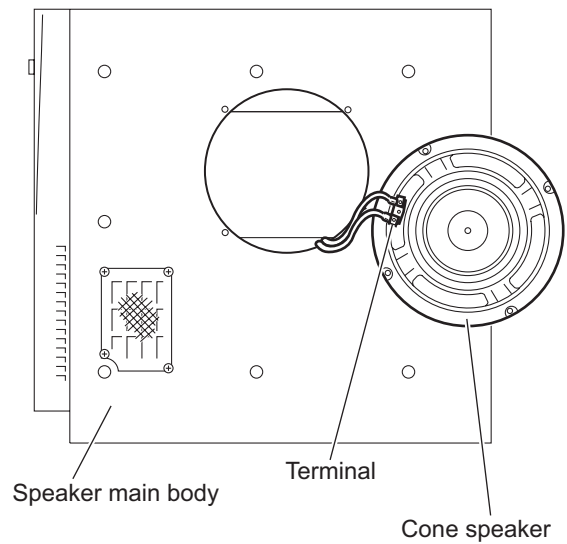

Fig.19

3.5 Receiver assembly section

3.5.1 Removing the side panel (L) and side panel (R) (See Fig.1)

- (1) From the back side of the receiver assembly, remove two screws **A** attaching the side panel (L) and side panel (R).
- (2) Take out the side panel (L) and side panel (R) upward.

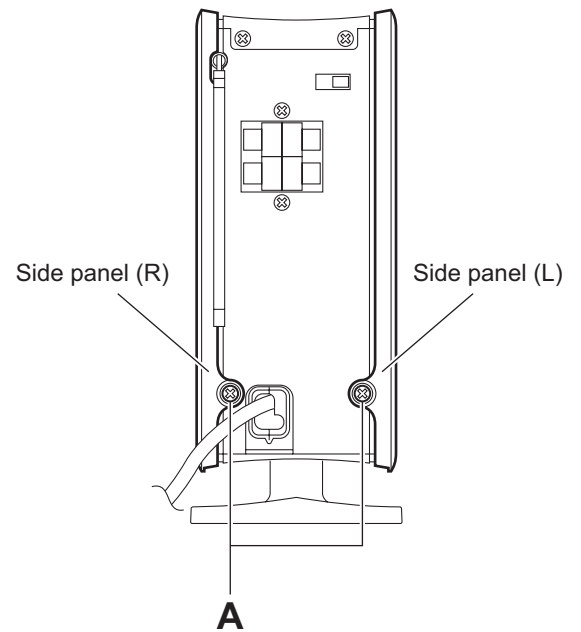

Fig.1

3.5.2 Removing the front board (See Figs.2 and 3)

- Prior to performing the following procedures, remove the side panel (L) and side panel (R).
 - (1) From the right side of the receiver assembly, remove the four screws **B** attaching the front board. (See Fig.2)
 - (2) From the back side of the receiver assembly, remove two screws **C** attaching the front board. (See Fig.3)
 - (3) From the right side of the receiver assembly, take out the front board, and disconnect the wires from the connectors [CN151](#), [CN152](#), [CN171](#) and [CN172](#) on the front board. (See Fig.2)

Caution:

When attaching the front board, exchange the spacer for the new part. If the front board is attached without exchanging the spacer, the chip parts may be damaged. (See Fig.2)

3.5.3 Removing the rear panel (See Figs.3 and 4)

- Prior to performing the following procedures, remove the side panel (L), side panel (R) and front board.
 - (1) From the back side of the receiver assembly, remove the two screws **D** attaching the rear panel. (See Fig.3)
 - (2) From the right side of the receiver assembly, cut off the tie bands. (See Fig.4)
 - (3) Take out the rear panel with RF module. (See Fig.4)

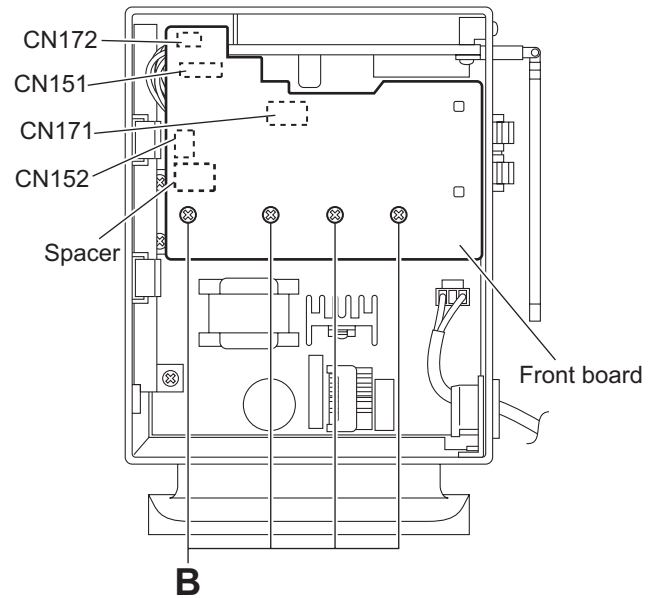

Fig.2

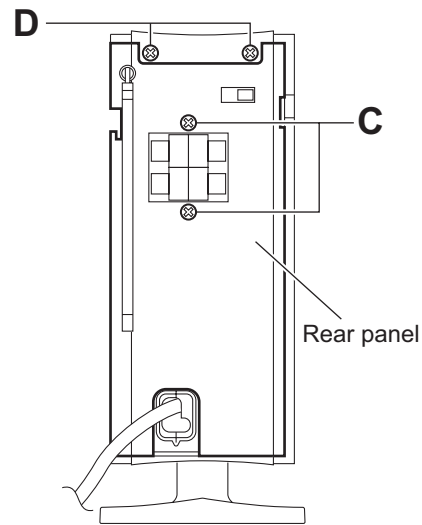

Fig.3

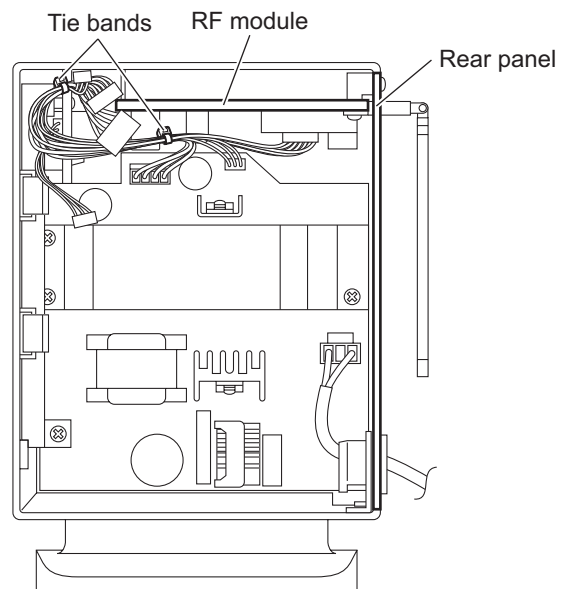

Fig.4

3.5.4 Removing the RF module and antenna (See Fig.5)

- Prior to performing the following procedures, remove the side panel (L), side panel (R), front board and rear panel.
 - (1) From the reverse side of the RF module, remove the screw **E** attaching the antenna to the rear panel and take out the antenna.
 - (2) Remove the screw **E'** attaching the RF module to the rear panel.
 - (3) Take out the RF module from the rear panel.

Reference:

When attaching the antenna, attach it through the hole **a** of the rear panel.

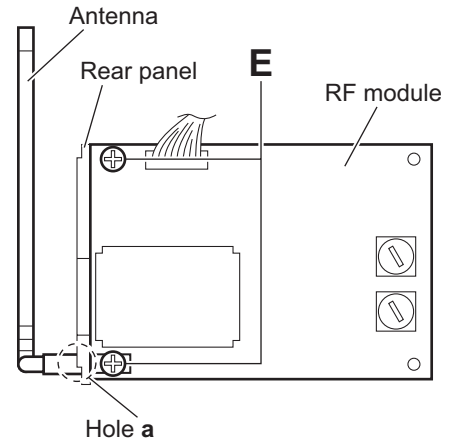

Fig.5

3.5.5 Removing the heat sink and power cord (See Fig.6)

- Prior to performing the following procedures, remove the side panel (L), side panel (R), front board and rear panel.
 - (1) From the right side of the receiver assembly, remove the three screws **F** attaching the heat sink to the power unit assembly.
 - (2) Take out the heat sink.
 - (3) Disconnect the power cord from the connector **CN3** on the power unit assembly.
 - (4) Take out the power cord.

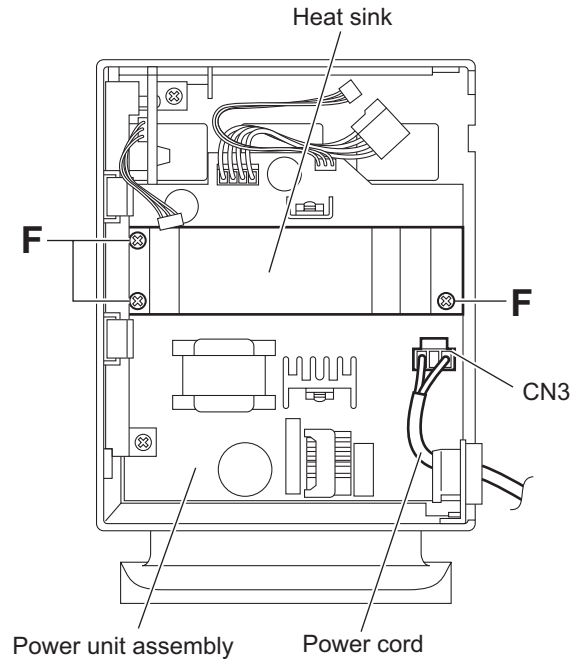
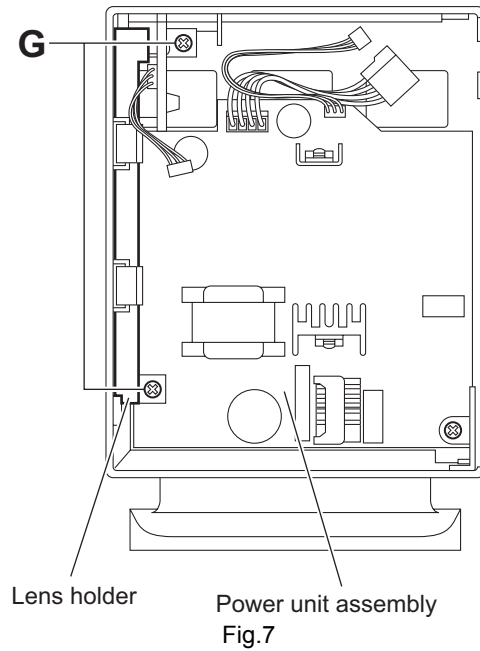

Fig.6

3.5.6 Removing the lens holder (See Fig.7)

- Prior to performing the following procedures, remove the side panel (L), side panel (R), front board, rear panel and heat sink.
 - (1) From the right side of the receiver assembly, remove the two screws **G** attaching the lens holder to the power unit assembly.
 - (2) Take out the lens holder.



3.5.7 Removing the power unit assembly (See Fig.8)

- Prior to performing the following procedures, remove the side panel (L), side panel (R), front board, rear panel, power cord and lens holder.
 - (1) From right side of the receiver assembly, remove the screw **H** attaching the power unit assembly.
 - (2) Take out the power unit assembly.

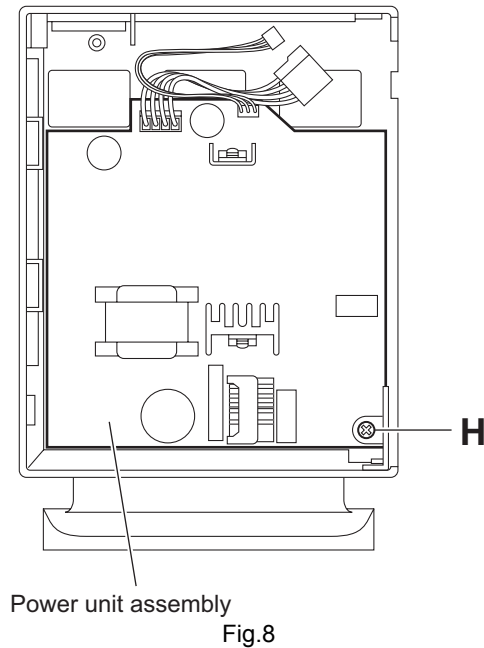

3.5.8 Removing the LED board (See Fig.9)

- Prior to performing the following procedures, remove the side panel (L), side panel (R), front board, rear panel, heat sink and lens holder.
 - (1) From the reverse side of the lens holder, remove the screw **J** attaching LED board to the lens holder.
 - (2) Release the two claws **b** attaching the LED board.
 - (3) Take out the LED board.

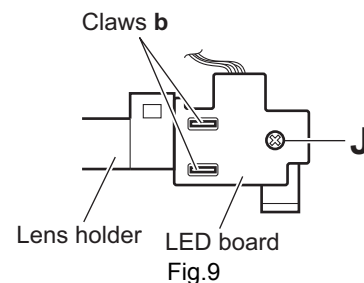

4.3 Method of displaying region code

- (1) Set the main body at test mode.
- (2) Press "MENU" key of the remote controller three times. Then, region code are displayed in the FL display.

4.4 Initialization method

Please initialize according to the following procedures in the following case:

- Just after you upgrade the firmware.
 - After you confirm the symptoms that a customer points out. First Initialize, and then confirm whether the symptoms are improved or not.
 - After servicing, before returning the main body to a customer. (Initialized main body should be returned to a customer.)
- (1) Set the main body at test mode.
 - (2) Press "PAUSE" key of the main body.
 - (3) When initialization is completed, "00" and "RDS" is displayed in the FL display.

4.5 Display of current value of laser

- (1) Set the main body at test mode.
- (2) Press "MENU" key of the remote controller five times. Then, FL display is displayed "CHECK".
- (3) The laser current value can be switched between the value of CD and that of DVD by pressing the following key of the remote controller.

FL Display (Example)

1419 0000

Remote controller "4" key --- Laser of CD
Remote controller "5" key --- Laser of DVD
Remote controller "6" key --- Jitter measurement mode

- The number shown in the FL display shows mA of current value of laser.
- The first two numbers ("14" in "1419") shows current value of laser at the time of adjustment after the latest all-initialization, 14mA in this example.
- The last two numbers ("19" in "1419") shows the present current value of laser, 19mA in this example.
- The first two numbers ("14" in "1419") usually shows current value of laser at the time of shipment, so you can see how the product has been deteriorated by comparing the first two numbers ("14" in "1419") and the last two numbers ("19" in "1419").

CD and DVD:

The laser current value of 80mA or less in normal. The laser current diode of the pickup has been deteriorated.

- To return to test mode, press "STOP" key of the main body.

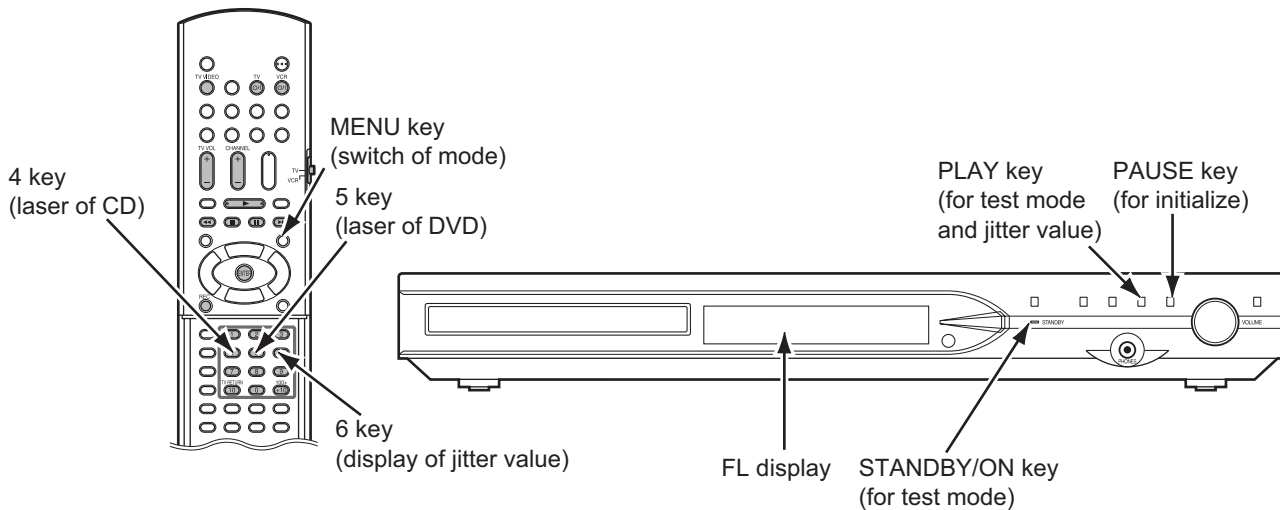

4.6 Upgrading of firmware (DVD UPGRADE)

The latest firmware for upgrading is updated in "Optical disc CSG" page in JS-net. At the time of service, compare the version of the product and the latest version, and upgrade the old version into the latest version.

- (1) Press "STANDBY/ON" key of the main body to turn it on.
- (2) Push "OPEN/CLOSE" key of the main body, and insert the upgrade disc in the tray.
- (3) When reading the data of the disc, the OSD screen is displayed "VERSION UP DISC", "PROGRAM & DESTINATION MODE" and "READING..".
- (4) When the screen changes from "READING.." to "WRITING..", upgrading starts.
- (5) After writing the data of the disc, the screen is displayed "OPEN".
- (6) Take out the disc, and press "STANDBY/ON" key of the main body.
- (7) When the stand-by indicator is lighted, upgrading is completed.
- (8) Set the main body at test mode, and confirm the version of the firmware. (Refer to "4.2 Method of displaying version firmware".)

4.7 Upgrading of system microcomputer (ROM CORRECTION)

- (1) Press "STANDBY/ON" key of the main body to turn it on.
- (2) Push "OPEN/CLOSE" key of the main body, and insert the upgrade disc in the tray.
- (3) When reading the data of the disc, the OSD screen is displayed "VERSION UP DISC", "SYSCON UPG MODE" and "READING..".
- (4) When the screen changes from "READING.." to "WRITING..", system data is written.
- (5) After writing the data of the disc, the FL display of the main body is displayed "COMPLETE".
- (6) Take out the disc, and press "STANDBY/ON" key of the main body.
- (7) When the stand-by indicator is lighted, upgrading is completed.
- (8) Set the main body at test mode, and confirm the version of the system microcomputer. (Refer to "4.2 Method of displaying version firmware".)

4.8 Upgrading of DVD region

- (1) Set the main body at test mode.
 - (2) Jig controller is connected to a terminal of AV COMPULINK.
 - (3) Use the controller, and transmit the command of rewriting region to a module.
- When the command is received as status, INFO segment of FL display.

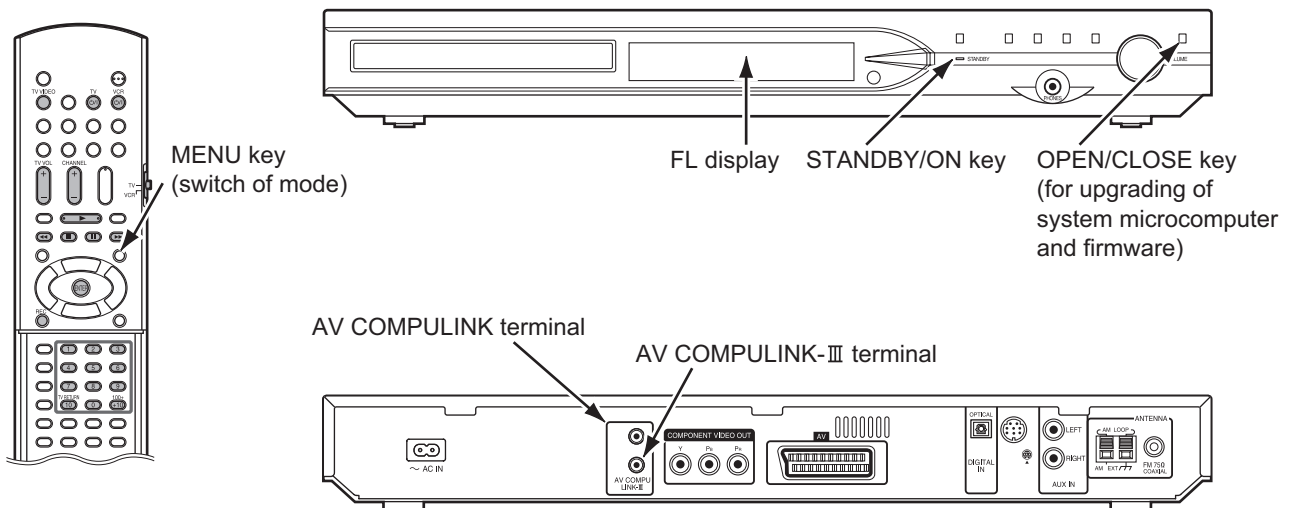

4.9 Compulsive NTSC mode

- (1) Unplug the power plug.
- (2) Insert power plug into outlet while pressing both "PAUSE" key and "STANDBY/ON" key of the main body.
- (3) The compulsive NTSC mode is set up.

NOTE:

In E series, Y/C mode is set up.

- (4) Unless the mode is canceled, regardless of input of "NTSEL" switch, it starts only at the time of the first power-on.
- (5) When power-off is carried out, the mode is canceled.

4.10 Locking disc tray

- (1) Unplug the power plug.
- (2) Insert power plug into outlet while pressing both "STOP" key and "OPEN/CLOSE" key of the main body.
- (3) Then, the FL display of main body is displayed "LOCKED" and the disc tray is locked.
- (4) For unlock the tray, press both "STOP" key and "OPEN/CLOSE" key.
- (5) Then, the FL display of main body is displayed "UNLOCKED" and the tray is unlocked.

NOTE:

Unless unlocking disc tray, it does not process to input "OPEN/CLOSE" key.

4.11 Switching tuner AM step (U series only)

- Switching 9kHz
 - (1) Press both "STOP" key and "PLAY" key of the main body.
- Switching 10kHz
 - (1) Press both "STOP" key and "PAUSE" key of main body.

NOTE:

Switching tuner AM step is effective only when source is AM.

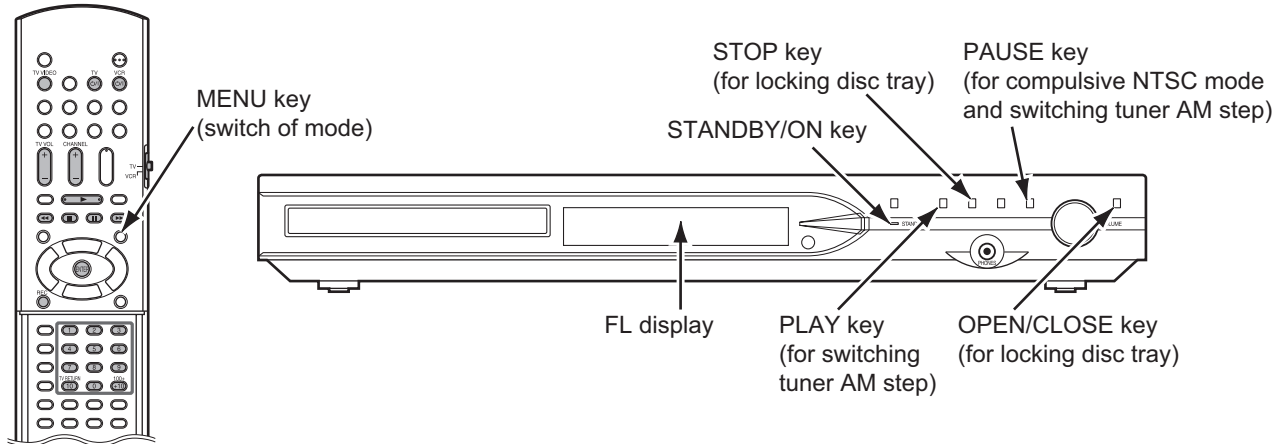

SECTION 5 TROUBLESHOOTING

This service manual does not describe TROUBLESHOOTING.



JVC

Victor Company of Japan, Limited
AV & MULTIMEDIA COMPANY AUDIO/VIDEO SYSTEMS CATEGORY 10-1,1chome,Ohwatari-machi,Maebashi-city,371-8543,Japan

(No.MB260)

JVC

SCHEMATIC DIAGRAMS

DVD DIGITAL CINEMA SYSTEM

TH-SW9, TH-SW8

CD-ROM No.SML200407

Area suffix

B ----- U.K.
E ----- Continental Europe
EN ----- Northern Europe
EV ----- Eastern Europe

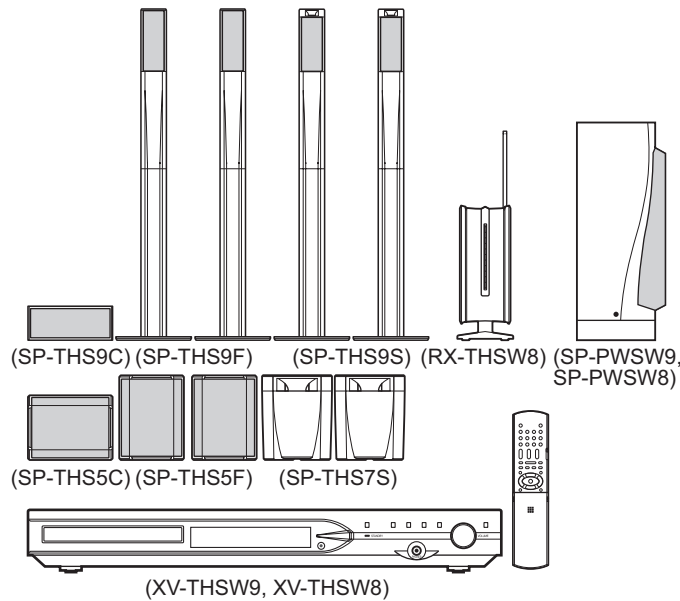

Digital Direct Progressive Scan

Contents

Block diagrams	2-1
Standard schematic diagrams	2-3 to 12
Printed circuit boards	2-13 to 17

In regard with component parts appearing on the silk-screen printed side (parts side) of the PWB diagrams, the parts that are printed over with black such as the resistor (■), diode (▬) and ICP (●) or identified by the "▲" mark nearby are critical for safety.

(This regulation does not correspond to J and C version.)

Block diagrams

<Main body section>

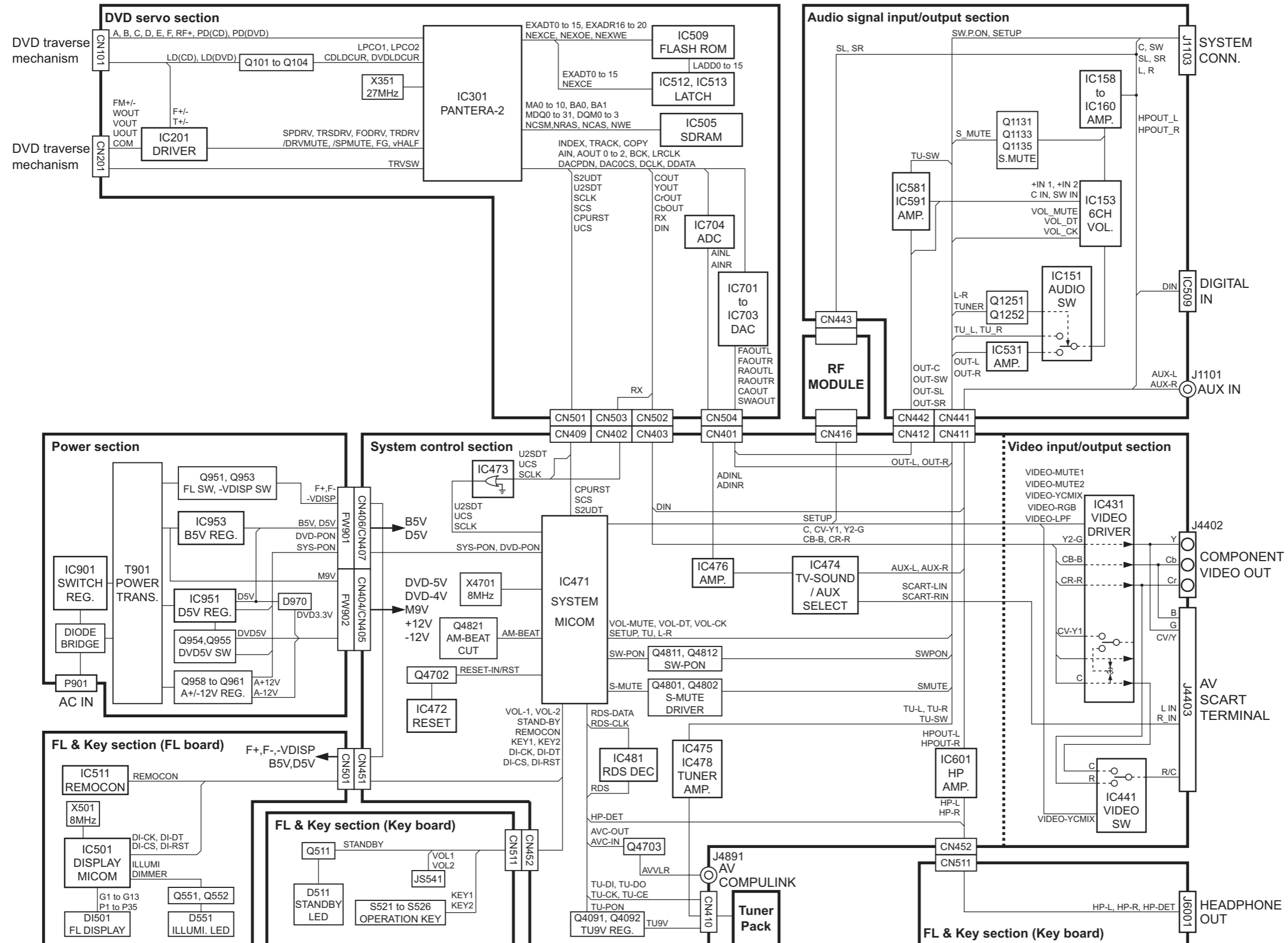

<Subwoofer section>

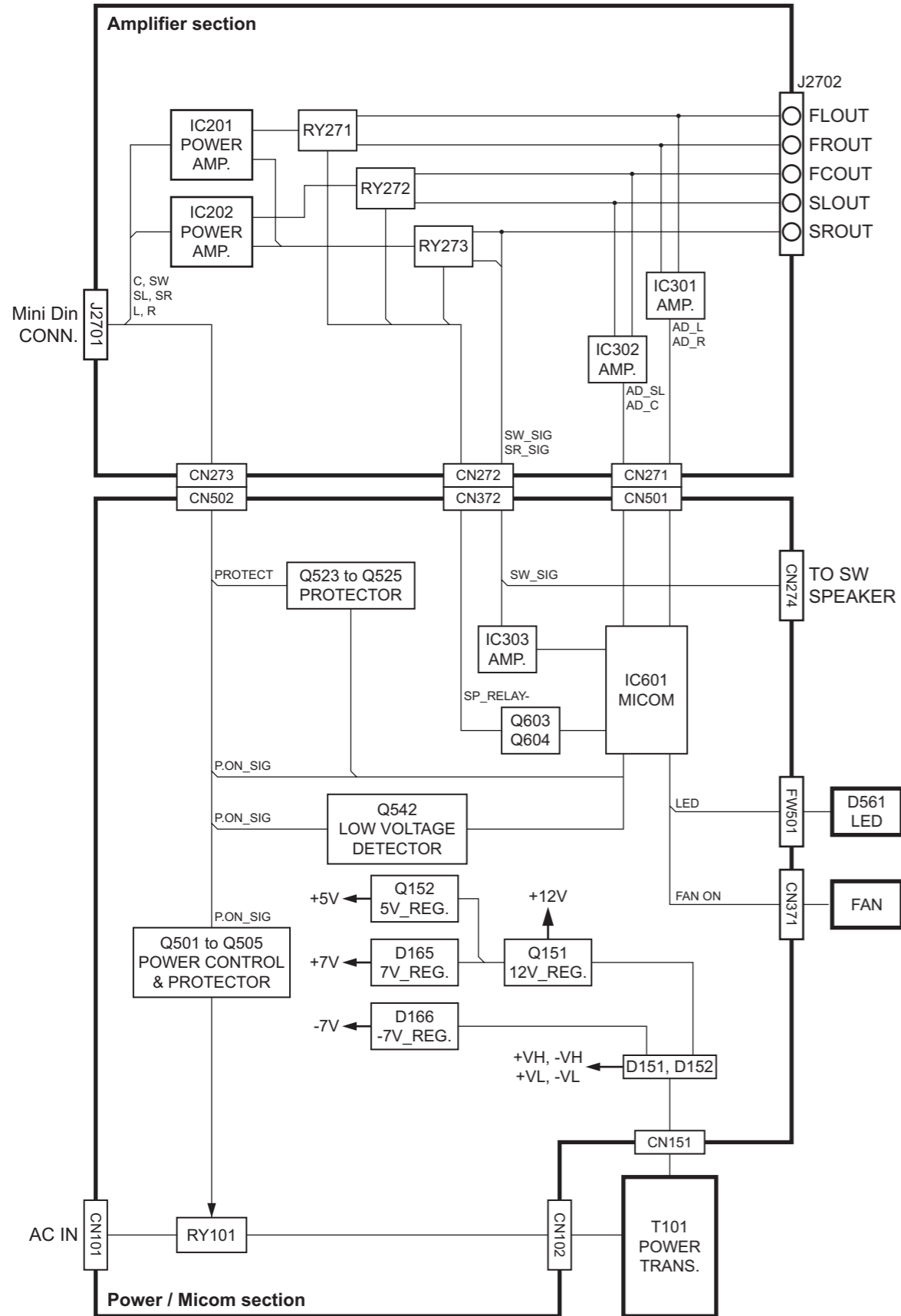

<Receiver unit section>

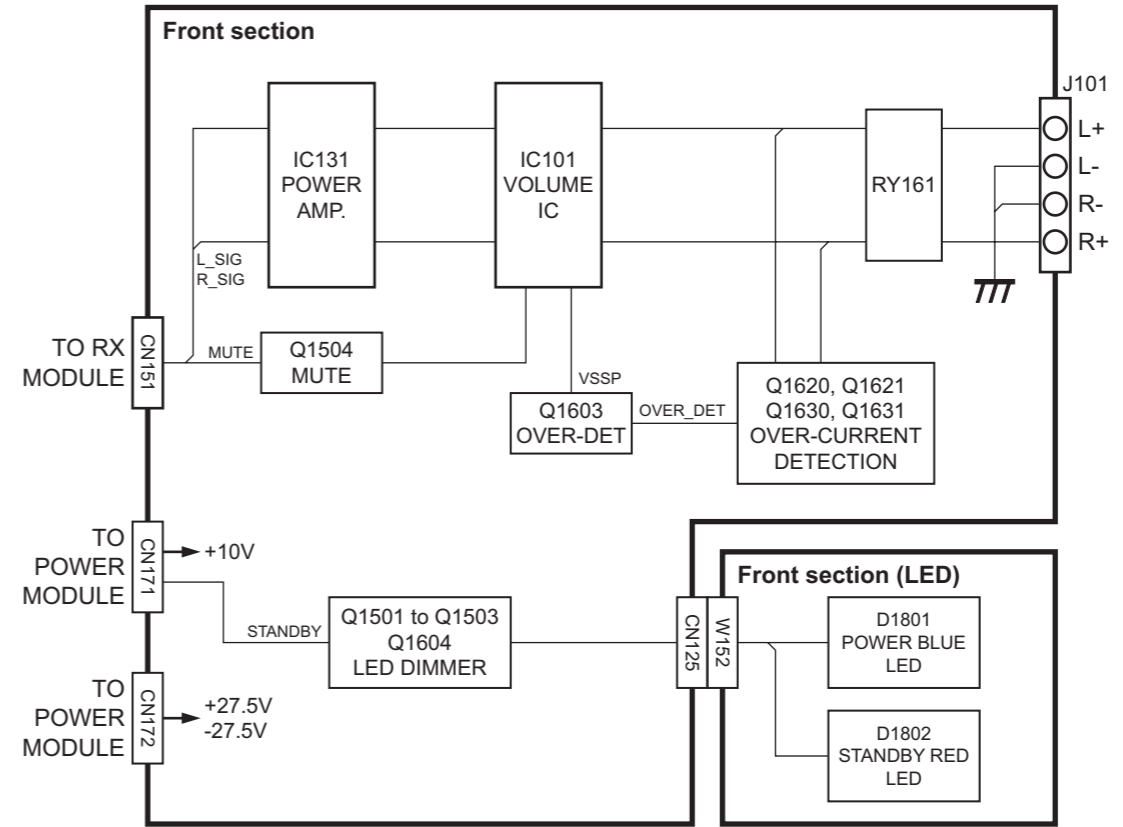

System control section

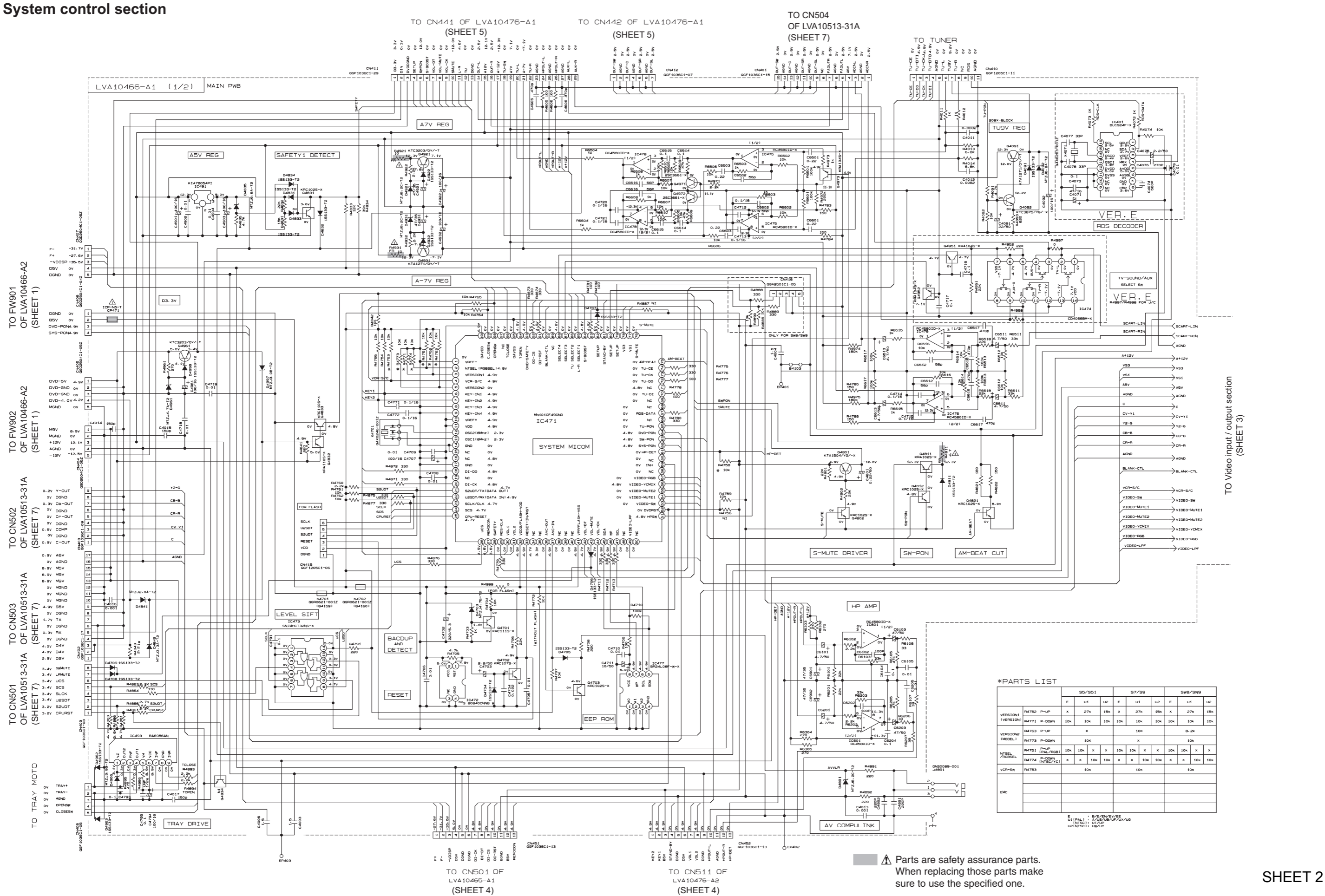

*PARTS LIST

VERSION1 (VERSION1)	R4752 P-UP	S5/S5.1		S7/S9		S8/S8.9							
		E	U1	U2	E	U1	U2	E	U1	U2			
VERSION1 (MODEL1)	R4771 P-DOWN	X	27k	10k	X	27k	10k	X	27k	10k	X	27k	10k
VERSION2 (MODEL1)	R4773 P-UP	X	10k	10k	X	10k	10k	X	10k	10k	X	10k	10k
VERSION2 (MODEL1)	R4773 P-DOWN	X	10k	10k	X	10k	10k	X	10k	10k	X	10k	10k
NTSEL /RBSSEL	R4751 P-UP (REAL/RGB)	10k	10k	X	X	10k	10k	X	X	10k	10k	X	X
VCR-SW	R4774 P-DOWN (NTSC/CI)	X	X	10k	10k	X	X	10k	10k	X	X	10k	10k
EMC	R4753	10k				10k				10k			

E: U1/PALL, B/E/TV/VE/EE
 U1: U1/PALL, B/E/TV/VE/EE
 U2: U2/UP, U1/UP, U2/UP, U1/UP

⚠ Parts are safety assurance parts. When replacing those parts make sure to use the specified one.

Video input / output section

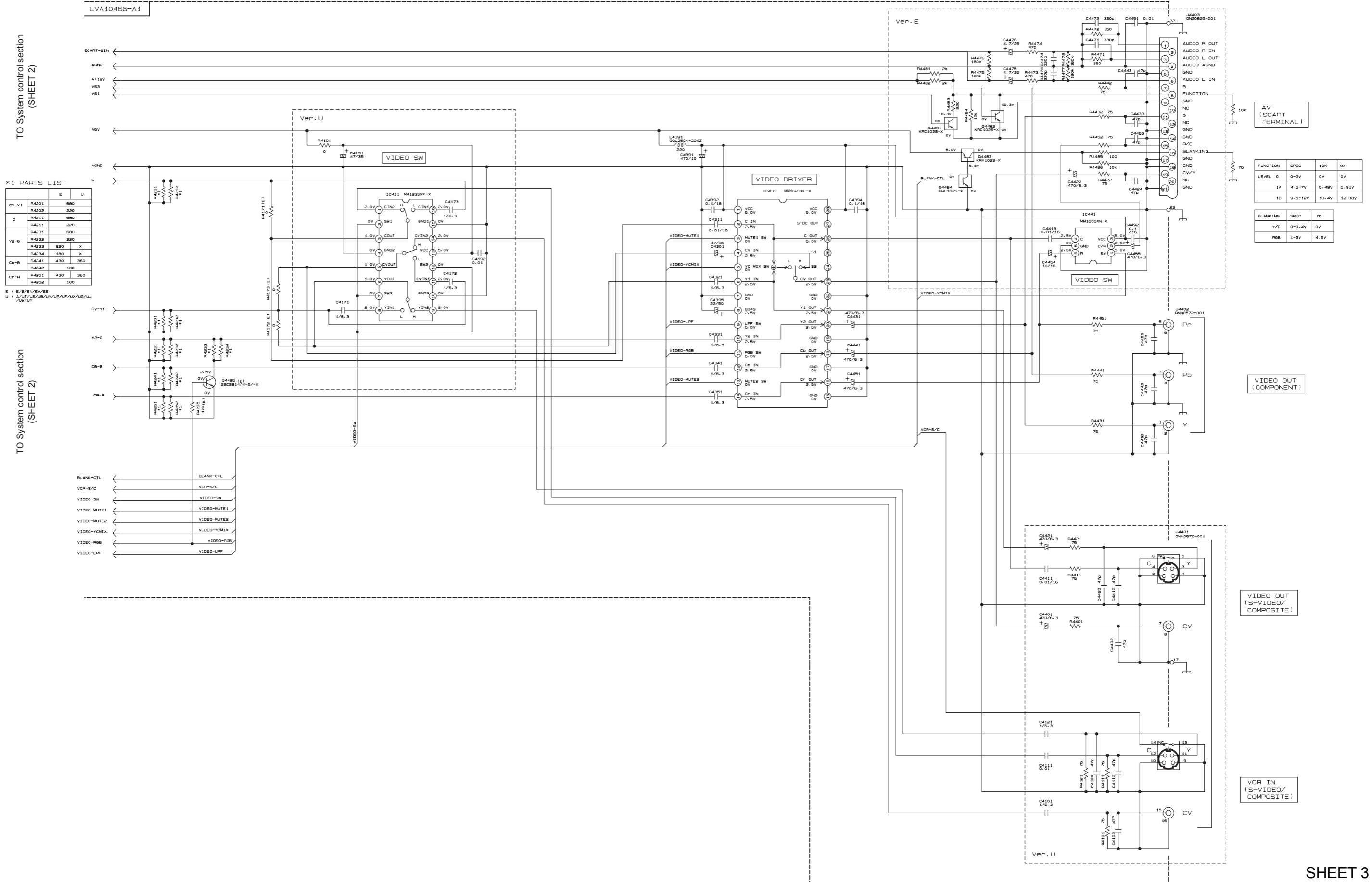

TO System control section
(SHEET 2)

*1 PARTS LIST

CV-Y1	E	U
R4201	680	
R4202	220	
R4211	680	
R4212	220	
R4231	680	
R4232	220	
R4233	820	X
R4234	180	X
R4241	430	360
R4242	100	
R4251	430	360
R4252	100	

E : E/B/EV/EVE
U : A/U/T/U/S/U/B/U/V/U/P/U/F/U/K/U/G/U/J/
/U/M/U/Y

TO System control section
(SHEET 2)

FUNCTION	SPEC	10K	∞
LEVEL 0	0-2V	0V	0V
1A	4.5-7V	5.49V	5.91V
1B	9.5-12V	10.4V	12.08V

BLANKING	SPEC	∞
Y/C	0-0.4V	0V
RGB	1-3V	4.0V

FL & Key section

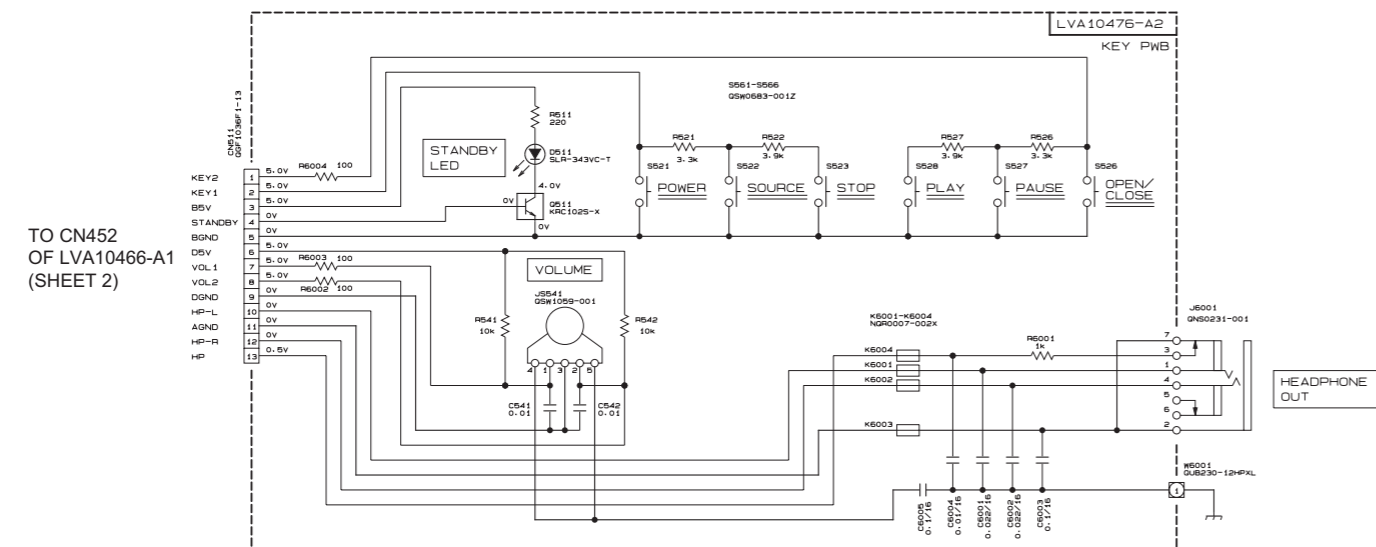
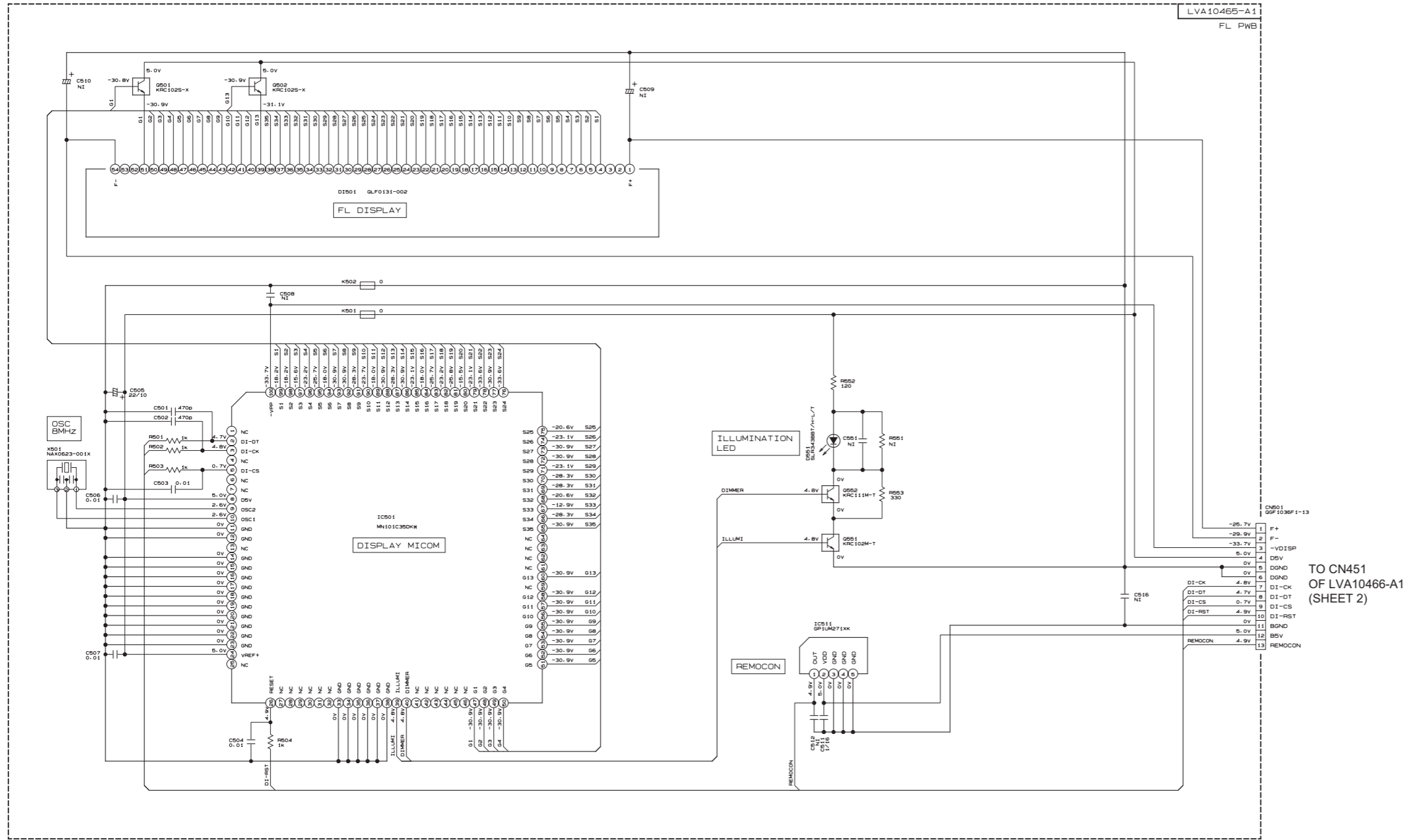

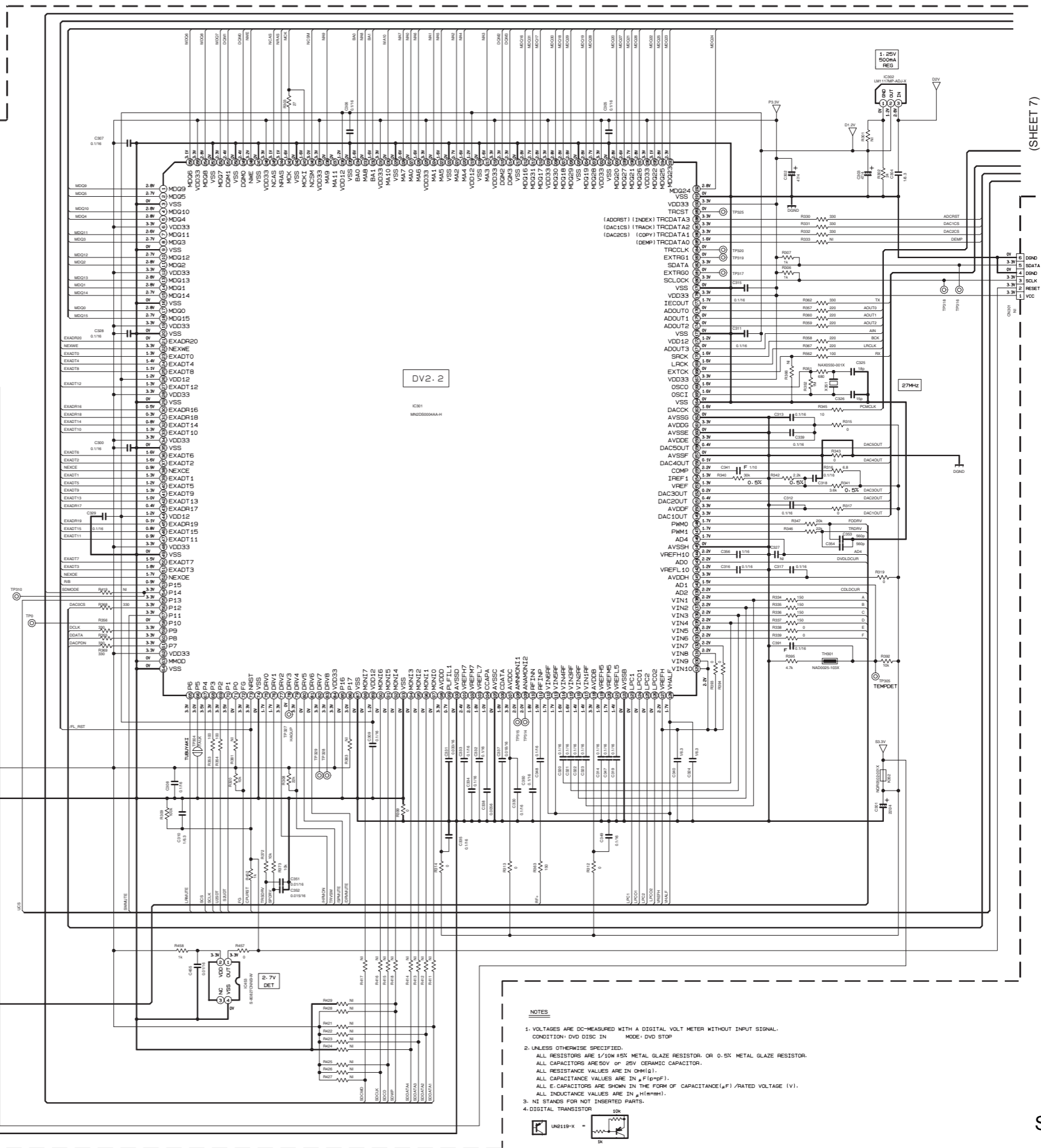
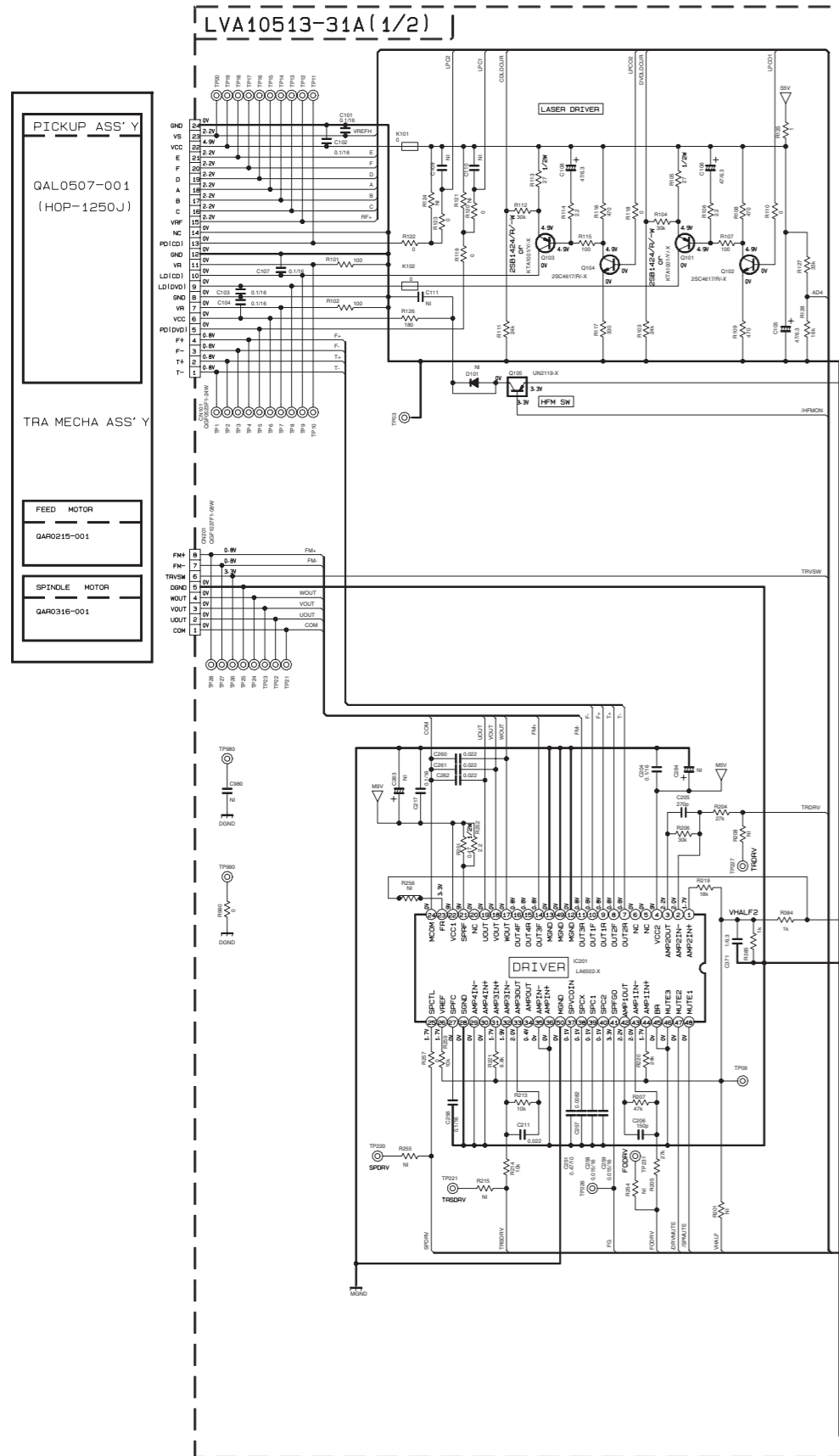

■ DVD servo section (2/2)

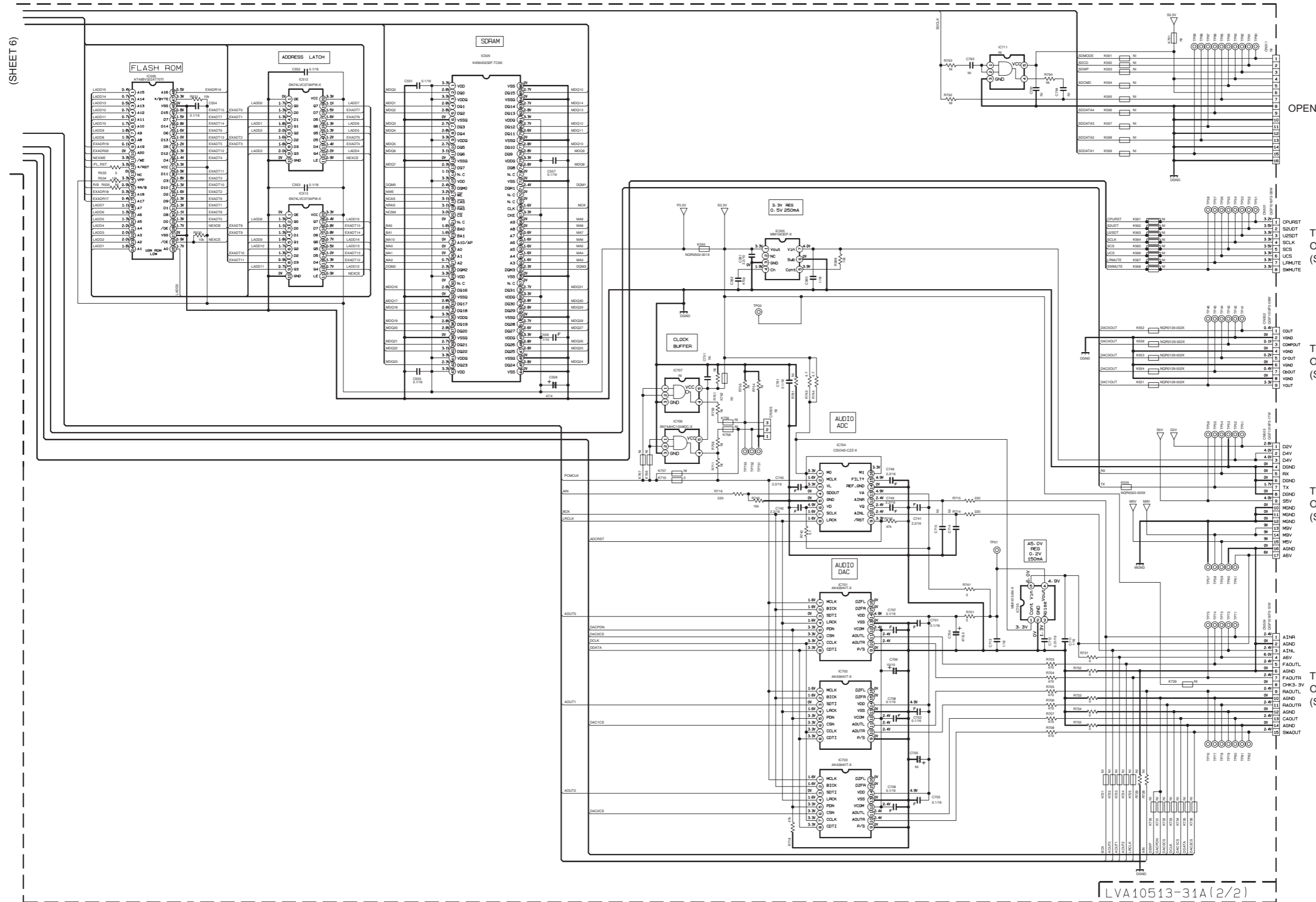

NOTES

1. VOLTAGES ARE DC-MEASURED WITH A DIGITAL VOLT METER WITHOUT INPUT SIGNAL. CONDITION: DVD DISC IN MODE: DVD STOP
2. UNLESS OTHERWISE SPECIFIED:
 ALL RESISTORS ARE 1/10W ±5% METAL GLAZE RESISTOR, OR 0.5% METAL GLAZE RESISTOR.
 ALL CAPACITORS ARE 50V or 25V CERAMIC CAPACITOR.
 ALL RESISTANCE VALUES ARE IN OHM(Ω).
 ALL CAPACITANCE VALUES ARE IN pF(pF).
 ALL E-CAPACITORS ARE SHOWN IN THE FORM OF CAPACITANCE(μF)/RATED VOLTAGE (V).
 ALL INDUCTANCE VALUES ARE IN mH(mH).
 3. NI STANDS FOR NOT INSERTED PARTS.

<Subwoofer section>

■ Amplifier section

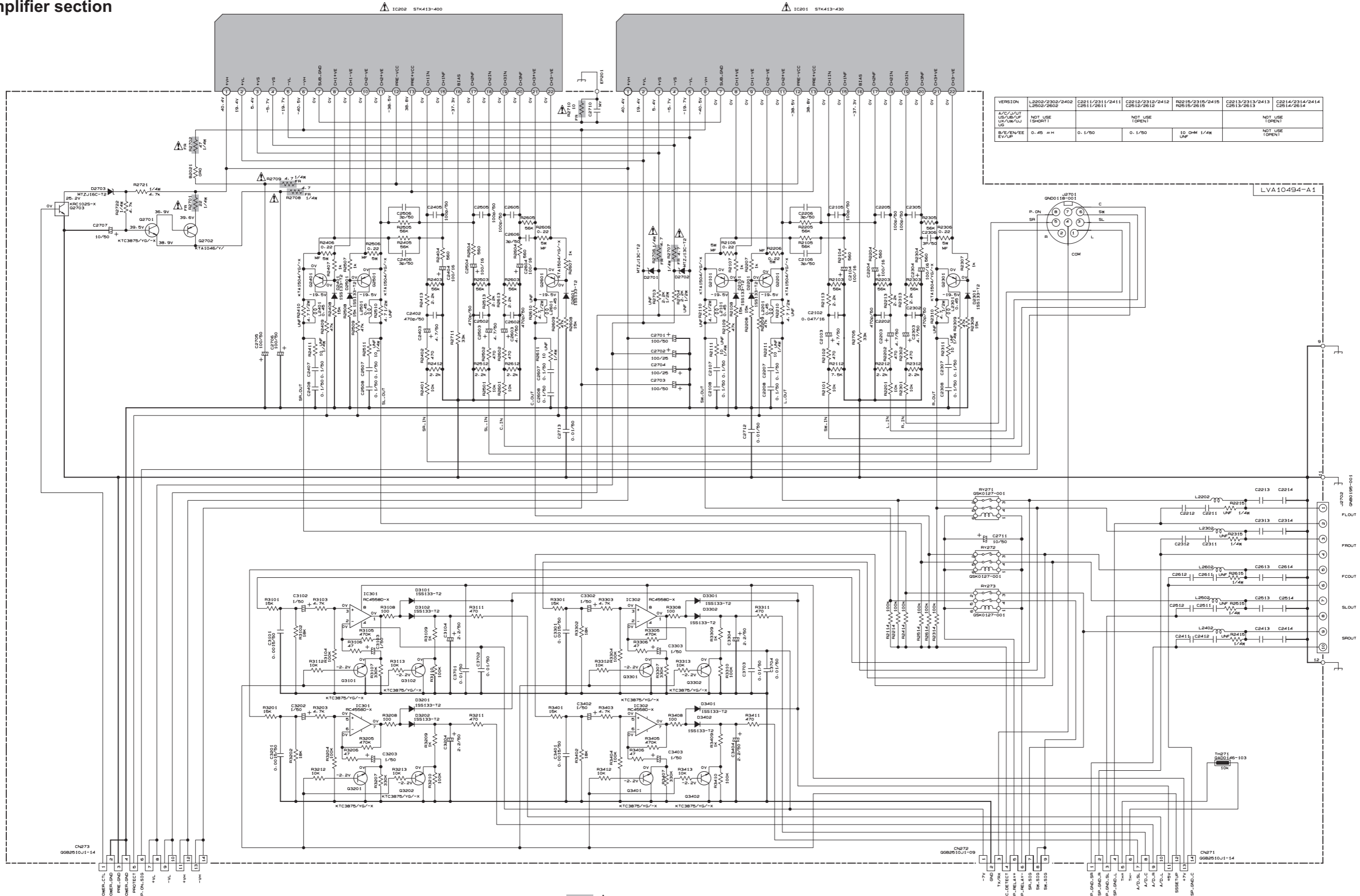

TO CN502
OF LVA10494-A2
(SHEET 9)

NOTES: UNLESS OTHERWISE SPECIFIED,
ALL RESISTANCE VALUES ARE IN OHMS.
ALL INDUCTANCE VALUES ARE IN H.
ALL CAPACITANCE VALUES ARE IN μF. (D*PF)
ALL CAPACITORS ARE SHOWN IN THE FORM OF CAPACITANCE(μF)/RATED VOLTAGE(V).
VOLTAGES ARE DC-MEASURED WITH A DIGITAL VOLT METER WITHOUT INPUT SIGNAL.

▲ Parts are safety assurance parts.
When replacing those parts make
sure to use the specified one.

TO CN372
OF LVA10494-A2
(SHEET 9)

TO CN501
OF LVA10494-A2
(SHEET 9)

<Receiver unit section>

■ Front section

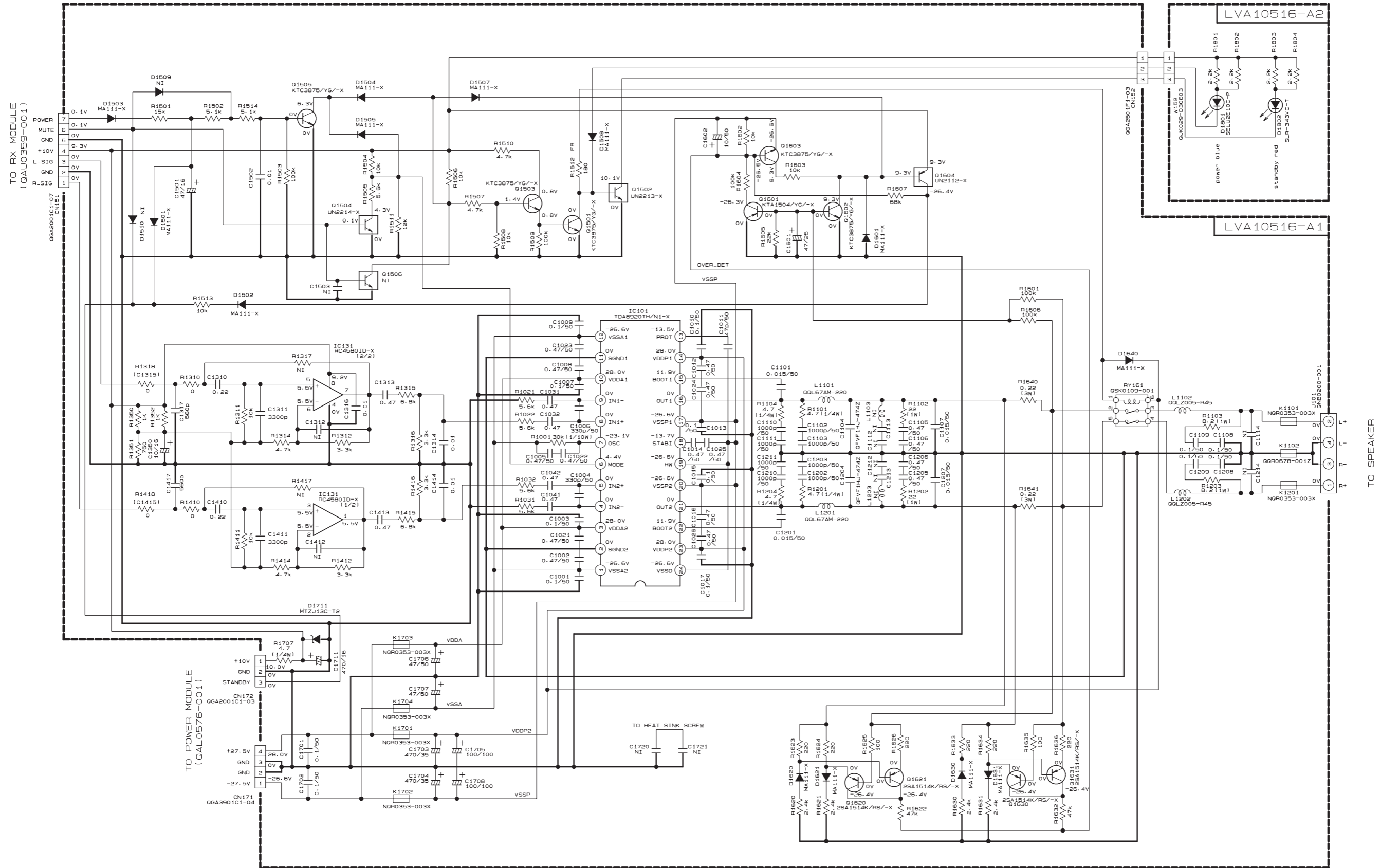

NOTES: UNLESS OTHERWISE SPECIFIED.
 1. VOLTAGES ARE DC-MEASURED WITH A DIGITAL VOLT METER WITHOUT INPUT SIGNAL.
 2. UNLESS OTHERWISE SPECIFIED,
 ALL RESISTORS ARE 1/16W OR 1/10W, ±5%
 ALL CAPACITANCES ARE CERAMIC CHIP CAPACITOR.
 ALL RESISTOR VALUES ARE IN OHM.
 ALL CAPACITANCE VALUES ARE IN UF (µF)
 ALL CAPACITORS ARE SHOWN IN THE FORM OF CAPACITANCE(UF)/RATED VOLTAGE(V)
 ALL INDUCTANCES VALUES ARE IN µH(m=MH)
 3. NI STANDS FOR NOT INSERTED PARTS.

Printed circuit boards

<Main body section>

■ Main board

(Main board)

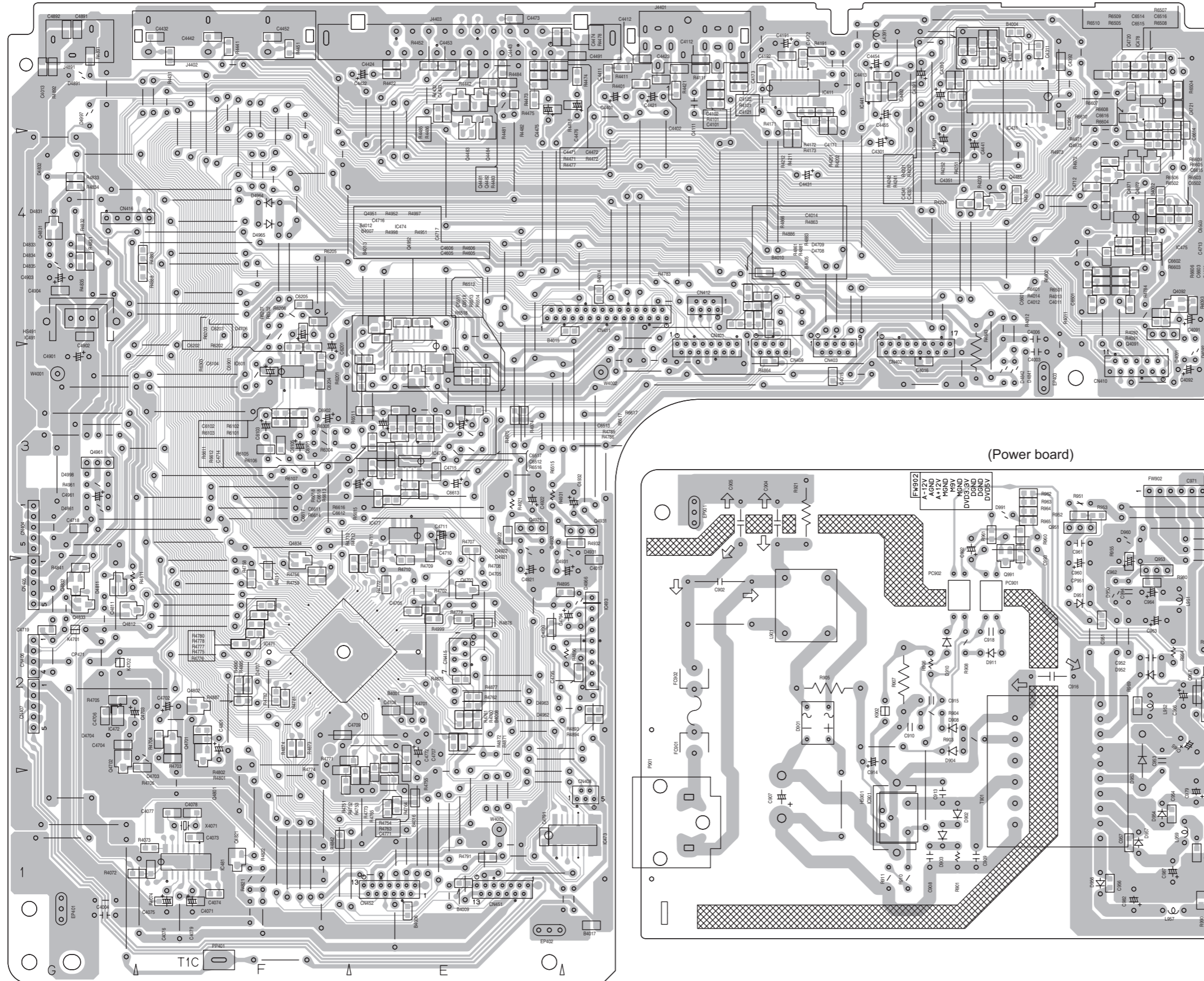

(Power board)

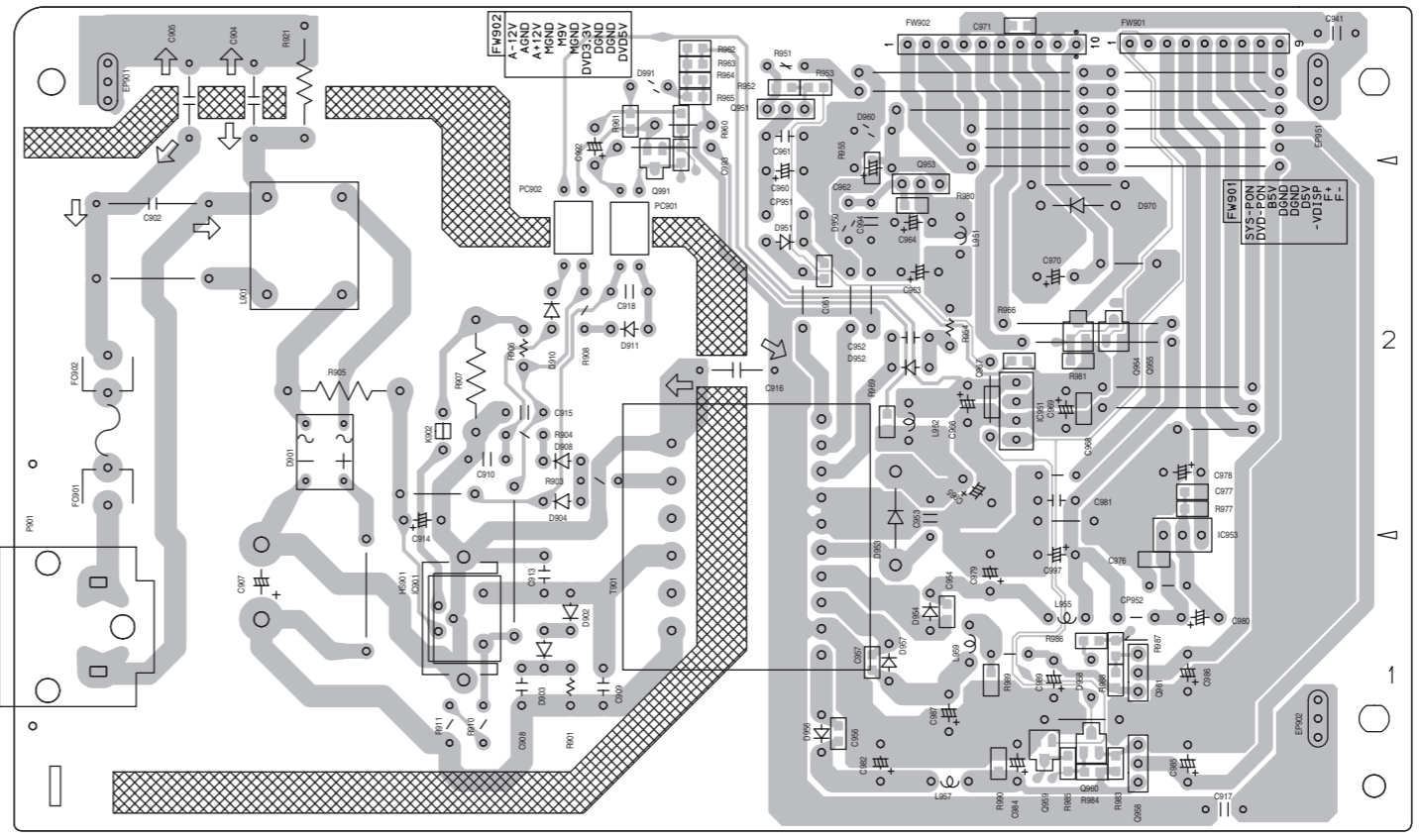

■ FL board

Forward side

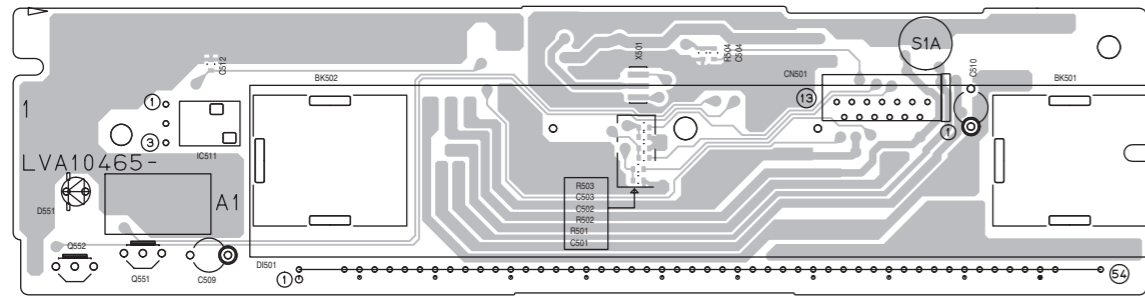

Reverse side

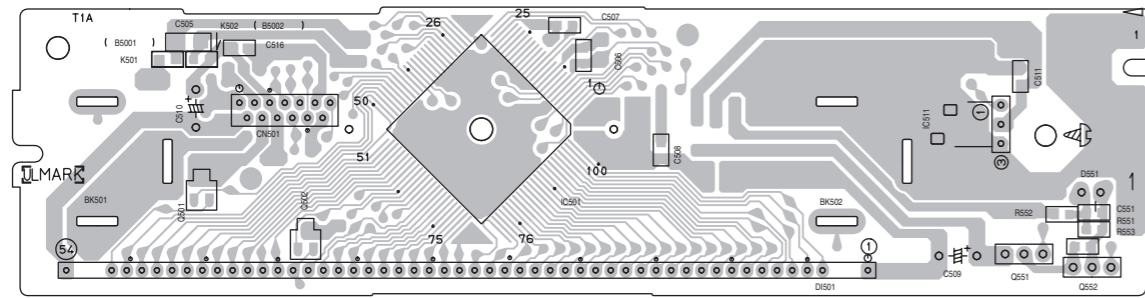

■ TX ant board

Forward side

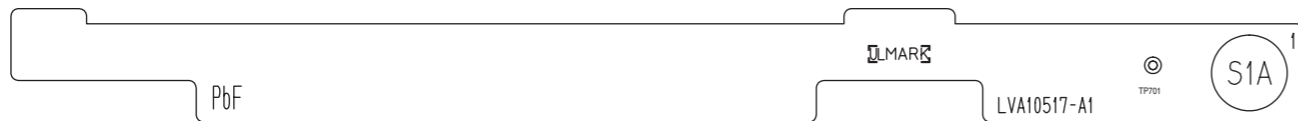

Reverse side

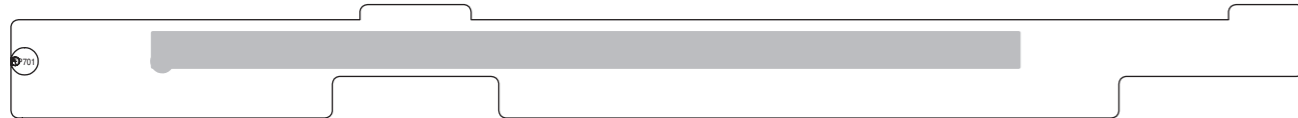

■ Audio board

(Audio signal input / output board)

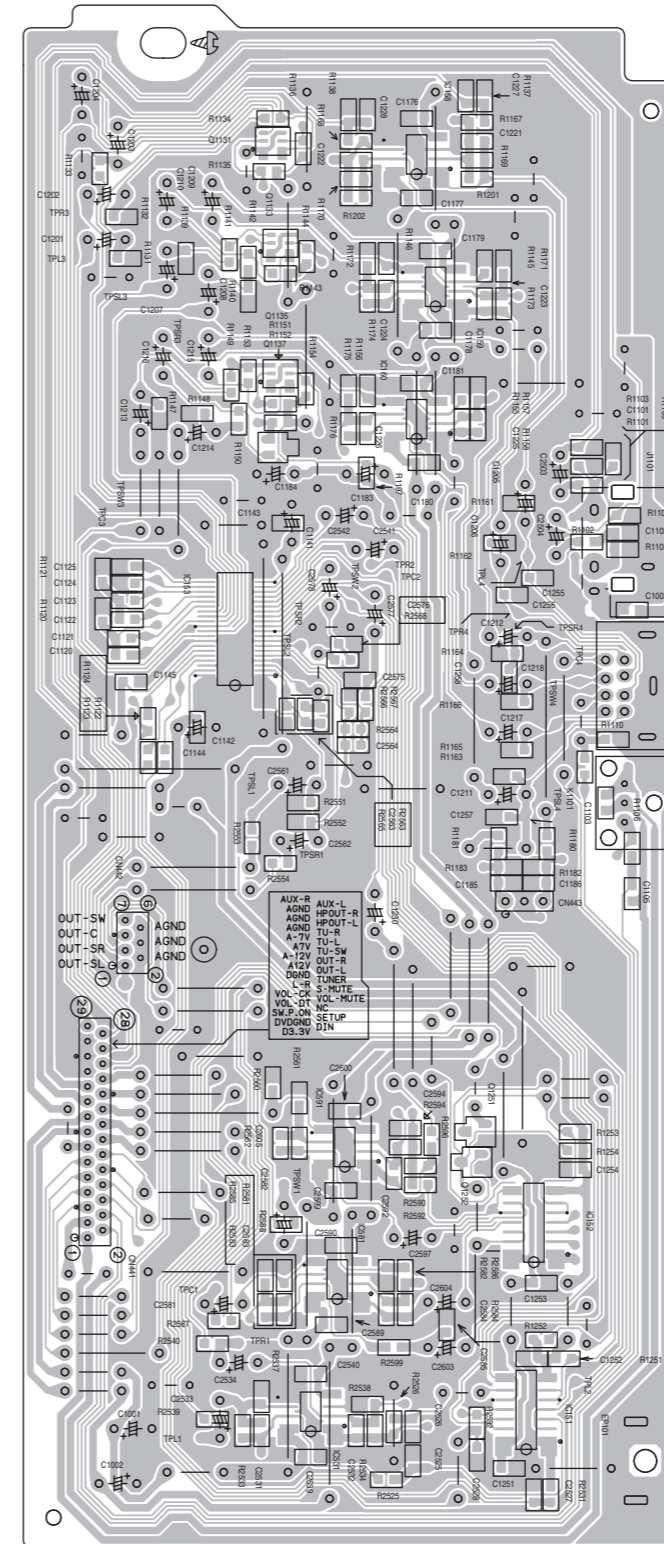

(Key board)

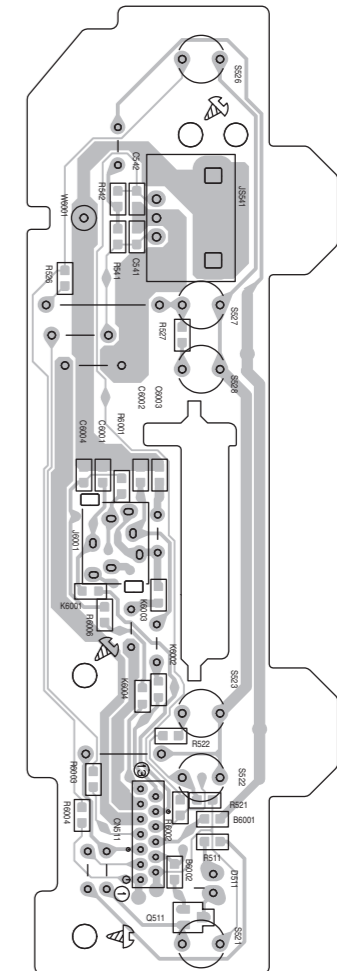

■ DVD servo board

Forward side

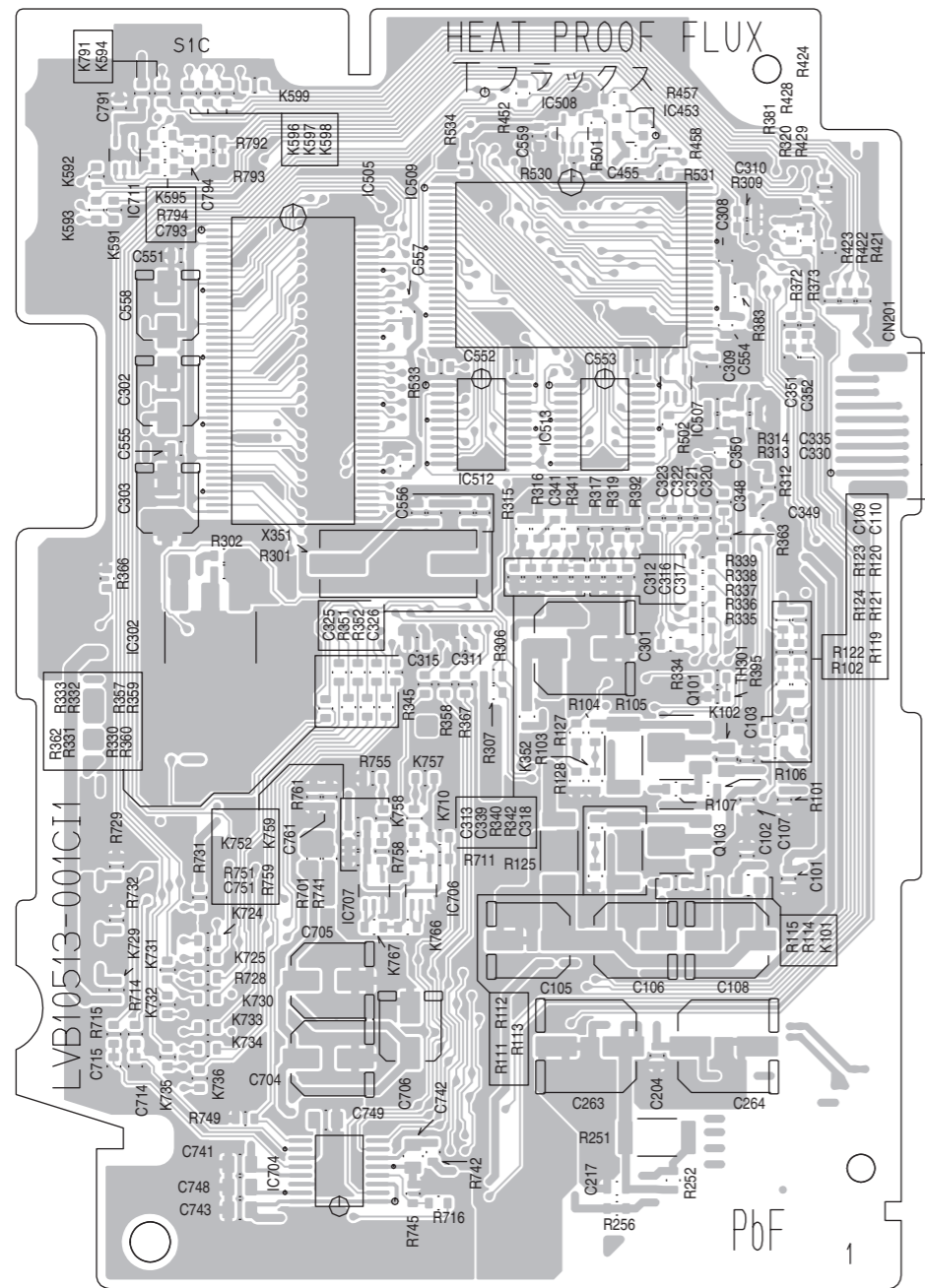

Reverse side

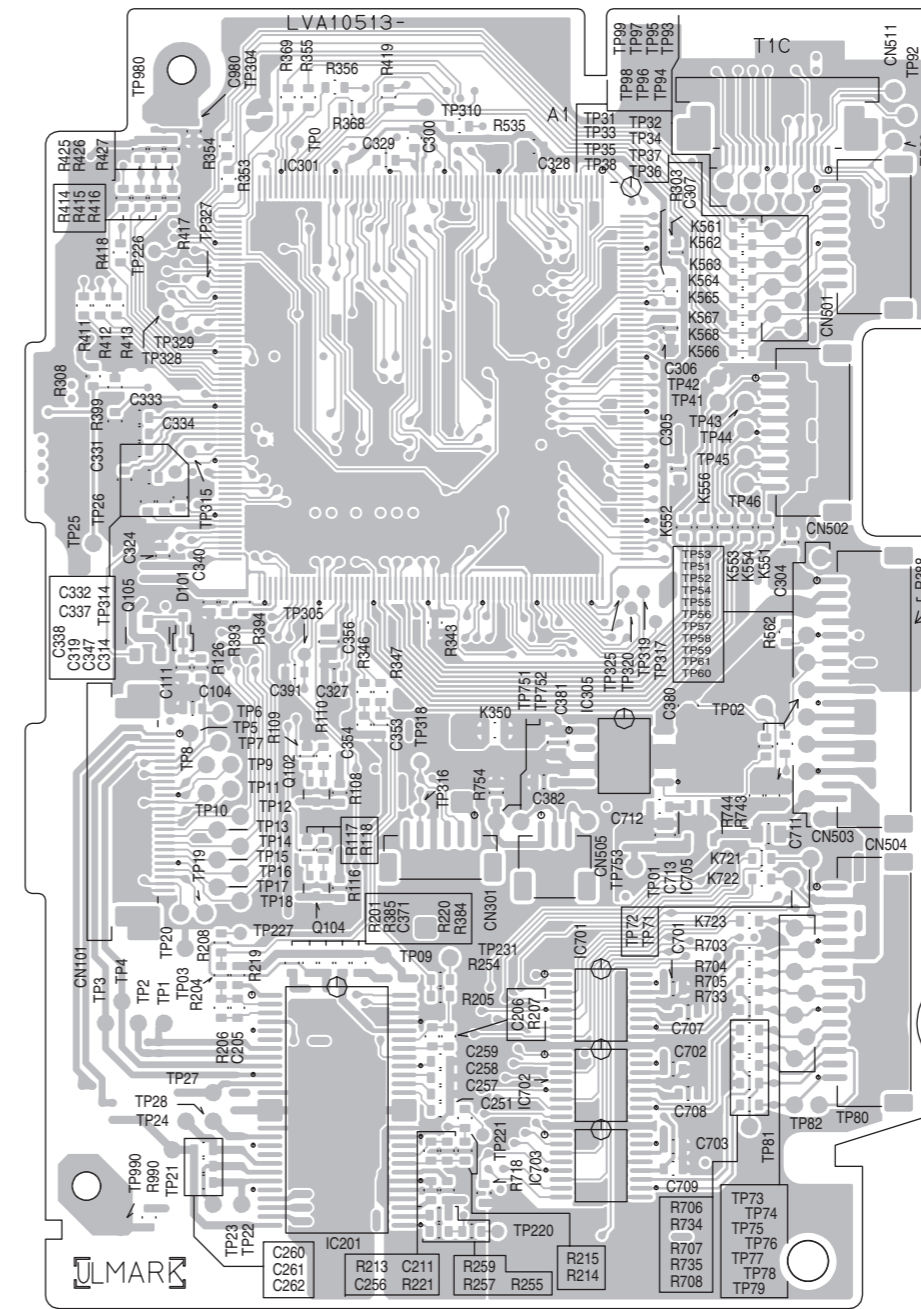

■ DVD loading switch board

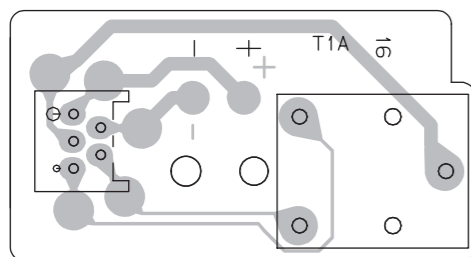

<Subwoofer section>

■ Amp. board

(Amplifier board)

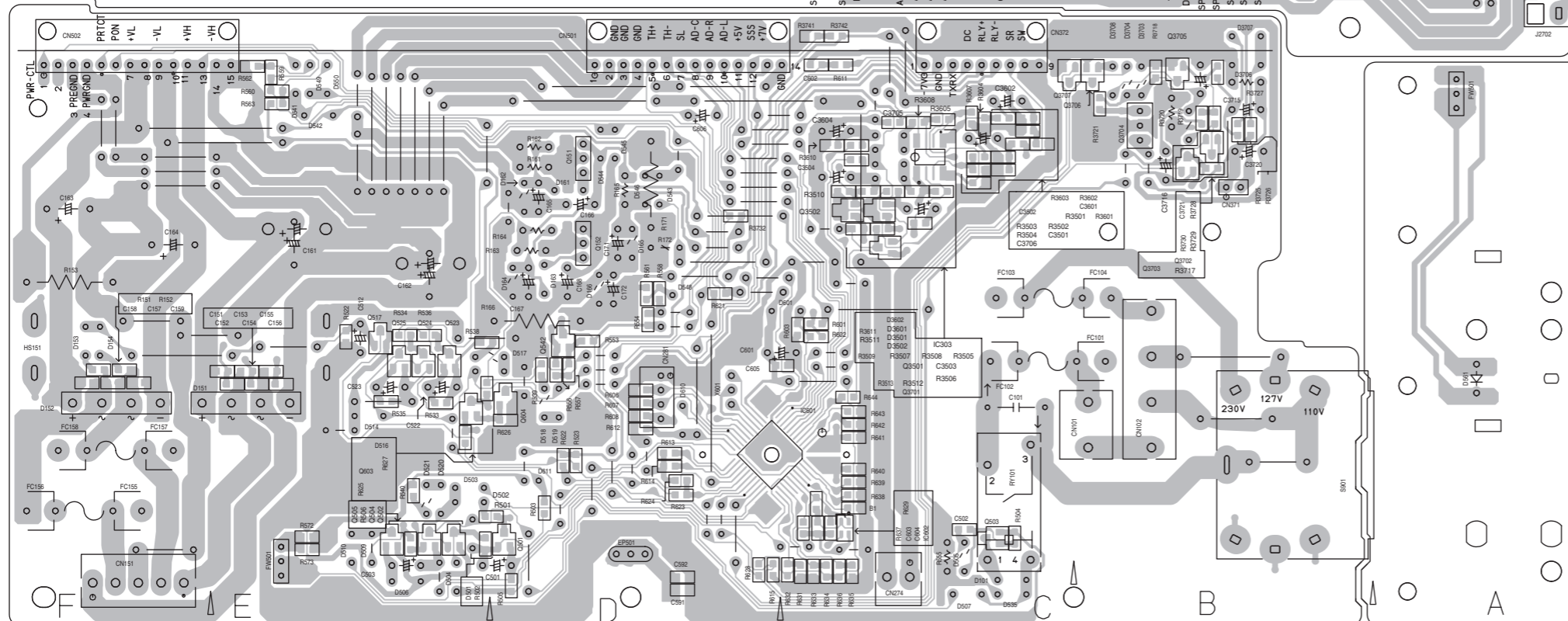
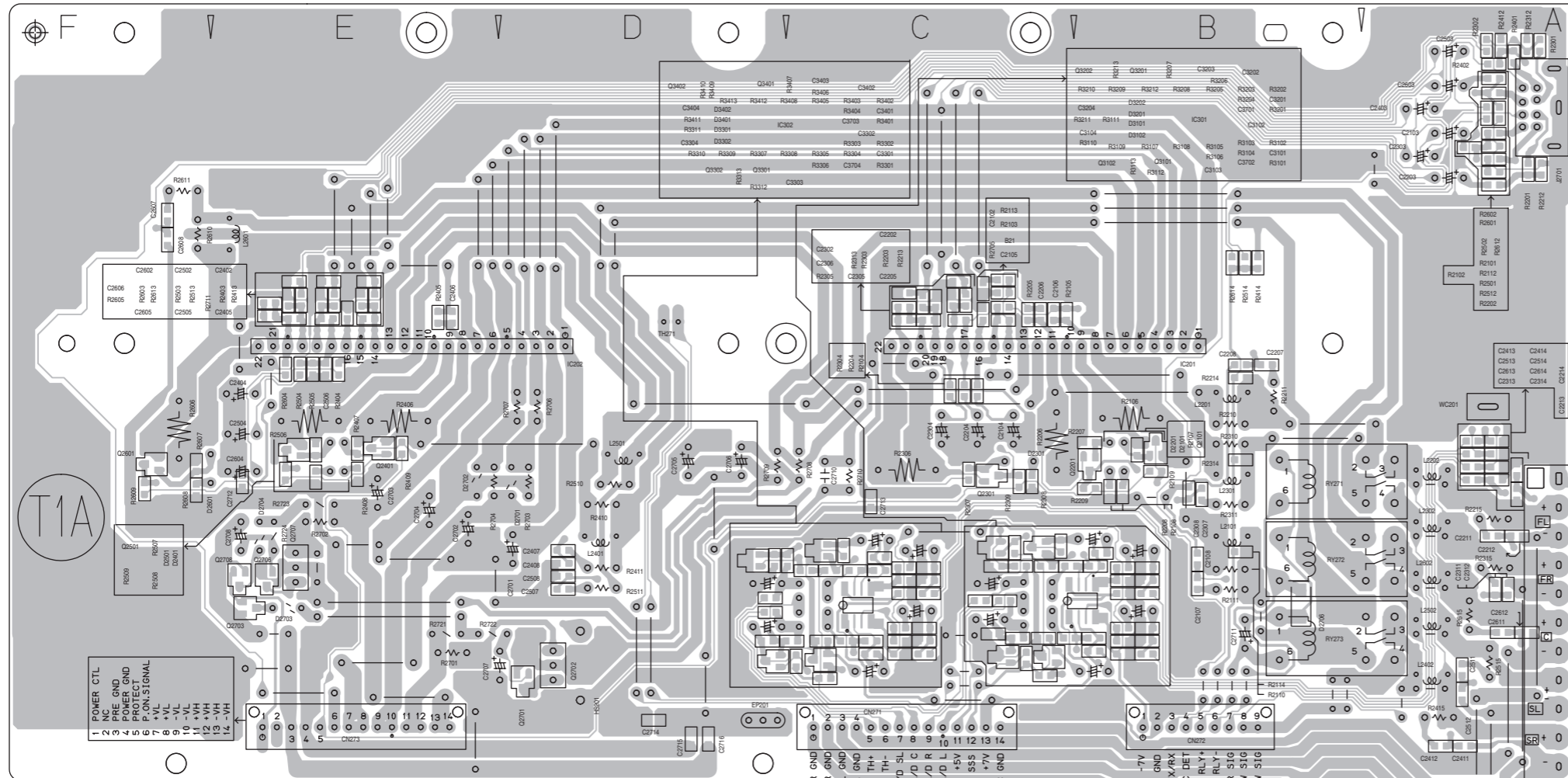

(Power / Micom board)

(LED board)

JVC

Victor Company of Japan, Limited

AV & MULTIMEDIA COMPANY AUDIO/VIDEO SYSTEMS CATEGORY 10-1, 1chome, Ohwatari-machi, Maebashi-city, 371-8543, Japan

(No.MB260SCH)



Printed in Japan
WPC

PARTS LIST

[TH-SW9]
[TH-SW8]

* All printed circuit boards and its assemblies are not available as service parts.

Area suffix

B ----- U.K.
E ----- Continental Europe
EN ----- Northern Europe
EV ----- Eastern Europe

- Contents -

Exploded view of general assembly and parts list (Block No.M1)	3- 2
Receiver assembly and parts list (Block No.M2)	3- 5
Speaker assembly and parts list(Subwoofer) (Block No.M6)	3- 7
DVD mechanism assembly and parts list (Block No.MJ)	3- 9
DVD loading base assembly and parts list (Block No.MN)	3-11
Electrical parts list (Block No.01~08)	3-13
Packing materials and accessories parts list (Block No.M3) (TH-SW9)	3-26
Packing materials and accessories parts list (Block No.M4) (TH-SW8)	3-28

Exploded view of general assembly and parts list

Block No.

M	1	M	M
---	---	---	---

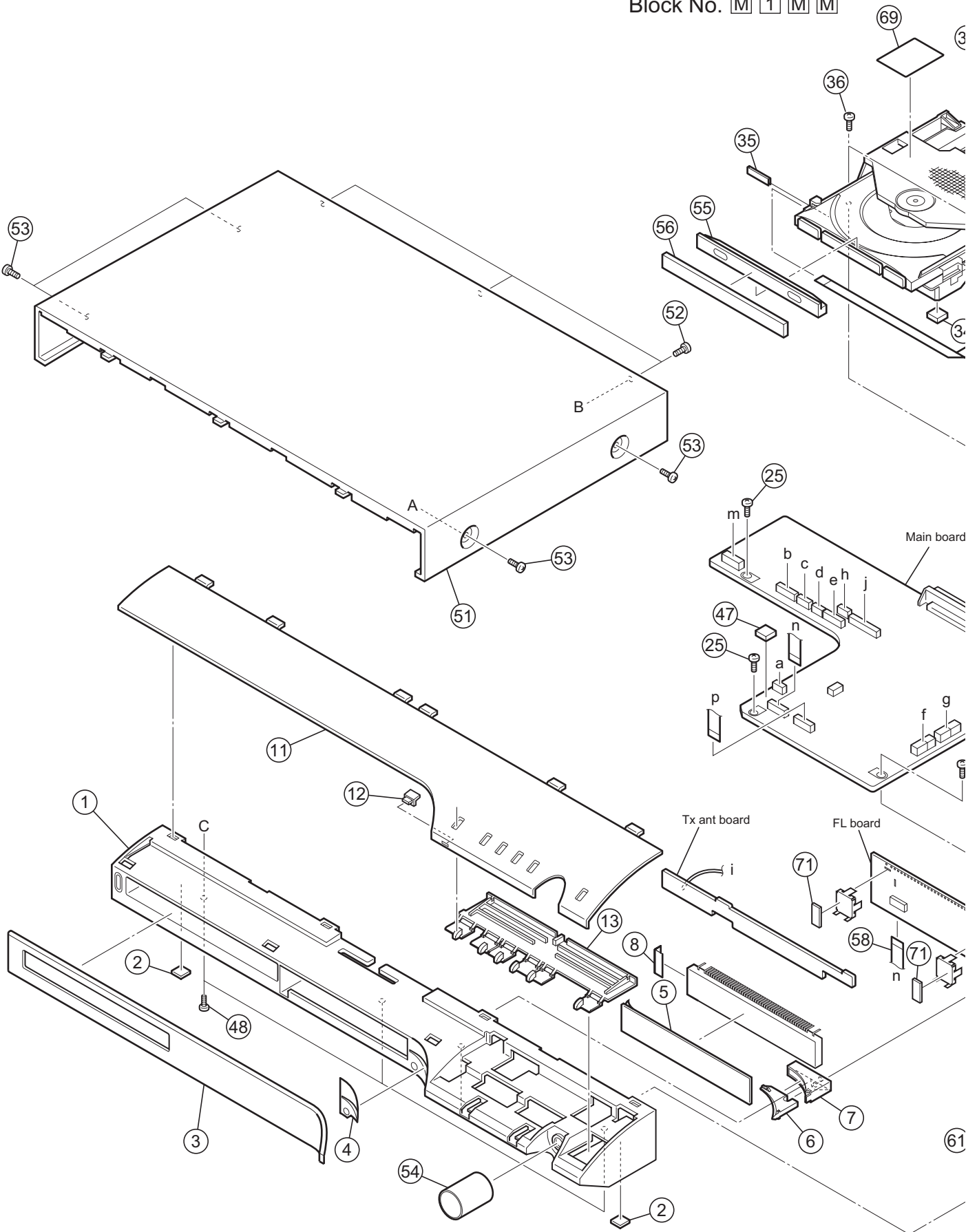

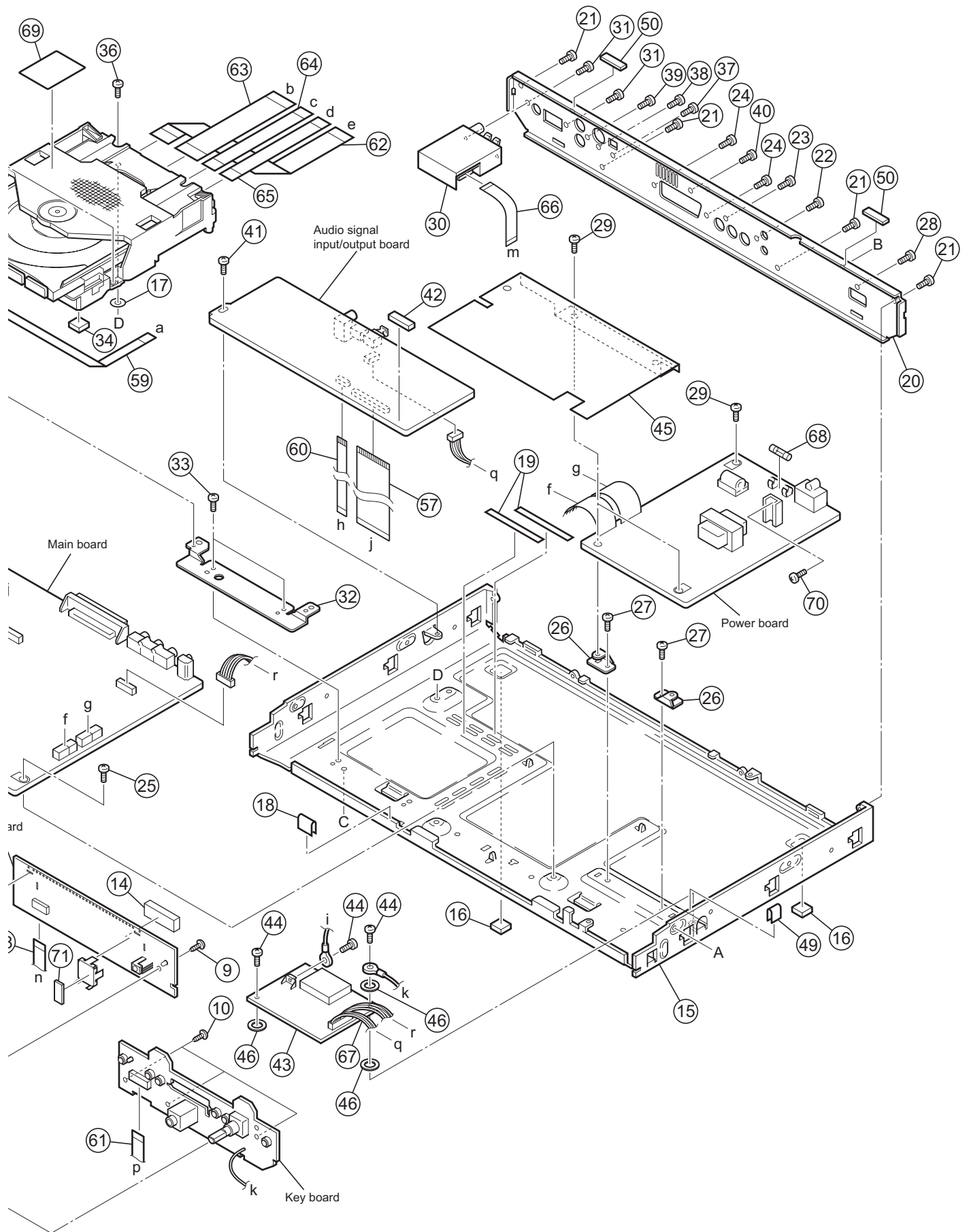

General Assembly

Block No. [M][1][M][M]

△	Symbol No.	Part No.	Part Name	Description	Local
	1	LV10859-001A	FRONT PANEL		
	2	LV40301-002A	FELT SPACER	(x2)	
	3	LV21618-005A	FL LENS		SW8
	3	LV21618-009A	FL LENS		SW9
	4	LV43921-001A	LENS SPACER		
	5	LV43704-001A	FL FILTER		
	6	LV34610-003A	LIGHT LENS		
	7	LV34611-002A	LENS COVER		
	8	LV30225-0U3A	SPACER		
	9	QYSDSF2608Z	TAP SCREW	M2.6 x 8mm	
	10	QYSDSF2608Z	TAP SCREW	M2.6 x 8mm(x3)	
	11	LV10874-001A	FRONT COVER		
	12	LV43680-001A	STANDBY LENS		
	13	LV21617-001A	PUSH BUTTON		
	14	LV30225-0P5A	SPACER		
	15	LV10860-001A	CHASSIS BASE		
	16	LV40301-002A	FELT SPACER	(x2)	
	17	LV30226-044A	SPACER		
	18	LV30225-0T2A	SPACER		
	19	LV30225-0T3A	SPACER	(x2)	
	20	LV21623-051A	REAR PANEL		SW8
	20	LV21623-053A	REAR PANEL		SW9
	21	QYSBSGY3008M	TAP SCREW	M3 x 8mm(x4)	
	22	QYSBSGY3008M	TAP SCREW	M3 x 8mm	
	23	QYSBSGY3008M	TAP SCREW	M3 x 8mm	
	24	QYSBSGY3008M	TAP SCREW	M3 x 8mm(x2)	
	25	QYS DST3006Z	TAP SCREW	M3 x 6mm(x3)	
	26	LV41548-001A-NK	C.B BKT	(x2)	
	27	QYS DST3006Z	TAP SCREW	M3 x 6mm(x2)	
	28	QYSBSGY3008M	TAP SCREW	M3 x 8mm	
	29	QYS DST3006Z	TAP SCREW	M3 x 6mm(x3)	
	30	QAU0347-001	TUNER	TU 1	
	31	QYSBSGY3008M	TAP SCREW	M3 x 8mm(x2)	
	32	LV34620-001A	MECHA BKT		
	33	QYS DST3006Z	TAP SCREW	M3 x 6mm(x2)	
	34	VYSH101-009	SPACER		
	35	LV30225-0U3A	SPACER		
	36	QYSBST3008Z	TAP SCREW	M3 x 8mm(x3)	
	37	QYSBSGY3008M	TAP SCREW	M3 x 8mm	
	38	QYSBST3006M	TAP SCREW	M3 x 6mm	
	39	QYSBSGY3008M	TAP SCREW	M3 x 8mm	
	40	QYSBSGY3008M	TAP SCREW	M3 x 8mm	
	41	QYS DST3006Z	TAP SCREW	M3 x 6mm	
	42	LV30225-095A	SPACER		
	43	QAU0360-001	RF MODULE		
	44	QYS DST3006Z	TAP SCREW	M3 x 6mm(x3)	
	45	LV35409-001A	SHIELD(B)		
	46	LV30226-037A	SPACER	(x3)	
	47	VYSH101-009	SPACER		
	48	QYSBSG3005M	TAP SCREW	M3 x 5mm(x4)	
	49	LV30225-0F4A	SPACER		
	50	LV30225-0U5A	SPACER	(x2)	
	51	LV21622-001A/S/	METAL COVER		
	52	QYSBSGY3008M	TAP SCREW	M3 x 8mm(x3)	
	53	QYSDSG3006N	TAP SCREW	M3 x 6mm(x4)	
	54	LV34614-001A	VOL KNOB		
	55	LV34612-001A	TRAY FITTING		
	56	LV34613-001A	FITTING LENS		
	57	QUQ410-2908CJ	FFC WIRE	29pin 8cm	
	58	QUQ410-1312CJ	FFC WIRE	13pin 12cm	
	59	QUQ410-0523CJ	FFC WIRE	5pin 23cm	
	60	QUQ410-0708CJ	FFC WIRE	7pin 8cm	
	61	QUQ110-1324AJ	FFC WIRE	13pin 24cm	
	62	QUQ410-1518CJ	FFC WIRE	15pin 18cm	
	63	QUQ410-1710CJ	FFC WIRE	17pin 10cm	
	64	QUQ410-0910CJ	FFC WIRE	9pin 10cm	
	65	QUQ410-0810CJ	FFC WIRE	8pin 10cm	
	66	QUQ412-1111CJ	FFC WIRE	11pin 11cm	
	67	WJN0136-001A	E-SH C WIRE C-C		
△	68	QMF51W2-1R6-J8	FUSE	F 901 1.6A AC250V	
	69	LV42035-002A	LASER CAUTION		
	70	QYSBSE3008Z	TAP SCREW	M3 x 8mm	
	71	LV30225-0M9A	SPACER	(x2)	

Receiver assembly and parts list

Block No. M 2 M M

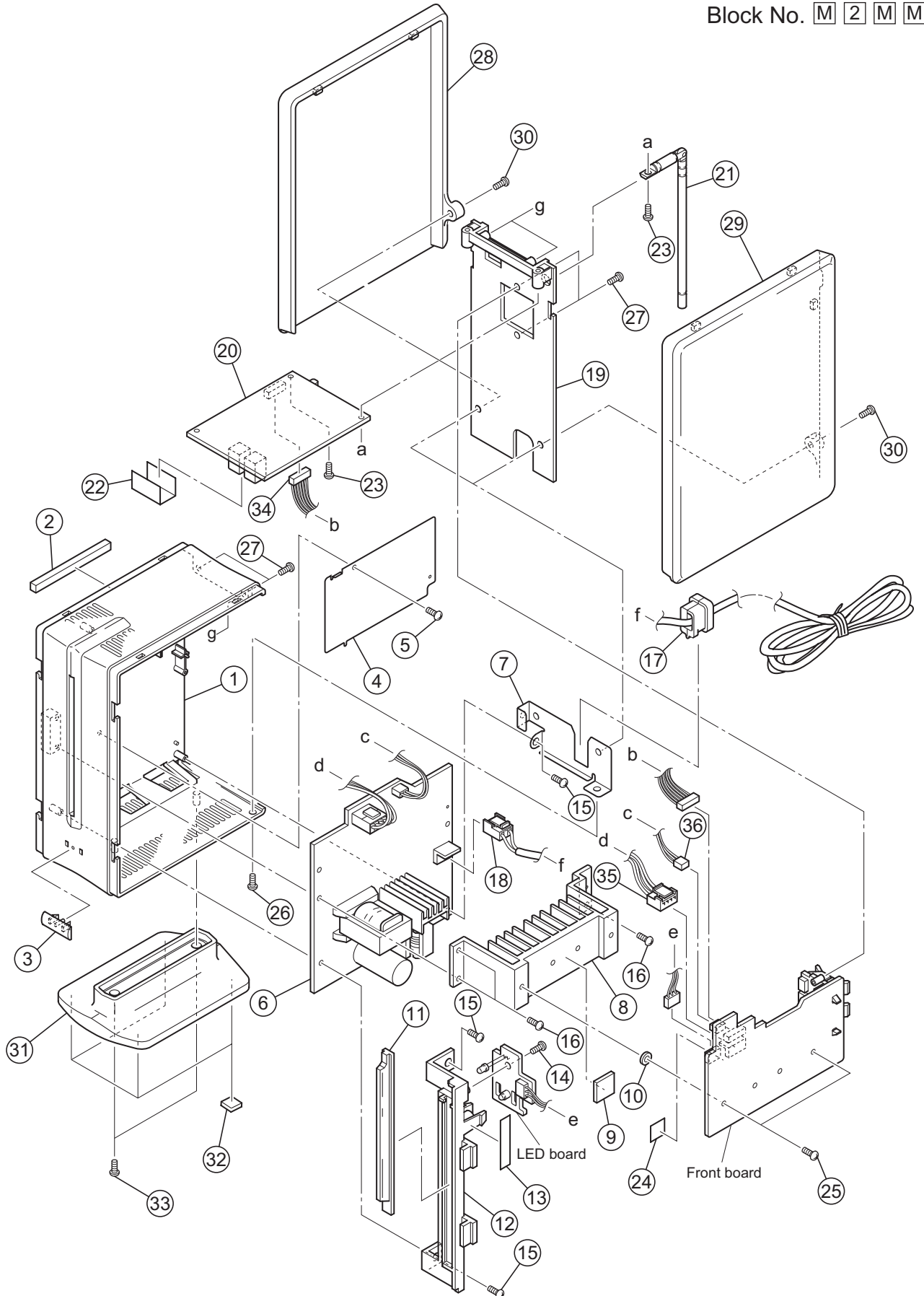

Receiver

Block No. [M][2][M][M]

△	Symbol No.	Part No.	Part Name	Description	Local
	1	LV10926-001A	FRAME		
	2	LV30225-0V5A	SPACER		
	3	LV43832-001A	JVC BADGE		
	4	LV34983-001A	BARRIER		
	5	QYSPSGT1735M	TAP SCREW	M1.7 x 3.5mm	
△	6	QAL0576-001	POWER UNIT ASSY		
	7	LV43831-001A	BRACKET		
	8	LV34985-001A	HEAT SINK		
	9	LV43407-004A	RUBBER SHEET		
	10	LV30226-037A	SPACER		
	11	LV34981-001A	LENS		
	12	LV21722-001A	LENS HOLDER		
	13	LV30225-0T4A	SPACER		
	14	QYSDSF2606Z	TAP SCREW	M2.6 x 6mm	
	15	QYSBSG3010Z	TAP SCREW	M3 x 10mm(x3)	
	16	QYSPSF3010Z	TAP SCREW	M3 x 10mm(x3)	
△	17	QZW0033-001	STRAIN RELIEF		
△	18	QMPK210-205-JN	POWER CORD(EU)	2.05m BLACK	SW8E,SW8EN,SW8EV, SW9E,SW9EN,SW9EV
△	18	QMPN150-200-JC	POWER CORD(EK)	2m BLACK	SW8B,SW9B
	19	LV21716-002A	REAR COVER		
	20	QAU0359-001	RF MODULE		
	21	QZW0141-001	ROD ANTENNA		
	22	LV44002-001A	BARRIER		
	23	QYSBSG3010Z	TAP SCREW	M3 x 10mm(x2)	
	24	LV30225-0C8A	SPACER		
	25	QYSBSG3010Z	TAP SCREW	M3 x 10mm(x2)	
	26	QYSBSG3008M	TAP SCREW	M3 x 8mm	
	27	QYSBSG3008M	TAP SCREW	M3 x 8mm(x4)	
	28	LV21714-001A	SIDE PANEL(L)		
	29	LV21715-001A	SIDE PANEL(R)		
	30	QYSBSG3008M	TAP SCREW	M3 x 8mm(x2)	
	31	LV21721-001A	STAND		
	32	LV40301-002A	FELT SPACER	(x4)	
	33	QYSBSG3010Z	TAP SCREW	M3 x 10mm(x2)	
	34	WJN0146-001A	E-SH C WIRE C-C	W 151	
	35	WJJ0471-001A	E-SI C WIRE C-C	W 171	
	36	QJJ009-031603	SIN CR C-C WIRE	W 172	

Speaker assembly and parts list

Block No. **M 6 M M**

(Subwoofer)

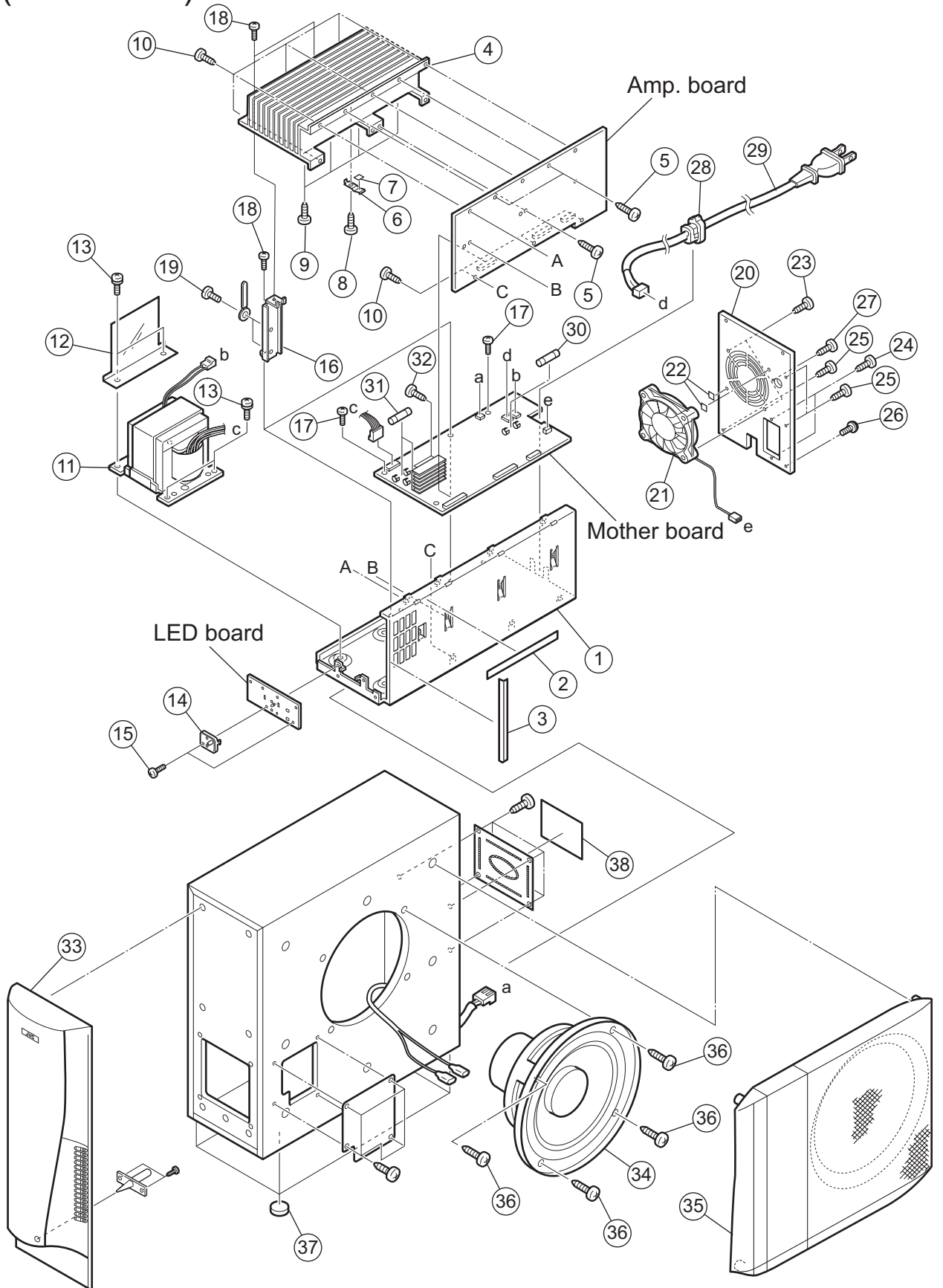

Speaker(Subwoofer)

Block No. [M][6][M][M]

△	Symbol No.	Part No.	Part Name	Description	Local
	1	LV10875-002A	CHASSIS BASE		
	2	LV30225-0T5A	SPACER		
	3	LV30225-0T6A	SPACER		
	4	LV10876-001A	HEAT SINK		
	5	QYSBSG3010E	TAP SCREW	M3 x 10mm(x3)	
	6	LV43691-001A	HOLD SPRING		
	7	LV43203-001A	SPACER		
	8	QYSBSG3010E	TAP SCREW	M3 x 10mm	
	9	QYSBSG3016E	TAP SCREW	M3 x 16mm(x4)	
	10	QYSBSG3010E	TAP SCREW	M3 x 10mm(x9)	
△	11	QQT0432-002	POWER TRANSF		
	12	LV43823-001A	BARRIER		
	13	QYSDSTL4008E	TAP SCREW	M4 x 8mm(x4)	
	14	LV43692-001A	LED HOLDER		
	15	QYSBSG3010E	TAP SCREW	M3 x 10mm(x2)	
	16	LV34712-001A	HEAT SINK BKT	(x2)	
	17	QYSBSG3010E	TAP SCREW	M3 x 10mm(x2)	
	18	QYSBSG3010E	TAP SCREW	M3 x 10mm(x4)	
	19	QYSBSG3006Z	TAP SCREW	M3 x 6mm(x4)	
	20	LV21652-006A	REAR PANEL		
	21	QAR0318-001	FAN MOTOR		
	22	LV30225-0D5A	SPACER	(x2)	
	23	QYSBSGY3008M	TAP SCREW	M3 x 8mm(x2)	
	24	QYSBSGY3008M	TAP SCREW	M3 x 8mm(x2)	
	25	QYSBSGY3008M	TAP SCREW	M3 x 8mm(x3)	
	26	E73562-003	SCREW		
	27	QYSBST3006M	TAP SCREW	M3 x 6mm	
△	28	QZW0033-001	STRAIN RELIEF		
△	29	QMPK210-205-JN	POWER CORD(EU)	2.05m BLACK	SW8E,SW8EN,SW8EV, SW9E,SW9EN,SW9EV SW8B,SW9B
△	29	QMPN150-200-JC	POWER CORD		
△	30	QMF51W2-3R15-J8	FUSE	F 101 3.15A AC250V	
△	31	QMFZ051-8R0-J8	FUSE	F 153 F 154 8A(x2)	
	32	QYSPSPD3008Z	SCREW	M3 x 8mm(x2)	
	33	5700067201	ORNAMENT		
	34	CR160068-01	CONE SPK		
	35	9916011701	NET ASSY		
	36	7001541606	TAPPING SCREW	(x4)	
	37	9000007931	RUBBER CUSHION	(x4)	
	38	6000208381	RATING LABEL		SW9B,SW9E,SW9EN
	38	6000210851	RATING LABEL		SW9EV
	38	6000208361	RATING LABEL		SW8B,SW8E,SW8EN
	38	6000208371	RATING LABEL		SW8EV

DVD mechanism

Block No. [M][J][M][M]

△	Symbol No.	Part No.	Part Name	Description	Local
	1	LE20725-001A	MECHA BASE		
	2	LE20699-002A	SPINDLE BASE		
	3	QYSDST2605M	TAP SCREW	M2.6 x 5mm(x2)	
	4	LE40931-001A	SHAFT		
	5	LV33991-001A	ADJUST SPRING		
	6	QYSPSFU2040M	TAP SCREW	M2 x 4mm	
	7	LE20698-004A	FEED HOLDER		
	8	QAR0215-001	FEED MOTOR		
	9	LV41510-201A	FEED GEAR T		
	10	QYSPSPU2040M	SCREW	M2 x 4mm(x2)	
	11	QYSDST2605M	TAP SCREW	M2.6 x 5mm(x2)	
	12	QAL0507-001	PICK UP		
	13	LE20700-001A	SW ACTUATOR		
	14	LE31067-002A	LEAD SPRING		
	15	QYSPSFU1740Z	TAP SCREW	M1.7 x 4mm(x2)	
	16	LE40929-001A	SW.LEVER		
	17	QYSPSFU1740Z	TAP SCREW	M1.7 x 4mm	
	18	QUQ105-2411AC	FFC		
	19	LE40931-001A	SHAFT		
	20	LE40855-002A	FEED GEAR E		
	21	LV41517-003A	LEAD SCREW		
	22	LE40930-001A	FEED GEAR M		
	23	LE40928-002A	THURUST SPRING		
	24	LE40927-002A	PLATE		
	25	QYSDST2614Z	TAP SCREW	M2.6 x 14mm	
	26	QAR0316-001	SPINDLE MOTOR		
	27	QYSPSPU1740Z	SCREW	M1.7 x 4mm(x3)	
	28	LE40858-002A	SPECIAL SCREW	(x3)	
	29	QYSDST2004Z	TAP SCREW	M2 x 4mm(x2)	

DVD loading base assembly and parts list

Block No. M N M M

Grease
 ★ JVG-31N
 ● JVS-1003

FMU-DE3-2M

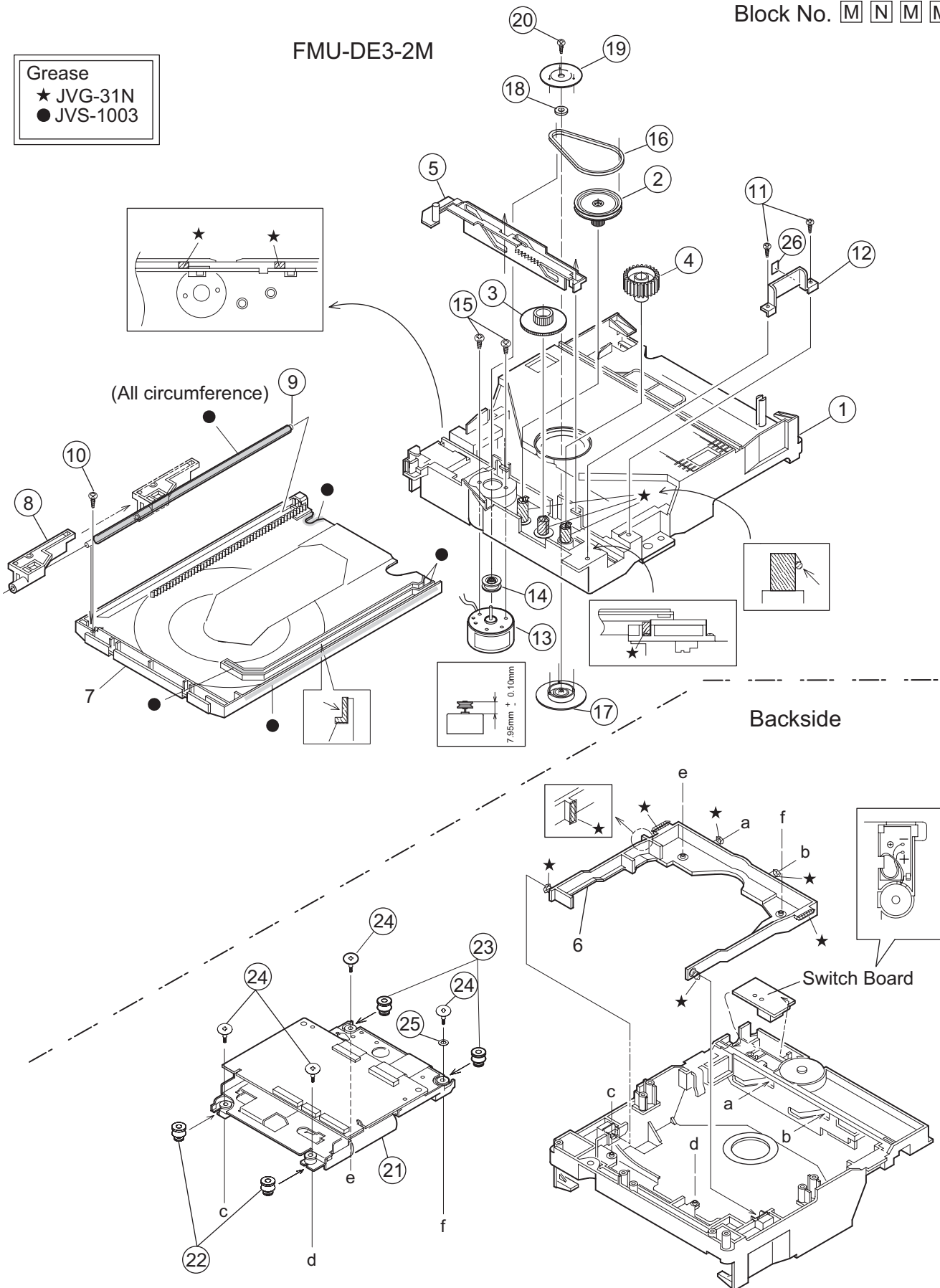

DVD loading base

Block No. [M][N][M][M]

△	Symbol No.	Part No.	Part Name	Description	Local
	1	LE10275-006A	LOADING BASE		
	2	LE31043-001A	PULLEY GEAR		
	3	LE31042-001A	MIDDLE GEAR		
	4	LE31044-001A	IDLE GEAR		
	5	LE20665-005A	SLIDE CAM		
	6	LE20666-003A	ELEVATOR		
	7	LE10276-002A	TRAY		
	8	LE31045-001A	BUSHING		
	9	LE40898-001A	SHAFT		
	10	QYSSSF2008Z	TAP SCREW	M2 x 8mm	
	11	QYSDSF2008Z	TAP SCREW	M2 x 8mm(x2)	
	12	LE40937-002A	LEAF SPRING		
	13	QAR0197-001	MOTOR		
	14	LV42087-002A	MOTOR PULLEY		
	15	QYSPSPU1730Z	SCREW	M1.7 x 3mm(x2)	
	16	LE40897-001A	BELT		
	17	LE31046-003A	CLAMPER		
	18	LV42930-003A	P.C.MAGNET		
	19	LE40899-001A	YOKE		
	20	LE40906-001A	SPECIAL SCREW		
	21	-----	DVD TRAMECHA		
	22	LE40900-003A	INSULATOR	(x2)	
	23	LE40900-005A	INSULATOR	(x2)	
	24	LE40901-001A	SPECIAL SCREW	(x4)	
	25	QYWFM419025	WASHER	9mm/4.1mm x 0.25mm	
	26	LV43828-001A	SPACER		

Electrical parts list

Main board

Block No. [0][1]

△ Symbol No.	Part No.	Part Name	Description	Local
	IC431	MM1623XF-X	IC	
	IC441	MM1505XN-X	IC	
	IC471	MN101C49GND1	IC	
	IC472	S-80840CNNB-W	IC	
	IC473	SN74HCT32NS-X	IC(DIGITAL)	
	IC474	CD4066BM-X	IC	
	IC475	RC4580ID-X	IC	
	IC476	RC4580ID-X	IC	
	IC477	BR24L08F-W-X	IC(DIGITAL)	
	IC478	RC4580ID-X	IC	
	IC481	BU1924F-X	IC	
	IC491	KIA7805API	IC	
	IC493	BA6956AN	IC	
	IC601	RC4580ID-X	IC	
△	IC901	STR-G6651	IC	
	IC951	PQ05RD21	IC	
	IC953	KIA7805API	IC	
	Q951	2SC3576-JVC-T	TRANSISTOR	
	Q953	KTA1267/YG/-T	TRANSISTOR	
	Q954	SI2305DS-X	TRANSISTOR	
	Q955	UN2212-X	DIGI TRANSISTOR	
	Q958	KTA1271/OY/-T	TRANSISTOR	
	Q959	UN2212-X	DIGI TRANSISTOR	
	Q960	2SB709A/QR/-X	TRANSISTOR	
	Q961	KTC3203/OY/-T	TRANSISTOR	
	Q991	2SD601A/QR/-X	TRANSISTOR	
	Q4091	KTA1271/OY/-T	TRANSISTOR	
	Q4092	2SD601A/QR/-X	TRANSISTOR	
	Q4481	UN2211-X	TRANSISTOR	
	Q4482	UN2211-X	TRANSISTOR	
	Q4483	UN2111-X	TRANSISTOR	
	Q4484	UN2211-X	TRANSISTOR	
	Q4485	2SC2814/4-5/-X	TRANSISTOR	
	Q4701	UN2215-X	TRANSISTOR	
	Q4702	UN2214-X	TRANSISTOR	
	Q4703	UN2211-X	TRANSISTOR	
	Q4801	2SB709A/QR/-X	TRANSISTOR	
	Q4802	UN2211-X	TRANSISTOR	
	Q4811	UN2111-X	TRANSISTOR	
	Q4812	UN2211-X	TRANSISTOR	
	Q4821	UN2211-X	TRANSISTOR	
	Q4831	UN2211-X	TRANSISTOR	
	Q4832	UN2116-X	TRANSISTOR	
	Q4833	UN2216-X	DIGI TRANSISTOR	
	Q4921	KTC3203/OY/-T	TRANSISTOR	
	Q4931	KTA1271/OY/-T	TRANSISTOR	
	Q4951	UN2113-X	DIGI TRANSISTOR	
	Q4952	UN2113-X	DIGI TRANSISTOR	
	Q4961	KTC3203/OY/-T	TRANSISTOR	
	Q4971	2SC3661-X	TRANSISTOR	
	Q4972	2SC3661-X	TRANSISTOR	
	Q4973	UN2113-X	DIGI TRANSISTOR	
△	D901	DI106	BRIDGE DIODE	
	D902	ERA18-04-T1	FR DIODE	
	D903	ERA18-04-T1	FR DIODE	
	D904	ERA18-04-T1	FR DIODE	
	D908	ERA18-04-T1	FR DIODE	
	D910	ERA18-04-T1	FR DIODE	
	D911	FR104S-T5	FR DIODE	
	D950	MTZJ30C-T2	Z DIODE	
	D951	FR104S-T5	FR DIODE	
	D952	FR104S-T5	FR DIODE	
△	D953	RK34-LFB2	FUSEIODE	
△	D954	FR104S-T5	FR DIODE	
△	D956	FR104S-T5	FR DIODE	
△	D957	FR104S-T5	FR DIODE	
	D958	1SS133-T2	DIODE	
	D960	MTZJ2.2A-T2	S.B.DIODE	
△	D970	ER204-F33	FR DIODE	
	D991	MTZJ5.1B-T2	Z DIODE	

△ Symbol No.	Part No.	Part Name	Description	Local
	D4091	1SS133-T2	DIODE	
	D4092	MTZJ6.8A-T2	Z DIODE	
	D4703	MTZJ4.7B-T2	Z DIODE	
	D4704	1SS133-T2	DIODE	
	D4705	1SS133-T2	DIODE	
	D4706	1SS133-T2	DIODE	
	D4707	1SS133-T2	DIODE	
	D4708	1SS133-T2	DIODE	
	D4709	1SS133-T2	DIODE	
	D4811	1SS133-T2	DIODE	
	D4831	1SS133-T2	DIODE	
	D4832	1SS133-T2	DIODE	
	D4833	1SS133-T2	DIODE	
	D4834	1SS133-T2	DIODE	
	D4835	MTZJ6.8A-T2	Z DIODE	
	D4841	MTZJ2.0A-T2	Z DIODE	
	D4842	MTZJ3.3A-T2	Z DIODE	
	D4891	MTZJ6.2C-T2	Z DIODE	
	D4921	MTZJ8.2C-T2	Z DIODE	
	D4922	1SS133-T2	DIODE	
	D4931	MTZJ8.2C-T2	Z DIODE	
	D4932	1SS133-T2	DIODE	
	D4961	MTZJ4.7A-T2	Z DIODE	
	D4962	1SS133-T2	DIODE	
	D4963	1SS133-T2	DIODE	
	D4966	MTZJ3.9B-T2	Z DIODE	
	D4997	MTZJ3.0B-T2	Z DIODE	
	D4998	1SS133-T2	DIODE	
△	PC901	PC123Y22FZ	PHOTO COUPLER	
△	PC902	PC123Y22FZ	PHOTO COUPLER	
△	C902	QFZ9075-683	MPP CAPACITOR	0.068uF AC275V M
△	C904	QCZ9079-102	C CAPACITOR	1000pF AC250V M
△	C905	QCZ9079-102	C CAPACITOR	1000pF AC250V M
△	C907	QEZO688-686	E CAPACITOR	68uF
	C908	QCZ0136-332Z	C CAPACITOR	3300pF 1kV K
	C909	QCZ0136-101Z	C CAPACITOR	100pF 1kV K
	C910	QCBB1HK-221Y	C CAPACITOR	220pF 50V K
	C913	QCZ0136-101Z	C CAPACITOR	100pF 1kV K
	C914	QEZO532-396Z	E CAPACITOR	39uF 25V M
	C915	QCBB1HK-471Y	C CAPACITOR	470pF 50V K
△	C916	QCZ9079-222	C CAPACITOR	2200pF AC250V M
	C917	QDGB1HK-102Y	C CAPACITOR	1000pF 50V K
	C918	QCFB1HZ-104Y	C CAPACITOR	0.1uF 50V Z
	C951	NDC31HJ-101X	C CAPACITOR	100pF 50V J
	C952	QCZ0136-101Z	C CAPACITOR	100pF 1kV K
	C953	QCBB1HK-101Y	C CAPACITOR	100pF 50V K
	C954	NDC31HJ-101X	C CAPACITOR	100pF 50V J
	C956	NDC31HJ-101X	C CAPACITOR	100pF 50V J
	C957	NDC31HJ-101X	C CAPACITOR	100pF 50V J
	C960	QEZO529-826Z	E CAPACITOR	82uF 10V M
	C961	QCZ0202-155Z	C CAPACITOR	1.5uF 25V Z
	C962	QETN1HM-226Z	E CAPACITOR	22uF 50V M
	C963	QEZO533-396Z	E CAPACITOR	39uF 50V M
	C964	QETN1HM-226Z	E CAPACITOR	22uF 50V M
	C965	QEZO528-108	E CAPACITOR	1000uF 10V M
	C966	QETN1AM-477Z	E CAPACITOR	470uF 10V M
	C967	NCB31CK-104X	C CAPACITOR	0.1uF 16V K
	C968	NCB31CK-104X	C CAPACITOR	0.1uF 16V K
	C969	QETN1AM-227Z	E CAPACITOR	220uF 10V M
	C976	NCB31CK-104X	C CAPACITOR	0.1uF 16V K
	C977	NCB31CK-104X	C CAPACITOR	0.1uF 16V K
	C978	QETN1AM-107Z	E CAPACITOR	100uF 10V M
	C979	QEZO530-827	E CAPACITOR	820uF 16V M
	C980	QETN1HM-106Z	E CAPACITOR	10uF 50V M
	C981	QCZ0202-155Z	C CAPACITOR	1.5uF 25V Z
	C982	QEZO531-567	E CAPACITOR	560uF 25V M
	C984	QETN1CM-227Z	E CAPACITOR	220uF 16V M
	C985	QETN1EM-107Z	E CAPACITOR	100uF 25V M
	C986	QETN1EM-107Z	E CAPACITOR	100uF 25V M
	C987	QEZO532-187Z	E CAPACITOR	180uF 25V M
	C989	QETN1CM-107Z	E CAPACITOR	100uF 16V M
	C992	QETN1HM-474Z	E CAPACITOR	0.47uF 50V M
	C993	NDC31HJ-101X	C CAPACITOR	100pF 50V J
	C994	QCBB1HK-223Y	C CAPACITOR	0.022uF 50V K

△ Symbol No.	Part No.	Part Name	Description	Local	△ Symbol No.	Part No.	Part Name	Description	Local
C997	QETN1CM-227Z	E CAPACITOR	220uF 16V M		C4791	NCB31CK-104X	C CAPACITOR	0.1uF 16V K	
C4001	NCB31HK-102X	C CAPACITOR	1000pF 50V K		C4793	NCB31CK-104X	C CAPACITOR	0.1uF 16V K	
C4003	QCZ0202-155Z	C CAPACITOR	1.5uF 25V Z		C4794	QETN1CM-107Z	E CAPACITOR	100uF 16V M	
C4004	QCZ0202-155Z	C CAPACITOR	1.5uF 25V Z		C4795	NCB31CK-104X	C CAPACITOR	0.1uF 16V K	
C4006	QCZ0202-155Z	C CAPACITOR	1.5uF 25V Z		C4801	QETN1HM-224Z	E CAPACITOR	0.22uF 50V M	
C4011	NCB31HK-822X	C CAPACITOR	8200pF 50V K		C4891	NCB31HK-221X	C CAPACITOR	220pF 50V K	
C4012	NCB31HK-822X	C CAPACITOR	8200pF 50V K		C4892	NCB31HK-221X	C CAPACITOR	220pF 50V K	
C4013	NCB31HK-102X	C CAPACITOR	1000pF 50V K		C4901	QETN1CM-107Z	E CAPACITOR	100uF 16V M	
C4014	NDC31HJ-151X	C CAPACITOR	150pF 50V J		C4902	NCB31HK-103X	C CAPACITOR	0.01uF 50V K	
C4015	NDC31HJ-151X	C CAPACITOR	150pF 50V J		C4903	QETN1CM-107Z	E CAPACITOR	100uF 16V M	
C4016	NCB31HK-102X	C CAPACITOR	1000pF 50V K		C4904	NCB31HK-103X	C CAPACITOR	0.01uF 50V K	
C4017	NDC31HJ-151X	C CAPACITOR	150pF 50V J		C4921	QETN1EM-476Z	E CAPACITOR	47uF 25V M	
C4071	QETN1CM-476Z	E CAPACITOR	47uF 16V M		C4922	QETN1CM-107Z	E CAPACITOR	100uF 16V M	
C4073	NCB31CK-104X	C CAPACITOR	0.1uF 16V K		C4931	QETN1EM-476Z	E CAPACITOR	47uF 25V M	
C4074	NCB31HK-561X	C CAPACITOR	560pF 50V K		C4932	QETN1CM-107Z	E CAPACITOR	100uF 16V M	
C4075	QETN1HM-225Z	E CAPACITOR	2.2uF 50V M		C4961	QETN1CM-107Z	E CAPACITOR	100uF 16V M	
C4076	NCB31HK-271X	C CAPACITOR	270pF 50V K		C6101	QETN1HM-475Z	E CAPACITOR	4.7uF 50V M	
C4077	NCS31HJ-330X	C CAPACITOR	33pF 50V J		C6102	NCS31HJ-101X	C CAPACITOR	100pF 50V J	
C4078	NCS31HJ-330X	C CAPACITOR	33pF 50V J		C6103	QETN1EM-476Z	E CAPACITOR	47uF 25V M	
C4079	NCB31HK-103X	C CAPACITOR	0.01uF 50V K		C6104	NCB31CK-104X	C CAPACITOR	0.1uF 16V K	
C4091	QETN1CM-226Z	E CAPACITOR	22uF 16V M		C6105	NCB31HK-103X	C CAPACITOR	0.01uF 50V K	
C4092	QETN1CM-107Z	E CAPACITOR	100uF 16V M		C6201	QETN1HM-475Z	E CAPACITOR	4.7uF 50V M	
C4301	QETN1EM-476Z	E CAPACITOR	47uF 25V M		C6202	NCS31HJ-101X	C CAPACITOR	100pF 50V J	
C4311	NCB31HK-103X	C CAPACITOR	0.01uF 50V K		C6203	QETN1EM-476Z	E CAPACITOR	47uF 25V M	
C4321	NCB30JK-105X	C CAPACITOR	1uF 6.3V K		C6204	NCB31CK-104X	C CAPACITOR	0.1uF 16V K	
C4331	NCB30JK-105X	C CAPACITOR	1uF 6.3V K		C6205	NCB31HK-103X	C CAPACITOR	0.01uF 50V K	
C4341	NCB30JK-105X	C CAPACITOR	1uF 6.3V K		C6501	NCB31CK-224X	C CAPACITOR	0.22uF 16V K	
C4351	NCB30JK-105X	C CAPACITOR	1uF 6.3V K		C6502	NCS31HJ-560X	C CAPACITOR	56pF 50V J	
C4391	QETN1AM-477Z	E CAPACITOR	470uF 10V M		C6503	NCB31CK-224X	C CAPACITOR	0.22uF 16V K	
C4392	NCB31CK-104X	C CAPACITOR	0.1uF 16V K		C6511	QETN1HM-475Z	E CAPACITOR	4.7uF 50V M	
C4394	NCB31CK-104X	C CAPACITOR	0.1uF 16V K		C6512	NCS31HJ-560X	C CAPACITOR	56pF 50V J	
C4395	QETN1CM-226Z	E CAPACITOR	22uF 16V M		C6513	QETN1HM-475Z	E CAPACITOR	4.7uF 50V M	
C4413	NCB31HK-103X	C CAPACITOR	0.01uF 50V K		C6514	NCB31CK-104X	C CAPACITOR	0.1uF 16V K	
C4422	QETN0JM-477Z	E CAPACITOR	470uF 6.3V M		C6515	NCB31CK-104X	C CAPACITOR	0.1uF 16V K	
C4424	NDC31HJ-470X	C CAPACITOR	47pF 50V J		C6516	NCS31HJ-560X	C CAPACITOR	56pF 50V J	
C4431	QETN0JM-477Z	E CAPACITOR	470uF 6.3V M		C6517	NCS31HJ-471X	C CAPACITOR	470pF 50V J	
C4432	NCS31HJ-470X	C CAPACITOR	47pF 50V J		C6518	NCS31HJ-471X	C CAPACITOR	470pF 50V J	
C4433	NDC31HJ-470X	C CAPACITOR	47pF 50V J		C6601	NCB31CK-224X	C CAPACITOR	0.22uF 16V K	
C4441	QETN0JM-477Z	E CAPACITOR	470uF 6.3V M		C6602	NCS31HJ-560X	C CAPACITOR	56pF 50V J	
C4442	NDC31HJ-470X	C CAPACITOR	47pF 50V J		C6603	NCB31CK-224X	C CAPACITOR	0.22uF 16V K	
C4443	NDC31HJ-470X	C CAPACITOR	47pF 50V J		C6611	QETN1HM-475Z	E CAPACITOR	4.7uF 50V M	
C4451	QETN0JM-477Z	E CAPACITOR	470uF 6.3V M		C6612	NCS31HJ-560X	C CAPACITOR	56pF 50V J	
C4452	NDC31HJ-470X	C CAPACITOR	47pF 50V J		C6613	QETN1HM-475Z	E CAPACITOR	4.7uF 50V M	
C4453	NDC31HJ-470X	C CAPACITOR	47pF 50V J		C6614	NCB31CK-104X	C CAPACITOR	0.1uF 16V K	
C4454	QETN1CM-106Z	E CAPACITOR	10uF 16V M		C6615	NCB31CK-104X	C CAPACITOR	0.1uF 16V K	
C4455	QETN0JM-477Z	E CAPACITOR	470uF 6.3V M		C6616	NCS31HJ-560X	C CAPACITOR	56pF 50V J	
C4471	NCB31HK-331X	C CAPACITOR	330pF 50V K		C6617	NCS31HJ-471X	C CAPACITOR	470pF 50V J	
C4472	NCB31HK-331X	C CAPACITOR	330pF 50V K		C6618	NCS31HJ-471X	C CAPACITOR	470pF 50V J	
C4473	NCB31HK-331X	C CAPACITOR	330pF 50V K		C6901	QETN1VM-476Z	E CAPACITOR	47uF 35V M	
C4474	NCB31HK-331X	C CAPACITOR	330pF 50V K		C6902	QETN1VM-476Z	E CAPACITOR	47uF 35V M	
C4475	QETN1EM-475Z	E CAPACITOR	4.7uF 25V M						
C4476	QETN1EM-475Z	E CAPACITOR	4.7uF 25V M		R901	QRL01DJ-683X	OMF RESISTOR	68kΩ 1W J	
C4491	NCB31HK-103X	C CAPACITOR	0.01uF 50V K		R903	QRE141J-270Y	C RESISTOR	27Ω 1/4W J	
C4492	NCB31CK-104X	C CAPACITOR	0.1uF 16V K		R904	QRE141J-222Y	C RESISTOR	2.2kΩ 1/4W J	
C4605	NCS31HJ-471X	C CAPACITOR	470pF 50V J		R905	QRL027J-683	OMF RESISTOR	68kΩ 2W J	
C4606	NCS31HJ-471X	C CAPACITOR	470pF 50V J		R906	QRJ146J-681X	UNF C RESISTOR	680Ω 1/4W J	
C4702	QETN0JM-227Z	E CAPACITOR	220uF 6.3V M		R907	QRT027J-R47	MF RESISTOR	0.47Ω 2W J	
C4703	QETN1HM-225Z	E CAPACITOR	2.2uF 50V M		R908	QRE141J-332Y	C RESISTOR	3.3kΩ 1/4W J	
C4704	NCB31CK-223X	C CAPACITOR	0.022uF 16V K		R910	QRE141J-474Y	C RESISTOR	470kΩ 1/4W J	
C4705	NCB31HK-103X	C CAPACITOR	0.01uF 50V K		R911	QRE141J-474Y	C RESISTOR	470kΩ 1/4W J	
C4706	NCB31HK-103X	C CAPACITOR	0.01uF 50V K		R951	QRE141J-150Y	C RESISTOR	15Ω 1/4W J	
C4707	QETN1CM-107Z	E CAPACITOR	100uF 16V M		R952	NRSA63J-103X	MG RESISTOR	10kΩ 1/16W J	
C4708	NCB31HK-103X	C CAPACITOR	0.01uF 50V K		R953	NRSA02J-223X	MG RESISTOR	22kΩ 1/10W J	
C4709	NCB31HK-103X	C CAPACITOR	0.01uF 50V K		△ R954	QRZ9005-100X	FUSI RESISTOR	10Ω	
C4710	NCB31HK-103X	C CAPACITOR	0.01uF 50V K		R955	NRSA63J-223X	MG RESISTOR	22kΩ 1/16W J	
C4711	QETN1HM-106Z	E CAPACITOR	10uF 50V M		R960	NRSA63J-101X	MG RESISTOR	100Ω 1/16W J	
C4712	NCB31CK-104X	C CAPACITOR	0.1uF 16V K		R961	NRSA63J-681X	MG RESISTOR	680Ω 1/16W J	
C4713	NCB31CK-104X	C CAPACITOR	0.1uF 16V K		R963	NRSA63J-181X	MG RESISTOR	180Ω 1/16W J	
C4714	NCB31CK-104X	C CAPACITOR	0.1uF 16V K		R964	NRSA63J-105X	MG RESISTOR	1MΩ 1/16W J	
C4715	NCB31CK-104X	C CAPACITOR	0.1uF 16V K		R965	NRSA63J-103X	MG RESISTOR	10kΩ 1/16W J	
C4716	NCB31CK-104X	C CAPACITOR	0.1uF 16V K		R966	NRSA63J-221X	MG RESISTOR	220Ω 1/16W J	
C4717	NCB31CK-104X	C CAPACITOR	0.1uF 16V K		R969	NRSA63J-221X	MG RESISTOR	220Ω 1/16W J	
C4718	NCB31HK-103X	C CAPACITOR	0.01uF 50V K		R977	NRSA63J-102X	MG RESISTOR	1kΩ 1/16W J	
C4719	NCB31HK-103X	C CAPACITOR	0.01uF 50V K		R980	NRSA63J-272X	MG RESISTOR	2.7kΩ 1/16W J	
C4720	NCB31CK-104X	C CAPACITOR	0.1uF 16V K		R981	NRSA63J-223X	MG RESISTOR	22kΩ 1/16W J	
C4721	NCB31CK-104X	C CAPACITOR	0.1uF 16V K		R983	NRSA63J-102X	MG RESISTOR	1kΩ 1/16W J	
C4771	NCB31CK-104X	C CAPACITOR	0.1uF 16V K		R984	NRSA63J-222X	MG RESISTOR	2.2kΩ 1/16W J	
C4772	NCB31CK-104X	C CAPACITOR	0.1uF 16V K		R985	NRSA02J-132X	MG RESISTOR	1.3kΩ 1/10W J	

△ Symbol No.	Part No.	Part Name	Description	Local	△ Symbol No.	Part No.	Part Name	Description	Local
R986	NRSA02J-152X	MG RESISTOR	1.5kΩ 1/10W J		R4771	NRSA63J-103X	MG RESISTOR	10kΩ 1/16W J	
R987	NRSA02J-152X	MG RESISTOR	1.5kΩ 1/10W J		R4772	NRSA63J-103X	MG RESISTOR	10kΩ 1/16W J	
R988	NRSA63J-222X	MG RESISTOR	2.2kΩ 1/16W J		R4773	NRSA63J-103X	MG RESISTOR	10kΩ 1/16W J	
R989	NRSA63J-333X	MG RESISTOR	33kΩ 1/16W J		R4775	NRSA63J-331X	MG RESISTOR	330Ω 1/16W J	
R990	NRSA63J-333X	MG RESISTOR	33kΩ 1/16W J		R4776	NRSA63J-331X	MG RESISTOR	330Ω 1/16W J	
R4011	NRSA63J-102X	MG RESISTOR	1kΩ 1/16W J		R4777	NRSA63J-101X	MG RESISTOR	100Ω 1/16W J	
R4012	NRSA63J-102X	MG RESISTOR	1kΩ 1/16W J		R4778	NRSA63J-101X	MG RESISTOR	100Ω 1/16W J	
R4013	NRSA63J-682X	MG RESISTOR	6.8kΩ 1/16W J		R4779	NRSA63J-331X	MG RESISTOR	330Ω 1/16W J	
R4014	NRSA63J-682X	MG RESISTOR	6.8kΩ 1/16W J		R4780	NRSA63J-331X	MG RESISTOR	330Ω 1/16W J	
R4072	NRSA63J-102X	MG RESISTOR	1kΩ 1/16W J		R4781	NRSA63J-101X	MG RESISTOR	100Ω 1/16W J	
R4073	NRSA63J-102X	MG RESISTOR	1kΩ 1/16W J		R4782	NRSA63J-101X	MG RESISTOR	100Ω 1/16W J	
R4074	NRSA63J-103X	MG RESISTOR	10kΩ 1/16W J		R4783	QRE141J-151Y	C RESISTOR	150Ω 1/4W J	
R4091	NRSA63J-472X	MG RESISTOR	4.7kΩ 1/16W J		R4784	QRE141J-151Y	C RESISTOR	150Ω 1/4W J	
R4092	NRSA63J-103X	MG RESISTOR	10kΩ 1/16W J		R4785	QRE141J-151Y	C RESISTOR	150Ω 1/4W J	
R4093	NRSA63J-821X	MG RESISTOR	820Ω 1/16W J		R4786	QRE141J-151Y	C RESISTOR	150Ω 1/4W J	
R4171	NRSA63J-0R0X	MG RESISTOR	0Ω 1/16W J		R4791	NRSA02J-221X	MG RESISTOR	220Ω 1/10W J	
R4172	NRSA63J-0R0X	MG RESISTOR	0Ω 1/16W J		R4801	NRSA63J-223X	MG RESISTOR	22kΩ 1/16W J	
R4173	NRSA63J-0R0X	MG RESISTOR	0Ω 1/16W J		R4802	NRSA63J-223X	MG RESISTOR	22kΩ 1/16W J	
R4201	NRSA63J-681X	MG RESISTOR	680Ω 1/16W J		△ R4811	QRZ9006-4R7X	F.RESISTOR	4.7Ω 1/4W J	
R4202	NRSA63J-221X	MG RESISTOR	220Ω 1/16W J		R4821	QRE141J-181Y	C RESISTOR	180Ω 1/4W J	
R4211	NRSA63J-681X	MG RESISTOR	680Ω 1/16W J		R4822	QRE141J-151Y	C RESISTOR	150Ω 1/4W J	
R4212	NRSA63J-221X	MG RESISTOR	220Ω 1/16W J		R4831	NRSA63J-153X	MG RESISTOR	15kΩ 1/16W J	
R4231	NRSA63J-681X	MG RESISTOR	680Ω 1/16W J		R4832	NRSA63J-223X	MG RESISTOR	22kΩ 1/16W J	
R4232	NRSA63J-221X	MG RESISTOR	220Ω 1/16W J		R4833	NRSA63J-123X	MG RESISTOR	12kΩ 1/16W J	
R4233	NRSA63J-821X	MG RESISTOR	820Ω 1/16W J		R4834	NRSA63J-393X	MG RESISTOR	39kΩ 1/16W J	
R4234	NRSA63J-181X	MG RESISTOR	180Ω 1/16W J		R4835	NRSA63J-472X	MG RESISTOR	4.7kΩ 1/16W J	
R4235	NRSA63J-103X	MG RESISTOR	10kΩ 1/16W J		R4841	NRSA63J-681X	MG RESISTOR	680Ω 1/16W J	
R4241	NRSA63J-431X	MG RESISTOR	430Ω 1/16W J		R4842	NRSA63J-103X	MG RESISTOR	10kΩ 1/16W J	
R4242	NRSA63J-101X	MG RESISTOR	100Ω 1/16W J		R4843	QRT017J-2R2	MF RESISTOR	2.2Ω 1W J	
R4251	NRSA63J-431X	MG RESISTOR	430Ω 1/16W J		R4861	NRSA63J-222X	MG RESISTOR	2.2kΩ 1/16W J	
R4252	NRSA63J-101X	MG RESISTOR	100Ω 1/16W J		R4863	NRSA63J-222X	MG RESISTOR	2.2kΩ 1/16W J	
R4422	NRSA63J-750X	MG RESISTOR	75Ω 1/16W J		R4864	NRSA63J-331X	MG RESISTOR	330Ω 1/16W J	
R4431	NRSA63J-750X	MG RESISTOR	75Ω 1/16W J		R4866	NRSA63J-272X	MG RESISTOR	2.7kΩ 1/16W J	
R4432	NRSA63J-750X	MG RESISTOR	75Ω 1/16W J		R4871	NRSA63J-331X	MG RESISTOR	330Ω 1/16W J	
R4441	NRSA63J-750X	MG RESISTOR	75Ω 1/16W J		R4872	NRSA63J-331X	MG RESISTOR	330Ω 1/16W J	
R4442	NRSA63J-750X	MG RESISTOR	75Ω 1/16W J		R4873	NRSA63J-331X	MG RESISTOR	330Ω 1/16W J	
R4451	NRSA63J-750X	MG RESISTOR	75Ω 1/16W J		R4874	NRSA63J-331X	MG RESISTOR	330Ω 1/16W J	
R4452	NRSA63J-750X	MG RESISTOR	75Ω 1/16W J		R4875	NRSA63J-331X	MG RESISTOR	330Ω 1/16W J	
R4471	NRSA63J-151X	MG RESISTOR	150Ω 1/16W J		R4876	NRSA63J-331X	MG RESISTOR	330Ω 1/16W J	
R4472	NRSA63J-151X	MG RESISTOR	150Ω 1/16W J		R4877	NRSA63J-331X	MG RESISTOR	330Ω 1/16W J	
R4473	NRSA63J-471X	MG RESISTOR	470Ω 1/16W J		R4881	NRSA63J-472X	MG RESISTOR	4.7kΩ 1/16W J	
R4474	NRSA63J-471X	MG RESISTOR	470Ω 1/16W J		R4883	NRSA63J-472X	MG RESISTOR	4.7kΩ 1/16W J	
R4475	NRSA63J-184X	MG RESISTOR	180kΩ 1/16W J		R4885	NRSA63J-103X	MG RESISTOR	10kΩ 1/16W J	
R4476	NRSA63J-184X	MG RESISTOR	180kΩ 1/16W J		R4886	NRSA63J-562X	MG RESISTOR	5.6kΩ 1/16W J	
R4477	NRSA63J-184X	MG RESISTOR	180kΩ 1/16W J		R4888	NRSA63J-331X	MG RESISTOR	330Ω 1/16W J	
R4478	NRSA63J-184X	MG RESISTOR	180kΩ 1/16W J		R4889	NRSA63J-331X	MG RESISTOR	330Ω 1/16W J	
R4481	QRE141J-202Y	C RESISTOR	2kΩ 1/4W J		R4890	NRSA63J-103X	MG RESISTOR	10kΩ 1/16W J	
R4482	NRSA63J-202X	MG RESISTOR	2kΩ 1/16W J		R4891	NRSA63J-221X	MG RESISTOR	220Ω 1/16W J	
R4483	NRSA63J-821X	MG RESISTOR	820Ω 1/16W J		R4892	NRSA63J-221X	MG RESISTOR	220Ω 1/16W J	
R4484	NRSA63J-123X	MG RESISTOR	12kΩ 1/16W J		R4893	NRSA63J-222X	MG RESISTOR	2.2kΩ 1/16W J	
R4485	NRSA63J-101X	MG RESISTOR	100Ω 1/16W J		R4894	NRSA63J-222X	MG RESISTOR	2.2kΩ 1/16W J	
R4486	NRSA63J-103X	MG RESISTOR	10kΩ 1/16W J		R4895	NRSA63J-471X	MG RESISTOR	470Ω 1/16W J	
R4605	NRSA63J-101X	MG RESISTOR	100Ω 1/16W J		R4896	QRK126J-1R0X	UNF C RESISTOR	1Ω 1/2W J	
R4606	NRSA63J-101X	MG RESISTOR	100Ω 1/16W J		△ R4921	QRZ9005-100X	FUSI RESISTOR	10Ω	
R4702	NRSA63J-102X	MG RESISTOR	1kΩ 1/16W J		R4922	NRSA63J-222X	MG RESISTOR	2.2kΩ 1/16W J	
R4703	NRSA63J-102X	MG RESISTOR	1kΩ 1/16W J		△ R4931	QRZ9005-100X	FUSI RESISTOR	10Ω	
R4704	NRSA63J-103X	MG RESISTOR	10kΩ 1/16W J		R4932	NRSA63J-222X	MG RESISTOR	2.2kΩ 1/16W J	
R4705	NRSA63J-472X	MG RESISTOR	4.7kΩ 1/16W J		R4951	NRSA63J-223X	MG RESISTOR	22kΩ 1/16W J	
R4706	NRSA63J-223X	MG RESISTOR	22kΩ 1/16W J		R4952	NRSA63J-223X	MG RESISTOR	22kΩ 1/16W J	
R4707	NRSA63J-103X	MG RESISTOR	10kΩ 1/16W J		R4961	QRE141J-271Y	C RESISTOR	270Ω 1/4W J	
R4708	QRE141J-221Y	C RESISTOR	220Ω 1/4W J		R4971	NRSA63J-222X	MG RESISTOR	2.2kΩ 1/16W J	
R4709	NRSA63J-101X	MG RESISTOR	100Ω 1/16W J		R4972	NRSA63J-224X	MG RESISTOR	220kΩ 1/16W J	
R4710	NRSA63J-104X	MG RESISTOR	100kΩ 1/16W J		R4973	NRSA63J-102X	MG RESISTOR	1kΩ 1/16W J	
R4711	NRSA63J-331X	MG RESISTOR	330Ω 1/16W J		R4974	NRSA63J-184X	MG RESISTOR	180kΩ 1/16W J	
R4712	NRSA63J-331X	MG RESISTOR	330Ω 1/16W J		R4975	NRSA63J-184X	MG RESISTOR	180kΩ 1/16W J	
R4713	NRSA63J-331X	MG RESISTOR	330Ω 1/16W J		R6101	NRSA63J-223X	MG RESISTOR	22kΩ 1/16W J	
R4751	NRSA63J-103X	MG RESISTOR	10kΩ 1/16W J		R6102	NRSA63J-222X	MG RESISTOR	2.2kΩ 1/16W J	
R4753	NRSA63J-103X	MG RESISTOR	10kΩ 1/16W J		R6103	NRSA63J-333X	MG RESISTOR	33kΩ 1/16W J	
R4754	NRSA63J-103X	MG RESISTOR	10kΩ 1/16W J		R6105	NRSA63J-473X	MG RESISTOR	47kΩ 1/16W J	
R4755	NRSA63J-103X	MG RESISTOR	10kΩ 1/16W J		R6106	QRE141J-330Y	C RESISTOR	33Ω 1/4W J	
R4758	NRSA63J-103X	MG RESISTOR	10kΩ 1/16W J		R6107	QRE141J-390Y	C RESISTOR	39Ω 1/4W J	
R4759	NRSA63J-103X	MG RESISTOR	10kΩ 1/16W J		R6201	NRSA63J-223X	MG RESISTOR	22kΩ 1/16W J	
R4760	NRSA63J-222X	MG RESISTOR	2.2kΩ 1/16W J		R6202	NRSA63J-222X	MG RESISTOR	2.2kΩ 1/16W J	
R4761	NRSA63J-103X	MG RESISTOR	10kΩ 1/16W J		R6203	NRSA63J-333X	MG RESISTOR	33kΩ 1/16W J	
R4762	NRSA63J-103X	MG RESISTOR	10kΩ 1/16W J		R6205	NRSA63J-473X	MG RESISTOR	47kΩ 1/16W J	
R4763	NRSA63J-822X	MG RESISTOR	8.2kΩ 1/16W J		R6206	QRE141J-330Y	C RESISTOR	33Ω 1/4W J	
R4764	NRSA63J-103X	MG RESISTOR	10kΩ 1/16W J		R6207	QRE141J-390Y	C RESISTOR	39Ω 1/4W J	
R4765	NRSA63J-103X	MG RESISTOR	10kΩ 1/16W J		R6302	QRE141J-271Y	C RESISTOR	270Ω 1/4W J	

△ Symbol No.	Part No.	Part Name	Description	Local
R6303	QRE141J-271Y	C RESISTOR	270Ω 1/4W J	
R6304	QRE141J-271Y	C RESISTOR	270Ω 1/4W J	
R6305	QRE141J-271Y	C RESISTOR	270Ω 1/4W J	
R6501	NRSA63J-104X	MG RESISTOR	100kΩ 1/16W J	
R6502	NRSA63J-103X	MG RESISTOR	10kΩ 1/16W J	
R6503	NRSA63J-102X	MG RESISTOR	1kΩ 1/16W J	
R6504	NRSA63J-102X	MG RESISTOR	1kΩ 1/16W J	
R6505	NRSA63J-103X	MG RESISTOR	10kΩ 1/16W J	
R6506	NRSA63J-103X	MG RESISTOR	10kΩ 1/16W J	
R6507	NRSA63J-103X	MG RESISTOR	10kΩ 1/16W J	
R6508	NRSA63J-102X	MG RESISTOR	1kΩ 1/16W J	
R6509	NRSA63J-473X	MG RESISTOR	47kΩ 1/16W J	
R6510	NRSA63J-104X	MG RESISTOR	100kΩ 1/16W J	
R6511	NRSA63J-333X	MG RESISTOR	33kΩ 1/16W J	
R6512	NRSA63J-103X	MG RESISTOR	10kΩ 1/16W J	
R6513	NRSA63J-104X	MG RESISTOR	100kΩ 1/16W J	
R6514	NRSA63J-103X	MG RESISTOR	10kΩ 1/16W J	
R6515	NRSA63J-102X	MG RESISTOR	1kΩ 1/16W J	
R6516	NRSA63J-103X	MG RESISTOR	10kΩ 1/16W J	
R6517	NRSA63J-104X	MG RESISTOR	100kΩ 1/16W J	
R6518	NRSA63J-223X	MG RESISTOR	22kΩ 1/16W J	
R6601	NRSA63J-104X	MG RESISTOR	100kΩ 1/16W J	
R6602	NRSA63J-103X	MG RESISTOR	10kΩ 1/16W J	
R6603	NRSA63J-102X	MG RESISTOR	1kΩ 1/16W J	
R6604	NRSA63J-102X	MG RESISTOR	1kΩ 1/16W J	
R6605	NRSA63J-103X	MG RESISTOR	10kΩ 1/16W J	
R6606	NRSA63J-103X	MG RESISTOR	10kΩ 1/16W J	
R6607	NRSA63J-103X	MG RESISTOR	10kΩ 1/16W J	
R6608	NRSA63J-102X	MG RESISTOR	1kΩ 1/16W J	
R6609	NRSA63J-473X	MG RESISTOR	47kΩ 1/16W J	
R6610	NRSA63J-104X	MG RESISTOR	100kΩ 1/16W J	
R6611	NRSA63J-333X	MG RESISTOR	33kΩ 1/16W J	
R6612	NRSA63J-103X	MG RESISTOR	10kΩ 1/16W J	
R6613	NRSA63J-104X	MG RESISTOR	100kΩ 1/16W J	
R6614	NRSA63J-103X	MG RESISTOR	10kΩ 1/16W J	
R6615	NRSA63J-102X	MG RESISTOR	1kΩ 1/16W J	
R6616	NRSA63J-103X	MG RESISTOR	10kΩ 1/16W J	
R6617	NRSA63J-104X	MG RESISTOR	100kΩ 1/16W J	
R6618	NRSA63J-223X	MG RESISTOR	22kΩ 1/16W J	
△ L901	QQR1105-001	LINE FILTER		
L951	QQL244K-R22Z	COIL	0.22uH K	
L952	QQL44BK-220Z	COIL	22uH K	
L955	QQL26AK-220Z	COIL	22uH K	
L957	QQL244K-100Z	COIL	10uH K	
L959	QQL244K-100Z	COIL	10uH K	
L4391	QQL25CK-221Z	COIL	220uH K	
△ T901	QQS0097-001	SW TRANSF		
CN401	QGF1036C1-15	CONNECTOR	FFC/FPC (1-15)	
CN402	QGF1036C1-17	CONNECTOR	FFC/FPC (1-17)	
CN403	QGF1036C1-09	CONNECTOR	FFC/FPC (1-9)	
CN404	QGD2504C1-05Z	CONNECTOR	(1-5)	
CN405	QGD2504C1-05Z	CONNECTOR	(1-5)	
CN406	QGD2504C1-04Z	CONNECTOR	(1-4)	
CN407	QGD2504C1-05Z	CONNECTOR	(1-5)	
CN408	QGF1036C1-05	CONNECTOR	FFC/FPC (1-5)	
CN409	QGF1036C1-08	CONNECTOR	FFC/FPC (1-8)	
CN410	QGF1205C1-11	CONNECTOR	FFC/FPC (1-11)	
CN411	QGF1036C1-29	CONNECTOR	FFC/FPC (1-29)	
CN412	QGF1036C1-07	CONNECTOR	FFC/FPC (1-7)	
CN416	QGA2501C1-05	CONNECTOR	W-B (1-5)	
CN451	QGF1036C1-13	CONNECTOR	FFC/FPC (1-13)	
CN452	QGF1036C1-13	CONNECTOR	FFC/FPC (1-13)	
△ CP471	ICP-N5-T	IC PROTECTOR	250mA	
△ CP951	ICP-N10-T	IC PROTECTOR	400mA	
△ CP952	ICP-N5-T	IC PROTECTOR	250mA	
EP401	QNZ0136-001Z	EARTH PLATE		
EP402	QNZ0136-001Z	EARTH PLATE		
EP403	QNZ0136-001Z	EARTH PLATE		
EP901	QNZ0136-001Z	EARTH PLATE		
EP902	QNZ0136-001Z	EARTH PLATE		
EP951	QNZ0136-001Z	EARTH PLATE		
FC901	QNG0003-001Z	FUSE CLIP		
FC902	QNG0003-001Z	FUSE CLIP		
FW901	QUM219-06DGZ4	PARA RIBON WIR		
FW902	QUM21A-06DGZ4	PARA RIBON WIR		
HS901	E70306-014	HEAT SINK		

△ Symbol No.	Part No.	Part Name	Description	Local
J4402	QNN0572-001	PIN JACK		
J4403	QNZ0625-001	RGB CONNECTOR		
J4891	QNS0089-001	3.5 JACK		
K4702	QQR0621-001Z	COIL		
△ P901	QNC0091-001	AC INLET		
PP401	QZW0112-001	WIRE CLAMP		
X4071	QAX0263-001Z	CRYSTAL	4.332MHz	
X4701	QAX0246-001Z	C RESONATOR	8.00MHz	

Front board

Block No. [0][2]

△ Symbol No.	Part No.	Part Name	Description	Local
IC501	MN101C35DKW	IC(MPU)		
IC511	GP1UM271XK	IR DETECT UNIT	38kHz	
Q501	UN2211-X	TRANSISTOR		
Q502	UN2211-X	TRANSISTOR		
Q551	KRC102M-T	DIGI TRANSISTOR		
Q552	KRC111M-T	TRANSISTOR		
D551	SLR343BBT/H-L/T	LED		
C501	NCB31HK-471X	C CAPACITOR	470pF 50V K	
C502	NCB31HK-471X	C CAPACITOR	470pF 50V K	
C503	NCB31HK-103X	C CAPACITOR	0.01uF 50V K	
C504	NCB31HK-103X	C CAPACITOR	0.01uF 50V K	
C505	NBE21AM-226X	TA E CAPACITOR	22uF 10V M	
C506	NCB31HK-103X	C CAPACITOR	0.01uF 50V K	
C507	NCB31HK-103X	C CAPACITOR	0.01uF 50V K	
C511	NCB21CK-105X	C CAPACITOR	1uF 16V K	
R501	NRSA63J-102X	MG RESISTOR	1kΩ 1/16W J	
R502	NRSA63J-102X	MG RESISTOR	1kΩ 1/16W J	
R503	NRSA63J-102X	MG RESISTOR	1kΩ 1/16W J	
R504	NRSA63J-102X	MG RESISTOR	1kΩ 1/16W J	
R552	NRSA63J-121X	MG RESISTOR	120Ω 1/16W J	
R553	NRSA63J-331X	MG RESISTOR	330Ω 1/16W J	
BK501	LV43659-001A	FL HOLDER		
BK502	LV43659-001A	FL HOLDER		
CN501	QGF1036F1-13	CONNECTOR	FFC/FPC (1-13)	
DI501	QLF0131-002	FL TUBE		
X501	NAX0623-001X	C RESONATOR	8.00MHz	

Audio board

Block No. [0][3]

△ Symbol No.	Part No.	Part Name	Description	Local
IC151	CD4066BM-X	IC		
IC152	CD4066BM-X	IC		
IC153	BD3814FV-X	IC		
IC158	RC4580ID-X	IC		
IC159	RC4580ID-X	IC		
IC160	RC4580ID-X	IC		
IC509	GP1FA352RZ	OPT RECEIVER		
IC531	RC4580ID-X	IC		
IC581	RC4580ID-X	IC		
IC591	RC4580ID-X	IC		
Q511	UN2211-X	TRANSISTOR		
Q1131	IMX9-W	TRANSISTOR		
Q1133	IMX9-W	TRANSISTOR		
Q1135	IMX9-W	TRANSISTOR		
Q1137	2SC3661-X	TRANSISTOR		
Q1251	UN2113-X	DIGI TRANSISTOR		
Q1252	UN2113-X	DIGI TRANSISTOR		

△ Symbol No.	Part No.	Part Name	Description	Local	△ Symbol No.	Part No.	Part Name	Description	Local
D511	SLR-343VC-T	LED			C2540	NCB31CK-104X	C CAPACITOR	0.1uF 16V K	
C541	NCB31HK-103X	C CAPACITOR	0.01uF 50V K		C2541	QETN1HM-475Z	E CAPACITOR	4.7uF 50V M	
C542	NCB31HK-103X	C CAPACITOR	0.01uF 50V K		C2542	QETN1HM-475Z	E CAPACITOR	4.7uF 50V M	
C1001	QETN1EM-107Z	E CAPACITOR	100uF 25V M		C2561	QETN1HM-105Z	E CAPACITOR	1uF 50V M	
C1002	QETN1EM-107Z	E CAPACITOR	100uF 25V M		C2562	QETN1HM-105Z	E CAPACITOR	1uF 50V M	
C1003	NCB31HK-103X	C CAPACITOR	0.01uF 50V K		C2563	NCB31HK-271X	C CAPACITOR	270pF 50V K	
C1101	NCS31HJ-331X	C CAPACITOR	330pF 50V J		C2564	NCB31HK-271X	C CAPACITOR	270pF 50V K	
C1102	NCS31HJ-331X	C CAPACITOR	330pF 50V J		C2575	NCB31HK-102X	C CAPACITOR	1000pF 50V K	
C1103	NCB31CK-104X	C CAPACITOR	0.1uF 16V K		C2576	NCB31HK-102X	C CAPACITOR	1000pF 50V K	
C1120	NCB31CK-104X	C CAPACITOR	0.1uF 16V K		C2577	QETN1HM-475Z	E CAPACITOR	4.7uF 50V M	
C1121	NCB31CK-104X	C CAPACITOR	0.1uF 16V K		C2578	QETN1HM-475Z	E CAPACITOR	4.7uF 50V M	
C1122	NCB31CK-104X	C CAPACITOR	0.1uF 16V K		C2581	QETN1HM-105Z	E CAPACITOR	1uF 50V M	
C1123	NCB31CK-104X	C CAPACITOR	0.1uF 16V K		C2582	QETN1HM-106Z	E CAPACITOR	10uF 50V M	
C1124	NCB31HK-472X	C CAPACITOR	4700pF 50V K		C2583	NCB31HK-271X	C CAPACITOR	270pF 50V K	
C1125	NCB31HK-472X	C CAPACITOR	4700pF 50V K		C2584	NCS31HJ-560X	C CAPACITOR	56pF 50V J	
C1141	QETN1EM-107Z	E CAPACITOR	100uF 25V M		C2585	NCB31HK-102X	C CAPACITOR	1000pF 50V K	
C1142	QETN1EM-107Z	E CAPACITOR	100uF 25V M		C2589	NCB31CK-104X	C CAPACITOR	0.1uF 16V K	
C1143	NCB31CK-104X	C CAPACITOR	0.1uF 16V K		C2590	NCB31CK-104X	C CAPACITOR	0.1uF 16V K	
C1144	NCB31CK-104X	C CAPACITOR	0.1uF 16V K		C2592	NCB31HK-472X	C CAPACITOR	4700pF 50V K	
C1145	NCB31CK-104X	C CAPACITOR	0.1uF 16V K		C2594	NCB31CK-223X	C CAPACITOR	0.022uF 16V K	
C1176	NCB31HK-103X	C CAPACITOR	0.01uF 50V K		C2597	QETN1HM-475Z	E CAPACITOR	4.7uF 50V M	
C1177	NCB31HK-103X	C CAPACITOR	0.01uF 50V K		C2599	NCB31CK-104X	C CAPACITOR	0.1uF 16V K	
C1178	NCB31HK-103X	C CAPACITOR	0.01uF 50V K		C2600	NCB31CK-104X	C CAPACITOR	0.1uF 16V K	
C1179	NCB31HK-103X	C CAPACITOR	0.01uF 50V K		C2603	QETN1HM-475Z	E CAPACITOR	4.7uF 50V M	
C1180	NCB31HK-103X	C CAPACITOR	0.01uF 50V K		C2604	QETN1HM-475Z	E CAPACITOR	4.7uF 50V M	
C1181	NCB31HK-103X	C CAPACITOR	0.01uF 50V K		C2605	NCS31HJ-560X	C CAPACITOR	56pF 50V J	
C1183	QETN1HM-475Z	E CAPACITOR	4.7uF 50V M		C6001	NCB31CK-223X	C CAPACITOR	0.022uF 16V K	
C1184	QETN1CM-476Z	E CAPACITOR	47uF 16V M		C6002	NCB31CK-223X	C CAPACITOR	0.022uF 16V K	
C1185	NCB31HK-103X	C CAPACITOR	0.01uF 50V K		C6003	NCB31CK-104X	C CAPACITOR	0.1uF 16V K	
C1186	NCB31HK-103X	C CAPACITOR	0.01uF 50V K		C6004	NCB31HK-103X	C CAPACITOR	0.01uF 50V K	
C1201	QETN1CM-476Z	E CAPACITOR	47uF 16V M		R511	NRSA63J-221X	MG RESISTOR	220Ω 1/16W J	
C1202	QETN1CM-476Z	E CAPACITOR	47uF 16V M		R521	NRSA63J-332X	MG RESISTOR	3.3kΩ 1/16W J	
C1203	QETN1CM-476Z	E CAPACITOR	47uF 16V M		R522	NRSA63J-392X	MG RESISTOR	3.9kΩ 1/16W J	
C1204	QETN1CM-476Z	E CAPACITOR	47uF 16V M		R526	NRSA63J-332X	MG RESISTOR	3.3kΩ 1/16W J	
C1205	QETN1HM-475Z	E CAPACITOR	4.7uF 50V M		R527	NRSA63J-392X	MG RESISTOR	3.9kΩ 1/16W J	
C1206	QETN1HM-475Z	E CAPACITOR	4.7uF 50V M		R541	NRSA63J-103X	MG RESISTOR	10kΩ 1/16W J	
C1207	QETN1HM-475Z	E CAPACITOR	4.7uF 50V M		R542	NRSA63J-103X	MG RESISTOR	10kΩ 1/16W J	
C1208	QETN1HM-475Z	E CAPACITOR	4.7uF 50V M		R1101	NRSA63J-471X	MG RESISTOR	470Ω 1/16W J	
C1209	QETN1HM-475Z	E CAPACITOR	4.7uF 50V M		R1102	NRSA63J-471X	MG RESISTOR	470Ω 1/16W J	
C1210	QETN1HM-475Z	E CAPACITOR	4.7uF 50V M		R1103	NRSA63J-564X	MG RESISTOR	560kΩ 1/16W J	
C1211	QETN1HM-475Z	E CAPACITOR	4.7uF 50V M		R1104	NRSA63J-564X	MG RESISTOR	560kΩ 1/16W J	
C1212	QETN1HM-475Z	E CAPACITOR	4.7uF 50V M		R1106	NRSA63J-101X	MG RESISTOR	100Ω 1/16W J	
C1213	QETN1HM-475Z	E CAPACITOR	4.7uF 50V M		R1108	NRSA63J-334X	MG RESISTOR	330kΩ 1/16W J	
C1214	QETN1HM-475Z	E CAPACITOR	4.7uF 50V M		R1109	NRSA63J-334X	MG RESISTOR	330kΩ 1/16W J	
C1215	QETN1HM-475Z	E CAPACITOR	4.7uF 50V M		R1110	NRSA63J-223X	MG RESISTOR	22kΩ 1/16W J	
C1216	QETN1HM-475Z	E CAPACITOR	4.7uF 50V M		R1120	NRSA63J-472X	MG RESISTOR	4.7kΩ 1/16W J	
C1217	QETN1HM-475Z	E CAPACITOR	4.7uF 50V M		R1121	NRSA63J-472X	MG RESISTOR	4.7kΩ 1/16W J	
C1218	QETN1HM-475Z	E CAPACITOR	4.7uF 50V M		R1122	NRSA63J-102X	MG RESISTOR	1kΩ 1/16W J	
C1221	NCS31HJ-470X	C CAPACITOR	47pF 50V J		R1123	NRSA63J-102X	MG RESISTOR	1kΩ 1/16W J	
C1222	NCS31HJ-470X	C CAPACITOR	47pF 50V J		R1124	NRSA63J-472X	MG RESISTOR	4.7kΩ 1/16W J	
C1223	NCS31HJ-470X	C CAPACITOR	47pF 50V J		R1131	NRSA63J-104X	MG RESISTOR	100kΩ 1/16W J	
C1224	NCS31HJ-470X	C CAPACITOR	47pF 50V J		R1132	NRSA63J-104X	MG RESISTOR	100kΩ 1/16W J	
C1225	NCS31HJ-471X	C CAPACITOR	470pF 50V J		R1133	NRSA63J-101X	MG RESISTOR	100Ω 1/16W J	
C1226	NCS31HJ-470X	C CAPACITOR	47pF 50V J		R1134	NRSA63J-101X	MG RESISTOR	100Ω 1/16W J	
C1227	NCB31CK-183X	C CAPACITOR	0.018uF 16V K		R1135	NRSA63J-332X	MG RESISTOR	3.3kΩ 1/16W J	
C1228	NCB31CK-183X	C CAPACITOR	0.018uF 16V K		R1136	NRSA63J-332X	MG RESISTOR	3.3kΩ 1/16W J	
C1230	QETN1HM-475Z	E CAPACITOR	4.7uF 50V M		R1137	NRSA63J-104X	MG RESISTOR	100kΩ 1/16W J	
C1251	NCB31HK-103X	C CAPACITOR	0.01uF 50V K		R1138	NRSA63J-104X	MG RESISTOR	100kΩ 1/16W J	
C1252	NCB31HK-103X	C CAPACITOR	0.01uF 50V K		R1139	NRSA63J-104X	MG RESISTOR	100kΩ 1/16W J	
C1253	NCB31HK-103X	C CAPACITOR	0.01uF 50V K		R1140	NRSA63J-104X	MG RESISTOR	100kΩ 1/16W J	
C1254	NCB31HK-103X	C CAPACITOR	0.01uF 50V K		R1141	NRSA63J-102X	MG RESISTOR	1kΩ 1/16W J	
C1255	NCS31HJ-101X	C CAPACITOR	100pF 50V J		R1142	NRSA63J-102X	MG RESISTOR	1kΩ 1/16W J	
C1256	NCS31HJ-101X	C CAPACITOR	100pF 50V J		R1143	NRSA63J-332X	MG RESISTOR	3.3kΩ 1/16W J	
C1257	NCS31HJ-101X	C CAPACITOR	100pF 50V J		R1144	NRSA63J-332X	MG RESISTOR	3.3kΩ 1/16W J	
C1258	NCS31HJ-101X	C CAPACITOR	100pF 50V J		R1145	NRSA63J-104X	MG RESISTOR	100kΩ 1/16W J	
C1259	QCBB1HK-101Y	C CAPACITOR	100pF 50V K		R1146	NRSA63J-104X	MG RESISTOR	100kΩ 1/16W J	
C2503	QETN1HM-475Z	E CAPACITOR	4.7uF 50V M		R1147	NRSA63J-104X	MG RESISTOR	100kΩ 1/16W J	
C2504	QETN1HM-475Z	E CAPACITOR	4.7uF 50V M		R1148	NRSA63J-104X	MG RESISTOR	100kΩ 1/16W J	
C2525	NCB31HK-102X	C CAPACITOR	1000pF 50V K		R1149	NRSA63J-471X	MG RESISTOR	470Ω 1/16W J	
C2526	NCB31HK-102X	C CAPACITOR	1000pF 50V K		R1150	NRSA63J-102X	MG RESISTOR	1kΩ 1/16W J	
C2527	NCB31HK-102X	C CAPACITOR	1000pF 50V K		R1151	NRSA63J-472X	MG RESISTOR	4.7kΩ 1/16W J	
C2528	NCB31HK-102X	C CAPACITOR	1000pF 50V K		R1152	NRSA63J-332X	MG RESISTOR	3.3kΩ 1/16W J	
C2531	NCB31HK-331X	C CAPACITOR	330pF 50V K		R1153	NRSA63J-471X	MG RESISTOR	470Ω 1/16W J	
C2532	NCB31HK-331X	C CAPACITOR	330pF 50V K		R1154	NRSA63J-472X	MG RESISTOR	4.7kΩ 1/16W J	
C2533	QETN1CM-476Z	E CAPACITOR	47uF 16V M		R1155	NRSA63J-104X	MG RESISTOR	100kΩ 1/16W J	
C2534	QETN1CM-476Z	E CAPACITOR	47uF 16V M		R1156	NRSA63J-104X	MG RESISTOR	100kΩ 1/16W J	
C2539	NCB31CK-104X	C CAPACITOR	0.1uF 16V K		R1157	NRSA63J-332X	MG RESISTOR	3.3kΩ 1/16W J	

△ Symbol No.	Part No.	Part Name	Description	Local
R1158	NRSA63J-104X	MG RESISTOR	100kΩ 1/16W J	
R1161	NRSA63J-104X	MG RESISTOR	100kΩ 1/16W J	
R1162	NRSA63J-104X	MG RESISTOR	100kΩ 1/16W J	
R1163	NRSA63J-104X	MG RESISTOR	100kΩ 1/16W J	
R1164	NRSA63J-104X	MG RESISTOR	100kΩ 1/16W J	
R1165	NRSA63J-104X	MG RESISTOR	100kΩ 1/16W J	
R1166	NRSA63J-104X	MG RESISTOR	100kΩ 1/16W J	
R1167	NRSA63J-332X	MG RESISTOR	3.3kΩ 1/16W J	
R1168	NRSA63J-332X	MG RESISTOR	3.3kΩ 1/16W J	
R1169	NRSA63J-393X	MG RESISTOR	39kΩ 1/16W J	
R1170	NRSA63J-393X	MG RESISTOR	39kΩ 1/16W J	
R1171	NRSA63J-332X	MG RESISTOR	3.3kΩ 1/16W J	SW8
R1171	NRSA63J-392X	MG RESISTOR	3.9kΩ 1/16W J	SW9
R1172	NRSA63J-332X	MG RESISTOR	3.3kΩ 1/16W J	SW8
R1172	NRSA63J-392X	MG RESISTOR	3.9kΩ 1/16W J	SW9
R1173	NRSA63J-473X	MG RESISTOR	47kΩ 1/16W J	
R1174	NRSA63J-473X	MG RESISTOR	47kΩ 1/16W J	
R1175	NRSA63J-432X	MG RESISTOR	4.3kΩ 1/16W J	
R1176	NRSA63J-393X	MG RESISTOR	39kΩ 1/16W J	
R1180	NRSA63J-222X	MG RESISTOR	2.2kΩ 1/16W J	
R1181	NRSA63J-222X	MG RESISTOR	2.2kΩ 1/16W J	
R1182	NRSA63J-202X	MG RESISTOR	2kΩ 1/16W J	SW8
R1182	NRSA63J-392X	MG RESISTOR	3.9kΩ 1/16W J	SW9
R1183	NRSA63J-202X	MG RESISTOR	2kΩ 1/16W J	SW8
R1183	NRSA63J-392X	MG RESISTOR	3.9kΩ 1/16W J	SW9
R1197	NRSA63J-474X	MG RESISTOR	470kΩ 1/16W J	
R1201	NRSA63J-124X	MG RESISTOR	120kΩ 1/16W J	
R1202	NRSA63J-124X	MG RESISTOR	120kΩ 1/16W J	
R1251	NRSA63J-223X	MG RESISTOR	22kΩ 1/16W J	
R1252	NRSA63J-223X	MG RESISTOR	22kΩ 1/16W J	
R1253	NRSA63J-223X	MG RESISTOR	22kΩ 1/16W J	
R1254	NRSA63J-223X	MG RESISTOR	22kΩ 1/16W J	
R2525	NRSA63J-102X	MG RESISTOR	1kΩ 1/16W J	
R2526	NRSA63J-102X	MG RESISTOR	1kΩ 1/16W J	
R2531	NRSA63J-102X	MG RESISTOR	1kΩ 1/16W J	
R2532	NRSA63J-102X	MG RESISTOR	1kΩ 1/16W J	
R2533	NRSA63J-472X	MG RESISTOR	4.7kΩ 1/16W J	
R2534	NRSA63J-472X	MG RESISTOR	4.7kΩ 1/16W J	
R2537	NRSA63J-104X	MG RESISTOR	100kΩ 1/16W J	
R2538	NRSA63J-104X	MG RESISTOR	100kΩ 1/16W J	
R2539	NRSA63J-272X	MG RESISTOR	2.7kΩ 1/16W J	
R2540	NRSA63J-272X	MG RESISTOR	2.7kΩ 1/16W J	
R2551	NRSA63J-104X	MG RESISTOR	100kΩ 1/16W J	
R2552	NRSA63J-104X	MG RESISTOR	100kΩ 1/16W J	
R2553	NRSA63J-102X	MG RESISTOR	1kΩ 1/16W J	
R2554	NRSA63J-102X	MG RESISTOR	1kΩ 1/16W J	
R2560	NRSA63J-472X	MG RESISTOR	4.7kΩ 1/16W J	
R2561	NRSA63J-273X	MG RESISTOR	27kΩ 1/16W J	
R2562	NRSA63J-102X	MG RESISTOR	1kΩ 1/16W J	
R2563	NRSA63J-103X	MG RESISTOR	10kΩ 1/16W J	
R2564	NRSA63J-103X	MG RESISTOR	10kΩ 1/16W J	
R2565	NRSA63J-682X	MG RESISTOR	6.8kΩ 1/16W J	
R2566	NRSA63J-682X	MG RESISTOR	6.8kΩ 1/16W J	
R2567	NRSA63J-102X	MG RESISTOR	1kΩ 1/16W J	
R2568	NRSA63J-102X	MG RESISTOR	1kΩ 1/16W J	
R2581	NRSA63J-104X	MG RESISTOR	100kΩ 1/16W J	
R2582	NRSA63J-104X	MG RESISTOR	100kΩ 1/16W J	
R2583	NRSA63J-103X	MG RESISTOR	10kΩ 1/16W J	
R2584	NRSA63J-333X	MG RESISTOR	33kΩ 1/16W J	
R2585	NRSA63J-682X	MG RESISTOR	6.8kΩ 1/16W J	
R2586	NRSA63J-123X	MG RESISTOR	12kΩ 1/16W J	
R2587	NRSA63J-102X	MG RESISTOR	1kΩ 1/16W J	
R2588	NRSA63J-102X	MG RESISTOR	1kΩ 1/16W J	
R2590	NRSA63J-333X	MG RESISTOR	33kΩ 1/16W J	
R2592	NRSA63J-333X	MG RESISTOR	33kΩ 1/16W J	
R2594	NRSA63J-333X	MG RESISTOR	33kΩ 1/16W J	
R2596	NRSA63J-102X	MG RESISTOR	1kΩ 1/16W J	
R2599	NRSA63J-102X	MG RESISTOR	1kΩ 1/16W J	
R6001	NRSA63J-102X	MG RESISTOR	1kΩ 1/16W J	
R6002	NRSA63J-101X	MG RESISTOR	100Ω 1/16W J	
R6003	NRSA63J-101X	MG RESISTOR	100Ω 1/16W J	
R6004	NRSA63J-101X	MG RESISTOR	100Ω 1/16W J	
R6006	NRSA63J-471X	MG RESISTOR	470Ω 1/16W J	
CN441	QGF1036C1-29	CONNECTOR	FFC/FPC (1-29)	
CN442	QGF1036C1-07	CONNECTOR	FFC/FPC (1-7)	
CN443	QGA2501C1-03	CONNECTOR	W-B (1-3)	
CN511	QGF1036F1-13	CONNECTOR	FFC/FPC (1-13)	

△ Symbol No.	Part No.	Part Name	Description	Local
EP101	E409182-001SM	GRAND TERMINAL		
J1101	QNN0215-001	SURROUND JACK		
J1103	QND0118-001	DIN CONNECTOR		
J6001	QNS0231-001	JACK		
JS541	QSW1059-001	JOG VOLUME		
K1101	NQR0007-002X	FERRITE BEADS		
K6001	NQR0007-002X	FERRITE BEADS		
K6002	NQR0007-002X	FERRITE BEADS		
K6003	NQR0007-002X	FERRITE BEADS		
K6004	NQR0007-002X	FERRITE BEADS		
S521	QSW0683-001Z	PUSH SW		
S522	QSW0683-001Z	PUSH SW		
S523	QSW0683-001Z	PUSH SW		
S526	QSW0683-001Z	PUSH SW		
S527	QSW0683-001Z	PUSH SW		
S528	QSW0683-001Z	PUSH SW		
W6001	QUB220-15DMHP	SINGLE WIRE		

TX ant board

△ Symbol No.	Part No.	Part Name	Description	Local
TP701	QNZ0104-001	POST PIN		

Block No. [0][4]

Front board (Receiver)

△ Symbol No.	Part No.	Part Name	Description	Local
IC101	TDA8920TH/N1-X	IC		
IC131	RC4580ID-X	IC		
Q1501	KTC3875/YG/-X	SI TRANSISTOR		
Q1502	UN2213-X	DIGI TRANSISTOR		
Q1503	KTC3875/YG/-X	SI TRANSISTOR		
Q1504	UN2214-X	TRANSISTOR		
Q1505	KTC3875/YG/-X	SI TRANSISTOR		
Q1601	KTA1504/YG/-X	SI TRANSISTOR		
Q1602	KTC3875/YG/-X	SI TRANSISTOR		
Q1603	KTC3875/YG/-X	SI TRANSISTOR		
Q1604	UN2112-X	DIGI TRANSISTOR		
Q1620	2SA1514K/RS/-X	TRANSISTOR		
Q1621	2SA1514K/RS/-X	TRANSISTOR		
Q1630	2SA1514K/RS/-X	TRANSISTOR		
Q1631	2SA1514K/RS/-X	TRANSISTOR		

Block No. [0][5]

D1501	MA111-X	SI DIODE		
D1502	MA111-X	SI DIODE		
D1503	MA111-X	SI DIODE		
D1504	MA111-X	SI DIODE		
D1505	MA111-X	SI DIODE		
D1507	MA111-X	SI DIODE		
D1508	MA111-X	SI DIODE		
D1601	MA111-X	SI DIODE		
D1620	MA111-X	SI DIODE		
D1621	MA111-X	SI DIODE		
D1630	MA111-X	SI DIODE		
D1631	MA111-X	SI DIODE		
D1640	MA111-X	SI DIODE		
D1711	MTZJ13C-T2	Z DIODE		
D1801	SELU2E10C-P	LED		
D1802	SLR-343VC-T	LED		
C1001	NCB21HK-104X	C CAPACITOR	0.1uF 50V K	
C1002	NCF21HZ-474X	C CAPACITOR	0.47uF 50V Z	
C1003	NCB21HK-104X	C CAPACITOR	0.1uF 50V K	
C1004	NCB31HK-331X	C CAPACITOR	330pF 50V K	
C1005	NCF21HZ-474X	C CAPACITOR	0.47uF 50V Z	
C1006	NCB31HK-331X	C CAPACITOR	330pF 50V K	

△ Symbol No.	Part No.	Part Name	Description	Local	△ Symbol No.	Part No.	Part Name	Description	Local
C1007	NCB21HK-104X	C CAPACITOR	0.1uF 50V K		R1201	NRS144J-4R7X	MG RESISTOR	4.7Ω 1/4W J	
C1008	NCF21HZ-474X	C CAPACITOR	0.47uF 50V Z		R1202	NRS016J-220X	MG RESISTOR	22Ω 1W J	
C1009	NCB21HK-104X	C CAPACITOR	0.1uF 50V K		R1203	NRS016J-8R2X	MG RESISTOR	8.2Ω 1W J	
C1010	NCB21HK-104X	C CAPACITOR	0.1uF 50V K		R1204	NRS144J-4R7X	MG RESISTOR	4.7Ω 1/4W J	
C1011	NDC31HJ-470X	C CAPACITOR	47pF 50V J		R1310	NRSA63J-0R0X	MG RESISTOR	0Ω 1/16W J	
C1012	NCF21HZ-474X	C CAPACITOR	0.47uF 50V Z		R1311	NRSA63J-103X	MG RESISTOR	10kΩ 1/16W J	
C1013	NCB21HK-104X	C CAPACITOR	0.1uF 50V K		R1312	NRSA63J-332X	MG RESISTOR	3.3kΩ 1/16W J	
C1014	NCF21HZ-474X	C CAPACITOR	0.47uF 50V Z		R1314	NRSA63J-472X	MG RESISTOR	4.7kΩ 1/16W J	
C1015	NCB21HK-104X	C CAPACITOR	0.1uF 50V K		R1315	NRSA63J-682X	MG RESISTOR	6.8kΩ 1/16W J	
C1016	NCF21HZ-474X	C CAPACITOR	0.47uF 50V Z		R1316	NRSA63J-332X	MG RESISTOR	3.3kΩ 1/16W J	
C1017	NCB21HK-104X	C CAPACITOR	0.1uF 50V K		R1318	NRSA63J-0R0X	MG RESISTOR	0Ω 1/16W J	
C1021	NCF21HZ-474X	C CAPACITOR	0.47uF 50V Z		R1350	NRSA02J-102X	MG RESISTOR	1kΩ 1/10W J	
C1022	NCF21HZ-474X	C CAPACITOR	0.47uF 50V Z		R1351	NRSA02J-751X	MG RESISTOR	750Ω 1/10W J	
C1023	NCF21HZ-474X	C CAPACITOR	0.47uF 50V Z		R1352	NRSA02J-102X	MG RESISTOR	1kΩ 1/10W J	
C1024	NCF21HZ-474X	C CAPACITOR	0.47uF 50V Z		R1410	NRSA63J-0R0X	MG RESISTOR	0Ω 1/16W J	
C1025	NCF21HZ-474X	C CAPACITOR	0.47uF 50V Z		R1411	NRSA63J-103X	MG RESISTOR	10kΩ 1/16W J	
C1026	NCF21HZ-474X	C CAPACITOR	0.47uF 50V Z		R1412	NRSA63J-332X	MG RESISTOR	3.3kΩ 1/16W J	
C1031	NCF21HZ-474X	C CAPACITOR	0.47uF 50V Z		R1414	NRSA63J-472X	MG RESISTOR	4.7kΩ 1/16W J	
C1032	NCF21HZ-474X	C CAPACITOR	0.47uF 50V Z		R1415	NRSA63J-682X	MG RESISTOR	6.8kΩ 1/16W J	
C1041	NCF21HZ-474X	C CAPACITOR	0.47uF 50V Z		R1416	NRSA63J-332X	MG RESISTOR	3.3kΩ 1/16W J	
C1042	NCF21HZ-474X	C CAPACITOR	0.47uF 50V Z		R1418	NRSA63J-0R0X	MG RESISTOR	0Ω 1/16W J	
C1101	NCB31HK-153X	C CAPACITOR	0.015uF 50V K		R1501	NRSA63J-153X	MG RESISTOR	15kΩ 1/16W J	
C1102	NCB31HK-102X	C CAPACITOR	1000pF 50V K		R1502	NRSA63J-512X	MG RESISTOR	5.1kΩ 1/16W J	
C1103	NCB31HK-102X	C CAPACITOR	1000pF 50V K		R1503	NRSA63J-104X	MG RESISTOR	100kΩ 1/16W J	
C1104	QFVF1HJ-474Z	MF CAPACITOR	0.47uF 50V J		R1504	NRSA63J-103X	MG RESISTOR	10kΩ 1/16W J	
C1105	NCF21HZ-474X	C CAPACITOR	0.47uF 50V Z		R1505	NRSA63J-562X	MG RESISTOR	5.6kΩ 1/16W J	
C1106	NCF21HZ-474X	C CAPACITOR	0.47uF 50V Z		R1506	NRSA63J-103X	MG RESISTOR	10kΩ 1/16W J	
C1107	NCB31HK-153X	C CAPACITOR	0.015uF 50V K		R1507	NRSA63J-472X	MG RESISTOR	4.7kΩ 1/16W J	
C1108	NCB21HK-104X	C CAPACITOR	0.1uF 50V K		R1508	NRSA63J-103X	MG RESISTOR	10kΩ 1/16W J	
C1109	NCB21HK-104X	C CAPACITOR	0.1uF 50V K		R1509	NRSA63J-104X	MG RESISTOR	100kΩ 1/16W J	
C1110	NCB31HK-102X	C CAPACITOR	1000pF 50V K		R1510	NRSA63J-472X	MG RESISTOR	4.7kΩ 1/16W J	
C1111	NCB31HK-102X	C CAPACITOR	1000pF 50V K		R1511	NRSA63J-123X	MG RESISTOR	12kΩ 1/16W J	
C1201	NCB31HK-153X	C CAPACITOR	0.015uF 50V K		R1512	QRZ9005-181X	FUSI RESISTOR	180Ω	
C1202	NCB31HK-102X	C CAPACITOR	1000pF 50V K		R1513	NRSA63J-103X	MG RESISTOR	10kΩ 1/16W J	
C1203	NCB31HK-102X	C CAPACITOR	1000pF 50V K		R1514	NRSA63J-512X	MG RESISTOR	5.1kΩ 1/16W J	
C1204	QFVF1HJ-474Z	MF CAPACITOR	0.47uF 50V J		R1601	NRSA63J-104X	MG RESISTOR	100kΩ 1/16W J	
C1205	NCF21HZ-474X	C CAPACITOR	0.47uF 50V Z		R1602	NRSA63J-103X	MG RESISTOR	10kΩ 1/16W J	
C1206	NCF21HZ-474X	C CAPACITOR	0.47uF 50V Z		R1603	NRSA63J-103X	MG RESISTOR	10kΩ 1/16W J	
C1207	NCB31HK-153X	C CAPACITOR	0.015uF 50V K		R1604	NRSA63J-104X	MG RESISTOR	100kΩ 1/16W J	
C1208	NCB21HK-104X	C CAPACITOR	0.1uF 50V K		R1605	NRSA63J-223X	MG RESISTOR	22kΩ 1/16W J	
C1209	NCB21HK-104X	C CAPACITOR	0.1uF 50V K		R1606	NRSA63J-104X	MG RESISTOR	100kΩ 1/16W J	
C1210	NCB31HK-102X	C CAPACITOR	1000pF 50V K		R1607	NRSA63J-683X	MG RESISTOR	68kΩ 1/16W J	
C1211	NCB31HK-102X	C CAPACITOR	1000pF 50V K		R1620	NRSA63J-242X	MG RESISTOR	2.4kΩ 1/16W J	
C1310	NCB21CK-224X	C CAPACITOR	0.22uF 16V K		R1621	NRSA63J-242X	MG RESISTOR	2.4kΩ 1/16W J	
C1311	NCB31HK-332X	C CAPACITOR	3300pF 50V K		R1622	NRSA63J-473X	MG RESISTOR	47kΩ 1/16W J	
C1313	NCF21HZ-474X	C CAPACITOR	0.47uF 50V Z		R1623	NRSA63J-221X	MG RESISTOR	220Ω 1/16W J	
C1314	NCB31HK-103X	C CAPACITOR	0.01uF 50V K		R1624	NRSA63J-221X	MG RESISTOR	220Ω 1/16W J	
C1316	NCB31HK-103X	C CAPACITOR	0.01uF 50V K		R1625	NRSA63J-101X	MG RESISTOR	100Ω 1/16W J	
C1317	QCBB1HK-561Y	C CAPACITOR	560pF 50V K		R1626	NRSA63J-221X	MG RESISTOR	220Ω 1/16W J	
C1350	NBE41CM-106X	TA E CAPACITOR	10uF 16V M		R1630	NRSA63J-242X	MG RESISTOR	2.4kΩ 1/16W J	
C1410	NCB21CK-224X	C CAPACITOR	0.22uF 16V K		R1631	NRSA63J-242X	MG RESISTOR	2.4kΩ 1/16W J	
C1411	NCB31HK-332X	C CAPACITOR	3300pF 50V K		R1632	NRSA63J-473X	MG RESISTOR	47kΩ 1/16W J	
C1413	NCF21HZ-474X	C CAPACITOR	0.47uF 50V Z		R1633	NRSA63J-221X	MG RESISTOR	220Ω 1/16W J	
C1414	NCB31HK-103X	C CAPACITOR	0.01uF 50V K		R1634	NRSA63J-221X	MG RESISTOR	220Ω 1/16W J	
C1417	QCBB1HK-561Y	C CAPACITOR	560pF 50V K		R1635	NRSA63J-101X	MG RESISTOR	100Ω 1/16W J	
C1501	QETN1CM-476Z	E CAPACITOR	47uF 16V M		R1636	NRSA63J-221X	MG RESISTOR	220Ω 1/16W J	
C1502	NCB31HK-103X	C CAPACITOR	0.01uF 50V K		R1640	QRM034J-R22	MP RESISTOR	0.22Ω 3W J	
C1601	QKCC1EM-476Z	E CAPACITOR	47uF 25V M		R1641	QRM034J-R22	MP RESISTOR	0.22Ω 3W J	
C1602	QKCC1HM-106Z	E CAPACITOR	10uF 50V M		R1707	NRS144J-4R7X	MG RESISTOR	4.7Ω 1/4W J	
C1701	NCB21HK-104X	C CAPACITOR	0.1uF 50V K		R1801	NRSA63J-222X	MG RESISTOR	2.2kΩ 1/16W J	
C1702	NCB21HK-104X	C CAPACITOR	0.1uF 50V K		R1802	NRSA63J-222X	MG RESISTOR	2.2kΩ 1/16W J	
C1703	QETN1VM-477Z	E CAPACITOR	470uF 35V M		R1803	NRSA63J-222X	MG RESISTOR	2.2kΩ 1/16W J	
C1704	QEHR1VM-477Z	E CAPACITOR	470uF 35V M		R1804	NRSA63J-222X	MG RESISTOR	2.2kΩ 1/16W J	
C1705	QEHR2AM-107Z	E CAPACITOR	100uF 100V M		L1101	QLL67AM-220	COIL	22uH M	
C1706	QETN1HM-476Z	E CAPACITOR	47uF 50V M		L1102	QLLZ005-R45	COIL	0.45uH	
C1707	QEHR1HM-476Z	E CAPACITOR	47uF 50V M		L1201	QLL67AM-220	COIL	22uH M	
C1708	QEHR2AM-107Z	E CAPACITOR	100uF 100V M		L1202	QLLZ005-R45	COIL	0.45uH	
C1711	QETN1CM-477Z	E CAPACITOR	470uF 16V M		R1001	NRSA02J-303X	MG RESISTOR	30kΩ 1/10W J	
R1001	NRSA02J-303X	MG RESISTOR	30kΩ 1/10W J		R1021	NRSA63J-562X	MG RESISTOR	5.6kΩ 1/16W J	
R1021	NRSA63J-562X	MG RESISTOR	5.6kΩ 1/16W J		R1022	NRSA63J-562X	MG RESISTOR	5.6kΩ 1/16W J	
R1022	NRSA63J-562X	MG RESISTOR	5.6kΩ 1/16W J		R1031	NRSA63J-562X	MG RESISTOR	5.6kΩ 1/16W J	
R1031	NRSA63J-562X	MG RESISTOR	5.6kΩ 1/16W J		R1032	NRSA63J-562X	MG RESISTOR	5.6kΩ 1/16W J	
R1101	NRS144J-4R7X	MG RESISTOR	4.7Ω 1/4W J		R1101	NRS144J-4R7X	MG RESISTOR	4.7Ω 1/4W J	
R1102	NRS016J-220X	MG RESISTOR	22Ω 1W J		R1102	NRS016J-220X	MG RESISTOR	22Ω 1W J	
R1103	NRS016J-8R2X	MG RESISTOR	8.2Ω 1W J		R1103	NRS016J-8R2X	MG RESISTOR	8.2Ω 1W J	
R1104	NRS144J-4R7X	MG RESISTOR	4.7Ω 1/4W J		R1201	NRS144J-4R7X	MG RESISTOR	4.7Ω 1/4W J	
R1201	NRS144J-4R7X	MG RESISTOR	4.7Ω 1/4W J		CN151	QGA2001C1-07	CONNECTOR	W-B (1-7)	
R1202	NRS016J-220X	MG RESISTOR	22Ω 1W J		CN152	QGA2501F1-03	CONNECTOR	W-B (1-3)	
R1203	NRS016J-8R2X	MG RESISTOR	8.2Ω 1W J		CN171	QGA3901C1-04	CONNECTOR	W-B (1-4)	
R1204	NRS144J-4R7X	MG RESISTOR	4.7Ω 1/4W J		CN172	QGA2001C1-03	CONNECTOR	W-B (1-3)	
R1310	NRSA63J-0R0X	MG RESISTOR	0Ω 1/16W J		J101	QNB0200-001	SPK TERMINAL		
R1311	NRSA63J-103X	MG RESISTOR	10kΩ 1/16W J		K1101	NQR0353-003X	FERRITE BEADS		
R1312	NRSA63J-332X	MG RESISTOR	3.3kΩ 1/16W J		K1102	QQR0678-001Z	FERRITE BEADS		
R1314	NRSA63J-472X	MG RESISTOR	4.7kΩ 1/16W J		K1201	NQR0353-003X	FERRITE BEADS		
R1315	NRSA63J-682X	MG RESISTOR	6.8kΩ 1/16W J		K1701	NQR0353-003X	FERRITE BEADS		
R1316	NRSA63J-332X	MG RESISTOR	3.3kΩ 1/16W J						
R1318	NRSA63J-0R0X	MG RESISTOR	0Ω 1/16W J						
R1350	NRSA02J-102X	MG RESISTOR	1kΩ 1/10W J						
R1351	NRSA02J-751X	MG RESISTOR	750Ω 1/10W J						
R1352	NRSA02J-102X	MG RESISTOR	1kΩ 1/10W J						
R1410	NRSA63J-0R0X	MG RESISTOR	0Ω 1/16W J						
R1411	NRSA63J-103X	MG RESISTOR	10kΩ 1/16W J						
R1412	NRSA63J-332X	MG RESISTOR	3.3kΩ 1/16W J						
R1414	NRSA63J-472X	MG RESISTOR	4.7kΩ 1/16W J						
R1415	NRSA63J-682X	MG RESISTOR	6.8kΩ 1/16W J						
R1416	NRSA63J-332X	MG RESISTOR	3.3kΩ 1/16W J						
R1418	NRSA63J-0R0X	MG RESISTOR	0Ω 1/16W J						
R1501	NRSA63J-153X	MG RESISTOR	15kΩ 1/16W J						
R1502	NRSA63J-512X	MG RESISTOR	5.1kΩ 1/16W J						
R1503	NRSA63J-104X	MG RESISTOR	100kΩ 1/16W J						
R1504	NRSA63J-103X	MG RESISTOR	10kΩ 1/16W J						
R1505	NRSA63J-562X	MG RESISTOR	5.6kΩ 1/16W J						
R1506	NRSA63J-103X	MG RESISTOR	10kΩ 1/16W J						
R1507	NRSA63J-472X	MG RESISTOR	4.7kΩ 1/16W J						
R1508	NRSA63J-103X	MG RESISTOR	10kΩ 1/16W J						
R1509	NRSA63J-104X	MG RESISTOR	100kΩ 1/16W J						
R1510	NRSA63J-472X	MG RESISTOR	4.7kΩ 1/16W J						
R1511	NRSA63J-123X	MG RESISTOR	12kΩ 1/16W J						
R1512	QRZ9005-181X	FUSI RESISTOR	180Ω						
R1513	NRSA63J-103X	MG RESISTOR	10kΩ 1/16W J						
R1514	NRSA63J-512X	MG RESISTOR	5.1kΩ 1/16W J						
R1601	NRSA63J-104X	MG RESISTOR	100kΩ 1/16W J						
R1602	NRSA63J-103X	MG RESISTOR	10kΩ 1/16W J						
R1603	NRSA63J-103X	MG RESISTOR	10kΩ 1/16W J						
R1604	NRSA63J-104X	MG RESISTOR	100kΩ 1/16W J						
R1605	NRSA63J-223X	MG RESISTOR	22kΩ 1/16W J						
R1606	NRSA63J-104X	MG RESISTOR	100kΩ 1/16W J						
R1607	NRSA63J-683X	MG RESISTOR	68kΩ 1/16W J						
R1620	NRSA63J-242X	MG RESISTOR	2.4kΩ 1/16W J						
R1621	NRSA63J-242X	MG RESISTOR	2.4kΩ 1/16W J						
R1622	NRSA63J-473X	MG RESISTOR	47kΩ 1/16W J						
R1623	NRSA63J-221X	MG RESISTOR	220Ω 1/16W J						
R1624	NRSA63J-221X	MG RESISTOR	220Ω 1/16W J						
R1625	NRSA63J-101X	MG RESISTOR	100Ω 1/16W J						
R1626	NRSA63J-221X	MG RESISTOR	220Ω 1/16W J						
R1630	NRSA63J-242X	MG RESISTOR	2.4kΩ 1/16W J						

Symbol No.	Part No.	Part Name	Description	Local
K1702	NQR0353-003X	FERRITE BEADS		
K1703	NQR0353-003X	FERRITE BEADS		
K1704	NQR0353-003X	FERRITE BEADS		
RY161	QSK0109-001	RELAY		

Symbol No.	Part No.	Part Name	Description	Local
D506	1SS133-T2	DIODE		
D507	1SS133-T2	DIODE		
D509	1SS133-T2	DIODE		
D510	1SS133-T2	DIODE		
D514	1SS133-T2	DIODE		
D518	MTZJ15C-T2	Z DIODE		
D519	1SS133-T2	DIODE		
D520	1SS133-T2	DIODE		
D521	MTZJ6.8C-T2	Z DIODE		
D535	1SS133-T2	DIODE		
D541	1SS133-T2	DIODE		
D542	1SS133-T2	DIODE		
D543	1SS133-T2	DIODE		
D544	1SS133-T2	DIODE		
D545	1SS133-T2	DIODE		
D546	1SS133-T2	DIODE		
D548	1SS133-T2	DIODE		
D549	1SS133-T2	DIODE		
D550	1SS133-T2	DIODE		
D551	1SS133-T2	DIODE		
D552	1SS133-T2	DIODE		
D553	1SS133-T2	DIODE		
D561	SLR-342MC-T12	LED		
D601	1SS133-T2	DIODE		
D610	1SS133-T2	DIODE		
D611	1SS133-T2	DIODE		
D2101	1SS133-T2	DIODE		
D2201	1SS133-T2	DIODE		
D2301	1SS133-T2	DIODE		
D2401	1SS133-T2	DIODE		
D2501	1SS133-T2	DIODE		
D2601	1SS133-T2	DIODE		
D2701	MTZJ13C-T2	Z DIODE		
D2702	MTZJ13C-T2	Z DIODE		
D2703	MTZJ16C-T2	Z DIODE		
D3101	1SS133-T2	DIODE		
D3102	1SS133-T2	DIODE		
D3201	1SS133-T2	DIODE		
D3202	1SS133-T2	DIODE		
D3301	1SS133-T2	DIODE		
D3302	1SS133-T2	DIODE		
D3401	1SS133-T2	DIODE		
D3402	1SS133-T2	DIODE		
D3501	1SS133-T2	DIODE		
D3502	1SS133-T2	DIODE		
D3601	1SS133-T2	DIODE		
D3602	1SS133-T2	DIODE		
D3703	MTZJ11C-T2	Z DIODE		
D3706	1SS133-T2	DIODE		
D3707	1SS133-T2	DIODE		
D3708	1SS133-T2	DIODE		

Mother board

Block No. [0][6]

Symbol No.	Part No.	Part Name	Description	Local
△ IC201	STK413-430	IC		
△ IC202	STK413-400	IC		
IC301	RC4558D-X	IC		
IC302	RC4558D-X	IC		
IC303	RC4558D-X	IC		
IC601	MN101C427NB	IC		
IC602	S-80840CNNB-W	IC		
Q151	KTC2026/Y/	TRANSISTOR		
Q152	KTC3203/OY/I-T	TRANSISTOR		
Q501	UN2113-X	DIGI TRANSISTOR		
Q502	UN2211-X	TRANSISTOR		
Q503	KTC3875/YG/-X	SI TRANSISTOR		
Q504	KTA1504/YG/-X	SI TRANSISTOR		
Q505	UN2211-X	TRANSISTOR		
Q517	UN2213-X	DIGI TRANSISTOR		
Q523	KTC3875/YG/-X	SI TRANSISTOR		
Q524	KTA1504/YG/-X	SI TRANSISTOR		
Q525	KTC3875/YG/-X	SI TRANSISTOR		
Q542	KTC3875/YG/-X	SI TRANSISTOR		
Q603	KTC3875/YG/-X	SI TRANSISTOR		
Q604	KTC3265/YI/-X	TRANSISTOR		
Q2101	KTA1504/YG/-X	SI TRANSISTOR		
Q2201	KTA1504/YG/-X	SI TRANSISTOR		
Q2301	KTA1504/YG/-X	SI TRANSISTOR		
Q2401	KTA1504/YG/-X	SI TRANSISTOR		
Q2501	KTA1504/YG/-X	SI TRANSISTOR		
Q2601	KTA1504/YG/-X	SI TRANSISTOR		
Q2701	KTC3875/YG/-X	SI TRANSISTOR		
Q2702	KTA1046/Y/	TRANSISTOR		
Q2703	UN2211-X	TRANSISTOR		
Q3101	KTC3875/YG/-X	SI TRANSISTOR		
Q3102	KTC3875/YG/-X	SI TRANSISTOR		
Q3201	KTC3875/YG/-X	SI TRANSISTOR		
Q3202	KTC3875/YG/-X	SI TRANSISTOR		
Q3301	KTC3875/YG/-X	SI TRANSISTOR		
Q3302	KTC3875/YG/-X	SI TRANSISTOR		
Q3401	KTC3875/YG/-X	SI TRANSISTOR		
Q3402	KTC3875/YG/-X	SI TRANSISTOR		
Q3501	KTC3875/YG/-X	SI TRANSISTOR		
Q3502	KTC3875/YG/-X	SI TRANSISTOR		
Q3701	UN2111-X	TRANSISTOR		
Q3702	UN2111-X	TRANSISTOR		
Q3703	UN2212-X	DIGI TRANSISTOR		
Q3704	KTC2026/Y/	TRANSISTOR		
Q3705	KTC3875/YG/-X	SI TRANSISTOR		
Q3706	UN2213-X	DIGI TRANSISTOR		
D101	1SS133-T2	DIODE		
△ D151	GBU803	BRIDGE DIODE		
△ D152	GBU803	BRIDGE DIODE		
D153	1SS133-T2	DIODE		
D154	1SS133-T2	DIODE		
D161	1SS133-T2	DIODE		
D162	MTZJ13C-T2	Z DIODE		
D163	1SS133-T2	DIODE		
D164	MTZJ6.2A-T2	Z DIODE		
D165	MTZJ6.8C-T2	Z DIODE		
D166	MTZJ6.8C-T2	Z DIODE		
D501	1SS133-T2	DIODE		
D502	1SS133-T2	DIODE		
D503	1SS133-T2	DIODE		
D504	1SS133-T2	DIODE		
D505	MTZJ5.1C-T2	Z DIODE		

△ C101	QCZ9105-472	C CAPACITOR	4700pF 250V M
C151	NCF21HZ-104X	C CAPACITOR	0.1uF 50V Z
C152	NCF21HZ-104X	C CAPACITOR	0.1uF 50V Z
C153	NCF21HZ-104X	C CAPACITOR	0.1uF 50V Z
C154	NCF21HZ-104X	C CAPACITOR	0.1uF 50V Z
C155	NCF21HZ-104X	C CAPACITOR	0.1uF 50V Z
C156	NCF21HZ-104X	C CAPACITOR	0.1uF 50V Z
C157	NCF21HZ-104X	C CAPACITOR	0.1uF 50V Z
C158	NCF21HZ-104X	C CAPACITOR	0.1uF 50V Z
C159	NCF21HZ-104X	C CAPACITOR	0.1uF 50V Z
C161	QETM1HM-338	E CAPACITOR	3300uF 50V M
C162	QETM1HM-338	E CAPACITOR	3300uF 50V M
C163	QETM1EM-478	E CAPACITOR	4700uF 25V M
C164	QETM1EM-478	E CAPACITOR	4700uF 25V M
C165	QETN1EM-476Z	E CAPACITOR	47uF 25V M
C166	QETN1EM-107Z	E CAPACITOR	100uF 25V M
C167	QETN1EM-476Z	E CAPACITOR	47uF 25V M
C168	QETN1CM-107Z	E CAPACITOR	100uF 16V M
C171	QETN1CM-107Z	E CAPACITOR	100uF 16V M
C172	QETN1CM-107Z	E CAPACITOR	100uF 16V M
C501	QETN1HM-475Z	E CAPACITOR	4.7uF 50V M
C502	NCF31HZ-103X	C CAPACITOR	0.01uF 50V Z
C503	QETN1HM-475Z	E CAPACITOR	4.7uF 50V M
C512	QETN1HM-475Z	E CAPACITOR	4.7uF 50V M
C522	QETN1HM-106Z	E CAPACITOR	10uF 50V M
C523	QETN1EM-476Z	E CAPACITOR	47uF 25V M

△ Symbol No.	Part No.	Part Name	Description	Local	△ Symbol No.	Part No.	Part Name	Description	Local
C571	QDYB1CM-103Y	C CAPACITOR	0.01uF 16V M		C3204	QETN1HM-225Z	E CAPACITOR	2.2uF 50V M	
C591	NCF31HZ-103X	C CAPACITOR	0.01uF 50V Z		C3301	NCB31HK-152X	C CAPACITOR	1500pF 50V K	
C592	NCF31HZ-103X	C CAPACITOR	0.01uF 50V Z		C3302	QETN1HM-105Z	E CAPACITOR	1uF 50V M	
C601	QETN1CM-107Z	E CAPACITOR	100uF 16V M		C3303	QETN1HM-105Z	E CAPACITOR	1uF 50V M	
C602	NCB31HK-102X	C CAPACITOR	1000pF 50V K		C3304	QETN1HM-225Z	E CAPACITOR	2.2uF 50V M	
C603	NCF31HZ-103X	C CAPACITOR	0.01uF 50V Z		C3401	NCB31HK-152X	C CAPACITOR	1500pF 50V K	
C604	NCF31HZ-103X	C CAPACITOR	0.01uF 50V Z		C3402	QETN1HM-105Z	E CAPACITOR	1uF 50V M	
C605	NCF31HZ-103X	C CAPACITOR	0.01uF 50V Z		C3403	QETN1HM-105Z	E CAPACITOR	1uF 50V M	
C606	QETN1HM-106Z	E CAPACITOR	10uF 50V M		C3404	QETN1HM-225Z	E CAPACITOR	2.2uF 50V M	
C2102	NCB31CK-473X	C CAPACITOR	0.047uF 16V K		C3501	NCB31HK-152X	C CAPACITOR	1500pF 50V K	
C2103	QETN1HM-475Z	E CAPACITOR	4.7uF 50V M		C3502	QETN1HM-105Z	E CAPACITOR	1uF 50V M	
C2104	QETN1CM-107Z	E CAPACITOR	100uF 16V M		C3503	QETN1HM-105Z	E CAPACITOR	1uF 50V M	
C2105	NDC31HJ-101X	C CAPACITOR	100pF 50V J		C3504	QETN1HM-225Z	E CAPACITOR	2.2uF 50V M	
C2106	NDC31HJ-3R0X	C CAPACITOR	3pF 50V J		C3601	NCB31HK-152X	C CAPACITOR	1500pF 50V K	
C2107	NCB21HK-104X	C CAPACITOR	0.1uF 50V K		C3602	QETN1HM-105Z	E CAPACITOR	1uF 50V M	
C2108	NCB21HK-104X	C CAPACITOR	0.1uF 50V K		C3604	QETN1HM-225Z	E CAPACITOR	2.2uF 50V M	
C2202	NCB31HK-471X	C CAPACITOR	470pF 50V K		C3701	NCF31HZ-103X	C CAPACITOR	0.01uF 50V Z	
C2203	QETN1HM-475Z	E CAPACITOR	4.7uF 50V M		C3702	NCF31HZ-103X	C CAPACITOR	0.01uF 50V Z	
C2204	QETN1CM-107Z	E CAPACITOR	100uF 16V M		C3703	NCF31HZ-103X	C CAPACITOR	0.01uF 50V Z	
C2205	NDC31HJ-101X	C CAPACITOR	100pF 50V J		C3704	NCF31HZ-103X	C CAPACITOR	0.01uF 50V Z	
C2206	NDC31HJ-3R0X	C CAPACITOR	3pF 50V J		C3705	NCF31HZ-103X	C CAPACITOR	0.01uF 50V Z	
C2207	NCB21HK-104X	C CAPACITOR	0.1uF 50V K		C3706	NCF31HZ-103X	C CAPACITOR	0.01uF 50V Z	
C2208	NCB21HK-104X	C CAPACITOR	0.1uF 50V K		C3715	QETN1CM-107Z	E CAPACITOR	100uF 16V M	
C2211	NCB21HK-104X	C CAPACITOR	0.1uF 50V K		C3716	QETN1AM-227Z	E CAPACITOR	220uF 10V M	
C2212	NCB21HK-104X	C CAPACITOR	0.1uF 50V K		C3720	QETN1EM-476Z	E CAPACITOR	47uF 25V M	
C2302	NCB31HK-471X	C CAPACITOR	470pF 50V K		C3721	QEKC1CM-107Z	E CAPACITOR	100uF 16V M	
C2303	QETN1HM-475Z	E CAPACITOR	4.7uF 50V M						
C2304	QETN1CM-107Z	E CAPACITOR	100uF 16V M		R151	NRSA63J-222X	MG RESISTOR	2.2kΩ 1/16W J	
C2305	NDC31HJ-101X	C CAPACITOR	100pF 50V J		R152	NRSA63J-222X	MG RESISTOR	2.2kΩ 1/16W J	
C2306	NDC31HJ-3R0X	C CAPACITOR	3pF 50V J		△ R161	QRZ9005-100X	FUSI RESISTOR	10Ω	
C2307	NCB21HK-104X	C CAPACITOR	0.1uF 50V K		R162	QRJ146J-102X	UNF C RESISTOR	1kΩ 1/4W J	
C2308	NCB21HK-104X	C CAPACITOR	0.1uF 50V K		△ R163	QRZ9005-100X	FUSI RESISTOR	10Ω	
C2311	NCB21HK-104X	C CAPACITOR	0.1uF 50V K		R164	QRJ146J-102X	UNF C RESISTOR	1kΩ 1/4W J	
C2312	NCB21HK-104X	C CAPACITOR	0.1uF 50V K		R165	QRJ146J-221X	UNF C RESISTOR	220Ω 1/4W J	
C2402	NCB31HK-471X	C CAPACITOR	470pF 50V K		R166	QRL027J-391	OMF RESISTOR	390Ω 2W J	
C2403	QETN1HM-475Z	E CAPACITOR	4.7uF 50V M		△ R171	QRL027J-470	OMF RESISTOR	47Ω 2W J	
C2404	QETN1CM-107Z	E CAPACITOR	100uF 16V M		R501	NRSA63J-102X	MG RESISTOR	1kΩ 1/16W J	
C2405	NDC31HJ-101X	C CAPACITOR	100pF 50V J		R502	NRSA63J-104X	MG RESISTOR	100kΩ 1/16W J	
C2406	NDC31HJ-3R0X	C CAPACITOR	3pF 50V J		R504	NRSA63J-102X	MG RESISTOR	1kΩ 1/16W J	
C2407	NCB21HK-104X	C CAPACITOR	0.1uF 50V K		R505	NRSA63J-102X	MG RESISTOR	1kΩ 1/16W J	
C2408	NCB21HK-104X	C CAPACITOR	0.1uF 50V K		R506	NRSA63J-103X	MG RESISTOR	10kΩ 1/16W J	
C2411	NCB21HK-104X	C CAPACITOR	0.1uF 50V K		R522	NRSA63J-103X	MG RESISTOR	10kΩ 1/16W J	
C2412	NCB21HK-104X	C CAPACITOR	0.1uF 50V K		R523	NRSA63J-223X	MG RESISTOR	22kΩ 1/16W J	
C2502	NCB31HK-471X	C CAPACITOR	470pF 50V K		R533	NRSA63J-103X	MG RESISTOR	10kΩ 1/16W J	
C2503	QETN1HM-475Z	E CAPACITOR	4.7uF 50V M		R534	NRSA63J-104X	MG RESISTOR	100kΩ 1/16W J	
C2504	QETN1CM-107Z	E CAPACITOR	100uF 16V M		R535	NRSA63J-104X	MG RESISTOR	100kΩ 1/16W J	
C2505	NDC31HJ-101X	C CAPACITOR	100pF 50V J		R536	NRSA63J-103X	MG RESISTOR	10kΩ 1/16W J	
C2506	NDC31HJ-3R0X	C CAPACITOR	3pF 50V J		R539	NRSA63J-472X	MG RESISTOR	4.7kΩ 1/16W J	
C2507	NCB21HK-104X	C CAPACITOR	0.1uF 50V K		R540	NRSA63J-472X	MG RESISTOR	4.7kΩ 1/16W J	
C2508	NCB21HK-104X	C CAPACITOR	0.1uF 50V K		R553	NRSA63J-153X	MG RESISTOR	15kΩ 1/16W J	
C2511	NCB21HK-104X	C CAPACITOR	0.1uF 50V K		R554	NRSA63J-223X	MG RESISTOR	22kΩ 1/16W J	
C2512	NCB21HK-104X	C CAPACITOR	0.1uF 50V K		R555	QRJ146J-271X	UNF C RESISTOR	270Ω 1/4W J	
C2602	NCB31HK-471X	C CAPACITOR	470pF 50V K		R556	NRSA63J-102X	MG RESISTOR	1kΩ 1/16W J	
C2603	QETN1HM-475Z	E CAPACITOR	4.7uF 50V M		R557	NRSA63J-104X	MG RESISTOR	100kΩ 1/16W J	
C2604	QETN1CM-107Z	E CAPACITOR	100uF 16V M		R558	NRSA63J-223X	MG RESISTOR	22kΩ 1/16W J	
C2605	NDC31HJ-101X	C CAPACITOR	100pF 50V J		R559	NRSA63J-223X	MG RESISTOR	22kΩ 1/16W J	
C2606	NDC31HJ-3R0X	C CAPACITOR	3pF 50V J		R560	NRSA63J-223X	MG RESISTOR	22kΩ 1/16W J	
C2607	NCB21HK-104X	C CAPACITOR	0.1uF 50V K		R561	NRSA63J-822X	MG RESISTOR	8.2kΩ 1/16W J	
C2608	NCB21HK-104X	C CAPACITOR	0.1uF 50V K		R562	NRSA63J-393X	MG RESISTOR	39kΩ 1/16W J	
C2611	NCB21HK-104X	C CAPACITOR	0.1uF 50V K		R563	NRSA63J-223X	MG RESISTOR	22kΩ 1/16W J	
C2612	NCB21HK-104X	C CAPACITOR	0.1uF 50V K		R574	QRE141J-151Y	C RESISTOR	150Ω 1/4W J	
C2701	QETN1HM-107Z	E CAPACITOR	100uF 50V M		R601	NRSA63J-103X	MG RESISTOR	10kΩ 1/16W J	
C2702	QETN1EM-107Z	E CAPACITOR	100uF 25V M		R602	NRSA63J-272X	MG RESISTOR	2.7kΩ 1/16W J	
C2703	QETN1HM-107Z	E CAPACITOR	100uF 50V M		R603	NRSA63J-222X	MG RESISTOR	2.2kΩ 1/16W J	
C2704	QETN1EM-107Z	E CAPACITOR	100uF 25V M		R606	NRSA63J-223X	MG RESISTOR	22kΩ 1/16W J	
C2705	QETN1HM-107Z	E CAPACITOR	100uF 50V M		R607	NRSA63J-223X	MG RESISTOR	22kΩ 1/16W J	
C2706	QETN1HM-107Z	E CAPACITOR	100uF 50V M		R608	NRSA63J-223X	MG RESISTOR	22kΩ 1/16W J	
C2707	QETN1HM-106Z	E CAPACITOR	10uF 50V M		R611	NRSA63J-471X	MG RESISTOR	470Ω 1/16W J	
C2711	QETN1HM-106Z	E CAPACITOR	10uF 50V M		R612	NRSA63J-223X	MG RESISTOR	22kΩ 1/16W J	
C2712	NCF31HZ-103X	C CAPACITOR	0.01uF 50V Z		R613	NRSA63J-223X	MG RESISTOR	22kΩ 1/16W J	
C2713	NCF31HZ-103X	C CAPACITOR	0.01uF 50V Z		R614	NRSA63J-223X	MG RESISTOR	22kΩ 1/16W J	
C3101	NCB31HK-152X	C CAPACITOR	1500pF 50V K		R621	NRSA63J-103X	MG RESISTOR	10kΩ 1/16W J	
C3102	QETN1HM-105Z	E CAPACITOR	1uF 50V M		R622	NRSA63J-223X	MG RESISTOR	22kΩ 1/16W J	
C3103	QETN1HM-105Z	E CAPACITOR	1uF 50V M		R623	NRSA63J-103X	MG RESISTOR	10kΩ 1/16W J	
C3104	QETN1HM-225Z	E CAPACITOR	2.2uF 50V M		R624	NRSA63J-472X	MG RESISTOR	4.7kΩ 1/16W J	
C3201	NCB31HK-152X	C CAPACITOR	1500pF 50V K		R625	NRSA63J-472X	MG RESISTOR	4.7kΩ 1/16W J	
C3202	QETN1HM-105Z	E CAPACITOR	1uF 50V M		R626	NRSA63J-103X	MG RESISTOR	10kΩ 1/16W J	
C3203	QETN1HM-105Z	E CAPACITOR	1uF 50V M		R627	NRSA63J-472X	MG RESISTOR	4.7kΩ 1/16W J	

△ Symbol No.	Part No.	Part Name	Description	Local	△ Symbol No.	Part No.	Part Name	Description	Local
R628	NRSA63J-223X	MG RESISTOR	22kΩ 1/16W J		R2508	NRSA63J-153X	MG RESISTOR	15kΩ 1/16W J	
R629	NRSA63J-103X	MG RESISTOR	10kΩ 1/16W J		R2509	NRSA63J-473X	MG RESISTOR	47kΩ 1/16W J	
R631	NRSA63J-223X	MG RESISTOR	22kΩ 1/16W J		R2510	QRK126J-4R7X	UNF C RESISTOR	4.7Ω 1/2W J	
R633	NRSA63J-223X	MG RESISTOR	22kΩ 1/16W J		R2511	QRJ146J-100X	UNF C RESISTOR	10Ω 1/4W J	
R635	NRSA63J-223X	MG RESISTOR	22kΩ 1/16W J		R2512	NRSA63J-222X	MG RESISTOR	2.2kΩ 1/16W J	
R637	NRSA63J-223X	MG RESISTOR	22kΩ 1/16W J		R2513	NRSA63J-222X	MG RESISTOR	2.2kΩ 1/16W J	
R640	NRSA63J-223X	MG RESISTOR	22kΩ 1/16W J		R2514	NRSA63J-104X	MG RESISTOR	100kΩ 1/16W J	
R641	NRSA63J-223X	MG RESISTOR	22kΩ 1/16W J		R2515	QRJ146J-100X	UNF C RESISTOR	10Ω 1/4W J	
R642	NRSA63J-223X	MG RESISTOR	22kΩ 1/16W J		R2601	NRSA63J-103X	MG RESISTOR	10kΩ 1/16W J	
R643	NRSA63J-223X	MG RESISTOR	22kΩ 1/16W J		R2602	NRSA63J-471X	MG RESISTOR	470Ω 1/16W J	
R644	NRSA63J-103X	MG RESISTOR	10kΩ 1/16W J		R2603	NRSA63J-563X	MG RESISTOR	56kΩ 1/16W J	
R645	NRSA63J-102X	MG RESISTOR	1kΩ 1/16W J		R2604	NRSA63J-561X	MG RESISTOR	560Ω 1/16W J	
R2101	NRSA63J-103X	MG RESISTOR	10kΩ 1/16W J		R2605	NRSA63J-563X	MG RESISTOR	56kΩ 1/16W J	
R2102	NRSA63J-471X	MG RESISTOR	470Ω 1/16W J		R2606	QRZ0224-R22	EMIT RESISTOR	0.22Ω	
R2103	NRSA63J-563X	MG RESISTOR	56kΩ 1/16W J		R2607	NRSA63J-102X	MG RESISTOR	1kΩ 1/16W J	
R2104	NRSA63J-561X	MG RESISTOR	560Ω 1/16W J		R2608	NRSA63J-153X	MG RESISTOR	15kΩ 1/16W J	
R2105	NRSA63J-563X	MG RESISTOR	56kΩ 1/16W J		R2609	NRSA63J-473X	MG RESISTOR	47kΩ 1/16W J	
R2106	QRZ0224-R22	EMIT RESISTOR	0.22Ω		R2610	QRK126J-4R7X	UNF C RESISTOR	4.7Ω 1/2W J	
R2107	NRSA63J-102X	MG RESISTOR	1kΩ 1/16W J		R2611	QRJ146J-100X	UNF C RESISTOR	10Ω 1/4W J	
R2108	NRSA63J-153X	MG RESISTOR	15kΩ 1/16W J		R2612	NRSA63J-222X	MG RESISTOR	2.2kΩ 1/16W J	
R2109	NRSA63J-473X	MG RESISTOR	47kΩ 1/16W J		R2613	NRSA63J-222X	MG RESISTOR	2.2kΩ 1/16W J	
R2110	QRK126J-4R7X	UNF C RESISTOR	4.7Ω 1/2W J		R2614	NRSA63J-104X	MG RESISTOR	100kΩ 1/16W J	
R2111	QRJ146J-100X	UNF C RESISTOR	10Ω 1/4W J		R2615	QRJ146J-100X	UNF C RESISTOR	10Ω 1/4W J	
R2112	NRSA63J-752X	MG RESISTOR	7.5kΩ 1/16W J		△ R2701	QRZ9005-220X	FUSI RESISTOR	22Ω	
R2113	NRSA63J-222X	MG RESISTOR	2.2kΩ 1/16W J		△ R2702	QRZ9005-470X	FUSI RESISTOR	47Ω 1/4W G	
R2114	NRSA63J-104X	MG RESISTOR	100kΩ 1/16W J		R2703	QRL01DJ-122X	OMF RESISTOR	1.2kΩ 1W J	
R2201	NRSA63J-103X	MG RESISTOR	10kΩ 1/16W J		R2704	QRL01DJ-122X	OMF RESISTOR	1.2kΩ 1W J	
R2202	NRSA63J-471X	MG RESISTOR	470Ω 1/16W J		R2705	NRSA63J-333X	MG RESISTOR	33kΩ 1/16W J	
R2203	NRSA63J-563X	MG RESISTOR	56kΩ 1/16W J		△ R2706	QRZ9006-4R7X	F.RESISTOR	4.7Ω 1/4W J	
R2204	NRSA63J-561X	MG RESISTOR	560Ω 1/16W J		△ R2707	QRZ9006-4R7X	F.RESISTOR	4.7Ω 1/4W J	
R2205	NRSA63J-563X	MG RESISTOR	56kΩ 1/16W J		△ R2708	QRZ9006-4R7X	F.RESISTOR	4.7Ω 1/4W J	
R2206	QRZ0224-R22	EMIT RESISTOR	0.22Ω		△ R2709	QRZ9006-4R7X	F.RESISTOR	4.7Ω 1/4W J	
R2207	NRSA63J-102X	MG RESISTOR	1kΩ 1/16W J		△ R2710	QRZ9005-100X	FUSI RESISTOR	10Ω	
R2208	NRSA63J-153X	MG RESISTOR	15kΩ 1/16W J		R2711	NRSA63J-333X	MG RESISTOR	33kΩ 1/16W J	
R2209	NRSA63J-473X	MG RESISTOR	47kΩ 1/16W J		R2721	QRE141J-472Y	C RESISTOR	4.7kΩ 1/4W J	
R2210	QRK126J-4R7X	UNF C RESISTOR	4.7Ω 1/2W J		R2722	QRE141J-472Y	C RESISTOR	4.7kΩ 1/4W J	
R2211	QRJ146J-100X	UNF C RESISTOR	10Ω 1/4W J		R3101	NRSA63J-153X	MG RESISTOR	15kΩ 1/16W J	
R2212	NRSA63J-222X	MG RESISTOR	2.2kΩ 1/16W J		R3102	NRSA63J-183X	MG RESISTOR	18kΩ 1/16W J	
R2213	NRSA63J-222X	MG RESISTOR	2.2kΩ 1/16W J		R3103	NRSA63J-472X	MG RESISTOR	4.7kΩ 1/16W J	
R2214	NRSA63J-104X	MG RESISTOR	100kΩ 1/16W J		R3104	NRSA63J-104X	MG RESISTOR	100kΩ 1/16W J	
R2215	QRJ146J-100X	UNF C RESISTOR	10Ω 1/4W J		R3105	NRSA63J-474X	MG RESISTOR	470kΩ 1/16W J	
R2301	NRSA63J-103X	MG RESISTOR	10kΩ 1/16W J		R3106	NRSA63J-470X	MG RESISTOR	47Ω 1/16W J	
R2302	NRSA63J-471X	MG RESISTOR	470Ω 1/16W J		R3107	NRSA63J-334X	MG RESISTOR	330kΩ 1/16W J	
R2303	NRSA63J-563X	MG RESISTOR	56kΩ 1/16W J		R3108	NRSA63J-101X	MG RESISTOR	100Ω 1/16W J	
R2304	NRSA63J-561X	MG RESISTOR	560Ω 1/16W J		R3109	NRSA63J-102X	MG RESISTOR	1kΩ 1/16W J	
R2305	NRSA63J-563X	MG RESISTOR	56kΩ 1/16W J		R3110	NRSA63J-104X	MG RESISTOR	100kΩ 1/16W J	
R2306	QRZ0224-R22	EMIT RESISTOR	0.22Ω		R3111	NRSA63J-471X	MG RESISTOR	470Ω 1/16W J	
R2307	NRSA63J-102X	MG RESISTOR	1kΩ 1/16W J		R3112	NRSA63J-103X	MG RESISTOR	10kΩ 1/16W J	
R2308	NRSA63J-153X	MG RESISTOR	15kΩ 1/16W J		R3113	NRSA63J-103X	MG RESISTOR	10kΩ 1/16W J	
R2309	NRSA63J-473X	MG RESISTOR	47kΩ 1/16W J		R3201	NRSA63J-153X	MG RESISTOR	15kΩ 1/16W J	
R2310	QRK126J-4R7X	UNF C RESISTOR	4.7Ω 1/2W J		R3202	NRSA63J-183X	MG RESISTOR	18kΩ 1/16W J	
R2311	QRJ146J-100X	UNF C RESISTOR	10Ω 1/4W J		R3203	NRSA63J-472X	MG RESISTOR	4.7kΩ 1/16W J	
R2312	NRSA63J-222X	MG RESISTOR	2.2kΩ 1/16W J		R3204	NRSA63J-104X	MG RESISTOR	100kΩ 1/16W J	
R2313	NRSA63J-222X	MG RESISTOR	2.2kΩ 1/16W J		R3205	NRSA63J-474X	MG RESISTOR	470kΩ 1/16W J	
R2314	NRSA63J-104X	MG RESISTOR	100kΩ 1/16W J		R3206	NRSA63J-470X	MG RESISTOR	47Ω 1/16W J	
R2315	QRJ146J-100X	UNF C RESISTOR	10Ω 1/4W J		R3207	NRSA63J-334X	MG RESISTOR	330kΩ 1/16W J	
R2401	NRSA63J-103X	MG RESISTOR	10kΩ 1/16W J		R3208	NRSA63J-101X	MG RESISTOR	100Ω 1/16W J	
R2402	NRSA63J-471X	MG RESISTOR	470Ω 1/16W J		R3209	NRSA63J-102X	MG RESISTOR	1kΩ 1/16W J	
R2403	NRSA63J-563X	MG RESISTOR	56kΩ 1/16W J		R3210	NRSA63J-104X	MG RESISTOR	100kΩ 1/16W J	
R2404	NRSA63J-561X	MG RESISTOR	560Ω 1/16W J		R3211	NRSA63J-471X	MG RESISTOR	470Ω 1/16W J	
R2405	NRSA63J-563X	MG RESISTOR	56kΩ 1/16W J		R3212	NRSA63J-103X	MG RESISTOR	10kΩ 1/16W J	
R2406	QRZ0224-R22	EMIT RESISTOR	0.22Ω		R3213	NRSA63J-103X	MG RESISTOR	10kΩ 1/16W J	
R2407	NRSA63J-102X	MG RESISTOR	1kΩ 1/16W J		R3301	NRSA63J-153X	MG RESISTOR	15kΩ 1/16W J	
R2408	NRSA63J-153X	MG RESISTOR	15kΩ 1/16W J		R3302	NRSA63J-183X	MG RESISTOR	18kΩ 1/16W J	
R2409	NRSA63J-473X	MG RESISTOR	47kΩ 1/16W J		R3303	NRSA63J-472X	MG RESISTOR	4.7kΩ 1/16W J	
R2410	QRK126J-4R7X	UNF C RESISTOR	4.7Ω 1/2W J		R3304	NRSA63J-104X	MG RESISTOR	100kΩ 1/16W J	
R2411	QRJ146J-100X	UNF C RESISTOR	10Ω 1/4W J		R3305	NRSA63J-474X	MG RESISTOR	470kΩ 1/16W J	
R2412	NRSA63J-222X	MG RESISTOR	2.2kΩ 1/16W J		R3306	NRSA63J-470X	MG RESISTOR	47Ω 1/16W J	
R2413	NRSA63J-222X	MG RESISTOR	2.2kΩ 1/16W J		R3307	NRSA63J-334X	MG RESISTOR	330kΩ 1/16W J	
R2414	NRSA63J-104X	MG RESISTOR	100kΩ 1/16W J		R3308	NRSA63J-101X	MG RESISTOR	100Ω 1/16W J	
R2415	QRJ146J-100X	UNF C RESISTOR	10Ω 1/4W J		R3309	NRSA63J-102X	MG RESISTOR	1kΩ 1/16W J	
R2501	NRSA63J-103X	MG RESISTOR	10kΩ 1/16W J		R3310	NRSA63J-104X	MG RESISTOR	100kΩ 1/16W J	
R2502	NRSA63J-471X	MG RESISTOR	470Ω 1/16W J		R3311	NRSA63J-471X	MG RESISTOR	470Ω 1/16W J	
R2503	NRSA63J-563X	MG RESISTOR	56kΩ 1/16W J		R3312	NRSA63J-103X	MG RESISTOR	10kΩ 1/16W J	
R2504	NRSA63J-561X	MG RESISTOR	560Ω 1/16W J		R3313	NRSA63J-103X	MG RESISTOR	10kΩ 1/16W J	
R2505	NRSA63J-563X	MG RESISTOR	56kΩ 1/16W J		R3401	NRSA63J-153X	MG RESISTOR	15kΩ 1/16W J	
R2506	QRZ0224-R22	EMIT RESISTOR	0.22Ω		R3402	NRSA63J-183X	MG RESISTOR	18kΩ 1/16W J	
R2507	NRSA63J-102X	MG RESISTOR	1kΩ 1/16W J		R3403	NRSA63J-472X	MG RESISTOR	4.7kΩ 1/16W J	

△ Symbol No.	Part No.	Part Name	Description	Local	△ Symbol No.	Part No.	Part Name	Description	Local
C308	NCB31CK-104X	C CAPACITOR	0.1uF 16V K		R106	NRSA63J-2R2X	MG RESISTOR	2.2Ω 1/16W J	
C309	NCB31CK-104X	C CAPACITOR	0.1uF 16V K		R107	NRSA63J-101X	MG RESISTOR	100Ω 1/16W J	
C310	NCB30JK-105X	C CAPACITOR	1uF 6.3V K		R108	NRSA63J-471X	MG RESISTOR	470Ω 1/16W J	
C311	NCB31CK-104X	C CAPACITOR	0.1uF 16V K		R109	NRSA63J-471X	MG RESISTOR	470Ω 1/16W J	
C312	NCB31CK-104X	C CAPACITOR	0.1uF 16V K		R110	NRSA63J-0R0X	MG RESISTOR	0Ω 1/16W J	
C313	NCB31CK-104X	C CAPACITOR	0.1uF 16V K		R111	NRSA63J-243X	MG RESISTOR	24kΩ 1/16W J	
C314	NCB31CK-104X	C CAPACITOR	0.1uF 16V K		R112	NRSA63J-303X	MG RESISTOR	30kΩ 1/16W J	
C315	NCB31CK-104X	C CAPACITOR	0.1uF 16V K		R113	NRS125J-270X	MG RESISTOR	27Ω 1/2W J	
C316	NCB31CK-104X	C CAPACITOR	0.1uF 16V K		R114	NRSA63J-2R2X	MG RESISTOR	2.2Ω 1/16W J	
C317	NCB31CK-104X	C CAPACITOR	0.1uF 16V K		R115	NRSA63J-101X	MG RESISTOR	100Ω 1/16W J	
C318	NCB31CK-104X	C CAPACITOR	0.1uF 16V K		R116	NRSA63J-471X	MG RESISTOR	470Ω 1/16W J	
C319	NCB31CK-104X	C CAPACITOR	0.1uF 16V K		R117	NRSA63J-331X	MG RESISTOR	330Ω 1/16W J	
C320	NCB31CK-104X	C CAPACITOR	0.1uF 16V K		R118	NRSA63J-0R0X	MG RESISTOR	0Ω 1/16W J	
C321	NCB31CK-104X	C CAPACITOR	0.1uF 16V K		R119	NRSA63J-0R0X	MG RESISTOR	0Ω 1/16W J	
C322	NCB31CK-104X	C CAPACITOR	0.1uF 16V K		R120	NRSA63J-0R0X	MG RESISTOR	0Ω 1/16W J	
C323	NCB31CK-104X	C CAPACITOR	0.1uF 16V K		R122	NRSA63J-0R0X	MG RESISTOR	0Ω 1/16W J	
C324	NCB30JK-105X	C CAPACITOR	1uF 6.3V K		R123	NRSA63J-0R0X	MG RESISTOR	0Ω 1/16W J	
C325	NDC31HJ-180X	C CAPACITOR	18pF 50V J		R125	NRS125J-1R0X	MG RESISTOR	1Ω 1/2W J	
C326	NDC31HJ-150X	C CAPACITOR	15pF 50V J		R126	NRSA63J-181X	MG RESISTOR	180Ω 1/16W J	
C328	NCB31CK-104X	C CAPACITOR	0.1uF 16V K		R127	NRSA63J-333X	MG RESISTOR	33kΩ 1/16W J	
C329	NCB31CK-104X	C CAPACITOR	0.1uF 16V K		R128	NRSA63J-163X	MG RESISTOR	16kΩ 1/16W J	
C330	NCB31CK-104X	C CAPACITOR	0.1uF 16V K		R204	NRSA63J-273X	MG RESISTOR	27kΩ 1/16W J	
C331	NCB31CK-333X	C CAPACITOR	0.033uF 16V K		R205	NRSA63J-273X	MG RESISTOR	27kΩ 1/16W J	
C332	NCB31CK-104X	C CAPACITOR	0.1uF 16V K		R206	NRSA63J-303X	MG RESISTOR	30kΩ 1/16W J	
C333	NCB31CK-104X	C CAPACITOR	0.1uF 16V K		R207	NRSA63J-473X	MG RESISTOR	47kΩ 1/16W J	
C334	NCB31CK-104X	C CAPACITOR	0.1uF 16V K		R213	NRSA63J-103X	MG RESISTOR	10kΩ 1/16W J	
C335	NCB31CK-104X	C CAPACITOR	0.1uF 16V K		R214	NRSA63J-103X	MG RESISTOR	10kΩ 1/16W J	
C337	NCB31CK-183X	C CAPACITOR	0.018uF 16V K		R219	NRSA63J-183X	MG RESISTOR	18kΩ 1/16W J	
C338	NCB31HK-562X	C CAPACITOR	5600pF 50V K		R220	NRSA63J-243X	MG RESISTOR	24kΩ 1/16W J	
C339	NCB31CK-104X	C CAPACITOR	0.1uF 16V K		R221	NRSA63J-682X	MG RESISTOR	6.8kΩ 1/16W J	
C340	NCB30JK-105X	C CAPACITOR	1uF 6.3V K		R251	NRS125J-R47X	MG RESISTOR	0.47Ω 1/2W J	
C341	NCF31AZ-105X	C CAPACITOR	1uF 10V Z		R252	NRSA63J-2R2X	MG RESISTOR	2.2Ω 1/16W J	
C347	NCB31CK-104X	C CAPACITOR	0.1uF 16V K		R257	NRSA63J-0R0X	MG RESISTOR	0Ω 1/16W J	
C348	NCB31CK-104X	C CAPACITOR	0.1uF 16V K		R259	NRSA63J-103X	MG RESISTOR	10kΩ 1/16W J	
C349	NCB31CK-104X	C CAPACITOR	0.1uF 16V K		R302	NRSA63J-240X	MG RESISTOR	24Ω 1/16W J	
C350	NCB31CK-104X	C CAPACITOR	0.1uF 16V K		R303	NRSA63J-270X	MG RESISTOR	27Ω 1/16W J	
C351	NCB31CK-103X	C CAPACITOR	0.01uF 16V K		R306	NRSA63J-102X	MG RESISTOR	1kΩ 1/16W J	
C352	NCB31CK-153X	C CAPACITOR	0.015uF 16V K		R307	NRSA63J-102X	MG RESISTOR	1kΩ 1/16W J	
C353	NCB31HK-561X	C CAPACITOR	560pF 50V K		R308	NRSA63J-223X	MG RESISTOR	22kΩ 1/16W J	
C354	NCB31HK-561X	C CAPACITOR	560pF 50V K		R309	NRSA63J-104X	MG RESISTOR	100kΩ 1/16W J	
C356	NCB21CK-105X	C CAPACITOR	1uF 16V K		R312	NRSA63J-0R0X	MG RESISTOR	0Ω 1/16W J	
C371	NCB30JK-105X	C CAPACITOR	1uF 6.3V K		R313	NRSA63J-0R0X	MG RESISTOR	0Ω 1/16W J	
C380	NCB21CK-105X	C CAPACITOR	1uF 16V K		R314	NRSA63J-0R0X	MG RESISTOR	0Ω 1/16W J	
C381	NCB21AK-225X	C CAPACITOR	2.2uF 10V K		R315	NRSA63J-0R0X	MG RESISTOR	0Ω 1/16W J	
C382	NCB31HK-471X	C CAPACITOR	470pF 50V K		R316	NRSA63J-6R8X	MG RESISTOR	6.8Ω 1/16W J	
C391	NCF31CZ-104X	C CAPACITOR	0.1uF 16V Z		R317	NRSA63J-0R0X	MG RESISTOR	0Ω 1/16W J	
C455	NCB31CK-103X	C CAPACITOR	0.01uF 16V K		R319	NRSA63J-0R0X	MG RESISTOR	0Ω 1/16W J	
C551	NCB31CK-104X	C CAPACITOR	0.1uF 16V K		R320	NRSA63J-103X	MG RESISTOR	10kΩ 1/16W J	
C552	NCB31CK-104X	C CAPACITOR	0.1uF 16V K		R330	NRSA63J-331X	MG RESISTOR	330Ω 1/16W J	
C553	NCB31CK-104X	C CAPACITOR	0.1uF 16V K		R331	NRSA63J-331X	MG RESISTOR	330Ω 1/16W J	
C554	NCB31CK-104X	C CAPACITOR	0.1uF 16V K		R332	NRSA63J-331X	MG RESISTOR	330Ω 1/16W J	
C555	NCB31CK-104X	C CAPACITOR	0.1uF 16V K		R334	NRSA63J-151X	MG RESISTOR	150Ω 1/16W J	
C556	NCF31AZ-105X	C CAPACITOR	1uF 10V Z		R335	NRSA63J-151X	MG RESISTOR	150Ω 1/16W J	
C557	NCB31CK-104X	C CAPACITOR	0.1uF 16V K		R336	NRSA63J-151X	MG RESISTOR	150Ω 1/16W J	
C558	NEA70GM-476X	E CAPACITOR	47uF 4V M		R337	NRSA63J-151X	MG RESISTOR	150Ω 1/16W J	
C701	NCF31CZ-104X	C CAPACITOR	0.1uF 16V Z		R338	NRSA63J-0R0X	MG RESISTOR	0Ω 1/16W J	
C702	NCF31CZ-104X	C CAPACITOR	0.1uF 16V Z		R339	NRSA63J-0R0X	MG RESISTOR	0Ω 1/16W J	
C703	NCF31CZ-104X	C CAPACITOR	0.1uF 16V Z		R340	NRSA63D-303X	MG RESISTOR	30kΩ 1/16W D	
C704	NEA70JM-476X	E CAPACITOR	47uF 6.3V M		R341	NRSA63D-362X	MG RESISTOR	3.6kΩ 1/16W D	
C706	NEA71AM-106X	E CAPACITOR	10uF 10V M		R342	NRSA63D-222X	MG RESISTOR	2.2kΩ 1/16W D	
C707	NCF31CZ-104X	C CAPACITOR	0.1uF 16V Z		R343	NRSA63J-0R0X	MG RESISTOR	0Ω 1/16W J	
C708	NCF31CZ-104X	C CAPACITOR	0.1uF 16V Z		R345	NRSA63J-221X	MG RESISTOR	220Ω 1/16W J	
C709	NCF31CZ-104X	C CAPACITOR	0.1uF 16V Z		R346	NRSA63J-223X	MG RESISTOR	22kΩ 1/16W J	
C711	NCB21CK-105X	C CAPACITOR	1uF 16V K		R347	NRSA63J-203X	MG RESISTOR	20kΩ 1/16W J	
C712	NCB31CK-103X	C CAPACITOR	0.01uF 16V K		R351	NRSA63J-681X	MG RESISTOR	680Ω 1/16W J	
C713	NCB21CK-105X	C CAPACITOR	1uF 16V K		R352	NRSA63J-105X	MG RESISTOR	1MΩ 1/16W J	
C741	NCF21CZ-225X	C CAPACITOR	2.2uF 16V Z		R353	NRSA63J-101X	MG RESISTOR	100Ω 1/16W J	
C742	NCF21CZ-225X	C CAPACITOR	2.2uF 16V Z		R354	NRSA63J-101X	MG RESISTOR	100Ω 1/16W J	
C743	NCF21CZ-225X	C CAPACITOR	2.2uF 16V Z		R355	NRSA63J-331X	MG RESISTOR	330Ω 1/16W J	
C748	NCF21CZ-225X	C CAPACITOR	2.2uF 16V Z		R356	NRSA63J-331X	MG RESISTOR	330Ω 1/16W J	
C749	NCF21CZ-225X	C CAPACITOR	2.2uF 16V Z		R357	NRSA63J-221X	MG RESISTOR	220Ω 1/16W J	
C761	NCB31CK-104X	C CAPACITOR	0.1uF 16V K		R358	NRSA63J-221X	MG RESISTOR	220Ω 1/16W J	
					R359	NRSA63J-221X	MG RESISTOR	220Ω 1/16W J	
R101	NRSA63J-101X	MG RESISTOR	100Ω 1/16W J		R360	NRSA63J-221X	MG RESISTOR	220Ω 1/16W J	
R102	NRSA63J-101X	MG RESISTOR	100Ω 1/16W J		R362	NRSA63J-331X	MG RESISTOR	330Ω 1/16W J	
R103	NRSA63J-243X	MG RESISTOR	24kΩ 1/16W J		R363	NRSA63J-151X	MG RESISTOR	150Ω 1/16W J	
R104	NRSA63J-303X	MG RESISTOR	30kΩ 1/16W J		R367	NRSA63J-221X	MG RESISTOR	220Ω 1/16W J	
R105	NRS125J-270X	MG RESISTOR	27Ω 1/2W J		R368	NRSA63J-331X	MG RESISTOR	330Ω 1/16W J	

△ Symbol No.	Part No.	Part Name	Description	Local
R369	NRSA63J-331X	MG RESISTOR	330Ω 1/16W J	
R372	NRSA63J-103X	MG RESISTOR	10kΩ 1/16W J	
R373	NRSA63J-103X	MG RESISTOR	10kΩ 1/16W J	
R384	NRSA63J-102X	MG RESISTOR	1kΩ 1/16W J	
R385	NRSA63J-102X	MG RESISTOR	1kΩ 1/16W J	
R388	NRSA63J-103X	MG RESISTOR	10kΩ 1/16W J	
R392	NRSA63J-103X	MG RESISTOR	10kΩ 1/16W J	
R393	NRSA63J-0R0X	MG RESISTOR	0Ω 1/16W J	
R394	NRSA63J-0R0X	MG RESISTOR	0Ω 1/16W J	
R395	NRSA63J-472X	MG RESISTOR	4.7kΩ 1/16W J	
R399	NRSA63J-0R0X	MG RESISTOR	0Ω 1/16W J	
R452	NRSA63J-102X	MG RESISTOR	1kΩ 1/16W J	
R457	NRSA63J-0R0X	MG RESISTOR	0Ω 1/16W J	
R458	NRSA63J-102X	MG RESISTOR	1kΩ 1/16W J	
R501	NRSA63J-0R0X	MG RESISTOR	0Ω 1/16W J	
R502	NRSA63J-0R0X	MG RESISTOR	0Ω 1/16W J	
R530	NRSA63J-103X	MG RESISTOR	10kΩ 1/16W J	
R531	NRSA63J-103X	MG RESISTOR	10kΩ 1/16W J	
R533	NRSA63J-0R0X	MG RESISTOR	0Ω 1/16W J	
R534	NRSA63J-103X	MG RESISTOR	10kΩ 1/16W J	
R562	NRSA63J-101X	MG RESISTOR	100Ω 1/16W J	
R701	NRSA63J-0R0X	MG RESISTOR	0Ω 1/16W J	
R703	NRSA63J-471X	MG RESISTOR	470Ω 1/16W J	
R704	NRSA63J-471X	MG RESISTOR	470Ω 1/16W J	
R705	NRSA63J-471X	MG RESISTOR	470Ω 1/16W J	
R706	NRSA63J-471X	MG RESISTOR	470Ω 1/16W J	
R707	NRSA63J-471X	MG RESISTOR	470Ω 1/16W J	
R708	NRSA63J-471X	MG RESISTOR	470Ω 1/16W J	
R714	NRSA63J-221X	MG RESISTOR	220Ω 1/16W J	
R715	NRSA63J-221X	MG RESISTOR	220Ω 1/16W J	
R716	NRSA63J-221X	MG RESISTOR	220Ω 1/16W J	
R718	NRSA63J-473X	MG RESISTOR	47kΩ 1/16W J	
R731	NRSA63J-0R0X	MG RESISTOR	0Ω 1/16W J	
R732	NRSA63J-0R0X	MG RESISTOR	0Ω 1/16W J	
R733	NRSA63J-0R0X	MG RESISTOR	0Ω 1/16W J	
R734	NRSA63J-0R0X	MG RESISTOR	0Ω 1/16W J	
R735	NRSA63J-0R0X	MG RESISTOR	0Ω 1/16W J	
R741	NRSA63J-0R0X	MG RESISTOR	0Ω 1/16W J	
R742	NRSA63J-5R1X	MG RESISTOR	5.1Ω 1/16W J	
R743	NRSA63J-4R7X	MG RESISTOR	4.7Ω 1/16W J	
R744	NRSA63J-4R7X	MG RESISTOR	4.7Ω 1/16W J	
R745	NRSA63J-103X	MG RESISTOR	10kΩ 1/16W J	
R749	NRSA63J-473X	MG RESISTOR	47kΩ 1/16W J	
R990	NRSA63J-0R0X	MG RESISTOR	0Ω 1/16W J	
CN101	QGF0523F1-24W	CONNECTOR	FFC/FPC (1-24)	
CN201	QGF1037F1-08W	CONNECTOR	FFC/FPC (1-8)	
CN501	QGF1016F2-08W	CONNECTOR	FFC/FPC (1-8)	
CN502	QGF1016F2-09W	CONNECTOR	FFC/FPC (1-9)	
CN503	QGF1016F2-17W	CONNECTOR	FFC/FPC (1-17)	
CN504	QGF1016F2-15W	CONNECTOR	FFC/FPC (1-15)	
K101	NRSA02J-0R0X	MG RESISTOR	0Ω 1/10W J	
K102	NRSA02J-0R0X	MG RESISTOR	0Ω 1/10W J	
K350	NQR0502-001X	FERRITE BEADS		
K352	NQR0502-001X	FERRITE BEADS		
K551	NQR0129-002X	FERRITE BEADS		
K552	NQR0129-002X	FERRITE BEADS		
K553	NQR0129-002X	FERRITE BEADS		
K554	NQR0129-002X	FERRITE BEADS		
K555	NQR0022-005X	FERRITE BEADS		
K556	NQR0129-002X	FERRITE BEADS		
K710	NQR0129-002X	FERRITE BEADS		
TH301	NAD0025-103X	N THERMISTOR	10kΩ	
X351	NAX0550-001X	CRYSTAL	27.000MHZ	

DVD loading board

Block No. [0][8]

△ Symbol No.	Part No.	Part Name	Description	Local
CN1	QGF1016F3-05	CONNECTOR	FFC/FPC (1-5)	
S1	QSW1007-001	DETECT SWITCH		

Packing materials and accessories parts list

(TH-SW9)

Block No. M 3 M M

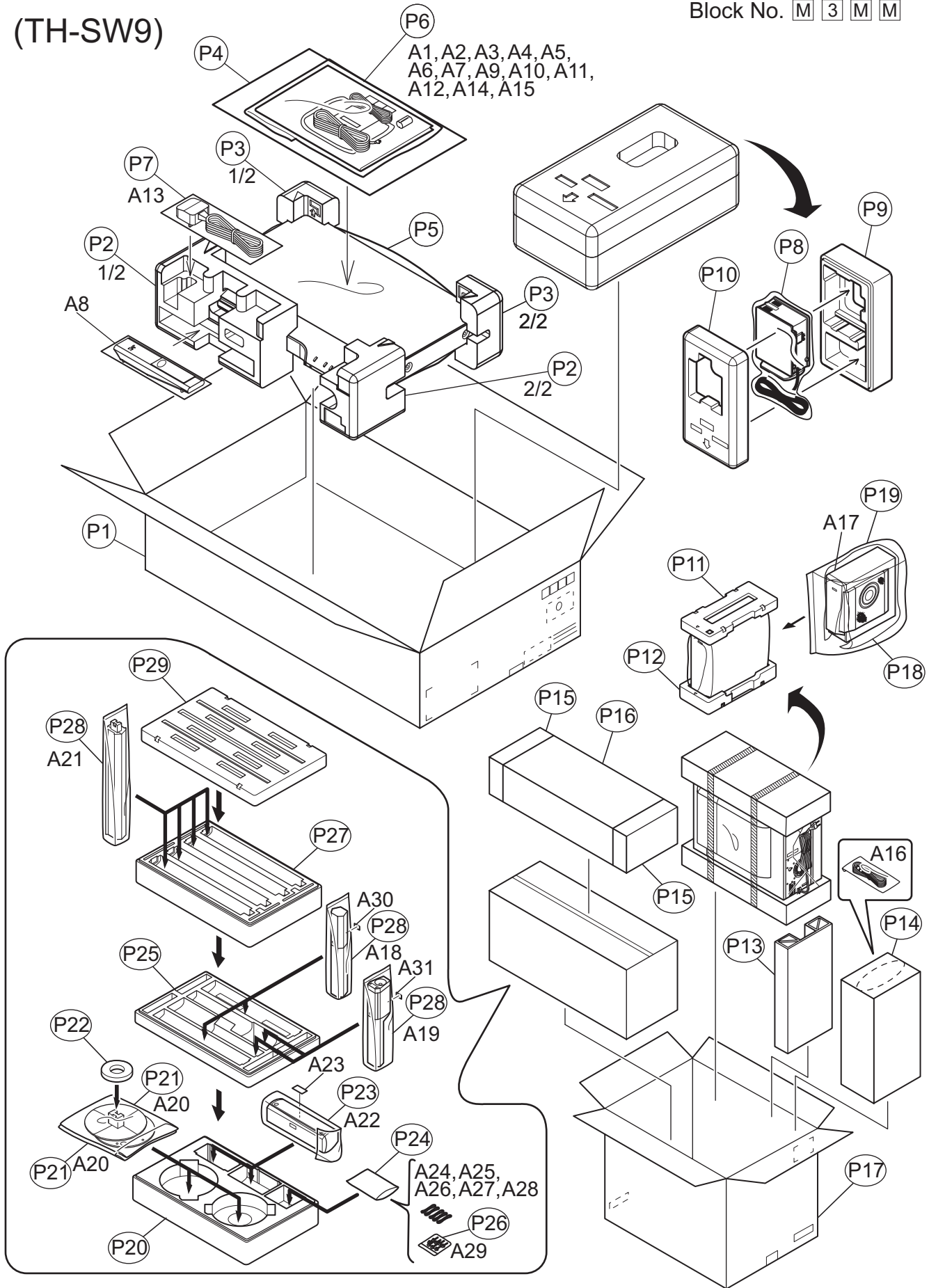

Packing and Accessories (TH-SW9)

Block No. [M][3][M][M]

△	Symbol No.	Part No.	Part Name	Description	Local
	A 1	LVT1150-003B	INST BOOK	ENG	SW9B
	A 1	LVT1150-004B	INST BOOK	GER,FRE	SW9E,SW9EN
	A 1	LVT1150-008A	INST BOOK	CZE,POL,HUN	SW9EV
	A 2	LVT1150-005B	INST BOOK	DUT	SW9E
	A 2	LVT1150-006B	INST BOOK	SPA,ITA	SW9EN
	A 3	LV44023-001A	CAUTION SHEET		SW9B,SW9E,SW9EN
	A 3	LV44023-002A	CAUTION SHEET		SW9EV
	A 4	BT-54013-7	WARRANTY CARD		
△	A 5	QMPL060-183-JD	POWER CORD(EU)	1.83m BLACK	SW9E,SW9EN,SW9EV
	A 6	QAL0457-001	ANT.WIRE		
	A 7	QAL0014-001	AM LOOP ANT		
	A 8	RM-STHS5R	REMOCON UNIT		
	A 9	-----	BATTERY	(x2)	
	A 10	LV44032-001A	CAUTION SHEETS2		SW9B,SW9E,SW9EN
	A 11	LV44033-002A	ECDOC SHEET		
	A 12	LV44048-001A	ERRATA SHEET		SW9B
	A 12	LV44048-002A	ERRATA SHEET		SW9E,SW9EN
△	A 13	QMPP060-183-JD	POWER CORD(EU)	1.83m BLACK	SW9B
	A 14	VNA3000-204	REGISTER CARD		SW9B
	A 15	LVT1150-007B	INST BOOK	SWE,FIN,DAN	SW9EN
	A 16	6200044901	DIN CABLE		
	A 17	SPPWS5E-SPBOX	SPEAKER BOX		
	A 18	SPS9-FRSPBOX	SPEAKER BOX	FRONT(x2)	
	A 19	SPS9-SUSPBOX	SPEAKER BOX	SURROUND(x2)	
	A 20	SPS9-STAND	STAND BASE	(x4)	
	A 21	SPS9-STANDREAR	STAND	(x4)	
	A 22	AB050019-01	SPEAKER BOX	CENTER	
	A 23	6000207011	RATING LABEL(C)	CENTER	
	A 24	6200044801	SPEAKER CORD		
	A 25	6200044811	SPEAKER CORD		
	A 26	6200044821	SPEAKER CORD		
	A 27	6200044831	SPEAKER CORD		
	A 28	6200044841	SPEAKER CORD		
	A 29	7001652506	SCREW	(x8)	
	A 30	6000207091	RATING LABEL(F)	FRONT(x2)	
	A 31	6000207301	RATING LABEL(S)	SURROUND(x2)	
	P 1	LV35032-001A	CARTON BOX		
	P 2	LV21624-001A	CUSHION(F)		
	P 3	LV21625-001A	CUSHION(R)		
	P 4	LV43940-001A	CARTON SPACER		
	P 5	QPC05006515P	POLY BAG	50cm x 65cm	
	P 6	QPA02503505P	POLY BAG	25cm x 35cm	
	P 7	QPA01503503	POLY BAG	15cm x 35cm	SW9B
	P 8	QPC03505015P	POLY BAG	35cm x 50cm	
	P 9	LV21717-001A	CUSHION(L)		
	P 10	LV21718-001A	CUSHION(U)		
	P 11	8000053901	TOP CUSHION		
	P 12	8000053911	BOTTOM CUSHION		
	P 13	8100124201	PARTITION		SW9B
	P 14	8300050361	CARTON BOX		SW9E,SW9EN,SW9EV
	P 14	8300050371	CARTON BOX		SW9B
	P 15	8000056501	CUSHION	(x2)	
	P 16	8100122801	PARTITION		
	P 17	8300051081	CARTON BOX		
	P 18	8500051881	MIRROR MAT		
	P 19	8500051901	POLY BAG		
	P 20	8000055001	CUSHION A		
	P 21	8500055801	MIRROR MAT BAG	(x4)	
	P 22	8000051901	CUSHION	LV34230-001A(x2)	
	P 23	8500051971	POLY BAG		
	P 24	8500041651	POLY BAG		
	P 25	8000055011	CUSHION B		
	P 26	8500047111	POLY BAG		
	P 27	8000055021	CUSHION C		
	P 28	8500043471	POLY BAG	(x8)	
	P 29	8000055031	CUSHION D		

Packing materials and accessories parts list

Block No. M 4 M M

(TH-SW8)

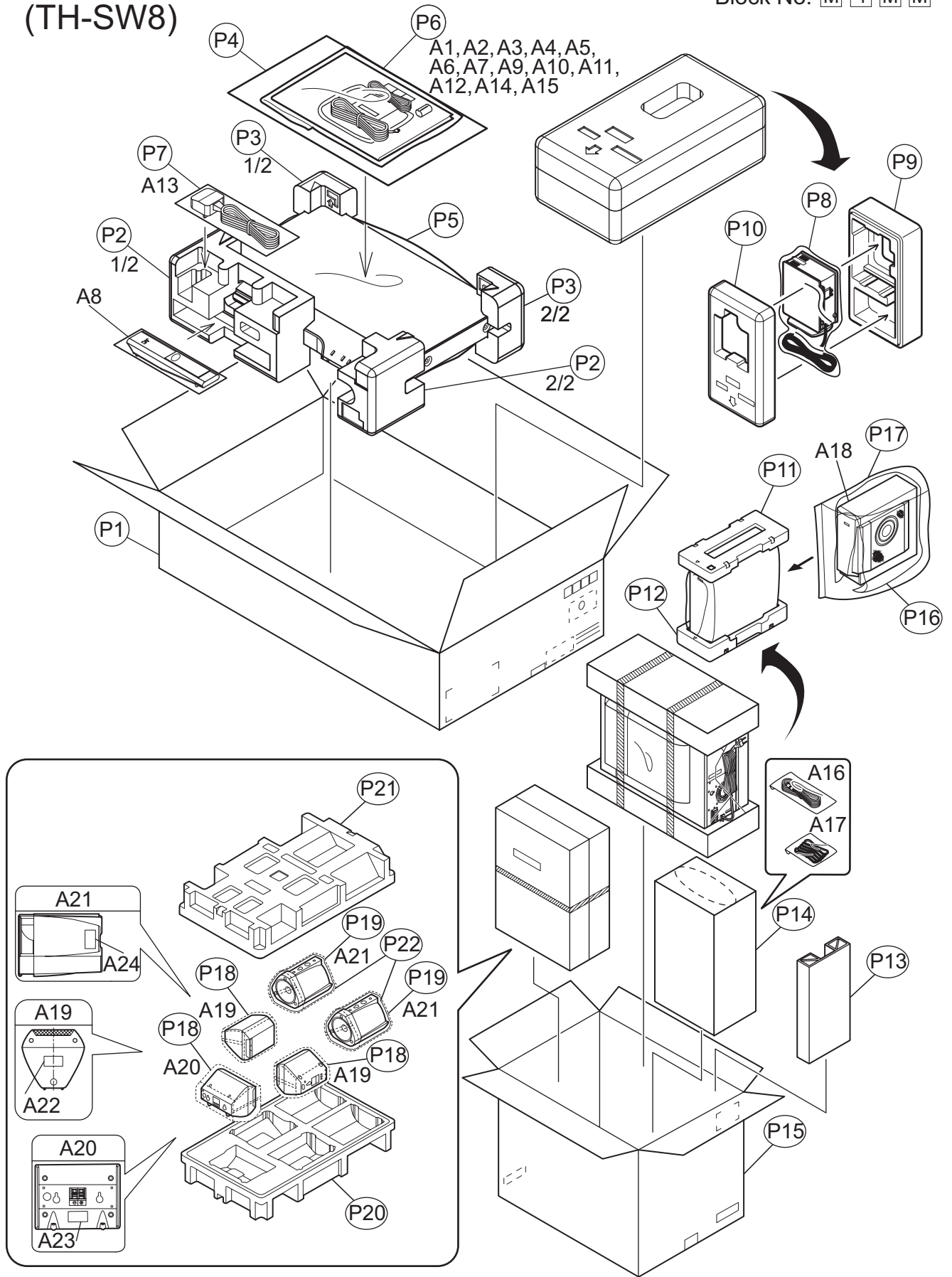

Packing and Accessories (TH-SW8)

Block No. [M][4][M][M]

△	Symbol No.	Part No.	Part Name	Description	Local
	A 1	LVT1150-003B	INST BOOK	ENG	SW8B
	A 1	LVT1150-004B	INST BOOK	GER,FRE SW8E,SW8EN	
	A 1	LVT1150-008A	INST BOOK	CZE,POL,HUN	SW8EV
	A 2	LVT1150-005B	INST BOOK	DUT	SW8E
	A 2	LVT1150-006B	INST BOOK	SPA,ITA	SW8EN
	A 3	LV44023-001A	CAUTION SHEET		SW8B,SW8E,SW8EN
	A 3	LV44023-002A	CAUTION SHEET		SW8EV
	A 4	BT-54013-7	WARRANTY CARD		
△	A 5	QMPL060-183-JD	POWER CORD(EU)	1.83m BLACK	SW8E,SW8EN,SW8EV
	A 6	QAL0457-001	ANT.WIRE		
	A 7	QAL0014-001	AM LOOP ANT		
	A 8	RM-STHS5R	REMOCON UNIT		
	A 9	-----	BATTERY	(x2)	
	A 10	LV44032-001A	CAUTION SHEETS2		SW8B,SW8E,SW8EN
	A 11	LV44033-001A	ECDOC SHEET		
	A 12	LV44048-001A	ERRATA SHEET		SW8B
	A 12	LV44048-002A	ERRATA SHEET		SW8E,SW8EN
△	A 13	QMPP060-183-JD	POWER CORD(EU)	1.83m BLACK	SW8B
	A 14	VNA3000-204	REGISTER CARD		SW8B
	A 15	LVT1150-007B	INST BOOK	SWE,FIN,DAN	SW8EN
	A 16	6200044901	DIN CABLE		
	A 17	6200045101	CORD SET		
	A 18	SPPWS5E-SPBOX	SPEAKER BOX		
	A 19	AB080048-01	SPEAKER BOX	FRONT(x2)	
	A 20	AB080049-01	SPEAKER BOX	CENTER	
	A 21	AB080047-01	SPEAKER BOX	SURROUND(x2)	
	A 22	6000206301	RATING LABEL(F)	FRONT(x2)	
	A 23	6000206311	RATING LABEL(C)	CENTER	
	A 24	6000206321	RATING LABEL(S)	SURROUND(x2)	
	P 1	LV34831-001A	CARTON BOX		
	P 2	LV21624-001A	CUSHION(F)		
	P 3	LV21625-001A	CUSHION(R)		
	P 4	LV43940-001A	CARTON SPACER		
	P 5	QPC05006515P	POLY BAG	50cm x 65cm	
	P 6	QPA02503505P	POLY BAG	25cm x 35cm	
	P 7	QPA01503503	POLY BAG	15cm x 35cm	SW8B
	P 8	QPC03505015P	POLY BAG	35cm x 50cm	
	P 9	LV21717-001A	CUSHION(L)		
	P 10	LV21718-001A	CUSHION(U)		
	P 11	8000053901	TOP CUSHION		
	P 12	8000053911	BOTTOM CUSHION		
	P 13	8100124201	PARTITION		SW8B
	P 14	8300050341	ACCESSORIES BOX		SW8E,SW8EN,SW8EV
	P 14	8300050351	ACCESSORIES BOX		SW8B
	P 15	8300050951	CARTON BOX		SW8E,SW8EN,SW8EV
	P 15	8300050961	CARTON BOX		SW8B
	P 16	8500051881	MIRROR MAT		
	P 17	8500051901	POLY BAG		
	P 18	8500051961	POLY BAG	(x3)	
	P 19	8500043421	POLY BAG	(x2)	
	P 20	8000054611	BOTTOM CUSHION		
	P 21	8000054601	TOP CUSHION		
	P 22	8500048061	MIRROR MAT	(x2)	