

JVC

SERVICE MANUAL

MODEL
T-X6

FM/AM STEREO TUNER



No.2511
JUL. 1980

Contents

1. Specifications	2	7-(3) MW Section	9
2. Names of Controls and Their Functions	3	8. Printed Curcuit Board Ass'y and Parts List	
3. Explanation of New Technology		8-(1) TXX-272 FM/AM Tuner and Power Supply	
3-(1) S/N of PLL Synthesizer System	4	P.C. Board Ass'y	10
3-(2) Composition of		8-(2) TXX-274 PLL Synthesizer and Control	
New PLL Synthesizer System	5	P.C. Board Ass'y	15
4. Block Diagram	6	8-(3) TPS-281 Fuse Circuit Board Ass'y	17
5. Exploded View and Part Numbers	7	8-(4) TPS-266 Voltage Selector	
6. Main Parts Location		P.C. Board Ass'y	17
6-(1) Top View	8	9. Packing Materials and Part Numbers	18
6-(2) Front View	8	10. T-X6 Schematic Diagram	18
6-(3) Rear View	8	11. Accessories List	20
7. FM/AM Tuner Adjustment Procedures		12. Parts List with Specified Numbers for	
7-(1) Frontend Section	9	Designated Areas	20
7-(2) FM Section	9		

Warning:

When replacing the parts maked with  , be sure to use the designated parts to ensure safety.

1. Specifications

FM Section (Based upon IHF Standard)

Tuning Range	: 87.9 – 107.9 MHz
CH Space	: 200 kHz (U.S.A. & Canada) 100 kHz (Other Areas)
Usable Sensitivity	: 0.85 μ V/75 Ω (9.8 dBf)
50 dB S/N Sensitivity	
Mono	: 1.5 μ V/75 Ω (14.8 dBf)
Stereo QSC AUTO	: 9.8 μ V/75 Ω (31.0 dBf)
QSC OFF	: 19 μ V/75 Ω (36.8 dBf)
Signal to Noise Ratio	
Mono	: 83 dB (73 dB, DIN)
Stereo	: 78 dB (69 dB, DIN)
Distortion	
Mono	100 Hz : 0.05 % 1 kHz : 0.05 % 6 kHz : 0.05 %
Stereo	100 Hz : 0.08 % 1 kHz : 0.08 % 6 kHz : 0.15 %
Capture Ratio	: 1.0 dB
Alternate Channel	: 80 dB, \pm 400 kHz
Selectivity	
Image Rejection	: 80 dB
IF Rejection	: 100 dB
Spurious Rejection	: 100 dB
AM Suppression	: 60 dB
Stereo Separation 1 kHz	: 55 dB

Frequency Response	: 30 Hz \sim 15 kHz +0.3 dB -1.0 dB
Sub-Carrier Suppression	: 68 dB
Output Level	: 600mV/2.2k Ω

MW Section

Tuning Range	: 530 – 1620 kHz or 531 – 1602 kHz
CH Space	: 9 kHz/10 kHz selectable
Sensitivity	
Bar Antenna	: 300 μ V/m
Ext Antenna	: 30 μ V
Total Harmonic Distortion	: 0.3 %
Signal to Noise Ratio	: 50 dB
Selectivity	: 40 dB \pm 9 kHz
Image Rejection Ratio	: 55 dB
IF Rejection Ratio	: 60 dB
Spurious Rejection	: 55 dB

Dimensions and Weight

Designated Areas	Dimensions (cm)			Weight (kg)	
	Height	Width	Depth	Net	Gross
U.S.A. & Canada	7.9 (3-1/8")	47.4 (18-3/4")	34.5 (13-5/8")	4.5 (9.9 lbs)	5.5 (12.1 lbs)
Other Countries	7.9 (3-1/8")	45.0 (17-3/4")	34.5 (13-5/8")	4.1 (9.0 lbs)	5.5 (12.1 lbs)

POWER SPECIFICATIONS

Designated Areas	Line Voltage & Frequency	Power Consumption
U.S.A. & Canada	AC 120 V \sim , 60 Hz	10 W
Other Countries	AC 110/120/220/240 V \sim selectable, 50/60 Hz (See Fig. 1)	10 W

This set (except for U.S.A. and Canada) is switchable to the proper line voltage by turning the Voltage Selector with a screwdriver or coin.

Voltage Selector is placed on the Rear Panel but not mounted for U.S.A. and Canada.

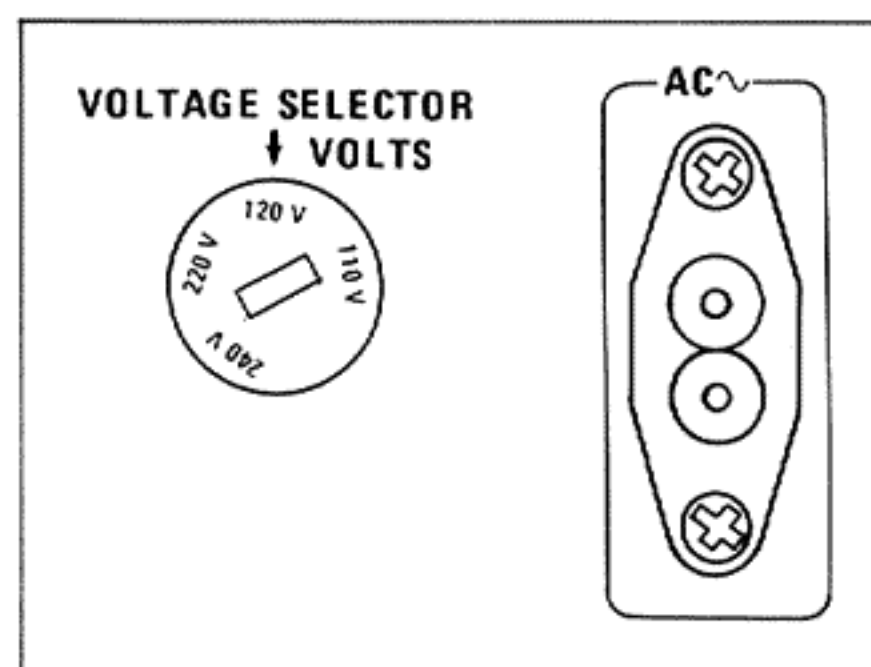
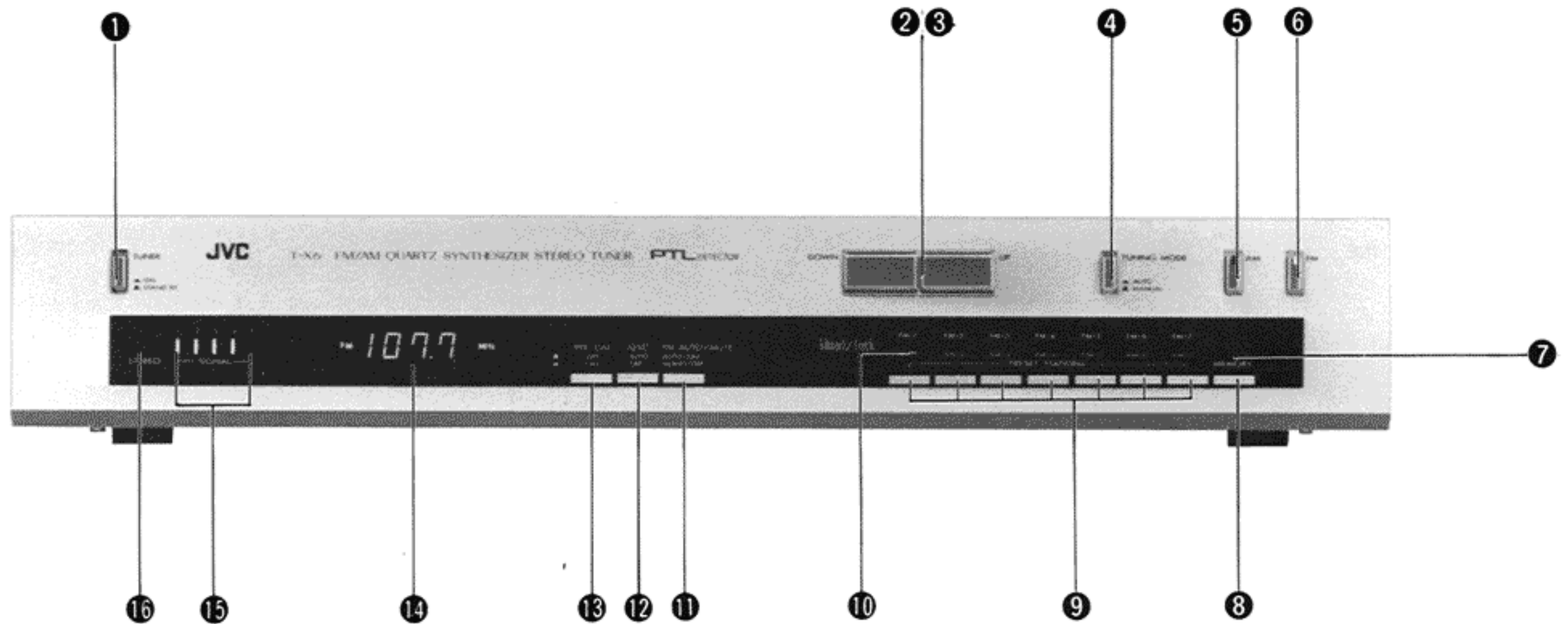

Fig. 1

2. Names of Controls and Their Functions



1. TUNER switch

ON: Press to ON () to listen to broadcasts.
STAND BY: When the power cord is plugged into the AC wall outlet, the preset stations are not subject to cancellation or alteration. The preset data are maintained even in the case of a power failure or when the power cord is disconnected, if the period of non-applied power does not exceed a couple of days.

2, 3. UP/DOWN buttons (TUNING)

Auto tuning

When the UP or DOWN button is pressed (but do not keep it pressed), scanning will be made automatically and simultaneously the frequency-display changes successively, until a broadcasting station is tuned in. When a station is tuned in, the scanning stops automatically and the display shows the frequency of the station tuned in. In the course of automatic scanning (tuning), when the frequency number reaches the upper or lower limit of the band, scanning will automatically reverse and continue scanning until a station is tuned in.

When the UP scanning button is pressed, the frequency number changes in the direction of increasing frequencies. When the DOWN button is pressed, the frequency number change in the direction of decreasing frequencies.

Manual tuning

Manual tuning is possible to set the TUNING MODE switch to the out position (). Pressing the Up-Down-scanning buttons, the tuned-in frequency changes in steps of predetermined frequencies (see table below). Tapping this button changes the tuner step by step, continuous pressing (more than 0.6 sec.) changes tuning in a high speed scanning sequence which released.

AM channel spacing switch is provided on the rear panel for selecting 9 kHz steps to which your channel frequency may change in the future.

Channel spacing

Band \ Area	FM	AM
USA, Canada	200 kHz	* 10kHz/9kHz
Other	100 kHz	* 9kHz/10kHz

Note: * Preset at the factory.

4. TUNING MODE switch

Press this switch in for AUTO tuning () and press again to set to the out position () for MANUAL tuning.

5. AM button

Press to listen to AM broadcasts.

6. FM button

Press to listen to FM broadcasts.

7. MEMORY indicator

When the MEMORY button is pressed, this MEMORY indicator lights to show that the unit is ready to register the preset station to memory. This indicator will go out automatically in about 5 sec. or by pressing the except PRESET STATIONS button.

8. MEMORY button

When this button is pressed, the MEMORY indicator lights. If the PRESET STATIONS button is pressed while this indicator is lighting the frequency of the station being received is displayed and becomes preset to that channel. When the PRESET STATIONS button is pressed after this indicator extinguishes, the frequency of the previously preset station is displayed on the frequency indicator. In that case, perform tuning once again and press the MEMORY button.

9. PRESET STATIONS buttons

These buttons are used to select one of the preset stations or to preset the station for an individual channel. For presetting, press one of these buttons while the MEMORY indicator remains lit after the MEMORY button has been pressed. Then the station which is being received will be "memorized". One of the PRESET STATIONS indicators will light to show which channel is in operation.

FM 7, AM 7, stations are possible to be preset.

10. PRESET STATIONS indicators

The indicator, corresponding to the selected station, lights when one of the PRESET STATIONS buttons is pressed.

11. FM AUTO/MUTE

AUTO/ON: For FM stereo and monaural broadcasts. Set to this "out" position for normal FM reception. This also eliminates inter-station noise during FM tuning.

MONO/OFF: For sub-standard FM broadcasts. Both stereo and monaural broadcasts are received in mono with less noise. Select this "in" position to bring in distant FM stations so that the muting circuit may not mute the broadcast signal.

12. QSC switch

AUTO: Hiss noise is liable to occur if input signals are weak during FM stereo reception. When this switch is set to its "AUTO" position (■), the Quieting Slope Control Circuit is activated automatically to reduce hiss noise if the signal strength is insufficient for lighting the SIGNAL strength indicator up to 3, (i.e. if the indicator should light up to only 2). If the input signal becomes higher than that level, the circuit is automatically released.

OFF: No noise reduction effect is obtainable (■) irrespective of the input signal level.

13. REC CAL switch

OFF: For normal broadcast listening.

CAL: Set to this position for level adjusting when recording FM broadcasts.

14. FREQUENCY indicator

The tuned-in frequency is displayed digitally. Four digits (kHz) are displayed for AM reception and four digits (MHz) are displayed for FM reception.

15. SIGNAL strength indicator

Indicates the strength of the signal being received. Best reception is obtained when all five LEDs light. Adjust the antenna so that the maximum number of LEDs light.

16. STEREO indicator

This indicator lights when you are tuned to a FM stereo broadcast with the FM AUTO/MUTE switch at "AUTO/ON".

3. Explanation of New Technology

3-(1) S/N of PLL Synthesizer System

■ S/N Ratio of PLL Synthesizer System

The PLL synthesizer tuner having accurate and stable tuning frequencies is chiefly characterized by the easy formation of preset selecting functions. However, the only demerit of the PLL synthesizer tuner is that its S/N ratio is lower than that of an analog tuner.

The main causes of S/N deterioration are broadly divided into two categories:

- 1) Logic noise entering into each section of the receiver.
- 2) Harmonic component of the logic noise that corresponds exactly to the reception frequency, intermediate frequency or the like.

The following is a typical example of the former. The variable capacitor has an applied voltage to control the tuner local oscillation frequency, in this case the logic noise slightly remains without DC conversion.

For example, with a variable capacitor with a 3 V – 23 V range, the AC noise level present when obtaining on 80 dB S/N is about 20 μ V from the point of calculation. To get an AC noise level of less than 20 μ V, it would be required to completely eliminate single spectrum noise. Possibly the main cause of noise is the dynamic interference from the indicator section, noise from the control logic section, hum induction from the power supply, reference frequency leakage, etc.

In general, the method of reducing the induction and leakage of the logic pulse is as follows:

- 1 To completely stop logic pulse by making the logic section static.
- 2 To make the pulse signal power sufficiently small.
- 3 To shorten the pulse signal transmission line.
- 4 To decrease the number of pulse signal lines, and the like.

Especially, high power pulses for operation of LEDs and fluorescent display tubes of the indication section are noise sources.

Since the T-X6 employs a newly developed static driver LSI for indicating the tuned frequency and the preset station, indication noise is completely eliminated.

In addition, since it is impossible to stop the logic circuit from controlling the system, the PLL synthesizer LSI in the T-X6 suppresses noise to a very low level through the use of an extremely low power CMOS.

Since the control and synthesizer sections are included in one chip LSI, running of data and clock lines to the PLL synthesizer on the circuit board is not necessary, thus removing the noise radiated by these lines.

Concerning hum induction, the output of the local oscillator and the DC line to the variable capacitors, both susceptible to induction noise are shielded thus permitting great reduction of hum induction.

For the reference frequency of the PLL synthesizer, a sufficiently high frequency outside the audio band is used; the employment of the pulse swallow system permits 25 kHz at FM. Thus, the S/N deterioration by the reference frequency is completely covered.

The latter (item 2) relates especially to the division ratio of the local oscillator including the prescaler. The tuner reception section is directly affected by the relatively high frequency pulse of the prescaler, etc. and thus a beat occurs. This occurrence may degrade the S/N.

Since a high frequency response is required for the prescaler, the ECL process is frequently used. Generally, in this process, the current consumption is about several tens of mA and therefore large, while in the prescaler of the T-X6, the current consumption is several mA and small so that no beat occurs.

Many factors of S/N deterioration in the PLL synthesizer tuner exist. This is the reason that S/N improvement is extremely difficult.

The newly developed PLL synthesizer system employed in the T-X6 solves these problems one by one to permit high S/N.

3-(2) Composition of New PLL Synthesizer System

■ Configuration of the newly developed PLL Synthesizer Tuner System

In the T-X6, the PLL synthesizer system consists of a newly developed PLL synthesizer LSI (IC511), an ex-

clusive-use prescaler IC (IC501) and a static driver LSI (IC601).

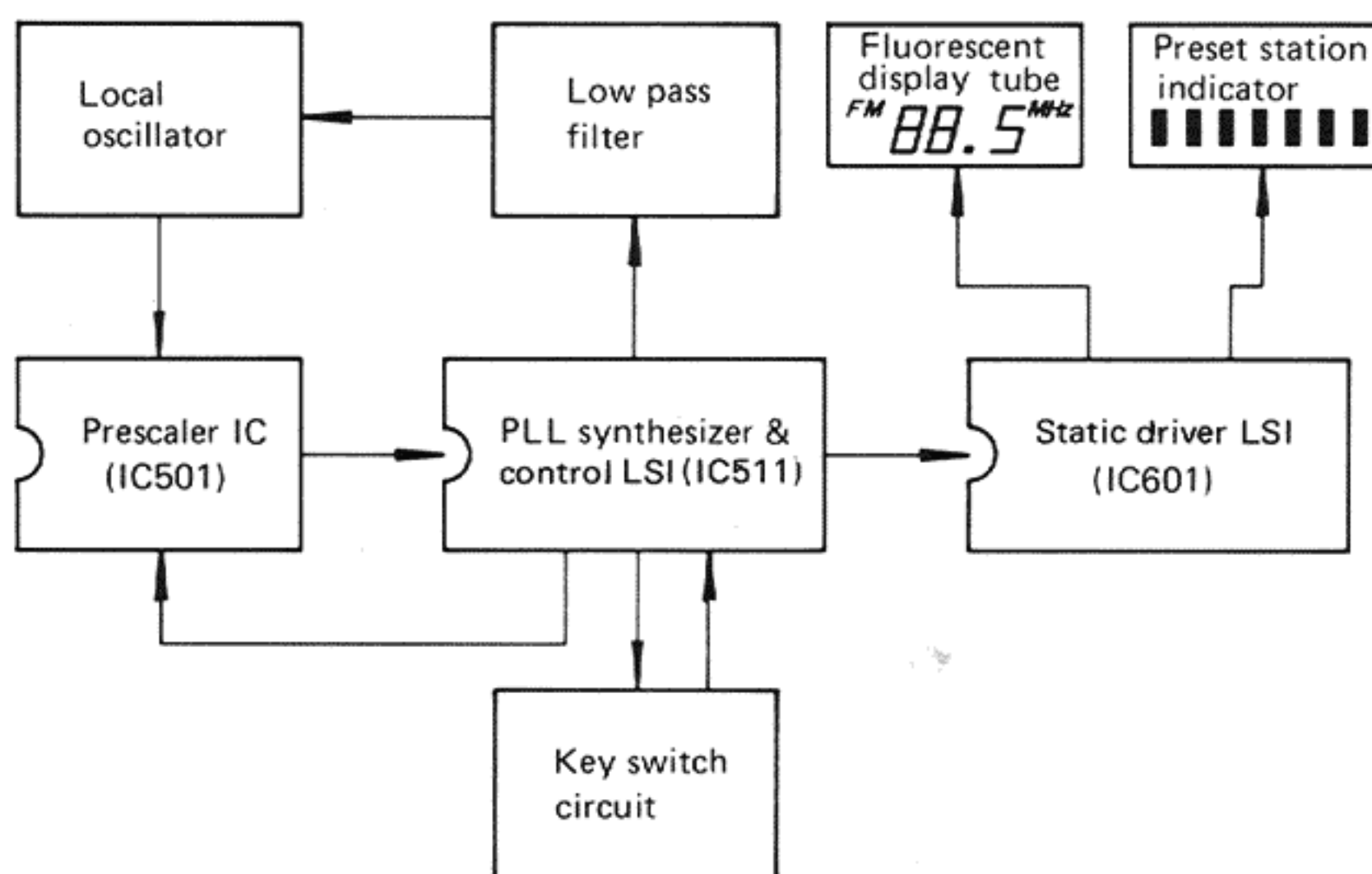

Conventionally, the PLL synthesizer section and the control section are composed of two chip ICs. In the T-X6, they are made into one chip LSI through use of high integration technology and their configuration is very simple.

Fig. 1 shows the block diagram of the T-X6. It is recommended that this block diagram is compared with the block diagram on page 27 in the previously issued service note (No. 2869) of the T-40P.

Since the control section in the PLL synthesizer LSI employs a 16-bit microcomputer, finer control operation is possible. In addition, since the PLL synthesizer section uses the pulse swallow system, heightening of the FM reference

frequency is possible, thus improving the S/N of FM. Likewise, the static driver LSI greatly improves the S/N of both AM and FM because it can indicate the tuned frequency and the preset station without the occurrence of noise.

The display data is emitted serially in synchronization with the clock pulse, from the microcomputer in the PLL synthesizer LSI, and is latched in the static driver LSI.

4. Block Diagram

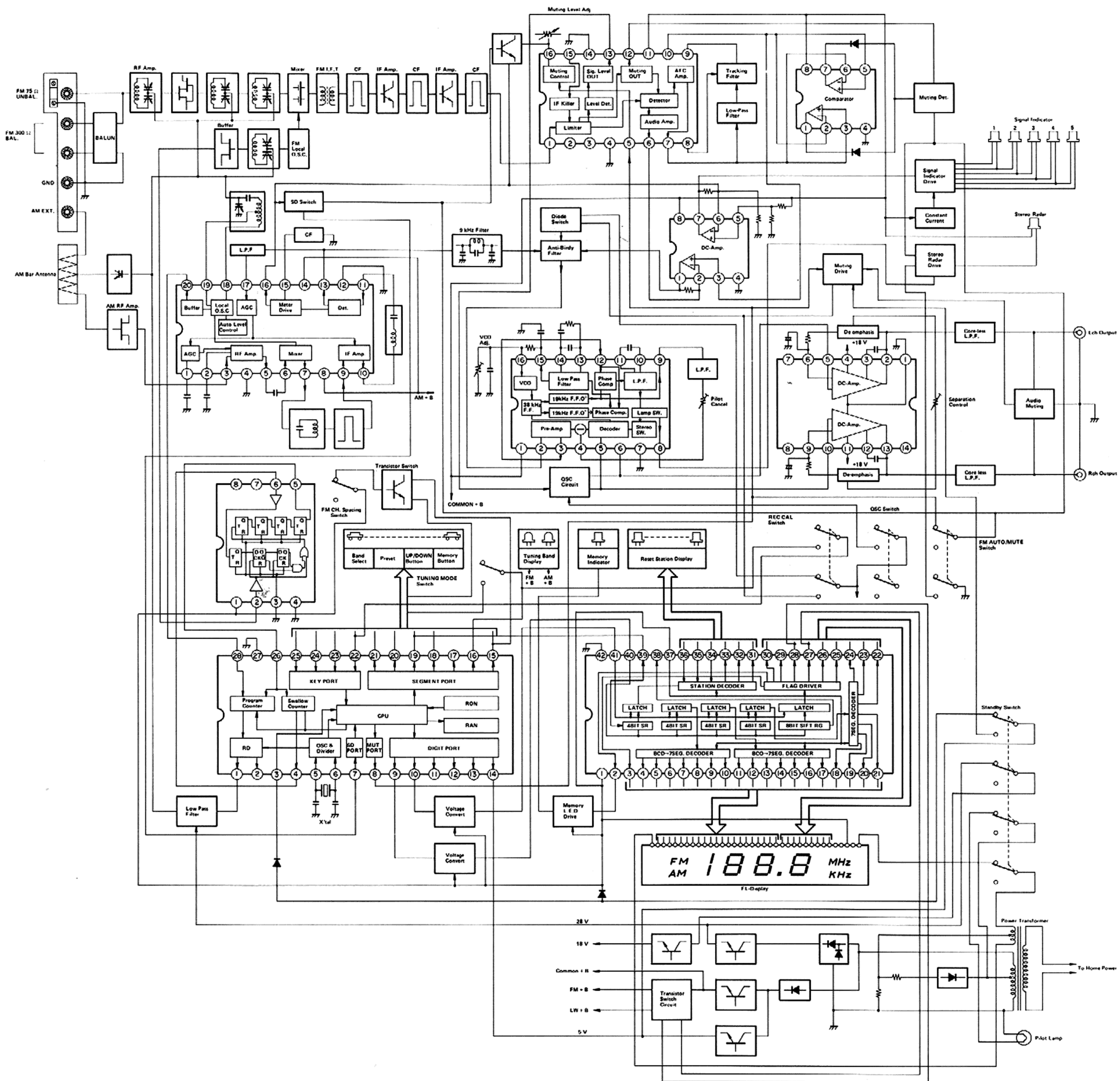

6. Main Parts Location

6-(1) Top View

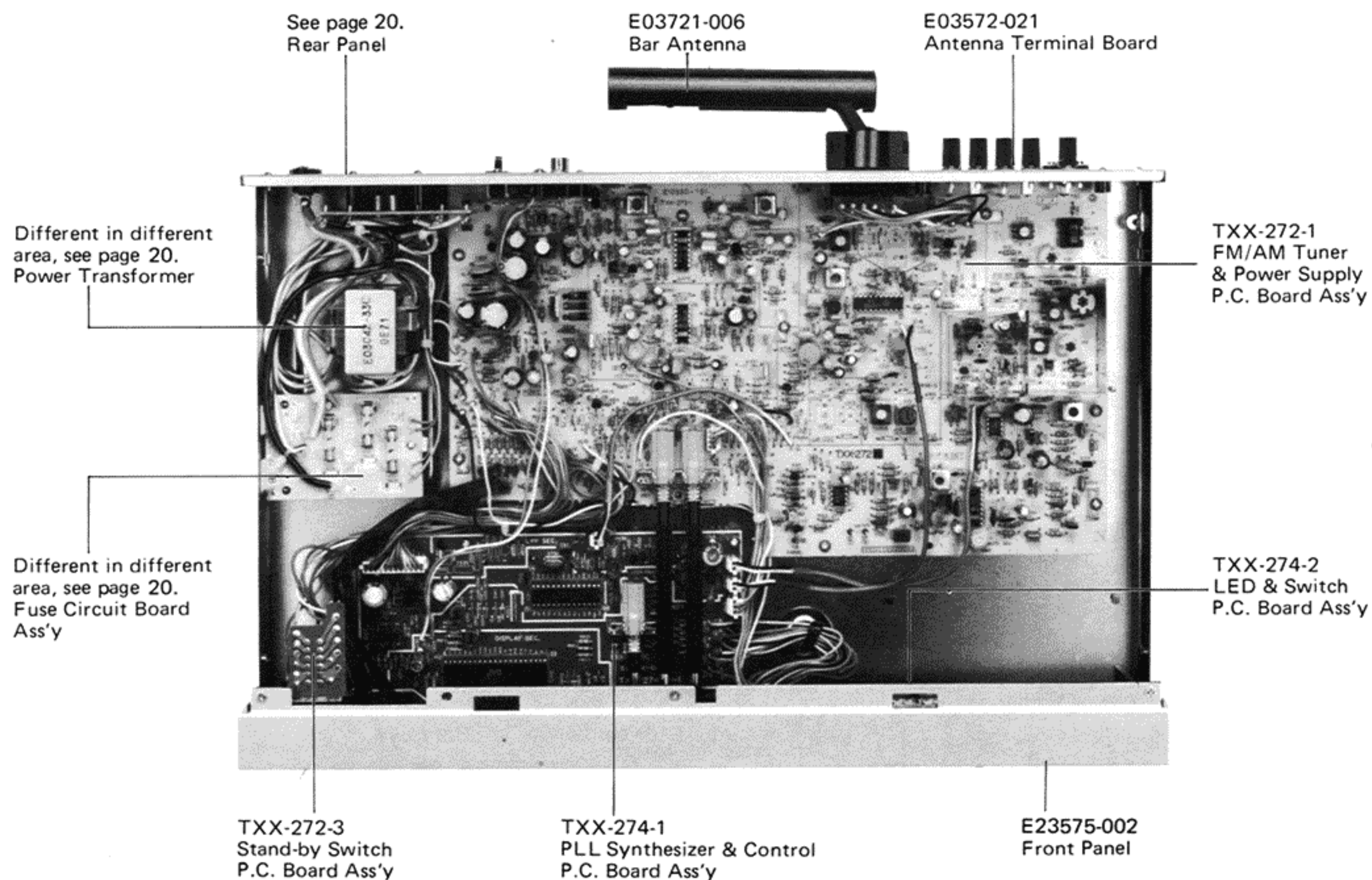

6-(2) Front View

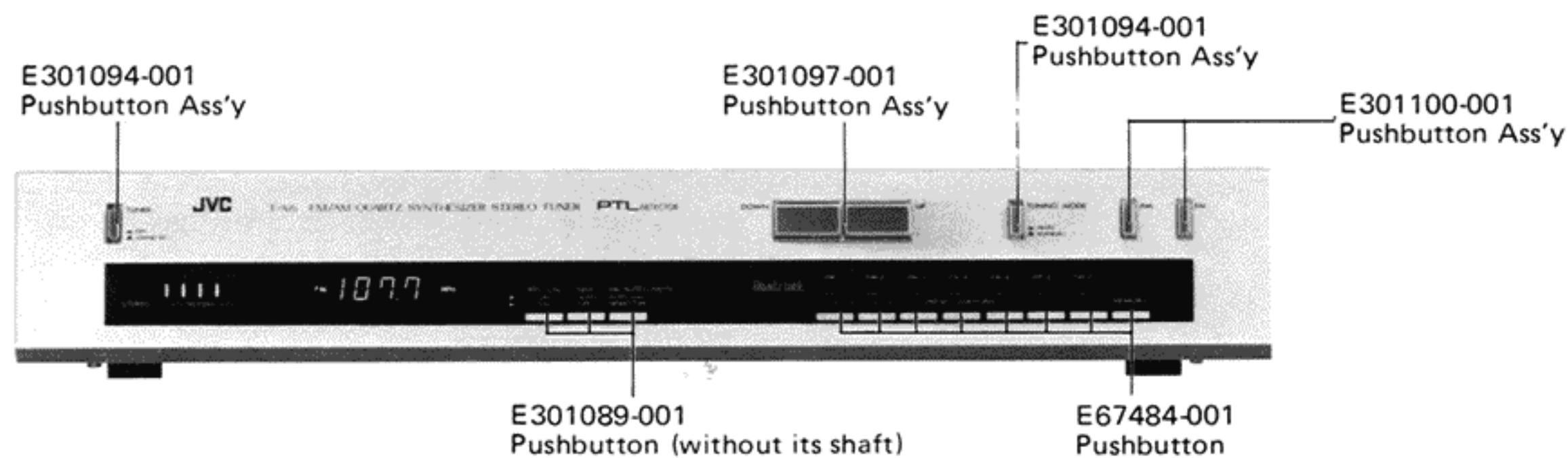

6-(3) Rear View

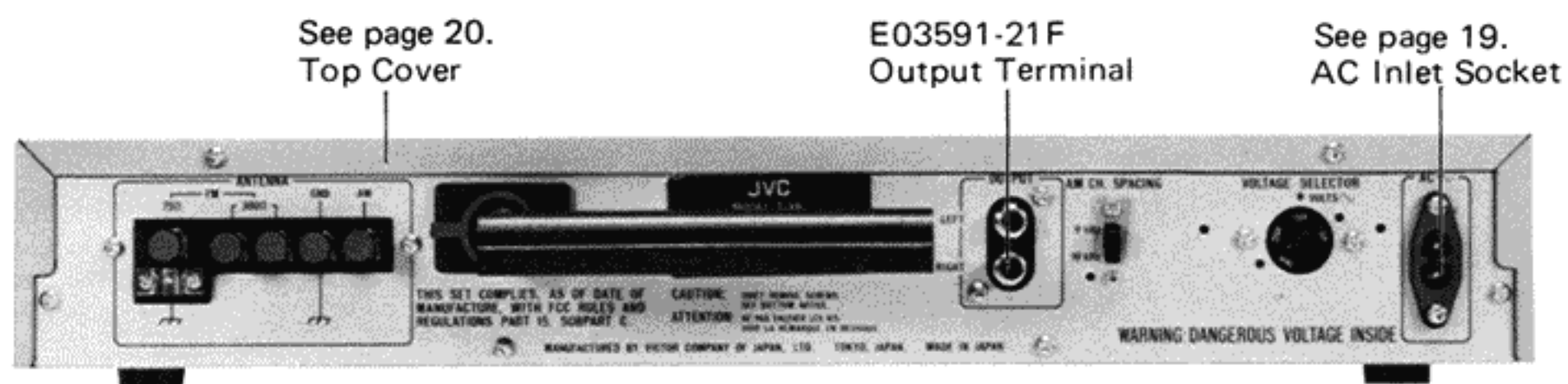

7. FM/AM Tuner Adjustment Procedures

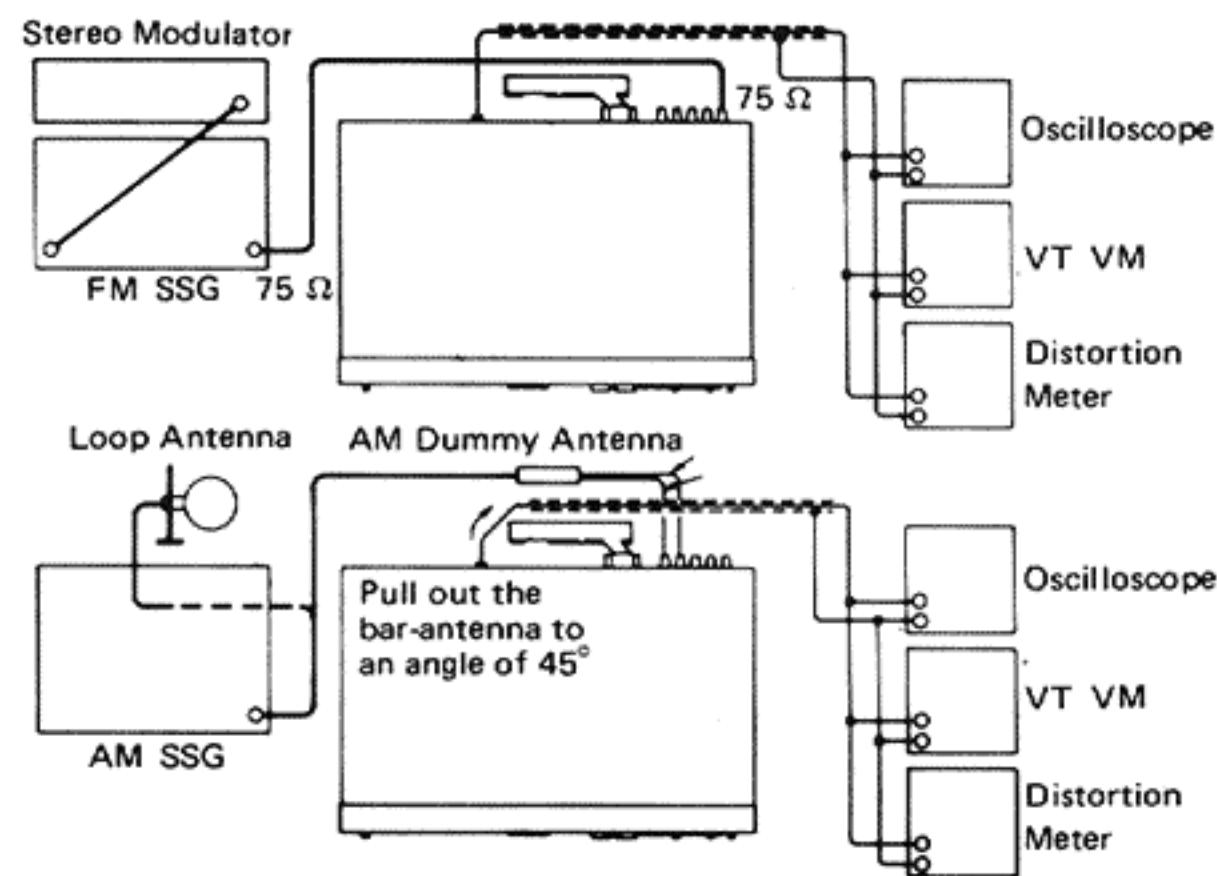
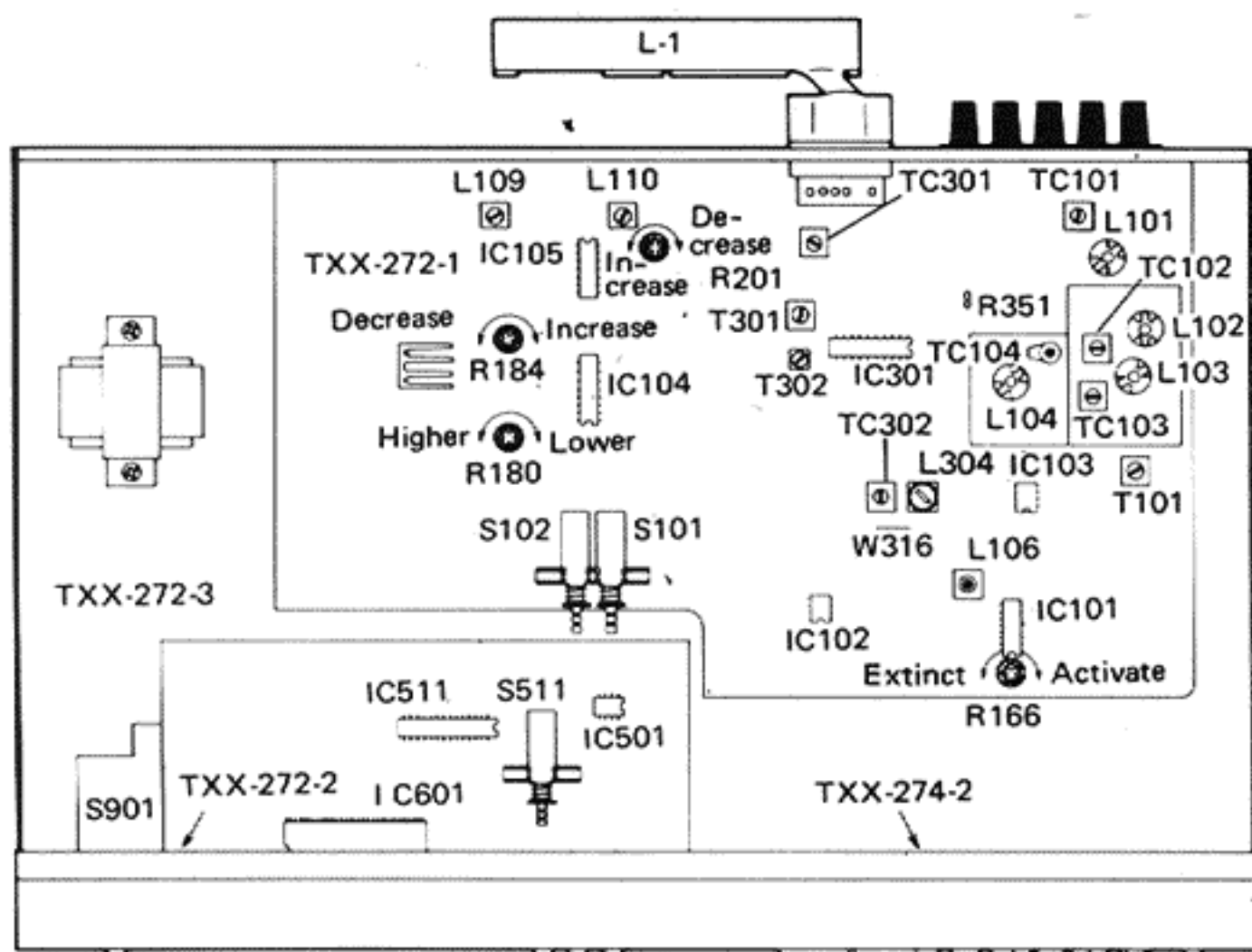

7-(1) Frontend Section

L104: FM oscillator tuning coil

Tune in to 87.9 MHz. Adjust the voltage at bus-wire W316 to 3.0 ± 0.1 V.

TC104: FM oscillator tuning trimmer

Tune in to 107.9 MHz. Adjust the voltage at bus-wire W316 to 22.0 ± 0.1 V.

L101: FM ANT tuning coil

L102: FM RF1 tuning coil

L103: FM RF2 tuning coil

} Maximize the sensitivity at 89.9 MHz.

TC101: FM ANT tuning trimmer

TC102: FM RF1 tuning trimmer

TC103: FM RF2 tuning trimmer

} Maximize the sensitivity at 105.9 MHz.

7-(2) FM Section

T101: FM IFT

Optimize sensitivity while the antenna input is reduced.

L106: FM detector coil

Connect the center meter to TP6 and 7 and adjust L106 for the center meter reading of "0" (zero).

R166: Muting level adjusting resistor

Set the FM AUTO/MUTE switch to AUTO/ON. Receiving a stereo signal, adjust the control so that muting circuit is activated when the antenna input is at about 15 dB.

R180: MPX VCO free-run frequency adjusting resistor

Adjust it so that the free-run frequency becomes 76 kHz between TP ② and ground.

R184: MPX pilot cancel control

Receiving a stereo signal, adjust the control so that leakage of the 19-kHz pilot signal is minimized.

R201: Stereo separation adjusting resistor

Adjust it so that the channel separation becomes maximum.

7-(3) AM Section

L304: AM oscillator tuning coil

Tune in to 530 (or 531) kHz. Adjust the voltage at bus-wire W316 to 2.0 ± 0.1 V.

TC302: AM oscillator tuning trimmer

Tune in to 1620 (or 1602) kHz. Adjust the voltage at bus-wire W316 to 22.0 ± 0.1 V.

L-1: AM bar antenna coil

Maximize the sensitivity at 600 (or 603) kHz

TC301: AM antenna tuning trimmer

Maximize sensitivity at 1400 (or 1404) kHz

8. Printed Curcuit Board Ass'y and Parts List

8-(1) TXX-272 FM/AM Tuner and Power Supply P.C. Board Ass'y

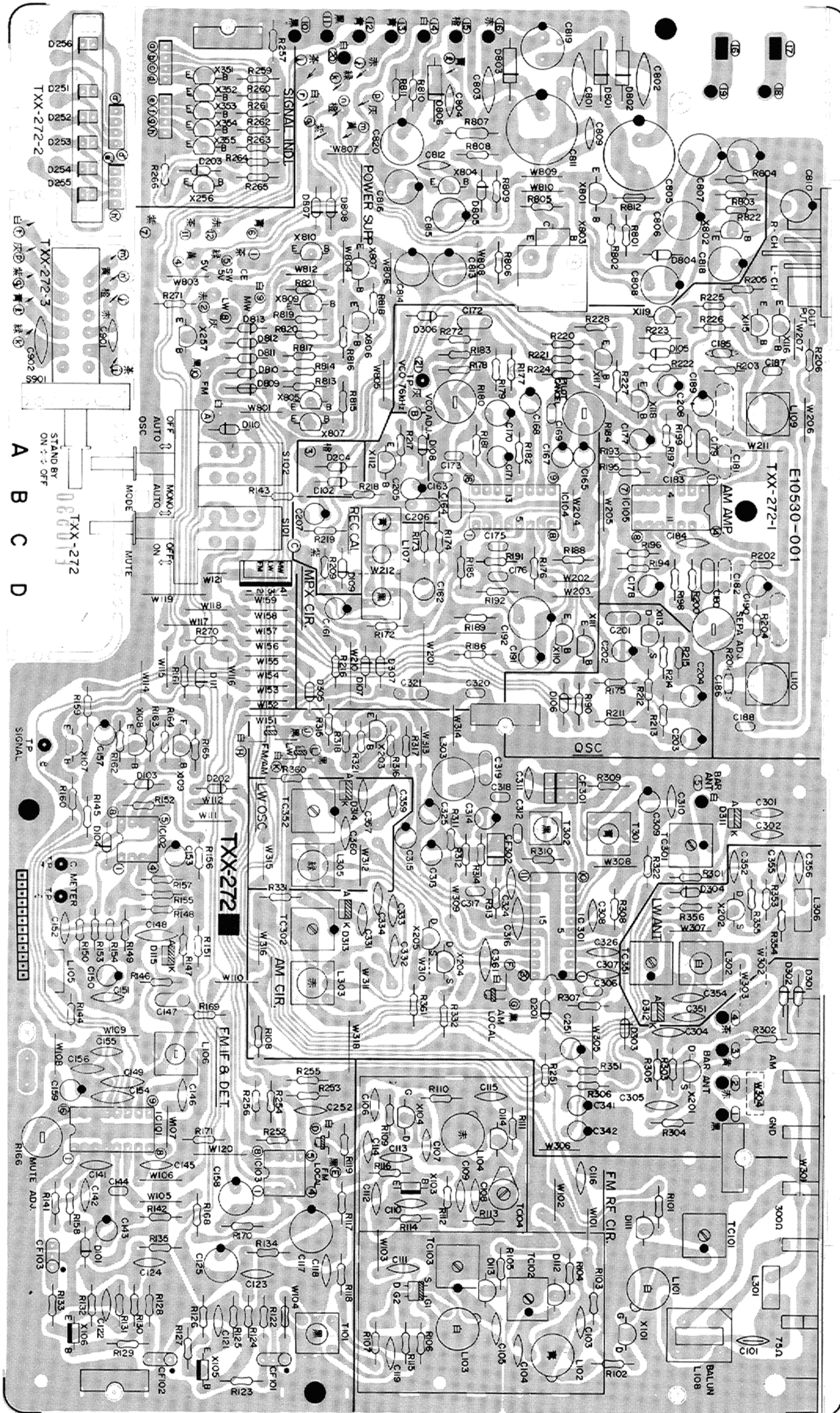

Each Individual P.C. Board Location

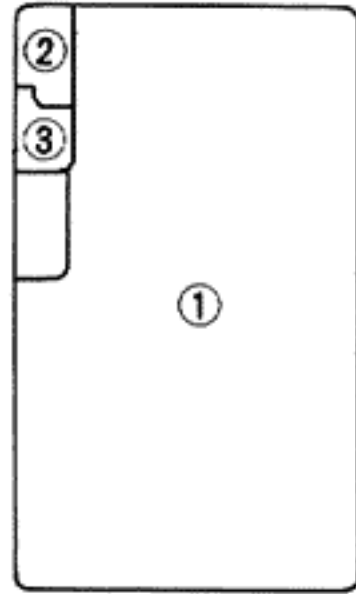

Note: The specific symbols (赤, 黒, 白 ... etc.) on a surface of P.C. Board are actually unrelated to the repair service and are significant denotement in order to process the proper assembly of P.C. Board at the factory.

1. TXX-272-1 FM/AM Tuner & Power Supply P.C. Board Ass'y
2. TXX-272-2 LED P.C. Board Ass'y
3. TXX-272-3 Stand-by Switch P.C. Board Ass'y

Transistors

Item No.	Part Number	Rating		Description	
		Pc	fT		Maker
X101	2SK168(E,F)	0.2 W		F.E.T.	Hitachi
X102	3SK73(Y,GR)	0.3 W		"	Toshiba
X103	2SC461(C)	0.2 W	230 MHz	Silicon	Hitachi
X104	2SK168(E)	0.2 W		F.E.T.	"
X105	2SC461(C)	0.2 W	230 MHz	Silicon	"
X106	2SC461(C)	"	"	"	"
X107	2SC458(C,D)	"	"	"	"
X108	2SC458(C,D)	"	"	"	"
X109	2SA1029(C)	"	200 MHz	"	"
X110	2SC458(C,D)	"	230 MHz	"	"
X111	2SC458(C,D)	"	"	"	"
X112	2SC458(C,D)	"	"	"	"
X113	2SK105(F)	0.25 W		F.E.T.	NEC
X115	2SD655(E,F)	0.5 W	250 MHz	Silicon	Hitachi
X116	2SD655(E,F)	"	"	"	"
X117	2SC458(C,D)	0.2 W	230 MHz	"	"
X118	2SC458(C,D)	"	"	"	"
X119	2SA872AV(D,E)	0.3 W	120 MHz	"	"
X201	2SK105(F,H)	0.25 W		F.E.T.	NEC
X202	2SK105(F,H)	"	"	"	"
X203	2SC458(D)	0.2 W	230 MHz	Silicon	Hitachi
X251	2SC458(D)	"	"	"	"
X252	2SC458(D)	"	"	"	"
X253	2SC458(D)	"	"	"	"
X254	2SC458(D)	"	"	"	"
X255	2SC458(D)	"	"	"	"
X256	2SB562(C)	0.9 W	350 MHz	"	"
X257	2SA1029(C)	0.2 W	200 MHz	"	"
X801	2SC2235(Y)	0.9 W	120 MHz	"	Toshiba
X802	2SC2235(Y)	"	"	"	"
X803	2SD313(E)	1.75 W	8 MHz	"	Sanyo
X804	2SC2235(Y)	0.9 W	120 MHz	"	Toshiba
X805	2SC458(D)	0.2 W	230 MHz	"	Hitachi
X806	2SC458(D)	"	"	"	"
X807	2SB562(C)	0.9 W	350 MHz	"	"
X808	2SB562(C)	"	"	"	"

Integrated Circuits

Item No.	Part Number	Rating		Description	
		Pc			Maker
IC101	HA12412			I.C.	Hitachi
IC102	AN6552			"	Matsushita
IC103	NJM4558D	0.5 W		"	JRC
IC104	HA11223W			"	Hitachi
IC105	HA1452W	0.54 W		"	"
IC301	LA1245			"	Sanyo

Diodes

Item No.	Part Number	Rating	Description	
				Maker
D101	1S2076-31		Silicon	Hitachi
D102	1S2076-31		"	"
D103	1S2076-31		"	"
D104	1S2076-31		"	"
D105	1S2076-31		"	"
D106	1S2076-31		"	"
D107	1S2076-31		"	"
D108	1S2076-31		"	"
D109	1S2076-31		"	"
D110	1S2076-31		"	"
D111	1SV55		V. CAP. DI.	"
D112	1SV55		"	"
D113	1SV55		"	"
D114	1SV55		"	"
D115	KV1226		"	Toko
D116	1S2076-31		Silicon	Hitachi
D201	1S2076-31		"	"
D202	1S2076-31		"	"
D203	1S2076-31		"	"
D204	1S2076-31		"	"
D251	TLG205V		L.E.D.	Toshiba
D252	TLG205V		"	"
D253	TLG205V		"	"
D254	TLG205V		"	"
D255	TLG205V		"	"
D256	TLR205	0.056 W	"	"
D301	1S2076-31		Silicon	Hitachi
D302	1S2076-31		"	"
D305	1S2076-31		"	"
D306	1S2076-31		"	"
D307	1S2076-31		"	"
D311	KV1226		V. CAP. DI.	Toko
D313	KV1226		"	"
D801	ERB12-02RKL1		Silicon	Fuji
D802	ERB12-02RKL1		"	"
D803	ERB12-02RKL1		"	"
D804	RD30EB3		Silicon (Zener)	NEC
D805	RD6.2EB3		"	"
D806	ERB12-02RKL1		"	"
D807	1S2076-31		Silicon	Fuji
D808	1S2076-31		"	Hitachi
D811	1S2076-31		"	"
D812	1S2076-31		"	"
D815	1S2076-31		"	"

Coil & Transformers

Item No.	Part Number	Rating	Description
L101	E03477-060		FM Antenna Coil (white)
L102	E03477-061		FM RF Coil (blue)
L103	E03477-060		" (white)
L104	E03477-050		FM OSC Coil (red)
L105	E03522-2R2KY		Choke Coil
L106	E03078-51		Detector Coil
L107	E03735-003		Anti-birdy Filter
L108	E03177-005		BALUN
L109	E03407-005		MPX Coil
L110	E03407-005		MPX Coil
L301	E03522-2R2KY		Choke Coil
L303	Y00118-103		Inductor
L304	E03079-40		MW OSC Coil
T101	E03078-39		FM IFT
T301	E03613-017		MW IFT
T302	E03062-39		AM IFT

Capacitors

Item No.	Part Number	Rating		Description
C159	QET51HR-475	4.7 μ F	50 V	Electrolytic
C161	QET51CR-476F	47 μ F	16 V	"
C162	QET51ER-106E	10 μ F	25 V	"
C163	QFM81HK-182	1800 pF	50 V	Mylar
C164	QFM81HK-473	0.047 μ F	"	"
C165	QET51HR-474	0.47 μ F	"	Electrolytic
C167	QET51HR-474	"	"	"
C168	QEB51EM-475	4.7 μ F	25 V	Low Leak Current Electrolytic
C169	QFM81HK-103	0.01 μ F	50 V	Mylar
C170	QEB51EM-106	10 μ F	25 V	Low Leak Current Electrolytic
C171	QEB51HM-474	0.47 μ F	50 V	"
C172	QFP31HJ-102	1000 pF	"	Polypropylene
C173	QFM81HK-222	2200 pF	"	Mylar
C175	QFM81HK-102	1000 pF	"	"
C176	QFM21HK-102	"	"	"
C177	QET51HR-105	1 μ F	"	Electrolytic
C178	QET51HR-105	"	"	"
C179	QFP31HJ-102	1000 pF	"	Polypropylene
C180	QFP31HJ-102	"	"	"
C181	QFP31HJ-511	510 pF	"	Polypropylene
C182	QFP31HJ-511	"	"	"
C183	QCS21HJ-101	100 pF	"	Ceramic
C184	QCS21HJ-101	"	"	"
C185	QCS21HJ-471	470 pF	"	"
C186	QCS21HJ-471	"	"	"
C187	QFM81HJ-272	2700 pF	"	Mylar
C188	QFM81HJ-272	"	"	"
C189	QEB51EM-225	2.2 μ F	25 V	Low Leak Current Electrolytic
C190	QEB51EM-225	"	"	"
C191	QET51CR-226	22 μ F	16 V	Electrolytic
C192	QET51CR-227	220 μ F	"	"
C201	QFM81HK-473	0.047 μ F	50 V	Mylar
C202	QEB51HM-224	0.22 μ F	"	Low Leak Current Electrolytic
C203	QET51HR-474	0.47 μ F	"	Electrolytic
C204	QET51HR-105	1 μ F	"	"
C205	QET51ER-106	10 μ F	25 V	Electrolytic
C206	QFM81HK-333	0.033 μ F	50 V	Mylar
C207	QET51HR-474	0.47 μ F	"	Electrolytic
C208	QET51HR-474	0.47 μ F	"	"
C251	QET51HR-475	4.7 μ F	"	"
C252	QCF21HP-223	0.022 μ F	"	Ceramic
C301	QCS21HJ-5R0	5 pF	"	"
C302	QCF21HP-223	0.022 μ F	"	"
C304	QCF21HP-223	"	"	"
C305	QCF21HP-223	"	"	"
C306	QFM81HK-102	1000 pF	"	Mylar
C307	QCF21HP-473	0.047 μ F	"	Ceramic
C308	QCF21HP-223	0.022 μ F	"	"
C309	QET51CR-476	47 μ F	16 V	Electrolytic
C310	QCF21HP-223	0.022 μ F	50 V	Ceramic
C311	QCS21HJ-560	56 pF	"	"
C312	QFM81HK-102	1000 pF	"	Mylar
C313	QET51HR-475	4.7 μ F	"	Electrolytic
C314	QET51HR-105	1.0 μ F	"	"
C315	QET51HR-225	"	"	"
C316	QCF21HP-473	0.047 μ F	"	Ceramic
C317	QFM81HK-103	0.01 μ F	"	Mylar
C318	QFM81HK-102	1000 pF	"	"
C319	QFM81HK-333	0.033 μ F	"	"

Capacitors

Item No.	Part Number	Rating		Description
C101	QCS21HJ-221	220 pF	50 V	Ceramic
C103	QCF21HP-103	0.01 μ F	"	"
C104	QCS21HJ-5R0	5 pF	"	"
C105	QCS21HJ-5R0	"	"	"
C106	QCF21HP-103	0.01 μ F	"	"
C107	QCT26CH-2R0	2 pF	"	"
C109	QCT26TH-100	10 pF	"	"
C110	QCT26TH-220	22 pF	"	"
C111	QCT26TH-330	33 pF	"	"
C112	QCT26TH-150	15 pF	"	"
C113	QCF21HP-103	0.01 μ F	"	"
C114	QCF21HP-103	"	"	"
C115	QCF21HP-473	0.047 μ F	"	"
C116	QCF21HP-103	0.01 μ F	"	"
C117	QET51CR-227	220 μ F	16 V	Electrolytic
C118	QCF21HP-103	0.01 μ F	50 V	Ceramic
C119	QCF21HP-103	"	"	"
C121	QCF21HP-223	0.022 μ F	"	"
C122	QCF21HP-223	"	"	"
C123	QCF21HP-223	"	"	"
C124	QCF21HP-223	"	"	"
C125	QET51CR-107	100 μ F	16 V	Electrolytic
C141	QCC21EM-473	0.047 μ F	25 V	Ceramic
C142	QCC21EM-473	"	"	"
C143	QET51HR-105	1 μ F	50 V	Electrolytic
C144	QFM21HJ-102	1000 pF	"	Mylar
C145	QCS21HJ-101	100 pF	"	Ceramic
C146	QCT26CH-100	10 pF	"	"
C147	QFM21HK-223	0.022 μ F	"	Mylar
C148	QCT26UJ-471A	470 pF	"	Ceramic
C149	QCC21EM-473	0.047 μ F	25 V	"
C150	QET51ER-106	10 μ F	"	Electrolytic
C151	QCC21EM-223	0.022 μ F	"	Ceramic
C152	QCF21HP-223	"	50 V	"
C153	QET51HR-474	0.47 μ F	"	Electrolytic
C154	QCC21EM-473	0.047 μ F	25 V	Ceramic
C155	QCF21HP-223	0.022 μ F	50 V	"
C156	QCF21HP-223	"	"	"
C157	QET51HR-105	1 μ F	"	Electrolytic
C158	QET51CR-107E	100 μ F	16 V	"

Capacitors

Item No.	Part Number	Rating		Description
C320	QFM81HK-103	0.01 μ F	"	"
C321	QFM81HK-683	0.068 μ F	"	"
C324	QCF21HP-223	0.022 μ F	"	Ceramic
C325	QET51ER-106	10 μ F	25 V	Electrolytic
C326	QCF21HP-223	0.022 μ F	50 V	Ceramic
C331	QCT26RH-180	18 pF	"	"
C332	QCT26CH-151	150 pF	50 V	Ceramic
C333	QCT26CH-151	"	"	"
C334	QCT26CH-151	"	"	"
C361	QCF21HP-473	0.047 μ F	"	"
C801	QCE22HP-103	0.01 μ F	500 V	"
C802	QCE22HP-103	"	"	"
C803	QCE22HP-103	"	"	"
C804	QCF21HP-103	"	50 V	Ceramic
C805	QET51HR-477	470 μ F	"	Electrolytic
C806	QET51VR-227	220 μ F	35 V	"
C807	QET51VR-227	"	"	"
C808	QET51VR-107	100 μ F	"	"
C809	QCF21HP-103	0.01 μ F	50 V	Ceramic
C810	QET51ER-107	100 μ F	25 V	Electrolytic
C811	QET51ER-228E	2200 μ F	"	"
C812	QCF21HP-103	0.01 μ F	50 V	Ceramic
C813	QET51CR-107	100 μ F	16 V	Electrolytic
C814	QET51CR-107	"	"	"
C815	QET51AR-107	"	10 V	"
C816	QET51AR-107	"	"	"
C818	QET51ER-107	"	25 V	"
C819	QET51VR-227	220 μ F	35 V	"
C820	QET51ER-227	"	25 V	"
C901	QCF21HP-103	0.01 μ F	50 V	Ceramic
C902	QCE22HP-103	"	500 V	"

Resistors

Item No.	Part Number	Rating		Description
R101	QRD141J-473S	47 k Ω	1/4 W	Carbon
R102	QRD141J-330S	33 Ω	"	"
R103	QRD141J-221S	220 Ω	"	"
R104	QRD141J-473S	47 k Ω	"	"
R105	QRD141J-473S	"	"	"
R106	QRD141J-392S	3.9 k Ω	"	"
R107	QRD141J-100S	10 Ω	"	"
R108	QRD141J-103S	10 k Ω	"	"
R109	QRD141J-331S	330 Ω	"	"
R110	QRD141J-105S	1 M Ω	"	"
R111	QRD141J-473S	47 k Ω	"	"
R112	QRD141J-103S	10 k Ω	"	"
R113	QRD141J-103S	"	"	"
R114	QRD141J-122S	1.2 k Ω	"	"
R115	QRD141J-563S	56 k Ω	"	"
R116	QRD141J-101S	100 Ω	"	"
R117	QRD141J-101S	"	"	"
R118	QRD141J-331S	330 Ω	"	"
R119	QRD141J-470S	47 Ω	"	"
R122	QRD141J-471S	470 Ω	"	"
R123	QRD141J-101S	100 Ω	"	"
R124	QRD141J-392S	3.9 k Ω	"	"
R125	QRD141J-102S	1 k Ω	"	"
R126	QRD141J-331S	330 Ω	"	"
R127	QRD141J-330S	33 Ω	"	"

Resistors

Item No.	Part Number	Rating		Description
R128	QRD141J-471S	470 Ω	1/4 W	Carbon
R129	QRD141J-101S	100 Ω	"	"
R130	QRD141J-392S	3.9 k Ω	"	"
R131	QRD141J-102S	1 k Ω	"	"
R132	QRD141J-331S	330 Ω	"	"
R133	QRD141J-330S	33 Ω	"	"
R134	QRZ0052-220	22 Ω	"	Fusible
R135	QRZ0052-220	"	"	"
R141	QRD141J-391S	390 Ω	"	Carbon
R142	QRD141J-123S	12 k Ω	"	"
R143	QRD141J-103S	10 k Ω	"	"
R144	QRD141J-104S	100 k Ω	"	"
R145	QRD141J-222S	2.2 k Ω	"	"
R146	QRD141J-334S	330 k Ω	"	"
R147	QRD141J-562S	5.6 k Ω	"	"
R148	QRD141J-103S	3.3 k Ω	"	"
R149	QRD141J-103S	1 k Ω	"	"
R150	QRD141J-102S	"	"	"
R151	QRD141J-273S	27 k Ω	"	"
R152	QRD141J-274S	270 k Ω	"	"
R153	QRD141J-103S	10 k Ω	"	"
R154	QRD141J-103S	"	"	"
R155	QRD141J-274S	270 k Ω	"	"
R156	QRD141J-102S	1 k Ω	"	"
R157	QRD141J-102S	"	"	"
R158	QRD141J-103S	10 k Ω	1/4 W	Carbon
R159	QRD141J-103S	"	"	"
R160	QRD141J-153S	15 k Ω	"	"
R161	QRD141J-682S	6.8 k Ω	"	"
R162	QRD141J-103S	10 k Ω	"	"
R163	QRD141J-223S	22 k Ω	"	"
R164	QRD141J-103S	10 k Ω	"	"
R165	QRD141J-472S	4.7 k Ω	"	"
R166	QVP4A0B-473	47 k Ω	"	Variable
R168	QRD141J-562S	5.6 k Ω	"	Carbon
R169	QRD141J-102S	1 k Ω	"	"
R170	QRD141J-183S	18 k Ω	"	"
R171	QRD141J-154S	150 k Ω	"	"
R172	QRD141J-123S	12 k Ω	"	"
R173	QRD141J-104S	100 k Ω	"	"
R174	QRD141J-102S	1 k Ω	"	"
R175	QRD141J-563S	56 k Ω	"	"
R176	QRD141J-104S	100 k Ω	"	"
R177	QRD141J-682S	6.8 k Ω	"	"
R178	QRD141J-822S	8.3 k Ω	"	"
R179	QRD141J-224S	220 k Ω	"	"
R180	QVP4A0B-222	2.2 k Ω	"	Variable
R181	QRD141J-333S	33 k Ω	"	Carbon
R182	QRD141J-102S	1 k Ω	"	"
R183	QRD141J-224S	220 k Ω	"	"
R184	QVP4A0B-104	100 k Ω	"	Variable
R185	QRD141J-221S	220 Ω	"	Carbon
R186	QRD141J-122S	1.2 k Ω	"	"
R188	QRD141J-102S	1 k Ω	"	"
R189	QRD141J-682S	6.8 k Ω	"	"
R190	QRD141J-103S	10 k Ω	"	"
R191	QRD141J-392S	3.9 k Ω	"	"
R192	QRD141J-392S	"	"	"
R193	QRD141J-472S	4.7 k Ω	"	"
R194	QRD141J-472S	"	"	"
R195	QRD141J-683S	68 k Ω	"	"
R196	QRD141J-683S	"	"	"
R197	QRD141J-221S	220 Ω	"	"
R198	QRD141J-221S	"	"	"
R199	QRD141J-473S	47 k Ω	"	"
R200	QRD141J-473S	"	"	"
R201	QVP4A0B-473	"	"	Variable
R202	QRD141J-222S	2.2 k Ω	"	Carbon
R203	QRD141J-332S	3.3 k Ω	"	"
R204	QRD141J-332S	"	"	"

Resistors

Item No.	Part Number	Rating		Description
R205	QRD141J-682S	6.8 kΩ	1/4 W	Carbon
R206	QRD141J-682S	"	"	"
R209	QRZ0052-220	22 Ω	"	Fusible
R211	QRD141J-104S	100 kΩ	"	Carbon
R212	QRD141J-563S	56 kΩ	"	"
R213	QRD141J-563S	"	"	"
R214	QRD141J-104S	100 kΩ	"	"
R215	QRD141J-123S	12 kΩ	"	"
R216	QRD141J-153S	15 kΩ	"	"
R217	QRD141J-103S	10 kΩ	"	"
R218	QRD141J-123S	12 kΩ	"	"
R219	QRD141J-104S	100 kΩ	"	"
R220	QRD141J-103S	10 kΩ	"	"
R221	QRD141J-103S	"	"	"
R222	QRD141J-103S	"	"	"
R223	QRD141J-104S	100 kΩ	"	"
R224	QRD141J-103S	10 kΩ	"	"
R225	QRD141J-103S	"	"	"
R226	QRD141J-103S	"	"	"
R227	QRD141J-103S	10 kΩ	"	"
R228	QRD141J-473S	47 kΩ	"	"
R251	QRD141J-223S	22 kΩ	"	"
R252	QRD141J-123S	12 kΩ	"	"
R253	QRD141J-152S	1.5 kΩ	"	"
R254	QRD141J-333S	33 kΩ	"	"
R255	QRD141J-103S	10 kΩ	"	"
R256	QRD141J-152S	1.5 kΩ	"	"
R257	QRD141J-152S	"	"	"
R259	QRD141J-183S	18 kΩ	"	"
R260	QRD141J-273S	27 kΩ	"	"
R261	QRD141J-153S	15 kΩ	"	"
R262	QRD141J-223S	22 kΩ	"	"
R263	QRD141J-153S	15 kΩ	"	"
R264	QRD141J-101S	100 Ω	"	"
R265	QRD141J-102S	1 kΩ	"	"
R266	QRD141J-682S	6.8 kΩ	"	"
R270	QRD141J-473S	47 kΩ	"	"
R271	QRD141J-223S	22 kΩ	"	"
R272	QRD141J-223S	"	"	"
R301	QRD141J-223S	"	"	"
R302	QRD141J-102S	1 kΩ	"	"
R303	QRD141J-224S	220 kΩ	"	"
R304	QRD141J-391S	390 Ω	"	"
R305	QRD141J-223S	22 kΩ	"	"
R306	QRD141J-102S	1 kΩ	"	"
R307	QRD141J-223S	22 kΩ	"	"
R308	QRD141J-152S	1.5 kΩ	"	"
R309	QRD141J-221S	220 Ω	"	"
R310	QRD141J-331S	330 Ω	"	"
R311	QRD141J-103S	10 kΩ	"	"
R312	QRD141J-103S	"	"	"
R313	QRD141J-820S	82 Ω	"	"
R314	QRD141J-822S	8.2 kΩ	"	"
R315	QRD141J-153S	15 kΩ	"	"
R316	QRD141J-683S	68 kΩ	"	"
R317	QRD141J-123S	12 kΩ	"	"
R318	QRD141J-223S	22 kΩ	"	"
R321	QRD141J-333S	33 kΩ	"	"
R322	QRD141J-151S	150 Ω	"	"
R331	QRD141J-473S	47 kΩ	"	"
R801	QRD141J-472S	4.7 kΩ	"	"
R803	QRD141J-562S	5.6 kΩ	"	"
R804	QRD141J-103S	10 kΩ	"	"
R805	QRD141J-332S	3.3 kΩ	"	"
R806	QRD141J-332S	"	"	"
R807	QRD129J-331	330 Ω	1/2 W	" (U.N.F.)

Resistors

Item No.	Part Number	Rating		Description
R808	QRD141J-472S	4.7 kΩ	1/4 W	Carbon
R809	QRD141J-221S	220 Ω	"	"
R810	QRD141J-561S	560 Ω	"	"
R811	QRD141J-222S	2.2 kΩ	"	"
R813	QRD141J-473S	47 kΩ	"	"
R814	QRD141J-103S	10 kΩ	"	"
R815	QRD141J-472S	4.7 kΩ	"	"
R816	QRD141J-473S	47 kΩ	"	"
R817	QRD141J-103S	10 kΩ	"	"
R818	QRD141J-472S	4.7 kΩ	"	"
R822	QRD141J-102S	1 kΩ	"	"

Others

Item No.	Part Number	Rating	Description
S101	QSP0229-055		Push Switch
S102	QSP0219-054		"
S901	QSP0219-054		"
CF101	E03357-011 (A,B,C)		Ceramic Filter (FM)
CF102	E03357-011 (A,B,C)		" "
CF103	E03357-011 (A,B,C)		" "
CF301	E03613-019		" (AM)
CF302	E03613-022		"
TC101	QAT2001-001		Trimmer Capacitor
TC102	QAT2001-001		"
TC103	QAT2001-001		"
TC104	QAT3001-005		"
TC301	QAT2001-005		"
TC302	QAT2001-005		"
TC351	QAT2001-005		"
TC352	QAT2001-005		"

Others

Item No.	Part Number	Rating	Description
	EWR34A-20NN	Flat Wire	
	EWS01C-004	SKT Wire Ass'y	12 Pin
	EWS012-042	SKT Wire Ass'y	AM LOCAL O.S.C.
	EWS012-043	SKT Wire Ass'y	FM LOCAL O.S.C.
	EWS012-044	SKT Wire Ass'y	FM-MW Vvvc
	E03572-021	ANT. Terminal	
	E03591-21F	2P Pin Jack	
	E300847-001	Shield Plate	
	E300848-001	"	
	E43727-002	Tab	
	E61537-001	Heat Sink	
	E65396-001	Earth Plate	
	E65792-001	LED Holder	
	QMV5005-004	4 Pin Plug Ass'y	
	SPSP3005MS	Screw	
	EWS013-050	Wire Ass'y	REC CAL

8-(2) TXX-274 PLL Synthesizer and Control P.C. Board Ass'y

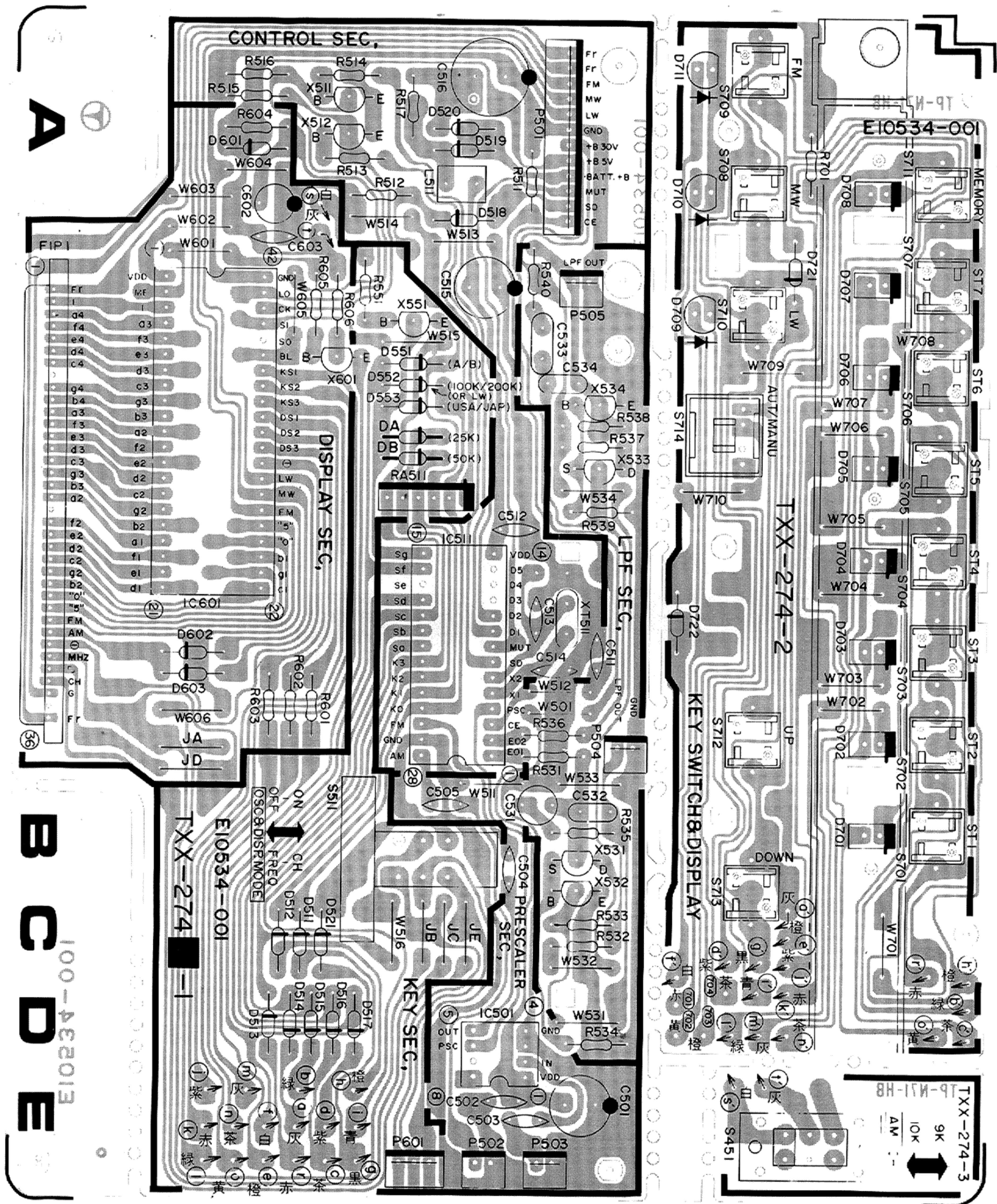

Each Individual P.C. Board Location

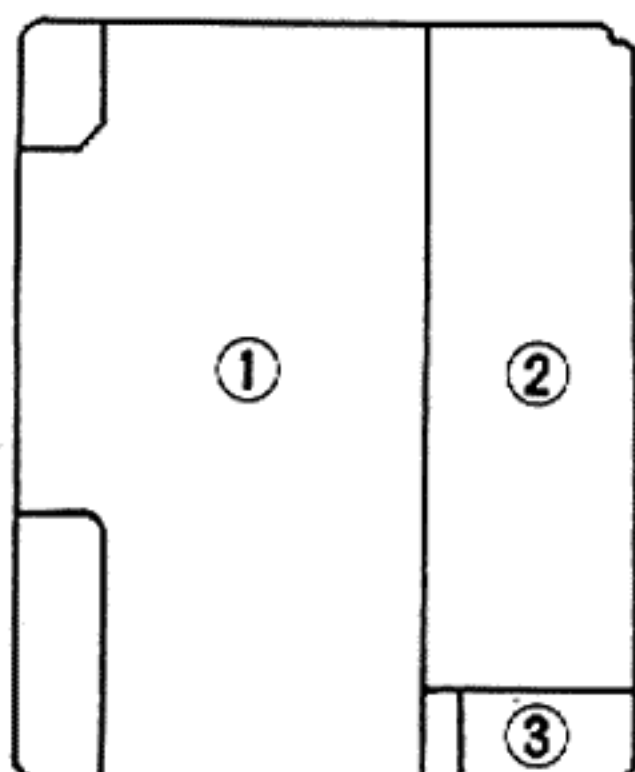

Note: The specific symbols (赤, 黒, 白... etc.) on a surface of P.C. Board are actually unrelated to the repair service and are significant denotement in order to process the proper assembly of P.C. Board at the factory.

- 1. TXX-274-1 PLL Synthesizer & Control P.C. Board Ass'y
- 2. TXX-274-2 LED & Switch P.C. Board Ass'y
- 3. TXX-274-3 AM CH. SPACING Switch P.C. Board Ass'y

Transistors

Item No.	Part Number	Rating		Description	
		Pc	fT		Maker
X511	2SA1029(C,D)	0.2 W	200 MHz	Silicon	Hitachi
X512	2SA1029(C,D)	"	"	"	"
X531	2SK105(F)	0.25 W		F.E.T.	NEC
X532	2SC458(C)	0.2 W	230 MHz	Silicon	Hitachi
X551	2SC458(C,D)	"	"	"	"
X601	2SC458(C,D)	"	"	"	"

Integrated Circuits

Item No.	Part Number	Rating		Description	
		pc			Maker
IC501	UPB553AC				NEC
IC511	UPD1703-014				"
IC601	MSM58282RS				OKI

Diodes

Item No.	Part Number	Rating		Description	
					Maker
DA	1S2076-31			Silicon	Hitachi
DB	1S2076-31			"	"
D511	1S2076-31			"	"
D512	1S2076-31			"	"
D513	1S2076-31			"	"
D514	1S2076-31			"	"
D515	1S2076-31			"	"
D516	1S2076-31			"	"
D517	1S2076-31			"	"
D518	1S2076-31			"	"
D519	1S2076-31			"	"
D520	1S2076-31			"	"
D521	1S2076-31			"	"
D551	1S2076-31			"	"
D552	1S2076-31			"	"
D601	1S2076-31			"	"
D602	1S2076-31			"	"
D701	TLR205	0.056 W		L.E.D.	Toshiba
D702	TLR205	"		"	"
D703	TLR205	"		"	"
D704	TLR205	"		"	"
D705	TLR205	"		"	"
D706	TLR205	"		"	"
D707	TLR205	"		"	"
D708	TLY205	"		"	"
D710	SLR-54GC4	0.75 W		"	ToyoDengu
D711	SLR-54GC4	"		"	"
D721	1S2076-31			Silicon	Hitachi
D722	1S2076-31			"	"

Coils & Transformers

Item No.	Part Number	Rating	Description
L511	E03522-391KY		Choke Coil

Capacitors

Item No.	Part Number	Rating		Description
C501	QET50JR-477	470 μ F	6.3 V	Electrolytic
C502	QCC21EM-223	0.022 μ F	25 V	Ceramic
C503	QCS21HJ-101	100 pF	50 V	
C504	QCF21HP-102	1000 pF	"	

Capacitors

Item No.	Part Number	Rating		Description
C505	QCF21HP-102	1000 pF	50 V	Ceramic
C511	QCC21EM-223	0.022 μ F	25 V	
C512	QCC21EM-223	"	"	Ceramic
C513	QCT26CH-220	22 pF	"	
C514	QCT26CH-220	"	"	"
C515	QET51CR-227	220 μ F	16 V	Electrolytic
C516	QET50JR-228	2200 μ F	6.3 V	"
C531	QEZ0046-225	2.2 μ F		Electrolytic
C532	QFM81HK-102	1000 pF	50 V	Mylar
C602	QET51AR-107	100 μ F	10 V	Electrolytic
C603	QCF21HP-223	0.022 μ F	50 V	Ceramic

Resistors

Item No.	Part Number	Rating		Description
R511	QRD141J-223S	22 k Ω	1/4 W	Carbon
R512	QRD141J-103S	10 k Ω	"	"
R513	QRD141J-223S	22 k Ω	"	"
R514	QRD141J-223S	"	"	"
R515	QRD141J-562S	5.6 k Ω	"	"
R516	QRD141J-562S	"	"	"
R517	QRD141J-102S	1 k Ω	"	"
R531	QRD141J-102S	"	"	"
R532	QRD141J-222S	2.2 k Ω	"	"
R533	QRD141J-682S	6.8 k Ω	"	"
R534	QRD141J-301S	300 Ω	"	"
R535	QRD141J-392S	3.9 k Ω	"	"
R551	QRD141J-105S	1 M Ω	"	"
R601	QRD141J-391S	390 Ω	"	"
R602	QRD141J-391S	"	"	"
R603	QRD141J-391S	"	"	"
R604	QRD141J-103S	10 k Ω	"	"
R605	QRD141J-682S	6.8 k Ω	"	"
R606	QRD141J-151S	150 Ω	"	"
R701	QRD141J-681S	680 Ω	"	"
RA511	ERGS5XK-223	22 k Ω	"	"

Others

Item No.	Part Number	Rating	Description
FIP1	ELU0001-005		FL Tube
P501	QMV5005-012		12 P Plug Ass'y
P502	QMV5005-002		2P Plug Ass'y
P503	QMV5005-002		"
P504	QMV5005-002		"
P601	QMV5005-003		3P Plug Ass'y
S511	QSS2201-002		Push Switch
S701	ESP0001-001		"
S702	ESP0001-001		"
S703	ESP0001-001		"
S704	ESP0001-001		"
S705	ESP0001-001		"
S706	ESP0001-001		"
S707	ESP0001-001		"
S708	ESP0001-001		"
S709	ESP0001-001		"
S711	ESP0001-001		"
S712	ESP0001-001		"
S713	ESP0001-001		"
S714	QSP0410-004		"
PT701	EWS014-037		Wire Ass'y
XT511	E03737-010		XTAL (4.5 MHz)
	E301093-001		LED Escutcheon

8-(3) TPS-281 Fuse Circuit Board Ass'y

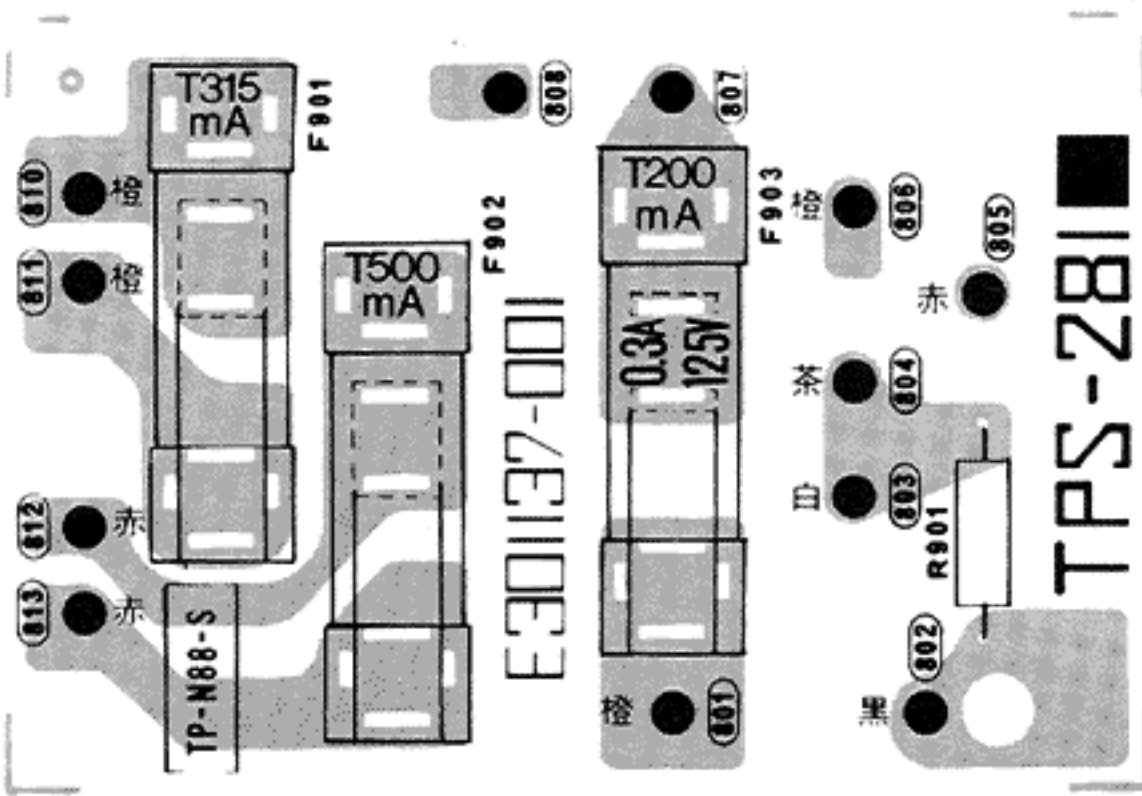

Part Number	Description
See page 20	Fuse Crip
E43727-002	TAB
E301137-001	P.C. Board
See page 20	Resistor (composition)

8-(4) TPS-266 Voltage Selector P.C. Board Ass'y (except U.S.A.&Canada)

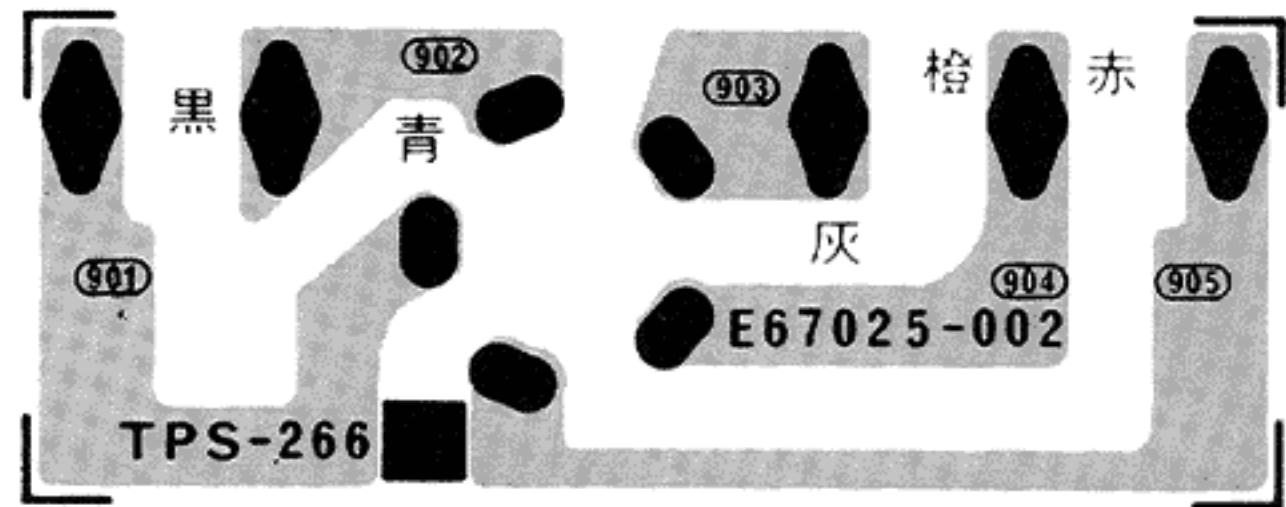

Part Number	Description
QSR0074-001	Voltage Selector
E66342-001	Voltage Selector Holder
E43727-002	TAB
E67025-002	P.C. Board

9. Packing Materials and Part Numbers

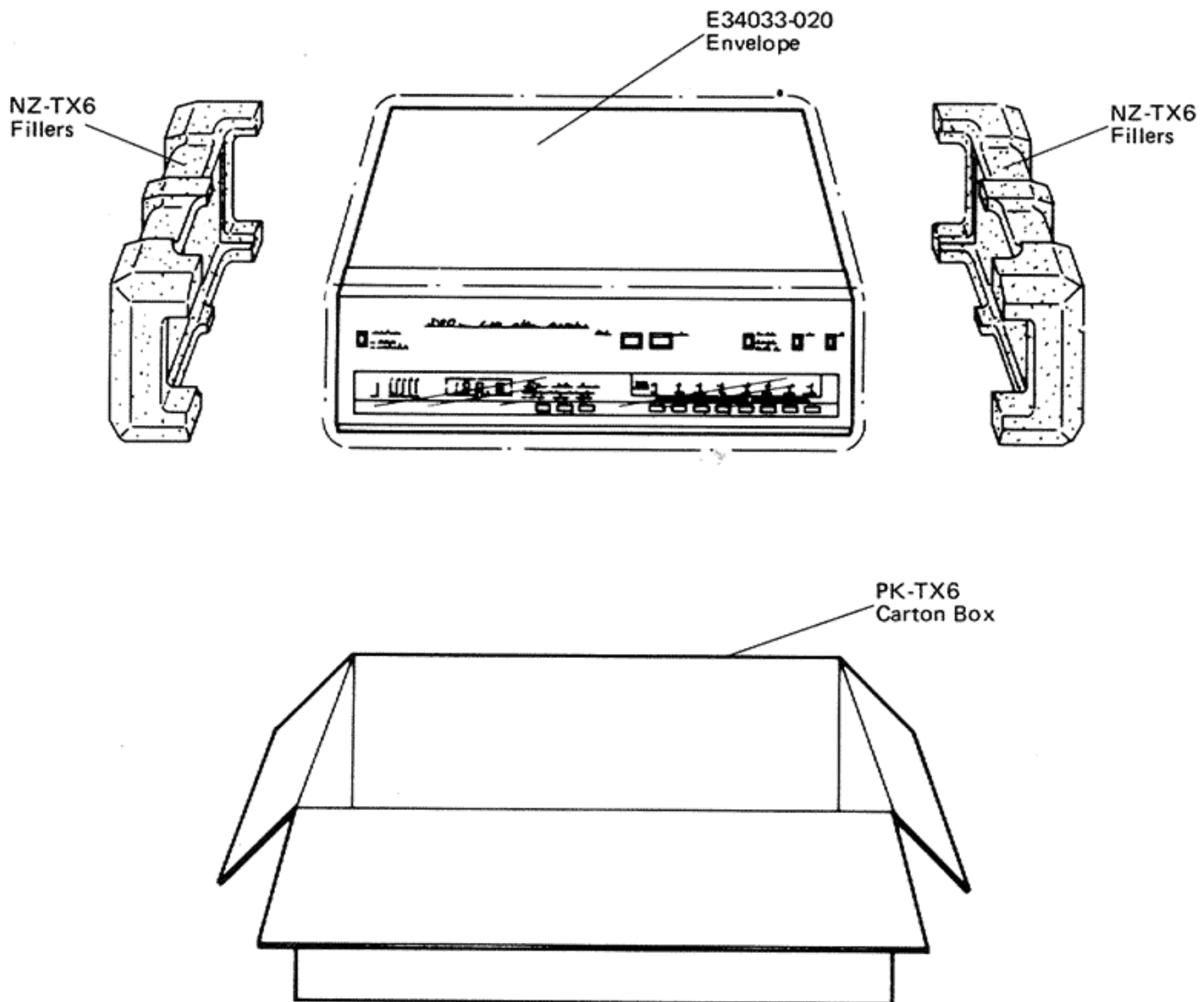

11. Accessories List

Item No.	Part Number	Description	Q'ty
1	E30580-860A	Instruction Book	1
2	E03479-001	Signal Cord	1
3	E03614-002	FM Antenna	1
4	E41202-2	Envelope (Instruction Book and Others)	1
5	See below	Power Cord	1
6	BT20042	"JVC DOES IT BETTER" (for U.S.A. only)	1
7	E04056	Siemens Plug (Except for U.S.A., Canada & Australia)	1
8	See below	Warranty Card	1

12. Parts List with Specified Numbers for Designated Areas

Page	Item No.	Description	U.S.A. & Canada	Australia	U.S. Military Market and Other Countries
6,8		Rear Panel	E23578-002	E23578-004	E23578-004
6,8		Top Cover (Metal)	E23580-003	E23580-002	E23580-002
6		Cosmetic Board (R)	ED92961-002	—	—
6		" (L)	ED92961-001	—	—
6		Side Fitting (R)	—	E301103-001	E301103-001
6		" (L)	—	E301103-002	E301103-002
8	T-1	Power Transformer \triangle	E03042-33B	E03042-33C	E03042-33C
17	8-(3)	Fuse Circuit Board Ass'y \triangle	TPS-281A	TPS-281B	TPS-281B
17	F903	Fuse (Primary) \triangle	QMF61U1-R30 (0.3 A)	QMF51A2-R20L (T200 mA)	QMF51A2-R20L (T200 mA)
17	F902	Fuse (Secondary) \triangle	—	QMF51A2-R50L (T500 mA)	QMF51A2-R50L (T500 mA)
17	F901	Fuse (Secondary) \triangle	—	QMF51A2-R315L (T315 mA)	QMF51A2-R315L (T315 mA)
17	8-(3)	Fuse Crip \triangle	E45525-002	E48965-002	E48965-002
17	8-(3)	Resistor (Composition) \triangle	QRC121K-275EM (2.7 M Ω , 1/2 W)	—	—
17	8-(3)	Voltage Selector P.C. Board Ass'y \triangle	—	TPS-266A	TPS-266A
20		Power Cord \triangle	QMP1230-183	QMP2530-200	QMP7630-183
20		Siemens Plug \triangle	—	—	E04056
20		JVC DOES IT BETTER	BT20042 (for U.S.A. only)	—	BT20042 (for US Military Market only)
20		Warranty Card	BT20032B (for U.S.A.) BT20025C (for Canada)	BT20029B	BT20032B (for US Military Market only)

NOTE: \triangle SAFETY PARTS

JVC

VICTOR COMPANY OF JAPAN, LIMITED, TOKYO, JAPAN