

JVC

SERVICE MANUAL

MICRO COMPONENT SYSTEM

UX-C7 A/US/UT/U



COMPACT
disc
DIGITAL AUDIO

Area suffix

A	Australia
US	Singapore
UT	Formosa
U	Other area

Contents

1. Safety Precautions	Page 2	9. Main Adjustment	Page 48
2. Safety Precaution about UX-C7	3	10. Block Diagram	58
3. Main Features	5	11. Wiring Connections	62
4. Specifications	5	12. Standard Schematic Diagram	64
5. Instructions (Extract)	6	13. Location of P.C. Board Parts	71
6. Location of Main Parts	26	14. Electrical Parts List	76
7. Removal of Main Parts	29	15. Illustration of Packing and Parts List	88
8. Analytic Drawing and Parts List	38	16. Accessories	89

1. Safety Precautions

1. The design of this product contains special hardware and many circuits and components specially for safety purposes. For continued protection, no changes should be made to the original design unless authorized in writing by the manufacturer. Replacement parts must be identical to those used in the original circuits. Service should be performed by qualified personnel only.
2. Alterations of the design or circuitry of the product should not be made. Any design alterations of the product should not be made. Any design alterations or additions will void the manufacture's warranty and will further relieve the manufacture of responsibility for personal injury or property damage resulting therefrom.
3. Many electrical and mechanical parts in the products have special safety — related characteristics. These characteristics are often not evident from visual inspection nor can the protection afforded by them necessarily be obtained by using replacement components rated for higher voltage, wattage, etc. Replacement parts which have these special safety characteristics are identified in the Parts List of Service Manual. Electrical components having such features are identified by shading on the schematic and by (\triangle) on the Parts List in the Service Manual. The use of a substitute replacement which does not have the same safety characteristics as the recommended replacement part shown in the Parts List of Service Manual may create shock, fire, or other hazards.
4. The leads in the products are routed and dressed with ties, clamps, tubings, barriers and the like to be separated from live parts, high temperature parts, moving parts and /or sharp edges for the prevention of electric shock and fire hazard. When service is required, the original lead routing and dress should be observed, and it should be confirmed that they have been returned to normal, after reassembling.

5. Leakage current check (Electrical shock hazard testing)

After reassembling the product, always perform an isolation check on the exposed metal parts of the product (antenna terminals, knobs, metal cabinet, screw heads, headphone jack, control shafts, etc.) to be sure the product is safe to operate without danger of electrical shock. Do not use a line isolation transformer during this check.

- Plug the AC line cord directly into the AC outlet. Using a "Leakage current tester", measure the leakage current from each exposed metal part of the cabinet, particularly any exposed metal part having a return path to the chassis, to a known good earth ground. Any leakage current must not exceed 0.5mA AC(r.m.s.).

• Alternate check method

Plug the AC line cord directly into the AC outlet. Use an AC voltmeter having, 1,000 ohms per volt or more sensitivity in the following manner. Connect a 1,500 ohms 10W resistor paralleled by a 0.15 μ F AC type capacitor between an exposed metal part and a known good earth ground. Measure the AC voltage across the resistor with the AC voltmeter. Move the resistor connection to each exposed metal part, particularly any exposed metal part having a

return path to the chassis, and measure the AC voltage across the resistor. Now, reverse the plug in the AC outlet and repeat each measurement. Any voltage measured must not exceed 0.75V AC(r.m.s.). This corresponds to 0.5mA AC(r.m.s.).

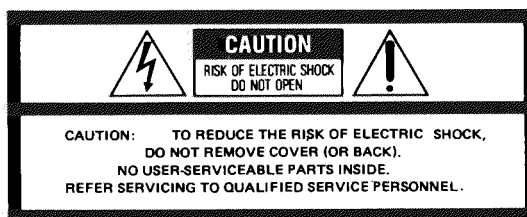
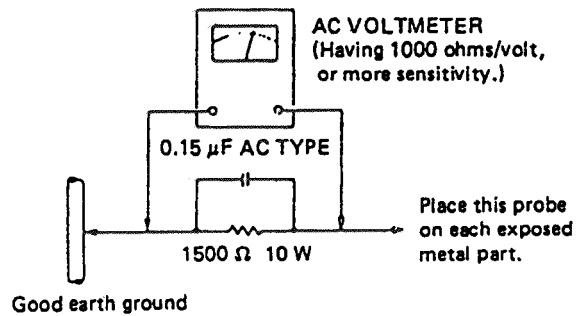

The lightning flash with arrowhead symbol, within an equilateral triangle, is intended to alert the user to the presence of uninsulated "dangerous voltage" within the product's enclosure that may be of sufficient magnitude to constitute a risk of electric shock to persons.



The exclamation point within an equilateral triangle is intended to alert the user to the presence of important operating and maintenance (servicing) instructions in the literature accompanying the appliance.

2. Safety Precautions about UX-C7

IMPORTANT FOR LASER PRODUCTS

PRECAUTIONS (Australia/Singapore only)

1. CLASS 1 LASER PRODUCT
2. **DANGER:** Invisible laser radiation when open and interlock failed or defeated. Avoid direct exposure to beam.
3. **CAUTION:** Do not open the rear cover. There are no user serviceable parts inside the unit; leave all servicing to qualified service personnel.
4. **CAUTION:** The compact disc player uses invisible laser radiation and is equipped with safety switches which prevent the emission of radiation when the CD tray is open. It is dangerous to defeat the safety switches.
5. **CAUTION:** Use of controls for adjustments and the performance of procedures other than those specified herein may result in exposure to hazardous radiation.
6. **CAUTION:** The laser is able to function, if safety switches out of function. The laser light is invisible, avoid exposure, do not disassemble the laser unit, but replace the complete unit.

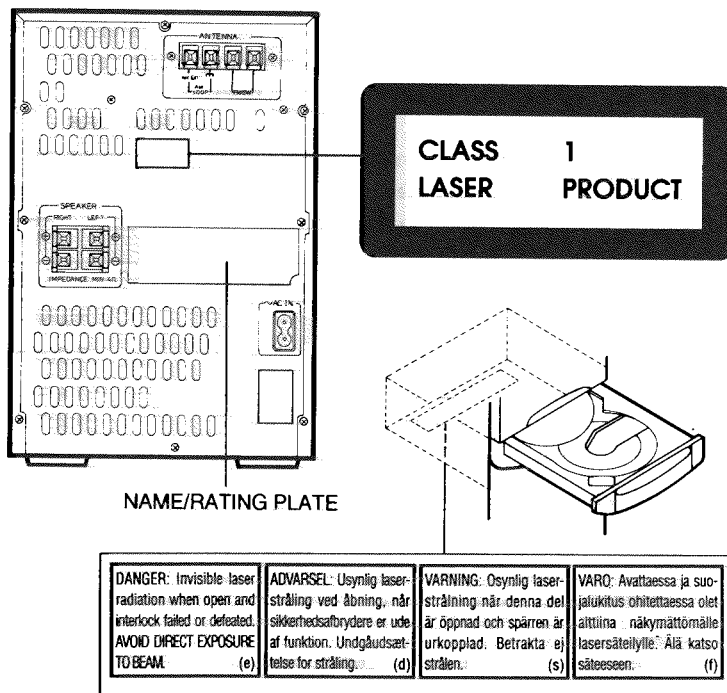

POWER SUPPLY

Connection of AC power cord

- Connect the AC power cord after all other connections have been made.
- The UX-C7A (for Australia) is not provided with voltage selectors.
- When the UX-C7U/US/UT is used in an area where the supply voltage is different from the preset voltage, reset the voltage selector to the correct position.

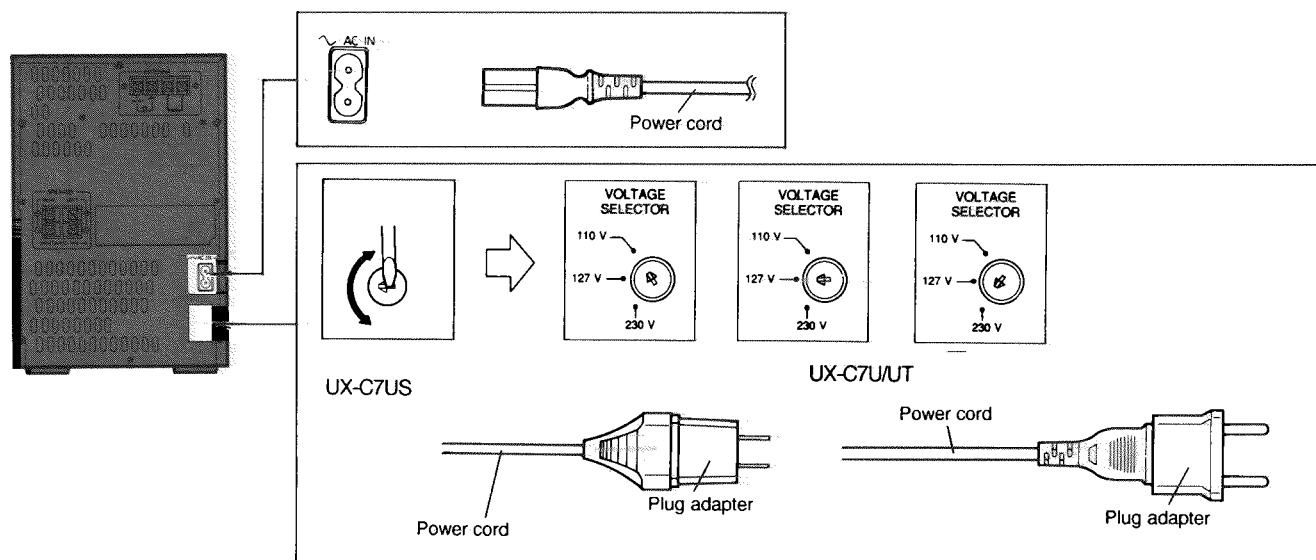

Note:

- For the UX-C7U/US/UT the AC plug adapter is provided. If required, use it.

CAUTIONS:

1. ONLY USE WITH JVC POWER CORD PROVIDED WITH THIS UNIT TO AVOID MALFUNCTION OR DAMAGE TO THE UNIT.
2. BE SURE TO UNPLUG THE POWER CORD FROM THE OUTLET WHEN GOING OUT OR WHEN THE UNIT IS NOT IN USE FOR AN EXTENDED PERIOD OF TIME.

Note:

- When there is a power failure or the AC power cord is disconnected, the timer/clock setting is erased from memory. Reset the clock when the power supply is restored.

Important management points regarding safety (Item demanding special safety precautions)

1. Power transformer marking: VTP66T4-24B (A version: Parts No.), VTP66G4-24B (US/UT/U version: Parts No.)
The torque of the screw driver for the power transformer must be controlled.
2. Concerning the AC socket, the next marking must be confirmed and to avoid printed circuit board pattern damage.
The AC socket must not float from printed circuit board
 - Marking HSC1466
3. Concerning the primary terminal and the adjacent secondary terminal on the printed circuit board to provide proper creeping and spatial distance, solder must not protrude from soldering round.
4. Before installation confirm the fuse capacity indication, (♡) and (S) marks on the fust holder.

Version	REF NO.	Capacity & Mark	Indication on P.C. board
A	F901	T400mA	T400mA
US/UT/U	F901	T800mA	T800mA
A/US/UT/U	F902	T2.5A	T2.5A
A/US/UT/U	F903	T2.5A	T2.5A

5. Wires must be clamped or secured at the locations shown in the figure so that the wire do not touch to live parts, moving part, hot part, or sharp edges.
6. Following parts are controlled as the heated parts. confirm that the flammable parts are lifted up the parts in.
 - Diode: D901 ~D905, IC: ICA35, ICA36 (US/UT/U only), Transistor: QA306, QA304 (US/UT/U only) Power transformer, Heat sink (US/UT/U only).
7. The single wire on the P.C. board must be fixed with spacer of bond.
8. Mark sure printing "Caution risk of Electrical Shock" do not open on the name plate.
9. The laser caution must be attached on the CD part (A/US only).
10. The class 1 label must be attached (A/US only)
11. Confirm the indication "HXW0353" on the voltage selection switch.

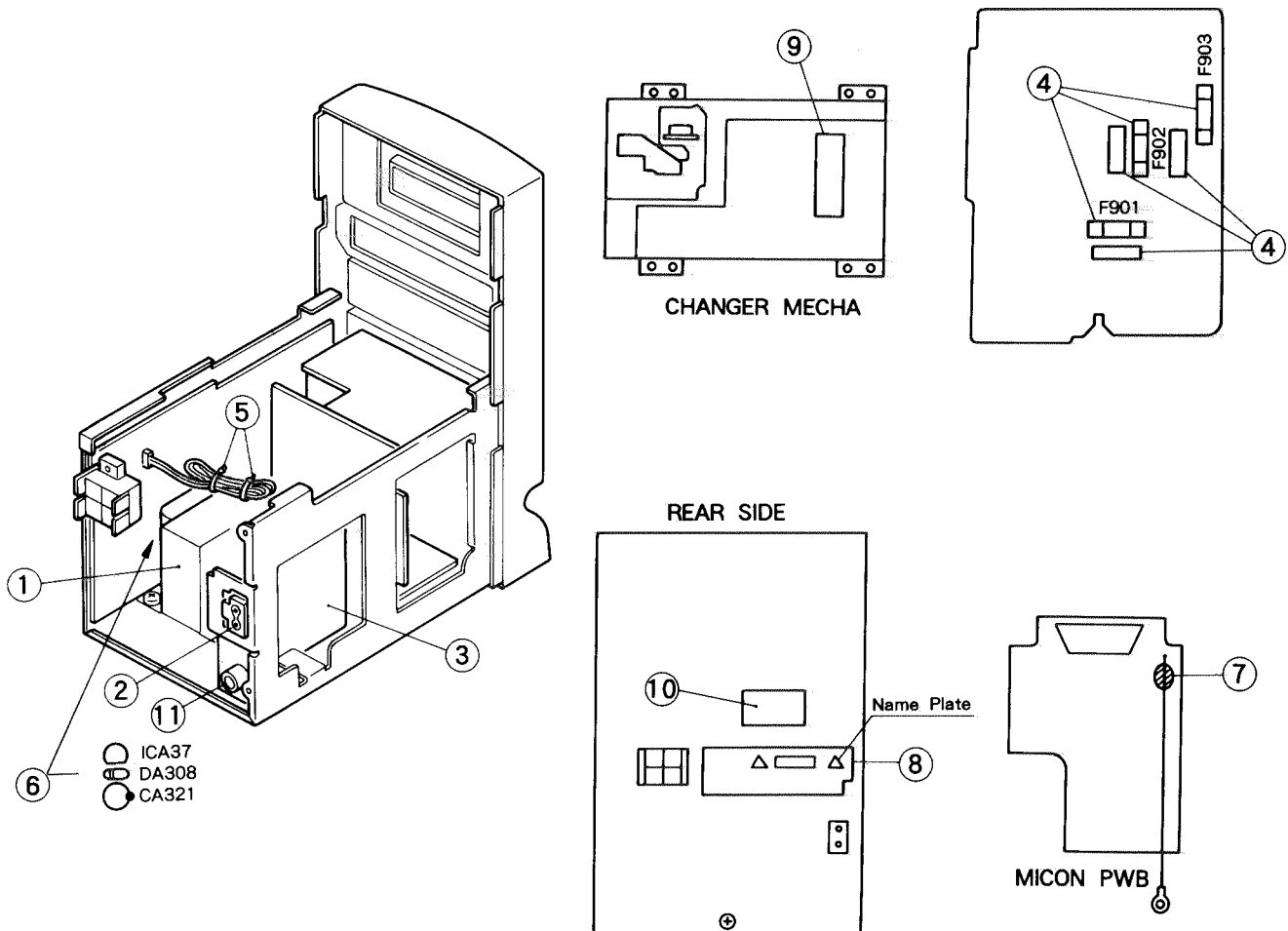

3. Main Features

1. **Disc-size micro component system consisting of 3 units**
2. **Multi-function 6-disc changer with extra-CD to play**
 - Direct Disc Select/Skip Play/Search Play/Continuous Play/Repeat Play/Random Play.
 - Programmed play of up to 20 tunes.
3. **One-touch operation (COMPU PLAY)**
 - When a source button (CD, tape or tuner) is pressed, the unit's power is turned ON and initiates playback, even when the power is set to STANDBY.
4. **40-key remote control unit operates all CD, cassette deck and tuner functions**
 - Remote control unit controls power ON/OFF switching, volume control, bass/treble control, Active Hyper-Bass ON/OFF switching and a variety of editing functions.
5. **Active Hyper-Bass circuit for low-frequency sound reproduction**
6. **U-Turn auto-reverse full-logic mechanism with Dolby* B NR**
 - Auto tape select mechanism.
 - Metal (type IV) and CrO₂ (type II) tape can be played back for superior tone quality.
 - CrO₂ (type II) tape recording capability.
 - Music scan in forward or reverse direction.
7. **3-Band digital synthesizer tuner with 45-station (15 FM, 15 AM and 15 SW) preset capability**
 - Seek/manual tuning.
 - Auto preset tuning.
8. **Timer/Clock function**
 - Timer on/off function.
 - Sleep timer can be set for up to 120 minutes.
9. **Microphone mixing facility**

* Dolby noise reduction manufactured under license from Dolby Laboratories Licensing Corporation. "Dolby" and the double-D symbol  are trade-marks of Dolby Laboratories Licensing Corporation.

4. Specifications

Compact disc player section

Type	: Compact disc player
Signal detection	: Non-contact optical pickup
Number of channels	: 2 channels
Frequency range	: 20 Hz – 20,000 Hz
Dynamic range	: 86 dB
Signal-to-noise ratio	: 86 dB
Total harmonic distortion	: 0.03 %
Wow & flutter	: Less than measurable limit

Radio section

Frequency ranges	: FM: 87.5 – 108 MHz AM: 531 – 1,602 kHz (with channel space mode set to AM 9 kHz) AM: 530 – 1,710 kHz (with channel space mode set to AM 10 kHz) SW: 2.3 – 21.85 MHz
Antennas	: Loop antenna for AM/SW (2.3 – 6.995 MHz) External antenna terminal for FM (75 ohms)/SW (7 – 21.85 MHz)

Tape deck section

Track system	: 4-track 2-channel stereo
Motor	: Electronic governor DC motor (capstan x 1, reel x 1)
Heads	: Hard permalloy head for recording/playback, 2 gap ferrite head for erasure (Combination head)
Frequency response	: 50 – 15,000 Hz (with CrO ₂ tape)
Wow and flutter	: 0.09 % (WRMS)
Fast wind time	: Approx. 120 sec (C-60 cassette)

Speaker section (each unit)

Speaker (Impedance)	: 12 cm x 1 (4 Ω), 5 cm x 1 (6 Ω)
Dimensions	: 160.5(W) x 270(H) x 215(D) mm (6-3/8" x 10-11/16" x 8-1/2")
Weight	: Approx. 2.3 kg (5.1 lbs)

General

Power output	: Max. 30 W (15 W + 15 W) at 4 Ω
Input jacks	: MIXING MIC (3.5 mm dia. mini plug) (Matching Impedance: 200 Ω–2kΩ)
Output jacks	: Speaker x 2 (matching impedance 4 Ω – 16 Ω) Headphones (0 – 15 mW/32 Ω) (matching impedance 16 Ω – 1 kΩ)
Power supply	: AC 240 V, 50/60 Hz (UX-C7A) AC 110/127/230 V, 50/60 Hz (UX-C7U/US/UT)
Power consumption	: 55 W (with POWER SW ON) (UX-C7A) 60 W (with POWER SW ON) (UX-C7 U/US/UT) 3.5 W (with POWER SW STANDBY)
Dimensions	: 501(W) x 270(H) x 280(D) mm (19-3/4" x 10-11/16" x 11-1/16") including knobs
Weight	: Approx. 10.4 kg (23 lbs)
Accessories provided	: Power cord x 1 Remote control unit (RM-RXC7) x 1 Battery "R6" x 2 (for the remote control) FM/SW feeder antenna x 1 Loop antenna stand x 1 AC plug adapter x 1 (UX-C7U/US/UT)

Design and specifications are subject to change without notice.

5. Instructions (Extract)

NAMES OF PARTS AND THEIR FUNCTIONS

CD changer section

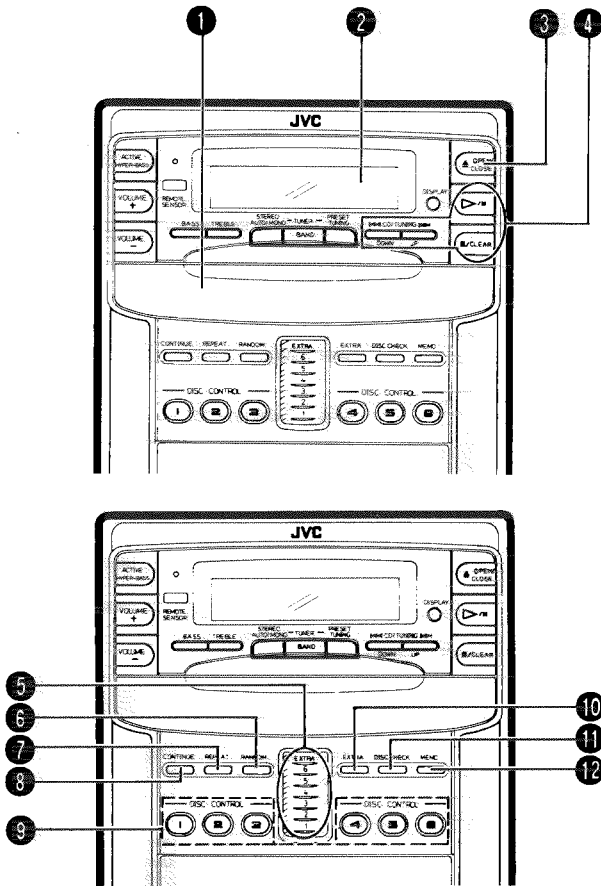

General section

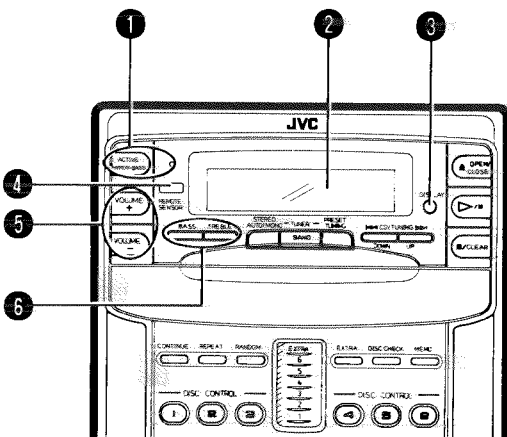

- 1 ACTIVE HYPER-BASS button and indicator
- 2 Display window
Volume (VOL) level indicator
BASS/TREBLE level indicator
- 3 DISPLAY button
- 4 REMOTE SENSOR section
- 5 VOLUME buttons
+: Use to increase the volume.
-: Use to decrease the volume.
(control range from VOL 0 to VOL 50)

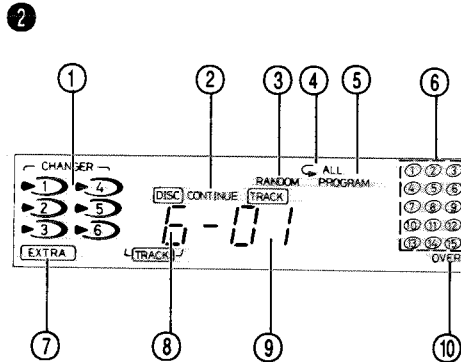

- 1 CD tray
- 2 Display window
 - 1 Disc mark display
 - 2 CONTINUE playback indicator
 - 3 RANDOM playback indicator
 - 4 Repeat playback indicator
 - 5 PROGRAM mode indicator
 - 6 Music calendar display
 - 7 EXTRA CD mode indicator
 - 8 Function/Disc number/Track number display
 - 9 Track number/Playback time display
 - 10 OVER indicator
- 3 CD tray (▲) OPEN/CLOSE button
- 4 CD operation buttons
Play/pause button (▷/||):
Press to play a disc or to stop temporarily.
Stop/CLEAR button (■):
Press to stop playing a disc or cancel programmed playback. This also sets CD mode.
CD search button (◀◀, ▶▶):
Press to locate the beginning of tunes and to start forward/reverse search operations.
- 5 Disc indicators
When a disc is loaded into the CD holder of the CD changer, the corresponding indicator is lit. When a disc is being operated, the indicator blinks.
- 6 RANDOM playback button
- 7 REPEAT playback button
- 8 CONTINUE playback button
- 9 DISC CONTROL buttons (No.1 to No.6)
- 10 EXTRA disc button
- 11 DISC CHECK button
- 12 Memorandum (MEMO) button

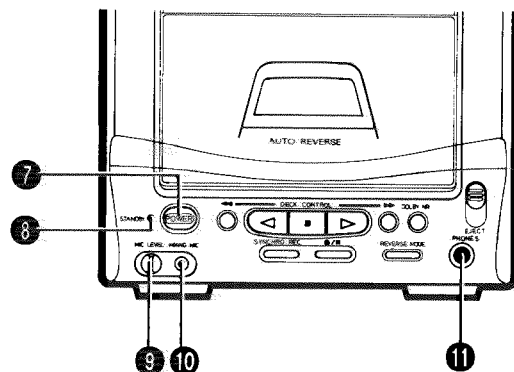

- 6 BASS/TREBLE buttons
- 7 POWER button
- 8 Power STANDBY indicator
- 9 MIC LEVEL control
- 10 MIXING MIC jack
- 11 Headphones jack (PHONES) (3.5 mm dia. stereo mini)
Connect headphones (impedance 16Ω to 1kΩ) to this jack. The speakers are automatically switched off when the headphones are connected.

Tuner/Deck section

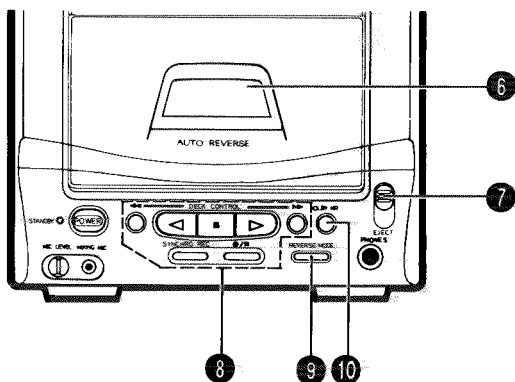
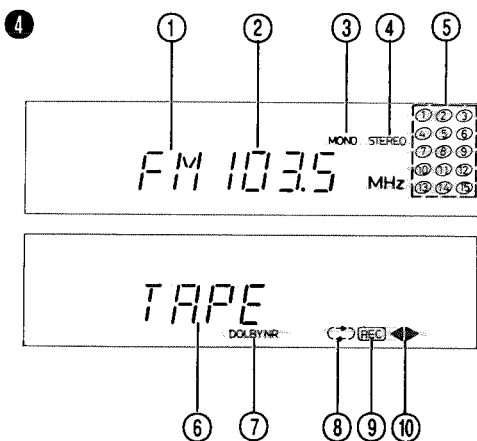
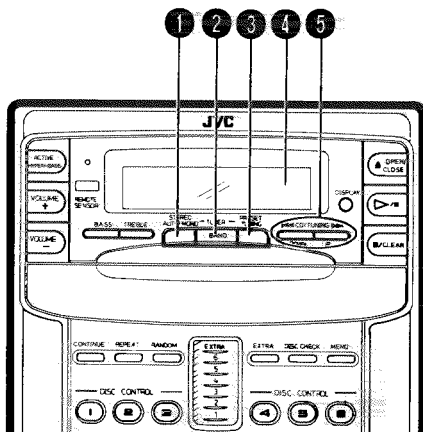

- 1 STEREO AUTO/MONO button
- 2 TUNER/BAND button
Press to select tuner mode.
Press to select the band (FM/AM/SW).
- 3 PRESET TUNING button
- 4 Display window
 - 1 Band indicator (FM/AM/SW)
 - 2 Radio frequency display
Channel space mode display
 - 3 MONO indicator
 - 4 STEREO indicator
 - 5 Preset station display
 - 6 Tape (TAPES) mode display
 - 7 DOLBY NR indicator (DOLBY NR)
 - 8 Reverse mode indicator (↔ / ↔ / ↔)
 - 9 Recording indicator (REC)
 - 10 Tape direction indicator (◀, ▶)
- 5 TUNING button (UP/DOWN)
- 6 Cassette holder
- 7 EJECT button

- 8 Cassette operation buttons
 - ◀◀ : Press to fast wind the tape from right to left/Music scan.
 - ◀ : Press to play back the tape in the reverse direction.
 - : Press to stop the tape. This also sets TAPE mode.
 - ▶ : Press to play back the tape in the forward direction.
 - ▶▶ : Press to fast wind the tape from left to right/Music scan.
- SYNCHRO REC : Press to start synchro recording.
- /|| : Press to set the unit to the record or record-pause mode.
- 9 REVERSE MODE switch
 - ↕ : For single-side recording or playback
 - ↔ : For both-sides recording or playback
 - ↔ : For continuous play
- 10 DOLBY NR button
Set to ON when recording or playing back tapes using the noise reduction system.

REMOTE CONTROL UNIT

Preparation before use

- Installing batteries in the remote control unit
 1. Remove the battery cover from the back of the remote control unit.
 2. Insert two "R6" size batteries.
 - Insert the batteries with the ⊕ and ⊖ terminals matching the indication inside the battery compartment.

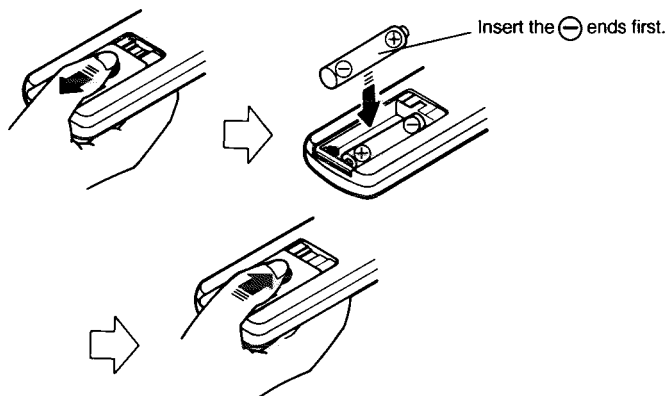

3. Replace the cover.

- Battery replacement
When the remote control operation becomes unstable or the distance from which remote control is possible becomes shorter, replace the batteries with new ones.

Using the remote control unit

To use the remote control unit, point it at the REMOTE SENSOR and press the buttons gently and firmly. Remote control operation is possible within about 7 m (approx. 23 ft). However, since the remote control range is less when the unit is used at an angle, use directly in front of the REMOTE SENSOR, as far much possible.

Do not expose the REMOTE SENSOR to strong light (direct sunlight or artificial lighting) and make sure that there are no obstacles between the REMOTE SENSOR and the remote control unit.

The following operations can be performed using the remote control unit.

- Check the functions of the operation buttons carefully and operate them correctly.

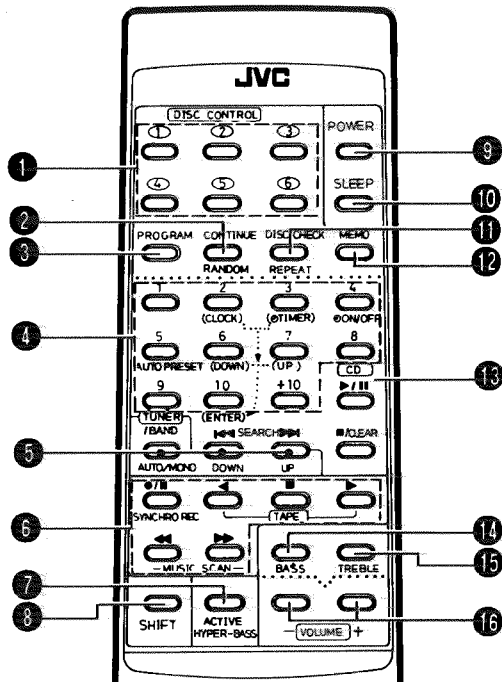

Use the following buttons with the SHIFT button.

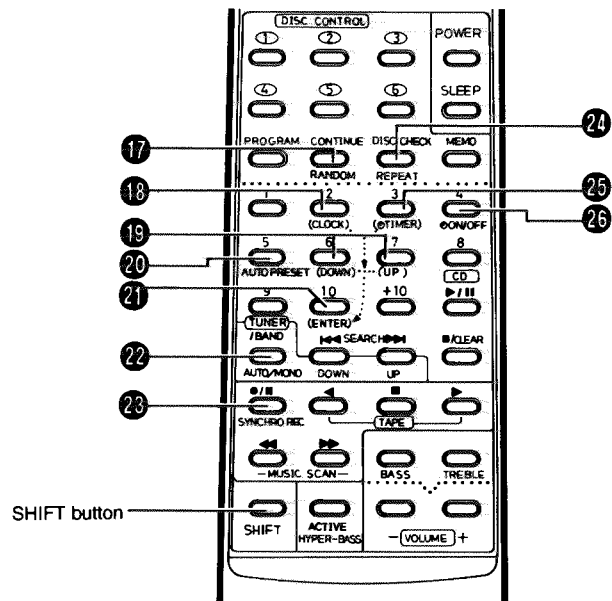

- ① DISC CONTROL buttons (No.1 to No.6)
- ② CONTINUE playback button
- ③ PROGRAM button
- ④ Track (tune) number buttons (No.1 to No.10, +10)
Preset station buttons (No.1 to No.10, +10)
- ⑤ TUNER/BAND button
UP and DOWN buttons
- ⑥ Cassette operation buttons
 - /|| : Record/Record-pause button
 - ◀ : Play button (reverse direction of tape)
 - : Stop button
 - ▶ : Play button (forward direction of tape)
 - ◀◀ : Fast wind (from right to left)/Music scan button
 - ▶▶ : Fast wind (from left to right)/Music scan button
- ⑦ ACTIVE HYPER-BASS button
- ⑧ SHIFT button
- ⑨ POWER button
- ⑩ SLEEP button
- ⑪ DISC CHECK button
- ⑫ MEMO button

- ⑬ CD operation buttons
 - CD ▶/|| : CD mode/play/pause button
 - /CLEAR : stop/clear button
 - SEARCH : to scan to the beginning of a tune and to (◀◀, ▶▶) start forward or reverse search.
- ⑭ BASS button
- ⑮ TREBLE button
- ⑯ VOLUME buttons (+,-)

Press the following buttons while holding down the SHIFT button ⑧.

- ⑰ RANDOM button
- ⑱ CLOCK button
- ⑲ UP-DOWN buttons
- ⑳ AUTO PRESET button
- ㉑ ENTER button
- ㉒ AUTO/MONO button
- ㉓ SYNCHRO REC button
- ㉔ REPEAT button
- ㉕ (⌚) TIMER button
- ㉖ TIMER (⌚) ON/OFF button

SWITCHING THE POWER ON/OFF

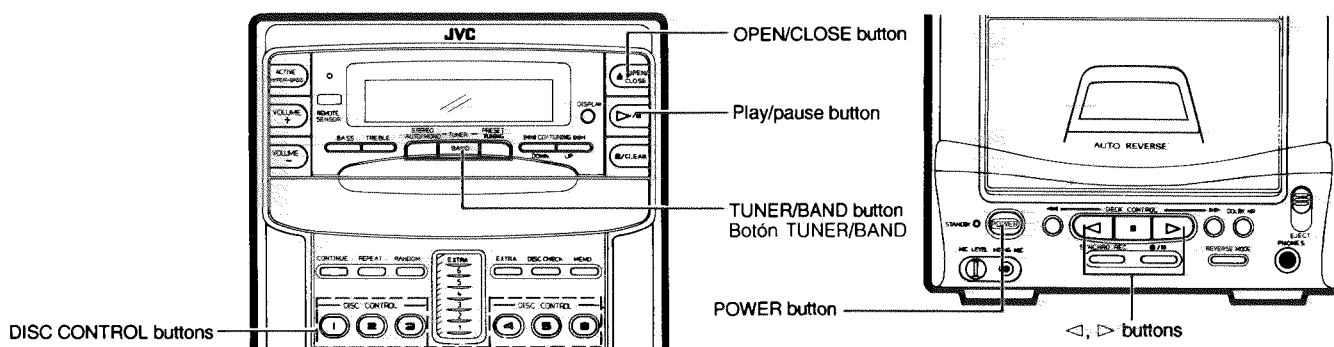

Switching the power on/off

• Switching on:



The indicator goes out.

- The indicator in the display window lights.

• Switching off:



The indicator lights.

- The indicator in the display window goes out and only the clock is indicated.

COMPU PLAY

Even when the power is set to STANDBY, pressing the button shown below switches on the power and selects the source.

	Function mode	Operations
	CD	When this button is pressed with a CD loaded, CD playback begins.
	TAPE	When this button is pressed with a tape loaded, tape playback begins.
	TUNER	When this button is pressed, the tuner is engaged

When the CD tray OPEN/CLOSE button (▲) is pressed, the source sound does not switched over, the CD tray can open or close.

Notes:

1. When switching off the power, be sure to press the power button.
2. The COMPU PLAY button on the remote control has the same function as the UX-C7.
3. When the CD tray opens and the Play/pause (▷/||) button is pressed, the CD tray closes and the CD play starts.

VOLUME, TONE AND OTHER CONTROLS

VOLUME button

+ : Use to increase the volume.
 - : Use to decrease the volume.
 (control range from VOL 0 to VOL 50)

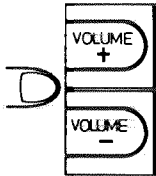

BASS/TREBLE button

To set the bass or treble level, press the corresponding button and adjust it using the VOLUME buttons. The level setting ranges are from -6 to 6.

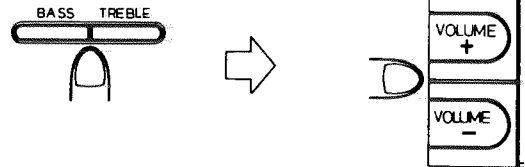

ACTIVE HYPER-BASS button

ON : The ACTIVE HYPER-BASS indicator lights. Set to this position when listening to ACTIVE HYPER-BASS sound.

OFF : The ACTIVE HYPER-BASS indicator goes out. Set to this position when ACTIVE HYPER-BASS sound is not required.

DISPLAY button

Use this button to switch between the function and time display.

- When using the tuner, press this button to display the tuned frequency and the time.

- When using a tape, press this button to show "TAPE" and the time.
- When using CD mode,
 - The display shows the following when CDs are not rotated with this button pressed:

DISPLAY



DISC TRACK
1-10

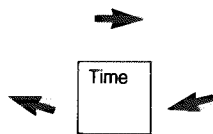

1048:57
 TRACK
 Total playback time

Total number of tracks (tunes)

2. The display shows the following when the CDs are played with this button pressed:

DISPLAY



DISC TRACK
1-01

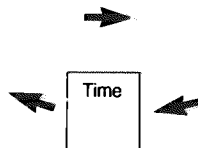

0100:05
 TRACK
 Displays elapsed playback time of each tune being played back

Track (tune) number

PLAYING COMPACT DISCS



CD changer operation

Operate in the order shown

- Loading Discs

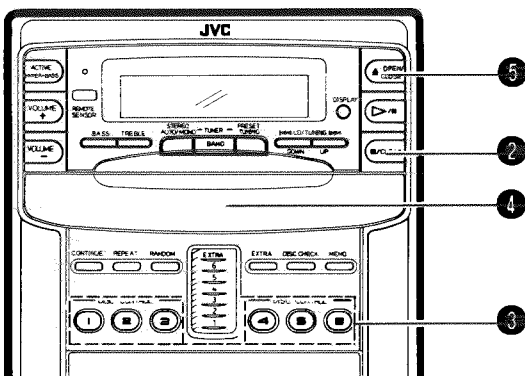

- When this unit is used for the first time (or not used for an extended period of time with an AC power cord disconnected) and the POWER switch is turned ON, CD changer mode is engaged. Disc check operation starts automatically to check if a disc is in the disc holder. ("CHECK" is shown in the display.)
- This unit can be used in two different modes.
 - In CD changer mode, it is possible to load up to six 12-cm (5") CDs in the disc holder. Various kinds of CD play can be performed.
 - In EXTRA mode, when 6 CDs are loaded in the disc changer section, a CD can be played without using the changer section.
- 8 cm (3-3/16") CDs
 - 8 cm (3-3/16") CDs can be used in this unit. (Do not use a CD adapter, as it may cause a malfunction.)
 - When an 8 cm CD is loaded, the CD changer cannot be operated. When the DISC CONTROL button is pressed, the CD tray opens for disc unloading and "PLEASE TAKE" is displayed.

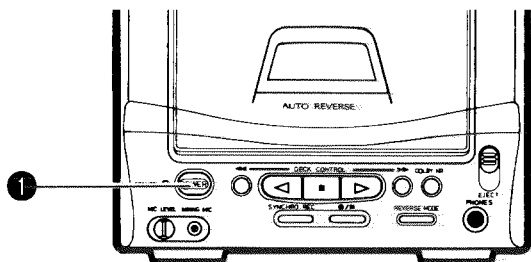
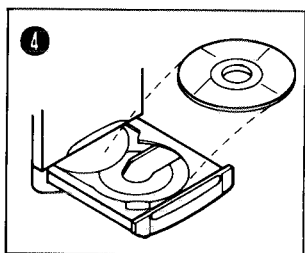

- 1 Set the POWER button to ON.
- 2 Press the ■/CLEAR button to set CD mode.
- 3 Press the required DISC CONTROL button (No. 1 to No. 6) and the CD tray opens.
- 4 Load a disc with the label side facing up.
- 5 Press the ▲ OPEN/CLOSE button to close the CD tray. (The mark which shows that the disc is loaded is shown in the display.)
 - Repeat procedures 3 to 5 to load the other discs.

Notes:

- When loading discs, be sure to place them correctly on the tray to prevent a malfunction.
- When an "Error" is displayed, press the ▲ OPEN/CLOSE button to erase the error message and perform the operation again.

• Unloading Discs

- 1 Press the required DISC CONTROL button of the disc to be unloaded.
- 2 Press the ▲ OPEN/CLOSE button to open the CD tray and unload the disc.
 - Repeat procedures 1 and 2 to unload the other discs.

Memorandum (MEMO) button

The type of music on the loaded CDs (in the CD changer) can be stored using this button. Each time the MEMO button is pressed, the display changes as follows:



Memorandum (MEMO) button

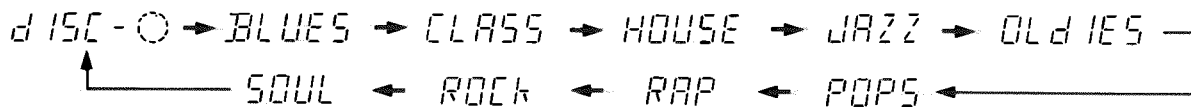

- 1 Press the DISC CONTROL button (No. 1 to No. 6) corresponding to the specified disc.
- 2 After CD play starts, select the correct type of music.
- 3 Press the MEMO button to select the type of music corresponding to the disc music.
 - After a short period, when the display changes, setting is completed.
 - Repeat procedures 1 to 3 to specify the other discs.

DISC CHECK button

Check the type of music on the loaded CDs (in the CD changer) using this button. When the DISC CHECK button is pressed, the type of music is shown in sequence.

Continuous play

How to play all tracks
Operate in the order shown

- 1 Load the required disc into the disc holder of the CD changer. (See page 21.)
- 2 Press the CONTINUE button to set continuous playback mode.
- 3 Press the No. 1 DISC CONTROL button to start playback.
- 4 Adjust.
 - CD play starts from disc No.1 and continues till the last tune of the last disc in the disc holder.

To stop play

- **To stop in the middle of a disc**
During playback, press the ■/CLEAR button to stop play.



- **To stop a disc temporarily**
Press the ▷/|| button to stop play temporarily and the playing time blinks. When pressed again, play resumes from the point where it was paused.

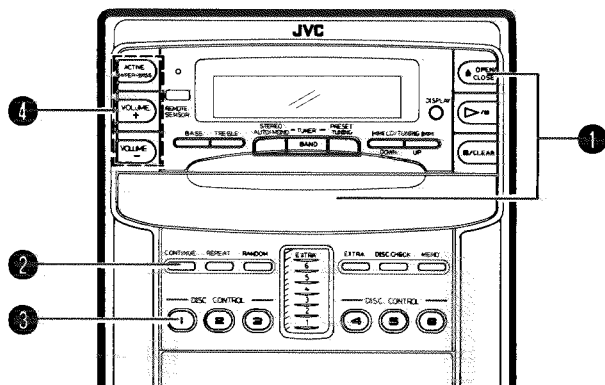

Notes:

- The following indication may be shown when a disc is dirty or scratched, or when the disc is loaded upside down.
In such a case, check the disc and insert again after cleaning the disc or turning it over.



- Do not use the unit at excessive high or low temperatures. The recommended temperature range is from 5°C (41°F) to 35°C (95°F).
- If mistracking occurs during play, lower the volume.

DISC CONTROL button

- **Direct Disc Selection**
Press the DISC CONTROL button (No.1 to No. 6) corresponding to the No. of the required disc.

Example: (to designate Disc 5)

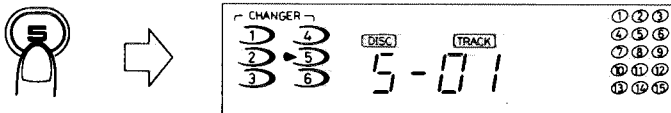

The tracks on the designated disc are played in sequence.

- When the unit is in continuous playback mode, by pressing the CONTINUE button, the next disc will be played after the end of the disc being played.

Note:

- When "PROGRAM" is shown in the display and the direct select operation is performed, the CD cannot be played.

Skip playback

- During playback, it is possible to skip forward to the beginning of the next tune or back to the beginning of the tune being played or the previous tune; when the beginning of the required tune has been located, play starts automatically.

To listen to the next tune ...

Press the ►► button once to skip to the beginning of the next tune.

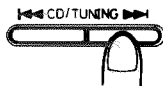

To listen to the previous tune ...

Press the ◀◀ button to skip to the beginning of the tune being played back and press again to skip to the beginning of the previous tune.



* When disc select and skip operations are performed in sequence, the required track from a required disc can be selected.

**Search playback
(to locate the required position on the disc)**

- The required position can be located using fast-forward or reverse search while playing a disc.



- Hold down the button; search play starts slowly and then gradually increases in speed.
- Since low-volume sound (at about one quarter of the normal level) can be heard in the search mode, monitor the sound and release the button when the required position is located.

Direct access playback using the remote control

- Example 1 (to designate Disc 3)

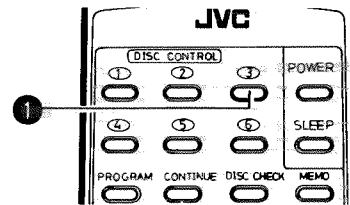

- ① Designate the required disc using the DISC CONTROL buttons (No. 1 to No. 6).
- CD play starts.

- Example 2 (to designate the 3rd tune of Disc 5)

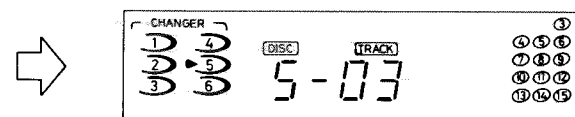
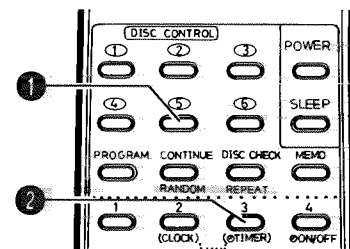

- ① Designate the required disc using the DISC CONTROL buttons (No.1 to No. 6).
- ② The music calendar of the required disc is displayed and the required tune is selected using the TRACK button.
- CD play starts.

Repeat playback

Press the REPEAT button before or during play. It is possible to perform repeat playback of a single tune, all tunes on one disc, or all tunes on all discs in the disc changer.

Each time the REPEAT button is pressed, the mode will change from a single tune (↻), to all tunes (↻ ALL), to clear mode, in this order.



- **Single tune repeat (↻)**
The current or specified tune will be played repeatedly.
- **All tune repeat of one disc (↻ ALL)**
All tunes on the current or specified CD will be played repeatedly.
- **All tune repeat of all discs (↻ ALL. CONTINUE)**
When the CONTINUE button is pressed during "↻ ALL" mode, CD play starts from the current or specified tune and all tunes on all discs will be played repeatedly.

Random playback

Press the RANDOM button before or during play. It is possible to perform random playback from one disc or all discs.

- **One disc random (RANDOM)**
Press the RANDOM button to randomly plays tracks on the current or specified disc, except in continuous mode.
- **All disc random (ALL DISC, RANDOM)**
Press the RANDOM button in continuous play mode to randomly selects and plays tracks from all of the discs in the CD changer.

Programmed playback (using the remote control)

- Up to 20 tunes can be programmed to be played in any required order from one disc or all discs in the holder.
- Example 1 (When programming from the 3rd disc, the 2nd tune to be played first, and the 5th tune next, then the 12th tune.)

Example 1

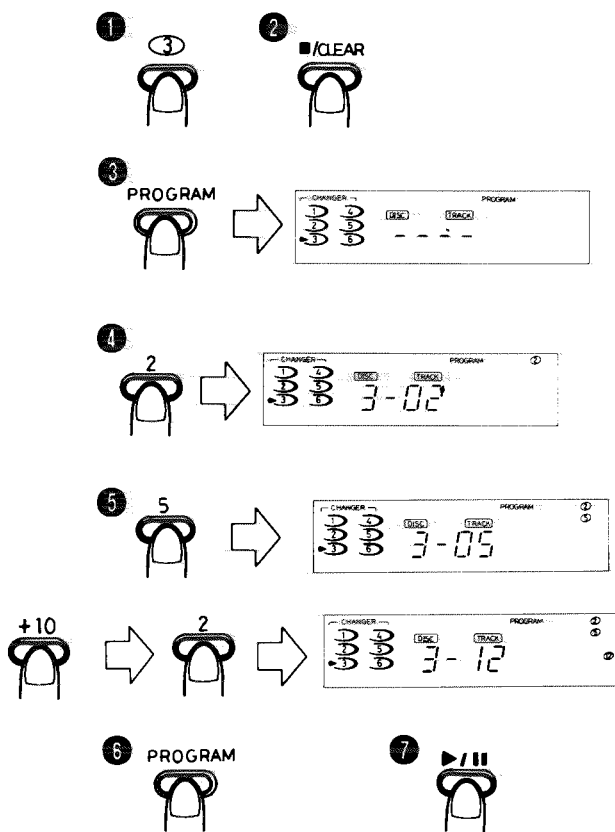
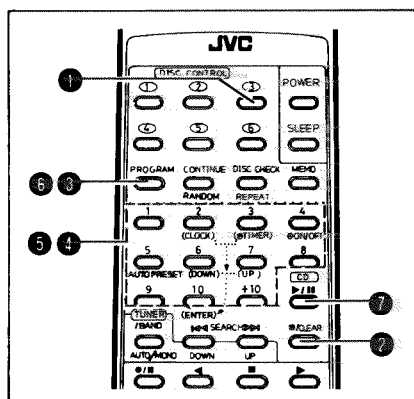

- 1 Press the No.3 DISC CONTROL button.
- 2 Press the ■/CLEAR button.
- 3 Press the PROGRAM button to set programming mode.
- 4 Press to designate the required track number.
- 5 Designate the remaining tunes by pressing the track number buttons.
- 6 Press the PROGRAM button to confirm the details of the program.
 - Repeat from step 2 to readjust the program.
 - Repeat from step 4 to add to the program.
- 7 Press the ►/|| button when programming is completed. Programmed playback starts.

- Example 2 (With programming from more than 2 discs, the 3rd tune of disc 1 is to be played first, and the 6th tune of disc 1 next, then the 12th tune of disc 6.)

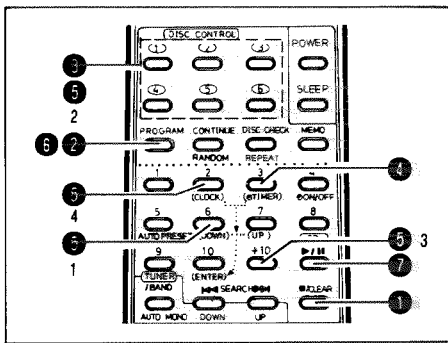

Example 2

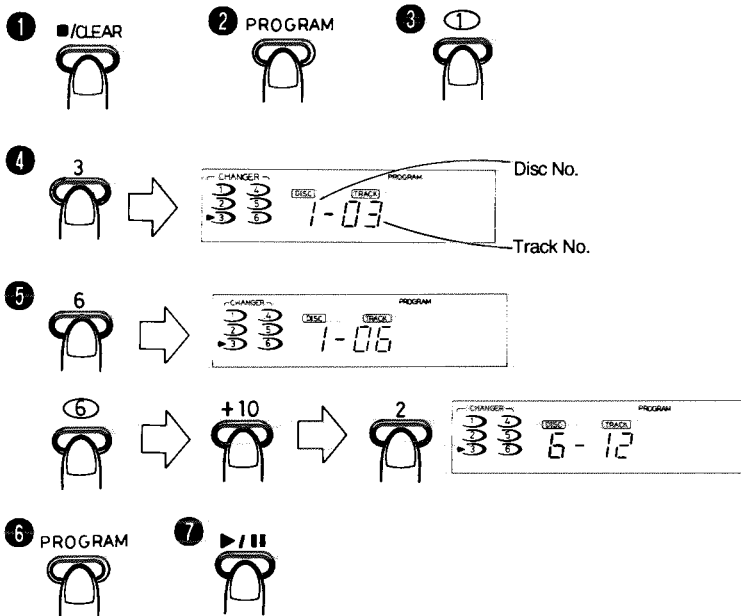

- 1 Press the **■/CLEAR** button.
- 2 Press the **PROGRAM** button to set programming mode.
- 3 Designate the required disc using the **DISC CONTROL** buttons (No. 1 to No. 6).
- 4 Designate the required tune using the track buttons (No. 1 to No. 10, +10).
- 5 Repeat procedures 3 and 4 to designate the other tunes.
- 6 Press the **PROGRAM** button to confirm the details of the program.
 - Repeat from step 1 to readjust the program.
 - Repeat from step 3 to add to the program.
- 7 Press the **▶/||** button when programming is completed.

To confirm the details of a program...

Press the **PROGRAM** button in stop mode: the tunes making up the program will be displayed in programmed order.

To clear the programmed tunes ...

Press the **■/CLEAR** button before playing the disc. During programmed playback, press this button twice. When the CD tray is opened, the programmed tunes are cleared automatically.

Notes:

1. Programming 21 or more tunes is impossible.
2. When a disc with 16 or more tunes is loaded, the "OVER" indicator will appear.
3. When performing timer playback in the order of "Programmed play", do not press the **▶/||** button in the above procedure.

EXTRA-CD operations

When 6 discs are loaded in the CD changer of this unit, use this button to listen to the extra-CD.

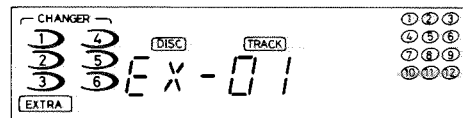
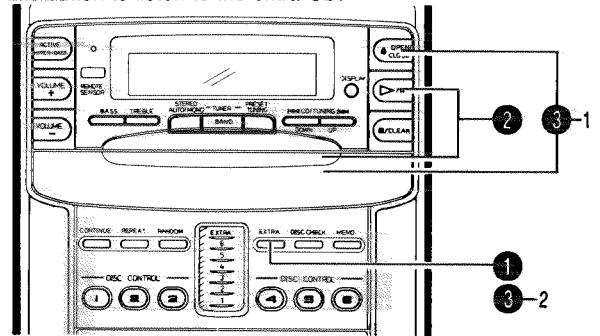

- 1 Press the **EXTRA** button during CD mode and the CD tray opens.
- 2 Load a disc and press the **▶/||** button.
- 3 Unload the disc after CD play has finished, by pressing the **▲ OPEN/CLOSE** button. Then, press the **EXTRA** button to switch back to CD changer mode.

Notes:

- When the **EXTRA-CD** is loaded, the CD changer cannot be used. When the **DISC CONTROL** button is pressed, the CD tray opens and the display shows "PLEASE TAKE", so unload the disc.
- When an **EXTRA-CD** is loaded and the **MEMO** button is pressed, "Ex" is displayed. However, the type of music cannot be stored.

Repeat playback

Press the **REPEAT** button before or during play. A single tune or all tunes can be repeated.

- **Repeat playback of a single tune (**↺**)**
The tune being played back will be heard repeatedly.
- **Repeat playback of all tunes (**↺ ALL**)**
When playing back an entire disc or programmed tunes, all tunes or the programmed tunes will be heard repeatedly.

Random playback

Press the **RANDOM** button, all tunes on the disc are played once, in random order.

CASSETTE PLAYBACK



Operate in the order shown

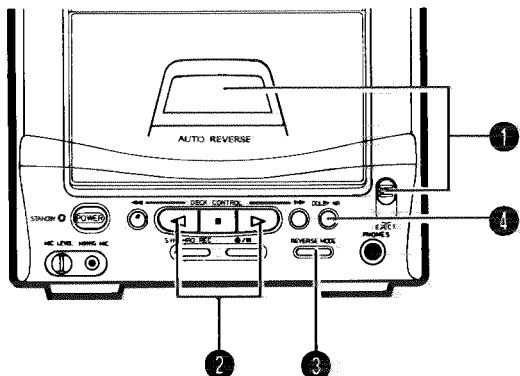

- ① Load a cassette tape with side A facing out.
- ② Press to start playback. (The power is switched on and the TAPE mode is engaged to start the tape playback.)
- ③ Select the reverse mode (↔ / ↔↔ / C↔↔).
- ④ Set the DOLBY NR switch as required.

- After loading a cassette tape, simply press the ◀ or ▶ button. The power is switched on and the tape starts playback.
- When the tape is played back with the reverse mode set to the ↔ (single side play) or ↔↔ (both side play) mode, the tape stops automatically at the end of tape after playing one side or both sides.

Notes:

- When switching to tape playback while playing a CD, tape sound will be heard after a few seconds.
- If the power is switched off while a tape is running, it may be impossible to remove the cassette. If this happens, switch the power on again before attempting to remove the cassette.

Music scan

- The beginning of the current tune or the next tune can be located using the music scan facility.

- ① Press the ▶ or ◀ button for tape playback.
- ② Press the ►► or ◀◀ button for music scan.

	• To the start of the next tune	• To the start of the tune being played back
(Forward (▶) direction playback)		
(Reverse (◀) direction playback)		

The tape direction indicators blinks during music scanning.

- ③ When music scanning is completed, playback will start automatically.
 - To skip two tunes or more, repeat the above steps ② and ③.

Notes:

With the following types of tape, the Music Scan mechanism may not operate correctly. This is not a malfunction; use the Music Scan facility only with suitable tapes.

- Tapes with tunes having long pianissimo passages (very quiet parts) or non-recorded portion during tunes.
- Tapes with short non-recorded sections.
- Tapes with high-level noise or hum between tunes.

RADIO RECEPTION

Operate in the order shown

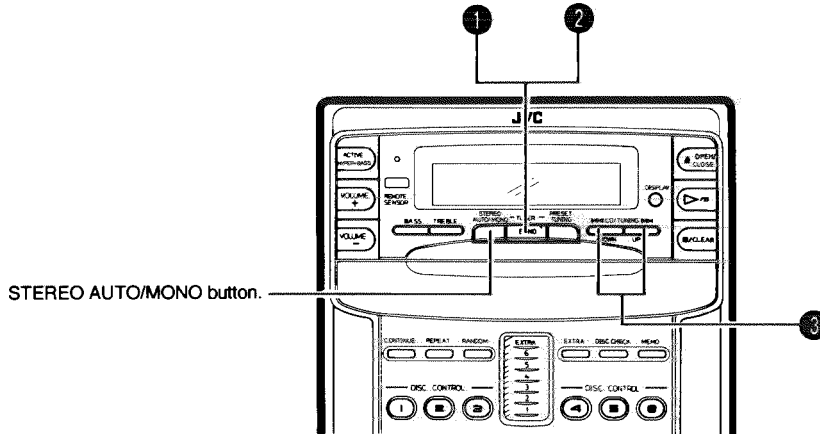

- ① Press the TUNER/BAND button.
 - The power is switched on and a band and radio frequency will be shown in the display.
- ② Select the band (FM, AM or SW).
- ③ Tune to the required station.

STEREO AUTO/MONO button

AUTO:

Set to this position when listening to or recording an FM stereo broadcast. The STEREO indicator lights when the FM stereo broadcast is received.

MONO:

Set to this position when FM stereo reception is noisy.

- **Seek tuning**
Press the UP or DOWN button for one second or more; the unit enters the seek tuning mode and tunes to higher or lower frequencies, and when the broadcast is received, it stops tuning automatically and the broadcast can be heard.
- **Manual tuning**
Each time the UP or DOWN button is pressed, the unit steps through the current frequency band. Tuning is in steps of 50 kHz/100 kHz for FM and 9 kHz/10 kHz for AM and 5 kHz for SW.

Notes:

- When switching to tuner mode while playing a CD, tuner sound will be heard after a few seconds.
- When seek tuning to the required station is not possible because it is broadcasting too weak a signal, press the UP or DOWN button momentarily to perform manual tuning.
- When the power is set to STANDBY, or another mode (TAPE or CD) is selected, the last tuned frequency is stored in memory. When the power is switched on again and TUNER/BAND button is pressed, the same station will be heard.

Auto preset tuning (using the remote control unit)

This function scans the current band (FM, AM or SW), detecting frequencies used to broadcast signals, and stores the first 15 frequencies in memory automatically.

- Press the AUTO PRESET button while pressing the SHIFT button. The frequencies of stations broadcasting signals can be preset automatically in the order of increasing frequency. (15 stations in each band (FM, AM and SW)).

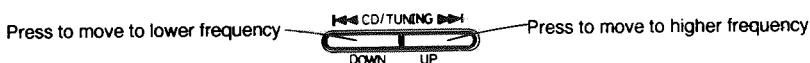

Presetting stations (using the remote control unit)

15 stations in each band (FM, AM and SW) can be preset as follows:

- Example (when presetting an FM station broadcasting at 103.5 MHz to preset button "15")

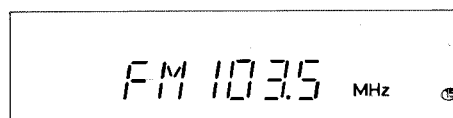
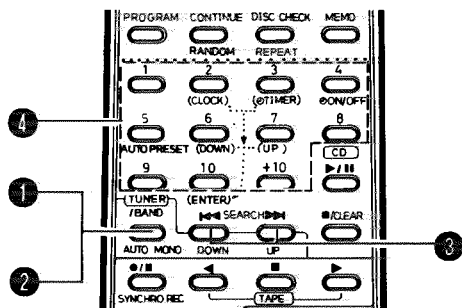

- 1 Press the TUNER/BAND button.
 - 2 Select the FM band using the TUNER/BAND button.
 - 3 Tune to the required station.
 - 4 Press preset button "+10", then "5" for more than 2 sec. (When "15" blinks in the preset station display, the station has been preset.)
- Repeat the above procedure for each of the other stations, using a different preset button each time..
 - Repeat the above procedure for the other band.
 - **To change preset stations**
Perform step 4 above after tuning to the required station.

Notes:

- The previous preset station is erased when a new station is set as the new station's frequency replaces the previous frequency in memory.
- When listening to an AM broadcast, noise may be heard if the remote control is used.
- All preset stations will be erased when the power cord is disconnected or a power failure occurs for more than 24 hours. In such cases, preset them again.

Preset tuning

- The stations must be preset before this operation can be performed.

(Using the controls of the main unit)

- 1 Press the TUNER/BAND button.
- 2 Select the band (FM, AM or SW) using the TUNER/BAND button.
- 3 Press the PRESET TUNING button to select the required preset station.

(using the remote control unit)

- 1 Press the TUNER/BAND button
 - 2 Select the band (FM, AM or SW) using the TUNER/BAND button.
 - 3 Press the required preset station buttons (No.1 - No.10, +10).
- The preset station number and frequency corresponding to the button pressed are shown.

Using the antennas

FM/SW: Connect the provided feeder antenna (see page 7).

AM: Adjust the position of AM loop antenna.

To Change the Channel Space Mode

When this unit is shipped, the channel space mode is set to **(AM-9 kHz)**.

Set it to **(AM-10 kHz)**, if the unit is to be used in North or South America. (This enables 10 kHz increment steps in AM frequencies and 100 kHz increment steps in FM frequencies.)

How To Operate (Using the main unit)

Press the POWER button while pressing the SEARCH/▶▶▶ button. **(AM-10 kHz)** is shown in the display window.

- To change back to the original mode, press the POWER button while pressing the SEARCH/◀◀◀ button, **(AM-9 kHz)** is shown in the display window.

RECORDING

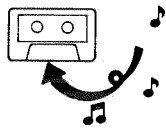

- In recording, the ALC circuit automatically optimizes the recording level; adjustment of the recording level is unnecessary.
- Check that the safety tab on the cassette tape is not broken off.

Notes:

This unit has recording characteristics suitable for normal and CrO₂ tapes. Normal and CrO₂ tapes have different characteristics from metal tape.

DOLBY NR SYSTEM

- Set the DOLBY NR as required. The DOLBY NR indicator lights.

Note:

The optimum sound quality will not be obtained if different DOLBY NR switch settings are used during recording and playback.

It may be unlawful to record or playback copyrighted material without the consent of the copyright owner.

Erasing

When recording on a pre-recorded tape, the previous recording is automatically erased and only the new material can be heard when the tape is played.
To erase a tape without making a new recording...
Press the ■ (stop) button to set to the TAPE mode, then perform recording.

Synchronized recording with the CD player

- In this system, the CD player starts playback when the cassette deck enters the recording mode.

Operate in the order shown

(Recording from the CD changer)

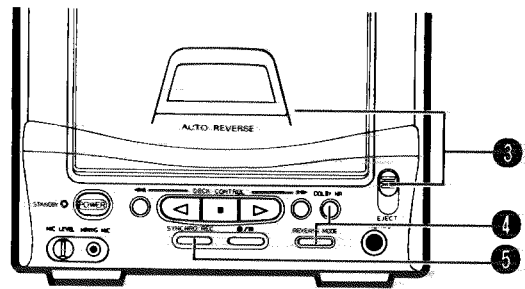
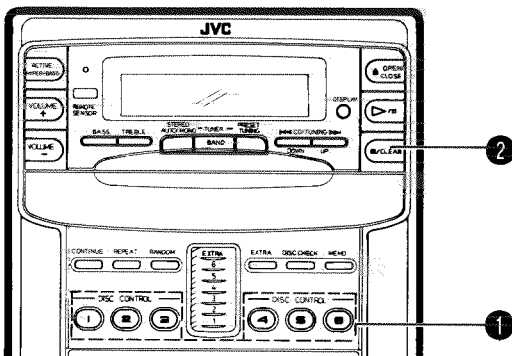

- 1 Press the DISC CONTROL button corresponding to the disc to be recorded.
- 2 Press the ■/CLEAR button to set stop mode.
- 3 Load a cassette with side A facing out. (Wind past the leader tape before starting recording.)
 - When programmed playback is required, program the required tunes using the remote control. (See page 28.)
 - Select tunes with a total playing time which does not exceed the tape length.
- 4 Select the required reverse mode (⇄ or ⇄⇄)
 - Set the DOLBY NR switch as required
- 5 Press the SYNCHRO REC button; synchronized recording will start.
 - Recording starts in the forward direction and CD play starts automatically.
 - When the CD player has played the disc or programmed tunes, the deck stops automatically.
 - Non-recorded sections of approx. 4 seconds are automatically left between tunes.
 - To stop recording, press the ■/CLEAR button of the CD player.

(Recording from the EXTRA-CD)

Load the EXTRA-CD and press the ■/CLEAR button to set stop mode, and press the SYNCHRO REC button.

When automatic spacing between tunes is not required ...

Perform the following.

1. Press the ▷/|| button of the CD player twice. The CD Player enters the pause mode.
2. Press the SYNCHRO REC button to start recording.

Note:

- Depending on the disc used, blanks of a specified length may be left between tunes.

CD complete recording function (Synchro recording mode only)

If the tape is reversed while a CD is being played, recording will be done on the reverse side of the tape as follows:

- * When less than 12 seconds of the last tune on the forward side of the tape have been recorded, recording on the other side of the tape will start from the beginning of the previous tune.
- * When more than 12 seconds of the last tune on the forward side of the tape have been recorded, recording on the other side of the tape will start from the beginning of the current tune.

To record an entire disc in the tune order of the CD

After the operations in steps 1 - 5 above, press the ▷/|| button of the CD player after the ●/|| and ▷ buttons have been pressed.

Note:

- During synchro recording, the ▷/|| and SEARCH buttons do not function.

Recording from the radio

Operate in the order shown

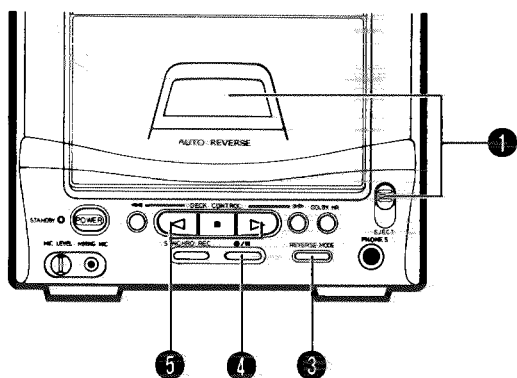
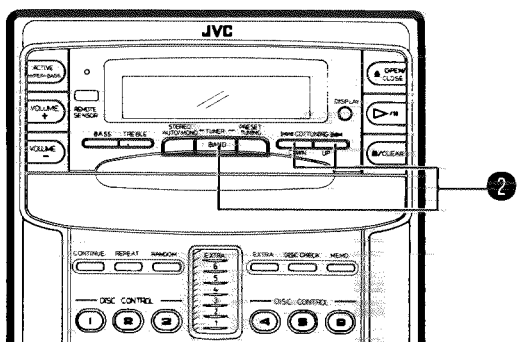

- 1 Load a cassette with side A facing out.
(Wind past the leader tape before starting recording.)
 - 2 Press the TUNER/BAND button. Tune to the required station.
 - 3 Select the required reverse mode (← or →).
 - 4 Press the ●/|| button (recording-pause mode).
 - The tape direction indicator (◀▶) blinks.
 - The function switch is locked and its position cannot be changed.
 - 5 Press to start recording.
- To stop recording temporarily, press the ●/|| button. To resume recording, press the ▷ or ◁ button corresponding to the tape direction indicator which is blinking.

Note:
When recording using the remote control, first press the ●/|| button to set Record Standby mode, then simply press the ◁ or ▶ button to start recording.

MICROPHONE MIXING

Microphone sound can be mixed with the source sound.

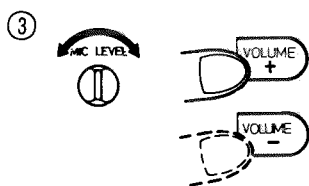
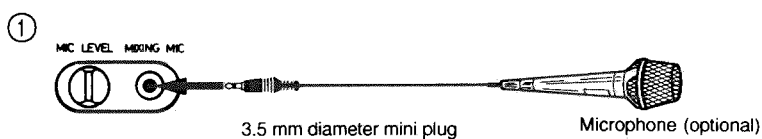

- Example of microphone mixing with CD sound

Operations

- 1 Connect a microphone with a mini plug to the MIXING MIC jack. (If there is a switch on the microphone, switch it on.)
 - 2 Select the source sound (CD/TAPE/TUNER).
 - Play back the source sound selected.
(The MIC sound is not output in the pause mode.)
 - 3 Adjust the MIC LEVEL control and main VOLUME controls.
- To record the mixed sound
In order to record this mixed sound onto a tape in the deck, press the ●/|| button to engage the record standby mode after the above procedure, then press the ◁ or ▷ button.

Note:

Use the microphone as far away the set as possible. When the microphone is too near the speakers, howling may occur.

CLOCK/TIMER ADJUSTMENT

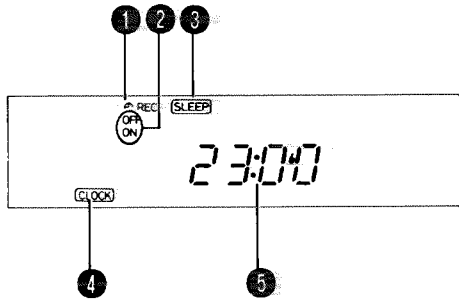

(Using the remote control)

Names of parts in the clock/time section, and their functions:



- ① Timer mode indicator
- ② Timer indicator (ON/OFF)
- ③ SLEEP indicator
- ④ CLOCK indicator
- ⑤ Time display
- ⑥ SLEEP button

Press the following buttons while holding down the SHIFT button.

- ⑦ TIMER () button
- ⑧ CLOCK button
- ⑨ DOWN/UP button
- ⑩ ENTER button
- ⑪ Timer () ON/OFF button

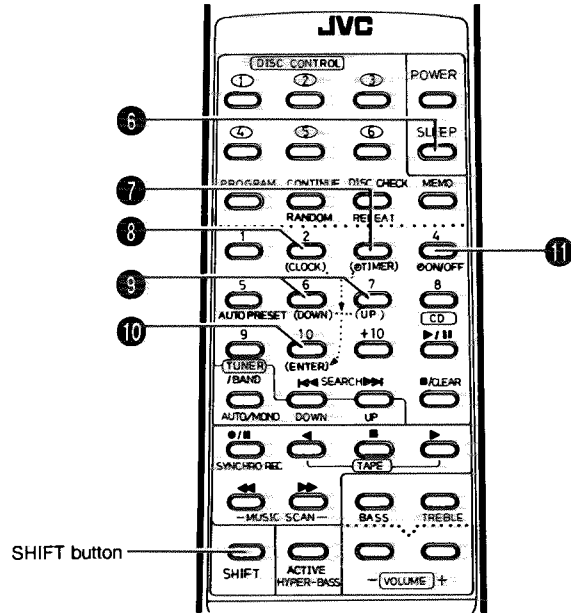

SHIFT button

Setting the current time (when the UX-C7 is used for the first time)

(Example: to set the clock to 13:15.)

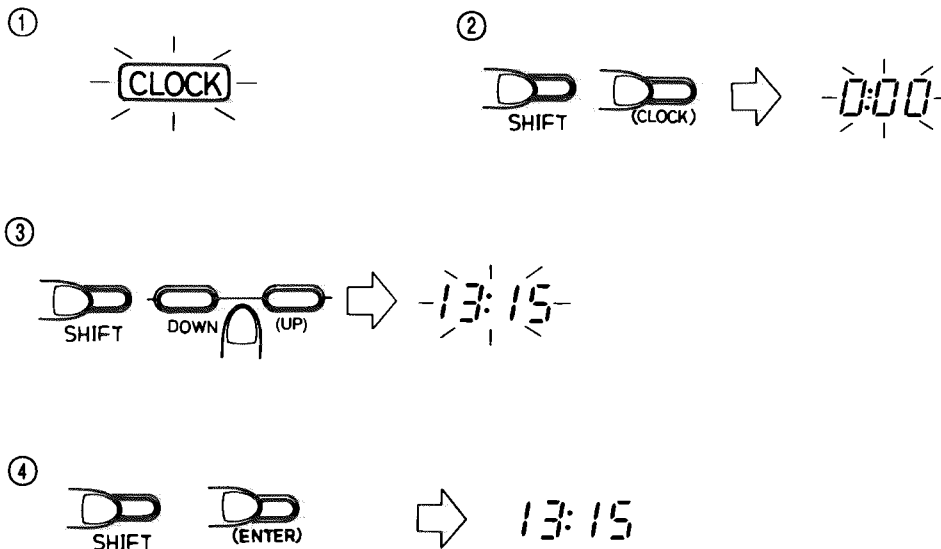

- ① Connect the AC power cord; "CLOCK" will blink in the display.
 - ② Press the CLOCK button while pressing the SHIFT button; "0:00" will blink in the display.
 - ③ Set to 13:15 by pressing the UP/DOWN buttons while pressing the SHIFT button. (When the buttons are kept pressed, the minute/hour indication changes continuously.)
 - ④ Press the ENTER button while pressing the SHIFT button; the time will light in the display.
- To set to the nearest second...
Press the ENTER button while pressing the SHIFT button when you hear the time signal from a TV or radio.

Notes:

- Before performing timer recording or playback, it is necessary to set the current time.
- It is recommended to set the current time with the power switch set to STANDBY so that the current display mode is maintained.
- When the power cord is plugged in again after being disconnected or power is restored after a power failure, "CLOCK" will blink in the display. Set the current time again.

Setting the timer

- The current time must be set before the timer can be used.
- ① Press the TIMER () button while pressing the SHIFT button.

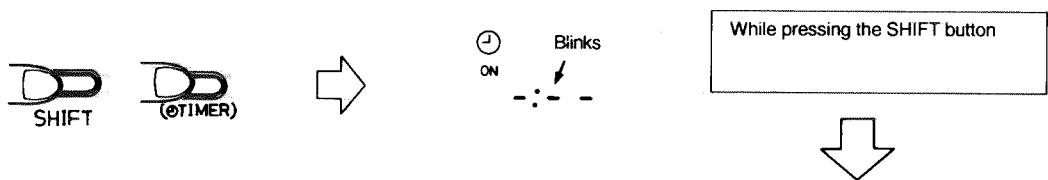

- ② Set the start time
(Example: when the timer start time is set to 12:15.)

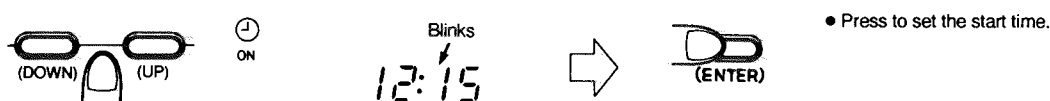

- ③ Set the stop time
(Example: when the timer stop time is set to 13:15.)

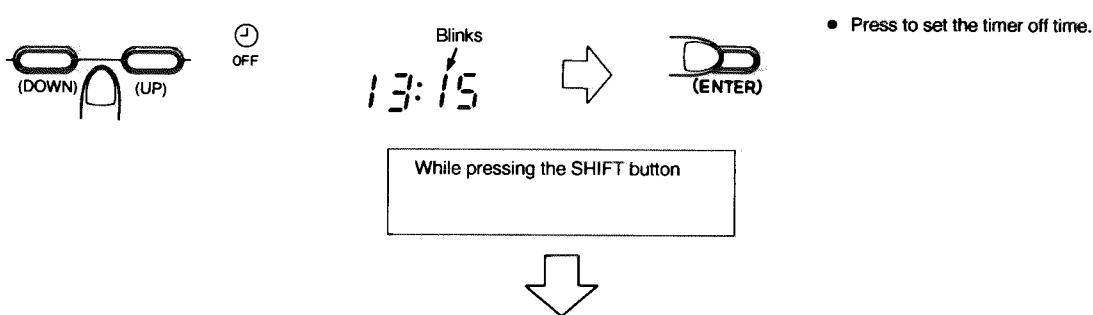

- ④ Select the TIMER mode.

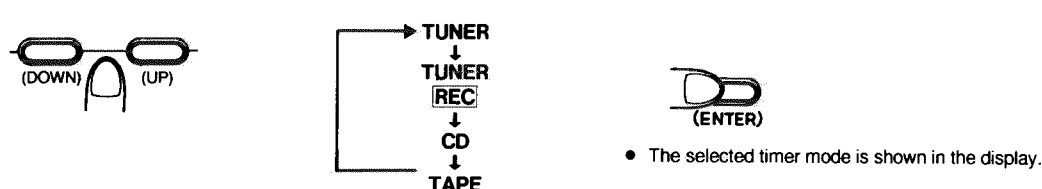

When the UP button is pressed to select the timer mode, the mode changes from the TUNER (timer reception of a broadcast) to TUNER/REC (timer recording of a broadcast), CD (timer playback of a CD), TAPE (timer playback of a tape), in this order.

- The unit enter the previously engaged mode and timer setting is complete.
- **To check the timer setting**
 1. Press the (⌚) TIMER button while pressing the SHIFT button.
 2. Press the ENTER button while pressing the SHIFT button to check the timer mode.
 3. When the previous engaged mode is displayed, timer setting has been completed.

Notes:

- When the timer is set incorrectly or the correct mode is not selected, perform "Setting the timer" from the beginning.
- When the timer is set, "-:--" in the display is replaced by the input digits.
- When the timer stop time is not set, the timer operates for 2 hours and then the unit is switched off.

- After setting the timer start and stop times, check that the unit is tuned to the required frequency.
- When the power cord is disconnected or there is a power failure, timer settings will be erased from memory. If this happens, set the current time and perform the timer setting again. (See pages 44 and 45.)

Timer playback

- Timer playback of tapes, broadcasts and CDs is possible.

Operations

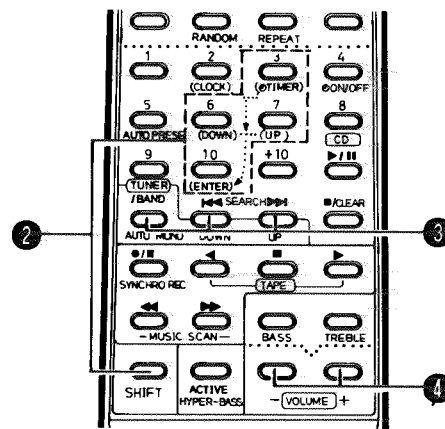

TIMER OPERATIONS

Timer recording of broadcast

- The current time must be set correctly before you set timer recording.
- Make sure that the erase protection tabs of the cassette have not been broken off.

Operations

1. Set the POWER button to ON.
2. Load a cassette.
 - Insert the cassette with the side to be recorded facing out.
 - Set the reverse mode button to "↔" or "↔" and set the DOLBY NR button as required.
3. Set the timer start and stop times, set the timer recording mode, in this order. (Refer to "Setting the timer" on page 45.)
 - Set the timer about a minute before the broadcast to be recorded is scheduled to start.
4. Tune to the station to be recorded. (Refer to page 34.)
5. Adjust the volume.
6. Set the POWER button to STANDBY.

- **Timer recording will start at preset start time and the power will be switched off at preset stop time.** (The timer mode is then released.)

• **To cancel timer operation**

Press the timer (⌚) ON/OFF button while pressing the SHIFT button so that the timer mode display (⌚) goes out.

If you do this, timer recording will not start at the timer start time.

Notes:

Once the timer has been set, the start and stop times, etc., are stored in memory. When timer recording or playback is required at different times, the timer must be set again.

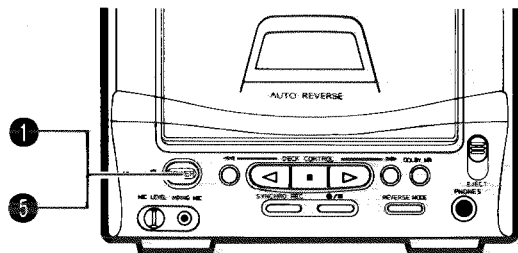

- 1 Set the POWER switch to ON.
- 2 Set the timer start and stop times, set the timer playback mode, in this order. (Refer to "Setting the timer" on page 45.)



- Timer playback of a CD is possible in programmed order. (See page 28.)

Source sound	Timer mode	Operations
CD play	CD	Load a disc.
Tape playback	TAPE	Load a cassette tape.
Broadcast	TUNER	_____

- ③ Tune to the required frequency when the timer playback of a broadcast is to be performed.
- ④ Adjust the volume.
- ⑤ Switch the power off.

- Timer playback will start at the timer start time and the power will be switched off at the timer stop time. The unit remains in the same timer mode even after the power is switched off and the same timer function will be repeated at the same time on the following day.

- **To cancel timer operation**

Press the timer () ON/OFF button while pressing the SHIFT button so that the timer mode indicator () disappears.

Note:

- To stop during timer playback, press the POWER button to switch the unit off.

SLEEP OPERATIONS

A. Use this when you want to fall asleep while listening to a tape, broadcast or CD.

- ① Set the required source and tune or play back (CD, tape).
- ② Press the SLEEP button to set to the sleep time.

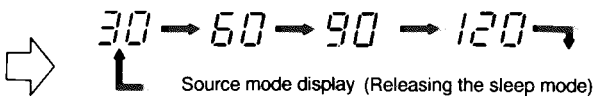
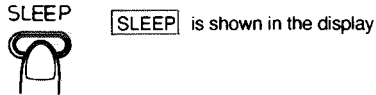

- Sleep times of 30, 60, 90 or 120 minutes can be set. When you release the SLEEP button, the source is displayed after 5 sec.
- The sleep operation will start and the power will be switched off after the specified time.
- **Checking the sleep time**
When the SLEEP button is pressed, the remaining sleep time is displayed. If it is pressed again, a new sleep time can be set.
- **To cancel the sleep operation**
Press the POWER button to switch the power off or press the SLEEP button until the sleep time indicator disappears.

B. To fall asleep while listening to a tape, a broadcast or CD and to perform timer playback the following morning

1. Set the timer playback start and stop times. (See the "Setting the timer" on page 45.)
2. Set the timer mode. (See "Setting the timer" on page 45.)
3. Set to the required source (broadcast, tape or CD).
4. Adjust the volume.
5. Press the SLEEP button to set the sleep time.

- Any required source can be selected when performing the sleep operation and time playback. For example;
 - CD play for sleep operation and broadcast reception for timer playback.
 - Tape playback for sleep operation and CD play for timer playback.

However, when broadcast reception is selected for both sleep operation and timer playback, the station you were listening to at night will be tuned to the following morning.

CONNECTIONS

- Do not switch the power on until all connections are completed.

Antenna connection and adjustment

- AM loop antenna adjustment

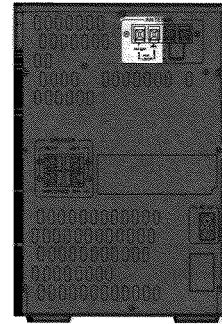

Loop antenna

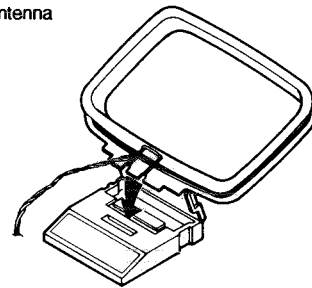

Insert in the direction of the arrow.

AM antenna

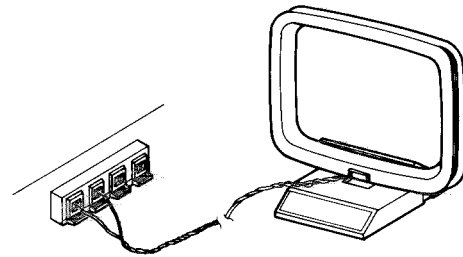

- Keep the loop antenna away from the rear panel of the unit and install it so that the best reception is obtained. (Do not leave the antenna wire in a bundle.)

• FM/SW antenna connections and adjustments

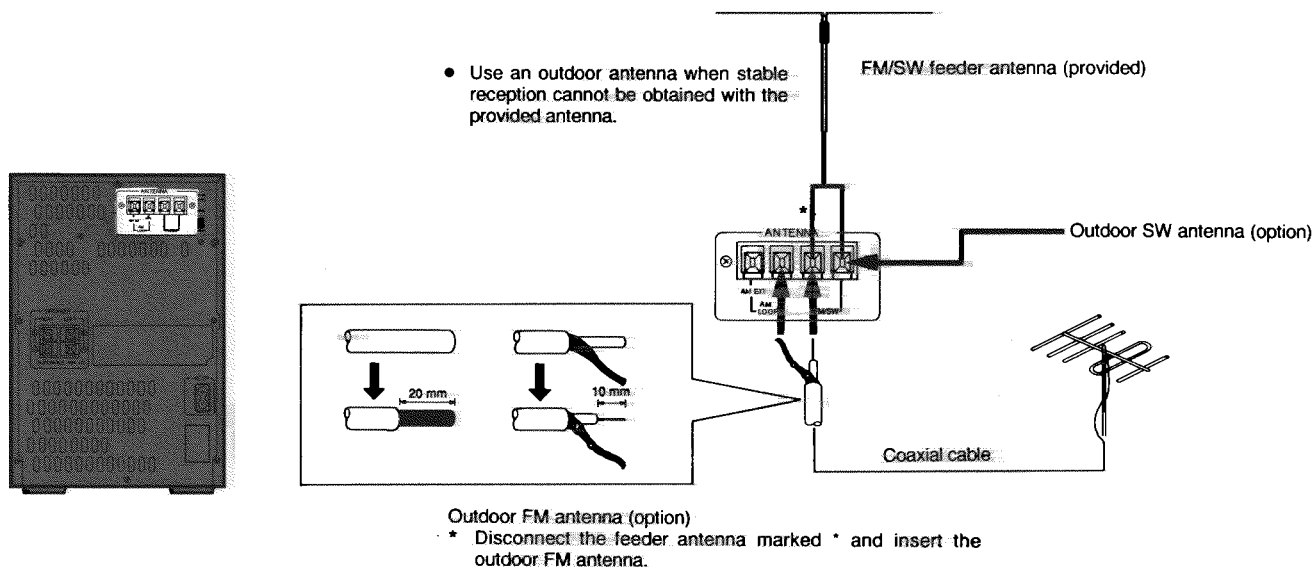

Notes:

- Do not place the loop antenna on a metal desk or near a TV or personal computer.
- Installing an outdoor antenna requires experience; we recommend that you consult an audio dealer.
- Install the antenna cord away from the power and speaker cords as these could generate noise. Install the loop antenna so that it does not touch the rear of the unit.

Speaker cord connection

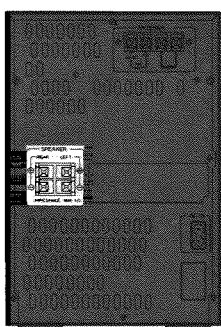

- Connect the cord from the speaker on the left to the (LEFT) terminals and the cord from the speaker on the right to the (RIGHT) terminals.

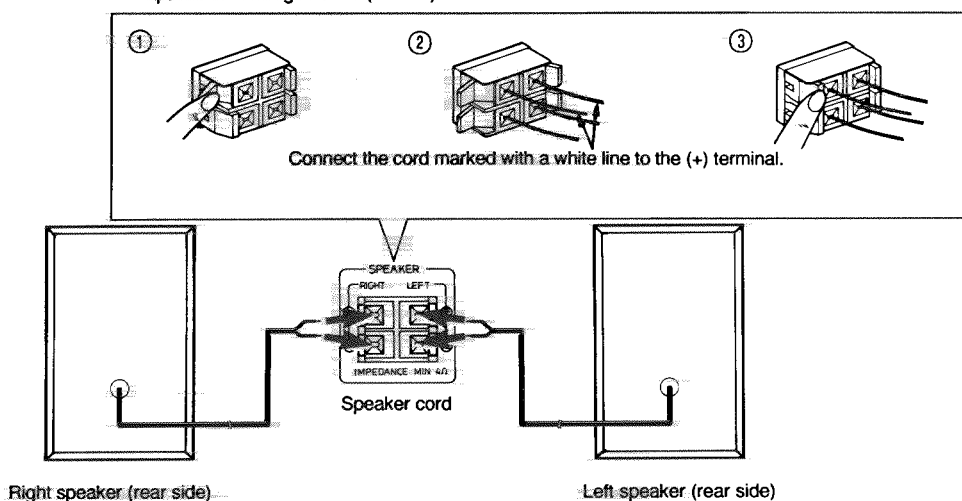

Notes:

- The polarity with which the two speakers are connected will be the same if the speaker cords marked with a white line are connected to the (+) terminals. If the speakers are connected with reverse polarity, the stereo effect and tone will be degraded.
- The speakers of this unit are not magnetically shielded. When they are placed directly on or adjacent to a TV, the TV's color could be distorted. Install the speakers more than 10 cm away from your TV.
- If the speakers are to be placed away from the main unit, purchase optional speaker cords from an audio store.

6. Location of Main Parts

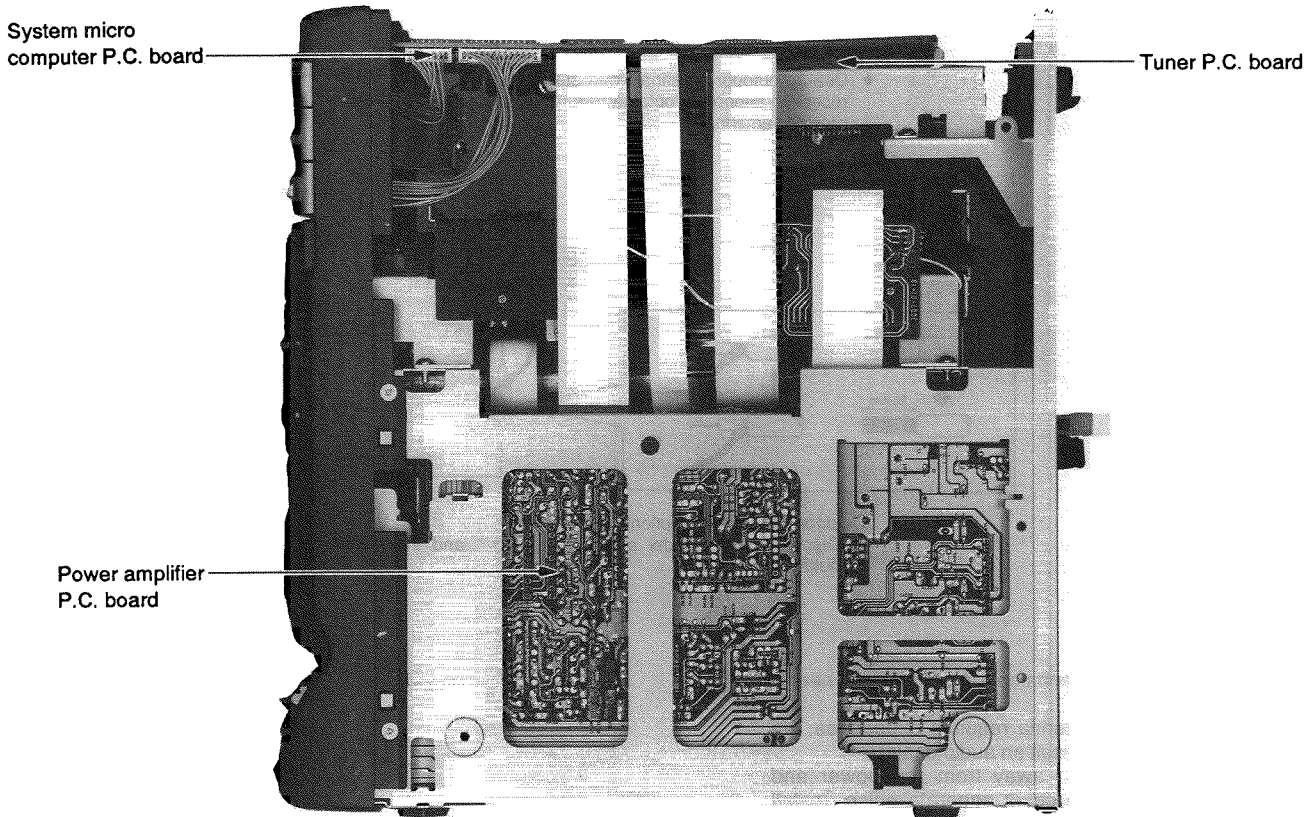

Fig. 6 - 1

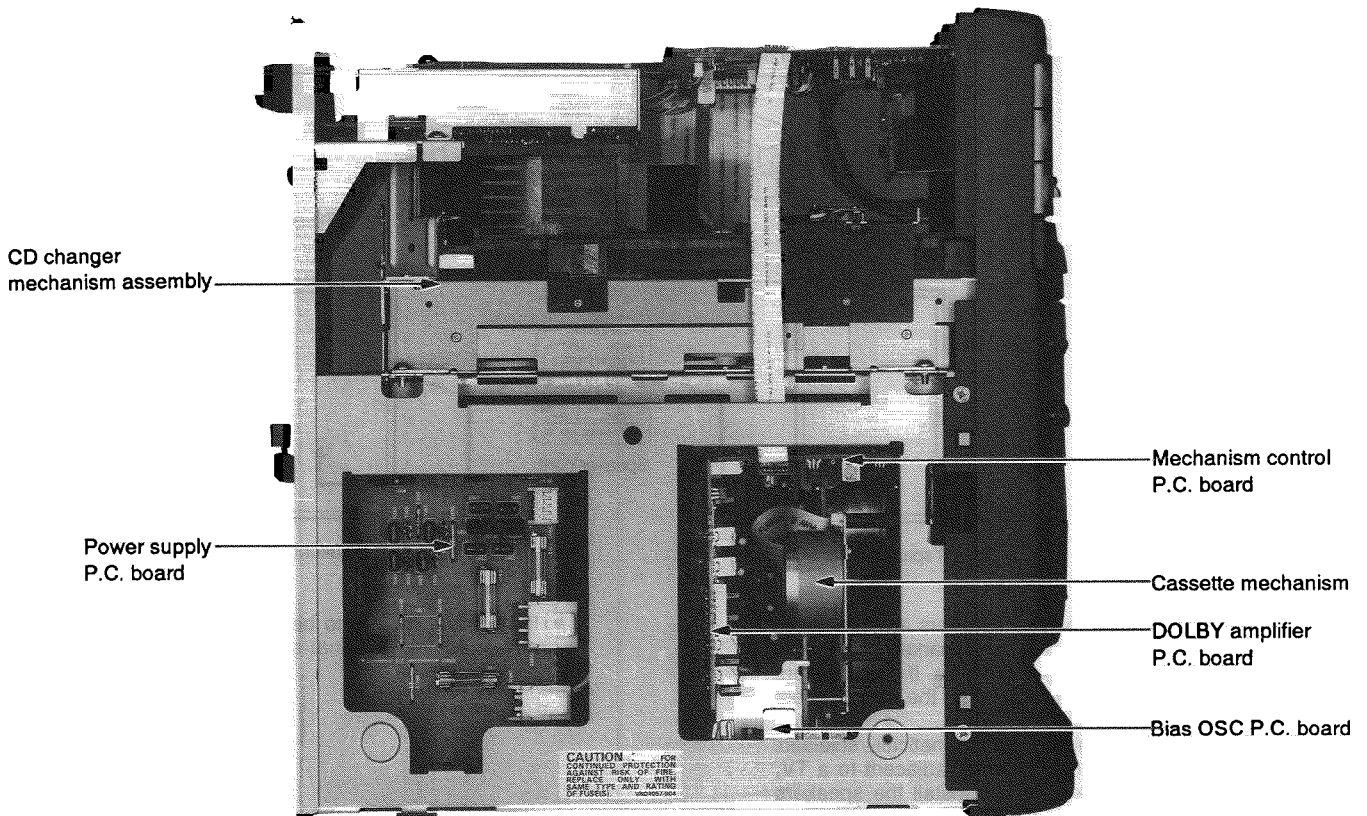

Fig. 6 - 2

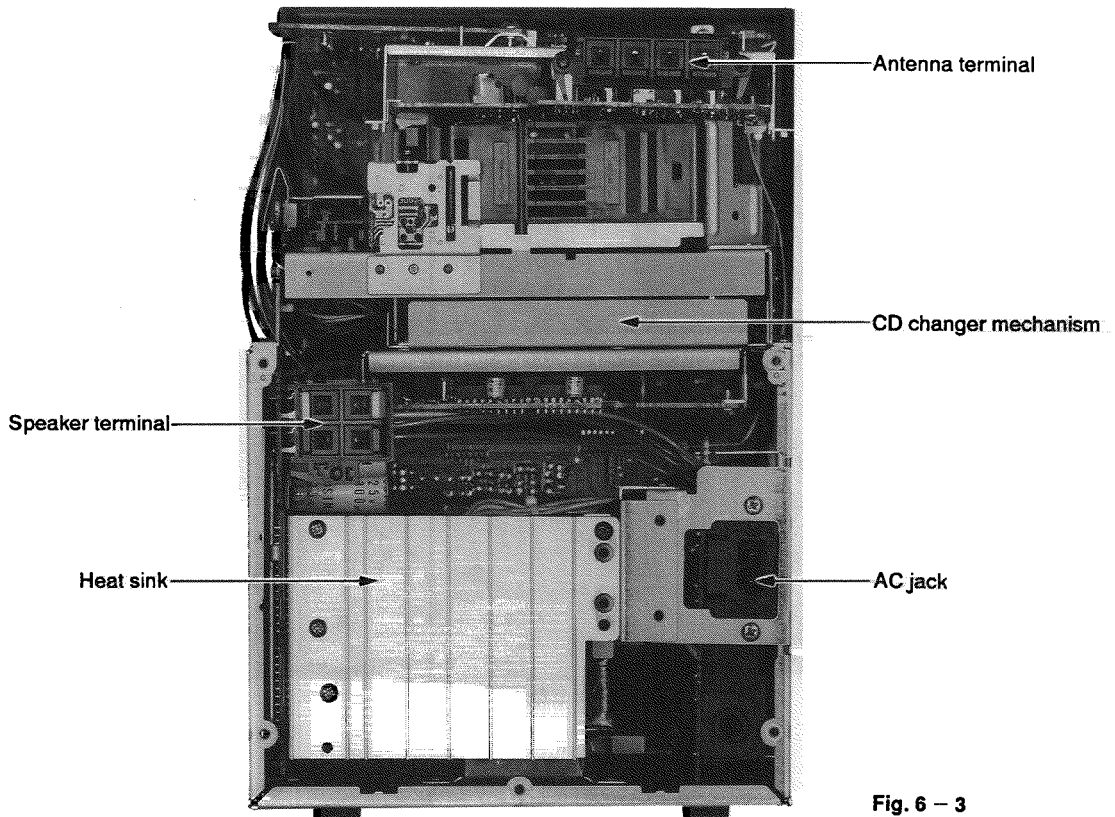

Fig. 6 - 3

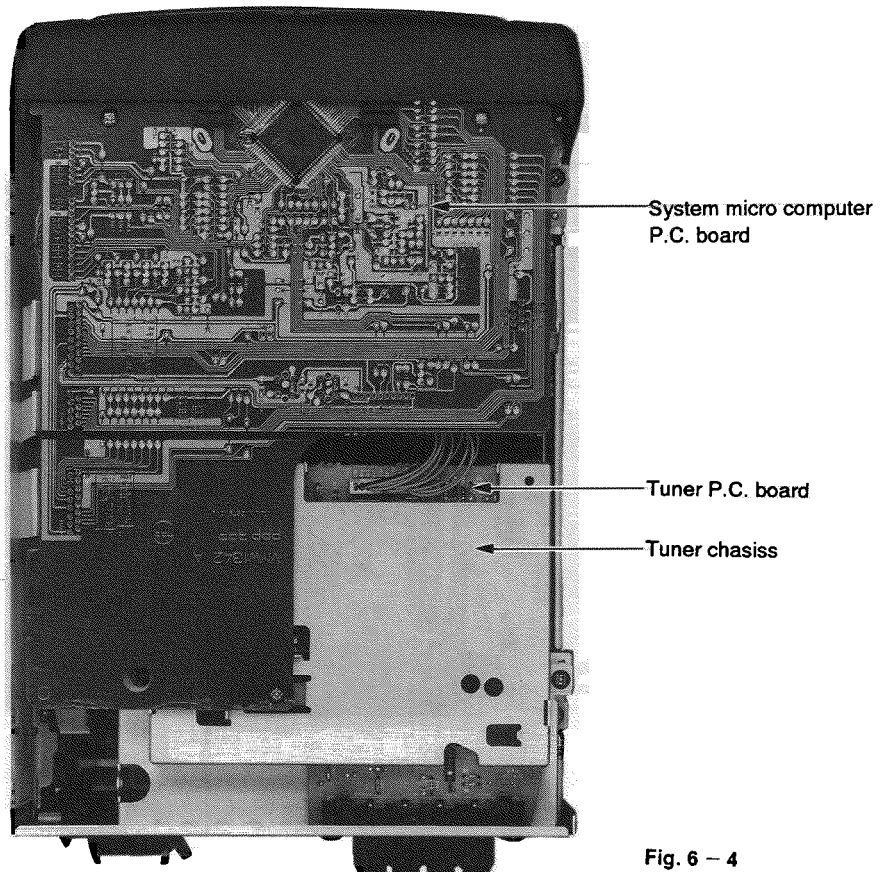

Fig. 6 - 4

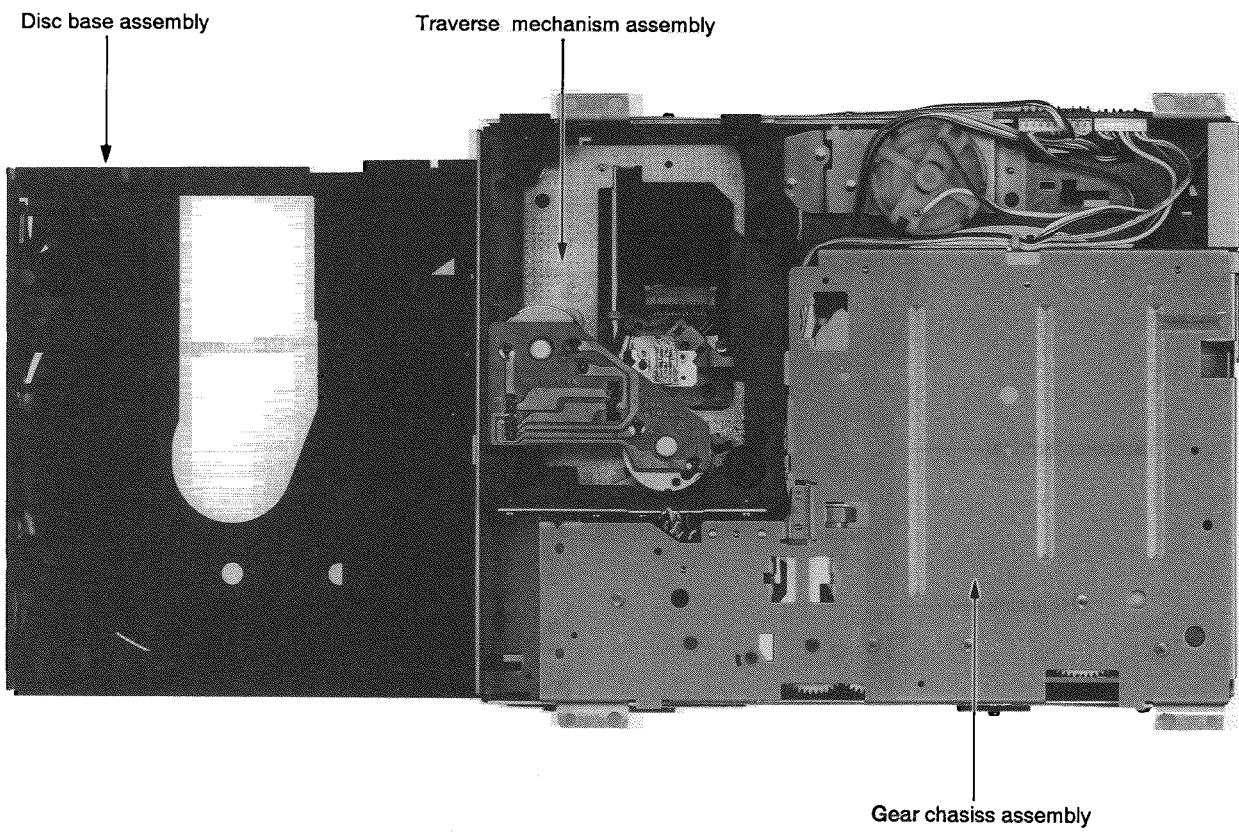

Fig. 6 - 5

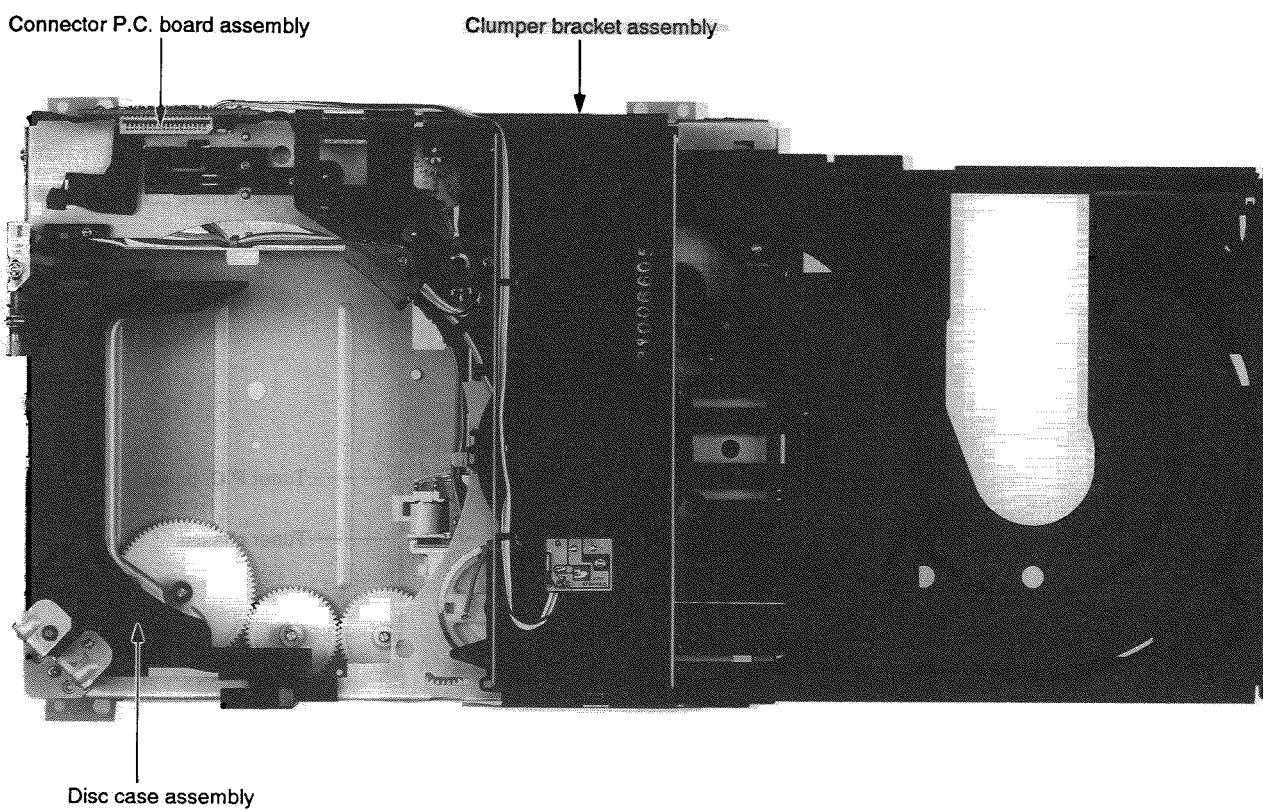

Fig. 6 - 6

7. Removal of Main Parts

■ Method of removing the top cover (Refer to Figs 7-1 ~ 7-3)

1. From the back surface of the body, remove the five screws ① retaining the top cover.
2. From the right and left sides of the body, remove the two screws ② retaining the top cover.
3. While manually expanding the sleeves on the right and left sides of the top cover to outside, remove the top cover from the back surface of the body by raising and falling the sleeves to the front side.

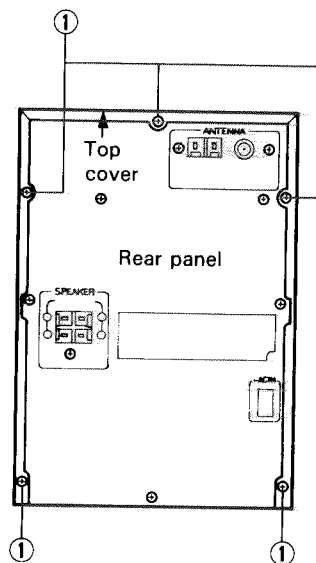

Fig. 7-1

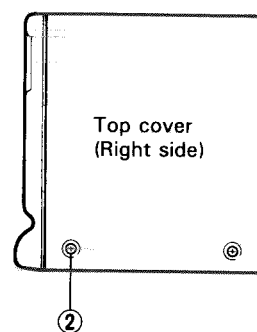

Fig. 7-2

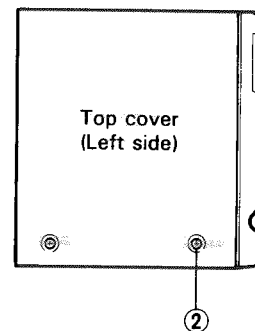

Fig. 7-3

■ Method of removing the system micro-computer P.C. board (Refer to Figs. 7-4 ~ 7-6)

1. From right above the body, remove the three screws ③ retaining the system microcomputer P.C. board.
2. From the connector CN1 on the tuner P.C. board, remove the # 10 PIN connector outgoing from W704 on the system microcomputer P.C. board.
3. After turning the body to the left side, the wire card outgoing from the connector CN854 on the cassette control P.C. board should be removed from the connector CN703 on the system microcomputer P.C. board.
4. After turning the body to the right side, the wire card outgoing from the connector CN801 on the CD changer control P.C. board should be removed from the connector CN704 on the system microcomputer P.C. board.
5. From the connector CN702 on the system microcomputer P.C. board, remove the wire card outgoing from the connector CN601 on the CD amplifier P.C. board.
6. From the connector CN701 on the system microcomputer P.C. board, remove the wire card outgoing from the connector CNA33 on the power amplifier P.C. board.
7. From the connector CN706 on the system microcomputer P.C. board, remove the # 13 PIN connector outgoing from W702 on the CD changer control P.C. board.
8. From the connector CN705 on the system microcomputer P.C. board, remove the connector outgoing from W701 on the CD operation switch control P.C. board.

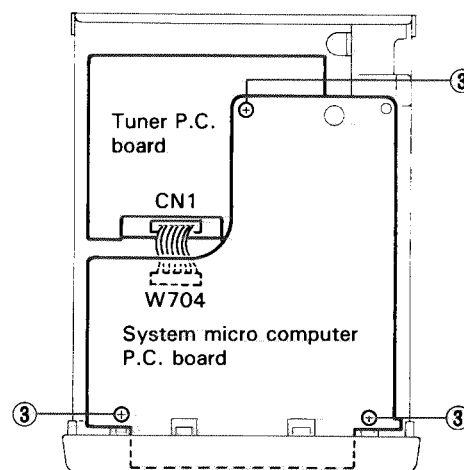

Fig. 7-4

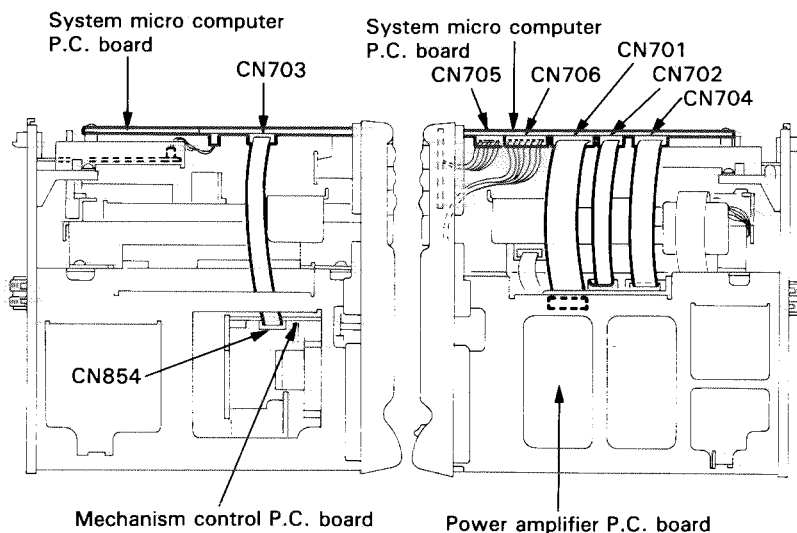

Fig. 7-5

Fig. 7-6

■ Method of removing the tuner P.C. board
(Refer to Figs. 7-7 ~ 7-9)

1. Remove the top cover (Refer to "Method of removing the top cover").
2. Remove the system microcomputer P.C. board (Refer to Items 1 and 2 of "Method of removing the system microcomputer P.C. board").
3. From the tuner bracket, remove the two screws ④ retaining the protector covering the tuner P.C. board (Refer to Fig. 7-7).
4. From the back surface of the body, remove the two screws ⑤ retaining the antenna terminal on the tuner P.C. board (Refer to Fig. 7-8).
5. From the tuner P.C. board assembly, remove the tuner bracket attached to the rear panel.
6. From the tuner bracket, remove the one screw ⑥ retaining the tuner P.C. board using the P.C. board assembly as a soldering surface (Refer to Fig. 7-9).

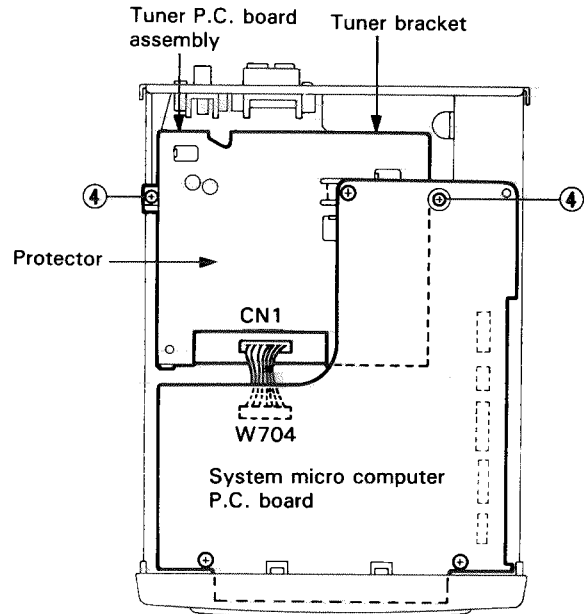

Fig. 7-7

■ Method of removing the rear panel
(Refer to Fig. 7-8)

1. Remove the top cover (Refer to "Method of removing the top cover").
2. Remove the system microcomputer P.C. board (Refer to Items 1 and 2 of "Method of removing the system microcomputer P.C. board").
3. From the rear panel, remove the one screw ⑦ retaining the speaker terminal (Refer to Fig. 7-8).
4. From the back surface of the body, remove the three screws ⑧ retaining the rear panel (Refer to Fig. 7-8).
5. Remove the rear panel together with the tuner bracket retaining the panel.

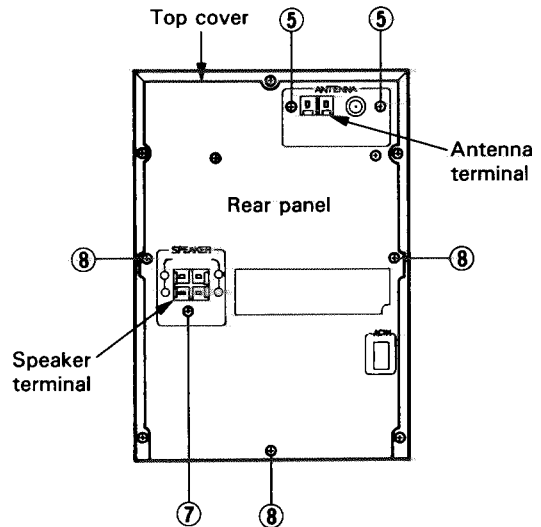

Fig. 7-8

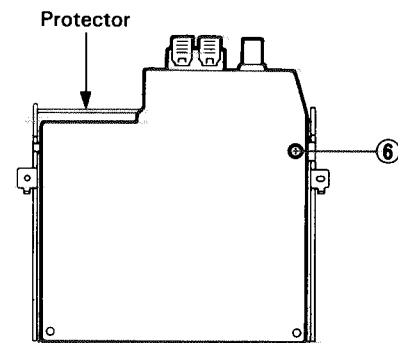

Fig. 7-9

■ **Method of removing the CD changer mechanism assembly**
(Refer to Figs. 7-10 ~ 7-12)

1. After turning on the power supply, press the CD tray [OPEN/CLOSE] button and draw out the CD tray. Next, pull out the power cord from the receptacle, and remove the CD fitting while pushing it in the direction of arrow. Subsequent to plug the power cord into the receptacle, press the CD tray [OPEN/CLOSE] button and return the CD tray. Then, turn off the power supply and pull out the power cord from the receptacle (Refer to Fig. 7-10).
2. Remove the top cover (Refer to "Method of removing the top cover").
3. Remove the system microcomputer P.C. board (Refer to "Method of removing the system microcomputer P.C. board").
4. Remove the rear panel assembly (Refer to "Method of removing the rear panel assembly").
5. From right above the body, remove the four screws ⑨ retaining the CD changer mechanism assembly (Refer to Fig. 7-11).
6. While putting the CD changer mechanism assembly on its left side (viewed from the rear panel side), the #5 PIN connector outgoing from FW501 on the CD amplifier P.C. board should be removed from the connector CNA32 on the power amplifier P.C. board.
7. Remove the CD changer mechanism body from the body.

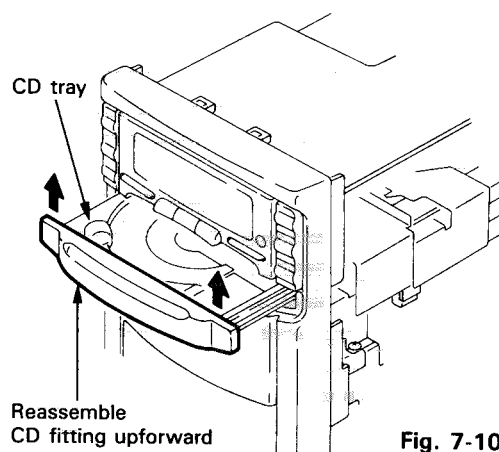

Fig. 7-10

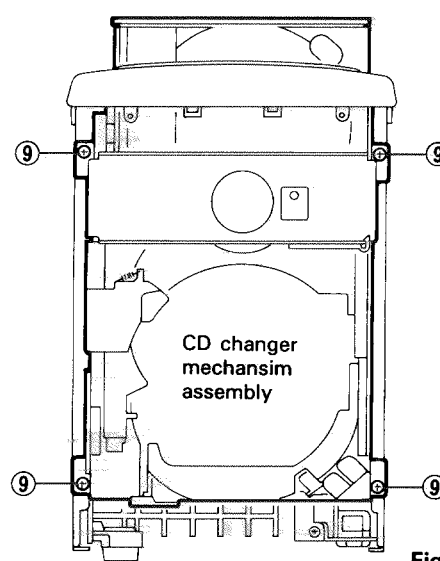

Fig. 7-11

■ **Method of removing the CD amplifier and CD changer control P.C. boards**
(Refer to Fig. 7-12)

1. Remove the top cover (Refer to "Method of removing the top cover").
2. Remove the system microcomputer P.C. board (Refer to "Method of removing the system microcomputer P.C. board").
3. Remove the rear panel assembly (Refer to "Method of removing the rear panel assembly").
4. Remove the CD changer mechanism assembly (Refer to "Method of removing the CD changer mechanism assembly").
5. After turning over the CD changer mechanism assembly, remove the three screws ⑩ retaining the CD amplifier P.C. board.
6. From the connector CN502 on the CD amplifier P.C. board, remove the #6 PIN connector outgoing from the spindle/feed motor P.C. board.
7. From the connector CN501 on the CD amplifier P.C. board, remove the wire card outgoing from the optical pickup unit P001.

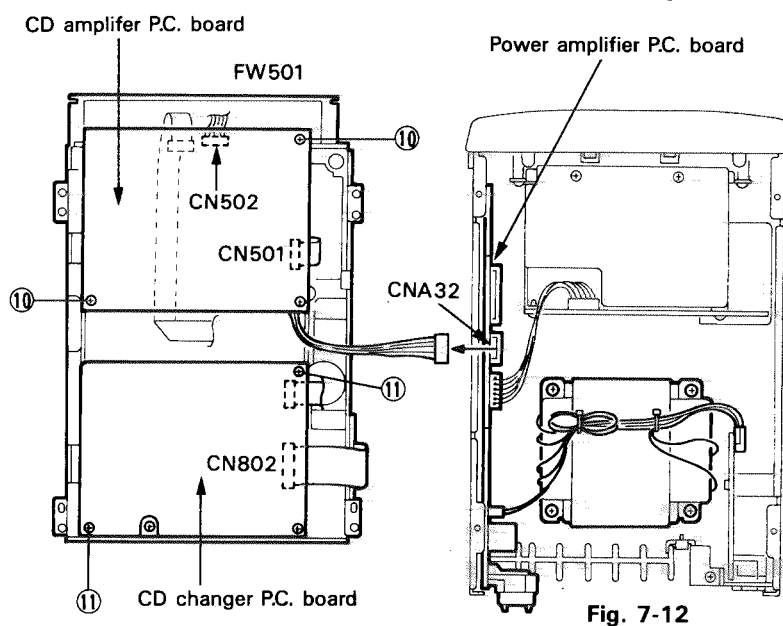

Fig. 7-12

8. Remove the three screws ⑪ retaining the CD changer control P.C. board.
9. From the connector CN802 on the CD changer control P.C. board, remove the wire card outgoing from the signal relay P.C. board attached to the CD changer mechanism.

Method of removing the front panel assembly (Refer to Figs. 7-13 ~ 7-14)

1. Remove the CD fitting (Refer to "Method of removing the CD changer mechanism assembly").
2. Remove the top cover (Refer to "Method of removing the top cover").
3. Remove the system microcomputer P.C. board (Refer to "Method of removing the system microcomputer P.C. board").
4. Remove the rear panel assembly (Refer to "Method of removing the rear panel assembly").
5. Remove the CD changer mechanism assembly (Refer to Item 2 and subsequent paragraphs of "Method of removing the CD changer mechanism assembly").
6. Remove the four conical screws (12) retaining both sides of the front panel assembly (Refer to Fig. 7-13).
7. With a minus screws driver, remove the four engagements (a) retaining both sides of the front panel assembly.
8. From the connector CNA34 on the power amplifier P.C. board, remove the # 7 PIN connector outgoing from W341 on the pre-amplifier P.C. board.

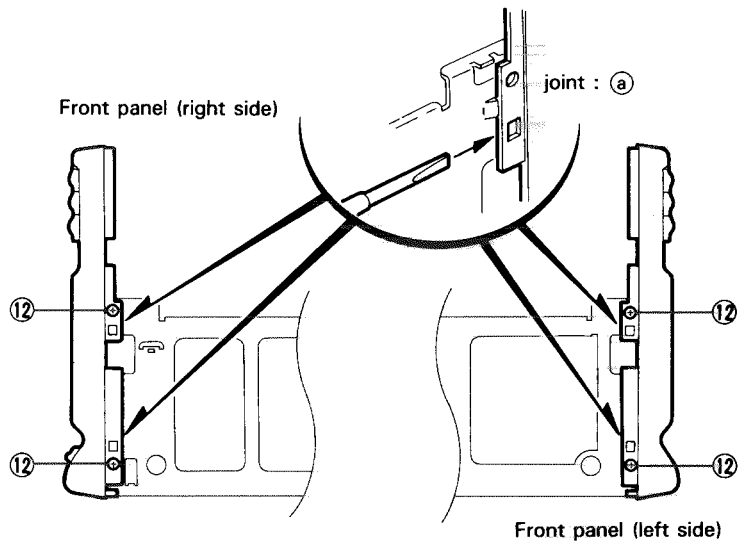

Fig. 7-13

Method of removing the power amplifier P.C. board (Refer to Fig. 7-14)

1. Remove the CD fitting (Refer to "Method of removing the CD changer mechanism assembly").
2. Remove the top cover (Refer to "Method of removing the top cover").
3. Remove the system microcomputer P.C. board (Refer to "Method of removing the system microcomputer P.C. board").
4. Remove the rear panel assembly (Refer to "Method of removing the rear panel assembly").
5. Remove the CD changer mechanism assembly (Refer to Item 2 and subsequent paragraphs of "Method of removing the CD changer mechanism assembly").
6. Remove the front panel assembly (Refer to "Method of removing the front panel assembly").
7. Remove the one screw (13) retaining the heat sink bracket on the power amplifier P.C. board (Refer to Fig. 7-14).
8. Remove the two wire treating clamps outgoing from W903 on the power transformer and power amplifier P.C. board (Refer to Fig. 7-14).
9. From the connector CN903 on the power supply P.C. board, remove the # 4 PIN connector outgoing from W903 on the power amplifier P.C. board (Refer to Fig. 7-14).

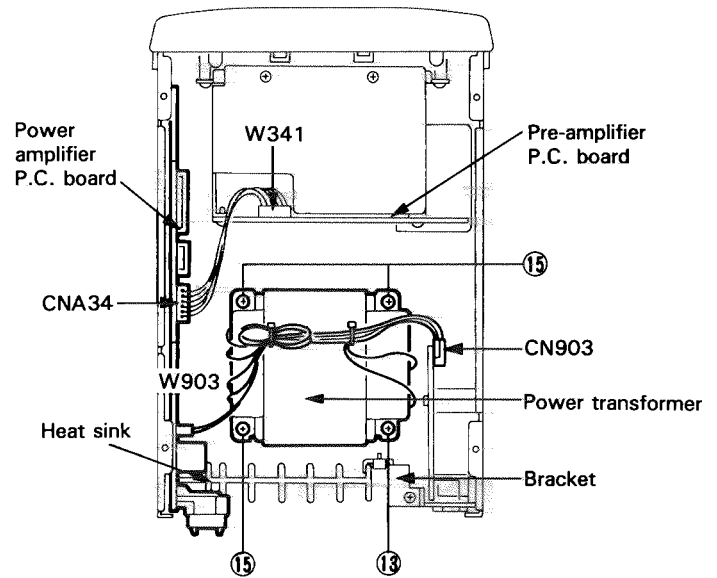

Fig. 7-14

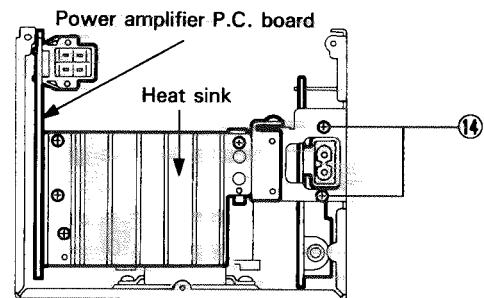

Fig. 7-15

■ **Method of removing the power transformer and power supply P.C. board**
(Refer to Figs. 7-14 and 7-15)

1. Refer to "Method of removing the power amplifier P.C. board" on Page 32 above.
2. Remove the four screws (15) retaining the power transformer (Refer to Fig. 7-14).
3. Remove the two screws (14) retaining the power supply P.C. board (Refer to Fig. 7-15).

■ **Method of removing the CD operation switch P.C. board, CD changer control switch P.C. board and so forth** (Refer to Fig. 7-16).

1. Remove the CD fitting (Refer to Item 1 of "Method of removing the CD changer mechanism assembly").
2. Remove the top cover (Refer to "Method of removing the top cover").
3. Remove the system microcomputer P.C. board (Refer to "Method of removing the system microcomputer P.C. board").
4. Remove the rear panel assembly (Refer to "Method of removing the rear panel assembly").
5. Remove the CD changer mechanism assembly (Refer to Item 2 and subsequent paragraphs of "Method of removing the CD changer mechanism assembly").
6. Remove the front panel assembly (Refer to "Method of removing the front panel assembly").
7. From the front panel assembly, remove the six screws (17) retaining the CD operation switch P.C. board.
8. Remove the six screws (18) retaining the CD changer control switch P.C. board.

■ **Method of removing the cassette mechanism assembly and door holder assembly**
(Refer to Fig. 7-16).

1. Refer to the procedures in Item 1 through Item 6 above.
2. Remove the four screws (19) retaining the cassette mechanism and door holder, and dismount these mechanism and assembly from the front panel assembly.
3. From the front panel, remove the three screws (31) retaining the door holder assembly.

■ **Method of removing the tape deck operation switch P.C. board** (Refer to Figs. 7-17 and 7-18)

1. Remove the cassette mechanism assembly (Refer to "Method of removing the cassette mechanism assembly").
2. By pressing the [EJECT] button, open the cassette door (Refer to Fig. 7-17).
3. By moving the cassette lid in the direction of arrow, remove the cassette from the cassette holder.
4. Remove the three screws (20) retaining the tape deck operation switch P.C. board (Refer to Fig. 7-18).

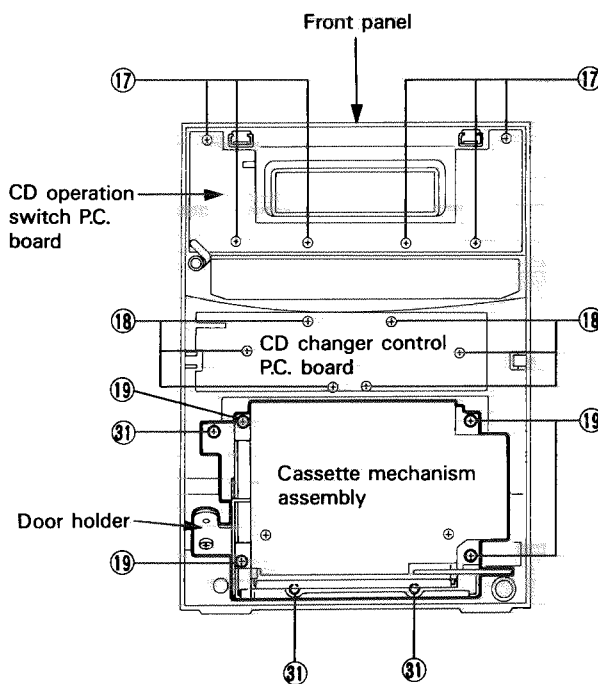

Fig. 7-16

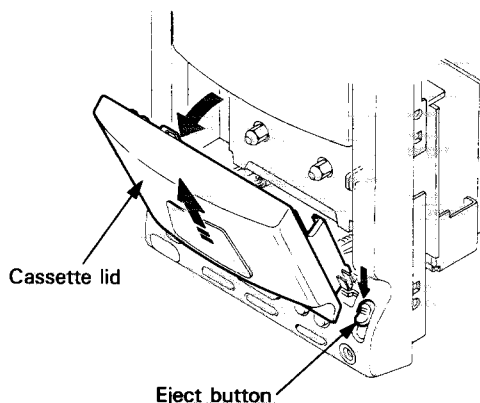
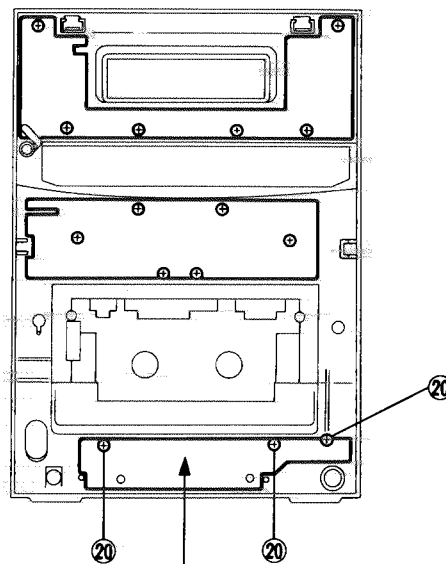

Fig. 7-17



Tape deck operation switch P.C. board

Fig. 7-18

■ **Method of removing the cassette mechanism control P.C. board and Dolby amplifier P.C. board (Refer to Fig. 7-19)**

1. Remove the CD fitting (Refer to Item 1 of "Method of removing the CD changer mechanism assembly").
2. Remove the top cover (Refer to "Method of removing the top cover").
3. Remove the system microcomputer P.C. board (Refer to "Method of removing the system microcomputer P.C. board").
4. Remove the rear panel assembly (Refer to "Method of removing the rear panel assembly").
5. Remove the CD changer mechanism assembly (Refer to Item 2 and subsequent paragraphs of "Method of removing the CD changer mechanism assembly").
6. Remove the front panel assembly (Refer to "Method of removing the front panel assembly").
7. Remove the cassette mechanism assembly and door holder assembly (Refer to "Method of removing the cassette mechanism assembly and door holder assembly").
8. From the cassette mechanism assembly, remove the four screws (21 × 2 and 22 × 2) retaining the cassette mechanism control P.C. board and Dolby amplifier P.C. board.
9. After respectively removing the connectors CN342 and CN343 on the Dolby amplifier P.C. board, CN322 on the bias OSC P.C. board and CN851 on the cassette mechanism control P.C. board, dismount the Dolby amplifier P.C. board.

10. While raising the cassette mechanism control P.C. board, remove the P.C. board respectively from the connectors CN852, CN853 and CN855 on the cassette mechanism control P.C. board, connector CN2 on the reel motor P.C. board, connector CN1 on the leaf switch P.C. board and connector CN302 on the preamplifier P.C. board.

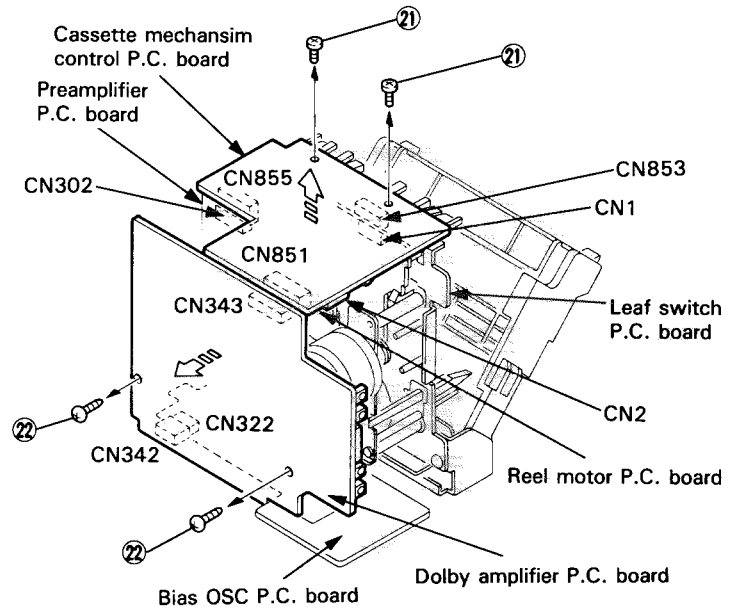

Fig. 7-19

■ **Method of removing the preamplifier P.C. board and bias OSC P.C. board (Refer to Fig. 7-20)**

1. Refer to the procedures in Item 1 through Item 10 on page 33.
2. From the connector CN301 on the preamplifier P.C. board, remove the flexible print card outgoing from the recording and playing head.
3. From the cassette mechanism assembly, remove the one screw (23) retaining the preamplifier P.C. board.
4. After moving the preamplifier P.C. board, remove the protruding portion (b) of the mechanism from the notched groove on the P.C. board.
5. From the bracket, remove the two screws (24) retaining the preamplifier P.C. board.
6. Remove the connectors CN303 on the preamplifier P.C. board and CN321 on the bias OSC P.C. board.
7. From the bracket, remove the one screws (25) retaining the bias OSC P.C. board.

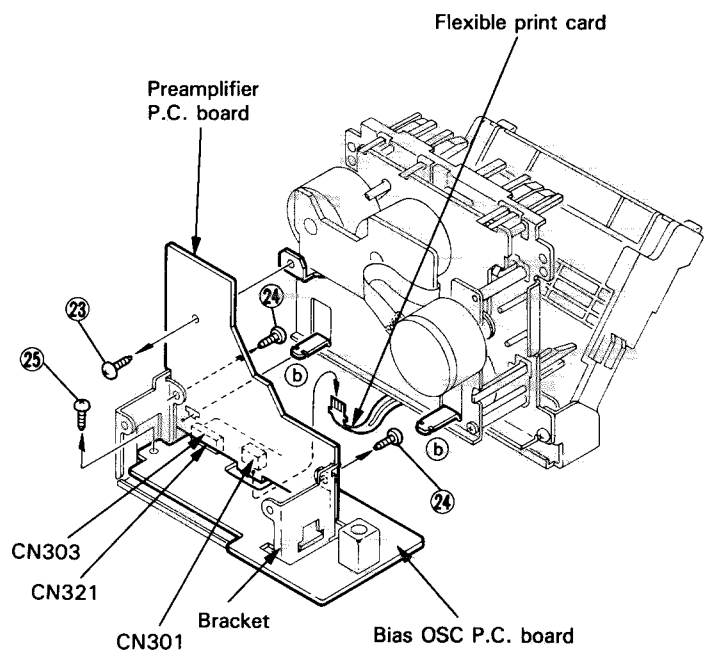

Fig. 7-20

■ **Method of removing the clamber base assembly (Refer to Fig. 7-21)**

1. Remove the CD fitting (Refer to Item 1 of "Method of removing the CD changer mechanism assembly").
2. Remove the top cover (Refer to "Method of removing the top cover").
3. Remove the system microcomputer P.C. board (Refer to "Method of removing the system microcomputer P.C. board").
4. Remove the rear panel assembly (Refer to "Method of removing the rear panel assembly").
5. Remove the CD changer mechanism assembly (Refer to Item 2 and subsequent paragraphs of "Method of removing the CD changer mechanism assembly").
6. From the CD changer mechanism assembly, remove the two screws (26) retaining the clamber base assembly.

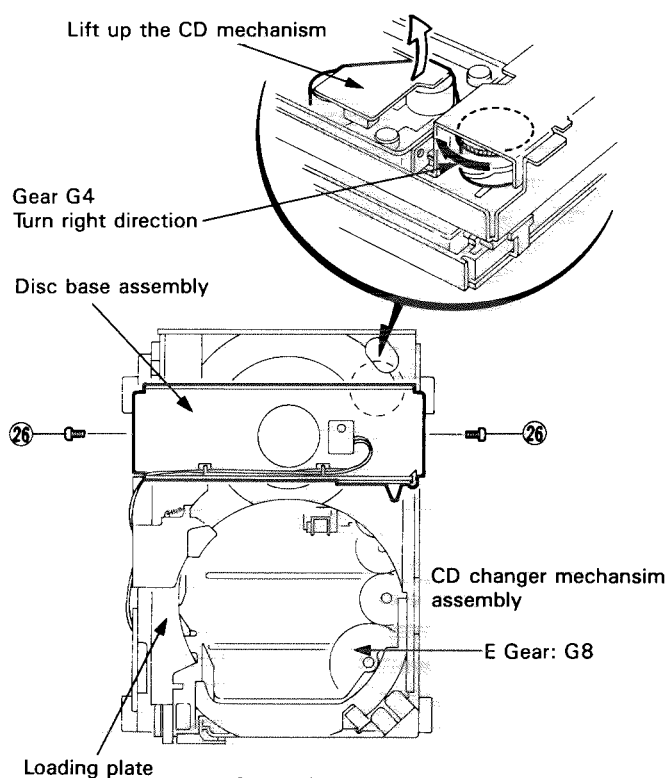

Fig. 7-21

■ **Forced ejection method of compact disc**

1. Remove the top cover. (Refer to "Method of removing the top cover").
2. Compact disc ejection method.
 - 2-1. Method of ejecting the compact disc on the disc base ass'y (Refer to Fig. 7-21).
 - (1) Turn the gear G4 clockwise and lower the CD mechanism.
 - (2) When the loading plate is located at the rearmost position, move the plate to the front panel side (At this time, the compact disc will be set on the disc base ass'y by the loading plate).
 - (3) By moving the disc base ass'y to the front panel side, take out the compact disc.
 - 2-2. Method of ejecting the compact disc left on the disc case ass'y (Refer to Fig. 7-22)
 - (1) Move the loading plate to the rearmost position.
 - (2) Turn the E gear G8 counterclockwise, and move up the disc case ass'y into which any compact disc has been loaded.
 - (3) While turning the E gear G8, align the first compact disc (the lowermost compact disc on the disc case ass'y) to its loading position to the loading plate.
 - (4) After the loading plate onto which the first compact disc is loaded has been moved to the front panel side, pull out the disc base ass'y from the front panel side and take out the compact disc.
 - (5) Eject the second through sixth compact discs as well similarly according to the procedures in Items 1 through 4. Whenever the second and subsequent discs are to be ejected, however, align the compact disc to be ejected to the height of the loading plate.

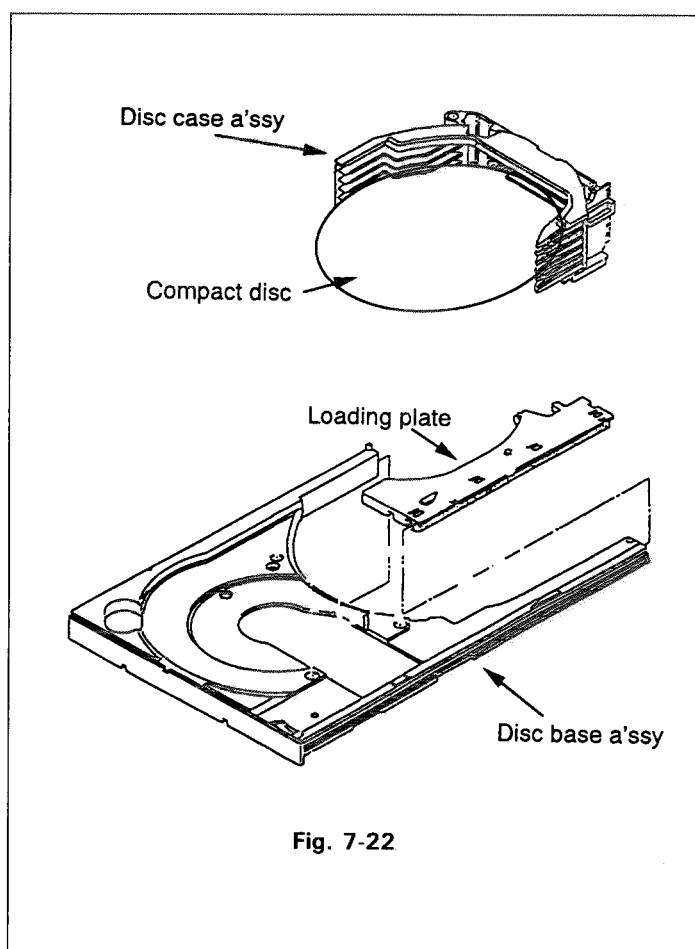

Fig. 7-22

■ **Method of removing the disc base assembly (Refer to Figs. 7-23 and 24)**

1. Refer to the procedures in Item 1 through Item 5 in the previous paragraph.
2. Remove the clamber assembly (Refer to "Method of removing the clamber assembly").
3. After turning over the CD changer mechanism assembly, turn the gear G4 manually in the direction of arrow as shown in Fig. 7-23, and raise the CD mechanism assembly.
4. Draw out the disc base assembly to the position the base is hooked.
5. After turning over the CD changer mechanism assembly, move the point (C) engaging the cover plate A (S) and disc base assembly in the direction of arrow and disengage the above plate and assembly.
6. After turning the CD changer mechanism assembly back to the normal position, remove the one screw (27) retaining the disc base bracket visible from notched window of the disc base assembly (Refer to Fig. 7-24).
7. Draw out the disc base assembly toward the front side until the assembly is hooked.
8. While lifting the tip of the disc base assembly, move the blue guide stopper slide switch in the direction of arrow, and remove the switch from the disc base assembly (Refer to Fig. 7-25).
9. Draw out the disc base assembly further toward the front side until it is hooked by the guide.
10. When the guide stopper switch and guide have been removed by lifting the tip of disc base assembly, then the disc base assembly will be dismounted.

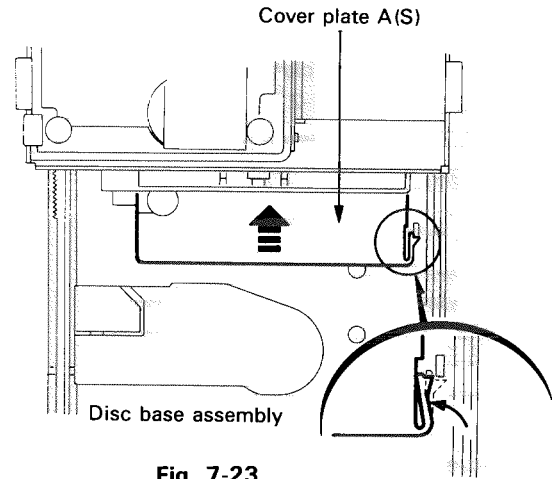

Fig. 7-23

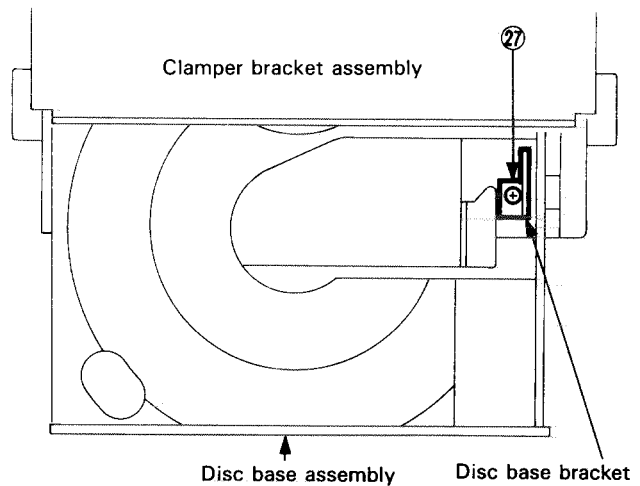

Fig. 7-24

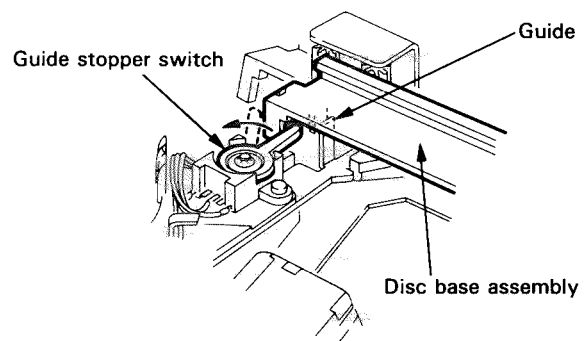

Fig. 7-25

■ Method of removing the CD mechanism
(Refer to Fig. 7-26)

1. Remove the CD fitting (Refer to Item 1 of "Method of removing the CD changer mechanism assembly").
2. Remove the top cover (Refer to "Method of removing the top cover").
3. Remove the system microcomputer P.C. board (Refer to "Method of removing the system microcomputer P.C. board").
4. Remove the rear panel assembly (Refer to "Method of removing the rear panel assembly").
5. Remove the CD changer mechanism assembly (Refer to Item 2 and subsequent paragraphs of "Method of removing the CD changer mechanism assembly").
6. Remove the CD amplifier and CD changer control P.C. board (Refer to "Methods of removing the CD amplifier and CD changer control P.C. board").
7. From the CD changer mechanism assembly, remove the two screws (28) retaining the P.C. board holder bracket (Refer to Fig. 7-26).
8. From the CD changer mechanism assembly, remove the two screws (29) retaining the CD mechanism (Refer to Fig. 7-26 and 7-27).

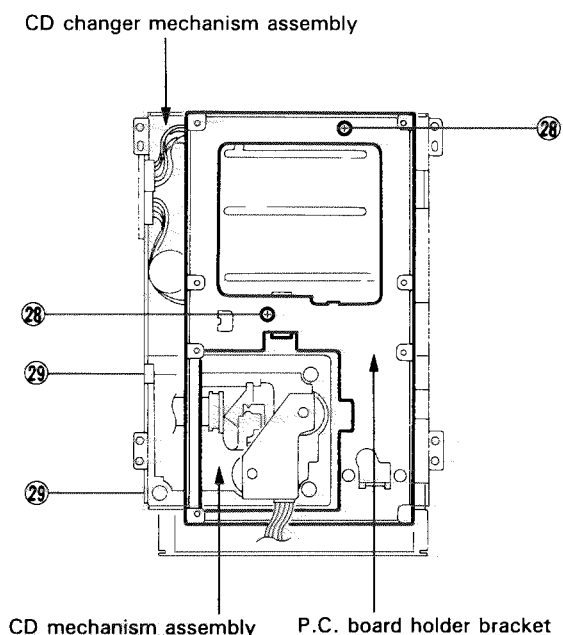

Fig. 7-26

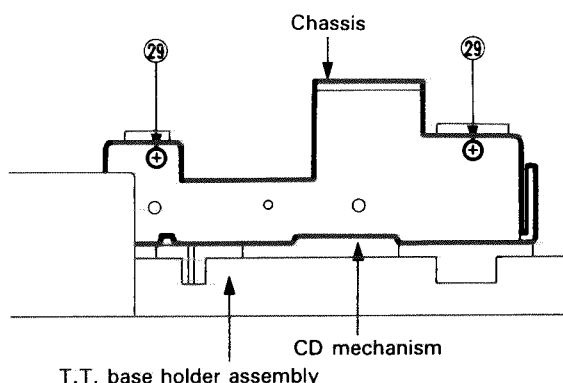
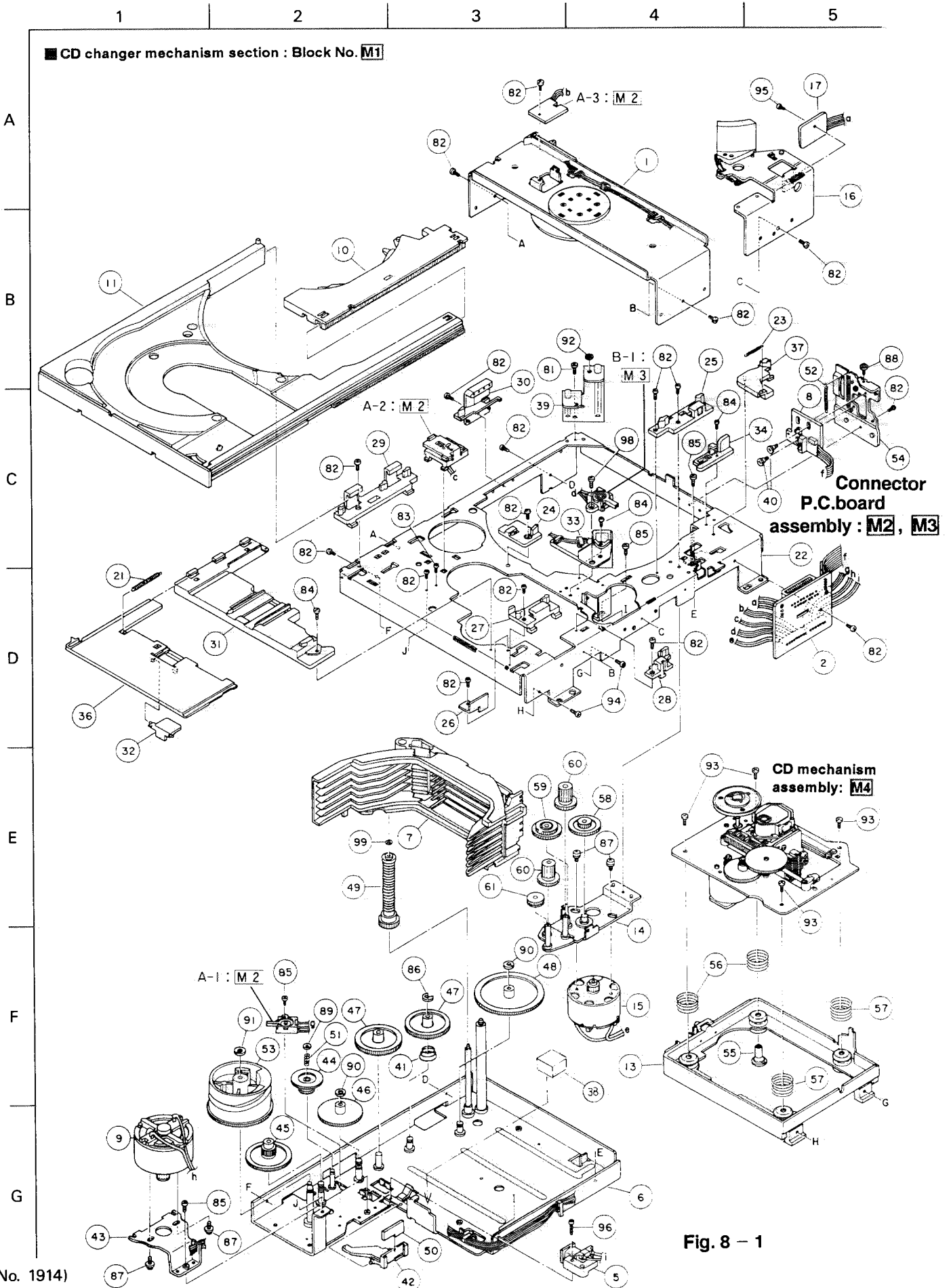

Fig. 7-27

8. Analytic Drawing and Parts List



■ CD Changer mechanism assembly parts list

BLOCK NO. M1MM III

△	REF.	PARTS NO.	PARTS NAME	REMARKS	QTY	SUFFIX	CLR
	1	300701307T	CLUMPER BKT ASY		1		
	2	*****	CONNECTOR PCB		1		
	2- 1	30070119T	CONNECTOR BOARD		1		
	2- 2	681402154T	CONNECTOR		1		
	2- 3	68190503T	RESISTOR		2		
	2- 4	30071016T	10PIN WIRE ASSY	= A BLOCK:M2	1		
	2- 5	30071015T	7PIN WIRE ASSY	= B BLOCK:M3	1		
	5	300702303T	COIL ASSY		1		
	6	300702505T	GEAR CHASSIS	ASSY	1		
	7	300702305T	DISC CASE ASSY		1		
	8	*****	E.SENSOR PCB	ASSY	1		
	8- 1	30070250T	E.SENSOR PCB(W)		1		
	8- 2	68190801T	PHO.INTERAPTOR		1		
	8- 3	64010401T	PUSH SWITCH		1		
	8- 4	64010402T	PUSH SWITCH		1		
	8- 5	30071017T	RIBBON WIRE		1		
	9	300702302T	E.MOTOR ASSY		1		
	10	300706301T	LAODING PLATE	ASSY	1		
	11	300706304T	DISC BASE ASSY		1		
	13	*****	T.T BASE HOLDER	ASSY	1		
	13- 1	30070713T	HOLDER	FLOAT RUBBER	4		
	13- 2	30070741T	RUBBER(S) B	FLOATING	4		
	13- 3	30070745T	HOLDER(S)	T.T.BASE	1		
	13- 4	30070750T	FORECEMENT	T.T.REIN	1		
	13- 5	9P0720531T	TAPPING SCREW	M2X3.5	4		
	14	300711501T	L.GEAR BKT ASSY		1		
	15	300711301T	L MOTOR ASSY		1		
	16	300711303T	GUIDE PLATE ASY		1		
	17	*****	L SENSOR PCB	ASSY	1		
	17- 1	30071116T	L.SENSOR PCB(W)		1		
	17- 2	68190801T	PHO.INTERAPTER		1		
	17- 3	30071018T	RIBBON WIRE		1		
	21	30070117T	SPRING	COVER PLATE	1		
	22	30070142T	CHASSIS		1		
	23	30070144T	SPRING	LOCK LEVER	1		
	24	30070165T	STOPPER		1		
	25	30070148T	GUIDE R3(S)		1		
	26	30070149T	DISC BASE BKT		1		
	27	30070150T	GUIDE R1(S)		1		
	28	30070151T	GUIDE R2(S)		1		
	29	30070153T	GUIDE L1(S)		1		
	30	30070154T	GUIDE L2(S)		1		
	31	30070155T	COVER PLATE B	(S)	1		
	32	30070156T	DISC STOPPER(S)		1		
	33	30070157T	GUIDE STOPPER A	(S)	1		
	34	30070158T	WIRE CLUMPER		1		
	36	30070162T	COVER PLATE A	(S)	1		
	37	30070163T	LOCK LEVER(S)		1		
	38	30070265T	CUSHION		1		
	39	30070240T	WORM GEAR BKT		1		
	40	19001204T	COLLAR SCREW		2		
	41	19210707T	SPRING	RF CLUTCH	1		
	42	30070202T	E CONTROL LEVER		1		
	43	30070203T	E MOTOR BKT		1		

BLOCK NO. M1MM

REF.	PARTS NO.	PARTS NAME	REMARKS	QTY	SUFFIX	CLR
44	30070214T	E GEAR G2		1		
45	30070215T	E GEAR G3		1		
46	30070217T	E GEAR G5		1		
47	30070218T	E GEAR G6		2		
48	30070220T	E GEAR G8		1		
49	30070221T	E GEAR G9		1		
50	30070228T	E CONTROL PLATE		1		
51	30070232T	SPRING	E GEAR G2	1		
52	30070233T	SPRING	E SENSOR	1		
53	30070259T	E GEAR G4(S)		1		
54	30070266T	E SENSOR BKT(S)		1		
56	30070755T	SPRING A	FLOATING	2		
57	30070756T	SPRING B	FLOATING	2		
58	30071103T	L GEAR B		1		
59	30071104T	L GEAR C		1		
60	30071105T	L GEAR D		2		
61	30071106T	L GEAR E		1		
81	9B0320041T	C TAPPING SCREW	M2X4	1		
82	9P0420041T	TAPPING SCREW	M2X4	18		
83	9P0420051T	TAPPING SCREW	M2X5	1		
84	9P0420061T	TAPPING SCREW	M2X6	4		
85	9C2020251T	SCREW	M2X2.5	3		
86	9E0100252T	E RING		1		
87	9P0226041T	SCREW	M2.6X4	4		
88	9P1720061T	SCREW	M2X6	1		
89	9W0250080T	WASHER	1.85X5X0.5	1		
90	9W0250110T	WASHER	2.6X6X0.5	2		
91	9W0250130T	WASHER	3X6X0.5	1		
92	9W0650220T	WASHER	2.6X4.5X0.5	1		
93	9B1220041T	TAPPING SCREW	M2X4	4		
94	9P0720061T	TAPPING SCREW	M2X6	3		
95	9C0320353T	CAMERA SCREW	M2X3.5	1		
96	9P0420081T	TAPPING SCREW	M2X8	2		
97	9C1920301T	TSS 2X3		1		
98	9P0426051T	TAPPING SCREW	M2.6X5	1		
99	9W0640070T	WASHER	2.1X4X0.4	1		

● Connector P.C.board assembly : REF.NO. 2

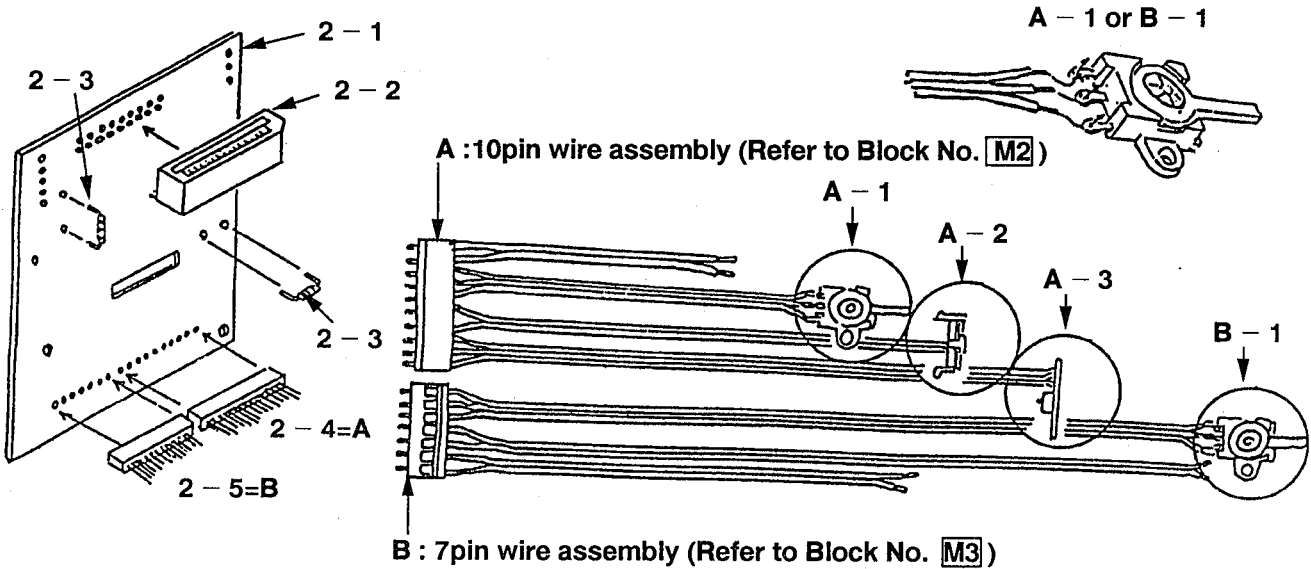

● Disc sensor P.C.board assembly : REF.NO. A - 2

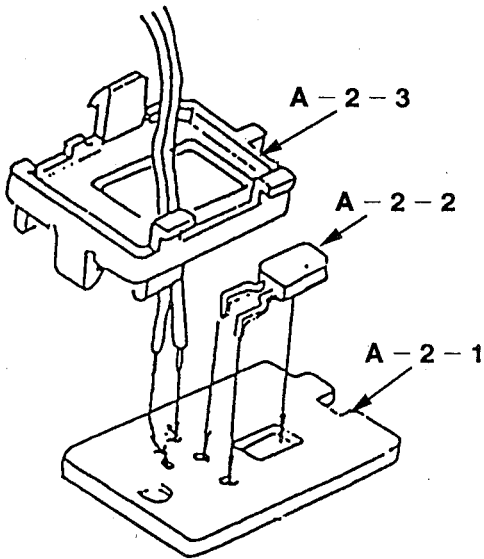

● Disc sensor P.C.board assembly REF.NO. A - 3

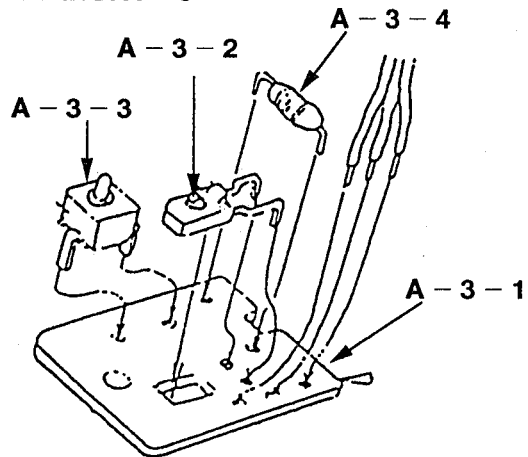

■ 2 - 4 = A : 10pin wire assembly parts list

BLOCK NO. M2MM | | | |

△	REF.	PARTS NO.	PARTS NAME	REMARKS	QTY	SUFFIX	CLR
	A	30071016T	10PIN WIRE ASSY	=2-4 BLOCK:M1	1		
	A-1	64020801T	SLIDE SWITCH		1		
	A-2	*****	DISC SENSOR PCB	A:ASS'Y	1		
	A-2-1	*****	DISC SENSOR PCB	"A"	1		
	A-2-2	30070127T	PHO.TRANSISTOR		1		
	A-2-3	30070122T	BRACKET	DISC SENSOR	1		
	A-3	*****	DISC SENSOR PCB	B:ASS'Y	1		
	A-3-1	30070125T	DISC SENSOR PCB	"B"	1		
	A-3-2	30070128T	PHOTO DIODE		1		
	A-3-3	64020412T	SWITCH		1		
	A-3-4	68190503T	RESISTOR		1		

■ 2 - 5 = B : 7pin wire assembly parts list

BLOCK NO. M3MM

△	REF.	PARTS NO.	PARTS NAME	REMARKS	QTY	SUFFIX	CLR
	B	30071015T	7PIN WIRE ASSY	=2-5 BLOCK:M1	1		
	B-1	64020801T	SLIDE SWITCH		1		

● E. Sensor P.C. board assembly
REF.No. 8

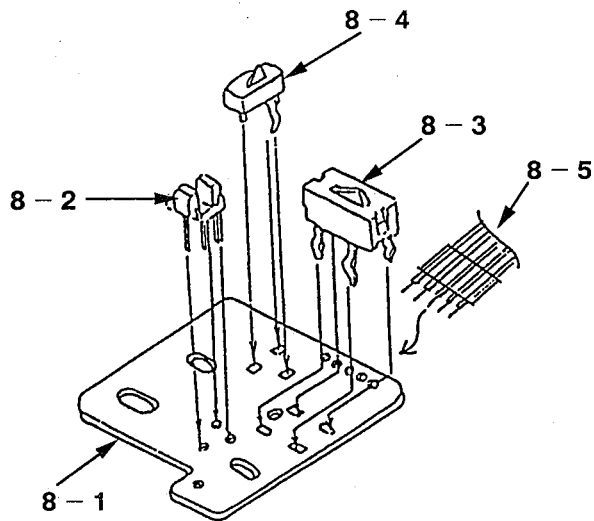

● L. sensor P.C. board assembly : REF.NO. 17

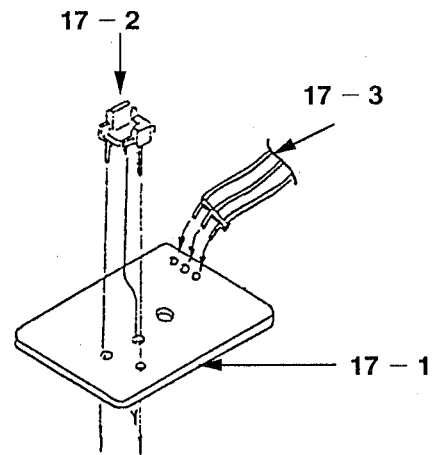

● T.T. base holder assembly : REF.NO. 13

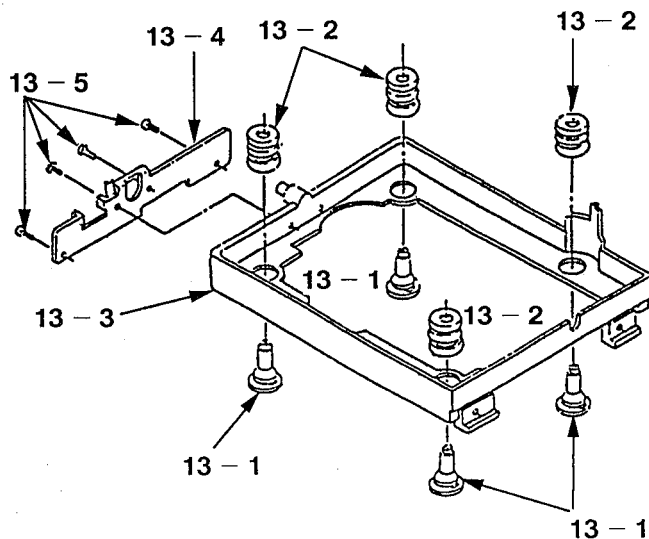

■ Enclosure Assembly Section: Block No. **M4**

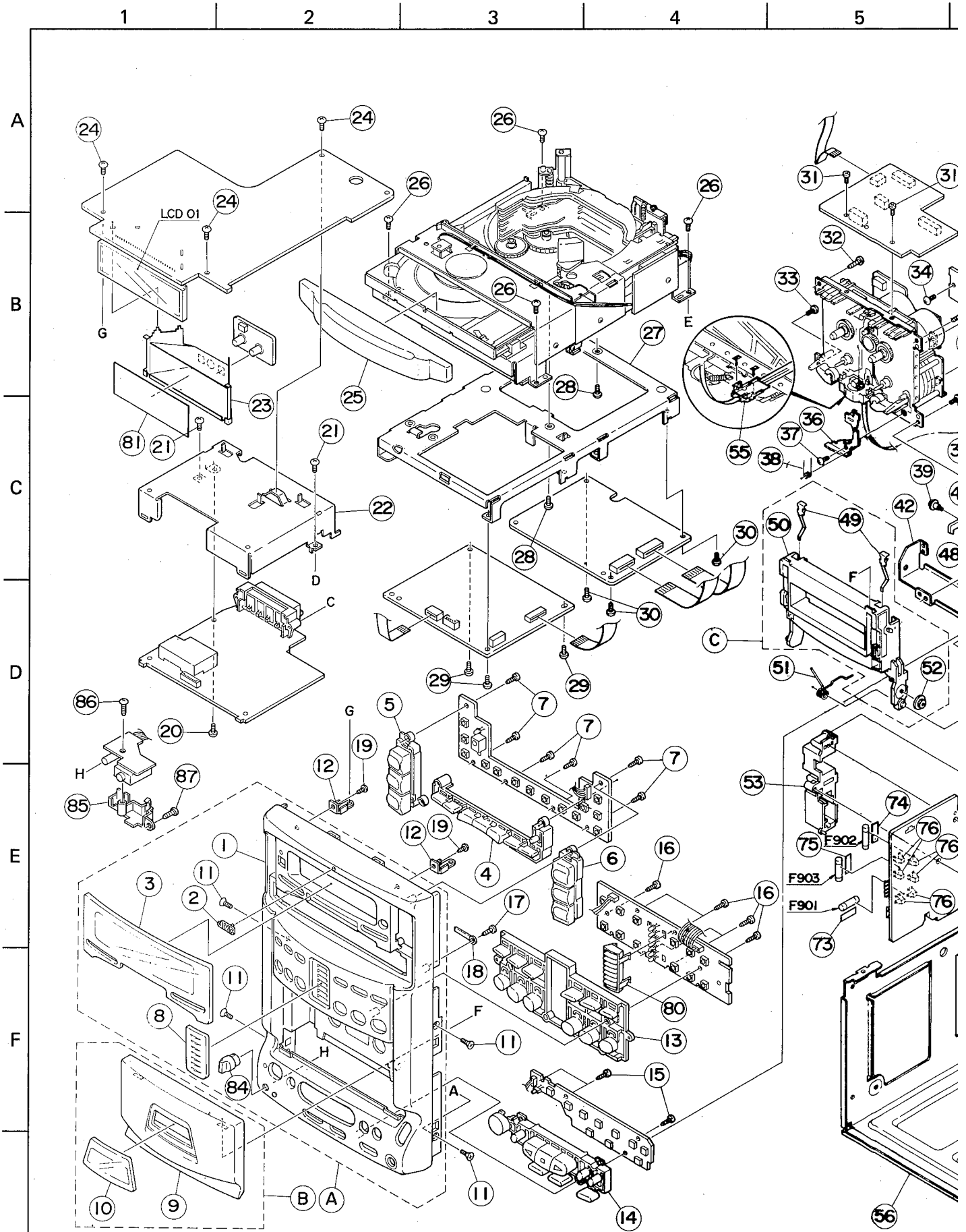

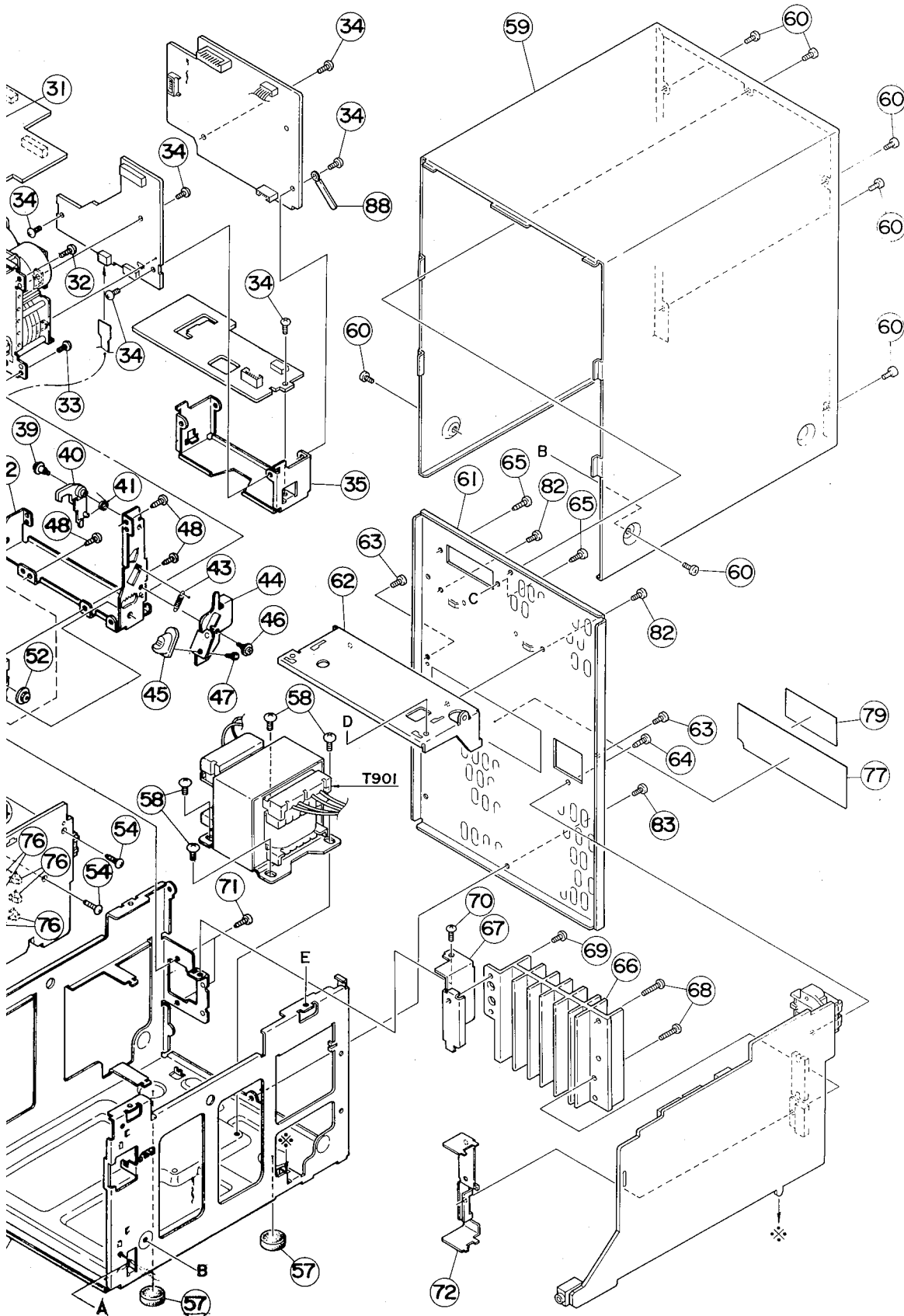

■ Enclosure Assembly Parts List

BLOCK NO. M4MM

△	REF.	PARTS NO.	PARTS NAME	REMARKS	QTY	SUFFIX	CLR
	A	ZCUXC7K-FB	FRONT CABINET	REF.1,2,3,8	1		
	B	ZCUXC7K-CH	CASSETTE HOLDER	REF.49,50,52	1		
	C	ZCUXC7K-CLB	CASSETTE LID	REF.9,10	1		
	1	VJG1275-003	FRONT PANEL		1		
	2	E406971-221	JVC MARK		1		
	3	VJK3637-002	LCD LENS		1		
	4	VXP3645-001	PUSH KNOB(A)		1		
	5	VXP5231-00A	BUTTON ASSY(L)		1		
	6	VXP5235-00A	BUTTON ASSY(R)		1		
	7	SDSF2608Z	SCREW	FOR KNOB/PWB	6		
	8	VJK4421-001	INDICATOR LENS		1		
	9	VJT2338-001	DOOR COVER		1		
	10	VJT4212-001	DOOR LENS		1		
	11	SSST3006Z	SCREW	FRONT+CHASSIS	4		
	12	VYH7872-001	PWB BKT(UCOM)		2		
	13	VXP3648-001	PUSH KNOB(B)		1		
	14	VXP3649-001	PUSH KNOB(C)		1		
	15	SDSF2608Z	SCREW	FOR KNOB/PWB	3		
	16	SDSF2608Z	SCREW	FOR KNOB/LED	6		
	17	SDSF2608Z	SCREW		1		
	18	VKZ4001-007	WIRE CLAMP		1		
	19	SDSF2608Z	SCREW	FOR PWB BKT	2		
	20	SBST3006Z	SCREW	T.CHASSIS+T.PWB	1		
	21	SBST3006Z	SCREW	T.BKT+CHASSIS	2		
	22	VYH3823-001	TUNER CHASSIS		1		
	23	VYH3825-002	LAMP CASE		1		
	24	SBST3006Z	SCREW	FOR CHG CTRL PW	3		
	25	VJT3361-001	TRAY FITTING		1		
	26	SBST3006Z	SCREW	CHG MECHA+CHASS	4		
	27	VYH2285-003	PWB BKT(CHG)		1		
	28	SBST3006Z	SCREW	P.BKT+CHG MECHA	2		
	29	SBST3006Z	SCREW	FOR CD AMP PWB	3		
	30	SBST3006Z	SCREW	U-CON PWB+T.CHA	1		
		SBST3006Z	SCREW	U-CON PWB+BKT	2		
	31	SDST2606Z	SCREW	MECHA CON PWB	2		
	32	SBSF3010Z	SCREW	F.PANEL+C.MECHA	2		
	33	SBST3006Z	SCREW	D.HOLDER+C.MECH	2		
	34	SBST3006Z	SCREW	FOR CASSETTE PW	6		
	35	VYH3819-001	PWB BKT(CASS)		1		
	36	VKL7293-001	EJECT SAFTY(R)		1		
	37	SBSF3010Z	SCREW	E.SAFTY+MECHA	1		
	38	VKW5069-002	TORSION SPRING	FOR EJECT SAFTY	1		
	39	VKZ4341-001	SPECIAL SCREW	E.ARM+D.HOLDER	1		
	40	VYH7347-001	EJECT ARM		1		
	41	VKW4938-001	TORTION SPRING	FOR EJECT LEVER	1		
	42	VYH3818-001	DOOR HOLDER		1		
	43	VKW3002-274	TENSION SPRING	FOR EJECT LEVER	1		
	44	VYH7873-001	EJECT LEVER		1		
	45	VXQ4121-001	EJECT KNOB		1		
	46	VKZ4323-002	SCREW	E.LEVER+D.HOLDE	1		
	47	SDSF2608Z	SCREW	E.LEVER+E.KNOB	1		
	48	SBSF3010Z	SCREW	D.HOLDER+F.PANE	3		
	49	VKY4180-001	CASSETTE SPRING		2		
	50	VJT2337-002	CASSETTE HOLDER		1		
	51	VKW5124-001	DOOR SPRING		1		

BLOCK NO. M4MM

REF.	PARTS NO.	PARTS NAME	REMARKS	QTY	SUFFIX	CLR
52	VYH5601-001	GEAR	DUNPING	1		
53	VYH3820-001	JACK HOLDER		1		
54	SBSF3010Z	SCREW	J.HOLDER+PRI PW	2		
55	VKS3655-002	F.P.C. HOLDER		1		
56	VKL1422-002	CHASSIS		1		
57	VJF4003-003	FOOT	TO CHASSIS	2		
58	SBST4006Z	SCREW	FOR TRANS	4		
59	VJG1276-001	TOP COVER		1		
60	SDST3006M	SCREW	FOR TOP COVER	7		
61	VJC2522-003	REAR PANEL		1		
62	VYH3821-001	TUNER BKT		1		
63	SDST3006M	SCREW	R.PANEL+CHASSIS	2		
64	SDSF3008M	SCREW	FOR SPEAKER JAC	1		
65	SDSF3008M	SCREW	FOR ANTENA	2		
66	VYH7802-002	RADIATION		1		
67	VYH7876-001	RADI.BKT		1		
68	SBST3012Z	SCREW	RADI.+IC HOLDER	3		
69	SBST3008Z	SCREW	RADI.+CHASSIS	1		
70	SBST3006Z	SCREW	CHASSIS+RADI.BK	1		
71	SDSF3008Z	SCREW	J.HOLDER+CHASSI	2		
72	VYH7801-002	IC HOLDER		1		
73	VND4003-029	FUSE LABEL		1		
74	VND4003-071	FUSE LABEL		1		
75	VND4003-071	FUSE LABEL		1		
76	VMZ0125-001Z	FUSE CLIP		6		
77	VYN9228-003	NAME PLATE	TO REAR PANEL	1	A	
	VYN9228-014	NAME PLATE	TO REAR PANEL	1	US	
	VYN9228-S007	NAME PLATE	TO REAR PANEL	1	U,UT	
79	VND4221-001	CLASS LABEL	TO REAR PANEL	1	A,US	
80	VYH7871-001	LED HOLDER		1		
81	VYTT627-001	LCD FILTER	FOR LCD	1		
82	SDST3006M	SCREW		2		
83	E73562-003	SPECIAL SCREW		1		
84	VXL4431-001	VOLUME KNOB	FOR MIC VOL	1		
85	VYH3817-001	HOLDER(JACK)	FOR MIC	1		
86	SDSF2608Z	SCREW	HOLDER+PWB	1		
87	SDSF2608Z	SCREW	HOLDER SA+PANEL	1		
88	VKZ4001-110	WIRE CLAMP		1		
△ F 901	QMF51E2-R80SBS	FUSE		1	US,UT,U	
△	QMF51E2-R40SBS	FUSE		1	A	
△ F 902	QMF51E2-2R5J1	FUSE		1	US,UT,U,A	
△ F 903	QMF51E2-2R5J1	FUSE		1	US,UT,U,A	
△ LCD01	VGL1155-001	LCD		1		
△ T 901	VTP66T4-24B	POWER TRANSF.		1	A	
△	VTP66G4-24B	POWER TRANSF.		1	US,UT,U	

1	2	3	4	5	6	7	8
---	---	---	---	---	---	---	---

A
B
C
D
E
F
G

■ CD Mechanism assembly section : M5

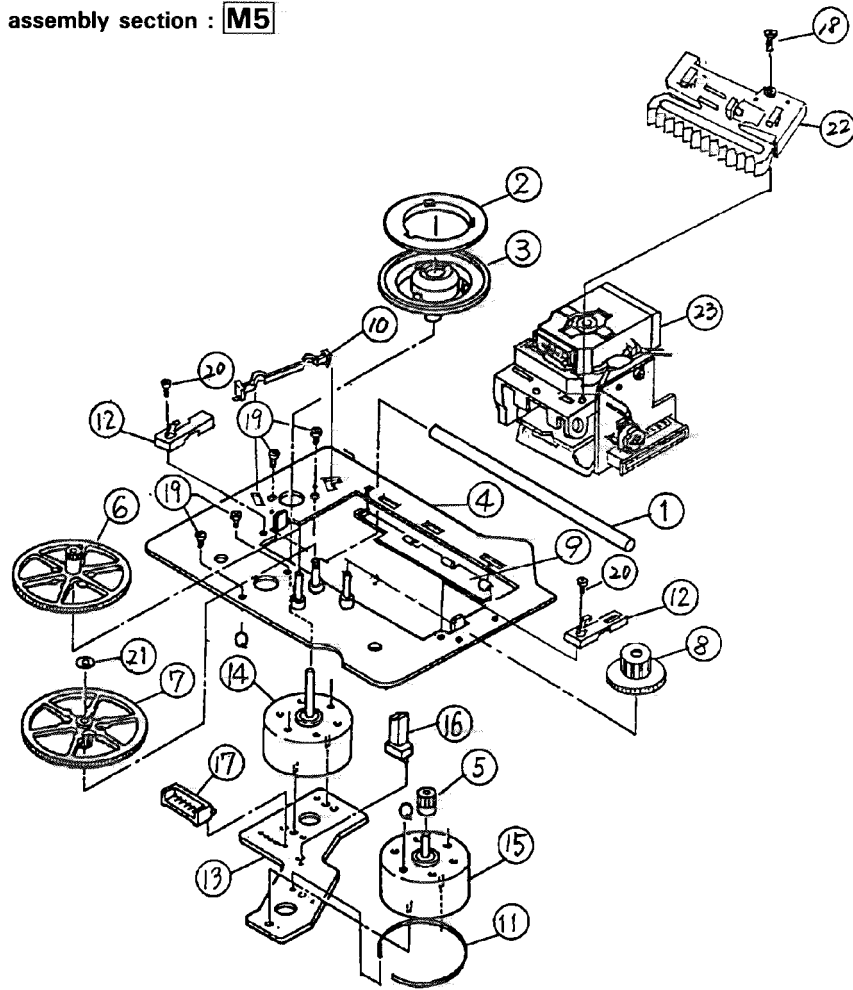

■ CD Mechanism assembly parts list

BLOCK NO. M5MM

REF.	PARTS NO.	PARTS NAME	REMARKS	QTY	SUFFIX	CLR
1	30020712T	PU.SHAFT		1		
2	30050713T	T.T.PLATE		1		
3	30070701T	TURN TABLE		1		
4	300707502T	TURN TABLE BASE		1		
5	30070726T	GEAR A		1		
6	30070727T	GEAR B		1		
7	30070728T	GEAR C		1		
8	30070729T	GEAR D		1		
9	30070730T	PU.SUPPORT		1		
10	30070739T	TENSION ARM		1		
11	30070746T	EARTH SPRING		1		
12	30070747T	SHAFT HOLDER		2		
13	30070751T	MOTOR PCB(J)		1		
14	60020902T	MOTOR		1		
15	60020903T	MOTOR		1		
16	640101195T	LEAF SWITCH		1		
17	68020264T	CONNECTOR		1		
18	9B1220061T	SCREW	M2X6	1		
19	9C0420303T	SCREW	M2X3	4		
20	9P0420061T	SCREW	M2X6	2		
21	9W0640070T	WASHER	2.1X4X0.4 CUT	1		
22	30070757T	CD RACK		1		
23	OPTIMA-6S	OPTICAL PICKUP		1		

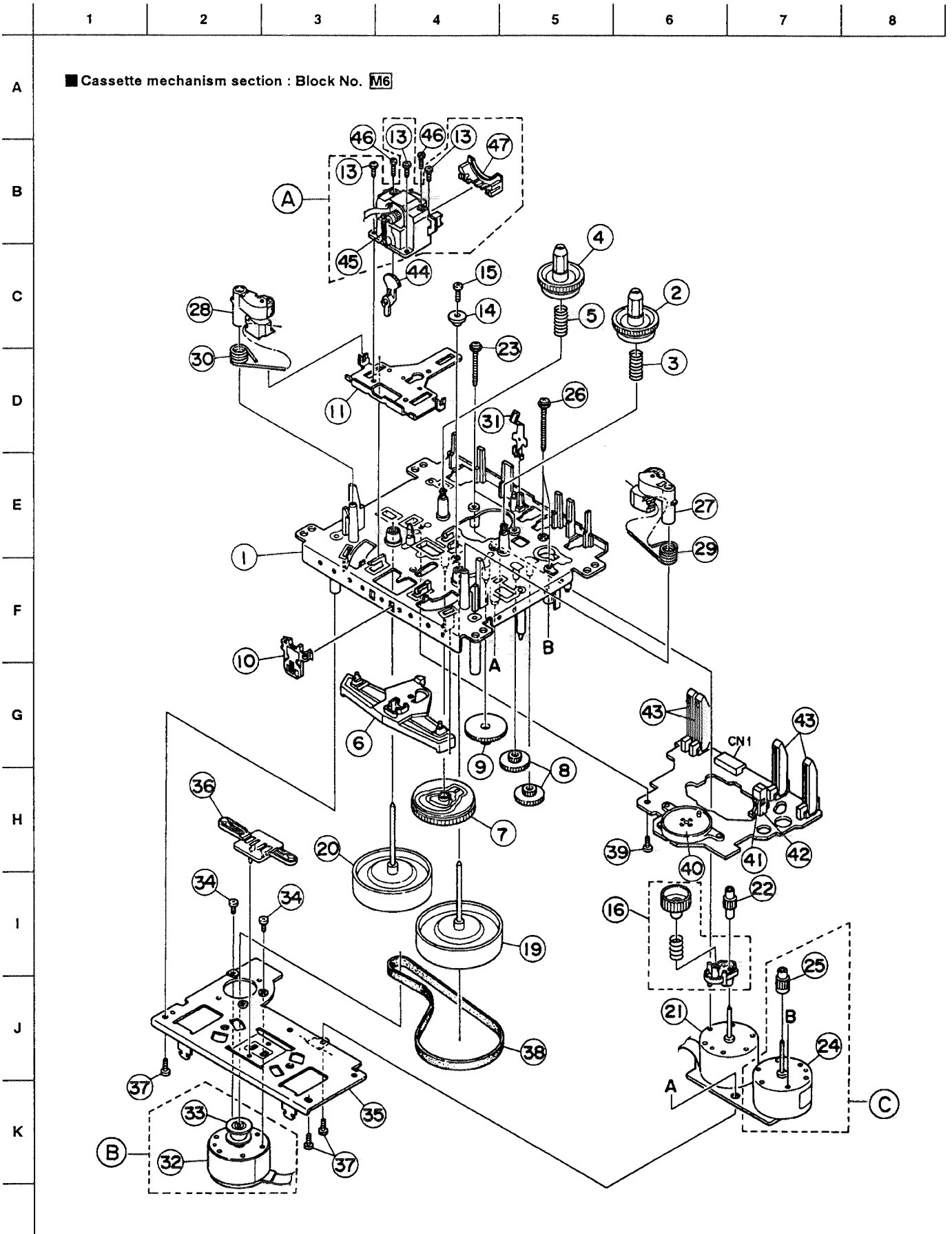

■ Cassette mechanism assembly parts list

BLOCK NO. M6MM IIII

REF.	PARTS NO.	PARTS NAME	REMARKS	QTY	SUFFIX	CLR
A	VKS3673-00A	H.MOUNT ASS'Y	REF.13,45,47	1		
B	MSI5B2LW-SA1	CAPSTAN MOTOR	REF.32,33	1		
C	MSN5D257A-SA1	DC MOTOR	REF.24,25	1		
1	VKS1126-00B	CHASSIS B ASS'Y		1		
2	VKS5428-00B	T-UP REEL ASSY		1		
3	VKW5043-001	B.T. SPRING		1		
4	VKS3617-002	REEL		1		
5	VKW5043-001	B.T. SPRING		1		
6	VKS3627-001	PINCH LEVER		1		
7	VKS2224-001	CONTROL CAM		1		
8	VKS5454-001	ACT GEAR(2)		2		
9	VKS5455-001	ACT GEAR(3)		1		
10	VKS3655-002	F.P.C. HOLDER		1		
11	VKM3632-001	HEAD BASE	VDL9212-001MK	1		
13	SDST2004Z	SCREW		3		
14	VKZ4708-001	SPECIAL SCREW		1		
15	SDSF2606Z	SCREW		1		
16	VKS5430-00C	FR ARM ASY		1		
19	VKF3184-00H	FLYWHEEL(R)ASY		1		
20	VKF3186-00H	FLYWHEEL(L)ASY		1		
21	MMN-6F4RA38	D.C.MOTOR	VDL9212-001MK1	1		
22	VKS5432-001	REEL MOT. GEAR	VDL9212-001MK	1		
23	VKZ4705-001	SPECIAL SCREW		2		
24	MSN-5D257A	D.C.MOTOR	VDL9212-001MK1	1		
25	VKS5433-001	ACT.MOTOR GEAR	VDL9212-001MK	1		
26	VKZ4705-002	SPECIAL SCREW		2		
27	VKP4227-00B	PINCH R.(R) ASY		1		
28	VKP4229-00B	PINCH R.(L) ASY		1		
29	VKW5045-003	P.R. SP.(R)	FOR PINCH (R)	1		
30	VKW5046-003	P.R. SP.(L)	FOR PINCH (L)	1		
31	VKY4670-001	CASSETTE SPRING	VDL9212-001MK	1		
32	MSI-5B2LW	D.C.MOTOR	VDL9212-001MK1	1		
33	VKR4364-002	MOTOR PULLEY		1		
34	SPSP2603Z	SCREW		2		
35	VKM3636-002	FM. BRACKET		1		
36	VKS5327-004	THRUST PLATE		1		
37	SDSF2608Z	SCREW		3		
38	VKB3001-051	BELT		1		
39	SDST2612Z	SCREW		1		
40	VKS3616-00A	CAM SW UNIT		1		
41	DN6851-HI	HALL IC		1		
42	VKS3630-001	IC HOLDER		1		
43	VSH1170-001	CASSETTE SWITCH		4		
44	VKS3614-001	TURN OVER GEAR		1		
45	VKW5063-003	HEAD SPRING		1		
46	VKZ4629-003	SPECIAL SCREW		2		
47	VKS3654-001	HEAD MT. COVER		1		

9. Main Adjustments

■ Test Instruments required for adjustment

1. Low frequency oscillator
(Frequency range: 50Hz to 20kHz)
(Output : 0 dBs across 600 Ω terminating resistor)
2. Attenuator (Impedance : 600 Ω)
3. Test Tapes
VTT712 For tape speed, wow and flutter measurement
VTT724 For playback output level measurement
VTT736 For playback frequency response check response check
VTT704 For head azimuth adjustment
4. Blank tapes
Normal : UR
Chrome : AC513
5. Electronic voltmeter,
6. Distortion meter
7. Frequency counter
8. Wow and flutter meter
9. Torque gauge : CTG - K
(Cassette type) For mechanism adjustment
10. Extension cord for check EXTUXC7 - KIT

■ Measuring conditions (Amplifier section)

- Supply voltage AC240V (50/60Hz)
(UX - C7A)
AC110~127/220~240V(50/60Hz)
(UX - C7UT/US/U)
- Reference output :Speaker 0 dBs (0.775V) / 4 Ω
: Headphone - 20 dBs (0.775V) / 32 Ω

● Standard position of switches

- Function switch TAPE
Timer, DOLBY NR, Active hyper bass switch OFF

● Standard position of controls

- BASS, TREBLE Flat position (BASS, TREBLE: 0)
Microphone mixing To minimum
Main volume adjust 0 dBs output (VOL.28)

- Standard test frequency 1kHz
: Unless otherwise specified
- Reference input level TP(CN344): - 7.5dBs
- Input for REC/PB, check & measuring CN344
(- 27.5dBs)
- Output for measuring unless otherwise specified
: At speaker terminal (Dummy load 4 Ω

● Test remarks

1. Negative side of the input and output terminals of the testing set, shall be isolated from each other. The negative side should not be commonly connected when a 2channel electronic voltmeter is connected.
2. A dummy load shall be connected to the output terminal and the lead wires of dummy load shall be as thick as possible.

■ Measuring condition (Tuner section)

- Power supply voltage to tuner DC 5.8V
- Reference output Speaker : 50mW(0.45 V / 4 Ω)
Headphon : 0.06V / 32 Ω
- AM modulation 400Hz, 30%
- FM modulation 400Hz deviation 22.5kHz

● Standard position of switches and controllers

- Function RADIO
Mode STEREO

● Remarks for alignment

1. Connect 30 pF capacitor and 33 k Ω resistor to the output terminal of the IF sweeper in series while 0.082 μ F capacitor and 100k Ω resistor to the input terminal in series.
2. Set the output level of the IF sweeper as low as adjustable.
3. IF alignment is not necessary for both AM and FM MPX alignment is not necessary either. All IFTs and MPX coil are non-adjusting type.

■ Procedure for Connection of Extension Cable for Checking the CD Changer Mechanism

1. Extension cable kit to be used: Parts No. [EXTUXC7-KIT]
2. Procedures for connecting the extension cable and method of checking the CD changer mechanism

- ① Prior to disassembly, remove the tray fittings from the CD tray.
- ② Remove the top cover (Refer to [Method of Removing the Top cover]).
- ③ Remove the system microcomputer P.C. board [Refer to [Method of Removing the System Microcomputer P.C. Board]].
- ④ Remove the tuner P.C. board assembly (Refer to [Method of Removing the Tuner P.C. Board Assembly]).
- ⑤ Disengage the four engagements between the front panel assembly and chassis, and raise the front panel assembly (Refer to "Method of Removing the Front Panel Assembly").
- ⑥ Remove the CD changer mechanism (Refer to [Method of Removing the CD Changer Mechanism]).
- ⑦ Set the CD changer mechanism vertically as indicated in the diagram below and fix it with screws.
- ⑧ Connect the extension cable of # 7PIN connector between the # 7PIN connector W701 on the CD operation switch P.C. board attached to the front panel assembly and the connector CN705 on the system microcomputer P.C. board.

- ⑨ CD operation switch.
Connect the extension cable of # 13PIN connector between the # 13PIN connector W702 on the P.C. board and connector CN706 on the system micro-computer P.C. board.
- ⑩ Connect the extension cable of # 7PIN connector between the 7PIN connector W341 on the Dolby P.C. board and connector CNA34 on the power amplifier P.C. board.
- ⑪ Connect the extension cable of # 7PIN card wire between the connector CN703 on the system micro-computer P.C. board and connector CN854 on the cassette mechanism control P.C. board.
- ⑫ In order to fill the portion lowered by the weight of the CD mechanism so that the CD changer mechanism can be operated even when it has been set vertically, insert a minus screw driver between an opening at the lower part of the CD mechanism.
- ⑬ Set a disc on the CD tray, and load the disc into the CD tray with the [OPEN/CLOSE] switch while holding it manually.

Now, it will be possible to check TOC reading, CD control P.C. board, CD amplifier P.C. board and so forth.

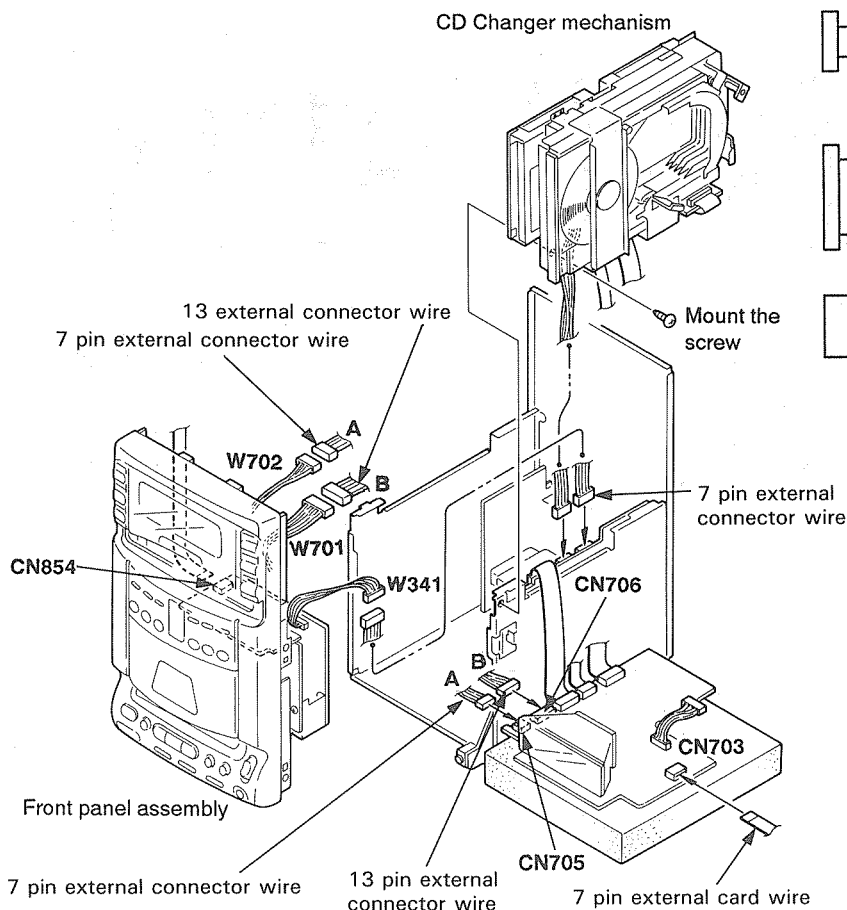

● Breakdown of extension cable kit (Parts No. EXTUXC7-KIT)

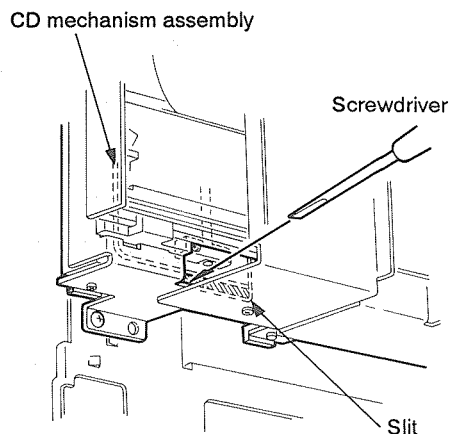
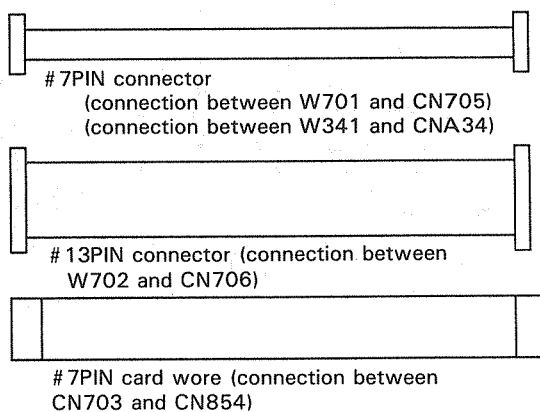

■ Initialization of microcomputer

- (1) After completion of repair, turn off the power source to the main system and pull out the power cord from the consent.
 - (2) Discharge the backup condenser C708 on the LCD/system microcomputer board for about five seconds.
- For Preserving the life of backup battery for about one month, it will sometimes become impossible to perform normal operation since the microcomputer remains under repair conditions. After completion of repair, therefore, discharge C708 and initialize the microcomputer. Otherwise, it is impossible to start normal operation of this system simply by resetting.

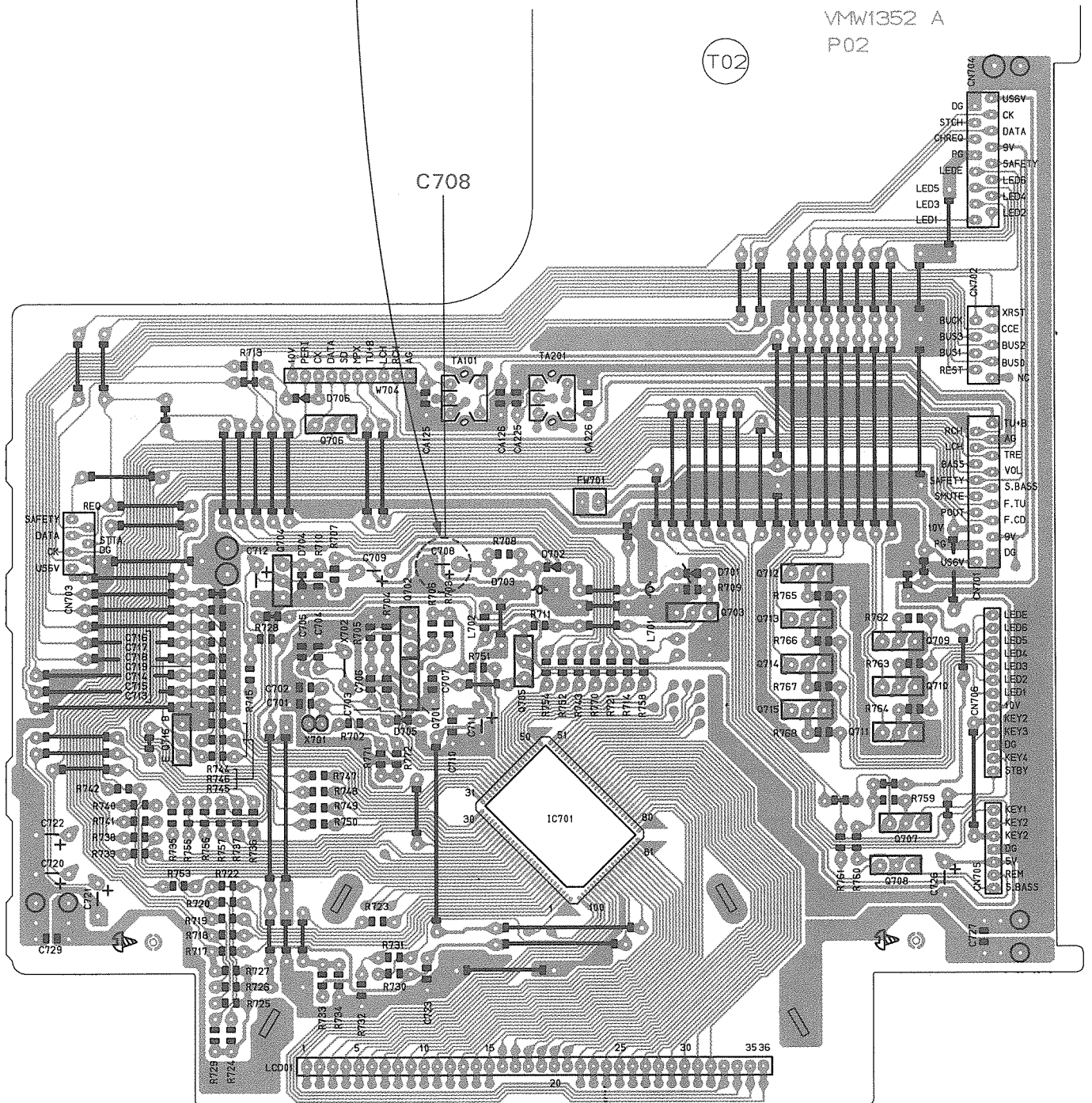

■ Mechanism & Amplifier Sections

Item	Conditions	Adjustment & Confirmation Methods	Stand. values	Adjust
Head azimuth adjustment	Test tape :VTT704 (12.5kHz) Test point :Headphone (Dummy load 32 Ω)	Play test tape VTT704(12.5kHz) and adjust the head azimuth so that output level is maximum and phase discrepancy is minimum between the two channels.	Output :maximum Phase difference :minimum	Head adjusting screw
Tape speed adjustment	Test tape : VTT712(3kHz) Test point : Headphone (Dummy load 32 Ω)	Play test tape VTT712 (3kHz) and near the end position. • Adjust the VR851 for the normal speed.	Normal speed :2940~3090Hz	VR851
Wow and flutter check	Test tape :VTT712(3kHz) Test point :Headphone (Dummy load 32 Ω)	Play test tape VTT712(3kHz) to tape start, middle and end position. Wow and flutter should be within the following allowance at the three positions.	Playback FWD / REV should be less than 0.2% (JIS RMS)	—
Playback output level adjustment	Test tape :VTT724(1kHz) Test point : DOLBY TP(CN344)	1. Play test tape VTT724(1kHz) and switch the tape select to Metal position. 2. Adjust VR241(Lch) and VR141(Rch) so that standard value obtain less than ± 2 dB. 3. L, R difference level to be less than ± 2 dB.	Less than ± 2 dB Less than ± 2 dB	Lch : VR241 Rch : VR141
Frequency response check	Test tape :VTT – 736 Test point : DOLBY TP (CN344)	Switch tape select to Normal position and volume at level 13 position. Play test tape VTT – 736 then compare the level between 1 kHz and 63Hz , 1 kHz / 12.5kHz. Then defference level should be within 0dB ± 4 dB, 0 dB ± 3 dB.	63 Hz/ 1 kHz level : within 0 \pm 4dB 1kHz / 12.5kHz : within 0 \pm 3dB	—

Item	Conditions	Adjustment & Confirmation Methods	Stand. values	Adjust
Bias frequency adjustment	<ul style="list-style-type: none"> • Adjust : FM mode • Confirm : AM mode Test point : DOLBY TP (CN344) 	<p>Switch tape select to Normal position. In case that the bias frequency is out of specification, L321 should be readjusted to standard and set to Tuner Rec. position for alignment.</p> <p>① Adjust bias frequency at FM mode. ② Confirm bias frequency at AM mode.</p>	<p>Tuner frequency : FM / Bias frequency ; 101.0kHz : AM530(M1) / Bias frequency ; 97.2kHz</p>	L321
Recording / playback frequency response check and adjustment	<p>Test tape : UR(Normal tape) Standard frequency : 1kHz (REF. - 20dB) Test point : DOLBY TP (CN344)</p>	<p>Select function to tape mode . Reference level of - 20 dB, (1 kHz and 12.5 kHz) perform the REC/PB function.</p> <p>Play back the recorded signals, adjust VR221(Lch) and VR121 (Rch), so that the level of the 12.5 kHz signal is +0.5 dB \pm 1 dB to the level of the 1 kHz signal.</p>	<p>1/12.5 kHz : +0.5 \pm 1 dB</p>	<p>Lch : VR221 Rch : VR121</p>
Recording / playback sensitivity check	<p>Test tape : UR(Normal tape) Input : Test point (Test point:CN344)</p>	<p>Supply 1 kHz, - 27.5 dBs signal to the Test point CN344 and record it.</p> <p>Play it back while checking that the level is within 0 \pm 3 dB to the monitor level.</p>	<p>Reference level : Monitor level Within 0 \pm 3 dB</p>	—
Recording / playback distortion check	<p>Test tape : UR(Normal tape) Input : AUX (Test point:CN344)</p>	<p>Supply 1 kHz, - 27.5dBs signal to the Test point CN344 and record it.</p> <p>Play it back while checking that distortion is less than 5 %.</p>	Less than 5 %	—

■ Arrangement of adjusting position

● Amplifier P.C. board part

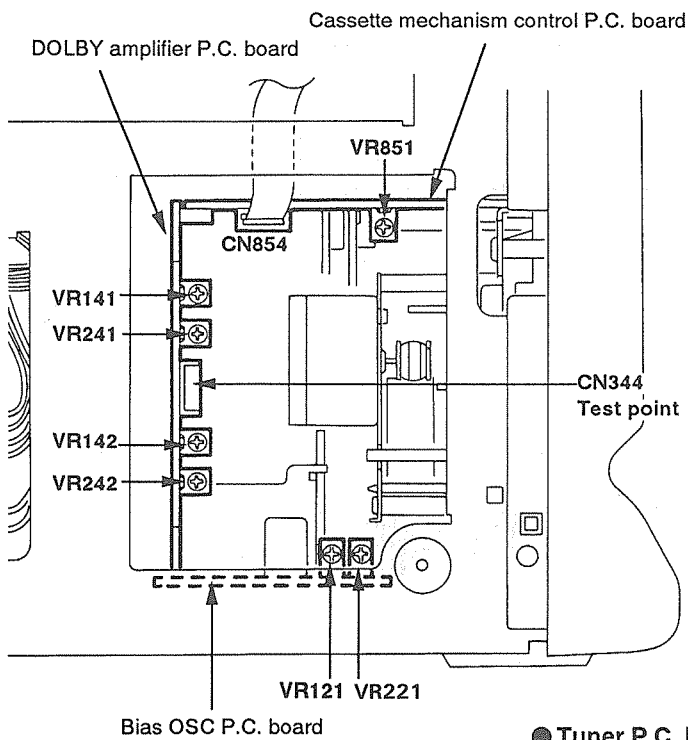

● Cassette mechanism part

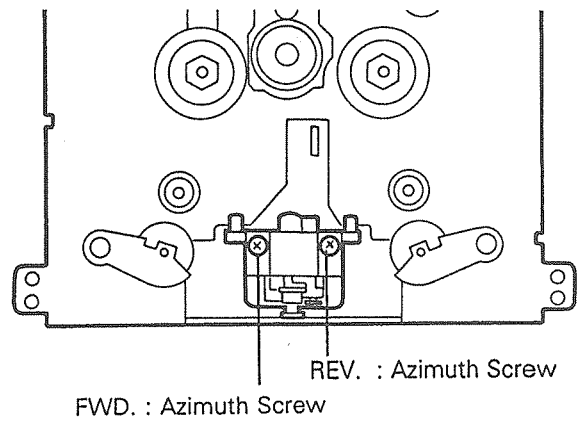

● Tuner P.C. board

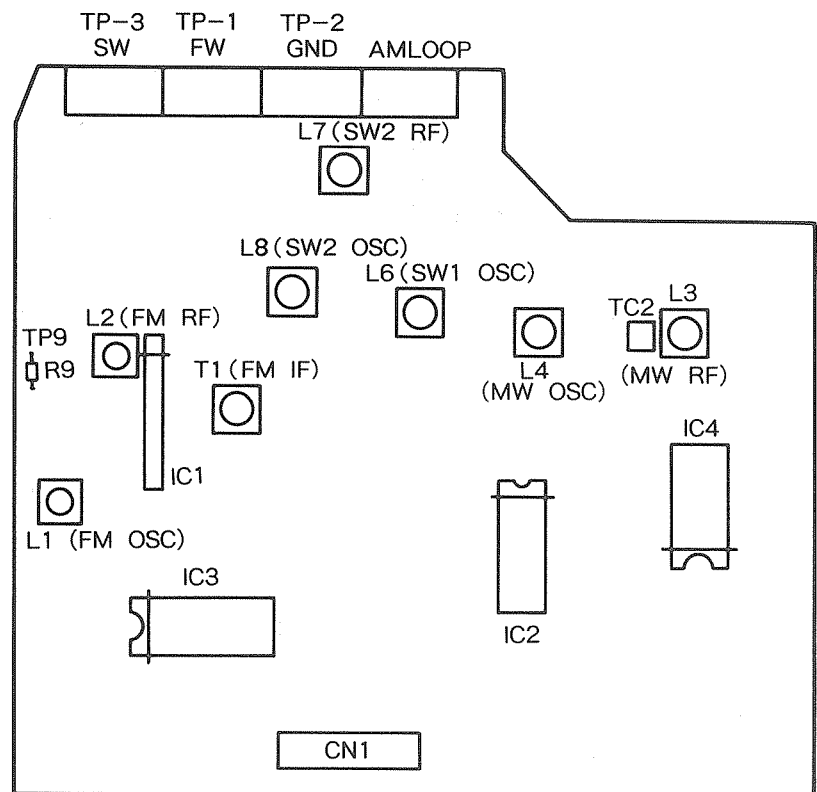

Tuner P.C.board

■ CD player Section

Item	Conditions	Adjustment & Confirmation Methods	Stand. values	Adjust
Tracking offset adjustment	Test disc :CTS1000 Oscilloscope	<ol style="list-style-type: none"> ① Connect an oscilloscope across the test points TP503 (hot side). ② Play the test disc CTS1000. ③ Shortcircuit the TP504 to the TP501 while playing, then the tracking error signal will be emitted for about 3 seconds. ④ Adjust the VR501 so that the waveform of the tracking error signal on the oscilloscope becomes symmetrical to the DC zero level. ⑤ Repeat the steps 2, 3, and 4 for the best result since the tracking error signal appears on the screen just for 3 seconds. 	Set the center of P – P to the DC zero level.	VR501

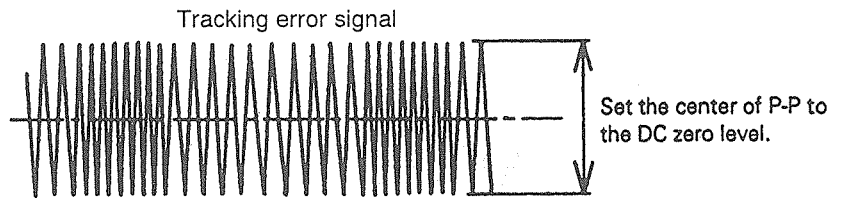

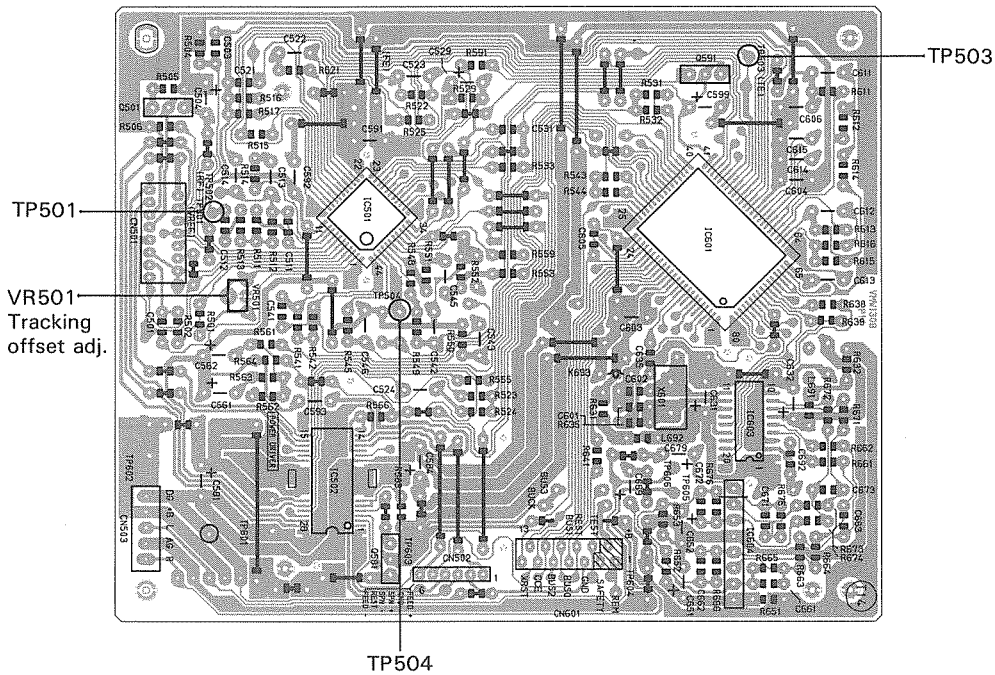

Note : The oscilloscope shall be connected by DC coupling.

■ Arrangement of adjusting positions: CD Amplifier P.C. board

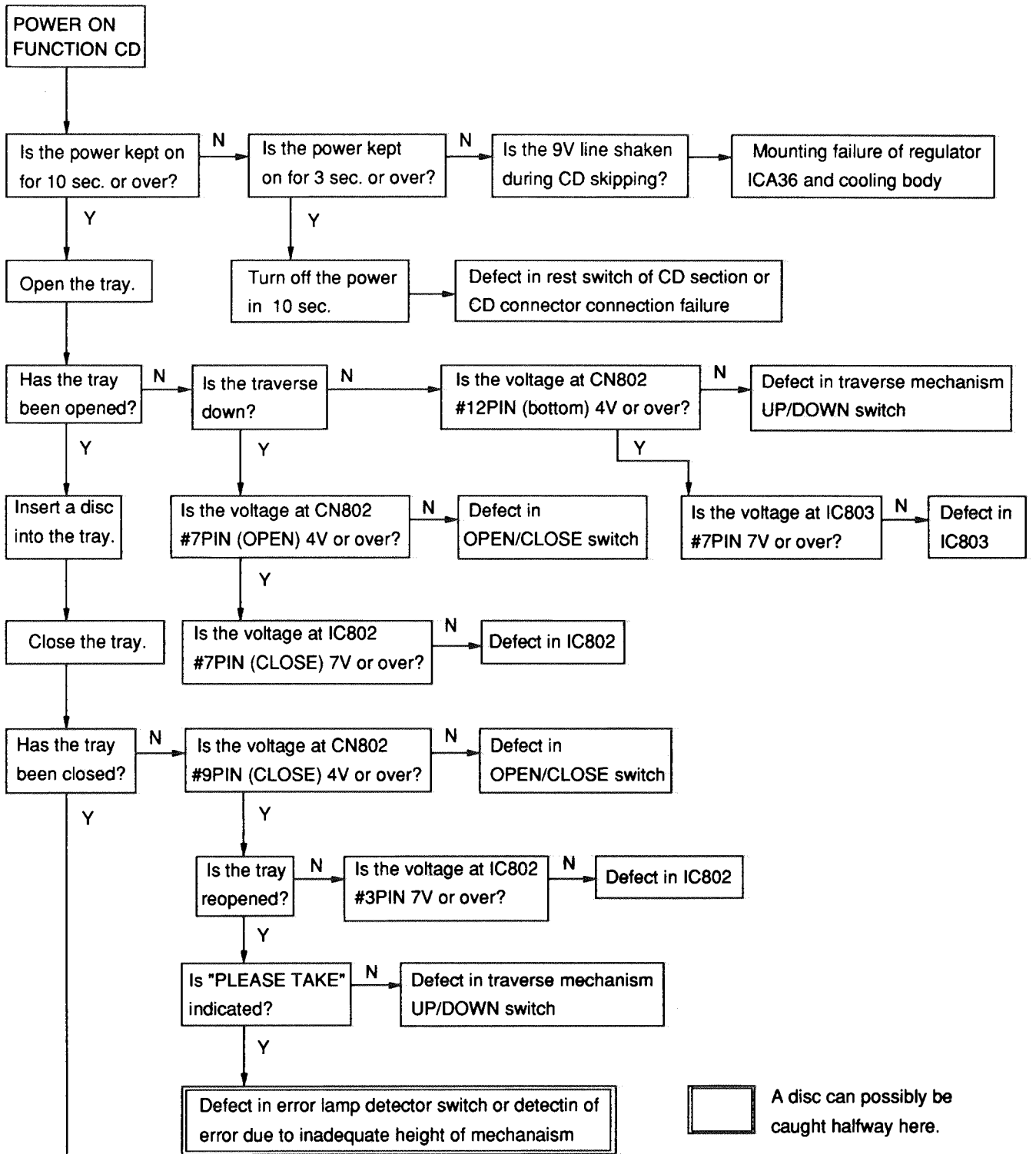

■ CD Changer mechanism troubleshooting



 A disc can possibly be caught halfway here.

* Next page

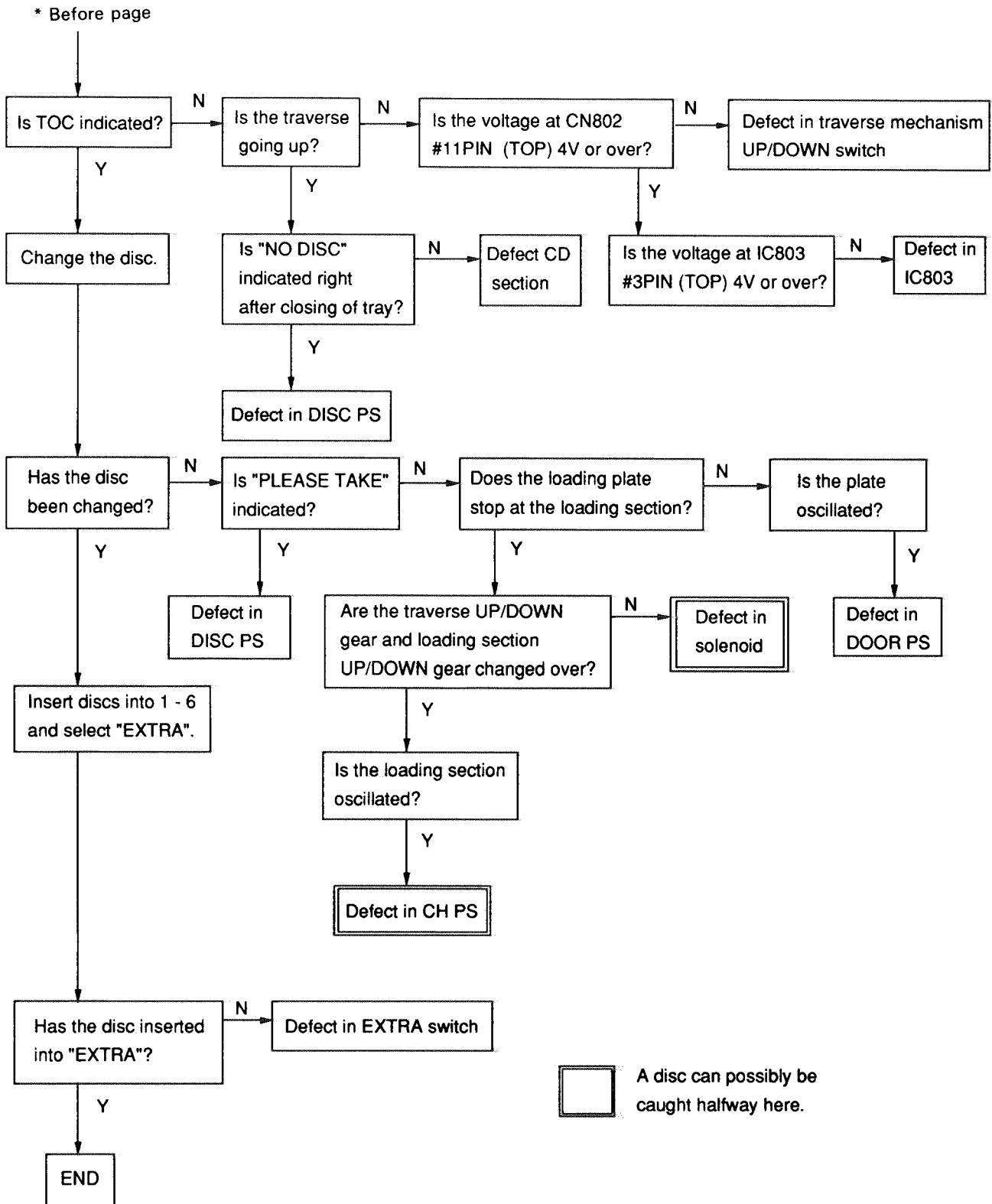

■ **Tuner Sections** *AM and FM IF adjustment: No alignment is necessary as non adjusting type IFTs are used.

Item	Conditions	Adjustment & Confirmation Methods	Stand. values	Adjust
AM RF tracking adjustment	<ul style="list-style-type: none"> • Band: AM • Signal input : Standard loop antenna 	<p>Confirm that the channel step is set to 9kHz.</p> <p>① Confirm that the terminal voltage of the TP9 is $5.0 \pm 0.1V$. at the 1710kHz (upper band edge). If the voltage exceeds the limit, adjust the L4 for the proper voltage.</p> <p>② Adjust the L3 for the maximum output while receiving 603kHz signal.</p> <p>③ Adjust the TC2 for the maximum output while receiving 1404kHz signal.</p> <p>④ Repeat the steps 2 and 3 for no further improvement.</p>	<p>$5.0 \pm 0.1V$</p> <p>Output level : Maximum</p>	<p>L4</p> <p>L3</p> <p>TC2</p> <p>L3, TC2</p>
SW 1 RF tracking adjustment	<ul style="list-style-type: none"> • Band: SW • Signal input : Standard loop antenna 	<ul style="list-style-type: none"> • Confirm that the terminal voltage of the TP9 is $5.0 \pm 0.02V$. at the 6.995MHz (upper band edge). If the voltage exceeds the limit, adjust the L6 for the proper voltage. 	<p>$5.0 \pm 0.02V$</p>	<p>L6</p>
SW 2 RF tracking adjustment	<ul style="list-style-type: none"> Band : SW or FM Dummy antenna Signal input : TP1(Positive) : TP2(Negative) 	<p>① Confirm that the terminal voltage of the TP9 is $5.0 \pm 0.02V$. at the 21.85 MHz (upper band edge). If the voltage exceeds the limit, adjust the L8 for the proper voltage.</p> <p>② Adjust the L7 for the maximum output while receiving 7.0 MHz signal.</p> <p>③ Repeat the steps 2 for no further improvement.</p>	<p>$5.0 \pm 0.02V$.</p> <p>Output level : Maximum</p>	<p>L8</p> <p>L7</p> <p>L7</p>
FM RF tracking adjustment		<p>Confirm that the terminal voltage of the TP9 is less than 5.4V. at the frequency of 108MHz</p> <p>① Adjust the L2 for the maximum output while receiving the 88.0MHz signal.</p> <p>② Repeat the above steps for no further improvement.</p>	<p>5.4V</p> <p>Output level : Maximum</p>	<p>L2</p> <p>L2</p>

10. Block Diagram

■ General Section

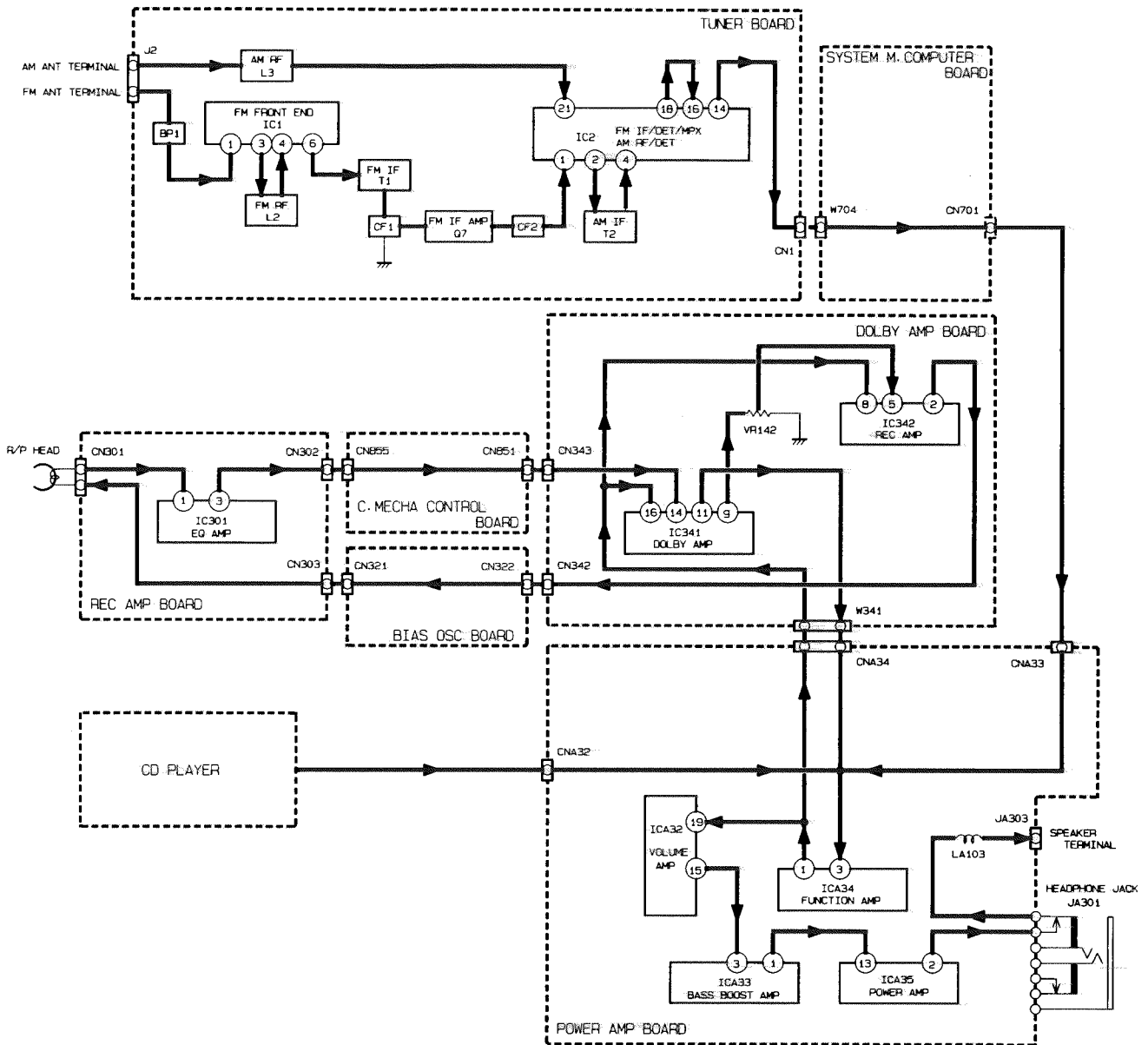
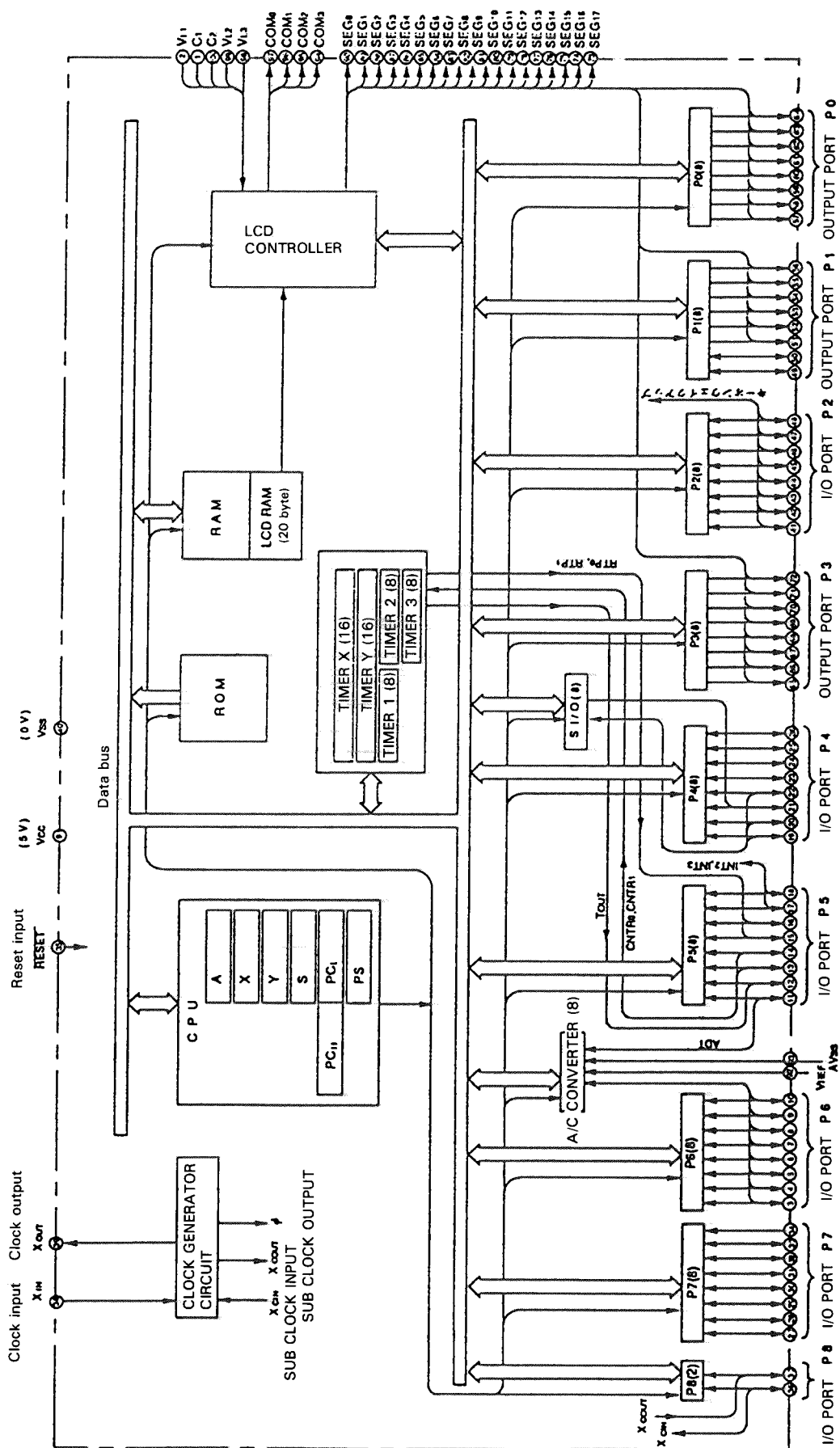

Fig. 10-1

■ Main IC Block Diagram

● IC701 : M38254M6-0735FP (System microcomputer)



■ IC701 : M38254M6-0735FP (System microcomputer)

● IC701 : M38254M6 – 073P

Pin No.	Terminal Name	Abbreviation	I/O	Remarks
1	C1	C1	I	
2	VL1	VL1	I	
3	AN7	KEY 1	I	Input the key...
4	AN6	KEY 2	I	Input the key
5	AN5	KEY 3	I	Input the key
6	AN4	KEY 4	I	Input the key
7	AN3	SAFETY	I	Detect the over current, Switch distinction.
8	AN2	VERSION	I	Distinate version with the destination.
9	P61	NC		
10	P60	NC		
11	P57	NC		
12	P56	STBY	O	Stanby by LED when POUT output.
13	P55	FCD	O	Function : CD
14	P54	POUT	O	Power supply for amplifier CTL.
15	P53	/FTUNER	O	Function : TUNER.
16	P52	SMUTE	O	System mute.
17	P51	S.BASS	O	Super bass CTL.
18	P50	VOL	O	PWM volume CTL
19	P47	NC		
20	P46	CK	O	TUNER,TAPE,CD SERIAL CLK.
21	P45	DATAOUT	O	Serial data 0
22	P44	DATAIN	I	Serial data I
23	P43	BUP	I	Detect the state of back up.
24	P42	/REM	I	Input the remote control.
25	P41	BASS	O	PWM BASS
26	P40	TRE	O	PWM TREBLE

Pin No.	Terminal Name	Abbreviation	I/O	Remarks
27	P77	BUS3	I/O	CD data bus 3
28	P76	BUS2	I/O	CD data bus 2
29	P75	BUS1	I/O	CD data bus 1
30	P74	BUS0	I/O	CD data bus 0
31	P73	/CCE	O	CD DATA chip enable.
32	P72	BUCK	O	CD bus clock.
33	P71	/XRST	O	CD LSI RESET.
34	P70	/REST	I	Detect the REST Switch of CD mechanism.
35	/RESET	RESET	I	
36	XCIN	XI		
37	XCOUT	XO		
38	XIN	OSCI		
39	XOUT	OSCO		
40	VSS	VSS		
41	P27	BEAT	O	Frequency shift for main clock.
42	P26	PERI	O	Strobe for TUNER PLL of correspondence.
43	P25	STTA	O	Strobe for tap of correspondence.
44	P24	STCH	O	Strobe for changer of correspondence.
45	P23	/CHREQ	I	Demand the receive when changer transmitted.
46	P22	REQ	I	Demand the receive when cassette mechanism transmitted.
47	P21	/SD	I	Tuner signal detect.
48	P20	/MPX	I	Destinate detector of TUNER stereo signal.
49	P17	BUPH	O	Stop the X'tal when back up.
50	P16	NC		
51	P15	NC		
52	P14	NC		
53	P13	NC		
54	P12	NC		
55	P11	NC		

Pin No.	Terminal Name	Abbreviation	I/O	Remarks
56	P10	NC		
57	P07	NC		
58	P06	NC		
59	SEG31	SEG0	O	LCD segment.
90	SEG0	SEG31	O	LCD segment.
91	VCC	VCC		
92	VREF	AVCC		
93	AVSS	AVSS		
94	COM3	COM3		LCD remote control.
95	COM2	COM2		LCD remote control.
96	COM1	COM1		LCD remote control.
97	COM0	COM0		LCD remote control.
98	VL3	VL3		
99	VL2	VL2		
100	C2	C2		

11. Wiring Connections

■ General section

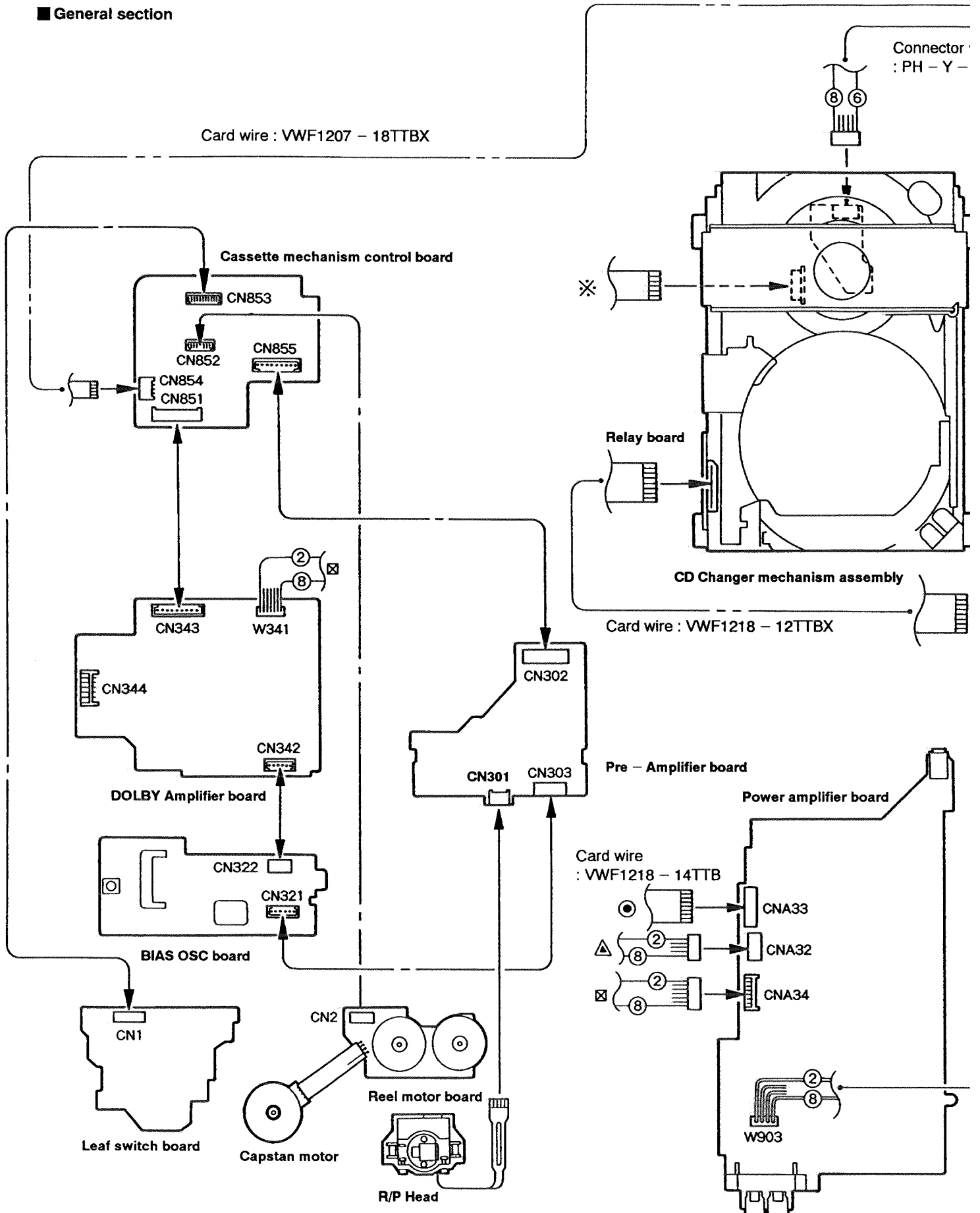
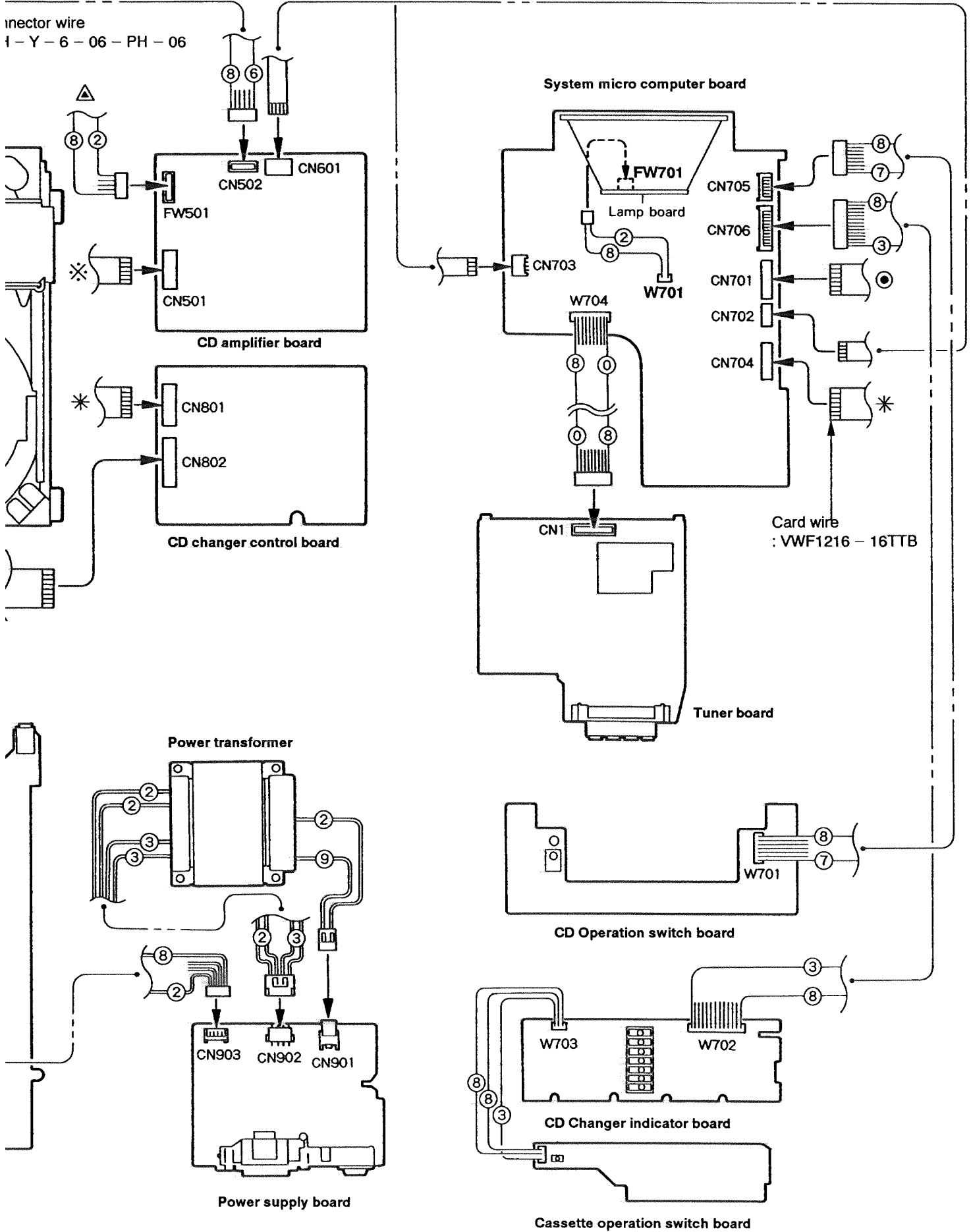

Fig. 11-1

Card wire : VWF1209 - 33TTBV

Injector wire
1 - Y - 6 - 06 - PH - 06



■ CD changer mechanism sections

18 pin Connector description

- 1.....UP/DOWN reset switch
- 2.....UP/DOWN P/S
- 3.....LOAD switch
- 4.....LOAD/UNLOAD P/S
- 5.....LOAD Motor(-)
- 6.....LOAD Motor(+)
- 7.....OPEN switch
- 8.....GRAND
- 9.....CLOSE switch
- 10.....Supply voltage 5V
- 11.....Traverse mechanism Up switch
- 12.....Traverse mechanism Down switch
- 13.....UP/DOWN Motor(+)
- 14.....UP/Down Motor(-)
- 15.....Plunger
- 16.....Plunger
- 17.....8cm disc detector
- 18.....Install a erroneous disc switch

● Location of main electrical parts
(Refer to Block No. **M1**:REF.Number)

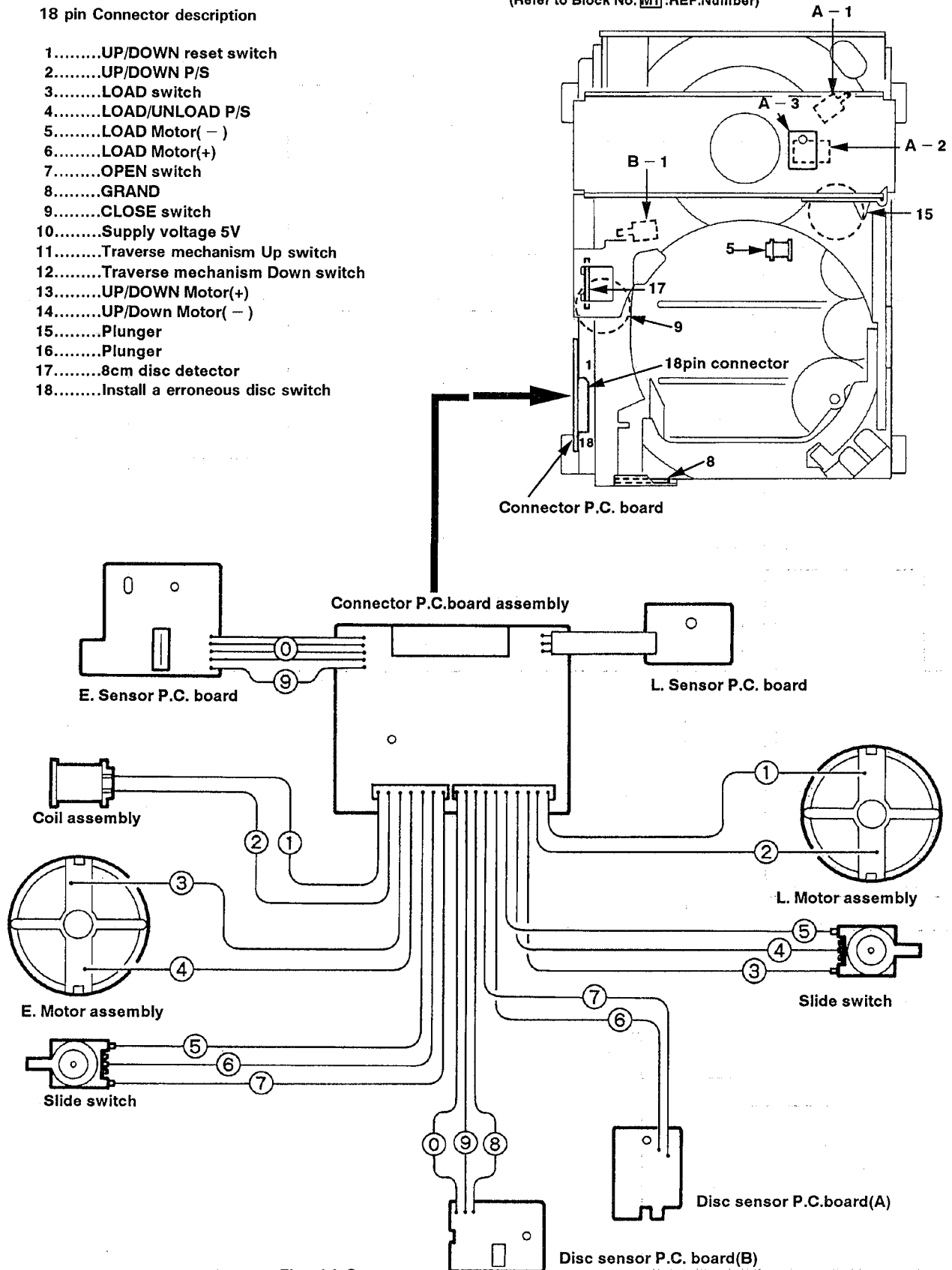

Fig. 11-2

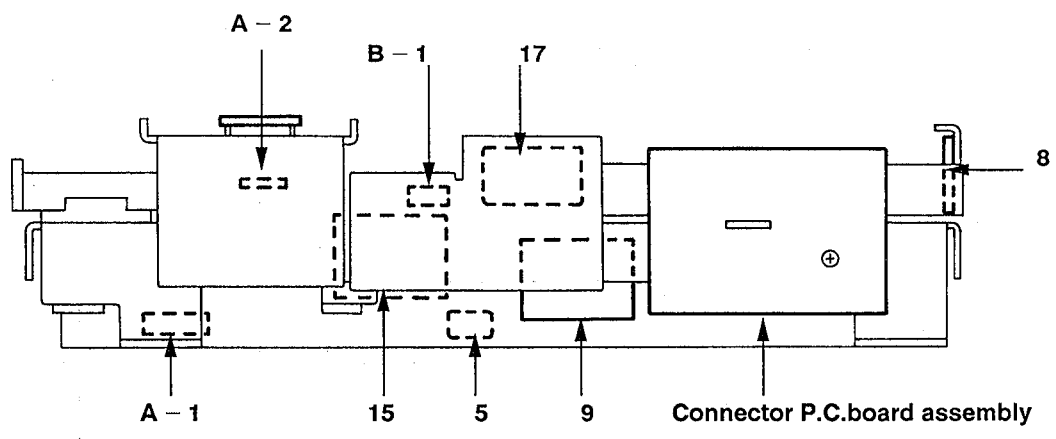
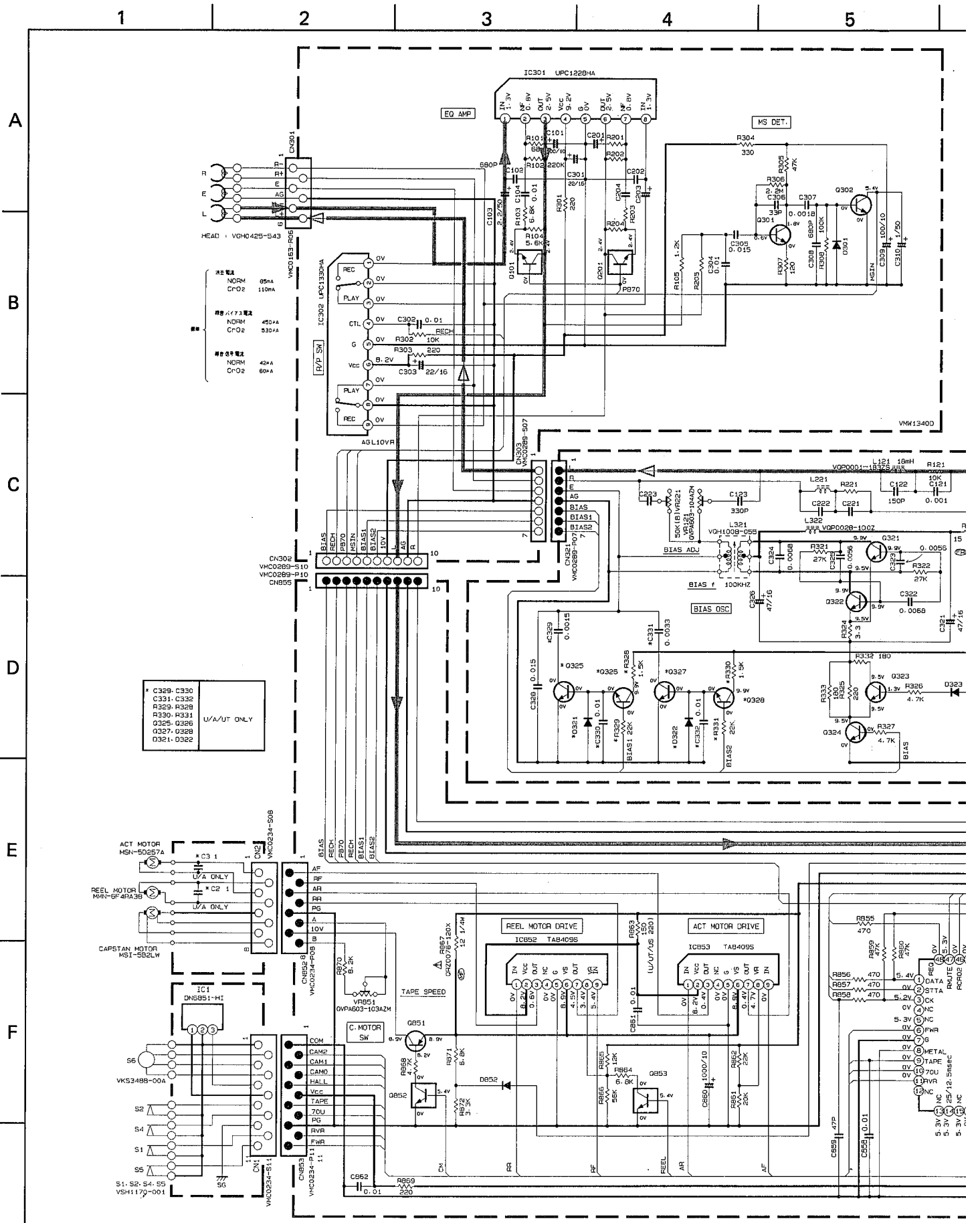

Fig. 11-3

● Color codes are shown below

1	Brown	8	Gray
2	Red	9	White
3	Orange	0	Black
4	Yellow	D	Pink
5	Green	C	Light Blue
7	Violet		

12. Standard Schematic Diagram ■ Pre-amplifier circuit: Drawing No. VDH9228-001PV



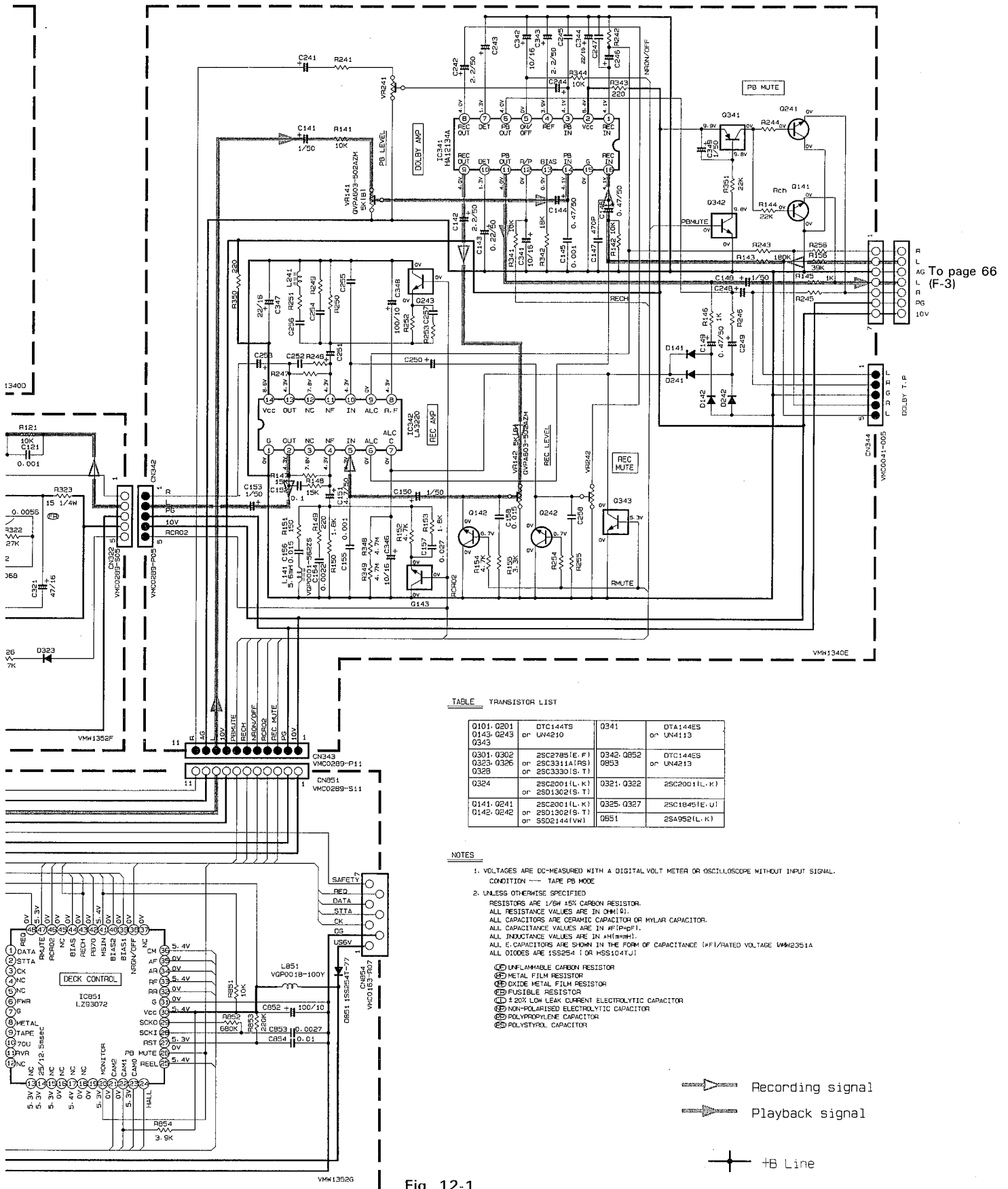

To page 66 (F-3)

Fig. 12-1

■ Power amplifier circuit: Drawing No. VDH9228-003AV (UX-C7A)

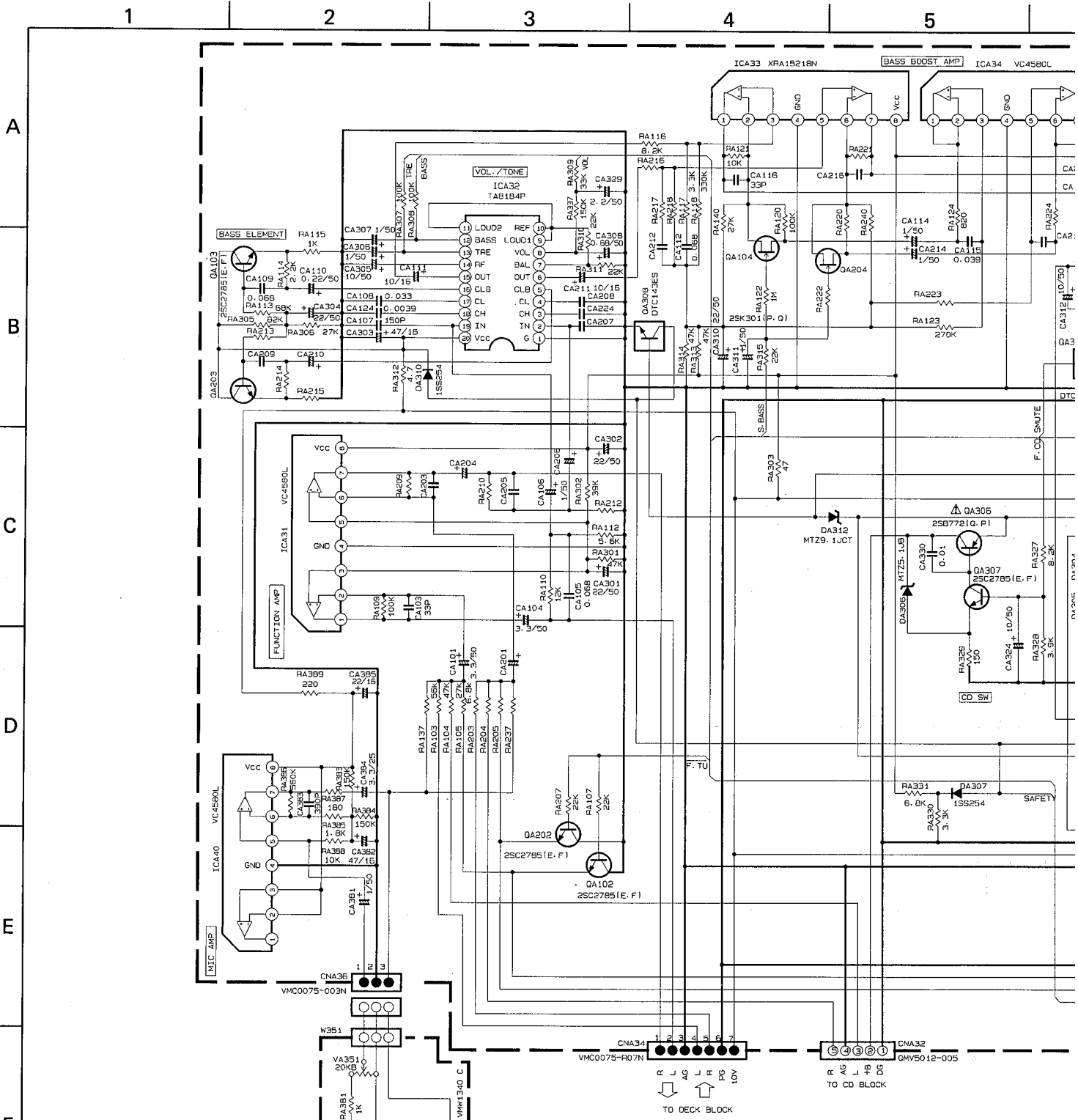

QA102/QA202	2SC2785(E, F)
QA103/QA203	or 2SC331A(RS)
QA305	or 2SC3301S(T)
QA104/QA204	2SK301(P, G)
	or 2SK105(H)
QA108/QA208	2SD1302(S, T)
	or 2SD2144S(VM)
QA301	DTA143ES
	or UN411L
QA308	DTC143ES
	or UN421L
QA310	DTC144ES
	or UN4213
QA311	DTA144ES
	or UN4113
QA101/QA201	2SD1302(S, T)
	or 2SC2001(L, K)
	or 2SD2144S(VM)

NOTES
 1. VOLTAGES ARE OC-MEASURED WITH A DIGITAL VOLT METER OR OSCILLOSCOPE WITHOUT INPUT SIGNAL.
 CONDITION --- CD MODE
 VOLTAGE VALUE MARKED * IS IN TUNER POSITION

6 7 8 9 10

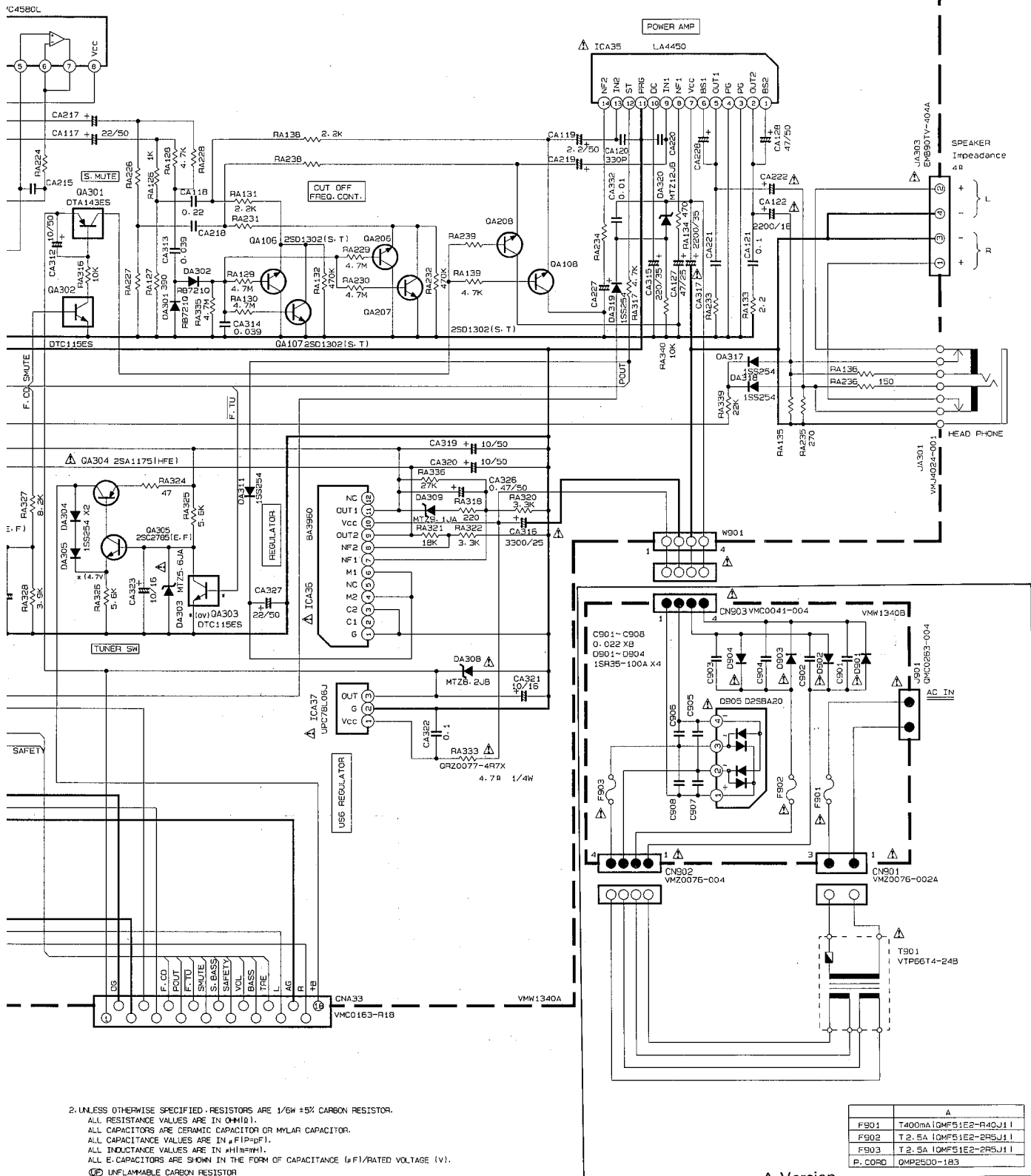

2. UNLESS OTHERWISE SPECIFIED, RESISTORS ARE 1/8W ±5% CARBON RESISTOR.
 ALL RESISTANCE VALUES ARE IN OHM(Ω).
 ALL CAPACITORS ARE CERAMIC CAPACITOR OR MYLAR CAPACITOR.
 ALL CAPACITANCE VALUES ARE IN μF(μF) OR P.F.
 ALL INDUCTANCE VALUES ARE IN MH(MH).
 ALL ELECTROLYTIC CAPACITORS ARE SHOWN IN THE FORM OF CAPACITANCE (μF)/RATED VOLTAGE (V).
- Ⓜ UNFLAMMABLE CARBON RESISTOR
 - Ⓝ METAL FILM RESISTOR
 - Ⓞ OXIDE METAL FILM RESISTOR
 - Ⓟ ±20% LOW LEAK CURRENT ELECTROLYTIC CAPACITOR
 - Ⓠ NON-POLARISED ELECTROLYTIC CAPACITOR
 - Ⓡ POLYPROPYLENE CAPACITOR
 - Ⓢ POLYSTYROL CAPACITOR

A	
F901	T400mA10MF51E2-R40J11
F902	T2.5A10MF51E2-2R5J11
F903	T2.5A10MF51E2-2R5J11
P. CORR	QMP2500-1B3

Fig. 12-2

■ Power amplifier circuit: Drawing No. VDH9228-007AV (UX-C7 US/UT/U)

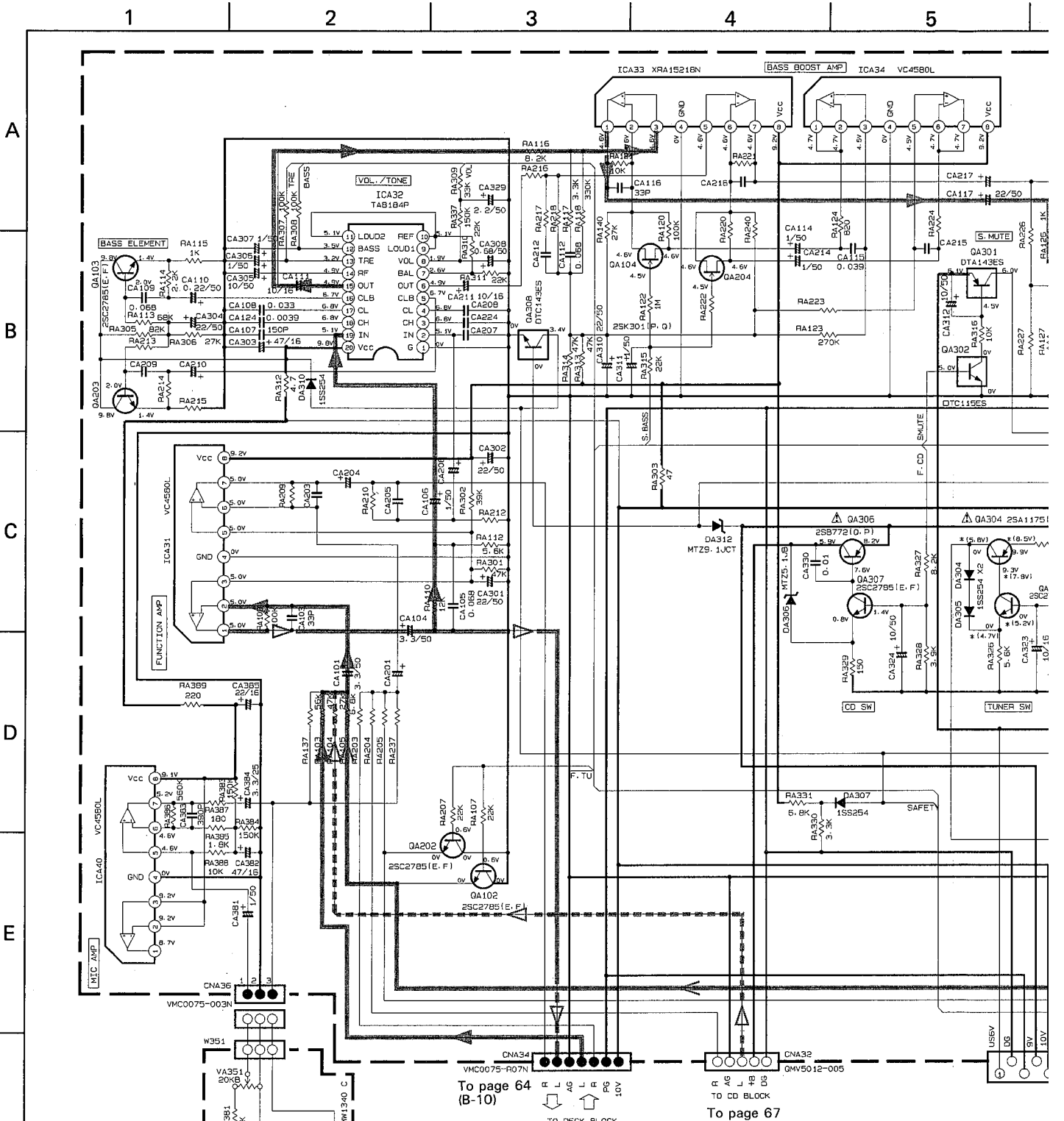

QA102/QA202	2SC2785 (E, F)
QA103/QA203	or 2SC3311A (RS)
QA305	or 2SC3330 (S, T)
QA104/QA204	2SK301 (P, Q)
	or 2SK105 (H)
QA108/QA208	2SD1302 (S, T)
	or 2SD2144S (VM)
QA301	DTA143ES
	or UN411L
QA306	DTC143ES
	or UN421L
QA310	DTC144ES
	or UN4213
QA311	DTA144ES
	or UN4113
QA101/QA201	2SD1302 (S, T)
	or 2SC2001 (L, K)
	or 2SD2144S (VM)

NOTES
 1. VOLTAGES ARE DC-MEASURED WITH A DIGITAL VOLT METER OR OSCILLOSCOPE WITHOUT INPUT SIGNAL.
 CONDITION --- CD MODE
 VOLTAGE VALUE MARKED * IS IN TUNER POSITION

2. UNLESS OTHERWISE ALL RESISTANCE ALL CAPACITORS ALL CAPACITANCE ALL INDUCTANCE ALL S. CAPACITORS
 UNFLAMMABLE METAL FILM OXIDE METAL ±20% LOW L NON-POLAR POLYPROPYLENE POLYSTYROL

Fig. 12-3

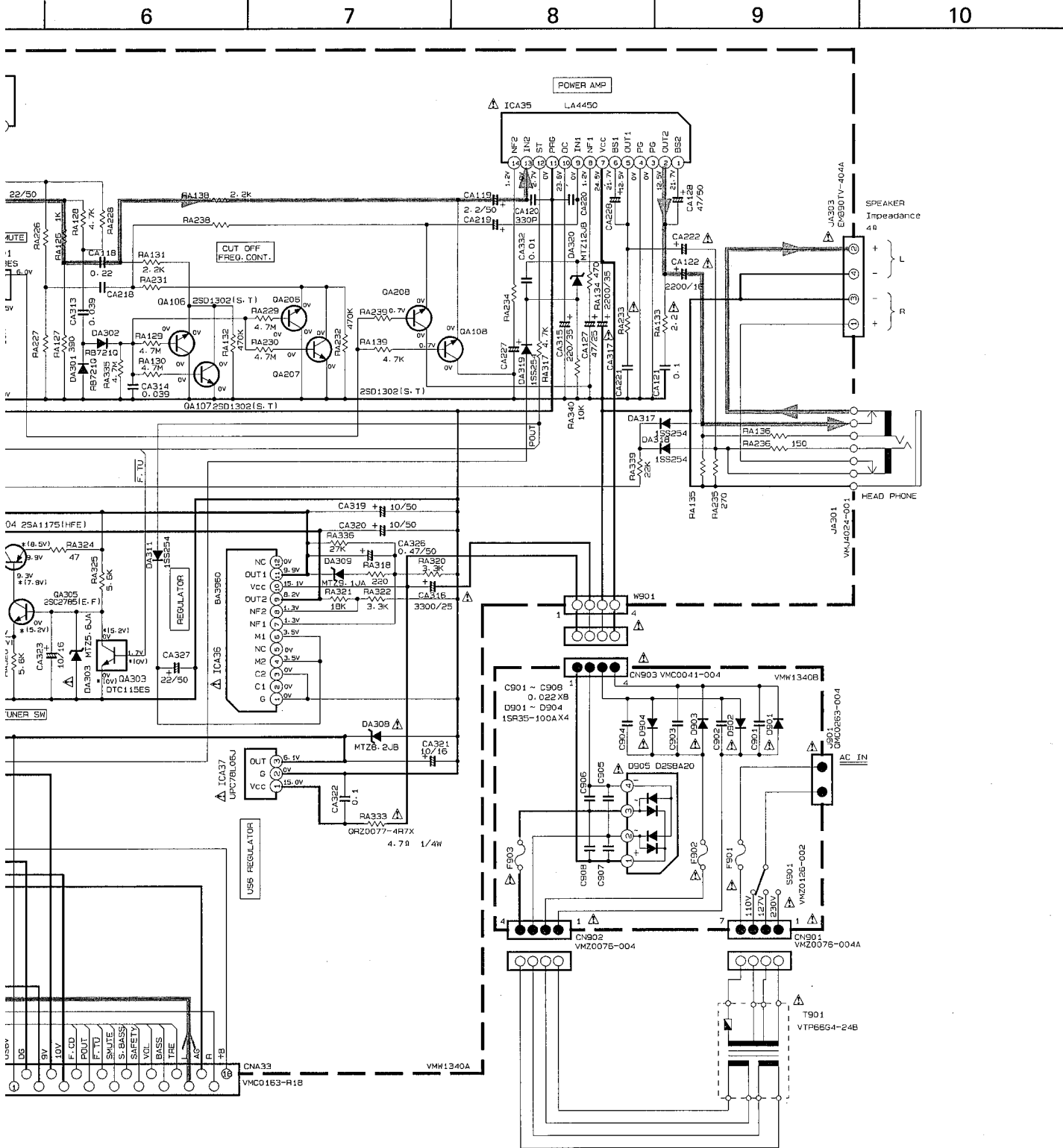

SS OTHERWISE SPECIFIED, RESISTORS ARE 1/6W ±5% CARBON RESISTOR.
 L RESISTANCE VALUES ARE IN OHM(Ω).
 L CAPACITORS ARE CERAMIC CAPACITOR OR MYLAR CAPACITOR.
 L CAPACITANCE VALUES ARE IN μF(μF).
 L INDUCTANCE VALUES ARE IN mH(mH).
 L E CAPACITORS ARE SHOWN IN THE FORM OF CAPACITANCE (μF)/RATED VOLTAGE (V).
 S UNFLAMMABLE CARBON RESISTOR
 M METAL FILM RESISTOR
 O OXIDE METAL FILM RESISTOR
 ±20% LOW LEAK CURRENT ELECTROLYTIC CAPACITOR
 N NON-POLARISED ELECTROLYTIC CAPACITOR
 P POLYPROPYLENE CAPACITOR
 S POLYSTYROL CAPACITOR

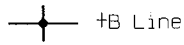
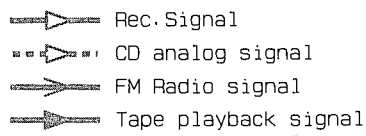

	U/UT	US
F901	T800mA (QMF51E2-PR0J1)	T800mA (QMF51E2-PR0J1)
F902	T2.5A (QMF51E2-PR5J1)	T2.5A (QMF51E2-PR5J1)
F903	T2.5A (QMF51E2-PR5J1)	T2.5A (QMF51E2-PR5J1)
P. CORD	QMP7350-150	QMP90FO-1831E1

■ CD amplifier circuit: Drawing No. VDH9228-006CV

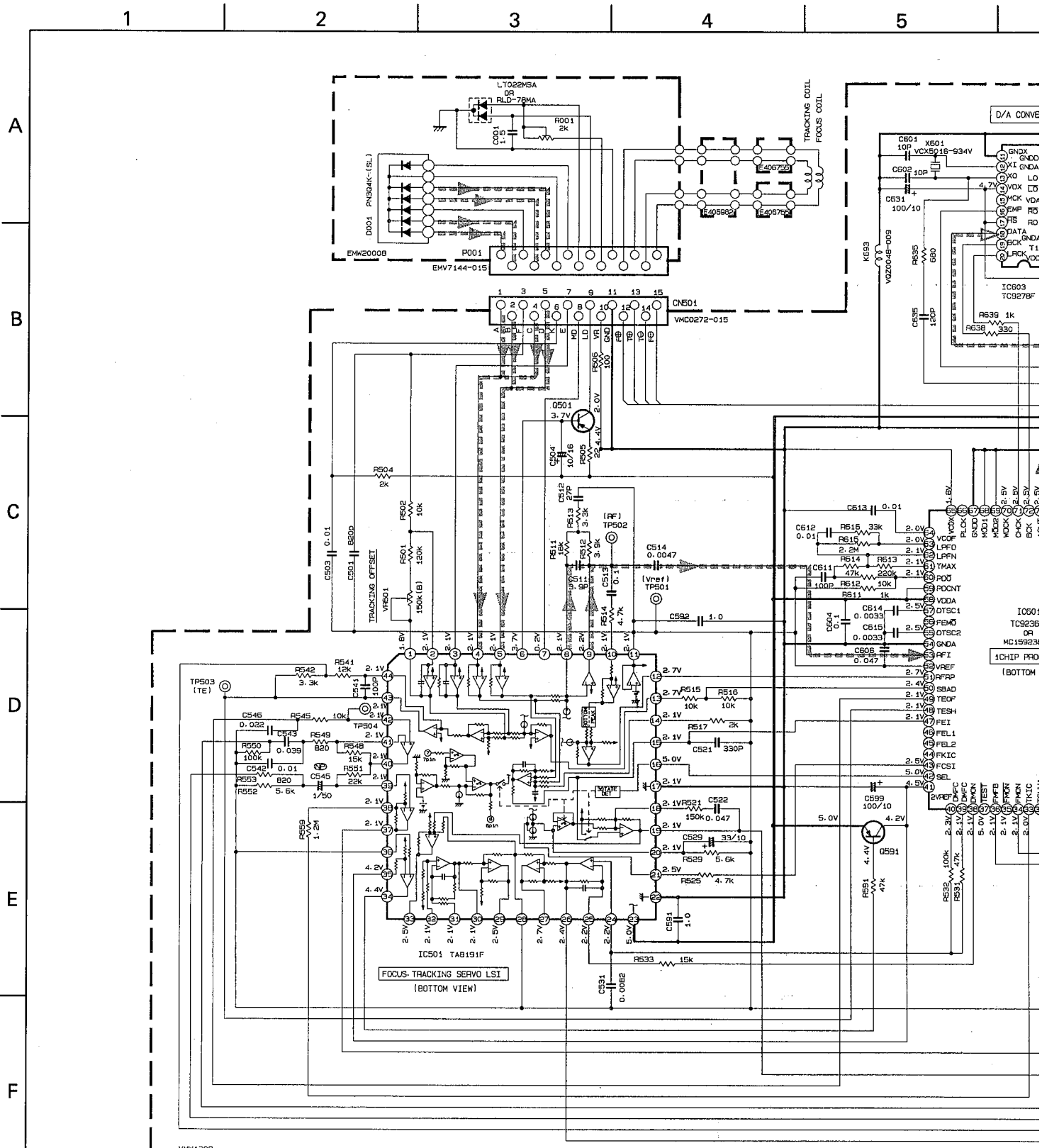

NOTES

1. VOLTAGES ARE DC-MEASURED WITH A DIGITAL VOLT METER IN PLAYBACK
2. UNLESS OTHERWISE SPECIFIED, RESISTORS ARE 1/6W ±5% CARBON RESISTOR. ALL RESISTANCE VALUES ARE IN Ω(M)G.
3. ALL CAPACITORS ARE CERAMIC CAPACITOR OR MYLAR CAPACITOR. ALL CAPACITANCE VALUES ARE IN μF(P=pF).
4. ALL INDUCTANCE VALUES ARE IN μH(m=μH).
5. ALL E-CAPACITORS ARE SHOWN IN THE FORM OF CAPACITANCE (μF)/RATED VOLTAGE (V).

(L) UNFLAMMABLE CARBON RESISTOR
 (M) METAL FILM RESISTOR
 (O) OXIDE METAL FILM RESISTOR
 (L) ±20% LOW LEAK CURRENT ELECTROLYTIC CAPACITOR
 (N) NON-POLARISED ELECTROLYTIC CAPACITOR
 (P) POLYPROPYLENE CAPACITOR
 (S) POLYSTYROL CAPACITOR

G501	2SA952(L,K)
G581	
G591	2SA1309(R,S) OR 2SA1179(H,F,E) OR 2SA933S(R,S)

Fig. 12-4

6

7

8

9

10

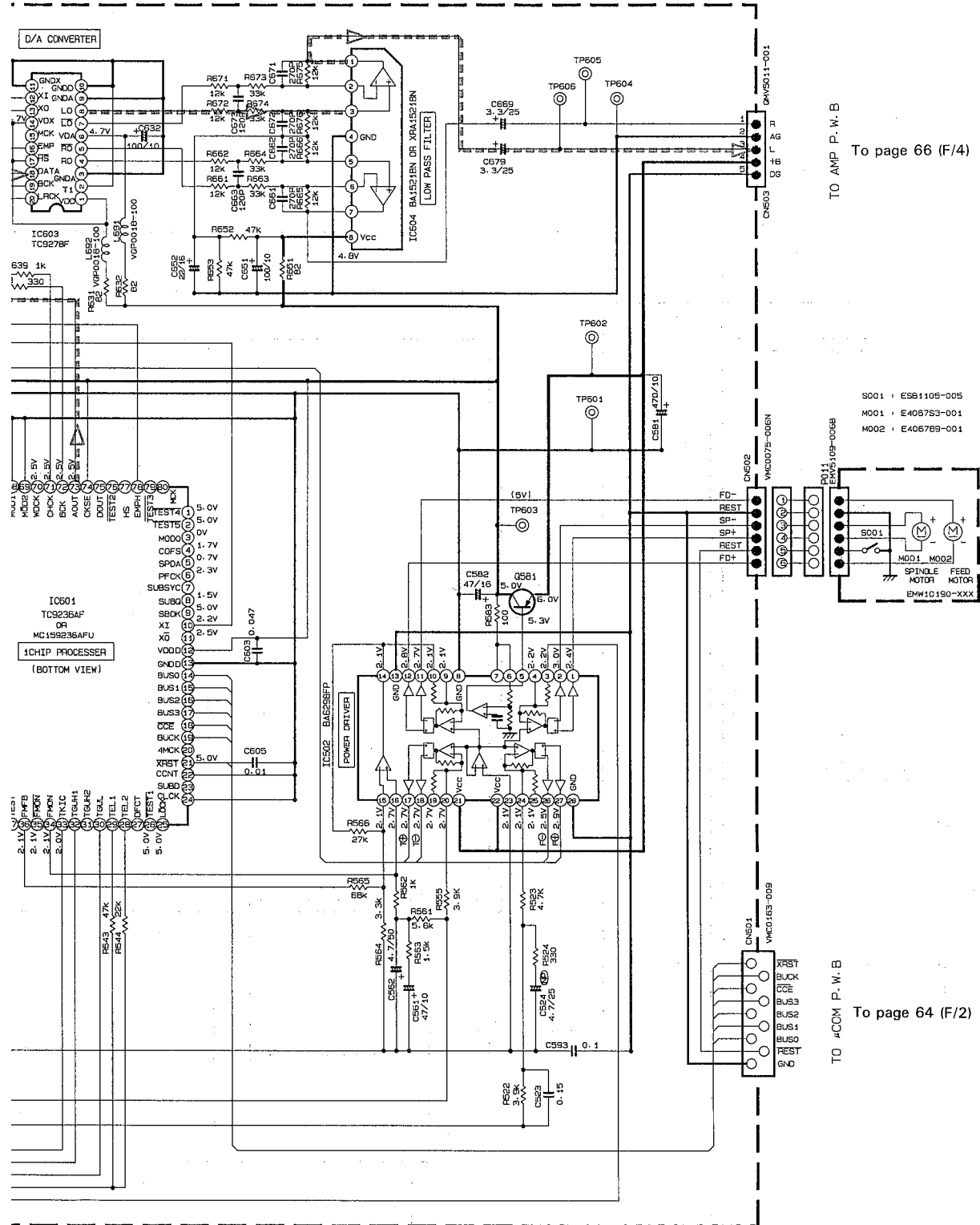

To page 66 (F/4)

TO AMP P. W. B

To page 64 (F/2)

TO COM P. W. B

- ⚡ CD Digital signal
- ⚡ CD Analog signal
- +B LINE

System microcomputer circuit: Drawing No. VDH9228-001SV

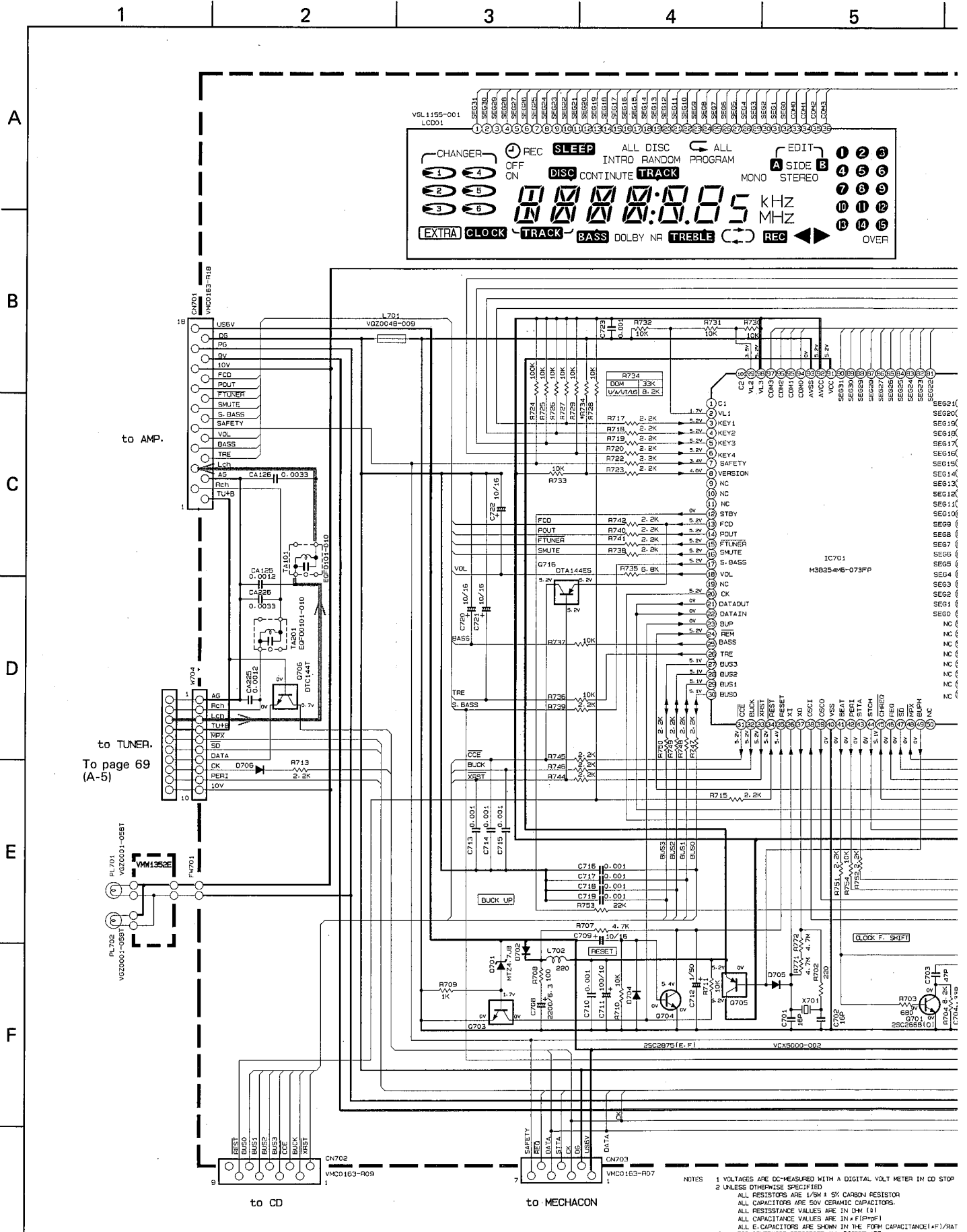

NOTES
 1 VOLTAGES ARE DC-MEASURED WITH A DIGITAL VOLT METER IN CD STOP
 2 UNLESS OTHERWISE SPECIFIED
 ALL RESISTORS ARE 1/8W ± 5% CARBON RESISTOR
 ALL CAPACITORS ARE 50V CERAMIC CAPACITORS
 ALL RESISTANCE VALUES ARE IN OHM (Ω)
 ALL CAPACITANCE VALUES ARE IN PICO-FARAD (pF)
 ALL E-CAPACITORS ARE SHOWN IN THE FORM CAPACITANCE(F)P/PAT
 3 UNLESS OTHERWISE SPECIFIED ALL DIODES ARE 1SS2541-77.

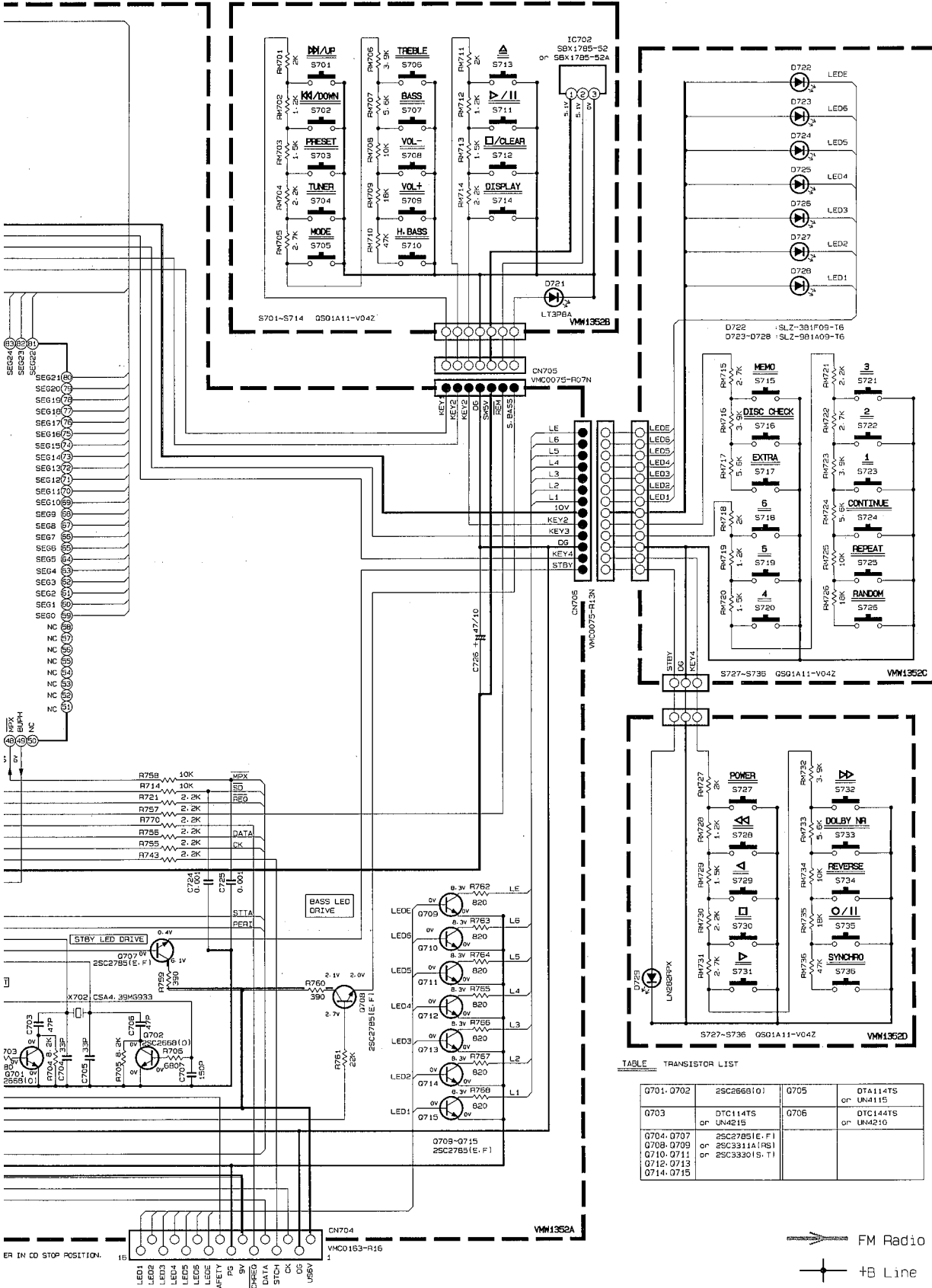

Fig. 12-5

[TANCE]4(F1)/RATED VOLTAGE(V)
241-77.

to CHANGER MECHAON

Tuner Circuit: Drawing No. VDH9228-007TW

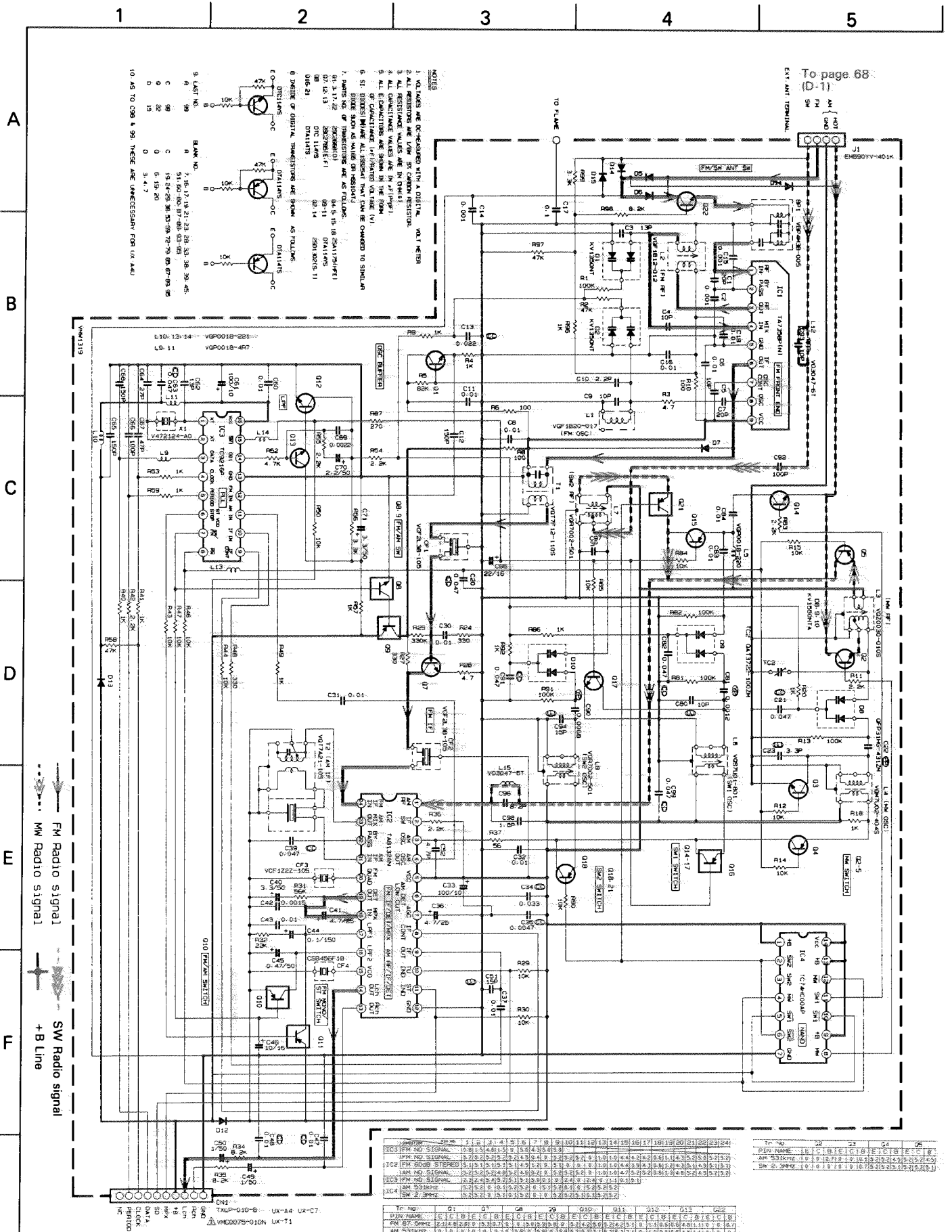
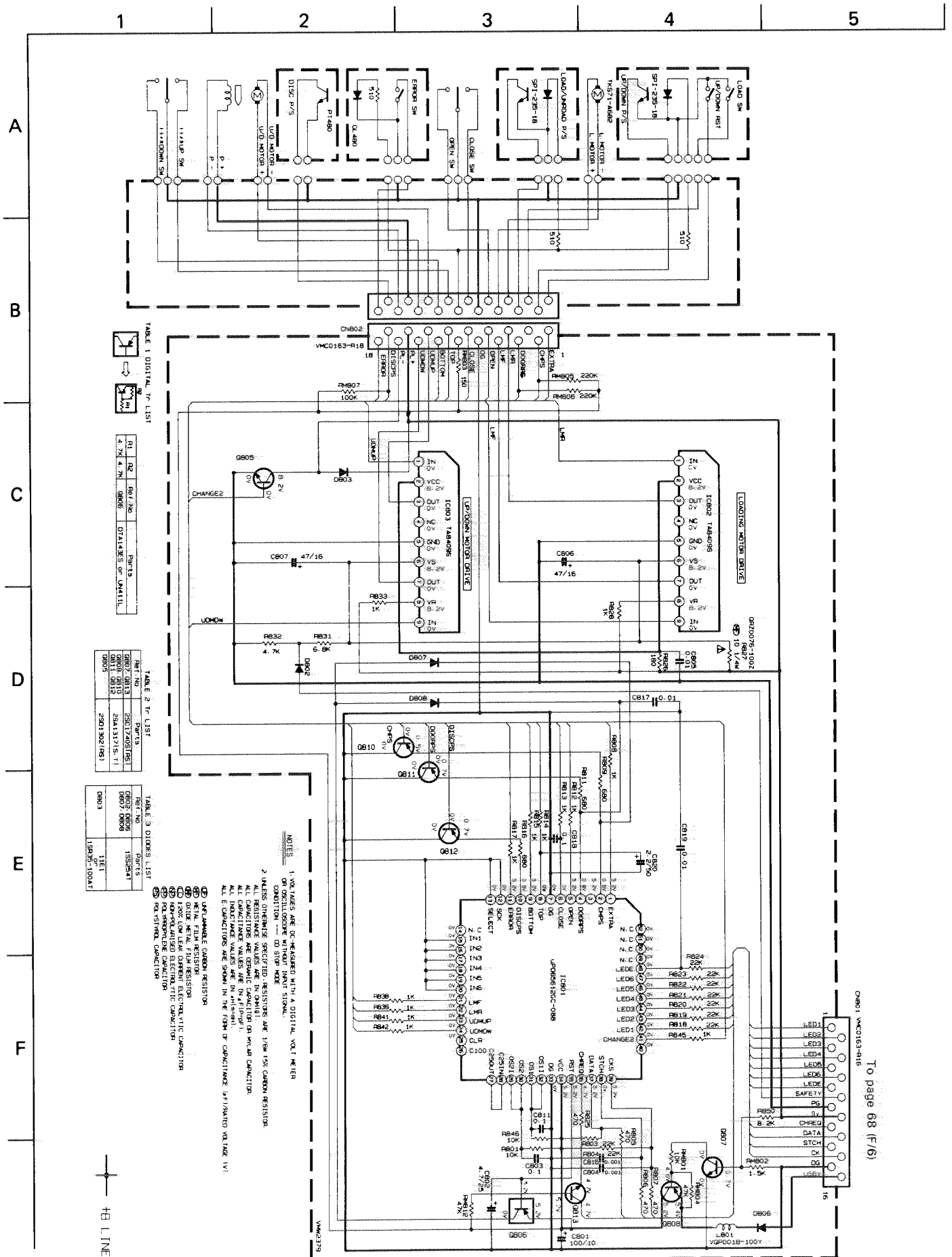

Fig. 12-6

■ Loading Control Circuit: Drawing No. VDH9228-006MW



6

7

8

9

10

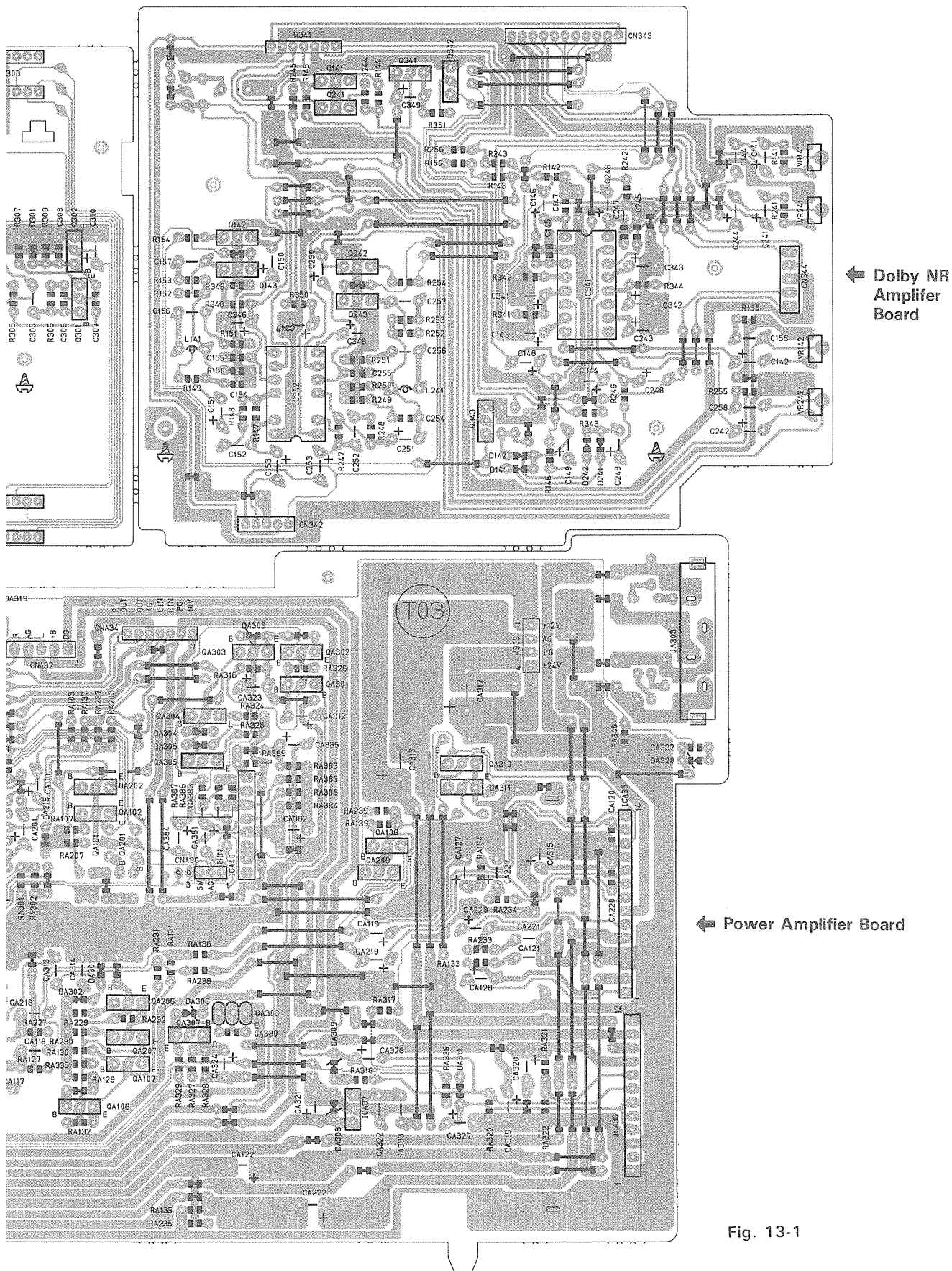

← Dolby NR Amplifier Board

← Power Amplifier Board

Fig. 13-1

System microcomputer & Cassette Mechanism Control P.C. Board: Block No. 0 2

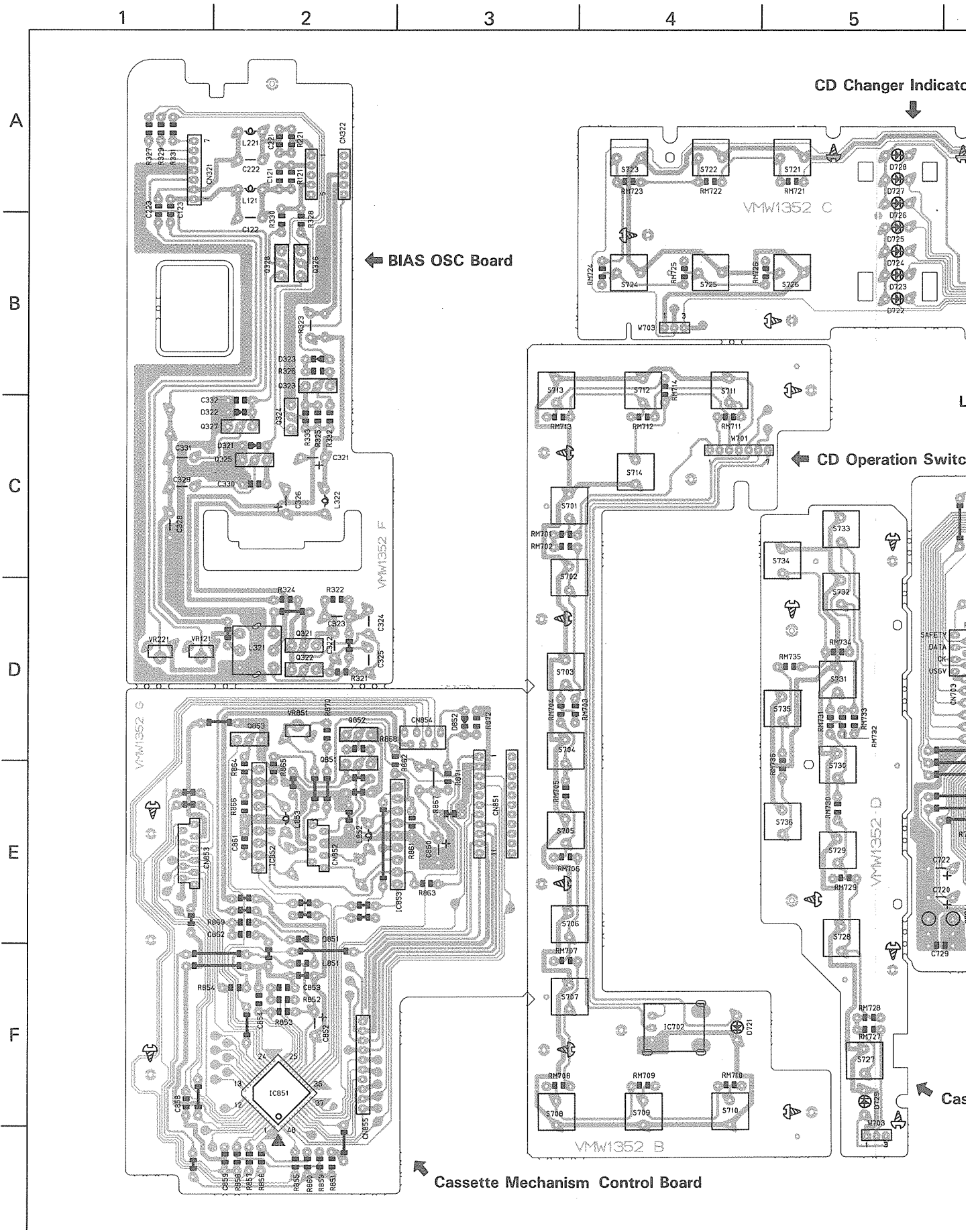

6

7

8

9

10

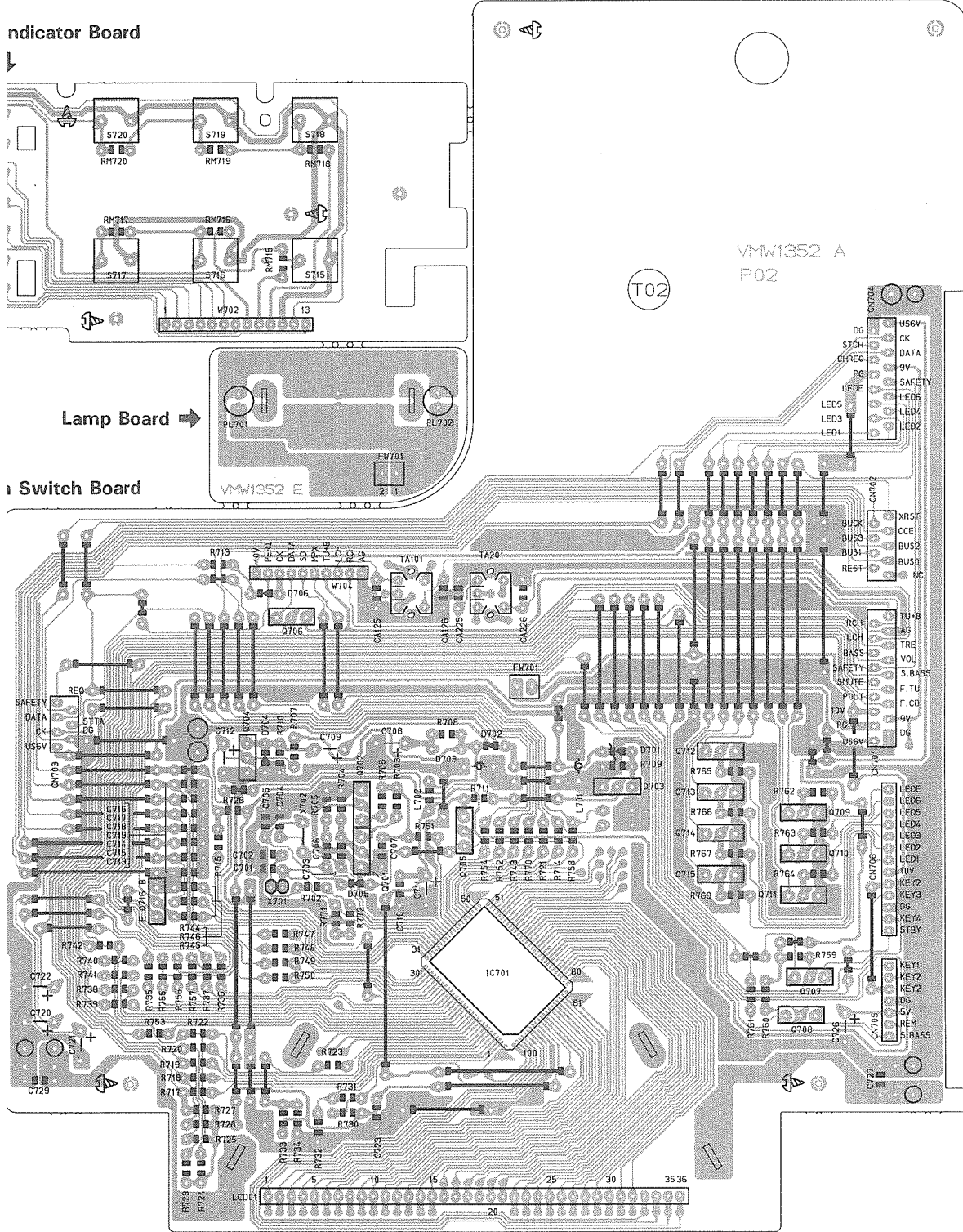

Indicator Board

Lamp Board

Switch Board

VMW1352 A
P02

T02

Cassette Operation Switch Board

LCD/System Micro-Computer Board

Fig. 13-2

1 2 3 4 5

■ CD Changer Control P.C. Board: Block No. 0 3

A

B

C

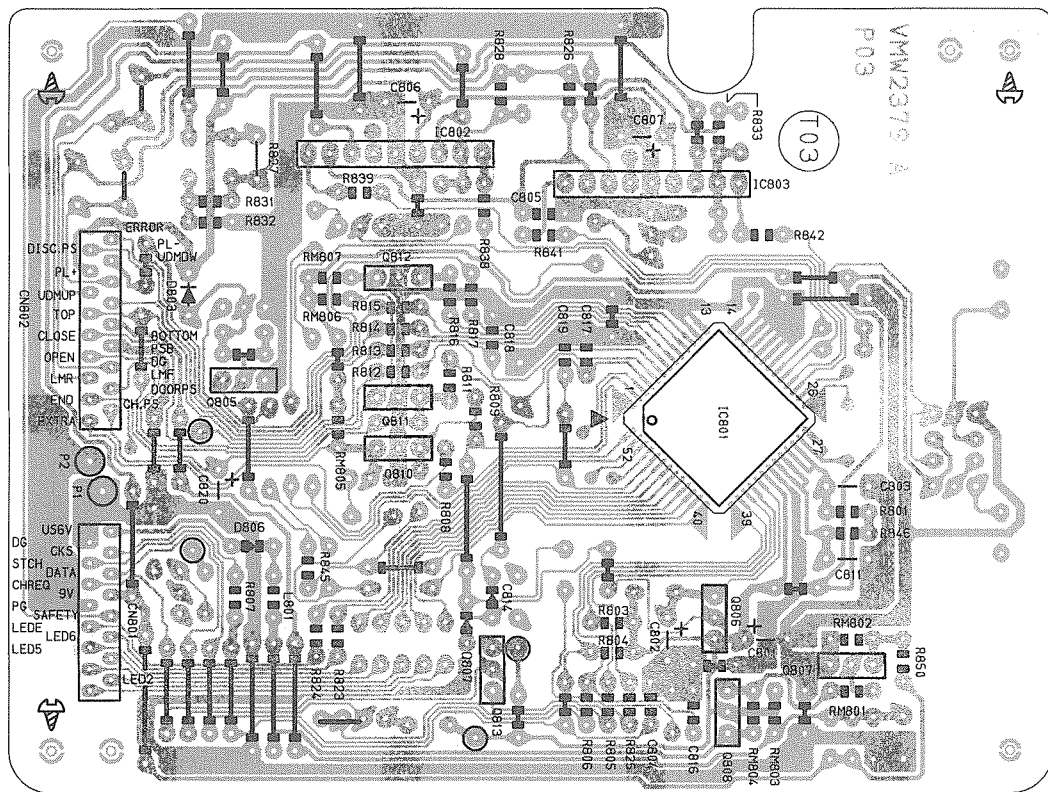

Fig. 13-3

■ CD Amplifier P.C. Board: Block No. 0 4

D

E

F

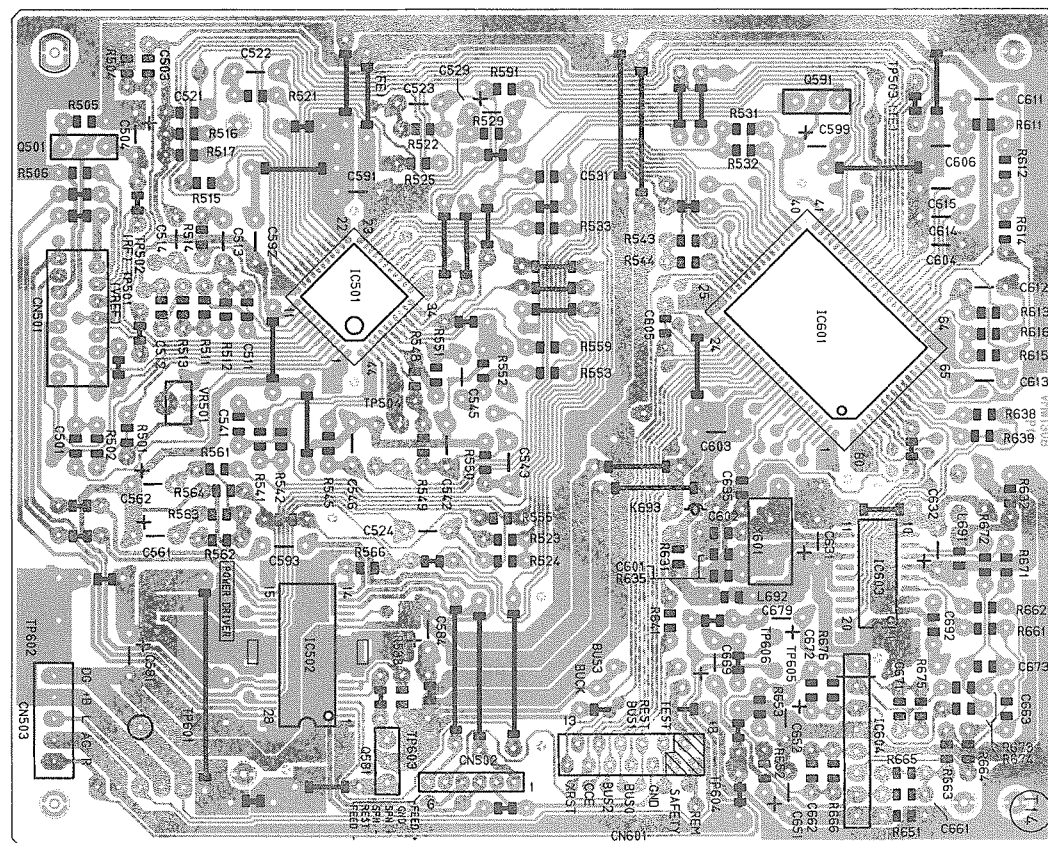

Fig. 13-4

1 2 3 4 5

■ Cassette Mechanism P.C. Board: Block No. 0 6

● Leaf Switch P.C. Board

A

B

C

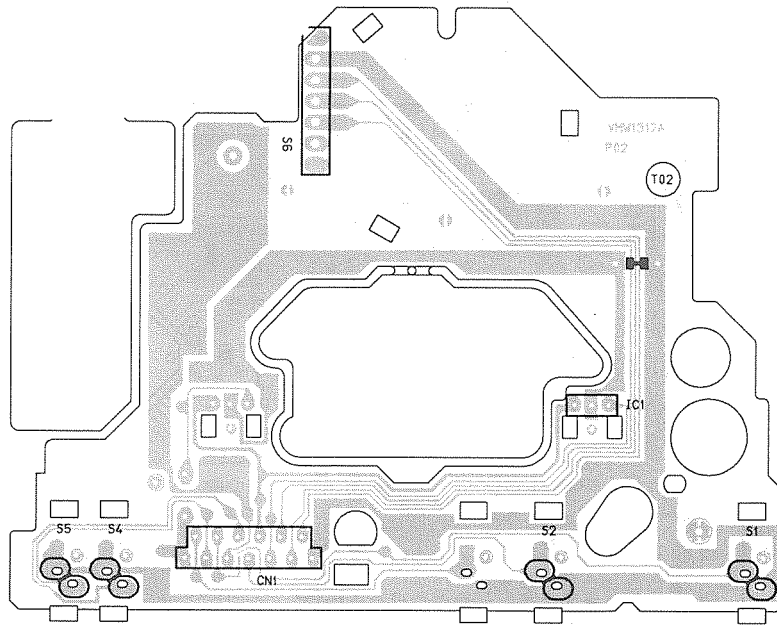

Fig. 13-5

D

E

● Actuator/Reel Motor P.C. Board

F

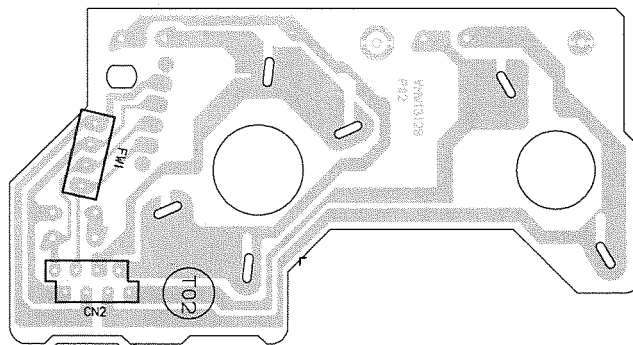

Fig. 13-6

G

1 2 3 4 5

■ Tuner P.C. Board: Block No. 05

A
B
C
D
E
F
G

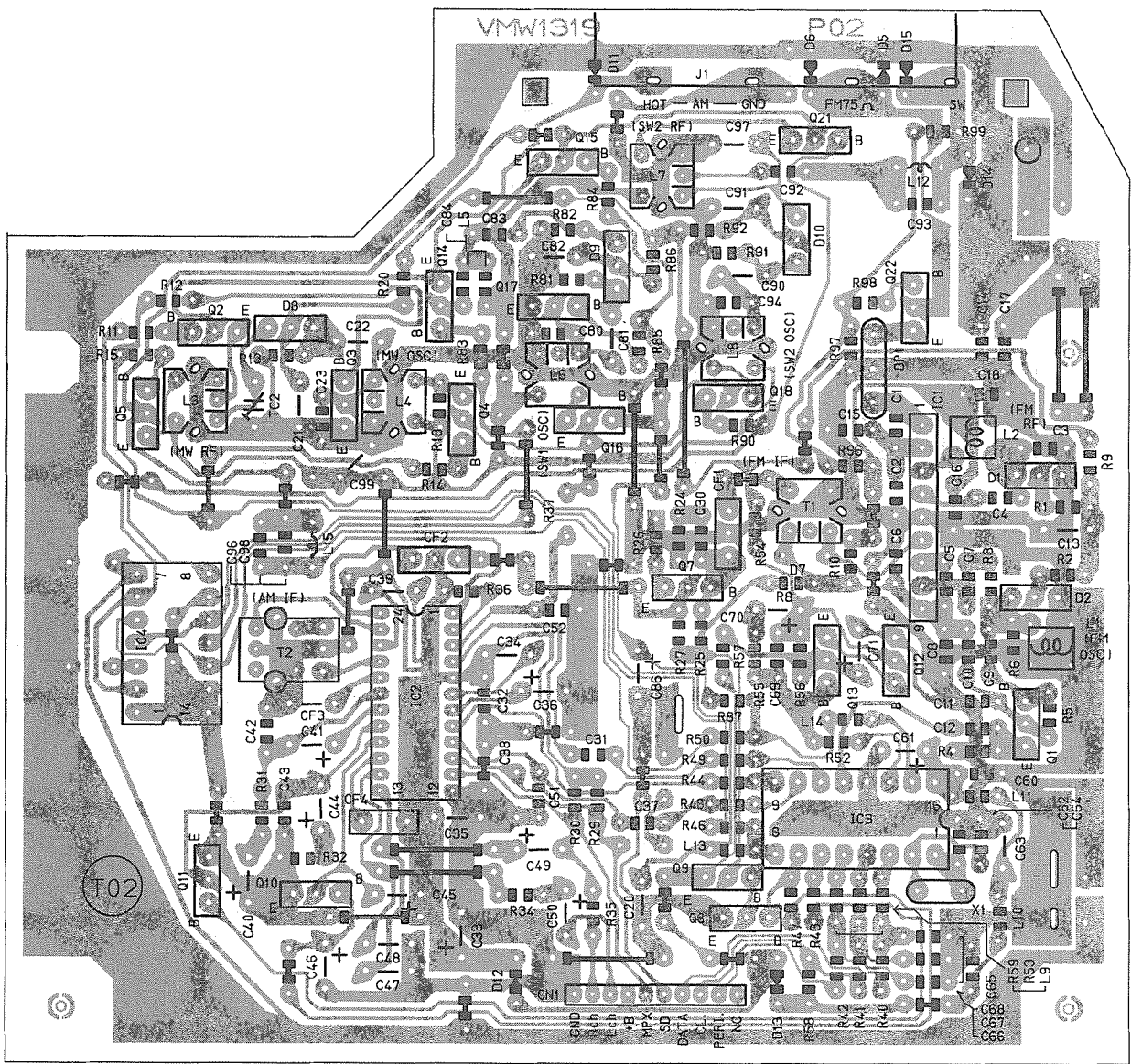

Fig. 13-7

14. Electrical Parts List

Main Amplifier P.C. board

BLOCK NO. 01		BLOCK NO. 01		
REF.	PARTS NO.	PARTS NAME	REMARKS	SUFFIX
C 101	QEK61AM-107ZM	E-CAPACITOR	100MF 20% 10V	
C 102	QCB81HK-681Y	E-CAPACITOR	680PF 10% 50V	
C 103	QEK41HM-225	E-CAPACITOR	2.2MF 20% 50V	
C 104	QFV71HJ-103	FILM CAPACITOR	.010MF 5% 50V	
C 121	QCB81HK-102Y	E-CAPACITOR	1000PF 10% 50V	
C 122	QCS32HJ-151ZV	E-CAPACITOR	150PF 5% 500V	
C 123	QCB81HK-331Y	E-CAPACITOR	330PF 10% 50V	
C 141	QET41HM-105	E-CAPACITOR	1.0MF 20% 50V	
C 142	QETN1HM-225Z	E-CAPACITOR	2.2MF 20% 50V	
C 143	QEK41HM-224	E-CAPACITOR	.22MF 20% 50V	
C 144	QET41HM-474	E-CAPACITOR	4.7MF 20% 50V	
C 145	QCB81HK-102Y	E-CAPACITOR	1000PF 10% 50V	
C 146	QET41HM-474	E-CAPACITOR	4.7MF 20% 50V	
C 147	QCB81HK-471Y	E-CAPACITOR	4.70PF 10% 50V	
C 148	QET41HM-105	E-CAPACITOR	1.0MF 20% 50V	
C 149	QEK41HM-474	E-CAPACITOR	4.7MF 20% 50V	
C 150	QET41HM-105	E-CAPACITOR	1.0MF 20% 50V	
C 151	QET41HM-475	E-CAPACITOR	4.7MF 20% 50V	
C 152	QCC11EM-104V	E-CAPACITOR	1.0MF 20% 25V	
C 153	QET41HM-105	E-CAPACITOR	1.0MF 20% 50V	
C 154	QCB81CM-222Y	E-CAPACITOR	2200PF 20% 16V	
C 155	QCB81HK-102Y	E-CAPACITOR	1000PF 10% 50V	
C 156	QFV41HJ-153ZM	FILM CAPACITOR	.015MF 5% 50V	
C 157	QFV81HJ-273	FILM CAPACITOR	.027MF 5% 50V	
C 158	QFV41HJ-153ZM	FILM CAPACITOR	.015MF 5% 50V	
C 201	QEK61AM-107ZM	E-CAPACITOR	100MF 20% 10V	
C 202	QCB81HK-681Y	E-CAPACITOR	680PF 10% 50V	
C 203	QEK41HM-225	E-CAPACITOR	2.2MF 20% 50V	
C 204	QFV71HJ-103	FILM CAPACITOR	.010MF 5% 50V	
C 221	QCB81HK-102Y	E-CAPACITOR	1000PF 10% 50V	
C 222	QCS32HJ-151ZV	E-CAPACITOR	150PF 5% 500V	
C 223	QCB81HK-331Y	E-CAPACITOR	330PF 10% 50V	
C 241	QET41HM-105	E-CAPACITOR	1.0MF 20% 50V	
C 242	QETN1HM-225Z	E-CAPACITOR	2.2MF 20% 50V	
C 243	QEK41HM-224	E-CAPACITOR	.22MF 20% 50V	
C 244	QET41HM-474	E-CAPACITOR	4.7MF 20% 50V	
C 245	QCB81HK-102Y	E-CAPACITOR	1000PF 10% 50V	
C 246	QET41HM-474	E-CAPACITOR	4.7MF 20% 50V	
C 247	QCB81HK-471Y	E-CAPACITOR	4.70PF 10% 50V	
C 248	QET41HM-105	E-CAPACITOR	1.0MF 20% 50V	
C 249	QEK41HM-474	E-CAPACITOR	4.7MF 20% 50V	
C 250	QET41HM-105	E-CAPACITOR	1.0MF 20% 50V	
C 251	QET41HM-475	E-CAPACITOR	4.7MF 20% 50V	
C 252	QCC11EM-104V	E-CAPACITOR	1.0MF 20% 25V	
C 253	QET41HM-105	E-CAPACITOR	1.0MF 20% 50V	
C 254	QCB81CM-222Y	E-CAPACITOR	2200PF 20% 16V	
C 255	QCB81HK-102Y	E-CAPACITOR	1000PF 10% 50V	
C 256	QFV41HJ-153ZM	FILM CAPACITOR	.015MF 5% 50V	
C 257	QFV81HJ-273	FILM CAPACITOR	.027MF 5% 50V	
C 258	QFV41HJ-153ZM	FILM CAPACITOR	.015MF 5% 50V	
C 301	QEK41CM-226	E-CAPACITOR	22MF 20% 16V	
C 302	QCB81CM-103Y	E-CAPACITOR	.010MF 20% 16V	
C 303	QEK41CM-226	E-CAPACITOR	22MF 20% 16V	
C 304	QFV71HJ-103	FILM CAPACITOR	.010MF 5% 50V	
C 305	QFV41HJ-153ZM	FILM CAPACITOR	.015MF 5% 50V	
A REF.	PARTS NO.	PARTS NAME	REMARKS	SUFFIX
C 306	QCS11HJ-330	E-CAPACITOR	33PF 5% 50V	
C 307	QCB81CM-182Y	E-CAPACITOR	1800PF 20% 16V	
C 308	QCB81HK-681Y	E-CAPACITOR	680PF 10% 50V	
C 309	QEK61AM-107ZM	E-CAPACITOR	100MF 20% 10V	
C 310	QEK41HM-105	E-CAPACITOR	1.0MF 20% 50V	
C 321	QET41CM-476	E-CAPACITOR	4.7MF 20% 16V	
C 322	QFN41HJ-682	M-CAPACITOR	6800PF 5% 50V	
C 323	QFN81HJ-562	M-CAPACITOR	5600PF 5% 50V	
C 324	QFN41HJ-682	M-CAPACITOR	6800PF 5% 50V	
C 325	QFN81HJ-562	M-CAPACITOR	5600PF 5% 50V	
C 326	QET41CM-476	E-CAPACITOR	4.7MF 20% 16V	
C 328	QFP32AJ-153ZM	PP-CAPACITOR	.015MF 5% 100V	
C 329	QFN81HJ-152	M-CAPACITOR	1500PF 5% 50V	
C 330	QCB81CM-103Y	E-CAPACITOR	.010MF 20% 16V	
C 331	QFN41HJ-332	M-CAPACITOR	3300PF 5% 50V	
C 332	QCB81CM-103Y	E-CAPACITOR	.010MF 20% 16V	
C 341	QEK41CM-106	E-CAPACITOR	10MF 20% 16V	
C 342	QEK41CM-106	E-CAPACITOR	10MF 20% 16V	
C 343	QETN1HM-225Z	E-CAPACITOR	2.2MF 20% 50V	
C 344	QET41HM-226	E-CAPACITOR	22MF 20% 50V	
C 346	QETN1HM-106Z	E-CAPACITOR	10MF 20% 50V	
C 347	QET41HM-226	E-CAPACITOR	22MF 20% 50V	
C 348	QET41AM-107	E-CAPACITOR	100MF 20% 10V	
C 349	QET41HM-105	E-CAPACITOR	1.0MF 20% 50V	
C 901	QFV81HJ-223	FILM CAPACITOR	.022MF 5% 50V	
C 902	QFV81HJ-223	FILM CAPACITOR	.022MF 5% 50V	
C 903	QFV81HJ-223	FILM CAPACITOR	.022MF 5% 50V	
C 904	QFV81HJ-223	FILM CAPACITOR	.022MF 5% 50V	
C 905	QCF11HP-223	E-CAPACITOR	.022MF +100:-0%	
C 906	QCF11HP-223	E-CAPACITOR	.022MF +100:-0%	
C 907	QCF11HP-223	E-CAPACITOR	.022MF +100:-0%	
C 908	QCF11HP-223	E-CAPACITOR	.022MF +100:-0%	
CA101	QETN1HM-335Z	E-CAPACITOR	3.3MF 20% 50V	
CA103	QCS11HJ-330	E-CAPACITOR	33PF 5% 50V	
CA104	QETN1HM-335Z	E-CAPACITOR	3.3MF 20% 50V	
CA105	QFV71HJ-683ZM	FILM CAPACITOR	.068MF 5% 50V	
CA106	QEK41HM-105	E-CAPACITOR	1.0MF 20% 50V	
CA107	QCB81HK-151Y	E-CAPACITOR	150PF 10% 50V	
CA108	QFV41HJ-333	FILM CAPACITOR	.033MF 5% 50V	
CA109	QFV71HJ-683ZM	FILM CAPACITOR	.068MF 5% 50V	
CA110	QEK41HM-224	E-CAPACITOR	.22MF 20% 50V	
CA111	QEK41CM-106	E-CAPACITOR	10MF 20% 16V	
CA112	QFV71HJ-683ZM	FILM CAPACITOR	.068MF 5% 50V	
CA114	QET41HM-105	E-CAPACITOR	1.0MF 20% 50V	
CA115	QFV11HJ-393AZM	FILM CAPACITOR	.039MF 5% 50V	
CA116	QCS11HJ-330	E-CAPACITOR	33PF 5% 50V	
CA117	QET41HM-226	E-CAPACITOR	22MF 20% 50V	
CA118	QFV41HJ-224	FILM CAPACITOR	.22MF 5% 50V	
CA119	QEK41HM-225	E-CAPACITOR	2.2MF 20% 50V	
CA120	QCB81HK-331Y	E-CAPACITOR	330PF 10% 50V	
CA121	QCC11EM-104V	E-CAPACITOR	.10MF 20% 25V	
CA122	QETB1CM-228N	E-CAPACITOR	2200PF 20% 16V	
CA124	QCB81CM-392Y	E-CAPACITOR	3900PF 20% 16V	
CA127	QET41EM-476	E-CAPACITOR	4.7MF 20% 25V	
CA128	QET41HM-476	E-CAPACITOR	4.7MF 20% 50V	

BLOCK NO. 01111111

REF.	PARTS NO.	PARTS NAME	REMARKS	SUFFIX
A	CA201	QETN1HM-335Z	E CAPACITOR	
	CA203	QCS11HJ-330	C. CAPACITOR	
	CA204	QETN1HM-335Z	E CAPACITOR	
	CA205	QFV71HJ-6833M	FILM CAPACITOR	
	CA206	QEK41HM-105	E. CAPACITOR	
	CA207	QCBBIHK-151Y	C. CAPACITOR	
	CA208	QFV41HJ-333	FILM CAPACITOR	
	CA209	QFV71HJ-6833M	FILM CAPACITOR	
	CA210	QEK41HM-224	E. CAPACITOR	
	CA211	QEK41CM-106	E. CAPACITOR	
	CA212	QFV71HJ-6833M	FILM CAPACITOR	
	CA214	QET41HM-105	E CAPACITOR	
	CA215	QFV11HJ-393AZM	FILM CAPACITOR	
	CA216	QCS11HJ-330	C. CAPACITOR	
	CA217	QET41HM-226	E CAPACITOR	
	CA218	QFV41HJ-224	FILM CAPACITOR	
	CA219	QEK41HM-225	E. CAPACITOR	
	CA220	QCBBIHK-331Y	C. CAPACITOR	
	CA221	QCC11EM-104V	C. CAPACITOR	
	CA222	QETB1CM-228N	E. CAPACITOR	
	CA224	QCBX1CM-392Y	C. CAPACITOR	
	CA227	QET41EM-476	E. CAPACITOR	
	CA228	QET41HM-476	E. CAPACITOR	
	CA301	QET41HM-226	E CAPACITOR	
	CA302	QET41HM-226	E CAPACITOR	
	CA303	QET41CM-476	E CAPACITOR	
	CA304	QET41HM-226	E CAPACITOR	
	CA305	QETN1HM-106Z	E CAPACITOR	
	CA306	QEK41HM-105	E. CAPACITOR	
	CA307	QET41HM-105	E. CAPACITOR	
	CA308	QEK61HM-6842N	E. CAPACITOR	
	CA310	QET41HM-226	E CAPACITOR	
	CA311	QET41HM-105	E CAPACITOR	
	CA312	QETN1HM-106Z	E CAPACITOR	
	CA313	QFV11HJ-393AZM	FILM CAPACITOR	
	CA314	QFV11HJ-393AZM	FILM CAPACITOR	
	CA315	QETC1VM-2277N	E. CAPACITOR	
	CA316	QETB1EM-338N	E. CAPACITOR	
	CA317	QETB1VM-228N	E. CAPACITOR	
	CA319	QETN1HM-106Z	E CAPACITOR	
	CA320	QETN1HM-106Z	E CAPACITOR	
	CA321	QEK41CM-106	E. CAPACITOR	
	CA322	QFV41HJ-104ZM	FILM CAPACITOR	
	CA323	QEK41CM-106	E. CAPACITOR	
	CA324	QETN1HM-106Z	E CAPACITOR	
	CA326	QET41HM-474	E CAPACITOR	
	CA327	QET41HM-226	E CAPACITOR	
	CA329	QEK41HM-225	E. CAPACITOR	
	CA330	QCVB1CM-103Y	C. CAPACITOR	
	CA332	QCVB1CM-103Y	C. CAPACITOR	
	CA381	QEK41HM-105	E. CAPACITOR	
	CA382	QEK41CM-476	E. CAPACITOR	
	CA383	QCBBIHK-391Y	C. CAPACITOR	
	CA384	QEK61EM-3357M	E. CAPACITOR	
	CA385	QEK41CM-226	E. CAPACITOR	

BLOCK NO. 01111111

REF.	PARTS NO.	PARTS NAME	REMARKS	SUFFIX
A	CNA32	QMV5012-005	CONNECTOR	
	CNA33	VMC0163-R18	CONNECTOR	
	CNA34	VMC0075-R07N	CONNECTOR	
	CNA36	VMC0075-003N	CONNECTOR	
	CN301	VMC0163-R06	CONNECTOR	
	CN302	VMC0289-S10	CONNECTOR	
	CN303	VMC0289-S07	CONNECTOR	
	CN321	VMC0289-P07	CONNECTOR	
	CN322	VMC0289-S05	CONNECTOR	
	CN342	VMC0289-P05	CONNECTOR	
	CN343	VMC0289-P11	CONNECTOR	
	CN344	VMC0041-005	CONNECTOR	
	CN901	VMZ0076-004A	CONNECTOR	
	CN902	VMZ0076-004	CONNECTOR	
	CN903	VMC0041-004	CONNECTOR	
	D 141	1SS133	SI DIODE	
	D 142	1SS133	SI DIODE	
	D 241	1SS133	SI DIODE	
	D 242	1SS133	SI DIODE	
	D 301	1SS133	SI DIODE	
	D 321	1SS133	SI DIODE	
	D 322	1SS133	SI DIODE	
	D 323	1SS133	SI DIODE	
	D 901	1SR35-100	SI DIODE	
	D 902	1SR35-100	SI DIODE	
	D 903	1SR35-100	SI DIODE	
	D 904	1SR35-100	SI DIODE	
	D 905	D2SBA204003	S DIODE	
	DA301	RB721Q	DIODE	
	DA302	RB721Q	DIODE	
	DA303	MTZ5-6JA	ZENER DIODE	
	DA304	1SS133	SI DIODE	
	DA305	1SS133	SI DIODE	
	DA306	MTZ5-1JB	ZENER DIODE	
	DA307	1SS133	SI DIODE	
	DA308	MTZ8-2JB	ZENER DIODE	
	DA309	MTZ9-1JA	ZENER DIODE	
	DA310	1SS133	SI DIODE	
	DA311	1SS133	SI DIODE	
	DA312	MTZ9-1JC	ZENER DIODE	
	DA317	1SS133	SI DIODE	
	DA318	1SS133	SI DIODE	
	DA319	1SS133	SI DIODE	
	DA320	MTZ12JB	ZENER DIODE	
	ICA31	VC4580L	IC	
	ICA32	TA8184P	IC	
	ICA33	BA15218N	IC	
	ICA34	VC4580L	IC	
	ICA35	LA4450	IC	
	ICA36	BA3960	IC	
	ICA37	UC78L06J	IC	
	ICA40	VC4580L	IC	
	IC301	UPC1228HA	IC	
	IC302	UPC1330HA	IC	
	IC341	HA12134A	IC	

BLOCK NO. 09111111

REF.	PARTS NO.	PARTS NAME	REMARKS	SUFFIX
R 104	QRD167J-562	CARBON RESISTOR	5.6K 5% 1/6W	
R 105	QRD161J-122	CARBON RESISTOR	1.2K 5% 1/6W	
R 121	QRD161J-103	CARBON RESISTOR	10K 5% 1/6W	
R 141	QRD161J-103	CARBON RESISTOR	10K 5% 1/6W	
R 142	QRD161J-103	CARBON RESISTOR	10K 5% 1/6W	
R 143	QRD161J-184	CARBON RESISTOR	180K 5% 1/6W	
R 144	QRD161J-225	CARBON RESISTOR	22K 5% 1/6W	
R 145	QRD161J-102	CARBON RESISTOR	1.0K 5% 1/6W	
R 146	QRD161J-102	CARBON RESISTOR	1.0K 5% 1/6W	
R 147	QRD161J-153	CARBON RESISTOR	15K 5% 1/6W	
R 148	QRD161J-153	CARBON RESISTOR	15K 5% 1/6W	
R 149	QRD161J-221	CARBON RESISTOR	220 5% 1/6W	
R 150	QRD161J-182	CARBON RESISTOR	1.8K 5% 1/6W	
R 151	QRD161J-151	CARBON RESISTOR	150 5% 1/6W	
R 152	QRD161J-472	CARBON RESISTOR	4.7K 5% 1/6W	
R 153	QRD161J-182	CARBON RESISTOR	1.8K 5% 1/6W	
R 154	QRD161J-472	CARBON RESISTOR	4.7K 5% 1/6W	
R 155	QRD167J-332	CARBON RESISTOR	3.3K 5% 1/6W	
R 156	QRD161J-393	CARBON RESISTOR	39K 5% 1/6W	
R 201	QRD161J-680	CARBON RESISTOR	68 5% 1/6W	
R 202	QRD161J-224	CARBON RESISTOR	220K 5% 1/6W	
R 203	QRD167J-682	CARBON RESISTOR	6.8K 5% 1/6W	
R 204	QRD167J-562	CARBON RESISTOR	5.6K 5% 1/6W	
R 205	QRD161J-122	CARBON RESISTOR	1.2K 5% 1/6W	
R 221	QRD161J-103	CARBON RESISTOR	10K 5% 1/6W	
R 241	QRD161J-103	CARBON RESISTOR	10K 5% 1/6W	
R 242	QRD161J-103	CARBON RESISTOR	10K 5% 1/6W	
R 243	QRD161J-184	CARBON RESISTOR	180K 5% 1/6W	
R 244	QRD161J-223	CARBON RESISTOR	22K 5% 1/6W	
R 245	QRD161J-102	CARBON RESISTOR	1.0K 5% 1/6W	
R 246	QRD161J-102	CARBON RESISTOR	1.0K 5% 1/6W	
R 247	QRD161J-153	CARBON RESISTOR	15K 5% 1/6W	
R 248	QRD161J-153	CARBON RESISTOR	15K 5% 1/6W	
R 249	QRD161J-221	CARBON RESISTOR	220 5% 1/6W	
R 250	QRD161J-182	CARBON RESISTOR	1.8K 5% 1/6W	
R 251	QRD161J-151	CARBON RESISTOR	150 5% 1/6W	
R 252	QRD161J-472	CARBON RESISTOR	4.7K 5% 1/6W	
R 253	QRD161J-182	CARBON RESISTOR	1.8K 5% 1/6W	
R 254	QRD161J-472	CARBON RESISTOR	4.7K 5% 1/6W	
R 255	QRD167J-332	CARBON RESISTOR	3.3K 5% 1/6W	
R 256	QRD161J-393	CARBON RESISTOR	39K 5% 1/6W	
R 301	QRD161J-221	CARBON RESISTOR	220 5% 1/6W	
R 302	QRD161J-103	CARBON RESISTOR	10K 5% 1/6W	
R 303	QRD161J-221	CARBON RESISTOR	220 5% 1/6W	
R 304	QRD161J-331	CARBON RESISTOR	330 5% 1/6W	
R 305	QRD161J-473	CARBON RESISTOR	47K 5% 1/6W	
R 306	QRD161J-225	CARBON RESISTOR	2.2M 5% 1/6W	
R 307	QRD161J-121	CARBON RESISTOR	120 5% 1/6W	
R 308	QRD161J-104	CARBON RESISTOR	100K 5% 1/6W	
R 321	QRD161J-273	CARBON RESISTOR	27K 5% 1/6W	
R 322	QRD161J-273	CARBON RESISTOR	27K 5% 1/6W	
R 323	GRZ0077-150X	F RES I/M	15 1/0W	
R 324	QRD161J-3R3	CARBON RESISTOR	3.3 5% 1/6W	
R 325	QRD161J-221	CARBON RESISTOR	220 5% 1/6W	
R 326	QRD161J-472	CARBON RESISTOR	4.7K 5% 1/6W	

BLOCK NO. 09111111

REF.	PARTS NO.	PARTS NAME	REMARKS	SUFFIX
IC342	LA3220	IC		
J 901	QMC0263-004BS	AC SOCKET	AC IN	
JA301	VMJ4024-001	JACK	HEAD PHONE	
JA303	EMB90TV-404A	SPK TERMINAL		
JA351	VMJ4024-001	JACK	MICJACK	
L 121	VQP0001-183	INDUCTOR		
L 141	VQP0001-562ZS	INDUCTOR		
L 221	VQP0001-183	INDUCTOR		
L 241	VQP0001-562ZS	INDUCTOR		
L 321	VGH1008-055	OSC. COIL(BIAS)		
L 322	VQP0028-100Z	INDUCTOR		
Q 101	DTC144TS	TRANSISTOR		
Q 141	2SC2001(L,K)	TRANSISTOR		
Q 142	2SC2001(L,K)	TRANSISTOR		
Q 143	DTC144TS	TRANSISTOR		
Q 201	DTC144TS	TRANSISTOR		
Q 241	2SC2001(L,K)	TRANSISTOR		
Q 242	2SC2001(L,K)	TRANSISTOR		
Q 243	DTC144TS	TRANSISTOR		
Q 301	2SC2785	TRANSISTOR		
Q 302	2SC2785	TRANSISTOR		
Q 321	2SC2001(L,K)	TRANSISTOR		
Q 322	2SC2001(L,K)	TRANSISTOR		
Q 323	2SC2785	TRANSISTOR		
Q 324	2SC2001(L,K)	TRANSISTOR		
Q 325	2SC1845	TRANSISTOR		
Q 326	2SC2785	TRANSISTOR		
Q 327	2SC1845	TRANSISTOR		
Q 328	2SC2785	TRANSISTOR		
Q 341	DTA144ES	TRANSISTOR		
Q 342	DTC144ES	TRANSISTOR		
Q 343	DTC144TS	TRANSISTOR		
QA102	2SC2785	TRANSISTOR		
QA103	2SC2785	TRANSISTOR		
QA304	2SK301(P,ø)	TRANSISTOR(FET)		
QA106	2SD1302	TRANSISTOR		
QA107	2SD1302	TRANSISTOR		
QA208	2SD1302	TRANSISTOR		
QA209	2SC2785	TRANSISTOR		
QA203	2SC2785	TRANSISTOR		
QA204	2SK301(P,ø)	TRANSISTOR(FET)		
QA206	2SD1302	TRANSISTOR		
QA207	2SD1302	TRANSISTOR		
QA208	2SD1302	TRANSISTOR		
QA301	DTA143ES	TRANSISTOR		
QA302	DTC143ES	TRANSISTOR		
QA303	DTC143ES	TRANSISTOR		
QA304	2SA1175	TRANSISTOR		
QA305	2SC2785	TRANSISTOR		
QA306	2SB772(Q,P)	TRANSISTOR		
QA307	2SC2785	TRANSISTOR		
QA308	DTC143ES	TRANSISTOR		
R 101	QRD161J-680	CARBON RESISTOR	68 5% 1/6W	
R 102	QRD161J-224	CARBON RESISTOR	220K 5% 1/6W	
R 103	QRD167J-682	CARBON RESISTOR	6.8K 5% 1/6W	

BLOCK NO. 04111111

REF.	PARTS NO.	PARTS NAME	REMARKS	SUFFIX
RA213	QRD161J-683	CARBON RESISTOR	68K 5% 1/6W	
RA214	QRD161J-222	CARBON RESISTOR	2.2K 5% 1/6W	
RA215	QRD161J-102	CARBON RESISTOR	1.0K 5% 1/6W	
RA216	QRD161J-822	CARBON RESISTOR	8.2K 5% 1/6W	
RA217	QRD161J-332	CARBON RESISTOR	3.3K 5% 1/6W	
RA218	QRD161J-334	CARBON RESISTOR	330K 5% 1/6W	
RA220	QRD161J-104	CARBON RESISTOR	100K 5% 1/6W	
RA221	QRD161J-103	CARBON RESISTOR	10K 5% 1/6W	
RA222	QRD161J-105	CARBON RESISTOR	1.0M 5% 1/6W	
RA223	QRD161J-274	CARBON RESISTOR	270K 5% 1/6W	
RA224	QRD161J-821	CARBON RESISTOR	820 5% 1/6W	
RA226	QRD161J-102	CARBON RESISTOR	1.0K 5% 1/6W	
RA227	QRD161J-391	CARBON RESISTOR	390 5% 1/6W	
RA228	QRD161J-472	CARBON RESISTOR	4.7K 5% 1/6W	
RA229	QRD161J-475	CARBON RESISTOR	4.7M 5% 1/6W	
RA230	QRD161J-475	CARBON RESISTOR	4.7M 5% 1/6W	
RA231	QRD161J-222	CARBON RESISTOR	2.2K 5% 1/6W	
RA232	QRD161J-474	CARBON RESISTOR	470K 5% 1/6W	
RA233	QRD161J-2R2	CARBON RESISTOR	2.2 5% 1/6W	
RA234	QRD161J-471	CARBON RESISTOR	470 5% 1/6W	
RA235	QRD161J-271	CARBON RESISTOR	270 5% 1/6W	
RA236	QRD161J-151	CARBON RESISTOR	150 5% 1/6W	
RA237	QRD161J-563	CARBON RESISTOR	U/US/A ONLY	
RA238	QRD161J-222	CARBON RESISTOR	G/GI	
RA239	QRD161J-472	CARBON RESISTOR	4.7K 5% 1/6W	
RA240	QRD161J-273	CARBON RESISTOR	27K 5% 1/6W	
RA301	QRD161J-473	CARBON RESISTOR	47K 5% 1/6W	
RA302	QRD161J-393	CARBON RESISTOR	39K 5% 1/6W	
RA303	QRD161J-470	CARBON RESISTOR	47 5% 1/6W	
RA305	QRD161J-823	CARBON RESISTOR	82K 5% 1/6W	
RA306	QRD161J-273	CARBON RESISTOR	27K 5% 1/6W	
RA307	QRD161J-104	CARBON RESISTOR	100K 5% 1/6W	
RA308	QRD161J-104	CARBON RESISTOR	100K 5% 1/6W	
RA309	QRD161J-333	CARBON RESISTOR	33K 5% 1/6W	
RA310	QRD161J-223	CARBON RESISTOR	22K 5% 1/6W	
RA311	QRD161J-223	CARBON RESISTOR	22K 5% 1/6W	
RA312	QRD161J-477	CARBON RESISTOR	4.7 5% 1/6W	
RA313	QRD161J-473	CARBON RESISTOR	47K 5% 1/6W	
RA314	QRD161J-473	CARBON RESISTOR	47K 5% 1/6W	
RA315	QRD161J-223	CARBON RESISTOR	22K 5% 1/6W	
RA316	QRD161J-103	CARBON RESISTOR	10K 5% 1/6W	
RA317	QRD161J-472	CARBON RESISTOR	4.7K 5% 1/6W	
RA318	QRD161J-221	CARBON RESISTOR	220 5% 1/6W	
RA320	QRD161J-332	CARBON RESISTOR	3.3K 5% 1/6W	
RA321	QRD161J-183	CARBON RESISTOR	18K 5% 1/6W	
RA322	QRD161J-332	CARBON RESISTOR	3.3K 5% 1/6W	
RA324	QRD161J-470	CARBON RESISTOR	47 5% 1/6W	
RA325	QRD161J-562	CARBON RESISTOR	5.6K 5% 1/6W	
RA326	QRD161J-562	CARBON RESISTOR	5.6K 5% 1/6W	
RA327	QRD161J-562	CARBON RESISTOR	8.2K 5% 1/6W	
RA328	QRD161J-392	CARBON RESISTOR	3.9K 5% 1/6W	
RA329	QRD161J-151	CARBON RESISTOR	150 5% 1/6W	
RA330	QRD161J-332	CARBON RESISTOR	3.3K 5% 1/6W	
RA331	QRD161J-682	CARBON RESISTOR	6.8K 5% 1/6W	
RA333	QR20077-4R7X	FUSE RESISTOR	4.7 1/0W	

BLOCK NO. 04111111

REF.	PARTS NO.	PARTS NAME	REMARKS	SUFFIX
R 327	QRD161J-472	CARBON RESISTOR	4.7K 5% 1/6W	
R 328	QRD161J-152	CARBON RESISTOR	1.5K 5% 1/6W	
R 329	QRD161J-223	CARBON RESISTOR	22K 5% 1/6W	
R 330	QRD161J-152	CARBON RESISTOR	1.5K 5% 1/6W	
R 331	QRD161J-223	CARBON RESISTOR	22K 5% 1/6W	
R 332	QRD161J-181	CARBON RESISTOR	180 5% 1/6W	
R 333	QRD161J-181	CARBON RESISTOR	180 5% 1/6W	
R 341	QRD161J-103	CARBON RESISTOR	10K 5% 1/6W	
R 342	QRD161J-183	CARBON RESISTOR	18K 5% 1/6W	
R 343	QRD161J-221	CARBON RESISTOR	220 5% 1/6W	
R 344	QRD161J-103	CARBON RESISTOR	10K 5% 1/6W	
R 348	QRD161J-475	CARBON RESISTOR	4.7M 5% 1/6W	
R 349	QRD161J-475	CARBON RESISTOR	4.7M 5% 1/6W	
R 350	QRD161J-221	CARBON RESISTOR	220 5% 1/6W	
R 351	QRD161J-223	CARBON RESISTOR	22K 5% 1/6W	
RA103	QRD161J-473	CARBON RESISTOR	47K 5% 1/6W	
RA104	QRD161J-273	CARBON RESISTOR	27K 5% 1/6W	
RA105	QRD161J-682	CARBON RESISTOR	6.8K 5% 1/6W	
RA107	QRD161J-223	CARBON RESISTOR	22K 5% 1/6W	
RA109	QRD161J-104	CARBON RESISTOR	100K 5% 1/6W	
RA110	QRD161J-123	CARBON RESISTOR	12K 5% 1/6W	
RA112	QRD161J-562	CARBON RESISTOR	5.6K 5% 1/6W	
RA113	QRD161J-683	CARBON RESISTOR	68K 5% 1/6W	
RA114	QRD161J-222	CARBON RESISTOR	2.2K 5% 1/6W	
RA115	QRD161J-102	CARBON RESISTOR	1.0K 5% 1/6W	
RA116	QRD161J-822	CARBON RESISTOR	8.2K 5% 1/6W	
RA117	QRD161J-332	CARBON RESISTOR	3.3K 5% 1/6W	
RA118	QRD161J-334	CARBON RESISTOR	330K 5% 1/6W	
RA120	QRD161J-104	CARBON RESISTOR	100K 5% 1/6W	
RA121	QRD161J-103	CARBON RESISTOR	10K 5% 1/6W	
RA122	QRD161J-105	CARBON RESISTOR	1.0M 5% 1/6W	
RA123	QRD161J-274	CARBON RESISTOR	270K 5% 1/6W	
RA124	QRD161J-821	CARBON RESISTOR	820 5% 1/6W	
RA126	QRD161J-102	CARBON RESISTOR	1.0K 5% 1/6W	
RA127	QRD161J-391	CARBON RESISTOR	390 5% 1/6W	
RA128	QRD161J-472	CARBON RESISTOR	4.7K 5% 1/6W	
RA129	QRD161J-475	CARBON RESISTOR	4.7M 5% 1/6W	
RA130	QRD161J-475	CARBON RESISTOR	4.7M 5% 1/6W	
RA131	QRD161J-222	CARBON RESISTOR	2.2K 5% 1/6W	
RA132	QRD161J-674	CARBON RESISTOR	670K 5% 1/6W	
RA133	QRD161J-2R2	CARBON RESISTOR	2.2 5% 1/6W	
RA134	QRD161J-471	CARBON RESISTOR	470 5% 1/6W	
RA135	QRD161J-271	CARBON RESISTOR	270 5% 1/6W	
RA136	QRD161J-151	CARBON RESISTOR	150 5% 1/6W	
RA137	QRD161J-563	CARBON RESISTOR	U/US/A ONLY	
RA138	QRD161J-222	CARBON RESISTOR	G/GI	
RA139	QRD161J-472	CARBON RESISTOR	4.7K 5% 1/6W	
RA140	QRD161J-273	CARBON RESISTOR	27K 5% 1/6W	
RA203	QRD161J-473	CARBON RESISTOR	47K 5% 1/6W	
RA204	QRD161J-273	CARBON RESISTOR	27K 5% 1/6W	
RA205	QRD161J-682	CARBON RESISTOR	6.8K 5% 1/6W	
RA207	QRD161J-223	CARBON RESISTOR	22K 5% 1/6W	
RA209	QRD161J-104	CARBON RESISTOR	100K 5% 1/6W	
RA210	QRD161J-123	CARBON RESISTOR	12K 5% 1/6W	
RA212	QRD161J-562	CARBON RESISTOR	5.6K 5% 1/6W	

■ LCD/System Microcomputer P.C. board

BLOCK NO. 02

A REF.	PARTS NO.	PARTS NAME	REMARKS	SUFFIX
C 701	QCS11HJ-180	C. CAPACITOR	18PF 5% 50V	
C 702	QCS11HJ-180	C. CAPACITOR	18PF 5% 50V	
C 703	QCS11HJ-470	C. CAPACITOR	47PF 5% 50V	
C 704	QCS11HJ-330	C. CAPACITOR	33PF 5% 50V	
C 705	QCS11HJ-330	C. CAPACITOR	33PF 5% 50V	
C 706	QCS11HJ-470	C. CAPACITOR	47PF 5% 50V	
C 707	QCB1HK-151Y	C. CAPACITOR	150PF 10% 50V	
C 708	QETMOJM-228	E. CAPACITOR	2200MF 20% 6.3V	
C 709	QETM1HM-106Z	E. CAPACITOR	100MF 20% 50V	
C 710	QCB1HK-102Y	C. CAPACITOR	1000PF 10% 50V	
C 711	QEK1AM-107ZM	E. CAPACITOR	100MF 20% 10V	
C 712	QET41HM-105	E. CAPACITOR	1.0MF 20% 50V	
C 713	QCB1HK-102Y	C. CAPACITOR	1000PF 10% 50V	
C 714	QCB1HK-102Y	C. CAPACITOR	1000PF 10% 50V	
C 715	QCB1HK-102Y	C. CAPACITOR	1000PF 10% 50V	
C 716	QCB1HK-102Y	C. CAPACITOR	1000PF 10% 50V	
C 717	QCB1HK-102Y	C. CAPACITOR	1000PF 10% 50V	
C 718	QCB1HK-102Y	C. CAPACITOR	1000PF 10% 50V	
C 719	QCB1HK-102Y	C. CAPACITOR	1000PF 10% 50V	
C 720	QEK41CM-106	E. CAPACITOR	10MF 20% 16V	
C 721	QEK41CM-106	E. CAPACITOR	10MF 20% 16V	
C 722	QEK41CM-106	E. CAPACITOR	10MF 20% 16V	
C 723	QCB1HK-102Y	C. CAPACITOR	1000PF 10% 50V	
C 726	QET41CM-476	E. CAPACITOR	47MF 20% 16V	
C 727	QCVB1CN-103Y	C. CAPACITOR	.010MF 30% 16V	
C 729	QCVB1CN-103Y	C. CAPACITOR	.010MF 30% 16V	
C 852	QEK61AM-107ZM	E. CAPACITOR	100MF 20% 10V	
C 853	QCB1CM-272Y	C. CAPACITOR	2700PF 20% 16V	
C 854	QCB1CM-103Y	C. CAPACITOR	.010MF 20% 16V	
C 858	QCVB1CM-103Y	C. CAPACITOR	.010MF 20% 16V	
C 859	QCS11HJ-470	C. CAPACITOR	47PF 5% 50V	
C 860	QET41AM-108	E. CAPACITOR	1000MF 20% 10V	
C 861	QCVB1CM-103Y	C. CAPACITOR	.010MF 20% 16V	
C 862	QCVB1CM-103Y	C. CAPACITOR	.010MF 20% 16V	
CA125	QCB1CM-122Y	C. CAPACITOR	1200PF 20% 16V	
CA126	QCB1CM-332Y	C. CAPACITOR	3300PF 20% 16V	
CA225	QCB1CM-122Y	C. CAPACITOR	1200PF 20% 16V	
CA226	QCB1CM-332Y	C. CAPACITOR	3300PF 20% 16V	
CN701	VMC0163-R18	CONNECTOR		
CN702	VMC0163-R09	CONNECTOR		
CN703	VMC0163-R07	CONNECTOR		
CN704	VMC0163-R16	CONNECTOR		
CN705	VMC0075-R07N	CONNECTOR		
CN706	VMC0075-R13N	CONNECTOR		
CN851	VMC0289-S11	CONNECTOR		
CN852	VMC0234-P08	CONNECTOR		
CN853	VMC0234-P11	CONNECTOR		
CN854	VMC0163-R07	CONNECTOR		
CN855	VMC0289-P10	CONNECTOR		
D 701	MT4.7JUB	Z. DIODE I/M		
D 702	1SS133	SI DIODE		
D 704	1SS133	SI DIODE		
D 705	1SS133	SI DIODE		
D 706	1SS133	SI DIODE		
D 721	GL-3PR8	LED	HYPER-BASS	

BLOCK NO. 01

A REF.	PARTS NO.	PARTS NAME	REMARKS	SUFFIX
RA335	GRD161J-475	CARBON RESISTOR	4.7M 5% 1/6W	
RA336	GRD161J-273	CARBON RESISTOR	27K 5% 1/6W	
RA337	GRD161J-154	CARBON RESISTOR	150K 5% 1/6W	
RA339	GRD161J-223	CARBON RESISTOR	22K 5% 1/6W	
RA340	GRD161J-103	CARBON RESISTOR	10K 5% 1/6W	
RA381	GRD161J-102	CARBON RESISTOR	1.0K 5% 1/6W	
RA383	GRD161J-154	CARBON RESISTOR	150K 5% 1/6W	
RA384	GRD161J-154	CARBON RESISTOR	150K 5% 1/6W	
RA385	GRD161J-182	CARBON RESISTOR	1.8K 5% 1/6W	
RA386	GRD161J-564	CARBON RESISTOR	560K 5% 1/6W	
RA387	GRD161J-181	CARBON RESISTOR	180 5% 1/6W	
RA388	GRD161J-103	CARBON RESISTOR	10K 5% 1/6W	
RA389	GRD161J-221	CARBON RESISTOR	220 5% 1/6W	
A S 901	VMZ0126-002	VOLTAGE SELECTOR	U/US/ONLY	
VA351	QVAA46B-V03M	V. RESISTOR	20KB	
VR121	QVPA603-104A	SEMI.-V. RESISTOR		
VR141	QVPA603-502AZM	SEMI.-V. RESISTOR		
VR142	QVPA603-502AZM	SEMI.-V. RESISTOR		
VR221	QVPA603-104A	SEMI.-V. RESISTOR		
VR241	QVPA603-502AZM	SEMI.-V. RESISTOR		
VR242	QVPA603-502AZM	SEMI.-V. RESISTOR		

BLOCK NO. 02

REF.	PARTS NO.	PARTS NAME	REMARKS	SUFFIX
R 720	QRD161J-222	CARBON RESISTOR	2.2K 5% 1/6W	
R 721	QRD161J-222	CARBON RESISTOR	2.2K 5% 1/6W	
R 722	QRD161J-222	CARBON RESISTOR	2.2K 5% 1/6W	
R 723	QRD161J-222	CARBON RESISTOR	2.2K 5% 1/6W	
R 724	QRD161J-104	CARBON RESISTOR	100K 5% 1/6W	
R 725	QRD161J-103	CARBON RESISTOR	10K 5% 1/6W	
R 726	QRD161J-103	CARBON RESISTOR	10K 5% 1/6W	
R 727	QRD161J-103	CARBON RESISTOR	10K 5% 1/6W	
R 728	QRD161J-103	CARBON RESISTOR	10K 5% 1/6W	
R 729	QRD161J-103	CARBON RESISTOR	10K 5% 1/6W	
R 730	QRD161J-103	CARBON RESISTOR	10K 5% 1/6W	
R 731	QRD161J-103	CARBON RESISTOR	10K 5% 1/6W	
R 732	QRD161J-103	CARBON RESISTOR	10K 5% 1/6W	
R 733	QRD161J-103	CARBON RESISTOR	10K 5% 1/6W	
R 734	QRD161J-822	CARBON RESISTOR	VERSION	
R 735	QRD161J-103	CARBON RESISTOR	10K 5% 1/6W	
R 736	QRD161J-103	CARBON RESISTOR	10K 5% 1/6W	
R 737	QRD161J-103	CARBON RESISTOR	10K 5% 1/6W	
R 738	QRD161J-222	CARBON RESISTOR	2.2K 5% 1/6W	
R 739	QRD161J-222	CARBON RESISTOR	2.2K 5% 1/6W	
R 740	QRD161J-222	CARBON RESISTOR	2.2K 5% 1/6W	
R 741	QRD161J-222	CARBON RESISTOR	2.2K 5% 1/6W	
R 742	QRD161J-222	CARBON RESISTOR	2.2K 5% 1/6W	
R 743	QRD161J-222	CARBON RESISTOR	2.2K 5% 1/6W	
R 744	QRD161J-222	CARBON RESISTOR	2.2K 5% 1/6W	
R 745	QRD161J-222	CARBON RESISTOR	2.2K 5% 1/6W	
R 746	QRD161J-222	CARBON RESISTOR	2.2K 5% 1/6W	
R 747	QRD161J-222	CARBON RESISTOR	2.2K 5% 1/6W	
R 748	QRD161J-222	CARBON RESISTOR	2.2K 5% 1/6W	
R 749	QRD161J-222	CARBON RESISTOR	2.2K 5% 1/6W	
R 750	QRD161J-222	CARBON RESISTOR	2.2K 5% 1/6W	
R 751	QRD161J-222	CARBON RESISTOR	2.2K 5% 1/6W	
R 752	QRD161J-222	CARBON RESISTOR	2.2K 5% 1/6W	
R 753	QRD161J-223	CARBON RESISTOR	22K 5% 1/6W	
R 754	QRD161J-103	CARBON RESISTOR	10K 5% 1/6W	
R 755	QRD161J-222	CARBON RESISTOR	2.2K 5% 1/6W	
R 756	QRD161J-222	CARBON RESISTOR	2.2K 5% 1/6W	
R 757	QRD161J-222	CARBON RESISTOR	2.2K 5% 1/6W	
R 758	QRD161J-103	CARBON RESISTOR	10K 5% 1/6W	
R 759	QRD161J-391	CARBON RESISTOR	390 5% 1/6W	
R 760	QRD161J-391	CARBON RESISTOR	390 5% 1/6W	
R 761	QRD161J-223	CARBON RESISTOR	22K 5% 1/6W	
R 762	QRD161J-821	CARBON RESISTOR	820 5% 1/6W	
R 763	QRD161J-821	CARBON RESISTOR	820 5% 1/6W	
R 764	QRD161J-821	CARBON RESISTOR	820 5% 1/6W	
R 765	QRD161J-821	CARBON RESISTOR	820 5% 1/6W	
R 766	QRD161J-821	CARBON RESISTOR	820 5% 1/6W	
R 767	QRD161J-821	CARBON RESISTOR	820 5% 1/6W	
R 768	QRD161J-821	CARBON RESISTOR	820 5% 1/6W	
R 770	QRD161J-222	CARBON RESISTOR	2.2K 5% 1/6W	
R 771	QRD161J-475	CARBON RESISTOR	4.7M 5% 1/6W	
R 772	QRD161J-475	CARBON RESISTOR	4.7M 5% 1/6W	
R 851	QRD161J-103	CARBON RESISTOR	10K 5% 1/6W	
R 852	QRD161J-684	CARBON RESISTOR	680K 5% 1/6W	
R 853	QRD161J-224	CARBON RESISTOR	220K 5% 1/6W	

BLOCK NO. 02

REF.	PARTS NO.	PARTS NAME	REMARKS	SUFFIX
D 722	SLZ-981F09-T6	LED	LED EXTRA	
D 723	SLZ-981A09-T6	LED	LED 6	
D 724	SLZ-981A09-T6	LED	LED 5	
D 725	SLZ-981A09-T6	LED	LED 4	
D 726	SLZ-981A09-T6	LED	LED 3	
D 727	SLZ-981A09-T6	LED	LED 2	
D 728	SLZ-981A09-T6	LED	LED 1	
D 729	LN282RPX	LED	POWER STANDBY	
D 851	1SS133	SI DIODE		
D 852	1SS133	SI DIODE		
IC701	M38254M6-073FP	IC		
IC702	SBX1785-52A	RM RECIVER		
IC851	LZ93D72	IC		
IC852	T8409S	IC		
IC853	T8409S	IC		
L 701	VQZ0048-009	INDUCTOR		
L 702	VQ0018-221	INDUCTOR		
L 851	VQ0018-100	INDUCTOR		
PL701	VGZ0001-058T	LAMP		
PL702	VGZ0001-058T	LAMP		
Q 701	2SC2668(0)	TRANSISTOR		
Q 702	2SC2668(0)	TRANSISTOR		
Q 703	DTC114TS	TRANSISTOR		
Q 704	2SC2785	TRANSISTOR		
Q 705	DTA114TS	TRANSISTOR		
Q 706	DTC144ES	TRANSISTOR		
Q 707	2SC2785	TRANSISTOR		
Q 708	2SC2785	TRANSISTOR		
Q 709	2SC2785	TRANSISTOR		
Q 710	2SC2785	TRANSISTOR		
Q 711	2SC2785	TRANSISTOR		
Q 712	2SC2785	TRANSISTOR		
Q 713	2SC2785	TRANSISTOR		
Q 714	2SC2785	TRANSISTOR		
Q 715	2SC2785	TRANSISTOR		
Q 716	DTA144ES	TRANSISTOR		
Q 851	2SA952(L-K)	TRANSISTOR		
Q 852	DTC144ES	TRANSISTOR		
Q 853	DTC144ES	TRANSISTOR		
R 702	QRD161J-221	CARBON RESISTOR	220 5% 1/6W	
R 703	QRD161J-681	CARBON RESISTOR	680 5% 1/6W	
R 704	QRD161J-822	CARBON RESISTOR	8.2K 5% 1/6W	
R 705	QRD161J-822	CARBON RESISTOR	8.2K 5% 1/6W	
R 706	QRD161J-681	CARBON RESISTOR	680 5% 1/6W	
R 707	QRD161J-472	CARBON RESISTOR	4.7K 5% 1/6W	
R 708	QRD161J-101	CARBON RESISTOR	100 5% 1/6W	
R 709	QRD161J-102	CARBON RESISTOR	1.0K 5% 1/6W	
R 710	QRD161J-103	CARBON RESISTOR	10K 5% 1/6W	
R 711	QRD161J-103	CARBON RESISTOR	10K 5% 1/6W	
R 713	QRD161J-222	CARBON RESISTOR	2.2K 5% 1/6W	
R 714	QRD161J-103	CARBON RESISTOR	10K 5% 1/6W	
R 715	QRD161J-222	CARBON RESISTOR	2.2K 5% 1/6W	
R 717	QRD161J-222	CARBON RESISTOR	2.2K 5% 1/6W	
R 718	QRD161J-222	CARBON RESISTOR	2.2K 5% 1/6W	
R 719	QRD161J-222	CARBON RESISTOR	2.2K 5% 1/6W	

BLOCK NO. 02

REF.	PARTS NO.	PARTS NAME	REMARKS	SUFFIX
S 701	QS01A11-V04Z	TACT SWITCH		
S 702	QS01A11-V04Z	TACT SWITCH		
S 703	QS01A11-V04Z	TACT SWITCH		
S 704	QS01A11-V04Z	TACT SWITCH		
S 705	QS01A11-V04Z	TACT SWITCH		
S 706	QS01A11-V04Z	TACT SWITCH		
S 707	QS01A11-V04Z	TACT SWITCH		
S 708	QS01A11-V04Z	TACT SWITCH		
S 709	QS01A11-V04Z	TACT SWITCH		
S 710	QS01A11-V04Z	TACT SWITCH		
S 711	QS01A11-V04Z	TACT SWITCH		
S 712	QS01A11-V04Z	TACT SWITCH		
S 713	QS01A11-V04Z	TACT SWITCH		
S 714	QS01A11-V04Z	TACT SWITCH		
S 715	QS01A11-V04Z	TACT SWITCH		
S 716	QS01A11-V04Z	TACT SWITCH		
S 717	QS01A11-V04Z	TACT SWITCH		
S 718	QS01A11-V04Z	TACT SWITCH		
S 719	QS01A11-V04Z	TACT SWITCH		
S 720	QS01A11-V04Z	TACT SWITCH		
S 721	QS01A11-V04Z	TACT SWITCH		
S 722	QS01A11-V04Z	TACT SWITCH		
S 723	QS01A11-V04Z	TACT SWITCH		
S 724	QS01A11-V04Z	TACT SWITCH		
S 725	QS01A11-V04Z	TACT SWITCH		
S 726	QS01A11-V04Z	TACT SWITCH		
S 727	QS01A11-V04Z	TACT SWITCH		
S 728	QS01A11-V04Z	TACT SWITCH		
S 729	QS01A11-V04Z	TACT SWITCH		
S 730	QS01A11-V04Z	TACT SWITCH		
S 731	QS01A11-V04Z	TACT SWITCH		
S 732	QS01A11-V04Z	TACT SWITCH		
S 733	QS01A11-V04Z	TACT SWITCH		
S 734	QS01A11-V04Z	TACT SWITCH		
S 735	QS01A11-V04Z	TACT SWITCH		
S 736	QS01A11-V04Z	TACT SWITCH		
TA101	EQF0101-010	FILTER		
TA201	EQF0101-010	FILTER		
VR851	QVPA603-103M	SEMI-V.RESISTOR		
X 701	VCX5000-002	CRYSTAL		
X 702	CSA4-19MG933	CERA LOCK		

BLOCK NO. 02

REF.	PARTS NO.	PARTS NAME	REMARKS	SUFFIX
R 854	QRD161J-392	CARBON RESISTOR	3.9K 5% 1/6W	
R 855	QRD161J-471	CARBON RESISTOR	470 5% 1/6W	
R 856	QRD161J-471	CARBON RESISTOR	470 5% 1/6W	
R 857	QRD161J-471	CARBON RESISTOR	470 5% 1/6W	
R 858	QRD161J-471	CARBON RESISTOR	470 5% 1/6W	
R 859	QRD161J-473	CARBON RESISTOR	47K 5% 1/6W	
R 860	QRD161J-473	CARBON RESISTOR	47K 5% 1/6W	
R 861	QRD161J-203	CARBON RESISTOR	20K 5% 1/6W	
R 862	QRD161J-223	CARBON RESISTOR	22K 5% 1/6W	
R 863	QRD161J-221	CARBON RESISTOR	220 5% 1/6W	
R 864	QRD167J-682	CARBON RESISTOR	6.8K 5% 1/6W	
R 865	QRD161J-123	CARBON RESISTOR	12K 5% 1/6W	
R 866	QRD161J-563	CARBON RESISTOR	56K 5% 1/6W	
R 867	QRZ0076-120X	FUSI RESISTOR	12 1/0W	
R 868	QRD161J-472	CARBON RESISTOR	4.7K 5% 1/6W	
R 869	QRD161J-221	CARBON RESISTOR	220 5% 1/6W	
R 870	QRD161J-822	CARBON RESISTOR	8.2K 5% 1/6W	
R 871	QRD167J-682	CARBON RESISTOR	6.8K 5% 1/6W	
R 872	QRD167J-332	CARBON RESISTOR	3.3K 5% 1/6W	
RM701	QRD161J-202	CARBON RESISTOR	2.0K 5% 1/6W	
RM702	QRD161J-122	CARBON RESISTOR	1.2K 5% 1/6W	
RM703	QRD161J-152	CARBON RESISTOR	1.5K 5% 1/6W	
RM704	QRD161J-222	CARBON RESISTOR	2.2K 5% 1/6W	
RM705	QRD161J-272	CARBON RESISTOR	2.7K 5% 1/6W	
RM706	QRD161J-392	CARBON RESISTOR	3.9K 5% 1/6W	
RM707	QRD167J-562	CARBON RESISTOR	5.6K 5% 1/6W	
RM708	QRD161J-103	CARBON RESISTOR	10K 5% 1/6W	
RM709	QRD161J-183	CARBON RESISTOR	18K 5% 1/6W	
RM710	QRD161J-473	CARBON RESISTOR	47K 5% 1/6W	
RM711	QRD161J-202	CARBON RESISTOR	2.0K 5% 1/6W	
RM712	QRD161J-122	CARBON RESISTOR	1.2K 5% 1/6W	
RM713	QRD161J-152	CARBON RESISTOR	1.5K 5% 1/6W	
RM714	QRD161J-222	CARBON RESISTOR	2.2K 5% 1/6W	
RM715	QRD161J-272	CARBON RESISTOR	2.7K 5% 1/6W	
RM716	QRD161J-392	CARBON RESISTOR	3.9K 5% 1/6W	
RM717	QRD167J-562	CARBON RESISTOR	5.6K 5% 1/6W	
RM718	QRD161J-202	CARBON RESISTOR	2.0K 5% 1/6W	
RM719	QRD161J-122	CARBON RESISTOR	1.2K 5% 1/6W	
RM720	QRD161J-152	CARBON RESISTOR	1.5K 5% 1/6W	
RM721	QRD161J-222	CARBON RESISTOR	2.2K 5% 1/6W	
RM722	QRD161J-272	CARBON RESISTOR	2.7K 5% 1/6W	
RM723	QRD161J-392	CARBON RESISTOR	3.9K 5% 1/6W	
RM724	QRD167J-562	CARBON RESISTOR	5.6K 5% 1/6W	
RM725	QRD161J-103	CARBON RESISTOR	10K 5% 1/6W	
RM726	QRD161J-183	CARBON RESISTOR	18K 5% 1/6W	
RM727	QRD161J-202	CARBON RESISTOR	2.0K 5% 1/6W	
RM728	QRD161J-122	CARBON RESISTOR	1.2K 5% 1/6W	
RM729	QRD161J-152	CARBON RESISTOR	1.5K 5% 1/6W	
RM730	QRD161J-222	CARBON RESISTOR	2.2K 5% 1/6W	
RM731	QRD161J-272	CARBON RESISTOR	2.7K 5% 1/6W	
RM732	QRD161J-392	CARBON RESISTOR	3.9K 5% 1/6W	
RM733	QRD167J-562	CARBON RESISTOR	5.6K 5% 1/6W	
RM734	QRD161J-103	CARBON RESISTOR	10K 5% 1/6W	
RM735	QRD161J-183	CARBON RESISTOR	18K 5% 1/6W	
RM736	QRD161J-473	CARBON RESISTOR	47K 5% 1/6W	

CD Changer Control P.C. board

BLOCK NO. 03111111

REF.	PARTS NO.	PARTS NAME	REMARKS	SUFFIX
C 801	GET41AM-407	E CAPACITOR	100MF 20% 10V	
C 802	GET41HM-475	E CAPACITOR	4.7MF 20% 50V	
C 803	QFV41HJ-104ZM	FILM CAPACITOR	.10MF 5% 50V	
C 804	QCBBAHK-102Y	C-CAPACITOR	1000PF 10% 50V	
C 805	QCBV1CM-103Y	C-CAPACITOR	.010MF 20% 16V	
C 806	GET41CM-476	E CAPACITOR	47MF 20% 16V	
C 807	GET41CM-476	E CAPACITOR	47MF 20% 16V	
C 811	QFV41HJ-104ZM	FILM CAPACITOR	.10MF 5% 50V	
C 816	QCBBAHK-102Y	C-CAPACITOR	1000PF 10% 50V	
C 817	QCBV1CM-103Y	C-CAPACITOR	.010MF 20% 16V	
C 818	QCFB1HZ-104Y	C-CAPACITOR	.10MF +80%-20%	
C 819	QCBV1CM-103Y	C-CAPACITOR	.010MF 20% 16V	
C 820	GETN1HM-225Z	E CAPACITOR	2.2MF 20% 50V	
CN801	VMC0163-R16	CONNECTOR	TO MICOM	
CN802	VMC0163-R18	CONNECTOR	TO CD MECHA	
D 802	1SS133	SI DIODE		
D 803	11E1	SI DIODE		
D 806	1SS133	SI DIODE		
D 807	1SS133	SI DIODE		
D 808	1SS133	SI DIODE		
IC801	UPD65612GC-08B	IC	CHANGER CTL	
IC802	T8409S	IC		
IC803	T8409S	IC		
L 801	VGP0018-100	INDUCTOR		
Q 805	2SD1302	TRANSISTOR		
Q 806	DTA13ES	TRANSISTOR		
Q 807	2SC1740S(R,S)	TRANSISTOR		
Q 808	2SA1317	TRANSISTOR		
Q 810	2SA1317	TRANSISTOR		
Q 811	2SA1317	TRANSISTOR		
Q 812	2SA1317	TRANSISTOR		
Q 813	2SC1740S(R,S)	TRANSISTOR		
R 801	QRD161J-103	CARBON RESISTOR	10K 5% 1/6W	
R 803	QRD161J-223	CARBON RESISTOR	22K 5% 1/6W	
R 804	QRD161J-223	CARBON RESISTOR	22K 5% 1/6W	
R 805	QRD161J-471	CARBON RESISTOR	470 5% 1/6W	
R 806	QRD161J-471	CARBON RESISTOR	470 5% 1/6W	
R 807	QRD161J-471	CARBON RESISTOR	470 5% 1/6W	
R 808	QRD161J-102	CARBON RESISTOR	1.0K 5% 1/6W	
R 809	QRD161J-681	CARBON RESISTOR	680 5% 1/6W	
R 811	QRD161J-681	CARBON RESISTOR	680 5% 1/6W	
R 812	QRD161J-102	CARBON RESISTOR	1.0K 5% 1/6W	
R 813	QRD161J-102	CARBON RESISTOR	1.0K 5% 1/6W	
R 814	QRD161J-102	CARBON RESISTOR	1.0K 5% 1/6W	
R 815	QRD161J-102	CARBON RESISTOR	1.0K 5% 1/6W	
R 816	QRD161J-681	CARBON RESISTOR	680 5% 1/6W	
R 817	QRD161J-102	CARBON RESISTOR	1.0K 5% 1/6W	
R 818	QRD161J-223	CARBON RESISTOR	22K 5% 1/6W	
R 819	QRD161J-223	CARBON RESISTOR	22K 5% 1/6W	
R 820	QRD161J-223	CARBON RESISTOR	22K 5% 1/6W	
R 821	QRD161J-223	CARBON RESISTOR	22K 5% 1/6W	
R 822	QRD161J-223	CARBON RESISTOR	22K 5% 1/6W	
R 823	QRD161J-223	CARBON RESISTOR	22K 5% 1/6W	
R 824	QRD161J-223	CARBON RESISTOR	22K 5% 1/6W	
R 825	QRD161J-471	CARBON RESISTOR	470 5% 1/6W	

BLOCK NO. 03111111

REF.	PARTS NO.	PARTS NAME	REMARKS	SUFFIX
R 826	QRD161J-181	CARBON RESISTOR	180 5% 1/6W	
R 827	QR20076-100X	FUSI RESISTOR	10 1/6W	
R 828	QRD161J-102	CARBON RESISTOR	1.0K 5% 1/6W	
R 831	QRD167J-682	CARBON RESISTOR	6.8K 5% 1/6W	
R 832	QRD161J-472	CARBON RESISTOR	4.7K 5% 1/6W	
R 833	QRD161J-102	CARBON RESISTOR	1.0K 5% 1/6W	
R 838	QRD161J-102	CARBON RESISTOR	1.0K 5% 1/6W	
R 839	QRD161J-102	CARBON RESISTOR	1.0K 5% 1/6W	
R 841	QRD161J-102	CARBON RESISTOR	1.0K 5% 1/6W	
R 842	QRD161J-102	CARBON RESISTOR	1.0K 5% 1/6W	
R 845	QRD161J-102	CARBON RESISTOR	1.0K 5% 1/6W	
R 846	QRD161J-103	CARBON RESISTOR	10K 5% 1/6W	
R 850	QRD161J-822	CARBON RESISTOR	8.2K 5% 1/6W	
RM801	QRD161J-103	CARBON RESISTOR	10K 5% 1/6W	
RM802	QRD161J-152	CARBON RESISTOR	1.5K 5% 1/6W	
RM803	QRD161J-151	CARBON RESISTOR	150 5% 1/6W	
RM804	QRD161J-473	CARBON RESISTOR	47K 5% 1/6W	
RM805	QRD161J-224	CARBON RESISTOR	220K 5% 1/6W	
RM806	QRD161J-224	CARBON RESISTOR	220K 5% 1/6W	
RM807	QRD161J-104	CARBON RESISTOR	100K 5% 1/6W	
RM812	QRD161J-473	CARBON RESISTOR	47K 5% 1/6W	

■ CD Amplifier P.C. board

		BLOCK NO. 04			
REF.	PARTS NO.	PARTS NAME	REMARKS	SUFFIX	
C 501	QCB81HK-821Y	C-CAPACITOR	820PF 10% 50V		
C 503	QCVB1CM-103Y	C-CAPACITOR	.010MF 20% 16V		
C 504	QET41CM-106	E-CAPACITOR	10MF 20% 16V		
C 511	QCSB1HJ-3R9	C-CAPACITOR	3.9PF 10% 50V		
C 512	QCSI1HJ-270	C-CAPACITOR	27PF 5% 50V		
C 513	QFLC1HJ-104ZM	M-CAPACITOR	.10MF 5% 50V		
C 514	QFN41HJ-672	M-CAPACITOR	4700PF 5% 50V		
C 521	QCB81HK-331Y	C-CAPACITOR	330PF 10% 50V		
C 522	QFLC1HJ-473ZM	M-CAPACITOR	.047MF 5% 50V		
C 523	QFV81HJ-154	FILM CAPACITOR	.15MF 5% 50V		
C 524	QEP1EM-475ZM	NP-E-CAPACITOR	4.7MF 20% 25V		
C 529	QET1AM-336ZN	E-CAPACITOR	33MF 20% 10V		
C 531	QCVB1CM-822Y	C-CAPACITOR	8200PF 20% 16V		
C 541	QCB81HK-101Y	C-CAPACITOR	100PF 10% 50V		
C 542	QFLC1HJ-103ZM	M-CAPACITOR	.010MF 5% 50V		
C 543	QFLC1HJ-393ZM	M-CAPACITOR	.039MF 5% 50V		
C 545	QEP1EM-105ZM	NP-E-CAPACITOR	1.0MF 20% 50V		
C 546	QFLC1HJ-223ZM	M-CAPACITOR	.022MF 5% 50V		
C 561	QET41AM-476	E-CAPACITOR	47MF 20% 10V		
C 562	QET41HM-475	E-CAPACITOR	4.7MF 20% 50V		
C 581	QET41AM-477	E-CAPACITOR	470MF 20% 10V		
C 582	QEK41CM-476	E-CAPACITOR	47MF 20% 16V		
C 591	VCP0012-105Z	C-CAPACITOR			
C 592	VCP0012-105Z	C-CAPACITOR			
C 593	QCC11EM-104V	C-CAPACITOR	.10MF 20% 25V		
C 599	QET41AM-107	E-CAPACITOR	100MF 20% 10V		
C 601	QCS11HJ-100	C-CAPACITOR	FOR CRYSTAL		
C 602	QCS11HJ-100	C-CAPACITOR	FOR CRYSTAL		
C 603	QCC11EM-473V	C-CAPACITOR	.047MF 20% 25V		
C 604	QCC11EM-104V	C-CAPACITOR	.10MF 20% 25V		
C 605	QCVB1CM-103Y	C-CAPACITOR	.010MF 20% 16V		
C 606	QCC11EM-473V	C-CAPACITOR	.047MF 20% 25V		
C 611	QCS11HJ-101	C-CAPACITOR	100PF 5% 50V		
C 612	QFLC1HJ-103ZM	M-CAPACITOR	.010MF 5% 50V		
C 613	QFLC1HJ-103ZM	M-CAPACITOR	.010MF 5% 50V		
C 614	QFN41HJ-332	M-CAPACITOR	3300PF 5% 50V		
C 615	QFN41HJ-332	M-CAPACITOR	3300PF 5% 50V		
C 631	QET41AM-107	E-CAPACITOR	100MF 20% 10V		
C 632	QET41AM-107	E-CAPACITOR	100MF 20% 10V		
C 635	QCB81HK-121Y	C-CAPACITOR	120PF 10% 50V		
C 651	QET41AM-107	E-CAPACITOR	100MF 20% 10V		
C 652	QET41CM-226	E-CAPACITOR	22MF 20% 16V		
C 661	QCB81HK-271Y	C-CAPACITOR	270PF 10% 50V		
C 662	QCB81HK-271Y	C-CAPACITOR	270PF 10% 50V		
C 663	QCB81HK-121Y	C-CAPACITOR	120PF 10% 50V		
C 669	QET1EM-335ZN	E-CAPACITOR	3.3MF 20% 25V		
C 671	QCB81HK-271Y	C-CAPACITOR	270PF 10% 50V		
C 672	QCB81HK-271Y	C-CAPACITOR	270PF 10% 50V		
C 673	QCB81HK-121Y	C-CAPACITOR	120PF 10% 50V		
C 679	QET1EM-335ZN	E-CAPACITOR	3.3MF 20% 25V		
CM501	VMC0272-015	CONNECTOR	TO PICK UP		
CM502	VMC0075-006N	CONNECTOR			
CM503	QMV5011-005	CONNECTOR	TO CPU		
CM601	VMC0163-009	CONNECTOR	SERVO LSI		
IC501	TAB191F	IC			

		BLOCK NO. 04			
REF.	PARTS NO.	PARTS NAME	REMARKS	SUFFIX	
IC502	BA6298FF	IC	POWER DRIVER		
IC601	TC9236AF	IC	1 CHIP PROCESSE		
IC603	TC9278F	IC	D/A CONVERTER		
IC604	KRA15218N	IC	L.P.F		
K 693	VQZ0048-009	INDUCTOR	FOR FTZ		
L 691	VQP0018-100	INDUCTOR	FOR FTZ		
L 692	VQP0018-100	INDUCTOR	FOR FTZ		
Q 501	2SA952(L,K)	TRANSISTOR			
Q 581	2SA952(L,K)	TRANSISTOR			
Q 591	2SA1309(RS)	TRANSISTOR	5V REGULATOR		
R 501	QRD161J-124	CARBON RESISTOR	120K 5% 1/6W		
R 502	QRD161J-103	CARBON RESISTOR	10K 5% 1/6W		
R 504	QRD161J-220	CARBON RESISTOR	2.0K 5% 1/6W		
R 505	QRD161J-220	CARBON RESISTOR	22.5K 1/6W		
R 506	QRD161J-101	CARBON RESISTOR	100.5K 1/6W		
R 511	QRD161J-183	CARBON RESISTOR	18K 5% 1/6W		
R 512	QRD161J-392	CARBON RESISTOR	3.9K 5% 1/6W		
R 513	QRD167J-332	CARBON RESISTOR	3.3K 5% 1/6W		
R 514	QRD161J-472	CARBON RESISTOR	4.7K 5% 1/6W		
R 515	QRD161J-103	CARBON RESISTOR	10K 5% 1/6W		
R 516	QRD161J-103	CARBON RESISTOR	10K 5% 1/6W		
R 517	QRD161J-202	CARBON RESISTOR	2.0K 5% 1/6W		
R 521	QRD161J-154	CARBON RESISTOR	150K 5% 1/6W		
R 522	QRD161J-392	CARBON RESISTOR	3.9K 5% 1/6W		
R 523	QRD161J-472	CARBON RESISTOR	4.7K 5% 1/6W		
R 524	QRD161J-331	CARBON RESISTOR	330.5K 1/6W		
R 525	QRD161J-472	CARBON RESISTOR	4.7K 5% 1/6W		
R 529	QRD167J-562	CARBON RESISTOR	5.6K 5% 1/6W		
R 531	QRD161J-473	CARBON RESISTOR	47K 5% 1/6W		
R 532	QRD161J-104	CARBON RESISTOR	100K 5% 1/6W		
R 533	QRD161J-153	CARBON RESISTOR	15K 5% 1/6W		
R 541	QRD161J-123	CARBON RESISTOR	12K 5% 1/6W		
R 542	QRD167J-332	CARBON RESISTOR	3.3K 5% 1/6W		
R 543	QRD161J-473	CARBON RESISTOR	47K 5% 1/6W		
R 544	QRD161J-223	CARBON RESISTOR	22K 5% 1/6W		
R 545	QRD161J-103	CARBON RESISTOR	10K 5% 1/6W		
R 548	QRD161J-153	CARBON RESISTOR	15K 5% 1/6W		
R 549	QRD161J-821	CARBON RESISTOR	820.5K 1/6W		
R 550	QRD161J-104	CARBON RESISTOR	100K 5% 1/6W		
R 551	QRD161J-223	CARBON RESISTOR	22K 5% 1/6W		
R 552	QRD167J-562	CARBON RESISTOR	5.6K 5% 1/6W		
R 553	QRD161J-821	CARBON RESISTOR	820.5K 1/6W		
R 559	QRD161J-392	CARBON RESISTOR	3.9K 5% 1/6W		
R 559	QRD161J-125	CARBON RESISTOR	1.2M 5% 1/6W		
R 561	QRD167J-562	CARBON RESISTOR	5.6K 5% 1/6W		
R 562	QRD161J-102	CARBON RESISTOR	1.0K 5% 1/6W		
R 563	QRD161J-152	CARBON RESISTOR	1.5K 5% 1/6W		
R 564	QRD167J-332	CARBON RESISTOR	3.3K 5% 1/6W		
R 565	QRD161J-683	CARBON RESISTOR	68K 5% 1/6W		
R 566	QRD161J-273	CARBON RESISTOR	27K 5% 1/6W		
R 583	QRD161J-101	CARBON RESISTOR	100.5K 1/6W		
R 591	QRD161J-473	CARBON RESISTOR	47K 5% 1/6W		
R 611	QRD161J-102	CARBON RESISTOR	1.0K 5% 1/6W		
R 612	QRD161J-103	CARBON RESISTOR	10K 5% 1/6W		
R 613	QRD161J-224	CARBON RESISTOR	220K 5% 1/6W		

■ Tuner P.C. board

BLOCK NO. 05		BLOCK NO. 05		BLOCK NO. 05		BLOCK NO. 05	
A	REF.	PARTS NO.	PARTS NAME	REMARKS	SUFFIX		
	BP 01	VBP6M3B-005	B-PASS FILTER				
	C 001	QCS11HJ-200	C.CAPACITOR	20PF 5% 50V			
	C 002	QCS11HJ-200	C.CAPACITOR	1000PF 10% 50V			
	C 003	QCSB1HK-102Y	C.CAPACITOR	13PF 5% 50V			
	C 004	QCS11HJ-100	C.CAPACITOR	10PF 5% 50V			
	C 005	QCS11HJ-100	C.CAPACITOR	10PF 5% 50V			
	C 006	QCVB1CN-103Y	C.CAPACITOR	.010MF 30% 16V			
	C 007	QCS11HJ-200	C.CAPACITOR	20PF 5% 50V			
	C 008	QCVB1CN-103Y	C.CAPACITOR	.010MF 30% 16V			
	C 009	QCSB1HK-8R2Y	C.CAPACITOR	8.2PF 10% 50V			
	C 010	QCSB1HK-2R2Y	C.CAPACITOR	2.2PF 10% 50V			
	C 011	QCVB1CN-103Y	C.CAPACITOR	.010MF 30% 16V			
	C 012	QCSB1HK-151Y	C.CAPACITOR	150PF 10% 50V			
	C 013	QCC11EM-223V	C.CAPACITOR	.022MF 20% 25V			
	C 014	QCSB1HK-102Y	C.CAPACITOR	1000PF 10% 50V			
	C 015	QCSB1HK-102Y	C.CAPACITOR	1000PF 10% 50V			
	C 016	QCVB1CN-103Y	C.CAPACITOR	.010MF 30% 16V			
	C 017	QCFB1HZ-104Y	C.CAPACITOR	.10MF +80:-20%			
	C 018	QCVB1CN-103Y	C.CAPACITOR	.010MF 30% 16V			
	C 020	QCC11EM-473V	C.CAPACITOR	.047MF 20% 25V			
	C 021	QCC11EM-473V	C.CAPACITOR	.047MF 20% 25V			
	C 022	QFP31HG-4312M	PP.CAPACITOR	430PF 2% 50V			
	C 023	QCT30UJ-3R3Y	C.CAPACITOR	3.3PF 5% 50V			
	C 030	QCVB1CN-103Y	C.CAPACITOR	.010MF 30% 16V			
	C 031	QCVB1CN-103Y	C.CAPACITOR	.010MF 30% 16V			
	C 032	QCVB1CN-103Y	C.CAPACITOR	.010MF 30% 16V			
	C 033	QET41AM-107	E.CAPACITOR	100MF 20% 10V			
	C 034	QCC31EM-333ZV	C.CAPACITOR	.033MF 20% 25V			
	C 035	QCC11EM-473V	C.CAPACITOR	.047MF 20% 25V			
	C 036	QEK41EM-475	E.CAPACITOR	4.7MF 20% 25V			
	C 037	QCVB1CN-103Y	C.CAPACITOR	.010MF 30% 16V			
	C 039	QCC11EM-473V	C.CAPACITOR	.047MF 20% 25V			
	C 040	QEK61HM-335ZM	E.CAPACITOR	3.3MF 20% 50V			
	C 041	QEK41EM-475	E.CAPACITOR	4.7MF 20% 25V			
	C 042	QCVB1CN-152Y	C.CAPACITOR	1500PF 20% 16V			
	C 043	QCVB1CN-103Y	C.CAPACITOR	.010MF 30% 16V			
	C 044	QEK41HM-104	E.CAPACITOR	.10MF 20% 50V			
	C 045	QEK41HM-474	E.CAPACITOR	.47MF 20% 50V			
	C 046	QEK41CM-106	E.CAPACITOR	10MF 20% 16V			
	C 047	QCC11EK-103ZV	C.CAPACITOR	.010MF 10% 25V			
	C 048	QCC11EK-103ZV	C.CAPACITOR	.010MF 10% 25V			
	C 049	QEK41HM-105	E.CAPACITOR	1.0MF 20% 50V			
	C 050	QEK41HM-105	E.CAPACITOR	1.0MF 20% 50V			
	C 051	QCT30UJ-150Y	C.CAPACITOR	15PF 5% 50V			
	C 052	QCS11HJ-150	C.CAPACITOR	15PF 5% 50V			
	C 060	QCVB1CN-103Y	C.CAPACITOR	.010MF 30% 16V			
	C 061	QEK61AM-107ZM	E.CAPACITOR	100MF 20% 10V			
	C 062	QCSB1HK-130Y	C.CAPACITOR	13PF 5% 50V			
	C 063	QCC11EM-473V	C.CAPACITOR	.047MF 20% 25V			
	C 064	QCS11HJ-270	C.CAPACITOR	27PF 5% 50V			
	C 065	QCSB1HK-151Y	C.CAPACITOR	150PF 10% 50V			
	C 066	QCSB1HK-101Y	C.CAPACITOR	100PF 10% 50V			
	C 067	QCS11HJ-470	C.CAPACITOR	47PF 5% 50V			
	C 068	QCSB1HK-331Y	C.CAPACITOR	330PF 10% 50V			
	C 069	QCVB1CN-222Y	C.CAPACITOR	2200PF 20% 16V			

BLOCK NO. 04		BLOCK NO. 04		BLOCK NO. 04		BLOCK NO. 04	
A	REF.	PARTS NO.	PARTS NAME	REMARKS	SUFFIX		
	R 614	GRD161J-473	CARBON RESISTOR	47K 5% 1/6W			
	R 615	GRD161J-225	CARBON RESISTOR	2.2M 5% 1/6W			
	R 616	GRD161J-333	CARBON RESISTOR	33K 5% 1/6W			
	R 631	GRD161J-820	CARBON RESISTOR	82 5% 1/6W			
	R 632	GRD161J-820	CARBON RESISTOR	82 5% 1/6W			
	R 635	GRD161J-681	CARBON RESISTOR	680 5% 1/6W			
	R 638	GRD161J-331	CARBON RESISTOR	330 5% 1/6W			
	R 639	GRD161J-102	CARBON RESISTOR	1.0K 5% 1/6W			
	R 651	GRD161J-820	CARBON RESISTOR	82 5% 1/6W			
	R 652	GRD161J-473	CARBON RESISTOR	47K 5% 1/6W			
	R 653	GRD161J-473	CARBON RESISTOR	47K 5% 1/6W			
	R 661	GRD161J-123	CARBON RESISTOR	12K 5% 1/6W			
	R 662	GRD161J-123	CARBON RESISTOR	12K 5% 1/6W			
	R 671	GRD161J-123	CARBON RESISTOR	12K 5% 1/6W			
	R 672	GRD161J-123	CARBON RESISTOR	12K 5% 1/6W			
	R 673	GRD161J-333	CARBON RESISTOR	33K 5% 1/6W			
	R 674	GRD161J-333	CARBON RESISTOR	33K 5% 1/6W			
	R 675	GRD161J-123	CARBON RESISTOR	12K 5% 1/6W			
	R 676	GRD161J-123	CARBON RESISTOR	12K 5% 1/6W			
	VR501	GVZ3523-154AZ	V.RESISTOR	16.9344MHZ			
	X 601	VCK5016-934V	CRYSTAL				

BLOCK NO. 05			BLOCK NO. 05		
REF.	PARTS NO.	PARTS NAME	REMARKS	SUFFIX	
Q 002	2SD1302	TRANSISTOR			
Q 003	2SC2668(C)	TRANSISTOR			
Q 004	2SA1175	TRANSISTOR			
Q 005	2SA1175	TRANSISTOR			
Q 007	2SC2668(C)	TRANSISTOR			
Q 008	DTA114YS	TRANSISTOR			
Q 009	DTA114YS	TRANSISTOR			
Q 010	DTA114YS	TRANSISTOR			
Q 011	DTA114YS	TRANSISTOR			
Q 012	2SC2785	TRANSISTOR			
Q 013	2SC2785	TRANSISTOR			
Q 014	2SD1302	TRANSISTOR			
Q 015	2SA1175	TRANSISTOR			
Q 016	DTA114YS	TRANSISTOR			
Q 017	2SC2668(C)	TRANSISTOR			
Q 018	2SA1175	TRANSISTOR			
Q 021	DTA114YS	TRANSISTOR			
Q 022	2SC2668(C)	TRANSISTOR			
R 001	QRD161J-104	CARBON RESISTOR	100K 5% 1/6W		
R 002	QRD161J-473	CARBON RESISTOR	47K 5% 1/6W		
R 003	QRD167J-4R7	CARBON RESISTOR	4.7 5% 1/6W		
R 004	QRD161J-102	CARBON RESISTOR	1.0K 5% 1/6W		
R 005	QRD161J-823	CARBON RESISTOR	82K 5% 1/6W		
R 006	QRD161J-101	CARBON RESISTOR	100 5% 1/6W		
R 008	QRD161J-101	CARBON RESISTOR	100 5% 1/6W		
R 009	QRD161J-102	CARBON RESISTOR	1.0K 5% 1/6W		
R 010	QRD161J-101	CARBON RESISTOR	100 5% 1/6W		
R 011	QRD161J-222	CARBON RESISTOR	2.2K 5% 1/6W		
R 012	QRD161J-103	CARBON RESISTOR	10K 5% 1/6W		
R 013	QRD161J-104	CARBON RESISTOR	100K 5% 1/6W		
R 014	QRD161J-103	CARBON RESISTOR	10K 5% 1/6W		
R 015	QRD161J-103	CARBON RESISTOR	10K 5% 1/6W		
R 018	QRD161J-102	CARBON RESISTOR	1.0K 5% 1/6W		
R 020	QRD161J-102	CARBON RESISTOR	1.0K 5% 1/6W		
R 024	QRD161J-331	CARBON RESISTOR	330K 5% 1/6W		
R 025	QRD161J-334	CARBON RESISTOR	4.7 5% 1/6W		
R 026	QRD167J-4R7	CARBON RESISTOR	4.7 5% 1/6W		
R 027	QRD161J-331	CARBON RESISTOR	330 5% 1/6W		
R 029	QRD161J-103	CARBON RESISTOR	10K 5% 1/6W		
R 030	QRD161J-103	CARBON RESISTOR	10K 5% 1/6W		
R 031	QRD161J-563	CARBON RESISTOR	56K 5% 1/6W		
R 032	QRD161J-223	CARBON RESISTOR	22K 5% 1/6W		
R 034	QRD161J-822	CARBON RESISTOR	8.2K 5% 1/6W		
R 035	QRD161J-822	CARBON RESISTOR	8.2K 5% 1/6W		
R 036	QRD161J-222	CARBON RESISTOR	2.2K 5% 1/6W		
R 040	QRD161J-560	CARBON RESISTOR	56 5% 1/6W		
R 041	QRD161J-102	CARBON RESISTOR	1.0K 5% 1/6W		
R 042	QRD161J-222	CARBON RESISTOR	2.2K 5% 1/6W		
R 043	QRD161J-103	CARBON RESISTOR	10K 5% 1/6W		
R 044	QRD161J-103	CARBON RESISTOR	10K 5% 1/6W		
R 046	QRD161J-103	CARBON RESISTOR	10K 5% 1/6W		
R 047	QRD161J-103	CARBON RESISTOR	10K 5% 1/6W		
R 048	QRD161J-331	CARBON RESISTOR	330 5% 1/6W		
R 049	QRD161J-102	CARBON RESISTOR	1.0K 5% 1/6W		

BLOCK NO. 05			BLOCK NO. 05		
REF.	PARTS NO.	PARTS NAME	REMARKS	SUFFIX	
C 070	QEK1HM-225	E-CAPACITOR	2.2MF 20% 50V		
C 071	QEK61HM-335Z	E-CAPACITOR	3.3MF 20% 50V		
C 080	QCT30UJ-100Y	C-CAPACITOR	10PF 5% 50V		
C 081	QCY31HK-122Z	C-CAPACITOR	1200PF 10% 50V		
C 082	QCC11EM-473V	C-CAPACITOR	.047MF 20% 25V		
C 083	QCVB1CN-103Y	C-CAPACITOR	.010MF 30% 16V		
C 084	QCVB1CN-103Y	C-CAPACITOR	.010MF 30% 16V		
C 086	QEK41CM-226	E-CAPACITOR	22MF 20% 16V		
C 090	QCY31HK-682Z	C-CAPACITOR	6800PF 10% 50V		
C 091	QCC11EM-473V	C-CAPACITOR	.047MF 20% 25V		
C 092	QCB1HK-101Y	C-CAPACITOR	100PF 10% 50V		
C 093	QCS11HJ-100	C-CAPACITOR	10PF 5% 50V		
C 094	QCT30UJ-100Y	C-CAPACITOR	10PF 5% 50V		
C 096	QCSB1HK-8R2Y	C-CAPACITOR	8.2PF 10% 50V		
C 097	QCS11HJ-3R0	C-CAPACITOR	3.0PF 5% 50V		
C 098	QCSB1HM-1R8Y	C-CAPACITOR	1.8PF 20% 50V		
C 099	QCC11EM-473V	C-CAPACITOR	.047MF 20% 25V		
CF 01	VCF2L3B-105	CERAMIC FILTER			
CF 02	VCF2L3B-105	CERAMIC FILTER			
CF 03	VCF12Z-105Z	CERAMIC FILTER			
CF 04	CSB456F18	CERA LOCK			
CN 01	VMC0075-010N	CONNECTOR	TO FUNCTION PMB		
D 001	SVC203SPA-AB-AL	VARI CAP	FM RF		
D 002	SVC203SPA-AB-AL	VARI CAP	FM OSC		
D 006	1SS133	SI DIODE			
D 008	SVC344-AA	VARI CAP			
D 009	SVC344-AA	VARI CAP			
D 010	SVC344-AA	VARI CAP			
D 011	1SS133	SI DIODE			
D 012	1SS133	SI DIODE			
D 013	1SS133	SI DIODE			
D 014	1SS133	SI DIODE			
D 015	1SS133	SI DIODE			
FW701	VMS102-083K3K	FF FRAT WIRE	LUMP-WICON		
IC 01	TA7338P(N)	IC			
IC 02	TAB132AN	IC			
IC 03	TC9216P	IC			
IC 04	TC74HC00AP	IC			
J 001	EMB90TV-601K	SPK TERMINAL	FM/AM ANT		
L 001	VGF1B20-017	OSC COIL	FM OSC		
L 002	VGF1B12-012	RF COIL	FM RF		
L 003	VGM7002-010	RF COIL(MW)	MW RF		
L 004	VGM7002-404	OSC COIL(MW)	MW OSC		
L 005	VGP0018-220	INDUCTOR			
L 006	VGS7001-801	OSC COIL	SW1 OSC		
L 007	VGR7002-501	RF COIL	SW2 RF		
L 008	VGR7002-501	RF COIL	SW2 OSC		
L 010	VGP0018-221	INDUCTOR			
L 011	VGP0018-4R7	INDUCTOR			
L 012	VQ3047-6	COIL			
L 013	VQP0018-221	INDUCTOR			
L 014	VQP0018-221	INDUCTOR			
L 015	VQ3047-6	COIL			
Q 001	2SC2668(C)	TRANSISTOR			

■ Cassette Mechanism P.C. board

BLOCK NO. 06

A REF.	PARTS NO.	PARTS NAME	REMARKS	SUFFIX
CN 1	VMC0234-R11	CONN.TERMINAL		
CN 2	VMC0234-R08	CONN.TERMINAL		
IC 1	DN6851-HI	I.C(M)		
S 1	VSH1170-001	LEAF SWITCH		
S 2	VSH1170-001	LEAF SWITCH		
S 4	VSH1170-001	LEAF SWITCH		
S 5	VSH1170-001	LEAF SWITCH		
S 6	VKS3616-00A	CAM SWITCH		

BLOCK NO. 05

A REF.	PARTS NO.	PARTS NAME	REMARKS	SUFFIX
R 050	QRD161J-103	CARBON RESISTOR	10K 5% 1/6W	
R 052	QRD161J-472	CARBON RESISTOR	4.7K 5% 1/6W	
R 053	QRD161J-102	CARBON RESISTOR	1.0K 5% 1/6W	
R 054	QRD161J-222	CARBON RESISTOR	2.2K 5% 1/6W	
R 055	QRD161J-222	CARBON RESISTOR	2.2K 5% 1/6W	
R 056	QRD167J-332	CARBON RESISTOR	3.3K 5% 1/6W	
R 057	QRD161J-102	CARBON RESISTOR	1.0K 5% 1/6W	
R 058	QRD161J-473	CARBON RESISTOR	47K 5% 1/6W	
R 059	QRD161J-102	CARBON RESISTOR	1.0K 5% 1/6W	
R 081	QRD161J-104	CARBON RESISTOR	100K 5% 1/6W	
R 082	QRD161J-104	CARBON RESISTOR	100K 5% 1/6W	
R 083	QRD161J-222	CARBON RESISTOR	2.2K 5% 1/6W	
R 084	QRD161J-103	CARBON RESISTOR	10K 5% 1/6W	
R 085	QRD161J-103	CARBON RESISTOR	10K 5% 1/6W	
R 086	QRD161J-102	CARBON RESISTOR	1.0K 5% 1/6W	
R 087	QRD161J-271	CARBON RESISTOR	270 5% 1/6W	
R 090	QRD161J-103	CARBON RESISTOR	10K 5% 1/6W	
R 091	QRD161J-104	CARBON RESISTOR	100K 5% 1/6W	
R 092	QRD161J-102	CARBON RESISTOR	1.0K 5% 1/6W	
R 096	QRD161J-102	CARBON RESISTOR	1.0K 5% 1/6W	
R 097	QRD161J-473	CARBON RESISTOR	47K 5% 1/6W	
R 098	QRD161J-822	CARBON RESISTOR	8.2K 5% 1/6W	
R 099	QRD167J-332	CARBON RESISTOR	3.3K 5% 1/6W	
RT 01	QRD161J-102	CARBON RESISTOR	1.0K 5% 1/6W	
T 001	VQT7F12-110	IFT	FM IF	
T 002	VQT7A21-105	IFT		
TC 02	GAT3722-100M	T.CAPACITOR	MW RF	
X 001	V472124-A0	CRYSTAL		

15. Illustration of Packing and Parts List

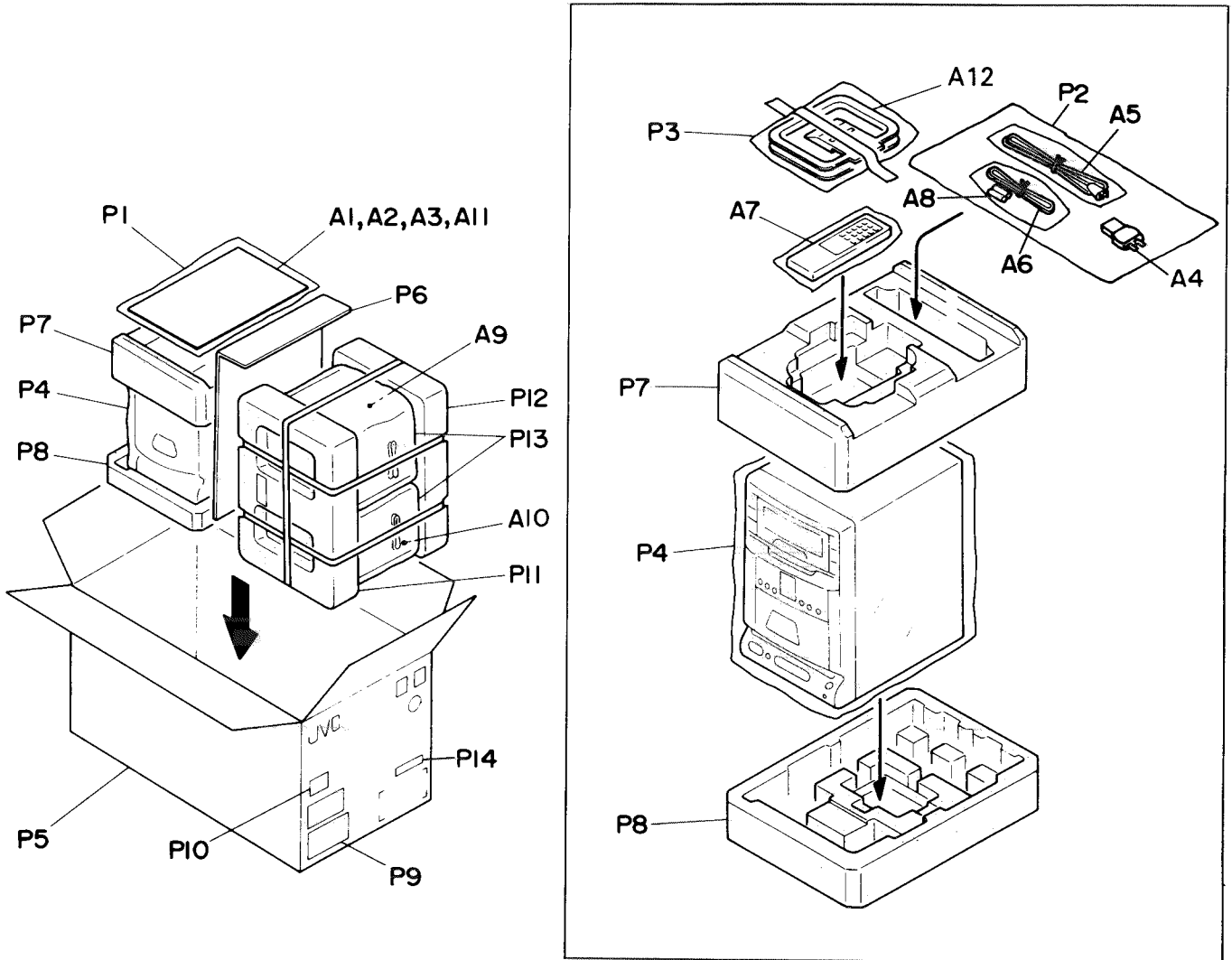

Fig. 15-1

■ Packing Parts List

BLOCK NO. M7MM

REF.	PARTS NO.	PARTS NAME	REMARKS	QTY	SUFFIX	CLR
P 1	VPE3005-007	POLY BAG	FOR INST/WARRAN	1		
P 2	QPGA015-03503	POLY BAG	P.CORD	1		
P 3	VPE3005-042	POLY BAG	FOR AM ANT	1		
P 4	VPE3020-022	POLY BAG	FOR RECEIVER	1		
P 5	VPC9228-S006	CARTON	JVC	1		
P 6	VPK3313-001	CARTON SHEET		1		
P 7	VPH1642-001	CUSHION(UPPER)		1		
P 8	VPH1643-001	CUSHION(BOTTOM)		1		
P 9	VND3044-001	SIRIAL TICKET		1		
P 10	VND3025-211	BAR CODE LABEL		1		
P 11	DH404-UX-C1-U	SIDE CUSHION	FOR SPEAKER	1		
P 12	DH404-UX-C1-B	SIDE CUSHION	FOR SPEAKER	1		
P 13	MIRRORBAG-SK015	MIRROR BAG	FOR SPEAKER	2		
P 14	VND4247-005	VOLTAGE LABEL		1		

16. Accessories

BLOCK NO.

REF.	PARTS NO.	PARTS NAME	REMARKS	QTY	SUFFIX	CLR
A 1	VNN9228-112	INSTRUCTIONS	COMMON USE A	1	A,US,UT,U	
A 2	VNN9228-141	INSTRUCTIONS		1	U	
A 3	BT-56001-1	WARRANTY CARD		1	A	
A 4	BT-56002-1	SERVICE NETWORK		1	A	
A 4	V04062-001	CONTI.PLUG		1	U,US,UT	
A 5	QMP90F0-183	POWER CORD		1	US	
A 5	QMP7530-183	POWER CORD		1	UT,U	
A 5	QMP25D0-183	POWER CORD		1	A	
A 6	EWP502-001	FM ANTENNA	FOR FM	1		
A 7	VGR0031-001	REMOCON UNIT	RM-RXUC1	1		
A 8	UM-3(DJ)-2PSA	BATTERY	FOR REMOCON	1		
A 9	UXB7K-SPBOX-L	SPEAKER BOX	LEFT	1		
A 10	UXB7K-SPBOX-R	SPEAKER BOX	RIGHT	1		
A 11	VNC1200-091	INST.SHEET		1	U	
A 12	EQB4001-015	AM LOOP ANT	FOR AM	1		

UX-C7 A/US/UT/U

JVC

VICTOR COMPANY OF JAPAN, LIMITED
AUDIO PRODUCTS DIVISION 10-1, 1-chome, Ohwatari-machi, Maebashi-city, Japan