

JVC

SERVICE MANUAL

MICRO COMPONENT MD SYSTEM

UX-F70MD UX-F72MD

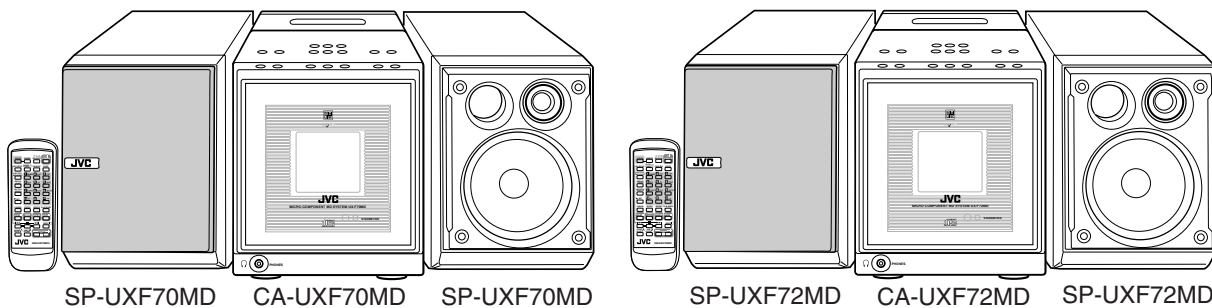

COMPACT
disc
DIGITAL AUDIO



MDLP

Area Suffix

UB Hong Kong
UF China

Contents

Safety precautions	1-2	Flow of functional operation	
Preventing static electricity	1-3	until TOC read (MD)	1-41
Important for laser products	1-5	Maintenance of laser pickup	1-42
Disassembly method	1-6	Replacement of laser pickup	1-42
Adjustment Method 1		Maintenance of MD pickup	1-43
(CD/MD section)	1-35	Procedures of changing	
Adjustment Method 2		the MD pickup	1-43
(Cassette mechanism section)	1-38	Description of major ICs	1-44~71
Flow of functional operation			
until TOC read (CD)	1-40		

Safety Precautions

1. This design of this product contains special hardware and many circuits and components specially for safety purposes. For continued protection, no changes should be made to the original design unless authorized in writing by the manufacturer. Replacement parts must be identical to those used in the original circuits. Services should be performed by qualified personnel only.
2. Alterations of the design or circuitry of the product should not be made. Any design alterations of the product should not be made. Any design alterations or additions will void the manufacturer's warranty and will further relieve the manufacturer of responsibility for personal injury or property damage resulting therefrom.
3. Many electrical and mechanical parts in the products have special safety-related characteristics. These characteristics are often not evident from visual inspection nor can the protection afforded by them necessarily be obtained by using replacement components rated for higher voltage, wattage, etc. Replacement parts which have these special safety characteristics are identified in the Parts List of Service Manual. Electrical components having such features are identified by shading on the schematics and by (\triangle) on the Parts List in the Service Manual. The use of a substitute replacement which does not have the same safety characteristics as the recommended replacement parts shown in the Parts List of Service Manual may create shock, fire, or other hazards.
4. The leads in the products are routed and dressed with ties, clamps, tubings, barriers and the like to be separated from live parts, high temperature parts, moving parts and/or sharp edges for the prevention of electric shock and fire hazard. When service is required, the original lead routing and dress should be observed, and it should be confirmed that they have been returned to normal, after re-assembling.
5. Leakage current check (Electrical shock hazard testing)
After re-assembling the product, always perform an isolation check on the exposed metal parts of the product (antenna terminals, knobs, metal cabinet, screw heads, headphone jack, control shafts, etc.) to be sure the product is safe to operate without danger of electrical shock. Do not use a line isolation transformer during this check.

- Plug the AC line cord directly into the AC outlet. Using a "Leakage Current Tester", measure the leakage current from each exposed metal parts of the cabinet, particularly any exposed metal part having a return path to the chassis, to a known good earth ground. Any leakage current must not exceed 0.5mA AC (r.m.s.)

- Alternate check method

Plug the AC line cord directly into the AC outlet. Use an AC voltmeter having, 1,000 ohms per volt or more sensitivity in the following manner. Connect a 1,500 Ω 10W resistor paralleled by a 0.15 μ F AC-type capacitor between an exposed metal part and a known good earth ground.

Measure the AC voltage across the resistor with the AC voltmeter.

Move the resistor connection to each exposed metal part, particularly any exposed metal part having a return path to the chassis, and measure the AC voltage across the resistor. Now, reverse the plug in the AC outlet and repeat each measurement. Any voltage measured must not exceed 0.75 V AC (r.m.s.). This corresponds to 0.5 mA AC (r.m.s.).

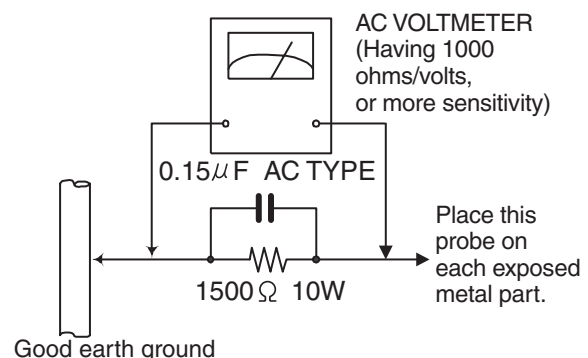

Warning

1. This equipment has been designed and manufactured to meet international safety standards.
2. It is the legal responsibility of the repairer to ensure that these safety standards are maintained.
3. Repairs must be made in accordance with the relevant safety standards.
4. It is essential that safety critical components are replaced by approved parts.
5. If mains voltage selector is provided, check setting for local voltage.

CAUTION Burrs formed during molding may be left over on some parts of the chassis. Therefore, pay attention to such burrs in the case of performing repair of this system.

Preventing static electricity

Electrostatic discharge (ESD), which occurs when static electricity stored in the body, fabric, etc. is discharged, can destroy the laser diode in the traverse unit (optical pickup). Take care to prevent this when performing repairs.

1.1. Grounding to prevent damage by static electricity

Static electricity in the work area can destroy the optical pickup (laser diode) in devices such as DVD players. Be careful to use proper grounding in the area where repairs are being performed.

1.1.1. Ground the workbench

1. Ground the workbench by laying conductive material (such as a conductive sheet) or an iron plate over it before placing the traverse unit (optical pickup) on it.

1.1.2. Ground yourself

1. Use an anti-static wrist strap to release any static electricity built up in your body.

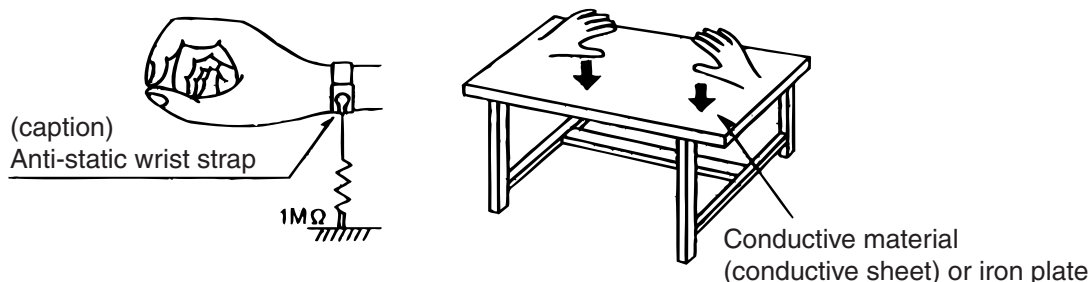

1.1.3. Handling the optical pickup

1. In order to maintain quality during transport and before installation, both sides of the laser diode on the replacement optical pickup are shorted. After replacement, return the shorted parts to their original condition. (Refer to the text.)
2. Do not use a tester to check the condition of the laser diode in the optical pickup. The tester's internal power source can easily destroy the laser diode.

1.2. Handling the traverse unit (optical pickup)

1. Do not subject the traverse unit (optical pickup) to strong shocks, as it is a sensitive, complex unit.
2. Cut off the shorted part of the flexible cable using nippers, etc. after replacing the optical pickup. For specific details, refer to the replacement procedure in the text. Remove the anti-static pin when replacing the traverse unit. Be careful not to take too long a time when attaching it to the connector.
3. Handle the flexible cable carefully as it may break when subjected to strong force.
4. It is not possible to adjust the semi-fixed resistor that adjusts the laser power. Do not turn it

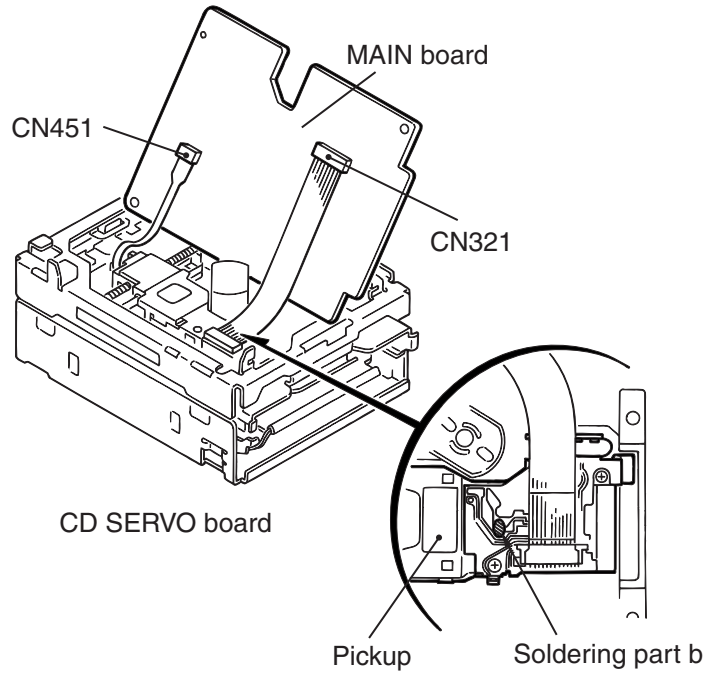

1.3. Cautions on removing the CD traverse unit

* For removing the CD traverse unit in detail, refer to the "Adjustment Method" section of this manual.

1. Before disconnecting the flexible wire from the connector CN601 on the CD SERVO board, solder the part shown in the figure below.
(Note: If the flexible wire is disconnected from the CN601 without presoldering, it may cause breakdown of the CD pickup assembly.)
2. When reassembling the CD traverse unit, be sure to remove the solder from the soldered part after reconnecting the flexible wire to the CN601.

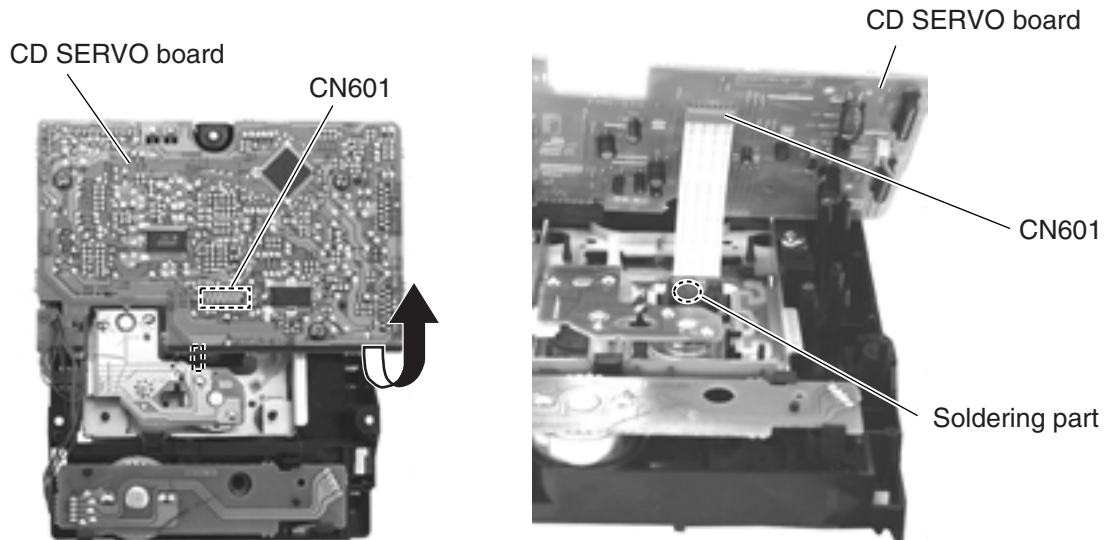

Important for laser products

1. CLASS 1 LASER PRODUCT

2. DANGER : Invisible laser radiation when open and interlock failed or defeated. Avoid direct exposure to beam.

3. CAUTION : There are no serviceable parts inside the Laser Unit. Do not disassemble the Laser Unit. Replace the complete Laser Unit if it malfunctions.

4. CAUTION : The compact disc player uses invisible laserradiation and is equipped with safety switches which prevent emission of radiation when the drawer is open and the safety interlocks have failed or are defeated. It is dangerous to defeat the safety switches.

5. CAUTION : If safety switches malfunction, the laser is able to function.

6. CAUTION : Use of controls, adjustments or performance of procedures other than those specified herein may result in hazardous radiation exposure.

⚠ CAUTION Please use enough caution not to see the beam directly or touch it in case of an adjustment or operation check.

VARNING : Osynlig laserstrålning är denna del är öppnad och spårren är urkopplad. Betrakta ej strålen.

VARO : Avattaessa ja suojalukitus ohitettaessa olet alttiina näkymättömälle lasersäteilylle. Älä katso säteeseen.

ADVARSEL : Usynlig laserstrålning ved åbning , når sikkerhedsafbrydere er ude af funktion. Undgå udsættelse for stråling.

ADVARSEL : Usynlig laserstrålning ved åpning, når sikkerhetsbryteren er avslott. unngå utsettelse for stråling.

REPRODUCTION AND POSITION OF LABELS

WARNING LABEL

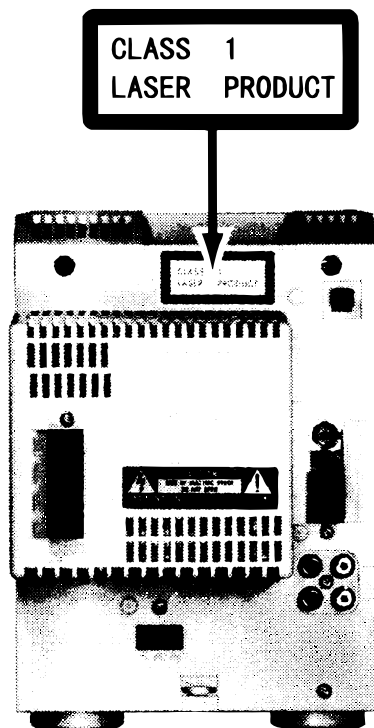

Disassembly method

<Main body>

■ Removing the rear cover

(See Fig.1 and 2)

1. Remove the seven screws **A** on the back of the body.
2. Remove the two screws **B** on the bottom of the body.
3. Unlock the speaker terminal and the antenna terminal, then remove the rear cover backward with releasing the hooks.

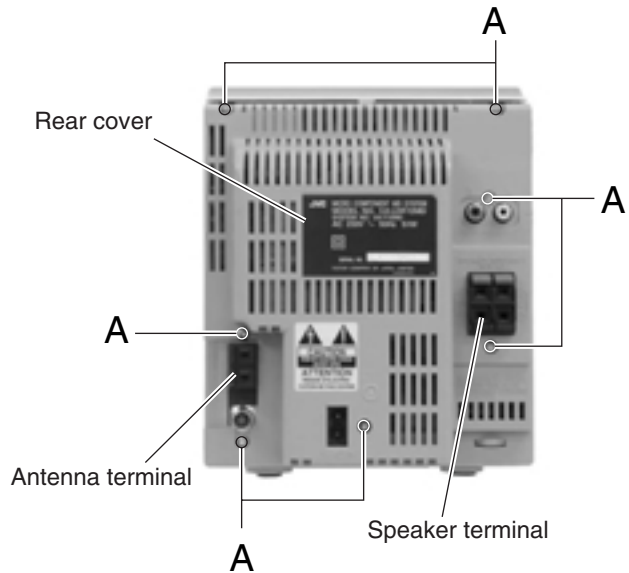

Fig.1

■ Removing the side panels

(See Fig.3 to 5)

- Prior to performing the following procedure, remove the rear cover.

1. Remove the two screws **C** attaching the side panels on the bottom of the body.
2. Remove each side panel backward while releasing the eight joints **a** as shown in Fig.4 and 5.

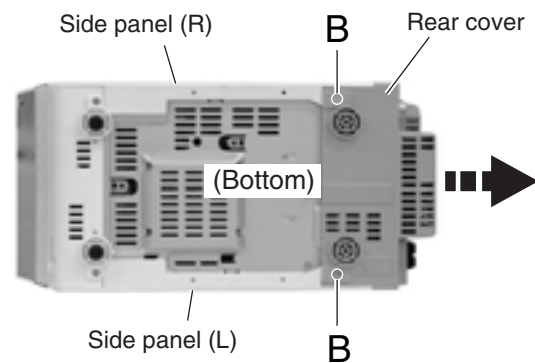

Fig.2

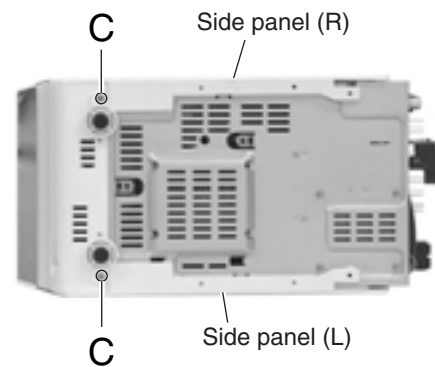

Fig.3

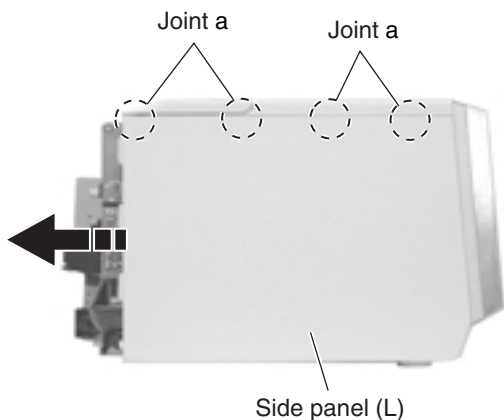

Fig.5

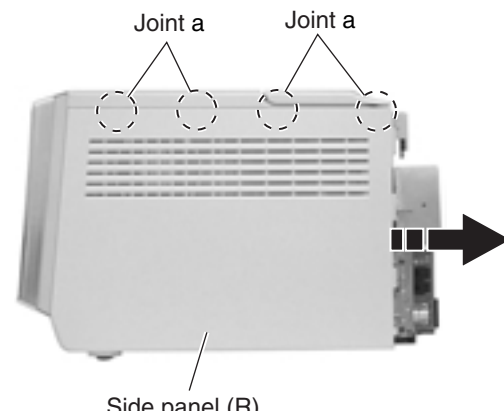
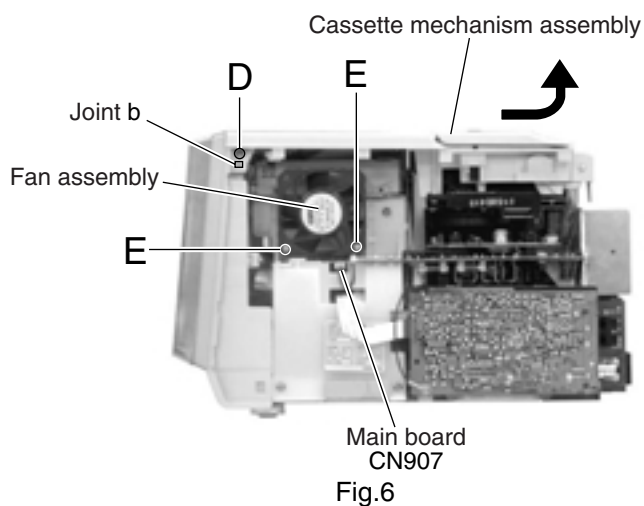

Fig.4

■ Removing the cassette mechanism assembly section (See Fig.6 and 7)

- Prior to performing the following procedure, remove the rear cover and the side panels.

1. Remove the two screw **D** on each side of the body.
2. Release the joint **b** on each side of the body and remove the cassette mechanism assembly section in the direction of the arrow.
3. Disconnect the card wires from connector CN705, CN743 and CN744 on the system control board on the left side of the body.



■ Removing the fan assembly (See Fig.6)

- Prior to performing the following procedure, remove the rear panel and the right side panel.

1. Disconnect the wire from connector CN907 on the main board on the right side of the body.
2. Remove the two screws **E** attaching the fan assembly.

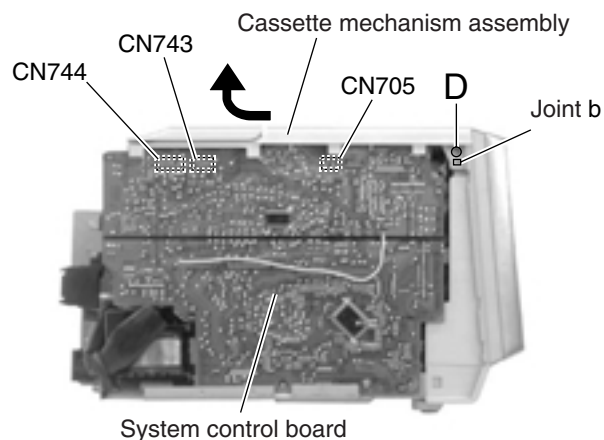

Fig.7

■ Removing the MD mechanism assembly section (See Fig.8)

- Prior to performing the following procedure, remove the rear cover, the side panels, the cassette mechanism assembly section and the fan assembly.

1. Disconnect the card wire from connector CN721 on the system control board.
2. Disconnect the card wire from connector CN522 on the underside of the MD mechanism assembly section.
3. Remove the four screws **F** and the MD mechanism assembly section upward.

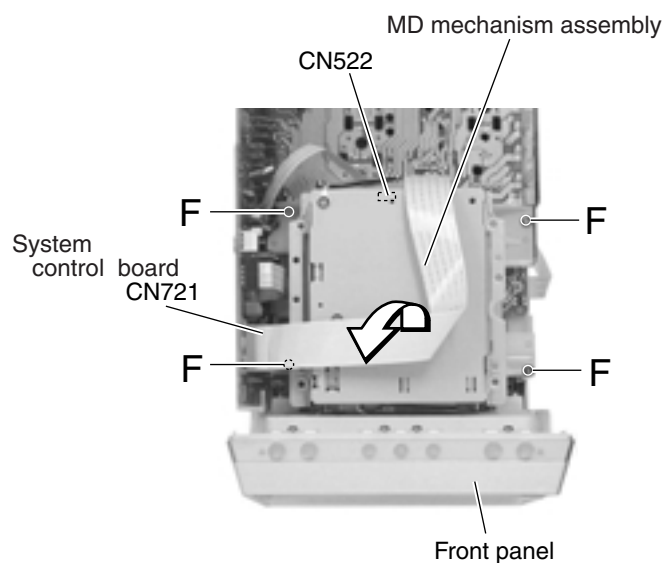

Fig.8

■ **Removing the system control board**
(See Fig.9)

· Prior to performing the following procedure, remove the rear cover, the side panels and the cassette mechanism assembly section.

1. Remove the screw **G** on the left side of the body.
2. Disconnect the card wire from connector CN701 and CN721 on the system control board.
3. Disconnect connector CN709, CN711 and CN712 on the system control board from the body outward.
4. Disconnect the card wire from connector CN704 on the underside of the system control board.

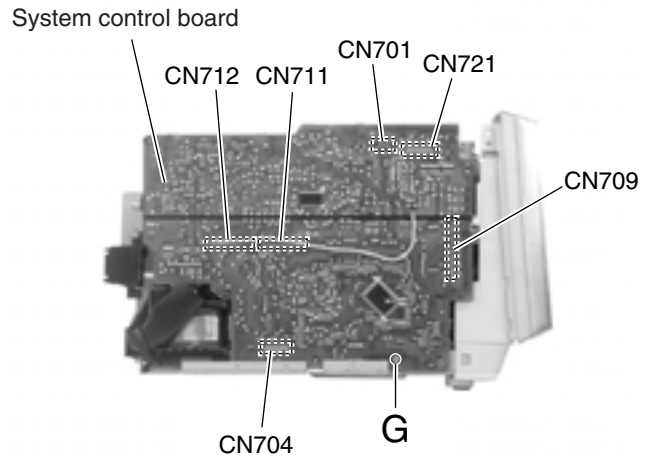

Fig.9

■ **Removing the tuner board (See Fig.10)**

· Prior to performing the following procedure, remove the rear cover and the right side panel.

1. Disconnect the card wire from connector CN1 on the tuner board on the right side of the body.
2. Remove the screw **H** and remove the tuner board upward while disengaging the three joint **c**.

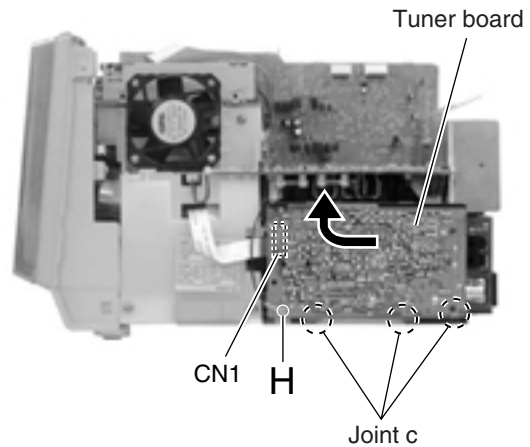

Fig.10

**■ Removing the front panel assembly
(See Fig.11 and 12)**

- Prior to performing the following procedure, remove the rear cover, the side panels, the cassette mechanism assembly section and the system control board.
1. Release the two joints **d** on the lower right and left sides of the front panel assembly, then remove the front panel assembly toward the front.

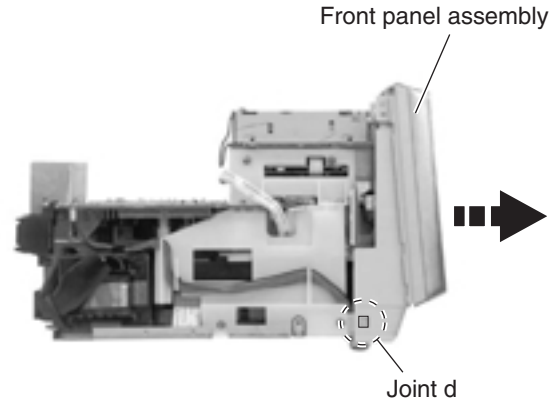

Fig.11

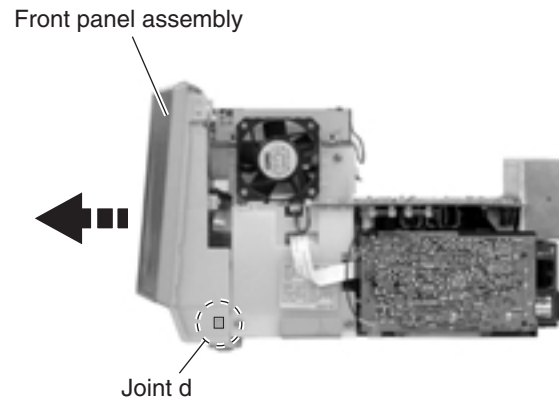

Fig.12

**■ Removing the headphone jack board
(See Fig.13 and 14)**

- Prior to performing the following rear cover, the side panels, the cassette mechanism assembly section, the system control board and the front panel assembly section.
1. Disconnect the wire from connector CN804 on the main board.
 2. Remove the plastic rivet fixing the headphone jack board.

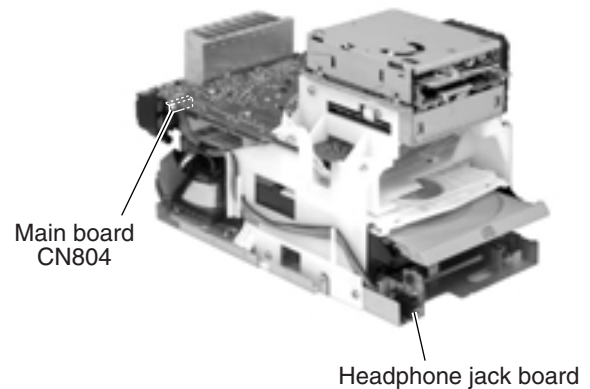

Fig.13

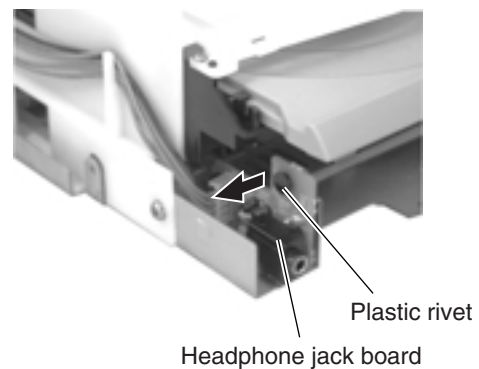

Fig.14

■ Removing the main board / the heat sink
(See Fig.15 to 17)

• Prior to performing the following procedure, remove the rear cover, the side panels, the cassette mechanism assembly section, the system control board and the MD mechanism assembly section.

1. Remove the screw **I** attaching the main board.
2. Remove the screw **H** attaching the grounding terminal extending from the main board.
3. Disconnect the wire from connector CN804 on the main board.
4. Disconnect connector CN805 on the main board from the AC jack board while pulling out it. Remove the main board in the direction of the arrow and disconnect the wire from connector CN803 on the reverse side of the main board.
5. Remove the three screws **J** attaching the heat sink on the reverse side of the main board.

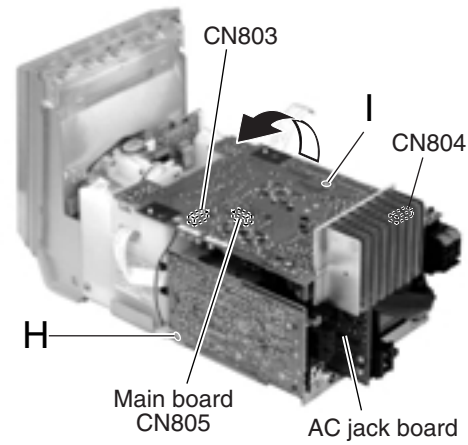

Fig.15

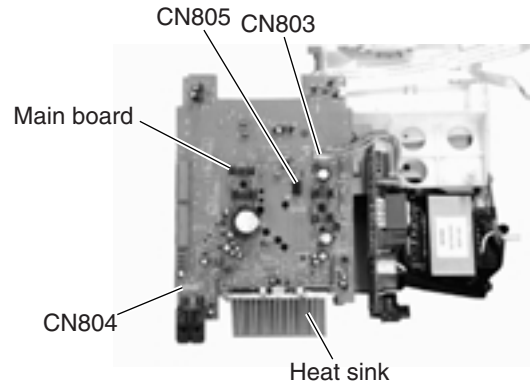

Fig.16

■ Removing the AC jack board
(See Fig.18 and 19)

• Prior to performing the following procedure, remove the rear cover, the side panels, the cassette mechanism assembly section, the system control board, the MD mechanism assembly section and the main board / the tuner board.

1. Disconnect the wire from connector CN809 on the AC jack board.
2. Remove the screw **K** and screw **L** attaching the AC jack board.

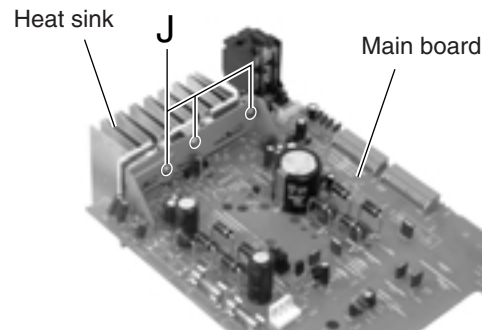

Fig.17

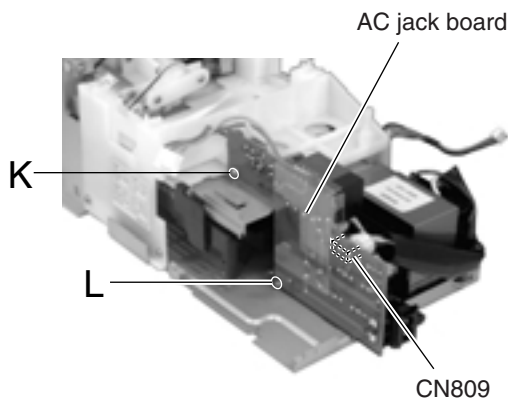

Fig.19

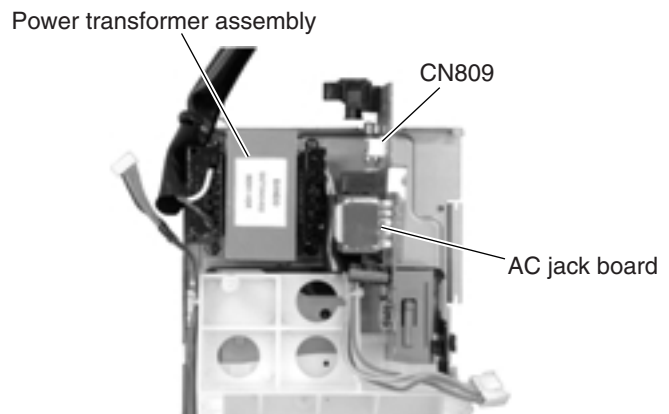
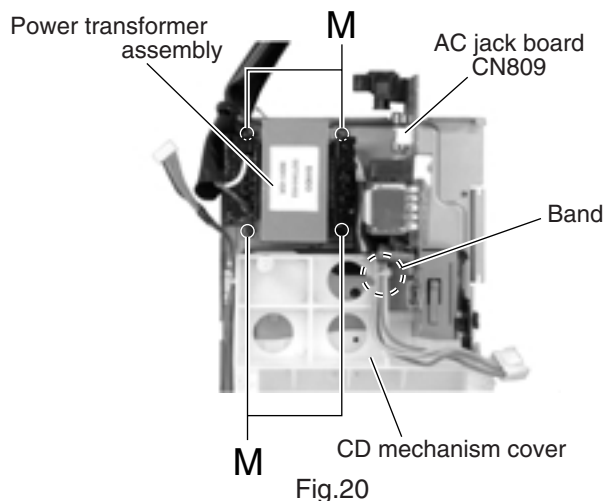

Fig.18

■ Removing the power transformer assembly (See Fig.20)

- Prior to performing the following procedure, remove the rear cover, the side panels, the cassette mechanism assembly section, the system control board, the MD mechanism assembly section and the main board.

1. Disconnect the wire from connector CN809 on the AC jack board.
2. Cut off the band setting the wire on the CD mechanism cover.
3. Remove the four screws **M** attaching the power transformer assembly.



■ Removing the CD mechanism assembly (See Fig.21 to 23)

- Prior to performing the following procedure, remove the rear cover, the side panels, the cassette mechanism assembly section, the system control board, the front panel assembly section, the MD mechanism assembly section, the main board / the tuner board and the AC jack board.

1. Cut off the band setting the wire on CD mechanism cover.
2. Release the wire extending from the headphone jack board from the three notches of the CD mechanism cover on the left side of the body.
3. Remove the four screws **N** on the left and right side of the CD mechanism cover. Then remove the CD mechanism cover upward.
4. Remove the three screws **O** attaching the CD mechanism assembly.

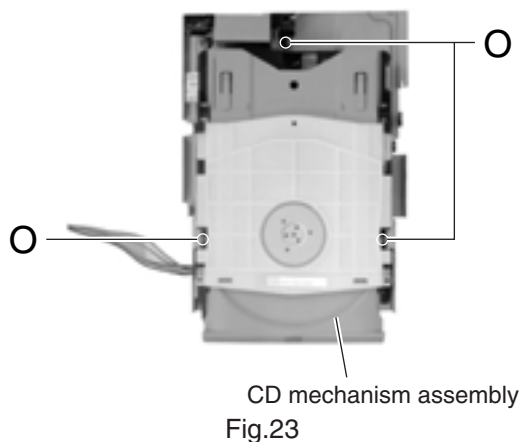
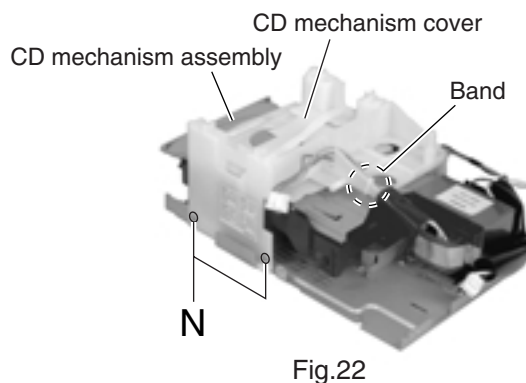
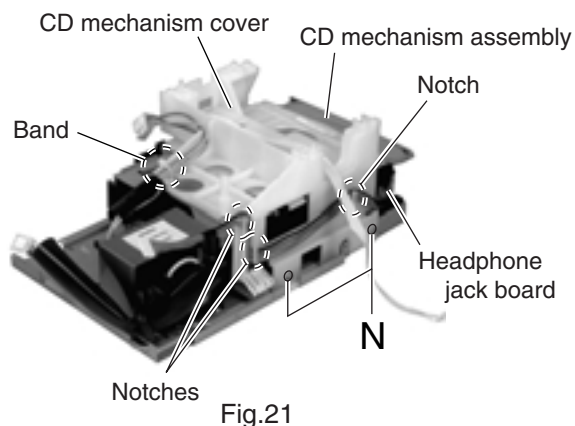

<MD mechanism assembly section>

- Prior to performing the following procedure, remove the rear cover, the side panels, the cassette mechanism assembly section, the fan assembly and the MD mechanism assembly section.

■ Removing the MD mechanism assembly (See Fig.24 to 26)

1. Remove the four screws **P** attaching the brackets (1) and (2) on the left and right side of the MD mechanism assembly.
2. Disconnect the card wire from connector CN521 on the MD mechanism board.
3. Remove the MD mechanism bottom cover downward.

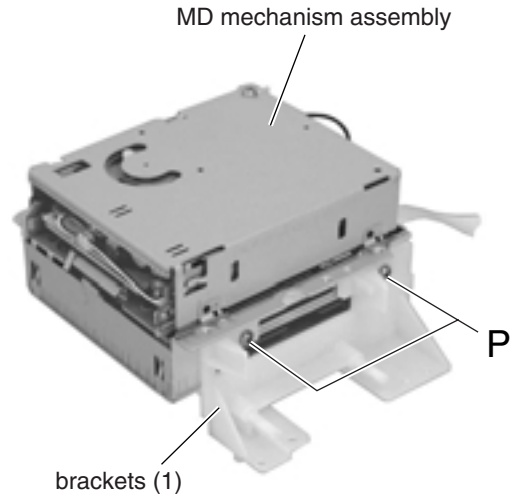

Fig.24

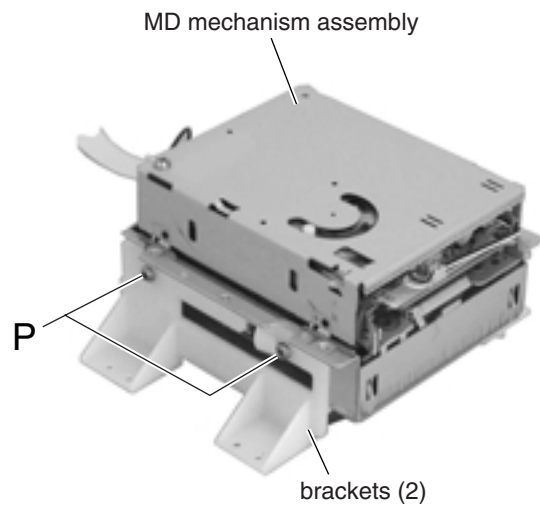

Fig.25

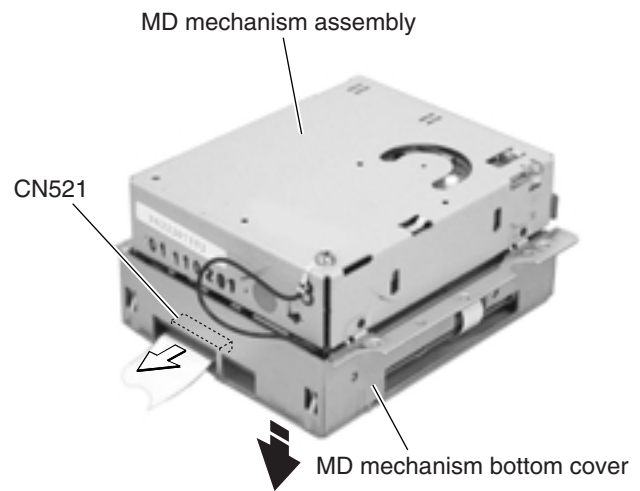

Fig.26

<Front panel assembly section>

- Prior to performing the following procedure, remove the rear cover, the side panels, the cassette mechanism assembly section, the system control board and the front panel assembly section.

■ Removing the relay board (See Fig. 27)

1. Disconnect the wire from connector CN906, CN907 and the card wire from CN908 on the relay board respectively.
2. Remove the two screws **Q**.

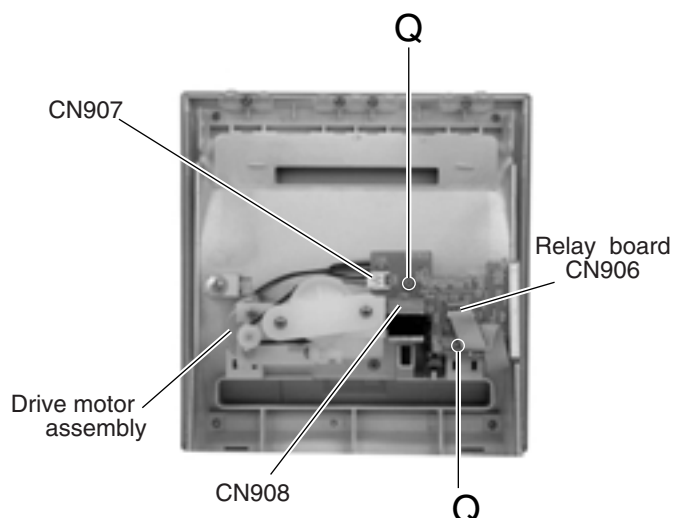

Fig.27

■ Removing the drive motor assembly (See Fig.28)

- Prior to performing the following procedure, remove the relay board.

1. Remove the four screws **R** attaching the drive motor assembly.

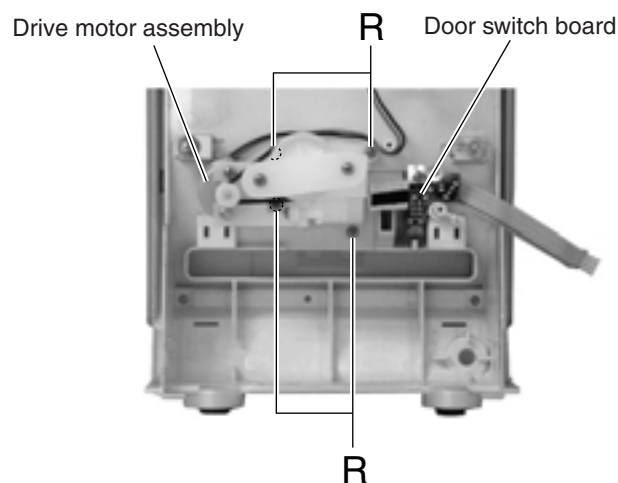

Fig.28

■ Removing the belt and the drive motor (See Fig.29)

REFERENCE: The belt and the drive motor can be removed respectively without removing the drive motor assembly from the front panel section.

1. Remove the two screws **S** attaching the plate.
2. Remove the belt from the two pulleys.
3. Remove the two screws **T** attaching the drive motor.

REFERENCE: When removing the drive motor only, remove the belt from the drive motor pulleys in advance.

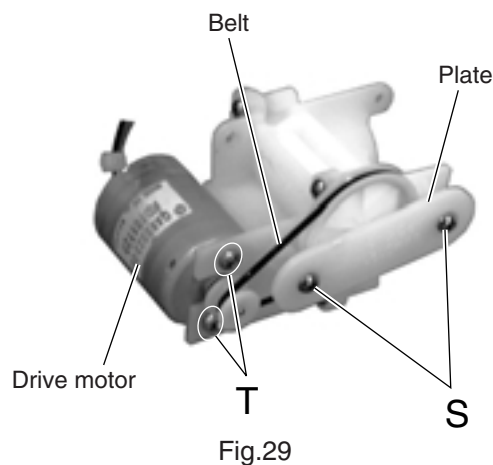

Fig.29

**■ Removing the door switch board
(See Fig.30 and 31)**

• Prior to performing the following procedure, remove the relay board.

1. Loosen the screw **U** attaching the door switch.
2. Remove the door switch board while releasing it from the joint **e**.

CAUTION: When reattaching the door switch board, fit it to the joint **e** and check the operating state of the switch before tightening the screw **U**.

**■ Removing the LCD section
(See Fig.32 to 34)**

• Prior to performing the following procedure, remove the relay board.

1. Loosen the two screws **V** attaching the lock lever.
2. Push the part **f** of the lock lever in the direction of the arrow as shown in Fig.33-1 / 33-2 and disengage the LCD section from the front panel assembly.

CAUTION: Because the LCD may come off, hold it when loosening the screws **V**.

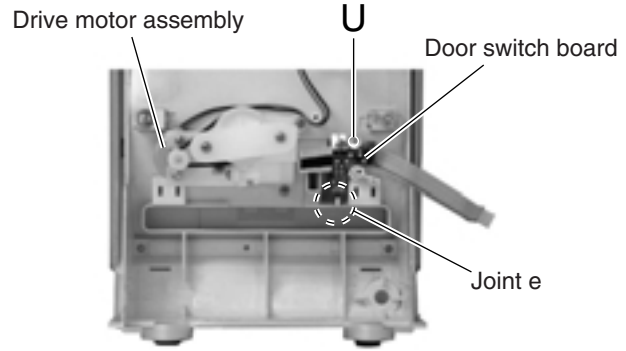

Fig.30

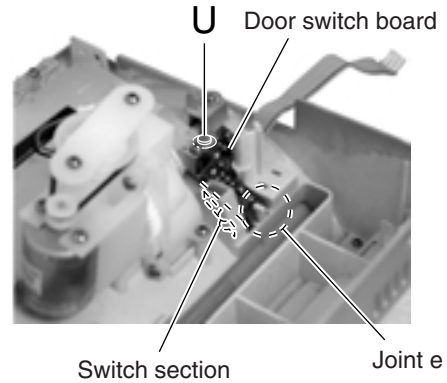

Fig.31

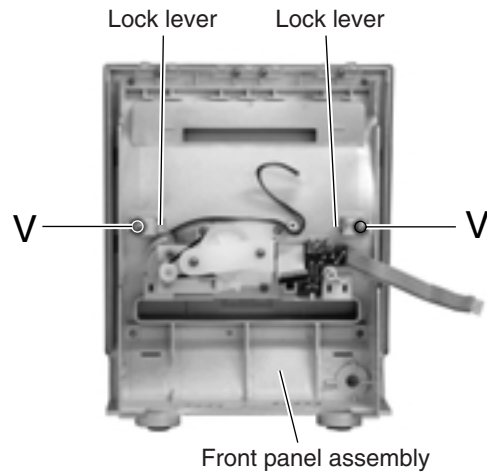

Fig.32

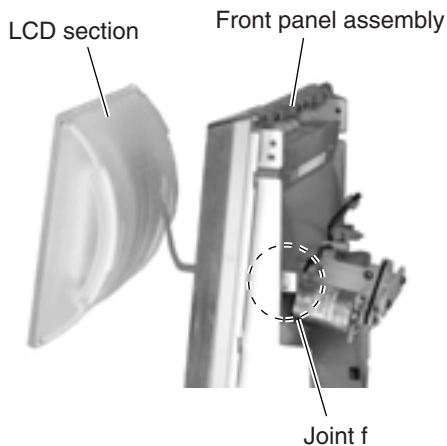

Fig.34

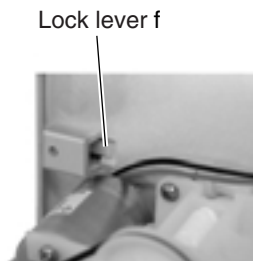

Fig.33-1

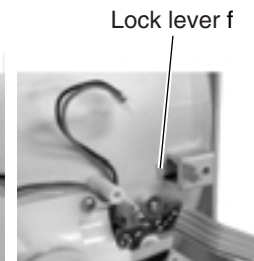

Fig.33-2

■ Removing the LCD board assembly (See Fig.35 to 39)

- Prior to performing the following procedure, remove the relay board and the LCD section.

1. Remove the four screws **W** attaching the case cover.
2. Remove the four screws **X** attaching the LCD panel on the back of the LCD section.
3. Remove the LCD cover.
4. Release the joint **g** and remove the LCD board assembly in the direction of the arrow.

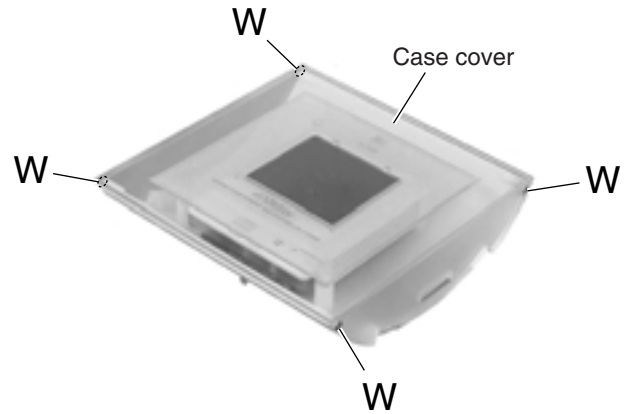

Fig.35

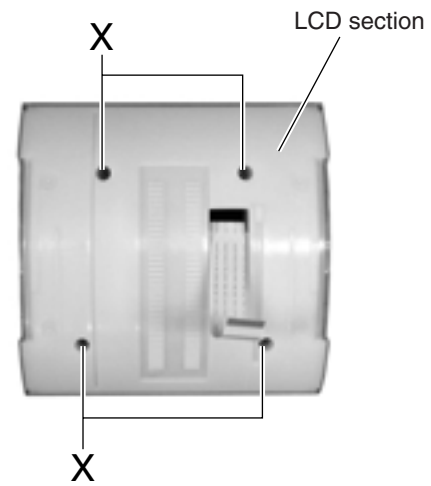

Fig.36

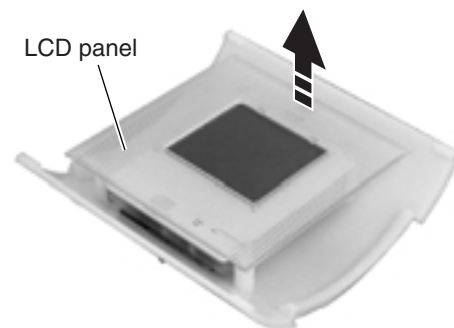

Fig.37

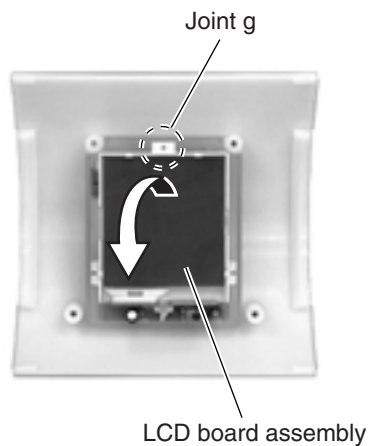

Fig.39

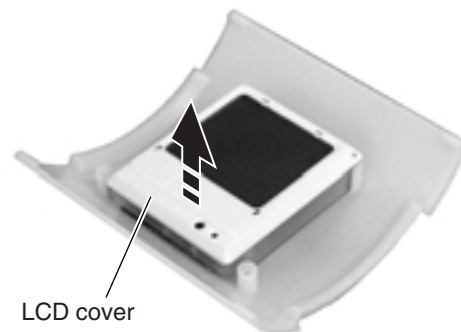

Fig.38

<Cassette mechanism assembly section>

- Prior to performing the following procedure, remove the rear cover, the side panels and the cassette mechanism assembly section.

■ Removing the operation switch board (See Fig.40)

1. Remove the seven screws **Y** attaching the operation switch board on the reverse side of the cassette mechanism assembly.

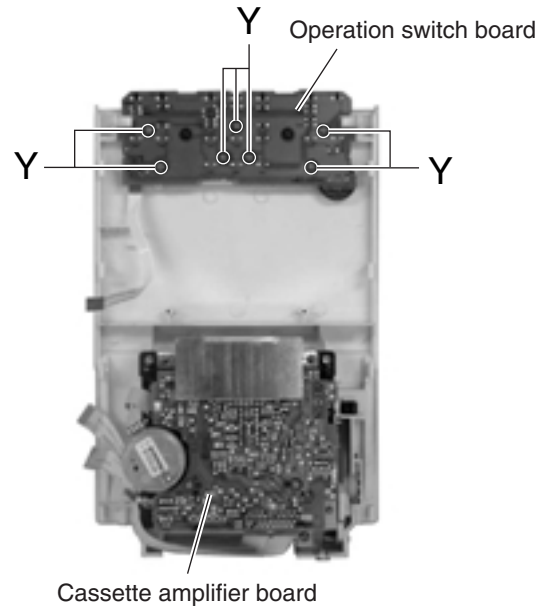

Fig.40

■ Removing the cassette mechanism assembly (See Fig.41)

1. Remove the four screws **Z** on the reverse side of the cassette mechanism assembly.

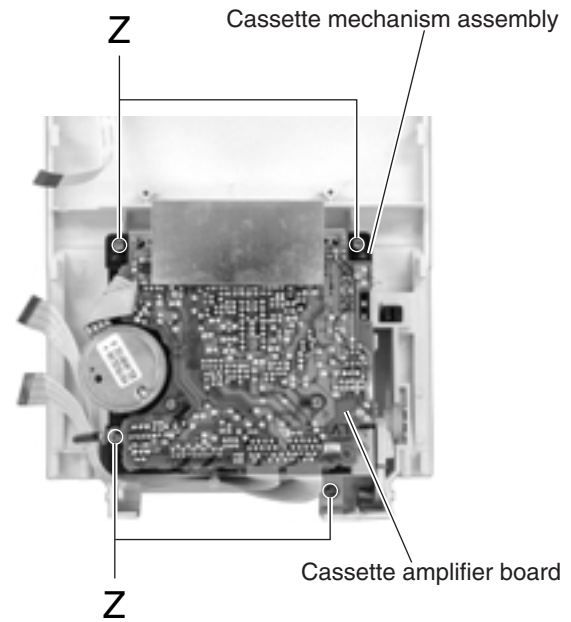

Fig.41

Disassembly method

<Main body>

■Removing the main board (See Fig.1 and 2)

1. Turn over the body and disconnect the card wire from connector CN408 and the flexible wire from CN407 on the main board.
2. Remove the two screws A attaching the main board. Slide the main board in the direction of the arrow to release the two joints a with the single flame.
3. Solder part b on the pickup in the body. Disconnect the flexible harness from connector CN321 and CN451 on the underside of the main board. Then remove the main board.

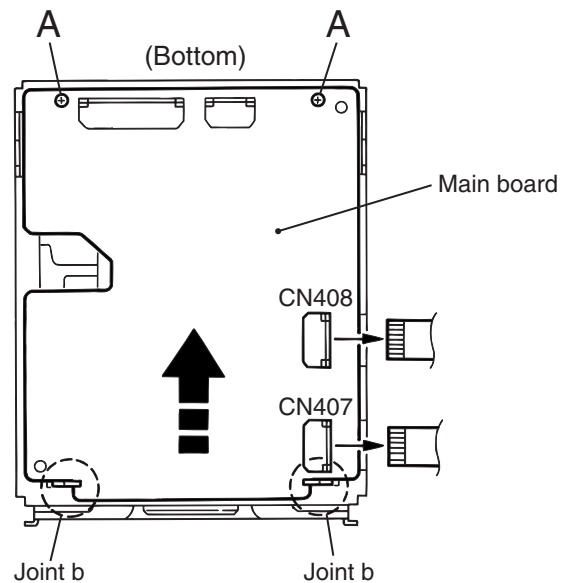

Fig.1

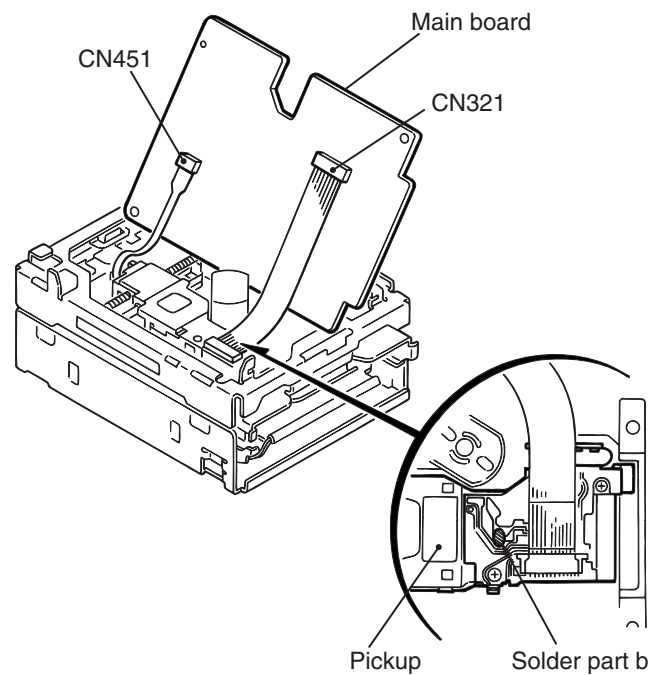

Fig.2

■Removing the mechanism cover (See Fig.3)

1. Remove the four screws B on both sides of the body.
2. Move the mechanism cover toward the front to disengage the front hook of the mechanism cover from the internal loading assembly (Joint c). Then remove the mechanism cover upward.

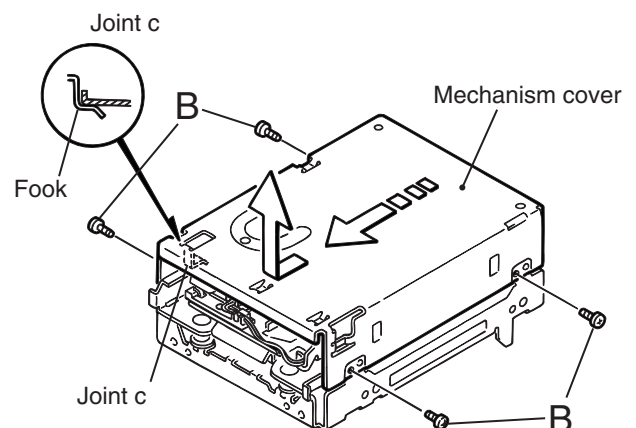
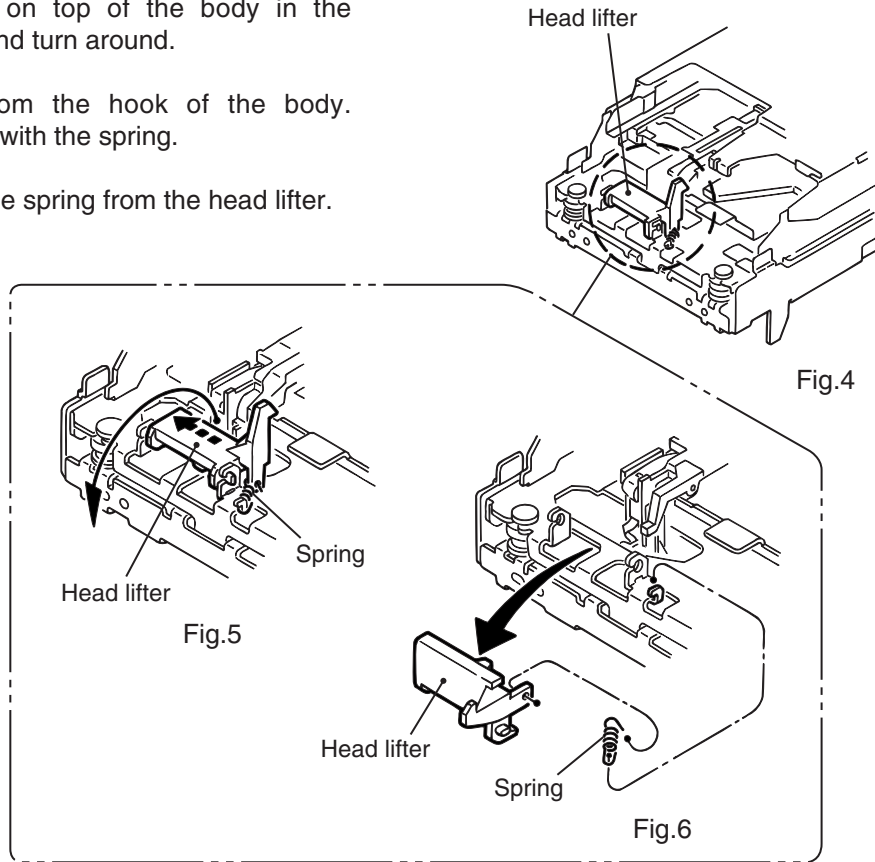

Fig.3

■Removing the head lifter (See Fig.4 to 6)

1. Move the head lifter on top of the body in the direction of the arrow and turn around.
2. Detach the spring from the hook of the body. Remove the head lifter with the spring.
3. If necessary, remove the spring from the head lifter.



■Removing the head assembly (See Fig.7)

1. Remove the screw C on the upper side of the body. Remove the head assembly while pulling the flexible harness from the body.

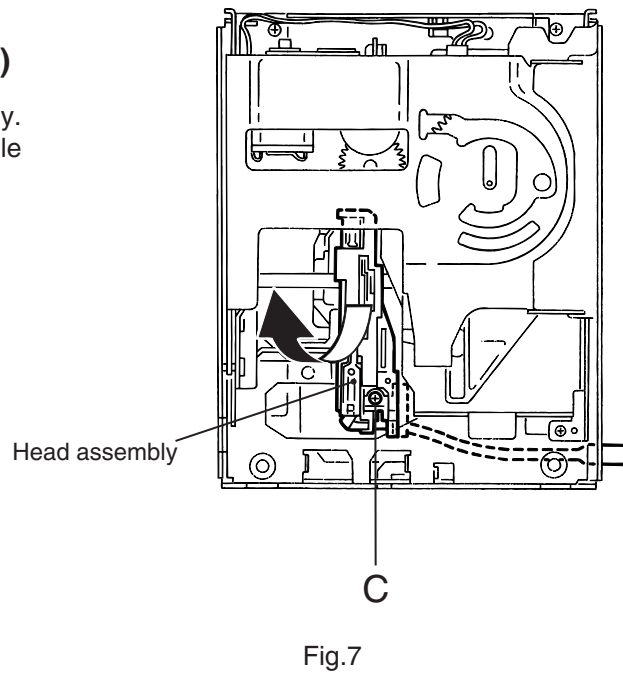

■ Removing the Loading assembly (See Fig.8 and 9)

Ref: The loading assembly, the traverse mechanism assembly and the single frame will be removable after removing the loading assembly from the body.

- Prior to performing the following procedure, remove the main board, the mechanism cover, the head lifter and the head assembly.
1. Remove the three screws D on the upper side of the body.
 2. Move the loading assembly forward to disengage it from the traverse mechanism assembly (Joint d). Then remove it upward.
 3. Remove the traverse mechanism assembly from the single frame.

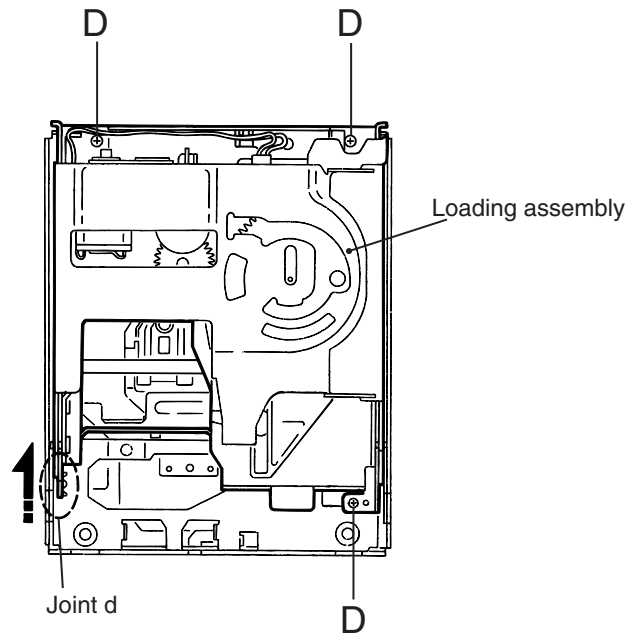

Fig.8

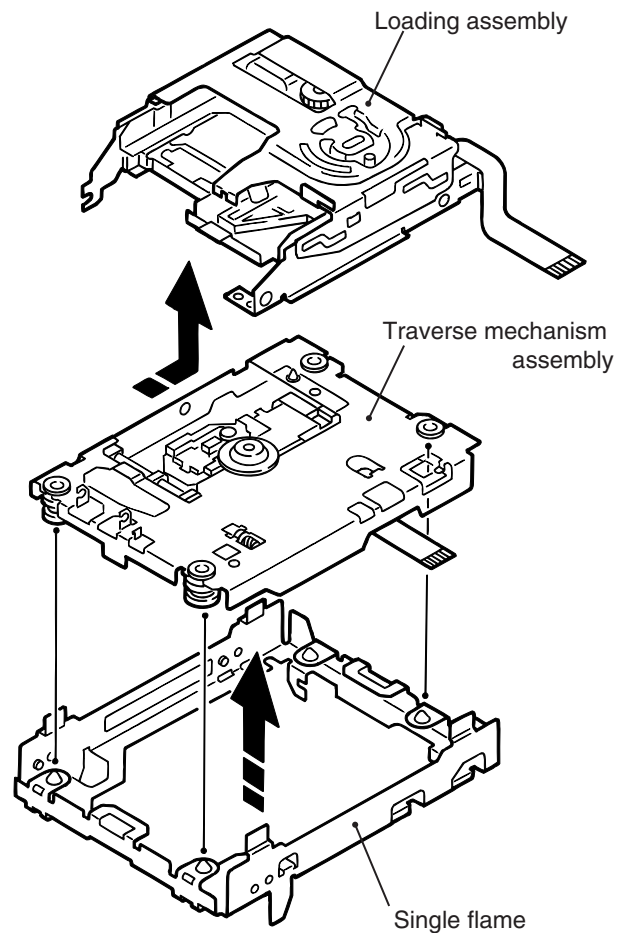

Fig.9

<Loading assembly>

■ **Removing the slide base (L) / (R)**
(See Fig.10)

1. Remove the two screws E on the upper side of the loading assembly.
2. Remove the slide base (L) outward. (Release it from the joint bosses E.)
3. Remove the slide base (R) outward.

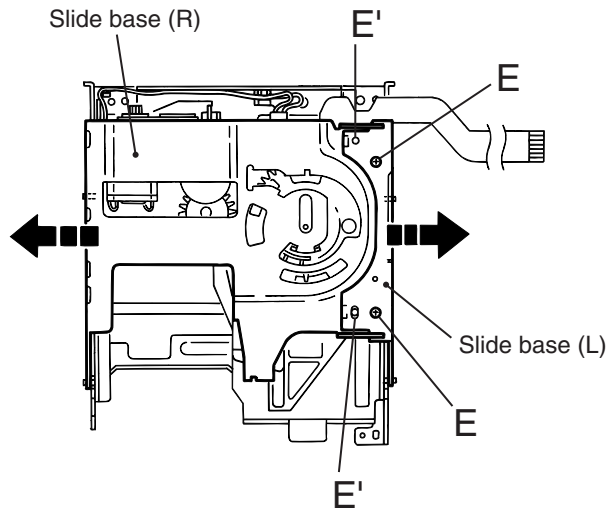

Fig.10

■ **Removing the loading mechanism assembly** (See Fig.11)

1. Detach the loading mechanism assembly upward to release the four pins on both sides from the loading motor, paying attention to the part e of the loading mechanism base.

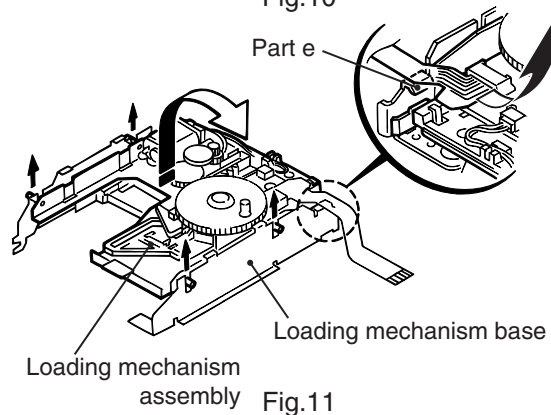

Fig.11

— Loading mechanism assembly —

■ **Removing the loading motor**
(See Fig.12 and 13)

1. Disconnect the harnesses from the wire holder and from connector CN612 on the cam switch board.
2. Remove the screw F attaching the loading motor and release the joint f.
3. Remove the belt from the loading motor assembly.
4. Remove the two screws G attaching the loading motor.

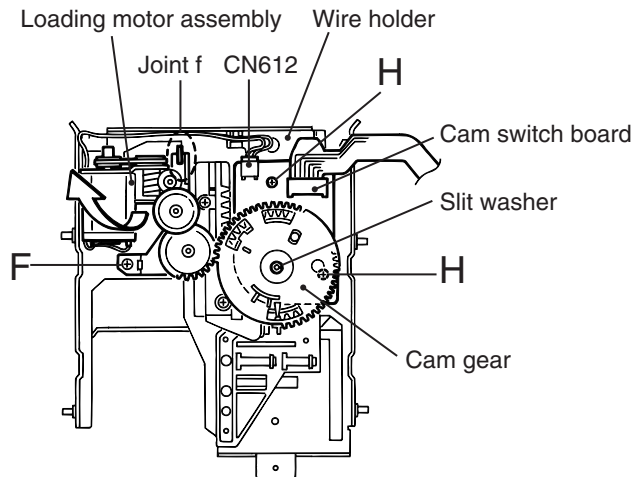

Fig.12

■ **Removing the cam gear and the cam switch board** (See Fig.12)

1. Remove the slit washer attaching the cam gear and pull out the cam gear.
2. Disconnect the harness from the wire holder and from connector CN612 on the cam switch board.
3. Remove the two screws H and the clamp. Remove the cam switch board.

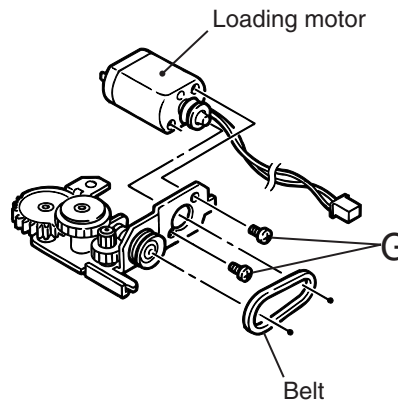

Fig.13

■ Removing the cartridge holder assembly (See Fig.14 and 15)

1. Remove the two screws I on the upper side of the loading assembly.

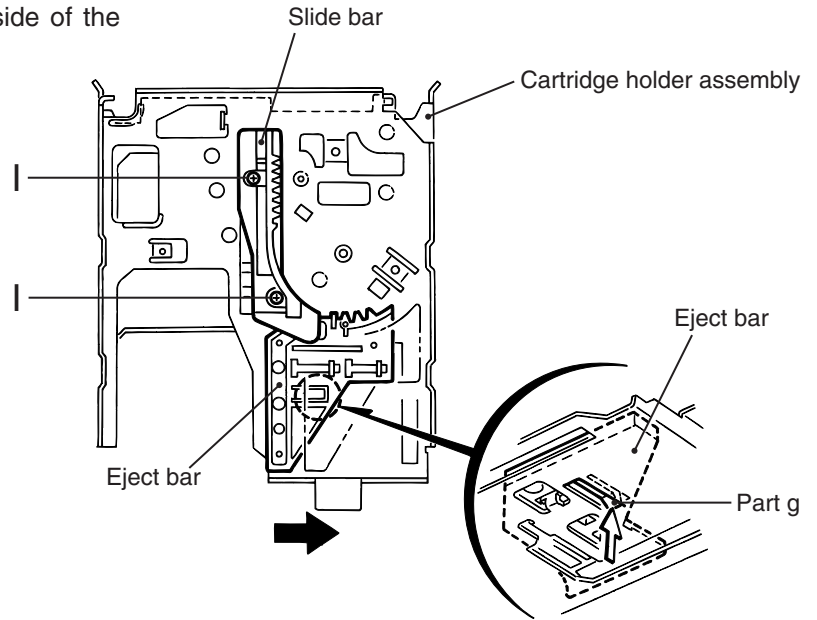

Fig.14

■ Removing the slide bar and the eject bar (See Fig.14 and 15)

- Prior to performing the following procedure, remove the cartridge holder assembly.

1. Remove the slide bar upward.
2. Move the eject bar outward until it stops as shown in Fig.14. Push the convex part g on the bottom of the body and remove the eject bar from the chassis.

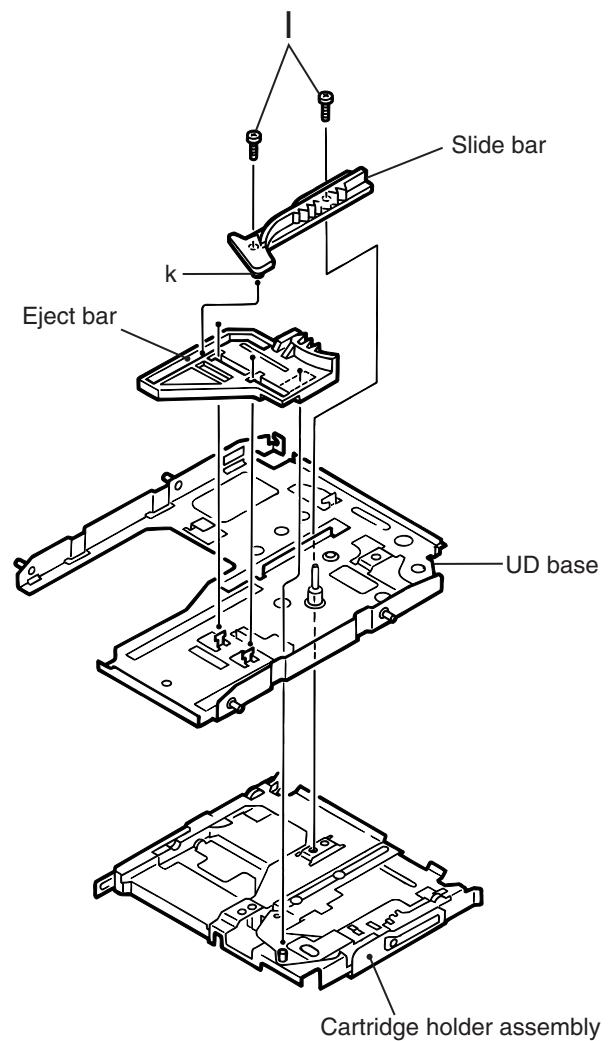

Fig.15

<Traverse mechanism assembly>

■Removing the Insulators (See Fig.16)

1. Disengage the four insulators from the notches of the traverse mechanism chassis.

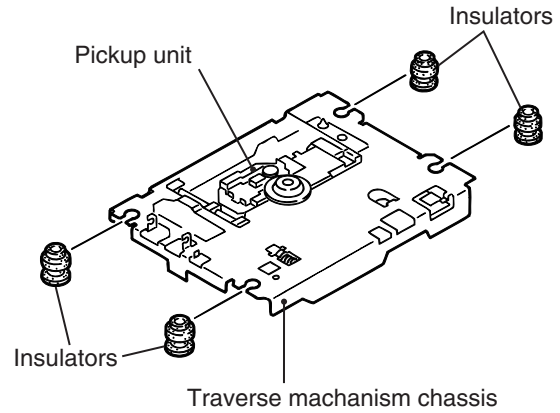

Fig.16

■Removing the pickup unit (See Fig.17)

1. Turn over the traverse mechanism assembly and remove the screw J attaching the shaft holder (F).
2. Move the shaft inward and remove it from the shaft holder (R).
3. Detach the shaft side of the pickup unit upward and release the joint h with the pickup guide. Then remove the pickup unit with the shaft.

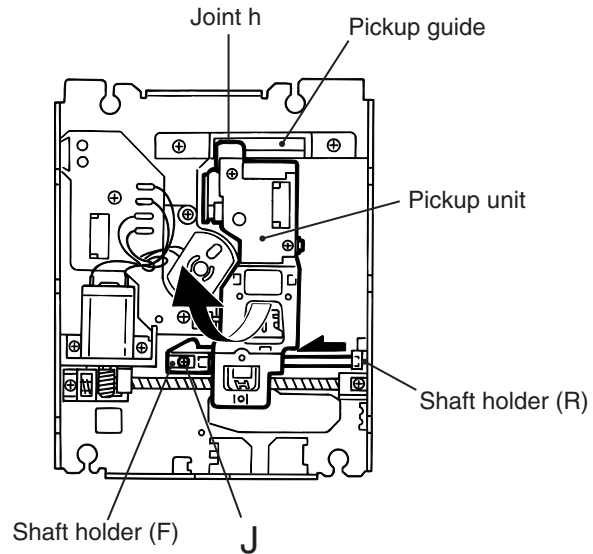

Fig.17

■Removing the pickup (See Fig.18)

1. Draw out the shaft from the pickup.
2. Remove the two screws K attaching the rack spring.

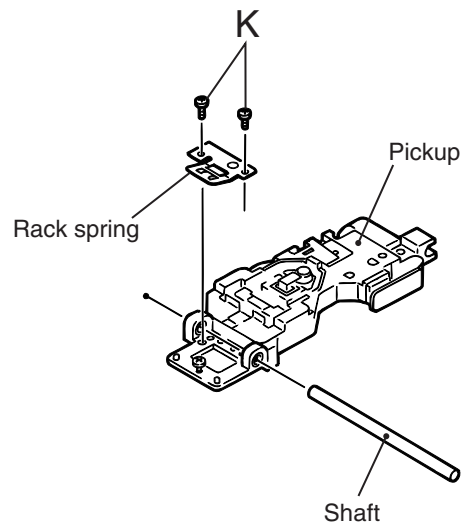

Fig.18

■ Removing the feed motor assembly (See Fig.19-1, 19-2)

- It is not necessary to remove the pickup unit.
1. For the white and black harnesses extending from the feed motor assembly, unsolder the soldering i on the traverse mechanism board.
 2. Remove the two screws L attaching the feed motor assembly.
 3. Remove the two screws N attaching the feed motor bracket.

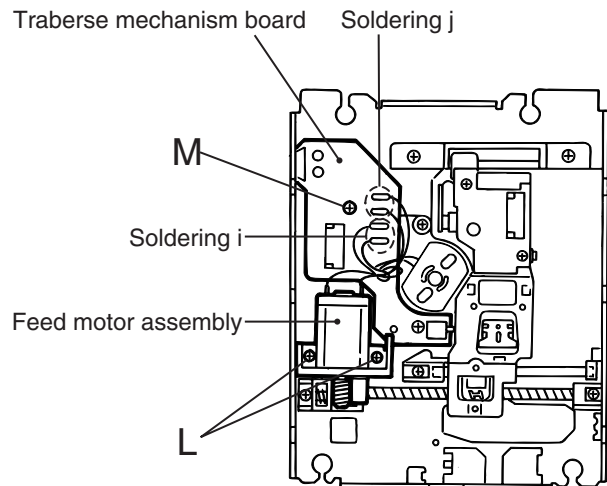

Fig.19-1

■ Removing the traverse mechanism board (See Fig.19-1)

- Prior to performing procedure, remove the feed motor assembly.
1. For the red and black harnesses extending from the spindle motor, unsolder the soldering j on the traverse mechanism board.
 2. Remove the screw M attaching the traverse mechanism board.

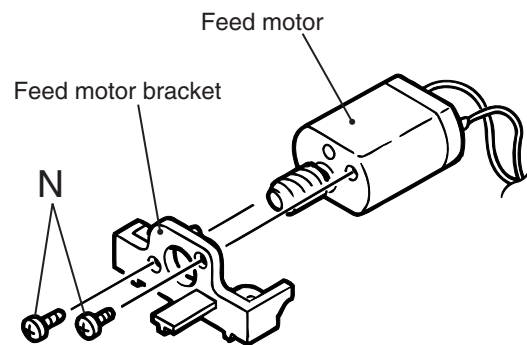

Fig.19-2

<Reattaching the loading assembly>

1. Reattach the eject bar to the UD base.
(Fig.15 and 20)
2. Reattach the slide bar to the loading mechanism chassis while fitting the boss marked k to the eject bar slot. (Fig.20)
3. Slide the slide bar and the eject bar in the direction of the arrow in Fig.20 and reattach the cartridge holder assembly using the two screws l.
(Fig.20 and 21)

ATTENTION: Make sure the pin of the eject lever marked l is fitted to the slot of the eject bar marked m at the bottom of the loading mechanism chassis after moving the eject lever and the loading slider of the cartridge holder assembly in the direction of the arrow.
(Refer to Fig.21)

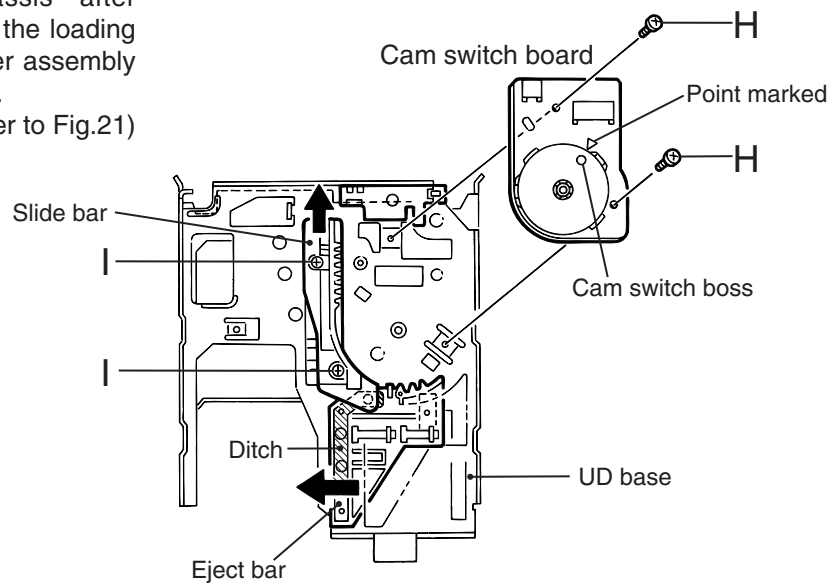

Fig.20

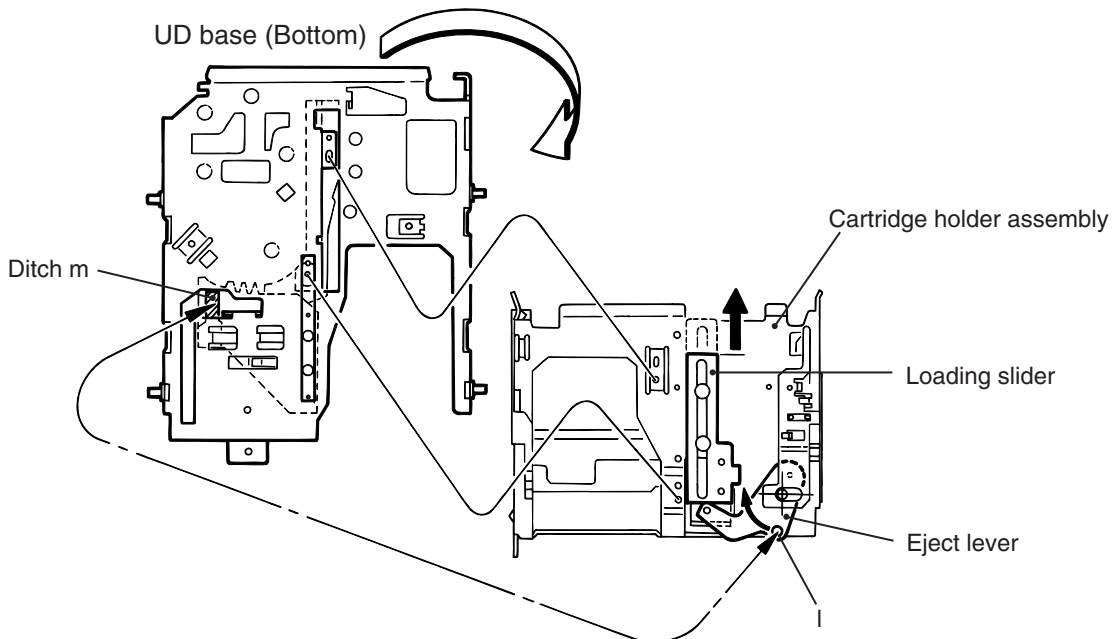

Fig.21

4. Reattach the wire holder to the UD base while engaging the UD base hook marked u to the wire holder slot marked t (At the same time, the boss on the reverse side of the wire holder is fitted to the UD base round hole).
5. Reattach the cam switch board using the two screws H. (Fig.22)
6. Turn the cam switch to bring the boss to the point marked Δ on the cam switch board. Reattach the cam gear using a slit washer while fitting the cam gear slot to the cam switch boss. (Fig.22)

ATTENTION: When reattaching the cam gear, the cam switch boss should be fitted to the cam gear slot, and the triangle mark of the cam gear should be aligned to the hole of the eject bar as shown in Fig.22.

7. Reattach the loading motor assembly, using the screw F. Connect the harness extending from the loading motor to connector CN612 on the switch board and fix it with the wire holder. (Fig.22)

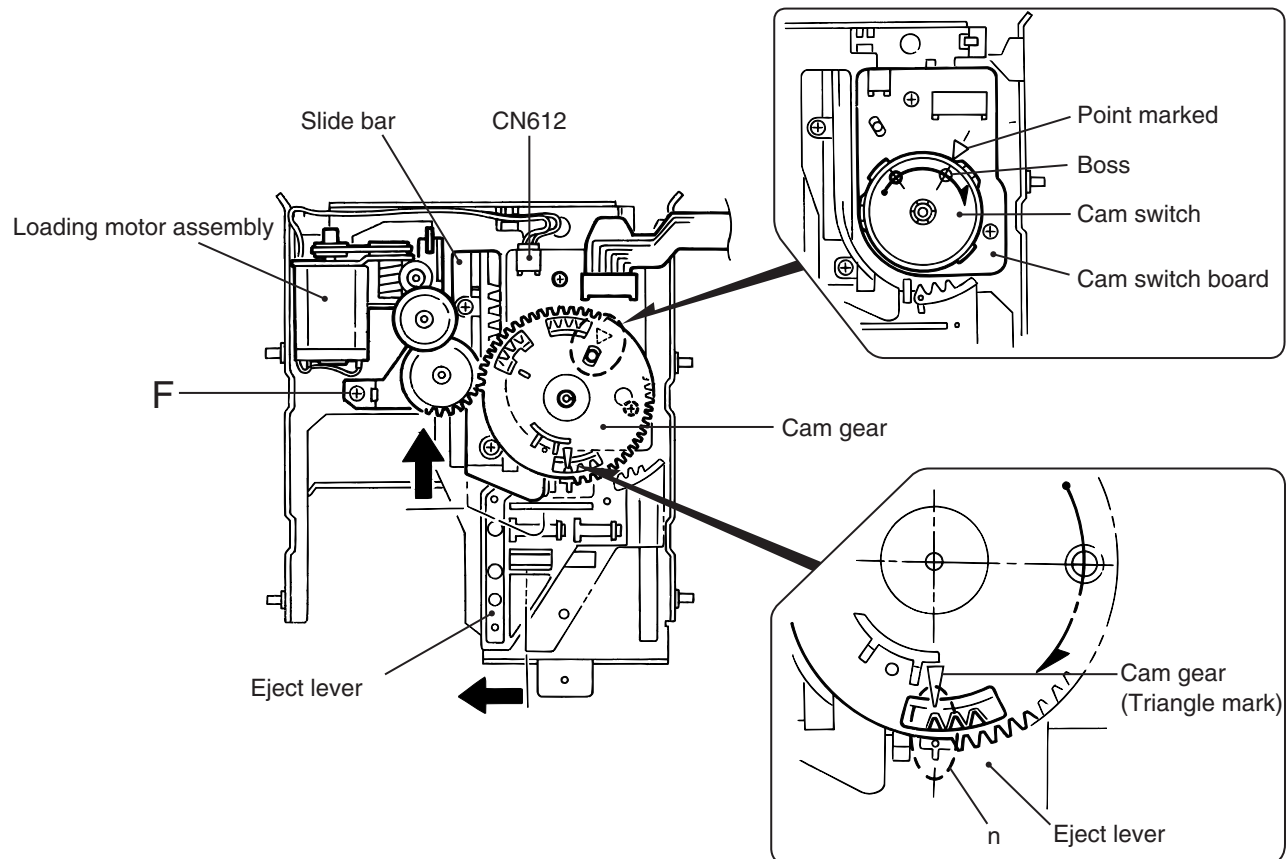

Fig.22

8. Reattach the UD base while engaging the four pins on both sides of the UD base to the notches of the loading mechanism base and placing the edge (marked e') of the cartridge holder assembly under the hook e of the loading mechanism base. (Fig.23)

9. Reattach the slide base (R) while fitting the two pins on another side of the UD base to the slots of the slide base (R). (Fig.24)

ATTENTION: Fit the part v of the slide base (R) to the part w on the inward side of the cam gear rib. (Fig.25)

10. Reattach the slide base (L) on the slide base (R) while fitting the two pins on another side of the UD base to the slots of the slide base (L) (Fig.25). Make sure the two slots of the slide base (L) are fitted to the two bosses marked E' and tighten the two screws E. (Fig.26)

Ref: To expedite the work, bring up the UD base slightly when fitting each pin to the appropriate notch.

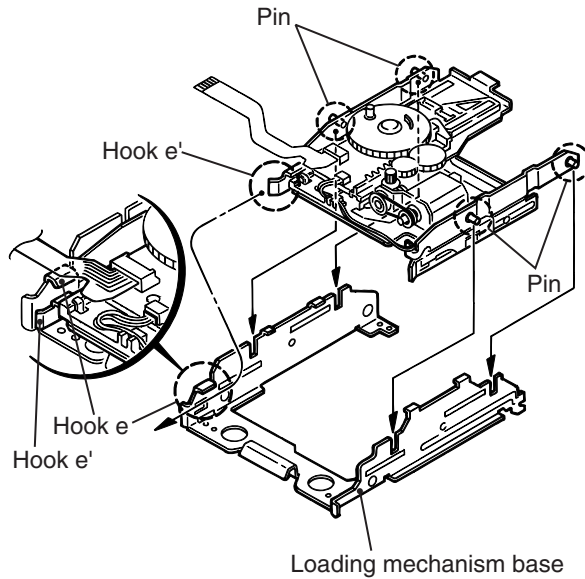

Fig.23

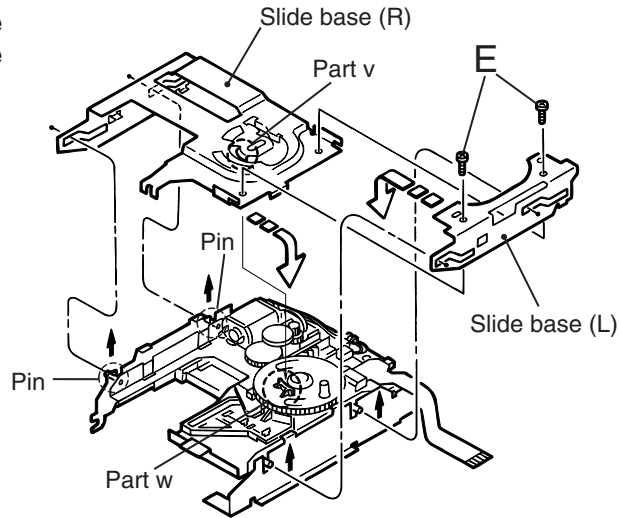

Fig.24

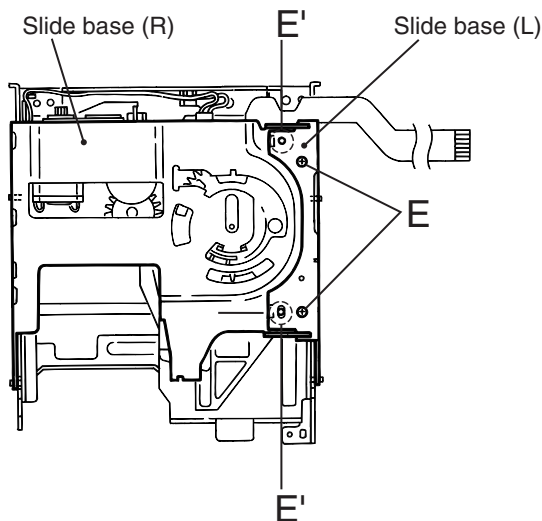

Fig.26

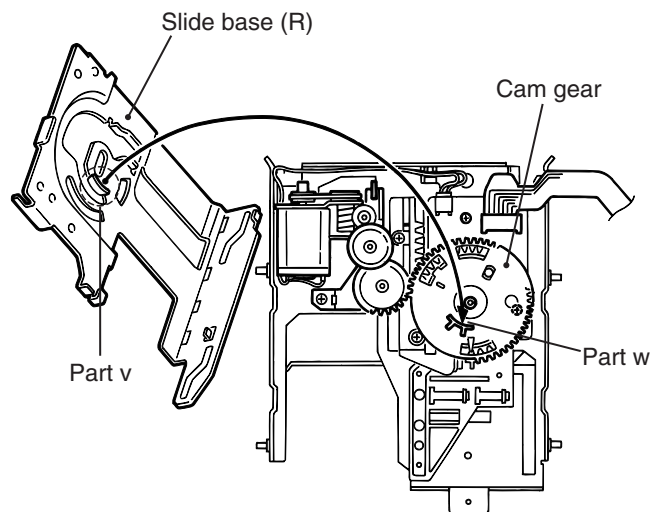

Fig.25

<Cassette Mechanism Section>

■ Removing the Recording, Playback / Erasing Head (Refer to Figs. 1 to 3.)

1. Shifting the trigger arm seen in the right side of the head mount in the arrow-marked direction, turn the flywheel (R) counterclockwise until the head mount clicks while moving forwards. (See Fig. 1.)
2. Turn the flywheel (R) counterclockwise. The playback head accordingly turns counterclockwise from the position shown in Fig. 2 to that in Fig. 3.
3. Leaving the playback head in the position shown in Fig. 3, disconnect the flexible wire coming from the playback head from the connector CN31 on the head amplifier & mechanism control P.C. board.
4. Remove the flexible wire from the hook b of the chassis base.
5. Remove the spring a from the back of the head.
6. Loosen the reversing azimuth screw A that fastens the head.
7. Remove the recording, playback/erasing head from the front side (head side) of the head mount.

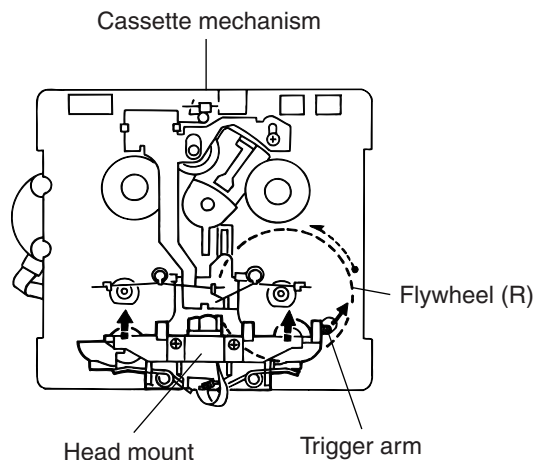

Fig. 1

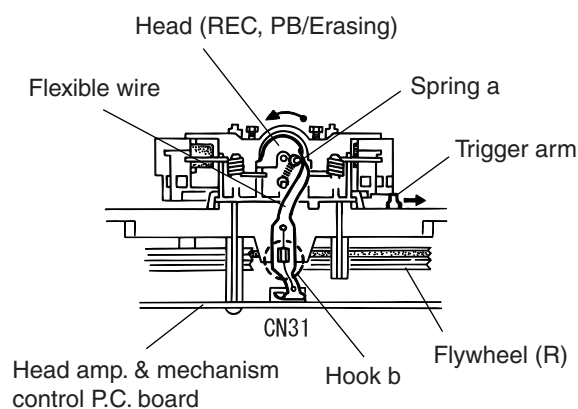

Fig. 2

■ Reinstalling the Recording, Playback / Erasing Head

1. Install the recording, playback/erasing head from the front side of the head mount as shown in Fig. 3.
2. Tighten the reversing azimuth screw A.
3. Install the spring a from the back of the head.
4. Set the flexible wire at the hook b of the chassis base.
5. Connect the flexible wire coming from the head to the connector CN31 on the head amplifier & mechanism control P.C. board.

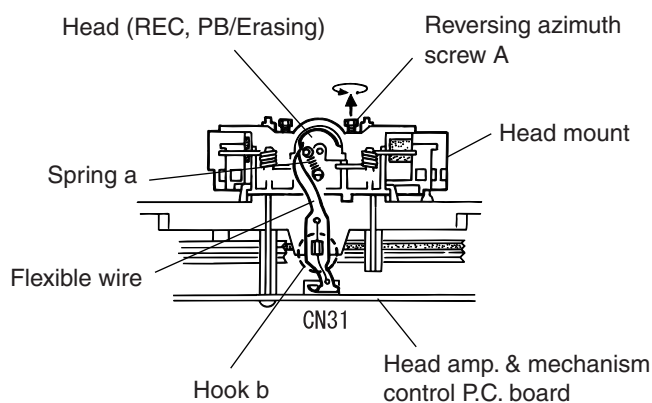

Fig. 3

■ Removing the Head Amplifier & Mechanism Control P.C. Board (Refer to Figs. 4 and 5.)

1. Disconnect the flexible wire from the connector CN31 on the head amplifier & mechanism control P.C. board mounted on the back of the cassette mechanism assembly.
2. Remove the three screws B fastening the head amplifier & mechanism control P.C. board.
3. Disconnect the connector CN32 of the head amplifier & mechanism control P.C. board from the connector CN1 on the reel pulse P.C. board.

Note: Remove the 4-pin parallel wire soldered to the main motor depending on the situation.

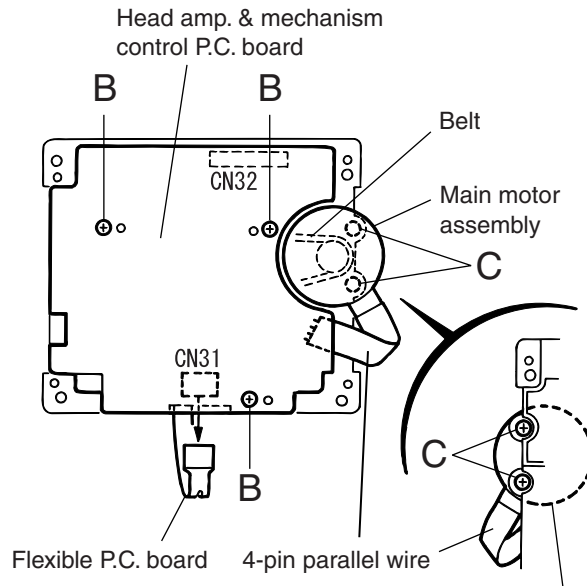

Fig. 4 Main motor assembly

■ Removing the Main Motor Assembly (Refer to Figs. 4 to 7.)

- The main motor assembly can be removed without removal of the head amplifier & mechanism control P.C. board.
1. Remove the two screws C fastening the main motor assembly.
 2. Lifting the main motor assembly slightly upwards, disengage the capstan belt from the motor pulley.

Note: Be careful not to soil the capstan belt with grease or the like. When reinstalling the main motor assembly, refer to Fig. 6 and Fig. 7 for engaging the capstan belt.

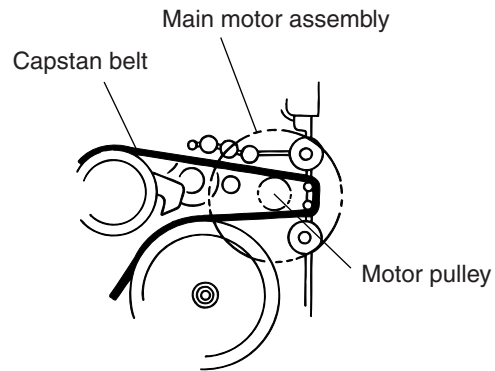

Fig. 5

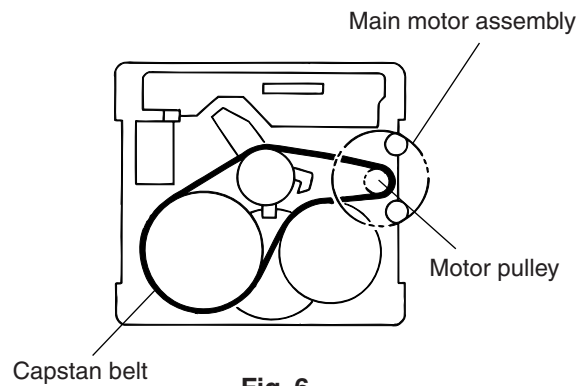

Fig. 6

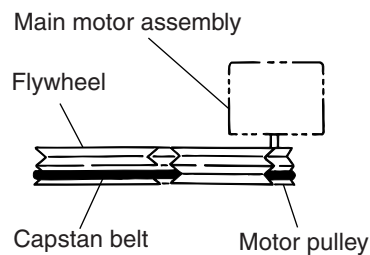

Fig. 7

■ Removing the Flywheel (Refer to Figs. 8 and 9.)

- Remove the head amplifier & mechanism control P.C. board.
 - Remove the main motor assembly.
1. Remove the slit washers c and d that fasten the capstan shafts (L) and (R) from the front side of the cassette mechanism assembly, and then draw out the flywheels (L) and (R) from the back side of the cassette mechanism assembly in the arrow-marked direction for removing them.

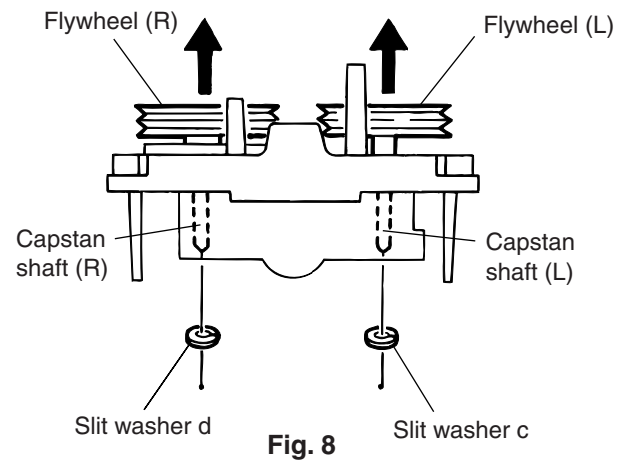

Fig. 8

■ Removing the Reel Pulse P.C. Board / Solenoid (Refer to Fig. 10.)

- Remove the head amplifier & mechanism control P.C. board.
 - Remove the main motor assembly.
1. Remove the screw D fastening the reel pulse P.C. board.
 2. Disengage the five hooks e that retain the reel pulse P.C. board by pressing each in the arrow-marked direction.
 3. Disengage the two hooks f that retain the solenoid by pressing each from the front side of the cassette mechanism assembly in the arrow-marked direction.

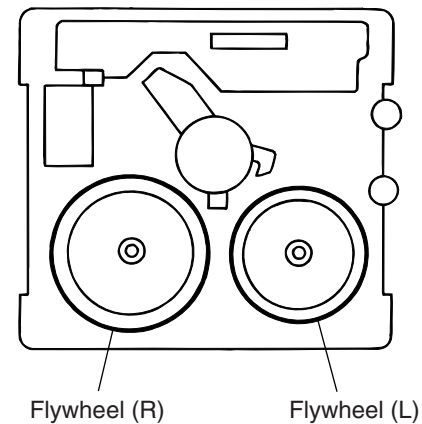
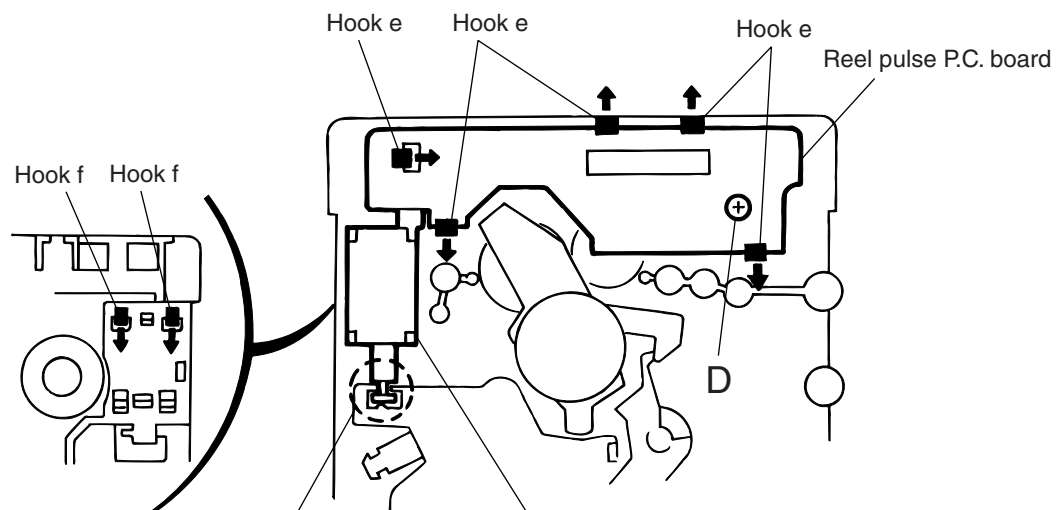

Fig. 9

Note: When reinstalling the reel pulse P.C. board and solenoid, make sure that the hook g of the solenoid is properly engaged.



Disassembly Method

<CD Mechanism Assembly>

■ Removing the CL. Base Assembly and Tray (Refer to Figs. 1 to 5.)

1. Remove the two screws A fastening the CL. base assembly from the top of the CD mechanism assembly.
2. Move the CL. base assembly diagonally upwards as indicated by the arrow to release it from the two hooks a.
3. Turn the idle gear in the arrow-marked direction from the upper side of the CD mechanism assembly. Accordingly, the TRAMECHA assembly moves downwards.

Note: When drawing out the tray, shift down the TRAMECHA assembly to the position where the tray does not contact the T-T assembly of the TRAMECHA assembly.

4. Draw out the tray frontwards for removing it.

Note: When reinstalling the tray:

- Turn the idle gear so that the part b of the tray gear is positioned in the part c shown in Fig. 4. (Eject position)
- Engage the right and left hooks d and e of the tray with the right and left grooves of the TRAMECHA assembly respectively for retaining the tray.

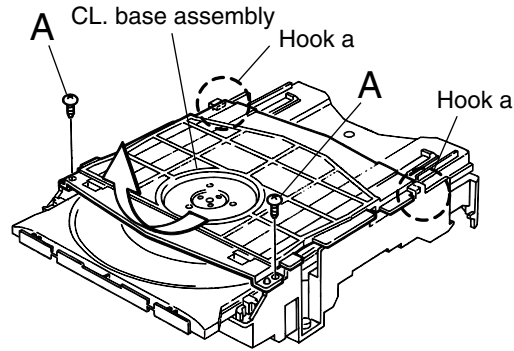

Fig. 1

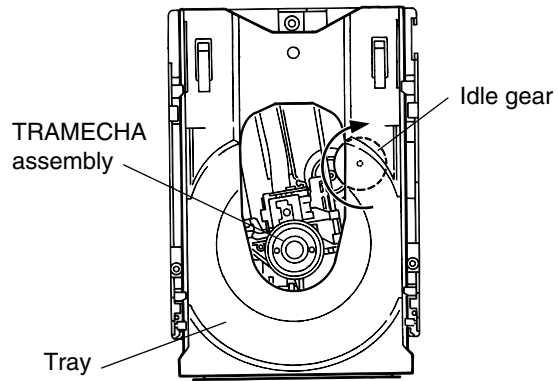

Fig. 2

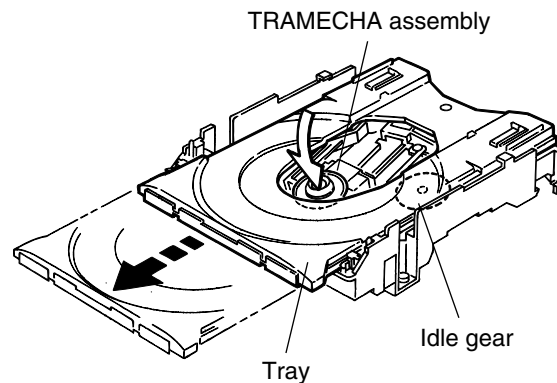

Fig. 3

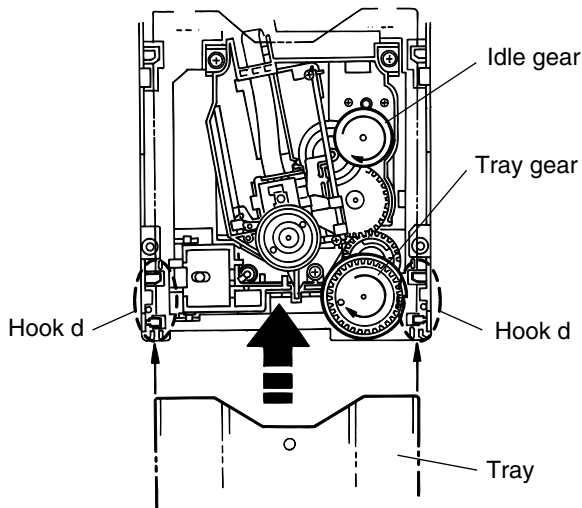

Fig. 5

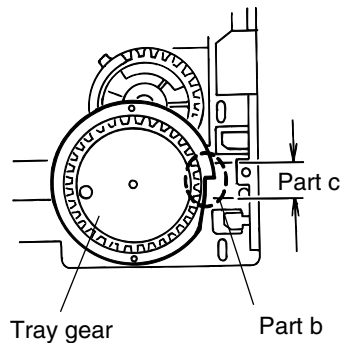

Fig. 4

**■ Removing the TRAMECHA Assembly
(Refer to Figs. 6 to 9.)**

- Remove the CL. base assembly and tray.

Reference: The TRAMECHA assembly can be removed without removal of the mechanism P.C. board.

1. If the TRAMECHA assembly is lowered and it is located out of the PLAY position, turn the idle gear in the arrow-marked direction so that the hole in the part f of the tray gear meets the hole on the CL. base assembly. (Set the TRAMECHA assembly at the PLAY position.)
2. Remove the three screws B fastening the TRAMECHA assembly and then remove the TRAMECHA assembly upwards from the front side.
3. At the same time, remove the spring from the groove of the CH. base assembly in the part g of the TRAMECHA assembly.

Note: When reinstalling the TRAMECHA assembly:

- Check to see if the spring is properly engaged with groove of the CH. base assembly in the part g of the TRAMECHA assembly.
- After making sure that the three insulators of the TRAMECHA assembly are properly set on the bosses of the L. base assembly's guide, fasten them with the screws.

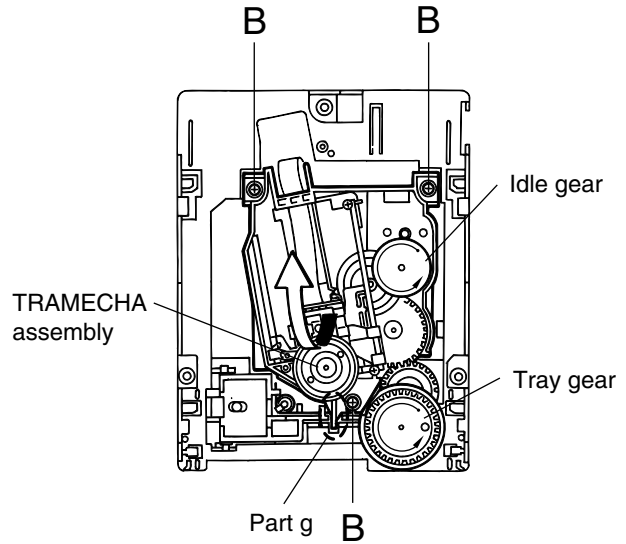

Fig. 6

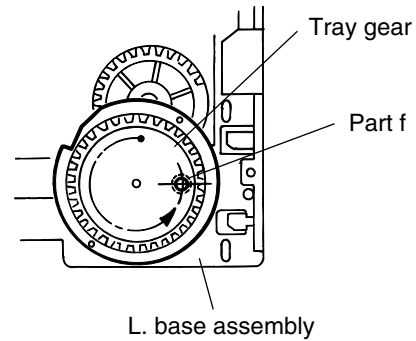

Fig. 7

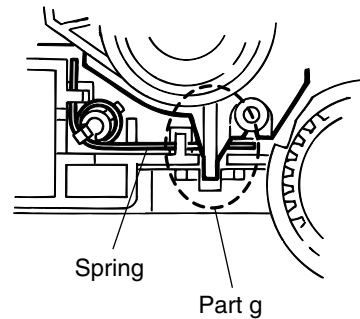

Fig. 8

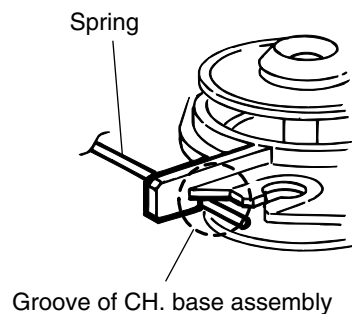

Fig. 9

■ **Removing the Mechanism P.C. Board**
(Refer to Fig 10.)

Reference: The mechanism P.C. board can be removed without removal of the TRAMECHA assembly.

Note: Before disconnecting the flexible wire coming from the pickup from the connector, be sure to solder its shorting round. If the flexible wire is connected without soldering, it may cause breakdown of the pickup.

1. Solder the shorting round of the flexible wire connected with the mechanism P.C. board from the back of the mechanism assembly.
2. Disconnect the flexible wire from the connector CN601 on the mechanism P.C. board.
3. Remove the three screws C fastening the mechanism P.C. board.
4. Unsolder the two points of the part h and one point of the part i of the mechanism P.C. board. Then, remove the mechanism P.C. board upwards.

Note: When reinstalling the mechanism P.C. board, connect the flexible wire coming from the pickup to the connector first and then remove the solder from the shorting round of the flexible cable.

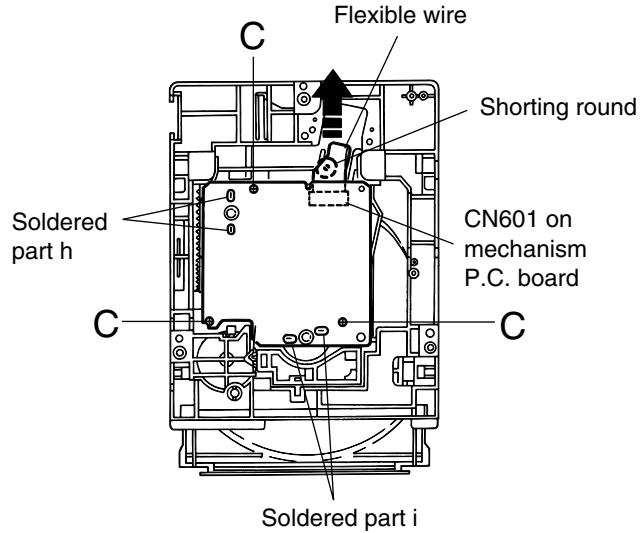

Fig. 10

**■ Removing the Pickup
(Refer to Figs. 11 to 14.)**

- Remove the CL. base assembly and tray.
- Remove the TRAMECHA assembly.

Reference: The pickup can be removed without removal of the mechanism P.C. board.

Note: Before disconnecting the flexible wire coming from the pickup from the connector, be sure to solder its shorting round.
If the flexible wire is connected without soldering, it may cause breakdown of the pickup.

1. Solder the shorting round of the flexible wire connected with the mechanism P.C. board from the back of the TRAMECHA assembly.
2. Disconnect the flexible wire from the connector CN601 on the mechanism P.C. board.
3. Turn the idle gear in the arrow-marked direction from the top of the TRAMECHA assembly so that the pickup assembly is shifted to the reverse side of the T-T assembly.
Move the pickup assembly until the part j of the rack plate in the lower part of the pickup assembly comes out of the CH. base assembly.
4. Remove the two screws D retaining the shaft of the pickup assembly. Next, disengage the hook k from the CH. base assembly and then remove the pickup assembly together with the shaft.
5. Pull the shaft out of the pickup.
6. Remove the two screws E fastening the rack plate from the pickup.
7. Remove the screw F retaining the P.S. spring from the pickup.

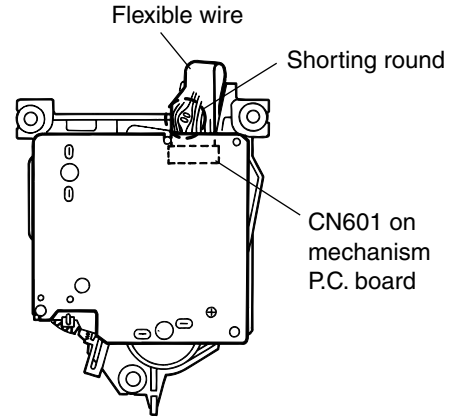

Fig. 11

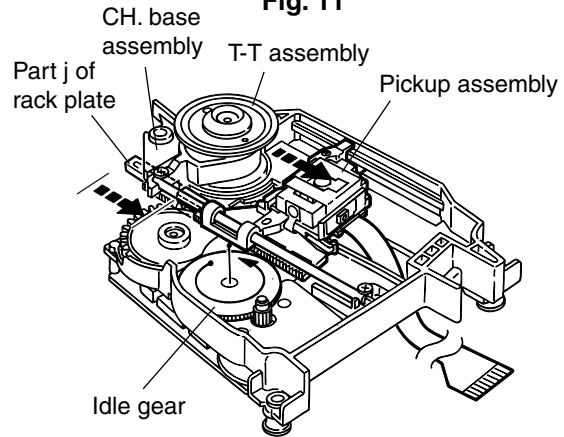

Fig. 12

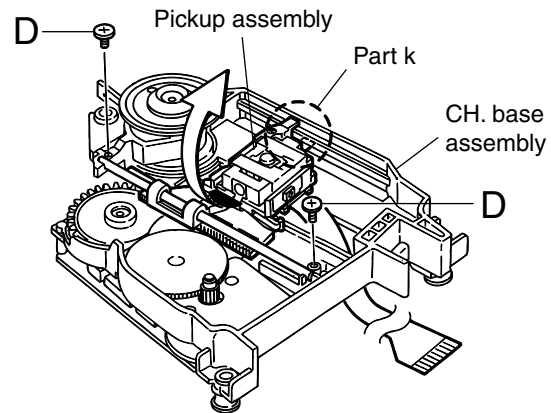

Fig. 13

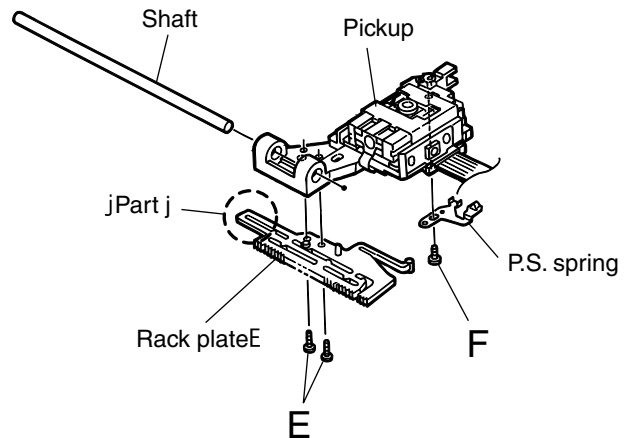

Fig. 14

■ Reinstalling the Pickup Assembly
(Refer to Figs. 15 and 16.)

Reference: Refer to the explanation of "Removing the Pickup" on the preceding page.

1. Fit the P.S. spring and rack plate to the pickup.
2. Insert the shaft into the pickup.
3. Engage the hook k of the pickup assembly with the CH. base assembly first, and set the part j of the rack plate in the opening I next. Then, reinstall the pickup assembly while shifting it to the T-T side (inward) so that the part m of the rack plate is positioned as shown in Fig. 16.
4. Move the pickup assembly to the center position and fasten the shaft with the two screws D. (Make sure that the part n of the rack plate is correctly engaged with the middle gear.)
5. After passing the flexible wire coming from the pickup through the opening of the CH. base assembly, connect it to the connector CN601.

Note: When reinstalling the pickup assembly, remove the solder from the shorting round after connecting the flexible wire coming from the pick to the connector CN601.

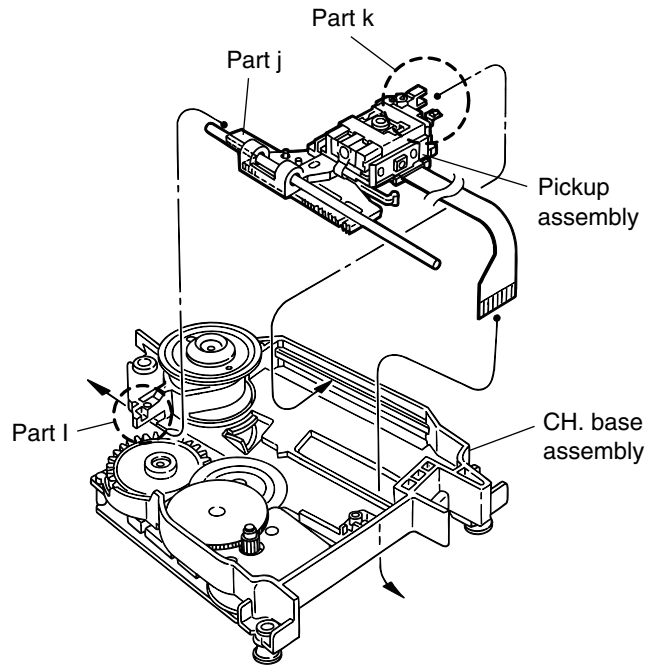

Fig. 15

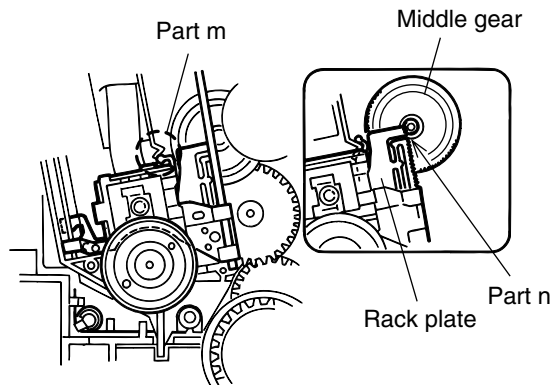

Fig. 16

■ Removing the Feed Motor Assembly
(Refer to Fig. 17.)

- Remove the CL. base assembly and tray.
- Remove the mechanism P.C. board.

Remove the two screws E fastening the feed motor assembly from the top of the mechanism assembly.

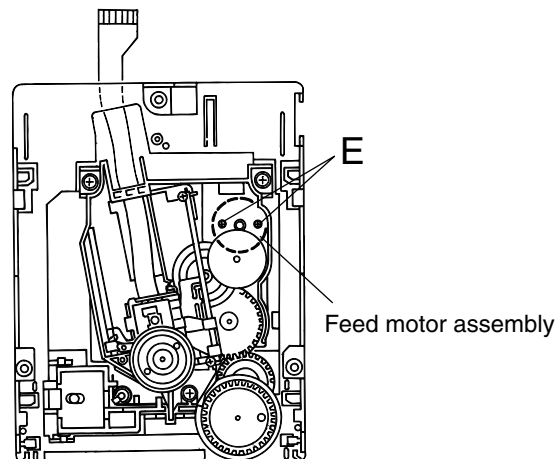

Fig. 17

Adjustment Method 1 (CD/MD section)

1. Jigs and test instruments

Laser power meter
 Laser power meter sensor (or disk sensor)
 Premastered disk (MRG-1018)
 Recordable disk (MDW-74/AU1)

2. Adjustment and check items

1) Indications in the modes that all LCD's are on

2) CD section

- (1) Indication of the C1 error
- (2) Cancel of the C1 error indication

3) MD section

- (1) Setup of the TEST MODE 1
- (2) Initialization of the EEPROM
- (3) Adjustment of the laser power
- (4) Adjustment of the disk
- (5) Setup of the TEST MODE 2
- (6) Indication of variation in the pickup adjustment value
- (7) Indication of the C1 error
- (8) Cancel of the TEST MODE

3. Adjustment and check method

1) CD section

- (1) Indication of the C1 error

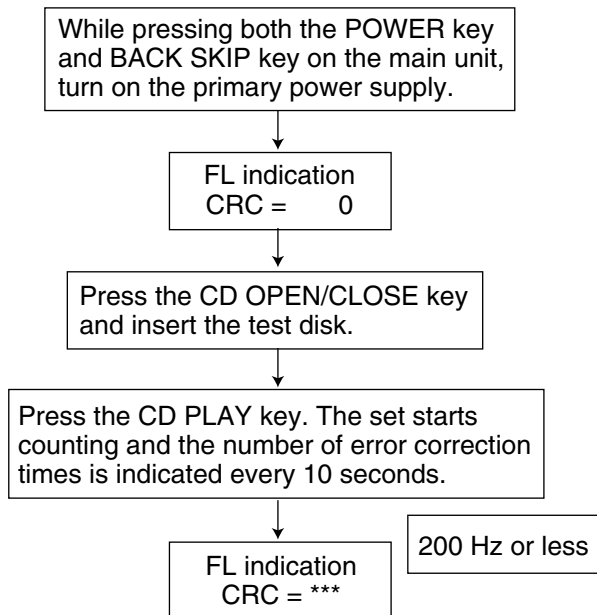

- (2) Cancel of the C1 error indication
 To cancel the C1 error indication, cut off the power supply.

2) MD section

(1) Setup of the TEST MODE 1

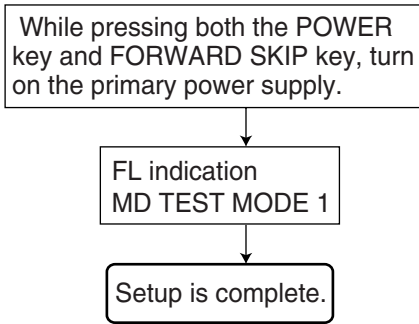

(2) Initializing the EEPROM
 (For initializing the EEPROM, it is the prerequisite that the test mode has been completely set up. Use the remote controller for the following operation.)
 ※ Among the keys on the main unit, only the EJECT key is used for ejecting the disk.)

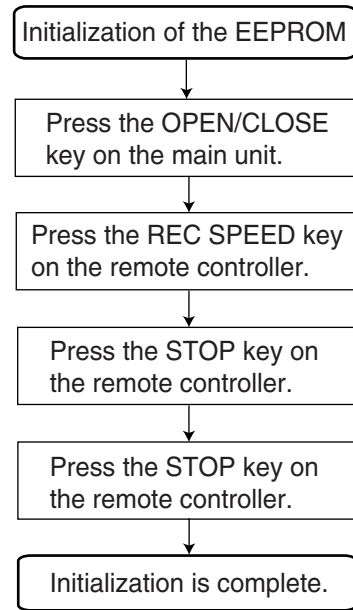

(3) Adjustment of the playback laser power

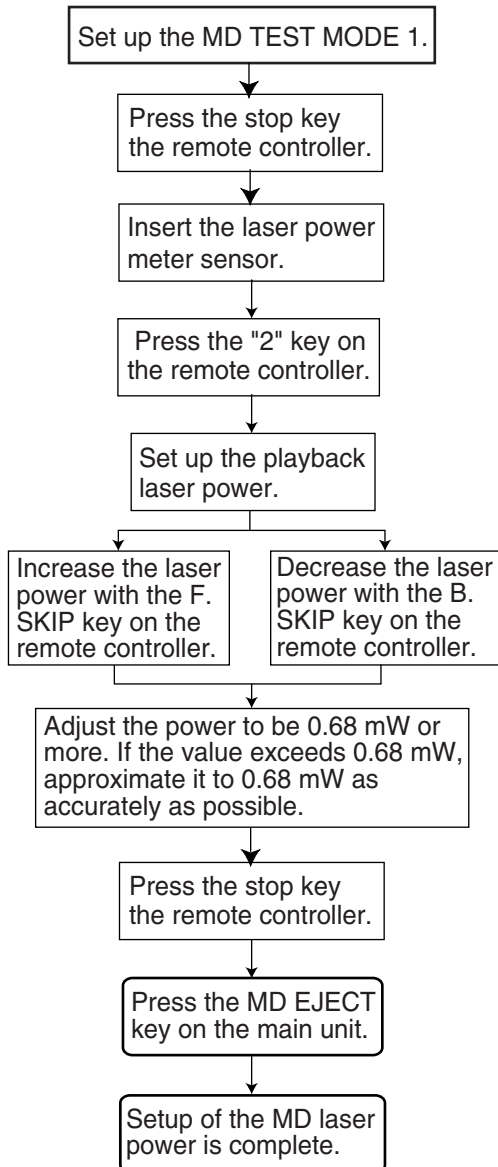

(4) Adjustment of the recording laser power

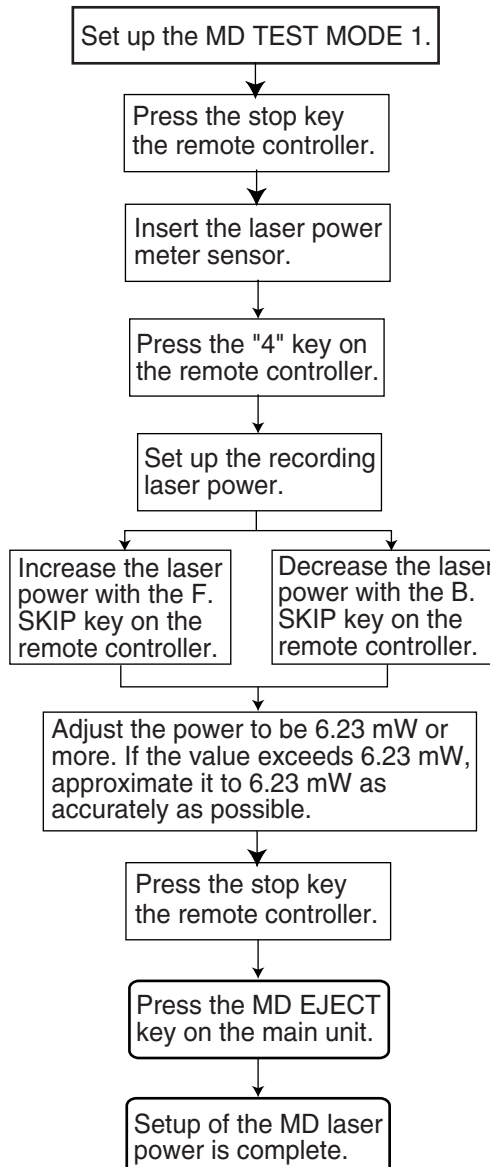

(5) Adjustment of the disk

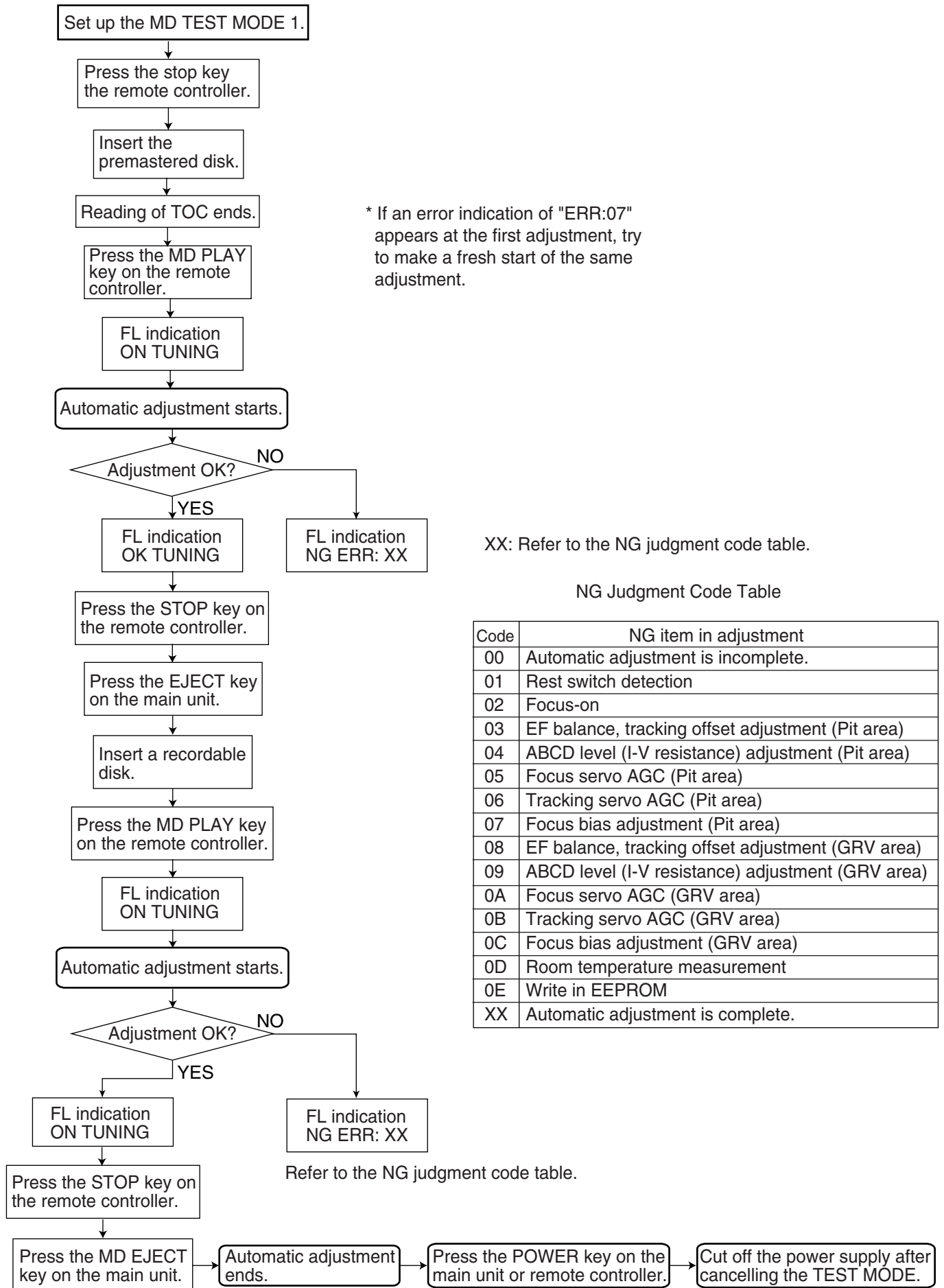

Adjustment Method 2 (Cassette mechanism section)

■ Tuner section

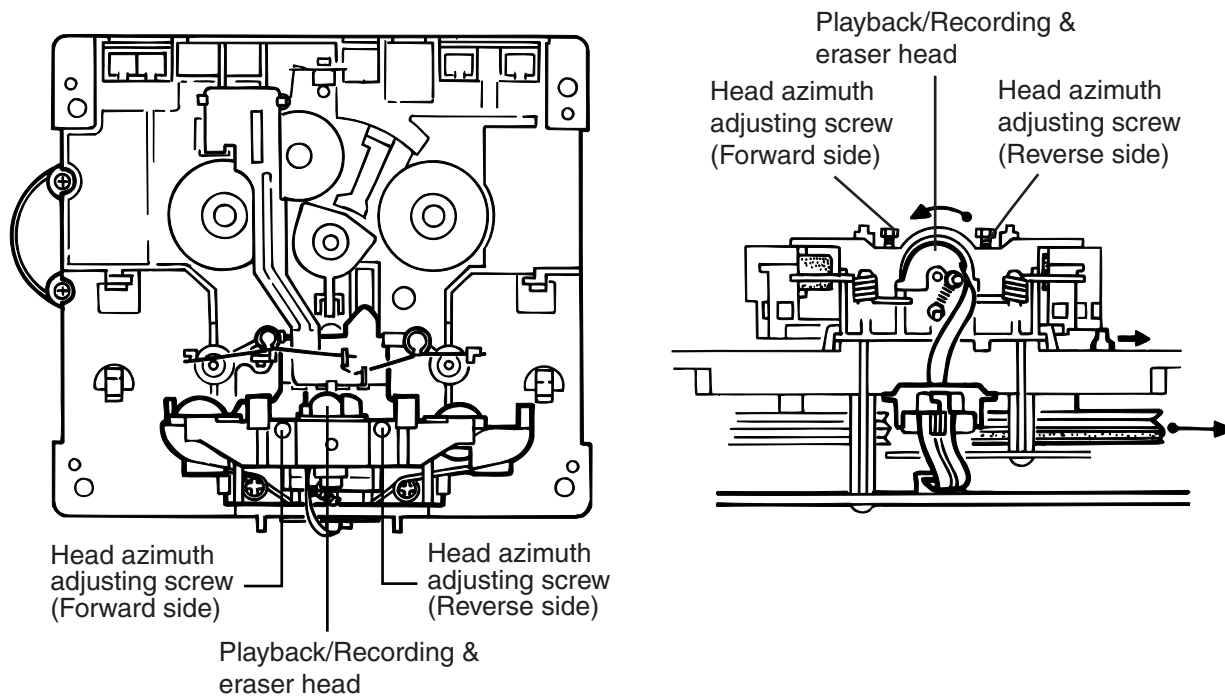

Removing the Cassette Mechanism Assembly

1. Remove the rear cover.
2. Remove the side panels (right and left).
3. Remove the cassette mechanism assembly.
4. Remove the four screws S fastening the cassette mechanism assembly from the back of the cassette mechanism.
5. Press the EJECT button on the front side of the cassette mechanism assembly to open the cassette door, and then remove the cassette mechanism assembly.

■ Check and Adjustment of the Head Amplifier Section

Item	Check/Adjustment Method	Adjusting Point	Standard Value
1. Head azimuth adjustment	1) Play back the end part of the test tape VT703 (10 kHz). 2) Adjust the head azimuth screws so that the output becomes maximum in both the normal and reverse directions. After adjustment, lock the screws with screw bond without fail. Measuring output terminal: Speaker terminal, 3Ω load resistance Difference between L-ch and R-ch: Within 3 dB Difference between FWD and REV directions: Within 4 dB	Head azimuth screw	Maximum output
2. Tape speed adjustment	1) Play back the end part of the test tape VT712 (3 kHz). 2) Adjust VR37 so that the frequency counter reads 3015 ± 15 Hz in playback in the normal direction. Measuring output terminal: Speaker terminal Make sure that speed difference between the normal and reverse directions is 60 Hz or less by reading of the frequency counter. (With the beginning part of the test tape)	VR37	3015 ± 15 Hz
(Reference value) Speed difference between the normal and reverse directions		—	60 Hz or less
Wow and flutter	Play back the end part of the test tape VT712 (3 kHz). Make sure that the wow and flutter meter reads 0.25 % (WRMS) or less.		0.25 % (WRMS) or less
3. Recording / playback frequency characteristic adjustment	1) Set a blank cassette tape (Type I: AC225) and enter the set into the recording pause mode. 2) Cancel the pause mode and start recording. Repeat to input the 1 kHz and 10 kHz reference signals alternately from the CD test disk to record the signals on the blank tape. 3) While playing back the repeatedly input 1 kHz and 10 kHz reference signals, adjust VR31 so that output distortion between the 1 kHz and 10 kHz signals is $-1 \text{ dB} \pm 1 \text{ dB}$.	VR31	$-1 \text{ dB} \pm 1 \text{ dB}$
(Reference value) Recording bias frequency	1) Set a blank cassette tape (Type I: AC225) and enter the set into the recording pause mode. 2) Make sure that the bias frequency at the bias test point on the head amplifier P.C. board is 70 ± 9 kHz.	—	70 ± 9 kHz
(Reference value) Erasing current	1) Set a blank cassette tape (Type I: AC225) and enter the set into the recording pause mode. 2) After connecting a 1Ω resistor to the erasing head in series, cancel the pause mode and start recording. Connect the electronic voltmeter to both the terminals and measure the erasing current.	—	Erasing current: 60 mA (Type I tape)

Flow of functional operation until TOC read (CD)

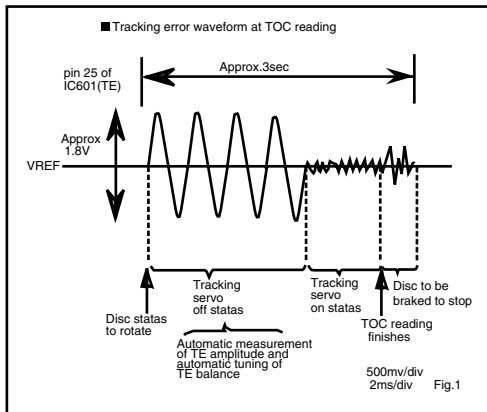
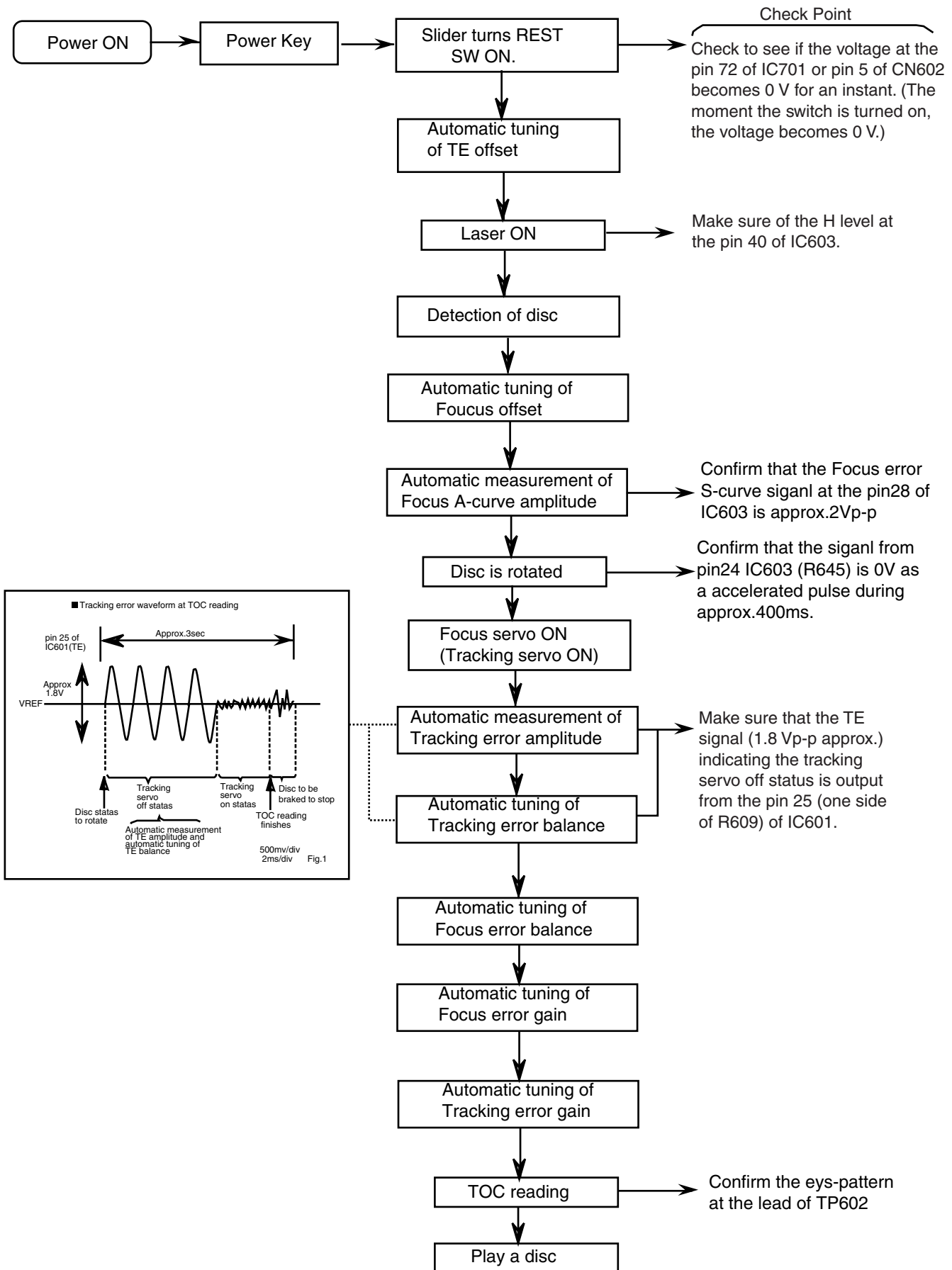

Flow of functional operation until TOC read (MD)

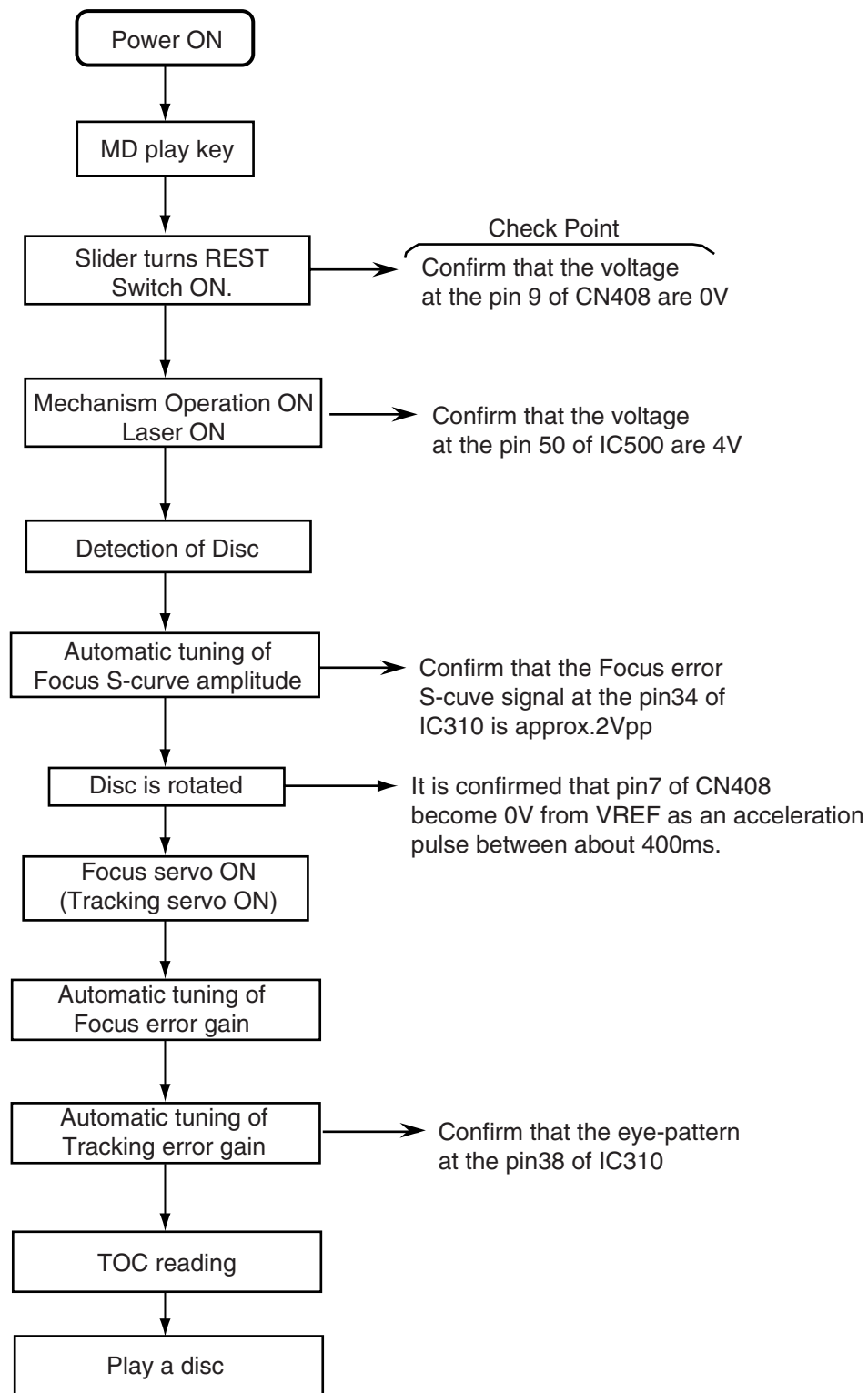

Maintenance of laser pickup

(1) Cleaning the pick up lens
 Before you replace the pick up, please try to clean the lens with a alcohol soaked cotton swab.

(2) Life of the laser diode (Fig.1)
 When the life of the laser diode has expired, the following symptoms will appear.

(1) The level of RF output (EFM output: amplitude of eye pattern) will below.

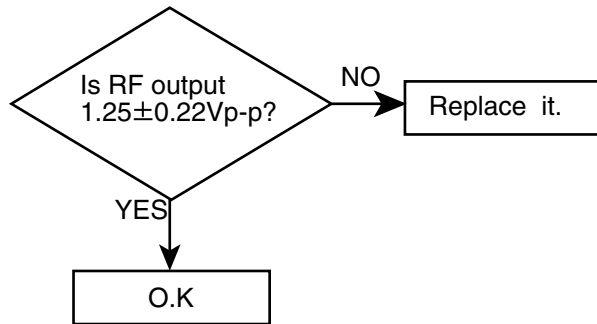

(Fig.1)

(3) Semi-fixed resistor on the APC PC board
 The semi-fixed resistor on the APC printed circuit board which is attached to the pickup is used to adjust the laser power. Since this adjustment should be performed to match the characteristics of the whole optical block, do not touch the semi-fixed resistor.
 If the laser power is lower than the specified value, the laser diode is almost worn out, and the laser pickup should be replaced.
 If the semi-fixed resistor is adjusted while the pickup is functioning normally, the laser pickup may be damaged due to excessive current.

Replacement of laser pickup

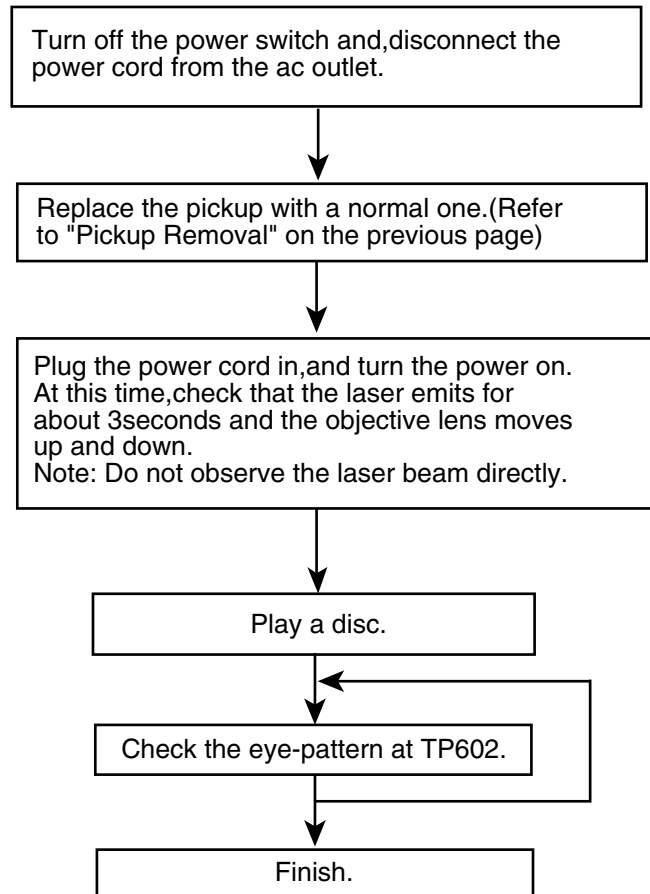

Maintenance of MD pickup

1. Cleaning of pickup lens

- (1) Prior to changing the pickup, clean the pickup lens.
- (2) For cleaning the lens, use the following cotton swab after mearsing it in alcohol.

Product No. JCB-B4; Manufacturer;Nippon Cotton Swab

2. Confirmation of the service life of laser diode when the service life of the laser diode has been exhausted, the following symptoms will appear.

- (1) Recording will become impossible.
- (2) The RF output (EFM output and eye pattern amplitude) will become lower.
- (3) The drive current required for light emitting of laser diode will be increased.

Confirm the service life according to the following flow chart:

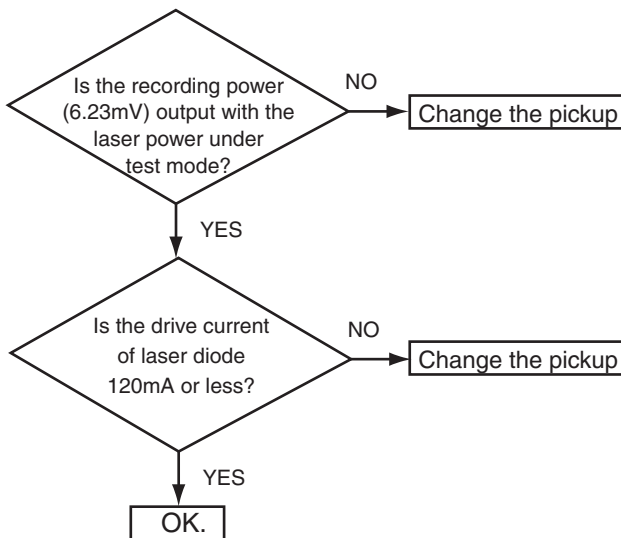

3. Method of measuring the drive current of laser diode

For disk check after the laser power adjustment, be sure to use a disk that is not only clean without scratch but full of circular recording, because the adjustment is automatically carried out and resultant setup values are written in the memory.

Procedures of changing the MD pickup

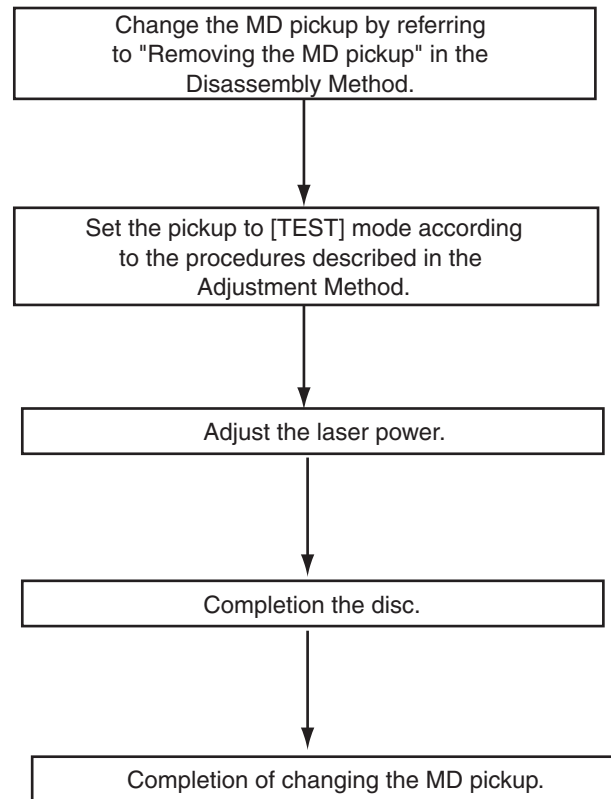

[Caution] Since this system is designed to perform magnetic recording, the laser power ten times or over of the conventional MD player will be output. Therefore, be sure to perform not only adjustment and operation of this system so carefully as not to directly look at the laser beam or touch on the body. Measure the voltage at both sides of R337 on the MD servo control P.C. board. If the voltage is 120 mV or more, the laser diode is judged as it has come to the end of its service life.

4. Semi-solid state resistors on the APC P.C. board

The semi-solid state resistor on the APC P.C.board attached to the pickup is used for adjusting the laser power. Since these resistor should be adjusted in pair according to the characteristics of the optical block, be sure not to touch on the resistors.

Since the service life of the laser diode will be exhausted when the laser power is low, it is necessary to change the pickup. Meanwhile, do not pickup. Otherwise, the pickup will be damaged due to over current.

Description of major ICs

■ UPD784216AGF(IC701) : System micon

1. Pin layout

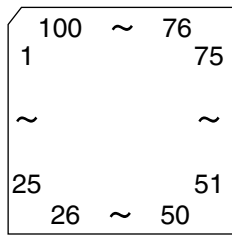

2. Block diagram

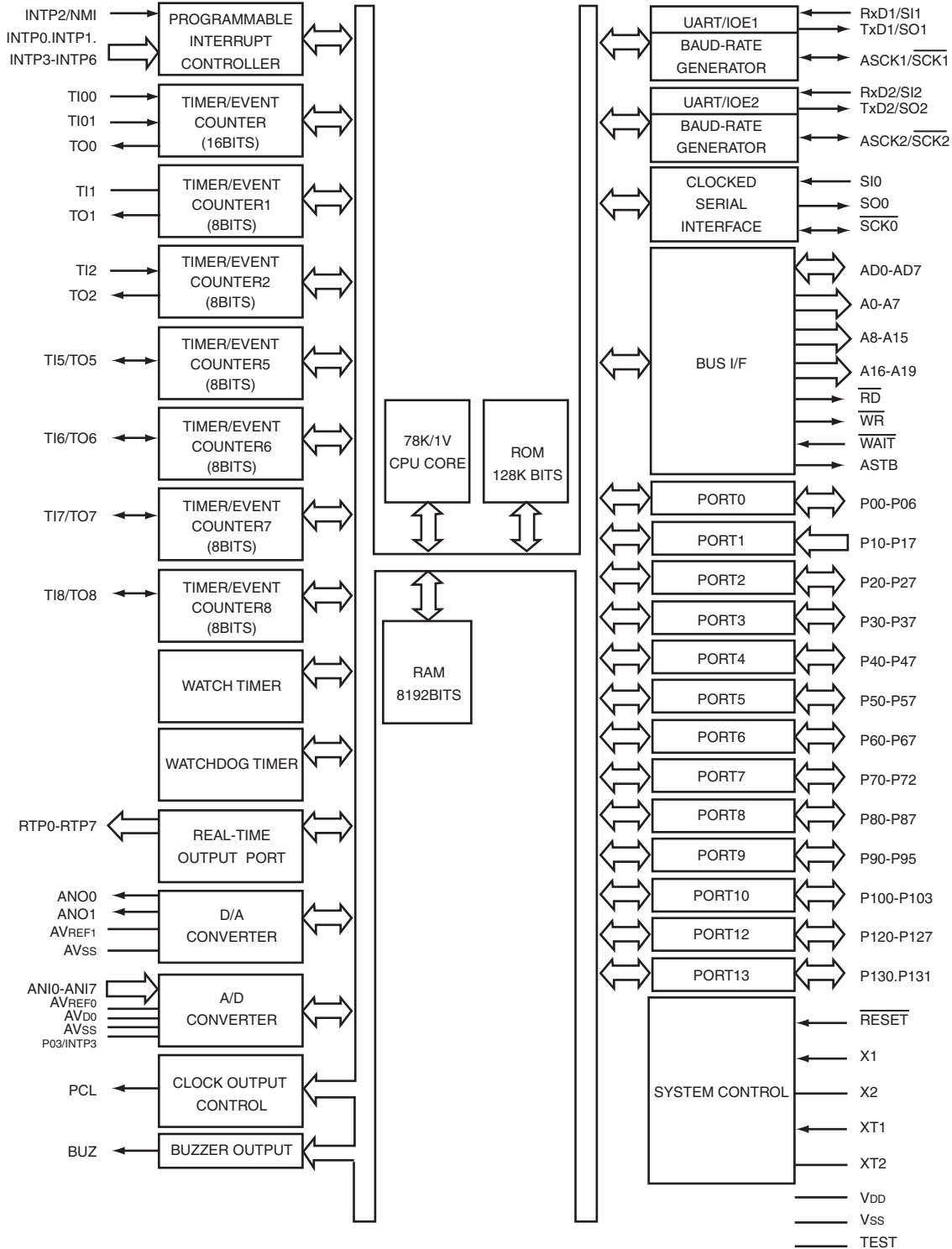

3. Pin function (1/2)

Pin No.	Symbol	I/O	Description
1	FAUX2	-	Not connected
2	NC	-	Not connected
3	RDSDATA	-	Not connected
4	MPX	I	Stereo detection
5	TUST	I	Stereo indicator detection
6	NC	O	Not connected
7	FTUNER	O	Tuner switch output
8	FCD	O	CD switch output
9	VDD	-	Connected with VDD
10	NC	-	Not connected
11	PBMUTE	O	PB mute output
12	NC	-	Not connected
13	PIN	I	Power key input
14	LEDCTL	O	LED control output
15	BUZER	O	Buzzer output
16	MDPOUT	O	MD PB output
17	MDRESET	O	MD reset output
18	SMUTE	O	System mute output
19	NC	-	Not connected
20	NC	-	Not connected
21	POUT	O	Power-on control output
22	VPP	I	GND
23	UP	I	Door position detection - UP
24	RMT0	O	Door open/shut motor control output
25	RMT1	O	Door open/shut motor control output
26	MIDDLE	I	Door position detection - MIDDLE
27	DOWN	I	Door position detection - DOWN
28	RMSPEED	O	Door open/shut motor speed control output
29	VOLCK	O	Volume control clock
30	VOLCE	O	Volume control chip enable
31	VOLDA	O	Volume control data
32	AHB	O	Active hyper bus control
33	BUB	I	Backup detection
34	BTCL	O	Battery control
35	NC	O	Not connected
36	XKILL	I/O	Power-off clock oscillator control
37	VDD	I	Power supply
38	X1	I	Master clock
39	X2	O	Master clock
40	VSS	I	GND
41	XT2	O	Clock for timer
42	XT1	I	Clock for timer
43	RESET	I	Power-on reset
44	REM	I	Remote control sensor
45	RDSCK	-	Not connected
46	NC	-	Not connected
47	PHOTO	I	Reel pulse detection
48	SAFTEY4	I	Current detection
49	NC	-	Not connected
50	NC	-	Not connected

3. Pin function (2/2)

UPD784216AGF(2/2)

Pin No.	Symbol	I/O	Description
51	AVREF	I	Reference power supply +5 V
52	AVREF0	I	Reference power supply +5 V
53	SEFTY2	I	Current detection
54	SEFTY3	I	Current detection
55	LDCK	I/O	
56	FKEY1	I	Function switch key input
57	VERSION	I	Destination switch input
58	FKEY2	I	Function switch key input
59	KEY1	I	Cassette key input
60	SEFTY1	I	Current detection
61	VSS	I	GND
62	RCDL	O	LED color display control
63	BCDL	O	LED color display control
64	AVREF1	I	Reference power supply +5 V
65	RXD	I	Digital input
66	TXD	O	Digital output
67	NC	-	Not connected
68	CDRXD	I	CD digital input
69	CDTXD	O	CD digital output
70	CDRST	O	CD reset
71	GCDL	O	LED color display control
72	NC	-	Not connected
73	TUDATA (1)	I	Tuner data
74	TUDATA	O	Tuner data
75	TUCK	O	Tuner clock
76	NC	-	Not connected
77	NC	-	Not connected
78	NC	-	Not connected
79	NC	-	Not connected
80	NC	-	Not connected
81	NC	-	Not connected
82	NC	-	Not connected
83	NC	-	Not connected
84	NC	-	Not connected
85	NC	-	Not connected
86	NC	-	Not connected
87	NC	-	Not connected
88	SCL	O	LCD clock
89	CS	O	LCD power supply
90	RESET	O	LCD reset
91	SDA	I/O	LCD serial data
92	NC	-	Not connected
93	RS	I	LCD start
94	NC	-	Not connected
95	NC	-	Not connected
96	SDATA	I/O	Cassette control serial data
97	SCK	I/O	Cassette control serial clock
98	STTA	I/O	Cassette control status signal
99	PLAY	O	Cassette PB switch detection
100	VSS	I	GND

UPD784217AGF139 (IC500) : MD micon

1. Pin layout

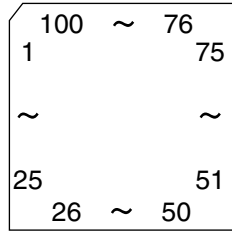

2. Block diagram

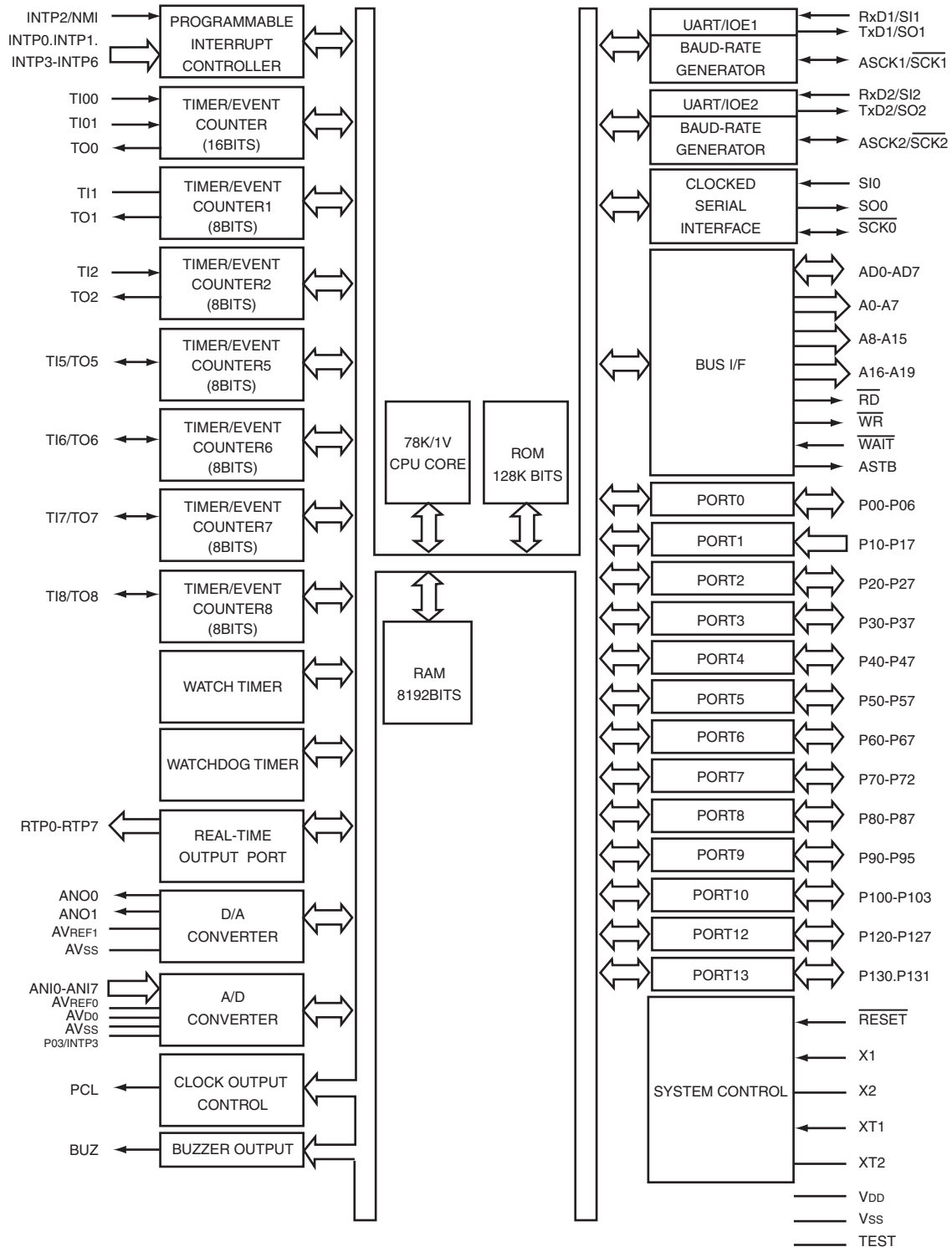

3. Pin function (1/2)

Pin No.	Symbol	I/O	Description
1	MPROT	I	Disk hole detection switch input (REC protection detection input)
2	SSTOP	I	Disk innermost circumference detection limit switch on/off detection signal input
3	MREF	I	Disk detection (premaster and recordable disk)
4	NC	-	Not connected
5	NC	-	Not connected
6	NC	-	Not connected
7	NC	-	Not connected
8	NC	-	Not connected
9	Vdd	-	Power supply
10	X2	-	Connected with 12 MHz oscillator
11	X1	-	Connected with 12 MHz oscillator
12	Vss	-	GND
13	XT2	-	Not used
14	XT1	-	Not used. Connected to GND
15	RESET	I	Reset input
16	MHON	O	Magnetic head drive control (L: Recording)
17	SQSY	I	Disk sub-code Q sync/ADIP sync input
18	DQSY	I	Digital input U-bit, Sub-code Q sync input
19	XINT	I	Connected with DSP (IC350) XINT terminal (Interrupt request output terminal)
20	CD_EMP	I	Emphasis detection
21	CD_CBIT	I	CD copy inhibit
22	CD_TNO	I	Non CD track detection
23	AVdd	-	Analog power supply
24	AVref0	-	Connected to GND
25	MT0	-	Not used. Connected to GND
26	MT1	-	Not used. Connected to GND
27	MT2	-	Not used. Connected to GND
28	MT3	-	Not used. Connected to GND
29	MODSEL	I	Microcomputer operation mode select (H: Usual)
30	UART	I	External communication system select (H: UART, L: 4-wire)
31	DOUT_SEL	I	Digital output select (H: DIN through output, L: FS convert output)
32	DOUT_OFF	I	Digital output select (H: Off, L: On)
33	AVss	-	GND
34	EJECT	O	Eject control signal output
35	LOAD	O	Load control signal output
36	AVref1	-	Connected with power supply terminal
37	COMIN	I	Command input
38	COMOUT	O	Command output
39	COMCLK	I/O	Command clock
40	SRDT	I	Data input for microcomputer serial interface
41	SWDT	O	Data output for microcomputer serial interface
42	SCLK	O	Shift clock for microcomputer serial interface
43	MONILT	-	Not used
44	NC	-	Not connected
45	NC	-	Not connected
46	MONIDATA	-	Not used
47	MONICLK	-	Not used
48	DINUNL	-	Not used
49	SVIB	O	Spindle servo brake
50	AXREC	O	Recording speed switch output

3. Pin function (2/2)

Pin No.	Symbol	I/O	Description
51	DO	O	Serial data output for external EEPROM
52	DI	I	Serial data input for external EEPROM
53	SCL	O	Clock output for external EEPROM
54	CS	O	Chip select output for external EEPROM
55	TEST	-	Test pin
56	STS_RDY	-	Not used
57	MMON10	I	Parallel operation monitor input
58	MMON11	I	Parallel operation monitor input
59	MMON12	I	Parallel operation monitor input
60	MMON13	I	Parallel operation monitor input
61	NC	-	Not connected
62	NC	-	Not connected
63	NC	-	Not connected
64	POWER	O	Power on/off control (H: Power on)
65	PWAD	O	Audio A-D converter on/off control (L: Power down)
66	PWDA	O	Audio D-A converter on/off control (L: Power down)
67	EMPHA	O	PB signal emphasis on/off signal (L: On)
68	ID0	-	Connected to GND
69	ID1	-	Connected to GND
70	ID2	-	Connected to GND
71	ID3	-	Connected to GND
72	Vss	-	GND
73	NC	-	Not connected
74	MODON	O	Laser pickup high frequency duplex on/off (L: On [in PB])
75	MODCHG	O	Laser pickup high frequency duplex voltage control (L: PB, H: REC)
76	NC	-	Not connected
77	NC	-	Not connected
78	NC	-	Not connected
79	DRIVER_ON	O	Driver shoot
80	XTSL	O	Connected with DSP (IC350) XTSL terminal (for switching input frequency)
81	Vdd	-	Power supply
82	TX	O	REC data output enable signal
83	NC	-	Not connected
84	RECP	O	Connected with DSP (IC350) RECP terminal (for switching laser power)
85	NC	-	Not connected
86	NC	-	Not connected
87	XRST	O	Connected with DSP (IC350) XRST terminal (reset input)
88	SENS	I	Connected with DSP (IC350) SENS terminal (internal status output)
89	XLAT	O	Connected with DSP (IC350) XLAT terminal (microcomputer serial interface latch input)
90	MNT3	I	Connected with DSP (IC350) MNT3 terminal (monitor output)
91	MNT2	I	Connected with DSP (IC350) MNT2 terminal (monitor output)
92	MNT1	I	Connected with DSP (IC350) MNT1 terminal (monitor output)
93	MNT0	I	Connected with DSP (IC350) MNT0 terminal (monitor input/output)
94	Vpp		
95	CAM4	I	Cam switch input 4
96	CAM3	I	Cam switch input 3
97	CAM1	I	Cam switch input 1
98	CAM2	I	Cam switch input 2
99	NC	-	Not connected
100	NC	-	Not connected

■ UPD780024AGKB21 (IC251) : Unit micon

1. Pin layout

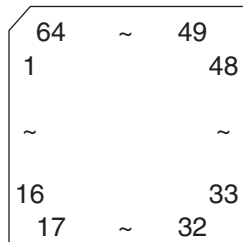

2. Pin function (1/2)

Pin No.	Symbol	I/O	Description
1	P50/A8		Connected to GND
2	P59/A9	-	Not used
3	MCS		Pull-up +B
4	MRDY	-	Not used
5	CDINDEX	-	Not used
6	CDEMP	I	CD emphasis detection
7	CDTNO	I	CD track No. detection
8	CDCOPY	I	CD copy detection
9	VSS0	-	GND
10	VDD0	-	Power supply
11	P30	-	Not used
12	P31	-	Not used
13	P32	-	Not used
14	MUTE	O	Mute output
15	SUBQ	I	Sub-code Q data input from IC651
16	P35/SO31	-	Not used
17	SQCK	O	Sub-code Q register clock output to IC651
18	KCMND	O	Kick command data
19	MSTAT	O	CD control status output to IC801
20	MCLK	I	CD control command clock input from IC801
21	RXDO	I	Digital data input
22	TXDO	O	Digital data output
23	P25/SCK0		Connected to GND
24	VDD1	-	Power supply
25	AVSS	-	GND
26	KEY1	I	Key input 1
27	KEY2	I	Key input 2
28	PCHK	I	Parity check
29	P14/AN14		Connected to GND
30	P13/AN13		Connected to GND
31	/OPEN	I	Open switch input
32	/REST	I	Rest switch input

2. Pin function (2/2)

Pin No.	Symbol	I/O	Function
33	P10/AN10		Connected to GND
34	AVREF	-	Analog circuit reference voltage. Connected with analog circuit power supply
35	AVDD	-	Analog circuit power supply
36	/RESET	I	CD control reset input from IC801
37	XT2	-	Not used
38	XT1	-	Connected with power supply
39	IC	O	Flash memory control
40	X2	-	Connected with external crystal oscillator
41	X1	-	Connected with external crystal oscillator
42	VSS1	-	GND
43	FLAG	I	Flag signal input from IC651
44	BLKCK	I	Sub-code block clock signal input from IC651
45	/RFDET	I	RF signal amplitude detection input
46	EQx2	O	×2 equalizer switch output
47	EQx4	O	×4 equalizer switch output
48	VCOx4	-	Not used
49	OPEN	I	Open door detection
50	/CLOSE	I	Closed door detection
51	IREFx4	O	×4 DSP current switch output
52	P75/BUZ	-	Not used
53	/RESET	O	Reset signal output to IC651 (L: Reset)
54	STAT	I	Status signal input from IC651
55	/DMUTE	O	Muting output to IC651
56	/P.ON	O	Power on/off switch signal output to IC291
57	MLD	O	Microcomputer command load signal output to IC651
58	MDATA	O	Microcomputer command data output to IC651
59	MCLK	O	Microcomputer command clock signal output to IC651
60	CLKSW	-	Not used
61	JIG	-	Not used
62	JIG	-	Not used
63	JIG	-	Not used
64	JIG		Connected to GND

■ LB1641 (IC703) : DC motor driver

1. Pin layout

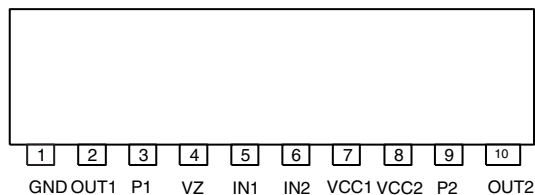

2. Pin function

Input		Output		Mode
IN1	IN2	OUT1	OUT2	
0	0	0	0	Brake
1	0	1	0	CLOCKWISE
0	1	0	1	COUNTER-CLOCKWISE
1	1	0	0	Brake

■ CXD2662R (IC350) : DSP

1.Pin layout

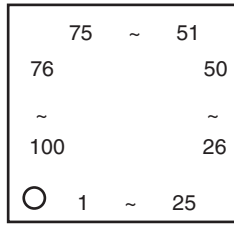

2.Block diagram

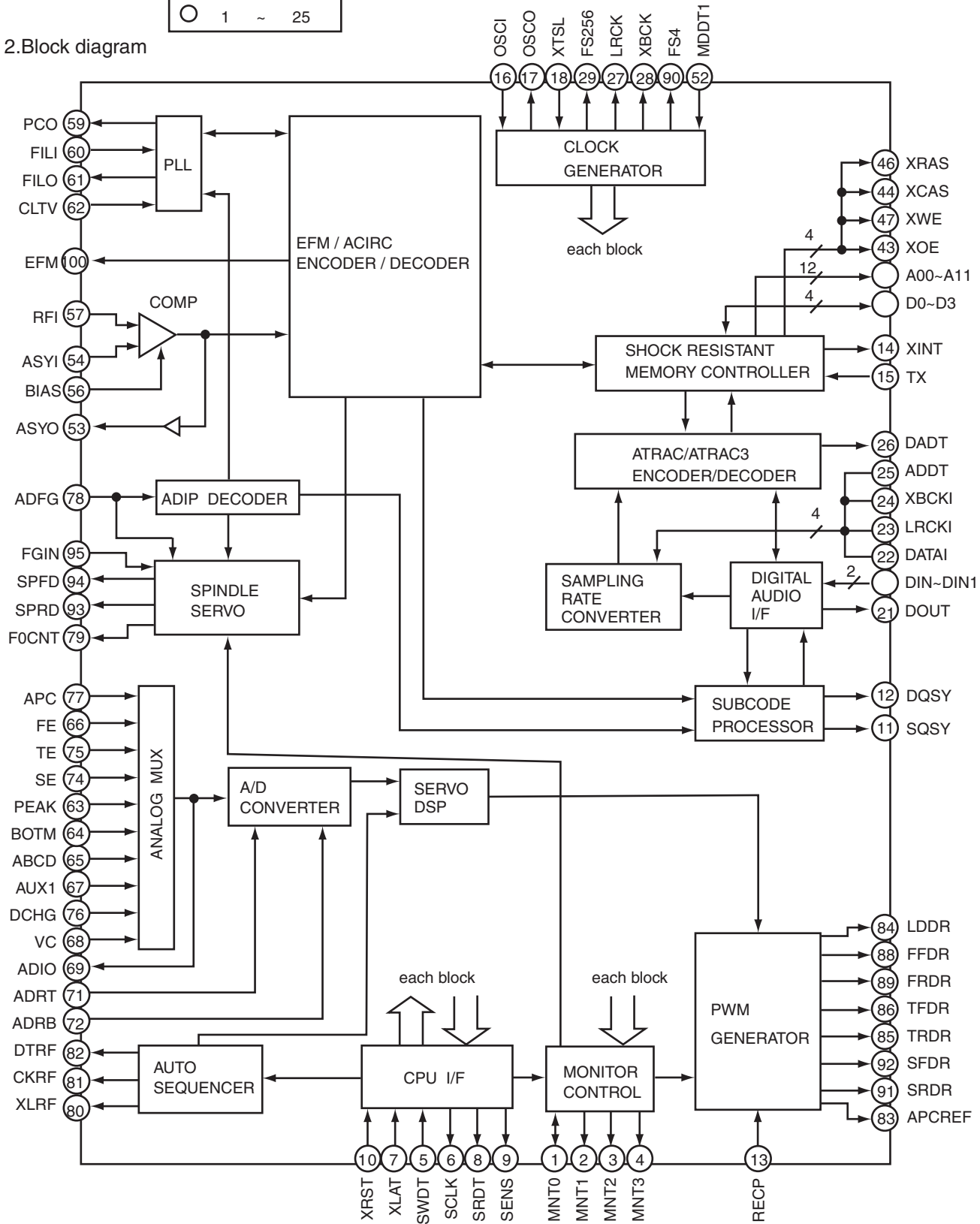

3.Pin function (1/3)

Pin No.	Symbol	I/O	Function
1	MNT0	I/O	Monitor output.
2	MNT1	O	Monitor output.
3	MNT2	O	Monitor output.
4	MNT3	O	Monitor output.
5	SWDT	I	Data input for microcomputer serial interface.
6	SCLK	I	Shift clock input for microcomputer serial interface.
7	XLAT	I	Latch input for microcomputer serial interface.Latched at the falling edge.
8	SRDT	O	Data output for microcomputer serial interface.
9	SENS	O	Outputs the internal status corresponding to the microcomputer serial interface address.
10	XRST	I	Reset input. Low : reset
11	SQSY	O	Disc subcode Q sync / ADIP sync output.
12	DQSY	O	Subcode Q sync output in U-bit CD or MD format when the Digital In source is CD or MD.
13	RECP	I	Laser power switching input. High : recording power ; low ; playback power
14	XINT	O	Interruption request output. Low when the interruption status occurs.
15	TX	I	Enable signal input for recoding data output. High : enabled
16	OSCI	I	Crystal oscillation circuit input.
17	OSCO	O	Crystal oscillation circuit output. (inverted output of the OSCI pin)
18	XTSL	I	OSCI input frequency switching. XTSL1(command) = low and XTSL = high : 512Fs (22.5792MHz) XTSL1(command) = low and XTSL = low : 1024Fs (45.1584MHz) XTSL1(command) = high : 2048Fs (90.3168MHz)
19	DIN0	I	Digital audio interface signal input 1.
20	DIN1	I	Digital audio interface signal input 2.
21	DOUT	O	Digital audio interface signal output.
22	DATAI	I	Test pin. Connect to GND.
23	LRCKI	I	Test pin. Connect to GND.
24	XBCKI	I	Test pin. Connect to GND.
25	ADDT	I	Data input from A / D converter.
26	DADT	O	REC monitor output / decoded audio data output.
27	LRCK	O	LA clock (44.1kHz) output to the external audio block.
28	XBCK	O	Bit clock (2.8224kHz) output to the external audio block.
29	FS256	O	256Fs output.
30	DVDD	-	Digital power supply.
31	A03	O	External DRAM address output.
32	A02	O	External DRAM address output.
33	A01	O	External DRAM address output.
34	A00	O	External DRAM address output.
35	A10	O	External DRAM address output.
36	A04	O	External DRAM address output.
37	A05	O	External DRAM address output.
38	A06	O	External DRAM address output.
39	A07	O	External DRAM address output.
40	A08	O	External DRAM address output.
41	A11	O	External DRAM address output.
42	DVSS	-	Digital ground.
43	XOE	O	External DRAM output enable.

3. Pin function (2/3)

Pin No.	Symbol	I/O	Function
44	XCAS	O	External DRAM CAS output.
45	A09	O	External DRAM address output.
46	XRAS	O	External DRAM RAS output.
47	XWE	O	External DRAM write enable.
48	D1	I/O	External DRAM data bus.
49	D0	I/O	External DRAM data bus.
50	D2	I/O	External DRAM data bus.
51	D3	I/O	External DRAM data bus.
52	MDDTI	I	MD-DATA mode 1 switching input. (Low : normal mode ; high : MD-DATA mode 1)
53	ASYO	O	Playback EFM full-swing output. (Low : vss ; high : Vdd)
54	ASYI	I	Playback EFM comparator slice voltage input.
55	AVDD	-	Analog power supply.
56	BIAS	I	Playback EFM comparator bias current input.
57	RFI	I	Playback EFM RE signal input.
58	AVSS	-	Analog ground.
59	PCO	O	Phase comparison output for master PLL of playback digital PLL and recording EFM PLL.
60	FILI	I	Filter input for master PLL of playback digital PLL and recording EFM PLL.
61	FILO	O	Filter output for master PLL of playback digital PLL and recording EFM PLL.
62	CLTV	I	Internal VCO control voltage input for master PLL of playback digital EFM PLL and recording EFM PLL.
63	PEAK	I	Peak hold signal input for quantity of light.
64	BOTM	I	Bottom hold signal input for quantity of light.
65	ABCD	I	Signal input for quantity of light.
66	FE	I	Focus error signal input.
67	AUXI	I	Auxillary input 1.
68	VC	I	Center voltage input.
69	ADIO	I	Monitor output for A / D converter input signal.
70	AVDD	-	Analog power supply.
71	ADRT	I	Voltage input for the upper limit of the A / D converter operating range.
72	ADRB	I	Voltage input for the lower limit of the A / D converter operating range.
73	AVSS	-	Analog ground.
74	SE	I	Sled error signal input.
75	TE	I	Tracking error signal input.
76	DCHG	I	Connect to the low-impedance power supply.
77	APC	I	Error signal input for laser digital APC.
78	ADFG	I	ADIP binary FM signal ($22.05 \pm 1\text{kHz}$) input.
79	F0CNT	O	CXA2523 current source setting output.
80	XLRF	O	CXA2523 control latch output. Latched at the falling edge.
81	CKRF	O	CXA2523 control shift clock output.
82	DTRF	O	CXA2523 control data output.
83	APCREF	O	Reference PWM output for laser APC.
84	LDDR	O	PWM output for laser digital APC.
85	TRDR	O	Tracking servo drive PWM output. (-)
86	TFDR	O	Tracking servo drive PWM output. (+)
87	DVDD	-	Digital power supply.
88	FFDR	O	Focus servo drive PWM output. (+)
89	FRDR	O	Focus servo drive PWM output. (-)
90	FS4	O	4Fs output. (176.4kHz)

3. Pin function (3/3)

Pin No.	Symbol	I/O	Function
91	SRDR	O	Sled servo drive PWM output. (-)
92	SFDR	O	Sled servo drive PWM output. (+)
93	SPRD	O	Spindle servo drive output. (PWM (-) or polarity)
94	SPFD	O	Spindle servo drive output. (PWM (+) or PWM absolute value)
95	FGIN	I	Spindle CAV servo FG input.
96	TEST1	I	Test pin. Connect to GND.
97	TEST2	I	Test pin. Connect to GND.
98	TEST3	I	Test pin. Connect to GND.
99	DVSS	-	Digital ground.
100	EFMO	O	Low when playback ; EFM (encoded data) output when recording.

■ **BD7910FV-X (IC450) : Pre driver**

1. Block diagram

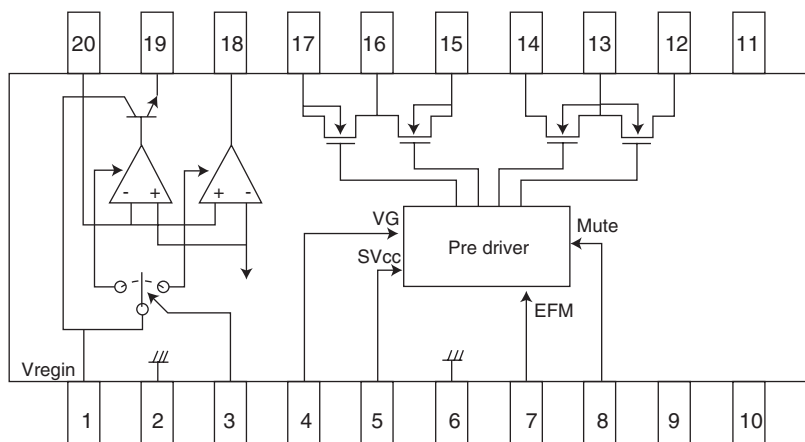

2. Pin function

Pin No.	Symbol	I/O	Function	Pin No.	Symbol	I/O	Function
1	Vreg IN	I	Regulator input and regulator power supply	11	NC	-	Non connect
2	Reg GN	-	Regulator GND	12	VOD2	O	Sync.output (Lower power MOS,drain)
3	NC	-	Non connect	13	VSS	-	"H"bridge GND (Lower power MOS,source)
4	VG	I	Voltage input for power MOS drive	14	VOD1	O	Sync.output (Lower power MOS,drain)
5	SVCC	O	EFM high level output voltage	15	VOS1	O	Source output (Upper power MOS,source)
6	PDGND	-	Pre-driver GND	16	VDD	-	"H" bridge power supply terminal (Upper power MOS,source)
7	EFM	I	EFM signal input	17	VOS2	O	Source output (Upper power MOS,source)
8	MUTE	I	Mute control (Low active)	18	Reg DRV	O	External PNP drive output for regulator
9	NC	O	Non connctet	19	Reg OUT	O	Reglator output (Emitter follower output)
10	NC	O	Non connect	20	Reg NF	-	Regulator feedback terminal

■ LC75345M-X(IC702) : E. volume

1. Pin layout & Block diagram

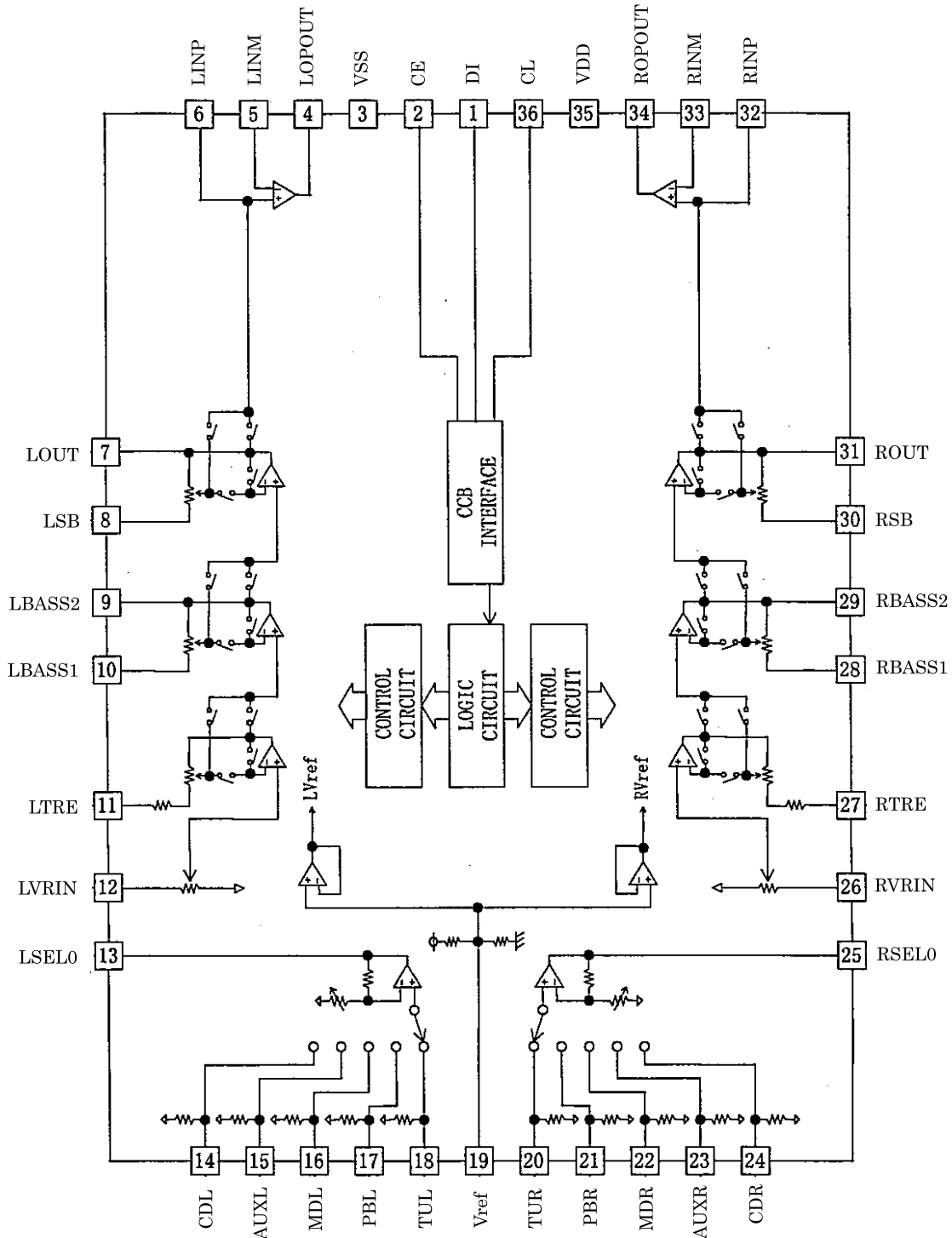

2. Block diagram

Pin No.	Symbol	Description
1	DI	Serial data/clock input terminal
2	CE	Chip enable terminal
3	Vss	GND
4	LOPOUT	Op-amp output
5	LINM	Op-amp inverse input
6	LINP	Op-amp non-inverse input
7	LOUT	C-connector terminal comprising volume + equalizer output and super-bass filter
8	LSB	Super-bass band filter C & R connector terminal
9	LBASS2	Bass band filter C & R connector terminal
10	LBASS1	Bass band filter C & R connector terminal
11	LTRE	Treble band filter C connector terminal
12	LVRIN	Volume input
13	LSELO	Input selector output
14	CDL	CD signal input
15	AUXL	AUX signal input
16	MDL	MD signal input
17	PBL	Tape PB signal input
18	TUL	FM tuner signal input
19	Vref	Analog GND
20	TUR	FM tuner signal input
21	PBR	Tape PB signal input
22	MDR	MD signal input
23	AUXR	AUX signal input
24	CDR	CD signal input
25	RSELO	Input selector output
26	RVRIN	Volume input
27	RTRE	Treble band filter C connector terminal
28	RBASS1	Bass band filter C & R connector terminal
29	RBASS2	Bass band filter C & R connector terminal
30	RSB	Super-bass band filter C & R connector terminal
31	ROUT	C connector terminal consisting of volume + equalizer output and super-bass filter
32	RINP	Op-amp non-inverse input
33	RINM	Op-amp inverse input
34	ROPOUT	Op-amp output
35	VDD	Power supply
36	CL	Serial data and clock input

■ CXA2523AR (IC310) : MD servo

1. Block diagram

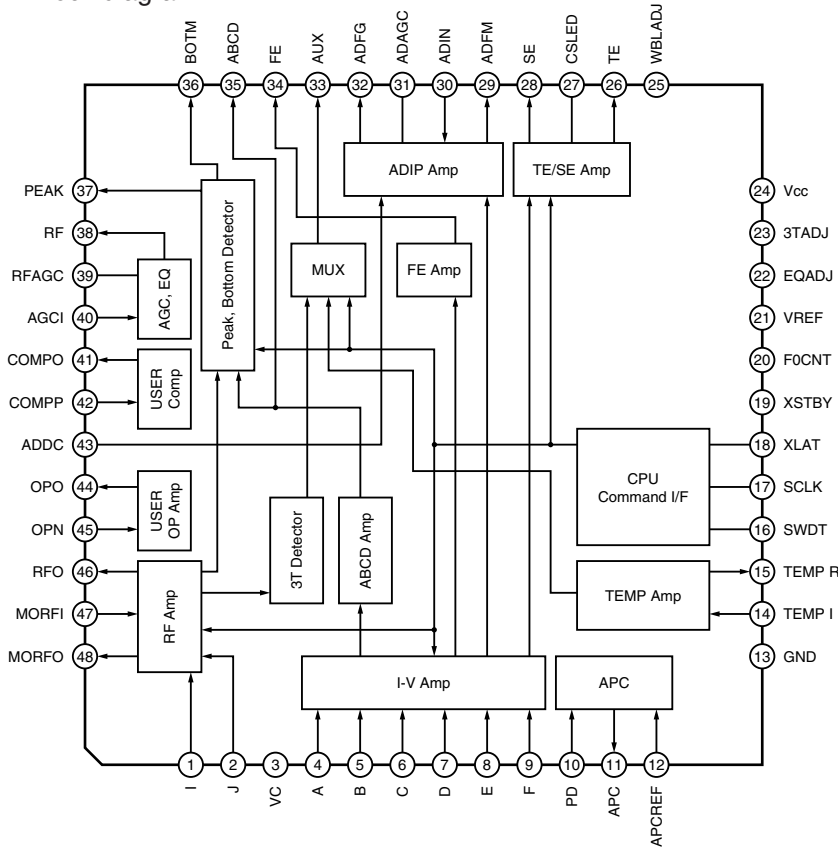

2. Pin function

Pin No.	Symbol	I/O	Function
1	I	I	I-V converted RF signal I input.
2	J	I	I-V converted RF signal J input.
3	VC	O	Vcc/2 voltage output.
4	A	I	A current input for main beam servo signal.
5	B	I	B current input for main beam servo signal.
6	C	I	C current input for main beam servo signal.
7	D	I	D current input for main beam servo signal.
8	E	I	E current input for side beam servo signal.
9	F	I	F current input for side beam servo signal.
10	PD	I	Reflection light quantity monitor signal input.
11	APC	O	Laser APC output.
12	APCREF	I	Reference voltage input for the laser power intensity setting.
13	GND	-	Connect to GND.
14	TEMP I	I	Connects the temperature sensor.
15	TEMP R	I	Connects the temperature sensor. outputs the reference voltage.
16	SWDT	I	Data input for microcomputer serial interface.
17	SCLK	I	Shift clock input for microcomputer serial interface.
18	XLAT	I	Latch signal input for microcomputer serial interface. Latched when low.
19	XSTBY	I	Standby setting pin. Normal operation when high Standby when low.
20	F0CNT	I	Internal current source setting pin.

Pin No.	Symbol	I/O	Function
21	VREF	O	Reference voltage output.
22	EQADJ	I/O	Equalizer center frequency setting pin.
23	3TADJ	I/O	BPF3T center frequency setting pin.
24	Vcc	-	Power supply.
25	WBLADJ	I/O	BPF22 center frequency setting pin.
26	TE	O	Tracking error signal output.
27	CSLED	-	Connects the sled error signal LPF capacitor.
28	SE	O	Sled error signal output.
29	ADFM	O	ADIP FM signal output.
30	ADIN	I	ADIP signal comparator input.
31	ADAGC	-	Connects the ADIPAGC capacitor.
32	ADFG	O	ADIP2 binary value signal output.
33	AUX	O	13 output / temperature signal output. Switched with serial commands.
34	FE	O	Focus error signal output.
35	ABCD	O	Reflection light quantity signal output for the main beam servo detector.
36	BOTM	O	RF/ABCD bottom hold signal output.
37	PEAK	O	Peak hold signal output for the RF/ABCD signals.
38	RF	O	RF equalizer output.
39	RFAGC	-	Connects the RFAGC capacitor.
40	AGCI	I	RFAGC input.
41	COMPO	O	User comparator output.
42	COMPP	I	User comparator non-inverted input.
43	ADDC	I/O	Connects the capacitor for ADIP amplifier feedback circuit.
44	OPO	O	User operational amplifier output.
45	OPN	I	User operational amplifier inverted input.
46	RFO	O	RF amplifier output. Eye pattern checkpoint.
47	MORFI	I	Input of the groove RF signal with AC coupling.
48	MORFO	O	Groove RF signal output.

■ GP1UM271XK (IC901) : Receiver for remote

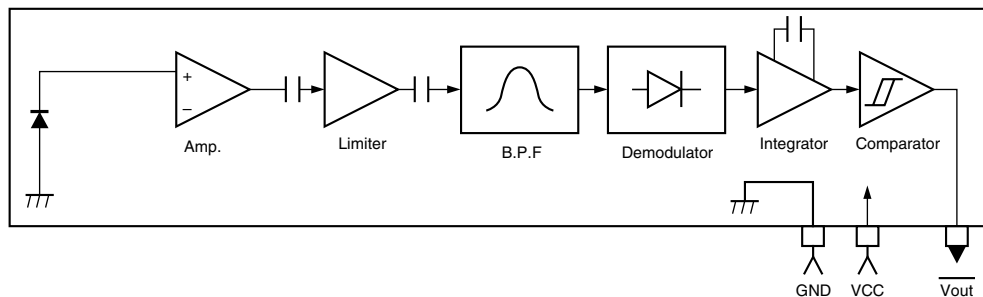

■ AK4519VF-X (IC480) : A / D D / A converter

1.Pin layout

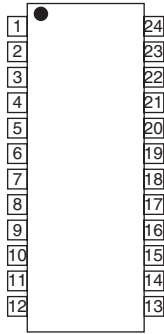

2.Block diagram

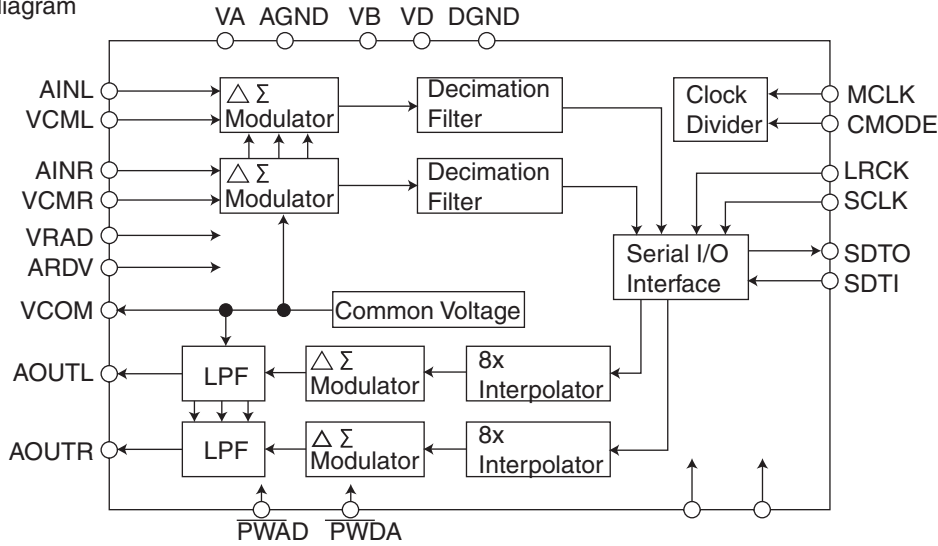

3.Pin Function

Pin NO.	Symbol	I/O	Function
1	VRDA	I	Voltage Reference Input Pin for DAC, VA
2	VRAD	I	Voltage Reference Input Pin for ADC, VA
3	AINR	I	RCh Analog Input Pin
4	VCMR	O	Rch Common Voltage Output Pin, 0.45xVA
5	VCML	O	Lch Common Voltage Output Pin, 0.45xVA
6	AINL	I	Lch Analog Input Pin
7	PWAD	I	ADC Power-Down Mode Pin "L":Power Down
8	PWDA	I	DAC Power-Down Mode Pin "L":Power Down
9	MCLK	I	Master Clock Input Pin
10	LRCK	I	Input/Output Channel Clock Pin
11	SCLK	I	Audio Serial Data Clock Pin
12	SDTO	O	Audio Serial Data Output Pin
13	DGND	-	Digital Ground Pin
14	VD	-	Digital Power Supply Pin
15	SDTI	I	Audio Serial Data Input Pin
16	CMODE	I	Master Clock Select Pin
17	DEM1	I	De-emphasis Frequency Select Pin
18	DEM0	I	De-emphasis Frequency Select Pin
19	AOUTL	O	Lch Analog Output Pin
20	AOUTR	O	Rch Analog Output Pin
21	VCOM	O	Common Voltage Output Pin, 0.45xVA
22	AGND	-	Analog Ground Pin
23	VB	-	Substrate Pin
24	VA	-	Analog Power Supply Pin

AN22000A(IC601):RF & SERVO AMP

1. Pin layout

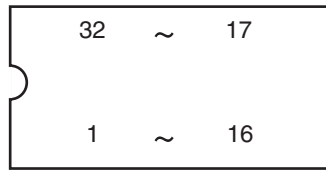

2. Block diagram

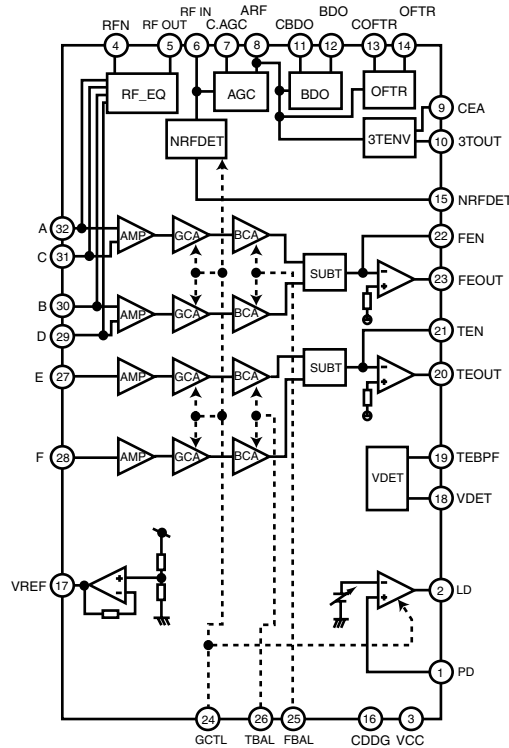

3. Pin function

Pin No.	Symbol	Function	Pin No.	Symbol	Function
1	PD	APC Amp. Input terminal	16	CDDG	Earth terminal
2	LD	APC Amp. Output terminal	17	VREF	VREF output terminal
3	VCC	Power supply terminal	18	VDET	VDET output terminal
4	RFN	RF addition Amp. Reversing input terminal	19	TEBPF	VDET input terminal
5	RF OUT	RF addition Amp. Output terminal	20	TEOUT	TE Amp. output terminal
6	RF IN	AGC input terminal	21	TEN	TE Amp. reversing input terminal
7	C.AGC	Terminal of connection of capacity of AGC loop filter.	22	FEN	FE Amp. reversing input terminal
8	ARF	AGC output terminal	23	FEOUT	FE Amp. output terminal
9	CEA	Capacity connection terminal for HPF-Amp.	24	GCTL	Terminal GCTL & APC
10	3TOUT	3TENV output terminal	25	FBAL	FBAL control terminal
11	CBDO	Capacity connection terminal for RF shade side envelope detection	26	TBAL	TBAL control terminal
12	BDO	BDO output terminal	27	E	Tracking signal input terminal 1
13	COFTR	Capacity connection terminal for RF discernment side envelope detection	28	F	Tracking signal input terminal 2
14	OFTR	OFTR output terminal	29	D	Focus signal input terminal 4
15	NRFDET	NRFDET output terminal	30	B	Focus signal input terminal 2
			31	C	Focus signal input terminal 3
			32	A	Focus signal input terminal 1

■ AN7317(IC32) : ALC & Pre Amplifier

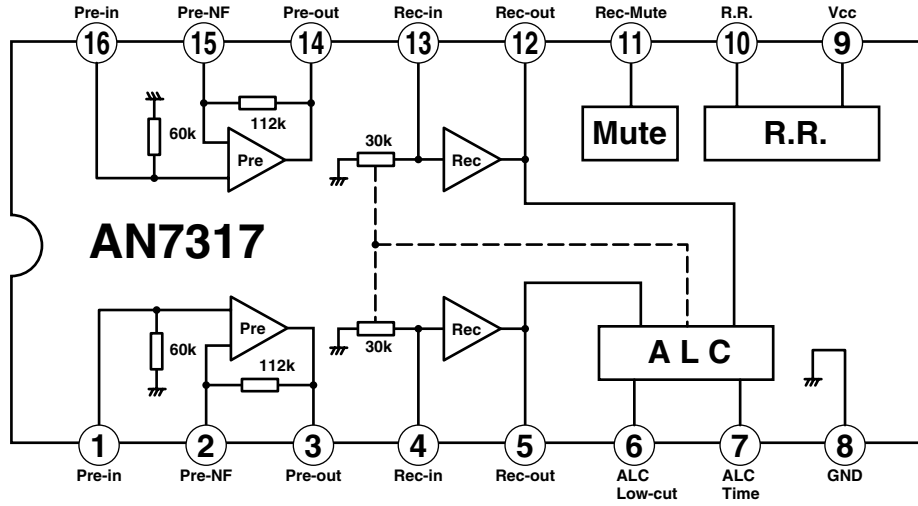

Pin No.	Pin Descriptions
1	Channel 1 Playback Amplifier Input
2	Channel 1 Playback Amplifier Negative Feedback
3	Channel 1 Playback Amplifier Output
4	Channel 1 Record Amplifier Input
5	Channel 1 Record Amplifier Output
6	ALC Low-Cut
7	ALC Time
8	Ground
9	Vcc
10	Ripple Filter
11	Record - Amplifier Mute
12	Channel 2 Record Amplifier Output
13	Channel 2 Record Amplifier Input
14	Channel 2 Playback Amplifier Output
15	Channel 2 Playback Amplifier Negative Feedback
16	Channel 2 Playback Amplifier Input

■ LA1838 (IC1): FM AM IF AMP&detector, FM MPX decoder

1. Block Diagram

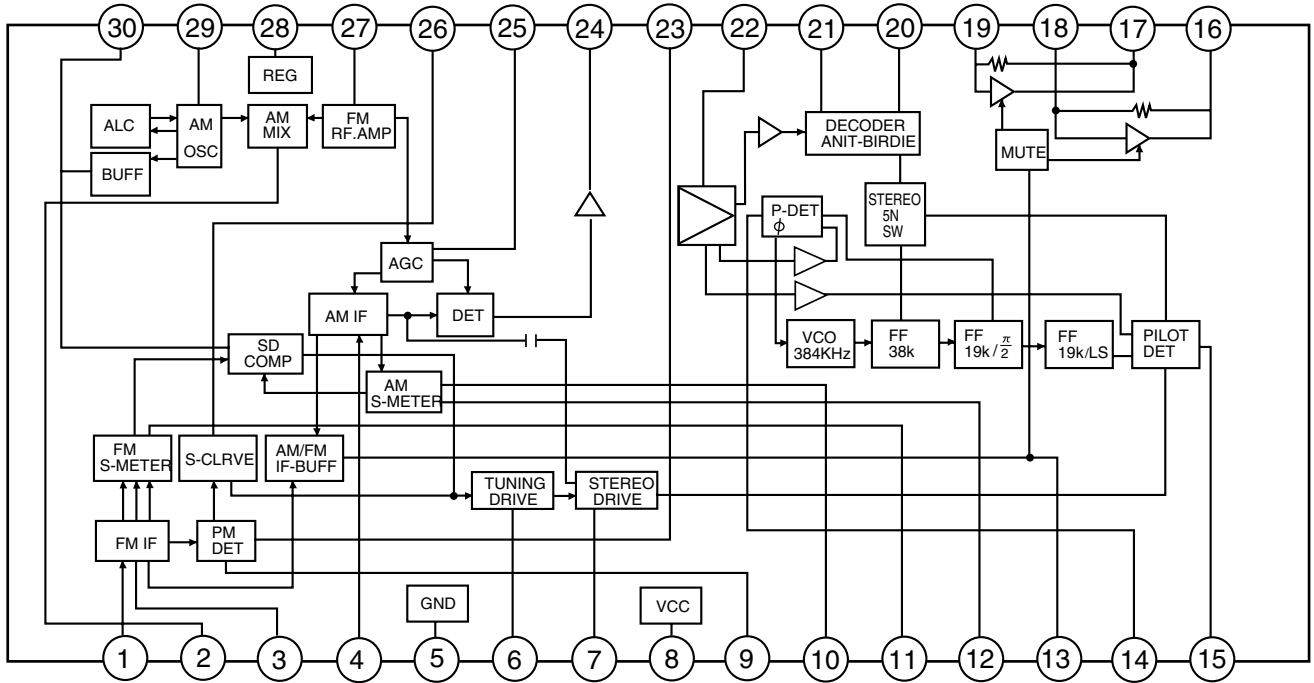

2. Pin Function

Pin No.	Symbol	I/O	Function	Pin No.	Symbol	I/O	Function
1	FM IN	I	This is an input terminal of FM IF signal.	16	L OUT	O	Left channel signal output.
2	AM MIX	O	This is an out put terminal for AM mixer.	17	R OUT	O	Right channel signal output.
3	FM IF	I	Bypass of FM IF	18	L IN	I	Input terminal of the left channel post AMP.
4	AM IF	I	Input of AM IF Signal.	19	R IN	I	Input terminal of the right channel post AMP.
5	GND	-	This is the device ground terminal.	20	RO	O	Mpx Right channel signal output.
6	TUNED	O	When the set is tuning, this terminal becomes "L".	21	LO	O	Mpx Left channel signal output.
7	STEREO	O	Stereo indicator output. Stereo "L", Mono: "H"	22	IF IN	I	Mpx input terminal
8	VCC	-	This is the power supply terminal.	23	FM OUT	O	FM detection output.
9	FM DET	-	FM detect transformer.	24	AM DET	O	AM detection output.
10	AM SD	-	This is a terminal of AM ceramic filter.	25	AM AGC	I	This is an AGC voltage input terminal for AM
11	FM VSM	O	Adjust FM SD sensitivity.	26	AFC	-	This is an output terminal of voltage for FM-AFC.
12	AM VSM	O	Adjust AM SD sensitivity.	27	AM RF	I	AM RF signal input.
13	MUTE	I/O	When the signal of IF REQ of IC121(LC72131) appear, the signal of FM/AM IF output. //Muting control input.	28	REG	O	Register value between pin 26 and pin28 desides the frequency width of the input signal.
14	FM/AM	I	Change over the FM/AM input. "H" :FM, "L" : AM	29	AM OSC	-	This is a terminal of AM Local oscillation circuit.
15	MONO/ST	O	Stereo : "H", Mono: "L"	30	OSC BUFFER	O	AM Local oscillation Signal output.

■ LA6541-X (IC801) : Servo driver

1. Pin Layout & block diagram

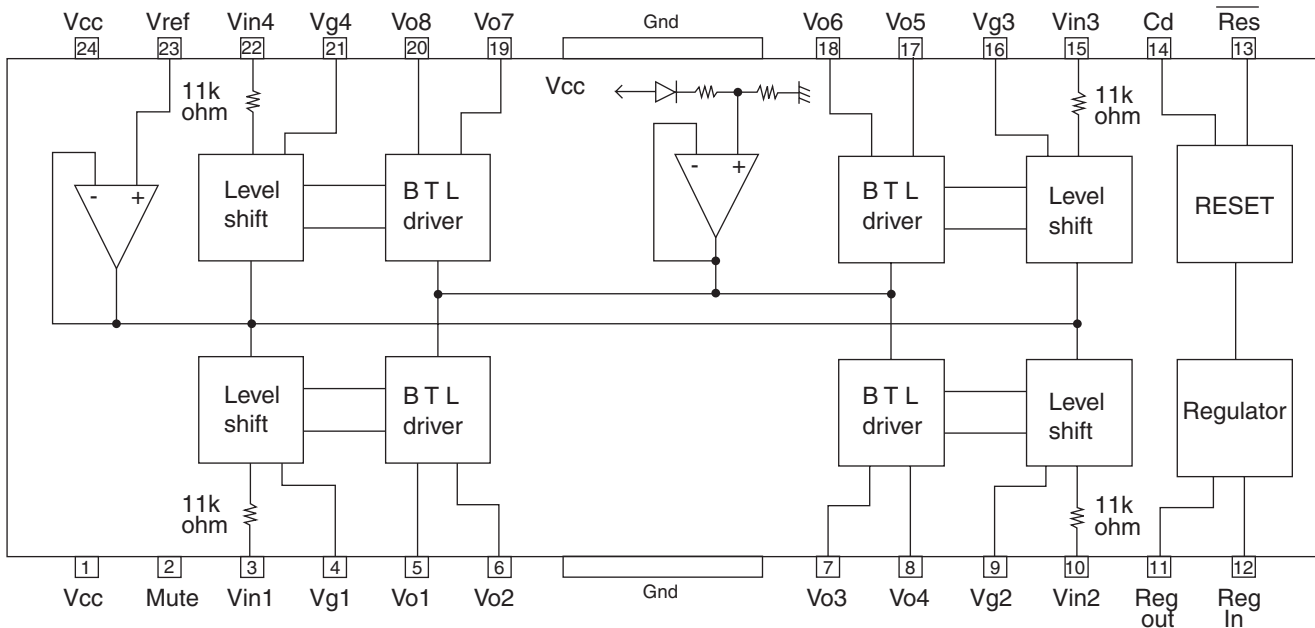

2. Pin function

Pin No.	Symbol	Function
1	Vcc	Power supply (Shorted to pin 24)
2	Mute	All BTL amplifier outputs ON/OFF
3	Vin1	BTL AMP 1 input pin
4	Vg1	BTL AMP 1 input pin (For gain adjustment)
5	Vo1	BTL AMP 1 input pin (Non inverting side)
6	Vo2	BTL AMP 1 input pin (Inverting side)
7	Vo3	BTL AMP 2 input pin (Inverting side)
8	Vo4	BTL AMP 2 input pin (Non inverting side)
9	Vg2	BTL AMP 2 input pin (For gain adjustment)
10	Vin2	BTL AMP 2 input pin
11	Reg Out	External transistor collector (PNP) connection. 5V power supply output
12	Reg In	External transistor (PNP) base connection
13	Res	Reset output
14	Cd	Reset output delay time setting (Capacitor connected externally)
15	Vin3	BTL AMP 3 input pin
16	Vg3	BTL AMP 3 input pin (For gain adjustment)
17	Vo5	BTL AMP 3 output pin (Non inverting side)
18	Vo6	BTL AMP 3 output pin (Inverting side)
19	Vo7	BTL AMP 4 output pin (Inverting side)
20	Vo8	BTL AMP 4 output pin (Non inverting side)
21	Vg4	BTL AMP 4 output pin (For gain adjustment)
22	Vin4	BTL AMP 4 output pin
23	Vref	Level shift circuit's reference voltage application
24	Vcc	Power supply (Shorted to pin 1)

■ LC72136N (IC2) : PLL frequency synthesizer

1. Pin layout

XT	1	22	XT
FM/AM	2	21	GND
CE	3	20	LPFOUT
DI	4	19	LPFIN
CLOCK	5	18	PD
DO	6	17	VCC
FM/ST/VCO	7	16	FMIN
AM/FM	8	15	AMIN
	9	14	
	10	13	IFCONT
SDIN	11	12	IFIN

2. Block diagram

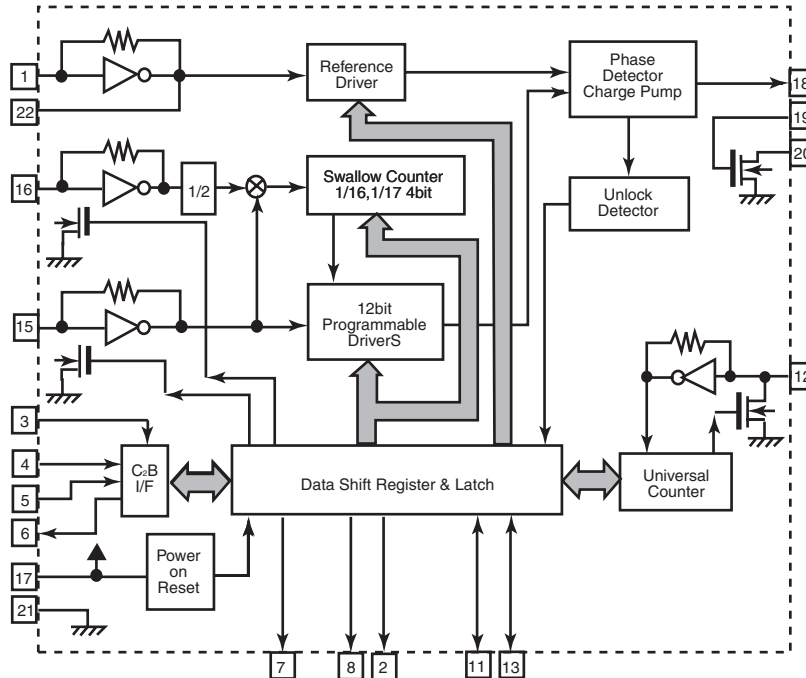

3. Pin function

Pin No.	Symbol	I/O	Function	Pin No.	Symbol	I/O	Function
1	XT	I	X'tal oscillator connect (75kHz)	12	IFIN	I	IF counter signal input
2	FM/AM	O	LOW:FM mode	13	IFCONT	O	IF signal output
3	CE	I	When data output/input for 4pin(input) and 6pin(output): H	14		-	Not use
4	DI	I	Input for receive the serial data from controller	15	AMIN	I	AM Local OSC signal output
5	CLOCK	I	Sync signal input use	16	FMIN	I	FM Local OSC signal input
6	DO	O	Data output for Controller Output port	17	VCC	-	Power supply(VDD=4.5-5.5V) When power ON:Reset circuit move
7	FM/ST/VCO	O	"Low": MW mode	18	PD	O	PLL charge pump output(H: Local OSC frequency Height than Reference frequency. L: Low Agreement: Height impedance)
8	AM/FM	O	Open state after the power on reset	19	LPFIN	I	Input for active lowpassfilter of PLL
9		-	Not use	20	LPFOUT	O	Output for active lowpassfilter of PLL
10		-	Not use	21	GND	-	Connected to GND
11	SDIN	I/O	Data input/output	22	XT	I	X'tal oscillator(75KHz)

■ M63008FP-X (IC410) : 5ch Actuator driver

1.Pin layout

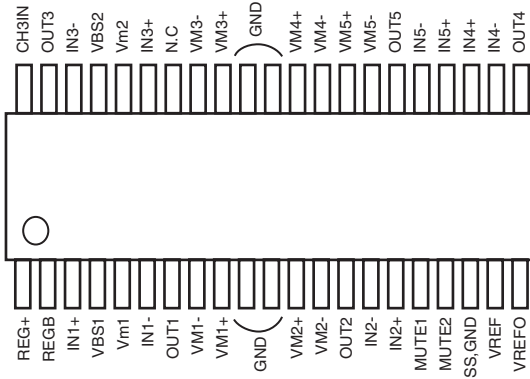

2.Block diagram

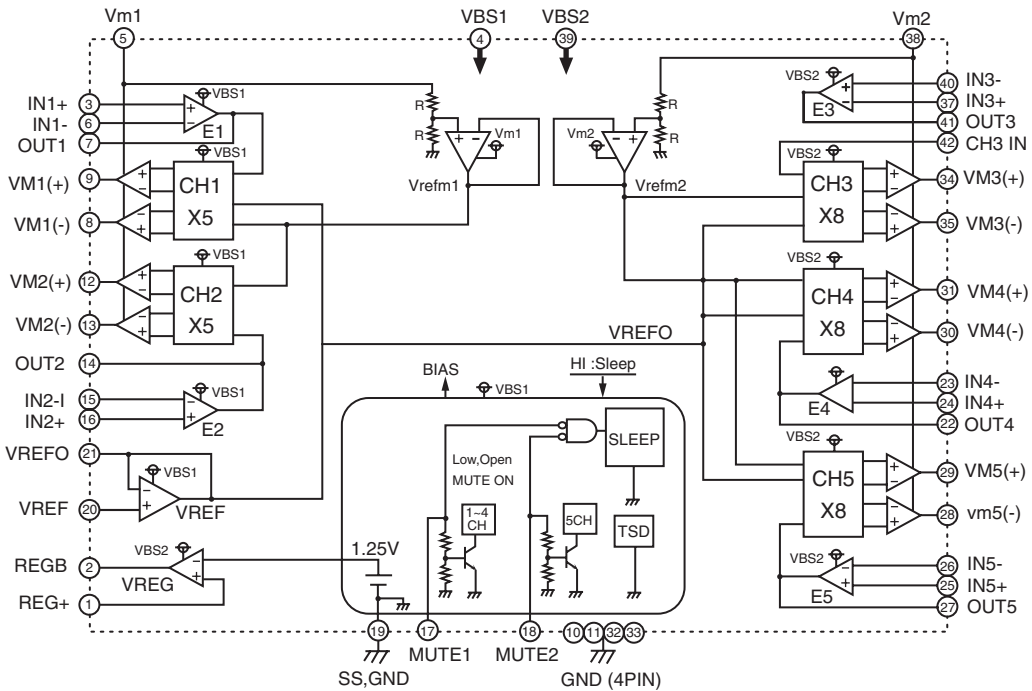

■ BA3126N(IC31) : R/P Switch

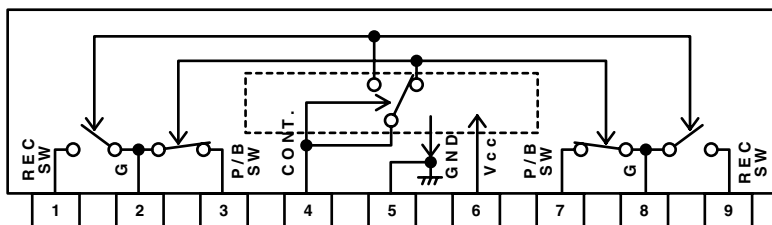

■ BU4094B(IC33):Serial to parallel port extension

1.Pin layout

STTA	1	16	VDD
SDATA	2	15	CE
SCK	3	14	RECH
BIAS1	4	13	SOLCTRL
BIAS2	5	12	MOTOR
BIAS3	6	11	RMUTE
RECB	7	10	NC
GND	8	9	NC

2.Block diagram

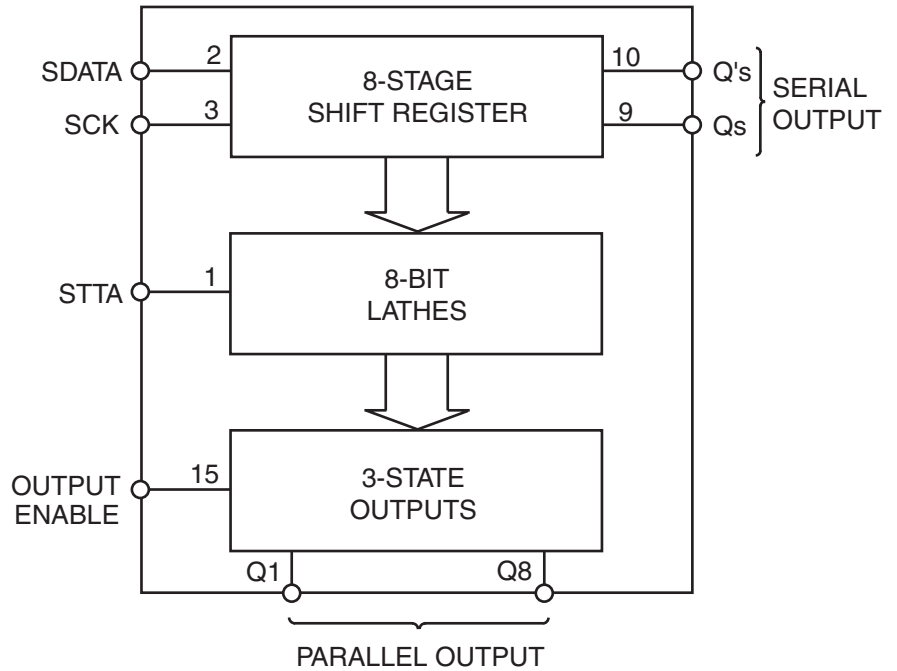

■ GM71VS17400CLT5(IC390) : DRAM

1. Pin layout

VCC	1	26	VSS
DQ0	2	25	DQ3
DQ1	3	24	DQ2
WE	4	23	CAS
RAS	5	22	OE
(NC)A11	6	21	A9
A10	8	19	A8
A0	9	18	A7
A1	10	17	A6
A2	11	16	A5
A3	12	15	A4
VCC	13	14	VSS

2. Block diagram

Pin No.	Symbol	Function
1.13	VCC	Power (+3.3V)
2.3.24.25	DQ0~DQ3	Data-input/Data-output
4	WE	Write Enable
5	RAS	Row Address Strobe
6.8~12. 15~19.21	AO~A11	Address Inputs (4K Refresh Product)
8~12. 15~19.21	AO~A10	Address Inputs (2K Refresh Product)
14.26	VSS	Ground
22	OE	Output Enable
23	CAS	Column Address Strobe

BR93LC66F-X(IC590):EEPROM

1. Pin layout

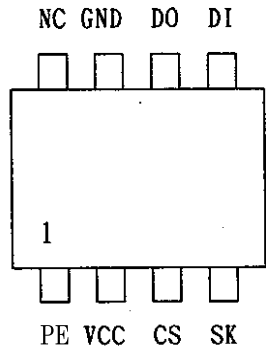

2. Pin function

Pin No.	Symbol	Pin function
1	PE	Program enable
2	VCC	Power supply
3	CS	Chip select
4	SK	Clock input
5	DI	Data input
6	DO	Data output
7	GND	Ground
8	NC	Non connect

3. Block diagram

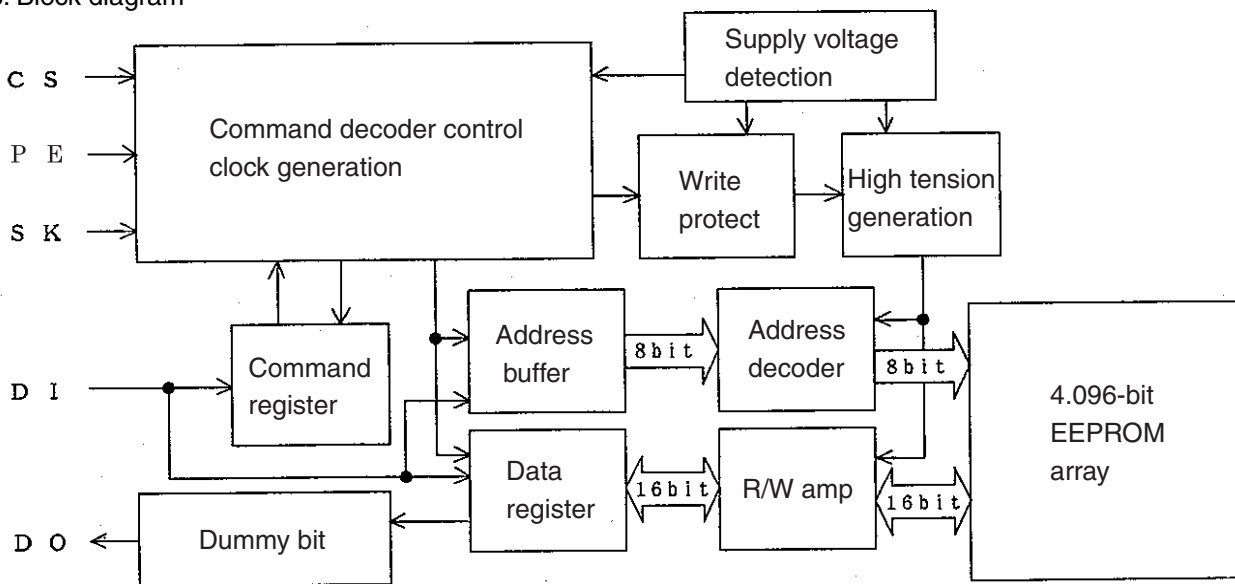

■ MN662790RSC (IC651) : Digital servo & Digital signal processor

1. Pin layout

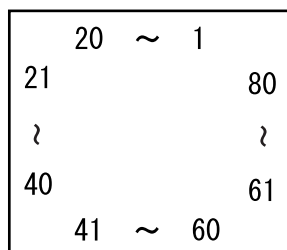

2. Pin function

Pin No.	Symbol	I/O	Description	Pin No.	Symbol	I/O	Description
1	BCLK	O	Bit clock output for SRDATA output (pin 3)	41	PLL2	I/O	PLL loop filter characteristic switching terminal
2	LRCK	O	L/R discrimination signal output	42	DSLBD	—	Not used
3	SRDATA	O	Serial data output	43	WVEL	—	Not used
4	DVDD1	—	Power supply for digital circuit	44	ARF	I	RF signal input
5	DVSS1	—	Digital circuit GND	45	IREF	I	Reference current input
6	TX	O	Digital audio interface output signal	46	DRF	I	DSL bias input
7	MCLK	I	Microcomputer command clock signal input	47	DSL	I/O	DSL loop filter input/output
8	MDATA	I	Microcomputer command data input	48	PLL	I/O	PLL loop filter input/output
9	MLD	I	Microcomputer command load signal input (L: Load)	49	VCOF	I/O	VCO loop filter input/output
10	SENSE	—	Not used	50	AVDD2	—	Power supply for analog circuit
11	FLOCK	—	Not used	51	AVSS2	—	Analog circuit GND
12	TLOCK	—	Not used	52	EFM	—	Not used
13	BLKCK	O	Sub-code block clock signal	53	DSL	O	DSL balance output
14	SQCK	I	External clock input for sub-code Q register	54	VCOF2	I/O	Digital servo 33.8688 MHz generator VCO loop filter input/output
15	SUBQ	O	Sub-code Q data output	55	SUBC	—	Not used
16	DMUTE	I	Muting input (H: Mute)	56	SBCK	—	Connected to GND
17	STAT	O	Status signal output	57	VSS	—	GND for transmission circuit
18	DSP-RST	I	Reset signal input (L: Reset)	58	X1	I	Crystal oscillator circuit input (f = 16.9344 MHz)
19	SMCK	—	Not used	59	X2	O	Crystal oscillator circuit output (f = 16.9344 MHz)
20	CSEL	I	Oscillation frequency selector	60	VDD	—	Power supply for oscillator circuit
21	TEST2	—	Not used	61	BYTCK	—	Not used
22	TVD	O	Traverse drive output	62	LD		
23	PC	—	Not used	63	GAIN		
24	ECM	O	Spindle motor drive signal (Forced mode output)	64	IPFLAG	—	Not used
25	ECS	O	Spindle motor drive signal (Servo malfunction signal output)	65	FLAG	O	Flag signal output
26	VDETMON	—	Not used	66	CLVS	—	Not used
27	TRD	O	Tracking drive output	67	CRC	—	Not used
28	FOD	O	Focus drive output	68	DEMPH	—	Not used
29	VREF	I	D/A output reference voltage	69	RESY	—	Not used
30	FBAL	O	Focus balance control output	70	IOSEL	I	Mode switching, Pull-up
31	TBAL	O	Tracking balance control output	71	TEST	I	Test pin (H: Usual)
32	FE	I	Focus error signal input (analog input)	72	AVDD1	—	Power supply for analog circuit
33	TE	I	Tracking error signal input (analog input)	73	OUTL	O	L-ch audio output
34	RF ENV	I	RF envelope signal input (analog input)	74	AVSS1	—	Analog circuit GND
35	TEST3	—	Connected to GND	75	OUTR	O	R-ch audio output
36	OFT	I	Off-track signal input (H: Off-track)	76	DQSY		
37	TRCRS	I	Track cross signal input	77	Vcc5V	—	Connected with power supply
38	RFDET	I	RF detection signal input (L: Detection)	78	PSEL	I	When IOSEL = H: Test pin (Usually L)
39	BDO	I	Dropout signal input (H: Dropout)	79	MSEL	—	When IOSEL = H: SMCK output frequency switching terminal (L: SMCK = 4.2336 MHz)
40	LDON	—	Not used	80	SSEL	I	When IOSEL = H: SUBQ output mode switching terminal (H: Q code buffer use mode)

LA4628 (IC801) : Power amp.

1. Pin layout

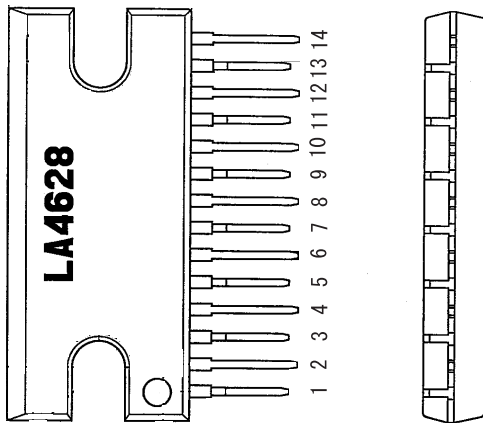

2. Block diagram

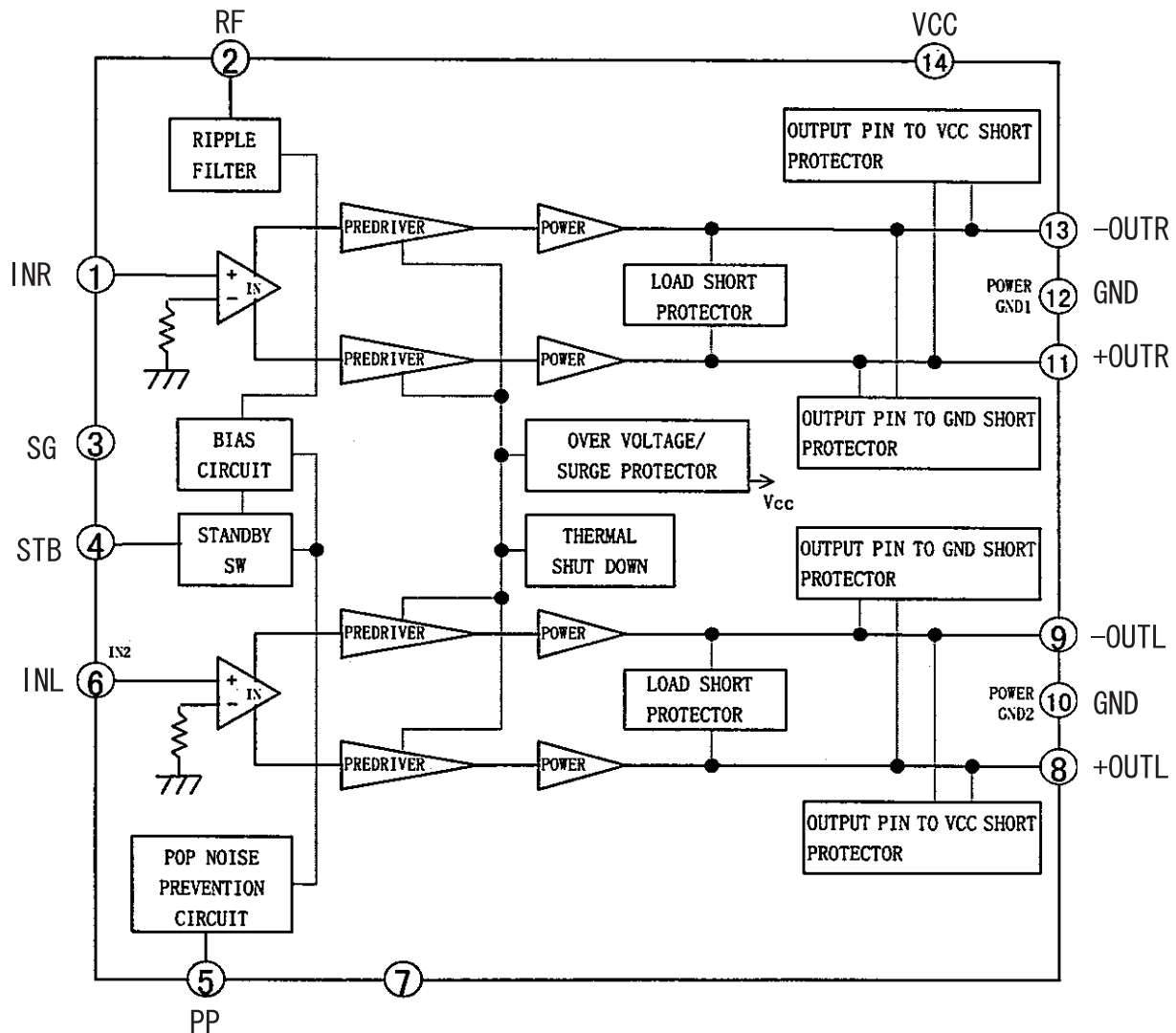

■ L4909 (IC802) : Regulator

1. Pin layout

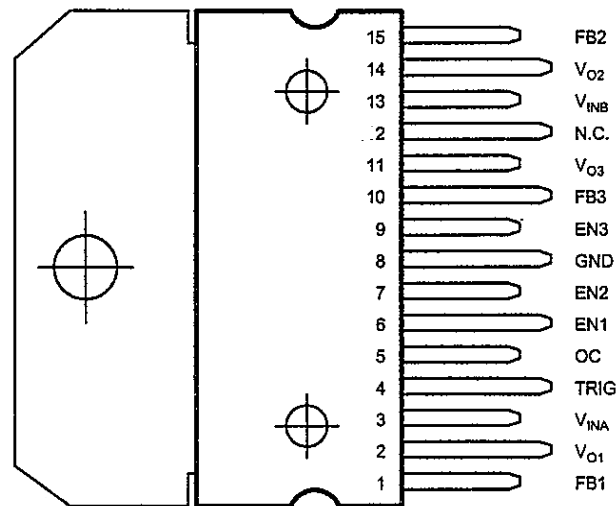

2. Pin function

Pin No.	Symbol	Description
1	FB1	REG1 feedback voltage input
2	Vo1	REG1 output voltage
3	VinA	Input DC supply voltage
4	TRIG	External SCR trigger (clover protection)
5	OC	Overcurrent warning output
6	EN1	REG1 enable input
7	EN2	REG2 enable input
8	GND	Analog GND
9	EN3	REG3 enable input
10	FB3	REG3 feedback voltage input
11	Vo3	REG3 output voltage
12	N.C.	Not connected
13	VinB	Input DC supply voltage
14	Vo2	REG2 output voltage
15	FB2	REG2 feedback voltage input

<<MEMO>>

JVC

VICTOR COMPANY OF JAPAN, LIMITED

AUDIO & COMMUNICATION BUSINESS DIVISION

PERSONAL & MOBILE NETWORK BUSINESS UNIT 10-1,1Chome,Ohwatari-machi,Maebashi-city,371-8543,Japan

Block diagram

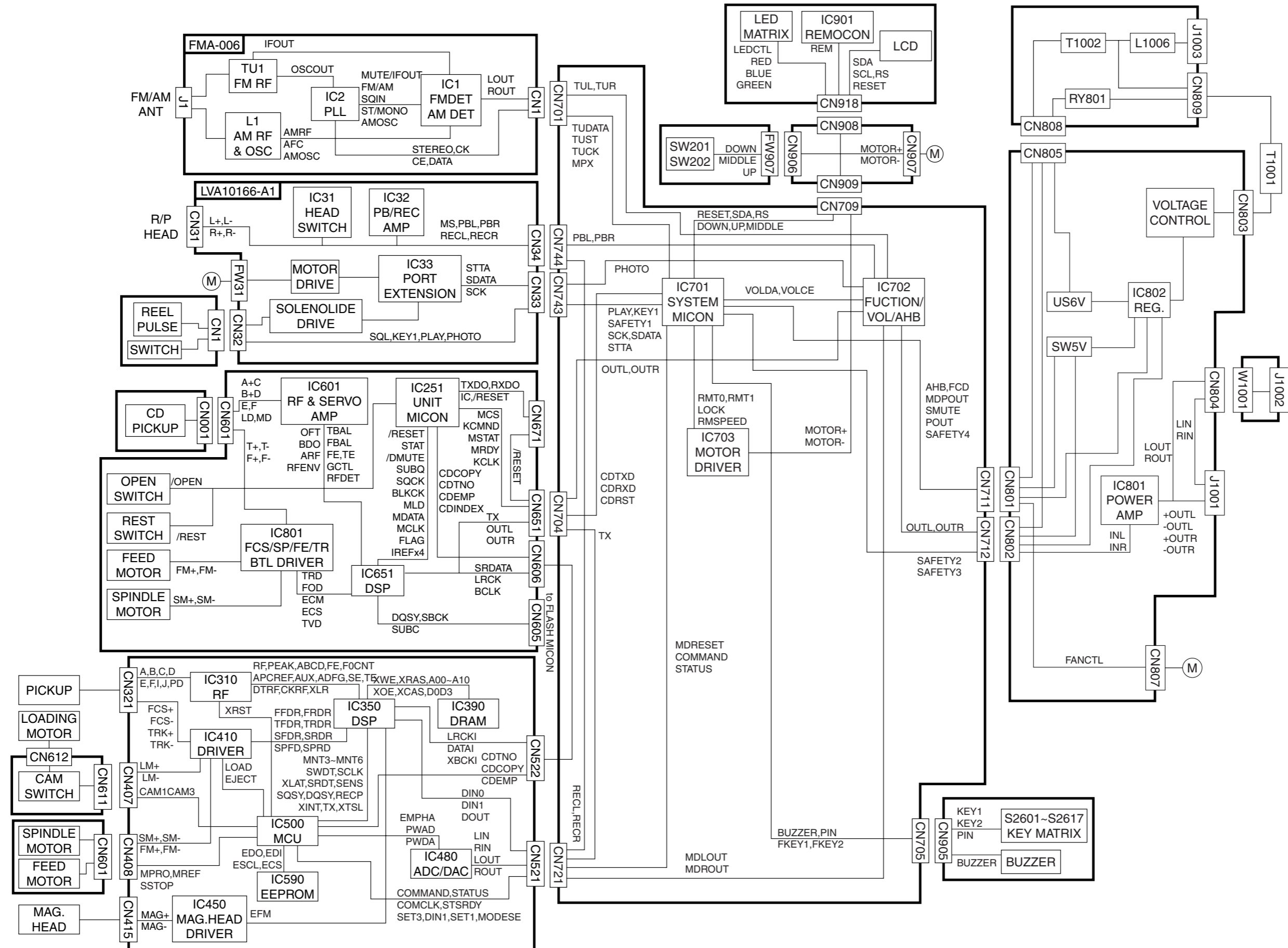

Standard schematic diagrams

■ Main & control circuit

6

5

4

3

2

1

ALL VALUES ARE MEASURED IN VOLTS

IC700	1	2	3	4	5	6	7	8	9	10	11	12	13	14	15	16	17	18
IC702	0	0	0	4.8	4.1	4.5	4.8	4.6	4.5	4.5	4.5	4.5	4.5	4.5	4.5	4.5	4.5	4.5
IC703	19	20	21	22	23	24	25	26	27	28	29	30	31	32	33	34	35	36
IC702	4.5	4.5	4.5	4.5	4.5	4.5	4.5	4.5	4.5	4.5	4.5	4.5	4.5	4.4	4.4	4.6	4.1	0

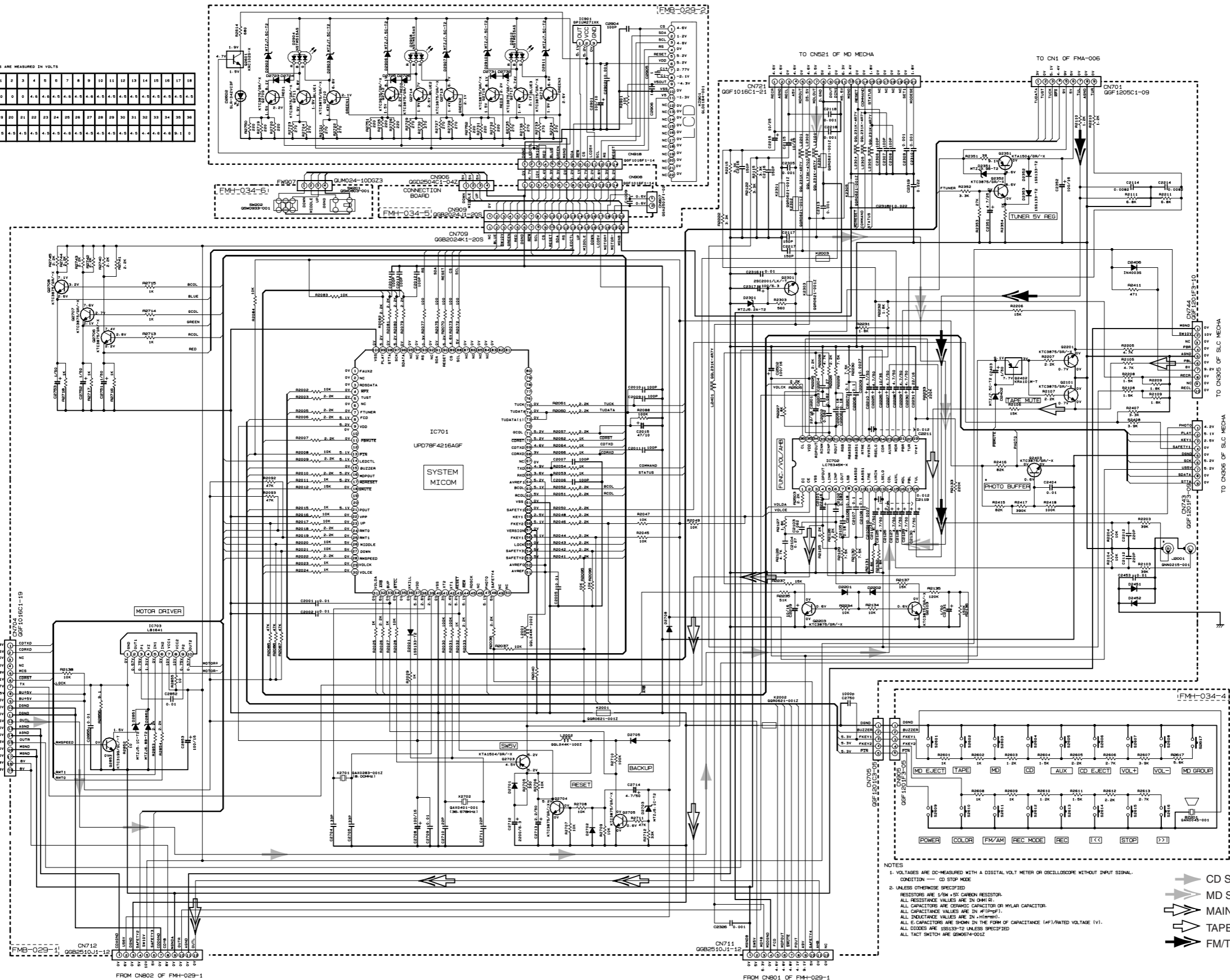

- NOTES
1. VOLTAGES ARE DC-MEASURED WITH A DIGITAL VOLT METER OR OSCILLOSCOPE WITHOUT INPUT SIGNAL.
CONDITION — CD STOP MODE
 2. UNLESS OTHERWISE SPECIFIED
RESISTORS ARE 1/8W ± 5% CARBON RESISTOR.
ALL RESISTANCE VALUES ARE IN OHM (Ω).
ALL CAPACITORS ARE CERAMIC CAPACITOR OR MYLAR CAPACITOR.
ALL CAPACITANCE VALUES ARE IN PICO-FARAD (pF).
ALL INDUCTANCE VALUES ARE IN MICROHENRY (μH).
ALL E. CAPACITORS ARE SHOWN IN THE FORM OF CAPACITANCE (μF)/RATED VOLTAGE (V).
ALL DIODES ARE 1SS133-12 UNLESS SPECIFIED.
ALL TACT SWITCHES ARE SMD204-001.
- ➡ CD SIGNAL
 - ➡ MD SIGNAL
 - ➡ MAIN SIGNAL
 - ➡ TAPE P. B. SIGNAL
 - ➡ FM/TUNER SIGNAL

A B C D E F G H I

Power amplifier & Power supply circuit

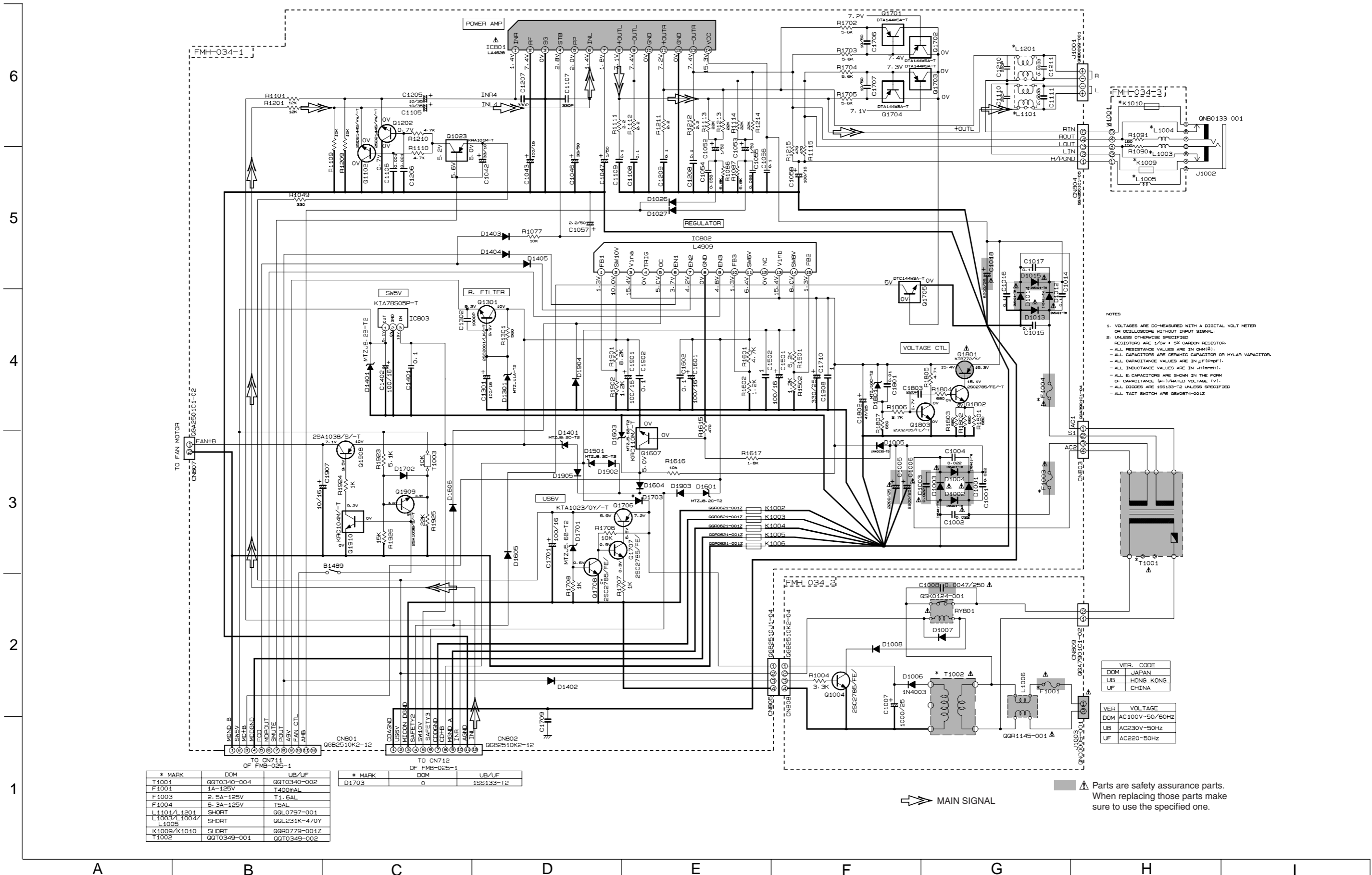

- NOTES
- 1. VOLTAGES ARE DC-MEASURED WITH A DIGITAL VOLT METER OR OSCILLOSCOPE WITHOUT INPUT SIGNAL.
 - 2. UNLESS OTHERWISE SPECIFIED RESISTORS ARE 1/8W ± 5% CARBON RESISTOR.
 - ALL RESISTANCE VALUES ARE IN OHMS.
 - ALL CAPACITORS ARE CERAMIC CAPACITOR OR MYLAR VAPACITOR.
 - ALL CAPACITANCE VALUES ARE IN μF (μ=10⁻⁶).
 - ALL INDUCTANCE VALUES ARE IN mH (m=10⁻³).
 - ALL E-CAPACITORS ARE SHOWN IN THE FORM OF CAPACITANCE (μF)-RATED VOLTAGE (V).
 - ALL DIODES ARE 1SS133-T2 UNLESS SPECIFIED
 - ALL TACT SWITCH ARE GSK0674-001Z

VER. CODE	
DOM	JAPAN
UB	HONG KONG
UF	CHINA

VER.	VOLTAGE
DOM	AC100V-50/60HZ
UB	AC230V-50HZ
UF	AC220-50HZ

* MARK	DOM	UB/UF
T1001	GGT0340-004	GGT0340-002
F1001	1A-125V	T400mAL
F1003	2.5A-125V	T1.6AL
F1004	6.3A-125V	T5AL
L1101/L1201	SHORT	GGL0797-001
L1003/L1004	SHORT	GGL231K-470Y
L1005	SHORT	GGL0779-001Z
K1009/K1010	SHORT	GGR0779-001Z
T1002	GGT0349-001	GGT0349-002

* MARK	DOM	UB/UF
D1703	0	1SS133-T2

▲ Parts are safety assurance parts. When replacing those parts make sure to use the specified one.

➔ MAIN SIGNAL

MD control circuit

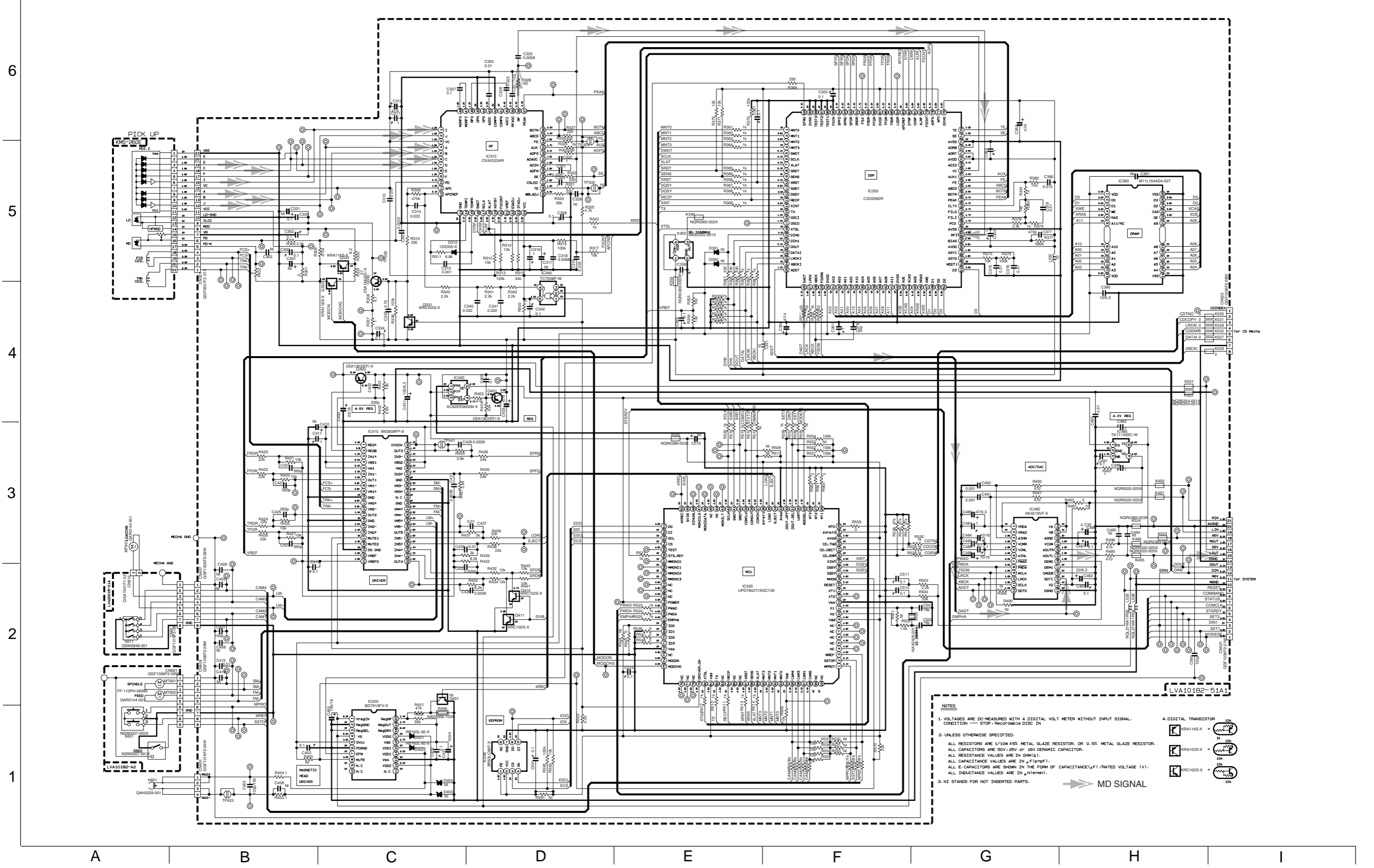

- NOTES**
1. VOLTAGES ARE DC-MEASURED WITH A DIGITAL VOLT METER WITHOUT INPUT SIGNAL. CONDITION --- STOP, Recor-On to DISC IN
 2. UNLESS OTHERWISE SPECIFIED.
ALL RESISTORS ARE 1/10W ±5% METAL GLAZE RESISTOR. OR 0.5X METAL GLAZE RESISTOR.
ALL CAPACITORS ARE 50V, 25V or 16V CERAMIC CAPACITOR.
ALL RESISTANCE VALUES ARE IN OHM (Ω).
ALL CAPACITANCE VALUES ARE IN PICO (pF).
ALL E-CAPACITORS ARE SHOWN IN THE FORM OF CAPACITANCE (μF) / RATED VOLTAGE (V).
ALL INDUCTANCE VALUES ARE IN MILLI (mH).
 3. NI STANDS FOR NOT INSERTED PARTS.
 4. DIGITAL TRANSISTOR
- MD SIGNAL

CD control circuit

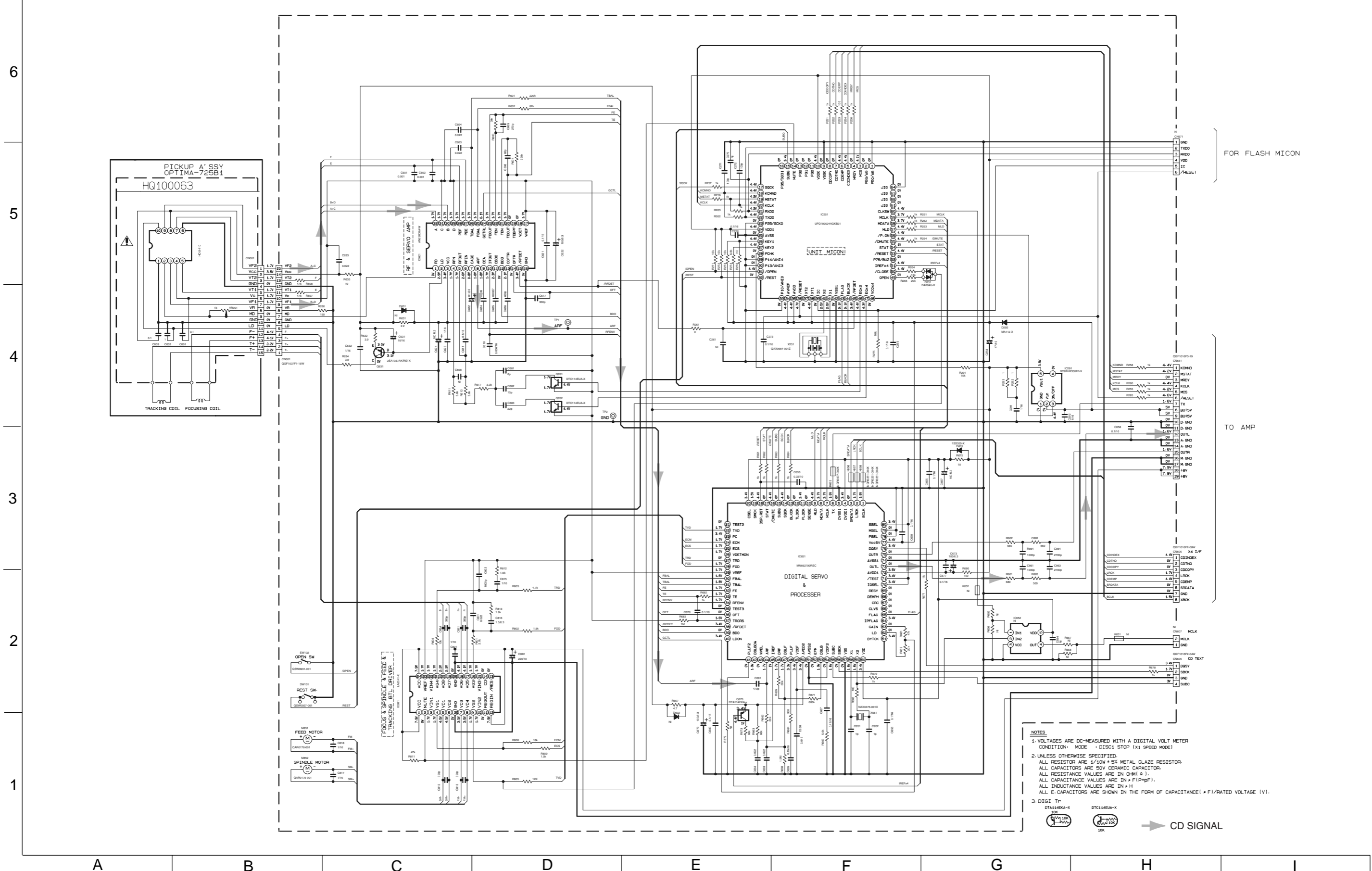

NOTES
 1. VOLTAGES ARE DC-MEASURED WITH A DIGITAL VOLT METER
 CONDITION: MODE = DISC1 STOP (x1 SPEED MODE)
 2. UNLESS OTHERWISE SPECIFIED,
 ALL RESISTORS ARE 1/10W ± 5% METAL GLAZE RESISTOR.
 ALL CAPACITORS ARE 50V CERAMIC CAPACITOR.
 ALL RESISTANCE VALUES ARE IN OHM (Ω).
 ALL CAPACITANCE VALUES ARE IN PICO (pF).
 ALL INDUCTANCE VALUES ARE IN μH.
 ALL E-CAPACITORS ARE SHOWN IN THE FORM OF CAPACITANCE (μF)/RATED VOLTAGE (V).
 3. DIGIT TR



➔ CD SIGNAL

■ Cassette control circuit

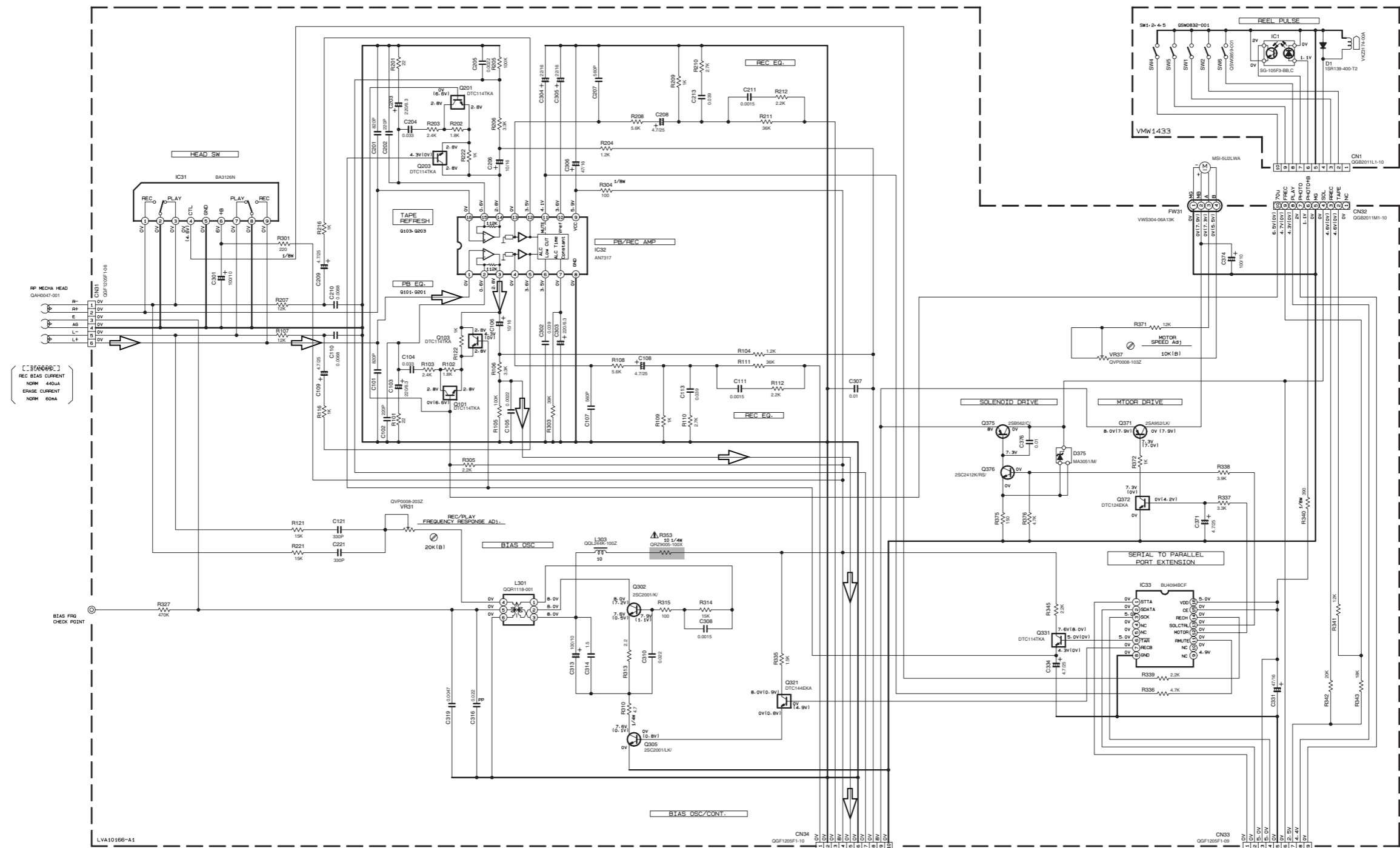

STANDARD
REC BIAS CURRENT
NORM 440uA
ERASE CURRENT
NORM 50uA

NOTES

1. VOLTAGES ARE DC-MEASURED WITH A DIGITAL VOLT METER OR OSCILLOSCOPE WITHOUT INPUT SIGNAL. CONDITION : MECHA STOP MODE

2. UNLESS OTHERWISE SPECIFIED - RESISTORS ARE 1/10W ±5% METAL GLAZE RESISTOR. ALL RESISTANCE VALUES ARE IN OHM(Ω). ALL CAPACITORS ARE CERAMIC CAPACITOR OR MYLAR CAPACITOR. ALL CAPACITANCE VALUES ARE IN nF(nF=10⁻⁹F). ALL INDUCTANCE VALUES ARE IN mH(mH=10⁻³H). ALL E-CAPACITORS ARE SHOWN IN THE FORM OF CAPACITANCE (#1/RATED VOLTAGE (V)). POLYPROPYLENE CAPACITOR

TO CN744
OF FMH-025-1
SHEET 5/7

PARTS	NAME	REF. NO
FA142	DT114TKA	Q101-Q103
FA144	DT144EKA	Q301
FA146	DT144EKA	Q372

➔ TAPE P. B. SIGNAL

⚠ Parts are safety assurance parts. When replacing those parts make sure to use the specified one.

SHEET 4/7

■ Tuner circuit

NOTES

1. VOLTAGES ARE DC-MEASURED WITH A DIGITAL VOLT METER.
2. ALL RESISTORS ARE 1/8W ±5% METAL GLAZE RESISTOR.
3. ALL RESISTANCE VALUES ARE IN OHM(Ω).
4. ALL CAPACITANCE VALUES ARE IN pF(pF).
5. ALL E-CAPACITORS ARE SHOWN IN THE FORM OF CAPACITANCE (μF)/RATED VOLTAGE (V).
6. SI DIODES (D) ARE ALL 1SS133-T THAT CAN BE CHANGED TO SIMILAR DIODE SUCH AS MA166 OR HSS104J.
7. PARTS NO. OF TRANSISTORS ARE AS FOLLOWS:
 Q1 2SC2814/4-S/-X Q2-Q3 2SC2412K/R/-X
 Q4-Q5 DTA114YA-X

B. INSIDE OF DIGITAL TRANSISTORS ARE SHOWN AS FOLLOWS:

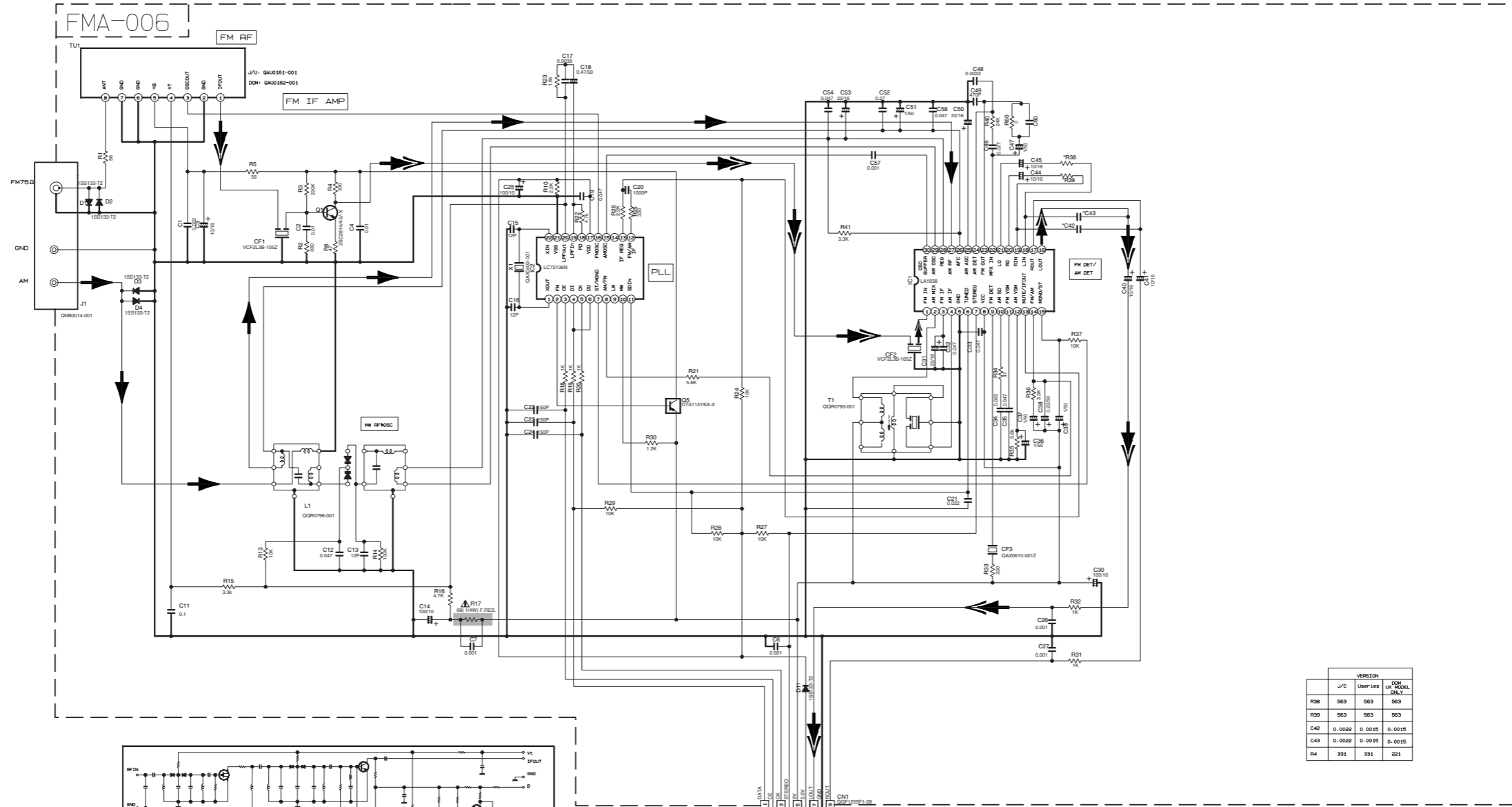
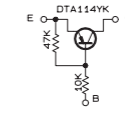

VERSION	J/C		
	Use1es	USE MODEL	USE MODEL
R38	563	563	563
R39	563	563	563
C42	0.0022	0.0015	0.0015
C43	0.0022	0.0015	0.0015
R4	331	331	331

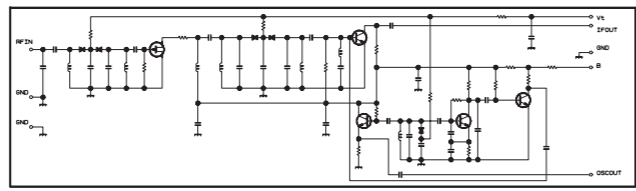

CONDITION	PIN NO.	1	2	3	4	5	6	7	8	9	10	11	12	13	14	15	16	17	18	19	20	21	22	23	24	25	26	27	28	29	30
IC1 FM NO SIGNAL		3.6	8.9	3.6	3.6	0	5.0	5.0	8.9	8.9	1.3	0.1	0	0.9	7.8	7.8	4.3	4.3	4.3	4.3	3.4	3.4	2.8	3.4	0	0	3.5	3.5	3.6	3.6	2.7
IC1 FM 60dB STEREO		3.6	8.9	3.6	3.6	0	5.0	5.0	8.9	8.9	1.3	4.3	0	0.9	7.8	7.8	4.3	4.3	4.3	4.3	3.4	3.4	2.8	3.4	0	0	3.6	3.6	3.6	3.6	2.7
IC1 AM NO SIGNAL		3.5	9.0	3.5	3.5	0	5.0	5.1	9.0	2.6	1.3	0	0	0.9	4.7	5.5	4.3	4.3	4.3	3.3	3.2	2.8	ust	0.7	0.7	3.6	3.6	3.6	3.6	2.7	
IC2 FM NO SIGNAL		2.5	0	0	5.0	4.9	5.0	7.9	7.8	3.6	6.1	5.1	0	0	0	0	2.5	5.1	0.9	0.9	3.8	0	2.3								

TP NO.	Q1	Q5				
PIN NO.	E	C	B	E	C	B
FM 87.5MHz NO SIGNAL	0	7.1	0.85	8.9	8.9	0
AM 520kHz NO SIGNAL	0	0	0	9.0	0	8.9
TP NO.	Q2	Q3	Q4			
PIN NO.	E	C	B	E	C	B
AM 520kHz NO SIGNAL	0	0	0.7	0	0	0.7
AM 1440Hz NO SIGNAL	0	0	0.3	0	0.3	3.6

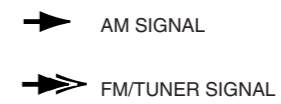

▲ Parts are safety assurance parts. When replacing those parts make sure to use the specified one.

Printed circuit boards

■ Main board Block No. 01

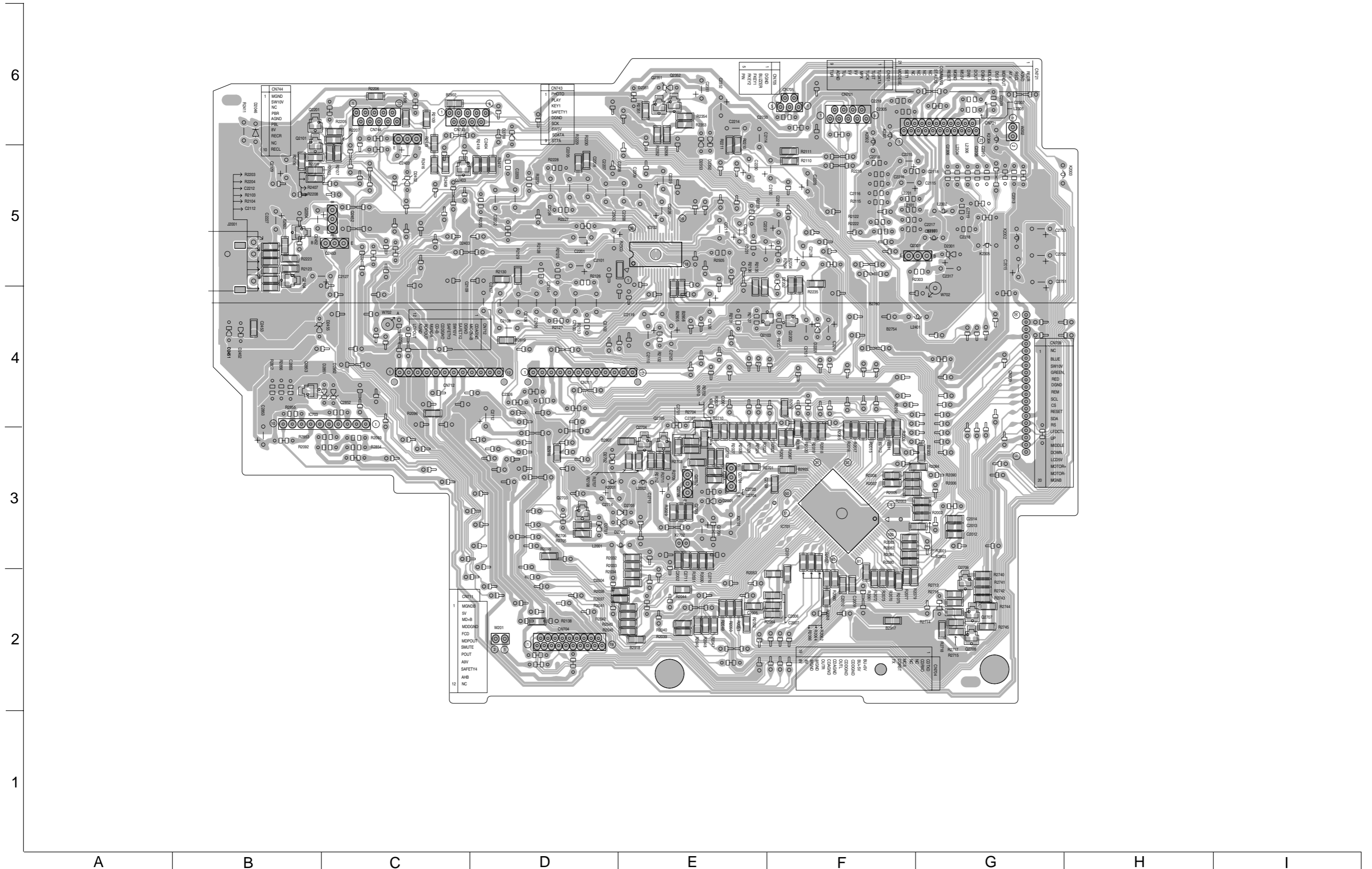

■ Power amplifier & control & AC jack board **Block No. 02**

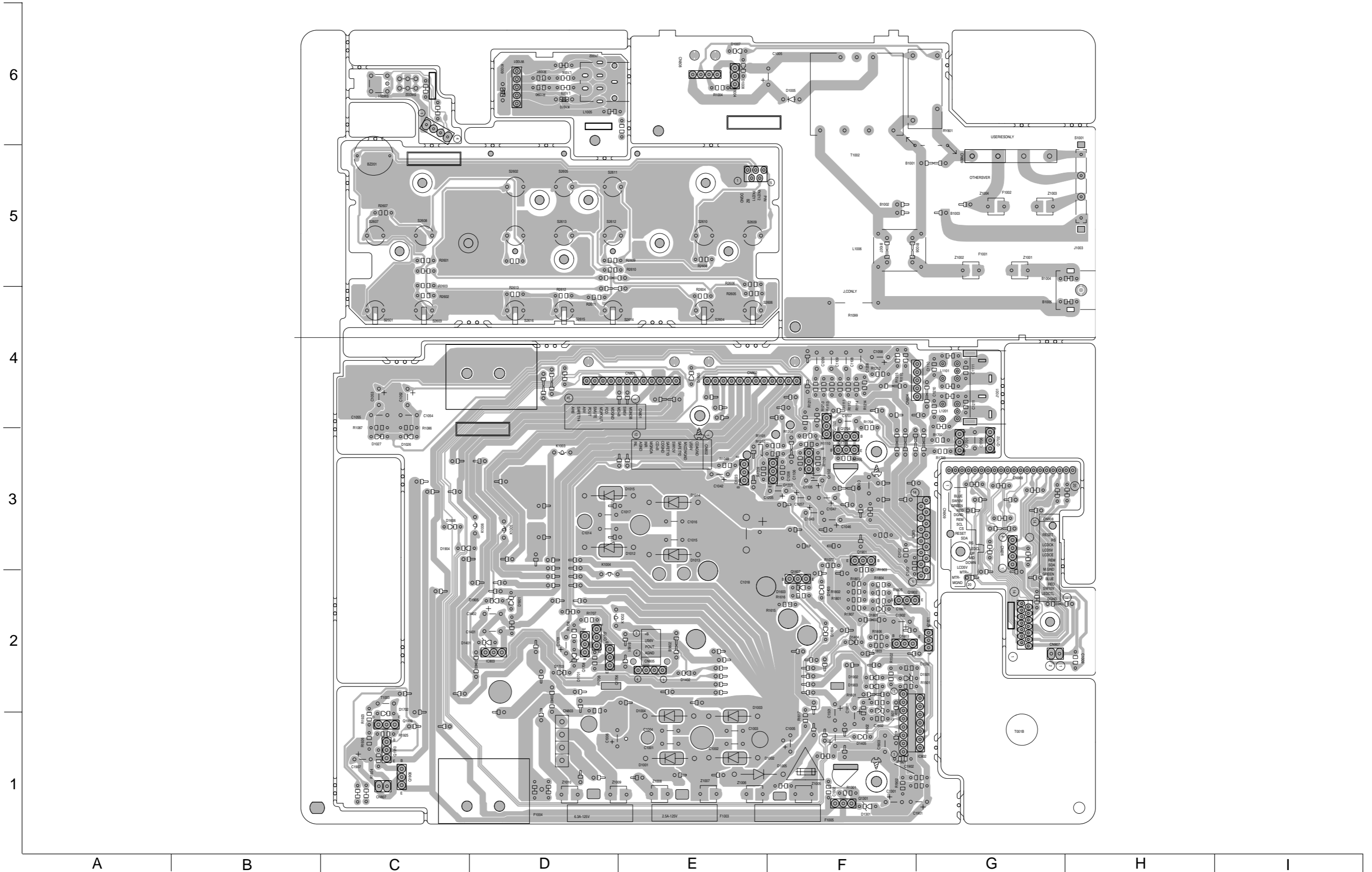

■ Tuner board Block No. 03



■ CD servo control board Block No. 04

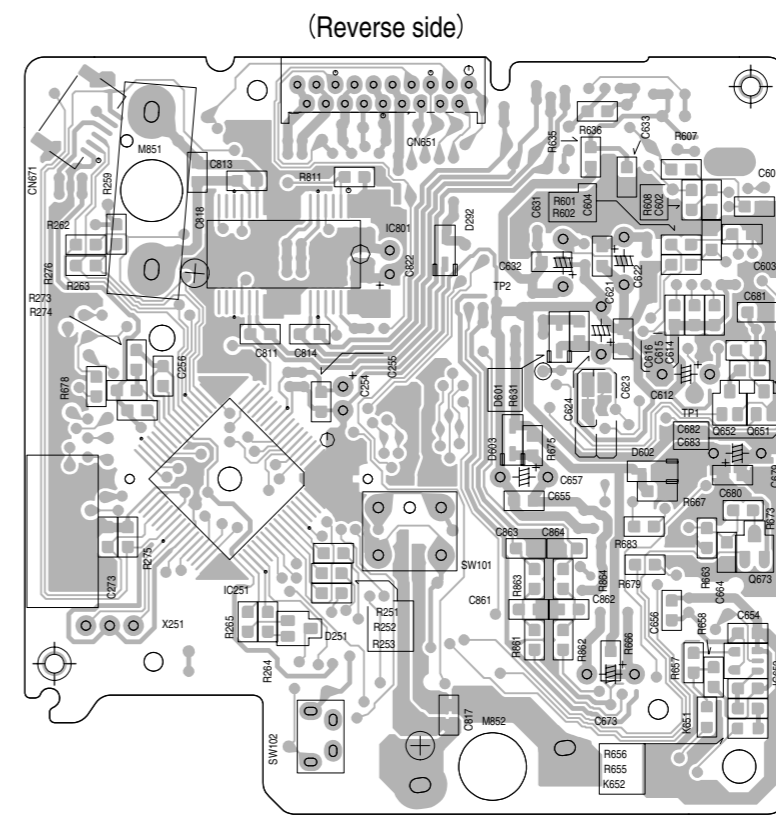
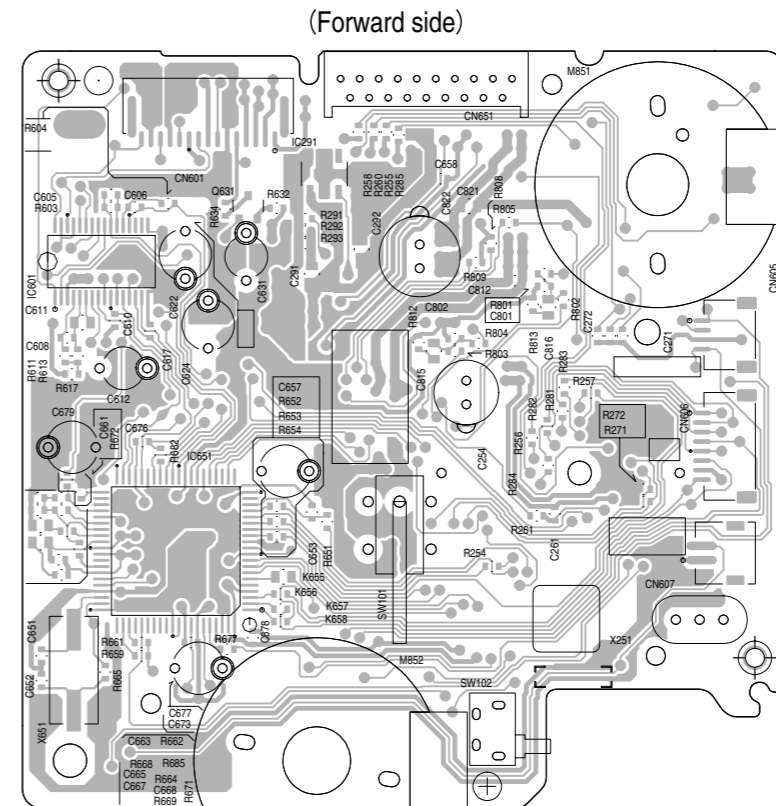

■ MD servo board Block No. 05

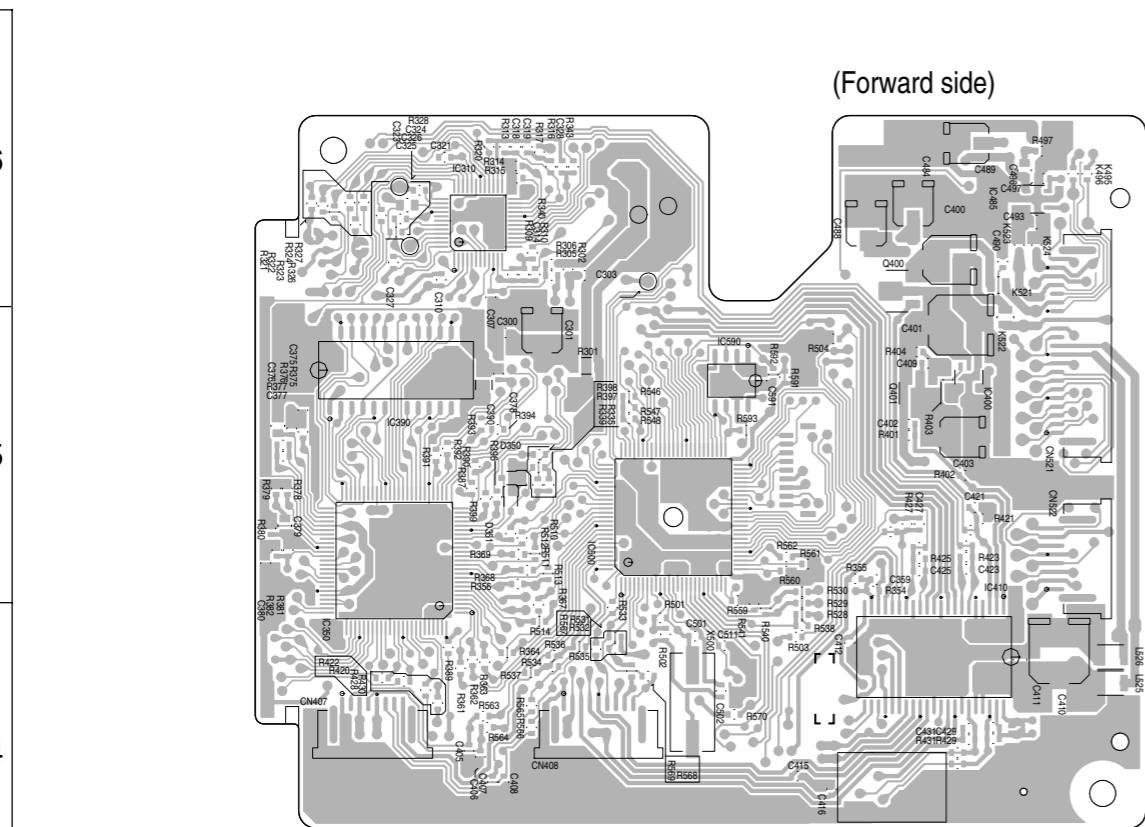

(MD servo board)

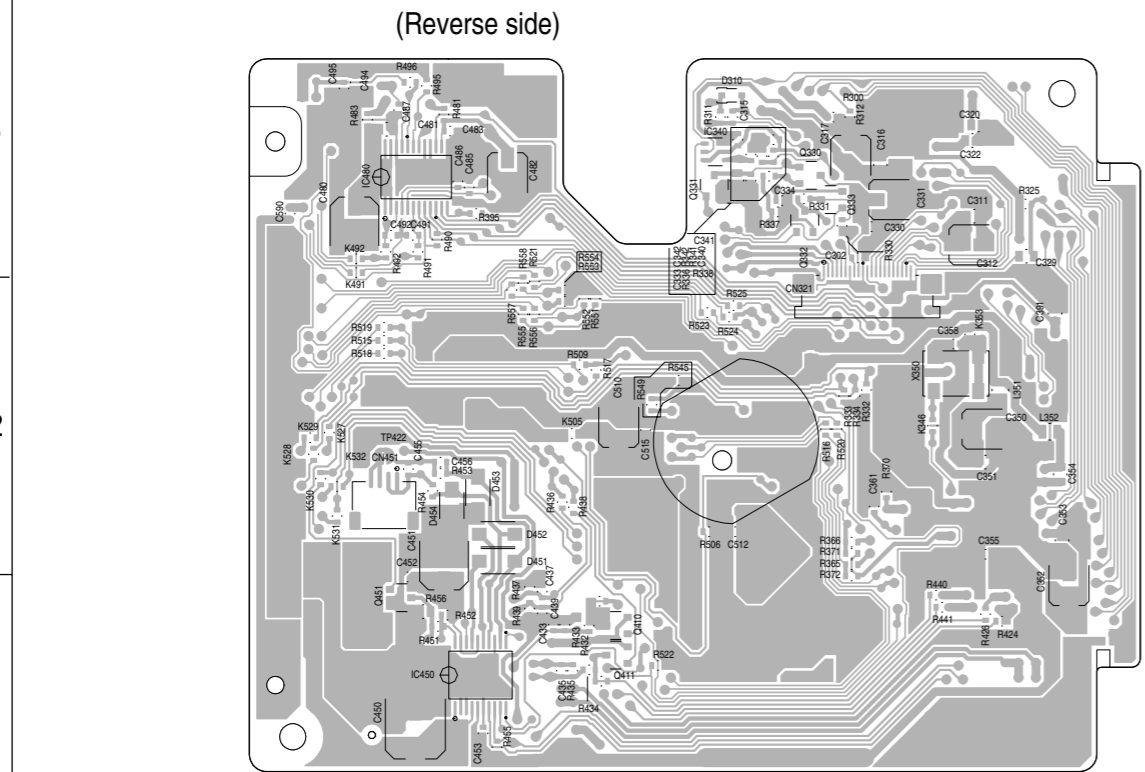

(Reverse side)

■ Traverse mechanism board Block No. 06

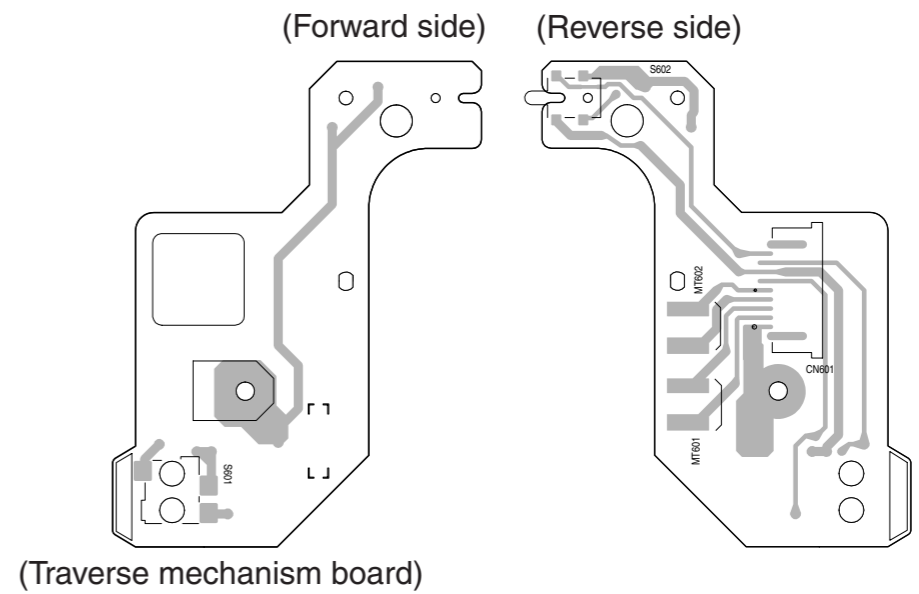

(Traverse mechanism board)

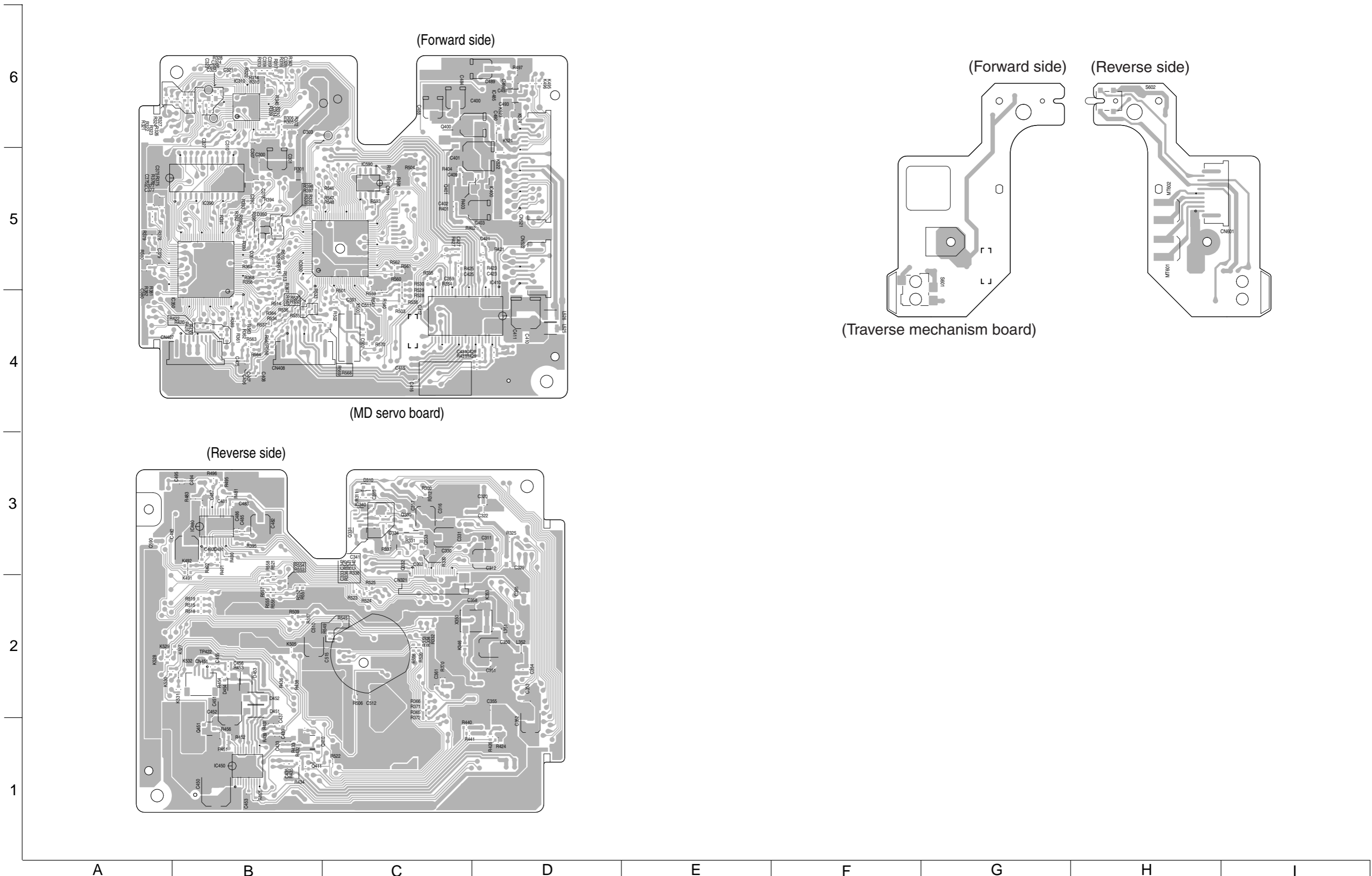

■ Head amplifier board Block No. 07

■ Cassette switch board Block No. 08

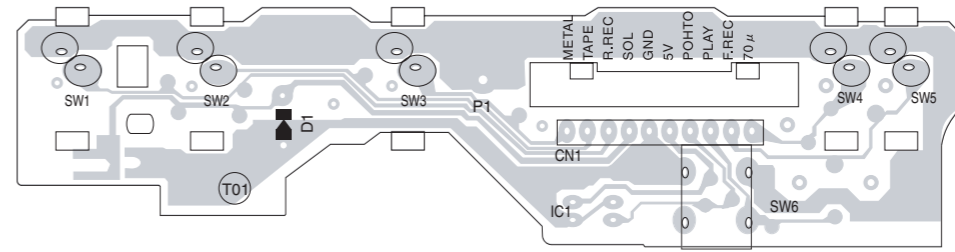
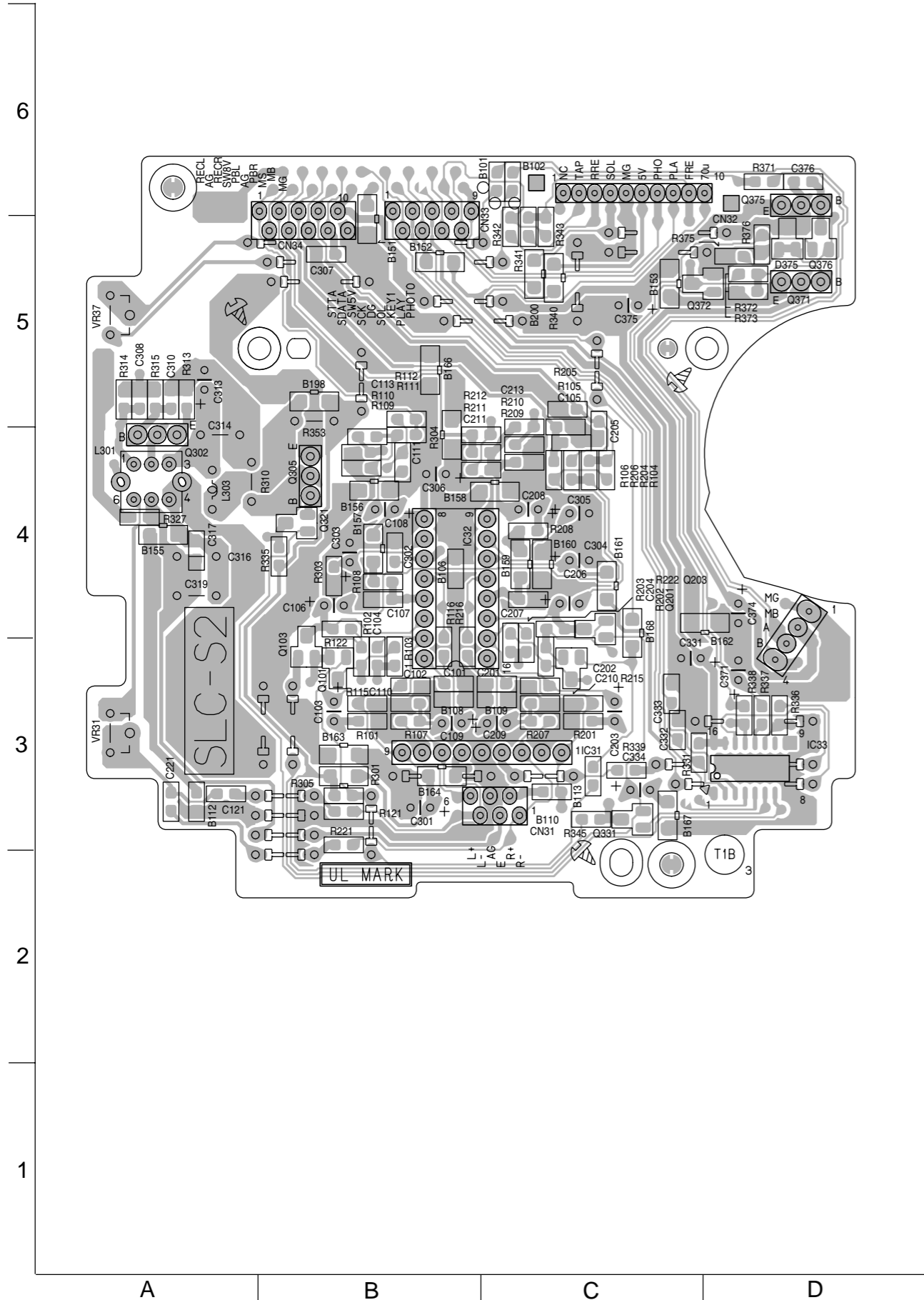

PARTS LIST

[UX-F70MD]

[UX-F72MD]

* All printed circuit boards and its assemblies are not available as service parts.

Area suffix

UB ----- Hong Kong

UF ----- China

- Contents -

Exploded view of general assembly and parts list (Block No.M1)	3- 3
CD mechanism assembly and parts list (Block No.MB)	3- 6
MD mechanism assembly and parts list (Block No.ME)	3- 8
Cassette mechanism assembly and parts list (Block No.MP)	3-11
Electrical parts list (Block No.01~08)	3-13
Packing materials and accessories parts list (Block No.M3,M5)	3-26

< M E M O >

Exploded view of general assembly and parts list

Block No. M 1 M M

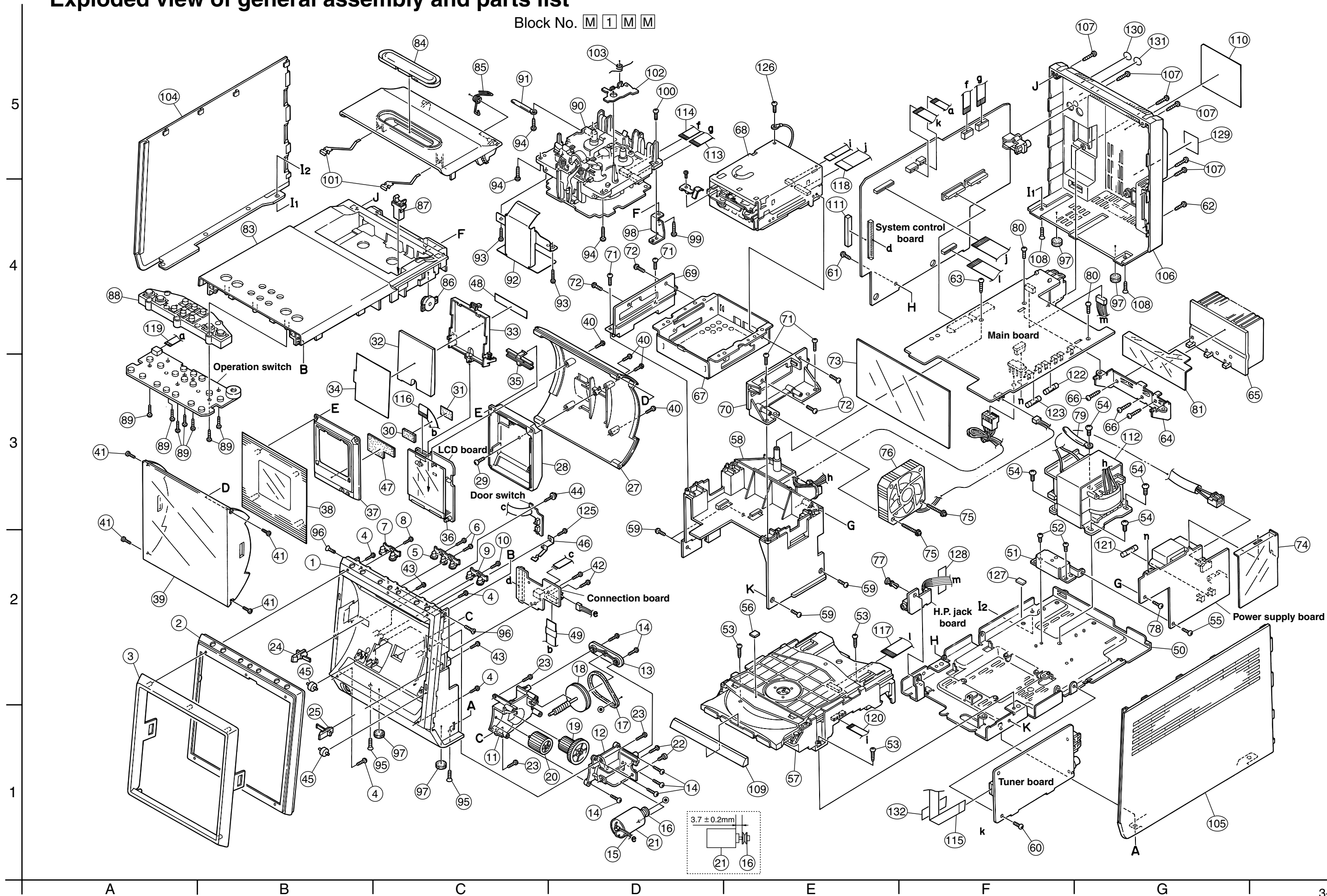

■ Parts list (General assembly)

Block No. M1MM

△	Item	Parts number	Parts name	Q'ty	Description	Area
	96	QYSBSF3008Z	SCREW	2	F.PANEL/T.COVER	
	97	GV40091-002A	FOOT	4	FRONT & REAR	
	98	GV40229-001A	SUPPORT BRACKET	1	SLC MECHA PROCE	
	99	QYSBSF3010Z	SCREW	1	FOR SUPPORT BKT	
	100	QYSBST3008Z	T.SCREW	1	SLC MECH./BRAC.	
	101	VKY4180-401	CASSETTE SPRING	2	PUT AT CASS.DOOR	
	102	VKL7850-002	EJECT SAFTY(R)	1		
	103	VKW5258-003	TORSION SPRING	1		
	104	GV10082-002A	SIDE PANEL(L)	1	UX-F72MD	
		GV10082-001A	SIDE PANEL(L)	1	UX-F70MD	
	105	GV10083-001A	SIDE PANEL(R)	1	UX-F70MD	
		GV10083-002A	SIDE PANEL(R)	1	UX-F72MD	
	106	GV10085-001A	REAR COVER	1		
	107	QYSBSF3010N	TAP SCREW	6	FOR REAR COVER	
	108	QYSSST3010Z	SCREW	2	BOTTOM+REAR COVER	
	109	GV30200-001A	CD FITTING	1	UX-F70MD	
		GV30200-002A	CD FITTING	1	UX-F72MD	
	110	GV30226-001A	RATING LABEL	1	UX-F72MD	UB
		GV30226-003A	RATING LABEL	1	UX-F72MD	UF
		GV30226-004A	RATING LABEL	1	UX-F70MD	UF
		GV30226-002A	RATING LABEL	1	UX-F70MD	UB
	111	GV40250-001A	BOARD SPACER	1	STICK AT FMB BOARD	
△	112	QQT0340-002	POWER TRANS	1	T1001	
	113	QUQ412-1018CJ	FFC WIRE	1	FMB-SLC	
	114	QUQ412-0919CJ	FFC WIRE	1	FMB-SLC	
	115	QUQ412-0932CJ	FFC WIRE	1	FMB-TUNER	
	116	QUQ610-1415BF	FFC WIRE	1	CONN-LCD	
	117	QUQ110-1915BJ	FFC WIRE	1	FMB-CD	
	118	QUQ110-2125BJ	CARD WIRE	1	FMB-MD	
	119	QUQ412-0512DJ	FFC WIRE	1	FMB-FKEY	
	120	QUQ110-0838AJ	FFC WIRE	1		
△	121	QMF51W2-R40-J8	FUSE	1	F1001	
△	122	QMF51W2-1R6-J8	FUSE	1	F1003	
△	123	QMF51W2-5R0-J8	FUSE	1	F1004	
	125	QYSBSF2608Z	T.SCREW	1	F.SPRING/F.BRD	
	126	QYSBST3006Z	T.SCREW	1	MD MECHA/S.WIRE	
	127	GV40251-001A	SPACER	1	STICK AT BOTTOM	
	128	GV40242-003A	COMMON SPACER	1	WIRE ARRANGEMENT	
	129	VND4118-003	CAUTION LABEL	1	STICK AT R.COVER	
	130	LV41768-001A	CCIB LABEL	1		UF
	131	E409372-001	CCEE LABEL	1		UF
	132	GV40242-003A	COMMON SPACER	1	STICK AT INNER	

CD mechanism assembly and parts list

Block No. M B M M

FMU-N1H-2M

Grease

- ★ UD-24H2
- ▲ EM-30L
- LEN-320M

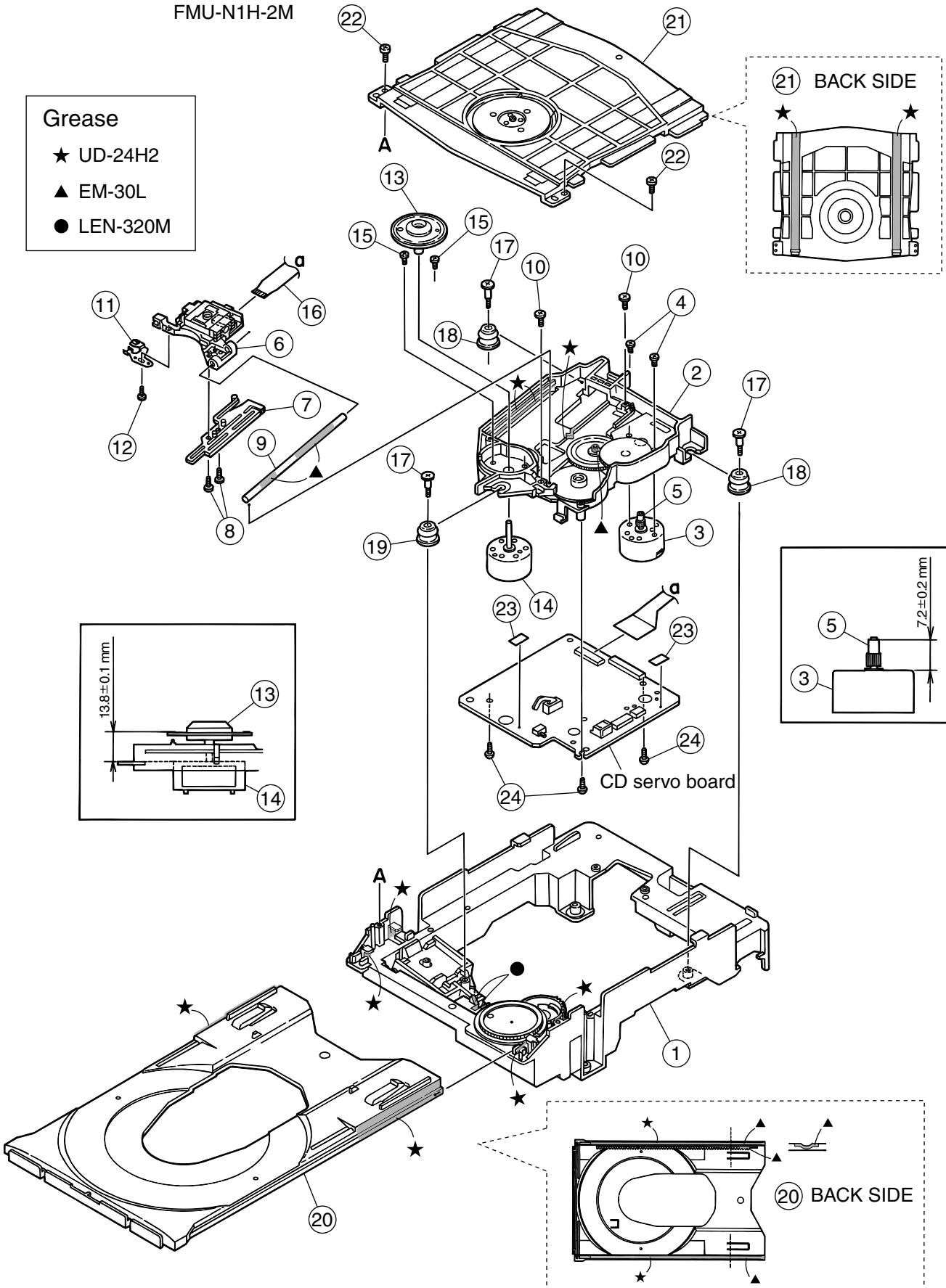

Parts list (CD mechanism)

Block No. MBMM

△	Item	Parts number	Parts name	Q'ty	Description	Area
	1	LV32649-005A	L.BASE ASSY	1		
	2	LV32651-002A	CH.BASE ASSY	1		
	3	QAR0176-001	FEED MOTOR	1		
	4	VKZ4743-001	SPECIAL SCREW	2		
	5	LV42229-001A	MOTOR GEAR	1		
	6	OPTIMA-725B1	CD PICK UP	1		
	7	LV20993-002A	RACK PLATE	1		
	8	QYSPSGT1735M	MINI SCREW	2		
	9	E406777-002SM	C.D SHAFT	1		
	10	LV41741-001A	SPECIAL SCREW	2		
	11	LV31744-001A	P.S.SPRING	1		
	12	QYSPSGT1425M	TAP SCREW	1		
	13	LV42350-001A	T.T.ASSY	1		
	14	QAR0175-001	SP.MOTOR	1		
	15	VKZ4743-001	SPECIAL SCREW	2		
	16	LVB30008-001A	FPC	1		
	17	LV41424-001A	SPECIAL SCREW	3		
	18	LV41659-001A	INSULATOR	2		
	19	LV41659-002A	INSULATOR	1		
	20	LV10503-002A	TRAY	1		
	21	LV32650-003A	CL.BASE ASSY	1		
	22	QYSBSF2005Z	T.SCREW	2		
	23	LV30225-0B6A	SPACER	2		
	24	QYSBSF2005Z	T.SCREW	3		

MD mechanism assembly and parts list

Block No. M E M M

Grease

- ★ = EM-30L
- ▲ = CFD-4007ZY2

FMU-S5M-2M

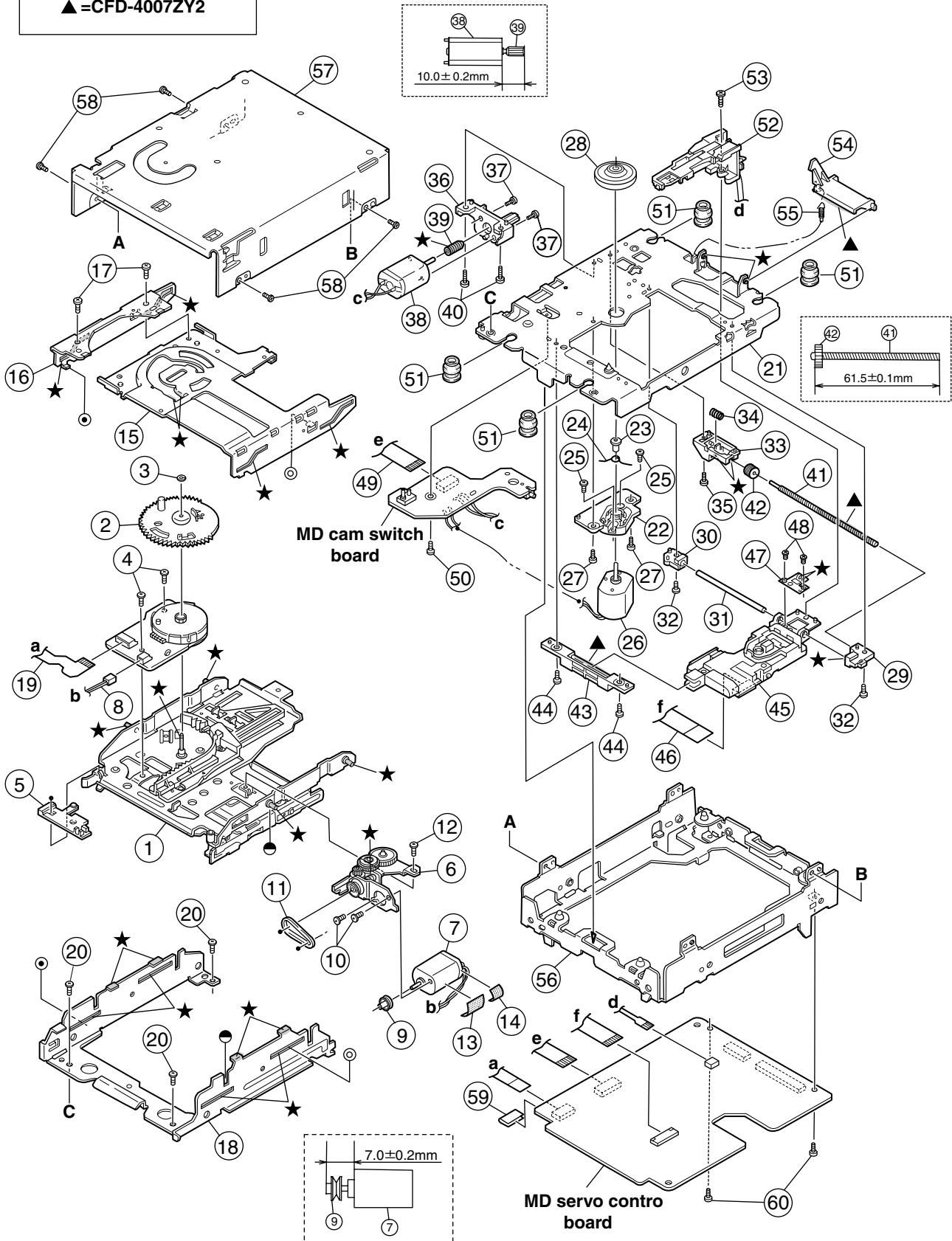

Parts list (MD mechanism)

Block No. MEMM

△	Item	Parts number	Parts name	Q'ty	Description	Area
	1	LV20548-013A	LOADING ASSY	1		
	2	LV31472-002A	CAM GEAR	1		
	3	QYWDL1230252	SLIT WASHER	1		
	4	LV41477-002A	MINI TAP SCREW	2	CAM SW PWB	
	5	LV32168-002A	WIRE HOLDER	1		
	6	LV31710-002A	L.MOTOR ASSY	1		
	7	QAR0144-001	MOTOR	1	MT601	
	8	WJM0117-003A	E-SI C WIRE C-F	1		
	9	LV41341-001A	MOTOR PULLEY	1		
	10	QYSPSPT2020M	MINI SCREW	2	LOAD.MOTOR	
	11	LV41342-001A	BELT	1		
	12	LV41477-002A	MINI TAP SCREW	1	L.MOTOR BKT.	
	13	LV30225-068A	SPACER	1		
	14	LV30225-085A	SPACER	1		
	15	LV20543-002A	SLIDE BASE R	1		
	16	LV31483-001A	SLIDE BASE L	1		
	17	LV41477-002A	MINI TAP SCREW	2	SLIDE BASE	
	18	LV10286-002A	LOAD.MECHA BASE	1		
	19	LVB40003-001A	FPC CABLE	1		
	20	LV41477-002A	MINI TAP SCREW	3	L.MECHA BASE	
	21	LV31709-003A	TM.CHASSIS ASSY	1		
	22	LV20545-001A	SP.MOTOR BASE	1		
	23	LE40515-001A	COLLAR	1		
	24	LE40516-001A	SPRING	1		
	25	QYSPSPU1720N	SCREW	2	SP.MOTOR	
	26	FF-110PH-08280	SP.MOTOR	1	MT603	
	27	LV41477-002A	MINI TAP SCREW	2	SP.MOTOR BASE	
	28	LE30470-202A	T.TABLE ASSY	1		
	29	LV41343-001A	SHAFT HOLDER R	1		
	30	LV41344-002A	SHAFT HOLDER F	1		
	31	VKH5803-001	GUIDE SHAFT	1		
	32	LV41477-002A	MINI TAP SCREW	2	SHAFT HOLDER	
	33	LV31484-001A	T.SPRING HOLDER	1		
	34	LV41350-001A	COM.SPRING	1		
	35	LV41477-002A	MINI TAP SCREW	1	T.SP.HOLDER	
	36	LV31485-001A	FEED MOTOR BKT.	1		
	37	QYSPSPT2025N	MINI SCREW	2	FEED MOTOR	
	38	QAR0144-001	MOTOR	1	MT602	
	39	LV41345-001A	FEED WORM	1		
	40	LV41477-002A	MINI TAP SCREW	2	FEED MOTOR BKT.	
	41	LV42702-001A	SCREW SHAFT	1		
	42	LV41347-001A	S.SHAFT GEAR	1		
	43	LV31486-001A	PICK UP GUIDE	1		
	44	LV41477-002A	MINI TAP SCREW	2	P-UP GUIDE	
	45	KMS-260E	MD PICK UNIT	1		
	46	LVB30007-002A	FPC CABLE	1		
	47	LV41348-001A	RACK SPRING	1		
	48	QYSPSPT1414M	MINI SCREW	2	RACK SPRING	

Parts list (MD mechanism)

Block No. MEMM

▲	Item	Parts number	Parts name	Q'ty	Description	Area
	49	WJT0042-001A	E-CARD WIRE	1		
	50	LV41477-002A	MINI TAP SCREW	1	T.MECHA PWB	
	51	LV40761-003A	INSULATOR	4		
	52	QAH0039-002	MD HEAD	1	H601	
	53	QYSPSPT1740N	MINI SCREW	1	MD HEAD	
	54	LV31487-002A	HEAD LIFTER	1		
	55	LV41349-001A	H.LIFTER SPRING	1		
	56	LV10284-002A	SINGLE FRAME	1		
	57	LV10285-003A	MECHA COVER	1		
	58	LV41477-002A	MINI TAP SCREW	4	MECHA COVER	
	59	LV30225-096A	SPACER	1		
	60	VKZ4539-024	MINI SCREW	2	SERVO PWB	

Cassette mechanism assembly and parts list

SLC-S21M

Block No. M P M M

Grease

- ★ =EM-30L
- ▲ =UD-24
- =UD-24H2
- =LEN-320M
- =JC-888B
- ◎ =MOBIL-1

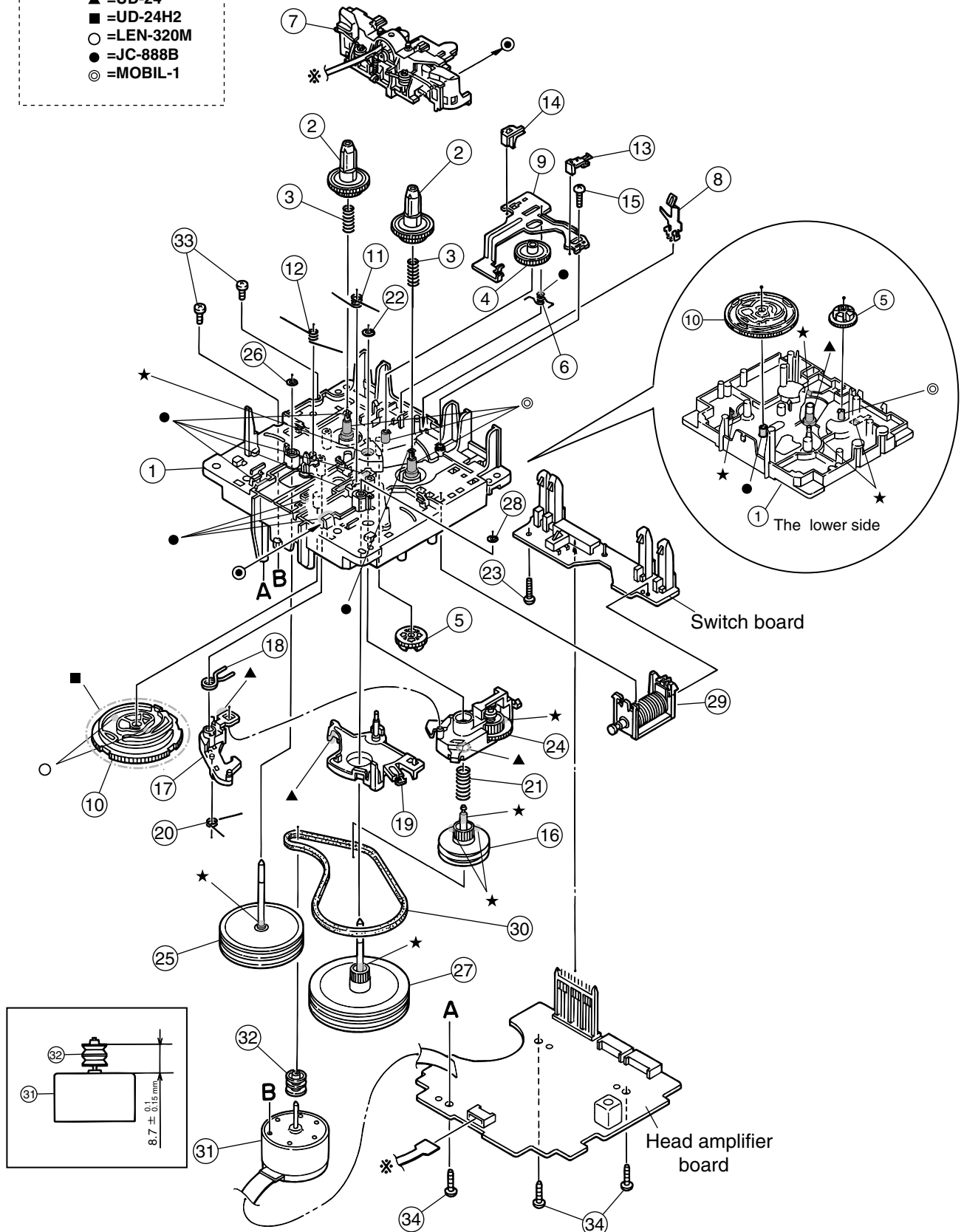

■ Parts list (Cassette mechanism)

Block No. MPMM

△	Item	Parts number	Parts name	Q'ty	Description	Area
	1	VKS1165-00J	CHASSIS B.ASS'Y	1		
	2	VKS2274-002	REEL GEAR	2		
	3	VKW5286-002	B.T. SPRING	2		
	4	VKS5559-001	PLAY IDLE GEAR	1		
	5	VKS5597-00B	BLIND	1		
	6	VKW5296-001	EARTH SPRING	1		
	7	SLC-RP1SVM	HEAD MOUNT ASSY	1		
	8	VKY3149-002	CASSETTE SP.	1		
	9	LV31786-001A	PLAY SW LEVER	1		
	10	VKS1166-003	CONTROL CAM	1		
	11	VKW5279-001	HEAD BASE SP(R)	1		
	12	VKW5280-001	HEAD BASE SP(L)	1		
	13	LV41584-001A	BRAKE(R)	1		
	14	LV41585-002A	BRAKE(L)	1		
	15	QYSBSF2005Z	T.SCREW	1		
	16	VKS5603-00G	MAIN PULLEY ASY	1		
	17	VKS3785-001MM	FR ARM	1		
	18	VKW5284-002	SWING SPRING	1		
	19	VKS2278-003	TRIGGER ARM	1		
	20	VKW5301-001	FR SPRING	1		
	21	VKW5266-001	ELEVATOR SPRING	1		
	22	WDL214025	WASHER	1		
	23	QYSBSF2005Z	T.SCREW	1		
	24	VKS3786-00G	CLUTCH ASS'Y	1		
	25	VKF3205-00B	F.WHEEL ASSY(R)	1		
	26	WDL183425	SLIT WASHER	1		
	27	VKF3207-00B	F.WHEEL ASSY(L)	1		
	28	WDL173525-6	SLIT WASHER	1		
	29	VKZ3174-00A	DC SOLENOID	1		
	30	LV42234-001A	CAPSTAN BELT	1		
	31	MSI-5U2LWA	D.C.MOTOR ASS'Y	1		
	32	VKR4761-001	MOTOR PULLEY	1		
	33	QYSPSP2604Z	SCREW	2		
	34	QYSBSF2608Z	T.SCREW	3	FOR P.W.B.	

■ Electrical parts list (System control board) Block No. 01

△	Item	Parts number	Parts name	Remarks	Area
	R2072	NRSA63J-101X	MG RESISTOR		
	R2073	NRSA63J-101X	MG RESISTOR		
	R2075	NRSA63J-101X	MG RESISTOR		
	R2077	NRSA63J-101X	MG RESISTOR		
	R2079	NRSA63J-222X	MG RESISTOR		
	R2080	NRSA63J-222X	MG RESISTOR		
	R2081	NRSA63J-222X	MG RESISTOR		
	R2082	NRSA63J-222X	MG RESISTOR		
	R2083	NRSA63J-103X	MG RESISTOR		
	R2084	NRSA63J-103X	MG RESISTOR		
	R2085	NRSA63J-473X	MG RESISTOR		
	R2086	NRSA63J-473X	MG RESISTOR		
	R2087	NRSA63J-473X	MG RESISTOR		
	R2088	NRSA63J-104X	MG RESISTOR		
	R2092	QRE141J-473Y	C RESISTOR	47K 5% 1/4W	
	R2093	QRE141J-473Y	C RESISTOR	47K 5% 1/4W	
	R2095	NRSA63J-103X	MG RESISTOR		
	R2096	NRSA63J-103X	MG RESISTOR		
	R2103	NRSA63J-393X	MG RESISTOR		
	R2104	NRSA63J-103X	MG RESISTOR		
	R2105	NRSA63J-472X	MG RESISTOR		
	R2106	NRSA63J-153X	MG RESISTOR		
	R2107	NRSA63J-222X	MG RESISTOR		
	R2108	NRSA63J-152X	MG RESISTOR		
	R2109	NRSA63J-182X	MG RESISTOR		
	R2110	NRSA63J-122X	MG RESISTOR		
	R2111	NRSA63J-682X	MG RESISTOR		
	R2115	QRE141J-332Y	C RESISTOR	3.3K 5% 1/4W	
	R2122	QRE141J-332Y	C RESISTOR	3.3K 5% 1/4W	
	R2125	QRE141J-222Y	C RESISTOR	2.2K 5% 1/4W	
	R2126	QRE141J-222Y	C RESISTOR	2.2K 5% 1/4W	
	R2127	QRE141J-182Y	C RESISTOR	1.8K 5% 1/4W	
	R2128	QRE141J-472Y	C RESISTOR	4.7K 5% 1/4W	
	R2129	NRSA63J-752X	MG RESISTOR		
	R2130	NRSA63J-752X	MG RESISTOR		
	R2131	QRE141J-182Y	C RESISTOR	1.8K 5% 1/4W	
	R2132	QRE141J-182Y	C RESISTOR	1.8K 5% 1/4W	
	R2133	QRE141J-224Y	C RESISTOR	220K 5% 1/4W	
	R2134	NRSA63J-103X	MG RESISTOR		
	R2135	NRSA63J-124X	MG RESISTOR		
	R2136	NRSA63J-154X	MG RESISTOR		
	R2137	QRE141J-153Y	C RESISTOR	15K 5% 1/4W	
	R2138	NRSA63J-103X	MG RESISTOR		
	R2203	NRSA63J-393X	MG RESISTOR		
	R2204	NRSA63J-103X	MG RESISTOR		
	R2205	NRSA63J-472X	MG RESISTOR		
	R2206	NRSA63J-153X	MG RESISTOR		
	R2207	NRSA63J-222X	MG RESISTOR		
	R2208	NRSA63J-152X	MG RESISTOR		
	R2209	NRSA63J-182X	MG RESISTOR		
	R2210	NRSA63J-122X	MG RESISTOR		
	R2211	NRSA63J-682X	MG RESISTOR		
	R2215	QRE141J-332Y	C RESISTOR	3.3K 5% 1/4W	
	R2222	QRE141J-332Y	C RESISTOR	3.3K 5% 1/4W	
	R2225	QRE141J-222Y	C RESISTOR	2.2K 5% 1/4W	
	R2226	QRE141J-222Y	C RESISTOR	2.2K 5% 1/4W	
	R2227	QRE141J-182Y	C RESISTOR	1.8K 5% 1/4W	
	R2228	QRE141J-472Y	C RESISTOR	4.7K 5% 1/4W	
	R2229	NRSA63J-752X	MG RESISTOR		
	R2230	NRSA63J-752X	MG RESISTOR		
	R2231	QRE141J-182Y	C RESISTOR	1.8K 5% 1/4W	
	R2232	QRE141J-182Y	C RESISTOR	1.8K 5% 1/4W	
	R2233	QRE141J-224Y	C RESISTOR	220K 5% 1/4W	

△	Item	Parts number	Parts name	Remarks	Area
	R2234	NRSA63J-103X	MG RESISTOR		
	R2235	NRSA63J-513X	MG RESISTOR		
	R2237	QRE141J-153Y	C RESISTOR	15K 5% 1/4W	
	R2303	QRE141J-561Y	C RESISTOR	560 5% 1/4W	
	R2351	NRSA63J-390X	MG RESISTOR		
	R2352	NRSA63J-332X	MG RESISTOR		
	R2353	NRSA63J-273X	MG RESISTOR		
	R2354	NRSA63J-102X	MG RESISTOR		
	R2407	NRSA63J-332X	MG RESISTOR		
	R2408	NRSA63J-392X	MG RESISTOR		
	R2415	NRSA63J-823X	MG RESISTOR		
	R2416	NRSA63J-823X	MG RESISTOR		
	R2417	NRSA63J-394X	MG RESISTOR		
	R2418	NRSA63J-104X	MG RESISTOR		
	R2503	NRSA63J-222X	MG RESISTOR		
	R2505	QRE141J-222Y	C RESISTOR	2.2K 5% 1/4W	
	R2614	NRSA63J-161X	MG RESISTOR		
	R2615	NRSA63J-470X	MG RESISTOR		
	R2705	NRSA63J-331X	MG RESISTOR		
	R2706	NRSA63J-103X	MG RESISTOR		
	R2707	NRSA63J-103X	MG RESISTOR		
	R2708	NRSA63J-103X	MG RESISTOR		
	R2709	NRSA63J-103X	MG RESISTOR		
	R2710	NRSA63J-104X	MG RESISTOR		
	R2711	NRSA63J-473X	MG RESISTOR		
	R2712	NRSA63J-333X	MG RESISTOR		
	R2713	NRSA63J-102X	MG RESISTOR		
	R2714	NRSA63J-102X	MG RESISTOR		
	R2715	NRSA63J-102X	MG RESISTOR		
	R2716	NRSA63J-102X	MG RESISTOR		
	R2717	NRSA63J-102X	MG RESISTOR		
	R2718	NRSA63J-102X	MG RESISTOR		
	R2719	NRSA63J-221X	MG RESISTOR		
	R2720	NRSA63J-221X	MG RESISTOR		
	R2721	NRSA63J-271X	MG RESISTOR		
	R2722	NRSA63J-271X	MG RESISTOR		
	R2723	NRSA63J-271X	MG RESISTOR		
	R2724	NRSA63J-271X	MG RESISTOR		
	R2725	NRSA63J-221X	MG RESISTOR		
	R2726	NRSA63J-221X	MG RESISTOR		
	R2727	NRSA63J-271X	MG RESISTOR		
	R2728	NRSA63J-271X	MG RESISTOR		
	R2729	NRSA63J-271X	MG RESISTOR		
	R2730	NRSA63J-271X	MG RESISTOR		
	R2731	NRSA63J-221X	MG RESISTOR		
	R2732	NRSA63J-221X	MG RESISTOR		
	R2733	NRSA63J-271X	MG RESISTOR		
	R2734	NRSA63J-271X	MG RESISTOR		
	R2735	NRSA63J-271X	MG RESISTOR		
	R2736	NRSA63J-271X	MG RESISTOR		
	R2740	NRSA63J-222X	MG RESISTOR		
	R2741	NRSA63J-222X	MG RESISTOR		
	R2742	NRSA63J-222X	MG RESISTOR		
	R2743	NRSA63J-222X	MG RESISTOR		
	R2744	NRSA63J-222X	MG RESISTOR		
	R2745	NRSA63J-222X	MG RESISTOR		
	R2750	NRSA63J-221X	MG RESISTOR		
	R2751	NRSA63J-221X	MG RESISTOR		
	R2752	NRSA63J-221X	MG RESISTOR		
	R2852	QRE141J-100Y	C RESISTOR	10 5% 1/4W	
	R2853	QRE141J-222Y	C RESISTOR	2.2K 5% 1/4W	
	R2854	QRE141J-222Y	C RESISTOR	2.2K 5% 1/4W	
	R2855	QRE141J-100Y	C RESISTOR	10 5% 1/4W	
	R2856	QRE141J-9R1Y	C RESISTOR	9.1 5% 1/4W	
	R2901	NRSA63J-103X	MG RESISTOR		
	X2701	QAX0283-001Z	RESONATOR	MAIN CLOCK	
	X2702	QAX0401-001	CRYSTAL	SUB CLOCK	

■ Electrical parts list (Main board)

Block No. 02

△	Item	Parts number	Parts name	Remarks	Area	△	Item	Parts number	Parts name	Remarks	Area
	CN801	QGB2510K2-12	CONNECTOR				C1706	QENC1EM-106Z	NP E CAPACITOR	10MF 20% 25V	
	CN802	QGB2510K2-12	CONNECTOR				C1707	QENC1EM-106Z	NP E CAPACITOR	10MF 20% 25V	
	CN803	QGA3901C1-04	4P CONNECTOR				C1709	QCBB1HK-101Y	C CAPACITOR	100PF 10% 50V	
	CN804	QGA2501C1-05	5P CONNECTOR				C1710	QETN1EM-337Z	E CAPACITOR	330MF 20% 25V	
	CN805	QGB2510J1-04	CONNECTOR				C1801	QDYB1CM-103Y	C CAPACITOR		
	CN807	QGA2501F1-02	CONNECTOR				C1802	EETC1EM-476ZJC	E CAPACITOR		
	CN808	QGB2510K2-04	CONNECTOR				C1803	QCBB1HK-221Y	C CAPACITOR	220PF 10% 50V	
	CN809	QGA7901C1-02	CONNECTOR				C1901	EETC1CM-107ZJC	E CAPACITOR		
	CN905	QGF1201F3-05	CONNECTOR				C1902	QCFB1HZ-104Y	C CAPACITOR	.10MF +80:-20%	
	CN906	QGD2504C1-04Z	SOCKET	TO FUNCTION KEY			C1907	EKCC1CM-106ZJC	E CAPACITOR		
	CN907	QGA2501F1-02	CONNECTOR				C1908	QCFB1HZ-105Y	ML C CAPACITOR	1.0MF +80:-20%	
	CN908	QGF1016F1-14	CONNECTOR	TO CONN. BOARD		△	D1001	1N5401-TM	DIODE		
	CN909	QGB2024J1-20S	B TO B CONNECTO			△	D1002	1N5401-TM	DIODE		
	C1001	QCF31HZ-223Z	C CAPACITOR	.022MF +80:-20%		△	D1003	1N5401-TM	DIODE		
	C1002	QCF31HZ-223Z	C CAPACITOR	.022MF +80:-20%		△	D1004	1N5401-TM	DIODE		
△	C1003	QCF31HZ-223Z	C CAPACITOR	.022MF +80:-20%		△	D1005	1N5401-TM	DIODE		
△	C1004	QCF31HZ-223Z	C CAPACITOR	.022MF +80:-20%		△	D1006	1N4003S-T5	SI DIODE		
△	C1005	QETM1EM-228	E CAPACITOR	2200MF 20% 25V		△	D1007	1SS133-T2	SI DIODE		
△	C1006	QETM1EM-228	E CAPACITOR	2200MF 20% 25V			D1008	1SS133-T2	SI DIODE		
△	C1007	QETM1EM-108	E CAPACITOR	1000MF 20% 25V		△	D1012	1N5401-TM	DIODE		
△	C1008	QZ9105-472	C CAPACITOR	4700PF		△	D1013	1N5401-TM	DIODE		
	C1009	QCFB1HZ-105Y	ML C CAPACITOR	1.0MF +80:-20%		△	D1014	1N5401-TM	DIODE		
	C1014	QFLA1HJ-104Z	M CAPACITOR	.10MF 5% 50V		△	D1015	1N5401-TM	DIODE		
	C1015	QFLA1HJ-104Z	M CAPACITOR	.10MF 5% 50V			D1026	1SS133-T2	SI DIODE		
	C1016	QFLA1HJ-104Z	M CAPACITOR	.10MF 5% 50V			D1027	1SS133-T2	SI DIODE		
	C1017	QFLA1HJ-104Z	M CAPACITOR	.10MF 5% 50V			D1301	MTZJ11A-T2	Z DIODE		
△	C1018	QE20512-828	E CAPACITOR	8200MF			D1401	MTZJ8.2B-T2	DIODE		
	C1042	QETC1AM-336Z	E CAPACITOR	33MF 20% 10V			D1402	1SS133-T2	SI DIODE		
	C1043	QETN1CM-107Z	E CAPACITOR	100MF 20% 16V			D1403	1SS133-T2	SI DIODE		
	C1046	QETN1HM-336Z	E CAPACITOR	33MF 20% 50V			D1404	1SS133-T2	SI DIODE		
	C1047	QETN1HM-105Z	E CAPACITOR	1.0MF 20% 50V			D1405	1SS133-T2	SI DIODE		
	C1052	EETC1HM-105ZJC	E CAPACITOR				D1501	MTZJ8.2C-T2	Z DIODE		
	C1053	EETC1HM-105ZJC	E CAPACITOR				D1601	MTZJ8.2C-T2	Z DIODE		
	C1054	QFLC1HJ-563Z	TF CAPACITOR	.056MF 5% 50V			D1603	MTZJ5.6B-T2	Z DIODE		
	C1055	QFLC1HJ-563Z	TF CAPACITOR	.056MF 5% 50V			D1604	1SS133-T2	SI DIODE		
	C1056	QFLA1HJ-104Z	M CAPACITOR	.10MF 5% 50V			D1605	1SS133-T2	SI DIODE		
	C1057	EETC1HM-225ZJC	E CAPACITOR				D1606	1SS133-T2	SI DIODE		
	C1058	QEKC1CM-107Z	E CAPACITOR	100MF 20% 16V			D1701	MTZJ5.6B-T2	Z DIODE		
	C1105	QTE1V06-106Z	E CAPACITOR				D1702	1SS133-T2	SI DIODE		
	C1106	QDGB1HK-102Y	C CAPACITOR				D1703	1SS133-T2	SI DIODE		
	C1107	QCBB1HK-331Y	C CAPACITOR	330PF 10% 50V			D1801	MTZJ10C-T2	Z DIODE		
	C1108	QFVF1HJ-104Z	MF CAPACITOR	.10MF 5% 50V			D1901	MTZJ8.2C-T2	Z DIODE		
	C1109	QFVF1HJ-104Z	MF CAPACITOR	.10MF 5% 50V			D1902	1SS133-T2	SI DIODE	UX-F70MD	
	C1110	QCBB1HK-221Y	C CAPACITOR	220PF 10% 50V			D1903	1SS133-T2	SI DIODE	UX-F70MD	
	C1111	QDXB1CM-332Y	C CAPACITOR				D1904	1SS133-T2	SI DIODE		
	C1205	QTE1V06-106Z	E CAPACITOR				D1905	1SS133-T2	SI DIODE		
	C1206	QDGB1HK-102Y	C CAPACITOR				FW906	QUM024-10DGZ3	PARA RIBON WIRE	TO CONN BOARD	
	C1207	QCBB1HK-331Y	C CAPACITOR	330PF 10% 50V		△	IC801	LA4628	IC		
	C1208	QFVF1HJ-104Z	MF CAPACITOR	.10MF 5% 50V		△	IC802	L4909	REGULATOR IC		
	C1209	QFVF1HJ-104Z	MF CAPACITOR	.10MF 5% 50V			IC803	KIA78S05P-T	IC	SW5V REG	
	C1210	QCBB1HK-221Y	C CAPACITOR	220PF 10% 50V			J1001	QNB0133-001	SPK TERMINAL		
	C1211	QDXB1CM-332Y	C CAPACITOR				J1002	QNS0030-001	JACK		
	C1301	QETN1CM-107Z	E CAPACITOR	100MF 20% 16V		△	J1003	QNC0006-001	AC SOCKET		
	C1302	QDGB1HK-102Y	C CAPACITOR				K1002	QQR0621-001Z	FERRITE BEADS		
	C1401	QFVF1HJ-104Z	MF CAPACITOR	.10MF 5% 50V			K1003	QQR0621-001Z	FERRITE BEADS		
	C1402	QEKC1CM-107Z	E CAPACITOR	100MF 20% 16V			K1004	QQR0621-001Z	FERRITE BEADS		
	C1501	EETC1CM-107ZJC	E CAPACITOR				K1005	QQR0621-001Z	FERRITE BEADS		
	C1502	QCFB1HZ-105Y	ML C CAPACITOR	1.0MF +80:-20%			K1006	QQR0621-001Z	FERRITE BEADS		
	C1601	EETC1CM-107ZJC	E CAPACITOR				K1009	QQR0779-001Z	INDUCTOR		
	C1602	QCFB1HZ-104Y	C CAPACITOR	.10MF +80:-20%			K1010	QQR0779-001Z	INDUCTOR		
	C1701	QETN1CM-107Z	E CAPACITOR	100MF 20% 16V			L1003	QQL231K-470Y	INDUCTOR		
	C1704	QDGB1HK-102Y	C CAPACITOR				L1004	QQL231K-470Y	INDUCTOR		
	C1705	QDGB1HK-102Y	C CAPACITOR				L1005	QQL231K-470Y	INDUCTOR		

■ Electrical parts list (Tuner board)

Block No. 03

△	Item	Parts number	Parts name	Remarks	Area
	C 1	NCB21HK-223X	C CAPACITOR		
	C 2	NCB21HK-103X	C CAPACITOR		
	C 3	EETC1CM-106ZJC	E CAPACITOR		
	C 4	NCB21HK-103X	C CAPACITOR		
	C 6	NCB21HK-102X	C CAPACITOR		
	C 7	NCB21HK-102X	C CAPACITOR		
	C 8	NCB21HK-102X	C CAPACITOR		
	C 10	NRSA02J-0R0X	MG RESISTOR		
	C 11	NCB21HK-104X	C CAPACITOR		
	C 12	NCB21HK-473X	C CAPACITOR		
	C 13	NCS21HJ-120X	C CAPACITOR		
	C 14	EEKC1AM-107ZJC	E CAPACITOR		
	C 15	NCS21HJ-120X	C CAPACITOR		
	C 16	NCS21HJ-120X	C CAPACITOR		
	C 17	NCB21HK-392X	C CAPACITOR		
	C 18	QEQ61HM-474Z	NP E CAPACITOR	.47MF 20% 50V	
	C 19	NCB21HK-473X	C CAPACITOR		
	C 20	NCB21HK-102X	C CAPACITOR		
	C 21	NCB21HK-223X	C CAPACITOR		
	C 22	NCS21HJ-151X	C CAPACITOR		
	C 23	NCS21HJ-151X	C CAPACITOR		
	C 24	NCS21HJ-151X	C CAPACITOR		
	C 25	EEKC1AM-107ZJC	E CAPACITOR		
	C 26	NCB21HK-102X	C CAPACITOR		
	C 27	NCB21HK-102X	C CAPACITOR		
	C 30	EEKC1CM-107ZJC	E CAPACITOR		
	C 31	EEKC1CM-226ZJC	E CAPACITOR		
	C 32	NCB21HK-473X	C CAPACITOR		
	C 33	NCB21HK-473X	C CAPACITOR		
	C 34	NCB21HK-223X	C CAPACITOR		
	C 35	NCB21HK-473X	C CAPACITOR		
	C 36	EEKC1HM-105ZJC	E CAPACITOR		
	C 37	EEKC1HM-105ZJC	E CAPACITOR		
	C 38	EETC1HM-224ZJC	E CAPACITOR		
	C 39	EETC1HM-105ZJC	E CAPACITOR		
	C 40	QETN1CM-106Z	E CAPACITOR	10MF 20% 16V	
	C 41	QETN1CM-106Z	E CAPACITOR	10MF 20% 16V	
	C 42	NCB21HK-152X	C CAPACITOR		
	C 43	NCB21HK-152X	C CAPACITOR		
	C 44	QETN1CM-106Z	E CAPACITOR	10MF 20% 16V	
	C 45	QETN1CM-106Z	E CAPACITOR	10MF 20% 16V	
	C 46	NCB21HK-273X	C CAPACITOR		
	C 47	EETC1HM-105ZJC	E CAPACITOR		
	C 48	NCB21HK-222X	C CAPACITOR		
	C 49	NCS21HJ-471X	C CAPACITOR		
	C 50	EEKC1CM-226ZJC	E CAPACITOR		
	C 51	EEKC1HM-105ZJC	E CAPACITOR		
	C 52	QFVJ1HJ-274Z	MF CAPACITOR	.27MF 5% 50V	
	C 53	EETC1CM-226ZJC	E CAPACITOR		
	C 54	NCB21HK-473X	C CAPACITOR		
	C 57	NCB21HK-102X	C CAPACITOR		
	C 58	NCB21HK-473X	C CAPACITOR		
	C 59	NCB21HK-102X	C CAPACITOR		
	CF 1	QAX0677-001Z	C FILTER		
	CF 2	QAX0677-001Z	C FILTER		
	CF 3	QAX0610-001Z	C DISCRIMINATOR		
	CN 1	QGF1205F1-09	CONNECTOR		
	D 1	1SS133-T2	SI DIODE		
	D 2	1SS133-T2	SI DIODE		
	D 3	1SS133-T2	SI DIODE		
	D 4	1SS133-T2	SI DIODE		
	D 11	1SS133-T2	SI DIODE		
	IC 1	LA1838	IC		

△	Item	Parts number	Parts name	Remarks	Area
	IC 2	LC72136N	IC		
	J 1	QNB0014-001	ANT TERMINAL		
	L 1	QQR0796-002	COIL BLOCK		
	Q 1	2SC2814/4-5/-X	TRANSISTOR		
	Q 5	DTA114YKA-X	TRANSISTOR		
	R 1	QRE141J-560Y	C RESISTOR	56 5% 1/4W	
	R 2	NRSA02J-331X	MG RESISTOR		
	R 3	NRSA02J-224X	MG RESISTOR		
	R 4	NRSA02J-331X	MG RESISTOR		
	R 5	NRSA02J-560X	MG RESISTOR		
	R 6	NRSA02J-240X	MG RESISTOR		
	R 10	NRSA02J-222X	MG RESISTOR		
	R 13	NRSA02J-103X	MG RESISTOR		
	R 14	NRSA02J-104X	MG RESISTOR		
	R 15	NRSA02J-332X	MG RESISTOR		
	R 16	NRSA02J-472X	MG RESISTOR		
△	R 17	QRZ9005-680X	F RESISTOR	68 1W	
	R 18	NRSA02J-102X	MG RESISTOR		
	R 19	NRSA02J-102X	MG RESISTOR		
	R 20	NRSA02J-102X	MG RESISTOR		
	R 21	NRSA02J-562X	MG RESISTOR		
	R 22	NRSA02J-472X	MG RESISTOR		
	R 23	NRSA02J-182X	MG RESISTOR		
	R 24	NRSA02J-103X	MG RESISTOR		
	R 25	NRSA02J-331X	MG RESISTOR		
	R 26	NRSA02J-222X	MG RESISTOR		
	R 27	NRSA02J-103X	MG RESISTOR		
	R 28	NRSA02J-103X	MG RESISTOR		
	R 29	NRSA02J-103X	MG RESISTOR		
	R 30	NRSA02J-122X	MG RESISTOR		
	R 31	NRSA02J-102X	MG RESISTOR		
	R 32	NRSA02J-102X	MG RESISTOR		
	R 33	NRSA02J-331X	MG RESISTOR		
	R 34	NRSA02J-470X	MG RESISTOR		
	R 35	NRSA02J-562X	MG RESISTOR		
	R 36	NRSA02J-332X	MG RESISTOR		
	R 37	NRSA02J-103X	MG RESISTOR		
	R 38	NRSA02J-563X	MG RESISTOR		
	R 39	NRSA02J-563X	MG RESISTOR		
	R 40	NRSA02J-243X	MG RESISTOR		
	R 41	NRSA02J-332X	MG RESISTOR		
	R 60	NRSA02J-0R0X	MG RESISTOR		
	T 1	QQR0793-001	IFT		
	TU 1	QAU0161-001	FRONT END		
	X 1	QAX0402-001	CRYSTAL		

■ Electrical parts list (CD servo board)

Block No. 04

△	Item	Parts number	Parts name	Remarks	Area
	R 634	NRSA63J-3R9X	MG RESISTOR		
	R 635	NRSA63J-100X	MG RESISTOR		
	R 636	NRSA63J-151X	MG RESISTOR		
	R 651	NRSA63J-102X	MG RESISTOR		
	R 652	NRSA63J-102X	MG RESISTOR		
	R 653	NRSA63J-102X	MG RESISTOR		
	R 654	NRSA63J-102X	MG RESISTOR		
	R 659	NRSA63J-203X	MG RESISTOR		
	R 661	NRSA63J-473X	MG RESISTOR		
	R 662	NRSA63J-683X	MG RESISTOR		
	R 663	NRSA63J-683X	MG RESISTOR		
	R 664	NRSA63J-331X	MG RESISTOR		
	R 665	NRSA63J-101X	MG RESISTOR		
	R 666	NRSA02J-101X	MG RESISTOR		
	R 667	NRSA63J-4R7X	MG RESISTOR		
	R 668	NRSA63J-155X	MG RESISTOR		
	R 669	NRSA63J-562X	MG RESISTOR		
	R 671	NRSA63J-684X	MG RESISTOR		
	R 673	NRSA63J-683X	MG RESISTOR		
	R 675	NRSA63J-100X	MG RESISTOR		
	R 677	NRSA63J-102X	MG RESISTOR		
	R 678	NRSA63J-102X	MG RESISTOR		
	R 679	NRSA63J-102X	MG RESISTOR		
	R 682	NRSA63J-102X	MG RESISTOR		
	R 683	NRSA63J-105X	MG RESISTOR		
	R 685	NRSA63J-683X	MG RESISTOR		
	R 801	NRSA63J-272X	MG RESISTOR		
	R 802	NRSA63J-152X	MG RESISTOR		
	R 803	NRSA63J-472X	MG RESISTOR		
	R 804	NRSA63J-103X	MG RESISTOR		
	R 805	NRSA63J-123X	MG RESISTOR		
	R 808	NRSA63J-183X	MG RESISTOR		
	R 809	NRSA63J-152X	MG RESISTOR		
	R 811	NRSA63J-473X	MG RESISTOR		
	R 812	NRSA63J-152X	MG RESISTOR		
	R 813	NRSA63J-182X	MG RESISTOR		
	R 861	NRSA63J-681X	MG RESISTOR		
	R 862	NRSA63J-681X	MG RESISTOR		
	R 863	NRSA63J-561X	MG RESISTOR		
	R 864	NRSA63J-561X	MG RESISTOR		
	SW101	QSW0927-001	SWITCH	REST SW	
	SW102	QSW0931-001	SWITCH	TRAY SW	
	X 251	QAX0664-001Z	C OSCILLATOR	FOR IC251 8.38M	
	X 651	NAX0476-001X	CRYSTAL	FOR IC651	

■ Electrical parts list (MD servo control board) Block No. 05

△	Item	Parts number	Parts name	Remarks	Area
	R 516	NRSA63J-102X	MG RESISTOR		
	R 518	NRSA63J-102X	MG RESISTOR		
	R 519	NRSA63J-102X	MG RESISTOR		
	R 520	NRSA63J-102X	MG RESISTOR		
	R 521	NRSA63J-102X	MG RESISTOR		
	R 522	NRSA63J-222X	MG RESISTOR		
	R 523	NRSA63J-102X	MG RESISTOR		
	R 524	NRSA63J-102X	MG RESISTOR		
	R 525	NRSA63J-102X	MG RESISTOR		
	R 528	NRSA63J-102X	MG RESISTOR		
	R 529	NRSA63J-102X	MG RESISTOR		
	R 530	NRSA63J-102X	MG RESISTOR		
	R 534	NRSA63J-103X	MG RESISTOR		
	R 536	NRSA63J-103X	MG RESISTOR		
	R 537	NRSA63J-103X	MG RESISTOR		
	R 538	NRSA63J-473X	MG RESISTOR		
	R 540	NRSA63J-473X	MG RESISTOR		
	R 541	NRSA63J-473X	MG RESISTOR		
	R 545	NRSA63J-0R0X	MG RESISTOR		
	R 546	NRSA63J-0R0X	MG RESISTOR		
	R 547	NRSA63J-0R0X	MG RESISTOR		
	R 548	NRSA63J-0R0X	MG RESISTOR		
	R 551	NRSA63J-104X	MG RESISTOR		
	R 552	NRSA63J-104X	MG RESISTOR		
	R 554	NRSA63J-104X	MG RESISTOR		
	R 555	NRSA63J-102X	MG RESISTOR		
	R 556	NRSA63J-102X	MG RESISTOR		
	R 557	NRSA63J-102X	MG RESISTOR		
	R 558	NRSA63J-102X	MG RESISTOR		
	R 559	NRSA63J-0R0X	MG RESISTOR		
	R 560	NRSA63J-0R0X	MG RESISTOR		
	R 561	NRSA63J-0R0X	MG RESISTOR		
	R 562	NRSA63J-0R0X	MG RESISTOR		
	R 563	NRSA63J-102X	MG RESISTOR		
	R 564	NRSA63J-102X	MG RESISTOR		
	R 565	NRSA63J-102X	MG RESISTOR		
	R 567	NRSA63J-102X	MG RESISTOR		
	R 568	NRSA63J-102X	MG RESISTOR		
	R 569	NRSA63J-102X	MG RESISTOR		
	R 570	NRSA63J-223X	MG RESISTOR		
	R 592	NRSA63J-104X	MG RESISTOR		
	R 593	NRSA63J-103X	MG RESISTOR		
	S 601	NSW0165-001X	DETECT SWITCH		
	S 602	NSW0007-001X	PUSH SWITCH		
	X 350	NAX0355-001X	CRYSTAL	90.3168MHZ	
	X 500	NAX0426-001X	CRYSTAL	12.288MHZ	

■ Electrical parts list (MD cam switch board) Block No. 06

△	Item	Parts number	Parts name	Remarks	Area
	CN611	QGF1016F3-08	CONNECTOR		
	CN612	QGA1501F1-02	CONNECTOR		
	S 611	QSW0848-001	CAM SW		

■ Electrical parts list (Cassette switch board) Block No. 08

△	Item	Parts number	Parts name	Remarks	Area
	CN 1	QGB2011L1-10	B TO B CONNECTO		
	D 1	1SR139-400-T2	SI DIODE		
	IC 1	SG-105F3-BB,C	PHOTO SENSER		
	P 1	QNZ0104-001	POST PIN		
	SW 1	QSW0832-001	LEAF SWITCH	R.REC	
	SW 2	QSW0832-001	LEAF SWITCH	TAPE	
	SW 4	QSW0832-001	LEAF SWITCH	70U	
	SW 5	QSW0832-001	LEAF SWITCH	F.REC	
	SW 6	QSW0859-001	DETECT SWITCH		

Packing materials and accessories parts list

Block No.

M	3	M	M
---	---	---	---

Block No.

M	5	M	M
---	---	---	---

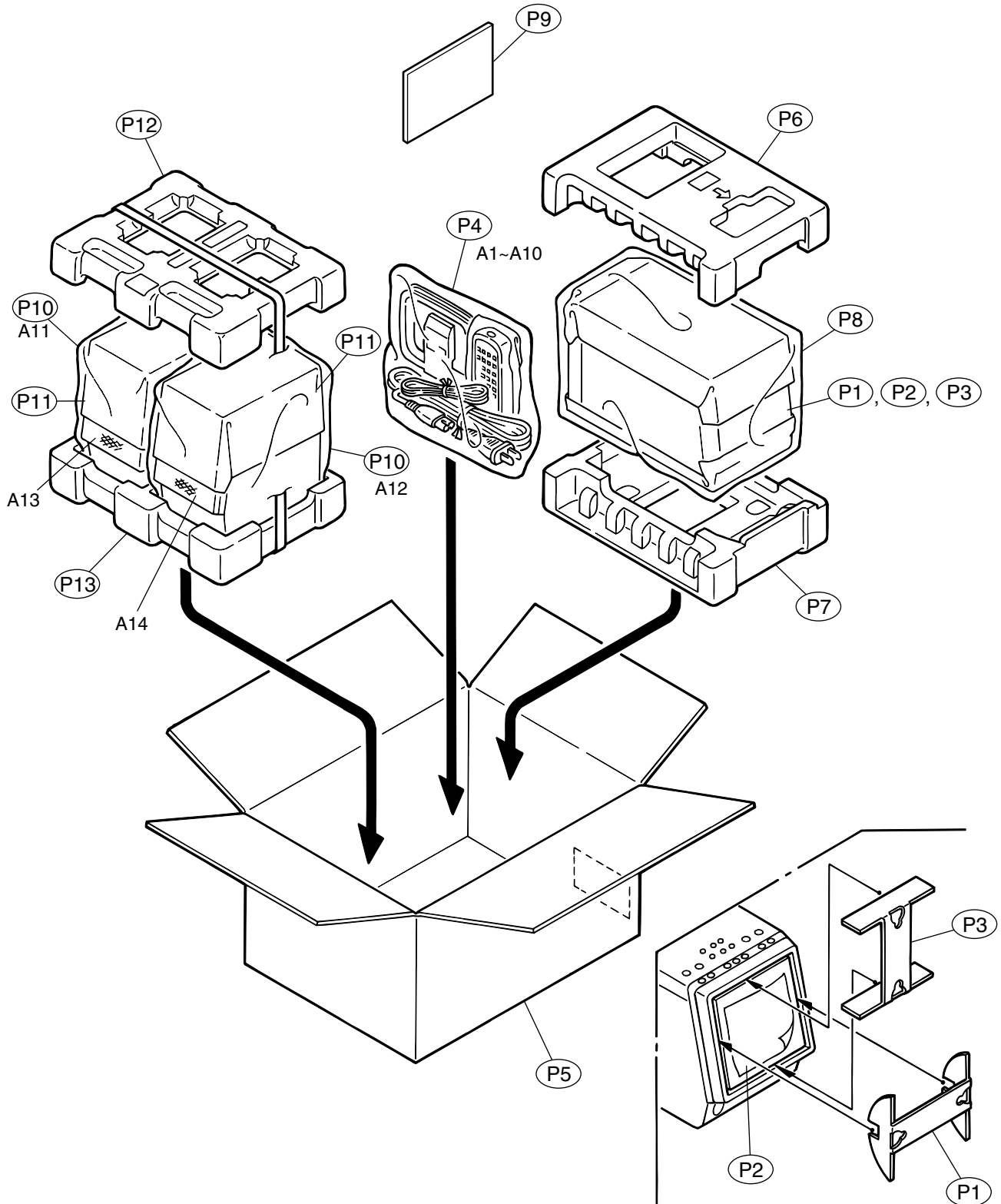

■ Parts list (Packing)

Block No. M3MM

△	Item	Parts number	Parts name	Q'ty	Description	Area
	P 1	GV30228-002A	CARTON SPACER	1	COVER MOVING PA	
	P 2	GV40168-004A	SHEET	1	STICK AT C.SPAC	
	P 3	GV30229-001A	CARTON SPACER	1		
	P 4	QPC02503515P	POLY BAG	1	FOR INST	
	P 5	GV20150-001A	PACKING CASE	1	UX-F70MD	
		GV20149-001A	PACKING CASE	1	UX-F72MD	
	P 6	GV10087-001A	CUSHION(TOP)	1		
	P 7	GV10088-001A	CUSHION(BOTTOM)	1		
	P 8	QPC05005015P	POLY BAG	1	FOR SET	
	P 9	GV40256-001A	CORRUGATED SPAC	1	INSERT REAR(CUS	
	P 10	700-120070-10	POLY BAG	2	FOR SPK	
	P 11	715-250035-00	MIRROR MAT	2	FOR SPK	
	P 12	720-TUXF70-00	TOP CUSHION	1	FOR SPK	
	P 13	720-BUXF70-00	BOTTOM CUSHION	1	FOR SPK	

■ Parts list (Accessories)

Block No. M5MM

△	Item	Parts number	Parts name	Q'ty	Description	Area
	A 1	EWP503-001C	ANT.WIRE	1		
	A 2	QAL0014-001	AM LOOP ANT	1		
	A 3	GVT0061-011A	INST BOOK	1	ENG CHI	UF
		GVT0061-003A	INST BOOK	1	ENG CHI	UB
△	A 4	QMPS020-183-JC	POWER CORD	1		UF
△		QMPP060-183-JD	POWER CORD	1		UB
	A 5	RM-SUXF70MDU	REMOCON	1		
	A 6	-----	BATTERY	2		
	A 7	GV30024-031A	UB SHEET	1	UX-F70MD	UB
		GV30024-030A	UB SHEET	1	UX-F72MD	UB
	A 8	GV40137-001A	SIDE SPACER	2		
	A 9	BT-59012-1	SERVICE NETWORK	1		UF
	A 10	BT-59011-2	WARRANTY CARD	1		UF
	A 11	UXF70MDK-SPK-L	SPEAKER BOX	1	UX-F70MD	
		UXF72MDK-SPK-L	SPEAKER BOX	1	UX-F72MD	
	A 12	UXF72MDK-SPK-R	SPEAKER BOX	1	UX-F72MD	
		UXF70MDK-SPK-R	SPEAKER BOX	1	UX-F70MD	
	A 13	201-0070US-10	SARAN BOARD	1	UX-F70MD	
		201-02XF72-10	SARAN BOARD	1	UX-F72MD	
	A 14	201-1070US-10	SARAN BOARD	1	UX-F70MD	
		201-12XF72-10	SARAN BOARD	1	UX-F72MD	