

JVC

SERVICE MANUAL

MICRO COMPONENT SYSTEM

UX-H10

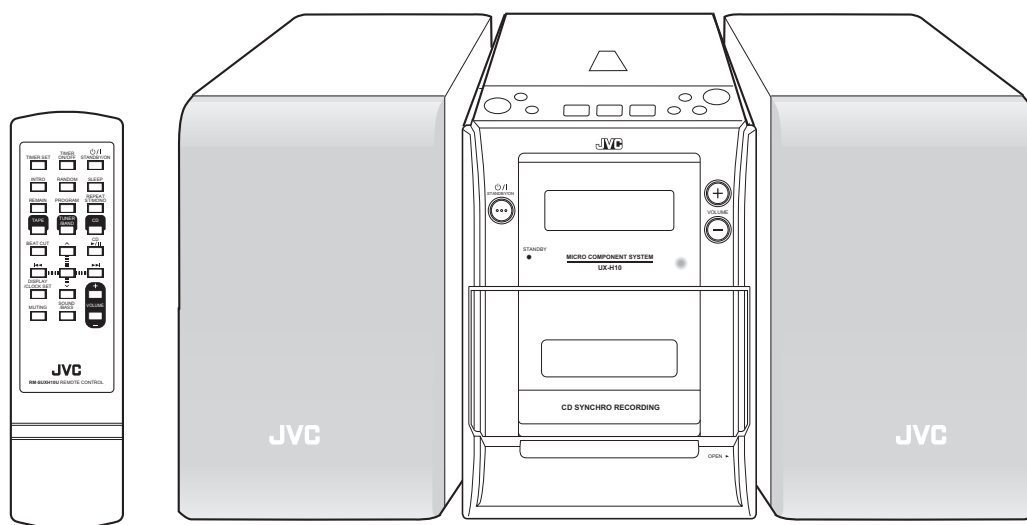

COMPACT
disc
DIGITAL AUDIO

Area Suffix

US ----- Singapore
UT ----- Taiwan
UW ---- Brazil, Mexico, Peru

TABLE OF CONTENTS

1	PRECAUTION	1-3
2	SPECIFIC SERVICE INSTRUCTIONS	1-5
3	DISASSEMBLY	1-6
4	ADJUSTMENT	1-12
5	TROUBLESHOOTING	1-16

SPECIFICATION

Amplifier Section CA-UXH10	Output Power (IEC 268-3)	10 W (5 W + 5 W) at 4 Ω (10% THD)	
	Speakers/Impedance	4 Ω - 16 Ω	
Tuner	FM tuning range	87.50 MHz-108.00 MHz	
	AM tuning range	AM 10 kHz intervals	530 kHz- 1 710 kHz
		AM 9 kHz intervals	531 kHz-1 710 kHz
CD player	Dynamic range	60 dB	
	Signal-to-noise ratio	60 dB	
	Wow and flutter	Immeasurable	
Cassette deck	Frequency response	Normal (type I)	100 Hz-10 000 Hz
	Wow and flutter	0.35 % (WRMS)	
General	Power requirement	AC 110 V-127 V/ 220 V-240 V , adjustable with the voltage selector, 50 Hz/ 60 Hz	
	Power consumption	22 W (at operation)	
		4.5 W (on standby)	
	Dimensions (W/H/D) (approx.)	145 mm \times 209 mm \times 226 mm	
Mass (approx.)	2.6 kg		
Speaker Section SP-UXH10	Type	Full range bass-reflex type	
	Speakers	10 cm cone x1	
	Power handling capacity	5 W	
	Impedance	4 Ω	
	Frequency range	100 Hz to 15 kHz	
	Dimensions (W/H/D) (approx.)	135 mm \times 209 mm \times 152 mm	
	Mass (approx.)	1.3 kg each	

Design and specifications are subject to change without notice.

SECTION 1 PRECAUTION

1.1 Safety Precautions

- (1) This design of this product contains special hardware and many circuits and components specially for safety purposes. For continued protection, no changes should be made to the original design unless authorized in writing by the manufacturer. Replacement parts must be identical to those used in the original circuits. Services should be performed by qualified personnel only.
- (2) Alterations of the design or circuitry of the product should not be made. Any design alterations of the product should not be made. Any design alterations or additions will void the manufacturer's warranty and will further relieve the manufacturer of responsibility for personal injury or property damage resulting therefrom.
- (3) Many electrical and mechanical parts in the products have special safety-related characteristics. These characteristics are often not evident from visual inspection nor can the protection afforded by them necessarily be obtained by using replacement components rated for higher voltage, wattage, etc. Replacement parts which have these special safety characteristics are identified in the Parts List of Service Manual. Electrical components having such features are identified by shading on the schematics and by (Δ) on the Parts List in the Service Manual. The use of a substitute replacement which does not have the same safety characteristics as the recommended replacement parts shown in the Parts List of Service Manual may create shock, fire, or other hazards.
- (4) The leads in the products are routed and dressed with ties, clamps, tubings, barriers and the like to be separated from live parts, high temperature parts, moving parts and/or sharp edges for the prevention of electric shock and fire hazard. When service is required, the original lead routing and dress should be observed, and it should be confirmed that they have been returned to normal, after reassembling.
- (5) Leakage shock hazard testing

After reassembling the product, always perform an isolation check on the exposed metal parts of the product (antenna terminals, knobs, metal cabinet, screw heads, headphone jack, control shafts, etc.) to be sure the product is safe to operate without danger of electrical shock. Do not use a line isolation transformer during this check.

- Plug the AC line cord directly into the AC outlet. Using a "Leakage Current Tester", measure the leakage current from each exposed metal part of the cabinet, particularly any exposed metal part having a return path to the chassis, to a known good earth ground. Any leakage current must not exceed 0.5mA AC (r.m.s.).
- Alternate check method
Plug the AC line cord directly into the AC outlet. Use an AC voltmeter having, 1,000 Ω per volt or more sensitivity in the following manner. Connect a 1,500 Ω 10W resistor paralleled by a 0.15 μ F AC-type capacitor between an exposed metal part and a known good earth ground. Measure the AC voltage across the resistor with the AC

voltmeter.

Move the resistor connection to each exposed metal part, particularly any exposed metal part having a return path to the chassis, and measure the AC voltage across the resistor. Now, reverse the plug in the AC outlet and repeat each measurement. Voltage measured any must not exceed 0.75 V AC (r.m.s.). This corresponds to 0.5 mA AC (r.m.s.).

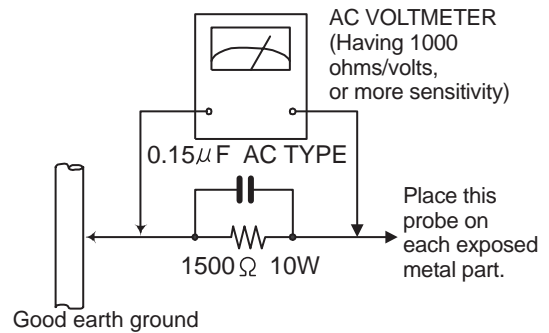

1.2 Warning

- (1) This equipment has been designed and manufactured to meet international safety standards.
- (2) It is the legal responsibility of the repairer to ensure that these safety standards are maintained.
- (3) Repairs must be made in accordance with the relevant safety standards.
- (4) It is essential that safety critical components are replaced by approved parts.
- (5) If mains voltage selector is provided, check setting for local voltage.

1.3 Caution

Burrs formed during molding may be left over on some parts of the chassis.

Therefore, pay attention to such burrs in the case of pre-forming repair of this system.

1.4 Critical parts for safety

In regard with component parts appearing on the silk-screen printed side (parts side) of the PWB diagrams, the parts that are printed over with black such as the resistor (■), diode (■) and ICP (●) or identified by the " Δ " mark nearby are critical for safety. When replacing them, be sure to use the parts of the same type and rating as specified by the manufacturer. (This regulation does not Except the J and C version)

1.5 Preventing static electricity

Electrostatic discharge (ESD), which occurs when static electricity stored in the body, fabric, etc. is discharged, can destroy the laser diode in the traverse unit (optical pickup). Take care to prevent this when performing repairs.

1.5.1 Grounding to prevent damage by static electricity

Static electricity in the work area can destroy the optical pickup (laser diode) in devices such as CD players. Be careful to use proper grounding in the area where repairs are being performed.

(1) Ground the workbench

Ground the workbench by laying conductive material (such as a conductive sheet) or an iron plate over it before placing the traverse unit (optical pickup) on it.

(2) Ground yourself

Use an anti-static wrist strap to release any static electricity built up in your body.

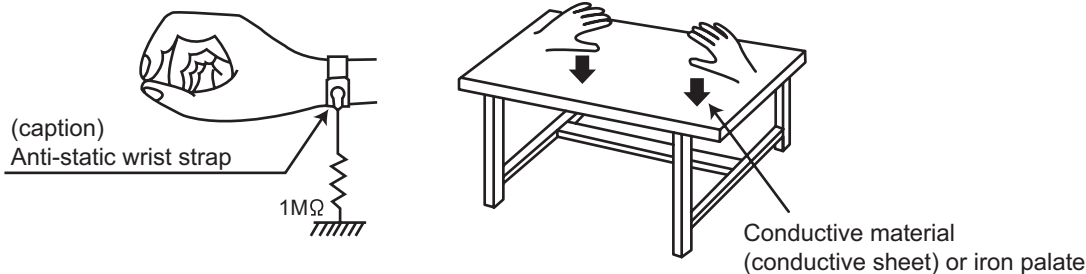

(3) Handling the optical pickup

- In order to maintain quality during transport and before installation, both sides of the laser diode on the replacement optical pickup are shorted. After replacement, return the shorted parts to their original condition. (Refer to the text.)
- Do not use a tester to check the condition of the laser diode in the optical pickup. The tester's internal power source can easily destroy the laser diode.

1.6 Handling the traverse unit (optical pickup)

- (1) Do not subject the traverse unit (optical pickup) to strong shocks, as it is a sensitive, complex unit.
- (2) Cut off the shorted part of the flexible cable using nippers, etc. after replacing the optical pickup. For specific details, refer to the replacement procedure in the text. Remove the anti-static pin when replacing the traverse unit. Be careful not to take too long a time when attaching it to the connector.
- (3) Handle the flexible cable carefully as it may break when subjected to strong force.
- (4) It is not possible to adjust the semi-fixed resistor that adjusts the laser power. Do not turn it.

1.7 Attention when traverse unit is decomposed

***Please refer to "Disassembly method" in the text for the CD pickup unit.**

- Apply solder to the short land sections before the flexible wire is disconnected from the connector on the CD servo board. (If the flexible wire is disconnected without applying solder, the CD pickup may be destroyed by static electricity.)
- In the assembly, be sure to remove solder from the short land sections after connecting the flexible wire.

SECTION 2
SPECIFIC SERVICE INSTRUCTIONS

This service manual does not describe SPECIFIC SERVICE INSTRUCTIONS.

SECTION 3 DISASSEMBLY

3.1 Main body

3.1.1 Removing the Front panel assembly (See Fig.1 ~ 5)

- (1) Remove the two screws **A** and the two screws **B** on the back of the body.
- (2) Remove the four screws **C** on each side of the body.
- (3) Remove the two screws **D** on the bottom of the body.
- (4) Move the front panel assembly in the direction of the arrow and detach. Disconnect the wire from connector **CN860** and FM-ANT.

Caution:

When reassembling, set the tab "a" on the right and left side to the groove, and move.

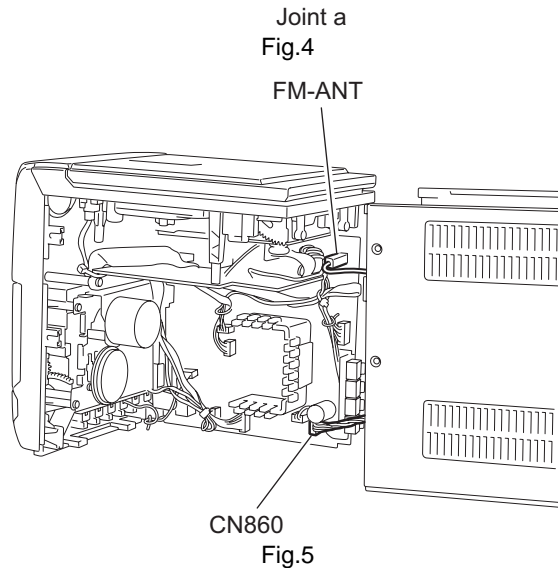
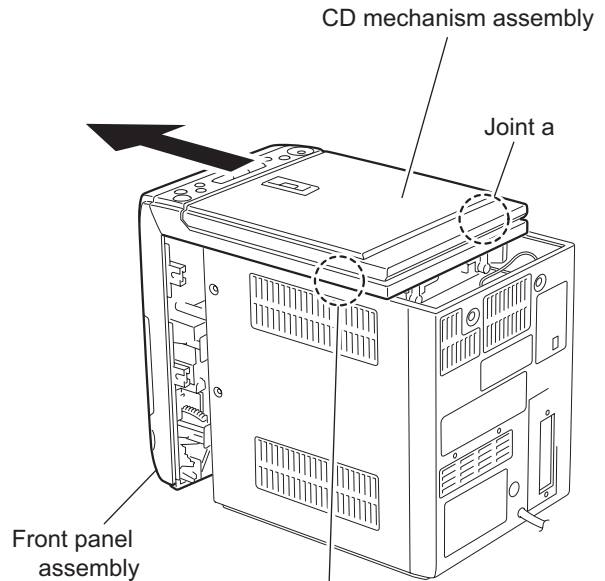
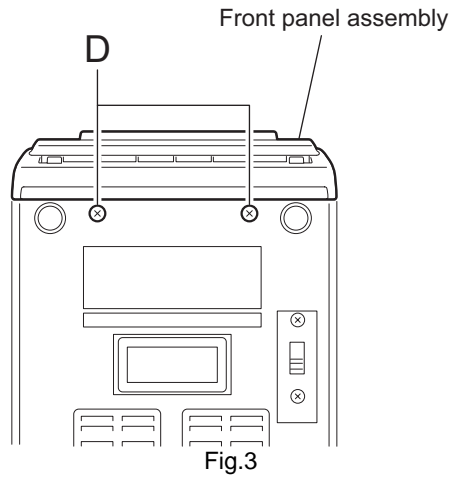
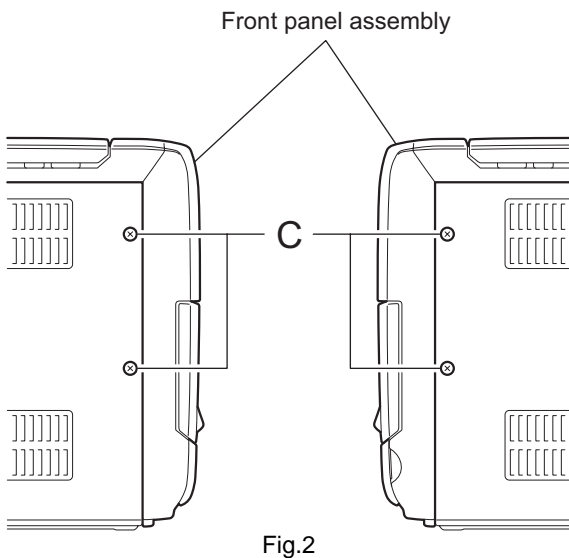
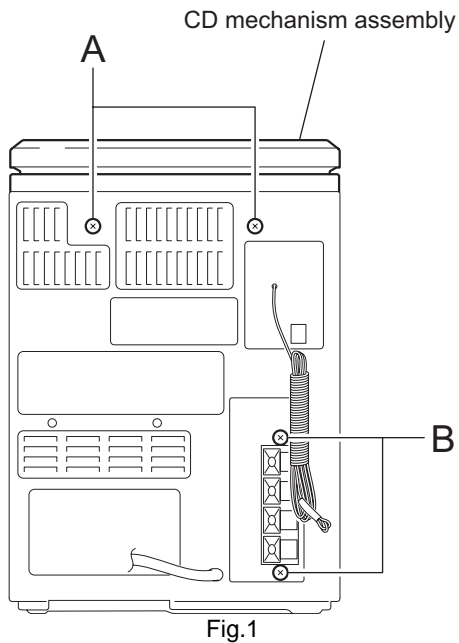

3.1.2 Removing the Main board (See Fig.6 , 7)

- Prior to performing the following procedure, remove the front panel assembly.
 - (1) Disconnect the wire from all connectors on the main board.
 - (2) Remove the two screws **E** and release the joint **b**.

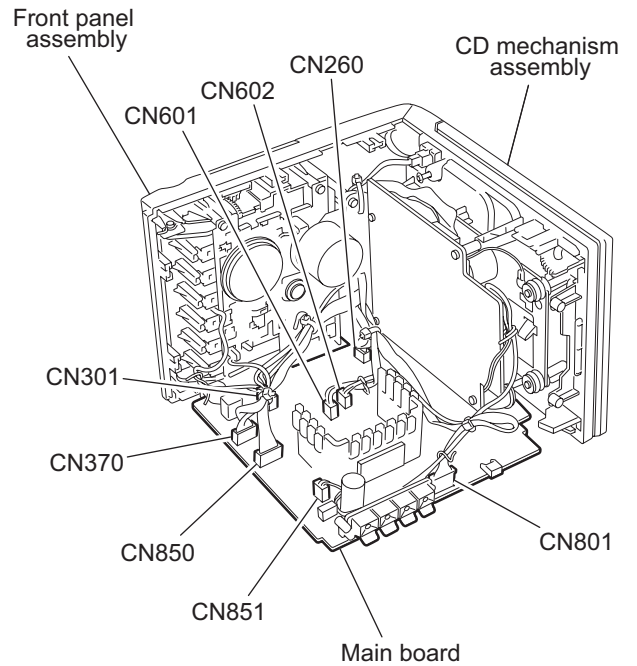

Fig.6

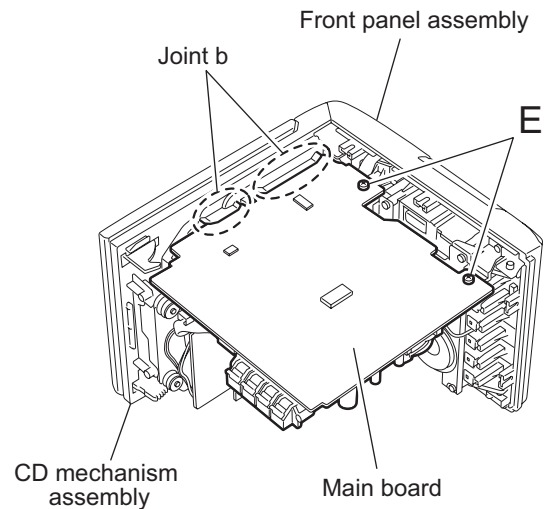

Fig.7

3.1.3 Removing the CD mechanism assembly and the Switch board (See Fig.8 ~ 10)

- Prior to performing the following procedure, remove the front panel assembly and the main board.
 - (1) Cut off the four bands setting the wires.
 - (2) Disconnect the wire from connector on the CD open switch and [CN705](#) on the CD mechanism board.
 - (3) Remove the two screws **F** on the front panel assembly.
 - (4) Release the joint **d** of the CD mechanism assembly.
 - (5) Remove the five screws **G** attaching the switch board to the CD mechanism assembly.

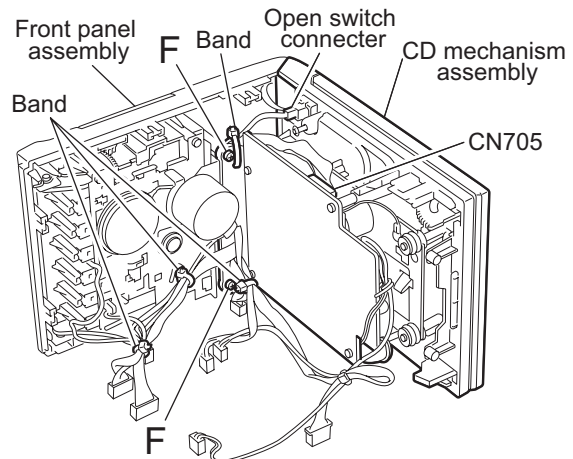

Fig.8

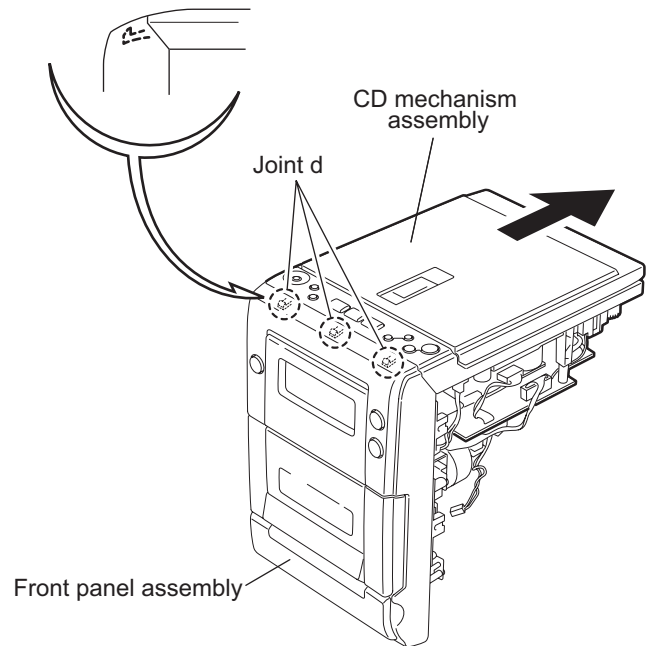

Fig.9

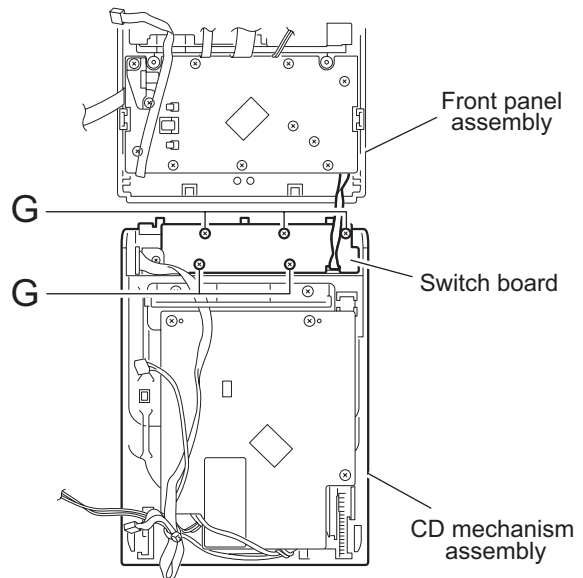

Fig.10

3.1.4 Removing the CD mechanism board (See Fig.11 ~ 13)

- Prior to performing the following procedure, remove the front panel assembly, the main board and the CD mechanism assembly.

- (1) Disconnect connector on the CD mechanism.
- (2) Remove the four screws **H** on the CD mechanism assembly.
- (3) Cut off the band setting each wire and disconnect the card wire from connector on the CD mechanism.
- (4) Remove the screw **J** attaching the wire on the CD mechanism board.

Caution:

The metal washer and nut come off.

- (5) Remove the four screws **K** attaching the CD mechanism.

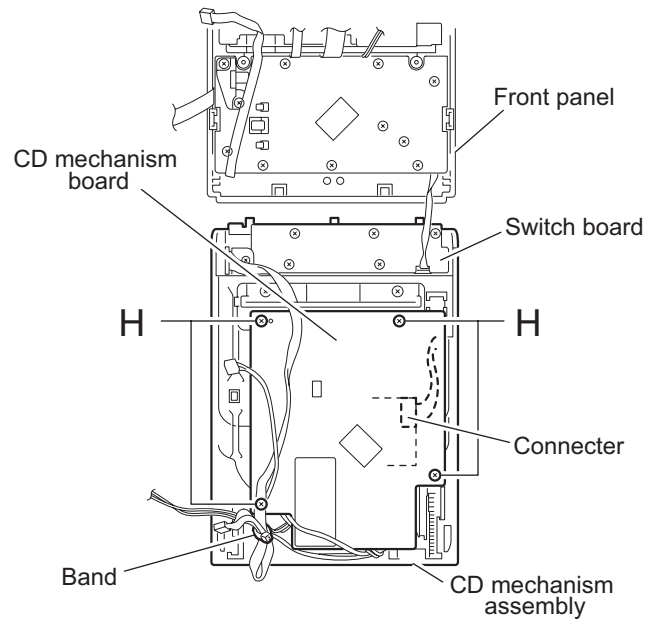

Fig.11

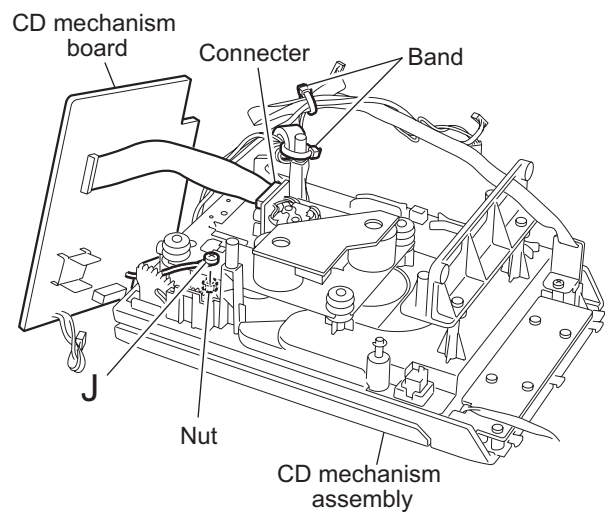

Fig.12

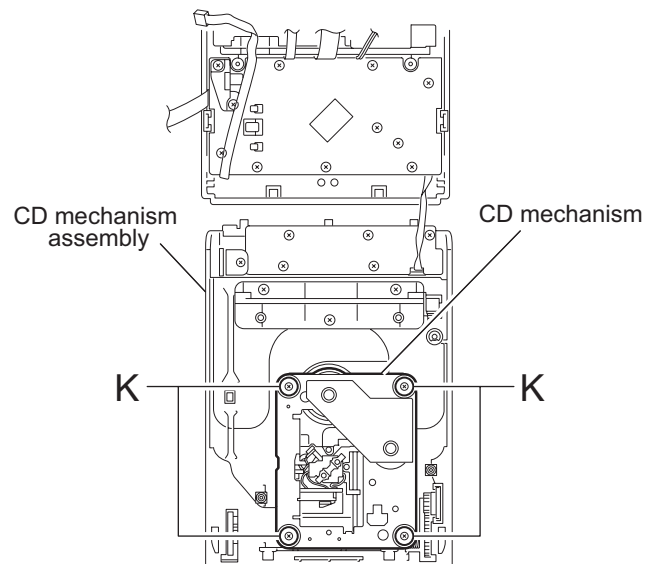

Fig.13

3.1.5 Removing the Headphone board (See Fig.14)

- Prior to performing the following procedure, remove the front panel assembly, the main board and the CD mechanism assembly.
 - (1) Remove the screw **L** on the bracket and pull out the headphone board.

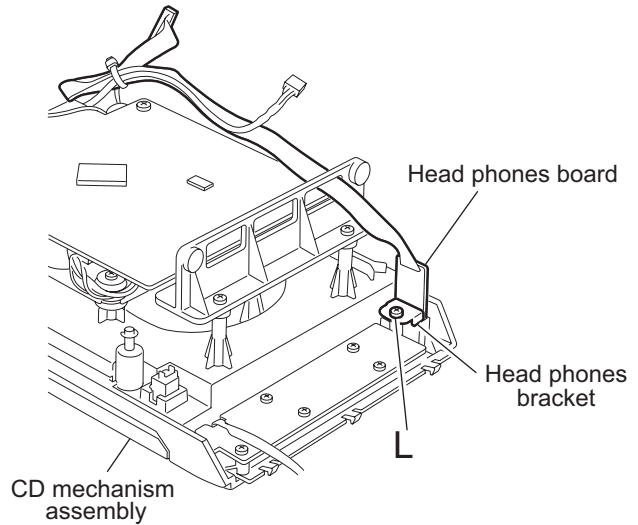

Fig.14

3.1.6 Removing the LCD board (See Fig.15)

- Prior to performing the following procedure, remove the front panel assembly, the main board and the CD mechanism assembly.
 - (1) Remove the ten screws **M** and the two screws **N** on the Front panel assembly.

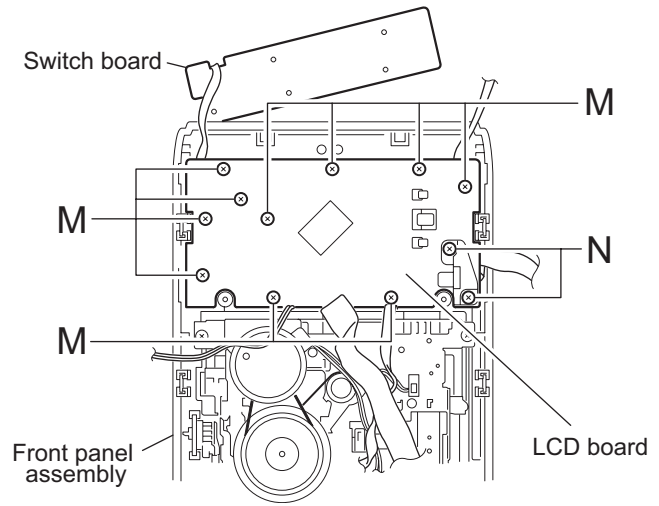

Fig.15

3.1.7 Removing the Cassette mechanism (See Fig.16)

- Prior to performing the following procedure, remove the front panel assembly and the main board.
 - (1) Remove the four screws **P** on the front panel assembly and press the eject button on the front side to remove the cassette mechanism assembly.

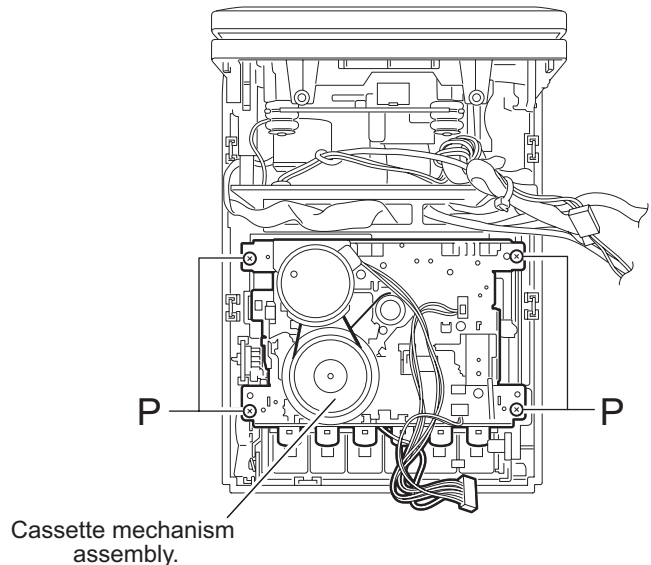

Fig.16

3.1.8 Removing the Transformer board (See Fig.17)

- Prior to performing the following procedure, remove the front panel assembly.
 - (1) Remove the screw **Q** on the rear cover assembly.
 - (2) Pull out the transformer board in the direction of the arrow.
 - (3) Unsolder the wire extending from the transformer.

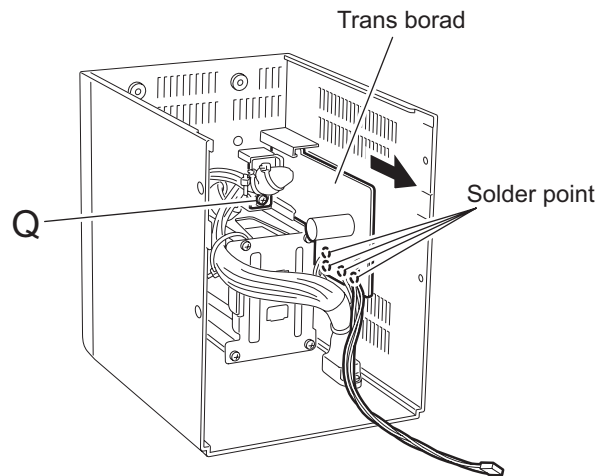

Fig.17

3.1.9 Removing the Transformer (See Fig.18 , 19)

- Prior to performing the following procedure, remove the front panel assembly and the transformer board.
 - (1) Remove the two screws **R** attaching the voltage selector on the bottom of the rear cover assembly.
 - (2) Remove the four screws **S** on the rear cover assembly.
 - (3) Remove the two screws **T** setting the power cord on the rear cover assembly.
 - (4) Cut off the band connecting the power cord to the transformer if necessary, remove the transformer.

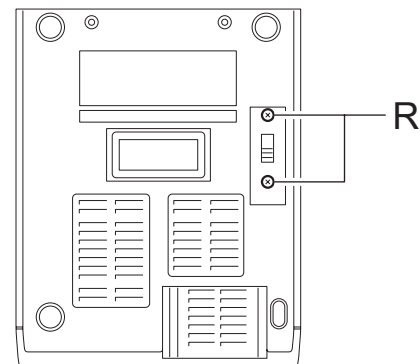

Fig.18

3.1.10 Removing the FM-antenna board (See Fig.19)

- Prior to performing the following procedure, remove the front panel assembly.
 - (1) Remove the screw **U** on the rear cover assembly.
 - (2) Unsolder the FM-antenna wire on the FM-antenna board.

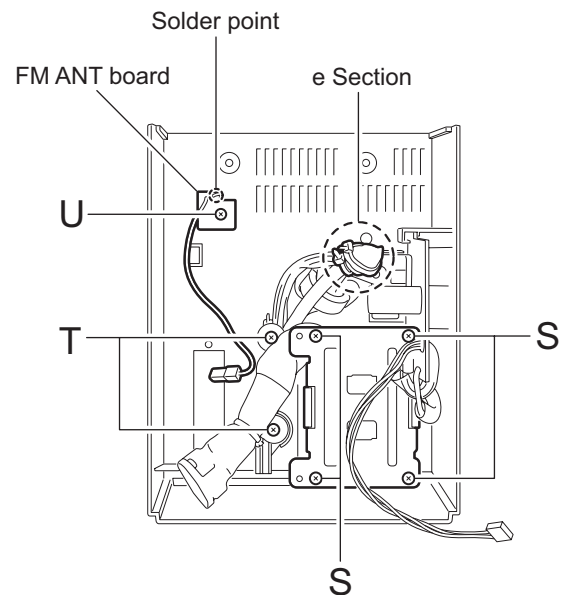

Fig.19

SECTION 4 ADJUSTMENT

4.1 Measuring instructions required for adjustment

- (1) AM signal generator
- (2) FM signal generator
- (3) Intermediate frequency sweep generator
- (4) FM stereo signal generator
- (5) Low-frequency oscillator (oscillation frequency 50 Hz-20 kHz, 0dB output with 600 Ω impedance)
- (6) Attenuator (600 Ω impedance)
- (7) Electric voltmeter
- (8) Distortion meter
- (9) Torque gauge (cassette for CTG-N)
- (10) Wow & flutter meter
- (11) Frequency counter meter

4.1.1 Amplifier section

Reference output

Speaker output 0 dB(1V)/ 4 Ω

H. Phone output -10 dB(0.1V) 32 Ω

4.1.2 CD section

Test disc: JVC standard disc

4.1.3 Test tape

JVC standard test tape

4.1.4 Measuring instruments Radio section

FM 1 kHz, 22.5 kHz deviation

FM STEREO : 1kHz, 67.5 kHz deviation

Pilot signal: 7.5 kHz

AM : 1 kHz, 30% modulation

Reference output:

Speaker output : 0 dB (1V) 4 Ω

Headphone output : -10 dB (0.1V) 32 Ω

4.1.5 Cassette Amplifier Section

Item	Measuring Condition	Check and adjustment procedure	Standard value	Adjusting part
Head azimuth adjustment	Test tape: 8 kHz Signal output terminal: PHONES (with 32 ohm load)	<ol style="list-style-type: none"> 1. Play back the test tape (8 kHz). 2. Adjust the head azimuth adjusting screw so that the phase difference between the R and L channels is minimized at an output level that is within ± 2 dB of the maximum output level. After this adjustment, lock the head azimuth adjusting screw with screw, sealant to cover more than a half of the screw head. 3. When the head azimuth is maladjusted, correct it with the head azimuth adjusting screw. 	Output level: Within ± 2 dB of maximum output level Phase difference L and R channels: Minimum	Head azimuth adjusting screw (To be used only after head replacement) See Fig 3-1
Tape speed and wow/flutter check and adjustment	Test tape: 3 kHz Signal output terminal: PHONES (with 32 ohm load)	<ol style="list-style-type: none"> 1. Play back the test tape (3 kHz) by the end portion. 2. Connect a frequency counter and check that it reads between 2940 and 3090 Hz. If not, adjust the frequency with the motor semifixed resistor. 3. Check that the wow/flutter is within 0.38% (unweighted.) 	2940 to 3090 Hz Within 0.38% (unweighted)	Tape speed: Motor semifixed resistor check only
PB frequency response check	Test tape: Signal output terminal: PHONES (with 32 ohm load)	Play back the test tape while confirming that deviation between the 1 kHz signal and 8 kHz signal should be 0 (+3~-6) dB.	Deviation between 1 kHz and 8 kHz: 0 (+3~-6) dB	
Bias frequency check	Tape: Normal Signal output terminal: Cassette REC./PLAY HEAD	Set the TUNER or CD function and with TAPE to record. Check to see if the frequency at the measuring point T360 is 60 kHz ± 1 kHz if not adjust T360 until the frequency counter indicates 60 kHz ± 1 kHz.	T360	
REC and PB frequency response adjustment	Test tape: Signal input FM22.5 DEV 60dB with Emphasis signal output terminal: PHONES (with 32 ohm load)	At TUNER, set the BAND to the FM position, and record the reference 1 kHz signal and 8kHz signal alternately repeatedly. While playing back the recorded signal differ from that of the 1 kHz signal by within 0 (+3~-6) dB.	Level difference between REC and PB: Within 0 (+3~-6) dB.	

4.1.6 Tuner Section

Item	Measuring Condition	Check and adjustment procedure	Standard value	Adjusting part
AM IF adjustment	Signal input: Loop ANTENNA Signal output: U201 PIN 16	1.Set the intermediate frequency sweep generator to AM 450 kHz. 2.Adjust the T201 for maximum and center output.		T201 See Fig 3-3
AM tracking adjustment	Signal input: Loop antenna PHONES (with 32 ohm Load)	1.Set the TUNER at 531 kHz adjust T202 until the test pin of R229 Voltage at 1.5V \pm 0.1V. 2.Set the TUNER at 1710 kHz, Check the pin of R229 Voltage at 8.4V \pm 6V. 3.Set the TUNER and S/G at 603 kHz, adjust T204 for maximum output. 4.Set the TUNER and S/G at 1404 kHz, adjust VC201 for maximum output. 5.Repeat the above steps 3 and 4.		T202 T204 R229 VC201
FM Tracking Adjustment	Signal input point: FM-ANT Phones With 32 ohm load	1.Set the Tuner at 87.5MHz adjust L203 until the test pin of R230 voltage at 2.4V \pm 0.1V 2.Set the Tuner at 108MHz. Check the pin of R230 voltage at 8 \pm 0.8V 3.Set the Tuner and S/G at 90.1MHz. Adjust L204 for maximum output. 4.Set the Tuner and S/G at 106.1MHz. Adjust VC 202 for maximum output. 5.Repeat the above step 3 and 4		R230 L204 VC202

Location of adjusting parts
Cassette mechanism section

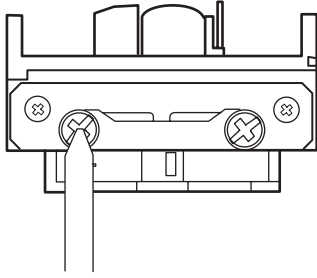

Figure 3-1 Head Output Signal

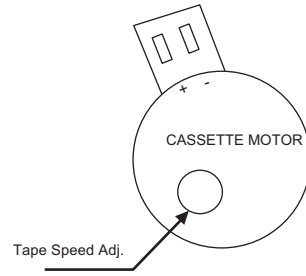
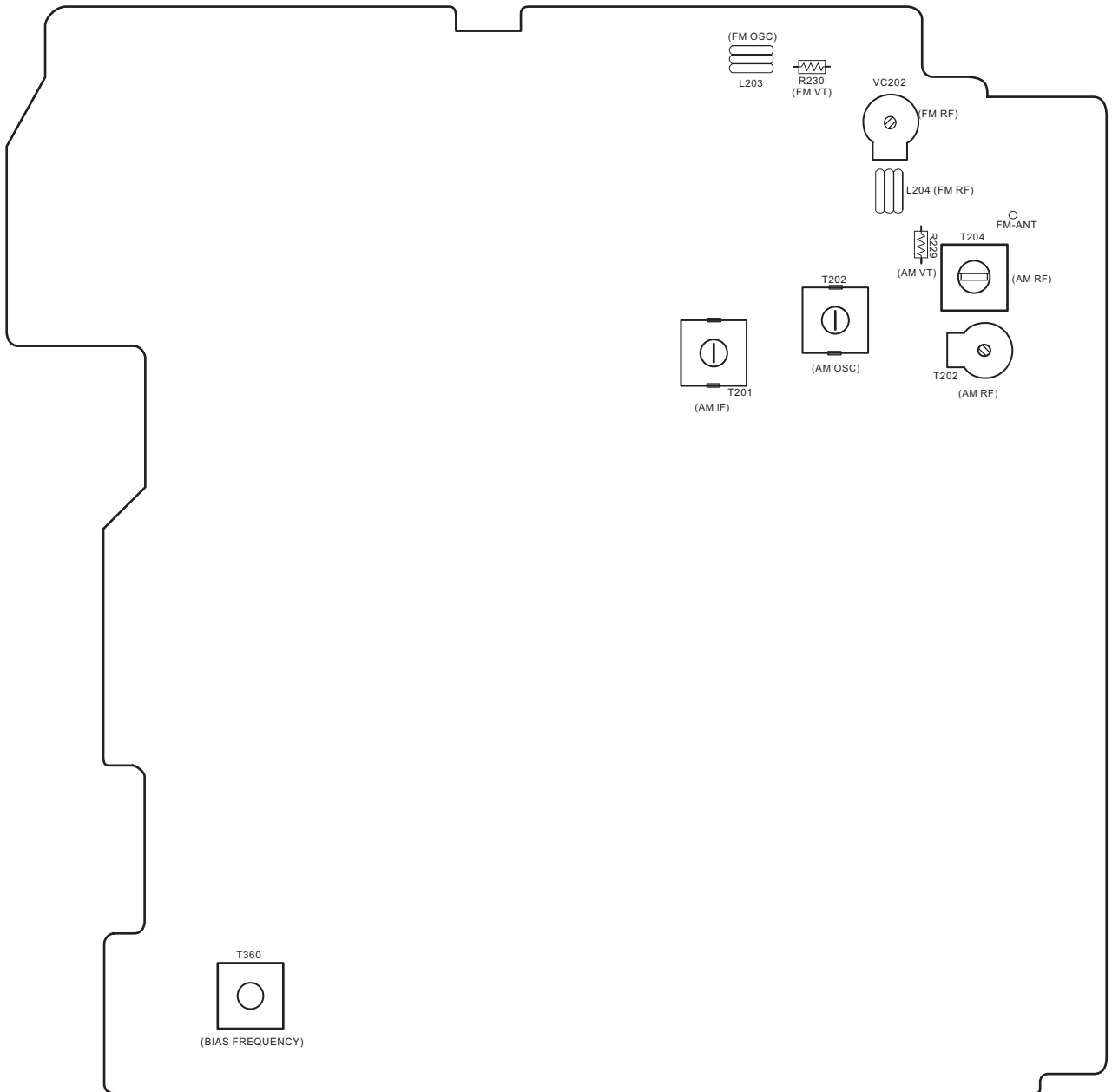

Figure 3-2

Main board assembly



SECTION 5 TROUBLESHOOTING

Circuit	Symptom	Cause and Remedy
General	No sound	Speakers are not connected: Check the speaker connection. Wrong function is selected: Set switch to the proper position. Defective volume control: Set the volume control to a proper sound level. Defective the Headphone jack: Replace the headphone jack. Defect in U801 Check voltages. Replace if necessary. Defect in U601 Check voltages. Replace if necessary.
AM	No sound, weak sound (Low sensitivity)	Improper location of unit: Rotate or reposition the unit. Defect in IF T201: Check resistance, voltage, and current. Replace as needed. Defect AM antenna coil L202 or oscilloscope coil T202: Replace if necessary. Intermediate frequency tuning faulty: Readjust (see "Adjustment"). RF tracking faulty: Readjust (see "Adjustment"). Defective U201: Check voltages. Replace if necessary. Defective U260: Check voltages. Replace if necessary. Poor contact in antenna circuit: Check resistance and resolder.
FM	No sound, weak sound (Low sensitivity)	FM antenna not connected: Connect the built-in or external antenna. Defective band selector switch: Replace or repair the switch. Defective U201: Check voltages. Replace if necessary. Defective U260: Check voltages. Replace if necessary. Intermediate frequency tuning faulty: Readjust (see "Adjustment"). Poor contact in FM antenna circuit: Resolder or repair as required.
Tape	No sound / Recording Unsteady tape sound, weak sound	Dirty capstan or head: Clean the capstan or head with alcohol. Irregular cassette tape winding: Replace tape. Defective U301: Check voltage. Replace if necessary. Cassette erasure prevention tabs broken out: Replace tape or cover tab openings with adhesive tape.
CD	Cannot read the TOC. no sound	Disc is inserted upside down: Insert disc correctly. Disc is dirty: Wipe clean with a soft cloth. Disc is scratched: Use a new disc. Disc is seriously warped: Use a new disc. A non-standard disc has been inserted: Use only a brand name disc. Moisture has formed inside the CD deck: Wait about 20 to 30 minutes. Defective IC701: Check voltages. Replace if necessary. Defective IC702: Check voltages. Replace if necessary. Defective IC703: Check voltages. Replace if necessary. Defect in the CD pickup mechanism: Replace as required.



JVC

VICTOR COMPANY OF JAPAN, LIMITED

AV & MULTIMEDIA COMPANY AUDIO/VIDEO SYSTEMS CATEGORY 10-1,1chome,Ohwatari-machi,Maebashi-city,371-8543,Japan

(No.MB066)



Printed in Japan
WPC

JVC

SCHEMATIC DIAGRAMS

MICRO COMPONENT SYSTEM

UX-H10

CD-ROM No.SML200401

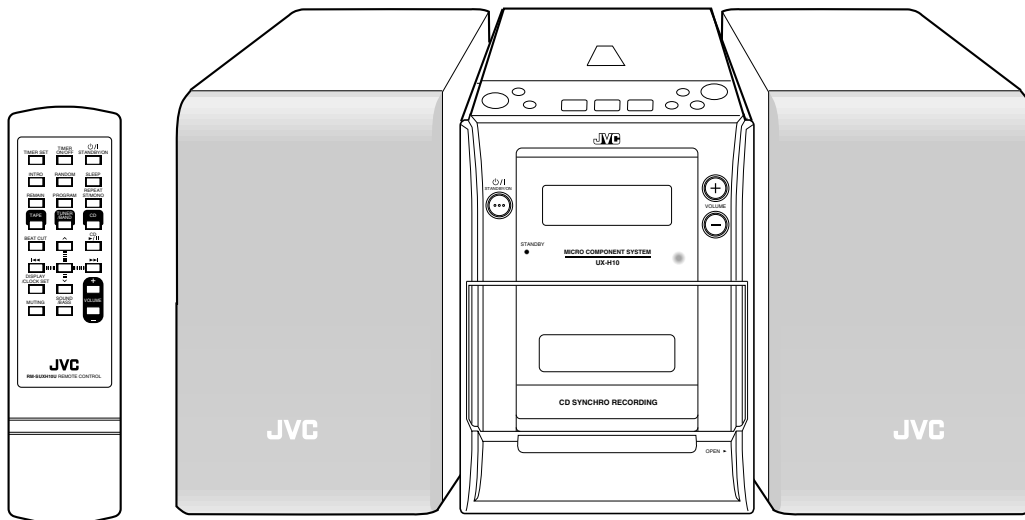

Area Suffix

US ----- Singapore
UT ----- Taiwan
UW ---- Brazil, Mexico, Peru

Contents

Block diagram	2-1
Standard schematic diagrams	2-2
Printed circuit boards	2-9 to 12

In regard with component parts appearing on the silk-screen printed side (parts side) of the PWB diagrams, the parts that are printed over with black such as the resistor (■), diode (▣) and ICP (●) or identified by the "△" mark nearby are critical for safety.

(This regulation does not correspond to J and C version.)

Block diagram

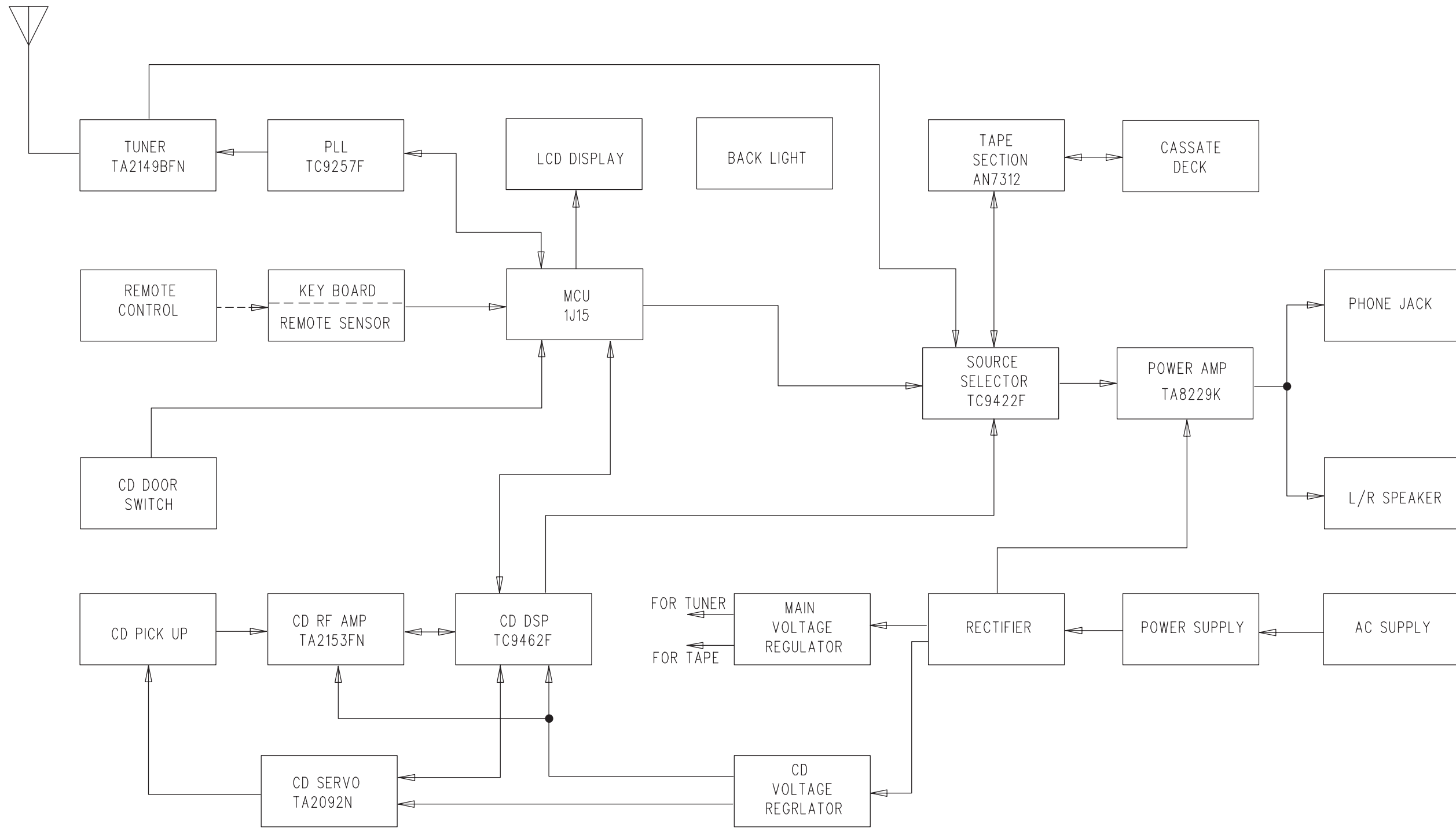

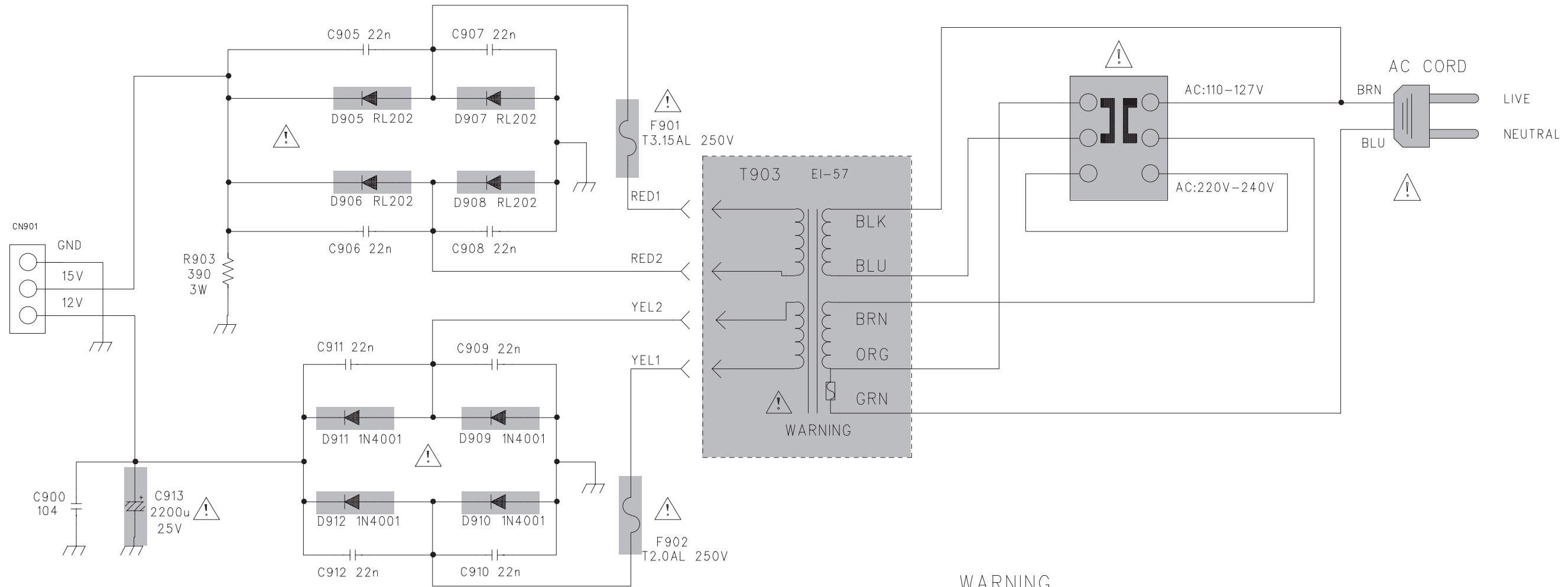

Standard schematic diagrams

■ Power supply section



SERVICING INSTRUCTIONS

1. DISCONNECT POWER CORD BEFORE SERVICING.
2. REPLACE CRITICAL COMPONENTS  ONLY WITH FACTORY PARTS OR RECOMMEND EQUIVALENTS.
3. FOR AC LINE POWERED UNITS – BEFORE RETURNING REPAIRED UNIT TO USER, USE AN OHMMETER TO MEASURE FROM BOTH AC PLUG BLADES TO ALL EXPOSED METALLIC PARTS. THE RESISTANCE SHOULD BE MORE THAN 100,000 OHMS.

 **Parts are safety assurance parts.**
When replacing those parts make
sure to use the specified one.

WARNING

AFTER COMPLETING THE SERVICING OF THIS PRODUCT AND BEFORE RETURNING IT TO YOUR CUSTOMER MEASURE THE RESISTANCE BETWEEN BOTH PRONGS OF THE AC PLUG AND ALL EXPOSED METAL PARTS TO BE SURE IT EXCEEDS 2.2 MEGAOHMS (POWER SWITCH IF ANY SHOULD BE IN ITS ON POSITION). IF THE RESISTANCE MEASURED IS LESS THAN 2.2 MEGAOHMS, THE UNIT SHOULD NOT BE RETURNED TO THE CUSTOMER UNTIL THE CAUSE FOR THE REDUCED POWER LINE. TO EXPOSED METAL PARTS RESISTANCE HAS BEEN CORRECTED AND THE UNIT PASSED THE ABOVE TEST.

 THIS MARK INDICATES THAT THE ADJACENT COMPONENT IS CONSIDERED CRITICAL WITH RESPECT TO THE RISK OF FIRE AND ELECTRICAL SHOCK ASSOCIATED WITH THIS PRODUCT. WHEN REPLACING ANY OF THESE COMPONENTS, USE ONLY PARTS SUPPLIED BY MANUFACTURERS WHOSE PART NUMBERS ARE INDICATED ON THE PARTS LIST ATTACHED.

■ Amp section

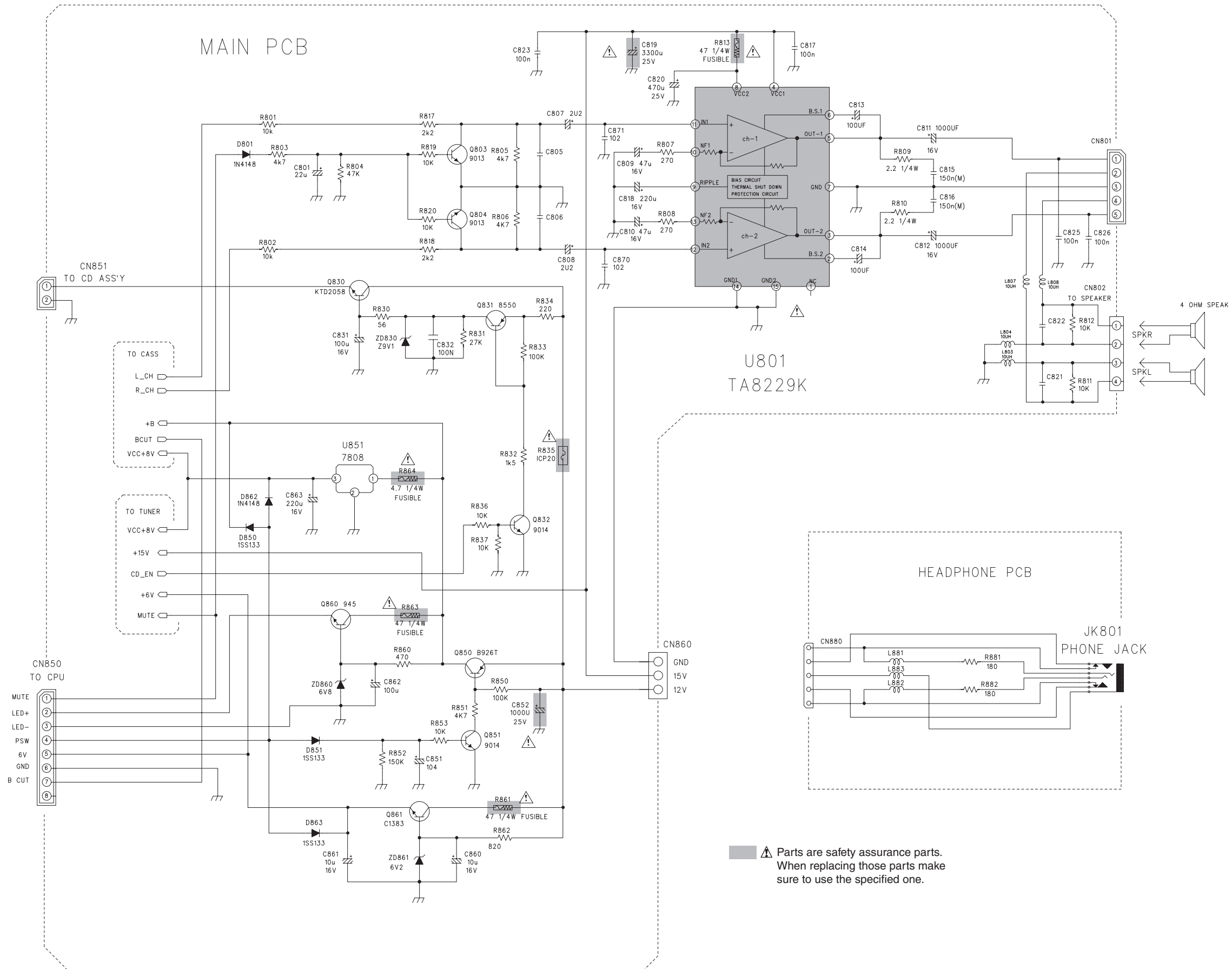

■ Display section

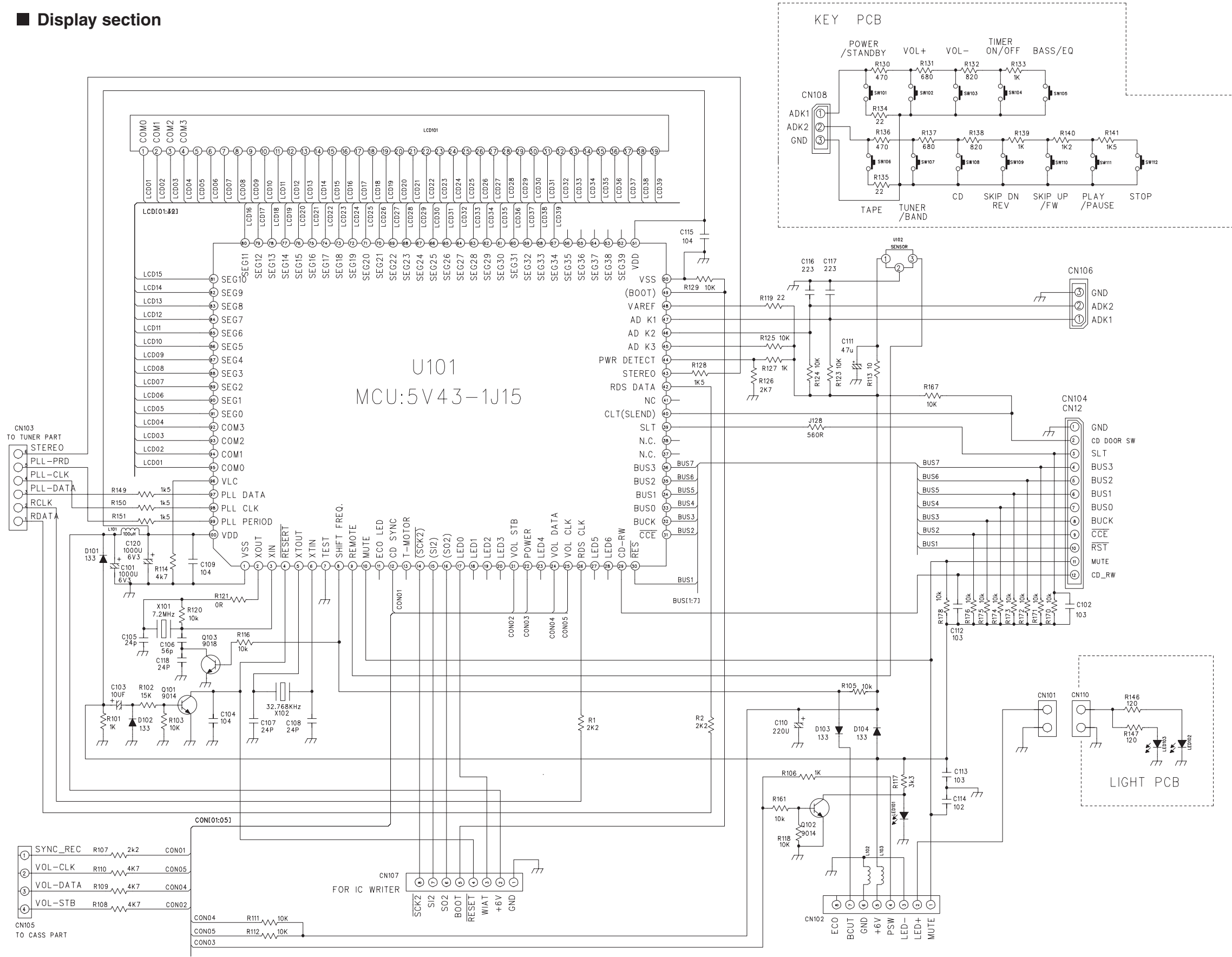

■ Remote section

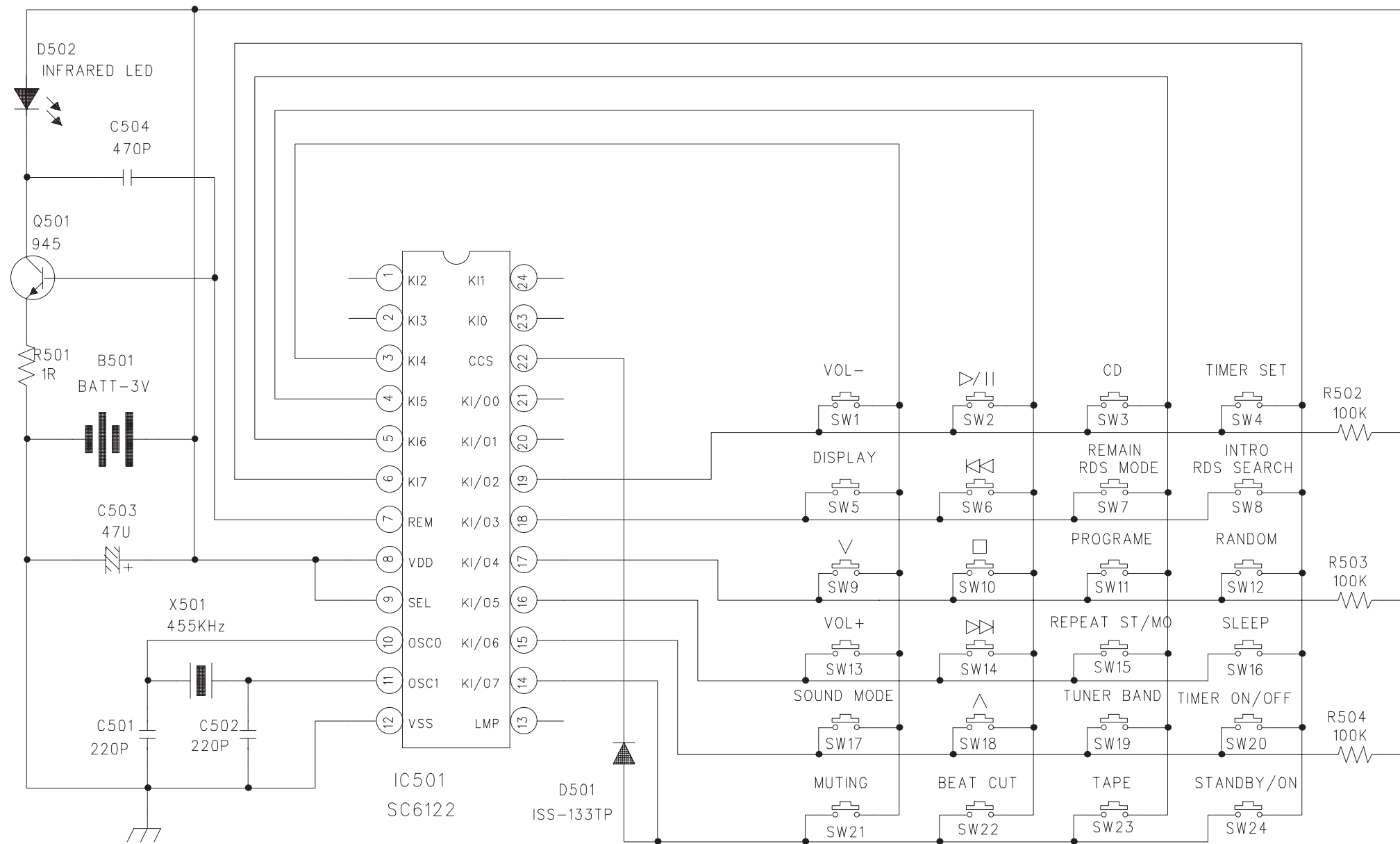

CD section

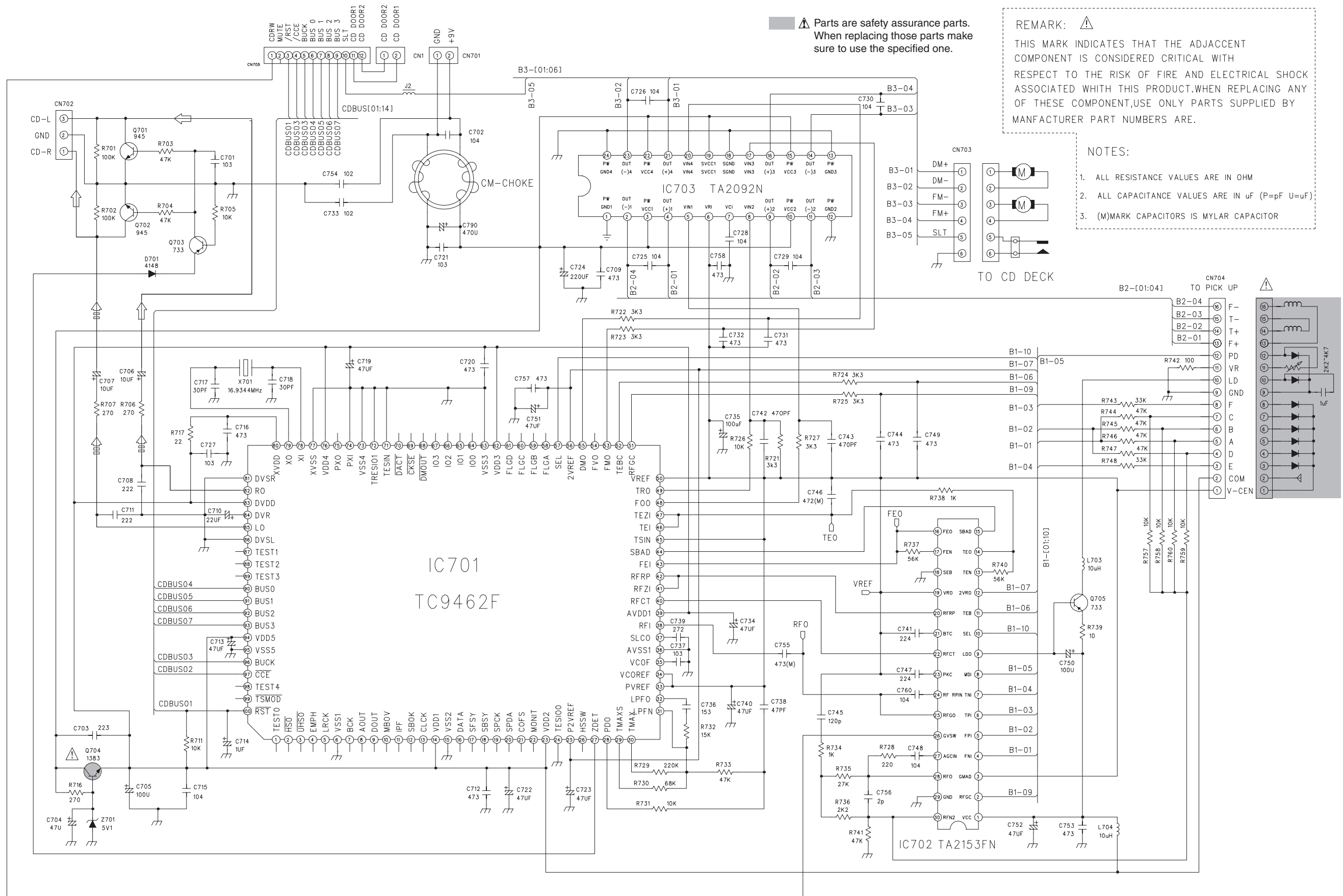

Parts are safety assurance parts. When replacing those parts make sure to use the specified one.

REMARK: THIS MARK INDICATES THAT THE ADJACENT COMPONENT IS CONSIDERED CRITICAL WITH RESPECT TO THE RISK OF FIRE AND ELECTRICAL SHOCK ASSOCIATED WITH THIS PRODUCT. WHEN REPLACING ANY OF THESE COMPONENTS, USE ONLY PARTS SUPPLIED BY MANUFACTURER PART NUMBERS ARE.

- NOTES:
1. ALL RESISTANCE VALUES ARE IN OHM
 2. ALL CAPACITANCE VALUES ARE IN uF (P=pF U=uF)
 3. (M) MARK CAPACITORS IS MYLAR CAPACITOR

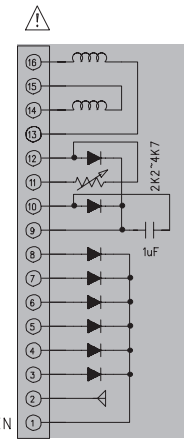

Cassette section

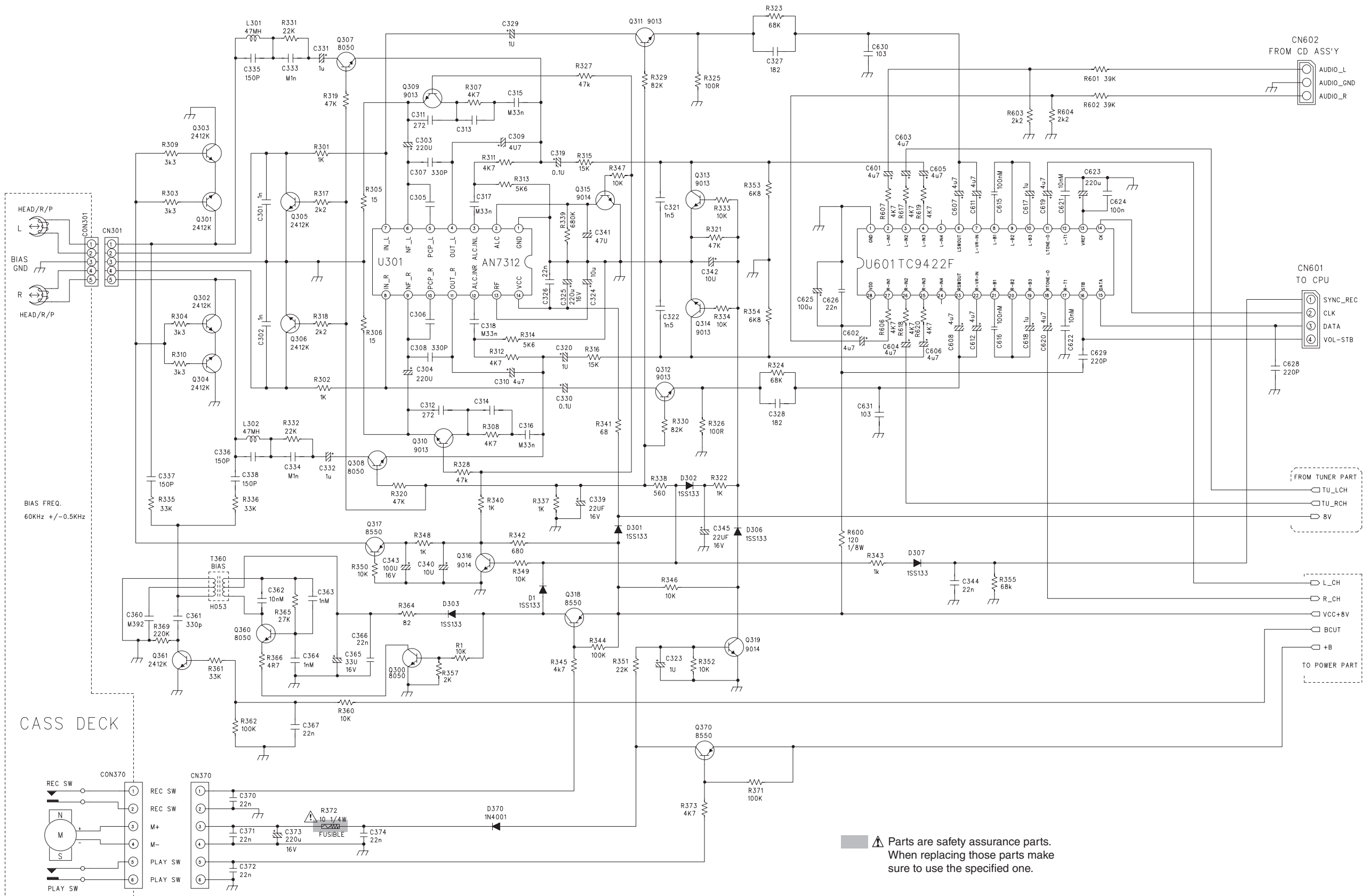

▲ Parts are safety assurance parts. When replacing those parts make sure to use the specified one.

Tuner section

FM/AM SIGNAL LINE

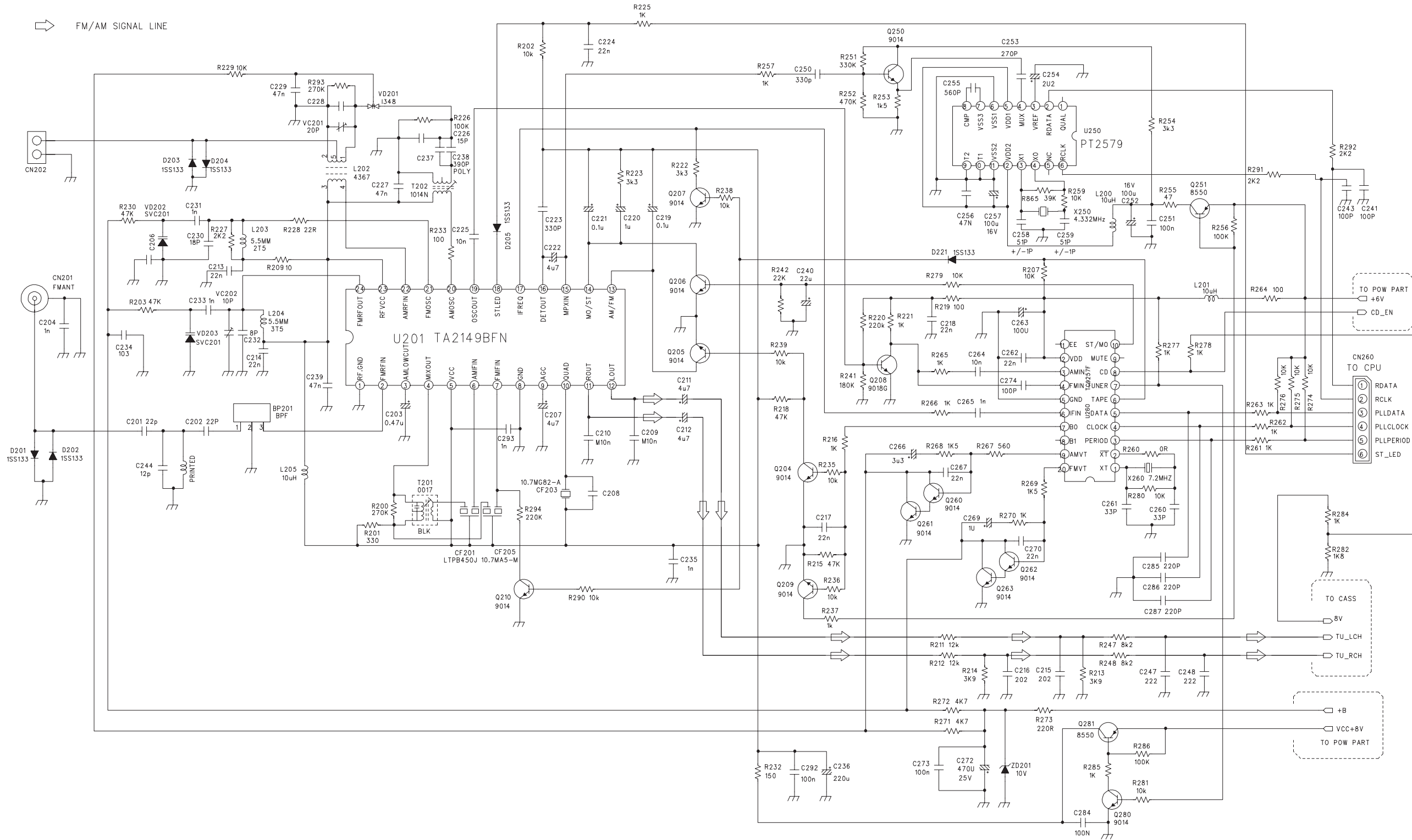

■ CD board

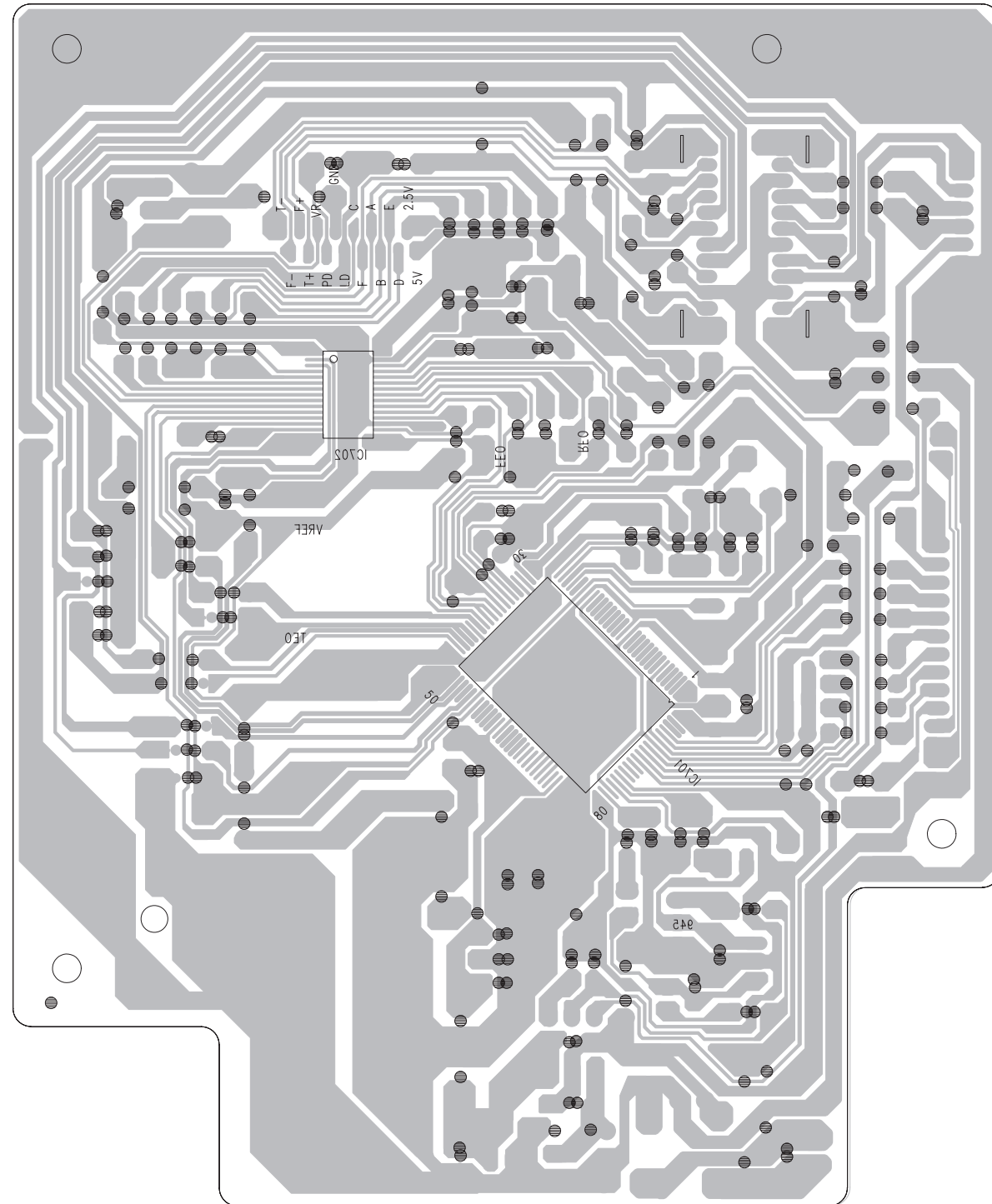
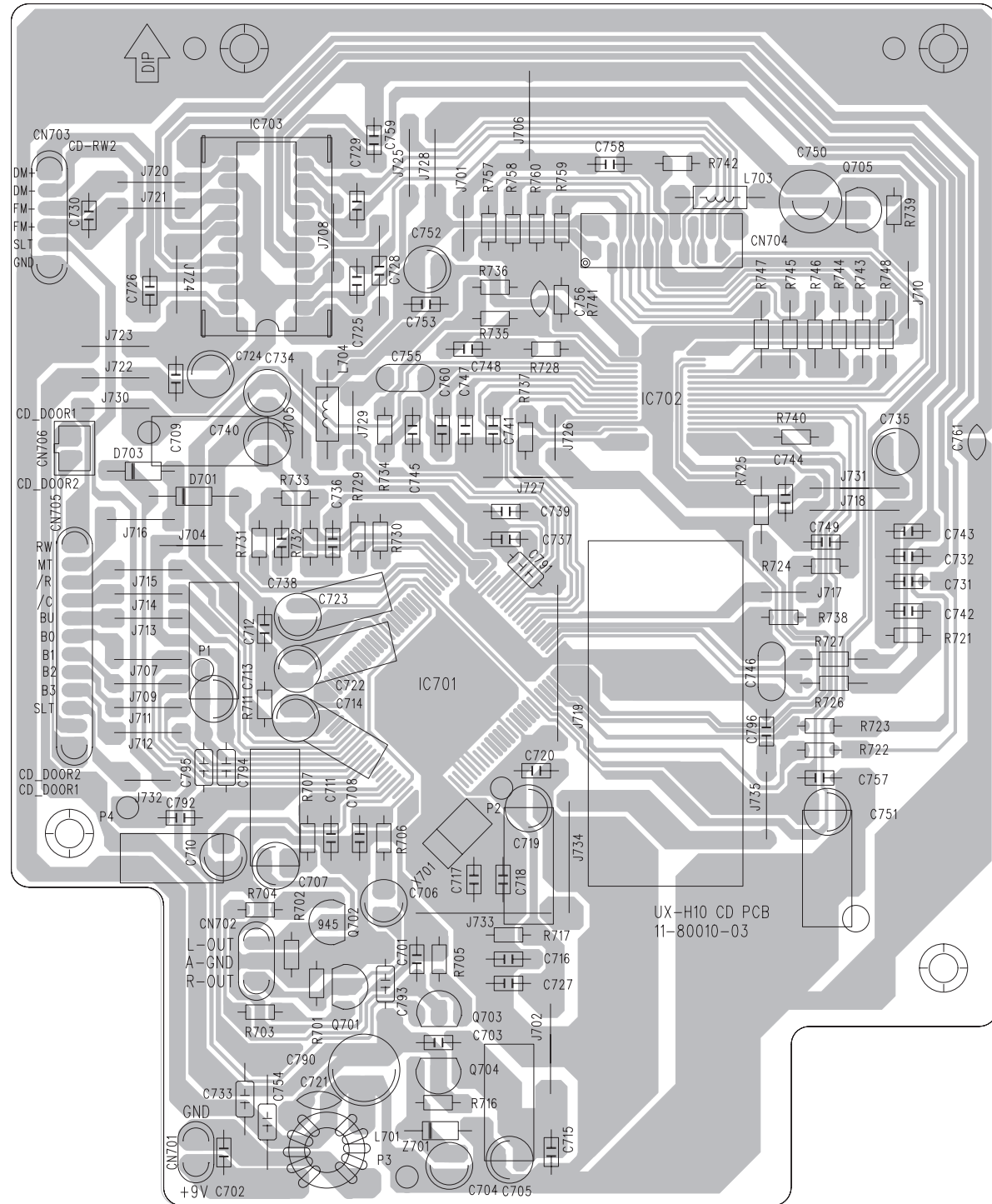

■ FM antenna board

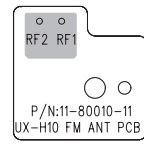

■ Headphone board

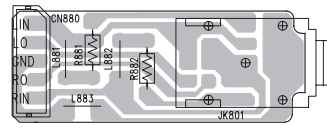

■ LED board

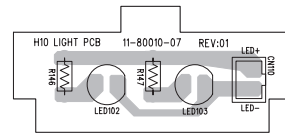

■ Remocon board (forward side)

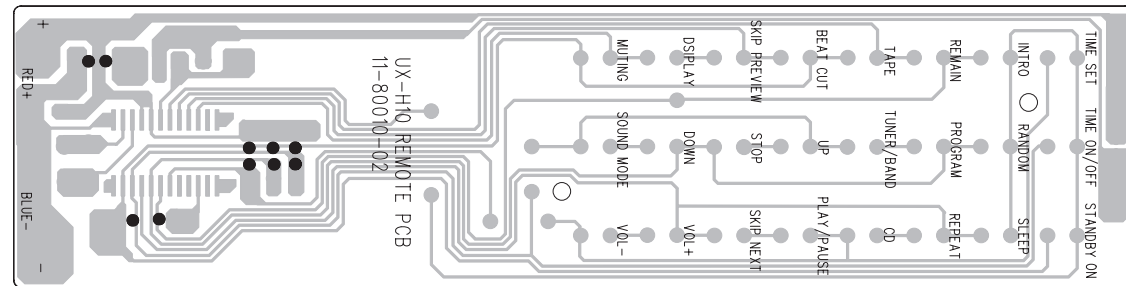

■ Remocon board (reverse side)

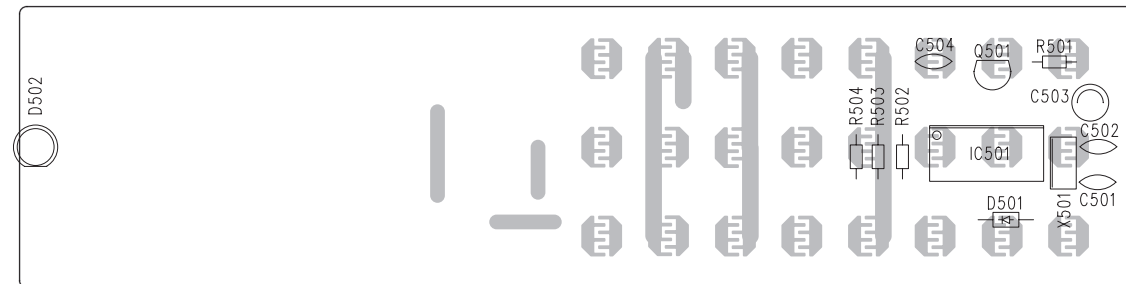

■ Key board (forward side)

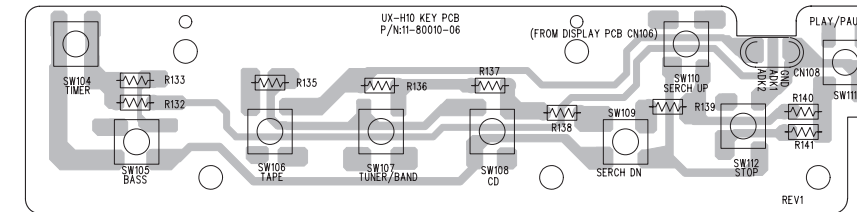

■ Key board (reverse side)

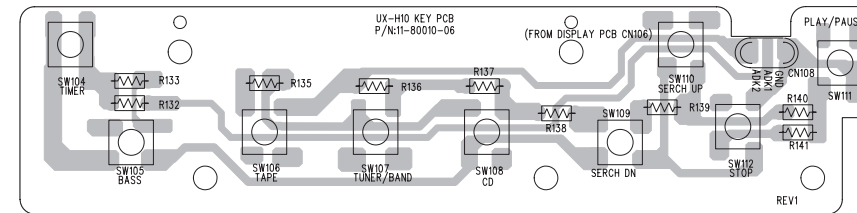

< MEMO >

JVC

VICTOR COMPANY OF JAPAN, LIMITED

AV & MULTIMEDIA COMPANY AUDIO/VIDEO SYSTEMS CATEGORY 10-1, 1chome, Ohwatari-machi, Maebashi-city, 371-8543, Japan

(No.MB066SCH)

 Printed in Japan
WPC

PARTS LIST

[UX-H10]

* All printed circuit boards and its assemblies are not available as service parts.

Area suffix	
US -----	Singapore
UT -----	Taiwan
UW -----	Brazil, Mexico, Peru

- Contents -

Exploded view of general assembly and parts list (Block No.M1)	3- 2
Electrical parts list (Block No.01~05)	3- 5
Packing materials and accessories parts list (Block No.M3)	3-12

Exploded view of general assembly and parts list

Block No. **M 1 M M**

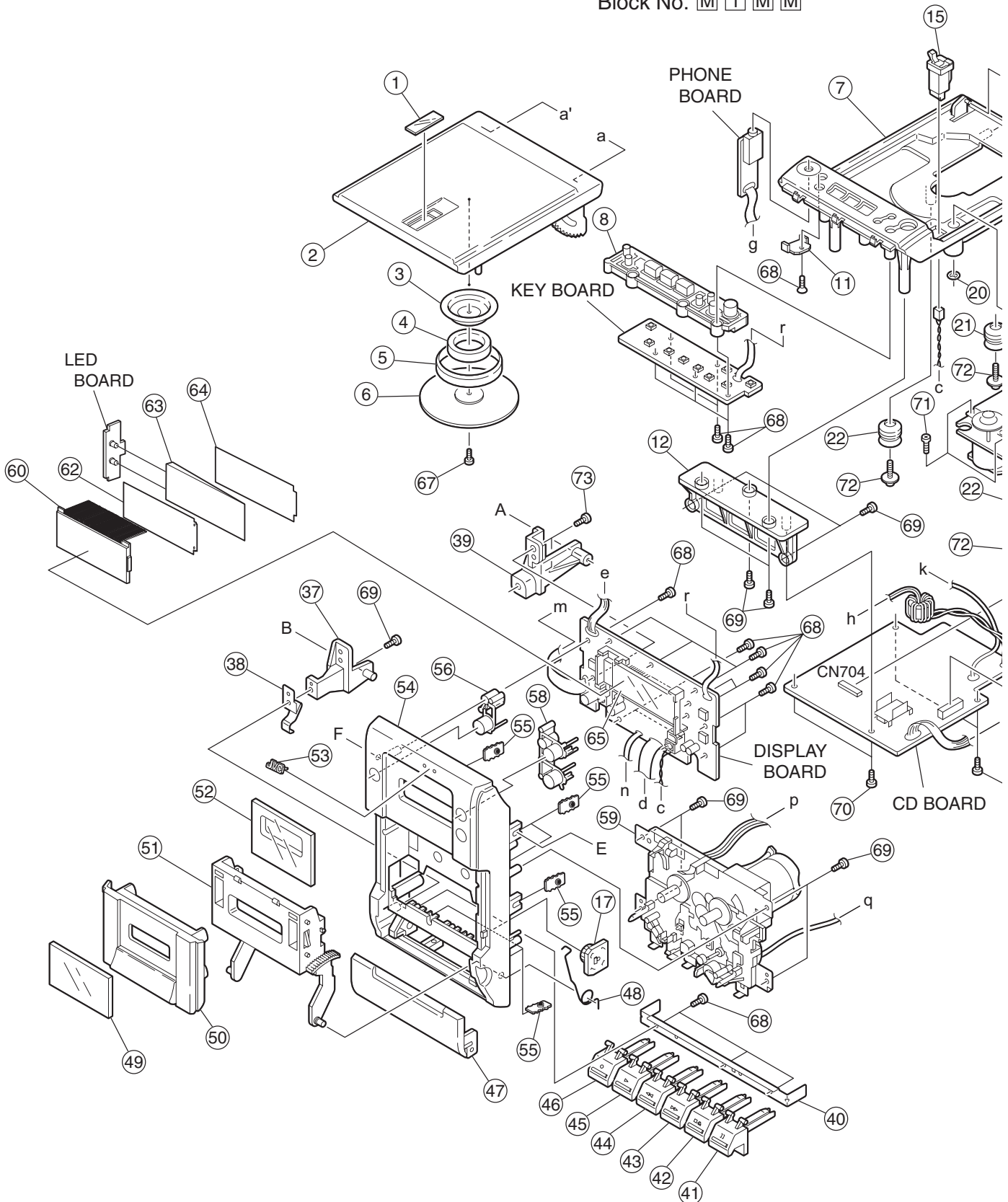

M M

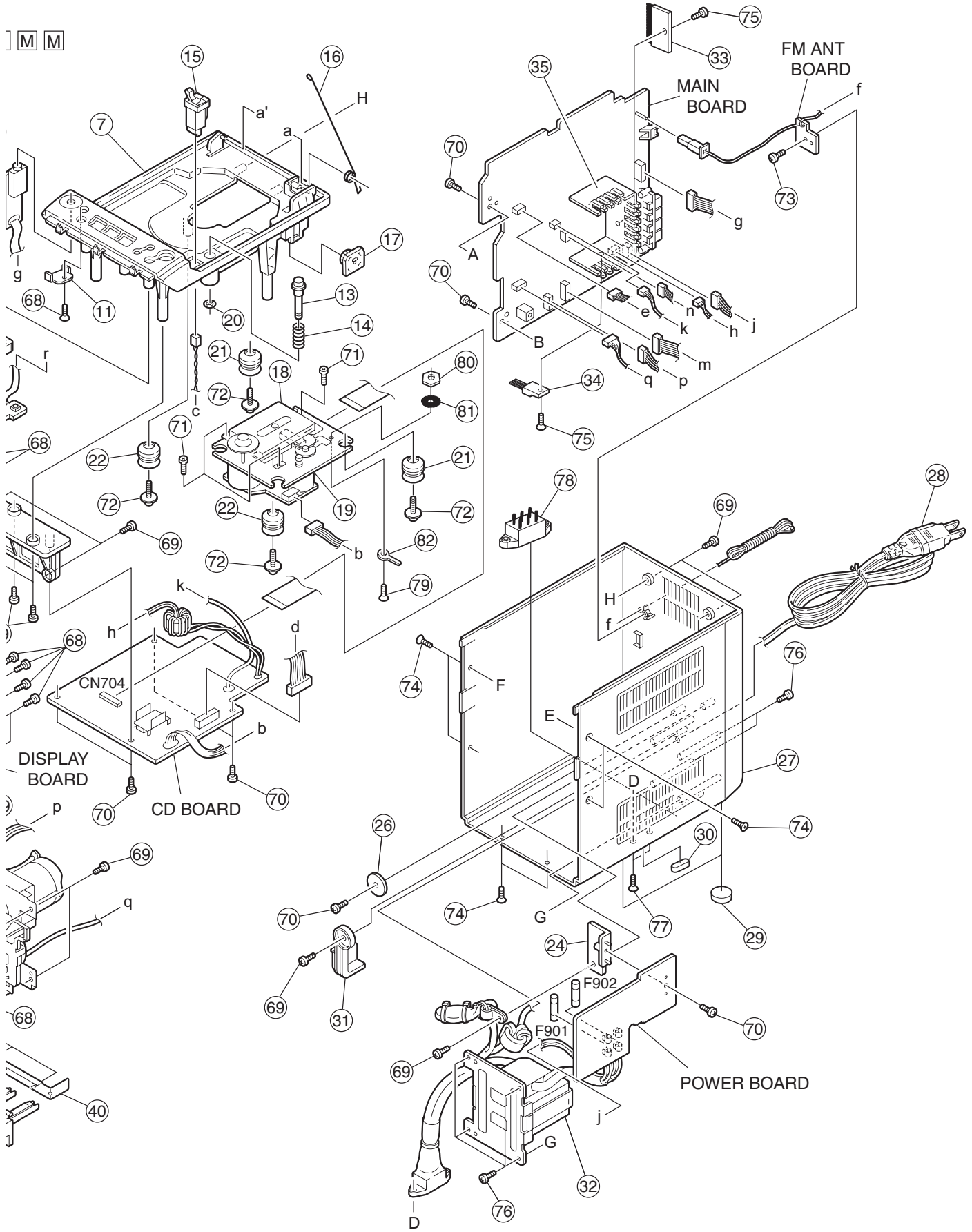

General assembly

Block No. [M][1][M][M]

Symbol No.	Part No.	Part Name	Description	Local
1	OW43-00010-00	CD DOOR LENS	PMMA	
2	OW66-00010-03	CD DOOR	ABS	
3	OW39-04200-00	METAL COVER		
4	OW97-09019-00	P.C.MAGNET	20495830	
5	OW49-04200-00	STABILIZER RING		
6	OW55-09019-01B	PLASTIC COVER	W/O Felt	
7	OW48-00010-05	CD TRAY	HIPS	
8	OW53-00010-00	FUNCTION KNOB	ABS	
11	OW39-00010-00	PHONE PCB BKT	BKT.	
12	OW48-04200-01	CD BKT.	ABS	
13	OW55-00141-02	PUSH ROD	NSX01-050	
14	OW36-00003-04	CD EJECT SPRING		
15	OW16-10101-92L	CD DOOR SWITCH	DLS-02-1	
16	OW36-03232-02	CD DOOR SPRING		
17	OW63-00303-01	DAMPER	Gear B40GG(x2)	
18	OW48-07930-08	CD MECHA COVER	Thomson CD	
19	OW98-04200-00	CD MECHA	Thomson TCP11TK	
20	OW35-00003-00	E RING	M3	
21	OW81-02750-00	CD DAMPER	3140-114-1389-2(x2)	
22	OW81-02750-01	CD DAMPER	3140-114-1390-2(x2)	
24	OW48-00010-01	POWER PCB BKT	BKT.	
26	OW35-10019-00	FIBRE WASHER	F14 X F3 X 1.5mm	
27	OW61-00010-03	REAR CABINET		
△ 28	OW30-00020-01S	AC POWER CORD		US
△ 28	OW30-00010-06	AC POWER CORD		UW
29	OW81-04200-00	RUBBER FOOT	F11X3mm W/ Tape(x2)	UT
30	OW81-00010-00	RUBBER FOOT	13X6mm	
△ 31	OW49-00010-00	AC CORD HOLDER	ABS	
△ 32	OW15-00010-05	TRANS FORMER		
33	TA8229K	IC	OW03-08229-00	
34	KTD2058	TRANSISTOR	OW01-02058-00	
35	OW39-04200-02	HEAT SINK		
37	OW48-00010-03	MAIN PCB BKT2		
38	OW36-00010-00	CASS KNOB	Door Plate	
39	OW48-00010-02	MAIN PCB BKT1		
40	OW39-04200-04	CASS KNOB BKT		
41	OW53-00010-06	CASS KNOB	Pause	
42	OW53-00010-08	CASS KNOB	Stop/Eject	
43	OW53-00010-04	CASS KNOB	F.FWD	
44	OW53-00010-05	CASS KNOB	REW.	
45	OW53-00010-03	CASS KNOB	Play	
46	OW53-00010-07	CASS KNOB	REC.	
47	OW66-00010-02	CASS KNOB	Door	
48	OW36-00010-01	CASS DOOR SPRIN	Spring	
49	OW43-00010-01	CASS DOOR LENS	Lens	
50	OW66-00010-01	CASS DOOR	ABS	
51	OW48-04200-04	CASS DOOR BKT	BKT.	
52	OW43-00010-03	DISPLAY LENS	PMMA	
53	OW55-30000-00	JVC BADGE	ABS	
54	OW60-00010-01	FRONT CABINET	HB	
55	OW39-04200-05	PANEL FIXING	Plate(x6)	
56	OW53-00010-01	POWER KNOB	ABS	
58	OW53-00010-02	VOLUME KNOB	ABS	
59	OW94-04200-00	CASS DECK	CS-2SC-3222	
60	OW91-80010-00	LCD		
62	OW43-00010-04	LCD FILTER		
63	OW43-00010-02	LIGHT GUIDE	PMMA	
64	OW68-00010-00	LIGHT GUIDE	Paper 0.15TH	
65	OW48-00010-00	LCD BKT	BKT.	
67	OW40-02045-90	SCREW	F 2.0 X 4.5	
68	OW40-12608-01	SCREW	F 2.6 X 8(x18)	
69	OW40-13010-01	SCREW	F 3.0 X 10(x14)	
70	OW40-13008-01	SCREW	F 3.0 X 8(x8)	
71	OW40-02005-90	SCREW	F2.0 X 5(x3)	
72	OW40-52610-03	SCREW	F2.6 X 10(x4)	
73	OW40-12606-01	SCREW	F2.6 X 12(x3)	
74	OW40-03006-22	SCREW	M3 X 6(x6)	
75	OW40-13008-41	SCREW	F3.0 X 8(x2)	
76	OW40-13012-01	SCREW	F3.0 X12(x6)	
77	OW40-03010-02	SCREW	M3 X 10(x2)	
78	OW16-10212-00	VOLTAGE SW.		

Symbol No.	Part No.	Part Name	Description	Local
79	OW40-03005-01	SCREW	M3 X 5	
80	OW35-40007-00	STEEL NUT	M3	
81	OW35-20001-04	TOOTH WASHER	M3	
82	OW35-30005-00	SOLDERING LUG	F3.5mm L=9mm	

Electrical parts list

Main board

Block No. [0][1][0][0]

Symbol No.	Part No.	Part Name	Description	Local
	Q204	9014	TRANSISTOR	OW01-09014-05 S
	Q205	9014	TRANSISTOR	OW01-09014-05 S
	Q206	9014	TRANSISTOR	OW01-09014-05 S
	Q207	9014	TRANSISTOR	OW01-09014-05 S
	Q209	9014	TRANSISTOR	OW01-09014-05 S
	Q210	9014	TRANSISTOR	OW01-09014-05 S
	Q260	9014	TRANSISTOR	OW01-09014-05 S
	Q261	9014	TRANSISTOR	OW01-09014-05 S
	Q262	9014	TRANSISTOR	OW01-09014-05 S
	Q263	9014	TRANSISTOR	OW01-09014-05 S
	Q280	9014	TRANSISTOR	OW01-09014-05 S
	Q281	8550	TRANSISTOR	OW01-08550-06 S
	Q300	8050	TRANSISTOR	OW01-08050-06 S
	Q301	2SC2412	TRANSISTOR	OW01-02412-00R
	Q302	2SC2412	TRANSISTOR	OW01-02412-00R
	Q303	2SC2412	TRANSISTOR	OW01-02412-00R
	Q304	2SC2412	TRANSISTOR	OW01-02412-00R
	Q305	2SC2412	TRANSISTOR	OW01-02412-00R
	Q306	2SC2412	TRANSISTOR	OW01-02412-00R
	Q307	8050	TRANSISTOR	OW01-08050-06 S
	Q308	8050	TRANSISTOR	OW01-08050-06 S
	Q309	9014	TRANSISTOR	OW01-09014-05 S
	Q310	9014	TRANSISTOR	OW01-09014-05 S
	Q311	9014	TRANSISTOR	OW01-09014-05 S
	Q312	9014	TRANSISTOR	OW01-09014-05 S
	Q313	9014	TRANSISTOR	OW01-09014-05 S
	Q314	9014	TRANSISTOR	OW01-09014-05 S
	Q315	9014	TRANSISTOR	OW01-09014-05 S
	Q316	9014	TRANSISTOR	OW01-09014-05 S
	Q317	8550	TRANSISTOR	OW01-08550-06 S
	Q318	8550	TRANSISTOR	OW01-08550-06 S
	Q319	9014	TRANSISTOR	OW01-09014-05 S
	Q360	8050	TRANSISTOR	OW01-08050-06 S
	Q361	2SC2412	TRANSISTOR	OW01-02412-00R
	Q370	8550	TRANSISTOR	OW01-08550-06 S
	Q803	9014	TRANSISTOR	OW01-09014-05 S
	Q804	9014	TRANSISTOR	OW01-09014-05 S
△	Q830	KTD2058Y	TRANSISTOR	OW01-02058-00 K
	Q831	8550	TRANSISTOR	OW01-08550-06 S
	Q832	9014	TRANSISTOR	OW01-09014-05 S
	Q850	2SB926T-AA	TRANSISTOR	OW01-00926-01
	Q851	9014	TRANSISTOR	OW01-09014-05 S
△	Q860	2SC945P	TRANSISTOR	OW01-00945-16 N
△	Q861	2SC1383R	TRANSISTOR	OW01-01383-19
	D201	1SS-133TP	FR DIODE	OW02-00133-00 R
	D202	1SS-133TP	FR DIODE	OW02-00133-00 R
	D203	1SS-133TP	FR DIODE	OW02-00133-00 R
	D204	1SS-133TP	FR DIODE	OW02-00133-00 R
	D205	1SS-133TP	FR DIODE	OW02-00133-00 R
	D221	1SS-133TP	FR DIODE	OW02-00133-00 R
	D301	1SS-133TP	FR DIODE	OW02-00133-00 R
	D302	1SS-133TP	FR DIODE	OW02-00133-00 R
	D303	1SS-133TP	FR DIODE	OW02-00133-00 R
	D304	1SS-133TP	FR DIODE	OW02-00133-00 R
	D306	1SS-133TP	FR DIODE	OW02-00133-00 R
	D307	1SS-133TP	FR DIODE	OW02-00133-00 R
	D370	1N4001	FR DIODE	OW02-04001-00
	D801	1SS-133TP	FR DIODE	OW02-00133-00 R
	D850	1SS-133TP	FR DIODE	OW02-00133-00 R
	D851	1SS-133TP	FR DIODE	OW02-00133-00 R
	D862	1SS-133TP	FR DIODE	OW02-00133-00 R
	D863	1SS-133TP	FR DIODE	OW02-00133-00 R
	C200	OW05-00220-06	C CAPACITOR	22PF NPO
	C201	OW05-00220-06	C CAPACITOR	22PF NPO
	C203	OW06-50474-20	E CAPACITOR	0.47MF 50V PITC
	C204	OW05-03102-06T	C CAPACITOR	1000PF
	C205	OW05-00102-82	C CAPACITOR	0.001MF +80-20%
	C206	OW05-00030-06	C CAPACITOR	3PF NPO
	C207	OW06-50475-02	E CAPACITOR	4.7MF 50V PITCH
	C209	OW05-02103-10	M CAPACITOR	0.01MF

Symbol No.	Part No.	Part Name	Description	Local
	C210	OW05-02103-10	M CAPACITOR	0.01MF
	C211	OW06-50475-02	E CAPACITOR	4.7MF 50V PITCH
	C212	OW06-50475-02	E CAPACITOR	4.7MF 50V PITCH
	C214	OW05-03223-06T	C CAPACITOR	0.022MF
	C215	OW05-02202-10	M CAPACITOR	0.002MF
	C216	OW05-02202-10	M CAPACITOR	0.002MF
	C217	OW05-03223-06T	C CAPACITOR	0.022MF
	C219	OW06-50104-03	E CAPACITOR	0.1MF 50V
	C220	OW06-50105-02	E CAPACITOR	1MF 50V PITCH=5
	C221	OW06-50104-03	E CAPACITOR	0.1MF 50V
	C222	OW06-50475-02	E CAPACITOR	4.7MF 50V PITCH
	C223	OW05-03331-03T	CHIP CAPACITOR	330PF
	C224	OW05-07223-82A	C CAPACITOR	0.022MF
	C225	OW05-03103-06T	C CAPACITOR	0.01MF B500 K10
	C226	OW05-03200-03T	C CAPACITOR	20PF N500 J200
	C227	OW05-03473-06T	C CAPACITOR	0.047MF B500 K4
	C229	OW05-00473-82	C CAPACITOR	0.047MF
	C230	OW05-00180-06	C CAPACITOR	18PF NPO
	C231	OW05-00102-82	C CAPACITOR	0.001MF +80/-20
	C232	OW05-03080-03T	C CAPACITOR	8PF
	C233	OW05-03102-06T	C CAPACITOR	1000PF B500 K10
	C234	OW05-03103-06T	C CAPACITOR	0.01MF B500 K10
	C235	OW05-03102-06T	C CAPACITOR	1000PF B500 K10
	C236	OW06-16227-02	E CAPACITOR	220MF 16V PITCH
	C237	OW05-03330-03T	CHIP CAPACITOR	33PF N500 J330
	C238	OW05-09391-05	P CAPACITOR	390PF
	C239	OW05-03473-06T	C CAPACITOR	0.047MF B500 K4
	C240	OW06-16226-02	E CAPACITOR	22MF 16V PITCH=
	C244	OW05-00120-06	C CAPACITOR	12PF NPO
	C245	OW05-00102-82	C CAPACITOR	0.001MF +80/-20
	C247	OW05-03222-06T	C CAPACITOR	2200PF B500 K22
	C248	OW05-03222-06T	C CAPACITOR	2200PF B500 K22
	C260	OW05-03330-03T	CHIP CAPACITOR	33PF N500 J330
	C261	OW05-03330-03T	CHIP CAPACITOR	33PF N500 J330
	C262	OW05-03223-06T	C CAPACITOR	0.022MF B500 K2
	C263	OW06-16107-02	E CAPACITOR	100MF 16V
	C264	OW05-03103-06T	C CAPACITOR	0.01MF B500 K10
	C265	OW05-03102-06T	C CAPACITOR	1000PF B500 K10
	C266	OW06-50335-02	E CAPACITOR	3.3MF 50V PITCH
	C267	OW05-03223-06T	C CAPACITOR	0.022MF B500 K2
	C269	OW06-50105-02	E CAPACITOR	1MF 50V PITCH=5
	C270	OW05-03223-06T	C CAPACITOR	0.022MF B500 K2
	C272	OW06-25477-02	E CAPACITOR	470MF 25V PITCH
	C273	OW05-07104-82B	C CAPACITOR	0.1MF 50V
	C274	OW05-03101-06T	C CAPACITOR	100PF N101J 500
	C284	OW05-03104-06T	C CAPACITOR	0.1MF
	C285	OW05-03221-03T	CHIP CAPACITOR	220PF N500 J221
	C286	OW05-03221-03T	CHIP CAPACITOR	220PF N500 J221
	C287	OW05-03221-03T	CHIP CAPACITOR	220PF N500 J221
	C292	OW05-03104-06T	C CAPACITOR	0.1MF
	C293	OW05-07102-10A	C CAPACITOR	1000PF
	C294	OW05-03223-06T	C CAPACITOR	0.022MF B500 K2
	C301	OW05-03102-06T	C CAPACITOR	1000PF B500 K10
	C302	OW05-03102-06T	C CAPACITOR	1000PF B500 K10
	C303	OW06-16227-02	E CAPACITOR	220MF 16V PITCH
	C304	OW06-16227-02	E CAPACITOR	220MF 16V PITCH
	C307	OW05-03331-03T	CHIP CAPACITOR	330PF N500 J331
	C308	OW05-03331-03T	CHIP CAPACITOR	330PF N500 J331
	C309	OW06-50475-02	E CAPACITOR	4.7MF 50V PITCH
	C310	OW06-50475-02	E CAPACITOR	4.7MF 50V PITCH
	C311	OW05-03272-06T	C CAPACITOR	0.002MF B500 K2
	C312	OW05-03272-06T	C CAPACITOR	0.0027MF
	C315	OW05-02333-10	M CAPACITOR	0.033MF
	C316	OW05-02333-10	M CAPACITOR	0.033MF
	C317	OW05-02333-10	M CAPACITOR	0.033MF
	C318	OW05-02333-10	M CAPACITOR	0.033MF
	C319	OW06-50104-03	E CAPACITOR	0.1MF 50V
	C320	OW06-50104-03	E CAPACITOR	0.1MF 50V
	C321	OW05-03152-06T	C CAPACITOR	1500PF B500 K15
	C322	OW05-03152-06T	C CAPACITOR	1500PF B500 K15
	C323	OW06-50105-02	E CAPACITOR	1MF 50V PITCH=5
	C324	OW06-25106-02	E CAPACITOR	10MF 25V PITCH=
	C325	OW06-16227-02	E CAPACITOR	220MF 16V PITCH
	C326	OW05-03223-06T	C CAPACITOR	0.022MF B500 K2
	C327	OW05-03182-06T	C CAPACITOR	0.0018MF B500 K
	C328	OW05-03182-06T	C CAPACITOR	0.0018MF B500 K

△ Symbol No.	Part No.	Part Name	Description	Local	△ Symbol No.	Part No.	Part Name	Description	Local
C329	OW06-50105-02	E CAPACITOR	1MF 50V PITCH=5		C832	OW05-03104-06T	C CAPACITOR	0.1MF	
C330	OW06-50105-02	E CAPACITOR	1MF 50V PITCH=5		C833	OW05-03104-06T	C CAPACITOR	0.1MF	
C331	OW06-50105-02	E CAPACITOR	1MF 50V PITCH=5		C851	OW05-00104-82	C CAPACITOR	0.1MF +80%-20%	
C332	OW06-50105-02	E CAPACITOR	1MF 50V PITCH=5		C852	OW06-25108-00	E CAPACITOR	1000MF 25V	
C333	OW05-02102-10	M CAPACITOR	0.001MF		C853	OW05-03104-06T	C CAPACITOR	0.1MF	
C334	OW05-02102-10	M CAPACITOR	0.001MF		C860	OW06-25106-02	E CAPACITOR	10MF 25V PITCH=	
C335	OW05-03151-03T	C CAPACITOR	150PF N151J 500		C861	OW06-25106-02	E CAPACITOR	10MF 25V PITCH=	
C336	OW05-03151-03T	C CAPACITOR	150PF N151J 500		C862	OW06-16107-02	E CAPACITOR	100MF 16V	
C337	OW05-03151-03T	C CAPACITOR	150PF N151J 500		C863	OW06-16227-02	E CAPACITOR	220MF 16V PITCH	
C338	OW05-03151-03T	C CAPACITOR	150PF N151J 500		VC201	OW05-08200-03	TR CAPACITOR	20PF 3PIN	
C339	OW06-16227-02	E CAPACITOR	220MF 16V PITCH		VC202	OW05-08100-03	TR CAPACITOR	10PF 3PIN	
C340	OW06-25106-02	E CAPACITOR	10MF 25V PITCH=						
C341	OW06-16476-02	E CAPACITOR	47MF 16V		R146	OW07-15121-50T	C RESISTOR	120 1/8W 52MM T	
C342	OW06-25106-02	E CAPACITOR	10MF 25V PITCH=		R147	OW07-15121-50T	C RESISTOR	120 1/8W 52MM T	
C343	OW06-16107-02	E CAPACITOR	100MF 16V		R200	OW07-25274-60K	C RESISTOR	270K RMC 1/16	
C344	OW05-03223-06T	C CAPACITOR	0.022MF B500 K2		R201	OW07-25331-60K	C RESISTOR	330 1/8W	
C345	OW06-16475-02	E CAPACITOR	4.7MF 16V		R202	OW07-25103-60K	C RESISTOR	10K RMC 1/16 10	
C360	OW05-02392-10	M CAPACITOR	0.0039MF		R203	OW07-15473-50T	C RESISTOR	47K 1/8W 52MM T	
C361	OW05-03331-03T	CHIP CAPACITOR	330PF N500 J331		R207	OW07-25103-60K	C RESISTOR	10K RMC 1/16 10	
C362	OW05-02103-10	M CAPACITOR	0.01MF		R209	OW07-15100-50T	C RESISTOR	10 1/8W 52MM T.	
C363	OW05-02102-10	M CAPACITOR	0.001MF		R211	OW07-25123-60K	C RESISTOR	12K RMC 1/16 12	
C364	OW05-02102-10	M CAPACITOR	0.001MF		R212	OW07-25123-60K	C RESISTOR	12K RMC 1/16 12	
C365	OW06-16336-02	E CAPACITOR	33MF 16V PITCH=		R213	OW07-25392-60K	C RESISTOR	3.9K RMC 1/16	
C366	OW05-03223-06T	C CAPACITOR	0.022MF B500 K2		R214	OW07-25392-60K	C RESISTOR	3.9K RMC 1/16	
C367	OW05-03223-06T	C CAPACITOR	0.022MF B500 K2		R215	OW07-25473-60K	C RESISTOR	47K RMC 1/16 47	
C370	OW05-03223-06T	C CAPACITOR	0.022MF B500 K2		R216	OW07-25102-60K	C RESISTOR	1K RMC 1/16 102	
C371	OW05-03223-06T	C CAPACITOR	0.022MF B500 K2		R218	OW07-25473-60K	C RESISTOR	47K RMC 1/16 47	
C372	OW05-03223-06T	C CAPACITOR	0.022MF B500 K2		R222	OW07-25332-60K	C RESISTOR	3.3K RMC 1/16	
C373	OW06-16227-02	E CAPACITOR	220MF 16V PITCH		R223	OW07-25332-60K	C RESISTOR	3.3K RMC 1/16	
C374	OW05-07223-82A	C CAPACITOR	0.022MF		R225	OW07-15102-50T	C RESISTOR	1K 1/8W 52MM T.	
C601	OW06-50475-02	E CAPACITOR	4.7MF 50V PITCH		R226	OW07-25104-60K	C RESISTOR	100K RMC 1/16	
C602	OW06-50475-02	E CAPACITOR	4.7MF 50V PITCH		R227	OW07-25222-60K	C RESISTOR	2.2K RMC 1/16	
C603	OW06-50475-02	E CAPACITOR	4.7MF 50V PITCH		R228	OW07-15220-50T	C RESISTOR	22 1/8W 52MM T.	
C604	OW06-50475-02	E CAPACITOR	4.7MF 50V PITCH		R229	OW07-15103-50T	C RESISTOR	10K 1/8W 52MM T	
C605	OW06-50475-02	E CAPACITOR	4.7MF 50V PITCH		R230	OW07-15473-50T	C RESISTOR	47K 1/8W 52MM T	
C606	OW06-50475-02	E CAPACITOR	4.7MF 50V PITCH		R232	OW07-15221-50T	C RESISTOR	220 1/8W 52MM T	
C607	OW06-50475-02	E CAPACITOR	4.7MF 50V PITCH		R233	OW07-15101-50T	C RESISTOR	100 1/8W 52MM T	
C608	OW06-50475-02	E CAPACITOR	4.7MF 50V PITCH		R235	OW07-25103-60K	C RESISTOR	10K RMC 1/16 10	
C611	OW06-50475-02	E CAPACITOR	4.7MF 50V PITCH		R236	OW07-25103-60K	C RESISTOR	10K RMC 1/16 10	
C612	OW06-50475-02	E CAPACITOR	4.7MF 50V PITCH		R238	OW07-25103-60K	C RESISTOR	10K RMC 1/16 10	
C615	OW05-02104-10	M CAPACITOR	0.1MF		R239	OW07-25103-60K	C RESISTOR	10K RMC 1/16 10	
C616	OW05-02104-10	M CAPACITOR	0.1MF		R242	OW07-25223-60K	C RESISTOR	22K RMC 1/16 22	
C617	OW06-50105-02	E CAPACITOR	1MF 50V PITCH=5		R247	OW07-25822-60K	C RESISTOR	8.2K RMC 1/16	
C618	OW06-50105-02	E CAPACITOR	1MF 50V PITCH=5		R248	OW07-25822-60K	C RESISTOR	8.2K RMC 1/16	
C619	OW06-50475-02	E CAPACITOR	4.7MF 50V PITCH		R260	OW07-25000-60K	C RESISTOR	0 RMC 1/16 000J	
C620	OW06-50475-02	E CAPACITOR	4.7MF 50V PITCH		R261	OW07-25102-60K	C RESISTOR	1K RMC 1/16 102	
C621	OW05-02103-10	M CAPACITOR	0.01MF		R262	OW07-25102-60K	C RESISTOR	1K RMC 1/16 102	
C622	OW05-02103-10	M CAPACITOR	0.01MF		R263	OW07-25102-60K	C RESISTOR	1K RMC 1/16 102	
C623	OW06-16227-02	E CAPACITOR	220MF 16V PITCH		R265	OW07-25102-60K	C RESISTOR	1K RMC 1/16 102	
C624	OW05-03104-06T	C CAPACITOR	0.1MF		R266	OW07-25102-60K	C RESISTOR	1K RMC 1/16 102	
C625	OW06-16107-02	E CAPACITOR	100MF 16V		R267	OW07-25561-60K	C RESISTOR	560 1/16 561JTP	
C626	OW05-07223-82A	C CAPACITOR	0.022MF		R268	OW07-25152-60K	C RESISTOR	1.5K RMC 1/16	
C628	OW05-03221-03T	CHIP CAPACITOR	220PF N500 J221		R269	OW07-25152-60K	C RESISTOR	1.5K RMC 1/16	
C629	OW05-03221-03T	CHIP CAPACITOR	220PF N500 J221		R270	OW07-25102-60K	C RESISTOR	1K RMC 1/16 102	
C630	OW05-03103-06T	C CAPACITOR	0.01MF B500 K10		R271	OW07-25472-60K	C RESISTOR	4.7K RMC 1/16	
C631	OW05-03103-06T	C CAPACITOR	0.01MF B500 K10		R272	OW07-25472-60K	C RESISTOR	4.7K RMC 1/16	
C801	OW06-16226-02	E CAPACITOR	22MF 16V PITCH=		R273	OW07-15221-50T	C RESISTOR	220 1/8W 52MM T	
C802	OW05-03102-06T	C CAPACITOR	1000PF B500 K10		R274	OW07-25103-60K	C RESISTOR	10K RMC 1/16 10	
C803	OW05-03102-06T	C CAPACITOR	1000PF B500 K10		R275	OW07-25103-60K	C RESISTOR	10K RMC 1/16 10	
C807	OW06-50225-02	E CAPACITOR	2.2MF 50V		R276	OW07-25103-60K	C RESISTOR	10K RMC 1/16 10	
C808	OW06-50225-02	E CAPACITOR	2.2MF 50V		R277	OW07-25102-60K	C RESISTOR	1K RMC 1/16 102	
C809	OW06-16476-02	E CAPACITOR	47MF 16V		R278	OW07-25102-60K	C RESISTOR	1K RMC 1/16 102	
C810	OW06-16476-02	E CAPACITOR	47MF 16V		R279	OW07-15103-50T	C RESISTOR	10K 1/8W 52MM T	
△ C811	OW06-16108-00	E CAPACITOR	1000MF 16V		R280	OW07-25103-60K	C RESISTOR	10K RMC 1/16 10	
△ C812	OW06-16108-00	E CAPACITOR	1000MF 16V		R281	OW07-15103-50T	C RESISTOR	10K 1/8W 52MM T	
C813	OW06-16107-02	E CAPACITOR	100MF 16V		R282	OW07-25182-60K	C RESISTOR	1.8K RMC 1/16	
C814	OW06-16107-02	E CAPACITOR	100MF 16V		R284	OW07-15102-50T	C RESISTOR	1K 1/8W 52MM T.	
C815	OW05-02154-10	M CAPACITOR	0.15MF		R285	OW07-15102-50T	C RESISTOR	1K 1/8W 52MM T.	
C816	OW05-02154-10	M CAPACITOR	0.15MF		R286	OW07-25104-60K	C RESISTOR	100K RMC 1/16	
C817	OW05-03104-06T	C CAPACITOR	0.1MF		R290	OW07-25103-60K	C RESISTOR	10K RMC 1/16 10	
C818	OW06-16227-02	E CAPACITOR	220MF 16V PITCH		R293	OW07-25274-60K	C RESISTOR	270K RMC 1/16	
△ C819	OW06-25338-00	E CAPACITOR	3300MF 25V		R294	OW07-25224-60K	C RESISTOR	220K RMC 1/16	
C820	OW06-25477-02	E CAPACITOR	470MF 25V		R301	OW07-25102-60K	C RESISTOR	1K RMC 1/16 102	
C823	OW05-07104-82B	C CAPACITOR	0.1MF 50V		R302	OW07-25102-60K	C RESISTOR	1K RMC 1/16 102	
C825	OW05-03104-06T	C CAPACITOR	0.1MF		R303	OW07-25332-60K	C RESISTOR	3.3K RMC 1/16	
C826	OW05-03104-06T	C CAPACITOR	0.1MF		R304	OW07-25332-60K	C RESISTOR	3.3K RMC 1/16	
C830	OW05-03104-06T	C CAPACITOR	0.1MF		R305	OW07-25150-60K	C RESISTOR	15 1/16 150JTP	
C831	OW06-16107-02	E CAPACITOR	100MF 16V		R306	OW07-25150-60K	C RESISTOR	15 1/16 150JTP	

△ Symbol No.	Part No.	Part Name	Description	Local	△ Symbol No.	Part No.	Part Name	Description	Local
R307	OW07-25472-60K	C RESISTOR	4.7K RMC 1/16		R805	OW07-25392-60K	C RESISTOR	3.9K RMC 1/16	
R308	OW07-25472-60K	C RESISTOR	4.7K RMC 1/16		R806	OW07-25392-60K	C RESISTOR	3.9K RMC 1/16	
R309	OW07-25332-60K	C RESISTOR	3.3K RMC 1/16		R807	OW07-25331-60K	C RESISTOR	330 1/8W	
R310	OW07-25332-60K	C RESISTOR	3.3K RMC 1/16		R808	OW07-25331-60K	C RESISTOR	330 1/8W	
R311	OW07-25472-60K	C RESISTOR	4.7K RMC 1/16		R809	OW07-15022-00	C RESISTOR	2.2 1/4W	
R312	OW07-25472-60K	C RESISTOR	4.7K RMC 1/16		R810	OW07-15022-00	C RESISTOR	2.2 1/4W	
R313	OW07-25562-60K	C RESISTOR	5.6K RMC 1/16		R811	OW07-25103-60K	C RESISTOR	10K RMC 1/16 10	
R314	OW07-25562-60K	C RESISTOR	5.6K RMC 1/16		R812	OW07-25103-60K	C RESISTOR	10K RMC 1/16 10	
R315	OW07-15153-50T	C RESISTOR	15K 1/8W 52MM T		△ R813	OW07-15470-08	FUSE RESISTOR	47 1/4W 52MM T.	
R316	OW07-15153-50T	C RESISTOR	15K 1/8W 52MM T		R819	OW07-25103-60K	C RESISTOR	10K RMC 1/16 10	
R317	OW07-25222-60K	C RESISTOR	2.2K RMC 1/16		R820	OW07-25103-60K	C RESISTOR	10K RMC 1/16 10	
R318	OW07-25222-60K	C RESISTOR	2.2K RMC 1/16		R830	OW07-25560-60K	C RESISTOR	56 RMC 1/16 560	
R319	OW07-25473-60K	C RESISTOR	47K RMC 1/16 47		R831	OW07-25273-60K	C RESISTOR	27K RMC 1/16 27	
R320	OW07-25473-60K	C RESISTOR	47K RMC 1/16 47		R832	OW07-25152-60K	C RESISTOR	1.5K RMC 1/16	
R321	OW07-25473-60K	C RESISTOR	47K RMC 1/16 47		R833	OW07-25104-60K	C RESISTOR	100K RMC 1/16	
R322	OW07-25102-60K	C RESISTOR	1K RMC 1/16 102		R834	OW07-15221-00	C RESISTOR	220 1/4W	
R323	OW07-25683-60K	C RESISTOR	68K RMC 1/16 68		△ R835	ICP-N20	IC PROTECTOR	OW03-00020-00R	
R324	OW07-25683-60K	C RESISTOR	68K RMC 1/16 68		R836	OW07-25103-60K	C RESISTOR	10K RMC 1/16 10	
R325	OW07-25101-60K	C RESISTOR	100 RMC 1/16		R837	OW07-25103-60K	C RESISTOR	10K RMC 1/16 10	
R326	OW07-25101-60K	C RESISTOR	100 RMC 1/16		R850	OW07-25104-60K	C RESISTOR	100K RMC 1/16	
R327	OW07-25473-60K	C RESISTOR	47K RMC 1/16 47		R851	OW07-25472-60K	C RESISTOR	4.7K RMC 1/16	
R328	OW07-25473-60K	C RESISTOR	47K RMC 1/16 47		R852	OW07-25154-60K	C RESISTOR	150K RMC 1/16	
R329	OW07-25823-60K	C RESISTOR	82K RMC 1/16 82		R853	OW07-25103-60K	C RESISTOR	10K RMC 1/16 10	
R330	OW07-25823-60K	C RESISTOR	82K RMC 1/16 82		R860	OW07-15471-50T	C RESISTOR	47 1/8W 52MM T	
R331	OW07-25223-60K	C RESISTOR	22K RMC 1/16 22		R861	OW07-15470-00	C RESISTOR	47 1/4W 52MM T.	
R332	OW07-25223-60K	C RESISTOR	22K RMC 1/16 22		R862	OW07-15821-00	C RESISTOR	820 1/4W 52MM T.	
R333	OW07-25103-60K	C RESISTOR	10K RMC 1/16 10		△ R863	OW07-15470-08	FUSE RESISTOR	47 1/4W 52MM T.	
R334	OW07-25103-60K	C RESISTOR	10K RMC 1/16 10		△ R864	OW07-15047-08	C RESISTOR	4.7 1/4W 52MM T	
R335	OW07-25333-60K	C RESISTOR	33K RMC 1/16 33		R881	OW07-15181-50T	C RESISTOR	180 1/8W 52MM T	
R336	OW07-25333-60K	C RESISTOR	33K RMC 1/16 33		R882	OW07-15181-50T	C RESISTOR	180 1/8W 52MM T	
R337	OW07-15181-50T	C RESISTOR	180 1/8W 52MM T		L201	OW09-70101-00	AXIAL LEAD	INDUCTOR 10MH	
R338	OW07-25151-50K	C RESISTOR	RMC SMD150 1/10		L203	OW09-25055-00W	FM COIL	F5.5MM X 2.5T	
R339	OW07-25684-60K	C RESISTOR	680K RMC 1/16		L204	OW09-35055-00W	FM COIL	F5.5MM X 3.5T 0	
R340	OW07-25102-60K	C RESISTOR	1K RMC 1/16 102		L205	OW09-70101-00	AXIAL LEAD	INDUCTOR 10MH	
R341	OW07-15680-50T	C RESISTOR	68 1/8W 52MM T.		L301	OW09-40474-00W	CHOKE COIL	47MH F6 X 8MM	
R342	OW07-25681-60K	C RESISTOR	680 RMC 1/16 68		L302	OW09-40474-00W	CHOKE COIL	47MH F6 X 8MM	
R343	OW07-25102-60K	C RESISTOR	1K RMC 1/16 102		L803	OW09-40080-00W	CHOKE COIL	8UH	
R344	OW07-25104-60K	C RESISTOR	100K RMC 1/16		L804	OW09-40080-00W	CHOKE COIL	8UH	
R345	OW07-25472-60K	C RESISTOR	4.7K RMC 1/16		L806	OW09-70101-00	AXIAL LEAD	INDUCTOR 10MH	
R346	OW07-25222-60K	C RESISTOR	2.2K RMC 1/16		L807	OW09-40080-00W	CHOKE COIL	8UH	
R347	OW07-25103-60K	C RESISTOR	10K RMC 1/16 10		L808	OW09-40080-00W	CHOKE COIL	8UH	
R348	OW07-25102-60K	C RESISTOR	1K RMC 1/16 102		L881	OW08-04344-40	FERRITE COIL	4T	
R349	OW07-25103-60K	C RESISTOR	10K RMC 1/16 10		L882	OW08-04344-40	FERRITE COIL	4T	
R350	OW07-25103-60K	C RESISTOR	10K RMC 1/16 10		L883	OW08-04344-40	FERRITE COIL	4T	
R351	OW07-15223-50T	C RESISTOR	22K 1/8W 52MM T		T201	OW08-00332-24C	IFT	YELLOW 10MM	
R352	OW07-25103-60K	C RESISTOR	10K RMC 1/16 10		T202	OW08-01014-02	IFT	RED 1A1014N	
R353	OW07-25562-60K	C RESISTOR	5.6K RMC 1/16		T204	OW08-86436-70	AM ANT	COIL OA10-86436	
R354	OW07-25562-60K	C RESISTOR	5.6K RMC 1/16		T360	OW08-00825-00L	REC BIAC	OSC 1A825N	
R355	OW07-25683-60K	C RESISTOR	68K RMC 1/16 68					BLA825N	
R356	OW07-25103-60K	C RESISTOR	10K RMC 1/16 10						
R357	OW07-25202-60K	C RESISTOR	2K RMC 1/16 202						
R358	OW07-25000-60K	C RESISTOR	0 RMC 1/16 000J		CF201	OW09-50450-00J	CER. FILTER	450HK2	
R360	OW07-25103-60K	C RESISTOR	10K RMC 1/16 10		CF203	OW09-50107-07J	CER. DIS.	JT10.7MG82	
R361	OW07-25333-60K	C RESISTOR	33K RMC 1/16 33		CF205	OW09-50107-20J	CER. FILTER	LT10.7MS3	
R362	OW07-25104-60K	C RESISTOR	100K RMC 1/16		CM1	OW05-00203-82	C CAPACITOR	0.02MF +80%-20%	
R364	OW07-15820-00	C RESISTOR	82 1/4W 52MM T.		CM2	OW05-00203-82	C CAPACITOR	0.02MF +80%-20%	
R365	OW07-15273-50T	C RESISTOR	27K 1/8W 52MM T		CM5	OW05-00104-82	C CAPACITOR	0.1MF +80%-20%	
R366	OW07-25047-60K	C RESISTOR	4.7 RMC 1/16		CM6	OW05-00104-82	C CAPACITOR	0.1MF +80%-20%	
R369	OW07-25224-60K	C RESISTOR	220K RMC 1/16		CN202	OW20-12020-01K	2PIN HEADER	P=2.5MM	
R371	OW07-25104-60K	C RESISTOR	100K RMC 1/16		CN260	OW20-11040-02	6PIN RED HEADER	P=2 RED B6B-PH	
△ R372	OW07-15100-08	FUSE RESISTOR	10 1/4W 52MM T.		CN301	OW20-11050-00	5PIN HEADER	B5B-PH JST 2MM	
R373	OW07-15472-50T	C RESISTOR	4.7K 1/8W 52MM		CN370	OW20-11060-00	6PIN HEADER	B6B-PH JST 2MM	
R600	OW07-15121-50T	C RESISTOR	120 1/8W 52MM T		CN601	OW20-11040-00	4PIN HEADER	P=2MM B4B-PH JS	
R601	OW07-15393-50T	C RESISTOR	39K 1/8W 52MM T		CN602	OW20-11030-00	3PIN HEADER	P=2MM B3B-PH JS	
R602	OW07-25393-60K	C RESISTOR	39K RMC 1/16		CN801	OW20-12050-00	5PIN HEADER	P=2.5MM	
R603	OW07-25182-60K	C RESISTOR	1.8K RMC 1/16		CN802	OW12-00006-00Q	SPK. TERMINAL	WP-4112AE	
R604	OW07-25182-60K	C RESISTOR	1.8K RMC 1/16		CN850	OW20-11070-00	7PIN HEADER	P=2MM B7B-PH JS	
R605	OW07-25000-60K	C RESISTOR	0 RMC 1/16 000J		CN851	OW20-12020-00	2PIN HEADER	P=2.5MM	
R606	OW07-25472-60K	C RESISTOR	4.7K RMC 1/16		CN860	OW20-12030-00	3PIN HEADER	P=2.5MM	
R607	OW07-25472-60K	C RESISTOR	4.7K RMC 1/16		J209	OW05-00104-82	C CAPACITOR	0.1MF +80%-20%	
R617	OW07-15472-50T	C RESISTOR	4.7K 1/8W 52MM		J244	OW07-25001-50K	RMC SMD	1206 0 1/8W JP	
R618	OW07-25472-60K	C RESISTOR	4.7K RMC 1/16		J259	OW07-25000-60K	C RESISTOR	0 RMC 1/16 000J	
R619	OW07-25472-60K	C RESISTOR	4.7K RMC 1/16		J263	OW07-25001-50K	RMC SMD	1206 0 1/8W JP	
R620	OW07-25472-60K	C RESISTOR	4.7K RMC 1/16		J265	OW07-25001-50K	RMC SMD	1206 0 1/8W JP	
R801	OW07-25123-60K	C RESISTOR	12K RMC 1/16 12		JK801	OW12-21235-15Q	JK	F3.5MM W/2P2T	
R802	OW07-25123-60K	C RESISTOR	12K RMC 1/16 12		TIE1	OW31-50040-50	UL-1007	WIRE 40MM	
R803	OW07-15472-50T	C RESISTOR	4.7K 1/8W 52MM					BLACK	
R804	OW07-25473-60K	C RESISTOR	47K RMC 1/16 47		TIE2	OW31-50040-50	UL-1007	WIRE 40MM	
								BLACK	

△ Symbol No.	Part No.	Part Name	Description	Local
TIE3	OW31-50040-50	UL-1007	WIRE 40MM BLACK	
TIE4	OW31-50040-50	UL-1007	WIRE 40MM BLACK	
U201	TA2149BFN	IC	OW03-02149-01	
U260	TC9257F	IC	OW03-09257-01	
U301	AN7312	IC	OW03-07312-00	
U601	TC9422F	IC	OW03-09422-00	
△ U801	TA8229K	IC	OW03-08229-00	
△ U851	ML7808FA	IC	OW03-07808-04	
VD201	SVC348-S	TUNING DIODE	OW02-00348-00 S	
VD202	SVC201SPA	TUNING DIODE	OW02-00201-00 S	
VD203	SVC201SPA	TUNING DIODE	OW02-00201-00 S	
X260	OW04-07200-08	CRYSTAL	HC-49/US+-20PPM	
XXXXX	OW20-42052-31	5PIN HEADER	CN880 TO CN801	
XXXXX	OW25-04300-01	CONNECT.BM	FM ANT	
XXXXX	OW29-00010-01	FM ANT.	FM PIG ANT	
XXXXX	OW20-41062-32K	6PIN	FOR CASS MECH	
XXXXX	OW20-61053-22	5PIN	FOR CASS HEAD	
XXXXX	OW25-84050-02	2PIN	FOR CN110 TO CN	
XXXXX	OW29-00010-00	FM ANT. WIRE	FOR RF2	
XXXXX	OW32-92070-20	DW	FM OSC.	
XXXXX	OW81-10001-00	SPONGE	FOR L203 204	
XXXXX	OW02-30005-03	F3MM SUPER	LED 102	
XXXXX	OW02-30005-03	F3MM SUPER	LED 103	
XXXXX	OW28-32010-00	FIBRE TUBE	2 X R372	
XXXXX	OW28-32010-00	FIBRE TUBE	2 X R863	
XXXXX	OW28-02010-01	PVC TUBE	UL ID F2MM L=10	
XXXXX	OW28-02013-01	PVC TUBE	UL ID F2MM L=13	
XXXXX	OW84-00003-00A	CABLE TIE	4 UL	
XXXXX	OW94-04200-00	CASS DECK	CS-21SC-3222	
△ ZD201	OW02-50100-00	Z DIODE	10V0.5W	
△ ZD830	OW02-50091-00	Z DIODE	9.1V0.5W	
△ ZD860	OW02-50068-00	Z DIODE	6.8V0.5W	
△ ZD861	OW02-50062-00	Z DIODE	6.2V0.5W	

△ Symbol No.	Part No.	Part Name	Description	Local
XXXXX	OW28-16020-01	TUBE	FOR VOLTAGE SW.	
XXXXX	OW28-00024-00	TUBE	FOR VOLTAGE SW.	
XXXXX	OW31-00210-80	UL1672	FOR DUAL POWER	
XXXXX	OW31-20050-51	UL1007	FOR DUAL POWER	
XXXXX	OW78-00004-05	SOLDERLESS	FOR AC POWER WI	
XXXXX	OW39-10001-00A	FUSE HOLDER	FOR F901 902	
XXXXX	OW28-00015-01	SHRINKAGE TUBE	VOLTAGE SW.	
XXXXX	OW28-14020-01	TUBE	F4 L=20MM UL	
XXXXX	OW08-04344-50	FERRITE CORE	T25 X 15 X 10	
XXXXX	OW37-00002-00	EYELET	F2 X 4MM	
XXXXX	OW84-00005-00	CABLE TIE	6.5 UL	
XXXXX	OW84-07635-00	UL CABLE CLAMP	UC-1	

CD board

Block No. [0][3][0][0]

△ Symbol No.	Part No.	Part Name	Description	Local
IC701	TC9462F	IC	OW03-09462-00	
IC702	TA2153FN	IC	OW03-02153-00	
IC703	TA2092N	IC	OW03-02092-00	
Q701	2SC945P	TRANSISTOR	OW01-00945-16 N	
Q702	2SC945P	TRANSISTOR	OW01-00945-16 N	
Q703	2SA733P	TRANSISTOR	OW01-00733-16 N	
Q704	2SC1383R	TRANSISTOR	OW01-01383-18 N	
Q705	2SA733P	TRANSISTOR	OW01-00733-16 N	

D701	1N4148	GE DIODE	OW2-04148-00C	
------	--------	----------	---------------	--

C701	OW05-07103-00A	C CAPACITOR	0.01MF	
C702	OW05-07104-82B	C CAPACITOR	0.1MF50V	
C703	OW05-07223-82A	C CAPACITOR	0.022MF	
C704	OW06-16476-00	E CAPACITOR	47MF 16V	
C705	OW06-16107-00	E CAPACITOR	100MF 16V	
C706	OW06-16106-00	E CAPACITOR	10MF 16V	
C707	OW06-16106-01	E CAPACITOR	10MF 16V	
C708	OW05-07222-10A	C CAPACITOR	2200PF EP050X22	
C709	OW05-07473-82A	C CAPACITOR	0.047MF	
C710	OW06-16226-01	E CAPACITOR	22MF 16V	
C711	OW05-07222-10A	C CAPACITOR	2200PF EP050X22	
C712	OW05-07473-82A	C CAPACITOR	0.047MF	
C713	OW06-16476-01	E CAPACITOR	47MF 16V	
C714	OW06-50105-01	E CAPACITOR	1MF 50V	
C715	OW05-07104-82B	C CAPACITOR	0.1MF50V	
C716	OW05-07473-82A	C CAPACITOR	0.047MF	
C719	OW06-16476-01	E CAPACITOR	47MF 16V	
C720	OW05-07473-82A	C CAPACITOR	0.047MF	
C721	OW05-00103-00	C CAPACITOR	0.01MF 50V	
C722	OW06-16476-01	E CAPACITOR	47MF 16V	
C723	OW06-16476-01	E CAPACITOR	47MF 16V	
C724	OW06-16227-02	E CAPACITOR	220MF 16V PITCH	
C725	OW05-07104-82B	C CAPACITOR	0.1MF50V	
C726	OW05-07104-82B	C CAPACITOR	0.1MF50V	
C727	OW05-00103-00	C CAPACITOR	0.01MF 50V	
C728	OW05-07104-82B	C CAPACITOR	0.1MF 50V	
C729	OW05-07104-82B	C CAPACITOR	0.1MF 50V	
C730	OW05-07104-82B	C CAPACITOR	0.1MF 50V	
C731	OW05-07473-82A	C CAPACITOR	0.047MF	
C732	OW05-07473-82A	C CAPACITOR	0.047MF	
C733	OW05-07102-10A	C CAPACITOR	1000PF	
C734	OW06-16476-00	E CAPACITOR	47MF 16V	
C735	OW06-16107-00	E CAPACITOR	100MF 16V	
C736	OW05-07153-20A	C CAPACITOR	0.015MF	
C737	OW05-07103-00A	C CAPACITOR	0.01MF	
C738	OW05-07470-00A	C CAPACITOR	47PF	
C739	OW05-07272-10A	C CAPACITOR	2700PF	
C740	OW06-16476-00	E CAPACITOR	47MF 16V	
C741	OW05-07224-00	C CAPACITOR	0.22MF	
C742	OW05-07471-10A	C CAPACITOR	470PF	

Power board

Block No. [0][2][0][0]

△ Symbol No.	Part No.	Part Name	Description	Local
△ D905	RL202	DIODE RECTIFIER	OW02-00202-00	
△ D906	RL202	DIODE RECTIFIER	OW02-00202-00	
△ D907	RL202	DIODE RECTIFIER	OW02-00202-00	
△ D908	RL202	DIODE RECTIFIER	OW02-00202-00	
△ D909	1N4001	FR DIODE	OW02-04001-00	
△ D910	1N4001	FR DIODE	OW02-04001-00	
△ D911	1N4001	FR DIODE	OW02-04001-00	
△ D912	1N4001	FR DIODE	OW02-04001-00	
C900	OW05-00104-82	C CAPACITOR	0.1MF +80%-20%	
C905	OW05-07223-82A	C CAPACITOR	0.022MF	
C906	OW05-07223-82A	C CAPACITOR	0.022MF	
C907	OW05-07223-82A	C CAPACITOR	0.022MF	
C908	OW05-07223-82A	C CAPACITOR	0.022MF	
C909	OW05-07223-82A	C CAPACITOR	0.022MF	
C910	OW05-07223-82A	C CAPACITOR	0.022MF	
C911	OW05-07223-82A	C CAPACITOR	0.022MF	
C912	OW05-07223-82A	C CAPACITOR	0.022MF	
△ C913	OW06-25228-00	E CAPACITOR	2200MF 25V	
R903	OW07-15391-36T	C RESISTOR	390 3W	
T902	OW15-00010-05	TRANS FORMER	T57-0313001-11	
CN901	OW20-42032-20	3PIN	CN901 TO CN860	
△ F901	OW33-57312-03W	FUSE	T3.15L 250V	
△ F902	OW33-57202-03W	FUSE	T2L 250V	
XXXXX	OW16-10212-00	VOLTAGE SW.	SL14-22AM5A	
XXXXX	OW28-31510-00	FIBRE TUBE	FOR D905-D912	
XXXXX	OW28-06085-01	PVC TUBE	FOR YEL	
XXXXX	OW28-06100-01	PVC TUBE	FOR RED	
XXXXX	OW28-08130-01	PVC TUBE	FOR ORG.BLK	
XXXXX	OW28-04140-01	PVC TUBE	FOR GRE FOR BAK	

△ Symbol No.	Part No.	Part Name	Description	Local	△ Symbol No.	Part No.	Part Name	Description	Local
C743	OW05-07471-10A	C CAPACITOR	470PF		XXXXX	OW20-42021-48	2PIN	CN701 TO CN851	
C744	OW05-07473-82A	C CAPACITOR	0.047MF		XXXXX	OW20-41032-21K	3PIN	CN702 TO CN602	
C745	OW05-07121-10A	C CAPACITOR	120PF-B50V 52MM		XXXXX	OW20-41061-37	6PIN	CN703 TO CD MOT	
C746	OW05-02472-10	M CAPACITOR	0.0047MF		XXXXX	OW25-61135-00	FFC 16PIN	CN704 TO CD PIC	
C747	OW05-07224-00	C CAPACITOR	0.22MF		XXXXX	OW08-04344-14	FERRITE CORE	FOR CD TO MAIN	
C748	OW05-07104-82B	C CAPACITOR	0.1MF50V		XXXXX	OW31-60050-10	UL-1007	FOR P4 TO CD ME	
C749	OW05-07473-82A	C CAPACITOR	0.047MF		XXXXX	OW39-00013-00A	HEAT SINK	IC703	
C750	OW06-16107-02	E CAPACITOR	100MF 16V PITCH		XXXXX	OW16-10101-92L	CD DOOR SWITCH	DLS-02-1	
C751	OW06-16476-01	E CAPACITOR	47MF 16V		XXXXX	OW98-04200-00	CD MECHA	THOMSON TCP11TK	
C752	OW06-16476-00	E CAPACITOR	47MF 16V						
C753	OW05-07473-82A	C CAPACITOR	0.047MF		Z701	OW02-50051-00	Z DIODE	5.1V0.5W	
C754	OW05-07102-10A	C CAPACITOR	1000PF						
C755	OW05-02473-10	M CAPACITOR	0.047MF						
C756	OW05-00020-06	C CAPACITOR	2PF NPO						
C757	OW05-07473-82A	C CAPACITOR	0.047MF						
C758	OW05-07473-82A	C CAPACITOR	0.047MF						
C759	OW05-07473-82A	C CAPACITOR	0.047MF						
C760	OW05-07104-82B	C CAPACITOR	0.1MF 50V						
C790	OW06-16477-00	E CAPACITOR	470MF 16V						
C791	OW05-07103-00A	C CAPACITOR	0.01MF						
C792	OW05-07103-00A	C CAPACITOR	0.01MF						
C793	OW05-07103-00A	C CAPACITOR	0.01MF						
C794	OW05-07103-00A	C CAPACITOR	0.01MF						
C795	OW05-07103-00A	C CAPACITOR	0.01MF						
R701	OW07-15104-50T	C RESISTOR	100K 1/8W		D101	1SS-133TP	FR DIODE	OW02-00133-00 R	
R702	OW07-15104-50T	C RESISTOR	100K 1/8W		D102	1SS-133TP	FR DIODE	OW02-00133-00 R	
R703	OW07-15473-50T	C RESISTOR	47K 1/8W		D103	1SS-133TP	FR DIODE	OW02-00133-00 R	
R704	OW07-15473-50T	C RESISTOR	47K 1/8W		D104	1SS-133TP	FR DIODE	OW02-00133-00 R	
R705	OW07-15103-50T	C RESISTOR	10K 1/8W 52MM T		D105	ELT-3142D	LED	OW02-30022-02E	
R706	OW07-15271-50T	C RESISTOR	270 1/8W 52MM T						
R707	OW07-15271-50T	C RESISTOR	270 1/8W 52MM T		C101	OW06-06108-01	E CAPACITOR	1000MF 6.3V	
R711	OW07-15103-50T	C RESISTOR	10K 1/8W 52MM T		C102	OW05-03103-06T	C CAPACITOR	0.01MF B500 K10	
R716	OW07-15271-50T	C RESISTOR	270 1/8W 52MM T		C103	OW06-10106-00	E CAPACITOR	10MF 10V	
R717	OW07-15220-50T	C RESISTOR	22 1/8W 52MM T.		C104	OW05-03104-06T	C CAPACITOR	0.1MF	
R721	OW07-15332-50T	C RESISTOR	3.3K 1/8W		C105	OW05-03240-03T	CHIP CAPACITOR	24PF N500 J240	
R722	OW07-15332-50T	C RESISTOR	3.3K 1/8W		C106	OW05-03560-03T	C CAPACITOR	56PF B500 K560	
R723	OW07-15332-50T	C RESISTOR	3.3K 1/8W		C107	OW05-03240-03T	CHIP CAPACITOR	24PF N500 J240	
R724	OW07-15332-50T	C RESISTOR	3.3K 1/8W		C108	OW05-03240-03T	CHIP CAPACITOR	24PF N500 J240	
R725	OW07-15332-50T	C RESISTOR	3.3K 1/8W		C109	OW05-03104-06T	C CAPACITOR	0.1MF	
R726	OW07-15103-50T	C RESISTOR	10K 1/8W 52MM T		C110	OW06-10227-00	E CAPACITOR	220MF 10V	
R727	OW07-15332-50T	C RESISTOR	3.3K 1/8W		C111	OW06-10476-00	E CAPACITOR	47MF 10V	
R728	OW07-15221-50T	C RESISTOR	220 1/8W 52MM T		C112	OW05-03103-06T	C CAPACITOR	0.01MF B500 K10	
R729	OW07-15224-50T	C RESISTOR	220K 1/8W		C113	OW05-03103-06T	C CAPACITOR	0.01MF B500 K10	
R730	OW07-15683-50T	C RESISTOR	68K 1/8W 52MM T		C114	OW05-03102-06T	C CAPACITOR	1000PF B500 K10	
R731	OW07-15103-50T	C RESISTOR	10K 1/8W 52MM T		C115	OW05-03104-06T	C CAPACITOR	0.1MF	
R732	OW07-15153-50T	C RESISTOR	15K 1/8W		C116	OW05-03223-06T	C CAPACITOR	0.022MF B500 K2	
R733	OW07-15473-50T	C RESISTOR	47K 1/8W		C117	OW05-03223-06T	C CAPACITOR	0.022MF B500 K2	
R734	OW07-15102-50T	C RESISTOR	1K 1/8W 52MM T.		C118	OW05-03240-03T	CHIP CAPACITOR	24PF N500 J240	
R735	OW07-15273-50T	C RESISTOR	27K 1/8W		C119	OW05-03104-06T	C CAPACITOR	0.1MF	
R736	OW07-15222-50T	C RESISTOR	2.2K 1/8W		C120	OW06-06108-01	E CAPACITOR	1000MF 6.3V	
R737	OW07-15563-50T	C RESISTOR	56K 1/8W		R101	OW07-25102-60K	C RESISTOR	1K RMC 1/16 102	
R738	OW07-15102-50T	C RESISTOR	1K 1/8W 52MM T.		R102	OW07-25153-60K	C RESISTOR	15K RMC 1/16 15	
R739	OW07-15100-50T	C RESISTOR	10 1/8W 52MM T.		R103	OW07-25103-60K	C RESISTOR	10K RMC 1/16 10	
R740	OW07-15563-50T	C RESISTOR	56K 1/8W		R105	OW07-25103-60K	C RESISTOR	10K RMC 1/16 10	
R741	OW07-15473-50T	C RESISTOR	47K 1/8W		R106	OW07-25102-60K	C RESISTOR	1K RMC 1/16 102	
R742	OW07-15101-50T	C RESISTOR	100 1/8W 52MM T		R107	OW07-25222-60K	C RESISTOR	2.2K RMC 1/16	
R743	OW07-15333-50T	C RESISTOR	33K 1/8W		R108	OW07-25472-60K	C RESISTOR	4.7K RMC 1/16	
R744	OW07-15473-50T	C RESISTOR	47K 1/8W		R109	OW07-25472-60K	C RESISTOR	4.7K RMC 1/16	
R745	OW07-15473-50T	C RESISTOR	47K 1/8W		R110	OW07-25472-60K	C RESISTOR	4.7K RMC 1/16	
R746	OW07-15473-50T	C RESISTOR	47K 1/8W		R111	OW07-25103-60K	C RESISTOR	10K RMC 1/16 10	
R747	OW07-15473-50T	C RESISTOR	47K 1/8W		R112	OW07-25103-60K	C RESISTOR	10K RMC 1/16 10	
R748	OW07-15333-50T	C RESISTOR	33K 1/8W		R113	OW07-25100-60K	C RESISTOR	10 RMC 1/16 100	
R757	OW07-15103-50T	C RESISTOR	10K 1/8W 52MM T		R114	OW07-25472-60K	C RESISTOR	4.7K RMC 1/16	
R758	OW07-15103-50T	C RESISTOR	10K 1/8W 52MM T		R115	OW07-25103-60K	C RESISTOR	10K RMC 1/16 10	
R759	OW07-15103-50T	C RESISTOR	10K 1/8W 52MM T		R116	OW07-25103-60K	C RESISTOR	10K RMC 1/16 10	
R760	OW07-15103-50T	C RESISTOR	10K 1/8W 52MM T		R117	OW07-25332-60K	C RESISTOR	3.3K RMC 1/16	
L701	OW09-01000-01	CHOKE COIL	W/MAGN. R295		R119	OW07-25220-60K	C RESISTOR	22 RMC 1/16 220	
L703	OW09-70101-02T	COIL	10UH-823465		R120	OW07-25103-60K	C RESISTOR	10K RMC 1/16 10	
L704	OW09-70101-02T	COIL	10UH-823465		R121	OW07-25001-60K	C RESISTOR	0 RMC 1/16 000J	
CN704	OW20-80160-00I	SOCKET	16PIN FFC		R123	OW07-25103-60K	C RESISTOR	10K RMC 1/16 10	
CN705	OW20-11100-00	10PIN HEADER	P=2 B10B-PH JST		R124	OW07-25103-60K	C RESISTOR	10K RMC 1/16 10	
P3	OW31-50040-50	UL-1007	WIRE 40MM BLACK		R125	OW07-25103-60K	C RESISTOR	10K RMC 1/16 10	
X701	OW09-51693-02Z	CER RES.	2TT16.93MX		R126	OW07-25272-60K	C RESISTOR	2.7K RMC 1/16	
					R127	OW07-25102-60K	C RESISTOR	1K RMC 1/16 102	
					R128	OW07-25152-60K	C RESISTOR	1.5K RMC 1/16	
					R129	OW07-25103-60K	C RESISTOR	10K RMC 1/16 10	

Display board

Block No. [0][4][0][0]

△ Symbol No.	Part No.	Part Name	Description	Local
Q101	9014	TRANSISTOR	OW01-09014-05	
Q102	9014	TRANSISTOR	OW01-09014-05	
Q103	9018	TRANSISTOR	OW01-09018-10	
D101	1SS-133TP	FR DIODE	OW02-00133-00 R	
D102	1SS-133TP	FR DIODE	OW02-00133-00 R	
D103	1SS-133TP	FR DIODE	OW02-00133-00 R	
D104	1SS-133TP	FR DIODE	OW02-00133-00 R	
D105	ELT-3142D	LED	OW02-30022-02E	
C101	OW06-06108-01	E CAPACITOR	1000MF 6.3V	
C102	OW05-03103-06T	C CAPACITOR	0.01MF B500 K10	
C103	OW06-10106-00	E CAPACITOR	10MF 10V	
C104	OW05-03104-06T	C CAPACITOR	0.1MF	
C105	OW05-03240-03T	CHIP CAPACITOR	24PF N500 J240	
C106	OW05-03560-03T	C CAPACITOR	56PF B500 K560	
C107	OW05-03240-03T	CHIP CAPACITOR	24PF N500 J240	
C108	OW05-03240-03T	CHIP CAPACITOR	24PF N500 J240	
C109	OW05-03104-06T	C CAPACITOR	0.1MF	
C110	OW06-10227-00	E CAPACITOR	220MF 10V	
C111	OW06-10476-00	E CAPACITOR	47MF 10V	
C112	OW05-03103-06T	C CAPACITOR	0.01MF B500 K10	
C113	OW05-03103-06T	C CAPACITOR	0.01MF B500 K10	
C114	OW05-03102-06T	C CAPACITOR	1000PF B500 K10	
C115	OW05-03104-06T	C CAPACITOR	0.1MF	
C116	OW05-03223-06T	C CAPACITOR	0.022MF B500 K2	
C117	OW05-03223-06T	C CAPACITOR	0.022MF B500 K2	
C118	OW05-03240-03T	CHIP CAPACITOR	24PF N500 J240	
C119	OW05-03104-06T	C CAPACITOR	0.1MF	
C120	OW06-06108-01	E CAPACITOR	1000MF 6.3V	
R101	OW07-25102-60K	C RESISTOR	1K RMC 1/16 102	
R102	OW07-25153-60K	C RESISTOR	15K RMC 1/16 15	
R103	OW07-25103-60K	C RESISTOR	10K RMC 1/16 10	
R105	OW07-25103-60K	C RESISTOR	10K RMC 1/16 10	
R106	OW07-25102-60K	C RESISTOR	1K RMC 1/16 102	
R107	OW07-25222-60K	C RESISTOR	2.2K RMC 1/16	
R108	OW07-25472-60K	C RESISTOR	4.7K RMC 1/16	
R109	OW07-25472-60K	C RESISTOR	4.7K RMC 1/16	
R110	OW07-25472-60K	C RESISTOR	4.7K RMC 1/16	
R111	OW07-25103-60K	C RESISTOR	10K RMC 1/16 10	
R112	OW07-25103-60K	C RESISTOR	10K RMC 1/16 10	
R113	OW07-25100-60K	C RESISTOR	10 RMC 1/16 100	
R114	OW07-25472-60K	C RESISTOR	4.7K RMC 1/16	
R115	OW07-25103-60K	C RESISTOR	10K RMC 1/16 10	
R116	OW07-25103-60K	C RESISTOR	10K RMC 1/16 10	
R117	OW07-25332-60K	C RESISTOR	3.3K RMC 1/16	
R119	OW07-25220-60K	C RESISTOR	22 RMC 1/16 220	
R120	OW07-25103-60K	C RESISTOR	10K RMC 1/16 10	
R121	OW07-25001-60K	C RESISTOR	0 RMC 1/16 000J	
R123	OW07-25103-60K	C RESISTOR	10K RMC 1/16 10	
R124	OW07-25103-60K	C RESISTOR	10K RMC 1/16 10	
R125	OW07-25103-60K	C RESISTOR	10K RMC 1/16 10	
R126	OW07-25272-60K	C RESISTOR	2.7K RMC 1/16	
R127	OW07-25102-60K	C RESISTOR	1K RMC 1/16 102	
R128	OW07-25152-60K</			

Symbol No.	Part No.	Part Name	Description	Local
R130	OW07-25471-60K	C RESISTOR	470 RMC 1/16 47	
R131	OW07-25681-60K	C RESISTOR	680 RMC 1/16 68	
R132	OW07-15821-50T	C RESISTOR	820 1/8W 52MM T	
R133	OW07-15102-50T	C RESISTOR	1K 1/8W 52MM T.	
R134	OW07-25220-60K	C RESISTOR	22 RMC 1/16 220	
R135	OW07-15220-50T	C RESISTOR	22 1/8W 52MM T.	
R136	OW07-15471-50T	C RESISTOR	470 1/8W 52MM T	
R137	OW07-15681-50T	C RESISTOR	680 1/8W 52MM T	
R138	OW07-15821-50T	C RESISTOR	820 1/8W 52MM T	
R139	OW07-15102-50T	C RESISTOR	1K 1/8W 52MM T.	
R140	OW07-15122-50T	C RESISTOR	1.2K 1/8W	
R141	OW07-15152-50T	C RESISTOR	1.5K 1/8W	
R149	OW07-25152-60K	C RESISTOR	1.5K RMC 1/16	
R150	OW07-25152-60K	C RESISTOR	1.5K RMC 1/16	
R151	OW07-25152-60K	C RESISTOR	1.5K RMC 1/16	
R167	OW07-25103-60K	C RESISTOR	10K RMC 1/16 10	
R168	OW07-25103-60K	C RESISTOR	10K RMC 1/16 10	
R170	OW07-25103-60K	C RESISTOR	10K RMC 1/16 10	
R171	OW07-25103-60K	C RESISTOR	10K RMC 1/16 10	
R172	OW07-25103-60K	C RESISTOR	10K RMC 1/16 10	
R173	OW07-25103-60K	C RESISTOR	10K RMC 1/16 10	
R174	OW07-25103-60K	C RESISTOR	10K RMC 1/16 10	
R175	OW07-25103-60K	C RESISTOR	10K RMC 1/16 10	
R176	OW07-25103-60K	C RESISTOR	10K RMC 1/16 10	
R178	OW07-25103-60K	C RESISTOR	10K RMC 1/16 10	
R179	OW07-25001-60K	C RESISTOR	0 RMC 1/16 000J	
L101	OW09-70102-00C	COIL	100UH	
L102	OW08-04344-40	FERRITE COIL	4T	
L103	OW08-04344-40	FERRITE COIL	4T	
J103	OW07-25001-50K	RMC SMD	1206 0 1/8 JPTP	
J112	OW07-25001-50K	RMC SMD	1206 0 1/8 JPTP	
J125	OW07-25001-60K	C RESISTOR	0 RMC 1/16 000J	
J126	OW07-25001-60K	C RESISTOR	0 RMC 1/16 000J	
J127	OW07-25001-60K	C RESISTOR	0 RMC 1/16 000J	
J128	OW07-25561-60K	C RESISTOR	560 1/16 561JTP	
J129	OW07-25001-60K	C RESISTOR	0 RMC 1/16 000J	
J130	OW07-25001-60K	C RESISTOR	0 RMC 1/16 000J	
SW101	OW16-10101-08S	TACT SWITCH	EVQJAE05R H=5MM	
SW102	OW16-10101-08S	TACT SWITCH	EVQJAE05R H=5MM	
SW103	OW16-10101-08S	TACT SWITCH	EVQJAE05R H=5MM	
SW104	OW16-10101-08S	TACT SWITCH	EVQJAE05R H=5MM	
SW105	OW16-10101-08S	TACT SWITCH	EVQJAE05R H=5MM	
SW106	OW16-10101-08S	TACT SWITCH	EVQJAE05R H=5MM	
SW107	OW16-10101-08S	TACT SWITCH	EVQJAE05R H=5MM	
SW108	OW16-10101-08S	TACT SWITCH	EVQJAE05R H=5MM	
SW109	OW16-10101-08S	TACT SWITCH	EVQJAE05R H=5MM	
SW110	OW16-10101-08S	TACT SWITCH	EVQJAE05R H=5MM	
SW111	OW16-10101-08S	TACT SWITCH	EVQJAE05R H=5MM	
SW112	OW16-10101-08S	TACT SWITCH	EVQJAE05R H=5MM	
U101	87EP26F-1J13	IC	OW03-87261-10W	
U102	FM-6038TM2-5A	SENSOR	OW02-66038-25	
X101	OW09-50720-00	CER. RES.	ZTA7.2MT	
X102	OW04-32768-03S	CRYSTAL	32.768 KHZ	
XXXXX	OW20-41071-22	7PIN	CN102 TO CN850	
XXXXX	OW20-41041-37	4PIN	CN103 TO CN260	
XXXXX	OW20-41102-34	10PIN	CN104 TO CN705	
XXXXX	OW20-41041-33K	4PIN	CN105 TO CN601	
XXXXX	OW25-84070-03	3PIN	CN106 TO CN108	
XXXXX	OW20-41021-46	2PIN	CN107 TO CD DOO	
XXXXX	OW91-80010-00	LCD	LCD101	

Remote board

Block No. [0][5][0][0]

Symbol No.	Part No.	Part Name	Description	Local
D501	1N4148	GE DIODE	OW02-04148-00C	
C501	OW05-00221-00	C CAPACITOR	220 PF	
C502	OW05-00221-00	C CAPACITOR	220 PF	
C504	OW05-00471-00	C CAPACITOR	470 PF	
C505	OW06-10476-00	E CAPACITOR	47MF 10V	
C506	OW07-05010-30	C RESISTOR	1 1/16W	
C507	OW07-05104-30	C RESISTOR	100K 1/16W	
C508	OW09-50455-00J	CER RESONATOR	ZTB455E	

<MEMO>

Packing materials and accessories parts list

Block No. M 3 M M

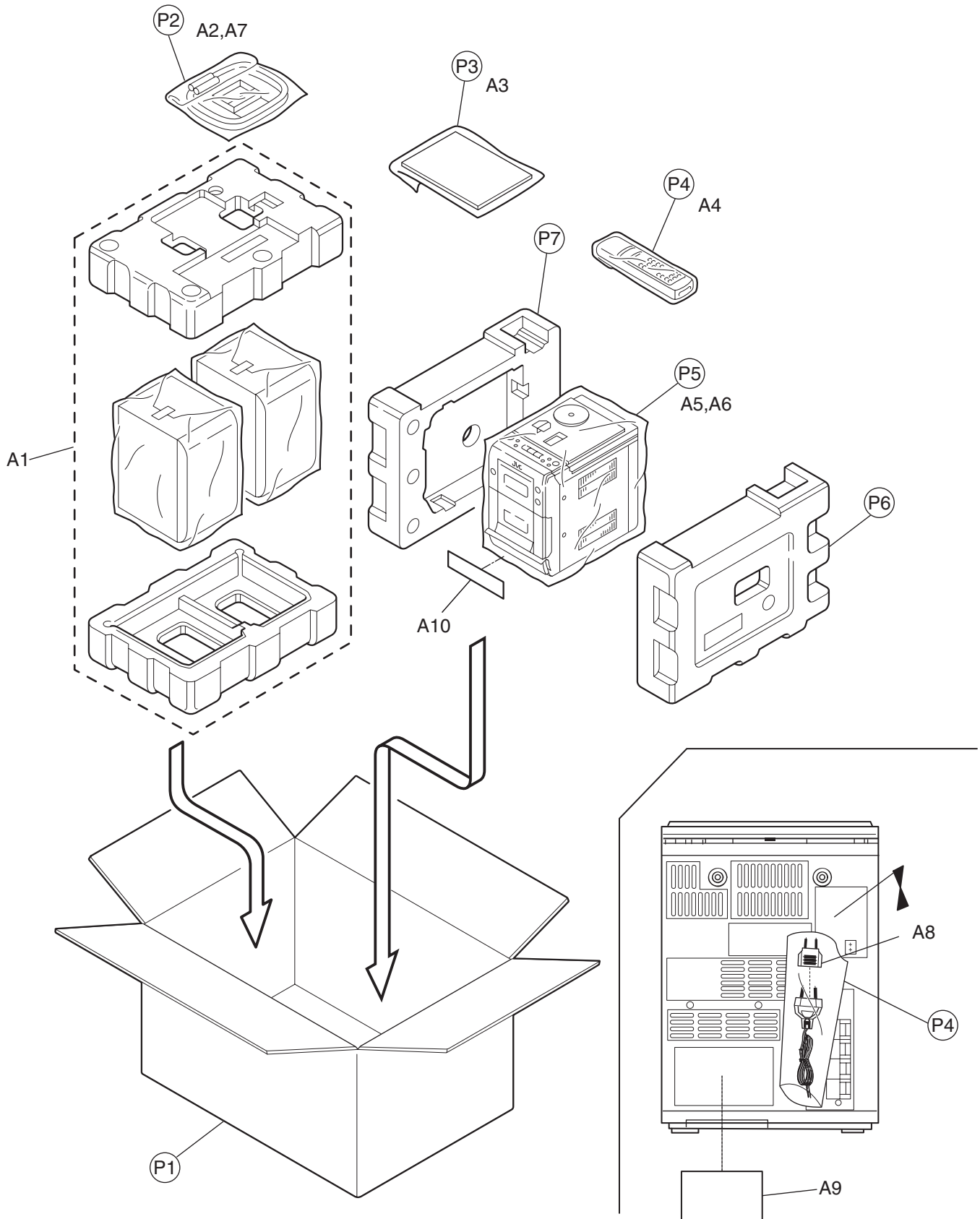

Packing and accessories

Block No. [M][3][M][M]

△ Symbol No.	Part No.	Part Name	Description	Local
A 1	OW00-00010-04	SPK BOX ASSY	5W 4ohm(x2)	
A 2	OW23-04910-02	AM LOOP ANT		
A 3	OW88-00010-10	INST SHEET		US
A 3	OW88-00010-11	INST SHEET		UT
A 3	OW88-00010-04	INST SHEET		UW
A 4	OWA-RE-JVC	REMOTE CONTROL		
A 5	OW81-01000-01	TRBLE CUSHION	F116 X F17 X 2mm	
A 6	OW89-09023-36	PROTECT	CD BOARD	
A 7	-----	BATTERY	(x2)	
△A 8	OW97-02755-00	AC PLUG ADAPTOR		
A 9	OW87-00010-06	RATING LABEL		US UW
A 9	OW87-00010-20	RATING LABEL		UT
A 10	OW81-03222-00	SHEET PROTECT	145 X 40mm	
P 1	OW89-00010-01	CARTON		
P 2	OW85-90710-04	POLY BAG		
P 3	OW85-91014-02	POLY BAG		
P 4	OW85-00025-01A	POLY BAG	(x2)	
P 5	OW85-91619-02	POLY BAG		
P 6	OW86-00010-01	POLY FOAM	Right	
P 7	OW86-00010-00	POLY FOAM	Left	