

JVC

SERVICE MANUAL

MICRO COMPONENT SYSTEM

UX-H30

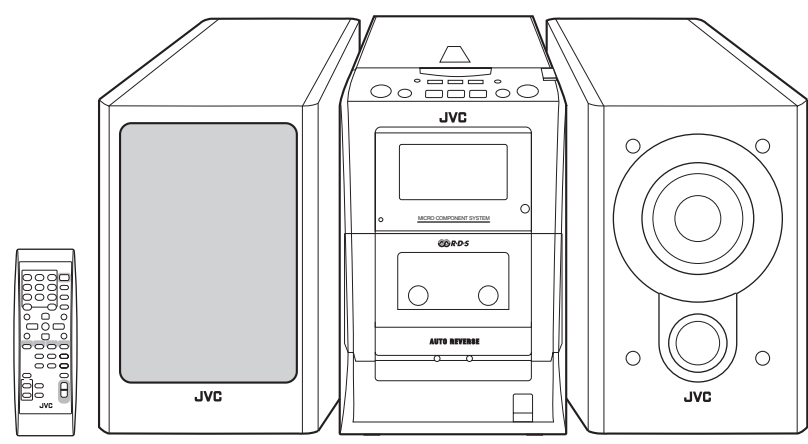

Area Suffix	
B	U.K.
E	Continental Europe
EN	Northern Europe

TABLE OF CONTENTS

1	Important Safety Precautions	1-2
2	Disassembly method	1-6
3	Adjustment.....	1-18
4	Description of major ICs.....	1-24

SECTION 1

Important Safety Precautions

1.1 Safety Precautions

- (1) This design of this product contains special hardware and many circuits and components specially for safety purposes. For continued protection, no changes should be made to the original design unless authorized in writing by the manufacturer. Replacement parts must be identical to those used in the original circuits. Services should be performed by qualified personnel only.
- (2) Alterations of the design or circuitry of the product should not be made. Any design alterations of the product should not be made. Any design alterations or additions will void the manufacturer's warranty and will further relieve the manufacturer of responsibility for personal injury or property damage resulting therefrom.
- (3) Many electrical and mechanical parts in the products have special safety-related characteristics. These characteristics are often not evident from visual inspection nor can the protection afforded by them necessarily be obtained by using replacement components rated for higher voltage, wattage, etc. Replacement parts which have these special safety characteristics are identified in the Parts List of Service Manual. Electrical components having such features are identified by shading on the schematics and by (Δ) on the Parts List in the Service Manual. The use of a substitute replacement which does not have the same safety characteristics as the recommended replacement parts shown in the Parts List of Service Manual may create shock, fire, or other hazards.
- (4) The leads in the products are routed and dressed with ties, clamps, tubings, barriers and the like to be separated from live parts, high temperature parts, moving parts and/or sharp edges for the prevention of electric shock and fire hazard. When service is required, the original lead routing and dress should be observed, and it should be confirmed that they have been returned to normal, after reassembling.
- (5) Leakage shock hazard testing)

After reassembling the product, always perform an isolation check on the exposed metal parts of the product (antenna terminals, knobs, metal cabinet, screw heads, headphone jack, control shafts, etc.) to be sure the product is safe to operate without danger of electrical shock. Do not use a line isolation transformer during this check.

 - Plug the AC line cord directly into the AC outlet. Using a "Leakage Current Tester", measure the leakage current from each exposed metal parts of the cabinet, particularly any exposed metal part having a return path to the chassis, to a known good earth ground. Any leakage current must not exceed 0.5mA AC (r.m.s.).
 - Alternate check method

Plug the AC line cord directly into the AC outlet. Use an AC voltmeter having, 1,000 ohms per volt or more sensitivity in the following manner. Connect a 1,500 ohm 10W resistor paralleled by a 0.15 μ F AC-type capacitor between an

exposed metal part and a known good earth ground.

Measure the AC voltage across the resistor with the AC voltmeter.

Move the resistor connection to each exposed metal part, particularly any exposed metal part having a return path to the chassis, and measure the AC voltage across the resistor. Now, reverse the plug in the AC outlet and repeat each measurement. Voltage measured any must not exceed 0.75 V AC (r.m.s.). This corresponds to 0.5 mA AC (r.m.s.).

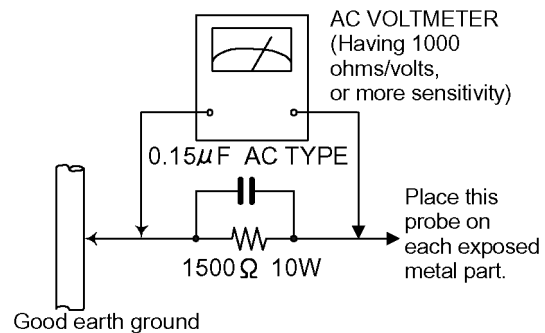

1.2 Warning

- (1) This equipment has been designed and manufactured to meet international safety standards.
- (2) It is the legal responsibility of the repairer to ensure that these safety standards are maintained.
- (3) Repairs must be made in accordance with the relevant safety standards.
- (4) It is essential that safety critical components are replaced by approved parts.
- (5) If mains voltage selector is provided, check setting for local voltage.

1.3 Caution

Burrs formed during molding may be left over on some parts of the chassis.

Therefore, pay attention to such burrs in the case of pre-forming repair of this system.

1.4 Critical parts for safety

In regard with component parts appearing on the silk-screen printed side (parts side) of the PWB diagrams, the parts that are printed over with black such as the resistor (\blacksquare), diode (\blacksquare) and ICP (\bullet) or identified by the " Δ " mark nearby are critical for safety.

When replacing them, be sure to use the parts of the same type and rating as specified by the manufacturer. (Except the JC version)

1.5 Safety Precautions (U.K only)

- (1) This design of this product contains special hardware and many circuits and components specially for safety purposes. For continued protection, no changes should be made to the original design unless authorized in writing by the manufacturer. Replacement parts must be identical to those used in the original circuits.
- (2) Any unauthorised design alterations or additions will void the manufacturer's guarantee; furthermore the manufacturer cannot accept responsibility for personal injury or property damage resulting therefrom.
- (3) Essential safety critical components are identified by () on the Parts List and by shading on the schematics, and must never be replaced by parts other than those listed in the manual. Please note however that many electrical and mechanical parts in the product have special safety related characteristics. These characteristics are often not evident from visual inspection. Parts other than specified by the manufacturer may not have the same safety characteristics as the recommended replacement parts shown in the Parts List of the Service Manual and may create shock, fire, or other hazards.
- (4) The leads in the products are routed and dressed with ties, clamps, tubings, barriers and the like to be separated from live parts, high temperature parts, moving parts and/or sharp edges for the prevention of electric shock and fire hazard. When service is required, the original lead routing and dress should be observed, and it should be confirmed that they have been returned to normal, after re-assembling.

1.5.1 Warning

- (1) Service should be performed by qualified personnel only.
- (2) This equipment has been designed and manufactured to meet international safety standards.
- (3) It is the legal responsibility of the repairer to ensure that these safety standards are maintained.
- (4) Repairs must be made in accordance with the relevant safety standards.
- (5) It is essential that safety critical components are replaced by approved parts.
- (6) If mains voltage selector is provided, check setting for local voltage.



CAUTION Burrs formed during molding may be left over on some parts of the chassis. Therefore, pay attention to such burrs in the case of preforming repair of this system.

1.6 Preventing static electricity

Electrostatic discharge (ESD), which occurs when static electricity stored in the body, fabric, etc. is discharged, can destroy the laser diode in the traverse unit (optical pickup). Take care to prevent this when performing repairs.

1.6.1 Grounding to prevent damage by static electricity

Static electricity in the work area can destroy the optical pickup (laser diode) in devices such as CD players. Be careful to use proper grounding in the area where repairs are being performed.

(1) Ground the workbench

Ground the workbench by laying conductive material (such as a conductive sheet) or an iron plate over it before placing the traverse unit (optical pickup) on it.

(2) Ground yourself

Use an anti-static wrist strap to release any static electricity built up in your body.

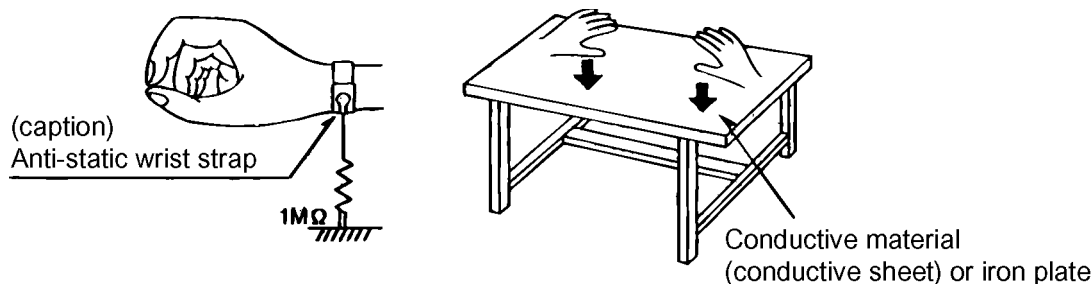

(3) Handling the optical pickup

- In order to maintain quality during transport and before installation, both sides of the laser diode on the replacement optical pickup are shorted. After replacement, return the shorted parts to their original condition. (Refer to the text.)
- Do not use a tester to check the condition of the laser diode in the optical pickup. The tester's internal power source can easily destroy the laser diode.

1.7 Handling the traverse unit (optical pickup)

(1) Do not subject the traverse unit (optical pickup) to strong shocks, as it is a sensitive, complex unit.

(2) Cut off the shorted part of the flexible cable using nippers, etc. after replacing the optical pickup. For specific details, refer to the replacement procedure in the text. Remove the anti-static pin when replacing the traverse unit. Be careful not to take too long a time when attaching it to the connector.

(3) Handle the flexible cable carefully as it may break when subjected to strong force.

(4) It is not possible to adjust the semi-fixed resistor that adjusts the laser power. Do not turn it.

1.8 Attention when traverse unit is decomposed

***Please refer to "Disassembly method" in the text for the CD pickup unit.**

- Apply solder to the short land sections before the flexible wire is disconnected from the connector CN101 on the CD servo board. (If the flexible wire is disconnected without applying solder, the CD pickup may be destroyed by static electricity.)
- In the assembly, be sure to remove solder from the short land sections after connecting the flexible wire.

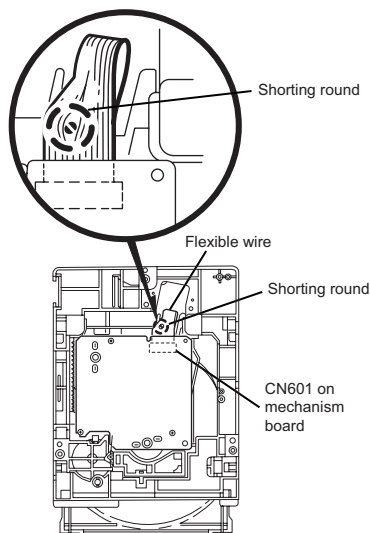

1.9 Important for laser products

- (1) **CLASS 1 LASER PRODUCT**
- (2) **DANGER** : Invisible laser radiation when open and inter lock failed or defeated. Avoid direct exposure to beam.
- (3) **CAUTION** : There are no serviceable parts inside the Laser Unit. Do not disassemble the Laser Unit. Replace the complete Laser Unit if it malfunctions.
- (4) **CAUTION** : The compact disc player uses invisible laser radiation and is equipped with safety switches which prevent emission of radiation when the drawer is open and the safety interlocks have failed or are de feated. It is dangerous to defeat the safety switches.
- (5) **CAUTION** : If safety switches malfunction, the laser is able to function.
- (6) **CAUTION** : Use of controls, adjustments or performance of procedures other than those specified herein may result in hazardous radiation exposure.

⚠ CAUTION
Please use enough caution not to see the beam directly or touch it in case of anadjustment or operation check.

VARNING

Osynlig laserstrålning är denna del är öppnad och spärren är urkopplad. Betrakta ej strålen.

VARO

Avattaessa ja suojalukitus ohitettaessa olet alttiina näkymätömälle lasersäteilylle. Älä katso säteeseen.

ADVARSEL

Usynlig laserstrålning ved åbning, når sikkerhedsafbrydere er ude af funktion. Undgå udsættelse for stråling.

ADVARSEL

Usynlig laserstrålning ved åbning, når sikkerhedsbryteren er avslott. unngå utsettelse for stråling.

REPRODUCTION AND POSITION OF LABELS

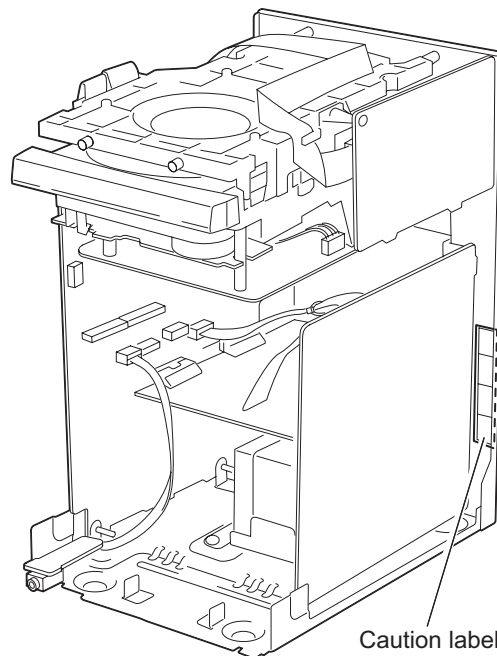

SECTION 2 Disassembly method

2.1 Main body

2.1.1 Removing the rear panel (See Fig.1,2)

- (1) From behind the body, remove the eight screws **A** attaching the rear panel.
- (2) Turing the body upside down, remove the two screws **B** attaching the rear panel, and remove.

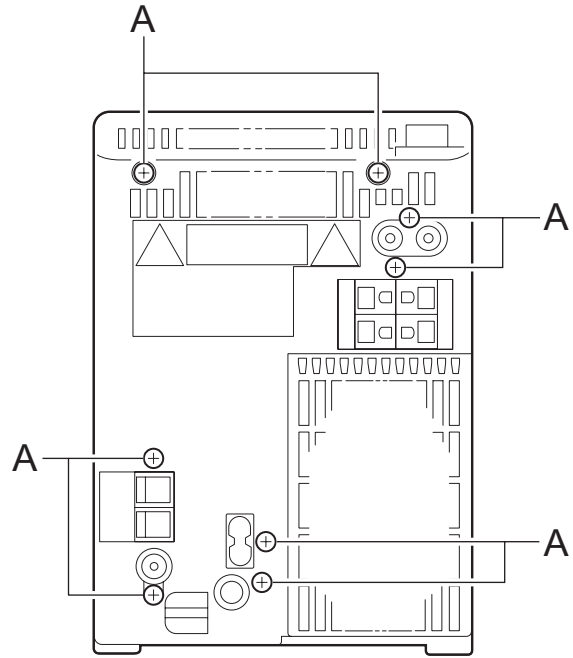

Fig.1

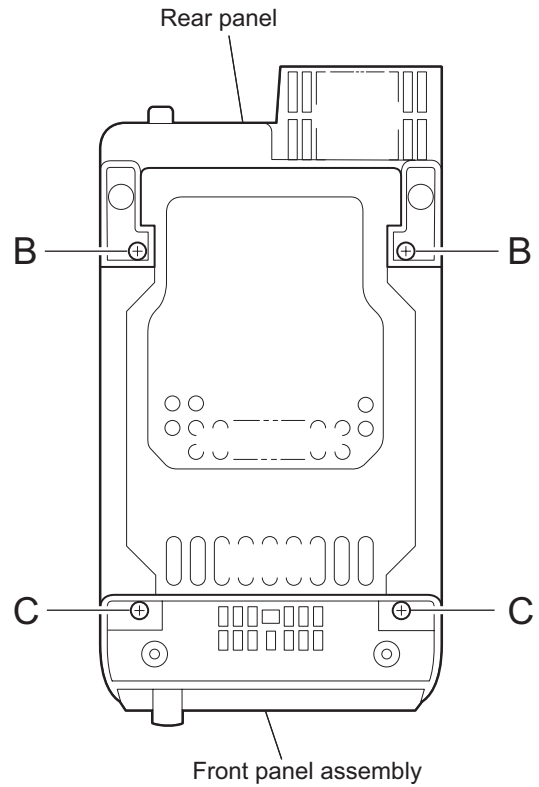

Fig.2

2.1.2 Removing the side panel (L) and (R) (See Fig.2~5)

- Prior to performing the following procedure, remove the rear panel.
 - (1) Turning the body upside down, remove the two screws **C** attaching the front panel assembly.
 - (2) Turning the body initial position, open the CD door while pressing the upper OPEN button.
 - (3) Moving the side panel (L) in the arrow direction, remove the panel from the left side of the body.
 - (4) Moving the side panel (R) in the arrow direction, remove the panel from the right side of the body.

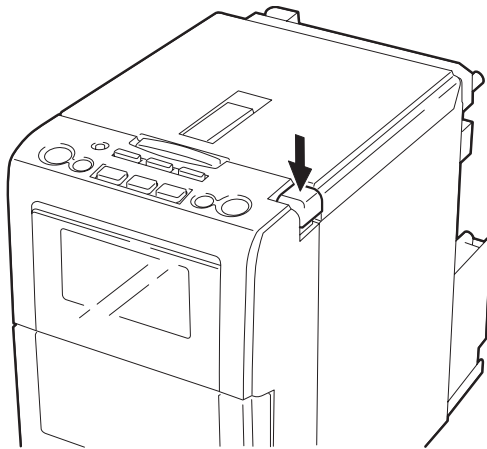

Fig.3

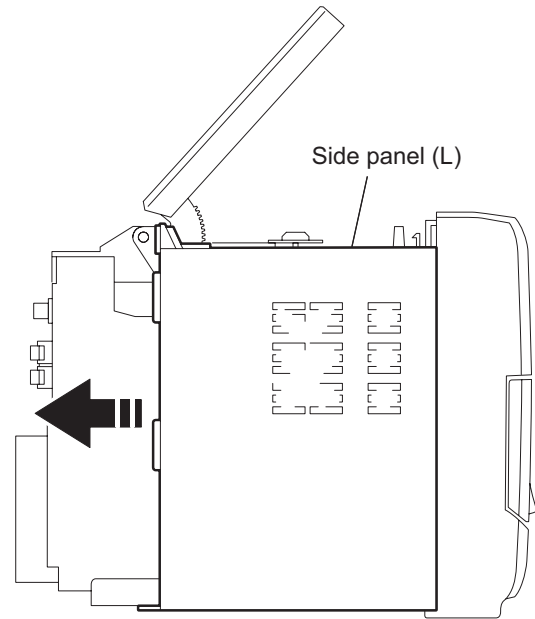

Fig.4

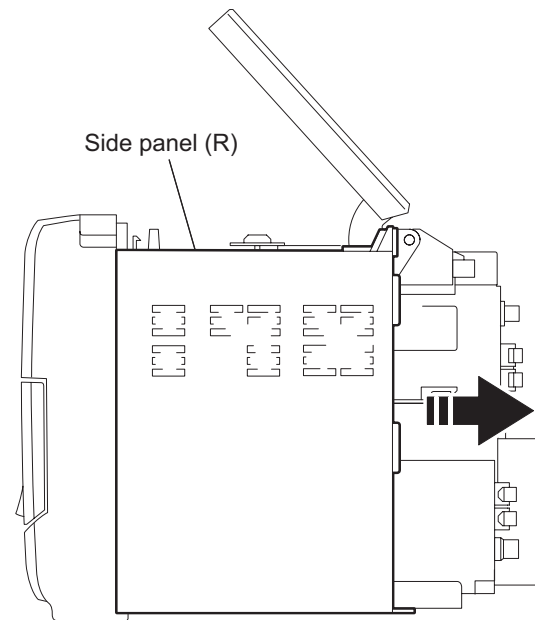

Fig.5

**2.1.3 Removing the CD player assembly
(See Fig.6,7)**

- Prior to performing the following procedure, remove the rear panel and the left and right side panels.
 - (1) Disconnect the card wires from the two connectors CN603 and CN604 on the CD servo control board.
 - (2) Remove the two screws **D** attaching the front panel assembly on the both sides.
 - (3) Release the two joints **a** on the both sides of the front panel assembly.
 - (4) Move the CD player assembly in the direction of the arrow.

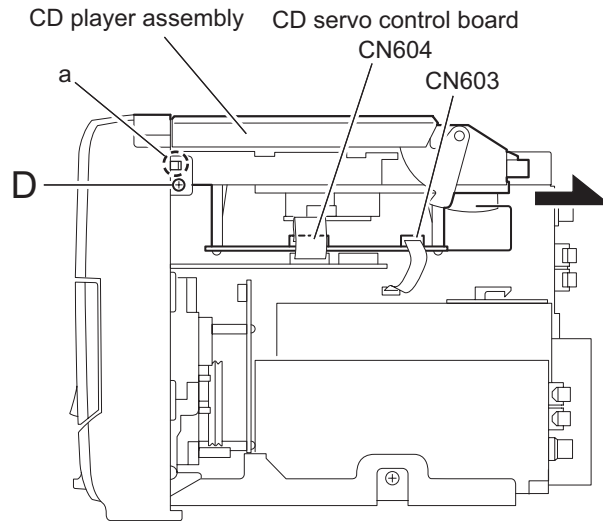

Fig.6

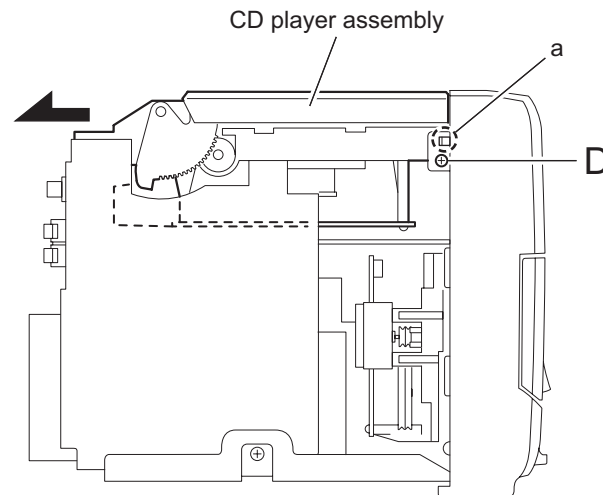

Fig.7

2.1.4 Removing the power amplifier board and heat sink (See Fig.8~10)

- Prior to performing the following procedure, remove the rear panel, the left and right side panels, and the CD player assembly.
 - (1) Remove the five screws **E** and **F** attaching the heat sink.
 - (2) Disconnect the wire from connector CN901 on the power supply board.
 - (3) Disconnect the card wire from connector CN305 on the power amplifier board.
 - (4) Remove the screw **G** attaching the power amplifier board.
 - (5) Disconnect the connector CN301 on the power amplifier board, and release the two joints **b**.

REFERENCE:

Remove the screw **F**, then power amplifier board can be removed without removing heat sink.

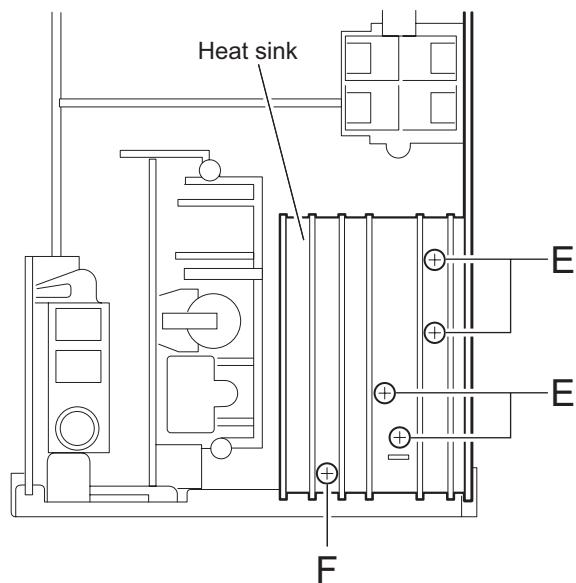

Fig.8

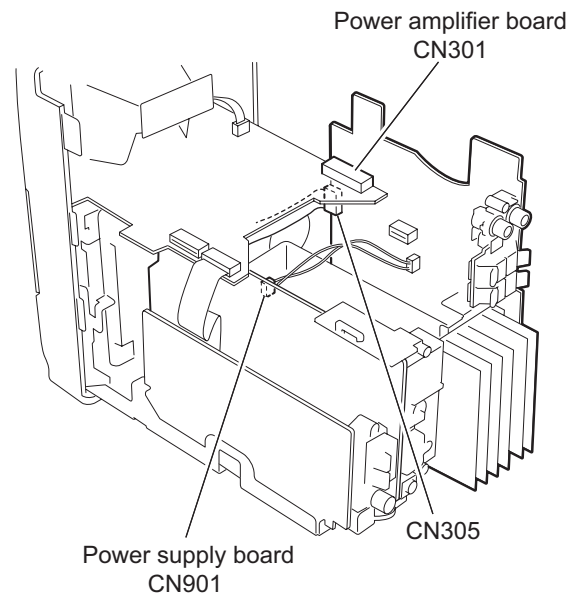

Fig.9

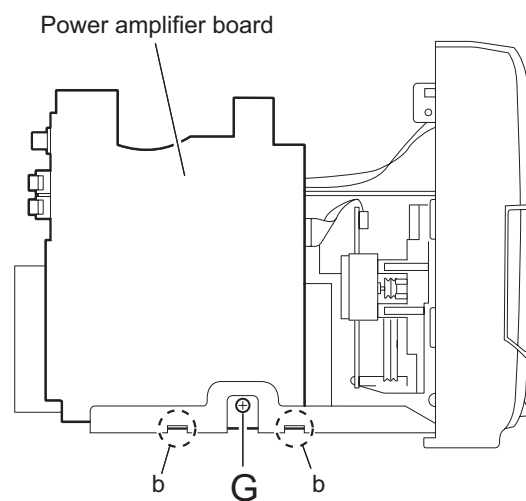

Fig.10

2.1.5 Removing the tuner board (See Fig.11)

- Prior to performing the following procedure, remove the rear panel, the left and right side panels, and the CD player assembly.
 - (1) Remove the screw **H** attaching the tuner board from the right side of the body.
 - (2) Disconnect the card wire from the connector **CN1** on the tuner board.
 - (3) Release the joint **c**, and remove the tuner board backward.

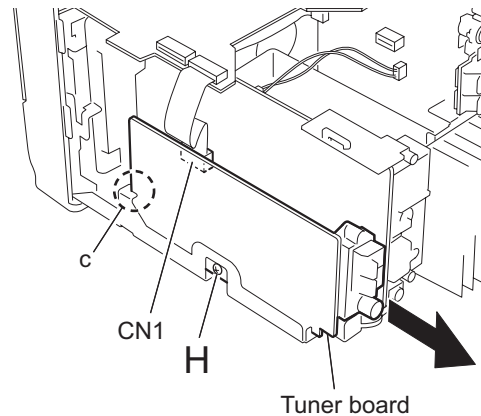

Fig.11

2.1.6 Removing the front panel assembly (See Fig.12,13)

- Prior to performing the following procedure, remove the rear panel the left and right side panels, the CD player assembly, the power amplifier board.
 - (1) Disconnect the card wire from the connector **CN714** on the LCD system CPU board.
 - (2) Release the joint **d** on the bottom of the front panel assembly using a screwdriver, and remove the front panel assembly toward the front.

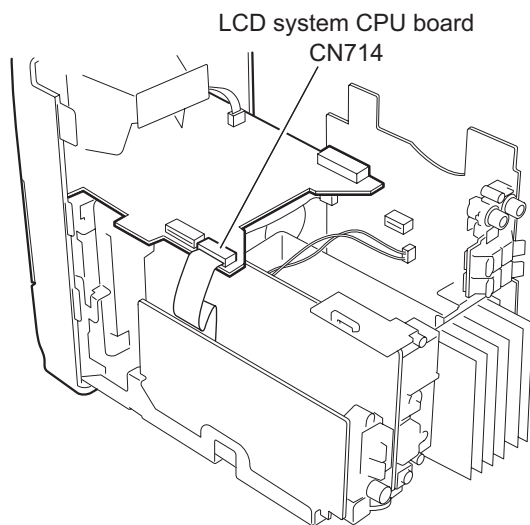

Fig.12

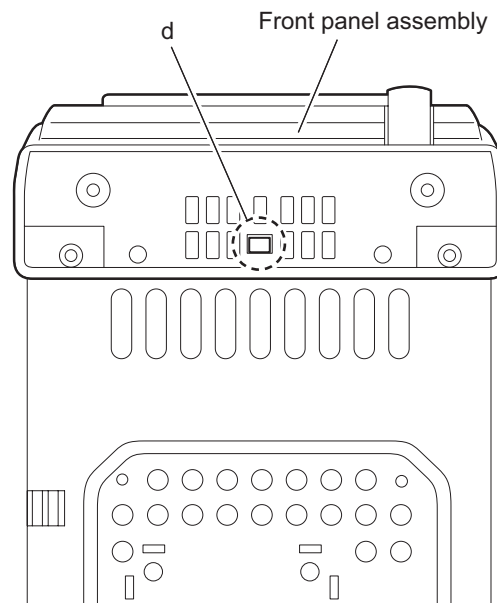

Fig.13

2.1.7 Remove the power transformer and power supply board (See Fig.14,15)

- Prior to performing the following procedure, remove the rear panel, the left and right side panels, the CD player assembly, the power amplifier board and the tuner board.
 - (1) Remove the screw **I** attaching the jack holder and release joint **e**, and then remove jack holder.
 - (2) Remove the four screws **J** attaching the power transformer and power supply board.

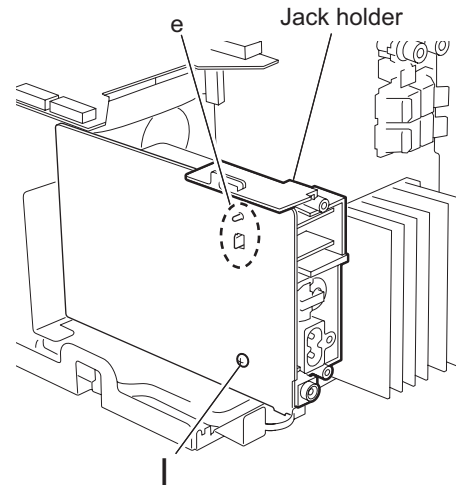

Fig.14

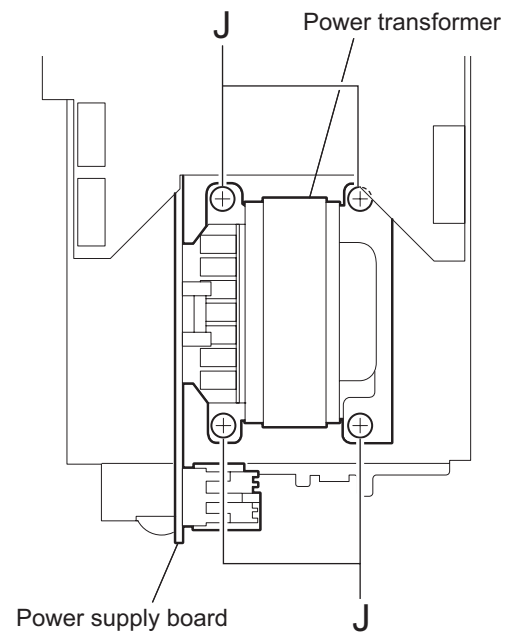

Fig.15

**2.1.8 Remove the cassette mechanism assembly
(See Fig.16,17)**

- Prior to performing the following procedure, remove the front panel assembly.
 - (1) Disconnect the card wire from the connector CN713 on the LCD system CPU board.
 - (2) Remove the four screws **K** and **L** attaching the cassette mechanism assembly, and remove.

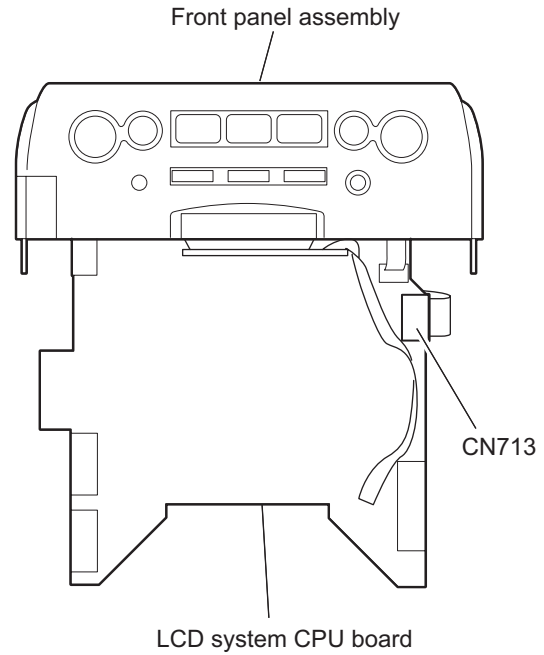

Fig.16

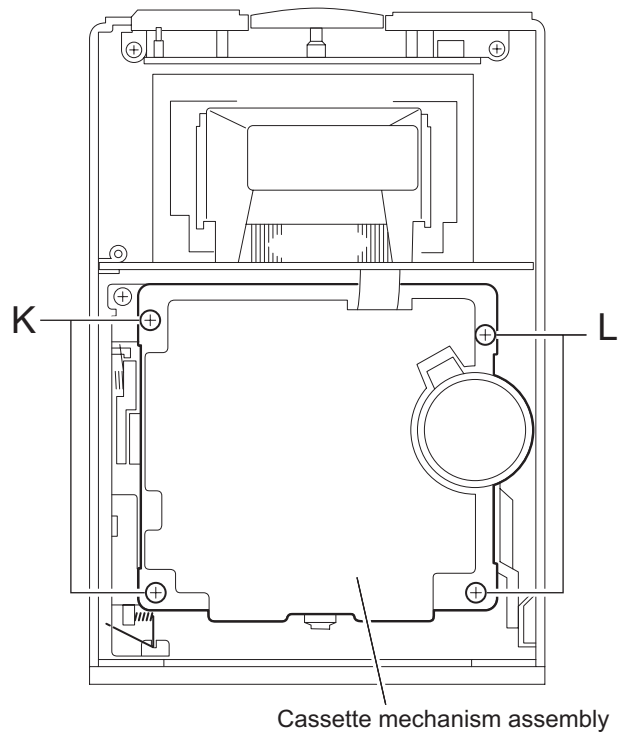

Fig.17

2.1.9 Remove the LCD system CPU board (See Fig.18)

- (1) Disconnect the wire from the connector CN716 on the LCD system CPU board.
- (2) Release the two joints **f** and pull out the LCD system CPU board.

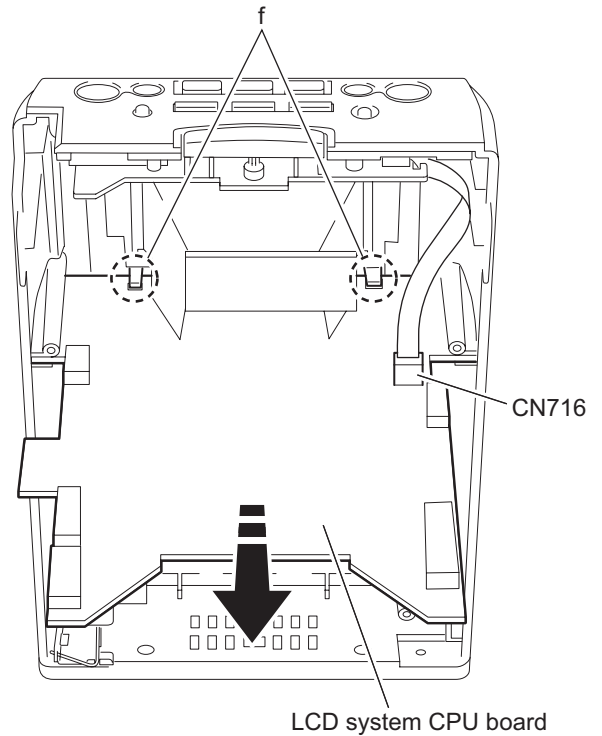

Fig.18

2.1.10 Removing the operating switch board (See Fig.19,20)

- Prior to performing the following procedure, remove the front panel assembly, the cassette mechanism assembly and the LCD system CPU board.
- (1) Remove the two screws **M** attaching the operating switch button.
 - (2) Remove the two screws **N** attaching the operating switch board, and remove.

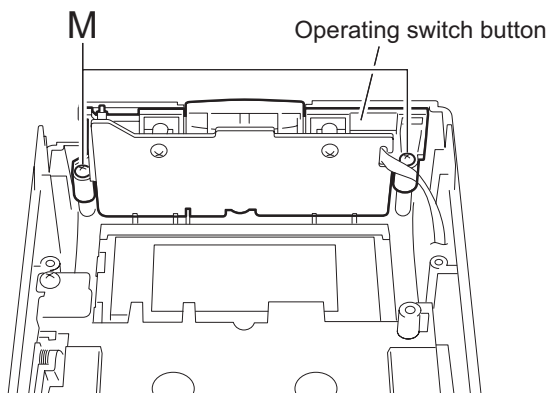

Fig.19

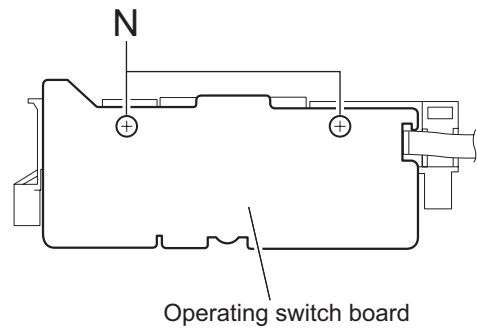

Fig.20

2.2 Cassette mechanism assembly

2.2.1 Removing the Play/Record & Clear head (See Fig.1~3)

- (1) While moving the trigger arm on the right side of the head mount in the direction of the arrow, turn the flywheel **R** counterclockwise until the head mount comes ahead and clicks.
- (2) The head turns counterclockwise as you turn the flywheel **R** counterclockwise (See Fig.2 and 3).
- (3) Disconnect the flexible wire from connector CN31 on the head amplifier & mechanism control board.
- (4) Remove the spring from the back of the head.
- (5) Loosen the azimuth screw for reversing attaching the head.
- (6) Remove the head on the front side of the head mount.

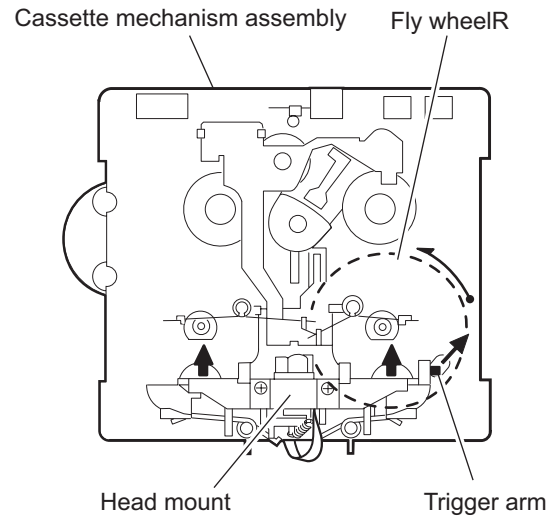

Fig.1

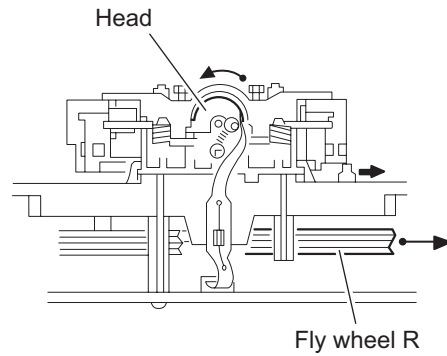

Fig.2

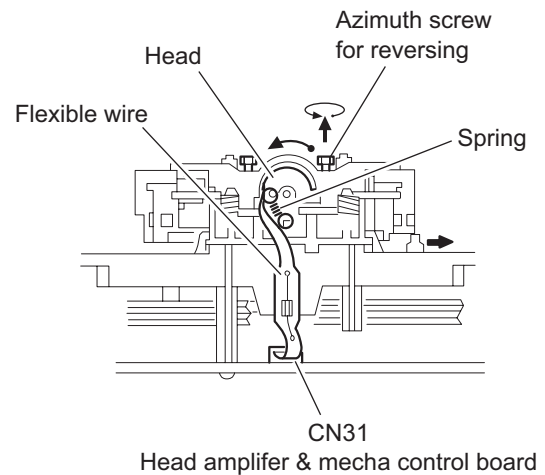

Fig.3

2.2.2 Removing the head amplifier & mechanism control board (See Fig.4)

- (1) Turn over the cassette mechanism assembly and remove the three screws **A** attaching the head amplifier & mechanism control board.
- (2) Disconnect the flexible wire from connector CN31 on the head amplifier & mechanism control board.
- (3) Disconnect connector CN32 of the head amplifier & mechanism control board from connector CN1 on the reel pulse board.

REFERENCE:

If necessary, unsolder the 4-pin wire soldered to the main motor.

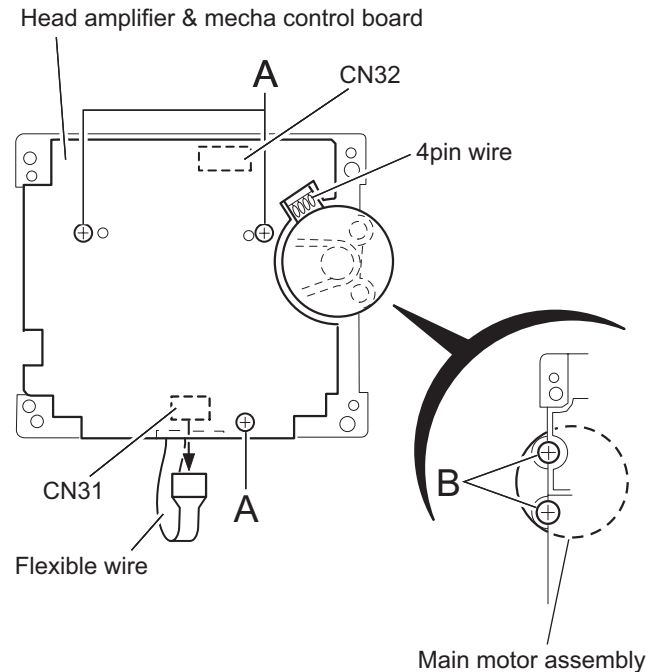

Fig.4

2.2.3 Removing the main motor (See Fig.4~7)

- (1) Remove the two screws **B**.
- (2) Half raise the motor and remove the capstan belt from the motor pulley.

ATTENTION:

Be careful to keep the capstan belt from grease. When reassembling, refer to Fig.6 and 7 for attaching the capstan belt.

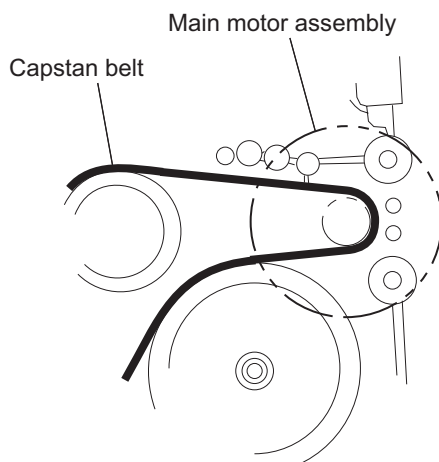

Fig.5

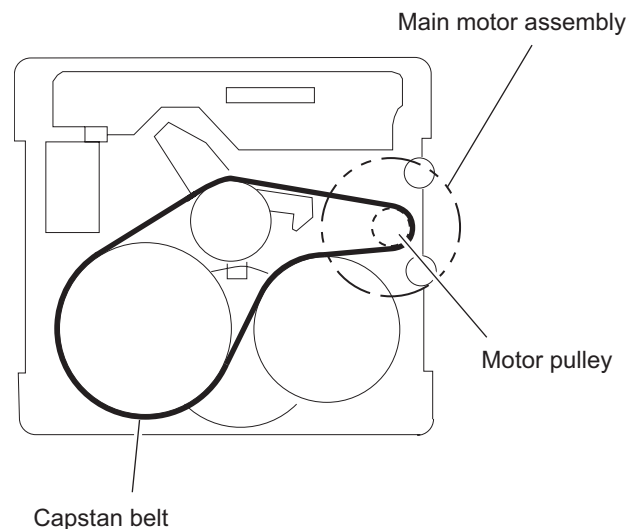

Fig.6

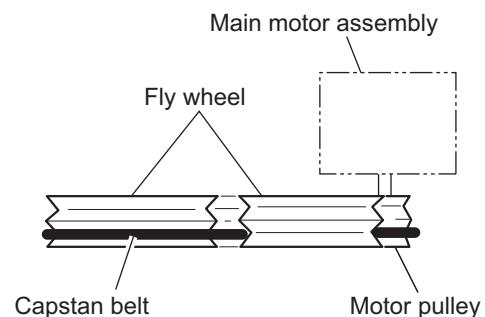

Fig.7

**2.2.4 Removing the flywheel
(See Fig.8, 9)**

- Prior to performing the following procedure, remove the head amplifier & mechanism control board and the main motor assembly.
- (1) From the front side of the cassette mechanism, remove the slit washers attaching the capstan shaft **L** and **R**. Pull out the flywheels backward.

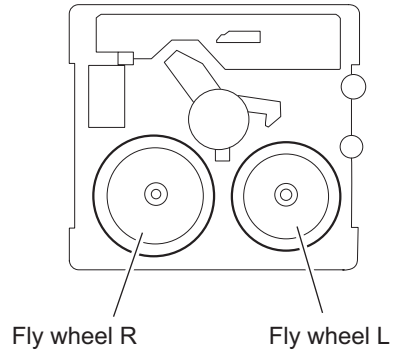

Fig.8

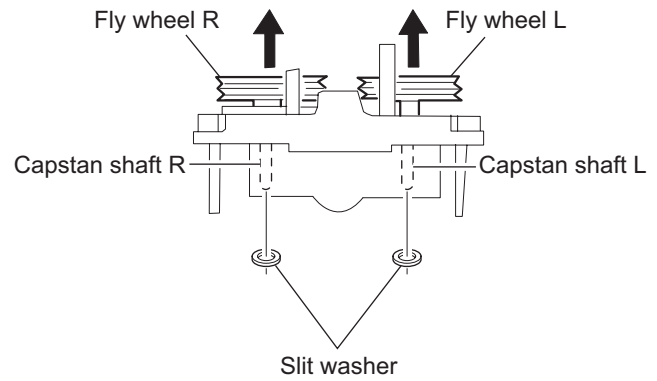

Fig.9

**2.2.5 Removing the reel pulse board and solenoid
(See Fig.10)**

- Prior to performing the following procedure, remove the head amplifier & mechanism control board.
- (1) Remove the screw **C**.
- (2) Release the tab **a**, **b**, **c**, **d** and **e** retaining the reel pulse board.
- (3) Release the tab **f** and **g** attaching the solenoid on the reel pulse board.
- (4) The reel pulse board and the solenoid come off.

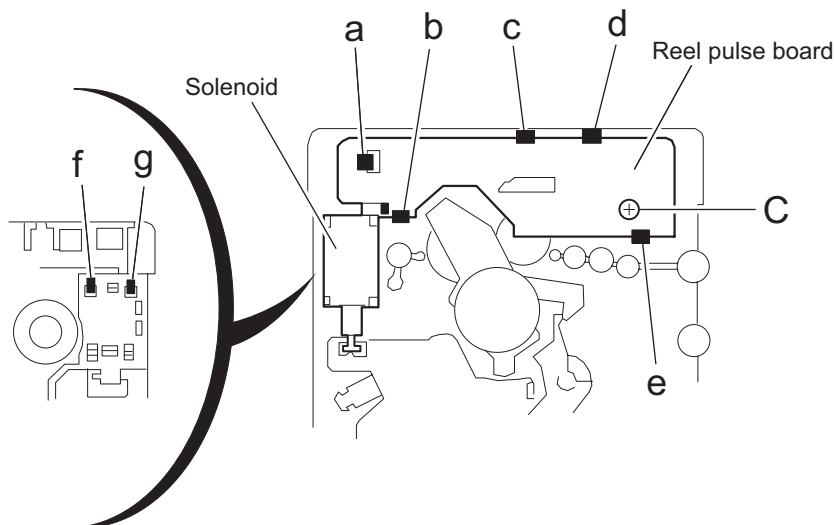

Fig.10

2.2.6 Reattaching the Play/ Record & Clear head (See Fig.11~13)

- (1) Reattaching the head mount assembly.
 - a) Change front of the direction cover of the head mount assembly to the left (Turn the head forward).
 - b) Fit the bosses **O'**, **P'**, **Q'**, **U'** and **V'** on the head mount assembly to the holes **P** and **V**, the slots **O**, **U** and **Q** of the mechanism sub assembly (See Fig.11 to 13).

CAUTION:

To remove the head mount assembly, turn the direction cover to the left to disengage the gear. If the gear can not be disengaged easily, push up the boss **Q'** slightly and raise the rear side of the head mounts slightly to return the direction lever to the reversing side.

- (2) Tighten the azimuth screw for reversing.
- (3) Reattach the spring from the back of the Play / Record & Clear head.
- (4) Connect the flexible wire to connector CN31 on the head amplifier & mechanism control board.

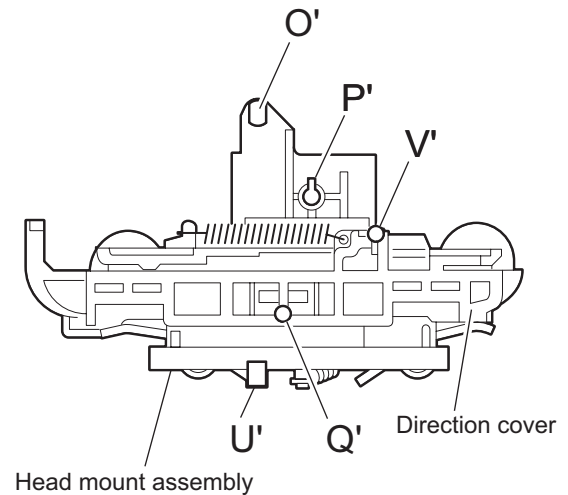

Fig.11

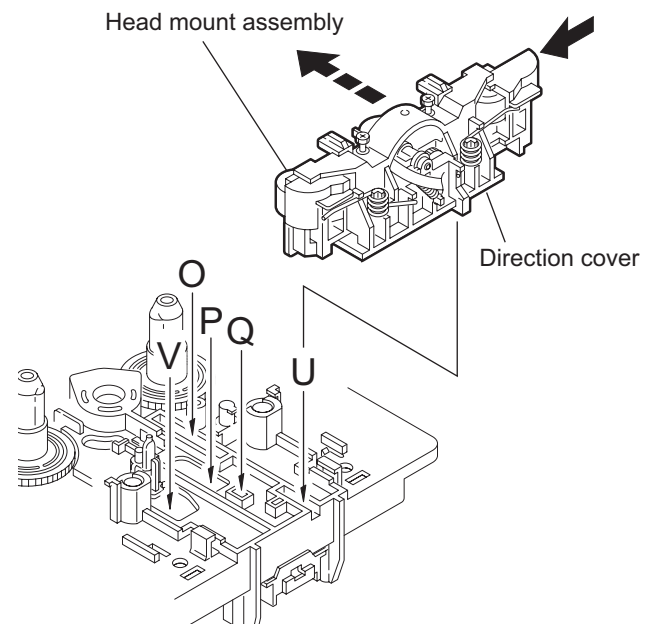

Fig.12

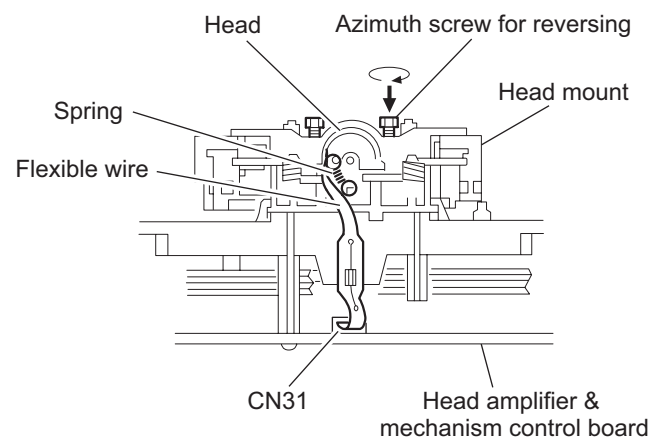

Fig.13

SECTION 3 Adjustment

3.1 Adjustment method

■ Measurement Instruments Required for Adjustment

- Low frequency oscillator
This oscillator should have a capacity to output 0dBs to 600 Ω at an oscillation frequency of 50Hz-20kHz.
- Attenuator impedance : 600 Ω
- Electronic voltmeter
- Distortion meter
- Frequency counter
- Wow & flutter meter
- Test tape
VT703L : Head azimuth
VT712 : Tape speed and running unevenness (3kHz)
VT724 : Reference level (1kHz)
- Blank tape
TYPE I : AC-225
TYPE II : AC-514
- Torque gauge : For play and back tension
FWD(TW2111A), REV(TW2121a) and
FF/REW(TW2231A)
- Test disc: CTS-1000

■ Measurement conditions

Power supply voltage
AC 230V ~ , 50Hz
Reference output : Speaker : 0.775V/4 Ω
: Headphone : 0.077V/32 Ω
Reference frequency and
input level ----- 1kHz, AUX : -8dBs
Measurement output terminal ----- at Speaker J3002
※ Load resistance ----- 4 Ω

● Radio Input signal

AM frequency ----- 400Hz
AM modulation ----- 30%
FM frequency ----- 400Hz
FM frequency deviation ----- 22.5kHz

● Tuner section

FM tuning range: 87.5MHz~108.00MHz
AM tuning range: 522kHz~1,629kHz

Voltage applied to tuner ----- +B : DC5.7V
VT : DC 12V

Reference measurement
output ----- 26.1mV(0.28V)/3 Ω
Input positions ----- AM : Standard loop antenna
FM : TP1 (hot) and TP2 (GND)

● Standard measurement position of volume

Function switch ----- to Tape
Beat cut switch ----- to Cut
Super Bass/Active hyper Bass ----- to OFF
Bass Treble ----- to Center
Adjustment of main volume to reference output
VOL : 28

Precautions for measurement

- Apply 30pF and 33k Ω to the IF sweeper output side and 0.082 μ F and 100k Ω in series to the sweeper input side.
- The IF sweeper output level should be made as low as possible within the adjustable range.
- Since the IF sweeper is a fixed device, there is no need to adjust this sweeper.
- Since a ceramic oscillator is used, there is no need to perform any MIX adjustment.
- Since a fixed coil is used, there is no need to adjust the FM tracking.
- The input and output earth systems are separated. In case of simultaneously measuring the voltage in both of the input and output systems with an electronic voltmeter for two channels, therefore, the earth should be connected particularly carefully.
- In the case of BTL connection amp., the minus terminal of speaker is not for earthing. Therefore, be sure not to connect any other earth terminal to this terminal. This system is of an BTL system.
- For connecting a dummy resistor when measuring the output, use the wire with a greater code size.
- Whenever any mixed tape is used, use the band pass filter (DV-12).

3.2 Cassette mechanism adjustment

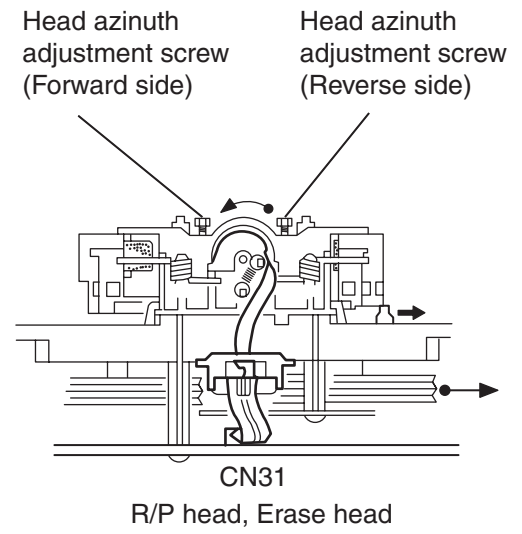
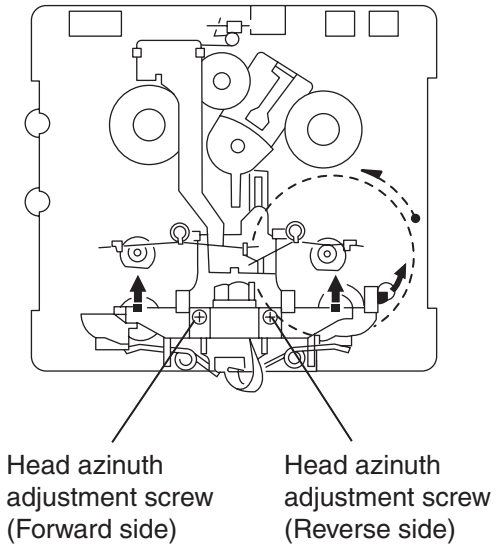

Mecha control board

Motor speed VR37

BIAS adjust VR31

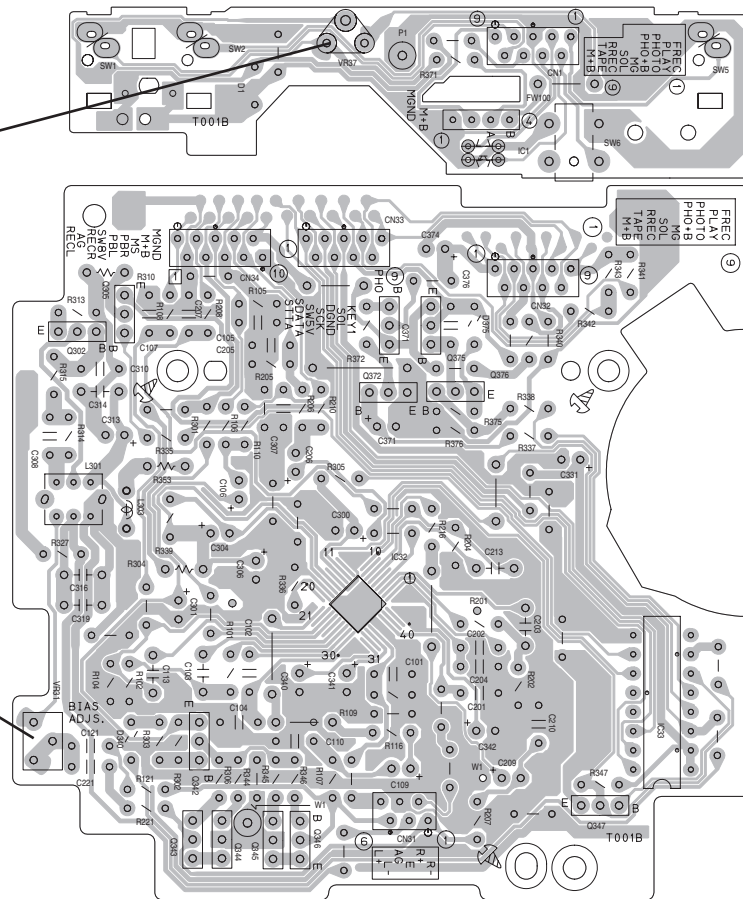

3.2.1 Mechanism section

Item	Condition	Measurement method	Ref.value	Adjustment position
Head azimuth	Test tape : VT703L (8kHz) Output terminal : Speaker out	1.Playback the test tape VT703L (8kHz). 2.Adjust to maximum output level by azimuth adjustment screw for forward side and reverse side. 3.This adjustment is adjust by adjustment screw of forward side and adjustment screw of reverse side.	Maximum output	Only adjust at changed head
Tape speed	Test tap : VT712 (3kHz) Output terminal : Speaker out or Headphone out	Playback the test tape VT712 (3kHz) at end of forward side,adjust to 2,940~3,90Hz indication of frequency counter by VR37.	2,940 ~ 3,090Hz	VR37

Item	Condition	Measurement method	Ref.value	Adjustment position
Tape speed diviation at FWD/REV	Test tape : VT712 (3kHz) Output terminal : Speaker out or Headphone out	Playback the test tape VT712 (3kHz) at end of forward and reverse, tape speed deviation should be less than 6.0Hz.	Leass than 6.0Hz	VR31
Wow & Flutter	Test tape : VT712 (3kHz) Output terminal : Speaker out or Headphone out	Playback the test tape VT712 (3kHz) at start of forward and reverse,Wow & Flutter are should be less than 0.25%(WRMS).	Less than 0.25% (WRMS)	

3.2.2 Electrical adjustment

Item	Condition	Measurement method	Ref.value	Adjustment position
Recording BIAS adjustment	<ul style="list-style-type: none"> ▪ Forward or Reverse ▪ Test tape :AC-514 TYPE II :AC-225 TYPE I ▪ Output terminal Recording head 	<ol style="list-style-type: none"> 1.Set the test tape(AC-514 TYPEII and AC-225 TYPEI), then make REC/PAUSE condition. 2.Connect 100 Ω to recording head by series, then connect to VTVM for measurement the current. 3.After setting, start the recording by release the PAUSE, in this time bias current adjust to next fig. by VR31 for Lch and VR32 for Rch. 4.0 μA (TYPE II) and 4.20 μA (TYPE I). 	AC-225 :4.20 μ A AC-514 :4.0 μ A	VR31
R/P playback frequency response	<ul style="list-style-type: none"> ▪Reference frequency : 1kHz / 10kHz (Reference: -20dB) ▪Test tape : AC-514 TYPE II ▪Input terminal : OSC IN 	<ol style="list-style-type: none"> 1.Set the test tape (AC-514 TYPE II), then make REC/PAUSE condition. 2.Release the PAUSE, then start recording the 1kHz and 10kHz of reference frequency from oscillator. 3.Playback the recorded position, 1kHz and 10kHz output deviation should -1dB \pm 2dB to readjust by VR31 for Lch and VR32 for Rch. 	Output deviation 1kHz/10kHz :-1dB \pm 2dB	VR31

3.2.3 Electrical response confirmation

Item	Condition	Measurement method	Ref.value	Adjustment position
Recording bias current	<ul style="list-style-type: none"> Forward or Reverse ▪Test tape : TYPE II (AC-514) ▪ Measurement terminal : BIAS test point on printed circuit board 	<ol style="list-style-type: none"> 1.Change BIAS1 and 2, confirm the frequency should be change. 2.Set the test tape (AC-514 TYPEII), then make REC/PAUSE condition. 3.Confirm the frequency should 100Hz\pm 6kHz at BIAS test point on printed circuit board. 	100 kHz \pm 6 kHz	
Erase current (reference value)	<ul style="list-style-type: none"> Forward or Reverse ▪Rec condition ▪Test tape : AC-514 TYPEII : AC-225 TYPEI ▪ Measurement terminal : Both side of Erase head 	<ol style="list-style-type: none"> 1.Set the test tape (AC-514 TYPE II and AC-225 TYPE I), then make REC/PAUSE condition. 2.Release the PAUSE to REC condition, connect 1W to ERASE head by series, then confirm the erase current at both side of erase head. 	TYPE II : 120 mA TYPEI : 75 mA	

3.3 Flow of functional operation until TOC read (CD)

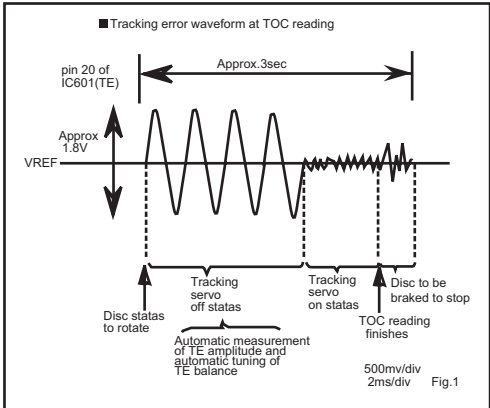
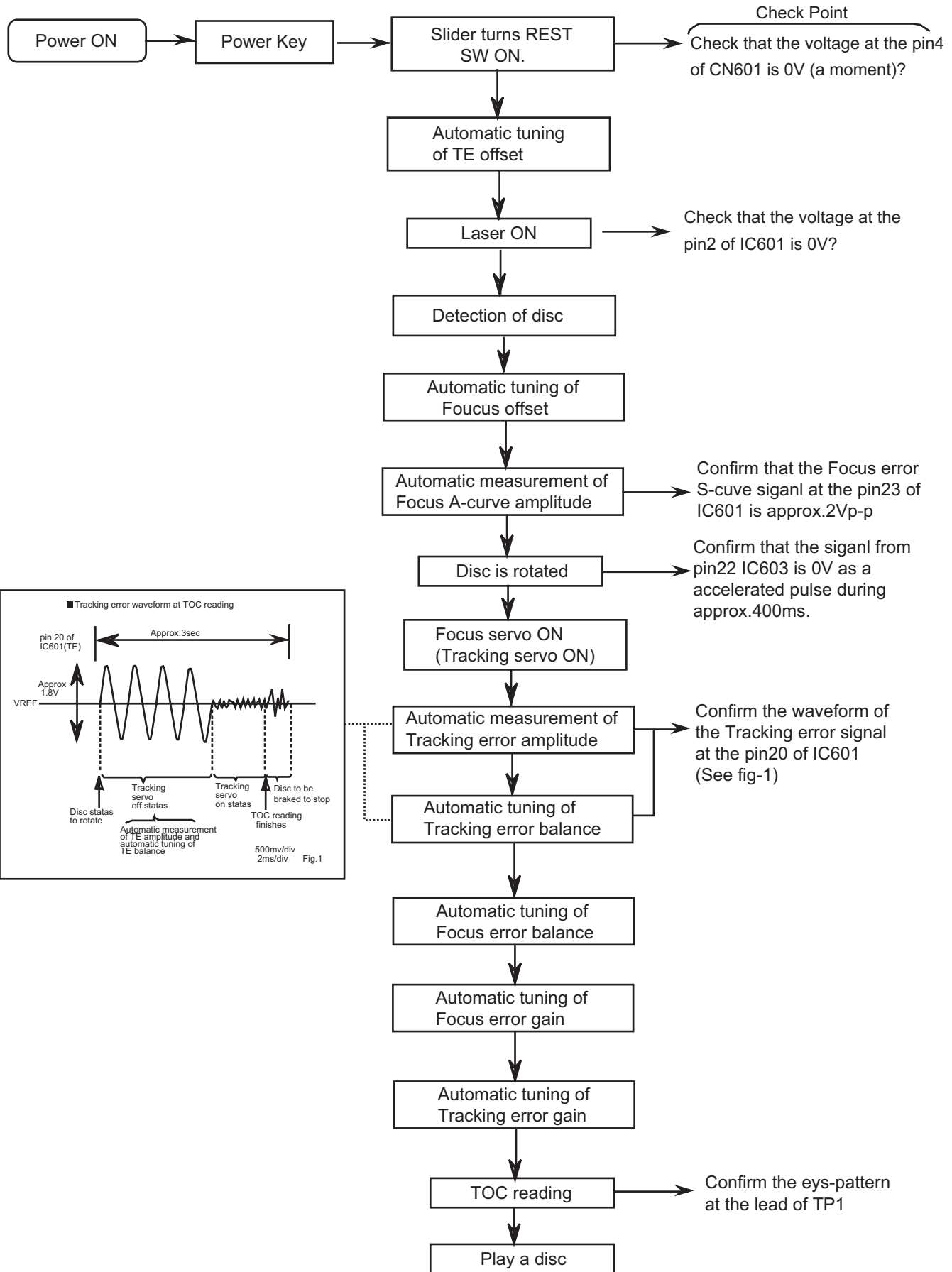

3.4 Maintenance of laser pickup (CD)

(1) Cleaning the pick up lens

Before you replace the pick up, please try to clean the lens with a alcohol soaked cotton swab.

(2) Life of the laser diode

When the life of the laser diode has expired, the following symptoms will appear.

- The level of RF output (EFM output : amplitude of eye pattern) will below.

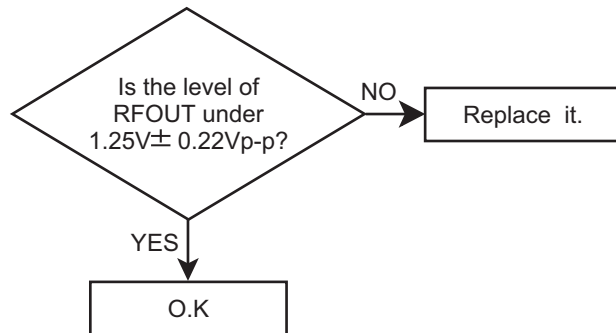

(3) Semi-fixed resistor on the APC PC board

The semi-fixed resistor on the APC printed circuit board which is attached to the pickup is used to adjust the laser power. Since this adjustment should be performed to match the characteristics of the whole optical block, do not touch the semi-fixed resistor.

If the laser power is lower than the specified value, the laser diode is almost worn out, and the laser pickup should be replaced.

If the semi-fixed resistor is adjusted while the pickup is functioning normally, the laser pickup may be damaged due to excessive current.

3.5 Replacement of laser pickup (CD)

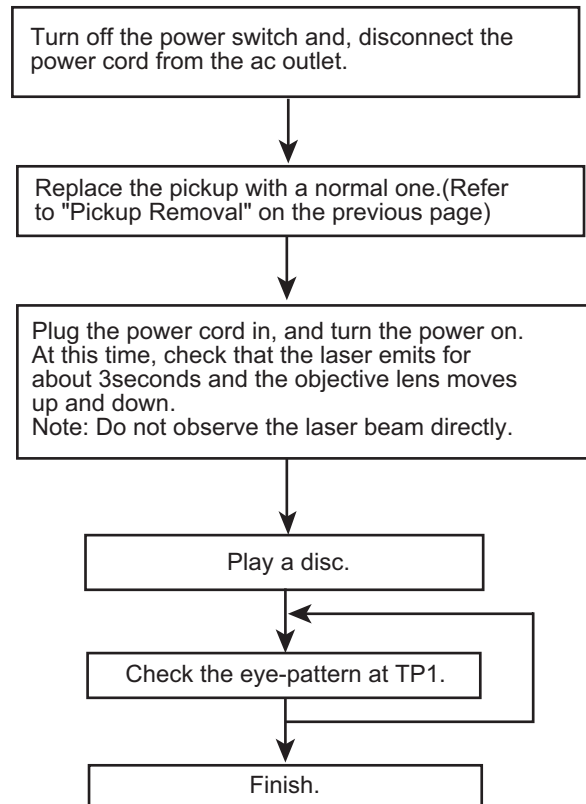

SECTION 4 Description of major ICs

4.1 AN22000A-W (IC601) : RF & SERVO AMP

- Terminal layout

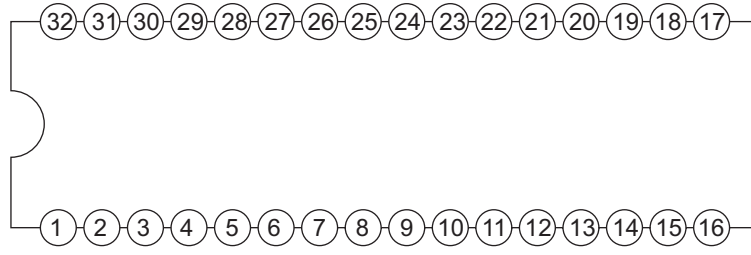

- Block diagram

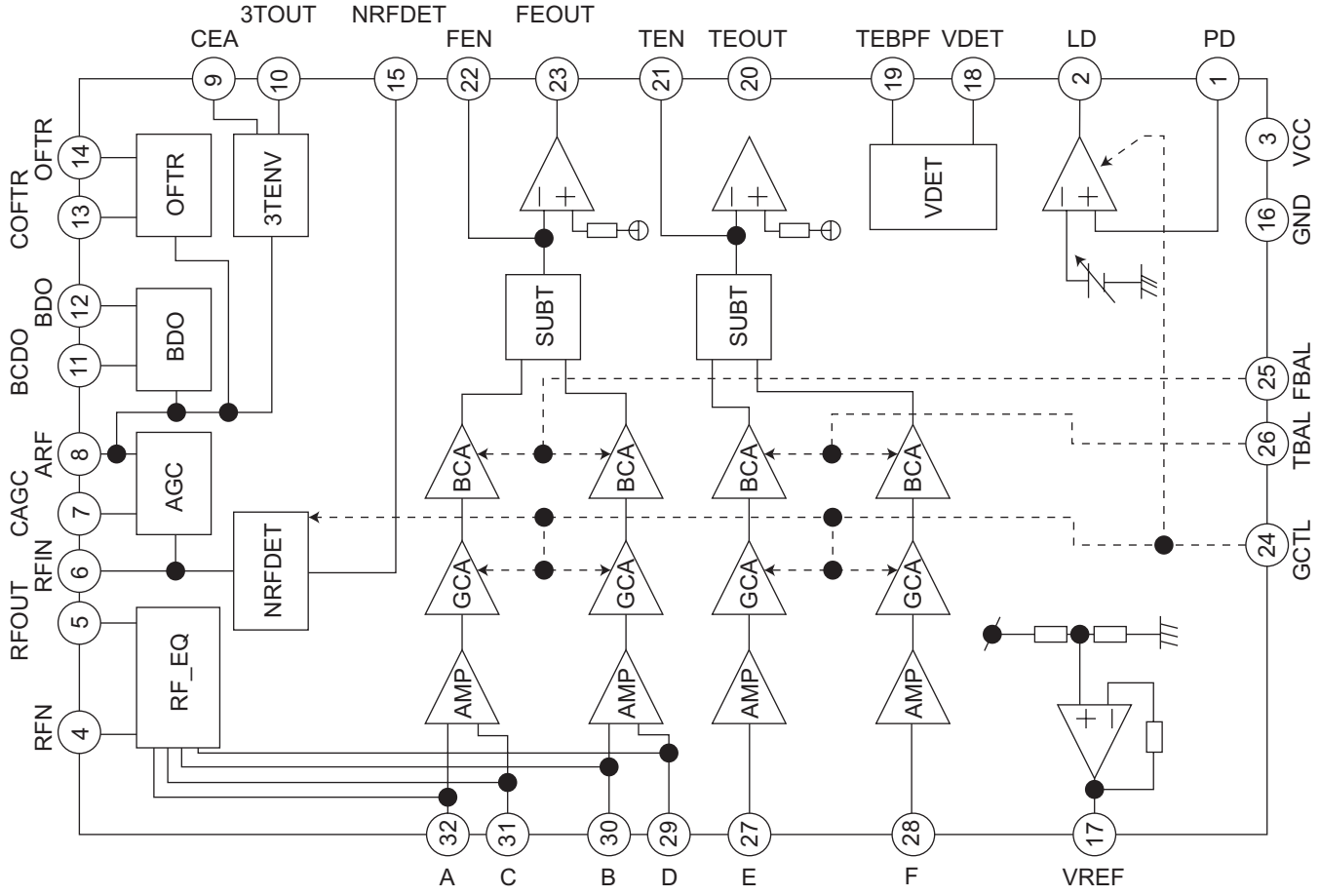

- Pin function

Pin No.	Symbol	I/O	Function
1	PD	I	APC Amp. input terminal
2	LD	O	APC Amp. output terminal
3	VCC	-	Power supply terminal
4	RFN	I	RF adder Amp. inverting input terminal
5	RFOUT	O	RF adder Amp. output terminal
6	RFIN	I	AGC input terminal
7	CAGC	I	Input terminal for AGC loop filter capacitor
8	ARF	O	AGC output terminal
9	CEA	I	Capacitor connecting terminal for HPF-Amp.
10	3TOUT	O	3 TENV output terminal
11	CBDO	I	Capacitor connecting terminal for envelope detection on the darkness side
12	BDO	O	BDO output terminal
13	COFTR	I	Capacitor connecting terminal for envelope detection on the light side
14	OFTR	O	OFTR output terminal
15	NRFDET	O	NRFDET output terminal

Pin No.	Symbol	I/O	Function
16	GND	-	Ground
17	VREF	O	VREF output terminal
18	VDET	O	VDET output terminal
19	TEBPF	I	VDET output terminal
20	TEOUT	O	TE Amp. output terminal
21	TEN	I	TE Amp. inverting input terminal
22	FEN	I	FE Amp. inverting input terminal
23	FEOUT	O	FE Amp. output terminal
24	GCTL	O	GCTL & APC terminal
25	FBAL	O	FBAL control terminal
26	TBAL	O	TBAL control terminal
27	E	I	Tracking signal input terminal 1
28	F	I	Tracking signal input terminal 2
29	D	I	Focus signal input terminal 4
30	B	I	Focus signal input terminal 3
31	C	I	Focus signal input terminal 2
32	A	I	Focus signal input terminal 1

4.2 GP101UM281YK (IC750) : Remocon receiver

- Block diagram

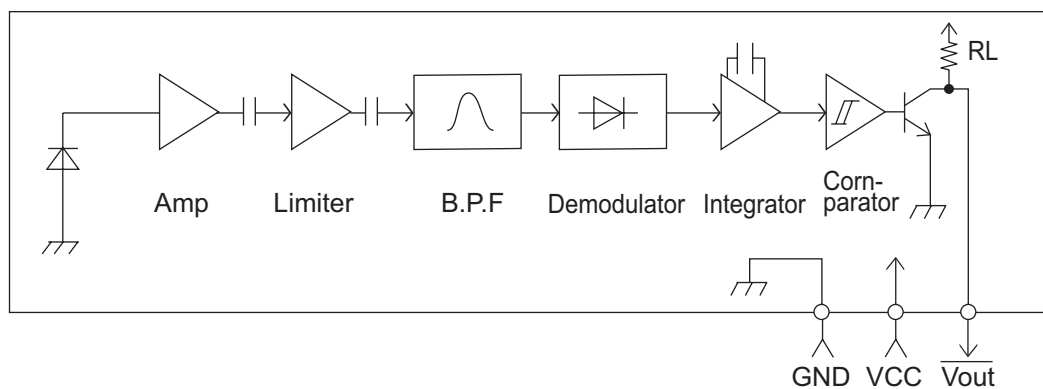

4.3 HA12238F (IC32) : R/P Equalizer

- Pin layout

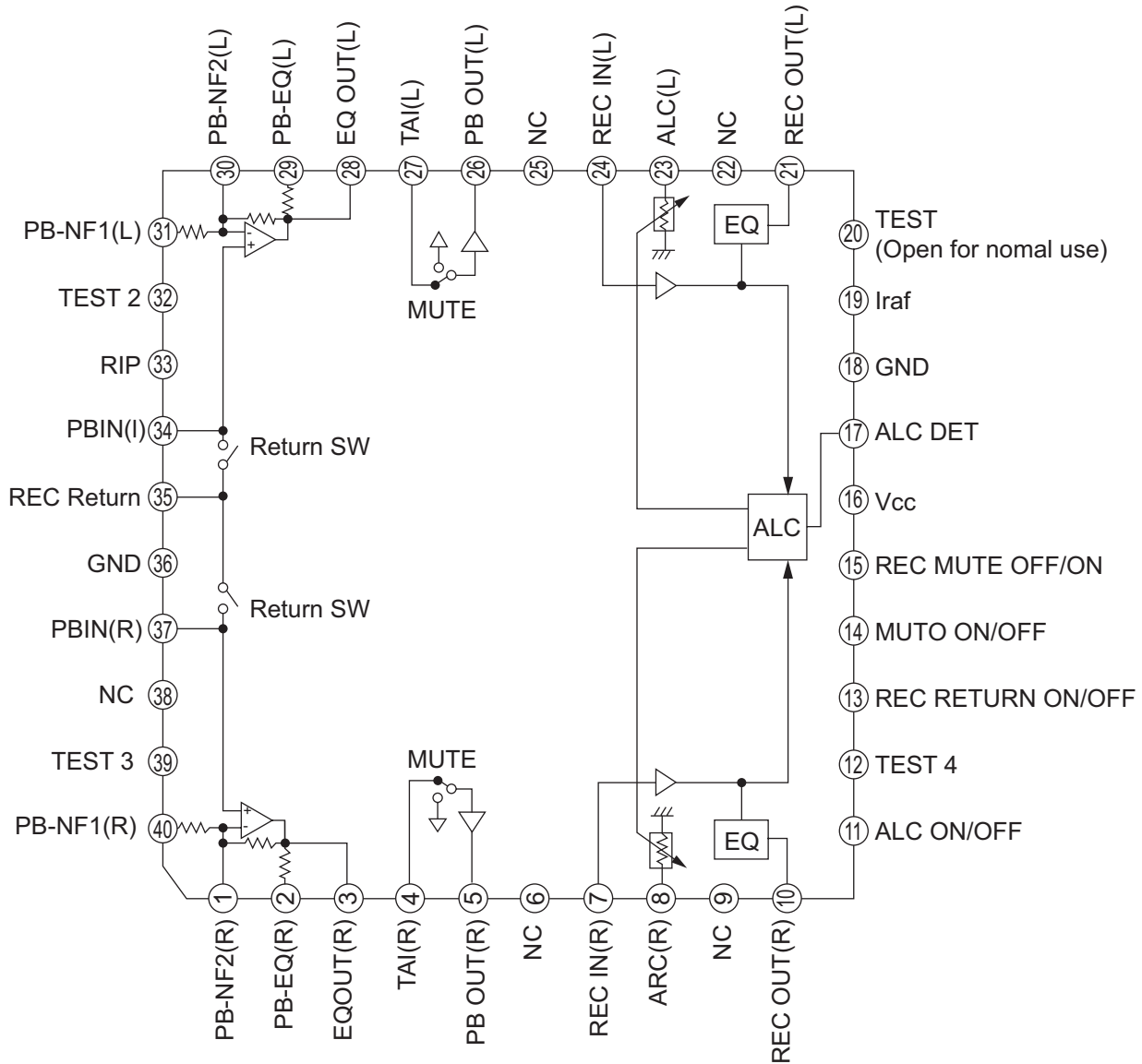

- Pin function

Pin No.	Symbol	Function
1	PB-NF2(R)	PB EQ feed back
2	PB-EQ(R)	NAB output
3	EQOUT(R)	EQ output
4	TAI(R)	Tape input
5	PBOUT(R)	PB output
6	NC	NC pin
7	REC IN(R)	REC-EQ input
8	ALC(R)	ALC(R) signal out put
9	NC	NC pin
10	REC OUT(R)	REC output
11	ALC ON/OFF	Mode control input
12	TEST4	TEST pin
13	REC Return ON/OFF	Mode control input
14	MUTE ON/OFF	Mode control input
15	REC Return ON/OFF	Mode control input
16	Vcc	Vcc Pin
17	ALC DET	ALC detection signal out put
18	GND	GND pin
19	I REF	Equalizer reference current input
20	Test mode	Test modepin
21	REC OUT(L)	REC output
22	NC	NC pin
23	ALC(L)	ALC(L) signal out put
24	REC IN(L)	REC-EQ input
25	NC	NC pin
26	PBOUT(L)	PB output
27	TAI(L)	Tape input
28	EQOUT(L)	EQ output
29	PB-EQ(L)	NAB output
30	PB-NF2(L)	PB EQ feed back
31	PB-NF1(L)	PB EQ feed back
32	TEST2	TEST pin
33	RIP	Ripple fillter
34	PBIN(L)	PB input
35	REC-RETURN	REC Return
36	GND	GND pin
37	PBIN(R)	PB input
38	NC	NC pin
39	TEST3	TEST pin
40	PB-NF1(R)	PB EQ feed back

4.4 HA17758A (IC301) : Dual operational amp

- Pin layout

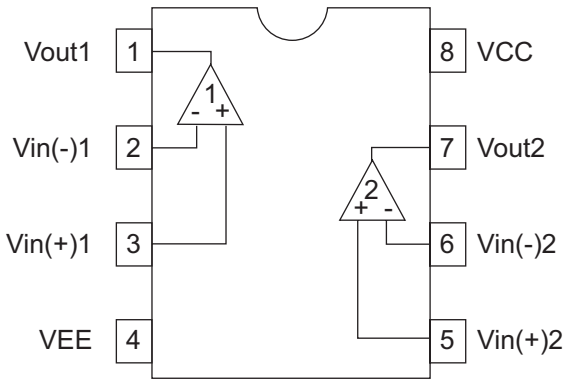

4.5 KIA78S05P-T (IC604) : Regulator

- Pin layout

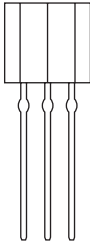

- Block diagram

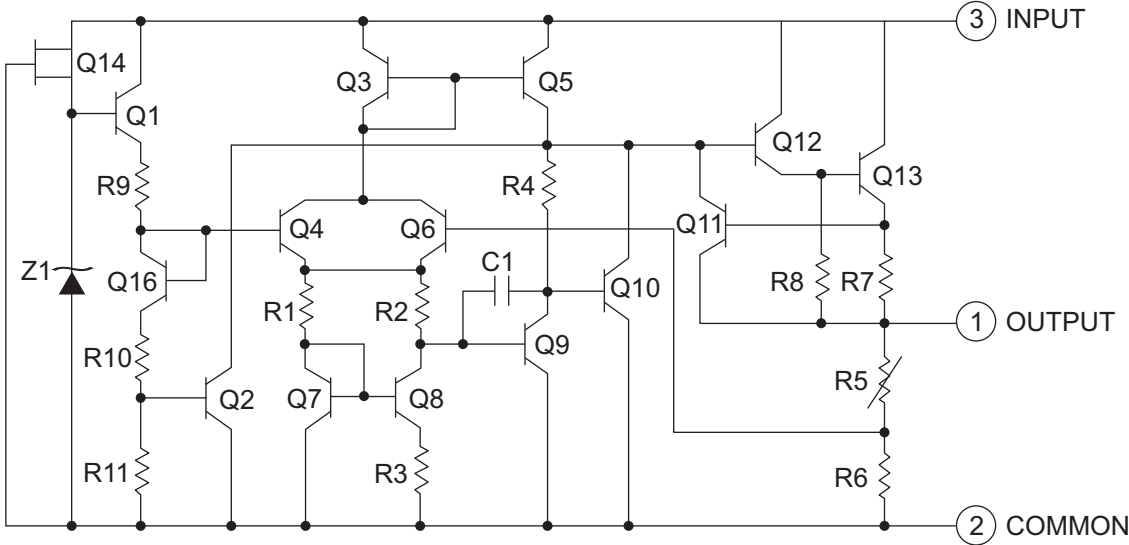

4.6 KIA78S06P-T (IC932) : Regulator

- Pin layout

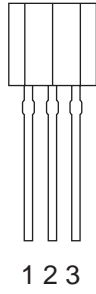

- Block diagram

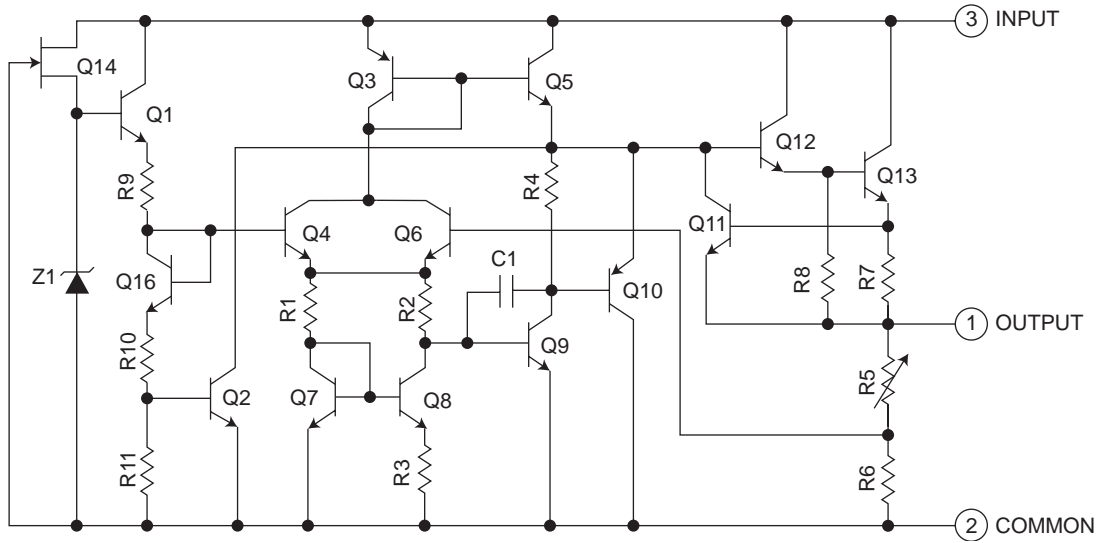

4.7 LA1838 (IC1): FM AM IF amp & Detector, FM MPX decoder

• Block Diagram

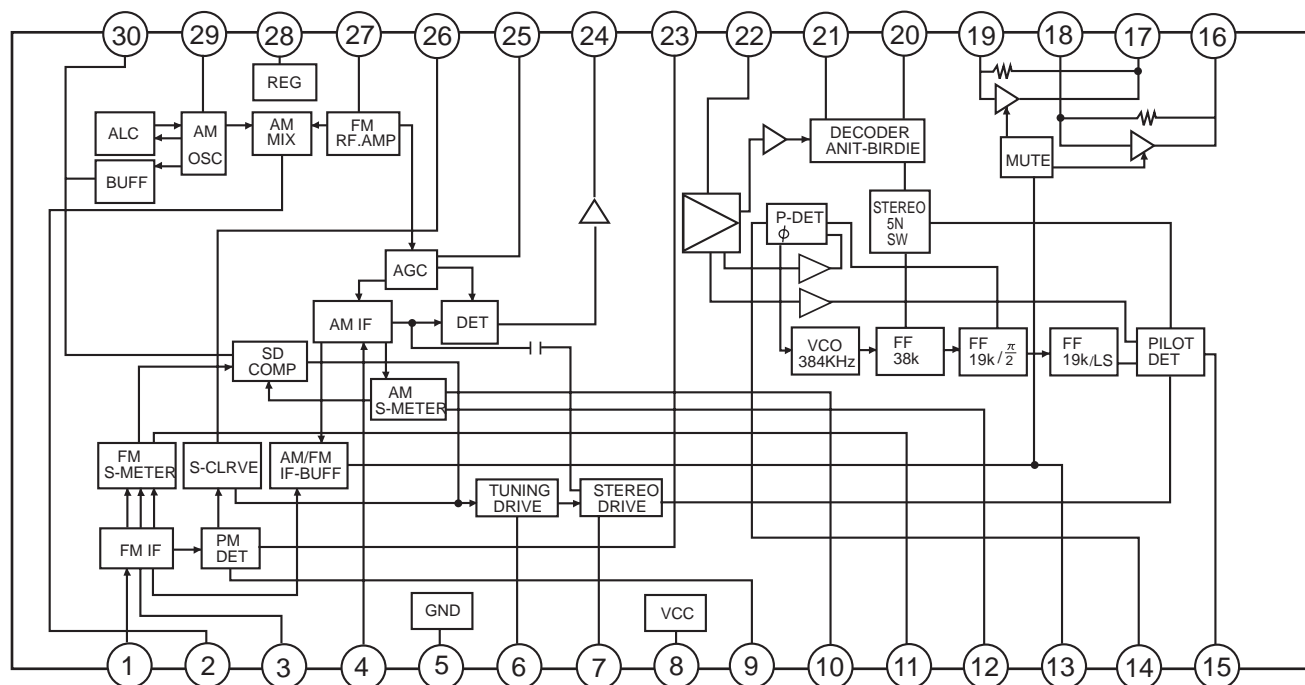

• Pin Function

Pin No.	Symbol	I/O	Function
1	FM IN	I	This is an input terminal of FM IF signal.
2	AM MIX	O	This is an out put terminal for AM mixer.
3	FM IF	I	Bypass of FM IF
4	AM IF	I	Input of AM IF Signal.
5	GND	-	This is the device ground terminal.
6	TUNED	O	When the set is tunning, this terminal becomes "L".
7	STEREO	O	Stereo indicator output. Stereo "L", Mono: "H"
8	VCC	-	This is the power supply terminal.
9	FM DET	-	FM detect transformer.
10	AM SD	-	This is a terminal of AM ceramic filter.
11	FM VSM	O	Adjust FM SD sensitivity.
12	AM VSM	O	Adjust AM SD sensitivity.
13	MUTE	I/O	When the signal of IF REQ of IC121(LC72131) appear, the signal of FM/AM IF output. //Muting control input.
14	FM/AM	I	Change over the FM/AM input. "H" :FM, "L" : AM
15	MONO/ST	O	Stereo : "H", Mono: "L"
16	L OUT	O	Left channel signal output.
17	R OUT	O	Right channel signal output.
18	L IN	I	Input terminal of the Left channel post AMP.
19	R IN	I	Input terminal of the Right channel post AMP.
20	RO	O	Mpx Right channel signal output.
21	LO	O	Mpx Left channel signal output.
22	MPX IN	I	Mpx input terminal
23	FM OUT	O	FM detection output.
24	AM DET	O	AM detection output.
25	AM AGC	I	This is an AGC voltage input terminal for AM
26	AFC	-	This is an output terminal of voltage for FM-AFC.
27	AM RF	I	AM RF signal input.
28	REG	O	Register value between pin 26 and pin28 besides the frequency width of the input signal.
29	AM OSC	-	This is a terminal of AM Local oscillation circuit.
30	OSC BUFFER	O	AM Local oscillation Signal output.

4.8 LA4663 (IC300) : 2ch power amp

- Pin layout

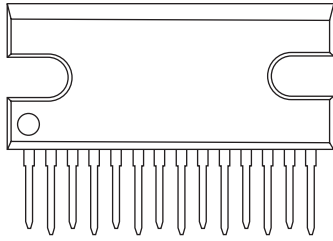

- Block diagram

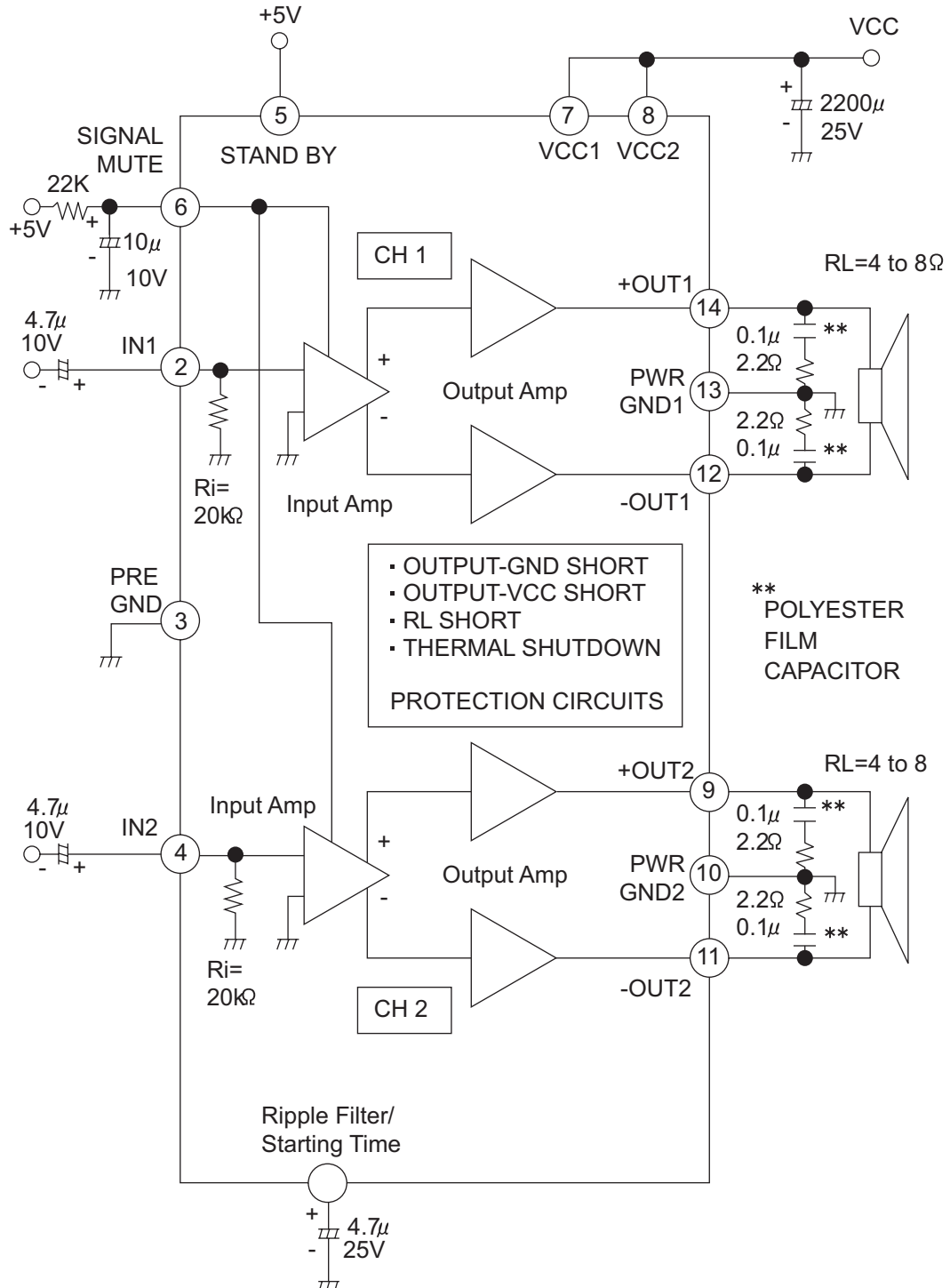

4.9 LA6541-X (IC801) : Servo driver

• Pin layout & Block diagram

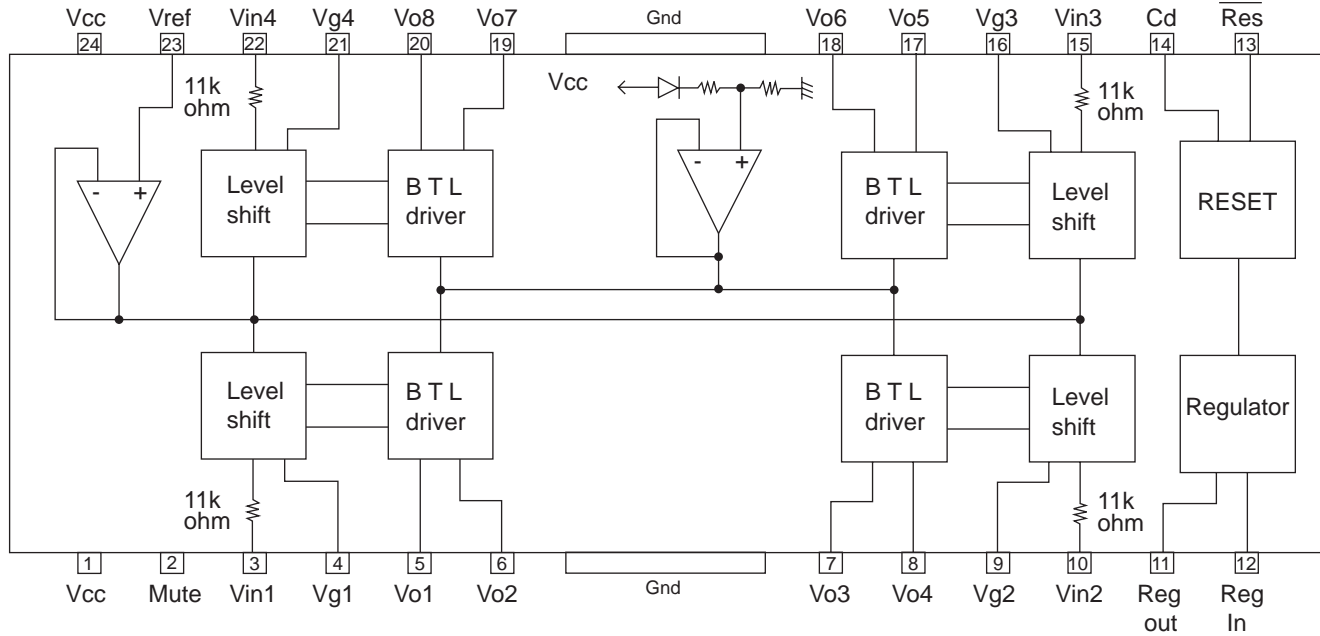

• Pin function

Pin No.	Symbol	Description
1	Vcc	Power supply (Shorted to pin 24)
2	Mute	All BTL amplifier outputs ON/OFF
3	Vin1	BTL AMP 1 input pin
4	Vg1	BTL AMP 1 input pin (For gain adjustment)
5	Vo1	BTL AMP 1 input pin (Non inverting side)
6	Vo2	BTL AMP 1 input pin (Inverting side)
7	Vo3	BTL AMP 2 input pin (Inverting side)
8	Vo4	BTL AMP 2 input pin (Non inverting side)
9	Vg2	BTL AMP 2 input pin (For gain adjustment)
10	Vin2	BTL AMP 2 input pin
11	Reg Out	External transistor collector (PNP) connection. 5V power supply output
12	Reg In	External transistor (PNP) base connection
13	Res	Reset output
14	Cd	Reset output delay time setting (Capacitor connected externally)
15	Vin3	BTL AMP 3 input pin
16	Vg3	BTL AMP 3 input pin (For gain adjustment)
17	Vo5	BTL AMP 3 output pin (Non inverting side)
18	Vo6	BTL AMP 3 output pin (Inverting side)
19	Vo7	BTL AMP 4 output pin (Inverting side)
20	Vo8	BTL AMP 4 output pin (Non inverting side)
21	Vg4	BTL AMP 4 output pin (For gain adjustment)
22	Vin4	BTL AMP 4 output pin
23	Vref	Level shift circuit's reference voltage application
24	Vcc	Power supply (Shorted to pin 1)

4.10 LC72136N (IC2) : PLL frequency synthesizer

- Pin layout

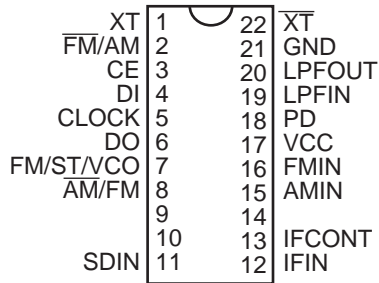

- Block diagram

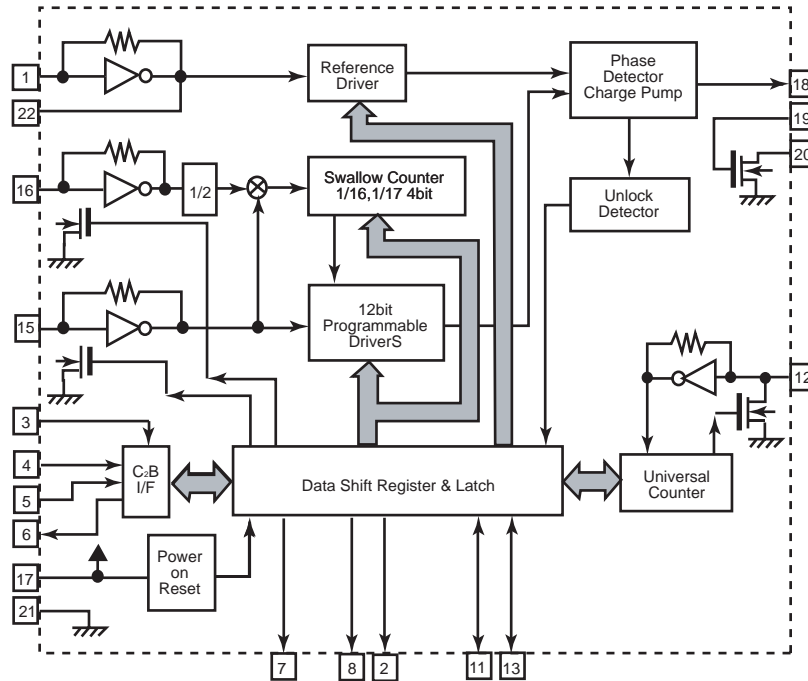

- Pin function

Pin No.	Symbol	I/O	Function
1	XT	I	X'tal oscillator connect (75kHz)
2	FM/AM	O	LOW:FM mode
3	CE	I	When data output/input for 4pin (input) and 6pin (output): H
4	DI	I	Input for receive the serial data from controller
5	CLOCK	I	Sync signal input use
6	DO	O	Data output for Controller Output port
7	FM/ST/VCO	O	Low: MW mode
8	AM/FM	O	Open state after the power on reset
9	LW	I/O	Input/output port
10	MW	I/O	Input/output port
11	SDIN	I/O	Data input/output
12	IFIN	I	IF counter signal input

Pin No.	Symbol	I/O	Function
13	IFCONT	O	IF signal output
14		-	Not use
15	AMIN	I	AM Local OSC signal output
16	FMIN	I	FM Local OSC signal input
17	VCC	-	Power suply (VDD=4.5-5.5V) When power ON:Reset circuit move
18	PD	O	PLL charge pump output (H: Local OSC frequency Height than Reference frequency. L: Low Agreement: Height impedance)
19	LPFIN	I	Input for active lowpassfilter of PLL
20	LPFOUT	O	Output for active lowpassfilter of PLL
21	GND	-	Connected to GND
22	XT	I	X'tal oscillator (75KHz)

4.11 LC72723(IC3): RDS demodulation

- Pin layout

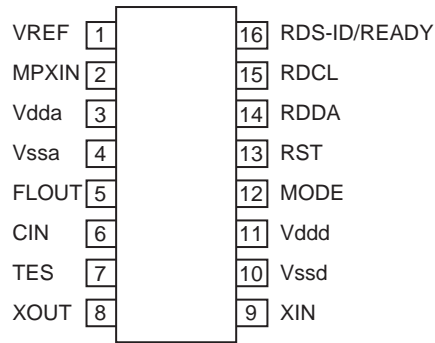

- Block Diagram

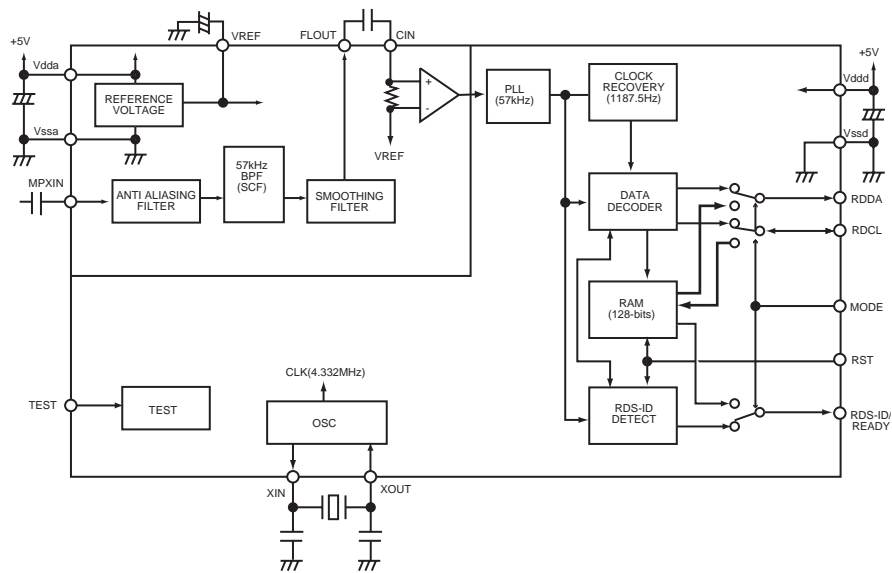

- Pin functions

Pin No.	Symbol	I/O	Function
1	VREF	O	Reference voltage output ($V_{dda}/2$)
2	MPXIN	I	Baseband (multiplexed) signal input
3	Vdda	-	Analog power supply (+5V)
4	Vssa	-	Analog ground
5	FLOUT	O	Subcarrier input (filter output)
6	CIN	I	Subcarrier input (comparator input)
7	TEST	I	Test input
8	XOUT	O	Crystal oscillator output (4.332MHz)
9	XIN	I	Crystal oscillator input (external reference input)
10	Vssd	-	Digital ground
11	Vddd	-	Digital power supply
12	MODE	I	Read mode setting (0:master, 1:slave)
13	RST	I	RDS-ID/RAM reset (positive polarity)
14	RDDA	O	RDS data output
15	RDCL	I/O	RDS clock output (master mode)/RDS clock input (slave mode)
16	RDS-ID/READY	O	RDS-ID/READY output (negative polarity)

4.12 LC75342 (IC302) : E. volume

- Terminal layout

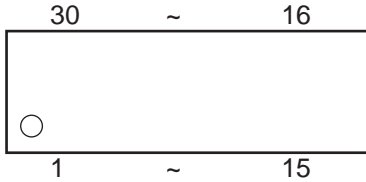

- Block diagram

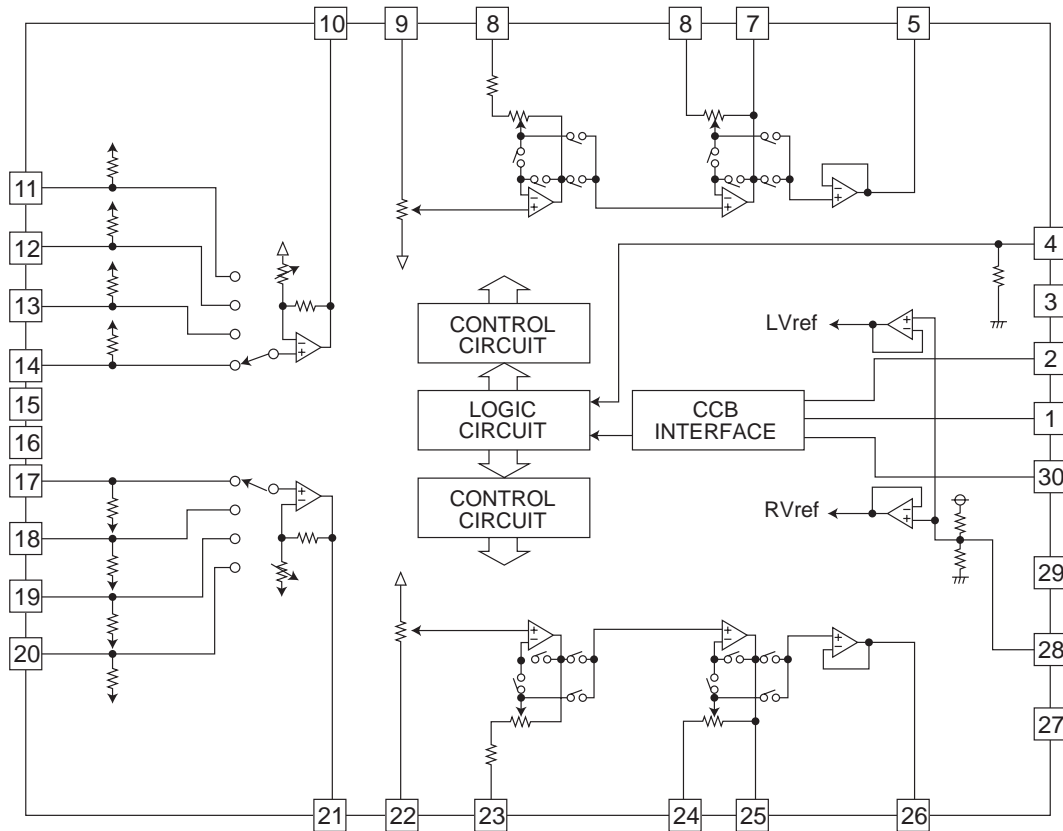

- Pin function

Pin No.	Symbol	Function
1	DI	Serial data and clock input for IC control
2	CE	Chip enable
3	VSS	GND
4	TEST	Electric volume connection for test
5	LOUT	Volume control and equalizer input
6	LBASS2	Connection for resistor and capacitor that
7	LBASS1	from the bass band filter
8	LTRE	Connection for capacitor that from the treble
9	LIN	Volume control and equalizer input
10	LSEL0	Input selector output
11	L4	Not used
12	L3	Input signal connections, not used
13	L2	Input signal connections
14	L1	Input signal connections
15	NC	GND

Pin No.	Symbol	Function
16	NC	GND
17	R1	Input signal connections
18	R2	Input signal connections
19	R3	Input signal connections, not used
20	R4	Not used
21	RSEL0	Input selector output
22	RIN	Volume control and equalizer input
23	RTRE	Connection for capacitor that from the treble
24	RBASS1	Connection for resistor and capacitor that
25	RBASS2	from the bass band filter
26	ROUT	Volume control and equalizer input
27	NC	Not used
28	VREF	Connection to the 0.5X VDD voltage gener-
29	VDD	Power supply
30	CL	Serial data and clock input for IC control

4.13 MN662748RPMFA (IC603) : Digital servo & Digital signal processor

- Pin layout

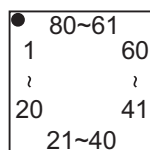

- Pin function

Pin No.	Symbol	I/O	Function
1	BCLK	-	Not use
2	LRCK	-	Not use
3	SRDATA	-	Not use
4	DVDDI	-	Power supply for digital circuit
5	DVSSI	-	GND for digital circuit
6	TX	-	Not use
7	MCLK	I	Micro computer command clock signal input
8	MDATA	I	Micro computer command data input
9	MLD	I	Micro computer command load signal input (L: Load)
10	SENSE	-	Not use connect to TP716
11	FLOCK	-	Not use connect to TP717
12	TLOCK	-	Not use connect to TP718
13	BLKCK	O	Sub code block clock signal output
14	SQCK	I	External clock input for sub code Q register input
15	SUBQ	O	Sub code Q data output
16	DMUTE	-	Not use connect to TP719
17	STAT	O	Status signal input
18	RST	I	Reset signal input (L: Reset)
19	SMCK	-	Not use
20	PMCK	-	Not use connect to TP720
21	TRV	O	Traverse enforced output
22	TVD	O	Traverse drive output
23	PC	-	Not used
24	ECM	O	Spindle motor drive signal (Enforced mode output)
25	ECS	O	Spindle motor drive signal (Servo error signal output)
26	KICK	O	Kick pulse output
27	TRD	O	Tracking drive output
28	FOD	O	Focus drive output
29	VREF	I	Reference voltage for D/A output block
30	FBAL	O	Focus balance adjust signal output
31	TBAL	O	Tracking balance adjust signal output
32	FE	I	Focus error signal input (Analog input)
33	TE	I	Tracking error signal input (Analog input)
34	RFENV	I	RF envelope signal input (Analog input)
35	VDET	I	Vibration detect signal input (H:Detect)
36	OFT	I	Off track signal input (H:Off track)
37	TRCRS	I	Track cross signal input
38	/RFDET	I	RF detect signal input (L:Detect)
39	BDO	I	Drop out signal input (H:Drop out)
40	LDON	O	Laser on signal output
41	PLL2	-	Not use
42	TOFS	-	Not use

Pin No.	Symbol	I/O	Function
43	WVEL	-	Not use
44	ARF	I	RF signal input
45	IREF	I	Reference current input
46	DRF	I	Bias pin for DSL
47	DSL2	I/O	Loop filter pin for DSL
48	PLL2	I/O	Loop filter pin for PLL
49	VCOF	I/O	Loop filter pin for VCO
50	AVDD2	-	Power supply for analog circuit
51	AVSS2	-	GND for analog circuit
52	EFM	-	Not use connect to TP724
53	PCK	O	Clock output for PLL
54	VCOF2	I/O	Loop filter pin for Digital servo VCO
55	SUBC	-	Not use
56	SBCK	-	Not use
57	VSS	-	GND for crystal oscillation circuit
58	X1	I	Input for crystal oscillation circuit (f=16.9344MHz)
59	X2	O	Output for crystal oscillation circuit (f=16.9344MHz)
60	VDD	-	Power supply for crystal oscillation circuit
61	BYTCK/ TRVSTP	-	Not use
62	CLDCK	O	Sub code frame clock signal output
63	FCLK	-	Not used
64	IPFLAG	O	Interpolation flag signal output Connect to TP721
65	FLAG	O	Flag signal output Connect to TP722
66	CLVS	-	Not use
67	CRC	-	Not use
68	DEMPH	O	De-emphasis detect signal output Connect to TP723
69	RESY	-	Not use
70	IOSEL	I	Mode select pin Connect to DVDD1 (H fix)
71	/TEST	I	Test pin Connect to DVDD1 (H fix)
72	AVDD1	-	Power supply for analog circuit
73	OUTL	O	L-channel audio output
74	AVSS1	-	GND for analog circuit
75	OUTR	O	R-channel audio output
76	RSEL	I	RF signal polarity setting pin Connect to DVDD1 (H fix)
77	CSEL	I	Oscillation frequency setting pin Connect to GND (L fix)
78	PSEL	I	IOSEL=H Test pin Connect to GND (L fix)
79	MSEL	I	IOSEL=H SMCK output Frequency select pin
80	SSEL	I	IOSEL=H SMCK output SUBQ output mode select pin

4.14 MN101C57CEW (IC931) : System micon

- Pin layout

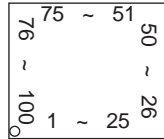

- Pin function

Pin No.	Symbol	I/O	Description
1~3	VLC1~VLC3	-	LCD BIAS VOLTAGE
4,5		-	Not use
6	REEL	I	Tape End Detection
7	_MPX	I	FM Stereo Detection ('L'=STEREO)
8	PERIOD	O	Tuner PLL Strobe
9	F_TU	O	Tuner Function ('H'=TUNER)
10	AHB	O	Active Hyper Bass('L'=ON)
11	VSS	-	GROUND
12,13	OSC1,OSC2	-	MAIN OSC
14	MMOD	-	GROUND
15,16	X1,X0	-	SUB OSC
17	VDD	-	5V
18	_RST	I/O	Micon Reset
19	VDD	O	5V
20	SDATA	O	Serial Data (Tuner PLL / Tape IC)
21	DIMCTL	O	LCD DIM control. DIMMER ON =L
22	SCK	I	Serial Clock (Tuner PLL / Tape IC)
23	STTA	O	Tape IC Strobe
24	QRIN	O	Q-code data input port
25	SQCK	I	Q-code serial clock
26	F_CD	O	CD Function ('H'=CD)
27	STAT	I	CD status input port
28	MUTE	O	BTL mute control port (MUTE ON = 'L')
29	RST/CLOSE	O	Door close detection
30	VOLCE	I	Volumn Chip Enable
31	BCTL	I	Switched 5V control('H'=5V/off)
32	BUP	I	Back up power detect('H'=BACKUP)
33	_REM	I	Remote control input
34	RDSCK	I	RDS clock
35	BLKCK	-	Block clock input port
36	FLAG	-	Error Correction Count
37,38		-	Not use
39	VDD	O	5V
40	VREF+	O	5V
41	_XRST	O	CD reset
42	MCLK	O	CD data clock
43	MDATA	I	CD data input port
44	MLD	I	CD command ready signal
45,46	KEY0,KEY1	I	Unit Key input 0,1
47	DOOR_RST	-	REST/CLOSE switch detect port
48	CDSAFETY	O	CD safety voltage detect port
49	VREF-	O	GROUND
50	P_OUT	O	Power On/Off ('H'=Power On)
51,52	TAPE0,TAPE1	O	Tape Switch 0Tape Switch 1
53~55	SAFETY2,0,1	O	Irregular voltage detection 201
56	_SMUTE	O	System mute (MUTE on = 'L')
57~96	S39~S0	O	SEGMENT OUTPUT
97~100	COM3~COM0	-	LCD BIAS GROUND

4.15 CD4094BC (IC33) : Serial to parallel port extension

- Pin layout

STROBE	1	16	Vdd
DATA	2	15	OUTPUT ENABLE
CLOCK	3	14	Q5
Q1	4	13	Q6
Q2	5	12	Q7
Q3	6	11	Q8
Q4	7	10	Q's
Vss	8	9	Qs

- Block diagram

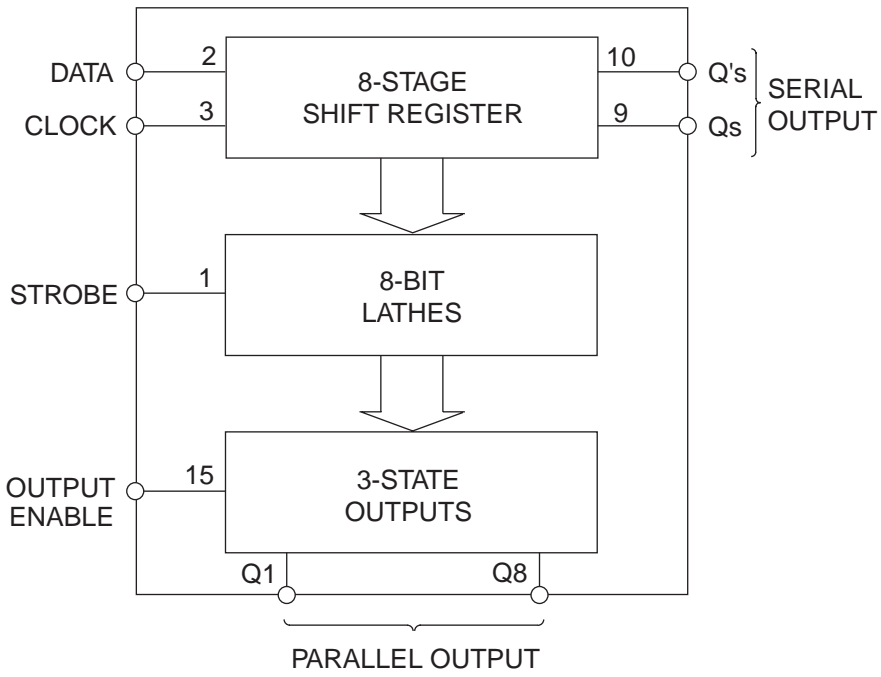

JVC

VICTOR COMPANY OF JAPAN, LIMITED

AV & MULTIMEDIA COMPANY AUDIO/VIDEO SYSTEMS CATEGORY 10-1,1chome,Ohwatari-machi,Maebashi-city,371-8543,Japan

(No.22033)



Printed in Japan
200303WPC

JVC

SCHEMATIC DIAGRAMS

MICRO COMPONENT SYSTEM

UX-H30

CD-ROM No.SML200303

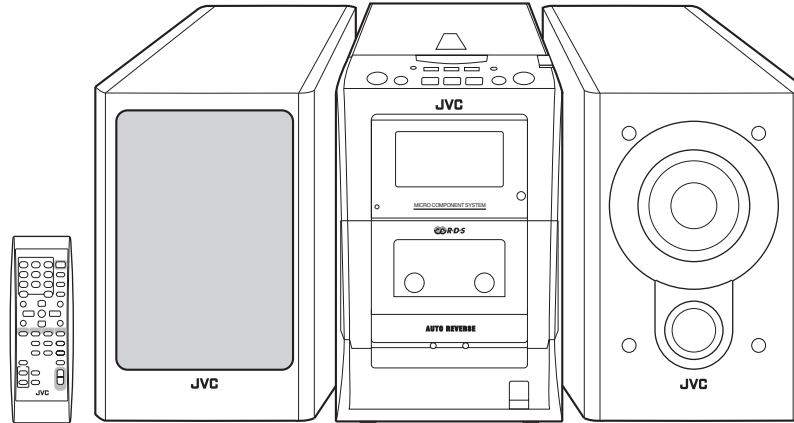

Area Suffix

B ----- U.K.
 E ----- Continental Europe
 EN ----- Northern Europe

Contents

Block diagram	2-1
Standard schematic diagrams	2-2
Printed circuit boards	2-8~10

In regard with component parts appearing on the silk-screen printed side (parts side) of the PWB diagrams, the parts that are printed over with black such as the resistor (■), diode (▣) and ICP (●) or identified by the "⚠" mark nearby are critical for safety.

(This regulation does not correspond to J and C version.)

Block diagram

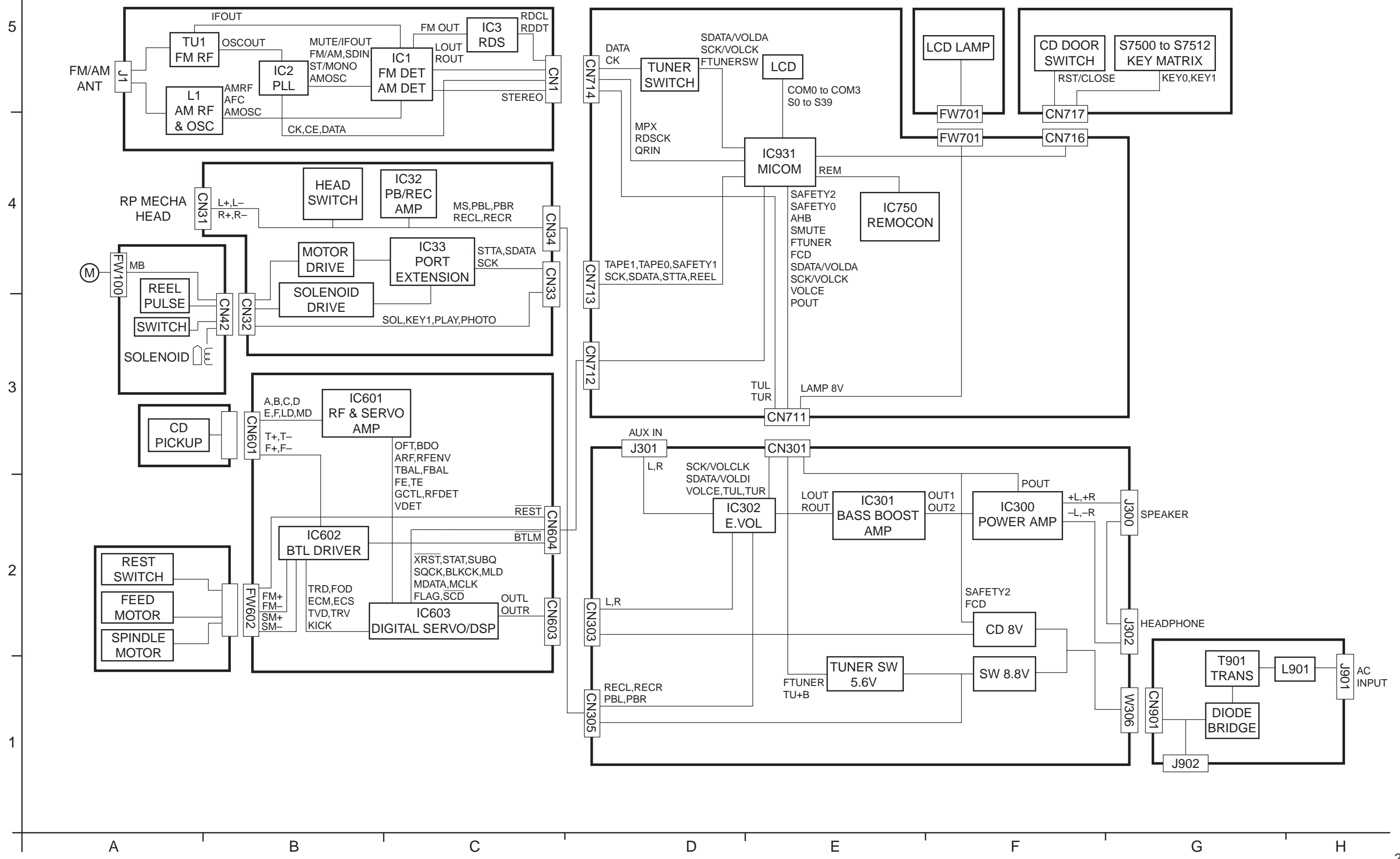

Standard schematic diagrams

Primary section

MODEL : FS/UX-H30/H33/H35		
SHEET NO.	MODEL NUMBERS TO BE APPLIED	CIRCUITS DESCRIPTION
1/7	FS/UX-H30/H33/H35	.PRIMARY WITH MAINS TRANSFORMER
2/7	FS/UX-H30/H33/H35	.DC REGULATOR, AUDIO OUTPUT
3/7	FS/UX-H30/H33/H35	.EXTERNAL INPUT, SOURCE SELECTOR SWITCH
4/7	FS/UX-H30/H33/H35	.LCD DISPLAY/SYSTEM CONTROL/USERS KEY CONTROL.
5/7	FS/UX-H30/H33/H35	.CD SERVO AND CD SYSTEM CONTROL
6/7	FS/UX-H30/H33/H35	.TAPE DECK MECHANISM CONTROL
7/7	FS/UX-H30/H33/H35	.TUNER RF/IF/FM MULTIPLEX (A/UF/E GROUPS)

VERSION CODES	
J	: USA
C	: CANADA
A	: AUSTRALIA
B	: U. K
E	: CONTINENTAL EUROPE
EN	: NORDIC COUNTRIES
EV	: EASTERN EUROPE & RUSSIA
UF	: CHINA
UP	: KOREA
UT	: TAIWAN
UW	: SOUTH AMERICA
U	: SINGAPORE AND UNIVERSAL
EXCEPT ALL OF ABOVE	

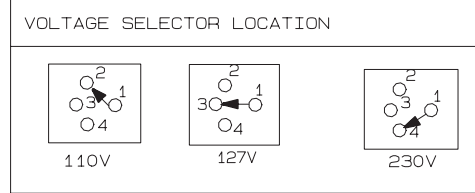

NOTES
 1. VOLTAGE ARE DC-MEASURED WITH A DIGITAL VOLT METER OR OSCILLOSCOPE WITHOUT INPUT SIGNAL.
 INSIDE BRACKET VALUES ARE OTHER FUNCTIONS
 2. UNLESS OTHERWISE SPECIFIED, RESISTOR ARE 1/8W±5% CARBON RESISTOR.
 ALL RESISTOR VALUES ARE IN OHM.
 ALL CAPACITOR ARE CERAMIC CAPACITOR OR MYLAR CAPACITOR.
 ALL CAPACITANCE VALUES ARE IN μF(±5%).
 ALL INDUCTANCE VALUES ARE IN μH(±5%).
 ALL E-CAPACITOR ARE SHOWN IN THE FORM OF CAPACITANCE (μF/RATED VOLTAGE(V)).

⚠ Parts are safety assurance parts.
 When replacing those parts make sure to use the specified one.

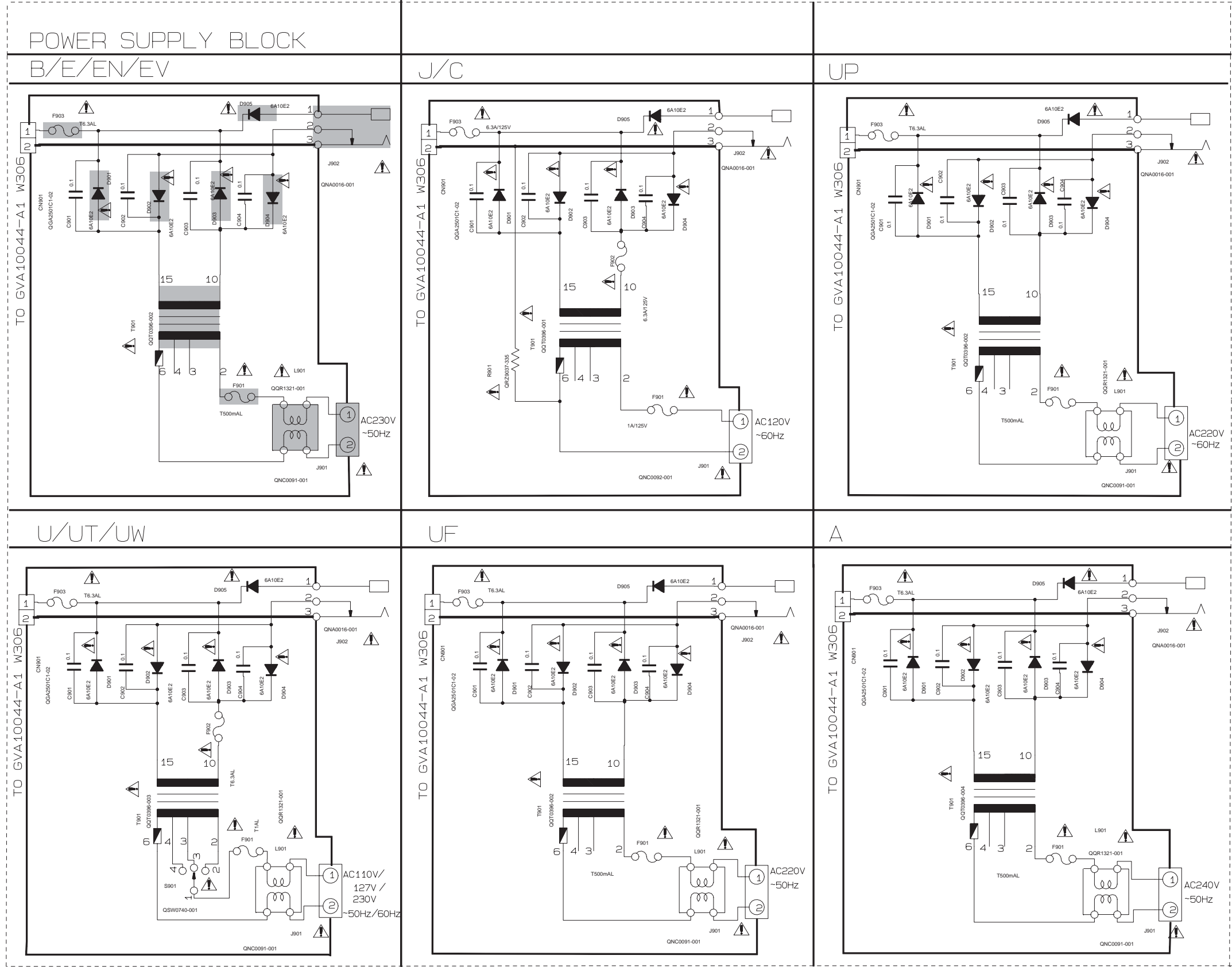

GVA10044-A2

5
4
3
2
1

A B C D E F G H

■ Amp section

5

4

3

2

1

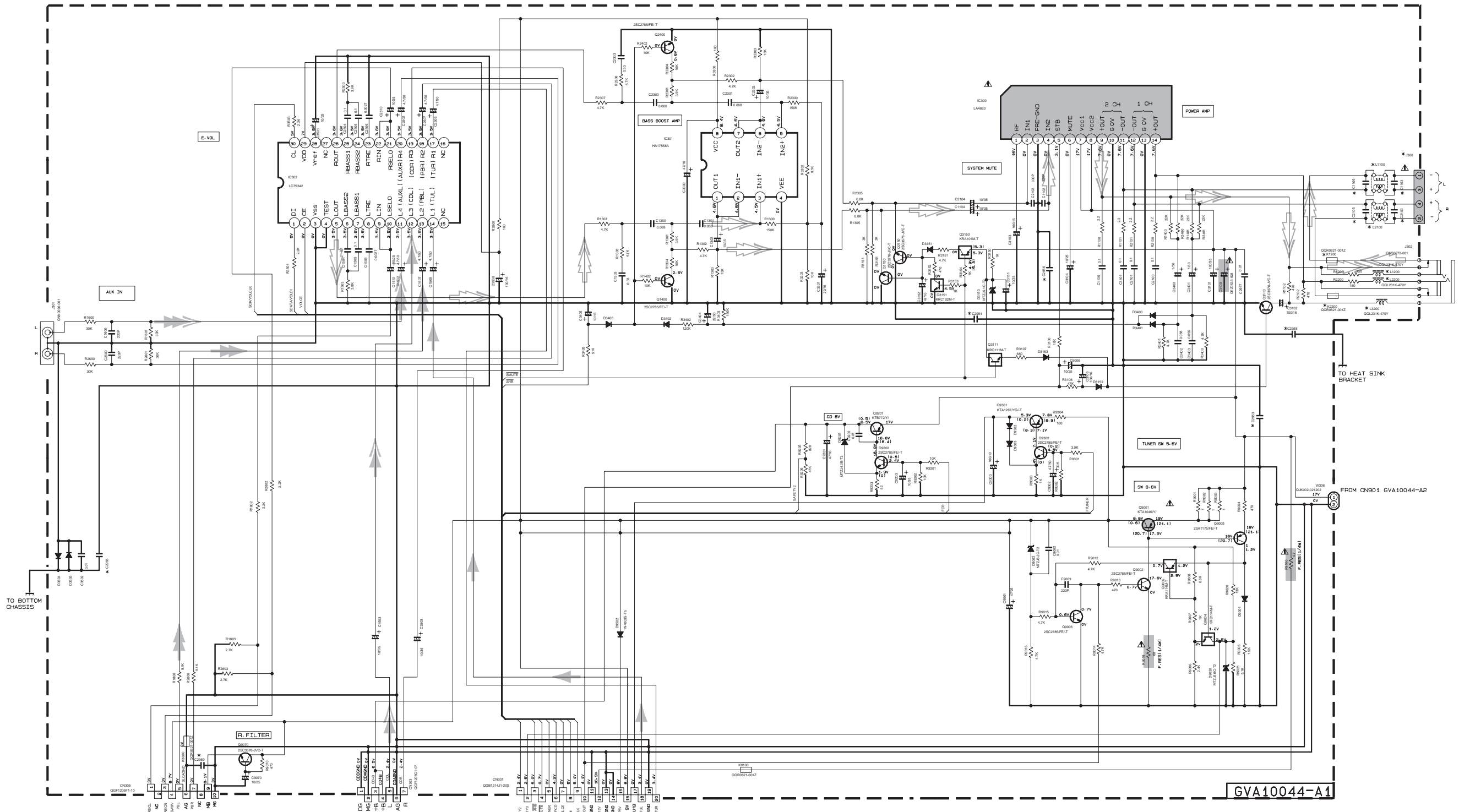

TO CN34 OF SLC-S202M

FROM CN603 OF GVA10044-A3

FROM CN711 OF GVA10045-A1

GVA10044-A1

*** PART LIST**

PART	VERSION	L1200/2800/3000	K1200/2000	C1105/2105	L1100	L3100	C1103/2103	J300	C2953/C2954/C2955/C2959	C2956/C2958
J/C		82029/2030/2031	82027/2028	—	87208/7209	87211/7212	—	0N80117-002	—	—
B/E/EN/EV		02L231K-470Y	02R0621-0012	220p	02R0797-002	02R0797-002	0.0033u	0N80117-001	—	0.001
A/U/UP/UT/UM		02L231K-470Y	02R0621-0012	220p	02R0797-002	02R0797-002	0.0033u	0N80117-001	—	0.001

NOTES

- VOLTAGES ARE DC-MEASURED WITH A DIGITAL VOLT METER OR OSCILLOSCOPE WITHOUT INPUT SIGNAL. CONDITION --- CD STOP MODE. INSIDE BRACKET VALUES ARE OTHER FUNCTIONS.
- UNLESS OTHERWISE SPECIFIED - RESISTORS ARE 1/8W ±5% CARBON RESISTOR. ALL RESISTANCE VALUES ARE IN OHM(S). ALL CAPACITORS ARE CERAMIC CAPACITOR OR MYLAR CAPACITOR. ALL CAPACITANCE VALUES ARE IN P(F)P(F). ALL INDUCTANCE VALUES ARE IN H(M)H(MH). ALL E. CAPACITORS ARE SHOWN IN THE FORM OF CAPACITANCE (μF)/RATED VOLTAGE (V).

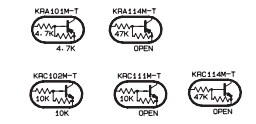

⚠ Parts are safety assurance parts. When replacing those parts make sure to use the specified one.

- ➔ TUNER SIGNAL
- ➔ CD SIGNAL
- ➔ TAPE SIGNAL
- ➔ AUX IN SIGNAL
- ➔ MAIN SIGNAL

A B C D E F G H

Micon / LCD & Key control section

5

4

3

2

1

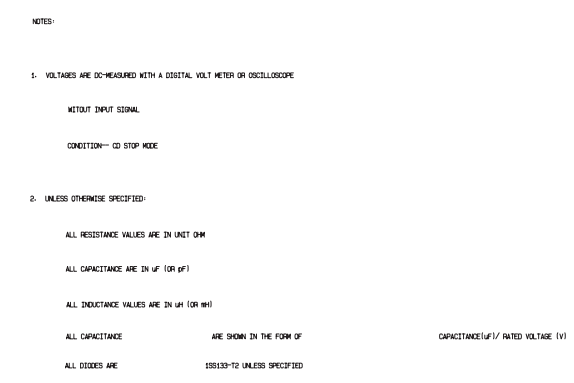
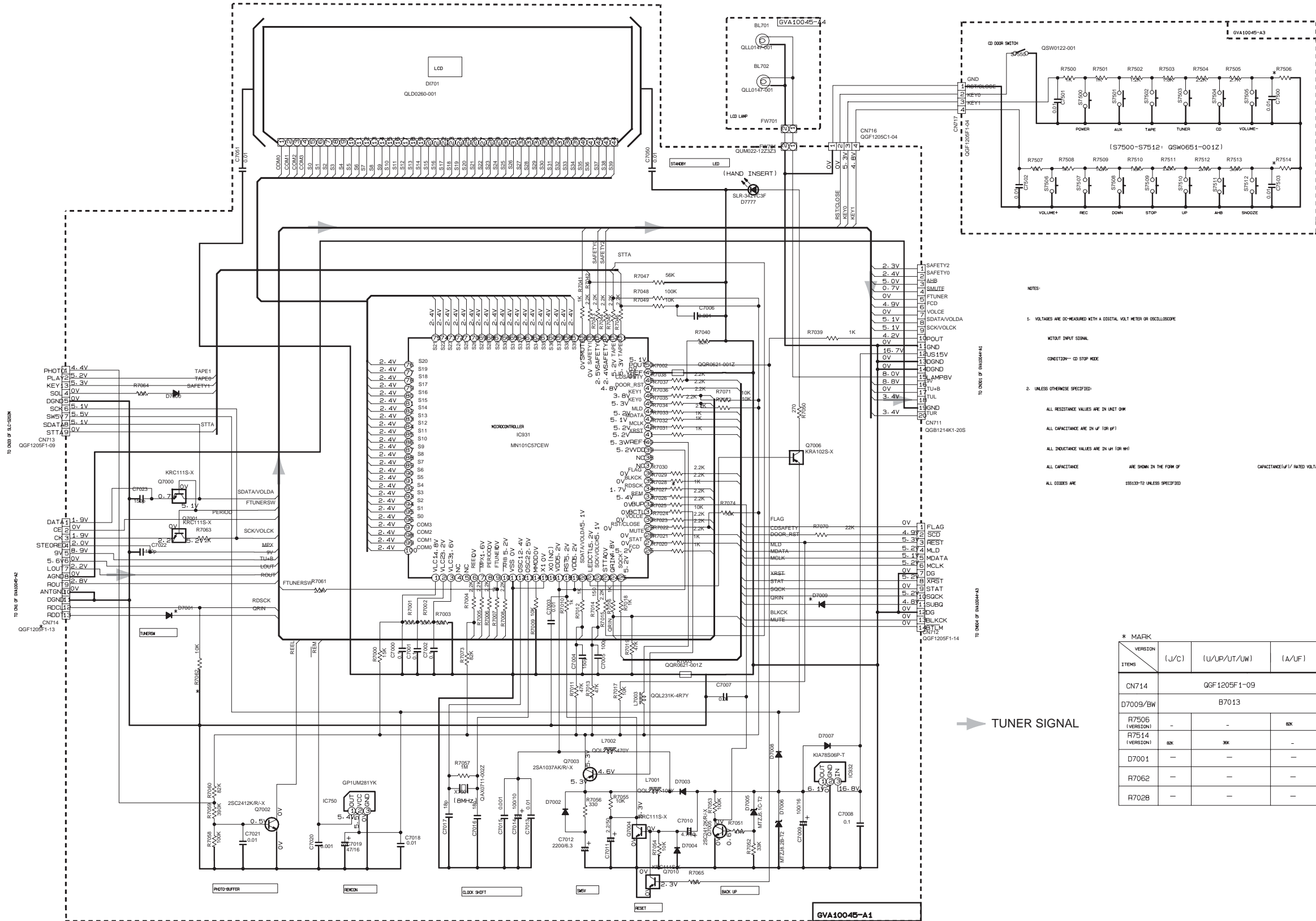

NOTES:

- VOLTAGES ARE MEASURED WITH A DIGITAL VOLT METER OR OSCILLOSCOPE WITH INPUT SIGNAL. CONNECTION - CD STOP MODE.
- UNLESS OTHERWISE SPECIFIED: ALL RESISTANCE VALUES ARE IN OHM. ALL CAPACITANCE VALUES ARE IN UF (OR NF). ALL CAPACITANCE ARE SHOWN IN THE FORM OF CAPACITANCE(UF// RATED VOLTAGE (V)). ALL DIMENSIONS ARE IN MM UNLESS SPECIFIED.

* MARK

VERSION	(J/C)	(U/UP/UT/LW)	(A/UF)	(B/E/EN/EV)
CN714		GGF1205F1-09		GGF1205F1-13
D7009/BW		B7013		D7009
R7506 (VERSION)	-	-	8K	8K
R7514 (VERSION)	8K	8K	-	-
D7001	-	-	-	1SS133-T2
R7062	-	-	-	10K
R702B	-	-	-	1K

CD servo control section

GVA10044-A3

5

4

3

2

1

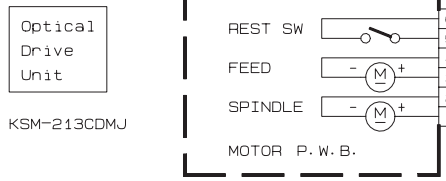
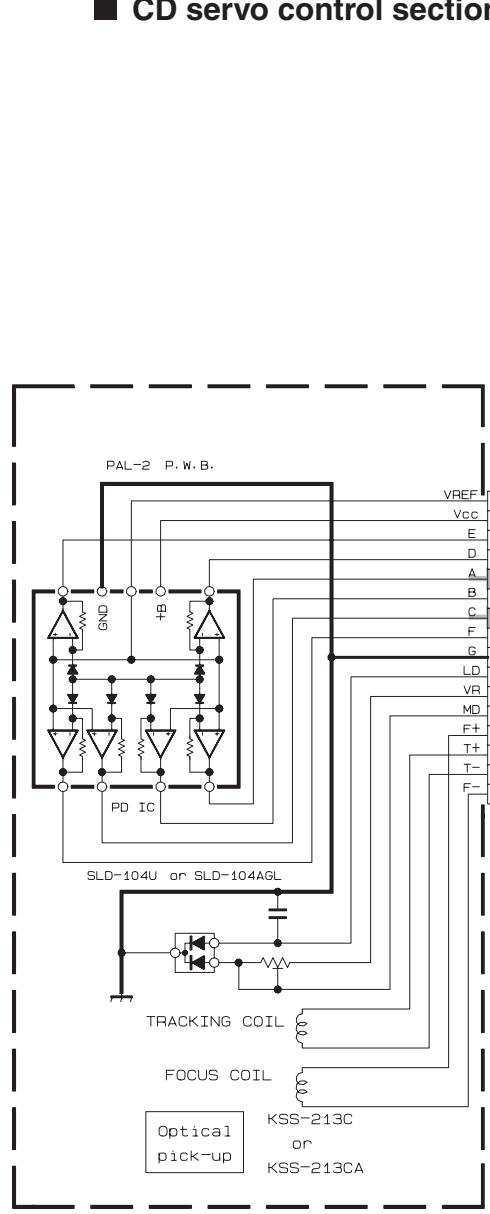

- NOTES
- VOLTAGES ARE DC-MEASURED WITH A DIGITAL VOLT METER CONDITION — INPUT VOLTAGE: AC 100V CD STOP MODE
 - UNLESS OTHERWISE SPECIFIED, RESISTORS ARE 1/6W ±5% CARBON RESISTOR. ALL RESISTANCE VALUES ARE IN OHM(Ω). ALL CAPACITORS ARE CERAMIC CAPACITOR OR MYLAR CAPACITOR. ALL CAPACITANCE VALUES ARE IN .F(P=PF). ALL E-CAPACITORS ARE SHOWN IN THE FORM OF CAPACITANCE (.F)/RATED VOLTAGE (V).

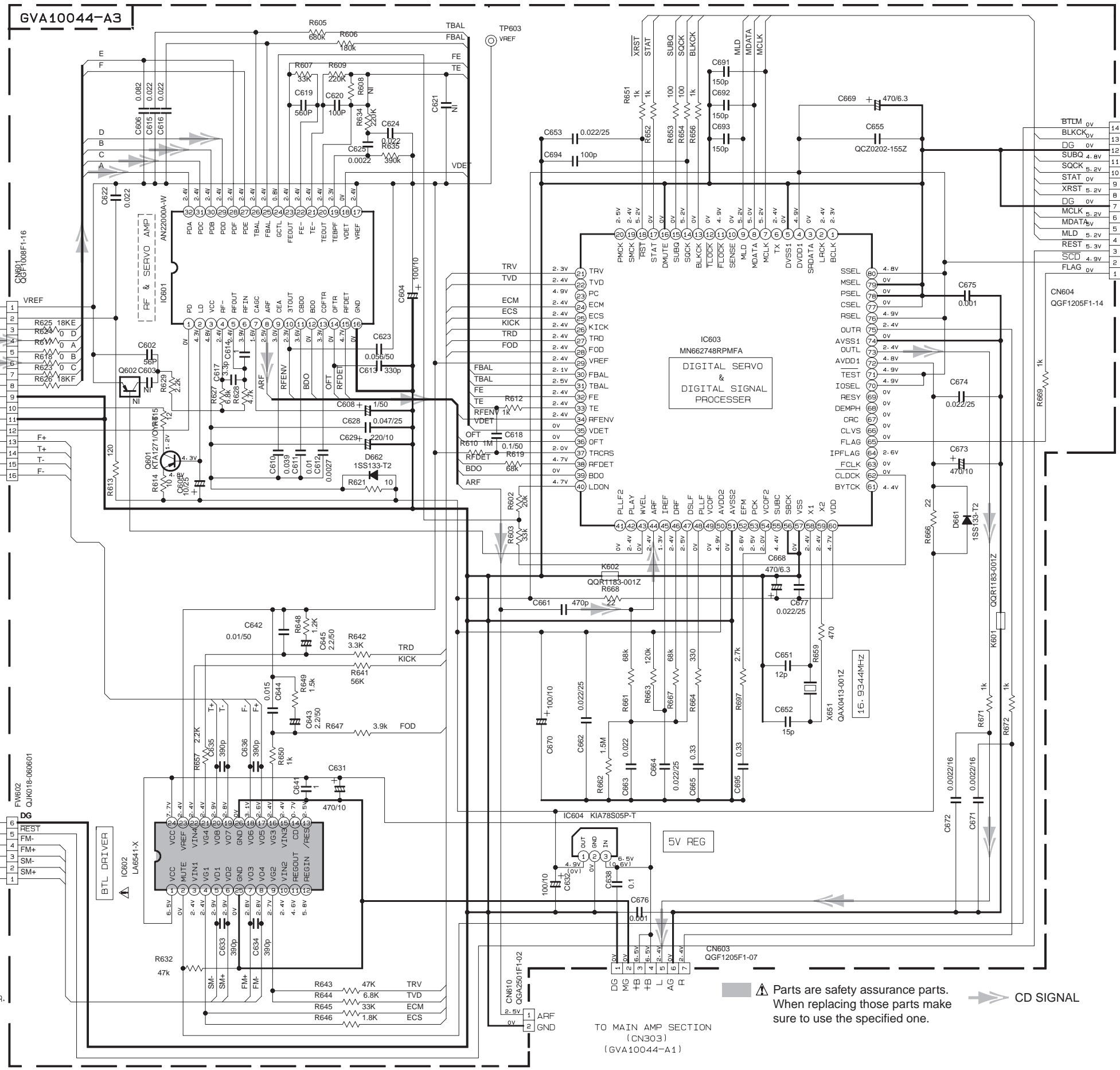

Parts are safety assurance parts. When replacing those parts make sure to use the specified one. → CD SIGNAL

TO MAIN AMP SECTION (CN303) (GVA10044-A1)

TO MICRON SECTION (CN712) (GVA10045-A1)

A B C D E F G H

Cassette mechanism control section

5

4

3

2

1

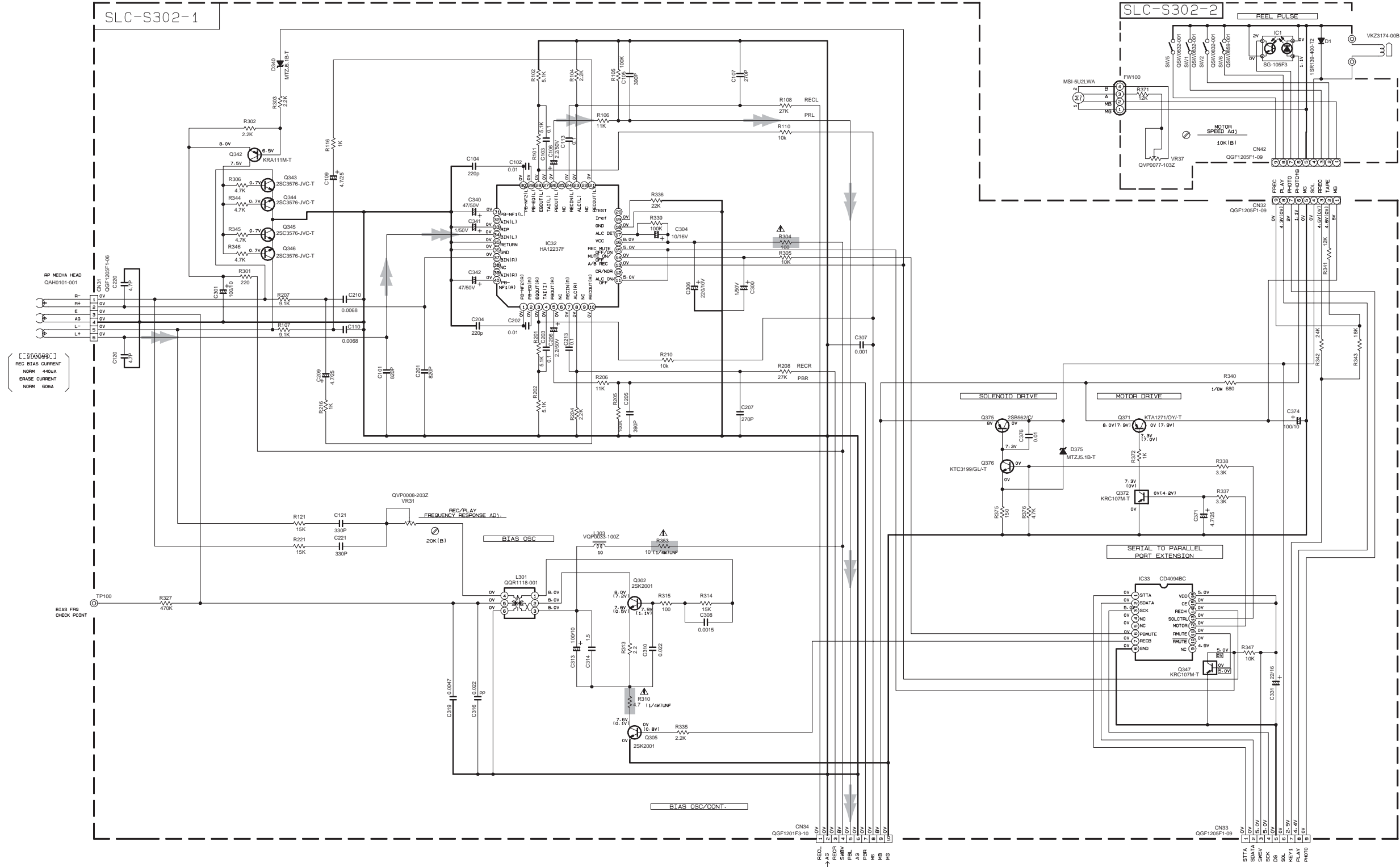

NOTES

1. VOLTAGES ARE DC-MEASURED WITH A DIGITAL VOLT METER OR OSCILLOSCOPE WITHOUT INPUT SIGNAL. CONDITION: MECHA STOP MODE

2. UNLESS OTHERWISE SPECIFIED, RESISTORS ARE 1/10W ±5% METAL GLAZE RESISTOR. ALL RESISTANCE VALUES ARE IN OHM(Ω).
 ALL CAPACITORS ARE CERAMIC CAPACITOR OR MYLAR CAPACITOR. ALL CAPACITANCE VALUES ARE IN #F(10⁻⁶F).
 ALL INDUCTANCE VALUES ARE IN #H(10⁻³H).
 ALL E-CAPACITORS ARE SHOWN IN THE FORM OF CAPACITANCE (#F)/RATED VOLTAGE (V).
 POLYPROPYLENE CAPACITOR

Parts are safety assurance parts. When replacing those parts make sure to use the specified one.

TAPE SIGNAL

Tuner section

CONDITION	PIN NO.	1	2	3	4	5	6	7	8	9	10	11	12	13	14	15	16	17	18	19	20	21	22	23	24	25	26	27	28	29	30	
IC1	FM NO SIGNAL	3.6	8.9	3.6	3.6	0	5.0	5.0	8.9	8.9	1.3	0.1	0	0.9	7.8	7.8	4.3	4.3	4.3	4.3	3.4	3.4	2.8	3.4	0	0	3.5	3.5	3.6	3.6	2.7	
	FM 60dB STEREO	3.6	8.9	3.6	3.6	0	0	5.0	8.9	8.9	1.3	4.3	0	0.9	7.8	7.8	4.3	4.3	4.3	4.3	3.4	3.4	2.8	3.4	0	0	3.6	3.6	3.6	3.6	2.7	
	AM NO SIGNAL	3.5	9.0	3.5	3.5	0	5.0	5.1	9.0	2.6	1.3	0	0	0.9	4.7	5.5	4.3	4.3	4.3	4.3	3.3	3.2	2.8	ust	0.7	0.7	3.6	3.6	3.6	3.6	2.1	
IC2	FM NO SIGNAL	2.5	0	0	5.0	4.9	5.0	7.9	7.8	3.6	6.1	5.1	0	0	0	0	2.5	5.1	0.9	0.9	3.8	0	2.3									

Tr. NO.	Q1	Q5				
PIN NO.	E	C	B	E	C	B
FM 87.5MHz NO SIGNAL	0	7.1	0.85	8.9	8.8	0
AM 522kHz NO SIGNAL	0	0	0	9.0	0	8.9

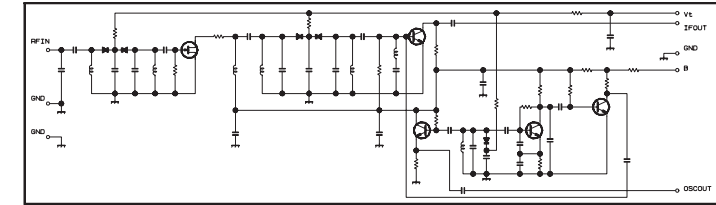

GVA10045-A2

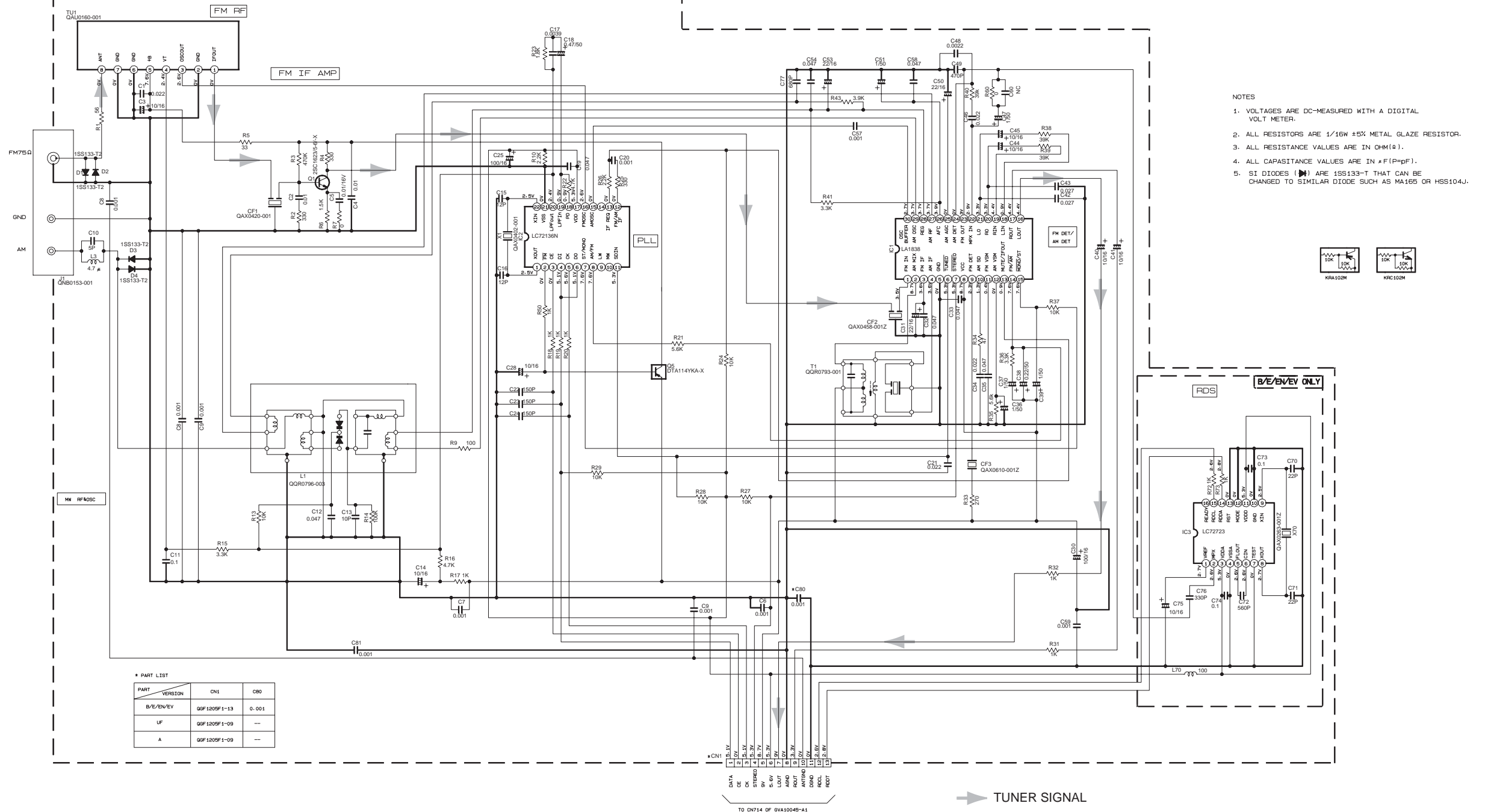

- NOTES
1. VOLTAGES ARE DC-MEASURED WITH A DIGITAL VOLT METER.
 2. ALL RESISTORS ARE 1/16W ±5% METAL GLAZE RESISTOR.
 3. ALL RESISTANCE VALUES ARE IN OHM(Ω).
 4. ALL CAPACITANCE VALUES ARE IN pF(pF).
 5. SI DIODES (D1-D4) ARE 1SS133-T THAT CAN BE CHANGED TO SIMILAR DIODE SUCH AS MA165 OR HSS104J.



* PART LIST

PART	VERSION	CN1	C80
B/E/ENVEY	GF1205F1-13	0.001	
UF	GF1205F1-09		
A	GF1205F1-09		

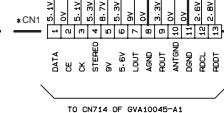

➔ TUNER SIGNAL

5
4
3
2
1

A B C D E F G H

UX-H30

UX-H30

Printed circuit boards

5

4

3

2

1

A

B

C

28 D

E

F

G

H

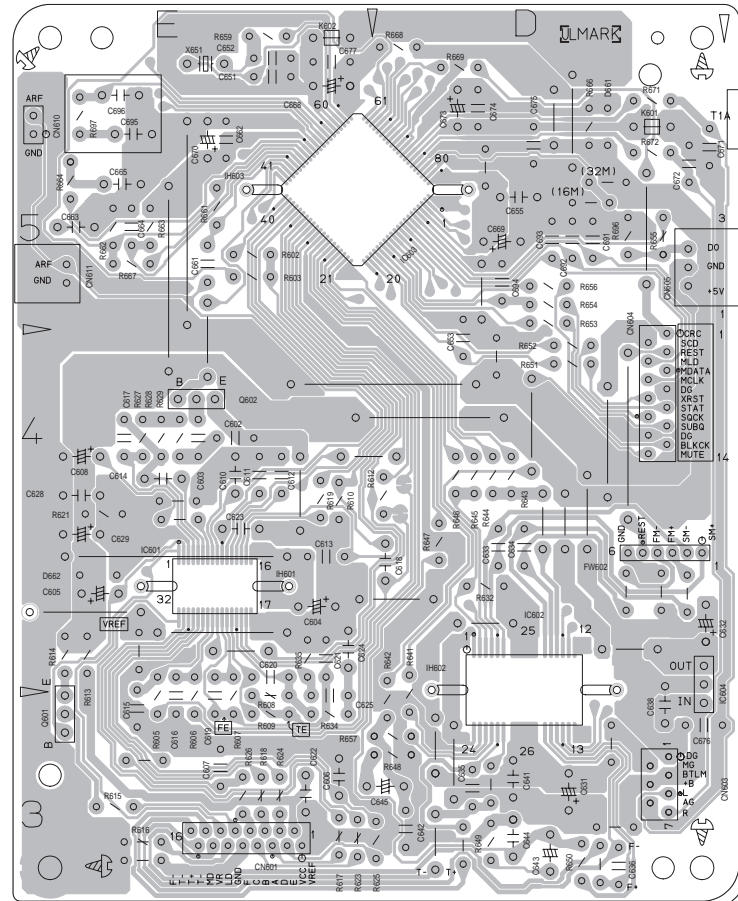

■ CD board

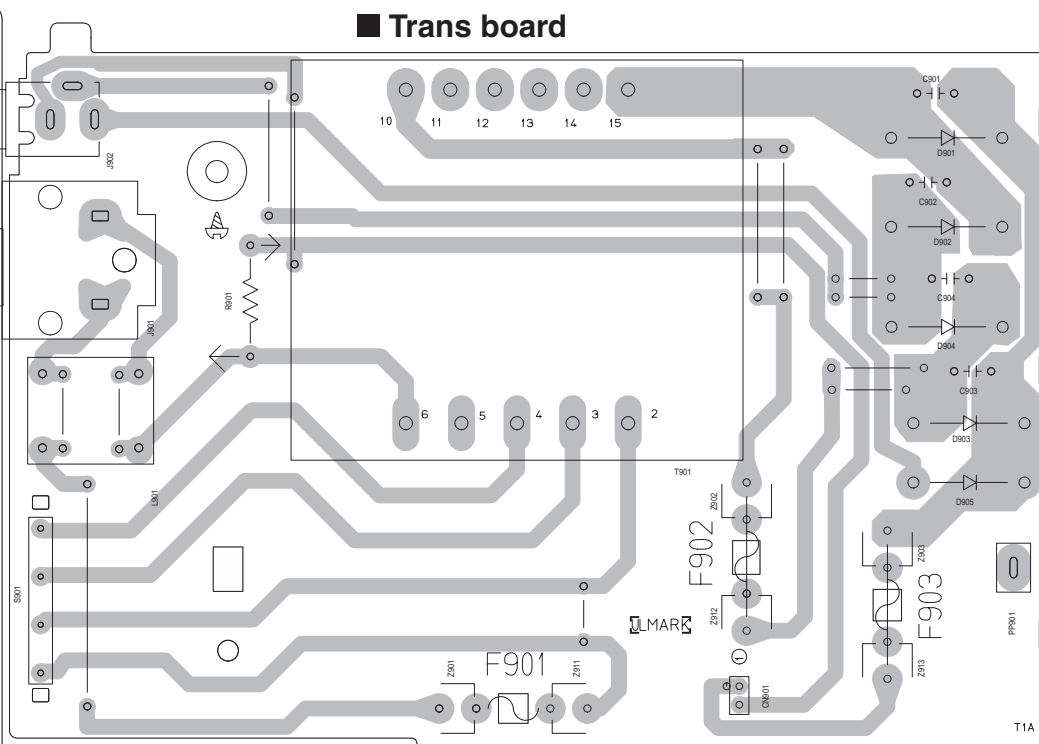

■ Trans board

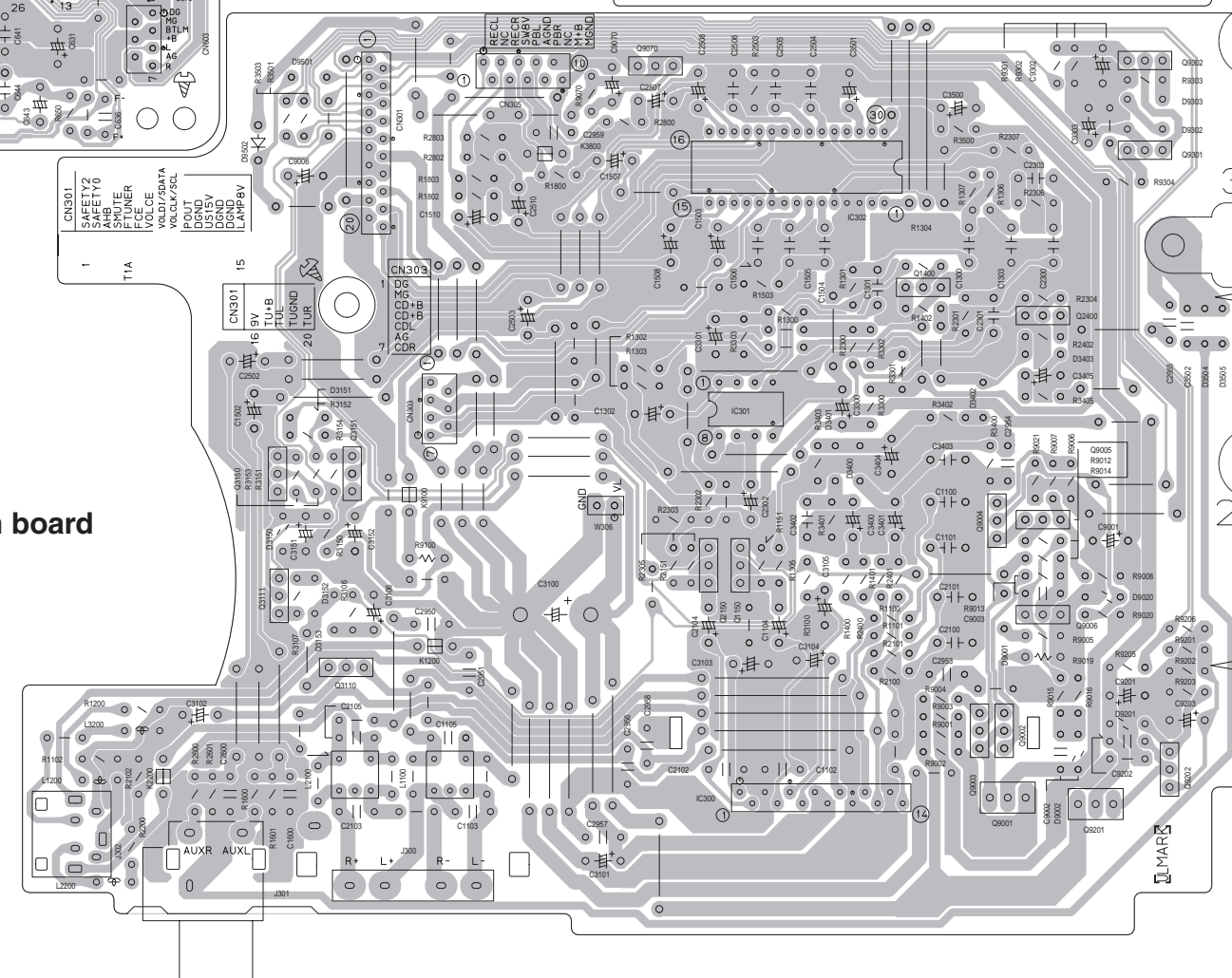

■ Main board

■ Micon board

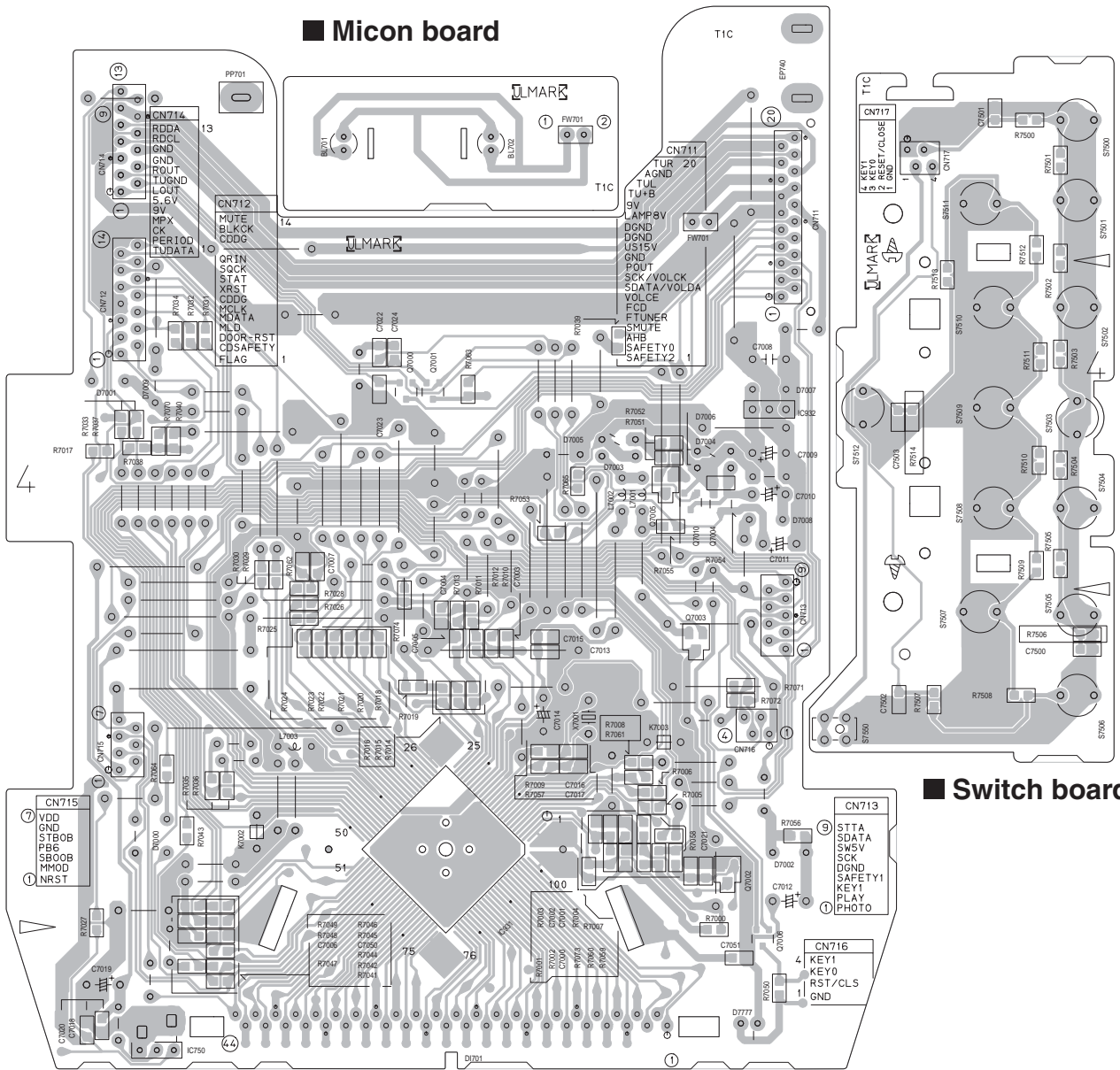

■ Switch board

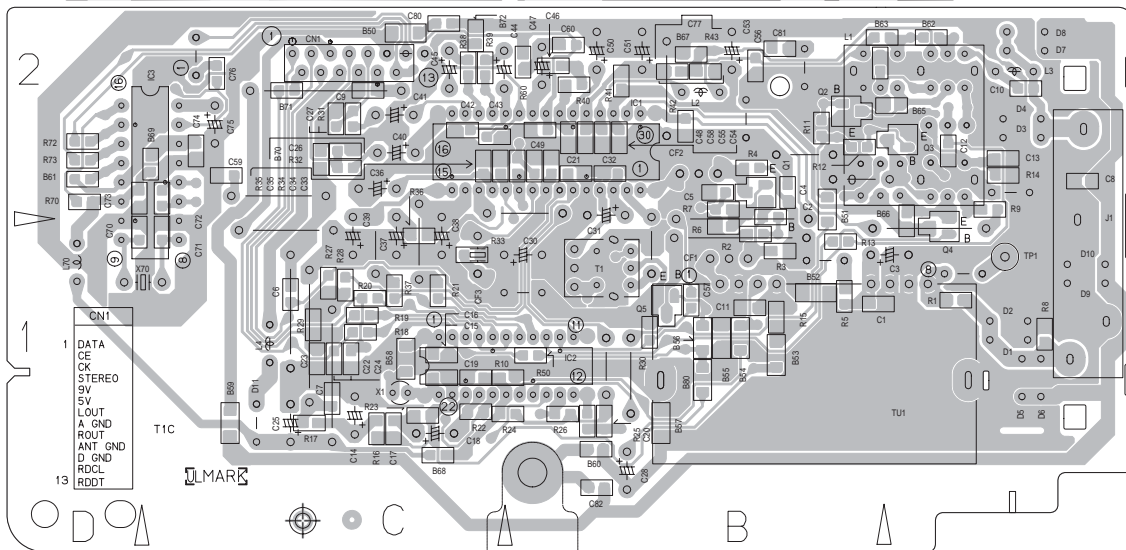

■ Tuner board

5

4

3

2

1

A

B

C

D

5

■ **Cassette (switch) board**

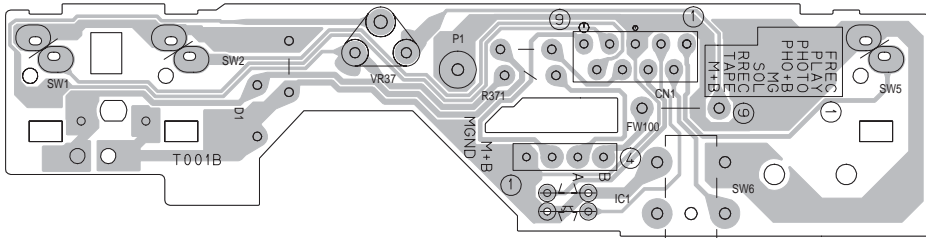

4

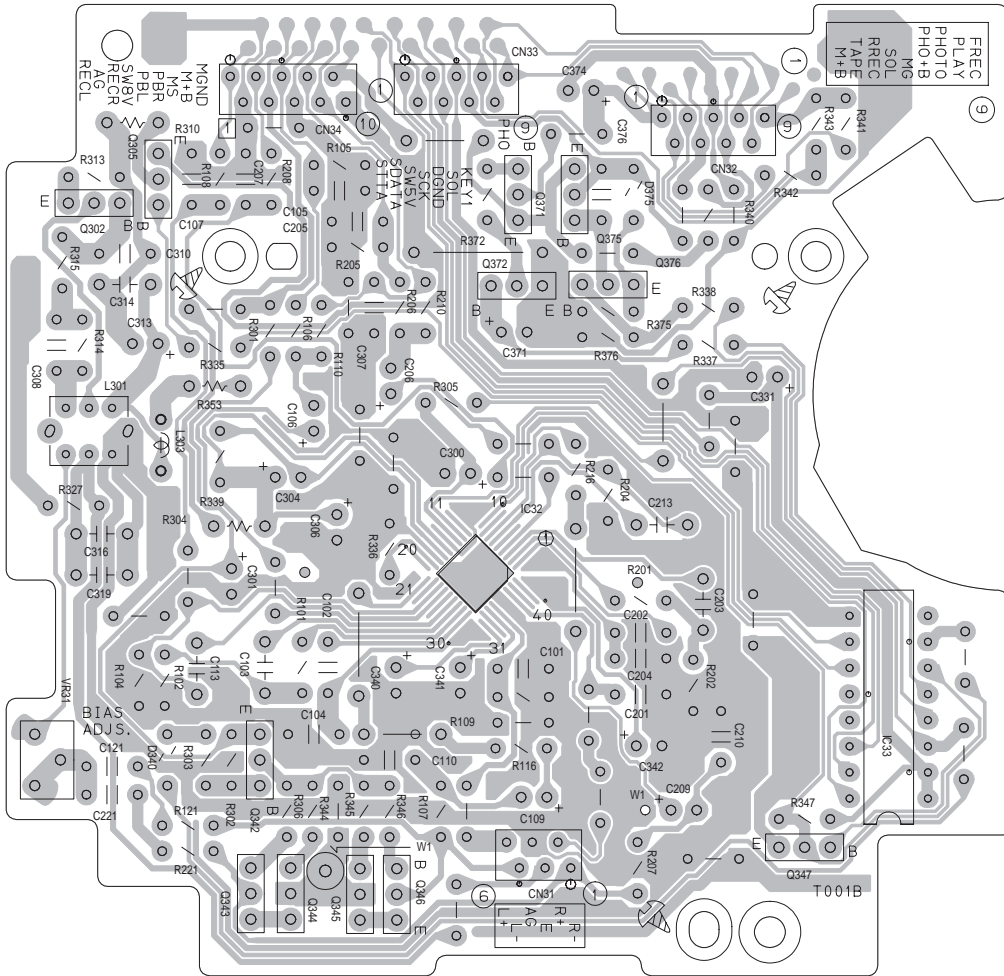

3

■ **Cassette board**

2

1

2-10

A

B

C

D

< MEMO >

UX-H30

JVC

VICTOR COMPANY OF JAPAN, LIMITED

AV & MULTIMEDIA COMPANY AUDIO/VIDEO SYSTEM CATEGORY 10-1,1chome,Ohwatari-machi,Maebashi-city,371-8543,Japan

(No.22033SCH)

 Printed in Japan
200303

PARTS LIST

[UX-H30]

* All printed circuit boards and its assemblies are not available as service parts.

Area suffix	
B -----	U.K.
E -----	Continental Europe
EN -----	Northern Europe

- Contents -

Exploded view of general assembly and parts list (Block No.M1)	3- 3
Speaker assembly and parts list (Block No.M2)	3- 5
Cassette mechanism assembly and parts list (Block No.MP)	3- 6
Electrical parts list (Block No.01~04)	3- 8
Packing materials and accessories parts list (Block No.M3,M5)	3-16

< MEMO >

Exploded view of general assembly and parts list

Block No. **M 1 M M**

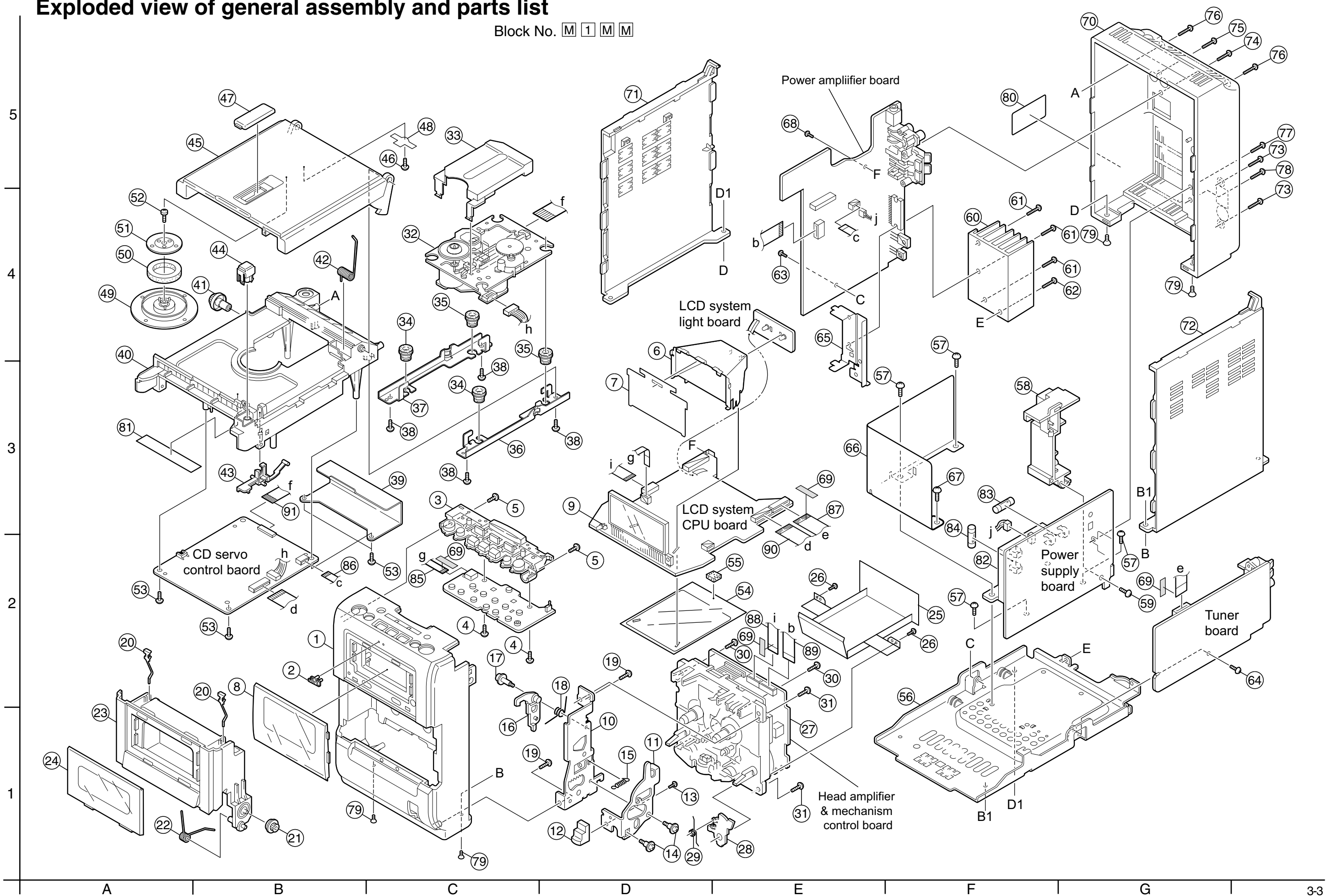

■ Parts list (General assembly)

Block No. M1MM

△	Item	Parts number	Parts name	Q'ty	Description	Area
	1	GV10127-003A	FRONT PANEL	1		
	2	GV40077-002A	JVC BADGE	1		
	3	GV20202-001A	PUSH BUTTON	1		
	4	QYSBSF2608Z	T.SCREW	2	PUSH BUT./PWB	
	5	QYSBSF2608Z	T.SCREW	2	F.PANEL/PWB	
	6	GV30423-001A	LAMP CASE	1		
	7	GV40384-001A	LCD FILTER	1		
	8	GV30402-001A	LCD LENS	1		
	9	GV30349-009A	SPACER	1	STICK TO LED	
	10	GV30424-001A	DOOR HOLDER	1		
	11	GV40393-001A	EJECT LEVER	1		
	12	GV40377-001A	EJECT KNOB	1		
	13	QYSBSF2608Z	T.SCREW	1	E.LEVER/E.KNOB	
	14	VKZ4323-202	SCREW	2	D.HOLDER/E.LEVE	
	15	GV30421-001A	TENSION SPRING	1		
	16	GV40394-001A	EJECT ARM	1		
	17	VKZ4341-205	SPECIAL SCREW	1	FOR EJECT ARM	
	18	GV40385-001A	TORSION SPRING	1		
	19	QYSBSF3010Z	SCREW	2	F.PNL/D.HOLDER	
	20	VKY4180-401	CASSETTE SPRING	2		
	21	VYH5601-001	GEAR	1		
	22	GV40386-001A	DOOR SPRING	1		
	23	GV20198-001A	CASSETTE HOLDER	1		
	24	GV30403-003A	DOOR LENS	1	CASS. DOOR/F.PA	
	25	GV30071-001A	HEAD SHIELD	1		
	26	QYSBSF2608Z	T.SCREW	2	H.SHIELD/SLC ME	
	27	-----	SINGLE C,MECHA	1		
	28	VKL7850-002	EJECT SAFTY(R)	1		
	29	VKW5258-003	TORSION SPRING	1		
	30	QYSBSF3012Z	SCREW	2	F.PANEL/MECHA	
	31	QYSBST3008Z	T.SCREW	2	D.HOLDER/MECHA	
	32	KSM-213CCMJ	CD MECHA ASSY.	1		
	33	GV30412-001A	PICK COVER	1		
	34	LV42763-001A	INSULATOR	2		
	35	LV42763-002A	INSULATOR	2		
	36	GV40379-001A	CDMECHAHOLDER	1		
	37	GV40379-002A	CDMECHAHOLDER	1		
	38	QYSBSF3010Z	SCREW	4	CD CASE/M.HOLDE	
	39	GV40390-001A	SHIELD	1		
	40	GV10134-001A	CD CASE	1		
	41	VYH4769-002SS	GEAR	1		
	42	GV40391-001A	CD DOOR SPRING	1		
	43	GV40395-001A	LOCK LEVER	1		
	44	GV40396-001A	CD EJECT KNOB	1		
	45	GV20199-001A	CD DOOR	1		
	46	QYSDSF2006M	SCREW	1	CLAMP.BKT/CD DO	
	47	GV40378-001A	CD LENS	1		
	48	GV40423-001A	CLAMPER BKT	1		

■ Parts list (General assembly)

Block No. M1MM

△	Item	Parts number	Parts name	Q'ty	Description	Area
	49	LV33270-001A	CLAMPER	1		
	50	VYH7313-005	MAGNET	1		
	51	VKL7757-001	YOKE	1		
	52	LV41741-001A	SPECIAL SCREW	1	TO CLAMPER	
	53	QYSBSF3010Z	SCREW	4	CD PWB/CD CASE	
	54	GV40392-001A	SHIELD	1	MICON PWB	
	55	E3400-431	SPACER	1	MICON PWB+SHIEL	
	56	GV10133-001A	BOTTOM CHASSIS	1		
	57	QYSBST4006Z	T.SCREW	4	CHASSIS/TRANS	
	58	GV30404-001A	JACK HOLDER	1		
	59	QYSBSF2608Z	T.SCREW	1	PWB/JACK HOLDER	
	60	GV30405-001A	RADIATION	1		
	61	QYSBST3012Z	T.SCREW	3	RADIATION/IC	
	62	QYSBST3006Z	T.SCREW	1	RADIA/CHASSIS	
	63	QYSBST3006Z	T.SCREW	1	MAIN PWB/CHASSI	
	64	QYSBST3006Z	T.SCREW	1	TNR.PWB/CHASSIS	
	65	GV30408-001A	IC HOLDER	1		
	66	GV30422-001A	SHIELD	1	FOR POWER TRANS	
	67	QYSBST4006Z	T.SCREW	1	SHIELD+BTM.CHAS	
	68	QYSBSG3006Z	T.SCREW	1	EARTH PLT/MAIN	
	69	LV30225-011A	SPACER	4		
	70	GV10128-003A	REAR PANEL	1		
	71	GV20221-001A	SIDE PANEL (L)	1		
	72	GV20218-001A	SIDE PANEL (R)	1		
	73	QYSBSF3010Z	SCREW	2	R.PANEL/TUNER	
	74	QYSBSF3010Z	SCREW	1	R.PANEL/SPK.JAC	
	75	QYSBSF3010Z	SCREW	1	R.PANEL/AUX	
	76	QYSBSF3010Z	SCREW	2	R.PANEL/CD CASE	
	77	QYSBSF3010Z	SCREW	1	R.PANEL/AC IN	
	78	QYSBSF3010Z	SCREW	1	R.PANEL/DC IN	
	79	QYSSST3008Z	SCREW	4	R.PANEL/CHASSIS	
	80	GV30406-001A	NAME PLATE	1		
△	81	LV41843-001A	LASER CAUTION	1		
△	82	QQT0396-002	POWER TRANSF	1	T 901	
△	83	QMF51W2-R50-J8	FUSE	1	F 901	
△	84	QMF51W2-6R3-J8	FUSE	1	F 903	
	85	QUQH12-0411BJ	FLAT WIRE	1	FC716	
	86	QUQH12-0714AJ	FLAT WIRE	1	FC303	
	87	QUQH12-1309BJ	FLAT WIRE	1	FC714	
	88	QUQH12-0913BJ	FLAT WIRE	1	FC713	
	89	QUQH12-1022BJ	FLAT WIRE	1	FC305	
	90	QUQH12-1406BJ	FLAT WIRE	1	FC712	
	91	QUQ110-1607AJ	FFC WIRE	1	FC601	

Speaker assembly and parts list

(SP-UXH30)

Block No. M 2 M M

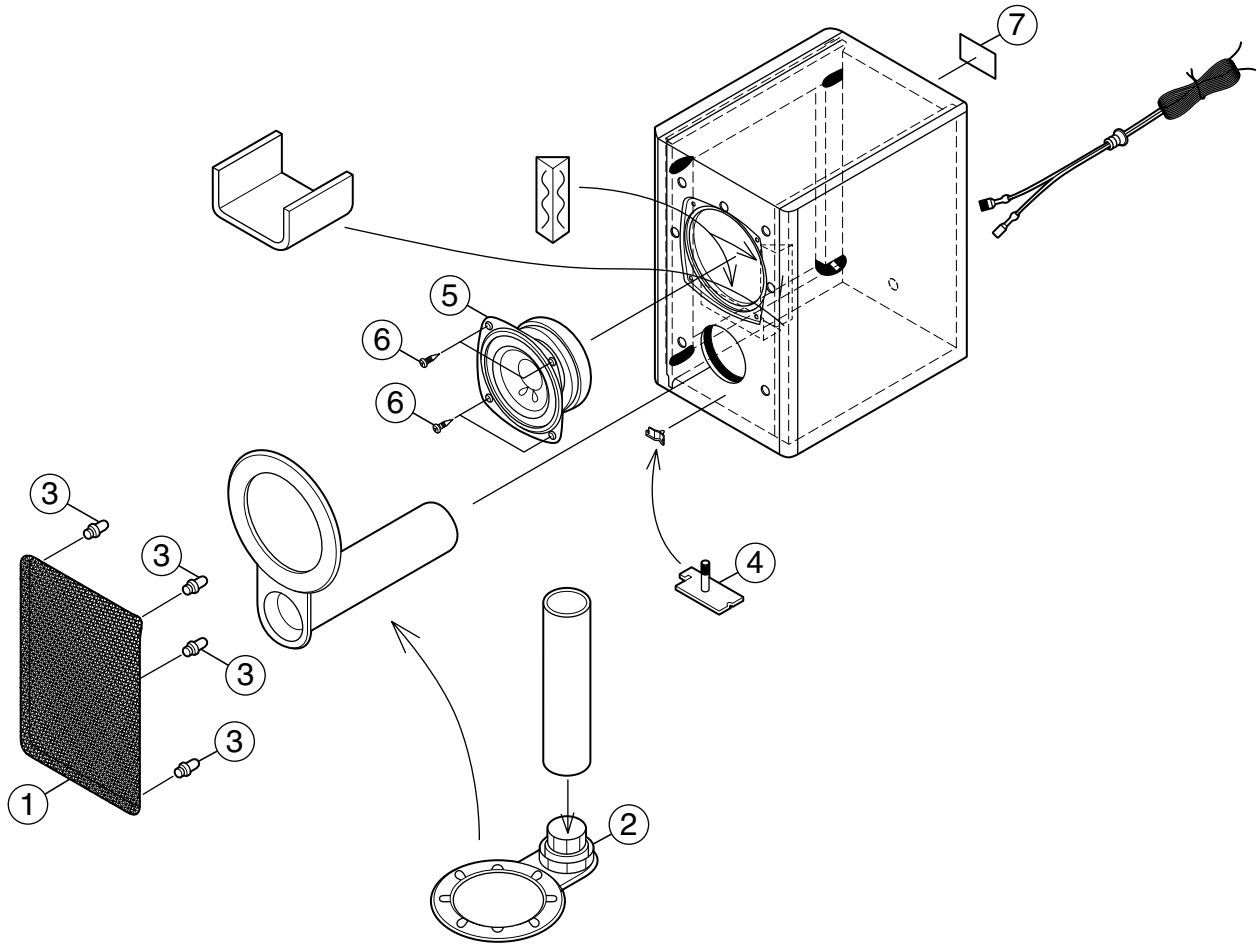

■ Parts list (Speaker)

Block No. M2MM

⚠	Item	Parts number	Parts name	Q'ty	Description	Area
	1	J201XH3000B10	SPEAKER FRAME	2		
	2	J200XH3000B00	FRONT PANEL	2		
	3	J282XH3000B00	LATCH	8		
	4	21302UXP510	JVC MARK	2		
	5	305J0XH3000800	WOOFER	2		
	6	411B84012AB1	SCREW	8		
	7	6000XH30E00	RATING LABEL	2		

Cassette mechanism assembly and parts list

Block No. M P M M

SLC-S302M

Grease

- ★ =EM-30L
- ▲ =UD-24
- =LEN-320M
- ◎ =MOBIL-1

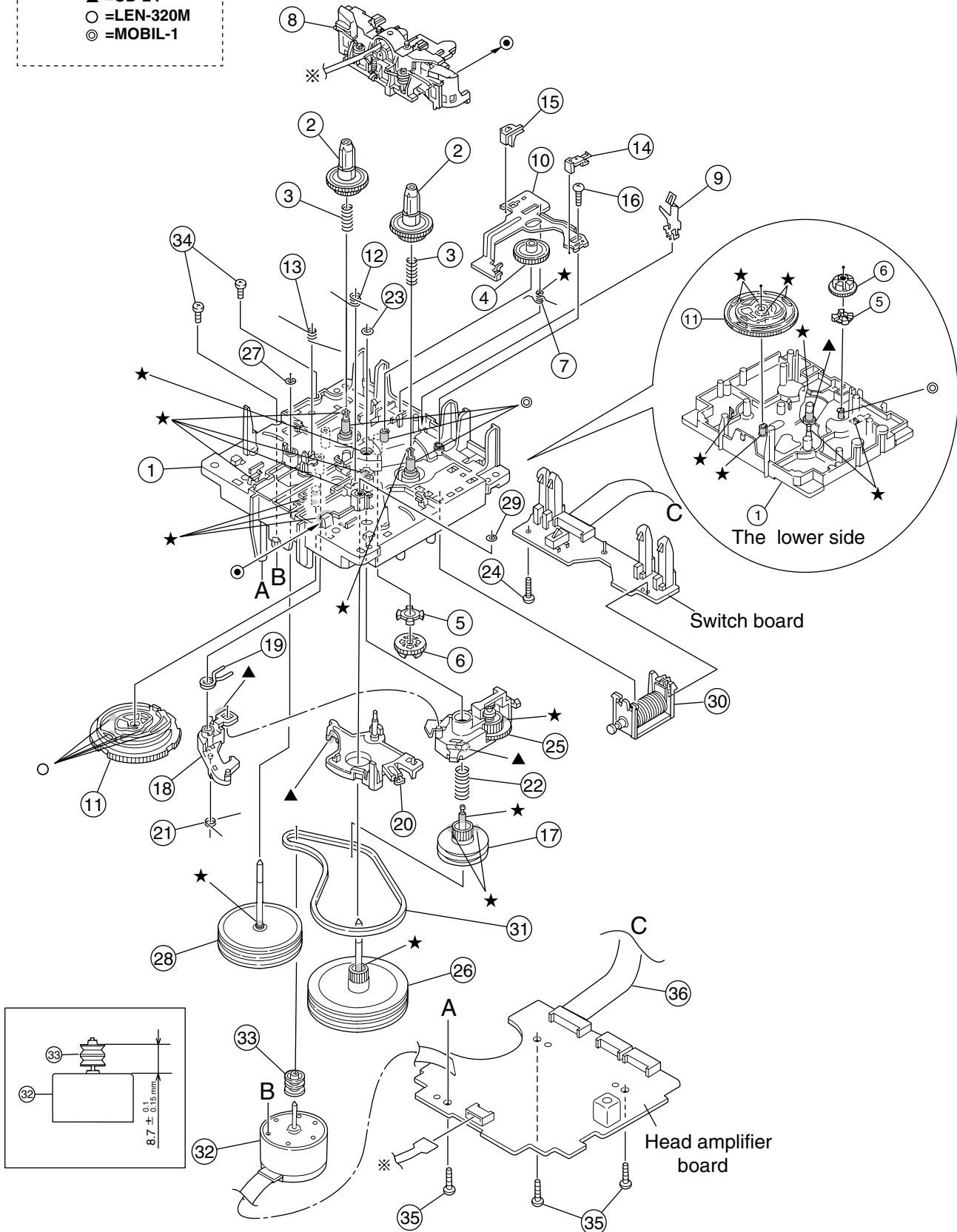

■ Parts list (Cassette mechanism)

Block No. MPMM

△	Item	Parts number	Parts name	Q'ty	Description	Area
	1	VKS1165-00L	CHASSIS B. ASSY	1		
	2	VKS2274-002	REEL GEAR	2		
	3	VKW5286-002	B.T. SPRING	2		
	4	VKS5559-001	PLAY IDLE GEAR	1		
	5	VKS5595-002	BLIND	1		
	6	VKS5560-003	FR IDLE GEAR	1		
	7	LV42013-001A	EARTH SPRING	1		
	8	SLC-PP3SVM	HEAD MOUNT ASSY	1		
	9	VKY3149-002	CASSETTE SP.	1		
	10	LV31786-001A	PLAY SW LEVER	1		
	11	VKS1166-004	CONTROL CAM	1		
	12	VKW5279-002	HEAD BASE SP(R)	1		
	13	VKW5280-001	HEAD BASE SP(L)	1		
	14	LV41584-001A	BRAKE(R)	1		
	15	LV41585-003A	BRAKE(L)	1		
	16	QYSBSF2005Z	T.SCREW	1		
	17	VKS5603-00G	MAIN PULLEY ASY	1		
	18	VKS3785-001MM	FR ARM	1		
	19	VKW5284-002	SWING SPRING	1		
	20	VKS2278-003	TRIGGER ARM	1		
	21	VKW5301-001	FR SPRING	1		
	22	VKW5266-001	ELEVATOR SPRING	1		
	23	WDL214025	WASHER	1		
	24	QYSBSF2005Z	T.SCREW	1		
	25	VKS3786-00G	CLUTCH ASS'Y	1		
	26	VKF3205-00B	F.WHEEL ASSY(R)	1		
	27	WDL183425	SLIT WASHER	1		
	28	VKF3207-00C	F.WHEEL ASSY(L)	1		
	29	WDL173525-6	SLIT WASHER	1		
	30	VKZ3174-00B	DC SOLENOID	1		
	31	LV42836-001A	CAPSTAN BELT	1		
	32	MSI-5U2LWA	D.C.MOTOR ASS'Y	1		
	33	VKR4761-003	MOTOR PULLEY	1		
	34	QYSPSP2604Z	SCREW	2		
	35	QYSBSF2608Z	T.SCREW	3	FOR P.W.B.	
	36	QUQH12-0906BF	WIER	1	FC32	

■ Electrical parts list (Main board)

Block No. 01

△	Item	Parts number	Parts name	Remarks	Area
	C 602	QCSB1HJ-560Y	C CAPACITOR	VREF	
	C 604	QEKC1AM-107Z	E CAPACITOR	VREF(IC601)	
	C 605	QETN1EM-106Z	E CAPACITOR	LD(IC601)	
	C 606	QFVF1HJ-823Z	MF CAPACITOR	PDF(IC601)	
	C 608	QETN1HM-105Z	E CAPACITOR	CAGC(IC601)	
	C 610	QFVF1HJ-393Z	MF CAPACITOR	CEA(IC601)	
	C 611	QCBB1HK-103Y	C CAPACITOR	CBDO(IC601)	
	C 612	QDXB1CM-272Y	C CAPACITOR	COFTR(IC601)	
	C 613	QCBB1HK-331Y	C CAPACITOR	OFTR(IC601)	
	C 614	QCZ0313-105Z	C CAPACITOR	RFIN(IC601)	
	C 615	QDVB1EZ-223Y	C CAPACITOR	TBAL(IC601)	
	C 616	QDVB1EZ-223Y	C CAPACITOR	FBAL(IC601)	
	C 617	QCSB1HK-3R3Y	C CAPACITOR	RFOUT(IC601)	
	C 618	QFVF1HJ-104Z	MF CAPACITOR	TE	
	C 619	QCBB1HK-561Y	C CAPACITOR	FEOOUT(IC601)	
	C 620	QCBB1HK-101Y	C CAPACITOR	TEOUT(IC601)	
	C 622	QFLC1HJ-223Z	M CAPACITOR	VREF-VCC	
	C 623	QFVF1HJ-563Z	MF CAPACITOR	RFENV	
	C 624	QFLC1HJ-223Z	M CAPACITOR	TEBPF	
	C 625	QDXB1CM-222Y	C CAPACITOR	TEBPF(IC601)	
	C 628	QDX31EM-473Z	C CAPACITOR	VCC(IC601)	
	C 629	QETN1AM-227Z	E CAPACITOR	VCC(IC601)	
	C 631	QETN1AM-477Z	E CAPACITOR	VCC(IC602)	
	C 632	QEKC1AM-107Z	E CAPACITOR	OUT(5V REG)	
	C 633	QCBB1HK-391Y	C CAPACITOR	SM+/-	
	C 634	QCBB1HK-391Y	C CAPACITOR	FM+/-	
	C 635	QCBB1HK-391Y	C CAPACITOR	T+/-	
	C 636	QCBB1HK-391Y	C CAPACITOR	F+/-	
	C 638	QFVF1HJ-104Z	MF CAPACITOR	IN(5V REG)	
	C 641	QCZ0313-105Z	C CAPACITOR	VCC(IC602)	
	C 642	QCBB1HK-103Y	C CAPACITOR	TRD	
	C 643	QEQ61HM-225Z	NP E CAPACITOR	FOD	
	C 644	QFN31HJ-153Z	M CAPACITOR	FOD	
	C 645	QEQ61HM-225Z	NP E CAPACITOR	TRD	
	C 651	QCSB1HJ-120Y	C CAPACITOR	X1(IC603)	
	C 652	QCSB1HJ-150Y	C CAPACITOR	X1(IC603)	
	C 653	QDVB1EZ-223Y	C CAPACITOR	RST(IC603)	
	C 655	QCZ0202-155Z	ML C CAPACITOR	DVDD1(IC603)	
	C 661	QCBB1HK-471Y	C CAPACITOR	ARF	
	C 662	QDVB1EZ-223Y	C CAPACITOR	AVDD2(IC603)	
	C 663	QFLC1HJ-223Z	M CAPACITOR	DSLFC(IC603)	
	C 664	QDVB1EZ-223Y	C CAPACITOR	IREF(IC603)	
	C 665	QFVF1HJ-334Z	MF CAPACITOR	PLLF(IC603)	
	C 668	QETN0JM-477Z	E CAPACITOR	VDD(IC603)	
	C 669	QETN0JM-477Z	E CAPACITOR	DVDD1(IC603)	
	C 670	QETN1AM-107Z	E CAPACITOR	AVDD2(IC603)	
	C 671	QDXB1CM-222Y	C CAPACITOR	OUTR	
	C 672	QDXB1CM-222Y	C CAPACITOR	OUTL	
	C 673	QETN1AM-477Z	E CAPACITOR	AVDD1(IC603)	
	C 674	QDVB1EZ-223Y	C CAPACITOR	AVDD1(IC603)	
	C 675	QDGB1HK-102Y	C CAPACITOR	AG-DG	
	C 676	QDGB1HK-102Y	C CAPACITOR	AG-DG	
	C 677	QDVB1EZ-223Y	C CAPACITOR	AG-DG	
	C 691	QCBB1HK-151Y	C CAPACITOR	DENGEN N-MCLK	
	C 692	QCBB1HK-151Y	C CAPACITOR	DENGEN N-MDATA	
	C 693	QCBB1HK-151Y	C CAPACITOR	DENGEN NOISE-ML	
	C 694	QCBB1HK-101Y	C CAPACITOR	DENGEN N-SQCK	
	C 695	QFVF1HJ-334Z	MF CAPACITOR	VCOF2(IC603)	
	C 901	QFLA1HJ-104Z	TF CAPACITOR	RECTIFIER	
	C 902	QFLA1HJ-104Z	TF CAPACITOR	RECTIFIER	
	C 903	QFLA1HJ-104Z	TF CAPACITOR	RECTIFIER	
	C 904	QFLA1HJ-104Z	TF CAPACITOR	RECTIFIER	
	CN301	QGB1214J1-20S	CONNECTOR	TO MICON	
	CN303	QGF1205C1-07	CONNECTOR	TO CD	
	CN305	QGF1205F1-10	CONNECTOR	TO SLC	
	CN601	QGF1008F1-16	CONNECTOR	TO RF	

△	Item	Parts number	Parts name	Remarks	Area
	CN603	QGF1205F1-07	CONNECTOR	TO AUDIO	
	CN604	QGF1205F1-14	CONNECTOR	TO MICON	
	CN610	QGA2501C1-02	2P CONNECTOR		
	CN901	QGA2501C1-02	2P CONNECTOR	VL/GND	
	C1100	QFLC1HJ-104Z	M CAPACITOR	2CHA +OUT	
	C1101	QFLC1HJ-104Z	M CAPACITOR	2CHA -OUT	
	C1102	QCBB1HK-331Y	C CAPACITOR	IN2	
	C1103	QDXB1CM-332Y	C CAPACITOR	EMC EXP J/C	
	C1104	QTE1V06-106Z	E CAPACITOR	IN2	
	C1105	QCBB1HK-221Y	C CAPACITOR	EMC EXP J/C	
	C1300	QFLC1HJ-683Z	M CAPACITOR	.068MF 5% 50V	
	C1301	QFLC1HJ-683Z	M CAPACITOR	.068MF 5% 50V	
	C1302	QTE1V06-106Z	E CAPACITOR		
	C1303	QFVJ1HJ-334Z	MF CAPACITOR	.33MF 5% 50V	
	C1502	QETN1HM-475Z	E CAPACITOR	AUXL	
	C1503	QTE1V06-106Z	E CAPACITOR	CDL	
	C1504	QFVF1HJ-104Z	MF CAPACITOR	.10MF 5% 50V	
	C1505	QFVF1HJ-104Z	MF CAPACITOR	.10MF 5% 50V	
	C1506	QFLC1HJ-272Z	M CAPACITOR	2700PF 5% 50V	
	C1507	QETN1HM-475Z	E CAPACITOR	PBL	
	C1508	QETN1HM-475Z	E CAPACITOR	TUL	
	C1510	QETN1EM-106Z	E CAPACITOR	RECL	
	C1600	QCBB1HK-221Y	C CAPACITOR	220PF 10% 50V	
	C2100	QFLC1HJ-104Z	M CAPACITOR	1CHA +OUT	
	C2101	QFLA1HJ-104Z	TF CAPACITOR	1CHA -OUT	
	C2102	QCBB1HK-331Y	C CAPACITOR	IN1	
	C2103	QDXB1CM-332Y	C CAPACITOR	EMC EXP J/C	
	C2104	QTE1V06-106Z	E CAPACITOR	IN1	
	C2105	QCBB1HK-221Y	C CAPACITOR	EMC EXP J/C	
	C2300	QFLC1HJ-683Z	M CAPACITOR	.068MF 5% 50V	
	C2301	QFLC1HJ-683Z	M CAPACITOR	.068MF 5% 50V	
	C2302	QTE1V06-106Z	E CAPACITOR		
	C2303	QFVJ1HJ-334Z	MF CAPACITOR	.33MF 5% 50V	
	C2502	QETN1HM-475Z	E CAPACITOR	AUXR	
	C2503	QTE1V06-106Z	E CAPACITOR	CDR	
	C2504	QFVF1HJ-104Z	MF CAPACITOR	.10MF 5% 50V	
	C2505	QFVF1HJ-104Z	MF CAPACITOR	.10MF 5% 50V	
	C2506	QFLC1HJ-272Z	M CAPACITOR	2700PF 5% 50V	
	C2507	QETN1HM-475Z	E CAPACITOR	PBR	
	C2508	QETN1HM-475Z	E CAPACITOR	TUR	
	C2510	QETN1EM-106Z	E CAPACITOR	RECR	
	C2600	QCBB1HK-221Y	C CAPACITOR	220PF 10% 50V	
	C2953	QDGB1HK-102Y	C CAPACITOR		
	C2954	QDGB1HK-102Y	C CAPACITOR		
	C2955	QDGB1HK-102Y	C CAPACITOR		
	C2956	QCBB1HK-103Y	C CAPACITOR	.010MF 10% 50V	
	C2957	QCBB1HK-103Y	C CAPACITOR	.010MF 10% 50V	
	C2958	QCBB1HK-103Y	C CAPACITOR	.010MF 10% 50V	
	C2959	QDGB1HK-102Y	C CAPACITOR		
△	C3100	QEZO635-828	E CAPACITOR	8200MF	
	C3101	QTE1V28-107Z	E CAPACITOR		
	C3102	QEKC1CM-107Z	E CAPACITOR	100MF 20% 16V	
	C3103	QETN1CM-107Z	E CAPACITOR	RF	
	C3104	QETN1EM-106Z	E CAPACITOR	RF	
	C3106	QETN1CM-107Z	E CAPACITOR	100MF 20% 16V	
	C3151	QETN1EM-106Z	E CAPACITOR	10MF 20% 25V	
	C3152	QETN1AM-476Z	E CAPACITOR	47MF 20% 10V	
	C3300	QETN1CM-476Z	E CAPACITOR	47MF 20% 16V	
	C3301	QTE1C06-226Z	E CAP. SILMIC		
	C3400	QETN1HM-105Z	E CAPACITOR	1.0MF 20% 50V	
	C3401	QETN1HM-105Z	E CAPACITOR	1.0MF 20% 50V	
	C3402	QFLC1HJ-563Z	M CAPACITOR	.056MF 5% 50V	
	C3403	QFLC1HJ-563Z	M CAPACITOR	.056MF 5% 50V	
	C3404	QETN1HM-226Z	E CAPACITOR	22MF 20% 50V	
	C3405	QETN1CM-106Z	E CAPACITOR	10MF 20% 16V	
	C3500	QETN1CM-107Z	E CAPACITOR	100MF 20% 16V	

■ Electrical parts list (Main board)

Block No. 01

Item	Parts number	Parts name	Remarks	Area	Item	Parts number	Parts name	Remarks	Area
C3501	QETN1EM-106Z	E CAPACITOR	10MF 20% 25V		Q 601	KTA1271/OY/-T	TRANSISTOR	LD SW	
C3502	QDYB1CM-103Y	C CAPACITOR	GND TO CHASSIS		Q1150	2SC3576-JVC-T	TRANSISTOR		
C9001	QETN1EM-476Z	E CAPACITOR	47MF 20% 25V		Q1400	2SC2785/FE/-T	TRANSISTOR		
C9002	QDYB1CM-103Y	C CAPACITOR			Q2150	2SC3576-JVC-T	TRANSISTOR		
C9003	QCB1HK-221Y	C CAPACITOR	220PF 10% 50V		Q2400	2SC2785/FE/-T	TRANSISTOR		
C9006	QETN1EM-106Z	E CAPACITOR	10MF 20% 25V		Q3110	2SC3576-JVC-T	TRANSISTOR		
C9070	QETN1EM-106Z	E CAPACITOR	10MF 20% 25V		Q3111	KRC111M-T	TRANSISTOR		
C9201	QETN1CM-476Z	E CAPACITOR	47MF 20% 16V		Q3150	KRA101M-T	TRANSISTOR		
C9202	QDYB1CM-103Y	C CAPACITOR			Q3151	KRC102M-T	D.TRANSISTOR		
C9203	QTE1V06-106Z	E CAPACITOR			△ Q9001	KTA1046/Y/	TRANSISTOR		
C9302	QEK1HM-475Z	E CAPACITOR	4.7MF 20% 50V		Q9002	2SC2785/FE/-T	TRANSISTOR		
C9303	QEK1AM-107Z	E CAPACITOR	100MF 20% 10V		Q9003	2SA1175/FE/-T	TRANSISTOR		
D 661	1SS133-T2	SI DIODE	AVDD1		Q9004	KRC114M-T	TRANSISTOR		
D 662	1SS133-T2	SI DIODE	VCC(IC602)		Q9005	KRA114M-T	D.TRANSISTOR		
△ D 901	6A10E2	SI DIODE	RECTIFIER		Q9006	2SC2785/FE/-T	TRANSISTOR		
△ D 902	6A10E2	SI DIODE	RECTIFIER		Q9070	2SC3576-JVC-T	TRANSISTOR		
△ D 903	6A10E2	SI DIODE	RECTIFIER		Q9201	KTB772/Y/	TRANSISTOR		
△ D 904	6A10E2	SI DIODE	RECTIFIER		Q9202	2SC2785/FE/-T	TRANSISTOR		
△ D 905	6A10E2	SI DIODE	DC BLOCK		Q9301	KTA1267/YG/-T	TRANSISTOR		
D3150	MTZJ5.1C-T2	ZENER DIODE			Q9302	2SC2785/FE/-T	TRANSISTOR		
D3151	1SS133-T2	SI DIODE			R 602	QRE141J-203Y	C RESISTOR	LDON(IC603)	
D3152	1SS133-T2	SI DIODE			R 603	QRE141J-333Y	C RESISTOR	CLDCK(IC603)	
D3153	1SS133-T2	SI DIODE			R 605	QRE141J-684Y	C RESISTOR	TBAL	
D3400	1SS133-T2	SI DIODE			R 606	QRE141J-184Y	C RESISTOR	FBAL	
D3401	1SS133-T2	SI DIODE			R 607	QRE141J-333Y	C RESISTOR	FE	
D3402	1SS133-T2	SI DIODE			R 609	QRE141J-224Y	C RESISTOR	TE	
D3403	1SS133-T2	SI DIODE			R 610	QRE141J-105Y	C RESISTOR	TRCRS(IC603)	
D3504	1SS133-T2	SI DIODE	GND TO CHASSIS		R 612	QRE141J-102Y	C RESISTOR	TE	
D3505	1SS133-T2	SI DIODE	GND TO CHASSIS		R 613	QRE141J-121Y	C RESISTOR	VCC	
D9001	1SS133-T2	SI DIODE			R 614	QRE141J-100Y	C RESISTOR	VCC-Q601	
D9002	MTZJ8.2C-T2	ZENER DIODE			R 615	QRE141J-120Y	C RESISTOR	LD(CN601)	
D9020	MTZJ5.6C-T2	ZENER DIODE			R 619	QRE141J-683Y	C RESISTOR	RFDET	
D9201	MTZJ4.3B-T2	ZENER DIODE			R 621	QRE141J-100Y	C RESISTOR	VCC	
D9302	1SS133-T2	SI DIODE			R 625	QRE141J-183Y	C RESISTOR	PDF	
D9303	1SS133-T2	SI DIODE			R 626	QRE141J-183Y	C RESISTOR	PDE	
D9501	1SS133-T2	SI DIODE	SAFETY0		R 627	QRE141J-682Y	C RESISTOR	RF-	
D9502	1N4003S-T5	SI DIODE	BYPASS LAMP8V		R 628	QRE141J-472Y	C RESISTOR	RFOUT	
FW602	QJK018-060601	SIN CR C-B WIRE	CD MECHA-CD AMP		R 629	QRE141J-222Y	C RESISTOR	VREF-RFIN	
△ IC300	LA4663	IC			R 632	QRE141J-473Y	C RESISTOR	BTLM	
IC301	HA17558A	IC			R 634	QRE141J-224Y	C RESISTOR	TEOUT	
IC302	LC75342	IC			R 635	QRE141J-394Y	C RESISTOR	TEBPF	
IC601	AN22000A-W	I.C	RF AMP		R 641	QRE141J-563Y	C RESISTOR	KICK	
△ IC602	LA6541-X	IC	DRIVER		R 642	QRE141J-332Y	C RESISTOR	TRD	
IC603	MN662748RPMFA	IC	1CHIP PROCESSER		R 643	QRE141J-473Y	C RESISTOR	TRV	
IC604	KIA78S05P-T	IC	5V REG		R 644	QRE141J-682Y	C RESISTOR	TVD	
IH601	VYH7237-004	IC HOLDER	FOR IC601		R 645	QRE141J-333Y	C RESISTOR	ECM	
IH602	VYH7237-001MM	IC HOLDER	FOR IC602		R 646	QRE141J-182Y	C RESISTOR	ECS	
IH603	VYH7237-003	IC HOLDER	FOR IC603		R 647	QRE141J-392Y	C RESISTOR	FOD	
J 300	QNB0117-001	SPK TERMINAL	SPEAKER		R 648	QRE141J-122Y	C RESISTOR	TRD	
J 301	QNN0090-001	PIN JACK	AUX IN		R 649	QRE141J-152Y	C RESISTOR	FOD	
J 302	QNS0072-001	HEADPHONE JACK			R 650	QRE141J-182Y	C RESISTOR	FOD	
J 901	QNC0091-001	AC INLET	AC IN		R 651	QRE141J-102Y	C RESISTOR	XRST	
△ J 902	QNA0016-001	DC JACK	DC IN		R 652	QRE141J-102Y	C RESISTOR	STAT	
K 601	QQR0621-001Z	FERRITE BEADS	AVSS1(IC603)		R 653	QRE141J-101Y	C RESISTOR	SUBQ	
K 602	QQR0621-001Z	FERRITE BEADS	VSS(IC603)		R 654	QRE141J-101Y	C RESISTOR	SQCK	
K1200	QQR0621-001Z	FERRITE BEADS	EMC EXP J/C		R 656	QRE141J-102Y	C RESISTOR	BLKCK	
K2200	QQR0621-001Z	FERRITE BEADS	EMC EXP J/C		R 657	QRE141J-222Y	C RESISTOR	TRD	
K3800	QQR0621-001Z	FERRITE BEADS	SLCAGND		R 659	QRE141J-471Y	C RESISTOR	X2(IC603)	
K9100	QQR0621-001Z	FERRITE BEADS	US15V		R 661	QRE141J-683Y	C RESISTOR	ARF	
△ L 901	QQR1321-001	LINE FILTER	EMC FILTER		R 662	QRE141J-155Y	C RESISTOR	DSLFI(IC603)	
L1100	QQR0797-002	INDUCTOR	EMC EXP J/C		R 663	QRE141J-124Y	C RESISTOR	AVDD2-IREF	
L1200	QQL231K-470Y	INDUCTOR	EMC EXP J/C		R 664	QRE141J-331Y	C RESISTOR	PLLF	
L2100	QQR0797-002	INDUCTOR	EMC EXP J/C		R 666	QRE141J-220Y	C RESISTOR	AVDD1	
L2200	QQL231K-470Y	INDUCTOR	EMC EXP J/C		R 667	QRE141J-683Y	C RESISTOR	DRFI(IC603)	
L3200	QQL231K-470Y	INDUCTOR	EMC EXP J/C		R 668	QRE141J-220Y	C RESISTOR	VDD(IC603)	
PP901	QZW0038-001	WIRE CLAMP			R 669	QRE141J-102Y	C RESISTOR	FLAG	

■ Electrical parts list (Main board)

Block No. 01

△	Item	Parts number	Parts name	Remarks	Area
	R 671	QRE141J-102Y	C RESISTOR	OUTL	
	R 672	QRE141J-102Y	C RESISTOR	OUTR	
	R 697	QRE141J-272Y	C RESISTOR	VCOF2(IC603)	
	R1100	QRE141J-2R2Y	C RESISTOR	2CHA +OUT	
	R1101	QRE141J-2R2Y	C RESISTOR	2CHA -OUT	
	R1102	QRE141J-471Y	C RESISTOR	470 5% 1/4W	
	R1151	QRE141J-302Y	C RESISTOR	3.0K 5% 1/4W	
	R1200	QRE141J-151Y	C RESISTOR	150 5% 1/4W	
	R1300	QRE141J-154Y	C RESISTOR	150K 5% 1/4W	
	R1301	QRE141J-392Y	C RESISTOR	3.9K 5% 1/4W	
	R1302	QRE141J-472Y	C RESISTOR	4.7K 5% 1/4W	
	R1303	QRE141J-153Y	C RESISTOR	15K 5% 1/4W	
	R1304	QRE141J-103Y	C RESISTOR	10K 5% 1/4W	
	R1305	QRE141J-682Y	C RESISTOR	6.8K 5% 1/4W	
	R1306	QRE141J-472Y	C RESISTOR	4.7K 5% 1/4W	
	R1307	QRE141J-472Y	C RESISTOR	4.7K 5% 1/4W	
	R1400	QRE141J-223Y	C RESISTOR	22K 5% 1/4W	
	R1401	QRE141J-223Y	C RESISTOR	22K 5% 1/4W	
	R1402	QRE141J-103Y	C RESISTOR	10K 5% 1/4W	
	R1503	QRE141J-392Y	C RESISTOR	3.9K 5% 1/4W	
	R1600	QRE141J-303Y	C RESISTOR	30K 5% 1/4W	
	R1601	QRE141J-303Y	C RESISTOR	30K 5% 1/4W	
	R1800	QRE141J-912Y	C RESISTOR	PBL	
	R1802	QRE141J-222Y	C RESISTOR	RECL	
	R1803	QRE141J-272Y	C RESISTOR	RECL	
	R2100	QRE141J-2R2Y	C RESISTOR	1CHA +OUT	
	R2101	QRE141J-2R2Y	C RESISTOR	1CHA -OUT	
	R2102	QRE141J-471Y	C RESISTOR	470 5% 1/4W	
	R2151	QRE141J-302Y	C RESISTOR	3.0K 5% 1/4W	
	R2200	QRE141J-151Y	C RESISTOR	150 5% 1/4W	
	R2300	QRE141J-154Y	C RESISTOR	150K 5% 1/4W	
	R2301	QRE141J-392Y	C RESISTOR	3.9K 5% 1/4W	
	R2302	QRE141J-472Y	C RESISTOR	4.7K 5% 1/4W	
	R2303	QRE141J-153Y	C RESISTOR	15K 5% 1/4W	
	R2304	QRE141J-103Y	C RESISTOR	10K 5% 1/4W	
	R2305	QRE141J-682Y	C RESISTOR	6.8K 5% 1/4W	
	R2306	QRE141J-472Y	C RESISTOR	4.7K 5% 1/4W	
	R2307	QRE141J-472Y	C RESISTOR	4.7K 5% 1/4W	
	R2400	QRE141J-223Y	C RESISTOR	22K 5% 1/4W	
	R2401	QRE141J-223Y	C RESISTOR	22K 5% 1/4W	
	R2402	QRE141J-103Y	C RESISTOR	10K 5% 1/4W	
	R2503	QRE141J-392Y	C RESISTOR	3.9K 5% 1/4W	
	R2600	QRE141J-303Y	C RESISTOR	30K 5% 1/4W	
	R2601	QRE141J-303Y	C RESISTOR	30K 5% 1/4W	
	R2800	QRE141J-912Y	C RESISTOR	PBR	
	R2802	QRE141J-222Y	C RESISTOR	RECR	
	R2803	QRE141J-272Y	C RESISTOR	RECR	
	R3100	QRE141J-103Y	C RESISTOR	STB	
	R3106	QRE141J-473Y	C RESISTOR	47K 5% 1/4W	
	R3107	QRE141J-681Y	C RESISTOR	680 5% 1/4W	
	R3150	QRE141J-102Y	C RESISTOR	1.0K 5% 1/4W	
	R3151	QRE141J-472Y	C RESISTOR	4.7K 5% 1/4W	
	R3152	QRE141J-471Y	C RESISTOR	470 5% 1/4W	
	R3153	QRE141J-102Y	C RESISTOR	1.0K 5% 1/4W	
	R3154	QRE141J-102Y	C RESISTOR	1.0K 5% 1/4W	
	R3300	QRE141J-101Y	C RESISTOR	100 5% 1/4W	
	R3302	QRE141J-912Y	C RESISTOR	9.1K 5% 1/4W	
	R3303	QRE141J-103Y	C RESISTOR	10K 5% 1/4W	
	R3400	QRE141J-472Y	C RESISTOR	4.7K 5% 1/4W	
	R3401	QRE141J-472Y	C RESISTOR	4.7K 5% 1/4W	
	R3402	QRE141J-124Y	C RESISTOR	120K 5% 1/4W	
	R3403	QRE141J-154Y	C RESISTOR	150K 5% 1/4W	
	R3405	QRE141J-513Y	C RESISTOR	51K 5% 1/4W	
	R3500	QRE141J-101Y	C RESISTOR	100 5% 1/4W	
	R3501	QRE141J-222Y	C RESISTOR	SDATA/VOLDI	
	R3503	QRE141J-222Y	C RESISTOR	SCK/VOLCLK	

△	Item	Parts number	Parts name	Remarks	Area
	R9001	QRE141J-1R0Y	C RESISTOR	1.0 5% 1/4W	
	R9002	QRE141J-1R0Y	C RESISTOR	1.0 5% 1/4W	
	R9003	QRE141J-1R0Y	C RESISTOR	1.0 5% 1/4W	
	R9004	QRE141J-471Y	C RESISTOR	470 5% 1/4W	
	R9005	QRE141J-152Y	C RESISTOR	1.5K 5% 1/4W	
	R9006	QRE141J-242Y	C RESISTOR	2.4K 5% 1/4W	
	R9007	QRE141J-102Y	C RESISTOR	1.0K 5% 1/4W	
	R9008	QRE141J-682Y	C RESISTOR	6.8K 5% 1/4W	
	R9012	QRE141J-472Y	C RESISTOR	4.7K 5% 1/4W	
	R9013	QRE141J-471Y	C RESISTOR	470 5% 1/4W	
	R9014	QRE141J-472Y	C RESISTOR	4.7K 5% 1/4W	
	R9015	QRE141J-472Y	C RESISTOR	4.7K 5% 1/4W	
	R9016	QRE141J-472Y	C RESISTOR	4.7K 5% 1/4W	
△	R9019	QRZ9005-680X	F RESISTOR	68 1/4W	
	R9020	QRE141J-133Y	C RESISTOR	13K 5% 1/4W	
	R9021	QRE141J-512Y	C RESISTOR	5.1K 5% 1/4W	
	R9070	QRE141J-471Y	C RESISTOR	470 5% 1/4W	
△	R9100	QRZ9006-4R7X	F RESISTOR	US15V	
	R9201	QRE141J-103Y	C RESISTOR	10K 5% 1/4W	
	R9202	QRE141J-103Y	C RESISTOR	10K 5% 1/4W	
	R9203	QRE141J-820Y	C RESISTOR	82 5% 1/4W	
	R9205	QRE141J-823Y	C RESISTOR	82K 5% 1/4W	
	R9206	QRE141J-473Y	C RESISTOR	47K 5% 1/4W	
	R9301	QRE141J-392Y	C RESISTOR	3.9K 5% 1/4W	
	R9302	QRE141J-333Y	C RESISTOR	33K 5% 1/4W	
	R9303	QRE141J-102Y	C RESISTOR	1.0K 5% 1/4W	
	R9304	QRE141J-101Y	C RESISTOR	100 5% 1/4W	
	W 306	QJK008-021002	FLAT WIRE	AMP-TRANS	
	X 651	QAX0413-001Z	CRYSTAL	16.9MHZ	
	Z 901	QNG0020-001Z	FUSE CLIP	FOR F901	
	Z 903	QNG0020-001Z	FUSE CLIP	FOR F903	
	Z 911	QNG0020-001Z	FUSE CLIP	FOR F901	
	Z 913	QNG0020-001Z	FUSE CLIP	FOR F903	

■ Electrical parts list (Micon board)

Block No. 02

△	Item	Parts number	Parts name	Remarks	Area	△	Item	Parts number	Parts name	Remarks	Area
	BL701	QLL0147-001	PILOT LAMP	LCDLAMP			CF 2	QAX0458-001Z	C FILTER		
	BL702	QLL0147-001	PILOT LAMP	LCDLAMP			CF 3	QAX0610-001Z	C DISCRIMINATOR		
	C 1	NCB31CK-223X	C CAPACITOR				CN 1	QGF1205F1-13	CONNECTOR		
	C 2	NCB31CK-103X	C CAPACITOR				CN711	QGB1214K1-20S	CONNECTOR	TO PWB	
	C 3	QEKC1CM-106Z	E CAPACITOR	10MF 20% 16V			CN712	QGF1205F1-14	CONNECTOR	TO CD MECHA	
	C 4	NCB31CK-103X	C CAPACITOR				CN713	QGF1205F1-09	CONNECTOR	TO SLC	
	C 5	NCB31CK-103X	C CAPACITOR				CN714	QGF1205F1-13	CONNECTOR	TO TUNER	
	C 6	NCB31HK-102X	C CAPACITOR				CN716	QGF1205C1-04	CONNECTOR	TO SWITCHBOARD	
	C 7	NCB31HK-102X	C CAPACITOR				CN717	QGF1205F1-04	CONNECTOR	SWITCHBOARD	
	C 8	NCB31HK-102X	C CAPACITOR				C7000	NCB31CK-104X	C CAPACITOR	MICON VLC1	
	C 9	NCB31HK-102X	C CAPACITOR				C7001	NCB31CK-104X	C CAPACITOR	MICON VLC2	
	C 10	NDC31HJ-5R0X	C CAPACITOR	EMC			C7002	NCB31CK-104X	C CAPACITOR	MICON VLC3	
	C 11	NCB31CK-104X	C CAPACITOR				C7003	NCB31HK-103X	C CAPACITOR	MICON RST	
	C 12	NCB31CK-473X	C CAPACITOR				C7004	NDC31HJ-151X	C CAPACITOR	MICON SDATA/VOL	
	C 13	NCS31HJ-100X	C CAPACITOR				C7005	NDC31HJ-101X	C.CAPACITOR	MICON SCK/VOLDA	
	C 14	QEKC1CM-106Z	E CAPACITOR	10MF 20% 16V			C7006	NCB31HK-102X	C CAPACITOR	STANDBY LED	
	C 15	NCS31HJ-120X	C CAPACITOR				C7007	NCB31HK-103X	C CAPACITOR	MICON BUP	
	C 16	NCS31HJ-120X	C CAPACITOR				C7008	QFLC1HJ-104Z	M CAPACITOR	BACK UP	
	C 17	NCB31HK-392X	C CAPACITOR				C7009	QEKC1CM-107Z	E CAPACITOR	BACK UP	
	C 18	QEKC1HM-474Z	E CAPACITOR	.47MF 20% 50V			C7010	QEKC1HM-475Z	E CAPACITOR	RESET	
	C 19	NCB31CK-473X	C CAPACITOR				C7011	QEKC1HM-225Z	E CAPACITOR	RESET	
	C 20	NCB31HK-102X	C CAPACITOR				C7012	EETB0JM-228JC	E CAPACITOR	BACKUP	
	C 21	NCB31CK-223X	C CAPACITOR				C7013	NCB31HK-103X	C CAPACITOR	USSV	
	C 22	NCS31HJ-151X	C CAPACITOR				C7014	QETN1AM-107Z	E CAPACITOR	USSV	
	C 23	NCS31HJ-151X	C CAPACITOR				C7015	NCB31HK-102X	C CAPACITOR	USSV	
	C 24	NCS31HJ-151X	C CAPACITOR				C7016	NDC31HJ-180X	C.CAPACITOR	CLOCK SHIFT	
	C 25	QEKC1CM-107Z	E CAPACITOR	100MF 20% 16V			C7017	NDC31HJ-180X	C.CAPACITOR	CLOCK SHIFT	
	C 28	QEKC1CM-106Z	E CAPACITOR	10MF 20% 16V			C7018	NCB31HK-103X	C CAPACITOR	REMCON	
	C 30	QEKC1CM-107Z	E CAPACITOR	100MF 20% 16V			C7019	QETN1CM-476Z	E CAPACITOR	REMCON	
	C 31	QEKC1CM-226Z	E CAPACITOR	22MF 20% 16V			C7020	NCB31HK-102X	C CAPACITOR	MICON REM	
	C 32	NCB31CK-473X	C CAPACITOR				C7021	NCB31HK-103X	C CAPACITOR	PHOTO-BUFFER	
	C 33	NCB31CK-473X	C CAPACITOR				C7022	NDC31HJ-151X	C CAPACITOR	SLC DGND	
	C 34	NCB31CK-223X	C CAPACITOR				C7023	NDC31HJ-151X	C CAPACITOR	MICON MPX	
	C 35	NCB31CK-473X	C CAPACITOR				C7050	NCB31HK-103X	C CAPACITOR		
	C 36	QEKC1HM-105Z	E CAPACITOR	1.0MF 20% 50V			C7051	NCB31HK-103X	C CAPACITOR		
	C 37	QEKC1HM-105Z	E CAPACITOR	1.0MF 20% 50V			C7500	NCB31HK-103X	C CAPACITOR		
	C 38	QEKC1HM-224Z	E CAPACITOR	.22MF 20% 50V			C7501	NCB31HK-103X	C CAPACITOR		
	C 39	QEKC1HM-105Z	E CAPACITOR	1.0MF 20% 50V			C7502	NCB31HK-103X	C CAPACITOR		
	C 40	QEKC1CM-106Z	E CAPACITOR	10MF 20% 16V			C7503	NCB31HK-103X	C CAPACITOR		
	C 41	QEKC1CM-106Z	E CAPACITOR	10MF 20% 16V			D 1	1SS133-T2	SI DIODE		
	C 42	NCB31CK-273X	C CAPACITOR				D 2	1SS133-T2	SI DIODE		
	C 43	NCB31CK-273X	C CAPACITOR				D 3	1SS133-T2	SI DIODE		
	C 44	QEKC1CM-106Z	E CAPACITOR	10MF 20% 16V			D 4	1SS133-T2	SI DIODE		
	C 45	QEKC1CM-106Z	E CAPACITOR	10MF 20% 16V			DI701	QLD0260-001	LCD MODULE	LCD DISPLAY	
	C 46	NCB31CK-223X	C CAPACITOR				D7000	1SS133-T2	SI DIODE	SAFETY1	
	C 47	QEKC1HM-105Z	E CAPACITOR	1.0MF 20% 50V			D7001	1SS133-T2	SI DIODE	RDS DATA	
	C 48	NCB31HK-222X	C CAPACITOR				D7002	1SS133-T2	SI DIODE	BACK UP	
	C 49	NCB31HK-471X	C CAPACITOR				D7003	1SS133-T2	SI DIODE	SW5V	
	C 50	QEKC1CM-226Z	E CAPACITOR	22MF 20% 16V			D7004	1SS133-T2	SI DIODE	RESET	
	C 51	QEKC1HM-105Z	E CAPACITOR	1.0MF 20% 50V			D7005	MTZJ5.1C-T2	ZENER DIODE	BACK UP	
	C 53	QEKC1CM-226Z	E CAPACITOR	22MF 20% 16V			D7006	MTZJ8.2B-T2	ZENER DIODE	US6V	
	C 54	NCB31CK-473X	C CAPACITOR				D7007	1SS133-T2	SI DIODE	US6V	
	C 57	NCB31HK-102X	C CAPACITOR				D7008	1SS133-T2	SI DIODE	USSV	
	C 58	NCB31CK-473X	C CAPACITOR				D7009	1SS133-T2	SI DIODE	QRIN (FOR RDS)	
	C 59	NCB31HK-102X	C CAPACITOR				D7777	SLR-342VC3F	LED	STDBY LED	
	C 70	NCS31HJ-220X	C CAPACITOR				EP740	E409182-001SM	GRAND TERMINAL		
	C 71	NCS31HJ-220X	C CAPACITOR				FW701	QUM022-12Z3Z3	FLAT WIRE	LAMP-MICON	
	C 72	NCB31HK-561X	C CAPACITOR				IC 1	LA1838	IC		
	C 73	NCB31CK-104X	C CAPACITOR				IC 2	LC72136N	IC		
	C 74	NCB31CK-104X	C CAPACITOR				IC 3	LC72723	IC(RDS)		
	C 75	QEKC1CM-106Z	E CAPACITOR	10MF 20% 16V			IC750	GP1UM281YK	IR DETECT UNIT	REMOCON SENSOR	
	C 76	NCB31HK-331X	C CAPACITOR				IC931	MN101C57CEW	I.C(MICRO-PROC)	SYSTEM MICON	
	C 77	NCB31HK-681X	C CAPACITOR				IC932	KIA78S06P-T	IC	US6V REGULATOR	
	C 80	NCB31HK-102X	C CAPACITOR				J 1	QNB0153-001	ANT TERMINAL		
	C 81	NCB31HK-102X	C CAPACITOR				K7002	QQR0621-001Z	FERRITE BEADS	MICON VREF-	
	CF 1	QAX0420-001	C FILTER				K7003	QQR0621-001Z	FERRITE BEADS	MICON VSS	

■ Electrical parts list (Micon board)

Block No. 02

△	Item	Parts number	Parts name	Remarks	Area
L 1	QQR0796-003		COIL BLOCK	MW ONLY	
L 3	QQL231K-4R7Y		INDUCTOR		
L 70	QQL231K-101Y		INDUCTOR		
L7001	QQL231K-100Y		INDUCTOR	US5V	
L7002	QQL231K-470Y		INDUCTOR	AVDD & VDD	
L7003	QQL231K-4R7Y		INDUCTOR	MICON VREF+	
PP701	QZW0038-001		WIRE CLAMP		
Q 1	2SC1623/5-6/-X		TRANSISTOR		
Q 5	DTA114YKA-X		TRANSISTOR		
Q7000	KRC111S-X		TRANSISTOR	TU DATA	
Q7001	KRC111S-X		TRANSISTOR	TU CLK	
Q7002	2SC2412K/R/-X		TRANSISTOR	PHOTO BUFFER	
Q7003	2SA1037AK/R/-X		TRANSISTOR	BCTL	
Q7004	KRC111S-X		TRANSISTOR	RESET	
Q7005	2SC2412K/R/-X		TRANSISTOR	BACK UP	
Q7006	KRA102S-X		DIGITAL.TR	POUT	
Q7010	KRC111S-X		TRANSISTOR		
R 1	NRSA63J-560X		MG RESISTOR		
R 2	NRSA63J-331X		MG RESISTOR		
R 3	NRSA63J-474X		MG RESISTOR		
R 4	NRSA63J-331X		MG RESISTOR		
R 5	NRSA63J-330X		MG RESISTOR		
R 6	NRSA63J-152X		MG RESISTOR		
R 7	NRSA63J-0R0X		MG RESISTOR		
R 9	NRSA63J-101X		MG RESISTOR		
R 10	NRSA63J-222X		MG RESISTOR		
R 13	NRSA63J-103X		MG RESISTOR		
R 14	NRSA63J-104X		MG RESISTOR		
R 15	NRSA63J-332X		MG RESISTOR		
R 16	NRSA63J-472X		MG RESISTOR		
R 17	NRSA63J-102X		MG RESISTOR		
R 18	NRSA63J-102X		MG RESISTOR		
R 19	NRSA63J-102X		MG RESISTOR		
R 20	NRSA63J-102X		MG RESISTOR		
R 21	NRSA63J-562X		MG RESISTOR		
R 22	NRSA63J-472X		MG RESISTOR		
R 23	NRSA63J-182X		MG RESISTOR		
R 24	NRSA63J-103X		MG RESISTOR		
R 25	NRSA63J-331X		MG RESISTOR		
R 26	NRSA63J-222X		MG RESISTOR		
R 27	NRSA63J-103X		MG RESISTOR		
R 28	NRSA63J-103X		MG RESISTOR		
R 29	NRSA63J-103X		MG RESISTOR		
R 31	NRSA63J-102X		MG RESISTOR		
R 32	NRSA63J-102X		MG RESISTOR		
R 33	NRSA63J-271X		MG RESISTOR		
R 34	NRSA63J-470X		MG RESISTOR		
R 35	NRSA63J-562X		MG RESISTOR		
R 36	NRSA63J-332X		MG RESISTOR		
R 37	NRSA63J-103X		MG RESISTOR		
R 38	NRSA63J-393X		MG RESISTOR		
R 39	NRSA63J-393X		MG RESISTOR		
R 40	NRSA63J-393X		MG RESISTOR		
R 41	NRSA63J-332X		MG RESISTOR		
R 43	NRSA63J-392X		MG RESISTOR		
R 50	NRSA63J-102X		MG RESISTOR		
R 60	NRSA63J-0R0X		MG RESISTOR		
R 72	NRSA63J-102X		MG RESISTOR		
R 73	NRSA63J-102X		MG RESISTOR		
R7000	NRSA63J-153X		MG RESISTOR		
R7001	NRSA63J-333X		MG RESISTOR	MICON VLC1	
R7002	NRSA63J-333X		MG RESISTOR	MICON VLC2	
R7003	NRSA63J-333X		MG RESISTOR	MICON VLC3	
R7004	NRSA63J-222X		MG RESISTOR	MICON REEL	
R7005	NRSA63J-222X		MG RESISTOR	MICON MPX	
R7006	NRSA63J-222X		MG RESISTOR	MICON PERIOD	

△	Item	Parts number	Parts name	Remarks	Area
R7007	NRSA63J-102X		MG RESISTOR	MICON FTUNER	
R7008	NRSA63J-222X		MG RESISTOR	MICON AHB	
R7009	NRSA63J-103X		MG RESISTOR	MICON MMOD	
R7010	NRSA63J-102X		MG RESISTOR	MICON RST	
R7011	NRSA63J-473X		MG RESISTOR	MICON SDATA	
R7012	NRSA63J-102X		MG RESISTOR	MICON SDATA	
R7013	NRSA63J-473X		MG RESISTOR	MICON SCK/VOLCK	
R7014	NRSA63J-151X		MG RESISTOR	MICON SCK/VOLCK	
R7015	NRSA63J-222X		MG RESISTOR	MICON STTA	
R7016	NRSA63J-102X		MG RESISTOR	MICON QRIN	
R7017	NRSA63J-103X		MG RESISTOR	DOOR RST	
R7018	NRSA63J-102X		MG RESISTOR	MICON SQCK	
R7019	NRSA63J-473X		MG RESISTOR	MICON QRIN	
R7020	NRSA63J-102X		MG RESISTOR	MICON FCD	
R7021	NRSA63J-102X		MG RESISTOR	MICON STAT	
R7022	NRSA63J-222X		MG RESISTOR	MICON MUTE	
R7023	NRSA63J-222X		MG RESISTOR	MICON RST/CLOSE	
R7024	NRSA63J-222X		MG RESISTOR	MICON VOLCE	
R7025	NRSA63J-103X		MG RESISTOR	MICON BCTL	
R7026	NRSA63J-222X		MG RESISTOR	MICON BUP	
R7027	NRSA63J-222X		MG RESISTOR	MICON REM	
R7028	NRSA63J-102X		MG RESISTOR	MICON RDSCK	
R7029	NRSA63J-222X		MG RESISTOR	MICON BLKCK	
R7030	NRSA63J-222X		MG RESISTOR	MICON FLAG	
R7031	NRSA63J-102X		MG RESISTOR	MICON XRST	
R7032	NRSA63J-102X		MG RESISTOR	MICON MCLK	
R7033	NRSA63J-102X		MG RESISTOR	MICON MDATA	
R7034	NRSA63J-222X		MG RESISTOR	MICON MLD	
R7035	NRSA63J-222X		MG RESISTOR	MICON KEY0	
R7036	NRSA63J-222X		MG RESISTOR	MICON KEY1	
R7037	NRSA63J-222X		MG RESISTOR	MICON DOOR RST	
R7038	NRSA63J-222X		MG RESISTOR	MICON CDSAFETY	
R7039	NRSA63J-102X		MG RESISTOR	MICON POUT	
R7040	NRSA63J-823X		MG RESISTOR	MICON CDSAFETY	
R7041	NRSA63J-102X		MG RESISTOR	MICON SMUTE	
R7042	NRSA63J-222X		MG RESISTOR	MICON SAFETY1	
R7043	NRSA63J-222X		MG RESISTOR	MICON SAFETY0	
R7044	NRSA63J-222X		MG RESISTOR	MICON SAFETY2	
R7045	NRSA63J-222X		MG RESISTOR	MICON TAPE1	
R7046	NRSA63J-222X		MG RESISTOR	MICON TAPE0	
R7047	NRSA63J-563X		MG RESISTOR	MICON SAFETY1	
R7048	NRSA63J-104X		MG RESISTOR	MICON TAPE1	
R7049	NRSA63J-103X		MG RESISTOR	MICON TAPE0	
R7050	NRSA63J-271X		MG RESISTOR	STANBY LED	
R7051	NRSA63J-473X		MG RESISTOR	BACK UP	
R7052	NRSA63J-333X		MG RESISTOR	BACK UP	
R7053	NRSA63J-104X		MG RESISTOR	BACK UP	
R7054	NRSA63J-103X		MG RESISTOR	RESET	
R7055	NRSA63J-103X		MG RESISTOR	RESET	
R7056	NRSA63J-331X		MG RESISTOR	BACK UP	
R7057	NRSA63J-105X		MG RESISTOR	CLOCK SHIFT	
R7058	NRSA63J-104X		MG RESISTOR	PHOTO-BUFFER	
R7059	NRSA63J-394X		MG RESISTOR	PHOTO BUFFER	
R7060	NRSA63J-823X		MG RESISTOR	PHOTO BUFFER	
R7061	NRSA63J-222X		MG RESISTOR	FTUNERSW	
R7062	NRSA63J-103X		MG RESISTOR	RDS CK	
R7063	NRSA63J-202X		MG RESISTOR	SCK/VOLCK	
R7064	NRSA63J-103X		MG RESISTOR	SLC SAFETY1	
R7065	NRSA63J-183X		MG RESISTOR		
R7070	NRSA63J-223X		MG RESISTOR	CDSAFETY	
R7071	NRSA63J-103X		MG RESISTOR	KEY1	
R7072	NRSA63J-103X		MG RESISTOR	KEY0	
R7073	NRSA63J-823X		MG RESISTOR	REEL	
R7074	NRSA63J-103X		MG RESISTOR		
R7500	NRSA63J-102X		MG RESISTOR		
R7501	NRSA63J-102X		MG RESISTOR		

■ Electrical parts list (Micon board)

Block No. 02

△	Item	Parts number	Parts name	Remarks	Area
	R7502	NRSA63J-122X	MG RESISTOR		
	R7503	NRSA63J-182X	MG RESISTOR		
	R7504	NRSA63J-222X	MG RESISTOR		
	R7505	NRSA63J-272X	MG RESISTOR		
	R7506	NRSA63J-363X	MG RESISTOR	VERSION	
	R7507	NRSA63J-102X	MG RESISTOR		
	R7508	NRSA63J-102X	MG RESISTOR		
	R7509	NRSA63J-122X	MG RESISTOR		
	R7510	NRSA63J-182X	MG RESISTOR		
	R7511	NRSA63J-222X	MG RESISTOR		
	R7512	NRSA63J-272X	MG RESISTOR		
	R7513	NRSA63J-392X	MG RESISTOR		
	S7500	QSW0651-001Z	TACT SWITCH	POWER	
	S7501	QSW0651-001Z	TACT SWITCH	AUX	
	S7502	QSW0651-001Z	TACT SWITCH	TAPE	
	S7503	QSW0651-001Z	TACT SWITCH	TUNER	
	S7504	QSW0651-001Z	TACT SWITCH	CD	
	S7505	QSW0651-001Z	TACT SWITCH	VOLUME-	
	S7506	QSW0651-001Z	TACT SWITCH	VOLUME+	
	S7507	QSW0651-001Z	TACT SWITCH	AHB	
	S7508	QSW0651-001Z	TACT SWITCH	UP	
	S7509	QSW0651-001Z	TACT SWITCH	STOP	
	S7510	QSW0651-001Z	TACT SWITCH	DOWN	
	S7511	QSW0651-001Z	TACT SWITCH	RECORD	
	S7512	QSW0651-001Z	TACT SWITCH	SNOOZE	
	S7550	QSW0122-001	PUSH SWITCH	OPEN/CLOSE	
	T 1	QQR0793-001	IFT		
	TU 1	QAU0160-001	FRONT END		
	X 1	QAX0402-001	CRYSTAL		
	X 70	QAX0263-001Z	CRYSTAL		
	X7001	QAX0711-002Z	CRYSTAL	MAIN CLOCK	

■ Electrical parts list (Head amplifier board) Block No. 03

△	Item	Parts number	Parts name	Remarks	Area
	CN 1	QGF1205F1-09	CONNECTOR		
	D 1	1SR139-400-T2	SI DIODE		
	IC 1	SG-105F3-BB,C	PHOTO SENSER		
	P 1	QNZ0104-001	POST PIN		
	SW 1	QSW0832-001	LEAF SWITCH		
	SW 2	QSW0832-001	LEAF SWITCH		
	SW 5	QSW0832-001	LEAF SWITCH		
	SW 6	QSW0859-001	SW		

■ Electrical parts list (Cassette switch board) Block No. 04

Item	Parts number	Parts name	Remarks	Area
C 101	QDGB1HK-821Y	C CAPACITOR		
C 102	QDYB1CM-103Y	C CAPACITOR		
C 103	QFLA1HJ-104Z	TF CAPACITOR	.10MF 5% 50V	
C 104	QCBB1HK-221Y	C CAPACITOR	220PF 10% 50V	
C 105	QCBB1HK-391Y	C CAPACITOR	390PF 10% 50V	
C 106	QERF1HM-225Z	E CAPACITOR	2.2MF 20% 50V	
C 107	QCBB1HK-271Y	C CAPACITOR	270PF 10% 50V	
C 109	QEKJ1EM-475Z	E CAPACITOR	4.7MF 20% 25V	
C 110	QDYB1CM-682Y	C CAPACITOR		
C 113	QFLA1HJ-104Z	TF CAPACITOR	.10MF 5% 50V	
C 120	QCSB1HK-4R7Y	C CAPACITOR	4.7PF 10% 50V	
C 121	QCBB1HK-331Y	C CAPACITOR	330PF 10% 50V	
C 201	QDGB1HK-821Y	C CAPACITOR		
C 202	QDYB1CM-103Y	C CAPACITOR		
C 203	QFLA1HJ-104Z	TF CAPACITOR	.10MF 5% 50V	
C 204	QCBB1HK-221Y	C CAPACITOR	220PF 10% 50V	
C 205	QCBB1HK-391Y	C CAPACITOR	390PF 10% 50V	
C 206	QERF1HM-225Z	E CAPACITOR	2.2MF 20% 50V	
C 207	QCBB1HK-271Y	C CAPACITOR	270PF 10% 50V	
C 209	QEKJ1EM-475Z	E CAPACITOR	4.7MF 20% 25V	
C 210	QDYB1CM-682Y	C CAPACITOR		
C 213	QFLA1HJ-104Z	TF CAPACITOR	.10MF 5% 50V	
C 220	QCSB1HK-4R7Y	C CAPACITOR	4.7PF 10% 50V	
C 221	QCBB1HK-331Y	C CAPACITOR	330PF 10% 50V	
C 300	QEKJ1HM-105Z	E CAPACITOR	1.0MF 20% 50V	
C 301	QEKJ1AM-107Z	E CAPACITOR	100MF 20% 10V	
C 304	QEKJ1CM-106Z	E CAPACITOR	10MF 20% 16V	
C 306	QETJ1AM-227Z	E CAPACITER	220MF 20% 10V	
C 307	QDGB1HK-102Y	C CAPACITOR		
C 308	QDXB1CM-152Y	C CAPACITOR		
C 310	QCBB1HK-223Y	C CAPACITOR	.022MF 10% 50V	
C 313	QEKJ1AM-107Z	E CAPACITOR	100MF 20% 10V	
C 314	QCFB1HZ-105Y	C CAPACITOR	1.0MF +80%-20%	
C 316	QFG32AJ-223Z	PP CAPACITOR	.022MF 5% 100V	
C 319	QFLC1HJ-472Z	M CAPACITOR	4700PF 5% 50V	
C 331	QEKJ1CM-476Z	E CAPACITOR	47MF 20% 16V	
C 340	QEKJ1CM-476Z	E CAPACITOR	47MF 20% 16V	
C 341	QEKJ1HM-105Z	E CAPACITOR	1.0MF 20% 50V	
C 342	QEKJ1CM-476Z	E CAPACITOR	47MF 20% 16V	
C 371	QEKJ1EM-475Z	E CAPACITOR	4.7MF 20% 25V	
C 374	QEKJ1AM-107Z	E CAPACITOR	100MF 20% 10V	
C 376	QDYB1CM-103Y	C CAPACITOR		
CN 31	QGF1205F1-06	CONNECTOR		
CN 32	QGF1205F1-09	CONNECTOR		
CN 33	QGF1205F1-09	CONNECTOR		
CN 34	QGF1201F3-10	CONNECTOR		
D 340	MTZJ5.1B-T2	ZENER DIODE		
D 375	MTZJ5.1B-T2	ZENER DIODE		
FW100	QUM024-07A2Z3	FLAT WIRE		
H 32	GV40397-001A	IC HOLDER		
IC 32	HA12238F	IC		
IC 33	CD4094BC	IC		
L 301	QQR1118-002	BIAS COIL		
L 303	QQL244K-100Z	INDUCTOR		
Q 302	2SC2001/K-T	TRANSISTOR		
Q 305	2SC2001/K-T	TRANSISTOR		
Q 342	KRA111M-T	D.TRANSISTOR		
Q 343	2SC3576-JVC-T	TRANSISTOR		
Q 344	2SC3576-JVC-T	TRANSISTOR		
Q 345	2SC3576-JVC-T	TRANSISTOR		
Q 346	2SC3576-JVC-T	TRANSISTOR		
Q 347	KRC107M-T	D.TRANSISTOR		
Q 371	KTA1271/OY-T	TRANSISTOR		
Q 372	KRC107M-T	D.TRANSISTOR		
Q 375	2SB562/C-T	TRANSISTOR		
Q 376	KTC3199/GL-T	TRANSISTOR		

Item	Parts number	Parts name	Remarks	Area
R 101	QRE141J-512Y	C RESISTOR	5.1K 5% 1/4W	
R 102	QRE141J-512Y	C RESISTOR	5.1K 5% 1/4W	
R 104	QRE141J-222Y	C RESISTOR	2.2K 5% 1/4W	
R 105	QRE141J-104Y	C RESISTOR	100K 5% 1/4W	
R 106	QRE141J-113Y	C RESISTOR	11K 5% 1/4W	
R 107	QRE141J-912Y	C RESISTOR	9.1K 5% 1/4W	
R 108	QRE141J-273Y	C RESISTOR	27K 5% 1/4W	
R 110	QRE141J-103Y	C RESISTOR	10K 5% 1/4W	
R 116	QRE141J-102Y	C RESISTOR	1.0K 5% 1/4W	
R 121	QRE141J-153Y	C RESISTOR	15K 5% 1/4W	
R 201	QRE141J-512Y	C RESISTOR	5.1K 5% 1/4W	
R 202	QRE141J-512Y	C RESISTOR	5.1K 5% 1/4W	
R 204	QRE141J-222Y	C RESISTOR	2.2K 5% 1/4W	
R 205	QRE141J-104Y	C RESISTOR	100K 5% 1/4W	
R 206	QRE141J-113Y	C RESISTOR	11K 5% 1/4W	
R 207	QRE141J-912Y	C RESISTOR	9.1K 5% 1/4W	
R 208	QRE141J-273Y	C RESISTOR	27K 5% 1/4W	
R 210	QRE141J-103Y	C RESISTOR	10K 5% 1/4W	
R 216	QRE141J-102Y	C RESISTOR	1.0K 5% 1/4W	
R 221	QRE141J-153Y	C RESISTOR	15K 5% 1/4W	
R 301	QRE141J-221Y	C RESISTOR	220 5% 1/4W	
R 302	QRE141J-222Y	C RESISTOR	2.2K 5% 1/4W	
R 303	QRE141J-222Y	C RESISTOR	2.2K 5% 1/4W	
△ R 304	QRJ146J-101X	UNF C RESISTOR	100 5% 1/4W	
R 305	QRE141J-103Y	C RESISTOR	10K 5% 1/4W	
R 306	QRE141J-472Y	C RESISTOR	4.7K 5% 1/4W	
△ R 310	QRJ146J-4R7X	UNF C RESISTOR	4.7 5% 1/4W	
R 313	QRE141J-2R2Y	C RESISTOR	2.2 5% 1/4W	
R 314	QRE141J-153Y	C RESISTOR	15K 5% 1/4W	
R 315	QRE141J-101Y	C RESISTOR	100 5% 1/4W	
R 327	QRE141J-474Y	C RESISTOR	470K 5% 1/4W	
R 335	QRE141J-222Y	C RESISTOR	2.2K 5% 1/4W	
R 336	QRE141J-223Y	C RESISTOR	22K 5% 1/4W	
R 337	QRE141J-332Y	C RESISTOR	3.3K 5% 1/4W	
R 338	QRE141J-392Y	C RESISTOR	3.9K 5% 1/4W	
R 339	QRE141J-104Y	C RESISTOR	100K 5% 1/4W	
R 340	QRE141J-681Y	C RESISTOR	680 5% 1/4W	
R 341	QRE141J-123Y	C RESISTOR	12K 5% 1/4W	
R 342	QRE141J-243Y	C RESISTOR	24K 5% 1/4W	
R 343	QRE141J-183Y	C RESISTOR	18K 5% 1/4W	
R 344	QRE141J-472Y	C RESISTOR	4.7K 5% 1/4W	
R 345	QRE141J-472Y	C RESISTOR	4.7K 5% 1/4W	
R 346	QRE141J-472Y	C RESISTOR	4.7K 5% 1/4W	
R 347	QRE141J-103Y	C RESISTOR	10K 5% 1/4W	
△ R 353	QRJ146J-100X	UNF C RESISTOR	10 5% 1/4W	
R 371	QRE141J-123Y	C RESISTOR	12K 5% 1/4W	
R 372	QRE141J-102Y	C RESISTOR	1.0K 5% 1/4W	
R 375	QRE141J-151Y	C RESISTOR	150 5% 1/4W	
R 376	QRE141J-472Y	C RESISTOR	4.7K 5% 1/4W	
VR 31	QVP0008-203Z	SEMI V RESISTOR		
VR 37	QVP0077-103Z	SEMI V RESISTOR		

Packing materials and accessories parts list

Block No.

M	3	M	M
---	---	---	---

Block No.

M	5	M	M
---	---	---	---

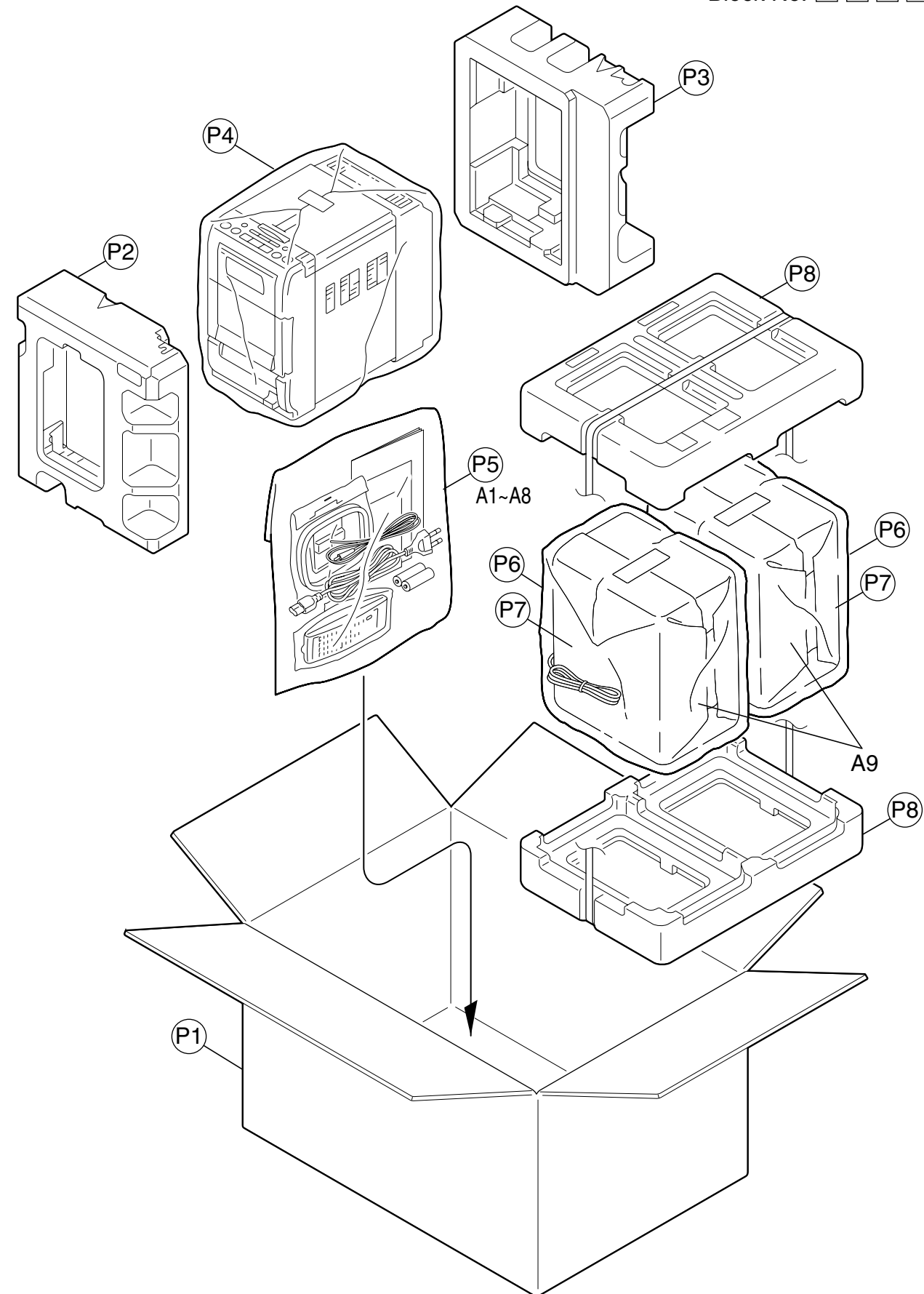

Parts list (Packing)

Block No. M3MM

⚠	Item	Parts number	Parts name	Q'ty	Description	Area
	P 1	GV30407-001A	CARTON	1		
	P 2	GV20200-001A	CUSHION(U)	1	(FRONT SIDE)	
	P 3	GV20200-002A	CUSHION(U)	1	(REAR SIDE)	
	P 4	QPC04504515P	POLY BAG	1		
	P 5	QPC02503515P	POLY BAG	1	FOR INST	
	P 6	70012006210	HOPE BAG	2		
	P 7	71525007400	PACKING SHEET	2		
	P 8	7200UXH3000	CUSHION	2		

Parts list (Accessories)

Block No. M5MM

⚠	Item	Parts number	Parts name	Q'ty	Description	Area
	A 1	GVT0101-007A	INST.BOOK	1	GER,FRE,SPA,ITA	EN
		GVT0101-007A	INST.BOOK	1	DAN,FIN,SWE	EN
		GVT0101-006A	INST.BOOK	1	GER,FRE,DUT	E
		GVT0101-008A	INST.BOOK	1	ENG	B
⚠	A 2	QMPP060-183-JD	POWER CORD	1		B
⚠		QMPL060-183-JD	POWER CORD	1		E,EN
	A 3	RM-SUXH30R	W.LESS REMOCON	1		
	A 4	-----	BATTERY	2	FOR REMOCON	
	A 5	BT-54013-5	W.CARD	1		
	A 6	QAL0457-001	ANT.WIRE	1	FM ANT	
	A 7	QAL0014-001	AM LOOP ANT	1	AM ANT	
	A 8	VNA3000-204	REGISTER CARD	1		B
	A 9	UXH30E-SPBOX	SPK WITH BOX	2		