

JVC

SERVICE MANUAL

MICRO COMPONENT SYSTEM

UX-J50

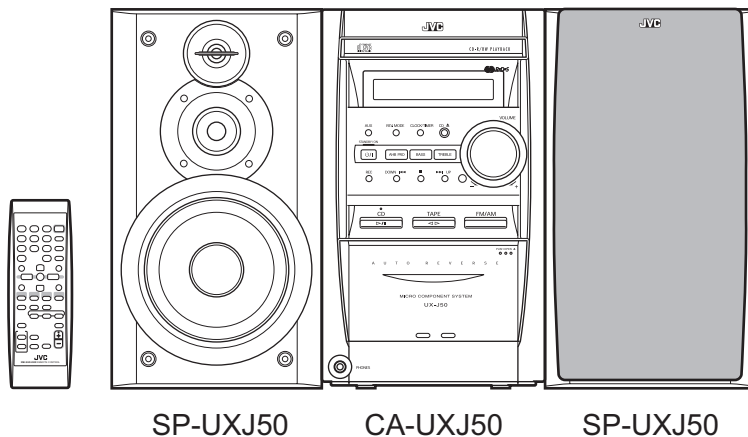

SP-UXJ50

CA-UXJ50

SP-UXJ50

COMPACT
disc
DIGITAL AUDIO

CD R·D·S

Area Suffix

B ----- U.K.
E ----- Continental Europe
EN ----- Northern Europe

TABLE OF CONTENTS

1	Important Safety Precautions	1-2
2	Disassembly method	1-6
3	Adjustment.....	1-19
4	Description of major ICs.....	1-25

SECTION 1

Important Safety Precautions

1.1 Safety Precautions

- (1) This design of this product contains special hardware and many circuits and components specially for safety purposes. For continued protection, no changes should be made to the original design unless authorized in writing by the manufacturer. Replacement parts must be identical to those used in the original circuits. Services should be performed by qualified personnel only.
- (2) Alterations of the design or circuitry of the product should not be made. Any design alterations of the product should not be made. Any design alterations or additions will void the manufacturers warranty and will further relieve the manufacture of responsibility for personal injury or property damage resulting therefrom.
- (3) Many electrical and mechanical parts in the products have special safety-related characteristics. These characteristics are often not evident from visual inspection nor can the protection afforded by them necessarily be obtained by using replacement components rated for higher voltage, wattage, etc. Replacement parts which have these special safety characteristics are identified in the Parts List of Service Manual. Electrical components having such features are identified by shading on the schematics and by (Δ) on the Parts List in the Service Manual. The use of a substitute replacement which does not have the same safety characteristics as the recommended replacement parts shown in the Parts List of Service Manual may create shock, fire, or other hazards.
- (4) The leads in the products are routed and dressed with ties, clamps, tubings, barriers and the like to be separated from live parts, high temperature parts, moving parts and/or sharp edges for the prevention of electric shock and fire hazard. When service is required, the original lead routing and dress should be observed, and it should be confirmed that they have been returned to normal, after reassembling.
- (5) Leakage shock hazard testing)

After reassembling the product, always perform an isolation check on the exposed metal parts of the product (antenna terminals, knobs, metal cabinet, screw heads, headphone jack, control shafts, etc.) to be sure the product is safe to operate without danger of electrical shock.

Do not use a line isolation transformer during this check.

 - Plug the AC line cord directly into the AC outlet. Using a "Leakage Current Tester", measure the leakage current from each exposed metal parts of the cabinet, particularly any exposed metal part having a return path to the chassis, to a known good earth ground. Any leakage current must not exceed 0.5mA AC (r.m.s.).
 - Alternate check method

Plug the AC line cord directly into the AC outlet. Use an AC voltmeter having, 1,000 ohms per volt or more sensitivity in the following manner. Connect a 1,500 ohm 10W resistor paralleled by a 0.15 μ F AC-type capacitor between an

exposed metal part and a known good earth ground.

Measure the AC voltage across the resistor with the AC voltmeter.

Move the resistor connection to each exposed metal part, particularly any exposed metal part having a return path to the chassis, and measure the AC voltage across the resistor. Now, reverse the plug in the AC outlet and repeat each measurement. Voltage measured any must not exceed 0.75 V AC (r.m.s.). This corresponds to 0.5 mA AC (r.m.s.).

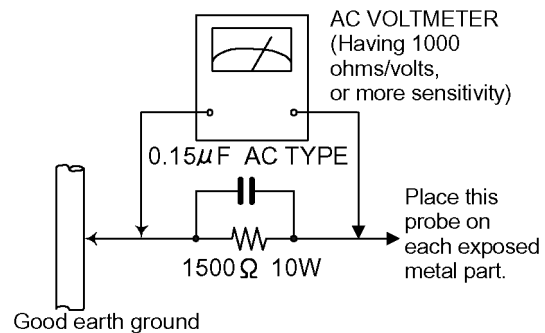

1.2 Warning

- (1) This equipment has been designed and manufactured to meet international safety standards.
- (2) It is the legal responsibility of the repairer to ensure that these safety standards are maintained.
- (3) Repairs must be made in accordance with the relevant safety standards.
- (4) It is essential that safety critical components are replaced by approved parts.
- (5) If mains voltage selector is provided, check setting for local voltage.

1.3 Caution

Burrs formed during molding may be left over on some parts of the chassis.

Therefore, pay attention to such burrs in the case of pre-forming repair of this system.

1.4 Critical parts for safety

In regard with component parts appearing on the silk-screen printed side (parts side) of the PWB diagrams, the parts that are printed over with black such as the resistor (\blacksquare), diode (\blacksquare) and ICP (\bullet) or identified by the " Δ " mark nearby are critical for safety.

When replacing them, be sure to use the parts of the same type and rating as specified by the manufacturer. (Except the JC version)

1.5 Safety Precautions (U.K only)

- (1) This design of this product contains special hardware and many circuits and components specially for safety purposes. For continued protection, no changes should be made to the original design unless authorized in writing by the manufacturer. Replacement parts must be identical to those used in the original circuits.
- (2) Any unauthorised design alterations or additions will void the manufacturer's guarantee; furthermore the manufacturer cannot accept responsibility for personal injury or property damage resulting therefrom.
- (3) Essential safety critical components are identified by () on the Parts List and by shading on the schematics, and must never be replaced by parts other than those listed in the manual. Please note however that many electrical and mechanical parts in the product have special safety related characteristics. These characteristics are often not evident from visual inspection. Parts other than specified by the manufacturer may not have the same safety characteristics as the recommended replacement parts shown in the Parts List of the Service Manual and may create shock, fire, or other hazards.
- (4) The leads in the products are routed and dressed with ties, clamps, tubings, barriers and the like to be separated from live parts, high temperature parts, moving parts and/or sharp edges for the prevention of electric shock and fire hazard. When service is required, the original lead routing and dress should be observed, and it should be confirmed that they have been returned to normal, after re-assembling.

1.5.1 Warning

- (1) Service should be performed by qualified personnel only.
- (2) This equipment has been designed and manufactured to meet international safety standards.
- (3) It is the legal responsibility of the repairer to ensure that these safety standards are maintained.
- (4) Repairs must be made in accordance with the relevant safety standards.
- (5) It is essential that safety critical components are replaced by approved parts.
- (6) If mains voltage selector is provided, check setting for local voltage.



CAUTION Burrs formed during molding may be left over on some parts of the chassis. Therefore, pay attention to such burrs in the case of preforming repair of this system.

1.6 Preventing static electricity

Electrostatic discharge (ESD), which occurs when static electricity stored in the body, fabric, etc. is discharged, can destroy the laser diode in the traverse unit (optical pickup). Take care to prevent this when performing repairs.

1.6.1 Grounding to prevent damage by static electricity

Static electricity in the work area can destroy the optical pickup (laser diode) in devices such as CD players. Be careful to use proper grounding in the area where repairs are being performed.

(1) Ground the workbench

Ground the workbench by laying conductive material (such as a conductive sheet) or an iron plate over it before placing the traverse unit (optical pickup) on it.

(2) Ground yourself

Use an anti-static wrist strap to release any static electricity built up in your body.

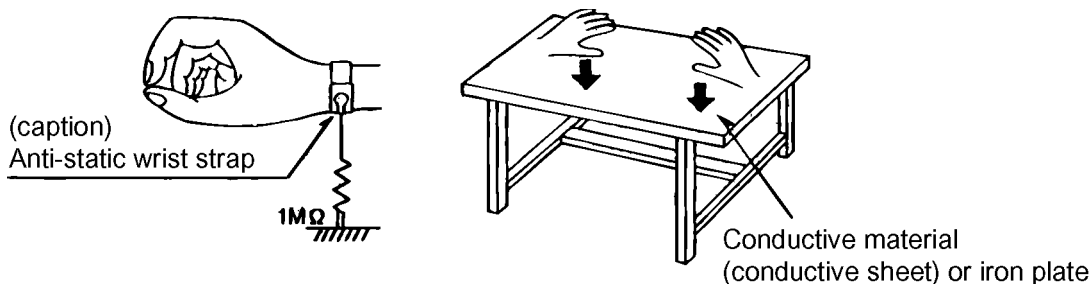

(3) Handling the optical pickup

- In order to maintain quality during transport and before installation, both sides of the laser diode on the replacement optical pickup are shorted. After replacement, return the shorted parts to their original condition. (Refer to the text.)
- Do not use a tester to check the condition of the laser diode in the optical pickup. The tester's internal power source can easily destroy the laser diode.

1.7 Handling the traverse unit (optical pickup)

(1) Do not subject the traverse unit (optical pickup) to strong shocks, as it is a sensitive, complex unit.

(2) Cut off the shorted part of the flexible cable using nippers, etc. after replacing the optical pickup. For specific details, refer to the replacement procedure in the text. Remove the anti-static pin when replacing the traverse unit. Be careful not to take too long a time when attaching it to the connector.

(3) Handle the flexible cable carefully as it may break when subjected to strong force.

(4) It is not possible to adjust the semi-fixed resistor that adjusts the laser power. Do not turn it.

1.8 Attention when traverse unit is decomposed

***Please refer to "Disassembly method" in the text for the CD pickup unit.**

- Apply solder to the short land sections before the flexible wire is disconnected from the connector CN101 on the CD servo board. (If the flexible wire is disconnected without applying solder, the CD pickup may be destroyed by static electricity.)
- In the assembly, be sure to remove solder from the short land sections after connecting the flexible wire.

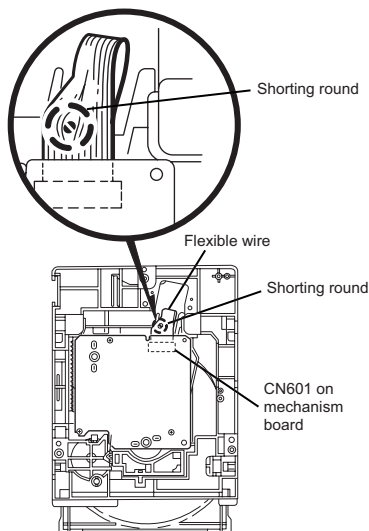

1.9 Important for laser products

(1) **CLASS 1 LASER PRODUCT**

(2) **DANGER** : Invisible laser radiation when open and inter lock failed or defeated. Avoid direct exposure to beam.

(3) **CAUTION** : There are no serviceable parts inside the Laser Unit. Do not disassemble the Laser Unit. Replace the complete Laser Unit if it malfunctions.

(4) **CAUTION** : The compact disc player uses invisible laser radiation and is equipped with safety switches which prevent emission of radiation when the drawer is open and the safety interlocks have failed or are de feated. It is dangerous to defeat the safety switches.

(5) **CAUTION** : If safety switches malfunction, the laser is able to function.

(6) **CAUTION** : Use of controls, adjustments or performance of procedures other than those specified herein may result in hazardous radiation exposure.

⚠ CAUTION

Please use enough caution not to see the beam directly or touch it in case of anadjustment or operation check.

VARNING

Osynlig laserstrålning är denna del är öppnad och spärren är urkopplad. Betrakta ej strålen.

VARO

Avattaessa ja suojalukitus ohitettaessa olet alltiina näkymätömälle lasersäteilylle. Älä katso säteeseen.

ADVARSEL

Usynlig laserstrålning ved åbning, når sikkerhedsafbrydere er ude af funktion. Undgå udsasttelse for stråling.

ADVARSEL

Usynlig laserstrålning ved åbning, når sikkerhetsbryteren er avslott. unngå utsettelse for stråling.

REPRODUCTION AND POSITION OF LABELS

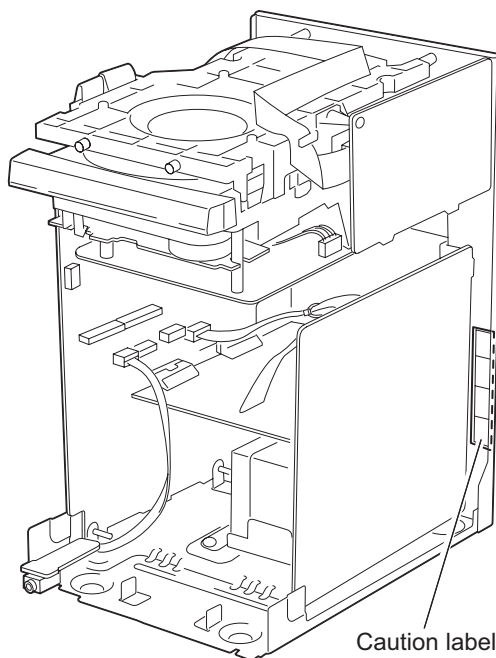

SECTION 2 Disassembly method

2.1 Main body

2.1.1 Removing the metal cover

(See Fig.1~3)

- (1) Remove the six screws **A** on the back of the main body.
- (2) Remove the two screws **B** on each side and remove the metal cover in the direction of the arrow.

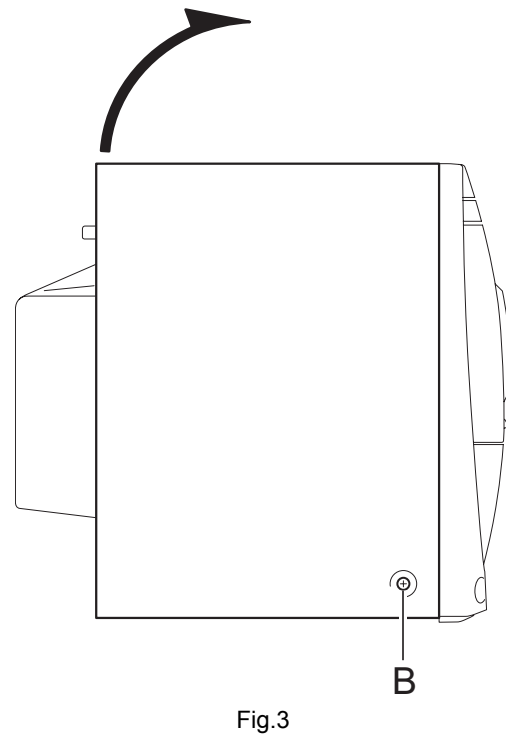
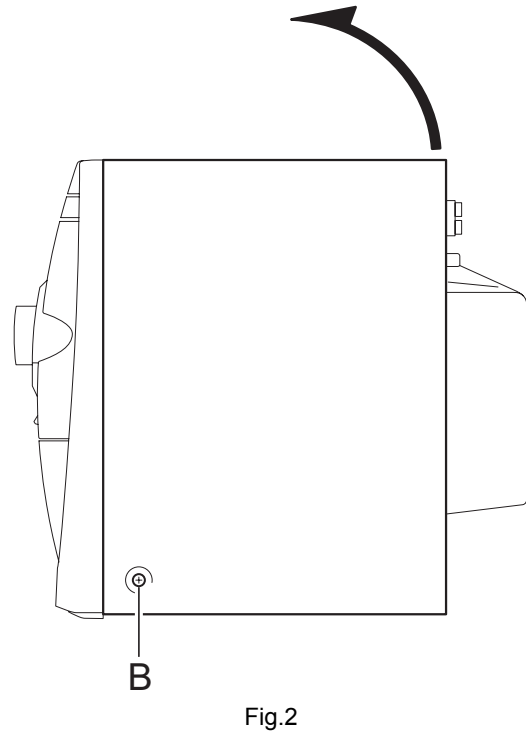
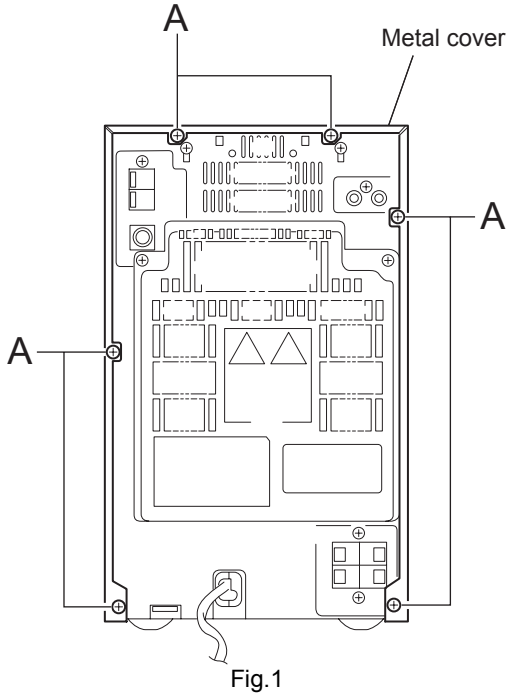

2.1.2 Removing the rear cover (See Fig.4)

- (1) Remove the two screws **C** attaching the rear cover.

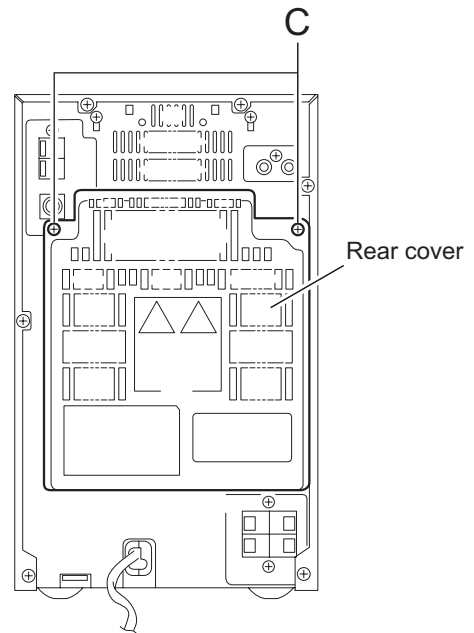

Fig.4

2.1.3 Removing the rear panel / fan assembly (See Fig.5,6)

- Prior to performing the following procedure, remove the metal cover and the rear cover.
- (1) Remove the nine screws **D** attaching the rear panel. Release the two joints **a** on the rear side and the two joints **b** on each side.
 - (2) Remove the two screws **E** attaching the fan bracket and release the two joints **c** on the rear panel, and remove.
 - (3) Disconnect the wire from the connector CN916 on the main board.

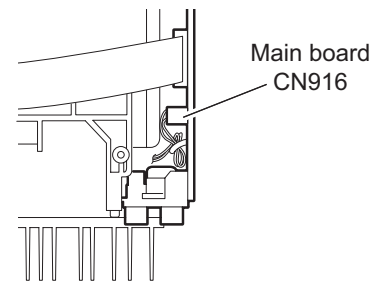

Fig.6

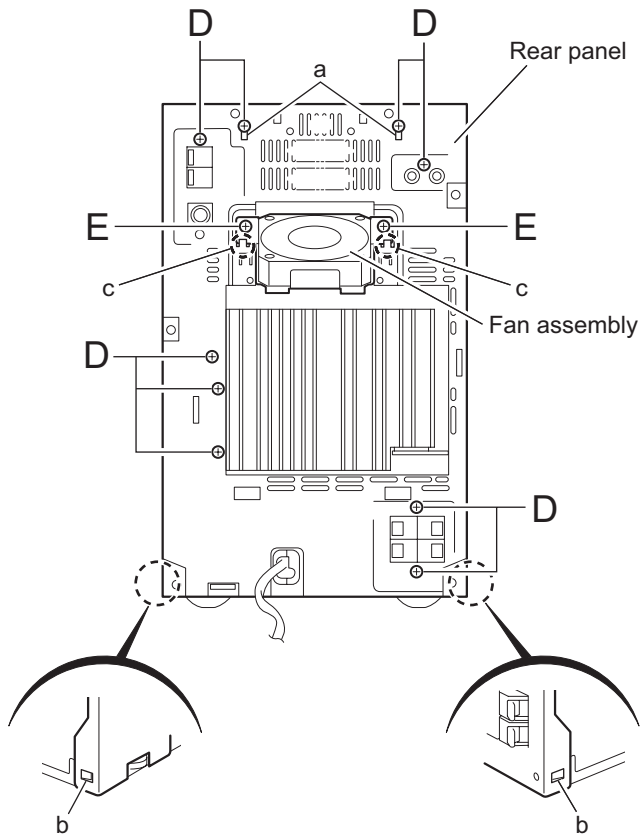

Fig.5

2.1.4 Removing the tuner board (See Fig.7)

- Prior to performing the following procedure, remove the metal cover.
 - (1) Disconnect the card wire from the connector CN1 on the tuner board.
 - (2) Remove the two screws **F** on the rear side and the screw **G** in the side.

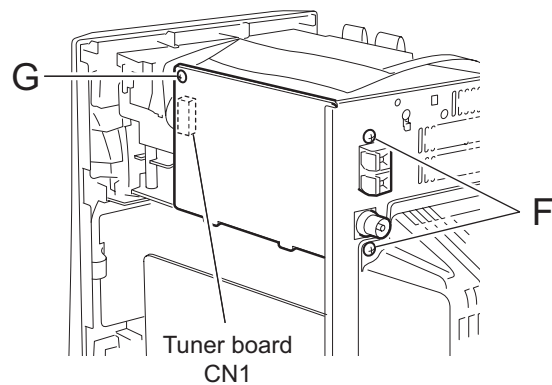

Fig.7

2.1.5 Removing the CD-R/RW mechanism assembly (See Fig.8)

- Prior to performing the following procedure, remove the metal cover, the rear cover, the rear panel and the tuner board.
 - (1) Disconnect the card wire from the connector CN903, CN902 and CN904 on the main board.
 - (2) Pull the joint **d** in the direction of the arrow and remove the CD-R/RW mechanism assembly backward while releasing the joint **e**.

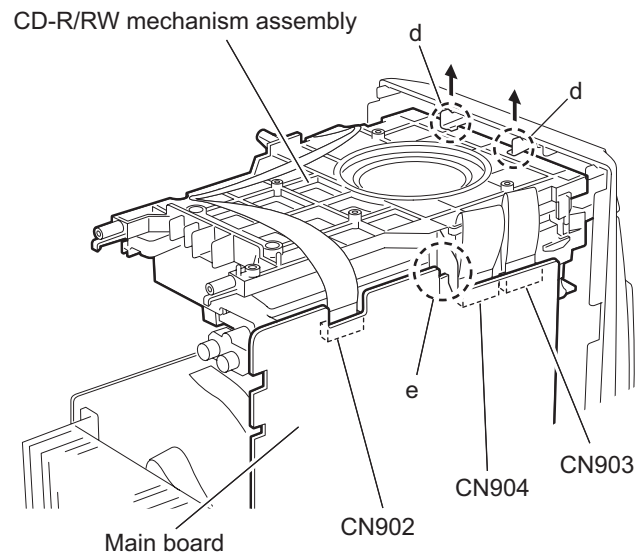

Fig.8

2.1.6 Removing the main board / the heat sink board / the speaker jack board

(See Fig.9~11)

- Prior to performing the following procedure, remove the metal cover, the rear cover, the rear panel, the tuner board and the CD-R/RW mechanism assembly.
 - (1) Remove the two screws **H** attaching the main board.
 - (2) Disconnect the card wire from the connector CN900, CN901, CN930, CN931 and CN932, and disconnect the flat wire from the connector CN913, CN917 and CN918 on the main board.
 - (3) Remove the band and disconnect the flat wire from the connector CN951 on the power transformer assembly, and then remove the main board / the heat sink board from the body.
 - (4) Release the two joints **f** of the main board and disconnect the connector CN944 and CN945 of the heat sink board from the connector CN912 and CN911 of the main board respectively, and remove.

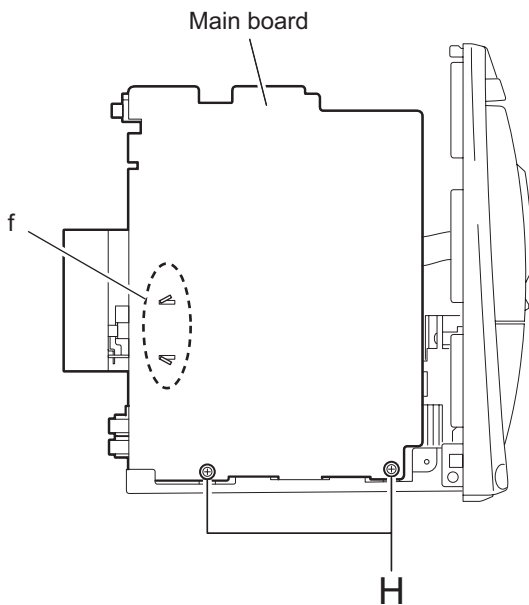

Fig.9

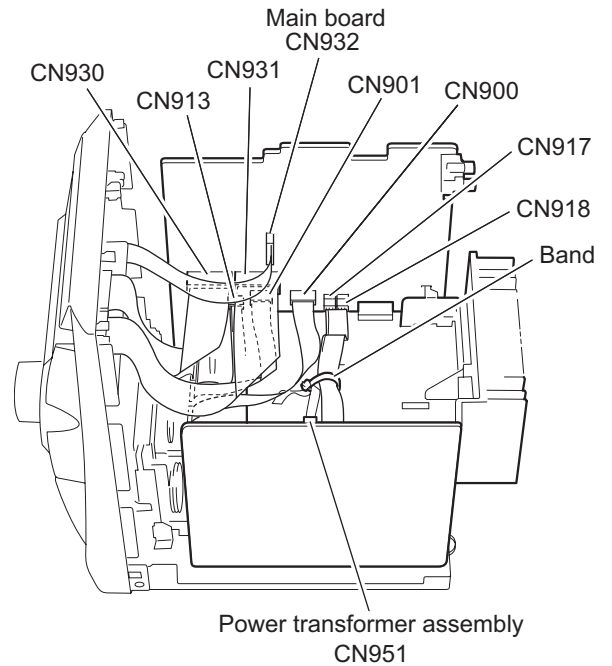

Fig.10

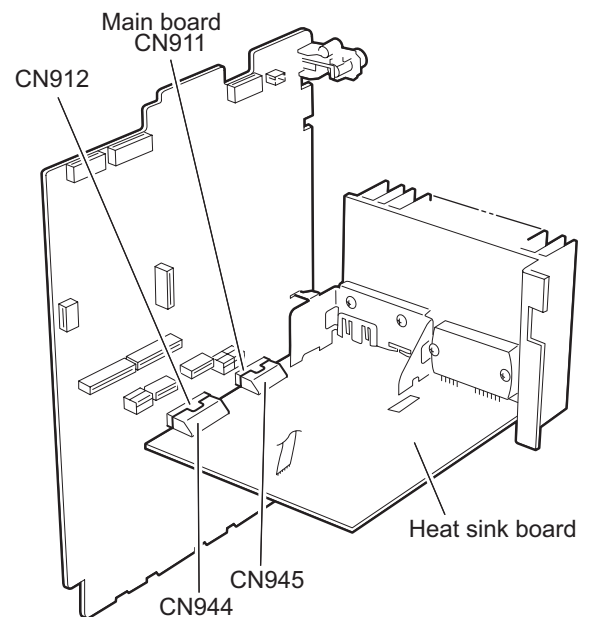

Fig.11

**2.1.7 Removing the power transformer assembly
(See Fig.12)**

- Prior to performing the following procedure, remove the metal cover, the rear cover, the rear panel, the CD-R/RW mechanism assembly and the main board.
- (1) Disconnect the power cord from the connector J1000 on the power transformer assembly.
- (2) Remove the four screws **J**.

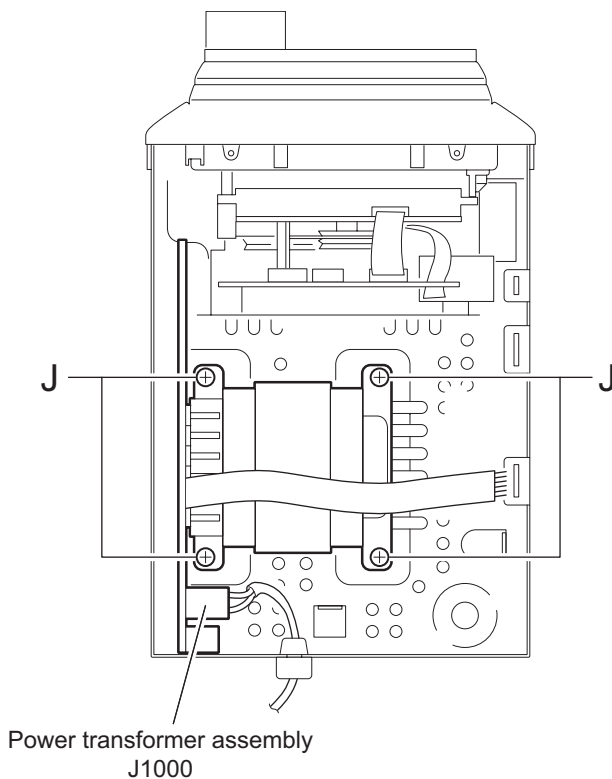

Fig.12

**2.1.8 Removing the front panel assembly
(See Fig.13,14)**

- Prior to performing the following procedure, remove the metal cover.
- (1) Remove the two screws **K** on each side. Release the two joints **g** on the both sides and lift the front panel assembly to release the joint **h**.
- (2) Disconnect the card wire from the connector CN900, CN901, CN930, CN931 and CN932 on the main board.

Front panel assembly

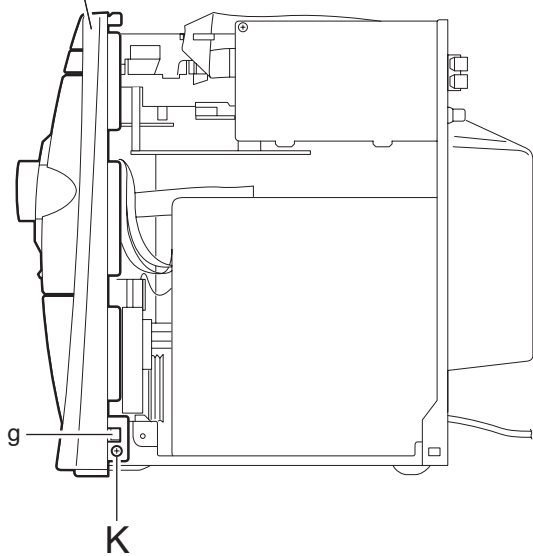

Fig.13

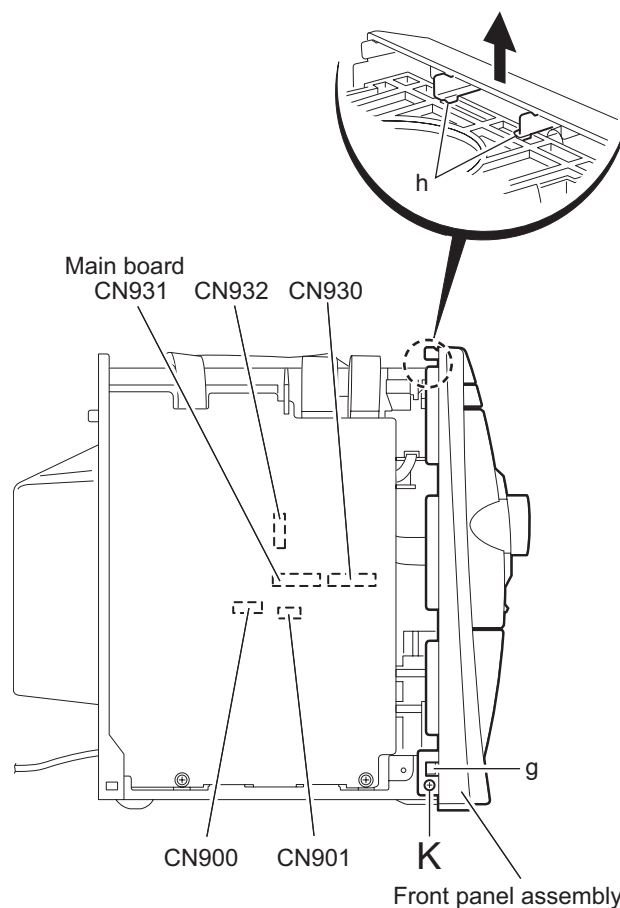

Fig.14

2.1.9 Removing the phones board (See Fig.15)

- Prior to performing procedure, remove the metal cover and the front panel assembly.
 - (1) Disconnect the flat wire from the connector CN913 on the main board.

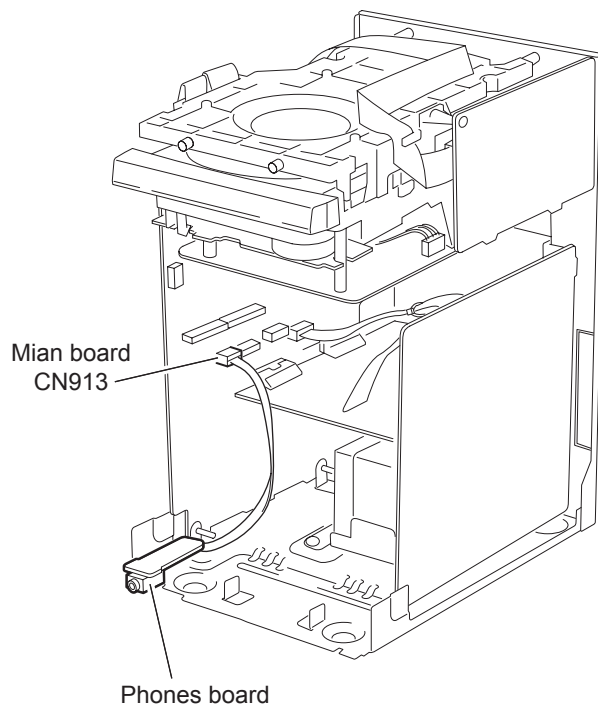
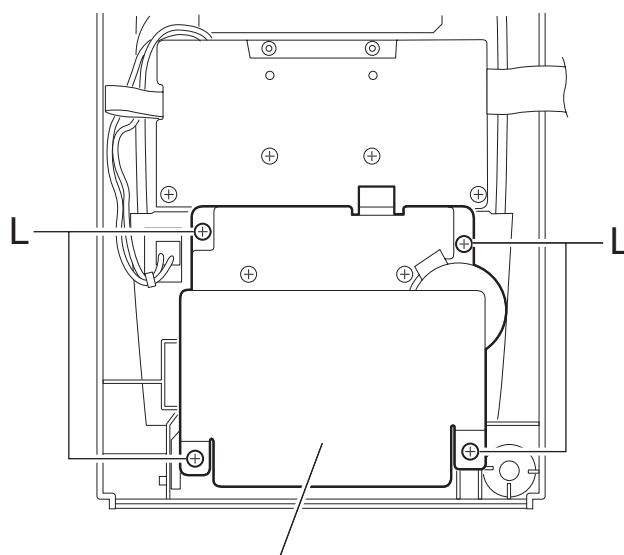

Fig.15

2.1.10 Removing the cassette mechanism assembly (See Fig.16)

- Prior to performing the following procedure, remove the metal cover and the front panel assembly.
 - (1) Remove the four screws L attaching the cassette mechanism assembly.

Cassette mechanism assembly
Fig.16

**2.1.11 Removing the switch board
(See Fig.17,18)**

- Prior to performing the following procedure, remove the metal cover and the front panel assembly.
 - (1) Remove the four screws **M** attaching the switch board.
 - (2) Move the switch board in the direction of the arrow to disconnect the wire from the connector CN762 and the card wire from the connector CN761.

**2.1.12 Remove the LCD board assembly
(See Fig.17)**

- Prior to performing the following procedure, remove the metal cover and the front panel assembly.
 - (1) Remove the four screws **N** attaching the LCD board assembly.

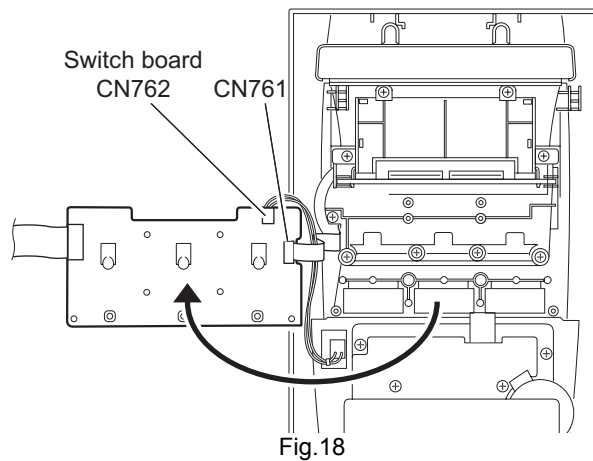
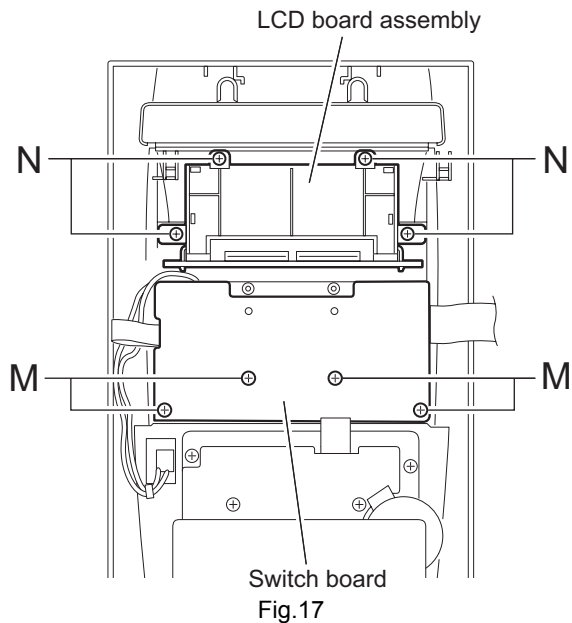

2.1.13 Removing the control panel assembly (See Fig.19,20)

- Prior to performing the following procedure, remove the metal cover, the front assembly, the switch board and the LCD board assembly.
 - (1) Remove the three screws **O** attaching the control panel assembly.
 - (2) Release the three joints **i** and open the cassette door while pressing the cassette door, and then remove the control panel assembly in the direction of the arrow.

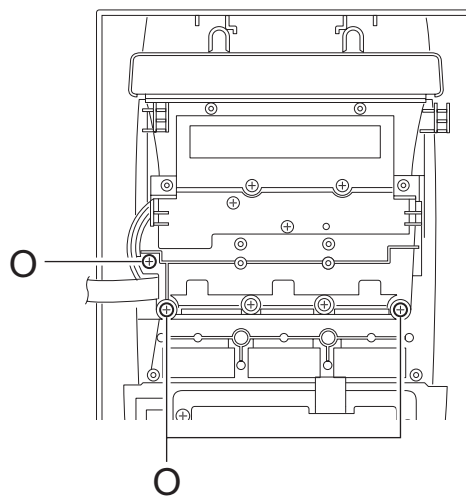

Fig.19

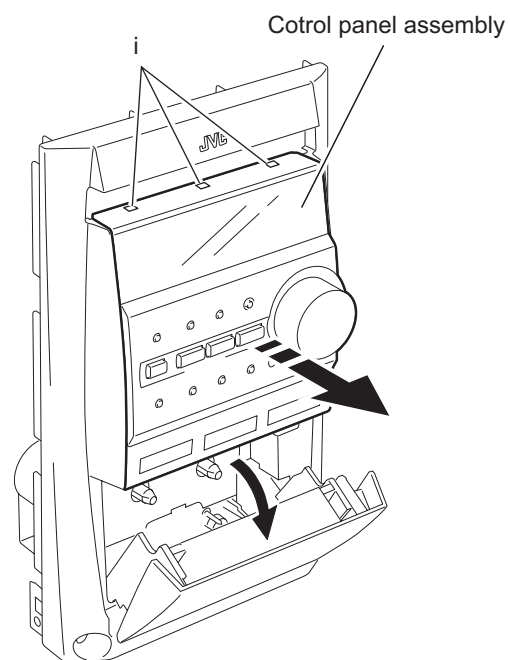
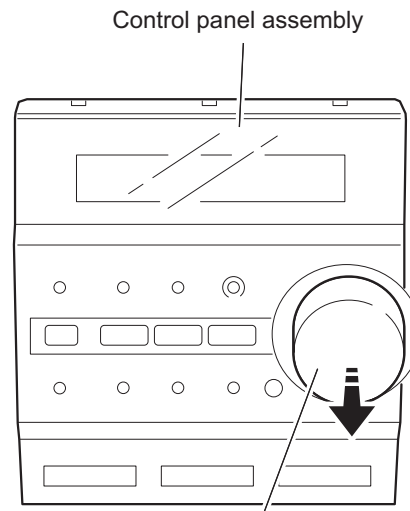

Fig.20

2.1.14 Removing the control board
(See Fig.21,22)

- Prior to performing the following procedure, remove the metal cover, the front panel assembly, the switch board, the LCD board assembly and the control panel assembly.
 - (1) Pull out the volume knob.
 - (2) Remove the six screws **P** attaching the control board.



Volume knob
Fig.21

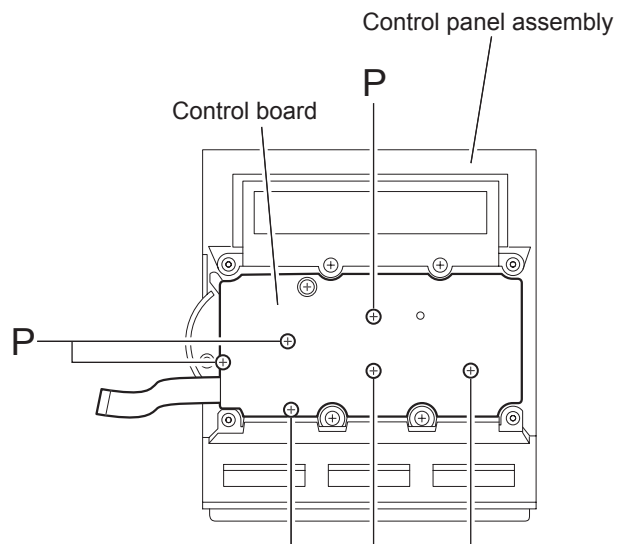

P
Fig.22

2.2 Cassette mechanism assembly

2.2.1 Removing the Play/Record & Clear head

(See Fig.1~3)

- (1) While moving the trigger arm on the right side of the head mount in the direction of the arrow, turn the flywheel R counterclockwise until the head mount comes ahead and clicks.
- (2) The head turns counterclockwise as you turn the flywheel R counterclockwise (See Fig.2 and 3).
- (3) Disconnect the flexible wire from connector CN31 on the head amplifier & mechanism control board.
- (4) Remove the spring from the back of the head.
- (5) Loosen the azimuth screw for reversing attaching the head.
- (6) Remove the head on the front side of the head mount.

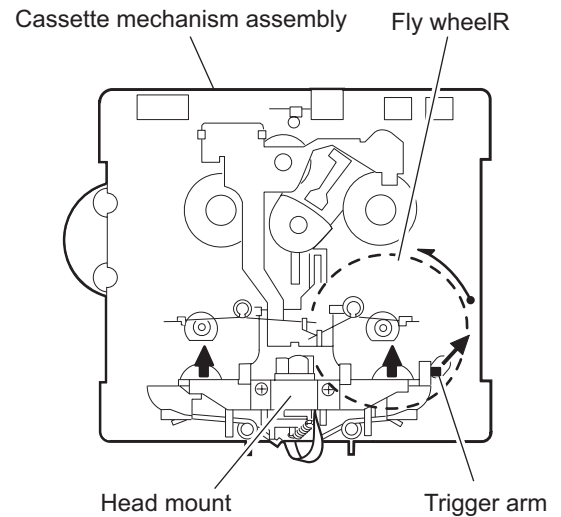

Fig.1

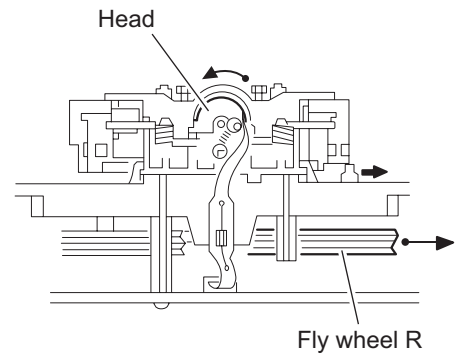

Fig.2

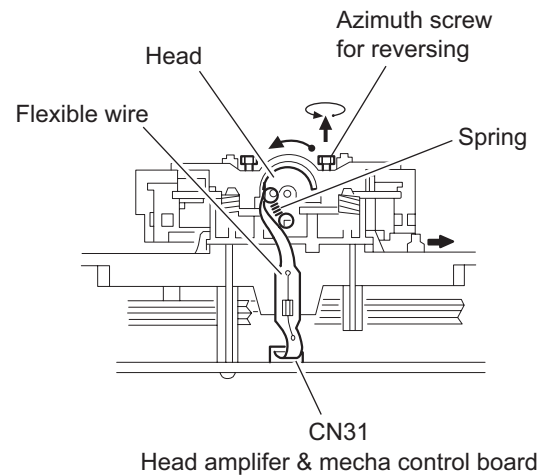

Fig.3

**2.2.2 Removing the head amplifier & mechanism control board
(See Fig.4)**

- (1) Turn over the cassette mechanism assembly and remove the three screws **A** attaching the head amplifier & mechanism control board.
- (2) Disconnect the flexible wire from connector CN31 on the head amplifier & mechanism control board.
- (3) Disconnect connector CN32 of the head amplifier & mechanism control board from connector CN1 on the reel pulse board. REFERENCE: If necessary, unsolder the 4-pin wire soldered to the main motor.

**2.2.3 Removing the main motor
(See Fig.4~7)**

- (1) Remove the two screws **B**.
- (2) Half raise the motor and remove the capstan belt from the motor pulley.

ATTENTION:

Be careful to keep the capstan belt from grease. When re-assembling, refer to Fig.6 and 7 for attaching the capstan belt.

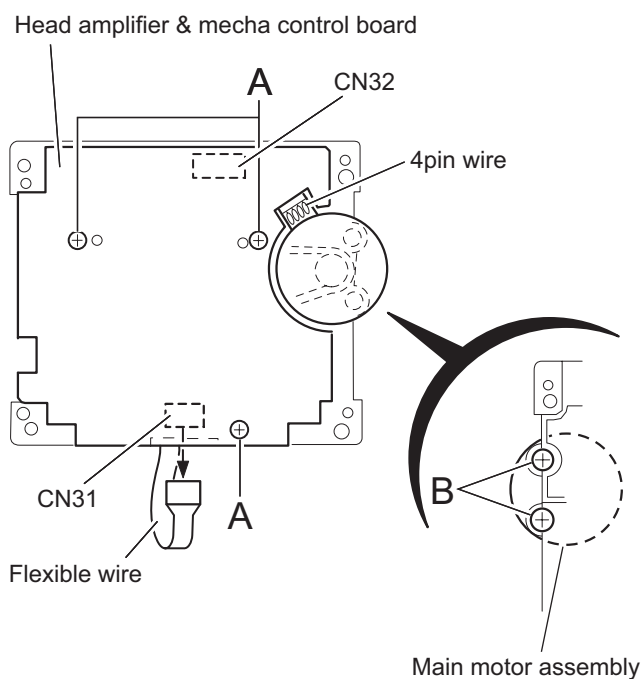

Fig.4

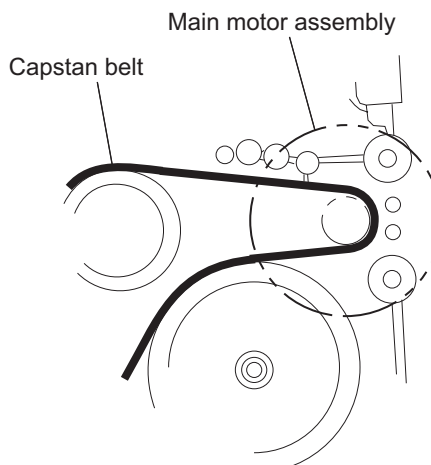

Fig.5

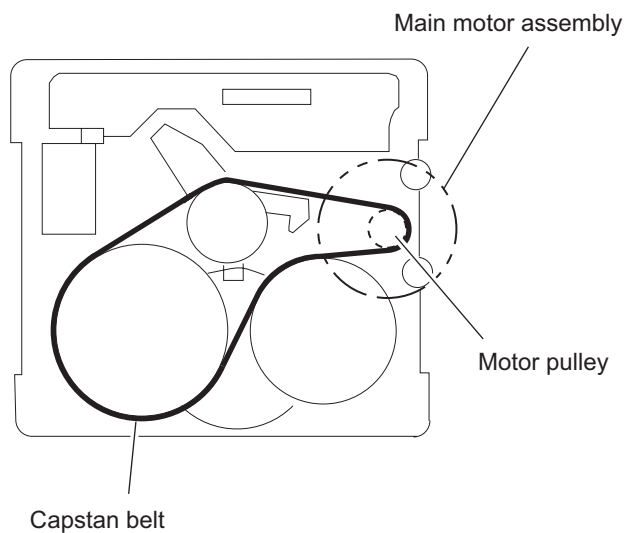

Fig.6

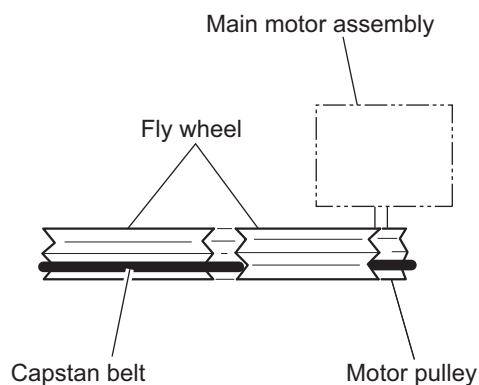
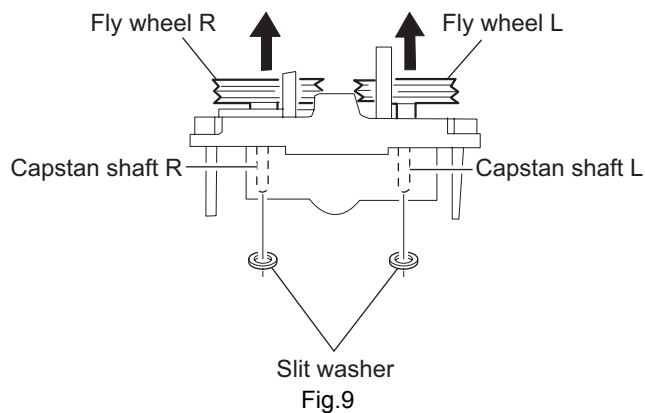
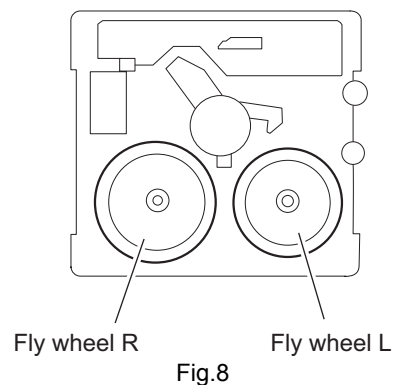

Fig.7

2.2.4 Removing the flywheel (See Fig.8, 9)

- Prior to performing the following procedure, remove the head amplifier & mechanism control board and the main motor assembly.
- (1) From the front side of the cassette mechanism, remove the slit washers attaching the capstan shaft **L** and **R**. Pull out the flywheels backward.



2.2.5 Removing the reel pulse board and solenoid (See Fig.10)

- Prior to performing the following procedure, remove the head amplifier & mechanism control board.
- (1) Remove the screw **C**.
- (2) Release the tab **a**, **b**, **c**, **d** and **e** retaining the reel pulse board.
- (3) Release the tab **f** and **g** attaching the solenoid on the reel pulse board.
- (4) The reel pulse board and the solenoid come off.

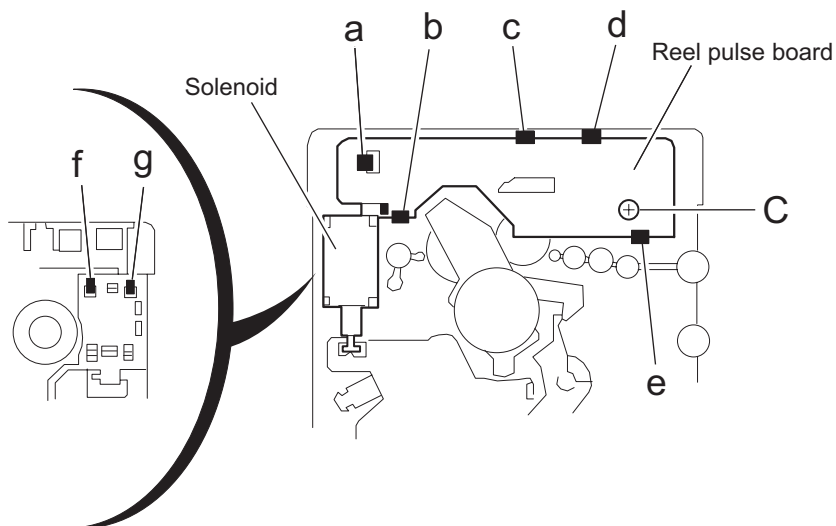

Fig.10

**2.2.6 Reattaching the Play/ Record & Clear head
(See Fig.11~13)**

- (1) Reattaching the head mount assembly.
 - a) Change front of the direction cover of the head mount assembly to the left (Turn the head forward).
 - b) Fit the bosses **O'**, **P'**, **Q'**, **U'** and **V'** on the head mount assembly to the holes **P** and **V**, the slots **O**, **U** and **Q** of the mechanism sub assembly (See Fig.11 to 13).

CAUTION:

To remove the head mount assembly, turn the direction cover to the left to disengage the gear. If the gear can not be disengaged easily, push up the boss **Q'** slightly and raise the rear side of the head mounts slightly to return the direction lever to the reversing side.

- (2) Tighten the azimuth screw for reversing.
- (3) Reattach the spring from the back of the Play/ Record & Clear head.
- (4) Connect the flexible wire to connector CN31 on the head amplifier & mechanism control board.

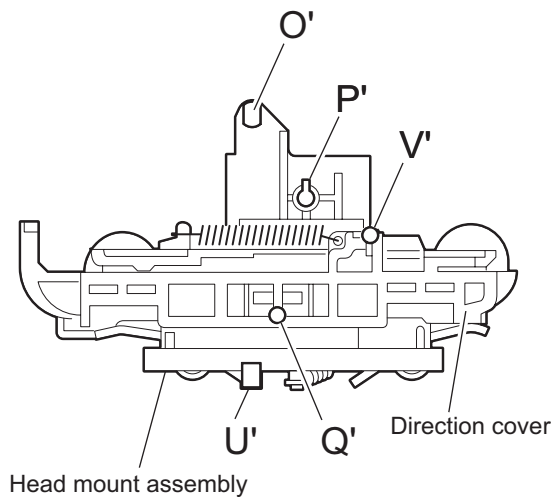

Fig.11

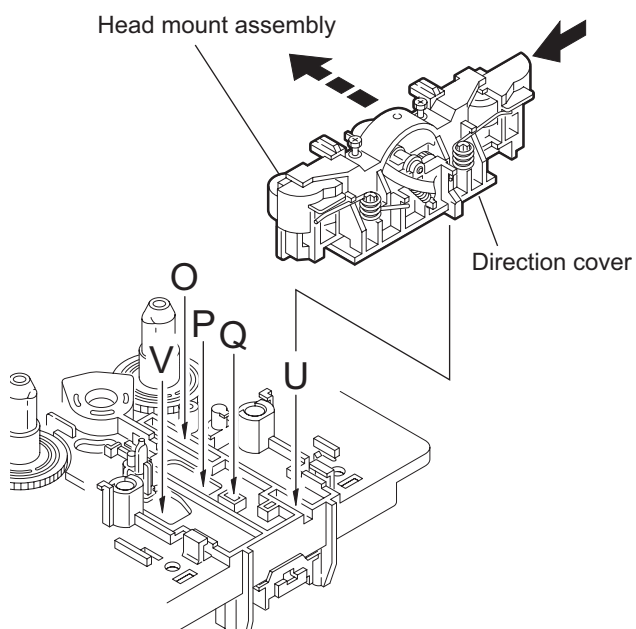

Fig.12

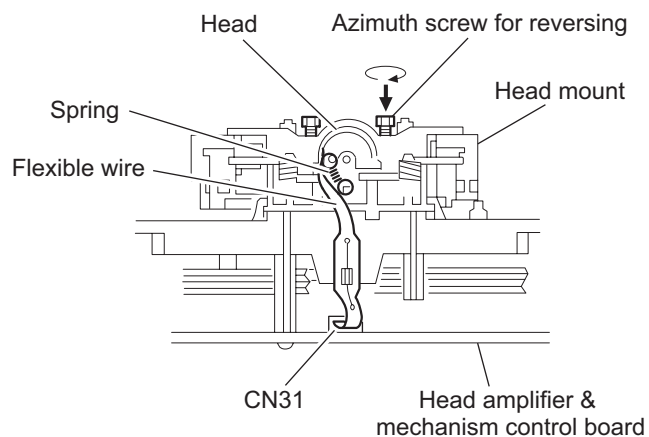

Fig.13

SECTION 3 Adjustment

3.1 Adjustment method

■ Measurement Instruments Required for Adjustment

1. Low frequency oscillator
This oscillator should have a capacity to output 0dBs to $600\ \Omega$ at an oscillation frequency of 50Hz-20kHz.
2. Attenuator impedance : $600\ \Omega$
3. Electronic voltmeter
4. Distortion meter
5. Frequency counter
6. Wow & flutter meter
7. Test tape
VT703L : Head azimuth
VT712 : Tape speed and running unevenness (3kHz)
VT724 : Reference level (1kHz)
8. Blank tape
TYPE I : AC-225
TYPE II : AC-514
9. Torque gauge : For play and back tension
FWD(TW2111A), REV(TW2121a) and
FF/REW(TW2231A)
10. Test disc: CTS-1000

■ Measurement conditions

Power supply voltage
AC 230V ~ , 50Hz
Reference output : Speaker : $0.775V/4\ \Omega$
: Headphone : $0.077V/32\ \Omega$
Reference frequency and
input level ----- 1kHz, AUX : -8dBs
Measurement output terminal ----- at Speaker J3002
※ Load resistance ----- $4\ \Omega$

● Radio Input signal

AM frequency ----- 400Hz
AM modulation ----- 30%
FM frequency ----- 400Hz
FM frequency deviation ----- 22.5kHz

● Tuner section

FM tuning range: 87.5MHz~108.00MHz
AM tuning range: 522kHz~1,629kHz

Voltage applied to tuner ----- +B : DC5.7V
VT : DC 12V

Reference measurement
output ----- 26.1mV(0.28V)/ $3\ \Omega$
Input positions ----- AM : Standard loop antenna
FM : TP1 (hot) and TP2 (GND)

● Standard measurement position of volume

Function switch ----- to Tape
Beat cut switch ----- to Cut
Super Bass/Active hyper Bass ----- to OFF
Bass Treble ----- to Center
Adjustment of main volume to reference output
VOL : 28

Precautions for measurement

1. Apply 30pF and $33\text{k}\Omega$ to the IF sweeper output side and $0.082\ \mu\text{F}$ and $100\text{k}\Omega$ in series to the sweeper input side.
2. The IF sweeper output level should be made as low as possible within the adjustable range.
3. Since the IF sweeper is a fixed device, there is no need to adjust this sweeper.
4. Since a ceramic oscillator is used, there is no need to perform any MIX adjustment.
5. Since a fixed coil is used, there is no need to adjust the FM tracking.
6. The input and output earth systems are separated. In case of simultaneously measuring the voltage in both of the input and output systems with an electronic voltmeter for two channels, therefore, the earth should be connected particularly carefully.
7. In the case of BTL connection amp., the minus terminal of speaker is not for earthing. Therefore, be sure not to connect any other earth terminal to this terminal. This system is of an BTL system.
8. For connecting a dummy resistor when measuring the output, use the wire with a greater code size.
9. Whenever any mixed tape is used, use the band pass filter (DV-12).

3.2 Cassette mechanism adjustment

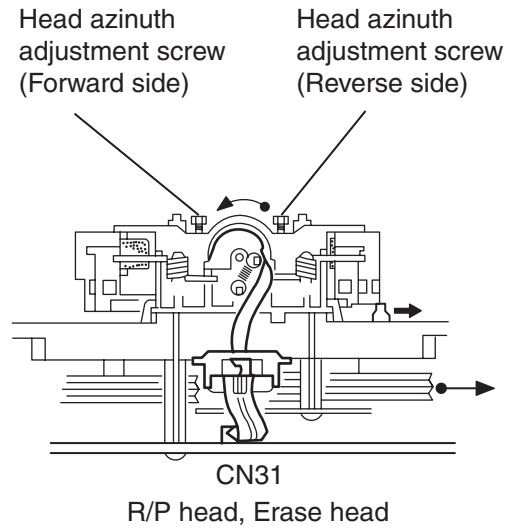
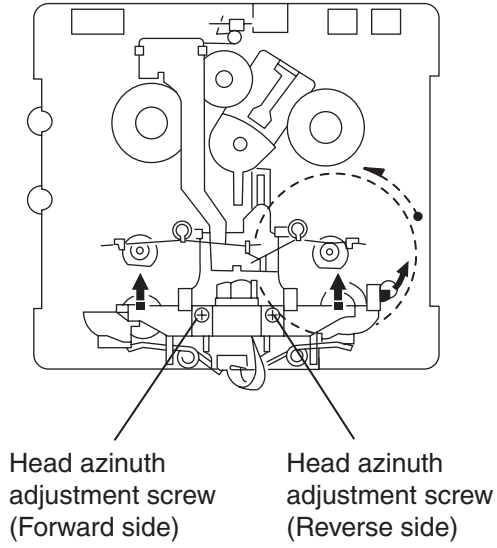

Mecha control board

Motor speed VR37

BIAS adjust VR31

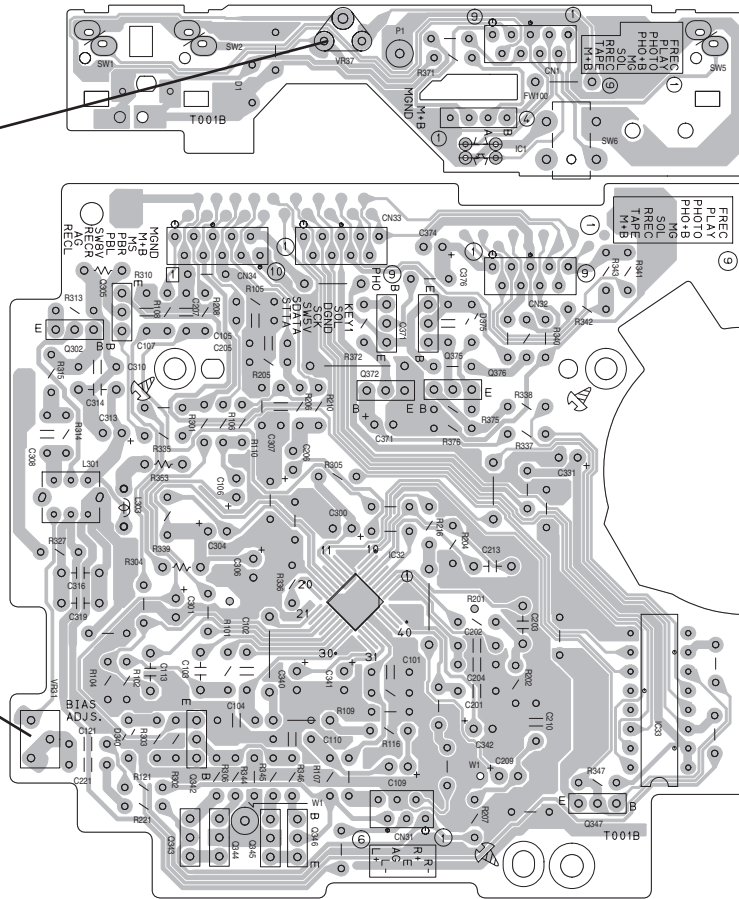

3.2.1 Mechanism section

Item	Condition	Measurement method	Ref.value	Adjustment position
Head azimuth	Test tape : VT703L (8kHz) Output terminal : Speaker out	1.Playback the test tape VT703L (8kHz). 2.Adjust to maximum output level by azimuth adjustment screw for forward side and reverse side. 3.This adjustment is adjust by adjustment screw of forward side and adjustment screw of reverse side.	Maximum output	Only adjust at changed head
Tape speed	Test tap : VT712 (3kHz) Output terminal : Speaker out or Headphone out	Playback the test tape VT712 (3kHz) at end of forward side,adjust to 2,940~3,90Hz indication of frequency counter by VR37.	2,940 ~ 3,090Hz	VR37

Item	Condition	Measurement method	Ref.value	Adjustment position
Tape speed diviation at FWD/REV	Test tape : VT712 (3kHz) Output terminal : Speaker out or Headphone out	Playback the test tape VT712 (3kHz) at end of forward and reverse, tape speed deviation should be less than 6.0Hz.	Leass than 6.0Hz	VR31
Wow & Flutter	Test tape : VT712 (3kHz) Output terminal : Speaker out or Headphone out	Playback the test tape VT712 (3kHz) at start of forward and reverse,Wow & Flutter are should be less than 0.25%(WRMS).	Less than 0.25% (WRMS)	

3.2.2 Electrical adjustment

Item	Condition	Measurement method	Ref.value	Adjustment position
Recording BIAS adjustment	<ul style="list-style-type: none"> ▪ Forward or Reverse ▪ Test tape :AC-514 TYPE II :AC-225 TYPE I ▪ Output terminal Recording head 	<ol style="list-style-type: none"> 1.Set the test tape(AC-514 TYPE II and AC-225 TYPE I), then make REC/PAUSE condition. 2.Connect 100 Ω to recording head by series, then connect to VTVM for measurement the current. 3.After setting, start the recording by release the PAUSE, in this time bias current adjust to next fig. by VR31 for Lch and VR32 for Rch. 4.0 μA (TYPE II) and 4.20 μA (TYPE I). 	AC-225 :4.20 μ A AC-514 :4.0 μ A	VR31
R/P playback frequency response	<ul style="list-style-type: none"> ▪ Reference frequency : 1kHz / 10kHz (Reference: -20dB) ▪ Test tape : AC-514 TYPE II ▪ Input terminal : OSC IN 	<ol style="list-style-type: none"> 1.Set the test tape (AC-514 TYPE II), then make REC/PAUSE condition. 2.Release the PAUSE, then start recording the 1kHz and 10kHz of reference frequency from oscillator. 3.Playback the recorded position, 1kHz and 10kHz output deviation should -1dB \pm 2dB to readjust by VR31 for Lch and VR32 for Rch. 	Output deviation 1kHz/10kHz :-1dB \pm 2dB	VR31

3.2.3 Electrical response confirmation

Item	Condition	Measurement method	Ref.value	Adjustment position
Recording bias current	<ul style="list-style-type: none"> Forward or Reverse ▪ Test tape : TYPE II (AC-514) ▪ Measurement terminal : BIAS test point on printed circuit board 	<ol style="list-style-type: none"> 1.Change BIAS1 and 2, confirm the frequency should be change. 2.Set the test tape (AC-514 TYPE II), then make REC/PAUSE condition. 3.Confirm the frequency should 100Hz\pm 6kHz at BIAS test point on printed circuit board. 	100 kHz \pm 6 kHz	
Erase current (reference value)	<ul style="list-style-type: none"> Forward or Reverse ▪ Rec condition ▪ Test tape : AC-514 TYPE II : AC-225 TYPE I ▪ Measurement terminal : Both side of Erase head 	<ol style="list-style-type: none"> 1.Set the test tape (AC-514 TYPE II and AC-225 TYPE I), then make REC/PAUSE condition. 2.Release the PAUSE to REC condition, connect 1W to ERASE head by series, then confirm the erase current at both side of erase head. 	TYPE II : 120 mA TYPE I : 75 mA	

3.3 Flow of functional operation until TOC read (CD)

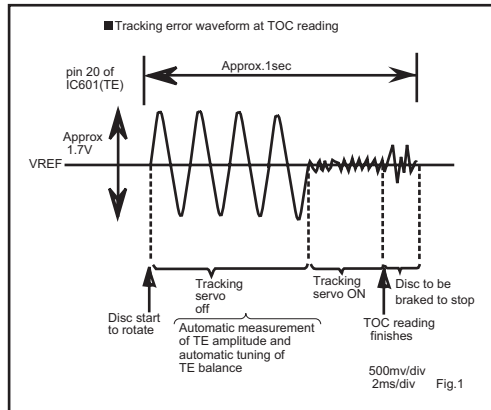
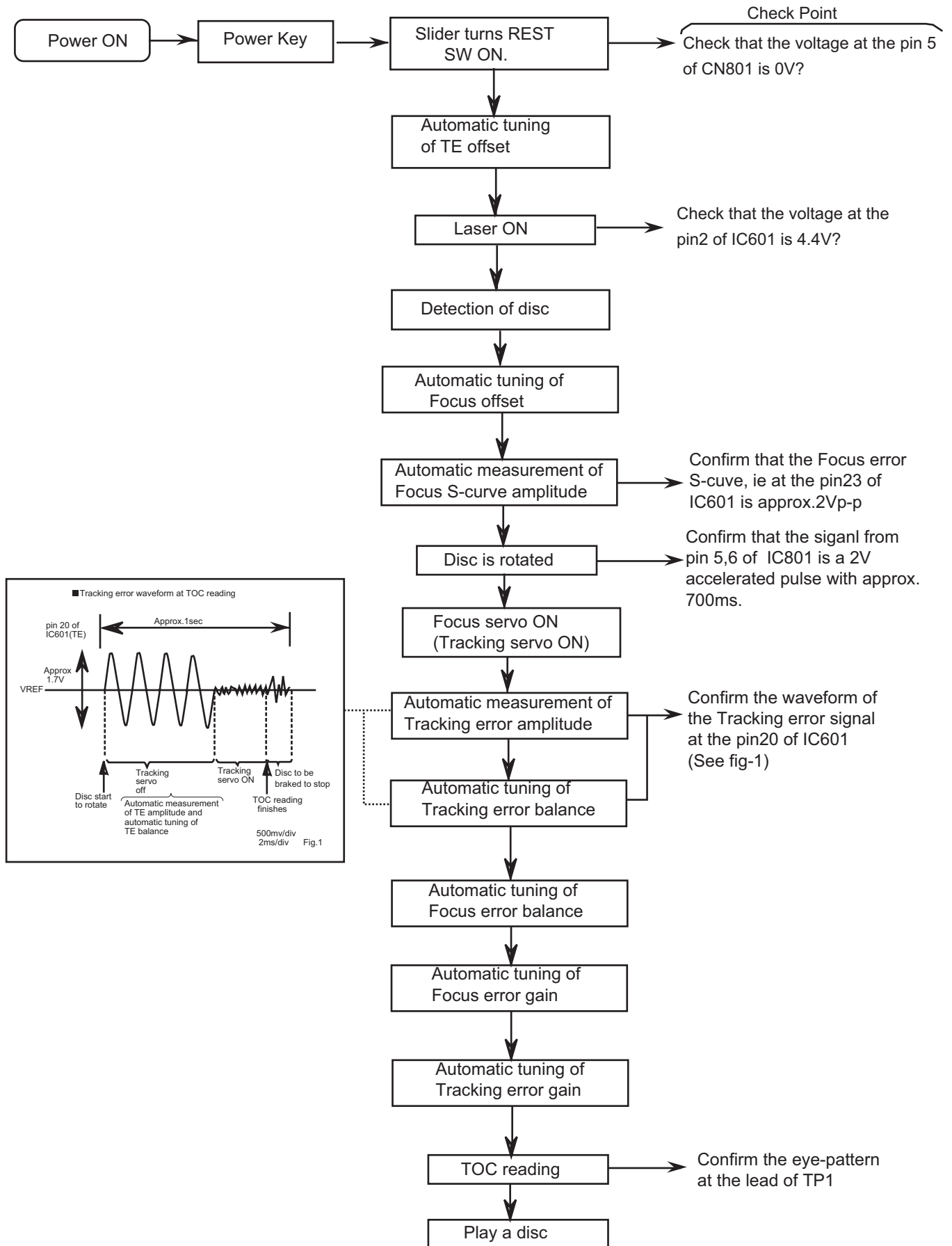

3.4 Maintenance of laser pickup (CD)

(1) Cleaning the pick up lens

Before you replace the pick up, please try to clean the lens with a alcohol soaked cotton swab.

(2) Life of the laser diode

When the life of the laser diode has expired, the following symptoms will appear.

- The level of RF output (EFM output: amplitude of eye pattern) will be low.

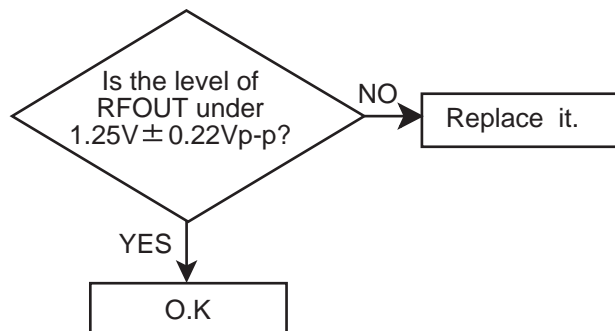

(3) Semi-fixed resistor on the APC PC board

The semi-fixed resistor on the APC printed circuit board which is attached to the pickup is used to adjust the laser power. Since this adjustment should be performed to match the characteristics of the whole optical block, do not touch the semi-fixed resistor.

If the laser power is lower than the specified value, the laser diode is almost worn out, and the laser pickup should be replaced. If the semi-fixed resistor is adjusted while the pickup is functioning normally, the laser pickup may be damaged due to excessive current.

3.5 Replacement of laser pickup (CD)

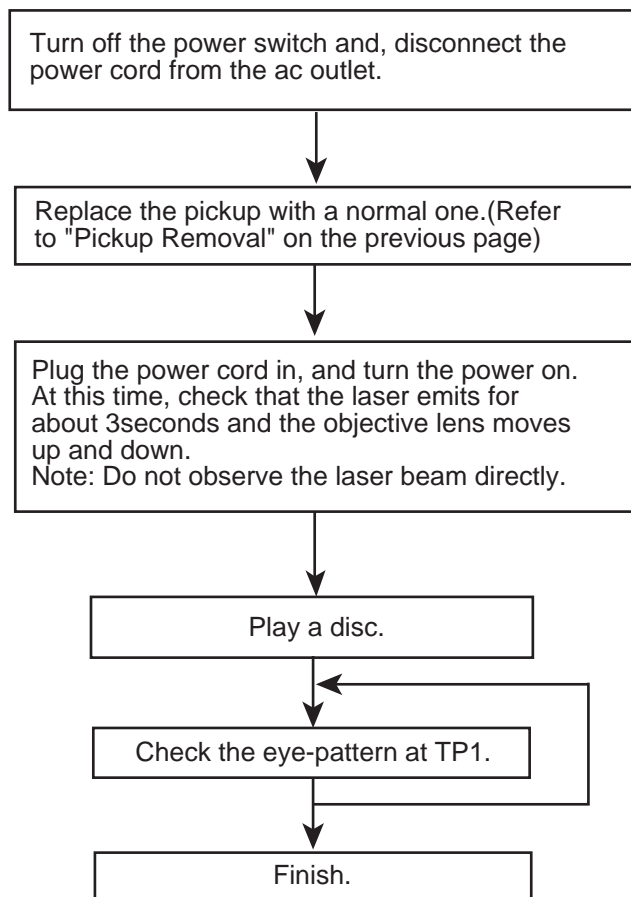

SECTION 4

Description of major ICs

4.1 AN22000A-W (IC601) : RF & SERVO AMP

• Terminal layout

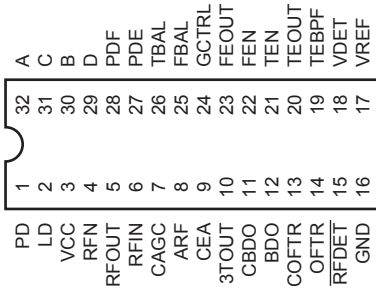

• Block diagram

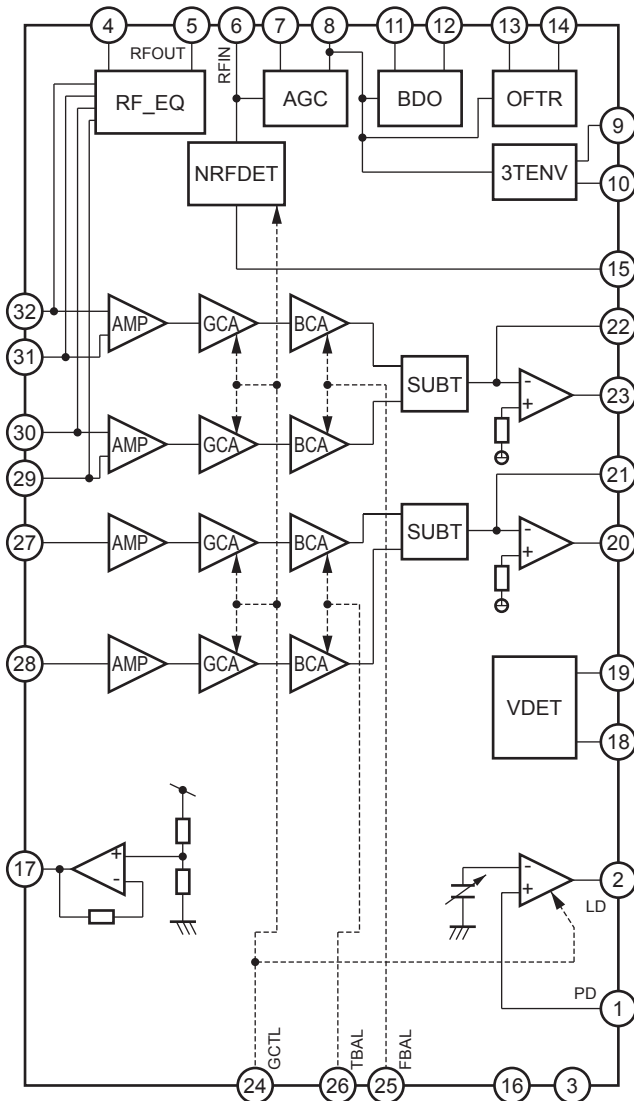

• Pin function

Pin No.	Symbol	I/O	Function
1	PD	I	APC Amp. input terminal
2	LD	O	APC Amp. output terminal
3	VCC	-	Power supply terminal
4	RFN	I	RF adder Amp. inverting input terminal
5	RFOUT	O	RF adder Amp. output terminal
6	RFIN	I	AGC input terminal
7	CAGC	I	Input terminal for AGC loop filter capacitor
8	ARF	O	AGC output terminal
9	CEA	I	Capacitor connecting terminal for HPF-Amp.
10	3TOUT	O	3 TENV output terminal
11	CBDO	I	Capacitor connecting terminal for envelope detection on the darkness side
12	BDO	O	BDO output terminal
13	COFTR	I	Capacitor connecting terminal for envelope detection on the light side
14	OFTR	O	OFTR output terminal
15	NRFDET	O	NRFDET output terminal
16	GND	-	Ground
17	VREF	O	VREF output terminal
18	VDET	O	VDET output terminal
19	TEBPF	I	VDET output terminal
20	TEOUT	O	TE Amp. output terminal
21	TEN	I	TE Amp. inverting input terminal
22	FEN	I	FE Amp. inverting input terminal
23	FEOUT	O	FE Amp. output terminal
24	GCTL	O	GCTL & APC terminal
25	FBAL	O	FBAL control terminal
26	TBAL	O	TBAL control terminal
27	E	I	Tracking signal input terminal 1
28	F	I	Tracking signal input terminal 2
29	D	I	Focus signal input terminal 4
30	B	I	Focus signal input terminal 3
31	C	I	Focus signal input terminal 2
32	A	I	Focus signal input terminal 1

4.2 HA12238F (IC32) : R/P Equalizer

- Pin layout

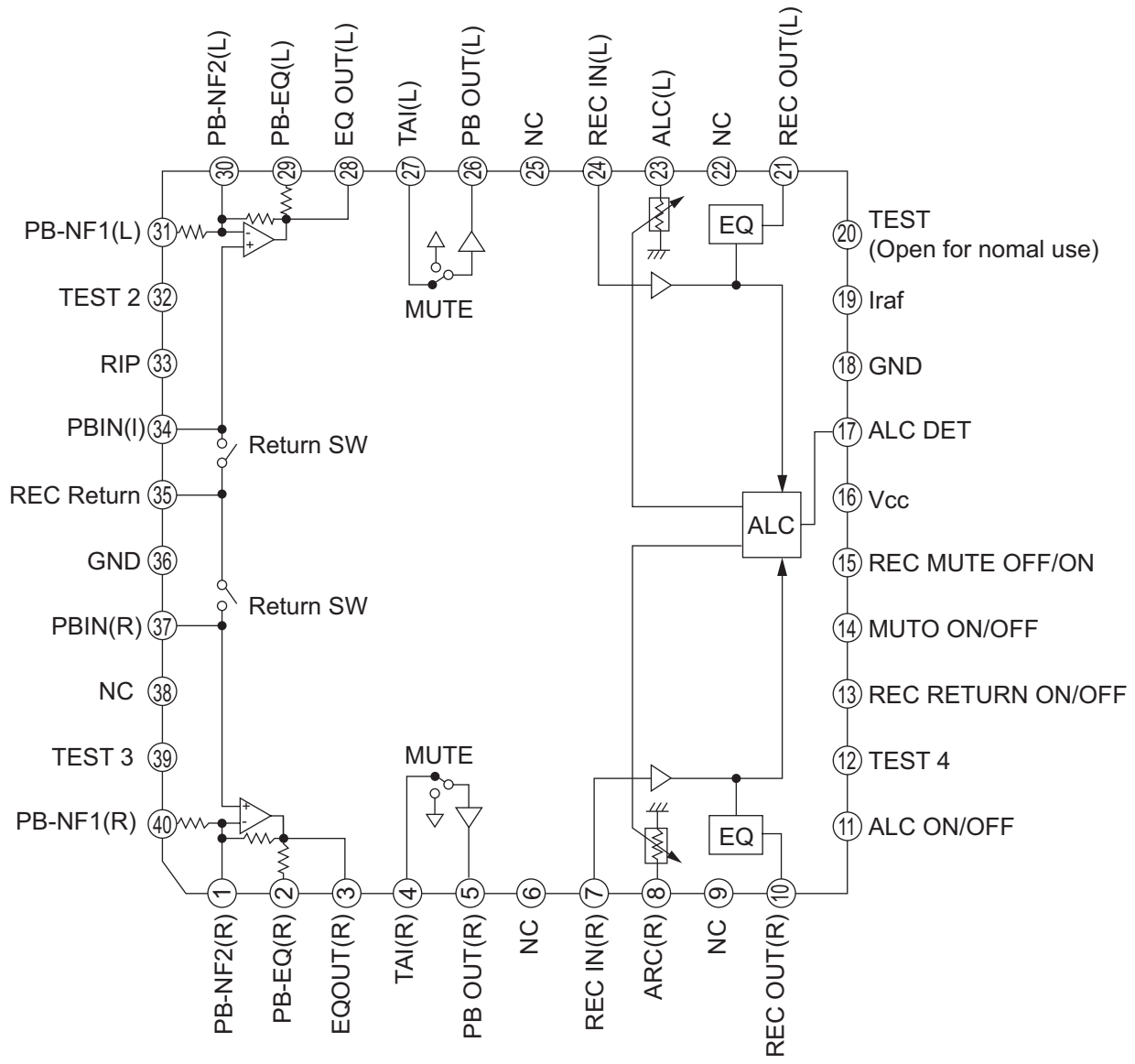

• Pin function

Pin No.	Symbol	Function
1	PB-NF2(R)	PB EQ feed back
2	PB-EQ(R)	NAB output
3	EQOUT(R)	EQ output
4	TAI(R)	Tape input
5	PBOUT(R)	PB output
6	NC	NC pin
7	REC IN(R)	REC-EQ input
8	ALC(R)	ALC(R) signal out put
9	NC	NC pin
10	REC OUT(R)	REC output
11	ALC ON/OFF	Mode control input
12	TEST4	TEST pin
13	REC Return ON/OFF	Mode control input
14	MUTE ON/OFF	Mode control input
15	REC Return ON/OFF	Mode control input
16	Vcc	Vcc Pin
17	ALC DET	ALC detection signal out put
18	GND	GND pin
19	I REF	Equalizer reference current input
20	Test mode	Test modepin
21	REC OUT(L)	REC output
22	NC	NC pin
23	ALC(L)	ALC(L) signal out put
24	REC IN(L)	REC-EQ input
25	NC	NC pin
26	PBOUT(L)	PB output
27	TAI(L)	Tape input
28	EQOUT(L)	EQ output
29	PB-EQ(L)	NAB output
30	PB-NF2(L)	PB EQ feed back
31	PB-NF1(L)	PB EQ feed back
32	TEST2	TEST pin
33	RIP	Ripple fillter
34	PBIN(L)	PB input
35	REC-RETURN	REC Return
36	GND	GND pin
37	PBIN(R)	PB input
38	NC	NC pin
39	TEST3	TEST pin
40	PB-NF1(R)	PB EQ feed back

4.3 GP1UM261XK (IC750) : Receiver

- Pin layout

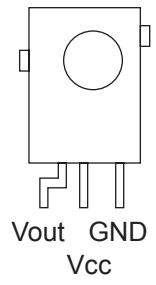

- Block diagram

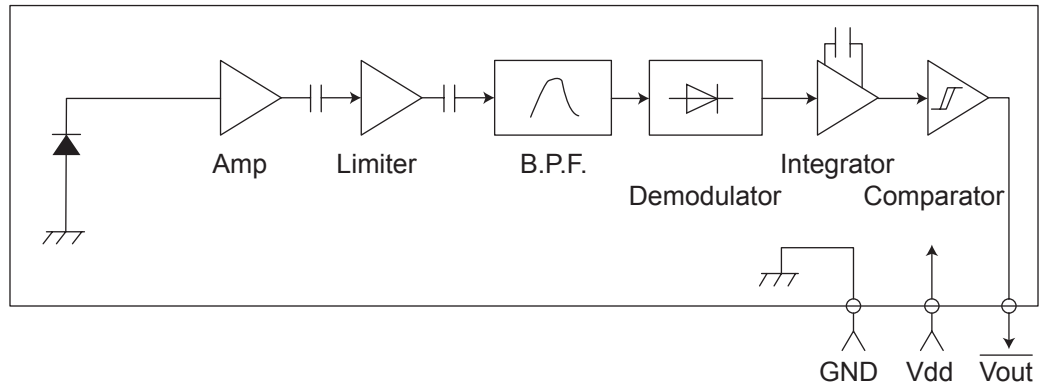

4.4 KIA78S06P-T (IC932) : Regulator

- Pin layout

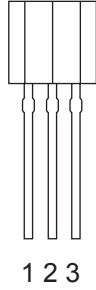

- Block diagram

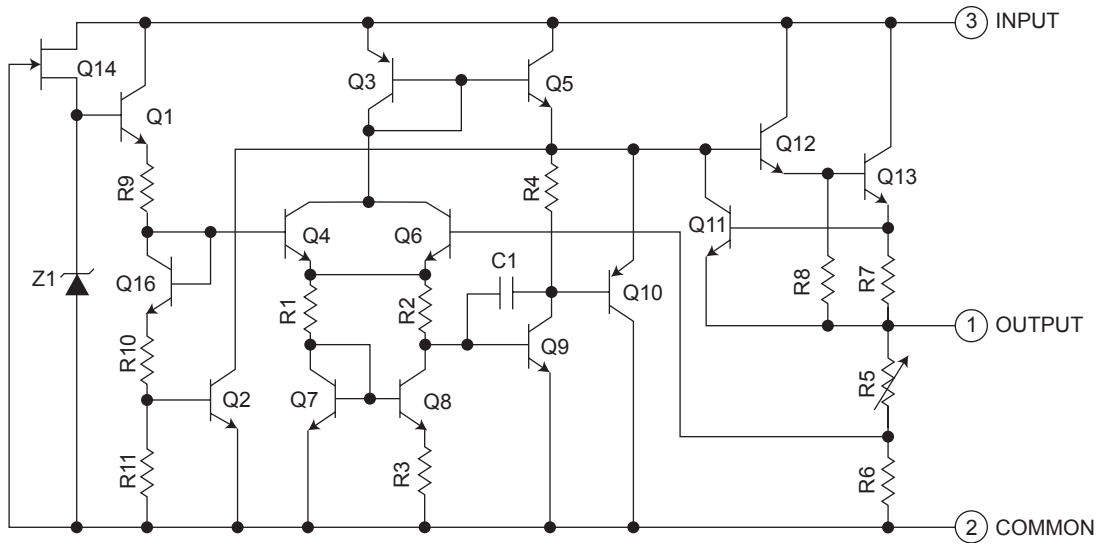

4.5 LB1641 (IC402) : DC Motor driver

- Pin layout

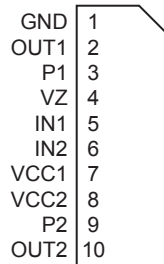

- Truth table

Input		Output		Mode
IN1	IN2	OUT1	OUT2	
0	0	0	0	Brake
1	0	1	0	CLOCKWISE
0	1	0	1	COUNTER-CLOCKWISE
1	1	0	0	Brake

4.6 LA1838 (IC1): FM AM IF AMP&detector, FM MPX Decoder

• Block Diagram

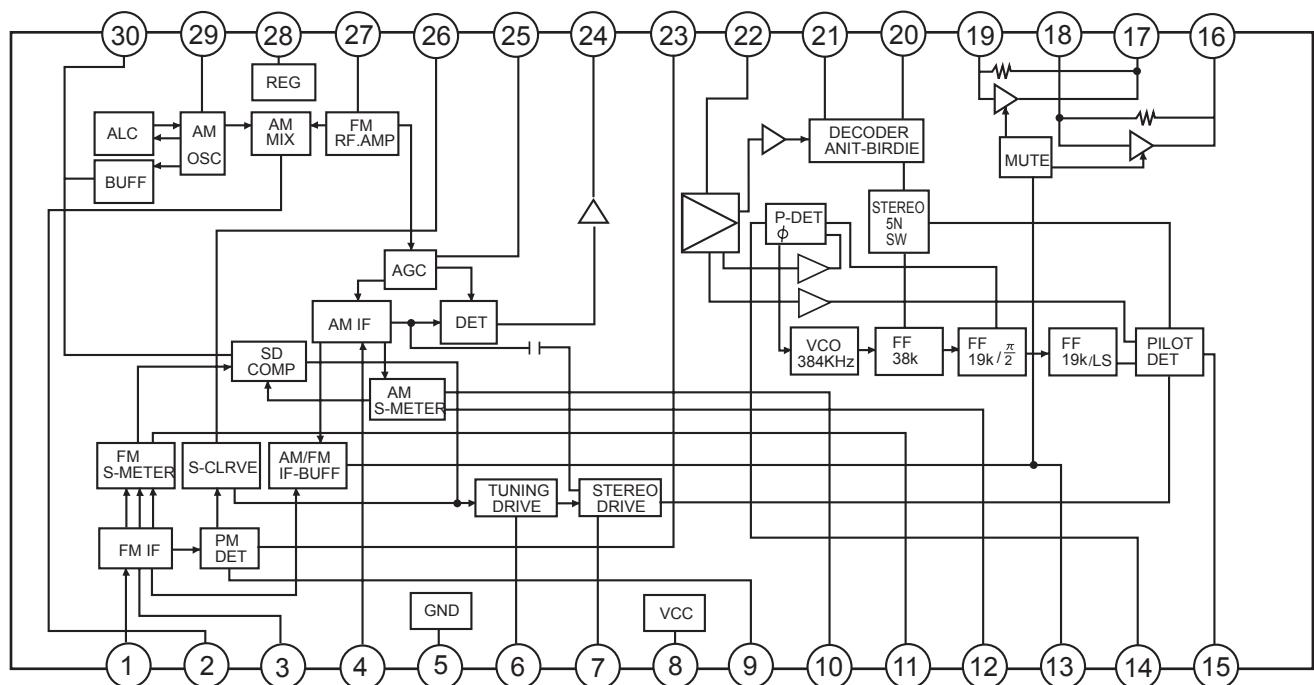

• Pin Function

Pin No.	Symbol	I/O	Function
1	FM IN	I	This is an input terminal of FM IF signal.
2	AM MIX	O	This is an out put terminal for AM mixer.
3	FM IF	I	Bypass of FM IF
4	AM IF	I	Input of AM IF Signal.
5	GND	-	This is the device ground terminal.
6	TUNED	O	When the set is tunning, this terminal becomes "L".
7	STEREO	O	Stereo indicator output. Stereo "L", Mono: "H"
8	VCC	-	This is the power supply terminal.
9	FM DET	-	FM detect transformer.
10	AM SD	-	This is a terminal of AM ceramic filter.
11	FM VSM	O	Adjust FM SD sensitivity.
12	AM VSM	O	Adjust AM SD sensitivity.
13	MUTE	I/O	When the signal of IF REQ of IC121(LC72131) appear, the signal of FM/AM IF output. //Muting control input.
14	FM/AM	I	Change over the FM/AM input. "H" :FM, "L" : AM
15	MONO/ST	O	Stereo : "H", Mono: "L"
16	L OUT	O	Left channel signal output.
17	R OUT	O	Right channel signal output.
18	L IN	I	Input terminal of the Left channel post AMP.
19	R IN	I	Input terminal of the Right channel post AMP.
20	RO	O	Mpx Right channel signal output.
21	LO	O	Mpx Left channel signal output.
22	MPX IN	I	Mpx input terminal
23	FM OUT	O	FM detection output.
24	AM DET	O	AM detection output.
25	AM AGC	I	This is an AGC voltage input terminal for AM
26	AFC	-	This is an output terminal of voltage for FM-AFC.
27	AM RF	I	AM RF signal input.
28	REG	O	Register value between pin 26 and pin28 besides the frequency width of the input signal.
29	AM OSC	-	This is a terminal of AM Local oscillation circuit.
30	OSC BUFFER	O	AM Local oscillation Signal output.

4.7 LA6541-X (IC801) : Servo driver

• Pin layout & Block diagram

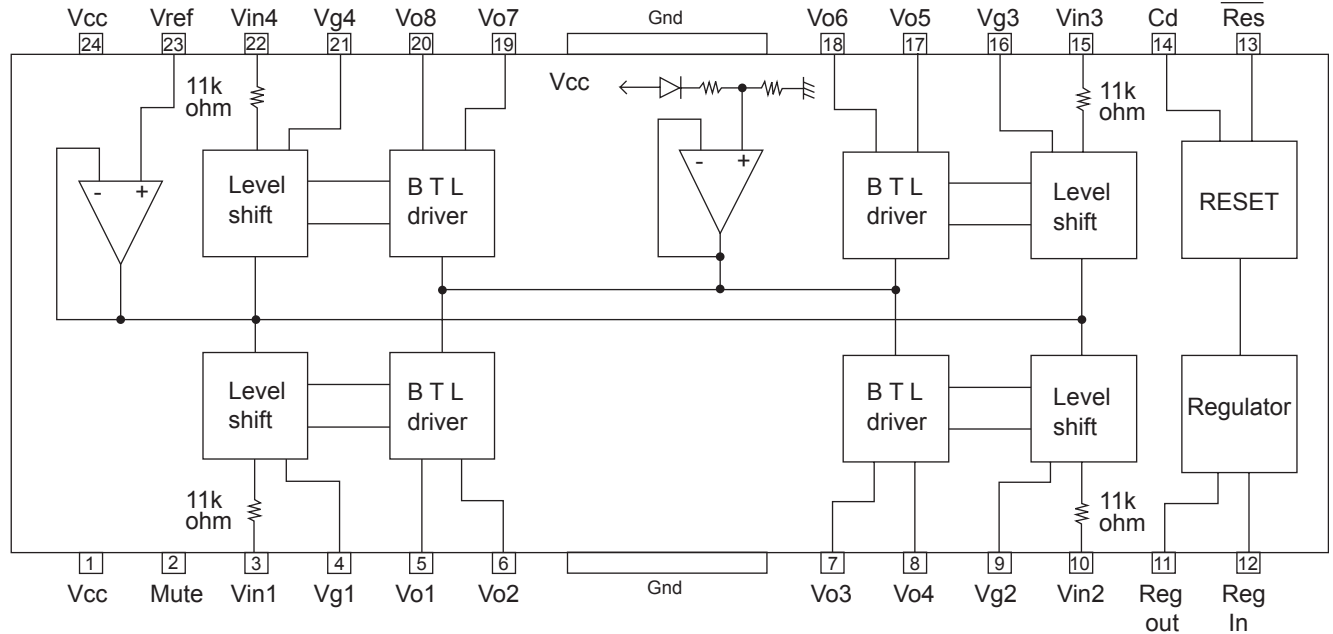

• Pin function

Pin No.	Symbol	Description
1	Vcc	Power supply (Shorted to pin 24)
2	Mute	All BTL amplifier outputs ON/OFF
3	Vin1	BTL AMP 1 input pin
4	Vg1	BTL AMP 1 input pin (For gain adjustment)
5	Vo1	BTL AMP 1 input pin (Non inverting side)
6	Vo2	BTL AMP 1 input pin (Inverting side)
7	Vo3	BTL AMP 2 input pin (Inverting side)
8	Vo4	BTL AMP 2 input pin (Non inverting side)
9	Vg2	BTL AMP 2 input pin (For gain adjustment)
10	Vin2	BTL AMP 2 input pin
11	Reg Out	External transistor collector (PNP) connection. 5V power supply output
12	Reg In	External transistor (PNP) base connection
13	Res	Reset output
14	Cd	Reset output delay time setting (Capacitor connected externally)
15	Vin3	BTL AMP 3 input pin
16	Vg3	BTL AMP 3 input pin (For gain adjustment)
17	Vo5	BTL AMP 3 output pin (Non inverting side)
18	Vo6	BTL AMP 3 output pin (Inverting side)
19	Vo7	BTL AMP 4 output pin (Inverting side)
20	Vo8	BTL AMP 4 output pin (Non inverting side)
21	Vg4	BTL AMP 4 output pin (For gain adjustment)
22	Vin4	BTL AMP 4 output pin
23	Vref	Level shift circuit's reference voltage application
24	Vcc	Power supply (Shorted to pin 1)

4.8 LC72136N (IC2) : PLL frequency synthesizer

- Pin layout

XT	1	22	$\overline{X\overline{T}}$
$\overline{FM/AM}$	2	21	GND
CE	3	20	LPFOUT
DI	4	19	LPFIN
CLOCK	5	18	PD
DO	6	17	VCC
$\overline{FM/ST/VCO}$	7	16	FMIN
$\overline{AM/FM}$	8	15	AMIN
	9	14	
SDIN	10	13	IFCONT
	11	12	IFIN

- Block diagram

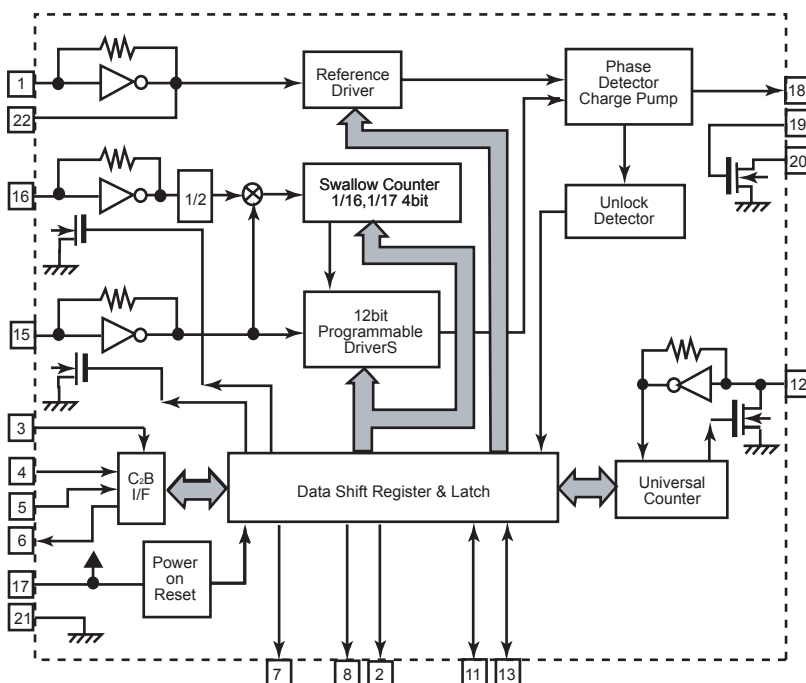

- Pin function

Pin No.	Symbol	I/O	Function
1	XT	I	X'tal oscillator connect (75kHz)
2	$\overline{FM/AM}$	O	LOW:FM mode
3	CE	I	When data output/input for 4pin(input) and 6pin(output): H
4	DI	I	Input for receive the serial data from controller
5	CLOCK	I	Sync signal input use
6	DO	O	Data output for Controller Output port
7	$\overline{FM/ST/VCO}$	O	Low: MW mode
8	$\overline{AM/FM}$	O	Open state after the power on reset
9	LW	I/O	Input/output port
10	MW	I/O	Input/output port
11	SDIN	I/O	Data input/output
12	IFIN	I	IF counter signal input

Pin No.	Symbol	I/O	Function
13	IFCONT	O	IF signal output
14		-	Not use
15	AMIN	I	AM Local OSC signal output
16	FMIN	I	FM Local OSC signal input
17	VCC	-	Power supply(VDD=4.5-5.5V) When power ON:Reset circuit move
18	PD	O	PLL charge pump output (H: Local OSC frequency Height than Reference frequency.L: Low Agreement: Height impedance)
19	LPFIN	I	Input for active lowpassfilter of PLL
20	LPFOUT	O	Output for active lowpassfilter of PLL
21	GND	-	Connected to GND
22	$\overline{X\overline{T}}$	I	X'tal oscillator(75KHz)

4.9 LC72723(IC3): RDS demodulation

- Pin layout

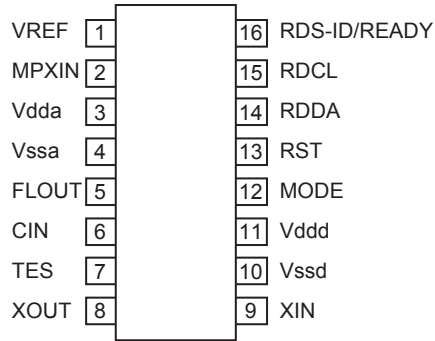

- Block Diagram

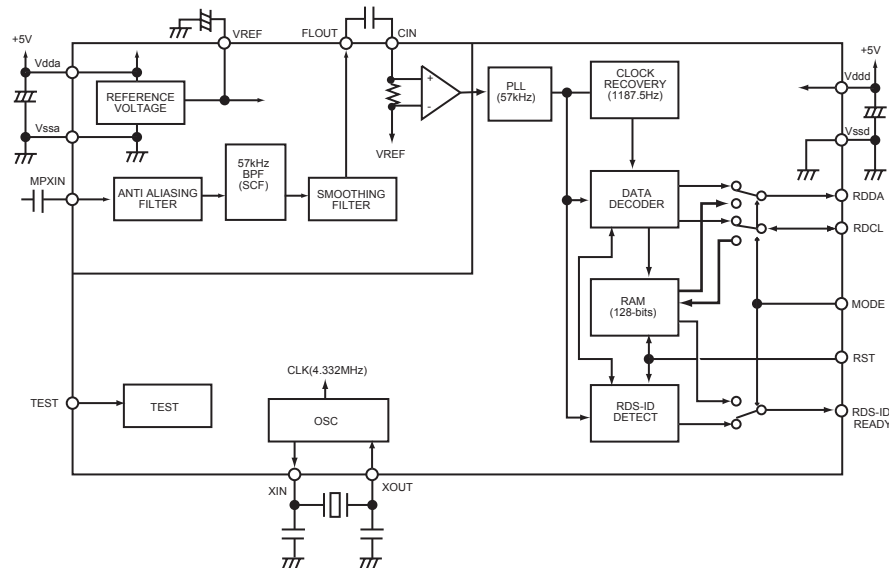

- Pin functions

Pin No.	Symbol	I/O	Function
1	VREF	O	Reference voltage output ($V_{dda}/2$)
2	MPXIN	I	Baseband (multiplexed) signal input
3	Vdda	-	Analog power supply (+5V)
4	Vssa	-	Analog ground
5	FLOUT	O	Subcarrier input (filter output)
6	CIN	I	Subcarrier input (comparator input)
7	TEST	I	Test input
8	XOUT	O	Crystal oscillator output (4.332MHz)
9	XIN	I	Crystal oscillator input (external reference input)
10	Vssd	-	Digital ground
11	Vddd	-	Digital power supply
12	MODE	I	Read mode setting (0:master, 1:slave)
13	RST	I	RDS-ID/RAM reset (positive polarity)
14	RDDA	O	RDS data output
15	RDCL	I/O	RDS clock output (master mode)/RDS clock input (slave mode)
16	RDS-ID/READY	O	RDS-ID/READY output (negative polarity)

4.10 LC75345M-X (IC901) : E.volume

- Pin layout

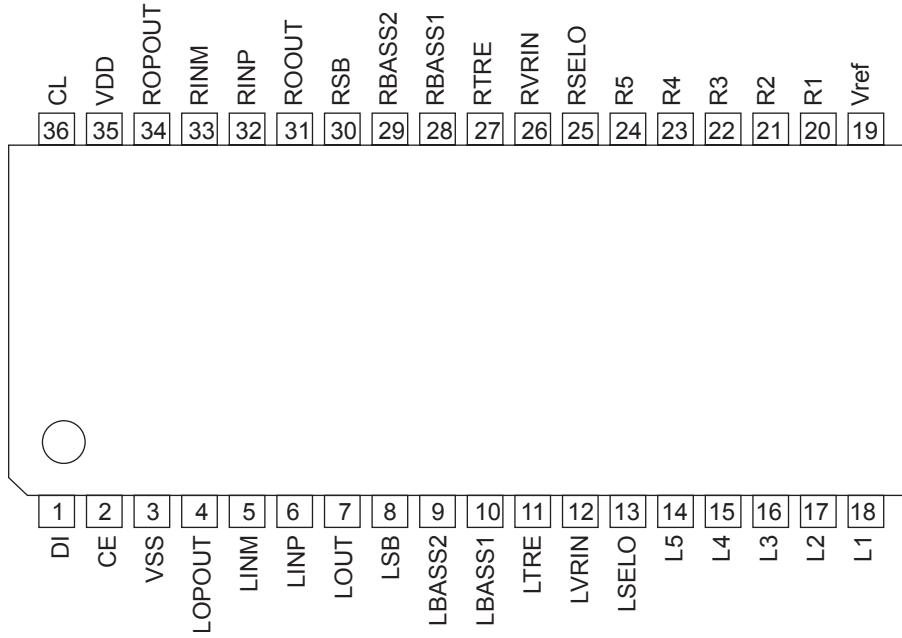

- Block diagram

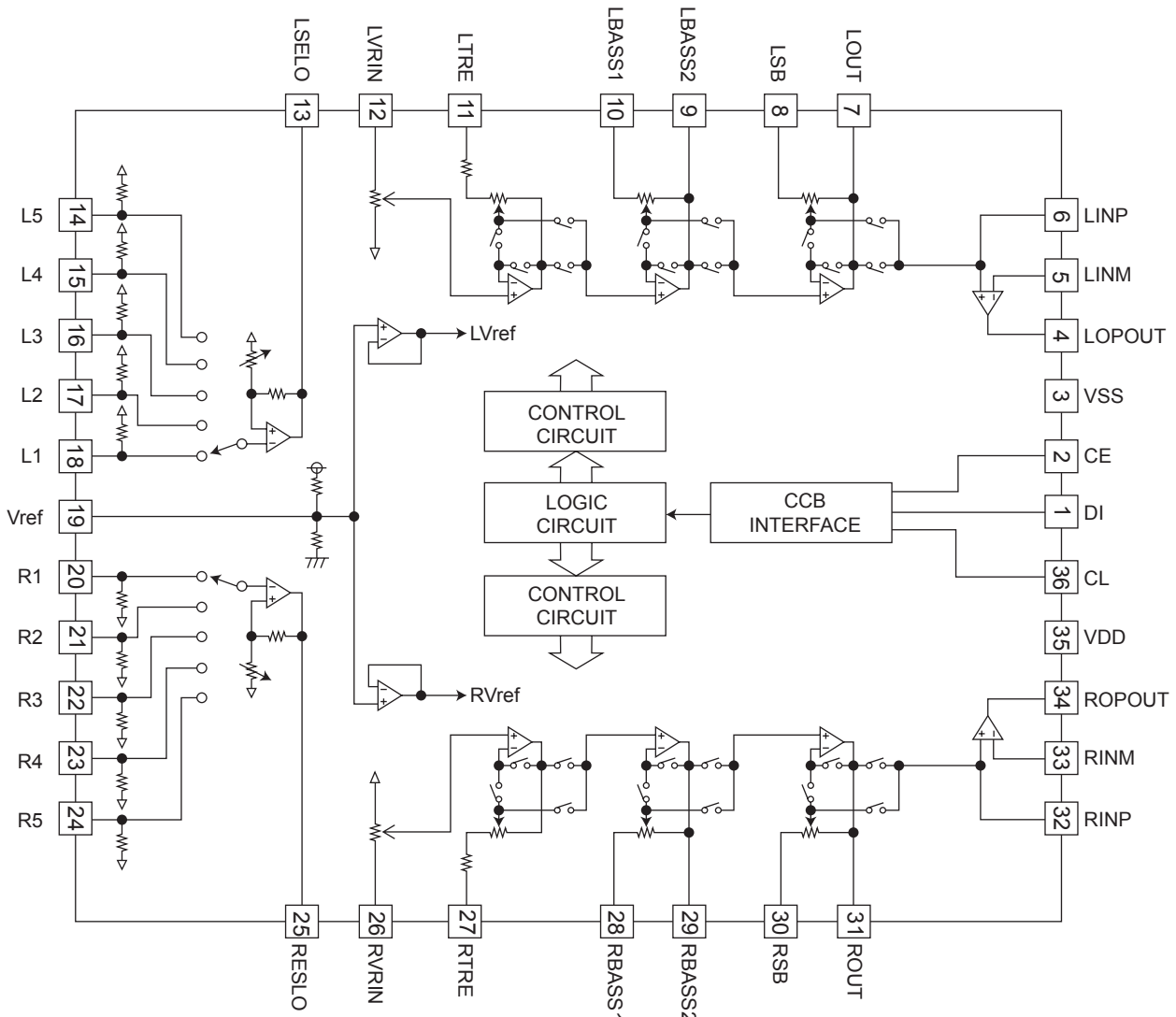

• Pin function

Pin No.	Symbol	Function
1	DI	Serial data and clock input pin for control.
2	CE	Chip enable pin.
3	VSS	Ground pin.
4	LOPOUT	Output pin of general-purpose operation amplifier.
5	LINM	Non-inverted input pin of general-purpuse operation amplifier.
6	LINP	Non-inverted input pin of general-purpuse operation amplifier.
7	LOUT	ATT + equalizer output pin.
8	LSB	Capacitor and resistor connection pin comprising filters for bass and super-bass band.
9	LBASS2	Capacitor and resistor connection pin comprising filters for bass and super-bass band.
10	LBASS1	Capacitor and resistor connection pin comprising filters for bass and super-bass band.
11	LTRE	Capacitor and resistor connection pin comprising treble band filter.
12	LVRIN	Volume input pin.
13	LSELO	Input selector output pin.
14	L5	Input signal pin.
15	L4	Input signal pin.
16	L3	Input signal pin.
17	L2	Input signal pin.
18	L1	Input signal pin.
19	Vref	0.5 x VDD voltage generation block for analog ground.
20	R1	Input signal pin.
21	R2	Input signal pin.
22	R3	Input signal pin.
23	R4	Input signal pin.
24	R5	Input signal pin.
25	RSELO	Input selector output pin.
26	RVRIN	Volume input pin.
27	RTRE	Capacitor connection pin comprising treble band filter.
28	RBASS1	Capacitor and resistor connection pin comprising filter for bass and super-bass band.
29	RBASS2	Capacitor and resistor connection pin comprising filter for bass and super-bass band.
30	RSB	Capacitor and resistor connection pin comprising filter for bass and super-bass band.
31	ROUT	ATT + equalizer output pin.
32	RINP	Non inverted input pin of general-purpose operation amplifier.
33	RINM	Non inverted input pin of general purpose operation amplifier.
34	ROPOUT	Output pin of general-purpose operation amplifier.
35	VDD	Supply pin.
36	CL	Serial data and clock input pin for control.

4.11 MN101C57DFB (IC931) : System micon

• Pin Layout

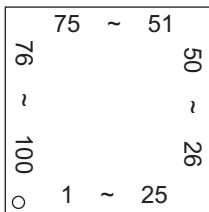

• Pin function

Pin No.	Symbol	I/O	Function
1~3	VLC1~VLC3	-	LCD BIAS VOLTAGE
4,5	NC	-	-
6	MLD	O	CD command ready signal
7	MDATA	O	CD data
8	MCLK	O	CD data clock
9	_XRST	O	CD reset
10	STAT	I	CD status input port
11	VSS	-	GROUND
12	OSC1	-	MAIN OSC
13	OSC2	-	MAIN OSC
14	MMOD	-	GROUND(10k ohm pull down)
15	XI	-	SUB OSC(Not use, connect to Vss)
16	XO	-	SUB OSC(Not use, open)
17	VDD	-	5V
18	NRST	-	RESET
19	VDD	-	5V
20	SDATA	I/O	Serial Data(Vol & Tape IC/Tuner)
21	_MPX	I	FM Stereo Detection ('L'=STEREO)
22	SCK	O	Serial Clock(Vol IC/Tape IC)
23	PERIOD	O	Tuner PLL Strobe(TUST/CE)
24	QRIN	I	Q-code/RDS data input(SUBQ/RDDA)
25	SQCK	O	Q-code serial clock
26	VOLCE	O	Volume Chip Enable
27	_AHB	O	Active Hyper Bass('L'=ON)
28	_SPKMUTE	O	Speaker mute
29	F_TU	O	Tuner Function ('H'=TUNER)
30	F_CD	O	CD Function ('H'=CD)
31	_SURR	O	SURROUND IC
32	SMUTE	O	System mute
33	RDSCK	I	RDS clock
34	BLKCK	I	Block clock input port
35	FLAG	I	Error Correction Count
36	_PROTR	I	Protector
37	_REM	I	Remote control input
38	BUP	I	Back up power detect('H'=BACKUP)
39	VDD	-	5V
40	VREF+	-	5V

Pin No.	Symbol	I/O	Function
41	DOOR_RST	I	REST/CLOSE switch detect port
42	SAFETY0	I	Irregular voltage detection 0
43	TAPE1	I	Tape Switch 0
44	TAPE0	I	Tape Switch 1
45	SAFETY1	I	Irregular voltage detection 1
46	STTA	O	Tape IC Strobe
47	BCTL	O	Switched 5V control('H'=5V(off))
48	CDSAFTY	I	CD safety voltage detect port
49	VREF-	-	GROUND
50	REEL	I	Tape End Detection
51	LEDCTL	O	Power Standby LED control(POUT)
52	KEY1	I	Unit Key input 1
53	KEY0	I	Unit Key input 0
54	VOLM	I	Volume Minus
55	VOLP	I	Volume Plus
56~72	SEG17~SEG33	O	SEGMENT OUTPUT
73,74	LED1,LED2	O	Back light color control(DIMCTL)
75,76	SEG34,SEG0	O	SEGMENT OUTPUT
77	MODEL	I	Model detection
78	CLOSE	O	Motor driver for door close
79	OPEN	O	Motor driver for door open
80	MUTE	O	BTL mute control port
81~96	SEG1~SEG16	O	SEGMENT OUTPUT
97~100	COM3~COM0	-	LCD BIAS GROUND

4.12 MN662748RPMFA (IC701) : Digital servo & Digital signal processor

- Pin layout

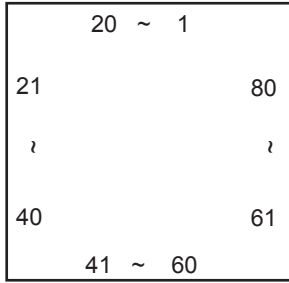

- Block diagram

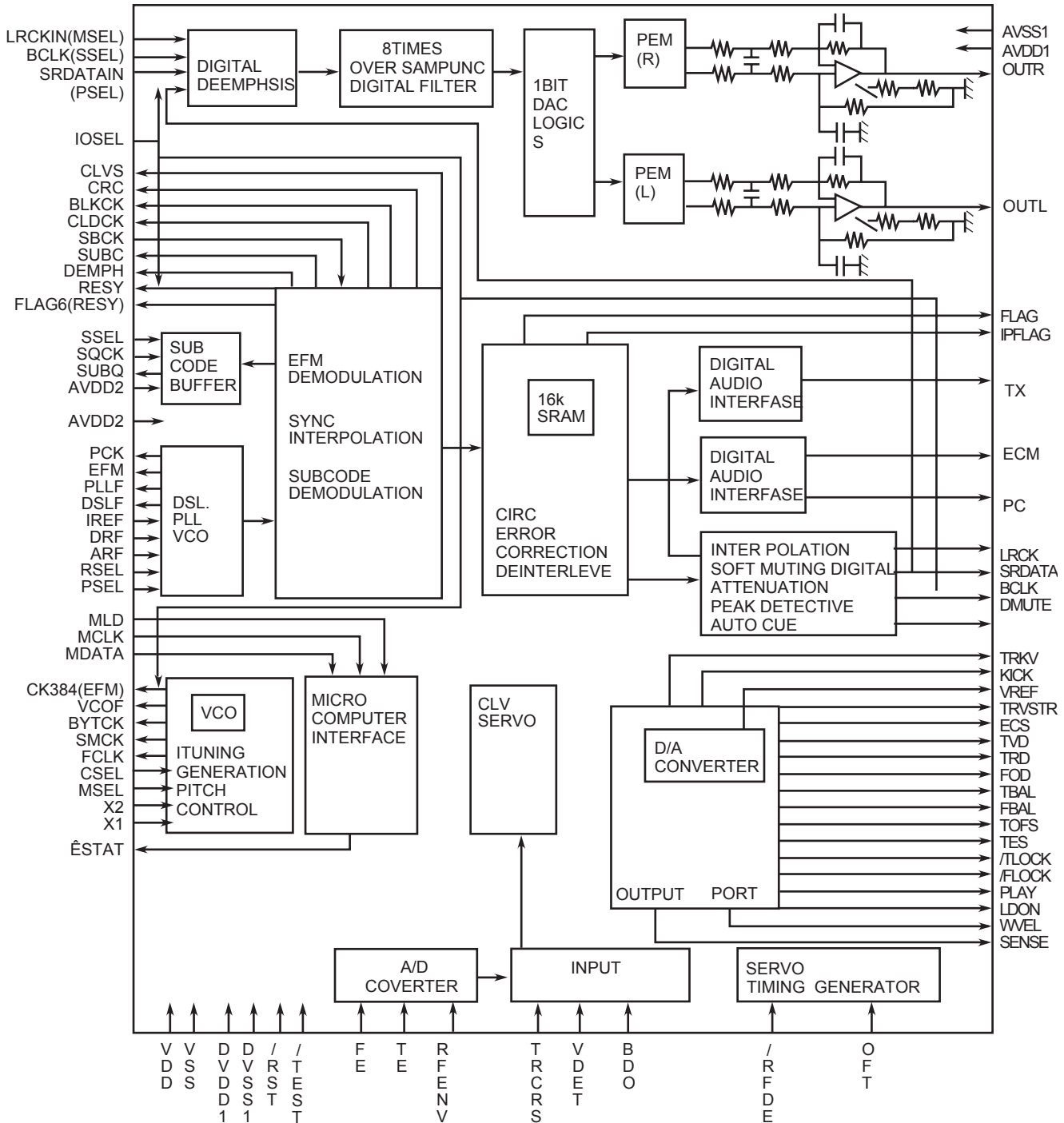

• Pin function

Pin No.	Symbol	I/O	Function
1	BCLK	O	Not used
2	LRCK	O	Not used
3	SRDATA	O	Not used
4	DVDD1	-	Power supply (Digital)
5	DVSS1	-	Connected to GND
6	TX	O	Digital audio interface output
7	MCLK	I	CPU command clock signal input (Data is latched at signal's rising point)
8	MDATA	I	CPU command data input
9	MLD	I	CPU command load signal input
10	SENSE	O	Sense signal output
11	FLOCK	O	Focus lock signal output Active :Low
12	TLOCK	O	Tracking lock signal output Active :Low
13	BLKCK	O	sub-code/block/clock signal output
14	SQCK	I	Outside clock for sub-code Q resister input
15	SUBQ	O	Sub-code Q -code output
16	DMUTE		Connected to GND
17	STATUS	O	"Status signal (CRC,CUE,CLVS,TTSTOP,ECLV,ECLV,SQOK)"
18	RST	I	Reset signal input (L:Reset)
19	SMCK	-	Not used
20	PMCK	-	Not used
21	TRV	O	Traverse enforced output
22	TVD	O	Traverse drive output
23	PC	-	Not used
24	ECM	O	Spindle motor drive signal (Enforced mode output) 3-State
25	ECS	O	"Spindle motor drive signal (Servo error signal output)"
26	KICK	O	Kick pulse output
27	TRD	O	Tracking drive output
28	FOD	O	Focus drive output
29	VREF	I	"Reference voltage input pin for D/A output block (TVD,FOD,FBA,TBAL)"
30	FBAL	O	Focus Balance adjust signal output
31	TBAL	O	Tracking Balance adjust signal output
32	FE	I	Focus error signal input (Analog input)
33	TE	I	Tracking error signal input (Analog input)
34	RF ENV	I	RF envelope signal input (Analog input)
35	VDET	I	Vibration detect signal input (H:detect)
36	OFT	I	Off track signal input (H:off track)
37	TRCRS	I	Track cross signal input
38	RFDET	I	RF detect signal input (L:detect)
39	BDO	I	BDO input pin (L:detect)

Pin No.	Symbol	I/O	Function
40	LDON	I	Laser ON signal output (H:on)
42	TES	O	Tracking error shunt signal output (H:shunt)
41	PLAY	-	Not used
43	WVEL	-	Not used
44	ARF	I	RF signal input
45	IREF	I	Reference current input pin
46	DRF	I	Bias pin for DSL
47	DSLFL	I/O	Loop filter pin for DSL
48	PLLFL	I/O	Loop filter pin for PLL
49	VCOF	-	Not used
50	AVDD2	-	Power supply (Analog)
51	AVSS2	-	Connected to GND (Analog)
52	EFM	-	Not used
53	PCK	-	Not used
54	PDO	-	Not used
55	SUBC	-	Not used
56	SBCK	-	Not used
57	VSS	-	"Connected to GND (for X'tal oscillation circuit)"
58	XI	I	Input of 16.9344MHz X'tal oscillation circuit
59	X2	O	Output of X'tal oscillation circuit
60	VDD	-	Power supply (for X'tal oscillation circuit)
61	BYTCK	-	Not used
62	CLDCK	-	Not used
63	FLAG	-	Not used
64	IPPLAG	-	Not used
65	FLAG	-	Not used
66	CLVS	-	Not used
67	CRC	-	Not used
68	DEMPH	-	Not used
69	RESY	-	Not used
70	IOSEL	-	pull up
71	TEST	-	pull up
72	AVDD1	-	Power supply (Digital)
73	OUT L	O	Lch audio output
74	AVSS1	-	Connected to GND
75	OUT R	O	Rch audio output
76	RSEL	-	pull up
77	CSEL	-	Connected to GND
78	PSEL	-	Connected to GND
79	MSEL	-	Connected to GND
80	SSEL	-	Pull up

JVC

VICTOR COMPANY OF JAPAN, LIMITED

AV & MULTIMEDIA COMPANY AUDIO/VIDEO SYSTEMS CATEGORY 10-1,1chome,Ohwatari-machi,Maebashi-city,371-8543,Japan

(No.22032)



Printed in Japan
200303WPC

PARTS LIST

[UX-J50]

* All printed circuit boards and its assemblies are not available as service parts.

Area suffix

B ----- U.K.
 E ----- Continental Europe
 EN ----- Northern Europe

- Contents -

Exploded view of general assembly and parts list (Block No.M1)	3- 3
Speaker assembly and parts list (Block No.M2)	3- 6
CD loading base assembly and parts list (Block No.MD)	3- 7
Cassette mechanism assembly and parts list (Block No.MP)	3- 9
Electrical parts list (Block No.01~06)	3-11
Packing materials and accessories parts list (Block No.M3,M5)	3-20

< MEMO >

Exploded view of general assembly and parts list

Block No. **M 1 M M**

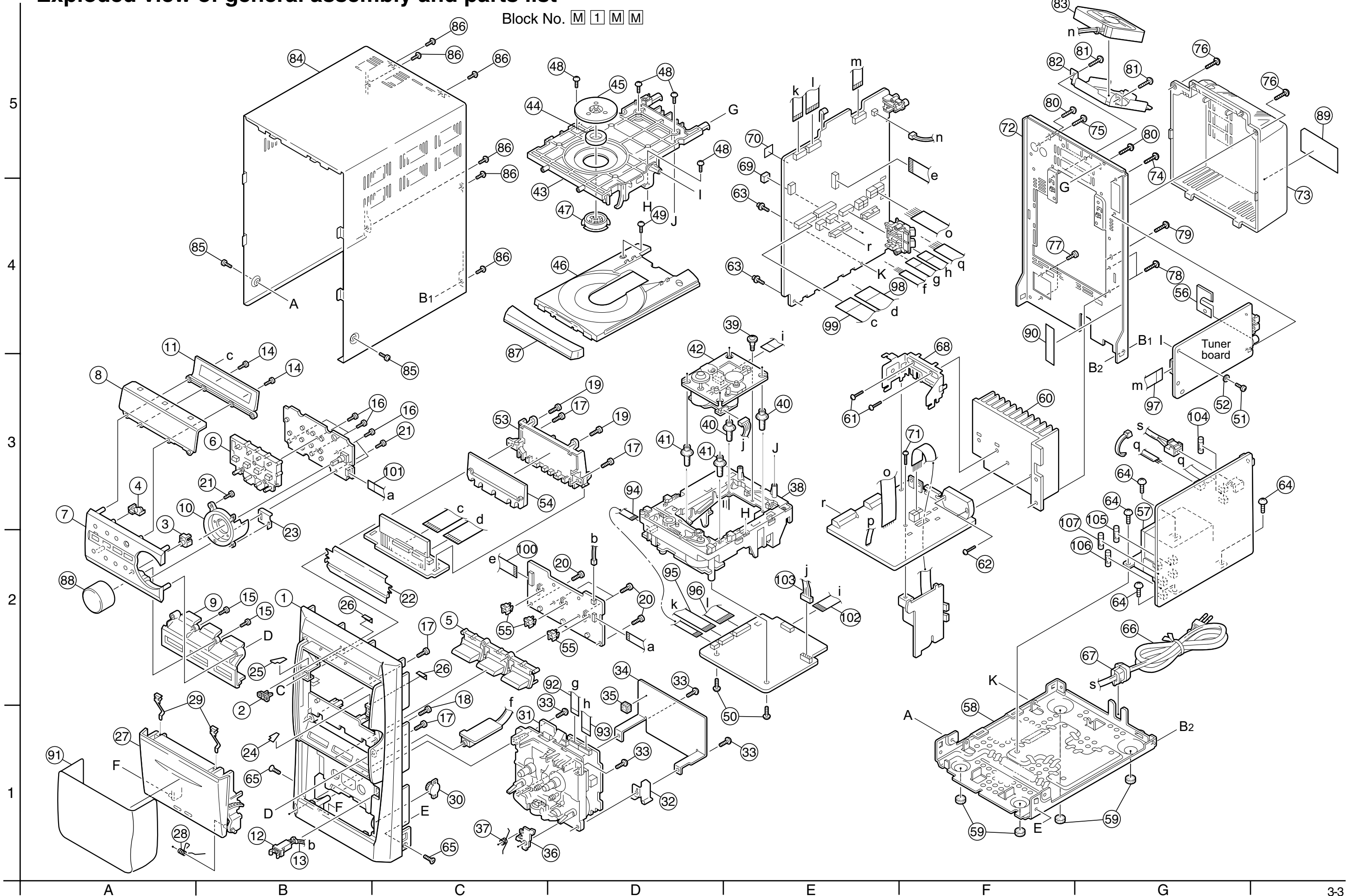

■ Parts list (General assembly)

Block No. M1MM

△	Item	Parts number	Parts name	Q'ty	Description	Area
	1	GV10123-001A	FRONT PANEL	1		
	2	GV40077-002A	JVC BADGE	1		
	3	GV40367-001A	REMOTE LENS	1		
	4	GV40366-001A	STANDBY LENS	1		
	5	GV30398-002A	FUNC.BTN.ASSY	1		
	6	GV20196-001A	CONTROL BUTTON	1		
	7	GV20195-001A	FRONT PLATE	1		
	8	GV30390-002A	FRONT LENS A	1		
	9	GV30391-001A	FRONT LENS B	1		
	10	GV30389-003A	VOLUME ORNAMENT	1		
	11	GV30393-002A	LCD COVER	1		
	12	QSW0920-001	PUCH LOCK SW	1		
	13	WJM0249-001A	E-SI C WIRE C-F	1	TO PUSH LOCK SW	
	14	QYSDSF2608Z	SCREW	2	F.LENS A/F.PLAT	
	15	QYSDSF2608Z	SCREW	2	F.LENS B/F.PLAT	
	16	QYSDSF2608Z	SCREW	5	PWB/F.PLATE	
	17	QYSDSF2608Z	SCREW	4	F.PLATE/F.PANEL	
	18	QYSDSF2608Z	SCREW	1	VOL.OR./F.PLATE	
	19	QYSDSF2608Z	SCREW	2	LCD HOL./F.PANEL	
	20	QYSDSF2608Z	SCREW	4	LED PWB/F.PANEL	
	21	QYSDSF2608Z	SCREW	2	VOL.OR./PWB	
	22	GV40412-001A	OPAQUE SHEET	1		
	23	GV40413-001A	OPAQUE SHEET B	1		
	24	GV40416-001A	MIRROR SHEET	1		
	25	GV40416-002A	MIRROR SHEET	1		
	26	GV40435-001A	SUPPORT SPACER	2	STICK AT F.PANE	
	27	GV10124-001A	CASSETTE DOOR	1		
	28	GV40277-001A	DOOR SPRING	1		
	29	VKY4180-401	CASSETTE SPRING	2		
	30	GV40034-001A	DAMPER ASSY	1		
	31	-----	CASSETTE MECHA	1		
	32	GV40369-001A	SPRING HOLDER	1		
	33	QYSBSF3012Z	SCREW	4	SLC./F.PANEL	
	34	GV30124-002A	TRANS SHIELD	1		
	35	GV40170-003A	SPACER	1	SLC(MOTOR)/T.SH	
	36	GV40414-001A	EJECT SAFETY	1		
	37	VKW5258-003	TORSION SPRING	1		
	38	-----	LOAD.BASE ASSY.	1		
	39	E406293-001	SPECIAL SCREW	1	CD MECHA/LOAD.B	
	40	GV40196-001A	INSULATOR	2		
	41	GV40196-002A	INSULATOR	2		
	42	KSM-213CCMJ	CD MECHA ASSY.	1		
	43	GV10102-002A	CLAMPER BASE	1		
	44	VYH7313-005	MAGNET	1		
	45	E306836-223SS	CD YOKE	1		
	46	VYH1240-001	TRAY	1		
	47	GV30202-001A	CD CLAMPER	1		
	48	QYSBSF3008Z	SCREW	4	CLAMP.BASE/LOAD	

■ Parts list (General assembly)

Block No. M1MM

△	Item	Parts number	Parts name	Q'ty	Description	Area
	49	QYSBSF3008Z	SCREW	1	CD TRAY STOPPER	
	50	QYSBSF3008Z	SCREW	2	CD BRD/LOAD.ASS	
	51	QYSDSF2608Z	SCREW	1	TUNER/C.BASE AS	
	52	GV40122-003A	SPACER	1	SCREW/TUNER PWB	
	53	GV30392-002A	LCD HOLDER	1		
	54	GV40368-001A	LCD LENS	1		
	55	GV40411-001A	LED HOLDER	3	FOR LEDS	
	56	GV40211-001A	EARTH PLATE	1		
△	57	QQT0389-002	POWER TRANSF	1	T1000	
	58	GV10103-002A	BOTTOM CHASSIS	1		
	59	GV40312-002A	FOOT SPACER	4	CHAS.BASE FOOT	
	60	GV30395-002A	HEAT SINK	1		
	61	QYSBSF3016Z	SCREW	2	IC HOL./H.SINK	
	62	QYSBSF3016Z	SCREW	2	POWER IC/H.SINK	
	63	QYSBSFG3016Z	SCREW	2	PWB BRD/CHA.BAS	
	64	QYSBST4006Z	T.SCREW	4	TRANS/CHA.BASE	
	65	QYSSST3008Z	SCREW	2	F.PANEL/C.BASE	
△	66	QMPK200-200-JD	POWER CORD	1		E,EN
△		QMPN150-200-JC	POWER CORD	1		B
	67	QZW0033-001	STRAIN RELIEF	1		
	68	GV30414-001A	IC HOLDER	1		
	69	GV40170-003A	SPACER	1	FOR C2200	
	70	GV30349-011A	SPACER	1		
	71	QYSBSF3008Z	SCREW	1	EARTH PLATE/SPK	
	72	GV10104-009A	REAR PANEL	1		
	73	GV10105-012A	REAR COVER	1		
	74	QYSBSGY3008E	SPECIAL SCREW	1	ANT.TEM/R.PANEL	
	75	QYSBSGY3008E	SPECIAL SCREW	1	AUX.TEM/R.PANEL	
	76	QYSBSGY3010E	SPECIAL SCREW	2	R.COVER/R.PANEL	
	77	QYSBSGY3008E	SPECIAL SCREW	2	SPEAKER/R.PANEL	
	78	QYSBSGY3008E	SPECIAL SCREW	2	R.PANEL/H.SINK	
	79	QYSBSGY3008E	SPECIAL SCREW	1	R.PANEL/GROUND	
	80	QYSBSGY3008E	SPECIAL SCREW	2	R.PNL/C.BASE AS	
	81	QYSBSGY3008E	SPECIAL SCREW	2	FAN / R.PANEL	
	82	GV30456-001A	FAN BRACKET	1		
	83	QAR0124-003	FAN MOTOR	1		
	84	GV10106-003A/S/	METAL COVER	1		
	85	QYSDSG3006M	T.SCREW	2	M.COVER/C.BASE	
	86	QYSBSGY3008E	SPECIAL SCREW	6	M.COVER/R.PANEL	
	87	GV30397-001A	CD FITTING	1		
	88	GV30396-001A	VOLUME KNOB	1		
	89	GV30427-001A	RATING LABEL	1		
△	90	LV41843-001A	LASER CAUTION	1		
	91	GV40168-005A	SHEET	1	STICK AT FRONT	
	92	QUQH12-0914AJ	CARD WIRE	1	FC 33	
	93	QUQH12-1018AJ	CARD WIRE	1	FC 34	
	94	QUQH12-0507BJ	CARD WIRE	1	FC606	
	95	QUQH12-1314BJ	FLAT WIRE	1	FC652	

■ Parts list (General assembly)

Block No. M1MM

⚠	Item	Parts number	Parts name	Q'ty	Description	Area
	96	QUQH12-1614BJ	FLAT WIRE	1	FC651	
	97	QUQH12-1332BJ	FLAT WIRE	1	FC 1	
	98	QUQH12-1922AJ	FLAT WIRE	1	FC731	
	99	QUQH12-2317AJ	FLAT WIRE	1	FC730	
	100	QUQH12-1316AJ	FLAT WIRE	1	FC760	
	101	QUQH10-0910BJ	FLAT WIRE	1	FC750	
	102	QUQ110-1609AJ	FFC WIRE	1	FC601	
	103	QJJ010-060801	SIN CR C-C WIRE	1	W 801	
⚠	104	QMF51W2-1R6-J8	FUSE	1	F1000	
⚠	105	QMF51W2-1R6-J8	FUSE	1	F1001	
⚠	106	QMF51W2-5R0-J8	FUSE	1	F1003	
⚠	107	QMF51W2-5R0-J8	FUSE	1	F1004	

Speaker assembly and parts list

(SP-UXJ50)

Block No. M 2 M M

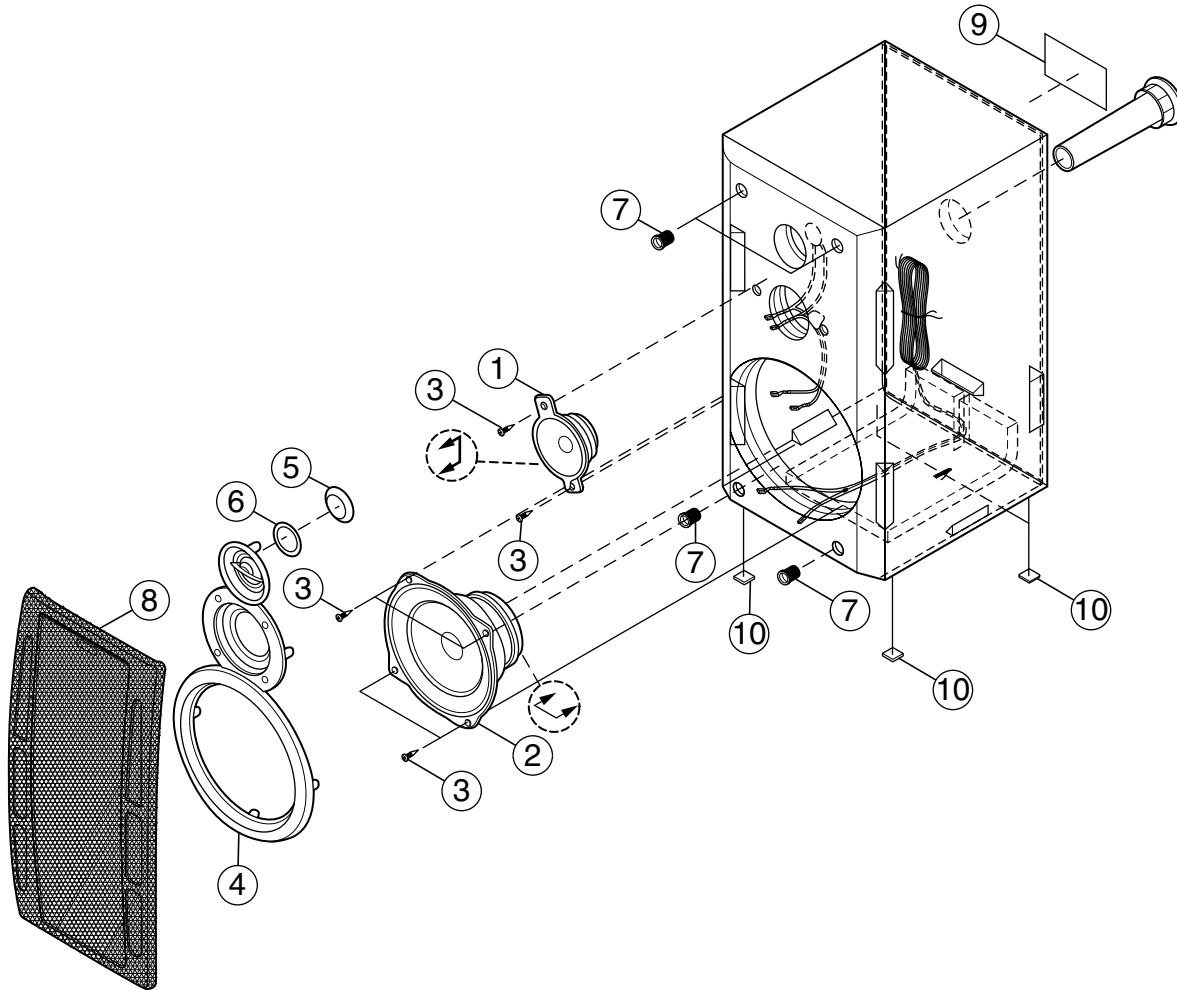

■ Parts list (Speaker)

Block No. M2MM

▲	Item	Parts number	Parts name	Q'ty	Description	Area
	1	993060400036	TWEETER ASSY	2		
	2	991061200061	WOOFER ASSY	2		
	3	135604141062	SCREW	12		
	4	151732601147	FRONT PANE	2		
	5	108650251048	DIAPHRAGM	2		
	6	138730251130	D.SIDE TAPE	2		
	7	147780121071	GROMMET	8		
	8	199732750179	GRILL FRAME ASS	2		
	9	137640601392	RATING LABEL	2		
	10	147760081069	LEG CUSHION	8		

CD loading base assembly and parts list

LOAD-JEM-2M

Block No. M D M M

Grease	
★	= G-474C
▲	= EBS0006-009B

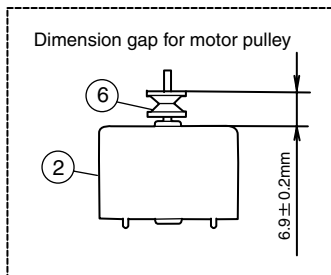
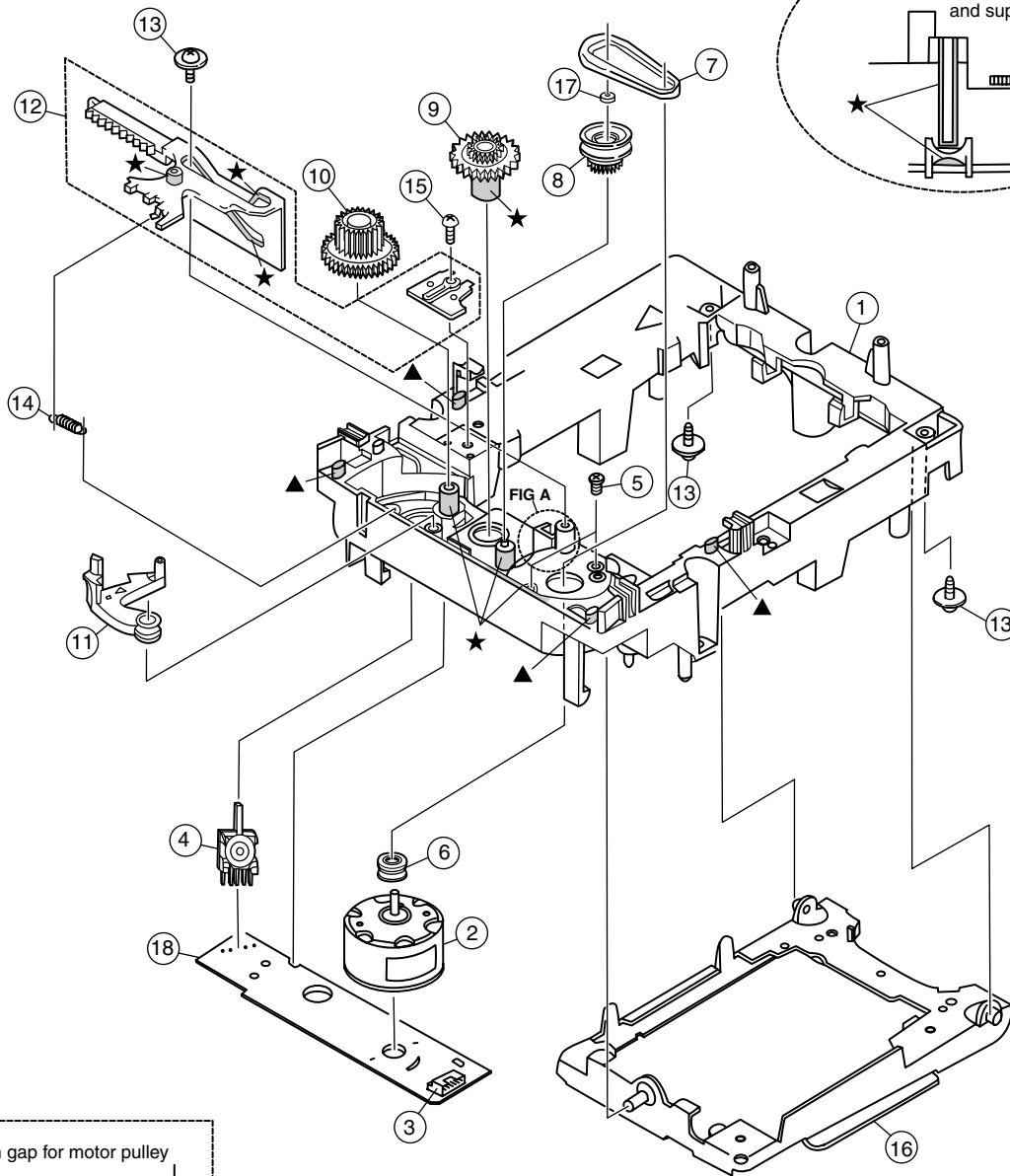

■ Parts list (CD loading mechanism)

Block No. MDMM

△	Item	Parts number	Parts name	Q'ty	Description	Area
	1	VYH1238-001	LOADING BASE	1		
	2	MMN-6F1LB8K	MOTOR	1		
	3	QGF1201F3-05	CONNECTOR	1	CN505	
	4	QSW0472-001	SWITCH	1	S851	
	5	QYSPSPT2640Z	MINI SCREW	2		
	6	E75984-221SS	C.D M.PULLEY	1		
	7	E75950-002	BELT	1		
	8	E75985-221SS	C.D GEAR (1)	1		
	9	E75986-221SS	C.D GEAR (2)	1	PBT	
	10	E75987-221SS	C.D GEAR (3)	1		
	11	E307162-331SS	LEVER	1		
	12	E307252-331SS	CAM PLATE	1		
	13	E65923-003	TAPPING SCREW	3		
	14	VYH7787-001	LEAF SPRING	1		
	15	QYSBSF3008Z	TAPPING SCREW	1		
	16	E307179-222SM	E.BASE ASS'Y	1		
	17	E60912-005SS	SPEED NUT	1		
	18	VMW1329-102	PRINTED BOARD	1		

Cassette mechanism assembly and parts list

Block No. M P M M

SLC-S302M

Grease

- ★ =EM-30L
- ▲ =UD-24
- =LEN-320M
- ◎ =MOBIL-1

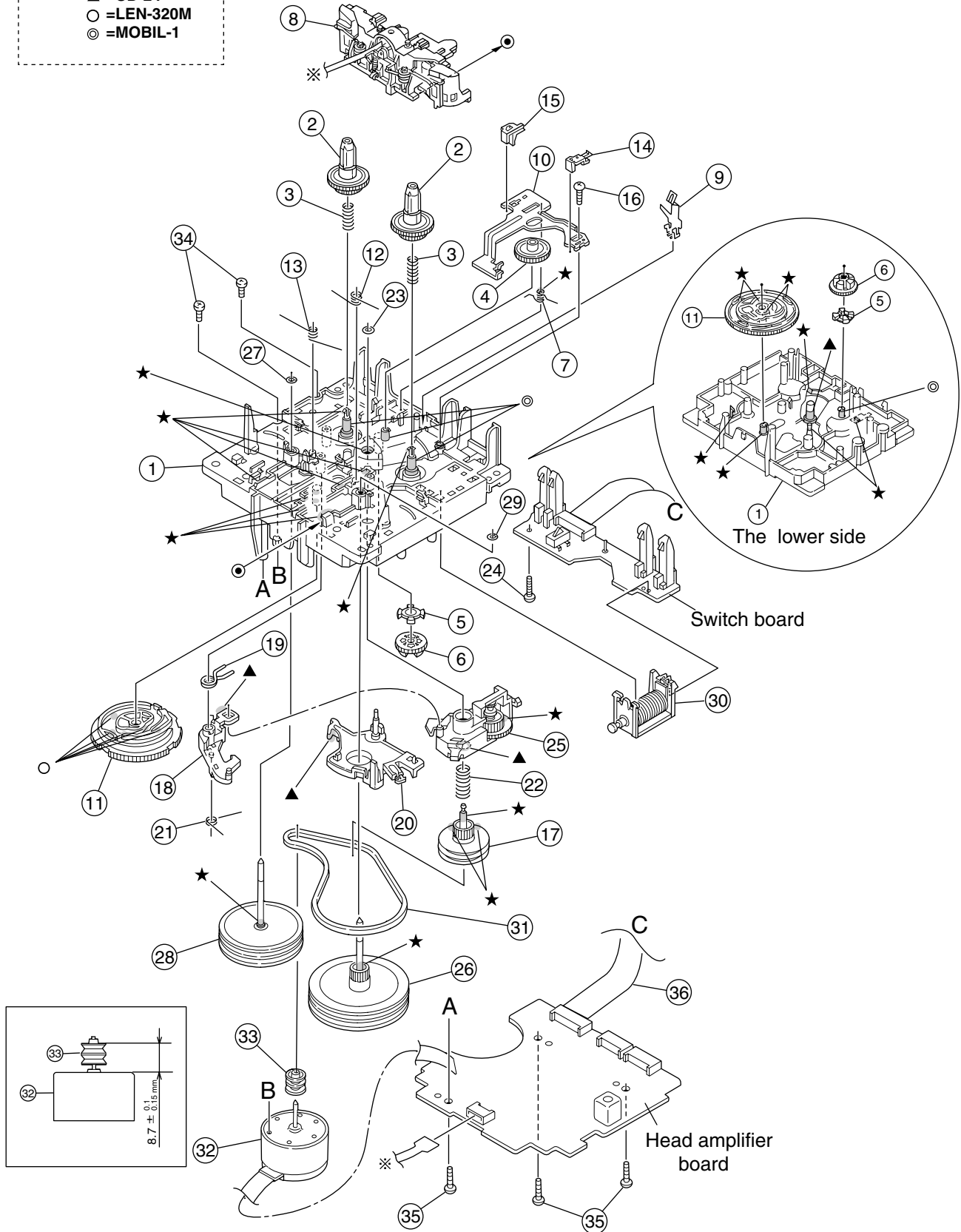

■ Parts list (Cassette mechanism)

Block No. MPMM

△	Item	Parts number	Parts name	Q'ty	Description	Area
	1	VKS1165-00L	CHASSIS B. ASSY	1		
	2	VKS2274-002	REEL GEAR	2		
	3	VKW5286-002	B.T. SPRING	2		
	4	VKS5559-001	PLAY IDLE GEAR	1		
	5	VKS5595-002	BLIND	1		
	6	VKS5560-003	FR IDLE GEAR	1		
	7	LV42013-001A	EARTH SPRING	1		
	8	SLC-PP3SVM	HEAD MOUNT ASSY	1		
	9	VKY3149-002	CASSETTE SP.	1		
	10	LV31786-001A	PLAY SW LEVER	1		
	11	VKS1166-004	CONTROL CAM	1		
	12	VKW5279-002	HEAD BASE SP(R)	1		
	13	VKW5280-001	HEAD BASE SP(L)	1		
	14	LV41584-001A	BRAKE(R)	1		
	15	LV41585-003A	BRAKE(L)	1		
	16	QYSBSF2005Z	T.SCREW	1		
	17	VKS5603-00G	MAIN PULLEY ASY	1		
	18	VKS3785-001MM	FR ARM	1		
	19	VKW5284-002	SWING SPRING	1		
	20	VKS2278-003	TRIGGER ARM	1		
	21	VKW5301-001	FR SPRING	1		
	22	VKW5266-001	ELEVATOR SPRING	1		
	23	WDL214025	WASHER	1		
	24	QYSBSF2005Z	T.SCREW	1		
	25	VKS3786-00G	CLUTCH ASS'Y	1		
	26	VKF3205-00B	F.WHEEL ASSY(R)	1		
	27	WDL183425	SLIT WASHER	1		
	28	VKF3207-00C	F.WHEEL ASSY(L)	1		
	29	WDL173525-6	SLIT WASHER	1		
	30	VKZ3174-00B	DC SOLENOID	1		
	31	LV42836-001A	CAPSTAN BELT	1		
	32	MSI-5U2LWA	D.C.MOTOR ASS'Y	1		
	33	VKR4761-003	MOTOR PULLEY	1		
	34	QYSPSP2604Z	SCREW	2		
	35	QYSBSF2608Z	T.SCREW	3	FOR P.W.B.	
	36	QUQH12-0906BF	WIER	1	FC32	

■ Electrical parts list (Main board)

Block No. 01

▲	Item	Parts number	Parts name	Remarks	Area	▲	Item	Parts number	Parts name	Remarks	Area
	CN900	QGF1201C3-10	CONNECTOR	SLC			C2508	QCBB1HK-331Y	C CAPACITOR	330PF 10% 50V	
	CN901	QGF1205C1-09	CONNECTOR	SLC			C2509	QCBB1HK-331Y	C CAPACITOR	330PF 10% 50V	
	CN902	QGF1205F1-13	CONNECTOR	*TURNER			C2701	QFVJ1HJ-184Z	MF CAPACITOR	.18MF 5% 50V	
	CN903	QGF1205F1-13	CONNECTOR	CD			C2702	QETN1HM-105Z	E CAPACITOR	1.0MF 20% 50V	
	CN904	QGF1205F1-16	CONNECTOR	CD			C2820	QCBB1HK-222Y	C CAPACITOR	2200PF 10% 50V	
	CN911	QGB2510J1-08	CONNECTOR	POWER AMP			C2821	QCBB1HK-222Y	C CAPACITOR	2200PF 10% 50V	
	CN912	QGB2510J1-10	CONNECTOR	POWER AMP			C2822	QCBB1HK-473Y	C CAPACITOR	.047MF 10% 50V	
	CN913	QGD2504C1-04Z	SOCKET	H/PHONE			C2823	QCBB1HK-473Y	C CAPACITOR	.047MF 10% 50V	
	CN916	QGA2501C1-02	2P CONNECTOR	FAN			C2824	QCBB1HK-473Y	C CAPACITOR	.047MF 10% 50V	
	CN917	QGD2504C1-03Z	SOCKET	TRANSFORMER			C2825	QCBB1HK-473Y	C CAPACITOR	.047MF 10% 50V	
	CN918	QGD2504C1-03Z	SOCKET	TRANSFORMER			C3500	QETN1EM-476Z	E CAPACITOR	47MF 20% 25V	
	CN930	QGF1205C1-23	CONNECTOR	TO FRONT PANEL			C3501	QETN1CM-106Z	E CAPACITOR	10MF 20% 16V	
	CN931	QGF1205C1-19	CONNECTOR	TO FRONT PANEL			C7001	QCSB1HJ-180Y	C CAPACITOR	18PF 5% 50V	
	CN932	QGF1205C1-13	CONNECTOR	TO FRONT PANEL			C7002	QCSB1HJ-180Y	C CAPACITOR	18PF 5% 50V	
	C2000	QCBB1HK-221Y	C CAPACITOR	220PF 10% 50V			C7003	QDGB1HK-102Y	C CAPACITOR		
	C2005	QETC1HM-475Z	E CAPACITOR	TUL			C7004	QETN1AM-107Z	E CAPACITOR	100MF 20% 10V	
	C2006	QETC1HM-475Z	E CAPACITOR	PBL			C7005	QDYB1CM-103Y	C CAPACITOR		
	C2007	QETC1HM-106Z	E CAPACITOR	CDL			C7008	QETN0JM-228Z	E CAPACITOR	2200MF 20% 6.3V	
	C2008	QETC1HM-475Z	E CAPACITOR	AUXL			C7009	QETN1HM-225Z	E CAPACITOR	2.2MF 20% 50V	
	C2009	QETC1HM-106Z	E CAPACITOR	RECL			C7010	QETN1HM-106Z	E CAPACITOR	10MF 20% 50V	
	C2010	QTE1V06-106Z	E CAPACITOR				C7011	QETN1CM-107Z	E CAPACITOR	100MF 20% 16V	
	C2011	QFLC1HJ-272Z	M CAPACITOR	2700PF 5% 50V			C7012	QCFB1HZ-104Y	C CAPACITOR	.10MF +80-20%	
	C2012	QFLC1HJ-104Z	M CAPACITOR	.10MF 5% 50V			C7041	QDYB1CM-103Y	C CAPACITOR		
	C2013	QFLC1HJ-104Z	M CAPACITOR	.10MF 5% 50V			C7061	QCBB1HK-151Y	C CAPACITOR	150PF 10% 50V	
	C2014	QFVJ1HJ-184Z	MF CAPACITOR	.18MF 5% 50V			C7063	QCBB1HK-151Y	C CAPACITOR	150PF 10% 50V	
	C2015	QFVJ1HJ-184Z	MF CAPACITOR	.18MF 5% 50V			C7101	QCFB1HZ-104Y	C CAPACITOR	.10MF +80-20%	
	C2016	QFVJ1HJ-154Z	MF CAPACITOR	.15MF 5% 50V			C7102	QCFB1HZ-104Y	C CAPACITOR	.10MF +80-20%	
	C2017	QETC1CM-226Z	E CAPACITOR	22MF 20% 16V			C7104	QCFB1HZ-104Y	C CAPACITOR	.10MF +80-20%	
	C2018	QFVJ1HJ-154Z	MF CAPACITOR	.15MF 5% 50V			C7110	QDGB1HK-102Y	C CAPACITOR		
	C2019	QFVJ1HJ-274Z	MF CAPACITOR	.27MF 5% 50V			C7121	QCBB1HK-101Y	C CAPACITOR	100PF 10% 50V	
	C2026	QFLC1HJ-183Z	M CAPACITOR	.018MF 5% 50V			C7123	QCBB1HK-151Y	C CAPACITOR	150PF 10% 50V	
	C2100	QCBB1HK-221Y	C CAPACITOR	220PF 10% 50V			C7126	QDYB1CM-103Y	C CAPACITOR		
	C2105	QETC1HM-475Z	E CAPACITOR	TUR			C7134	QCBB1HK-101Y	C CAPACITOR	100PF 10% 50V	
	C2106	QETC1HM-475Z	E CAPACITOR	PBR			C7143	QCBB1HK-101Y	C CAPACITOR	100PF 10% 50V	
	C2107	QETC1HM-106Z	E CAPACITOR	CDR			C7145	QDGB1HK-102Y	C CAPACITOR		
	C2108	QETC1HM-475Z	E CAPACITOR	AUXR			C7159	QDYB1CM-103Y	C CAPACITOR		
	C2109	QETC1HM-106Z	E CAPACITOR	RECR			C7161	QCBB1HK-101Y	C CAPACITOR	100PF 10% 50V	
	C2110	QTE1V06-106Z	E CAPACITOR				D2200	1SS119-041-T2	SI DIODE	FREEWHEEL DIODE	
	C2111	QFLC1HJ-272Z	M CAPACITOR	2700PF 5% 50V			D2201	1SS119-041-T2	SI DIODE	FREEWHEEL DIODE	
	C2112	QFLC1HJ-104Z	M CAPACITOR	.10MF 5% 50V			D2204	1N4003S-T5	SI DIODE	SW10V (SLC)	
	C2113	QFLC1HJ-104Z	M CAPACITOR	.10MF 5% 50V			D2205	1SS119-041-T2	SI DIODE		
	C2114	QFVJ1HJ-184Z	MF CAPACITOR	.18MF 5% 50V			D2206	1SS119-041-T2	SI DIODE		
	C2115	QFVJ1HJ-184Z	MF CAPACITOR	.18MF 5% 50V			D2701	1SS119-041-T2	SI DIODE		
	C2116	QFVJ1HJ-154Z	MF CAPACITOR	.15MF 5% 50V		▲	D2800	MTZJ24C-T2	Z DIODE		
	C2117	QETC1CM-226Z	E CAPACITOR	22MF 20% 16V			D2804	1SS119-041-T2	SI DIODE	SPK F/B TO FAN	
	C2118	QFVJ1HJ-154Z	MF CAPACITOR	.15MF 5% 50V			D2805	1SS119-041-T2	SI DIODE	SPK F/B TO FAN	
	C2119	QFVJ1HJ-274Z	MF CAPACITOR	.27MF 5% 50V			D7002	1SS119-041-T2	SI DIODE		
	C2126	QFLC1HJ-183Z	M CAPACITOR	.018MF 5% 50V			D7003	1SS119-041-T2	SI DIODE	RESET	
	C2200	QETM1EM-228	E CAPACITOR	FILTER CAPACITO			D7004	1SS119-041-T2	SI DIODE	BACK UP	
	C2211	QDYB1CM-103Y	C CAPACITOR	EMC CAP			D7005	1SS119-041-T2	SI DIODE	USSV	
	C2213	QETN1CM-106Z	C CAPACIT O R	10MF 20% 16V			D7006	1SS119-041-T2	SI DIODE		
	C2215	QETN1CM-226Z	E CAPACITOR	22MF 20% 16V			D7007	MTZJ5.1B-T2	ZENER DIODE		
	C2221	QETN1AM-107Z	E CAPACITOR	100MF 20% 10V			D7008	MTZJ6.2C-T2	ZENER DIODE		
	C2222	QETN1CM-107Z	E CAPACITOR	100MF 20% 16V			D7009	1SS119-041-T2	SI DIODE		
	C2223	QFLC1HJ-104Z	M CAPACITOR	.10MF 5% 50V			D7010	1SS119-041-T2	SI DIODE		
	C2228	QETN1HM-475Z	E CAPACITOR	4.7MF 20% 50V			D7061	1SS119-041-T2	SI DIODE	RDDA	
	C2236	QFLM1HJ-104Z	M CAPACITOR	.10MF 5% 50V			D7062	1SS119-041-T2	SI DIODE	SAFETY1	
	C2239	QETN1HM-105Z	E CAPACITOR	1.0MF 20% 50V			D7071	1SS119-041-T2	SI DIODE	E.EN.B.EV ONLY	
	C2500	QETN1HM-106Z	E CAPACITOR	EMC			IC901	LC75345M-X	IC		
	C2501	QDGB1HK-102Y	C CAPACITOR	EMC			IC931	MN101C57DFB	I.C(MICRO-PROC)	SYSTEM MICOM	
	C2502	QDGB1HK-103Y	C CAPACITOR	EMC			IC932	KIA78S06P-T	IC	US6V REG	
	C2503	QDGB1HK-102Y	C CAPACITOR	EMC			IH901	VYH7653-003	IC HOLDER		
	C2504	QDGB1HK-102Y	C CAPACITOR	EMC			IH931	VYH7653-001	IC HOLDER	IC HOLDER	
	C2505	QDGB1HK-102Y	C CAPACITOR				J 900	QNN0215-001	PIN JACK		
	C2506	QCBB1HK-331Y	C CAPACITOR	330PF 10% 50V			JA940	QNB0117-001	SPK TERMINAL		
	C2507	QCBB1HK-331Y	C CAPACITOR	330PF 10% 50V			K2200	QQR0621-001Z	FERRITE BEADS		

■ Electrical parts list (Main board)

Block No. 01

△	Item	Parts number	Parts name	Remarks	Area
	K7001	QQR0621-001Z	FERRITE BEADS		
	K7002	QQR0621-001Z	FERRITE BEADS		
	K7003	QQR0621-001Z	FERRITE BEADS		
	L2500	QQL231K-820Y	INDUCTOR		
	L2501	QQL231K-820Y	INDUCTOR		
	L2800	QQR0797-002	INDUCTOR		
	L2801	QQR0797-002	INDUCTOR		
	L3500	QQL231K-4R7Y	INDUCTOR		
	L7001	QQL231K-100Y	INDUCTOR	US5V	
	L7002	QQL231K-470Y	INDUCTOR	AVDD & VDD	
	L7003	QQL231K-4R7Y	INDUCTOR	AVREF	
	PP 3	QZW0038-001	WIRE CLAMP		
	Q2209	2SC3576-JVC-T	TRANSISTOR	MAIN AHB	
	Q2210	2SC3576-JVC-T	TRANSISTOR	MAIN AHB	
	Q2211	2SC2001/LK/-T	TRANSISTOR		
	Q2217	KRA102M-T	D.TRANSISTOR		
	Q2219	2SC3576-JVC-T	TRANSISTOR		
	Q2220	2SC3576-JVC-T	TRANSISTOR		
	Q2222	KRC104M-T	D.TRANSISTOR		
	Q2800	KTC3199/GL/-T	TRANSISTOR		
	Q3500	KTA1267/YG/-T	TRANSISTOR		
	Q3501	KRC104M-T	D.TRANSISTOR		
	Q7001	KTA1267/YG/-T	TRANSISTOR	SW5V	
	Q7002	KRC111M-T	TRANSISTOR	RESET SW	
	Q7003	2SC2785/FE/-T	TRANSISTOR	BACKUP CONT	
	Q7031	2SC2785/FE/-T	TRANSISTOR	POUT SW	
	Q7041	2SC2785/FE/-T	TRANSISTOR	PHOTO BUFFER	
	Q7061	KRC111M-T	TRANSISTOR	TUNER SW	
	Q7062	KRC111M-T	TRANSISTOR	TUNER SW	
	Q7063	KRA111M-T	D.TRANSISTOR	TUNER 5.6V	
	Q7064	KRC111M-T	TRANSISTOR	TUNER 5.6V	
	Q7091	KRC111M-T	TRANSISTOR	DIMMER	
	Q7092	KTA1267/YG/-T	TRANSISTOR	DIMMER	
	RY901	QSK0109-001	RELAY		
	R2000	QRE141J-303Y	C RESISTOR	30K 5% 1/4W	
	R2001	QRE141J-303Y	C RESISTOR	30K 5% 1/4W	
	R2006	QRE141J-222Y	C RESISTOR	PBREC	
	R2007	QRE141J-622Y	C RESISTOR	PBREC	
	R2008	QRE141J-912Y	C RESISTOR	PBMUTE	
	R2010	QRE141J-752Y	C RESISTOR	7.5K 5% 1/4W	
	R2011	QRE141J-752Y	C RESISTOR	7.5K 5% 1/4W	
	R2012	QRE141J-152Y	C RESISTOR	1.5K 5% 1/4W	
	R2013	QRE141J-222Y	C RESISTOR	2.2K 5% 1/4W	
	R2014	QRE141J-303Y	C RESISTOR	30K 5% 1/4W	
	R2015	QRE141J-473Y	C RESISTOR	47K 5% 1/4W	
	R2016	QRE141J-622Y	C RESISTOR	6.2K 5% 1/4W	
	R2017	QRE141J-182Y	C RESISTOR	1.8K 5% 1/4W	
	R2032	QRJ146J-821X	UNF C RESISTOR	820 5% 1/4W	
	R2038	QRJ146J-821X	UNF C RESISTOR	820 5% 1/4W	
	R2039	QRE141J-222Y	C RESISTOR	2.2K 5% 1/4W	
	R2040	QRE141J-471Y	C RESISTOR	470 5% 1/4W	
	R2041	QRE141J-182Y	C RESISTOR	1.8K 5% 1/4W	
	R2047	QRE141J-154Y	C RESISTOR	*BY MODEL	
	R2100	QRE141J-303Y	C RESISTOR	30K 5% 1/4W	
	R2101	QRE141J-303Y	C RESISTOR	30K 5% 1/4W	
	R2106	QRE141J-222Y	C RESISTOR	PBREC	
	R2107	QRE141J-622Y	C RESISTOR	PBREC	
	R2108	QRE141J-912Y	C RESISTOR	PBMUTE	
	R2110	QRE141J-752Y	C RESISTOR	7.5K 5% 1/4W	
	R2111	QRE141J-752Y	C RESISTOR	7.5K 5% 1/4W	
	R2112	QRE141J-152Y	C RESISTOR	1.5K 5% 1/4W	
	R2113	QRE141J-222Y	C RESISTOR	2.2K 5% 1/4W	
	R2114	QRE141J-303Y	C RESISTOR	30K 5% 1/4W	
	R2115	QRE141J-473Y	C RESISTOR	47K 5% 1/4W	
	R2116	QRE141J-622Y	C RESISTOR	6.2K 5% 1/4W	
	R2117	QRE141J-182Y	C RESISTOR	1.8K 5% 1/4W	

△	Item	Parts number	Parts name	Remarks	Area
	R2132	QRJ146J-821X	UNF C RESISTOR	820 5% 1/4W	
	R2138	QRJ146J-821X	UNF C RESISTOR	820 5% 1/4W	
	R2139	QRE141J-222Y	C RESISTOR	2.2K 5% 1/4W	
	R2140	QRE141J-471Y	C RESISTOR	470 5% 1/4W	
	R2141	QRE141J-182Y	C RESISTOR	1.8K 5% 1/4W	
	R2147	QRE141J-154Y	C RESISTOR	*BY MODEL	
	R2200	QRE141J-273Y	C RESISTOR	FILTER CAPACITO	
	R2207	QRE141J-513Y	C RESISTOR	51K 5% 1/4W	
	R2208	QRE141J-124Y	C RESISTOR	120K 5% 1/4W	
	R2216	QRE141J-103Y	C RESISTOR	10K 5% 1/4W	
	R2218	QRE141J-471Y	C RESISTOR	470 5% 1/4W	
	R2221	QRE141J-101Y	C RESISTOR	VDD	
	R2222	QRE141J-222Y	C RESISTOR	SCK	
	R2224	QRE141J-222Y	C RESISTOR	SDATA	
	R2228	QRE141J-334Y	C RESISTOR	330K 5% 1/4W	
	R2500	QRE141J-103Y	C RESISTOR	SIGL	
	R2501	QRE141J-103Y	C RESISTOR	SIGR	
	R2502	QRE141J-1R0Y	C RESISTOR	CD 8V	
	R2503	QRE141J-1R0Y	C RESISTOR	CD 8V	
	R2702	QRE141J-563Y	C RESISTOR	56K 5% 1/4W	
	R2703	QRE141J-302Y	C RESISTOR	3.0K 5% 1/4W	
	R2712	QRE141J-563Y	C RESISTOR	56K 5% 1/4W	
	R2800	QRE141J-152Y	C RESISTOR	1.5K 5% 1/4W	
	R2801	QRE141J-621Y	C RESISTOR	620 5% 1/4W	
	R2802	QRE141J-681Y	C RESISTOR	680 5% 1/4W	
	R2803	QRE141J-681Y	C RESISTOR	680 5% 1/4W	
	R2804	QRE141J-103Y	C RESISTOR	SPK F/B TO FAN	
	R2805	QRE141J-103Y	C RESISTOR	SPK F/B TO FAN	
△	R2806	QRJ146J-102X	UNF C RESISTOR	1.0K 5% 1/4W	
△	R2807	QRJ146J-102X	UNF C RESISTOR	1.0K 5% 1/4W	
	R2820	QRE141J-4R7Y	C RESISTOR	4.7 5% 1/4W	
	R2821	QRE141J-4R7Y	C RESISTOR	4.7 5% 1/4W	
	R3500	QRE141J-102Y	C RESISTOR	1.0K 5% 1/4W	
	R3501	QRE141J-103Y	C RESISTOR	10K 5% 1/4W	
	R3502	QRE141J-104Y	C RESISTOR	100K 5% 1/4W	
	R7002	QRE141J-103Y	C RESISTOR	10K 5% 1/4W	
	R7003	QRE141J-331Y	C RESISTOR	330 5% 1/4W	
	R7004	QRE141J-103Y	C RESISTOR	10K 5% 1/4W	
	R7005	QRE141J-103Y	C RESISTOR	10K 5% 1/4W	
	R7006	QRE141J-104Y	C RESISTOR	100K 5% 1/4W	
	R7007	QRE141J-473Y	C RESISTOR	47K 5% 1/4W	
	R7008	QRE141J-333Y	C RESISTOR	33K 5% 1/4W	
	R7041	QRE141J-823Y	C RESISTOR	82K 5% 1/4W	
	R7042	QRE141J-394Y	C RESISTOR	390K 5% 1/4W	
	R7043	QRE141J-104Y	C RESISTOR	100K 5% 1/4W	
	R7062	QRE141J-102Y	C RESISTOR	1.0K 5% 1/4W	
	R7063	QRE141J-470Y	C RESISTOR	47 5% 1/4W	
	R7064	QRE141J-103Y	C RESISTOR	10K 5% 1/4W	
	R7075	QRE141J-222Y	C RESISTOR	2.2K 5% 1/4W	
	R7076	QRE141J-473Y	C RESISTOR	47K 5% 1/4W	
	R7077	QRE141J-913Y	C RESISTOR	91K 5% 1/4W	
	R7078	QRE141J-102Y	C RESISTOR	1.0K 5% 1/4W	
	R7079	QRE141J-223Y	C RESISTOR	22K 5% 1/4W	
	R7091	QRE141J-103Y	C RESISTOR	DIMMER	
	R7092	QRE141J-473Y	C RESISTOR	DIMMER	
	R7093	QRE141J-102Y	C RESISTOR	DIMMER	
	R7102	QRE141J-333Y	C RESISTOR	33K 5% 1/4W	
	R7103	QRE141J-333Y	C RESISTOR	33K 5% 1/4W	
	R7104	QRE141J-333Y	C RESISTOR	33K 5% 1/4W	
	R7105	QRE141J-222Y	C RESISTOR	2.2K 5% 1/4W	
	R7106	QRE141J-104Y	C RESISTOR	100K 5% 1/4W	
	R7107	QRE141J-222Y	C RESISTOR	2.2K 5% 1/4W	
	R7108	QRE141J-563Y	C RESISTOR	56K 5% 1/4W	
	R7109	QRE141J-222Y	C RESISTOR	2.2K 5% 1/4W	
	R7110	QRE141J-103Y	C RESISTOR	10K 5% 1/4W	
	R7111	QRE141J-222Y	C RESISTOR	2.2K 5% 1/4W	

■ Electrical parts list (Main board)

Block No. 01

△	Item	Parts number	Parts name	Remarks	Area
	R7112	QRE141J-222Y	C RESISTOR	2.2K 5% 1/4W	
	R7113	QRE141J-103Y	C RESISTOR	10K 5% 1/4W	
	R7114	QRE141J-222Y	C RESISTOR	2.2K 5% 1/4W	
	R7115	QRE141J-103Y	C RESISTOR	10K 5% 1/4W	
	R7116	QRE141J-222Y	C RESISTOR	2.2K 5% 1/4W	
	R7117	QRE141J-103Y	C RESISTOR	10K 5% 1/4W	
	R7118	QRE141J-222Y	C RESISTOR	2.2K 5% 1/4W	
	R7119	QRE141J-823Y	C RESISTOR	82K 5% 1/4W	
	R7120	QRE141J-102Y	C RESISTOR	1.0K 5% 1/4W	
	R7121	QRE141J-473Y	C RESISTOR	47K 5% 1/4W	
	R7122	QRE141J-102Y	C RESISTOR	1.0K 5% 1/4W	
	R7123	QRE141J-473Y	C RESISTOR	47K 5% 1/4W	
	R7124	QRE141J-102Y	C RESISTOR	1.0K 5% 1/4W	
	R7125	QRE141J-473Y	C RESISTOR	47K 5% 1/4W	
	R7126	QRE141J-102Y	C RESISTOR	1.0K 5% 1/4W	
	R7127	QRE141J-222Y	C RESISTOR	2.2K 5% 1/4W	
	R7128	QRE141J-222Y	C RESISTOR	2.2K 5% 1/4W	
	R7129	QRE141J-222Y	C RESISTOR	2.2K 5% 1/4W	
	R7130	QRE141J-103Y	C RESISTOR	10K 5% 1/4W	
	R7131	QRE141J-222Y	C RESISTOR	2.2K 5% 1/4W	
	R7132	QRE141J-102Y	C RESISTOR	1.0K 5% 1/4W	
	R7133	QRE141J-102Y	C RESISTOR	1.0K 5% 1/4W	
	R7134	QRE141J-102Y	C RESISTOR	1.0K 5% 1/4W	
	R7135	QRE141J-102Y	C RESISTOR	1.0K 5% 1/4W	
	R7136	QRE141J-222Y	C RESISTOR	2.2K 5% 1/4W	
	R7137	QRE141J-222Y	C RESISTOR	2.2K 5% 1/4W	
	R7138	QRE141J-102Y	C RESISTOR	1.0K 5% 1/4W	
	R7140	QRE141J-222Y	C RESISTOR	2.2K 5% 1/4W	
	R7141	QRE141J-102Y	C RESISTOR	1.0K 5% 1/4W	
	R7142	QRE141J-102Y	C RESISTOR	1.0K 5% 1/4W	
	R7143	QRE141J-102Y	C RESISTOR	1.0K 5% 1/4W	
	R7144	QRE141J-222Y	C RESISTOR	2.2K 5% 1/4W	
	R7145	QRE141J-222Y	C RESISTOR	2.2K 5% 1/4W	
	R7146	QRE141J-222Y	C RESISTOR	2.2K 5% 1/4W	
	R7147	QRE141J-823Y	C RESISTOR	82K 5% 1/4W	
	R7148	QRE141J-222Y	C RESISTOR	2.2K 5% 1/4W	
	R7149	QRE141J-103Y	C RESISTOR	10K 5% 1/4W	
	R7150	QRE141J-222Y	C RESISTOR	2.2K 5% 1/4W	
	R7151	QRE141J-103Y	C RESISTOR	10K 5% 1/4W	
	R7152	QRE141J-222Y	C RESISTOR	2.2K 5% 1/4W	
	R7153	QRE141J-102Y	C RESISTOR	1.0K 5% 1/4W	
	R7154	QRE141J-102Y	C RESISTOR	1.0K 5% 1/4W	
	R7155	QRE141J-103Y	C RESISTOR	10K 5% 1/4W	
	R7156	QRE141J-102Y	C RESISTOR	1.0K 5% 1/4W	
	R7157	QRE141J-103Y	C RESISTOR	10K 5% 1/4W	
	R7158	QRE141J-123Y	C RESISTOR	12K 5% 1/4W	
	R7159	QRE141J-222Y	C RESISTOR	2.2K 5% 1/4W	
	R7160	QRE141J-222Y	C RESISTOR	2.2K 5% 1/4W	
	R7162	QRE141J-222Y	C RESISTOR	2.2K 5% 1/4W	
	R7163	QRE141J-103Y	C RESISTOR	10K 5% 1/4W	
	R7164	QRE141J-104Y	C RESISTOR	100K 5% 1/4W	
	R7165	QRE141J-222Y	C RESISTOR	CD ERROR FLAG	
	R7166	QRE141J-105Y	C RESISTOR	XTAL SPEC	
	R7200	QRE141J-222Y	C RESISTOR	LED1 & DIMMER	
	R7800	QRE141J-103Y	C RESISTOR	MODEL DETECT	
	R7802	QRE141J-103Y	C RESISTOR	FLASH MICON	
	X7001	QAX0711-002Z	CRYSTAL	MAIN CLOCK(8MHZ)	

■ Electrical parts list (Power board)

Block No. 02

△	Item	Parts number	Parts name	Remarks	Area	△	Item	Parts number	Parts name	Remarks	Area
	CN732	QGF1205F1-19	CONNECTOR				D1000	1N4003S-T5	SI DIODE		
	CN733	QGF1205F1-23	CONNECTOR				D1001	1N4003S-T5	SI DIODE		
	CN750	QGF1016F3-09	CONNECTOR				D1002	1N4003S-T5	SI DIODE		
	CN760	QGF1205F1-13	CONNECTOR				D1003	1N4003S-T5	SI DIODE		
	CN761	QGF1016F3-09	CONNECTOR				D1004	1N5401-TM	DIODE		
	CN762	QGA2001F1-02	CONNECTOR				D1005	1N5401-TM	DIODE		
	CN944	QGB2510K2-10	CONNECTOR				D1006	1N5401-TM	DIODE		
	CN945	QGB2510K2-08	CONNECTOR				D1007	1N5401-TM	DIODE		
	CN951	QGD2504C1-03Z	SOCKET				D1008	1SS119-041-T2	SI DIODE		
	C1000	QFLC1HJ-104Z	M CAPACITOR	.10MF 5% 50V			D1009	1N4003S-T5	SI DIODE		
	C1001	QFLC1HJ-104Z	M CAPACITOR	.10MF 5% 50V			D1011	MTZJ6.2C-T2	ZENER DIODE		
	C1002	QFLC1HJ-104Z	M CAPACITOR	.10MF 5% 50V			D1012	1SS119-041-T2	SI DIODE		
	C1003	QFLC1HJ-104Z	M CAPACITOR	.10MF 5% 50V			D1013	MTZJ5.1B-T2	ZENER DIODE		
	C1004	QFLC2AJ-104Z	M CAPACITOR	.10MF 5% 100V			D4000	1SS119-041-T2	SI DIODE		
	C1005	QFLC2AJ-104Z	M CAPACITOR	.10MF 5% 100V			D4001	1SS119-041-T2	SI DIODE		
	C1006	QFLC2AJ-104Z	M CAPACITOR	.10MF 5% 100V			D4002	MTZJ9.1B-T2	ZENER DIODE		
	C1007	QFLC2AJ-104Z	M CAPACITOR	.10MF 5% 100V			D4003	MTZJ9.1B-T2	ZENER DIODE		
△	C1008	QCZ9105-472	C.CAPACITOR	4700PF			D4200	MTZJ11B-T2	ZENER DIODE		
	C1009	QFLC1HJ-472Z	M CAPACITOR	4700PF 5% 50V			D4201	MTZJ11B-T2	ZENER DIODE		
	C1010	EETC0JM-477ZJC	C.CAPACITOR				D4202	1SS119-041-T2	SI DIODE		
	C1011	QETB1EM-108	E CAPACITOR	1000MF 20% 25V			D4300	1SS119-041-T2	SI DIODE		
	C1012	EETC1HM-106ZJC	E CAPACITOR				D7300	MTZJ10C-T2	Z.DIODE		
	C4000	QCBB1HK-101Y	C CAPACITOR	100PF 10% 50V			D7301	MTZJ10C-T2	Z.DIODE		
	C4001	QCBB1HK-101Y	C CAPACITOR	100PF 10% 50V			D7302	MTZJ10C-T2	Z.DIODE		
	C4002	QTE1V06-106Z	E CAPACITOR				D7303	SELU1E54CM-S	LED		
	C4003	QTE1V06-106Z	E CAPACITOR				D7304	SELU1E54CM-S	LED		
	C4006	QCBB1HK-101Y	C CAPACITOR	100PF 10% 50V			D7305	SELU1E54CM-S	LED		
	C4007	QCBB1HK-101Y	C CAPACITOR	100PF 10% 50V			D7501	1SS119-041-T2	SI DIODE		
	C4008	QETC1HM-476Z	E CAPACITOR	47MF 20% 50V			D7502	SPR-39MVWF	LED	STANDBY LED	
	C4009	QETC1HM-476Z	E CAPACITOR	47MF 20% 50V			D7503	1SS119-041-T2	SI DIODE		
	C4010	QCSB1HJ-100Y	C CAPACITOR	10PF 5% 50V			D7600	SELU1E54CM-S	LED		
	C4011	QCSB1HJ-100Y	C CAPACITOR	10PF 5% 50V			D7601	MTZJ10C-T2	Z.DIODE		
	C4012	QFLC1HJ-104Z	M CAPACITOR	.10MF 5% 50V			D7602	SELU1E54CM-S	LED		
	C4013	QFLC1HJ-104Z	M CAPACITOR	.10MF 5% 50V			D7603	MTZJ10C-T2	Z.DIODE		
	C4014	QFLC1HJ-104Z	M CAPACITOR	.10MF 5% 50V			D7604	SELU1E54CM-S	LED		
	C4015	QFLC1HJ-104Z	M CAPACITOR	.10MF 5% 50V			D7605	MTZJ10C-T2	Z.DIODE		
	C4016	FQCF31HZ-223Z	D.CAPACITOR				EP400	E409182-001SM	GRAND TERMINAL		
	C4017	FQCF31HZ-223Z	D.CAPACITOR				EP940	E409182-001SM	GRAND TERMINAL		
	C4030	QETN1HM-476Z	E CAPACITOR	47MF 20% 50V			FW500	QUM154-15DGZ4	PARA RIBON WIRE		
	C4031	QETC1HM-106Z	E CAPACITOR	10MF 20% 50V			FW945	QUM153-12DGZ4	PARA RIBON WIRE		
	C4032	QETC1HM-106Z	E CAPACITOR	10MF 20% 50V			FW950	QUM156-16DGZ4	PARA RIBON WIRE		
	C4033	QETN1HM-476Z	E CAPACITOR	47MF 20% 50V			IC750	GP1UM261XK	IR DETECT UNIT		
	C4035	FQCF31HZ-223Z	D.CAPACITOR				△ IC940	STK432-070	IC(HYBRID)		
	C4036	QFLC1HJ-223Z	M CAPACITOR	.022MF 5% 50V			△ IC942	KIA7810API	I.C(MONO-ANA)		
	C4037	QETM1HM-228	E CAPACITOR	2200MF 20% 50V			△ IC943	KIA78R08PI	IC		
	C4038	QETM1HM-228	E CAPACITOR	2200MF 20% 50V			JS751	QSW0993-001	ROTARY ENCODER		
	C4200	QETN1HM-106Z	E CAPACITOR	10MF 20% 50V			△ J1000	QGA7901C1-02	CONNECTOR		
	C4201	QETN1CM-106Z	E CAPACITOR	10MF 20% 16V			J5000	QNS0170-001	JACK		
	C4202	QETN1CM-106Z	E CAPACITOR	10MF 20% 16V			K5022	QQR0621-001Z	FERRITE BEADS		
	C4203	QETN1HM-106Z	E CAPACITOR	10MF 20% 50V			△ L1000	QQR1145-001	LINE FILTER	A.B & E SERIES	
	C4301	QETC1EM-226Z	E CAPACITOR	22MF 20% 25V			L4000	QQLZ035-R39	INDUCTOR		
	C4302	QETC1CM-476Z	E CAPACITOR	47MF 20% 16V			L4001	QQLZ035-R39	INDUCTOR		
	C4303	QETC1HM-226Z	E CAPACITOR	22MF 20% 50V			L5030	QQL231K-470Y	INDUCTOR		
	C4500	QETC1EM-106Z	E CAPACITOR	10MF 20% 25V			L5033	QQL231K-470Y	INDUCTOR		
	C5010	QDYB1CM-103Y	C CAPACITOR				Q1000	2SC2785/FE/-T	TRANSISTOR		
	C5011	QDYB1CM-103Y	C CAPACITOR				Q1001	KTC1027/OY/-T	TRANSISTOR		
	C7501	QEK1CM-476Z	E CAPACITOR	47MF 20% 16V			Q1002	KTC3199/GL/-T	TRANSISTOR		
	C7502	QDYB1CM-103Y	C CAPACITOR				Q4000	KTA1268/GL/-T	TRANSISTOR		
	C7503	QDGB1HK-102Y	C CAPACITOR				Q4001	KTA1268/GL/-T	TRANSISTOR		
	C7504	QDYB1CM-103Y	C CAPACITOR				Q4300	KTC3199/GL/-T	TRANSISTOR		
	C7507	QDYB1CM-103Y	C CAPACITOR				Q4301	KTA1267/YG/-T	TRANSISTOR		
	C7510	QDYB1CM-103Y	C CAPACITOR				Q4302	KTC3199/GL/-T	TRANSISTOR		
	C7511	QDYB1CM-103Y	C CAPACITOR				Q4502	2SC3576-JVC-T	TRANSISTOR		
	C7520	QDYB1CM-103Y	C CAPACITOR				Q4503	2SC3576-JVC-T	TRANSISTOR		
	C7600	QDYB1CM-103Y	C CAPACITOR				Q4504	KRA102M-T	D.TRANSISTOR		
	DI731	QLD0261-001	LCD MODULE				Q7500	KRC111M-T	TRANSISTOR	POUT/LEDCTRL	

■ Electrical parts list (Power board)

Block No. 02

△	Item	Parts number	Parts name	Remarks	Area	△	Item	Parts number	Parts name	Remarks	Area
△	RY940	QSK0124-001	RELAY				R7523	QRE141J-392Y	C RESISTOR	3.9K 5% 1/4W	
	R1001	QRE141J-332Y	C RESISTOR	3.3K 5% 1/4W			R7600	QRE141J-102Y	C RESISTOR	1.0K 5% 1/4W	
	R1002	QRE141J-821Y	C RESISTOR	820 5% 1/4W			R7601	QRE141J-102Y	C RESISTOR	1.0K 5% 1/4W	
	R1003	QRE141J-103Y	C RESISTOR	10K 5% 1/4W			R7602	QRE141J-122Y	C RESISTOR	1.2K 5% 1/4W	
	R1004	QRE141J-472Y	C RESISTOR	4.7K 5% 1/4W			R7613	QRE141J-201Y	C RESISTOR		
	R1005	QRE141J-472Y	C RESISTOR	4.7K 5% 1/4W			R7615	QRE141J-201Y	C RESISTOR		
	R4000	QRE141J-472Y	C RESISTOR	4.7K 5% 1/4W			R7617	QRE141J-201Y	C RESISTOR		
	R4001	QRE141J-472Y	C RESISTOR	4.7K 5% 1/4W			S7510	QSW0825-001Z	TACT SWITCH		
	R4002	QRE141J-473Y	C RESISTOR	47K 5% 1/4W			S7511	QSW0825-001Z	TACT SWITCH		
	R4003	QRE141J-473Y	C RESISTOR	47K 5% 1/4W			S7512	QSW0825-001Z	TACT SWITCH		
	R4004	QRT01DJ-R22X	MF RESISTOR				S7513	QSW0825-001Z	TACT SWITCH		
	R4005	QRT01DJ-R22X	MF RESISTOR				S7514	QSW0825-001Z	TACT SWITCH		
	R4006	QRT01DJ-R22X	MF RESISTOR	5% 1/1W			S7515	QSW0825-001Z	TACT SWITCH		
	R4007	QRT01DJ-R22X	MF RESISTOR	5% 1/1W			S7516	QSW0825-001Z	TACT SWITCH		
△	R4008	QRJ146J-100X	UNF C RESISTOR	10 5% 1/4W			S7517	QSW0825-001Z	TACT SWITCH		
△	R4009	QRJ146J-100X	UNF C RESISTOR	10 5% 1/4W			S7520	QSW0825-001Z	TACT SWITCH		
	R4010	QRE141J-473Y	C RESISTOR	47K 5% 1/4W			S7521	QSW0825-001Z	TACT SWITCH		
	R4011	QRE141J-473Y	C RESISTOR	47K 5% 1/4W			S7522	QSW0825-001Z	TACT SWITCH		
	R4012	FQRJ143J-821X	C RESISTOR				S7523	QSW0825-001Z	TACT SWITCH		
	R4013	FQRJ143J-821X	C RESISTOR				S7601	QSW0825-001Z	TACT SWITCH		
	R4014	FQRJ143J-100X	C RESISTOR				S7602	QSW0825-001Z	TACT SWITCH		
	R4015	FQRJ143J-100X	C RESISTOR				S7603	QSW0825-001Z	TACT SWITCH		
	R4016	QRE141J-103Y	C RESISTOR	10K 5% 1/4W			△ T1001	QQT0253-002	POWER TRANS		
	R4017	QRE141J-103Y	C RESISTOR	10K 5% 1/4W			Z1000	QNG0003-001Z	FUSE CLIP		
	R4018	QRE141J-221Y	C RESISTOR	220 5% 1/4W			Z1001	QNG0003-001Z	FUSE CLIP		
	R4019	QRE141J-221Y	C RESISTOR	220 5% 1/4W			Z1002	QNG0003-001Z	FUSE CLIP		
	R4020	QRE141J-222Y	C RESISTOR	2.2K 5% 1/4W			Z1003	QNG0003-001Z	FUSE CLIP		
	R4021	QRE141J-222Y	C RESISTOR	2.2K 5% 1/4W			Z1006	QNG0003-001Z	FUSE CLIP		
	R4022	QRE141J-392Y	C RESISTOR	3.9K 5% 1/4W			Z1007	QNG0003-001Z	FUSE CLIP		
	R4023	QRE141J-392Y	C RESISTOR	3.9K 5% 1/4W			Z1008	QNG0003-001Z	FUSE CLIP		
	R4030	QRE141J-333Y	C RESISTOR	33K 5% 1/4W			Z1009	QNG0003-001Z	FUSE CLIP		
	R4031	QRJ146J-101X	UNF C RESISTOR	100 5% 1/4W							
	R4032	QRJ146J-101X	UNF C RESISTOR	100 5% 1/4W							
	R4033	QRJ146J-100X	UNF C RESISTOR	10 5% 1/4W							
△	R4036	QRZ9006-4R7X	F RESISTOR	4.7 1/4W							
	R4200	QRE141J-103Y	C RESISTOR	10K 5% 1/4W							
	R4201	QRT01DJ-R33X	MF RESISTOR	5% 1/1W							
	R4202	QRE141J-103Y	C RESISTOR	10K 5% 1/4W							
	R4203	QRE141J-103Y	C RESISTOR	10K 5% 1/4W							
	R4204	QRT01DJ-R33X	MF RESISTOR	5% 1/1W							
	R4300	QRE141J-823Y	C RESISTOR	82K 5% 1/4W							
	R4301	QRE141J-104Y	C RESISTOR	100K 5% 1/4W							
	R4302	QRE141J-103Y	C RESISTOR	10K 5% 1/4W							
	R4303	QRE141J-104Y	C RESISTOR	100K 5% 1/4W							
	R4304	QRE141J-124Y	C RESISTOR	120K 5% 1/4W							
	R4305	QRE141J-122Y	C RESISTOR	1.2K 5% 1/4W							
	R4306	QRE141J-103Y	C RESISTOR	10K 5% 1/4W							
	R4307	QRE141J-104Y	C RESISTOR	100K 5% 1/4W							
	R4502	QRE141J-222Y	C RESISTOR	2.2K 5% 1/4W							
	R4503	QRE141J-222Y	C RESISTOR	2.2K 5% 1/4W							
	R7309	QRE141J-161Y	C RESISTOR								
	R7310	QRE141J-161Y	C RESISTOR								
	R7311	QRE141J-161Y	C RESISTOR								
	R7501	QRE141J-161Y	C RESISTOR	160 5% 1/4W							
	R7510	QRE141J-102Y	C RESISTOR	1.0K 5% 1/4W							
	R7511	QRE141J-102Y	C RESISTOR	1.0K 5% 1/4W							
	R7512	QRE141J-122Y	C RESISTOR	1.2K 5% 1/4W							
	R7513	QRE141J-182Y	C RESISTOR	1.8K 5% 1/4W							
	R7514	QRE141J-222Y	C RESISTOR	2.2K 5% 1/4W							
	R7515	QRE141J-272Y	C RESISTOR	2.7K 5% 1/4W							
	R7516	QRE141J-392Y	C RESISTOR	3.9K 5% 1/4W							
	R7517	QRE141J-562Y	C RESISTOR	5.6K 5% 1/4W							
	R7518	QRE141J-273Y	C RESISTOR	27K 5% 1/4W							
	R7520	QRE141J-182Y	C RESISTOR	1.8K 5% 1/4W							
	R7521	QRE141J-222Y	C RESISTOR	2.2K 5% 1/4W							
	R7522	QRE141J-272Y	C RESISTOR	2.7K 5% 1/4W							

■ Electrical parts list (CD amp. board)

Block No. 03

△	Item	Parts number	Parts name	Remarks	Area	△	Item	Parts number	Parts name	Remarks	Area
	C 601	NCB31CK-104X	C CAPACITOR				D 601	MA111-X	DIODE		
	C 602	NCB31HK-222X	C CAPACITOR				D 602	MA111-X	DIODE		
	C 603	NCB31HK-223X	C CAPACITOR				D 831	DZ5.6BSB-T2	ZENER DIODE		
	C 604	NCB31HK-223X	C CAPACITOR				IC601	AN22000A-W	I.C		
	C 605	NCS31HJ-391X	C CAPACITOR				IC651	MN662748RPMFA	IC		
	C 606	NCS31HJ-560X	C CAPACITOR				IC801	LA6541-X	IC		
	C 610	NCB31CK-273X	C CAPACITOR				IC802	LB1641	IC		
	C 612	QERF1HM-105Z	E CAPACITOR	1.0MF 20% 50V			L 831	QQL244K-100Z	INDUCTOR		
	C 613	NCB31AK-224X	C CAPACITOR				Q 631	2SB709A/QR/-X	TRANSISTOR		
	C 614	NCB31CK-273X	C CAPACITOR				Q 801	KTA1271/OY/-T	TRANSISTOR		
	C 615	NCB31HK-472X	C CAPACITOR				R 601	NRSA63J-274X	MG RESISTOR		
	C 616	NCB31HK-103X	C CAPACITOR				R 602	NRSA63J-684X	MG RESISTOR		
	C 617	NCS31HJ-331X	C CAPACITOR				R 603	NRSA63J-433X	MG RESISTOR		
	C 619	NCS31HJ-330X	C CAPACITOR				R 604	NRSA63J-274X	MG RESISTOR		
	C 621	NCF31AZ-105X	C CAPACITOR				R 605	NRSA63J-472X	MG RESISTOR		
	C 622	NCB31CK-473X	C CAPACITOR				R 606	NRSA63J-472X	MG RESISTOR		
	C 623	NCF31AZ-105X	C CAPACITOR				R 607	NRSA63J-623X	MG RESISTOR		
	C 624	QERF0JM-107Z	E CAPACITOR	100MF 20% 6.3V			R 610	NRSA63J-223X	MG RESISTOR		
	C 631	QERF1CM-106Z	E CAPACITOR	10MF 20% 16V			R 611	NRSA63J-223X	MG RESISTOR		
	C 632	NCF31AZ-105X	C CAPACITOR				R 612	NRSA63J-822X	MG RESISTOR		
	C 633	NCB31HK-223X	C CAPACITOR				R 613	NRSA63J-472X	MG RESISTOR		
	C 641	NCB31CK-473X	C CAPACITOR				R 615	NRSA63J-472X	MG RESISTOR		
	C 642	NCB31HK-472X	C CAPACITOR				R 616	NRSA63J-472X	MG RESISTOR		
	C 643	NCS31HJ-821X	C CAPACITOR				R 617	NRSA63J-472X	MG RESISTOR		
	C 651	NCS31HJ-120X	C CAPACITOR				R 631	NRSA63J-2R2X	MG RESISTOR		
	C 652	NCS31HJ-120X	C CAPACITOR				R 632	NRSA63J-100X	MG RESISTOR		
	C 653	NCB31CK-104X	C CAPACITOR				R 634	NRSA63J-120X	MG RESISTOR		
	C 654	NCS31HJ-151X	C CAPACITOR				R 635	NRSA63J-121X	MG RESISTOR		
	C 655	NCB31CK-104X	C CAPACITOR				R 636	NRSA63J-910X	MG RESISTOR		
	C 656	NCB31CK-104X	C CAPACITOR				R 641	NRSA63J-184X	MG RESISTOR		
	C 657	QERF1AM-227Z	E CAPACITOR	220MF 20% 10V			R 642	NRSA63J-564X	MG RESISTOR		
	C 658	NCB31CK-104X	C CAPACITOR				R 643	NRSA63J-153X	MG RESISTOR		
	C 661	NCS31HJ-471X	C CAPACITOR				R 647	NRSA63J-0R0X	MG RESISTOR		
	C 663	NCB31HK-223X	C CAPACITOR				R 651	NRSA63J-102X	MG RESISTOR		
	C 664	NCB31HK-223X	C CAPACITOR				R 652	NRSA63J-102X	MG RESISTOR		
	C 665	NCB31AK-334X	C CAPACITOR				R 653	NRSA63J-102X	MG RESISTOR		
	C 669	QERF1AM-227Z	E CAPACITOR	220MF 20% 10V			R 654	NRSA63J-101X	MG RESISTOR		
	C 670	NCS31HJ-151X	C CAPACITOR				R 655	NRSA63J-102X	MG RESISTOR		
	C 671	NCS31HJ-151X	C CAPACITOR				R 656	NRSA63J-102X	MG RESISTOR		
	C 672	NCS31HJ-151X	C CAPACITOR				R 657	NRSA63J-0R0X	MG RESISTOR		
	C 673	QERF1AM-227Z	E CAPACITOR	220MF 20% 10V			R 658	NRSA63J-0R0X	MG RESISTOR		
	C 676	NCB31CK-104X	C CAPACITOR				R 659	NRSA63J-0R0X	MG RESISTOR		
	C 677	NCB31CK-104X	C CAPACITOR				R 661	NRSA63J-393X	MG RESISTOR		
	C 679	QERF0JM-107Z	E CAPACITOR	100MF 20% 6.3V			R 662	NRSA63J-683X	MG RESISTOR		
	C 680	NCB31CK-104X	C CAPACITOR				R 663	NRSA63J-124X	MG RESISTOR		
	C 681	NCB31AK-334X	C CAPACITOR				R 664	NRSA63J-331X	MG RESISTOR		
	C 693	NCB31HK-222X	C CAPACITOR				R 665	NRSA63J-271X	MG RESISTOR		
	C 694	NCB31HK-222X	C CAPACITOR				R 666	NRSA63J-221X	MG RESISTOR		
	C 801	NCB31HK-682X	C CAPACITOR				R 667	NRSA63J-4R7X	MG RESISTOR		
	C 802	NCB31HK-472X	C CAPACITOR				R 670	NRSA63J-101X	MG RESISTOR		
	C 811	NCS31HJ-391X	C CAPACITOR				R 681	NRSA63J-272X	MG RESISTOR		
	C 812	NCS31HJ-391X	C CAPACITOR				R 682	NRSA63J-102X	MG RESISTOR		
	C 813	NCS31HJ-391X	C CAPACITOR				R 683	NRSA63J-105X	MG RESISTOR		
	C 814	NCS31HJ-391X	C CAPACITOR				R 684	NRSA63J-155X	MG RESISTOR		
	C 821	NCF31AZ-105X	C CAPACITOR				R 691	NRSA63J-102X	MG RESISTOR		
	C 822	QERF1AM-227Z	E CAPACITOR	220MF 20% 10V			R 692	NRSA63J-102X	MG RESISTOR		
	C 823	QERF1AM-227Z	E CAPACITOR	220MF 20% 10V			R 801	NRSA63J-272X	MG RESISTOR		
	C 824	NCB31HK-222X	C CAPACITOR				R 802	NRSA63J-472X	MG RESISTOR		
	C 831	QEKJ1CM-107Z	E CAPACITOR	100MF 20% 16V			R 803	NRSA63J-472X	MG RESISTOR		
	C 832	NCB31HK-103X	C CAPACITOR				R 804	NRSA63J-823X	MG RESISTOR		
	C 833	NCB31CK-104X	C CAPACITOR				R 805	NRSA63J-912X	MG RESISTOR		
	CN601	QGF1016F1-16	CONNECTOR				R 806	NRSA63J-513X	MG RESISTOR		
	CN606	QGF1205F1-05	CONNECTOR				R 807	NRSA63J-392X	MG RESISTOR		
	CN651	QGF1205F1-16	CONNECTOR				R 808	NRSA63J-393X	MG RESISTOR		
	CN652	QGF1205F1-13	CONNECTOR				R 821	NRSA63J-0R0X	MG RESISTOR		
	CN801	QGA2001C1-06	6P PLUG ASSY				R 822	NRSA63J-473X	MG RESISTOR		
							R 831	QRE141J-100Y	C RESISTOR	10 5% 1/4W	
							X 651	QAX0413-001Z	CRYSTAL		

■ Electrical parts list (Tuner board)

Block No. 04

△	Item	Parts number	Parts name	Remarks	Area
	C 1	NCB21HK-223X	C CAPACITOR		
	C 2	NCB21HK-103X	C CAPACITOR		
	C 3	EETC1CM-106ZJC	E.CAPACITOR		
	C 4	NCB21HK-103X	C CAPACITOR		
	C 6	NCB21HK-222X	C CAPACITOR		
	C 7	NCB21HK-102X	C CAPACITOR		
	C 8	NCB21HK-102X	C CAPACITOR		
	C 9	NCB21HK-102X	C CAPACITOR		
	C 10	NRSA02J-0R0X	MG RESISTOR		
	C 11	NCB21HK-104X	C CAPACITOR		
	C 12	NCB21HK-473X	C CAPACITOR		
	C 13	NCS21HJ-100X	C CAPACITOR		
	C 14	QEK1AM-107Z	E CAPACITOR	100MF 20% 10V	
	C 15	NCS21HJ-120X	C CAPACITOR		
	C 16	NCS21HJ-120X	C CAPACITOR		
	C 17	NCB21HK-392X	C CAPACITOR		
	C 18	QEQ61HM-474Z	NP E CAPACITOR	.47MF 20% 50V	
	C 19	NCB21HK-473X	C CAPACITOR		
	C 20	NCB21HK-102X	C CAPACITOR		
	C 21	NCB21HK-223X	C CAPACITOR		
	C 22	NCS21HJ-151X	C CAPACITOR		
	C 23	NCS21HJ-151X	C CAPACITOR		
	C 24	NCS21HJ-151X	C CAPACITOR		
	C 25	QEK1AM-107Z	E CAPACITOR	100MF 20% 10V	
	C 26	NCB21HK-103X	C CAPACITOR		
	C 27	NCB21HK-103X	C CAPACITOR		
	C 30	EEK1CM-107ZJC	E CAPACITOR		
	C 31	EEK1CM-226ZJC	E CAPACITOR		
	C 32	NCB21HK-473X	C CAPACITOR		
	C 33	NCB21HK-473X	C CAPACITOR		
	C 34	NCB21HK-223X	C CAPACITOR		
	C 35	NCB21HK-473X	C CAPACITOR		
	C 36	EEK1HM-105ZJC	E CAPACITOR		
	C 37	EEK1HM-105ZJC	E CAPACITOR		
	C 38	EETC1HM-224ZJC	E CAPACITOR		
	C 39	EETC1HM-105ZJC	E CAPACITOR		
	C 40	QETN1CM-106Z	E CAPACITOR	10MF 20% 16V	
	C 41	QETN1CM-106Z	E CAPACITOR	10MF 20% 16V	
	C 42	NCB21HK-182X	C CAPACITOR		
	C 43	NCB21HK-182X	C CAPACITOR		
	C 44	QETN1CM-106Z	E CAPACITOR	10MF 20% 16V	
	C 45	QETN1CM-106Z	E CAPACITOR	10MF 20% 16V	
	C 46	NCB21HK-223X	C CAPACITOR		
	C 47	EETC1HM-105ZJC	E CAPACITOR		
	C 48	NCB21HK-222X	C CAPACITOR		
	C 49	NCS21HJ-471X	C CAPACITOR		
	C 50	EEK1CM-226ZJC	E CAPACITOR		
	C 51	EEK1HM-105ZJC	E CAPACITOR		
	C 52	QFV1HJ-274Z	MF CAPACITOR	.27MF 5% 50V	
	C 53	EETC1CM-226ZJC	E CAPACITOR		
	C 54	NCB21HK-473X	C CAPACITOR		
	C 57	NCB21HK-102X	C CAPACITOR		
	C 58	NCB21HK-473X	C CAPACITOR		
	C 59	NCB21HK-102X	C CAPACITOR		
	C 70	NCS21HJ-220X	C CAPACITOR		
	C 71	NCS21HJ-220X	C CAPACITOR		
	C 72	NCB21HK-561X	C CAPACITOR		
	C 73	NCB21HK-104X	C CAPACITOR		
	C 74	NCB21HK-104X	C CAPACITOR		
	C 75	EETC1HM-106ZJC	E CAPACITOR		
	C 76	NCB21HK-331X	C CAPACITOR		
	CF 1	QAX0420-001	C FILTER		
	CF 2	QAX0458-001Z	C FILTER		
	CF 3	QAX0610-001Z	C DISCRIMINATOR		
	CN 1	QGF1205F1-13	CONNECTOR		
	D 1	1SS133-T2	SI DIODE		

△	Item	Parts number	Parts name	Remarks	Area
	D 2	1SS133-T2	SI DIODE		
	D 3	1SS133-T2	SI DIODE		
	D 4	1SS133-T2	SI DIODE		
	D 11	1SS133-T2	SI DIODE		
	IC 1	LA1838	IC		
	IC 2	LC72136N	IC		
	IC 3	LC72723	IC(RDS)		
	J 1	QNB0014-001	ANT TERMINAL		
	L 1	QQR0796-003	COIL BLOCK		
	L 70	QQL231K-101Y	INDUCTOR		
	Q 1	2SC2814/4-5/-X	TRANSISTOR		
	Q 5	KRA107S-X	TRANSISTOR		
	R 2	NRSA02J-331X	MG RESISTOR		
	R 3	NRSA02J-224X	MG RESISTOR		
	R 4	NRSA02J-331X	MG RESISTOR		
	R 5	NRSA02J-560X	MG RESISTOR		
	R 6	NRSA02J-120X	MG RESISTOR		
	R 10	NRSA02J-222X	MG RESISTOR		
	R 13	NRSA02J-103X	MG RESISTOR		
	R 14	NRSA02J-104X	MG RESISTOR		
	R 15	NRSA02J-332X	MG RESISTOR		
	R 16	NRSA02J-472X	MG RESISTOR		
△	R 17	QRZ9005-680X	F RESISTOR	68 1/4W	
	R 18	NRSA02J-102X	MG RESISTOR		
	R 19	NRSA02J-102X	MG RESISTOR		
	R 20	NRSA02J-102X	MG RESISTOR		
	R 21	NRSA02J-562X	MG RESISTOR		
	R 22	NRSA02J-472X	MG RESISTOR		
	R 23	NRSA02J-182X	MG RESISTOR		
	R 24	NRSA02J-103X	MG RESISTOR		
	R 25	NRSA02J-331X	MG RESISTOR		
	R 26	NRSA02J-222X	MG RESISTOR		
	R 27	NRSA02J-103X	MG RESISTOR		
	R 28	NRSA02J-103X	MG RESISTOR		
	R 29	NRSA02J-103X	MG RESISTOR		
	R 31	NRSA02J-102X	MG RESISTOR		
	R 32	NRSA02J-102X	MG RESISTOR		
	R 33	NRSA02J-331X	MG RESISTOR		
	R 34	NRSA02J-470X	MG RESISTOR		
	R 35	NRSA02J-562X	MG RESISTOR		
	R 36	NRSA02J-332X	MG RESISTOR		
	R 37	NRSA02J-103X	MG RESISTOR		
	R 38	NRSA02J-393X	MG RESISTOR		
	R 39	NRSA02J-393X	MG RESISTOR		
	R 40	NRSA02J-393X	MG RESISTOR		
	R 41	NRSA02J-332X	MG RESISTOR		
	R 60	NRSA02J-0R0X	MG RESISTOR		
	R 72	NRSA02J-102X	MG RESISTOR		
	R 73	NRSA02J-102X	MG RESISTOR		
	T 1	QQR0793-001	IFT		
	TU 1	QAU0160-001	FRONT END		
	X 1	QAX0402-001	CRYSTAL		
	X 70	QAX0263-001Z	CRYSTAL		

■ Electrical parts list (Head amplifier board)

Block No. 05

△	Item	Parts number	Parts name	Remarks	Area
	CN 1	QGF1205F1-09	CONNECTOR		
	D 1	1SR139-400-T2	SI DIODE		
	IC 1	SG-105F3-BB,C	PHOTO SENSER		
	P 1	QNZ0104-001	POST PIN		
	SW 1	QSW0832-001	LEAF SWITCH		
	SW 2	QSW0832-001	LEAF SWITCH		
	SW 5	QSW0832-001	LEAF SWITCH		
	SW 6	QSW0859-001	SW		

■ Electrical parts list (Cassette switch board) Block No. 06

△	Item	Parts number	Parts name	Remarks	Area
	C 101	QDGB1HK-821Y	C CAPACITOR		
	C 102	QDYB1CM-103Y	C CAPACITOR		
	C 103	QFLA1HJ-104Z	TF CAPACITOR	.10MF 5% 50V	
	C 104	QCBB1HK-221Y	C CAPACITOR	220PF 10% 50V	
	C 105	QCBB1HK-391Y	C CAPACITOR	390PF 10% 50V	
	C 106	QERF1HM-225Z	E CAPACITOR	2.2MF 20% 50V	
	C 107	QCBB1HK-271Y	C CAPACITOR	270PF 10% 50V	
	C 109	QEKJ1EM-475Z	E CAPACITOR	4.7MF 20% 25V	
	C 110	QDYB1CM-682Y	C CAPACITOR		
	C 113	QFLA1HJ-104Z	TF CAPACITOR	.10MF 5% 50V	
	C 120	QCSB1HK-4R7Y	C CAPACITOR	4.7PF 10% 50V	
	C 121	QCBB1HK-331Y	C CAPACITOR	330PF 10% 50V	
	C 201	QDGB1HK-821Y	C CAPACITOR		
	C 202	QDYB1CM-103Y	C CAPACITOR		
	C 203	QFLA1HJ-104Z	TF CAPACITOR	.10MF 5% 50V	
	C 204	QCBB1HK-221Y	C CAPACITOR	220PF 10% 50V	
	C 205	QCBB1HK-391Y	C CAPACITOR	390PF 10% 50V	
	C 206	QERF1HM-225Z	E CAPACITOR	2.2MF 20% 50V	
	C 207	QCBB1HK-271Y	C CAPACITOR	270PF 10% 50V	
	C 209	QEKJ1EM-475Z	E CAPACITOR	4.7MF 20% 25V	
	C 210	QDYB1CM-682Y	C CAPACITOR		
	C 213	QFLA1HJ-104Z	TF CAPACITOR	.10MF 5% 50V	
	C 220	QCSB1HK-4R7Y	C CAPACITOR	4.7PF 10% 50V	
	C 221	QCBB1HK-331Y	C CAPACITOR	330PF 10% 50V	
	C 300	QEKJ1HM-105Z	E CAPACITOR	1.0MF 20% 50V	
	C 301	QEKJ1AM-107Z	E CAPACITOR	100MF 20% 10V	
	C 304	QEKJ1CM-106Z	E CAPACITOR	10MF 20% 16V	
	C 306	QETJ1AM-227Z	E CAPACITER	220MF 20% 10V	
	C 307	QDGB1HK-102Y	C CAPACITOR		
	C 308	QDXB1CM-152Y	C CAPACITOR		
	C 310	QCBB1HK-223Y	C CAPACITOR	.022MF 10% 50V	
	C 313	QEKJ1AM-107Z	E CAPACITOR	100MF 20% 10V	
	C 314	QCFB1HZ-105Y	C CAPACITOR	1.0MF +80:-20%	
	C 316	QFG32AJ-223Z	PP CAPACITOR	.022MF 5% 100V	
	C 319	QFLC1HJ-472Z	M CAPACITOR	4700PF 5% 50V	
	C 331	QEKJ1CM-476Z	E CAPACITOR	47MF 20% 16V	
	C 340	QEKJ1CM-476Z	E CAPACITOR	47MF 20% 16V	
	C 341	QEKJ1HM-105Z	E CAPACITOR	1.0MF 20% 50V	
	C 342	QEKJ1CM-476Z	E CAPACITOR	47MF 20% 16V	
	C 371	QEKJ1EM-475Z	E CAPACITOR	4.7MF 20% 25V	
	C 374	QEKJ1AM-107Z	E CAPACITOR	100MF 20% 10V	
	C 376	QDYB1CM-103Y	C CAPACITOR		
	CN 31	QGF1205F1-06	CONNECTOR		
	CN 32	QGF1205F1-09	CONNECTOR		
	CN 33	QGF1205F1-09	CONNECTOR		
	CN 34	QGF1201F3-10	CONNECTOR		
	D 340	MTZJ5.1B-T2	ZENER DIODE		
	D 375	MTZJ5.1B-T2	ZENER DIODE		
	FW100	QUM024-07A2Z3	FLAT WIRE		
	H 32	GV40397-001A	IC HOLDER		
	IC 32	HA12238F	IC		
	IC 33	CD4094BC	IC		
	L 301	QQR1118-002	BIAS COIL		
	L 303	QQL244K-100Z	INDUCTOR		
	Q 302	2SC2001/K-T	TRANSISTOR		
	Q 305	2SC2001/K-T	TRANSISTOR		
	Q 342	KRA111M-T	D.TRANSISTOR		
	Q 343	2SC3576-JVC-T	TRANSISTOR		
	Q 344	2SC3576-JVC-T	TRANSISTOR		
	Q 345	2SC3576-JVC-T	TRANSISTOR		
	Q 346	2SC3576-JVC-T	TRANSISTOR		
	Q 347	KRC107M-T	D.TRANSISTOR		
	Q 371	KTA1271/OY-T	TRANSISTOR		
	Q 372	KRC107M-T	D.TRANSISTOR		
	Q 375	2SB562/C-T	TRANSISTOR		
	Q 376	KTC3199/GL-T	TRANSISTOR		

△	Item	Parts number	Parts name	Remarks	Area
	R 101	QRE141J-512Y	C RESISTOR	5.1K 5% 1/4W	
	R 102	QRE141J-512Y	C RESISTOR	5.1K 5% 1/4W	
	R 104	QRE141J-222Y	C RESISTOR	2.2K 5% 1/4W	
	R 105	QRE141J-104Y	C RESISTOR	100K 5% 1/4W	
	R 106	QRE141J-113Y	C RESISTOR	11K 5% 1/4W	
	R 107	QRE141J-912Y	C RESISTOR	9.1K 5% 1/4W	
	R 108	QRE141J-273Y	C RESISTOR	27K 5% 1/4W	
	R 110	QRE141J-103Y	C RESISTOR	10K 5% 1/4W	
	R 116	QRE141J-102Y	C RESISTOR	1.0K 5% 1/4W	
	R 121	QRE141J-153Y	C RESISTOR	15K 5% 1/4W	
	R 201	QRE141J-512Y	C RESISTOR	5.1K 5% 1/4W	
	R 202	QRE141J-512Y	C RESISTOR	5.1K 5% 1/4W	
	R 204	QRE141J-222Y	C RESISTOR	2.2K 5% 1/4W	
	R 205	QRE141J-104Y	C RESISTOR	100K 5% 1/4W	
	R 206	QRE141J-113Y	C RESISTOR	11K 5% 1/4W	
	R 207	QRE141J-912Y	C RESISTOR	9.1K 5% 1/4W	
	R 208	QRE141J-273Y	C RESISTOR	27K 5% 1/4W	
	R 210	QRE141J-103Y	C RESISTOR	10K 5% 1/4W	
	R 216	QRE141J-102Y	C RESISTOR	1.0K 5% 1/4W	
	R 221	QRE141J-153Y	C RESISTOR	15K 5% 1/4W	
	R 301	QRE141J-221Y	C RESISTOR	220 5% 1/4W	
	R 302	QRE141J-222Y	C RESISTOR	2.2K 5% 1/4W	
	R 303	QRE141J-222Y	C RESISTOR	2.2K 5% 1/4W	
	R 304	QRJ146J-101X	UNF C RESISTOR	100 5% 1/4W	
	R 305	QRE141J-103Y	C RESISTOR	10K 5% 1/4W	
	R 306	QRE141J-472Y	C RESISTOR	4.7K 5% 1/4W	
△	R 310	QRJ146J-4R7X	UNF C RESISTOR	4.7 5% 1/4W	
	R 313	QRE141J-2R2Y	C RESISTOR	2.2 5% 1/4W	
	R 314	QRE141J-153Y	C RESISTOR	15K 5% 1/4W	
	R 315	QRE141J-101Y	C RESISTOR	100 5% 1/4W	
	R 327	QRE141J-474Y	C RESISTOR	470K 5% 1/4W	
	R 335	QRE141J-222Y	C RESISTOR	2.2K 5% 1/4W	
	R 336	QRE141J-223Y	C RESISTOR	22K 5% 1/4W	
	R 337	QRE141J-332Y	C RESISTOR	3.3K 5% 1/4W	
	R 338	QRE141J-392Y	C RESISTOR	3.9K 5% 1/4W	
	R 339	QRE141J-104Y	C RESISTOR	100K 5% 1/4W	
	R 340	QRE141J-681Y	C RESISTOR	680 5% 1/4W	
	R 341	QRE141J-123Y	C RESISTOR	12K 5% 1/4W	
	R 342	QRE141J-243Y	C RESISTOR	24K 5% 1/4W	
	R 343	QRE141J-183Y	C RESISTOR	18K 5% 1/4W	
	R 344	QRE141J-472Y	C RESISTOR	4.7K 5% 1/4W	
	R 345	QRE141J-472Y	C RESISTOR	4.7K 5% 1/4W	
	R 346	QRE141J-472Y	C RESISTOR	4.7K 5% 1/4W	
	R 347	QRE141J-103Y	C RESISTOR	10K 5% 1/4W	
△	R 353	QRJ146J-100X	UNF C RESISTOR	10 5% 1/4W	
	R 371	QRE141J-123Y	C RESISTOR	12K 5% 1/4W	
	R 372	QRE141J-102Y	C RESISTOR	1.0K 5% 1/4W	
	R 375	QRE141J-151Y	C RESISTOR	150 5% 1/4W	
	R 376	QRE141J-472Y	C RESISTOR	4.7K 5% 1/4W	
	VR 31	QVP0008-203Z	SEMI V RESISTOR		
	VR 37	QVP0077-103Z	SEMI V RESISTOR		

< MEMO >

Packing materials and accessories parts list

Block No.

M	3	M	M
---	---	---	---

Block No.

M	5	M	M
---	---	---	---

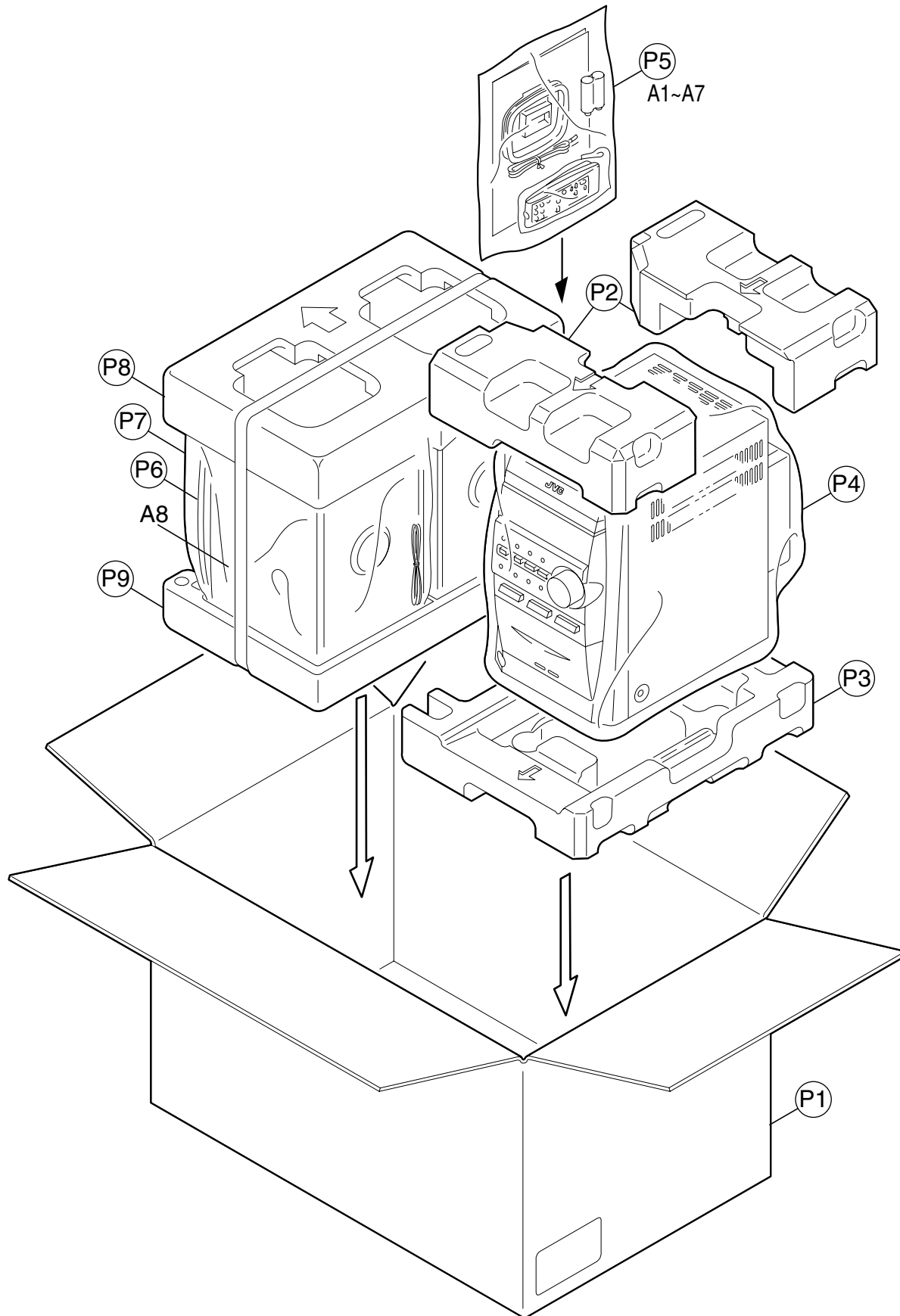

■ Parts list (Packing)

Block No. M3MM

△	Item	Parts number	Parts name	Q'ty	Description	Area
	P 1	GV20219-001A	CARTON ASSY.	1		
	P 2	GV10135-001A	CUSHION (FRONT)	1	(UPPER SIDE)	
	P 3	GV10136-001A	CUSHION (REAR)	1	(BOTTOM SIDE)	
	P 4	QPC05006515P	POLY BAG	1		
	P 5	QPC02503515P	POLY BAG	1	FOR INST.	
	P 6	138763001072	MIRAMAT SHEET	2		
	P 7	138764601090	POLY BAG	2		
	P 8	139763681086	POLYFOAM(TOP)	1		
	P 9	139763681087	POLYFOAM(BTTM)	1		

■ Parts list (Accessories)

Block No. M5MM

△	Item	Parts number	Parts name	Q'ty	Description	Area
	A 1	GVT0102-007A	INST.BOOK	1	GER,FRE,SPA,ITA	EN
		GVT0102-007A	INST.BOOK	1	DAN,FIN,SWE	EN
		GVT0102-008A	INST.BOOK	1	ENG	B
		GVT0102-006A	INST.BOOK	1	GER,FRE,DUT	E
	A 2	QAL0457-001	ANT.WIRE	1	FM ANT	
	A 3	QAL0014-001	AM LOOP ANT	1	AM ANT	
	A 4	RM-SUXJ50R	W.LESS REMOCON	1		
	A 5	-----	BATTERY	2	FOR REMOCON	
	A 6	BT-54013-5	W.CARD	1		
	A 7	VNA3000-204	REGIST.CARD	1		B
	A 8	UXJ50E-SPBOX	SPK WITH BOX	2		