

# Block diagrams

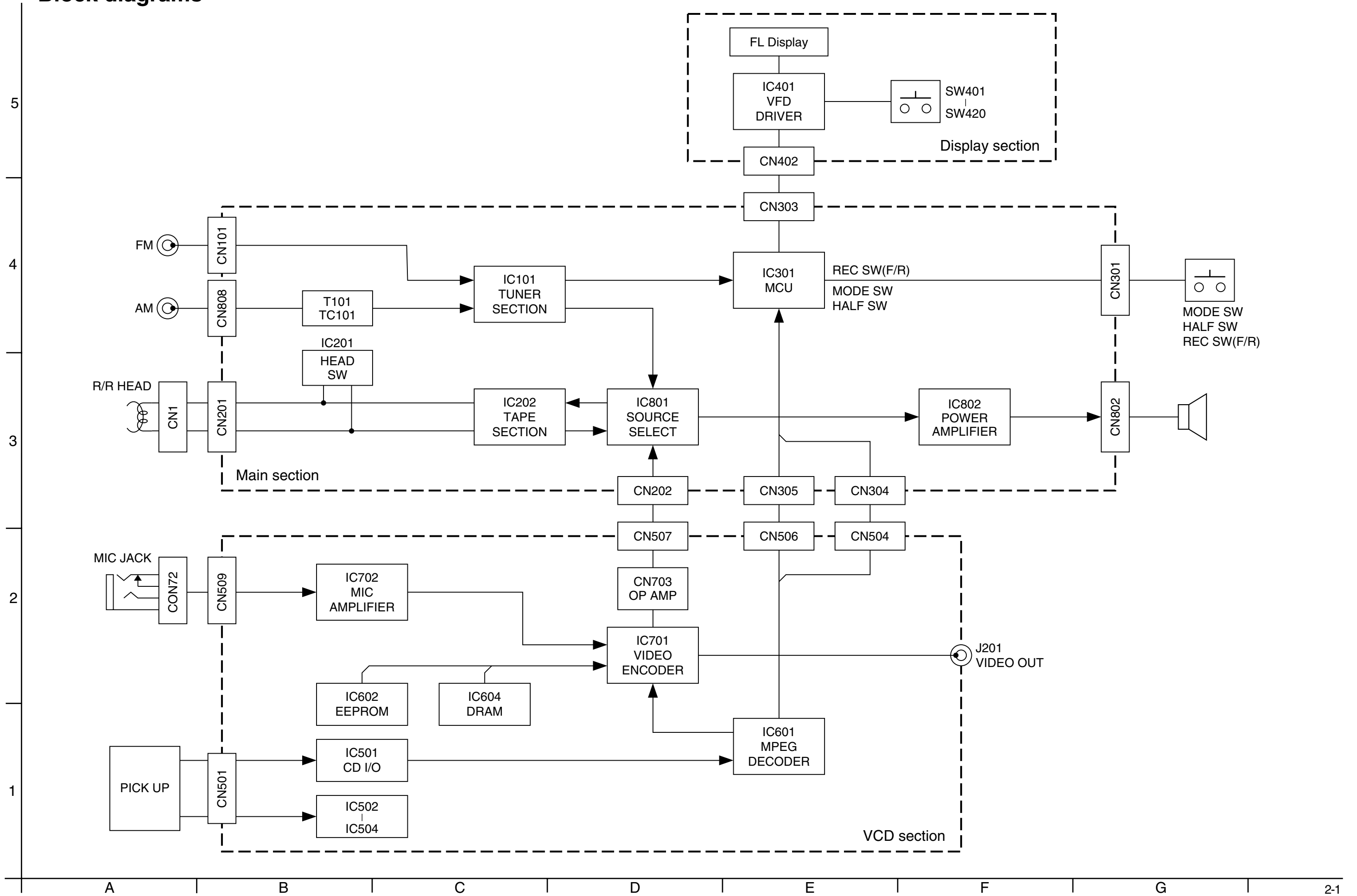

# Standard schematic diagrams

## Main section

5

4

3

2

1

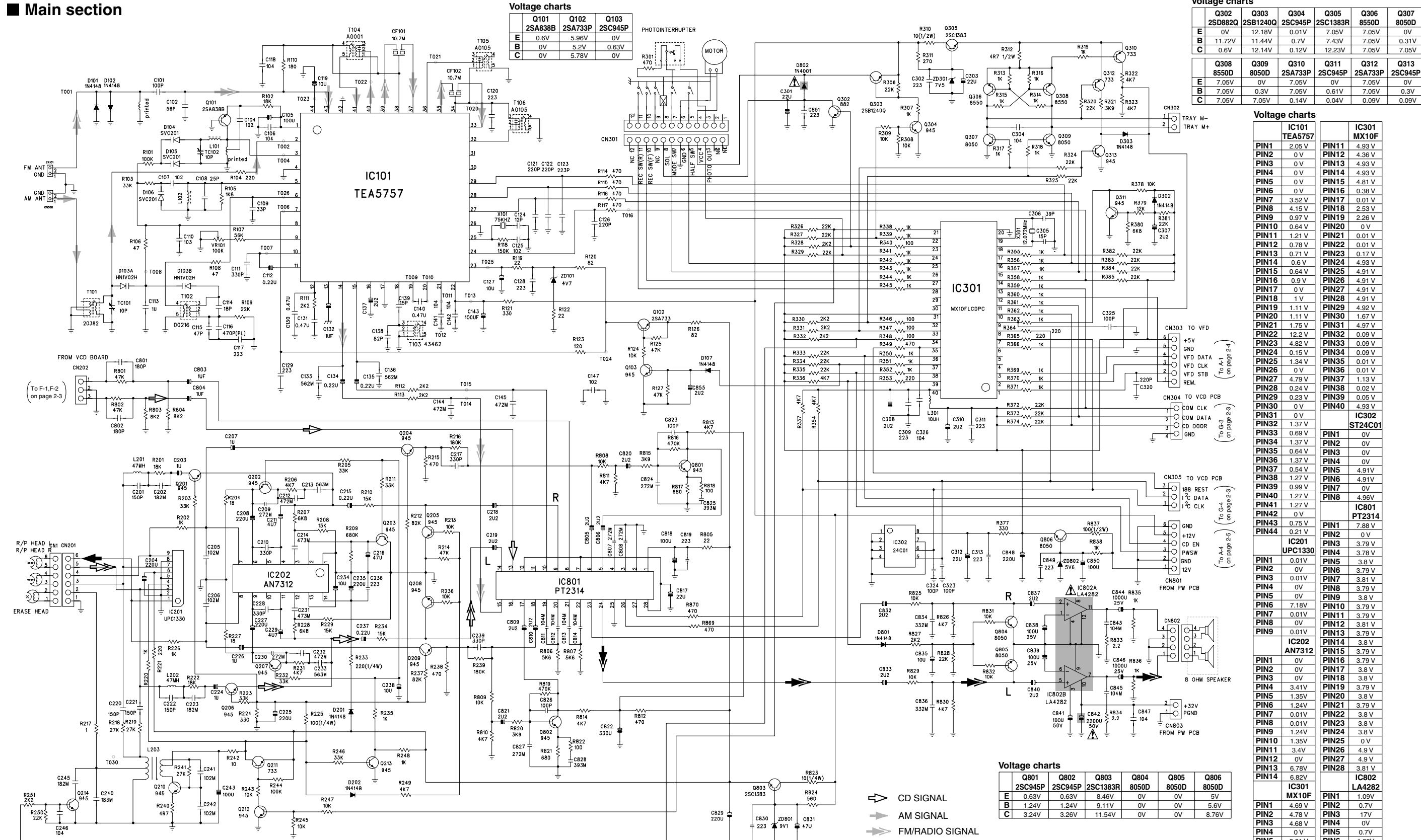

Voltage charts

	Q101 2SA838B	Q102 2SA733P	Q103 2SC945P
E	0.6V	5.96V	0V
B	0V	5.2V	0.63V
C	0V	5.78V	0V

Voltage charts

	Q302 2SD882Q	Q303 8050D	Q304 2SA733P	Q305 2SC945P	Q306 8550D	Q307 8050D
E	0V	12.18V	0.01V	7.05V	7.05V	0V
B	11.72V	11.44V	0.7V	7.43V	7.05V	0.31V
C	0.6V	12.14V	0.12V	12.23V	7.05V	7.05V

	Q308 8550D	Q309 8050D	Q310 2SA733P	Q311 2SC945P	Q312 2SA733P	Q313 2SC945P
E	7.05V	0V	7.05V	0V	7.05V	0V
B	7.05V	0.3V	7.05V	0.61V	7.05V	0.3V
C	7.05V	7.05V	0.14V	0.04V	0.09V	0.09V

Voltage charts

	IC101 TEA5757	IC301 MX10FLC DPC	IC202 AN7312	IC801 PT2314	IC802A LA4282	IC301 MX10FLC DPC	IC802 LA4282	
PIN1	2.05 V	PIN11	4.93 V	PIN1	0V	PIN1	1.09V	
PIN2	0V	PIN12	4.36 V	PIN2	0V	PIN2	0.7V	
PIN3	0V	PIN13	4.93 V	PIN3	0V	PIN3	1.7V	
PIN4	0V	PIN14	4.93 V	PIN4	0V	PIN4	0V	
PIN5	0V	PIN15	4.81 V	PIN5	0V	PIN5	0.7V	
PIN6	0V	PIN16	0.38 V	PIN6	0V	PIN6	1.09V	
PIN7	3.52 V	PIN17	0.01 V	PIN7	7.18V	PIN7	16.8V	
PIN8	4.15 V	PIN18	2.53 V	PIN8	0.01V	PIN8	0V	
PIN9	0.97 V	PIN19	2.26 V	PIN9	0.01V	PIN9	0V	
PIN10	0.64 V	PIN20	0V	PIN10	1.35V	PIN10	34.9V	
PIN11	1.21 V	PIN21	0.01 V	PIN11	3.79 V	PIN11	16.75V	
PIN12	0.78 V	PIN22	0.01 V	PIN12	0.01V	PIN12	0V	
PIN13	0.71 V	PIN23	0.17 V	PIN13	0.01V	PIN13	3.8V	
PIN14	0.6 V	PIN24	4.93 V	PIN14	0.01V	PIN14	3.8V	
PIN15	0.64 V	PIN25	4.91 V	PIN15	0.01V	PIN15	3.8V	
PIN16	0.9 V	PIN26	4.91 V	PIN16	0.01V	PIN16	3.8V	
PIN17	0V	PIN27	4.91 V	PIN17	0.01V	PIN17	3.8V	
PIN18	1V	PIN28	4.91 V	PIN18	0.01V	PIN18	3.8V	
PIN19	1.11 V	PIN29	4.92 V	PIN19	0.01V	PIN19	3.8V	
PIN20	1.11 V	PIN30	1.67 V	PIN20	0.01V	PIN20	3.8V	
PIN21	1.75 V	PIN31	4.97 V	PIN21	0.01V	PIN21	3.8V	
PIN22	12.2 V	PIN32	0.09 V	PIN22	0.01V	PIN22	3.8V	
PIN23	4.82 V	PIN33	0.09 V	PIN23	0.01V	PIN23	3.8V	
PIN24	0.15 V	PIN34	0.09 V	PIN24	0.01V	PIN24	3.8V	
PIN25	1.34 V	PIN35	0.01 V	PIN25	0.01V	PIN25	0V	
PIN26	0V	PIN36	0.01 V	PIN26	0.01V	PIN26	4.9V	
PIN27	4.79 V	PIN37	1.13 V	PIN27	0.01V	PIN27	4.9V	
PIN28	0.24 V	PIN38	0.02 V	PIN28	0.01V	PIN28	3.8V	
PIN29	0.23 V	PIN39	0.05 V	PIN29	0.01V	PIN29	3.8V	
PIN30	0V	PIN40	4.93 V	PIN30	0.01V	PIN30	3.8V	
PIN31	0V	IC302	0V	PIN31	0.01V	PIN31	3.8V	
PIN32	1.37 V	ST24C01	PIN1	0V	PIN32	0.01V	PIN32	3.8V
PIN33	0.69 V	PIN1	0V	PIN33	0.01V	PIN33	3.8V	
PIN34	1.37 V	PIN2	0V	PIN34	0.01V	PIN34	3.8V	
PIN35	0.64 V	PIN3	0V	PIN35	0.01V	PIN35	3.8V	
PIN36	1.37 V	PIN4	0V	PIN36	0.01V	PIN36	3.8V	
PIN37	0.54 V	PIN5	4.91V	PIN37	0.01V	PIN37	3.8V	
PIN38	1.27 V	PIN6	4.91V	PIN38	0.01V	PIN38	3.8V	
PIN39	0.99 V	PIN7	0V	PIN39	0.01V	PIN39	3.8V	
PIN40	1.27 V	PIN8	4.96V	PIN40	0.01V	PIN40	3.8V	
PIN41	1.27 V	IC801	PT2314	PIN41	0.01V	PIN41	3.8V	
PIN42	0V	PIN1	7.88 V	PIN42	0.01V	PIN42	3.8V	
PIN43	0.75 V	PIN2	0V	PIN43	0.01V	PIN43	3.8V	
PIN44	0.21 V	PIN3	3.79 V	PIN44	0.01V	PIN44	3.8V	
PIN45	0.21 V	PIN4	3.79 V	PIN45	0.01V	PIN45	3.8V	
PIN46	0.21 V	PIN5	3.79 V	PIN46	0.01V	PIN46	3.8V	
PIN47	0.21 V	PIN6	3.79 V	PIN47	0.01V	PIN47	3.8V	
PIN48	0.21 V	PIN7	3.79 V	PIN48	0.01V	PIN48	3.8V	
PIN49	0.21 V	PIN8	3.79 V	PIN49	0.01V	PIN49	3.8V	
PIN50	0.21 V	PIN9	3.79 V	PIN50	0.01V	PIN50	3.8V	
PIN51	0.21 V	PIN10	3.79 V	PIN51	0.01V	PIN51	3.8V	
PIN52	0.21 V	PIN11	3.79 V	PIN52	0.01V	PIN52	3.8V	
PIN53	0.21 V	PIN12	3.79 V	PIN53	0.01V	PIN53	3.8V	
PIN54	0.21 V	PIN13	3.79 V	PIN54	0.01V	PIN54	3.8V	
PIN55	0.21 V	PIN14	3.8V	PIN55	0.01V	PIN55	3.8V	
PIN56	0.21 V	PIN15	3.79 V	PIN56	0.01V	PIN56	3.8V	
PIN57	0.21 V	PIN16	3.79 V	PIN57	0.01V	PIN57	3.8V	
PIN58	0.21 V	PIN17	3.8V	PIN58	0.01V	PIN58	3.8V	
PIN59	0.21 V	PIN18	3.8V	PIN59	0.01V	PIN59	3.8V	
PIN60	0.21 V	PIN19	3.8V	PIN60	0.01V	PIN60	3.8V	
PIN61	0.21 V	PIN20	3.8V	PIN61	0.01V	PIN61	3.8V	
PIN62	0.21 V	PIN21	3.79 V	PIN62	0.01V	PIN62	3.8V	
PIN63	0.21 V	PIN22	3.8V	PIN63	0.01V	PIN63	3.8V	
PIN64	0.21 V	PIN23	3.8V	PIN64	0.01V	PIN64	3.8V	
PIN65	0.21 V	PIN24	3.8V	PIN65	0.01V	PIN65	3.8V	
PIN66	0.21 V	PIN25	0V	PIN66	0.01V	PIN66	3.8V	
PIN67	0.21 V	PIN26	4.9V	PIN67	0.01V	PIN67	3.8V	
PIN68	0.21 V	PIN27	4.9V	PIN68	0.01V	PIN68	3.8V	
PIN69	0.21 V	PIN28	3.81 V	PIN69	0.01V	PIN69	3.8V	
PIN70	0.21 V	IC802	LA4282	PIN70	0.01V	PIN70	3.8V	
PIN71	0.21 V	PIN1	1.09V	PIN71	0.01V	PIN71	3.8V	
PIN72	0.21 V	PIN2	0.7V	PIN72	0.01V	PIN72	3.8V	
PIN73	0.21 V	PIN3	1.7V	PIN73	0.01V	PIN73	3.8V	
PIN74	0.21 V	PIN4	0V	PIN74	0.01V	PIN74	3.8V	
PIN75	0.21 V	PIN5	0.7V	PIN75	0.01V	PIN75	3.8V	
PIN76	0.21 V	PIN6	1.09V	PIN76	0.01V	PIN76	3.8V	
PIN77	0.21 V	PIN7	16.8V	PIN77	0.01V	PIN77	3.8V	
PIN78	0.21 V	PIN8	0V	PIN78	0.01V	PIN78	3.8V	
PIN79	0.21 V	PIN9	0V	PIN79	0.01V	PIN79	3.8V	
PIN80	0.21 V	PIN10	34.9V	PIN80	0.01V	PIN80	3.8V	
PIN81	0.21 V	PIN11	16.75V	PIN81	0.01V	PIN81	3.8V	
PIN82	0.21 V	PIN12	0V	PIN82	0.01V	PIN82	3.8V	

Voltage charts

	Q201 2SC945P	Q202 2SC945P	Q203 2SC945P	Q204 2SC945P	Q205 2SC945P	Q206 2SC945P	Q207 2SC945P	Q208 2SC945P	Q209 2SC945P	Q210 2SC945P	Q211 2SA733P	Q212 2SC945P	Q213 2SC945P	Q214 2SC945P
E	0V	0V	0V	0V	0V	0V	0V	0V	0V	0V	8.4V	0V	0V	0.1V
B	0V	0.6V	0.6V	0.6V	0.6V	0.63V	0V	0V	0V	0V	8.36V	0.1V	0V	0.28V
C	-0.03V	0V	0V	-0.04V	0.44V	-0.16V	0V	0.5V	0.01V	0V	0V	8.33V	7.85V	0.5V

Voltage charts

	Q801 2SC945P	Q802 2SC945P	Q803 2SC1383R	Q804 8050D	Q805 8050D	Q806 8050D
E	0.63V	0.63V	8.46V	0V	0V	5V
B	1.24V	1.24V	9.11V	0V	0V	5.6V
C	3.24V	3.26V	11.54V	0V	0V	8.76V

- ➡ CD SIGNAL
- ➡ AM SIGNAL
- ➡ FM/RADIO SIGNAL
- ➡ TAPE REC SIGNAL
- ➡ TAPE PB SIGNAL
- ➡ MAIN SIGNAL

⚠ Parts are safety assurance parts. When replacing those parts make sure to use the specified one.

VCD section

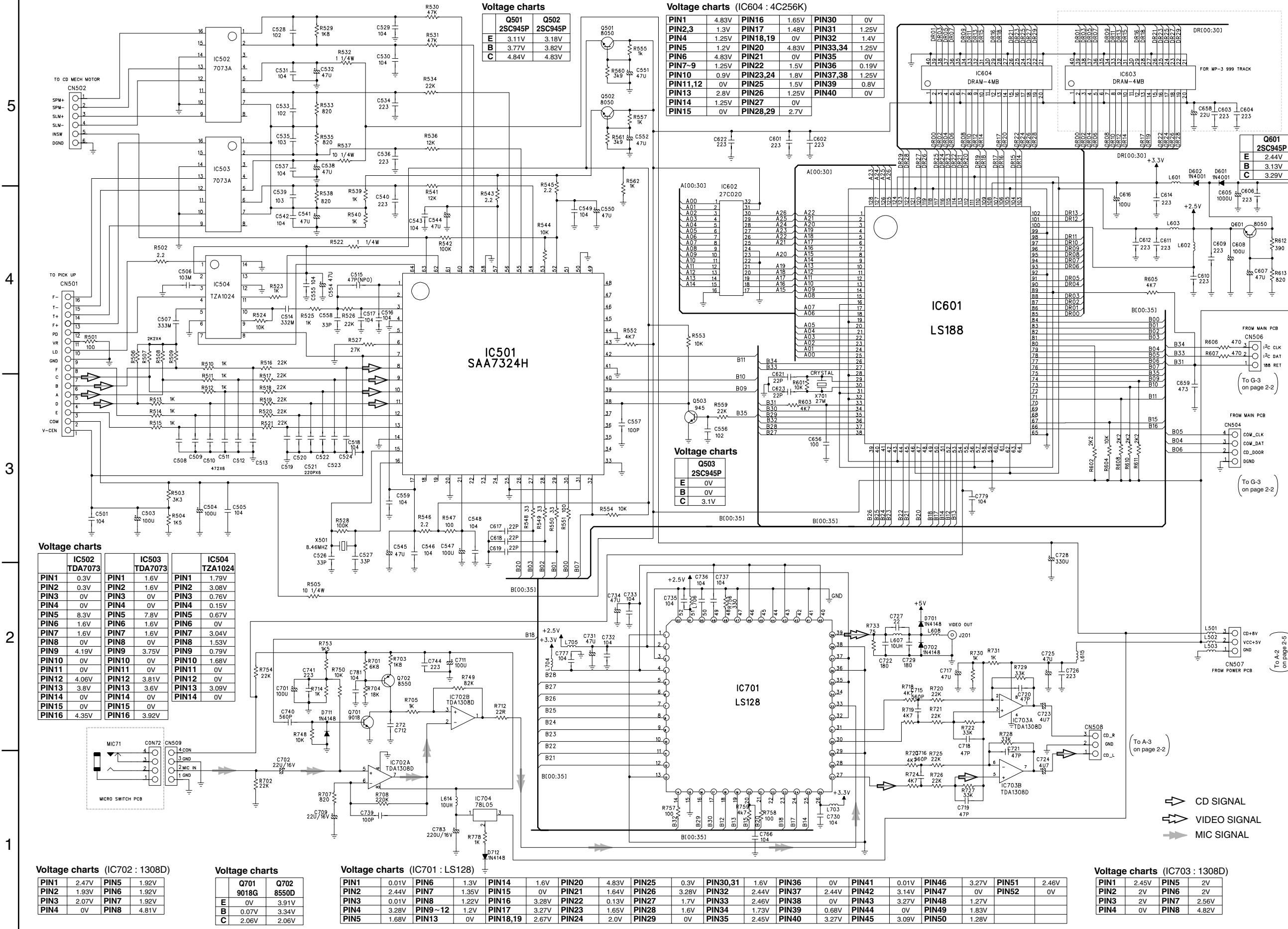

**Voltage charts**

	Q501 2SC945P	Q502 2SC945P
E	3.11V	3.18V
B	3.77V	3.82V
C	4.84V	4.83V

**Voltage charts (IC604 : 4C256K)**

PIN	VOL	PIN	VOL	PIN	VOL
PIN1	4.83V	PIN16	1.65V	PIN30	0V
PIN2,3	1.3V	PIN17	1.48V	PIN31	1.25V
PIN4	1.25V	PIN18,19	0V	PIN32	1.4V
PIN5	1.2V	PIN20	4.83V	PIN33,34	1.25V
PIN6	4.83V	PIN21	0V	PIN35	0V
PIN7-9	1.25V	PIN22	1.5V	PIN36	0.19V
PIN10	0.9V	PIN23,24	1.8V	PIN37,38	1.25V
PIN11,12	0V	PIN25	1.5V	PIN39	0.8V
PIN13	2.8V	PIN26	1.25V	PIN40	0V
PIN14	1.25V	PIN27	0V		
PIN15	0V	PIN28,29	2.7V		

**Voltage charts**

	IC501 SA7324H	IC601 LS188	
PIN1	1.4V	PIN42	0V
PIN2	1.55V	PIN43	0.01V
PIN3	1.55V	PIN44,45	1.2V
PIN4	0V	PIN46	2.46V
PIN5	3.1V	PIN47	3.1V
PIN6	1.23V	PIN48	1.62V
PIN7	1.53V	PIN49,50	1.65V
PIN8	1.52V	PIN51	0.34V
PIN9	1.53V	PIN52	3.45V
PIN10	1.52V	PIN53	3.53V
PIN11	1.52V	PIN54	4.82V
PIN12	1.52V	PIN55	0.01V
PIN13	1.52V	PIN56	3.29V
PIN14	0V	PIN57-61	0.01V
PIN15	1.54V	PIN62	2.46V
PIN16	1.52V	PIN63	1.15V
PIN17	3.1V	PIN64	3.74V
PIN18	0V	PIN65	0.01V
PIN19	0V	PIN66	3.13V
PIN20	0V	PIN67	4.82V
PIN21	3.1V	PIN68,69	3.17V
PIN22	0V	PIN70	4.65V
PIN23	0V	PIN71	3.2V
PIN24	3.16V	PIN72-74	4.7V
PIN25	0V	PIN75	0.01V
PIN26	1.64V	PIN76	0.03V
PIN27	1.6V	PIN77-79	5V
PIN28	1.58V	PIN80	4.83V
PIN29	1.6V	PIN81,82	1.58V
PIN30	0V	PIN83	1.57V
PIN31	0V	PIN84	0V
PIN32	0.03V	PIN85	1.4V
PIN33	0V	PIN86	1.2V
PIN34	3.15V	PIN87	1.5V
PIN35	0V	PIN88	0.7V
PIN36	0V	PIN89	3.29V
PIN37	0V	PIN90	1.2V
PIN38	3.11V	PIN91	1.16V
PIN39	4.72V	PIN92	0.01V
PIN40	4.7V	PIN93	1.34V
PIN41	0V	PIN94	1.2V
PIN42	4.6V	PIN95	1.1V
PIN43	3.72V	PIN96,97	0.7V
PIN44	0V	PIN98	1.4V
PIN45	0V	PIN99	0.01V
PIN46	0V	PIN100	2.5V
PIN47	1.83V	PIN101	0.6V
PIN48	0V	PIN102	1.3V
PIN49	0V	PIN103,104	1.1V
PIN50	0V	PIN105	0V
PIN51	1.6V	PIN106	2.8V
PIN52	3.17V	PIN107	2.82V
PIN53	0.3V	PIN108	3.3V
PIN54	1.56V	PIN109	2.5V
PIN55	1.7V	PIN110	3.27V
PIN56	1.6V	PIN111	2.5V
PIN57	3.16V	PIN112	1.4V
PIN58	0V	PIN113	1.6V
PIN59	0.6V	PIN114	1.7V
PIN60	0V	PIN115	1.4V
PIN61	3.7V	PIN116,117	1.6V
PIN62	0V	PIN118	0V
PIN63	3.15V	PIN119	1.7V
PIN64	3.03V	PIN120	1.9V
		PIN121	0V
		PIN122,123	1.7V
		PIN124	2.46V
		PIN125	0.18V
		PIN126	0.58V
		PIN127	0.32V
		PIN128	0.58V
		IC602	27C020
		PIN1	0.01V
		PIN2,3	0.12V
		PIN4	1.67V
		PIN5	1.35V
		PIN6	1.44V
		PIN7	1.38V
		PIN8,9	1.35V
		PIN10	1.37V
		PIN11,12	1.35V
		PIN14	1.5V
		PIN15	1.52V
		PIN16	0V
		PIN17	0.9V
		PIN18	1.6V
		PIN19	1.2V
		PIN20	0.01V
		PIN21	0.01V
		PIN22	0.01V
		PIN23	0.01V
		PIN24	0.01V
		PIN25	0.01V
		PIN26	0.01V
		PIN27	0.01V
		PIN28	0.01V
		PIN29	0.01V
		PIN30	0.01V
		PIN31	0.01V
		PIN32	0.01V
		PIN33	0.01V
		PIN34	0.01V
		PIN35	0.01V
		PIN36	0.01V
		PIN37	0.01V
		PIN38	0.01V
		PIN39	0.01V
		PIN40	0.01V
		PIN41	0.01V

**Voltage charts**

	IC502 TDA7073	IC503 TDA7073	IC504 TZA1024		
PIN1	0.3V	PIN1	1.6V	PIN1	1.79V
PIN2	0.3V	PIN2	1.6V	PIN2	3.08V
PIN3	0V	PIN3	0V	PIN3	0.76V
PIN4	0V	PIN4	0V	PIN4	0.15V
PIN5	8.3V	PIN5	7.8V	PIN5	0.67V
PIN6	1.6V	PIN6	1.6V	PIN6	0V
PIN7	1.6V	PIN7	1.6V	PIN7	3.04V
PIN8	0V	PIN8	0V	PIN8	1.53V
PIN9	4.19V	PIN9	3.75V	PIN9	0.79V
PIN10	0V	PIN10	0V	PIN10	1.68V
PIN11	0V	PIN11	0V	PIN11	0V
PIN12	4.06V	PIN12	3.81V	PIN12	0V
PIN13	3.8V	PIN13	3.6V	PIN13	3.09V
PIN14	0V	PIN14	0V	PIN14	0V
PIN15	0V	PIN15	0V		
PIN16	4.35V	PIN16	3.92V		

**Voltage charts (IC702 : 1308D)**

PIN1	2.47V	PIN5	1.92V
PIN2	1.93V	PIN6	1.92V
PIN3	2.07V	PIN7	1.92V
PIN4	0V	PIN8	4.81V

**Voltage charts**

	Q701 9018G	Q702 8550D
E	0V	3.91V
B	0.07V	3.34V
C	2.06V	2.06V

**Voltage charts (IC701 : LS128)**

PIN1	0.01V	PIN6	1.3V	PIN14	1.6V	PIN20	4.83V	PIN25	0.3V	PIN30,31	1.6V	PIN36	0V	PIN41	0.01V	PIN46	3.27V	PIN51	2.46V
PIN2	2.44V	PIN7	1.35V	PIN15	0V	PIN21	1.64V	PIN26	3.28V	PIN32	2.44V	PIN37	2.44V	PIN42	3.14V	PIN47	0V	PIN52	0V
PIN3	0.01V	PIN8	1.22V	PIN16	3.28V	PIN22	0.13V	PIN27	1.7V	PIN33	2.46V	PIN38	0V	PIN43	3.27V	PIN48	1.27V		
PIN4	3.28V	PIN9-12	1.2V	PIN17	3.27V	PIN23	1.65V	PIN28	1.6V	PIN34	1.73V	PIN39	0.68V	PIN44	0V	PIN49	1.83V		
PIN5	1.68V	PIN13	0V	PIN18,19	2.67V	PIN24	2.0V	PIN29	0V	PIN35	2.45V	PIN40	3.27V	PIN45	3.09V	PIN50	1.28V		

**Voltage charts (IC703 : 1308D)**

PIN1	2.45V	PIN5	2V
PIN2	2V	PIN6	2V
PIN3	2V	PIN7	2.56V
PIN4	0V	PIN8	4.82V



Display section

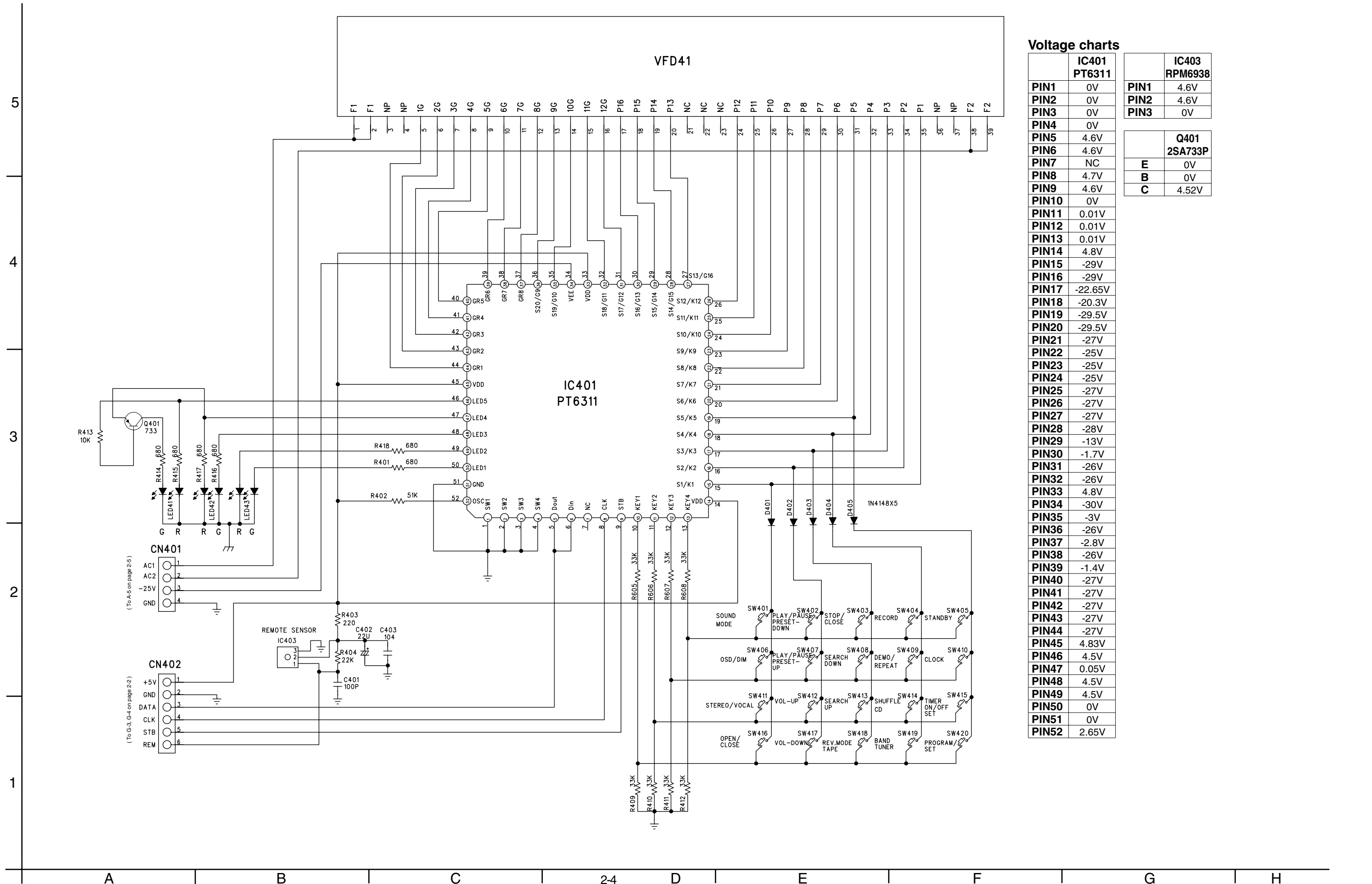

Voltage charts

	IC401 PT6311
PIN1	0V
PIN2	0V
PIN3	0V
PIN4	0V
PIN5	4.6V
PIN6	4.6V
PIN7	NC
PIN8	4.7V
PIN9	4.6V
PIN10	0V
PIN11	0.01V
PIN12	0.01V
PIN13	0.01V
PIN14	4.8V
PIN15	-29V
PIN16	-29V
PIN17	-22.65V
PIN18	-20.3V
PIN19	-29.5V
PIN20	-29.5V
PIN21	-27V
PIN22	-25V
PIN23	-25V
PIN24	-25V
PIN25	-27V
PIN26	-27V
PIN27	-27V
PIN28	-28V
PIN29	-13V
PIN30	-1.7V
PIN31	-26V
PIN32	-26V
PIN33	4.8V
PIN34	-30V
PIN35	-3V
PIN36	-26V
PIN37	-2.8V
PIN38	-26V
PIN39	-1.4V
PIN40	-27V
PIN41	-27V
PIN42	-27V
PIN43	-27V
PIN44	-27V
PIN45	4.83V
PIN46	4.5V
PIN47	0.05V
PIN48	4.5V
PIN49	4.5V
PIN50	0V
PIN51	0V
PIN52	2.65V

	IC403 RPM6938
PIN1	4.6V
PIN2	4.6V
PIN3	0V

	Q401 2SA733P
E	0V
B	0V
C	4.52V

■ Power section

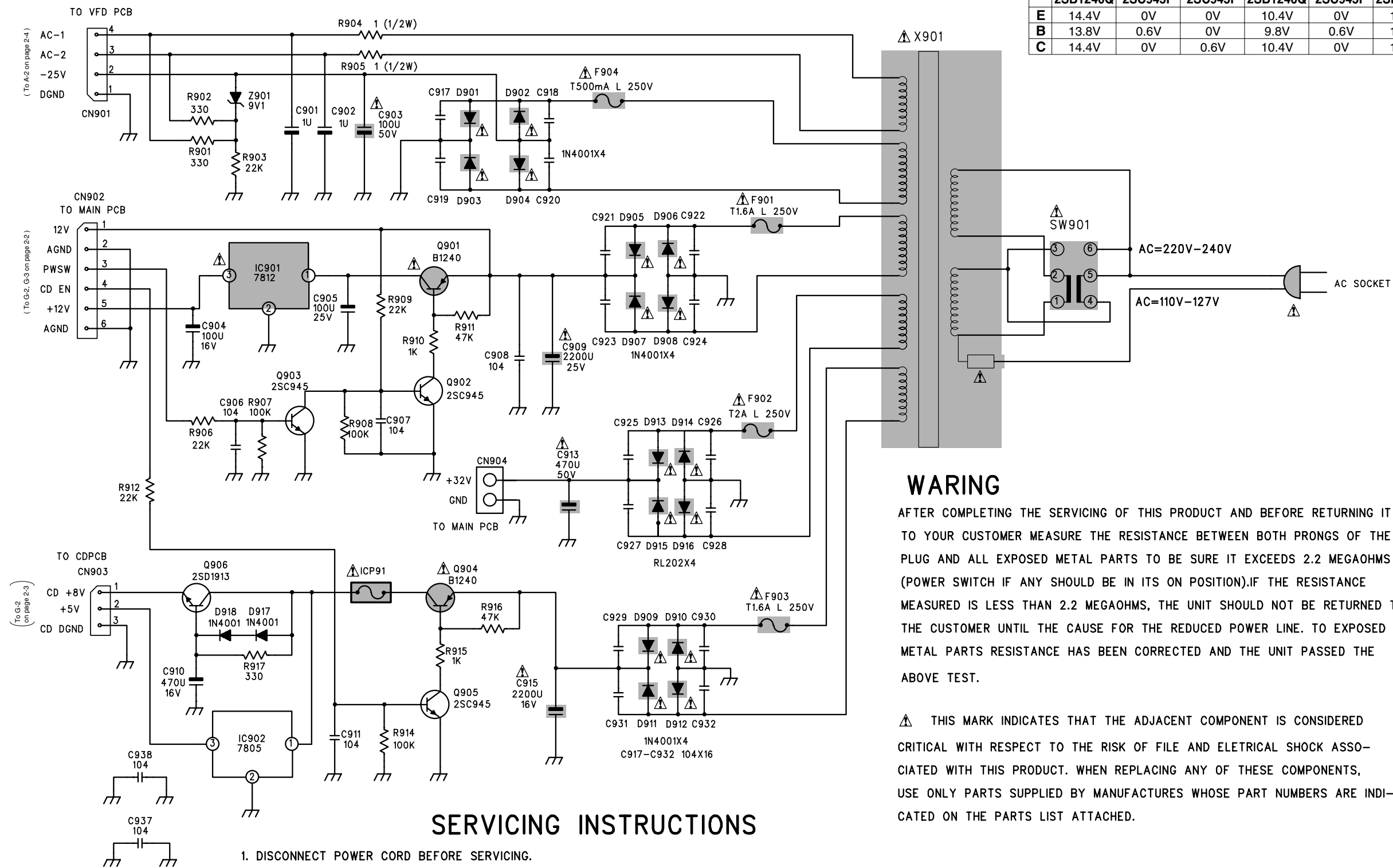

Voltage charts

	Q901 2SB1240Q	Q902 2SC945P	Q903 2SC945P	Q904 2SB1240Q	Q905 2SC945P	Q906 2SD1913R
E	14.4V	0V	0V	10.4V	0V	10.2V
B	13.8V	0.6V	0V	9.8V	0.6V	10.4V
C	14.4V	0V	0.6V	10.4V	0V	10.4V

**WARING**

AFTER COMPLETING THE SERVICING OF THIS PRODUCT AND BEFORE RETURNING IT TO YOUR CUSTOMER MEASURE THE RESISTANCE BETWEEN BOTH PRONGS OF THE AC PLUG AND ALL EXPOSED METAL PARTS TO BE SURE IT EXCEEDS 2.2 MEGAOHMS (POWER SWITCH IF ANY SHOULD BE IN ITS ON POSITION).IF THE RESISTANCE MEASURED IS LESS THAN 2.2 MEGAOHMS, THE UNIT SHOULD NOT BE RETURNED TO THE CUSTOMER UNTIL THE CAUSE FOR THE REDUCED POWER LINE. TO EXPOSED METAL PARTS RESISTANCE HAS BEEN CORRECTED AND THE UNIT PASSED THE ABOVE TEST.

⚠ THIS MARK INDICATES THAT THE ADJACENT COMPONENT IS CONSIDERED CRITICAL WITH RESPECT TO THE RISK OF FIRE AND ELECTRICAL SHOCK ASSOCIATED WITH THIS PRODUCT. WHEN REPLACING ANY OF THESE COMPONENTS, USE ONLY PARTS SUPPLIED BY MANUFACTURERS WHOSE PART NUMBERS ARE INDICATED ON THE PARTS LIST ATTACHED.

⚠ Parts are safety assurance parts. When replacing those parts make sure to use the specified one.

**SERVICING INSTRUCTIONS**

1. DISCONNECT POWER CORD BEFORE SERVICING.
2. REPLACE CRITICAL COMPONENTS ⚠ ONLY WITH FACTORY PARTS OR RECOMMENDED EQUIVALENTS.
3. FOR AC LINE POWERED UNITS—BEFORE RETURNING REPAIRED UNIT TO USER, USE AN OHMMETER TO MEASURE FROM BOTH AC PLUG BLADES TO ALL EXPOSED METALLIC PARTS.THE RESISTANCE SHOULD BE MORE THAN 100,000 OHMS.



# Printed circuit boards

■ Main board

5

4

3

2

1

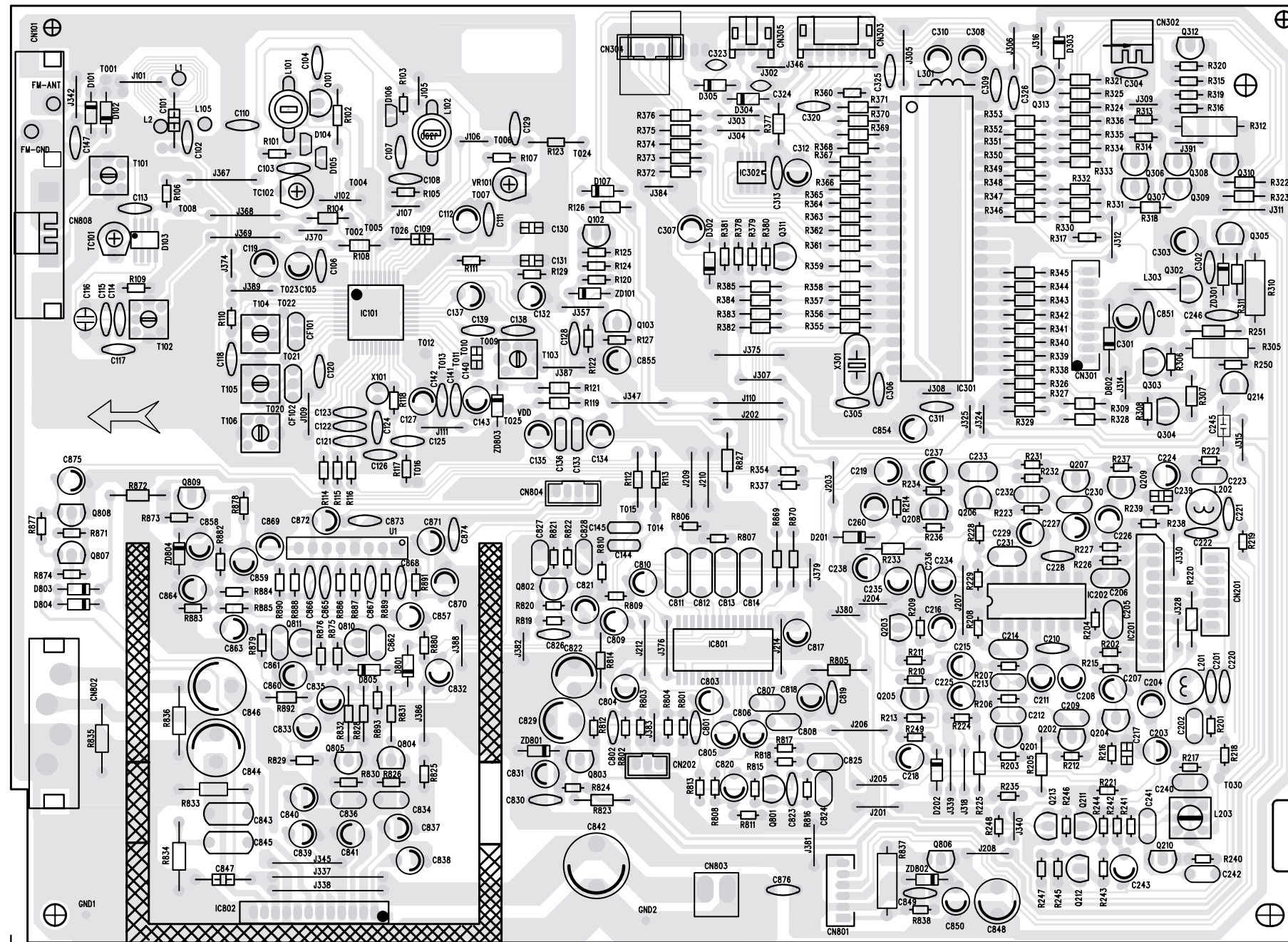

A

B

C

2-6

D

E

F

G

H

■ VCD board

5  
4  
3  
2  
1  
A B C

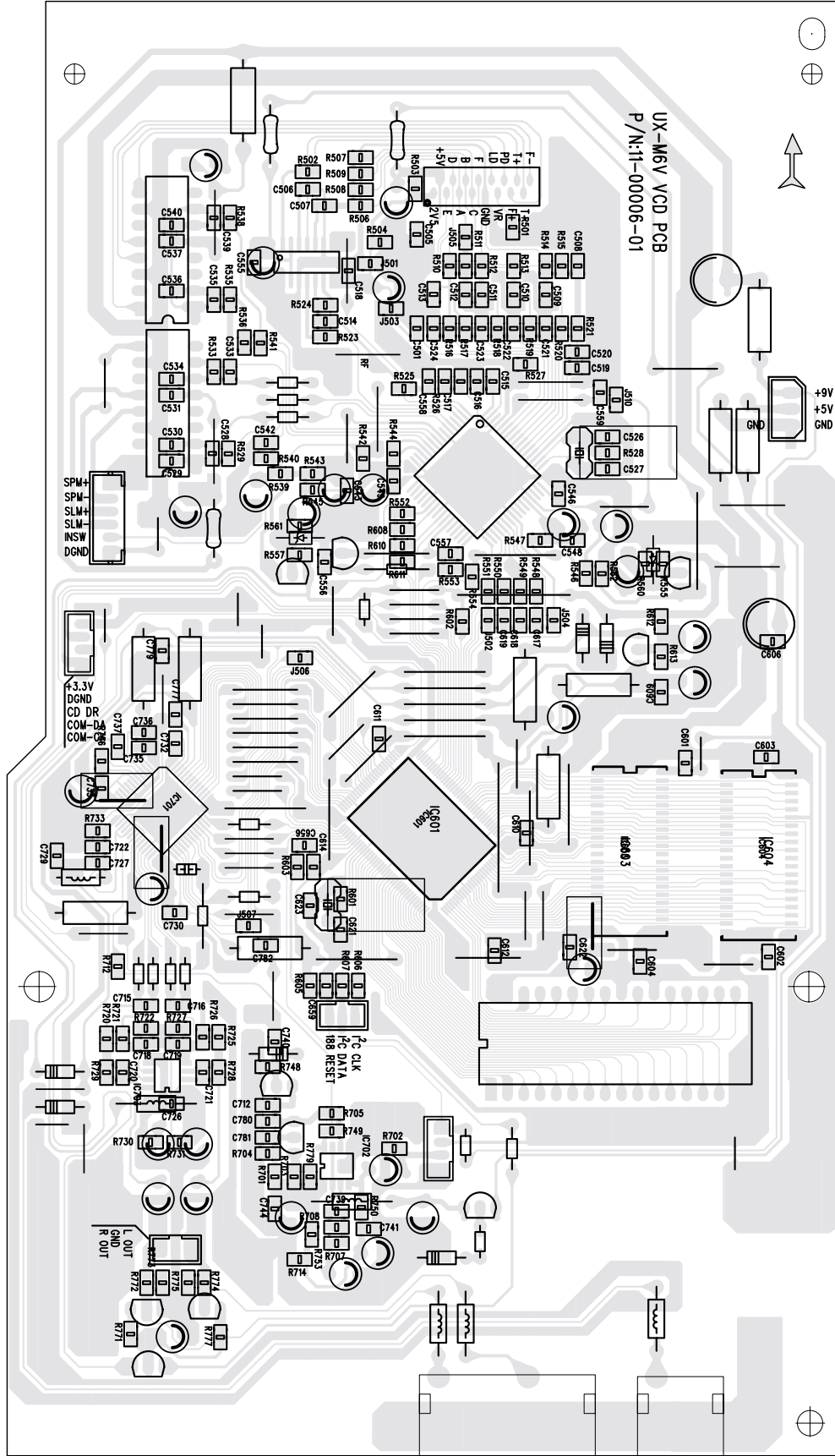

■ Display board

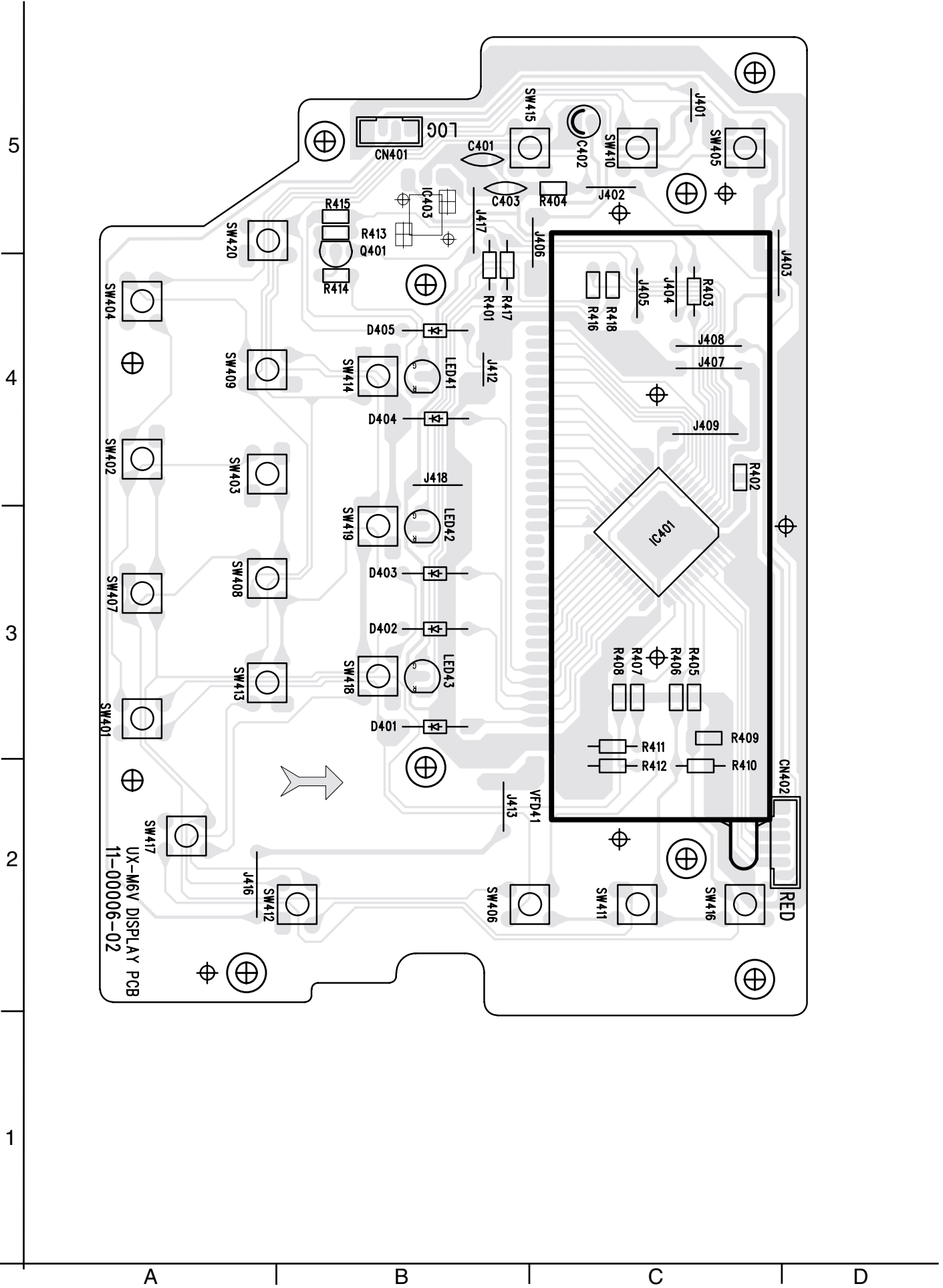



■ Power board

5  
4  
3  
2  
1

(Power board)

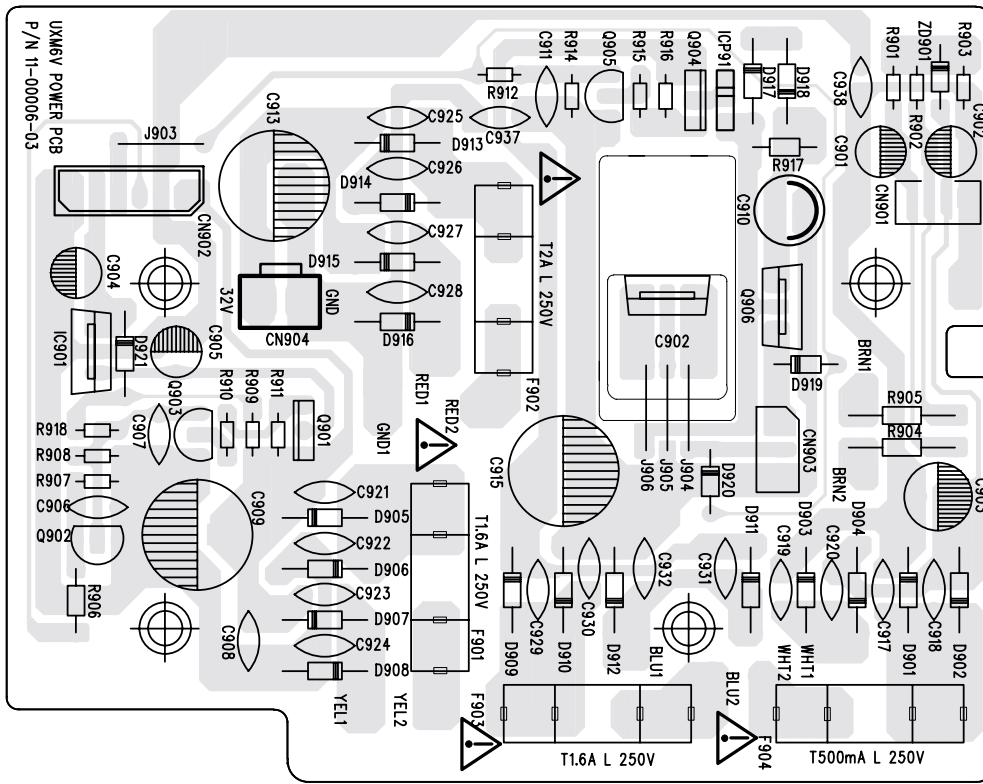

(Motor board)

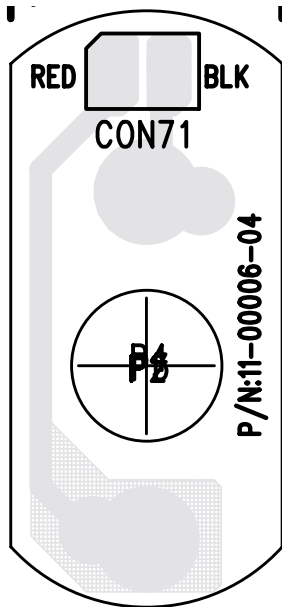

(Microphone board)

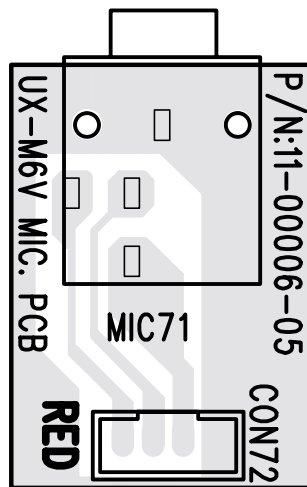

(Voltage switch board)

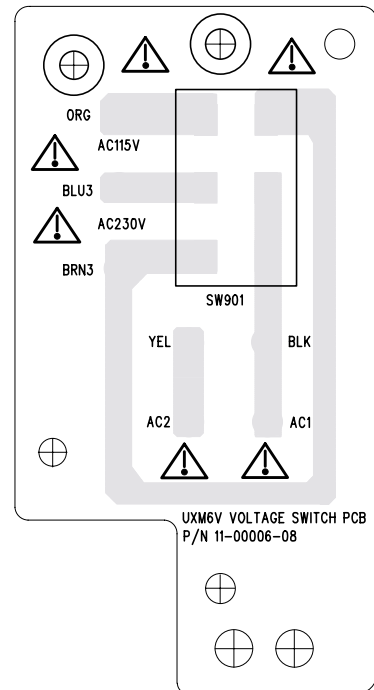

A

B

C