

JVC

SERVICE MANUAL

MICRO COMPONENT SYSTEM

UX-P3

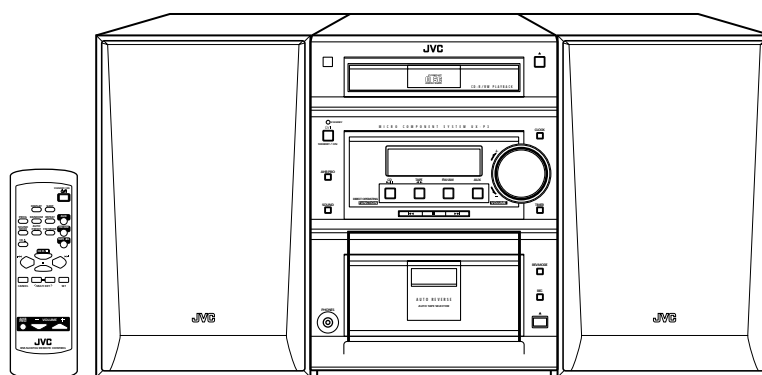

SP-UXP3

CA-UXP3

SP-UXP3

COMPACT
disc
DIGITAL AUDIO

Area Suffix

UB	Hong Kong
UP	Korea
US	Singapore
UW	South Africa
UY	Argentina

Contents

Safety precautions	1-2	Maintenance of laser pickup	1-19
Preventing static electricity	1-4	Replacement of laser pickup	1-19
Important for laser products	1-6	Description of major ICs	1-20
Disassembly method	1-7	Internal connection of display	1-39
Main adjustment	1-14		
Flow of functional operation until TOC read (CD)	1-18		

Safety Precautions

1. This design of this product contains special hardware and many circuits and components specially for safety purposes. For continued protection, no changes should be made to the original design unless authorized in writing by the manufacturer. Replacement parts must be identical to those used in the original circuits. Services should be performed by qualified personnel only.
2. Alterations of the design or circuitry of the product should not be made. Any design alterations of the product should not be made. Any design alterations or additions will void the manufacturer's warranty and will further relieve the manufacture of responsibility for personal injury or property damage resulting therefrom.
3. Many electrical and mechanical parts in the products have special safety-related characteristics. These characteristics are often not evident from visual inspection nor can the protection afforded by them necessarily be obtained by using replacement components rated for higher voltage, wattage, etc. Replacement parts which have these special safety characteristics are identified in the Parts List of Service Manual. Electrical components having such features are identified by shading on the schematics and by (\triangle) on the Parts List in the Service Manual. The use of a substitute replacement which does not have the same safety characteristics as the recommended replacement parts shown in the Parts List of Service Manual may create shock, fire, or other hazards.
4. The leads in the products are routed and dressed with ties, clamps, tubings, barriers and the like to be separated from live parts, high temperature parts, moving parts and/or sharp edges for the prevention of electric shock and fire hazard. When service is required, the original lead routing and dress should be observed, and it should be confirmed that they have been returned to normal, after re-assembling.
5. Leakage current check (Electrical shock hazard testing)
After re-assembling the product, always perform an isolation check on the exposed metal parts of the product (antenna terminals, knobs, metal cabinet, screw heads, headphone jack, control shafts, etc.) to be sure the product is safe to operate without danger of electrical shock.
Do not use a line isolation transformer during this check.

- Plug the AC line cord directly into the AC outlet. Using a "Leakage Current Tester", measure the leakage current from each exposed metal parts of the cabinet, particularly any exposed metal part having a return path to the chassis, to a known good earth ground. Any leakage current must not exceed 0.5mA AC (r.m.s.).

- Alternate check method

Plug the AC line cord directly into the AC outlet. Use an AC voltmeter having, 1,000 ohms per volt or more sensitivity in the following manner. Connect a $1,500\ \Omega$ 10W resistor paralleled by a $0.15\ \mu\text{F}$ AC-type capacitor between an exposed metal part and a known good earth ground. Measure the AC voltage across the resistor with the AC voltmeter.

Move the resistor connection to each exposed metal part, particularly any exposed metal part having a return path to the chassis, and measure the AC voltage across the resistor. Now, reverse the plug in the AC outlet and repeat each measurement. Voltage measured any must not exceed 0.75 V AC (r.m.s.). This corresponds to 0.5 mA AC (r.m.s.).

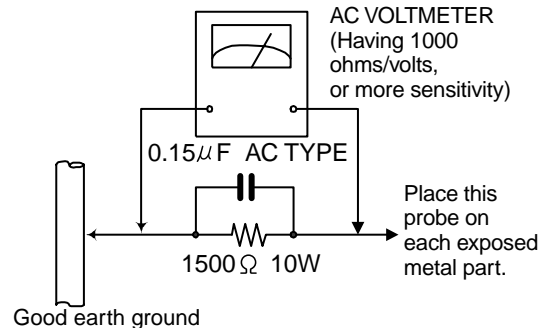

Warning

1. This equipment has been designed and manufactured to meet international safety standards.
2. It is the legal responsibility of the repairer to ensure that these safety standards are maintained.
3. Repairs must be made in accordance with the relevant safety standards.
4. It is essential that safety critical components are replaced by approved parts.
5. If mains voltage selector is provided, check setting for local voltage.

CAUTION

Burrs formed during molding may be left over on some parts of the chassis. Therefore, pay attention to such burrs in the case of performing repair of this system.

In regard with component parts appearing on the silk-screen printed side (parts side) of the PWB diagrams, the parts that are printed over with black such as the resistor (■), diode (▬) and ICP (●) or identified by the (\triangle) mark nearby are critical for safety.

When replacing them, be sure to use the parts of the same type and rating as specified by the manufacturer. (Except the J and C version)

Safety precautions (U.K only)

1. This design of this product contains special hardware and many circuits and components specially for safety purposes. For continued protection, no changes should be made to the original design unless authorized in writing by the manufacturer. Replacement parts must be identical to those used in the original circuits.
2. Any unauthorised design alterations or additions will void the manufacturer's guarantee ; furthermore the manufacturer cannot accept responsibility for personal injury or property damage resulting therefrom.
3. Essential safety critical components are identified by () on the Parts List and by shading on the schematics, and must never be replaced by parts other than those listed in the manual. Please note however that many electrical and mechanical parts in the product have special safety related characteristics. These characteristics are often not evident from visual inspection. Parts other than specified by the manufacturer may not have the same safety characteristics as the recommended replacement parts shown in the Parts List of the Service Manual and may create shock, fire, or other hazards.
4. The leads in the products are routed and dressed with ties, clamps, tubings, barriers and the like to be separated from live parts, high temperature parts, moving parts and/or sharp edges for the prevention of electric shock and fire hazard. When service is required, the original lead routing and dress should be observed, and it should be confirmed that they have been returned to normal, after re-assembling.

Warning

1. Service should be performed by qualified personnel only.
2. This equipment has been designed and manufactured to meet international safety standards.
3. It is the legal responsibility of the repairer to ensure that these safety standards are maintained.
4. Repairs must be made in accordance with the relevant safety standards.
5. It is essential that safety critical components are replaced by approved parts.
6. If mains voltage selector is provided, check setting for local voltage.

 **CAUTION** Burrs formed during molding may be left over on some parts of the chassis. Therefore, pay attention to such burrs in the case of performing repair of this system.

Preventing static electricity

Electrostatic discharge (ESD), which occurs when static electricity stored in the body, fabric, etc. is discharged, can destroy the laser diode in the traverse unit (optical pickup). Take care to prevent this when performing repairs.

1.1. Grounding to prevent damage by static electricity

Static electricity in the work area can destroy the optical pickup (laser diode) in devices such as DVD players. Be careful to use proper grounding in the area where repairs are being performed.

1.1.1. Ground the workbench

1. Ground the workbench by laying conductive material (such as a conductive sheet) or an iron plate over it before placing the traverse unit (optical pickup) on it.

1.1.2. Ground yourself

1. Use an anti-static wrist strap to release any static electricity built up in your body.

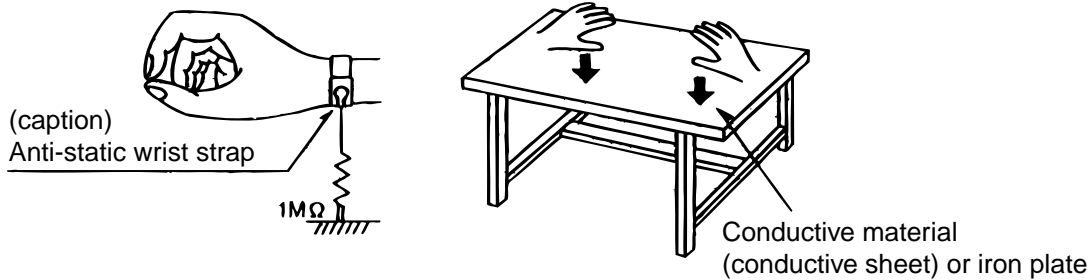

1.1.3. Handling the optical pickup

1. In order to maintain quality during transport and before installation, both sides of the laser diode on the replacement optical pickup are shorted. After replacement, return the shorted parts to their original condition. (Refer to the text.)
2. Do not use a tester to check the condition of the laser diode in the optical pickup. The tester's internal power source can easily destroy the laser diode.

1.2. Handling the traverse unit (optical pickup)

1. Do not subject the traverse unit (optical pickup) to strong shocks, as it is a sensitive, complex unit.
2. Cut off the shorted part of the flexible cable using nippers, etc. after replacing the optical pickup. For specific details, refer to the replacement procedure in the text. Remove the anti-static pin when replacing the traverse unit. Be careful not to take too long a time when attaching it to the connector.
3. Handle the flexible cable carefully as it may break when subjected to strong force.
4. It is not possible to adjust the semi-fixed resistor that adjusts the laser power. Do not turn it

1.3. Cautions on removing the CD traverse unit

* For removing the CD traverse unit in detail, refer to the "Adjustment Method" section of this manual.

1. Before disconnecting the flexible wire from the connector CN601 on the CD SERVO board, solder the part shown in the figure below.
(Note: If the flexible wire is disconnected from the CN601 without presoldering, it may cause breakdown of the CD pickup assembly.)
2. When reassembling the CD traverse unit, be sure to remove the solder from the soldered part after reconnecting the flexible wire to the CN601.

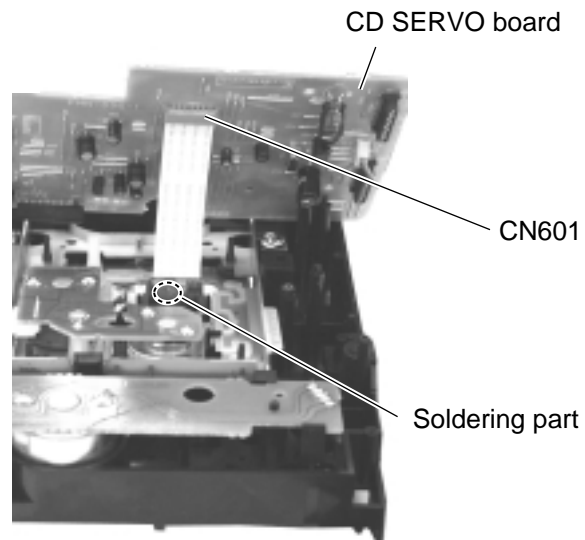
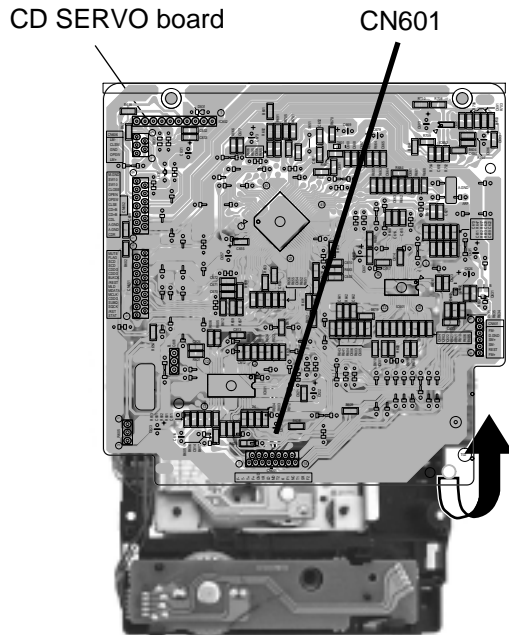

Important for laser products

1.CLASS 1 LASER PRODUCT

2.DANGER : Invisible laser radiation when open and interlock failed or defeated. Avoid direct exposure to beam.

3.CAUTION : There are no serviceable parts inside the Laser Unit. Do not disassemble the Laser Unit. Replace the complete Laser Unit if it malfunctions.

4.CAUTION : The compact disc player uses invisible laserradiation and is equipped with safety switches which prevent emission of radiation when the drawer is open and the safety interlocks have failed or are defeated. It is dangerous to defeat the safety switches.

5.CAUTION : If safety switches malfunction, the laser is able to function.

6.CAUTION : Use of controls, adjustments or performance of procedures other than those specified herein may result in hazardous radiation exposure.

⚠ CAUTION Please use enough caution not to see the beam directly or touch it in case of an adjustment or operation check.

WARNING : Osynlig laserstråling är denna del är öppnad och spårren är urkopplad. Betrakta ej strålen.

VARO : Avattaessa ja suojalukitus ohitettaessa olet alltiina näkymättömälle lasersäteilylle. Älä katso säteeseen.

ADVARSEL : Usynlig laserstråling ved åbning , når sikkerhedsafbrydere er ude af funktion. Undgå udsættelse for stråling.

ADVARSEL : Usynlig laserstråling ved åpning,når sikkerhetsbryteren er avslott. unngå utsettelse for stråling.

REPRODUCTION AND POSITION OF LABELS



WARNING LABEL

**CLASS 1
LASER PRODUCT**

Disassembly method

<Main body>

■ Removing the metal cover

(See Fig.1 and 2)

1. Remove the six screws **A** on the back of the body.
2. Remove the two screws **B** on the side of the body.
3. Pull both sides of the metal cover outward and lift the rear part of the cover.

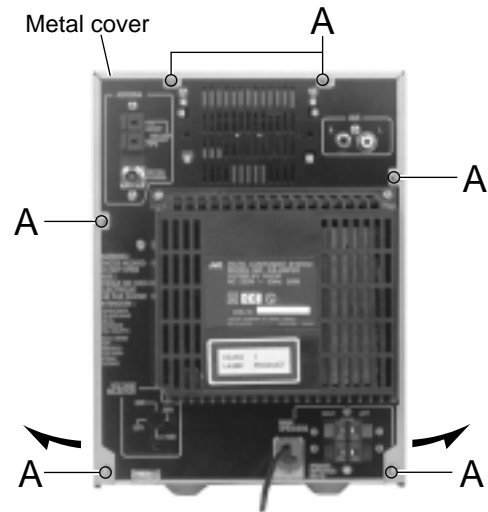

Fig.1

■ Removing the rear cover (See Fig.3)

- Prior to performing the following procedure, remove the metal cover.
1. Remove the two screws **C** on the back of the body.

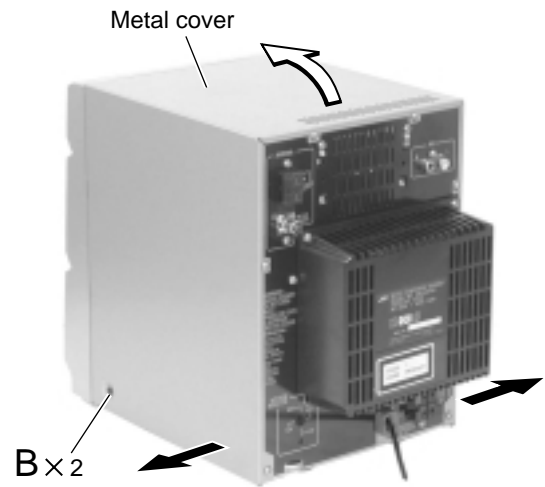

Fig.2

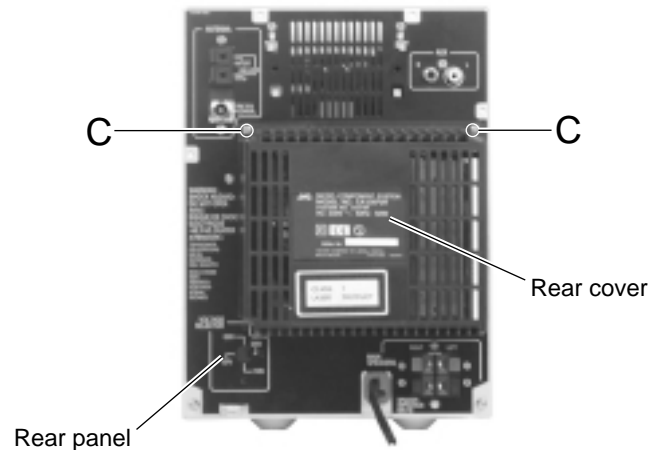

Fig.3

■ Removing the tuner board
(See Fig.4 and 5)

• Prior to performing the following procedure, remove the metal cover.

1. Disconnect the card wire from connector CN1 on the tuner board.
2. Remove the screw **D** on the right side of the body.
3. Remove the two screws **E** on the rear panel.

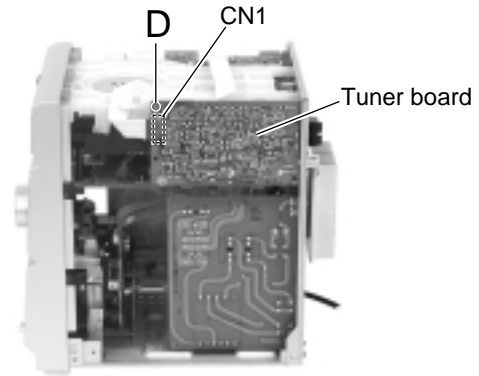

Fig.4

■ Removing the CD mechanism assembly
(See Fig.6 to 8)

• Prior to performing the following procedure, remove the metal cover and the rear cover.

1. Disconnect the card wires from connector CN903, CN904 on the main board on the upper side of the body.
2. Remove the screw **D** attaching the tuner board and the CD mechanism on the right side of the body.
3. Remove the two screws **F** attaching the rear panel and the CD mechanism on the back of the body.
4. Move the rear part of the CD mechanism assembly upwards to disengage the two joints **a** and release from the rear panel.

Pull the front panel toward the front and move the rear part of the CD mechanism assembly upwards. Then pull out the CD mechanism assembly from the front panel backward.

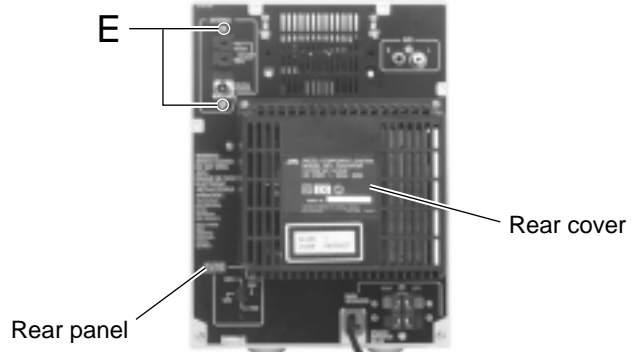

Fig.5

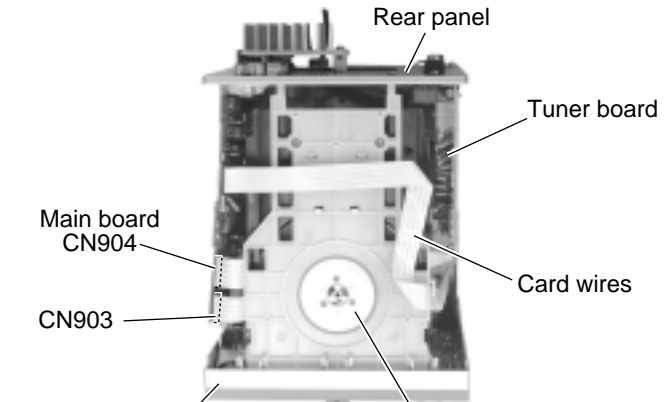

Fig.6

REFERENCE: To remove the CD mechanism assembly efficiently, disconnect the card wire connecting the tuner board with the main board in advance.

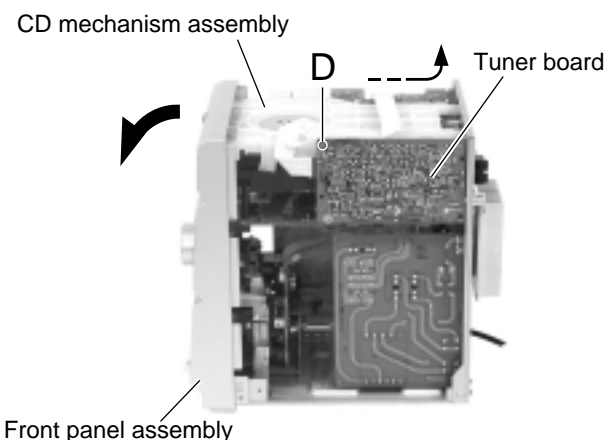

Fig.7

Remove the rear panel (See Fig.8 to 11)

· Prior to performing the following procedure, remove the metal cover, rear cover and the CD mechanism assembly.

1. Remove the five screws **G** attaching the rear panel.
2. Disconnect the card wire from CN902 on the main board.
3. Disengage the lower two joints **b** on each side of the rear panel using a screwdriver and remove the rear panel backward (The tuner board and the fan will be also detached. Remove them as needed).

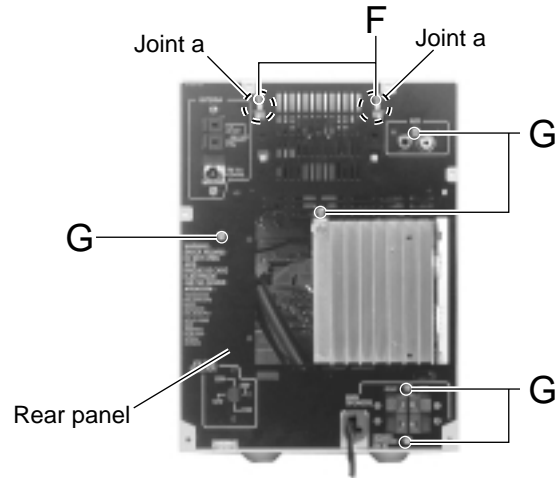

Fig.8

Removing the fan (See Fig.9 and 12)

· Prior to performing the following procedure, remove the metal cover, the rear cover and the CD mechanism assembly.

1. Disconnect the wire from connector CN908 on the main board.
2. Remove the two screws **H** on the back of the body.
3. Move the fan upwards to disengage the four joints **c** and release from the rear panel.

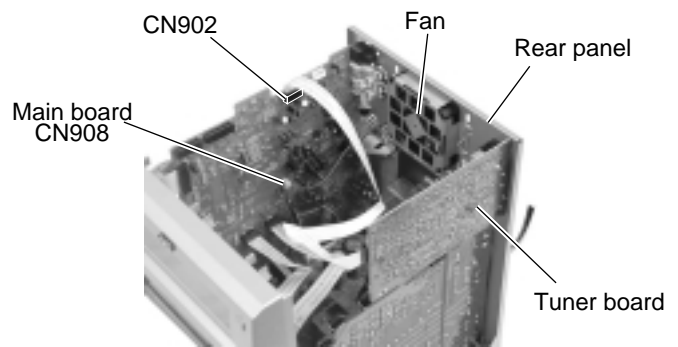

Fig.9

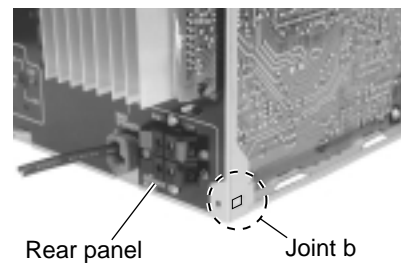

Fig.10

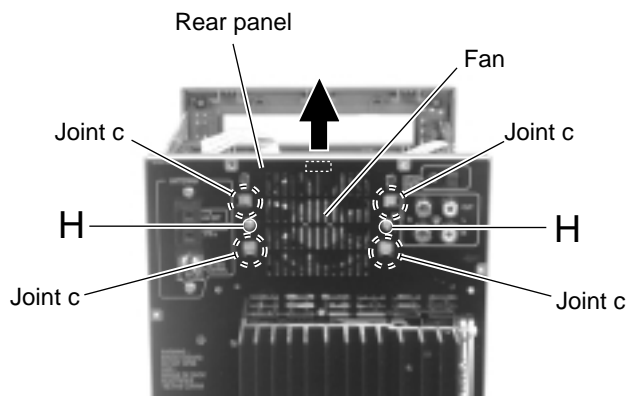

Fig.12

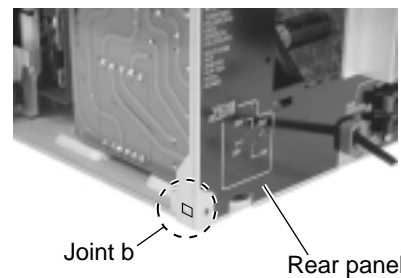

Fig.11

■ Removing the main board / heat sink
(See Fig.13 to 15)

• Prior to performing the following procedure, remove the metal cover, the rear cover, the CD mechanism assembly and the rear panel.

1. Disconnect the card wire from connector CN900, CN901 and CN931 on the main board.

Disconnect the wire from CN906 and FW903 respectively.

2. Disconnect the wire from W950 on the underside of the main board.

3. Remove the two screws **I** attaching the main board to the chassis on the left side of the body and disengage the two joints **c**.

4. Remove the two screws **J** attaching the heat sink to the main board.

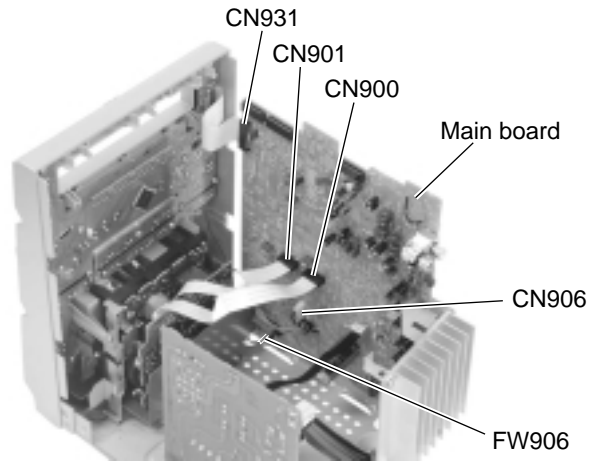

Fig.13

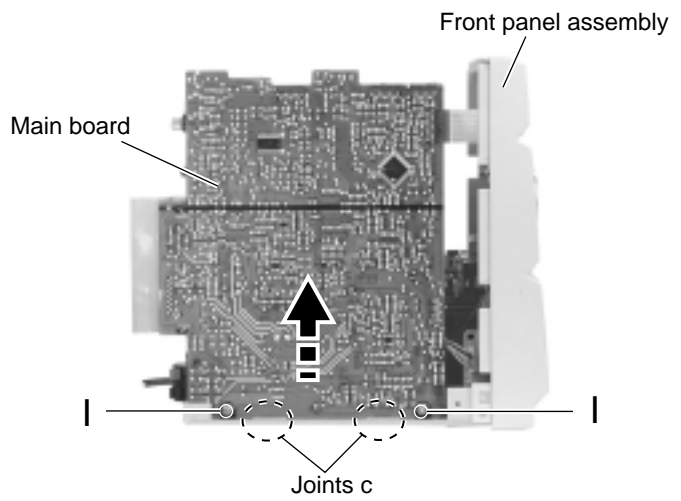

Fig.14

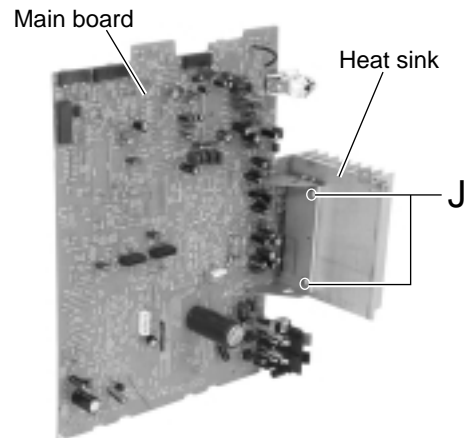

Fig.15

■ Removing the power transformer assembly (See Fig.16 and 17)

• Prior to performing the following procedure, remove the metal cover, the rear cover, the CD mechanism assembly and the rear panel.

1. Remove the cord stopper upwards on the back of the body.
2. Disconnect the power cord from connector J1000 on the board of the power transformer assembly.
3. Disconnect the wire from connector FW903 on the main board.
4. Remove the four screws **K** attaching the power transformer assembly.

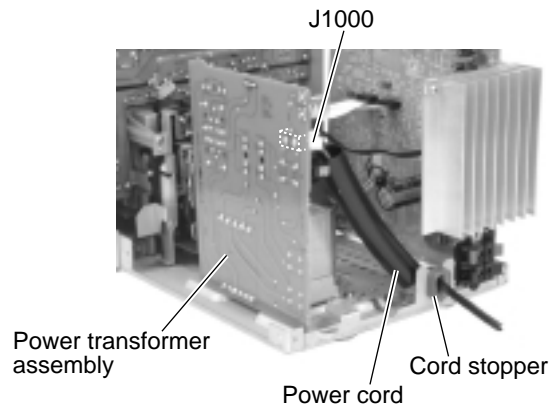

Fig.16

■ Removing the front panel assembly (See Fig.13, 18 and 19)

• Prior to performing the following procedure, remove the metal cover, the rear cover, the CD mechanism assembly and the rear panel.

1. Disconnect the card wire from connector CN900, CN901 and CN931 on the main board (Refer to Fig.13).
2. Disconnect the wire from CN906 and FW903 respectively (Refer to Fig.13).

Disconnect the wire from W950 on the underside of the main board.

3. Remove the two screws **L** on each lower side of the body.
4. Release the lower joints **d** on each side of the body using a screwdriver. Pull out the front panel assembly toward the front.

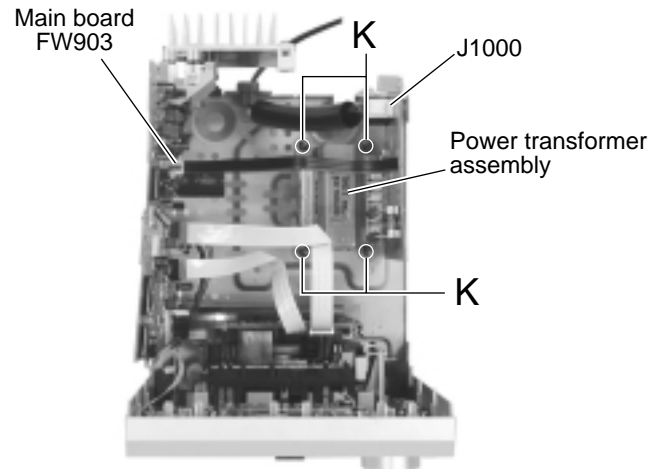

Fig.17

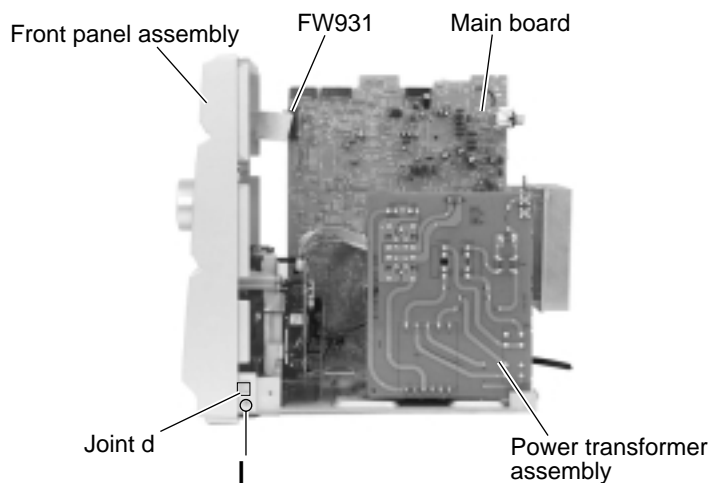

Fig.19

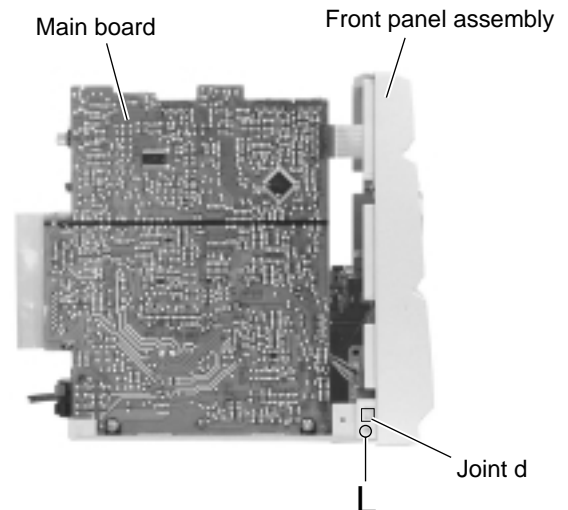

Fig.18

■Removing the display board / switch board (See Fig.20 to 22)

• Prior to performing the following procedure, remove the front panel assembly.

1. Pull out the VOLUME knob on the front panel.
2. Remove the fifteen screws **M** attaching the display board and the switch board on the back of the front panel. Remove the display board with the switch board.
3. Remove the screw **N** attaching the switch board to the LCD holder.
4. If necessary, unsolder the wire extending from connector FW931 on the display board and FW931 on the switch board.
5. If necessary, remove the band bundling the wires extending from the headphone board and the display board.

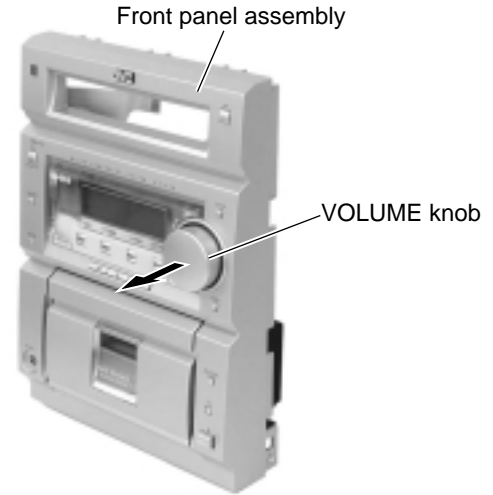

Fig.20

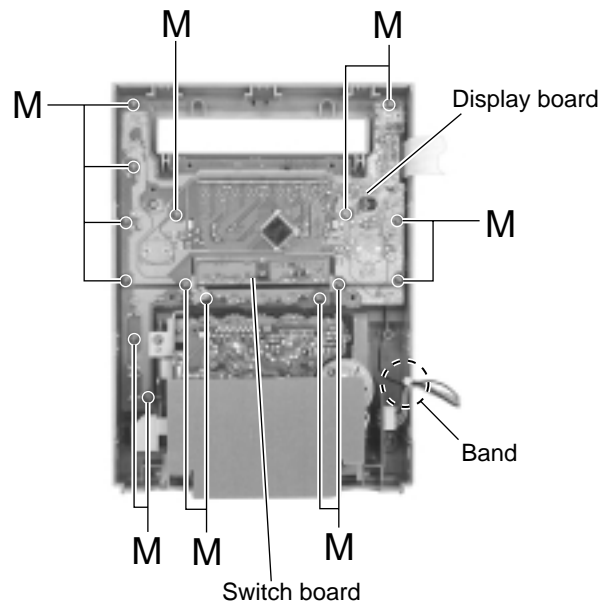

Fig.21

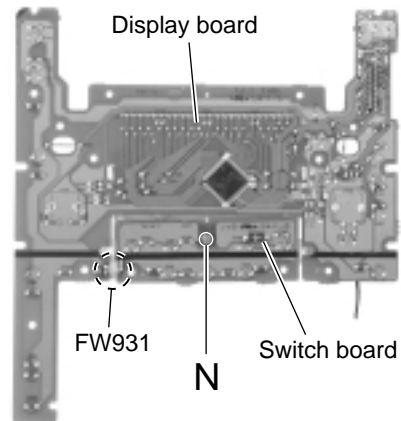

Fig.22

**■Removing the headphone board
(See Fig.23)**

- Prior to performing the following procedure, remove the front panel assembly.
1. Remove the screw **O** on the back of the front panel.
 2. If necessary, remove the band bundling the wire extending from the headphone board and the display board.

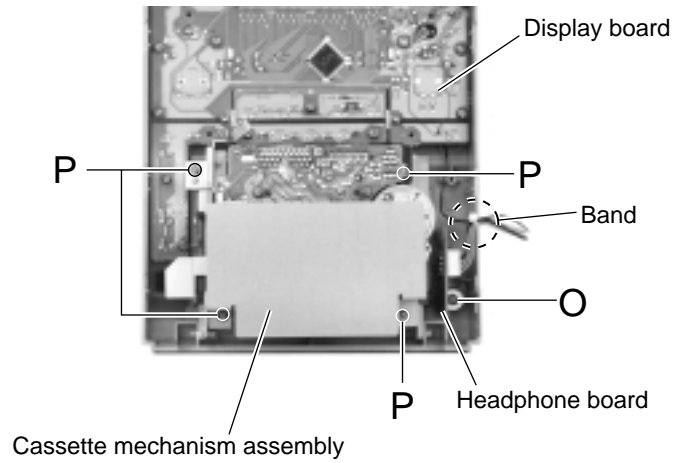

Fig.23

■Removing the cassette mechanism assembly (See Fig.23 and 24)

- Prior to performing the following procedure, remove the front panel assembly.
1. Press the EJCT button on the front panel to open the cassette door.
 2. Remove the four screws **P** on the back of the front panel.

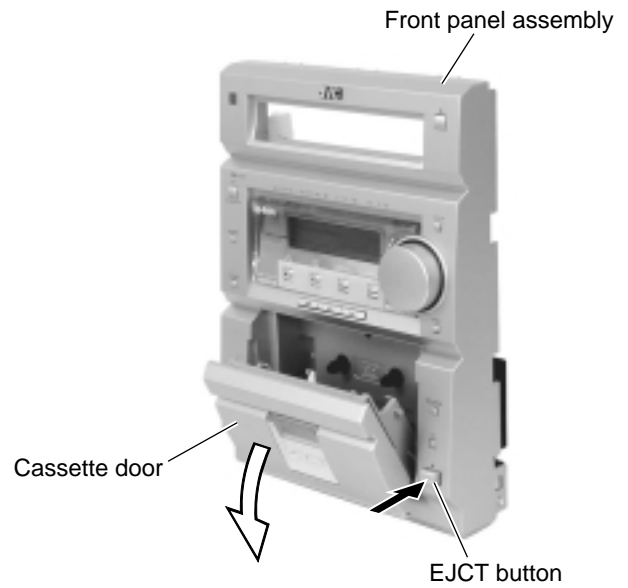

Fig.24

Main adjustment

■ Measurement Instruments Required for Adjustment

1. Low frequency oscillator
This oscillator should have a capacity to output 0dBs to 600 Ω at an oscillation frequency of 50Hz-20kHz.
2. Attenuator impedance : 600 Ω
3. Electronic voltmeter
4. Distortion meter
5. Frequency counter
6. Wow & flutter meter
7. Test tape
VTT703L : Head azimuth
VT712 : Tape speed and running unevenness (3kHz)
VT724 : Reference level (1kHz)
8. Blank tape
TYPE I : AC-225
TYPE II : AC-514
9. Torque gauge : For play and back tension
FWD(TW2111A), REV(TW2121a) and
FF/REW(TW2231A)
10. Test disc: CTS-1000

■ Measurement conditions

- Power supply voltage
: AC230V (50Hz)---B/E/EE/EN
: AC110/127V/230V(50/60Hz)
: UB/UF/US/UX/U
- Reference output : Speaker : 0.775V/4 Ω
: Headphone : 0.077V/32 Ω
- Reference frequency and
input level ----- 1kHz, AUX : -8dBs
MIX MIC: -54dBs (UB/UF/US/UX/U)
Input for confirming recording and playback
characteristics ----- AUX : -28dBs
Measurement output terminal ----- at Speaker J3002
※ Load resistance ----- 4 Ω

● Radio Input signal

- AM frequency ----- 400Hz
AM modulation ----- 30%
FM frequency ----- 400Hz
FM frequency deviation ----- 22.5kHz

● Tuner section

- B/E/EN version
FM Band cover: 87.5~108MHz
MW Band cover: 522~1,629kHz
LW Band cover: 144~288kHz
- EE version
FM Band cover: 65~74MHz, 87.5~108MHz
MW Band cover: 522~1,629kHz
LW Band cover: 144~288kHz
- UB/UF/US/UX/U version
FM Band cover: 87.5~108MHz
MW Band cover: 531~1,602kHz, 530~1,710kHz
SW Band cover: SW1 2.3~6.995MHz
: SW2 7~21.85MHz
- Voltage applied to tuner ----- +B : DC5.7V
VT : DC 12V
- Reference measurement
output ----- 26.1mV(0.28V)/3 Ω
Input positions ----- AM : Standard loop antenna
FM : TP1 (hot) and TP2 (GND)

● Standard measurement position of volume

- Function switch ----- to Tape
Beat cut switch ----- to Cut
Super Bass/Active hyper Bass ----- to OFF
Bass Treble ----- to Center
Adjustment of main volume to reference output
VOL : 28

Precautions for measurement

1. Apply 30pF and 33k Ω to the IF sweeper output side and 0.082 μ F and 100k Ω in series to the sweeper input side.
2. The IF sweeper output level should be made as low as possible within the adjustable range.
3. Since the IF sweeper is a fixed device, there is no need to adjust this sweeper.
4. Since a ceramic oscillator is used, there is no need to perform any MIX adjustment.
5. Since a fixed coil is used, there is no need to adjust the FM tracking.
6. The input and output earth systems are separated. In case of simultaneously measuring the voltage in both of the input and output systems with an electronic voltmeter for two channels, therefore, the earth should be connected particularly carefully.
7. In the case of BTL connection amp., the minus terminal of speaker is not for earthing. Therefore, be sure not to connect any other earth terminal to this terminal. This system is of an BTL system.
8. For connecting a dummy resistor when measuring the output, use the wire with a greater code size.
9. Whenever any mixed tape is used, use the band pass filter (DV-12).

<<Arrangement of Adjusting Position>>

Cassette mechanism section

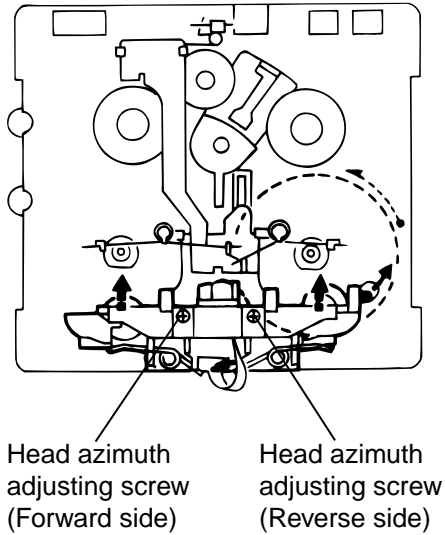

Cassette mechanism section (Back side)

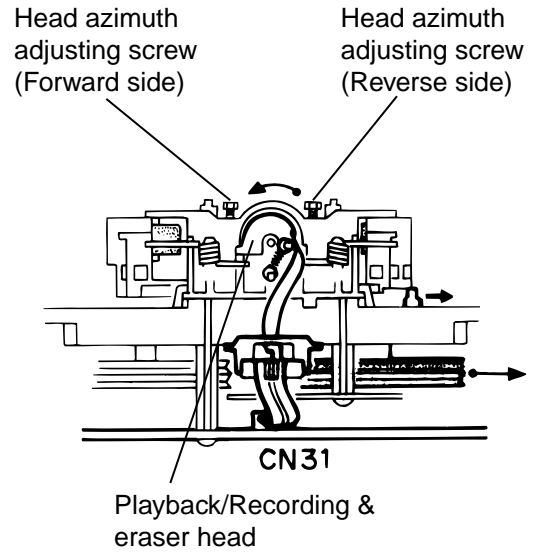

Cassette AMP board

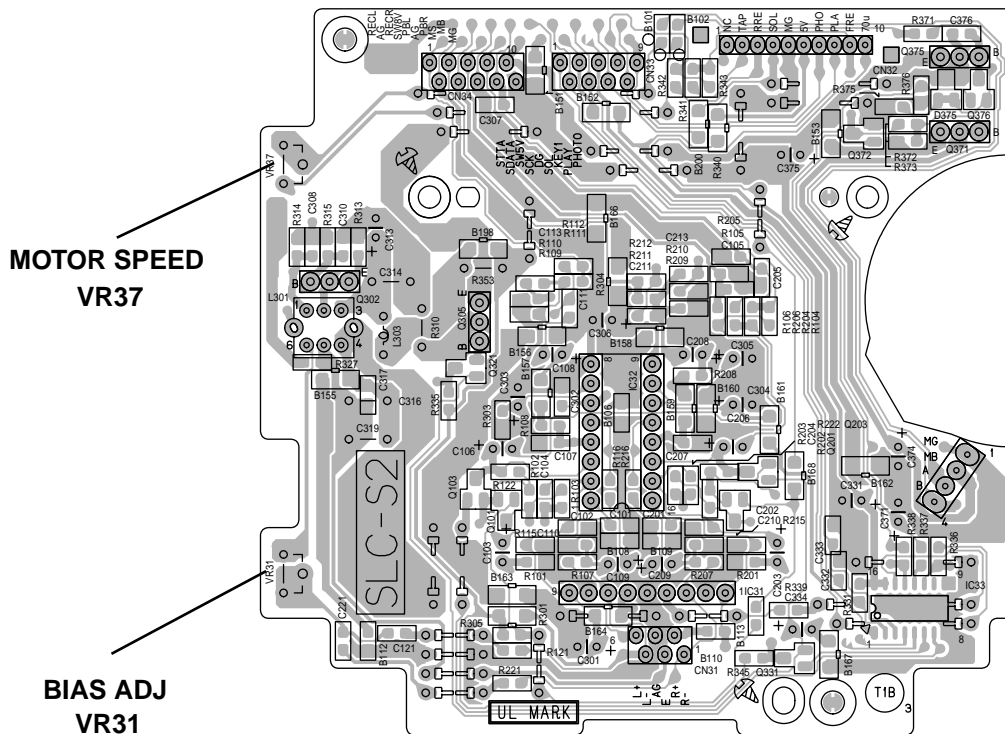

■ Tape Recorder Section

Items	Measurement conditions	Measurement method	Standard Values	Adjusting positions
Confirmation of head angle	Test tape : VTT703L (8kHz) Measurement output terminal : Speaker terminal Speaker R (Load resistance: 4Ω) : Headphone terminal	1 Playback the test tape VTT703L (8kHz) 2 With the recording & playback mechanism, adjust the head azimuth screw so that the forward and reverse output levels become maximum. After adjustment, lock the head azimuth at least by half turn. 3 In either case, this adjustment should be performed in both the forward and reverse directions with the head azimuth screw.	Maximum output	Adjust the head azimuth screw only when the head has been changed.
Confirmation of tape speed	Test tape : VT712 (3kHz) Measurement output terminal : Headphone terminal	Adjust VR37 so that the frequency counter reading becomes 2,940~3,090Hz \pm when playing back the test tape VT712 (3kHz) with playback and recording mechanism after ending forward winding of the tape.	Tape speed of deck : 2,940 ~ 3,090Hz	VR37

■ Reference Values for Confirmation Items

Items	Measurement conditions	Measurement method	Standard Values	Adjusting positions
Difference between the forward and reverse speed	Test tape : VT712 (3kHz) Measurement output terminal : Speaker terminal Speaker R (Load resistance: 4 Ω) Measurement output terminal : Headphone	When the test tape VT712 (3kHz) has been played back with the recording and playback mechanism at the beginning of forward winding, the frequency counter reading of the difference between both of the mechanism should be 6.0Hz or less.	6.0Hz or less	Head azimuth screw
Wow & flutter	Test tape : VT712 (3kHz) Measurement output terminal : Headphone terminal	When the test tape VT712 (3kHz) has been played back with the recording and playback mechanism at the beginning of forward winding, the frequency counter reading of wow & flutter should be 0.25% or less (WRMS).	0.25% or less (WRMS)	

■ Electrical Performance

Items	Measurement conditions	Measurement method	Standard Values	Adjusting positions
Adjustment of recording bias current (Reference Value)	<ul style="list-style-type: none"> ▪ Mode: Forward or reverse mode ▪ Recording mode ▪ Test tape : AC-514 to TYPE II and AC-225 to TYPE I Measurement output terminal : Both recording and headphone terminals	<ol style="list-style-type: none"> 1 With the recording and playback mechanism, load the test tapes (AC-514 to TYPE II and AC-225 to TYPE I), and set the mechanism to the recording and pausing condition in advance. 2 After connecting 100 Ω in series to the recorder head, measure the bias current with a valve voltmeter at both of the terminals. 3 After resetting the [PAUSE] mode, start recording. At this time, adjust VR31 for Lch and VR32 for Rch so that the recording bias current values become 4.0 μ A (TYPE I) and 4.20 μ A (TYPE II). 	AC-225 : 4.20 μ A AC-514 : 4.0 μ A	VR31
Adjustment of recording and playback frequency characteristics	Reference frequency : 1kHz and 10kHz (REF.: -20dB) Test tape : AC-514 to TYPE II Measurement input terminal : OSC IN	<ol style="list-style-type: none"> 1 With the recording and playback mechanism, load the test tapes (AC-514 to TYPE II), and set the mechanism to the recording and pausing condition in advance. 2 While repetitively inputting the reference frequency signal of 1kHz and 10kHz from OSC IN, record and playback the tape. 3 While recording and playback the test tape in TYPE II, adjust VR31 for Lch and VR32 for Rch so that the output deviation between 1kHz and 10kHz becomes -1dB\pm2dB. 	Output deviation between 1kHz and 10kHz : -1dB \pm 2dB	VR31

■ Reference Values for Electrical Function Confirmation Items

Items	Measurement conditions	Measurement method	Standard Values	Adjusting positions
Recording bias frequency	Forward or reverse <ul style="list-style-type: none"> ▪ Test tape : TYPE II (AC-514) ▪ Measurement terminal : BIAS TP on P.C. board 	<ol style="list-style-type: none"> 1 While changing over to and from BIAS 1 and 2, confirm that the frequency is changed. 2 With the recording and playback mechanism, load the test tape (AC-514 to TYPE II), and set the mechanism to the recording and pausing condition in advance. 3 Confirm that the BIAS TP frequency on the P.C. board is 100kHz \pm 6kHz. 	100 kHz \pm 6 kHz	
Eraser current (Reference value)	Forward or reverse <ul style="list-style-type: none"> ▪ Recording mode ▪ Test tape : AC-514 to TYPE II and AC-225 to TYPE I Measurement terminal : Both of the eraser head terminals	<ol style="list-style-type: none"> 1 While recording and playback mechanism, load the test tapes (AC-514 to TYPE II and AC-225 to TYPE I), and set the mechanism to the recording and pausing conditions in advance. 2 After setting to the recording conditions, connect 1W in series to the eraser head on the recording and playback mechanism side, and measure the eraser current from both of the eraser terminals. 	TYPE II : 120 mA TYPE I : 75 mA	

Flow of functional operation until TOC read (CD)

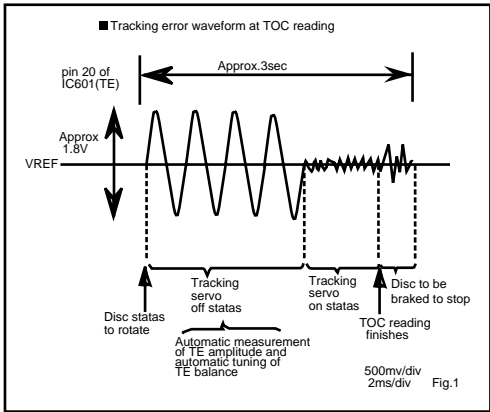
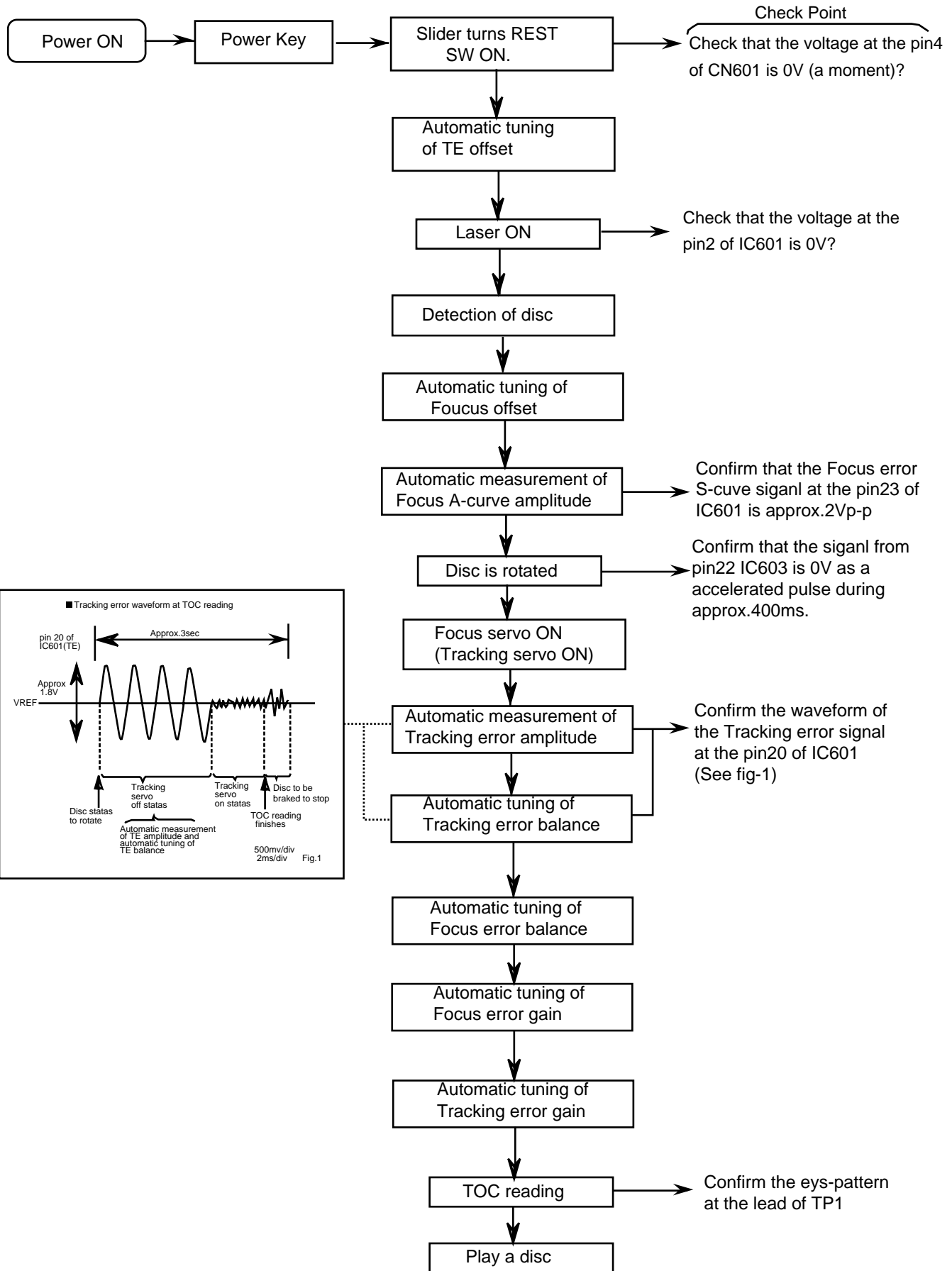

Maintenance of laser pickup

- (1) Cleaning the pick up lens
 Befor you replace the pick up, please try to clean the lens with a alcohol soaked cotton swab.
- (2) Life of the laser diode (Fig.1)
 When the life of the laser diode has expired, the following symptoms wil appear.
 (1) The level of RF output (EFM output:ampli tude of eye pattern) will below.

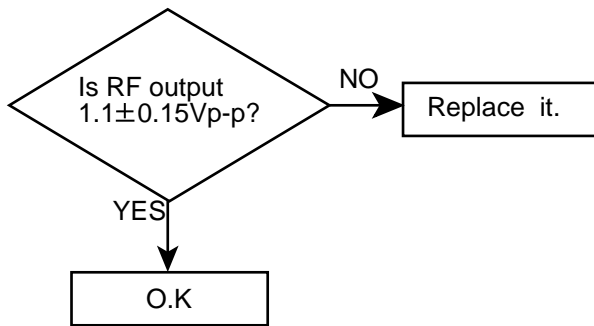

(Fig.1)

- (3) Semi-fixed resistor on the APC PC board
 The semi-fixed resistor on the APC printed circuit board which is attached to the pickup is used to adjust the laser power. Since this adjustment should be performed to match the characteristics of the whole optical block, do not touch the semi-fixed resistor.
 If the laser power is lower than the specified value, the laser diode is almost worn out, and the laser pickup should be replaced.
 If the semi-fixed resistor is adjusted while the pickup is functioning normally, the laser pickup may be damaged due to excessive current.

Replacement of laser pickup

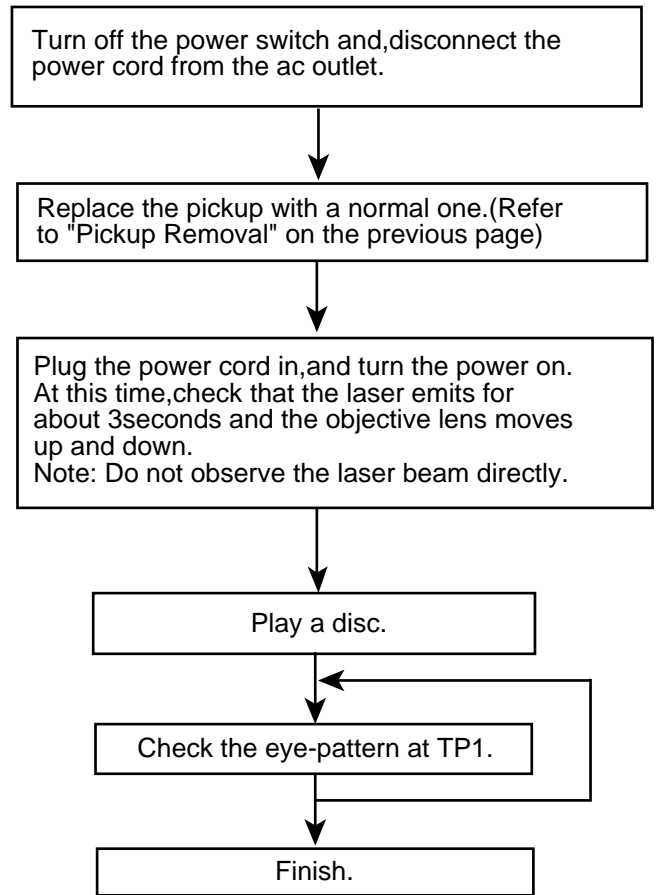

Description of major ICs

■ UPD780058 (IC931) : Main micon

1. Pin layout

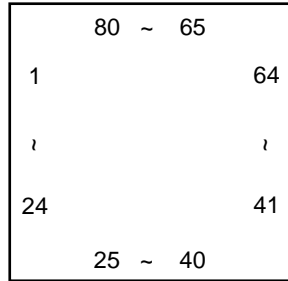

2. Pin function

Pin No.	Port	Name	I/O	Function	Function
1	P15/AN15	SAFETY0	I	Irregular voltage detection 0	Safety
2	P16/AN16	DOOR_RST	I	REST/CLOSE switch detect port	Door
3	P17/AN17	CDSAFETY	I	CD safety voltage detect port	Safety
4	AVss				
5	P130/ANO0	EQSW	O	CD speed control	CD
6	P131/ANO1	GCTRL	O	CD Gain Control	CD
7	AVREF1				
8	P70/SI2/RxD0	QRIN	I	Q-code data input port	CD
9	P71/SO2/TxD0				
10	P72/ $\overline{\text{SCK2}}$ /ASCK	SQCK	O	Q-code serial clock	CD
11	P20/SI1	STAT	I	CD status input port	CD
12	P21/SO1	MDATA	O	CD data input port	CD
13	P22/ $\overline{\text{SCK1}}$	MCLK	O	CD data clock	CD
14	P23/STB/TxD1	_XRST	O	CD reset	CD
15	P24/BUSY/RxD1	MLD	O	CD command ready signal	CD
16	P25/SI0/SB0	MUTE	O	BTL mute control port	CD
17	P26/SO0/SB1	SDATA	O	Serial Date (Tuner PLL/Tape IC)	Tuner/Tape
18	P27/ $\overline{\text{SCK0}}$	SCK	O	Serial Clock (Tuner PLL/Tape IC)	Tuner/Tape
19	P40/AD0				
20	P41/AD1	CLOSE	I	Door close switch input port	Door
21	P42/AD2	OPEN	I	Door poen switch input port	Door
22	P43/AD3	F_CD	O	CD Function ("H"=CD)	CD
23	P44/AD4				
24	P45/AD5	_AHB1	O	Subwoofer Amp AHB control	Sound (P7only)
25	P46/AD6	VOLCE	O	Volumn Chip Enable	Sound
26	P47/AD7				
27	P50/A8	_F_AUX			AUX
28	P51/A9	_PBMUTE	O	Tape play mute ("L"=mute)	Tape
29	P52/A10	_SMUTE	O	System mute	Sound
30	P53/A11	SPKMUTE	O	Speaker mute	Sound
31	P54/A12	_AHB	O	Active Hyper Bass On/off ("L"=ON)	Sound
32	P55/A13	P_OUT	O	Power On/off ("H"=Power On)	AMP
33	Vss1				
34	P56/A14	PROTR	O	Protector	Safety
35	P57/A15	MODEL1	I	MODEL 0: P3/P5; 1: P7	
36	P60	MODEL2	I	MODEL2 0: P3; 1: P5	
37	P61				
38	P62				

Pin No.	Port	Name	I/O	Function	Function
39	P63				
40	P64/RD	LEDRV	O	Lite LED indicate Reverse	LED
41	P65/WR	LED_REC	O	Lite LED indicate REC	LED
42	P66/WAIT	LEDFR	O	Lite LED indicate Forward	LED
43	P67/ASTB	STTA	O	Tape IC Strobe	Tape
44	P30/TO0	LCDAT	O	LCD data	LCD
45	P31/TO1	LMODE	O	LCD date mode control	LCD
46	P32/TO2	LCDCK	O	LCD clock	LCD
47	P33/TI1				
48	P34/TI2	REEL	I	Tape End Detection	Tape
49	P35/PCL	INH_	O	LCD Driver inhibit ("L" at end of tran)	LCD
50	P36/BUZ	LCDCE	O	LCD driver chip enable	LCD
51	P37	DIMCTL	O	LCD DIM Control	LED
52	P120/RTP0	VOLP	I	Volumn Plus	Sound
53	P121/RTP1	LEDCTL	O	Power Standby LED control	LED
54	P122/RTP2	BASM	I	Bass Minus	Sound (P7 only)
55	P123/RTP3	VOLM	I	Volumn Minus	Sound
56	P124/RTP4	BASP	I	Bass plus	Sound (P7 only)
57	P125/RTP5	PERIOD	O	Tuner PLL Strode	Tuner
58	P126/RTP6	F_TU	O	Tuner Function ("H"=TUNER)	Tuner
59	P127/RTP7	BUZ	O	Back up power detect ("H"=BACKUP)	Backup
60	RESET				
61	P00/INTP0/TI00	_REM	I	Remote control input	Remote con
62	P01/INTP1/TI01	RDCK	I	RDS clock	Tuner
63	P02/INTP2	_MPX	I	FM Stereo Detection ("L"=STEREO)	Tuner
64	P03/INTP3				
65	P04/INTP4	BCTL	O	Switched 5V controller ("H"=5Vüf off)	AMP
66	P05/INTP5	BLKCK	I	Block clock input port	CD
67	Vss0				
68	VDD1				
69	X2				
70	X1				
71	IC (VPP)				
72	XT2				
73	XT1/P07				
74	VDD0				
75	AVREF0				
76	P10/ANI0	SAFETY1	I	Irregular voltage detection 1	Safety
77	P11/ANI1	TAPE0	I	Tape Switch 0	Tape
78	P12/ANI2	TAPE1	I	Tape Switch 1	Tape
79	P13/ANI3	KEY1	I	Unit Key input 1	Key
80	P14/ANI4	KEY2	I	Unit Key input 0	Key

■ LA6541 (IC801) : Focus & Spindle & Feed & Tracking BTL driver

1. Pin Layout & block diagram

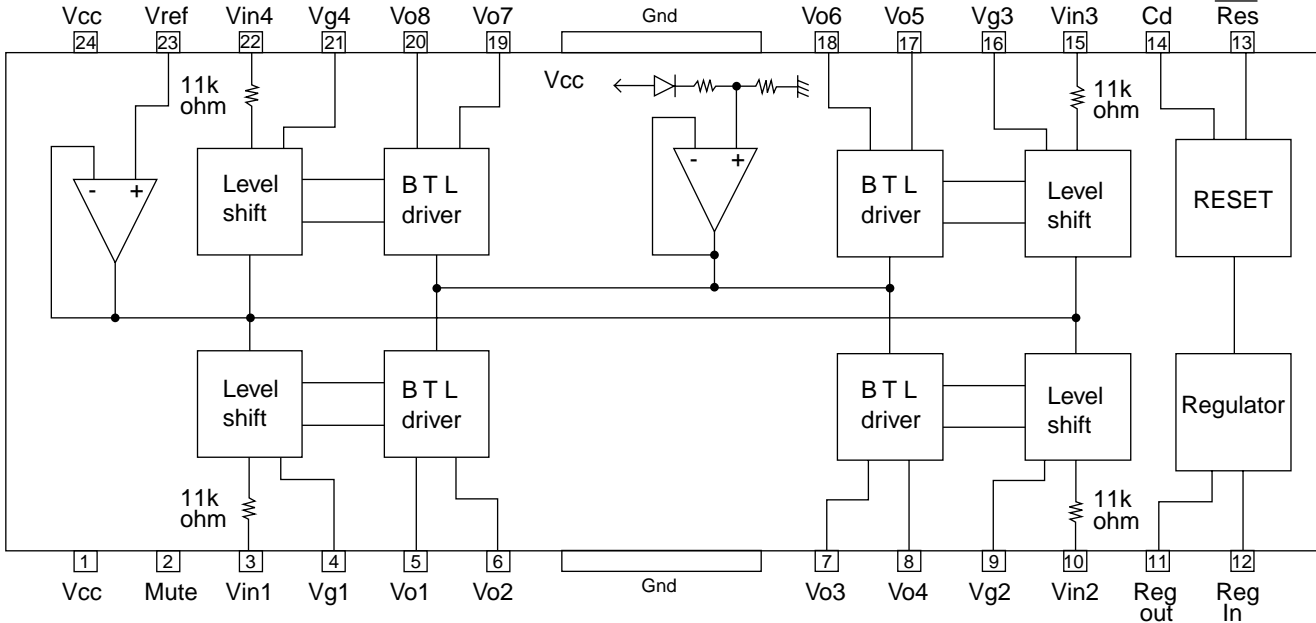

2. Pin function

Pin No.	Symbol	Function
1	Vcc	Power supply (Shorted to pin 24)
2	Mute	All BTL amplifier outputs ON/OFF
3	Vin1	BTL AMP 1 input pin
4	Vg1	BTL AMP 1 input pin (For gain adjustment)
5	Vo1	BTL AMP 1 input pin (Non inverting side)
6	Vo2	BTL AMP 1 input pin (Inverting side)
7	Vo3	BTL AMP 2 input pin (Inverting side)
8	Vo4	BTL AMP 2 input pin (Non inverting side)
9	Vg2	BTL AMP 2 input pin (For gain adjustment)
10	Vin2	BTL AMP 2 input pin
11	Reg Out	External transistor collector (PNP) connection. 5V power supply output
12	Reg In	External transistor (PNP) base connection
13	Res	Reset output
14	Cd	Reset output delay time setting (Capacitor connected externally)
15	Vin3	BTL AMP 3 input pin
16	Vg3	BTL AMP 3 input pin (For gain adjustment)
17	Vo5	BTL AMP 3 output pin (Non inverting side)
18	Vo6	BTL AMP 3 output pin (Inverting side)
19	Vo7	BTL AMP 4 output pin (Inverting side)
20	Vo8	BTL AMP 4 output pin (Non inverting side)
21	Vg4	BTL AMP 4 output pin (For gain adjustment)
22	Vin4	BTL AMP 4 output pin
23	Vref	Level shift circuit's reference voltage application
24	Vcc	Power supply (Shorted to pin 1)

■ MN662748RPM (IC651) : Digital servo & digital signal processor

1. Pin layout

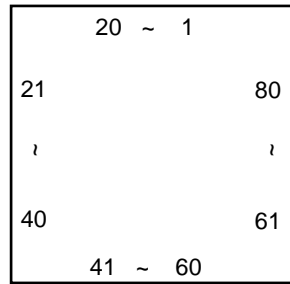

2. Block diagram

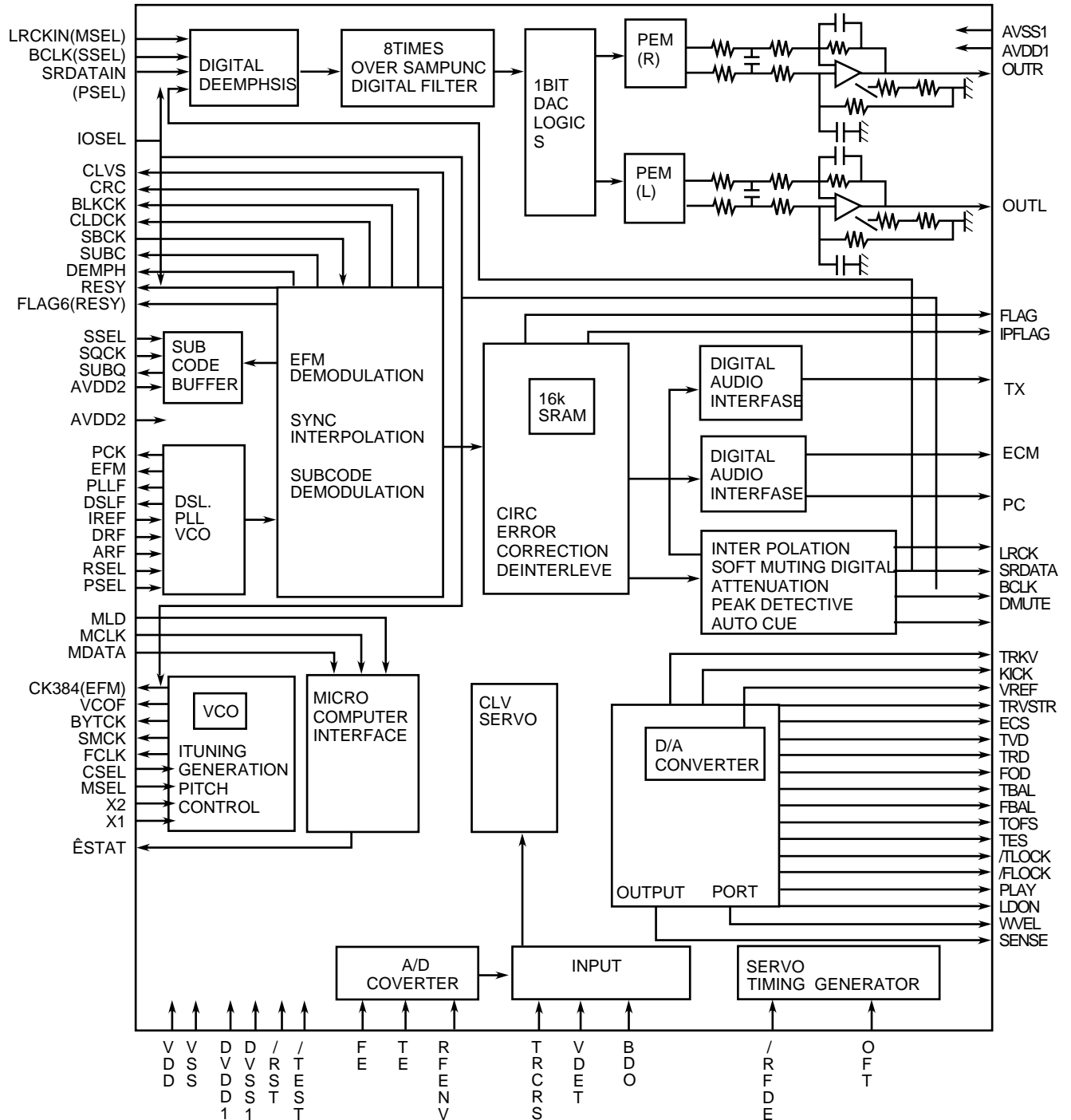

3. Pin function

Pin No.	Symbol	I/O	Function	Pin No.	Symbol	I/O	Function
1	BCLK	O	Not used	41	TES	O	Tracking error shunt signal output (H:shunt)
2	LRCK	O	Not used	42	PLAY	—	Not used
3	SRDATA	O	Not used	43	WVEL	—	Not used
4	DVDD1	—	Power supply (Digital)	44	ARF	I	RF signal input
5	DVSS1	—	Connected to GND	45	IREF	I	Reference current input pin
6	TX	O	Digital audio interface output	46	DRF	I	Bias pin for DSL
7	MCLK	I	CPU command clock signal input (Data is latched at signal's rising point)	47	DSL F	I/O	Loop filter pin for DSL
8	M DATA	I	CPU command data input	48	PLL F	I/O	Loop filter pin for PLL
9	MLD	I	CPU command load signal input	49	VCOF	—	Not used
10	SENSE	O	Sense signal output	50	AVDD2	—	Power supply (Analog)
11	FLOCK	O	Focus lock signal output Active :Low	51	AVSS2	—	Connected to GND (Analog)
12	TLOCK	O	Tracking lock signal output Active :Low	52	EFM	—	Not used
13	BLKCK	O	sub-code/block/clock signal output	53	PCK	—	Not used
14	SQCK	I	Outside clock for sub-code Q resister input	54	PDO	—	Not used
15	SUBQ	O	Sub-code Q -code output	55	SUBC	—	Not used
16	DMUTE	—	Connected to GND	56	SBCK	—	Not used
17	STATUS	O	Status signal (CRC,CUE,CLVS,TTSTOP,ECLV,SQOK)	57	VSS	—	Connected to GND (for X'tal oscillation circuit)
18	RST	I	Reset signal input (L:Reset)	58	XI	I	Input of 16.9344MHz X'tal oscillation circuit
19	SMCK	—	Not used	59	X2	O	Output of X'tal oscillation circuit
20	PMCK	—	Not used	60	VDD	—	Power supply (for X'tal oscillation circuit)
21	TRV	O	Traverse enforced output	61	BYTCK	—	Not used
22	TVD	O	Traverse drive output	62	CLDCK	—	Not used
23	PC	—	Not used	63	FLAG	—	Not used
24	ECM	O	Spindle motor drive signal (Enforced mode output) 3-State	64	IPPLAG	—	Not used
25	ECS	O	Spindle motor drive signal (Servo error signal output)	65	FLAG	—	Not used
26	KICK	O	Kick pulse output	66	CLVS	—	Not used
27	TRD	O	Tracking drive output	67	CRC	—	Not used
28	FOD	O	Focus drive output	68	DEMPH	—	Not used
29	VREF	I	Reference voltage input pin for D/A output block (TVD,FOD,FBA,TBAL)	69	RESY	—	Not used
30	FBAL	O	Focus Balance adjust signal output	70	IOSEL	—	pull up
31	TBAL	O	Tracking Balance adjust signal output	71	TEST	—	pull up
32	FE	I	Focus error signal input (Analog input)	72	AVDD1	—	Power supply (Digital)
33	TE	I	Tracking error signal input (Analog input)	73	OUT L	O	Lch audio output
34	RF ENV	I	RF envelope signal input (Analog input)	74	AVSS1	—	Connected to GND
35	VDET	I	Vibration detect signal input (H:detect)	75	OUT R	O	Rch audio output
36	OFT	I	Off track signal input (H:off track)	76	RSEL	—	pull up
37	TRCRS	I	Track cross signal input	77	CSEL	—	Connected to GND
38	RFDET	I	RF detect signal input (L:detect)	78	PSEL	—	Connected to GND
39	BDO	I	BDO input pin (L:detect)	79	MSEL	—	Connected to GND
40	LDON	O	Laser ON signal output (H:on)	80	SSEL	—	Pull up

■ BA15218F-XE (IC904) : Dual operation amplifier

1. Pin layout

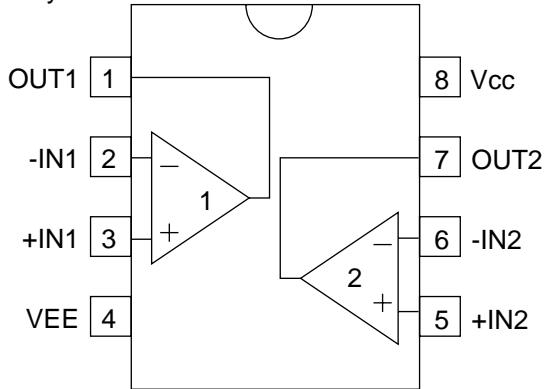

2. Block diagram

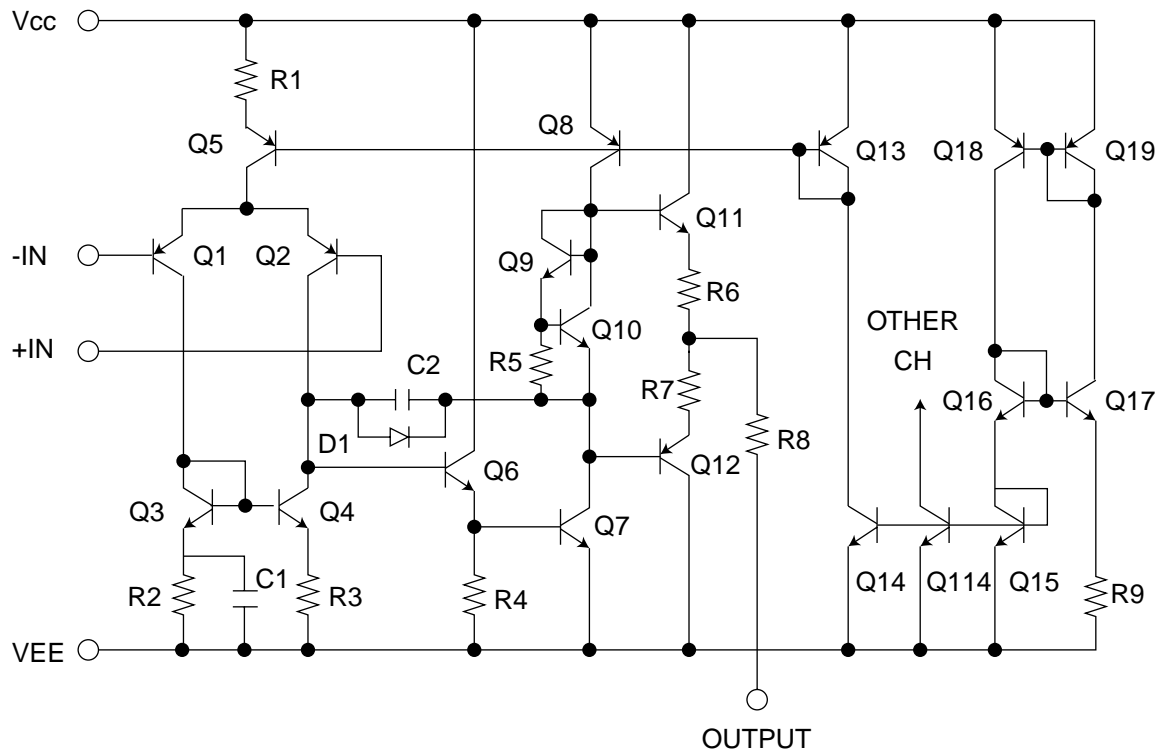

■ KIA78S06P-T (IC933) : Regulator

1. Pin layout

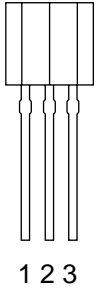

2. Block diagram

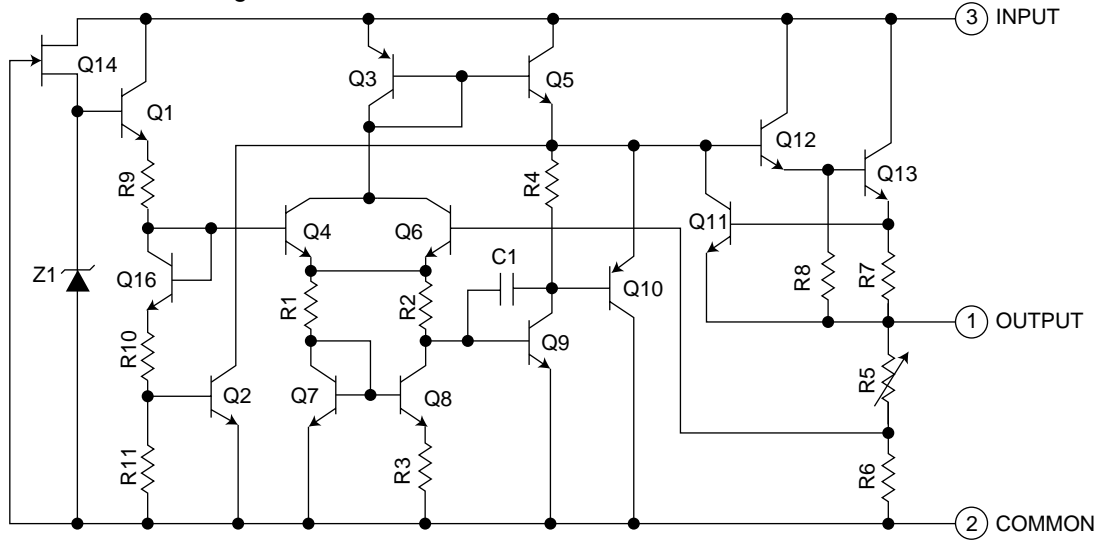

■ LA4628 (IC905) : Power amp

1. Pin layout

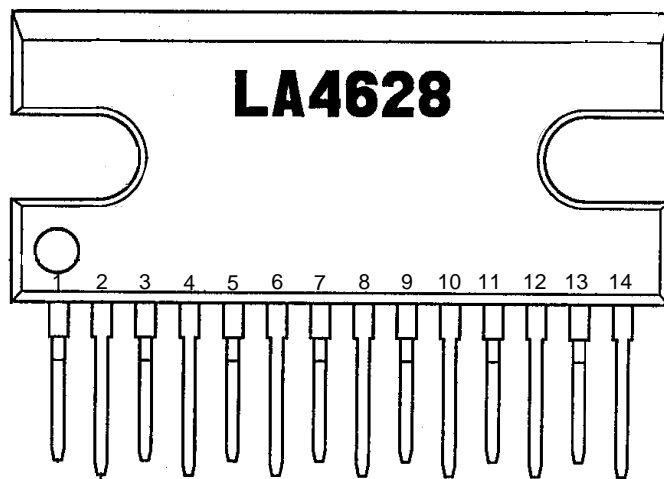

2. Block diagram

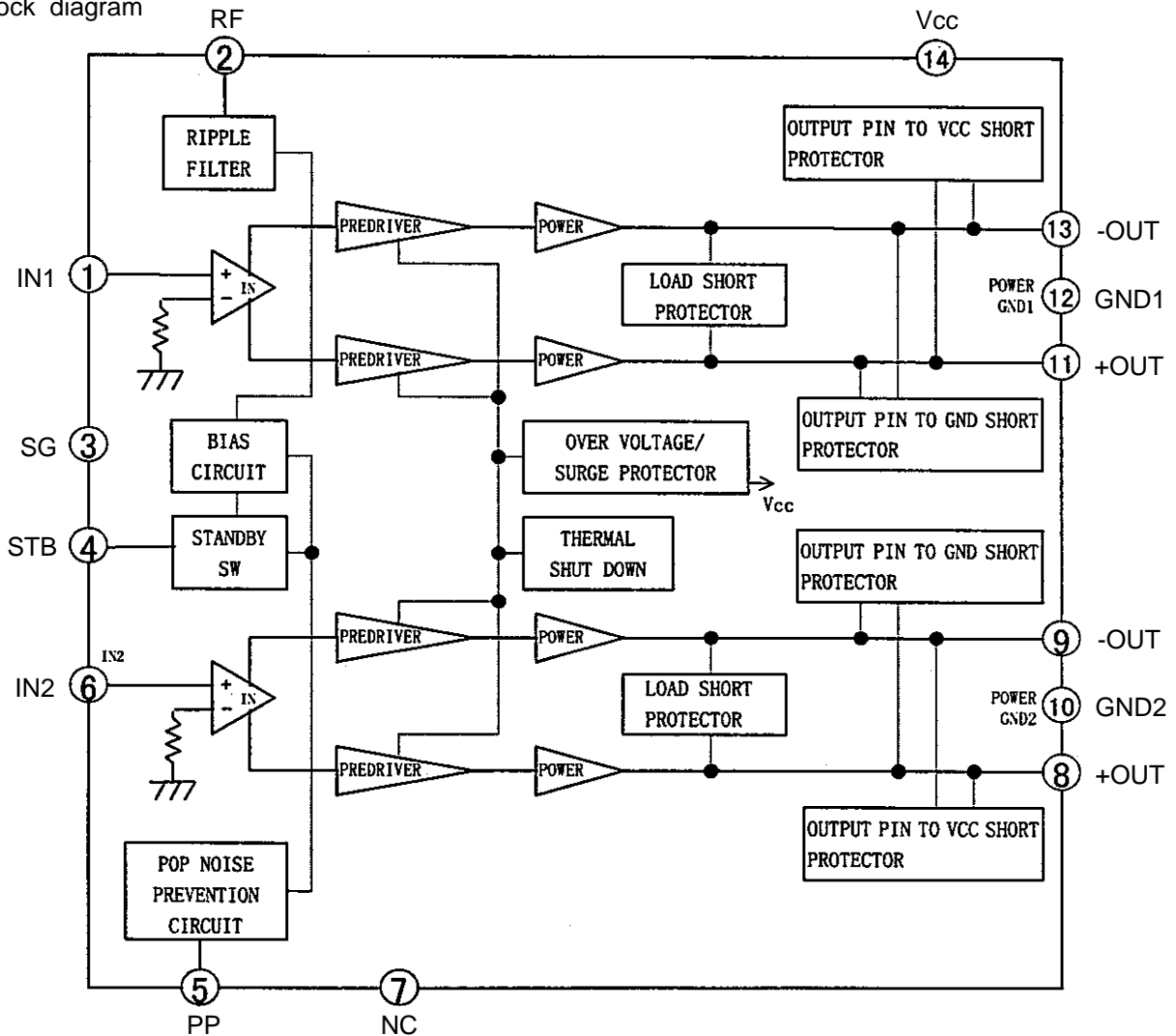

AN22000A(IC601):RF & SERVO AMP

1. Pin layout

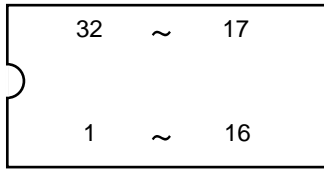

2. Block

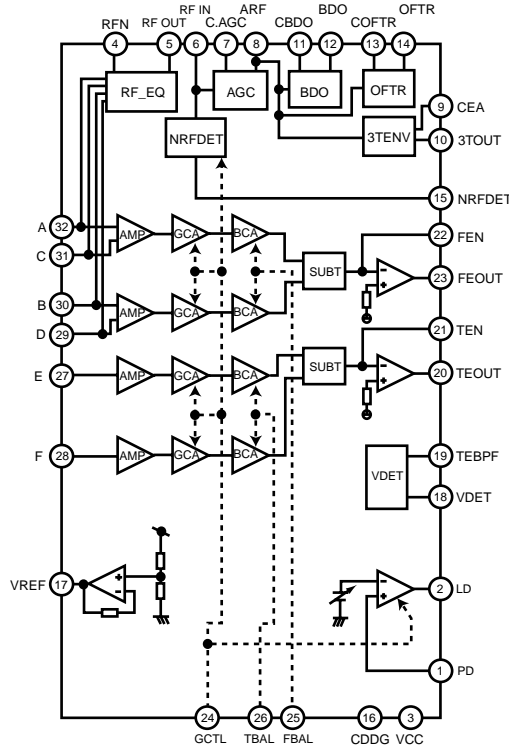

3. Function

Pin No.	Symbol	Function	Pin No.	Symbol	Function
1	PD	APC Amp. Input terminal	16	CDDG	Earth terminal
2	LD	APC Amp. Output terminal	17	VREF	VREF output terminal
3	VCC	Power supply terminal	18	VDET	VDET output terminal
4	RFN	RF addition Amp. Reversing input terminal	19	TEBPF	VDET input terminal
5	RF OUT	RF addition Amp. Output terminal	20	TEOUT	TE Amp. output terminal
6	RF IN	AGC input terminal	21	TEN	TE Amp. reversing input terminal
7	C.AGC	Terminal of connection of capacity of AGC loop filter.	22	FEN	FE Amp. reversing input terminal
8	ARF	AGC output terminal	23	FEOUT	FE Amp. output terminal
9	CEA	Capacity connection terminal for HPF-Amp.	24	GCTL	Terminal GCTL & APC
10	3TOUT	3TENV output terminal	25	FBAL	FBAL control terminal
11	CBDO	Capacity connection terminal for RF shade side envelope detection	26	TBAL	TBAL control terminal
12	BDO	BDO output terminal	27	E	Tracking signal input terminal 1
13	COFTR	Capacity connection terminal for RF discernment side envelope detection	28	F	Tracking signal input terminal 2
14	OFTR	OFTR output terminal	29	D	Focus signal input terminal 4
15	NRFDET	NRFDET output terminal	30	B	Focus signal input terminal 2
			31	C	Focus signal input terminal 3
			32	A	Focus signal input terminal 1

■ LA1838 (IC1): FM AM IF AMP&detector, FM MPX decoder

1. Block Diagram

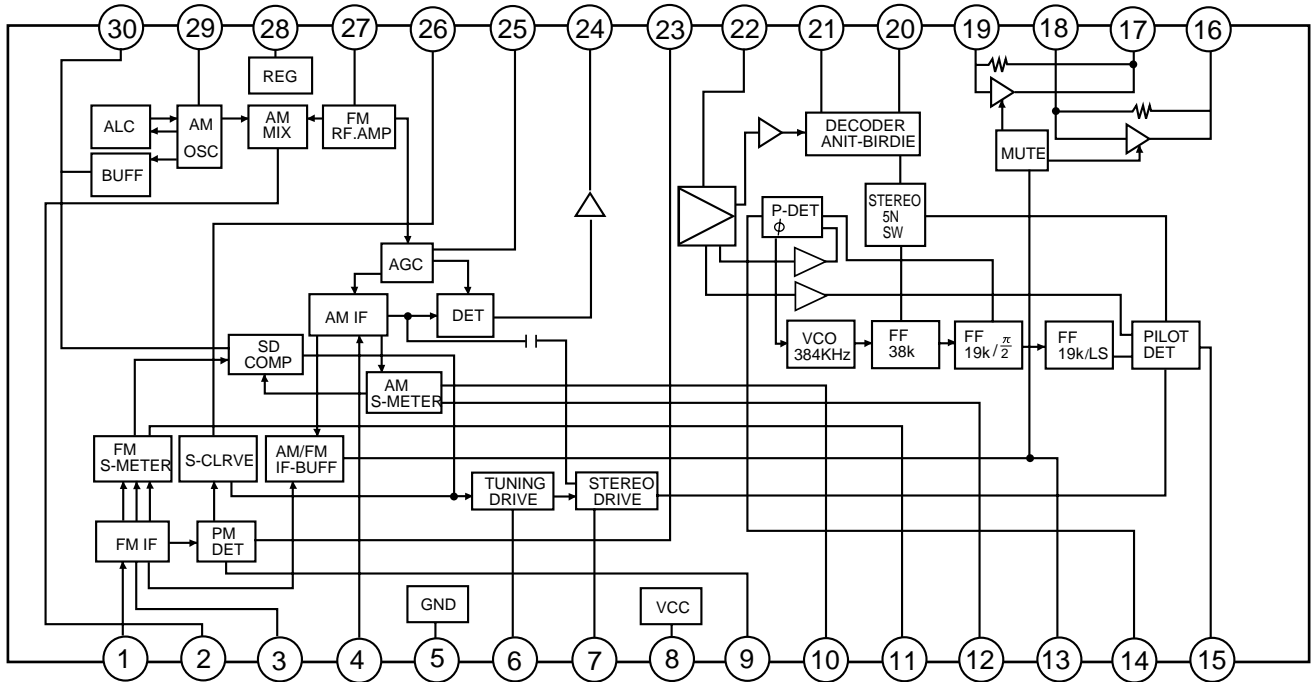

2. Pin Function

Pin No.	Symbol	I/O	Function	Pin No.	Symbol	I/O	Function
1	FM IN	I	This is an input terminal of FM IF signal.	16	L OUT	O	Left channel signal output.
2	AM MIX	O	This is an out put terminal for AM mixer.	17	R OUT	O	Right channel signal output.
3	FM IF	I	Bypass of FM IF	18	L IN	I	Input terminal of the left channel post AMP.
4	AM IF	I	Input of AM IF Signal.	19	R IN	I	Input terminal of the right channel post AMP.
5	GND	-	This is the device ground terminal.	20	RO	O	Mpx Right channel signal output.
6	TUNED	O	When the set is tuning, this terminal becomes "L".	21	LO	O	Mpx Left channel signal output.
7	STEREO	O	Stereo indicator output. Stereo "L", Mono: "H"	22	IF IN	I	Mpx input terminal
8	VCC	-	This is the power supply terminal.	23	FM OUT	O	FM detection output.
9	FM DET	-	FM detect transformer.	24	AM DET	O	AM detection output.
10	AM SD	-	This is a terminal of AM ceramic filter.	25	AM AGC	I	This is an AGC voltage input terminal for AM
11	FM VSM	O	Adjust FM SD sensitivity.	26	AFC	-	This is an output terminal of voltage for FM-AFC.
12	AM VSM	O	Adjust AM SD sensitivity.	27	AM RF	I	AM RF signal input.
13	MUTE	I/O	When the signal of IF REQ of IC121(LC72131) appear, the signal of FM/AM IF output. //Muting control input.	28	REG	O	Register value between pin 26 and pin28 desides the frequency width of the input signal.
14	FM/AM	I	Change over the FM/AM input. "H" :FM, "L" : AM	29	AM OSC	-	This is a terminal of AM Local oscillation circuit.
15	MONO/ST	O	Stereo : "H", Mono: "L"	30	OSC BUFFER	O	AM Local oscillation Signal output.

■ LC72136N (IC2) : PLL frequency synthesizer

1. Pin layout

XT	1	22	XT
FM/AM	2	21	GND
CE	3	20	LPFOUT
DI	4	19	LPFIN
CLOCK	5	18	PD
DO	6	17	VCC
FM/ST/VCO	7	16	FMIN
AM/FM	8	15	AMIN
	9	14	
	10	13	IFCONT
SDIN	11	12	IFIN

2. Block diagram

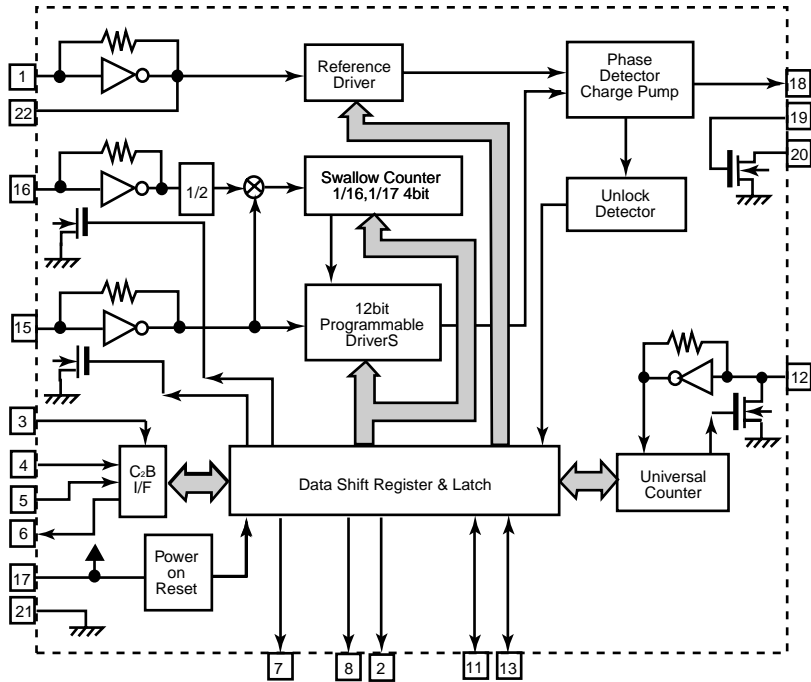

3. Pin function

Pin No.	Symbol	I/O	Function	Pin No.	Symbol	I/O	Function
1	XT	I	X'tal oscillator connect (75kHz)	12	IFIN	I	IF counter signal input
2	FM/AM	O	LOW:FM mode	13	IFCONT	O	IF signal output
3	CE	I	When data output/input for 4pin(input) and 6pin(output): H	14		-	Not use
4	DI	I	Input for receive the serial data from controller	15	AMIN	I	AM Local OSC signal output
5	CLOCK	I	Sync signal input use	16	FMIN	I	FM Local OSC signal input
6	DO	O	Data output for Controller Output port	17	VCC	-	Power supply(VDD=4.5-5.5V) When power ON:Reset circuit move
7	FM/ST/VCO	O	"Low": MW mode	18	PD	O	PLL charge pump output(H: Local OSC frequency Height than Reference frequency. L: Low Agreement: Height impedance)
8	AM/FM	O	Open state after the power on reset	19	LPFIN	I	Input for active lowpassfilter of PLL
9	LW	I/O	Input/output port	20	LPFOUT	O	Output for active lowpassfilter of PLL
10	MW	I/O	Input/output port	21	GND	-	Connected to GND
11	SDIN	I/O	Data input/output	22	XT	I	X'tal oscillator(75KHz)

■ LC72723(IC3):RDS

1. Pin Assignment

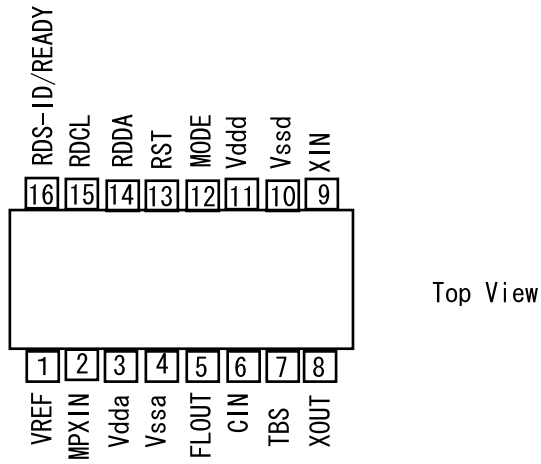

2. Block diagram

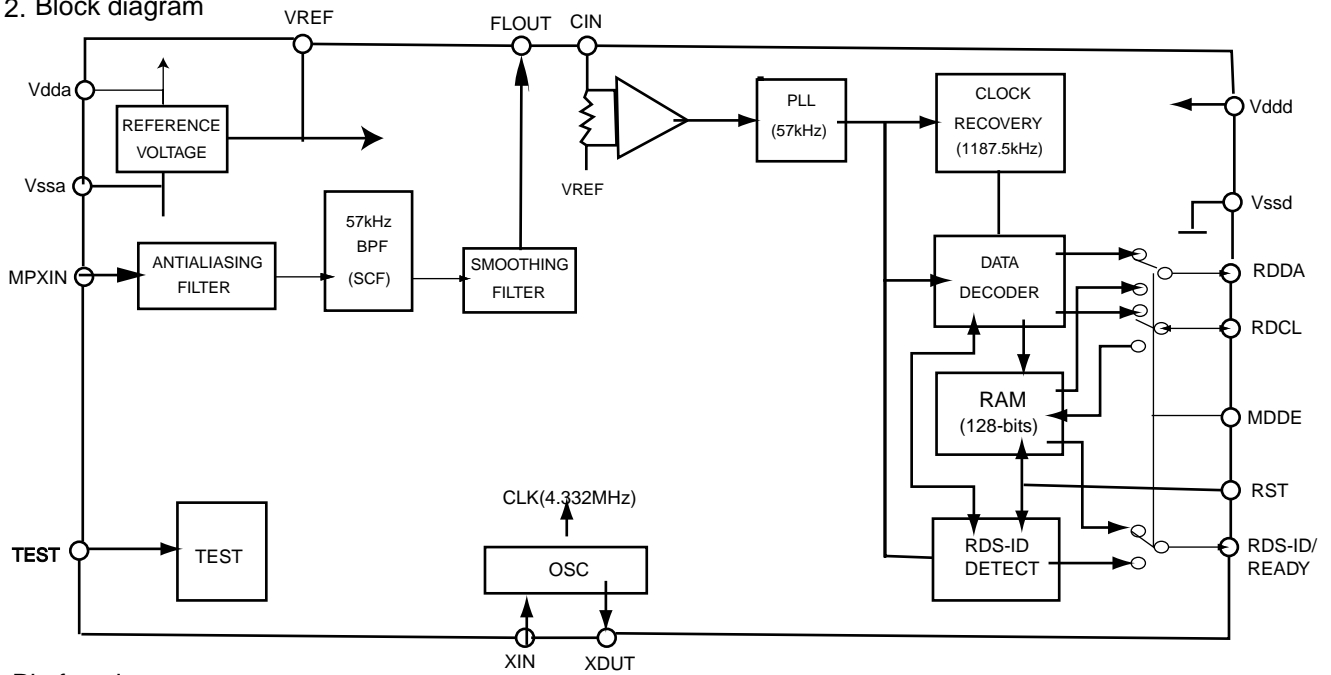

3. Pin functions

Pin No.	Symbol	I/O	Function
1	VREF	O	Reference voltage output (Vdda/2)
2	MPXIN	I	Baseband (multiplexed) signal input
3	Vdda	—	Analog power supply (+5V)
4	Vssa	—	Analog ground
5	FLOUT	O	Subcarrier input (filter output)
6	CIN	I	Subcarrier input (comparator input)
7	TEST	I	Test input
8	XOUT	O	Crystal oscillator output (4.332MHz)
9	XIN	I	Crystal oscillator input (external reference input)
10	Vssd	—	Digital ground
11	Vddd	—	Digital power supply
12	MODE	I	Read mode setting (0:master,1:slave)
13	RST	I	RDS-ID/RAM reset (positive polarity)
14	RDDA	O	RDS data output
15	RDCL	I/O	RDS clock output (master mode)/RDS clock input (slave mode)
16	RDS-ID READY	O	RDS-ID/READY output (negative polarity)

■ **LB1641 (IC802) : DC Motor driver**

1. Pin layout

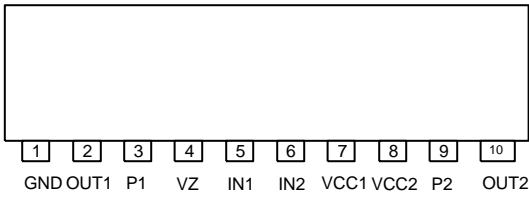

2. Pin function

Input		Output		Mode
IN1	IN2	OUT1	OUT2	
0	0	0	0	Brake
1	0	1	0	CLOCKWISE
0	1	0	1	COUNTER-CLOCKWISE
1	1	0	0	Brake

■ **BU4094BC(IC33):Serial to parallel port extension**

1.Pin layout

STROBE	1	16	Vdd
DATA	2	15	OUTPUT ENABLE
CLOCK	3	14	Q5
Q1	4	13	Q6
Q2	5	12	Q7
Q3	6	11	Q8
Q4	7	10	Q's
Vss	8	9	Qs

2.Block diagram

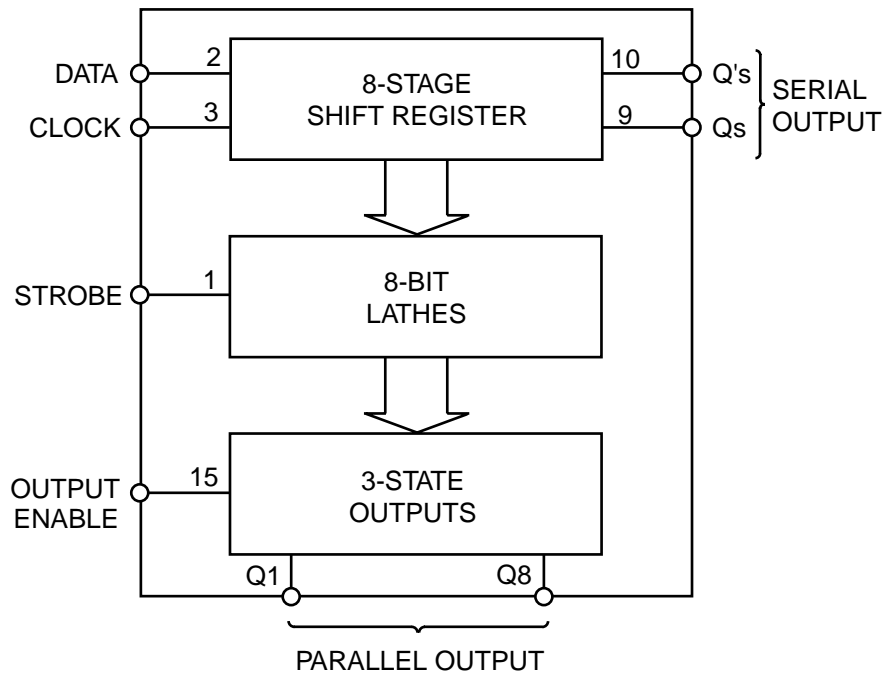

■ BA3126N(IC31) : R/P Switch

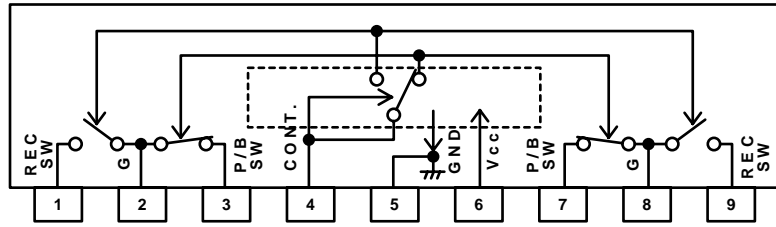

■ GP1U26X (IC933)

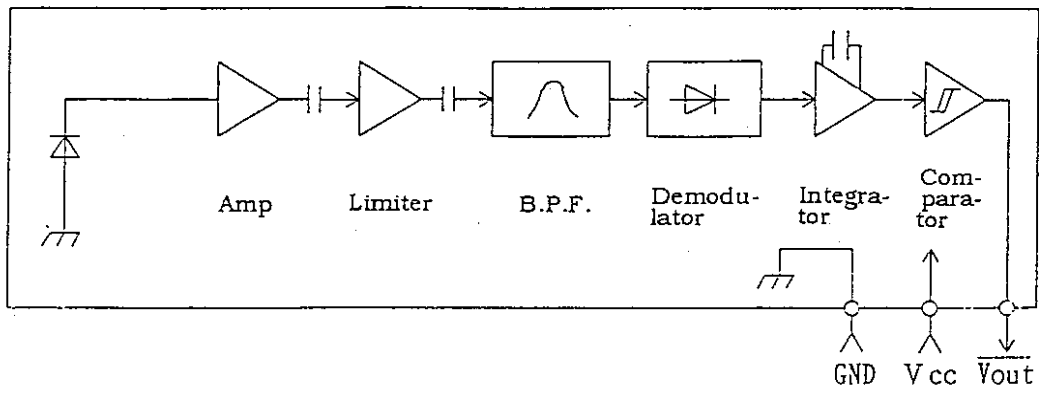

■ NJU6433FG1 (IC934)

1. Pin layout

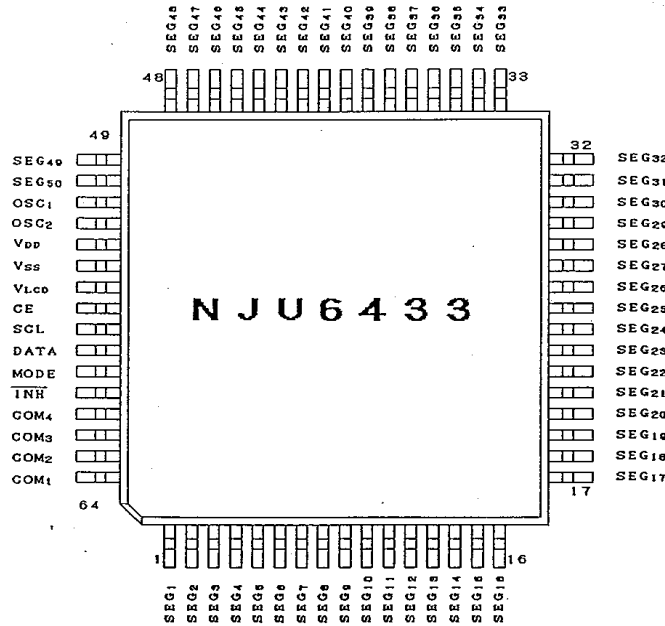

2. Block diagram

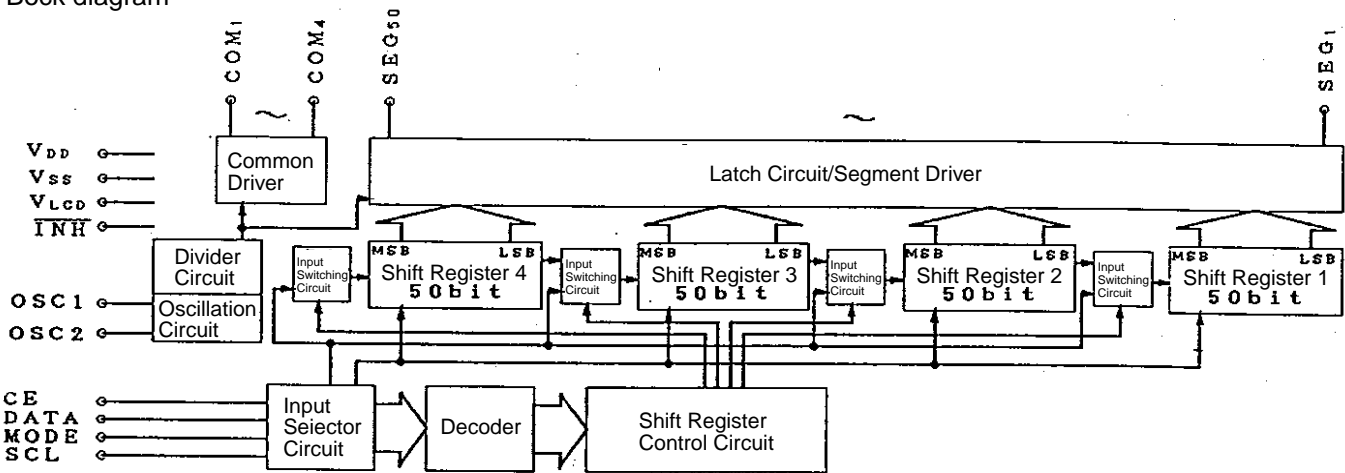

3. Pin function

Pin No.	Symbol	Pin No.	Symbol	Pin No.	Symbol	Pin No.	Symbol
1	SEG ₁	17	SEG ₁₇	33	SEG ₃₃	49	SEG ₄₉
2	SEG ₂	18	SEG ₁₈	34	SEG ₃₄	50	SEG ₅₀
3	SEG ₃	19	SEG ₁₉	35	SEG ₃₅	51	OSC ₁
4	SEG ₄	20	SEG ₂₀	36	SEG ₃₆	52	OSC ₂
5	SEG ₅	21	SEG ₂₁	37	SEG ₃₇	53	V _{DD}
6	SEG ₆	22	SEG ₂₂	38	SEG ₃₈	54	V _{SS}
7	SEG ₇	23	SEG ₂₃	39	SEG ₃₉	55	V _{LCD}
8	SEG ₈	24	SEG ₂₄	40	SEG ₄₀	56	CE
9	SEG ₉	25	SEG ₂₅	41	SEG ₄₁	57	SCL
10	SEG ₁₀	26	SEG ₂₆	42	SEG ₄₂	58	DATA
11	SEG ₁₁	27	SEG ₂₇	43	SEG ₄₃	59	MODE
12	SEG ₁₂	28	SEG ₂₈	44	SEG ₄₄	60	INH
13	SEG ₁₃	29	SEG ₂₉	45	SEG ₄₅	61	COM ₄
14	SEG ₁₄	30	SEG ₃₀	46	SEG ₄₆	62	COM ₃
15	SEG ₁₅	31	SEG ₃₁	47	SEG ₄₇	63	COM ₂
16	SEG ₁₆	32	SEG ₃₂	48	SEG ₄₈	64	COM ₁

■ LC75345M (IC901)

1. Pin layout

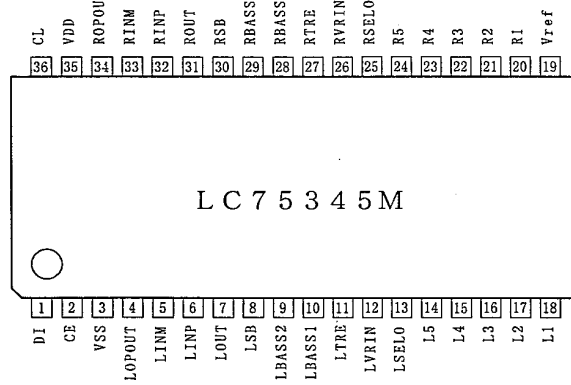

2. Block Diagram

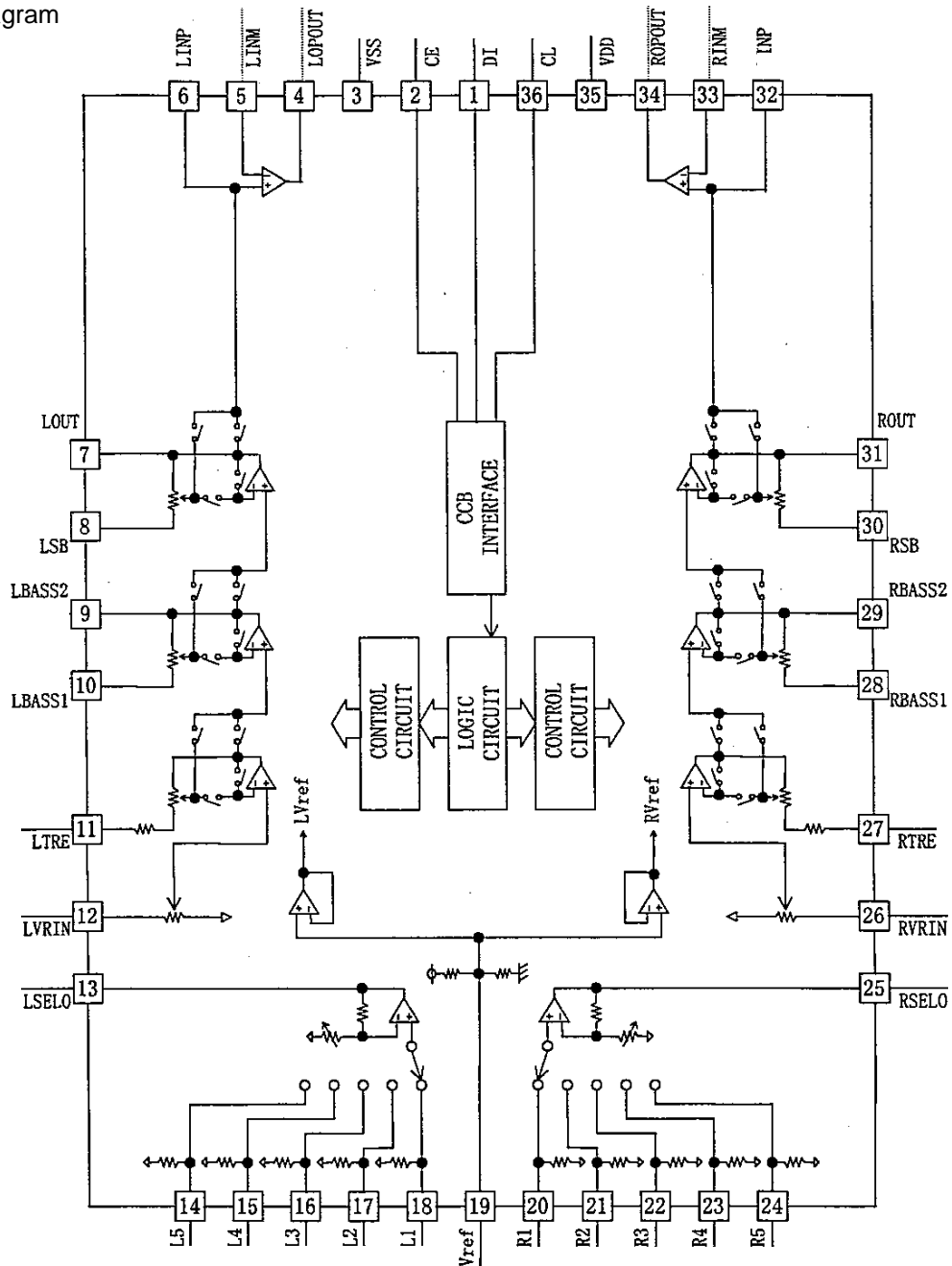

3. Descriptions

Pin name	Pin No.	Descriptions
L1 L2 L3 L4 L5 R1 R2 R3 R4 R5	18 17 16 15 14 20 21 22 23 24	Input signal pin
LSEL0 RSEL0	13 25	Input selector output pin.
LBASS1 LBASS2 RBASS1 RBASS2 LSB RSB	10 9 28 29 8 30	Capacitor and resistor connection pins comprising filters for bass and super-bass band.
LOUT ROUT	7 31	ATT + equalizer output pin/capacitor connection pin comprising filter for super-bass
LVRIN RVRIN	12 26	Volume input pin
LTRE RTRE	11 27	Capacitor connection pin comprising treble band filter.

Pin name	Pin No.	Descriptions
Vref	19	0.5 × VDD voltage generation block for analog ground. Capacitor of several 10 μF to be connected between Vref and AWSS (VSS) as a counter-measure against power ripple.
VSS	3	Ground pin
VDD	35	Supply pin
CE	2	Chip enable pin. Data written into an internal latch in a timing of [H] → [L]. Each analog switch is activated. Data transfer enabled at [H] level.
DI CL	1 36	Serial data and clock input pin for control.
LINP RINP	6 32	Non-inverted input pin of general-purpose operation amplifier. Keep this pin open when not used.
LINM RINM	5 33	Non-inverted input pin of general-purpose operation amplifier. Connect to L (R) OPOUT pin when not used. (Connect between pins 5 and 4) (Connect between pins 33 and 34)
LOPOUT ROPOUT	4 34	Output pin of general-purpose operation amplifier. Connect to L (R) INN pin when not used. (Connect between pins 5 and 4) (Connect between pins 33 and 34)

■ AN7317 (IC32) : PB/REC amp

Block Diagram

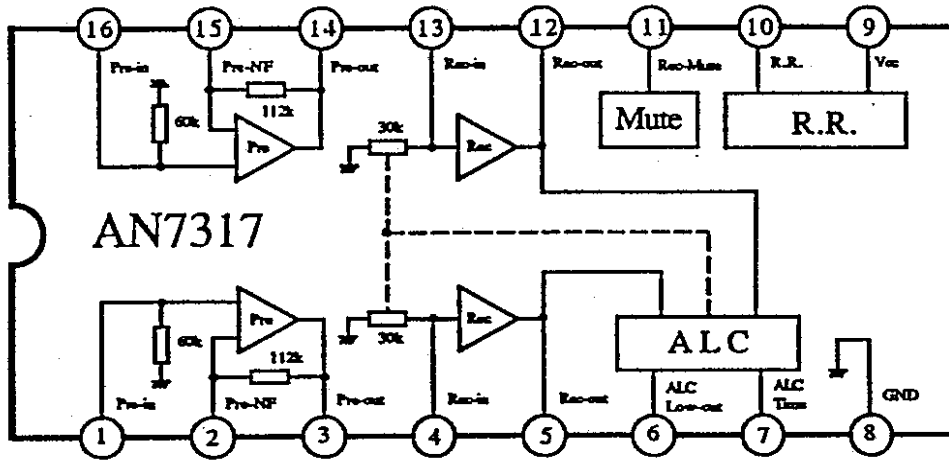

Pin Descriptions

Pin No.	Pin Descriptions
1	Channel 1 Playback Amplifier Input
2	Channel 1 Playback Amplifier Negative Feedback
3	Channel 1 Playback Amplifier Output
4	Channel 1 Record Amplifier Input
5	Channel 1 Record Amplifier Output
6	ALC Low-Cut
7	ALC Time
8	Ground
9	Vcc
10.	Ripple Filter
11	Record - Amplifier Mute
12	Channel 2 Record Amplifier Output
13	Channel 2 Record Amplifier Input
14	Channel 2 Playback Amplifier Output
15	Channel 2 Playback Amplifier Negative Feedback
16	Channel 2 Playback Amplifier Input

<<MEMO>>

JVC

VICTOR COMPANY OF JAPAN, LIMITED

AUDIO & COMMUNICATION BUSINESS DIVISION

PERSONAL & MOBILE NETWORK BUSINESS UNIT 10-1,1Chome,Ohwatari-machi,Maebashi-city,371-8543,Japan

Block diagram

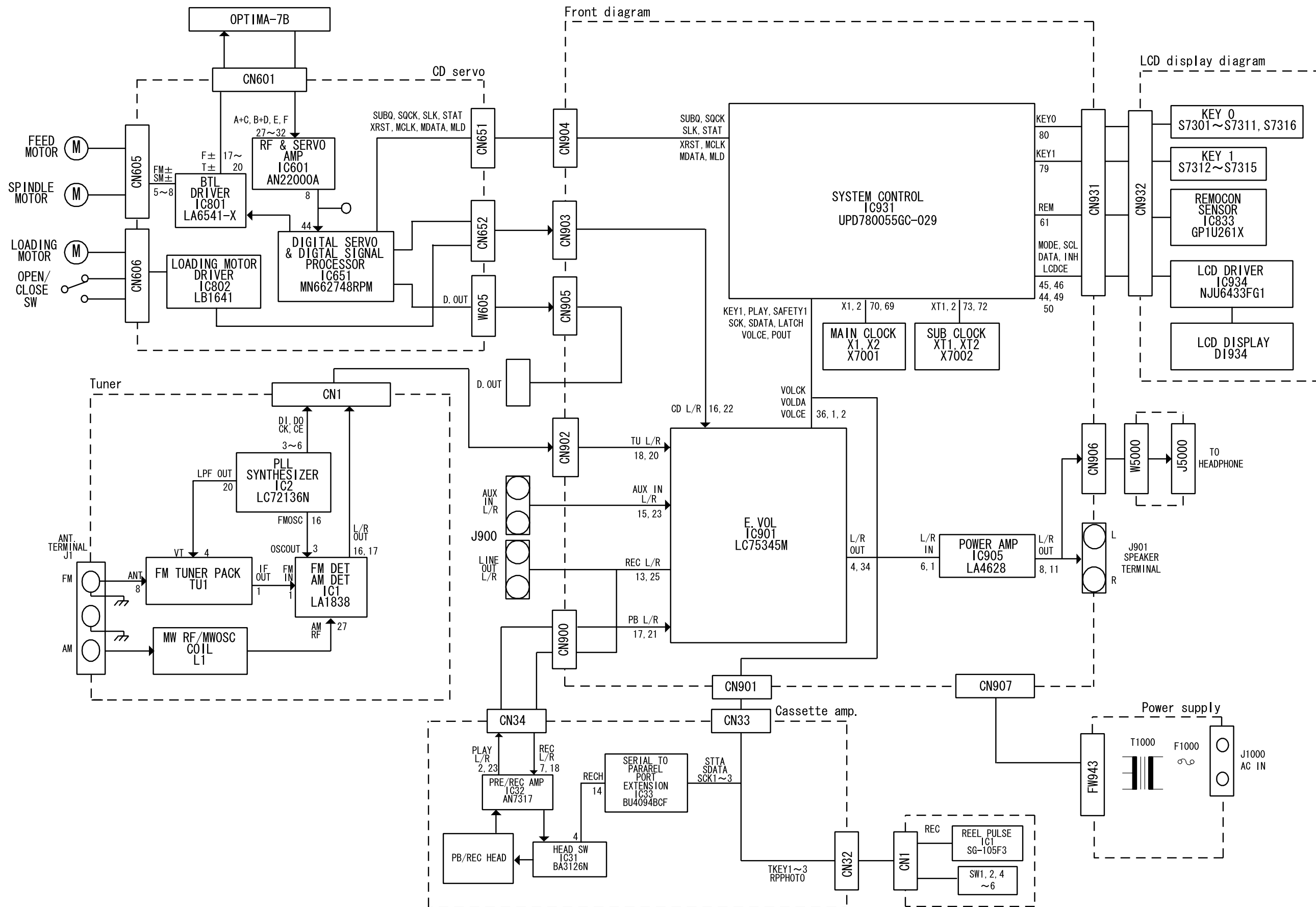

Standard schematic diagrams

■ Front circuit

6

5

4

3

2

1

DTC144TKA-X 47K OPEN D7061/07062	DTC144TKA-X 10K OPEN D7002	DTC144EK-X 10K D7091/07401/07402/07403
---	-------------------------------------	--

MARK

VERSION	PS-PS	UX-P3	UX-P3R
ITEMS	(L)	(A)	(E)
D7059	1K	1K	1K
D7061	BLUE	BLUE	BLUE
D7062	BLUE	BLUE	BLUE
D7071/07	BK		D7071
R7314 (VERSION1)	10K	B/W	B/W
R7315 (VERSION1)	50K	47K	47K
C7010	4.7/50	10/50	10/50
D7009	NONE	USE	NONE
R0018	USE	NONE	USE
R0021	NONE	USE	NONE
R0023	USE	NONE	USE
C0002	GPF 120PF 1-09		GPF 120PF 1-13

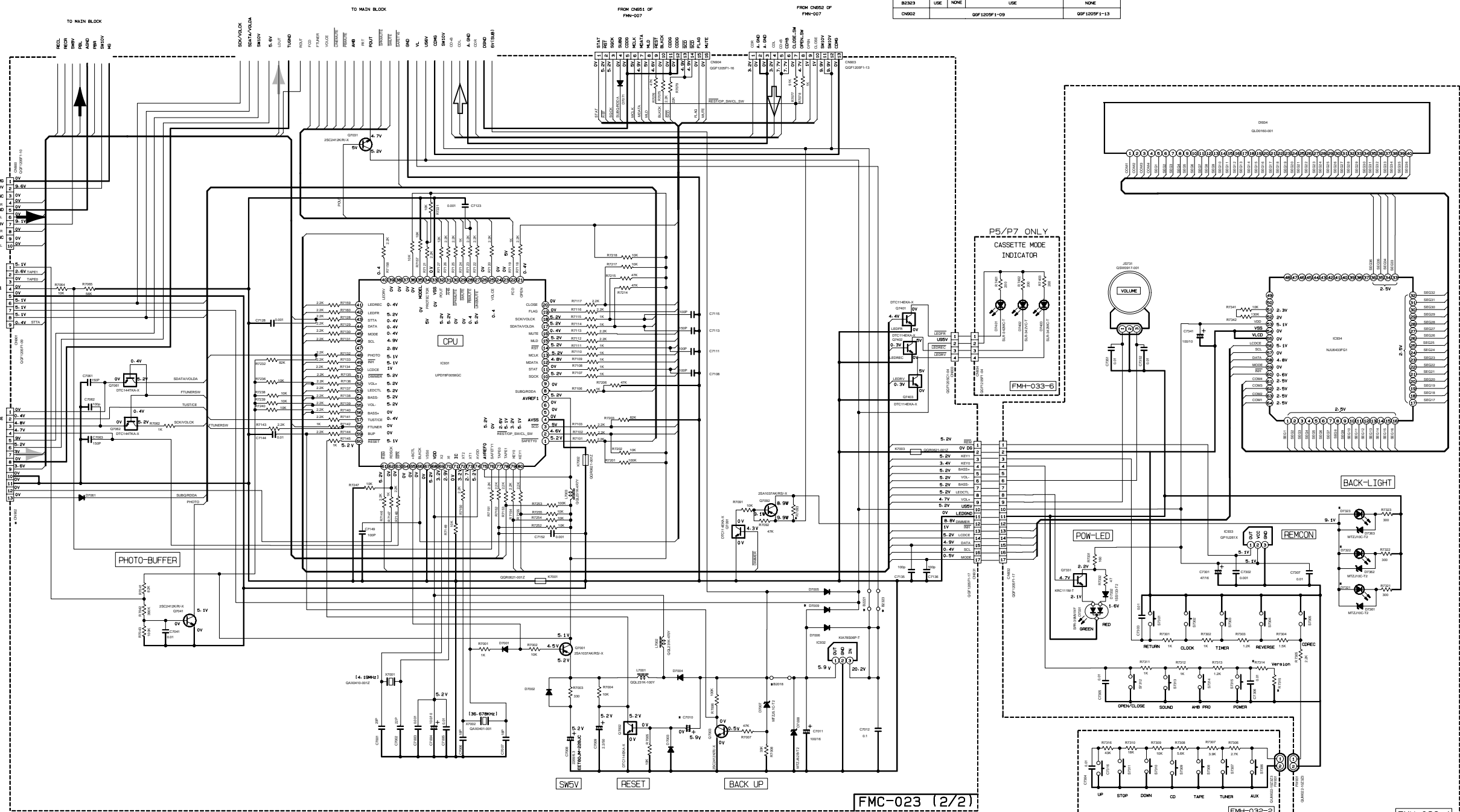

NOTES
 1. VOLTAGES ARE DC-MEASURED WITH A DIGITAL VOLT METER OR OSCILLOSCOPE WITHOUT INPUT SIGNAL.
 CONDITION --- CD STOP MODE
 2. UNLESS OTHERWISE SPECIFIED,
 ALL RESISTORS ARE 1/10W ±5% METAL GLAZE RESISTOR.
 ALL CAPACITORS ARE CERAMIC CAPACITOR OR MYLAR CAPACITOR.
 ALL RESISTANCE VALUES ARE IN OHM(Ω).
 ALL CAPACITANCE VALUES ARE IN nF(nPF).
 ALL INDUCTANCE VALUES ARE IN μH(μMH).
 ALL E-CAPACITORS ARE SHOWN IN THE FORM OF CAPACITANCE(μF)/RATED VOLTAGE (V).
 ALL DIODES ARE IN 1SS133-T7 UNLESS SPECIFIED.

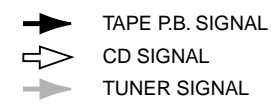

A B C D E F G H I

CD servo circuit

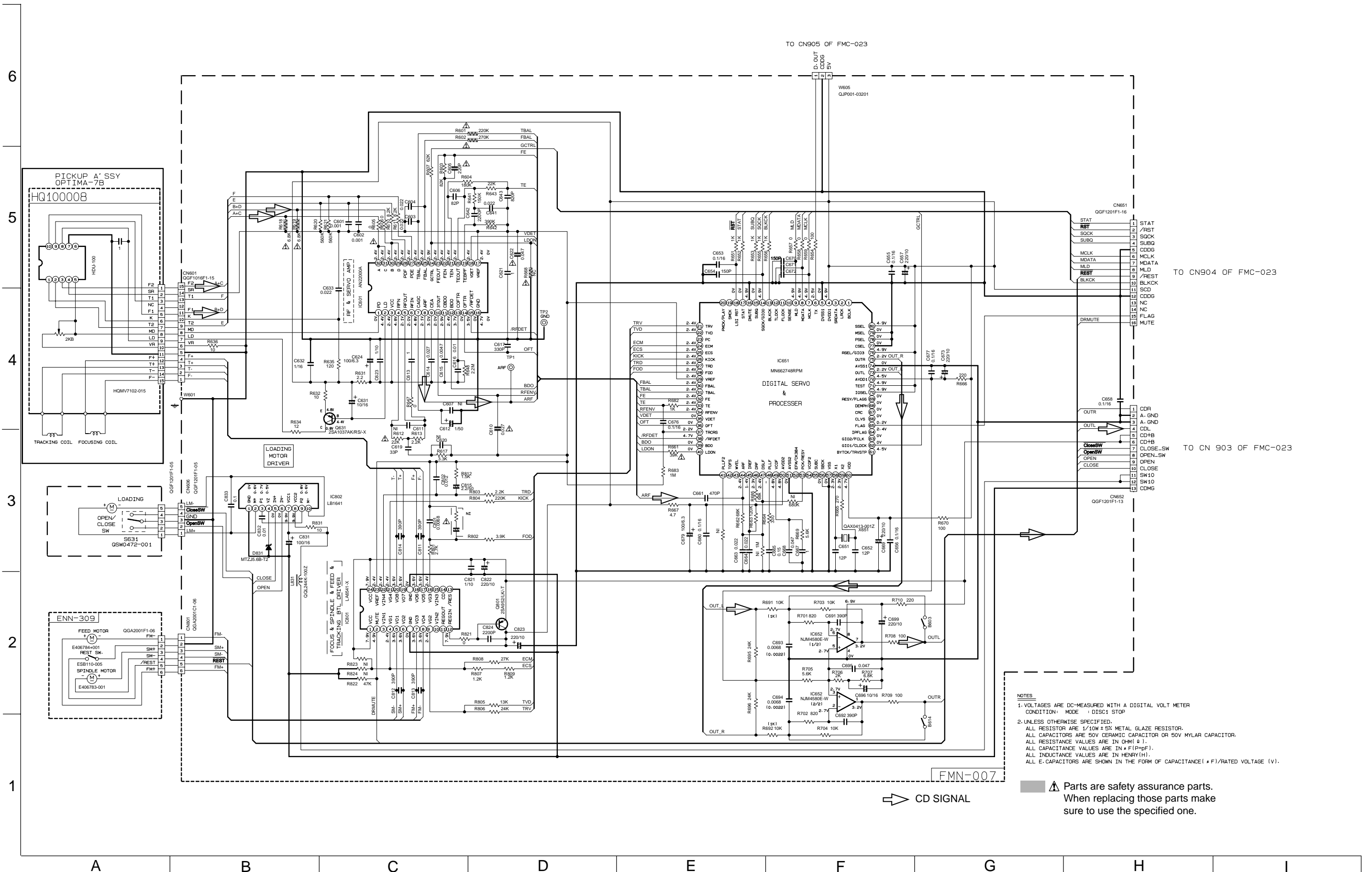

NOTES
 1. VOLTAGES ARE DC-MEASURED WITH A DIGITAL VOLT METER
 CONDITION: MODE : DISC1 STOP
 2. UNLESS OTHERWISE SPECIFIED,
 ALL RESISTOR ARE 1/10W ± 5% METAL GLAZE RESISTOR.
 ALL CAPACITORS ARE 50V CERAMIC CAPACITOR OR 50V MYLAR CAPACITOR.
 ALL RESISTANCE VALUES ARE IN OHM(Ω).
 ALL CAPACITANCE VALUES ARE IN PICO(FpF).
 ALL INDUCTANCE VALUES ARE IN HENRY(H).
 ALL E-CAPACITORS ARE SHOWN IN THE FORM OF CAPACITANCE(μF)/RATED VOLTAGE (V).

▲ Parts are safety assurance parts.
 When replacing those parts make sure to use the specified one.

Cassette amplifier circuit

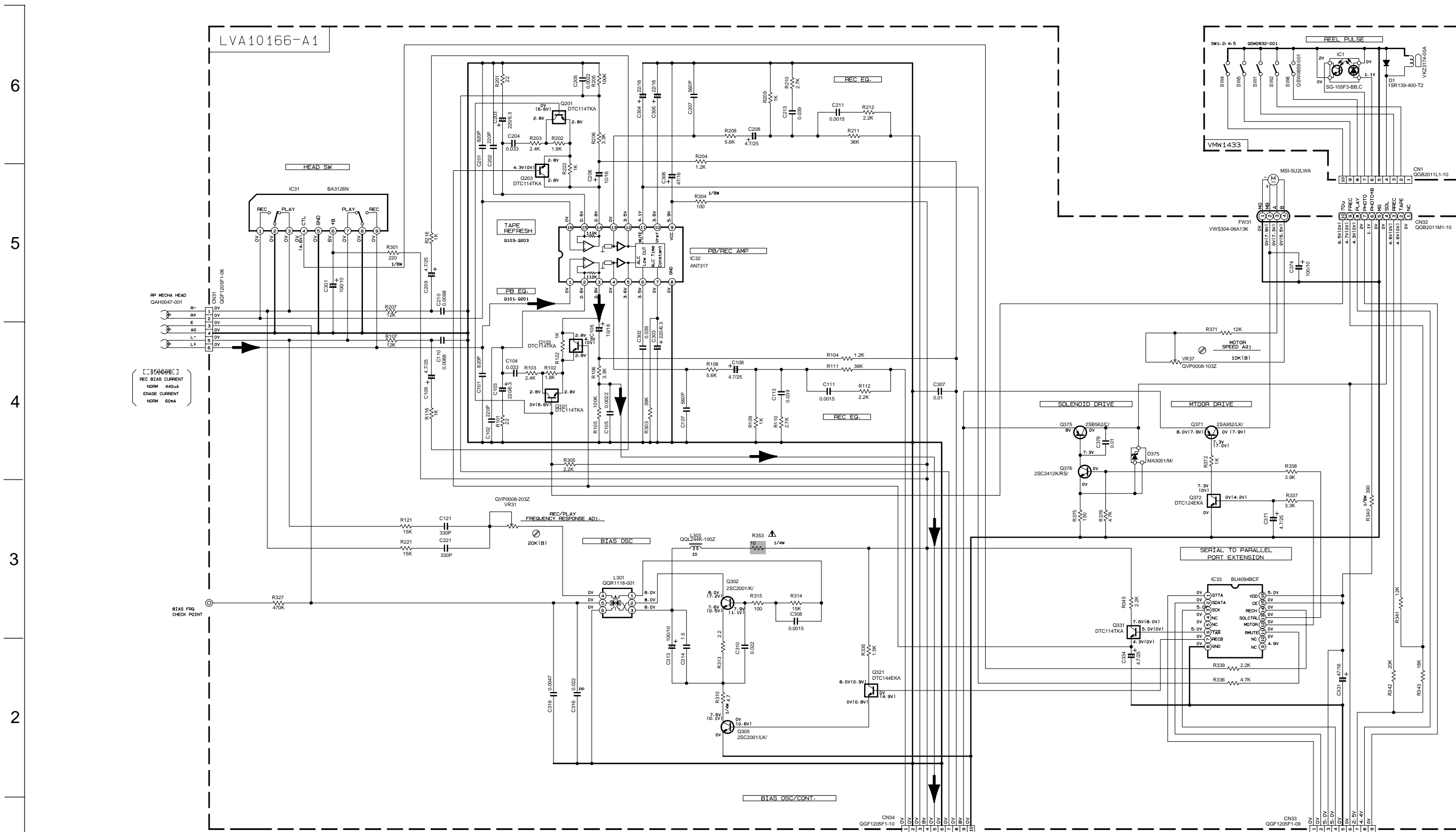

NOTES

1. VOLTAGES ARE DC-MEASURED WITH A DIGITAL VOLT METER OR OSCILLOSCOPE WITHOUT INPUT SIGNAL. CONDITION : MECHA STOP MODE

2. UNLESS OTHERWISE SPECIFIED, RESISTORS ARE 1/10W ±5% METAL GLAZE RESISTOR. ALL RESISTANCE VALUES ARE IN Ω(M)(k). ALL CAPACITORS ARE CERAMIC CAPACITOR OR MYLAR CAPACITOR. ALL CAPACITANCE VALUES ARE IN nF(pF)(μF). ALL INDUCTANCE VALUES ARE IN μH(mH)(mH). ALL E-CAPACITORS ARE SHOWN IN THE FORM OF CAPACITANCE (μF)/RATED VOLTAGE (V). POLYPROPYLENE CAPACITOR

PARTS	NAME	REF. NO
	FA1A4Z OF DTC114TKA	Q101-Q201 Q103-Q203 Q331
	FA1F4H OF DTC144EKA	Q321
	FA1F4H OF DTC124EKA	Q372

Parts are safety assurance parts. When replacing those parts make sure to use the specified one.

▶ TAPE P.B. SIGNAL

TO CN90 OF FMC-023

TO CN901 OF FMC-023

A B C D E F G H I

■ Tuner circuit

6
5
4
3
2
1

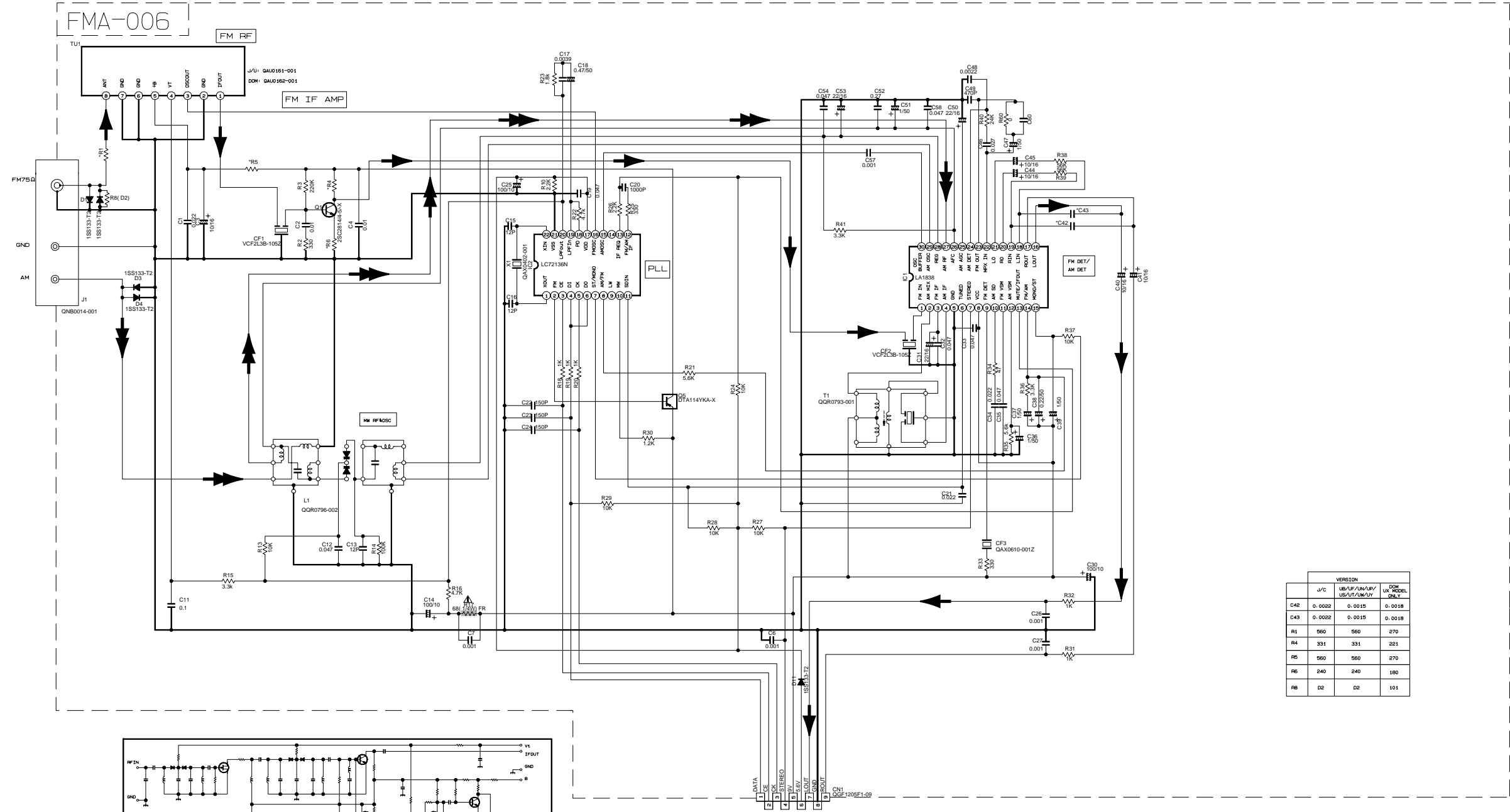

- NOTES
- VOLTAGES ARE DC-MEASURED WITH A DIGITAL VOLT METER.
 - ALL RESISTORS ARE 1/8W ±5% METAL GLAZE RESISTOR.
 - ALL RESISTANCE VALUES ARE IN OHM(Ω).
 - ALL CAPASITANCE VALUES ARE IN *F(P=PF).
 - ALL E. CAPASITORS ARE SHOWN IN THE FORM OF CAPASITANCE (*F)/RATED VOLTAGE (V).
 - SI DIODES (D) ARE ALL 1SS133-T THAT CAN BE CHANGED TO SIMILAR DIODE SUCH AS MA165 OR HSS104J.
 - PARTS NO. OF TRANSISTORS ARE AS FOLLOWS.
 Q1 2SC2814/4-5/-X Q2-Q3 2SC2412K/R/-X
 Q4-Q5 DTA114YKA-X

B. INSIDE OF DIGITAL TRANSISTORS ARE SHOWN AS FOLLOWS.

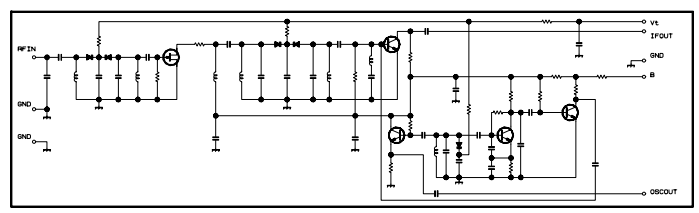
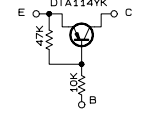

CONDITION	PIN NO.	1	2	3	4	5	6	7	8	9	10	11	12	13	14	15	16	17	18	19	20	21	22	23	24	25	26	27	28	29	30
IC1 FM NO SIGNAL		3.6	8.9	3.6	3.6	0	5.0	5.0	8.9	8.9	1.3	0.1	0	0.9	7.8	7.8	4.3	4.3	4.3	3.4	3.4	2.8	3.4	0	0	3.5	3.5	3.6	3.6	2.7	
IC1 FM 60dB STEREO		3.6	8.9	3.6	3.6	0	5.0	5.0	8.9	8.9	1.3	4.3	0	0.9	7.8	7.8	4.3	4.3	4.3	3.4	3.4	2.8	3.4	0	0	3.6	3.6	3.6	3.6	2.7	
IC1 AM NO SIGNAL		3.5	9.0	3.5	3.5	0	5.0	5.1	9.0	2.6	1.3	0	0	0.9	4.7	5.5	4.3	4.3	4.3	3.3	3.2	2.8	ust	0.7	0.7	3.6	3.6	3.6	3.6	2.1	
IC2 FM NO SIGNAL		2.5	0	0	5.0	4.9	5.0	7.9	7.8	3.6	6.1	5.1	0	0	0	2.5	5.1	0.9	0.9	3.8	0	2.3									

VERSION	J/C		DOM
	USE/F/AN/AY/	USE/TA/NA/AY	
C42	0.0022	0.0015	0.0018
C43	0.0022	0.0015	0.0018
R1	560	560	270
R4	331	331	221
R5	560	560	270
R6	240	240	180
R8	02	02	101

Tr. NO.	Q1			Q5		
	E	C	B	E	C	B
FM 87.5MHz NO SIGNAL	0	7.1	0.85	8.9	8.8	0
AM 522kHz NO SIGNAL	0	0	9.0	0	8.9	

Tr. NO.	Q2			Q3			Q4		
	E	C	B	E	C	B	E	C	B
AM 522kHz NO SIGNAL	0	0	7.0	0	0	7.0	0	3.6	0.7
AM 144kHz NO SIGNAL	0	0	0.3	0	0.3	0.3	3.6	3.6	3.6

➔ FM/TUNER MAIN SIGNAL
 ➔ AM SIGNAL

▲ Parts are safety assurance parts. When replacing those parts make sure to use the specified one.

A B C D E F G H I

Power supply circuit

6
5
4
3
2
1

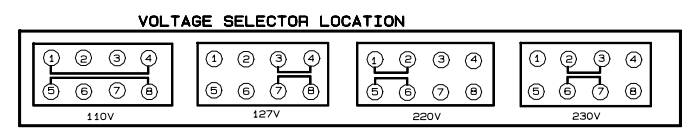
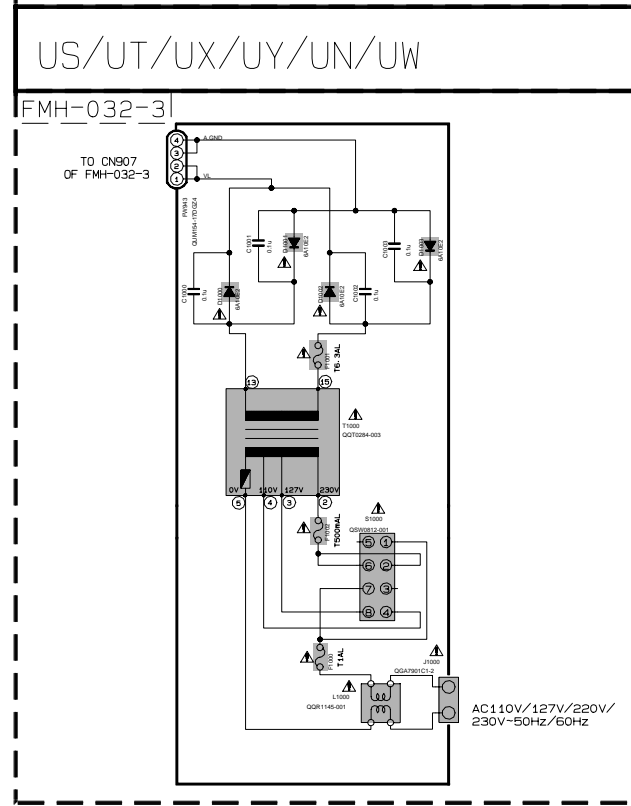
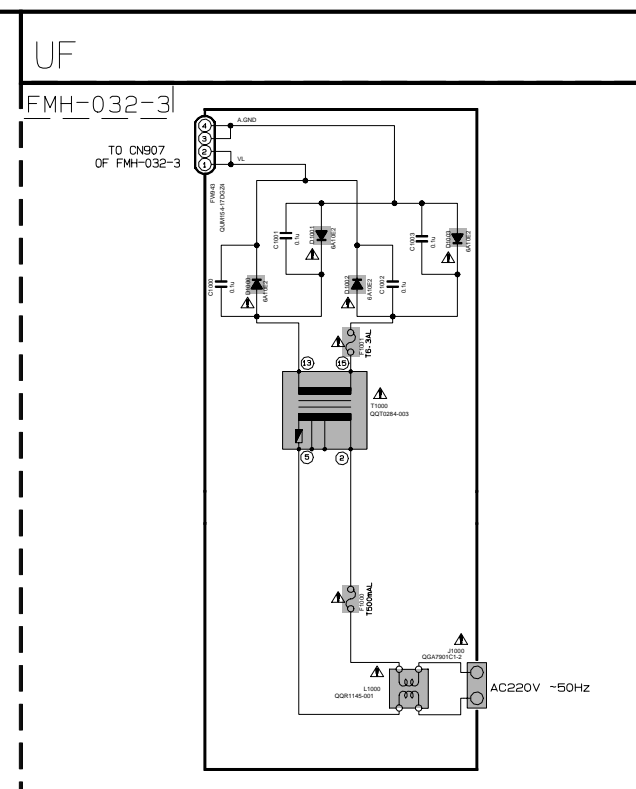
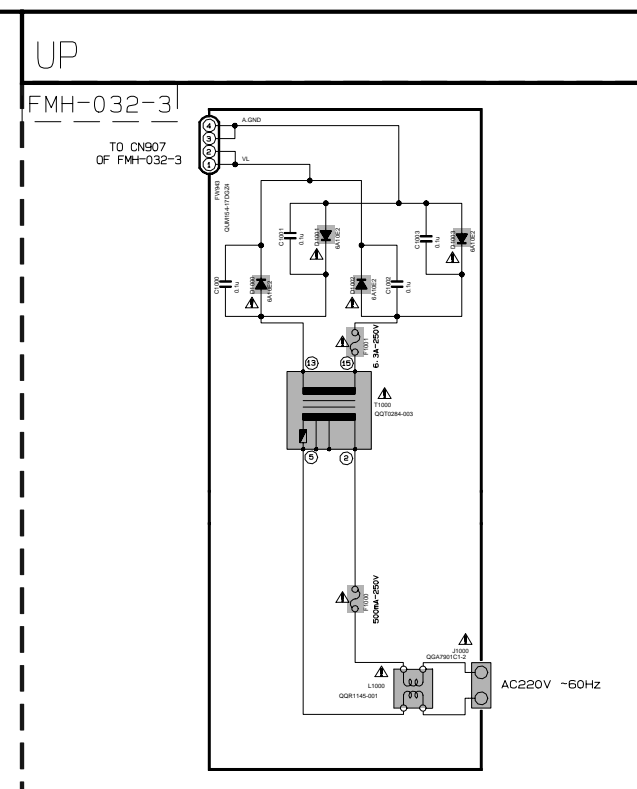
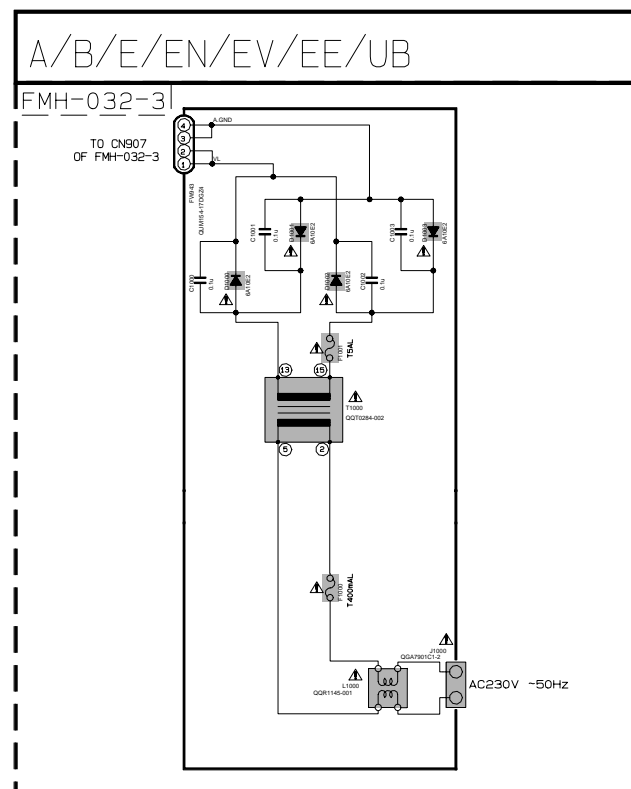

EXPLANATION OF OVERALL OF SCHEMATIC

MODEL : UX-P3/UX-P3R/UX-P4R

SHEET NUMBER	MODEL NUMBERS TO BE APPLIED	CIRCUITS DESCRIPTION
1/8	UX-P3/UX-P3R/UX-P4R	PRIMARY WITH MAINS TRANSFORMER
2/8	UX-P3/UX-P3R/UX-P4R	DC REGULATOR, AUDIO OUTPUT, EXTERNAL INPUT, SOURCE SELECTOR SWITCH
3/8	UX-P3/UX-P3R/UX-P4R	LCD DISPLAY/SYSTEM CONTROL/USERS KEY CONTROL
4/8	UX-P3/UX-P3R/UX-P4R	CD SERVO AND CD SYSTEM CONTROL, CD CHANGER MECHANISM CONTROL
5/8	UX-P3/UX-P3R/UX-P4R	TAPE DECK MECHANISM CONTROL, TAPE CIRCUITS SUCH AS PRE-AMP AND BIAS
6/8	UX-P3	TUNER RF/IF/FM MULTIPLEX (ONLY FOR A, UB, UF, UN, UP, US, UT, UW, UX, UY)
7/8	UX-P3R/UX-P4R	TUNER RF/IF/FM MULTIPLEX (ONLY FOR B, E, EN, EV)
8/8	UX-P3REEM	TUNER RF/IF/FM MULTIPLEX (ONLY FOR EE)

NOTE : MARK(*) IS TO SHOW DEVIATION IN VERSIONS. DETAILS ARE EXPLAINED NEAR MARK.

VERSION CODES

A	: AUSTRALIA
B	: U.K
E	: CONTINENTAL EUROPE
EE	: RUSSIA
EN	: NORDIC COUNTRIES
EV	: EASTERN EUROPE
UB	: HONG KONG
UF	: CHINA
UN	: INDONESIA
UP	: KOREA
UW	: SOUTH AFRICA
UT	: TAIWAN
UX	: SAUDI ARABIA
UY	: ARGENTINA
US	: SINGAPORE AND UNIVERSAL EXCEPT ALL OF ABOVE

NOTES

- VOLTAGES ARE DC-MEASURED WITH A DIGITAL VOLT METER OR OSCILLOSCOPE WITHOUT SHUNT SIGNAL. CONDITION --- CD STOP MODE. INSIDE BRACKET VALUES ARE OTHER FUNCTIONS.
- UNLESS OTHERWISE SPECIFIED, RESISTORS ARE 1/8W ±5% CARBON RESISTOR. ALL RESISTANCE VALUES ARE IN OHM(S). ALL CAPACITORS ARE CERAMIC CAPACITOR OR MYLAR CAPACITOR. ALL CAPACITANCE VALUES ARE IN μF(FPMF). ALL INDUCTANCE VALUES ARE IN mH(MPMH). ALL ELECTROLYTIC CAPACITORS ARE SHOWN IN THE FORM OF CAPACITANCE (μF)/RATED VOLTAGE (V).

⚠ Parts are safety assurance parts. When replacing those parts make sure to use the specified one.

A B C D E F G H I

Printed circuit boards

■ Main board

Block No. 01

6

5

4

3

2

1

A

B

C

D

E

F

G

H

I

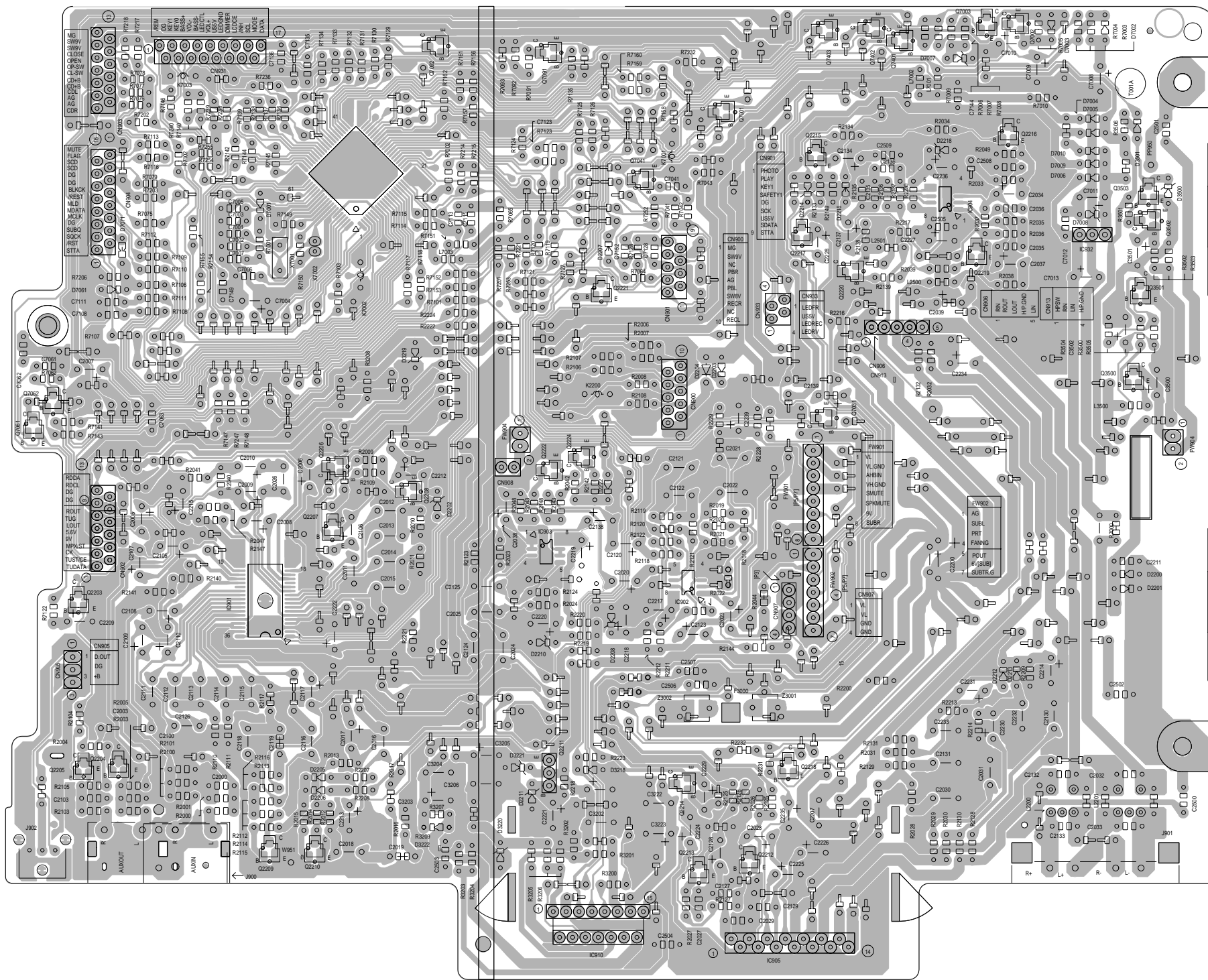

■ Front board Block No. 02

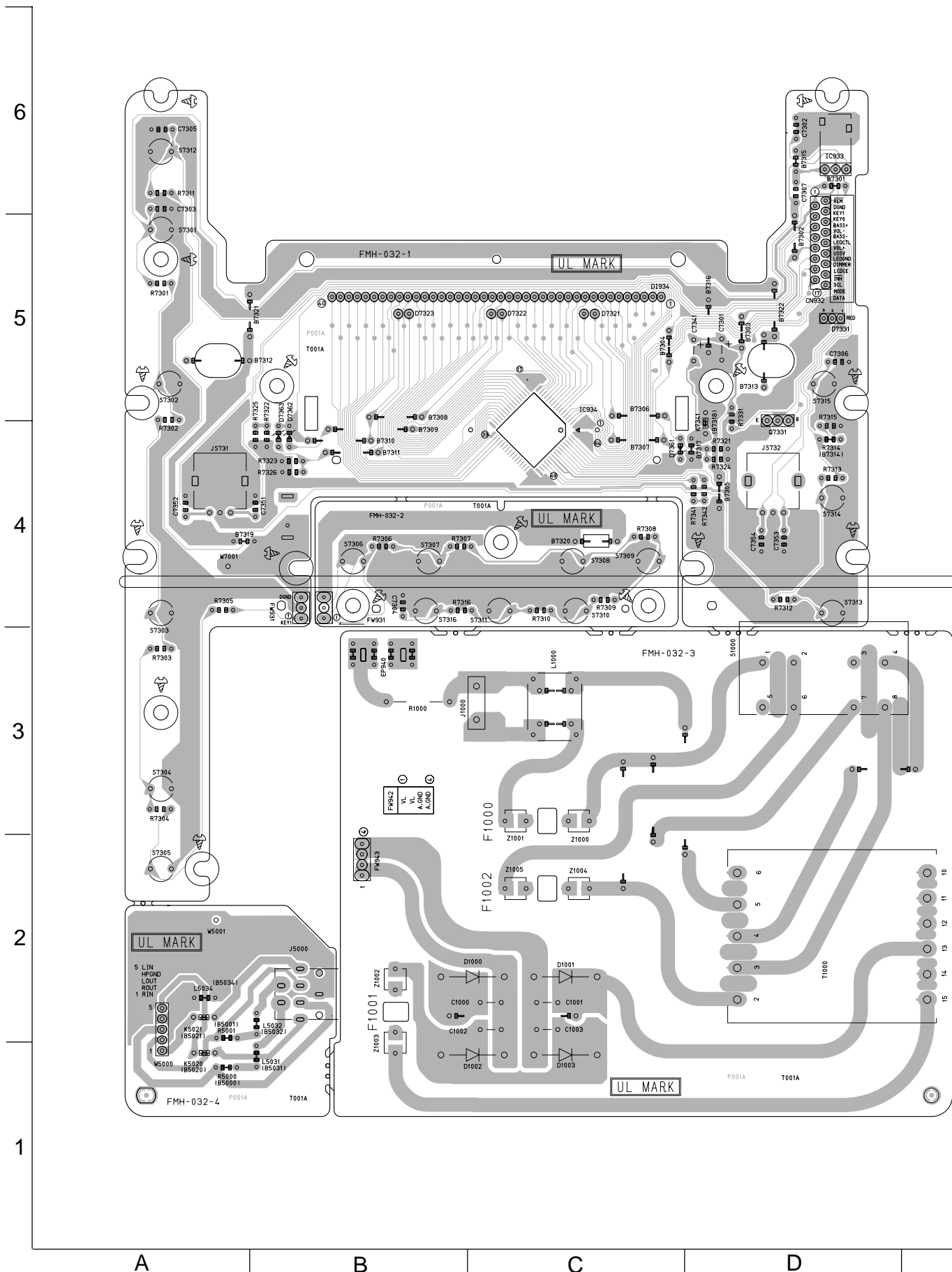

■ CD servo board Block No. 03

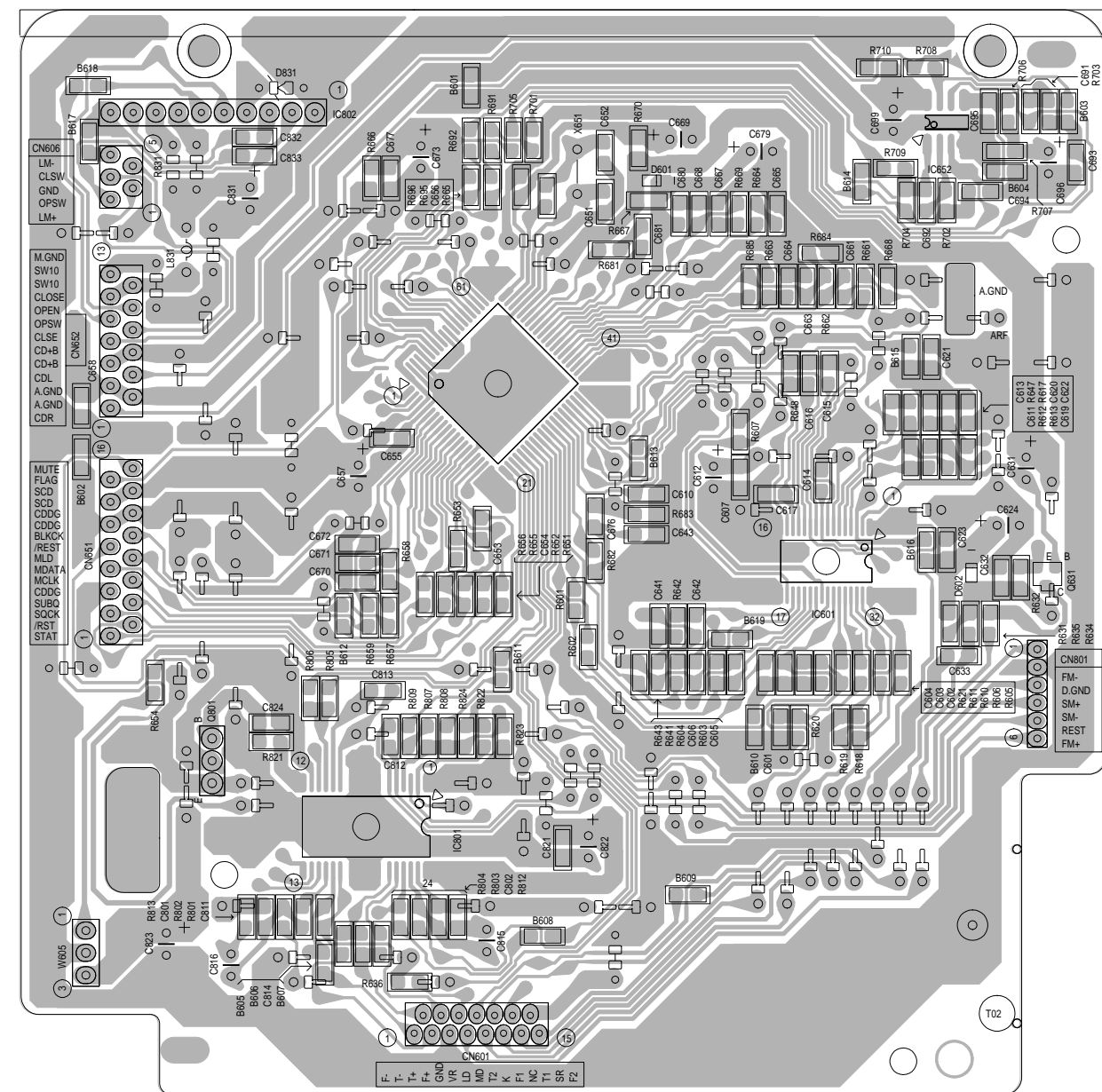

■ Tuner board Block No. 04

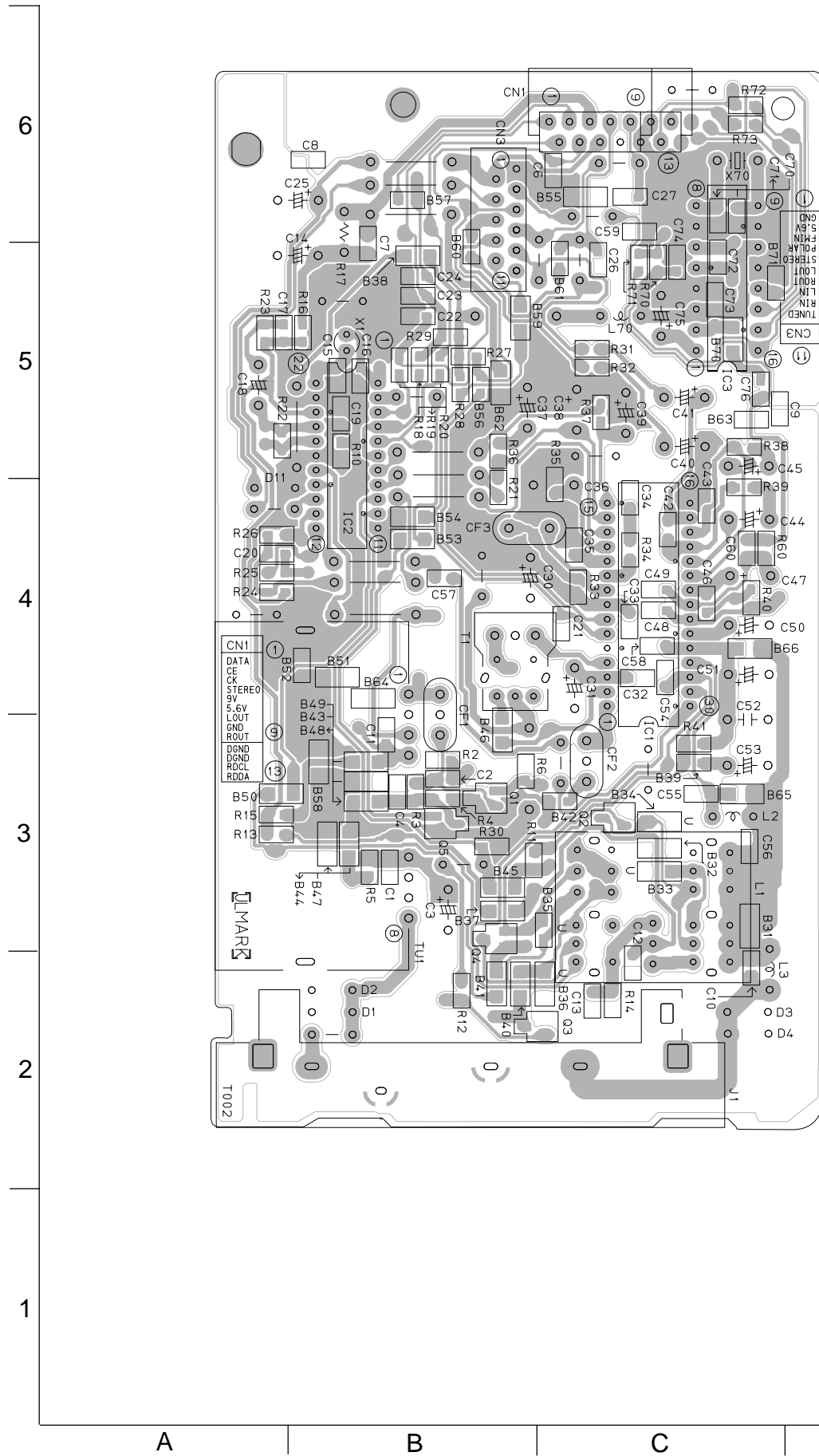

■ Head amplifier board Block No. 05

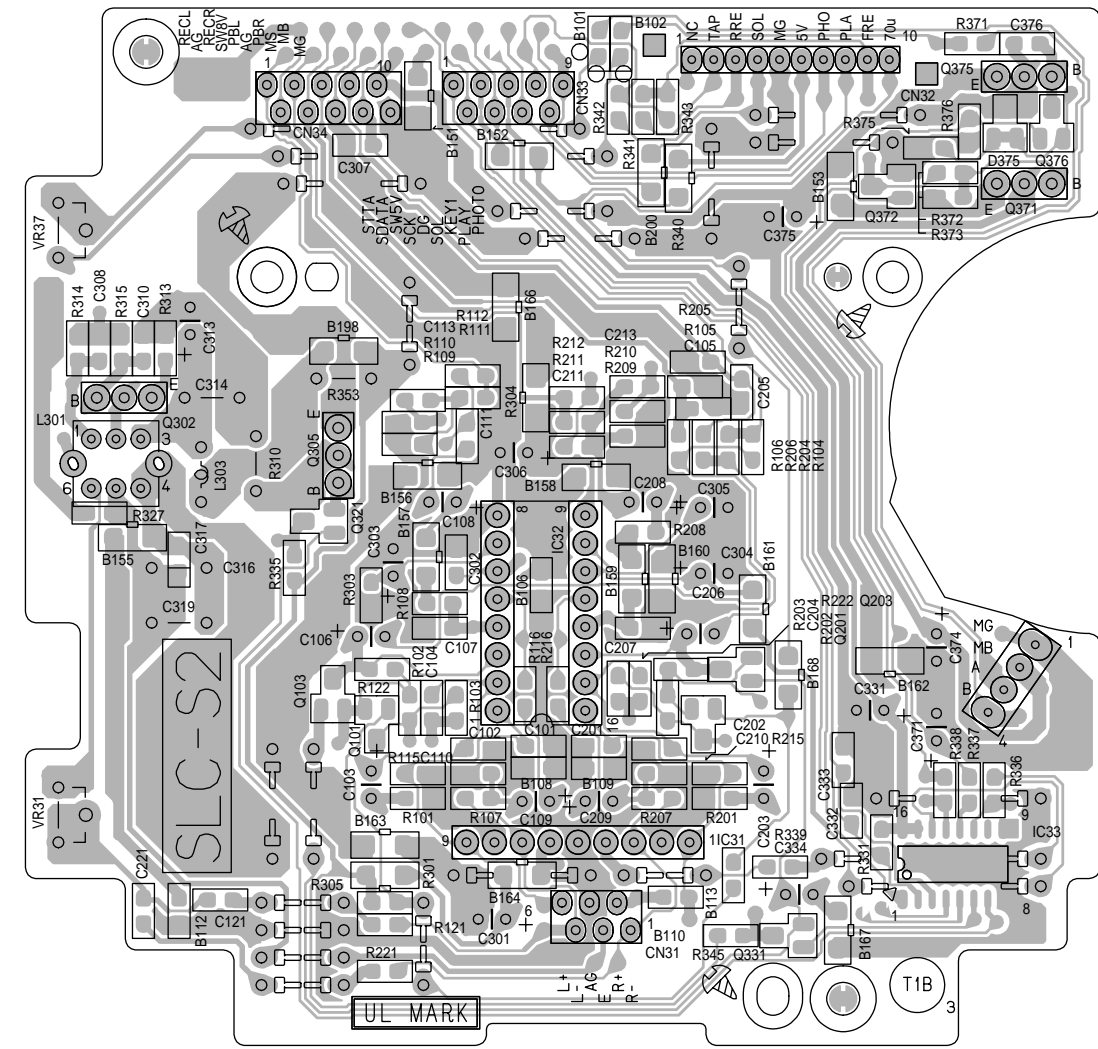

■ Cassett switch board Block No. 06

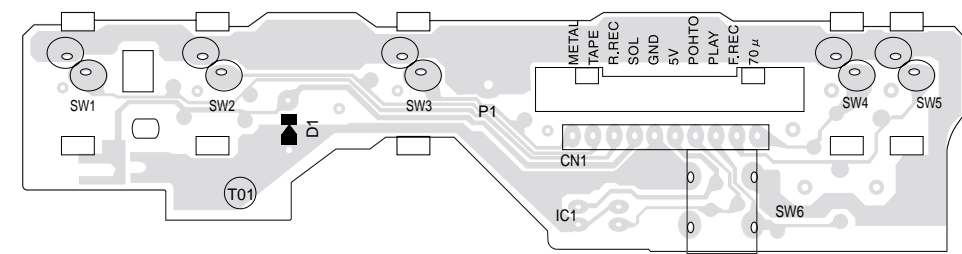

PARTS LIST

[UX-P3]

* All printed circuit boards and its assemblies are not available as service parts.

Area suffix	
UB -----	Hong Kong
UP -----	Korea
US -----	Singapore
UY -----	Argentina
UW -----	Brazil, Mexico, Peru

- Contents -

Exploded view of general assembly and parts list	3- 3
Cassette mechanism assembly and parts list	3- 6
CD loading base assembly and parts list	3- 8
CD mechanism assembly and parts list	3-10
Electrical parts list	3-11
Packing materials and accessories parts list	3-20

< MEMO >

■ Parts list (General assembly)

Block No. M1MM

△	Item	Parts number	Parts name	Q'ty	Description	Area
	1	GV10064-002A	FRONT PANEL	1		
	2	GV40077-002A	JVC BADGE	1		
	3	GV40147-001A	REMOTE LENS	1		
	4	GV40150-001A	CD EJECT BUTTON	1		
	5	GV30158-001A	FUNCTION BUTTON	1		
	6	GV40153-001A	SOUND BUTTON	1		
	7	GV30156-001A	BUTTON B	1		
	8	GV30159-001A	CONTROL BUTTON	1		
	9	GV40149-001A	BUTTON A	1		
	10	GV40151-001A	CASS.BUTTON	1		
	11	GV40158-001A	ORNAMENT BKT	1		
	12	GV40156-001A	VOL. ORNAMENT	1		
	13	GV40179-001A	LCD SHEET	1		
	14	QYSBSG3006Z	T.SCREW	2	VOL.ORN/ORN.BKT	
	15	QYSBSF3008Z	SCREW	2	ORN.BKT/F.PANEL	
	16	QYSBSF3008Z	SCREW	16	PWB BRD/F.PANEL	
	17	E65923-003	TAPPING SCREW	1	PHONE BRD./F.PANEL	
	18	GV30162-001A	LCD HOLDER	1		
	19	GV40173-001A	LCD LENS	1		
	20	GV40194-001A	LED HOLDER	1	LED(STANDBY)	
	21	GV40212-001A	SPRING	1	INSERT F.PANEL	
	22	GV20109-001A	CASS.HOLDER	1		
	23	GV20110-001A	DOOR COVER	1		
	24	GV40213-001A	CASS.DOOR LENS	1		
	25	GV30178-002A	CASS EJECT BUTTON.	1		
	26	GV40161-001A	DDOR SPRING	1		
	27	GV40034-001A	DAMPER ASSY	1		
	28	VKY4180-401	CASSETTE SPRING	2		
	29	-----	CASSETTE MECHA	1		
	30	VKL7850-002	EJECT SAFETY(R)	1		
	31	VKW5258-003	TORSION SPRING	1	FOR EJECT SAFET	
	32	GV40162-001A	MECHA BRACKET	1		
	33	QYSBSG3008Z	T.SCREW	1	M.BKT/SLC MECHA	
	34	GV30173-002A	LOCK ARM	1		
	35	GV40164-001A	SPECIAL SCREW	2	LOCK ARM/M.BKT	
	36	QYSBSF3012Z	SCREW	4	SLC./F.PANEL	
	37	GV30124-001A	TRANS SHIELD	1		
	38	GV40170-003A	SPACER	1	SLC(MOTOR)/T.SHIELD	
	39	-----	LOAD BASE ASSY	1		
	40	E406293-001	SPECIAL SCREW	1	CD MECHA/LOAD.BASE	
	41	-----	CD MECHA	1		
	42	GV10066-001A	CLAMPER BASE	1		
	43	VYH7313-005	MAGNET	1		
	44	E306836-223SS	CD YOKE (JES)	1		
	45	VYH1240-001	TRAY	1		
	46	E306835-221SS	CD CLAMPER	1		
	47	VMA4619-002	SHIELD CASE	1		
	48	QYSDSR2606Z	SCREW	2	FOR SHLD CASE	

■ Parts list (General assembly)

Block No. M1MM

△	Item	Parts number	Parts name	Q'ty	Description	Area
	49	QYSBSF3008Z	SCREW	4	CLAMP.BASE/LOAD	
	50	QYSBSF3008Z	SCREW	1	CD TRAY STOPPER	
	51	QYSBSF3008Z	SCREW	2	CD BRD/LOAD.ASSY	
	52	QYSSSF3008Z	SCREW	1	TUNER/C.BASE ASSY	
	53	GV40122-003A	SPACER	1		
	55	GV10065-001A	BOTTOM CHASSIS	1		
	56	GV40184-001A	FOOT SPACER	4	CHAS.BASE FOOT	
	57	GV30166-001A	HEAT SINK A	1		
	58	GV40206-001A	MICA SHEET(A)	1		
	59	QYSBSF3012Z	SCREW	2	IC BKT./H.SINK	
	60	QYSBSFG3016Z	SCREW	2	PWB BRD/CHA.BASE	
	61	GV30168-001A	IC BRACKET	1		
	63	QYSBST4006Z	T.SCREW	4	TRANS/CHA.BASE	
	64	QYSSST3008Z	SCREW	2	F.PANEL/C.BASE	
△	66	QMPN160-200-JD	POWER CORD	1		UB
△		QMPR310-200-JC	POWER CORD	1		UP
△		QMPK210-205-JN	POWER CORD	1		US,UW
△		QMPR300-200-JC	POWER CORD	1		UY
	67	QZW0033-001	STRAIN RELIEF	1		
	71	QUQ412-0914CJ	FFC WIRE	1	FC33	
	72	QUQ412-1018CJ	FFC WIRE	1	FC34	
	73	QUQ412-1314DJ	FFC WIRE	1	FC652	
	74	QUQ412-1614DJ	FFC WIRE	1	FC651	
	75	QUQ412-0507DJ	FFC WIRE	1	FC631	
	76	QUQ110-1509AJ	FFC WIRE	1	FC601	
	77	QUQ412-1710DJ	FFC WIRE	1	FC932	
	78	QUQ412-0932DJ	FFC WIRE	1	FC1	
	81	VKZ4001-110S	WIRE HOLDER	1		
	83	GV40223-001A	PUSH SPACER	1	MAIN BRD./M.COVER	
	85	VYSA1R4-100	SPACER	1		
	86	GV10067-002A	REAR PANEL	1		US,UW,UY
		GV10067-012A	REAR PANEL	1		UB
		GV10067-001A	REAR PANEL	1		UP
	87	GV10068-002A	REAR COVER	1		
	88	QYSBSGY3008E	SPECIAL SCREW	2	ANT.TEM/R.PANEL	
	89	QYSBSGY3008E	SPECIAL SCREW	1	AUX.TEM/R.PANEL	
	90	QYSBSGY3008E	SPECIAL SCREW	2	R.COVER/R.PANEL	
	91	QYSBSGY3008E	SPECIAL SCREW	2	SPEAKER/R.PANEL	
	94	QYSBSGY3008E	SPECIAL SCREW	1	R.PANEL/GROUND	
	95	QYSBSGY3008E	SPECIAL SCREW	2	R.PANEL/CLAMPER	
	97	GV10069-001A/S/	METAL CAVER	1		
	98	QYSDSG3006M	T.SCREW	2	M.COVER/C.BASE	
	99	QYSBSGY3008E	SPECIAL SCREW	6	M.COVER/R.PANEL	
	100	GV30164-003A	TRAY FITTING	1		
	102	GV40154-001A	VOL.KNOB A	1		
	103	GV30160-002A	FRONT LENS A	1		
	104	GV30172-005A	RATING LABEL	1		UP
		GV30172-002A	RATING LABEL	1		US,UW,UY

■ **Parts list (General assembly)**

Block No. M1MM

⚠	Item	Parts number	Parts name	Q'ty	Description	Area
⚠	105	QQT0284-003	POWER TRANSF	1	T1000	US,UW,UY,UP
⚠		QQT0284-002	POWER TRANSF	1	T1000	UB
	108	GV40121-003A	SPACER	1		
	110	GV40167-001A	H.SINL BRACKET	1		
	111	QYSBSF3012Z	SCREW	1	H.SINK/H.SINK BKT	
	112	QYSBSGY3008E	SPECIAL SCREW	1	R.PANEL/H.SINK	
	113	QYSBSF3012E	SPECIAL SCREW	2	VOL.SEL./R.PANEL	US,UW,UY

Cassette mechanism assembly and parts list

SLC-S21M

Block No. M 2 M M

Grease

- ★ =EM-30L
- ▲ =UD-24
- =UD-24H2
- =LEN-320M
- =JC-888B
- ◎ =MOBIL-1

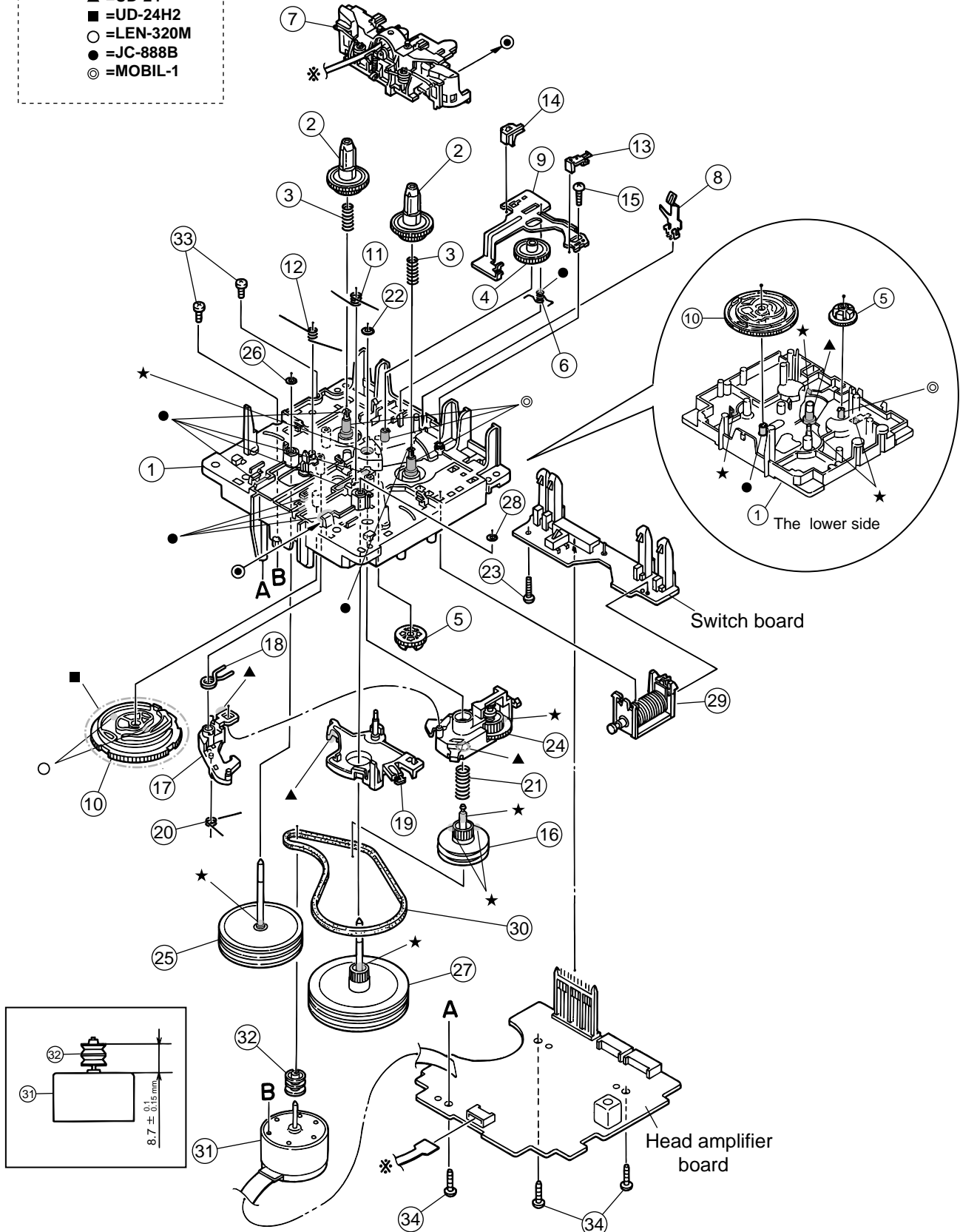

Parts list (Cassette mechanism)

Block No. M2MM

△	Item	Parts number	Parts name	Q'ty	Description	Area
	1	VKS1165-00J	CHASSIS B.ASS'Y	1		
	2	VKS2274-002	REEL GEAR	2		
	3	VKW5286-002	B.T. SPRING	2		
	4	VKS5559-001	PLAY IDLE GEAR	1		
	5	VKS5597-00B	BLIND	1		
	6	VKW5296-001	EARTH SPRING	1		
	7	SLC-RP1SVM	HEAD MOUNT ASSY	1		
	8	VKY3149-002	CASSETTE SP.	1		
	9	LV31786-001A	PLAY SW LEVER	1		
	10	VKS1166-003	CONTROL CAM	1		
	11	VKW5279-001	HEAD BASE SP(R)	1		
	12	VKW5280-001	HEAD BASE SP(L)	1		
	13	LV41584-001A	BRAKE(R)	1		
	14	LV41585-002A	BRAKE(L)	1		
	15	QYSBSF2005Z	T.SCREW	1		
	16	VKS5603-00G	MAIN PULLEY ASY	1		
	17	VKS3785-001MM	FR ARM	1		
	18	VKW5284-002	SWING SPRING	1		
	19	VKS2278-003	TRIGGER ARM	1		
	20	VKW5301-001	FR SPRING	1		
	21	VKW5266-001	ELEVATOR SPRING	1		
	22	WDL214025	WASHER	1		
	23	QYSBSF2005Z	T.SCREW	1		
	24	VKS3786-00G	CLUTCH ASS'Y	1		
	25	VKF3205-00B	F.WHEEL ASSY(R)	1		
	26	WDL183425	SLIT WASHER	1		
	27	VKF3207-00B	F.WHEEL ASSY(L)	1		
	28	WDL173525-6	SLIT WASHER	1		
	29	VKZ3174-00A	DC SOLENOID	1		
	30	LV42234-001A	CAPSTAN BELT	1		
	31	MSI-5U2LWA	D.C.MOTOR ASS'Y	1		
	32	VKR4761-001	MOTOR PULLEY	1		
	33	QYSPSP2604Z	SCREW	2		
	34	QYSBSF2608Z	T.SCREW	3	FOR P.W.B.	

CD loading base assembly and parts list

Block No. M 3 M M

Grease

- ★ = G-474C
- ▲ = EBS0006-009B

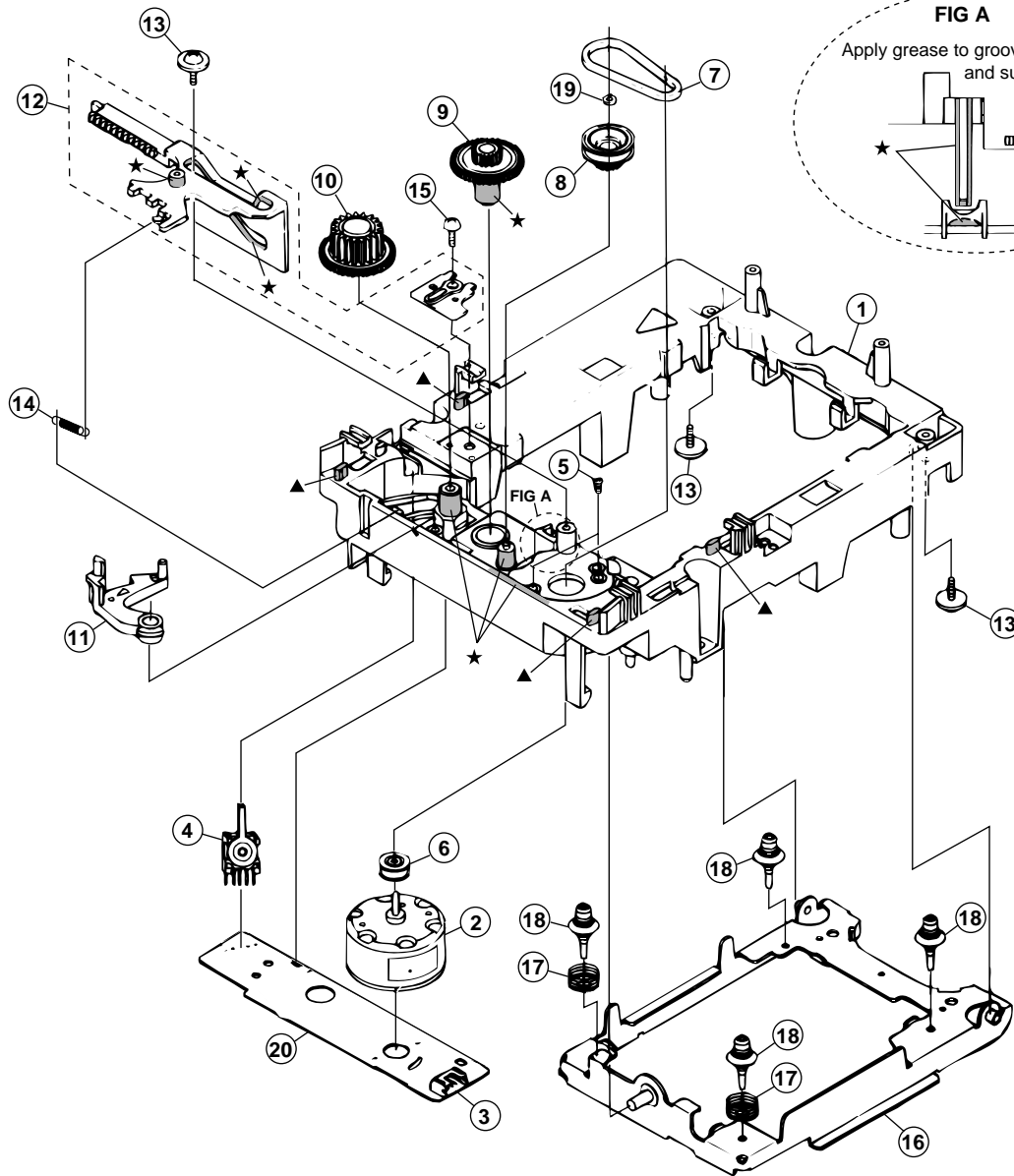

Dimension gap for motor pulley

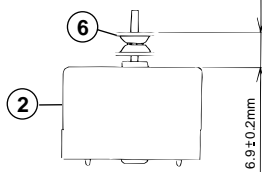

Parts list (CD loading baes)
Block No. M3MM

△	Item	Parts number	Parts name	Q'ty	Description	Area
	1	VYH1238-001	LODING BASE	1	ABS	
	2	MMN-6F1LB8K	MOTOR	1		
	3	QGF1201F3-05	CONNECTOR	1	CN505	
	4	QSW0472-001	SWITCH	1	S851	
	5	QYSPSPT2640Z	MINI SCREW	2		
	6	E75984-221	MOTOR PULLEY	1		
	7	E75950-002	BELT	1		
	8	E75985-221	GEAR(1)	1		
	9	E75986-221	GEAR(2)	1	PBT	
	10	E75987-221	GEAR(3)	1		
	11	E307162-331SS	LEVER	1		
	12	E307252-331SS	CAM PLATE	1		
	13	E65923-003	TAPPING SCREW	3		
	14	VYH7787-001	SPRING	1		
	15	QYSBSF3008Z	SCREW	1		
	16	E307179-332	E.BASE ASS'Y	1		
	17	E406871-001	SPRING	2		
	18	E406294-002	INSULATOR	4		
	19	E60912-005SS	SPEED NUT	1		
	20	VMW1329-101PP	PW BNOARD	1		

CD mechanism assembly and parts list

Block No. M 4 M M

Grease & Bond

★ = EBS0006-013B
 ▲ = 1401B

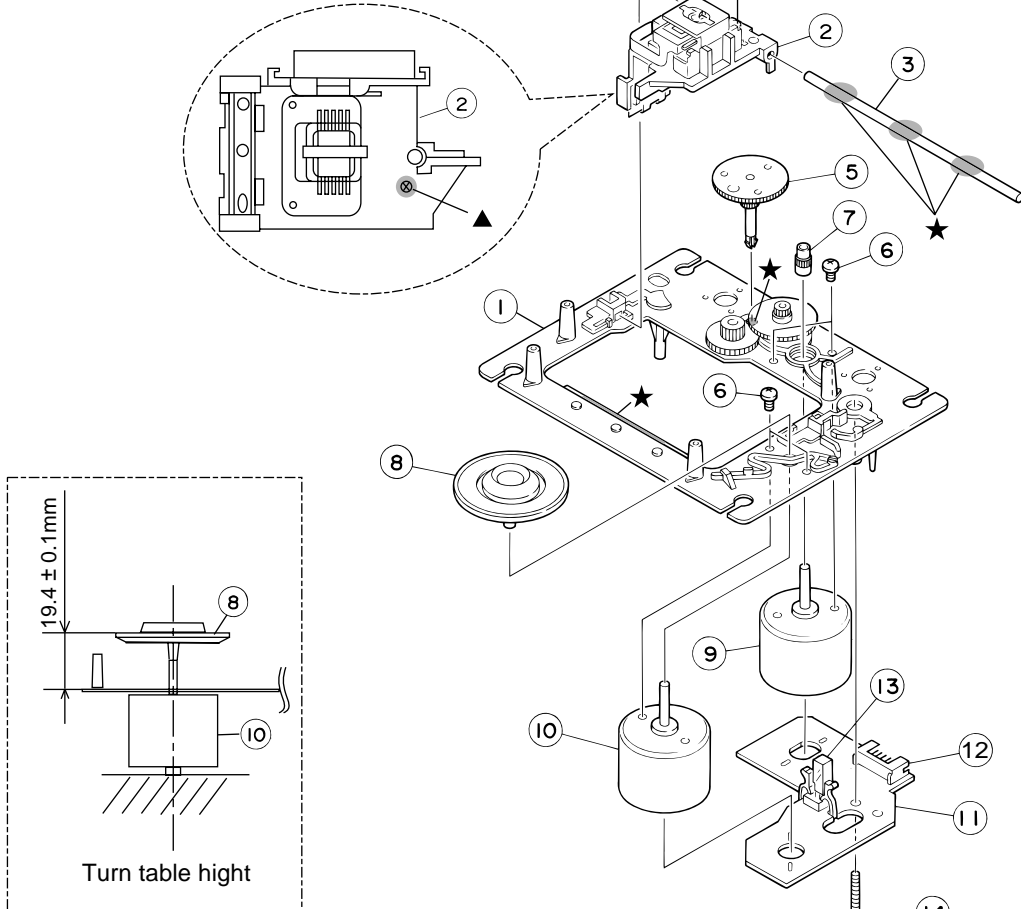

EXL-M7MB

■ **Parts list (CD mechanism)**

Block No. **M4MM**

▲	Item	Parts number	Parts name	Q'ty	Description	Area
	1	E102731-221SM	CD MECHA BASE A	1		
	2	OPTIMA-7B	CD PICK	1		
	3	E406777-002SM	CD SHAFT	1		
	4	LV31002-001A	CD RACK	1		
	5	E307745-441SM	CD GEAR 3	1		
	6	QYSDSP2003N	SCREW	4		
	7	E406750-442SM	PINION	1		
	8	EPB-001PK	T.TABLE ASSY	1		
	9	E406784-001	FEED MOTOR	1		
	10	QAR0130-001	SP MOTOR	1		
	11	EMW10190-441	CIR BOARD	1		
	12	QGA2001F1-06	6P PLUG ASSY	1	FOR P011	
	13	QSW0506-001	LEAF SW	1	FOR S001	
	14	E75832-221SS	SPECIAL SCREW	1	FOR M.CB	
	15	QYSDSF2606Z	SCREW	1		

■ Electrical parts list (Main board)

Block No. 01

△	Item	Parts number	Parts name	Remarks	Area	△	Item	Parts number	Parts name	Remarks	Area
	CN900	QGF1205C1-10	CONNECTOR	SLC			C2212	EETC1HM-105ZJC	E CAPACITOR		
	CN901	QGF1205C1-09	CONNECTOR	SLC			C2213	EETC1CM-106ZJC	E CAPACITOR		
	CN902	QGF1205F1-09	CONNECTOR	TUNER			C2214	EETC1HM-105ZJC	E CAPACITOR		
	CN903	QGF1205F1-13	CONNECTOR	CD			C2215	EEKC1CM-226ZJC	E CAPACITOR		
	CN904	QGF1205F1-16	CONNECTOR	CD			C2221	EETC1AM-107ZJC	E CAPACITOR		
	CN905	QGA2501F1-03	CONNECTOR		UB		C2222	EEKC1CM-107ZJC	E CAPACITOR		
	CN906	QGA2501C1-05	5P CONNECTOR	H/P			C2224	EETC1CM-107ZJC	E CAPACITOR		
	CN907	QGD2504C1-04Z	SOCKET	TRANS			C2225	QETC1AM-336Z	E CAPACITOR	33MF 20% 10V	
	CN931	QGF1205F1-17	CONNECTOR				C2226	EETC1HM-105ZJC	E CAPACITOR		
	C2000	QCBB1HK-221Y	C CAPACITOR	220PF 10% 50V			C2229	EETC1EM-106ZJC	E CAPACITOR		
	C2003	QCBB1HK-221Y	C CAPACITOR	220PF 10% 50V	UB		C2230	QETN1HM-105Z	E CAPACITOR	1.0MF 20% 50V	
	C2005	QEK1HM-475Z	E CAPACITOR	4.7MF 20% 50V			C2231	QETN1HM-105Z	E CAPACITOR	1.0MF 20% 50V	
	C2006	QEK1HM-475Z	E CAPACITOR	4.7MF 20% 50V			C2232	QFLM1HJ-563Z	M CAPACITOR	.056MF 5% 50V	
	C2007	QTE1V06-106Z	E CAPACITOR				C2233	QFLM1HJ-563Z	M CAPACITOR	.056MF 5% 50V	
	C2008	QEK1HM-475Z	E CAPACITOR	4.7MF 20% 50V			C2234	QEK1CM-107Z	E CAPACITOR	100MF 20% 16V	
	C2009	QEK1HM-475Z	E CAPACITOR	4.7MF 20% 50V			C2235	EETC1HM-225ZJC	E CAPACITOR		
	C2010	QEK1HM-475Z	E CAPACITOR	4.7MF 20% 50V			C2503	QDGB1HK-102Y	C CAPACITOR		
	C2011	QFLM1HJ-272Z	M CAPACITOR	2700PF 5% 50V			C3201	EETC1CM-107ZJC	E CAPACITOR		
	C2012	QFVJ1HJ-104Z	MF CAPACITOR	.10MF 5% 50V			C3202	QFLM1HJ-104Z	M CAPACITOR	.10MF 5% 50V	
	C2013	QFVJ1HJ-104Z	MF CAPACITOR	.10MF 5% 50V			C3203	EETC1CM-107ZJC	E CAPACITOR		
	C2014	QFVJ1HJ-184Z	MF CAPACITOR	.18MF 5% 50V			C3204	QFLM1HJ-104Z	M CAPACITOR	.10MF 5% 50V	
	C2015	QFVJ1HJ-184Z	MF CAPACITOR	.18MF 5% 50V			C3205	EETC1CM-107ZJC	E CAPACITOR		
	C2016	QFLM1HJ-823Z	M CAPACITOR	.082MF 5% 50V			C3206	QFLM1HJ-104Z	M CAPACITOR	.10MF 5% 50V	
	C2017	QTE1C06-226Z	E CAPACITOR				C3222	QFVJ1HJ-334Z	M CAPACITOR	.33MF 5% 50V	
	C2018	QFLM1HJ-823Z	M CAPACITOR	.082MF 5% 50V			C7001	QCSB1HJ-200Y	C CAPACITOR	20PF 5% 50V	
	C2019	QFVF1HJ-274Z	MF CAPACITOR	.27MF 5% 50V			C7002	QCSB1HJ-220Y	C CAPACITOR	22PF 5% 50V	
	C2026	QFLM1HJ-123Z	M CAPACITOR	.012MF 5% 50V			C7003	QDGB1HK-102Y	C CAPACITOR		
	C2027	QDGB1HK-102Y	C CAPACITOR				C7004	EEKC1AM-107ZJC	E CAPACITOR		
	C2028	QTE1V06-106Z	E CAPACITOR				C7005	QDYB1CM-103Y	C CAPACITOR		
	C2029	QCBB1HK-331Y	C CAPACITOR	330PF 10% 50V			C7006	QCSB1HJ-180Y	C CAPACITOR	18PF 5% 50V	
	C2030	QFLM1HJ-104Z	M CAPACITOR	.10MF 5% 50V			C7007	QCSB1HJ-180Y	C CAPACITOR	18PF 5% 50V	
	C2031	QFLM1HJ-104Z	M CAPACITOR	.10MF 5% 50V			C7008	EETB0JM-228JJC	E CAPACITOR		
	C2032	QCBB1HK-221Y	C CAPACITOR	220PF 10% 50V			C7009	EETC1HM-225ZJC	E CAPACITOR		
	C2033	QDXB1CM-332Y	C CAPACITOR				C7010	EETC1HM-475ZJC	E CAPACITOR		
	C2100	QCBB1HK-221Y	C CAPACITOR	220PF 10% 50V			C7011	EETC1CM-107ZJC	E CAPACITOR		
	C2103	QCBB1HK-221Y	C CAPACITOR	220PF 10% 50V	UB		C7012	QCFB1HZ-104Y	C CAPACITOR	.10MF +80:-20%	
	C2105	QEK1HM-475Z	E CAPACITOR	4.7MF 20% 50V			C7041	QDYB1CM-103Y	C CAPACITOR		
	C2106	QEK1HM-475Z	E CAPACITOR	4.7MF 20% 50V			C7061	QCBB1HK-151Y	C CAPACITOR	150PF 10% 50V	
	C2107	QTE1V06-106Z	E CAPACITOR				C7063	QCBB1HK-151Y	C CAPACITOR	150PF 10% 50V	
	C2108	QEK1HM-475Z	E CAPACITOR	4.7MF 20% 50V			C7108	QCBB1HK-101Y	C CAPACITOR	100PF 10% 50V	
	C2109	QEK1HM-475Z	E CAPACITOR	4.7MF 20% 50V			C7111	QCBB1HK-101Y	C CAPACITOR	100PF 10% 50V	
	C2110	QEK1HM-475Z	E CAPACITOR	4.7MF 20% 50V			C7113	QCBB1HK-151Y	C CAPACITOR	150PF 10% 50V	
	C2111	QFLM1HJ-272Z	M CAPACITOR	2700PF 5% 50V			C7115	QCBB1HK-101Y	C CAPACITOR	100PF 10% 50V	
	C2112	QFVJ1HJ-104Z	MF CAPACITOR	.10MF 5% 50V			C7123	QDGB1HK-102Y	C CAPACITOR		
	C2113	QFVJ1HJ-104Z	MF CAPACITOR	.10MF 5% 50V			C7128	QDGB1HK-102Y	C CAPACITOR		
	C2114	QFVJ1HJ-184Z	MF CAPACITOR	.18MF 5% 50V			C7135	QCBB1HK-101Y	C CAPACITOR	100PF 10% 50V	
	C2115	QFVJ1HJ-184Z	MF CAPACITOR	.18MF 5% 50V			C7136	QCBB1HK-101Y	C CAPACITOR	100PF 10% 50V	
	C2116	QFLM1HJ-823Z	M CAPACITOR	.082MF 5% 50V			C7144	QDYB1CM-103Y	C CAPACITOR		
	C2117	QTE1C06-226Z	E CAPACITOR				C7149	QCBB1HK-101Y	C CAPACITOR	100PF 10% 50V	
	C2118	QFLM1HJ-823Z	M CAPACITOR	.082MF 5% 50V			C7152	QDGB1HK-102Y	C CAPACITOR		
	C2119	QFVF1HJ-274Z	MF CAPACITOR	.27MF 5% 50V			D2200	1SS133-T2	SI DIODE		
	C2126	QFLM1HJ-123Z	M CAPACITOR	.012MF 5% 50V			D2201	1SS133-T2	SI DIODE		
	C2127	QDGB1HK-102Y	C CAPACITOR				D2202	MTZJ6.8B-T2	Z DIODE		
	C2128	QTE1V06-106Z	E CAPACITOR				D2203	1SS133-T2	SI DIODE		
	C2129	QCBB1HK-331Y	C CAPACITOR	330PF 10% 50V			D2204	1N4003S-T5	SI DIODE		
	C2130	QFLM1HJ-104Z	M CAPACITOR	.10MF 5% 50V			D2205	1SS133-T2	SI DIODE		
	C2131	QFLM1HJ-104Z	M CAPACITOR	.10MF 5% 50V			D2206	1SS133-T2	SI DIODE		
	C2132	QCBB1HK-221Y	C CAPACITOR	220PF 10% 50V			D2212	1SS133-T2	SI DIODE		
	C2133	QDXB1CM-332Y	C CAPACITOR				D2213	1SS133-T2	SI DIODE		
	C2200	QETM1EM-828	E CAPACITOR	8200MF 20% 25V			D3218	1SS133-T2	SI DIODE		
	C2207	QFLK1HJ-104Z	TF CAPACITOR	.10MF 5% 50V			D3219	MTZJ8.2C-T2	Z DIODE		
	C2209	QETC1HM-684Z	E CAPACITOR	.68MF 20% 50V	UB		D3220	MTZJ11B-T2	Z DIODE		
	C2211	QDYB1CM-103Y	C CAPACITOR				D3221	MTZJ11B-T2	Z DIODE		

■ Electrical parts list (Main board)

Block No. 01

△	Item	Parts number	Parts name	Remarks	Area
	D7001	1SS133-T2	SI DIODE	US5V	
	D7002	1SS133-T2	SI DIODE		
	D7003	1SS133-T2	SI DIODE	RESET	
	D7004	1SS133-T2	SI DIODE	BACK UP	
	D7005	1SS133-T2	SI DIODE	US5V	
	D7006	1SS133-T2	SI DIODE		
	D7007	MTZJ5.1C-T2	Z DIODE	BACK UP CONT.	
	D7008	MTZJ8.2B-T2	DIODE		
	D7061	1SS133-T2	SI DIODE		
△	F3000	QMF51W2-1R0-J8	FUSE		
△	IC901	LC75345M-X	IC		
△	IC905	LA4628	IC		
	IC910	L4909	REGULATOR IC		
	IC931	UPD780055GC-029	MASK ROM	SYSTEM MICOM	
	IC932	KIA78S06P-T	IC	US6V REG	
	J 900	QNN0018-002	PIN JACK		UB
	J 900	QNN0215-001	PIN JACK		US,UW,UY,UP
	J 901	QNB0117-001	SPK TERMINAL		
	J 902	GP1FA550TZ	OUTPUT TRANSF		UB
	K2200	QQR0621-001Z	FERRITE BEADS		
	K7001	QQR0621-001Z	FERRITE BEADS		
	K7002	QQR0621-001Z	FERRITE BEADS		
	K7003	QQR0621-001Z	FERRITE BEADS		
	L2200	QQR0797-001	INDUCTOR		
	L2201	QQR0797-001	INDUCTOR		
	L7001	QQL231K-100Y	INDUCTOR	US5V	
	L7002	QQL231K-470Y	INDUCTOR	AVDD & VDD	
	L7003	QQL231K-4R7Y	INDUCTOR	AVREF	
	PP900	QZW0038-001	WIRE CLAMP		UB
	PP901	QZW0038-001	WIRE CLAMP		
	Q2203	2SC2412K/R/-X	SI TRANSISTOR		UB
	Q2204	2SC2412K/R/-X	SI TRANSISTOR		UB
	Q2205	2SC2412K/R/-X	SI TRANSISTOR		UB
	Q2206	2SC2412K/R/-X	TRANSISTOR		
	Q2207	2SC2412K/R/-X	TRANSISTOR		
	Q2208	DTA143EKA-X	TRANSISTOR		
	Q2209	2SC2412K/R/-X	TRANSISTOR		
	Q2210	2SC2412K/R/-X	TRANSISTOR		
	Q2211	2SC2001/LK/-T	TRANSISTOR		
	Q2212	2SC2412K/R/-X	TRANSISTOR		
	Q2213	2SC2412K/R/-X	TRANSISTOR		
	Q2214	DTA143EKA-X	TRANSISTOR		
	Q7001	2SA1037AK/RS/-X	TRANSISTOR	SW5V	
	Q7002	DTC114TKA-X	TRANSISTOR	RESET SW	
	Q7003	2SC2412K/R/-X	TRANSISTOR	BACKUP CONT	
	Q7031	2SC2412K/R/-X	TRANSISTOR	POUT SW	
	Q7041	2SC2412K/R/-X	TRANSISTOR	PHOTO BUFFER	
	Q7061	DTC114TKA-X	TRANSISTOR		
	Q7062	DTC114TKA-X	TRANSISTOR		
	R2000	QRE141J-303Y	C RESISTOR	30K 5% 1/4W	
	R2001	QRE141J-303Y	C RESISTOR	30K 5% 1/4W	
	R2003	QRE141J-221Y	C RESISTOR	220 5% 1/4W	UB
	R2004	QRE141J-103Y	C RESISTOR	10K 5% 1/4W	UB
	R2005	QRE141J-562Y	C RESISTOR	5.6K 5% 1/4W	UB
	R2006	QRE141J-222Y	C RESISTOR	2.2K 5% 1/4W	
	R2007	QRE141J-622Y	C RESISTOR	6.2K 5% 1/4W	
	R2008	QRE141J-912Y	C RESISTOR	9.1K 5% 1/4W	
	R2009	QRE141J-272Y	C RESISTOR	2.7K 5% 1/4W	
	R2010	QRE141J-752Y	C RESISTOR	7.5K 5% 1/4W	
	R2011	QRE141J-752Y	C RESISTOR	7.5K 5% 1/4W	
	R2012	QRE141J-202Y	C RESISTOR	2.0K 5% 1/4W	
	R2013	QRE141J-222Y	C RESISTOR	2.2K 5% 1/4W	
	R2014	QRE141J-153Y	C RESISTOR	15K 5% 1/4W	

△	Item	Parts number	Parts name	Remarks	Area
	R2015	QRE141J-473Y	C RESISTOR	47K 5% 1/4W	
	R2016	QRE141J-622Y	C RESISTOR	6.2K 5% 1/4W	
	R2017	QRE141J-182Y	C RESISTOR	1.8K 5% 1/4W	
	R2025	QRE141J-103Y	C RESISTOR	10K 5% 1/4W	
	R2026	QRE141J-332Y	C RESISTOR	3.3K 5% 1/4W	
	R2027	QRE141J-472Y	C RESISTOR	4.7K 5% 1/4W	
	R2028	QRE141J-2R2Y	C RESISTOR	2.2 5% 1/4W	
	R2029	QRE141J-2R2Y	C RESISTOR	2.2 5% 1/4W	
	R2030	QRE141J-163Y	C RESISTOR	16K 5% 1/4W	
	R2031	QRE141J-163Y	C RESISTOR	16K 5% 1/4W	
	R2032	QRE141J-222Y	C RESISTOR	2.2K 5% 1/4W	
	R2040	QRE141J-471Y	C RESISTOR	470 5% 1/4W	
	R2041	QRE141J-182Y	C RESISTOR	1.8K 5% 1/4W	
	R2047	QRE141J-224Y	C RESISTOR	220K 5% 1/4W	
	R2100	QRE141J-303Y	C RESISTOR	30K 5% 1/4W	
	R2101	QRE141J-303Y	C RESISTOR	30K 5% 1/4W	
	R2103	QRE141J-221Y	C RESISTOR	220 5% 1/4W	UB
	R2104	QRE141J-103Y	C RESISTOR	10K 5% 1/4W	UB
	R2105	QRE141J-562Y	C RESISTOR	5.6K 5% 1/4W	UB
	R2106	QRE141J-222Y	C RESISTOR	2.2K 5% 1/4W	
	R2107	QRE141J-622Y	C RESISTOR	6.2K 5% 1/4W	
	R2108	QRE141J-912Y	C RESISTOR	9.1K 5% 1/4W	
	R2109	QRE141J-272Y	C RESISTOR	2.7K 5% 1/4W	
	R2110	QRE141J-752Y	C RESISTOR	7.5K 5% 1/4W	
	R2111	QRE141J-752Y	C RESISTOR	7.5K 5% 1/4W	
	R2112	QRE141J-202Y	C RESISTOR	2.0K 5% 1/4W	
	R2113	QRE141J-222Y	C RESISTOR	2.2K 5% 1/4W	
	R2114	QRE141J-153Y	C RESISTOR	15K 5% 1/4W	
	R2115	QRE141J-473Y	C RESISTOR	47K 5% 1/4W	
	R2116	QRE141J-622Y	C RESISTOR	6.2K 5% 1/4W	
	R2117	QRE141J-182Y	C RESISTOR	1.8K 5% 1/4W	
	R2125	QRE141J-103Y	C RESISTOR	10K 5% 1/4W	
	R2126	QRE141J-332Y	C RESISTOR	3.3K 5% 1/4W	
	R2127	QRE141J-472Y	C RESISTOR	4.7K 5% 1/4W	
	R2128	QRE141J-2R2Y	C RESISTOR	2.2 5% 1/4W	
	R2129	QRE141J-2R2Y	C RESISTOR	2.2 5% 1/4W	
	R2130	QRE141J-163Y	C RESISTOR	16K 5% 1/4W	
	R2131	QRE141J-163Y	C RESISTOR	16K 5% 1/4W	
	R2132	QRE141J-471Y	C RESISTOR	470 5% 1/4W	
	R2140	QRE141J-471Y	C RESISTOR	470 5% 1/4W	
	R2141	QRE141J-182Y	C RESISTOR	1.8K 5% 1/4W	
	R2147	QRE141J-224Y	C RESISTOR	220K 5% 1/4W	
	R2200	QRE141J-273Y	C RESISTOR	27K 5% 1/4W	
	R2207	QRE141J-513Y	C RESISTOR	51K 5% 1/4W	
	R2208	QRE141J-124Y	C RESISTOR	120K 5% 1/4W	
	R2209	QRE141J-154Y	C RESISTOR	150K 5% 1/4W	
	R2213	QRE141J-682Y	C RESISTOR	6.8K 5% 1/4W	
	R2214	QRE141J-682Y	C RESISTOR	6.8K 5% 1/4W	
	R2218	QRE141J-471Y	C RESISTOR	470 5% 1/4W	
	R2221	QRE141J-101Y	C RESISTOR	100 5% 1/4W	
	R2222	QRE141J-222Y	C RESISTOR	2.2K 5% 1/4W	
	R2224	QRE141J-222Y	C RESISTOR	2.2K 5% 1/4W	
	R2231	QRE141J-222Y	C RESISTOR	2.2K 5% 1/4W	
	R3200	QRE141J-102Y	C RESISTOR	1.0K 5% 1/4W	
	R3201	QRE141J-822Y	C RESISTOR	8.2K 5% 1/4W	
	R3202	QRE141J-122Y	C RESISTOR	1.2K 5% 1/4W	
	R3203	QRE141J-472Y	C RESISTOR	4.7K 5% 1/4W	
	R3204	QRE141J-122Y	C RESISTOR	1.2K 5% 1/4W	
	R3205	QRE141J-622Y	C RESISTOR	6.2K 5% 1/4W	
	R3206	QRE141J-122Y	C RESISTOR	1.2K 5% 1/4W	
	R3207	QRE141J-820Y	C RESISTOR	82 5% 1/4W	
	R3209	QRE141J-820Y	C RESISTOR	82 5% 1/4W	
	R7000	QRZ9006-4R7X	F RESISTOR	4.7 1/0W	

■ Electrical parts list (Main board)

Block No. 01

△	Item	Parts number	Parts name	Remarks	Area
	R7001	QRE141J-102Y	C RESISTOR	1.0K 5% 1/4W	
	R7002	QRE141J-103Y	C RESISTOR	10K 5% 1/4W	
	R7003	QRE141J-331Y	C RESISTOR	330 5% 1/4W	
	R7004	QRE141J-103Y	C RESISTOR	10K 5% 1/4W	
	R7005	QRE141J-103Y	C RESISTOR	10K 5% 1/4W	
	R7006	QRE141J-104Y	C RESISTOR	100K 5% 1/4W	
	R7007	QRE141J-473Y	C RESISTOR	47K 5% 1/4W	
	R7008	QRE141J-333Y	C RESISTOR	33K 5% 1/4W	
	R7041	QRE141J-823Y	C RESISTOR	82K 5% 1/4W	
	R7042	QRE141J-394Y	C RESISTOR	390K 5% 1/4W	
	R7043	QRE141J-104Y	C RESISTOR	100K 5% 1/4W	
	R7062	QRE141J-102Y	C RESISTOR	1.0K 5% 1/4W	
	R7064	QRE141J-103Y	C RESISTOR	10K 5% 1/4W	
	R7065	QRE141J-563Y	C RESISTOR	56K 5% 1/4W	
	R7075	QRE141J-222Y	C RESISTOR	2.2K 5% 1/4W	
	R7076	QRE141J-473Y	C RESISTOR	47K 5% 1/4W	
	R7077	QRE141J-913Y	C RESISTOR	91K 5% 1/4W	
	R7078	QRE141J-102Y	C RESISTOR	1.0K 5% 1/4W	
	R7079	QRE141J-223Y	C RESISTOR	22K 5% 1/4W	
	R7101	QRE141J-222Y	C RESISTOR	2.2K 5% 1/4W	
	R7102	QRE141J-222Y	C RESISTOR	2.2K 5% 1/4W	
	R7103	QRE141J-222Y	C RESISTOR	2.2K 5% 1/4W	
	R7106	QRE141J-102Y	C RESISTOR	1.0K 5% 1/4W	
	R7108	QRE141J-102Y	C RESISTOR	1.0K 5% 1/4W	
	R7109	QRE141J-102Y	C RESISTOR	1.0K 5% 1/4W	
	R7110	QRE141J-102Y	C RESISTOR	1.0K 5% 1/4W	
	R7111	QRE141J-102Y	C RESISTOR	1.0K 5% 1/4W	
	R7112	QRE141J-222Y	C RESISTOR	2.2K 5% 1/4W	
	R7113	QRE141J-222Y	C RESISTOR	2.2K 5% 1/4W	
	R7114	QRE141J-102Y	C RESISTOR	1.0K 5% 1/4W	
	R7115	QRE141J-102Y	C RESISTOR	1.0K 5% 1/4W	
	R7116	QRE141J-222Y	C RESISTOR	2.2K 5% 1/4W	
	R7117	QRE141J-222Y	C RESISTOR	2.2K 5% 1/4W	
	R7118	QRE141J-222Y	C RESISTOR	2.2K 5% 1/4W	
	R7119	QRE141J-102Y	C RESISTOR	1.0K 5% 1/4W	
	R7120	QRE141J-222Y	C RESISTOR	2.2K 5% 1/4W	
	R7122	QRE141J-222Y	C RESISTOR	2.2K 5% 1/4W	
	R7123	QRE141J-222Y	C RESISTOR	2.2K 5% 1/4W	
	R7124	QRE141J-153Y	C RESISTOR	15K 5% 1/4W	
	R7126	QRE141J-222Y	C RESISTOR	2.2K 5% 1/4W	
	R7127	QRE141J-123Y	C RESISTOR	12K 5% 1/4W	
	R7128	QRE141J-222Y	C RESISTOR	2.2K 5% 1/4W	
	R7129	QRE141J-222Y	C RESISTOR	2.2K 5% 1/4W	
	R7130	QRE141J-222Y	C RESISTOR	2.2K 5% 1/4W	
	R7131	QRE141J-222Y	C RESISTOR	2.2K 5% 1/4W	
	R7132	QRE141J-222Y	C RESISTOR	2.2K 5% 1/4W	
	R7133	QRE141J-222Y	C RESISTOR	2.2K 5% 1/4W	
	R7134	QRE141J-222Y	C RESISTOR	2.2K 5% 1/4W	
	R7136	QRE141J-222Y	C RESISTOR	2.2K 5% 1/4W	
	R7137	QRE141J-222Y	C RESISTOR	2.2K 5% 1/4W	
	R7138	QRE141J-222Y	C RESISTOR	2.2K 5% 1/4W	
	R7139	QRE141J-222Y	C RESISTOR	2.2K 5% 1/4W	
	R7140	QRE141J-222Y	C RESISTOR	2.2K 5% 1/4W	
	R7141	QRE141J-222Y	C RESISTOR	2.2K 5% 1/4W	
	R7142	QRE141J-102Y	C RESISTOR	1.0K 5% 1/4W	
	R7143	QRE141J-222Y	C RESISTOR	2.2K 5% 1/4W	
	R7144	QRE141J-222Y	C RESISTOR	2.2K 5% 1/4W	
	R7145	QRE141J-102Y	C RESISTOR	1.0K 5% 1/4W	
	R7146	QRE141J-222Y	C RESISTOR	2.2K 5% 1/4W	
	R7148	QRE141J-222Y	C RESISTOR	2.2K 5% 1/4W	
	R7149	QRE141J-103Y	C RESISTOR	10K 5% 1/4W	
	R7150	QRE141J-222Y	C RESISTOR	2.2K 5% 1/4W	
	R7151	QRE141J-222Y	C RESISTOR	2.2K 5% 1/4W	

△	Item	Parts number	Parts name	Remarks	Area
	R7152	QRE141J-222Y	C RESISTOR	2.2K 5% 1/4W	
	R7153	QRE141J-222Y	C RESISTOR	2.2K 5% 1/4W	
	R7154	QRE141J-222Y	C RESISTOR	2.2K 5% 1/4W	
	R7155	QRE141J-222Y	C RESISTOR	2.2K 5% 1/4W	
	R7157	QRE141J-103Y	C RESISTOR	10K 5% 1/4W	
	R7162	QRE141J-103Y	C RESISTOR	10K 5% 1/4W	
	R7201	QRE141J-104Y	C RESISTOR	100K 5% 1/4W	
	R7202	QRE141J-103Y	C RESISTOR	10K 5% 1/4W	
	R7203	QRE141J-823Y	C RESISTOR	82K 5% 1/4W	
	R7206	QRE141J-473Y	C RESISTOR	47K 5% 1/4W	
	R7214	QRE141J-473Y	C RESISTOR	47K 5% 1/4W	
	R7215	QRE141J-473Y	C RESISTOR	47K 5% 1/4W	
	R7217	QRE141J-103Y	C RESISTOR	10K 5% 1/4W	
	R7218	QRE141J-103Y	C RESISTOR	10K 5% 1/4W	
	R7232	QRE141J-823Y	C RESISTOR	82K 5% 1/4W	
	R7236	QRE141J-103Y	C RESISTOR	10K 5% 1/4W	
	R7238	QRE141J-103Y	C RESISTOR	10K 5% 1/4W	
	R7239	QRE141J-103Y	C RESISTOR	10K 5% 1/4W	
	R7240	QRE141J-103Y	C RESISTOR	10K 5% 1/4W	
	R7252	QRE141J-103Y	C RESISTOR	10K 5% 1/4W	
	R7253	QRE141J-104Y	C RESISTOR	100K 5% 1/4W	
	R7254	QRE141J-103Y	C RESISTOR	10K 5% 1/4W	
	R7255	QRE141J-103Y	C RESISTOR	10K 5% 1/4W	
	X7001	QAX0410-001Z	CERA LOCK		
	X7002	QAX0401-001	CRYSTAL		
	Z3001	QNG0020-001Z	FUSE CLIP		
	Z3002	QNG0020-001Z	FUSE CLIP		

■ Electrical parts list (Front board)

Block No. 02

△	Item	Parts number	Parts name	Remarks	Area
	CN932	QGF1205F1-17	CONNECTOR		
	C1000	QFLM1HJ-104Z	M CAPACITOR	.10MF 5% 50V	
	C1001	QFLM1HJ-104Z	M CAPACITOR	.10MF 5% 50V	
	C1002	QFLM1HJ-104Z	M CAPACITOR	.10MF 5% 50V	
	C1003	QFLM1HJ-104Z	M CAPACITOR	.10MF 5% 50V	
	C7301	QEK1CM-476Z	E CAPACITOR	47MF 20% 16V	
	C7302	QDGB1HK-102Y	C CAPACITOR		
	C7303	QDYB1CM-103Y	C CAPACITOR		
	C7304	QDYB1CM-103Y	C CAPACITOR		
	C7305	QDYB1CM-103Y	C CAPACITOR		
	C7306	QDYB1CM-103Y	C CAPACITOR		
	C7307	QDYB1CM-103Y	C CAPACITOR		
	C7341	QEK1AM-107Z	E CAPACITOR	100MF 20% 10V	
	C7351	QDYB1CM-103Y	C CAPACITOR		
	C7352	QDYB1CM-103Y	C CAPACITOR		
	DI934	QLD0160-001	LCD	LCD DISPLAY	
△	D1000	6A10E2	SI DIODE		
△	D1001	6A10E2	SI DIODE		
△	D1002	6A10E2	SI DIODE		
△	D1003	6A10E2	SI DIODE		
	D7321	QLMP-AL49	LED	BACK LIGHT	
	D7322	QLMP-AL49	LED	BACK LIGHT	
	D7323	QLMP-AL49	LED	BACK LIGHT	
	D7331	SPR-39MVWF	LED	POW INDICATOR	
	EP940	E409182-001SM	GRAND TERMINAL		
	FW931	QUM023-05Z4Z4	TM FLAT	FLAT WIRE	
	FW943	QUM154-17DGZ4	FLAT WIRE		
△	F1000	QMF51W2-1R0-J8	FUSE		US,UW,UY
△	F1000	QMF51W2-R50-J8	FUSE		UP
△	F1000	QMF51W2-R40-J8	FUSE		UB
△	F1001	QMF51W2-5R0-J8	FUSE		UB
△	F1001	QMF51W2-6R3-J8	FUSE		US,UW,UY,UP
△	F1002	QMF51W2-R50-J8	FUSE		US,UW,UY
	IC933	GP1U261X	IR DETECT UNIT	IR RX	
	IC934	NJU6433FG1	IC	LCD DRIVER	
	JS731	QSW0917-001	R ENCODER	VOLUME	
△	J1000	QGA7901C1-02	CONNECTOR		
	J5000	QNS0170-001	JACK		
	K5020	QQR0779-001Z	INDUCTOR		
	K5021	QQR0779-001Z	INDUCTOR		
△	L1000	QQR1145-001	LINE FILTER	EMC FILTER	
	L5031	QQL231K-470Y	INDUCTOR		
	L5032	QQL231K-470Y	INDUCTOR		
	L5034	QQL231K-470Y	INDUCTOR		
	Q7331	KRC111M-T	TRANSISTOR		
	R5000	QRE141J-151Y	C RESISTOR	150 5% 1/4W	
	R5001	QRE141J-151Y	C RESISTOR	150 5% 1/4W	
	R7301	QRE141J-102Y	C RESISTOR	1.0K 5% 1/4W	
	R7302	QRE141J-102Y	C RESISTOR	1.0K 5% 1/4W	
	R7303	QRE141J-122Y	C RESISTOR	1.2K 5% 1/4W	
	R7304	QRE141J-152Y	C RESISTOR	1.5K 5% 1/4W	
	R7305	QRE141J-222Y	C RESISTOR	2.2K 5% 1/4W	
	R7306	QRE141J-272Y	C RESISTOR	2.7K 5% 1/4W	
	R7307	QRE141J-392Y	C RESISTOR	3.9K 5% 1/4W	
	R7308	QRE141J-562Y	C RESISTOR	5.6K 5% 1/4W	
	R7309	QRE141J-103Y	C RESISTOR	10K 5% 1/4W	
	R7310	QRE141J-183Y	C RESISTOR	18K 5% 1/4W	
	R7311	QRE141J-102Y	C RESISTOR	1.0K 5% 1/4W	
	R7312	QRE141J-102Y	C RESISTOR	1.0K 5% 1/4W	
	R7313	QRE141J-122Y	C RESISTOR	1.2K 5% 1/4W	
	R7315	QRE141J-473Y	C RESISTOR	47K 5% 1/4W	UB,US,UW,UP
	R7315	QRE141J-152Y	C RESISTOR	1.5K 5% 1/4W	UY
	R7316	QRE141J-433Y	C RESISTOR	43K 5% 1/4W	

△	Item	Parts number	Parts name	Remarks	Area
	R7321	QRE141J-391Y	C RESISTOR	390 5% 1/4W	
	R7322	QRE141J-391Y	C RESISTOR	390 5% 1/4W	
	R7323	QRE141J-391Y	C RESISTOR	390 5% 1/4W	
	R7331	QRE141J-391Y	C RESISTOR	390 5% 1/4W	
	R7341	QRE141J-103Y	C RESISTOR	10K 5% 1/4W	
	R7342	QRE141J-134Y	C RESISTOR	130K 5% 1/4W	
	S1000	QSW0812-001	VOLTAGE SWITCH		US,UW,UY
	S7302	QSW0825-001Z	TACT SWITCH	CLOCK	
	S7303	QSW0825-001Z	TACT SWITCH	TIMER	
	S7304	QSW0825-001Z	TACT SWITCH	REVERSE	
	S7305	QSW0825-001Z	TACT SWITCH	CD REC	
	S7306	QSW0825-001Z	TACT SWITCH	AUX	
	S7307	QSW0825-001Z	TACT SWITCH	TUNER	
	S7308	QSW0825-001Z	TACT SWITCH	TAPE	
	S7309	QSW0825-001Z	TACT SWITCH	CD	
	S7310	QSW0825-001Z	TACT SWITCH	DOWN	
	S7311	QSW0825-001Z	TACT SWITCH	STOP	
	S7312	QSW0825-001Z	TACT SWITCH	OPEN/CLOSE	
	S7313	QSW0825-001Z	TACT SWITCH	SOUND	
	S7314	QSW0825-001Z	TACT SWITCH	AHB-PRO	
	S7315	QSW0825-001Z	TACT SWITCH	POWER	
	S7316	QSW0825-001Z	TACT SWITCH	UP	
	W5000	QJK017-051400	WIRE		
	Z1000	QNG0020-001Z	FUSE CLIP		
	Z1001	QNG0020-001Z	FUSE CLIP		
	Z1002	QNG0020-001Z	FUSE CLIP		
	Z1003	QNG0020-001Z	FUSE CLIP		
	Z1004	QNG0020-001Z	FUSE CLIP		US,UW,UY
	Z1005	QNG0020-001Z	FUSE CLIP		US,UW,UY

■ Electrical parts list (CD servo board)

Block No. 03

△	Item	Parts number	Parts name	Remarks	Area	△	Item	Parts number	Parts name	Remarks	Area
	C 601	NCB31HK-102X	C CAPACITOR				CN606	QGF1205F1-05	CONNECTOR		
	C 602	NCB31HK-102X	C CAPACITOR				CN651	QGF1205F1-16	CONNECTOR		
	C 603	NCB31HK-223X	C CAPACITOR				CN652	QGF1205F1-13	CONNECTOR		
	C 604	NCB31HK-223X	C CAPACITOR				CN801	QGA2001C1-06	6P PLUG ASSY		
	C 605	NCS31HJ-151X	C CAPACITOR				D 601	1SS355-X	DIODE		
	C 606	NCS31HJ-560X	C CAPACITOR				D 602	1SS355-X	DIODE		
	C 610	NCB31CK-273X	C CAPACITOR				D 831	MTZJ5.6B-T2	Z DIODE		
	C 612	QERF1HM-105Z	E CAPACITOR	1.0MF 20% 50V			IC601	AN22000A-W	IC		
	C 613	NCF31AZ-105X	C CAPACITOR				IC651	MN662748RPM	IC		
	C 614	NCB31CK-273X	C CAPACITOR				IC801	LA6541-X	IC		
	C 615	NCB31HK-472X	C CAPACITOR				IC802	LB1641	IC		
	C 616	NCB31HK-103X	C CAPACITOR				L 831	QQL244K-100Z	INDUCTOR		
	C 617	NCS31HJ-331X	C CAPACITOR				Q 631	2SA1037AK/RS/-X	TRANSISTOR		
	C 619	NCS31HJ-470X	C CAPACITOR				Q 801	2SA952/LK/-T	TRANSISTOR		
	C 621	NCF31AZ-105X	C CAPACITOR				R 601	NRSA63J-224X	MG RESISTOR		
	C 622	NCB31CK-473X	C CAPACITOR				R 602	NRSA63J-274X	MG RESISTOR		
	C 623	NCF31AZ-105X	C CAPACITOR				R 603	NRSA63J-124X	MG RESISTOR		
	C 624	QERF0JM-107Z	E CAPACITOR	100MF 20% 6.3V			R 604	NRSA63J-274X	MG RESISTOR		
	C 631	QERF1CM-106Z	E CAPACITOR	10MF 20% 16V			R 605	NRSA63J-0R0X	MG RESISTOR		
	C 632	NCF31AZ-105X	C CAPACITOR				R 606	NRSA63J-0R0X	MG RESISTOR		
	C 633	NCB31HK-223X	C CAPACITOR				R 607	NRSA63J-623X	MG RESISTOR		
	C 641	NCB31HK-223X	C CAPACITOR				R 610	NRSA63J-822X	MG RESISTOR		
	C 642	NCB31HK-222X	C CAPACITOR				R 611	NRSA63J-822X	MG RESISTOR		
	C 643	NCS31HJ-821X	C CAPACITOR				R 612	NRSA63J-223X	MG RESISTOR		
	C 651	NCS31HJ-120X	C CAPACITOR				R 613	NRSA63J-222X	MG RESISTOR		
	C 652	NCS31HJ-120X	C CAPACITOR				R 617	NRSA63J-332X	MG RESISTOR		
	C 653	NCB31CK-104X	C CAPACITOR				R 618	NRSA63J-153X	MG RESISTOR		
	C 654	NCS31HJ-151X	C CAPACITOR				R 619	NRSA63J-153X	MG RESISTOR		
	C 655	NCB31CK-104X	C CAPACITOR				R 620	NRSA63J-564X	MG RESISTOR		
	C 656	NCB31CK-104X	C CAPACITOR				R 621	NRSA63J-564X	MG RESISTOR		
	C 657	QERF1AM-227Z	E CAPACITOR	220MF 20% 10V			R 631	NRSA63J-2R2X	MG RESISTOR		
	C 658	NCB31CK-104X	C CAPACITOR				R 632	NRSA63J-100X	MG RESISTOR		
	C 661	NCS31HJ-471X	C CAPACITOR				R 634	NRSA63J-120X	MG RESISTOR		
	C 663	NCB31HK-223X	C CAPACITOR				R 635	NRSA63J-121X	MG RESISTOR		
	C 664	NCB31HK-223X	C CAPACITOR				R 636	NRSA63J-100X	MG RESISTOR		
	C 665	NCB31AK-154X	C CAPACITOR				R 641	NRSA63J-154X	MG RESISTOR		
	C 669	QERF1AM-227Z	E CAPACITOR	220MF 20% 10V			R 642	NRSA63J-394X	MG RESISTOR		
	C 670	NCS31HJ-151X	C CAPACITOR				R 643	NRSA63J-223X	MG RESISTOR		
	C 671	NCS31HJ-151X	C CAPACITOR				R 647	NRSA63J-0R0X	MG RESISTOR		
	C 672	NCS31HJ-151X	C CAPACITOR				R 651	NRSA63J-102X	MG RESISTOR		
	C 673	QERF1AM-227Z	E CAPACITOR	220MF 20% 10V			R 652	NRSA63J-102X	MG RESISTOR		
	C 676	NCB31CK-104X	C CAPACITOR				R 653	NRSA63J-102X	MG RESISTOR		
	C 677	NCB31CK-104X	C CAPACITOR				R 654	NRSA63J-101X	MG RESISTOR		
	C 679	QERF0JM-107Z	E CAPACITOR	100MF 20% 6.3V			R 655	NRSA63J-102X	MG RESISTOR		
	C 680	NCB31CK-104X	C CAPACITOR				R 656	NRSA63J-102X	MG RESISTOR		
	C 681	NCB31AK-334X	C CAPACITOR				R 657	NRSA63J-0R0X	MG RESISTOR		
	C 693	NCB31HK-222X	C CAPACITOR				R 658	NRSA63J-0R0X	MG RESISTOR		
	C 694	NCB31HK-222X	C CAPACITOR				R 659	NRSA63J-0R0X	MG RESISTOR		
	C 801	NCB31HK-682X	C CAPACITOR				R 661	NRSA63J-393X	MG RESISTOR		
	C 802	NCB31HK-123X	C CAPACITOR				R 662	NRSA63J-683X	MG RESISTOR		
	C 811	NCS31HJ-391X	C CAPACITOR				R 663	NRSA63J-124X	MG RESISTOR		
	C 812	NCS31HJ-391X	C CAPACITOR				R 664	NRSA63J-331X	MG RESISTOR		
	C 813	NCS31HJ-391X	C CAPACITOR				R 665	NRSA63J-271X	MG RESISTOR		
	C 814	NCS31HJ-391X	C CAPACITOR				R 666	NRSA63J-221X	MG RESISTOR		
	C 815	QEZF1HM-225Z	E CAPACITOR	2.2MF 20% 50V			R 667	NRSA63J-4R7X	MG RESISTOR		
	C 821	NCF31AZ-105X	C CAPACITOR				R 670	NRSA63J-101X	MG RESISTOR		
	C 822	QERF1AM-227Z	E CAPACITOR	220MF 20% 10V			R 681	NRSA63J-272X	MG RESISTOR		
	C 823	QERF1AM-227Z	E CAPACITOR	220MF 20% 10V			R 682	NRSA63J-102X	MG RESISTOR		
	C 824	NCB31HK-222X	C CAPACITOR				R 683	NRSA63J-105X	MG RESISTOR		
	C 831	EEKJ1CM-107ZJC	E CAPACITOR				R 684	NRSA63J-155X	MG RESISTOR		
	C 832	NCB31HK-103X	C CAPACITOR				R 691	NRSA63J-102X	MG RESISTOR		
	C 833	NCB31CK-104X	C CAPACITOR				R 692	NRSA63J-102X	MG RESISTOR		
	CN601	QGF1016F1-15	15FFC CONNECTOR				R 801	NRSA63J-272X	MG RESISTOR		

■ Electrical parts list (CD servo board)

Block No. 03

△	Item	Parts number	Parts name	Remarks	Area
	R 802	NRSA63J-392X	MG RESISTOR		
	R 803	NRSA63J-222X	MG RESISTOR		
	R 804	NRSA63J-224X	MG RESISTOR		
	R 805	NRSA63J-133X	MG RESISTOR		
	R 806	NRSA63J-243X	MG RESISTOR		
	R 807	NRSA63J-122X	MG RESISTOR		
	R 808	NRSA63J-273X	MG RESISTOR		
	R 809	NRSA63J-122X	MG RESISTOR		
	R 812	NRSA63J-152X	MG RESISTOR		
	R 821	NRSA63J-0R0X	MG RESISTOR		
	R 822	NRSA63J-473X	MG RESISTOR		
	R 831	QRE141J-100Y	C RESISTOR	10 5% 1/4W	
	W 605	QJP001-031601	CONN.WIRE ASSY		UB
	X 651	QAX0413-001Z	CRYSTAL		

■ Electrical parts list (Tuner board)

Block No. 04

△	Item	Parts number	Parts name	Remarks	Area
	C 1	NCB21HK-223X	C CAPACITOR		
	C 2	NCB21HK-103X	C CAPACITOR		
	C 3	EETC1CM-106ZJC	E CAPACITOR		
	C 4	NCB21HK-103X	C CAPACITOR		
	C 6	NCB21HK-102X	C CAPACITOR		
	C 7	NCB21HK-102X	C CAPACITOR		
	C 8	NCB21HK-102X	C CAPACITOR		
	C 10	NRSA02J-0R0X	MG RESISTOR		
	C 11	NCB21HK-104X	C CAPACITOR		
	C 12	NCB21HK-473X	C CAPACITOR		
	C 13	NCS21HJ-120X	C CAPACITOR		
	C 14	EEKC1AM-107ZJC	E CAPACITOR		
	C 15	NCS21HJ-120X	C CAPACITOR		
	C 16	NCS21HJ-120X	C CAPACITOR		
	C 17	NCB21HK-392X	C CAPACITOR		
	C 18	QEQ61HM-474Z	NP E CAPACITOR	.47MF 20% 50V	
	C 19	NCB21HK-473X	C CAPACITOR		
	C 20	NCB21HK-102X	C CAPACITOR		
	C 21	NCB21HK-223X	C CAPACITOR		
	C 22	NCS21HJ-151X	C CAPACITOR		
	C 23	NCS21HJ-151X	C CAPACITOR		
	C 24	NCS21HJ-151X	C CAPACITOR		
	C 25	EEKC1AM-107ZJC	E CAPACITOR		
	C 26	NCB21HK-102X	C CAPACITOR		
	C 27	NCB21HK-102X	C CAPACITOR		
	C 30	EEKC1CM-107ZJC	E CAPACITOR		
	C 31	EETC1CM-226ZJC	E CAPACITOR		
	C 32	NCB21HK-473X	C CAPACITOR		
	C 33	NCB21HK-473X	C CAPACITOR		
	C 34	NCB21HK-223X	C CAPACITOR		
	C 35	NCB21HK-473X	C CAPACITOR		
	C 36	EEKC1HM-105ZJC	E CAPACITOR		
	C 37	EEKC1HM-105ZJC	E CAPACITOR		
	C 38	EETC1HM-224ZJC	E CAPACITOR		
	C 39	EETC1HM-105ZJC	E CAPACITOR		
	C 40	QETN1CM-106Z	E CAPACITOR	10MF 20% 16V	
	C 41	QETN1CM-106Z	E CAPACITOR	10MF 20% 16V	
	C 42	NCB21HK-152X	C CAPACITOR		
	C 43	NCB21HK-152X	C CAPACITOR		
	C 44	QETN1CM-106Z	E CAPACITOR	10MF 20% 16V	
	C 45	QETN1CM-106Z	E CAPACITOR	10MF 20% 16V	
	C 46	NCB21HK-273X	C CAPACITOR		
	C 47	EETC1HM-105ZJC	E CAPACITOR		
	C 48	NCB21HK-222X	C CAPACITOR		
	C 49	NCS21HJ-471X	C CAPACITOR		
	C 50	EETC1CM-226ZJC	E CAPACITOR		
	C 51	EEKC1HM-105ZJC	E CAPACITOR		
	C 52	QFVJ1HJ-274Z	MF CAPACITOR	.27MF 5% 50V	
	C 53	EETC1CM-226ZJC	E CAPACITOR		
	C 54	NCB21HK-473X	C CAPACITOR		
	C 57	NCB21HK-102X	C CAPACITOR		
	C 58	NCB21HK-473X	C CAPACITOR		
	C 59	NCB21HK-102X	C CAPACITOR		
	CF 1	VCF2L3B-105Z	CERAMIC FILTER		
	CF 2	VCF2L3B-105Z	CERAMIC FILTER		
	CF 3	QAX0610-001Z	C DISCRIMINATOR		
	CN 1	QGF1205F1-09	CONNECTOR		
	D 1	1SS133-T2	SI DIODE		
	D 2	1SS133-T2	SI DIODE		
	D 3	1SS133-T2	SI DIODE		
	D 4	1SS133-T2	SI DIODE		
	D 11	1SS133-T2	SI DIODE		
	IC 1	LA1838	IC		

△	Item	Parts number	Parts name	Remarks	Area
	IC 2	LC72136N	IC		
	J 1	QNB0014-001	ANT TERMINAL		
	L 1	QQR0796-002	COIL BLOCK		
	Q 1	2SC2814/4-5-X	TRANSISTOR		
	Q 5	DTA114YKA-X	TRANSISTOR		
	R 1	QRE141J-560Y	C RESISTOR	56 5% 1/4W	
	R 2	NRSA02J-331X	MG RESISTOR		
	R 3	NRSA02J-224X	MG RESISTOR		
	R 4	NRSA02J-331X	MG RESISTOR		
	R 5	NRSA02J-560X	MG RESISTOR		
	R 6	NRSA02J-240X	RESISTOR		
	R 10	NRSA02J-222X	MG RESISTOR		
	R 13	NRSA02J-103X	MG RESISTOR		
	R 14	NRSA02J-104X	MG RESISTOR		
	R 15	NRSA02J-222X	MG RESISTOR		
	R 16	NRSA02J-472X	MG RESISTOR		
△	R 17	QRZ9005-680X	F RESISTOR	68 1/0W	
	R 18	NRSA02J-102X	MG RESISTOR		
	R 19	NRSA02J-102X	MG RESISTOR		
	R 20	NRSA02J-102X	MG RESISTOR		
	R 21	NRSA02J-562X	MG RESISTOR		
	R 22	NRSA02J-472X	MG RESISTOR		
	R 23	NRSA02J-182X	MG RESISTOR		
	R 24	NRSA02J-103X	MG RESISTOR		
	R 25	NRSA02J-331X	MG RESISTOR		
	R 26	NRSA02J-222X	MG RESISTOR		
	R 27	NRSA02J-103X	MG RESISTOR		
	R 28	NRSA02J-103X	MG RESISTOR		
	R 29	NRSA02J-103X	MG RESISTOR		
	R 30	NRSA02J-122X	MG RESISTOR		
	R 31	NRSA02J-102X	MG RESISTOR		
	R 32	NRSA02J-102X	MG RESISTOR		
	R 33	NRSA02J-331X	MG RESISTOR		
	R 34	NRSA02J-470X	MG RESISTOR		
	R 35	NRSA02J-562X	MG RESISTOR		
	R 36	NRSA02J-332X	MG RESISTOR		
	R 37	NRSA02J-103X	MG RESISTOR		
	R 38	NRSA02J-563X	MG RESISTOR		
	R 39	NRSA02J-563X	MG RESISTOR		
	R 40	NRSA02J-243X	MG RESISTOR		
	R 41	NRSA02J-332X	MG RESISTOR		
	R 60	NRSA02J-0R0X	MG RESISTOR		
	T 1	QQR0793-001	IFT		
	TU 1	QAU0161-001	FRONT END		
	X 1	QAX0402-001	CRYSTAL		

Electrical parts list (Head amplifier board) Block No. 05

△	Item	Parts number	Parts name	Remarks	Area
	C 101	NCS21HJ-821X	C CAPACITOR		
	C 102	NCS21HJ-221X	C CAPACITOR		
	C 103	QEKJ0JM-227Z	E CAPACITOR	220MF 20% 6.3V	
	C 104	NCB21HK-333X	C CAPACITOR		
	C 105	NCB21HK-222X	C CAPACITOR		
	C 106	QEK41CM-106	E CAPACITOR	10MF 20% 16V	
	C 107	NCS21HJ-561X	C CAPACITOR		
	C 108	QEK41EM-475	E CAPACITOR	4.7MF 20% 25V	
	C 109	QEK41EM-475	E CAPACITOR	4.7MF 20% 25V	
	C 110	NCB21HK-682X	C CAPACITOR		
	C 111	NCB21HK-152X	C CAPACITOR		
	C 113	NCB21HK-393X	C CAPACITOR		
	C 121	NCS21HJ-331X	C CAPACITOR		
	C 201	NCS21HJ-821X	C CAPACITOR		
	C 202	NCS21HJ-221X	C CAPACITOR		
	C 203	QEKJ0JM-227Z	E CAPACITOR	220MF 20% 6.3V	
	C 204	NCB21HK-333X	C CAPACITOR		
	C 205	NCB21HK-222X	C CAPACITOR		
	C 206	QEK41CM-106	E CAPACITOR	10MF 20% 16V	
	C 207	NCS21HJ-561X	C CAPACITOR		
	C 208	QEK41EM-475	E CAPACITOR	4.7MF 20% 25V	
	C 209	QEK41EM-475	E CAPACITOR	4.7MF 20% 25V	
	C 210	NCB21HK-682X	C CAPACITOR		
	C 211	NCB21HK-152X	C CAPACITOR		
	C 213	NCB21HK-393X	C CAPACITOR		
	C 221	NCS21HJ-331X	C CAPACITOR		
	C 301	QEKJ1AM-107Z	E CAPACITOR	100MF 20% 10V	
	C 302	NCB21HK-393X	C CAPACITOR		
	C 303	QEKJ0JM-227Z	E CAPACITOR	220MF 20% 6.3V	
	C 304	QEKJ1CM-226Z	E CAPACITOR	22MF 20% 16V	
	C 305	QEKJ1CM-226Z	E CAPACITOR	22MF 20% 16V	
	C 306	QEK41CM-476	E CAPACITOR	47MF 20% 16V	
	C 307	NCB21HK-103X	C CAPACITOR		
	C 308	NCB21HK-152X	C CAPACITOR		
	C 310	NCB21HK-223X	C CAPACITOR		
	C 313	QEKJ1AM-107Z	E CAPACITOR	100MF 20% 10V	
	C 314	QCZ0205-155Z	ML C CAPACITOR	1.5MF	
	C 316	QFG32AJ-223Z	PP CAPACITOR	.022MF 5% 100V	
	C 319	QFLM1HJ-472Z	M CAPACITOR	4700PF 5% 50V	
	C 331	QEK41CM-476	E CAPACITOR	47MF 20% 16V	
	C 334	QEK41EM-475	E CAPACITOR	4.7MF 20% 25V	
	C 371	QEK41EM-475	E CAPACITOR	4.7MF 20% 25V	
	C 374	QEKJ1AM-107Z	E CAPACITOR	100MF 20% 10V	
	C 376	NCB21HK-103X	C CAPACITOR		
	CN 31	QGF1201F3-06	CONNECTOR	PRI/HEAD	
	CN 32	QGB2011M1-10	B TO B CONNECTO	PRI/MECHA	
	CN 33	QGF1205F1-09	CONNECTOR	PRI/MICON	
	CN 34	QGF1201F3-10	CONNECTOR	PRI/AMP	
	D 375	MA3051/M-X	ZENER DIODE		
	FW 31	QUM024-06A2Z3	PARA RIBON WIRE		
	IC 31	BA3126N	IC	HEAD SW	
	IC 32	AN7317	IC	PB&REC	
	IC 33	BU4094BCF-X	IC		
	L 301	QQR1118-001	OSC COIL(BIAS)		
	L 303	QQL244K-100Z	INDUCTOR		
	Q 101	DTC114TKA-X	TRANSISTOR	70U/12U	
	Q 103	DTC114TKA-X	TRANSISTOR	TAR	
	Q 201	DTC114TKA-X	TRANSISTOR	70U/12U	
	Q 203	DTC114TKA-X	TRANSISTOR	TAR	
	Q 302	2SC2001/K-T	TRANSISTOR	OSC	
	Q 305	2SC2001/LK-T	TRANSISTOR	SW	
	Q 321	DTC144EKA-X	TRANSISTOR	BUFFER	
	Q 331	DTC114TKA-X	TRANSISTOR		

△	Item	Parts number	Parts name	Remarks	Area
	Q 371	2SA952/LK-T	TRANSISTOR	MOTER+B	
	Q 372	DTC124EKA-X	TRANSISTOR		
	Q 375	2SB562/C-T	TRANSISTOR	SOLENOID DRIVE	
	Q 376	2SC2412K/RS/-X	CHIP TRANSISTOR		
	R 101	NRSA63J-220X	MG RESISTOR		
	R 102	NRSA63J-182X	MG RESISTOR		
	R 103	NRSA63J-242X	MG RESISTOR		
	R 104	NRSA63J-122X	MG RESISTOR		
	R 105	NRSA63J-104X	MG RESISTOR		
	R 106	NRSA63J-332X	MG RESISTOR		
	R 107	NRSA63J-123X	MG RESISTOR		
	R 108	NRSA63J-562X	MG RESISTOR		
	R 109	NRSA63J-102X	MG RESISTOR		
	R 110	NRSA63J-272X	MG RESISTOR		
	R 111	NRSA63J-363X	MG RESISTOR		
	R 112	NRSA63J-222X	MG RESISTOR		
	R 116	NRSA63J-102X	MG RESISTOR		
	R 121	NRSA63J-153X	MG RESISTOR		
	R 122	NRSA63J-102X	MG RESISTOR		
	R 201	NRSA63J-220X	MG RESISTOR		
	R 202	NRSA63J-182X	MG RESISTOR		
	R 203	NRSA63J-242X	MG RESISTOR		
	R 204	NRSA63J-122X	MG RESISTOR		
	R 205	NRSA63J-104X	MG RESISTOR		
	R 206	NRSA63J-332X	MG RESISTOR		
	R 207	NRSA63J-123X	MG RESISTOR		
	R 208	NRSA63J-562X	MG RESISTOR		
	R 209	NRSA63J-102X	MG RESISTOR		
	R 210	NRSA63J-272X	MG RESISTOR		
	R 211	NRSA63J-363X	MG RESISTOR		
	R 212	NRSA63J-222X	MG RESISTOR		
	R 216	NRSA63J-102X	MG RESISTOR		
	R 221	NRSA63J-153X	MG RESISTOR		
	R 222	NRSA63J-102X	MG RESISTOR		
	R 301	NRS181J-221X	MG RESISTOR		
	R 303	NRSA63J-393X	MG RESISTOR		
	R 304	NRS181J-101X	MG RESISTOR		
	R 305	NRSA63J-222X	MG RESISTOR		
	R 310	QRJ146J-4R7X	UNF C RESISTOR	4.7 5% 1/4W	
	R 313	NRSA63J-2R2X	MG RESISTOR		
	R 314	NRSA63J-153X	MG RESISTOR		
	R 315	NRSA63J-101X	MG RESISTOR		
	R 327	NRSA63J-474X	MG RESISTOR		
	R 335	NRSA63J-152X	MG RESISTOR		
	R 336	NRSA63J-472X	MG RESISTOR		
	R 337	NRSA63J-332X	MG RESISTOR		
	R 338	NRSA63J-392X	MG RESISTOR		
	R 339	NRSA63J-222X	MG RESISTOR		
	R 340	NRS181J-391X	MG RESISTOR		
	R 341	NRSA63J-123X	MG RESISTOR		
	R 342	NRSA63J-203X	MG RESISTOR		
	R 343	NRSA63J-183X	MG RESISTOR		
	R 345	NRSA63J-222X	MG RESISTOR		
△	R 353	QRZ9005-100X	F RESISTOR	10 1/0W	
	R 371	NRSA63J-123X	MG RESISTOR		
	R 372	NRSA63J-102X	MG RESISTOR		
	R 375	NRSA02J-151X	MG RESISTOR	1/8W	
	R 376	NRSA63J-472X	MG RESISTOR		
	VR 31	QVP0008-203Z	SEMI V RESISTOR	BIAS ADJ	
	VR 37	QVP0008-103Z	SEMI.V.RESISTOR	TAPE SPEED ADJ	

■ Electrical parts list (Cassette switch board) Block No. 06

△	Item	Parts number	Parts name	Remarks	Area
	CN 1	QGB2011L1-10	B TO B CONNECTO		
	D 1	1SR139-400-T2	SI DIODE		
	IC 1	SG-105F3-BB,C	PHOTO SENSER		
	P 1	QNZ0104-001	POST PIN		
	SW 1	QSW0832-001	LEAF SWITCH	R.REC	
	SW 2	QSW0832-001	LEAF SWITCH	TAPE	
	SW 4	QSW0832-001	LEAF SWITCH	70U	
	SW 5	QSW0832-001	LEAF SWITCH	F.REC	
	SW 6	QSW0859-001	DETECT SWITCH		

Packing materials and accessories parts list

Block No.

M	5	M	M
---	---	---	---

Block No.

M	6	M	M
---	---	---	---

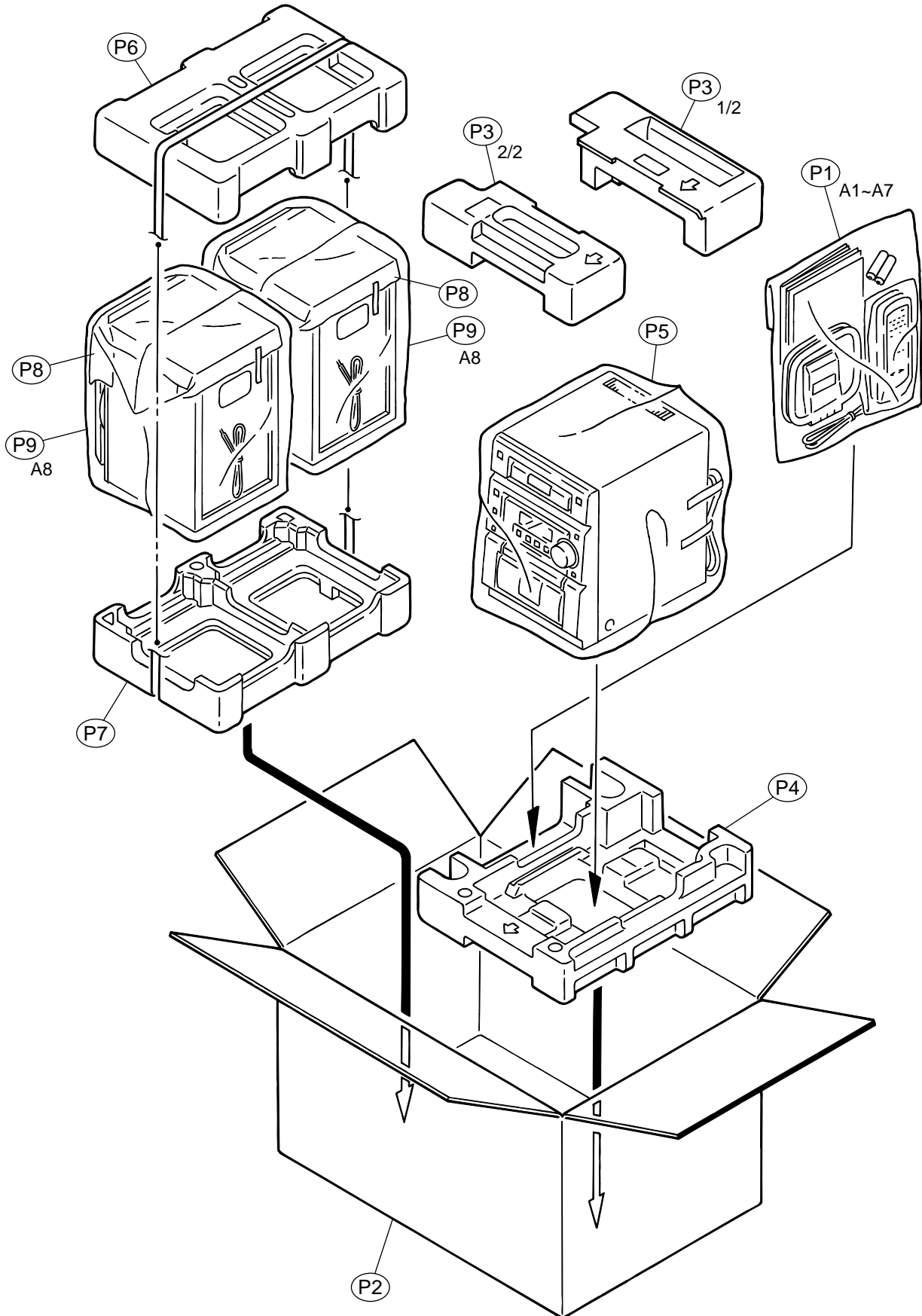

Parts list (Packing)

Block No. M5MM

△	Item	Parts number	Parts name	Q'ty	Description	Area
	P 1	QPC02503515P	POLY BAG	1	FOR INST	
	P 2	GV20111-001A	CARTON ASSY	1		
	P 3	GV10070-001A	CUSHION UPPER	1	TOP / REAR	
	P 4	GV10075-001A	CUSHION BOTTOM	1	TOP / REAR	
	P 5	QPC05006515P	POLY BAG	1		
	P 6	139763681053	TOP CUSHION	1		
	P 7	139763681054	BOTTOM CUSHION	1		
	P 8	138763001072	MIRROR MAT	2		
	P 9	138764601090	POLY BAG	2	FOR SPK	

Parts list (Accessories)

Block No. M6MM

△	Item	Parts number	Parts name	Q'ty	Description	Area
	A 1	QAL0014-001	AM LOOP ANT	1		
	A 2	EWP503-001C	ANT.WIRE	1		
	A 3	GVT0053-003A	INST BOOK	1	ENG, CHI	US
		GVT0053-013A	INST BOOK	1	ENG, SPA, POR	UW,UY
		GVT0053-014A	INST BOOK	1	ENG, CHI	UB
		GVT0053-004A	INST BOOK	1	KOR	UP
△	A 4	QAM0112-001	AC PLUG ADAPTER	1		US,UW
	A 5	RM-SUXP3U	REMOCON	1		
	A 6	-----	BATTERY	2		
	A 7	GV30024-026A	UB SHEET	1		UB
	A 8	UXP3K-SPBOX	SPEAKER BOX	2		
	A 9	BT-56010-1	WARRANTY CARD	1		UP