

JVC

SERVICE MANUAL

MICRO COMPONENT SYSTEM

UX-V10GN

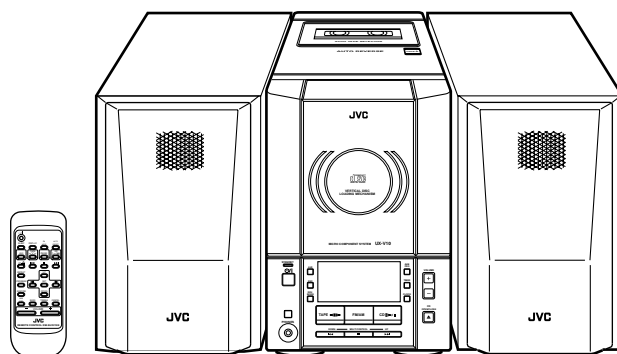

COMPACT
disc
DIGITAL AUDIO

Area Suffix

UF China
UN Indonesia

Contents

Safety precautions	1-2	Maintenance of laser pickup	1-20
Important for laser products	1-4	Replacement of laser pickup	1-20
Disassembly method	1-5	Description of major ICs	1-21
Main adjustment	1-15		
Flow of functional operation			
until TOC read	1-19		

Safety Precautions

1. This design of this product contains special hardware and many circuits and components specially for safety purposes. For continued protection, no changes should be made to the original design unless authorized in writing by the manufacturer. Replacement parts must be identical to those used in the original circuits. Services should be performed by qualified personnel only.
2. Alterations of the design or circuitry of the product should not be made. Any design alterations of the product should not be made. Any design alterations or additions will void the manufacturer's warranty and will further relieve the manufacture of responsibility for personal injury or property damage resulting therefrom.
3. Many electrical and mechanical parts in the products have special safety-related characteristics. These characteristics are often not evident from visual inspection nor can the protection afforded by them necessarily be obtained by using replacement components rated for higher voltage, wattage, etc. Replacement parts which have these special safety characteristics are identified in the Parts List of Service Manual. Electrical components having such features are identified by shading on the schematics and by (\triangle) on the Parts List in the Service Manual. The use of a substitute replacement which does not have the same safety characteristics as the recommended replacement parts shown in the Parts List of Service Manual may create shock, fire, or other hazards.
4. The leads in the products are routed and dressed with ties, clamps, tubings, barriers and the like to be separated from live parts, high temperature parts, moving parts and/or sharp edges for the prevention of electric shock and fire hazard. When service is required, the original lead routing and dress should be observed, and it should be confirmed that they have been returned to normal, after re-assembling.

5. Leakage current check (Electrical shock hazard testing)

After re-assembling the product, always perform an isolation check on the exposed metal parts of the product (antenna terminals, knobs, metal cabinet, screw heads, headphone jack, control shafts, etc.) to be sure the product is safe to operate without danger of electrical shock.

Do not use a line isolation transformer during this check.

- Plug the AC line cord directly into the AC outlet. Using a "Leakage Current Tester", measure the leakage current from each exposed metal parts of the cabinet, particularly any exposed metal part having a return path to the chassis, to a known good earth ground. Any leakage current must not exceed 0.5mA AC (r.m.s.)

- Alternate check method

Plug the AC line cord directly into the AC outlet. Use an AC voltmeter having, 1,000 ohms per volt or more sensitivity in the following manner. Connect a 1,500 Ω 10W resistor paralleled by a 0.15 μ F AC-type capacitor between an exposed metal part and a known good earth ground.

Measure the AC voltage across the resistor with the AC voltmeter.

Move the resistor connection to each exposed metal part, particularly any exposed metal part having a return path to the chassis, and measure the AC voltage across the resistor. Now, reverse the plug in the AC outlet and repeat each measurement. voltage measured Any must not exceed 0.75 V AC (r.m.s.). This corresponds to 0.5 mA AC (r.m.s.).

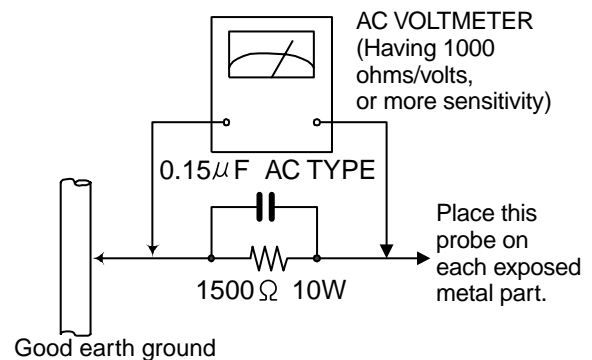

Warning

1. This equipment has been designed and manufactured to meet international safety standards.
2. It is the legal responsibility of the repairer to ensure that these safety standards are maintained.
3. Repairs must be made in accordance with the relevant safety standards.
4. It is essential that safety critical components are replaced by approved parts.
5. If mains voltage selector is provided, check setting for local voltage.

CAUTION Burrs formed during molding may be left over on some parts of the chassis. Therefore, pay attention to such burrs in the case of performing repair of this system.

Safety precautions (U.K only)

1. This design of this product contains special hardware and many circuits and components specially for safety purposes. For continued protection, no changes should be made to the original design unless authorized in writing by the manufacturer. Replacement parts must be identical to those used in the original circuits.
2. Any unauthorised design alterations or additions will void the manufacturer's guarantee ; furthermore the manufacturer cannot accept responsibility for personal injury or property damage resulting therefrom.
3. Essential safety critical components are identified by () on the Parts List and by shading on the schematics, and must never be replaced by parts other than those listed in the manual. Please note however that many electrical and mechanical parts in the product have special safety related characteristics. These characteristics are often not evident from visual inspection. Parts other than specified by the manufacturer may not have the same safety characteristics as the recommended replacement parts shown in the Parts List of the Service Manual and may create shock, fire, or other hazards.
4. The leads in the products are routed and dressed with ties, clamps, tubings, barriers and the like to be separated from live parts, high temperature parts, moving parts and/or sharp edges for the prevention of electric shock and fire hazard. When service is required, the original lead routing and dress should be observed, and it should be confirmed that they have been returned to normal, after re-assembling.

Warning

1. Service should be performed by qualified personnel only.
2. This equipment has been designed and manufactured to meet international safety standards.
3. It is the legal responsibility of the repairer to ensure that these safety standards are maintained.
4. Repairs must be made in accordance with the relevant safety standards.
5. It is essential that safety critical components are replaced by approved parts.
6. If mains voltage selector is provided, check setting for local voltage.

 **CAUTION** Burrs formed during molding may be left over on some parts of the chassis. Therefore, pay attention to such burrs in the case of performing repair of this system.

Important for laser products

1.CLASS 1 LASER PRODUCT

2.DANGER : Invisible laser radiation when open and inter lock failed or defeated. Avoid direct exposure to beam.

3.CAUTION : There are no serviceable parts inside the Laser Unit. Do not disassemble the Laser Unit. Replace the complete Laser Unit if it malfunctions.

4.CAUTION : The compact disc player uses invisible laserradiation and is equipped with safety switches which prevent emission of radiation when the drawer is open and the safety interlocks have failed or are defeated. It is dangerous to defeat the safety switches.

5.CAUTION : If safety switches malfunction, the laser is able to function.

6.CAUTION : Use of controls, adjustments or performance of procedures other than those specified herein may result in hazardous radiation exposure.

⚠ CAUTION Please use enough caution not to see the beam directly or touch it in case of an adjustment or operation check.

WARNING : Osynlig laserstrålning är denna del är öppnad och spårren är urkopplad. Betrakta ej strålen.

VARO : Avattaessa ja suojalukitus ohitettaessa olet alltiina näkymättömälle lasersäteilylle. Älä katso säteeseen.

ADVARSEL : Usynlig laserstrålning ved åbning , når sikkerhedsafbrydere er ude af funktion. Undgå udsættelse for stråling.

ADVARSEL : Usynlig laserstrålning ved åpning,når sikkerhetsbryteren er avslott. unngå utsettelse for stråling.

REPRODUCTION AND POSITION OF LABELS

WARNING LABEL

CLASS 1
LASER PRODUCT



Disassembly method

<Main body>

■ Removing the rear cover

(See Fig.1 and 2)

1. Remove the eight screws A attaching the rear cover on the back of the body.
2. Remove the two screws B attaching the rear cover on the bottom of the body.
3. Unlock the speaker terminal and the antenna terminal, then remove the rear cover backward with releasing the hooks.

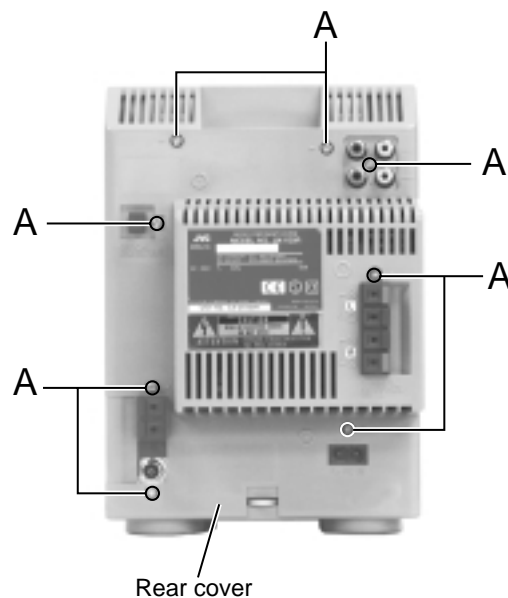

Fig.1

■ Removing the side panels

(See Fig.3 and 4)

- Prior to performing the following procedure, remove the rear cover.
1. Move the side panels in the direction of the arrow and remove them backward.

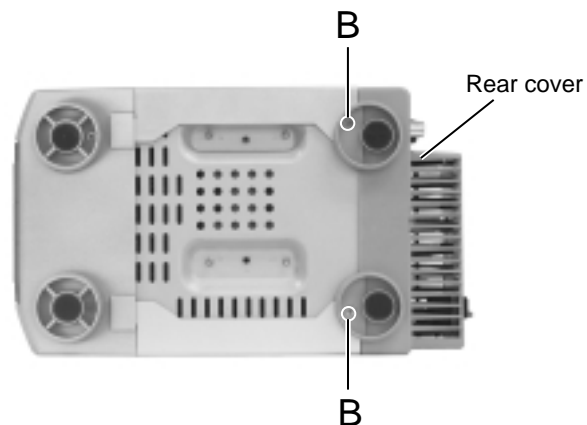

Fig.2

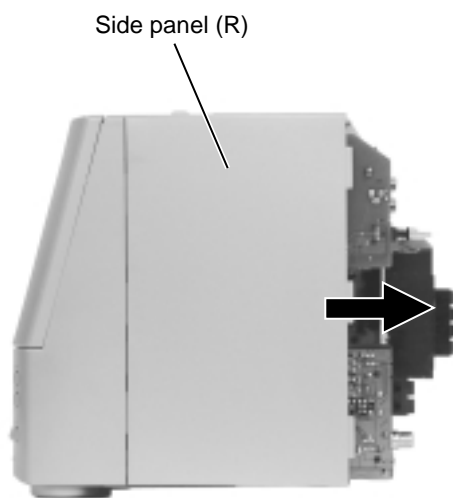

Fig.4

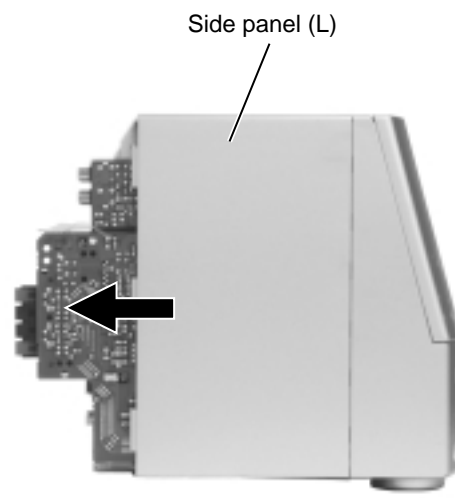

Fig.3

■Removing the cassette mechanism assembly (See Fig.5 and 6)

• Prior to performing the following procedure, remove the rear cover and the side panels.

1. Disconnect the card wires from connector CN304 and CN305 on the main board on the left side of the body.
2. Disconnect the harness from connector CN309 on the Opt, Dig.out board on the right side of the body. Cut off the band fixing the harness.
3. Remove the two screws C attaching the cassette mechanism assembly on both sides of the body and release the two joints a.
4. Remove the cassette mechanism assembly in the direction of the arrow.

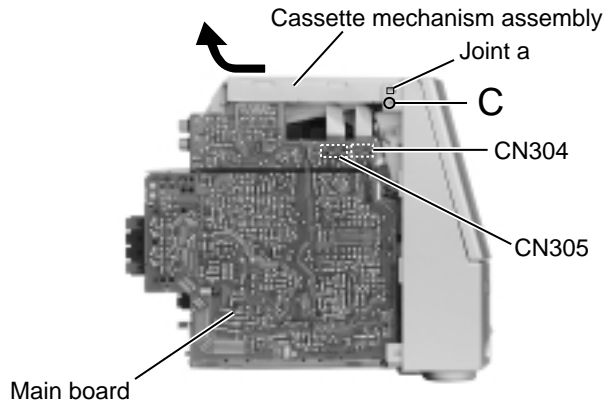

Fig.5

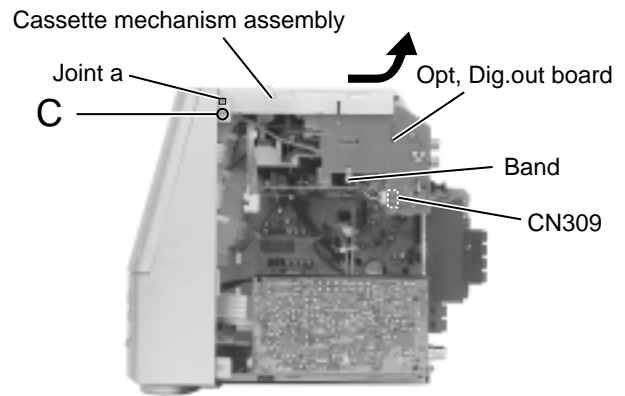

Fig.6

■Removing the main board / the heat sink (See Fig.7 to 9)

• Prior to performing the following procedure, remove the rear cover, the side panels and the cassette mechanism assembly.

1. Disconnect the card wire from connector CN303 and the harness from CN306 and CN307 on the main board respectively.
2. Disconnect the harness from connector CN902 on the power transformer.
3. Remove the screw E attaching the main board on the right side of the body.
4. Remove the screw F and the two screws G attaching the heat sink on the back of the body.

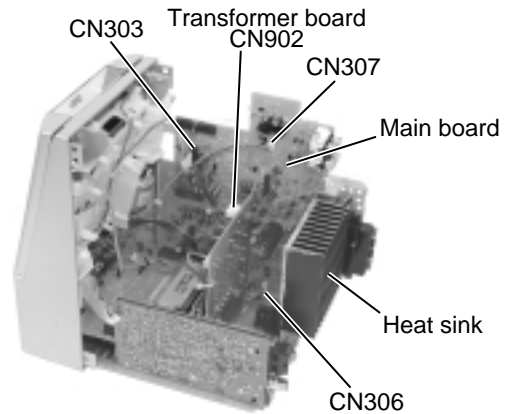

Fig.7

ATTENTION: The heat sink can be removed even if the main board is attached to the body.

5. Disconnect connector CN301 and CN302 on the main board from the main body. Remove the main board upward by releasing the two joints b in the lower part of the main board.

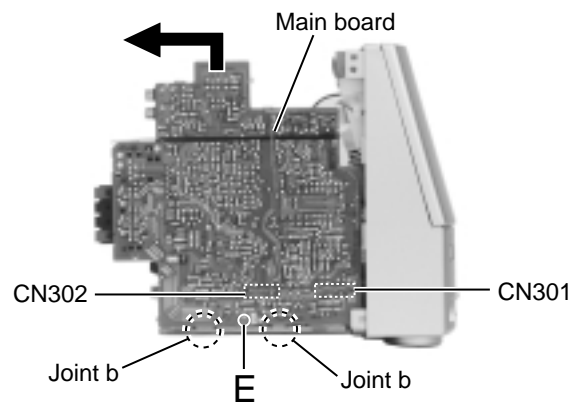

Fig.8

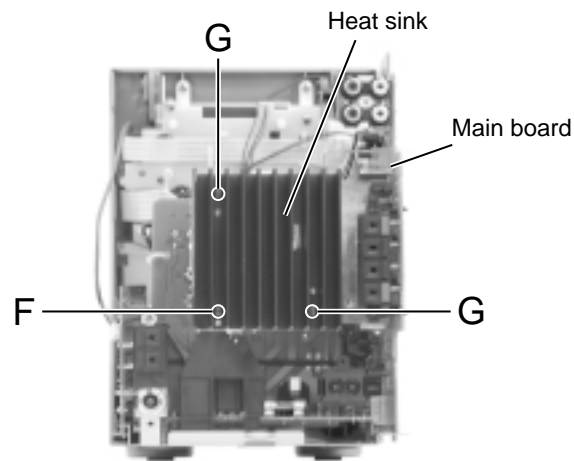

Fig.9

**■ Removing the front panel assembly
(See Fig.10 to 12)**

• Prior to performing the following procedure, remove the rear cover, the side panels, the cassette mechanism assembly and the main board.

1. Disconnect the card wire from connector CN732 on the LCD board.
2. Remove the two screws D attaching the front panel assembly on the bottom of the body.
3. Release the two joints c on the lower right and left sides of the body. Pull out the front panel assembly toward the front.

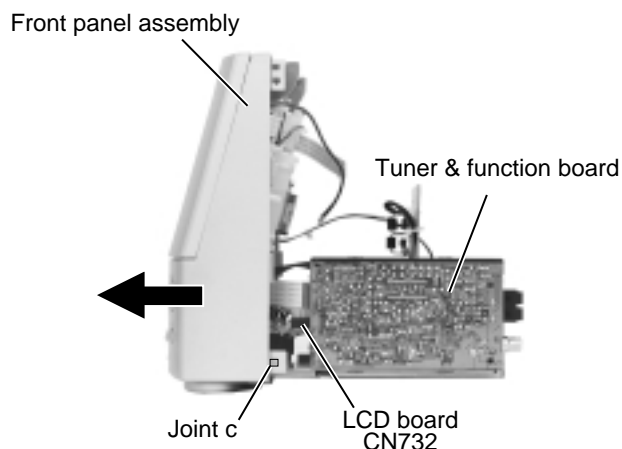

Fig.10

**■ Removing the head phone board
(See Fig.13)**

• Prior to performing the following procedure, remove the rear cover, the side panels, the cassette mechanism assembly, the main board and the front panel assembly.

1. Remove the plastic rivet attaching the head phone board and release the joint d.

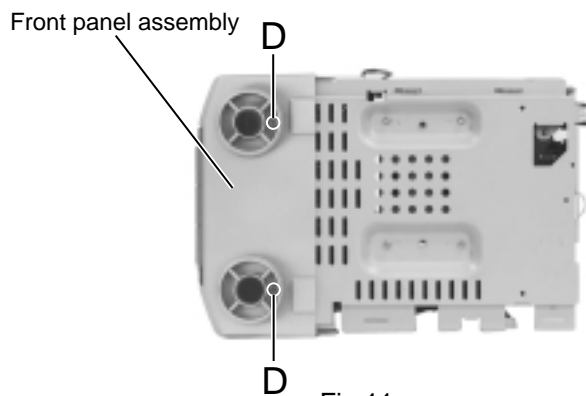

Fig.11

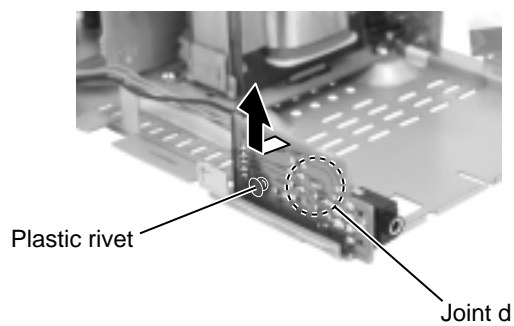

Fig.13

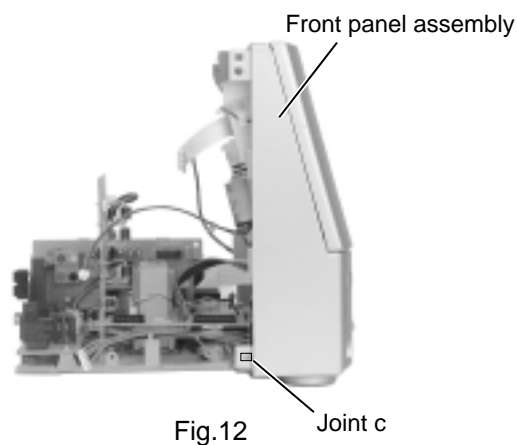

Fig.12

■ Removing the tuner & function board
(See Fig.14)

- Prior to performing the following procedure, remove the rear cover, the side panels and the cassette mechanism assembly.
1. Disconnect the card wire from connector CN1 on the tuner & function board.
 2. Remove the screw H attaching the tuner & function board.
 3. Release the two joints e and the joint f of the tuner & function board.

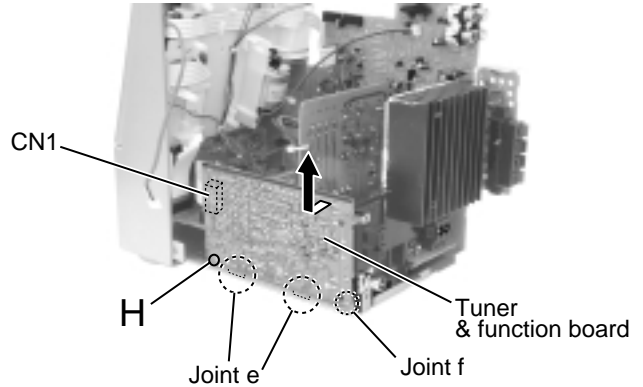

Fig.14

■ Removing the power transformer
(See Fig.15)

- Prior to performing the following procedure, remove the rear cover, the side panels and the cassette mechanism assembly.
1. Disconnect the harness from connector CN902 on the power transformer.
 2. Disconnect the harness from connector CN901 on the AC supply board.
 3. Remove the four screws I attaching the power transformer.

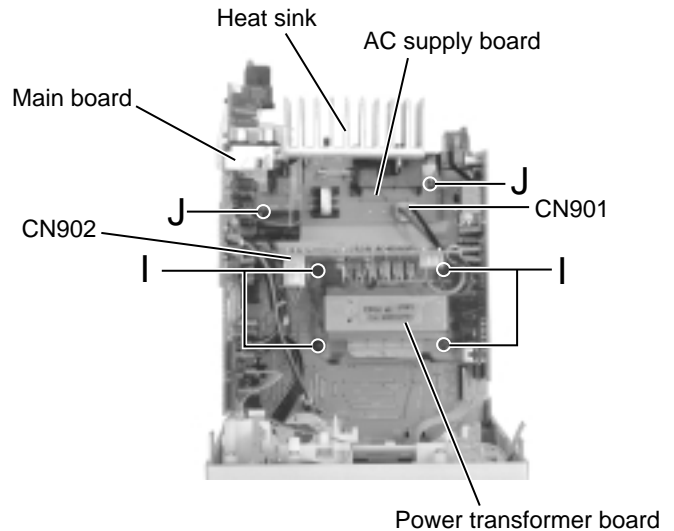

Fig.15

■ Removing the AC supply board
(See Fig.15)

- *Prior to performing the following procedure, remove the rear cover, the side panels and the cassette mechanism assembly.
1. Disconnect the harness from connector CN901 on the AC supply board.
 2. Remove the screw F attaching the heat sink on the back of the body (Refer to Fig.9).
 3. Remove the two screws J attaching the AC supply board.

ATTENTION: To remove the AC supply board efficiently, remove the main board in advance.

<Cassette mechanism assembly>

- Prior to performing the following procedure, remove the rear cover, the side panels and the cassette mechanism assembly.

■ Removing the Opt.Dig.out board (See Fig.16)

1. Remove the two screws K attaching the Opt.Dig.out board on the side of the cassette mechanism assembly.

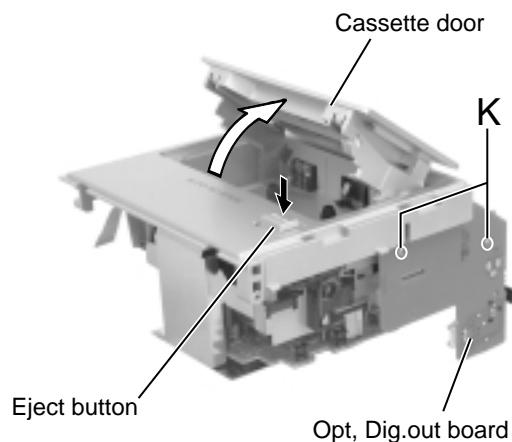

Fig.16

■ Removing the cassette mechanism assembly (See Fig.16 and 17)

- Prior to performing the following procedure, remove the Opt.Dig.out board.
1. Press the eject button on the front side of the cassette mechanism assembly to open the cassette door.
 2. Remove the four screws L attaching the cassette mechanism assembly on the back of the assembly.

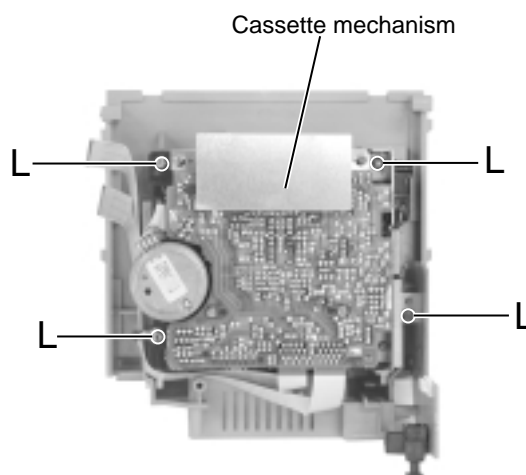

Fig.17

<Front panel assembly>

- Prior to performing the following procedure, remove the rear cover, the side panels, the cassette mechanism assembly, the main board and the front panel assembly.

■ Removing the CD mechanism assembly (See Fig.18 to 21)

1. Disconnect the harness from connector CN721 and CN722, and the card wire from CN766 on the LCD board on the back of the front panel assembly.
2. Remove the five screws M attaching the CD mechanism cover to the front panel. Remove the CD mechanism cover together with the CD mechanism assembly.
3. Release the harness from each hook on the CD mechanism cover.
4. Remove the five screws N attaching the CD mechanism cover and the CD mechanism case. Release the three joints g of the CD mechanism cover and the CD mechanism case by pushing the joint hooks inward.
5. Disconnect the card wire from connector CN603 and the harness from CN605 on the CD servo control board.
6. Remove the CD mechanism assembly from the CD mechanism cover by pulling out it from the three bosses h.

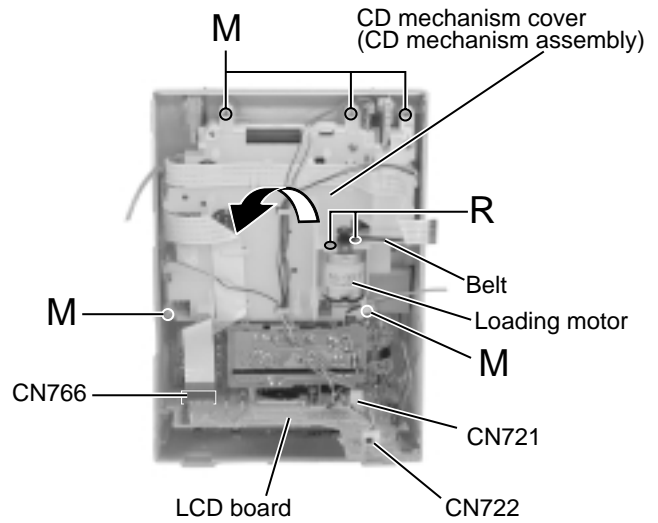

Fig.18

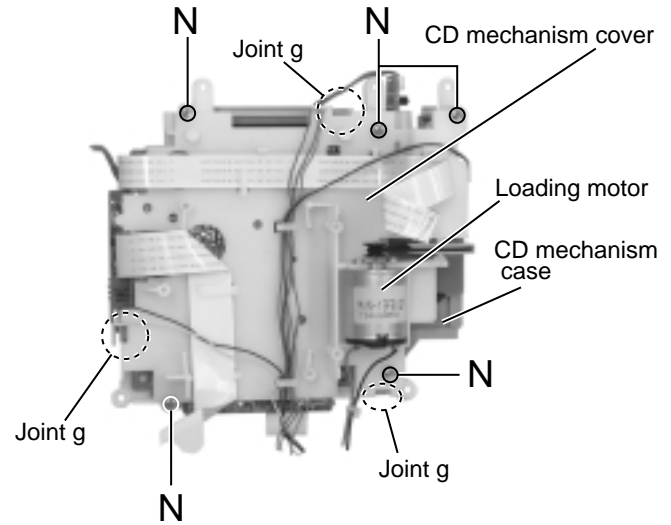

Fig.19

■ Removing the LED board (A) (See Fig.21)

1. Remove the screw O attaching the LED board (A).

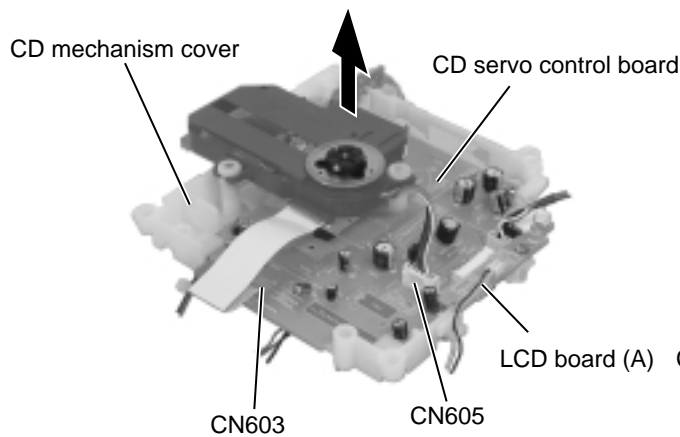

Fig.21

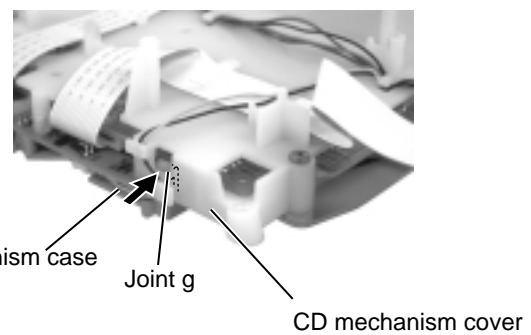

Fig.20

■ Removing the LED board (B) (See Fig.22)

- Prior to performing the following procedure, remove the CD mechanism assembly.

1. Remove the screw P attaching the LED board (B).

■ Removing the CD door switch board (See Fig.22)

1. Release the hook i fixing the CD door switch board to the CD mechanism cover.

■ Removing the CD servo control board (See Fig.22)

- Prior to performing the following procedure, remove the CD mechanism assembly and the LED board (A) / (B).

1. Remove the two screws Q attaching the CD servo control board.

2. Pull out the CD servo control board in the direction of the arrow by releasing the two joints j.

■ Removing the loading motor (See Fig.18)

1. Remove the belt and the two screws R attaching the loading motor on the back of the front panel assembly.

■ Removing the LCD board assembly (See Fig.23)

- Prior to performing the following procedure, remove the CD mechanism cover (CD mechanism assembly).

1. Remove the two screws S attaching the LCD board assembly.

2. Disconnect connector CN781 on the LCD board assembly from the operation switch board.

■ Removing the operation switch board (See Fig.24)

- Prior to performing the following procedure, remove the LCD board assembly.

1. Remove the eight screws T attaching the operation switch board.

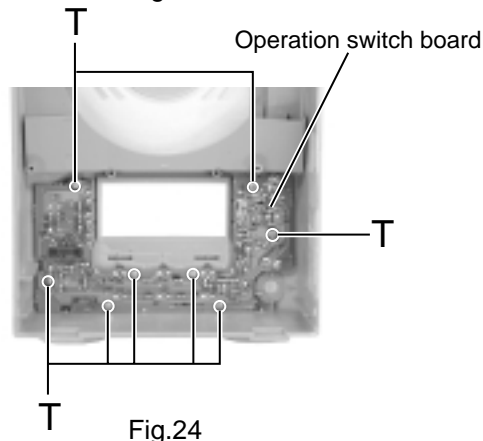
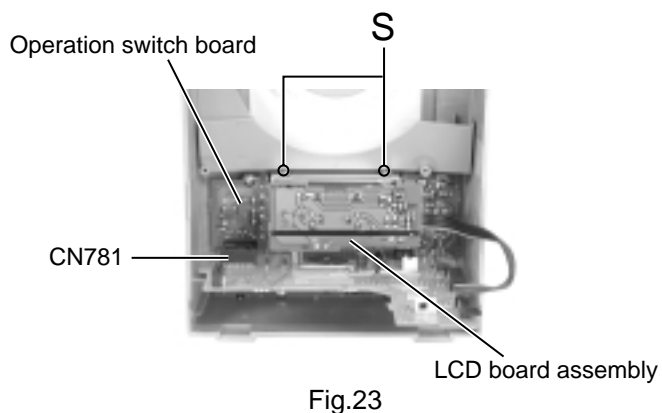
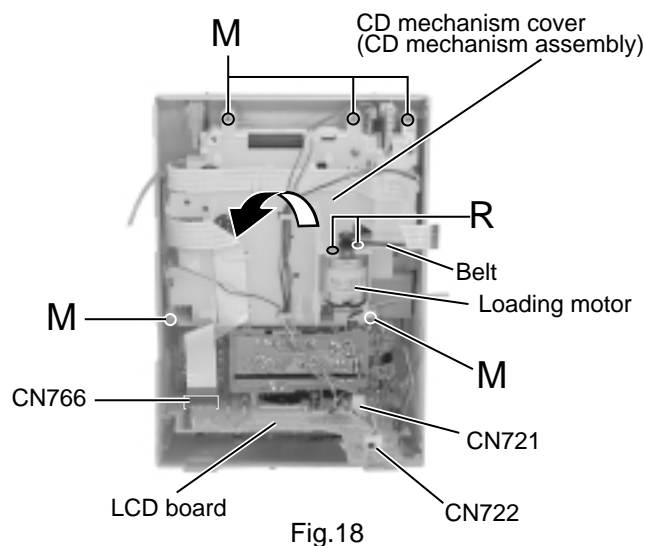
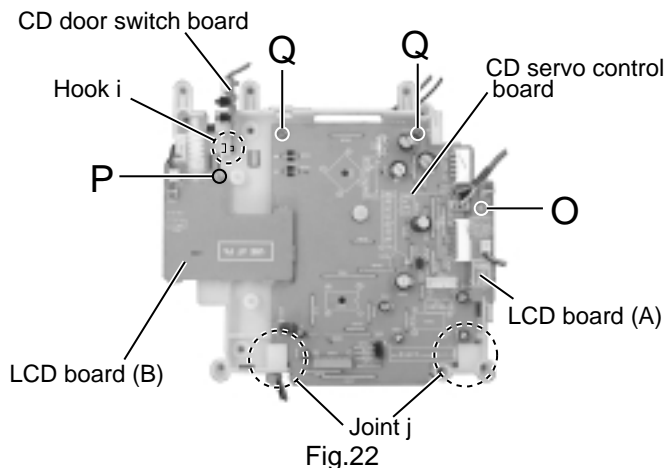

<<Cassette Mechanism Section>>

■ Removing the Playback/Recording & Eraser Head (See Figs. 1 and 2)

1. While shifting the trigger arms seen on the right side of the head mount in the arrow direction, turn the flywheel R in counterclockwise direction until the head mount has gone out with a click (See Fig. 1).
2. When the flywheel R is rotated in counterclockwise direction, the Playback/Recording & Eraser head will be turned in counterclockwise direction from the position in Fig. 2 to that in Fig. 3.
3. At this position, disconnect the flexible P.C. board (outgoing from the Playback/Recording & Eraser head) from the connector CN31 on the head amplifier & mechanism control P.C. board.
4. After dismantling the FPC holder, remove the flexible P.C. board.
5. Remove the flexible P.C. board from the chassis base.
6. Remove the spring Afro behind the Playback/Recording & Eraser head.
7. Loosen the reversing azimuth screw retaining the Playback /Recording & Eraser head.
8. Take out the Playback/Recording & Eraser head from the front of the head mount.
9. The Playback/Recording & Eraser head should also be removed similarly according to Steps 1 ~ 8 above.

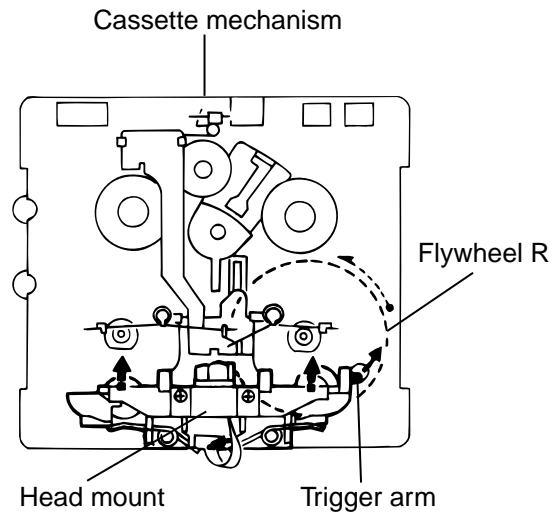

Fig. 1

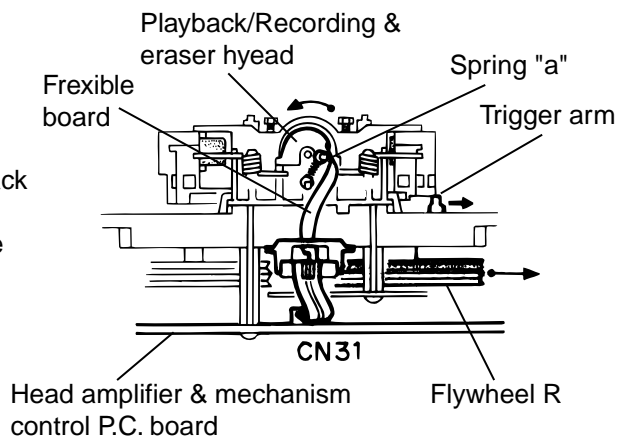

Fig. 2

■ Reassembling the Playback/Recording & Eraser Head

1. Reassemble the playback head from the front of the head mount to the position as shown in Fig. 3.
2. Fix the reversing azimuth screw.
3. Set the spring "a" from behind the Playback/Recording & Eraser head.
4. Attach the flexible P.C. board to the chassis base, and fix it with the FPC holder as shown in Fig. 3.
5. The Playback/Recording & Eraser head should also be reassembled similarly to Step 1 ~ 4 above.

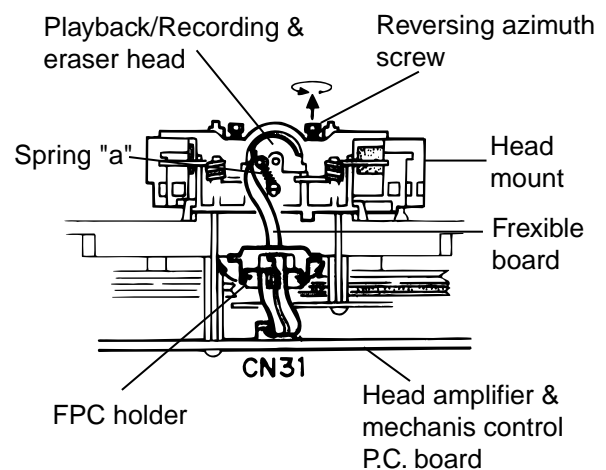
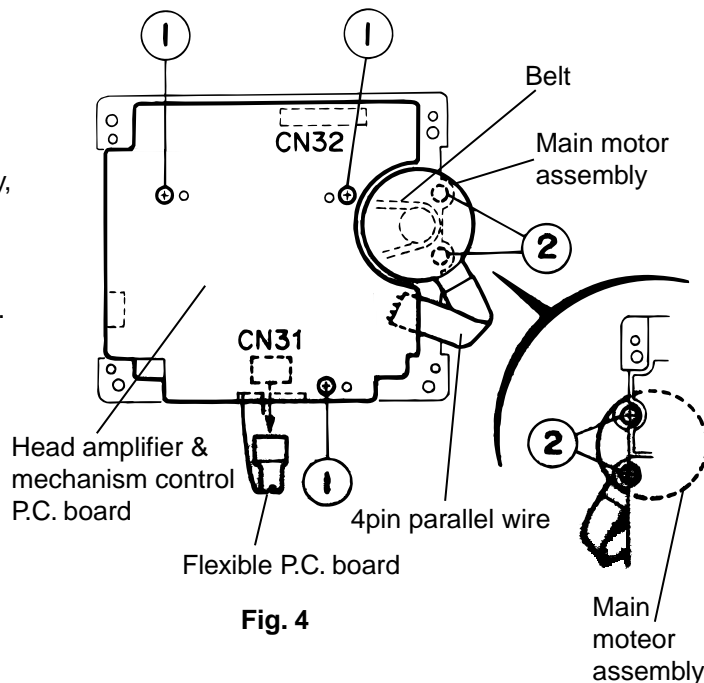

Fig. 3

■ **Removing the Head amplifier & Mechanism control P.C. board**

(See Fig. 4)

1. Remove the cassette mechanism assembly.
2. After turning over th cassette mechanism assembly, remove the three screws "1" retaining the head amplifier & mechanism control P.C. board.
3. Disconnect the connector CN32 on the P.C. board including the connector CN 1 on the reel pulse P.C. board.
4. When necessary, remove the 4 pin parallel wire soldered to the main motor.



■ **Removing the Main Motor Assembly**

(See Fig. 4-6)

1. Remove the two screws "2" retaining the main motor assembly (See Fig. 4, 4a).
2. While raising the main motor, remove the capstan belt from the motor pulley (See Fig. 4a).

Caution 1: Be sure to handle the capstan belt so carefully that this belt will not be stained by grease and other foreign matter. Moreover, this belt should be hanged while referring to the capstan belt hanging method in Fig. 5, 6.

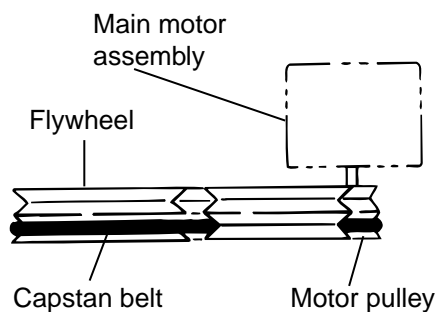
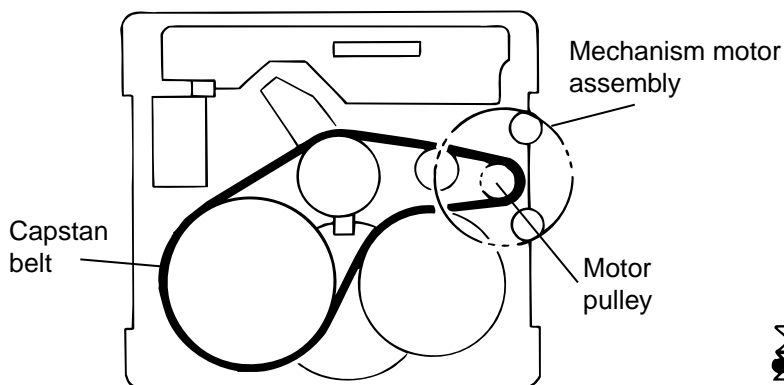
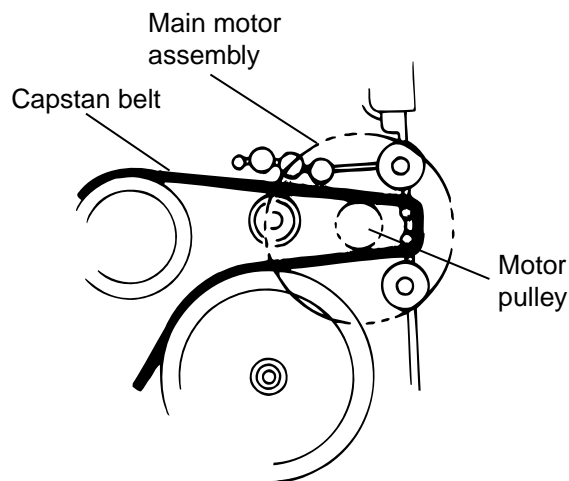

■ **Removing the Flywheel**

(See Figs. 7 and 8)

1. Remove the head amplifier & mechanism control P.C. board.
2. Remove the main motor assembly.
3. After turning over the cassette mechanism, remove the slit washers "b" and "c" fixing the capstan shafts R and L, and pull out the flywheel R and L respectively from behind the cassette mechanism.

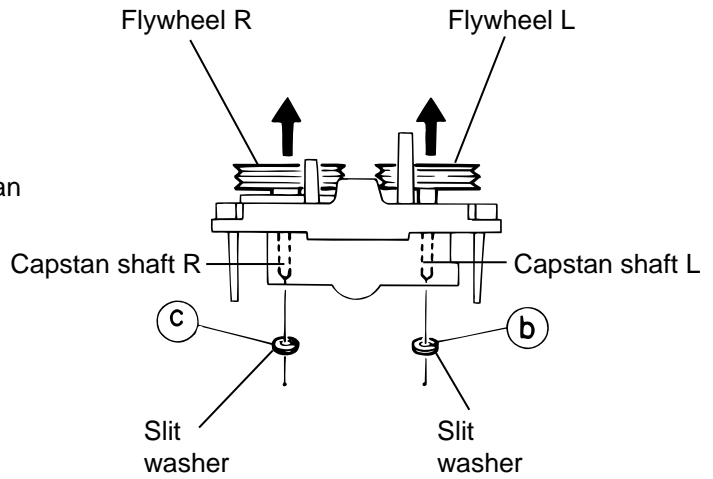

Fig.7

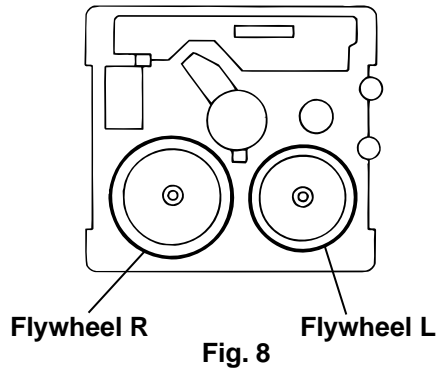

Fig. 8

■ **Removing the Reel Pulse P.C. board and Solenoid**

(See Fig. 9)

1. Remove the five pails "d"~"h" retaining the reel pulse P.C. board.
2. From the surface of the reel pulse P.C. board parts, remove the two pawls "i" and "j" retaining the solenoid.

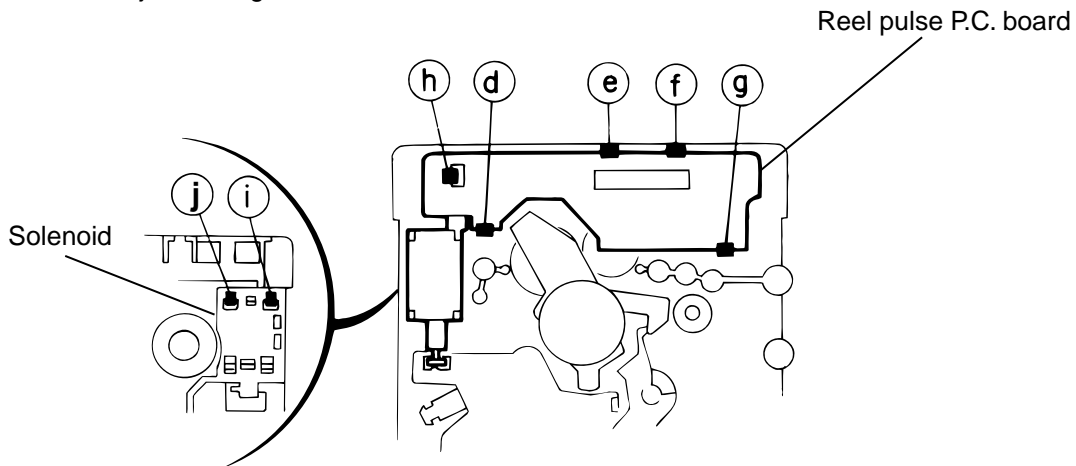

Fig. 9

Main adjustment

■ Measurement Instruments Required for Adjustment

1. Low frequency oscillator
This oscillator should have a capacity to output 0dBs to 600 Ω at an oscillation frequency of 50Hz-20kHz.
2. Attenuator impedance : 600 Ω
3. Electronic voltmeter
4. Distortion meter
5. Frequency counter
6. Wow & flutter meter
7. Test tape
VT703L : Head azimuth
VT712 : Tape speed and running unevenness (3kHz)
VT724 : Reference level (1kHz)
8. Blank tape
TYPE I : AC-225
TYPE II : AC-514
9. Torque gauge : For play and back tension
FWD(TW2111A), REV(TW2121a) and
FF/REW(TW2231A)
10. Test disc: CTS-1000

■ Measurement conditions

- Power supply voltage
: AC230V (50Hz)---B/E/EE/EN
: AC110/127V/230V(50/60Hz)
: UB/UF/US/UX/U
- Reference output : Speaker : 0.775V/4 Ω
: Headphone : 0.077V/32 Ω
- Reference frequency and
input level ----- 1kHz, AUX : -8dBs
MIX MIC: -54dBs (UB/UF/US/UX/U)
Input for confirming recording and playback
characteristics ----- AUX : -28dBs
Measurement output terminal ----- at Speaker J3002
※ Load resistance ----- 4 Ω

● Radio Input signal

- AM frequency ----- 400Hz
AM modulation ----- 30%
FM frequency ----- 400Hz
FM frequency deviation ----- 22.5kHz

● Tuner section

B/E/EN version

- FM Band cover: 87.5~108MHz
MW Band cover: 522~1,629kHz
LW Band cover: 144~288kHz

EE version

- FM Band cover: 65~74MHz, 87.5~108MHz
MW Band cover: 522~1,629kHz
LW Band cover: 144~288kHz

UB/UF/US/UX/U version

- FM Band cover: 87.5~108MHz
MW Band cover: 531~1,602kHz, 530~1,710kHz
SW Band cover: SW1 2.3~6.995MHz
: SW2 7~21.85MHz

Voltage applied to tuner ----- +B : DC5.7V
VT : DC 12V

Reference measurement

output ----- 26.1mV(0.28V)/3 Ω
Input positions ----- AM : Standard loop antenna
FM : TP1 (hot) and TP2 (GND)

● Standard measurement position of volume

Function switch ----- to Tape
Beat cut switch ----- to Cut
Super Bass/Active hyper Bass ----- to OFF
Bass Treble ----- to Center
Adjustment of main volume to reference output
VOL : 28

Precautions for measurement

1. Apply 30pF and 33k Ω to the IF sweeper output side and 0.082 μ F and 100k Ω in series to the sweeper input side.
2. The IF sweeper output level should be made as low as possible within the adjustable range.
3. Since the IF sweeper is a fixed device, there is no need to adjust this sweeper.
4. Since a ceramic oscillator is used, there is no need to perform any MIX adjustment.
5. Since a fixed coil is used, there is no need to adjust the FM tracking.
6. The input and output earth systems are separated. In case of simultaneously measuring the voltage in both of the input and output systems with an electronic voltmeter for two channels, therefore, the earth should be connected particularly carefully.
7. In the case of BTL connection amp., the minus terminal of speaker is not for earthing. Therefore, be sure not to connect any other earth terminal to this terminal. This system is of an BTL system.
8. For connecting a dummy resistor when measuring the output, use the wire with a greater code size.
9. Whenever any mixed tape is used, use the band pass filter (DV-12).

<<Arrangement of Adjusting Position>>

Cassette mechanism section

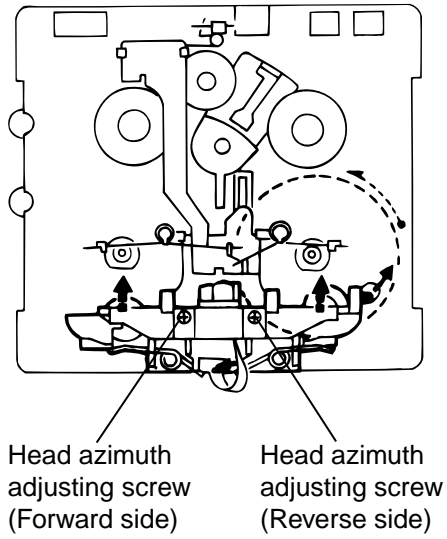

Cassette mechanism section (Back side)

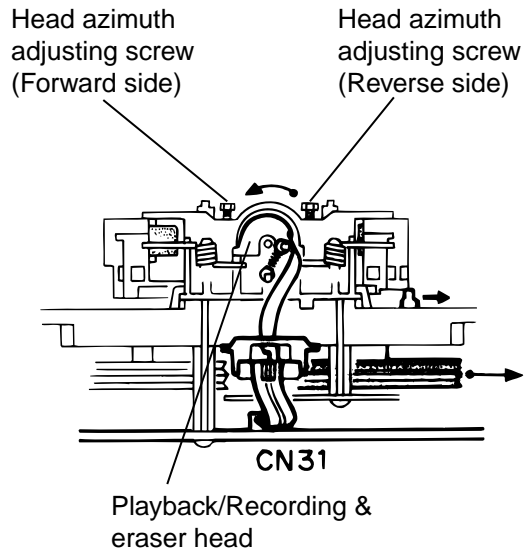

Front panel assembly section

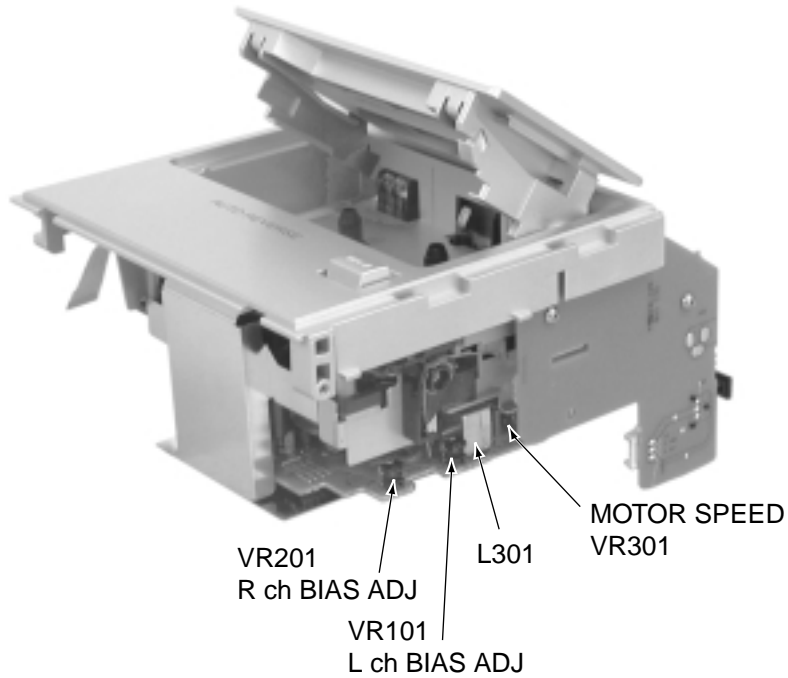

■ Tape Recorder Section

Items	Measurement conditions	Measurement method	Standard Values	Adjusting positions
Confirmation of head angle	Test tape : VTT703L (8kHz) Measurement output terminal : Speaker terminal Speaker R (Load resistance: 4Ω) : Headphone terminal	1 Playback the test tape VTT703L (8kHz) 2 With the recording & playback mechanism, adjust the head azimuth screw so that the forward and reverse output levels become maximum. After adjustment, lock the head azimuth at least by half turn. 3 In either case, this adjustment should be performed in both the forward and reverse directions with the head azimuth screw.	Maximum output	Adjust the head azimuth screw only when the head has been changed.
Confirmation of tape speed	Test tape : VT712 (3kHz) Measurement output terminal : Headphone terminal	Adjust VR37 so that the frequency counter reading becomes 2,940~3,090Hz \pm when playing back the test tape VT712 (3kHz) with playback and recording mechanism after ending forward winding of the tape.	Tape speed of deck : 2,940 ~ 3,090Hz	VR301

■ Reference Values for Confirmation Items

Items	Measurement conditions	Measurement method	Standard Values	Adjusting positions
Difference between the forward and reverse speed	Test tape : VT712 (3kHz) Measurement output terminal : Speaker terminal Speaker R (Load resistance: 4Ω) Measurement output terminal : Headphone	When the test tape VT712 (3kHz) has been played back with the recording and playback mechanism at the beginning of forward winding, the frequency counter reading of the difference between both of the mechanism should be 6.0Hz or less.	6.0Hz or less	Head azimuth screw
Wow & flutter	Test tape : VT712 (3kHz) Measurement output terminal : Headphone terminal	When the test tape VT712 (3kHz) has been played back with the recording and playback mechanism at the beginning of forward winding, the frequency counter reading of wow & flutter should be 0.25% or less (WRMS).	0.25% or less (WRMS)	

■ Electrical Performance

Items	Measurement conditions	Measurement method	Standard Values	Adjusting positions
Adjustment of recording bias current (Reference Value)	<ul style="list-style-type: none"> • Mode: Forward or reverse mode • Recording mode • Test tape : AC-514 to TYPE II and AC-225 to TYPE I Measurement output terminal : Both recording and headphone terminals	<ol style="list-style-type: none"> 1 With the recording and playback mechanism, load the test tapes (AC-514 to TYPE II and AC-225 to TYPE I), and set the mechanism to the recording and pausing condition in advance. 2 After connecting 100 Ω in series to the recorder head, measure the bias current with a valve voltmeter at both of the terminals. 3 After resetting the [PAUSE] mode, start recording. At this time, adjust VR31 for Lch and VR32 for Rch so that the recording bias current values become 4.0 μ A (TYPE I) and 4.20 μ A (TYPE II). 	AC-225 : 4.20 μ A AC-514 : 4.0 μ A	L ch : VR101 R ch : VR201
Adjustment of recording and playback frequency characteristics	Reference frequency : 1kHz and 10kHz (REF.: -20dB) Test tape : AC-514 to TYPE II Measurement input terminal : OSC IN	<ol style="list-style-type: none"> 1 With the recording and playback mechanism, load the test tapes (AC-514 to TYPE II), and set the mechanism to the recording and pausing condition in advance. 2 While repetitively inputting the reference frequency signal of 1kHz and 10kHz from OSC IN, record and playback the tape. 3 While recording and playback the test tape in TYPE II, adjust VR31 for Lch and VR32 for Rch so that the output deviation between 1kHz and 10kHz becomes -1dB \pm 2dB. 	Output deviation between 1kHz and 10kHz : -1dB \pm 2dB	L ch : VR101 R ch : VR201

■ Reference Values for Electrical Function Confirmation Items

Items	Measurement conditions	Measurement method	Standard Values	Adjusting positions
Recording bias frequency	Forward or reverse <ul style="list-style-type: none"> • Test tape : TYPE II (AC-514) • Measurement terminal : BIAS TP on P.C. board 	<ol style="list-style-type: none"> 1 While changing over to and from BIAS 1 and 2, confirm that the frequency is changed. 2 With the recording and playback mechanism, load the test tape. (AC-514 to TYPE II), and set the mechanism to the recording and pausing condition in advance. 3 Confirm that the BIAS TP frequency on the P.C. board is 100kHz \pm 6kHz. 	100 kHz \pm 6 kHz	
Eraser current (Reference value)	Forward or reverse <ul style="list-style-type: none"> • Recording mode • Test tape : AC-514 to TYPE II and AC-225 to TYPE I Measurement terminal : Both of the eraser head terminals	<ol style="list-style-type: none"> 1 While recording and playback mechanism, load the test tapes (AC-514 to TYPE II and AC-225 to TYPE I), and set the mechanism to the recording and pausing conditions in advance. 2 After setting to the recording conditions, connect 1W in series to the eraser head on the recording and playback mechanism side, and measure the eraser current from both of the eraser terminals. 	TYPE II : 120 mA TYPE I : 75 mA	

Flow of functional operation until TOC read

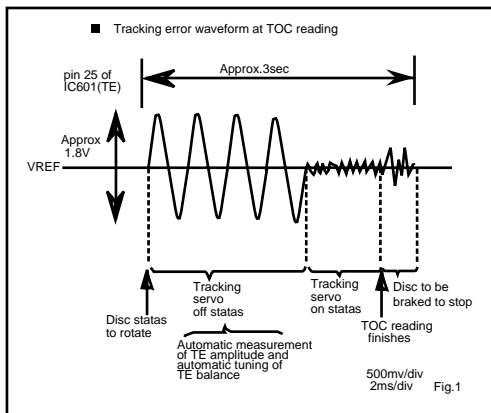
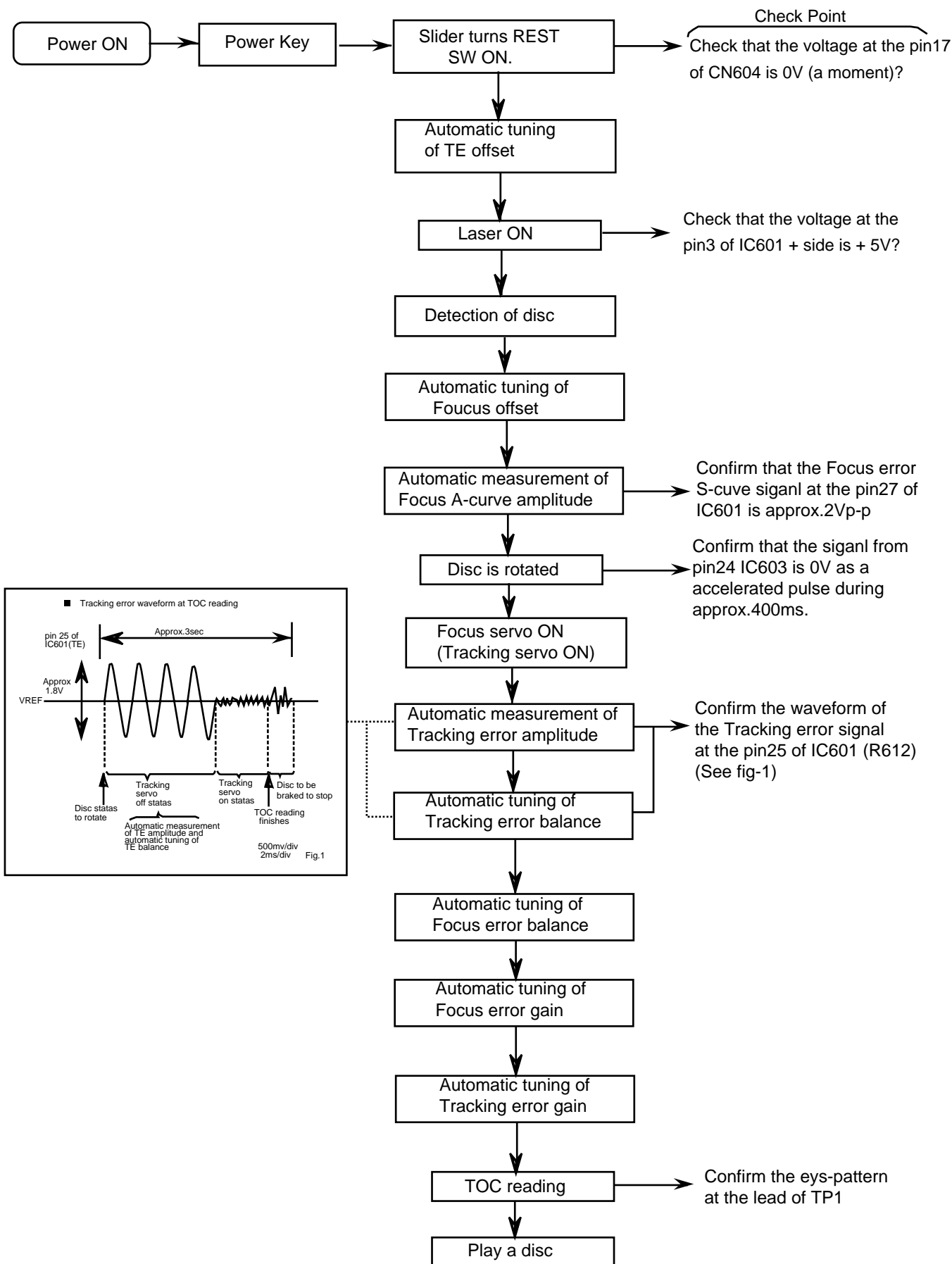

Maintenance of laser pickup

- (1) Cleaning the pick up lens
 Befor you replace the pick up, please try to clean the lens with a alcohol soaked cotton swab.
- (2) Life of the laser diode (Fig.1)
 When the life of the laser diode has expired, the following symptoms will appear.
 - (1) The level of RF output (EFM output:amplitude of eye pattern) will below.

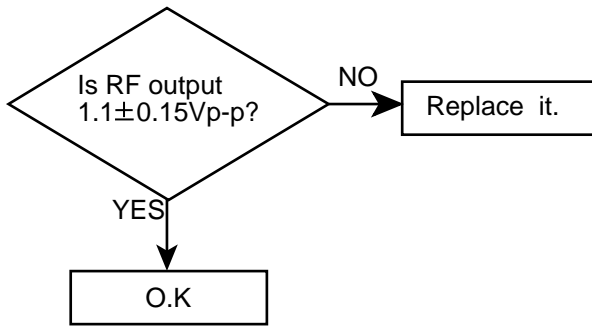

(Fig.1)

- (3) Semi-fixed resistor on the APC PC board
 The semi-fixed resistor on the APC printed circuit board which is attached to the pickup is used to adjust the laser power. Since this adjustment should be performed to match the characteristics of the whole optical block, do not touch the semi-fixed resistor.
 If the laser power is lower than the specified value, the laser diode is almost worn out, and the laser pickup should be replaced.
 If the semi-fixed resistor is adjusted while the pickup is functioning normally, the laser pickup may be damaged due to excessive current.

Replacement of laser pickup

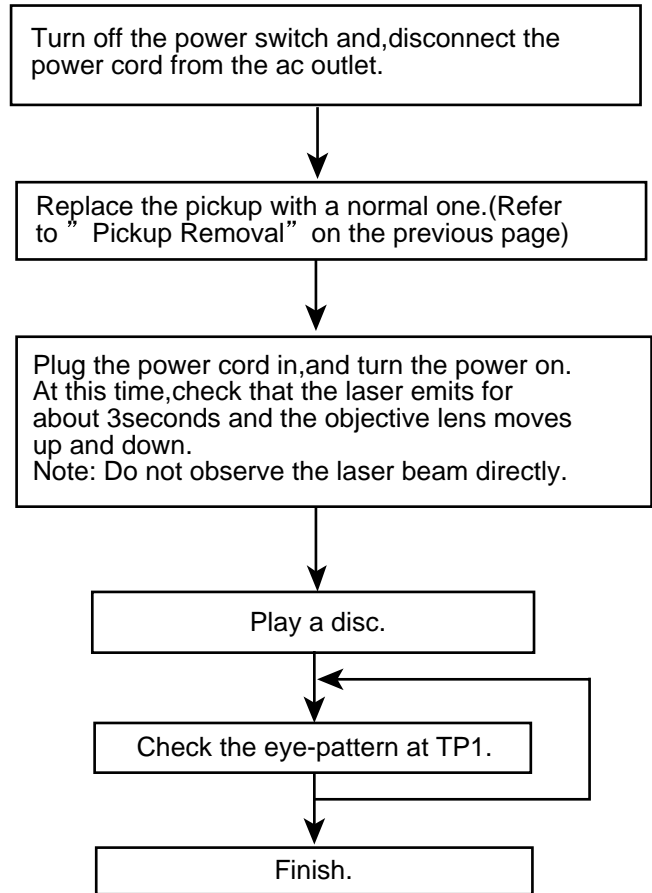

Description of major ICs

LA6541-X(IC541) : Servo Driver

1. Pin Layout & Block Diagram

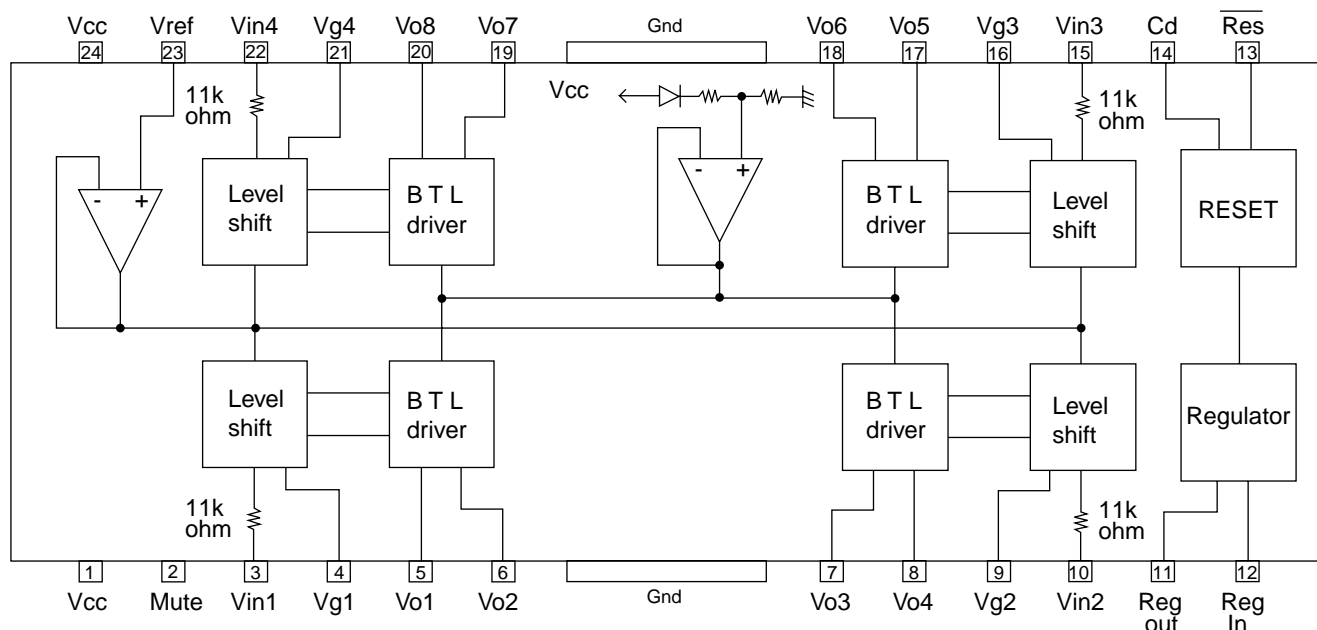

2. Pin functions

Pin No.	Symbol	Function
1	Vcc	Power supply (Shorted to pin 24)
2	Mute	All BTL amplifier outputs ON/OFF
3	Vin1	BTL AMP 1 input pin
4	Vg1	BTL AMP 1 input pin (For gain adjustment)
5	Vo1	BTL AMP 1 input pin (Non inverting side)
6	Vo2	BTL AMP 1 input pin (Inverting side)
7	Vo3	BTL AMP 2 input pin (Inverting side)
8	Vo4	BTL AMP 2 input pin (Non inverting side)
9	Vg2	BTL AMP 2 input pin (For gain adjustment)
10	Vin2	BTL AMP 2 input pin
11	Reg Out	External transistor collector (PNP) connection. 5V power supply output
12	Reg In	External transistor (PNP) base connection
13	Res	Reset output
14	Cd	Reset output delay time setting (Capacitor connected externally)
15	Vin3	BTL AMP 3 input pin
16	Vg3	BTL AMP 3 input pin (For gain adjustment)
17	Vo5	BTL AMP 3 output pin (Non inverting side)
18	Vo6	BTL AMP 3 output pin (Inverting side)
19	Vo7	BTL AMP 4 output pin (Inverting side)
20	Vo8	BTL AMP 4 output pin (Non inverting side)
21	Vg4	BTL AMP 4 output pin (For gain adjustment)
22	Vin4	BTL AMP 4 output pin
23	Vref	Level shift circuit's reference voltage application
24	Vcc	Power supply (Shorted to pin 1)

■ MN35510 (IC651) : DIGITAL SERVO&DIGITAL SIGNAL PROCESSER

1. Terminal Layout

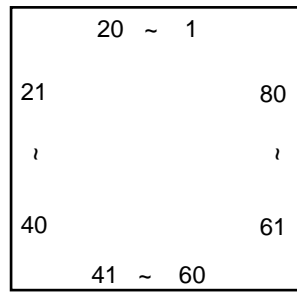

2. Block Diagram

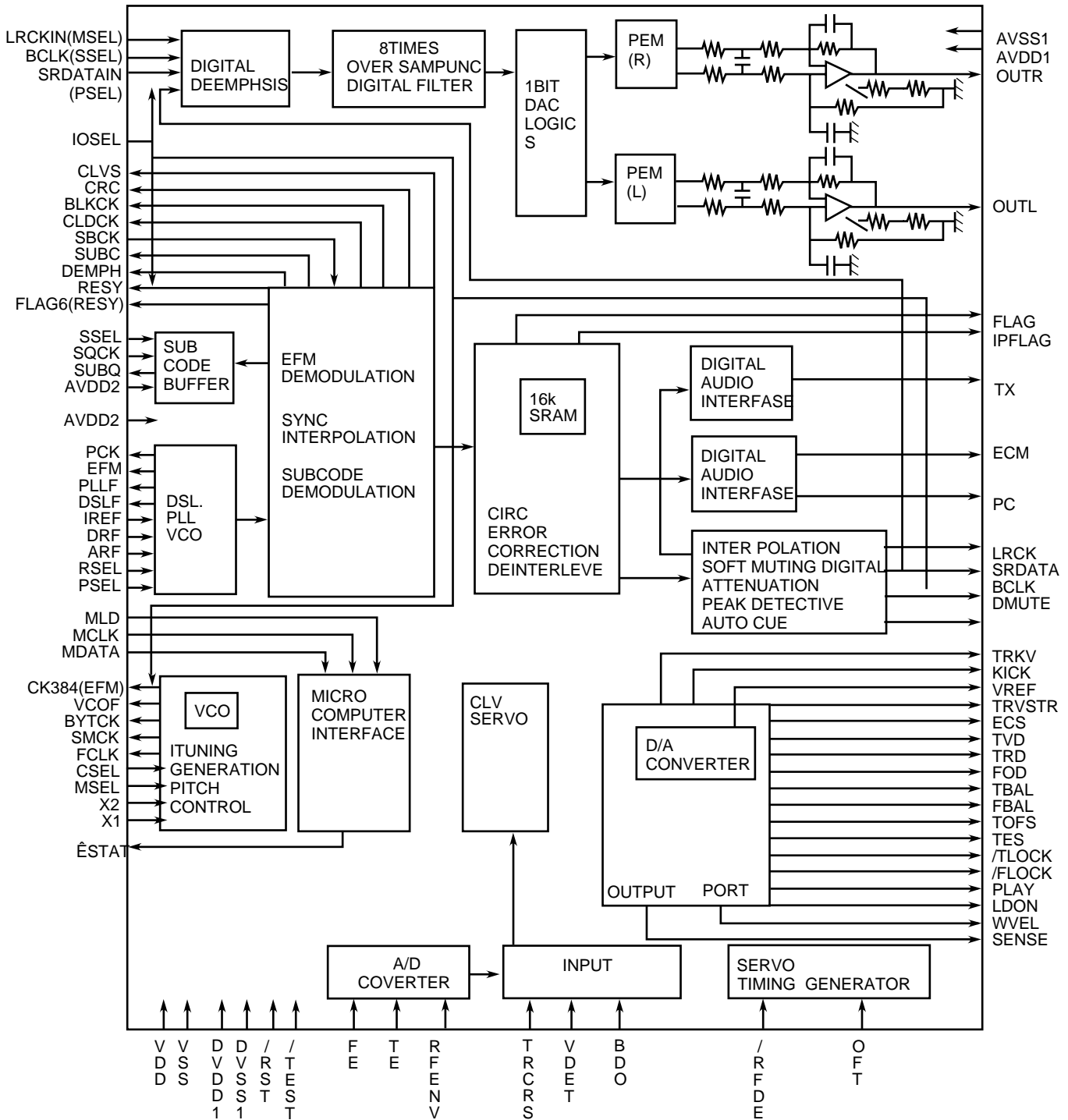

3. Description

Pin No.	symbol	I/O	Description	Pin No.	symbol	I/O	Description
1	BCLK	O	Not used	41	TES	O	Tracking error shunt signal output(H:shunt)
2	LRCK	O	Not used	42	PLAY	—	Not used
3	SRDATA	O	Not used	43	WVEL	—	Not used
4	DVDD1	—	Power supply (Digital)	44	ARF	I	RF signal input
5	DVSS1	—	Connected to GND	45	IREF	I	Reference current input pin
6	TX	O	Digital audio interface output	46	DRF	I	Bias pin for DSL
7	MCLK	I	μ com command clock signal input (Data is latched at signal's rising point)	47	DSL F	I/O	Loop filter pin for DSL
8	MDATA	I	μ com command data input	48	PLL F	I/O	Loop filter pin for PLL
9	MLD	I	μ com command load signal input	49	VCOF	—	Not used
10	SENSE	O	Sence signal output	50	AVDD2	—	Power supply(Analog)
11	FLOCK	O	Focus lock signal output Active :Low	51	AVSS2	—	Connected to GND(Analog)
12	TLOCK	O	Tracking lock signal output Active :Low	52	EFM	—	Not used
13	BLKCK	O	sub-code·block·clock signal output	53	PCK	—	Not used
14	SQCK	I	Outside clock for sub-code Q resistor input	54	PDO	—	Not used
15	SUBQ	O	Sub-code Q -code output	55	SUBC	—	Not used
16	DMUTE	—	Connected to GND	56	SBCK	—	Not used
17	STATUS	O	Status signal (CRC,CUE,CLVS,TTSTOP,ECLV,SQOK)	57	VSS	—	Connected to GND(for X'tal oscillation circuit)
18	RST	I	Reset signal input (L:Reset)	58	XI	I	Input of 16.9344MHz X'tal oscillation circuit
19	SMCK	—	Not used	59	X2	O	Output of X'tal oscillation circuit
20	PMCK	—	Not used	60	VDD	—	Power supply(for X'tal cscillation circuit)
21	TRV	O	Traverse enforced output	61	BYTCK	—	Not used
22	TVD	O	Traverse drive output	62	CLDCK	—	Not used
23	PC	—	Not used	63	FLAG	—	Not used
24	ECM	O	Spindle motor drive signal (Enforced mode output) 3-State	64	IPPLAG	—	Not used
25	ECS	O	Spindle motor drive signal (Servo error signal output)	65	FLAG	—	Not used
26	KICK	O	Kick pulse output	66	CLVS	—	Not used
27	TRD	O	Tracking drive output	67	CRC	—	Not used
28	FOD	O	Focus drive output	68	DEMPH	—	Not used
29	VREF	I	Reference voltage input pin for D/A output block (TVD,FOD,FBA,TBAL)	69	RESY	—	Not used
30	FBAL	O	Focus Balance adjust signal output	70	IOSEL	—	pull up
31	TBAL	O	Tracking Balance adjust signal output	71	TEST	—	pull up
32	FE	I	Focus error signal input(Analog input)	72	AVDD1	—	Power supply(Digital)
33	TE	I	Tracking error signal input(Analog input)	73	OUT L	O	Lch audio output
34	RF ENV	I	RF envelope signal input(Analog input)	74	AVSS1	—	Connected to GND
35	VDET	I	Vibration detect signal input(H:detect)	75	OUT R	O	Rch audio output
36	OFT	I	Off track signal input(H:off track)	76	RSEL	—	pull up
37	TRCRS	I	Track cross signal input	77	CSEL	—	Connected to GND
38	RFDET	I	RF detect signal input(L:detect)	78	PSEL	—	Connected to GND
39	BDO	I	BDO input pin(L:detect)	79	MSEL	—	Connected to GND
40	LDON	O	Laser ON signal output(H:on)	80	SSEL	—	Pull up

■AN8806SB-W(IC301) :RF&SERVO AMP

1.Pin layout

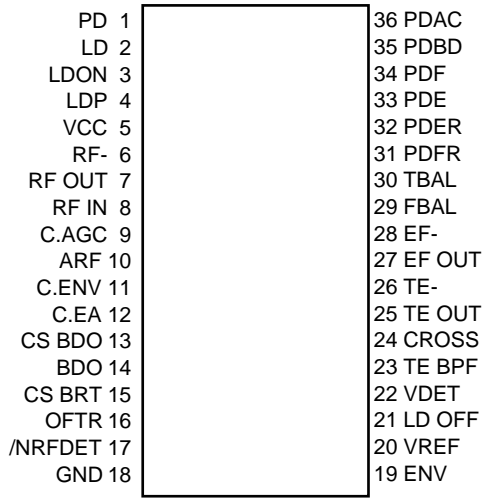

2.Block diagram

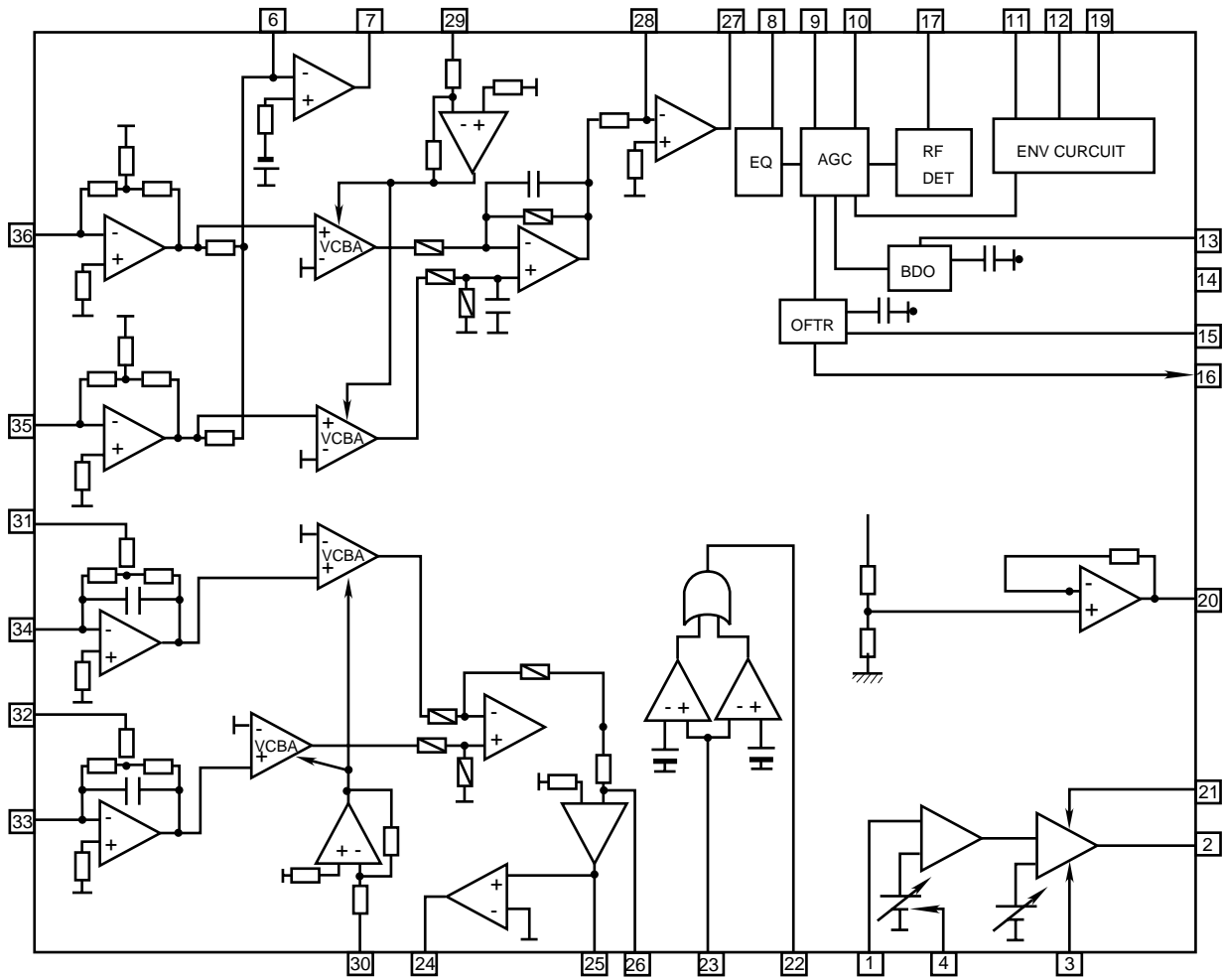

3. Pin function

Pin No.	symbol	I/O	Function
1	PD	I	APC amp . Input terminal
2	LD	O	APC amp . Output terminal
3	LD ON	I	LD ON/OFF control terminal
4	LDP	--	Connect to GND
5	VCC	--	Power supply
6	RF-	I	RF amp . Reversing input terminal
7	RF OUT	O	RFamp . Output terminal
8	RF IN	I	AGC input terminal
9	C.AGC	I/O	AGC loop filter connection terminal
10	ARF	O	ARF output terminal
11	C.ENV	I/O	RF detection capacity connection terminal
12	C.EA	I/O	HPF-amp capacity connection terminal
13	CS BDO	I/O	Capacity connection terminal for RF discernment side envelope detection
14	BDO	O	BDO output terminal
15	CS BRT	I/O	Capacity connection terminal for RF discernment side envelope detection
16	OFTR	O	OFTR output terminal
17	/NRFDET	O	RFDET output terminal
18	GND	--	Connect to GND
19	ENV	O	3TENV output terminal
20	VREF	O	VREF output terminal
21	LD OFF	--	APC OFF control terminal
22	VDET	O	VDET output terminal
23	TE BPF	I	VDET input terminal
24	CROSS	O	CROSS output terminal
25	TE OUT	O	TE amp . Output terminal
26	TE-	I	FE amp . Reversing input terminal
27	FE OUT	O	FE amp . output terminal
28	FE-	I	FE amp . Reversing input terminal
29	FBAL	I	F.BAL control terminal
30	TBAL	I	T.BAL control terminal
31	PDFR	I/O	I-V amp conversion resistance adjustment terminal
32	PDER	I/O	I-V amp conversion resistance adjustment terminal
33	PDF	I	I-V amp input terminal
34	PDE	I	I-V amp input terminal
35	PD BD	I	I-V amp input terminal
36	PD AC	I	I-V amp input terminal

■ UPD78064GF-108 (IC701): System CPU

1. Pin layout

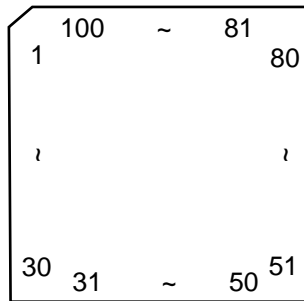

2. Pin function

Pin No.	Symbol	I/O	Function	Pin No.	Symbol	I/O	Function
1	USDATA	I/O	Serial data	29	URESET/CLOSE	I	[RESET/CLOSE] switch
2	USCK	O	Serial clock	30	USAFETY1	I	Abnormal voltage detection 1
3	UQRIN	I	CD Q code data	31	USAFETY0	I	Abnormal voltage detection 2
4	UNC	-	Non connect	32	UKEY1	I	Body key input 1
5	USQCK	O	CD Q code data synchronizing clock	33	UKEY0	I	Body key input 0
6	ICVSS	-	Connected to VSS	34	UTAPE0	I	Tape switch 0
7	UX2	-	Main system clock	35	UTAPE1	I	Tape switch 1
8	UX1	I	Main system clock	36	AVDD	-	AD converter power supply
9	VDD	-	Power supply	37	UAVREF	-	AD converter reference voltage
10	UXT1	I	Sub system clock	38	UBUP	I	Backup power supply decision
11	UXT2	-	Sub system clock	39	UFTUNER	O	Function tuner
12	URESET	I	Reset	40	VSS	-	GND
13	UREM	I	Remote control	41	UMPX	I	FM stereo detection
14	URDSCK	-	Non connect	42	UPERIOD	O	Tuner PLL strobe
15	UJOG1	I	Jog encoder 1	43	UJOGB	I	JOG encoder 2
16	UBEAT2	O	Main clock selection 2	44	UBASS	O	BASS control
17	UBEAT1	O	Main clock selection 1	45	UTRE	O	TRE control
18	U+BCTL	O	Switched 5V control	46	UVOL	O	VOL.control
19	UXRESET	O	CD LSI reset	47	USBASS	O	AHB on/off
20	UMCLK	O	CD LSI command clock	48	USMUTE	O	System muting
21	UMDATA	O	CD LSI command data	49	UPOUT	O	Power ON/OFF
22	UMLD	O	CD LSI command load	50	UFCD	O	Function CD
23	UPBMUTE	O	Tape playback mute	51~54	COM0~3	O	LCD common
24	ULATCH	O	Tape IC strobe	55	BIAS	-	LCD bias voltage
25	UREEL	I	Tape end detection	56~58	VLC0~2	-	LCD bias voltage
26	UFAUX	O	Function AUX	59	VSS	-	GND
27	UAVSS	-	AD converter GND	60~99	S0~39	O	LCD segment
28	USAFEYCD	I	CD abnormal voltage detection	100	USTATUS	I	LCD LSI status

■ LA1838(IC102): FM AM IF AMP&detector, FM MPX Decoder

1. Block Diagram

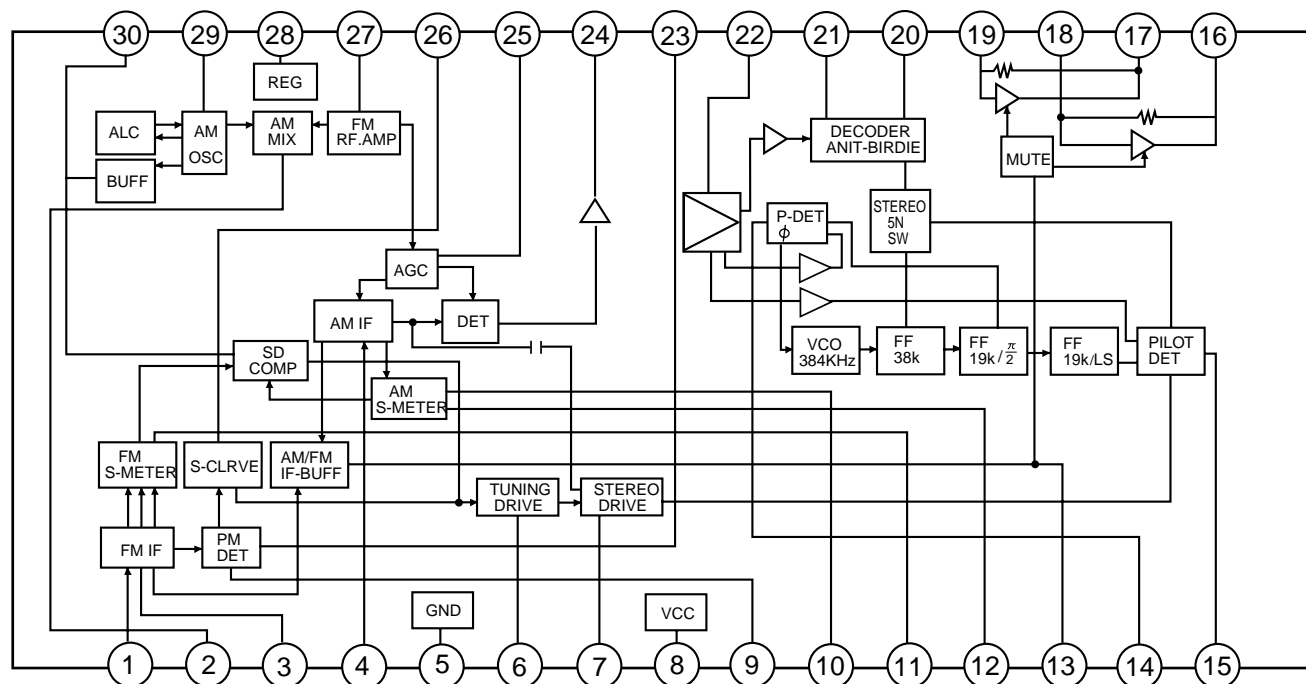

2. Pin Function

Pin No.	Symbol	I/O	Function	Pin No.	Symbol	I/O	Function
1	FM IN	I	This is an input terminal of FM IF signal.	16	R OUT	O	Right channel signal output.
2	AM MIX	O	This is an out put terminal for AM mixer.	17	L OUT	O	Left channel signal output.
3	FM IF	I	Bypass of FM IF	18	R IN	I	Input terminal of the Right channel post AMP.
4	AM IF	I	Input of AM IF Signal.	19	L IN	I	Input terminal of the Left channel post AMP.
5	GND	-	This is the device ground terminal.	20	RO	O	Mpx Right channel signal output.
6	TUNED	O	When the set is tuning,this terminal becomes "L".	21	LO	O	Mpx Left channel signal output.
7	STEREO	O	Stereo indicator output. Stereo "L", Mono: "H"	22	IF IN	I	Mpx input terminal
8	VCC	-	This is the power supply terminal.	23	FM OUT	O	FM detection output.
9	FM DET	-	FM detect transformer.	24	AM DET	O	AM detection output.
10	AM SD	-	This is a terminal of AM ceramic filter.	25	AM AGC	I	This is an AGC voltage input terminal for AM
11	FM VSM	O	Adjust FM SD sensitivity.	26	AFC	-	This is an output terminal of voltage for FM-AFC.
12	AM VSM	O	Adjust AM SD sensitivity.	27	AM RF	I	AM RF signal input.
13	MUTE	I/O	When the signal of IF REQ of IC121(LC72131) appear, the signal of FM/AM IF output. //Muting control input.	28	REG	O	Register value between pin 26 and pin28 besides the frequency width of the input signal.
14	FM/AM	I	Change over the FM/AM input. "H" :FM, "L" : AM	29	AM OSC	-	This is a terminal of AM Local oscillation circuit.
15	MONO/ST	O	Stereo : "H", Mono: "L"	30	OSC BUFFER	O	AM Local oscillation Signal output.

■ LC72136N (IC121) : PLL Frequency Synthesizer

1. Pin layout

XT	1	22	XT
FM/AM	2	21	GND
CE	3	20	LPFOUT
DI	4	19	LPFIN
CLOCK	5	18	PD
DO	6	17	VCC
FM/ST/VCO	7	16	FMIN
AM/FM	8	15	AMIN
	9	14	
	10	13	IFCONT
SDIN	11	12	IFIN

2. Block diagram

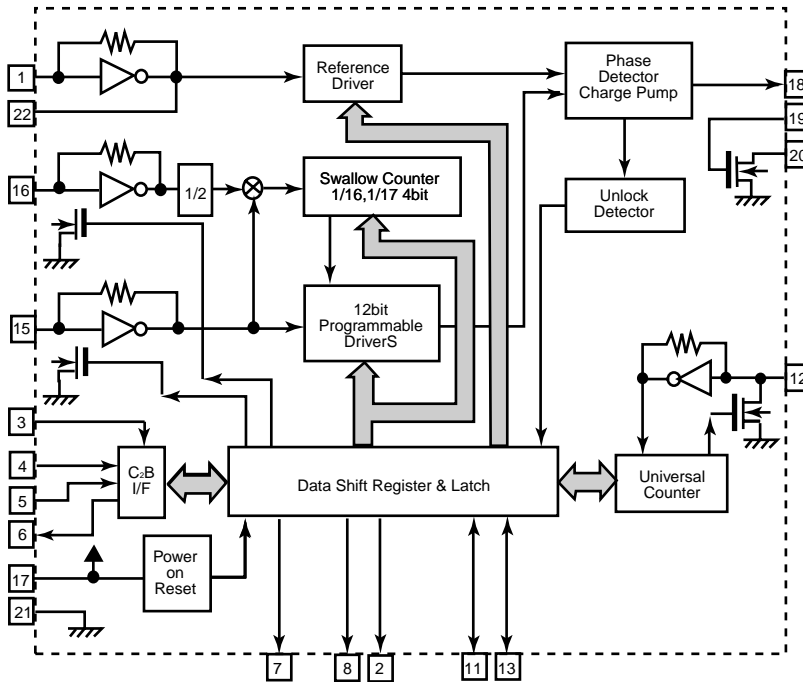

3. Pin function

Pin No.	Symbol	I/O	Function	Pin No.	Symbol	I/O	Function
1	XT	I	X'tal oscillator connect (75kHz)	12	IFIN	I	IF counter signal input
2	FM/AM	O	LOW:FM mode	13	IFCONT	O	IF signal output
3	CE	I	When data output/input for 4pin(input) and 6pin(output): H	14		-	Not use
4	DI	I	Input for receive the serial data from controller	15	AMIN	I	AM Local OSC signal output
5	CLOCK	I	Sync signal input use	16	FMIN	I	FM Local OSC signal input
6	DO	O	Data output for Controller Output port	17	VCC	-	Power supply(VDD=4.5-5.5V) When power ON:Reset circuit move
7	FM/ST/VCO	O	"Low": MW mode	18	PD	O	PLL charge pump output(H: Local OSC frequency Height than Reference frequency. L: Low Agreement: Height impedance)
8	AM/FM	O	Open state after the power on reset	19	LPFIN	I	Input for active lowpassfilter of PLL
9	LW	I/O	Input/output port	20	LPFOUT	O	Output for active lowpassfilter of PLL
10	MW	I/O	Input/output port	21	GND	-	Connected to GND
11	SDIN	I/O	Data input/output	22	XT	I	X'tal oscillator(75KHz)

■ **BA15218N (IC342/IC343/IC391/IC453/IC362/IC363)**
: Dual Ope. Amp.

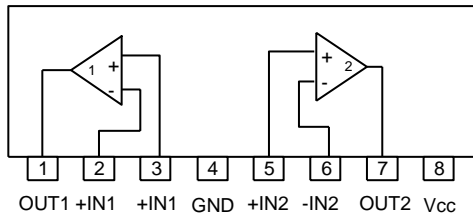

■ **BU4094BCF-X(IC304,IC303):Serial to parallel port extension**

1.Pin layout

STROBE	1	16	Vdd
DATA	2	15	OUTPUT ENABLE
CLOCK	3	14	Q5
Q1	4	13	Q6
Q2	5	12	Q7
Q3	6	11	Q8
Q4	7	10	Q's
Vss	8	9	Qs

2.Block diagram

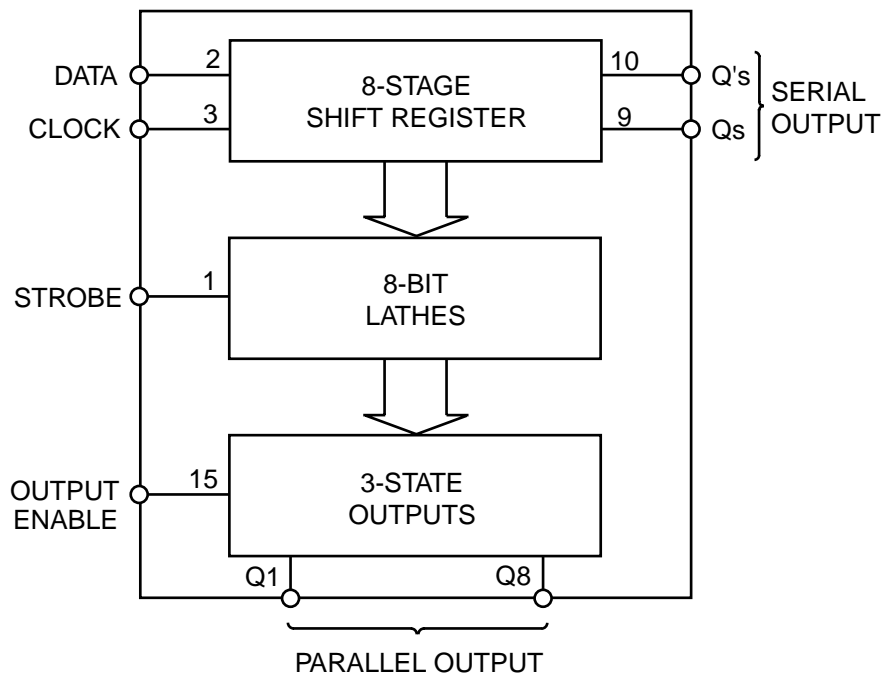

■ GP1U271X (IC701) : Receiver for remote

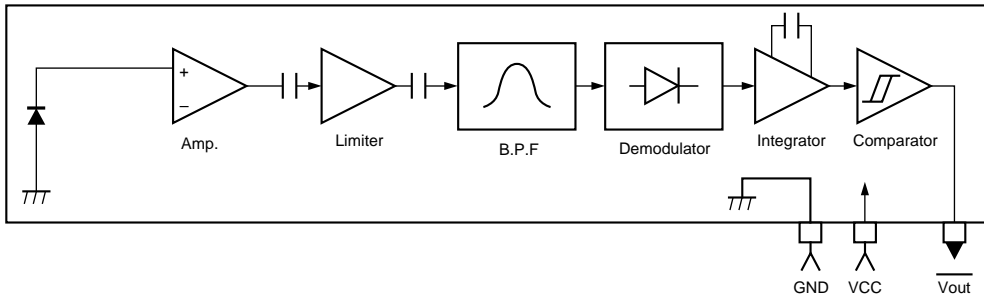

■ LB1641 (IC501) : DC Motor Driver

1. Pin Layout

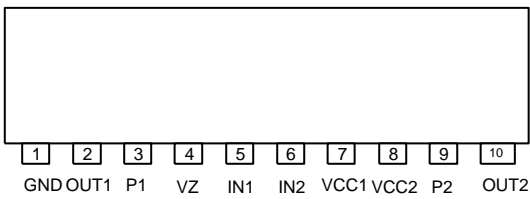

2. Pin Functions

Input		Output		Mode
IN1	IN2	OUT1	OUT2	
0	0	0	0	Brake
1	0	1	0	CLOCKWISE
0	1	0	1	COUNTER-CLOCKWISE
1	1	0	0	Brake

AN7345(IC302) PB/REC AMP

1. Block diagram

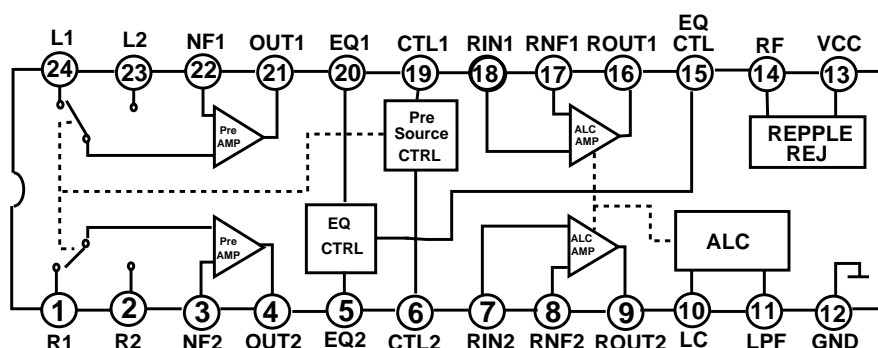

2. Pin Function

Pin No.	Symbol	I/O	Function	Pin No.	Symbol	I/O	Function
1	R1	I	Playback amplifier input	13	Vcc	I	Power supply
2	R2	I	Playback amplifier input	14	RF	I	Repple filter
3	NF2	I	Playback amplifier negative feedback	15	EQCTL	I	EQ control
4	OUT2	O	Playback amplifier output	16	ROUT 1	O	Recording amplifier output
5	EQ2	I	Equalaizer	17	RNF1	I	Recording amplifier negative feedback
6	CTL2	I	Pre Amplifier input swithing time constant	18	RIN1	I	Recording amplifier input
7	RIN2	I	Recording amplifier input	19	CTL1	I	Pre amplifier input swithing control
8	RNF2	I	Recording amplifier negative feedback	20	EQ1	I	Equalayzer
9	ROUT2	O	Recording amplifier output	21	OUT1	O	Playback amplifier output
10	LC	I	ALC low cut	22	NF1	I	Playback amplifier negative feedback
11	LPF	I	ALC low pass filter	23	L2	I	Playback amplifier input
12	GND	I	—	24	L1	I	Playback amplifier input

LC75342

1. Pin assignment

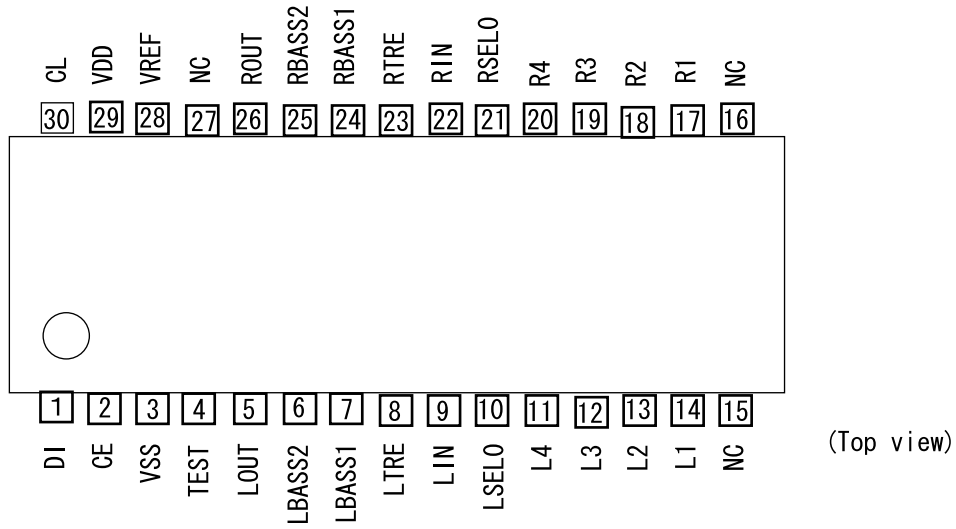

2. Block

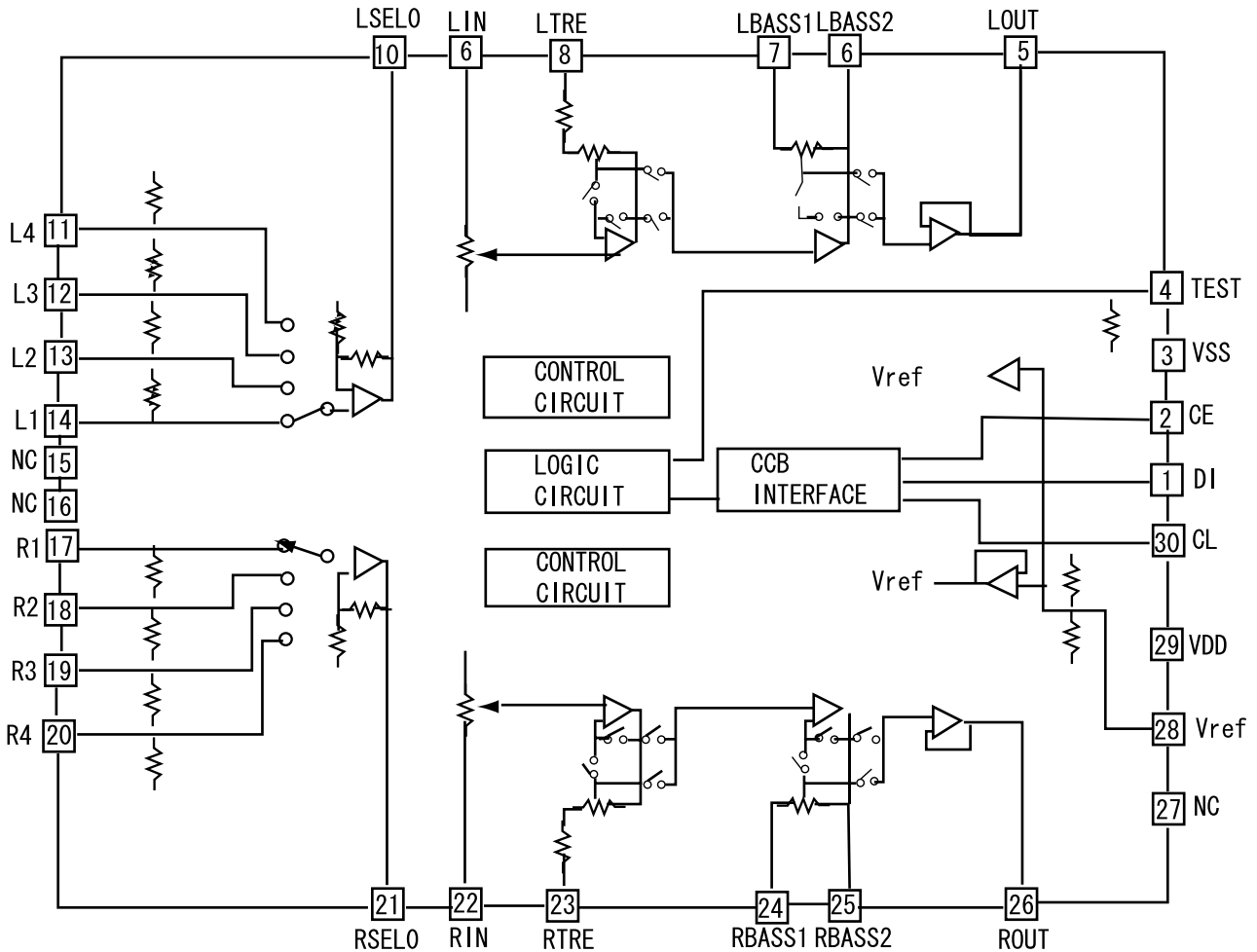

3. Pin function

Pin No.	symbol	I/O	Function
1	D1	I	Serial data input pin for control
2	CE	I	Chip enable pin
3	Vss	--	Ground
4	TEST	I	TEST pin for electronic volume control
5	LOUT	O	Volume+equalizer output
6	LBASS2	O	Bas-band filter comprising capacitor and resistor connection
7	LBASS1	I	Bas-band filter comprising capacitor and resistor connection
8	LTRE	I	Capacitor connection pin comprising treble band filter
9	LIN	I	Volume+equalizer input
10	LSEL0	O	Input selector output pin
11	L4	I	Input signal pin
12	L3	I	Input signal pin
13	L2	I	Input signal pin
14	L1	I	Input signal pin
15	NC	--	No connect
16	NC	--	No connect
17	R1	I	Input signal pin
18	R2	I	Input signal pin
19	R3	I	Input signal pin
20	R4	I	Input signal pin
21	RSEL0	O	Input selector output pin
22	RIN	I	Volume+equalizer input
23	RTRE	I	Capacitor connection pin comprising treble band filter
24	RBASS1	I	Bas-band filter comprising capacitor and resistor connection
25	RBASS2	O	Bas-band filter comprising capacitor and resistor connection
26	ROUT	O	Volume+equalizer output
27	NC	--	No connect
28	Vref	O	Analog ground
29	VDD	I	Power Supply
30	CL	I	Clock input

■ LC72723

1. Pin Assignment

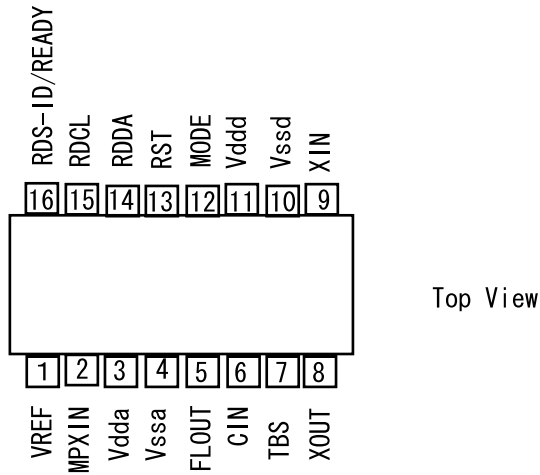

2. Block diagram

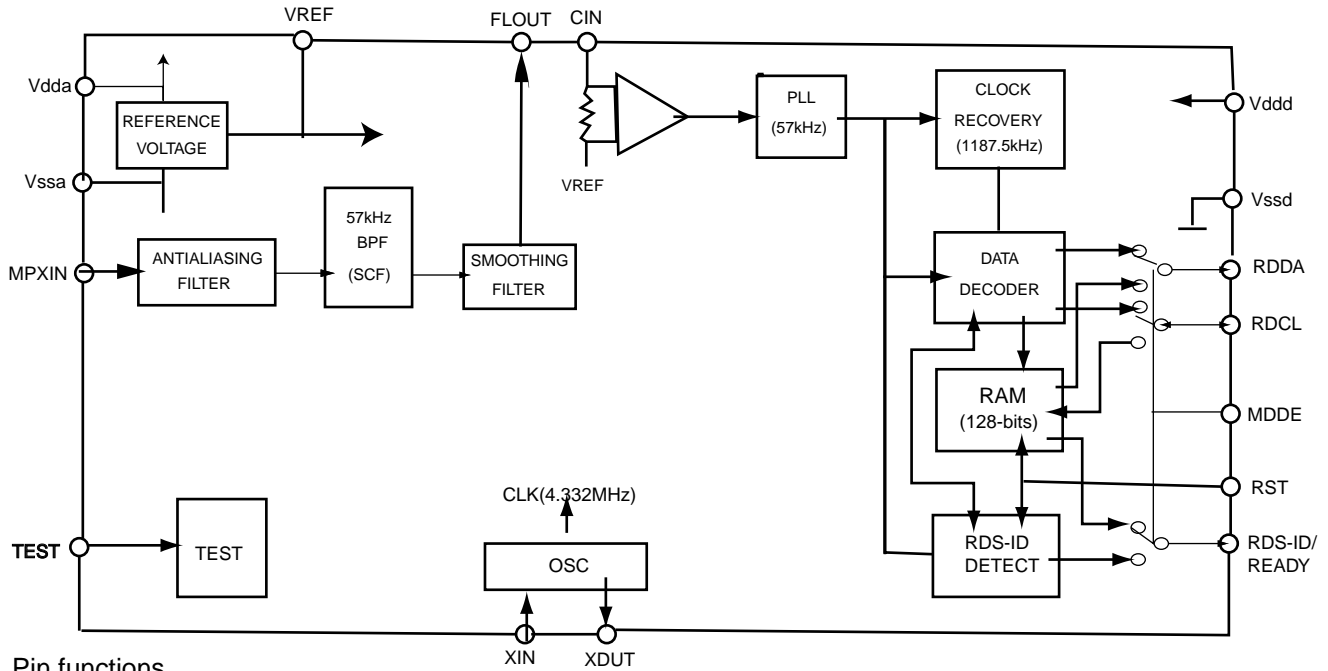

3. Pin functions

Pin No.	Symbol	I/O	Function
1	VREF	O	Reference voltage output ($V_{dda}/2$)
2	MPXIN	I	Baseband (multiplexed) signal input
3	Vdda	—	Analog power supply (+5V)
4	Vssa	—	Analog ground
5	FLOUT	O	Subcarrier input (filter output)
6	CIN	I	Subcarrier input (comparator input)
7	TEST	I	Test input
8	XOUT	O	Crystal oscillator output (4.332MHz)
9	XIN	I	Crystal oscillator input (external reference input)
10	Vssd	—	Digital ground
11	Vddd	—	Digital power supply
12	MODE	I	Read mode setting (0:master,1:slave)
13	RST	I	RDS-ID/RAM reset (positive polarity)
14	RDDA	O	RDS data output
15	RDCL	I/O	RDS clock output (master mode)/RDS clock input (slave mode)
16	RDS-ID READY	O	RDS-ID/READY output (negative polarity)

JVC

VICTOR COMPANY OF JAPAN, LIMITED

AUDIO & COMMUNICATION BUSINESS DIVISION

PERSONAL & MOBILE NETWORK BUSINESS UNIT 10-1,1Chome,Ohwatari-machi,Maebashi-city,371-8543,Japan

Block diagram

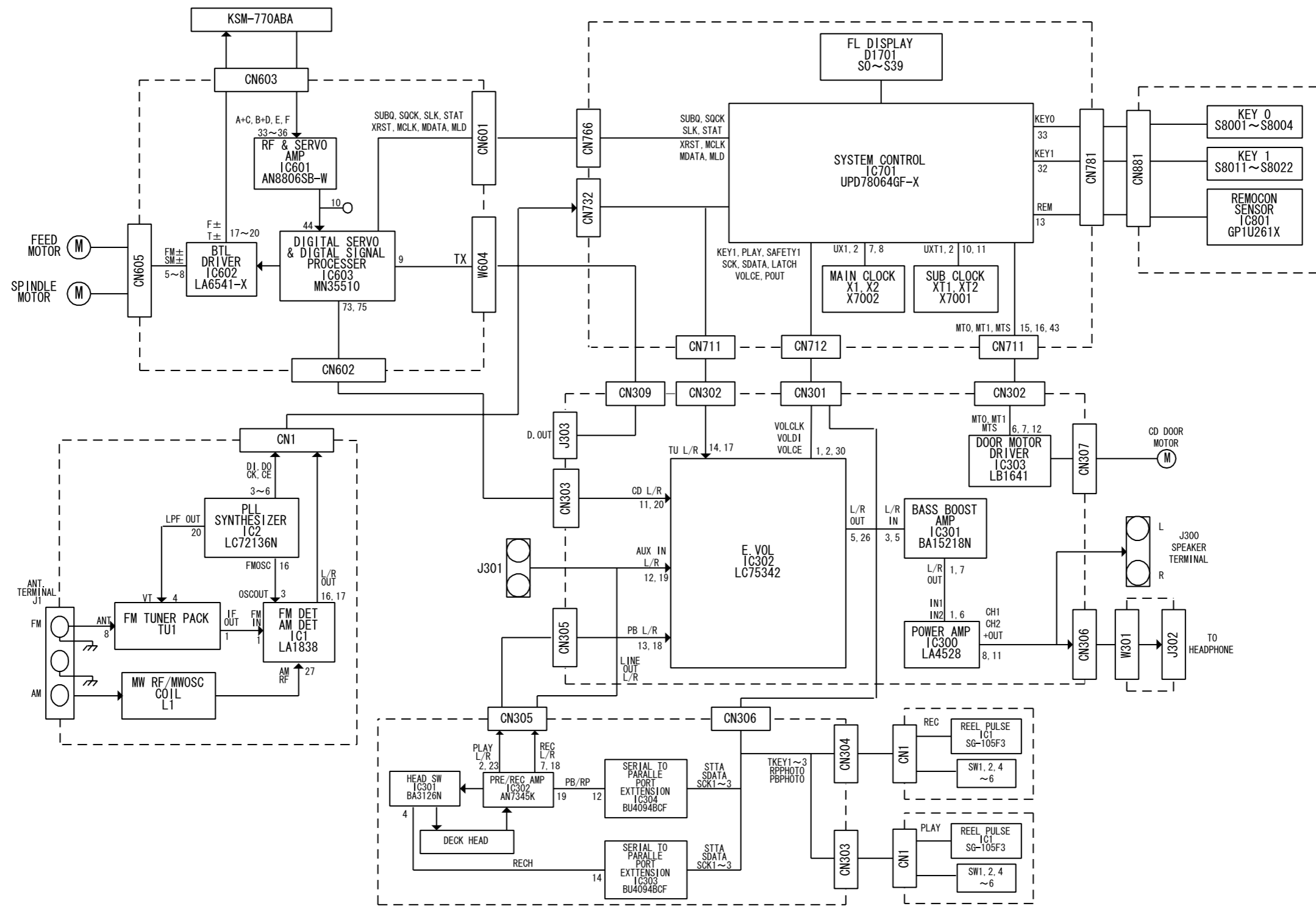

Standard schematic diagrams

■ CPU & LCD driver circuit (UX-V10)

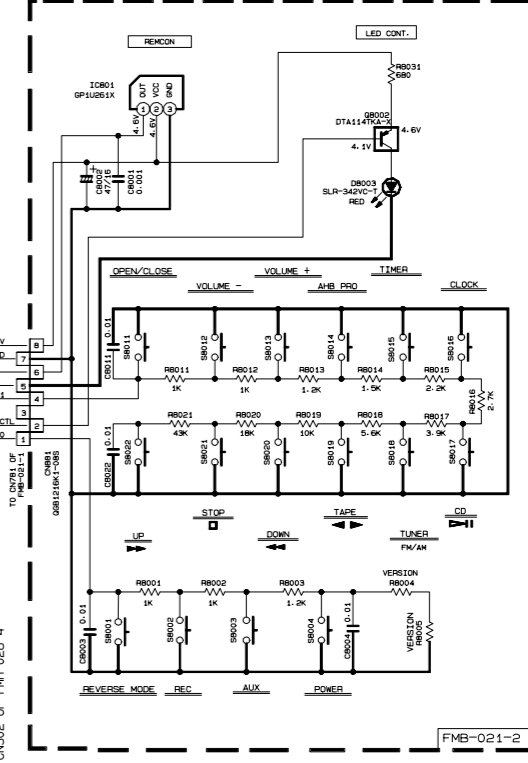
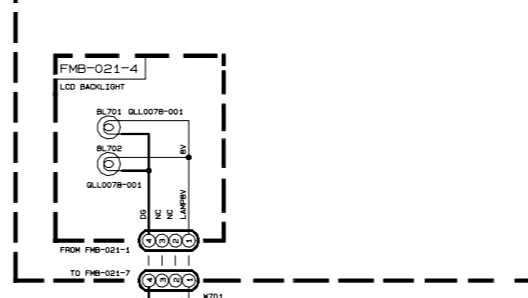
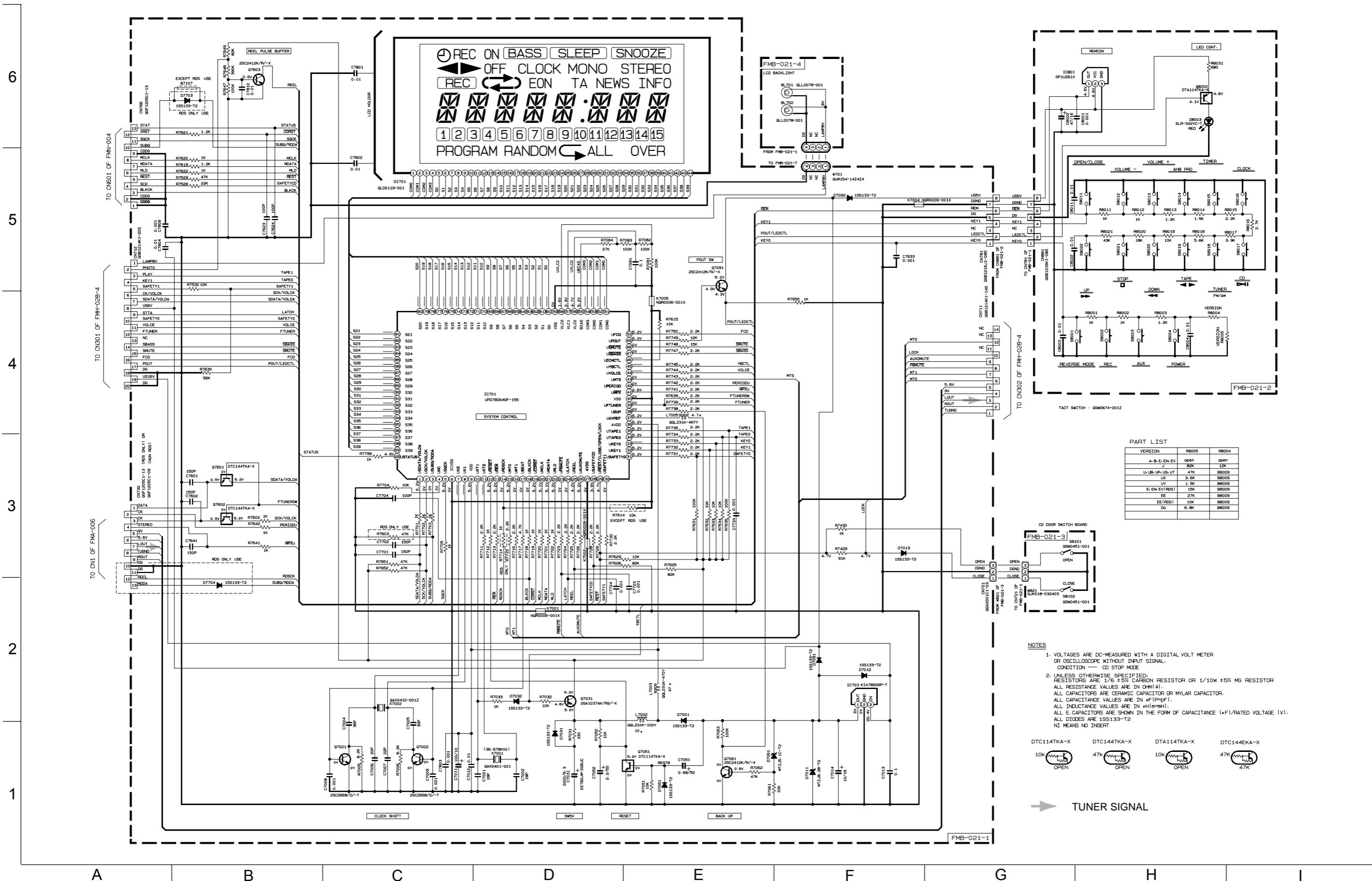

PART LIST

VERSION	R8005	R8004
A-B-E-EN-EV	open	open
J	82K	12K
U-LB-UP-UB-UT	47K	R8009
UX	1K	R8003
UY	1.5K	R8002
E-EN-EV(RDS)	15K	R8009
EE	27K	R8009
EE(RDS)	10K	R8009
Do	6.8K	R8009

- NOTES**
- VOLTAGES ARE DC-MEASURED WITH A DIGITAL VOLT METER OR OSCILLOSCOPE WITHOUT INPUT SIGNAL.
CONDITION — CD STOP MODE
 - UNLESS OTHERWISE SPECIFIED:
RESISTORS ARE 1/6 ±5% CARBON RESISTOR OR 1/10W ±5% MG RESISTOR
ALL RESISTANCE VALUES ARE IN OHM(Ω).
ALL CAPACITORS ARE CERAMIC CAPACITOR OR MYLAR CAPACITOR.
ALL CAPACITANCE VALUES ARE IN #F(PPF).
ALL INDUCTANCE VALUES ARE IN #H(MH).
ALL E-CAPACITORS ARE SHOWN IN THE FORM OF CAPACITANCE (#F)/RATED VOLTAGE (V).
ALL DIODES ARE 1SS133-T2
NI MEANS NO INSERT



➔ TUNER SIGNAL

CD servo circuit (UX-V10)

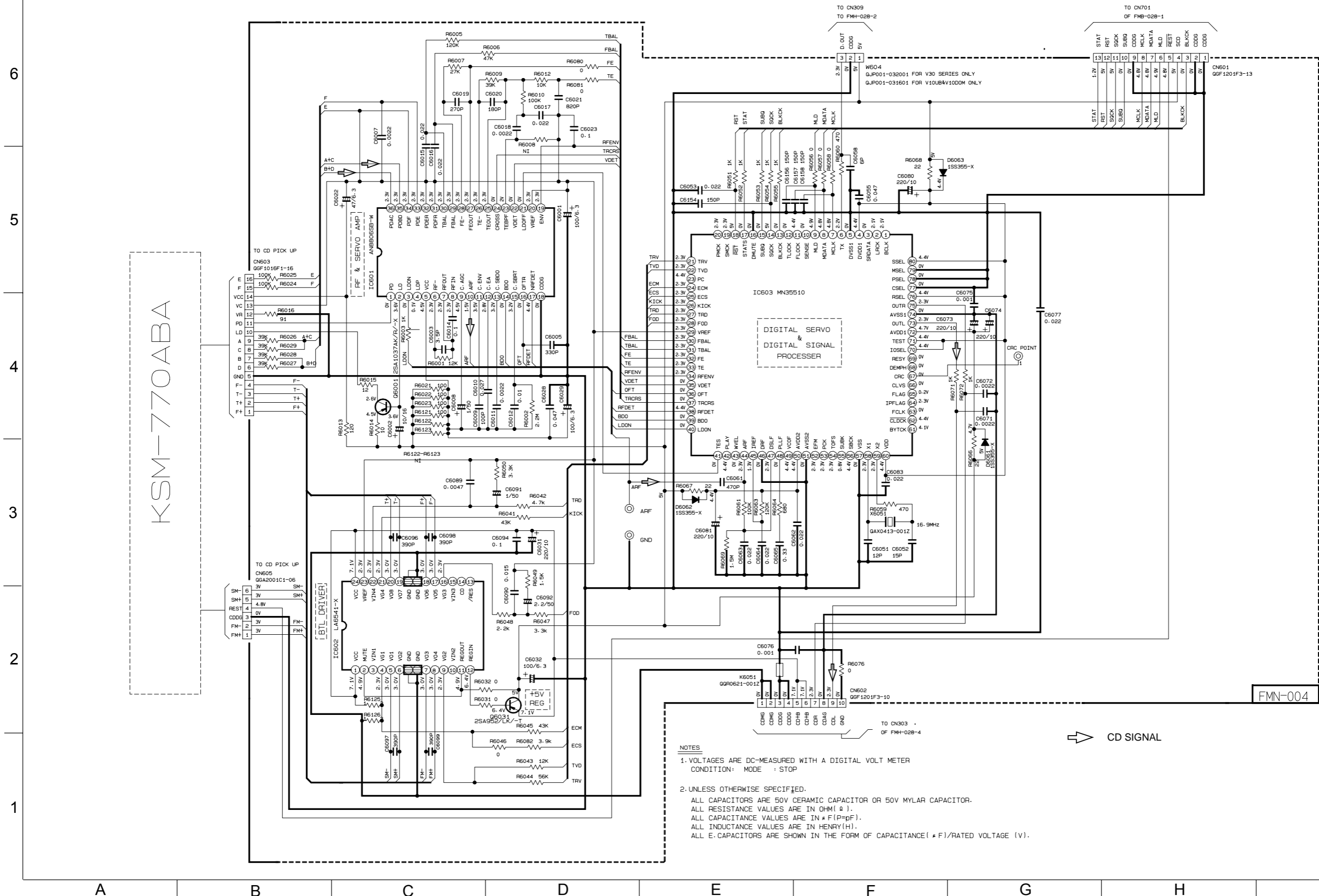

- NOTES
1. VOLTAGES ARE DC-MEASURED WITH A DIGITAL VOLT METER
CONDITION: MODE : STOP
 2. UNLESS OTHERWISE SPECIFIED.
ALL CAPACITORS ARE 50V CERAMIC CAPACITOR OR 50V MYLAR CAPACITOR.
ALL RESISTANCE VALUES ARE IN OHM (Ω).
ALL CAPACITANCE VALUES ARE IN PICO (pF).
ALL INDUCTANCE VALUES ARE IN HENRY (H).
ALL E-CAPACITORS ARE SHOWN IN THE FORM OF CAPACITANCE (μF)/RATED VOLTAGE (V).

CD SIGNAL

Power amplifier circuit (UX-V10)

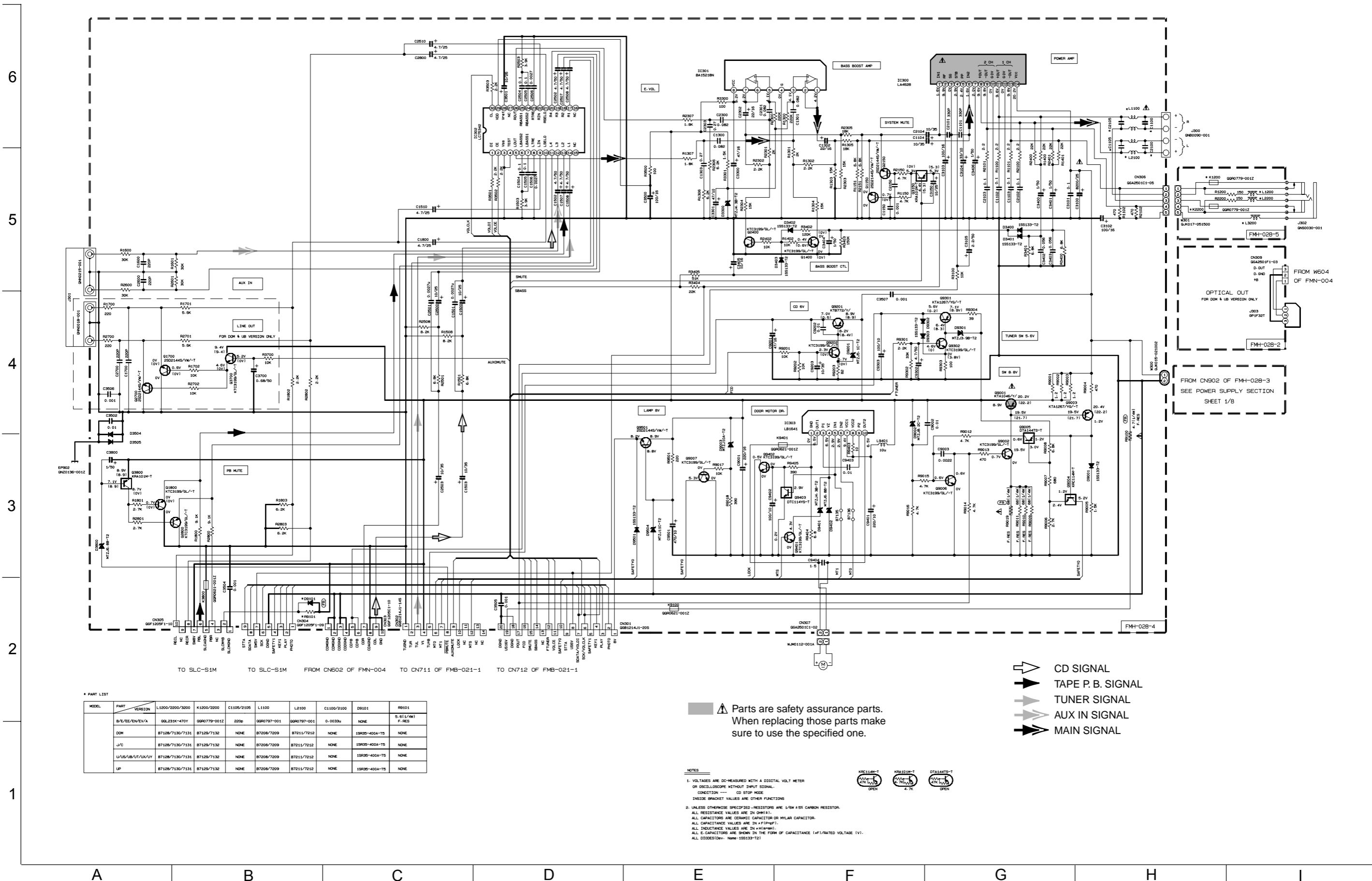

*** PART LIST**

MODEL	PART	VERSION	L1000/2000/3000	R1000/2000	C1100/2100	L1100	L2100	C1100/2100	D9101	R9101
B/E/EE/EN/EA	00L231K-470Y	090779-0012	2006	090779-001	090779-001	0.0033u	NONE	5.612/4W F-RES		
DOM	87128/7130/7131	87128/7132	NONE	87208/7209	87211/7212	NONE	19K95-400A-T5	NONE		
J/C	87128/7130/7131	87128/7132	NONE	87208/7209	87211/7212	NONE	19K95-400A-T5	NONE		
U/A/S/UB/UT/U/A/UY	87128/7130/7131	87128/7132	NONE	87208/7209	87211/7212	NONE	19K95-400A-T5	NONE		
LP	87128/7130/7131	87128/7132	NONE	87208/7209	87211/7212	NONE	19K95-400A-T5	NONE		

- CD SIGNAL
- TAPE P.B. SIGNAL
- TUNER SIGNAL
- AUX IN SIGNAL
- MAIN SIGNAL

⚠ Parts are safety assurance parts.
When replacing those parts make sure to use the specified one.

NOTES

- VOLTAGES ARE DC-MEASURED WITH A DIGITAL VOLT METER OR OSCILLOSCOPE WITHOUT INPUT SIGNAL.
CONDITION: — CD STOP MODE
INSIDE BRACKET VALUES ARE OTHER FUNCTIONS
- UNLESS OTHERWISE SPECIFIED, RESISTORS ARE 1/8W ± 5% CARBON RESISTOR.
ALL RESISTANCE VALUES ARE IN OHM(Ω).
ALL CAPACITORS ARE CERAMIC CAPACITOR OR MYLAR CAPACITOR.
ALL CAPACITANCE VALUES ARE IN P(F)P(F).
ALL INDUCTANCE VALUES ARE IN M(H)M(H).
ALL S-CAPACITORS ARE SHOWN IN THE FORM OF CAPACITANCE (μF)/RATED VOLTAGE (V).
ALL DIODES(DiV, Name: 1S5133-12)



■ Tuner circuit (UX-V10 B/E/EN)

6
5
4
3
2
1

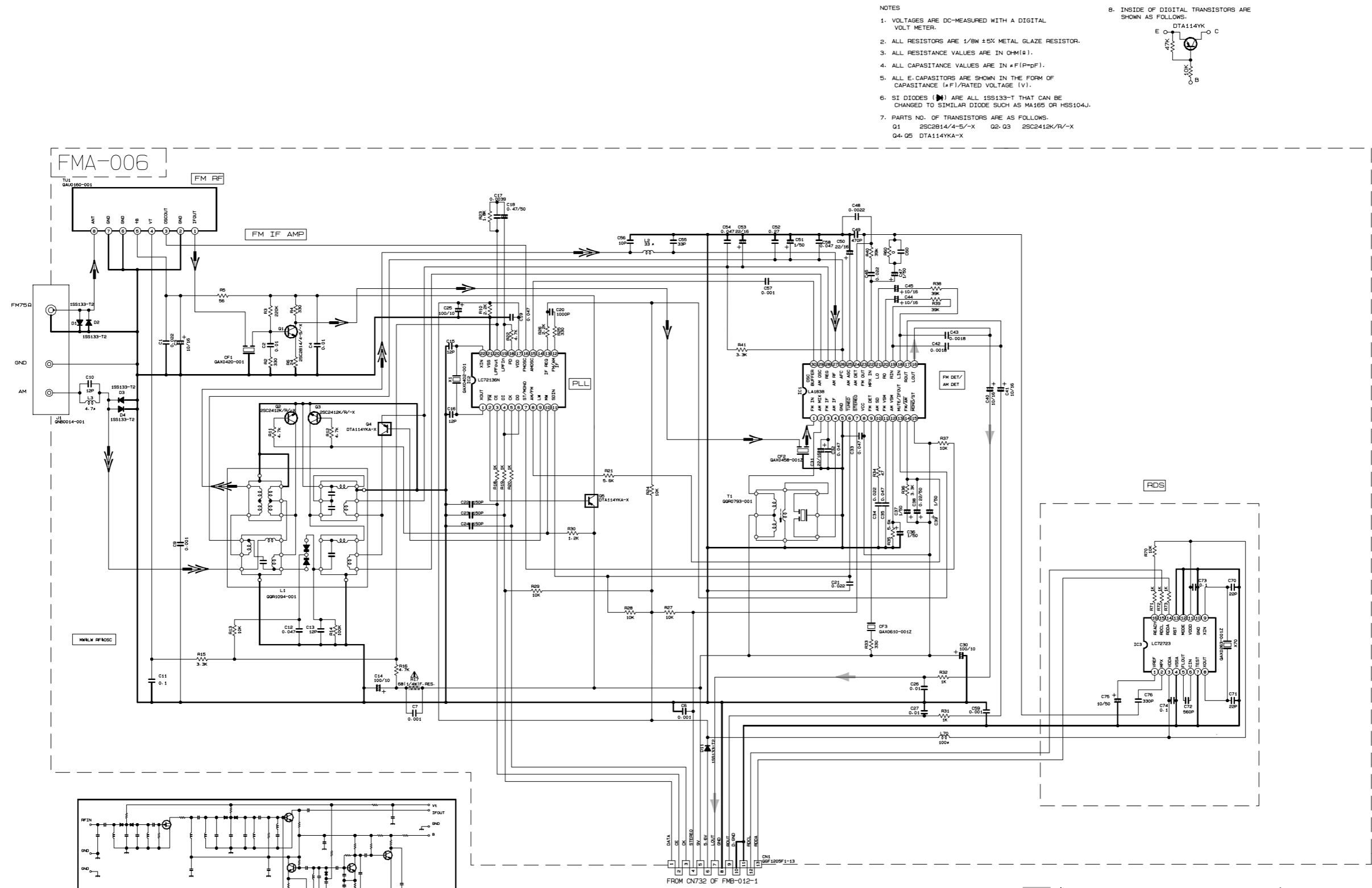

- NOTES
1. VOLTAGES ARE DC-MEASURED WITH A DIGITAL VOLT METER.
 2. ALL RESISTORS ARE 1/8W ±5% METAL GLAZE RESISTOR.
 3. ALL RESISTANCE VALUES ARE IN OHM(Ω).
 4. ALL CAPACITANCE VALUES ARE IN pF(p-pF).
 5. ALL E.CAPACITORS ARE SHOWN IN THE FORM OF CAPASITANCE (±F)/RATED VOLTAGE (V).
 6. SI DIODES (⚡) ARE ALL 1SS133-T THAT CAN BE CHANGED TO SIMILAR DIODE SUCH AS MA165 OR HSS104J.
 7. PARTS NO. OF TRANSISTORS ARE AS FOLLOWS:
Q1 2SC2814/4-5/-X Q2-Q3 2SC2412K/R/-X
Q4-Q5 DTA114YKA-X

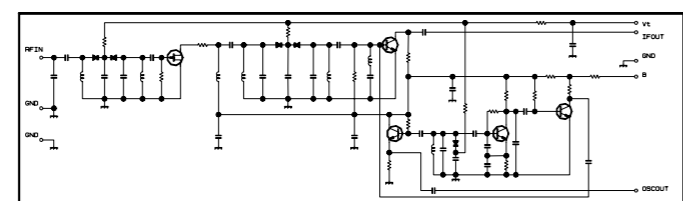
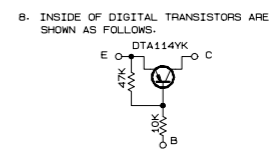

CONDITION	PIN NO.	1	2	3	4	5	6	7	8	9	10	11	12	13	14	15	16	17	18	19	20	21	22	23	24	25	26	27	28	29	30
IC1	FM NO SIGNAL	3.6	8.9	3.6	3.6	0	5.0	5.0	8.9	8.9	1.3	0.1	0	0.9	7.8	7.8	4.3	4.3	4.3	3.4	3.4	2.8	3.4	0	0	3.5	3.5	3.6	3.6	2.7	
	FM 60dB STEREO	3.6	8.9	3.6	3.6	0	5.0	5.0	8.9	8.9	1.3	4.3	0	0.9	7.8	7.8	4.3	4.3	4.3	3.4	3.4	2.8	3.4	0	0	3.6	3.6	3.6	3.6	2.7	
	AM NO SIGNAL	3.5	9.0	3.5	3.5	0	5.0	5.1	9.0	2.6	1.3	0	0	0.9	4.7	5.5	4.3	4.3	4.3	3.3	3.2	2.8	UST	0.7	0.7	3.6	3.6	3.6	3.6	2.1	
IC2	FM NO SIGNAL	2.5	0	0	5.0	4.9	5.0	7.9	7.8	3.6	6.1	5.1	0	0	0	0	2.5	5.1	0.9	0.9	3.8	0	2.3								

Tr. NO.	Q1	Q5
PIN NO.	E C B E C B	E C B E C B
FM 87.5MHz NO SIGNAL	0 7.1 0.85 8.9 8.8 0	
AM 528kHz NO SIGNAL	0 0 0 9.0 0 8.9	

Tr. NO.	Q2	Q3	Q4
PIN NO.	E C B E C B E C B		
AM 528kHz NO SIGNAL	0 0 0.7 0 0 0.7 0 3.6 0.7		
AM 144kHz NO SIGNAL	0 0 0.3 0 0.3 0.3 3.6 3.6 3.6		

⚠ Parts are safety assurance parts. When replacing those parts make sure to use the specified one.

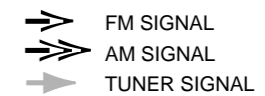

A B C D E F G H I

■ Cassette mecha control circuit (UX-V10)

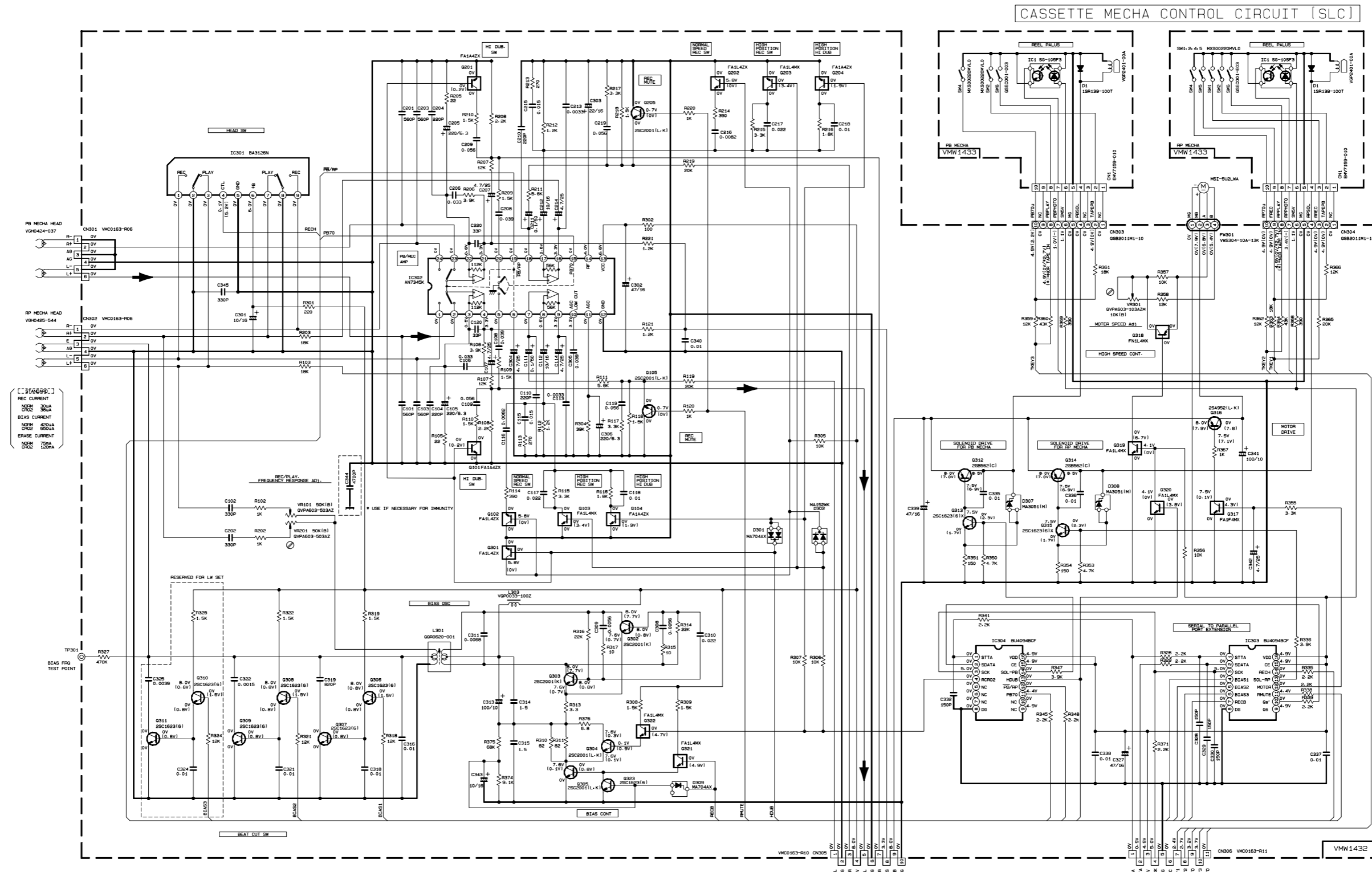

CASSETTE MECHA CONTROL CIRCUIT [SLC]

- [[STANDARD]]
 REC CURRENT
 NORM 300A
 CROD 300A
 BIAS CURRENT
 NORM 4800A
 CROD 4800A
 ERASE CURRENT
 NORM 1500A
 CROD 1500A

NOTES
 1. VOLTAGES ARE DC-MEASURED WITH A DIGITAL VOLT METER OR OSCILLOSCOPE WITHOUT INPUT SIGNAL. () IS INVERT MODE
 2. UNLESS OTHERWISE SPECIFIED
 ALL RESISTANCE VALUES ARE IN OHM(Ω).
 ALL CAPACITORS ARE CERAMIC CAPACITOR
 ALL CAPACITANCE VALUES ARE IN μF(PF).
 ALL INDUCTANCE VALUES ARE IN mH(MPH).
 ALL E. CAPACITORS ARE SHOWN IN THE FORM OF CAPACITANCE (μF)/RATED VOLTAGE (V).
 PLYPROPYLENE CAPACITOR

TABLE 1. DIGITAL TR LIST

PART. NO.	CONSTRUCTION	REF. NO.	SYMBOL	REF. NO.
FA144K	47K	Q318	FA144K	Q317
FA144Z	10K	Q101/Q201	FA144K	Q103/Q203
FA144Z	47K	Q104/Q204	FA144K	Q319
FA144Z	47K	Q102/Q202	FA144K	Q320/Q321/Q322
		Q301		

FROM PRE-AMP CIRCUIT
 FROM CN305 OF FMH-028-4

FROM MICOM THRU MAIN BOARD
 FROM CN304 OF FMH-028-4

TEPE P.B. SIGNAL

6
5
4
3
2
1

A B C D E F G H I

■ Power supply circuit (UX-V10)

POWER SUPPLY BLOCK

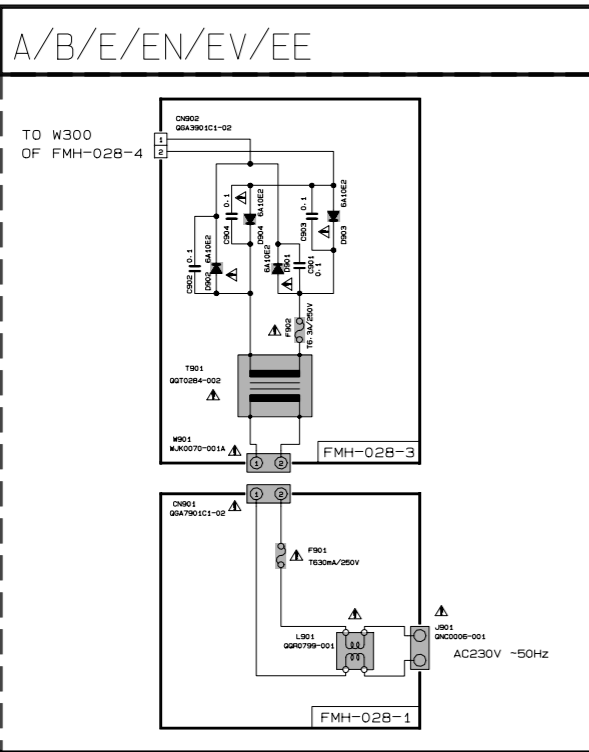

EXPLANATION OF OVERALL OF SCHEMATIC		
MODEL : FS-V10/UX-V10/UX-V20R		
SHEET NUMBER	MODEL NUMBERS TO BE APPLIED	CIRCUITS DESCRIPTION
1/8	FS-V10/UX-V10/UX-V20R	. PRIMARY WITH MAINS TRANSFORMER
2/8	FS-V10/UX-V10/UX-V20R	. DC REGULATORS/AUDIO OUTPUT . EXTERNAL INPUT. SOURCE SELECTOR SWITCH
3/8	FS-V10/UX-V10/UX-V20R	. LCD DISPLAY/SYSTEM CONTROL/USERS KEY CONTROL
4/8	FS-V10/UX-V10/UX-V20R	. CD SERVO AND CD SYSTEM CONTROL . CD CHANGER MECHANISM CONTROL
5/8	FS-V10/UX-V10/UX-V20R	. TAPE DECK MECHANISM CONTROL . TAPE CIRCUITS SUCH AS PRE-AMP AND BIAS
6/8	FS-V10/UX-V10	. TUNER RF/IF/FM MULTIPLEX (ONLY FOR J, C, U, UP, UR, US, UT, UV, UX, UY, A, DDM)
7/8	UX-V10/UX-V20R	. TUNER RF/IF/FM MULTIPLEX (ONLY FOR B, E, EN, EV)
8/8	UX-V10/UX-V20R	. TUNER RF/IF/FM MULTIPLEX (ONLY FOR EE)

NOTE : MARK(*) IS TO SHOW DEVIATION IN VERSIONS. DETAILS ARE EXPLAINED NEAR MARK.

VERSION CODES	
J	. U. S. A.
B	. U. K.
E	. CONTINENTAL EUROPE
EE	. RUSSIA
EN	. NORDIC COUNTRIES
EV	. EASTERN EUROPE
A	. AUSTRALIA
UP	. KOREA
US	. SINGAPORE
UT	. TAIWAN
UX	. SAUDI ARABIA
UY	. ARGENTINA
UB	. HONG KONG
U	. UNIVERSIAL EXCEPT ALL OF ABOVE

NOTES

- VOLTAGES ARE DC-MEASURED WITH A DIGITAL VOLT METER OR OSCILLOSCOPE WITHOUT INPUT SIGNAL. CONDITION --- CD STOP MODE INSIDE BRACKET VALUES ARE OTHER FUNCTIONS
- UNLESS OTHERWISE SPECIFIED, RESISTORS ARE 1/6W ±5% CARBON RESISTOR. ALL RESISTANCE VALUES ARE IN OHM(Ω). ALL CAPACITORS ARE CERAMIC CAPACITOR OR MYLAR CAPACITOR. ALL CAPACITANCE VALUES ARE IN #F(#=pF). ALL INDUCTANCE VALUES ARE IN #H(#=mH). ALL E-CAPACITORS ARE SHOWN IN THE FORM OF CAPACITANCE (#F)/RATED VOLTAGE (V). ALL DIODES(Dev. Name: 1SS133-T2)

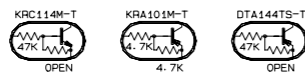

▲ Parts are safety assurance parts. When replacing those parts make sure to use the specified one.

Printed circuit boards

■ Main board

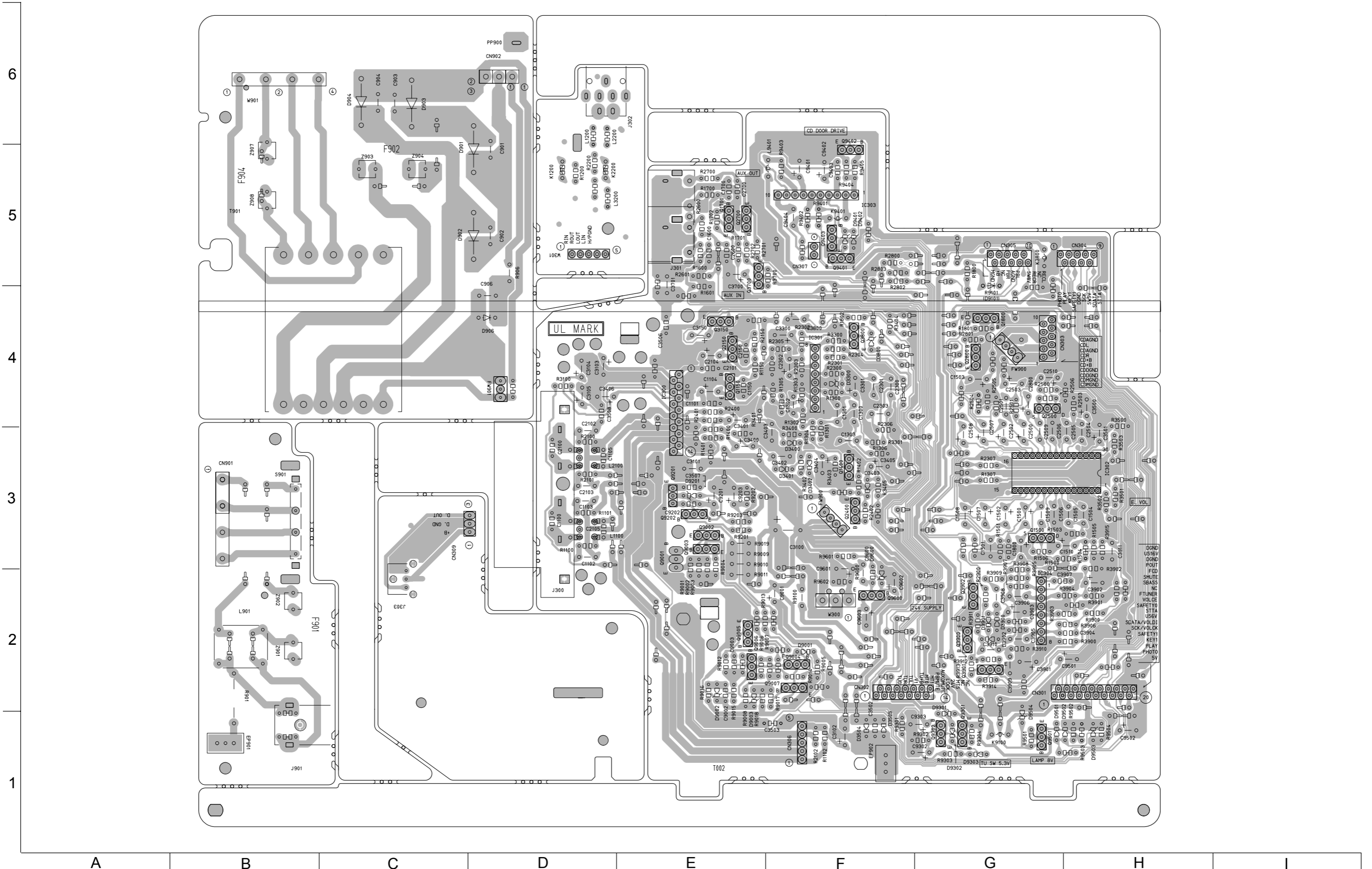

■ Micon P. C. board

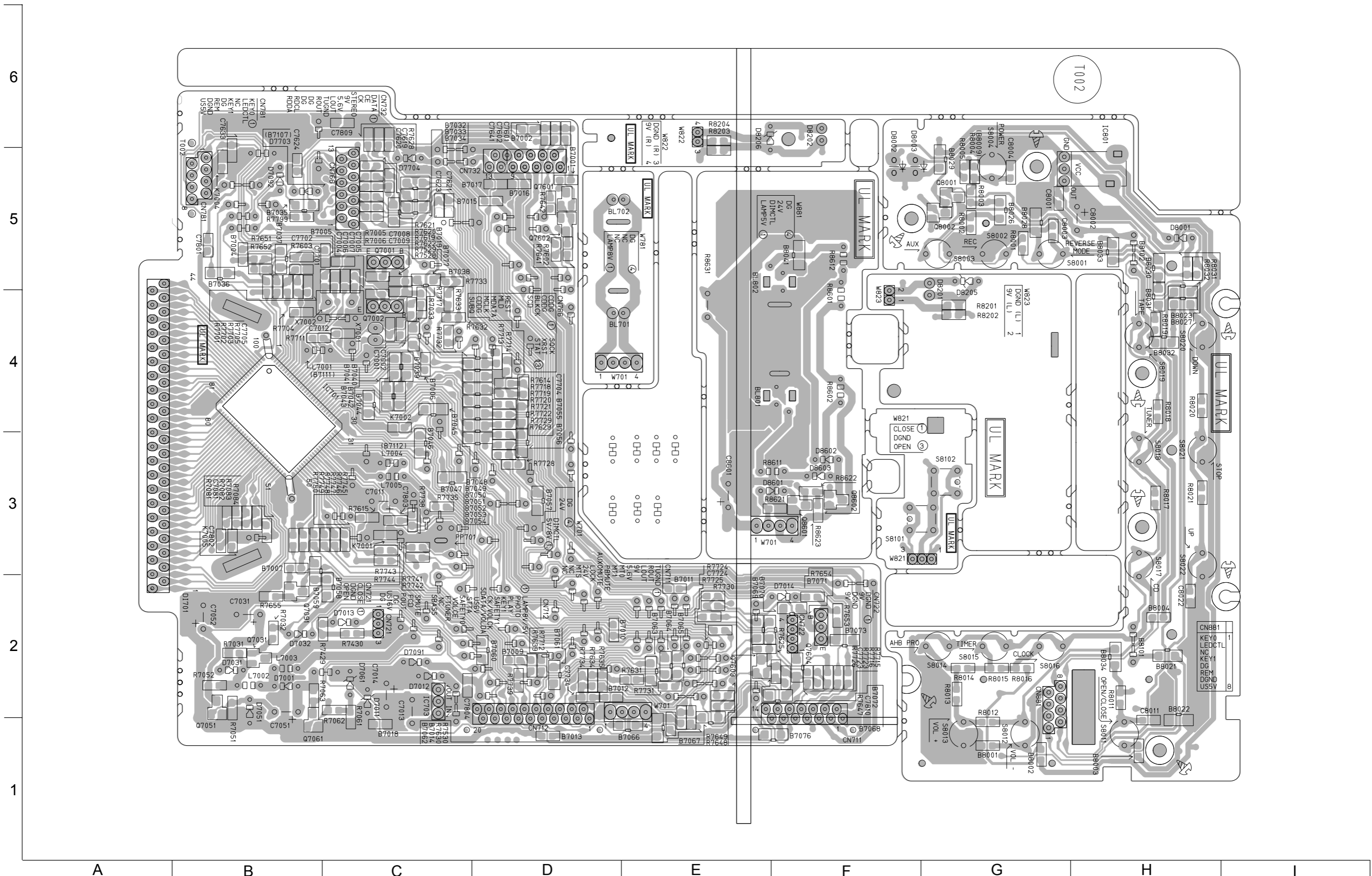

■ CD board

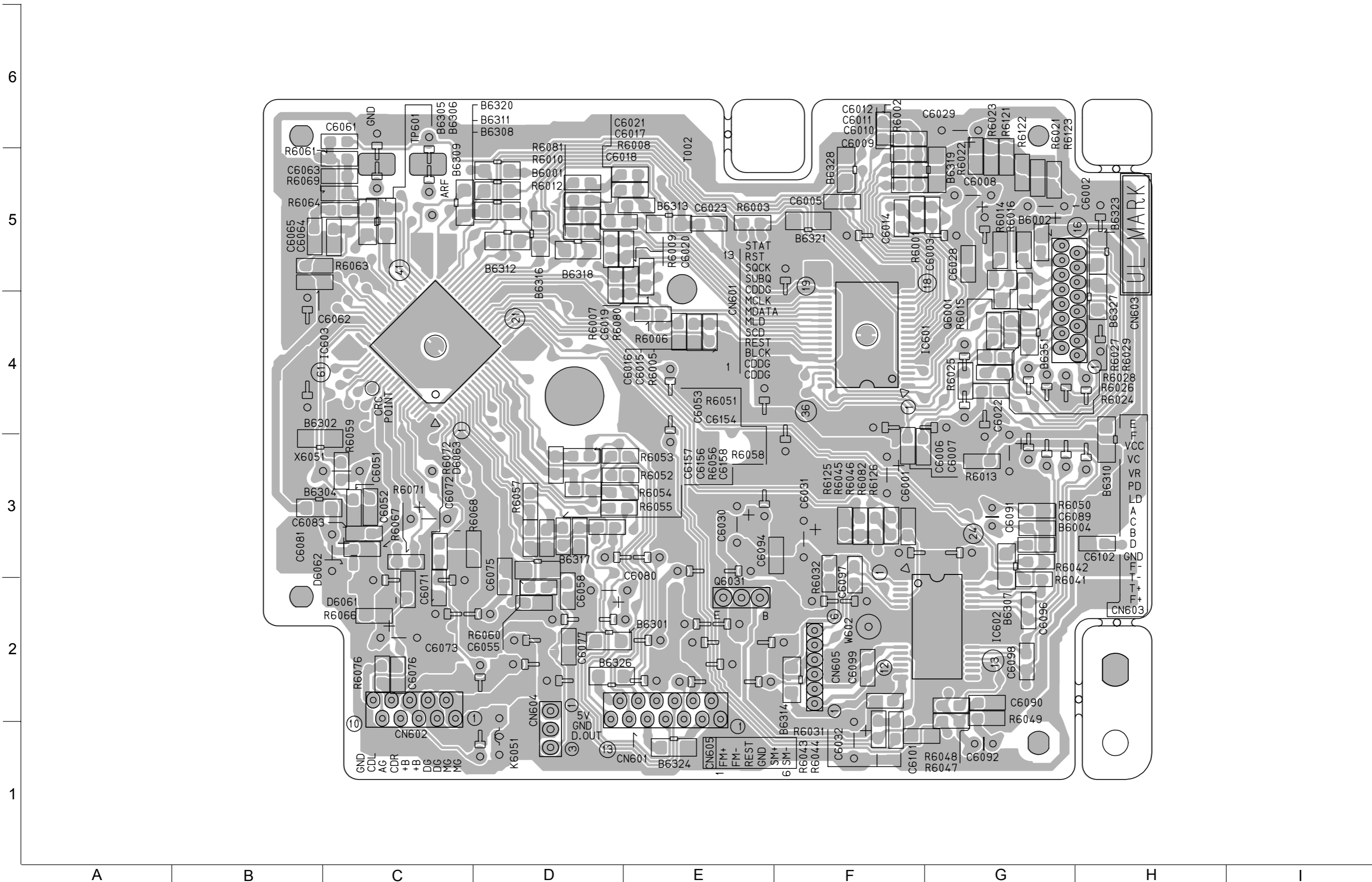

■ Tuner P. W. B

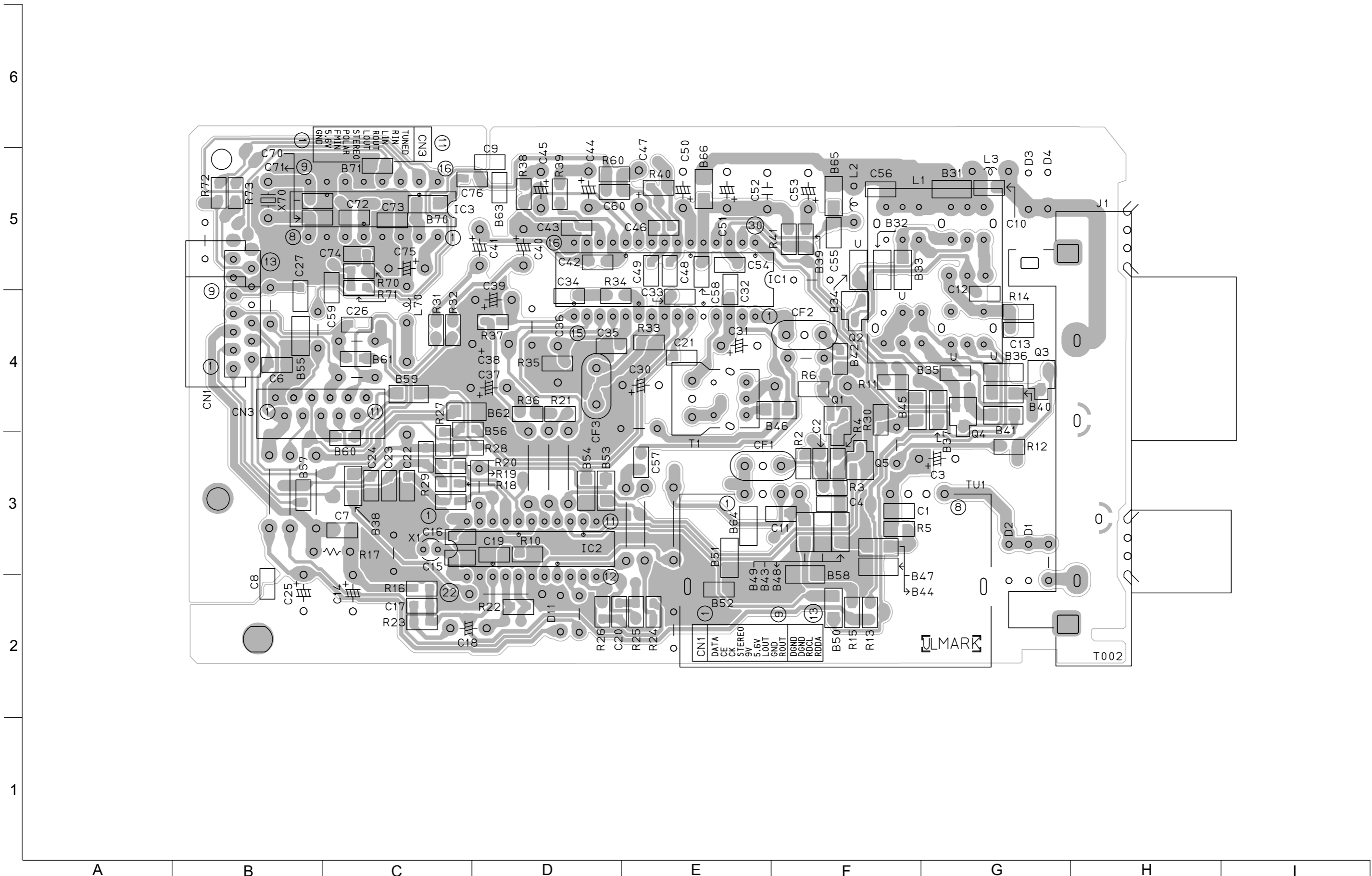

<<MEMO>>

PARTS LIST

[UX-V10GN]

* All printed circuit boards and its assemblies are not available as service parts.

Area suffix

UF -----China
UN -----Indonesia

- Contents -

Exploded view of general assembly and parts list	3- 3
Electrical parts list	3-10
Packing materials and accessories parts list	3-21

<<MEMO>>

Exploded view of general assembly and parts list

Block No. M 1 M M

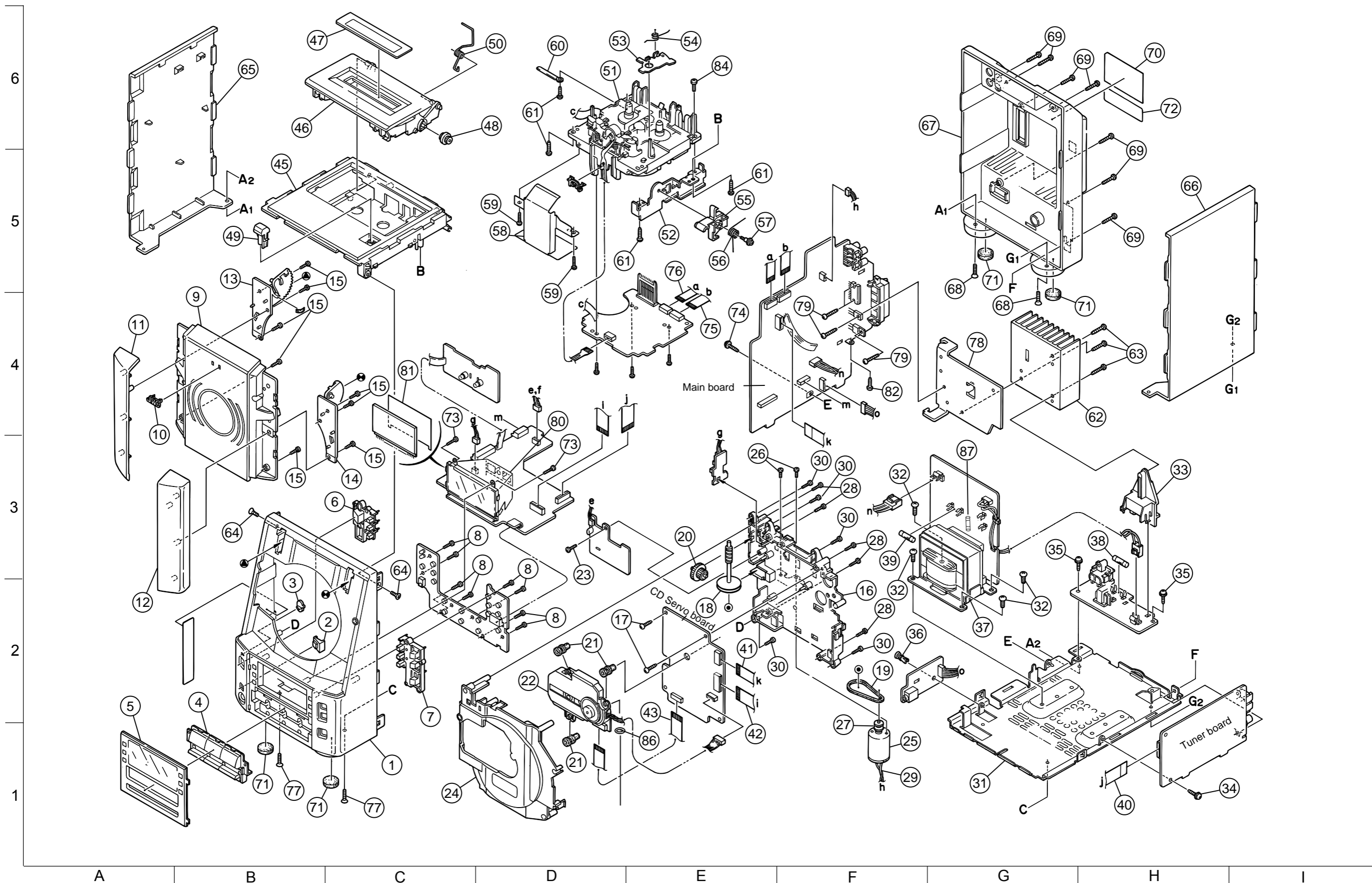

■ Parts list(General assembly)

Block No. M1MM

△	Item	Parts number	Parts name	Q'ty	Description	Area
	1	GV10020-016A	FRONT PANEL	1		
	2	GV40067-001A	REMOTE LENS	1		
	3	GV40068-001A	STANDBY LENS	1		
	4	GV30060-004A	FRONT BUTTON AS	1	F.BTN+FUNC.BTN	
	5	GV40116-004A	FRONT LENS ASSY	1		
	6	GV30063-001A	POWER BUTTON	1		
	7	GV30064-001A	VOLUME BUTTON	1		
	8	QYSDSF2608Z	SCREW	8	SW.PWB+FR.PANEL	
	9	GV20044-017A	CD DOOR LENS	1		
	10	GV40077-001A	JVC BADGE	1		
	11	GV30065-001A	CD DOOR PLATE(L	1		
	12	GV30065-002A	CD DOOR PLATE(R	1		
	13	GV30066-001A	CD DOOR HOLDER	1	DOOR LEFT	
	14	GV30066-002A	CD DOOR HOLDER	1	DOOR RIGHT	
	15	QYSDSF2006M	SCREW	8	CD DOOR ASSY	
	16	GV20046-006A	CD CHASSIS	1		
	17	QYSDSF2608Z	SCREW	2	CD PWB+CD CHASI	
	18	GV40072-003A	WORM PULLEY	1		
	19	GV30038-001A	BELT	1		
	20	GV40071-002A	GEAR	1		
	21	GV40070-002A	INSULATOR	3		
	22	KSM-770ABA	CD MECHA	1		
	23	QYSDSF2608Z	SCREW	1	ILM PWB L+CD CH	
	24	GV20045-004A	CD CASE	1		
	25	MXN-13FB12F	DC MOTOR ASS'Y	1		
	26	QYSPSP3004Z	SCREW	2	MOTOR+CD CHASSI	
	27	VYH7699-001SS	PULLEY	1		
	28	QYSDSF2608Z	SCREW	5	CD CHASSIS+CD C	
	29	WJM0112-001A	MOTOR WIRE	1		
	30	QYSDSF2608Z	SCREW	5	CD CHASIS+F.PAN	
	31	GV10021-001A	BOTTOM CHASSIS	1		
	32	QYSBST4006Z	T.SCREW	4	TRANS+B.CHASSIS	
	33	GV30073-001A	JACK HOLDER	1		
	34	QYSBSTG3006Z	T.SCREW	1	M.BRD+B.CHASSIS	
	35	QYSBSTG3006Z	T.SCREW	2	AC J.PWB+B.CHAS	
△	37	QQT0284-003	POWER TRANSF	1		
△	38	QMF51E2-1R0-J1	FUSE	1	(F901)	UN
△		QMF51E2-R63-J1	FUSE	1	(F901)	UF
△	39	QMF51E2-6R3-J1	FUSE	1	(F902)	
	40	QUQ412-0908DJ	FFC WIRE	1	TU TO FMB	
	41	QUQ412-1022CJ	FFC WIRE	1	CD TO MAIN	
	42	QUQ412-1320CJ	FFC WIRE	1	CD TO FMB	
	43	QUQ110-1607BJ	FFC WIRE	1	PICK UP TO CD	
	45	GV10022-001A	TOP COVER	1		
	46	GV20047-001A	CASSETTE DOOR	1		
	47	GV40074-003A	CASS DOOR LENS	1		
	48	VYH7366-001MM	GEAR	1		
	49	GV40073-001A	EJECT KNOB	1		

■ Parts list(General assembly)

Block No. M1MM

△	Item	Parts number	Parts name	Q'ty	Description	Area
	50	GV40085-002A	DOOR SPRING	1		
	51	-----	S.CASSETTE MECH	1		
	52	VYH3965-001	SIDE BRACKET(R)	1		
	53	VKL7850-002	EJECT SAFTY(R)	1		
	54	VKW5258-003	TORSION SPRING	1		
	55	VYH8146-012	EJECT ARM(R)	1		
	56	VKW3006-230	TORSION SPRING	1		
	57	VKZ4341-004	SPECIAL SCREW	1		
	58	GV30071-001A	HEAD SHIELD	1		
	59	QYSBSF2606Z	SCREW	2	H.SHIELD+SLC.ME	
	60	VKZ4001-110S	WIRE HOLDER	1		
	61	QYSBSF3010Z	SCREW	4	SLC + TOP COVER	
	62	GV30068-001A	HEAT SINK	1		
	63	QYSPSF3010Z	TAP SCREW	3	H.SINK+IC HOLDE	
	64	QYSSSF3008Z	SCREW	2	T.COVER+F.PANEL	
	65	GV20048-001A	SIDE PANEL (L)	1		
	66	GV20048-002A	SIDE PANEL (R)	1		
	67	GV10023-010A	REAR PANEL	1		UF
		GV10023-012A	REAR PANEL	1		UN
	68	QYSSST3010Z	SCREW	2	F.PANEL+B.CHASS	
	69	QYSBSF3010N	TAP SCREW	6	REAR PANEL	
	70	GV30099-032A	NAME PLATE	1		UN
		GV30099-040A	NAME PLATE	1		UF
	71	GV40091-001A	FOOT	4		
	72	VND4118-004	CAUTION LABEL	1		
	73	QYSDSF2608Z	SCREW	2	L.CASE+F.PANEL	
	74	QYSBSTG3006Z	T.SCREW	1	TUNER PWB+B.CHA	
	75	QUQ412-1024CJ	FFC WIRE	1	SLC TO MAIN	
	76	QUQ412-0924CJ	FFC WIRE	1	SLC TO MAIN	
	77	QYSST3010Z	SCREW	2		
	78	VYH7237-002	I.C.COVER	1		
	79	QYSBSF3010N	TAP SCREW	4		
	80	GV30070-002A	LAMP CASE	1		
	81	GV40084-002A	L.C.D.SHEET	1		
	82	QYSBSFG3008Z	T.SCREW	1	M.BOARD +IC HOL	
	84	QYSBSG3008Z	T.SCREW	1	SLC+SIDE BKT.	
	86	GV40122-002A	FOOT SPACER	1	STICK AT CD MEC	
△	87	QMF51E2-R63-J1	FUSE	1	(F904)	UN

Cassette mechanism assembly and parts list

Block No. M 2 M M

SLC-S1YPM

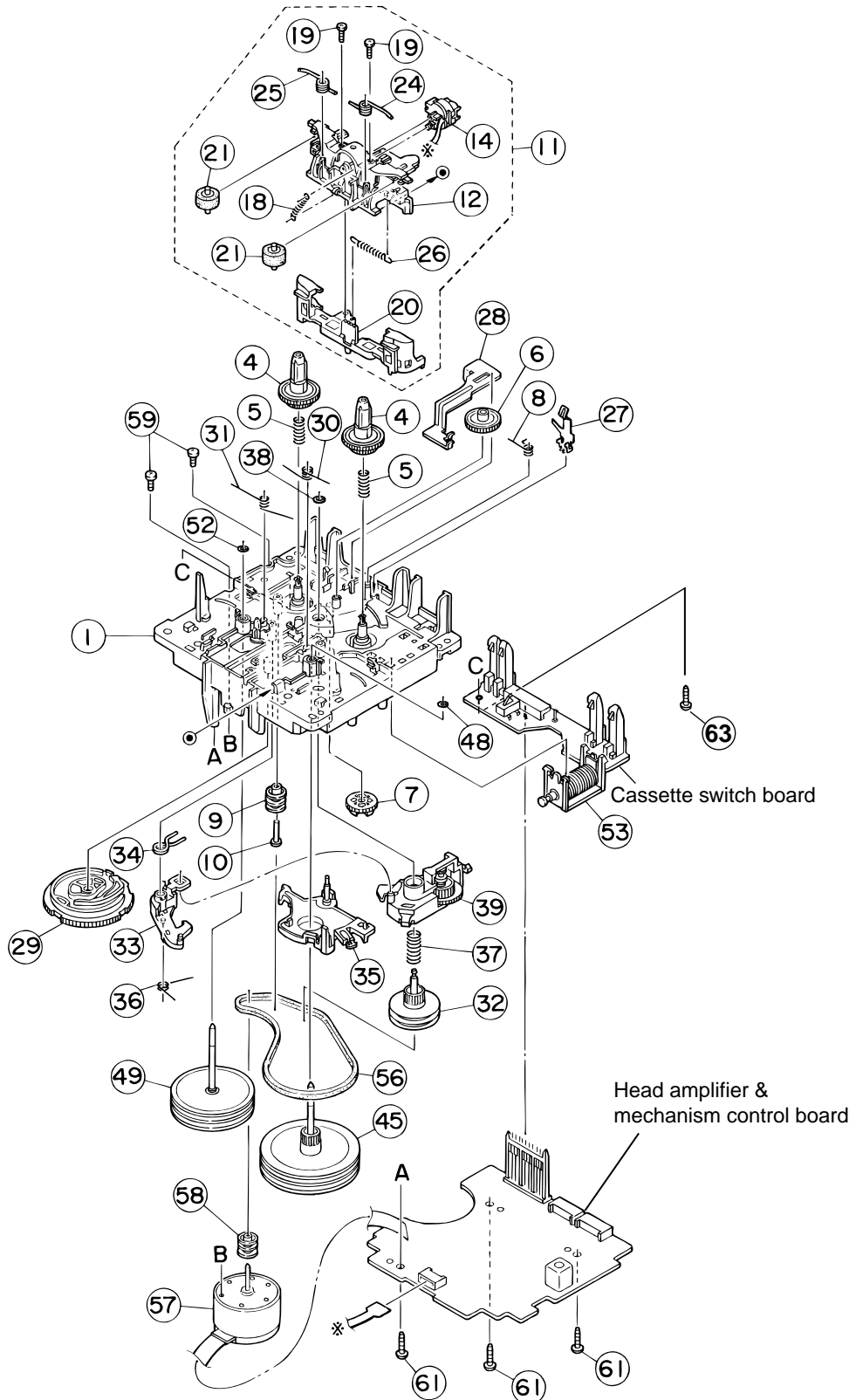

■ Parts list (Cassette mechanism)

Block No. M2MM

△	Item	Parts number	Parts name	Q'ty	Description	Area
	1	VKS1165-00G	CHASSIS B.ASS'Y	1		
	4	VKS2274-002	REEL GEAR	2		
	5	VKW5286-002	B.T. SPRING	2		
	6	VKS5559-001	PLAY IDLE GEAR	1		
	7	VKS5597-00A	BUND ASS'Y	1		
	8	VKW5296-001	EARTH SPRING	1		
	9	VKR4749-003	IDLE PULLEY	1		
	10	VKH5786-003	SHAFT	1		
	11	VKS2275-00E	HEAD MOUNT ASSY	1		
	12	VKS1167-003	HEAD MOUNT BASE	1		
	14	LV41089-001A	R/P&E HEAD	1	VKS2275-00B	
	18	VKW5302-001	HEAD SPRING	1		
	19	VKZ4730-001	SPECIAL SCREW	2		
	20	VKS2277-005	DIRECTION LEVER	1		
	21	VKP4233-00A	PINCH ROL. ASSY	2		
	24	VKW5299-002	PIN ROL.SP.(R)	1		
	25	VKW5300-002	PIN ROL.SP.(L)	1		
	26	VKW5285-001	RETURN SPRING	1		
	27	VKY3149-002	CASSETTE SP.	1		
	28	VKM3906-002	PLAY SW LEVER	1		
	29	VKS1166-003	CONTROL CAM	1		
	30	VKW5279-001	HEAD BASE SP(R)	1		
	31	VKW5280-001	HEAD BASE SP(L)	1		
	32	VKS5603-00D	MAIN PULLEY ASY	1		
	33	VKS3785-001MM	FR ARM	1		
	34	VKW5284-002	SWING SPRING	1		
	35	VKS2278-003	TRIGGER ARM	1		
	36	VKW5301-001	FR SPRING	1		
	37	VKW5266-001	ELEVATOR SPRING	1		
	38	WDL214025	WASHER	1		
	39	VKS3786-00G	CLUTCH ASS'Y	1		
	45	VKF3205-00B	F.WHEEL ASSY(R)	1		
	48	WDL183425	SLIT WASHER	1		
	49	VKF3207-00B	F.WHEEL ASSY(L)	1		
	52	WDL173525-6	SLIT WASHER	1		
	53	VKZ3174-00A	DC SOLENOID	1		
	56	VKB3000-181	CAPSTAN BELT	1		
	57	MSI-5U2LWA	D.C.MOTOR ASS'Y	1		
	58	VKR4761-001	MOTOR PULLEY	1		
	59	QYSPSP2604Z	SCREW	2		
	61	QYSBSF2608Z	T.SCREW	3	FOR P.W.B.	
	63	QYSBSF2006Z	SCREW	1		

Grease point 1/3

- Grease
- * EM-30L
 - UD-24
 - ◆ LEN-320M

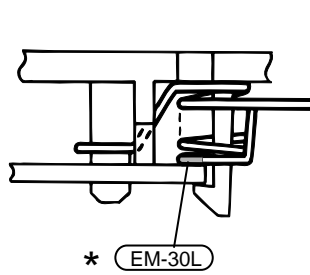

Fig.1

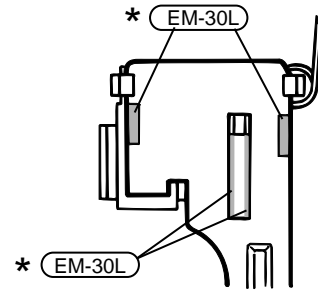

Fig.2

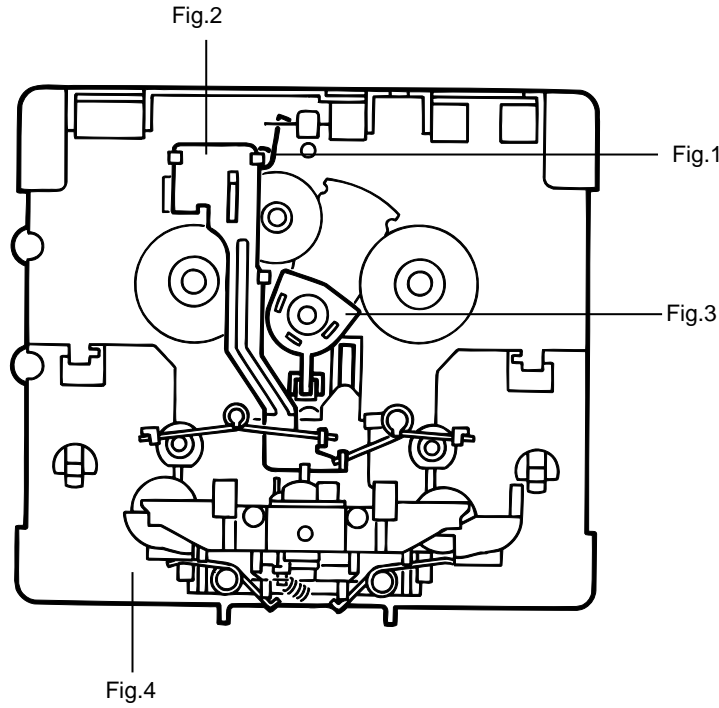

Fig.4

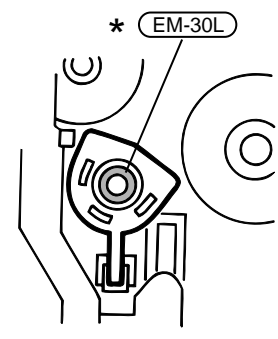

Fig.3

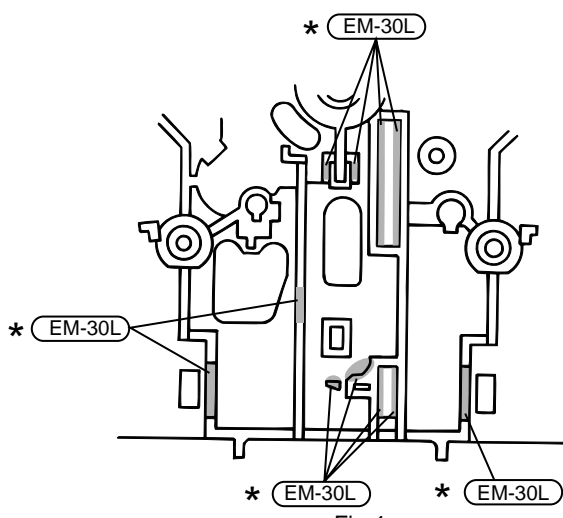

Fig.4

(Remove the Head mount Ass'y on the Chasis Base)

Grease point 2/3

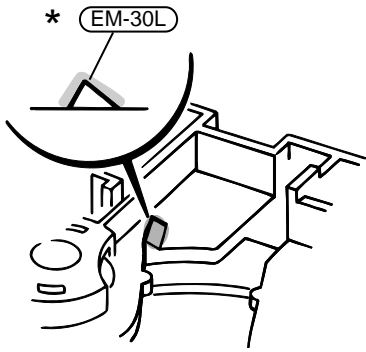

Fig.5

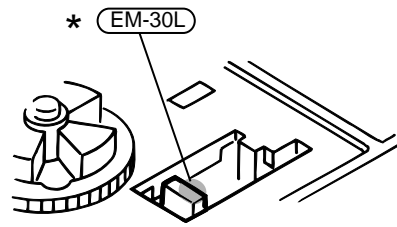

Fig.1

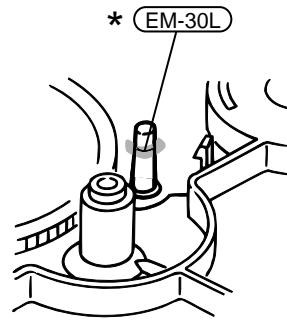
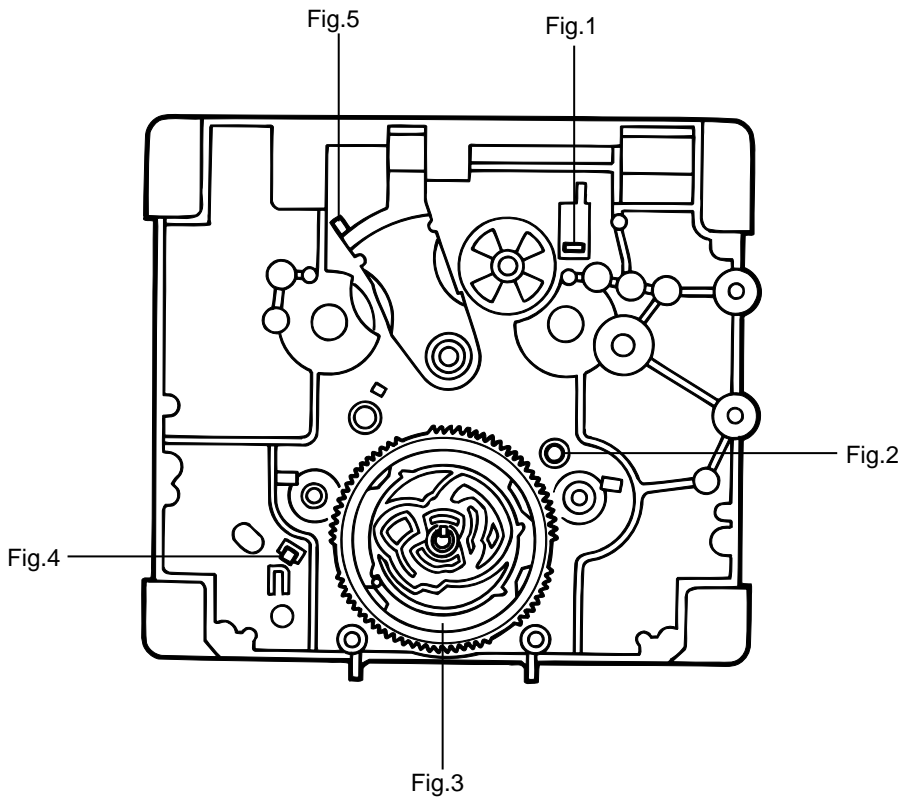

Fig.2

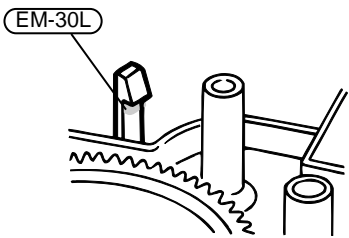

Fig.4

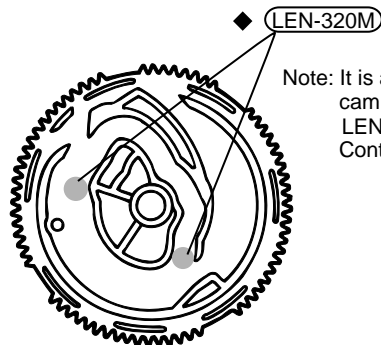

Fig.3

Note: It is a putting up of the control cam to UD-24H(Hanari) and LEN-320M(Grease)dipping on the Control cam

Grease point 3/3

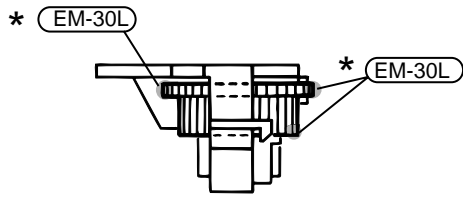

Fig.1

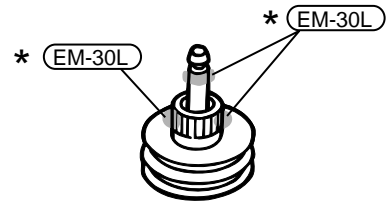

Fig.2

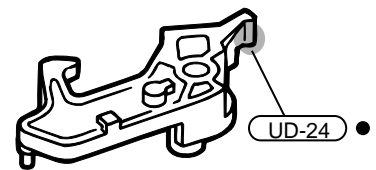
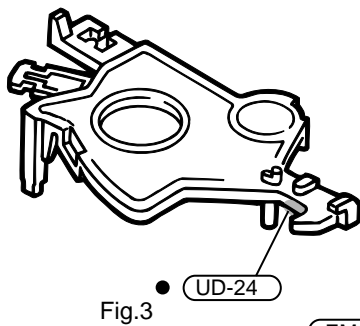
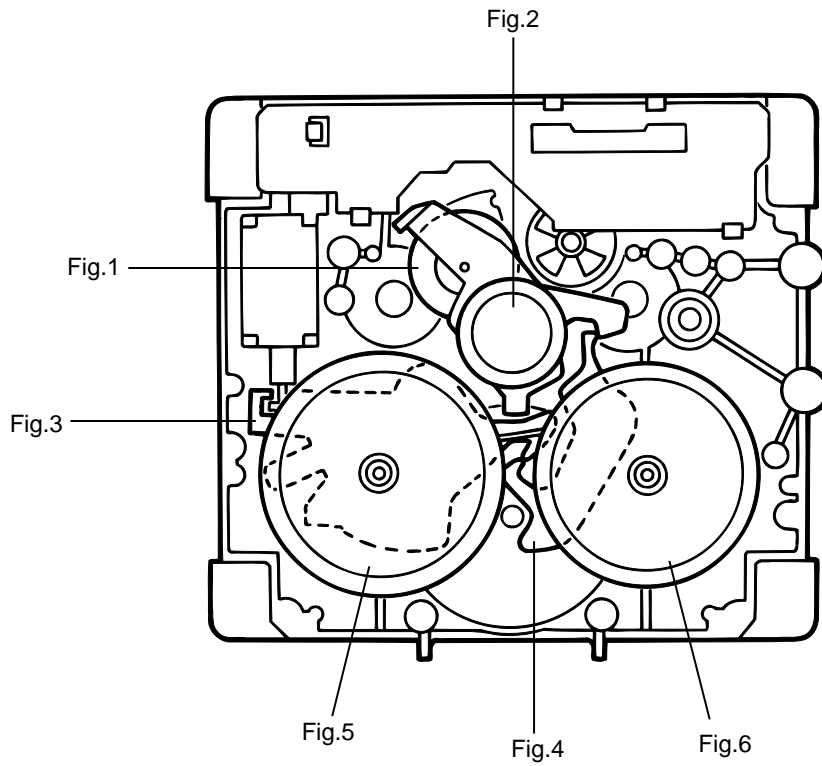

Fig.4

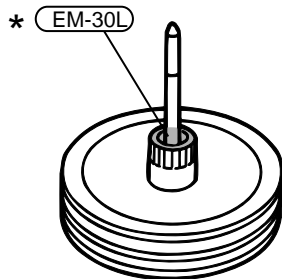

Fig.5

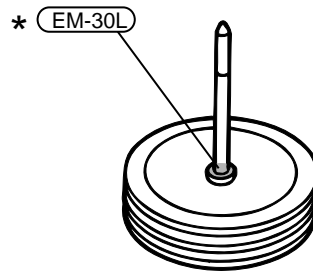

Fig.6

■ Electrical parts list(Main board)

Block No. 01

△	Item	Parts number	Parts name	Remarks	Area
	C 901	QFLK1HJ-104Z	MF CAPACITOR	.10MF 5% 50V	
	C 902	QFLK1HJ-104Z	TF CAPACITOR	.10MF 5% 50V	
	C 903	QFVK1HJ-104Z	MF CAPACITOR	.10MF 5% 50V	
	C 904	QFVF1HJ-104Z	MF CAPACITOR	.10MF 5% 50V	
	CN301	QGB1214J1-20S	CONNECTOR	MICON	
	CN302	QGB1214J1-14S	CONNECTOR	MICON	
	CN303	QGF1205C1-10	CONNECTOR	CD	
	CN304	QGF1205F1-09	CONNECTOR	SLC	
	CN305	QGF1205F1-10	CONNECTOR	SLC	
	CN306	QGA2501C1-05	5P CONNECTOR	HEADPHONE	
	CN307	QGA2501C1-02	2P CONNECTOR	CD DOOR	
△	CN901	QGA7901C1-02	CONNECTOR		UF
△	CN901	QGA7901C1-04	CONNECTOR		UN
	CN902	QGA3901C1-02	CONNECTOR		
	C1101	QCB1HK-331Y	C CAPACITOR	330PF 10% 50V	
	C1102	QFLM1HJ-104Z	M CAPACITOR	.10MF 5% 50V	
	C1103	QFLM1HJ-104Z	M CAPACITOR	.10MF 5% 50V	
	C1104	QTE1V06-106Z	E CAPACITOR		
	C1150	QDGB1HK-102Y	C CAPACITOR		
	C1300	QFLM1HJ-823Z	M CAPACITOR	.082MF 5% 50V	
	C1301	QFLM1HJ-823Z	M CAPACITOR	.082MF 5% 50V	
	C1302	QTE1C06-226Z	E CAPACITOR		
	C1303	QFVJ1HJ-274Z	MF CAPACITOR	.27MF 5% 50V	
	C1500	QETN1EM-106Z	E CAPACITOR	10MF 20% 25V	
	C1501	QFLM1HJ-272Z	M CAPACITOR	3900PF 5% 50V	
	C1502	EETC1HM-475ZJC	E CAPACITOR	4.7MF 20% 50V	
	C1503	QTE1V06-106Z	E CAPACITOR		
	C1504	QFVF1HJ-104Z	MF CAPACITOR	.10MF 5% 50V	
	C1505	QFVF1HJ-104Z	MF CAPACITOR	.10MF 5% 50V	
	C1506	QFLM1HJ-272Z	M CAPACITOR	2700PF 5% 50V	
	C1507	EETC1HM-475ZJC	E CAPACITOR	4.7MF 20% 50V	
	C1508	EETC1HM-475ZJC	E.CAPA. I.M		
	C1510	QETN1EM-475Z	E CAPACITOR	4.7MF 20% 25V	
	C1600	QCB1HK-221Y	C CAPACITOR	220PF 10% 50V	
	C1800	QETN1EM-475Z	E CAPACITOR	4.7MF 20% 25V	
	C2101	QCB1HK-331Y	C CAPACITOR	330PF 10% 50V	
	C2102	QFLM1HJ-104Z	MF CAPACITOR	.10MF 5% 50V	
	C2103	QFLM1HJ-104Z	MF CAPACITOR	.10MF 5% 50V	
	C2104	QTE1V06-106Z	E CAPACITOR		
	C2150	QDGB1HK-102Y	C CAPACITOR		
	C2300	QFLM1HJ-823Z	M CAPACITOR	.082MF 5% 50V	
	C2301	QFLM1HJ-823Z	M CAPACITOR	.082MF 5% 50V	
	C2302	QTE1C06-226Z	E CAPACITOR		
	C2303	QFVJ1HJ-274Z	MF CAPACITOR	.27MF 5% 50V	
	C2500	QETN1EM-106Z	E CAPACITOR	10MF 20% 25V	
	C2501	QFLM1HJ-272Z	M CAPACITOR	2700PF 5% 50V	
	C2502	EETC1HM-475ZJC	E.CAPA. I.M		
	C2503	QTE1V06-106Z	E CAPACITOR		
	C2504	QFVF1HJ-104Z	MF CAPACITOR	.10MF 5% 50V	
	C2505	QFVF1HJ-104Z	MF CAPACITOR	.10MF 5% 50V	
	C2506	QFLM1HJ-272Z	M CAPACITOR	2700PF 5% 50V	
	C2507	EETC1HM-475ZJC	E.CAPA. I.M		
	C2508	EETC1HM-475ZJC	E CAPACITOR	4.7MF 20% 50V	
	C2510	QETN1EM-475Z	E CAPACITOR	4.7MF 20% 25V	
	C2600	QCB1HK-221Y	C CAPACITOR	220PF 10% 50V	
	C2800	QETN1EM-475Z	E CAPACITOR	4.7MF 20% 25V	
△	C3100	QETM1EM-828	E CAPACITOR	8200MF 20% 25V	
	C3101	QFLM1HJ-104Z	M CAPACITOR	.10MF 5% 50V	
	C3102	EEKC1CM-107ZJC	E CAPACITOR		
	C3103	QETN1CM-107Z	E CAPACITOR	100MF 20% 16V	
	C3104	QETC1AM-336Z	E CAPACITOR	33MF 20% 10V	
	C3105	QETN1HM-225Z	E CAPACITOR	2.2MF 20% 50V	
	C3150	QETN1EM-106Z	E CAPACITOR	10MF 20% 25V	

△	Item	Parts number	Parts name	Remarks	Area
	C3300	QETN1CM-476Z	E CAPACITOR	47MF 20% 16V	
	C3301	QETN1AM-476Z	E CAPACITOR	47MF 20% 10V	
	C3400	QETN1HM-105Z	E CAPACITOR	1.0MF 20% 50V	
	C3401	QETN1HM-105Z	E CAPACITOR	1.0MF 20% 50V	
	C3402	QFLC1HJ-563Z	TF CAPACITOR	.056MF 5% 50V	
	C3403	QFLC1HJ-563Z	TF CAPACITOR	.056MF 5% 50V	
	C3404	QETN1HM-105Z	E CAPACITOR	1.0MF 20% 50V	
	C3405	QETN1CM-106Z	E CAPACITOR	10MF 20% 16V	
	C3406	QETN1HM-105Z	E CAPACITOR	1.0MF 20% 50V	
	C3500	QETN1CM-107Z	E CAPACITOR	100MF 20% 16V	
	C3501	QETN1EM-106Z	E CAPACITOR	10MF 20% 25V	
	C3502	QDYB1CM-103Y	C.CAPACITOR		
	C3503	QDGB1HK-102Y	C CAPACITOR		UN
	C3504	QDGB1HK-102Y	C CAPACITOR		
	C3505	QDGB1HK-102Y	C CAPACITOR		
	C3506	QDGB1HK-102Y	C CAPACITOR		
	C3507	QDGB1HK-102Y	C CAPACITOR		
	C3800	EETC1HM-105ZJC	E CAPACITOR	1.0MF 20% 50V	
	C9001	EETC1CM-227ZJC	E CAPACITOR		
	C9002	QDYB1CM-103Y	C.CAPACITOR		
	C9003	QDXB1CM-222Y	C CAPACITOR	220PF 10% 50V	
	C9201	QETN1CM-476Z	E CAPACITOR	47MF 20% 16V	
	C9202	QDYB1CM-103Y	C.CAPACITOR		
	C9203	QTE1V06-106Z	E CAPACITOR		
	C9302	QEKC1HM-475Z	E.CAPACITOR	4.7MF 20% 50V	
	C9303	QEKC1AM-107Z	E.CAPACITOR	100MF 20% 10V	
	C9401	EEKC1AM-227ZJC	E CAPACITOR	220MF 20% 10V	
	C9402	EEKC1AM-107ZJC	E CAPACITOR		
	C9403	QDYB1CM-103Y	C.CAPACITOR		
	C9404	QCZ0205-155Z	ML C CAPACITOR	1.5MF	
	C9501	EETC1AM-477ZJC	E CAPACITOR	470MF 20% 10V	
△	D 901	6A10E2	SI DIODE		
△	D 902	6A10E2	SI DIODE		
△	D 903	6A10E2	SI DIODE		
△	D 904	6A10E2	SI DIODE		
	D3300	MTZJ4.3B-T2	ZENER DIODE		
	D3400	1SS133-T2	SI DIODE		
	D3401	1SS133-T2	SI DIODE		
	D3402	1SS133-T2	SI DIODE		
	D3403	1SS133-T2	SI DIODE		
	D3504	1SS133-T2	SI DIODE		
	D3505	1SS133-T2	SI DIODE		
	D3800	MTZJ6.8B-T2	ZENER DIODE		
	D9001	1SS133-T2	SI DIODE		
	D9002	MTZJ8.2C-T2	ZENER DIODE		
	D9003	MTZJ10A-T2	ZENER DIODE		
	D9101	1SR35-400A-T5	DIODE I/M		
	D9201	MTZJ5.1C-T2	ZENER DIODE		
	D9301	MTZJ3.9B-T2	Z DIODE IM		
	D9302	1SS133-T2	SI DIODE		
	D9303	1SS133-T2	SI DIODE		
	D9401	MTZJ5.1B-T2	ZENER DIODE		
	D9402	MTZJ6.2A-T2	Z.DIODE IDM		
	D9501	1SS133-T2	SI DIODE		
	D9504	MTZJ9.1C-T2	Z DIODE I/M		
	EP901	QNZ0136-001Z	EARTH PLATE		
	EP902	QNZ0136-001Z	EARTH PLATE		
	EP903	QNZ0136-001Z	EARTH PLATE		UN
	FW900	QUM134-11Z4Z4	FLAT WIRE		
△	IC300	LA4628	IC		
	IC301	BA15218N	IC		
	IC302	LC75342	IC		
	IC303	LB1641	IC		

■ Electrical parts list (Main board)

Block No. 01

△	Item	Parts number	Parts name	Remarks	Area
	J 300	QNB0090-001	SPK TERMINAL		
	J 301	QNN0215-001	PIN JACK		
	J 302	QNS0030-001	JACK		
△	J 901	QNC0006-001	AC SOCKET		
	K3800	QUY150-050Y	BUS WIRE		
	K9100	QUY150-050Y	BUS WIRE		
	K9401	QUY150-050Y	FERRITE BEADS		
	L 901	QQR1145-001	LINE FILTER	EMC FILTER	
	L9401	QUY150-050Y	INDUCTOR		
	PP900	QZW0038-001	WIRE CLAMP		
	Q1150	2SC3576-JVC-T	TRANSISTOR		
	Q1400	KTC3199/GL/-T	TRANSISTOR		
	Q1800	KTC3199/GL/-T	TRANSISTOR		
	Q2150	2SC3576-JVC-T	TRANSISTOR I/M		
	Q2400	KTC3199/GL/-T	TRANSISTOR		
	Q2800	KTC3199/GL/-T	TRANSISTOR		
	Q3150	KRA101M-T	TR I/M		
	Q3800	KRA101M-T	TR I/M		
△	Q9001	KTA1046/Y/	TRANSISTOR *		
	Q9002	KTC3199/GL/-T	TRANSISTOR		
	Q9003	KTA1267/YG/-T	TRANSISTOR		
	Q9004	KRC114M-T	TR I.M *		
	Q9005	DTA144TS-T	D.TRANSISTOR		
	Q9006	KTC3199/GL/-T	TRANSISTOR		
	Q9007	KTC3199/GL/-T	TRANSISTOR		
	Q9201	KTb772/Y/	TRANSISTOR		
	Q9202	KTC3199/GL/-T	TRANSISTOR		
	Q9301	KTA1267/YG/-T	TRANSISTOR		
	Q9302	KTC3199/GL/-T	TRANSISTOR		
	Q9401	KTC3199/GL/-T	TRANSISTOR		
	Q9402	KTC3199/GL/-T	TRANSISTOR		
	Q9403	DTC114YS-T	TR I.M		
	Q9501	2SD2144S/VW/-T	TRANSISTOR		
	R1100	QRE141J-2R2Y	C RESISTOR	2.2 5% 1/4W	
	R1101	QRE141J-2R2Y	C RESISTOR	2.2 5% 1/4W	
	R1102	QRE141J-471Y	C RESISTOR	470 5% 1/4W	
	R1150	QRE141J-472Y	C RESISTOR	4.7K 5% 1/4W	
	R1151	QRE141J-472Y	C RESISTOR	4.7K 5% 1/4W	
	R1200	QRE141J-151Y	C RESISTOR	150 5% 1/4W	
	R1300	QRE141J-224Y	C RESISTOR	220K 5% 1/4W	
	R1301	QRE141J-202Y	C RESISTOR	2.0K 5% 1/4W	
	R1302	QRE141J-222Y	C RESISTOR	2.0K 5% 1/4W	
	R1303	QRE141J-153Y	C RESISTOR	15K 5% 1/4W	
	R1304	QRE141J-153Y	C RESISTOR	15K 5% 1/4W	
	R1305	QRE141J-183Y	C RESISTOR	10K 5% 1/4W	
	R1306	QRE141J-622Y	C RESISTOR	4.7K 5% 1/4W	
	R1307	QRE141J-182Y	C RESISTOR	1.8K 5% 1/4W	
	R1400	QRE141J-223Y	C RESISTOR	22K 5% 1/4W	
	R1401	QRE141J-223Y	C RESISTOR	22K 5% 1/4W	
	R1402	QRE141J-103Y	C RESISTOR	10K 5% 1/4W	
	R1501	QRE141J-682Y	C RESISTOR	6.8K 5% 1/4W	
	R1503	QRE141J-392Y	C RESISTOR	3.9K 5% 1/4W	
	R1507	QRE141J-104Y	C RESISTOR	100K 5% 1/4W	UN
	R1508	QRE141J-822Y	C RESISTOR	8.2K 5% 1/4W	
	R1600	QRE141J-303Y	C RESISTOR	30K 5% 1/4W	
	R1601	QRE141J-303Y	C RESISTOR	30K 5% 1/4W	
	R1800	QRE141J-912Y	C RESISTOR	9.1K 5% 1/4W	
	R1801	QRE141J-272Y	C RESISTOR	2.7K 5% 1/4W	
	R1802	QRE141J-222Y	C RESISTOR	2.2K 5% 1/4W	
	R1803	QRE141J-622Y	C RESISTOR	6.2K 5% 1/4W	
	R2100	QRE141J-2R2Y	C RESISTOR	2.2 5% 1/4W	
	R2101	QRE141J-2R2Y	C RESISTOR	2.2 5% 1/4W	
	R2102	QRE141J-471Y	C RESISTOR	470 5% 1/4W	

△	Item	Parts number	Parts name	Remarks	Area
	R2150	QRE141J-472Y	C RESISTOR	4.7K 5% 1/4W	
	R2151	QRE141J-682Y	C RESISTOR	4.7K 5% 1/4W	
	R2200	QRE141J-151Y	C RESISTOR	150 5% 1/4W	
	R2300	QRE141J-224Y	C RESISTOR	220K 5% 1/4W	
	R2301	QRE141J-202Y	C RESISTOR	2.0K 5% 1/4W	
	R2302	QRE141J-202Y	C RESISTOR	2.0K 5% 1/4W	
	R2303	QRE141J-153Y	C RESISTOR	15K 5% 1/4W	
	R2304	QRE141J-153Y	C RESISTOR	15K 5% 1/4W	
	R2305	QRE141J-183Y	C RESISTOR	10K 5% 1/4W	
	R2306	QRE141J-622Y	C RESISTOR	4.7K 5% 1/4W	
	R2307	QRE141J-182Y	C RESISTOR	3.6K 5% 1/4W	
	R2400	QRE141J-223Y	C RESISTOR	22K 5% 1/4W	
	R2401	QRE141J-223Y	C RESISTOR	22K 5% 1/4W	
	R2402	QRE141J-103Y	C RESISTOR	10K 5% 1/4W	
	R2501	QRE141J-682Y	C RESISTOR	4.7K 5% 1/4W	
	R2503	QRE141J-392Y	C RESISTOR	3.9K 5% 1/4W	
	R2507	QRE141J-104Y	C RESISTOR	100K 5% 1/4W	UN
	R2508	QRE141J-822Y	C RESISTOR	8.2K 5% 1/4W	
	R2600	QRE141J-303Y	C RESISTOR	30K 5% 1/4W	
	R2601	QRE141J-303Y	C RESISTOR	30K 5% 1/4W	
	R2800	QRE141J-912Y	C RESISTOR	9.1K 5% 1/4W	
	R2801	QRE141J-272Y	C RESISTOR	2.7K 5% 1/4W	
	R2802	QRE141J-222Y	C RESISTOR	2.2K 5% 1/4W	
	R2803	QRE141J-622Y	C RESISTOR	6.2K 5% 1/4W	
	R3100	QRE141J-103Y	C RESISTOR	10K 5% 1/4W	
	R3300	QRE141J-101Y	C RESISTOR	100 5% 1/4W	
	R3301	QRE141J-152Y	C RESISTOR	1.5K 5% 1/4W	
	R3400	QRE141J-682Y	C RESISTOR	4.7K 5% 1/4W	
	R3401	QRE141J-682Y	C RESISTOR	6.8K 5% 1/4W	
	R3402	QRE141J-124Y	C RESISTOR	120K 5% 1/4W	
	R3403	QRE141J-154Y	C RESISTOR	150K 5% 1/4W	
	R3404	QRE141J-223Y	C RESISTOR	22K 5% 1/4W	
	R3405	QRE141J-513Y	C RESISTOR	51K 5% 1/4W	
	R3500	QRE141J-101Y	C RESISTOR	100 5% 1/4W	
	R3501	QRE141J-222Y	C RESISTOR	2.2K 5% 1/4W	
	R3502	QRE141J-222Y	C RESISTOR	2.2K 5% 1/4W	
	R3503	QRE141J-222Y	C RESISTOR	2.2K 5% 1/4W	
	R9001	QRE141J-1R2Y	C RESISTOR	1.0 5% 1/4W	
	R9002	QRE141J-1R2Y	C RESISTOR	1.2 5% 1/4W	
	R9003	QRE141J-1R2Y	C RESISTOR	1.0 5% 1/4W	
	R9004	QRE141J-471Y	C RESISTOR	470 5% 1/4W	
	R9005	QRE141J-152Y	C RESISTOR	1.5K 5% 1/4W	
	R9006	QRE141J-272Y	C RESISTOR	2.4K 5% 1/4W	
	R9007	QRE141J-681Y	C RESISTOR	680 5% 1/4W	
	R9008	QRE141J-682Y	C RESISTOR	6.8K 5% 1/4W	
△	R9009	QRZ9005-680X	F.RES I/M	68 1/0W	
△	R9010	QRZ9005-680X	F.RES I/M	68 1/0W	
△	R9011	QRZ9005-680X	F.RES I/M	68 1/0W	
	R9012	QRE141J-472Y	C RESISTOR	4.7K 5% 1/4W	
	R9013	QRE141J-471Y	C RESISTOR	470 5% 1/4W	
	R9014	QRE141J-472Y	C RESISTOR	4.7K 5% 1/4W	
	R9015	QRE141J-472Y	C RESISTOR	4.7K 5% 1/4W	
	R9016	QRE141J-472Y	C RESISTOR	4.7K 5% 1/4W	
	R9017	QRE141J-103Y	C RESISTOR	10K 5% 1/4W	
	R9018	QRE141J-391Y	C RESISTOR	390 5% 1/4W	
△	R9019	QRZ9005-680X	F.RES I/M	68 1/0W	
	R9201	QRE141J-103Y	C RESISTOR	10K 5% 1/4W	
	R9202	QRE141J-103Y	C RESISTOR	10K 5% 1/4W	
	R9203	QRE141J-820Y	C RESISTOR	220 5% 1/4W	
	R9301	QUY150-050Y	C RESISTOR	4.7K 5% 1/4W	
	R9302	QRE141J-333Y	C RESISTOR	33K 5% 1/4W	
	R9303	QRE141J-101Y	C RESISTOR	100 5% 1/4W	
	R9304	QRE141J-390Y	C RESISTOR	39 5% 1/4W	

■ Electrical parts list (Main board)

Block No. 01

△	Item	Parts number	Parts name	Remarks	Area
	R9403	QRE141J-100Y	C RESISTOR	10 5% 1/4W	
	R9404	QRE141J-6R8Y	C RESISTOR	3.9 5% 1/4W	
	R9405	QRE141J-391Y	C RESISTOR	390 5% 1/4W	
	R9501	QRE141J-471Y	C RESISTOR	220 5% 1/4W	
△	S 901	QSW0740-001	VOLTAGE SWITCH		UN
	W 300	QJK015-021002	WIRE	SECONDARY	
	W 301	QJK017-051400	WIRE		
△	W 901	WJK0070-001A	WIRE		
△	Z 901	QNG0020-001Z	FUSE CLIP		
△	Z 902	QNG0020-001Z	FUSE CLIP		
△	Z 903	QNG0020-001Z	FUSE CLIP		
△	Z 904	QNG0020-001Z	FUSE CLIP		
	Z 907	QNG0020-001Z	FUSE CLIP		UN
	Z 908	QNG0020-001Z	FUSE CLIP		UN

■ Electrical parts list (Micon board & regulator) Block No. 02

△	Item	Parts number	Parts name	Remarks	Area
	BL701	QLL0078-001	P.LAMP	BLUE LED	
	BL702	QLL0078-001	P.LAMP	BLUE LED	
	CN711	QGB1214K1-14S	CONNECTOR	TO MAIN PWB	
	CN712	QGB1214K1-20S	CONNECTOR	TO MAIN PWB	
	CN721	QGA2001C1-03	3P PLUG ASSY	TO CD DOOR SW P	
	CN732	QGF1205C1-09	CONNECTOR	TO TUNER PWB	
	CN766	QGF1205C1-13	CONNECTOR	TO CD PWB	
	CN781	QGB1216J1-08S	CONNECTOR	TO FRONT SW PWB	
	CN881	QGB1216K1-08S	CONNECTOR		
	C7001	NCS21HJ-180X	C CAPACITOR	CLOCK	
	C7002	NCS21HJ-180X	C CAPACITOR	CLOCK	
	C7004	NCS21HJ-360X	C CAPACITOR	MAIN CLOCK SHIF	
	C7005	NCS21HJ-390X	C CAPACITOR	MAIN CLOCK SHIF	
	C7006	NCS21HJ-200X	C CAPACITOR	MAIN CLOCK	
	C7007	NCS21HJ-220X	C CAPACITOR	MAIN CLOCK	
	C7008	NCB21HK-102X	C CAPACITOR		
	C7009	NCB21HK-102X	C CAPACITOR		
	C7011	EKEC1AM-107ZJC	E.CAPACITOR	100MF 20% 10V	
	C7012	NCB21HK-103X	C CAPACITOR		
	C7013	QFVF1HJ-104Z	MF CAPACITOR	.10MF 5% 50V	
	C7014	EETC1CM-106ZJC	E CAPACITOR	10MF 20% 16V	
	C7031	EETB0JM-228JC	E CAPACITOR	BACKUP CAPACITO	
	C7051	QETN1HM-684Z	E CAPACITOR	.68MF 20% 50V	
	C7052	EETC1HM-225ZJC	E CAPACITOR	2.2MF 20% 50V	
	C7081	NCB21CK-104X	C.CAPA. C.M	AM LCD NOISE	
	C7601	NCS21HJ-151X	C CAPACITOR		
	C7602	NCS21HJ-151X	C CAPACITOR		
	C7623	NCS21HJ-101X	C CAPACITOR		UN
	C7624	NCS21HJ-101X	C CAPACITOR		UN
	C7633	NCB21HK-102X	C CAPACITOR		
	C7641	NCS21HJ-151X	C CAPACITOR		
	C7701	NCS21HJ-151X	C CAPACITOR		
	C7702	NCS21HJ-151X	C CAPACITOR		
	C7704	NCS21HJ-101X	C CAPACITOR		
	C7723	NCB21HK-102X	C CAPACITOR		
	C7724	NCB21HK-102X	C CAPACITOR		
	C7734	NCB21HK-102X	C CAPACITOR		
	C7801	NCB21HK-103X	C CAPACITOR	MICOM NOISE	UN
	C7802	NCB21HK-103X	C CAPACITOR	MICOM NOISE	UN
	C7803	NCB21HK-102X	C CAPACITOR		
	C7804	NCB21HK-103X	C CAPACITOR		
	C7809	NCB21HK-102X	C CAPACITOR		
	C7810	NCB21HK-103X	C CAPACITOR		
	C8001	NCB21HK-102X	C CAPACITOR		
	C8002	QEK41CM-476	E.CAPACITOR	47MF 20% 16V	
	C8003	NCB21HK-103X	C CAPACITOR		
	C8004	NCB21HK-103X	C CAPACITOR		
	C8011	NCB21HK-103X	C CAPACITOR		
	C8022	NCB21HK-103X	C CAPACITOR		
	D1701	QLD0119-001	LCD	44 PIN LCD	
	D7001	1SS133-T2	SI DIODE	US5V	
	D7011	MTZJ8.2B-T2	DIODE	SHORT HOGO	
	D7012	1SS133-T2	SI DIODE	SHORT HOGO	
	D7013	1SS133-T2	SI DIODE		
	D7031	1SS133-T2	SI DIODE	BACK UP	
	D7032	1SS133-T2	SI DIODE	CLOCK	
	D7051	1SS133-T2	SI DIODE	RESET	
	D7061	MTZJ5.1C-T2	ZENER DIODE	BACK UP CONT.	
	D7091	1SS133-T2	SI DIODE	US5V	
	D7092	1SS133-T2	SI DIODE	5V-REMCON&STBLE	
	D7703	1SS133-T2	SI DIODE		
	D8003	SLR-342VC-T	LED	RED LED	
	IC701	UPD78064GF-172	IC	SYSTEM MICOM	

△	Item	Parts number	Parts name	Remarks	Area
	IC703	KIA78S06P-T	IC	US6V REG	
	IC801	GP1U261X	IR DETECT UNIT		
	K7001	NQR0006-001X	FERRITE BEAD	ICVSS	
	K7002	NQR0006-001X	FERRITE BEAD	AVSS	
	K7004	NQR0006-001X	FERRITE BEAD	SW GND	
	K7005	NQR0006-001X	FERRITE BEAD	VSS	
	L7002	QLL231K-100Y	INDUCTOR	US5V	
	L7003	QLL231K-470Y	INDUCTOR	AVDD & VDD	
	L7005	QLL231K-4R7Y	INDUCTOR	AVREF	
	PP701	QZW0007-001	POST PIN		UN
	Q7001	2SC2668/O/-T	TRANSISTOR	CLOCK SHIFT	
	Q7002	2SC2668/O/-T	TRANSISTOR	CLOCK SHIFT	
	Q7031	2SA1037AK/RS/-X	TRANSISTOR	SW5V	
	Q7051	DTC114TKA-X	TRANSISTOR	RESET SW	
	Q7061	2SC2412K/R/-X	TRANSISTOR	BACKUP CONT	
	Q7091	2SC2412K/R/-X	TRANSISTOR	POUT DRIVER	
	Q7601	DTC144TKA-X	TRANSISTOR		
	Q7602	DTC144TKA-X	TRANSISTOR		
	Q7603	2SC2412K/R/-X	TRANSISTOR		
	Q8002	DTA114TKA-X	DIGITAL.TR		
	R7005	NRSA02J-822X	MG RESISTOR		
	R7006	NRSA02J-822X	MG RESISTOR		
	R7031	NRSA02J-331X	MG RESISTOR		
	R7032	NRSA02J-103X	MG RESISTOR		
	R7033	NRSA02J-102X	MG RESISTOR		
	R7051	NRSA02J-103X	MG RESISTOR		
	R7052	NRSA02J-103X	MG RESISTOR		
	R7061	NRSA02J-333X	MG RESISTOR		
	R7062	NRSA02J-473X	MG RESISTOR		
	R7063	NRSA02J-104X	MG RESISTOR		
	R7081	NRSA02J-104X	MG RESISTOR		
	R7082	NRSA02J-104X	MG RESISTOR		
	R7083	NRSA02J-104X	MG RESISTOR		
	R7084	NRSA02J-273X	MG RESISTOR		
	R7429	NRSA02J-913X	MG RESISTOR		
	R7430	NRSA02J-102X	MG RESISTOR		
	R7528	NRSA02J-223X	MG RESISTOR		
	R7529	NRSA02J-473X	MG RESISTOR		
	R7530	NRSA02J-103X	MG RESISTOR		
	R7602	NRSA02J-102X	MG RESISTOR		
	R7602	NRSA02J-102X	MG RESISTOR		
	R7603	NRSA02J-473X	MG RESISTOR		
	R7614	NRSA02J-103X	MG RESISTOR		
	R7615	NRSA02J-103X	MG RESISTOR		
	R7619	NRSA02J-122X	MG RESISTOR		
	R7620	NRSA02J-102X	MG RESISTOR		
	R7621	NRSA02J-122X	MG RESISTOR		
	R7622	NRSA02J-102X	MG RESISTOR		
	R7625	NRSA02J-823X	MG RESISTOR		
	R7628	NRSA02J-823X	MG RESISTOR		
	R7629	NRSA02J-103X	MG RESISTOR		
	R7630	NRSA02J-563X	MG RESISTOR		
	R7631	NRSA02J-104X	MG RESISTOR		
	R7632	NRSA02J-103X	MG RESISTOR		
	R7633	NRSA02J-103X	MG RESISTOR		
	R7634	NRSA02J-103X	MG RESISTOR		
	R7635	NRSA02J-104X	MG RESISTOR		
	R7639	NRSA02J-222X	MG RESISTOR		
	R7641	NRSA02J-102X	MG RESISTOR		
	R7642	NRSA02J-102X	MG RESISTOR		
	R7647	NRSA02J-104X	MG RESISTOR		
	R7648	NRSA02J-394X	MG RESISTOR		
	R7649	NRSA02J-823X	MG RESISTOR		

■ Electrical parts list (Micon board & regurator) Block No. 02

△	Item	Parts number	Parts name	Remarks	Area
	R7651	NRSA02J-473X	MG RESISTOR		
	R7652	NRSA02J-473X	MG RESISTOR		
	R7655	NRSA02J-102X	MG RESISTOR		
	R7701	NRSA02J-102X	MG RESISTOR		
	R7702	NRSA02J-102X	MG RESISTOR		
	R7703	NRSA02J-102X	MG RESISTOR		
	R7704	NRSA02J-103X	MG RESISTOR		
	R7705	NRSA02J-102X	MG RESISTOR		
	R7711	NRSA02J-222X	MG RESISTOR		
	R7712	NRSA02J-102X	MG RESISTOR		
	R7713	NRSA02J-222X	MG RESISTOR		
	R7715	NRSA02J-222X	MG RESISTOR		
	R7716	NRSA02J-222X	MG RESISTOR		
	R7717	NRSA02J-472X	MG RESISTOR		
	R7718	NRSA02J-102X	MG RESISTOR		
	R7719	NRSA02J-102X	MG RESISTOR		
	R7720	NRSA02J-102X	MG RESISTOR		
	R7721	NRSA02J-102X	MG RESISTOR		
	R7722	NRSA02J-102X	MG RESISTOR		
	R7723	NRSA02J-222X	MG RESISTOR		
	R7724	NRSA02J-222X	MG RESISTOR		
	R7725	NRSA02J-222X	MG RESISTOR		
	R7726	NRSA02J-222X	MG RESISTOR		
	R7728	NRSA02J-222X	MG RESISTOR		
	R7729	NRSA02J-222X	MG RESISTOR		
	R7730	NRSA02J-222X	MG RESISTOR		
	R7731	NRSA02J-222X	MG RESISTOR		
	R7732	NRSA02J-222X	MG RESISTOR		
	R7733	NRSA02J-222X	MG RESISTOR		
	R7734	NRSA02J-222X	MG RESISTOR		
	R7735	NRSA02J-222X	MG RESISTOR		
	R7738	NRSA02J-222X	MG RESISTOR		
	R7739	NRSA02J-222X	MG RESISTOR		
	R7741	NRSA02J-222X	MG RESISTOR		
	R7742	NRSA02J-222X	MG RESISTOR		
	R7743	NRSA02J-222X	MG RESISTOR		
	R7744	NRSA02J-222X	MG RESISTOR		
	R7745	NRSA02J-222X	MG RESISTOR		
	R7747	NRSA02J-222X	MG RESISTOR		
	R7748	NRSA02J-153X	MG RESISTOR		
	R7749	NRSA02J-123X	MG RESISTOR		
	R7750	NRSA02J-222X	MG RESISTOR		
	R7799	NRSA02J-102X	MG RESISTOR		
	R8001	NRSA02J-102X	MG RESISTOR		
	R8002	NRSA02J-102X	MG RESISTOR		
	R8003	NRSA02J-122X	MG RESISTOR		
	R8004	NRSA02J-123X	MG RESISTOR		
	R8005	NRSA02J-473X	MG RESISTOR		
	R8011	NRSA02J-102X	MG RESISTOR		
	R8012	NRSA02J-102X	MG RESISTOR		
	R8013	NRSA02J-122X	MG RESISTOR		
	R8014	NRSA02J-152X	MG RESISTOR		
	R8015	NRSA02J-222X	MG RESISTOR		
	R8016	NRSA02J-272X	MG RESISTOR		
	R8017	NRSA02J-392X	MG RESISTOR		
	R8018	NRSA02J-562X	MG RESISTOR		
	R8019	NRSA02J-103X	MG RESISTOR		
	R8020	NRSA02J-183X	MG RESISTOR		
	R8021	NRSA02J-433X	MG RESISTOR		
	R8031	NRSA02J-681X	MG RESISTOR		
	S8001	QSW0674-001Z	TACT SW	REVERSE MODE	
	S8002	QSW0674-001Z	TACT SW	REC	
	S8003	QSW0674-001Z	TACT SW	AUX	

△	Item	Parts number	Parts name	Remarks	Area
	S8004	QSW0674-001Z	TACT SW	POWER	
	S8011	QSW0674-001Z	TACT SW	OPEN/CLOSE	
	S8012	QSW0674-001Z	TACT SW	VOLUME -	
	S8013	QSW0674-001Z	TACT SW	VOLUME +	
	S8014	QSW0674-001Z	TACT SW	AHB PRO	
	S8015	QSW0674-001Z	TACT SW	TIMER	
	S8016	QSW0674-001Z	TACT SW	CLOCK	
	S8017	QSW0674-001Z	TACT SW	CD	
	S8018	QSW0674-001Z	TACT SW	TUNER	
	S8019	QSW0674-001Z	TACT SW	TAPE	
	S8020	QSW0674-001Z	TACT SW	DOWN	
	S8021	QSW0674-001Z	TACT SW	STOP	
	S8022	QSW0674-001Z	TACT SW	UP	
	S8101	QSW0451-001	DETECT SW	OPEN SWITCH	
	S8102	QSW0451-001	DETECT SW	CLOSE SWITCH	
	W 701	QUM154-12Z4Z4	FLAT WIRE		
	W 821	QJK018-032403	WIRE		
	X7001	QAX0401-001	CRYSTAL	SUB CLOCK	
	X7002	QAX0410-001Z	CERA LOCK	MAIN CLOCK	

■ Electrical parts list (CD board)

Block No. 03

△	Item	Parts number	Parts name	Remarks	Area	△	Item	Parts number	Parts name	Remarks	Area
	CN601	QGF1201F3-13	CONNECTOR				D6063	1SS355-X	DIODE		
	CN602	QGF1201F3-10	CONNECTOR				IC601	AN8806SB-W	IC		
	CN603	QGF1016F1-16	FFC/FPC CONNE				IC602	LA6541-X	IC		
	CN605	QGA2001C1-06	6P PLUG ASSY				IC603	MN35510AL	IC		
	C6001	QEKC0JM-107Z	E CAPACITOR	100MF 20% 6.3V			K6051	QQR0621-001Z	FERRITE BEADS		
	C6002	QEK41CM-106	E CAPACITOR	10MF 20% 16V			Q6001	2SA1037AK/R/-X	TRANSISTOR		
	C6003	NDC21HJ-3R5X	C CAPACITOR				Q6031	2SA952/LK/-T	TRANSISTOR		
	C6005	NCS21HJ-331X	C CAPACITOR				R6001	NRSA02J-123X	MG RESISTOR		
	C6007	NCB21HK-222X	C CAPACITOR				R6002	NRSA02J-225X	MG RESISTOR		
	C6008	QEKC1HM-105Z	E.CAPACITOR	1.0MF 20% 50V			R6003	NRSA02J-102X	MG RESISTOR		
	C6009	NCS21HJ-101X	C CAPACITOR				R6005	NRSA02J-274X	MG RESISTOR		
	C6010	NCB21HK-273X	C CAPACITOR				R6006	NRSA02J-473X	MG RESISTOR		
	C6011	NCB21HK-222X	C CAPACITOR				R6007	NRSA02J-273X	MG RESISTOR		
	C6012	NCB21HK-103X	C CAPACITOR				R6008	NRSA02J-564X	MG RESISTOR		
	C6014	NCB21EK-104X	C CAPACITOR				R6009	NRSA02J-563X	MG RESISTOR		
	C6015	NCB21HK-223X	C CAPACITOR				R6010	NRSA02J-104X	MG RESISTOR		
	C6016	NCB21HK-223X	C CAPACITOR				R6012	NRSA02J-103X	MG RESISTOR		
	C6017	NCB21HK-223X	C CAPACITOR				R6013	NRSA02J-121X	MG RESISTOR		
	C6018	NCB21HK-222X	C CAPACITOR				R6014	NRSA02J-100X	MG RESISTOR		
	C6019	NCS21HJ-271X	C CAPACITOR				R6015	NRSA02J-120X	MG RESISTOR		
	C6020	NCS21HJ-181X	C CAPACITOR				R6016	NRSA02J-910X	MG RESISTOR		
	C6021	NCS21HJ-821X	C CAPACITOR				R6021	NRSA02J-101X	MG RESISTOR		
	C6022	QEKC0JM-476Z	E.CAPACITOR	47MF 20% 6.3V			R6022	NRSA02J-101X	MG RESISTOR		
	C6023	NCB21EK-104X	C CAPACITOR				R6023	NRSA02J-101X	MG RESISTOR		
	C6028	NCB21EK-473X	C CAPACITOR				R6024	NRSA02J-154X	MG RESISTOR		
	C6029	QEKC0JM-107Z	E CAPACITOR	100MF 20% 6.3V			R6025	NRSA02J-154X	MG RESISTOR		
	C6031	EEKC1AM-227Z	E CAPACITOR	220MF 20% 10V			R6026	NRSA02J-393X	MG RESISTOR		
	C6032	QEKC0JM-107Z	E CAPACITOR	100MF 20% 6.3V			R6027	NRSA02J-393X	MG RESISTOR		
	C6051	NDC21HJ-120X	C CAPACITOR				R6028	NRSA02J-393X	MG RESISTOR		
	C6052	NDC21HJ-150X	C CAPACITOR				R6029	NRSA02J-393X	MG RESISTOR		
	C6053	NCB21HK-223X	C CAPACITOR				R6031	NRSA02J-0R0X	MG RESISTOR		
	C6055	NCB21EK-473X	C CAPACITOR				R6032	NRSA02J-0R0X	MG RESISTOR		
	C6058	NCS21HJ-6R0X	C CAPACITOR				R6041	NRSA02J-104X	MG RESISTOR		
	C6061	NCS21HJ-471X	C CAPACITOR				R6042	NRSA02J-472X	MG RESISTOR		
	C6062	NCB21HK-223X	C CAPACITOR				R6043	NRSA02J-392X	MG RESISTOR		
	C6063	NCB21HK-223X	C CAPACITOR				R6044	NRSA02J-683X	MG RESISTOR		UF
	C6064	NCB21HK-223X	C CAPACITOR				R6044	NRSA02J-623X	MG RESISTOR		UN
	C6065	NCB21CK-334X	C CAPACITOR				R6045	NRSA02J-433X	MG RESISTOR		
	C6071	NCB21HK-222X	C CAPACITOR				R6046	NRSA02J-0R0X	MG RESISTOR		
	C6072	NCB21HK-222X	C CAPACITOR				R6047	NRSA02J-332X	MG RESISTOR		
	C6073	EEKC1AM-227ZJC	E CAPACITOR	220MF 20% 10V			R6048	NRSA02J-222X	MG RESISTOR		
	C6074	EEKC1AM-227ZJC	E CAPACITOR				R6049	NRSA02J-152X	MG RESISTOR		
	C6075	NCB21HK-102X	C CAPACITOR				R6050	NRSA02J-332X	MG RESISTOR		
	C6076	NCB21HK-102X	C CAPACITOR				R6051	NRSA02J-102X	MG RESISTOR		
	C6077	NCB21HK-223X	C CAPACITOR				R6052	NRSA02J-102X	MG RESISTOR		
	C6080	EEKC1AM-227ZJC	E CAPACITOR	220MF 20% 10V			R6053	NRSA02J-102X	MG RESISTOR		
	C6081	EEKC1AM-227ZJC	E CAPACITOR				R6054	NRSA02J-102X	MG RESISTOR		
	C6083	NCB21HK-223X	C CAPACITOR				R6055	NRSA02J-102X	MG RESISTOR		
	C6089	NCB21HK-472X	C CAPACITOR				R6056	NRSA02J-0R0X	MG RESISTOR		
	C6090	NCB21HK-153X	C CAPACITOR				R6057	NRSA02J-0R0X	MG RESISTOR		
	C6091	QEKF1HM-105Z	NP E CAPACITOR	1.0MF 20% 50V			R6058	NRSA02J-0R0X	MG RESISTOR		
	C6092	QEKF1HM-225Z	E CAPACITOR	2.2MF 20% 50V			R6059	NRSA02J-471X	MG RESISTOR		
	C6094	NCB21HK-104X	C CAPACITOR				R6060	NRSA02J-471X	MG RESISTOR		
	C6096	NCS21HJ-391X	C CAPACITOR				R6061	NRSA02J-104X	MG RESISTOR		
	C6097	NCS21HJ-391X	C CAPACITOR				R6063	NRSA02J-124X	MG RESISTOR		
	C6098	NCS21HJ-391X	C CAPACITOR				R6064	NRSA02J-681X	MG RESISTOR		
	C6099	NCS21HJ-391X	C CAPACITOR				R6066	NRSA02J-220X	MG RESISTOR		
	C6154	NCS21HJ-151X	C CAPACITOR				R6067	NRSA02J-220X	MG RESISTOR		
	C6156	NCS21HJ-151X	C CAPACITOR				R6068	NRSA02J-220X	MG RESISTOR		
	C6157	NCS21HJ-151X	C CAPACITOR				R6069	NRSA02J-155X	MG RESISTOR		
	C6158	NCS21HJ-151X	C CAPACITOR				R6071	NRSA02J-102X	MG RESISTOR		
	D6061	1SS355-X	DIODE				R6072	NRSA02J-102X	MG RESISTOR		
	D6062	1SS355-X	DIODE				R6076	NRSA02J-0R0X	MG RESISTOR		

■ Electrical parts list(CD board)

Block No. 03

△	Item	Parts number	Parts name	Remarks	Area
	R6080	NRSA02J-0R0X	MG RESISTOR		
	R6081	NRSA02J-0R0X	MG RESISTOR		
	R6082	NRSA02J-392X	MG RESISTOR		
	R6121	NRSA02J-101X	MG RESISTOR		
	R6124	NRSA02J-0R0X	MG RESISTOR		
	X6051	QAX0413-001Z	CRYSTAL		

■ Electrical parts list (Tuner board)

Block No. 04

▲	Item	Parts number	Parts name	Remarks	Area	▲	Item	Parts number	Parts name	Remarks	Area
	C 1	NCB21HK-223X	C CAPACITOR				IC 2	LC72136N	IC		
	C 2	NCB21HK-103X	C CAPACITOR				J 1	QNB0014-001	ANT TERMINAL		
	C 3	EETC1CM-106ZJC	E.CAPACITOR				L 1	QQR0796-002	COIL BLOCK		
	C 4	NCB21HK-103X	C CAPACITOR				Q 1	2SC2814/4-5/-X	TRANSISTOR		
	C 6	NCB21HK-102X	C CAPACITOR				Q 5	DTA114YKA-X	TRANSISTOR		
	C 7	NCB21HK-102X	C CAPACITOR				R 1	QRE141J-560Y	C RESISTOR	56 5% 1/4W	
	C 8	NCB21HK-102X	C CAPACITOR				R 2	NRSA02J-331X	MG RESISTOR		
	C 10	NRSA02J-0R0X	MG RESISTOR				R 3	NRSA02J-224X	MG RESISTOR		
	C 11	NCB21HK-104X	C CAPACITOR				R 4	NRSA02J-331X	MG RESISTOR		
	C 12	NCB21HK-473X	C CAPACITOR				R 5	NRSA02J-560X	MG RESISTOR		
	C 13	NCS21HJ-120X	C CAPACITOR				R 6	NRSA02J-240X	RES. C.M		
	C 14	QEK1AM-107Z	E.CAPACITOR	100MF 20% 10V			R 10	NRSA02J-222X	MG RESISTOR		
	C 15	NCS21HJ-120X	C CAPACITOR				R 13	NRSA02J-103X	MG RESISTOR		
	C 16	NCS21HJ-120X	C CAPACITOR				R 14	NRSA02J-104X	MG RESISTOR		
	C 17	NCB21HK-392X	C CAPACITOR				R 15	NRSA02J-332X	MG RESISTOR		
	C 18	QE61HM-474Z	N.P.E.CAPA	.47MF 20% 50V			R 16	NRSA02J-472X	MG RESISTOR		
	C 19	NCB21HK-473X	C CAPACITOR				R 17	QRZ9005-680X	F.RES I/M	68 1/0W	
	C 20	NCB21HK-102X	C CAPACITOR				R 18	NRSA02J-102X	MG RESISTOR		
	C 21	NCB21HK-223X	C CAPACITOR				R 19	NRSA02J-102X	MG RESISTOR		
	C 22	NCS21HJ-151X	C CAPACITOR				R 20	NRSA02J-102X	MG RESISTOR		
	C 23	NCS21HJ-151X	C CAPACITOR				R 21	NRSA02J-562X	MG RESISTOR		
	C 24	NCS21HJ-151X	C CAPACITOR				R 22	NRSA02J-472X	MG RESISTOR		
	C 25	QEK1AM-107Z	E.CAPACITOR	100MF 20% 10V			R 23	NRSA02J-182X	MG RESISTOR		
	C 26	NCB21HK-102X	C CAPACITOR				R 24	NRSA02J-103X	MG RESISTOR		
	C 27	NCB21HK-102X	C CAPACITOR				R 25	NRSA02J-331X	MG RESISTOR		
	C 30	EETC1CM-107ZJC	E CAPACITOR				R 26	NRSA02J-222X	MG RESISTOR		
	C 31	QEK1CM-226Z	E CAPACITOR	22MF 20% 16V			R 27	NRSA02J-103X	MG RESISTOR		
	C 32	NCB21HK-473X	C CAPACITOR				R 28	NRSA02J-103X	MG RESISTOR		
	C 33	NCB21HK-473X	C CAPACITOR				R 29	NRSA02J-103X	MG RESISTOR		
	C 34	NCB21HK-223X	C CAPACITOR				R 30	NRSA02J-122X	MG RESISTOR		
	C 35	NCB21HK-473X	C CAPACITOR				R 31	NRSA02J-102X	MG RESISTOR		
	C 36	EETC1HM-105ZJC	E.CAPA. I.M				R 32	NRSA02J-102X	MG RESISTOR		
	C 37	EETC1HM-105ZJC	E.CAPA. I.M				R 33	NRSA02J-331X	MG RESISTOR		
	C 38	EETC1HM-224ZJC	E.CAPA. I.M				R 34	NRSA02J-470X	MG RESISTOR		
	C 39	EETC1HM-105ZJC	E.CAPA. I.M				R 35	NRSA02J-562X	MG RESISTOR		
	C 40	QETN1CM-106Z	E CAPACITOR	10MF 20% 16V			R 36	NRSA02J-332X	MG RESISTOR		
	C 41	QETN1CM-106Z	E CAPACITOR	10MF 20% 16V			R 37	NRSA02J-103X	MG RESISTOR		
	C 42	NCB21HK-152X	C CAPACITOR				R 38	NRSA02J-563X	MG RESISTOR		
	C 43	NCB21HK-152X	C CAPACITOR				R 39	NRSA02J-563X	MG RESISTOR		
	C 44	QETN1CM-106Z	E CAPACITOR	10MF 20% 16V			R 40	NRSA02J-243X	MG RESISTOR		
	C 45	QETN1CM-106Z	E CAPACITOR	10MF 20% 16V			R 41	NRSA02J-332X	MG RESISTOR		
	C 46	NCB21HK-273X	C CAPACITOR				R 60	NRSA02J-0R0X	MG RESISTOR		
	C 47	EETC1HM-105ZJC	E.CAPA. I.M				T 1	QQR0793-001	IFT		
	C 48	NCB21HK-222X	C CAPACITOR				TU 1	QAU0161-001	FRONT END		
	C 49	NCS21HJ-471X	C CAPACITOR				X 1	QAX0402-001	CRYSTAL		
	C 50	QEK1CM-226Z	E CAPACITOR	22MF 20% 16V							
	C 51	QEK1HM-105Z	E.CAPACITOR	1.0MF 20% 50V							
	C 52	QFVJ1HJ-274Z	MF CAPACITOR	.27MF 5% 50V							
	C 53	EETC1CM-226ZJC	E.CAPA. I.M								
	C 54	NCB21HK-473X	C CAPACITOR								
	C 57	NCB21HK-102X	C CAPACITOR								
	C 58	NCB21HK-473X	C CAPACITOR								
	C 59	NCB21HK-102X	C CAPACITOR								
	CF 1	VCF2L3B-105Z	CERAMIC FILTER								
	CF 2	VCF2L3B-105Z	CERAMIC FILTER								
	CF 3	QAX0610-001Z	C DISCRIMINATOR								
	CN 1	QGF1205F1-09	CONNECTOR								
	D 1	1SS133-T2	SI DIODE								
	D 2	1SS133-T2	SI DIODE								
	D 3	1SS133-T2	SI DIODE								
	D 4	1SS133-T2	SI DIODE								
	D 11	1SS133-T2	SI DIODE								
	IC 1	LA1838	IC								

■ Electrical parts list (Head amp board) Block No. 05

△	Item	Parts number	Parts name	Remarks	Area	△	Item	Parts number	Parts name	Remarks	Area
	C 101	NCS21HJ-821X	C CAPACITOR	820PF 5% 50V			IC 33	BU4094BCF-X	IC		
	C 102	NCS21HJ-221X	C CAPACITOR	220PF 5% 50V			L 301	QQR0620-001	OSC COIL(BIAS)		
	C 103	QEKJ0JM-227Z	E CAPACITOR	220MF 20% 6.3V			L 303	QQL01BK-100Z	INDUCTOR		
	C 104	NCB21HK-333X	C CAPACITOR	.033MF 10% 50V			Q 101	DTC114TKA-X	TRANSISTOR		
	C 105	NCB21HK-222X	C CAPACITOR	2200PF 10% 50V			Q 102	DTC114TKA-X	TRANSISTOR	REC EQ CONT.	
	C 106	QEKJ1CM-106Z	E CAPACITOR	10MF 20% 16V			Q 201	DTC114TKA-X	TRANSISTOR		
	C 107	NCS21HJ-561X	C CAPACITOR	560PF 5% 50V			Q 202	DTC114TKA-X	TRANSISTOR	REC EQ CONT.	
	C 108	QEKJ1EM-475Z	E CAPACITOR	4.7MF 20% 25V			Q 301	DTA144EKA-X	TRANSISTOR	REC EQ CONT.	
	C 109	QEKJ1EM-475Z	E CAPACITOR	4.7MF 20% 25V			Q 302	2SC2001/K/-T	TR I/M		
	C 110	NCB21HK-682X	C.CAPA. C.M	6800PF 10% 50V			Q 303	2SC2001/K/-T	TR I/M		
	C 111	NCB21HK-122X	C CAPACITOR	1200PF 10% 50V			Q 304	2SC2001/LK/-T	TRANSISTOR		
	C 112	NCB21EK-683X	C CAPACITOR	.068MF 10% 25V			Q 305	2SC2001/LK/-T	TRANSISTOR		
	C 113	NCB21HK-222X	C CAPACITOR	2200PF 10% 50V			Q 306	2SC2412K/RS/-X	CHIP TR.C.M		
	C 121	NCS21HJ-331X	C CAPACITOR	330PF 5% 50V			Q 307	2SC2412K/RS/-X	CHIP TR.C.M		
	C 201	NCS21HJ-821X	C CAPACITOR	820PF 5% 50V			Q 308	2SC2412K/RS/-X	CHIP TR.C.M		
	C 202	NCS21HJ-221X	C CAPACITOR	220PF 5% 50V			Q 309	2SC2412K/RS/-X	CHIP TR.C.M		
	C 203	QEKJ0JM-227Z	E CAPACITOR	220MF 20% 6.3V			Q 321	DTC144EKA-X	TRANSISTOR		
	C 204	NCB21HK-333X	C CAPACITOR	.033MF 10% 50V			Q 323	2SC2412K/RS/-X	CHIP TR.C.M		
	C 205	NCB21HK-222X	C CAPACITOR	2200PF 10% 50V			Q 371	2SA952/LK/-T	TRANSISTOR	MOTER+B	
	C 206	QEKJ1CM-106Z	E CAPACITOR	10MF 20% 16V			Q 372	DTC124EKA-X	TRANSISTOR		
	C 207	NCS21HJ-561X	C CAPACITOR	560PF 5% 50V			Q 375	2SB562/C/-T	TRANSISTOR	SOLENOID DRIVE	
	C 208	QEKJ1EM-475Z	E CAPACITOR	4.7MF 20% 25V			Q 376	2SC2412K/RS/-X	CHIP TR.C.M		
	C 209	QEKJ1EM-475Z	E CAPACITOR	4.7MF 20% 25V			R 101	NRSA02J-220X	MG RESISTOR	22 5% 1/10W	
	C 210	NCB21HK-682X	C.CAPA. C.M	6800PF 10% 50V			R 102	NRSA02J-182X	MG RESISTOR	1.8K 5% 1/10W	
	C 211	NCB21HK-122X	C CAPACITOR	1200PF 10% 50V			R 103	NRSA02J-242NY	MG RESISTOR	2.4K 5% 1/10W	
	C 212	NCB21EK-683X	C CAPACITOR	.068MF 10% 25V			R 104	NRSA02J-122X	MG RESISTOR	1.2K 5% 1/10W	
	C 213	NCB21HK-222X	C CAPACITOR	2200PF 10% 50V			R 105	NRSA02J-104X	MG RESISTOR	100K 5% 1/10W	
	C 221	NCS21HJ-331X	C CAPACITOR	330PF 5% 50V			R 106	NRSA02J-332X	MG RESISTOR	3.3K 5% 1/10W	
	C 301	QEKJ1AM-107Z	E CAPACITOR	100MF 20% 10V			R 107	NRSA02J-123X	RES. C.M	12K 5% 1/10W	
	C 302	NCB21HK-393X	C CAPACITOR	.039MF 10% 50V			R 108	NRSA02J-562X	MG RESISTOR	5.6K 5% 1/10W	
	C 303	QEKJ0JM-227Z	E CAPACITOR	220MF 20% 6.3V			R 109	NRSA02J-122X	MG RESISTOR	1.2K 5% 1/10W	
	C 304	QEKJ1CM-226Z	E CAPACITOR	22MF 20% 16V			R 110	NRSA02J-472X	RES. C.M	4.7K 5% 1/10W	
	C 305	QEKJ1CM-226Z	E CAPACITOR	22MF 20% 16V			R 111	NRSA02J-333X	MG RESISTOR	33K 5% 1/10W	
	C 306	QEKJ1CM-476Z	E CAPACITOR	47MF 20% 16V			R 112	NRSA02J-222X	MG RESISTOR	2.2K 5% 1/10W	
	C 307	NCB21HK-103X	C CAPACITOR	.010MF 10% 50V			R 113	NRSA02J-472X	RES. C.M	4.7K 5% 1/10W	
	C 308	NCB21HK-562X	C CAPACITOR	5600PF 10% 50V			R 114	NRSA02J-272X	MG RESISTOR	2.7K 5% 1/10W	
	C 309	NCB21HK-562X	C CAPACITOR	5600PF 10% 50V			R 116	NRSA02J-102X	RES. C.M	1.0K 5% 1/10W	
	C 310	NCB21HK-223X	C CAPACITOR	.022MF 10% 50V			R 121	NRSA02J-102X	RES. C.M	1.0K 5% 1/10W	
	C 311	NCB21HK-682X	C.CAPA. C.M	6800PF 10% 50V			R 201	NRSA02J-220X	MG RESISTOR	22 5% 1/10W	
	C 313	QEKJ1AM-107Z	E CAPACITOR	100MF 20% 10V			R 202	NRSA02J-182X	MG RESISTOR	1.8K 5% 1/10W	
	C 314	QCZ0205-155Z	ML C CAP I/M	1.5MF			R 203	NRSA02J-242NY	MG RESISTOR	2.4K 5% 1/10W	
	C 315	QCZ0205-155Z	ML C CAP I/M	1.5MF			R 204	NRSA02J-122X	MG RESISTOR	1.2K 5% 1/10W	
	C 316	QFG32AJ-103Z	PP CAPACITOR	.010MF 5% 100V			R 205	NRSA02J-104X	MG RESISTOR	100K 5% 1/10W	
	C 318	NCB21HK-103X	C CAPACITOR	.010MF 10% 50V			R 206	NRSA02J-332X	MG RESISTOR	3.3K 5% 1/10W	
	C 319	QFG32AJ-821Z	TF CAPACITOR	820PF 5% 100V			R 207	NRSA02J-123X	RES. C.M	12K 5% 1/10W	
	C 321	NCB21HK-103X	C CAPACITOR	.010MF 10% 50V			R 208	NRSA02J-562X	MG RESISTOR	5.6K 5% 1/10W	
	C 322	QFG32AJ-152Z	M CAPACITOR	1500PF 5% 100V			R 209	NRSA02J-122X	MG RESISTOR	1.2K 5% 1/10W	
	C 331	QEKJ1CM-476Z	E CAPACITOR	47MF 20% 16V			R 210	NRSA02J-472X	RES. C.M	4.7K 5% 1/10W	
	C 351	QEK41CM-106	E CAPACITOR	10MF 20% 16V			R 211	NRSA02J-333X	MG RESISTOR	33K 5% 1/10W	
	C 371	QEKJ1EM-475Z	E CAPACITOR	4.7MF 20% 25V			R 212	NRSA02J-222X	MG RESISTOR	2.2K 5% 1/10W	
	C 374	QEKJ1AM-107Z	E CAPACITOR	MOTOR +B			R 213	NRSA02J-472X	RES. C.M	4.7K 5% 1/10W	
	C 375	QEKJ1AM-107Z	E CAPACITOR	100MF 20% 10V			R 214	NRSA02J-272X	MG RESISTOR	2.7K 5% 1/10W	
	C 376	NCB21HK-103X	C CAPACITOR	.010MF 10% 50V			R 216	NRSA02J-102X	RES. C.M	1.0K 5% 1/10W	
	CN 31	QGF1205F1-06	CONNECTOR	PRI/HEAD			R 221	NRSA02J-102X	RES. C.M	1.0K 5% 1/10W	
	CN 32	QGB2011M1-10	PWB CONECTOR	PRI/MECHA			R 301	NRS181J-221X	MG RESISTOR	220 5% 1/8W	
	CN 33	QGF1205F1-09	CONNECTOR	PRI/MICON			R 303	NRSA02J-393X	MG RESISTOR	39K 5% 1/10W	
	CN 34	QGF1205F1-10	CONNECTOR	PRI/AMP			R 304	NRS181J-101X	MG RESISTOR	100 5% 1/8W	
	D 301	MA152WA-X	DIODE				R 305	NRSA02J-222X	MG RESISTOR	2.2K 5% 1/10W	
	D 309	MA704A-X	S.K.DIODE				R 306	NRSA02J-222X	MG RESISTOR	2.2K 5% 1/10W	
	D 375	MA3051/M/-X	ZENER DIODE				R 310	NRS181J-560X	MG RESISTOR	56 5% 1/8W	
	FW 31	QUM024-06A2Z3	EF FLAT				R 311	NRS181J-560X	MG RESISTOR	56 5% 1/8W	
	IC 31	BA3126N	IC	HEAD SW			R 313	NRSA02J-3R3NY	RES. C.M	3.3 5% 1/10W	
	IC 32	AN7317	IC	PB&REC			R 314	NRSA02J-223X	RES. C.M	22K 5% 1/10W	

■ Electrical parts list (Head amp board) Block No. 05

△	Item	Parts number	Parts name	Remarks	Area
	R 315	NRSA02J-100X	MG RESISTOR	10 5% 1/10W	
	R 316	NRSA02J-223X	RES. C.M	22K 5% 1/10W	
	R 317	NRSA02J-100X	MG RESISTOR	10 5% 1/10W	
	R 319	NRSA02J-152X	MG RESISTOR	1.5K 5% 1/10W	
	R 322	NRSA02J-152X	MG RESISTOR	1.5K 5% 1/10W	
	R 327	NRSA02J-474X	MG RESISTOR	470K 5% 1/10W	
	R 332	NRSA02J-123X	RES. C.M	12K 5% 1/10W	
	R 333	NRSA02J-123X	RES. C.M	12K 5% 1/10W	
	R 335	NRSA02J-152X	MG RESISTOR	1.5K 5% 1/10W	
	R 336	NRSA02J-472X	RES. C.M	4.7K 5% 1/10W	
	R 337	NRSA02J-332X	MG RESISTOR	3.3K 5% 1/10W	
	R 338	NRSA02J-392X	MG RESISTOR	3.9K 5% 1/10W	
	R 339	NRSA02J-222X	MG RESISTOR	2.2K 5% 1/10W	
	R 340	NRS181J-391X	MG RESISTOR	390 5% 1/8W	
	R 341	NRSA02J-123X	RES. C.M	12K 5% 1/10W	
	R 342	NRSA02J-203X	MG RESISTOR	20K 5% 1/10W	
	R 343	NRSA02J-183X	MG RESISTOR	18K 5% 1/10W	
	R 351	NRSA02J-683X	MG RESISTOR	68K 5% 1/10W	
	R 352	NRSA02J-912X	RES. C.M	9.1K 5% 1/10W	
	R 371	NRSA02J-123X	RES. C.M	12K 5% 1/10W	
	R 372	NRSA02J-102X	RES. C.M	1.0K 5% 1/10W	
	R 375	NRSA02J-151X	MG RESISTOR	150 5% 1/10W	
	R 376	NRSA02J-472X	RES. C.M	4.7K 5% 1/10W	
	VR 31	QVP0008-503Z	SEMI V RESISTOR	BIAS ADJ	
	VR 32	QVP0008-503Z	SEMI V RESISTOR	BIAS ADJ	
	VR 37	QVP0008-103Z	SEMI V RESISTOR	TAPE SPEED ADJ	

■ Electrical parts list (Switch board)

Block No. 06

△	Item	Parts number	Parts name	Remarks	Area
	CN 1	QGB2011L1-10	10P PLUG ASSY		
	D 1	1SR139-400-T2	SI DIODE		
	IC 1	SG-105F3-BB,C	PHOTO SENSER		
	P 1	QNZ0104-001	POST PIN		
	SW 1	QSW0832-001	CASSETTE SWITCH	R.REC	
	SW 2	QSW0832-001	CASSETTE SWITCH	TAPE	
	SW 4	QSW0832-001	CASSETTE SWITCH	70U	
	SW 5	QSW0832-001	CASSETTE SWITCH	F.REC	
	SW 6	QSW0859-001	SWITCH		

Packing materials and accessories parts list

Block No.

M	3	M	M
---	---	---	---

Block No.

M	4	M	M
---	---	---	---

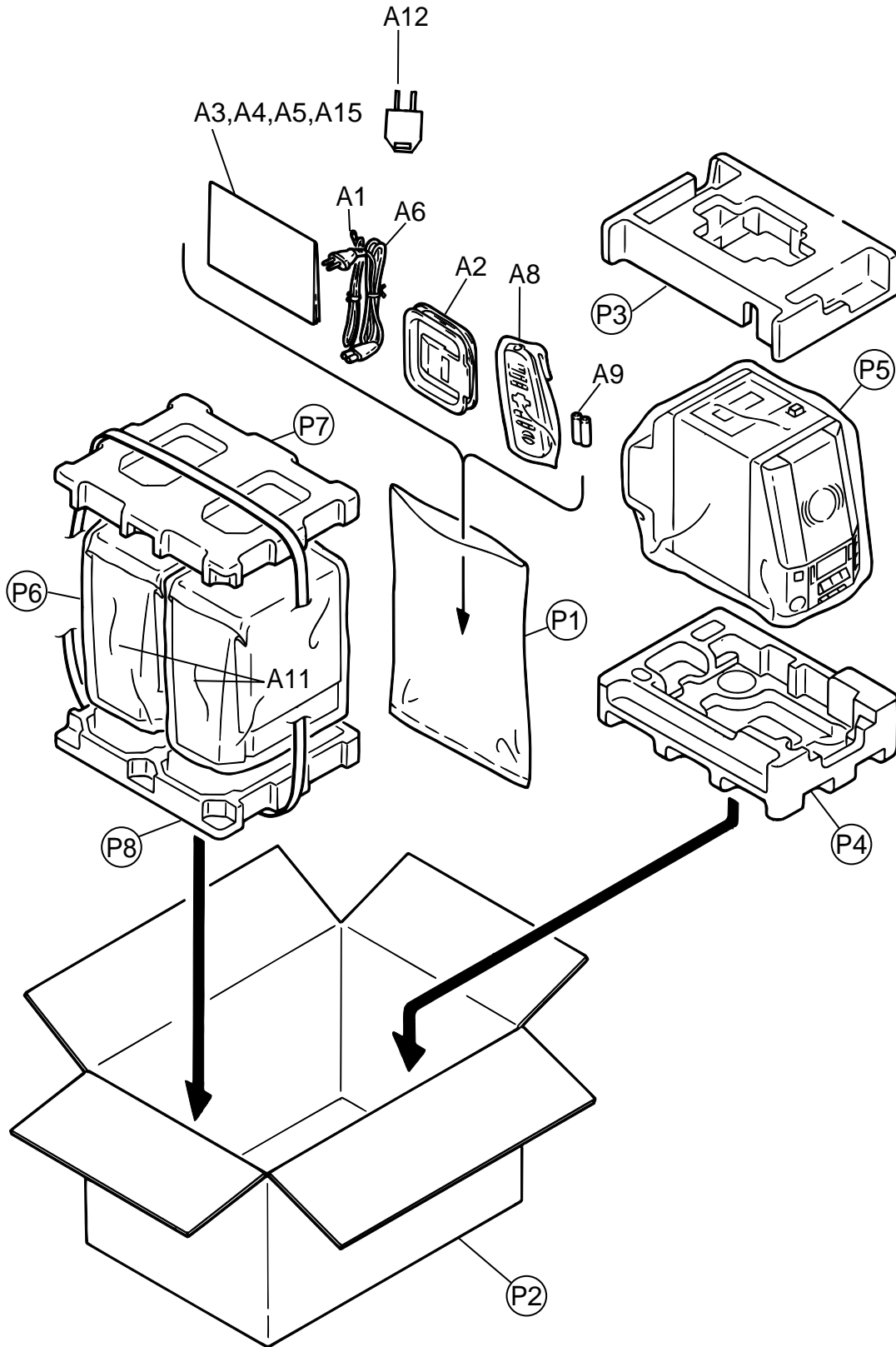

■ Packing parts list

Block No. M3MM

△	Item	Parts number	Parts name	Q'ty	Description	Area
	P 1	QPA02503503P	POLY BAG	1	FOR INST. BOOK	
	P 2	GV20060-005A	CARTON	1		
	P 3	GV10038-001A	CUSHION(TOP)	1		
	P 4	GV10039-001A	CUSHION(BOTTOM)	1		
	P 5	GV30126-001A	POLYBAG	1		
	P 6	138734501073	POLYBAG	2	FOR SPEAKER	
	P 7	139763351046	CUSHION(TOP)	1	FOR SPEAKER	
	P 8	139763351047	CUSHION(BOTTOM)	1	FOR SPEAKER	

■ Accessories list

Block No. M4MM

△	Item	Parts number	Parts name	Q'ty	Description	Area
	A 1	EWP503-001	ANT.WIRE	1		
	A 2	QAL0014-001	AM LOOP ANT	1		
	A 3	GVT0031-003A	INST.BOOK	1	ENG SPA CHI	UN
		GVT0031-004A	INST.BOOK	1	KOR	UF
	A 4	BT-59012-1	SVC CENTER LIST	1		UF
	A 5	GV40176-001A	ERRATA SHEET	1		UN
△	A 6	QMPL060-183-JD	POWER CORD	1		UN
△		QMPS020-183-JC	POWER CORD	1		UF
	A 8	RM-SUXV10E	REMOCON	1		
	A 9	-----	BATTERY	2		
	A 11	UXV10G-SPBOX	SPEAKER BOX	2		
△	A 12	QAM0112-001	AC PLUG ADAPTER	1		UN
	A 15	BT-59011-2	WARRANTY CARD	1		UF

<<MEMO>>