

JVC

SERVICE MANUAL

MICRO COMPONENT MD SYSTEM

UX-Z7MDR

Area Suffix
E ----- Continental Europe

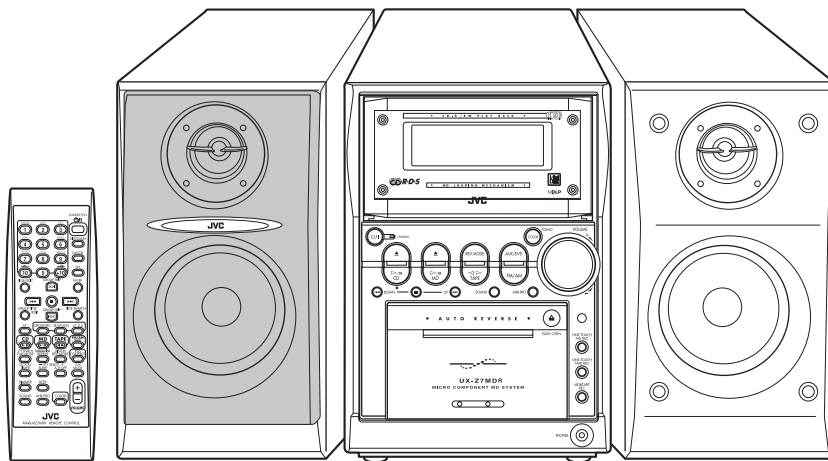

MDLP



TABLE OF CONTENTS

1	Important Safety Precautions	1-2
2	Disassembly Method.....	1-5
3	Adjustment method.....	1-37
4	Description of major ICs.....	1-44

SECTION 1

Important Safety Precautions

1.1 Safety Precautions

- (1) This design of this product contains special hardware and many circuits and components specially for safety purposes. For continued protection, no changes should be made to the original design unless authorized in writing by the manufacturer. Replacement parts must be identical to those used in the original circuits. Services should be performed by qualified personnel only.
- (2) Alterations of the design or circuitry of the product should not be made. Any design alterations of the product should not be made. Any design alterations or additions will void the manufacturer's warranty and will further relieve the manufacturer of responsibility for personal injury or property damage resulting therefrom.
- (3) Many electrical and mechanical parts in the products have special safety-related characteristics. These characteristics are often not evident from visual inspection nor can the protection afforded by them necessarily be obtained by using replacement components rated for higher voltage, wattage, etc. Replacement parts which have these special safety characteristics are identified in the Parts List of Service Manual. Electrical components having such features are identified by shading on the schematics and by (Δ) on the Parts List in the Service Manual. The use of a substitute replacement which does not have the same safety characteristics as the recommended replacement parts shown in the Parts List of Service Manual may create shock, fire, or other hazards.
- (4) The leads in the products are routed and dressed with ties, clamps, tubings, barriers and the like to be separated from live parts, high temperature parts, moving parts and/or sharp edges for the prevention of electric shock and fire hazard. When service is required, the original lead routing and dress should be observed, and it should be confirmed that they have been returned to normal, after reassembling.
- (5) Leakage shock hazard testing

After reassembling the product, always perform an isolation check on the exposed metal parts of the product (antenna terminals, knobs, metal cabinet, screw heads, headphone jack, control shafts, etc.) to be sure the product is safe to operate without danger of electrical shock. Do not use a line isolation transformer during this check.

 - Plug the AC line cord directly into the AC outlet. Using a "Leakage Current Tester", measure the leakage current from each exposed metal part of the cabinet, particularly any exposed metal part having a return path to the chassis, to a known good earth ground. Any leakage current must not exceed 0.5mA AC (r.m.s.).
 - Alternate check method

Plug the AC line cord directly into the AC outlet. Use an AC voltmeter having, 1,000 ohms per volt or more sensitivity in the following manner. Connect a 1,500 ohm 10W resistor paralleled by a 0.15 μ F AC-type capacitor between an

exposed metal part and a known good earth ground.

Measure the AC voltage across the resistor with the AC voltmeter.

Move the resistor connection to each exposed metal part, particularly any exposed metal part having a return path to the chassis, and measure the AC voltage across the resistor. Now, reverse the plug in the AC outlet and repeat each measurement. Voltage measured any must not exceed 0.75 V AC (r.m.s.). This corresponds to 0.5 mA AC (r.m.s.).

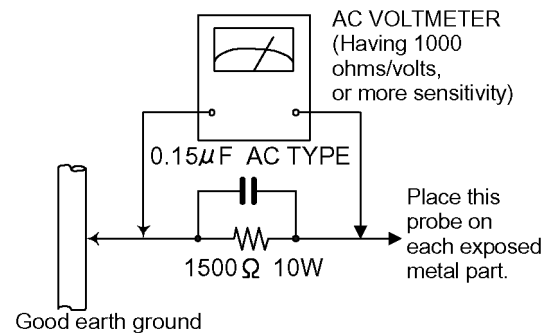

1.2 Warning

- (1) This equipment has been designed and manufactured to meet international safety standards.
- (2) It is the legal responsibility of the repairer to ensure that these safety standards are maintained.
- (3) Repairs must be made in accordance with the relevant safety standards.
- (4) It is essential that safety critical components are replaced by approved parts.
- (5) If mains voltage selector is provided, check setting for local voltage.

1.3 Caution

Burrs formed during molding may be left over on some parts of the chassis.

Therefore, pay attention to such burrs in the case of pre-forming repair of this system.

1.4 Critical parts for safety

In regard with component parts appearing on the silk-screen printed side (parts side) of the PWB diagrams, the parts that are printed over with black such as the resistor (\blacksquare), diode (\blacksquare) and ICP (\bullet) or identified by the " Δ " mark nearby are critical for safety.

When replacing them, be sure to use the parts of the same type and rating as specified by the manufacturer. (Except the JC version)

1.5 Preventing static electricity

Electrostatic discharge (ESD), which occurs when static electricity stored in the body, fabric, etc. is discharged, can destroy the laser diode in the traverse unit (optical pickup). Take care to prevent this when performing repairs.

1.5.1 Grounding to prevent damage by static electricity

Static electricity in the work area can destroy the optical pickup (laser diode) in devices such as DVD players. Be careful to use proper grounding in the area where repairs are being performed.

(1) Ground the workbench

Ground the workbench by laying conductive material (such as a conductive sheet) or an iron plate over it before placing the traverse unit (optical pickup) on it.

(2) Ground yourself

Use an anti-static wrist strap to release any static electricity built up in your body.

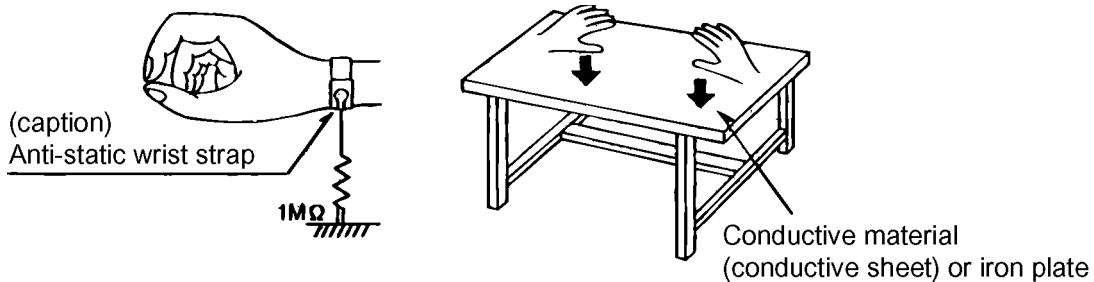

(3) Handling the optical pickup

- In order to maintain quality during transport and before installation, both sides of the laser diode on the replacement optical pickup are shorted. After replacement, return the shorted parts to their original condition. (Refer to the text.)
- Do not use a tester to check the condition of the laser diode in the optical pickup. The tester's internal power source can easily destroy the laser diode.

1.6 Handling the traverse unit (optical pickup)

(1) Do not subject the traverse unit (optical pickup) to strong shocks, as it is a sensitive, complex unit.

(2) Cut off the shorted part of the flexible cable using nippers, etc. after replacing the optical pickup. For specific details, refer to the replacement procedure in the text. Remove the anti-static pin when replacing the traverse unit. Be careful not to take too long a time when attaching it to the connector.

(3) Handle the flexible cable carefully as it may break when subjected to strong force.

(4) It is not possible to adjust the semi-fixed resistor that adjusts the laser power. Do not turn it.

1.7 Attention when traverse unit is decomposed

***Please refer to "Disassembly method" in the text for the CD pickup unit.**

- Apply solder to the short land before the flexible wire is disconnected from the connector on the CD pickup unit. (If the flexible wire is disconnected without applying solder, the CD pickup may be destroyed by static electricity.)
- In the assembly, be sure to remove solder from the short land after connecting the flexible wire.

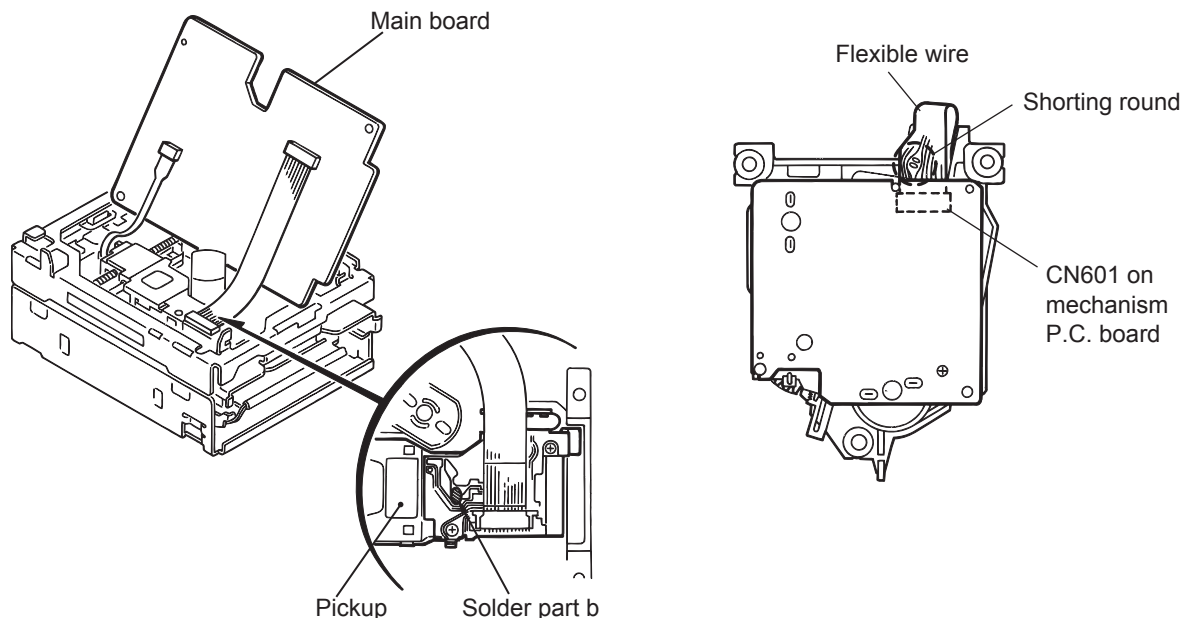

1.8 Important for laser products

- (1) **CLASS 1 LASER PRODUCT**
- (2) **DANGER** : Invisible laser radiation when open and interlock failed or defeated. Avoid direct exposure to beam.
- (3) **CAUTION** : There are no serviceable parts inside the Laser Unit. Do not disassemble the Laser Unit. Replace the complete Laser Unit if it malfunctions.
- (4) **CAUTION** : The compact disc player uses invisible laser radiation and is equipped with safety switches which prevent emission of radiation when the drawer is open and the safety interlocks have failed or are defeated. It is dangerous to defeat the safety switches.

- (5) **CAUTION** : If safety switches malfunction, the laser is able to function.
- (6) **CAUTION** : Use of controls, adjustments or performance of procedures other than those specified herein may result in hazardous radiation exposure.

⚠CAUTION
Please use enough caution not to see the beam directly or touch it in case of an adjustment or operation check.

VARNING

Osynlig laserstrålning är denna del är öppnad och spärren är urkopplad. Betrakta ej strålen.

VARO

Avattaessa ja suojalukitus ohitettaessa olet alltiina näkymättömälle lasersäteilylle. Älä katso säteeseen.

ADVARSEL

Usynlig laserstrålning ved åbning, når sikkerhedsafbrydere er ude af funktion. Undgå udsættelse for stråling.

ADVARSEL

Usynlig laserstrålning ved åbning, når sikkerhedsbryteren er avslott. unngå utsettelse for stråling.

REPRODUCTION AND POSITION OF LABELS

WARNING LABEL

<p>DANGER : Invisible laser radiation when open and interlock or defeated. AVOID DIRECT EXPOSURE TO BEAM (e)</p>	<p>VARO : Avattaessa ja suojalukitus ohitettaessa olet alltiina näkymättömälle lasersäteilylle. Älä katso säteeseen. (d)</p>	<p>VARNING : Osynlig laserstrålning är denna del är öppnad och spärren är urkopplad. Betrakta ej strålen. (s)</p>	<p>ADVARSEL :Usynlig laserstrålning ved åbning , når sikkerhedsafbrydere er ude af funktion. Undgå udsættelse for stråling. (f)</p>
---	--	---	---

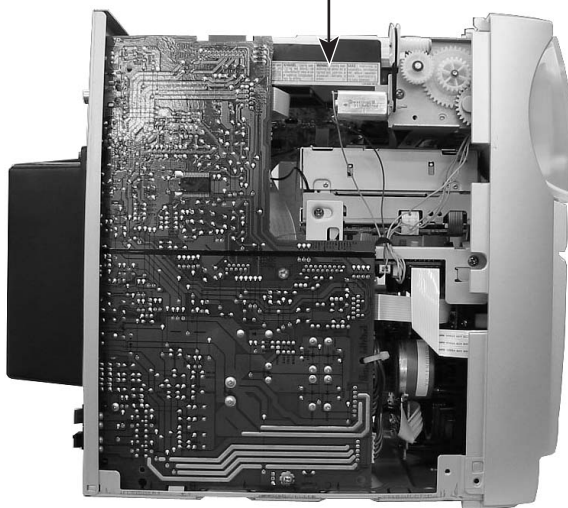

SECTION 2

Disassembly Method

2.1 Main body

2.1.1 Removing the metal cover (See Fig.1 to 3.)

- (1) Remove the six screws **A** on the rear part of the main body that attach the metal cover.
- (2) Remove the two screws **B** on each side of the main body that attach the metal cover.
- (3) Lift the rear part of the metal cover upward while releasing the lower sides of the metal cover in the right and left direction. The metal cover will be removed.

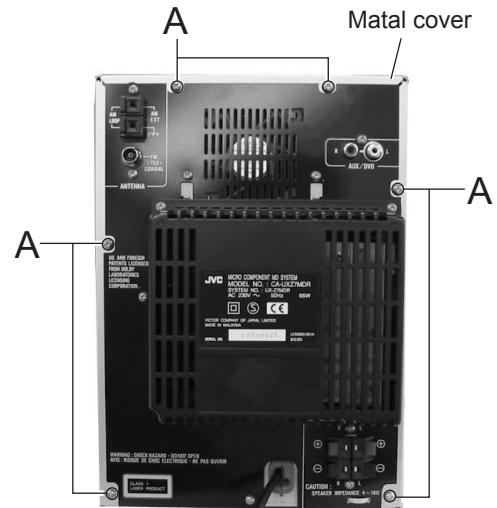

Fig.1

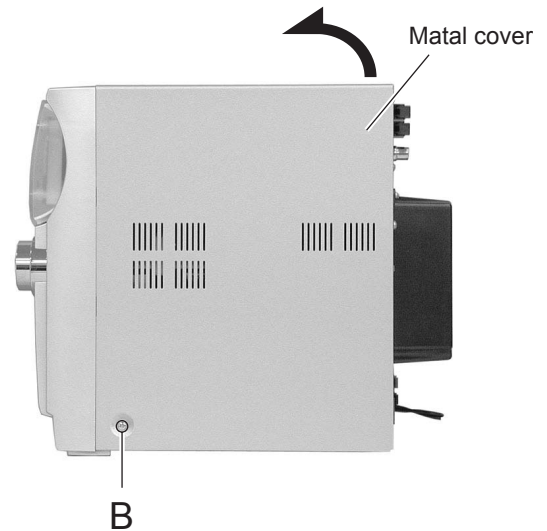

Fig.2

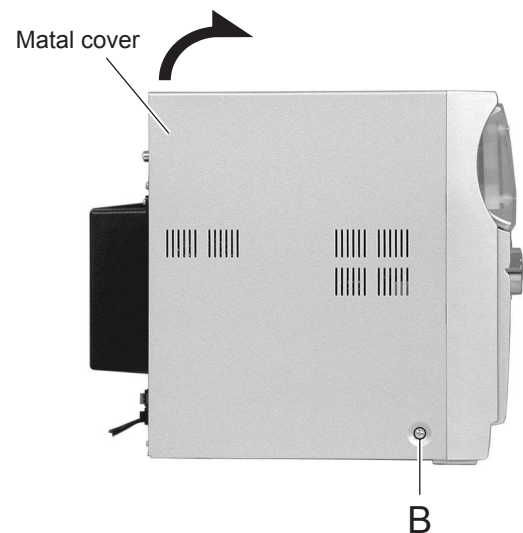

Fig.3

**2.1.2 Removing the CD mechanism assembly
(See Fig.4 to 7.)**

- Prior to this procedure, remove the metal cover.
 - (1) Remove the card wire from the connector CN302 on amp board on the left side of the main body.
 - (2) Remove the three screws **C** on top of the body that attach the CD mechanism assembly.
 - (3) Lift the CD mechanism assembly upward and move it backward to remove.
 - (4) Remove the card wire from CN606 on CD servo board, on the bottom of the CD mechanism assembly.

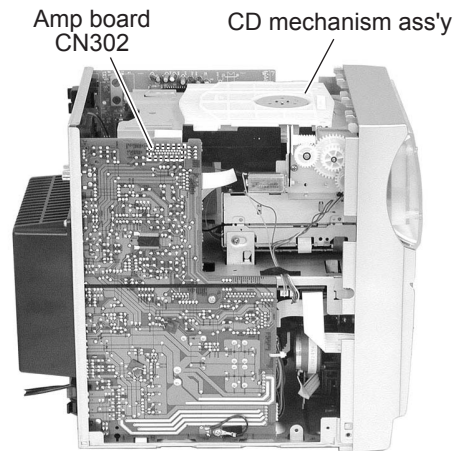

Fig.4

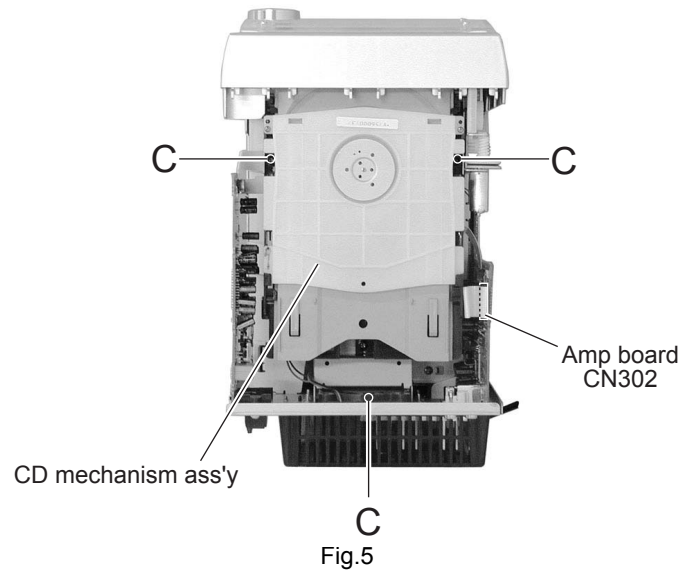

Fig.5

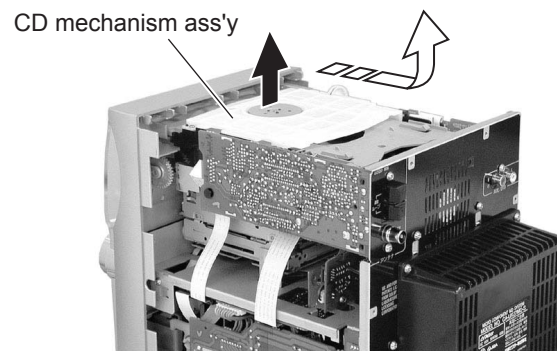

Fig.6

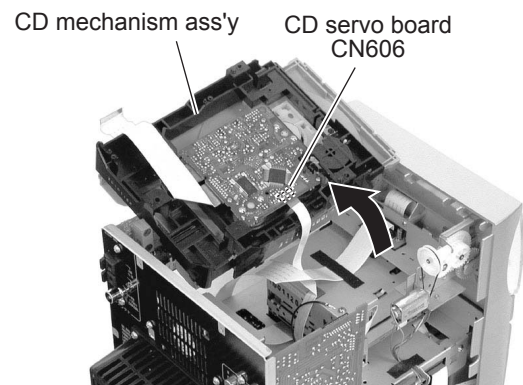
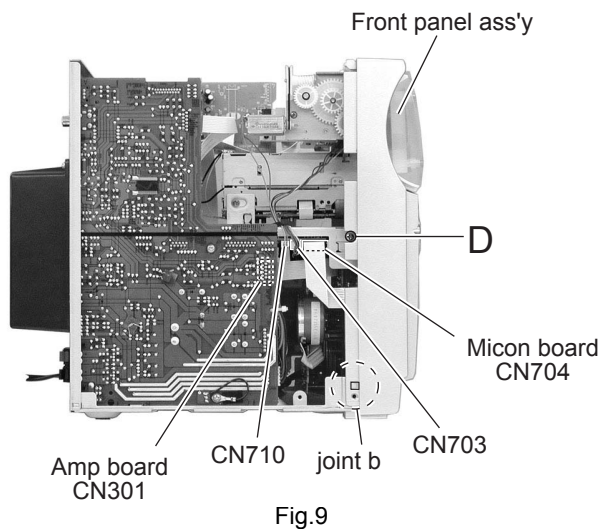
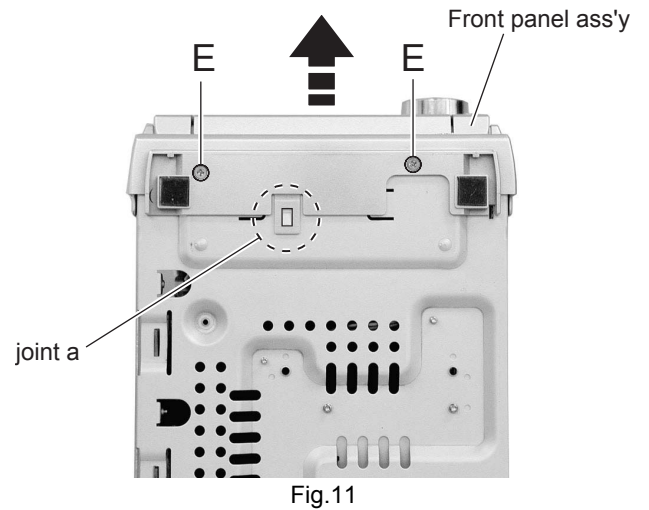
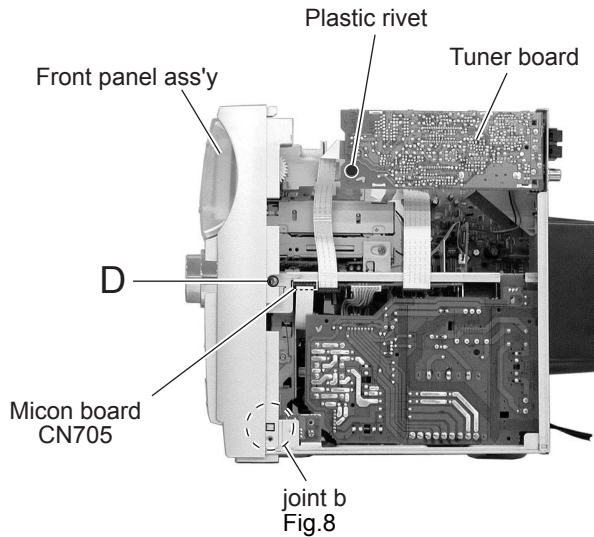
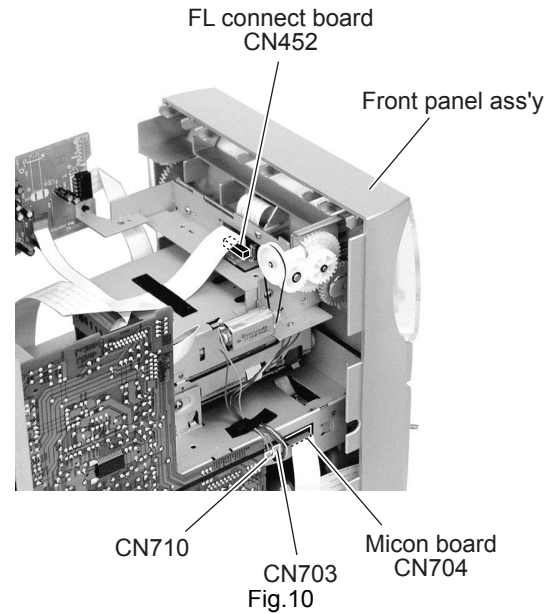

Fig.7

2.1.3 Removing the front panel
(See Fig.8 to11.)

- Prior to this procedure, remove the metal cover and the CD mechanism assembly.
- (1) Remove the card wire from the connector CN705 on micon board, in the center of the right side of the main body.
- (2) Remove the plastic rivet in the right side of the main body that attaches tuner board.
- (3) Remove the card wire from the connector CN301 on amp board in the center of the left side of the main body.
 Remove the card wire from the connector CN704 on micon board.
 Remove the wire from each connector CN703 and CN710 respectively.
- (4) Remove the card wire from the connector CN452 on FL connection board on top of the main body.
- (5) Remove the two screws **D** on the right and left sides of the main body that attach the front panel assembly.
- (6) Remove the two screws **E** on the bottom of the main body that attach the front panel assembly.
- (7) Remove the joint "a" on the bottom of the main body and the joint "b" on the right and left sides respectively by using a screwdriver. Remove the front panel assembly in the front direction.



2.1.4 Removing the tuner board (See Fig.12.)

- Prior to this procedure, remove the metal cover.
- (1) Remove the card wire on the right side of the main body from the connector CN1 on the tuner board.
- (2) Remove the plastic rivet on the right side of the main body that attaches the tuner board.
- (3) Remove the two screws **F** on the rear side of the main body that attach the tuner board.

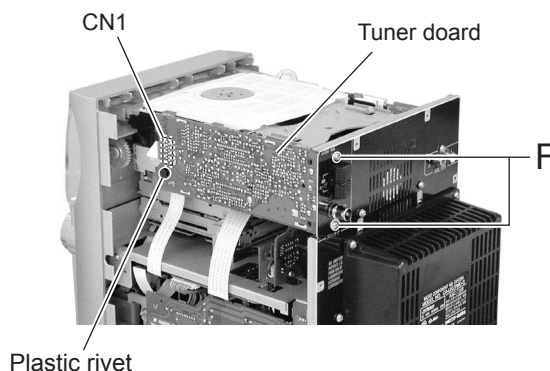

Fig.12

2.1.5 Removing the rear cover (See Fig.13.)

- Prior to this procedure, remove the metal cover and the CD mechanism assembly.
- (1) Remove the two screws **G** on the rear side of the main body that attach the rear cover.

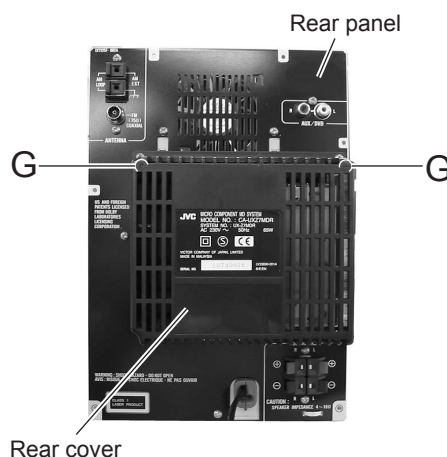

Fig.13

2.1.6 Removing the fan (See Fig.14 to 16.)

- Prior to this procedure, remove the metal cover, the CD mechanism assembly, and the rear cover.
- (1) Remove the wire from the connector CN603 on the MD connect board in the right side of the main body.
- (2) Remove the four screws **H** on the rear side of the main body that attach the fan.
- (3) Move the fan bracket that attaches the fan from inside the rear panel upward to remove the two fixing points "c". Fan will be detached at the same time.

Notice

When attaching the fan, attach the two "e" to the two "d" respectively before pressing the fan with fan bracket.

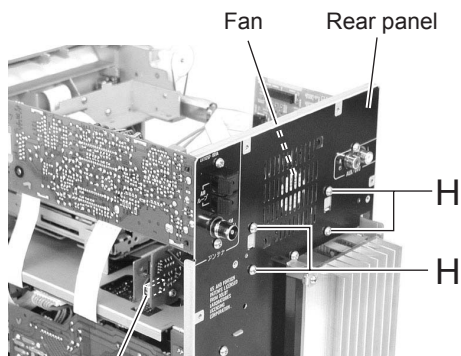

Fig.14

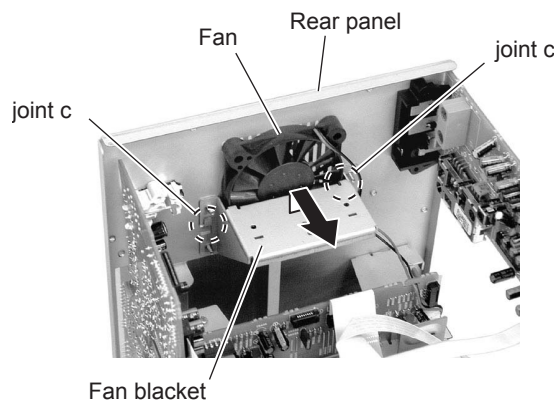

Fig.15

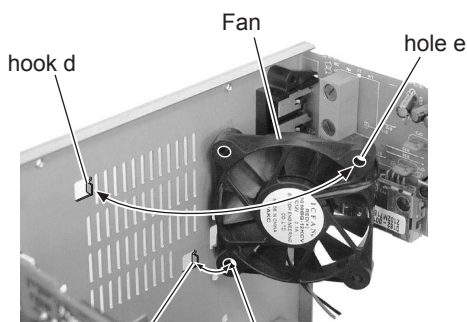

Fig.16

2.1.7 Removing the rear panel
(See Fig.17 to 20.)

- Prior to this procedure, remove the metal cover, the CD mechanism assembly, and the rear cover.
- (1) Remove the wire from the connector CN603 on MD connect board on the right side of the main body.
- (2) Remove the eight screws **F** on the rear side of the main body that attach the rear panel.
- (3) Remove the two joint "f" on the right and left bottom of the rear panel.

Notice

The fan assembly will be kept attached to the rear panel.

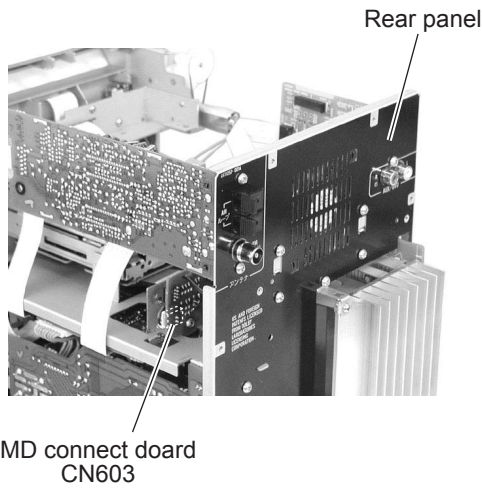
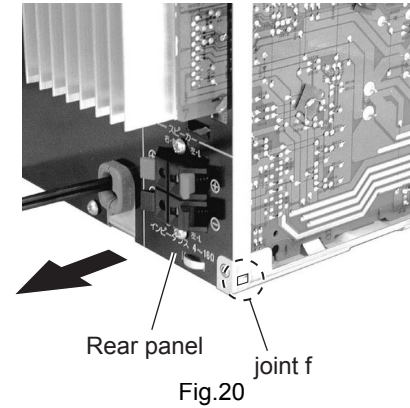
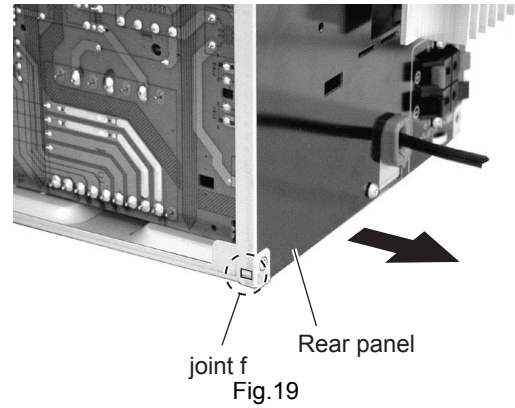

Fig.17

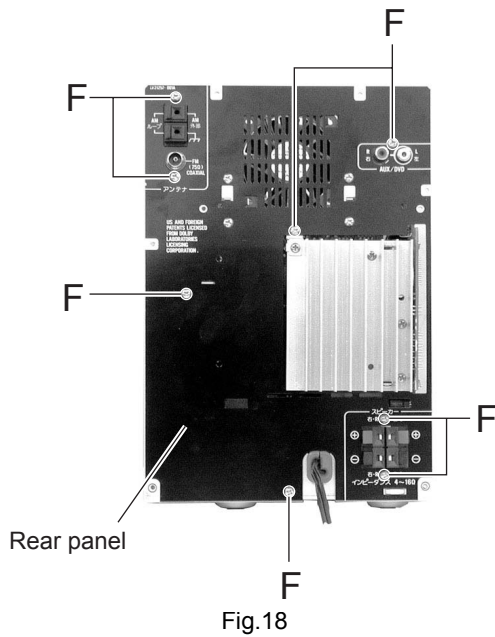

Fig.18

**2.1.8 Removing the MD mechanism assembly
(See Fig.21 and 22.)**

- Prior to this procedure, remove the metal cover, the CD mechanism assembly, and the rear cover.
 - (1) Remove the card wire from the connector CN601 on the MD connect board in the rear part of the MD mechanism assembly.
 - (2) Remove the four screws **H** on the front side and the rear side that attach the MD mechanism assembly. Remove the MD mechanism assembly upward.

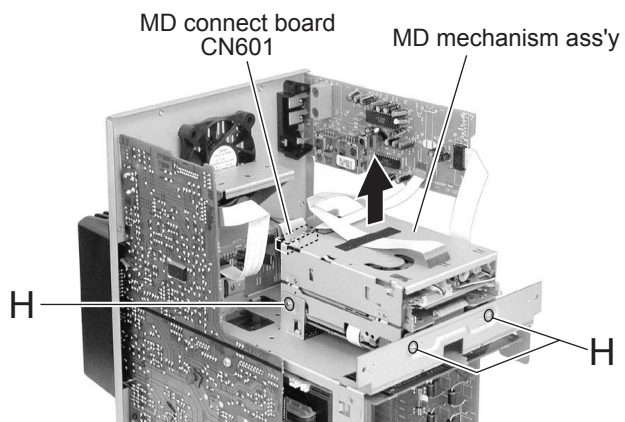

Fig.21

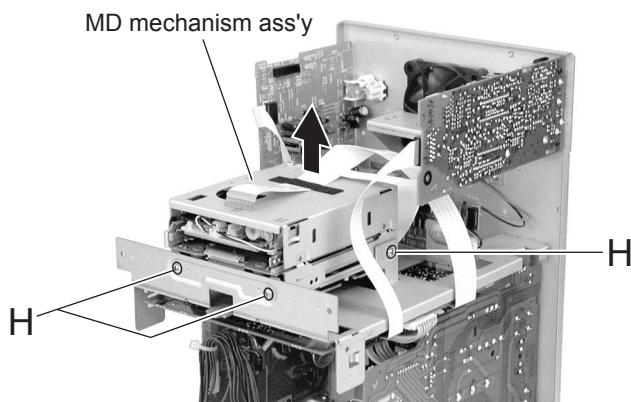

Fig.22

**2.1.9 Removing the headphone board
(See Fig.23 and 24.)**

- Prior to this procedure, remove the metal cover, the CD mechanism assembly, and the rear cover.
 - (1) Remove the wire from the connector CN101 on the amp board on the left side of the main body.
 - (2) Remove the band that fixes the wire to the amp board. Remove the wire from the two clamps in the bottom chassis.
 - (3) Remove the screw **I** on the right side of the main body that attaches the headphone board.

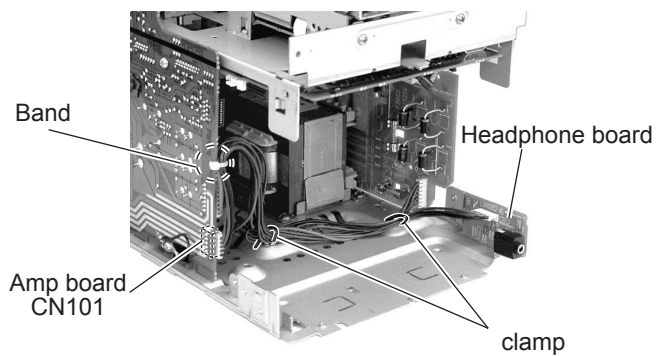

Fig.23

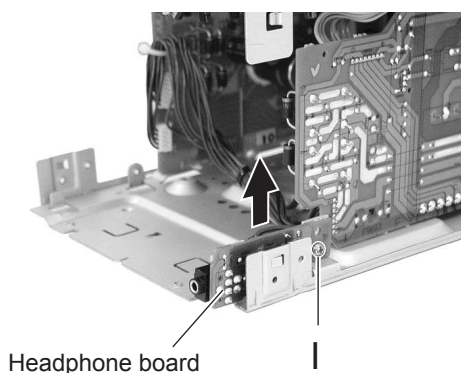

Fig.24

2.1.10 Removing the amp board and heat sink (See Fig.25 and 26.)

- Prior to this procedure, remove the metal cover, the CD mechanism assembly, the front panel assembly, and the rear cover.
 - (1) Remove the wire from the connector CN101 and CN102 on the amp board on the left side of the main body. Remove the band that fixes the wire. Remove the card wire from the connector CN303.
 - (2) Remove the two screws **J** that attach the amp board.
 - (3) Pull out and remove the connector CN304 and CN305 on the amp board outward. Remove the two joint "g" that fix the bottom chassis.

Notice

The heat sink will be kept attached to the amp board. The heat sink can be removed without removing the amp board.

- (4) Remove the three screws **K** that attach the heat sink.

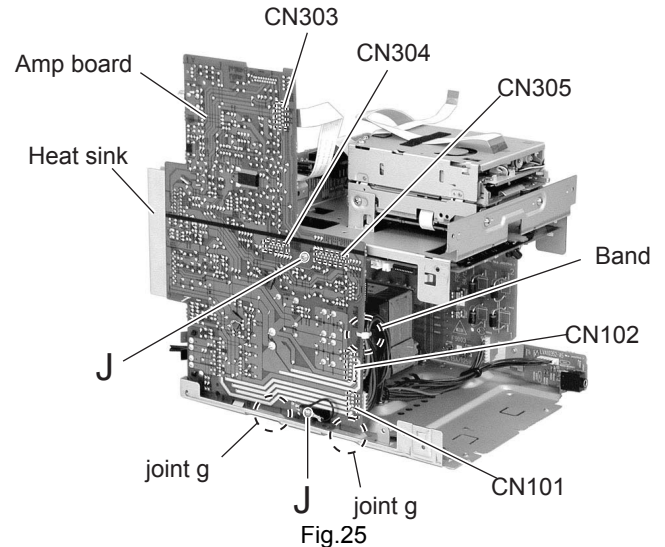

Fig.25

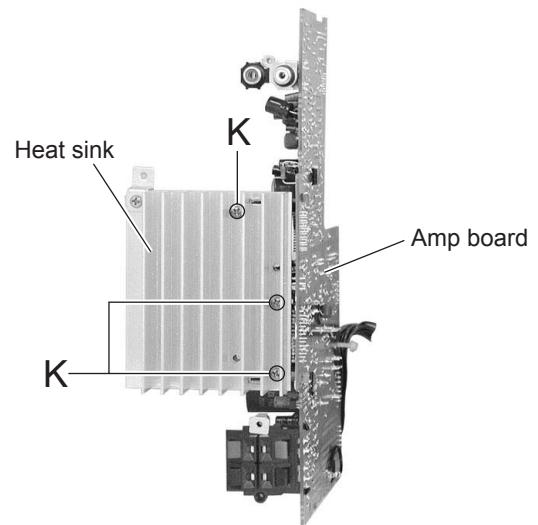

Fig.26

2.1.11 Removing the MD connect board (See Fig.27.)

- Prior to this procedure, remove the metal cover, the CD mechanism assembly, and the rear cover.
 - (1) Remove the card wire from the connector CN601 on the MD connect board.
 - (2) Remove the two screws **L** on the rear side of the main body that attach the MD connect board.
 - (3) Pull out the connector CN604 on the MD connect board in the rear direction.

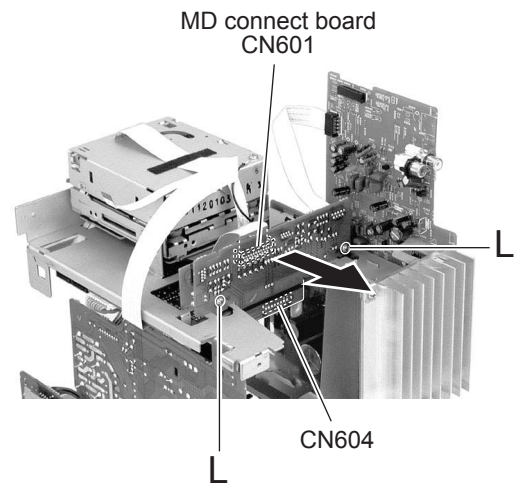

Fig.27

2.1.12 Removing the MD base chassis/the micon board
(See Fig.28 to 30.)

- Prior to this procedure, remove the metal cover, the CD mechanism assembly, the front panel assembly, the rear cover, the amp board, and the MD connect board.

Notice

The MD base chassis/the micon board can be removed without removing the MD mechanism assembly.

- (1) Remove the wire from the micon board connector CN707 in the center of the right side of the main body. Remove the card wire from the connector CN708.
- (2) Remove the screw **M** on top of the main body that attaches the MD base chassis.

Notice

The MD mechanism assembly will be kept attached to the MD base chassis.

- (3) Remove the two screws **N** that attach the micon board. Remove the two joint **"h"** that fix the MD base chassis.

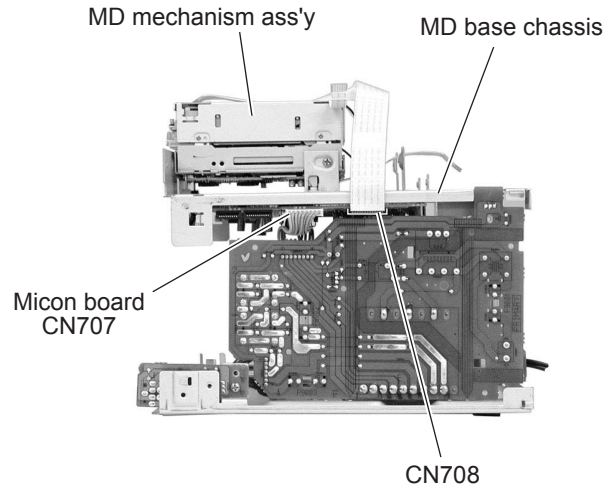

Fig.28

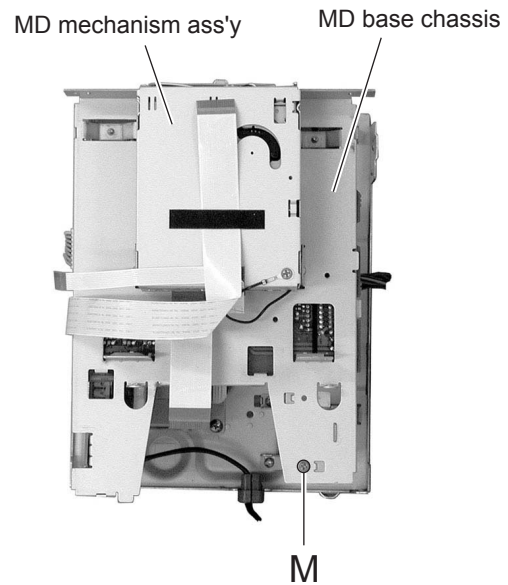

Fig.29

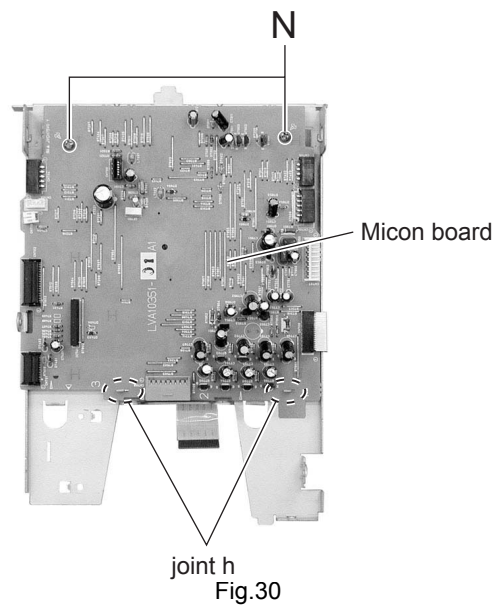

Fig.30

**2.1.13 Removing the power trans assembly
(See Fig.31 and 32.)**

- Prior to this procedure, remove the metal cover, the CD mechanism assembly, the front panel assembly, the rear cover, the amp board, and the MD base chassis.
- (1) Move the power cord stopper upward from the rear part of the main body to remove. Remove the power supply cord from the connector CN901 on the power trans board.

Notice

The power cord can be removed without removing the power trans assembly.

- (2) Remove the four screws **O** on top of the main body that attach the power trans assembly. Remove the wire from the two clamps on the bottom chassis.

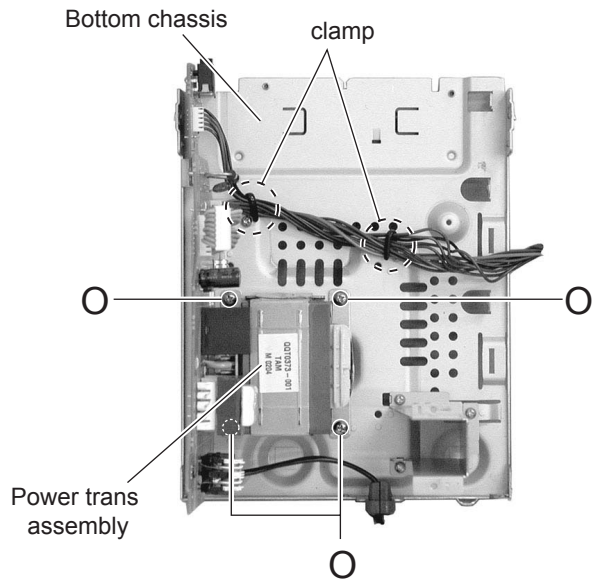
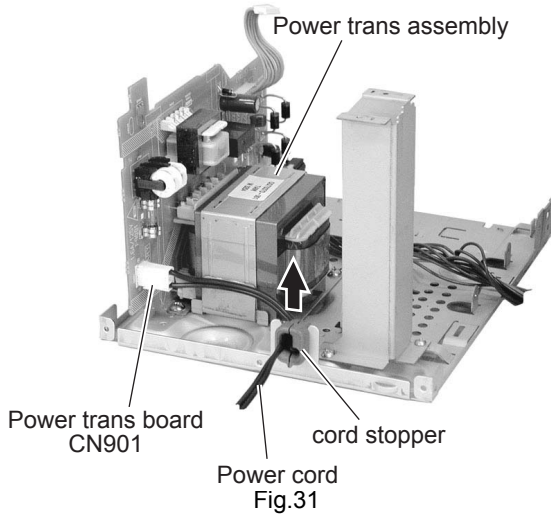

Fig.32

2.2 Front panel assembly

- Prior to this procedure, remove the metal cover, the CD mechanism assembly, and the front panel assembly.

**2.2.1 Removing the cassette mechanism assembly
(See Fig.33 and 34.)**

- (1) Remove the spring that is attached to the cassette door from inside the front panel.
- (2) Remove the four screws **P** that attach the cassette mechanism assembly.

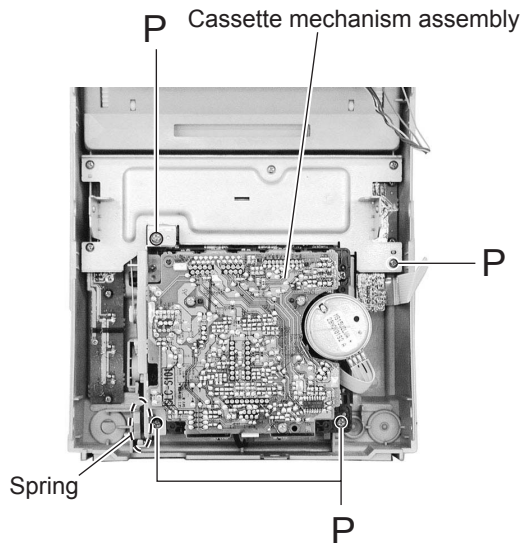
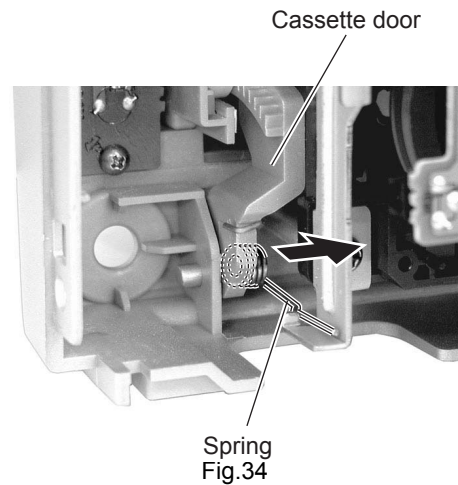

Fig.33



2.2.2 Removing the key board
(See Fig.35 to 37.)

- Prior to this procedure, remove the cassette mechanism assembly.
 - (1) Pull out the volume knob in the front side of the front panel to remove.
 - (2) Remove the five screws **Q** that attach the bracket (1) from inside the front panel.
 - (3) Remove the ten screws **R** that attach the key board.

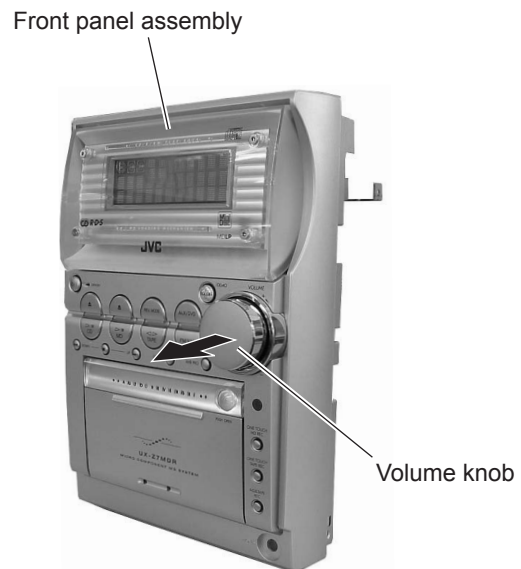
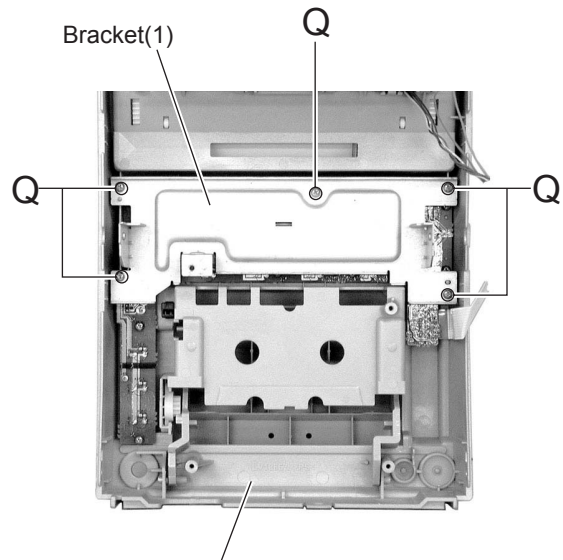

Fig.35



Front panel
 Fig.36

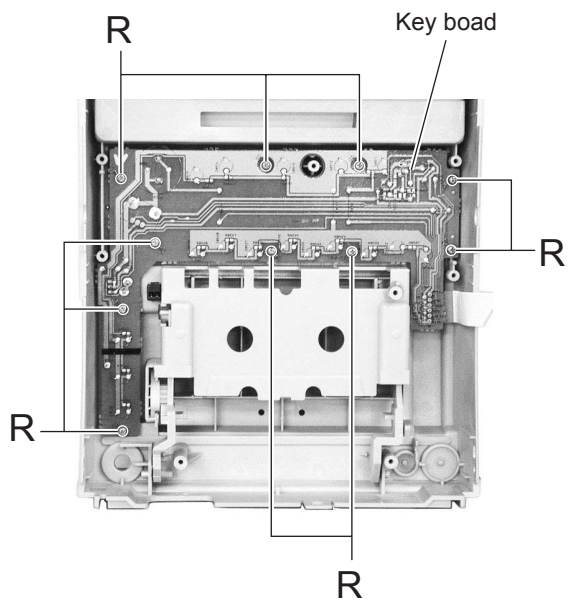

Fig.37

**2.2.3 Removing the FM connection board
(See Fig.38 to 40.)**

- (1) Remove the three screws **S** and the screw **T** that attach the bracket (2) from inside the front panel.
- (2) Remove the card wire from the connector CN451 on the FL connection board.
- (3) Press the tab in the front panel and the one in joint "i" downward to remove. Pull out the FL connection board to remove.

**2.2.4 Removing the drive motor assembly
(See Fig.38, 39, and 41.)**

- (1) Remove the three screws **S** and the screw **T** that attach the bracket (2) from inside the front panel.
- (2) Remove the screw **U** that attaches the drive motor assembly. Remove the tab in joint "j" that fixes the front panel. Pull out the drive motor assembly to remove.

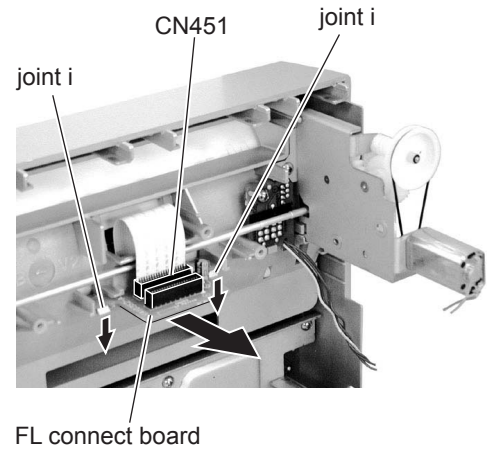

Fig.40

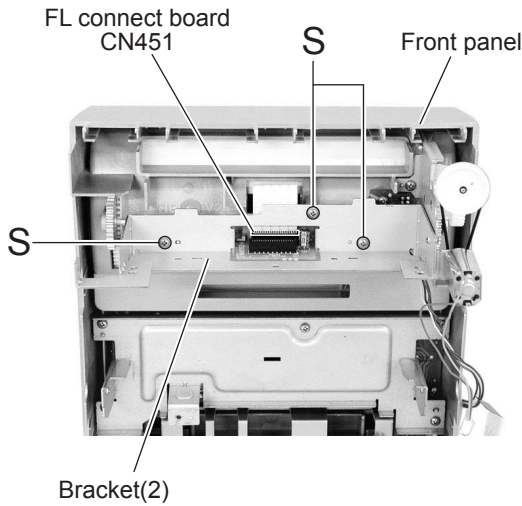

Fig.38

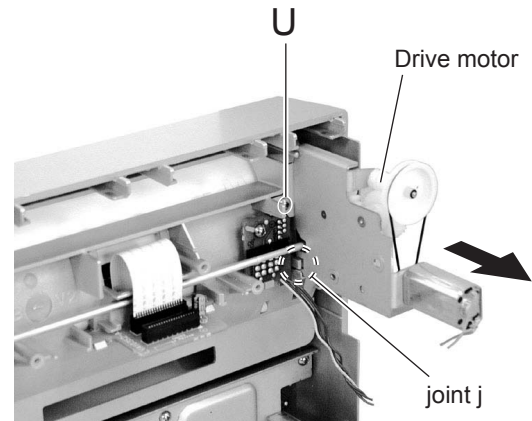

Fig.41

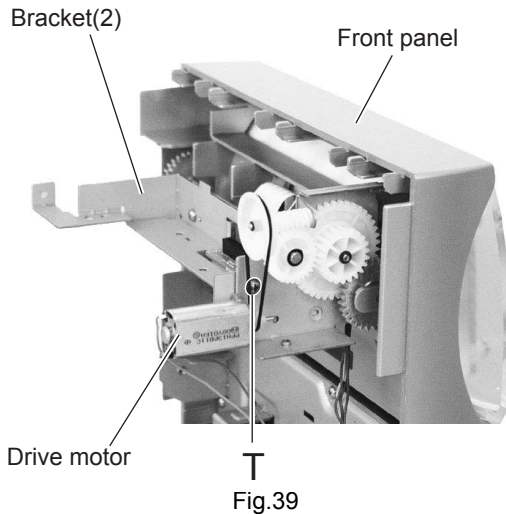

Fig.39

**2.2.5 Removing the belt/drive motor
(See Fig.42.)**

- Prior to this procedure, remove the drive motor assembly.
 - (1) Remove the belt from the pulley.
 - (2) Remove the two screws **V** that attach the drive motor.

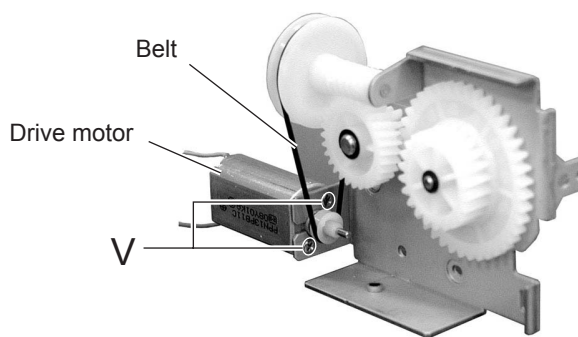

Fig.42

**2.2.6 Removing the switch board
(See Fig.43 and 44.)**

- Prior to this procedure, remove the bracket (2) / the drive motor assembly.
 - (1) Remove the card wire from the connector CN451 on FL connection board.
 - (2) Remove the joint "k" by releasing it outward. And then, remove the joint "l" in the same way.
 - (3) Remove the screw **W** that attaches the switch board. Remove the tab on the joint "m" that fixes the front panel.

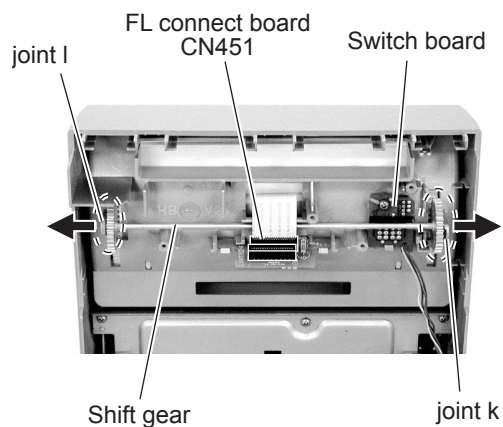

Fig.43

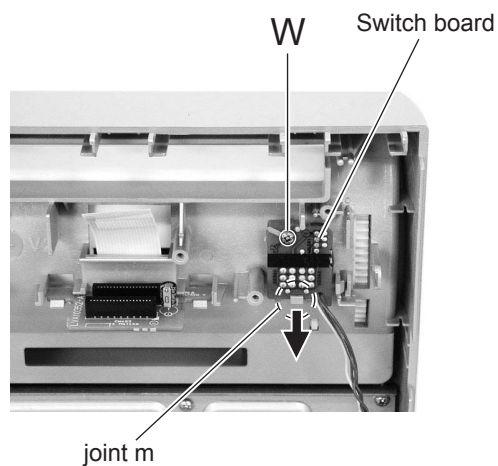

Fig.44

2.2.7 Removing the FL display
(See Fig.45 to 50.)

- (1) Remove the four screws **X** on the front side of the front panel that attach the case cover.
- (2) Pull out the FL panel from the bosses of the four joint "n" on the FL display cover.
- (3) Remove the four screws **Y** that attach the FL display cover. Remove the card wire from the connector CN671 and CN672 on the FL connect board inside the FL display cover.

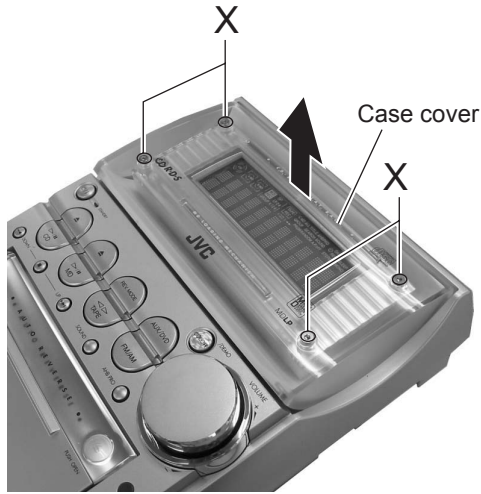

Fig.45

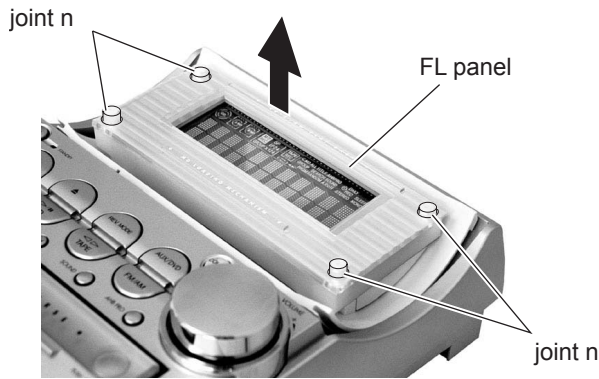

Fig.46

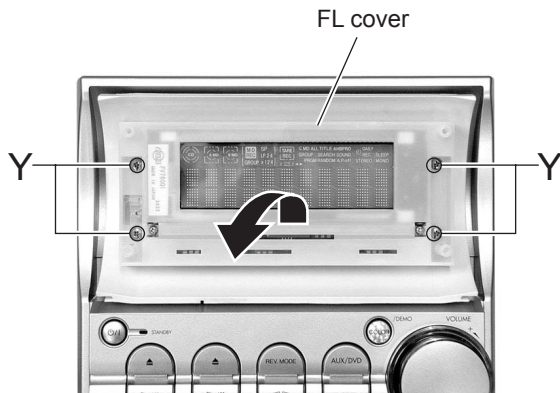

Fig.47

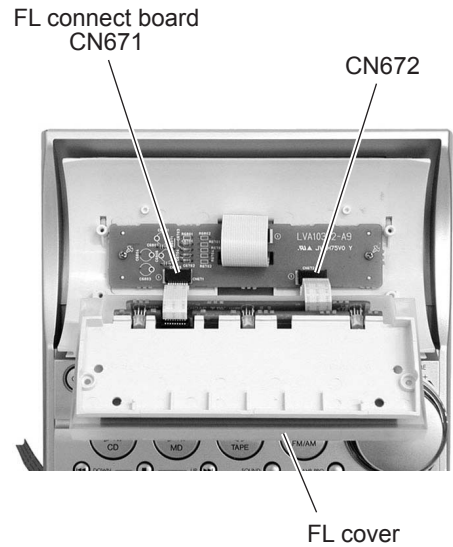

Fig.48

- (4) Remove the two screws **Z** on the front side of the FL display cover that attach the FL display.
- (5) FL board and lens will be detached from the FL display.

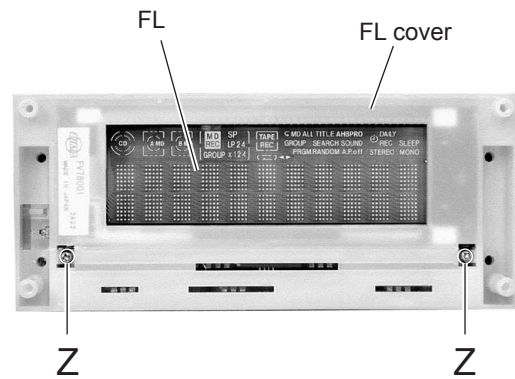

Fig.49

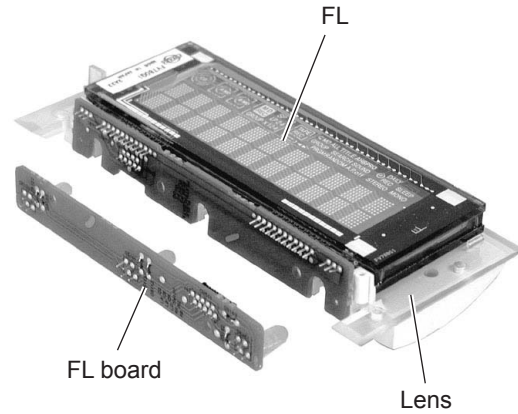

Fig.50

2.2.8 Removing the FL connect board

(See Fig.51.)

- Prior to this procedure, remove the FL display cover.
 - (1) Remove the card wire from the connector CN673 on the FL connect board.
 - (2) Remove the two screws **Z'** that attach the FL connect board.

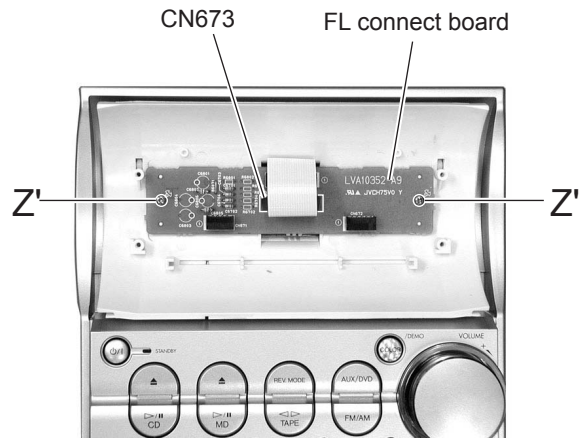

Fig.51

2.3 CD Mechanism Assembly

2.3.1 Removing the CL. Base Assembly and Tray (Refer to Figs. 1 to 5.)

- (1) Remove the two screws **A** fastening the CL. base assembly from the top of the CD mechanism assembly.
- (2) Move the CL. base assembly diagonally upwards as indicated by the arrow to release it from the two hooks **a**.
- (3) Turn the idle gear in the arrow-marked direction from the upper side of the CD mechanism assembly. Accordingly, the TRAMECHA assembly moves downwards.

Note:

When drawing out the tray, shift down the TRAMECHA assembly to the position where the tray does not contact the T-T assembly of the TRAMECHA assembly.

- (4) Draw out the tray frontwards for removing it.

Note:

When reinstalling the tray:

- Turn the idle gear so that the part **b** of the tray gear is positioned in the part **c** shown in Fig. 4. (Eject position)
- Engage the right and left hooks **d** and **e** of the tray with the right and left grooves of the TRAMECHA assembly respectively for retaining the tray.

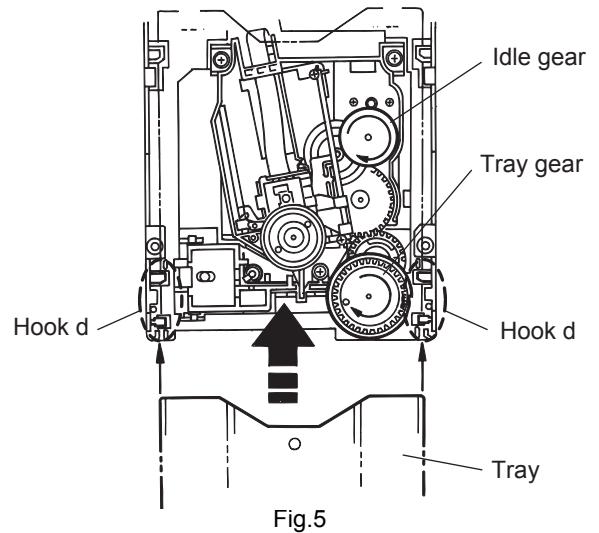
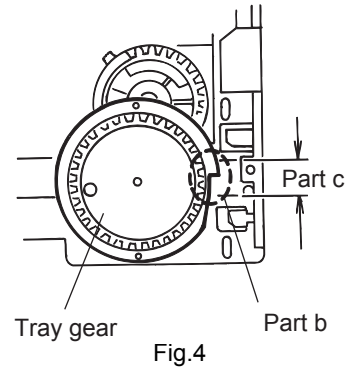
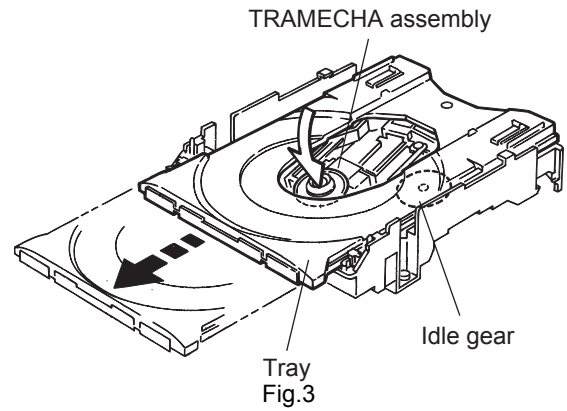
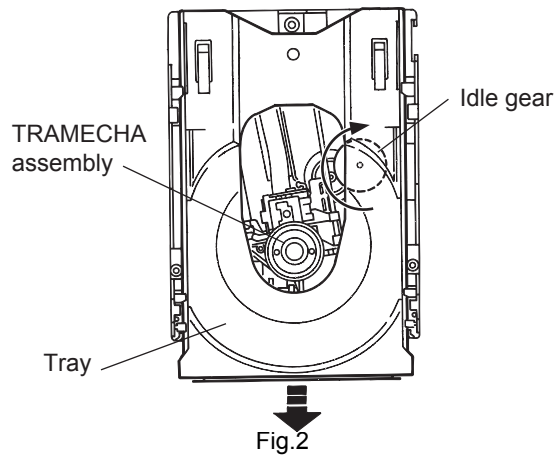
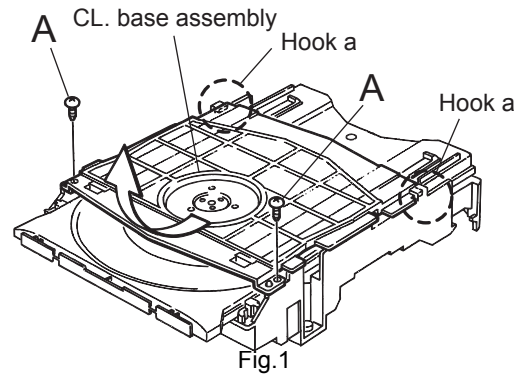

2.3.2 Removing the TRAMECHA Assembly (Refer to Figs. 6 to 9.)

- Remove the CL. base assembly and tray.

Reference:

The TRAMECHA assembly can be removed without removal of the mechanism P.C. board.

- If the TRAMECHA assembly is lowered and it is located out of the PLAY position, turn the idle gear in the arrow-marked direction so that the hole in the part f of the tray gear meets the hole on the CL. base assembly. (Set the TRAMECHA assembly at the PLAY position.)
- Remove the three screws **B** fastening the TRAMECHA assembly and then remove the TRAMECHA assembly upwards from the front side.
- At the same time, remove the spring from the groove of the CH. base assembly in the part **g** of the TRAMECHA assembly.

Note:

When reinstalling the TRAMECHA assembly:

- Check to see if the spring is properly engaged with groove of the CH. base assembly in the part **g** of the TRAMECHA assembly.
- After making sure that the three insulators of the TRAMECHA assembly are properly set on the bosses of the L. base assembly's guide, fasten them with the screws.

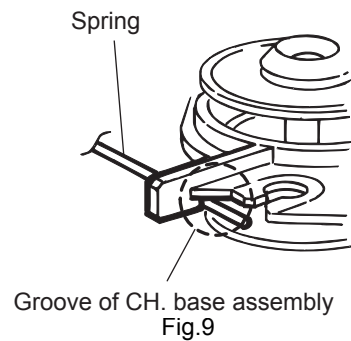
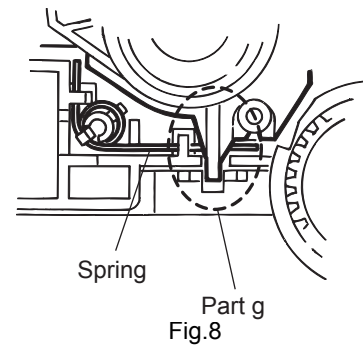
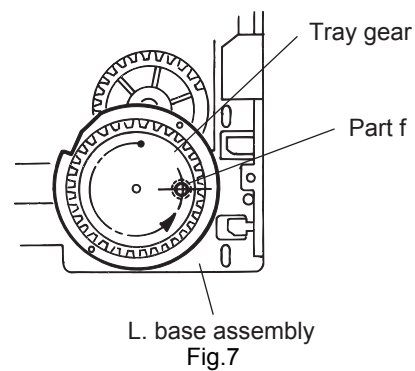
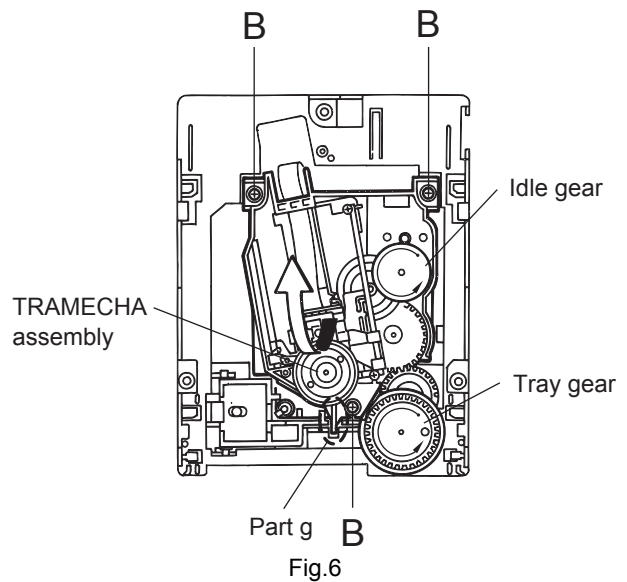

2.3.3 Removing the Mechanism P.C. Board (Refer to Fig 10.)

Reference:

The mechanism P.C. board can be removed without removal of the TRAMECHA assembly.

Note:

Before disconnecting the flexible wire coming from the pickup from the connector, be sure to solder its shorting round.

If the flexible wire is connected without soldering, it may cause breakdown of the pickup.

- (1) Solder the shorting round of the flexible wire connected with the mechanism P.C. board from the back of the mechanism assembly.
- (2) Disconnect the flexible wire from the connector CN601 on the mechanism P.C. board.
- (3) Remove the three screws **C** fastening the mechanism P.C. board.
- (4) Unsolder the two points of the part **h** and one point of the part **i** of the mechanism P.C. board. Then, remove the mechanism P.C. board upwards.

Note:

When reinstalling the mechanism P.C. board, connect the flexible wire coming from the pickup to the connector first and then remove the solder from the shorting round of the flexible cable.

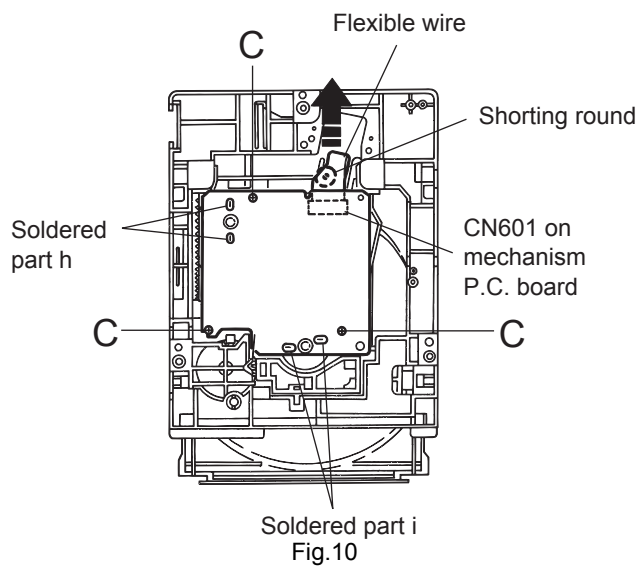

2.3.4 Removing the Pickup(Refer to Figs. 11 to 14.)

- Remove the CL. base assembly and tray.
- Remove the TRAMECHA assembly.

Reference:

The pickup can be removed without removal of the mechanism P.C. board.

Note:

Before disconnecting the flexible wire coming from the pickup from the connector, be sure to solder its shorting round.

If the flexible wire is connected without soldering, it may cause breakdown of the pickup.

- (1) Solder the shorting round of the flexible wire connected with the mechanism P.C. board from the back of the TRAMECHA assembly.
- (2) Disconnect the flexible wire from the connector CN601 on the mechanism P.C. board.
- (3) Turn the idle gear in the arrow-marked direction from the top of the TRAMECHA assembly so that the pickup assembly is shifted to the reverse side of the T-T assembly. Move the pickup assembly until the part j of the rack plate in the lower part of the pickup assembly comes out of the CH. base assembly.
- (4) Remove the two screws **D** retaining the shaft of the pickup assembly. Next, disengage the hook **k** from the CH. base assembly and then remove the pickup assembly together with the shaft.
- (5) Pull the shaft out of the pickup.
- (6) Remove the two screws **E** fastening the rack plate from the pickup.
- (7) Remove the screw **F** retaining the P.S. spring from the pickup.

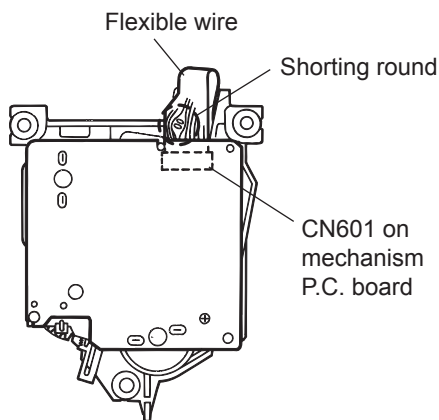

Fig.11

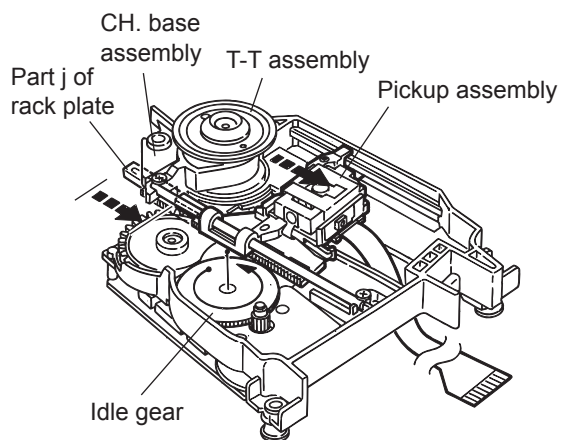

Fig.12

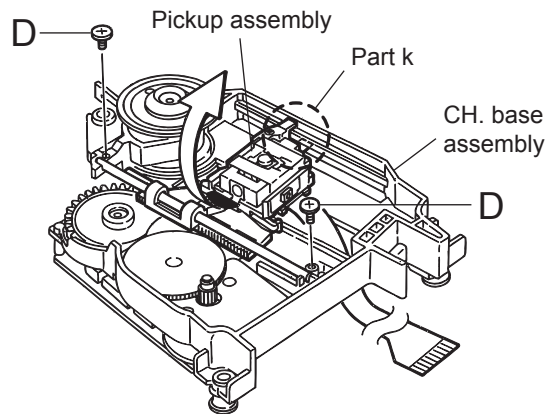

Fig.13

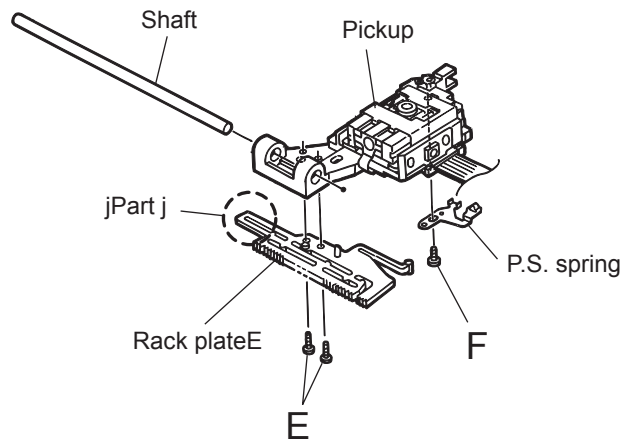

Fig.14

2.3.5 Reinstalling the Pickup Assembly (Refer to Figs. 15 and 16.)

Reference:

Refer to the explanation of "Removing the Pickup" on the preceding page.

- (1) Fit the P.S. spring and rack plate to the pickup.
- (2) Insert the shaft into the pickup.
- (3) Engage the hook **k** of the pickup assembly with the CH. base assembly first, and set the part **j** of the rack plate in the opening **l** next. Then, reinstall the pickup assembly while shifting it to the T-T side (inward) so that the part **m** of the rack plate is positioned as shown in Fig. 16.
- (4) Move the pickup assembly to the center position and fasten the shaft with the two screws **D**. (Make sure that the part **n** of the rack plate is correctly engaged with the middle gear.)
- (5) After passing the flexible wire coming from the pickup through the opening of the CH. base assembly, connect it to the connector CN601.

Note:

When reinstalling the pickup assembly, remove the solder from the shorting round after connecting the flexible wire coming from the pick to the connector CN601.

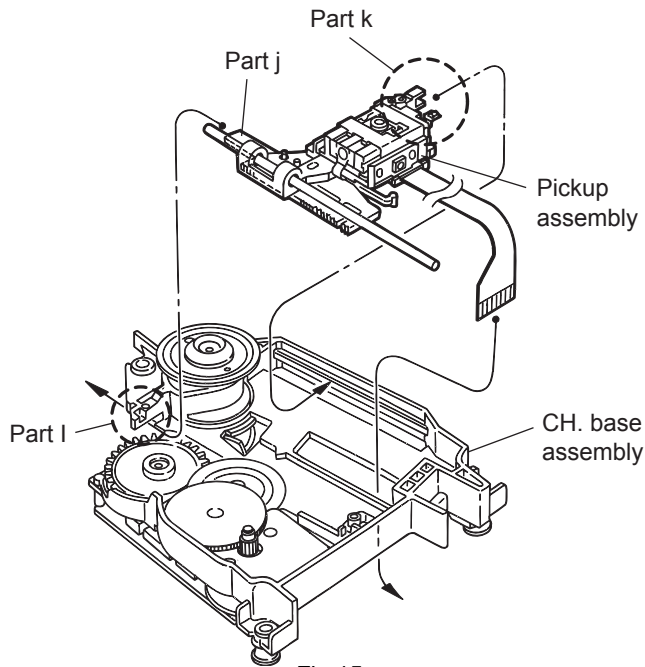

Fig.15

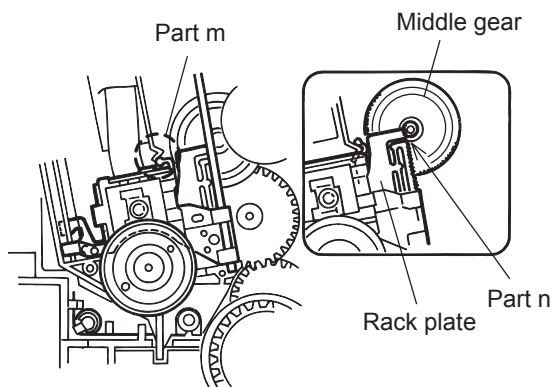

Fig.16

2.3.6 Removing the Feed Motor Assembly (Refer to Fig. 17.)

- Remove the CL. base assembly and tray.
 - Remove the mechanism P.C. board.
- Remove the two screws **E** fastening the feed motor assembly from the top of the mechanism assembly.

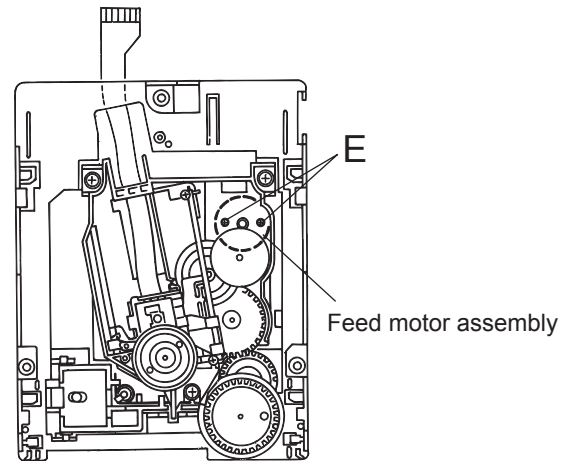
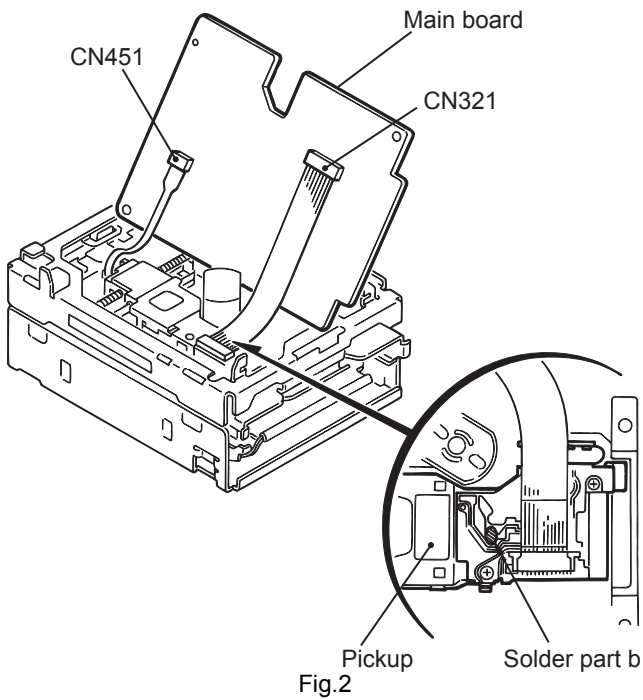
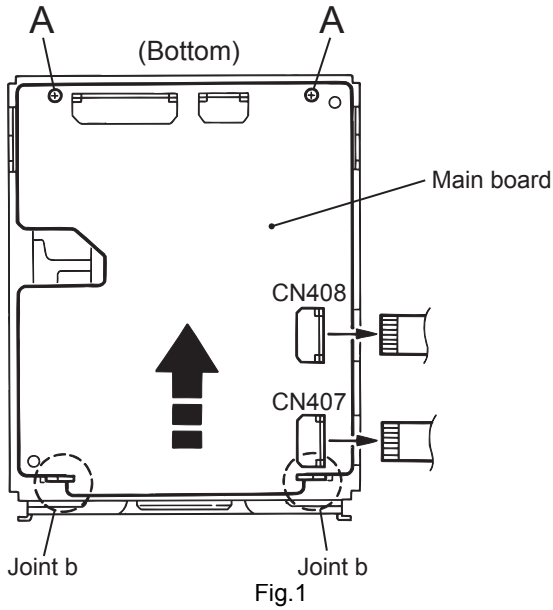

Fig.17

2.4 MD mechanism assembly

2.4.1 Removing the main board (See Fig.1 and 2)

- (1) Turn over the body and disconnect the card wire from connector CN408 and the flexible wire from CN407 on the main board.
- (2) Remove the two screws **A** attaching the main board. Slide the main board in the direction of the arrow to release the two joints a with the single frame.
- (3) Solder part **b** on the pickup in the body. Disconnect the flexible harness from connector CN321 and CN451 on the underside of the main board. Then remove the main board.



2.4.2 Removing the mechanism cover (See Fig.3)

- (1) Remove the four screws **B** on both sides of the body.
- (2) Move the mechanism cover toward the front to disengage the front hook of the mechanism cover from the internal loading assembly (Joint c). Then remove the mechanism cover upward.

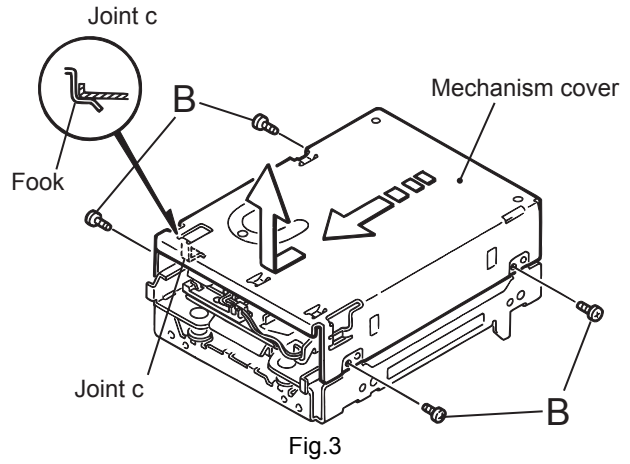

2.4.3 Removing the head lifter (See Fig.4 to 6)

- (1) Move the head lifter on top of the body in the direction of the arrow and turn around.
- (2) Detach the spring from the hook of the body. Remove the head lifter with the spring.
- (3) If necessary, remove the spring from the head lifter.

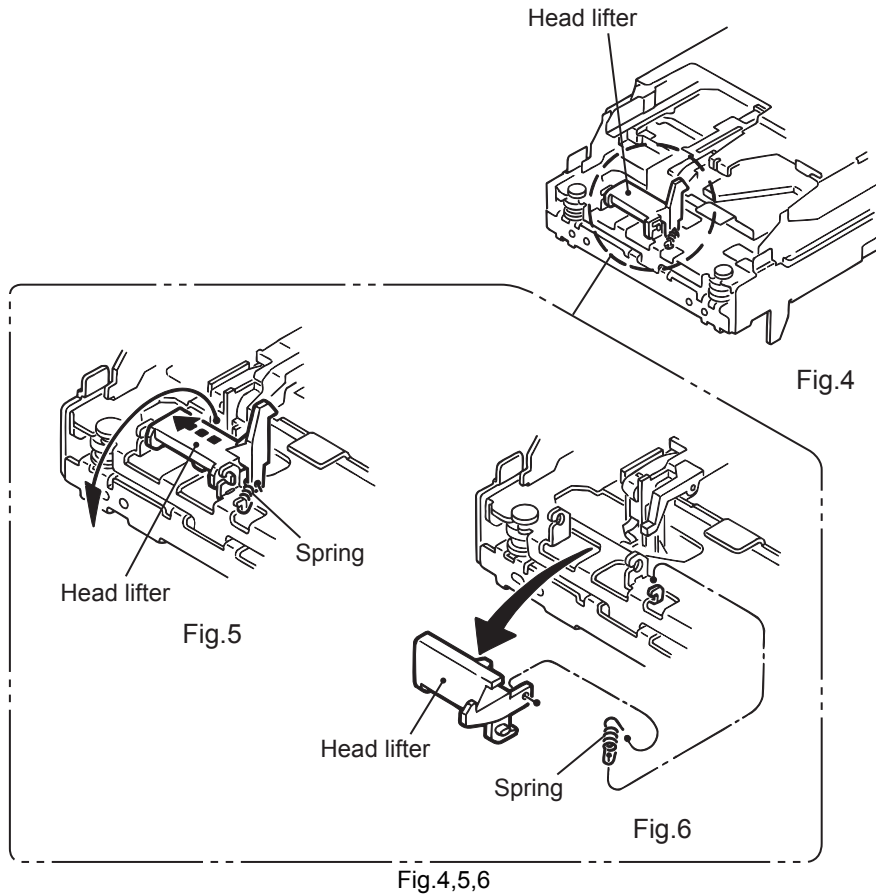

2.4.4 Removing the head assembly (See Fig.7)

- (1) Remove the screw **C** on the upper side of the body.
Remove the head assembly while pulling the flexible harness from the body.

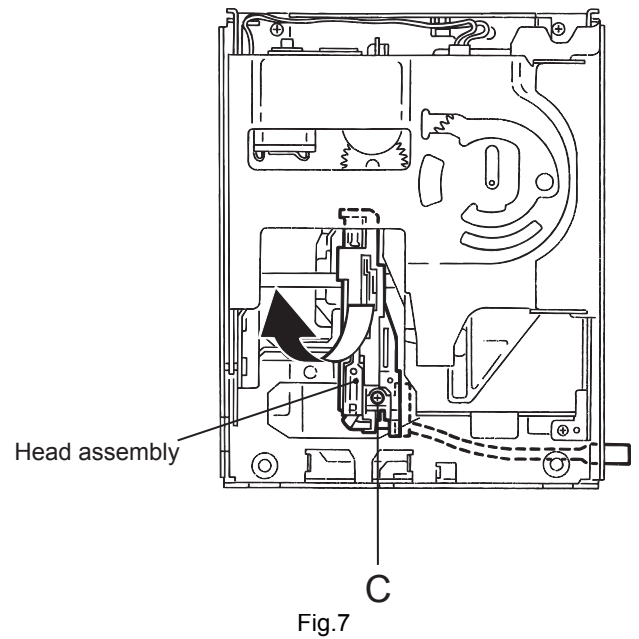

2.4.5 Removing the Loading assembly (See Fig.8 and 9)

Ref:

The loading assembly, the traverse mechanism assembly and the single flame will be removable after removing the loading assembly from the body.

- Prior to performing the following procedure, remove the main board, the mechanism cover, the head lifter and the head assembly.
 - (1) Remove the three screws **D** on the upper side of the body.
 - (2) Move the loading assembly forward to disengage it from the traverse mechanism assembly (Joint **d**). Then remove it upward.
 - (3) Remove the traverse mechanism assembly from the single flame.

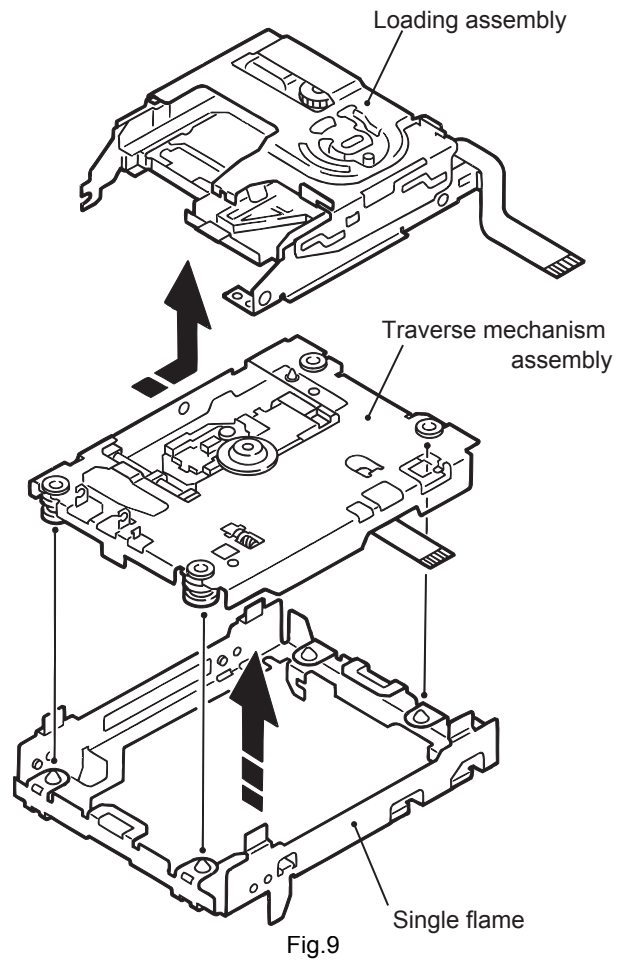
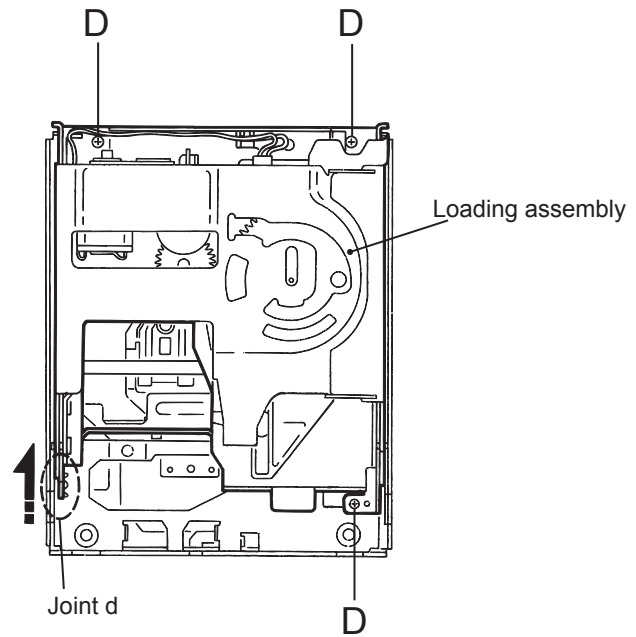

2.4.6 Loading assembly

2.4.6.1 Removing the slide base (L) / (R) (See Fig.10)

- (1) Remove the two screws **E** on the upper side of the loading assembly.
- (2) Remove the slide base (**L**) outward. (Release it from the joint bosses **E**.)
- (3) Remove the slide base (**R**) outward.

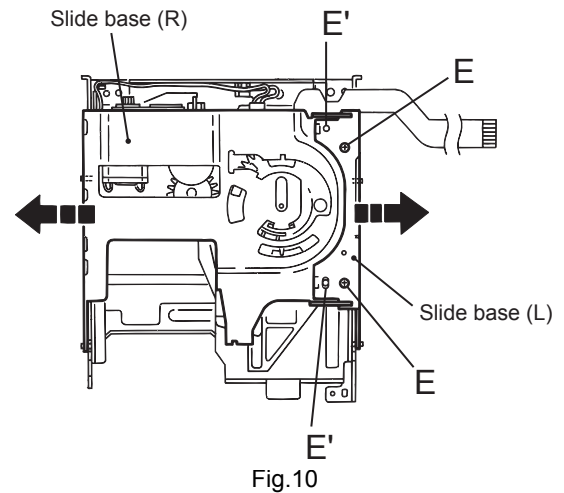

Fig.10

2.4.6.2 Removing the loading mechanism assembly (See Fig.11)

- (1) Detach the loading mechanism assembly upward to release the four pins on both sides from the loading motor, paying attention to the part e of the loading mechanism base.

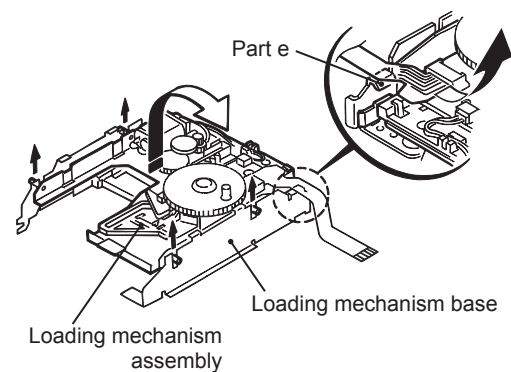

Fig.11

2.4.7 Loading mechanism assembly

2.4.7.1 Removing the loading motor (See Fig.12 and 13)

- (1) Disconnect the harnesses from the wire holder and from connector CN612 on the cam switch board.
- (2) Remove the screw **F** attaching the loading motor and release the joint f.
- (3) Remove the belt from the loading motor assembly.
- (4) Remove the two screws **G** attaching the loading motor.

2.4.7.2 Removing the cam gear and the cam switch board (See Fig.12)

- (1) Remove the slit washer attaching the cam gear and pull out the cam gear.
- (2) Disconnect the harness from the wire holder and from connector CN612 on the cam switch board.
- (3) Remove the two screws **H** and the clamp. Remove the cam switch board.

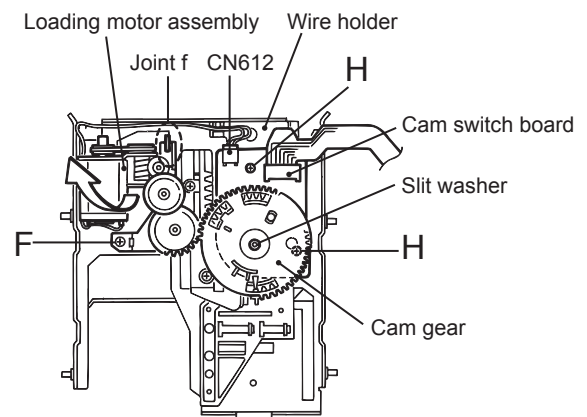

Fig.12

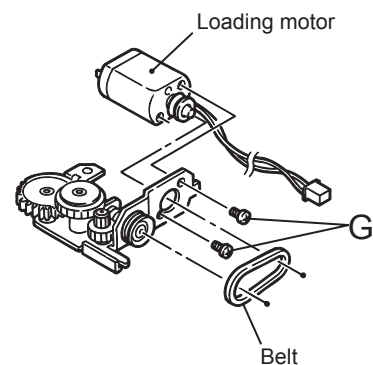

Fig.13

**2.4.7.3 Removing the cartridge holder assembly
(See Fig.14 and 15)**

(1) Remove the two screws I on the upper side of the loading assembly.

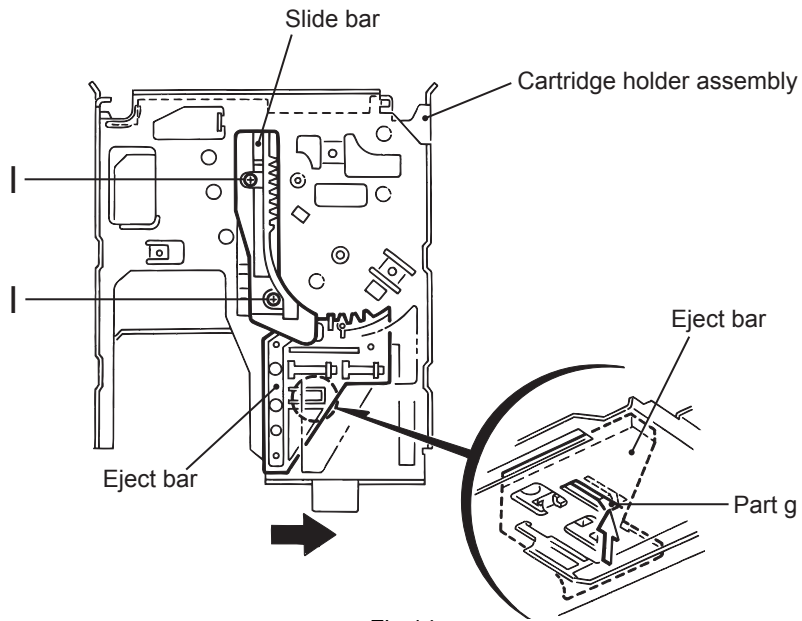

Fig.14

**2.4.7.4 Removing the slide bar and the eject bar
(See Fig.14 and 15)**

• Prior to performing the following procedure, remove the cartridge holder assembly.

- (1) Remove the slide bar upward.
- (2) Move the eject bar outward until it stops as shown in Fig.14. Push the convex part g on the bottom of the body and remove the eject bar from the chassis.

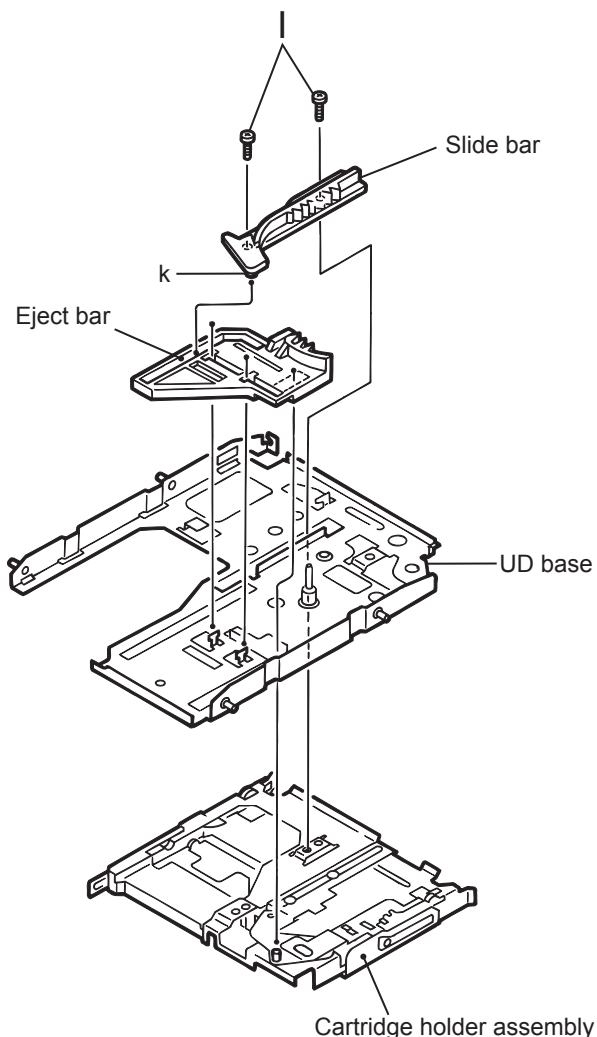
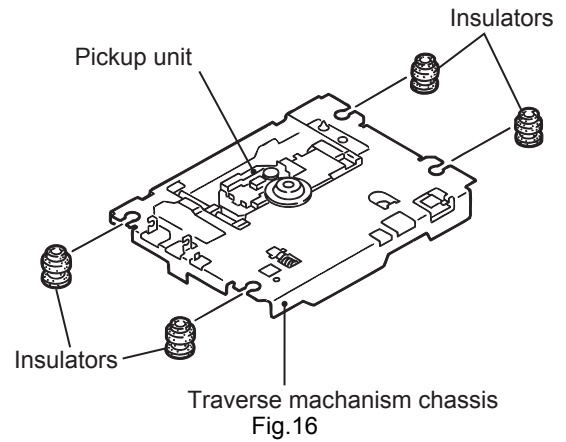

Fig.15

2.4.8 Traverse mechanism assembly

2.4.8.1 Removing the Insulators (See Fig.16)

- (1) Disengage the four insulators from the notches of the traverse mechanism chassis.



2.4.8.2 Removing the pickup unit (See Fig.17)

- (1) Turn over the traverse mechanism assembly and remove the screw **J** attaching the shaft holder (**F**).
- (2) Move the shaft inward and remove it from the shaft holder (**R**).
- (3) Detach the shaft side of the pickup unit upward and release the joint **h** with the pickup guide. Then remove the pickup unit with the shaft.

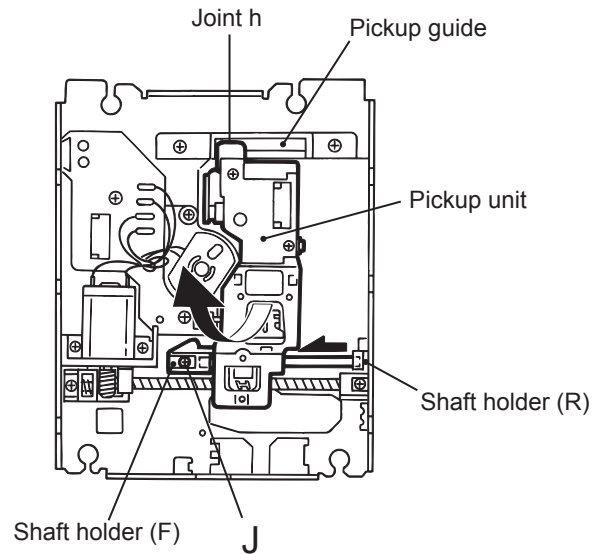

2.4.8.3 Removing the pickup (See Fig.18)

- (1) Draw out the shaft from the pickup.
- (2) Remove the two screws **K** attaching the rack spring.

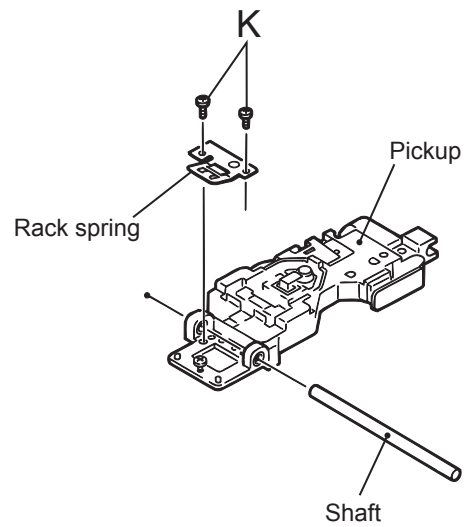

2.4.8.4 Removing the feed motor assembly (See Fig.15, 20)

- It is not necessary to remove the pickup unit.
 - (1) For the white and black harnesses extending from the feed motor assembly, unsolder the soldering **i** on the traverse mechanism board.
 - (2) Remove the two screws **L** attaching the feed motor assembly.
 - (3) Remove the two screws **N** attaching the feed motor bracket.

2.4.8.5 Removing the traverse mechanism board (See Fig.19)

- Prior to performing procedure, remove the feed motor assembly.
 - (1) For the red and black harnesses extending from the spindle motor, unsolder the soldering **j** on the traverse mechanism board.
 - (2) Remove the screw **M** attaching the traverse mechanism board.

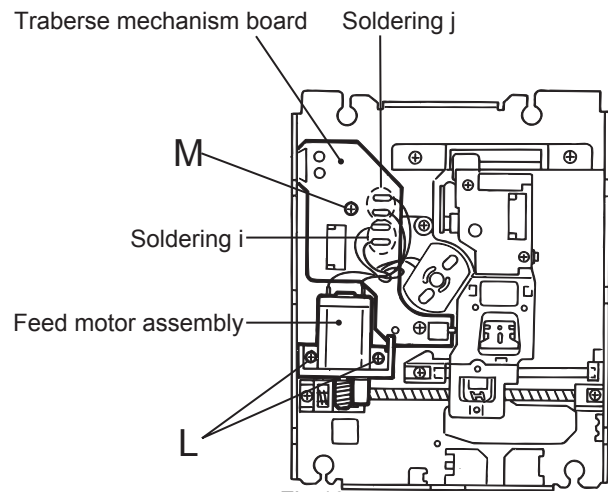

Fig.19

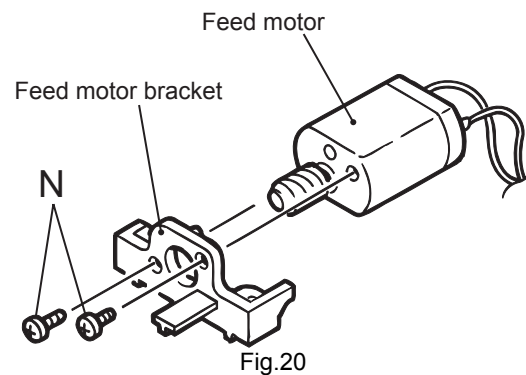

Fig.20

2.4.9 Reattaching the loading assembly

- (1) Reattach the eject bar to the UD base. (Fig.15 and 21)
- (2) Reattach the slide bar to the loading mechanism chassis while fitting the boss marked k to the eject bar slot. (Fig.21)
- (3) Slide the slide bar and the eject bar in the direction of the arrow in Fig.20 and reattach the cartridge holder assembly using the two screws I. (Fig.21 and 22)

ATTENTION:

Make sure the pin of the eject lever marked l is fitted to the slot of the eject bar marked m at the bottom of the loading mechanism chassis after moving the eject lever and the loading slider of the cartridge holder assembly in the direction of the arrow. (Refer to Fig.22)

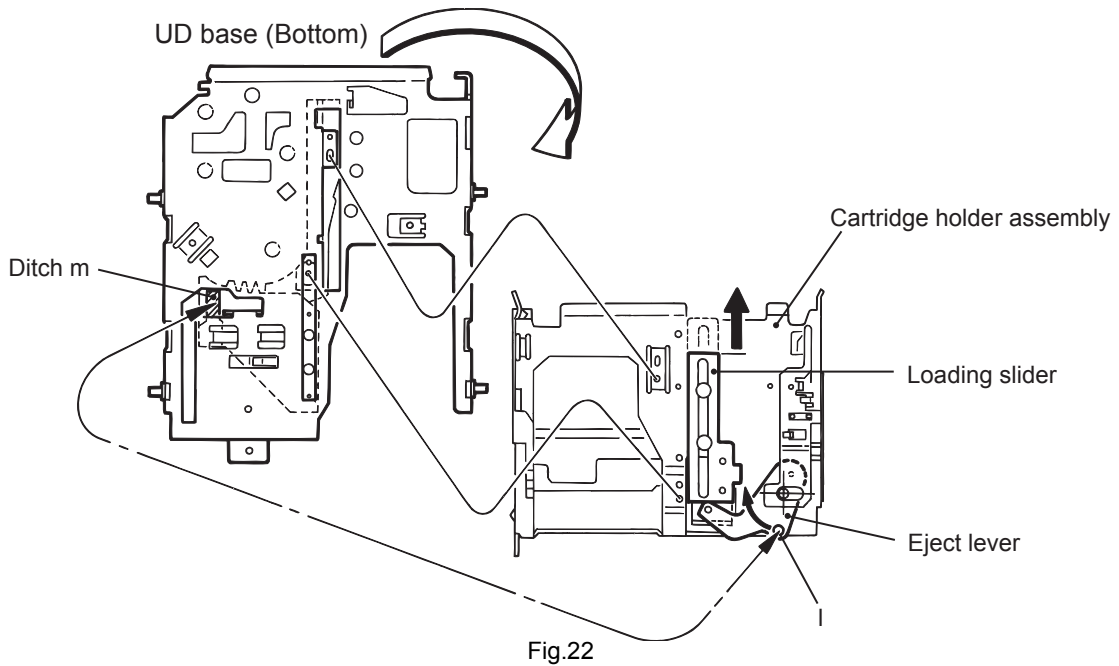
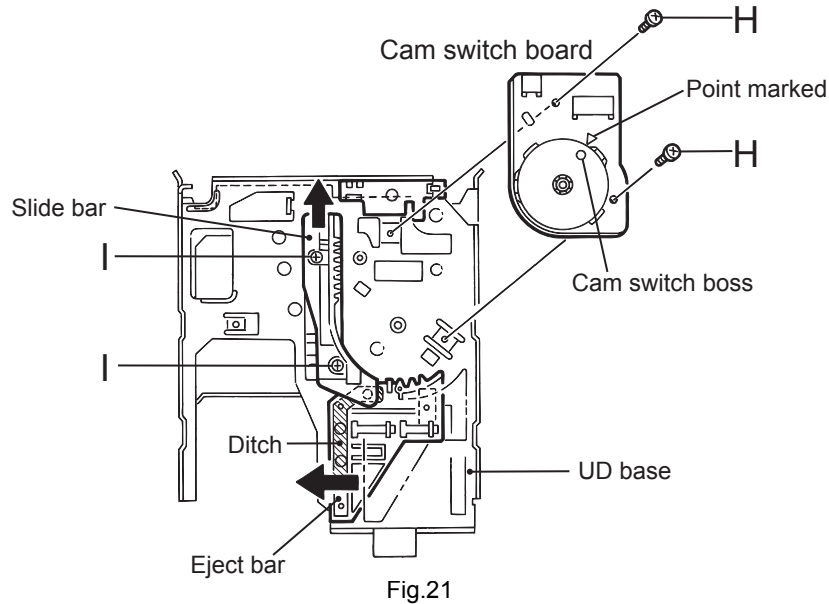

- (4) Reattach the wire holder to the UD base while engaging the UD base hook marked u to the wire holder slot marked t (At the same time, the boss on the reverse side of the wire holder is fitted to the UD base round hole).
- (5) Reattach the cam switch board using the two screws **H**. (Fig.23)
- (6) Turn the cam switch to bring the boss to the point marked ∇ on the cam switch board. Reattach the cam gear using a slit washer while fitting the cam gear slot to the cam switch boss. (Fig.23)

ATTENTION:

When reattaching the cam gear, the cam switch boss should be fitted to the cam gear slot, and the triangle mark of the cam gear should be aligned to the hole of the eject bar as shown in Fig.23.

- (7) Reattach the loading motor assembly, using the screw **F**. Connect the harness extending from the loading motor to connector CN612 on the switch board and fix it with the wire holder. (Fig.23)

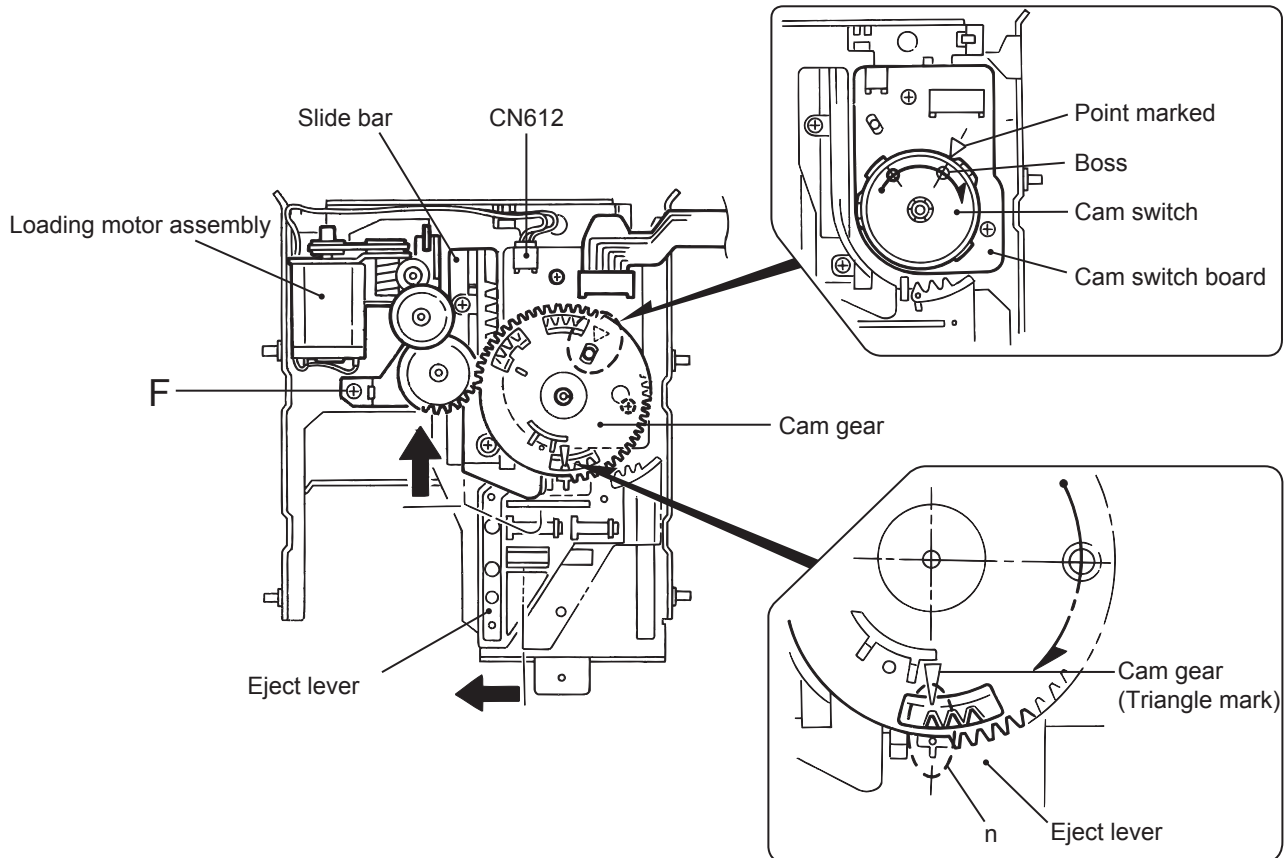

Fig.23

(8) Reattach the UD base while engaging the four pins on both sides of the UD base to the notches of the loading mechanism base and placing the edge (marked e') of the cartridge holder assembly under the hook e of the loading mechanism base. (Fig.24)

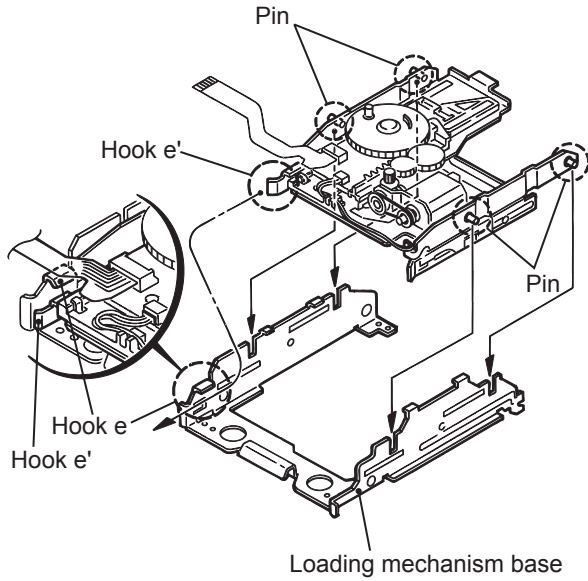

Fig.24

(9) Reattach the slide base (R) while fitting the two pins on another side of the UD base to the slots of the slide base (R). (Fig.25)

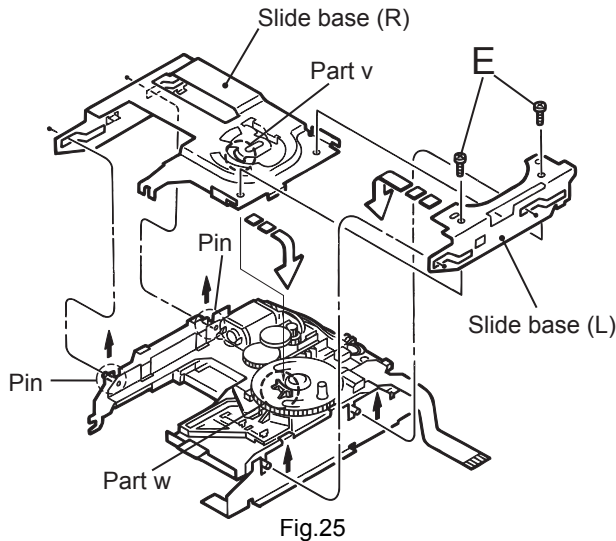

Fig.25

ATTENTION:

Fit the part v of the slide base (R) to the part w on the inward side of the cam gear rib. (Fig.26)

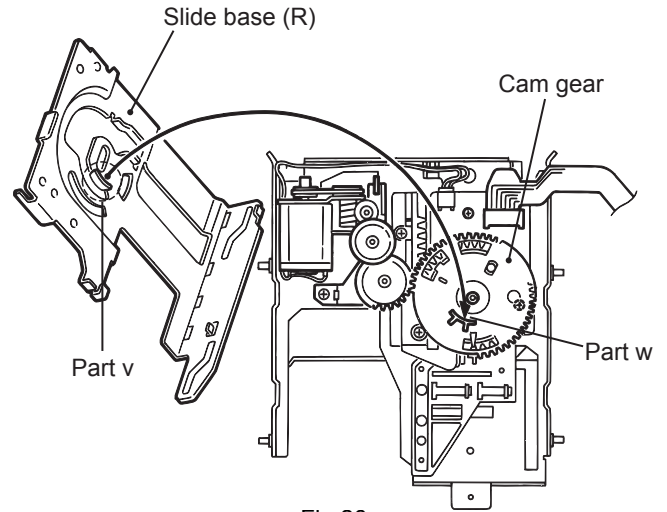

Fig.26

(10) Reattach the slide base (L) on the slide base (R) while fitting the two pins on another side of the UD base to the slots of the slide base (L) (Fig.26). Make sure the two slots of the slide base (L) are fitted to the two bosses marked E' and tighten the two screws E. (Fig.27)

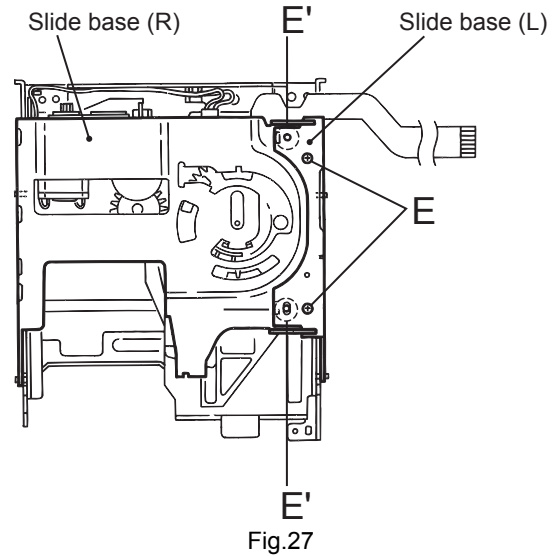

Fig.27

Ref:

To expedite the work, bring up the UD base slightly when fitting each pin to the appropriate notch.

2.5 Cassette mechanism section

2.5.1 Removing the playback / recording & eraser head (See Fig. 1 to 3)

- (1) While shifting the trigger arms seen on the right side of the head mount in the arrow direction, turn the flywheel **R** in counterclockwise direction until the head mount has gone out with a click (See Fig. 1).
- (2) When the flywheel **R** is rotated in counterclockwise direction, the playback / recording & eraser head will be turned in counterclockwise direction from the position in Fig. 2 to that in Fig. 3.
- (3) At this position, disconnect the flexible P.C. board (outgoing from the playback / recording & eraser head) from the connector CN31 on the head amplifier & mechanism control P.C. board.
- (4) Remove the flexible P.C. board from the chassis base.
- (5) Remove the spring 1 from behind the playback / recording & eraser head.
- (6) Loosen the reversing azimuth screw retaining the playback / recording & eraser head.
- (7) Take out the playback / recording & eraser head from the front of the head mount.
- (8) The playback / recording & eraser head should also be removed similarly according to steps 1 to 7 above.

2.5.2 Reassembling the playback / recording & eraser head (See Fig.3)

- (1) Reassemble the playback head from the front of the head mount to the position as shown in Fig. 3.
- (2) Fix the reversing azimuth screw.
- (3) Set the spring 1 from behind the playback / recording & eraser head. Attach the flexible P.C. board to the chassis base, as shown in Fig. 3.
- (4) Attach the flexible P.C. board to the chassis base, as shown in Fig. 3.
- (5) The playback / recording & eraser head should also be re-assembled similarly to step 1 to 4 above.

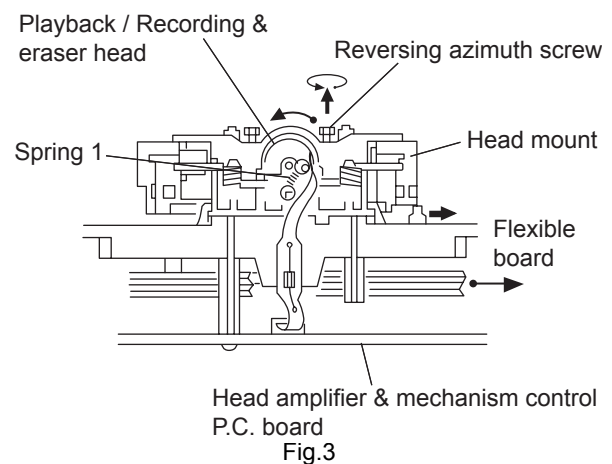
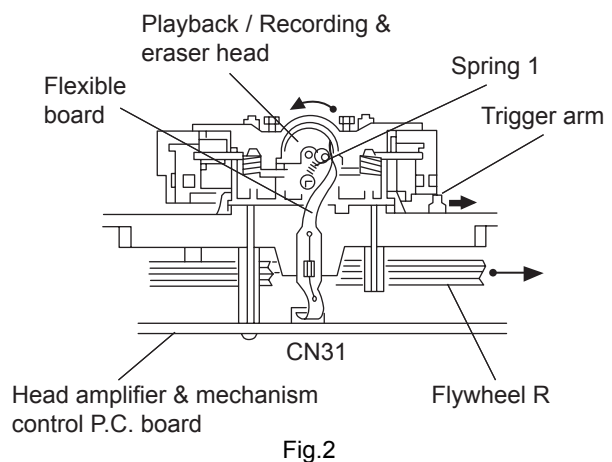
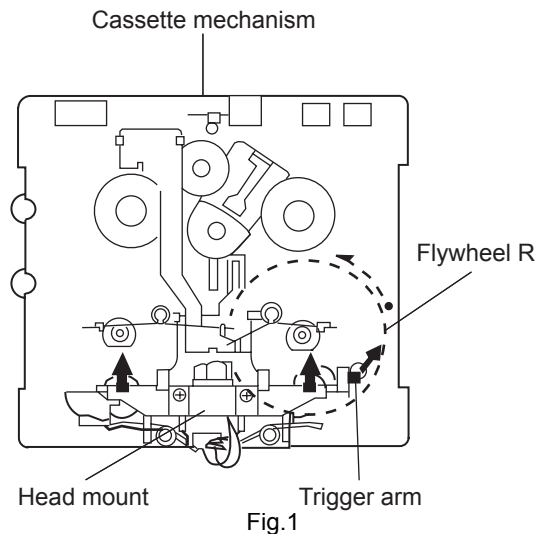

2.5.3 Removing the head amplifier & mechanism control board

(See Fig. 4)

- (1) Remove the cassette mechanism assembly.
- (2) After turning over the cassette mechanism assembly, remove the three screws **A** retaining the head amplifier & mechanism control board.
- (3) Disconnect the connector CN32 on the board including the connector CN 1 on the reel pulse P.C. board.
- (4) When necessary, remove the 4 pin parallel wire soldered to the main motor.

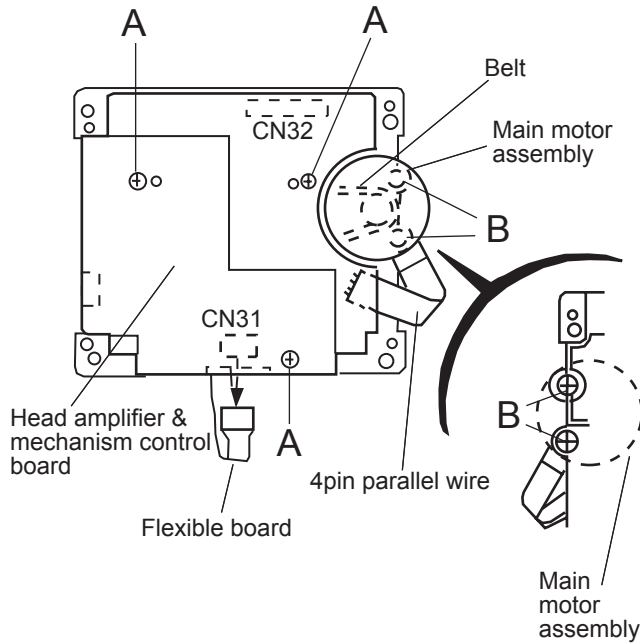

2.5.4 Removing the main motor assembly

- (1) Remove the two screws **B** retaining the main motor assembly (See Fig. 4 and 5).
- (2) While raising the main motor, remove the capstan belt from the motor pulley (See Fig. 5).

CAUTION:

Be sure to handle the capstan belt so carefully that this belt will not be stained by grease and other foreign matter. Moreover, this belt should be hanged while referring to the capstan belt hanging method in Fig. 5 and 6.

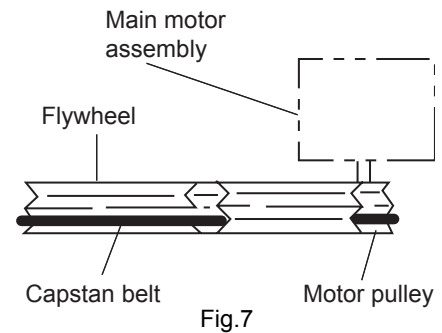
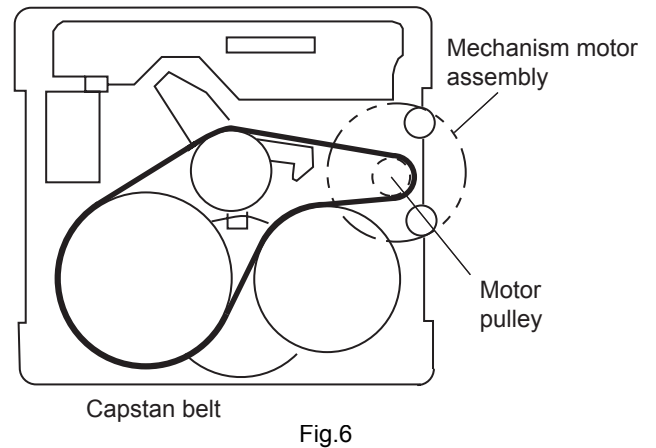
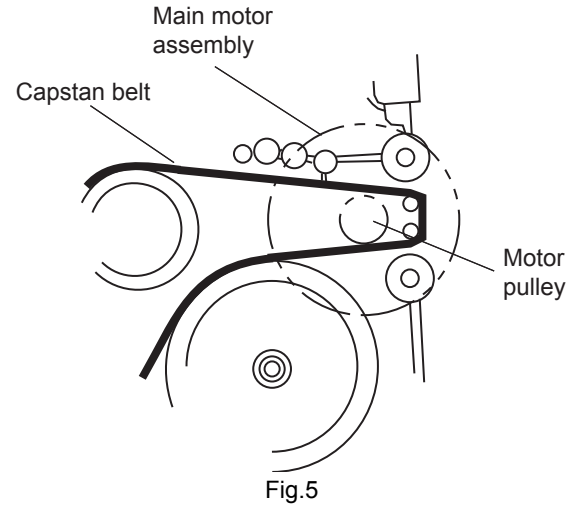

**2.5.5 Removing the flywheel
(See Fig. 8 and 9)**

- (1) Remove the head amplifier & mechanism control P.C. board.
- (2) Remove the main motor assembly.
- (3) After turning over the cassette mechanism, remove the two slit washers **1** and fixing the capstan shafts **R** and **L**, and pull out the flywheel **R** and **L** respectively from behind the cassette mechanism.

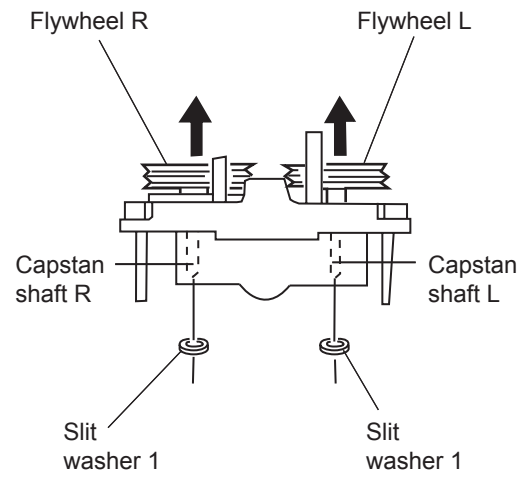

Fig.8

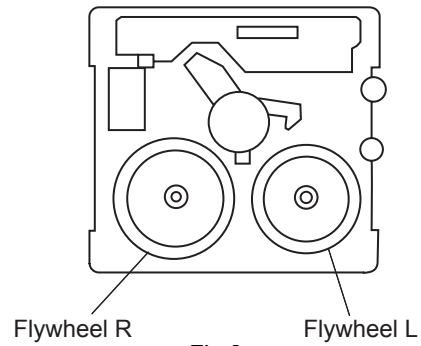

Fig.9

**2.5.6 Removing the reel pulse P.C. board and solenoid
(See Fig. 10)**

- (1) Remove the five pawls **a** to **e** reattaining the reel pulse board.
- (2) From the surface of the reel pulse board parts, remove the two pawls **f** and **g** retaining the solenoid.

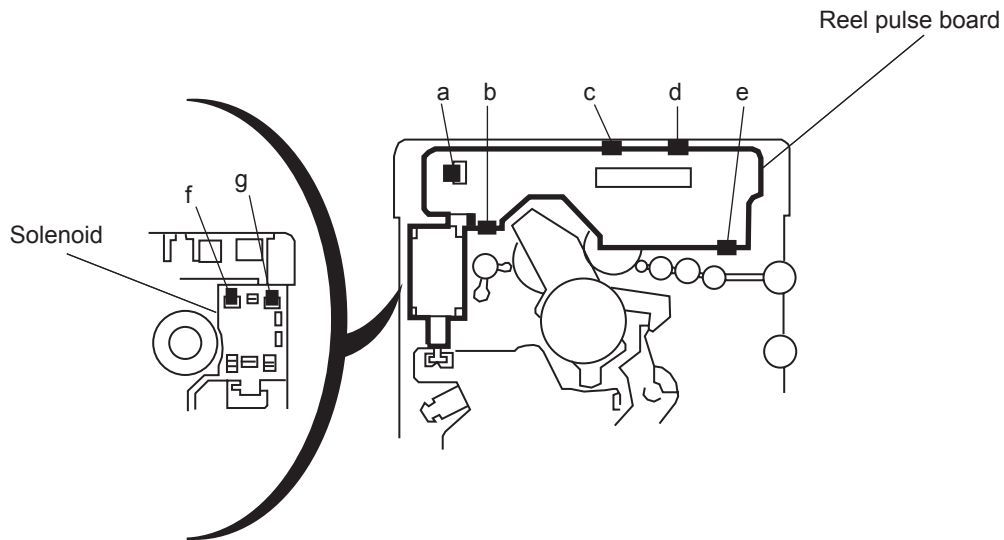
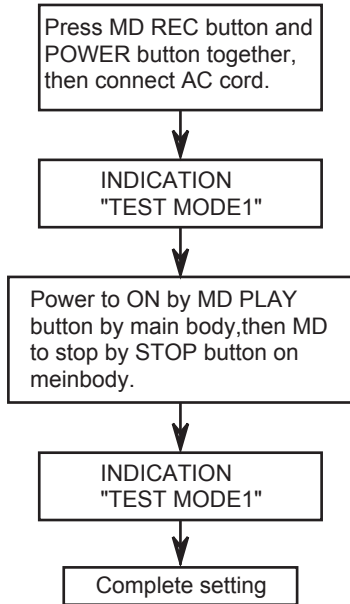

Fig.10

SECTION 3 Adjustment method

3.1 MD adjustment(Auto adjust)

(1) Setting of MD adjustment



(2) Initialize of EEPROM

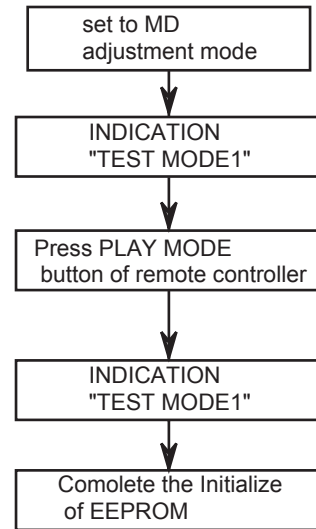

(3) Adjust the laser power

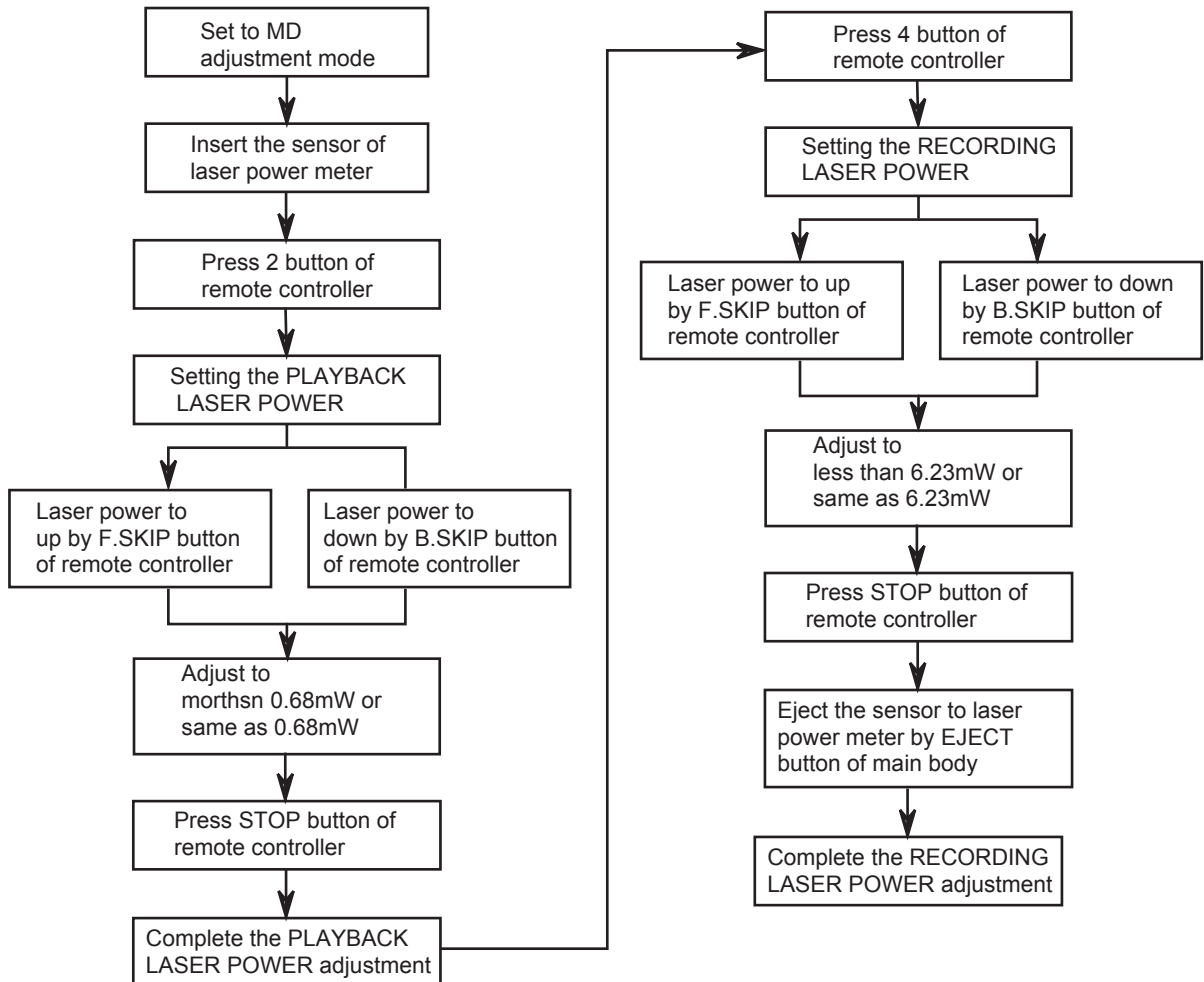

(4) Disc adjustment(Auto adjust)

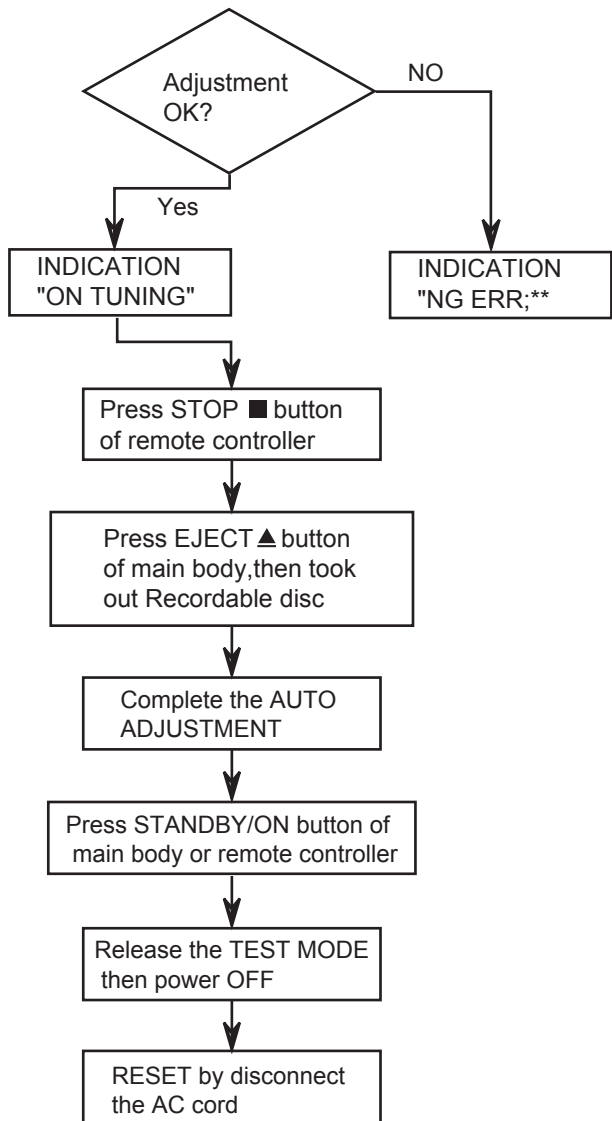
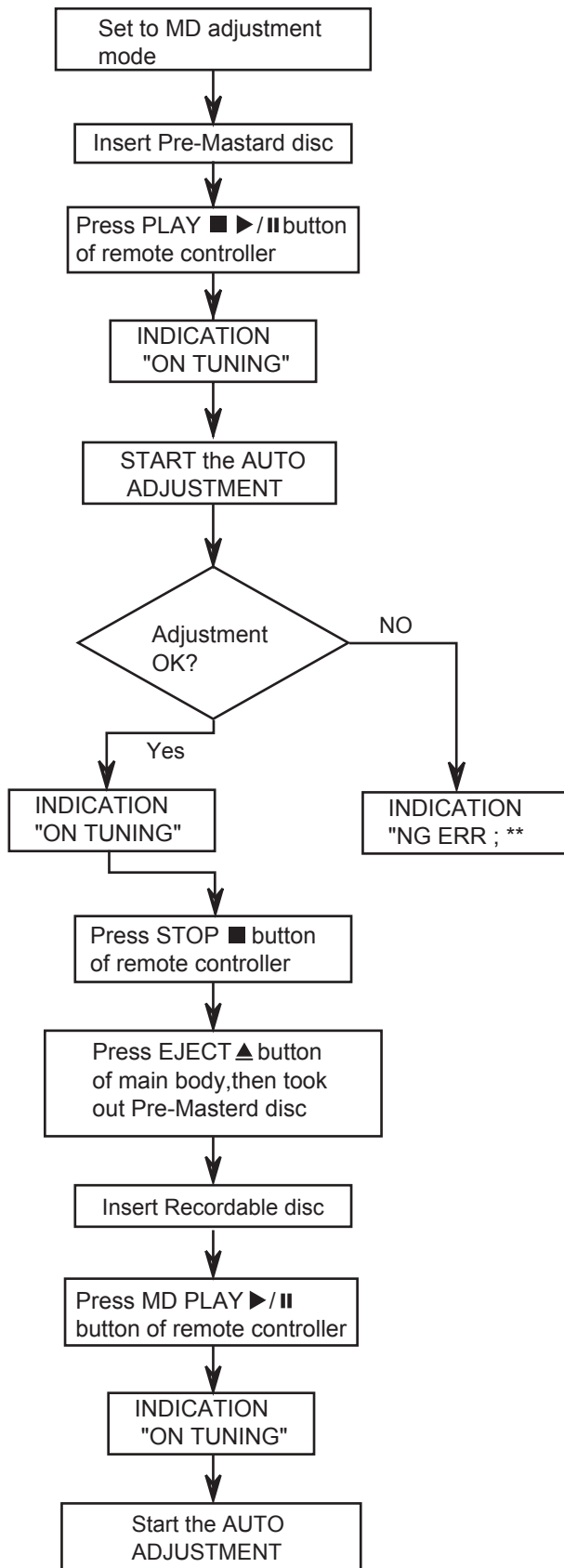

CODE	Adjustment NG part
00	Not complete the AUTO ADJUSTMENT
01	Rest swith detection
02	Focus ON
03	Pit area EF barance, Tr offset adj
04	Pit area ABCD level adj
05	Pit area Focus servo AGC
06	Pit area Tracking servo AGC
07	Pit area Focus bias adj
08	GRV area EF baranee, TR offset adj
09	GRV area ABCD level adj
0A	GRV area Focus servo AGC
0B	GRV area Tracking servo AGC
0C	GRV area Focus bias adj
0D	Temp
0E	EEPROM write
FF	AUTO ADJUST complte

3.2 Cassette adjustment

3.2.1 Cassette mechanism section

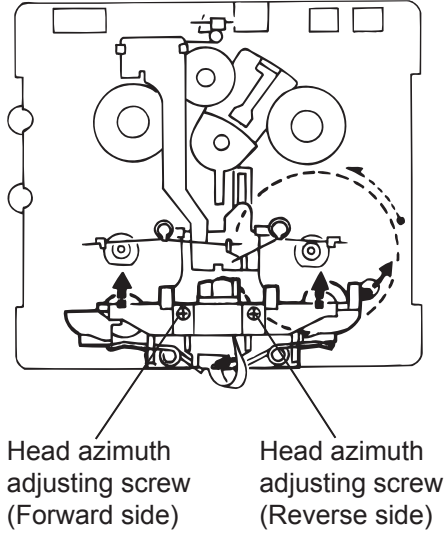

3.2.2 Cassette mechanism section (Back side)

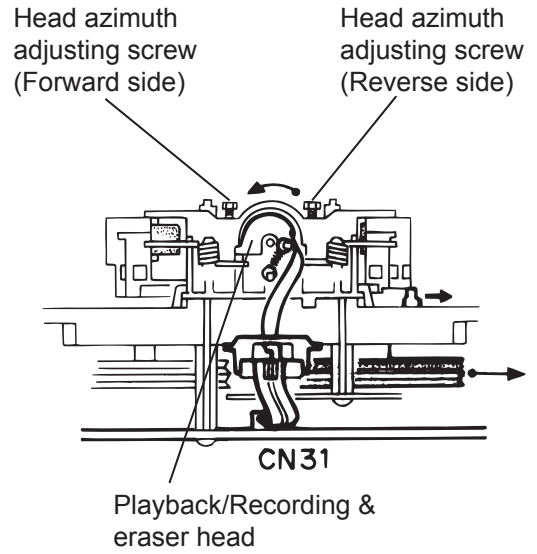

3.2.3 Cassette AMP board

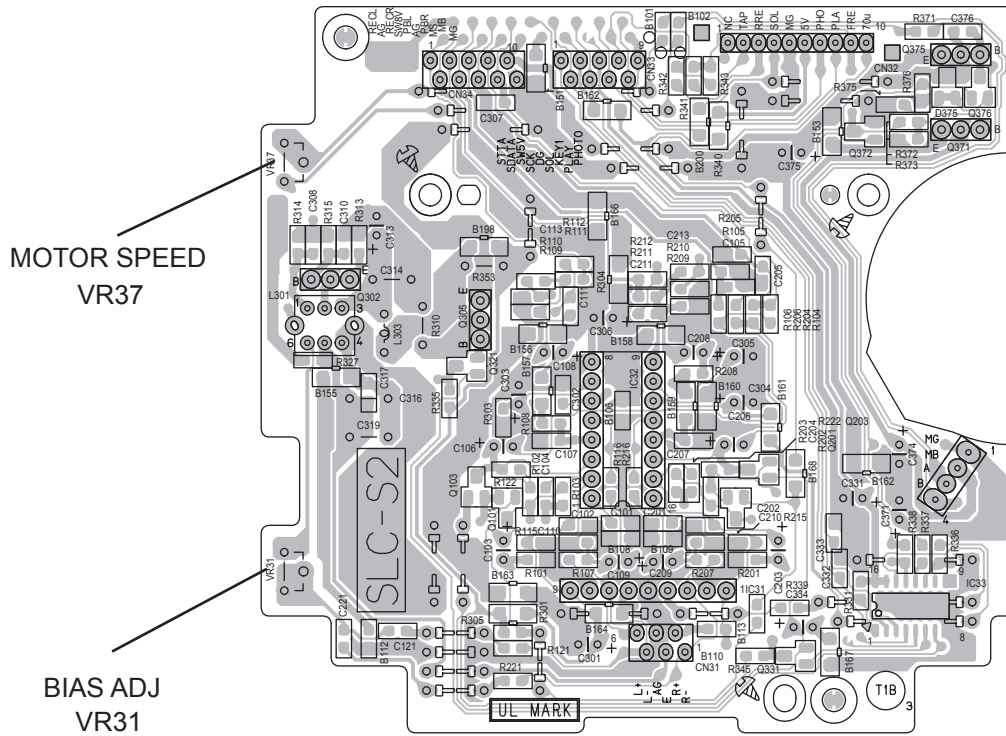

3.2.4 Tape Recorder Section

Items	Measurement conditions	Measurement method	Standard Values	Adjusting positions
Confirmation of head angle	Test tape : VT703L (8kHz) Measurement output terminal : Speaker terminal Speaker R (Load resistance: 4 ohm) : Headphone terminal	1 Playback the test tape VT703L (8kHz) 2 With the recording & playback mechanism, adjust the head azimuth screw so that the forward and reverse output levels become maximum. After adjustment lock the head azimuth at least by half turn. 3 In either case this adjustment should be performed in both the forward and reverse directions with the head azimuth screw.	Maximum output	Adjust the head azimuth screw only when the head has been changed.
Confirmation of tape speed	Test tape : VT712 (3kHz) Measurement output terminal : Headphone terminal	Adjust VR37 so that the frequency counter reading becomes 2,940~3,090Hz \pm when playing back the test tape VT712 (3kHz) with playback and recording mechanism after ending forward winding of the tape.	Tape speed of deck : 2,940 ~ 3,090Hz	VR37

3.2.5 Reference Values for Confirmation Items

Items	Measurement conditions	Measurement method	Standard Values	Adjusting positions
Difference between the forward and reverse speed	Test tape : VT712 (3kHz) Measurement output terminal : Speaker terminal Speaker R (Load resistance: 4 ohm) Measurement output terminal : Headphone	When the test tape VT712 (3kHz) has been played back with the recording and playback mechanism at the beginning of forward winding, the frequency counter reading of the difference between both of the mechanism should be 6.0Hz or less.	6.0Hz or less	Head azimuth screw
Wow & flutter	Test tape : VT712 (3kHz) Measurement output terminal : Headphone terminal	When the test tape VT712 (3kHz) has been played back with the recording and playback mechanism at the beginning of forward winding, the frequency counter reading of wow & flutter should be 0.25% or less (WRMS).	0.25% or less (WRMS)	

3.2.6 Electrical Performance

Items	Measurement conditions	Measurement method	Standard Values	Adjusting positions
Adjustment of recording bias current (Reference Value)	Mode : Forward or reverse mode • Recording mode • Test tape : AC-514 to TYPE II and AC-225 to TYPE I Measurement output terminal : Both recording and headphone terminals	1 With the recording and playback mechanism load the test tapes(AC-514 to TYPE II and AC-225 to TYPE I), and set the mechanism to the recording and pausing condition in advance. 2 After connecting 100 ohm in series to the recorder head measure the bias current with a valve voltmeter at both of the terminals. 3 After resetting the [PAUSE] mode start recording. At this time adjust VR31 for Lch and VR32 for Rch so that the recording bias current values become 4.0μA (TYPE I) and 4.20μA (TYPE II).	AC-225 : 4.20μA AC-514 : 4.0μA	VR31
Adjustment of recording and playback frequency characteristics	Reference frequency : 1kHz and 10kHz (REF.: -20dB) Test tape : AC-514 to TYPE II Measurement input terminal : OSC IN	1 With the recording and playback mechanism load the test tapes (AC-514 to TYPE II), and set the mechanism to the recording and pausing condition in advance. 2 While repetitively inputting the reference frequency signal of 1kHz and 10kHz from OSC IN record and playback the tape. 3 While recording and playback the test tape in TYPE II ,adjust VR31 for Lch and VR32 for Rch so that the output deviation between 1kHz and 10kHz becomes -1dB ± 2dB.	Output deviation between 1kHz and 10kHz : -1dB ± 2dB	VR31

3.2.7 Reference Values for Electrical Function Confirmation Items

Items	Measurement conditions	Measurement method	Standard Values	Adjusting positions
Recording bias frequency	Forward or reverse • Test tape : TYPE II (AC-514) Measurement terminal : BIAS TP on P.C. board	1 While changing over to and from BIAS 1 and 2, confirm that the frequency is changed. 2 With the recording and playback mechanism load the test tape. (AC-514 to TYPE II), and set the mechanism to the recording and pausing condition in advance. 3 Confirm that the BIAS TP frequency on the P.C. board is 100kHz ± 6kHz.	100 kHz ± 6 kHz	
Eraser current (Reference value)	Forward or reverse • Recording mode • Test tape : AC-514 to TYPE II and AC-225 to TYPE I Measurement terminal : Both of the eraser head terminals	1 While recording and playback mechanism, load the test tapes (AC-514 to TYPE II and AC-225 to TYPE I), and set the mechanism to the recording and pausing conditions in advance. 2 After setting to the recording conditions, connect 1W in series to the eraser head on connect 1W in series to the eraser head on the recording and playback mechanism side and measure the eraser current from both of the eraser terminals.	TYPE II : 120 mA TYPE I : 75 mA	

3.3 Flow of functional operation until TOC read

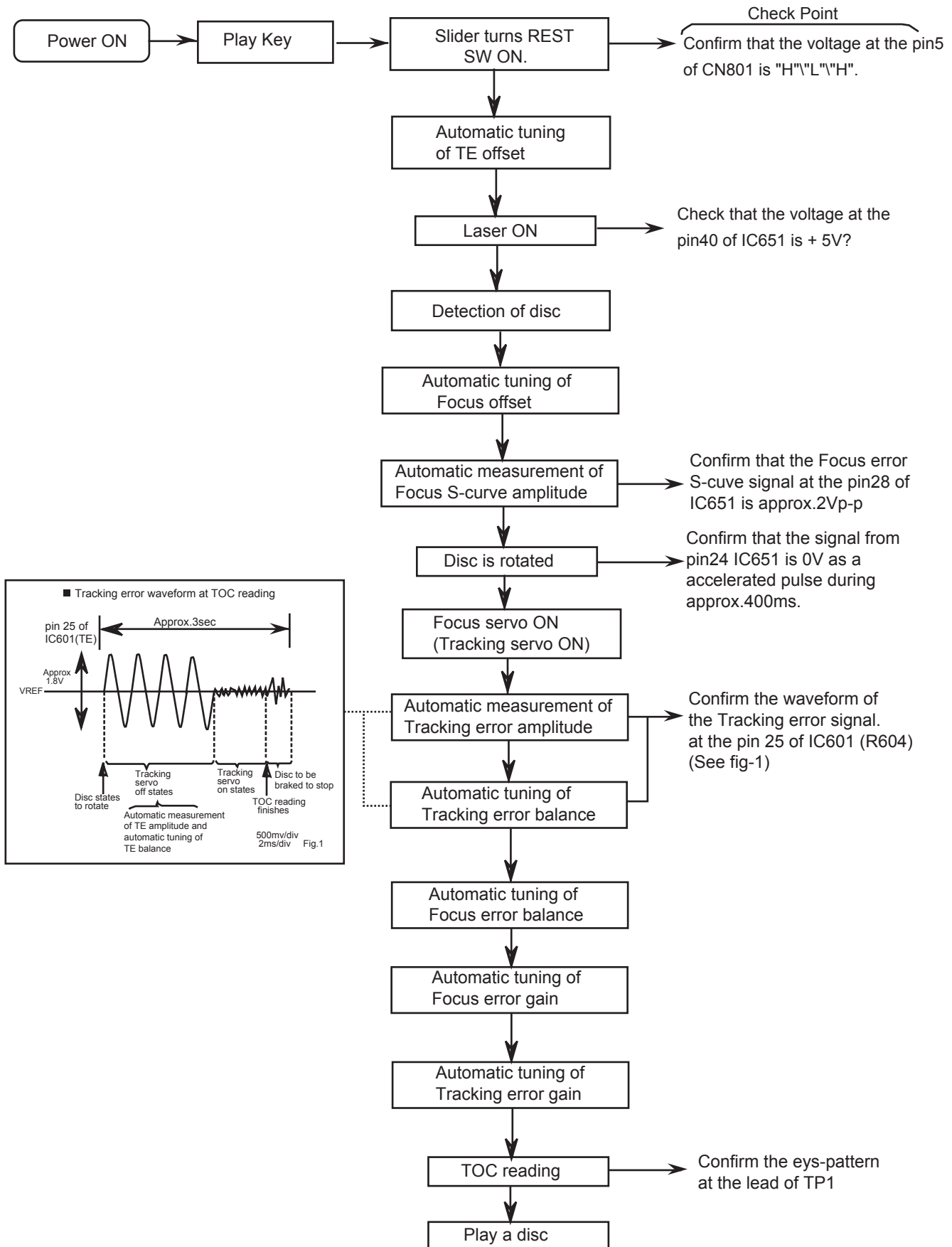

3.4 Maintenance of laser pickup

- (1) Cleaning the pick up lens
Before you replace the pick up, please try to clean the lens with a alcohol soaked cotton swab.
- (2) Life of the laser diode
When the life of the laser diode has expired, the following symptoms will appear.
 - 1.The level of RF output (EFM output : amplitude of eye pattern) will below.

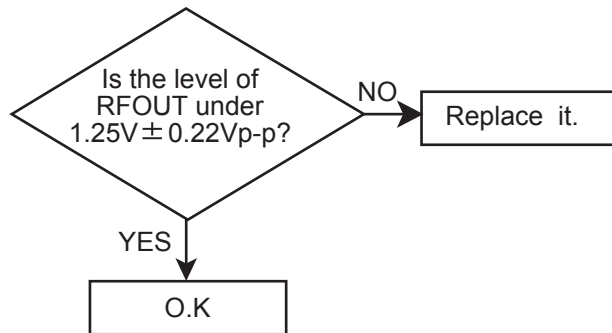

- (3) Semi-fixed resistor on the APC PC board
The semi-fixed resistor on the APC printed circuit board which is attached to the pickup is used to adjust the laser power. Since this adjustment should be performed to match the characteristics of the whole optical block, do not touch the semi-fixed resistor.
If the laser power is lower than the specified value, the laser diode is almost worn out, and the laser pickup should be replaced.
If the semi-fixed resistor is adjusted while the pickup is functioning normally, the laser pickup may be damaged due to excessive current.

3.5 Replacement of laser pickup

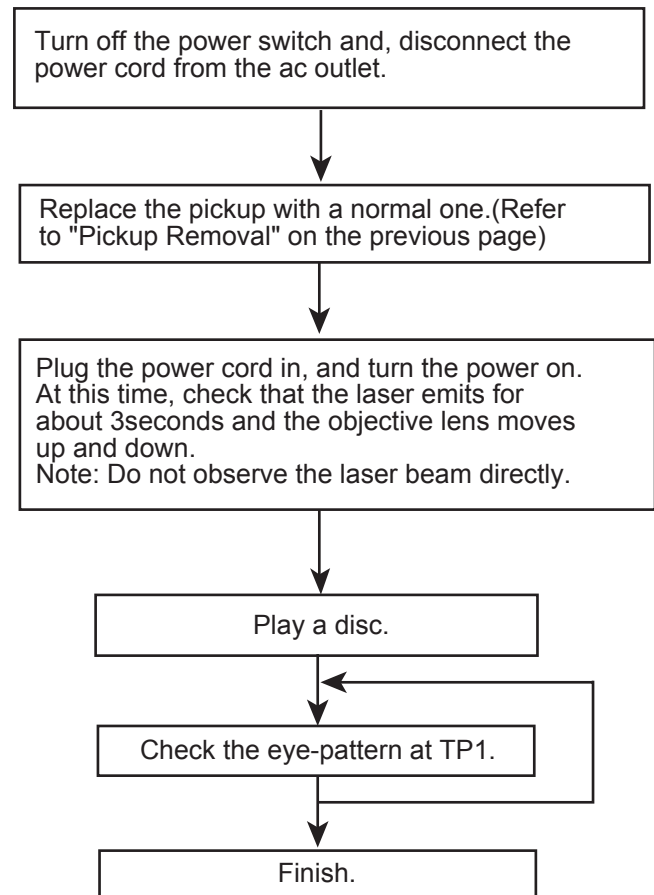

SECTION 4

Description of major ICs

4.1 AK4519VF-X (IC480) : A/D D/A converter

- Pin layout

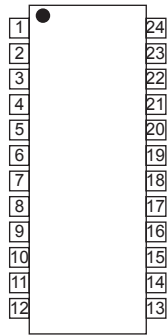

- Block diagram

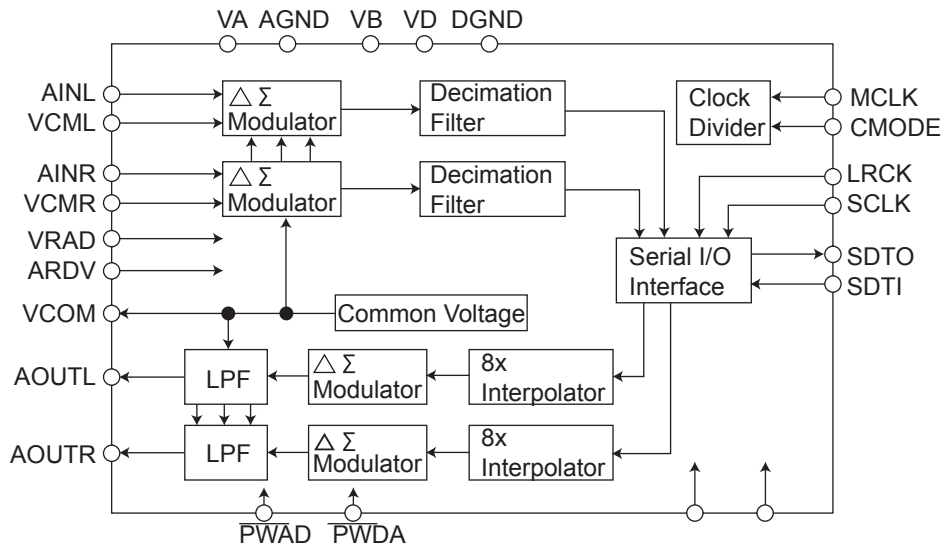

- Pin Function

Pin No.	Symbol	I/O	Function
1	VRDA	I	Voltage Reference Input Pin for DAC, VA
2	VRAD	I	Voltage Reference Input Pin for ADC, VA
3	AINR	I	Rch Analog Input Pin
4	VCMR	O	Rch Common Voltage Output Pin, 0.45xVA
5	VCML	O	Lch Common Voltage Output Pin, 0.45xVA
6	AINL	I	Lch Analog Input Pin
7	PWAD	I	ADC Power-Down Mode Pin "L":Power Down
8	PWDA	I	DAC Power-Down Mode Pin "L":Power Down
9	MCLK	I	Master Clock Input Pin
10	LRCK	I	Input/Output Channel Clock Pin
11	SCLK	I	Audio Serial Data Clock Pin

Pin No.	Symbol	I/O	Function
12	SDTO	O	Audio Serial Data Output Pin
13	DGND	-	Digital Ground Pin
14	VD	-	Digital Power Supply Pin
15	SDTI	I	Audio Serial Data Input Pin
16	CMODE	I	Master Clock Select Pin
17	DEM1	I	De-emphasis Frequency Select Pin
18	DEM0	I	De-emphasis Frequency Select Pin
19	AOUTL	O	Lch Analog Output Pin
20	AOUTR	O	Rch Analog Output Pin
21	VCOM	O	Common Voltage Output Pin, 0.45xVA
22	AGND	-	Analog Ground Pin
23	VB	-	Substrate Pin
24	VA	-	Analog Power Supply Pin

4.2 AN22000A-W (IC601) : RF & SERVO AMP

• Terminal layout

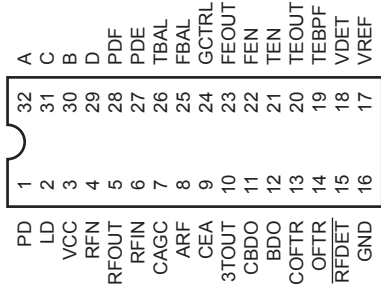

• Block diagram

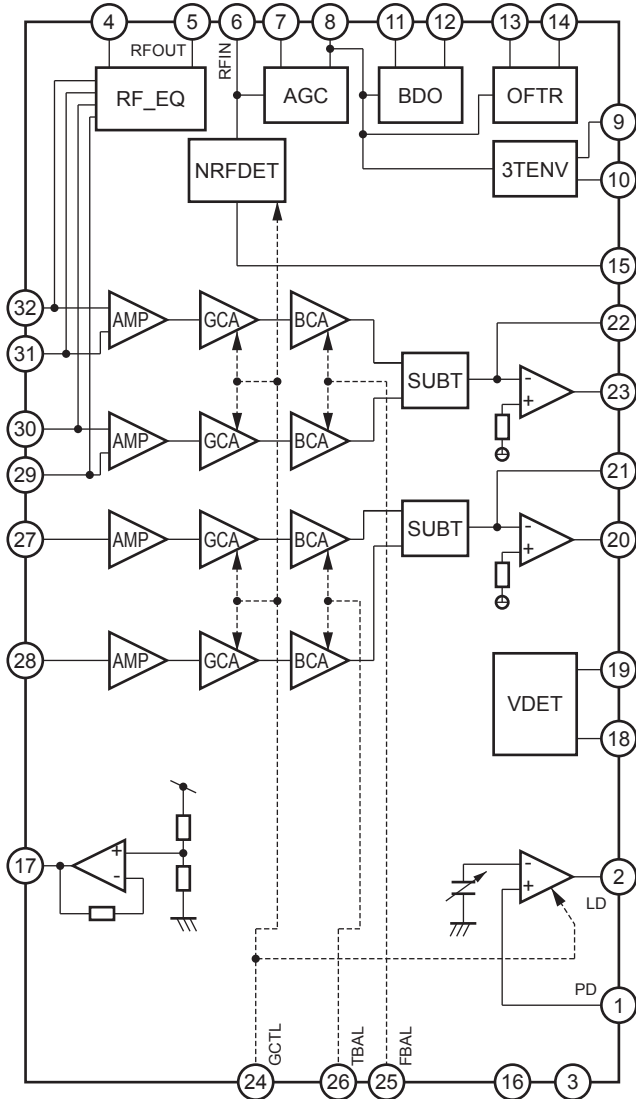

• Pin function

Pin No.	Symbol	I/O	Function
1	PD	I	APC Amp. input terminal
2	LD	O	APC Amp. output terminal
3	VCC	-	Power supply terminal
4	RFN	I	RF adder Amp. inverting input terminal
5	RFOUT	O	RF adder Amp. output terminal
6	RFIN	I	AGC input terminal
7	CAGC	I	Input terminal for AGC loop filter capacitor
8	ARF	O	AGC output terminal
9	CEA	I	Capacitor connecting terminal for HPF-Amp.
10	3TOUT	O	3 TENV output terminal
11	CBDO	I	Capacitor connecting terminal for envelope detection on the darkness side
12	BDO	O	BDO output terminal
13	COFTR	I	Capacitor connecting terminal for envelope detection on the light side
14	OFTR	O	OFTR output terminal
15	NRFDET	O	NRFDET output terminal
16	GND	-	Ground
17	VREF	O	VREF output terminal
18	VDET	O	VDET output terminal
19	TEBPF	I	VDET output terminal
20	TEOUT	O	TE Amp. output terminal
21	TEN	I	TE Amp. inverting input terminal
22	FEN	I	FE Amp. inverting input terminal
23	FEOUT	O	FE Amp. output terminal
24	GCTL	O	GCTL & APC terminal
25	FBAL	O	FBAL control terminal
26	TBAL	O	TBAL control terminal
27	E	I	Tracking signal input terminal 1
28	F	I	Tracking signal input terminal 2
29	D	I	Focus signal input terminal 4
30	B	I	Focus signal input terminal 3
31	C	I	Focus signal input terminal 2
32	A	I	Focus signal input terminal 1

4.3 AN7317 (IC32) : R / P amp.

- Pin layout & block diagram

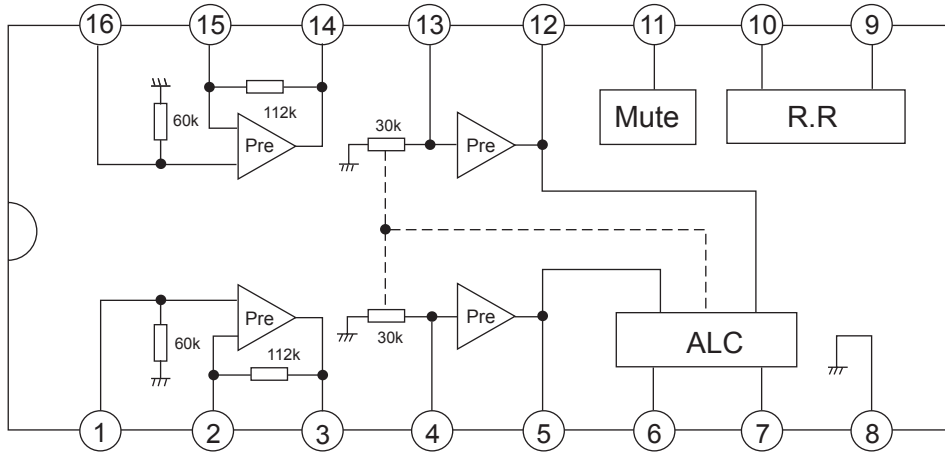

- Pin functions

Pin No.	Function
1	Channel 1 playback amplifier input
2	Channel 1 playback amplifier negative feedback
3	Channel 1 playback amplifier output
4	Channel 1 record amplifier input
5	Channel 1 record amplifier output
6	ALC low-cut
7	ALC time
8	Ground
9	Vcc
10	Ripple filter
11	Record-Amplifier mute
12	Channel 2 record amplifier output
13	Channel 2 record amplifier input
14	Channel 2 playback amplifier output
15	Channel 2 playback amplifier negative feedback
16	Channel 2 playback amplifier input

4.4 BU4094BCF-X (IC33) : Shift / store register

- Pin layout

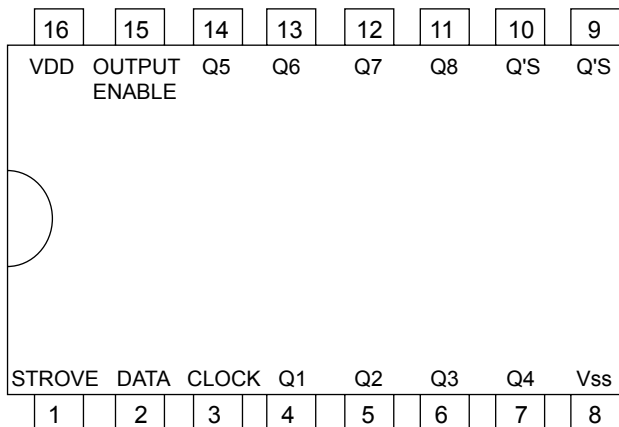

- Block diagram

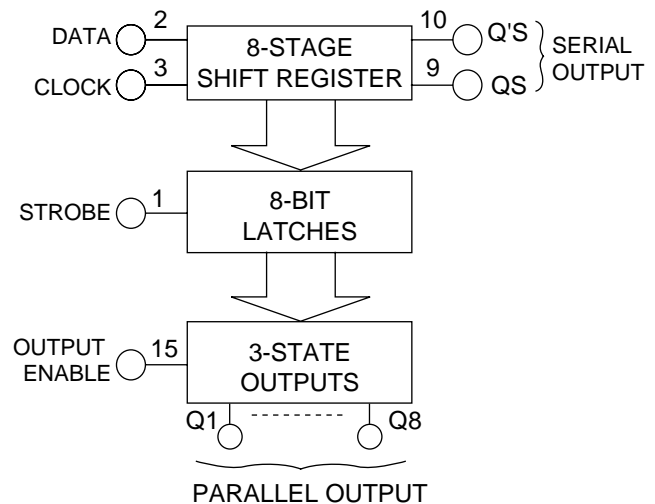

4.5 XC62HR3502P-X (IC291) : Regulator

- Pin layout

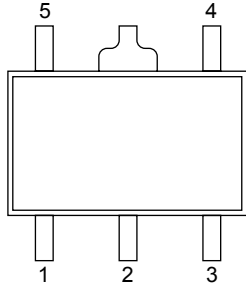

- Pin function

Pin No.	Symbol	Function
1	VSS	Ground
2	VIN	Supply voltage input
3	CE	Chip enable
4	NC	Non connect
5	VOUT	Regulated output voltage

- Block diagram

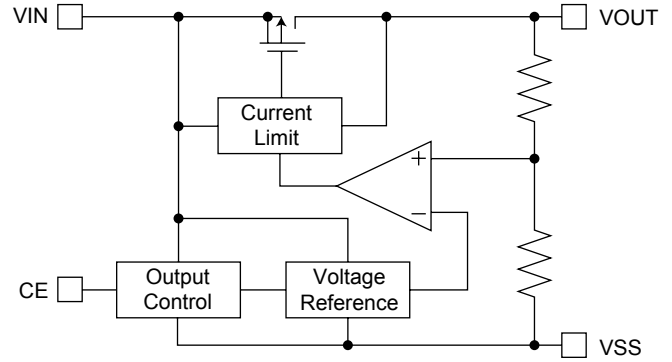

4.6 GM71VS17400CLT5 (IC390,IC790) : DRAM

- Pin layout

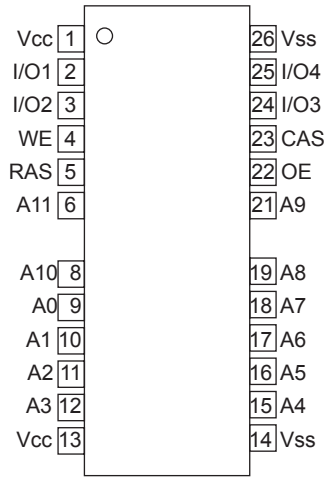

- Pin function

Pin No.	Symbol	Function
1	Vcc	Power supply (+3.3V)
2	I/O1	Date input/output
3	I/O2	Date input/output
4	WE	Read/write enable
5	RAS	Address stroke
6	A11	Address input
7	-	Not use
8	A10	Address input
9~12	A0~A3	Address input
13	Vcc	Power supply (+3.3V)
14	Vss	GND
15~19	A4~A8	Address input
20	-	Not use
21	A9	Address input
22	OE	Output enable
23	CAS	Calum address stroke
24	I/O3	Date input/output
25	I/O4	Date input/output
26	Vss	GND

4.7 MN662790RSC(IC651):Digital servo & processor

• Pin layout

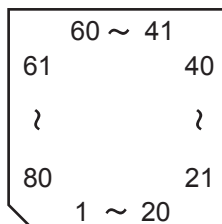

• Pin function

Pin No.	Symbol	I/O	Description
1	BCLK	O	Bit clock output for SRDATA
2	LRCK	O	Identifying signal output of L,R
3	SRDATA	O	Serial data output
4	DVDD1	-	Power supply for digital circuit
5	DVSS1	-	Connect to ground for digital circuit
6	TX	O	Digital audio interface output signal
7	MCLK	I	Micom command clock signal input
8	MDATA	I	Micom command data signal input
9	MLD	I	Micom command load signal input L:load
10	SENSE	-	Non connect
11	FLOCK	-	Non connect
12	TLOCK	-	Non connect
13	BLKCK	O	Sub code block clock signal (Command execution : CD-TEXT data readout enabling signal (DQSY) output)
14	SQCK	I	Export clock signal input for sub code Q register
15	SUBQ	O	Sub code Q data output
16	DMUTE	I	Muting input H:muting
17	STAT	O	Status signal output
18	LSI_RST	I	Reset signal input L:reset
19	SMCK	O	Clock signal output MSEL is H : 8.4672 MHz MSEL is L : 4.2336 MHz
20	CSEL	I	Oscillation frequency specification terminal H:33.8688 MHz L:16.9344 MHz
21	TEST2	-	TEST2 terminal usually : open
22	TVD	O	Traverse drive output
23	PC	-	Non connect
24	ECM	O	Spindle motor drive signal output (Compulsion mode output)
25	ECS	O	Spindle motor drive signal output (Servo error signal output)
26	VDETMON	-	Non connect
27	TRD	O	Tracking drive signal output
28	FOD	O	Focus drive signal output
29	VREF	-	Reference voltage for DA output section
30	FBAL	O	Focus balance adjust signal output
31	TBAL	O	Tracking balance adjust signal output
32	FE	I	Focus error signal input (analog input)
33	TE	I	Tracking error signal input (analog input)
34	RFENV	I	RF Envelope signal input (analog input)
35	TEST3	I	TEST3 Terminal usually : Fixation L
36	OFT	I	Off track signal input H : off track
37	TRCRS	I	Track cross signal input (analog input)

Pin No.	Symbol	I/O	Description
38	RFDET	I	RF detection signal input L : detection
39	BDO	I	Dropout signal input H : dropout
40	LDON	I	Non connect
41	PLL2	I/O	Terminal for loop filter characteristic switch for PLL
42	DSLBD	-	Non connect
43	WVEL	-	Non connect
44	ARF	I	RF Signal output
45	IREF	I	Standard electric current input terminal
46	DRF	I	Bias terminal for DSL
47	DSL2	I/O	Loop filter terminal for DSL
48	PLL	I/O	Loop filter terminal for PLL
49	VCO	I/O	Loop filter terminal for VCO
50	AVDD2	-	Power supply terminal for analog circuit
51	AVSS2	-	Connect to ground terminal for analog circuit
52	EFM	-	Non connect
53	DSL	O	PLL extraction clock output
54	VCO2	I/O	Loop filter terminal for VCO
55	SUBC	O	Sub code serial output
56	SBCK	I	Clock signal input for sub code serial output
57	VSS	-	Connect to ground terminal for oscillation circuit
58	X1	I	Oscillation circuit input terminal f=16.9344 MHz,33.8688 MHz
59	X2	O	Oscillation circuit output terminal f=16.9344 MHz,33.8688 MHz
60	VDD	-	Power supply terminal for oscillation circuit
61	BYTCK	-	Non connect
62	LDON	O	Laser ON signal output H : ON
63	GCTRL	O	General I/O port
64	IPFLA	-	Non connect
65	FLAG	O	Flag signal output
66	CLVS	-	Non connect
67	CRC	-	Non connect
68	DEMPH	O	De-emphasis detection signal output
69	RESY	-	Non connect
70	IOSEL	I	Mode switch terminal
71	TEST	I	TEST terminal usually : H
72	AVDD1	-	Power supply terminal for analog circuit (for audio output section)
73	OUTL	O	Lch audio output
74	AVSS1	-	Connect to ground terminal for analog circuit (for audio output section)
75	OUTR	O	Rch audio output
76	DQSY	I	RF signal polarity specification terminal
77	VCC5V	-	Power supply terminal (5V)
78	PSEL	O	IOSEL=H TEST terminal IOSEL=L SRDATA input
79	MSEL	O	IOSEL=H SMCK terminal output (frequency switch terminal) IOSEL=L LRCK input
80	SSEL	O	IOSEL=H SUBQ terminal output mode switch terminal IOSEL=L BCLK input

4.8 GP1UM261XK (IC602) : Receiver

- Pin layout

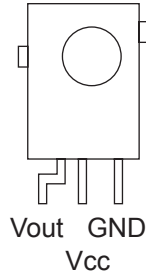

- Block diagram

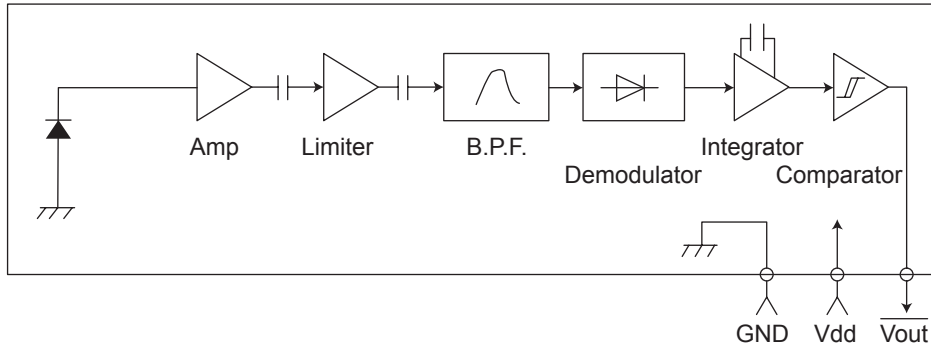

4.9 M63008FP-X (IC604) : 5ch Actuator driver

- Pin layout

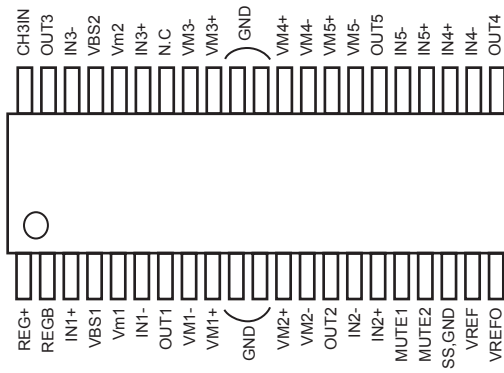

- Block diagram

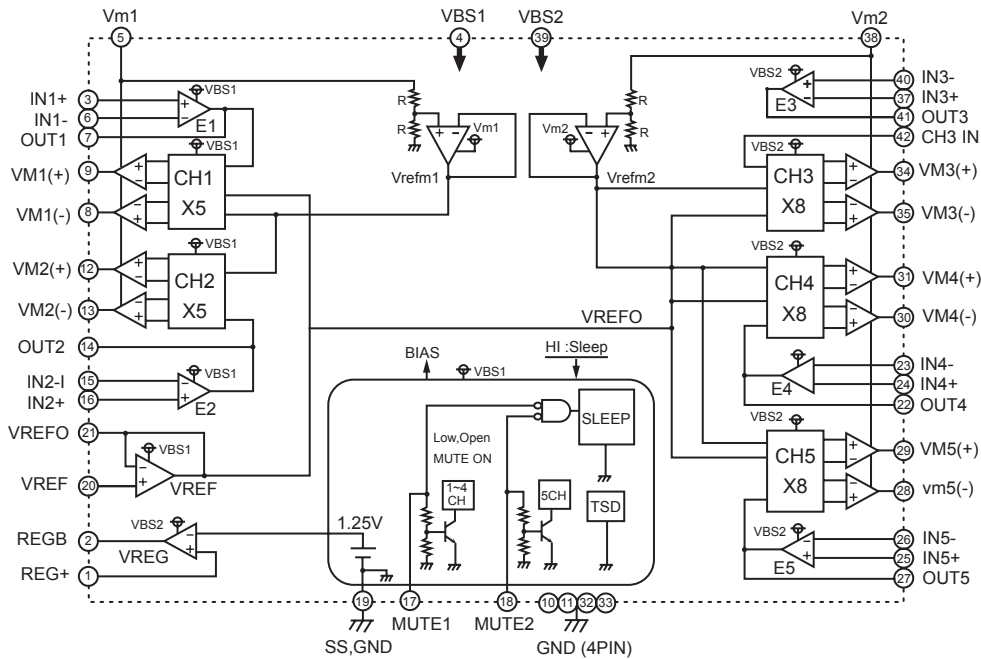

4.10 LB1641 (IC402) : DC Motor driver

- Pin layout

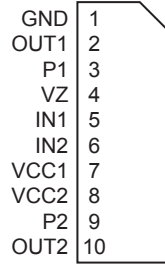

- Truth table

Input		Output		Mode
IN1	IN2	OUT1	OUT2	
0	0	0	0	Brake
1	0	1	0	CLOCKWISE
0	1	0	1	COUNTER-CLOCKWISE
1	1	0	0	Brake

4.11 BD7910FV-X (IC450) : Pre driver

- Block diagram

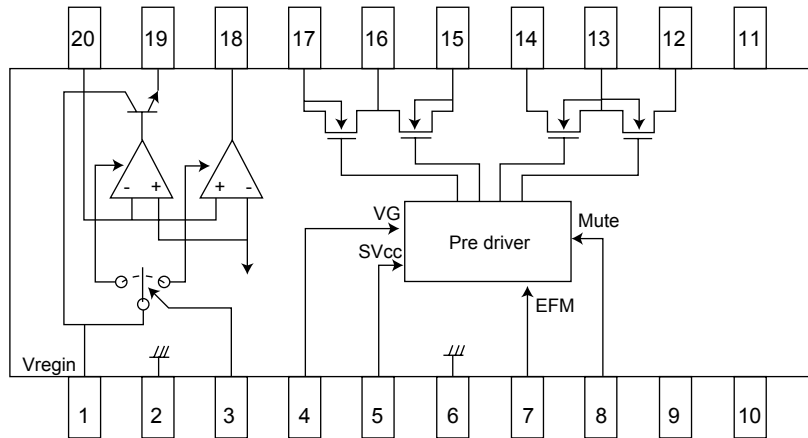

- Pin function

Pin No.	Symbol	I/O	Function
1	Vreg IN	I	Regulator input and regulator power supply
2	Reg GN	-	Regulator GND
3	NC	-	Non connect
4	VG	I	Voltage input for power MOS drive
5	SVCC	O	EFM high level output voltage
6	PDGND	-	Pre-driver GND
7	EFM	I	EFM signal input
8	MUTE	I	Mute control (Low active)
9	NC	O	Non connct
10	NC	O	Non connect
11	NC	-	Non connect
12	VOD2	O	Sync.output (Lower power MOS,drain)
13	VSS	-	Hbridge GND (Lower power MOS,source)
14	VOD1	O	Sync.output (Lower power MOS,drain)
15	VOS1	O	Source output (Upper power MOS,source)
16	VDD	-	H bridge power supply terminal(Upper power MOSsource)
17	VOS2	O	Source output (Upper power MOSsource)
18	Reg DRV	O	External PNP drive output for regulator
19	Reg OUT	O	Reglator output (Emitter follower output)
20	Reg NF	-	Regulator feedbaack terminal

4.12 BA3126N(IC31) : R/P Switch

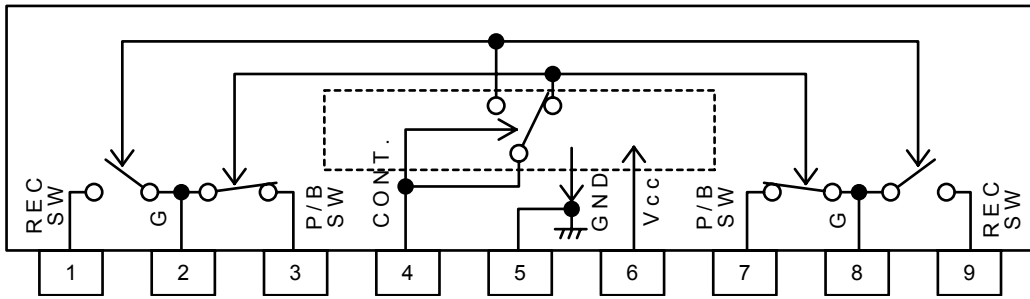

4.13 BR93LC66F-X (IC403):EEPROM

• Terminal layout

NC	1	8	NC
VCC	2	7	GND
CS	3	6	DO
SK	4	5	DI

• Pin Functions

Symbol	I/O	Function
VCC	-	Power supply
GND	-	Connect to GND
CS	I	Chip select input
SK	I	Serial clock input
DI	I	Start bit, OP-code, address, serial data input
DO	O	Serial data output Internal state display output of READY/BUSY

4.14 CXA2523AR (IC300) : MD servo

• Block diagram

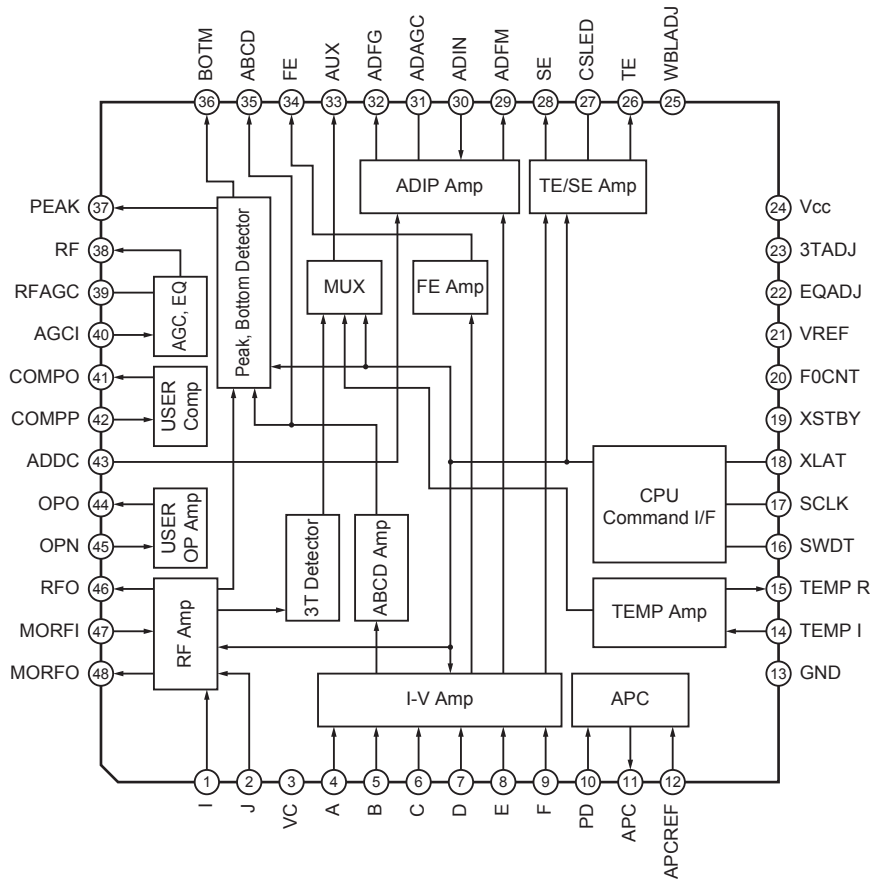

• Pin function

Pin No.	Symbol	I/O	Function
1	I	I	I-V converted RF signal I input.
2	J	I	I-V converted RF signal J input.
3	VC	O	Vcc/2 voltage output.
4	A	I	A current input for main beam servo signal.
5	B	I	B current input for main beam servo signal.
6	C	I	C current input for main beam servo signal.
7	D	I	D current input for main beam servo signal.
8	E	I	E current input for side beam servo signal.
9	F	I	F current input for side beam servo signal.
10	PD	I	Reflection light quantity monitor signal input.
11	APC	O	Laser APC output.
12	APCREF	I	Reference voltage input for the laser power intensity setting.
13	GND	-	Connect to GND.
14	TEMPI	I	Connects the temperature sensor.
15	TEMP R	I	Connects the temperature sensor. outputs the reference voltage.
16	SWDT	I	Data input for microcomputer serial interface.
17	SCLK	I	Shift clock input for microcomputer serial interface.
18	XLAT	I	Latch signal input for microcomputer serial interface. Latched when low.
19	XSTBY	I	Standby setting pin. Normal operation when high Standby when low.
20	F0CNT	I	Internal current source setting pin.
21	VREF	O	Reference voltage output.
22	EQADJ	I/O	Equalizer center frequency setting pin.
23	3TADJ	I/O	BPF3T center frequency setting pin.
24	Vcc	-	Power supply.
25	WBLADJ	I/O	BPF22 center frequency setting pin.
26	TE	O	Tracking error signal output.
27	CSLED	-	Connects the sled error signal LPF capacitor.
28	SE	O	Sled error signal output.
29	ADFM	O	ADIP FM signal output.
30	ADIN	I	ADIP signal comparator input.
31	ADAGC	-	Connects the ADIPAGC capacitor.
32	ADFG	O	ADIP2 binary value signal output.
33	AUX	O	13 output / temperature signal output. Switched with serial commands.
34	FE	O	Focus error signal output.
35	ABCD	O	Reflection light quantity signal output for the main beam servo detector.
36	BOTM	O	RF/ABCD bottom hold signal output.
37	PEAK	O	Peak hold signal output for the RF/ABCD signals.
38	RF	O	RF equalizer output.
39	RFAGC	-	Connects the RFAGC capacitor.
40	AGCI	I	RFAGC input.
41	COMPO	O	User comparator output.
42	COMPP	I	User comparator non-inverted input.
43	ADDC	I/O	Connects the capacitor for ADIP amplifier feedback circuit.
44	OPO	O	User operational amplifier output.
45	OPN	I	User operational amplifier inverted input.
46	RFO	O	RF amplifier output. Eye pattern checkpoint.
47	MORFI	I	Input of the groove RF signal with AC coupling.
48	MORFO	O	Groove RF signal output.

4.15 CXD2662R (IC350) : DSP

- Pin layout

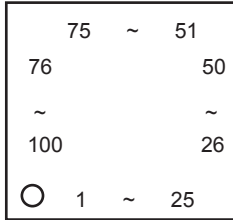

- Block diagram

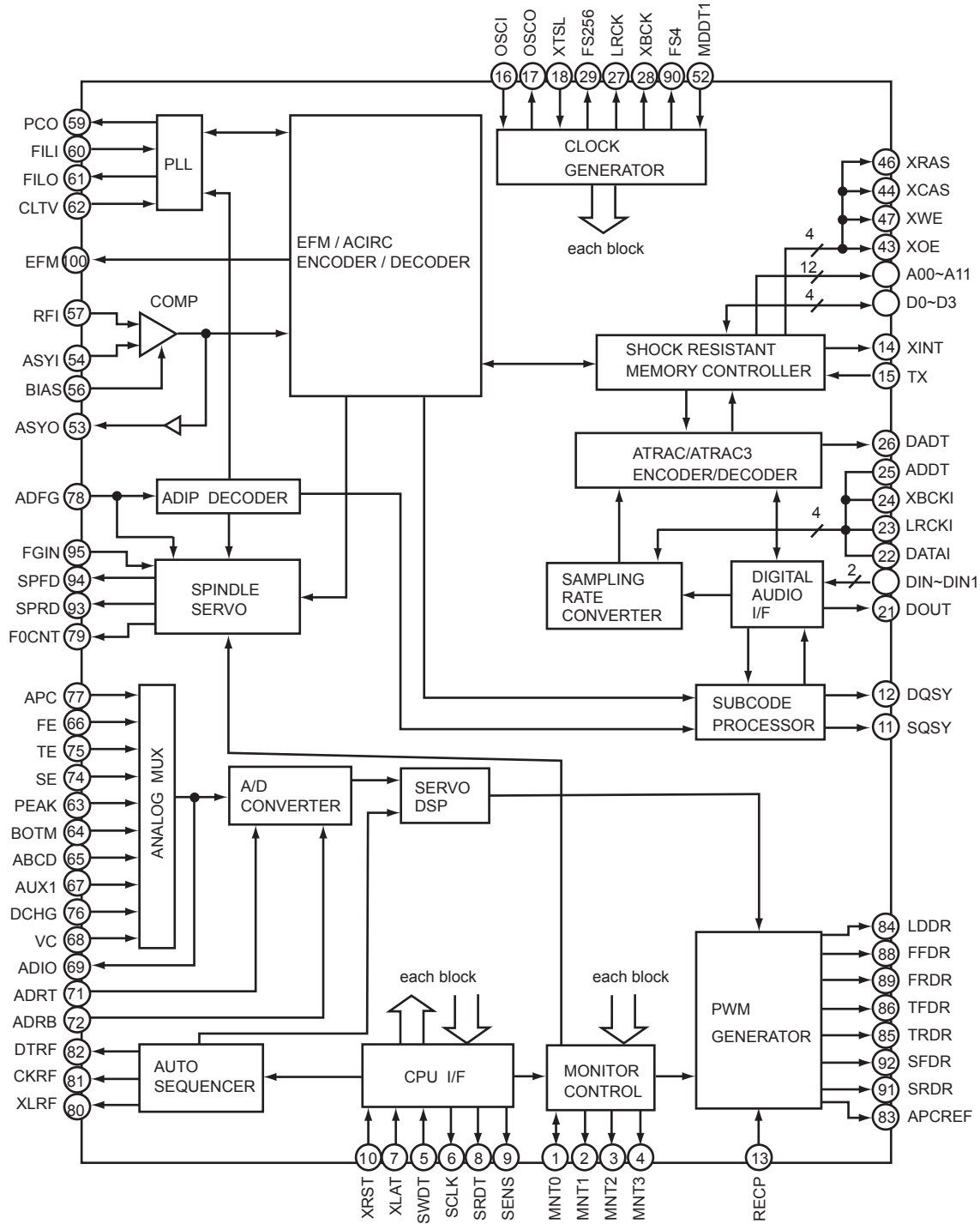

• Pin function (CXD2662R)

Pin No.	Symbol	I/O	Function
1	MNT0	I/O	Monitor output.
2	MNT1	O	Monitor output.
3	MNT2	O	Monitor output.
4	MNT3	O	Monitor output.
5	SWDT	I	Data input for microcomputer serial interface.
6	SCLK	I	Shift clock input for microcomputer serial interface.
7	XLAT	I	Latch input for microcomputer serial interface. Latched at the falling edge.
8	SRDT	O	Data output for microcomputer serial interface.
9	SENS	O	Outputs the internal status corresponding to the microcomputer serial interface address.
10	XRST	I	Reset input. Low : reset
11	SQSY	O	Disc subcode Q sync / ADIP sync output.
12	DQSY	O	Subcode Q sync output in U-bit CD or MD format when the Digital In source is CD or MD.
13	RECP	I	Laser power switching input. High : recording power ; low ; playback power
14	XINT	O	Interruption request output. Low when the interruption status occurs.
15	TX	I	Enable signal input for recoding data output. High : enabled
16	OSCI	I	Crystal oscillation circuit input.
17	OSCO	O	Crystal oscillation circuit output. (inverted output of the OSCI pin)
18	OSCO	I	OSCI input frequency switching. XTSL1(command) = low and XTSL = high : 512Fs (22.5792MHz) XTSL1(command) = low and XTSL = low : 1024Fs (45.1584MHz) XTSL1(command) = high : 2048Fs (90.3168MHz)
19	DIN0	I	Digital audio interface signal input 1.
20	DIN1	I	Digital audio interface signal input 2.
21	DOUT	O	Digital audio interface signal output.
22	DATAI	I	Test pin. Connect to GND.
23	LRCKI	I	Test pin. Connect to GND.
24	XBCKI	I	Test pin. Connect to GND.
25	ADDT	I	Data input from A / D converter.
26	DADT	O	REC monitor output / decoded audio data output.
27	LRCK	O	LA clock (44.1kHz) output to the external audio block.
28	XBCK	O	Bit clock (2.8224kHz) output to the external audio block.
29	FS256	O	256Fs output.
30	DVDD	-	Digital power supply.
31	A03	O	External DRAM address output.
32	A02	O	External DRAM address output.
33	A01	O	External DRAM address output.
34	A00	O	External DRAM address output.
35	A10	O	External DRAM address output.
36	A04	O	External DRAM address output.
37	A05	O	External DRAM address output.
38	A06	O	External DRAM address output.
39	A07	O	External DRAM address output.
40	A08	O	External DRAM address output.
41	A11	O	External DRAM address output.
42	DVSS	-	Digital ground.
43	XOE	O	External DRAM output enable.
44	XCAS	O	External DRAM CAS output.
45	A09	O	External DRAM address output.
46	XRAS	O	External DRAM RAS output.
47	XWE	O	External DRAM write enable.
48	D1	I/O	External DRAM data bus.
49	D0	I/O	External DRAM data bus.
50	D2	I/O	External DRAM data bus.

Pin No.	Symbol	I/O	Function
51	D3	I/O	External DRAM data bus.
52	MDDTI	I	MD-DATA mode 1 switching input. (Low : normal mode ; high : MD-DATA mode 1)
53	ASYO	O	Playback EFM full-swing input. (Low : vss ; high : Vdd)
54	ASYI	I	Playback EFM comparator slice voltage input.
55	AVDD	-	Analog power supply.
56	BIAS	I	Playback EFM comparator bias current input.
57	RFI	I	Playback EFM RE signal input.
58	AVSS	-	Analog ground.
59	PCO	O	Phase comparison output for master PLL of playback digital PLL and recording EFM PLL.
60	FILI	I	Filter input for master PLL of playback digital PLL and recording EFM PLL.
61	FILO	O	Filter output for master PLL of playback digital PLL and recording EFM PLL.
62	CLTV	I	Internal VCO control voltage input for master PLL of playback digital EFM PLL and recording EFM PLL.
63	PEAK	I	Peak hold signal input for quantity of light.
64	BOTM	I	Bottom hold signal input for quantity of light.
65	ABCD	I	Signal input for quantity of light.
66	FE	I	Focus error signal input. Auxillary input 1.
67	AUXI	I	Auxillary input 1.
68	VC	I	Center voltage input.
69	ADIO	I	Monitor output for A / D converter input signal.
70	AVDD	-	Analog power supply.
71	ADRT	I	Voltage input for the upper limit of the A / D converter operating range.
72	ADRB	I	Voltage input for the lower limit of the A / D converter operating range.
73	AVSS	-	Analog ground.
74	SE	I	Sled error signal input.
75	TE	I	Tracking error signal input.
76	DCHG	I	Connect to the low-impedance power supply.
77	APC	I	Error signal input for laser digital APC.
78	ADFG	I	ADIP binary FM signal (22.05 +/- 1kHz) input.
79	F0CNT	O	CXA2523 current source setting output.
80	XLRF	O	CXA2523 control latch output. Latched at the falling edge.
81	CKRF	O	CXA2523 control shift clock output.
82	DTRF	O	CXA2523 control data output.
83	APCREF	O	Reference PWM output for laser APC.
84	LDDR	O	PWM output for laser digital APC.
85	TRDR	O	Tracking servo drive PWM output. (-)
86	TFDR	O	Tracking servo drive PWM output. (+)
87	DVDD	-	Digital power supply.
88	FFDR	O	Focus servo drive PWM output. (+)
89	FRDR	O	Focus servo drive PWM output. (-)
90	FS4	O	4Fs output. (176.4kHz)
91	SRDR	O	Sled servo drive PWM output. (-)
92	SFDR	O	Sled servo drive PWM output. (+)
93	SPRD	O	Spindle servo drive output. (PWM (-) or polarity)
94	SPFD	O	Spindle servo drive output. (PWM (+) or PWM absolute value)
95	FGIN	I	Spindle CAV servo FG input.
96	TEST1	I	Test pin. Connect to GND.
97	TEST2	I	Test pin. Connect to GND.
98	TEST3	I	Test pin. Connect to GND.
99	DVSS	-	Digital ground.
100	EFMO	O	Low when playback ; EFM (encoded data) output when recording.

4.16 L4909 (IC910) : Regulator

- Pin layout

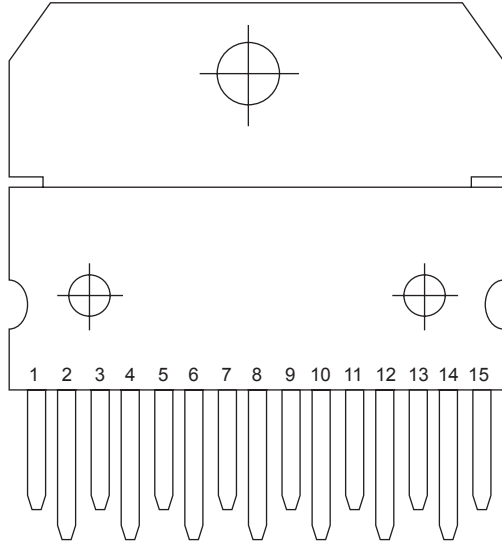

- Block diagram

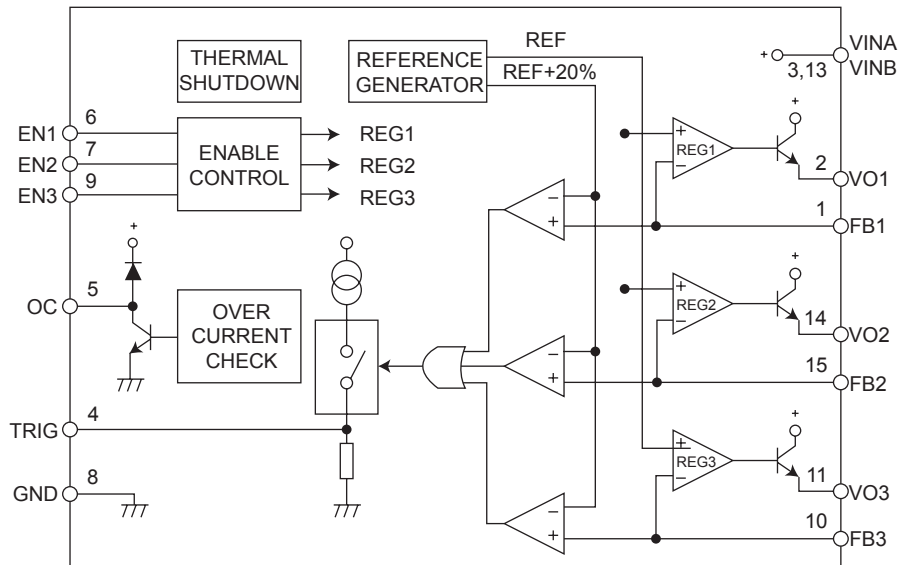

- Pin functions

Pin No.	Symbol	Function
1	FB1	REG1 feedback voltage input
2	VO1	REG1 output voltage
3	VINA	Input DC supply voltage
4	TRIG	Trigger for external SCR (crowbar protection)
5	OC	Over current warning output
6	EN1	REG1 enable input
7	EN2	REG2 enable input
8	GND	Analog ground
9	EN3	REG3 enable input
10	FB3	REG3 feedback voltage input
11	VO3	REG3 output voltage
12	N.C.	Not connected
13	VINB	Input DC supply voltage
14	VO2	REG2 output voltage
15	FB2	REG2 feedback voltage input

4.17 LA1838 (IC1): FM AM IF AMP&detector, FM MPX Decoder

• Block Diagram

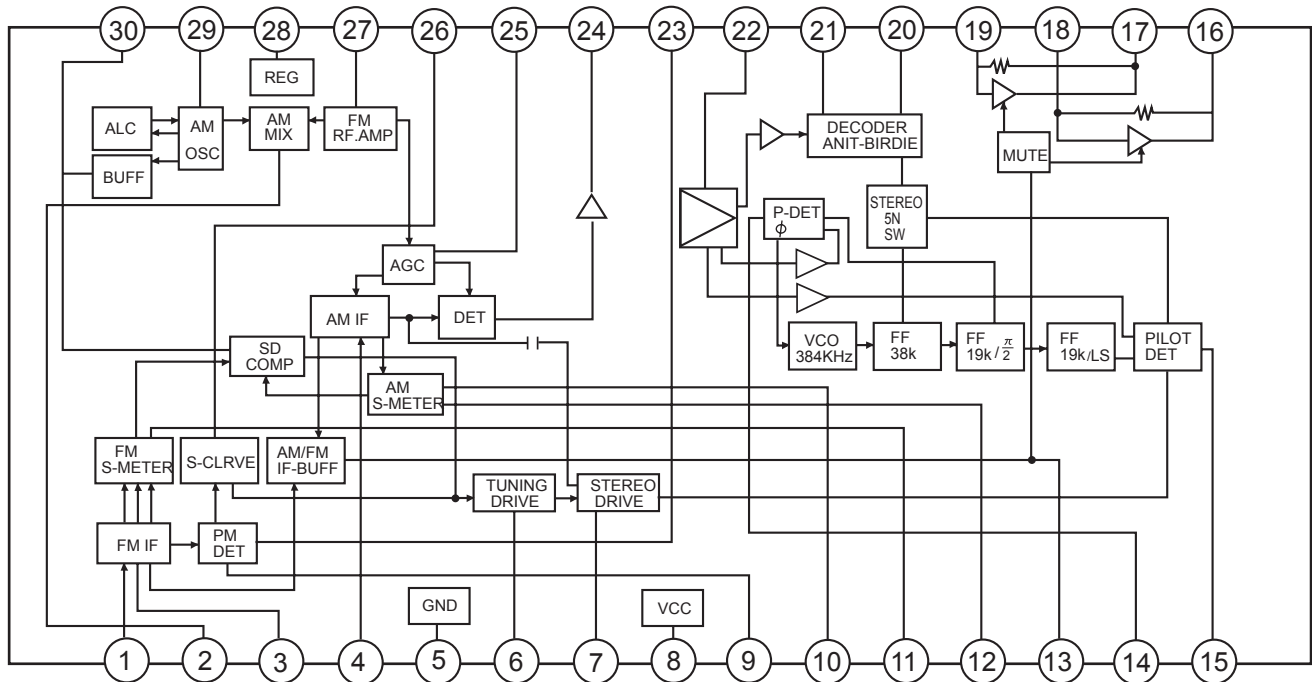

• Pin Function

Pin No.	Symbol	I/O	Function
1	FM IN	I	This is an input terminal of FM IF signal.
2	AM MIX	O	This is an out put terminal for AM mixer.
3	FM IF	I	Bypass of FM IF
4	AM IF	I	Input of AM IF Signal.
5	GND	-	This is the device ground terminal.
6	TUNED	O	When the set is tuning,this terminal becomes "L".
7	STEREO	O	Stereo indicator output. Stereo "L", Mono: "H"
8	VCC	-	This is the power supply terminal.
9	FM DET	-	FM detect transformer.
10	AM SD	-	This is a terminal of AM ceramic filter.
11	FM VSM	O	Adjust FM SD sensitivity.
12	AM VSM	O	Adjust AM SD sensitivity.
13	MUTE	I/O	When the signal of IF REQ of IC121(LC72131) appear, the signal of FM/AM IF output. //Muting control input.
14	FM/AM	I	Change over the FM/AM input. "H" :FM, "L" : AM
15	MONO/ST	O	Stereo : "H", Mono: "L"
16	L OUT	O	Left channel signal output.
17	R OUT	O	Right channel signal output.
18	L IN	I	Input terminal of the Left channel post AMP.
19	R IN	I	Input terminal of the Right channel post AMP.
20	RO	O	Mpx Right channel signal output.
21	LO	O	Mpx Left channel signal output.
22	MPX IN	I	Mpx input terminal
23	FM OUT	O	FM detection output.
24	AM DET	O	AM detection output.
25	AM AGC	I	This is an AGC voltage input terminal for AM
26	AFC	-	This is an output terminal of voltage for FM-AFC.
27	AM RF	I	AM RF signal input.
28	REG	O	Register value between pin 26 and pin28 besides the frequency width of the input signal.
29	AM OSC	-	This is a terminal of AM Local oscillation circuit.
30	OSC BUFFER	O	AM Local oscillation Signal output.

4.18 LA4628 (IC905) : Power amp.

- Pin layout

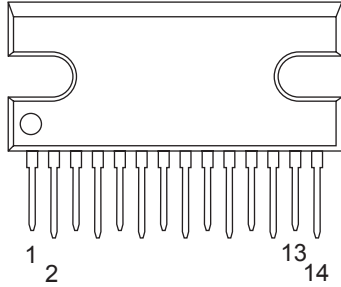

- Block diagram

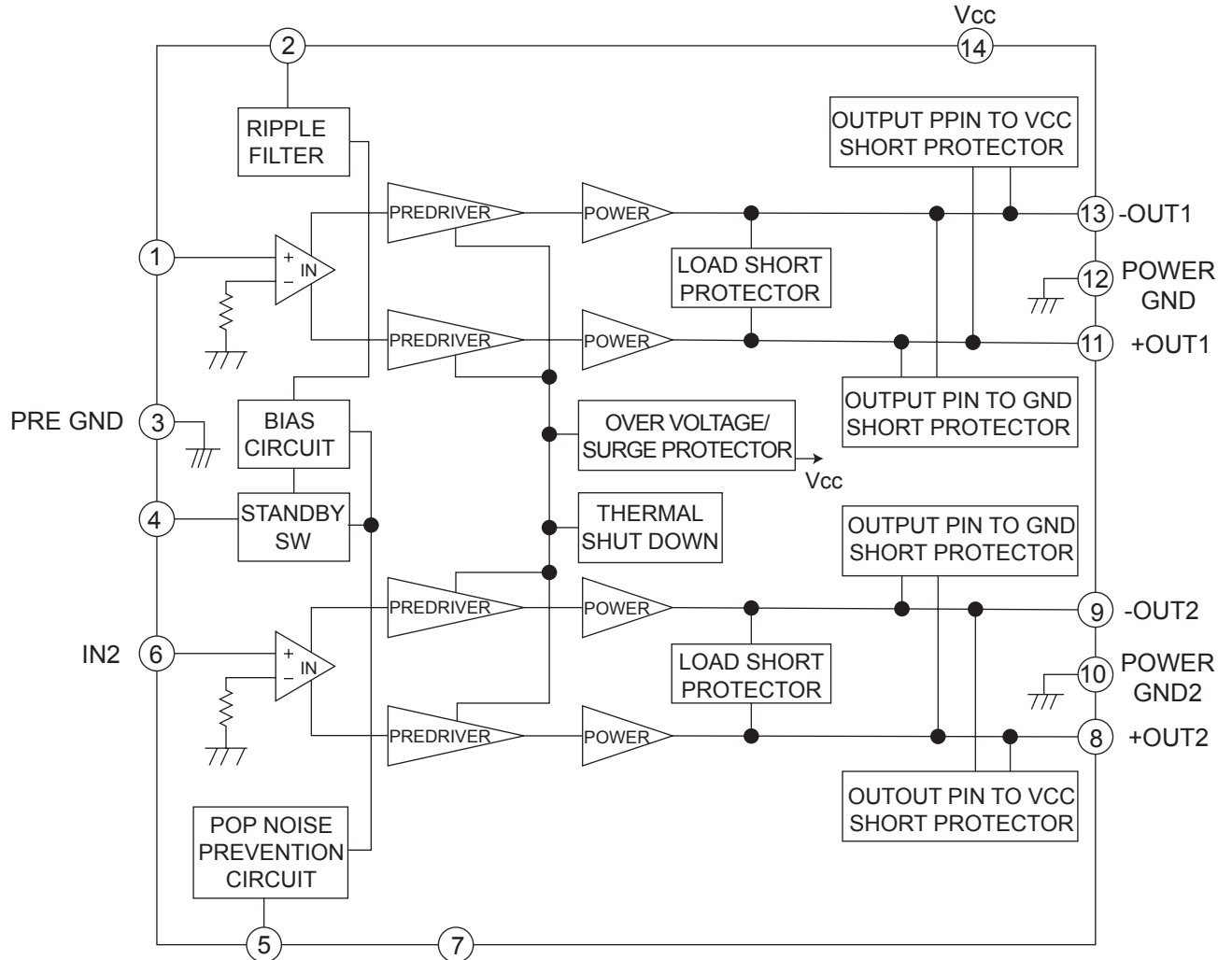

4.19 TC7S08F-W (IC340) : Buffer

- Pin layout

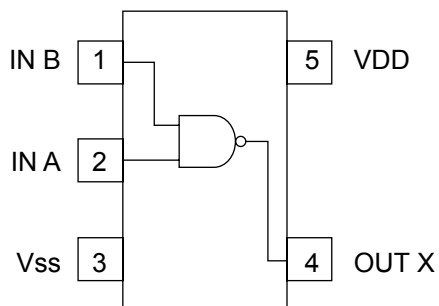

- Block diagram

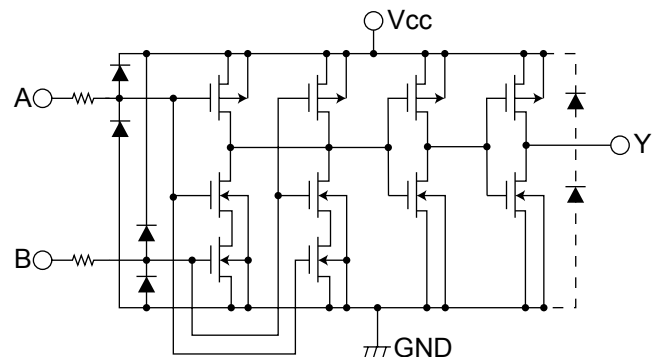

4.20 LC72136N (IC2) : PLL frequency synthesizer

- Pin layout

XT	1	22	XT
FM/AM	2	21	GND
CE	3	20	LPFOUT
DI	4	19	LPFIN
CLOCK	5	18	PD
DO	6	17	VCC
FM/ST/VCO	7	16	FMIN
AM/FM	8	15	AMIN
	9	14	
SDIN	10	13	IFCONT
	11	12	IFIN

- Block diagram

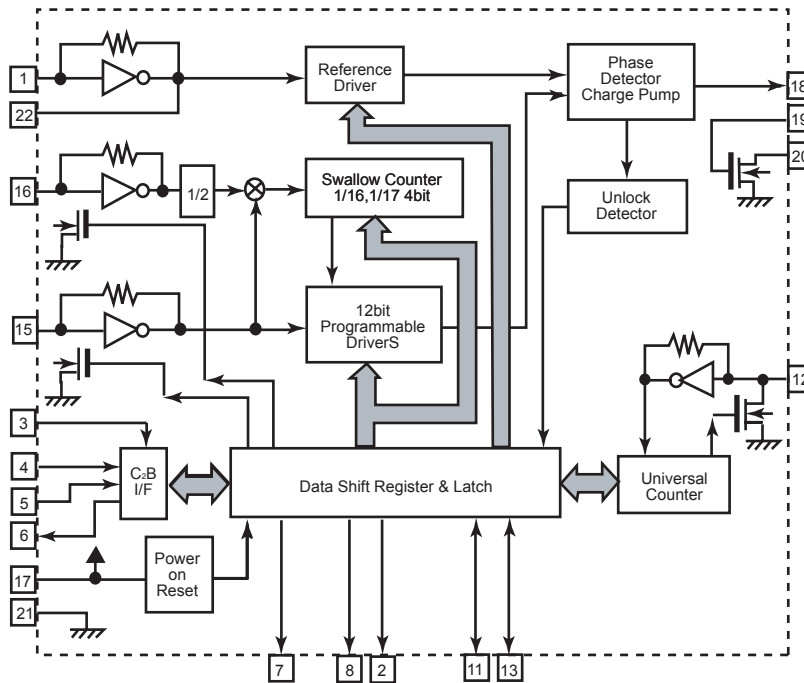

- Pin function

Pin No.	Symbol	I/O	Function
1	XT	I	X'tal oscillator connect (75kHz)
2	FM/AM	O	LOW:FM mode
3	CE	I	When data output/input for 4pin(input) and 6pin(output): H
4	DI	I	Input for receive the serial data from controller
5	CLOCK	I	Sync signal input use
6	DO	O	Data output for Controller Output port
7	FM/ST/VCO	O	Low: MW mode
8	AM/FM	O	Open state after the power on reset
9	LW	I/O	Input/output port
10	MW	I/O	Input/output port
11	SDIN	I/O	Data input/output
12	IFIN	I	IF counter signal input

Pin No.	Symbol	I/O	Function
13	IFCONT	O	IF signal output
14		-	Not use
15	AMIN	I	AM Local OSC signal output
16	FMIN	I	FM Local OSC signal input
17	VCC	-	Power supply(VDD=4.5-5.5V) When power ON:Reset circuit move
18	PD	O	PLL charge pump output (H: Local OSC frequency Height than Reference frequency.L: Low Agreement: Height impedance)
19	LPFIN	I	Input for active lowpassfilter of PLL
20	LPFOUT	O	Output for active lowpassfilter of PLL
21	GND	-	Connected to GND
22	XT	I	X'tal oscillator(75KHz)

4.21 LA6541-X (IC801) : Servo driver

• Pin layout & Block diagram

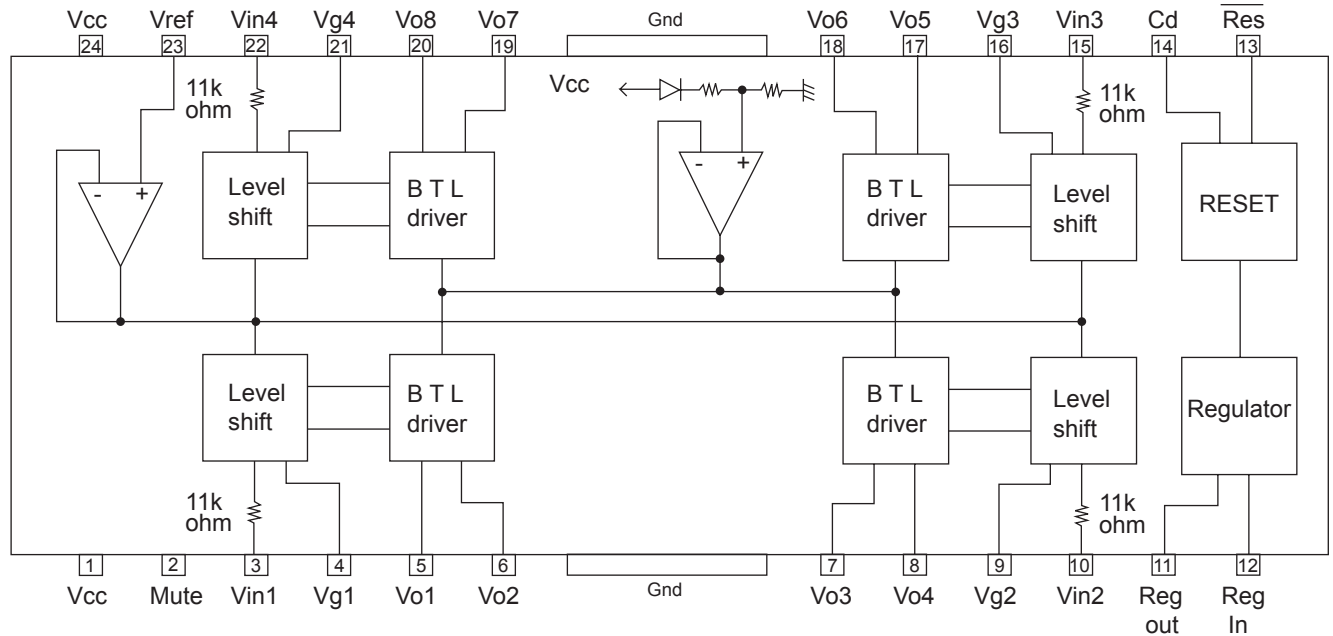

• Pin function

Pin No.	Symbol	Description
1	Vcc	Power supply (Shorted to pin 24)
2	Mute	All BTL amplifier outputs ON/OFF
3	Vin1	BTL AMP 1 input pin
4	Vg1	BTL AMP 1 input pin (For gain adjustment)
5	Vo1	BTL AMP 1 input pin (Non inverting side)
6	Vo2	BTL AMP 1 input pin (Inverting side)
7	Vo3	BTL AMP 2 input pin (Inverting side)
8	Vo4	BTL AMP 2 input pin (Non inverting side)
9	Vg2	BTL AMP 2 input pin (For gain adjustment)
10	Vin2	BTL AMP 2 input pin
11	Reg Out	External transistor collector (PNP) connection. 5V power supply output
12	Reg In	External transistor (PNP) base connection
13	Res	Reset output
14	Cd	Reset output delay time setting (Capacitor connected externally)
15	Vin3	BTL AMP 3 input pin
16	Vg3	BTL AMP 3 input pin (For gain adjustment)
17	Vo5	BTL AMP 3 output pin (Non inverting side)
18	Vo6	BTL AMP 3 output pin (Inverting side)
19	Vo7	BTL AMP 4 output pin (Inverting side)
20	Vo8	BTL AMP 4 output pin (Non inverting side)
21	Vg4	BTL AMP 4 output pin (For gain adjustment)
22	Vin4	BTL AMP 4 output pin
23	Vref	Level shift circuit's reference voltage application
24	Vcc	Power supply (Shorted to pin 1)

4.22 LA72723(IC3): RDS demodulation

• Pin layout

VREF	1	16	RDS-ID/READY
MPXIN	2	15	RDCL
Vdda	3	14	RDDA
Vssa	4	13	RST
FLOUT	5	12	MODE
CIN	6	11	Vddd
TES	7	10	Vssd
XOUT	8	9	XIN

• Block Diagram

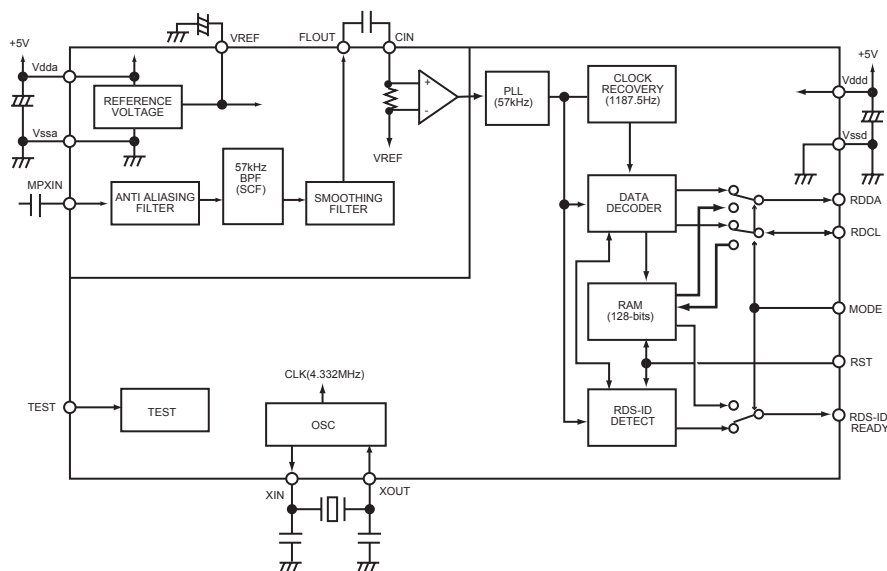

• Pin functions

Pin No.	Symbol	I/O	Function
1	VREF	O	Reference voltage output ($V_{dda}/2$)
2	MPXIN	I	Baseband (multiplexed) signal input
3	Vdda	-	Analog power supply (+5V)
4	Vssa	-	Analog ground
5	FLOUT	O	Subcarrier input (filter output)
6	CIN	I	Subcarrier input (comparator input)
7	TEST	I	Test input
8	XOUT	O	Crystal oscillator output (4.332MHz)
9	XIN	I	Crystal oscillator input (external reference input)
10	Vssd	-	Digital ground
11	Vddd	-	Digital power supply
12	MODE	I	Read mode setting (0:master, 1:slave)
13	RST	I	RDS-ID/RAM reset (positive polarity)
14	RDDA	O	RDS data output
15	RDCL	I/O	RDS clock output (master mode)/RDS clock input (slave mode)
16	RDS-ID/READY	O	RDS-ID/READY output (negative polarity)

4.23 XC62ER3602M-X (IC400) : Regulator

- Pin layout

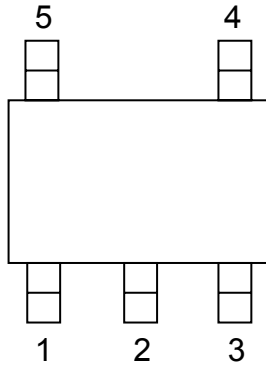

- Block diagram

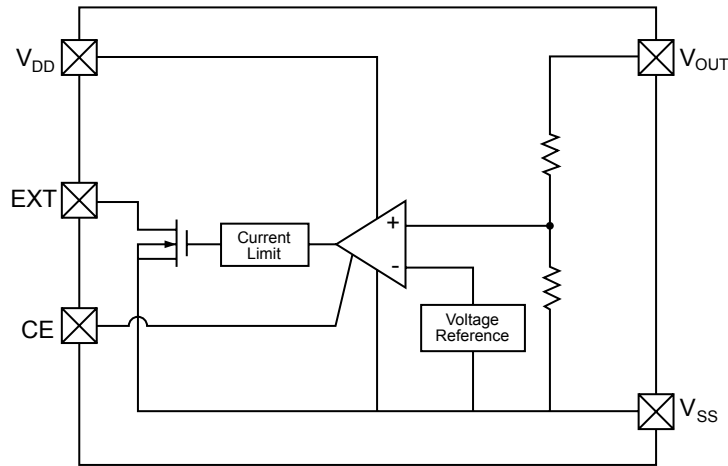

- Pin function

Pin No.	Symbol	Function
1	V _{SS}	GND
2	V _{IN}	Power supply input
3	V _{OUT}	Regulator output
4	EXT	Base current control terminal
5	CE	Chip enable

4.24 TK11140SC-W (IC485) : Regulator

- Pin layout

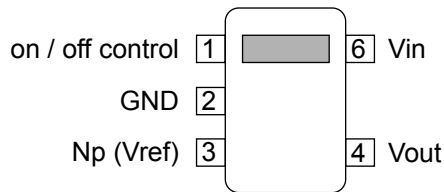

- Block diagram

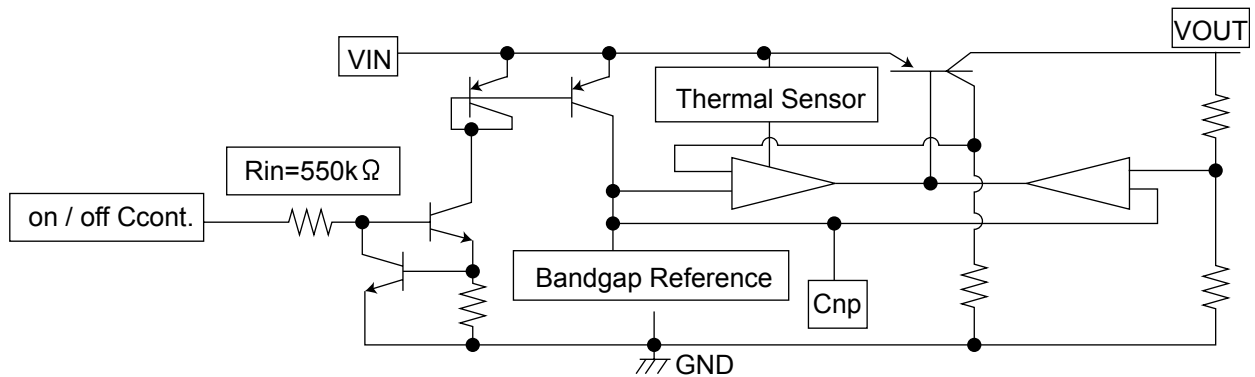

4.25 LC75345M-X (IC901) : E.volume

- Pin layout

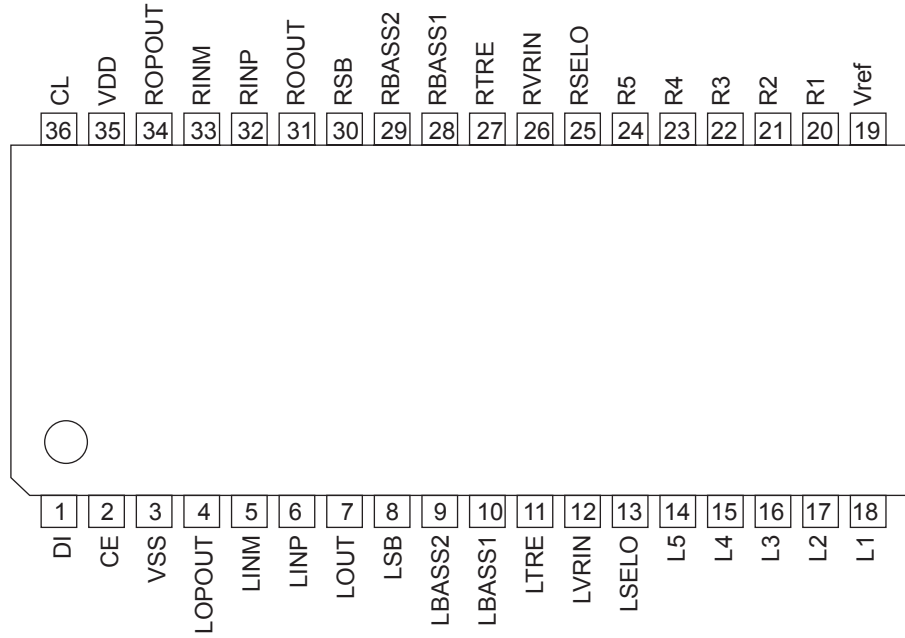

- Block diagram

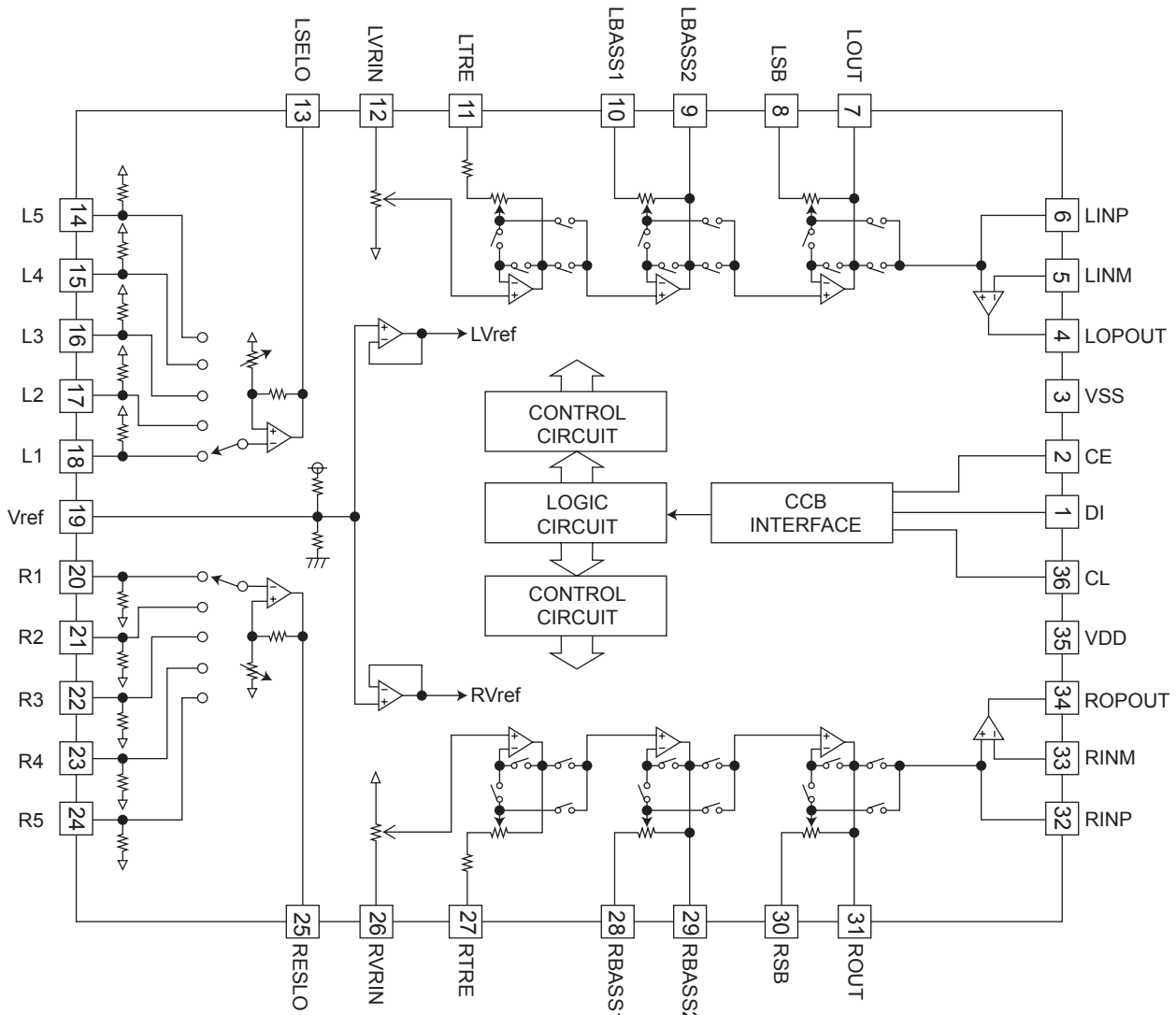

• Pin function

Pin No.	Symbol	Function
1	DI	Serial data and clock input pin for control.
2	CE	Chip enable pin.
3	VSS	Ground pin.
4	LOPOUT	Output pin of general-purpose operation amplifier.
5	LINM	Non-inverted input pin of general-purpuse operation amplifier.
6	LINP	Non-inverted input pin of general-purpuse operation amplifier.
7	LOUT	ATT + equalizer output pin.
8	LSB	Capacitor and resistor connection pin comprising filters for bass and super-bass band.
9	LBASS2	Capacitor and resistor connection pin comprising filters for bass and super-bass band.
10	LBASS1	Capacitor and resistor connection pin comprising filters for bass and super-bass band.
11	LTRE	Capacitor and resistor connection pin comprising treble band filter.
12	LVRIN	Volume input pin.
13	LSELO	Input selector output pin.
14	L5	Input signal pin.
15	L4	Input signal pin.
16	L3	Input signal pin.
17	L2	Input signal pin.
18	L1	Input signal pin.
19	Vref	0.5 x VDD voltage generation block for analog ground.
20	R1	Input signal pin.
21	R2	Input signal pin.
22	R3	Input signal pin.
23	R4	Input signal pin.
24	R5	Input signal pin.
25	RSELO	Input selector output pin.
26	RVRIN	Volume input pin.
27	RTRE	Capacitor connection pin comprising treble band filter.
28	RBASS1	Capacitor and resistor connection pin comprising filter for bass and super-bass band.
29	RBASS2	Capacitor and resistor connection pin comprising filter for bass and super-bass band.
30	RSB	Capacitor and resistor connection pin comprising filter for bass and super-bass band.
31	ROUT	ATT + equalizer output pin.
32	RINP	Non inverted input pin of general-purpose operation amplifier.
33	RINM	Non inverted input pin of general purpose operation amplifier.
34	ROPOUT	Output pin of general-purpose operation amplifier.
35	VDD	Supply pin.
36	CL	Serial data and clock input pin for control.



VICTOR COMPANY OF JAPAN, LIMITED
AV & MULTIMEDIA COMPANY 10-1, 1chome, Ohwatari-machi, Maebashi-city, 371-8543, Japan

(No.22042)



Printed in Japan
200302WPC

JVC

SCHEMATIC DIAGRAMS

MICRO COMPONENT MD SYSTEM

UX-Z7MDR

CD-ROM No.SML200302

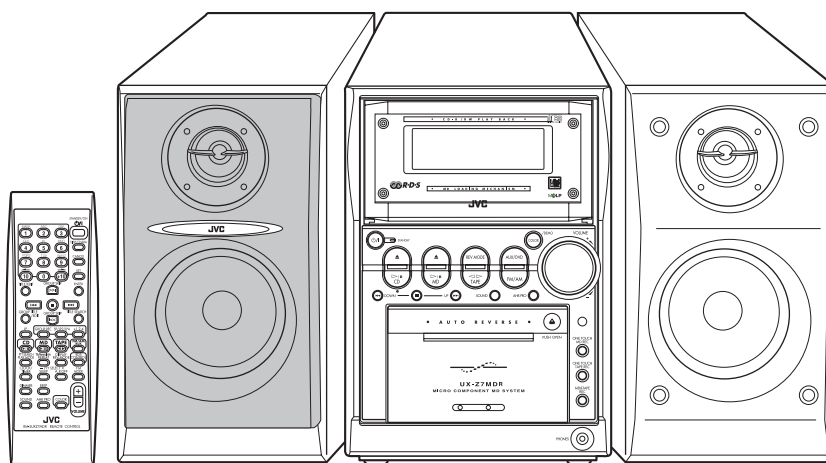

R-D-S

MDLP

**Mini
Disc**

**COMPACT
disc
DIGITAL AUDIO**

Area Suffix

E ----- Continental Europe

Contents

Block diagram	2-1
Standard schematic diagrams	2-2
Printed circuit boards	2-9~12

In regard with component parts appearing on the silk-screen printed side (parts side) of the PWB diagrams, the parts that are printed over with black such as the resistor (■), diode (⬤) and ICP (●) or identified by the "⚠" mark nearby are critical for safety.

(This regulation does not correspond to J and C version.)

Block diagram

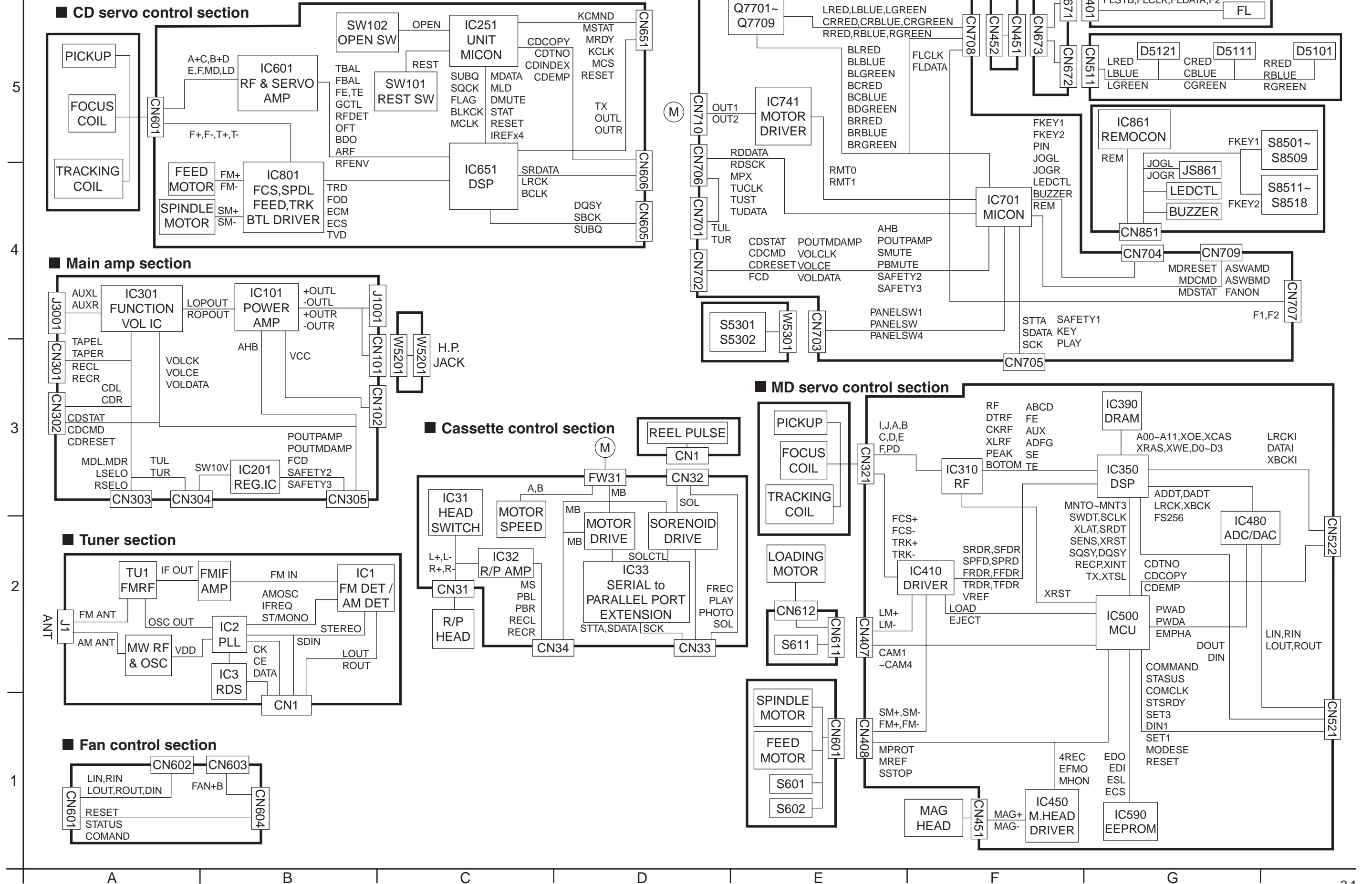

Standard schematic diagrams

Main amp section

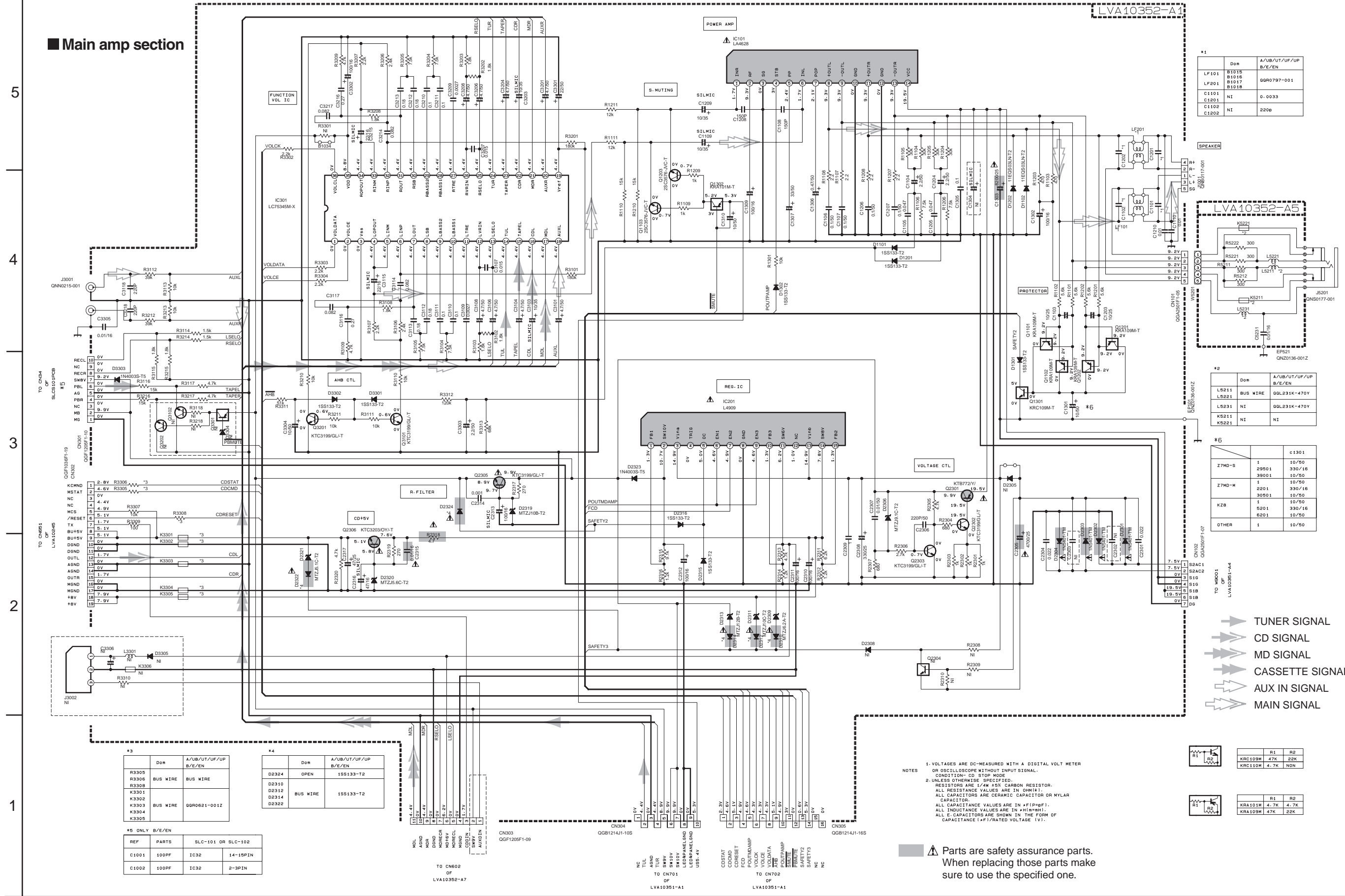

#1	Dom	A/UB/UT/UF/UP B/E/EN
LF101	B1015	
LF201	B1016	
	B1017	00R0797-001
	B1018	
C1101	NI	0.0033
C1201	NI	
C1102	NI	
C1202	NI	220p

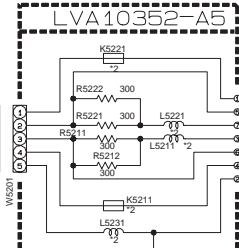

#2	Dom	A/UB/UT/UF/UP B/E/EN
L5211	BUS WIRE	G0L231K-470Y
L5212	BUS WIRE	G0L231K-470Y
L5213	NI	NI
K5211	NI	NI
K5221	NI	NI

#3	Dom	A/UB/UT/UF/UP B/E/EN
7ZMD-S	1	10/50
	2	390/16
	3	900/1
7ZMD-H	1	10/50
	2	390/16
	3	3050/1
KZ8	5201	10/50
	6201	10/50
OTHER	1	10/50

- ➔ TUNER SIGNAL
- ➔ CD SIGNAL
- ➔ MD SIGNAL
- ➔ CASSETTE SIGNAL
- ➔ AUX IN SIGNAL
- ➔ MAIN SIGNAL

#3	Dom	A/UB/UT/UF/UP B/E/EN
R3305	BUS WIRE	BUS WIRE
R3306	BUS WIRE	BUS WIRE
R3308	NI	
K3301	NI	00R0621-001Z
K3302	BUS WIRE	
K3303	BUS WIRE	
K3304	NI	
K3305	NI	

#5 ONLY B/E/EN	REF	PARTS	SLC-101 OR SLC-102
	C1001	100PF	IC32
	C1002	100PF	IC32

NOTES
 1. VOLTAGES ARE DC-MEASURED WITH A DIGITAL VOLT METER OR OSCILLOSCOPE WITHOUT INPUT SIGNAL.
 CONDITION: CD STOP MODE
 2. UNLESS OTHERWISE SPECIFIED:
 RESISTORS ARE 1/4W ±5% CARBON RESISTOR.
 ALL RESISTANCE VALUES ARE IN OHM(Ω).
 ALL CAPACITORS ARE CERAMIC CAPACITOR OR MYLAR CAPACITOR.
 ALL CAPACITANCE VALUES ARE IN pF(pF) OR μF(μF).
 ALL INDUCTANCE VALUES ARE IN mH(mH).
 ALL E-CAPACITORS ARE SHOWN IN THE FORM OF CAPACITANCE 1 x F1/RATED VOLTAGE (V).

⚠ Parts are safety assurance parts.
 When replacing those parts make
 sure to use the specified one.

5

4

3

2

1

A B C D E F G H

FL & Key control section

5

4

3

2

1

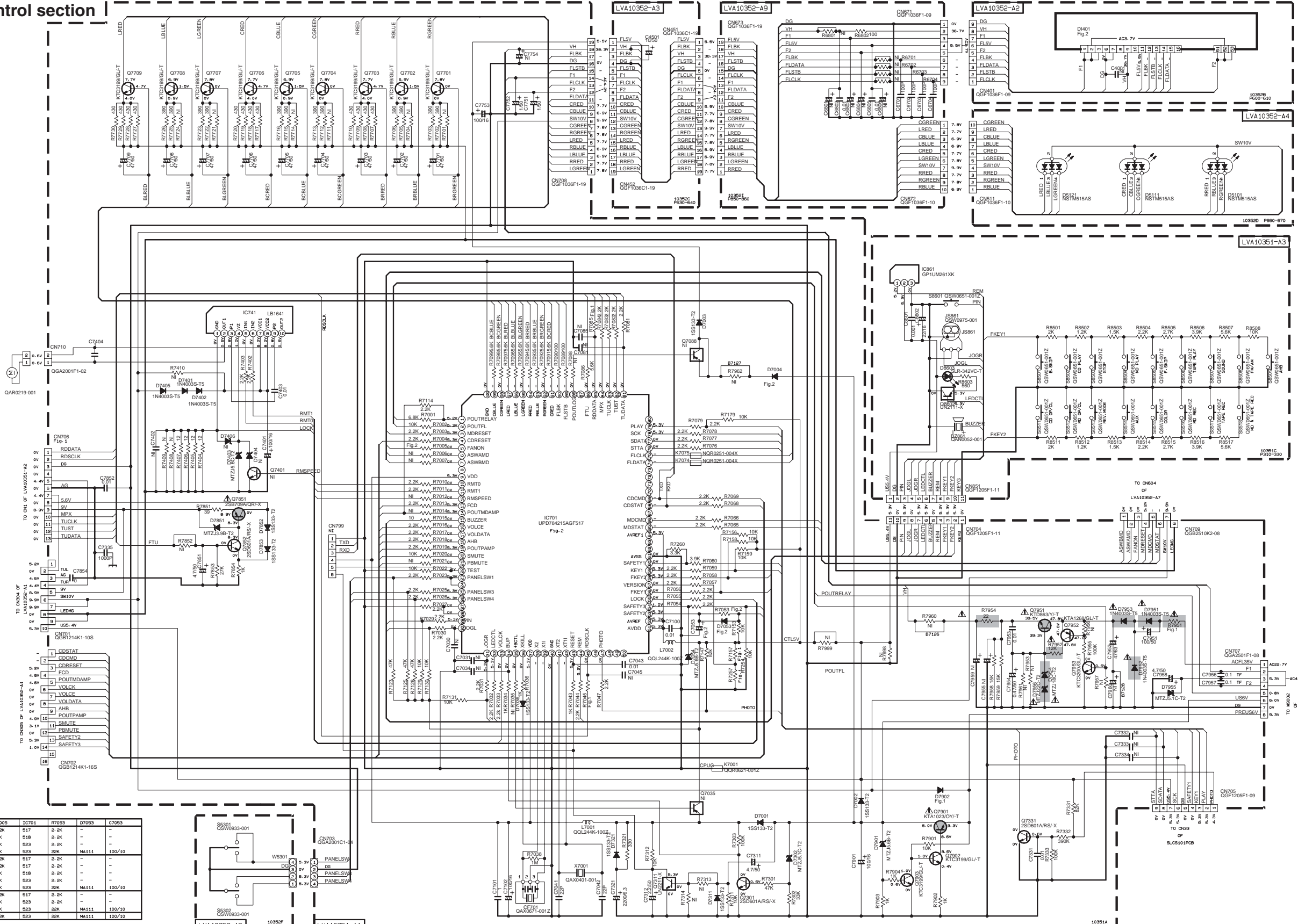

Fig. 2

770-S	D1401	D7004	R7005	C7011	R7053	D7053	C7053
1	-001	-	517	2.2K	517	2.2K	-
29501	-002	-	1.3K	518	2.2K	-	-
31400	-002	-	1.3K	523	2.2K	-	-
39001	-002	MA700A	1.3K	523	2.2K	MA111	100/10
770-H	-001	-	2.2K	517	2.2K	-	-
22001	-002	-	2.2K	517	2.2K	-	-
23501	-002	-	1.3K	518	2.2K	-	-
25270	-002	-	1.3K	523	2.2K	-	-
30501	-002	MA700A	1.3K	523	2.2K	MA111	100/10
K2B	-001	-	2.2K	517	2.2K	-	-
5201	-002	-	1.3K	523	2.2K	-	-
6201	-002	MA700A	1.3K	523	2.2K	MA111	100/10
D7902	-001	-	2.2K	517	2.2K	-	-
D7951	33	MA700A	2.2K	523	2.2K	MA111	100/10

Fig. 1

Ver.10R	770-S/770-H/UX-K2MD-H	KT-UX7	E/V/B	UB/UP/UF	A	UT
R7197	OPEN	30K	10K	0.1K	0.1K	10K
R7257	10K	10K	OPEN	10K	10K	10K
CN706	QGF1205F1-09	QGF1205F1-09	QGF1205F1-13	QGF1205F1-09	QGF1205F1-09	QGF1205F1-09
R7045	OPEN	OPEN	1K	1K	1K	1K
R7085	OPEN	OPEN	2.2K	2.2K	2.2K	2.2K
D7902	185133-T2	185133-T2	185133-T2	185133-T2	185133-T2	OPEN
R7951	33	33	4.7	4.7	4.7	4.7

NOTES

- VOLTAGES ARE DC-MEASURED WITH A DIGITAL VOLT METER WITHOUT INPUT SIGNAL. CONDITION: CD STOP MODE /A/B OFF/COLOR MANUAL/NO TAPE
- UNLESS OTHERWISE SPECIFIED, ALL RESISTANCE VALUES ARE IN OHM(S). ALL CAPACITORS ARE 50V CERAMIC CAPACITOR. ALL CAPACITANCE VALUES ARE IN nF (PF). ALL E-CAPACITORS ARE SHOWN IN THE FORM OF CAPACITANCE (nF)/RATED VOLTAGE (V). ALL INDUCTANCE VALUES ARE IN mH (mH).

■ PARTS ARE SAFETY ASSURANCE PARTS. WHEN REPLACING THOSE PARTS MAKE SURE TO USE THE SPECIFIED ONE.

Primary section

5
4
3
2
1

VER: ALL

VER: E, EN, B, UB, UP, UF

	B9021	B9022
E, EN, B	-	o
UB, UP, UF	o	-

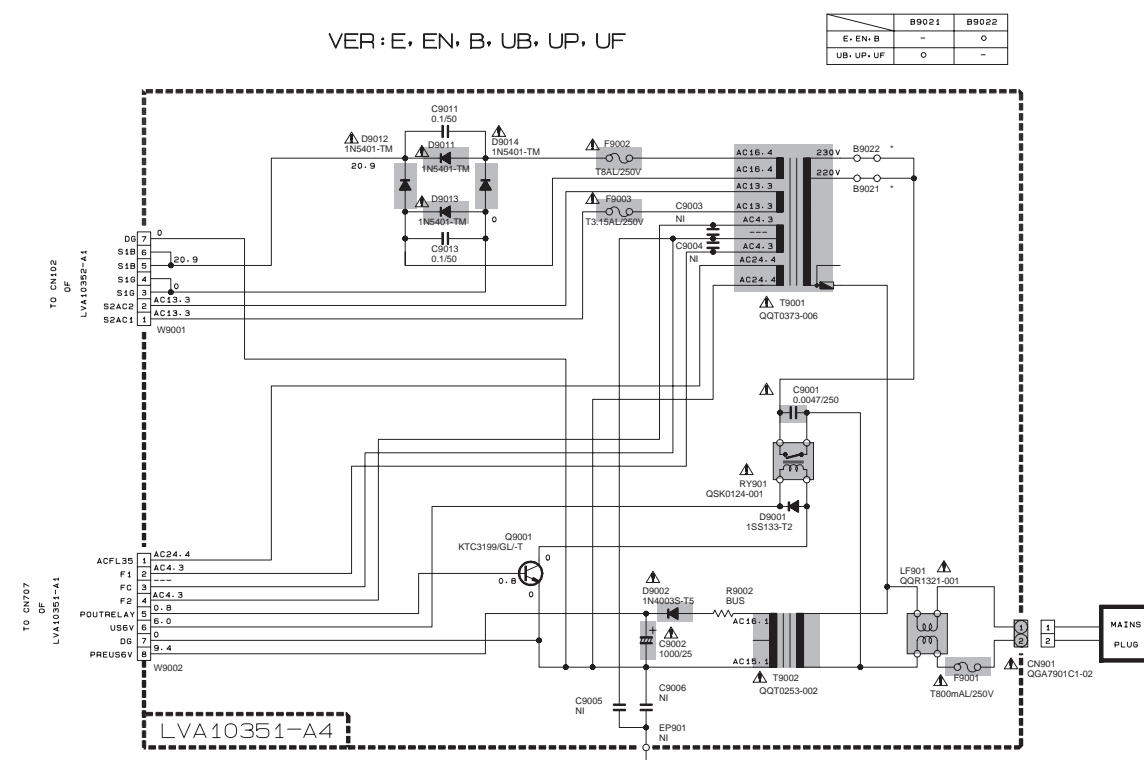
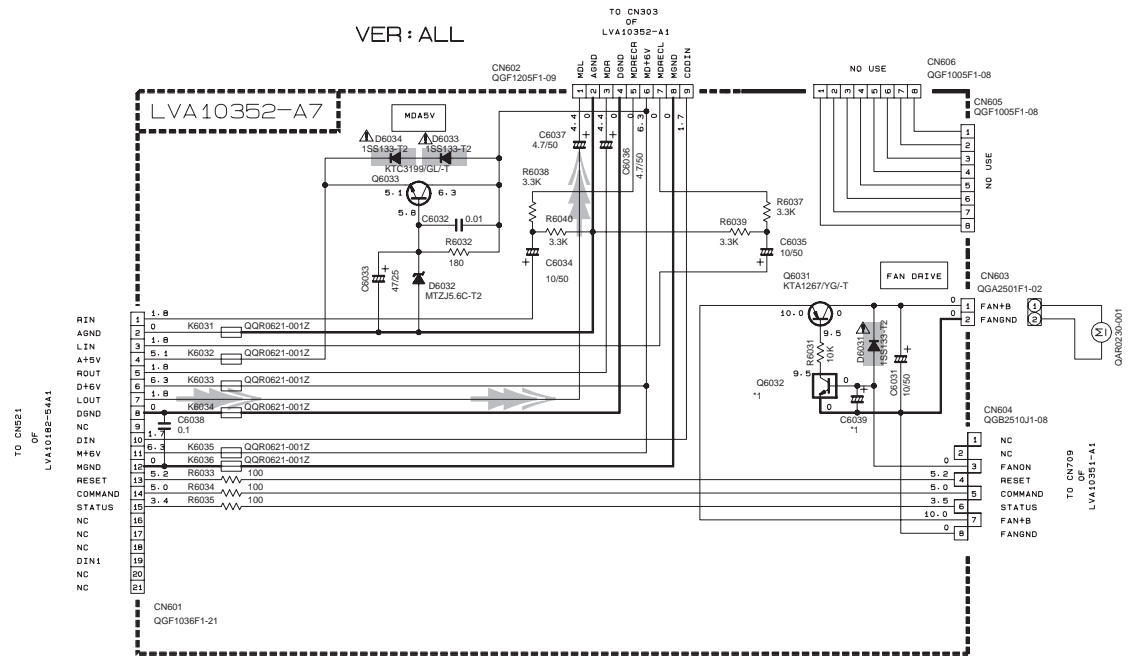

MD SIGNAL

	C6039	Q6032
Z7MD-S	1	-
	29501	1000/6.3
	35001	-
Z7MD-M	1	-
	29501	1000/6.3
	28501	-
K2B	1	-
	RCH0	1000/6.3
	S201	-
OTHER	1	-
	-	KRC102M-T

Parts are safety assurance parts. When replacing those parts make sure to use the specified one.

NOTES

- VOLTAGES ARE DC-MEASURED WITH A DIGITAL VOLT METER OR OSCILLOSCOPE WITHOUT INPUT SIGNAL. CONDITION- CD STOP MODE
- UNLESS OTHERWISE SPECIFIED, RESISTORS ARE 1/4W ±5% CARBON RESISTOR. ALL RESISTANCE VALUES ARE IN OHM(Ω). ALL CAPACITORS ARE CERAMIC CAPACITOR OR MYLAR CAPACITOR. ALL CAPACITANCE VALUES ARE IN μF(P+PF). ALL INDUCTANCE VALUES ARE IN mH(mH). ALL E-CAPACITORS ARE SHOWN IN THE FORM OF CAPACITANCE (μF)/RATED VOLTAGE (V).

Tuner section

CONDITION	PIN NO.	1	2	3	4	5	6	7	8	9	10	11	12	13	14	15	16	17	18	19	20	21	22	23	24	25	26	27	28	29	30
IC1	FM NO SIGNAL	3.6	8.9	3.6	3.6	0	5.0	5.0	8.9	8.9	1.3	0.1	0	0.9	7.8	7.8	4.3	4.3	4.3	4.3	3.4	3.4	2.8	3.4	0	0	3.5	3.5	3.6	3.6	2.7
	FM 60dB STEREO	3.6	8.9	3.6	3.6	0	5.0	5.0	8.9	8.9	1.3	4.3	0	0.9	7.8	7.8	4.3	4.3	4.3	4.3	3.4	3.4	2.8	3.4	0	0	3.6	3.6	3.6	3.6	2.7
	AM NO SIGNAL	3.5	9.0	3.5	3.5	0	5.0	5.1	9.0	2.6	1.3	0	0	0.9	4.7	5.5	4.3	4.3	4.3	4.3	3.3	3.2	2.8	3.4	0.7	0.7	3.6	3.6	3.6	3.6	2.1
IC2	FM NO SIGNAL	2.5	0	0	5.0	4.9	5.0	7.9	7.8	3.6	6.1	5.1	0	0	0	0	2.5	5.1	0.9	0.9	3.6	0	2.3								

Tr. NO.	Q1	Q5
PIN NO.	E C B	E C B
FM 87.5MHz NO SIGNAL	0 7.1 0.85	8.9 8.8 0
AM 52KHz NO SIGNAL	0 0 0	9.0 0 8.9

Tr. NO.	Q2	Q3	Q4
PIN NO.	E C B	E C B	E C B
AM 52KHz NO SIGNAL	0 0 0	0.7 0 0	0.7 0 3.6
AM 144KHz NO SIGNAL	0 0 0	0.3 0 0.3	0.3 3.6 3.6

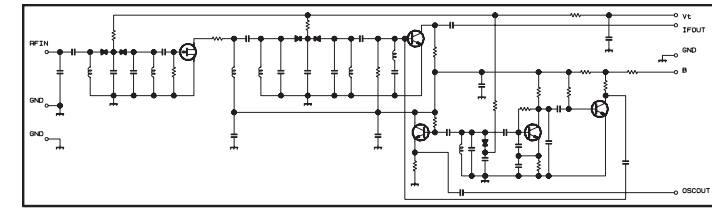

5

4

3

2

1

LVA10351-A2

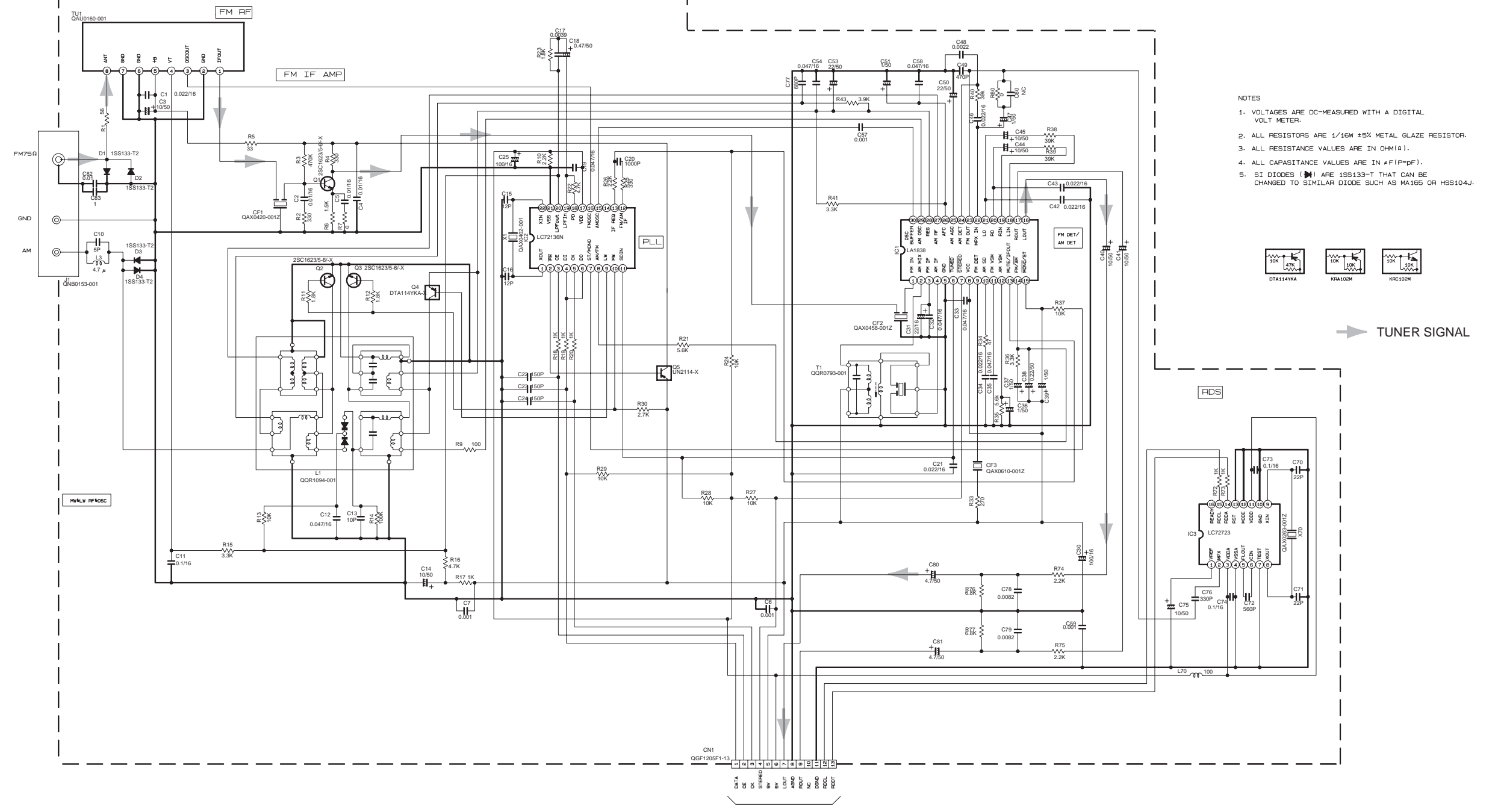

- NOTES
1. VOLTAGES ARE DC-MEASURED WITH A DIGITAL VOLT METER.
 2. ALL RESISTORS ARE 1/16W ±5% METAL GLAZE RESISTOR.
 3. ALL RESISTANCE VALUES ARE IN Ω(M).
 4. ALL CAPACITANCE VALUES ARE IN P(F) (P=pF).
 5. SI DIODES (D) ARE 1SS133-T THAT CAN BE CHANGED TO SIMILAR DIODE SUCH AS MA165 OR HSS104J.

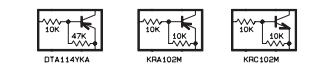

TUNER SIGNAL

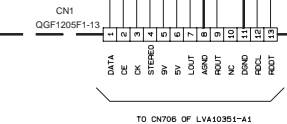

A | B | C | D | E | F | G

MD servo control section

5

4

3

2

1

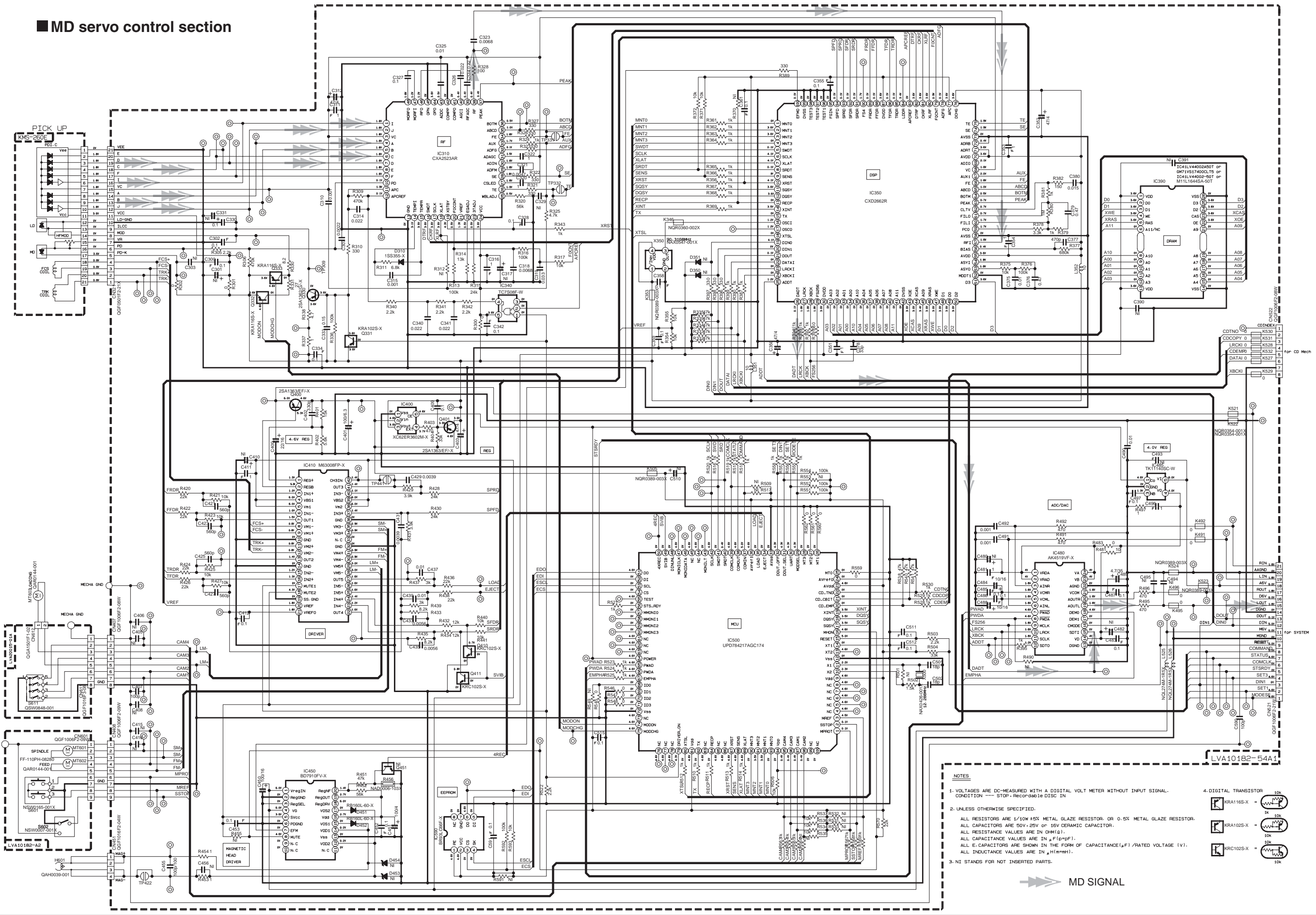

- NOTES**
1. VOLTAGES ARE DC-MEASURED WITH A DIGITAL VOLT METER WITHOUT INPUT SIGNAL. CONDITION — STOP - Recordable DISC IN
 2. UNLESS OTHERWISE SPECIFIED. ALL RESISTORS ARE 1/10W ±5% METAL GLAZE RESISTOR. OR 0.5% METAL GLAZE RESISTOR. ALL CAPACITORS ARE 50V, 25V OR 16V CERAMIC CAPACITOR. ALL RESISTANCE VALUES ARE IN OHM(Ω). ALL CAPACITANCE VALUES ARE IN pF(pF). ALL ELECTROLYTIC CAPACITORS ARE SHOWN IN THE FORM OF CAPACITANCE(μF)/RATED VOLTAGE (V). ALL INDUCTANCE VALUES ARE IN μH(μH).
 3. NI STANDS FOR NOT INSERTED PARTS.
4. DIGITAL TRANSISTOR
- KRA116S-X =
 - KRA102S-X =
 - KRC102S-X =

MD SIGNAL

CD servo control section

5

4

3

2

1

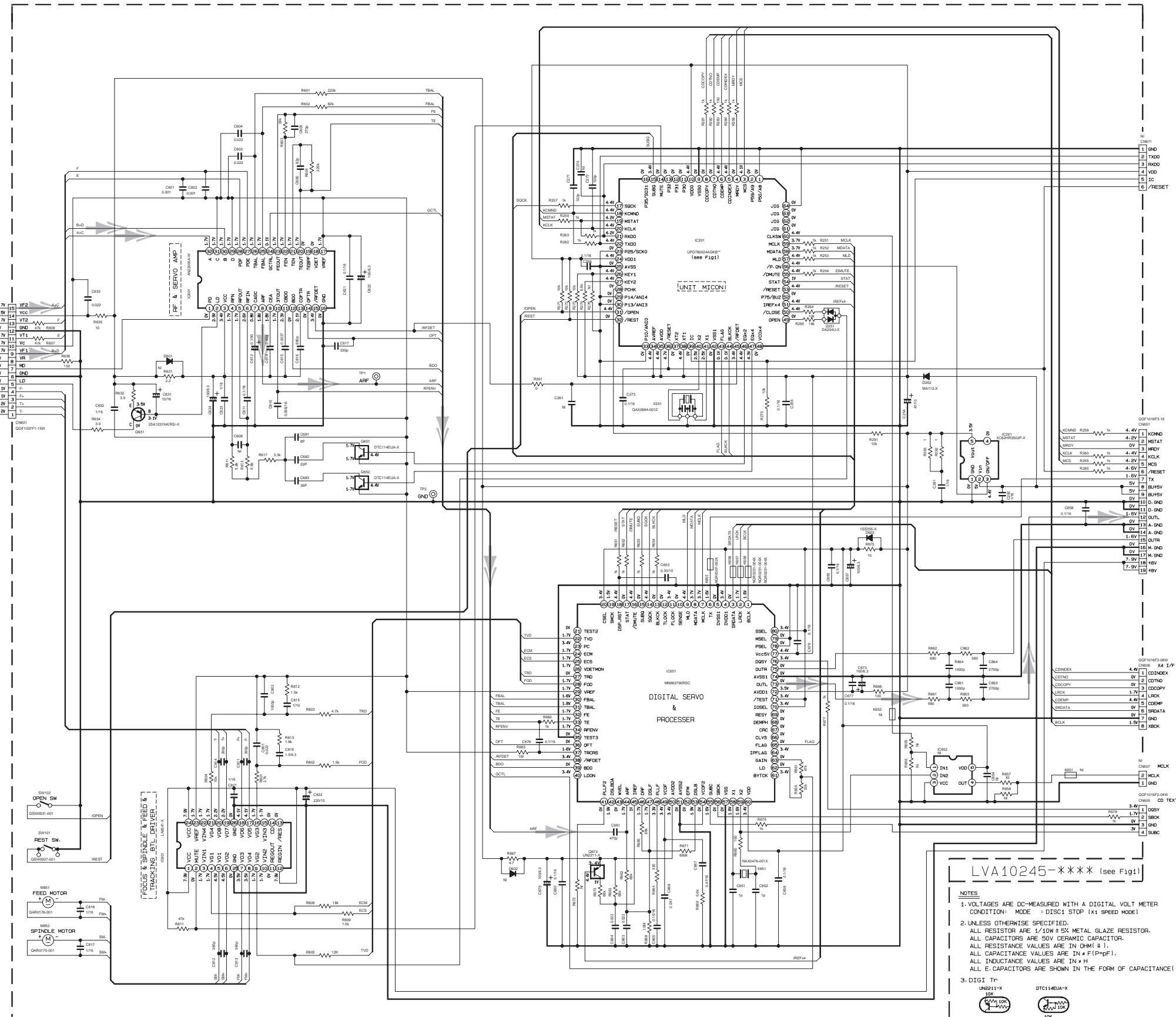
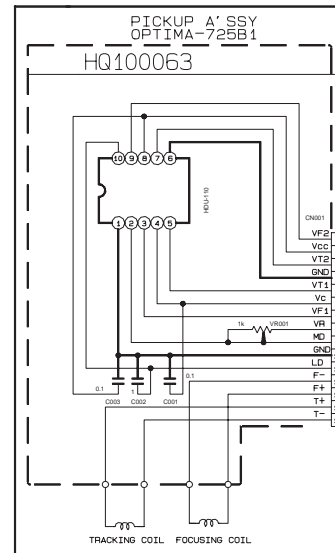

FOR FLASH MICON

TO AMP

LVA10245-**** (see Fig1)

- NOTES
- VOLTAGES ARE DC-MEASURED WITH A DIGITAL VOLT METER CONDITION: MODE = DISC1 STOP (x1 SPEED MODE)
 - UNLESS OTHERWISE SPECIFIED, ALL RESISTORS ARE 1/10W ± 5% METAL GLAZE RESISTOR. ALL CAPACITORS ARE 50V CERAMIC CAPACITOR. ALL RESISTANCE VALUES ARE IN OHM (Ω). ALL CAPACITANCE VALUES ARE IN μF (P=PF).
 - DIGIT. TP: UNLESS OTHERWISE SPECIFIED, ALL CAPACITANCE VALUES ARE IN μF (P=PF). ALL E-CAPACITORS ARE SHOWN IN THE FORM OF CAPACITANCE / RATED VOLTAGE (V).

➔ CD SIGNAL

Fig1

Ass'y NO.	MODEL	PARTS NO
LVA10245-11A	FMU-N1-1.N1H-1.N1H-2	UPD780024AGKB21
LVA10245-131A	FMU-N1-31	UPD780024AGKB63

A B C D E F G

Cassette mechanism control section

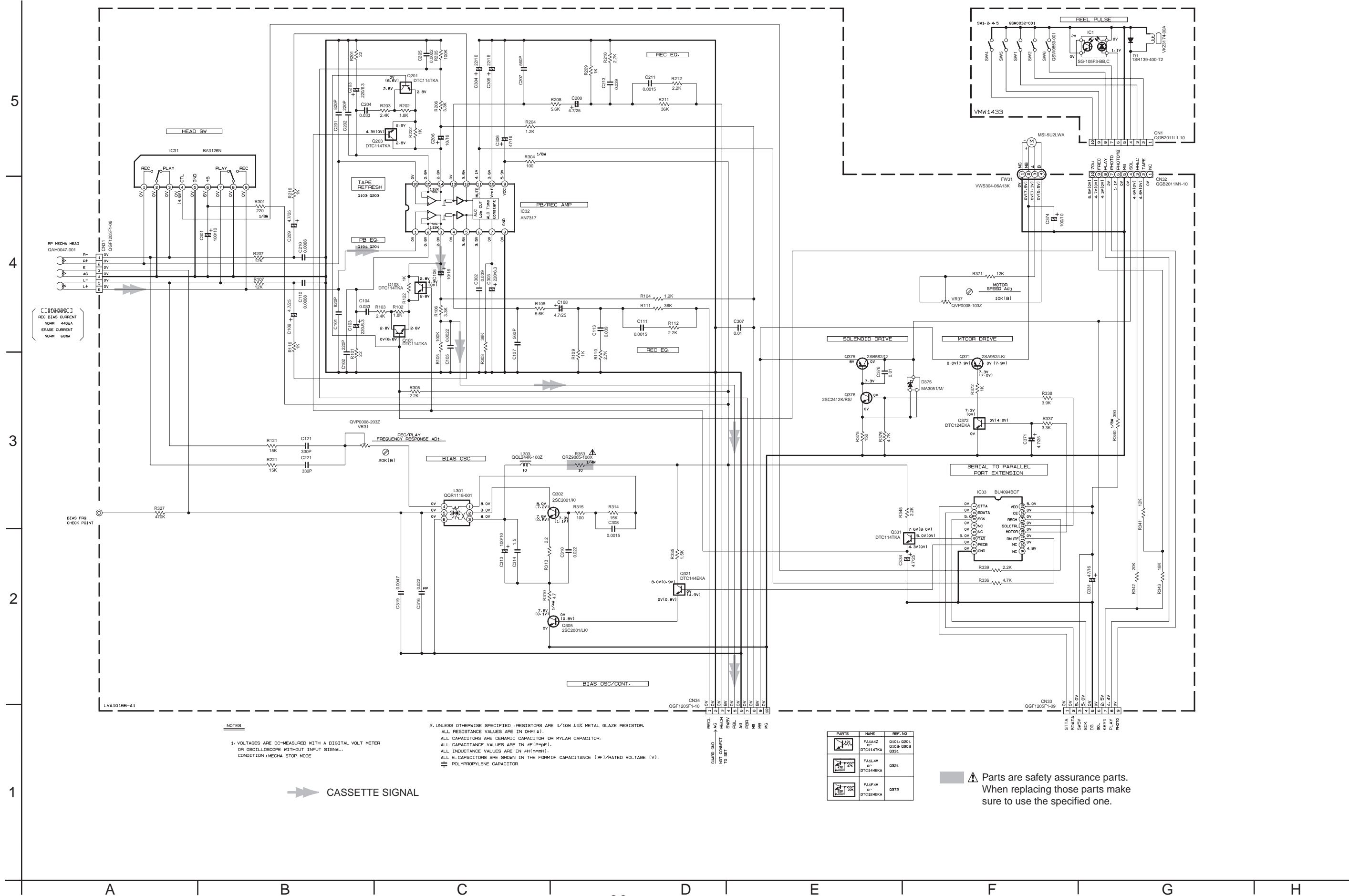

NOTES

- VOLTAGES ARE DC-MEASURED WITH A DIGITAL VOLT METER OR OSCILLOSCOPE WITHOUT INPUT SIGNAL. CONDITION : MECHA STOP MODE.
- UNLESS OTHERWISE SPECIFIED, RESISTORS ARE 1/10W ±5% METAL GLAZE RESISTOR. ALL RESISTANCE VALUES ARE IN OHM(Ω). ALL CAPACITORS ARE CERAMIC CAPACITOR OR MYLAR CAPACITOR. ALL CAPACITANCE VALUES ARE IN PICO(F). ALL INDUCTANCE VALUES ARE IN MILLI(MH). ALL C CAPACITORS ARE SHOWN IN THE FORM OF CAPACITANCE (C) / RATED VOLTAGE (V). POLYPROPYLENE CAPACITOR

CASSETTE SIGNAL

FIGURE	NAME	REF. NO.
F114Z	DTC114TKA	G101-G103
F114M	DTC144EKA	G301
F114N	DTC124EKA	G372

Parts are safety assurance parts. When replacing those parts make sure to use the specified one.

5

4

3

2

1

Printed circuit boards

■ Main board

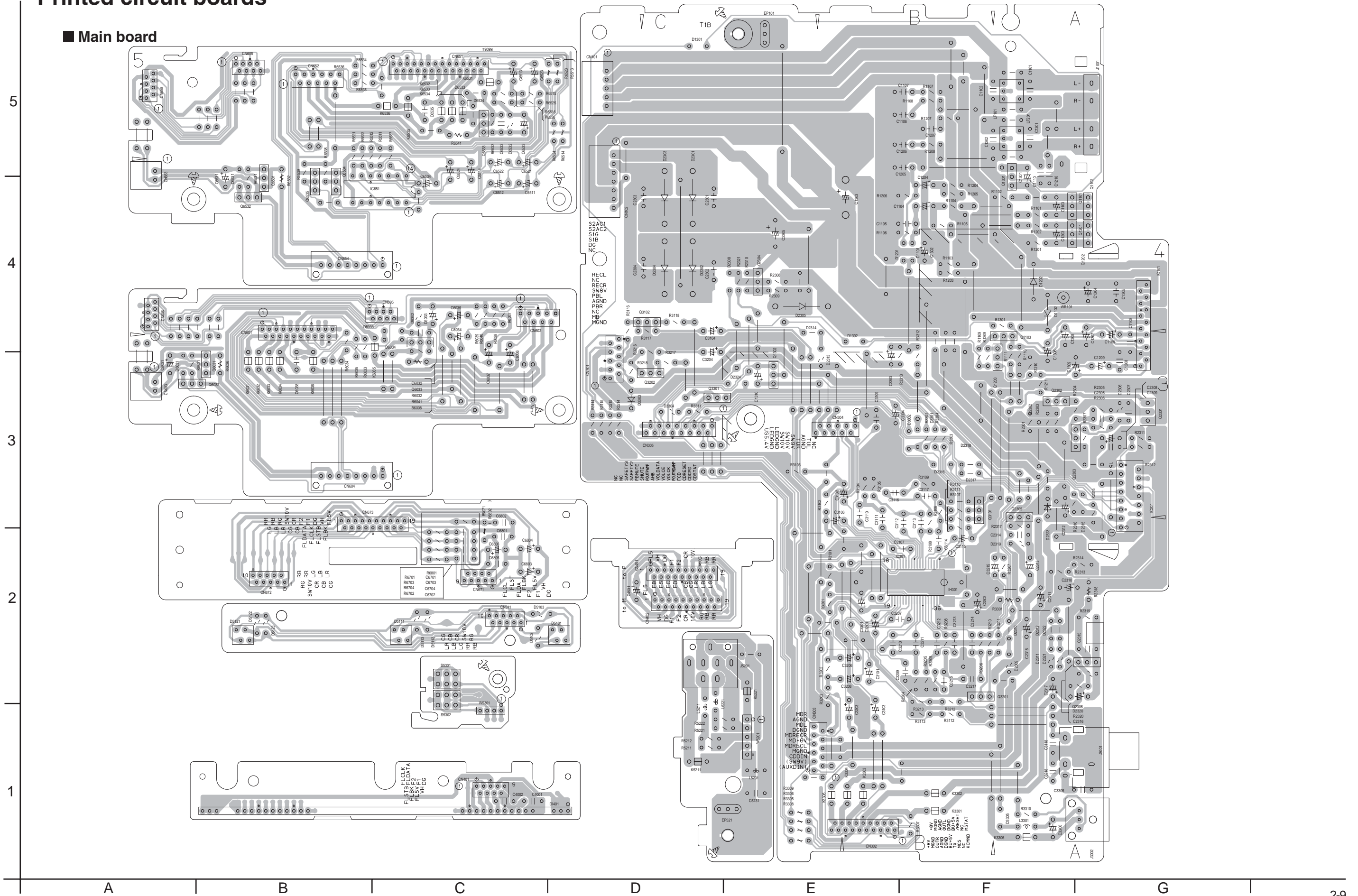

Micon board

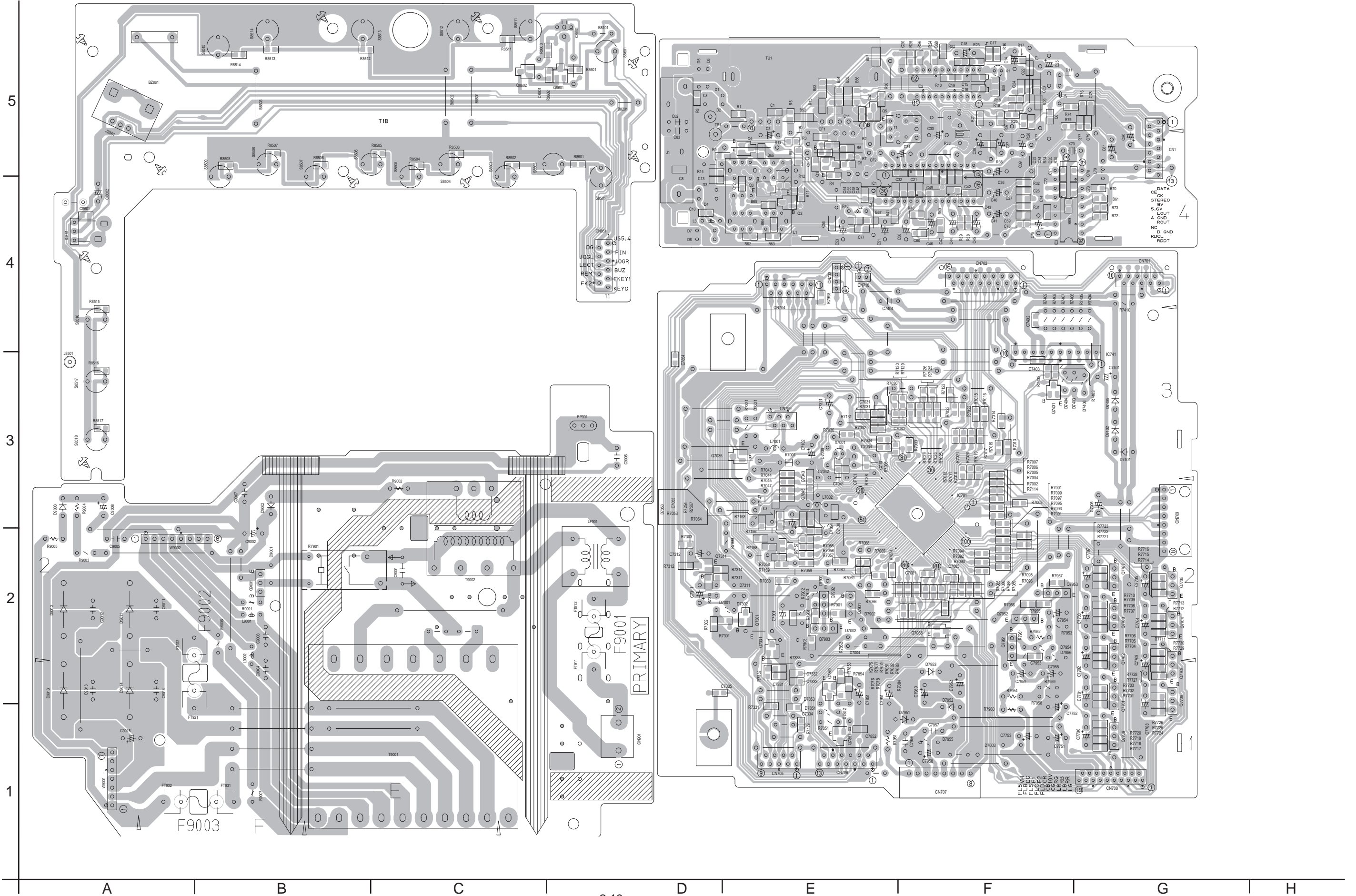

■ Traverse mechanism board (Forward side)

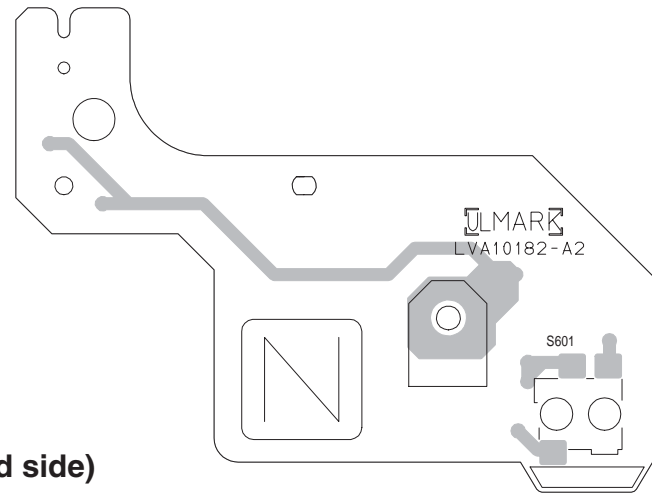

■ Traverse mechanism board (Reverse side)

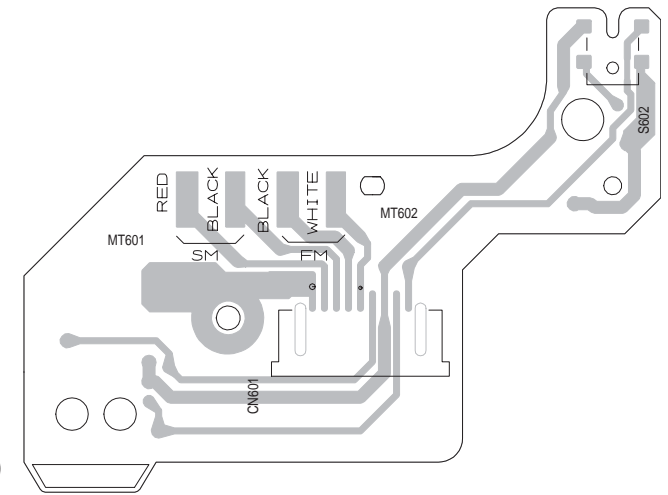

■ MD servo board (Forward side)

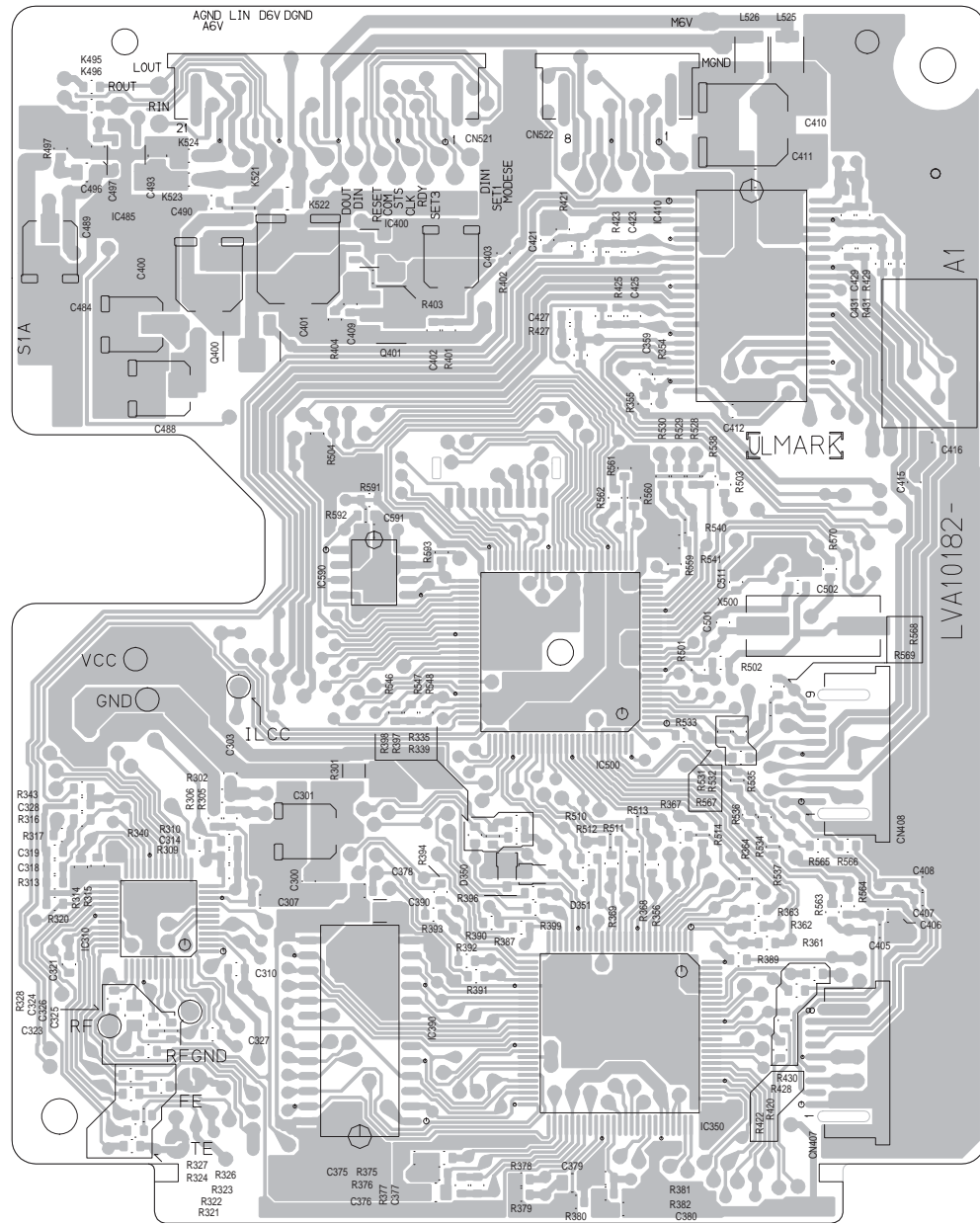

■ MD servo board (Reverse side)

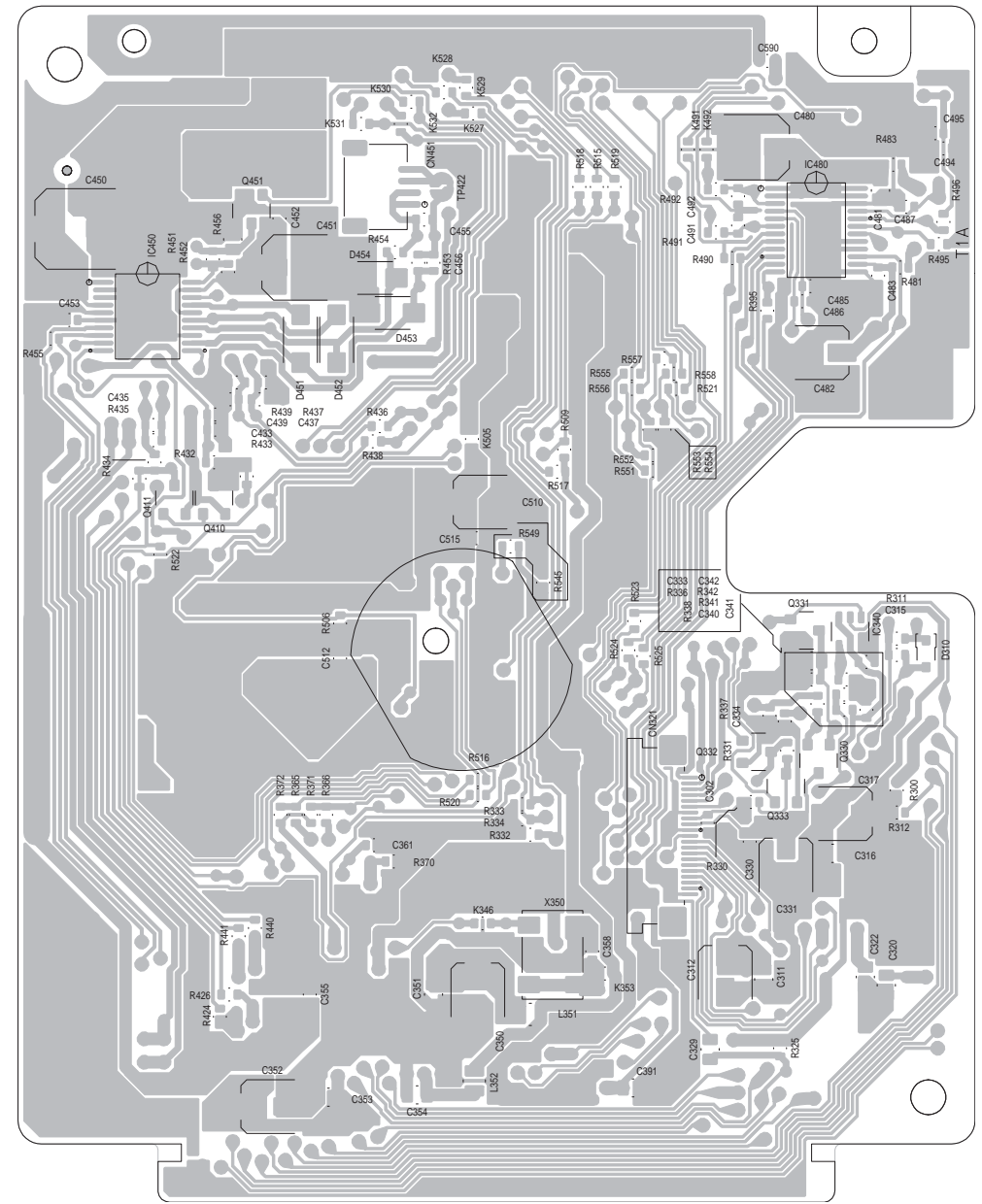

5
4
3
2
1

A | B | C | D | E | F | G

■ CD servo board (Forward side)

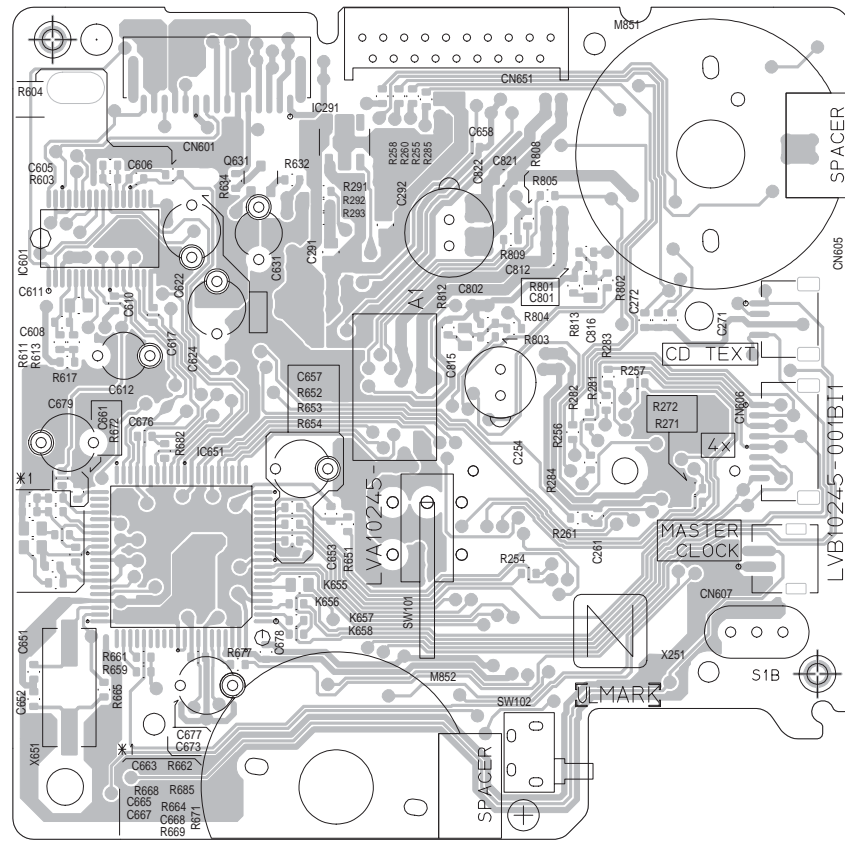

■ CD servo board (Reverse side)

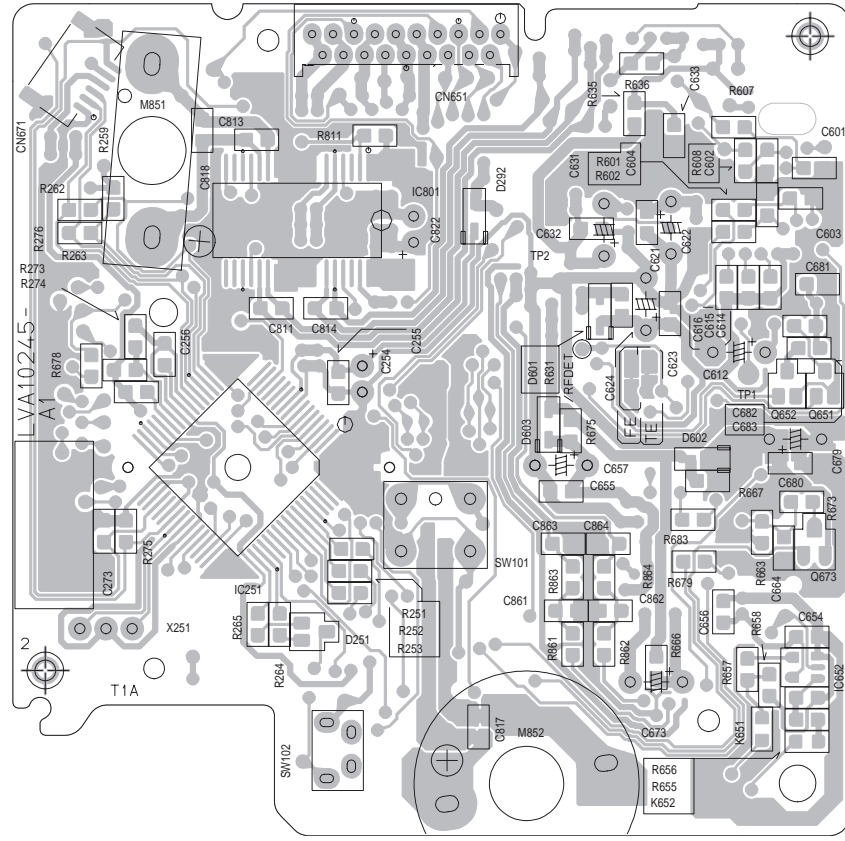

■ Cassette mechanism control board

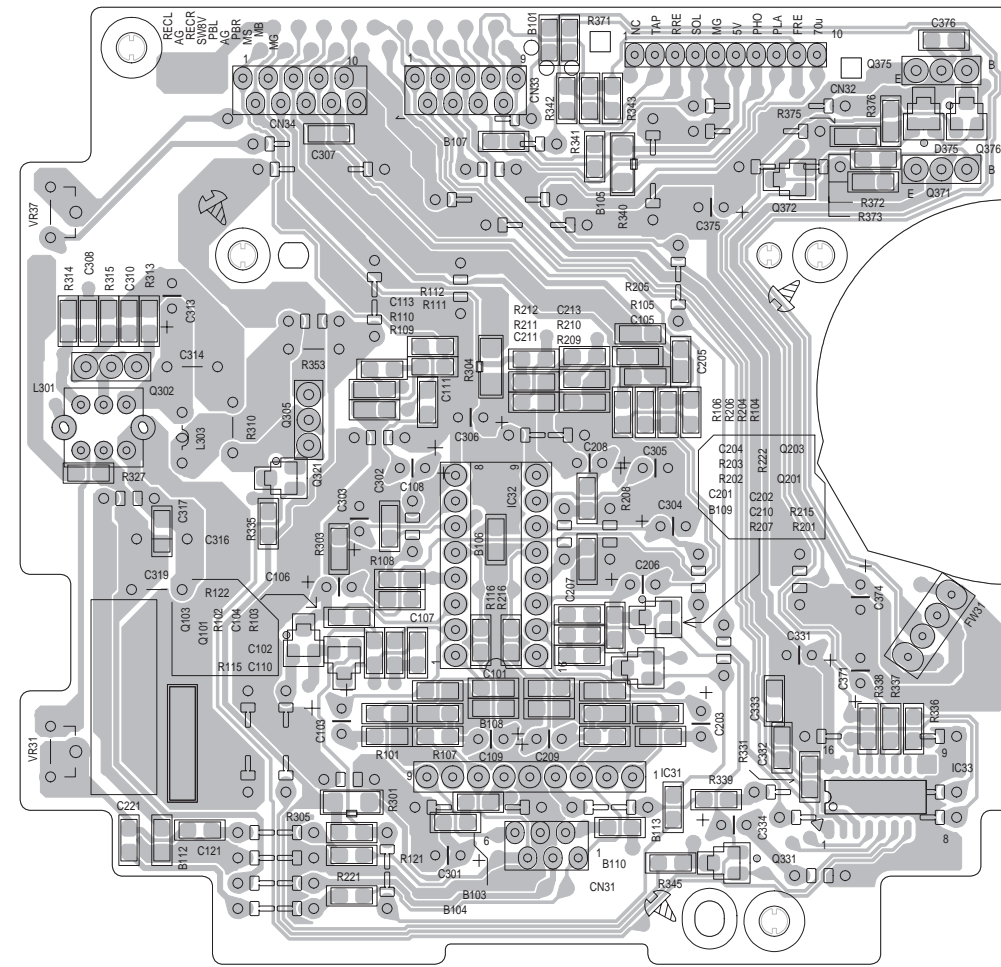

5

4

3

2

1

A

B

C

2-12

D

E

F

G

H

< MEMO >

UX-Z7MDR

JVC

VICTOR COMPANY OF JAPAN, LIMITED

AUDIO & COMMUNICATION BUSINESS DIVISION

PERSONAL & MOBILE NETWORK BUSINESS UNIT. 10-1,1chome,Ohwatari-machi,Maebashi-city,371-8543,Japan

(No.22042SCH)

 Printed in Japan
200302

PARTS LIST

[UX-Z7MDR]

* All printed circuit boards and its assemblies are not available as service parts.

Area suffix

E ----- Continental Europe

- Contents -

Exploded view of general assembly and parts list (Block No.M1)	3- 3
Speaker assembly and parts list (Block No.M2)	3- 6
CD mechanism assembly and parts list (Block No.MB)	3- 7
MD mechanism assembly and parts list (Block No.ME)	3- 9
Cassette mechanism assembly and parts list (Block No.MP)	3-12
Electrical parts list (Block No.01~07)	3-14
Packing materials and accessories parts list (Block No.M3,M5)	3-28

< MEMO >

Exploded view of general assembly and parts list

Block No. **M 1 M M**

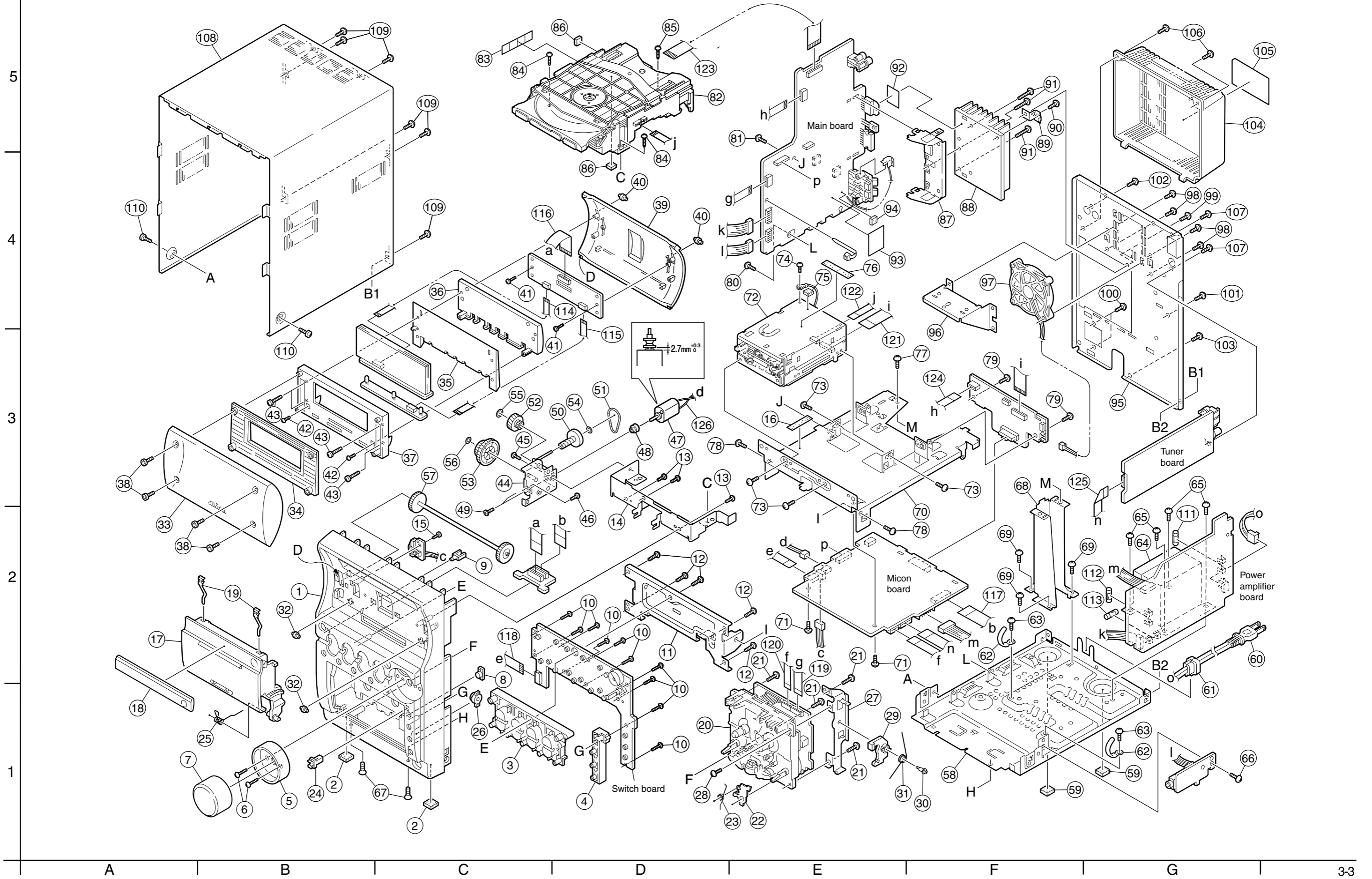

■ Parts list (General assembly)

Block No. M1MM

△	Item	Parts number	Parts name	Q'ty	Description	Area
	1	LV10667-009A	FRONT PANEL	1	PS/SPRAY/PADX2	
	2	LV40301-001A	FELT SPACER	2	FOOT	
	3	LV21252-005A	MAIN BUTTON	1	PS/SPRAY/PADX2	
	4	LV33551-001A	REC BUTTON	1	PS/SPRAY	
	5	LV42979-001A	VOL RING	1	ABS/PLATING	
	6	QYSBSF2608Z	T.SCREW	2	VOL RING+F.PANE	
	7	LV33553-001A	VOL KNOB	1	ABS/PLATING	
	8	E408131-001SM	REMOTE LENS	1	ABS	
	9	LV41550-001A	INDICATOR	1	PS CLEAR	
	10	QYSBSF2608Z	T.SCREW	10	SW PWB	
	11	LV21253-001A	MD STAY BKT	1	EGC T1.0	
	12	QYSBSF2608Z	T.SCREW	5	MD STAY+F.PANEL	
	13	QYSBSF2608Z	T.SCREW	3	CD BKT(F)+F.PAN	
	14	LV33554-001A	CD BKT(FRONT)	1	EGC T1.0	
	15	QYSBSF2608Z	T.SCREW	1	F.PANEL+O/C SW	
	16	LV30225-011A	SPACER	1	O/C SW PWB(WIRE	
	17	LV10668-003A	CASS DOOR	1	PS/SPRAY/SILK X	
	18	LV33555-004A	CASS LENS	1	PMMA/SILKX1/H.S	
	19	VKY4180-401	CASSETTE SPRING	2		
	20	-----	SLC MECHA.	1	PP=SLC-S101YPM	
	21	QYSBSF3012Z	SCREW	4	SLC+F.PANEL	
	22	VKL7850-002	EJECT SAFTY(R)	1		
	23	VKW5258-003	TORSION SPRING	1		
	24	GV40220-001A	LACH	1		
	25	LV43142-001A	DOOR SPRING	1		
	26	GV40034-001A	DAMPER ASSY	1		
	27	GV30268-001A	MECHA BRACKET	1		
	28	QYSBSG3008Z	T.SCREW	1	M.BKT+SLC	
	29	GV40278-001A	SAFTY ARM	1		
	30	VKZ4341-205	SPECIAL SCREW	1	S.ARM+M.BKT	
	31	GV40279-001A	ARM SPRING	1		
	32	GV40269-001A	ROLLER	2	FRONT PANEL	
	33	LV21254-002A	FRONT LENS	1	PMMA/SILK X1	
	34	LV33556-001A	FL LENS	1	GPPS/SILK/HOT S	
	35	LV33557-002A	LED LENS	1	PMMA/EMBOSS	
	36	LV33558-001A	LENS HOLDER	1	ABS/WHITE	
	37	LV33559-001A	FL COVER	1	PS/SPRAY	
	38	LV40744-001A	SOCKET BOLT	4	F.LEN+F.CASE	
	39	LV21255-003A	FRONT CASE	1	PS	
	40	GV40269-001A	ROLLER	2	F.CASE	
	41	QYSDSF2006Z	SCREW	2	F.CASE+PWB	
	42	QYSDSF2006Z	SCREW	2	FL COVER+LENS H	
	43	QYSDSF2612Z	SCREW	4	F.CASE+FL COVER	
	44	LV33560-001A	MOTOR BKT ASSY	1		
	45	QYSBST2604Z	T.SCREW	1	M.BKT+CD S.BKT	
	46	QYSBSF2608Z	T.SCREW	1	M.BKT+F.PANEL	
	47	QAR0219-001	LOADING MOTOR	1		
	48	LV41341-001A	MOTOR PULLEY	1	POM	

■ Parts list (General assembly)

Block No. M1MM

△	Item	Parts number	Parts name	Q'ty	Description	Area
	49	QYSPSPT2020Z	MINI SCREW	2	MOTOR+M.BKT ASS	
	50	LV42525-001A	PULLY WORM	1	POM	
	51	LV42972-001A	BELT	1		
	52	LV42491-001A	GEAR4	1	POM	
	53	LV33561-001A	GEAR A	1	POM	
	54	WDL163225-0	SLIT WASHER	1	WORM	
	55	LV42701-001A	WASHER	1	GEAR4	
	56	WDM214540	WASHER	1	GEAR A	
	57	LV33602-001A	ROD GEAR	1		
	58	LV10669-002A	BOTTOM CHASSIS	1	EGC T1.0	
	59	LV40301-002A	FELT SPACER	2	FOOT(BOTTOM C)	
△	60	QMPK200-200-JD	POWER CORD	1		
△	61	QZW0033-001	STRAIN RELIEF	1		
	62	VKZ4001-111S	WIRE CLAMP	2	HP/TRANS WIRE	
	63	QYSBST3006Z	T.SCREW	2	WIRE.H+B.CHASS	
△	64	QQT0373-006	POWER TRANS	1	T9001	
	65	QYSBST4006Z	T.SCREW	4	TRANS+B.CHASSIS	
	66	QYSBST3006Z	T.SCREW	1	HP PWB+B.CHASS	
	67	QYSSST3006Z	SCREW	2	F.PANEL+B.CHASS	
	68	LV33563-001A	C CHASSISS BKT	1	EGC T1.0	
	69	QYSBSG3006E	T.SCREW	3	C.C.BKT+B.CHASS	
	70	LV10670-001A	CENTER CHASSISS	1	EGC T1.0	
	71	QYSBST3006Z	T.SCREW	2	MICON+C.CHASS	
	72	-----	JEM MD MECHA	1		
	73	QYSBST3006Z	T.SCREW	4	S5M+C.CHASSIS	
	74	QYSBST3006Z	T.SCREW	1	S5 EARTH WIRE	
	75	VYSH101-009	SPACER	1	CD-MD FFC	
	76	LV30225-079A	SPACER	1	FL-MICON FFC	
	77	QYSBSG3006E	T.SCREW	1	C.C.BKT+C.CHASS	
	78	QYSBST3006Z	T.SCREW	2	MD S.BKT+C.CHAS	
	79	QYSBST3006Z	T.SCREW	2	MD CONECT+C.CHA	
	80	QYSBSG3014E	T.SCREW	1	CHASSIS	
	81	QYSBSG3006E	T.SCREW	1	MAIN PWB+C.CHAS	
	82	-----	CD UNIT	1		
△	83	LV41843-001A	LASER CAUTION	1	N1 LEFT SIDE	
	84	QYSBSG3008Z	T.SCREW	2	CD BKT(F)	
	85	QYSBSG3008Z	T.SCREW	1	CD BKT(R)	
	86	VYSH101-009	SPACER	2	FOR CD FFC	
	87	LV33564-002A	IC BRACKET	1		
△	88	GV30166-003A	HEAT SINK(A)	1		
	89	GV40167-001A	H.SINL BRACKET	1		
	90	QYSBSG3008Z	T.SCREW	1	H.S.BKT+H.SINK	
	91	QYSBSF3012Z	SCREW	3	IC HOLD.+ H.SIN	
	92	LV43100-001A	MICA SHEET	1	HEAT SINK	
	93	LV43303-001A	SHIELD CASE	1		
	94	VYSH101-009	SPACER	1		
	95	LV21257-002A	REAR PANEL	1	EGC T0.8	
	96	GV30413-001A	CD BKT(REAR)	1	EGC T1.0	

■ Parts list (General assembly)

Block No. M1MM

⚠	Item	Parts number	Parts name	Q'ty	Description	Area
	97	QAR0124-003	FAN MOTOR	1	FAN MOTOR	
	98	QYSBSGY3008E	SPECIAL SCREW	4	FAN+CD BKT+R.PA	
	99	QYSBSGY3008E	SPECIAL SCREW	1	H.S.BKT+R.PANEL	
	100	QYSBSGY3008E	SPECIAL SCREW	2	SPK+R.PANEL	
	101	QYSBSGY3008E	SPECIAL SCREW	1	C.CHASS+R.PANEL	
	102	QYSBSGY3008E	SPECIAL SCREW	1	AUX+R.PANEL	
	103	QYSBSGY3008E	SPECIAL SCREW	1	BTM CHASS+R.PAN	
	104	GV10068-002A	REAR COVER	1	PS/EMBOSS	
	105	LV33690-001A	RATING LABEL	1	E/B/EN	
	106	QYSBSGY3008E	SPECIAL SCREW	2	R.COVER+R.PANEL	
	107	QYSBSGY3008E	SPECIAL SCREW	2	TUNER+R.PANEL	
	108	LV21258-001A/S/	METAL COVER	1	EGC T0.6	
	109	QYSBSGY3008E	SPECIAL SCREW	6	M.COVER+R.PANEL	
	110	QYSDSG3006N	T.SCREW	2	M.COVER+B.CHASS	
⚠	111	QMF51W2-R80-J8	FUSE	1	F9001	
⚠	112	QMFZ051-8R0-J8	FUSE	1	F9002	
⚠	113	QMF51W2-3R15-J8	FUSE	1	F9003	
	114	QUQ110-0908AF	FFC WIRE	1	FL - FL JOIN	
	115	QUQH10-1006AJ	FFC WIRE	1	LED - FL JOIN	
	116	QUQ610-1910AJ	FFC WIRE	1	FL JON-MOVE JON	
	117	QUQH10-1926AJ	FFC WIRE	1	MOVE JON - MICO	
	118	QUQH12-1112AJ	FFC WIRE	1	KEY - MICON	
	119	QUQH12-1016AJ	FFC WIRE	1	SLC - MAIN	
	120	QUQH12-0913AJ	FFC WIRE	1	SLC - MICON	
	121	QUQ110-2110AM	FFC WIRE	1	MD - MD JOIN	
	122	QUQH10-0817AJ	FFC WIRE	1	MD - CD	
	123	QUQH10-1917AJ	FFC WIRE	1	CD - MAIN	
	124	QUQH12-0912AJ	FFC WIRE	1	MAIN - MD JOIN	
	125	QUQH12-1315AJ	FFC WIRE	1	TUNER - MICON	
	126	WJM0195-003A	E-SI C WIRE C-F	1	MOTOR - MICON	

Speaker assembly and parts list

Block No. M 2 M M

SP-UXZ7MD

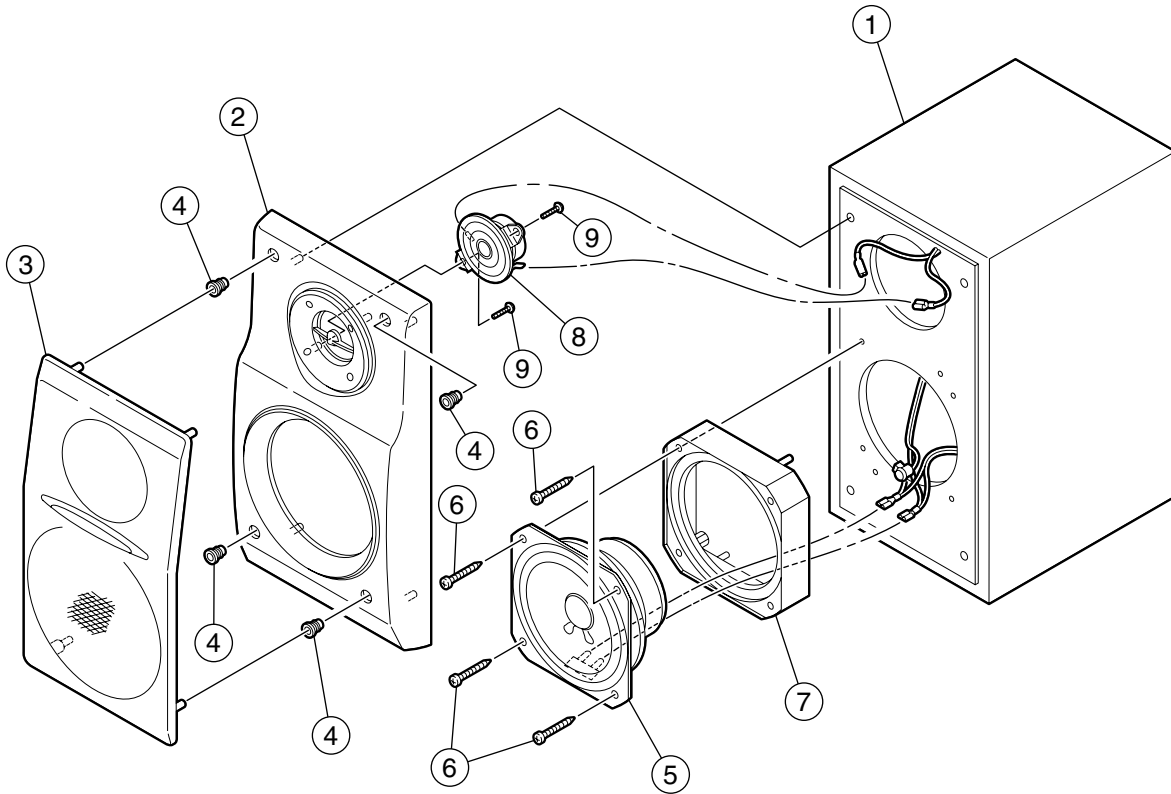

■ Parts list (Speaker)

Block No. M2MM

▲	Item	Parts number	Parts name	Q'ty	Description	Area
	1	-----	CABINET ASSY	2		
	2	53-000-173-01	FRONT PANEL	2		
	3	99-100-066-11	SARAN BOARD	2		
	4	56-000-033-11	HOLDER	8		
	5	CF100147-01	SPK	2		
	6	70-015-440-01	SCREW	8		
	7	28-100-042-01	SPACER	2		
	8	TF040011-01	SPK	2		
	9	70-069-308-01	SCREW	4		

CD mechanism assembly and parts list

Block No. M B M M

FMU-N1H-1M

Grease
 ★ UD-24H2
 ▲ EM-30L

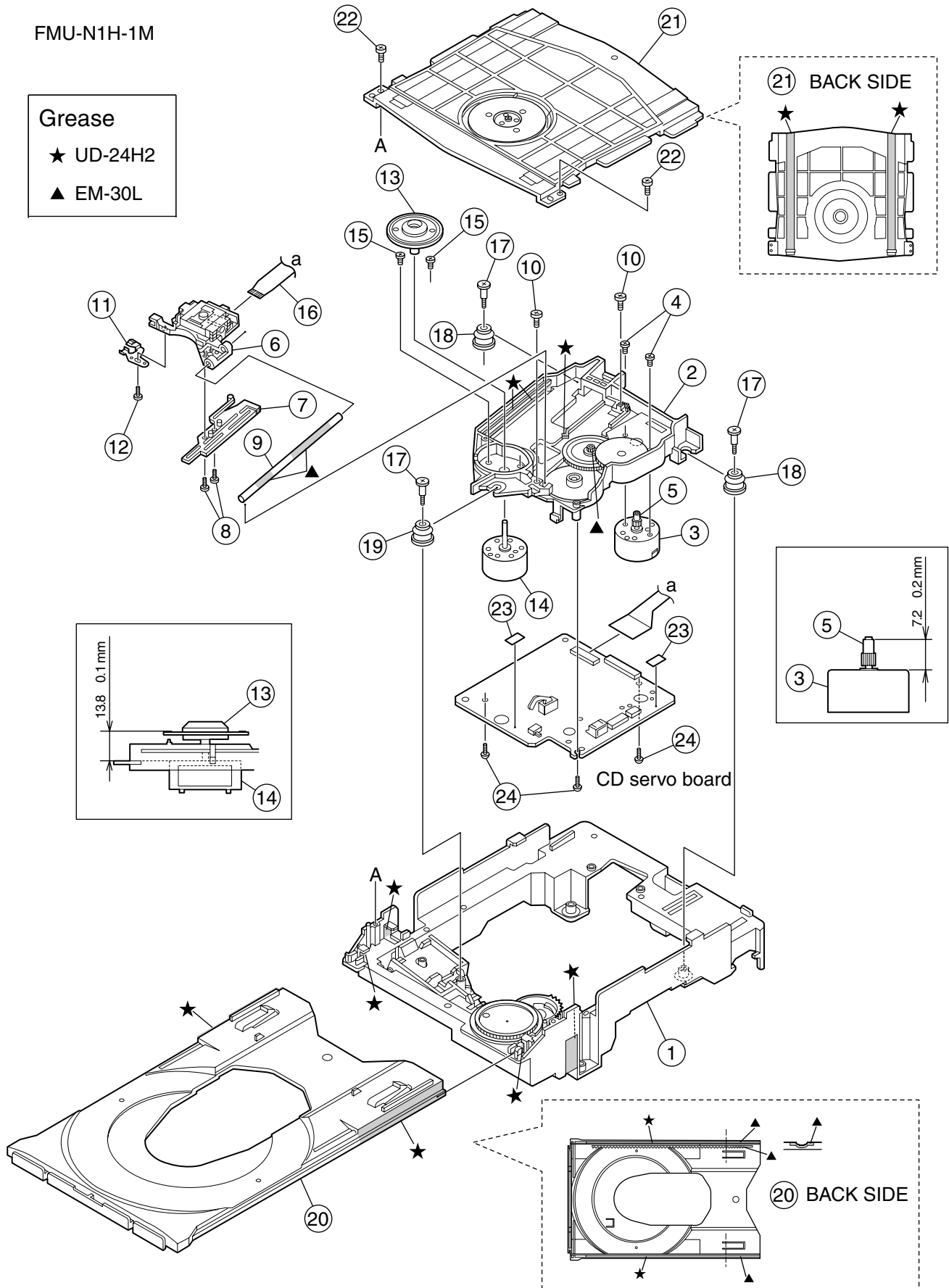

■ Parts list (CD mechanism)

Block No. MBMM

△	Item	Parts number	Parts name	Q'ty	Description	Area
	1	LV32649-005A	L.BASE ASSY	1		
	2	LV32651-002A	CH.BASE ASSY	1		
	3	QAR0176-001	FEED MOTOR	1		
	4	VKZ4743-001	SPECIAL SCREW	2		
	5	LV42229-001A	MOTOR GEAR	1		
	6	OPTIMA-725B1	CD PICK UP	1		
	7	LV20993-002A	RACK PLATE	1		
	8	QYSPSGT1735M	MINI SCREW	2		
	9	E406777-002SM	C.D SHAFT	1		
	10	LV41741-001A	SPECIAL SCREW	2		
	11	LV31744-001A	P.S.SPRING	1		
	12	QYSPSGT1425M	TAP SCREW	1		
	13	LV42350-001A	T.T.ASSY	1		
	14	QAR0175-001	SP.MOTOR	1		
	15	VKZ4743-001	SPECIAL SCREW	2		
	16	LVB30008-001A	FPC	1		
	17	LV41424-001A	SPECIAL SCREW	3		
	18	LV41659-001A	INSULATOR	2		
	19	LV41659-002A	INSULATOR	1		
	20	LV10503-002A	TRAY	1		
	21	LV32650-001A	CL.BASE ASSY	1		
	22	QYSBSF2005Z	T.SCREW	2		
	23	LV30225-0B6A	SPACER	2		
	24	QYSBSF2005Z	T.SCREW	3		

MD mechanism assembly and parts list

Block No. **M E M M**

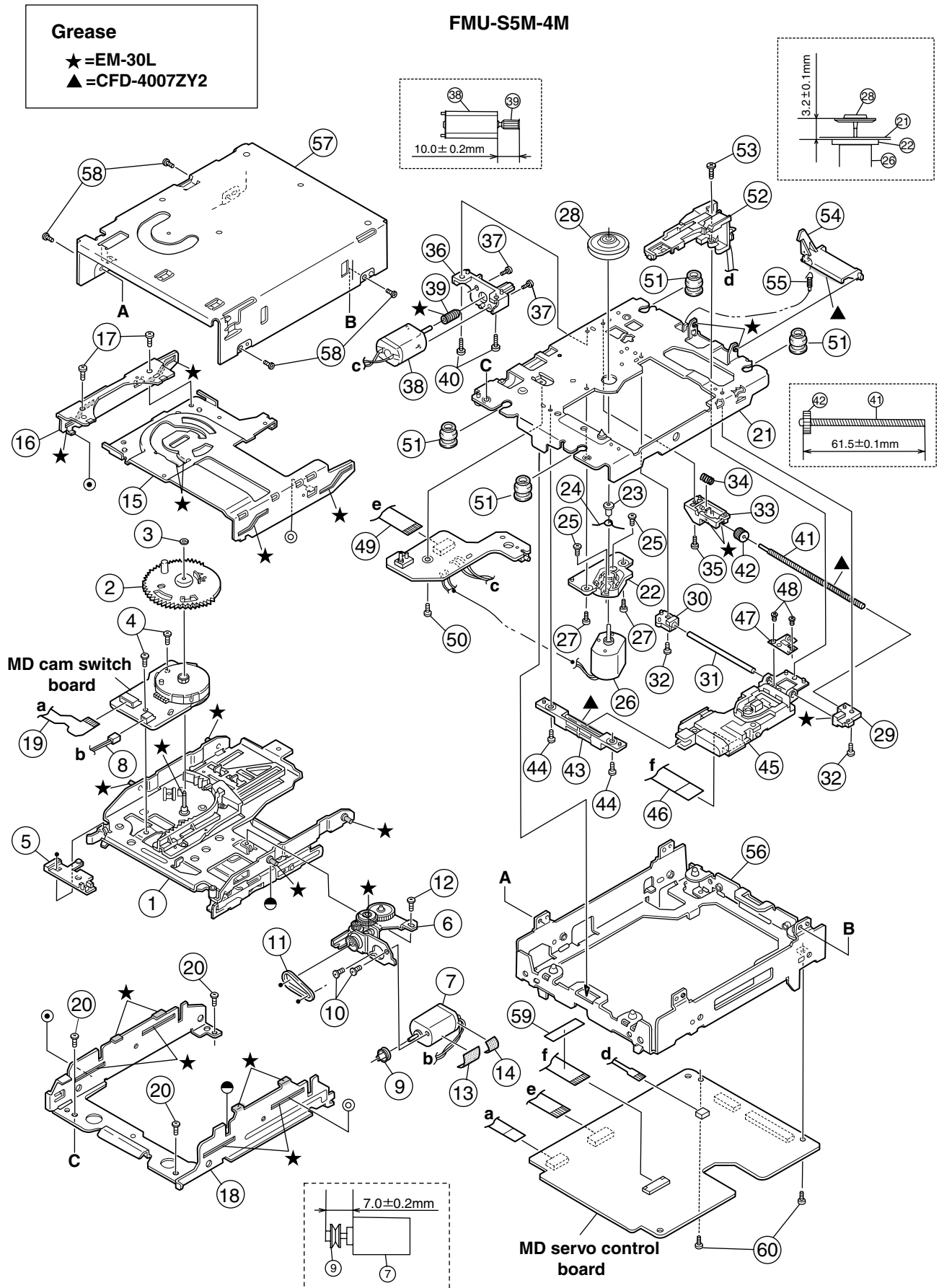

■ Parts list (MD mechanism)

Block No. MEMM

△	Item	Parts number	Parts name	Q'ty	Description	Area
	1	LV20548-019A	LOADING ASSY	1		
	2	LV31472-004A	CAM GEAR	1		
	3	QYWDL1230252	SLIT WASHER	1	RED(OR BLUE)	
	4	LV41477-002A	MINI TAP SCREW	2	CAM SW PWB	
	5	LV32168-002A	WIRE HOLDER	1		
	6	LV31710-002A	L.MOTOR ASSY	1		
	7	QAR0144-001	MOTOR	1	MT601	
	8	WJM0117-003A	E-SI C WIRE C-F	1		
	9	LV41341-001A	MOTOR PULLEY	1		
	10	QYSPSPT2020M	MINI SCREW	2	LOAD.MOTOR	
	11	LV41342-001A	BELT	1		
	12	LV41477-002A	MINI TAP SCREW	1	L.MOTOR BKT.	
	13	LV30225-068A	SPACER	1		
	14	LV30225-085A	SPACER	1		
	15	LV20543-002A	SLIDE BASE R	1		
	16	LV31483-001A	SLIDE BASE L	1		
	17	LV41477-002A	MINI TAP SCREW	2	SLIDE BASE	
	18	LV10286-003A	LOAD.MECHA BASE	1		
	19	LVB40003-001A	FPC CABLE	1		
	20	LV41477-002A	MINI TAP SCREW	3	L.MECHA BASE	
	21	LV31709-004A	TM.CHASSIS ASSY	1		
	22	LV20545-001A	SP.MOTOR BASE	1		
	23	LE40515-001A	COLLAR	1		
	24	LV42825-001A	S.R.SPRING	1		
	25	QYSPSPU1720N	SCREW	2	SP.MOTOR	
	26	FF-110PH-08280	SP.MOTOR	1	MT603	
	27	LV41477-002A	MINI TAP SCREW	2	SP.MOTOR BASE	
	28	LE30470-202A	T.TABLE ASSY	1		
	29	LV41343-001A	SHAFT HOLDER R	1		
	30	LV41344-002A	SHAFT HOLDER F	1		
	31	VKH5803-001	GUIDE SHAFT	1		
	32	LV41477-002A	MINI TAP SCREW	2	SHAFT HOLDER	
	33	LV31484-001A	T.SPRING HOLDER	1		
	34	LV41350-001A	COM.SPRING	1		
	35	LV41477-002A	MINI TAP SCREW	1	T.SP.HOLDER	
	36	LV31485-001A	FEED MOTOR BKT.	1		
	37	QYSPSPT2025N	MINI SCREW	2	FEED MOTOR	
	38	QAR0144-001	MOTOR	1	MT602	
	39	LV41345-001A	FEED WORM	1		
	40	LV41477-002A	MINI TAP SCREW	2	FEED MOTOR BKT.	
	41	LV42702-001A	SCREW SHAFT	1		
	42	LV41347-001A	S.SHAFT GEAR	1		
	43	LV31486-001A	PICK UP GUIDE	1		
	44	LV41477-002A	MINI TAP SCREW	2	P-UP GUIDE	
	45	KMS-260E	MD PICK UNIT	1		
	46	LVB30007-002A	FPC CABLE	1		
	47	LV41348-001A	RACK SPRING	1		
	48	QYSPSPT1414M	MINI SCREW	2	RACK SPRING	

■ Parts lis (MD mechanism)

Block No. MEMM

⚠	Item	Parts number	Parts name	Q'ty	Description	Area
	49	WJT0042-001A	E-CARD WIRE	1		
	50	LV41477-002A	MINI TAP SCREW	1	T.MECHA PWB	
	51	LV40761-003A	INSULATOR	4		
	52	QAH0039-002	MD HEAD	1	H601	
	53	QYSPSPT1740N	MINI SCREW	1	MD HEAD	
	54	LV31487-003A	HEAD LIFTER	1		
	55	LV41349-001A	H.LIFTER SPRING	1		
	56	LV10284-002A	SINGLE FRAME	1		
	57	LV10285-003A	MECHA COVER	1		
	58	LV41477-002A	MINI TAP SCREW	4	MECHA COVER	
	59	LV30225-096A	SPACER	1		
	60	VKZ4539-024	MINI SCREW	2	SERVO PWB	

Cassette mechanism assembly and parts list

Block No. M P M M

SLC-S102M

Grease

- ★ =EM-30L
- ▲ =UD-24
- =UD-24H2
- =LEN-320M
- =JC-888B
- ◎ =MOBIL-1

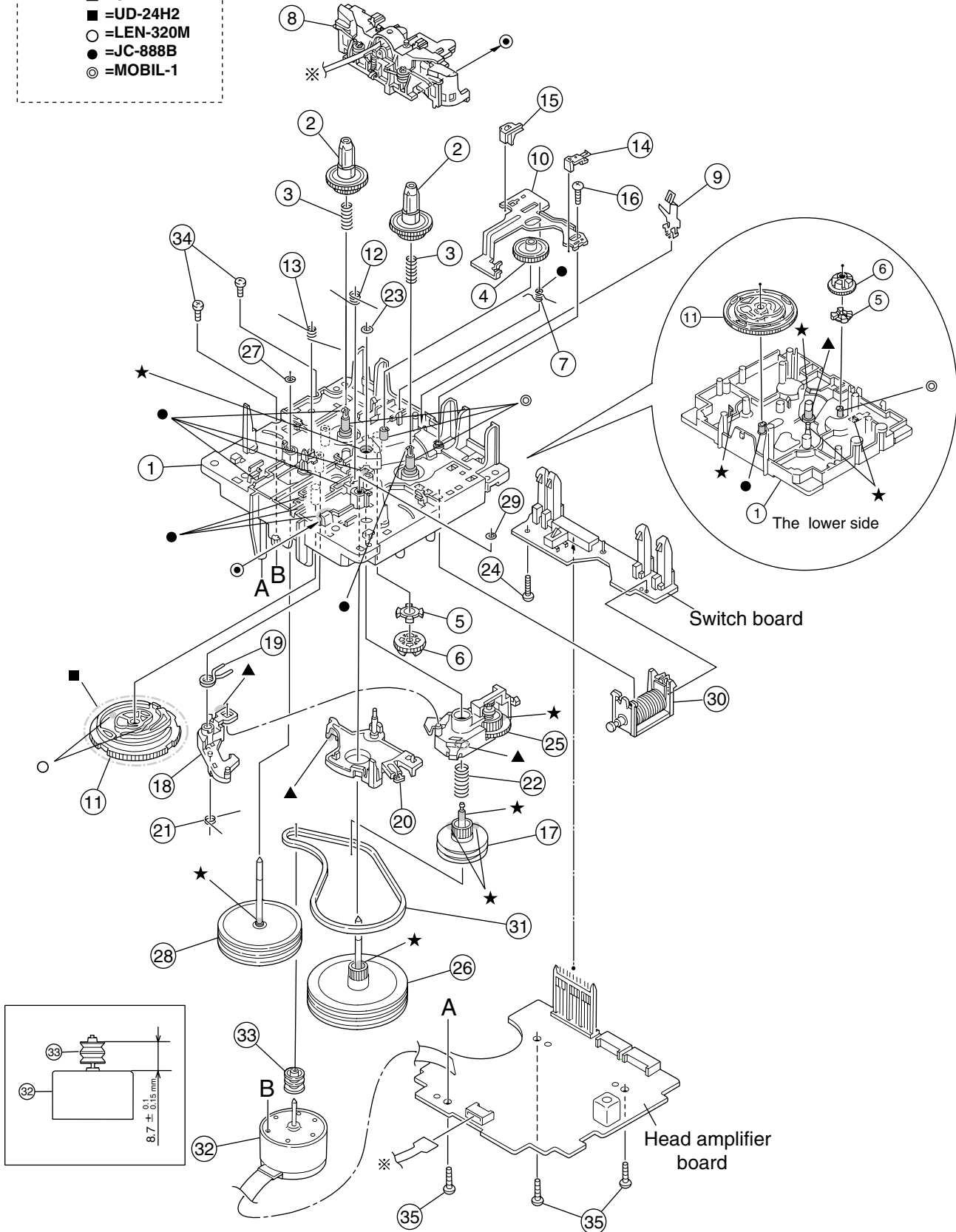

■ Parts list (Cassette mechanism)

Block No. MPMM

△	Item	Parts number	Parts name	Q'ty	Description	Area
	1	VKS1165-00L	CHASSIS B.ASS'Y	1		
	2	VKS2274-002	REEL GEAR	2		
	3	VKW5286-002	B.T. SPRING	2		
	4	VKS5559-001	PLAY IDLE GEAR	1		
	5	VKS5595-002	BLIND	1		
	6	VKS5560-003	FR IDLE GEAR	1		
	7	LV42013-001A	EARTH SPRING	1		
	8	SLC-RP3SVM	HEAD MOUNT ASSY	1		
	9	VKY3149-002	CASSETTE SP.	1		
	10	LV31786-001A	PLAY SW LEVER	1		
	11	VKS1166-003	CONTROL CAM	1		
	12	VKW5279-002	HEAD BASE SP(R)	1		
	13	VKW5280-001	HEAD BASE SP(L)	1		
	14	LV41584-001A	BRAKE(R)	1		
	15	LV41585-003A	BRAKE(L)	1		
	16	QYSBSF2005Z	T.SCREW	1		
	17	VKS5603-00G	MAIN PULLEY ASY	1		
	18	VKS3785-001MM	FR ARM	1		
	19	VKW5284-002	SWING SPRING	1		
	20	VKS2278-003	TRIGGER ARM	1		
	21	VKW5301-001	FR SPRING	1		
	22	VKW5266-001	ELEVATOR SPRING	1		
	23	WDL214025	WASHER	1		
	24	QYSBSF2005Z	T.SCREW	1		
	25	VKS3786-00G	CLUTCH ASS'Y	1		
	26	VKF3205-00B	F.WHEEL ASSY(R)	1		
	27	WDL183425	SLIT WASHER	1		
	28	VKF3207-00C	F.WHEEL ASSY(L)	1		
	29	WDL173525-6	SLIT WASHER	1		
	30	VKZ3174-00A	DC SOLENOID	1		
	31	LV42836-001A	CAPSTAN BELT	1		
	32	MSI-5U2LWA	D.C.MOTOR ASS'Y	1		
	33	VKR4761-003	MOTOR PULLEY	1		
	34	QYSPSP2604Z	SCREW	2		
	35	QYSBSF2608Z	T.SCREW	3	FOR P.W.B.	

■ Electrical parts list (Main board)

Block No. 01

△	Item	Parts number	Parts name	Remarks	Area	△	Item	Parts number	Parts name	Remarks	Area
	CN101	QGA2501F1-05	CONNECTOR	FOR HP			C3101	QETN1HM-475Z	E CAPACITOR	4.7MF 20% 50V	
	CN102	QGA2501F1-07	CONNECTOR	FOR PRI			C3103	QTE1V06-106Z	E CAPACITOR		
	CN301	QGF1201F3-10	CONNECTOR	FOR SLC			C3104	QETN1HM-475Z	E CAPACITOR	4.7MF 20% 50V	
	CN302	QGF1036F1-19	FFC/FPC CONNE	FOR CD			C3106	QETN1HM-475Z	E CAPACITOR	4.7MF 20% 50V	
	CN303	QGF1205F1-09	CONNECTOR	FOR MD JOIN			C3107	QFLC1HJ-153Z	M CAPACITOR	.015MF 5% 50V	
	CN304	QGB1214J1-10S	CONNECTOR	FOR U-CON			C3108	QETN1HM-475Z	E CAPACITOR	4.7MF 20% 50V	
	CN305	QGB1214J1-16S	CONNECTOR	FOR U-CON			C3109	QFG32AJ-272Z	PP CAPACITOR	2700PF 5% 100V	
	CN401	QGF1036F1-09	FFC/FPC CONNE				C3110	QFLC1HJ-104Z	M CAPACITOR	.10MF 5% 50V	
	CN451	QGF1036C1-19	FFC/FPC CONNE				C3111	QFLC1HJ-104Z	M CAPACITOR	.10MF 5% 50V	
	CN452	QGF1036C1-19	FFC/FPC CONNE				C3112	QFVF1HJ-184Z	MF CAPACITOR	.18MF 5% 50V	
	CN511	QGF1036F1-10	CONNECTOR				C3113	QFVF1HJ-184Z	MF CAPACITOR	.18MF 5% 50V	
	CN601	QGF1036F1-21	CONNECTOR	TO S5MD			C3114	QFLC1HJ-823Z	M CAPACITOR	.082MF 5% 50V	
	CN602	QGF1205F1-09	CONNECTOR	TO AMP			C3115	QTE1C06-226Z	E CAP. SILMIC		
	CN603	QGA2501F1-02	CONNECTOR	TO FAN			C3116	QFVF1HJ-274Z	MF CAPACITOR	(B1033)	
	CN604	QGB2510J1-08	CONNECTOR	TO UCON			C3117	QFLC1HJ-823Z	M CAPACITOR	.082MF 5% 50V	
	CN671	QGF1036F1-09	FFC/FPC CONNE	TO FL			C3118	QCBB1HK-221Y	C CAPACITOR	220PF 10% 50V	
	CN672	QGF1036F1-10	CONNECTOR	TO LED			C3201	QETN1HM-475Z	E CAPACITOR	4.7MF 20% 50V	
	CN673	QGF1036F1-19	FFC/FPC CONNE	TO FL JOIN			C3203	QTE1V06-106Z	E CAPACITOR		
	C1101	QCBB1HK-332Y	C CAPACITOR	3300PF 10% 50V			C3204	QETN1HM-475Z	E CAPACITOR	4.7MF 20% 50V	
	C1102	QCBB1HK-221Y	C CAPACITOR	220PF 10% 50V			C3206	QETN1HM-475Z	E CAPACITOR	4.7MF 20% 50V	
	C1103	QENC1EM-106Z	NP E CAPACITOR	10MF 20% 25V			C3207	QFLC1HJ-153Z	M CAPACITOR	.015MF 5% 50V	
	C1104	QETN1HM-225Z	E CAPACITOR	2.2MF 20% 50V			C3208	QETN1HM-475Z	E CAPACITOR	4.7MF 20% 50V	
	C1105	QFLC1HJ-473Z	M CAPACITOR	.047MF 5% 50V			C3209	QFG32AJ-272Z	PP CAPACITOR	2700PF 5% 100V	
	C1106	QFLC1HJ-104Z	M CAPACITOR	.10MF 5% 50V			C3210	QFLC1HJ-104Z	M CAPACITOR	.10MF 5% 50V	
	C1107	QFLC1HJ-104Z	M CAPACITOR	.10MF 5% 50V			C3211	QFLC1HJ-104Z	M CAPACITOR	.10MF 5% 50V	
	C1108	QCBB1HK-151Y	C CAPACITOR	150PF 10% 50V			C3212	QFVF1HJ-184Z	MF CAPACITOR	.18MF 5% 50V	
	C1109	QTE1V06-106Z	E CAPACITOR				C3213	QFVF1HJ-184Z	MF CAPACITOR	.18MF 5% 50V	
	C1110	QCBB1HK-103Y	C CAPACITOR	.010MF 10% 50V			C3214	QFLC1HJ-823Z	M CAPACITOR	.082MF 5% 50V	
	C1201	QCBB1HK-332Y	C CAPACITOR	3300PF 10% 50V			C3215	QTE1C06-226Z	E CAP. SILMIC		
	C1202	QCBB1HK-221Y	C CAPACITOR	220PF 10% 50V			C3216	QFVF1HJ-274Z	MF CAPACITOR	(B1033)	
	C1203	QENC1EM-106Z	NP E CAPACITOR	10MF 20% 25V			C3217	QFLC1HJ-823Z	M CAPACITOR	.082MF 5% 50V	
	C1204	QETN1HM-225Z	E CAPACITOR	2.2MF 20% 50V			C3218	QCBB1HK-221Y	C CAPACITOR	220PF 10% 50V	
	C1205	QFLC1HJ-473Z	M CAPACITOR	.047MF 5% 50V			C3301	QETN1HM-226Z	E CAPACITOR	22MF 20% 50V	
	C1206	QFLC1HJ-104Z	M CAPACITOR	.10MF 5% 50V			C3302	QETN1CM-107Z	E CAPACITOR	100MF 20% 16V	
	C1207	QFLC1HJ-104Z	M CAPACITOR	.10MF 5% 50V			C3303	QETN1HM-225Z	E CAPACITOR	2.2MF 20% 50V	
	C1208	QCBB1HK-151Y	C CAPACITOR	150PF 10% 50V			C3304	QETN1HM-106Z	E CAPACITOR	10MF 20% 50V	
	C1209	QTE1V06-106Z	E CAPACITOR				C3305	QDYB1CM-103Y	C CAPACITOR		
	C1210	QCBB1HK-103Y	C CAPACITOR	.010MF 10% 50V			C4501	QEKC1HM-106Z	E CAPACITOR	10MF 20% 50V	
	C1301	QETN1HM-106Z	E CAPACITOR	10MF 20% 50V			C5231	QDYB1CM-103Y	C CAPACITOR		
	C1302	QETN1CM-107Z	E CAPACITOR	100MF 20% 16V			C6031	QETN1HM-106Z	E CAPACITOR	10MF 20% 50V	
△	C1303	QEZ0578-828	E CAPACITOR	8200MF			C6032	QCBB1HK-103Y	C CAPACITOR	MDA5V	
	C1305	QFLC1HJ-104Z	M CAPACITOR	.10MF 5% 50V			C6033	QETN1EM-476Z	E CAPACITOR	MDA5V	
	C1306	QETN1HM-474Z	E CAPACITOR	.47MF 20% 50V			C6034	QETN1HM-106Z	E CAPACITOR	MD REC R	
	C1307	QETN1HM-336Z	E CAPACITOR	33MF 20% 50V			C6035	QETN1HM-106Z	E CAPACITOR	MD REC L	
	C1309	QETN1CM-107Z	E CAPACITOR	100MF 20% 16V			C6036	QETN1HM-475Z	E CAPACITOR	MD R	
	C1310	QETN1HM-106Z	E CAPACITOR	10MF 20% 50V			C6037	QETN1HM-475Z	E CAPACITOR	MD R	
	C2301	QFLC1HJ-223Z	M CAPACITOR	.022MF 5% 50V			C6038	QFLC1HJ-104Z	M CAPACITOR	.10MF 5% 50V	
	C2304	QFLC1HJ-223Z	M CAPACITOR	.022MF 5% 50V			C6701	QCBB1HK-101Y	C CAPACITOR	MDA5V	
△	C2305	QETM1EM-478	E CAPACITOR	4700MF 20% 25V			C6702	QCBB1HK-101Y	C CAPACITOR	MDA5V	
	C2306	QCBB1HK-221Y	C CAPACITOR	220PF 10% 50V			C6703	QCBB1HK-101Y	C CAPACITOR	MDA5V	
	C2307	QCBB1HK-103Y	C CAPACITOR	.010MF 10% 50V			C6704	QCBB1HK-101Y	C CAPACITOR	MDA5V	
	C2308	QETN1EM-337Z	E CAPACITOR	330MF 20% 25V			C6802	QCBB1HK-103Y	C CAPACITOR	MDA5V	
	C2309	QCFB1HZ-105Y	C CAPACITOR	1.0MF +80:-20%			C6805	QCBB1HK-103Y	C CAPACITOR	MDA5V	
	C2310	QETN1CM-107Z	E CAPACITOR	100MF 20% 16V			D1401	QLF0104-002	FL TUBE		
	C2311	QETN1CM-107Z	E CAPACITOR	100MF 20% 16V			D1101	1SS133-T2	SI DIODE		
	C2312	QETN1CM-107Z	E CAPACITOR	100MF 20% 16V			D1102	11EQS03LN-T2	SB DIODE	10MM PITCH IM	
	C2313	QTE1C06-107Z	E CAPACITOR				D1201	1SS133-T2	SI DIODE		
	C2314	QDGB1HK-102Y	C CAPACITOR				D1202	11EQS03LN-T2	SB DIODE	10MM PITCH IM	
△	C2315	QDYB1CM-103Y	C CAPACITOR				D1301	1SS133-T2	SI DIODE		
	C2316	QTE1C06-476Z	E CAP. SILMIC				D1302	1SS133-T2	SI DIODE		
	C2317	QETN1EM-476Z	E CAPACITOR	47MF 20% 25V		△	D2301	1N5401-TM	DIODE		

■ Electrical parts list (Main board)

Block No. 01

Item	Parts number	Parts name	Remarks	Area	Item	Parts number	Parts name	Remarks	Area
△	D2302	1N5401-TM	DIODE		△	Q2301	KTB772/Y/	TRANSISTOR	
△	D2303	1N5401-TM	DIODE			Q2302	KTC3199/GL/-T	TRANSISTOR	
△	D2304	1N5401-TM	DIODE			Q2303	KTC3199/GL/-T	TRANSISTOR	
	D2306	MTZJ9.1C-T2	ZENER DIODE		△	Q2305	KTC3199/GL/-T	TRANSISTOR	
△	D2309	MTZJ6.2A-T2	ZENER DIODE		△	Q2306	KTC3203/OY/-T	TRANSISTOR	
	D2310	1SS133-T2	SI DIODE	(B1036)		Q3101	KTC3199/GL/-T	TRANSISTOR	
△	D2311	MTZJ10C-T2	Z.DIODE			Q3201	KTC3199/GL/-T	TRANSISTOR	
	D2312	1SS133-T2	SI DIODE	(B1037)		Q6031	KTA1267/YG/-T	TRANSISTOR	
△	D2313	MTZJ12B-T2	ZENER DIODE			Q6032	KRC102M-T	D.TRANSISTOR	
	D2314	1SS133-T2	SI DIODE	(B1035)		Q6033	KTC3199/GL/-T	TRANSISTOR	MDA5V
	D2315	1SS133-T2	SI DIODE			R1101	QRE141J-562Y	C RESISTOR	5.6K 5% 1/4W
	D2316	1SS133-T2	SI DIODE			R1102	QRE141J-562Y	C RESISTOR	5.6K 5% 1/4W
	D2319	MTZJ10B-T2	ZENER DIODE			R1103	QRE141J-471Y	C RESISTOR	470 5% 1/4W
	D2320	MTZJ5.6C-T2	ZENER DIODE			R1104	QRE141J-303Y	C RESISTOR	30K 5% 1/4W
	D2321	MTZJ5.1C-T2	ZENER DIODE			R1105	QRE141J-303Y	C RESISTOR	30K 5% 1/4W
△	D2322	1SS133-T2	SI DIODE	(B1038)		R1106	QRE141J-752Y	C RESISTOR	7.5K 5% 1/4W
	D2323	1N4003S-T5	SI DIODE	=B1043		R1107	QRE141J-2R2Y	C RESISTOR	2.2 5% 1/4W
△	D2324	1SS133-T2	SI DIODE	R-FIL SAFETY		R1108	QRE141J-2R2Y	C RESISTOR	2.2 5% 1/4W
	D3301	1SS133-T2	SI DIODE			R1109	QRE141J-102Y	C RESISTOR	1.0K 5% 1/4W
	D3302	1SS133-T2	SI DIODE			R1110	QRE141J-153Y	C RESISTOR	15K 5% 1/4W
	D3303	1N4003S-T5	SI DIODE			R1111	QRE141J-123Y	C RESISTOR	12K 5% 1/4W
	D5101	NSTM515AS	LED	MDA5V		R1201	QRE141J-562Y	C RESISTOR	5.6K 5% 1/4W
	D5111	NSTM515AS	LED	MDA5V		R1202	QRE141J-562Y	C RESISTOR	5.6K 5% 1/4W
	D5121	NSTM515AS	LED	MDA5V		R1203	QRE141J-471Y	C RESISTOR	470 5% 1/4W
△	D6031	1SS133-T2	SI DIODE			R1204	QRE141J-303Y	C RESISTOR	30K 5% 1/4W
	D6032	MTZJ5.6C-T2	ZENER DIODE	MDA5V		R1205	QRE141J-303Y	C RESISTOR	30K 5% 1/4W
△	D6033	1SS133-T2	SI DIODE	MDA5V SAFETY		R1206	QRE141J-752Y	C RESISTOR	7.5K 5% 1/4W
△	D6034	1SS133-T2	SI DIODE	MDA5V SAFETY		R1207	QRE141J-2R2Y	C RESISTOR	2.2 5% 1/4W
	EP101	QNZ0136-001Z	EARTH PLATE			R1208	QRE141J-2R2Y	C RESISTOR	2.2 5% 1/4W
	EP521	QNZ0136-001Z	EARTH PLATE			R1209	QRE141J-102Y	C RESISTOR	1.0K 5% 1/4W
△	IC101	LA4628	IC	POWER AMP		R1210	QRE141J-153Y	C RESISTOR	15K 5% 1/4W
△	IC201	L4909	REGULATOR IC			R1211	QRE141J-123Y	C RESISTOR	12K 5% 1/4W
	IC301	LC75345M-X	IC			R1301	QRE141J-103Y	C RESISTOR	10K 5% 1/4W
	IH301	VYH7653-003	IC HOLDER	FOR IC301		R2301	QRE141J-102Y	C RESISTOR	1.0K 5% 1/4W
	J1001	QNB0117-001	SPK TERMINAL	SPK		R2302	QRE141J-102Y	C RESISTOR	1.0K 5% 1/4W
	J3001	QNN0215-001	PIN JACK			R2303	QRE141J-102Y	C RESISTOR	1.0K 5% 1/4W
	J5201	QNS0177-001	JACK	SILVER		R2304	QRE141J-681Y	C RESISTOR	680 5% 1/4W
	K3301	QQR0621-001Z	FERRITE BEADS	(B1028)		R2305	QRE141J-472Y	C RESISTOR	4.7K 5% 1/4W
	K3302	QQR0621-001Z	FERRITE BEADS	(B1027)		R2306	QRE141J-272Y	C RESISTOR	2.7K 5% 1/4W
	K3303	QQR0621-001Z	FERRITE BEADS	(B1026)		R2307	QRE141J-681Y	C RESISTOR	680 5% 1/4W
	K3304	QQR0621-001Z	FERRITE BEADS	(B1025)		R2311	QRE141J-622Y	C RESISTOR	6.2K 5% 1/4W
	K3305	QQR0621-001Z	FERRITE BEADS	(B1024)		R2312	QRE141J-122Y	C RESISTOR	1.2K 5% 1/4W
	K6031	QQR0621-001Z	FERRITE BEADS			R2313	QRE141J-472Y	C RESISTOR	4.7K 5% 1/4W
	K6032	QQR0621-001Z	FERRITE BEADS			R2314	QRE141J-122Y	C RESISTOR	1.2K 5% 1/4W
	K6033	QQR0621-001Z	FERRITE BEADS			R2315	QRE141J-912Y	C RESISTOR	9.1K 5% 1/4W
	K6034	QQR0621-001Z	FERRITE BEADS			R2316	QRE141J-122Y	C RESISTOR	1.2K 5% 1/4W
	K6035	QQR0621-001Z	FERRITE BEADS			R2317	QRE141J-271Y	C RESISTOR	270 5% 1/4W
	K6036	QQR0621-001Z	FERRITE BEADS		△	R2318	QRZ9006-4R7X	F RESISTOR	(B1031)
	LF101	QQR0797-001	INDUCTOR			R2319	QRE141J-271Y	C RESISTOR	270 5% 1/4W
	LF201	QQR0797-001	INDUCTOR			R2320	QRE141J-472Y	C RESISTOR	4.7K 5% 1/4W
	L5211	QQL231K-470Y	INDUCTOR			R3101	QRE141J-184Y	C RESISTOR	180K 5% 1/4W
	L5221	QQL231K-470Y	INDUCTOR			R3102	QRE141J-182Y	C RESISTOR	1.8K 5% 1/4W
	L5231	QQL231K-470Y	INDUCTOR			R3103	QRE141J-182Y	C RESISTOR	1.8K 5% 1/4W
	Q1101	KRA109M-T	D.TRANSISTOR			R3104	QRE141J-752Y	C RESISTOR	7.5K 5% 1/4W
	Q1102	KRA109M-T	D.TRANSISTOR			R3105	QRE141J-752Y	C RESISTOR	7.5K 5% 1/4W
	Q1103	2SC3576-JVC-T	TRANSISTOR			R3106	QRE141J-242Y	C RESISTOR	2.4K 5% 1/4W
	Q1201	KRA109M-T	D.TRANSISTOR			R3107	QRE141J-222Y	C RESISTOR	2.2K 5% 1/4W
	Q1202	KRA109M-T	D.TRANSISTOR			R3108	QRE141J-182Y	C RESISTOR	1.8K 5% 1/4W
	Q1203	2SC3576-JVC-T	TRANSISTOR			R3109	QRE141J-472Y	C RESISTOR	4.7K 5% 1/4W
	Q1301	KRC109M-T	D.TRANSISTOR			R3110	QRE141J-103Y	C RESISTOR	10K 5% 1/4W
	Q1302	KRA101M-T	TRANSISTOR			R3111	QRE141J-103Y	C RESISTOR	10K 5% 1/4W

■ Electrical parts list (Main board)

Block No. 01

△	Item	Parts number	Parts name	Remarks	Area
	R3112	QRE141J-393Y	C RESISTOR	39K 5% 1/4W	
	R3113	QRE141J-103Y	C RESISTOR	10K 5% 1/4W	
	R3114	QRE141J-152Y	C RESISTOR	1.5K 5% 1/4W	
	R3115	QRE141J-182Y	C RESISTOR	1.8K 5% 1/4W	
	R3116	QRE141J-153Y	C RESISTOR	15K 5% 1/4W	
	R3117	QRE141J-472Y	C RESISTOR	4.7K 5% 1/4W	
	R3201	QRE141J-184Y	C RESISTOR	180K 5% 1/4W	
	R3202	QRE141J-182Y	C RESISTOR	1.8K 5% 1/4W	
	R3203	QRE141J-182Y	C RESISTOR	1.8K 5% 1/4W	
	R3204	QRE141J-752Y	C RESISTOR	7.5K 5% 1/4W	
	R3205	QRE141J-752Y	C RESISTOR	7.5K 5% 1/4W	
	R3206	QRE141J-242Y	C RESISTOR	2.4K 5% 1/4W	
	R3207	QRE141J-222Y	C RESISTOR	2.2K 5% 1/4W	
	R3208	QRE141J-182Y	C RESISTOR	1.8K 5% 1/4W	
	R3209	QRE141J-472Y	C RESISTOR	4.7K 5% 1/4W	
	R3210	QRE141J-103Y	C RESISTOR	10K 5% 1/4W	
	R3211	QRE141J-103Y	C RESISTOR	10K 5% 1/4W	
	R3212	QRE141J-393Y	C RESISTOR	39K 5% 1/4W	
	R3213	QRE141J-103Y	C RESISTOR	10K 5% 1/4W	
	R3214	QRE141J-152Y	C RESISTOR	1.5K 5% 1/4W	
	R3215	QRE141J-182Y	C RESISTOR	1.8K 5% 1/4W	
	R3216	QRE141J-153Y	C RESISTOR	15K 5% 1/4W	
	R3217	QRE141J-472Y	C RESISTOR	4.7K 5% 1/4W	
	R3302	QRE141J-222Y	C RESISTOR	2.2K 5% 1/4W	
	R3303	QRE141J-222Y	C RESISTOR	2.2K 5% 1/4W	
	R3304	QRE141J-222Y	C RESISTOR	2.2K 5% 1/4W	
	R3307	QRE141J-103Y	C RESISTOR	10K 5% 1/4W	
	R3309	QRE141J-101Y	C RESISTOR	(B1020)	
	R3311	QRE141J-513Y	C RESISTOR	51K 5% 1/4W	
	R3312	QRE141J-124Y	C RESISTOR	120K 5% 1/4W	
	R3313	QRE141J-683Y	C RESISTOR	68K 5% 1/4W	
	R5211	QRE141J-301Y	C RESISTOR	300 5% 1/4W	
	R5212	QRE141J-301Y	C RESISTOR	300 5% 1/4W	
	R5221	QRE141J-301Y	C RESISTOR	300 5% 1/4W	
	R5222	QRE141J-301Y	C RESISTOR	300 5% 1/4W	
	R6031	QRE141J-103Y	C RESISTOR	10K 5% 1/4W	
	R6032	QRE141J-181Y	C RESISTOR	MDA5V	
	R6033	QRE141J-101Y	C RESISTOR	100 5% 1/4W	
	R6034	QRE141J-101Y	C RESISTOR	100 5% 1/4W	
	R6035	QRE141J-101Y	C RESISTOR	100 5% 1/4W	
	R6036	QRE141J-470Y	C RESISTOR	=B6007	
	R6037	QRE141J-332Y	C RESISTOR	MD REC R	
	R6038	QRE141J-332Y	C RESISTOR	MD REC R	
	R6039	QRE141J-332Y	C RESISTOR	MD REC R	
	R6040	QRE141J-332Y	C RESISTOR	MD REC R	
	R6802	QRE141J-101Y	C RESISTOR	100 5% 1/4W	
	S5301	QSW0933-001	DETECT SWITCH		
	S5302	QSW0933-001	DETECT SWITCH		
	W5201	QJK007-053200	SIN CR C-B WIRE	HP - MAIN	
	W5301	QJB002-041804	SIN ID C-B WIRE	PANL SW - MICON	

■ Electrical parts list (Micon board)

Block No. 02

▲	Item	Parts number	Parts name	Remarks	Area	▲	Item	Parts number	Parts name	Remarks	Area
	BZ861	QAN0052-001	BUZZER				C 80	QETN1HM-475Z	E CAPACITOR	4.7MF 20% 50V	
	C 1	NCB31CK-223X	C CAPACITOR				C 81	QETN1HM-475Z	E CAPACITOR	4.7MF 20% 50V	
	C 2	NCB31CK-103X	C CAPACITOR				C 82	QCB31HK-103Y	C CAPACITOR	.010MF 10% 50V	
	C 3	QETN1HM-106Z	E CAPACITOR	10MF 20% 50V			C 83	QCFB1HZ-105Y	C CAPACITOR	AM999	
	C 4	NCB31CK-103X	C CAPACITOR				CF 1	QAX0420-001Z	C FILTER		
	C 5	NCB31CK-103X	C CAPACITOR				CF 2	QAX0458-001Z	C FILTER		
	C 6	NCB31HK-102X	C CAPACITOR				CF 3	QAX0610-001Z	C DISCRIMINATOR		
	C 7	NCB31HK-102X	C CAPACITOR				CF701	QAX0671-001Z	RESONATOR	8MHZ	
	C 10	NDC31HJ-5R0X	C CAPACITOR				CN 1	QGF1205F1-13	CONNECTOR		
	C 11	NCB31CK-104X	C CAPACITOR				CN701	QGB1214K1-10S	CONNECTOR	TO MAIN	
	C 12	NCB31CK-473X	C CAPACITOR				CN702	QGB1214K1-16S	CONNECTOR	TO MAIN	
	C 13	NCS31HJ-100X	C CAPACITOR				CN703	QGA2001C1-04	4P PLUG ASSY	TO PANEL SW	
	C 14	QETN1HM-106Z	E CAPACITOR	10MF 20% 50V			CN704	QGF1205F1-11	CONNECTOR	TO KEY	
	C 15	NCS31HJ-120X	C CAPACITOR				CN705	QGF1205F1-09	CONNECTOR	TO SLC	
	C 16	NCS31HJ-120X	C CAPACITOR				CN706	QGF1205F1-13	CONNECTOR	TO TUNER	
	C 17	NCB31HK-392X	C CAPACITOR				CN707	QGA2501F1-08	CONNECTOR	TO PRIMARY	
	C 18	QETN1HM-474Z	E CAPACITOR	.47MF 20% 50V			CN708	QGF1036F1-19	FFC/FPC CONNE	TO CHUKE1	
	C 19	NCB31CK-473X	C CAPACITOR				CN709	QGB2510K2-08	CONNECTOR	TO CHUKE12	
	C 20	NCB31HK-102X	C CAPACITOR				CN710	QGA2001F1-02	CONNECTOR	TO MOVING MOTOR	
	C 21	NCB31CK-223X	C CAPACITOR				CN851	QGF1205F1-11	CONNECTOR	TO UCON	
	C 22	NCS31HJ-151X	C CAPACITOR			▲	CN901	QGA7901C1-02	CONNECTOR	POWER CORD(PRI)	
	C 23	NCS31HJ-151X	C CAPACITOR				C7041	NCS31HJ-220X	C CAPACITOR		
	C 24	NCS31HJ-151X	C CAPACITOR				C7042	NCS31HJ-220X	C CAPACITOR		
	C 25	QETN1CM-107Z	E CAPACITOR	100MF 20% 16V			C7043	NCB31HK-103X	C CAPACITOR		
	C 30	QETN1CM-107Z	E CAPACITOR	100MF 20% 16V			C7053	QETN1AM-107Z	E CAPACITOR	100MF 20% 10V	
	C 31	QEK1CM-226Z	E CAPACITOR	22MF 20% 16V			C7100	NCB31HK-103X	C CAPACITOR		
	C 32	NCB31CK-473X	C CAPACITOR				C7101	QCFB1HZ-105Y	C CAPACITOR	1.0MF +80:-20%	
	C 33	NCB31CK-473X	C CAPACITOR				C7102	QETN1CM-107Z	E CAPACITOR	100MF 20% 16V	
	C 34	NCB31CK-223X	C CAPACITOR				C7311	QETN1HM-475Z	E CAPACITOR	4.7MF 20% 50V	
	C 35	NCB31CK-473X	C CAPACITOR				C7312	QETN1HM-225Z	E CAPACITOR	2.2MF 20% 50V	
	C 36	QETN1HM-105Z	E CAPACITOR	1.0MF 20% 50V			C7321	QETN0JM-228Z	E CAPACITOR	2200MF 20% 6.3V	
	C 37	QETN1HM-105Z	E CAPACITOR	1.0MF 20% 50V			C7331	NCB31HK-103X	C CAPACITOR		
	C 38	QETN1HM-224Z	E CAPACITOR	.22MF 20% 50V			C7335	NCB31HK-102X	C CAPACITOR		
	C 39	QETN1HM-105Z	E CAPACITOR	1.0MF 20% 50V			C7401	QETN1CM-107Z	E CAPACITOR	100MF 20% 16V	
	C 40	QETN1HM-106Z	E CAPACITOR	10MF 20% 50V			C7403	NCB31HK-103X	C CAPACITOR		
	C 41	QETN1HM-106Z	E CAPACITOR	10MF 20% 50V			C7404	QCFB1HZ-105Y	C CAPACITOR	1.0MF +80:-20%	
	C 42	NCB31CK-223X	C CAPACITOR				C7701	QETN1HM-476Z	E CAPACITOR	47MF 20% 50V	
	C 43	NCB31CK-223X	C CAPACITOR				C7702	QETN1HM-476Z	E CAPACITOR	47MF 20% 50V	
	C 44	QETN1HM-106Z	E CAPACITOR	10MF 20% 50V			C7703	QETN1HM-476Z	E CAPACITOR	47MF 20% 50V	
	C 45	QETN1HM-106Z	E CAPACITOR	10MF 20% 50V			C7704	QETN1HM-476Z	E CAPACITOR	47MF 20% 50V	
	C 46	NCB31CK-223X	C CAPACITOR				C7705	QETN1HM-476Z	E CAPACITOR	47MF 20% 50V	
	C 47	QETN1HM-105Z	E CAPACITOR	1.0MF 20% 50V			C7706	QETN1HM-476Z	E CAPACITOR	47MF 20% 50V	
	C 48	NCB31HK-222X	C CAPACITOR				C7707	QETN1HM-476Z	E CAPACITOR	47MF 20% 50V	
	C 49	NCB31HK-471X	C CAPACITOR				C7708	QETN1HM-476Z	E CAPACITOR	47MF 20% 50V	
	C 50	QETN1HM-226Z	E CAPACITOR	22MF 20% 50V			C7709	QETN1HM-476Z	E CAPACITOR	47MF 20% 50V	
	C 51	QETN1HM-105Z	E CAPACITOR	1.0MF 20% 50V			C7751	QETN1HM-105Z	E CAPACITOR	1.0MF 20% 50V	
	C 53	QETN1HM-226Z	E CAPACITOR	22MF 20% 50V			C7752	QETN1HM-105Z	E CAPACITOR	1.0MF 20% 50V	
	C 54	NCB31CK-473X	C CAPACITOR				C7753	QETN1CM-107Z	E CAPACITOR	100MF 20% 16V	
	C 57	NCB31HK-102X	C CAPACITOR				C7851	QETN1HM-475Z	E CAPACITOR	4.7MF 20% 50V	
	C 58	NCB31CK-473X	C CAPACITOR				C7852	NCB31HK-103X	C CAPACITOR		
	C 59	NCB31HK-102X	C CAPACITOR				C7854	NRSA63J-0R0X	MG RESISTOR	FOR TUNER	
	C 70	NCS31HJ-220X	C CAPACITOR				C7901	QETN1CM-107Z	E CAPACITOR	100MF 20% 16V	
	C 71	NCS31HJ-220X	C CAPACITOR				C7951	QETN1HM-107Z	E CAPACITOR	100MF 20% 50V	
	C 72	NCB31HK-561X	C CAPACITOR				C7952	QETN1JM-476Z	E CAPACITOR	47MF 20% 63V	
	C 73	NCB31CK-104X	C CAPACITOR				C7953	NCB31HK-103X	C CAPACITOR		
	C 74	NCB31CK-104X	C CAPACITOR				C7954	QETN1HM-474Z	E CAPACITOR	.47MF 20% 50V	
	C 75	QETN1HM-106Z	E CAPACITOR	10MF 20% 50V			C7956	QFLC1HJ-104Z	M CAPACITOR	.10MF 5% 50V	
	C 76	NCB31HK-331X	C CAPACITOR				C7957	QFLC1HJ-104Z	M CAPACITOR	.10MF 5% 50V	
	C 77	NCB31HK-681X	C CAPACITOR				C7958	QETN1HM-475Z	E CAPACITOR	4.7MF 20% 50V	
	C 78	NCB31HK-822X	C CAPACITOR	FOR IMMUNITY			C8601	NCB31HK-102X	C CAPACITOR	MDA5V	
	C 79	NCB31HK-822X	C CAPACITOR	FOR IMMUNITY			C8602	QEK1CM-226Z	E CAPACITOR	22MF 20% 16V	

■ Electrical parts list (Micon board)

Block No. 02

△	Item	Parts number	Parts name	Remarks	Area	△	Item	Parts number	Parts name	Remarks	Area
△	C9001	QCZ9104-472	C.CAPACITOR	4700PF			L7001	QQL244K-100Z	INDUCTOR		
△	C9002	QETM1EM-108	E CAPACITOR	1000MF 20% 25V			L7002	QQL244K-100Z	INDUCTOR		
	C9011	QFLC1HJ-104Z	M CAPACITOR	.10MF 5% 50V			Q 1	2SC1623/5-6/-X	TRANSISTOR		
	C9013	QFLC1HJ-104Z	M CAPACITOR	.10MF 5% 50V			Q 2	2SC1623/5-6/-X	TRANSISTOR		
	D 1	1SS133-T2	SI DIODE				Q 3	2SC1623/5-6/-X	TRANSISTOR		
	D 2	1SS133-T2	SI DIODE				Q 4	DTA114YKA-X	TRANSISTOR		
	D 3	1SS133-T2	SI DIODE				Q 5	UN2114-X	D.TRANSISTOR		
	D 4	1SS133-T2	SI DIODE				Q7301	2SD601A/RS/-X	TRANSISTOR		
	D7001	1SS133-T2	SI DIODE				Q7311	UN2211-X	TRANSISTOR		
	D7002	1SS133-T2	SI DIODE				Q7331	2SD601A/RS/-X	TRANSISTOR		
	D7003	1SS133-T2	SI DIODE				Q7701	KTC3199/GL/-T	TRANSISTOR		
	D7004	MA700A-T2	S.B.DIODE				Q7702	KTC3199/GL/-T	TRANSISTOR		
	D7036	1SS133-T2	SI DIODE				Q7703	KTC3199/GL/-T	TRANSISTOR		
	D7053	MA1111-X	DIODE				Q7704	KTC3199/GL/-T	TRANSISTOR		
	D7054	MTZJ5.6B-T2	ZENER DIODE				Q7705	KTC3199/GL/-T	TRANSISTOR		
	D7302	MTZJ5.1C-T2	ZENER DIODE				Q7706	KTC3199/GL/-T	TRANSISTOR		
	D7311	1SS133-T2	SI DIODE				Q7707	KTC3199/GL/-T	TRANSISTOR		
	D7321	1SS133-T2	SI DIODE				Q7708	KTC3199/GL/-T	TRANSISTOR		
	D7401	1N4003S-T5	SI DIODE				Q7709	KTC3199/GL/-T	TRANSISTOR		
	D7402	1N4003S-T5	SI DIODE				△ Q7851	2SB709A/QR/-X	TRANSISTOR		
	D7403	MTZJ5.6C-T2	ZENER DIODE				Q7852	2SD601A/RS/-X	TRANSISTOR		
	D7405	1N4003S-T5	SI DIODE				△ Q7901	KTA1023/OY/-T	TRANSISTOR		
	D7851	MTZJ3.9B-T2	ZENER DIODE				Q7902	KTC3199/GL/-T	TRANSISTOR		
	D7852	1SS133-T2	SI DIODE				Q7903	KTC3199/GL/-T	TRANSISTOR		
	D7853	1SS133-T2	SI DIODE				△ Q7951	KTD863/Y/-T	TRANSISTOR		
	D7901	MTZJ5.6B-T2	ZENER DIODE				Q7952	KTA1268/GL/-T	TRANSISTOR		
	D7902	1SS133-T2	SI DIODE				Q7953	KTC3200/GL/-T	TRANSISTOR		
△	D7951	1N4003S-T5	SI DIODE				Q8602	UN2111-X	TRANSISTOR		
△	D7952	1N4003S-T5	SI DIODE				Q9001	KTC3199/GL/-T	TRANSISTOR		
△	D7953	1N4003S-T5	SI DIODE				R 1	NRSA63J-560X	MG RESISTOR		
△	D7954	MTZJ18C-T2	Z.DIODE				R 2	NRSA63J-331X	MG RESISTOR		
△	D7955	MTZJ5.1C-T2	ZENER DIODE				R 3	NRSA63J-474X	MG RESISTOR		
△	D7956	MTZJ22C-T2	Z.DIODE				R 4	NRSA63J-331X	MG RESISTOR		
	D8603	SLR-342VC-T	LED	MDA5V			R 5	NRSA63J-330X	MG RESISTOR		
	D9001	1SS133-T2	SI DIODE				R 6	NRSA63J-152X	MG RESISTOR		
△	D9002	1N4003S-T5	SI DIODE				R 7	NRSA63J-0R0X	MG RESISTOR		
△	D9011	1N5401-TM	DIODE				R 9	NRSA63J-101X	MG RESISTOR		
△	D9012	1N5401-TM	DIODE				R 10	NRSA63J-222X	MG RESISTOR		
△	D9013	1N5401-TM	DIODE				R 11	NRSA63J-182X	MG RESISTOR		
△	D9014	1N5401-TM	DIODE				R 12	NRSA63J-182X	MG RESISTOR		
	FT911	QNG0003-001Z	FUSE CLIP	FOR F9001			R 13	NRSA63J-103X	MG RESISTOR		
	FT912	QNG0003-001Z	FUSE CLIP	FOR F9001			R 14	NRSA63J-104X	MG RESISTOR		
	FT921	QNG0003-001Z	FUSE CLIP	FOR F9002			R 15	NRSA63J-332X	MG RESISTOR		
	FT922	QNG0003-001Z	FUSE CLIP	FOR F9002			R 16	NRSA63J-472X	MG RESISTOR		
	FT931	QNG0003-001Z	FUSE CLIP	FOR F9003			R 17	NRSA63J-102X	MG RESISTOR		
	FT932	QNG0003-001Z	FUSE CLIP	FOR F9003			R 18	NRSA63J-102X	MG RESISTOR		
	IC 1	LA1838	IC				R 19	NRSA63J-102X	MG RESISTOR		
	IC 2	LC72136N	IC				R 20	NRSA63J-102X	MG RESISTOR		
	IC 3	LC72723	IC(RDS)				R 21	NRSA63J-562X	MG RESISTOR		
	IC701	UPD784215AGF523	IC				R 22	NRSA63J-472X	MG RESISTOR		
	IC741	LB1641	IC	PANEL M.DRIVE			R 23	NRSA63J-182X	MG RESISTOR		
	IC861	GP1UM261XK	IR DETECT UNIT				R 24	NRSA63J-103X	MG RESISTOR		
	J 1	QNB0153-001	ANT TERMINAL				R 25	NRSA63J-331X	MG RESISTOR		
	JS861	QSW0975-001	ROTARY ENCODER				R 26	NRSA63J-222X	MG RESISTOR		
	K7001	QQR0621-001Z	FERRITE BEADS				R 27	NRSA63J-103X	MG RESISTOR		
	K7074	NQR0251-004X	FERRITE BEADS	(R7074)			R 28	NRSA63J-103X	MG RESISTOR		
	K7075	NQR0251-004X	FERRITE BEADS	(R7075)			R 29	NRSA63J-103X	MG RESISTOR		
	L 1	QQR1094-001	COIL BLOCK				R 30	NRSA63J-272X	MG RESISTOR		
	L 3	QQL231K-4R7Y	INDUCTOR				R 31	NRSA63J-0R0X	MG RESISTOR		
	L 70	QQL231K-101Y	INDUCTOR				R 32	NRSA63J-0R0X	MG RESISTOR		
△	LF901	QQR1321-001	LINE FILTER				R 33	NRSA63J-271X	MG RESISTOR		

■ Electrical parts list (Micon board)

Block No. 02

▲	Item	Parts number	Parts name	Remarks	Area	▲	Item	Parts number	Parts name	Remarks	Area
	R 34	NRSA63J-470X	MG RESISTOR				R7077	NRSA63J-222X	MG RESISTOR		
	R 35	NRSA63J-562X	MG RESISTOR				R7078	NRSA63J-222X	MG RESISTOR		
	R 36	NRSA63J-332X	MG RESISTOR				R7079	NRSA63J-222X	MG RESISTOR		
	R 37	NRSA63J-103X	MG RESISTOR				R7081	NRSA63J-222X	MG RESISTOR		
	R 38	NRSA63J-393X	MG RESISTOR				R7082	NRSA63J-222X	MG RESISTOR		
	R 39	NRSA63J-393X	MG RESISTOR				R7083	NRSA63J-222X	MG RESISTOR		
	R 40	NRSA63J-393X	MG RESISTOR				R7084	NRSA63J-222X	MG RESISTOR		
	R 41	NRSA63J-332X	MG RESISTOR				R7085	NRSA63J-222X	MG RESISTOR		
	R 43	NRSA63J-392X	MG RESISTOR				R7086	NRSA63J-562X	MG RESISTOR		
	R 60	NRSA63J-0R0X	MG RESISTOR				R7089	NRSA63J-101X	MG RESISTOR		
	R 72	NRSA63J-102X	MG RESISTOR				R7090	NRSA63J-101X	MG RESISTOR		
	R 73	NRSA63J-102X	MG RESISTOR				R7091	NRSA63J-562X	MG RESISTOR		
	R 74	NRSA63J-222X	MG RESISTOR				R7092	NRSA63J-562X	MG RESISTOR		
	R 75	NRSA63J-222X	MG RESISTOR				R7093	NRSA63J-562X	MG RESISTOR		
	R 76	NRSA63J-682X	MG RESISTOR				R7094	NRSA63J-562X	MG RESISTOR		
	R 77	NRSA63J-682X	MG RESISTOR				R7095	NRSA63J-562X	MG RESISTOR		
▲	RY901	QSK0124-001	RELAY	PRI RELAY			R7096	NRSA63J-562X	MG RESISTOR		
	R7001	NRSA63J-682X	MG RESISTOR				R7097	NRSA63J-562X	MG RESISTOR		
	R7002	NRSA63J-103X	MG RESISTOR				R7098	NRSA63J-562X	MG RESISTOR		
	R7003	NRSA63J-222X	MG RESISTOR				R7099	NRSA63J-562X	MG RESISTOR		
	R7004	NRSA63J-222X	MG RESISTOR				R7114	NRSA63J-222X	MG RESISTOR		
	R7005	NRSA63J-222X	MG RESISTOR				R7123	NRSA63J-473X	MG RESISTOR		
	R7010	NRSA63J-222X	MG RESISTOR				R7125	NRSA63J-473X	MG RESISTOR		
	R7011	NRSA63J-222X	MG RESISTOR				R7126	NRSA63J-473X	MG RESISTOR		
	R7013	NRSA63J-222X	MG RESISTOR				R7129	NRSA63J-103X	MG RESISTOR		
	R7015	NRSA63J-100X	MG RESISTOR				R7130	NRSA63J-103X	MG RESISTOR		
	R7016	NRSA63J-222X	MG RESISTOR				R7131	NRSA63J-103X	MG RESISTOR		
	R7017	NRSA63J-222X	MG RESISTOR				R7147	NRSA63J-823X	MG RESISTOR	PHOTO GR->YG	
	R7018	NRSA63J-222X	MG RESISTOR				R7153	NRSA63J-103X	MG RESISTOR		
	R7019	NRSA63J-222X	MG RESISTOR				R7156	NRSA63J-103X	MG RESISTOR		
	R7020	NRSA63J-103X	MG RESISTOR				R7157	NRSA63J-103X	MG RESISTOR		
	R7022	NRSA63J-103X	MG RESISTOR				R7158	NRSA63J-103X	MG RESISTOR		
	R7023	NRSA63J-222X	MG RESISTOR				R7159	NRSA63J-103X	MG RESISTOR		
	R7025	NRSA63J-222X	MG RESISTOR				R7179	NRSA63J-103X	MG RESISTOR		
	R7026	NRSA63J-222X	MG RESISTOR				R7254	NRSA63J-103X	MG RESISTOR		
	R7027	NRSA63J-222X	MG RESISTOR				R7260	NRSA63J-332X	MG RESISTOR		
	R7029	NRSA63J-222X	MG RESISTOR				R7301	NRSA63J-473X	MG RESISTOR		
	R7030	NRSA63J-222X	MG RESISTOR				R7302	NRSA63J-333X	MG RESISTOR		
	R7031	NRSA63J-222X	MG RESISTOR				R7303	NRSA63J-104X	MG RESISTOR		
	R7032	NRSA63J-222X	MG RESISTOR				R7311	NRSA63J-103X	MG RESISTOR		
	R7033	NRSA63J-222X	MG RESISTOR				R7312	NRSA63J-103X	MG RESISTOR		
	R7034	NRSA63J-102X	MG RESISTOR				R7321	QRE141J-331Y	C RESISTOR	330 5% 1/4W	
	R7036	NRSA63J-102X	MG RESISTOR				R7331	NRSA63J-823X	MG RESISTOR		
	R7038	NRSA63J-105X	MG RESISTOR				R7332	NRSA63J-394X	MG RESISTOR		
	R7043	NRSA63J-102X	MG RESISTOR				R7333	NRSA63J-104X	MG RESISTOR		
	R7044	NRSA63J-222X	MG RESISTOR				R7402	NRSA63J-222X	MG RESISTOR		
	R7045	NRSA63J-102X	MG RESISTOR				R7403	NRSA63J-222X	MG RESISTOR		
	R7047	NRSA63J-222X	MG RESISTOR				R7404	QRE141J-120Y	C RESISTOR	12 5% 1/4W	
	R7053	NRSA63J-223X	MG RESISTOR				R7405	QRE141J-120Y	C RESISTOR	12 5% 1/4W	
	R7054	NRSA63J-222X	MG RESISTOR				R7406	QRE141J-120Y	C RESISTOR	12 5% 1/4W	
	R7055	NRSA63J-222X	MG RESISTOR				R7407	QRE141J-120Y	C RESISTOR	12 5% 1/4W	
	R7056	NRSA63J-222X	MG RESISTOR				R7702	NRSA63J-391X	MG RESISTOR		
	R7057	NRSA63J-222X	MG RESISTOR				R7703	NRSA63J-391X	MG RESISTOR		
	R7058	NRSA63J-222X	MG RESISTOR				R7705	NRSA63J-391X	MG RESISTOR		
	R7059	NRSA63J-222X	MG RESISTOR				R7706	NRSA63J-391X	MG RESISTOR		
	R7060	NRSA63J-392X	MG RESISTOR				R7707	NRSA63J-431X	MG RESISTOR		
	R7065	NRSA63J-222X	MG RESISTOR				R7708	NRSA63J-431X	MG RESISTOR		
	R7066	NRSA63J-222X	MG RESISTOR				R7709	NRSA63J-431X	MG RESISTOR		
	R7068	NRSA63J-222X	MG RESISTOR				R7710	NRSA63J-431X	MG RESISTOR		
	R7069	NRSA63J-222X	MG RESISTOR				R7712	NRSA63J-391X	MG RESISTOR		
	R7076	NRSA63J-222X	MG RESISTOR				R7713	NRSA63J-391X	MG RESISTOR		

■ Electrical parts list (Micon board)

Block No. 02

△	Item	Parts number	Parts name	Remarks	Area
	R7715	NRSA63J-391X	MG RESISTOR		
	R7716	NRSA63J-391X	MG RESISTOR		
	R7717	NRSA63J-431X	MG RESISTOR		
	R7718	NRSA63J-431X	MG RESISTOR		
	R7719	NRSA63J-431X	MG RESISTOR		
	R7720	NRSA63J-431X	MG RESISTOR		
	R7722	NRSA63J-391X	MG RESISTOR		
	R7723	NRSA63J-391X	MG RESISTOR		
	R7725	NRSA63J-391X	MG RESISTOR		
	R7726	NRSA63J-391X	MG RESISTOR		
	R7727	NRSA63J-431X	MG RESISTOR		
	R7728	NRSA63J-431X	MG RESISTOR		
	R7729	NRSA63J-431X	MG RESISTOR		
	R7730	NRSA63J-431X	MG RESISTOR		
	R7851	QRE141J-390Y	C RESISTOR	39 5% 1/4W	
	R7853	NRSA63J-273X	MG RESISTOR		
	R7854	NRSA63J-102X	MG RESISTOR		
	R7901	NRSA63J-103X	MG RESISTOR		
	R7902	NRSA63J-102X	MG RESISTOR		
	R7903	NRSA63J-102X	MG RESISTOR		
	R7904	NRSA63J-102X	MG RESISTOR		
△	R7951	QRZ9006-4R7X	F RESISTOR	4.7 1/4W	
△	R7952	QRE141J-123Y	C RESISTOR	12K 5% 1/4W	
△	R7954	QRZ9005-220X	F RESISTOR	22 1/0W	
	R7955	NRSA63J-104X	MG RESISTOR		
	R7958	QRE141J-153Y	C RESISTOR	15K 5% 1/4W	
	R7959	QRE141J-153Y	C RESISTOR	15K 5% 1/4W	
	R8501	NRSA63J-202X	MG RESISTOR		
	R8502	NRSA63J-122X	MG RESISTOR	MDA5V	
	R8503	NRSA63J-152X	MG RESISTOR		
	R8504	NRSA63J-222X	MG RESISTOR		
	R8505	NRSA63J-272X	MG RESISTOR		
	R8506	NRSA63J-392X	MG RESISTOR		
	R8507	NRSA63J-562X	MG RESISTOR	MDA5V	
	R8508	NRSA63J-103X	MG RESISTOR		
	R8511	NRSA63J-202X	MG RESISTOR	MDA5V	
	R8512	NRSA63J-122X	MG RESISTOR		
	R8513	NRSA63J-152X	MG RESISTOR		
	R8514	NRSA63J-222X	MG RESISTOR		
	R8515	NRSA63J-272X	MG RESISTOR		
	R8516	NRSA63J-392X	MG RESISTOR		
	R8517	NRSA63J-562X	MG RESISTOR	MDA5V	
	R8603	NRSA63J-561X	MG RESISTOR		
	S8501	QSW0651-001Z	TACT SWITCH		
	S8502	QSW0651-001Z	TACT SWITCH		
	S8503	QSW0651-001Z	TACT SWITCH		
	S8504	QSW0651-001Z	TACT SWITCH		
	S8505	QSW0651-001Z	TACT SWITCH		
	S8506	QSW0651-001Z	TACT SWITCH		
	S8507	QSW0651-001Z	TACT SWITCH		
	S8508	QSW0651-001Z	TACT SWITCH		
	S8509	QSW0651-001Z	TACT SWITCH		
	S8511	QSW0651-001Z	TACT SWITCH		
	S8512	QSW0651-001Z	TACT SWITCH		
	S8513	QSW0651-001Z	TACT SWITCH		
	S8514	QSW0651-001Z	TACT SWITCH		
	S8515	QSW0651-001Z	TACT SWITCH		
	S8516	QSW0651-001Z	TACT SWITCH		
	S8517	QSW0651-001Z	TACT SWITCH		
	S8518	QSW0651-001Z	TACT SWITCH		
	S8601	QSW0651-001Z	TACT SWITCH		

△	Item	Parts number	Parts name	Remarks	Area
	T 1	QQR0793-001	IFT		
	TU 1	QAU0160-001	FRONT END		
△	T9002	QQT0253-002	POWER TRANS		
	W9001	QJK007-072402	SIN CR C-B WIRE	TRANS - MAIN	
	W9002	QJK008-080703	SIN CR C-B WIRE	TRANS - MICON	
	X 1	QAX0402-001	CRYSTAL		
	X 70	QAX0263-001Z	CRYSTAL		
	X7001	QAX0401-001	CRYSTAL	32KHZ	

■ Electrical parts list (CD servo board)

Block No. 03

▲	Item	Parts number	Parts name	Remarks	Area	▲	Item	Parts number	Parts name	Remarks	Area
	C 254	QERF1AM-476Z	E CAPACITOR	47MF 20% 10V			C 822	QERF1AM-227Z	E CAPACITOR	220MF 20% 10V	
	C 255	NCB31CK-104X	C CAPACITOR				C 861	NCB31HK-102X	C CAPACITOR		
	C 256	NCB31CK-104X	C CAPACITOR				C 862	NCB31HK-102X	C CAPACITOR		
	C 271	NCS31HJ-101X	C CAPACITOR				C 863	NCB31HK-272X	C CAPACITOR		
	C 272	NCS31HJ-101X	C CAPACITOR				C 864	NCB31HK-272X	C CAPACITOR		
	C 273	NCB31CK-104X	C CAPACITOR				CN601	QGF1037F1-15W	CONNECTOR	PICK UP/TR.MECH	
	C 291	NCB21CK-105X	C CAPACITOR				CN605	QGF1016F2-04W	CONNECTOR	CD TEXT	
	C 292	NCB21CK-105X	C CAPACITOR				CN606	QGF1016F2-08W	CONNECTOR	4T I/F	
	C 601	NCB31HK-102X	C CAPACITOR				CN651	QGF1016F3-19	CONNECTOR	MAIN	
	C 602	NCB31HK-102X	C CAPACITOR				D 251	DA204U-X	DIODE		
	C 603	NCB31EK-223X	C CAPACITOR				D 292	MA112-X	DIODE		
	C 604	NCB31EK-223X	C CAPACITOR				D 603	1SS355-X	DIODE		
	C 605	NCS31HJ-271X	C CAPACITOR				HL251	VYH7653-002	IC HOLDER	FOR IC251	
	C 606	NCS31HJ-820X	C CAPACITOR				IC251	UPD780024AGKB21	IC	MICOM	
	C 610	NCB31CK-563X	C CAPACITOR				IC291	XC62HR3502P-X	IC	3.5VREG	
	C 611	NCB21CK-104X	C CAPACITOR				IC601	AN22000A-W	IC	RF AMP	
	C 612	QEKC1HM-104Z	E CAPACITOR	.10MF 20% 50V			IC651	MN662790RSC	IC	DSP & DAC	
	C 614	NCB31CK-393X	C CAPACITOR				IC801	LA6541-X	IC	PU DRIVE	
	C 615	NCB31HK-272X	C CAPACITOR				K 655	NQR0007-002X	FERRITE BEADS	TX	
	C 616	NCB31HK-681X	C CAPACITOR				K 656	NQR0251-004X	FERRITE BEADS	SRDATA	
	C 617	NCB31HK-331X	C CAPACITOR				K 657	NQR0251-004X	FERRITE BEADS	LRCK	
	C 621	NCB31CK-104X	C CAPACITOR				K 658	NQR0251-004X	FERRITE BEADS	BCLK	
	C 622	QEKC0JM-107Z	E CAPACITOR	100MF 20% 6.3V			Q 631	2SA1037AK/RS/-X	TRANSISTOR	APC	
	C 623	NCF21CZ-105X	C CAPACITOR				Q 651	DTC114EUA-X	TRANSISTOR		
	C 624	QEKC0JM-107Z	E CAPACITOR	100MF 20% 6.3V			Q 652	DTC114EUA-X	TRANSISTOR	RF EQ	
	C 631	QEKC1CM-106Z	E CAPACITOR	10MF 20% 16V			Q 673	DTA114EKA-X	DIGITAL TRANSIS	IREF CHANGE	
	C 632	NCF21CZ-105X	C CAPACITOR				R 251	NRSA63J-102X	MG RESISTOR		
	C 633	NCB31EK-223X	C CAPACITOR				R 252	NRSA63J-102X	MG RESISTOR		
	C 651	NCS31HJ-1R0X	C CAPACITOR				R 253	NRSA63J-102X	MG RESISTOR		
	C 652	NCS31HJ-1R0X	C CAPACITOR				R 254	NRSA63J-102X	MG RESISTOR		
	C 653	NCB31AK-334X	C CAPACITOR				R 255	NRSA63J-102X	MG RESISTOR		
	C 655	NCB31CK-104X	C CAPACITOR				R 256	NRSA63J-102X	MG RESISTOR		
	C 656	NCB31CK-104X	C CAPACITOR				R 257	NRSA63J-102X	MG RESISTOR		
	C 657	QEKC0JM-107Z	E CAPACITOR	100MF 20% 6.3V			R 258	NRSA63J-102X	MG RESISTOR		
	C 658	NCB31CK-104X	C CAPACITOR				R 259	NRSA63J-102X	MG RESISTOR		
	C 661	NCS31HJ-471X	C CAPACITOR				R 260	NRSA63J-102X	MG RESISTOR		
	C 663	NCB31EK-223X	C CAPACITOR				R 261	NRSA63J-0R0X	MG RESISTOR		
	C 664	NCB31EK-223X	C CAPACITOR				R 262	NRSA63J-102X	MG RESISTOR		
	C 665	NCB21CK-154X	C CAPACITOR				R 263	NRSA63J-102X	MG RESISTOR		
	C 667	NCB21CK-474X	C CAPACITOR				R 264	NRSA63J-103X	MG RESISTOR		
	C 668	NCB31CK-473X	C CAPACITOR				R 265	NRSA63J-183X	MG RESISTOR		
	C 673	QER60JM-107Z	E CAPACITOR	100MF 20% 6.3V			R 271	NRSA63J-103X	MG RESISTOR		
	C 676	NCB31CK-104X	C CAPACITOR				R 272	NRSA63J-103X	MG RESISTOR		
	C 677	NCB31CK-104X	C CAPACITOR				R 273	NRSA63J-103X	MG RESISTOR		
	C 678	NCB31CK-104X	C CAPACITOR				R 274	NRSA63J-682X	MG RESISTOR		
	C 679	QEKC0JM-107Z	E CAPACITOR	100MF 20% 6.3V			R 275	NRSA63J-103X	MG RESISTOR		
	C 680	NCB31CK-104X	C CAPACITOR				R 281	NRSA63J-102X	MG RESISTOR		
	C 681	NCS31HJ-6R0X	C CAPACITOR				R 282	NRSA63J-102X	MG RESISTOR		
	C 682	NCS31HJ-150X	C CAPACITOR				R 283	NRSA63J-101X	MG RESISTOR		
	C 683	NCS31HJ-220X	C CAPACITOR				R 284	NRSA63J-102X	MG RESISTOR		
	C 801	NCB31EK-223X	C CAPACITOR				R 285	NRSA63J-102X	MG RESISTOR		
	C 802	NCS31HJ-102X	C CAPACITOR				R 291	NRSA63J-103X	MG RESISTOR		
	C 811	NCS31HJ-391X	C CAPACITOR				R 292	NRSA63J-1R0X	MG RESISTOR		
	C 812	NCS31HJ-391X	C CAPACITOR				R 293	NRSA63J-1R0X	MG RESISTOR		
	C 813	NCS31HJ-391X	C CAPACITOR				R 601	NRSA63J-224X	MG RESISTOR		
	C 814	NCS31HJ-391X	C CAPACITOR				R 602	NRSA63J-823X	MG RESISTOR		
	C 815	NCB21AK-105X	C CAPACITOR				R 603	NRSA63J-393X	MG RESISTOR		
	C 816	NCB20JK-155X	C CAPACITOR				R 604	NRSA63J-224X	MG RESISTOR		
	C 817	NCF21CZ-105X	C CAPACITOR				R 607	NRSA63J-473X	MG RESISTOR		
	C 818	NCF21CZ-105X	C CAPACITOR				R 608	NRSA63J-473X	MG RESISTOR		
	C 821	NCF21CZ-105X	C CAPACITOR				R 611	NRSA63J-562X	MG RESISTOR		

■ Electrical parts list (CD servo board)

Block No. 03

△	Item	Parts number	Parts name	Remarks	Area
	R 613	NRSA63J-562X	MG RESISTOR		
	R 617	NRSA63J-332X	MG RESISTOR		
	R 631	NRSA63J-2R2X	MG RESISTOR		
	R 632	NRSA63J-3R9X	MG RESISTOR		
	R 634	NRSA63J-3R9X	MG RESISTOR		
	R 635	NRSA63J-100X	MG RESISTOR		
	R 636	NRSA63J-151X	MG RESISTOR		
	R 651	NRSA63J-102X	MG RESISTOR		
	R 652	NRSA63J-102X	MG RESISTOR		
	R 653	NRSA63J-102X	MG RESISTOR		
	R 654	NRSA63J-102X	MG RESISTOR		
	R 659	NRSA63J-203X	MG RESISTOR		
	R 661	NRSA63J-473X	MG RESISTOR		
	R 662	NRSA63J-683X	MG RESISTOR		
	R 663	NRSA63J-683X	MG RESISTOR		
	R 664	NRSA63J-331X	MG RESISTOR		
	R 665	NRSA63J-101X	MG RESISTOR		
	R 666	NRSA02J-101X	MG RESISTOR		
	R 667	NRSA63J-4R7X	MG RESISTOR		
	R 668	NRSA63J-155X	MG RESISTOR		
	R 669	NRSA63J-562X	MG RESISTOR		
	R 671	NRSA63J-684X	MG RESISTOR		
	R 673	NRSA63J-683X	MG RESISTOR		
	R 675	NRSA63J-100X	MG RESISTOR		
	R 677	NRSA63J-102X	MG RESISTOR		
	R 678	NRSA63J-102X	MG RESISTOR		
	R 679	NRSA63J-102X	MG RESISTOR		
	R 682	NRSA63J-102X	MG RESISTOR		
	R 683	NRSA63J-105X	MG RESISTOR		
	R 685	NRSA63J-683X	MG RESISTOR		
	R 801	NRSA63J-272X	MG RESISTOR		
	R 802	NRSA63J-152X	MG RESISTOR		
	R 803	NRSA63J-472X	MG RESISTOR		
	R 804	NRSA63J-103X	MG RESISTOR		
	R 805	NRSA63J-123X	MG RESISTOR		
	R 808	NRSA63J-183X	MG RESISTOR		
	R 809	NRSA63J-152X	MG RESISTOR		
	R 811	NRSA63J-473X	MG RESISTOR		
	R 812	NRSA63J-152X	MG RESISTOR		
	R 813	NRSA63J-182X	MG RESISTOR		
	R 861	NRSA63J-681X	MG RESISTOR		
	R 862	NRSA63J-681X	MG RESISTOR		
	R 863	NRSA63J-561X	MG RESISTOR		
	R 864	NRSA63J-561X	MG RESISTOR		
	SW101	QSW0927-001	SWITCH	REST SW	
	SW102	QSW0931-001	SWITCH	TRAY SW	
	X 251	QAX0664-001Z	C OSCILLATOR	FOR IC251 8.38M	
	X 651	NAX0476-001X	CRYSTAL	FOR IC651	

■ Electrical parts list (MD servo control board) Block No. 04

△	Item	Parts number	Parts name	Remarks	Area	△	Item	Parts number	Parts name	Remarks	Area
	C 300	NCF31CZ-104X	C CAPACITOR				C 452	NCF31CZ-104X	C CAPACITOR		
	C 302	NCF31CZ-104X	C CAPACITOR				C 453	NCF31CZ-104X	C CAPACITOR		
	C 307	NCB31HK-222X	C CAPACITOR				C 455	NDC32AJ-101X	C CAPACITOR		
	C 310	NCB31HK-102X	C CAPACITOR				C 481	NCF21CZ-105X	C CAPACITOR		
	C 311	NCF21CZ-105X	C CAPACITOR				C 483	NCF31CZ-104X	C CAPACITOR		
	C 312	NEA70GM-476X	E CAPACITOR				C 484	NEAD1CM-106X	E CAPACITOR		
	C 314	NCB31CK-223X	C CAPACITOR				C 485	NCF31CZ-104X	C CAPACITOR		
	C 315	NCB31HK-102X	C CAPACITOR				C 486	NCF31CZ-104X	C CAPACITOR		
	C 316	NCF21CZ-105X	C CAPACITOR				C 487	NCF31CZ-104X	C CAPACITOR		
	C 318	NCB31HK-682X	C CAPACITOR				C 488	NEAD1CM-106X	E CAPACITOR		
	C 319	NCB31CK-333X	C CAPACITOR				C 489	NEAD1VM-475X	E CAPACITOR		
	C 320	NCB21AK-105X	C CAPACITOR				C 490	NCB31CK-103X	C CAPACITOR		
	C 321	NCB31HK-472X	C CAPACITOR				C 491	NCB31HK-102X	C CAPACITOR		
	C 322	NCB21AK-105X	C CAPACITOR				C 492	NCB31HK-102X	C CAPACITOR		
	C 323	NCB31HK-682X	C CAPACITOR				C 496	NCF21CZ-105X	C CAPACITOR		
	C 324	NCB21CK-224X	C CAPACITOR				C 497	NCF31CZ-104X	C CAPACITOR		
	C 325	NCB31CK-103X	C CAPACITOR				C 501	NCS31HJ-180X	C CAPACITOR		
	C 326	NCB31CK-223X	C CAPACITOR				C 502	NCS31HJ-180X	C CAPACITOR		
	C 327	NCB31CK-104X	C CAPACITOR				C 511	NCF31CZ-104X	C CAPACITOR		
	C 328	NCB31CK-104X	C CAPACITOR				C 512	NCF31CZ-104X	C CAPACITOR		
	C 330	NCF31CZ-104X	C CAPACITOR				C 515	NCF31CZ-104X	C CAPACITOR		
	C 333	NCB21CK-154X	C CAPACITOR				C 590	NCS31HJ-101X	C CAPACITOR		
	C 334	NCF31CZ-104X	C CAPACITOR				C 591	NCF31CZ-104X	C CAPACITOR		
	C 340	NCB31CK-223X	C CAPACITOR				CN321	QGF0501F2-21X	CONNECTOR	FOR PICK-UP A'S	
	C 341	NCB31CK-223X	C CAPACITOR				CN407	QGF1006F2-08W	SOCKET	FOR CAM SW	
	C 342	NCF31CZ-104X	C CAPACITOR				CN408	QGF1006F2-09W	CONNECTOR	FOR TRAMECHA PW	
	C 350	NEA70GM-476X	E CAPACITOR				CN451	QGF1016F2-04W	CONNECTOR	FOR HEAD	
	C 351	NCF21CZ-105X	C CAPACITOR				CN521	QGF1006F2-21W	SOCKET	FOR SYSTEM	
	C 352	NEA70GM-476X	E CAPACITOR				CN522	QGF1006F2-08W	SOCKET	FOR CD	
	C 353	NCF21CZ-105X	C CAPACITOR				CN601	QGF1006F2-09W	CONNECTOR		
	C 354	NCF21CZ-105X	C CAPACITOR				D 310	1SS355-X	DIODE	TEMP DET	
	C 355	NCF31CZ-104X	C CAPACITOR				D 451	RB160L-60-X	SB DIODE		
	C 358	NCF31CZ-104X	C CAPACITOR				D 452	RB160L-60-X	SB DIODE		
	C 359	NCF31CZ-104X	C CAPACITOR				IC310	CXA2523AR	IC	RF	
	C 361	NCF31CZ-104X	C CAPACITOR				IC340	TC7S08F-W	IC	APC PWM BUFFER	
	C 375	NCB31CK-103X	C CAPACITOR				IC350	CXD2662R	IC	MD DSP	
	C 376	NCB21CK-474X	C CAPACITOR				IC390	GM71VS17400CLT5	IC	4M*4 DRAM	
	C 377	NCB31HK-471X	C CAPACITOR				IC400	XC62ER3602M-X	IC	3.6V REG	
	C 378	NCS31HJ-330X	C CAPACITOR				IC410	M63008FP-X	IC	BTL DRIVER	
	C 379	NCB21CK-474X	C CAPACITOR				IC450	BD7910FV-X	IC M.HEAD DRIVE	DRIVER	
	C 380	NCB31CK-153X	C CAPACITOR				IC480	AK4519VF-X	IC A/D.D/A CONV		
	C 400	NEAD1CM-226X	E CAPACITOR				IC485	TK11140SC-W	IC 4.0V REG		
	C 401	NEAD0JM-107X	E CAPACITOR				IC500	UPD784217AGC174	IC(MCU)		
	C 402	NCB31HK-331X	C CAPACITOR				IC590	BR93LC66F-X	IC	256*16BIT EEPROM	
	C 403	NEAD0GM-476X	E CAPACITOR				K 346	NQR0360-002X	FERRITE BEADS		
	C 407	NCS31HJ-101X	C CAPACITOR				K 353	NQR0389-003X	FERRITE BEADS		
	C 409	NCB31CK-104X	C CAPACITOR				K 491	NRSA63J-0R0X	MG RESISTOR		
	C 411	NCF21CZ-105X	C CAPACITOR				K 492	NRSA63J-0R0X	MG RESISTOR		
	C 412	NCF31CZ-104X	C CAPACITOR				K 495	NRSA63J-0R0X	MG RESISTOR		
	C 421	NCB31HK-561X	C CAPACITOR				K 496	NRSA63J-0R0X	MG RESISTOR		
	C 423	NCB31HK-561X	C CAPACITOR				K 505	NQR0389-003X	FERRITE BEADS		
	C 425	NCB31HK-561X	C CAPACITOR				K 521	NQR0354-001X	FERRITE BEADS		
	C 427	NCB31HK-561X	C CAPACITOR				K 522	NQR0354-001X	FERRITE BEADS		
	C 429	NCB31HK-392X	C CAPACITOR				K 523	NQR0389-003X	FERRITE BEADS		
	C 431	NCB31HK-392X	C CAPACITOR				K 524	NQR0389-003X	FERRITE BEADS		
	C 433	NCB31HK-562X	C CAPACITOR				K 527	NRSA63J-0R0X	MG RESISTOR		
	C 435	NCB31HK-562X	C CAPACITOR				K 528	NRSA63J-0R0X	MG RESISTOR		
	C 437	NCB31CK-103X	C CAPACITOR				K 529	NRSA63J-0R0X	MG RESISTOR		
	C 439	NCB31CK-103X	C CAPACITOR				K 530	NRSA63J-0R0X	MG RESISTOR		
	C 450	NEA71CM-107X	E CAPACITOR				K 531	NRSA63J-0R0X	MG RESISTOR		
	C 451	NEA70GM-107X	E CAPACITOR				K 532	NRSA63J-0R0X	MG RESISTOR		

■ Electrical parts list (MD servo control board) Block No. 04

△	Item	Parts number	Parts name	Remarks	Area	△	Item	Parts number	Parts name	Remarks	Area
	L 351	NQL38DK-100X	INDUCTOR				R 372	NRSA63J-103X	MG RESISTOR		
	L 352	NQL38DK-100X	INDUCTOR				R 375	NRSA63J-103X	MG RESISTOR		
	L 525	NQL274M-1R5X	INDUCTOR				R 376	NRSA63J-104X	MG RESISTOR		
	L 526	NQL274M-1R5X	INDUCTOR				R 377	NRSA63J-684X	MG RESISTOR		
	Q 330	2SA1362/G/-X	TRANSISTOR				R 378	NRSA63J-332X	MG RESISTOR		
	Q 331	KRA102S-X	TRANSISTOR				R 379	NRSA63J-102X	MG RESISTOR		
	Q 332	KRA116S-X	TRANSISTOR				R 380	NRSA63J-105X	MG RESISTOR		
	Q 333	KRA116S-X	TRANSISTOR				R 381	NRSA63J-102X	MG RESISTOR		
	Q 400	2SA1363/EF/-X	TRANSISTOR	4.6V REG			R 382	NRSA63J-151X	MG RESISTOR		
	Q 401	2SA1363/EF/-X	TRANSISTOR	3.6V REG			R 387	NRSA63J-102X	MG RESISTOR		
	Q 410	KRC102S-X	TRANSISTOR				R 389	NRSA63J-331X	MG RESISTOR		
	Q 411	KRC102S-X	TRANSISTOR				R 390	NRSA63J-102X	MG RESISTOR		
	R 300	NRSA63J-0R0X	MG RESISTOR				R 391	NRSA63J-561X	MG RESISTOR		
	R 301	NRS181J-0R0X	MG RESISTOR				R 392	NRSA63J-102X	MG RESISTOR		
	R 302	NRSA63J-0R0X	MG RESISTOR				R 393	NRSA63J-102X	MG RESISTOR		
	R 305	NRSA63J-222X	MG RESISTOR				R 394	NRSA63J-102X	MG RESISTOR		
	R 306	NRSA63J-474X	MG RESISTOR				R 395	NRSA63J-102X	MG RESISTOR		
	R 309	NRSA63J-474X	MG RESISTOR				R 396	NRSA63J-331X	MG RESISTOR		
	R 310	NRSA63J-331X	MG RESISTOR				R 397	NRSA63J-331X	MG RESISTOR		
	R 311	NRSA63J-682X	MG RESISTOR				R 398	NRSA63J-331X	MG RESISTOR		
	R 313	NRSA63J-104X	MG RESISTOR				R 399	NRSA63J-102X	MG RESISTOR		
	R 314	NRSA63J-133X	MG RESISTOR				R 401	NRSA63D-153X	MG RESISTOR		
	R 315	NRSA63J-243X	MG RESISTOR				R 402	NRSA63D-562X	MG RESISTOR		
	R 316	NRSA63J-104X	MG RESISTOR				R 403	NRSA63J-471X	MG RESISTOR		
	R 317	NRSA63J-103X	MG RESISTOR				R 404	NRSA63J-333X	MG RESISTOR		
	R 320	NRSA63J-563X	MG RESISTOR				R 420	NRSA63D-223X	MG RESISTOR		
	R 321	NRSA63J-331X	MG RESISTOR				R 421	NRSA63D-103X	MG RESISTOR		
	R 322	NRSA63J-331X	MG RESISTOR				R 422	NRSA63D-223X	MG RESISTOR		
	R 323	NRSA63J-331X	MG RESISTOR				R 423	NRSA63D-103X	MG RESISTOR		
	R 324	NRSA63J-102X	MG RESISTOR				R 424	NRSA63D-223X	MG RESISTOR		
	R 325	NRSA63J-472X	MG RESISTOR				R 425	NRSA63D-103X	MG RESISTOR		
	R 326	NRSA63J-331X	MG RESISTOR				R 426	NRSA63D-223X	MG RESISTOR		
	R 327	NRSA63J-331X	MG RESISTOR				R 427	NRSA63D-103X	MG RESISTOR		
	R 328	NRSA63J-101X	MG RESISTOR				R 428	NRSA63D-243X	MG RESISTOR		
	R 330	NRSA63J-8R2X	MG RESISTOR				R 429	NRSA63D-392X	MG RESISTOR		
	R 331	NRSA63J-270X	MG RESISTOR				R 430	NRSA63D-243X	MG RESISTOR		
	R 332	NRSA63J-473X	MG RESISTOR				R 431	NRSA63D-392X	MG RESISTOR		
	R 333	NRSA63J-473X	MG RESISTOR				R 432	NRSA63D-123X	MG RESISTOR		
	R 334	NRSA63J-473X	MG RESISTOR				R 433	NRSA63D-822X	MG RESISTOR		
	R 335	NRSA63J-473X	MG RESISTOR				R 434	NRSA63D-123X	MG RESISTOR		
	R 336	NRSA63J-104X	MG RESISTOR				R 435	NRSA63D-822X	MG RESISTOR		
	R 337	NRSA63J-1R0X	MG RESISTOR				R 436	NRSA63J-223X	MG RESISTOR		
	R 338	NRSA63J-4R7X	MG RESISTOR				R 437	NRSA63J-302X	MG RESISTOR		
	R 339	NRSA63J-473X	MG RESISTOR				R 438	NRSA63J-223X	MG RESISTOR		
	R 340	NRSA63J-222X	MG RESISTOR				R 439	NRSA63J-302X	MG RESISTOR		
	R 341	NRSA63J-222X	MG RESISTOR				R 440	NRSA63D-103X	MG RESISTOR		
	R 342	NRSA63J-222X	MG RESISTOR				R 441	NRSA63D-103X	MG RESISTOR		
	R 343	NRSA63J-102X	MG RESISTOR				R 451	NRSA63J-473X	MG RESISTOR		
	R 354	NRSA63D-103X	MG RESISTOR				R 452	NRSA63J-563X	MG RESISTOR		
	R 355	NRSA63D-103X	MG RESISTOR				R 453	NRSA63J-1R0X	MG RESISTOR		
	R 356	NRSA63J-102X	MG RESISTOR				R 454	NRSA63J-1R0X	MG RESISTOR		
	R 361	NRSA63J-102X	MG RESISTOR				R 456	NAD0006-103X	THERMISTOR		
	R 362	NRSA63J-102X	MG RESISTOR				R 481	NRSA63J-100X	MG RESISTOR		
	R 363	NRSA63J-102X	MG RESISTOR				R 483	NRSA63J-0R0X	MG RESISTOR		
	R 364	NRSA63J-102X	MG RESISTOR				R 491	NRSA63J-471X	MG RESISTOR		
	R 365	NRSA63J-102X	MG RESISTOR				R 492	NRSA63J-471X	MG RESISTOR		
	R 366	NRSA63J-102X	MG RESISTOR				R 495	NRSA63J-471X	MG RESISTOR		
	R 367	NRSA63J-102X	MG RESISTOR				R 496	NRSA63J-471X	MG RESISTOR		
	R 368	NRSA63J-102X	MG RESISTOR				R 497	NRSA63J-1R0X	MG RESISTOR		
	R 369	NRSA63J-102X	MG RESISTOR				R 502	NRSA63J-152X	MG RESISTOR		
	R 371	NRSA63J-103X	MG RESISTOR				R 503	NRSA63J-222X	MG RESISTOR		

■ Electrical parts list (MD servo control board) Block No. 04

△	Item	Parts number	Parts name	Remarks	Area
	R 504	NRSA63J-333X	MG RESISTOR		
	R 506	NRSA63J-103X	MG RESISTOR		
	R 510	NRSA63J-102X	MG RESISTOR		
	R 511	NRSA63J-102X	MG RESISTOR		
	R 512	NRSA63J-102X	MG RESISTOR		
	R 513	NRSA63J-102X	MG RESISTOR		
	R 514	NRSA63J-102X	MG RESISTOR		
	R 515	NRSA63J-102X	MG RESISTOR		
	R 516	NRSA63J-102X	MG RESISTOR		
	R 518	NRSA63J-102X	MG RESISTOR		
	R 519	NRSA63J-102X	MG RESISTOR		
	R 520	NRSA63J-102X	MG RESISTOR		
	R 521	NRSA63J-102X	MG RESISTOR		
	R 522	NRSA63J-222X	MG RESISTOR		
	R 523	NRSA63J-102X	MG RESISTOR		
	R 524	NRSA63J-102X	MG RESISTOR		
	R 525	NRSA63J-102X	MG RESISTOR		
	R 528	NRSA63J-102X	MG RESISTOR		
	R 529	NRSA63J-102X	MG RESISTOR		
	R 530	NRSA63J-102X	MG RESISTOR		
	R 534	NRSA63J-103X	MG RESISTOR		
	R 536	NRSA63J-103X	MG RESISTOR		
	R 537	NRSA63J-103X	MG RESISTOR		
	R 538	NRSA63J-473X	MG RESISTOR		
	R 540	NRSA63J-473X	MG RESISTOR		
	R 541	NRSA63J-473X	MG RESISTOR		
	R 545	NRSA63J-0R0X	MG RESISTOR		
	R 546	NRSA63J-0R0X	MG RESISTOR		
	R 547	NRSA63J-0R0X	MG RESISTOR		
	R 548	NRSA63J-0R0X	MG RESISTOR		
	R 551	NRSA63J-104X	MG RESISTOR		
	R 552	NRSA63J-104X	MG RESISTOR		
	R 554	NRSA63J-104X	MG RESISTOR		
	R 555	NRSA63J-102X	MG RESISTOR		
	R 556	NRSA63J-102X	MG RESISTOR		
	R 557	NRSA63J-102X	MG RESISTOR		
	R 558	NRSA63J-102X	MG RESISTOR		
	R 559	NRSA63J-0R0X	MG RESISTOR		
	R 560	NRSA63J-0R0X	MG RESISTOR		
	R 561	NRSA63J-0R0X	MG RESISTOR		
	R 562	NRSA63J-0R0X	MG RESISTOR		
	R 563	NRSA63J-102X	MG RESISTOR		
	R 564	NRSA63J-102X	MG RESISTOR		
	R 565	NRSA63J-102X	MG RESISTOR		
	R 567	NRSA63J-102X	MG RESISTOR		
	R 568	NRSA63J-102X	MG RESISTOR		
	R 569	NRSA63J-102X	MG RESISTOR		
	R 570	NRSA63J-223X	MG RESISTOR		
	R 592	NRSA63J-104X	MG RESISTOR		
	R 593	NRSA63J-103X	MG RESISTOR		
	S 601	NSW0165-001X	DETECT SWICH		
	S 602	NSW0007-001X	PUSH SWITCH		
	X 350	NAX0547-001X	CRYSTAL	90.3168MHZ	
	X 500	NAX0426-001X	CRYSTAL	12.288MHZ	

■ Electrical parts list (MD cam switch board) Block No. 05

△	Item	Parts number	Parts name	Remarks	Area
	CN611	QGF1016F3-08	CONNECTOR		
	CN612	QGA1501F1-02	CONNECTOR		
	S 611	QSW0848-001	CAM SWITCH		

■ Electrical parts list (Head amplifier board) Block No. 06

△	Item	Parts number	Parts name	Remarks	Area
	C 101	NCS21HJ-821X	C CAPACITOR		
	C 102	NCS21HJ-221X	C CAPACITOR		
	C 103	QEKJ0JM-227Z	E CAPACITOR	220MF 20% 6.3V	
	C 104	NCB21HK-333X	C CAPACITOR		
	C 105	NCB21HK-222X	C CAPACITOR		
	C 106	QEKJ1CM-106Z	E CAPACITOR	10MF 20% 16V	
	C 107	NCS21HJ-561X	C CAPACITOR		
	C 108	QEKJ1EM-475Z	E CAPACITOR	4.7MF 20% 25V	
	C 109	QEKJ1EM-475Z	E CAPACITOR	4.7MF 20% 25V	
	C 110	NCB21HK-682X	C CAPACITOR		
	C 111	NCB21HK-152X	C CAPACITOR		
	C 113	NCB21HK-393X	C CAPACITOR		
	C 121	NCS21HJ-331X	C CAPACITOR		
	C 201	NCS21HJ-821X	C CAPACITOR		
	C 202	NCS21HJ-221X	C CAPACITOR		
	C 203	QEKJ0JM-227Z	E CAPACITOR	220MF 20% 6.3V	
	C 204	NCB21HK-333X	C CAPACITOR		
	C 205	NCB21HK-222X	C CAPACITOR		
	C 206	QEKJ1CM-106Z	E CAPACITOR	10MF 20% 16V	
	C 207	NCS21HJ-561X	C CAPACITOR		
	C 208	QEKJ1EM-475Z	E CAPACITOR	4.7MF 20% 25V	
	C 209	QEKJ1EM-475Z	E CAPACITOR	4.7MF 20% 25V	
	C 210	NCB21HK-682X	C CAPACITOR		
	C 211	NCB21HK-152X	C CAPACITOR		
	C 213	NCB21HK-393X	C CAPACITOR		
	C 221	NCS21HJ-331X	C CAPACITOR		
	C 301	QEKJ1AM-107Z	E CAPACITOR	100MF 20% 10V	
	C 302	NCB21HK-393X	C CAPACITOR		
	C 303	QEKJ0JM-227Z	E CAPACITOR	220MF 20% 6.3V	
	C 304	QEKJ1CM-226Z	E CAPACITOR	22MF 20% 16V	
	C 305	QEKJ1CM-226Z	E CAPACITOR	22MF 20% 16V	
	C 306	QEKJ1CM-226Z	E CAPACITOR	22MF 20% 16V	
	C 307	NCB21HK-103X	C CAPACITOR		
	C 308	NCB21HK-152X	C CAPACITOR		
	C 310	NCB21HK-223X	C CAPACITOR		
	C 313	QEKJ1AM-107Z	E CAPACITOR	100MF 20% 10V	
	C 314	QCZ0202-155Z	ML C CAPACITOR	1.5MF	
	C 316	QFG32AJ-223Z	PP CAPACITOR	.022MF 5% 100V	
	C 319	QFLM1HJ-472Z	M CAPACITOR	4700PF 5% 50V	
	C 331	QEKJ1CM-476Z	E CAPACITOR	47MF 20% 16V	
	C 371	QEKJ1EM-475Z	E CAPACITOR	4.7MF 20% 25V	
	C 374	QEKJ1AM-107Z	E CAPACITOR	100MF 20% 10V	
	C 376	NCB21HK-103X	C CAPACITOR		
	CN 31	QGF1205F1-06	CONNECTOR	PRI/HEAD	
	CN 32	QGB2011M1-10	B TO B CONNECTO	PRI/MECHA	
	CN 33	QGF1205F1-09	CONNECTOR	PRI/MICON	
	CN 34	QGF1201F3-10	CONNECTOR	PRI/AMP	
	D 375	MA3051/M/-X	ZENER DIODE		
	FW 31	QUM024-06A2Z3	PARA RIBON WIRE		
	IC 31	BA3126N	IC	HEAD SW	
	IC 32	AN7317	IC	PB&REC	
	IC 33	BU4094BCF-X	IC		
	L 301	QQR1292-001	BIAS COIL		
	L 303	QQL244K-100Z	INDUCTOR		
	Q 302	KTC3203/Y/-T	TRANSISTOR	OSC	
	Q 305	KTC3203/Y/-T	TRANSISTOR	SW	
	Q 321	UN2213-X	TRANSISTOR	BUFFER	
	Q 371	KTA1271/OY/-T	TRANSISTOR	MOTER+B	
	Q 372	UN2212-X	TRANSISTOR		
	Q 375	2SB562/C/-T	TRANSISTOR	SOLENOID DRIVE	
	Q 376	2SD601A/QR/-X	TRANSISTOR		
	R 101	NRSA63J-220X	MG RESISTOR		
	R 102	NRSA63J-182X	MG RESISTOR		
	R 103	NRSA63J-242X	MG RESISTOR		

△	Item	Parts number	Parts name	Remarks	Area
	R 104	NRSA63J-122X	MG RESISTOR		
	R 105	NRSA63J-104X	MG RESISTOR		
	R 106	NRSA63J-332X	MG RESISTOR		
	R 107	NRSA63J-123X	MG RESISTOR		
	R 108	NRSA63J-562X	MG RESISTOR		
	R 109	NRSA63J-102X	MG RESISTOR		
	R 110	NRSA63J-272X	MG RESISTOR		
	R 111	NRSA63J-363X	MG RESISTOR		
	R 112	NRSA63J-222X	MG RESISTOR		
	R 116	NRSA63J-102X	MG RESISTOR		
	R 121	NRSA63J-153X	MG RESISTOR		
	R 122	NRSA63J-102X	MG RESISTOR		
	R 201	NRSA63J-220X	MG RESISTOR		
	R 202	NRSA63J-182X	MG RESISTOR		
	R 203	NRSA63J-242X	MG RESISTOR		
	R 204	NRSA63J-122X	MG RESISTOR		
	R 205	NRSA63J-104X	MG RESISTOR		
	R 206	NRSA63J-332X	MG RESISTOR		
	R 207	NRSA63J-123X	MG RESISTOR		
	R 208	NRSA63J-562X	MG RESISTOR		
	R 209	NRSA63J-102X	MG RESISTOR		
	R 210	NRSA63J-272X	MG RESISTOR		
	R 211	NRSA63J-363X	MG RESISTOR		
	R 212	NRSA63J-222X	MG RESISTOR		
	R 216	NRSA63J-102X	MG RESISTOR		
	R 221	NRSA63J-153X	MG RESISTOR		
	R 222	NRSA63J-102X	MG RESISTOR		
	R 301	NRS181J-221X	MG RESISTOR		
	R 303	NRSA63J-393X	MG RESISTOR		
	R 304	NRS181J-101X	MG RESISTOR		
	R 310	QRJ146J-4R7X	UNF C RESISTOR	4.7 5% 1/4W	
	R 313	NRSA63J-2R2X	MG RESISTOR		
	R 314	NRSA63J-153X	MG RESISTOR		
	R 315	NRSA63J-101X	MG RESISTOR		
	R 327	NRSA63J-474X	MG RESISTOR		
	R 335	NRSA63J-152X	MG RESISTOR		
	R 336	NRSA63J-472X	MG RESISTOR		
	R 337	NRSA63J-332X	MG RESISTOR		
	R 338	NRSA63J-392X	MG RESISTOR		
	R 339	NRSA63J-222X	MG RESISTOR		
	R 340	NRS181J-391X	MG RESISTOR		
	R 341	NRSA63J-123X	MG RESISTOR		
	R 342	NRSA63J-203X	MG RESISTOR		
	R 343	NRSA63J-183X	MG RESISTOR		
△	R 353	QRJ146J-100X	UNF C RESISTOR	10 5% 1/4W	
	R 371	NRSA63J-123X	MG RESISTOR		
	R 372	NRSA63J-102X	MG RESISTOR		
	R 375	NRSA02J-151X	MG RESISTOR	1/8W	
	R 376	NRSA63J-472X	MG RESISTOR		
	VR 31	QVP0008-203Z	SEMI V RESISTOR	BIAS ADJ	
	VR 37	QVP0008-103Z	SEMI V RESISTOR	TAPE SPEED ADJ	

■ Electrical parts list (Cassette switch board) Block No. 07

△	Item	Parts number	Parts name	Remarks	Area
	CN 1	QGB2011L1-10	B TO B CONNECTO		
	D 1	1T3-T2	SI DIODE		
	IC 1	SG-105F3-BB,C	PHOTO SENSER		
	P 1	QNZ0104-001	POST PIN		
	SW 1	QSW0832-001	LEAF SWITCH	R.REC	
	SW 2	QSW0832-001	LEAF SWITCH	TAPE	
	SW 5	QSW0832-001	LEAF SWITCH	F.REC	
	SW 6	QSW0859-001	SW		

< MEMO >

Packing materials and accessories parts list

Block No.

M	3	M	M
---	---	---	---

Block No.

M	5	M	M
---	---	---	---

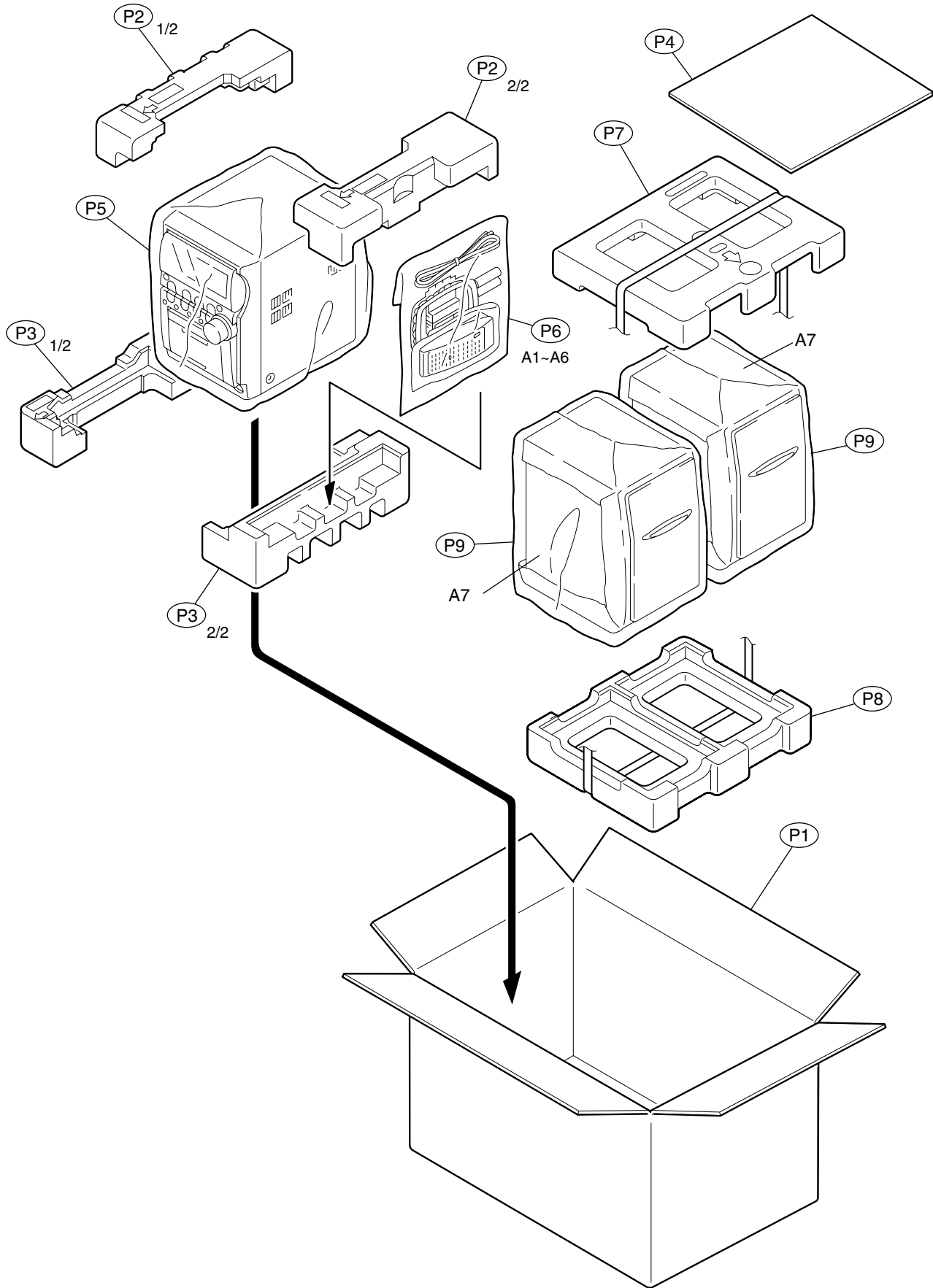

Parts list (Packing)

Block No. M3MM

	Item	Parts number	Parts name	Q'ty	Description	Area
	P 1	LV33689-001A	CARTON	1		
	P 2	LV21259-001A	CUSHION(TOP)	1		
	P 3	LV21260-002A	CUSHION(BTM R)	1		
	P 4	LV33569-001A	CARTON SPACER	1	SPK	
	P 5	QPC05006515P	POLY BAG	1	FOR SET	
	P 6	QPC02505010P	POLY BAG	1	FOR ACCESSORIES	
	P 7	80-000-494-01	CUSHION(TOP)	1		
	P 8	80-000-494-11	CUSHION(BTTM)	1		
	P 9	85-000-327-81	POLY BAG	2		

Parts list (Accessories)

Block No. M5MM

	Item	Parts number	Parts name	Q'ty	Description	Area
	A 1	LVT0900-001A	INST BOOK	1	GER,FRE,DUT	
	A 2	RM-SUXZ7MDR	REMOCON	1		
	A 3	-----	BATTERY	2		
	A 4	BT-54013-5	W.CARD	1		
	A 5	EWP503-001C	ANT.WIRE	1		
	A 6	QAL0014-001	AM LOOP ANT	1		
	A 7	UXZ7MDR-SPBOX	SPK WITH BOX	2		