

JVC

SERVICE MANUAL

COMPACT DISC CHANGER

XL-M309TN
XL-M408BK
XL-M409TN



XL-M409TN/XL-M408BK

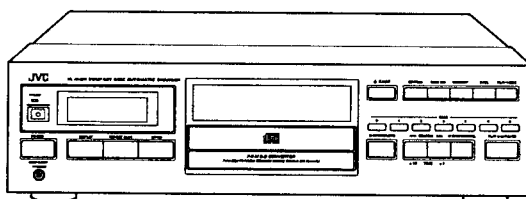

COMPU LINK
 Remote Control Component

XL-M309TN

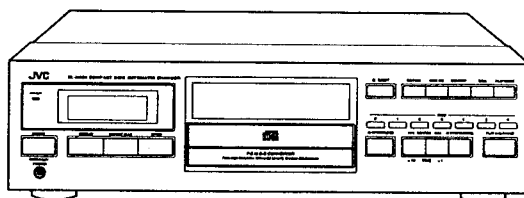

COMPU LINK
 Component

Contents

Safety Precautions	1-2	Initial Operation Mechanism	1-37
Important for Laser Products	1-3	Operation check by each switch	1-40
Instruction Book	1-4	Flow of Functional Operation	
Discription of Major LSIs	1-24	Until TOC is Read	1-41
Internal Block Diagrams of Other ICs	1-31	Troubleshooting	1-42
Internal Connection		Block Diagrams	Insertion
for the FL Display Tube ...	1-32	Schematic Diagrams	Insertion
Disassembly Procedures	1-33	Printed Circuit Board	Insertion
Adjustment Procedures	1-35	Exploded View of Assemblies and	
Maintenance of Laser Pickup	1-36	Application Points for Grease .	Insertion
Replacement of Laser Pickup	1-36	Parts list	Insertion

Safety Precautions

1. The design of this product contains special hardware and many circuits and components specially for safety purposes. For continued protection, no changes should be made to the original design unless authorized in writing by the manufacturer. Replacement parts must be identical to those used in the original circuits. Services should be performed by qualified personnel only.
2. Alterations of the design or circuitry of the product should not be made. Any design alterations of the product should not be made. Any design alterations or additions will void the manufacturer's warranty and will further relieve the manufacture of responsibility for personal injury or property damage resulting therefrom.
3. Many electrical and mechanical parts in the products have special safety-related characteristics. These characteristics are often not evident from visual inspection nor can the protection afforded by them necessarily be obtained by using replacement components rated for higher voltage, wattage, etc. Replacement parts which have these special safety characteristics are identified in the Parts List of Service Manual. Electrical components having such features are identified by shading on the schematics and by (Δ) on the Parts List in the Service Manual. The use of a substitute replacement which does not have the same safety characteristics as the recommended replacement parts shown in the Parts List of Service Manual may create shock, fire, or other hazards.
4. The leads in the products are routed and dressed with ties, clamps, tubings, barriers and the like to be separated from live parts, high temperature parts, moving parts and/or sharp edges for the prevention of electric shock and fire hazard. When service is required, the original lead routing and dress should be observed, and it should be confirmed that they have been returned to normal, after re-assembling.
5. Leakage current check (Electrical shock hazard testing)
After re-assembling the product, always perform an isolation check on the exposed metal parts of the product (antenna terminals, knobs, metal cabinet, screw heads, headphone jack, control shafts, etc.) to be sure the product is safe to operate without danger of electrical shock.
Do not use a line isolation transformer during this check.
 - Plug the AC line cord directly into the AC outlet. Using a "Leakage Current Tester", measure the leakage current from each exposed metal parts of the cabinet, particularly any exposed metal part having a return path to the chassis, to a known good earth ground. Any leakage current must not exceed 0.5mA AC (r.m.s.).

- Alternate check method

Plug the AC line cord directly into the AC outlet. Use an AC voltmeter having, 1,000 ohms per volt or more sensitivity in the following manner. Connect a 1,500 Ω 10 W resistor paralleled by a 0.15 μ F AC-type capacitor between an exposed metal part and a known good earth ground.

Measure the AC voltage across the resistor with the AC voltmeter.

Move the resistor connection to each exposed metal part, particularly any exposed metal part having a return path to the chassis, and measure the AC voltage across the resistor.

Now, reverse the plug in the AC outlet and repeat each measurement. Any voltage measured must not exceed 0.75 V AC (r.m.s.). This corresponds to 0.5 mA AC (r.m.s.).

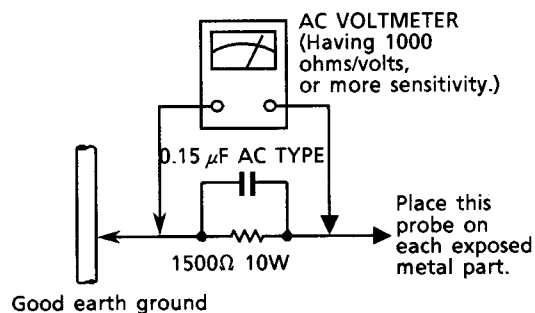

Warning

1. This equipment has been designed and manufactured to meet international safety standards.
2. It is the legal responsibility of the repairer to ensure that these safety standards are maintained.
3. Repairs must be made in accordance with the relevant safety standards.
4. It is essential that safety critical components are replaced by approved parts.
5. If mains voltage selector is provided, check setting for local voltage.

Important for Laser Products

1. **CLASS 1 LASER PRODUCT**
2. **DANGER** : Invisible laser radiation when open and interlock failed or defeated. Avoid direct exposure to beam.
3. **CAUTION** : There are no serviceable parts inside the Laser Unit. Do not disassemble the Laser Unit. Replace the complete Laser Unit if it malfunctions.
4. **CAUTION** : The compact disc player uses invisible laser radiation and is equipped with safety switches which prevent emission of radiation when the drawer is open and the safety interlocks have failed or are defeated. It is dangerous to defeat the safety switches.
5. **CAUTION** : If safety switches malfunction, the laser is able to function.
6. **CAUTION** : Use of controls, adjustments or performance of procedures other than those specified herein may result in hazardous radiation exposure.
7. **CAUTION** : The compact disc player provides a laser diode of wavelength 780-790nm and optical output power typical 3mW at the laser diode.

VARNING : Osynlig laserstrålning när denna del är öppnad och spärren är urkopplad. Betrakta ej strålen.

VARO : Avattaessa ja suojalukitus ohitettaessa olet alttiina näkymättömälle lasersäteilylle. Älä katso säteeseen.

ADVARSEL : Usynlig laserstrålning ved åbning, når sikkerhedsafbrydere er ude af funktion. Undgå udsættelse for stråling.

ADVARSEL : Usynlig laserstrålning ved åbning, når sikkerhedsbryteren er avslott. unngå utsettelse for stråling.

REPRODUCTION AND POSITION OF LABELS

WARNING LABEL

(Except for the U. S. A.)

DANGER: Invisible laser radiation when open and interlock failed or defeated. AVOID DIRECT EXPOSURE TO BEAM. (e)

VARNING: Osynlig laserstrålning när denna del är öppnad och spärren är urkopplad. Betrakta ej strålen. (s)

ADVARSEL: Usynlig laserstrålning ved åbning, når sikkerhedsafbrydere er ude af funktion. Undgå udsættelse for stråling. (d)

VARO: Avattaessa ja suojalukitus ohitettaessa olet alttiina näkymättömälle lasersäteilylle. Älä katso säteeseen. (f)

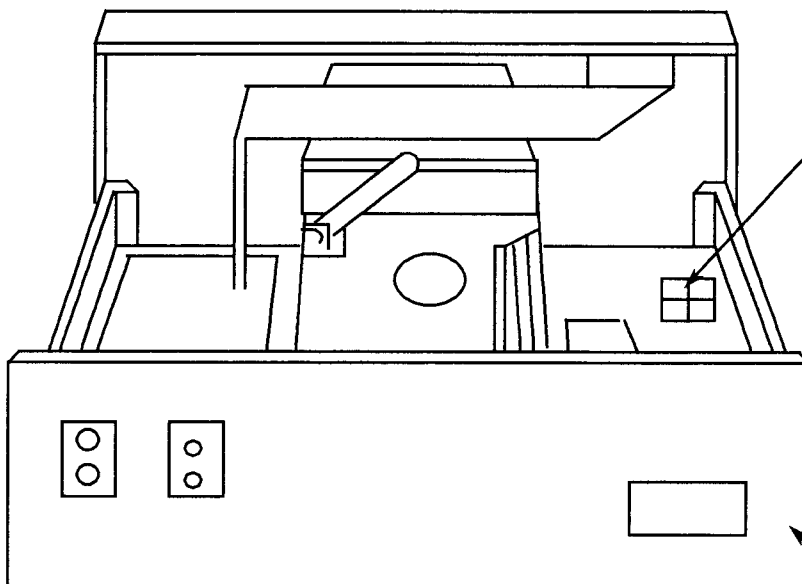

**CLASS 1
 LASER PRODUCT**

CLASSIFICATION LABEL

(Except for the U. S. A. and Canada)

Introduction

We would like to thank you for purchasing one of our JVC products.

Before connecting this unit to the wall outlet, please read the instructions carefully to ensure that you obtain the best possible performance.

If you have any questions, please consult your JVC dealer.

For XL-M309TN

Since the remote control unit is supplied with the XL-M409TN/XL-M408BK only, the description for the remote control unit is not concerned with the XL-M309TN.

This manual is organized as follows:

The first part of this manual, "PRECAUTIONS", tells you where to place this unit for best results, how to prevent malfunctions and what types of discs can be used in this unit.

The second part, "BEFORE USING FOR THE FIRST TIME", tells you what kind of operations you should do before playing a disc. This part describes how to install batteries in the remote control unit and how to connect this unit to the amplifier and other components.

The third part, "LOCATION OF BUTTONS", shows the names of buttons and their location and gives you basic knowledge of the functions of buttons on the main unit and the remote control unit. Refer to the section on the indicated page for each button.

The fourth part, "BASIC OPERATIONS", describes how to load discs, and convenient basic functions for playing discs.

The fifth part, "VARIOUS PLAYBACK PATTERNS", describes various functions for playing discs, and convenient functions for recording.

The sixth part, "APPENDIX", describes the compu link remote control system which facilitates various operations between JVC components, and explains how to take care of discs and magazines.

The seventh part, "TROUBLESHOOTING", tells you how to check the unit if a malfunction occurs.

The eighth part, "SPECIFICATIONS", gives you technical information regarding this unit and tells you what accessories you have.

Contents

PRECAUTIONS	2
Installation	2
Preventing malfunctions	2
Applicable discs	2
BEFORE USING FOR THE FIRST TIME	3
Installing batteries in the remote control unit	3
Connections	4
Audio signal output jacks	4
Control signal output/input jacks for Compu Link Remote Control System	4
AC power supply	4
LOCATION OF BUTTONS	5
Main unit	5
Remote control unit	6
BASIC OPERATIONS	7
Preliminary operations before playing a disc	7
Turning on the power of this unit	7
Loading a disc in the single disc tray	7
Loading discs in the magazine	7
Inserting the magazine	8
Basic functions for disc playback	8
Playing a disc	8
Stopping playback	8
Searching for a desired track or section	9
Specifying a desired track	9
Specifying a desired disc	9
Specifying the tape playing time	9
Switching the time display	10
Switching the playback mode	10
Remote control operation	10
VARIOUS PLAYBACK PATTERNS	11
Guidance for various functions	11
CONTINUE PLAY	11
RANDOM PLAY	12
PROGRAM PLAY	12
DELETE PROGRAM PLAY	13
INTRO SCAN	14
Disc intro scan	14
Track intro scan	14
REPEAT	15
REPEAT ALL	15
REPEAT 1	15
EDIT	15
PROGRAM EDIT	15
INTRO EDIT	16
APPENDIX	18
Compu link remote control system	18
Care of discs and magazines	19
TROUBLESHOOTING	20
SPECIFICATIONS	20

PRECAUTIONS

Installation

Best location

Select a location which is level, dry and neither too cold nor too hot (temperature range 5°C (41°F) to 35°C (95°F)). Also, avoid dusty locations or any location subject to vibration.

If interference occurs

If this equipment is placed near a tuner or a radio receiver tuned to AM frequencies, interference may occur. If this happens, we recommend either that you move this unit as far away as possible from the tuner or receiver or briefly turn off the power to this unit.

Preventing malfunctions

Load compact discs only

Never insert anything other than a compact disc into any part of the player or magazine.

If a problem persists

If something goes wrong, turn the power off immediately. If the same problem reoccurs when the power is turned on once more, turn the power off again and consult your JVC dealer.

Handling the power cord

When unplugging from the wall socket, always pull the plug body, never the power cable.

Volume settings

A CD player has almost zero background noise. Because of this, the technique of listening to the background level and then setting the volume before the music starts, as used with analog turntables or tape decks, cannot be used. If you raise the volume level too high, speaker damage may result.

Condensation

The CD player uses optical components. If it is moved from a cold location to a warm one, or is used in a room subject to excessive humidity or where a fire has just been lit, condensation could form on the optical components.

This may prevent the laser beam from being properly transmitted and thus cause noise or even a malfunction.

If condensation has formed and the CD player does not function correctly, we recommend that you leave it turned on for an hour or two. If at the end of this time the CD player still does not function properly, please consult your JVC dealer.

Transporting the unit

When carrying this unit, it is best to avoid either tilting it or turning it upside-down. Where you cannot avoid doing so, please remove the disc and magazine first.

Using compact discs

Compact discs are made of plastic and can be easily damaged. If the disc is dirty, scratched, warped or otherwise damaged, the digital information may not be picked up correctly.

Applicable discs

This unit can only be used with compact discs bearing the mark below. Never use other types of discs.



BEFORE USING FOR THE FIRST TIME

Installing batteries in the remote control unit

(XL-M409TN/XL-M408BK only)

Before operating the remote control unit, install two batteries.

1. Remove the rear cover of the remote control unit by pressing down and simultaneously pulling it backwards.

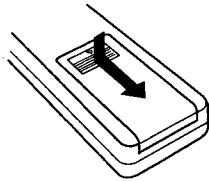

2. Install batteries. Be sure batteries are installed with correct polarity, (+) and (-).

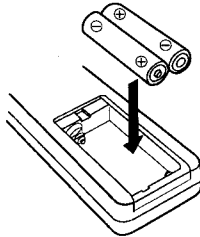

3. Attach the rear cover by sliding it back into position.

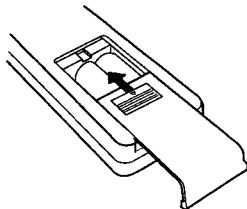

Notes

Incorrect use of batteries can cause corrosion or damage. Note the following points to lengthen battery life.

- Install batteries observing the correct polarity, (+) and (-).
- Do not use new and old batteries simultaneously.
- Batteries with similar shapes may have different voltage ratings. Be sure to use the correct batteries.
- Remove batteries from the remote control unit if it will not be used for a long period of time.

Battery replacement

Service life of batteries depends on the condition of use; standard life is about one year. When the batteries become weak, the operating distance of the remote control unit becomes short. If this happens, replace the batteries (1.5 V, R6P, size AA) with new ones.

Notes

- The lower the temperature, the shorter the battery life.

BEFORE USING FOR THE FIRST TIME

Connections

This diagram shows a typical connection.

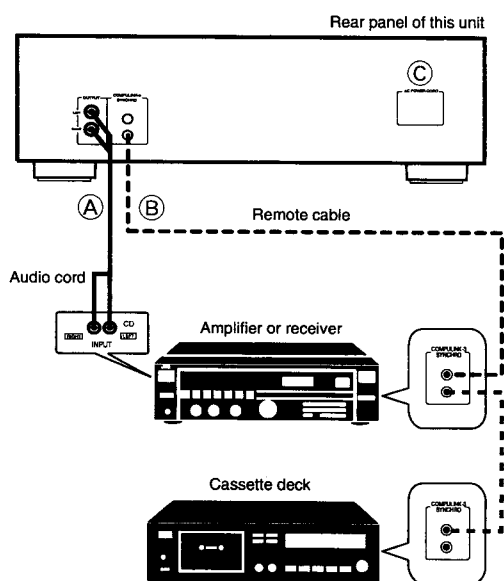

Notes on connections

- Do not connect the power plug until all connections are completed.
- Connect the plugs firmly. Loose connections may cause noise or malfunction.

Audio signal output jacks

(A) OUTPUT jacks

The audio signals are output from these jacks. Connecting to an amplifier or receiver allows you to listen to the sound from the speakers.

Connect the OUTPUT jacks of this unit to the CD jacks or AUX input jacks of an amplifier or receiver with the supplied audio cable.

Notes

- Never connect the OUTPUT jacks to the PHONO jacks of the amplifier or receiver. This may cause damage to the components.
- Make sure that the same channels are connected between this unit and the amplifier or receiver: LEFT to LEFT and RIGHT to RIGHT.

Control signal output/input jacks for Compu Link Remote Control System

(B) COMPU LINK SYNCHRO jacks

These jacks are used to output and input the control signal for the compu link remote control system. Connecting JVC audio components with the COMPU LINK SYNCHRO jacks automatically controls relative operations between components and facilitates various operations.

Connect the COMPU LINK SYNCHRO jacks of this unit and JVC components with the supplied remote cable. Since each component has two COMPU LINK SYNCHRO jacks (there is no difference between the two jacks), you can connect two components to these jacks.

Note

Make sure that the COMPU LINK SYNCHRO jacks of the individual components are connected with the supplied remote cables. Also, be sure to fully read the instructions for each component.

AC power supply

(C) AC POWER CORD inlet

The AC power cord is supplied separately and must be connected to the unit.

Plug the power cord into the AC POWER CORD inlet of this unit and connect to an AC household electrical outlet after all connections are completed.

Note

When using the Compu Link Remote Control System version 3, do not connect the power cord to the SWITCHED AC OUTLET of an amplifier or receiver. Otherwise, the automatic power on/off function cannot be carried out.

LOCATION OF BUTTONS

Main unit

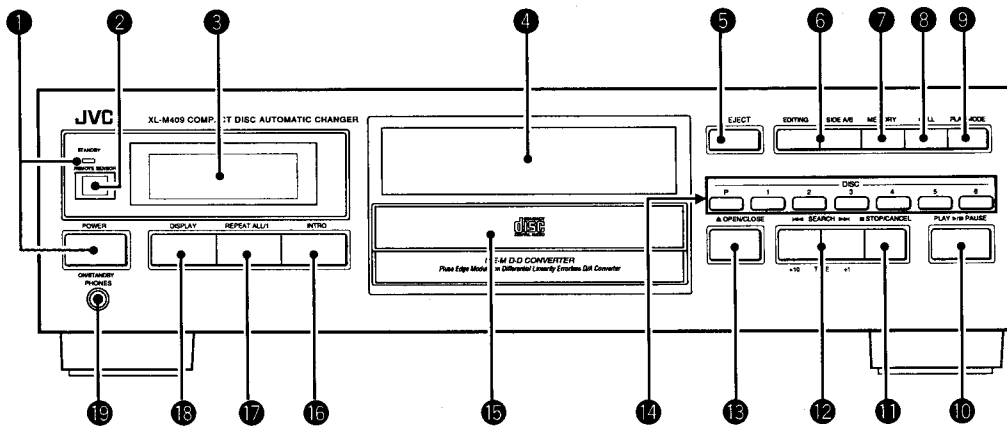

The operation for each button is described in the section indicated with the → mark.

- 1 POWER (ON/STANDBY) switch and STANDBY indicator**
 → "Turning on the power of this unit" on page 7.
 To turn off the power completely, disconnect the power cord from the wall outlet.
- 2 REMOTE SENSOR (XL-M409TN/XL-M408BK only)**
 → "Remote control operation" on page 10.
- 3 Display window**
 This shows disc status information.
- 4 Disc magazine slot**
 Insert the magazine into this slot.
 → "Inserting the magazine" on page 8.
- 5 EJECT ▲ button**
 → "Inserting the magazine" on page 8.
- 6 EDITING and SIDE A/B buttons**
 These buttons are used to edit tracks.
 → "EDIT" on page 15.
- 7 MEMORY button**
 This button is used to memorize the disc number and/or track number in the following operation modes.
 → "PROGRAM PLAY" on page 12.
 → "DELETE PROGRAM PLAY" on page 13.
 → "EDIT" on page 15.
- 8 CALL button**
 This button is used to display the program contents in the following operation modes.
 → "PROGRAM PLAY" on page 12.
 → "DELETE PROGRAM PLAY" on page 13.
 → "EDIT" on page 15.
- 9 PLAY MODE button**
 → "Switching the playback mode" on page 10.

- 10 PLAY ►/|| PAUSE button**
 → "Playing a disc" on page 8.
- 11 ■ STOP/CANCEL button**
 → "Stopping playback" on page 8.
- 12 SEARCH ◀◀/▶▶ buttons**
 → "Searching for a desired track or section" on page 9.
- 13 OPEN/CLOSE ▲ button**
 → "Loading a disc in the single disc tray" on page 7.
- 14 DISC buttons**
 → "Specifying a desired disc" on page 9.
- 15 Single disc tray**
 Load a disc in this disc tray.
 → "Loading a disc in the single disc tray" on page 7.
- 16 INTRO button**
 This button is used to carry out the intro scan function.
 → "INTRO SCAN" on page 14.
- 17 REPEAT ALL/1 button**
 This button is used to carry out the repeat function.
 → "REPEAT" on page 15.
- 18 DISPLAY button**
 → "Switching the time display" on page 10.
- 19 PHONES jack**
 Insert the headphones plug into the jack.

LOCATION OF BUTTONS

Remote control unit

(XL-M409TN/XL-M408BK only)

The operation for each button is described in the section indicated with the ➔ mark.

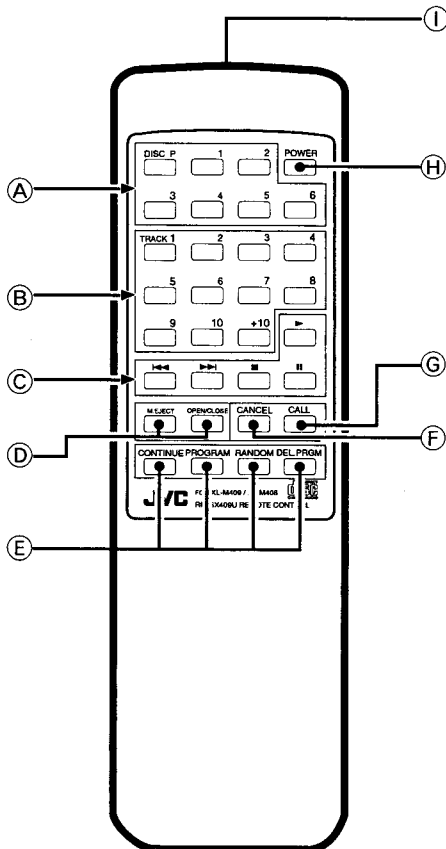

- (A) DISC buttons**
 ➔ "Specifying a desired disc" on page 9.
- (B) TRACK buttons**
 ➔ "Specifying a desired track" on page 9 and "Specifying the playing time" on page 10.
- (C) Basic play control buttons**
 ▶: Press to start playback.
 II: Press to stop play temporarily.
 To resume playback, press the ▶ button.
 ■: Press to stop playback.
 ◀▶ and ▶▶: Press to skip to the previous track or next track.
- (D) Magazine and single disc tray control buttons**
M. EJECT: Press to eject the magazine.
OPEN/CLOSE: Press to open or close the single disc tray.
- (E) Play mode buttons**
 ➔ "Switching the playback mode" on page 10.
- (F) CANCEL button**
 This button is used to erase the displayed programmed track in the following operation modes.
 ➔ "PROGRAM PLAY" on page 12
 ➔ "DELETE PROGRAM PLAY" on page 13
 ➔ "EDIT" on page 15
- (G) CALL button**
 This button is used to display the program contents in the following operation modes.
 ➔ "PROGRAM PLAY" on page 12.
 ➔ "DELETE PROGRAM PLAY" on page 13.
 ➔ "EDIT" on page 15.
- (H) POWER button**
 ➔ "Turning on the power of this unit" on page 7.
- (I) Remote control signal transmit section**

BASIC OPERATIONS

Preliminary operations before playing a disc

Turning on the power of this unit

Press the **POWER** switch to turn on this unit.

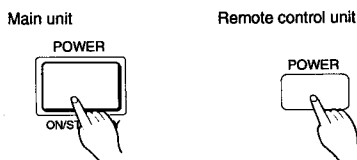

Press again to turn the power off and activate the standby mode.

The power is automatically turned on also by;

- pressing **▲ OPEN/CLOSE** button,
- pressing **▲ EJECT** button,
- pressing **PLAY ►/|| PAUSE** button,
- or inserting the disc magazine into the magazine slot.

Note

A small amount of power (3 watts) is consumed and the **STANDBY** indicator is lit in the standby mode. To turn the power off completely, disconnect the power cord from the wall outlet.

Loading a disc in the single disc tray

Use the **▲ OPEN/CLOSE** button to open and close the single disc tray.

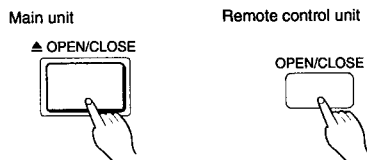

1. Open the single disc tray by pressing the **▲ OPEN/CLOSE** button.
2. Place a disc on the disc tray according to the groove with its label side up.
3. Close the single disc tray by pressing the **▲ OPEN/CLOSE** button.

Note

When loading a disc in the single disc tray, be sure to put the disc according to the groove. Otherwise, the disc will be damaged when the disc tray is closed, and the disc cannot be removed from the unit.

Auto close function

If the unit changes the disc in the magazine when the single disc tray is left open, the unit automatically closes the tray. The **AUTO CLOSE** indicator blinks for about 2 seconds before the unit closes the tray.

Loading discs in the magazine

When playing 2 discs or more, load discs in the magazine beforehand.

1. Slide the disc tray out while pressing the tray release button.

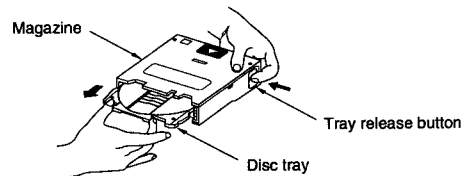

2. Place a disc on the disc tray with its label side up.

It is not possible to play a disc if it is inserted upside-down. Also, never place a disc directly in the magazine without using the disc tray.

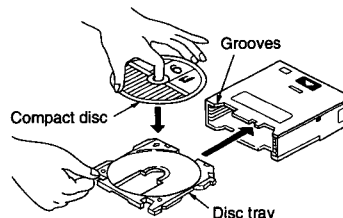

3. Line up the disc tray with the grooves in the magazine and push the disc tray in.

It is unnecessary to press the tray release button when inserting the disc tray.

BASIC OPERATIONS

Basic functions for disc playback

When inserting and removing the disc tray, be careful with the following.

- Never bend the disc tray or force it into the magazine.
 A disc tray which is inserted skewed may cause a malfunction.

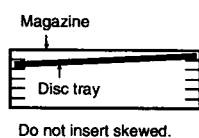

- When removing or inserting disc trays, the magazine should be held horizontal.
- The openings in the disc trays are for passage of the laser signal. These openings leave part of the shiny surface of the disc exposed. Please take care not to touch this shiny surface.

Optional magazines

If you wish to use 8 cm (3 inches) CDs, please obtain the special magazine (XC-M73) designed for these discs.

If you wish to use a magazine additionally to the supplied magazine, please obtain the special magazine (XC-M75) designed for 12 cm (5 inches) CDs.

Inserting the magazine

Insert a magazine, with discs loaded, into the 6-disc magazine slot and push it lightly until it clicks into place.

To remove the magazine, press the EJECT button.

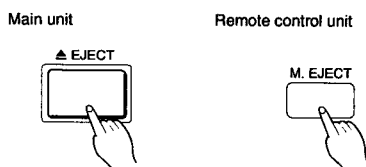

Caution

The player may be damaged if the magazine is pushed in with too much force.

Playing a disc

Press the PLAY ►/|| PAUSE button of the main unit or ► button on the remote control unit.

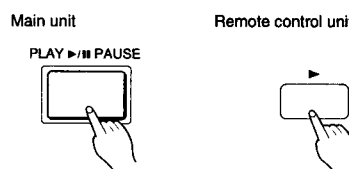

The ► indicator lights on the display and playback starts.

To stop playback temporarily, press the PLAY ►/|| PAUSE button again or || button on the remote control unit.

The || indicator lights on the display and playback stops temporarily. To resume playback, press the PLAY ►/|| PAUSE button again or ► button on the remote control unit.

Stopping playback

Press the ■ button.

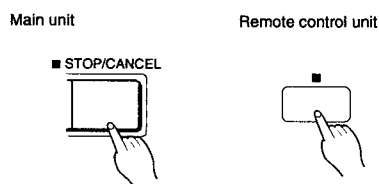

BASIC OPERATIONS

Searching for a desired track or section

Use the **SEARCH** buttons.

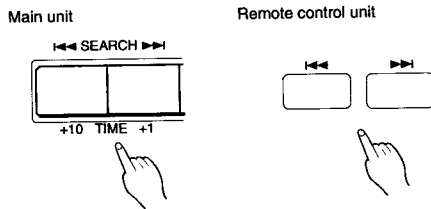

To skip to a desired track during playback

To skip back to the beginning of the track being played, tap the **SEARCH** button. When the beginning of the track is reached, tapping this button again skips to the previous track. To skip to the next track, tap the **SEARCH** button.

To search for a desired section during playback

When the **SEARCH** or **SEARCH** button of the main unit is kept pressed, playback advances or reverses rapidly. While the **SEARCH** button is kept pressed, playback rapidly reverses toward the beginning of the track. While the **SEARCH** button is kept pressed, playback rapidly advances toward the end of the track. When the desired section is reached, release the button. The player resumes normal playback from that point.

Specifying a desired track

(XL-M409TN/XL-M408BK only)

To specify the desired track number, use the **TRACK** buttons.

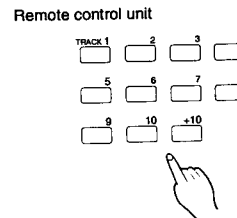

The unit searches for the selected track and playback starts automatically.

When selecting track number 10 or less, press the corresponding **TRACK** button. When selecting track number 11 or above, use the **[+10]** button.

Example: To select track number 12, press **[+10]** and then **[2]**.

To select track number 25, press **[+10]** twice and then **[5]**.

To select track number 30, press **[+10]** twice and then **[10]**.

Note

If the selected track number does not exist on the selected disc, playback starts from the final track on that disc.

Specifying a desired disc

Use the **DISC** buttons.

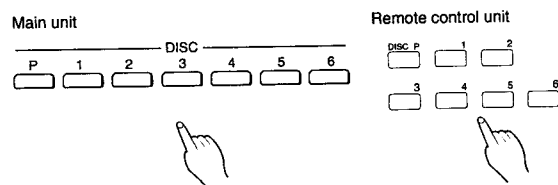

To specify the disc loaded in the single disc tray

Press the **[P]** button.

To select a disc loaded in the magazine

Press the desired disc number (1 - 6).

Note

If the selected disc is not loaded in the magazine, the indicator of that disc () goes out within about 4 seconds and then playback starts from the next disc.

BASIC OPERATIONS

Specifying the tape playing time

Use the  button.

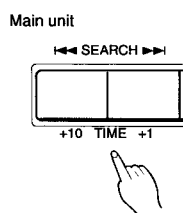

When entering 9 minutes or less, press the [+1] button sequentially so that the desired playing time appears on the display. When entering 10 minutes or more, use the [+10] button.

Example: To enter 46 minutes, press the [+10] button four times and then the [+1] button six times.

To enter 60 minutes, press the [+10] button six times.

For XL-M409TN/XL-M408BK only

You can specify the tape playing time (in minutes) with the TRACK buttons by following the procedure of "Specifying a desired track" on page 9.

Switching the time display

Each time the DISPLAY button is pressed the time display changes as the following.

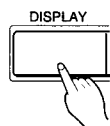

Elapsed time display → Remaining play time → total playback time of the disc → Elapsed time display

The corresponding indicator lights in each time mode.

EACH: Shows the elapsed time of the track being played.

EACH REMAIN: Shows the remaining playback time of the track being played.

When the EACH and EACH REMAIN indicators go out: Shows the total playing time of the disc being played.

Switching the playback mode

Use the PLAY MODE button of the main unit or play mode buttons on the remote control unit. The playback mode can be switched only in stop mode.

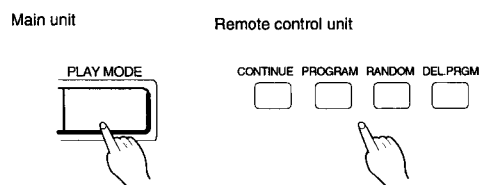

Each time the PLAY MODE button of the main unit is pressed, the playback mode changes in the following order:

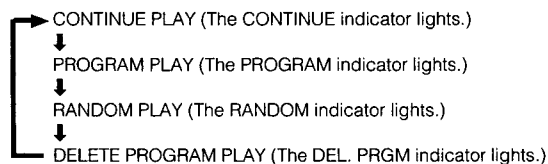

When using the play mode buttons on the remote control unit, press the corresponding play mode button.

Note

The setting of the playback mode is not canceled even when the unit is in standby mode.

Remote control operation

(XL-M409TN/XL-M408BK only)

Point the remote control unit towards the REMOTE SENSOR and operate it steadily and carefully. The remote control unit can be used within a range of about 7 meters (23 feet) from the REMOTE SENSOR, and at angles of up to about 30 degrees.

VARIOUS PLAYBACK PATTERNS

Guidance for various functions

This unit has edit functions for recording and a disc title memory bank function in addition to various playback functions. Please read this section to familiarize yourself with this unit.

CONTINUE PLAY

You can continuously play from any track on any disc through the final track on disc number 6.

PROGRAM PLAY

You can play only the desired tracks in any desired order.

DELETE PROGRAM PLAY

You can play tracks other than undesired tracks in order of track number and disc number by programming the undesired tracks.

RANDOM PLAY

The unit selects and plays tracks at random from among all discs loaded in the unit.

INTRO SCAN

The disc intro scan function allows you to check all discs in the unit by playing the beginning of the first track on each disc.

The track intro scan function allows you to check all tracks on all discs in the unit by playing the beginning of each track.

REPEAT

You can play all discs or a track repeatedly.

EDIT

You can program tracks within the specified recording time of a cassette tape while listening to the beginning of each track (Intro edit) or by designating the track number (Program edit).

CONTINUE PLAY

In continuous playback mode, you can continuously play from any track on any disc through the final track on disc number 6. When discs are inserted into both the single disc tray and the magazine, the unit starts playback from the disc in the single disc tray.

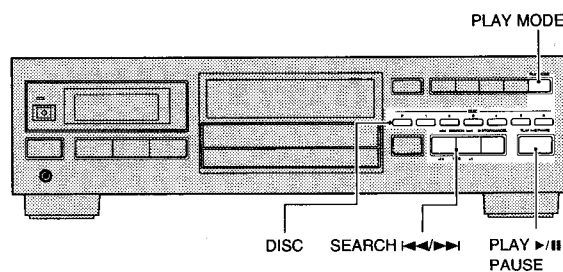

1. Press the **PLAY MODE** button so that the **CONTINUE** indicator lights on the display.

When you want to play from a desired disc or track, go to step 3.

2. Press the **PLAY ►/|| PAUSE** button to start playback.

Playback starts from the first disc in the magazine (without loading a disc in the single disc tray) or the disc loaded in the single tray. If the single disc tray is not closed, pressing the **PLAY ►/|| PAUSE** button closes the disc tray and then starts playback.

The following display appears.

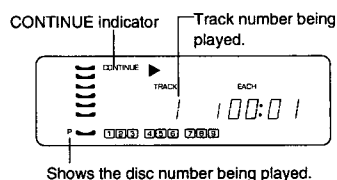

3. Use the **DISC** button to select the disc number which contains the track to be played.

When you want to play from the first track on the selected disc, it is not necessary to select the track number.

4. Select the track number with the **SEARCH** buttons so that the desired track number appears on the display.

Playback starts from the selected track automatically.

For XL-M409TN/XL-M408BK only

You can select the track number with the **TRACK** buttons on the remote control unit. Refer to "Specifying a desired track" on page 9 for using the **TRACK** buttons.

VARIOUS PLAYBACK PATTERNS

RANDOM PLAY

In random mode, the unit selects and plays tracks at random from among all discs loaded in the unit. Selections are made so that each track is played only once.

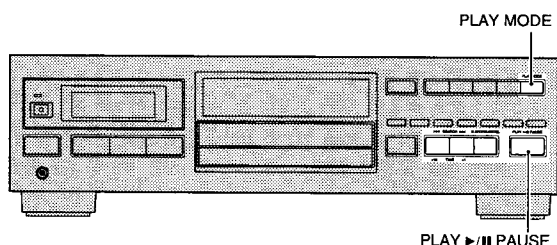

1. Press the **PLAY MODE** button so that the **RANDOM** indicator lights on the display.
2. Press the **PLAY >|| PAUSE** button to start playback.
 - To skip to the track to be next played, press the **SEARCH >>>** button.
 - To repeatedly play all tracks in random order, press **REPEAT ALL/1** button so that the **REPEAT** indicator lights on the display.

To cancel random playback

Select other playback mode (**CONTINUE**, **PROGRAM** or **DEL. PRGM**) with the **PLAY MODE** button. The **RANDOM** indicator goes out and the unit enters the selected play mode.

PROGRAM PLAY

You can program up to 32 steps in any desired order from among the discs in the magazine and single disc tray.

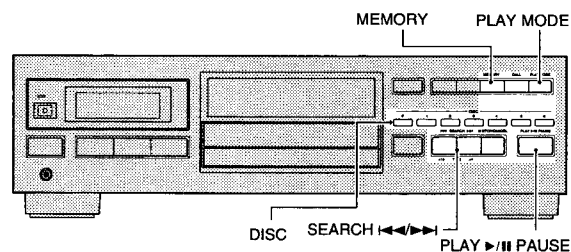

As an example, the following steps show how to program track number 9 on disc number 2 and track number 3 on disc number 4 in this order.

1. In stop mode, press the **PLAY MODE** button so that the **PROGRAM** indicator lights on the display.
2. Use the **DISC** button to select the disc which contains the track to be programmed. "AL" (all tracks) appears on the display.

To program the entire disc

Skip step 3 below. When the track number is not specified after selecting the disc number, all tracks on the displayed disc are programmed.

3. Press the **SEARCH <<<** or **>>>** buttons so that the desired track number appears on the display.
For XL-M409TN/XL-M408BK only: You can select the desired track number with the **TRACK** buttons on the remote control unit. Refer to "Specifying a desired track" on page 9 for entering the track number. In this case, it is not necessary to press the **MEMORY** button after selecting the track number. Skip step 4.

4. Press the **MEMORY** button.

The selected track number is programmed and the following display appears.

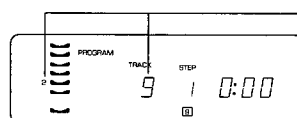

Display shows the disc number and track number selected for step 1.

- If you want to cancel the displayed program step, press the **STOP/CANCEL** button and then enter the new disc number and/or track number.

VARIOUS PLAYBACK PATTERNS

5. Select the disc number and track number to be programmed for step 2.

In this example, enter disc number 4 with the DISC button and track number 3 with the SEARCH ◀◀ or ▶▶ button and then press the MEMORY button. When the TRACK button (XL-M409TN/XL-M408BK only) is used for entering the track number, it is not necessary to press the MEMORY button.

After entering the track, the following display appears.

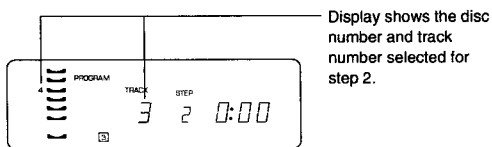

6. If necessary, repeat steps 2 and 4 for other tracks and/or discs to be programmed.

7. Start program playback with the PLAY ▶/II PAUSE button.

The programmed tracks and/or discs are played in the programmed order.

- You can skip to a desired program step with the SEARCH ◀◀ or ▶▶ button.
- To repeatedly play the programmed tracks and/or discs, press the REPEAT ALL/1 button so that the REPEAT indicator lights on the display.

To check the program contents

Each time the CALL button is pressed, the program contents are displayed in the programmed order.

- When the unit is in program play mode, press the ■ STOP/CANCEL button to enter stop mode and then operate the CALL button.

To modify the program contents

Press the CALL button until the display shows the program step to be corrected. Enter the new disc number and/or track number referring to step 2 and 4 above.

To delete a program step, press the CALL button until the display shows the program step to be deleted and then press the ■ STOP/CANCEL button. You can also delete a displayed program step during programming.

- When the unit is in program play mode, press the ■ STOP/CANCEL button to enter stop mode and then delete the program step.

To exit program mode

Select another playback mode with the PLAY MODE button. The unit enters the selected playback mode. However, the program contents are not erased and whenever the program mode is selected with the PLAY MODE button, you can play the tracks in the programmed order.

To clear the entire program

Eject the magazine and open the single disc tray. The program contents will be cleared, however, the program mode is not canceled.

DELETE PROGRAM PLAY

You can program undesired tracks and/or discs from among the discs in the 6-disc magazine and single disc tray. With this function, only the remaining tracks and/or discs are played. Up to 32 steps can be programmed.

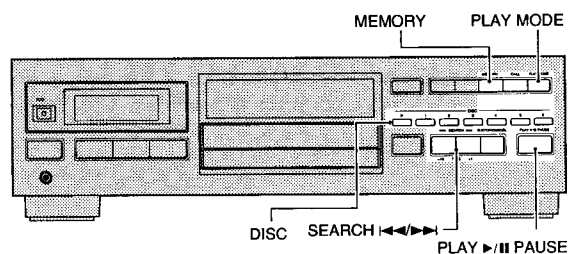

As an example, the following steps show how to delete track number 9 on disc number 2 and track number 3 on disc number 4.

1. In stop mode, press the PLAY MODE button so that the DEL.PRGM indicator lights on the display.

2. Use the DISC button to select the disc number which contains the track to be deleted.

"AL" (all tracks) appears on the display.

To delete the entire disc

Skip step 3 below. When the track number is not specified after selecting the disc number, all tracks on the displayed disc are deleted.

3. Press the SEARCH ◀◀ or ▶▶ button so that the track number to be deleted appears on the display.

For XL-M409TN/XL-M408BK only: You can select the number with the TRACK buttons on the remote control unit. Refer to "Specifying a desired track" on page 9 for entering the track number. In this case, it is not necessary to press the MEMORY button after selecting the track number. Skip step 4.

4. Press the MEMORY button.

The selected track number is deleted and the following display appears.

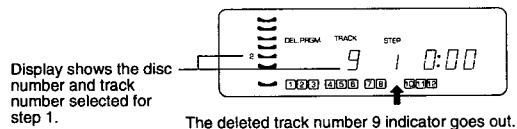

- If you want to cancel the displayed program step, press the ■ STOP/CANCEL button and then enter the new disc number and/or track number.

VARIOUS PLAYBACK PATTERNS

5. Select the disc number and track number to be deleted for step 2.

In this example, enter disc number 4 with the DISC button and track number 3 with the ◀ or ▶ button and then press the MEMORY button. When the TRACK button (XL-M409TN/XL-M408BK only) is used for entering the track number, it is not necessary to press the MEMORY button.

After entering the track, the following display appears.

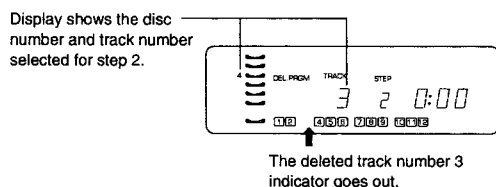

6. If necessary, repeat steps 2 and 4 for other tracks and/or discs to be deleted.

7. Start delete program playback with the PLAY ▶/II PAUSE button.

All tracks other than deleted tracks and/or discs are played in the order of the disc and track numbers.

- You can skip to a desired track other than deleted tracks with the SEARCH ◀◀ or ▶▶ button.
- To repeatedly play the tracks and/or discs other than deleted tracks and/or discs, press the REPEAT ALL/1 button so that the REPEAT indicator lights on the display.

To check the delete program contents

Each time the CALL button is pressed, the delete program contents are displayed in the programmed order.

- When the unit is in delete program playback mode, press the ■ STOP/CANCEL button to enter stop mode and then operate the CALL button.

To modify the delete program contents

Press the CALL button until the display shows the program step to be corrected. Enter the new disc number and/or track number referring to step 2 and 4 above.

To erase a program step, press the CALL button until the display shows the program step to be erased and then press the ■ STOP/CANCEL button. You can also erase a displayed program step during programming.

- When the unit is in delete program play mode, press the ■ STOP/CANCEL button to enter stop mode and then delete the program step.

To clear the entire program

Change the playback mode with the PLAY MODE button or eject the magazine and single disc tray. The program contents will be cleared.

INTRO SCAN

You can use 2 types of intro scan functions (Disc intro scan and Track intro scan) to search for a desired disc or track.

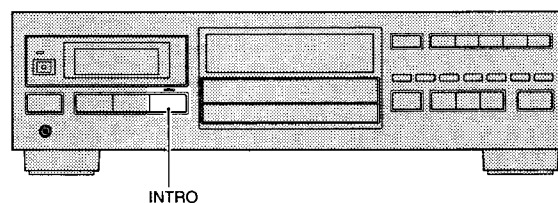

Each time the INTRO button is pressed, the intro scan mode changes in the following order; Disc intro scan (DISC INTRO) → Track intro scan (INTRO) → Intro scan off → Disc intro scan.

Make sure that the CONTINUE indicator is lit on the display. Otherwise, intro scan playback cannot be carried out.

Disc intro scan

In stop mode, press the INTRO button so that the DISC INTRO indicator lights on the display.

The beginning of the first track on each disc is played for about 15 seconds starting with the disc in single disc tray and continuing through to the 6th disc in the magazine. When the desired disc is reached, press the SEARCH ◀◀ button. The disc intro scan mode is canceled and normal playback continues.

Track intro scan

In stop mode, press the INTRO button so that the INTRO indicator lights on the display.

The beginning of each track on each disc is played for about 15 seconds starting with the disc in single disc tray and continuing through to the 6th disc in the magazine. When the desired track is reached, press the SEARCH ◀◀ button. The track intro scan mode is canceled and normal playback continues.

The following operations also cancel the intro scan mode.

- When the playback mode is changed with the PLAY MODE button.
- When the SEARCH ▶▶ button, DISC button or TRACK button is pressed.

VARIOUS PLAYBACK PATTERNS

REPEAT

With the repeat functions, you can repeatedly play all discs or one track.

With the REPEAT ALL function, all discs are played repeatedly. To repeatedly play one track, use the REPEAT 1 function.

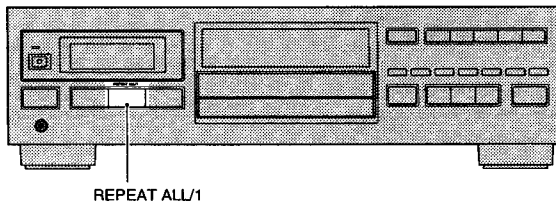

REPEAT ALL

Press the REPEAT ALL/1 button so that the REPEAT indicator lights on the display.

All discs loaded in the player are played repeatedly.

REPEAT 1

Press the REPEAT ALL/1 button so that the REPEAT 1 indicator lights on the display.

The displayed track number is played repeatedly.

To cancel repeat mode

Press the REPEAT ALL/1 button so that the REPEAT and REPEAT 1 indicators go out.

EDIT

With the edit functions, you can program the desired tracks within the specified recording time by observing the amount of recording time remaining as each track is programmed.

Up to 16 steps can be programmed for each side of a cassette tape. The programming cannot be carried out with track number 32 or above.

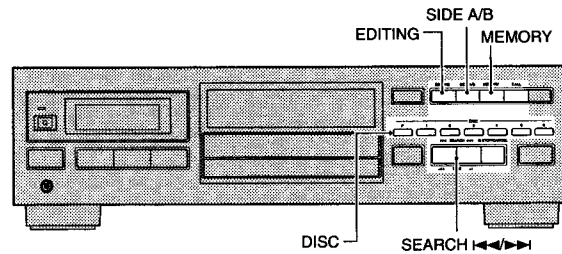

PROGRAM EDIT

You can program tracks from among discs in the unit by specifying the disc number and track number.

1. Press the EDITING button so that the PRGM EDIT indicator lights on the display.
2. Enter the tape playing time (in minutes) of your cassette tape with the SEARCH <<< and >>> buttons.
Refer to 'Specifying the tape playing time' on page 10 for entering the time.
For XL-M409TN/XL-M408BK only: You can enter the tape playing time with the TRACK buttons on the remote control unit. In this case, it is not necessary to press the SIDE A/B button. Skip step 3.
3. Press the SIDE A/B button.

When 46 minutes is entered:

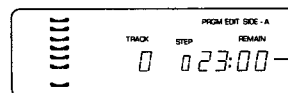

4. Select the disc which contains tracks to be programmed with the DISC number button.
5. Press the SEARCH <<< and >>> buttons so that the desired track number appears on the display.
For XL-M409TN/XL-M408BK only: You can enter the track number with the TRACK buttons on the remote control unit. In this case, it is not necessary to press the MEMORY button. Skip step 5.

VARIOUS PLAYBACK PATTERNS

6. Press the MEMORY button.

The displayed track number is stored.

- If you want to cancel the displayed program step, press the ■ STOP/CANCEL button and then enter the new disc number and/or track number.

7. Repeat steps 4 through 6 for other tracks to be programmed.

8. When the remaining time is not long enough to program any more tracks, press the SIDE A/B button so that the SIDE-B indicator lights on the display.

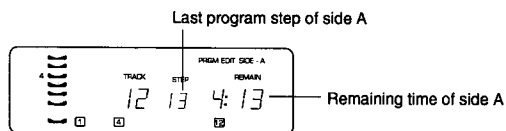

- Once you program 16 steps, no more tracks can be programmed.

9. Program the track for side B by repeating steps 4 through 7.

When total playing time of the programmed tracks has exceeded the specified time:

The excess time display blinks and no more tracks can be programmed. In this case, press the ■ STOP/CANCEL button to delete the last programmed step so the tracks fit within the specified time.

INTRO EDIT

You can program tracks while listening to the beginning of each track on the selected disc.

1. In stop mode, press the EDITING button so that the INTRO EDIT indicator lights on the display.

2. Enter the tape playing time (in minutes) of your cassette tape with the SEARCH ◀ and ▶ buttons.

Refer to "Specifying the tape playing time" on page 10 for entering the time.

For XL-M409TN/XL-M408BK only: You can enter the tape playing time with the TRACK buttons on the remote control unit. In this case, it is not necessary to press the SIDE A/B button. Skip step 3.

3. Press the SIDE A/B button.

When 46 minutes is entered:



4. Select the disc which contains tracks to be programmed with the DISC number button.

Intro scan playback starts on the selected disc. The beginning of each track is played for about 15 seconds.

5. Press the MEMORY button when the desired track is reached.

When the MEMORY button is pressed, the track being played is programmed and the unit searches for the next track. Whenever a desired track is reached, you can program it by pressing the MEMORY button. In this way up to 16 steps can be programmed.

- With the SEARCH ▶ or ◀ button, you can skip to the desired track.

VARIOUS PLAYBACK OPERATIONS

6. When the remaining time is not long enough to program any more tracks, press the ■ STOP/CANCEL button.

Intro scan playback stops and the display shows the last program step.

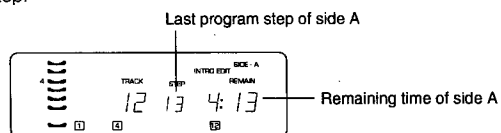

- Once you program 16 steps, intro scan playback stops and no more tracks can be programmed.

7. To program tracks for side B, press the SIDE A/B button so that the SIDE-B indicator lights on the display and repeat steps 4 through 6.

When total playing time of the programmed tracks has exceeded the specified time:

Intro scan playback stops and the excess time display blinks. In this case, press the ■ STOP/CANCEL button to delete the last programmed step so that the tracks fit within the specified time.

Operations after editing tracks

To record the programmed tracks

1. Set the cassette deck to record-standby mode.
2. Press the PLAY ►/|| PAUSE button to start edit program play. If this unit and the cassette deck are connected with the COMPU LINK terminals, the cassette deck enters record mode automatically. When the program for side A finishes playing, this unit and cassette deck enter pause mode. Set the cassette deck for recording of side B, and press the PLAY ►/|| PAUSE button of this unit to start playback of side B. The cassette deck enters record mode automatically.

To check the program contents

Each time the CALL button is pressed, the program contents are displayed in the programmed order.

- When the unit is in playback mode, press the ■ STOP/CANCEL button to enter stop mode and then operate the CALL button.

To modify the program contents

Press the CALL button until the display shows the program step to be corrected. Enter the new track number with the numeric buttons or the SEARCH ◀▶ buttons. When the SEARCH ◀ or ▶ button is used, be sure to press the MEMORY button after selecting the track number.

To delete a program step, press the CALL button until the display shows the program step to be deleted and then press the ■ STOP/CANCEL button.

- When the unit is in playback mode, press the ■ STOP/CANCEL button to enter stop mode and then delete the program step.

To clear the entire program

Change the playback mode with the PLAY MODE button or eject the magazine and single disc tray. The program contents will be cleared.

APPENDIX

Compu link remote control system

The Compu Link Remote Control System controls relative operations between components automatically and facilitates various operations.

COMPU LINK Remote Control System

This is a system originated and developed by JVC for facilitating various system operations. There are two versions of this system; version 1 and 3. (For version 1 components, "COMPU LINK-1 SYNCHRO" is marked on the rear panel. For version 3 components, "COMPU LINK-3 SYNCHRO" is marked on the rear panel. This unit belongs to version 3.) The version 3 system controls relative functions between this unit and an amplifier or receiver, in addition to all of the functions of version 1.

The following is a brief explanation of this system:

Automatic source selection

When the remote cable provided is utilized to connect this unit to others equipped with COMPU LINK jacks, switching-in of each system component can be performed with a single touch of the source selector button located on a JVC amplifier or receiver.

When selection is carried out in this manner, the corresponding unit will automatically start operation.

Upon pressing the play button, the source selector for the amplifier or receiver changes automatically. When a new unit is switched in, the previously selected component stops operation within five seconds.

Synchronized recording

Synchronized recording refers to the process in which a JVC cassette deck starts recording, synchronized with this unit. Synchronized recording is carried out as follows:

1. Set the cassette deck to the REC/PAUSE mode in accordance with its instructions.
2. To record only certain tracks, program the tracks in any order, as desired.
3. Press the PLAY ►/|| PAUSE button of this unit. The cassette deck automatically starts recording, synchronized with this unit.

Notes

- Synchronized recording stops automatically when this unit stops playback.
- To cancel synchronized recording, press the stop button of this unit or the cassette deck.
- If the REC/PAUSE mode is set on the cassette deck by pressing the PAUSE || button after pressing the REC ● and PLAY ► buttons simultaneously, synchronized recording is not possible. For details, refer to the instructions for the cassette deck.

Automatic power on/off function

This function is possible when this unit is connected to an amplifier or receiver of version 3.

This function is to control the power on/off of the receiver or amplifier or this unit respectively as the followings.

- When this unit enters playback mode, the power of the receiver or amplifier is turned on.
- When a magazine is inserted in this unit, the power of the receiver or amplifier is turned on.
- When the source selector of the receiver or amplifier is set to CD function mode, the power of this unit is turned on.

Cautions

- Abnormal operation will result if the power supply of the component(s) is interrupted. If this happens, you must start over again.
- Ensure that the COMPU LINK jacks of the individual components are connected with the provided remote cables. Also be sure to fully read the instructions for each component.

APPENDIX

Care of discs and magazines

How to handle CDs

When handling compact discs, do not touch the surface of the disc (reflective silver side - the side without the label).

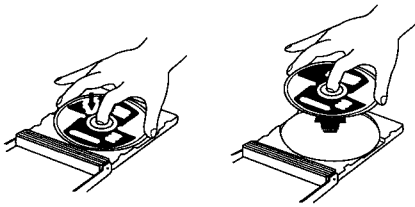

Since compact discs are made of plastic, they are easily damaged. If the disc gets dirty, dusty, scratched or warped, the sound will not be picked up correctly and, in addition, such discs may cause the CD player to malfunction.

Even on label side

Do not damage the label side, stick paper to or use any adhesive on this surface.

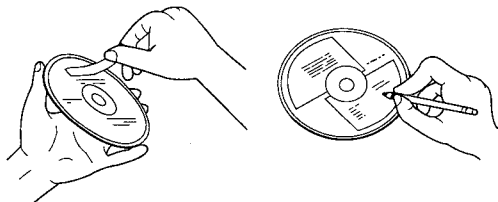

Storage

Make sure that discs are kept in their cases. If discs are piled one on top of another without their protective cases, they can be damaged. Do not put discs in any location where they can be exposed to direct sunlight - or in any place where humidity or temperature is high. Avoid leaving discs in your car!

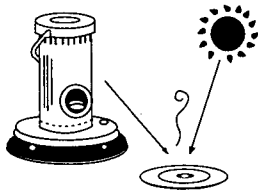

Maintenance of discs

- When there are fingerprints or other dirt adhering to a disc, wipe the disc with a soft, dry cloth with a movement going from the inside outwards.

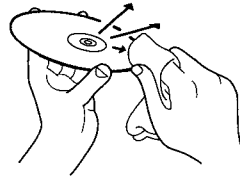

- If difficult to clean, wipe the disc with a cloth moistened with water.
- Never use record cleaners, petrol, alcohol or any anti-static agents.

Recommendations for handling the magazine

- Always keep the magazine loaded with its six disc trays.
- Do not expose it to high temperatures or to direct sunlight.
- Do not dismantle the magazine.
- Take care not to drop or hit the magazine. Do not apply any pressure to the disc trays, particularly when removed from the magazine.
- Never apply solvents such as petrol, thinner or insecticide to the surfaces of the magazine or the disc trays. Such solvents may damage their surfaces.

TROUBLESHOOTING

What appears to be a malfunction may not always be serious. Please go through the following list before requesting service.

Symptom	Possible cause	Remedy
The magazine is not expelled when the ▲ EJECT button is pressed.	Power plug is disconnected from the AC outlet.	Connect the plug to an AC outlet.
No sound.	Incorrect output connections.	Connect properly.
Programming is not possible.	The appropriate program indicator does not light.	Select the program or delete program mode with the PLAY MODE button. In edit mode, select the intro edit or program edit with the EDITING button.
The sound is intermittent and is harsh to the ear.	Disc is dirty.	Wipe off the disc surface with a soft cloth.
	Disc is scratched.	Replace the disc with a new one.
	Disc is warped.	Replace the disc with a new one.
A track on a CD is not played.	A CD is missing.	Load a CD.
	A CD is loaded upside-down.	Load the CD with its label-side up on the disc tray or in the magazine.

SPECIFICATIONS

General

System:	Compact disc digital audio system
Signal detection system:	Non-contact optical detection system
CD capacity:	7 discs (one disc in single disc tray and 6 discs in the magazine)
Power requirements:	U.S.A. AC 120 V \sim , 60Hz Australia, U.K. AC 240 V \sim , 50Hz
Power consumption:	18 watts
Dimensions (W x H x D):	435 x 128 x 319 mm 17-3/16 x 5- 1/16 x 12-9/16 inches
Weight:	5.0 kg 11.1 lbs

Accessories

Magazine	1
Remote control unit (XL-M409TN/XL-M408BK only) (RM-SX409U)	1
Battery (R6P, AA)	2
Remote cable	1
Audio cord	1

Design and specifications subject to change without notice.

Audio performance

Frequency response:	2 Hz to 20,000 Hz
Dynamic range:	More than 99 dB at 1 kHz
Signal to noise ratio:	More than 107 dB
Channel separation:	More than 94 dB at 1 kHz
Total harmonic distortion:	Less than 0.002% at 1 kHz
Wow and flutter:	Below the measurable limit
Audio output level:	2.0 Vrms at full scale

Description of Major LSIs

■ MN171602JHC (IC201) : CD SYSTEM CONTROLLER

1. Terminal Layout

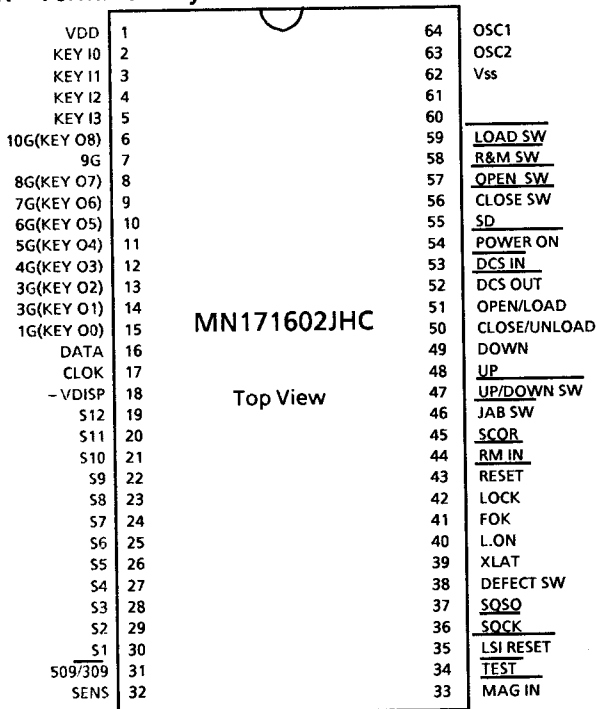

2. Key Matrix

	KEY IN 0	KEY IN 1	KEY IN 2	KEY IN 3
KEY OUT 3	DISC 9	DISC 1	DISC 2	DISC 3
KEY OUT 4	DISC 4	DISC 5	DISC 6	OPEN/CLOSE
KEY OUT 5	◀◀	▶▶	■/CANCEL	▶▶▶
KEY OUT 6	EJECT	EDIT	SIDE A / B	MEMORY
KEY OUT 7	CALL	P.MODE		

3. Pin Functions Description

Pin NO.	symbol	I/O	Function	Pin NO.	symbol	I/O	Function
1	VDD	I	Power supply	33	MAG-IN	I	Magazine in signal
2	KEY I0	I	Key matrix input	34	TEST	I	Entering test mode with "L"
3	KEY I1	I	Key matrix input	35	LSI RESET	I	Reset signal input
4	KEY I2	I	Key matrix input	36	SQCK	O	Clock output for data transfers
5	KEY I3	I	Key matrix input	37	SQSO	O	80-bit sub Q and 16-bit PCM level data
6	10G(KEY O8)	O	FL grid control output (Key matrix output)	38	DEFECT SW	O	Signal that goes "H" during focus searches
7	9G	O	FL grid control output	39	XLAT	O	Latch signal for serial data transfer
8	8G(KEY O7)	O	FL grid control output (Key matrix output)	40	L.ON	O	Turns on laser
9	7G(KEY O6)	O	FL grid control output (Key matrix output)	41	FOK	I	Focus OK signal input
10	6G(KEY O5)	O	FL grid control output (Key matrix output)	42	LOCK	I	Lock signal input
11	5G(KEY O4)	O	FL grid control output (Key matrix output)	43	RESET	I	Reset signal input
12	4G(KEY O3)	O	FL grid control output (Key matrix output)	44	RM IN	I	Remote control signal input.
13	3G(KEY O2)	O	FL grid control output (Key matrix output)	45	SCOR	O	Turns "H" when detecting sub code sync
14	2G(KEY O1)	O	FL grid control output (Key matrix output)	46	JAB SW	I	JAB switch signal
15	1G(KEY O0)	O	FL grid control output (Key matrix output)	47	UP/DOWN SW	I	Height detection signal
16	DATA	O	Serial data output	48	UP	O	Lifter driving control signal
17	CLOK	O	Clock Signal output	49	DOWN	O	Lifter driving control signal
18	-VDISP	I	FL power supply	50	CLOSE/UNLOAD	O	P1 CLOSE or UNLOAD driving control signal.
19	S12	O	FL segment control output	51	OPEN/LOAD	O	P1 OPEN or LOAD.
20	S11	O	FL segment control output	52	DCS OUT	O	Compulink signal output
21	S10	O	FL segment control output	53	DCS IN	I	Compulink signal input
22	S9	O	FL segment control output	54	POWER ON	O	H: power off, L: power on.
23	S8	O	FL segment control output	55	SD	O	LOAD drive speed Down output.
24	S7	O	FL segment control output	56	CLOSE SW	I	"L" with tray closed
25	S6	O	FL segment control output	57	OPEN SW	I	"L" with tray opened
26	S5	O	FL segment control output	58	R&M SW	I	Reset&Memory SW input.
27	S4	O	FL segment control output	59	LOAD SW	I	Disc load detect signal
28	S3	O	FL segment control output	60		-	Connect to GND
29	S2	O	FL segment control output	61		-	Non connect
30	S1	O	FL segment control output	62	Vss	-	GND
31	509/309	I	Chip select input (H: 508/509, L: 309)	63	OSC2	O	Clock oscillation output
32	SENS	I	Sense Signal input	64	OSC1	I	Clock oscillation input

■ CDX2500BQ(IC401) : DIGITAL SIGNAL PROCESSOR

1. Outline

The CDX2500BQ is a digital signal processing LSI designed for use in compact disc players. It has the following functions:

- All digital signals for regeneration are processed using one chip.
- The built-in RAM enables high-integration mounting.
- Generation by the use of a digital PLL of bit clock pulses for strobing the EFM signal.
- EFM data demodulation
- Subcode demodulation and subcode Q data error detection
- Digital spindle servo system (incorporating an oversampling filter)

2. Terminal Layout

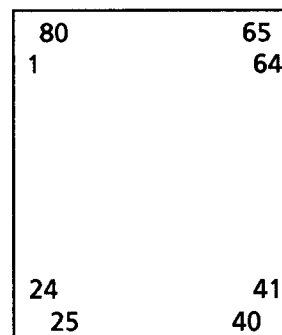

3. Block Diagram

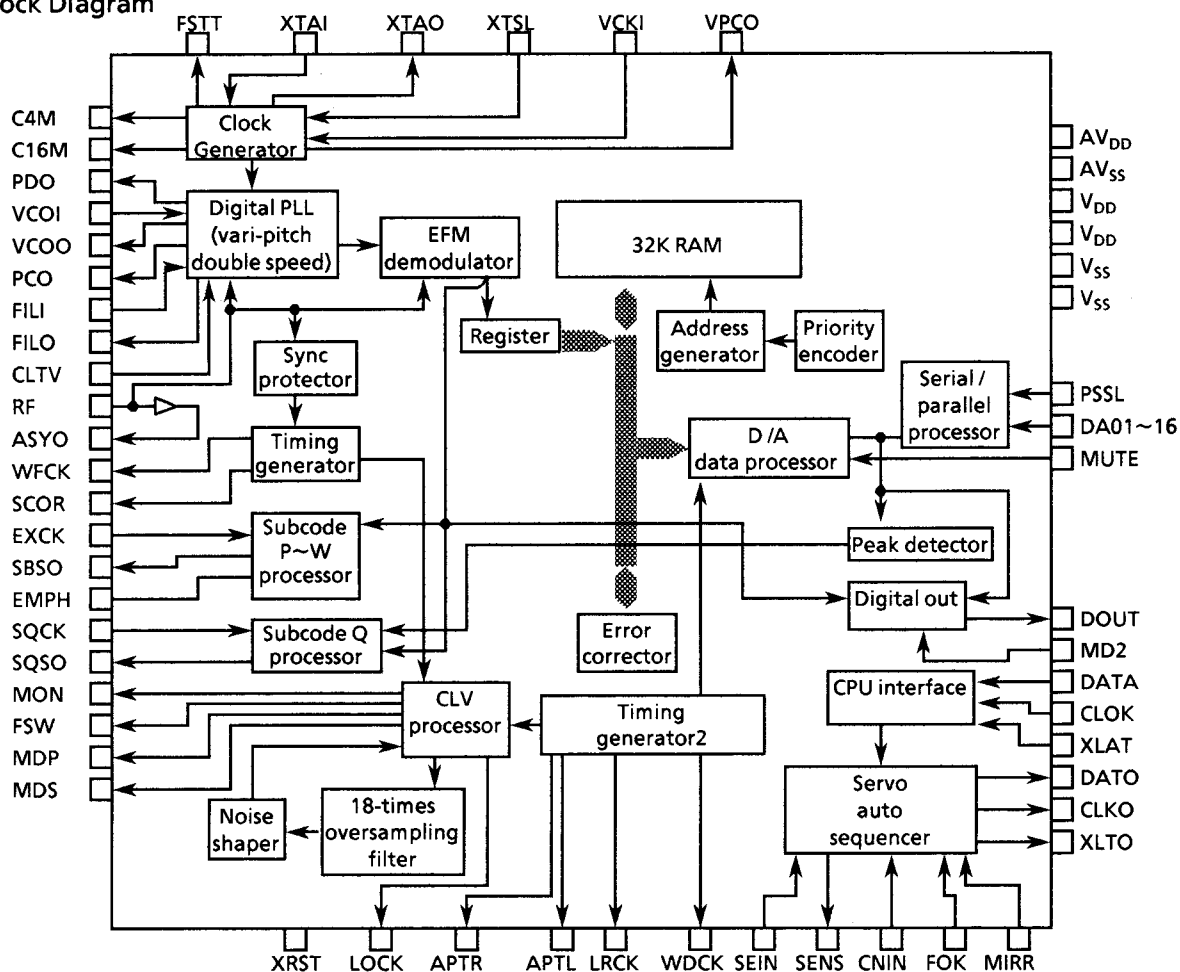

Notes:

- The data at the 64-bit slot is output in 2's complements on an LSB-first basis. The data at the 48-bit slot is output in 2's complements on an MSB-first basis.
- GTOP monitors the state of Frame Sync protection. ("H" : Sync protection window released)
- XUFG is a negative Frame Sync pulse obtained from the EFM signal before Frame Sync protection is effected.
- XPLCK is an inversion of the EFM PLL clock. The PLL is designed so that the falling edge of XPLCK coincides with a change point of the EFM signal.
- The GFS signal turns "H" upon coincidence between Frame Sync and the timing of interpolation protection.
- RFCK is a signal generated at 136- μ s periods using a crystal oscillator.
- C2PO is a signal to indicate a data error.
- XRAOF is a signal issued when a jitter margin of $\pm 28F$ is exceeded by the 32K RAM.

XL-M309TN
 XL-M408BK
 XL-M409TN

4. Pin Description

Pin No.	Symbol	I/O	Description
1	FOK	I	Focus OK input pin. Used for SENS output and servo auto sequencer.
2	FNW	O	Non connection
3	MON	O	Output for spindle motor ON / OFF control.
4	MDP	O	Output for spindle servo control.
5	MDS	O	Output for spindle servo control (Non connection).
6	LOCK	O	This terminal is "H" when the GFS signal sampled at 460Hz is "H". It turns "L" when the GFS signal turns out "L" 8 or more times in succession.
7~9	—	--	Non connection
10	TEST	I	Test pin (Normally at 0V)
11	PDO	O	Output of charge pump for analog EFM PLL (Non connection).
12	Vss	--	GND
13~16	—	--	Non connection
17	VCKI	O	Clock input from external VCO for vari-pitch control. $f_c = 16.9344\text{MHz}$.
18	FILO	O	Output of filter for masterPLL (Slave = Digital PLL)
19	FILI	I	Input to filter for master PLL.
20	PCO	O	Output of charge pump for master PLL.
21	AVss		Analog GND
22	CLTV	I	VCO control voltage input for master PLL.
23	AV _{DD}	--	Analog power supply
24	RF	I	EFM signal input
25	TEST2	I	TEST pin (Connected to GND)
26	TEST3	I	TEST pin (Connected to GND)
27	ASYO	O	EFM full-swing output
28	TEST4	I	TEST pin (Connected to GND)
29	NC	--	Non connection
30	PSSL	I	Input used to switch the audio data output mode. "L" for serial output, "H" for parallel output.
31	WDCK	O	D / A interface for 48-bit slot. Word clock $f = 2F_s$.
32	LRCK	O	D / A interface for 48-bit slot. LR clock $f = F_s$.
33	V _{DD}	--	Power supply
34	DA16	O	Output DA16(MSB) when PSSL = 1 or serial data from 48-bit slot(2's complements, MSB first) when PSSL = 0.
35	DDA15	O	Output DA15 when PSSL = 1 or bit clock from 48-bit slot when PSSL = 0.
36~51	—	--	Non connection
52	VSS	--	GND
53	XTAI	I	Input to 16.9344MHz Xtal oscillation circuit or 33.8688MHz input.
54	XTAO	O	Output of 16.9344 MHz Xtal oscillation circuit.
55	XTSL	I	Xtal selection input pin. "L" for 16,344MHz Xtal, "H" for 33.8688 MHz Xtal.
56~58			Non connection
59	MD2	I	Digital-Out ON/OFF control. "H" for ON, "L" for OFF.
60	DOUT	O	Digital-Out output pin.
61,62	—	--	Non connection
63	SCOR	O	Turns "H" when subcode Sync S0 or S1 is detected.
64	SBSO	O	Serial output of Sub P to W.
65	EXCK	I	Clock input for reading SBSO.
66	SQSO	O	Outputs 80-bit Sub Q and 16-bit PCM peak-level data.
67	SQCK	I	Clock input for reading SQSO.
68	MUTE	I	"H" for muting, "L" for release.
69	SENS	--	SENS output to CPU.
70	XRST	I	System reset. "L" for resetting.
71	DATA	I	Inputs serial data from CPU.
72	XLAT	I	Latches serial data input from CPU at falling edge.
73	V _{DD}	--	Power supply(+ 5V)
74	CLOK	I	Inputs serial data transfer clock from CPU.
75	SEIN	I	Inputs SENSE from SSP.
76	CNIN	I	Inputs track jump count signal.
77	DATO	O	Outputs serial data to SSP.
78	XLYTO	O	Latches serial data output to SSP at falling edge.
79	CLKO	O	Outputs serial data transfer clock to SSP.
80	MIRR	I	Inputs mirror signal to be used by auto sequencer when jumping 128 or more tracks.

■ CXA1372S (IC601) : RF SIGNAL PROCESSING SERVO AMPLIFIER

1. Outline

The CXA1372S is a bipolar IC developed for RF signal processing (focus OK, mirror, defect detection, EFM comparator) and servo control.

2. Functions

- Auto asymmetry control
- Focus OK detection circuit
- Mirror detection circuit
- Defects detection, counter measures circuit
- EFM comparator
- Focus servo control
- Tracking servo control
- Sled servo control

3. Terminal Layout

TE	1	48	TZC
TDFCT	2	47	DVVEE
ATSC	3	46	RFO
FZC	4	45	RFI
FE	5	44	CP
FDCT	6	43	CB
VC	7	42	DVCC
FGD	8	41	CC2
FS3	9	40	CC1
FLB	10	39	FOK
FEO	11	38	EFM
FE-	12	37	ASY
SRCH	13	36	DFCT
TGU	14	35	MIRR
TG2	15	34	DGND
AVCC	16	33	SENS
TAO	17	32	C.OUT
TA-	18	31	XRST
SL+	19	30	DATA
SLO	20	29	XLT
SL-	21	28	CLK
FSET	22	27	LOCK
ISET	23	26	DIRC
SSTOP	24	25	AVEE

4. Internal Block Diagram

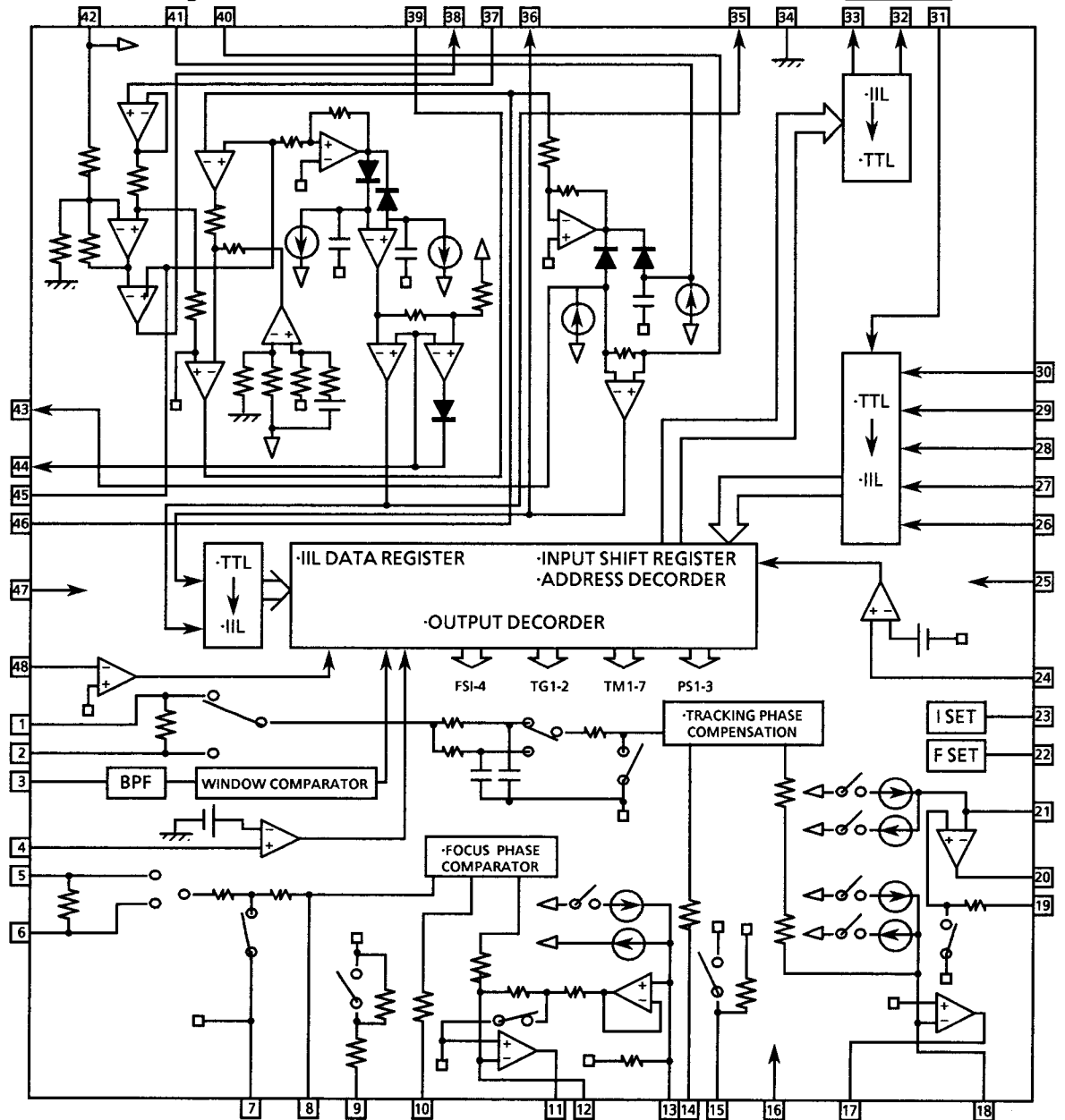

XL-M309TN
 XL-M408BK
 XL-M409TN
 5.Pin Description

Pin No	Symbol	I/O	Description
1	TE	I	Input pin of tracking error amplifier.
2	TDFCT	I	Capacitor connecting pin for time constant during defects.
3	ATSC	I	Window comparator input pin for ATSC detection.
4	FZC	I	Pin for focus zero-cross comparator input.
5	FE	I	Input pin of focus error.
6	FDFCT	I	Capacitor connecting pin for time constant during defect functions.
7	VC	I	Center voltage input pin. For dual power: GND For single power supply: (VCC + GND)/2
8	FGD	I	Connect a capacitor between this pin and pin3 to reduce high-frequency gain.
9	FS3	I	The high-frequency gain of the focus servo is switched through FS3 ON and OFF.
10	FLB	I	Time constant external pin to raise the low bandwidth of the focus servo.
11	FEO	O	Focus drive output.
12	FE-	I	Inverse input for focus amplifier.
13	SRCH	I	Time constant external pin for formation of focus search waveform.
14	TGU	I	Time constant external pin for the selection of tracking high band gain.
15	TG2	I	Time constant external pin for the selection of tracking high band gain.
16	AVCC	--	Power supply
17	TAO	O	Tracking drive output.
18	TA-	I	Inverse input pin for tracking amplifier.
19	SL+	I	Non- inverse input pin for sled amplifier.
20	SLO	O	Sled drive output.
21	SL-	I	Inverse input pin for sled amplifier.
22	FSET	I	Pin to set peak frequency of focus tracking phase compensation and fo of CLV LPF.
23	ISET	I	Current is input to determine focus search, track jump, and sled kick height.
24	SSTOP	I	Limit SW ON/OFF signal detection pin for disc inner periphery detection.
25	AVEE	--	- 5V
26	DIRC	I	Pin for one-track jump. Contains 47kΩpull-up resistor.
27	LOCK	I	At "L" sled runaway prevention circuit operate. Contains a 47kΩpull-up resistor.
28	CLK	I	Serial data transfer clock input from CPU.
29	XLT	I	Latch input from CPU.
30	DATA	I	Serial data input from CPU.
31	XRST	I	Reset input pin, reset at "L".
32	C.OUT	O	Track number count signal output.
33	SENS	O	Outputs FZC, AS, TZC and S STOP through command from CPU.
34	DGND	--	GND
35	MIRR	O	MIRR comparator output pin.
36	DFCT	O	Output pin of DEFECT comparator.
37	ASY	I	Input pin of auto asymmetry control.
38	EFM	O	Output pin of EFM comparator.
39	FOK	O	Output pin of FOK comparator.
40	CC1	I	Output pin of DEFECT bottom hold.
41	CC2	O	Input pin for the capacitance coupled output of DEFECT bottom hold.
42	DVCC	--	- 5V
43	CB	I	Connection pin of DEFECT bottom hold capacitor.
44	CP	I	Connecting pin of MIRR hold condenser. Non-inverted input pin of MIRR comparator.
45	RFI	I	Input pin with coupling capacitor where RF summing amplifier output is connected.
46	RFO	O	Output pin of RF summing amplifier and check point of eye pattern.
47	DVEE	--	- 5V
48	TZC	I	Input pin of tracking zero-cross comparator.

■ MN35500(IC301) : D / A CONVERTER

1. Terminal Layout

DIN	1	28 RSDN
LRCK	2	27 RSBUP
BCK	3	26 M3
M4	4	25 DVDD1
DVDD2	5	24 XIN
CKO	6	23 XOUT
DVSS2	7	22 DVSS1
M1	8	21 M2
OUT1C	9	20 OUT2C
OUT1B	10	19 OUT2B
AVDD1	11	18 AVDD2
OUT1D	12	17 OUT2D
OUT1A	13	16 OUT2A
AVSS1	14	15 AVSS2

2. Block Diagram

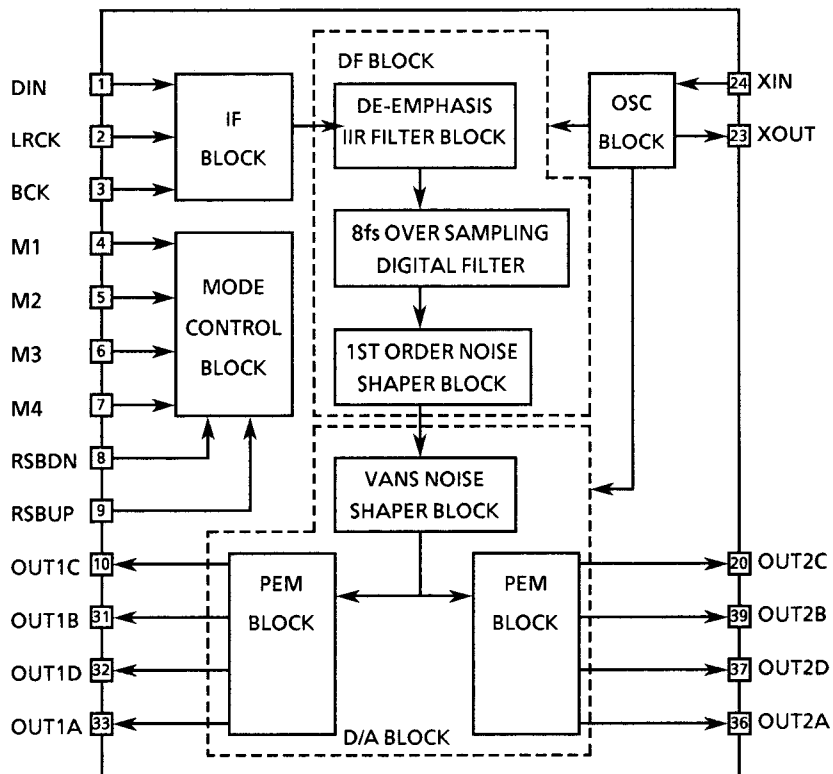

3. Description

Pin No	Symbol	I/O	Description	Pin No	Symbol	I/O	Description
1	DIN	I	Data input	15	AVSS2	--	Analog ground 2
2	LRCK	I	LR clock input	16	OUT2A	O	2A PEM output
3	BCK	I	Bit clock input pin	17	OUT2D	O	2D PEM output
4	M4	--	Operational mode control 4	18	AVDD2	--	Analog power supply 2
5	DVDD2	--	Digital power supply 2	19	OUT2B	O	2B PEM output
6	CKO	I	Clock output	20	OUT2C	O	2C PEM output
7	DVSS2	--	Digital ground 2	21	M2	--	Operational mode control 2
8	M1	--	Operational mode control 1	22	DVSS1	--	Digital ground pin 1
9	OUT1C	O	1C PEM output	23	XOUT	O	Crystal oscillator output
10	OUT1B	O	1B PEM output	24	XIN	I	Crystal oscillator input
11	AVDD1	--	Analog power supply 1	25	DVDD1	--	Digital power supply 1
12	OUT1D	O	1D PEM output	26	M3	--	Operational mode control 3
13	OUT1A	O	1A PEM output	27	RSBUP	I	Reset pin
14	AVSS1	--	Analog ground 1	28	RSDN	I	Reset pin

■ CXA1571S(IC501) : RF AMP FOR COMPACT DISC

1.Outline

The CXA1571S IC for compact disc #-point method optical pickup output has following functions.

- RF amplifier
- Focus error amp
- Tracking error
- APC circuit

2. Internal Block Diagram

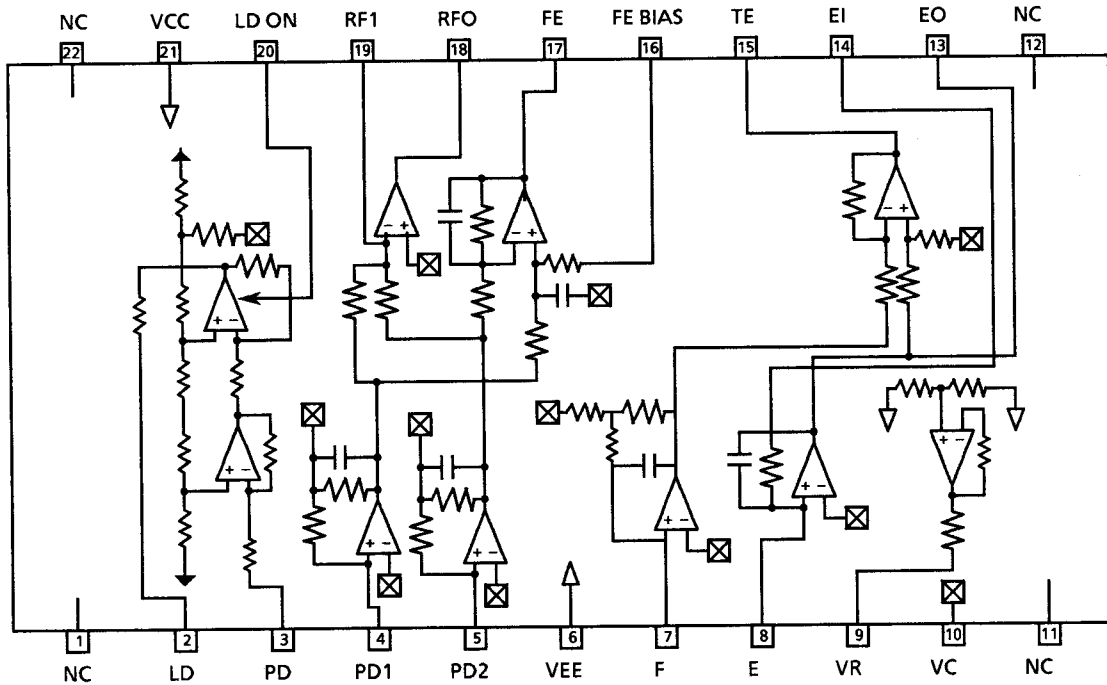

3. Pin Description

Pin No.	Symbol	I/O	Description
2	LD	O	APC amp output pin.
3	PD	I	APC amp input pin.
4	PD1	I	RF I-V amp inverted input pins; they are connected to the A + C and B + D pins of the photodiode and receive current input.
5	PD2	I	
7	F-IN	I	F and E I-V amp inverted input pin; they are connected to Photodiodes F and E and receive current input.
8	E-IN	I	
9	VR	O	$(VCC + VEE) / 2$ DC voltage output pin.
10	VC	I	VC intermediate voltage input pin; when dual $\pm 5V$ power supplies are used, this pin is connected to GND; for a single +5V power supply, it is connected to the VR pin.
13	EO	O	Monitor output pin for I-V amp E.
14	EI	I	Gain adjustment pin for I-V amp E.
15	TE	O	Tracking error amp output pin.
16	FE-BIAS	I	Bias adjustment pin for the mon-inverted side of the focus error amp.
17	FE	O	Focus error amp output pin.
18	RFO	O	RF amp output pin.
19	RFI	I	RF inverted side input pin; the resistor connected between this pin and the RFO pin determines the gain of the RF amp.
20	LD-ON	I	This pin switches the APC amp on / off: on for VCC, off for ground.

Internal Block Diagram of Other ICs

■ VC4580D (IC303,304,251) : Dual OP Amp.

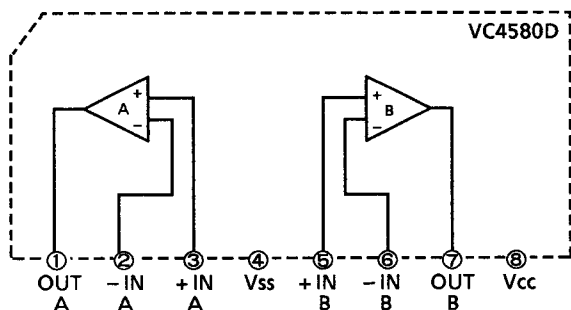

■ M5218AL (IC802,871) : Dual OP Amp.

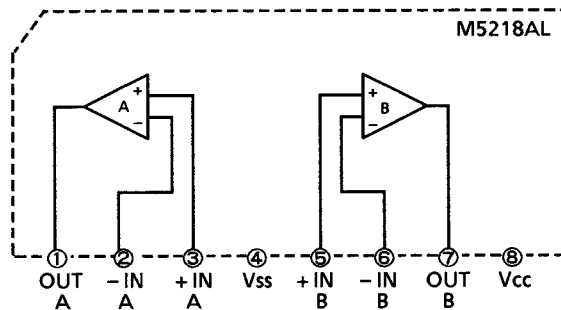

■ GP1U571X (IC203) : Receiver for remote controller

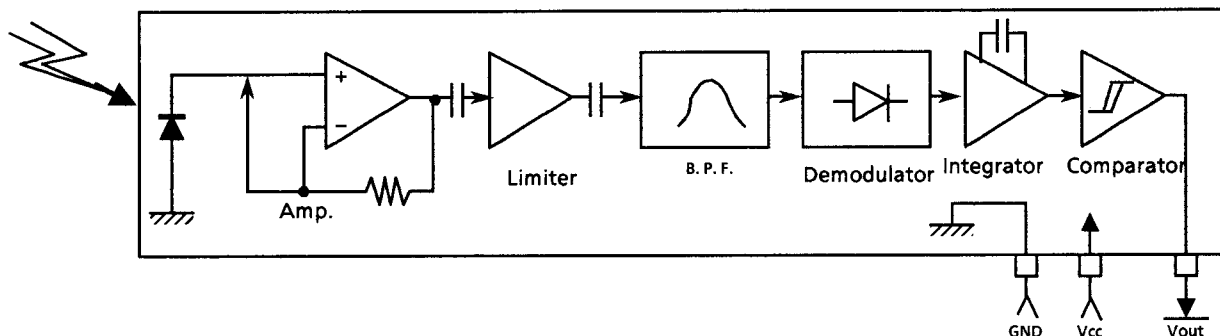

■ MN1281 (IC202) : Reset IC

Block Diagram

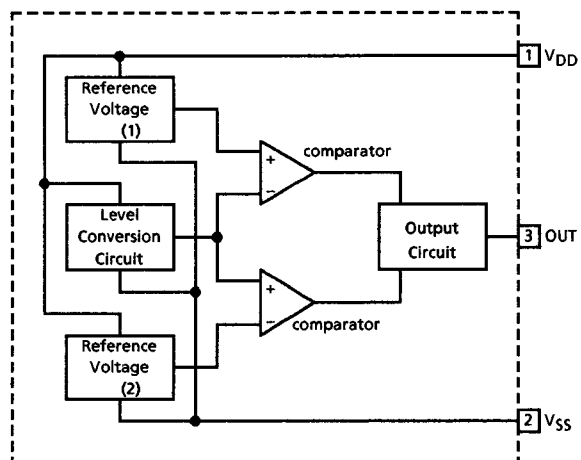

Pin No.	Pin Name	Functions
1	V _{DD}	Power supply
2	V _{SS}	Ground
3	OUT	Reset signal output : Low level is output when resetting : High level is output when cancelling the reset.

Internal Connections of FL Display Tube

■ ELU0001-132 (FL201)

1. Grid Layout

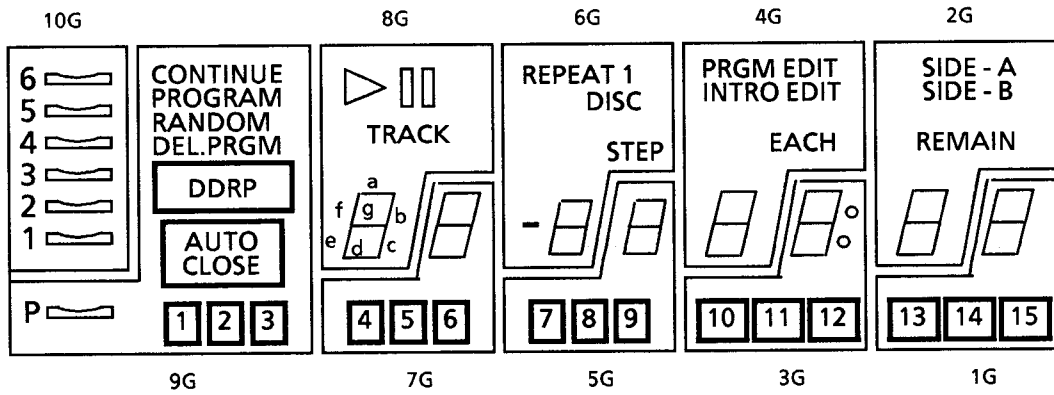

2. Pin Connections

Terminal No	1	2	3	4	5	6	7	8	9	10	11	12	13	14	15	16	17	18
ELECTRODE	F1	F1	F1	NP	10G	9G	8G	7G	6G	5G	4G	3G	2G	1G	NC	NC	P(S12)	P(S11)
Terminal No	19	20	21	22	23	24	25	26	27	28	29	30	31	32				
ELECTRODE	P(S10)	P(S9)	P(S8)	P(S7)	P(S6)	P(S5)	P(S4)	P(S3)	P(S2)	P(S1)	NP	F2	F2	F2				

Notes F: Filament NP: No Pin
 G: Grid NC: No Connection
 P: Anode

3. Anode Connection Table

	10G	9G	8G	7G	6G	5G	4G	3G	2G	1G
S1	6	—	—	—	—	—	—	—	—	—
S2	5	CONTINUE	TRACK	—	STEP	—	EACH	○	REMAIN	—
S3	4	PROGRAM	a	a	a	a	a	a	a	a
S4	3	RANDOM	b	b	b	b	b	b	b	b
S5	2	DEL.PRGM	c	c	c	c	c	c	c	c
S6	1	DDRP	d	d	d	d	d	d	d	d
S7	(6)	AUTO CLOSE	e	e	e	e	e	e	e	e
S8	(5)	P	f	f	f	f	f	f	f	f
S9	(4)	(P)	g	g	g	g	g	g	g	g
S10	(3)	1	▶	4	REPEAT	7	PRGM EDIT	10	SIDE-A	13
S11	(2)	2	▯▯	5	1	8	INTRO	11	SIDE-B	14
S12	(1)	3	—	6	DISC	9	EDIT	12	—	15

Disassembly Procedures

1. Removing the top cover

- 1) Remove the 4 screws fastening both sides of the Top Cover, and the 2 screws fastening the rear sides.
- 2) Remove the Top Cover.

2. Removing the front panel

- 1) Remove the screw (A)
- 2) Remove the 2 screws fastening both sides of the Front Panel, and the 3 screws fastening bottom of the Front Panel.
- 3) Disconnect the connector. (J201)
- 4) Remove the Front Panel.

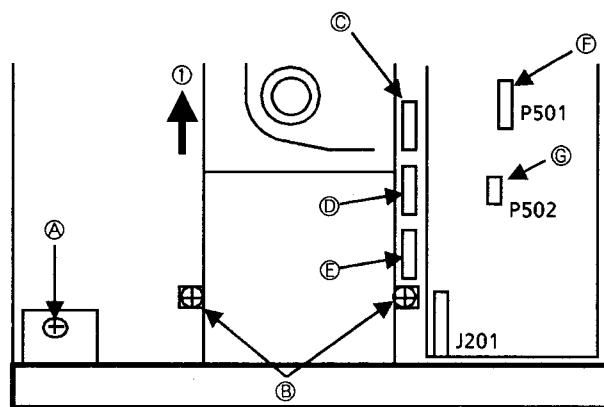

Fig.1

3. Removing the changer assembly

- 1) Remove the top cover.
- 2) Remove the front panel.
- 3) Remove the 2 screws (B) fastening the changer assembly.
- 4) Disconnect the connectors. (C, D, E, F, G)
- 5) Slide the changer assembly to arrow direction (I).
- 6) Remove the changer assembly.
 * NOTICE (for reinstalling)
 Wire (H) should be set as Fig.2.

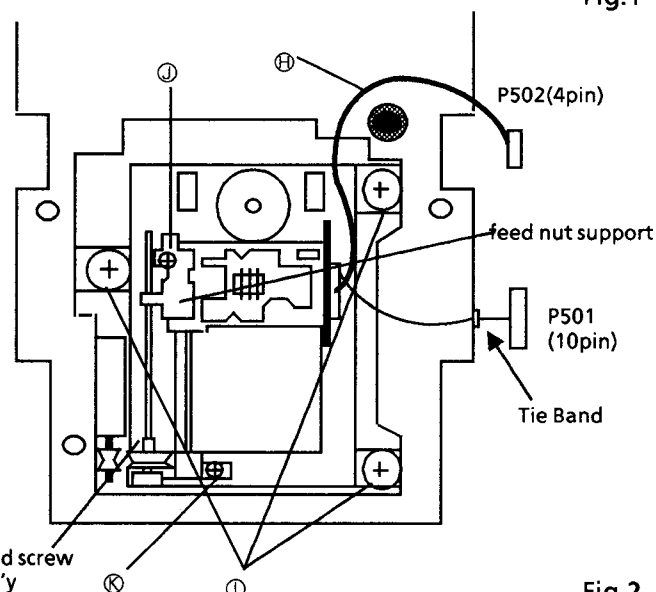

Fig.2

4. Removing the turntable base (Fig.2)

- 1) Remove the changer assembly.
- 2) Turn over the changer assembly.
- 3) Remove the 3 screws (O).
 * NOTICE : The left side spring differs from the right side ones.
- 4) Take the turntable base out.

5. Exchanging the pickup (Fig.2)

- 1) Remove the screw (O), and remove the feed nut support.
- 2) Remove the screw (P).
- 3) Remove the Feed Screw assembly, and remove the Pickup with the pickup shaft.
- 4) Exchange the pickup.

6. Removing the magazine holder (Fig.3)

- 1) Remove the 2 screws fastening the magazine holder.
- 2) Slide the magazine holder to arrow direction (Q).
- 3) Remove the magazine holder to upside, and remove the tray stopper at the same time.

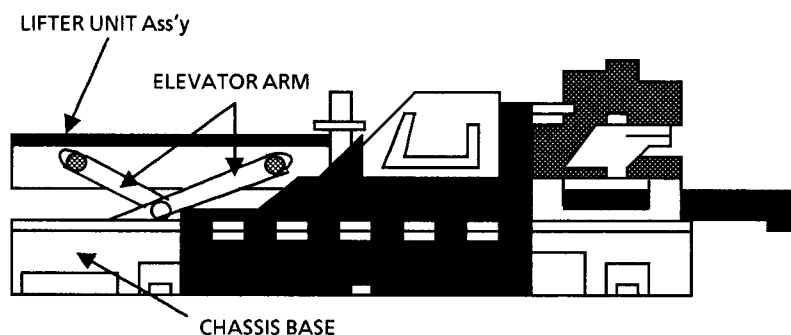

Fig.3

7. Removing the LIFTER UNIT Ass'y (Fig.3)

- 1) Remove the MAGAZINE HOLDER.
- 2) Lift the LIFTER UNIT Ass'y to the top position.
- 3) Remove the ELEVATOR ARMS from the CHASSIS BASE and the LIFTER UNIT Ass'y.
- 4) Remove the LIFTER UNIT Ass'y.

※ The LIFT CAM can be released, After removing the LIFTER UNIT Ass'y (Fig.8)

- 1) When installing the lift cam, Put the cam slider to the position shown in fig 8.
- 2) Install the changer assembly.
- 3) Set the power ON to operate the mechanism.
- 4) Set the power OFF while the disc is playing.
- 5) Set the power ON again.
 In this case the unit will be reseted.

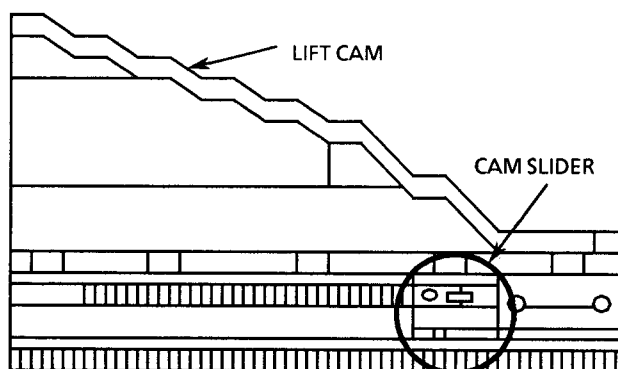

Fig.4

8. Removing the P1 RAIL BASE Ass'y (Fig.6,8)

- 1) Rotate the gear (V) clockwise a little.
- 2) Remove the P1 TRAY.
- 3) Remove the screw (W).
- 4) Remove the P1 RAIL BASE Ass'y.

9. Removing the P1 RAIL BASE (Fig.6,7,8)

- 1) Remove the P1 RAIL BASE Ass'y.
- 2) Remove the screw ① fixing the open/close sw and the sw.
- 3) Pull the P1 RAIL BASE by pulling up the hook ② slightly.
- 4) Remove the P1 RAIL BASE.

※ Install gear ③ so that part ④ shown in fig.7 is perpendicular to the P1 rail base.

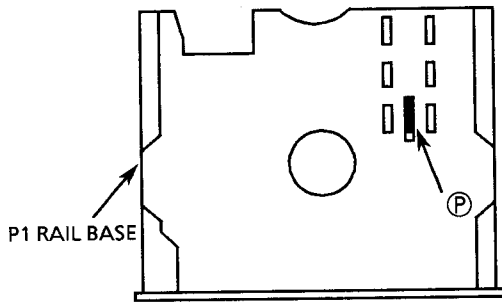

Fig.5

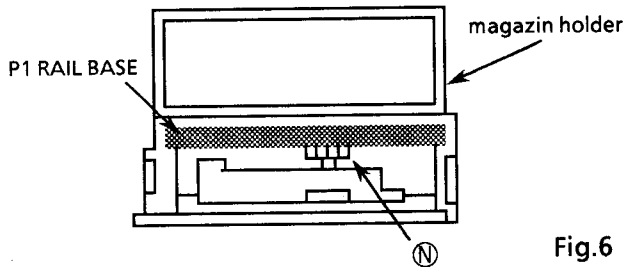

Fig.6

The Gear Position when the P1 Rail Base is pulled out forward.

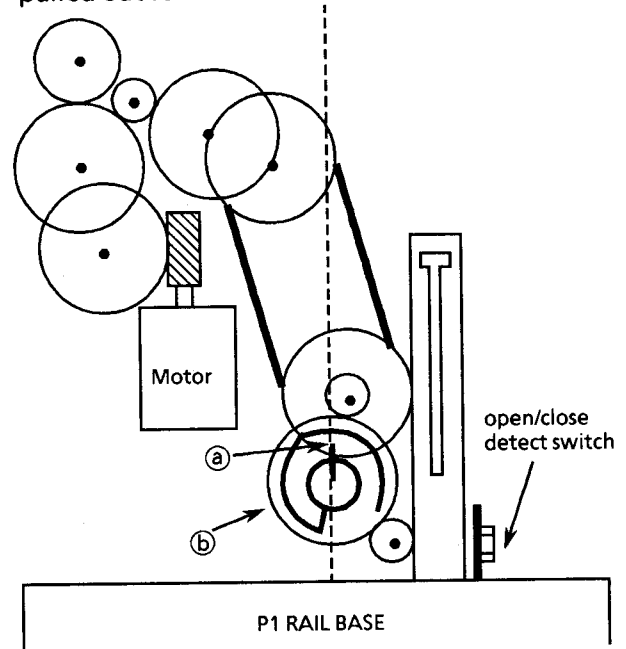

Fig.7

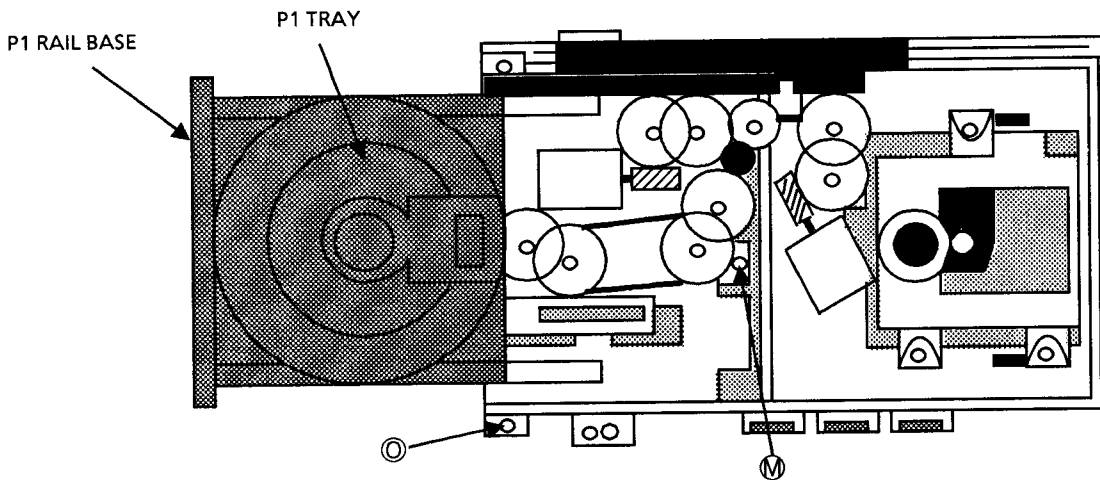
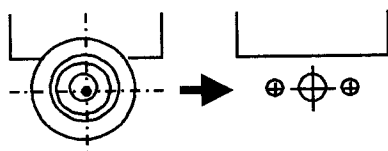

Fig.8

10. Removing the spindle motor

- 1) Remove the TURN TABLE BASE.
- 2) Turn over TURN TABLE BASE.
- 3) Remove the pressed-in turntable.
- 4) Remove the 2 screws fastening the motor.
- 5) Remove the spindle motor.



11. Mounting the spindle motor

- 1) Alternately tighten the 2 screws.
- 2) Fit the turntable by pressing gently at the centre to obtain a distance of $10.3\text{mm} \pm 0.1\text{mm}$ from the mechanism base to the top of the turntable.

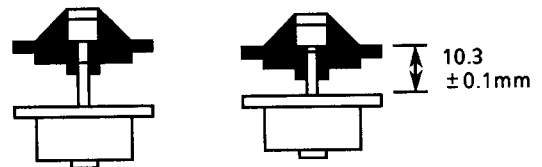

Adjustment Procedures

1. FE Bias

- 1) Connect an oscilloscope to TP 6(FE) and TP 3(GND).
- 2) Adjust R512(FE bias) so that the DC voltage becomes $0 \pm 10\text{mV}$.

2. EF balance

- 1) Connect an oscilloscope to TP 4(TE) and TP 3(GND).
- 2) Play a disc.
- 3) Short-circuit between TP 1(TEST) and TP 3(GND).
- 4) Adjust R513(EF balance) so that the center of the waveform at TP4(TE) becomes 0V.

3. Focus gain

- 1) Connect an oscilloscope to TP 6(FE) and TP 3(GND).
- 2) Play a disc.
- 3) Adjust R603(F.GAIN ADJ.) so that the waveform becomes below figure 1.

4. Tracking gain

- 1) Connect an oscilloscope to TP 4(TE) and TP 3(GND).
- 2) Play a disc.
- 3) Short circuit TP5(TEIN) to TP3(GND).
- 3) Adjust R604(T.GAIN ADJ.) so that the waveform becomes below figure 2.

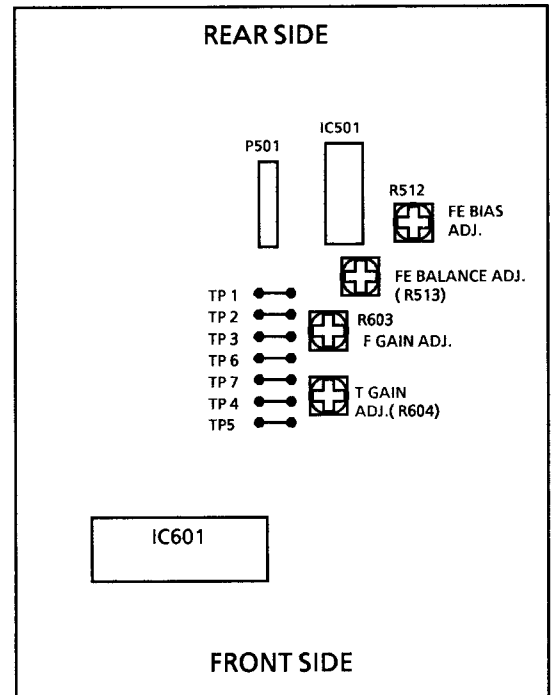

Focus Gain Adjustment

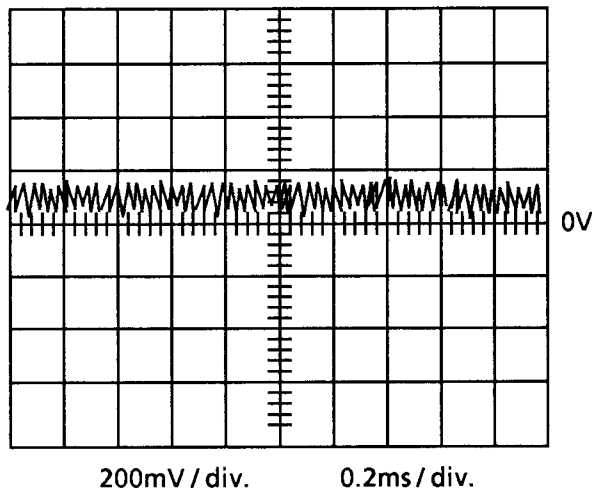

Figure. 1

Tracking Gain Adjustment

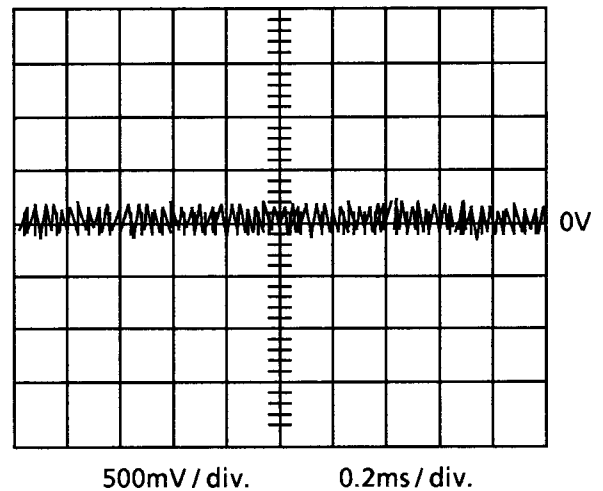

Figure. 2

Note :

If the gain is out of adjustment, the symptoms below will appear.

● Gain too low

- Focus gain : Focus is not obtained and disc does not rotate.
- Tracking gain : Mechanical shock occurs easily and sound is interrupted. Or time counter display stop counting.

● Gain too high

- Focus gain : Scratches (on the disc) easily interrupt play, and noise is increased during play.
- Tracking gain : Since the follow-up ability of the pickup is too high, the pickup may oscillate and oscillating sound may output.

As described above, the focus and tracking gain adjustment are performed so as to satisfy mutually contradictory characteristics. Asimplified adjustment procedure is described below. However, since exact adjustment can not be performed prior to adjustments, note(or mark) the positions of the semi-fixed VRs. If the positions after the simplified adjustment are only different, return the VRs to their original position.

Maintenance of Laser Pickup

(1) Life of the laser diode

When the life of the laser diode has expired, the following symptoms will appear.

1. The level of RF output (EFM output: amplitude of eye pattern) will be low.
 2. The drive current required by the laser diode will be increased.
- In such a case, check the life of the laser diode following the flowchart below

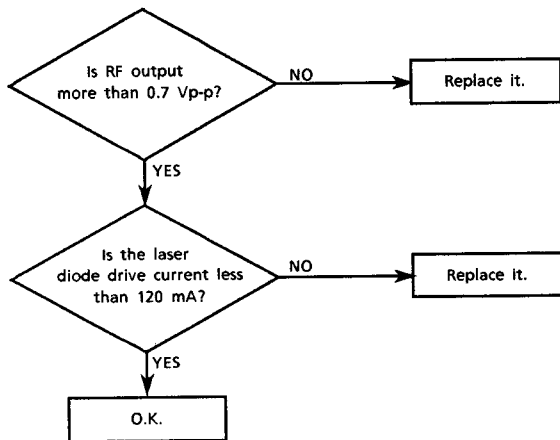

(2) Measurement of laser diode drive current

Replace the jump wire (W199) shown below with the resistor (1Ω).

Measure the voltage across the resistor with a milli-voltmeter. When the voltage is more than 120mV, it shows that the life of the laser diode has expired

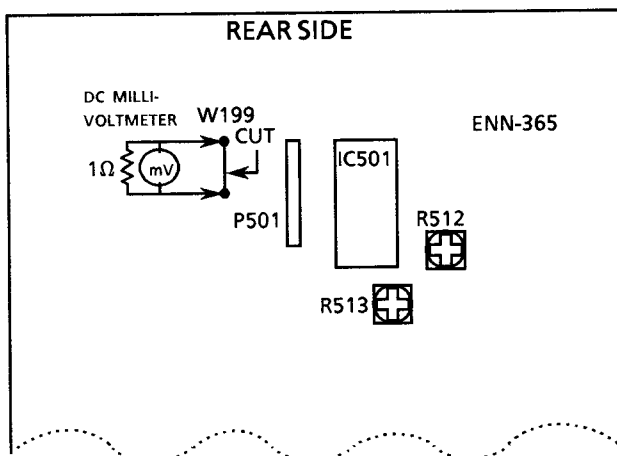

(3) Semi-fixed resistor on the APC PC board

The semi-fixed resistor on the APC printed circuit board which is attached to the pickup is used to adjust the laser power. Since this adjustment should be performed to match the characteristics of the whole optical block, do not touch the semi-fixed resistor.

If the laser power is lower than the specified value, the laser diode is almost worn out, and the laser pickup should be replaced.

If the semi-fixed resistor is adjusted while the pickup is functioning normally, the laser pickup may be damaged due to excessive current.

Replacement of Laser Pickup

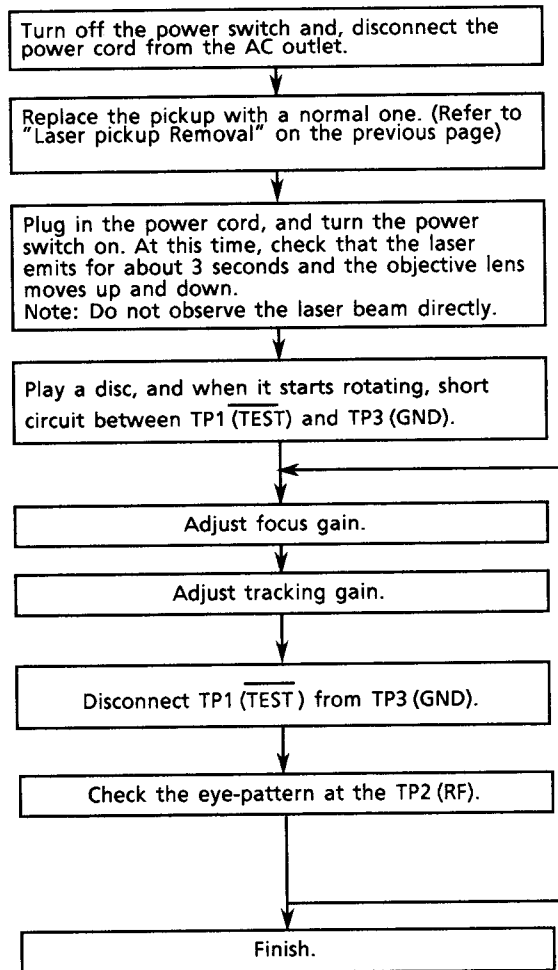

Note: Since one adjustment may affect other settings, repeat these adjustments a few times.

Initial Operation of Mechanism

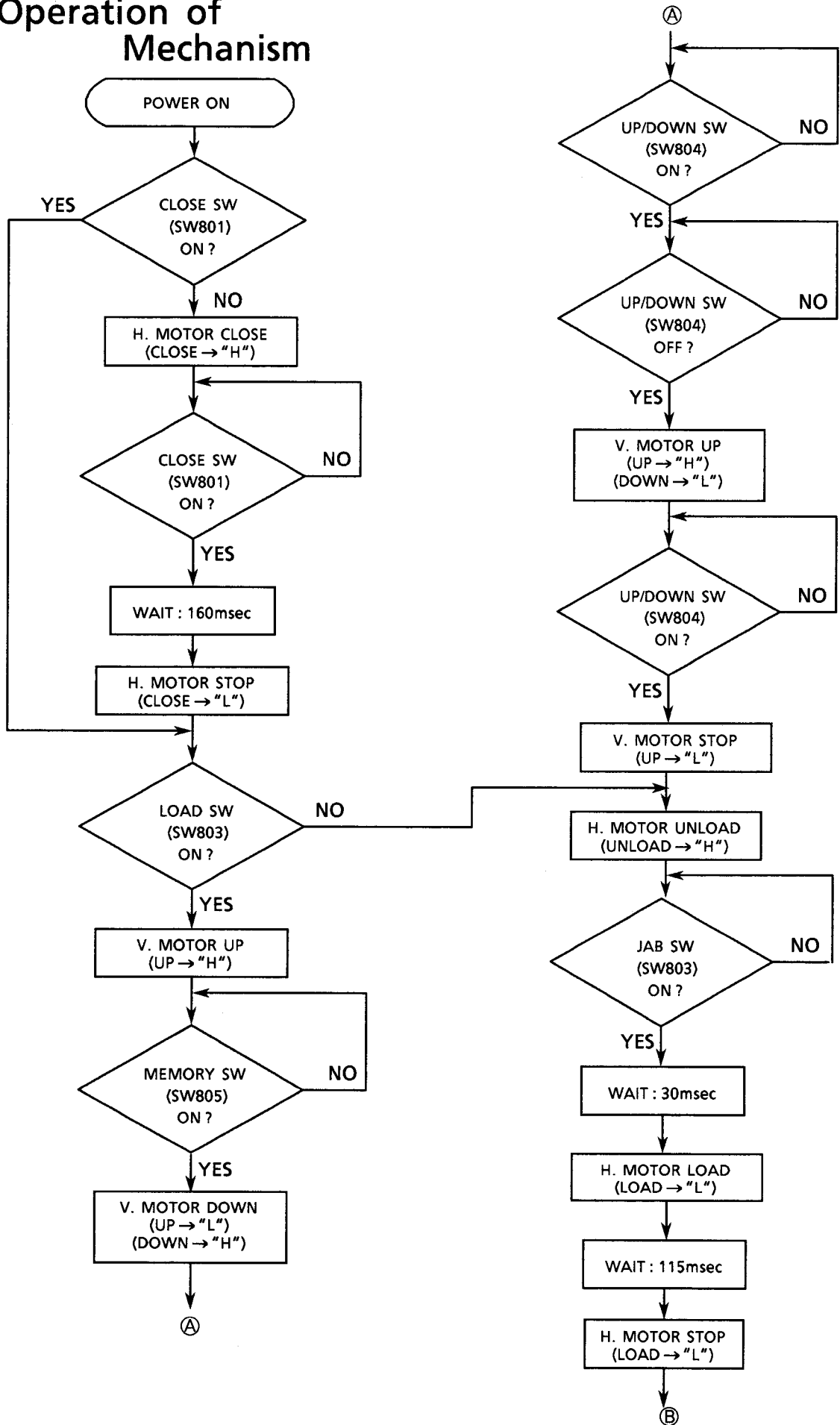

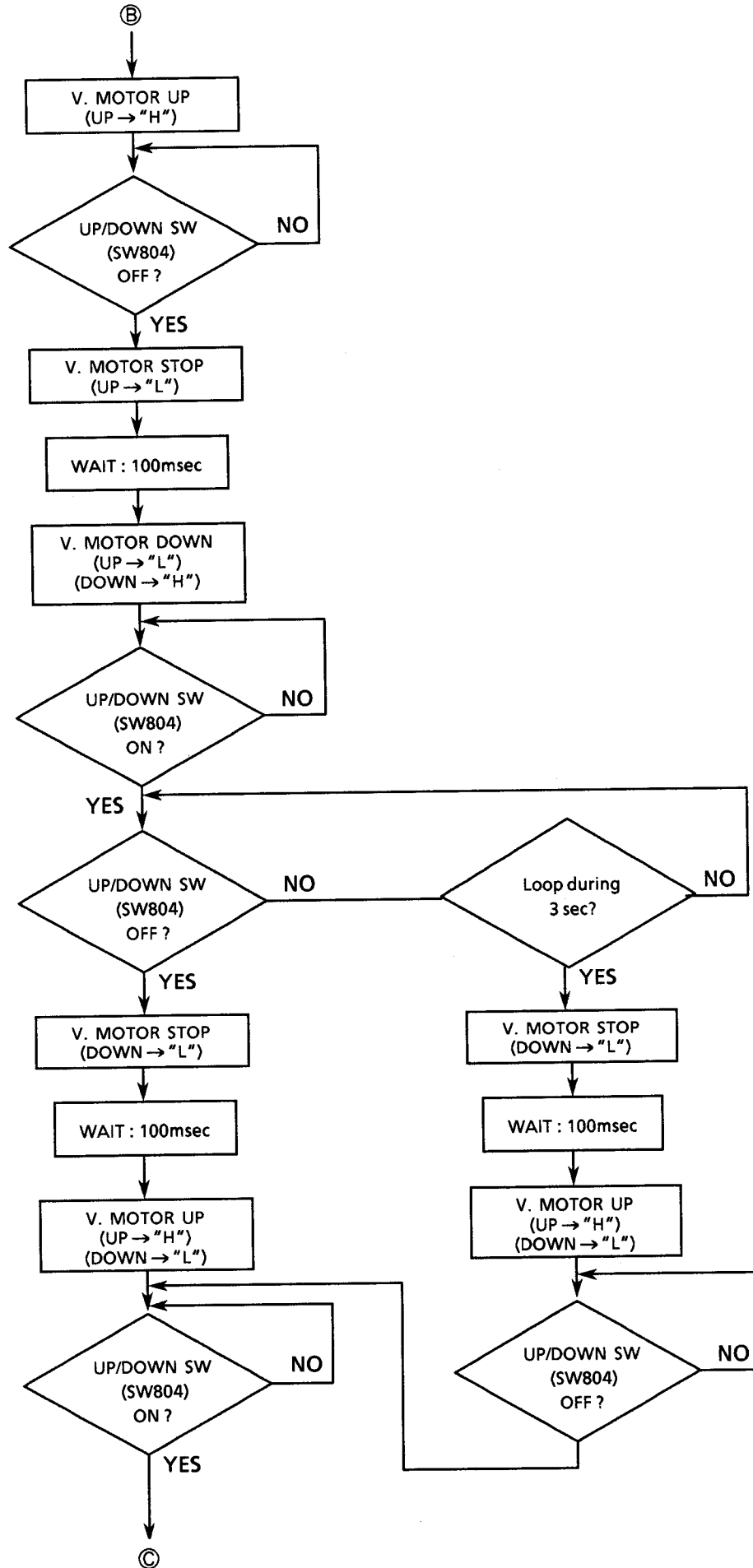

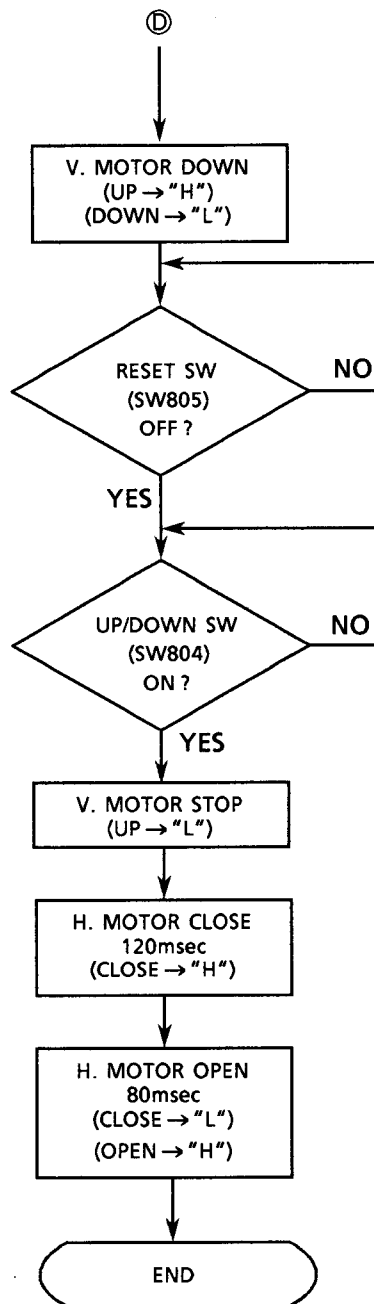
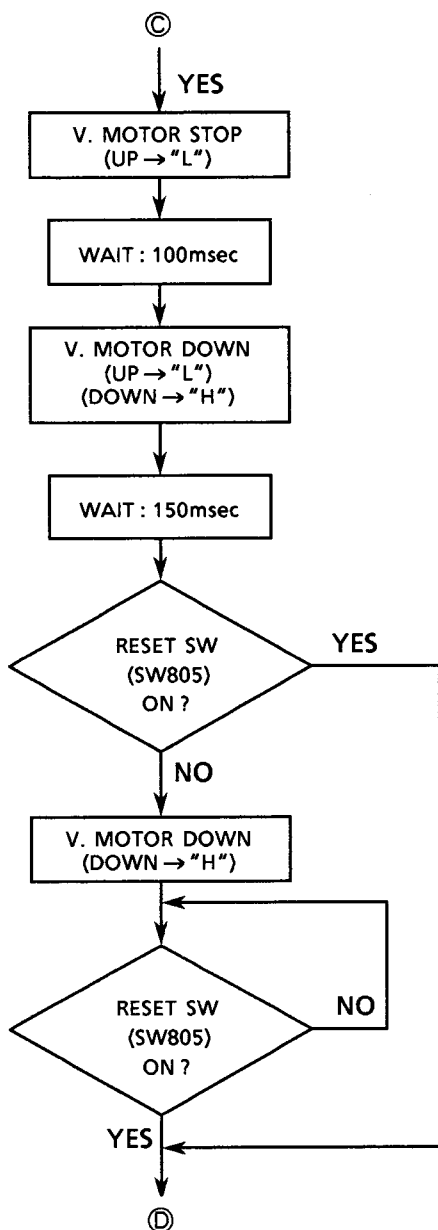

(note) XL-M309TN/ XL-M408BK/XL-M409TN takes 100ms to shift from vertical action to horizontal action and vice versa.

Operation check by each switch.

- SW801 : Single tray open / close detect switch.
When a single tray is ejected, the open signal is "L" and when it is closed, the close signal is "L"
- SW802 : Magazine in switch.
When a magazine is inserted, the switch is turned on.
- SW803 : JAB switch.
When drive plate comes toward, the switch is turned on. (The switch is turned on momentarily.)
- SW803 : Tray load switch.
When the tray of a disc is loaded, the switch is turned on.
- SW804 : UP/DOWN switch.
When the mechanism goes up or down, this sw turns on and off alternately.
- SW805 : Reset switch.
When the mechanism comes to the point under the initial position, the switch is turned on.
- SW805 : Memory switch.
When the power is off in playing a disc, and on again, the switch detects which height the tray should be returned.
- SW807 : Pickup rest switch.
When pickup comes to the initial position, the switch is turned on.

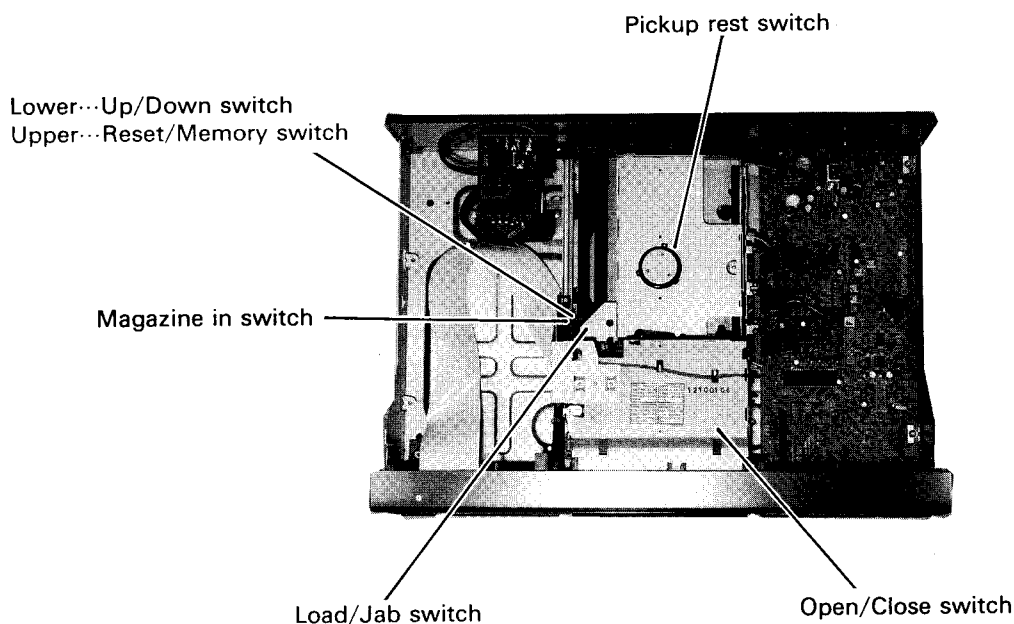

Flow of Functional Operation Until TOC is Read

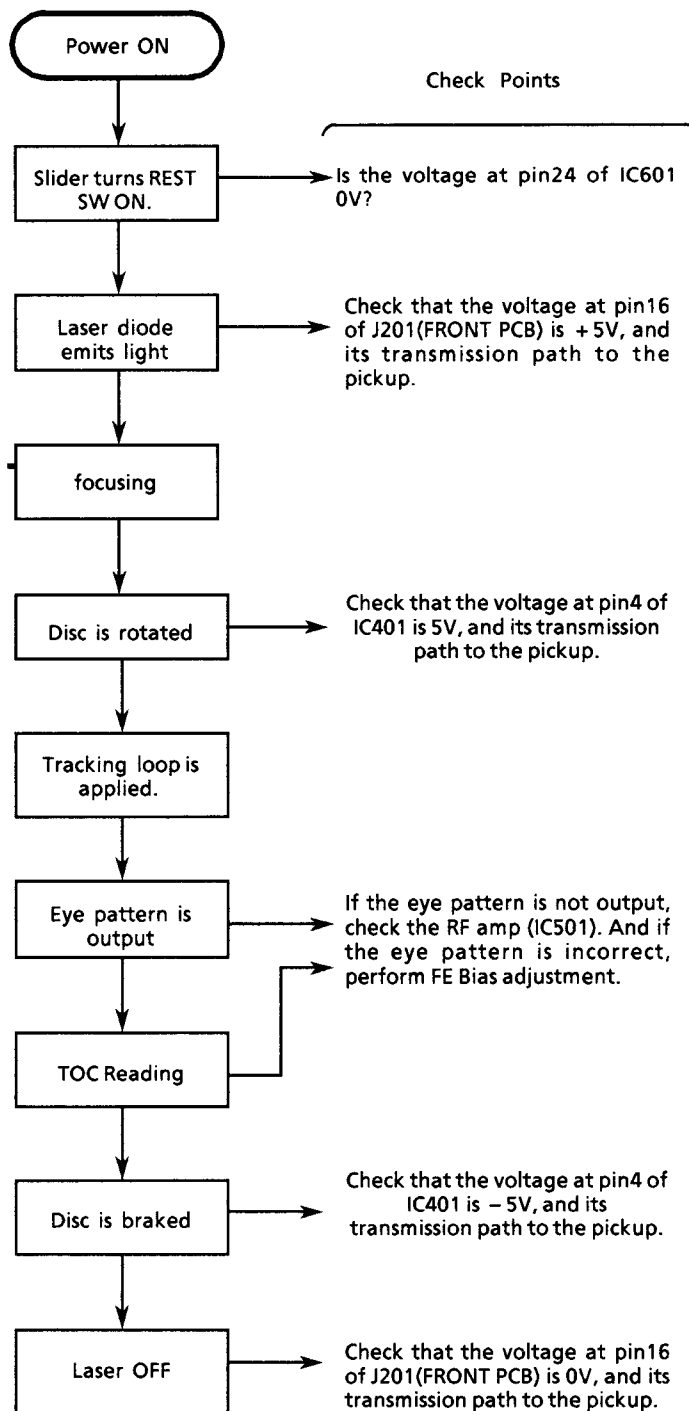
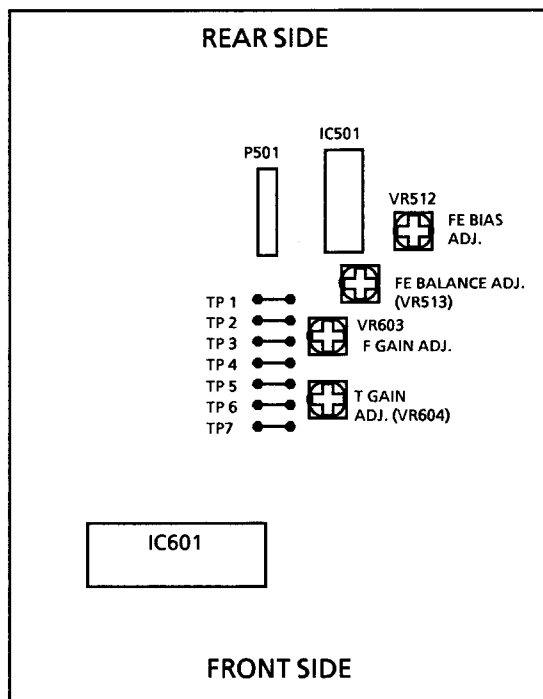
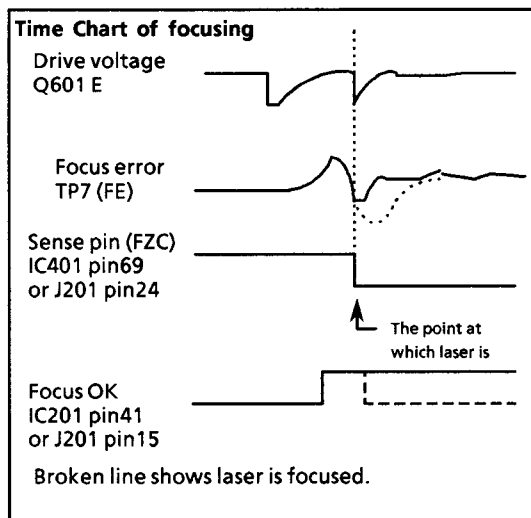

Troubleshooting

The following flowchart shows each circuit's condition about from "power on" until "ready to play".

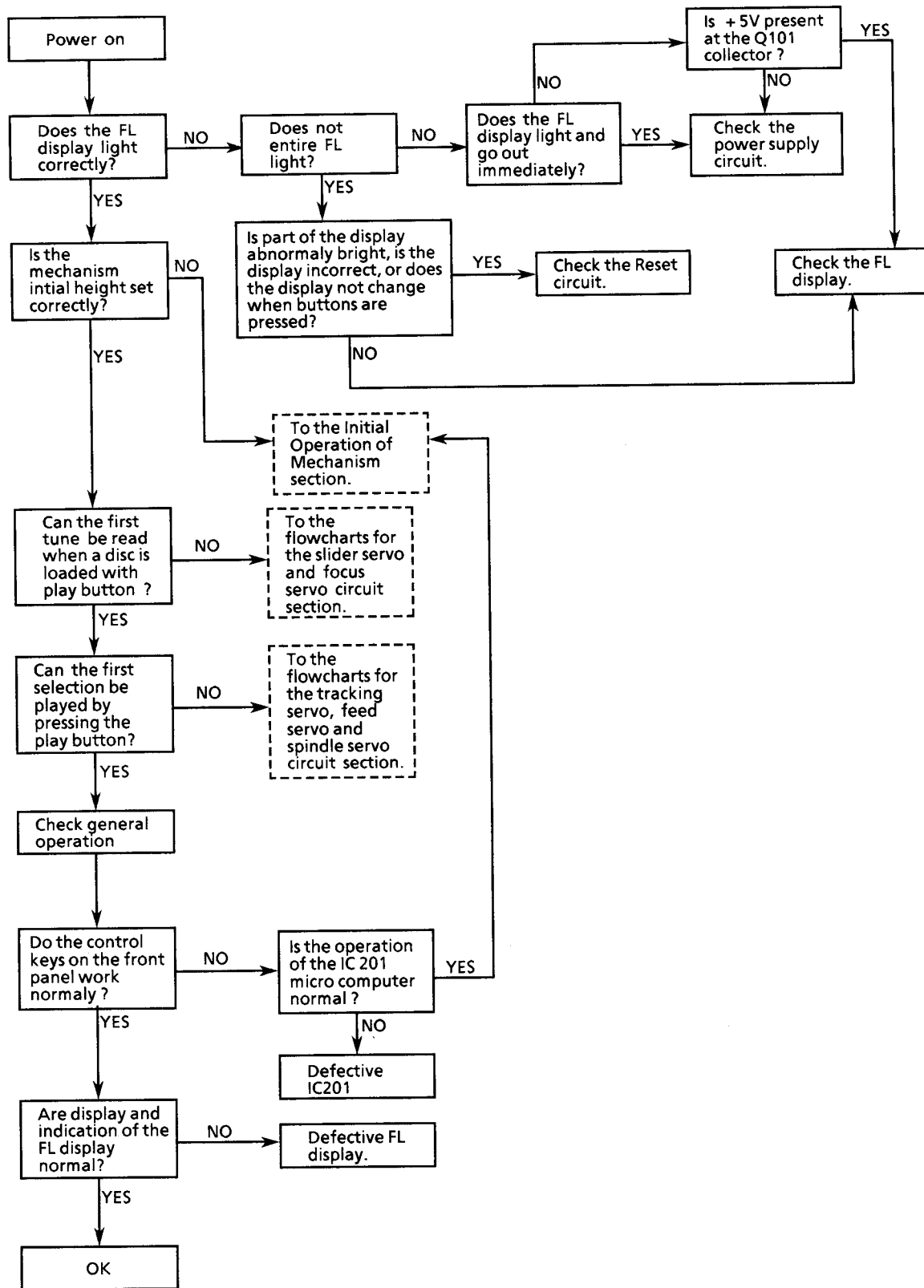

Front Section

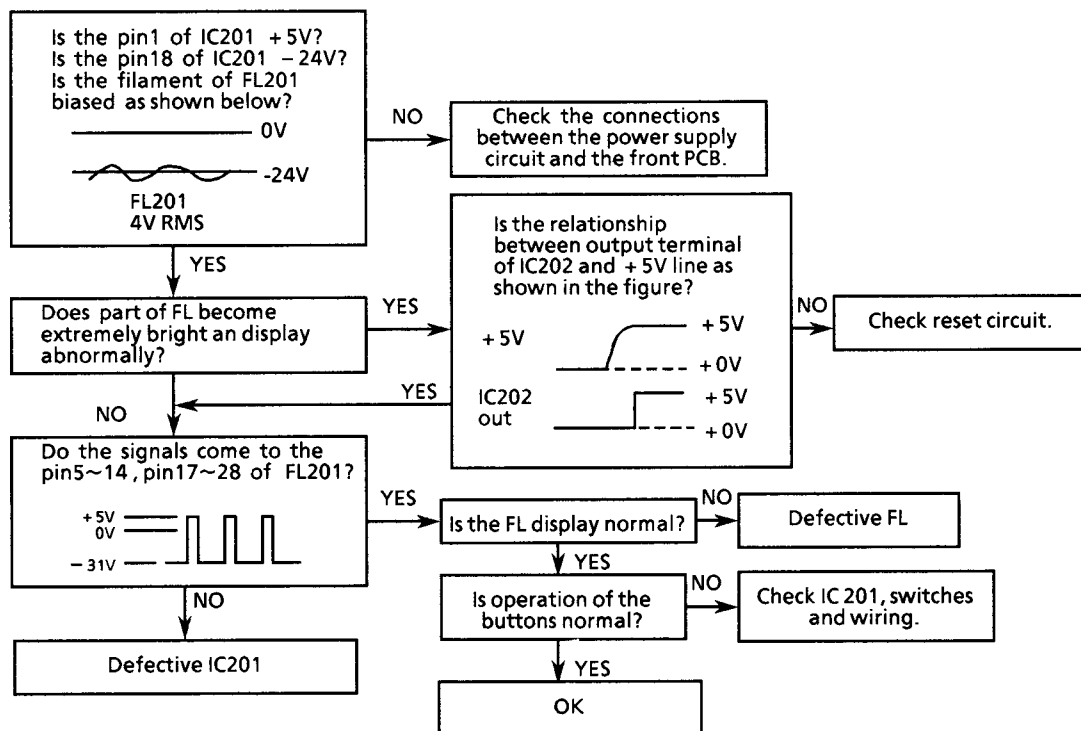

Focus section

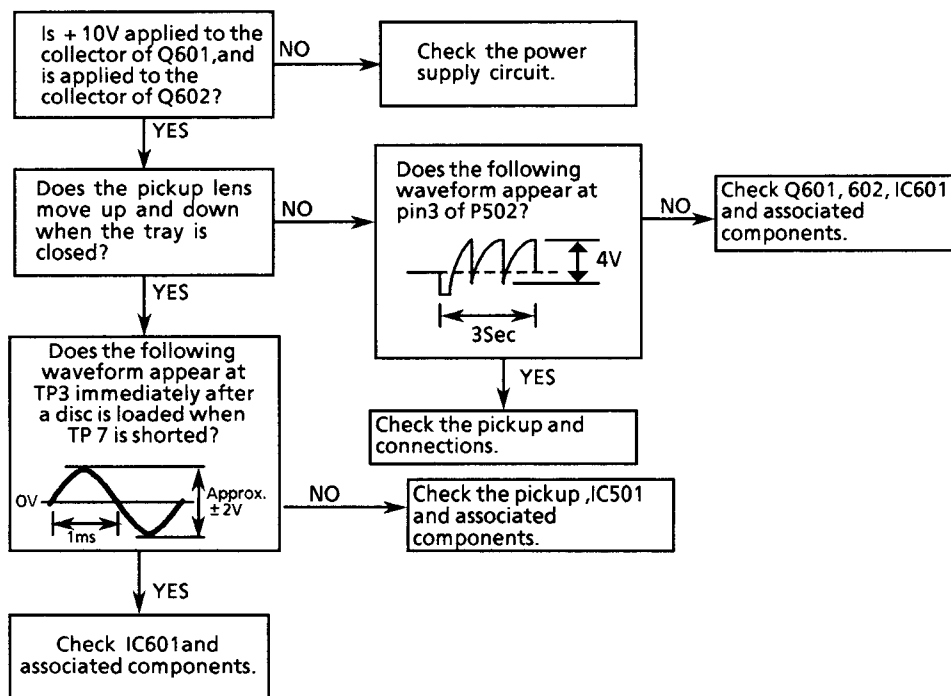

Tracking section

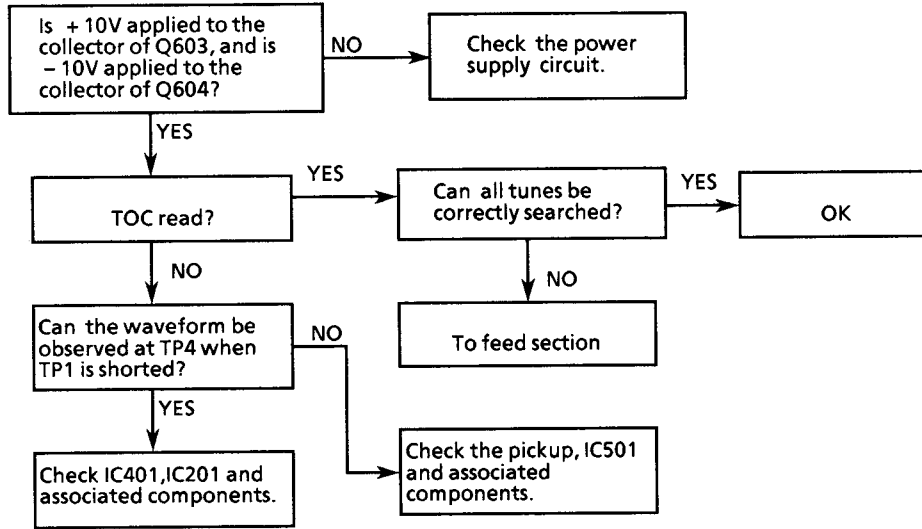

Feed section

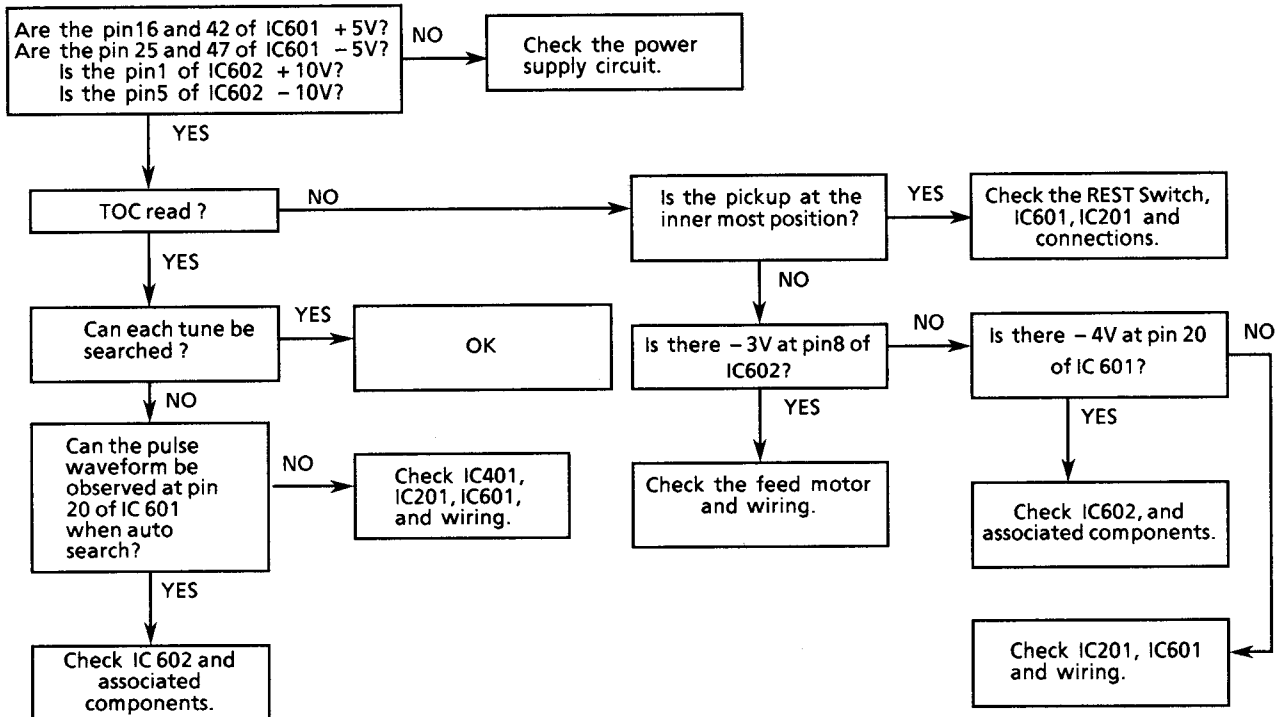

Spindle section

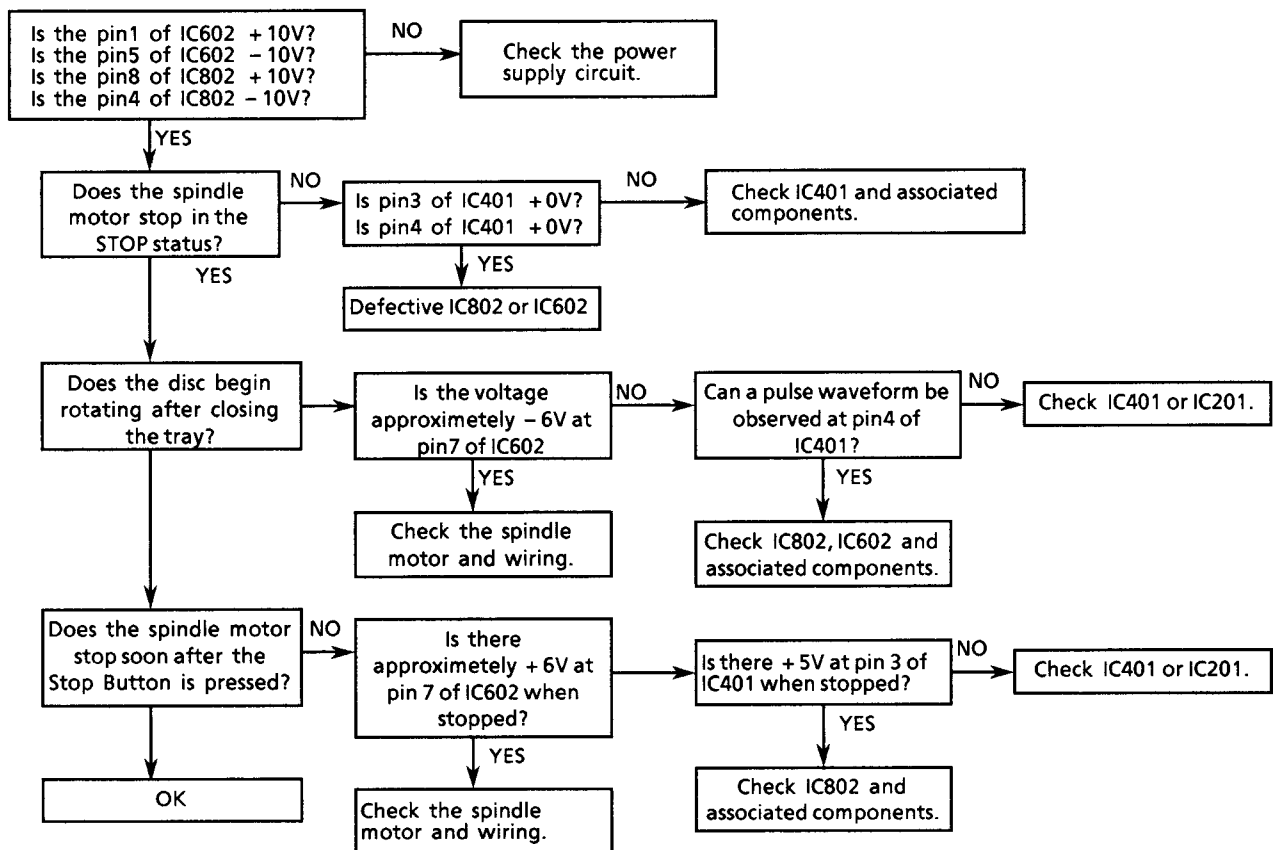

XL-M309TN
XL-M408BK
XL-M409TN

— MEMO —



Block Diagram

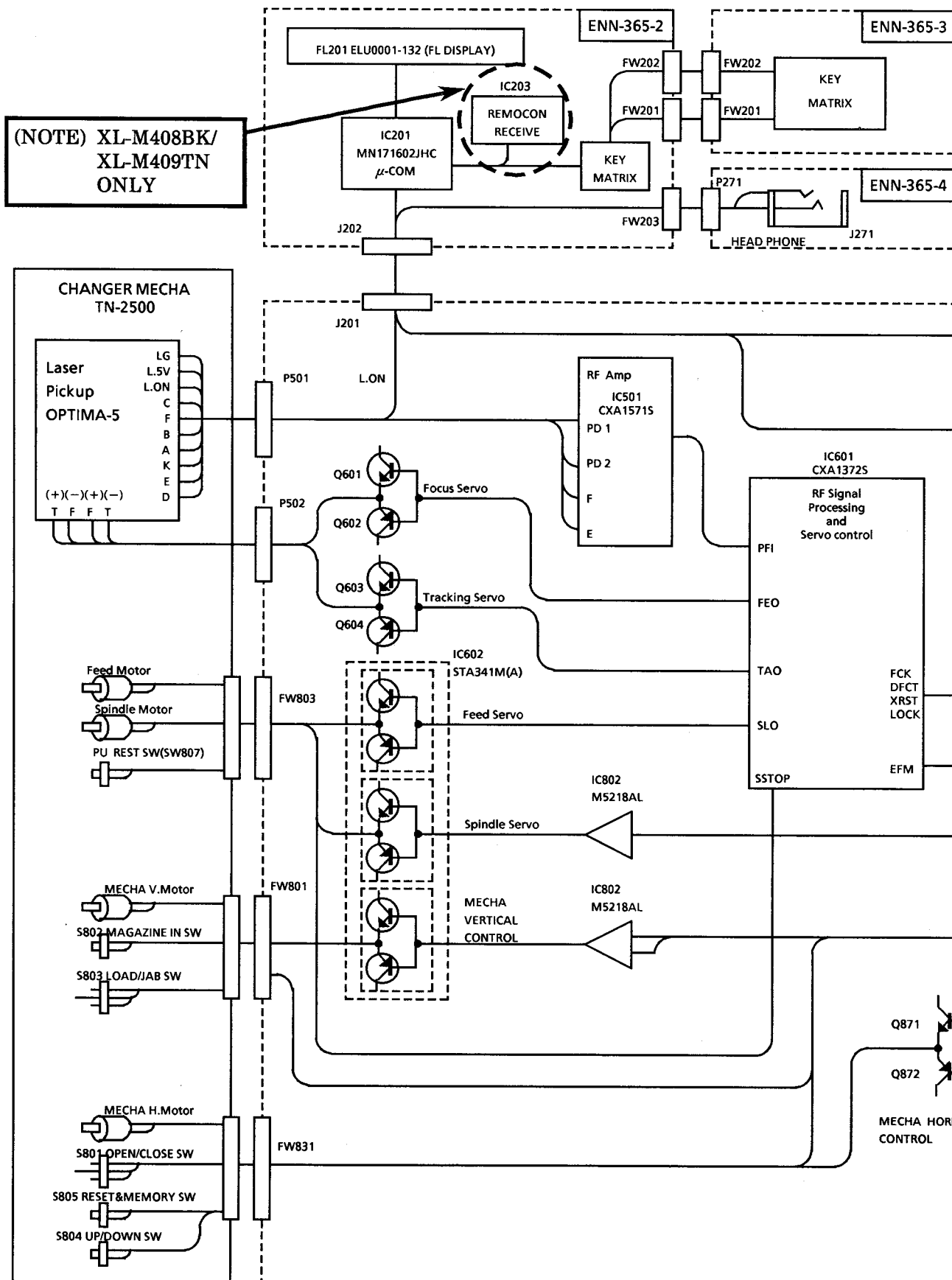

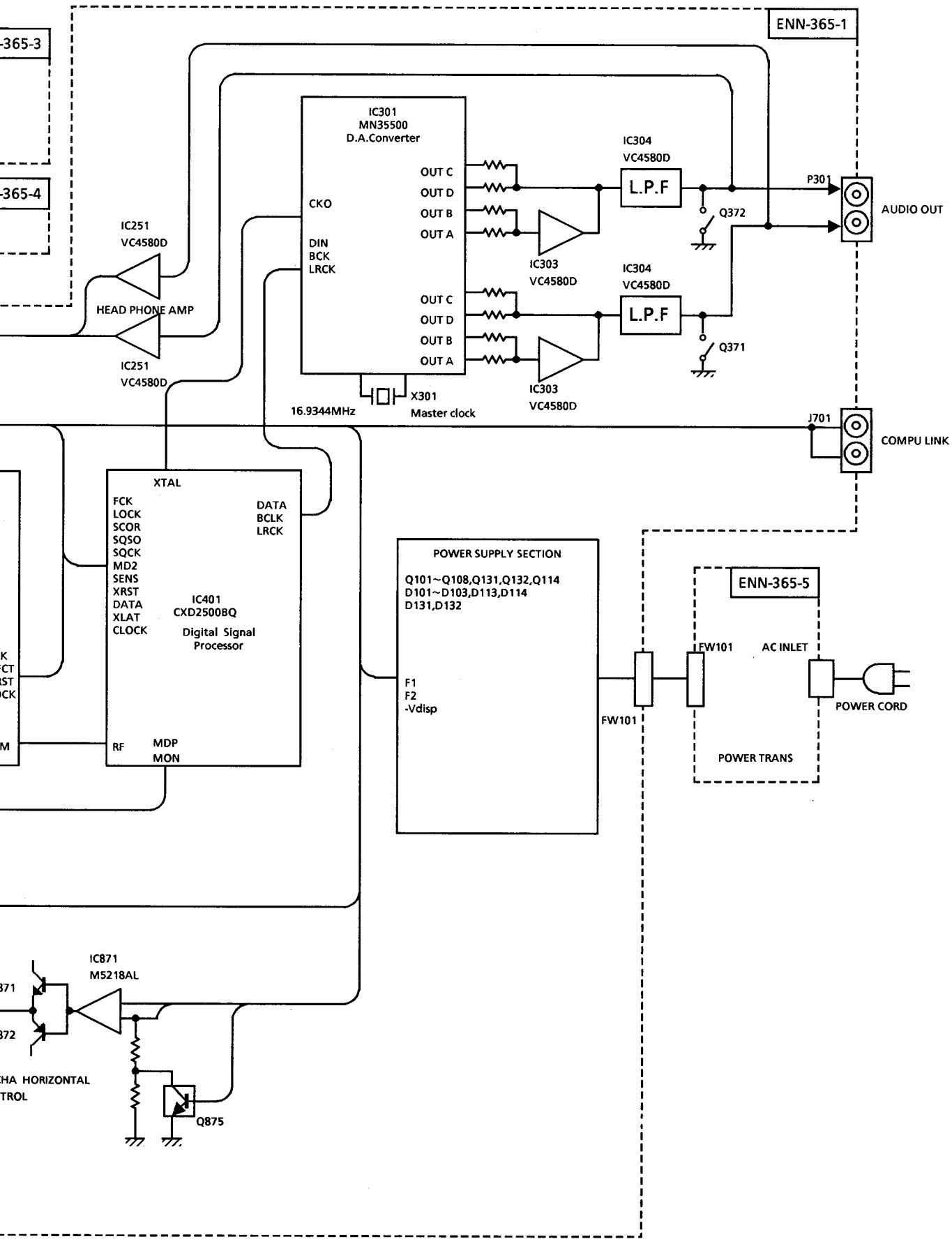

Printed Circuit Boards

■ Main&Front P.C.Board(ENN-365)

XL-M309TN
XL-M408BK
XL-M409TN

XI
XI
XI

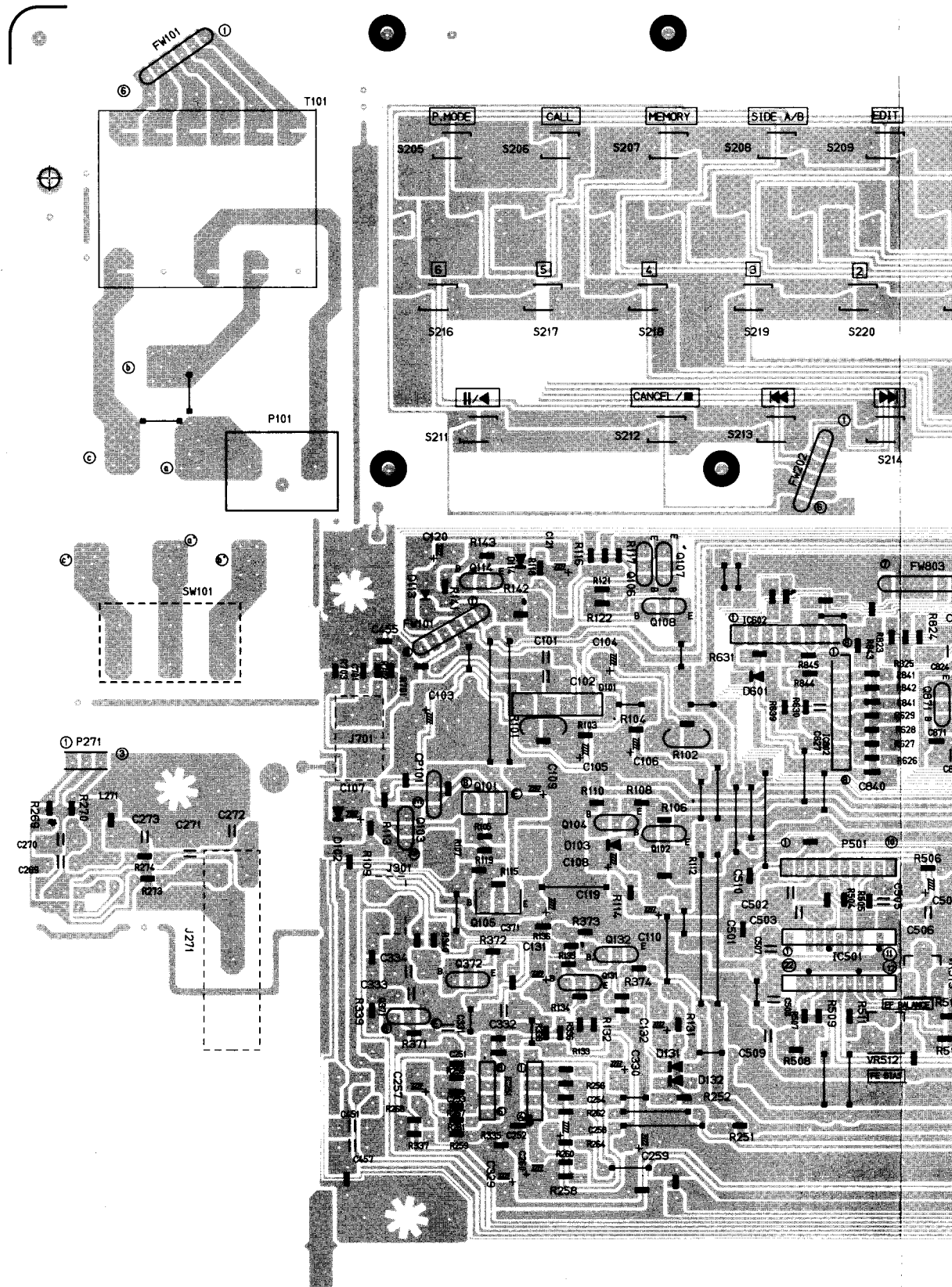

XL-M309TN
XL-M408BK
XL-M409TN

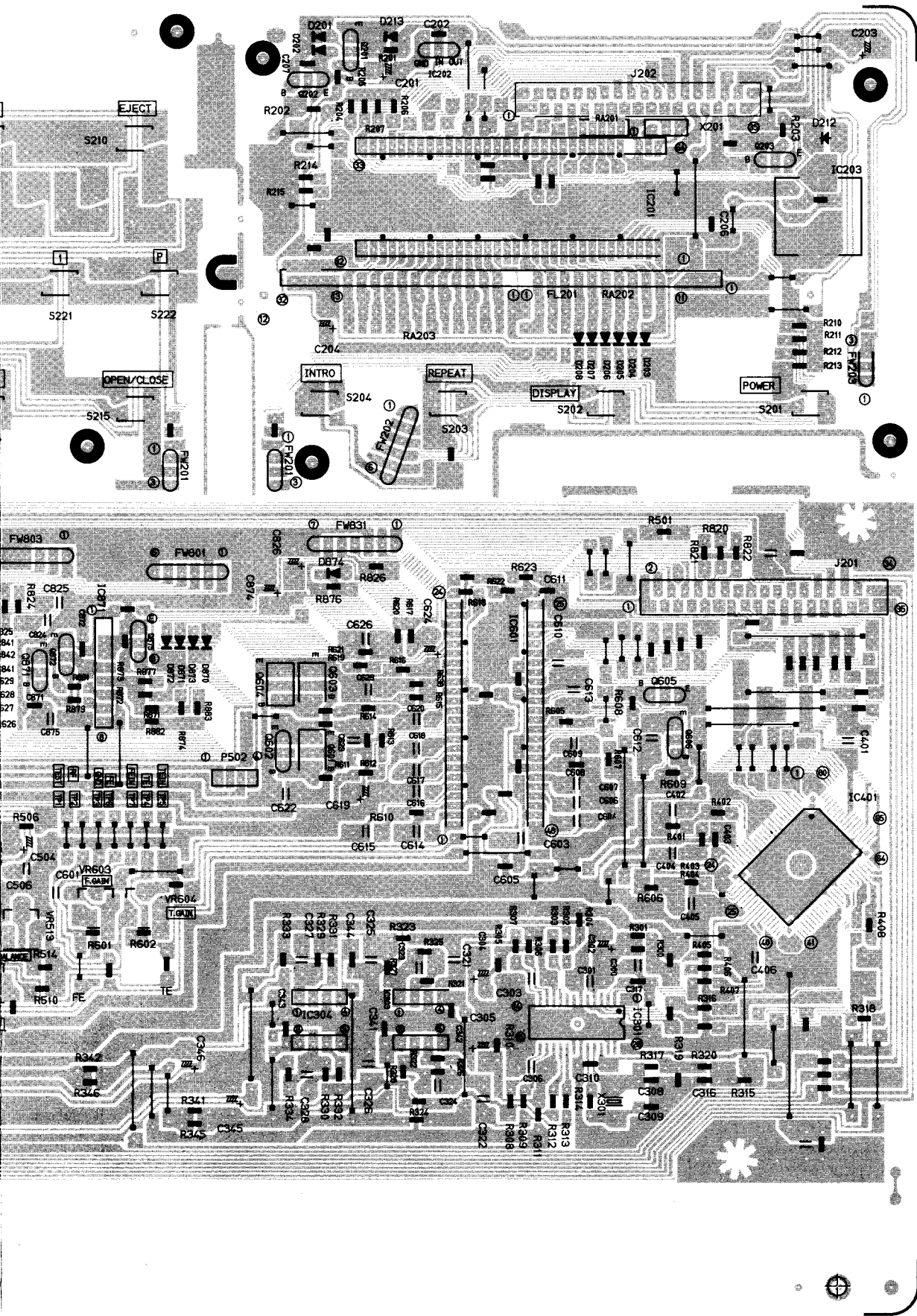

Schematic Diagrams

(1) Main Section

How to Use Schematic Diagrams

1. ——— indicates the +B line.
2. - - - - - indicates the -B line.
3. [Hatched Box] indicates signal path.

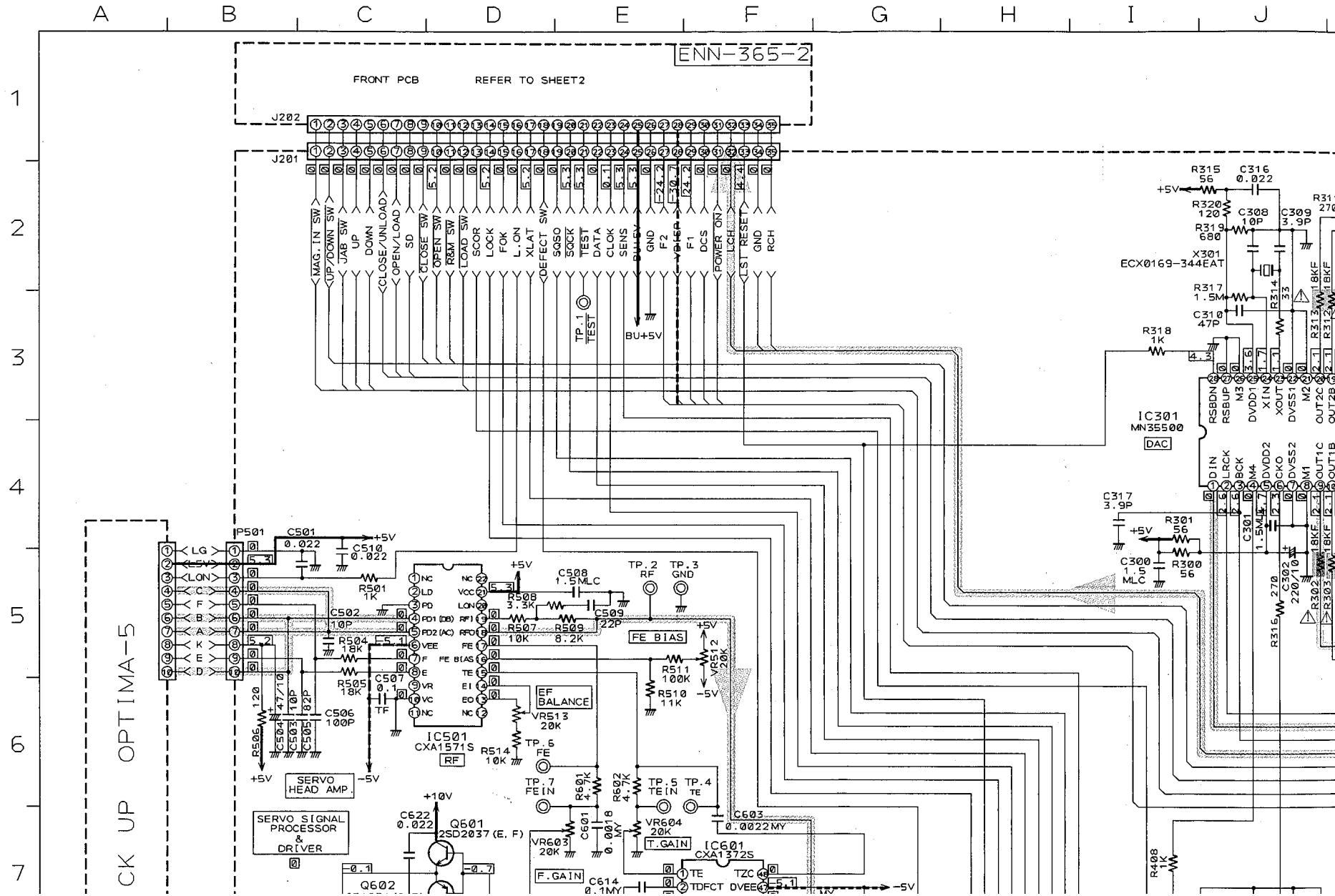

Schematic Diagrams

- ates the +B line.
- ates the -B line.
- ates signal path.
- 4. Parts marked with Δ and those in the shaded area are parts for safety.
- Be sure to use one with the specified part number.
- 5. This is the standard circuit diagram. The circuits and circuit constants are subject to change for improvement without notice.

I J K L M N O P Q R S T

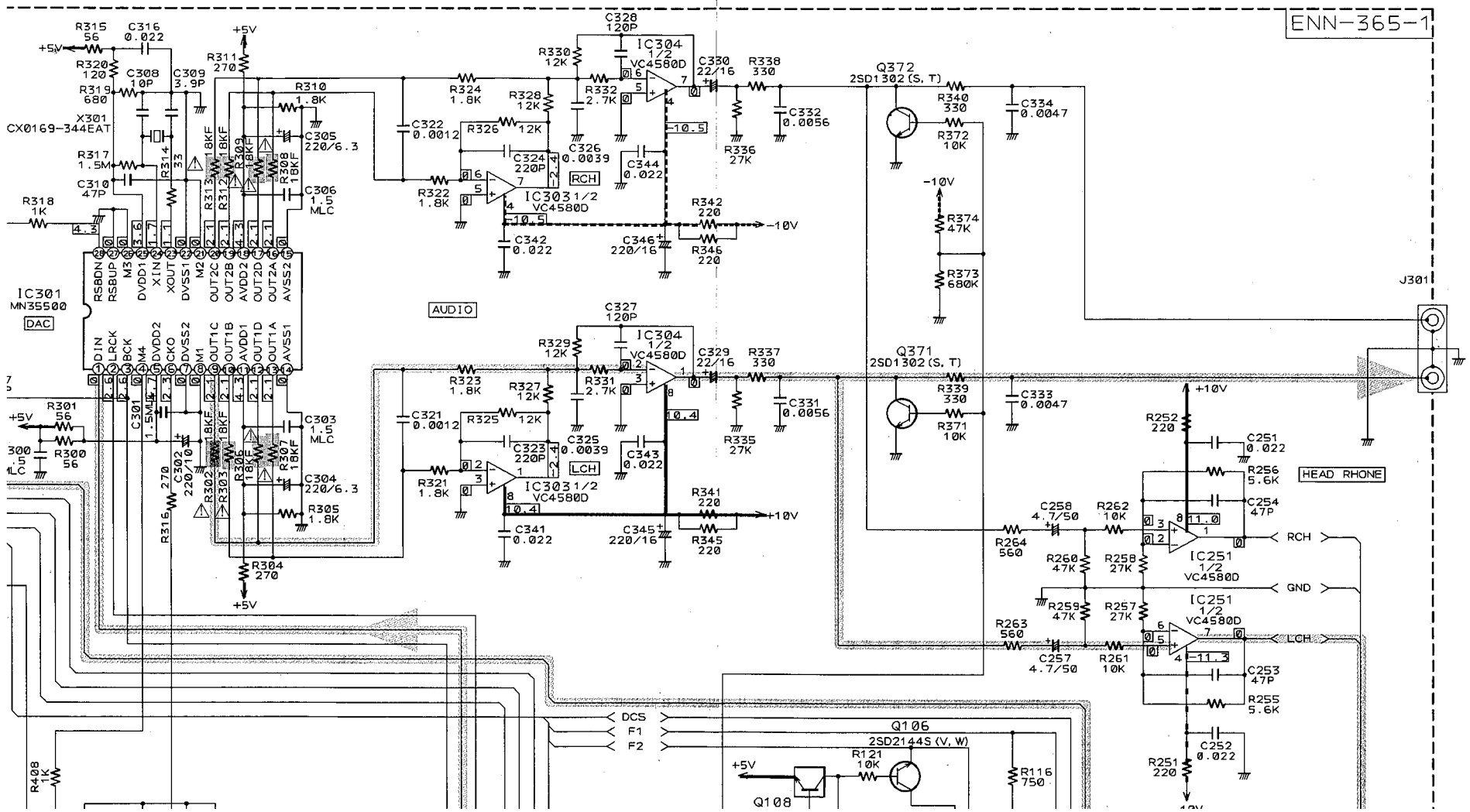

8

9

10

11

12

13

14

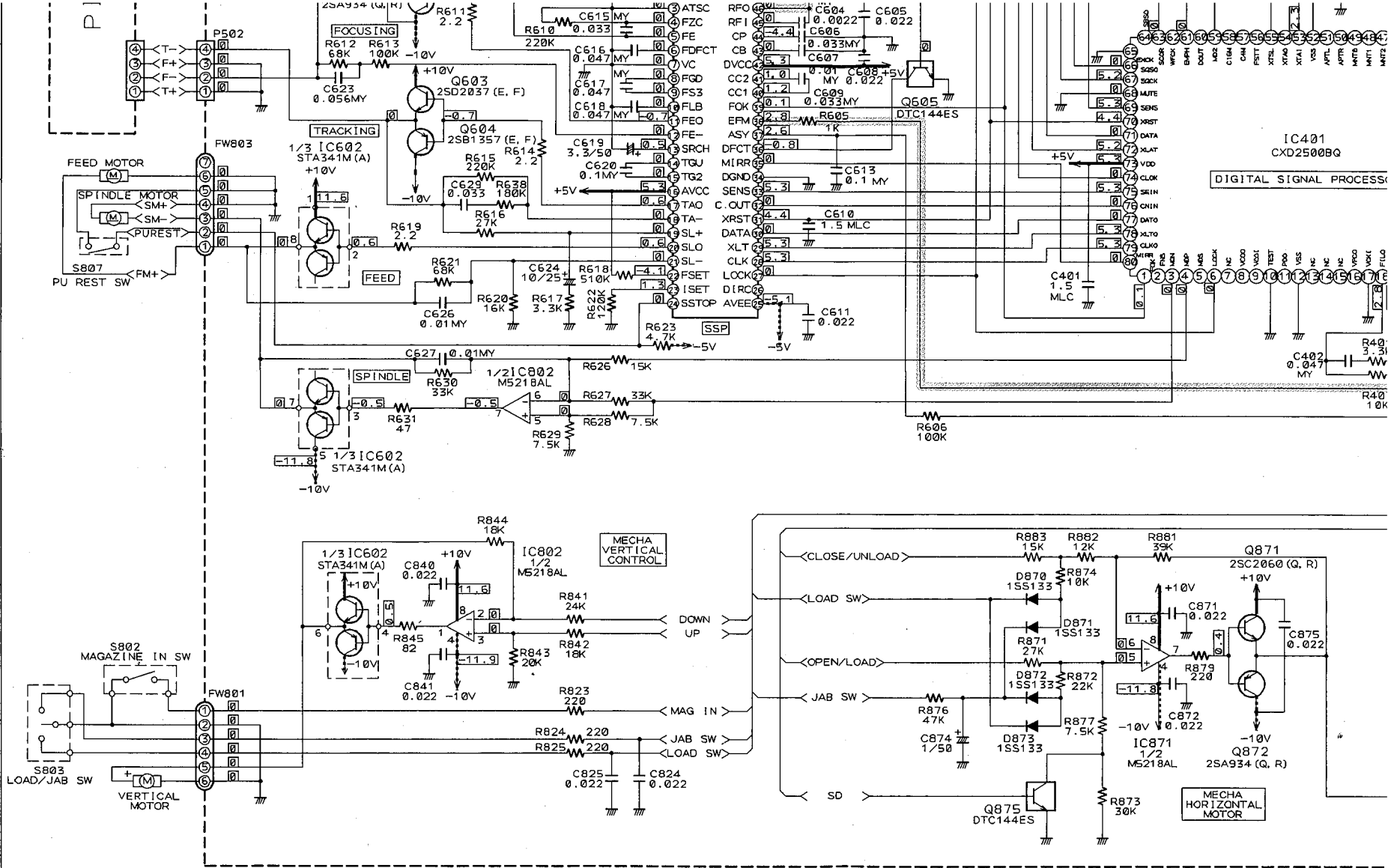

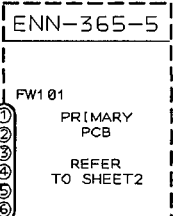
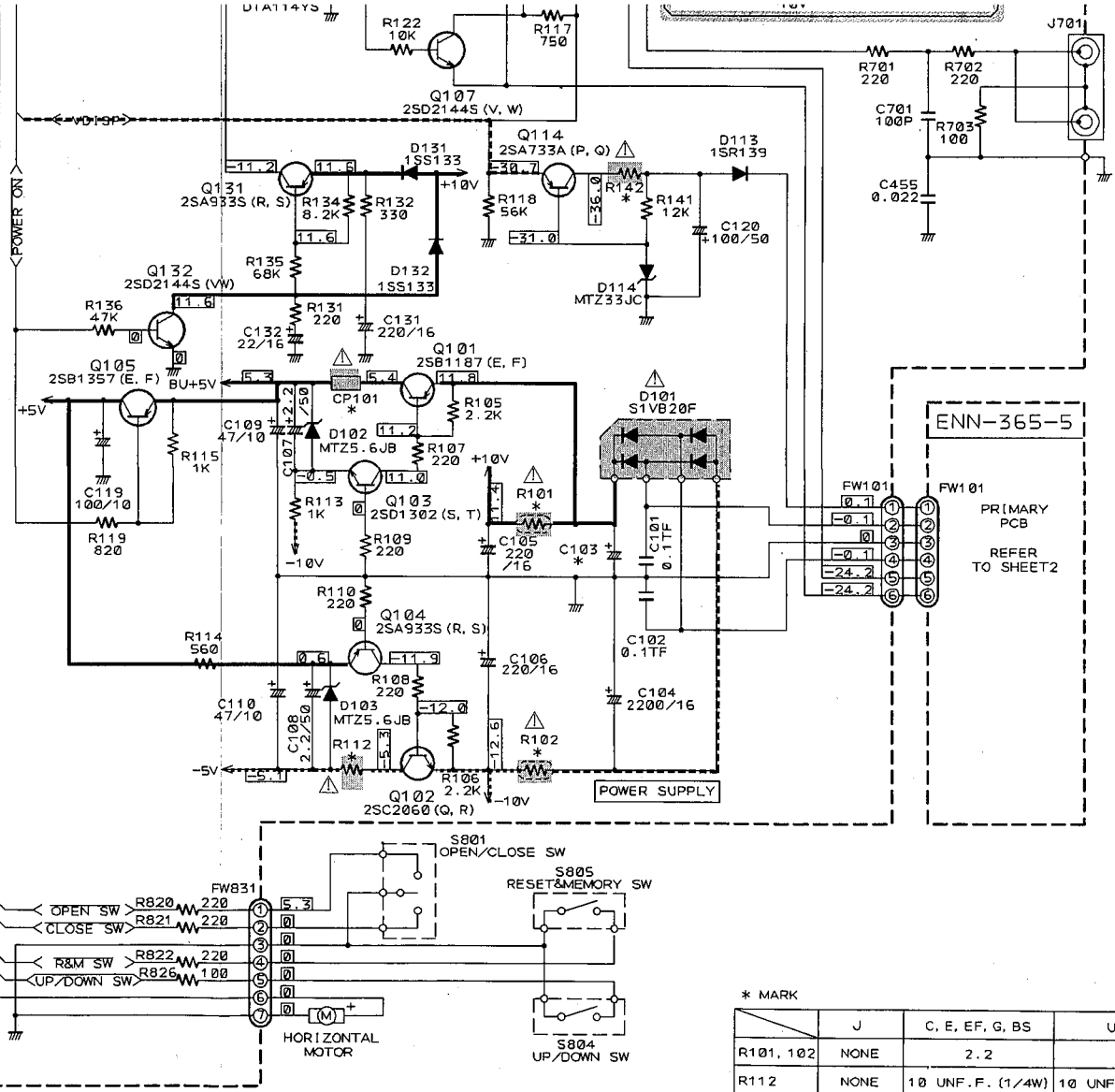
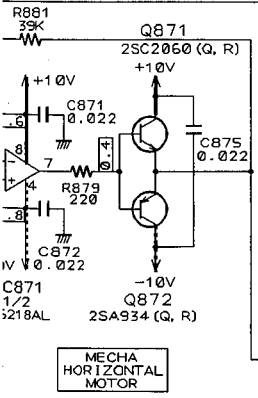
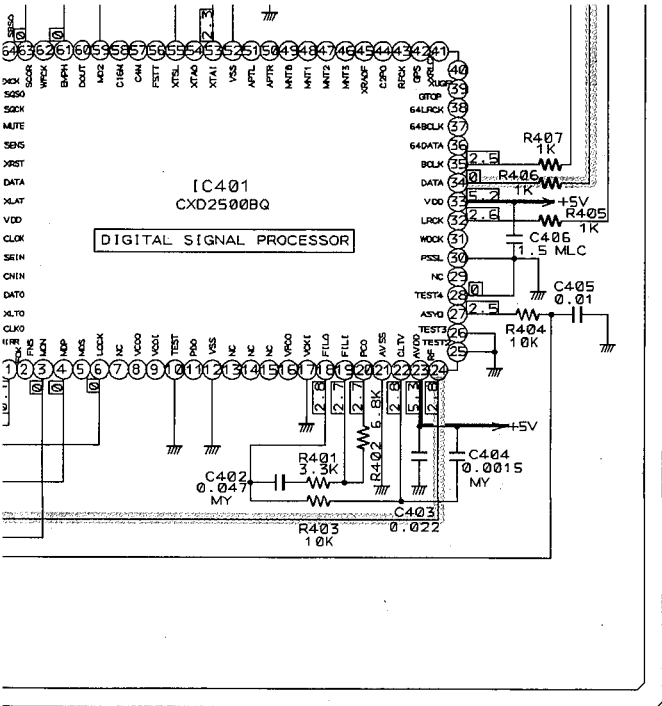

* MARK

	J	C, E, EF, G, BS	U, UT
R101, 102	NONE	2.2	2.2
R112	NONE	10 UNF.F. (1/4W)	10 UNF.F. (1/4W)
CP101	NONE	ICP-N5	ICP-N5
R142	NONE	56 UNF.F. (1/4W)	56 UNF.F. (1/4W)
C103	2200/16	2200/16	3300/16

(2) Front Section

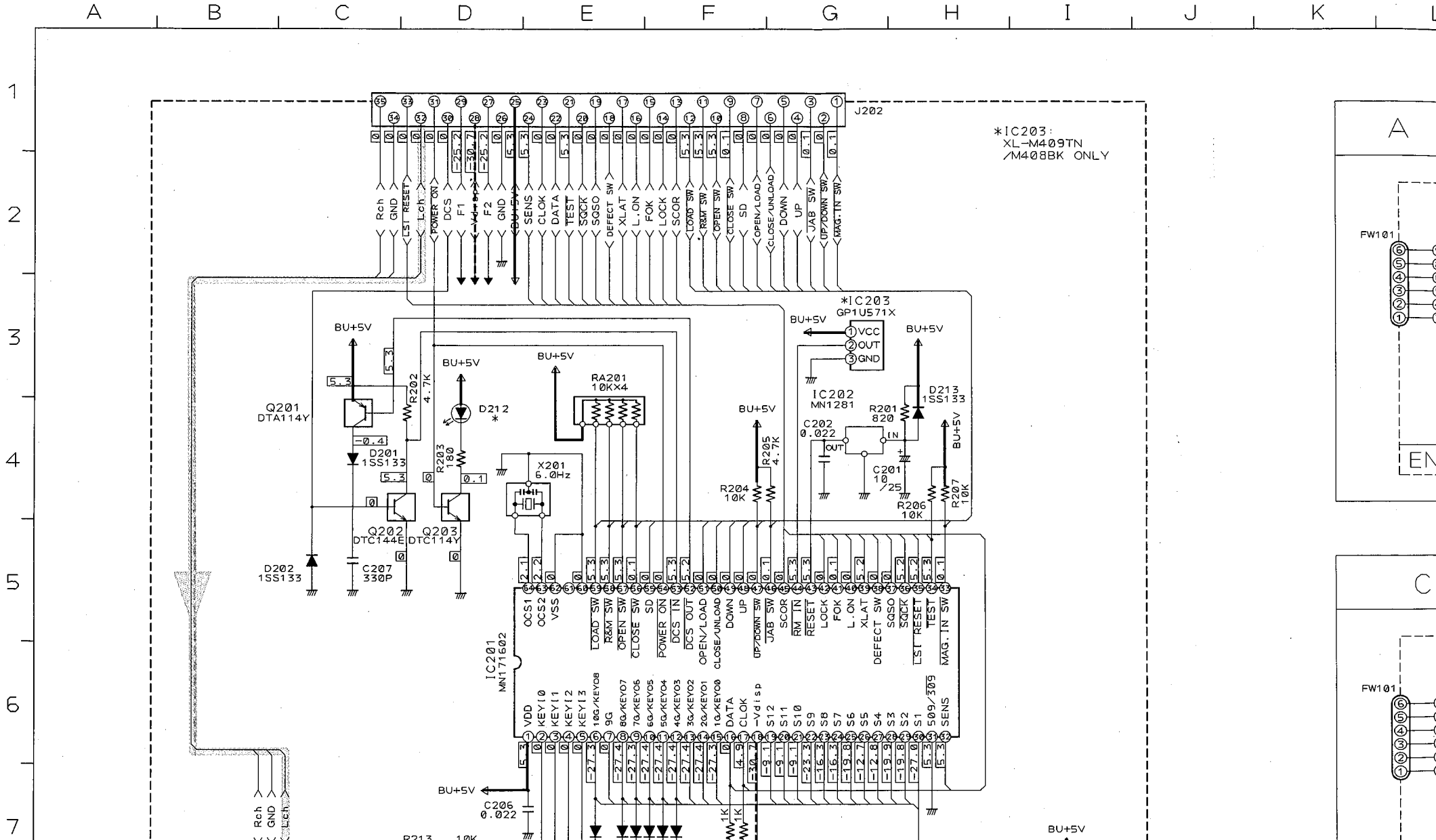

A (FOR AUSTRALIA)

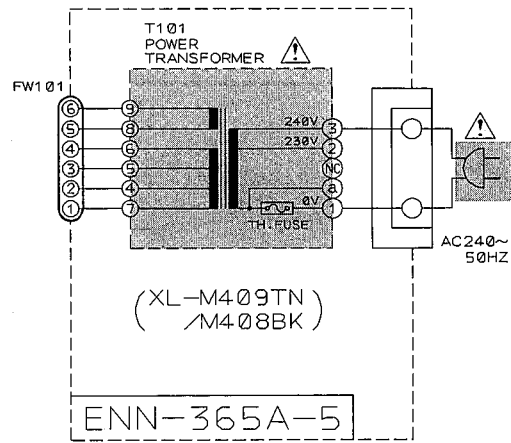

BS (FOR U.K.)

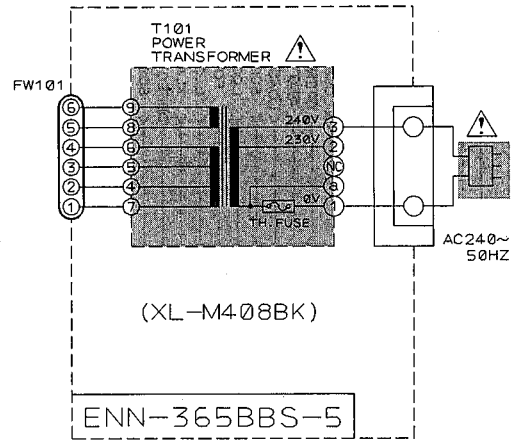

C (FOR CANADA)

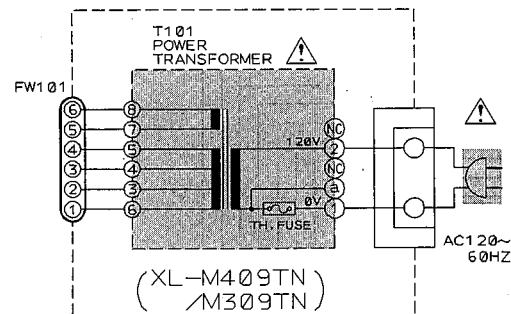

J (FOR U.S.A.)

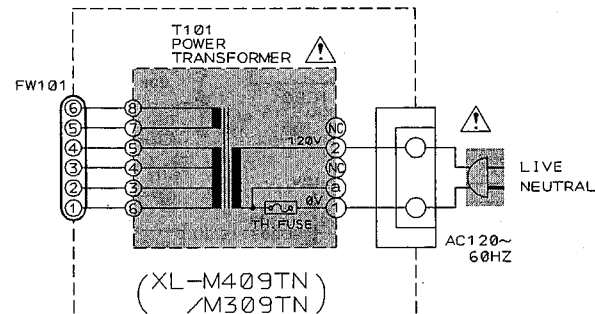

8
9
10
11
12
13
14

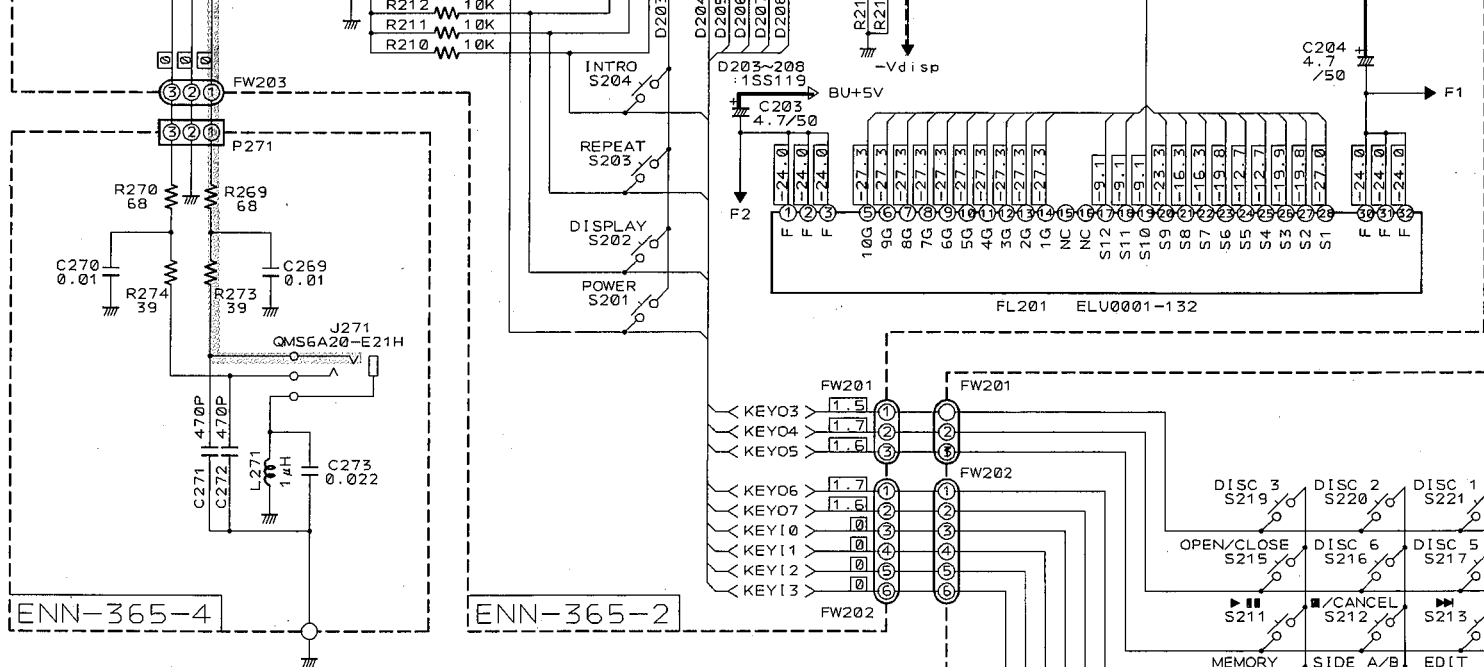

ENN-365-4

ENN-365-2

* MARK

	BS	OTHER
D212	SLA-580 LT70F124	SLH-56 VC70F130

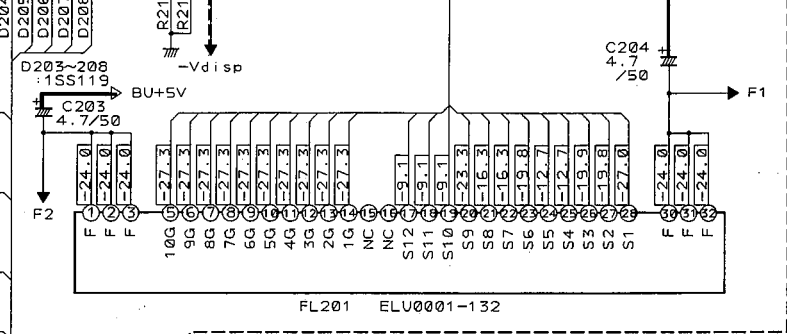

FL201 ELU0001-132

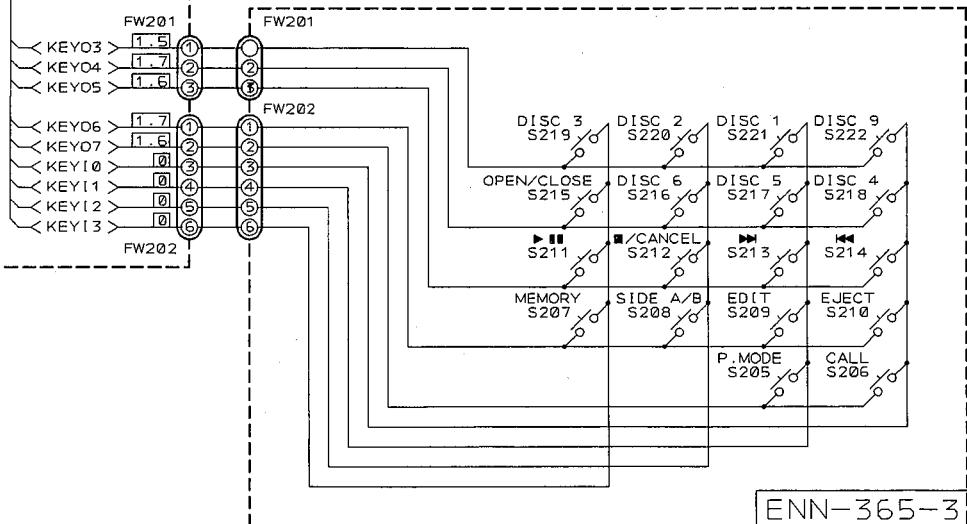

ENN-365-3

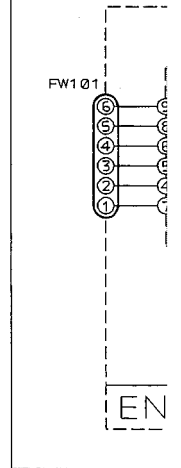
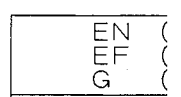
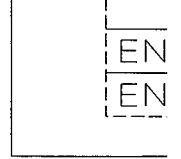

A, BS,

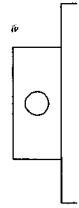

ENN-365C-5

ENN-365H-5

ENN-365D-5

ENN-365G-5

EN (FOR SCANDINAVIA)
EF (FOR CONTINENTAL EUROPE)
G (FOR GERMANY)

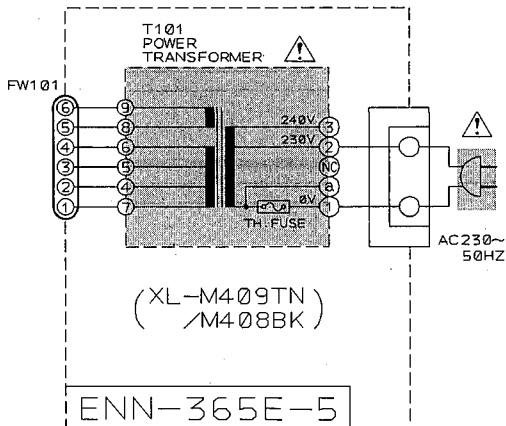

U (FOR OTHER AREAS)
UT (FOR TAIWAN)

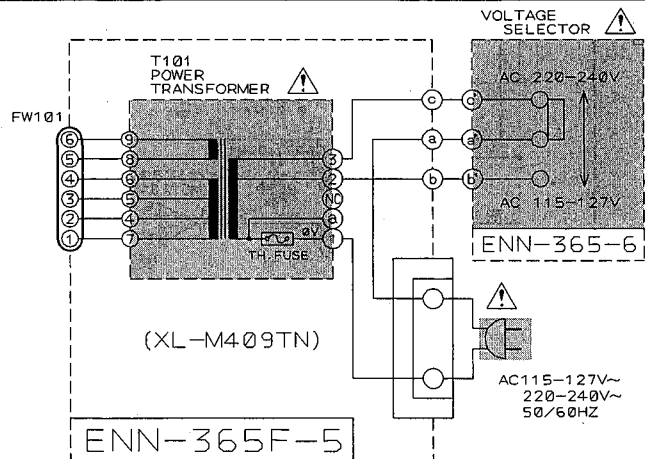

A, BS, EN, EF, U, UT, G

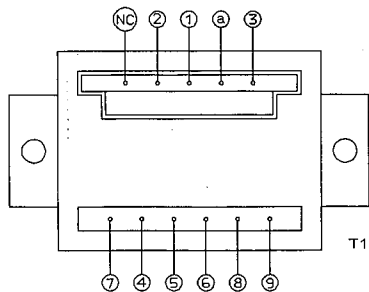

T101 POWER TRANSFORMER
(BOTTOM VIEW)

C, J

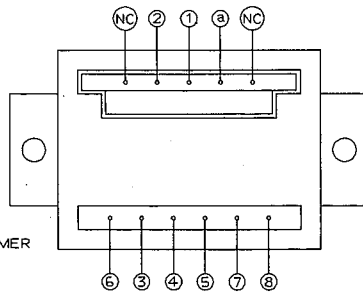

Exploded View of Assemblies and Application points for Grease

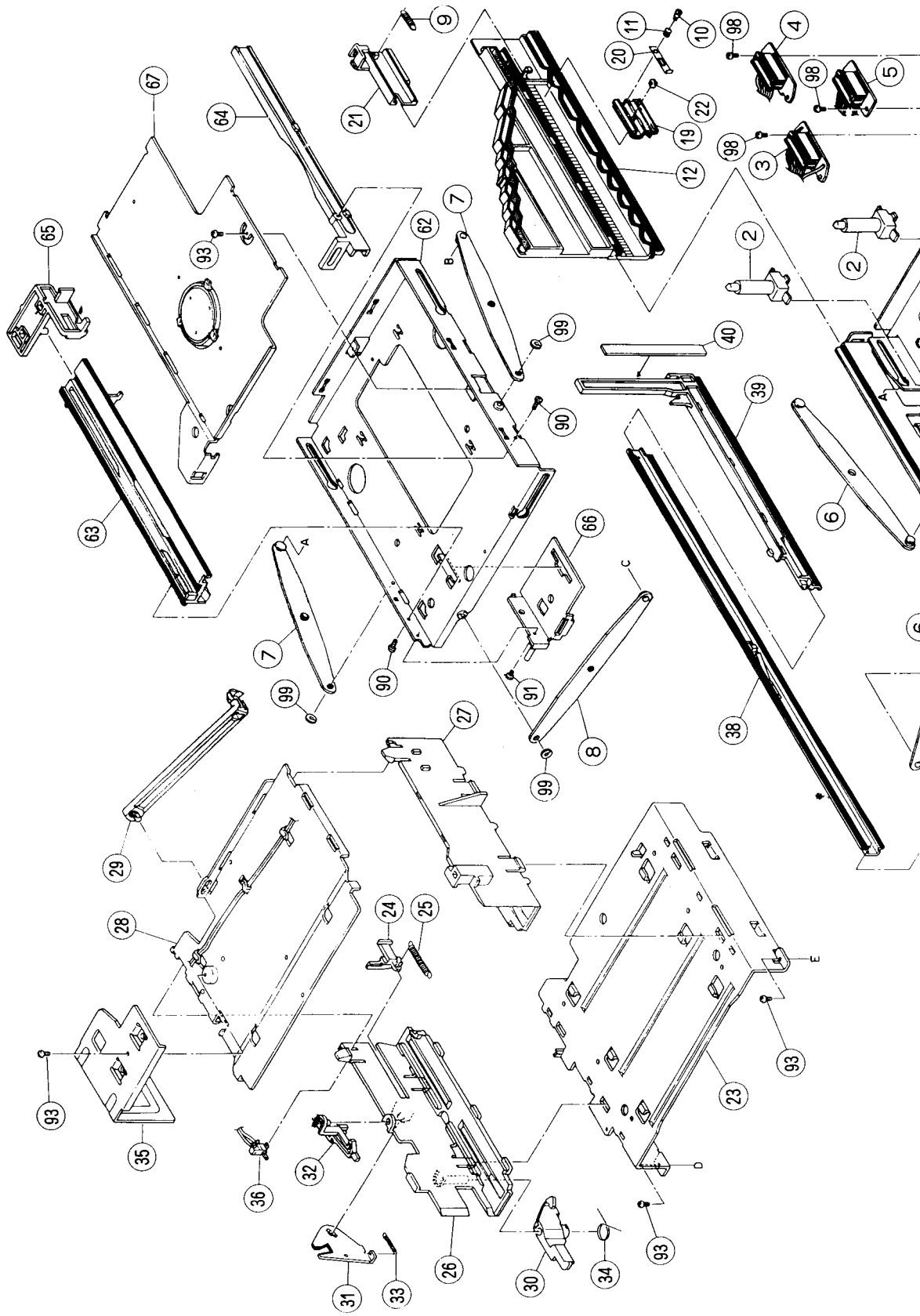

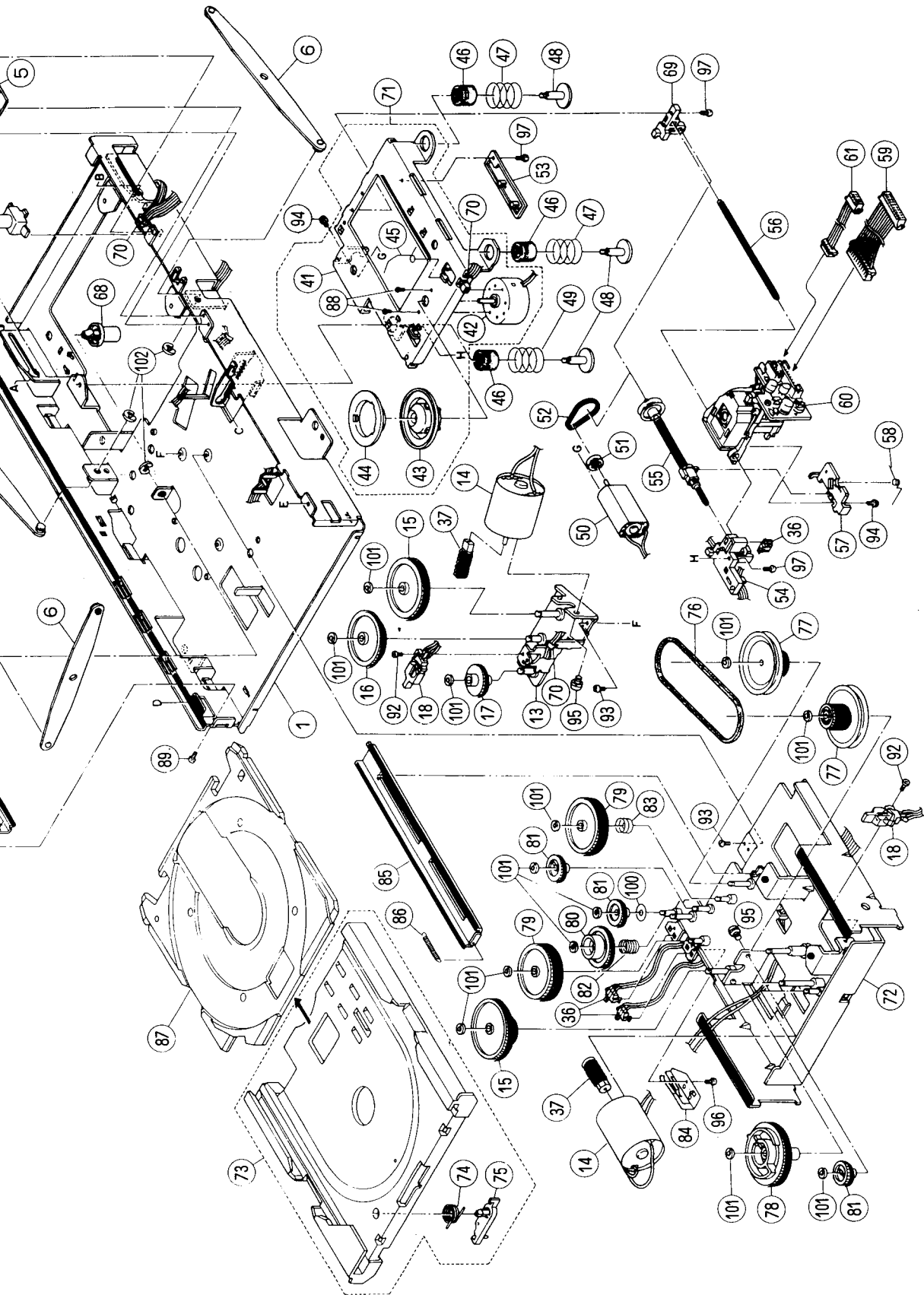





PARTS LIST

※ All printed circuit board assemblies are not available as service parts.

Contents

General Exploded View and Parts List	2-2
CD Changer Ass'y and Parts List	2-5
■ How to install the gears and pulley when servicing	2-10
Printed Circuit Board Ass'y and Parts List	2-11
■ ENN-365 □ Main & Front PC Board Ass'y	2-11
Accessories List	2-15
Packing Materials and Part Numbers	2-16

General Exploded View and Parts List

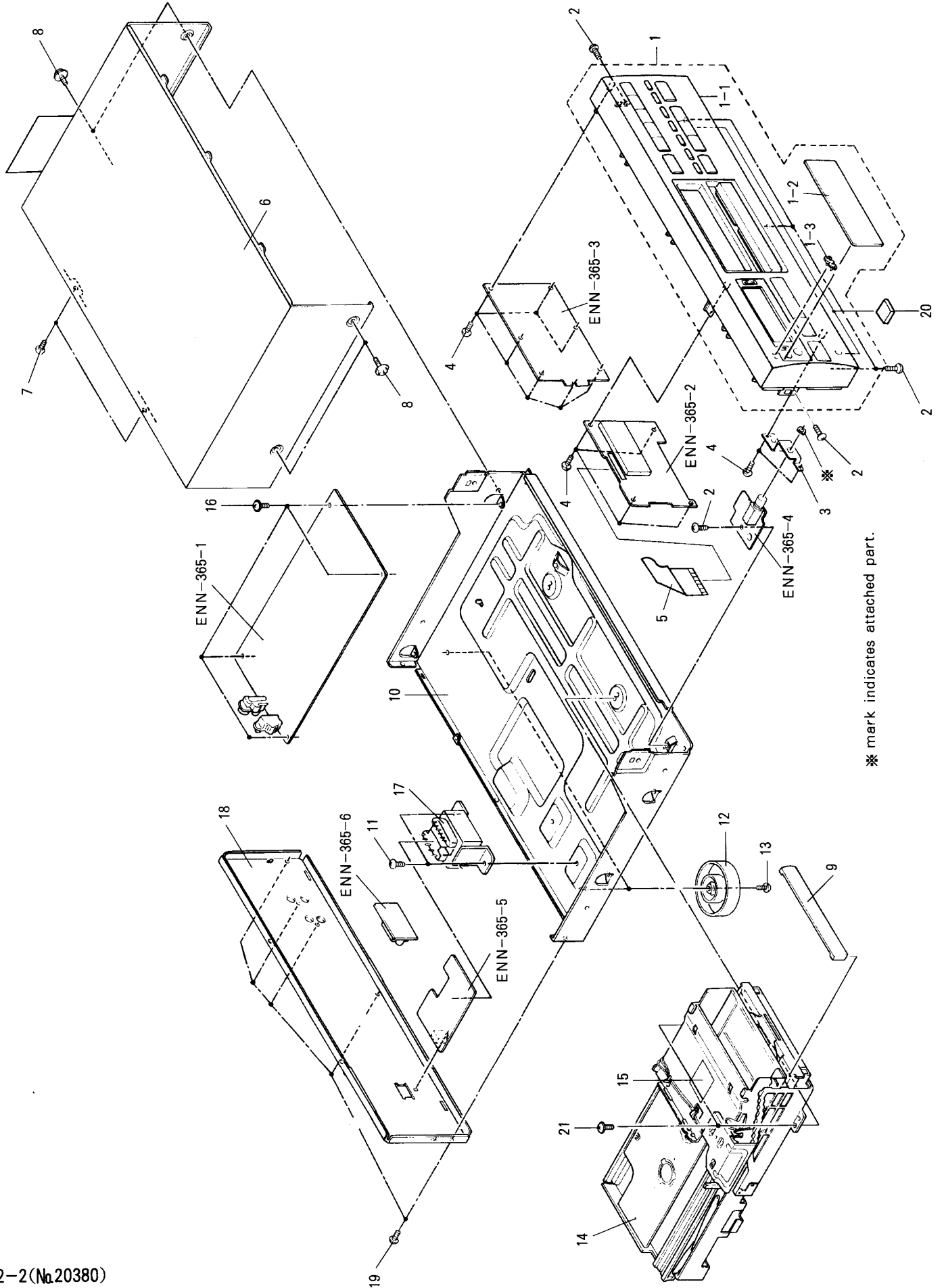

■ Parts List

△	Item	Part Number	Part Name	Q'ty	Description	Area
	1	EFP-XLM408BKE(S)	FRONT PANEL ASS'Y	1		
	1-1	E102653-009	FRONT PANEL	1		
	1-2	E308282-002	WINDOW SCREEN	1		
	1-3	E72968-001	JVC MARK	1		
	2	SDSG3006M	SCREW	6		
	3	E308284-001	HEADPHONE BRACKET	1		
	4	SDSF2608Z	SCREW	13		
	5	EWR135K-42TT	FLAT WIRE	1		
	6	E25834-006	METAL COVER	1		
	7	SBSG3008M	SCREW	2		
	8	E406308-001	SPECIAL SCREW	4		
	9	E308285-002	CD FITTING	1		
	10	E102650-001	CHASSIS BASE	1		
	11	E65389-004	SPECIAL SCREW	2	FOR POWER TRANS	
	12	E406472-004	FOOT ASSY	2		
	13	SBST3008Z	SCREW	2		
	14	-----	CD CHANGER MECHANISM UNIT ASS'Y	1	SEE PAGE 2-7	
	15	E406507-001	CAUTION LABEL	1		A
	15	E406507-001	CAUTION LABEL	1		BS
	15	E406507-001	CAUTION LABEL	1		EF
	15	E406507-001	CAUTION LABEL	1		EN
	15	E406507-001	CAUTION LABEL	1		G
	16	GBSG3008CC	SCREW	4		
△	17	ETP1010-51EA	POWER TRANSFORMER	1		A
△	17	ETP1010-51EA	POWER TRANSFORMER	1		EF
△	17	ETP1010-51EA	POWER TRANSFORMER	1		EN
△	17	ETP1010-51EA	POWER TRANSFORMER	1		G
△	17	ETP1010-51EABS	POWER TRANSFORMER	1		BS
	18	E207686-006	REAR PANEL	1		A
	18	E207686-006	REAR PANEL	1		BS
	18	E207686-006	REAR PANEL	1		EF
	18	E207686-006	REAR PANEL	1		EN
	18	E207686-005	REAR PANEL	1		G
		E308453-007	RATING LABEL	1		EF,EN
		E308453-008F	RATING LABEL	1		G
	19	E73273-006	SPECIAL SCREW	6		
	20	E75896-001	SPACER	2	FRONT FOOT	
	21	SBST3006M	SCREW	2		
	-	E61029-005	NUMBER LABEL	1		A
	-	E61029-005	NUMBER LABEL	1		BS
	-	E61029-005	NUMBER LABEL	1		EF
	-	E61029-005	NUMBER LABEL	1		EN
	-	E61029-005	NUMBER LABEL	1		G
	-	E70891-001	LABEL	1		A
	-	E70891-001	LABEL	1		EF
	-	E70891-001	LABEL	1		EN
	-	E70891-001	LABEL	1		BS
	-	E70891-001	LABEL	1		G
	-	QZL1031-101	LABEL	1		EF
	-	E70027-001	LABEL	1		EN
	-	E307570-001	NUMBER LABEL	1		J
	-	E70491-002F	LABEL	1		G

The Marks for Designated Areas

G Germany A Australia BS the U.K.
 EN Scandinavia EF Continental Europe

No mark indicates all area.

— MEMO —

CD Changer Ass'y and Parts List

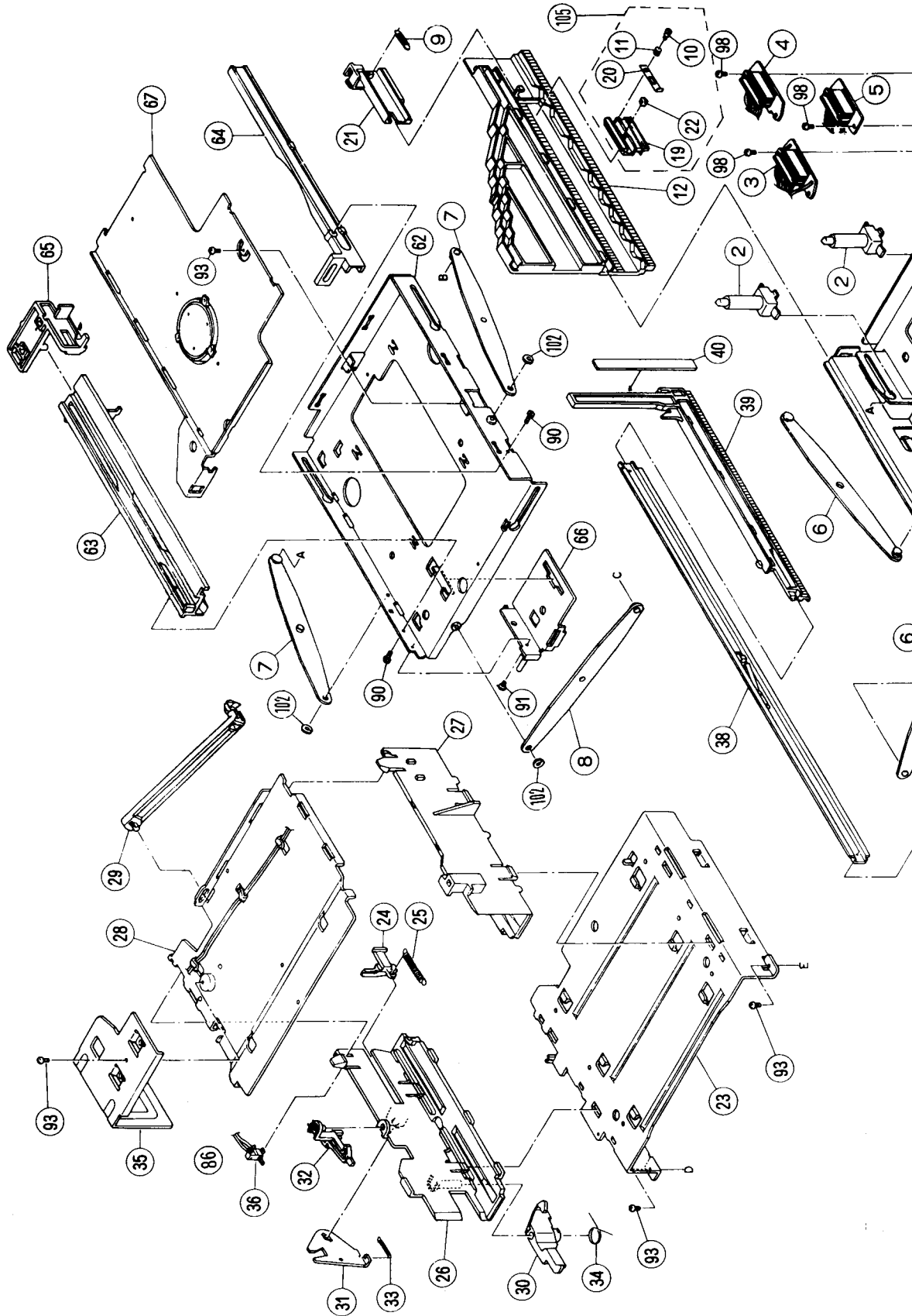

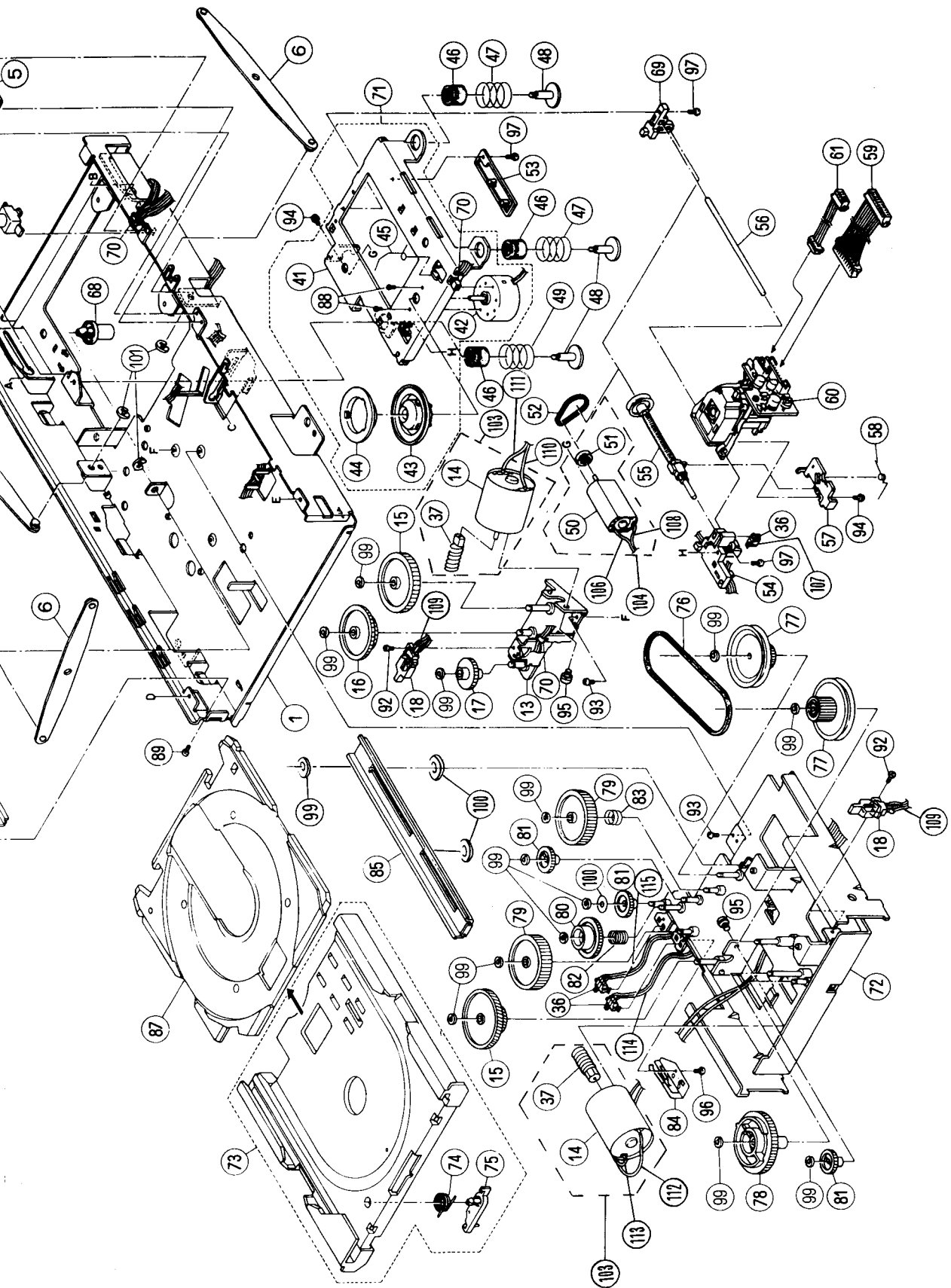

■ Parts List (CD Changer Mechanism Ass'y)

Item	Part Number	Part Name	Q'ty	Description	Areas
1	30100101T	CHASSIS BASE	1		
2	30050115T	GUIDE BOSS	2		
3	300501302T	PRINTED CIRCUIT BOARD A ASSY	1		
4	301001301T	PRINTED CIRCUIT BOARD D ASSY	1		
5	300501304T	PRINTED CIRCUIT BOARD P ASSY	1		
6	301002502T	ELEVATOR ARM A ASSY	3		
7	301002503T	ELEVATOR SIDE ARM B ASSY	2		
8	301002504T	ELEVATOR FRONT ARM A ASSY	1		
9	30100221T	CAM LEVER SPRING	1		
10	30100222T	CS COLLAR SCREW	1		
11	30100223T	CAM SPRING	1		
12	30100202T	LIFT CAM	1		
13	301002501T	ELEVATOR MOTOR BRACKET ASSY	1		
14	RF-370C-15370	MOTOR	2		
15	30100210T	ELEVATOR GEAR B	2		
16	30100211T	ELEVATOR GEAR C	1		
17	30100212T	ELEVATOR GEAR D	1		
18	640101204T	LEAF SWITCH	2		
19	30100204T	CAM SLIDER	1		
20	30100205T	CAM SPRING PLATE	1		
21	30100206T	CAM LEVER	1		
22	30100207T	CAM ROLLER	1		
23	30100301T	GUIDE BASE	1		
24	30100311T	ELEVATOR SLIDE LEVER	1		
25	30100312T	ELEVATOR SLIDE LEVER SPRING	1		
26	30100303T	MAGAZINE GUIDE	1	LEFT	
27	30100304T	MAGAZINE GUIDE	1	RIGHT	
28	30100305T	GUIDE COVER	1		
29	30050309T	TRAY STOPPER	1		
30	30100310T	RELEASE LEVER	1		
31	30100308T	ELEVATOR KICK LEVER	1		
32	30100307T	LOCK LEVER	1		
33	30100309T	ELEVATOR KICK LEVER SPRING	1		
34	30100313T	RELEASE LEVER SPRING	1		
35	30100306T	CAM STABILIZER	1		
36	64020403T	PUSH SWITCH	4		
37	30050508T	FEED GEAR A	2		
38	301005501T	FEED RAIL ASSY	1		
39	30100504T	HOOK SLIDE GEAR	1		
40	30100505T	SLIDE GEAR PLATE	1		
41	30050738T	TURNTABLE BASE	1		
42	60020705T	MOTOR	1		
43	30050729T	TURNTABLE	1		
44	30050713T	TURNTABLE PLATE	1		
45	30050742T	CONTROLLER SPRING	1		
46	30050721T	FLOATING RUBBER	3		
47	30050715T	FLOATING SPRING (B)	2		
48	30050743T	FLOATING SCREW	3		
49	30050740T	FLOATING SPRING	1		
50	60021102T	MOTOR	1		
51	30050709T	MOTOR PULLEY	1		
52	30050714T	FEED MOTOR BELT	1		
53	30050737T	PICK UP SUPPORT	1		
54	30050724T	SHAFT HOLDER A	1		
55	300507303T	FEED SCREW ASSY	1		

Item	Part Number	Part Name	Q'ty	Description	Areas
56	30050728T	PICK UP SHAFT	1		
57	30050735T	FEED NUT HOLDER	1		
58	30050739T	FEED NUT SPRING	1		
59	EWS26A-B921	SOCKET WIRE	1		
60	OPTIMA-5S	PICK UP	1		
61	EWS264-B924	SOCKET WIRE ASSY	1		
62	301008503T	RAIL BASE ASSY	1		
63	30100802T	RAIL	1	LEFT	
64	30100803T	RAIL	1	RIGHT	
65	30100804T	HOOK LEVER	1		
66	301008502T	LP BRACKET ASSY	1		
67	301008301T	MAGAZINE HOLDER ASSY	1		
68	30050114T	CHASSIS SUPPORT	1		
69	30050725T	SHAFT HOLDER B	1		
70	12030105T	TIE BAND	4		
71	300507305T	TURNTABLE BASE ASSY	1		
72	301004502T	PLUS 1 BASE ASSY	1		
73	301004302T	PLUS 1 RAIL BASE ASSY	1		
74	30100415T	STOPPER SPRING	1		
75	30050416T	STOPPER	1		
76	30100411T	PIUS 1 BELT	1		
77	30100403T	PLUS 1 GEAR A	2		
78	30100404T	PLUS 1 GEAR B	1		
79	30100515T	FEED GEAR C	2		
80	30100506T	FEED GEAR D	1		
81	30100516T	FEED GEAR E	3		
82	30100413T	FEED GEAR D SPRING	1		
83	30100412T	FEED GEAR E SPRING	1		
84	30100414T	SWITCH ACTUATOR	1		
85	30100418T	PLUS 1 SLIDE RAIL	1		
86	30101015T	WIRE	1		
87	E26554-005	TRAY	1		
88	SPSK1722M	SCREW	2		
89	9C0420253T	SCREW	1		
90	9C0720601T	SCREW	2		
91	9C0420303T	SCREW	1		
92	9C0420403T	SCREW	2		
93	9P0420031T	SCREW	4		
94	9P0220031T	SCREW	2		
95	9P0230041T	SCREW	2		
96	9P3320032T	SCREW	1		
97	9P0420051T	SCREW	3		
98	9P0420041T	SCREW	3		
99	9W0250110T	WASHER	14		
100	9W0113080T	WASHER	3		
101	REE3000X	E.RING	3		
102	9W0640040T	WASHER	3		
103	301002301T	ELEVATOR MOTOR ASSY	2		
104	300507306T	FEED MOTOR ASSY	1		
105	301002302T	CAM SLIDE ASSY	1		
106	30051007T	WIRE	1	ORANGE	
107	30051011T	WIRE	2	YELLOW	
108	30051014T	WIRE	1	BLUE	
109	30101001T	WIRE	2		
110	30101002T	WIRE	1	YELLOW	
111	30101003T	WIRE	1	BRACK	

Item	Part Number	Part Name	Q'ty	Description	Areas
112	30101005T	WIRE	1	BRACK	
113	30101006T	WIRE	1	RED	
114	30101007T	WIRE	1		
115	30101008T	WIRE	1		

■ How to install the gears and pulley when servicing.

1. Elevator Motor , Loading Motor

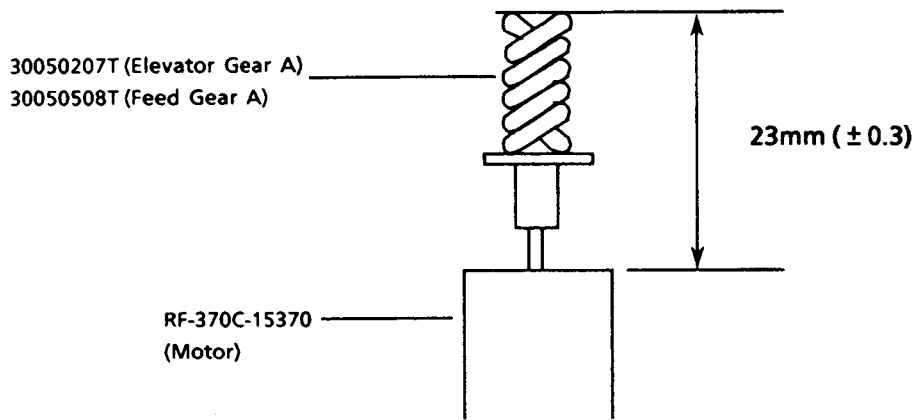

2. Loading Motor for single tray

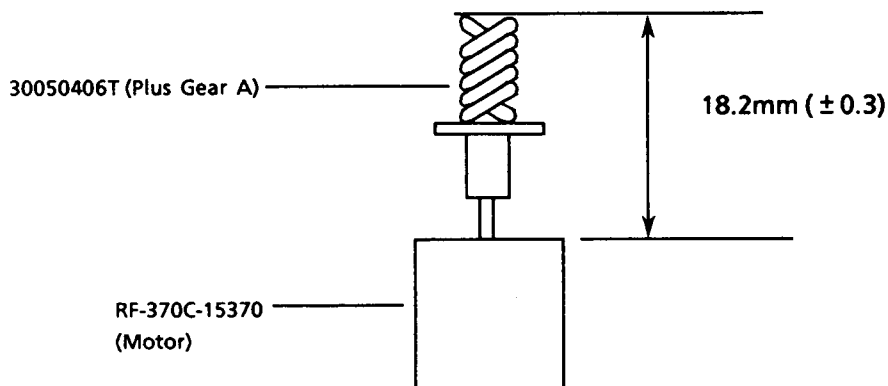

3. Feed Motor

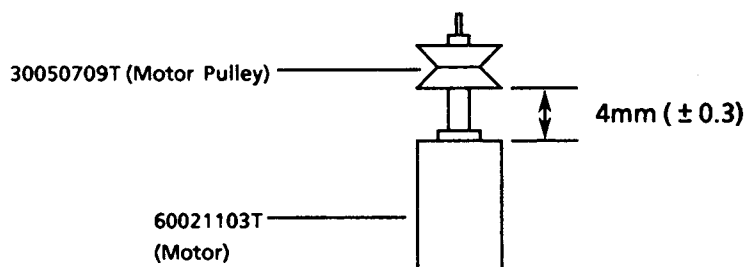

Printed Circuit Board Ass'y and Parts List

■ ENN-365 □ Main & Front PC Board Ass'y

Note : ENN-365 □ varies according to the areas employed. See note (1) when placing an order.

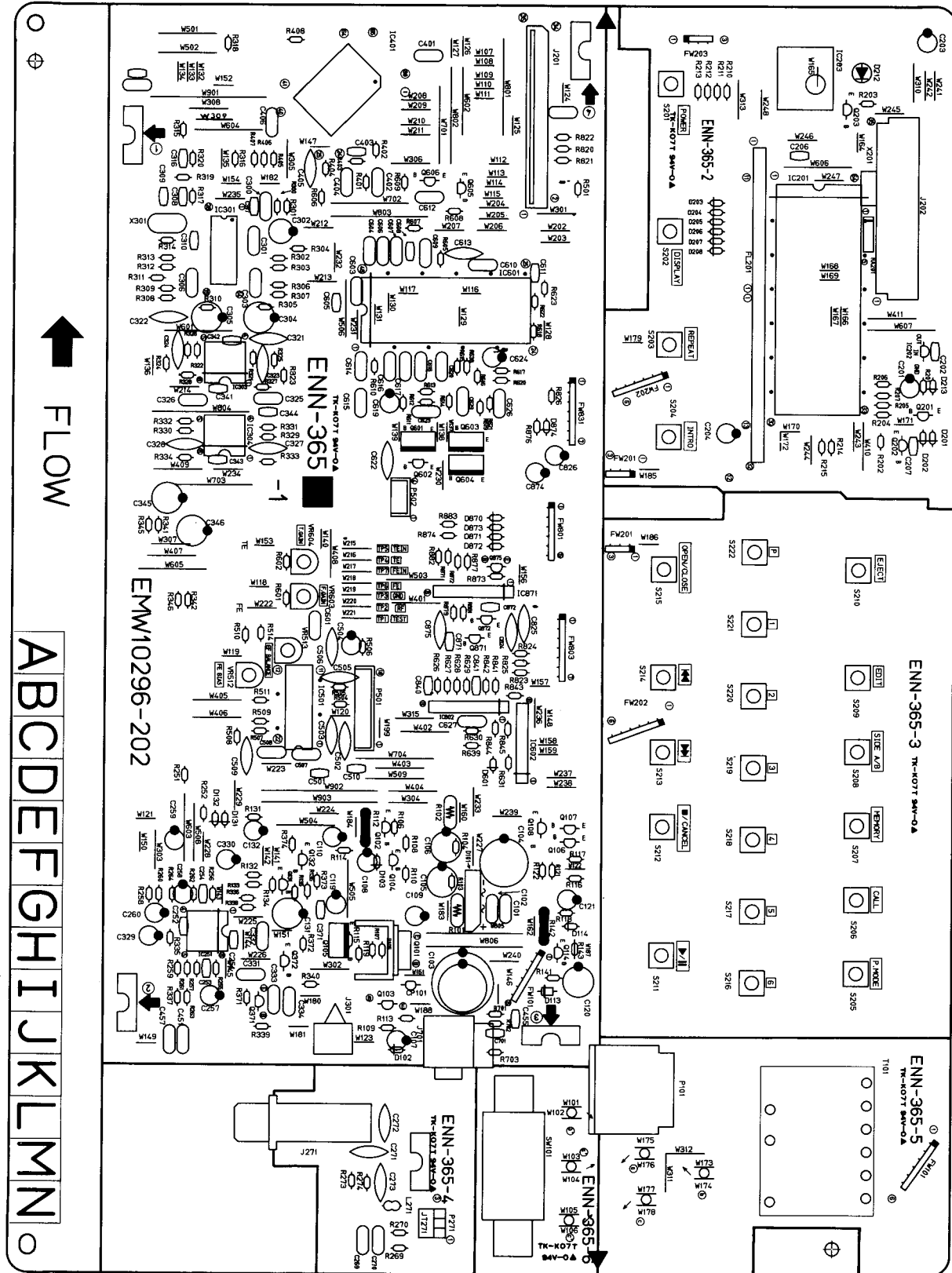

DIODES

Note (1)

PC Board Ass'y	Designated Areas
ENN-365 A	Australia
ENN-365 E	Continental Europe Scandinavia Germany
ENN-365 B BS	the U.K.

△	ITEM	PART NUMBER	DESCRIPTION	AREA
	D204	1SS119	SILICON HITACHI	
	D205	1SS119	SILICON HITACHI	
	D206	1SS119	SILICON HITACHI	
	D207	1SS119	SILICON HITACHI	
	D208	1SS119	SILICON HITACHI	
	D212	SLH-56VC50F130	L.E.D. ROHM	
	D213	1SS133	SILICON ROHM	
	D870	1SS133	SILICON ROHM	
	D871	1SS133	SILICON ROHM	
	D872	1SS133	SILICON ROHM	
	D873	1SS133	SILICON ROHM	

TRANSISTORS

△	ITEM	PART NUMBER	DESCRIPTION	AREA
	Q101	2SB1187(E,F)	SILICON ROHM	
	Q102	2SC2060(Q,R)	SILICON ROHM	
	Q103	2SD1302(S,T)	SILICON MATSUSHITA	
	Q104	2SA933S(R,S)	SILICON ROHM	
	Q105	2SB1357(E,F)	SILICON ROHM	
	Q106	2SD2144S(VW)	SILICON ROHM	
	Q107	2SD2144S(VW)	SILICON ROHM	
	Q108	DTA114YS	SILICON ROHM	
	Q114	2SA733A(P,Q)	SILICON NEC	
	Q131	2SA933S(S,S)	SILICON ROHM	
	Q132	2SD2144S(VW)	SILICON ROHM	
	Q201	DTA114YS	SILICON ROHM	
	Q202	DTC144ES	SILICON ROHM	
	Q203	DTC114YS	SILICON ROHM	
	Q371	2SD1302(S,T)	SILICON MATSUSHITA	
	Q372	2SD1302(S,T)	SILICON MATSUSHITA	
	Q601	2SD2037(E,F)	SILICON ROHM	
	Q602	2SA934(Q,R)	SILICON ROHM	
	Q603	2SD2037(E,F)	SILICON ROHM	
	Q604	2SB1357(E,F)	SILICON ROHM	
	Q605	DTC144ES	SILICON ROHM	
	Q871	2SC2060(Q,R)	SILICON ROHM	
	Q872	2SA934(Q,R)	SILICON ROHM	
	Q875	DTC144ES	SILICON ROHM	

CAPACITORS

△	ITEM	PART NUMBER	DESCRIPTION	AREA
	C101	QFV81HJ-104	0.1MF 50V T.FILM	
	C102	QFV81HJ-104	0.1MF 50V T.FILM	
	C103	QETB1CM-228	2200MF 16V ELECTRO	A
	C103	QETB1CM-228	2200MF 16V ELECTRO	C
	C103	QETB1CM-228	2200MF 16V ELECTRO	D
	C103	QETB1CM-228	2200MF 16V ELECTRO	E
	C103	QETB1CM-228	2200MF 16V ELECTRO	F
	C103	QETB1CM-338	3300MF 16V ELECTRO	
	C104	QETB1CM-228	2200MF 16V ELECTRO	
	C105	QETB1CM-227	220MF 16V ELECTRO	
	C106	QETB1CM-227	220MF 16V ELECTRO	
	C107	QETB1HM-225	2.2MF 50V ELECTRO	
	C108	QETB1HM-225	2.2MF 50V ELECTRO	
	C109	QETB1AM-476	47MF 10V ELECTRO	
	C110	QETB1AM-476	47MF 10V ELECTRO	
	C119	QETB0JM-477	470MF 6.3V ELECTRO	
	C120	QETB1HM-107	100MF 50V ELECTRO	
	C131	QETB1CM-227	220MF 16V ELECTRO	
	C132	QETB1CM-226	22MF 16V ELECTRO	
	C201	QETB1EM-106	10MF 25V ELECTRO	
	C202	QCHB1EZ-223	0.022MF 25V CERAMIC	
	C203	QETB1HM-475	4.7MF 50V ELECTRO	
	C204	QEK51HM-475	4.7MF 50V ELECTRO	
	C206	QCHB1EZ-223	0.022MF 25V CERAMIC	
	C207	QCB1HK-331	330PF 50V CERAMIC	
	C210	QFV81HJ-104	0.1MF 50V T.FILM	
	C251	QCHB1EZ-223	0.022MF 25V CERAMIC	
	C252	QCHB1EZ-223	0.022MF 25V CERAMIC	
	C253	QCSB1HJ-470	47PF 50V CERAMIC	
	C254	QCSB1HJ-470	47PF 50V CERAMIC	
	C257	QETB1HM-475	4.7MF 50V ELECTRO	
	C258	QETB1HM-475	4.7MF 50V ELECTRO	
	C269	QFN81HJ-103	0.01MF 50V MYLAR	
	C270	QFN81HJ-103	0.01MF 50V MYLAR	
	C271	QCS21HJ-471	470PF 50V CERAMIC	
	C272	QCS21HJ-471	470PF 50V CERAMIC	
	C273	QCF21HP-223	0.022MF 50V CERAMIC	
	C300	QCZ0205-155	1.5MF 25V CERAMIC	
	C301	QCZ0205-155	1.5MF 25V CERAMIC	
	C302	QETB1AM-227	220MF 10V ELECTRO	
	C303	QCZ0205-155	1.5MF 25V CERAMIC	
	C304	QETB0JM-227	220MF 6.3V ELECTRO	
	C305	QETB0JM-227	220MF 6.3V ELECTRO	
	C306	QCZ0205-155	1.5MF 25V CERAMIC	
	C308	QCT30CH-120	12PF 50V CERAMIC	
	C309	QCT30CH-3R9	3.9PF 50V CERAMIC	
	C310	QCSB1HJ-270	27PF 50V CERAMIC	
	C316	QCHB1EZ-223	0.022MF 25V CERAMIC	
	C317	QCT30CH-100	10PF 50V CERAMIC	
	C321	QFN81HJ-122	1200PF 50V MYLAR	
	C322	QFN81HJ-122	1200PF 50V MYLAR	
	C323	QCS21HJ-221	220PF 50V CERAMIC	
	C324	QCS21HJ-221	220PF 50V CERAMIC	
	C325	QFN81HJ-392	3900PF 50V MYLAR	
	C326	QFN81HJ-392	3900PF 50V MYLAR	
	C327	QCS21HJ-121	120PF 50V CERAMIC	
	C328	QCS21HJ-121	120PF 50V CERAMIC	
	C329	QETB1CM-226	22MF 16V ELECTRO	
	C330	QETB1CM-226	22MF 16V ELECTRO	
	C331	QFN81HJ-562	5600PF 50V MYLAR	
	C332	QFN81HJ-562	5600PF 50V MYLAR	
	C333	QFN81HJ-472	4700PF 50V MYLAR	
	C334	QFN81HJ-472	4700PF 50V MYLAR	
	C341	QCHB1EZ-223	0.022MF 25V CERAMIC	
	C342	QCHB1EZ-223	0.022MF 25V CERAMIC	
	C343	QCHB1EZ-223	0.022MF 25V CERAMIC	
	C344	QCHB1EZ-223	0.022MF 25V CERAMIC	
	C345	QETB1CM-227	220MF 16V ELECTRO	
	C346	QETB1CM-227	220MF 16V ELECTRO	
	C401	QCZ0205-155	1.5MF 25V CERAMIC	
	C402	QFN81HJ-473	0.047MF 50V MYLAR	

I. C. S.

△	ITEM	PART NUMBER	DESCRIPTION	AREA
	IC201	MN171602JHC	I.C. MATSUSHITA	
	IC202	MN1281(P,Q)	I.C. MATSUSHITA	
	IC203	GP1U571X	I.C. SHARP	
	IC251	VC4580D	I.C. DAINICHI	
	IC301	MN35500	I.C. MATSUSHITA	
	IC302	VC4580D	I.C. DAINICHI	
	IC304	VC4580D	I.C. DAINICHI	
	IC401	CXD2500BQ	I.C. 1680	
	IC501	CXA1571S	I.C. 1680	
	IC601	CXA1372S	I.C. 1680	
	IC602	STA341M(A)	I.C. SANKEN	
	IC802	M5218AL	I.C. MITSUBISHI	
	IC871	M5218AL	I.C. MITSUBISHI	

DIODES

△	ITEM	PART NUMBER	DESCRIPTION	AREA
	D101	S1VB20F	SILICON SINDENGEN	
	D102	MT25.6JB	ZENER ROHM	
	D103	MT25.6JB	ZENER ROHM	
	D113	1SR139-200	SILICON ROHM	
	D114	MT233JC	ZENER ROHM	
	D131	1SS133	SILICON ROHM	
	D132	1SS133	SILICON ROHM	
	D201	1SS133	SILICON ROHM	
	D202	1SS133	SILICON ROHM	
	D203	1SS119	SILICON HITACHI	

△ : SAFETY PARTS

△ : SAFETY PARTS

CAPACITORS

△	ITEM	PART NUMBER	DESCRIPTION	AREA
	C403	QCHB1EZ-223	0.022MF 25V CERAMIC	
	C404	QFN81HJ-152	1500PF 50V MYLAR	
	C405	QCF21HP-103	0.01MF 50V CERAMIC	
	C406	QCZ0205-155	1.5MF 25V CERAMIC	
	C407	QCS21HJ-120	12PF 50V CERAMIC	E
	C451	QCZ0205-155	1.5MF 25V CERAMIC	E
	C455	QCHB1EZ-223	0.022MF 25V CERAMIC	
	C457	QCF21HP-223	0.022MF 50V CERAMIC	E
	C501	QCHB1EZ-223	0.022MF 25V CERAMIC	
	C502	QCS21HJ-100	10PF 50V CERAMIC	
	C503	QCS21HJ-100	10PF 50V CERAMIC	
	C504	QETB1AM-476	47MF 10V ELECTRO	
	C505	QCS21HJ-820	82PF 50V CERAMIC	
	C506	QCS21HJ-101	100PF 50V CERAMIC	
	C507	QFV81HJ-104	0.1MF 50V T.FILM	
	C508	QCZ0205-155	1.5MF 25V CERAMIC	
	C509	QCS21HJ-220	22PF 50V CERAMIC	
	C510	QCHB1EZ-223	0.022MF 25V CERAMIC	
	C601	QFN81HJ-182	1800PF 50V MYLAR	
	C603	QFN81HJ-222	2200PF 50V MYLAR	
	C604	QFN81HJ-222	2200PF 50V MYLAR	
	C605	QCHB1EZ-223	0.022MF 25V CERAMIC	
	C606	QFN81HJ-333	0.033MF 50V MYLAR	
	C607	QFN81HJ-103	0.01MF 50V MYLAR	
	C608	QCHB1EZ-223	0.022MF 25V CERAMIC	
	C609	QFN81HJ-333	0.033MF 50V MYLAR	
	C610	QCZ0205-155	1.5MF 25V CERAMIC	
	C611	QCHB1EZ-223	0.022MF 25V CERAMIC	
	C613	QFV81HJ-104	0.1MF 50V T.FILM	
	C614	QFN81HJ-104	0.1MF 50V MYLAR	
	C615	QFN81HJ-333	0.033MF 50V MYLAR	
	C616	QFN81HJ-473	0.047MF 50V MYLAR	
	C617	QFN81HJ-473	0.047MF 50V MYLAR	
	C618	QFN81HJ-473	0.047MF 50V MYLAR	
	C619	QETB1HM-335	3.3MF 50V ELECTRO	
	C620	QFN81HJ-104	0.1MF 50V MYLAR	
	C622	QCF21HP-223	0.022MF 50V CERAMIC	
	C623	QFN81HJ-563	0.056MF 50V MYLAR	
	C624	QETB1EM-106	10MF 25V ELECTRO	
	C626	QFN81HJ-103	0.01MF 50V MYLAR	
	C627	QFN81HJ-103	0.01MF 50V MYLAR	
	C629	QFN81HJ-333	0.033MF 50V MYLAR	
	C701	QCB1HK-101	100PF 50V CERAMIC	
	C824	QCF21HP-223	0.022MF 50V CERAMIC	
	C825	QCF21HP-223	0.022MF 50V CERAMIC	
	C840	QCHB1EZ-223	0.022MF 25V CERAMIC	
	C841	QCHB1EZ-223	0.022MF 25V CERAMIC	
	C871	QCHB1EZ-223	0.022MF 25V CERAMIC	
	C872	QCHB1EZ-223	0.022MF 25V CERAMIC	
	C874	QETB1HM-105	1MF 50V ELECTRO	
	C875	QCF21HP-223	0.022MF 50V CERAMIC	

RESISTORS

△	ITEM	PART NUMBER	DESCRIPTION	AREA
△	R101	PTH61G30BD2R2N	FUSIBLE RE	SI A
△	R101	PTH61G30BD2R2N	FUSIBLE RE	SI C
△	R101	PTH61G30BD2R2N	FUSIBLE RE	SI E
△	R101	PTH61G30BD2R2N	FUSIBLE RE	SI F
△	R102	PTH61G30BD2R2N	FUSIBLE RE	SI A
△	R102	PTH61G30BD2R2N	FUSIBLE RE	SI C
△	R102	PTH61G30BD2R2N	FUSIBLE RE	SI E
△	R102	PTH61G30BD2R2N	FUSIBLE RE	SI F
	R105	QRD167J-222	2.2K 1/6W CARBON	
	R106	QRD167J-222	2.2K 1/6W CARBON	
	R107	QRD161J-221	220 1/6W CARBON	
	R108	QRD161J-221	220 1/6W CARBON	
	R109	QRD161J-221	220 1/6W CARBON	
	R110	QRD161J-221	220 1/6W CARBON	
△	R112	QRZ0077-100	10 1/4W FUSIBLE	A
△	R112	QRZ0077-100	10 1/4W FUSIBLE	C
△	R112	QRZ0077-100	10 1/4W FUSIBLE	E
△	R112	QRZ0077-100	10 1/4W FUSIBLE	F
	R113	QRD167J-222	2.2K 1/6W CARBON	
	R114	QRD167J-821	820 1/6W CARBON	
	R115	QRD167J-102	1K 1/6W CARBON	
	R116	QRD167J-152	1.5K 1/6W CARBON	
	R117	QRD167J-152	1.5K 1/6W CARBON	
	R118	QRD167J-563	56K 1/6W CARBON	
	R119	QRD167J-821	820 1/6W CARBON	
	R121	QRD167J-103	10K 1/6W CARBON	
	R122	QRD167J-103	10K 1/6W CARBON	
	R131	QRD161J-221	220 1/6W CARBON	
	R132	QRD167J-331	330 1/6W CARBON	
	R134	QRD167J-822	8.2K 1/6W CARBON	
	R135	QRD167J-683	68K 1/6W CARBON	
	R136	QRD167J-473	47K 1/6W CARBON	
	R141	QRD167J-123	12K 1/6W CARBON	
△	R142	QRZ0077-560	56 1/4W FUSIBLE	A
△	R142	QRZ0077-560	56 1/4W FUSIBLE	C

RESISTORS

△	ITEM	PART NUMBER	DESCRIPTION	AREA
△	R142	QRZ0077-560	56 1/4W FUSIBLE	E
△	R142	QRZ0077-560	56 1/4W FUSIBLE	F
	R201	QRD167J-821	820 1/6W CARBON	
	R202	QRD167J-472	4.7K 1/6W CARBON	
	R203	QRD167J-181	180 1/6W CARBON	
	R204	QRD167J-103	10K 1/6W CARBON	
	R205	QRD167J-472	4.7K 1/6W CARBON	
	R206	QRD167J-103	10K 1/6W CARBON	
	R207	QRD167J-103	10K 1/6W CARBON	
	R210	QRD167J-103	10K 1/6W CARBON	
	R211	QRD167J-103	10K 1/6W CARBON	
	R212	QRD167J-103	10K 1/6W CARBON	
	R213	QRD167J-103	10K 1/6W CARBON	
	R214	QRD167J-102	1K 1/6W CARBON	
	R215	QRD167J-102	1K 1/6W CARBON	
	R251	QRD161J-221	220 1/6W CARBON	
	R252	QRD161J-221	220 1/6W CARBON	
	R255	QRD167J-562	5.6K 1/6W CARBON	
	R256	QRD167J-562	5.6K 1/6W CARBON	
	R257	QRD167J-273	27K 1/6W CARBON	
	R258	QRD167J-273	27K 1/6W CARBON	
	R259	QRD167J-473	47K 1/6W CARBON	
	R260	QRD167J-473	47K 1/6W CARBON	
	R261	QRD167J-103	10K 1/6W CARBON	
	R262	QRD167J-103	10K 1/6W CARBON	
	R263	QRD167J-561	560 1/6W CARBON	
	R264	QRD167J-561	560 1/6W CARBON	
	R269	QRD167J-680	68 1/6W CARBON	
	R270	QRD167J-680	68 1/6W CARBON	
	R273	QRD167J-390	39 1/6W CARBON	
	R274	QRD167J-390	39 1/6W CARBON	
	R300	QRD167J-560	56 1/6W CARBON	
	R301	QRD167J-560	56 1/6W CARBON	
△	R302	QRV144F-1802	18K 1/4W M.FILM	
△	R303	QRV144F-1802	18K 1/4W M.FILM	
△	R304	QRD167J-271	270 1/6W CARBON	
△	R305	QRD167J-182	1.8K 1/6W CARBON	
△	R306	QRV144F-1802	18K 1/4W M.FILM	
△	R307	QRV144F-1802	18K 1/4W M.FILM	
△	R308	QRV144F-1802	18K 1/4W M.FILM	
△	R309	QRV144F-1802	18K 1/4W M.FILM	
△	R310	QRD167J-182	1.8K 1/6W CARBON	
△	R311	QRD167J-271	270 1/6W CARBON	
△	R312	QRV144F-1802	18K 1/4W M.FILM	
△	R313	QRV144F-1802	18K 1/4W M.FILM	
△	R314	QRD167J-330	33 1/6W CARBON	
	R315	QRD167J-560	56 1/6W CARBON	
	R316	QRD167J-271	270 1/6W CARBON	
	R317	QRD167J-155	1.5M 1/6W CARBON	
	R318	QRD167J-102	1K 1/6W CARBON	
	R319	QRD167J-681	680 1/6W CARBON	
	R320	QRD167J-121	120 1/6W CARBON	
	R321	QRD167J-182	1.8K 1/6W CARBON	
	R322	QRD167J-182	1.8K 1/6W CARBON	
	R323	QRD167J-182	1.8K 1/6W CARBON	
	R324	QRD167J-182	1.8K 1/6W CARBON	
	R325	QRD167J-123	12K 1/6W CARBON	
	R326	QRD167J-123	12K 1/6W CARBON	
	R327	QRD167J-123	12K 1/6W CARBON	
	R328	QRD167J-123	12K 1/6W CARBON	
	R329	QRD167J-123	12K 1/6W CARBON	
	R330	QRD167J-123	12K 1/6W CARBON	
	R331	QRD167J-272	2.7K 1/6W CARBON	
	R332	QRD167J-272	2.7K 1/6W CARBON	
	R335	QRD167J-273	27K 1/6W CARBON	
	R336	QRD167J-273	27K 1/6W CARBON	
	R337	QRD167J-331	330 1/6W CARBON	
	R338	QRD167J-331	330 1/6W CARBON	
	R339	QRD167J-331	330 1/6W CARBON	
	R340	QRD167J-331	330 1/6W CARBON	
	R341	QRD161J-221	220 1/6W CARBON	
	R342	QRD161J-221	220 1/6W CARBON	
	R345	QRD161J-221	220 1/6W CARBON	
	R346	QRD161J-221	220 1/6W CARBON	
	R371	QRD167J-103	10K 1/6W CARBON	
	R372	QRD167J-103	10K 1/6W CARBON	
	R373	QRD167J-684	680K 1/6W CARBON	
	R374	QRD167J-473	47K 1/6W CARBON	
	R401	QRD167J-332	3.3K 1/6W CARBON	
	R402	QRD167J-682	6.8K 1/6W CARBON	
	R403	QRD167J-103	10K 1/6W CARBON	
	R404	QRD167J-103	10K 1/6W CARBON	
	R405	QRD167J-102	1K 1/6W CARBON	
	R406	QRD167J-102	1K 1/6W CARBON	
	R407	QRD167J-102	1K 1/6W CARBON	
	R408	QRD167J-102	1K 1/6W CARBON	
	R409	QRD167J-560	56 1/6W CARBON	
	R501	QRD167J-102	1K 1/6W CARBON	E
	R504	QRD167J-183	18K 1/6W CARBON	
	R505	QRD167J-183	18K 1/6W CARBON	
	R506	QRD167J-121	120 1/6W CARBON	
	R507	QRD167J-103	10K 1/6W CARBON	
	R508	QRD167J-332	3.3K 1/6W CARBON	
	R509	QRD167J-822	8.2K 1/6W CARBON	
	R510	QRD167J-113	11K 1/6W CARBON	

△ : SAFETY PARTS

△ : SAFETY PARTS

RESISTORS

△	ITEM	PART NUMBER	DESCRIPTION			AREA
	R511	QRD167J-104	100K	1/6W	CARBON	
	R514	QRD167J-103	10K	1/6W	CARBON	
	R601	QRD167J-472	4.7K	1/6W	CARBON	
	R602	QRD167J-472	4.7K	1/6W	CARBON	
	R605	QRD167J-102	1K	1/6W	CARBON	
	R606	QRD167J-104	100K	1/6W	CARBON	
	R610	QRD167J-224	220K	1/6W	CARBON	
	R611	QRD167J-2R2	2.2	1/6W	CARBON	
	R612	QRD167J-683	68K	1/6W	CARBON	
	R613	QRD167J-104	100K	1/6W	CARBON	
	R614	QRD167J-2R2	2.2	1/6W	CARBON	
	R615	QRD167J-224	220K	1/6W	CARBON	
	R616	QRD167J-273	27K	1/6W	CARBON	
	R617	QRD167J-332	3.3K	1/6W	CARBON	
	R618	QRD167J-514	510K	1/6W	CARBON	
	R619	QRD167J-2R2	2.2	1/6W	CARBON	
	R620	QRD167J-562	5.6K	1/6W	CARBON	
	R621	QRD167J-683	68K	1/6W	CARBON	
	R622	QRD167J-124	120K	1/6W	CARBON	
	R623	QRD167J-472	4.7K	1/6W	CARBON	
	R626	QRD167J-153	15K	1/6W	CARBON	
	R627	QRD167J-333	33K	1/6W	CARBON	
	R628	QRD167J-752	7.5K	1/6W	CARBON	
	R629	QRD167J-752	7.5K	1/6W	CARBON	
	R630	QRD167J-333	33K	1/6W	CARBON	
	R631	QRD167J-470	47	1/6W	CARBON	
	R638	QRD167J-184	180K	1/6W	CARBON	
	R640	QRD167J-475	4.7M	1/6W	CARBON	
	R701	QRD161J-221	220	1/6W	CARBON	
	R702	QRD161J-221	220	1/6W	CARBON	
	R703	QRD167J-101	100	1/6W	CARBON	
	R820	QRD161J-221	220	1/6W	CARBON	
	R821	QRD161J-221	220	1/6W	CARBON	
	R822	QRD161J-221	220	1/6W	CARBON	
	R823	QRD161J-221	220	1/6W	CARBON	
	R824	QRD161J-221	220	1/6W	CARBON	
	R825	QRD161J-221	220	1/6W	CARBON	
	R826	QRD167J-101	100	1/6W	CARBON	
	R841	QRD167J-243	24K	1/6W	CARBON	
	R842	QRD167J-183	18K	1/6W	CARBON	
	R843	QRD167J-203	20K	1/6W	CARBON	
	R844	QRD167J-183	18K	1/6W	CARBON	
	R845	QRD167J-820	82	1/6W	CARBON	
	R871	QRD167J-273	27K	1/6W	CARBON	
	R872	QRD167J-223	22K	1/6W	CARBON	
	R873	QRD167J-303	30K	1/6W	CARBON	
	R874	QRD167J-103	10K	1/6W	CARBON	
	R876	QRD167J-473	47K	1/6W	CARBON	
	R877	QRD167J-752	7.5K	1/6W	CARBON	
	R879	QRD161J-221	220	1/6W	CARBON	
	R881	QRD167J-393	39K	1/6W	CARBON	
	R882	QRD167J-123	12K	1/6W	CARBON	
	R883	QRD167J-153	15K	1/6W	CARBON	
	RA201	QRB049J-103	10K	1/10W	R.NETWORK	
	VR512	QVPA601-203A	20K		VARIABLE	
	VR513	QVPA601-203A	20K		VARIABLE	
	VR603	QVPA601-203A	20K		VARIABLE	
	VR604	QVPA601-203A	20K		VARIABLE	

△ : SAFETY PARTS

OTHERS

△	ITEM	PART NUMBER	DESCRIPTION		AREA
		E3400-439	FELT SPACER		
		E70306-001	HEAT SINK		
		E70859-001	EARTH PLATE		
		E75819-001	SUPPORT HOLDER		
		E75820-001	SUPPORT HOLDER		
		SBSE3008Z	SCREW		
		E70859-001	EARTH PLATE		E
	J201	EMV7123-035	CONNECTOR		
	J202	EMV7123-035R	CONNECTOR		
	J271	QMS6A20-E21H	HEADPHONE JACK		
	J301	EMN00TV-214A	2P PIN JACK		
	J701	QMS3501-020	MINI JACK		
	L108	EQL4004-100	INDUCTOR		A
	L108	EQL4004-100	INDUCTOR		E
	L108	EQL4004-100	INDUCTOR		F
	L197	EQL4004-100	INDUCTOR		A
	L197	EQL4004-100	INDUCTOR		E
	L197	EQL4004-100	INDUCTOR		F
	L271	EQL4004-1R0	INDUCTOR		
	P101	QMCB001-E02H	AC SOCKET		A
	P101	QMCB001-E03H	AC INLET		C
	P101	QMCB001-E03H	AC INLET		D
	P101	QMCB001-E02H	AC SOCKET		E
	P101	QMCB001-E02H	AC SOCKET		F
	P501	EMV5109-010A	PLUG ASSY		
	P502	EMV5109-004A	PLUG ASSY		
	S201	ESP0001-018	TACT SWITCH		
	S202	ESP0001-018	TACT SWITCH		
	S203	ESP0001-018	TACT SWITCH		
	S204	ESP0001-018	TACT SWITCH		
	S205	ESP0001-018	TACT SWITCH		
	S206	ESP0001-018	TACT SWITCH		
	S207	ESP0001-018	TACT SWITCH		
	S208	ESP0001-018	TACT SWITCH		
	S209	ESP0001-018	TACT SWITCH		
	S210	ESP0001-018	TACT SWITCH		
	S211	ESP0001-018	TACT SWITCH		
	S212	ESP0001-018	TACT SWITCH		
	S213	ESP0001-018	TACT SWITCH		
	S214	ESP0001-018	TACT SWITCH		
	S215	ESP0001-018	TACT SWITCH		
	S216	ESP0001-018	TACT SWITCH		
	S217	ESP0001-018	TACT SWITCH		
	S218	ESP0001-018	TACT SWITCH		
	S219	ESP0001-018	TACT SWITCH		
	S220	ESP0001-018	TACT SWITCH		
	S221	ESP0001-018	TACT SWITCH		
	S222	ESP0001-018	TACT SWITCH		
	X201	ECX0060-000EM	RESONATOR		
	X301	ECX0169-344EA	RESONATOR		
△	CP101	ICP-N5	I.C. PROTECTOR		A
△	CP101	ICP-N5	I.C. PROTECTOR		C
△	CP101	ICP-N5	I.C. PROTECTOR		E
△	CP101	ICP-N5	I.C. PROTECTOR		F
	FL201	ELU0001-132	FL TUBE		
	FW101	EWR36B-40SST	FLAT WIRE		
	FW201	EWR33B-20SST	FLAT WIRE		
	FW202	EWR36B-30SST	FLAT WIRE		
	FW203	EWR33B-10LST	FLAT WIRE		
	FW801	EWR36B-10KST	FLAT WIRE		
	FW803	EWR37B-10KST	FLAT WIRE		
	FW831	EWR37B-10KST	FLAT WIRE		
	JT271	EMV7122-103	CONNECTOR		
	SW101	QSS1L22-E01	SLIDE SWITCH		F

△ : SAFETY PARTS

Accessories List

△	Part Number	Part Name	Q'ty	Description	Area
	E30580-1948A	INSTRUCTION BOOK	1		A
	E30580-1950A	INSTRUCTION BOOK	1		G
	E30580-1950A	INSTRUCTION BOOK	1		EF
	E30580-1949A	INSTRUCTION BOOK	1		EN
	E30580-1948ABS	INSTRUCTION BOOK	1		BS
△	QMP5520-1835BS	POWER CORD	1		BS
△	QMP25D0-183	POWER CORD	1		A
△	QMP39F0-183	POWER CORD	1		EF
△	QMP39F0-183	POWER CORD	1		EN
	EWP302-013K	SIGNAL CORD	1		
	EWP805-009K	PLUG WIRE ASSY	1		
	BT20060	WARRANTY CARD	1		BS
	BT-20122-1	STICKER	1		A
	BT-20134	WARRANTY CARD	1		G
	E300196-010	ENVELOPE	1		A
	E300196-010	ENVELOPE	1		G
	E300196-010	ENVELOPE	1		EF
	E300196-010B	ENVELOPE	1		EN
	E26072-005	CD RACK	1		BS
	RM-SX409U	WIRE-LESS REMOTE CONTROL	1		
	UM-3(DJ)-2PSA	BATTERY	1		
	56V723A	BATTERY COVER	1		
	E300196-010	ENVELOPE	1		A
	E300196-010	ENVELOPE	1		G
	E300196-010	ENVELOPE	1		EF
	E300196-010	ENVELOPE	1		EN
	E300196-010B	ENVELOPE	1		BS

The Marks for Designated Areas

G Germany A Australia BS the U.K.

EN Scandinavia EF Continental Europe

No mark indicates all area.

Packing Materials and Part Numbers

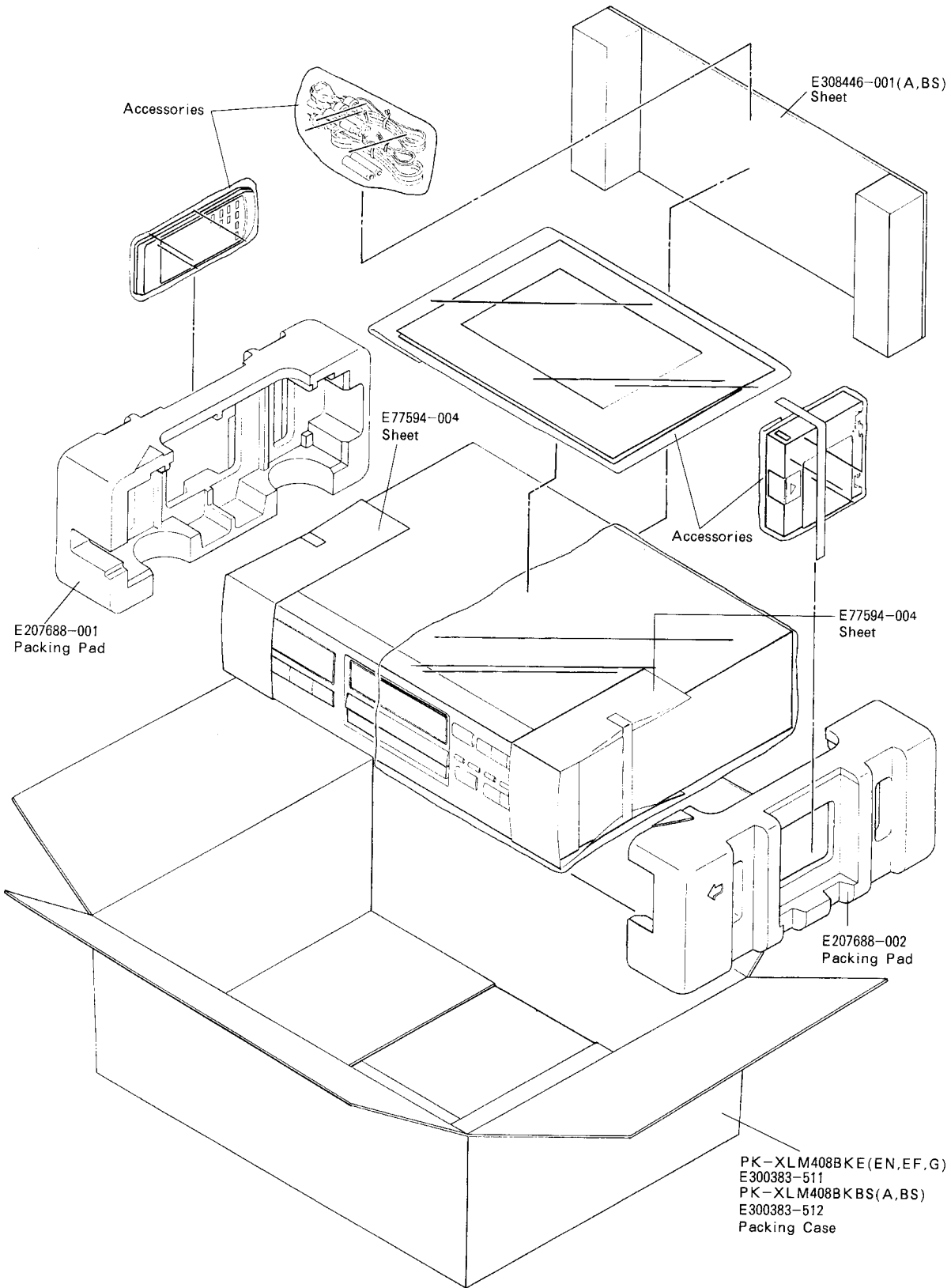

The Marks for Designated Areas

A	Australia	EF	Continental Europe	EN	Scandinavia
G	Germany	BS	the U.K.	No mark indicates all area.		

— MEMO —

— MEMO —



PARTS LIST

※ All printed circuit board assemblies are not available as service parts.

Contents

General Exploded View and Parts List	3-2
CD Changer Ass'y and Parts List	3-5
■ How to install the gears and pulley when servicing	3-10
Printed Circuit Board Ass'y and Parts List	3-11
■ ENN-365 □ Main & Front PC Board Ass'y	3-11
Accessories List	3-15
Packing Materials and Part Numbers	3-16

General Exploded View and Parts List

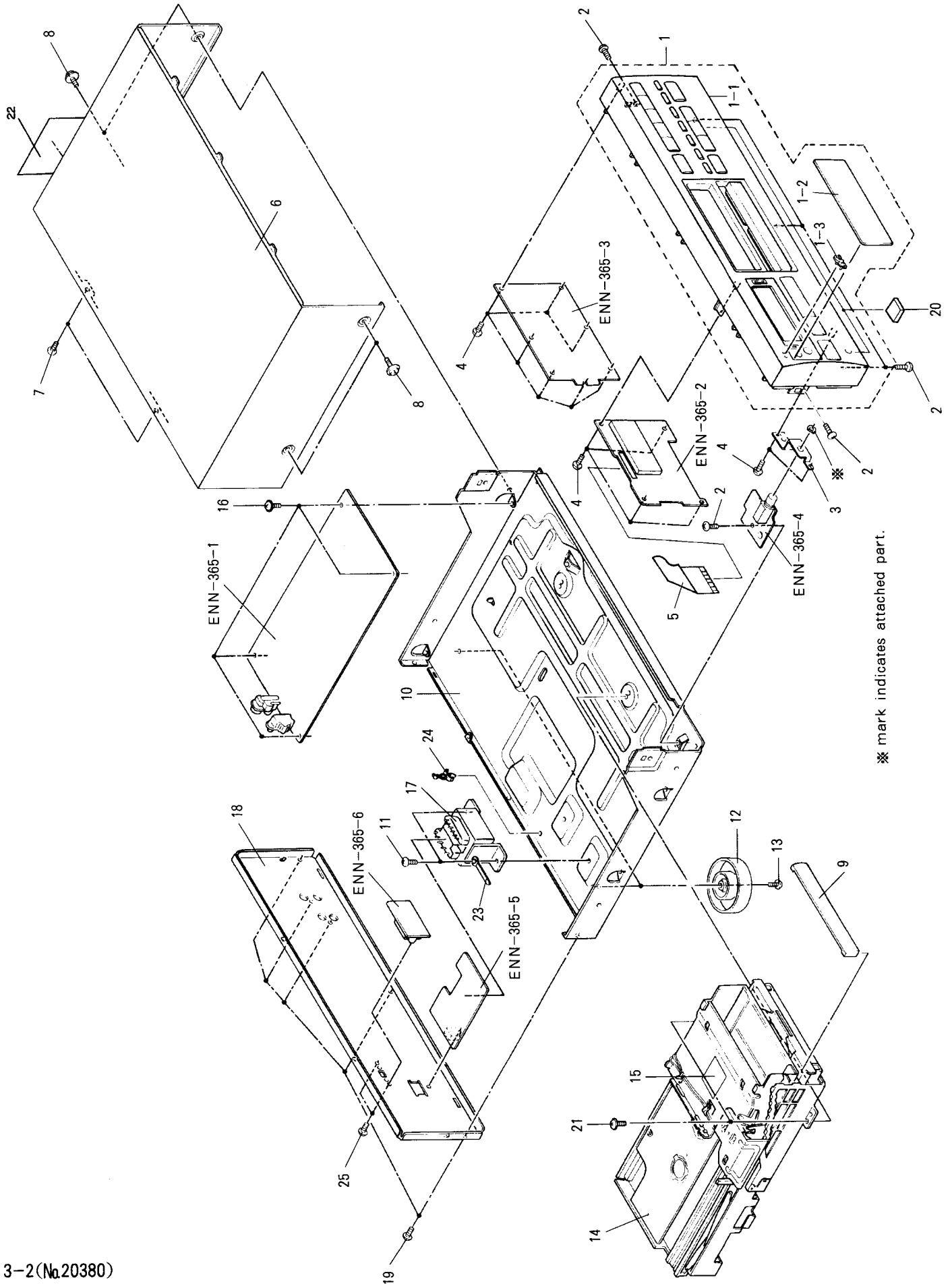

Parts List

Item	Part Number	Part Name	Q'ty	Description	Area
1	EFP-XLM409TNJ(S)	FRONT PANEL ASS'Y	1		
1-1	E102653-008	FRONT PANEL	1		
1-2	E308282-001	WINDOW SCREEN	1		
1-3	E72968-001	JVC MARK	1		
2	SDSG3006M	SCREW	6		
3	E308284-001	HEADPHONE BRACKET	1		
4	SDSF2608Z	SCREW	13		
5	EWR135K-42TT	FLAT WIRE	1		
6	E25834-010	METAL COVER	1		
7	SBSG3008M	SCREW	2		
8	E406308-001	SPECIAL SCREW	4		
9	E308285-001	CD FITTING	1		
10	E102650-001	CHASSIS BASE	1		
11	E65389-004	SPECIAL SCREW	2	FOR POWER TRANS	
12	E406472-003	FOOT ASSY	2		
13	SBST3008Z	SCREW	2		
14	-----	CD CHANGER MECHANISM UNIT ASS'Y	1	SEE PAGE 3-7	
15	E406507-001	CAUTION LABEL	1		A
15	E406507-001	CAUTION LABEL	1		C
15	E406507-001	CAUTION LABEL	1		EF
15	E406507-001	CAUTION LABEL	1		EN
15	E406507-001	CAUTION LABEL	1		U
15	E406507-001	CAUTION LABEL	1		UT
16	GBSG3008CC	SCREW	4		
17	ETP1010-51EA	POWER TRANSFORMER	1		A
17	ETP1010-51EA	POWER TRANSFORMER	1		C
17	ETP1010-51EA	POWER TRANSFORMER	1		EF
17	ETP1010-51EA	POWER TRANSFORMER	1		EN
17	ETP1010-51JA	POWER TRANSFORMER	1		J
17	ETP1010-51LA	POWER TRANSFORMER	1		U
17	ETP1010-51LA	POWER TRANSFORMER	1		UT
18	E207686-006	REAR PANEL	1		A
18	E207686-006	REAR PANEL	1		C
18	E207686-006	REAR PANEL	1		EF
18	E207686-006	REAR PANEL	1		EN
18	E207686-005	REAR PANEL	1		G
18	E207686-007	REAR PANEL	1		U
18	E207686-007	REAR PANEL	1		UT
	E308453-005	RATING LABEL	1		C
	E308453-006	RATING LABEL	1		EF
19	E73273-006	SPECIAL SCREW	6		
20	E75896-001	SPACER	2	FRONT FOOT	
21	SBST3006Z	SCREW	2		
22	E308287-026	RATING LABEL	1		
23	E72018-001	WIRE CLAMP	1		
24	E75217-001	WIRE CLAMP	6		
25	SBSF2608M	SCREW	2		U
25	SBSF2608M	SCREW	2		UT
-	E61029-005	NUMBER LABEL	1		A
-	E61029-005	NUMBER LABEL	1		C

△	Item	Part Number	Part Name	Q'ty	Description	Area
	-	E61029-005	NUMBER LABEL	1		EF
	-	E61029-005	NUMBER LABEL	1		EN
	-	E61029-005	NUMBER LABEL	1		U
	-	E61029-005	NUMBER LABEL	1		UT
	-	E70891-001	LABEL	1		A
	-	E70891-001	LABEL	1		EF
	-	E70891-001	LABEL	1		EN
	-	E70891-001	LABEL	1		U
	-	E70891-001	LABEL	1		UT
	-	E45858-002	LABEL	1		C
	-	QZL1031-101	LABEL	1		EF
	-	E70027-001	LABEL	1		EN
	-	E307570-001	NUMBER LABEL	1		J

The Marks for Designated Areas

J the U.S.A. A Australia C Canada
 U Universal EN Scandinavia EF Continental Europe
 UT Taiwan No mark indicates all area.

CD Changer Ass'y and Parts List

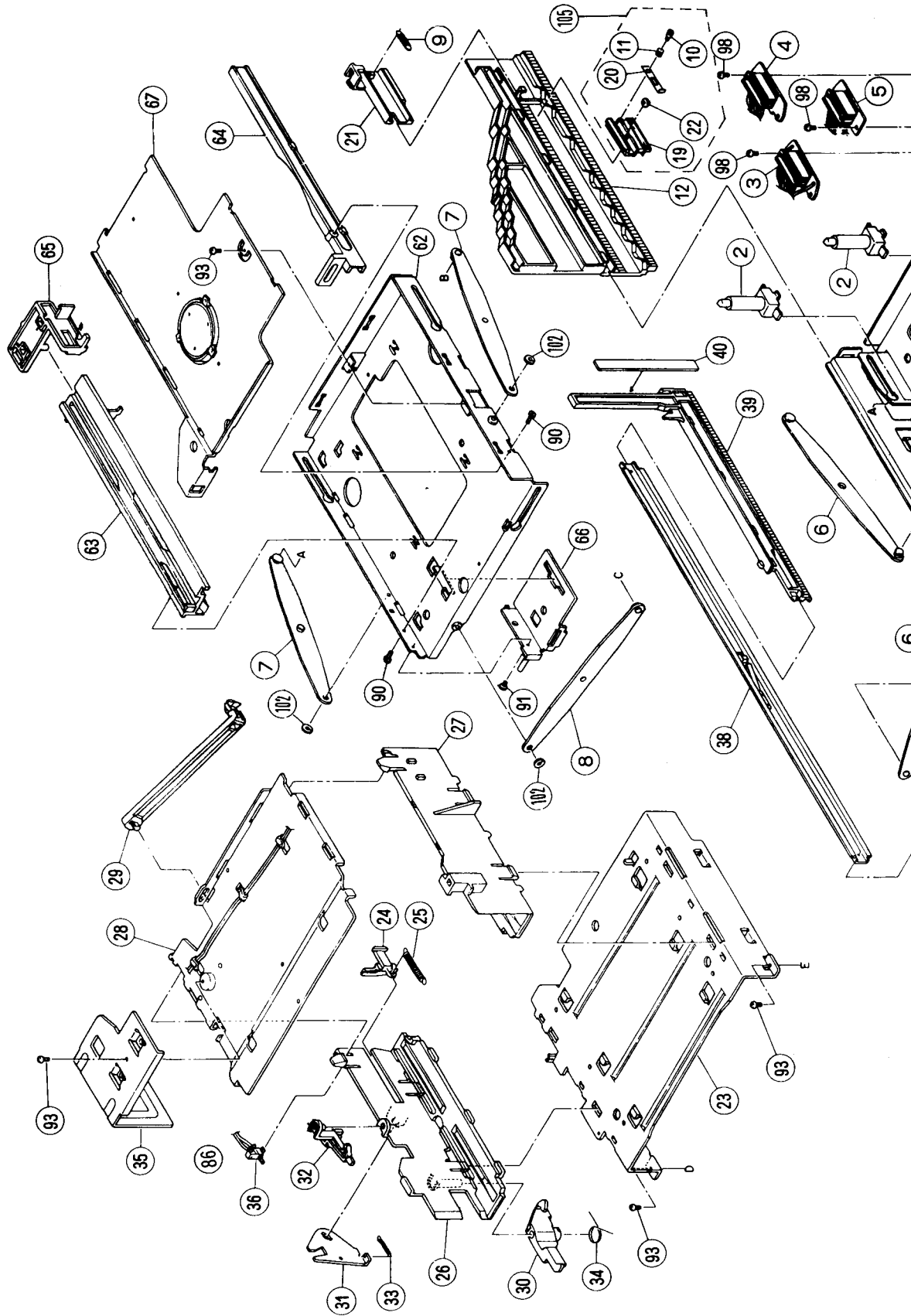

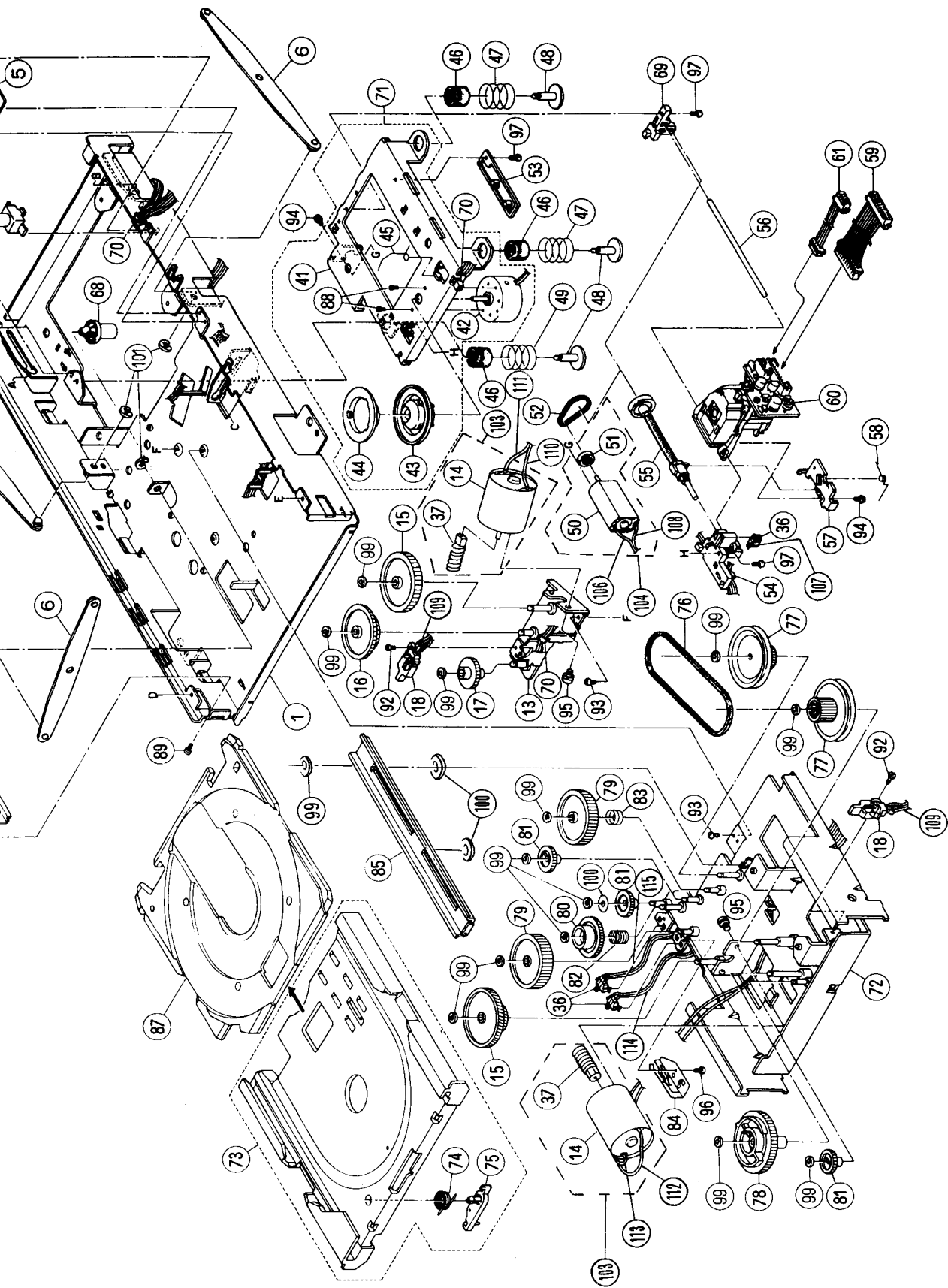

■ Parts List (CD Changer Mechanism Ass'y)

Item	Part Number	Part Name	Q'ty	Description	Areas
1	30100101T	CHASSIS BASE	1		
2	30050115T	GUIDE BOSS	2		
3	300501302T	PRINTED CIRCUIT BOARD A ASSY	1		
4	301001301T	PRINTED CIRCUIT BOARD D ASSY	1		
5	300501304T	PRINTED CIRCUIT BOARD P ASSY	1		
6	301002502T	ELEVATOR ARM A ASSY	3		
7	301002503T	ELEVATOR SIDE ARM B ASSY	2		
8	301002504T	ELEVATOR FRONT ARM A ASSY	1		
9	30100221T	CAM LEVER SPRING	1		
10	30100222T	CS COLLAR SCREW	1		
11	30100223T	CAM SPRING	1		
12	30100202T	LIFT CAM	1		
13	301002501T	ELEVATOR MOTOR BRACKET ASSY	1		
14	RF-370C-15370	MOTOR	2		
15	30100210T	ELEVATOR GEAR B	2		
16	30100211T	ELEVATOR GEAR C	1		
17	30100212T	ELEVATOR GEAR D	1		
18	640101204T	LEAF SWITCH	2		
19	30100204T	CAM SLIDER	1		
20	30100205T	CAM SPRING PLATE	1		
21	30100206T	CAM LEVER	1		
22	30100207T	CAM ROLLER	1		
23	30100301T	GUIDE BASE	1		
24	30100311T	ELEVATOR SLIDE LEVER	1		
25	30100312T	ELEVATOR SLIDE LEVER SPRING	1		
26	30100303T	MAGAZINE GUIDE	1	LEFT	
27	30100304T	MAGAZINE GUIDE	1	RIGHT	
28	30100305T	GUIDE COVER	1		
29	30050309T	TRAY STOPPER	1		
30	30100310T	RELEASE LEVER	1		
31	30100308T	ELEVATOR KICK LEVER	1		
32	30100307T	LOCK LEVER	1		
33	30100309T	ELEVATOR KICK LEVER SPRING	1		
34	30100313T	RELEASE LEVER SPRING	1		
35	30100306T	CAM STABILIZER	1		
36	64020403T	PUSH SWITCH	4		
37	30050508T	FEED GEAR A	2		
38	301005501T	FEED RAIL ASSY	1		
39	30100504T	HOOK SLIDE GEAR	1		
40	30100505T	SLIDE GEAR PLATE	1		
41	30050738T	TURNTABLE BASE	1		
42	60020705T	MOTOR	1		
43	30050729T	TURNTABLE	1		
44	30050713T	TURNTABLE PLATE	1		
45	30050742T	CONTROLLER SPRING	1		
46	30050721T	FLOATING RUBBER	3		
47	30050715T	FLOATING SPRING (B)	2		
48	30050743T	FLOATING SCREW	3		
49	30050740T	FLOATING SPRING	1		
50	60021102T	MOTOR	1		
51	30050709T	MOTOR PULLEY	1		
52	30050714T	FEED MOTOR BELT	1		
53	30050737T	PICK UP SUPPORT	1		
54	30050724T	SHAFT HOLDER A	1		
55	300507303T	FEED SCREW ASSY	1		

Item	Part Number	Part Name	Q'ty	Description	Areas
56	30050728T	PICK UP SHAFT	1		
57	30050735T	FEED NUT HOLDER	1		
58	30050739T	FEED NUT SPRING	1		
59	EWS26A-B921	SOCKET WIRE	1		
60	OPTIMA-5S	PICK UP	1		
61	EWS264-B924	SOCKET WIRE ASSY	1		
62	301008503T	RAIL BASE ASSY	1		
63	30100802T	RAIL	1	LEFT	
64	30100803T	RAIL	1	RIGHT	
65	30100804T	HOOK LEVER	1		
66	301008502T	LP BRACKET ASSY	1		
67	301008301T	MAGAZINE HOLDER ASSY	1		
68	30050114T	CHASSIS SUPPORT	1		
69	30050725T	SHAFT HOLDER B	1		
70	12030105T	TIE BAND	4		
71	300507305T	TURNTABLE BASE ASSY	1		
72	301004502T	PLUS 1 BASE ASSY	1		
73	301004302T	PLUS 1 RAIL BASE ASSY	1		
74	30100415T	STOPPER SPRING	1		
75	30050416T	STOPPER	1		
76	30100411T	PIUS 1 BELT	1		
77	30100403T	PLUS 1 GEAR A	2		
78	30100404T	PLUS 1 GEAR B	1		
79	30100515T	FEED GEAR C	2		
80	30100506T	FEED GEAR D	1		
81	30100516T	FEED GEAR E	3		
82	30100413T	FEED GEAR D SPRING	1		
83	30100412T	FEED GEAR E SPRING	1		
84	30100414T	SWITCH ACTUATOR	1		
85	30100418T	PLUS 1 SLIDE RAIL	1		
86	30101015T	WIRE	1		
87	E26554-005	TRAY	1		
88	SPSK1722M	SCREW	2		
89	9C0420253T	SCREW	1		
90	9C0720601T	SCREW	2		
91	9C0420303T	SCREW	1		
92	9C0420403T	SCREW	2		
93	9P0420031T	SCREW	4		
94	9P0220031T	SCREW	2		
95	9P0230041T	SCREW	2		
96	9P3320032T	SCREW	1		
97	9P0420051T	SCREW	3		
98	9P0420041T	SCREW	3		
99	9W0250110T	WASHER	14		
100	9W0113080T	WASHER	3		
101	REE3000X	E.RING	3		
102	9W0640040T	WASHER	3		
103	301002301T	ELEVATOR MOTOR ASSY	2		
104	300507306T	FEED MOTOR ASSY	1		
105	301002302T	CAM SLIDE ASSY	1		
106	30051007T	WIRE	1	ORANGE	
107	30051011T	WIRE	2	YELLOW	
108	30051014T	WIRE	1	BLUE	
109	30101001T	WIRE	2		
110	30101002T	WIRE	1	YELLOW	
111	30101003T	WIRE	1	BRACK	

Item	Part Number	Part Name	Q'ty	Description	Areas
112	30101005T	WIRE	1	BRACK	
113	30101006T	WIRE	1	RED	
114	30101007T	WIRE	1		
115	30101008T	WIRE	1		

■ How to install the gears and pulley when servicing.

1. Elevator Motor , Loading Motor

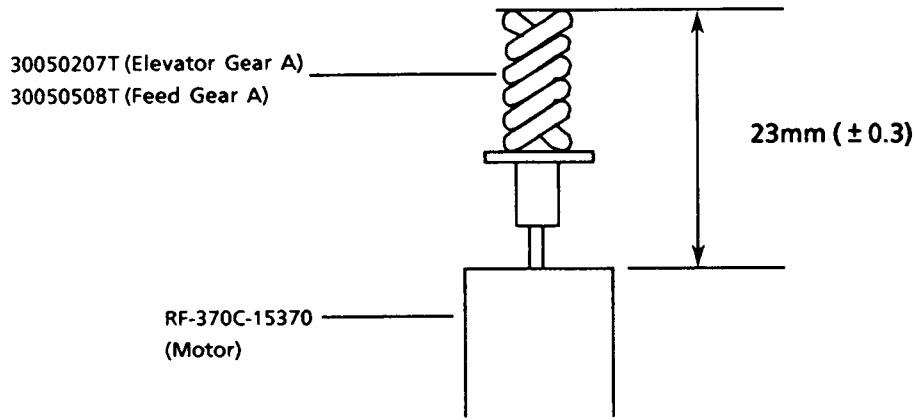

2. Loading Motor for single tray

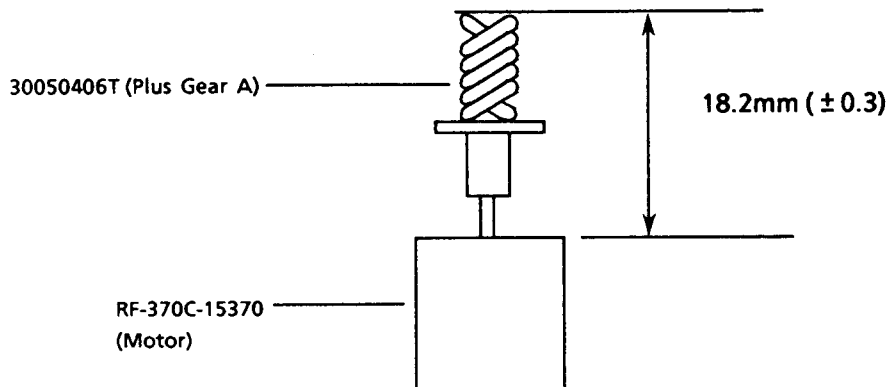

3. Feed Motor

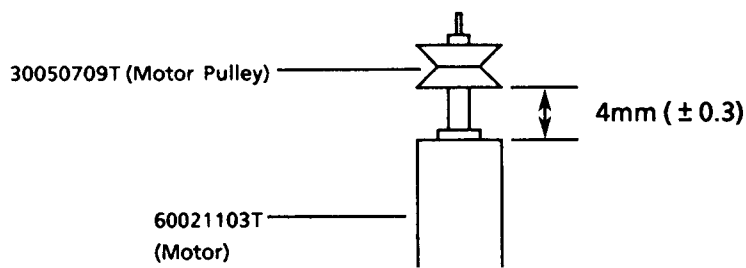

Printed Circuit Board Ass'y and Parts List

■ ENN-365 □ Main & Front PC Board Ass'y

Note : ENN-365 □ varies according to the areas employed. See note (1) when placing an order.

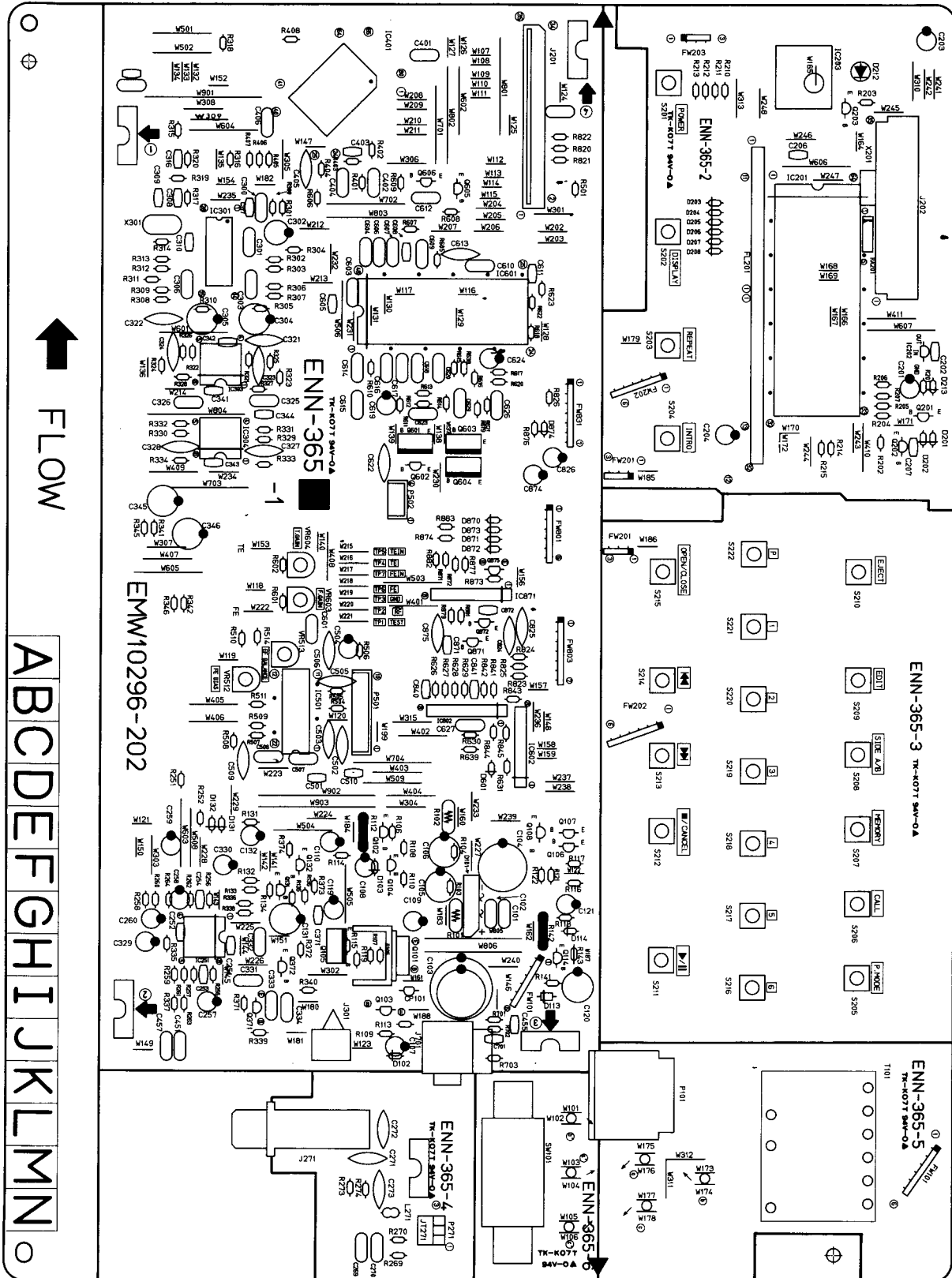

↑ FLOW

A
B
C
D
E
F
G
H
I
J
K
L
M
N
○

EMW10296-202

ENN-365-3 TR-KOT7 SAW-QA

ENN-365-5 TR-KOT7 SAW-QA

ENN-365-6 TR-KOT7 SAW-QA

DIODES

Note (1)

PC Board Ass'y	Designated Areas
ENN-365 D	the U.S.A.
ENN-365 C	Canada
ENN-365 F	Universal Type Taiwan
ENN-365 A	Australia
ENN-365 E	Continental Europe Scandinavia

ITEM	PART NUMBER	DESCRIPTION	AREA
D204	1SS119	SILICON HITACHI	
D205	1SS119	SILICON HITACHI	
D206	1SS119	SILICON HITACHI	
D207	1SS119	SILICON HITACHI	
D208	1SS119	SILICON HITACHI	
D212	SLH-56VC50F130	L.E.D. ROHM	
D213	1SS133	SILICON ROHM	
D870	1SS133	SILICON ROHM	
D871	1SS133	SILICON ROHM	
D872	1SS133	SILICON ROHM	
D873	1SS133	SILICON ROHM	

TRANSISTORS

ITEM	PART NUMBER	DESCRIPTION	AREA
Q101	2SB1187(E,F)	SILICON ROHM	
Q102	2SC2060(Q,R)	SILICON ROHM	
Q103	2SD1302(S,T)	SILICON MATSUSHITA	
Q104	2SA933S(R,S)	SILICON ROHM	
Q105	2SB1357(E,F)	SILICON ROHM	
Q106	2SD2144S(VW)	SILICON ROHM	
Q107	2SD2144S(VW)	SILICON ROHM	
Q108	DTA114YS	SILICON ROHM	
Q114	2SA733A(P,Q)	SILICON NEC	
Q131	2SA933S(R,S)	SILICON ROHM	
Q132	2SD2144S(VW)	SILICON ROHM	
Q201	DTA114YS	SILICON ROHM	
Q202	DTC144ES	SILICON ROHM	
Q203	DTC114YS	SILICON ROHM	
Q371	2SD1302(S,T)	SILICON MATSUSHITA	
Q372	2SD1302(S,T)	SILICON MATSUSHITA	
Q601	2SD2037(E,F)	SILICON ROHM	
Q602	2SA934(Q,R)	SILICON ROHM	
Q603	2SD2037(E,F)	SILICON ROHM	
Q604	2SB1357(E,F)	SILICON ROHM	
Q605	DTC144ES	SILICON ROHM	
Q871	2SC2060(Q,R)	SILICON ROHM	
Q872	2SA934(Q,R)	SILICON ROHM	
Q875	DTC144ES	SILICON ROHM	

CAPACITORS

ITEM	PART NUMBER	DESCRIPTION	AREA
C101	QFV81HJ-104	0.1MF 50V T.FILM	
C102	QFV81HJ-104	0.1MF 50V T.FILM	
C103	QETB1CM-228	2200MF 16V ELECTRO	A
C103	QETB1CM-228	2200MF 16V ELECTRO	C
C103	QETB1CM-228	2200MF 16V ELECTRO	D
C103	QETB1CM-228	2200MF 16V ELECTRO	E
C103	QETB1CM-338	3300MF 16V ELECTRO	F
C104	QETB1CM-228	2200MF 16V ELECTRO	
C105	QETB1CM-227	220MF 16V ELECTRO	
C106	QETB1CM-227	220MF 16V ELECTRO	
C107	QETB1HM-225	2.2MF 50V ELECTRO	
C108	QETB1HM-225	2.2MF 50V ELECTRO	
C109	QETB1AM-476	47MF 10V ELECTRO	
C110	QETB1AM-476	47MF 10V ELECTRO	
C119	QETB0JM-477	470MF 6.3V ELECTRO	
C120	QETB1HM-107	100MF 50V ELECTRO	
C131	QETB1CM-227	220MF 16V ELECTRO	
C132	QETB1CM-226	22MF 16V ELECTRO	
C201	QETB1EM-106	10MF 25V ELECTRO	
C202	QCHB1EZ-223	0.022MF 25V CERAMIC	
C203	QETB1HM-475	4.7MF 50V ELECTRO	
C204	QEK51HM-475	4.7MF 50V ELECTRO	
C206	QCHB1EZ-223	0.022MF 25V CERAMIC	
C207	QCSB1HK-331	330PF 50V CERAMIC	
C210	QFV81HJ-104	0.1MF 50V T.FILM	
C251	QCHB1EZ-223	0.022MF 25V CERAMIC	
C252	QCHB1EZ-223	0.022MF 25V CERAMIC	
C253	QCSB1HJ-470	47PF 50V CERAMIC	
C254	QCSB1HJ-470	47PF 50V CERAMIC	
C257	QETB1HM-475	4.7MF 50V ELECTRO	
C258	QETB1HM-475	4.7MF 50V ELECTRO	
C269	QFN81HJ-103	0.01MF 50V MYLAR	
C270	QFN81HJ-103	0.01MF 50V MYLAR	
C271	QCS21HJ-471	470PF 50V CERAMIC	
C272	QCS21HJ-471	470PF 50V CERAMIC	
C273	QCF21HP-223	0.022MF 50V CERAMIC	
C300	QCZ0205-155	1.5MF 25V CERAMIC	
C301	QCZ0205-155	1.5MF 25V CERAMIC	
C302	QETB1AM-227	220MF 10V ELECTRO	
C303	QCZ0205-155	1.5MF 25V CERAMIC	
C304	QETB0JM-227	220MF 6.3V ELECTRO	
C305	QETB0JM-227	220MF 6.3V ELECTRO	
C306	QCZ0205-155	1.5MF 25V CERAMIC	
C308	QCT30CH-120	12PF 50V CERAMIC	
C309	QCT30CH-3R9	3.9PF 50V CERAMIC	
C310	QCSB1HJ-270	27PF 50V CERAMIC	
C316	QCHB1EZ-223	0.022MF 25V CERAMIC	
C317	QCT30CH-100	10PF 50V CERAMIC	
C321	QFN81HJ-122	1200PF 50V MYLAR	
C322	QFN81HJ-122	1200PF 50V MYLAR	
C323	QCS21HJ-221	220PF 50V CERAMIC	
C324	QCS21HJ-221	220PF 50V CERAMIC	
C325	QFN81HJ-392	3900PF 50V MYLAR	
C326	QFN81HJ-392	3900PF 50V MYLAR	
C327	QCS21HJ-121	120PF 50V CERAMIC	
C328	QCS21HJ-121	120PF 50V CERAMIC	
C329	QETB1CM-226	22MF 16V ELECTRO	
C330	QETB1CM-226	22MF 16V ELECTRO	
C331	QFN81HJ-562	5600PF 50V MYLAR	
C332	QFN81HJ-562	5600PF 50V MYLAR	
C333	QFN81HJ-472	4700PF 50V MYLAR	
C334	QFN81HJ-472	4700PF 50V MYLAR	
C341	QCHB1EZ-223	0.022MF 25V CERAMIC	
C342	QCHB1EZ-223	0.022MF 25V CERAMIC	
C343	QCHB1EZ-223	0.022MF 25V CERAMIC	
C344	QCHB1EZ-223	0.022MF 25V CERAMIC	
C345	QETB1CM-227	220MF 16V ELECTRO	
C346	QETB1CM-227	220MF 16V ELECTRO	
C401	QCZ0205-155	1.5MF 25V CERAMIC	
C402	QFN81HJ-473	0.047MF 50V MYLAR	

I. C. S.

ITEM	PART NUMBER	DESCRIPTION	AREA
IC201	MN171602JHC	I.C. MATSUSHITA	
IC202	MN1281(P,Q)	I.C. MATSUSHITA	
IC203	GP1U571X	I.C. SHARP	
IC251	VC4580D	I.C. DAINICHI	
IC301	MN35500	I.C. MATSUSHITA	
IC302	VC4580D	I.C. DAINICHI	
IC304	VC4580D	I.C. DAINICHI	
IC401	CXD2500BQ	I.C. 1680	
IC501	CXA1571S	I.C. 1680	
IC601	CXA1372S	I.C. 1680	
IC602	STA341M(A)	I.C. SANKEN	
IC802	M5218AL	I.C. MITSUBISHI	
IC871	M5218AL	I.C. MITSUBISHI	

DIODES

ITEM	PART NUMBER	DESCRIPTION	AREA
D101	S1VB20F	SILICON SINDENGEN	
D102	MTZ5.6JB	ZENER ROHM	
D103	MTZ5.6JB	ZENER ROHM	
D113	1SR139-200	SILICON ROHM	
D114	MTZ33JC	ZENER ROHM	
D131	1SS133	SILICON ROHM	
D132	1SS133	SILICON ROHM	
D201	1SS133	SILICON ROHM	
D202	1SS133	SILICON ROHM	
D203	1SS119	SILICON HITACHI	

△ : SAFETY PARTS

△ : SAFETY PARTS

CAPACITORS

ITEM	PART NUMBER	DESCRIPTION	AREA
C403	QCHB1EZ-223	0.022MF 25V CERAMIC	
C404	QFN81HJ-152	1500PF 50V MYLAR	
C405	QCF21HP-103	0.01MF 50V CERAMIC	
C406	QCZ0205-155	1.5MF 25V CERAMIC	
C407	QCS21HJ-120	12PF 50V CERAMIC	
C451	QCZ0205-155	1.5MF 25V CERAMIC	E
C455	QCHB1EZ-223	0.022MF 25V CERAMIC	E
C457	QCF21HP-223	0.022MF 50V CERAMIC	E
C501	QCHB1EZ-223	0.022MF 25V CERAMIC	
C502	QCS21HJ-100	10PF 50V CERAMIC	
C503	QCS21HJ-100	10PF 50V CERAMIC	
C504	QETB1AM-476	47MF 10V ELECTRO	
C505	QCS21HJ-820	82PF 50V CERAMIC	
C506	QCS21HJ-101	100PF 50V CERAMIC	
C507	QFV81HJ-104	0.1MF 50V T.FILM	
C508	QCZ0205-155	1.5MF 25V CERAMIC	
C509	QCS21HJ-220	22PF 50V CERAMIC	
C510	QCHB1EZ-223	0.022MF 25V CERAMIC	
C601	QFN81HJ-182	1800PF 50V MYLAR	
C603	QFN81HJ-222	2200PF 50V MYLAR	
C604	QFN81HJ-222	2200PF 50V MYLAR	
C605	QCHB1EZ-223	0.022MF 25V CERAMIC	
C606	QFN81HJ-333	0.033MF 50V MYLAR	
C607	QFN81HJ-103	0.01MF 50V MYLAR	
C608	QCHB1EZ-223	0.022MF 25V CERAMIC	
C609	QFN81HJ-333	0.033MF 50V MYLAR	
C610	QCZ0205-155	1.5MF 25V CERAMIC	
C611	QCHB1EZ-223	0.022MF 25V CERAMIC	
C613	QFV81HJ-104	0.1MF 50V T.FILM	
C614	QFN81HJ-104	0.1MF 50V MYLAR	
C615	QFN81HJ-333	0.033MF 50V MYLAR	
C616	QFN81HJ-473	0.047MF 50V MYLAR	
C617	QFN81HJ-473	0.047MF 50V MYLAR	
C618	QFN81HJ-473	0.047MF 50V MYLAR	
C619	QETB1HM-335	3.3MF 50V ELECTRO	
C620	QFN81HJ-104	0.1MF 50V MYLAR	
C622	QCF21HP-223	0.022MF 50V CERAMIC	
C623	QFN81HJ-563	0.056MF 50V MYLAR	
C624	QETB1EM-106	10MF 25V ELECTRO	
C626	QFN81HJ-103	0.01MF 50V MYLAR	
C627	QFN81HJ-103	0.01MF 50V MYLAR	
C629	QFN81HJ-333	0.033MF 50V MYLAR	
C701	QCB11K-101	100PF 50V CERAMIC	
C824	QCF21HP-223	0.022MF 50V CERAMIC	
C825	QCF21HP-223	0.022MF 50V CERAMIC	
C840	QCHB1EZ-223	0.022MF 25V CERAMIC	
C841	QCHB1EZ-223	0.022MF 25V CERAMIC	
C871	QCHB1EZ-223	0.022MF 25V CERAMIC	
C872	QCHB1EZ-223	0.022MF 25V CERAMIC	
C874	QETB1HM-105	1MF 50V ELECTRO	
C875	QCF21HP-223	0.022MF 50V CERAMIC	

RESISTORS

ITEM	PART NUMBER	DESCRIPTION	AREA
R101	PTH61G30BD2R2N	FUSIBLE RE	SI A
R101	PTH61G30BD2R2N	FUSIBLE RE	SI C
R101	PTH61G30BD2R2N	FUSIBLE RE	SI E
R101	PTH61G30BD2R2N	FUSIBLE RE	SI F
R102	PTH61G30BD2R2N	FUSIBLE RE	SI A
R102	PTH61G30BD2R2N	FUSIBLE RE	SI C
R102	PTH61G30BD2R2N	FUSIBLE RE	SI E
R102	PTH61G30BD2R2N	FUSIBLE RE	SI F
R105	QRD167J-222	2.2K 1/6W CARBON	
R106	QRD167J-222	2.2K 1/6W CARBON	
R107	QRD161J-221	220 1/6W CARBON	
R108	QRD161J-221	220 1/6W CARBON	
R109	QRD161J-221	220 1/6W CARBON	
R110	QRD161J-221	220 1/6W CARBON	
R112	QRZ0077-100	10 1/4W FUSIBLE	A
R112	QRZ0077-100	10 1/4W FUSIBLE	C
R112	QRZ0077-100	10 1/4W FUSIBLE	E
R112	QRZ0077-100	10 1/4W FUSIBLE	F
R113	QRD167J-222	2.2K 1/6W CARBON	
R114	QRD167J-821	820 1/6W CARBON	
R115	QRD167J-102	1K 1/6W CARBON	
R116	QRD167J-152	1.5K 1/6W CARBON	
R117	QRD167J-152	1.5K 1/6W CARBON	
R118	QRD167J-563	56K 1/6W CARBON	
R119	QRD167J-821	820 1/6W CARBON	
R121	QRD167J-103	10K 1/6W CARBON	
R122	QRD167J-103	10K 1/6W CARBON	
R131	QRD161J-221	220 1/6W CARBON	
R132	QRD167J-331	330 1/6W CARBON	
R134	QRD167J-822	8.2K 1/6W CARBON	
R135	QRD167J-683	68K 1/6W CARBON	
R136	QRD167J-473	47K 1/6W CARBON	
R141	QRD167J-123	12K 1/6W CARBON	
R142	QRZ0077-560	56 1/4W FUSIBLE	A
R142	QRZ0077-560	56 1/4W FUSIBLE	C

△: SAFETY PARTS

RESISTORS

ITEM	PART NUMBER	DESCRIPTION	AREA
R142	QRZ0077-560	56 1/4W FUSIBLE	E
R142	QRZ0077-560	56 1/4W FUSIBLE	F
R201	QRD167J-821	820 1/6W CARBON	
R202	QRD167J-472	4.7K 1/6W CARBON	
R203	QRD167J-181	180 1/6W CARBON	
R204	QRD167J-103	10K 1/6W CARBON	
R205	QRD167J-472	4.7K 1/6W CARBON	
R206	QRD167J-103	10K 1/6W CARBON	
R207	QRD167J-103	10K 1/6W CARBON	
R210	QRD167J-103	10K 1/6W CARBON	
R211	QRD167J-103	10K 1/6W CARBON	
R212	QRD167J-103	10K 1/6W CARBON	
R213	QRD167J-103	10K 1/6W CARBON	
R214	QRD167J-102	1K 1/6W CARBON	
R215	QRD167J-102	1K 1/6W CARBON	
R251	QRD161J-221	220 1/6W CARBON	
R252	QRD161J-221	220 1/6W CARBON	
R255	QRD167J-562	5.6K 1/6W CARBON	
R256	QRD167J-562	5.6K 1/6W CARBON	
R257	QRD167J-273	27K 1/6W CARBON	
R258	QRD167J-273	27K 1/6W CARBON	
R259	QRD167J-473	47K 1/6W CARBON	
R260	QRD167J-473	47K 1/6W CARBON	
R261	QRD167J-103	10K 1/6W CARBON	
R262	QRD167J-103	10K 1/6W CARBON	
R263	QRD167J-561	560 1/6W CARBON	
R264	QRD167J-561	560 1/6W CARBON	
R269	QRD167J-680	68 1/6W CARBON	
R270	QRD167J-680	68 1/6W CARBON	
R273	QRD167J-390	39 1/6W CARBON	
R274	QRD167J-390	39 1/6W CARBON	
R300	QRD167J-560	56 1/6W CARBON	
R301	QRD167J-560	56 1/6W CARBON	
R302	QRV144F-1802	18K 1/4W M.FILM	
R303	QRV144F-1802	18K 1/4W M.FILM	
R304	QRD167J-271	270 1/6W CARBON	
R305	QRD167J-182	1.8K 1/6W CARBON	
R306	QRV144F-1802	18K 1/4W M.FILM	
R307	QRV144F-1802	18K 1/4W M.FILM	
R308	QRV144F-1802	18K 1/4W M.FILM	
R309	QRV144F-1802	18K 1/4W M.FILM	
R310	QRD167J-182	1.8K 1/6W CARBON	
R311	QRD167J-271	270 1/6W CARBON	
R312	QRV144F-1802	18K 1/4W M.FILM	
R313	QRV144F-1802	18K 1/4W M.FILM	
R314	QRD167J-330	33 1/6W CARBON	
R315	QRD167J-560	56 1/6W CARBON	
R316	QRD167J-271	270 1/6W CARBON	
R317	QRD167J-155	1.5M 1/6W CARBON	
R318	QRD167J-102	1K 1/6W CARBON	
R319	QRD167J-681	680 1/6W CARBON	
R320	QRD167J-121	120 1/6W CARBON	
R321	QRD167J-182	1.8K 1/6W CARBON	
R322	QRD167J-182	1.8K 1/6W CARBON	
R323	QRD167J-182	1.8K 1/6W CARBON	
R324	QRD167J-182	1.8K 1/6W CARBON	
R325	QRD167J-123	12K 1/6W CARBON	
R326	QRD167J-123	12K 1/6W CARBON	
R327	QRD167J-123	12K 1/6W CARBON	
R328	QRD167J-123	12K 1/6W CARBON	
R329	QRD167J-123	12K 1/6W CARBON	
R330	QRD167J-123	12K 1/6W CARBON	
R331	QRD167J-272	2.7K 1/6W CARBON	
R332	QRD167J-272	2.7K 1/6W CARBON	
R335	QRD167J-273	27K 1/6W CARBON	
R336	QRD167J-273	27K 1/6W CARBON	
R337	QRD167J-331	330 1/6W CARBON	
R338	QRD167J-331	330 1/6W CARBON	
R339	QRD167J-331	330 1/6W CARBON	
R340	QRD167J-331	330 1/6W CARBON	
R341	QRD161J-221	220 1/6W CARBON	
R342	QRD161J-221	220 1/6W CARBON	
R345	QRD161J-221	220 1/6W CARBON	
R346	QRD161J-221	220 1/6W CARBON	
R371	QRD167J-103	10K 1/6W CARBON	
R372	QRD167J-103	10K 1/6W CARBON	
R373	QRD167J-684	680K 1/6W CARBON	
R374	QRD167J-473	47K 1/6W CARBON	
R401	QRD167J-332	3.3K 1/6W CARBON	
R402	QRD167J-682	6.8K 1/6W CARBON	
R403	QRD167J-103	10K 1/6W CARBON	
R404	QRD167J-103	10K 1/6W CARBON	
R405	QRD167J-102	1K 1/6W CARBON	
R406	QRD167J-102	1K 1/6W CARBON	
R407	QRD167J-102	1K 1/6W CARBON	
R408	QRD167J-102	1K 1/6W CARBON	
R409	QRD167J-560	56 1/6W CARBON	
R501	QRD167J-102	1K 1/6W CARBON	E
R504	QRD167J-183	18K 1/6W CARBON	
R505	QRD167J-183	18K 1/6W CARBON	
R506	QRD167J-121	120 1/6W CARBON	
R507	QRD167J-103	10K 1/6W CARBON	
R508	QRD167J-332	3.3K 1/6W CARBON	
R509	QRD167J-822	8.2K 1/6W CARBON	
R510	QRD167J-113	11K 1/6W CARBON	

△: SAFETY PARTS

RESISTORS

ITEM	PART NUMBER	DESCRIPTION	AREA
R511	QRD167J-104	100K 1/6W CARBON	
R514	QRD167J-103	10K 1/6W CARBON	
R601	QRD167J-472	4.7K 1/6W CARBON	
R602	QRD167J-472	4.7K 1/6W CARBON	
R605	QRD167J-102	1K 1/6W CARBON	
R606	QRD167J-104	100K 1/6W CARBON	
R610	QRD167J-224	220K 1/6W CARBON	
R611	QRD167J-2R2	2.2 1/6W CARBON	
R612	QRD167J-683	68K 1/6W CARBON	
R613	QRD167J-104	100K 1/6W CARBON	
R614	QRD167J-2R2	2.2 1/6W CARBON	
R615	QRD167J-224	220K 1/6W CARBON	
R616	QRD167J-273	27K 1/6W CARBON	
R617	QRD167J-332	3.3K 1/6W CARBON	
R618	QRD167J-514	510K 1/6W CARBON	
R619	QRD167J-2R2	2.2 1/6W CARBON	
R620	QRD167J-562	5.6K 1/6W CARBON	
R621	QRD167J-683	68K 1/6W CARBON	
R622	QRD167J-124	120K 1/6W CARBON	
R623	QRD167J-472	4.7K 1/6W CARBON	
R626	QRD167J-153	15K 1/6W CARBON	
R627	QRD167J-333	33K 1/6W CARBON	
R628	QRD167J-752	7.5K 1/6W CARBON	
R629	QRD167J-752	7.5K 1/6W CARBON	
R630	QRD167J-333	33K 1/6W CARBON	
R631	QRD167J-470	47 1/6W CARBON	
R638	QRD167J-184	180K 1/6W CARBON	
R640	QRD167J-475	4.7M 1/6W CARBON	
R701	QRD161J-221	220 1/6W CARBON	
R702	QRD161J-221	220 1/6W CARBON	
R703	QRD167J-101	100 1/6W CARBON	
R820	QRD161J-221	220 1/6W CARBON	
R821	QRD161J-221	220 1/6W CARBON	
R822	QRD161J-221	220 1/6W CARBON	
R823	QRD161J-221	220 1/6W CARBON	
R824	QRD161J-221	220 1/6W CARBON	
R825	QRD161J-221	220 1/6W CARBON	
R826	QRD167J-101	100 1/6W CARBON	
R841	QRD167J-243	24K 1/6W CARBON	
R842	QRD167J-183	18K 1/6W CARBON	
R843	QRD167J-203	20K 1/6W CARBON	
R844	QRD167J-183	18K 1/6W CARBON	
R845	QRD167J-820	82 1/6W CARBON	
R871	QRD167J-273	27K 1/6W CARBON	
R872	QRD167J-223	22K 1/6W CARBON	
R873	QRD167J-303	30K 1/6W CARBON	
R874	QRD167J-103	10K 1/6W CARBON	
R876	QRD167J-473	47K 1/6W CARBON	
R877	QRD167J-752	7.5K 1/6W CARBON	
R879	QRD161J-221	220 1/6W CARBON	
R881	QRD167J-393	39K 1/6W CARBON	
R882	QRD167J-123	12K 1/6W CARBON	
R883	QRD167J-153	15K 1/6W CARBON	
RA201	QRB049J-103	10K 1/10W R.NETWORK	
VR512	QVPA601-203A	20K VARIABLE	
VR513	QVPA601-203A	20K VARIABLE	
VR603	QVPA601-203A	20K VARIABLE	
VR604	QVPA601-203A	20K VARIABLE	

△ : SAFETY PARTS

OTHERS

ITEM	PART NUMBER	DESCRIPTION	AREA
	E3400-439	FELT SPACER	
	E70306-001	HEAT SINK	
	E70859-001	EARTH PLATE	
	E75819-001	SUPPORT HOLDER	
	E75820-001	SUPPORT HOLDER	
	SBSE3008Z	SCREW	
	E70859-001	EARTH PLATE	E
J201	EMV7123-035	CONNECTOR	
J202	EMV7123-035R	CONNECTOR	
J271	QMS6A20-E21H	HEADPHONE JACK	
J301	EMN00TV-214A	2P PIN JACK	
J701	QMS3501-020	MINI JACK	
L108	EQL4004-100	INDUCTOR	A
L108	EQL4004-100	INDUCTOR	E
L108	EQL4004-100	INDUCTOR	F
L197	EQL4004-100	INDUCTOR	A
L197	EQL4004-100	INDUCTOR	E
L197	EQL4004-100	INDUCTOR	F
L271	EQL4004-1R0	INDUCTOR	
P101	QMCB001-E02H	AC SOCKET	A
P101	QMCB001-E03H	AC INLET	C
P101	QMCB001-E03H	AC INLET	D
P101	QMCB001-E02H	AC SOCKET	E
P101	QMCB001-E02H	AC SOCKET	F
P501	EMV5109-010A	PLUG ASSY	
P502	EMV5109-004A	PLUG ASSY	
S201	ESP0001-018	TACT SWITCH	
S202	ESP0001-018	TACT SWITCH	
S203	ESP0001-018	TACT SWITCH	
S204	ESP0001-018	TACT SWITCH	
S205	ESP0001-018	TACT SWITCH	
S206	ESP0001-018	TACT SWITCH	
S207	ESP0001-018	TACT SWITCH	
S208	ESP0001-018	TACT SWITCH	
S209	ESP0001-018	TACT SWITCH	
S210	ESP0001-018	TACT SWITCH	
S211	ESP0001-018	TACT SWITCH	
S212	ESP0001-018	TACT SWITCH	
S213	ESP0001-018	TACT SWITCH	
S214	ESP0001-018	TACT SWITCH	
S215	ESP0001-018	TACT SWITCH	
S216	ESP0001-018	TACT SWITCH	
S217	ESP0001-018	TACT SWITCH	
S218	ESP0001-018	TACT SWITCH	
S219	ESP0001-018	TACT SWITCH	
S220	ESP0001-018	TACT SWITCH	
S221	ESP0001-018	TACT SWITCH	
S222	ESP0001-018	TACT SWITCH	
X201	ECX0060-000EM	RESONATOR	
X301	ECX0169-344EA	RESONATOR	
△ CP101	ICP-N5	I.C. PROTECTOR	A
△ CP101	ICP-N5	I.C. PROTECTOR	C
△ CP101	ICP-N5	I.C. PROTECTOR	E
△ CP101	ICP-N5	I.C. PROTECTOR	F
FL201	ELU0001-132	FL TUBE	
FW101	EWR36B-40SST	FLAT WIRE	
FW201	EWR33B-20SST	FLAT WIRE	
FW202	EWR36B-30SST	FLAT WIRE	
FW203	EWR33B-10LST	FLAT WIRE	
FW801	EWR36B-10KST	FLAT WIRE	
FW803	EWR37B-10KST	FLAT WIRE	
FW831	EWR37B-10KST	FLAT WIRE	
JT271	EMV7122-103	CONNECTOR	
SW101	QSS1L22-E01	SLIDE SWITCH	F

△ : SAFETY PARTS

Accessories List

△	Part Number	Part Name	Q'ty	Description	Area
	E30580-1948A	INSTRUCTION BOOK	1		A
	E30580-1950A	INSTRUCTION BOOK	1		C
	E30580-1950A	INSTRUCTION BOOK	1		EF
	E30580-1949A	INSTRUCTION BOOK	1		EN
	E30580-1948A	INSTRUCTION BOOK	1		J
	E30580-1950A	INSTRUCTION BOOK	1		U
	E30580-1950A	INSTRUCTION BOOK	1		UT
△	QMP25D0-183	POWER CORD	1		A
△	QMP1E00-183J5	POWER CORD	1		C
△	QMP39F0-183	POWER CORD	1		EF
△	QMP39F0-183	POWER CORD	1		EN
△	QMP1E00-183J5	POWER CORD	1		J
△	QMP7530-183	POWER CORD	1		U
△	QMP7530-183	POWER CORD	1		UT
	EWP302-013K	SIGNAL CORD	1		
	EWP805-009K	PLUG WIRE ASSY	1		
	BT-20044G	SAFETY SHEET	1		J
	BT-20025K	WARRANTY CARD	1		C
	BT20071A	SERVICE NETWORK	1		C
	BT-20122-1	STICKER	1		A
	BT-20122	WARRANTY CARD	1		A
	E35497-022	CAUTION SHEET	1		U
	E35497-022	CAUTION SHEET	1		UT
△	E04056	SIEMENS PLUG	1		U
△	E04056	SIEMENS PLUG	1		UT
	E300196-010	ENVELOPE	1		A
	E300196-010	ENVELOPE	1		C
	E300196-010	ENVELOPE	1		EF
	E300196-010	ENVELOPE	1		EN
	E300196-010B	ENVELOPE	1		J
	E300196-010	ENVELOPE	1		U
	E300196-010	ENVELOPE	1		UT
	E26072-005	CD RACK	1		
	RM-SX409U	WIRE-LESS REMOTE CONTROL	1		
	56V723A	BATTERY COVER	1		
	R6PRPA-2ST	DRY CELL	2		J
	R6PRPA-2ST	DRY CELL	2		C
	UM-3(DJ)-2PSA	BATTERY	1		A
	UM-3(DJ)-2PSA	BATTERY	1		EF
	UM-3(DJ)-2PSA	BATTERY	1		EN
	UM-3(DJ)-2PSA	BATTERY	1		U
	UM-3(DJ)-2PSA	BATTERY	1		UT
	BT-51001-1	WARRANTY CARD	1		J
	BT-51006-1	REGISTER CARD	1		J
	E300196-010	ENVELOPE	1		A
	E300196-010	ENVELOPE	1		C
	E300196-010	ENVELOPE	1		EF
	E300196-010	ENVELOPE	1		EN
	E300196-010B	ENVELOPE	1		J
	E300196-010	ENVELOPE	1		U
	E300196-010	ENVELOPE	1		UT

The Marks for Designated Areas

J the U.S.A.

U Universal

UT Taiwan

A Australia

EN Scandinavia

No mark indicates all area.

C Canada

EF Continental Europe

Packing Materials and Part Numbers

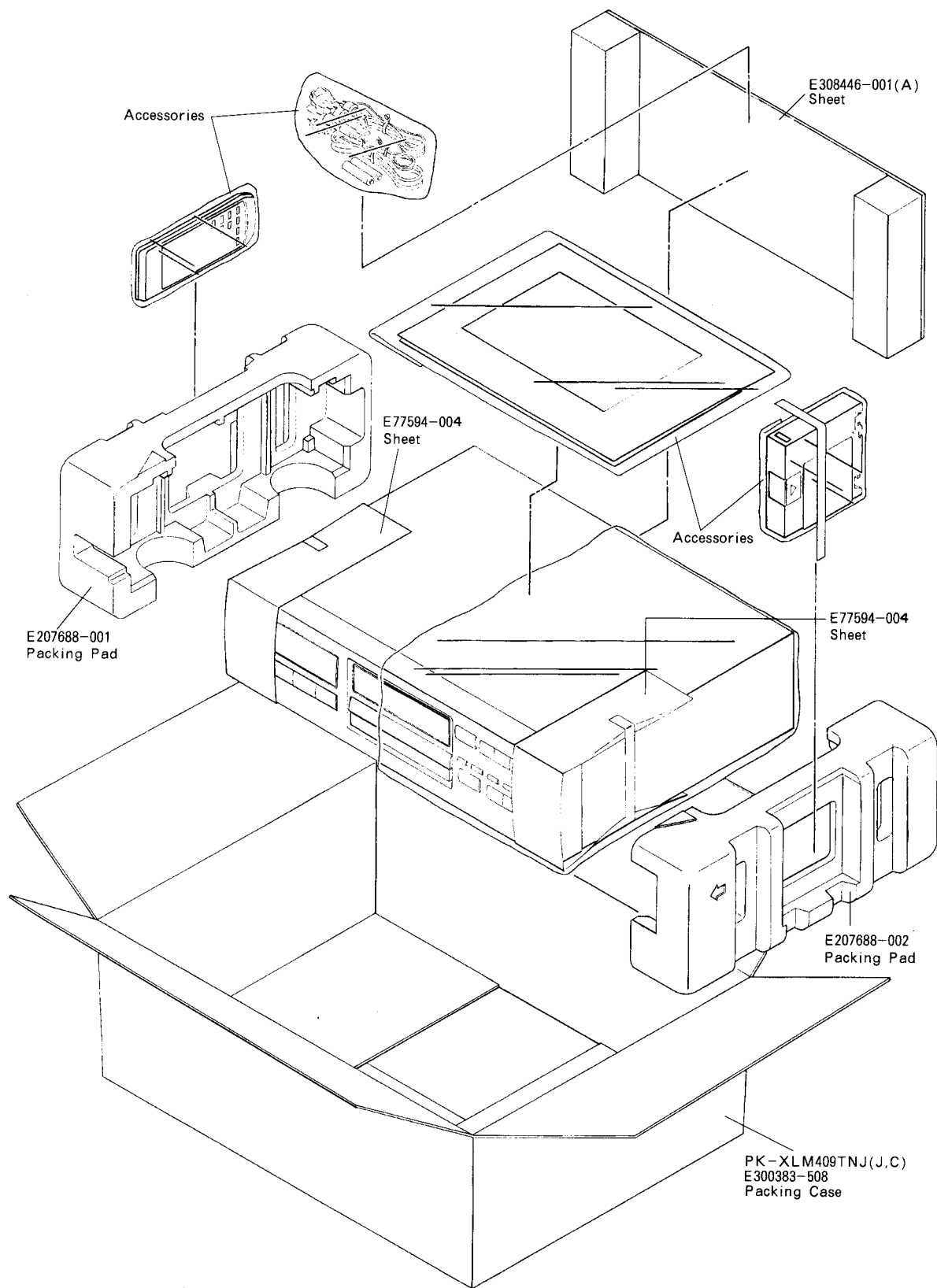

The Marks for Designated Areas

A	Australia	EF	Continental Europe	EN	Scandinavia
C	Canada	J	the U.S.A.	U	Universal Type
UT	Taiwan	No mark indicates all area.			

— MEMO —

— MEMO —



XL-M309TN
XL-M408BK
XL-M409TN

— MEMO —

XL-M309TN
XL-M408BK
XL-M409TN



JVC

VICTOR COMPANY OF JAPAN, LIMITED

AUDIO DIVISION, 1644, SHIMOTURUMA, YAMATO-SHI, KANAGAWA-KEN, 242, JAPAN

(No.20380)



Printed in Japan
9212 (V)