

# JVC

# SERVICE MANUAL

## PORTABLE CD PLAYER

### XL-PM11/XL-PM1



Area Suffix
<b>XL-PM11</b>
C ----- Canada

Area Suffix
<b>XL-PM1</b>
J ----- U.S.A.
C ----- Canada
B ----- U.K.
E ----- Continental Europe



Model XL-PM11 is an exclusive use for Canada. As for the difference between XL-PM11 and XL-PM1, the packing specification is different.

	<b>XL-PM11</b>	<b>XL-PM1</b>
PACKING	Gift box	Blister pack

### Contents

Safety Precautions .....	1-2	Explanation of MP3 .....	1-8
Important for laser products .....	1-3	Description of major ICs .....	1-9
Preventing static electricity .....	1-4	Parts list .....	1-13 ~18
Disassembly method .....	1-5		
Troubleshooting .....	1-7		

## Safety Precautions

1. This design of this product contains special hardware and many circuits and components specially for safety purposes. For continued protection, no changes should be made to the original design unless authorized in writing by the manufacturer. Replacement parts must be identical to those used in the original circuits. Services should be performed by qualified personnel only.
2. Alterations of the design or circuitry of the product should not be made. Any design alterations of the product should not be made. Any design alterations or additions will void the manufacturer's warranty and will further relieve the manufacture of responsibility for personal injury or property damage resulting therefrom.
3. Many electrical and mechanical parts in the products have special safety-related characteristics. These characteristics are often not evident from visual inspection nor can the protection afforded by them necessarily be obtained by using replacement components rated for higher voltage, wattage, etc. Replacement parts which have these special safety characteristics are identified in the Parts List of Service Manual. Electrical components having such features are identified by shading on the schematics and by ( $\triangle$ ) on the Parts List in the Service Manual. The use of a substitute replacement which does not have the same safety characteristics as the recommended replacement parts shown in the Parts List of Service Manual may create shock, fire, or other hazards.
4. The leads in the products are routed and dressed with ties, clamps, tubings, barriers and the like to be separated from live parts, high temperature parts, moving parts and/or sharp edges for the prevention of electric shock and fire hazard. When service is required, the original lead routing and dress should be observed, and it should be confirmed that they have been returned to normal, after re-assembling.

### 5. Leakage current check (Electrical shock hazard testing)

After re-assembling the product, always perform an isolation check on the exposed metal parts of the product (antenna terminals, knobs, metal cabinet, screw heads, headphone jack, control shafts, etc.) to be sure the product is safe to operate without danger of electrical shock.

Do not use a line isolation transformer during this check.

- Plug the AC line cord directly into the AC outlet. Using a "Leakage Current Tester", measure the leakage current from each exposed metal parts of the cabinet, particularly any exposed metal part having a return path to the chassis, to a known good earth ground. Any leakage current must not exceed 0.5mA AC (r.m.s.).

- Alternate check method

Plug the AC line cord directly into the AC outlet. Use an AC voltmeter having, 1,000 ohms per volt or more sensitivity in the following manner. Connect a 1,500  $\Omega$  10W resistor paralleled by a 0.15  $\mu$ F AC-type capacitor between an exposed metal part and a known good earth ground. Measure the AC voltage across the resistor with the AC voltmeter.

Move the resistor connection to each exposed metal part, particularly any exposed metal part having a return path to the chassis, and measure the AC voltage across the resistor. Now, reverse the plug in the AC outlet and repeat each measurement. Voltage measured any must not exceed 0.75 V AC (r.m.s.). This corresponds to 0.5 mA AC (r.m.s.).

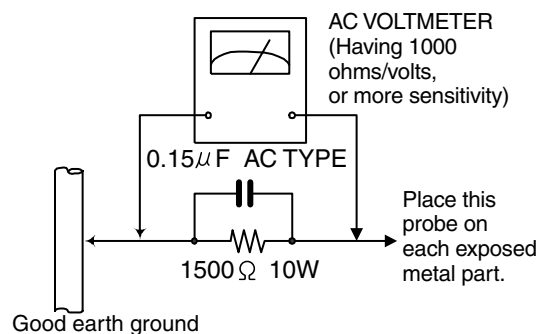

## Warning

1. This equipment has been designed and manufactured to meet international safety standards.
2. It is the legal responsibility of the repairer to ensure that these safety standards are maintained.
3. Repairs must be made in accordance with the relevant safety standards.
4. It is essential that safety critical components are replaced by approved parts.
5. If mains voltage selector is provided, check setting for local voltage.

## CAUTION

**Burrs formed during molding may be left over on some parts of the chassis. Therefore, pay attention to such burrs in the case of preforming repair of this system.**

In regard with component parts appearing on the silk-screen printed side (parts side) of the PWB diagrams, the parts that are printed over with black such as the resistor (■), diode (▣) and ICP (●) or identified by the " $\triangle$ " mark nearby are critical for safety.

When replacing them, be sure to use the parts of the same type and rating as specified by the manufacturer. (Except the J and C version)

# Important for laser products

**1.CLASS 1 LASER PRODUCT**

**2.DANGER :** Invisible laser radiation when open and inter lock failed or defeated. Avoid direct exposure to beam.

**3.CAUTION :** There are no serviceable parts inside the Laser Unit. Do not disassemble the Laser Unit. Replace the complete Laser Unit if it malfunctions.

**4.CAUTION :** The compact disc player uses invisible laserradiation and is equipped with safety switches which prevent emission of radiation when the drawer is open and the safety interlocks have failed or are defeated. It is dangerous to defeat the safety switches.

**5.CAUTION :** If safety switches malfunction, the laser is able to function.

**6.CAUTION :** Use of controls, adjustments or performance of procedures other than those specified herein may result in hazardous radiation exposure.

**⚠ CAUTION** Please use enough caution not to see the beam directly or touch it in case of an adjustment or operation check.

## Reproduction and position of labels

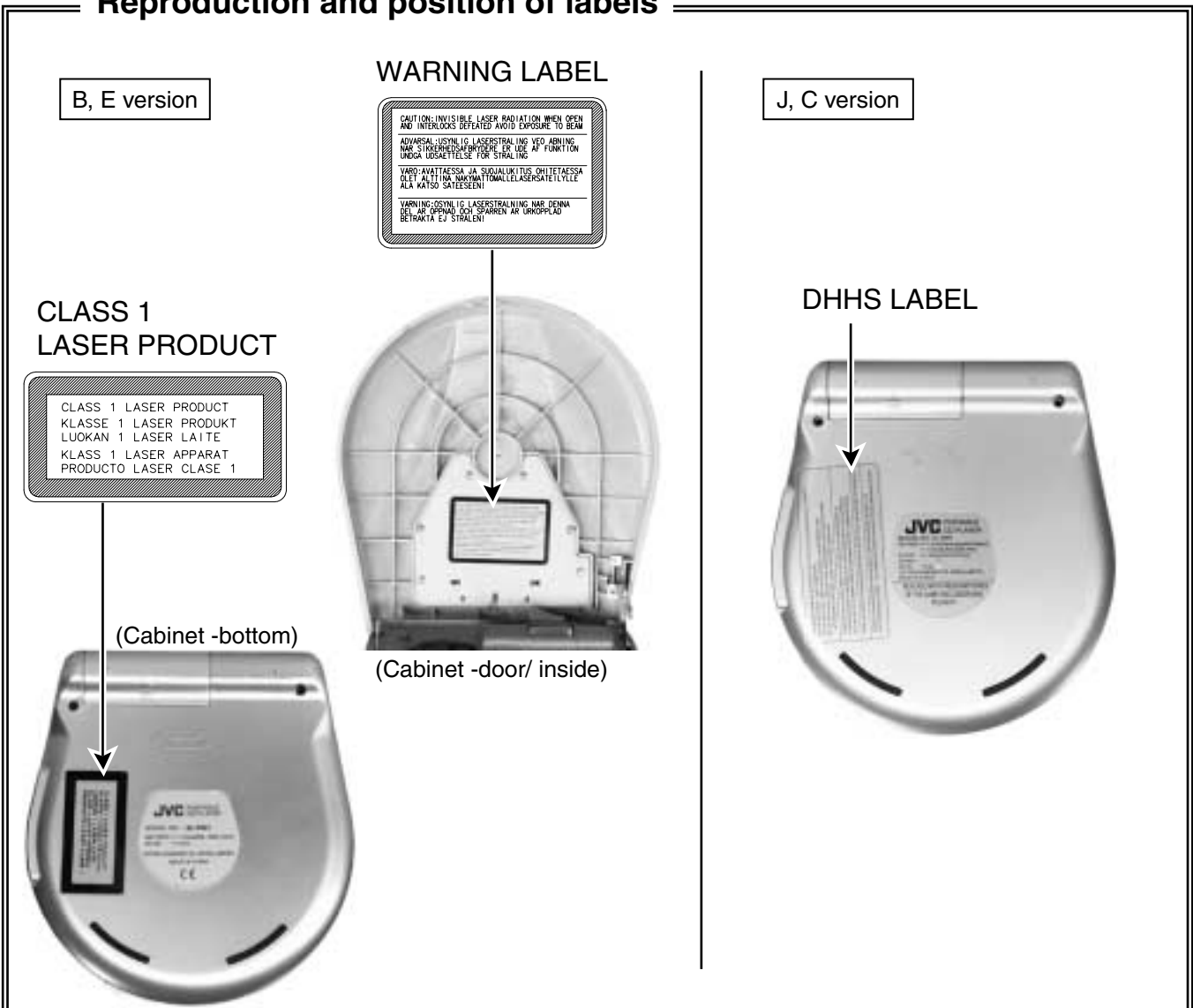

## Preventing static electricity

### 1. Grounding to prevent damage by static electricity

Electrostatic discharge (ESD), which occurs when static electricity stored in the body, fabric, etc. is discharged, can destroy the laser diode in the traverse unit (optical pickup). Take care to prevent this when performing repairs.

### 2. About the earth processing for the destruction prevention by static electricity

In the equipment which uses optical pick-up (laser diode), optical pick-up is destroyed by the static electricity of the work environment.

Be careful to use proper grounding in the area where repairs are being performed.

#### 2-1 Ground the workbench

Ground the workbench by laying conductive material (such as a conductive sheet) or an iron plate over it before placing the traverse unit (optical pickup) on it.

#### 2-2 Ground yourself

Use an anti-static wrist strap to release any static electricity built up in your body.

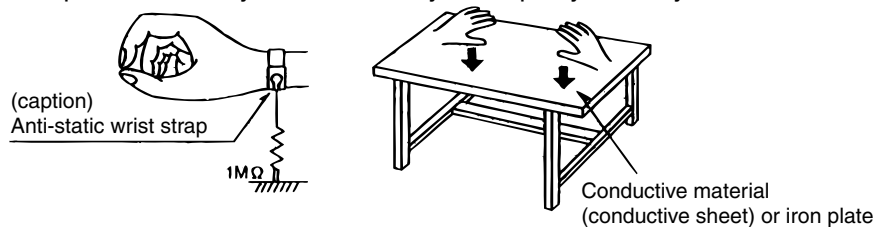

### 3. Handling the optical pickup

1. In order to maintain quality during transport and before installation, both sides of the laser diode on the replacement optical pickup are shorted. After replacement, return the shorted parts to their original condition. (Refer to the text.)

2. Do not use a tester to check the condition of the laser diode in the optical pickup. The tester's internal power source can easily destroy the laser diode.

### 4. Handling the traverse unit (optical pickup)

1. Do not subject the traverse unit (optical pickup) to strong shocks, as it is a sensitive, complex unit.

2. Cut off the shorted part of the flexible cable using nippers, etc. after replacing the optical pickup. For specific details, refer to the replacement procedure in the text. Remove the anti-static pin when replacing the traverse unit. Be careful not to take too long a time when attaching it to the connector.

3. Handle the flexible cable carefully as it may break when subjected to strong force.

4. It is not possible to adjust the semi-fixed resistor that adjusts the laser power. Do not turn it.

### Attention when CD mechanism assembly is decomposed

\*Please refer to "Disassembly method" in the text for pick-up and how to detach the CD mechanism assembly.

1. Remove the door & middle cabinet.

2. Solder the short-circuit land on the flexible board, before the flexible board is removed from connector CON1 on the main board.

(When the flexible board is removed without putting up solder, the CD mechanism assembly might destroy.)

3. Please unsolder the short-circuit land after connecting the flexible board with the CON1 on the main board, when you install CD mechanism assembly in the substrate.

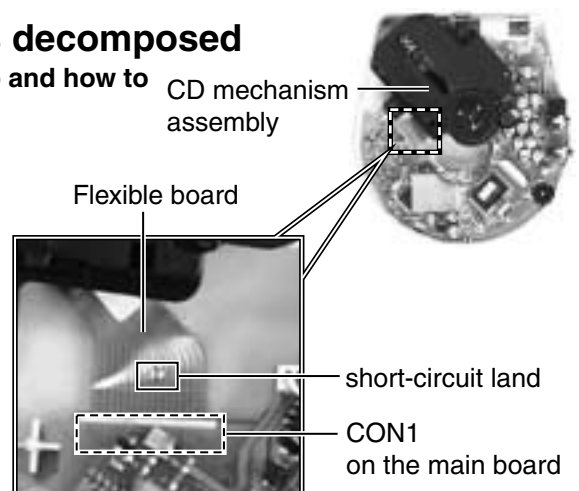

# Disassembly method

## ■ Removing the cabinet -door & cabinet -middle (See Fig.1 to 4)

1. Remove the two screws **A** attaching the cabinet -door on the back of the body.
2. Remove the two screws **B** on the cabinet -bottom.
3. Remove the three screws **C** attaching the cabinet -middle and remove the cabinet -middle from the cabinet -bottom.

ONE POINT: Flexible board is bonded with couple-face tapes internally in the cabinet -middle.

4. Disconnect the flexible board from connector FRW000 on the main board, and remove the cabinet -door with cabinet -middle.

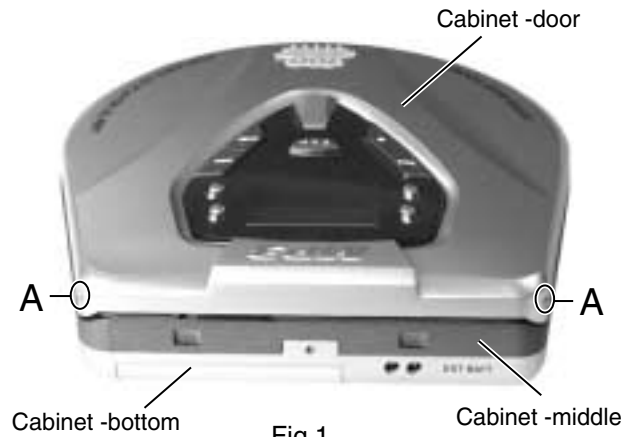

Fig.1

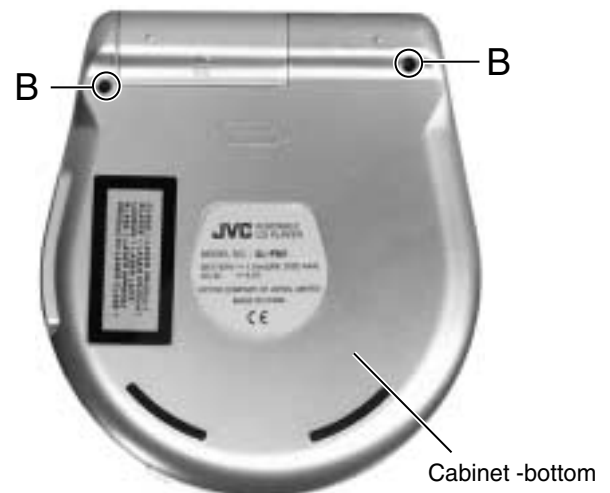

Fig.2 (The photograph is one of the B and E version.)

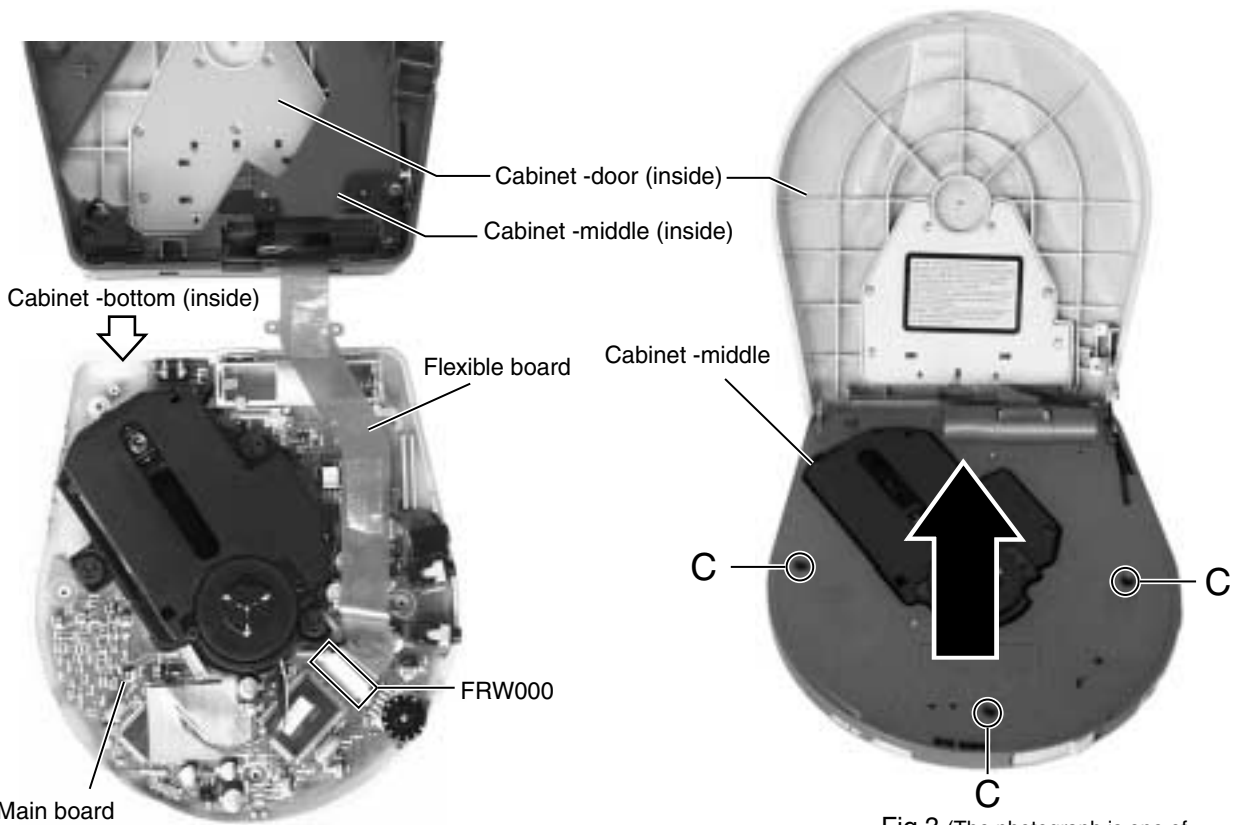

Fig.4

Fig.3 (The photograph is one of the B and E version.)

### ■ Removing the CD mechanism (See Fig.5)

• Prior to performing the following procedure, remove the cabinet -door and cabinet -middle.

1. Disconnect the harness(motor) from connector CON2(MOW000) on the main board .
2. Disconnect the flexible board(pick-up) from connector CON1 on the main board and remove the CD mechanism.

**Attention**

Solder the short-circuit land on the flexible board, before the flexible board is removed from connector OCN1 on the main board.

When reassembling, unsolder the short-circuit land on the flexible board after connecting the flexible board.

(Note : See page 1-4)

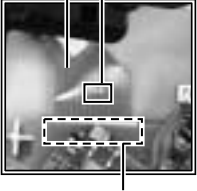

ONE POINT : Flexible board is bonded with a couple-face tape on the bottom cabinet.

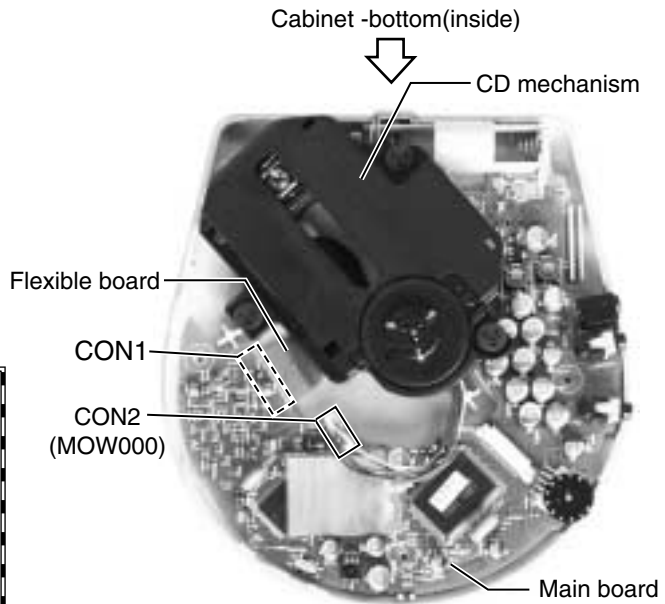

Fig.5

### ■ Removing the main board & EXT battery terminal board (See Fig.6)

• Prior to performing the following procedure, remove the cabinet -door, cabinet -middle and CD mechanism.

1. Remove the screw **D** attaching the EXT battery terminal board, and remove the main board with the EXT battery terminal board.

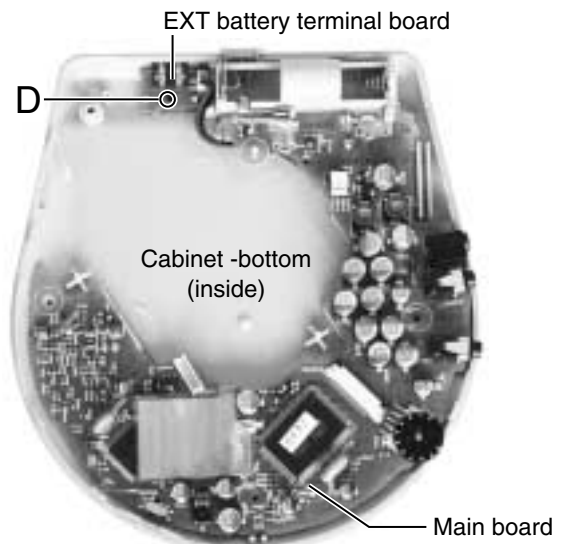

Fig.6

### ■ Removing the system control board (See Fig.7a and 7b)

• Prior to performing the following procedure, remove the cabinet -door and cabinet -middle.

1. Remove the eight screws **E** attaching the metal cover (Peel off the warning label if necessary).
2. Remove the metal cover and system control board.
3. Disconnect the flexible board from connector CON4 on the system control board.

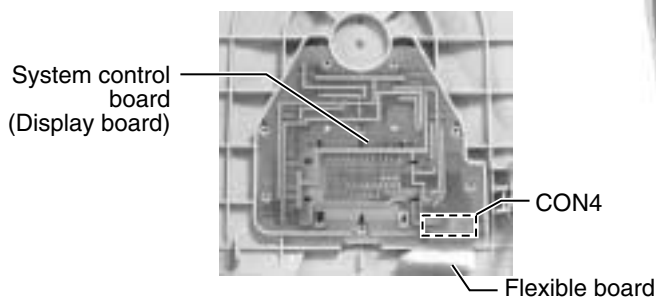

Fig.7b

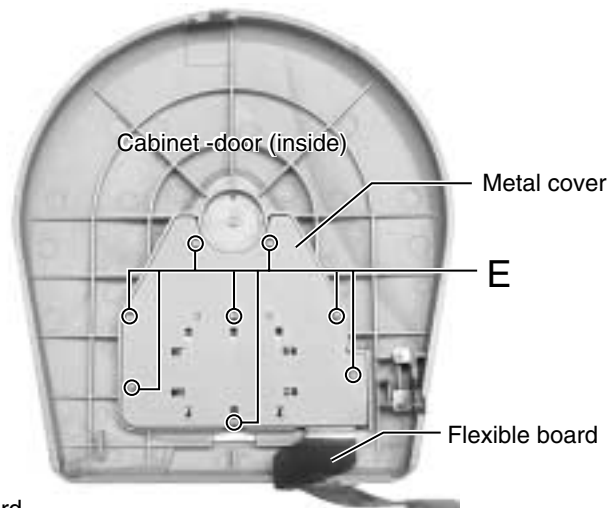
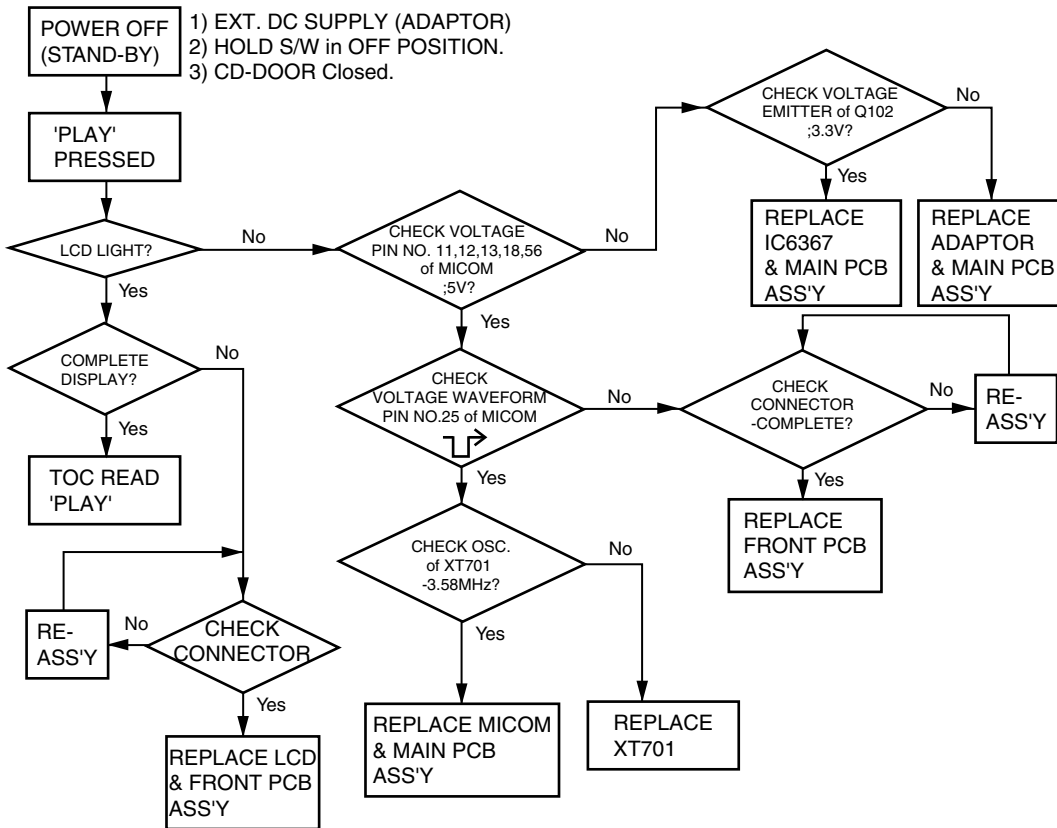

Fig.7a

# Troubleshooting

## 1. POWER / KEY



## 2. PLAY

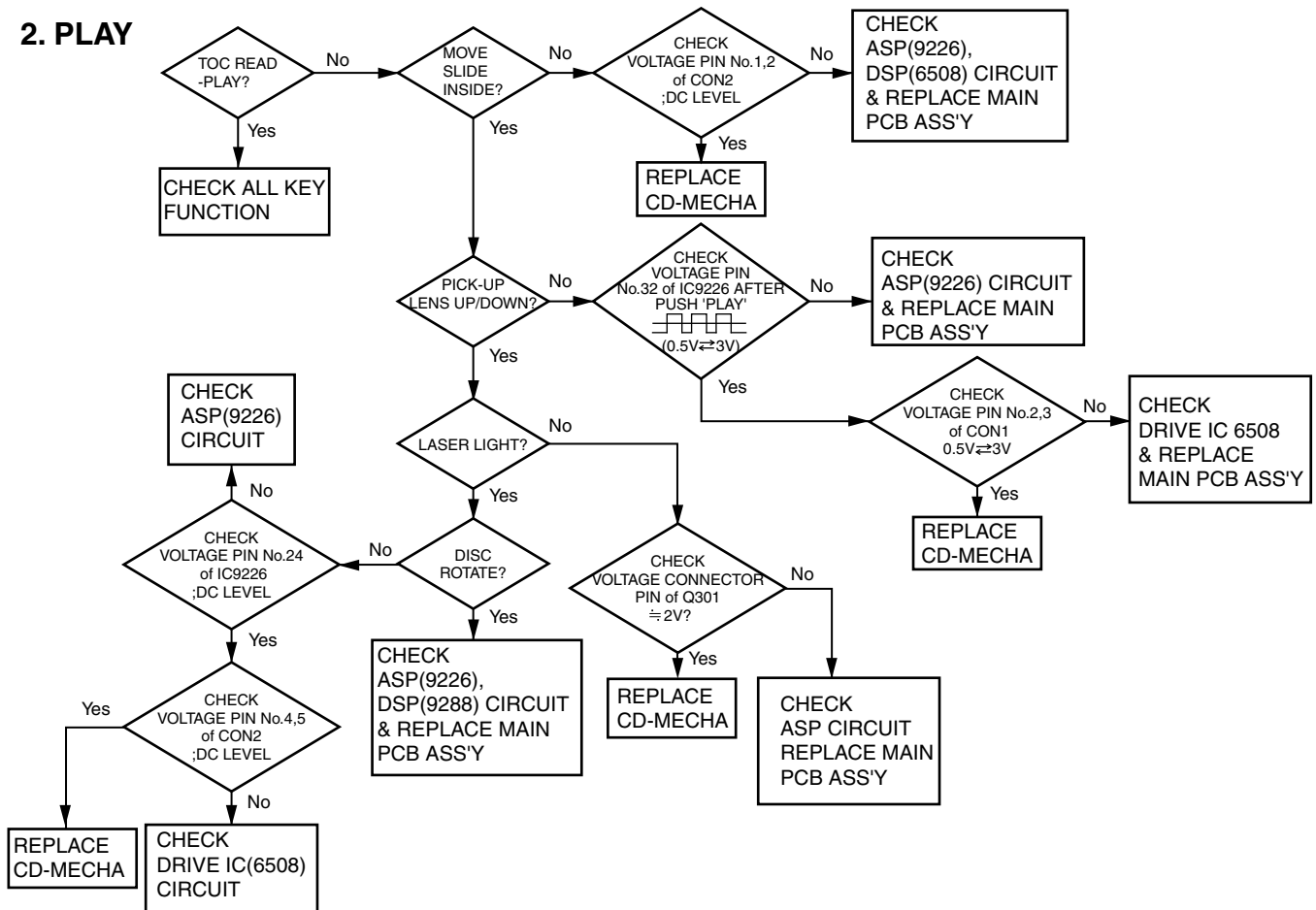

### 3. AUDIO OUTPUT (LINE OUT, EARPHONE OUT)

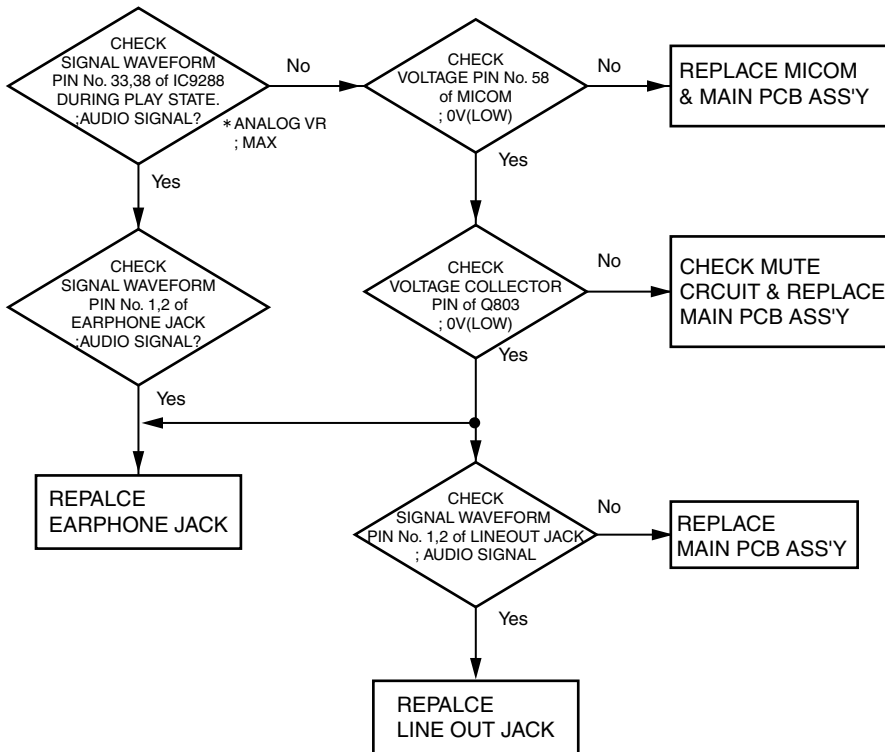

## Explanation of MP3

### MP3 (MPEG-1 Audio Layer 3)

An audio compression format that is part of the MPEG-1 specification, which was standardized by the Moving Picture Experts Group, a working group of ISO (International Organization for Standardization), in 1992.

MPEG-1, which is used by VideoCDs, etc., refers to the international standard for audio/video compression technology and its format. The audio part of the standard is known as MPEG-1Audio (ISO/IEC 11172-3).

MPEG-1 Audio is an audio coding system that can efficiently compress sound by discarding frequencies below the range of human hearing(1), as well as sound which is masked(2). MPEG-1Audio is divided into three layers: Layer 1, Layer 2 and Layer 3. The higher the Layer number, the higher the compression rate and the better the sound quality.

32 kHz, 44.1 kHz and 48 kHz sampling rates are supported. Monaural and 2-channel stereo can be compressed to 32-448 kbps with Layer 1, 32-384 kbps with Layer 2 and 32-320kbps with Layer 3.

The following is a summary of each Layer:

#### Layer 3

To create efficiently compressed audio data that is perceptually the same as the original, the following modes have been added to Layer 2.

MDCT (Modified Diskrete Cosine Transform) for subdivision of bandwidth.

Huffman coding that assigns the short bit to the data that frequently appears, and the long bit to the data that does not appear much.

MS (Middle/Side) stereo coding(3) that divides the stereo signal into the sum signal (L+R) and the difference signal (L-R).

(1) The human ear cannot detect sound above or below 3 kHz in the silent situation.

(2) Auditory masking is the phenomenon where low-frequency sound that occurs immediately after a loud sound cannot be heard by the human ear.

(3) Joint stereo coding that compresses 2 channels separately or recognizes only the scale factor of each channel that is compressed by monaural encoding is used in Layer 1 and 2.



# Description of major ICs

## ■ BH6508FS (IC6508) : Motor driver

### 1. Block diagram

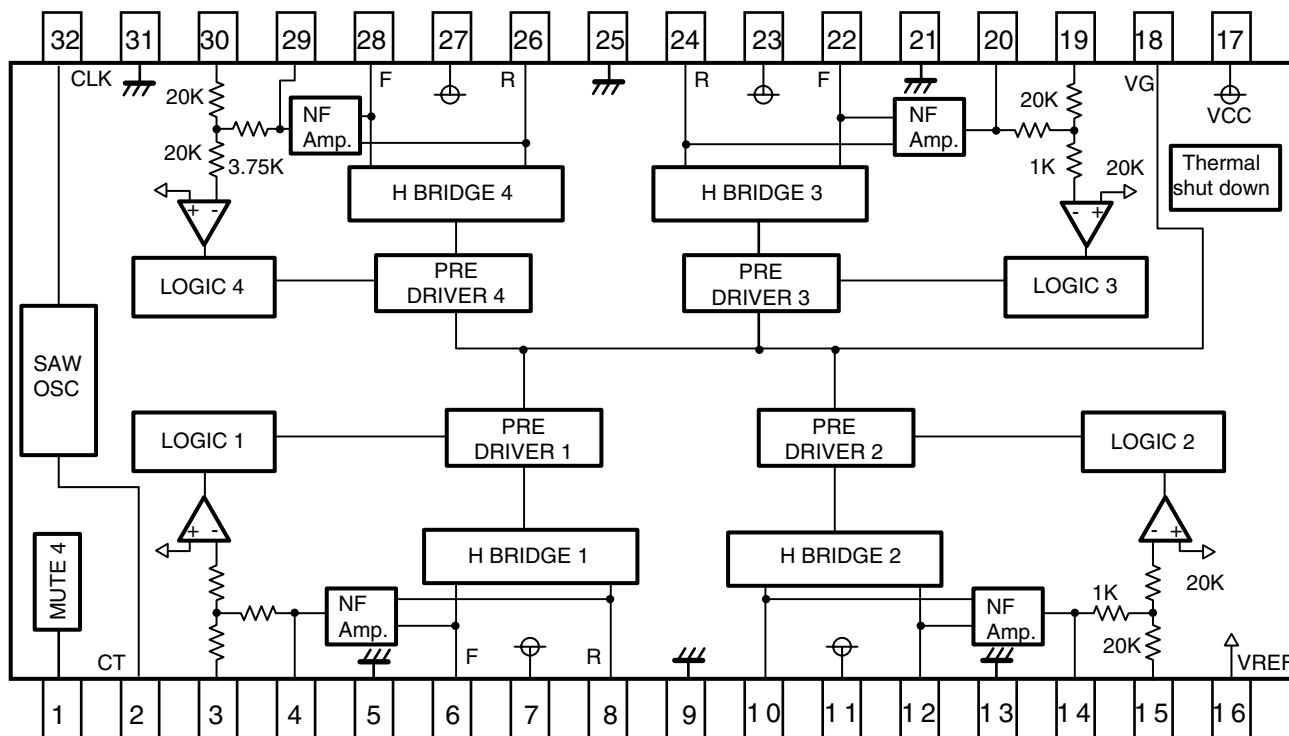

### 2. Pin function

Pin No.	Symbol	Function	Pin No.	Symbol	Function
1	MUTE 4	Mute terminal	17	VCC	Control circuit power supply
2	CT	Triangular wave output terminal	18	VG	Pre-drive circuit power supply
3	IN 1	CH1 Control signal input terminal	19	IN3	CH3 Control signal input terminal
4	CN 1	CH1 Feedback filter terminal	20	CN3	CH3 Feedback filter terminal
5	POWGND 1	Ground for power and analog block	21	POWGND3	Ground for power block
6	OUT_IF	CH1 Non-inverted output terminal	22	OUT_3F	CH3 Non-inverted output terminal
7	POWVCC 1	Vcc for power block	23	POWVCC3	Vcc for power block
8	OUT_1R	CH1 Inverted output terminal	24	OUT_3R	CH3 inverted output terminal
9	POWGND12	Ground for power block	25	POWGND34	Ground for power block
10	OUT_2R	CH2 Inverted output terminal	26	OUT_4R	CH4 inverted output terminal
11	POWVCC2	Vcc for power block	27	POWVCC4	Vcc for power block
12	OUT_2F	CH2 Non-inverted output terminal	28	OUT_4F	CH4 Non-inverted output terminal
13	POWGND 2	Ground for power and digital block	29	CN4	CH4 Feedback filter terminal
14	CN 2	CH2 Feedback filter terminal	30	IN4	CH4 Control signal input terminal
15	IN 2	CH2 Control signal input terminal	31	POWGND4	Ground for power block
16	VREF	Reference voltage input terminal	32	CLK	External clock input terminal

Note: Nin-inverted output and inverted output if driver are the polarity to an input terminal.

## ■ KS9288 (IC9288) : DSP/ ESP

### 1. Pin layout

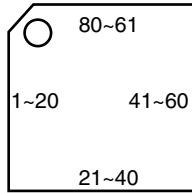

### 2. Pin function

(1/2)

Pin No.	Symbol	I/O	Function
1	VDD_PLL	-	Analog Power for DPLL
2	VSSA_PLL	-	Analog Ground for DPLL
3	VBBA_PLL	-	Analog Bulk Bias Ground for DPLL
4	VCO1LF	O	Pump out for VCO1
5	VCO2LF	O	Pump out for VCO2
6	VSSD_PLL	-	Digital Ground Separated Bulk Bias for DPLL
7	VDDD_PLL	-	Digital Power Separated Bulk Bias for DPLL
8	PBCK	-	VCO1/2 clock output (4.3218MHz)
9	VDDD1	-	Digital Power
10	XIN	I	X'tal oscillator input (16,9344MHz)
11	XOUT	O	X'tal oscillator output
12	VSSD1	-	Digital Power
13	TEST0	I	Test input
14	EFMI	I	EFM signal input
15	LOCK	O	CLV Servo locking status output
16	SMEF	O	LPF time constant control of the spindle servo error signal
17	SMON	O	ON/OFF control signal for spindle servo
18	SMDP	O	Phase control output for Spindle Motor drive
19	SMDS	O	Speed control output for Spindle Motor drive
20	WDCK	O	Word clock output (X1: 88.2KHz, X2: 176.4KHz)
21	VDDD2	-	Digital Power
22	TESTV	I	Various Test input
23	WFCK	O	Write base clock output
24	LKFS	O	The Lock status output of frame sync
25	RESETB	I	System Reset at 'L'
26	MLT	I	Latch signal input from Micom
27	MDAT	I	Serial data input from Micom
28	MCK	I	Serial data receiving clock input from Micom
29	ISTAT	O	The internal stats output to Micom
30	SOS1	I/O	Subcode sync signal (S0+S1) output
31	SQCK	I	Subcode-Q data transferring bit clock input
32	SQDT	O	Subcode-Q data serial output
33	LCHOUT	O	Left-Channel audio output through DAC
34	VDDA_DAC	-	Analog Power for DAC
35	VHALF	O	Reference Voltage output for bypass
36	VREF	O	Reference Voltage output for bypass
37	VSSA_DAC	-	Analog Power for DAC
38	RCHOUT	O	Right-Channel audio output through DAC
39	VDDD_DAC	-	Digital Power for DAC
40	VSSD_DAC	-	Digital Ground for DAC
41	TEST1	I	Test Input
42	TEST2	I	Test Input
43	TEST3	I	Test Input
44	MUTE	I	System mute at 'H'
45	SBCK	I	Subcode data transferring bit clock
46	SBDT	I/O	Subcode data serial output
47	C4M	O	4.2336MHz clock output
48	VSSD2	-	Digital Ground
49	VDDD3	-	Digital Power
50	DATX	O	Digital audio data output
51	JITB	I/O	Internal SRAM filter margin status output
52	C2PO	I/O	C2 Pointer output

2. Pin function

(2/2)

Pin No.	Symbol	I/O	Function
53	RFCK	I/O	Read base clock output
54~59	MNT0~5	I/O	Monitoring signal output
60	VSSD3	-	Digital Ground
61	VDDD4	-	Digital Power
62	D0	I/O	DRAM data Input/Output 0
63	D1	I/O	DRAM data Input/Output 1
64	WE	O	DRAM Write Enable output (active Low)
65	RAS	O	DRAM Row Address Selection output (active Low)
66	D2	I/O	DRAM data Input/Output 2
67	D3	I/O	DRAM data Input/Output 3
68	CAS0	O	DRAM Column Address Selection output 0 (active Low)
69	CAS1(AD10)	O	DRAM Column Address Selection output 1 (active Low)
70	AD8	O	DRAM Address output 8
71	AD7	O	DRAM Address output 7
72	AD6	O	DRAM Address output 6
73	AD5	O	DRAM Address output 5
74	AD4	O	DRAM Address output 4
75	AD9	O	DRAM Address output 9
76	AD0	O	DRAM Address output 0
77	AD1	O	DRAM Address output 1
78	AD2	O	DRAM Address output 2
79	AD3	O	DRAM Address output 3
80	VSSD4	-	Digital Ground

3. Block diagram

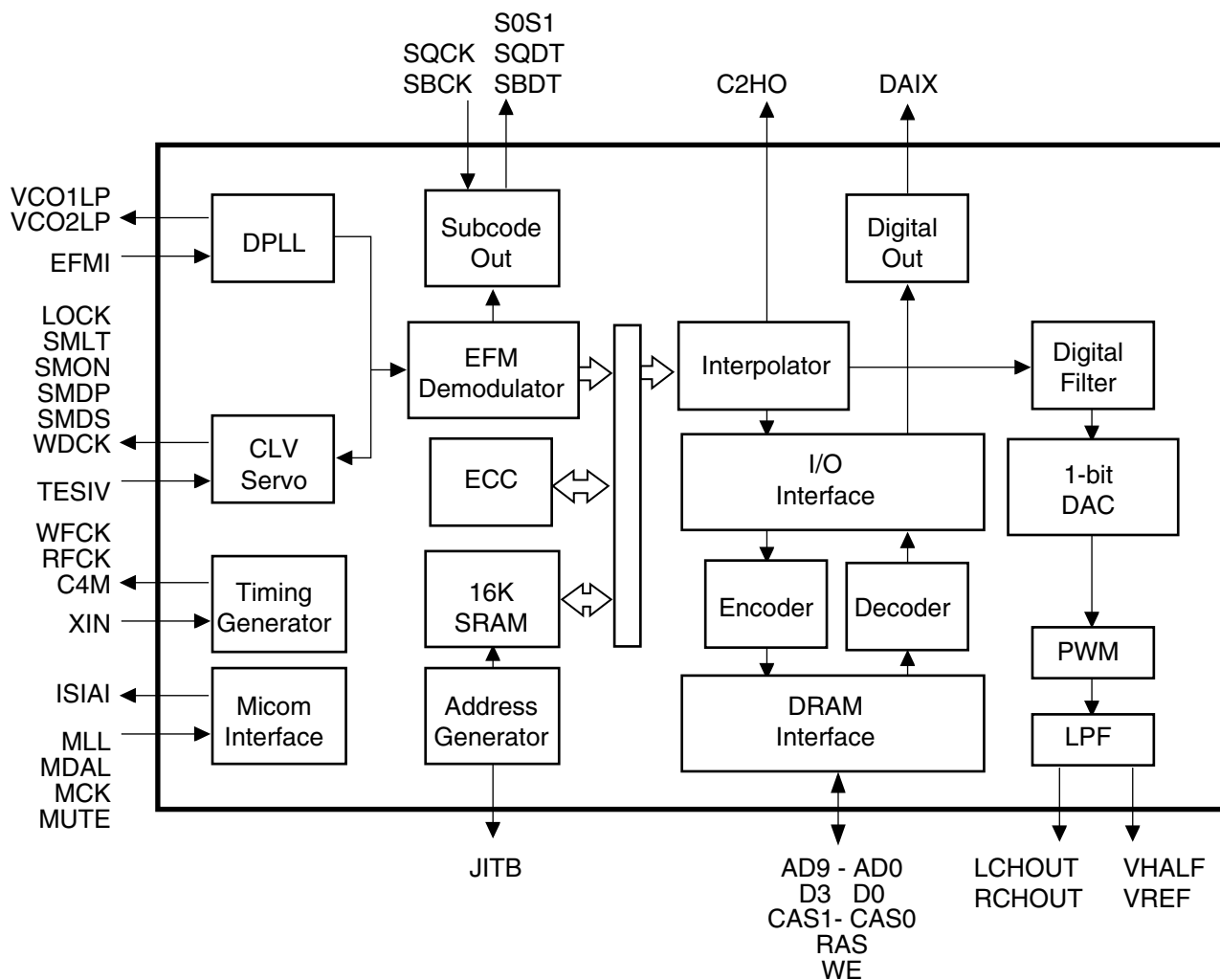

■ M11L1644 (IC1644) : DRAM

1. Block diagram

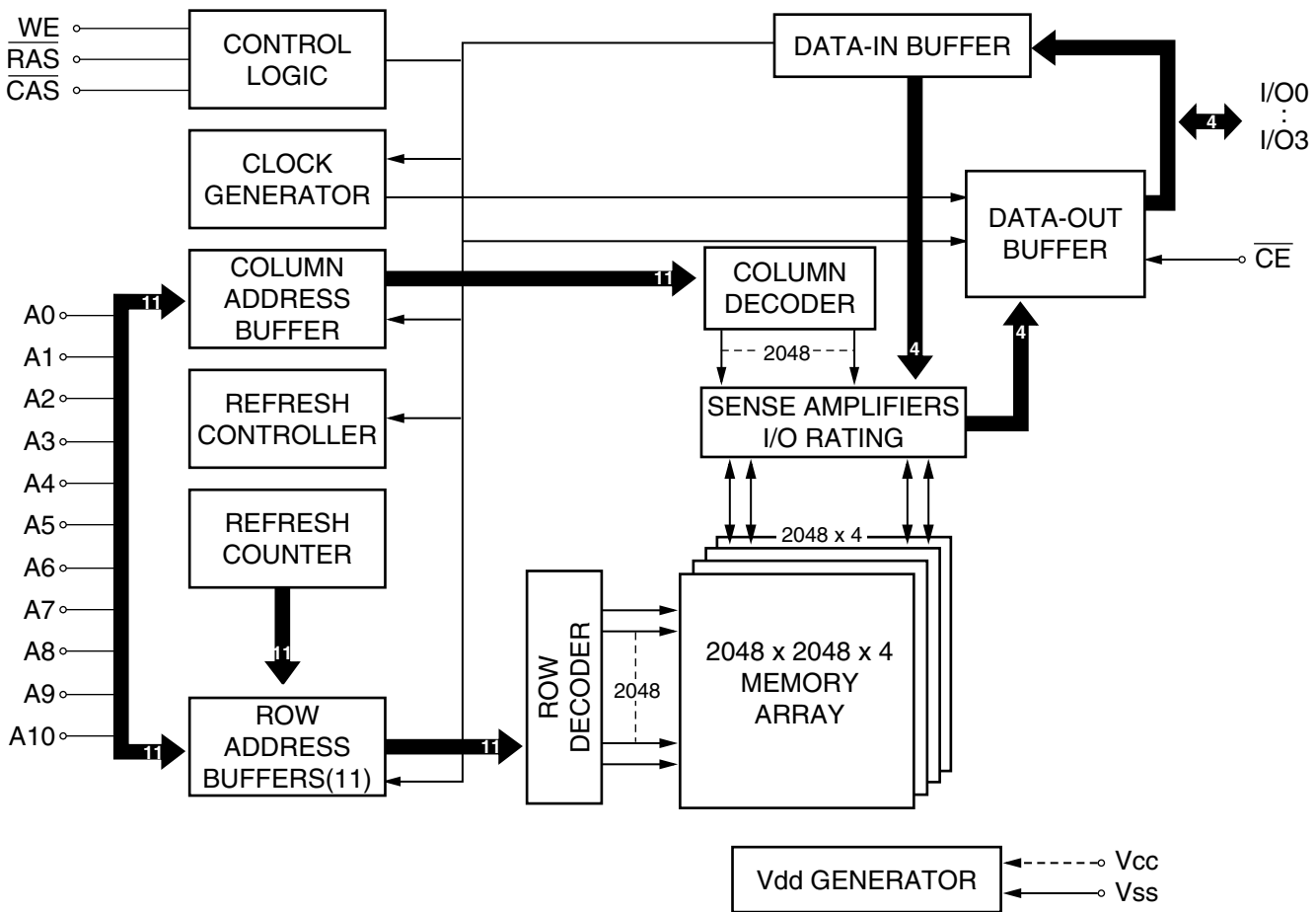

2. Pin function

Pin No.	Symbol	I/O	Function
3~11, 14~19, 7	A0~A10	I	Address Input Row Address : A0~A10 Column Address : A0~A10
5	RAS	I	Row Address Strobe
21	CAS	I	Column Address Strobe
4	WE	I	Write Enable
20	OE	I	Output Enable
2, 3, 22, 23	I/O0~I/O3	I/O	Data Input/ Output
1, 12	Vcc		Power (5V or 3.3V)
13, 24	Vss		Ground
6	NC	-	No Connect

■ XC6367 (IC6367, 63670) : Regulator

1. Pin layout

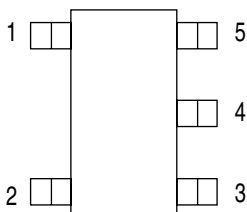

2. Pin function

Pin No.	Symbol	Function
1	EXT	External transistor connection
2	GND	Ground
3	CE	Chip enable
4	VDD	Power supply
5	VOUT	Voltage output

# Parts list

Block No. M 1 M M

## ■ Integrated decomposition chart

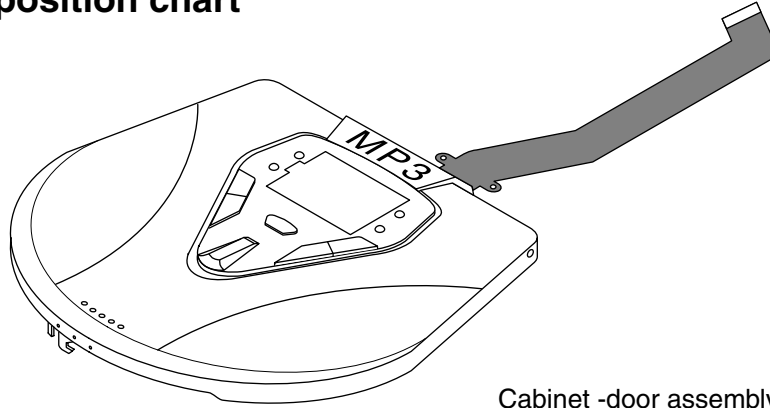

Cabinet -door assembly  
(See page 1-14)

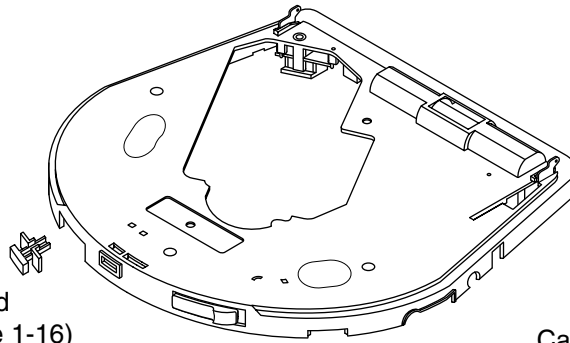

Knob -hold  
(See page 1-16)

Cabinet -middle assembly  
(See page 1-14)

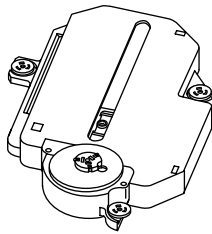

CD mechanism assembly  
(See page 1-15)

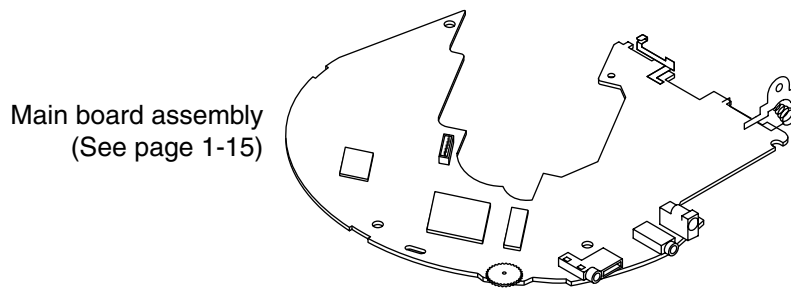

Main board assembly  
(See page 1-15)

Holder -battery  
(See page 1-16)

Cabinet -bottom assembly  
(See page 1-16)

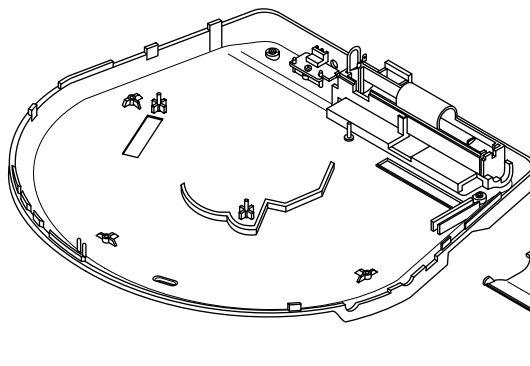

Lid -battery  
(See page 1-16)

■ Cabinet -door assembly



(XL-PM1)

Parts number	Parts name	Description	Area suffix
AH64-01527A	CABINET -DOOR	WITH FRONT BOARD	ALL

(XL-PM11C)

Parts number	Parts name	Description	Area suffix
AH64-01527B	CABINET -DOOR	WITH FRONT BOARD	C

■ Cabinet -middle assembly



Parts number	Parts name	Description	Area suffix
AH64-01528A	CABINET -MIDDLE	WITH RIBBON	ALL

## ■ CD mechanism assembly



	Parts number	Parts name	Description	Area suffix
	AH59-00968A	CD MECHANISM ASSY	MECH+ RUBBER CD	ALL

## ■ Main board assembly

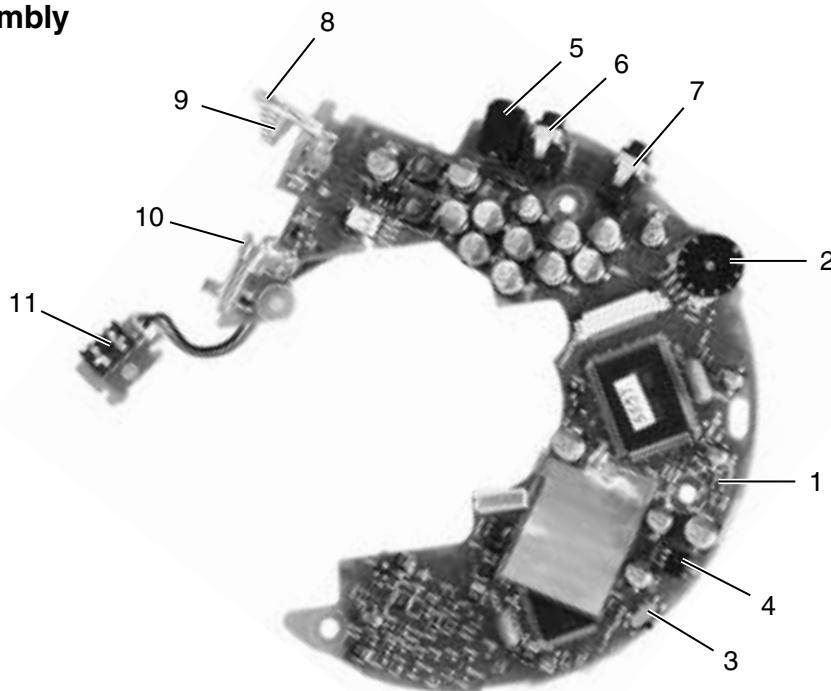

	Parts number	Parts name	Description	Area suffix
1	AH92-01161A	MAIN BOARD ASSY	PCB MAIN	ALL
2	2102-001063	VR -ROTARY	VOLUME	ALL
3	3408-001038	SWITCH -SLIDE	HOLD S/W	ALL
4	3409-001004	SWITCH-DETECTOR	DOOR - S/W	ALL
5	3722-001525	JACK -DC POWER		ALL
6	3722-001525	JACK -LINE OUT		ALL
7	3722-001493	JACK -PHONE		ALL
8	AH61-00595A	BRACKET -BATTERY.P		ALL
9	AH61-00600A	SPRING -BATTERY		ALL
10	AH61-00594A	BRACKET-CHARGER		ALL
11	3710-001696	CONNECTOR - SOCKET		ALL

■ Cabinet -bottom assembly



Does not contain the bottom side label.

	Parts number	Parts name	Description	Area suffix
	AH64-01529A	CABINET -BOTTOM	WITH BATTERY COVER	ALL

■ Other parts

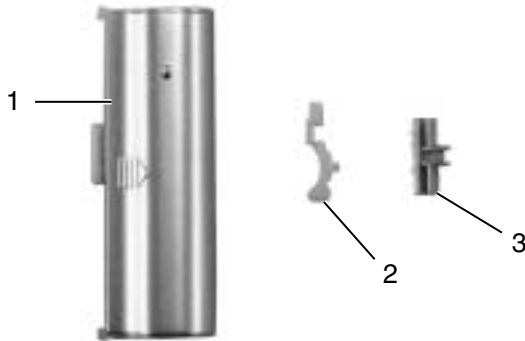

	Parts number	Parts name	Description	Area suffix
1	AH64-01021A	LID -BATTERY	BATTERY -COVER	ALL
2	AH61-00734A	HOLDER -BATTERY		ALL
3	AH64-01029A	KNOB -HOLD		ALL

■ Labels

	Parts number	Parts name	Description	Area suffix
	AH68-50482B	LABEL -CLASS 1	BOTTOM SIDE	B, E
	AH68-00875A	LABEL -RATING	BOTTOM SIDE	J, C
	AH68-00875B	LABEL -RATING	BOTTOM SIDE	E
	AH68-00875D	LABEL -RATING	BOTTOM SIDE	B
	AH68-50275D	LABEL -WARNING	CABINET -MIDDLE INSIDE	B, E
	AH68-00907A	LABEL -DHHS	BOTTOM SIDE	J, C

(XL-PM11C)

	Parts number	Parts name	Description	Area suffix
	AH68-00875C	LABEL -RATING	BOTTOM SIDE	C



# Packing materials and accessories parts list

## ■ Gift box (XL-PM11C/ XL-PM1B/ XL-PM1E)

Block No. M 3 M M

Block No. M 5 M M

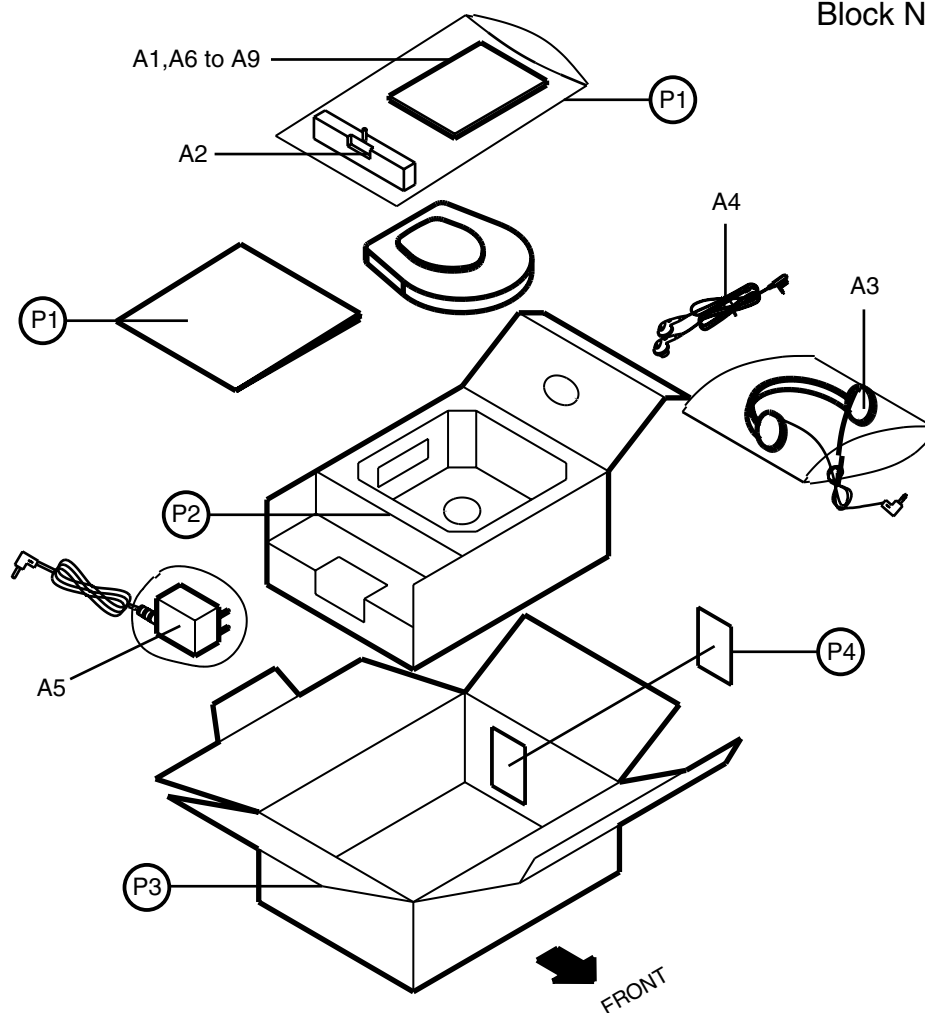

## ■ Blister (XL-PM1J/ XL-PM1C)

No do after-sales service of blister pack packing.

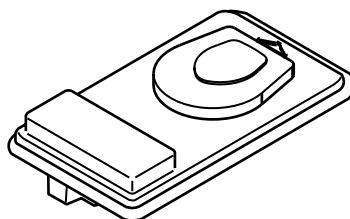

## ■ Parts list (Packing)

Block No. M3MM

Item	Parts number	Parts name	Q'ty	Description	Area
P1	AH69-00359A	PE-BAG	2	HDPE	ALL
P2	AH69-00538A	PAD-CUSHION	1	SW-1	11C, B, E
P3	AH69-00538B	PACKING-CASE	1	SW-1	11C
	AH69-00538C	PACKING-CASE	1	SW-1	B, E
P4	AH68-00930A	LABEL-GIFT BOX	1	ART PAPER	11C, B, E

## ■ Parts list (Accessories)

Block No. M5MM

Item	Parts number	Parts name	Q'ty	Description	Area
A1	AH68-00944C	INSTRUCTIONS	1	EN/FR	C, 11C
	AH68-00944E	INSTRUCTIONS	1	EN/SP/NL/GE/IT/ FR/SW/FI/DA	E
	AH68-00944D	INSTRUCTIONS	1	EN	J, B
A2	AH64-01082A	CASE-BATTERY	1	ASSY	ALL
A3	AH30-00016A	HEAD-PHONE	1	OVER HEAD	J, C, 11C
A4	AH30-00015A	EAR-PHONE	1	INNER EAR	B, E
A5	AH44-00022A	AC-ADAPTER	1	AA-R4510	J, C, 11C
	AH44-00021A	AC-ADAPTER	1	AA-R4511	E
	AH44-00020A	AC-ADAPTER	1	AA-R4512	B
A6	BT-51626-1	WARRANTY CARD	1		J
	BT-52004-1	WARRANTY CARD	1		C
	BT-54008-2	WARRANTY CARD	1		B, E
A7	BT-20071B	SVC LIST	1		C
A8	BT-20044G	S.INST SHEET	1		J
	E43486-340B	S.INST SHEET	1		B
A9	BT-51020-2	REGISTRATION CARD	1		J

< M E M O >



**VICTOR COMPANY OF JAPAN, LIMITED**

PERSONAL & MOBILE NETWORK BUSINESS UNIT. 10-1, 1chome, Ohwatari-machi, Maebashi-city, 371-8543, Japan

# Block diagram

5  
4  
3  
2  
1

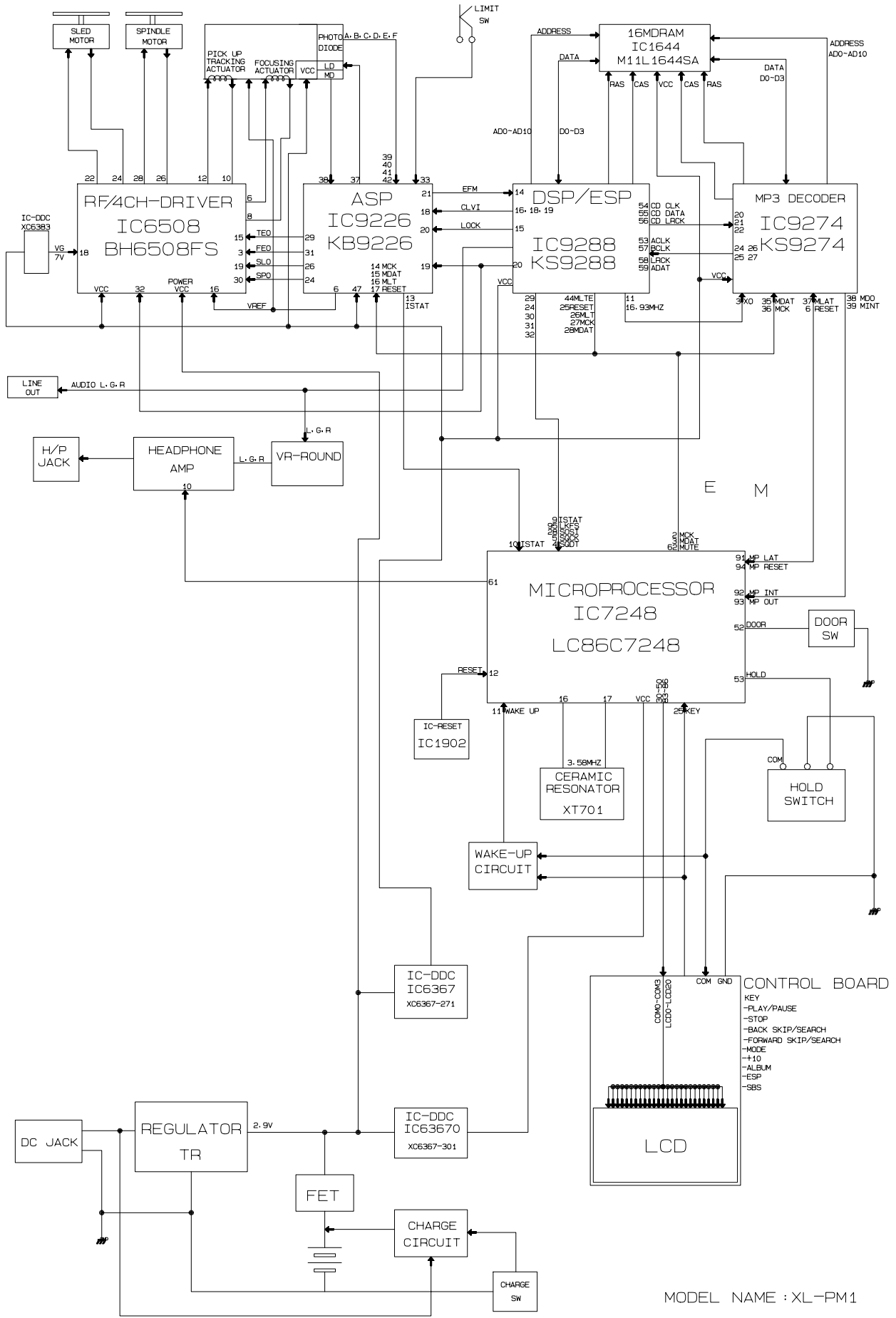

# Standard schematic diagram

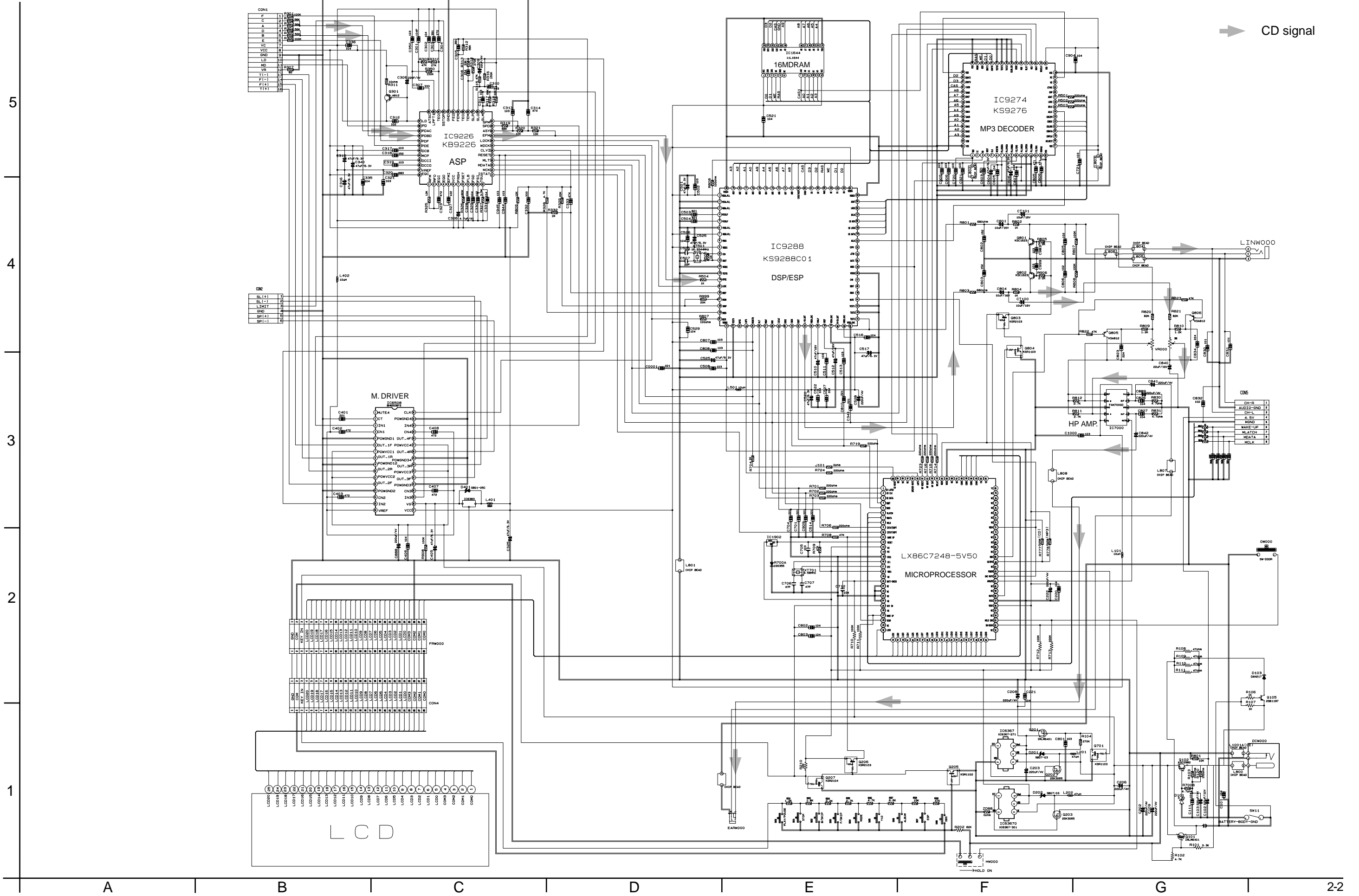

**JVC****Manual Change Information****SUBJECT : Part number change****Date : 23th. JUL. 2001**

The following parts have been changed. Please note these new parts in your service manual.  
We suggest that you order the parts concerned as apares.

Parts identified by the  symbol are critical for safety. Replace only with specified part numbers.

Model & Manual No.	Location	Reference Information	Performed at factory
XL-PM11/XL-PM1 J/C/B/E  (No.21018)  CD-ROM No. SML200107	Parts list	-----	#1~

Page	Item	Old parts	Parts No.	Parts Name	FOB (New Parts)	Itg	Rsn	Note
1-15	Main Board assembly #6	3722-001525	3722-001493	Jack Line out	----	D	G	

**COMMENTS :****ATTACHMENT**

- (x) NONE ( ) COMPONENT / PWBLAYOUT  
( ) SCHEMATIC DIAGRAM ( ) ADJUSTMENT PROCEDURE  
( ) EXPLODED VIEW

**INTERCHANGEABILITY**

- A. Completely interchangeable.  
B. Previous part can be used for new set, but new part can not be used for previous set.  
C. New part can be used for previous set, but previous part can not be used for new set.  
D. Not interchangeable.  
E. Addition  
F. Deletion

**REASON FOR CHANGE**

- A. To improve performance.  
B. To improve reliability.  
C. To improve safety.  
D. To improductivity  
E. Standardization of part.  
F. For your demand.  
G. Correction of misprint.  
H. Others.

**VICTOR COMPANY OF JAPAN, LTD, AV & MULTIMEDIA COMPANY**  
AUDIO & COMMUNICATION BUSINESS DIV.

QUALITY ASSURANCE DEPARTMENT  
SERVICE ENGINEERING GROUP 15300

1-10-1, Ohwatari-chou. Maebashi-shi, Gunma-ken. 371-8543, Japan Facsimile : 81-27-254-8977 Telephone : 81-27-254-8952