

JVC

SERVICE MANUAL

COMPACT COMPONENT SYSTEM

CA-MXG7BK/XT-MXG7BK

(Unit No. TD-MXG7BK)

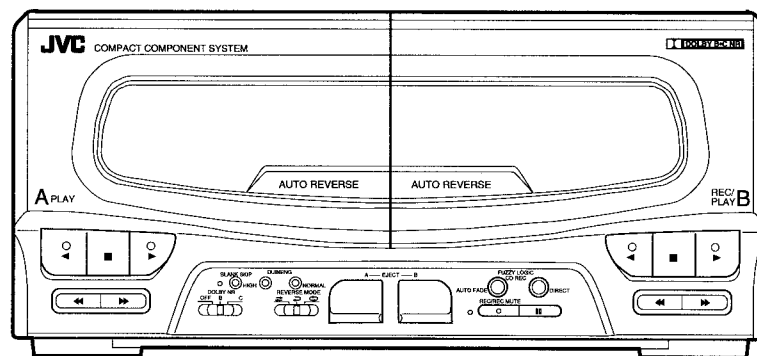

* For instruction manual, packing materials and accessories, please refer to the RX-MXG7BK (S.M.No.20393).

* RX-MXG7BK is needed (for power supply etc.) when servicing.

〒103 東京都中央区日本橋本町1-8-14
 日本ビクター株式会社
 サービス部 部品管理課

Contents

Safety Precautions	1-2	Adjustment Procedures	1-11
Description of Major LSIs	1-3	Block Diagram	1-12
Internal Block Diagrams of Other ICs	1-4	Schematic Diagram	Insertion
Disassembly Procedures	1-6	Printed Circuit Board	Insertion
		Parts List	Insertion

Safety Precautions

1. The design of this product contains special hardware and many circuits and components specially for safety purposes. For continued protection, no changes should be made to the original design unless authorized in writing by the manufacturer. Replacement parts must be identical to those used in the original circuits. Services should be performed by qualified personnel only.
2. Alterations of the design or circuitry of the product should not be made. Any design alterations of the product should not be made. Any design alterations or additions will void the manufacturer's warranty and will further relieve the manufacture of responsibility for personal injury or property damage resulting therefrom.
3. Many electrical and mechanical parts in the products have special safety-related characteristics. These characteristics are often not evident from visual inspection nor can the protection afforded by them necessarily be obtained by using replacement components rated for higher voltage, wattage, etc. Replacement parts which have these special safety characteristics are identified in the Parts List of Service Manual. Electrical components having such features are identified by shading on the schematics and by (Δ) on the Parts List in the Service Manual. The use of a substitute replacement which does not have the same safety characteristics as the recommended replacement parts shown in the Parts List of Service Manual may create shock, fire, or other hazards.
4. The leads in the products are routed and dressed with ties, clamps, tubings, barriers and the like to be separated from live parts, high temperature parts, moving parts and/or sharp edges for the prevention of electric shock and fire hazard. When service is required, the original lead routing and dress should be observed, and it should be confirmed that they have been returned to normal, after re-assembling.
5. Leakage current check (Electrical shock hazard testing)
After re-assembling the product, always perform an isolation check on the exposed metal parts of the product (antenna terminals, knobs, metal cabinet, screw heads, headphone jack, control shafts, etc.) to be sure the product is safe to operate without danger of electrical shock.

Do not use a line isolation transformer during this check.

- Plug the AC line cord directly into the AC outlet. Using a "Leakage Current Tester", measure the leakage current from each exposed metal parts of the cabinet, particularly any exposed metal part having a return path to the chassis, to a known good earth ground. Any leakage current must not exceed 0.5mA AC (r.m.s.).

- Alternate check method

Plug the AC line cord directly into the AC outlet. Use an AC voltmeter having, 1,000 ohms per volt or more sensitivity in the following manner. Connect a 1,500 Ω 10 W resistor paralleled by a 0.15 μ F AC-type capacitor between an exposed metal part and a known good earth ground.

Measure the AC voltage across the resistor with the AC voltmeter.

Move the resistor connection to each exposed metal part, particularly any exposed metal part having a return path to the chassis, and measure the AC voltage across the resistor.

Now, reverse the plug in the AC outlet and repeat each measurement. Any voltage measured must not exceed 0.75 V AC (r.m.s.). This corresponds to 0.5 mA AC (r.m.s.).

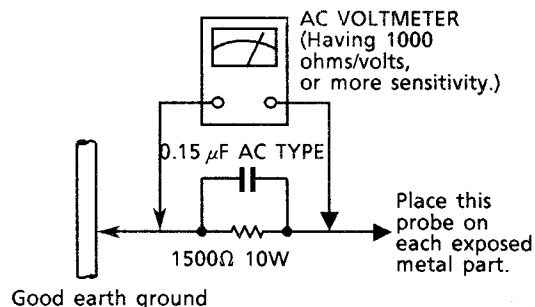

Warning

1. This equipment has been designed and manufactured to meet international safety standards.
2. It is the legal responsibility of the repairer to ensure that these safety standards are maintained.
3. Repairs must be made in accordance with the relevant safety standards.
4. It is essential that safety critical components are replaced by approved parts.
5. If mains voltage selector is provided, check setting for local voltage.

Description of Major LSIs

■ HD614081SD39(IC401) : System controller

1. Terminal Layout

A SPEED UP	1	64	B FWD LED
B SPEED UP	2	63	B REV LED
A FWD LED	3	62	
A REV LED	4	61	
CAP MOTOR	5	60	NR OFF/ON
REC	6	59	NR B/C
REC LED	7	58	BIAS
BLANK SKIP LED	8	57	GND
	9	56	REC MUTE
A CAM SW-2	10	55	DCS IN
A CAM SW-1	11	54	DCS OUT
A CA SW-0	12	53	GND
A PULSE IN	13	52	4.19MHzOSC IN
B CAM SW-2	14	51	4.19MHzOSC IN
B CAM SW-1	15	50	TO VCC
B CAM SW-0	16	49	RESET IN
B PULSE IN	17	48	KEY&SW IN-4
POWER OFF IN	18	47	KEY&SW IN-3
MSI	19	46	KEY&SW IN-2
A FWD REEL MOTOR	20	45	KEY&SW IN-1
A REV REEL MOTOR	21	44	KEY OUT-7
A REV CAM MOTOR	22	43	KEY OUT-6
A FWD CAM MOTOR	23	42	KEY OUT-5
B FWD REEL MOTOR	24	41	KEY OUT-4
B REV REEL MOTOR	25	40	KEY OUT-3
B REV CAM MOTOR	26	39	KEY OUT-2
B FWD CAM MOTOR	27	38	KEY OUT-1
O MUTE	28	37	STB
METAL	29	36	CS
DUB	30	35	DATA
BEQ	31	34	DO
+5V	32	33	CLK

2. Key Matrix

	KEY&SW-1 (Pin45)	KEY&SW-2 (Pin46)	KEY&SW-3 (Pin47)	KEY&SW-4 (Pin48)
KEY OUT 1 (Pin38)	A ◀	A ◀◀	A ▶▶	A ▶
KEY OUT 2 (Pin39)	B ◀	B ◀◀	B ▶▶	B ▶
KEY OUT 3 (Pin40)	A ■	B ■	B ●	B ▯
KEY OUT 4 (Pin41)	A▶▶B	A▶B	—	BLANK SKIP
KEY OUT 5 (Pin42)	FUZZY DIRECT	FUZZY AUTO	—	—
KEY OUT 6 (Pin43)	B PACK	REV REC	FWD REC	A PACK
KEY OUT 7 (Pin44)	—	B CrO2	B METAL	—

3. Terminal Description

Pin	Symbol	I/O	Description	Pin	Symbol	I/O	Description
1	A SPEED UP	O	A deck speed control output	33	CLK	O	Clock for data transfer
2	B SPEED UP	O	B deck speed control output	34	DO	O	Data output
3	A FWD LED	O	Indication signal for A forward LED	35	DATA	I	Data input
4	A REV LED	O	Indication signal for A reverse LED	36	CS	O	Chip select signal
5	CAP MOTOR	O	Capstan motor control signal	37	STB	O	Strobe signal output
6	REC	O	Recording control signal (H : REC)	38	KO 1	O	Key matrix output
7	B REC LED	O	Indication signal for recording	39	KO 2	O	〃
8	BLA. SKIP LED	O	Indication signal for Blank skip	40	KO 3	O	〃
9		--	Not used	41	KO 4	O	〃
10	A CAM SW 2	I	Input terminal for mech. and head status	42	KO 5	O	〃
11	A CAM SW 1	I	〃	43	KO 6	O	〃
12	A CAM SW 0	I	〃	44	KO 7	O	〃
13	A PULSE IN	I	Pulse signal input from Reel	45	KI 1	I	Key matrix input
14	B CAM SW 2	I	Input terminal for mech. and head status	46	KI 2	I	〃
15	B CAM SW 1	I	〃	47	KI 3	I	〃
16	B CAM SW 0	I	〃	48	KI 4	I	〃
17	B PULSE	I	Pulse signal input from Reel	49	RESET	I	Reset signal input
18	POW. OFF IN	I	Power ON/OFF signal input	50	TO VCC	--	Connected to +5V
19	MS IN	I	Blank detect terminal for music scan	51	4.19MHzOSC	I/O	Clock oscillation terminal
20	AFWD REEL	O	Reel motor control signal	52	4.19MHzOSC	I/O	〃
21	A REV REEL	O	Reel motor control signal	53	GND	--	Ground
22	A REV CAM	O	Cam motor control signal	54	DCS OUT	O	Compulink signal output
23	AFWD CAM	O	Cam motor control signal	55	DCS IN	I	Compulink signal input
24	B FWD REEL	O	Reel motor control signal	56	REC. MUTE	O	Recording mute signal output
25	B REV REEL	O	Reel motor control signal	57	GND	--	Ground
26	B REV CAM	O	Cam motor control signal	58	BIAS	O	ON / OFF signal for bias circuit
27	B FWD CAM	O	Cam motor control signal	59	NR B/C	O	NR B / C switching signal
28	OMUTE	O	Play muting control	60	NR OFF/ON	O	NR ON/OFF signal output
29	METAL	O	Recording bias control for METAL tape	61		--	Not used
30	DUB	O	High speed dubbing control	62	B REV LED	O	Indication signal for B reverse
31	BEQ	O	Equalizer switching signal	63	B FWD LED	O	Indication signal for B forward
32	+5V	--	Power supply	64		--	Not used

Internal Block Diagram of Other ICs

■ M62302P(IC202) : A/D converter for AV level

1. Terminal Layout

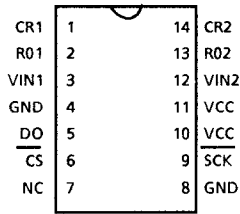

2. Terminal Description

Pin No.	Symbol	I/O	Description
1	CR1	O	This is a terminal to determine the response of the output.
14	CR2	O	This is a terminal to determine the response of the output.
2	R01	O	This is a terminal to determine the response of the output.
13	R02	O	This is a terminal to determine the response of the output.
3	VIN1	I	Analog signal input terminal
12	VIN2	I	
4	GND	-	Ground
8	GND	-	Ground
5	DO	O	Digital output terminal
6	$\overline{\text{CS}}$	I	Chip select terminal DO terminal is enable when this terminal is "L".
9	$\overline{\text{SCK}}$	I	Clock signal input The accuracy of the A/D conversion depends on this clock speed.
10	VCC	-	+5V
11			

3. Block Diagram

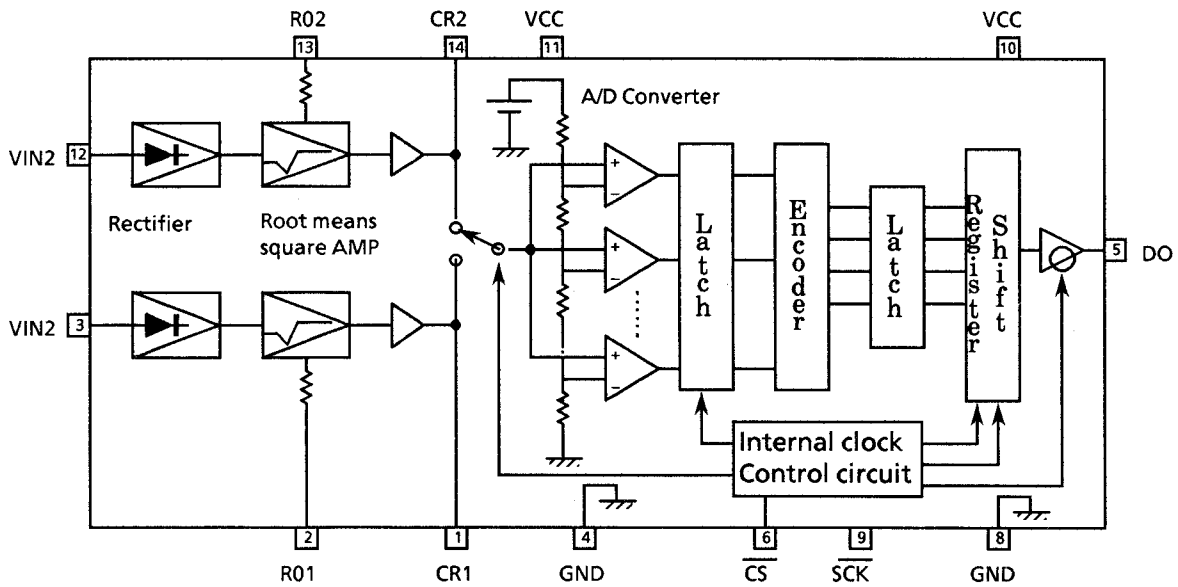

■ TA8409S (IC451~454) : DC motor driver

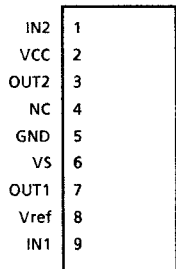

Function

Input		Output		Mode
IN1	IN2	OUT1	OUT2	
0	0	∞	∞	STOP
1	0	H	L	OPEN
0	1	L	H	CLOSE
1	1	L	L	BRAKE

∞ : High impedance

■ VC4580LD (IC111,112) : Dual OP Amp.

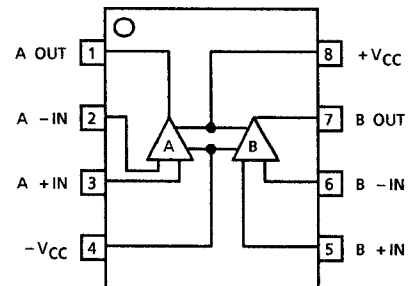

■ HA12155NT (IC201) : Signal processor

Function

- REC Equalizer
- Dolby B/C
- Electric Volume
- Level meter

Description

- 1) REC level automatic control
- 2) The signal which is not decoded is output from REC OUT during Playback.
- 3) Standard/high speed, Normal/CrO2/METAL switching
- 4) NR-ON/OFF,Dolby B/C,switching

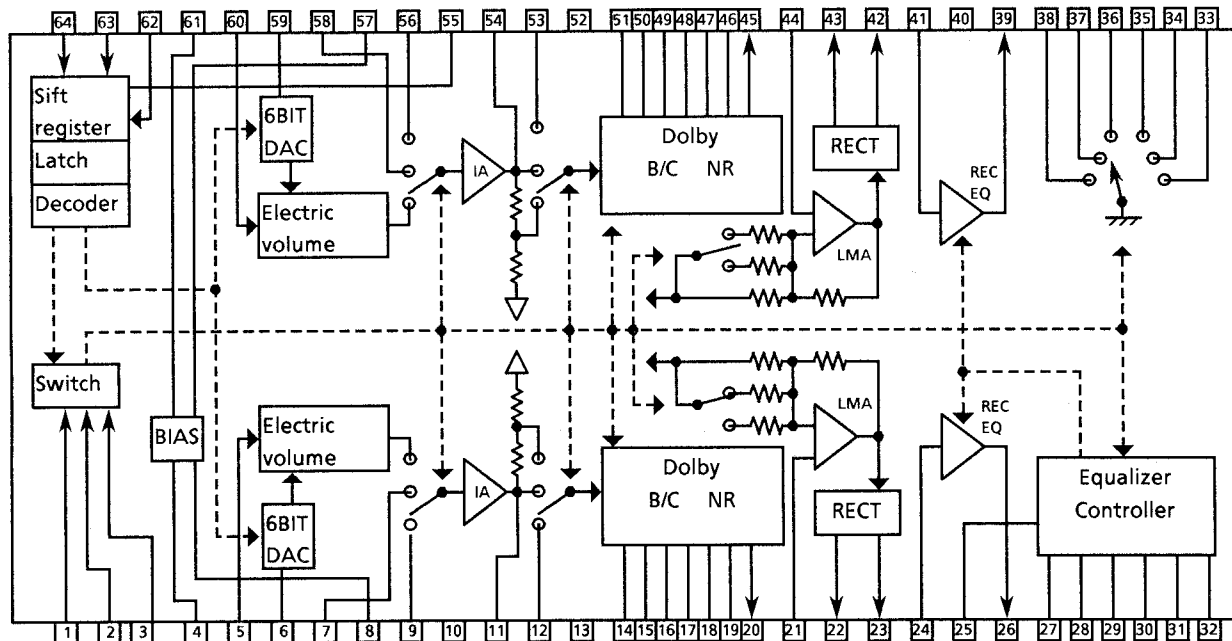

PinNO	Function	PinNO	Function	PinNO	Function
1	NR ON/OFF input	10	Connected to +5V	25	EQ Constant current input
2	NR B/C switching	14,51	Playback signal output	26,39	Recording signal input
3	Not used	15,50	Spectram slanting AMP	27~32	EQ parameter current input
4	Power supply	16,49	Spectram slanting AMP	33~38	EQ parameter select
5,60	Recording signal input	20,45	Output for REC equalizer	40,61	Ground
6,59	Capacitors are connected	21,44	Not used	55	Digital ground
7,58	Deck A playback signal input	22,43	Conected to capacitor	57	Current input for Dolby NR
8	Not used	23,42	Music scan output	62	Strobe signal input
9,56	Deck B playback signal input	24,41	Equalizer input	63	Clock input
11,12,13 54,53,52	Not used	17,18,19 48,47,46	Not used	64	Data input

■ μPC1330 HA (IC101) : HEAD SWITCH

Function

	4pin
PB	L
REC	H

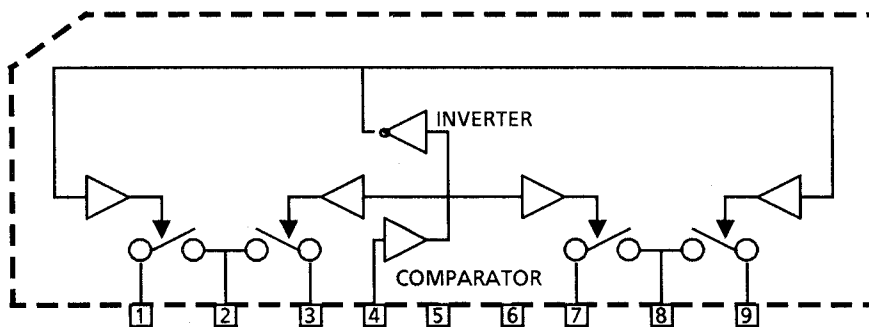

Disassembly Procedures

■ Top cover removal

1. Remove the screws fastening both sides of the Top cover and rear side.
2. Remove the Top cover spreading both sides and lifting the rear up.

■ Front panel block removal

1. Remove the Top cover.
2. Disconnect the connectors P101, P102, J401, J402, J403.
3. Remove the screw ⑥ on the bottom.
4. Release the 3 hooks ④ and remove the front panel block.

■ Cassette mechanism block removal

1. Remove the front panel block.
2. Disconnect the connectors J408, J409.
3. Remove the 8 blue colored screws ③ fixing the mechanism.
4. Push the cassette button and remove the cassette mechanism block.

NOTE

The cassette mechanism is grounded through the bottom cover, so when checking the operations with the bottom cover removed (especially when checking the signal system), be sure to ground the chassis by using an alligator clip or other suitable gadget. Also, this mechanism is designed for pack sensing, remember that it can not be operated without any tape.

■ Cassette holder removal

1. Remove the cassette mechanism from the front panel block.
2. Remove the dampers.
3. Remove the holder spring from the holder bracket.
4. Remove the cassette holder from the holder bracket.

■ System controller PCB removal

1. Remove the front panel block.
2. Remove the screw ⑤ and remove the PCB.

■ Cassette lid removal

1. Open the doors and slide them in the direction of the arrows.

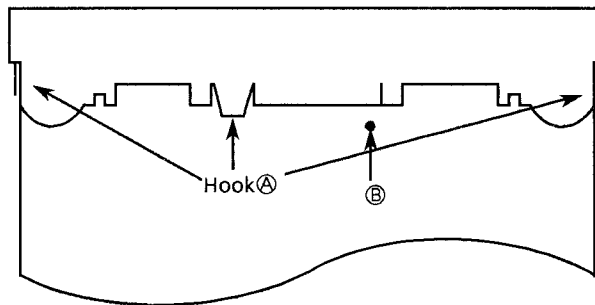

Figure 1 Bottom view of the front panel

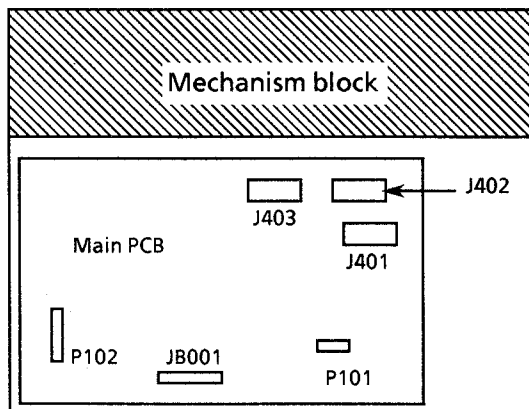

Figure 2 Top view

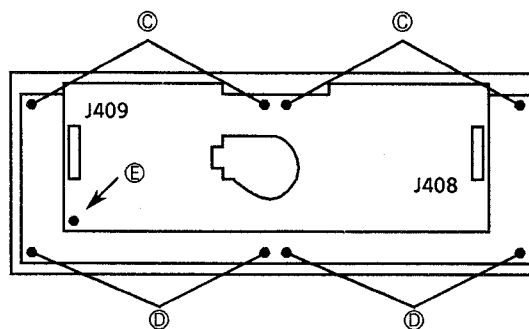

Figure 3 Rear view of the front panel block



Figure 4 Cassette lids

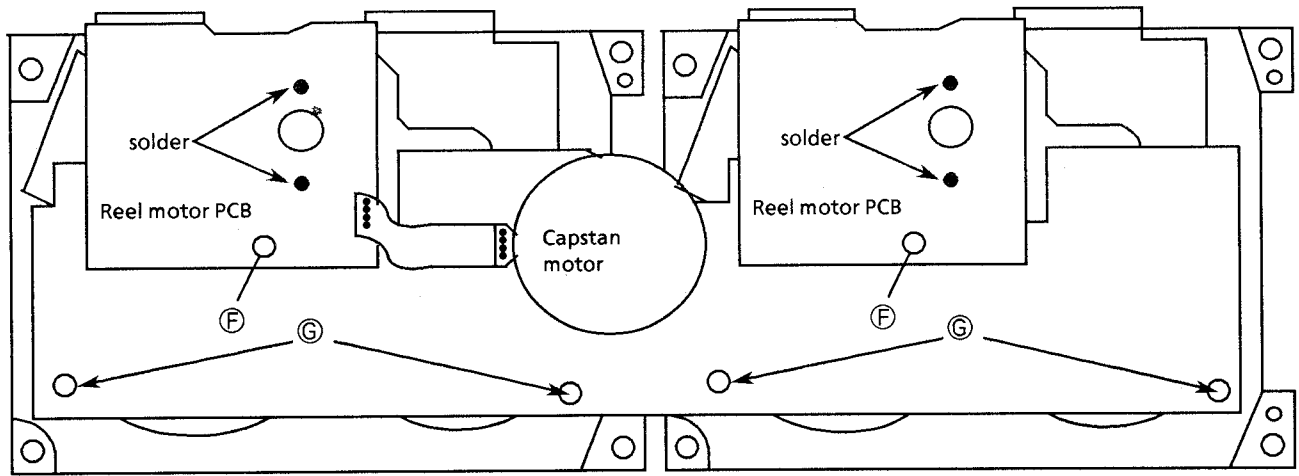

Figure 5 Rear view of the cassette mechanism

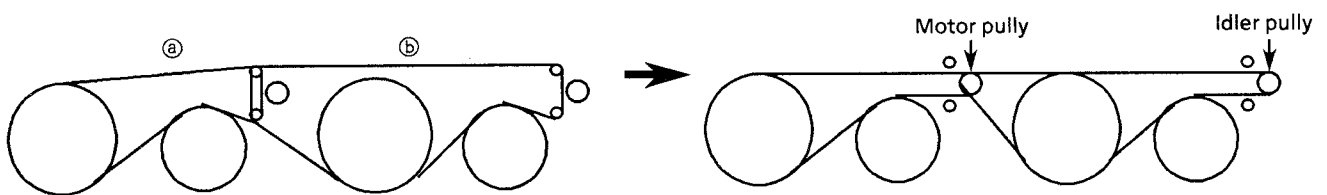

Figure 6 How to put the belts

■ Flywheel removal

1. Remove the mechanism block.
2. Remove the system controller PCB.
3. Remove the reel motor PCBs.
4. Remove the 4 screws fixing the bracket on which capstan motor is installed.
5. Remove the bracket and the belts.
6. Release the flywheel from the washer.

INSTALL

Install the flywheel and the belts to the mechanism as shown in figure 6. (When putting the belts, put the belt ③ first.)

At last, install the bracket with the capstan motor and put the belts on the pulleys.

■ CAM switch PCB removal

1. Remove the flywheels.
 2. Release the hook fixing the PCB and remove the PCB.
- (When installing the CAM switch gears, assemble the PCB so that part ④ meets part ①. figure7)

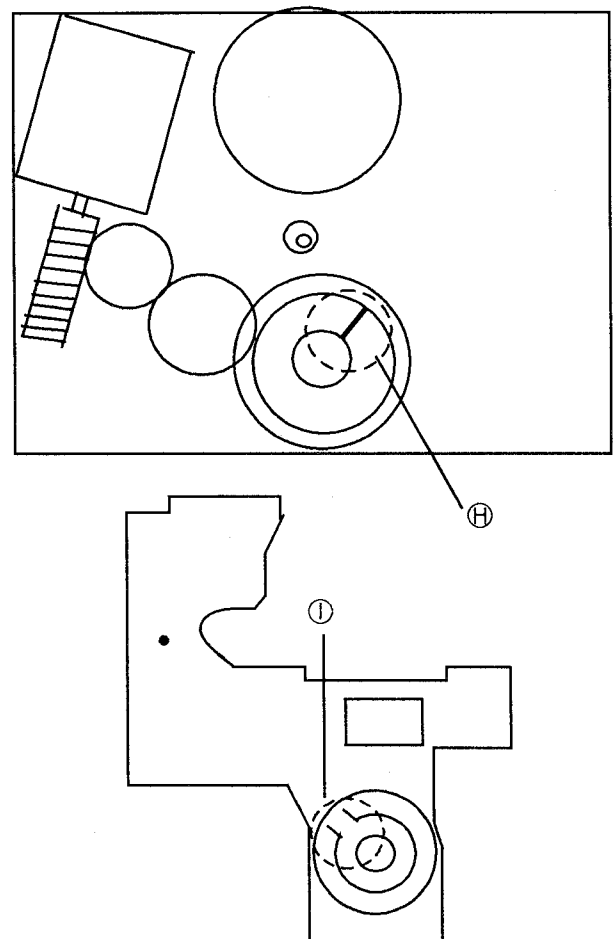

Figure 7 Gear position

■ Head assembly

1. Remove the cassette mechanism.
2. Unsolder the flexible wire on the relay PCB, and remove the 2 screws fixing the head assembly (Figure 10).

Notice for installing the head assembly

The direction of the head for forward or reverse mode is switched by the cam gear.

The point of the rib for the head assembly installation differs with the head direction. Figure 8 shows the relation of the gears.

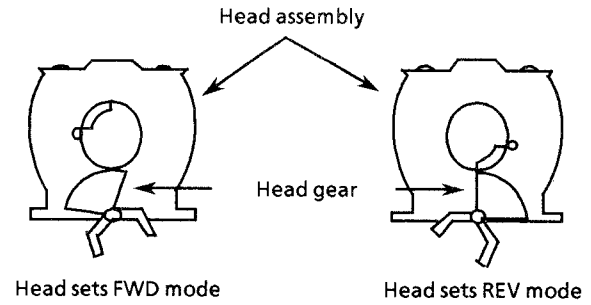

Figure 8 Bottom view of the head assembly

■ Pinch roller arm assembly removal (FWD / REV)

1. Release the pinch roller return spring from the hook (Figure 10).
2. Remove the hook fixing the pinch roller assembly, and remove the pinch roller assembly (Figure 9).

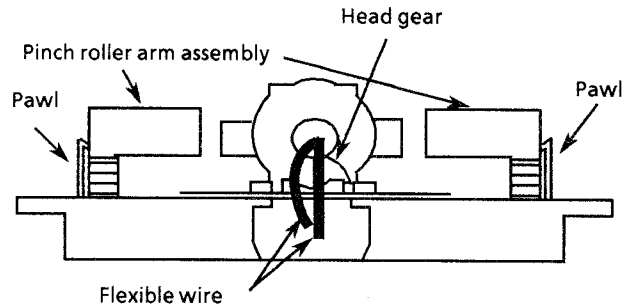

Figure 9 Bottom view of the cassette mechanism

■ Reel motor PCB removal

1. Remove the mechanism block.
2. Remove the system controller PCB.
3. Remove the screw fixing the reel motor PCB (Figure 5).
4. Unsolder the reel motor.
5. Remove the PCB.

■ Reel motor removal

1. Remove the mechanism block.
2. Remove the reel motor PCB.
3. Remove the FR arm assembly (Figure 10).
4. Remove the screws ① fixing the motor.
5. Release the pawl fixing the motor and remove the motor.

■ Capstan motor removal

1. Remove the mechanism block.
2. Remove the system controller PCB.
3. Remove the reel motor PCB.
4. Remove the 4 screws ② fixing the bracket (Figure 5).
5. Release the pawl fixing the bracket and remove the capstan motor with the bracket.
6. Remove the 2 screws fixing the motor on the bracket and remove the motor from the bracket.

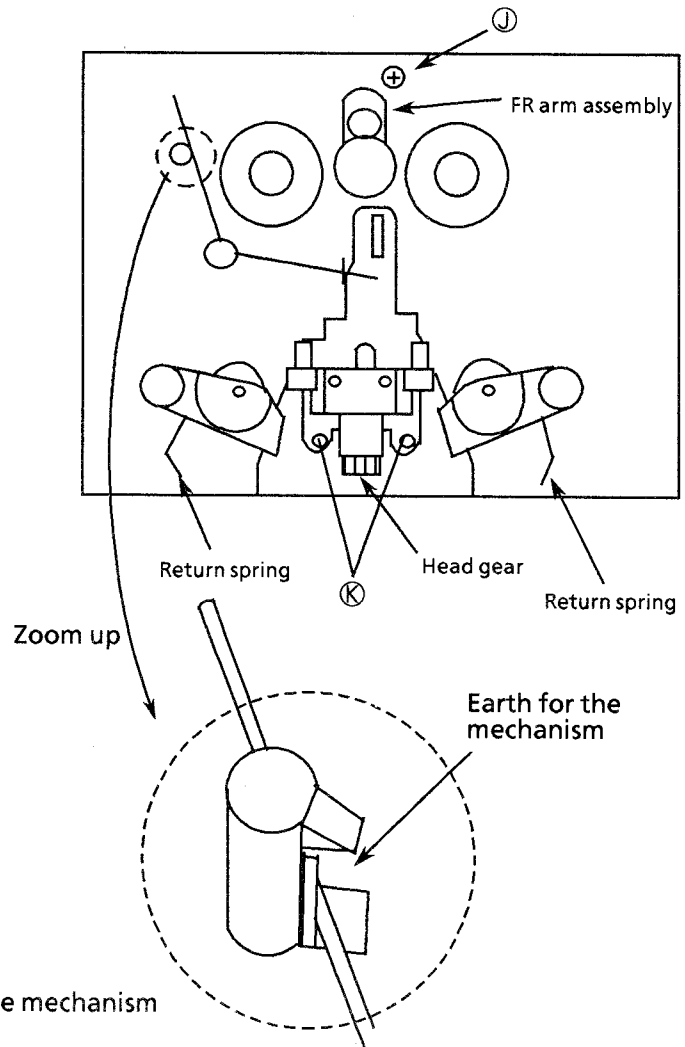

Figure 10 Front view of the cassette mechanism

Adjustment Procedures (Cassette Deck)

1. Measuring instruments

- Audio frequency signal generator (0dbs output at the 600 ohm output terminal from 50Hz to 20KHz)
- Electronic voltmeter
- Frequency counter
- Wow & Flutter meter
- Distortion Meter with band pass filter
- Attenuator (600 ohm impedance)
- A resistor with 600Ω

Standard Tape

0dBs = 0.775V

Tape No.	Frequency	Level (Wow & Fkutter)	Purpose
VTT-703L	10kHz	- 10dBs	Head azimuth , Frequency Response
VTT-712	3000Hz	0dBs 0.025%WRMS	Tape Speed , Wow & Flutter
VTT-724	1kHz	- 4dBs	Standard Level
TMT-6447	—	—	Blunk Skip
TMT-6247 , TMT-6237	—	—	Music Scan
TMT-7046	—	—	Recording standard Normal : UR
AC-712	—	—	Recording standard METAL : MA
AC-513	—	—	Recording standard CrO ₂ : SA
TW-2111, TW-2121	—	—	Forward /reverse play torque measuring
TW-2231	—	—	Feed forward /rewind torque measuring
C-120 Tape	—	—	Confirming the tape running

2. Adjustment and repairing the mechanism

Item	Adjustment method	Standard value	Remarks
Head azimuth	<p>Deck A</p> <ol style="list-style-type: none"> 1. Connect an electronic voltmeter to the DOLBY TP (figure 3) to playback VTT-703L. 2. Adjust screw Ⓐ so that the indication of the voltmeter becomes maximum when PLAY (▶) is pressed. 3. Adjust screw Ⓑ so that the indication of the voltmeter becomes maximum when PLAY (◀) is pressed. <p>Deck B</p> <ol style="list-style-type: none"> 4. Adjust screw Ⓒ so that the indication of the voltmeter becomes maximum when PLAY (▶) is pressed. 5. Adjust screw Ⓓ so that the indication of the voltmeter becomes maximum when PLAY (◀) is pressed. 6. After making the adjustment, apply screw lock to prevent screws Ⓐ, Ⓑ, Ⓒ and Ⓓ coming loose. 	Maximum	<ol style="list-style-type: none"> 1. Refer to figure 1. 2. When the specified characteristic cannot be obtained because of head wear, excessive magnetization, etc., replace the head assembly and adjust the head azimuth. Also, perform the electric adjustment. 3. When there is the difference of more than 3 ~ 4 dB between left and right output levels, replace the head assembly to avoid complaints.
Playback torque	1. Measure the torque in the playback mode by the torqu meter.	26 ~ 67 g-cm	When the standard torque cannot be obtained, replace the FR arm assembly or motor.
Fast forward torque	1. Measure the torque in the fast forward mode by the torqu meter.	80 ~ 200 g-cm	When the standard torque cannot be obtained, replace the FR arm assembly or motor.
Rewind torque	1. Measure the torque in the rewind mode by the torqu meter.	80 ~ 200 g-cm	When the standard torque cannot be obtained, replace the FR arm assembly or motor.
Wow & flutter	<ol style="list-style-type: none"> 1. Connect the wow & flutter meter to the DOLBY TP (figure 3) and play back VTT-712. 2. Its reading should be within 0.2% (WTD). 	Less than 0.2%	As a complaint may occur if the wow & flutter fluctuates by 0.1% even though it is allowed in the standard, repairing is required.

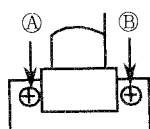

Deck A

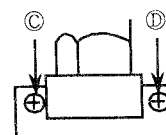

Deck B

Figure 1

3. Electrical Adjustments (Make the following adjustments after adjusting the head azimuth.)

In principle, the adjustments should be made in the following sequence.

Set the NR switch to OFF and the BEAT CUT switch to "1".

Adjustments marked with an asterisk (*) should always be made after the head is replaced

0dBs = 0.775V.

Item	Adjustment Method	Adjustment Location	Standard Value	Remarks
1 Tape Speed	1. Connect a frequency counter to the DOLBY TP (figure 3) and play back VTT-712. 2. Normal speed Adjustment 1) Mechanism B Play back deck B to adjust the semi-fixed resistor VR451 on ENJ-069-2. 2) Mechanism A Play back deck A to confirm that the difference between deck A and deck B is within $\pm 51\text{Hz}$. 3. High-speed adjustment 1) Mechanism B Play back deck B and adjust the semi-fixed resistor VR452 on ENJ-069-2.	VR451 VR452	3,000 Hz $\pm 10\text{Hz}$ 6,000Hz $\pm 20\text{Hz}$	1) Adjust the normal speed first, and perform the high speed adjustment.
* 2 Standard level (Playback Level)	1. Connect an electronic voltmeter to the DOLBY TP (figure 3). Play back VTT-724 (1 kHz : -4dBs) to adjust the semi-fixed resistors.	Deck A L: VR111 R: VR112 Deck B L: VR141 R: VR142	- 5.5dBs (411mV) $\pm 1\text{dB}$	1) The playback level varies when the head is replaced so should be adjusted. Use an electronic voltmeter with an impedance of 100 k Ω or more.
* 3 Playback Frequency Response	1. Connect an electronic voltmeter to the DOLBY TP (figure 3). 2. Play VTT-703L (10kHz : -10dBs) and adjust semi-fixed resistors to obtain the standard values.	Deck A L: VR113 R: VR114 Deck B L: VR143 R: VR144	- 11.5dBs (206mV) $\pm 3\text{dB}$	—
* 4 Recording Bias Frequency	1. Connect a frequency counter to the BIAS TP (figure 3), and perform a recording to adjust bias frequency.	L351	100 kHz $\pm 5\text{ kHz}$	Set the BEAT CUT SWITCH to "1".
* 5 Record / Play Frequency Response (Bias current)	1. Supply 1kHz and 12.5kHz with 30mV signals to VCR/DAT terminals respectively. to record them. 2. Connect an electronic voltmeter to the DOLBY TP (figure 3) to confirm the values. 3. If the values are not satisfied, adjust the semi-fixed resistors and record the signal again to confirm the values.	L: VR361 R: VR362	0 \pm 3 dB for 12.5 kHz with 1 kHz as the standard.	Refer to figure 2 below. 1) The recording and playback frequencies of a cassette deck are adjusted by adjusting the bias. 2) Perform the adjustment with normal tape and confirm that the values are within the range for metal tape.

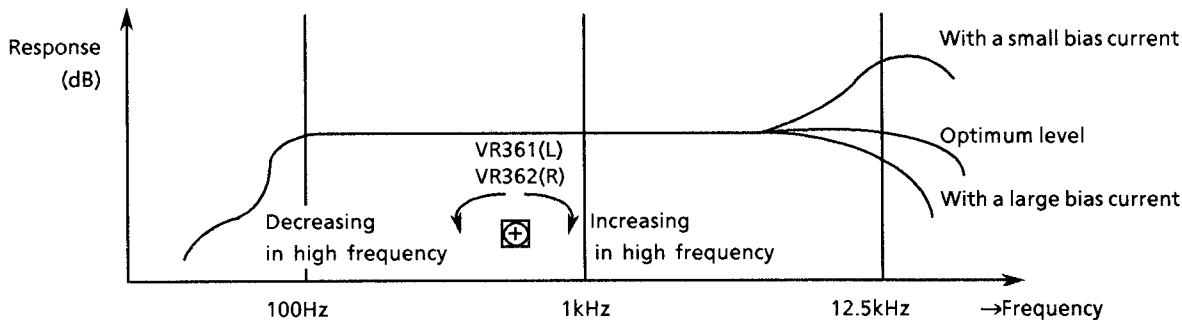

Figure 2

Item	Adjustment Method	Adjustment Location	Standard Value	Remarks
* 6 Record / Playback Sensitivity	1. Input a 1 kHz (-8.2dBs: 300mV) signal to VCR /DAT terminals and record it on the left and right channels . 2. Connect an electronic voltmeter to the DOLBY TP (figure 3) to confirm the values . 3. If the values are not satisfied , adjust the semi-fixed resistors and record the signal again to confirm the values.	L : VR185 R : VR186	- 5.5dBs (411mV)	Adjust with normal tape and make sure that the left /right level difference is 1.0dB or less
7 Erase ratio check	1. Record a music source using the Metal tape. 2. Rewind and erase the recorded section. 3. Comfirm nothing can be heard.	-	-	-
8 Auto-stop check	1. Make sure to operate AUTO STOP at the end of tape running and not to operate on the way of the playing.	-	-	-
9 Music Scan	1. Make sure not to work the music scanning operation at the start of tape wind. 2. Make sure to work the music scanning operation at the end of tape wind.	-	-	-

Mechanism controller PCB (ENJ-069-2)

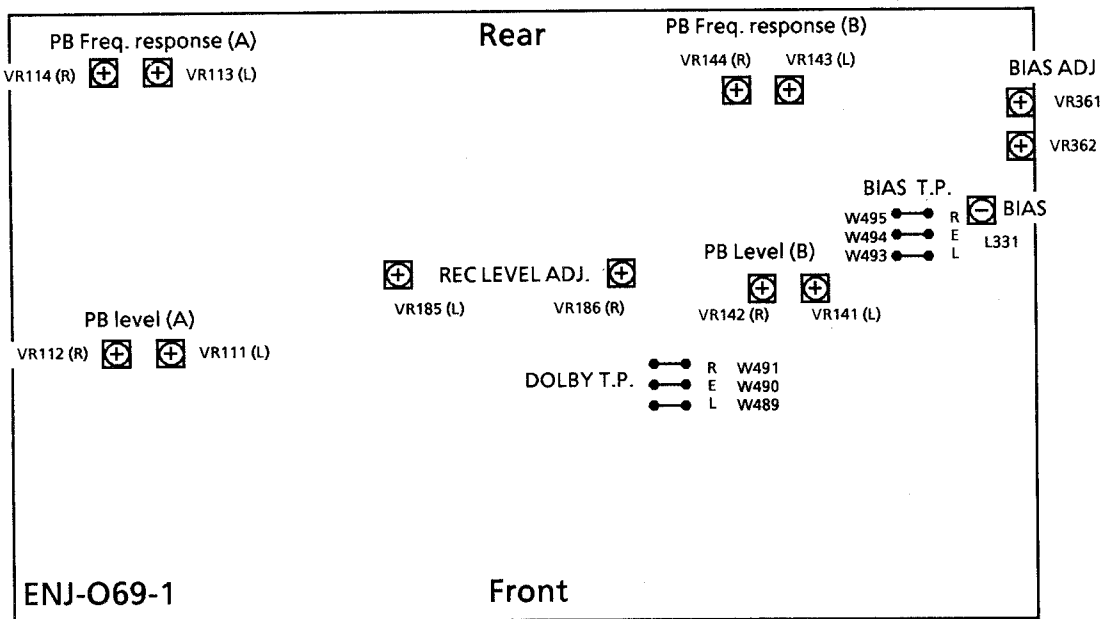
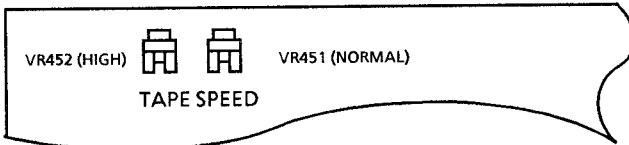
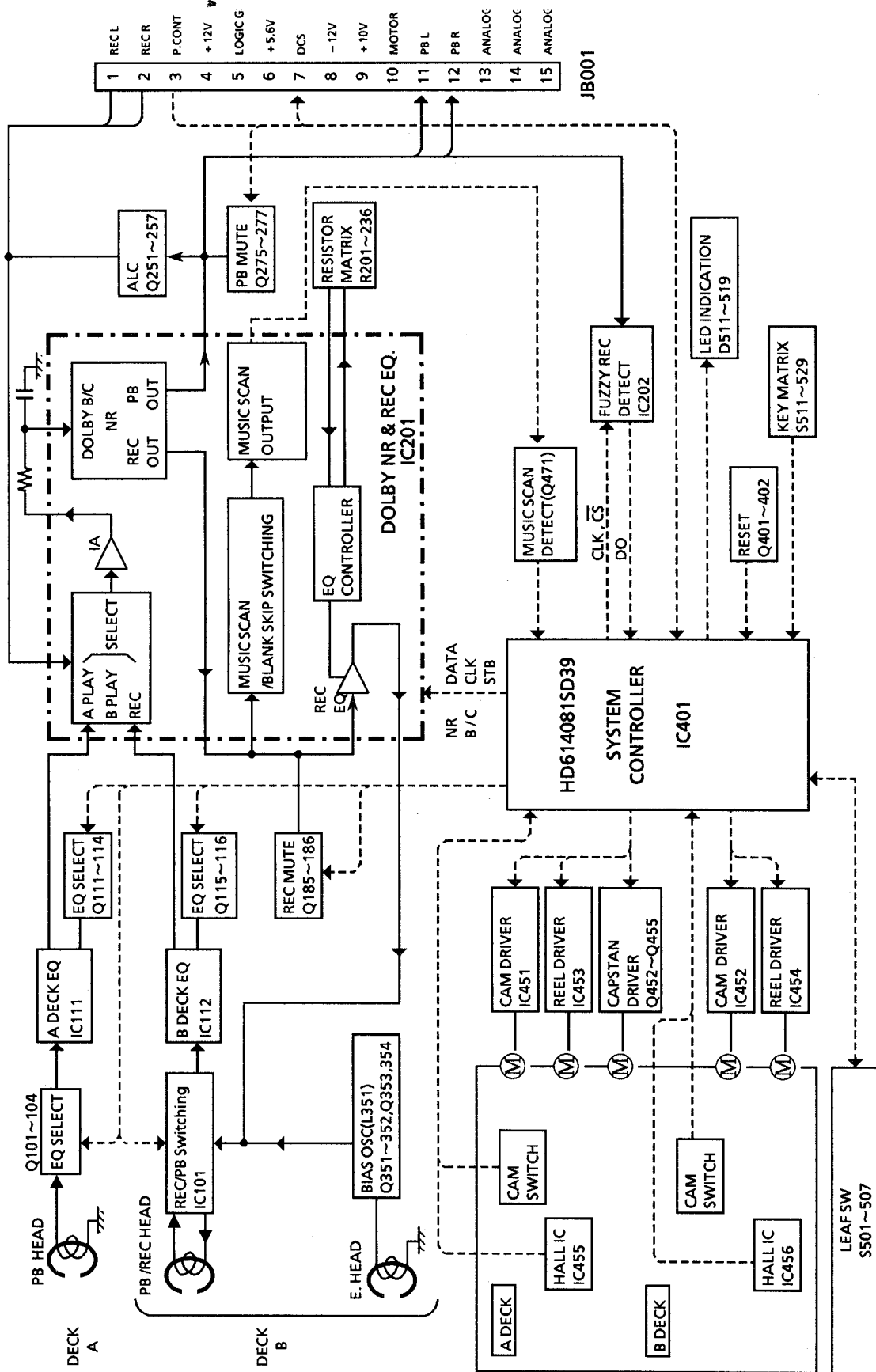
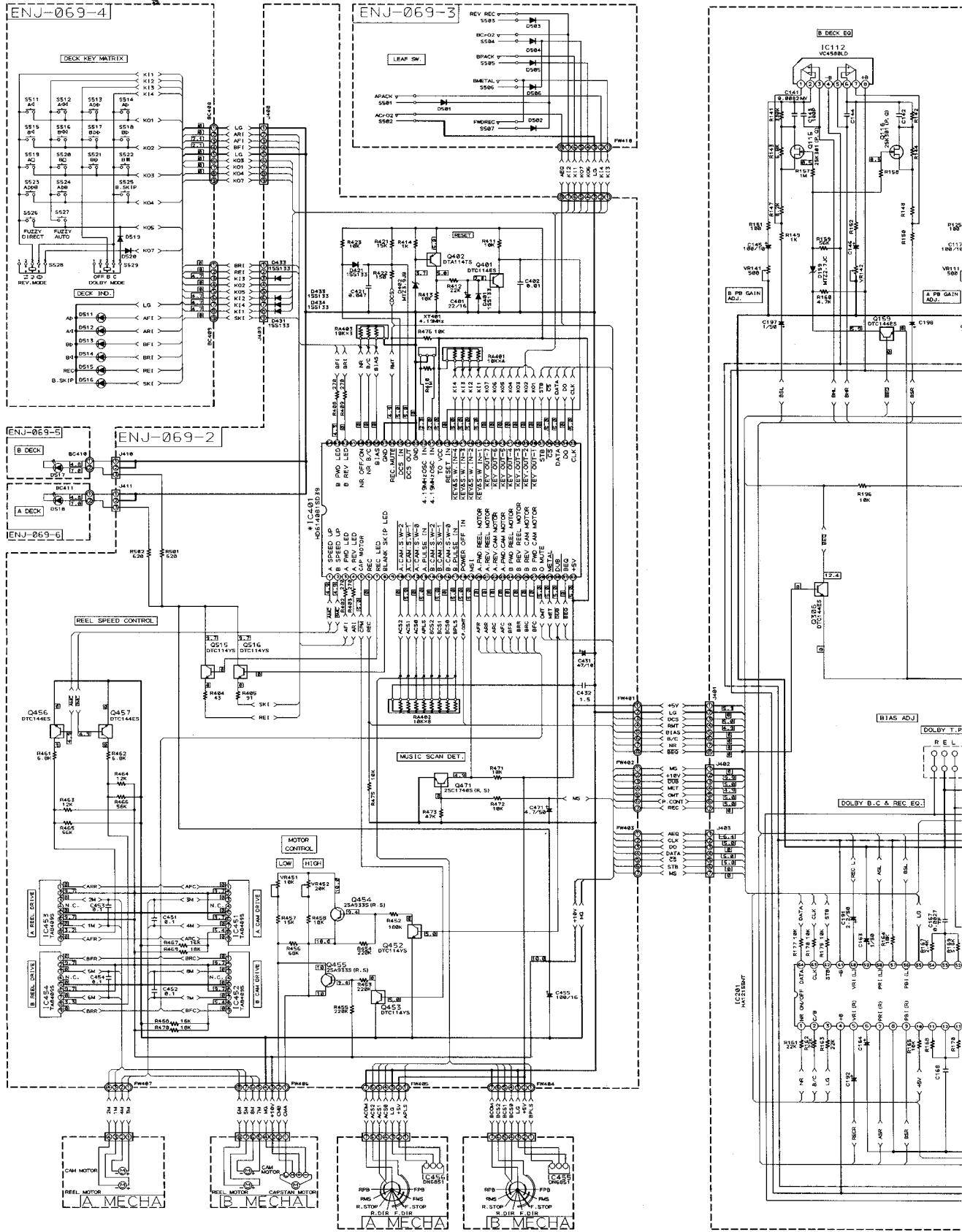

Figure 3

Block Diagram



Schematic Diagram



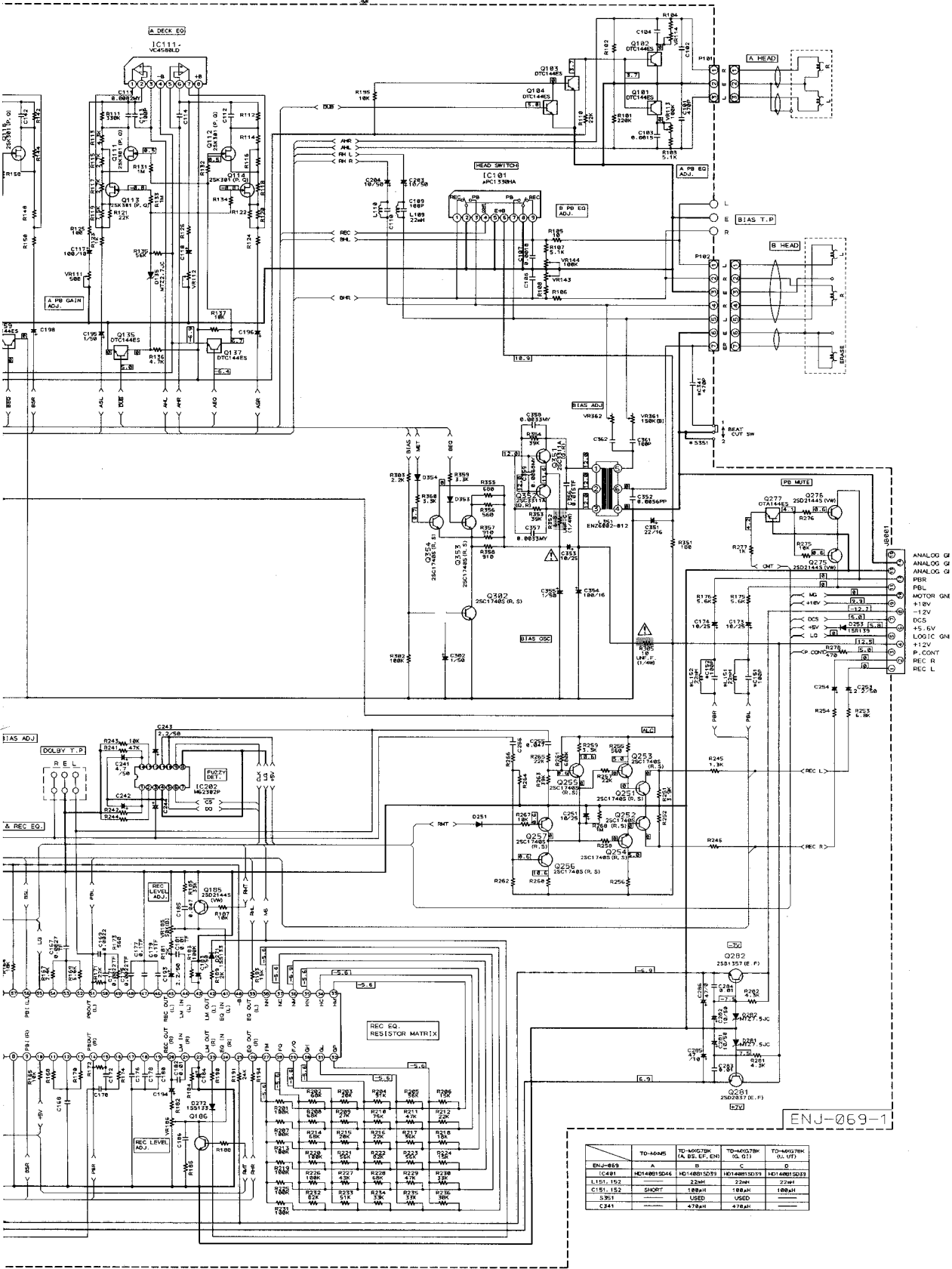

Notes:

1. indicates +B power supply
2. indicates -B power supply.
3. indicates main signal path.
4. When replacing the parts in the shaded are () and those marked with , be sure to use the designated parts to ensure safety.
5. The design and contents are subject to change without notice.

	TO-46MS	TO-46C7BK (A, BS, EF, EH)	TO-46C7BK (G, G1)	TO-46C7BK (L, LT)
ENJ-069	A	B	C	D
C491	2C148013046	1D-148013075	1D-148013075	1D-148013075
L151, 152		22mH	22mH	22mH
C161, 162	SHQPT	100µH	100µH	100µH
3951		470µF	470µF	470µF
C341		470µH	470µH	470µH

Printed Circuit Board

■ ENJ-069

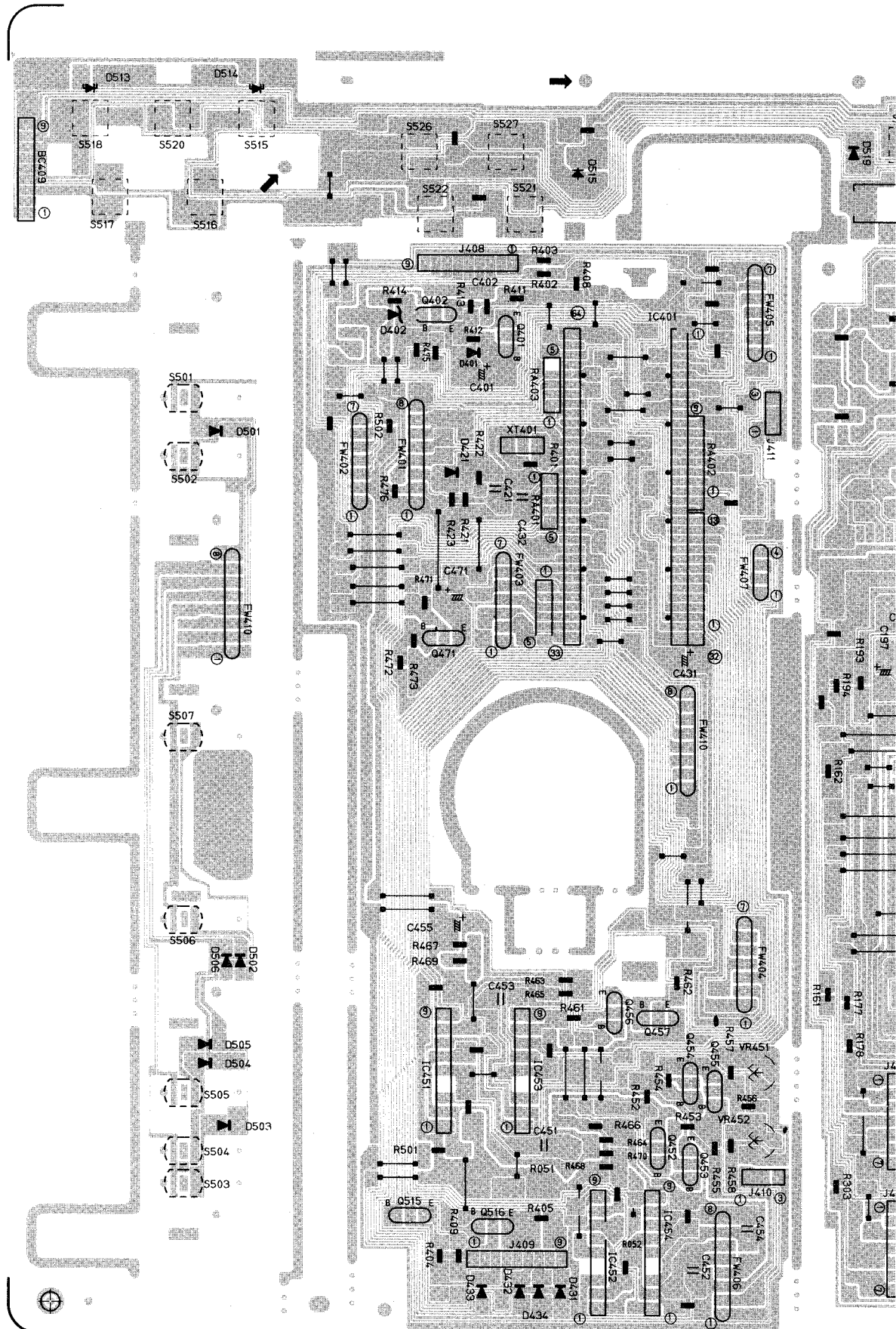

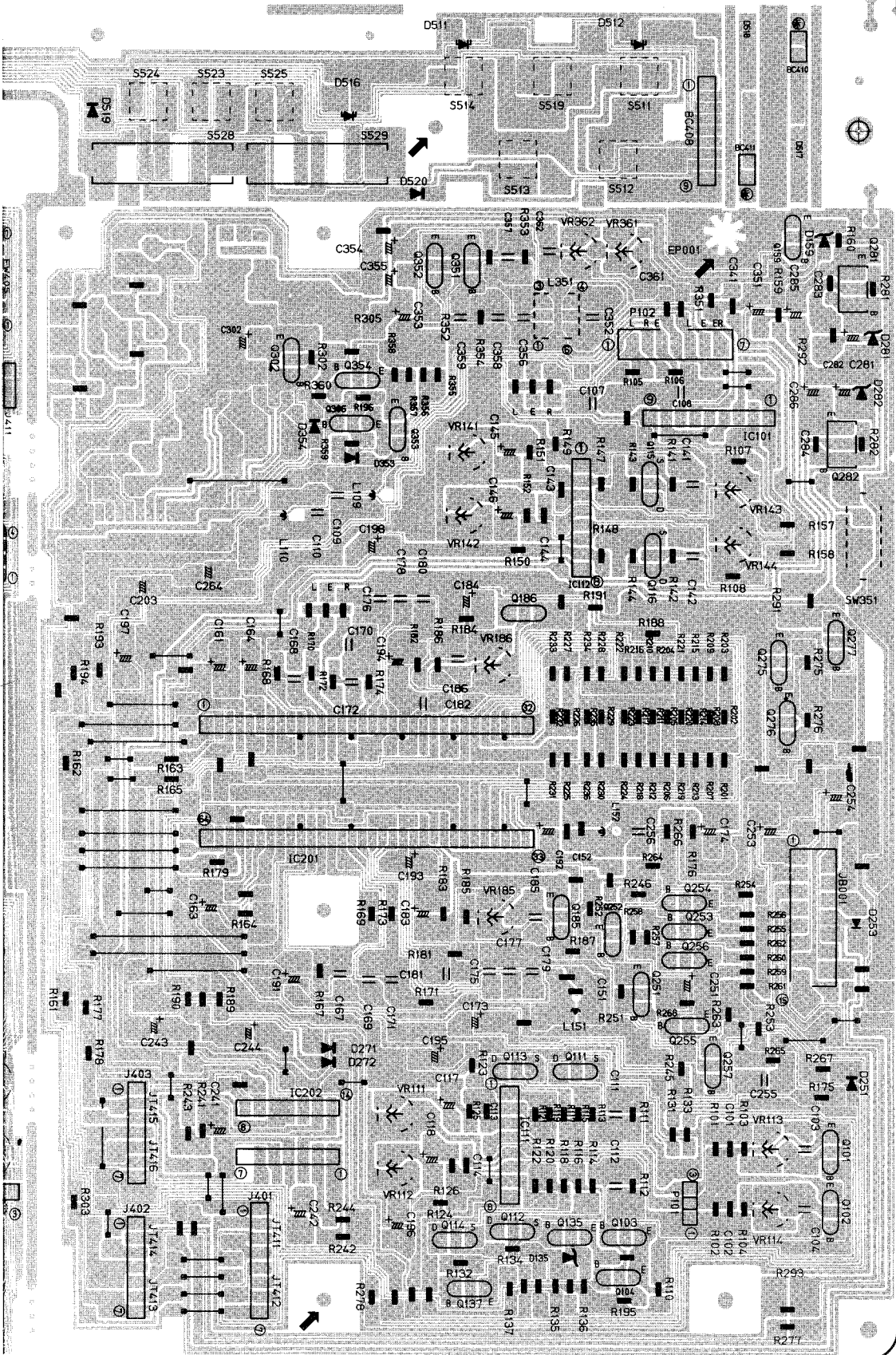

PARTS LIST

Note : All printed circuit boards and its assemblies are not available as service parts.

Contents

General Exploded View and Parts List	2-3
Cassette Mechanism Ass'y and Parts List	2-5
Printed Circuit Board Ass'y and Parts List	2-8
<input checked="" type="checkbox"/> ENJ-069 <input type="checkbox"/> Cassette PC Board Ass'y	2-8

General Exploded View and Parts List

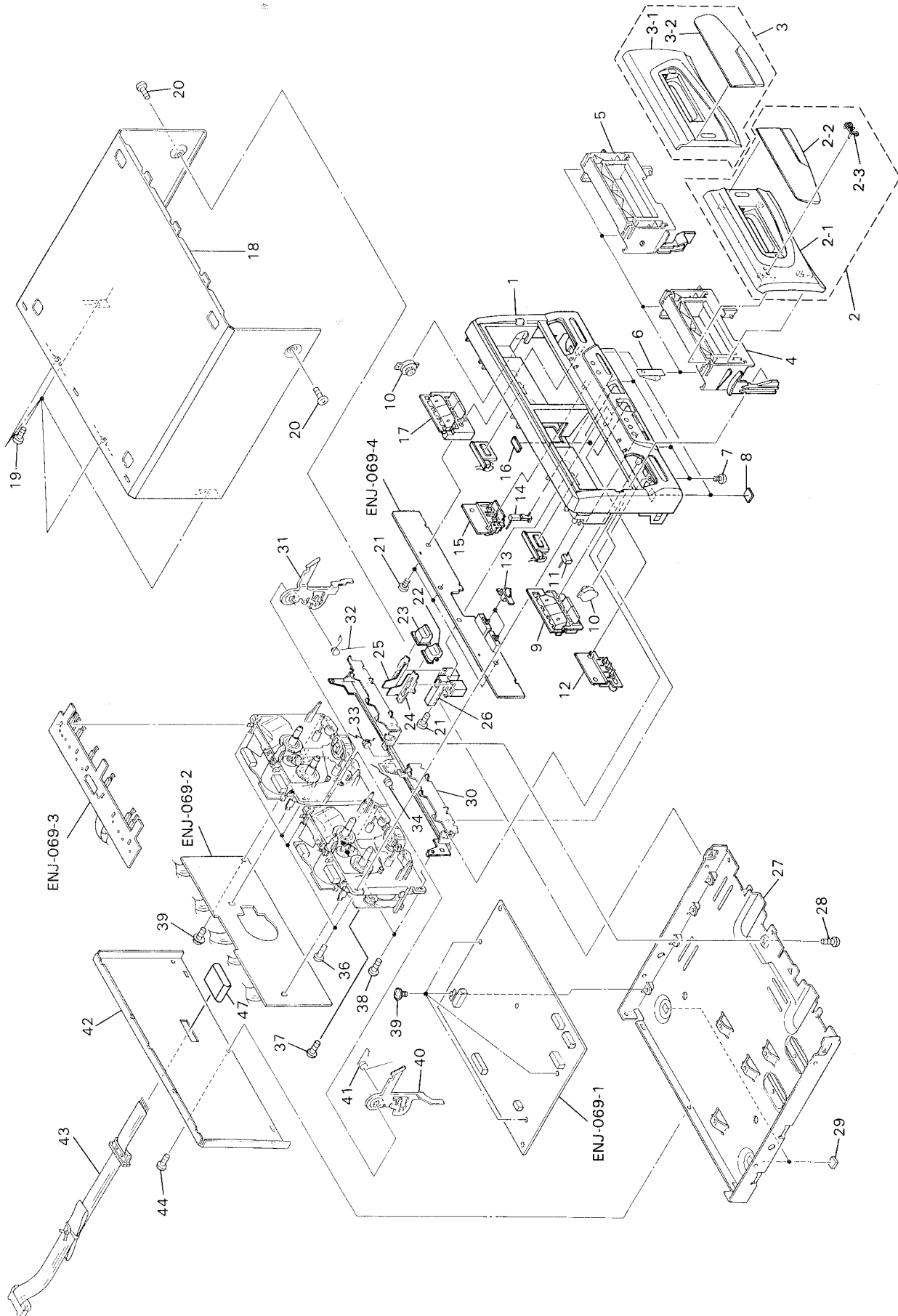

■ Parts List

Item	Part Number	Part Name	Q'ty	Description	Areas
1	E102632-005	FRONT PANEL	1		
2	E102637-002SA	CASSETTE LID ASSY	1	A	
2-1	E102637-002	CASSETTE LID	1	A	
2-2	E308209-001	CASSETTE LENS	1	A	
2-3	E406971-221	JVC MARK	1	A	
3	E102639-003SA	CASSETTE LID ASSY	1	B	
3-1	E102639-003	CASSETTE LID	1	B	
3-2	E308211-001	CASSETTE LENS	1	B	
4	E207642-001	CASSETTE HOLDER	1	A	
5	E207643-001	CASSETTE HOLDER	1	B	
6	E406713-001	CASSETTE SPRING	4		
7	SBST3006M	SCREW	4		
8	E406855-008	SPACER	2	FRONT FOOT	
9	E207648-001	PUSH BUTTON ASSY	1		
10	E304434-003	DAMPER ASSY	2		
11	E407241-001	INDICATOR	1		
12	E207654-001	PUSH BUTTON	1		
13	E407239-001	SLIDE KNOB	2		
14	E407242-001	INDICATOR	1		
15	E207655-002	PUSH BUTTON	1		
16	EXO010005A03S14	SPACER	2		
17	E207651-001	PUSH BUTTON ASSY	1		
18	E207591-002	METAL COVER	1		
19	E73273-003	SPECIAL SCREW	4		
20	SDSG3008M	SCREW	2		
21	SDSF2608Z	SCREW	4		
22	E308205-001	EJECT BUTTON	1	A	
23	E308207-001	EJECT BUTTON	1	B	
24	E407237-001	PUSH PLATE	1	A	
25	E407238-001	PUSH PLATE	1	B	
26	E308204-002	EJECT GUIDE	1		
27	E102462-001	CHASSIS BASE	1		
28	SBST3006Z	SCREW	1		
29	E406855-005	SPACER	2	REAR FOOT	
30	E207641-002	HOLDER BRACKET	1		
31	E308203-001	EJECT LEVER	1	B	
32	E406670-001	EJECT SPRING	1	B	
33	E407325-001	HOLDER SPRING	1	B	
34	E407324-001	HOLDER SPRING	1	A	
35	-----	CASSETTE MECHANISM ASSY	1	SEE PAGE 2-5	
36	SBSF3010C	SCREW	4		
37	E65923-001	SPECIAL SCREW	1		
38	SBST3008C	SCREW	4		
39	GBSG3008CC	SCREW	5		
40	E308202-001	EJECT LEVER	1		
41	E406669-001	EJECT SPRING	1		
42	E207639-005	REAR PANEL	1		A
	E207639-005	REAR PANEL	1		BS
	E207639-005	REAR PANEL	1		EF
	E207639-005	REAR PANEL	1		EN
	E207639-005	REAR PANEL	1		G
	E207639-005	REAR PANEL	1		GI
	E207639-003	REAR PANEL	1		U
	E207639-003	REAR PANEL	1		UT
43	EWP907-003	PLUG CORD ASSY	1		Except G, GI

	Item	Part Number	Part Name	Q'ty	Description	Areas
	43	EWP907-013	PLUG CORD ASSY	1		Except G, GI
	44	SBSG3008CC	SCREW	1		
	45	E60912-003	SPEED NUT	2		
	46	E73967-010	SPACER	1		
	47	EN28104-001	CAMP FILTER	1		G,GA
	—	E61029-005	NUMBER LABEL	1		

 SAFETY PARTS

The Marks for Designated Areas

A	Australia	EN	Scandinavia	EF	Continental Europe
BS	the U.K.	G	Germany	GI	Italy
UT	Taiwan	U	Universal Type	No mark indicates all areas.	

Cassette Mechanism Ass'y and Parts List

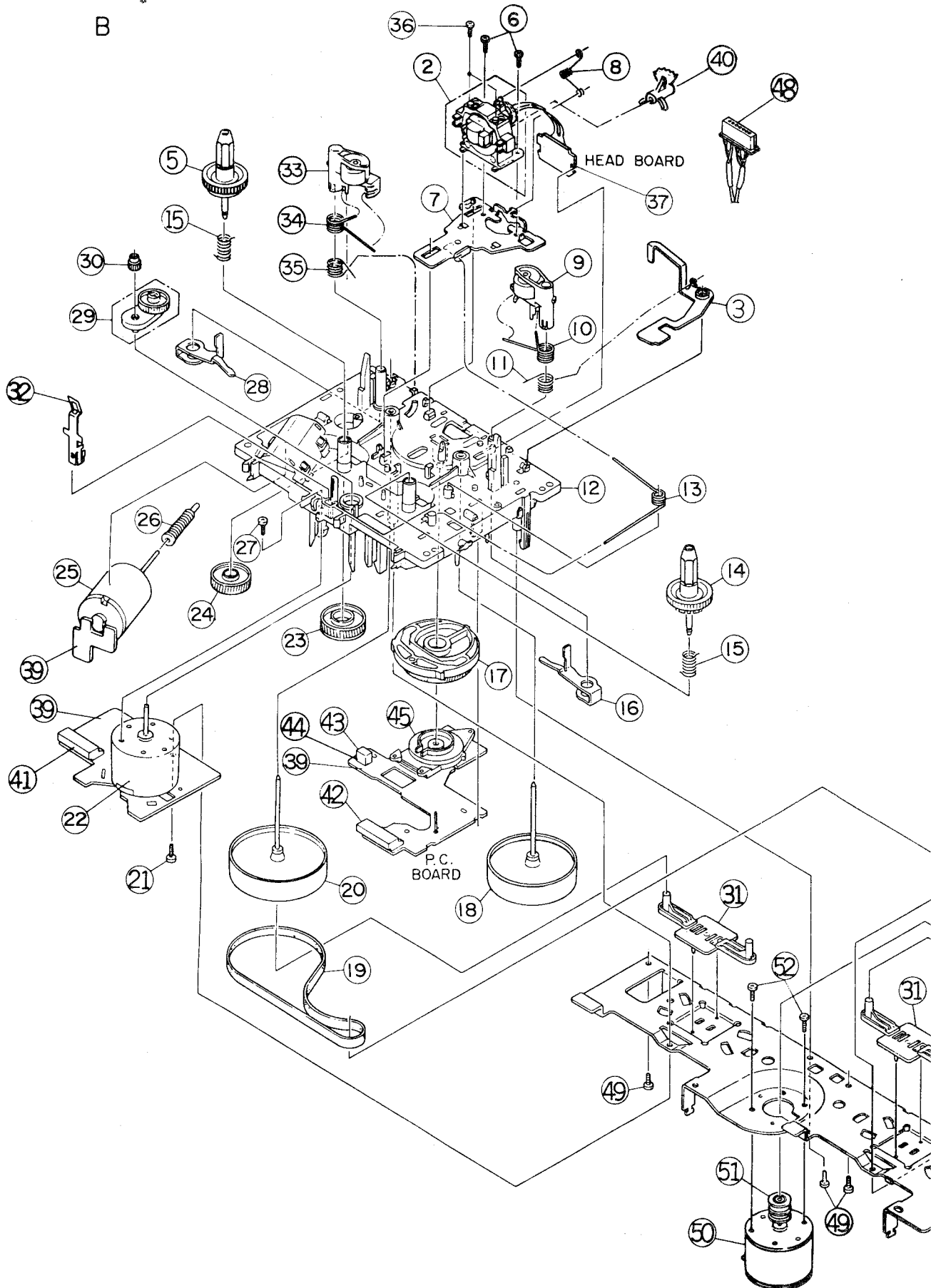

A

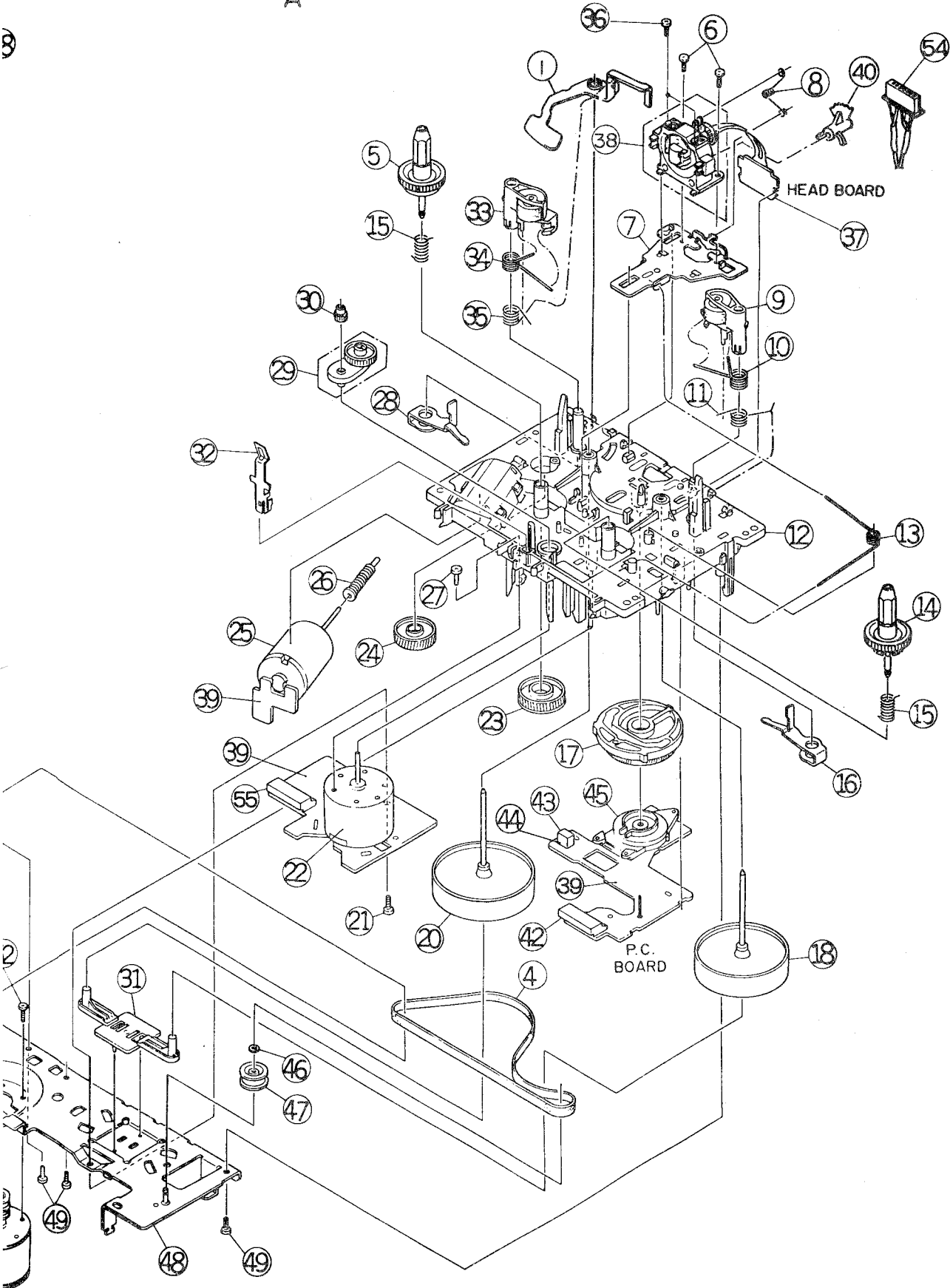

■ Parts List (Cassette Mechanism)

Item	Part Number	Part Name	Q'ty	Description	Areas
1	VKL6954-007	EJECT SAFETY LEVER	1	A MECHANISM	
2	VKS3551-00C	HEAD BLOCK ASSY	1	B MECHANISM	
3	VKL6943-005	EJECT SAFETY LEVER	1	B MECHANISM	
4	VKB3001-050	CAPSTAN BELT	1	A MECHANISM	
5	VKS5321-00D	REEL ASSY	2	RIGHT	
6	SDST2004Z	SCREW	4	FOR HEAD MOUNT ASSY	
7	VKL6942-00E	HEAD BASE ASSY	2		
8	VKW4994-001	HEAD SPRING	2		
9	VKP4221-00C	PINCH ROLLER ASSY	2	LEFT	
10	VKW4982-001	TORSION SPRING	2	LEFT	
11	VKW4933-005	TORSION SPRING	2	LEFT	
12	VKS1112-30E	CHASSIS BASE ASSY	2		
13	VKW4930-002	RETURN SPRING	2		
14	VKS3480-005	REEL ASSY	2	LEFT	
15	VKW4928-003	B.T SPRING	4	FOR REEL ASSY	
16	VKL6940-002	PINCH ROLLER LEVER	2	LEFT	
17	VKS2209-006	CONTROLLER CAM	2		
18	VKF3186-00C	FLYWHEEL ASSY	2	LEFT	
19	VKB3001-048	CAPSTAN BELT	1	B MECHANISM	
20	VKF3184-00C	FLYWHEEL ASSY	2	RIGHT	
21	SDSF2608Z	SCREW	2	PC BOARD - FM BRACKET	
22	MMN-6F4RA38	DC MOTOR	2	REEL	
23	VKS5331-002	GEAR (6)	2		
24	VKS5330-004	GEAR (5)	2		
25	MXN-13FB12F	DC MOTOR	2	CAM	
26	VKS5329-002	GEAR (4)	2		
27	SDSP2605Z	SCREW	2	CHASSIS BASE - D.C. MOTOR	
28	VKL6939-002	PINCH ROLLER LEVER	2	RIGHT	
29	VKS5325-00F	FR ARM ASSY	2		
30	VKS5328-002	REEL MOTOR GEAR	2		
31	VKS5327-003	THRUST PALTE	2		
32	VKY4628-002	PACK SPRING	2		
33	VKP4219-00C	PINCH ROLLER ASSY	2	RIGHT	
34	VKW4981-001	TORSION SPRING	2	RIGHT	
35	VKW4932-005	TORSION SPRING	2	RIGHT	
36	VKZ4629-003	SCREW	4		
37	VMW4816-001	PRINTED BOARD	2		
38	VKS3550-00C	HEAD MOUNT ASSY	1	A MECHANISM	
39	VMW2345-002	PRINTED BOARD	2		
40	VKS3485-002	HEAD BLOCK GEAR	2		
41	VMC0249-R08	CONNECTOR	1	B MECHANISM	
42	VMC0249-R07	CONNECTOR	2		
43	DN6851A	HALL IC	2		
44	VKS3487-002	IC HALL	2		
45	VKS3587-00A	CAM SWITCH ASSY	2		
46	WDL163525-4	WASHER	1		
47	VKR4631-002	IDLER PULLEY	1		
48	VKM3419-00E	FM BRACKET	1		
49	SDSF2605Z	SCREW	4	CHASSIS BASE - BRACKET	
50	MMI-6H2LWSK	MOTOR	1	CAPSTAN	
51	VKR4632-003	MOTOR PULLEY	1		
52	SPSP2603Z	SCREW	2		
53	VDM107P-040	HEAD WIRE	1	B MECHANISM	
54	VDM103P-040	HEAD WIRE	1	A MECHANISM	
55	VMC0249-R04	CONNECTOR	1	A MECHANISM	

Printed Circuit Board Ass'y and Parts List

■ ENJ-069 Cassette PC-Board Ass'y

Note : ENJ-069 □ varies according to the areas employed. See note (1) when placing an order.

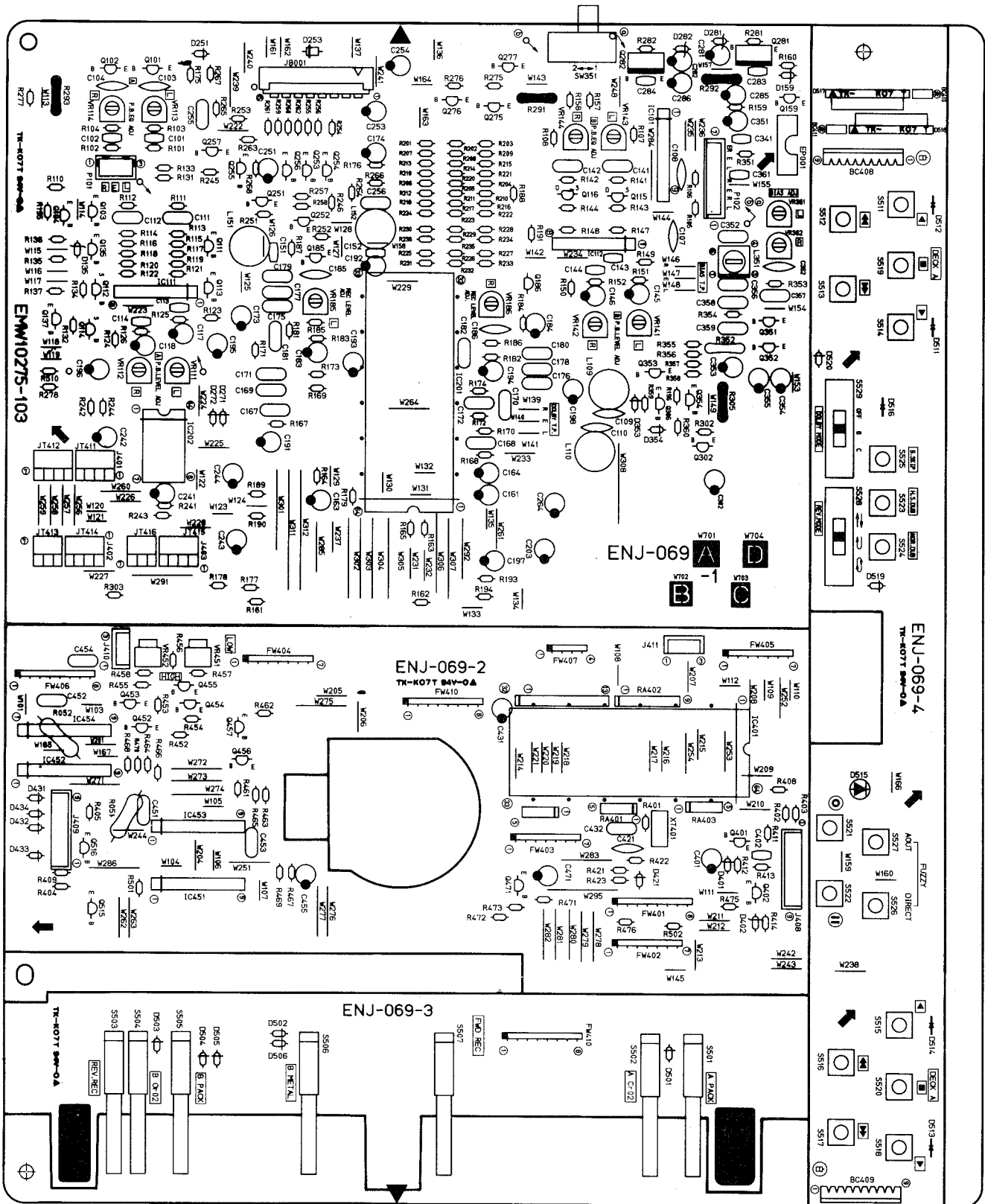

Note (1)

PC Board Ass'y	Designated Areas
ENJ-069 B	Australia the U.K. Continental Europe Scandinavia
ENJ-069 C	Germany Italy
ENJ-069 D	Universal Type Taiwan

TRANSISTORS

ITEM	PART NUMBER	DESCRIPTION	AREA
Q101	DTC144ES	SILICON ROHM	
Q102	DTC144ES	SILICON ROHM	
Q103	DTC144ES	SILICON ROHM	
Q104	DTC144ES	SILICON ROHM	
Q111	2SK301(P,Q)	F.E.T MATSUSHITA	
Q112	2SK301(P,Q)	F.E.T MATSUSHITA	
Q113	2SK301(P,Q)	F.E.T MATSUSHITA	
Q114	2SK301(P,Q)	F.E.T MATSUSHITA	
Q115	2SK301(P,Q)	F.E.T MATSUSHITA	
Q116	2SK301(P,Q)	F.E.T MATSUSHITA	
Q135	DTC144ES	SILICON ROHM	
Q137	DTC144ES	SILICON ROHM	
Q159	DTC144ES	SILICON ROHM	
Q185	2SD2144S(VW)	SILICON ROHM	
Q186	2SD2144S(VW)	SILICON ROHM	
Q251	2SC1740S(R,S)	SILICON ROHM	
Q252	2SC1740S(R,S)	SILICON ROHM	
Q253	2SC1740S(R,S)	SILICON ROHM	
Q254	2SC1740S(R,S)	SILICON ROHM	
Q255	2SC1740S(R,S)	SILICON ROHM	
Q256	2SC1740S(R,S)	SILICON ROHM	
Q257	2SC1740S(R,S)	SILICON ROHM	
Q275	2SD2144S(VW)	SILICON ROHM	
Q276	2SD2144S(VW)	SILICON ROHM	
Q277	DTA144ES	SILICON ROHM	
Q281	2SD2037(E,F)	SILICON ROHM	
Q282	2SB1357(E,F)	SILICON ROHM	
Q302	2SC1740S(R,S)	SILICON ROHM	
Q306	DTC144ES	SILICON ROHM	
Q351	2SC3311A(Q,R)	SILICON MATSUSHITA	
Q352	2SC3311A(Q,R)	SILICON MATSUSHITA	
Q353	2SC1740S(R,S)	SILICON ROHM	
Q354	2SC1740S(R,S)	SILICON ROHM	
Q401	DTC114ES	SILICON ROHM	
Q402	DTA114TS	SILICON ROHM	
Q452	DTC114YS	SILICON ROHM	
Q453	DTC114YS	SILICON ROHM	
Q454	2SA933S(R,S)	SILICON ROHM	
Q455	2SA933S(R,S)	SILICON ROHM	
Q456	DTC144ES	SILICON ROHM	
Q457	DTC144ES	SILICON ROHM	
Q471	2SC1740S(R,S)	SILICON ROHM	
Q515	DTC114YS	SILICON ROHM	
Q516	DTC114YS	SILICON ROHM	

△ SAFETY PARTS

I. C. S.

ITEM	PART NUMBER	DESCRIPTION	AREA
IC101	UPC1330HA	I.C. NEC	
IC111	VC4580LD	I.C. DAINICHI	
IC112	VC4580LD	I.C. DAINICHI	
IC201	HA12155NT	I.C. HITACHI	
IC202	M62302P	I.C. MITSUBISHI	
IC401	HD614081SD39	I.C. HITACHI	
IC451	TAB409S	I.C. TOSHIBA	
IC452	TAB409S	I.C. TOSHIBA	
IC453	TAB409S	I.C. TOSHIBA	
IC454	TAB409S	I.C. TOSHIBA	

△ SAFETY PARTS

DIODES

ITEM	PART NUMBER	DESCRIPTION	AREA
D135	MTZ2.7JB	ZENER ROHM	
D159	MTZ2.7JB	ZENER ROHM	
D251	1SS119	SILICON HITACHI	
D253	1SR35-200A	SILICON ROHM	
D271	1SS119	SILICON HITACHI	
D272	1SS119	SILICON HITACHI	
D281	MTZ7.5JC	ZENER ROHM	
D282	MTZ7.5JC	ZENER ROHM	
D353	1SS119	SILICON HITACHI	
D354	1SS119	SILICON HITACHI	
D401	1SS119	SILICON HITACHI	
D402	MTZ3.9JB	ZENER ROHM	
D421	1SS119	SILICON HITACHI	
D431	1SS119	SILICON HITACHI	
D432	1SS119	SILICON HITACHI	
D433	1SS119	SILICON HITACHI	
D434	1SS119	SILICON HITACHI	
D501	1SS119	SILICON HITACHI	
D502	1SS119	SILICON HITACHI	
D503	1SS119	SILICON HITACHI	
D504	1SS119	SILICON HITACHI	
D505	1SS119	SILICON HITACHI	
D506	1SS119	SILICON HITACHI	
D511	SLR-342MCA47	L.E.D. ROHM	
D512	SLR-342MCA47	L.E.D. ROHM	
D513	SLR-342MCA47	L.E.D. ROHM	
D514	SLR-342MCA47	L.E.D. ROHM	
D515	SLH-34VC50F124	L.E.D. ROHM	
D516	SLR-342VC3F	L.E.D. ROHM	
D517	LD-702MG	L.E.D. ROHM	
D518	LD-702MG	L.E.D. ROHM	
D519	1SS119	SILICON HITACHI	
D520	1SS119	SILICON HITACHI	

△ SAFETY PARTS

CAPACITORS

ITEM	PART NUMBER	DESCRIPTION	AREA
C101	QCBB1HK-471	470PF 50V CERAMIC	
C102	QCBB1HK-471	470PF 50V CERAMIC	
C103	QCY21HK-152	1500PF 50V CERAMIC	
C104	QCY21HK-152	1500PF 50V CERAMIC	
C107	QCY21HK-182	1800PF 50V CERAMIC	
C108	QCY21HK-182	1800PF 50V CERAMIC	
C109	QCS21HJ-101	100PF 50V CERAMIC	
C110	QCS21HJ-101	100PF 50V CERAMIC	
C111	QFLB1HJ-822	8200PF 50V MYLAR	
C112	QFLB1HJ-822	8200PF 50V MYLAR	
C113	QCBB1HK-101	100PF 50V CERAMIC	
C114	QCBB1HK-101	100PF 50V CERAMIC	
C117	QEK51CM-107	100MF 16V ELECTRO	
C118	QETB1CM-107	100MF 16V ELECTRO	
C141	QFLB1HJ-822	8200PF 50V MYLAR	
C142	QFLB1HJ-822	8200PF 50V MYLAR	
C143	QCBB1HK-101	100PF 50V CERAMIC	
C144	QCBB1HK-101	100PF 50V CERAMIC	
C145	QETB1AM-107	100MF 10V ELECTRO	
C146	QETB1AM-107	100MF 10V ELECTRO	
C151	QCBB1HK-101	100PF 50V CERAMIC	
C152	QCBB1HK-101	100PF 50V CERAMIC	
C161	QETB1AM-107	100MF 10V ELECTRO	
C163	QETB1HM-105	1MF 50V ELECTRO	
C164	QETB1HM-105	1MF 50V ELECTRO	
C167	QFLB1HJ-272	2700PF 50V MYLAR	
C168	QFLB1HJ-272	2700PF 50V MYLAR	
C169	QFLB1HJ-222	2200PF 50V MYLAR	
C170	QFLB1HJ-222	2200PF 50V MYLAR	
C171	QFLB1HJ-222	2200PF 50V MYLAR	
C172	QFLB1HJ-222	2200PF 50V MYLAR	
C173	QETB1EM-106	10MF 25V ELECTRO	
C174	QETB1EM-106	10MF 25V ELECTRO	
C175	QFLB1HJ-222	2200PF 50V MYLAR	
C176	QFLB1HJ-222	2200PF 50V MYLAR	
C177	QFV81HJ-104	0.1MF 50V T.FILM	
C178	QFV81HJ-104	0.1MF 50V T.FILM	
C179	QFV81HJ-104	0.1MF 50V T.FILM	
C180	QFV81HJ-104	0.1MF 50V T.FILM	
C181	QFLB1HJ-103	0.01MF 50V MYLAR	
C182	QFLB1HJ-103	0.01MF 50V MYLAR	
C183	QETB1HM-105	1MF 50V ELECTRO	
C184	QETB1HM-105	1MF 50V ELECTRO	
C185	QCF21HP-473	0.047MF 50V CERAMIC	
C186	QCF21HP-473	0.047MF 50V CERAMIC	
C191	QETB1HM-225	2.2MF 50V ELECTRO	
C192	QETB1HM-225	2.2MF 50V ELECTRO	
C193	QETB1HM-225	2.2MF 50V ELECTRO	
C194	QETB1HM-225	2.2MF 50V ELECTRO	
C195	QETB1HM-105	1MF 50V ELECTRO	
C196	QETB1HM-105	1MF 50V ELECTRO	
C197	QETB1HM-105	1MF 50V ELECTRO	
C198	QETB1HM-105	1MF 50V ELECTRO	
C203	QETB1EM-106	10MF 25V ELECTRO	
C204	QETB1EM-106	10MF 25V ELECTRO	

△ SAFETY PARTS

CAPACITORS

Δ	ITEM	PART NUMBER	DESCRIPTION			AREA
	C241	QETB1HM-475	4.7MF	50V	ELECTRO	
	C242	QETB1HM-475	4.7MF	50V	ELECTRO	
	C243	QETB1HM-225	2.2MF	50V	ELECTRO	
	C244	QETB1HM-225	2.2MF	50V	ELECTRO	
	C251	QETB1EM-106	10MF	25V	ELECTRO	
	C253	QETB1HM-225	2.2MF	50V	ELECTRO	
	C254	QETB1HM-225	2.2MF	50V	ELECTRO	
	C255	QFLB1HJ-473	0.047MF	50V	MYLAR	
	C256	QFLB1HJ-473	0.047MF	50V	MYLAR	
	C281	QETB1HM-106	10MF	50V	ELECTRO	
	C282	QETB1HM-106	10MF	50V	ELECTRO	
	C283	QCVB1CM-103	0.01MF	16V	CERAMIC	
	C284	QCVB1CM-103	0.01MF	16V	CERAMIC	
	C285	QETB1AM-476	47MF	10V	ELECTRO	
	C286	QETB1AM-476	47MF	10V	ELECTRO	
	C302	QETB1HM-105	1MF	50V	ELECTRO	
	C341	QCBB1HK-471	470PF	50V	CERAMIC	B
	C341	QCBB1HK-471	470PF	50V	CERAMIC	C
	C351	QETB1CM-226	22MF	16V	ELECTRO	
	C352	QFP81HG-562	5600PF	50V	POLY	
	C353	QETB1EM-106	10MF	25V	ELECTRO	
	C354	QETB1EM-106	10MF	25V	ELECTRO	
	C355	QETB1HM-105	1MF	50V	ELECTRO	
	C356	QFLB1HJ-153	0.015MF	50V	MYLAR	
	C357	QFLB1HJ-332	3300PF	50V	MYLAR	
	C358	QFLB1HJ-332	3300PF	50V	MYLAR	
	C359	QFLB1HJ-682	6800PF	50V	MYLAR	
	C361	QCS21HJ-221	220PF	50V	CERAMIC	
	C362	QCS21HJ-221	220PF	50V	CERAMIC	
	C401	QETB1CM-226	22MF	16V	ELECTRO	
	C402	QCVB1CM-103	0.01MF	16V	CERAMIC	
	C421	QCF21HP-473	0.047MF	50V	CERAMIC	
	C431	QETB1AM-476	47MF	10V	ELECTRO	
	C432	QCZ0205-155	1.5MF	25V	CERAMIC	
	C451	QFLB1HJ-104	0.1MF	50V	MYLAR	
	C452	QFLB1HJ-104	0.1MF	50V	MYLAR	
	C453	QFLB1HJ-104	0.1MF	50V	MYLAR	
	C454	QFLB1HJ-104	0.1MF	50V	MYLAR	
	C455	QETB1CM-107	100MF	16V	ELECTRO	

Δ : SAFETY PARTS

RESISTORS

Δ	ITEM	PART NUMBER	DESCRIPTION			AREA
	R101	QRD167J-224	220K	1/6W	CARBON	
	R102	QRD167J-224	220K	1/6W	CARBON	
	R103	QRD167J-512	5.1K	1/6W	CARBON	
	R104	QRD167J-512	5.1K	1/6W	CARBON	
	R105	QRD167J-100	10	1/6W	CARBON	
	R106	QRD167J-100	10	1/6W	CARBON	
	R107	QRD167J-512	5.1K	1/6W	CARBON	
	R108	QRD167J-512	5.1K	1/6W	CARBON	
	R110	QRD167J-223	22K	1/6W	CARBON	
	R111	QRD167J-334	330K	1/6W	CARBON	
	R112	QRD167J-334	330K	1/6W	CARBON	
	R113	QRD167J-432	4.3K	1/6W	CARBON	
	R114	QRD167J-432	4.3K	1/6W	CARBON	
	R115	QRD167J-272	2.7K	1/6W	CARBON	
	R116	QRD167J-272	2.7K	1/6W	CARBON	
	R117	QRD167J-272	2.7K	1/6W	CARBON	
	R118	QRD167J-272	2.7K	1/6W	CARBON	
	R119	QRD167J-752	7.5K	1/6W	CARBON	
	R120	QRD167J-752	7.5K	1/6W	CARBON	
	R121	QRD167J-223	22K	1/6W	CARBON	
	R122	QRD167J-223	22K	1/6W	CARBON	
	R123	QRD167J-102	1K	1/6W	CARBON	
	R124	QRD167J-102	1K	1/6W	CARBON	
	R125	QRD167J-101	100	1/6W	CARBON	
	R126	QRD167J-101	100	1/6W	CARBON	
	R131	QRD167J-105	1M	1/6W	CARBON	
	R132	QRD167J-105	1M	1/6W	CARBON	
	R133	QRD167J-105	1M	1/6W	CARBON	
	R134	QRD167J-105	1M	1/6W	CARBON	
	R135	QRD167J-563	56K	1/6W	CARBON	
	R136	QRD167J-472	4.7K	1/6W	CARBON	
	R137	QRD167J-103	10K	1/6W	CARBON	
	R141	QRD167J-334	330K	1/6W	CARBON	
	R142	QRD167J-334	330K	1/6W	CARBON	
	R143	QRD167J-682	6.8K	1/6W	CARBON	
	R144	QRD167J-682	6.8K	1/6W	CARBON	
	R147	QRD167J-822	8.2K	1/6W	CARBON	
	R148	QRD167J-822	8.2K	1/6W	CARBON	
	R149	QRD167J-102	1K	1/6W	CARBON	
	R150	QRD167J-102	1K	1/6W	CARBON	
	R151	QRD167J-101	100	1/6W	CARBON	
	R152	QRD167J-101	100	1/6W	CARBON	
	R157	QRD167J-105	1M	1/6W	CARBON	
	R158	QRD167J-105	1M	1/6W	CARBON	
	R159	QRD167J-563	56K	1/6W	CARBON	
	R160	QRD167J-472	4.7K	1/6W	CARBON	
	R161	QRD167J-223	22K	1/6W	CARBON	
	R162	QRD167J-223	22K	1/6W	CARBON	
	R163	QRD167J-223	22K	1/6W	CARBON	
	R164	QRD167J-183	18K	1/6W	CARBON	

Δ : SAFETY PARTS

RESISTORS

Δ	ITEM	PART NUMBER	DESCRIPTION			AREA
	R165	QRD167J-103	10K	1/6W	CARBON	
	R167	QRD167J-242	2.4K	1/6W	CARBON	
	R168	QRD167J-242	2.4K	1/6W	CARBON	
	R169	QRD167J-562	5.6K	1/6W	CARBON	
	R170	QRD167J-562	5.6K	1/6W	CARBON	
	R171	QRD167J-223	22K	1/6W	CARBON	
	R172	QRD167J-223	22K	1/6W	CARBON	
	R173	QRD167J-561	560	1/6W	CARBON	
	R174	QRD167J-561	560	1/6W	CARBON	
	R175	QRD167J-562	5.6K	1/6W	CARBON	
	R176	QRD167J-562	5.6K	1/6W	CARBON	
	R177	QRD167J-103	10K	1/6W	CARBON	
	R178	QRD167J-103	10K	1/6W	CARBON	
	R179	QRD167J-103	10K	1/6W	CARBON	
	R181	QRD167J-202	2K	1/6W	CARBON	
	R182	QRD167J-202	2K	1/6W	CARBON	
	R183	QRD167J-104	100K	1/6W	CARBON	
	R184	QRD167J-104	100K	1/6W	CARBON	
	R185	QRD167J-333	33K	1/6W	CARBON	
	R186	QRD167J-333	33K	1/6W	CARBON	
	R187	QRD167J-103	10K	1/6W	CARBON	
	R188	QRD167J-103	10K	1/6W	CARBON	
	R189	QRD167J-202	2K	1/6W	CARBON	
	R190	QRD167J-202	2K	1/6W	CARBON	
	R191	QRD167J-243	24K	1/6W	CARBON	
	R193	QRD167J-153	15K	1/6W	CARBON	
	R194	QRD167J-153	15K	1/6W	CARBON	
	R195	QRD167J-103	10K	1/6W	CARBON	
	R196	QRD167J-103	10K	1/6W	CARBON	
	R201	QRD167J-104	100K	1/6W	CARBON	
	R202	QRD167J-683	68K	1/6W	CARBON	
	R203	QRD167J-203	20K	1/6W	CARBON	
	R204	QRD167J-913	91K	1/6W	CARBON	
	R205	QRD167J-563	56K	1/6W	CARBON	
	R206	QRD167J-153	15K	1/6W	CARBON	
	R207	QRD167J-104	100K	1/6W	CARBON	
	R208	QRD167J-683	68K	1/6W	CARBON	
	R209	QRD167J-273	27K	1/6W	CARBON	
	R210	QRD167J-753	75K	1/6W	CARBON	
	R211	QRD167J-473	47K	1/6W	CARBON	
	R212	QRD167J-223	22K	1/6W	CARBON	
	R213	QRD167J-104	100K	1/6W	CARBON	
	R214	QRD167J-683	68K	1/6W	CARBON	
	R215	QRD167J-203	20K	1/6W	CARBON	
	R216	QRD167J-223	22K	1/6W	CARBON	
	R217	QRD167J-363	36K	1/6W	CARBON	
	R218	QRD167J-183	18K	1/6W	CARBON	
	R219	QRD167J-104	100K	1/6W	CARBON	
	R220	QRD167J-104	100K	1/6W	CARBON	
	R221	QRD167J-563	56K	1/6W	CARBON	
	R222	QRD167J-823	82K	1/6W	CARBON	
	R223	QRD167J-563	56K	1/6W	CARBON	
	R224	QRD167J-153	15K	1/6W	CARBON	
	R225	QRD167J-104	100K	1/6W	CARBON	
	R226	QRD167J-104	100K	1/6W	CARBON	
	R227	QRD167J-433	43K	1/6W	CARBON	
	R228	QRD167J-683	68K	1/6W	CARBON	
	R229	QRD167J-473	47K	1/6W	CARBON	
	R230	QRD167J-333	33K	1/6W	CARBON	
	R231	QRD167J-104	100K	1/6W	CARBON	
	R232	QRD167J-823	82K	1/6W	CARBON	
	R233	QRD167J-513	51K	1/6W	CARBON	
	R234	QRD167J-333	33K	1/6W	CARBON	
	R235	QRD167J-333	33K	1/6W	CARBON	
	R236	QRD167J-303	30K	1/6W	CARBON	
	R241	QRD167J-473	47K	1/6W	CARBON	
	R242	QRD167J-473	47K	1/6W	CARBON	
	R243	QRD167J-103	10K	1/6W	CARBON	
	R244	QRD167J-103	10K	1/6W	CARBON	
	R245	QRD167J-132	1.3K	1/6W	CARBON	
	R246	QRD167J-132	1.3K	1/6W	CARBON	
	R251	QRD167J-392	3.9K	1/6W	CARBON	
	R252	QRD167J-392	3.9K	1/6W	CARBON	
	R253	QRD167J-682	6.8K	1/6W	CARBON	
	R254	QRD167J-682	6.8K	1/6W	CARBON	
	R255	QRD167J-561	560	1/6W	CARBON	
	R256	QRD167J-561	560	1/6W	CARBON	
	R257	QRD167J-223	22K	1/6W	CARBON	
	R258	QRD167J-223	22K	1/6W	CARBON	
	R259	QRD167J-332	3.3K	1/6W	CARBON	
	R260	QRD167J-332	3.3K	1/6W	CARBON	
	R261	QRD167J-684	680K	1/6W	CARBON	
	R262	QRD167J-684	680K	1/6W	CARBON	
	R263	QRD167J-393	39K	1/6W	CARBON	
	R264	QRD167J-393	39K	1/6W	CARBON	
	R265	QRD167J-223	22K	1/6W	CARBON	
	R266	QRD167J-223	22K	1/6W	CARBON	
	R267	QRD167J-103	10K	1/6W	CARBON	
	R268	QRD167J-105	1M	1/6W	CARBON	
	R275	QRD167J-103	10K	1/6W	CARBON	
	R276	QRD167J-103	10K	1/6W	CARBON	
	R277	QRD167J-102	1K	1/6W	CARBON	
	R278	QRD167J-471	470	1/6W	CARBON	
	R281	QRD167J-432	4.3K	1/6W	CARBON	
	R282	QRD167J-432	4.3K	1/6W	CARBON	

Δ : SAFETY PARTS

RESISTORS

Δ	ITEM	PART NUMBER	DESCRIPTION	AREA
	R302	QRD167J-104	100K * 1/6W CARBON	
	R303	QRD167J-102	1K 1/6W CARBON	
	R305	QRZ0077-100	10 1/4W FUSIBLE	
	R351	QRD167J-181	180 1/6W CARBON	
	R352	QRD14CJ-6R8S	6.8 1/4W UNF. CARBON	
	R353	QRD167J-393	39K 1/6W CARBON	
	R354	QRD167J-393	39K 1/6W CARBON	
	R355	QRD167J-301	300 1/6W CARBON	
	R356	QRD167J-561	560 1/6W CARBON	
	R357	QRD167J-511	510 1/6W CARBON	
	R358	QRD167J-911	910 1/6W CARBON	
	R359	QRD167J-332	3.3K 1/6W CARBON	
	R360	QRD167J-332	3.3K 1/6W CARBON	
	R401	QRD167J-105	1M 1/6W CARBON	
	R402	QRD167J-271	270 1/6W CARBON	
	R403	QRD167J-271	270 1/6W CARBON	
	R404	QRD167J-430	43 1/6W CARBON	
	R405	QRD167J-910	91 1/6W CARBON	
	R408	QRD167J-271	270 1/6W CARBON	
	R409	QRD167J-271	270 1/6W CARBON	
	R411	QRD167J-103	10K 1/6W CARBON	
	R412	QRD167J-223	22K 1/6W CARBON	
	R413	QRD167J-103	10K 1/6W CARBON	
	R414	QRD167J-102	1K 1/6W CARBON	
	R421	QRD167J-153	15K 1/6W CARBON	
	R422	QRD167J-151	150 1/6W CARBON	
	R423	QRD167J-103	10K 1/6W CARBON	
	R452	QRD167J-184	180K 1/6W CARBON	
	R453	QRD167J-224	220K 1/6W CARBON	
	R454	QRD167J-224	220K 1/6W CARBON	
	R455	QRD167J-224	220K 1/6W CARBON	
	R456	QRD167J-683	68K 1/6W CARBON	
	R457	QRD167J-153	15K 1/6W CARBON	
	R458	QRD167J-183	18K 1/6W CARBON	
	R461	QRD167J-682	6.8K 1/6W CARBON	
	R462	QRD167J-682	6.8K 1/6W CARBON	
	R463	QRD167J-123	12K 1/6W CARBON	
	R464	QRD167J-123	12K 1/6W CARBON	
	R465	QRD167J-563	56K 1/6W CARBON	
	R466	QRD167J-563	56K 1/6W CARBON	
	R467	QRD167J-163	16K 1/6W CARBON	
	R468	QRD167J-163	16K 1/6W CARBON	
	R469	QRD167J-183	18K 1/6W CARBON	
	R470	QRD167J-183	18K 1/6W CARBON	
	R471	QRD167J-103	10K 1/6W CARBON	
	R472	QRD167J-103	10K 1/6W CARBON	
	R475	QRD167J-103	10K 1/6W CARBON	
	R476	QRD167J-103	10K 1/6W CARBON	
	R501	QRD167J-621	620 1/6W CARBON	
	R502	QRD167J-621	620 1/6W CARBON	
	RA401	QRB049J-103	10K 1/10W R.NETWORK	
	RA402	QRB089J-103	10K 1/10W R.NETWORK	
	RA403	QRB049J-103	10K 1/10W R.NETWORK	
	VR111	QVPA601-501A	500 VARIABLE	
	VR112	QVPA601-501A	500 VARIABLE	
	VR113	QVPA601-104A	100K VARIABLE	
	VR114	QVPA601-104A	100K VARIABLE	
	VR141	QVPA601-501A	500 VARIABLE	
	VR142	QVPA601-501A	500 VARIABLE	
	VR143	QVPA601-104A	100K VARIABLE	
	VR144	QVPA601-104A	100K VARIABLE	
	VR185	QVPA601-503A	50K VARIABLE	
	VR186	QVPA601-503A	50K VARIABLE	
	VR361	QVPA601-503A	50K VARIABLE	
	VR362	QVPA601-503A	50K VARIABLE	
	VR451	QVPA603-103A	10K VARIABLE	
	VR452	QVPA603-203A	20K VARIABLE	

Δ : ISAFETY PARTS

OTHERS

Δ	ITEM	PART NUMBER	DESCRIPTION	AREA
	J408	EMV5109-009A	PLUG ASSY 9PIN	
	J409	EMV5109-009A	PLUG ASSY 9PIN	
	J410	EMV5133-003	PLUG ASSY 3PIN	
	J411	EMV5133-003	PLUG ASSY 3PIN	
	L109	EQL2106-223	INDUCTOR	
	L110	EQL2106-223	INDUCTOR	
	L151	EQL2106-223	INDUCTOR	
	L152	EQL2106-223	INDUCTOR	
	L351	ENZ6002-012	OSCILLATOR COIL	
	P101	QMV5011-003K	PLUG ASSY 3PIN	
	P102	QMV5011-007K	PLUG ASSY 7PIN	
	S501	ESB1100-007	LEAF SWITCH A PACK	
	S502	ESB1100-007	LEAF SWITCH A CrO2	
	S503	ESB1100-007	LEAF SWITCH REV REC	
	S504	ESB1100-007	LEAF SWITCH B CrO2	
	S505	ESB1100-007	LEAF SWITCH B PACK	
	S506	ESB1100-007	LEAF SWITCH B METAC	
	S507	ESB1100-007	LEAF SWITCH FWD REC	
	S511	ESPO001-023M	TACT SWITCH A	
	S512	ESPO001-023M	TACT SWITCH A	
	S513	ESPO001-023M	TACT SWITCH A	
	S514	ESPO001-023M	TACT SWITCH A	
	S515	ESPO001-023M	TACT SWITCH B	
	S516	ESPO001-023M	TACT SWITCH B	
	S517	ESPO001-023M	TACT SWITCH B	
	S518	ESPO001-023M	TACT SWITCH B	
	S519	ESPO001-023M	TACT SWITCH A	
	S520	ESPO001-023M	TACT SWITCH B	
	S521	ESPO001-023M	TACT SWITCH B	
	S522	ESPO001-023M	TACT SWITCH B	
	S523	ESPO001-023M	TACT SWITCH A	
	S524	ESPO001-023M	TACT SWITCH A	
	S525	ESPO001-023M	TACT SWITCH B SKIP	
	S526	ESPO001-023M	TACT SWITCH FUZZY DIRECT	
	S527	ESPO001-023M	TACT SWITCH FUZZY AUTO	
	S528	QSS4001-E01M	SLIDE SWITCH DOLBY MODE	
	S529	QSS4001-E01M	SLIDE SWITCH 9PIN	
	BC408	EWS269-A916	SOCKET WIRE 9PIN	
	BC409	EWS269-A916	SOCKET WIRE 2PIN	
	BC410	EWS243-054	SOCKET WIRE 2PIN	
	BC411	EWS243-054	SOCKET WIRE 2PIN	
	EP001	E70859-001	EARTH PLATE	
	FW401	EWR38B-16LST	FLAT WIRE 8PIN	
	FW402	EWR37B-10LST	FLAT WIRE 7PIN	
	FW403	EWR37B-10LST	FLAT WIRE 7PIN	
	FW404	EWR37B-10LST	FLAT WIRE 7PIN	
	FW405	EWR37B-10LST	FLAT WIRE 7PIN	
	FW406	EWR38B-08LST	FLAT WIRE 8PIN	
	FW407	EWR34B-08LST	FLAT WIRE 4PIN	
	FW410	EWR38B-16SST	FLAT WIRE 8PIN	
	JB001	EMV7141-015	CONNECTOR 10PIN	
	JT411	EMV7122-004	CONNECTOR 4PIN	
	JT412	EMV7122-004	CONNECTOR 4PIN	
	JT413	EMV7122-103	CONNECTOR 3PIN	
	JT414	EMV7122-004	CONNECTOR 4PIN	
	JT415	EMV7122-004	CONNECTOR 4PIN	
	JT416	EMV7122-103	CONNECTOR 3PIN	
	SW351	QSS6A12-E01	SLIDE SWITCH BEAT CUT SW	B
	SW351	QSS6A12-E01	SLIDE SWITCH BEAT CUT SW	C
	XT401	ECX0004-194KM	RESONATOR	

Δ : ISAFETY PARTS

4

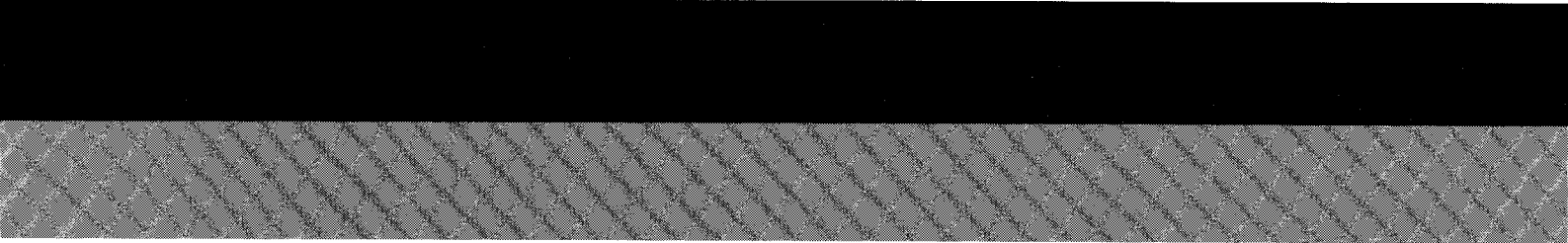

JVC

VICTOR COMPANY OF JAPAN, LIMITED
AUDIO DIVISION, YAMATO PLANT, 1644, SHIMOTSURUMA, YAMATO-SHI, KANAGAWA-KEN, 242, JAPAN