

# 103SW/SW-301 1050SW/SW-501 SERVICE MANUAL

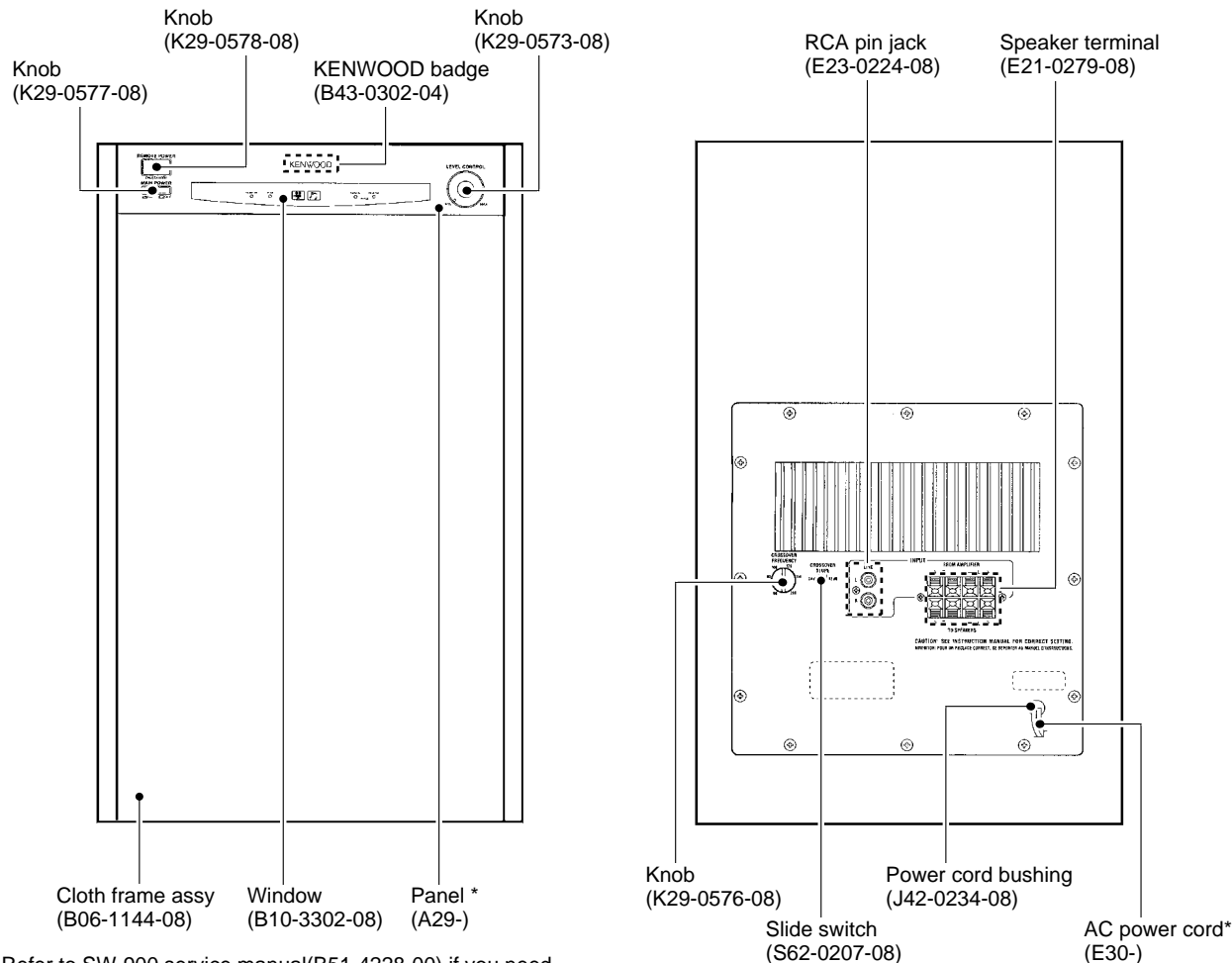

Note : Refer to SW-900 service manual(B51-4228-00) if you need the microprocessor information.

\* Refer to parts list on page 8.

## SPECIFICATIONS

### Amplifier

Power output

#### 1050SW(SW-501)

150 watts RMS into 4 ohms, from 20 Hz to 200 Hz, with no more than 0.09%total harmonic distortion

#### 103SW(SW-301)

100 watts RMS into 4 ohms, from 20 Hz to 200 Hz, with no more than 0.09%total harmonic distortion

Phase switching

Normal, Reverse

Normal, Reverse

Input sensitivity and input impedance

RCA-type jack  
Push-type terminals

70 mV (12 k-ohms)  
1.7 V(15 k-ohms)  
AC 110 V~120 V (1050SW)  
150 watts

70 mV (12 k-ohms)  
1.7 V(15 k-ohms)  
AC 110 V~120 V(103SW)  
110 watts

Supply voltage

Rated power consumption

### Speaker

Enclosure  
Speaker units

Ported  
12 in (300 mm) polypropylene cone  
4 ohms  
14.3 in (363 mm)  
21.7 in (550 mm)  
18.9 in (480 mm) with grille  
53 lb (24 kg)

Ported  
10 in (250 mm) polypropylene cone  
4 ohms  
11.8 in (300 mm)  
18.9 in (480 mm)  
15.6 in (395 mm)  
40 lb (18 kg)

Nominal impedance

Width

Height

Depth

Net weight

Since Kenwood follows a policy of continuous advancement in development, these specifications may change without notice.

# 103SW/SW-301/1050SW/SW-501

## CONTENTS/DISASSEMBLY FOR REPAIR/ADJUSTMENT

### Contents

SPECIFICATIONS .....	Top cover	PC BOARD .....	3
CONTENTS .....	2	SCHEMATIC DIAGRAM .....	5
DISASSEMBLY FOR REPAIR .....	2	EXPLODED VIEW .....	7
ADJUSTMENT .....	2	PARTS LIST .....	8

### DISASSEMBLY FOR REPAIR

#### < How to remove the front panel >

1. Remove the decoration plate (①) by a pincette to the bottom of the front panel, then remove the 3 screws (②).
2. 103SW/SW-301: Remove the front panel in the upper slanting direction of the arrow (③).
- 1050SW/SW-501 : Remove the front panel just the frontwards.

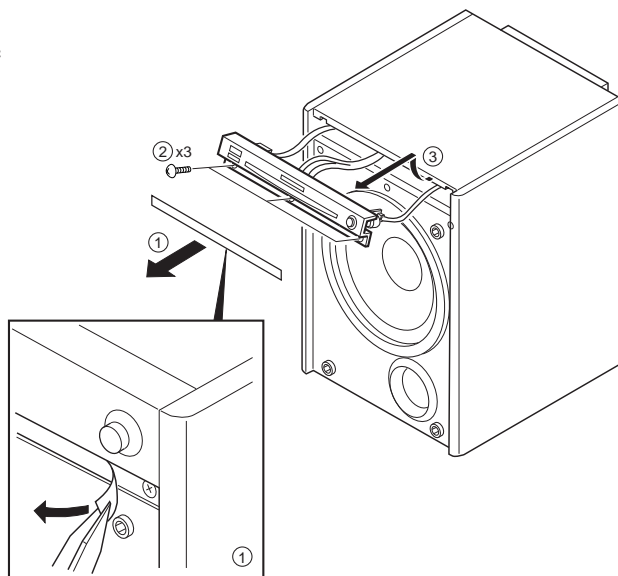

### ADJUSTMENT

No.	ITEM	INPUT SETTINGS	OUTPUT SETTINGS	AMPLIFIER SETTINGS	ALIGNMENT POINTS	ALIGN FOR	FIG.
Unless otherwise specified, the individual switches should be set as following :							
		POWER : ON		NO SIGNAL INPUT			
1	IDLE CURRENT	-	Connect a DC voltmeter to R611	VOLUME : 0	VR601	5 mV	(a)

(a)

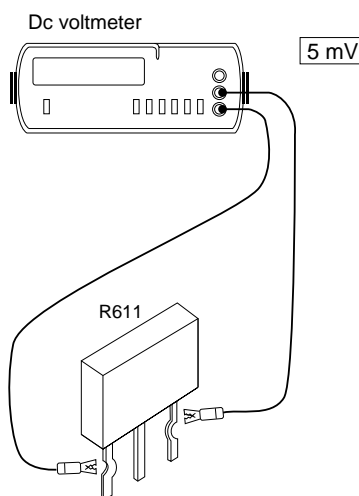

# PC BOARD(Component side view)

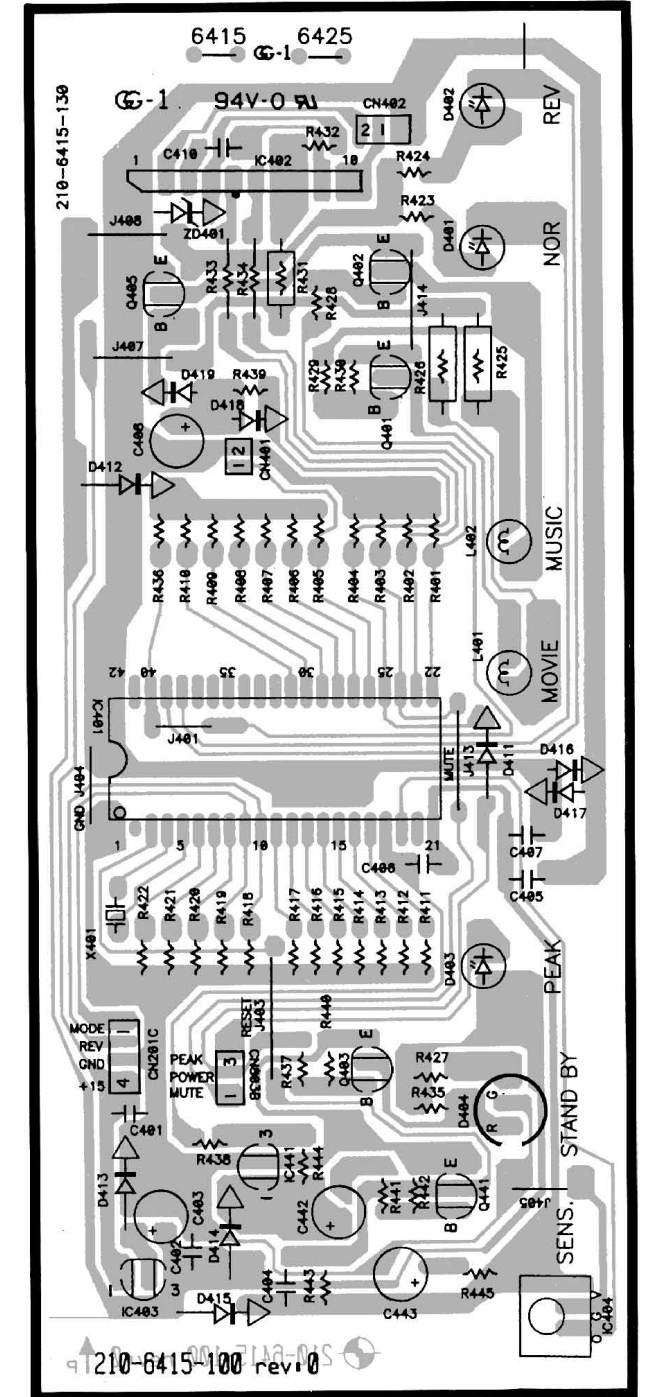
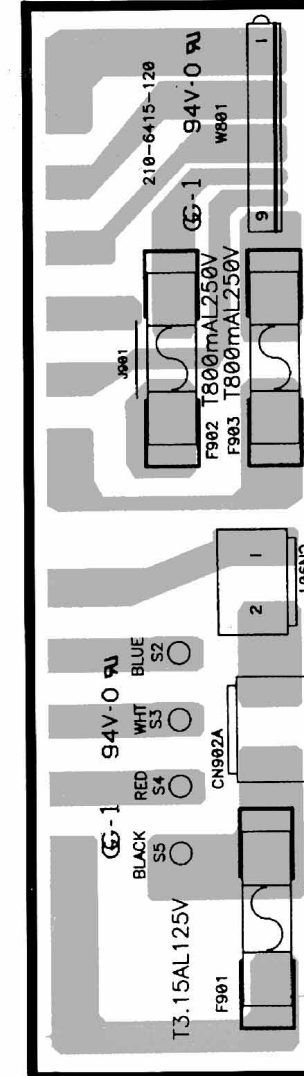
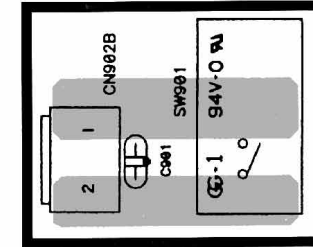
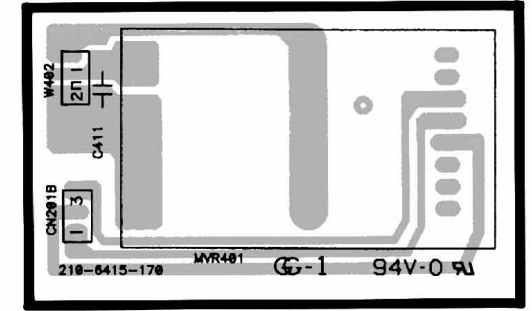
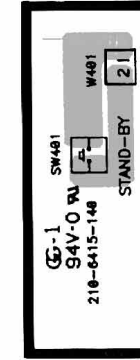
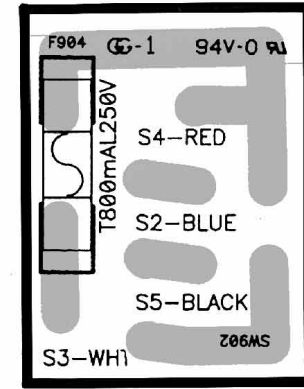
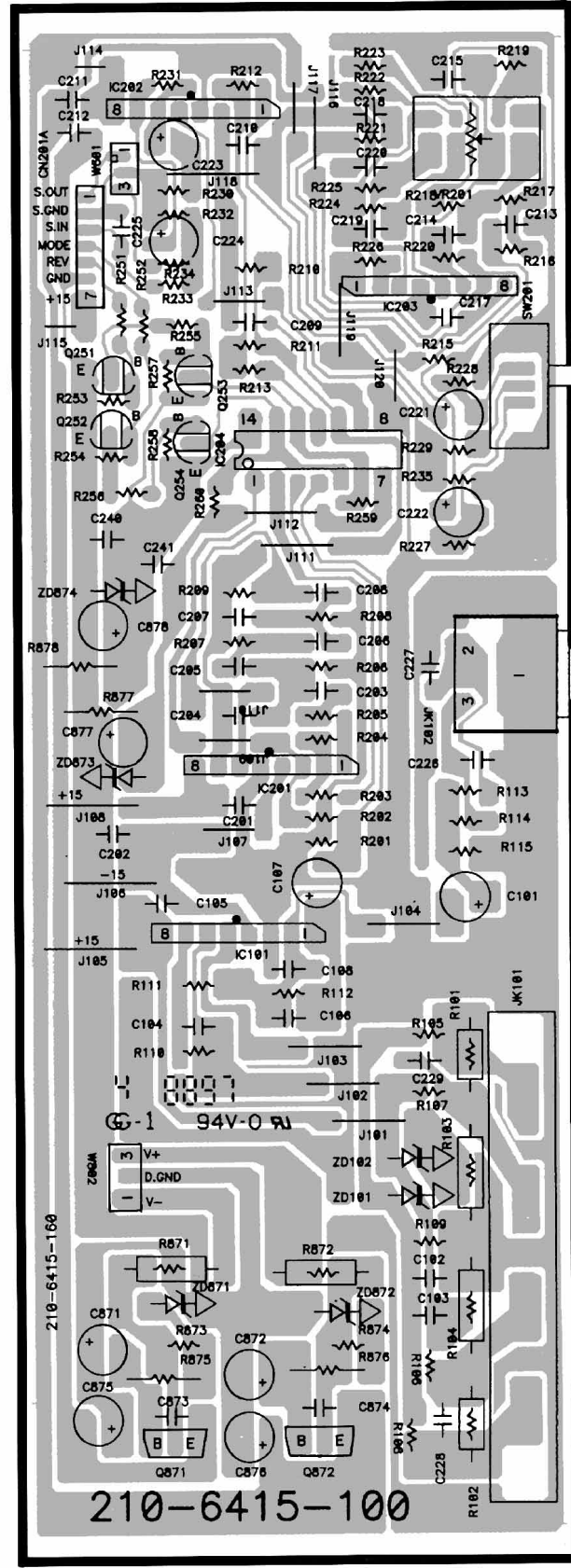
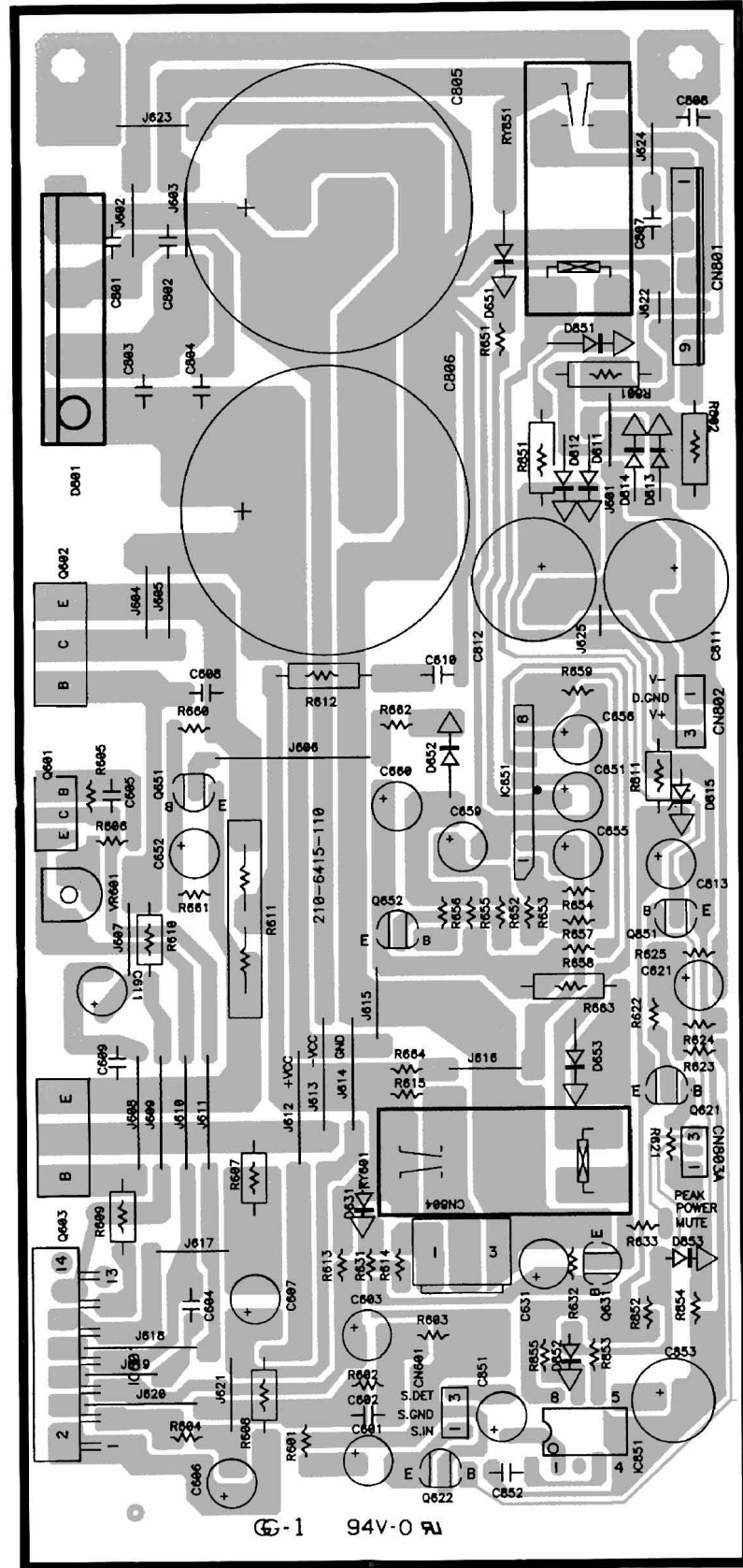



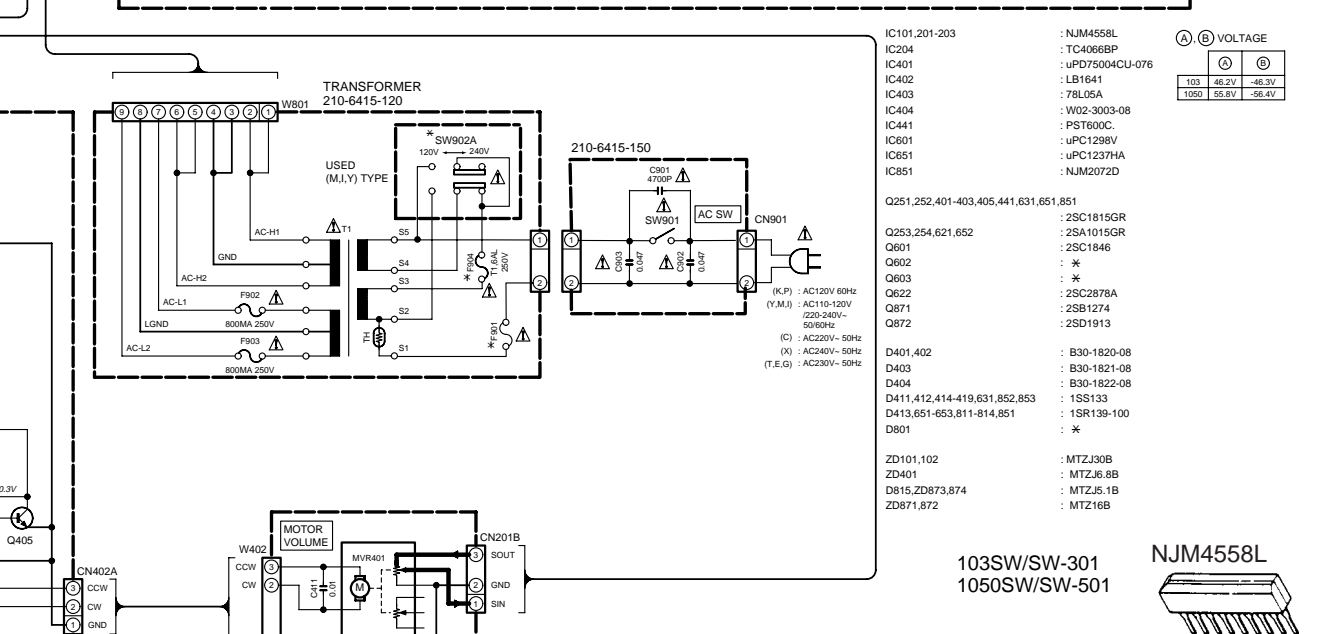
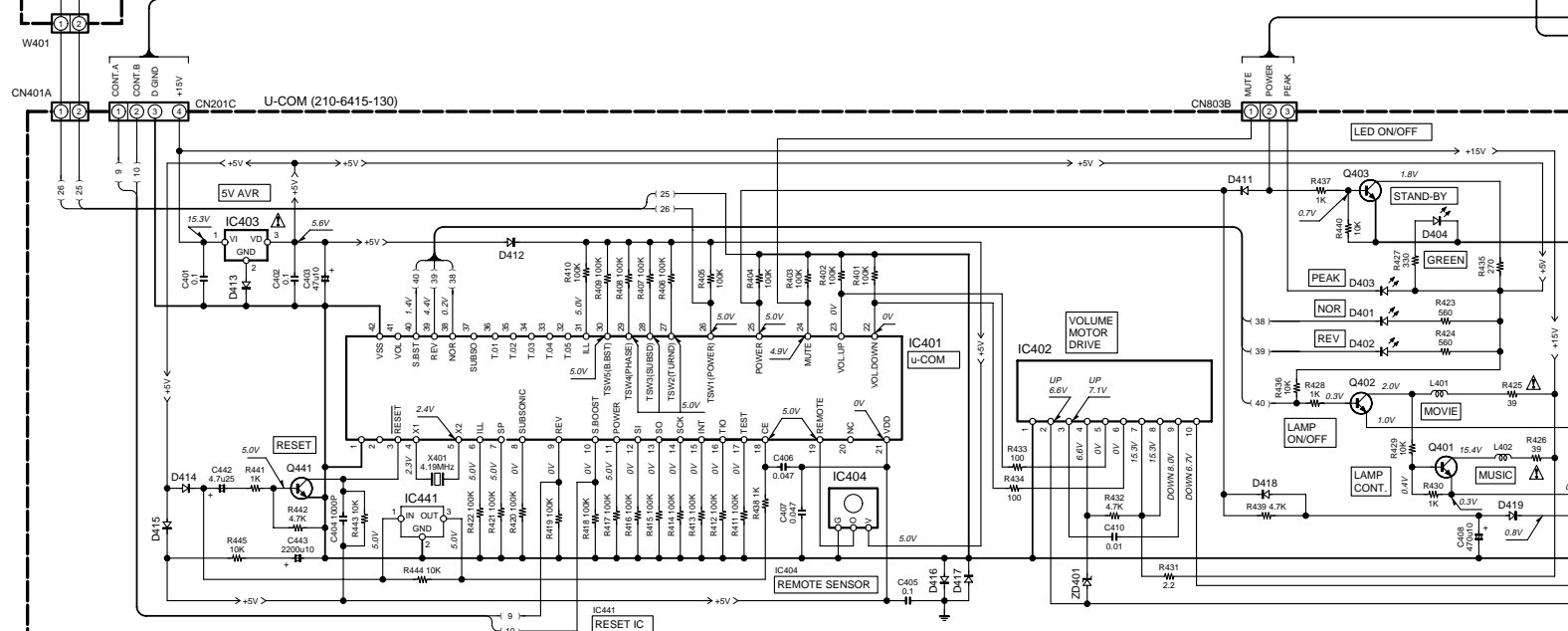
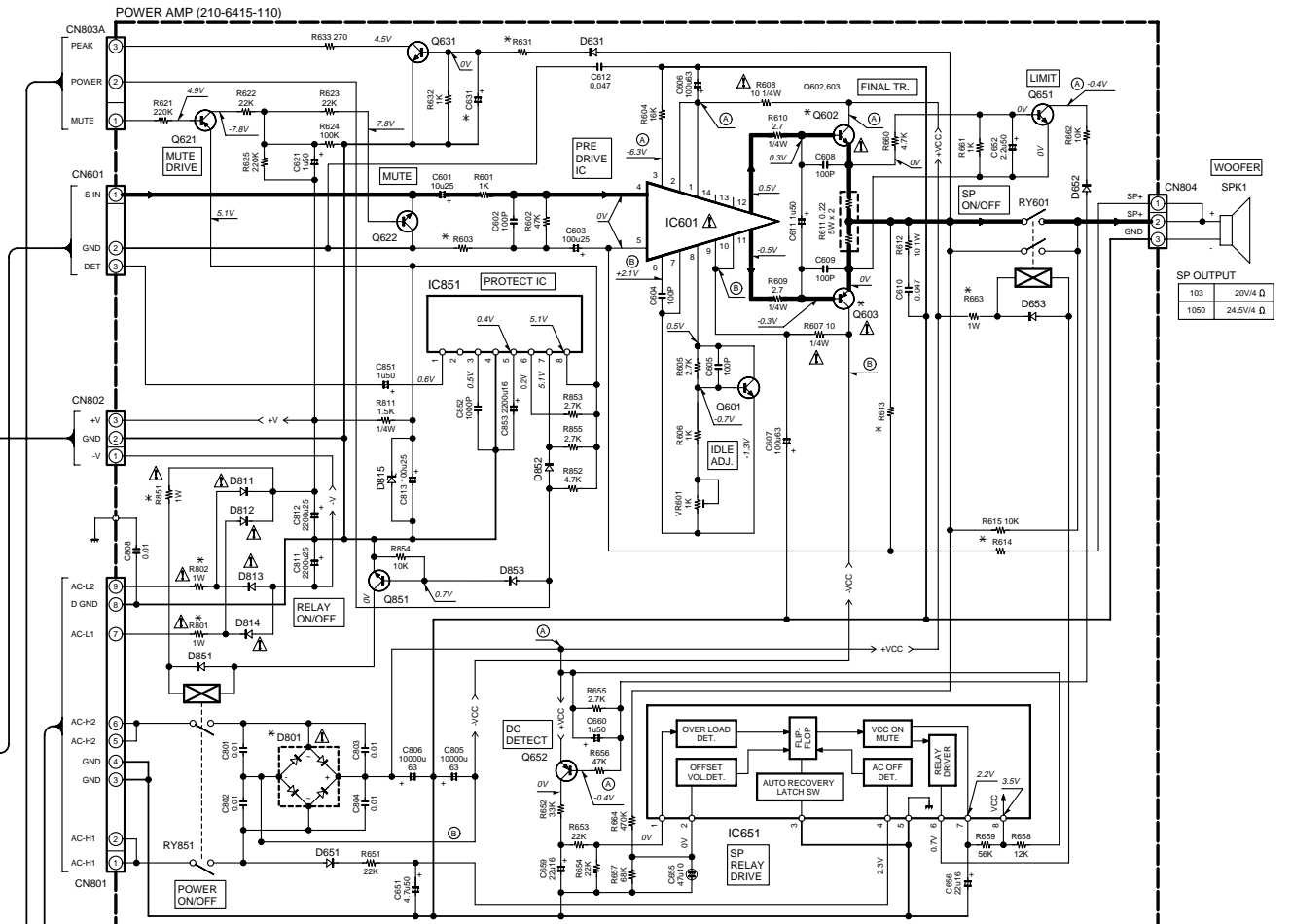
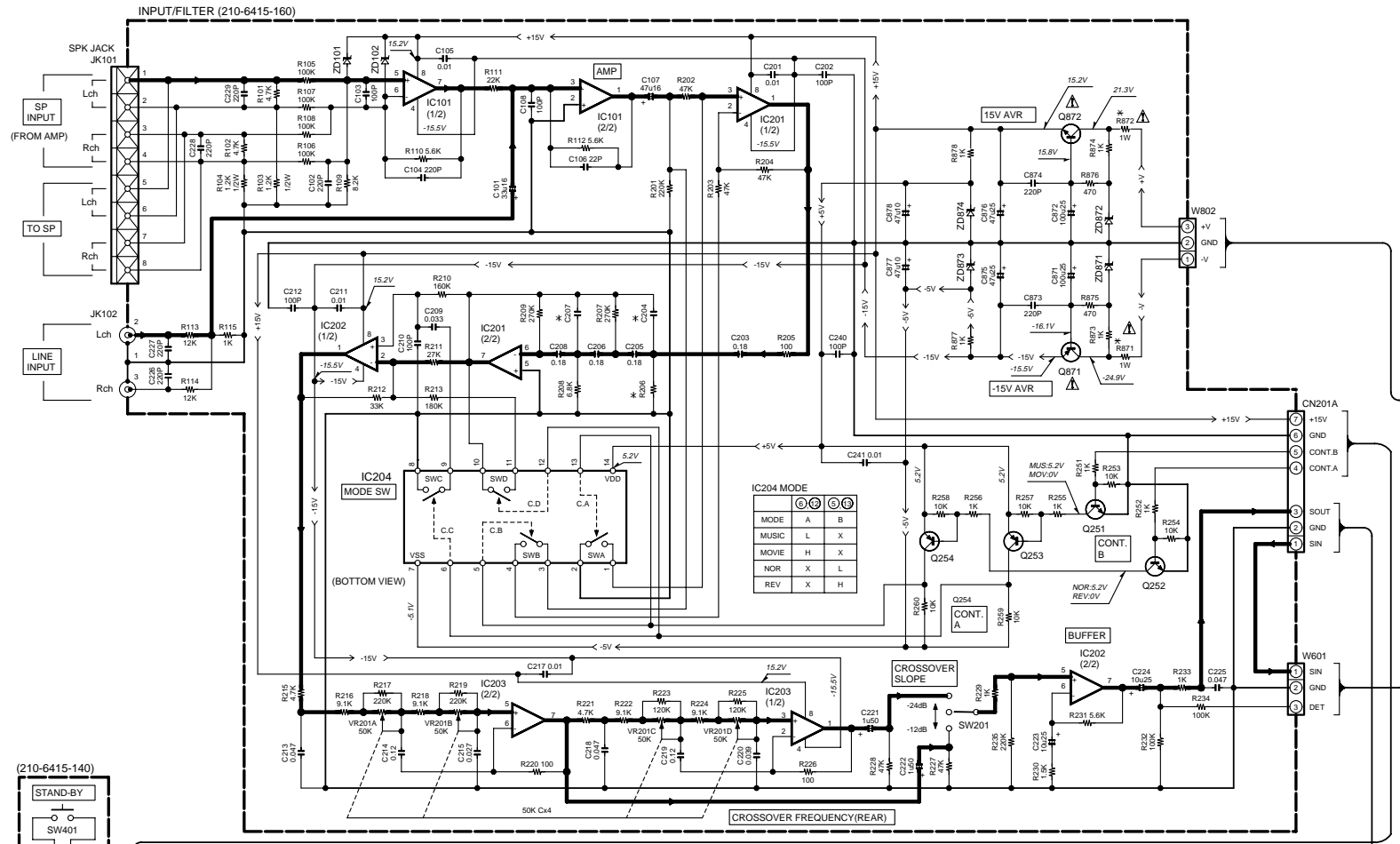

DESTINATION COUNTRY	ABB	C204	C207	C631	F901	F902.3	R206	R603	R606	R613
USA	K	0.047UF/0.056VF	0.047UF/0.039VF	100U10/220V16	3.15A/4A	0.8A/0.8A	12K/27K	1K/20	-1K	220K/270K
CANADA	P	0.047UF/0.056VF	0.047UF/0.039VF	100U10/220V16	3.15A/4A	0.8A/0.8A	12K/27K	1K/20	-1K	220K/270K
EUROPE	E	0.047UF/0.056VF	0.047UF/0.039VF	100U10/220V16	1.6A/2A	0.8A/0.8A	12K/27K	1K/20	-1K	220K/270K
ENGLAND	T	0.047UF/0.056VF	0.047UF/0.039VF	100U10/220V16	1.6A/2A	0.8A/0.8A	12K/27K	1K/20	-1K	220K/270K
GERMANY	G	0.047UF/0.056VF	0.047UF/0.039VF	100U10/220V16	1.6A/2A	0.8A/0.8A	12K/27K	1K/20	-1K	220K/270K
AUSTRALIA	X	0.047UF/0.056VF	0.047UF/0.039VF	100U10/220V16	1.6A/2A	0.4A/0.4A	12K/27K	1K/20	-1K	180K/180K
CHINA	C	0.047UF/0.056VF	0.047UF/0.039VF	100U10/100V10	1.6A/2A	1.6A/2A	12K/27K	1K/20	-1K	180K/180K
GENERAL MARKET	M	0.047UF/0.056VF	0.047UF/0.039VF	100U10/220V16	1.6A/2A	0.4A/0.4A	12K/27K	1K/20	-1K	180K/180K
MALAYSIA	I	0.047UF/0.056VF	0.047UF/0.039VF	100U10/220V16	1.6A/2A	0.4A/0.4A	12K/27K	1K/20	-1K	180K/180K
PX	Y	0.047UF/0.056VF	0.047UF/0.039VF	100U10/100V10	1.6A/2A	1.6A/2A	12K/27K	1K/20	-1K	220K/270K
JAPAN	J	0.047UF/0.056VF	0.047UF/0.039VF	100U10/220V16	3.15A/4A	0.4A/0.4A	12K/27K	1K/20	-1K	15K/18K

R614	R631	R663	R801.2	R851	R871	R872	SW902A	D801	Q602	Q603
82K/120K	18K/22K	8201.5K	4.7/4.7	220/220	4.7/4.7	4.7/4.7	X/X	D3SBA20/D5SBA20	2SC1982/2SC3281 (R)	2SA1941 (R) / 2SA1302 (R)
82K/120K	18K/22K	8201.5K	4.7/4.7	220/220	4.7/4.7	4.7/4.7	X/X	D3SBA20/D5SBA20	2SC1982/2SC3281 (R)	2SA1941 (R) / 2SA1302 (R)
82K/120K	18K/22K	8201.5K	4.7/4.7	220/220	10/10	10/10	X/X	D3SBA20/D5SBA20	2SC1982/2SC3281 (R)	2SA1941 (R) / 2SA1302 (R)
82K/120K	18K/22K	8201.5K	4.7/4.7	220/220	10/10	10/10	X/X	D3SBA20/D5SBA20	2SC1982/2SC3281 (R)	2SA1941 (R) / 2SA1302 (R)
82K/120K	18K/22K	8201.5K	4.7/4.7	220/220	10/10	10/10	X/X	D3SBA20/D5SBA20	2SC1982/2SC3281 (R)	2SA1941 (R) / 2SA1302 (R)
56K/15K	15K/18K	560/560	-	180/180	4.7/4.7	4.7/4.7	X/X	D3SBA20/D5SBA20	2SC1982/2SC3281 (R)	2SA1941 (R) / 2SA1302 (R)
56K/15K	15K/18K	560/560	-	180/180	4.7/4.7	4.7/4.7	X/X	D3SBA20/D5SBA20	2SC1982/2SC3281 (R)	2SA1941 (R) / 2SA1302 (R)
56K/15K	15K/18K	560/560	-	180/180	4.7/4.7	4.7/4.7	X/X	D3SBA20/D5SBA20	2SC1982/2SC3281 (R)	2SA1941 (R) / 2SA1302 (R)
56K/15K	15K/18K	560/560	-	180/180	4.7/4.7	4.7/4.7	X/X	D3SBA20/D5SBA20	2SC1982/2SC3281 (R)	2SA1941 (R) / 2SA1302 (R)
56K/15K	15K/18K	560/560	-	180/180	4.7/4.7	4.7/4.7	X/X	D3SBA20/D5SBA20	2SC1982/2SC3281 (R)	2SA1941 (R) / 2SA1302 (R)

Note: 103SW(SW-301)/1050SW(SW-501)

CAUTION: For continued safety, replace safety critical components only with manufacturer's recommended parts (refer to parts list). Δ indicates safety critical components. For continued protection against risk of fire, replace only with same type and rating fuse(s). To reduce the risk of electric shock, leakage-current or resistance measurements shall be carried out (exposed parts are acceptably insulated from the supply circuit) before the appliance is returned to the customer.

The DC voltage is an actual reading measured with a high impedance type voltmeter. The measurement value may vary depending on the measuring instruments used or on the product.

**PST600C**  
**TC4066BP**  
**2SA1015GR**  
**2SC2878A**  
**UPD75004CU-076**  
**UPC1237HA**  
**78L05A**  
**LB1641**  
**UPC1298V**  
**2SC1846**  
**2SB1274**  
**2SD1913**

103SW/SW-301/1050SW/SW-501

Y19-3900-10

KENWOOD

Parts with exploded numbers larger than 700 are not supplied.

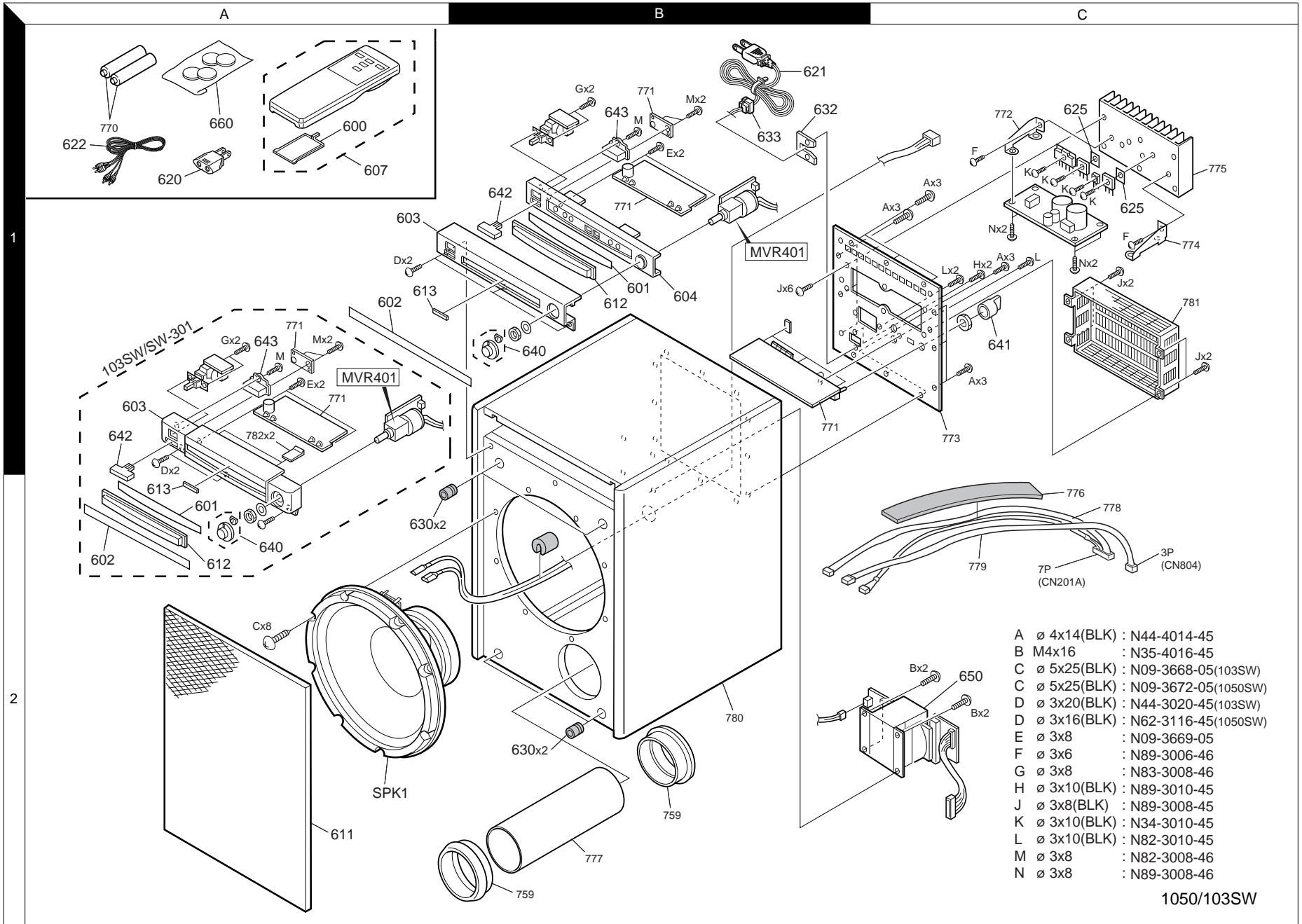

- A  $\varnothing$  4x14(BLK) : N44-4014-45
- B M4x16 : N35-4016-45
- C  $\varnothing$  5x25(BLK) : N09-3668-05(103SW)
- D  $\varnothing$  5x25(BLK) : N09-3672-05(1050SW)
- E  $\varnothing$  3x20(BLK) : N44-3020-45(103SW)
- F  $\varnothing$  3x16(BLK) : N62-3116-45(1050SW)
- G  $\varnothing$  3x8 : N09-3669-05
- H  $\varnothing$  3x6 : N89-3006-46
- I  $\varnothing$  3x8 : N83-3008-46
- J  $\varnothing$  3x10(BLK) : N89-3010-45
- K  $\varnothing$  3x8(BLK) : N89-3008-45
- L  $\varnothing$  3x10(BLK) : N82-3010-45
- M  $\varnothing$  3x8 : N82-3008-46
- N  $\varnothing$  3x8 : N89-3008-46

1050/103SW

**103SW/SW-301/1050SW/SW-501**  
**EXPLODED VIEW (UNIT)**

\* New Parts  
Parts without **Parts No.** are not supplied.  
Les articles non mentionnés dans le **Parts No.** ne sont pas fournis.  
Teile ohne **Parts No.** werden nicht geliefert.

1

Ref. No	Add-ress	New Parts	Parts No.	Description	Desti-nation	Re-marks
<b>103SW/SW-301 (103SW: KP type only)</b>						
600	1A	*	A09-0753-05	BATTERY COVER		
601	2A	*	A29-0915-08	PVC TRIM FOR WINDOW		
602	2A	*	A29-0917-08	PVC TRIM FOR PANEL TOP		
603	1A	*	A29-0919-08	PANEL TOP W/PAINTING & LOGO	KP	
603	1A	*	A29-0920-08	PANEL TOP W/PAINTING & LOGO	MICTEG	
603	1A	*	A29-0920-08	PANEL TOP W/PAINTING & LOGO	XY	
607	1A	*	A70-0404-05	REMOTE CONTROL ASSY		
611	2A	*	B06-1144-08	CLOTH FRAME ASSY		
612	2A	*	B10-3302-08	WINDOW		
613	2A	*	B43-0302-04	BADGE		
Δ 620	1A	*	E03-0115-05	AC PLUG ADAPTER	MIY	
Δ 621	1B	*	E30-5432-08	AC CORD,181-SA-W541	KP	
Δ 621	1B	*	E30-5438-08	AC CORD	MIEGY	
Δ 621	1B	*	E30-5439-08	AC CORD	X	
Δ 621	1B	*	E30-5440-08	AC CORD	T	
Δ 621	1B	*	E30-5442-08	AC CORD	C	
622	1C	*	E30-5466-08	AUDIO CORD		
625	1C	*	F20-0702-08	ISOLATION SHEET 19X24		
630	2A,2B	*	J19-3988-08	CATCH BLACK(75)		
632	1B	*	J21-8750-08	AC CORD HOLDER		
633	1B	*	J42-0234-08	CORD BUSHING,3-703-244-021		
640	2A	*	K29-0573-08	VOLUME KNOB W/PAINTING		
641	1C	*	K29-0576-08	LOW/PASS PUSH KNOB W/PAINTING		
642	1A	*	K29-0577-08	POWER PUSH KNOB W/PAINTING		
643	1A	*	K29-0578-08	TACT PUSH KNOB W/PAINTING		
Δ 650	2C	*	L07-3010-05	POWER TRANSFORMER	KP	
Δ 650	2C	*	L07-3011-05	POWER TRANSFORMER	MIY	
Δ 650	2C	*	L07-3012-05	POWER TRANSFORMER	C	
Δ 650	2C	*	L07-3013-05	POWER TRANSFORMER	TEG	
Δ 650	2C	*	L07-3014-05	POWER TRANSFORMER	X	
660	1A	*	J02-0622-08	FOOT		
-			B46-0096-53	WARRANTY CARD	X	
-			B46-0310-03	WARRANTY CARD	TEG	
-			B46-0326-03	WARRANTY CARD	C	
-			B46-0330-03	WARRANTY CARD	KY	
-			B59-1104-00	SERVICE STATIONS LIST	Y	
-		*	B61-0886-00	INSTRUCTION MANUAL	KP	
-		*	B61-0887-00	INSTRUCTION MANUAL	MIXY	
-		*	B61-0888-00	INSTRUCTION MANUAL	TEG	
-		*	B61-0889-00	INSTRUCTION MANUAL	C	
-		*	B61-0940-00	INSTRUCTION MANUAL	Y	
-		*	H10-6447-08	PLYFOAM 310G/SET(TOP)		
-		*	H10-6448-08	PLYFOAM 310G/SET(BOTTOM)		
-		*	H21-1284-08	MIRAMAT 1640X540X0.5T		
-		*	H25-2180-08	PROTECTION BAG	CY	
-		*	H51-0979-08	CARTON	KP	
-		*	H51-0980-08	CARTON	MIY	
-		*	H51-0981-08	CARTON	C	
-		*	H51-0982-08	CARTON	TEGX	
A		*	N44-4014-45	WOOD SCREW		
B		*	N35-4016-45	MACHINE SCREW(M4X16)		
C		*	N09-3668-05	WOOD SCREW		
D		*	N44-3020-45	WOOD SCREW		

L : Scandinavia    K : USA    P : Canada    R : Mexico  
Y : PX(Far East, Hawaii)    T : Europe    E : Europe    G : Germany  
Y : AAFES(Europe)    X : Australia    M : Other Areas

Δ indicates safety critical components.

2

\* New Parts  
Parts without **Parts No.** are not supplied.  
Les articles non mentionnés dans le **Parts No.** ne sont pas fournis.  
Teile ohne **Parts No.** werden nicht geliefert.

Ref. No	Add-ress	New Parts	Parts No.	Description	Desti-nation	Re-marks
E		*	N09-3669-05	SCREW		
F		*	N89-3006-46	SCREW		
G		*	N83-3008-46	SCREW		
H		*	N89-3010-45	SCREW		
J		*	N89-3008-45	SCREW		
K		*	N34-3010-45	SCREW		
L		*	N82-3010-45	SCREW		
M		*	N82-3008-46	SCREW		
N		*	N89-3008-46	SCREW		
SPK1	2A	*	T10-0782-15	SPEAKER 10,A25GU25-51C-D	KP	
SPK1	2A	*	T10-0788-05	SPEAKER 10	MIXY	
SPK1	2A	*	T10-0814-05	SPEAKER 10	C	
SPK1	2A	*	T10-0822-05	SPEAKER 10	TEG	
<b>1050SW/SW-501 (1050 SW: KP type only)</b>						
600	1A	*	A09-0753-05	BATTERY COVER		
601	1B	*	A29-0915-08	PVC TRIM FOR WINDOW		
602	1A	*	A29-0916-08	PVC TRIM FOR PANEL		
603	1A	*	A29-0909-08	PANEL	KP	
603	1A	*	A29-0921-08	PANEL	MIETGX	
604	1B	*	A29-0922-08	PANEL ,FRONT		
607	1A	*	A70-0404-05	REMOTE CONTROL ASSY		
611	2A	*	B06-1146-08	CLOTH FRAME ASSY		
612	1B	*	B10-3302-08	WINDOW		
613	1A	*	B43-0302-04	BADGE		
Δ 620	2A	*	E03-0115-05	AC PLUG ADAPTER	MI	
Δ 621	1B	*	E30-5432-08	AC CORD,181-SA-W541	KP	
Δ 621	1B	*	E30-5438-08	AC CORD	MIEGY	
Δ 621	1B	*	E30-5440-08	AC CORD	T	
622	1C	*	E30-5466-08	AUDIO CORD		
625	1C	*	F20-0702-08	ISOLATION SHEET 19X24		
630	2A,2B	*	J19-3988-08	CATCH BLACK(75)		
632	1B	*	J21-8750-08	AC CORD HOLDER		
633	1B	*	J42-0234-08	CORD BUSHING,3-703-244-021		
640	1B	*	K29-0573-08	VOLUME KNOB W/PAINTING		
641	1C	*	K29-0576-08	LOW/PASS PUSH KNOB W/PAINTING		
642	1B	*	K29-0577-08	POWER PUSH KNOB W/PAINTING		
643	1B	*	K29-0578-08	TACT PUSH KNOB W/PAINTING		
Δ 650	2C	*	L07-3015-05	POWER TRANSFORMER	KP	
Δ 650	2C	*	L07-3016-05	POWER TRANSFORMER	MI	
Δ 650	2C	*	L07-3017-05	POWER TRANSFORMER	TEG	
Δ 650	2C	*	L07-3018-05	POWER TRANSFORMER	X	
660	1A	*	J02-0622-08	FOOT		
-			B46-0096-53	WARRANTY CARD	X	
-			B46-0310-03	WARRANTY CARD	TEG	
-			B46-0330-03	WARRANTY CARD	K	
-			B46-0336-03	WARRANTY CARD	P	
-		*	B61-0886-00	INSTRUCTION MANUAL	KP	
-		*	B61-0887-00	INSTRUCTION MANUAL	MIXY	
-		*	B61-0888-00	INSTRUCTION MANUAL	TEG	
-		*	H10-6449-08	PLYFOAM 392G/SET(TOP)		
-		*	H10-6450-08	PLYFOAM                    BOTTOM		
-		*	H21-1285-08	MIRAMAT 1900X600X0.5T		
-		*	H51-0983-08	CARTON	KP	
-		*	H51-0984-08	CARTON	MI	
-		*	H51-0986-08	CARTON	TEGX	

L : Scandinavia    K : USA    P : Canada    R : Mexico  
Y : PX(Far East, Hawaii)    T : Europe    E : Europe    G : Germany  
Y : AAFES(Europe)    X : Australia    M : Other Areas

Δ indicates safety critical components.

\* New Parts

Parts without **Parts No.** are not supplied.  
Les articles non mentionnés dans le **Parts No.** ne sont pas fournis.  
Teile ohne **Parts No.** werden nicht geliefert.

③

Ref. No	Add-ress	New Parts	Parts No.	Description	Desti-nation	Re-marks
A			N44-4014-45	WOOD SCREW		
B			N35-4016-45	MACHINE SCREW(M4X16)		
C			N09-3672-05	SCREW		
D			N62-3116-45	SCREW		
E			N09-3669-05	SCREW		
F			N89-3006-46	SCREW		
G			N83-3008-46	SCREW		
H			N89-3010-45	SCREW		
J			N89-3008-45	SCREW		
K			N34-3010-45	SCREW		
L			N82-3010-45	SCREW		
M			N82-3008-46	SCREW		
N			N89-3008-46	SCREW		
SPK1		*	T10-0785-05	SPEAKER 10	KPTEG	
SPK1		*	T10-0789-05	SPEAKER 10	MIX	
<b>ELECTRIC PARTS</b>						
D401,402		*	B30-1820-08	LED		
D403		*	B30-1821-08	LED		
D404		*	B30-1822-08	LED		
L401,402		*	B30-1819-08	LAMP,12V/60MA		
C101			CE04KW1C330M	ELECTRO 33UF 16WV		
C102			CC45FSL1H221K	CERAMIC 220PF K		
C103			CC45FSL1H101J	CERAMIC 100PF J		
C104			CC45FSL1H221K	CERAMIC 220PF K		
C105			CQ92FM1H103J	MYLAR 0.010UF J		
C106			CC45FSL1H220J	CERAMIC 22PF J		
C107			CE04KW1C470M	ELECTRO 47UF 16WV		
C108			CC45FSL1H101J	CERAMIC 100PF J		
C201			CQ92FM1H103J	MYLAR 0.010UF J		
C202			CC45FSL1H101J	CERAMIC 100PF J		
C203			CQ92FM1H184J	MYLAR 0.18UF J		
C204	3		CQ92FM1H473J	MYLAR 0.047UF J		
C204	5		CQ92FM1H563J	MYLAR 0.056UF J		
C205,206			CQ92FM1H184J	MYLAR 0.18UF J		
C207	5		CQ92FM1H393J	MYLAR 0.039UF J		
C207	3		CQ92FM1H473J	MYLAR 0.047UF J		
C208			CQ92FM1H184J	MYLAR 0.18UF J		
C209			CQ92FM1H333J	MYLAR 0.033UF J		
C210			CC45FSL1H101J	CERAMIC 100PF J		
C211			CQ92FM1H103J	MYLAR 0.010UF J		
C212			CC45FSL1H101J	CERAMIC 100PF J		
C213			CQ92FM1H473J	MYLAR 0.047UF J		
C214			CQ92FM1H124J	MYLAR 0.12UF J		
C215			CQ92FM1H273J	MYLAR 0.027UF J		
C217			CQ92FM1H103J	MYLAR 0.010UF J		
C218			CQ92FM1H473J	MYLAR 0.047UF J		
C219			CQ92FM1H124J	MYLAR 0.12UF J		
C220			CQ92FM1H393J	MYLAR 0.039UF J		
C221,222			CE04KW1H010M	ELECTRO 1.0UF 50WV		
C223,224			CE04KW1E100M	ELECTRO 10UF 25WV		
C225			CQ92FM1H473J	MYLAR 0.047UF J		
C226-229			CC45FSL1H221K	CERAMIC 220PF K		
C240			CC45FSL1H101J	CERAMIC 100PF J		
C241			CQ92FM1H103J	MYLAR 0.010UF J		
C401,402			CQ92FM1H104J	MYLAR 0.10UF J		

L : Scandinavia K : USA P : Canada R : Mexico  
Y : PX(Far East, Hawaii) T : Europe E : Europe G : Germany  
Y : AAFES(Europe) X : Australia M : Other Areas

△ indicates safety critical components.

\* New Parts

Parts without **Parts No.** are not supplied.  
Les articles non mentionnés dans le **Parts No.** ne sont pas fournis.  
Teile ohne **Parts No.** werden nicht geliefert.

④

Ref. No	Add-ress	New Parts	Parts No.	Description	Desti-nation	Re-marks
C403			CE04KW1A470M	ELECTRO 47UF 10WV		
C404			CK45FB1H102K	CERAMIC 1000PF K		
C405			CQ92FM1H104J	MYLAR 0.10UF J		
C406,407			CQ92FM1H473J	MYLAR 0.047UF J		
C408			CE04KW1A471M	ELECTRO 470UF 10WV		
C410,411			CQ92FM1H103J	MYLAR 0.010UF J		
C442			CE04KW1H4R7M	ELECTRO 4.7UF 50WV		
C443			CE04KW1A222M	ELECTRO 2200UF 10WV		
C601			CE04KW1E100M	ELECTRO 10UF 25WV		
C602			CC45FSL1H101J	CERAMIC 100PF J		
C603			CE04KW1E101M	ELECTRO 100UF 25WV		
C604,605			CC45FSL1H101J	CERAMIC 100PF J		
C606,607			CE04KW1J101M	ELECTRO 100UF 63WV		
C608,609			CC45FSL1H101J	CERAMIC 100PF J		
C610			CQ92FM1H473J	MYLAR 0.047UF J		
C611			CE04KW1H010M	ELECTRO 1.0UF 50WV		
C621			CE04KW1H010M	ELECTRO 1.0UF 50WV		
C631	3		CE04KW1A101M	ELECTRO 100UF 10WV		
C631	5		CE04KW1C221M	ELECTRO 220UF 16WV		
C651			CE04KW1H4R7M	ELECTRO 4.7UF 50WV		
C652			CE04KW1H2R2M	ELECTRO 2.2UF 50WV		
C655			CE04HW1A470M	NP-ELEC 47UF 10WV		
C656			CE04KW1C220M	ELECTRO 22UF 16WV		
C659			CE04KW1C220M	ELECTRO 22UF 16WV		
C660			CE04KW1H010M	ELECTRO 1.0UF 50WV		
C801-804			CQ92FM1H103J	MYLAR 0.010UF J		
C805,806		*	C90-5024-08	ELECTRO 10000UF 63WV		
C807,808			CK45FB1H103M	CERAMIC 0.010UF M		
C811,812			CE04KW1E222M	ELECTRO 2200UF 25WV		
C813			CE04KW1E101M	ELECTRO 100UF 25WV		
C851			CE04KW1H010M	ELECTRO 1.0UF 50WV		
C852			CK45FB1H102K	CERAMIC 1000PF K		
C853			CE04KW1C222M	ELECTRO 2200UF 16WV		
C871,872			CE04KW1E101M	ELECTRO 100UF 25WV		
C873,874			CC45FSL1H221K	CERAMIC 220PF K		
C875,876			CE04KW1E470M	ELECTRO 47UF 25WV		
C877,878			CE04KW1A470M	ELECTRO 47UF 10WV		
△ C901			C91-1441-08	CERAMIC 4700PF 250WV		
△ C902,903		*	C91-0211-08	FILM 4700PF 250WV		
JK101			E21-0279-08	SPEAKER TERMINAL		
JK102		*	E23-0224-08	RCA PIN JACK, LINE		
△ F901	3		F05-1623-05	FUSE,1.6A/250V		ETGXCM
△ F901	3		F05-1623-05	FUSE,1.6A/250V		IY
△ F901	5		F06-2021-05	FUSE,2A/250V		ETGXMI
△ F901	3		F50-0072-05	FUSE,3.15A/125V		KP
△ F901	5		F50-0073-05	FUSE,4A/125V		KP
△ F902,903			F05-4016-05	FUSE,400MA/250V		XCMI
△ F902,903			F05-8013-05	FUSE,800MA/250V		ETGY
△ F902,903			F50-0062-05	FUSE,800MA/250V		KP
△ F904	3		F05-1623-05	FUSE,1.6A/250V		MIY
△ F904	5		F06-2021-05	FUSE,2A/250V		MI
-		*	J13-0210-08	FUSE HOLDER		
X401		*	L78-0902-08	CRYSTAL		

L : Scandinavia K : USA P : Canada R : Mexico  
Y : PX(Far East, Hawaii) T : Europe E : Europe G : Germany  
Y : AAFES(Europe) X : Australia M : Other Areas

△ indicates safety critical components.

PARTS LIST

103SW/SW-301/1050SW/SW-501

## PARTS LIST

5

\* New Parts  
Parts without **Parts No.** are not supplied.  
Les articles non mentionnés dans le **Parts No.** ne sont pas fournis.  
Teile ohne **Parts No.** werden nicht geliefert.

Ref. No	Add-ress	New Parts	Parts No.	Description	Desti-nation	Re-marks
IC401			UPD75004CU-076	IC(4bit MICROPROCESSOR)		
IC402			LB1641	IC(MOTOR DRIVER)		
IC403			78L05A	IC(VOLTAGE REGULATOR+5V)		
IC404			W02-3003-08	REMOTE PREAMP		
IC441			PST600C	IC(SYSTEM RESET)		
IC601			UPC1298V	IC(POWER AMP DRIVER)		
IC651			UPC1237HA	IC(POWER AMP)		
IC851			NJM2072D	IC		
Q251,252			2SC1815GR	TRANSISTOR		
Q253,254			2SA1015GR	TRANSISTOR		
Q401-403			2SC1815GR	TRANSISTOR		
Q405			2SC1815GR	TRANSISTOR		
Q441			2SC1815GR	TRANSISTOR		
Q601			2SC1846	TRANSISTOR		
Q602	5		2SC3281(R)	TRANSISTOR		
Q602	3	*	2SC5198	TRANSISTOR		
Q603	5		2SA1302(R)	TRANSISTOR		
Q603	3		2SA1941(R)	TRANSISTOR		
Q621			2SA1015GR	TRANSISTOR		
Q622			2SC2878A	TRANSISTOR		
Q631			2SC1815GR	TRANSISTOR		
Q651			2SC1815GR	TRANSISTOR		
Q652			2SA1015GR	TRANSISTOR		
Q851			2SC1815GR	TRANSISTOR		
Q871			2SB1274	TRANSISTOR		
Q872			2SD1913	TRANSISTOR		
ZD101,102			MTZJ30B	ZENER DIODE		
ZD401			MTZJ6.8B	ZENER DIODE		
ZD871,872			MTZJ16B	ZENER DIODE		
ZD873,874			MTZJ5.1B	ZENER DIODE		

L : Scandinavia  
Y : PX(Far East, Hawaii)  
Y : AAFES(Europe)

K : USA  
T : Europe  
X : Australia

P : Canada  
E : Europe  
M : Other Areas

R : Mexico  
G : Germany

Δ indicates safety critical components.

5

\* New Parts  
Parts without **Parts No.** are not supplied.  
Les articles non mentionnés dans le **Parts No.** ne sont pas fournis.  
Teile ohne **Parts No.** werden nicht geliefert.

Ref. No	Add-ress	New Parts	Parts No.	Description	Desti-nation	Re-marks
R103,104			RD14BB2H122J	RD 1.2K J 1/2W		
R425,426			RD14BB2E390J	RD 39 J 1/4W		
R603	3		RD14BB2C102J	RD 1.0K J 1/6W		
R603	5		RD14BB2C821J	RD 820 J 1/6W		
R606	5		RD14BB2C102J	RD 1.0K J 1/6W		
R607,608			RN14BK2E100J	RN 10 J 1/4W		
R609,610			RN14BK2E2R7J	RN 2.7 J 1/4W		
R611			R90-0826-05	MULTI-COMP 0.22X2 J 5W		
R612			RS14GB3A100J	FL-PROOF RS 10 J 1W		
R613	3		RD14BB2C184J	RD 180K J 1/6W	XCMI	
R613	5		RD14BB2C184J	RD 180K J 1/6W	XMI	
R613	3		RD14BB2C224J	RD 220K J 1/6W	KPETGY	
R613	5		RD14BB2C274J	RD 270K J 1/6W	KPETGY	
R614	3		RD14BB2C124J	RD 120K J 1/6W	KPETGY	
R614	5		RD14BB2C563J	RD 56K J 1/6W	XCMI	
R614	5		RD14BB2C753J	RD 75K J 1/6W	XMI	
R614	3		RD14BB2C823J	RD 82K J 1/6W	KPETGY	
R631	3		RD14BB2C153J	RD 15K J 1/6W	XCMI	
R631	5		RD14BB2C183J	RD 18K J 1/6W	XMI	
R631	3		RD14BB2C183J	RD 18K J 1/6W	KPETGY	
R631	5		RD14BB2C223J	RD 22K J 1/6W	KPETGY	
R663	5		RS14GB3A152J	FL-PROOF RS 1.5K J 1W	KPETGY	
R663	3		RS14GB3A561J	FL-PROOF RS 560 J 1W	XCMI	
R663	3		RS14GB3A821J	FL-PROOF RS 820 J 1W	KPETGY	
R801,802			RS14GB3A4R7J	FL-PROOF RS 4.7 J 1W	KPETGY	
R811			RN14BK2E151F	RN 150 F 1/4W		
R851	3		RS14GB3A181J	FL-PROOF RS 180 J 1W	XCMI	
R851	3		RS14GB3A221J	FL-PROOF RS 220 J 1W	KPETGY	
R871	3		RS14GB3A221J	FL-PROOF RS 220 J 1W	ETGY	
R871	3		RS14GB3A4R7J	FL-PROOF RS 4.7 J 1W	KPXCMI	
R872	3		RD14GB2H100J	FL-PROOF RD 10 J 1/2W	ETGY	
R872	3		RS14GB3A4R7J	FL-PROOF RS 4.7 J 1W	KPXCMI	
VR201		*	R31-0409-08	POTENTIOMETER CROSSOVER FREQ		
VR601		*	R31-0408-08	TRIMMING POT BIAS		
RY601			S51-2092-05	RELAY SPEAKER		
RY851			S51-2094-05	RELAY POWER		
SW201		*	S62-0207-08	SLIDE SWITCH SLOPE		
SW401		*	S70-0203-08	TACT SWITCH STANDBY		
SW901		*	S68-0202-08	POWER SWITCH		
SW902A		*	S31-2115-05	SLIDE SWITCH VOLTAGE	MICY	
D411,412			1SS133	DIODE		
D413			1SR139-100	DIODE		
D414-419			1SS133	DIODE		
D631			1SS133	DIODE		
D651-653			1SR139-100	DIODE		
D801	3	*	D3SBA20	DIODE		
D801	5		D5SBA20	DIODE		
D811-814			1SR139-100	DIODE		
D815			MTZJ5.1B	ZENER DIODE		
D851			1SR139-100	DIODE		
D852,853			1SS133	DIODE		
IC101			NJM4558L	IC(OP AMP X2)		
IC201-203			NJM4558L	IC(OP AMP X2)		
IC204			TC4066BP	IC(ANALOG/ DIGITAL SW)		

L : Scandinavia  
Y : PX(Far East, Hawaii)  
Y : AAFES(Europe)

K : USA  
T : Europe  
X : Australia

P : Canada  
E : Europe  
M : Other Areas

R : Mexico  
G : Germany

Δ indicates safety critical components.

**Note:**  
Component and circuit are subject to modification to insure best operation under differ-  
ing local conditions. This manual is based on Europe (E) standard, and provides infor-  
mation on regional circuit modification through use of alternate schematic diagrams,  
and information on regional component variations through use of parts list.

**KENWOOD CORPORATION**  
14-6, Dogenzaka 1-chome, Shibuya-ku, Tokyo, 150 Japan  
**KENWOOD SERVICE CORPORATION**  
P.O. BOX 22745, 2201 East Dominguez St., Long Beach, CA 90801-5745, U.S.A.