

KENWOOD
HI/FI STEREO COMPONENTS

SERVICE MANUAL

Model 500
Model 600
(Model 650)



STEREO INTEGRATED AMPLIFIER

CONTENTS

EXTERNAL & INTERNAL VIEW (Model 600)	3
MODEL 500 & MODEL 650	4
DISASSEMBLY (Model 600)	5
BLOCK DIAGRAM	6
PACKING	6
CIRCUIT DESCRIPTIONS	7
ADJUSTMENTS	8
TROUBLESHOOTING	9
PARTS LIST	
Model 500, 600 & 650	10
POWER SUPPLY (A) (X00-1700-10,11,61,62,81,82)	11
POWER SUPPLY (B) (X00-1720-10,11)	11
POWER AMP (X07-1440-00,01)	12
PREAMP (X08-1470-01)	12
TONE AMP (X11-1310-00)	13
FILTER (X12-1130-10)	13
IMPEDANCE SELECTOR (X13-2230-10)	13
DESTINATIONS' PARTS LIST (Model 600 & 650)	14
DESTINATIONS' PARTS LIST (Model 500)	15
PC BOARD	
POWER SUPPLY (A)	16
POWER SUPPLY (B)	16
IMPEDANCE SELECTOR	16
POWER AMP	17
PREAMP	17
TONE AMP	18
FILTER	18
SEMICONDUCTOR SUBSTITUTIONS & LEADS	18
SCHEMATIC DIAGRAM (Model 600, 650)	19
SCHEMATIC DIAGRAM (Model 500)	20
SPECIFICATIONS	21

Note 1:

The products are subject to modification in components and circuits in different countries and regions. This is because each products must be used under the best condition.

This manual provides information of modification based on the standard in the U.S. for the convenience of ordering associated components and parts.

U.S.A.	K
Canada	P
PX	U
Australia	X
Europe	W
England	T
Scandinavia	L
South Africa	S
Other area	M

Note 2:

Symbol ⇨ and symbol ● in parts list mean the new parts and the parts not being kept in stock, respectively.

EXTERNAL & INTERNAL VIEW (Model 600)

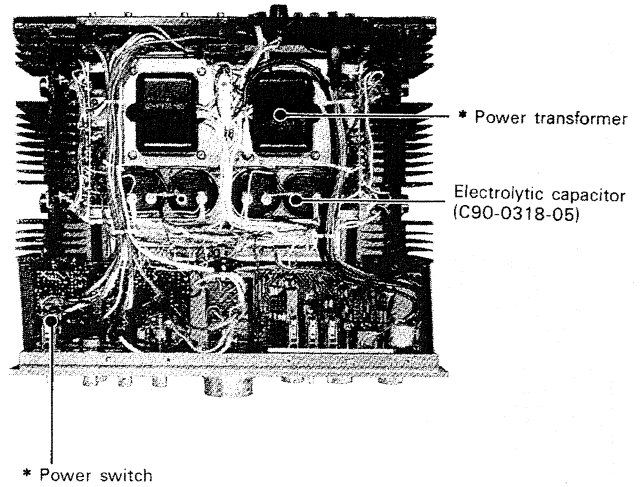
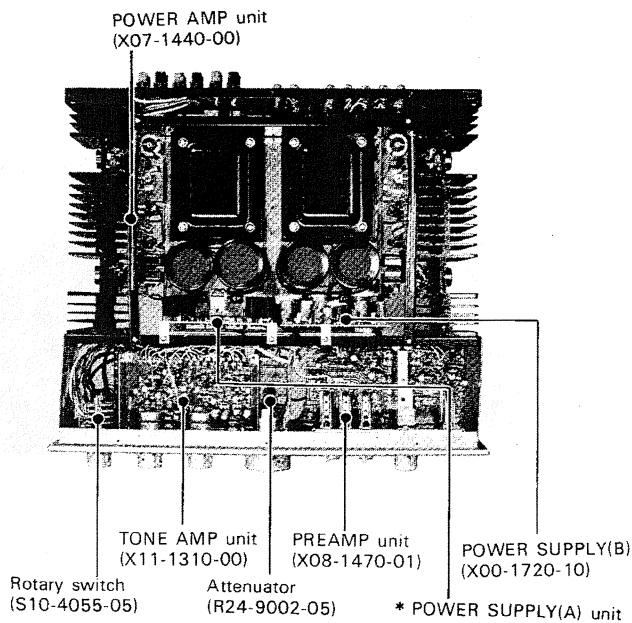
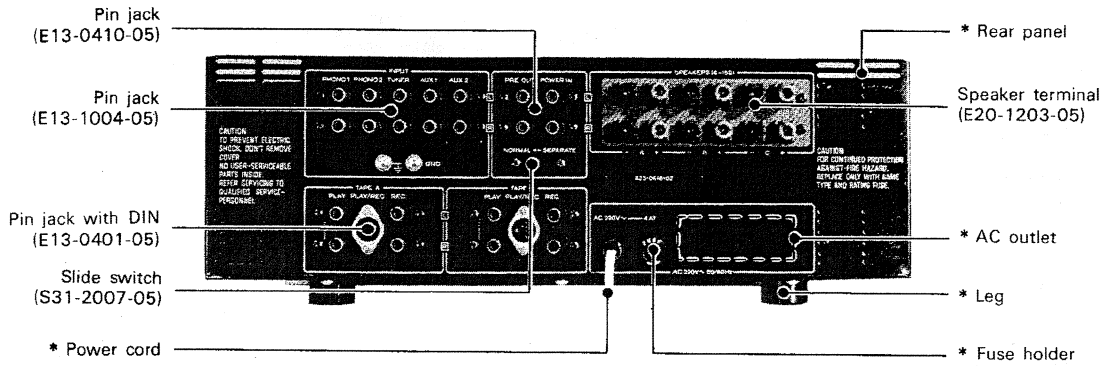
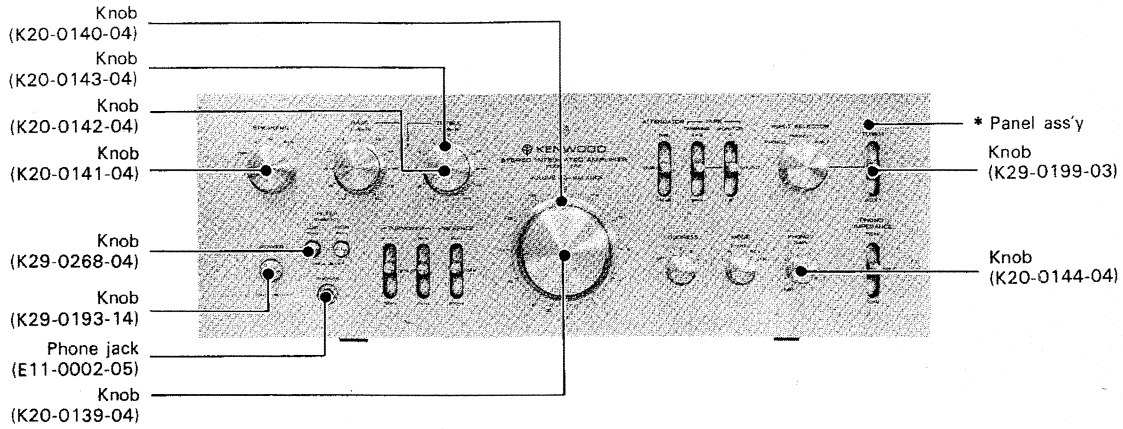

* Refer to DESTINATIONS' PARTS LIST.

Model 500 & 650

Model 500

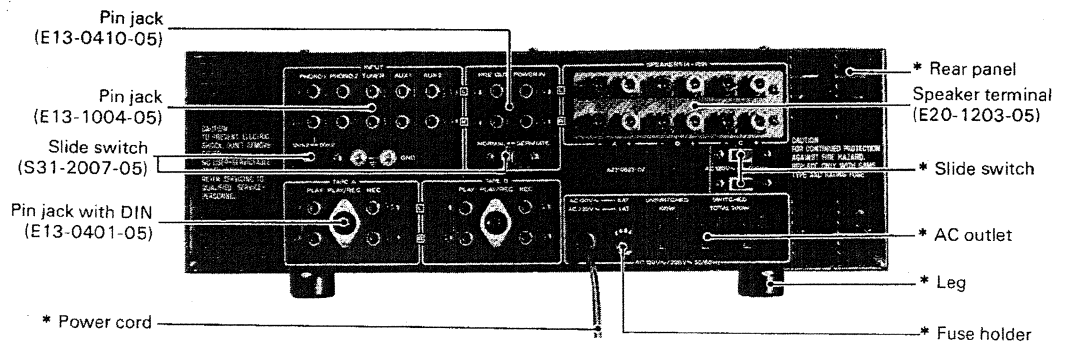
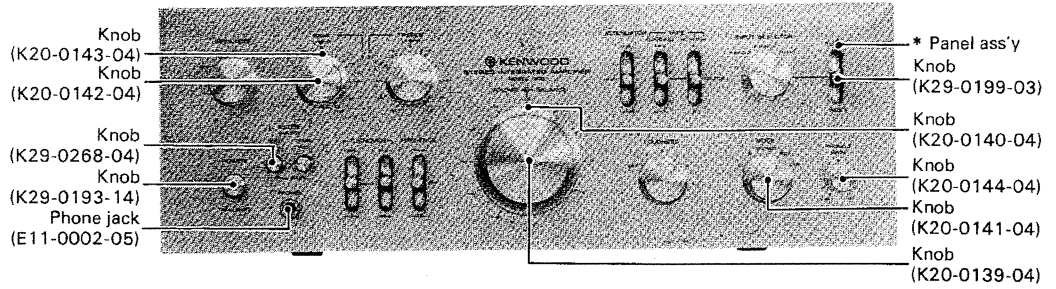

* Refer to DESTINATIONS' PARTS LIST

SUMMARY OF MODEL 500 & 650

This service manual is made for Model 600 fundamentally. Therefore, refer to PARTS LIST, SCHEMATIC DIAGRAM and SPECIFICATIONS as for Model 500. Points of difference between Model 600 and Model 500 are described there.

Model 650 shipped to AUDIO CLUB is same to Model 600 except the external appearance. (See photograph)

Model 650

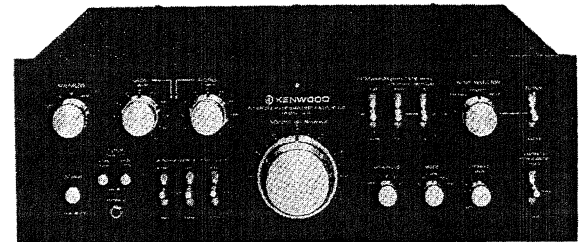

Model name	Model 600	Model 500
POWER OUTPUT	130W x 2 (8Ω)	100W x 2 (8Ω)
PHONO 1 IMPEDANCE SELECTOR	on the front panel 3 steps (X13-2230-10)	on the rear panel 2 steps

DISASSEMBLY (Model 600)

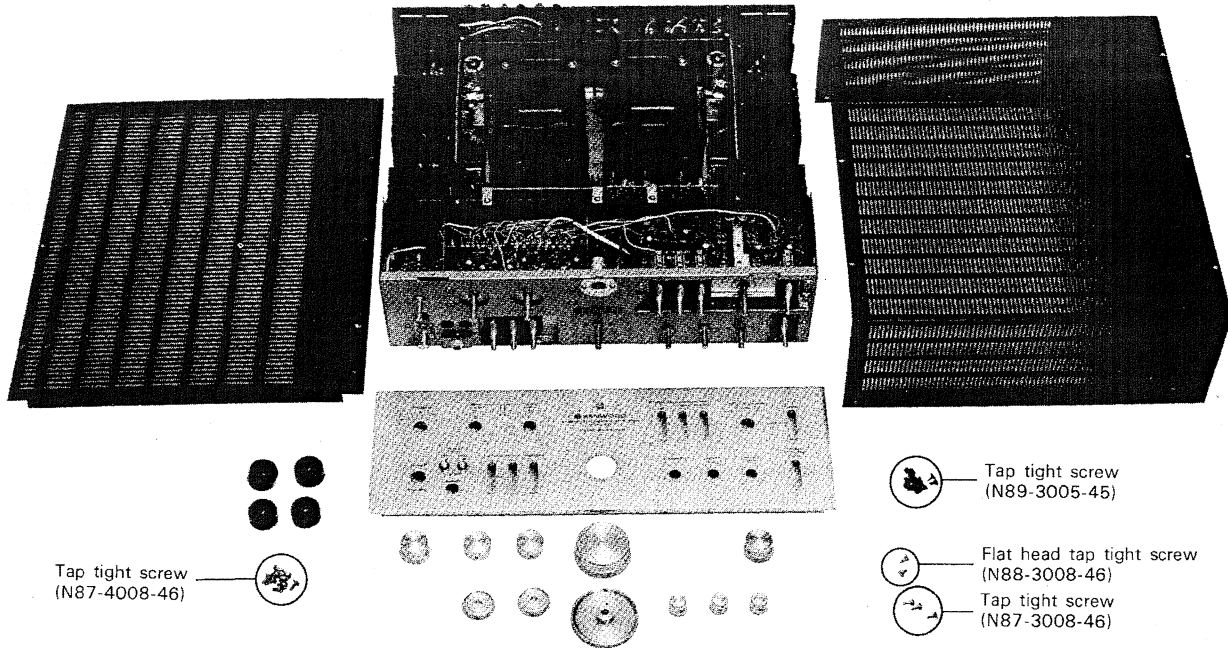

DISASSEMBLY FOR POWER AMP REPAIRING

1. Remove the screws (indicated by arrow).

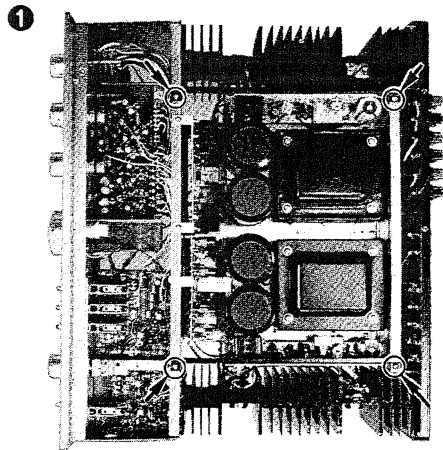

2. Pull out POWER AMP unit.

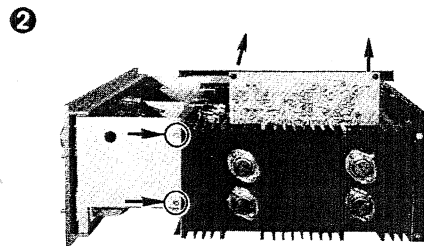

DISASSEMBLY FOR TONE AMP AND PREAMP REPAIRING

1. Remove the screws (indicating by arrow).

2. TONE AMP unit and PREAMP unit can be removed.

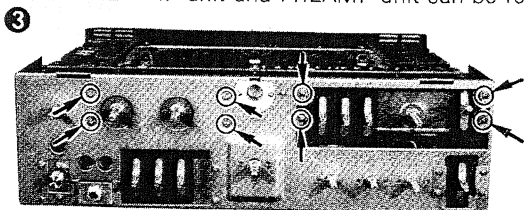

3. Remove the screws (indicated by arrow in photo 2).

4. Sub panel can be removed from the chassis.

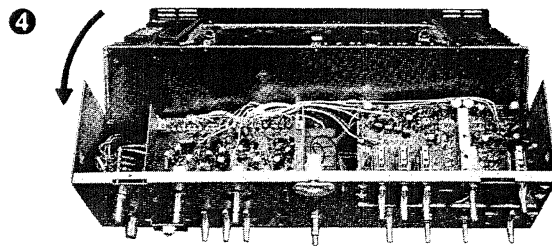

BLOCK DIAGRAM / PACKING

BLOCK DIAGRAM

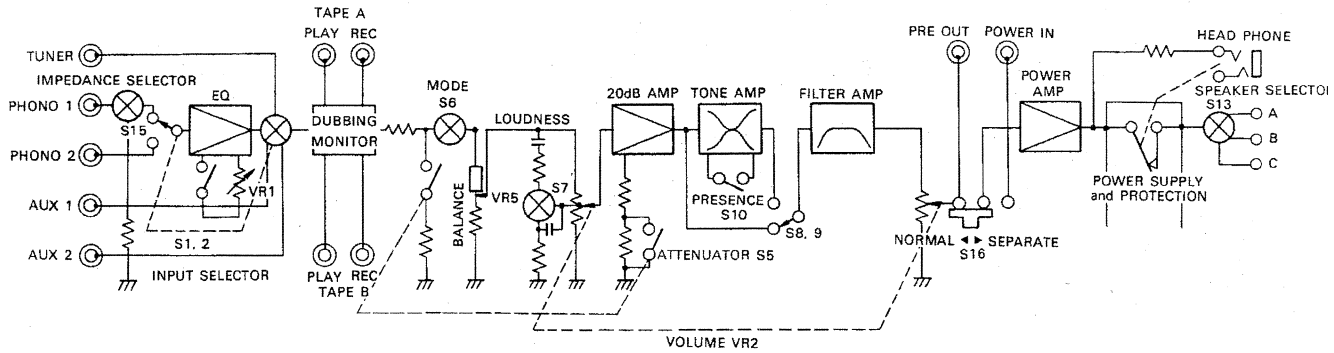

PACKING

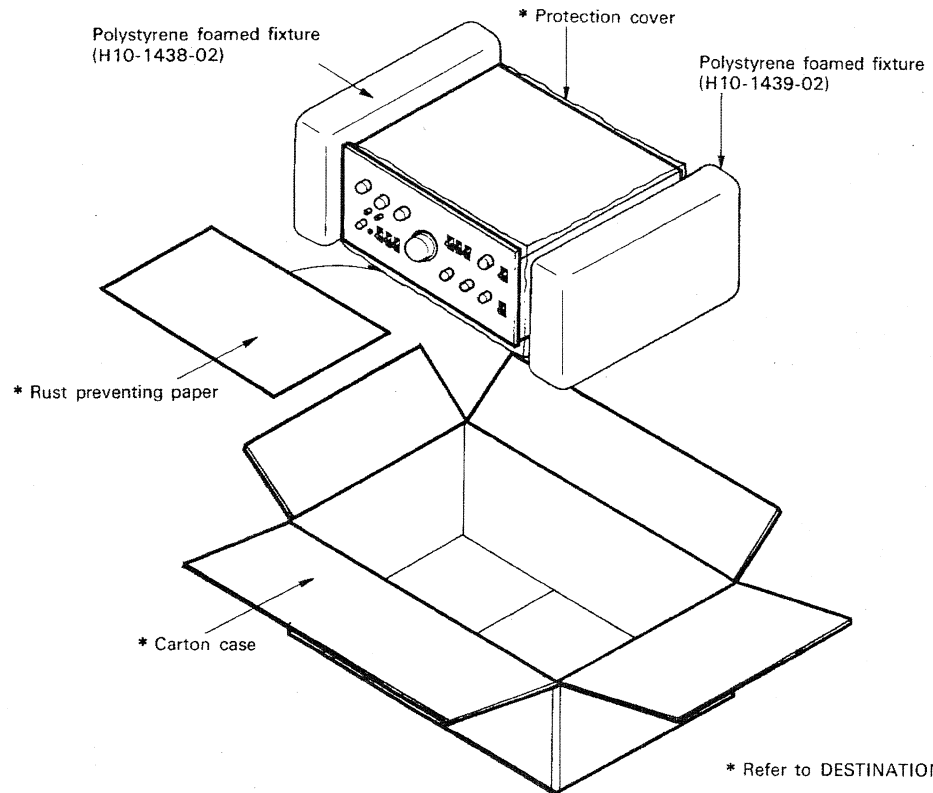

CIRCUIT DESCRIPTIONS

PHONO IMPEDANCE, ATTENUATOR AND LOUDNESS

The input impedance of PHONO 1 can be selected from 100k, 50k and 30k ohms so as to match various types of moving-magnet cartridges. (Model 600 & 650)

The gain of PHONO 2 can be adjusted to the characteristics of PHONO 1 cartridge since the resistance of the negative feedback loop is variable.

An ATTENUATOR-type volume controls the input and output signals of the tone control amplifier simultaneously and improves the dynamic range and S/N ratio.

The loudness control switches over four steps, enhancing the low frequency range at steps 1, 2 and 3, and both low and high frequency ranges at step 4.

- (1) 100 Hz: +2 dB
- (2) 100 Hz: +4 dB
- (3) 100 Hz: +6 dB
- (4) 100 Hz: +8 dB, 10 kHz: +3 dB

POWER SUPPLY (X00-1700-10)

This is an L-R independent power supply in which a 18,000 μ F electrolytic capacitor smoothes the output voltage.

POWER SUPPLY (X00-1720-10)

This is a stabilized power supply which supplies power of +40V and \pm 28V independently to the left and right channels.

As to the positive voltages, an NF type stabilized power supply generates 40V which is further stabilized into 28V with a Zener diode.

The negative voltage, -28V, is generated with an NF type stabilized power supply circuit.

- Qz1 (Qz2): transistor controlling positive voltages
- Qz3 (Qz4): transistor controlling negative voltage
- Qz5 (Qz6): transistor detecting positive voltages
- Qz7 (Qz8): transistor detecting negative voltage
- Dz1 (Dz2): Zener diode regulating negative voltage
- Dz3 (Dz4): Zener diode regulating +28V

SPEAKER PROTECTION CIRCUIT (X00-1720-10)

This circuit protects speakers when a DC voltage has developed in the speaker output circuit. To cope with both positive and negative DC voltages, NPN and PNP transistors constitute an OR circuit which cuts off the speakers whether a positive voltage or a negative one develops.

- Qz9: transistor detecting negative voltage
- Qz10: transistor detecting positive voltage
- Qz11: transistor driving relay

POWER AMP (X07-1440-00)

This is a direct-coupled DC amplifier which does not use any coupling capacitor in the signal path including negative feedback loops, from the input end to the output end.

The first stage is a differential amplifier which consists of N channel multiple FET and it will not suffer drift caused by dispersion and temperature change of the characteristics of FET.

The voltages of +24V and -14V supplied to the amplifier are stabilized by Zener diodes.

The second stage is a differential amplifier of NPN transistors and the third stage is that of PNP transistors. They contribute to improve the stability with large bare gain and DC feedback.

The fourth stage driven by constant current for the sake of stability drives the last stage.

The power amplification stage consists of two-stage complementary Darlington circuits connected in parallel at the output end.

The bias current adjusting circuit is controlled by varying the internal resistance of transistors, and a thermistor placed in the base current supply circuit compensates temperature change of the circuit.

The ASO detection circuit detects the emitter potential of the final transistor to control the input signal of the power amplification circuit.

- ICe1: differential amplifier
- Qe1, Qe2: differential amplifier
- Qe3, Qe4: differential amplifier driver
- Qe5: bias current adjusting circuit
- Qe6: constant-current circuit
- Qe7 ~ Qe10: ASO detection and protection circuit
- Qe11, Qe12: complementary circuit
- Q101 ~ Q104: final transistors
- De1: to stabilize the positive voltage supplied to the first stage FET differential amplifier
- De2: to stabilize the negative voltage supplied to the first stage FET differential amplifier
- De3, De4: to stabilize the base potential of the constant current circuit transistor
- De5, De6: to detect the emitter potential of the final transistors for the ASO detection circuit

PREAMP (X08-1470-01)

The four-stage equalizer amplifier consists of six FET's.

The first stage is a differential amplifier which improves DC stability.

The second stage is a class A amplifier and the third stage is a buffer circuit to raise the overall gain. The final stage is a class A amplifier provided with a constant current circuit.

The first stage FETs have reduced the leak current of gate to less than 10^{-9} A. No input coupling capacitor is needed since the gate potential is zero. The S/N ratio has been also improved.

CIRCUIT DESCRIPTIONS / ADJUSTMENTS

The overall bare gain is large due to the use of the buffer circuit and the final stage constant current circuit, which has made it possible to apply the negative feedback of low frequency range sufficiently to reduce distortion.

- Qd1, Qd3: first stage differential amplifier (Qd2, Qd4)
- Qd5 (Qd6): class A amplifier
- Qd7 (Qd8): buffer circuit
- Qd9, (Qd10): constant current circuit
- Qd11 (Qd12): class A amplifier

TONE CONTROL AMP (X11-1310-00)

This consists of a flat amplifier and a BAX type tone control unit.

The flat amplifier has a low output impedance since the input end of the first stage differential amplifier is an SRPP (shunt regulated push pull) circuit and it is stabilized with a constant current circuit added.

The final stage performs class A amplification using P channel FET.

The tone control unit changes the frequency response by applying negative feedback to a class A amplifier provided with a constant current circuit. It uses a pair of the same circuits in two stages to control treble and bass independently.

The flat amplifier has a gain of 19.5 dB or 4.5 dB when attenuated by -15 dB. The tone control unit has a gain of 0 dB when defeated.

The flat amplifier is supplied with DC voltages of $\pm 28V$ and the tone control unit -40V.

- Qi1, Qi3: differential amplifier (Qi2, Qi4)
- Qi5 (Qi6): class A amplifier
- Qi7 (Qi8): constant current circuit
- Qi9 (Qi10): constant current circuit for treble control
- Qi11 (Qi12): class A amplifier for treble control
- Qi13 (Qi14): constant current circuit for bass control
- Qi15 (Qi16): class A amplifier for bass control
- Qi17 (Qi18): SRPP with Qi1 (Qi2)

PRESENCE CONTROL

Presence control is performed making use of the tone control amplifier.

The gain is boosted by 6 dB at 800 Hz or 3 kHz.

FILTER AMP (X12-1130-10)

This consists of negative feedback type filters of source follower provided with a constant current circuit.

The low cut filter attenuates at a rate of -12 dB/oct below 40 Hz and the high cut filter at -12 dB/oct above 8 kHz.

- Qs1 (Qs2): source follower
- Qs3 (Qs4): constant current circuit

ADJUSTMENTS

1. Offset voltage adjustment (VRe1 and VRe3)
VRe3 is a semi-variable resistor for coarse adjustment and VRe1 for fine adjustment.
Measure the DC voltage at No. 13 terminal of the power amplifier PC board with a multimeter set at a DC range. If the DC voltage is 100 mV or more, adjust it roughly to 0V with VRe3 and exactly to 0V with VRe1. Leave VRe1 in the middle of the control range when turning VRe3.
2. Bias current adjustment (VRe2)
The bias current must be 25 mA. Without inputting any signal to the power amplifier, adjust the current with VRe2 so that a DC voltmeter or BIAS current meter (B31-0125-05) connected across No. 5 and 6 terminal of the power amplifier PC board indicates 25 mV.

POWER AMP (X07-1440-00,01)

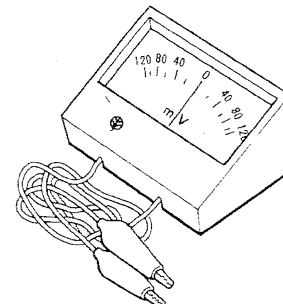
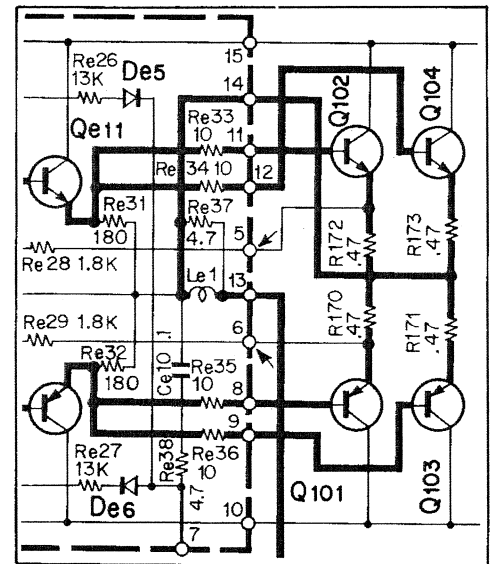

BIAS current meter (B31-0125-05)

TROUBLESHOOTING

● POWER AMP unit

NOTE: Only L-ch troubleshooting is described here.

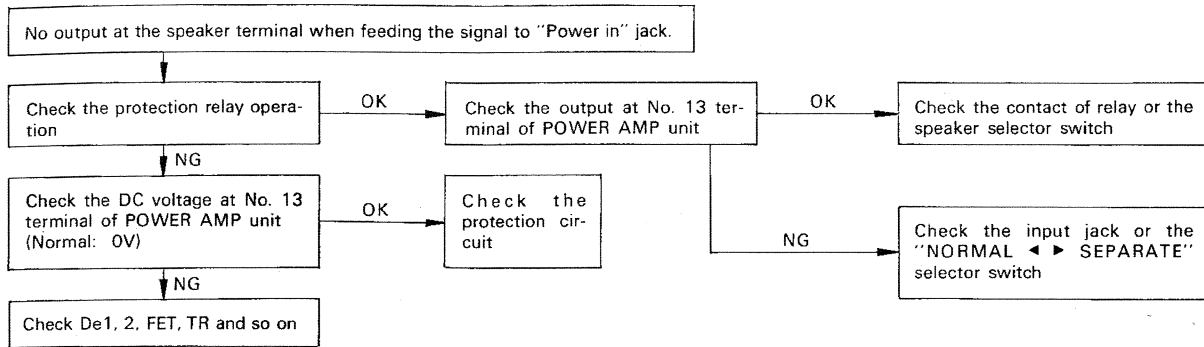

● TONE AMP unit, FILTER AMP unit

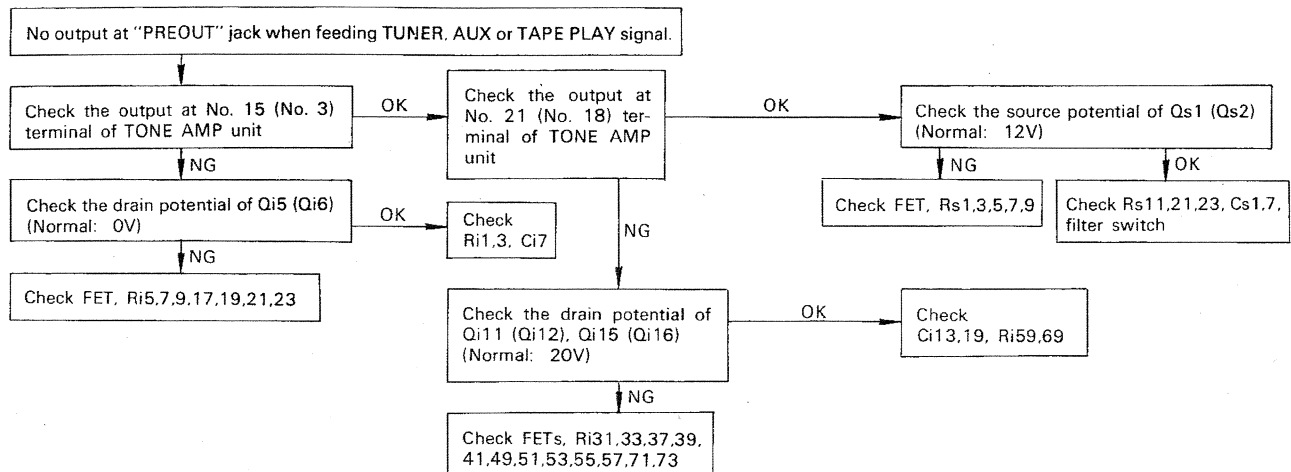

● PREAMP unit

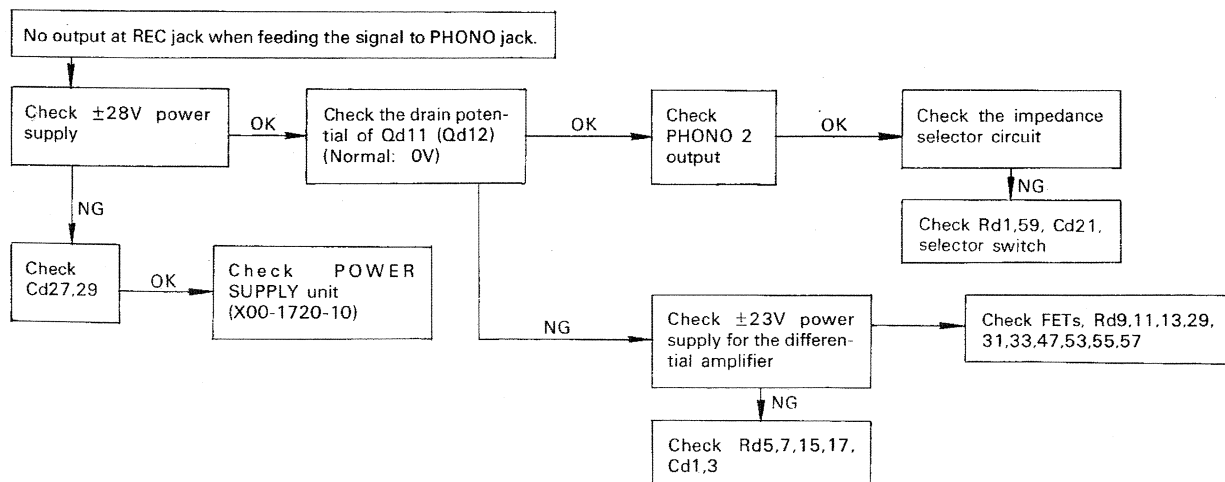

● When the frequency response of PREAMP is against the specification.

(RIAA Standard curve ± 0.2 dB)

Equalizer characteristic is determined by Cd11, 13, 15, 17, Rd43,

45. So, check them.

PARTS LIST

Symbol ☆ : new parts

Symbol ● : the parts not being kept in stock

□ Model 500

■ Model 600(650)

Model 500, 600 & 650

Ref. No.	Parts No.	Description	Re- marks
CAPACITOR			
C131	CQ93M1H473J	Mylar 0.047 μ F \pm 5%	
C132	CQ93M1H183J	Mylar 0.018 μ F \pm 5%	
C133	CQ93M1H103J	Mylar 0.01 μ F \pm 5%	
C134	CQ93M1H183J	Mylar 0.018 μ F \pm 5%	
C231	CQ93M1H473J	Mylar 0.047 μ F \pm 5%	
C232	CQ93M1H183J	Mylar 0.018 μ F \pm 5%	
C233	CQ93M1H103J	Mylar 0.01 μ F \pm 5%	
C234	CQ93M1H183J	Mylar 0.018 μ F \pm 5%	
C303~ 306	C90-0318-05	(Electrolytic 18000 μ F \times 2 71WV) \times 2	■
C303~ 306	C90-0319-05	(Electrolytic 15000 μ F \times 2 71WV) \times 2	□
—	CK45F1H403Z	(Ceramic 0.04 μ F \times 4 \pm 80%,-20%) \times 4	
RESISTOR			
R101	PD14BY2E104JKW	Carbon 100k Ω \pm 5% 1/4W	□
R110	PD14BY2E104JKW	Carbon 100k Ω \pm 5% 1/4W	
R120	PD14BY2E394JKW	Carbon 390k Ω \pm 5% 1/4W	
R121	PD14BY2E104JKW	Carbon 100k Ω \pm 5% 1/4W	
R122	PD14BY2E394JKW	Carbon 390k Ω \pm 5% 1/4W	
R123	PD14BY2E104JKW	Carbon 100k Ω \pm 5% 1/4W	
R131	PD14BY2E223JKW	Carbon 22k Ω \pm 5% 1/4W	
R132	PD14BY2E104JKW	Carbon 100k Ω \pm 5% 1/4W	
R133	PD14BY2E184JKW	Carbon 180k Ω \pm 5% 1/4W	
R134	PD14BY2E223JKW	Carbon 22k Ω \pm 5% 1/4W	
R170~ 173	R92-0115-05	Metal plate 0.47 Ω \pm 5% 3W	
R174	RN14AB3D681J	Metal film 680 Ω \pm 5% 2W	
R201	PD14BY2E104JKW	Carbon 100k Ω \pm 5% 1/4W	□
R210	PD14BY2E104JKW	Carbon 100k Ω \pm 5% 1/4W	
R220	PD14BY2E394JKW	Carbon 390k Ω \pm 5% 1/4W	
R221	PD14BY2E104JKW	Carbon 100k Ω \pm 5% 1/4W	
R222	PD14BY2E394JKW	Carbon 390k Ω \pm 5% 1/4W	
R223	PD14BY2E104JKW	Carbon 100k Ω \pm 5% 1/4W	
R231	PD14BY2E223JKW	Carbon 22k Ω \pm 5% 1/4W	
R232	PD14BY2E104JKW	Carbon 100k Ω \pm 5% 1/4W	
R233	PD14BY2E184JKW	Carbon 180k Ω \pm 5% 1/4W	
R234	PD14BY2E223JKW	Carbon 22k Ω \pm 5% 1/4W	
R270~ 273	R92-0115-05	Metal plate 0.47 Ω \pm 5% 3W	
R274	RN14AB3D681J	Metal film 680 Ω \pm 5% 2W	
R301,302	RN14AB3D562J	Metal film 5.6k Ω \pm 5% 2W	
SEMICONDUCTOR			
Q101	V01-0166-05	Transistor 2SA747A	
Q102	V03-0441-05	Transistor 2SC1116A	
Q103	V01-0166-05	Transistor 2SA747A	
Q104	V03-0441-05	Transistor 2SC1116A	
Q201	V01-0166-05	Transistor 2SA747A	
Q202	V03-0441-05	Transistor 2SC1116A	
Q203	V01-0166-05	Transistor 2SA747A	
Q204	V03-0441-05	Transistor 2SC1116A	
TH1.2	V22-0027-05	Thermister 5TP-41L	
POTENTIOMETER			
VR1	R08-2008-05	5k Ω (B) \times 2 PHONO 2 GAIN	
VR2.5	R24-9002-05	BALANCE, VOLUME	
SWITCH			
S6	S01-2042-05	Rotary MODE	
S7	S10-2113-05	Rotary LOUDNESS	
S13	S10-4055-05	Rotary SPEAKERS	
S15.16	S31-2007-05	Slide(NORMAL \blacklozenge SEPARATE, IMPEDANCE) \times 2	□
S15	S31-2007-05	Slide(NORMAL \blacklozenge SEPARATE)	■

Ref. No.	Parts No.	Description	Re- marks
MISCELLANEOUS			
—	A01-0281-02	Case	●☆
—	A10-0478-12	Chassis	●☆
—	A13-0140-12	Frame (A)	●☆
—	A13-0141-12	Frame (B)	●☆
—	A22-0188-12	Sub panel (Model 600, 650)	●☆
—	A22-0189-12	Sub panel (Model 500)	●☆
—	A40-0145-02	Bottom plate	●☆
—	B07-0162-04	Ring(pushbutton switch) \times 2	☆
—	B07-0165-04	Ring(power switch)	☆
—	B08-9009-04	Display window	
—	B30-0068-05	Pilot lamp(200mA 8V)	
—	B42-0009-04	Passed sticker	
—	B47-0037-00	Caution card	
—	D19-0050-14	Holding plate \times 2	●
—	D32-0075-04	Switch stopper	
—	E02-0001-05	Transistor socket \times 8	☆
—	E10-1808-05	Multi-connector 18P	
—	E11-0002-05	Phone jack	
—	E13-0401-05	Pin jack(4P with DIN) \times 2	
—	E13-0410-05	Pin jack(4P)	
—	E13-1004-05	Pin jack(10P)	
—	E14-0107-05	Short pin plug \times 2	
—	E20-1203-05	Speaker terminal(12P)	☆
—	E21-0138-15	GND terminal \times 2	
—	F01-0233-02	Heat sink \times 2	☆
—	F10-0415-03	Shield plate (B) for the input wire	●☆
—	F10-0416-04	Shield plate (C) for the speaker rotary switch	●☆
—	F14-0081-14	Douser ring	
—	F15-0200-14	Felt \times 2	☆
—	F15-0201-14	Felt \times 2	☆
—	F19-0208-04	Lamp box	☆
—	F20-0066-05	Mica insulating plate \times 8	
—	F31-0034-23	Reinforcing metal fittings	●☆
—	G01-0312-04	Spring for the pushbutton switch \times 2	
—	H10-1438-02	Polystyrene foamed fixture	☆
—	H10-1439-02	Polystyrene foamed fixture	☆
—	H25-0078-00	Instruction bag	
—	J19-0306-05	Lead wire holder \times 5	
—	J21-1475-24	PC board mounting hardware (power amp) \times 4	●☆
—	J21-1478-14	PC board mounting hardware (power amp) \times 2	●☆
—	K20-0139-04	Knob(VOLUME)	□☆
—	K20-0140-04	Knob(BALANCE)	□☆
—	K20-0141-04	Knob(SP. SEL, LOUD, MODE) \times 4	□☆
—	K20-0142-04	Knob(TONE, inside) \times 2	□
—	K20-0143-04	Knob(TONE, outside) \times 2	□
—	K20-0144-04	Knob(PHONO 2 level)	□☆
—	K29-0193-14	Knob(POWER)	□
—	K29-0199-03	Knob(lever) \times 7	□
—	K29-0268-04	Knob(LOW,HIGH FIL) \times 2	□☆
—	K20-0139-04	Knob(VOLUME)	■
—	K20-0140-04	Knob(BALANCE)	■
—	K20-0141-04	Knob(SP.SEL) \times 2	■
—	K20-0142-04	Knob(TONE,inside) \times 2	■
—	K20-0143-04	Knob(TONE,outside) \times 2	■

PARTS LIST

KOR
MODEL
500

Ref. No.	Parts No.	Description	Re- marks
—	K20-0144-04	Knob(MODE.LOUD.PHONO 2 level) × 3	■
—	K29-0193-14	Knob(POWER)	■
—	K29-0199-03	Knob(lever) × 8	■
—	K29-0268-04	Knob(LOW.HIGH FIL) × 2	■
—	N10-2030-46	Hexagonal nut (φ3, rear panel) × 16	
—	N14-0115-05	Flange nut(power transformer) × 8	
—	N30-3006-46	Pan head screw (3 × 6, power switch) × 2	
—	N35-3018-21	Binding screw(brass, heat sink) × 16	
—	N86-3008-45	Tap-tight screw(3 × 8 black, rear panel)	
—	N87-3006-46	Tap-tight screw(3 × 6, heat sink) × 7	
—	N87-3008-46	Tap-tight screw(3 × 8)	
—	N87-4008-46	Tap-tight screw(4 × 8, bottom plate) × 15	
—	N87-4012-46	Tap-tight screw(4 × 12, leg)	
—	N88-3008-46	Flat head tap-tight screw(3 × 8)	
—	N89-3008-45	Tap-tight screw(3 × 8 black, rear panel) × 4	
—	N89-3005-45	Tap-tight screw(3 × 5, case) × 14	
—	X00-1720-11	Power supply(B) unit	□ ☆
—	X07-1440-00	Power amp(L) unit	□ ☆
—	X07-1440-01	Power amp(R) unit	□ ☆
—	X08-1470-01	Preamp unit	□ ☆
—	X11-1310-00	Tone amp unit	□ ☆
—	X12-1130-10	Filter unit	□ ☆
—	X00-1720-10	Power supply(B) unit	■ ☆
—	X07-1440-00	Power amp(L) unit	■ ☆
—	X07-1440-01	Power amp(R) unit	■ ☆
—	X08-1470-01	Preamp unit	■ ☆
—	X11-1310-00	Tone amp unit	■ ☆
—	X12-1130-10	Filter unit	■ ☆
—	X13-2230-10	Impedance selector unit	■ ☆
—	W01-0077-15	Hexagonal wrench	

POWER SUPPLY (A)(X00-1700-10,11,61,62,81,82)

Ref. No.	Parts No.	Description	Re- marks
CAPACITOR			
Ck1~8	CK45E2H103P	Ceramic 0.01μF +100%—0%	
RESISTOR			
RK3	RN14AB3D102JB	Metal film 1kΩ ±5% 2W -10,-61,-81	
	RN14AB3D681JB	Metal film 680Ω ±5% 2W -11,-62,-82	
SEMICONDUCTOR			
Dk1,2	V11-0415-05	Diode M4C-5	
Dk3	V11-0219-05	Diode V06B	☆
MISCELLANEOUS			
Fk1	F05-5011-05	Fuse 0.5A UL	-10,-11
	F05-5013-05	Fuse 0.5A	-81,-82
	F05-5016-05	Fuse 500mA T	-61,-62
—	J13-0032-05	Fuse holder	
—	J13-0040-05	Fuse holder	-61,-62
—	J21-0744-04	L shaped holder × 2	-10,-11,-81,-82
—	S51-4030-15	Relay	

POWER SUPPLY (B) (X00-1720-10, 11)

Ref. No.	Parts No.	Description	Re- marks
CAPACITOR			
Cz5~8	CE04W1H101EL	Electrolytic 100μF 50WV	
Cz9~12	CK45E1H102P	Ceramic 1000pF +100%,-0%	
Cz13,14	CE04W1H010EL	Electrolytic 1μF 50WV	
Cz15,16	CE04W1A100EL	Electrolytic 10μF 10WV	
Cz17,18	CE04W1H101EL	Electrolytic 100μF 50WV	
Cz19,20	CE04W1H010EL	Electrolytic 1μF 50WV	
Cz21~24	CE04W1V221EL	Electrolytic 220μF 35WV	
Cz25,26	CE04W1C101NP	Non-pole electrolytic 100μF 16WV	
Cz27	C90-0337-05	Electrolytic 1000μF 3.15WV	☆
Cz28	CE04W2A4R7BR	Electrolytic 4.7μF 100WV	
RESISTOR			
Rz1	RN14AB3A101J	Metal film 100Ω ±5% 1W	-10
	RN14AB3A470J	Metal film 47Ω ±5% 1W	-11
Rz2	RN14AB3A331J	Metal film 330Ω ±5% 1W	-10
	RN14AB3A271J	Metal film 270Ω ±5% 1W	-11
Rz3	RN14AB3A101J	Metal film 100Ω ±5% 1W	-10
	RN14AB3A470J	Metal film 47Ω ±5% 1W	-11
Rz4	RN14AB3A331J	Metal film 330Ω ±5% 1W	-10
	RN14AB3A271J	Metal film 270Ω ±5% 1W	-11
Rz5~8	PD14BY2E681JB	Carbon 680Ω ±5% 1/4W	
Rz9~12	PD14BY2E392JKW	Carbon 3.9kΩ ±5% 1/4W	
Rz13,14	PD14BY2E472JKW	Carbon 4.7kΩ ±5% 1/4W	
Rz15,16	PD14BY2E393JKW	Carbon 39kΩ ±5% 1/4W	
Rz17,18	PD14BY2E303JKW	Carbon 30kΩ ±5% 1/4W	
Rz19,20	PD14BY2E243JKW	Carbon 24kΩ ±5% 1/4W	
Rz21,22	PD14BY2E752JKW	Carbon 7.5kΩ ±5% 1/4W	
Rz23,24	RN14AB3A221J	Metal film 220Ω ±5% 1W	
Rz25	PD14BY2E334JKW	Carbon 330kΩ ±5% 1/4W	
Rz26,27	PD14BY2E273JKW	Carbon 27kΩ ±5% 1/4W	
Rz28	PD14BY2E244JKW	Carbon 240kΩ ±5% 1/4W	
Rz31,32	PD14BY2E223JKW	Carbon 22kΩ ±5% 1/4W	
Rz33,34	PD14BY2E103JKW	Carbon 10kΩ ±5% 1/4W	
Rz35	PD14BY2E222JKW	Carbon 2.2kΩ ±5% 1/4W	
Rz36	PD14BY2E473JKW	Carbon 47kΩ ±5% 1/4W	
Rz37	PD14BY2E222JKW	Carbon 2.2kΩ ±5% 1/4W	
Rz38	PD14BY2E332JKW	Carbon 3.3kΩ ±5% 1/4W	
Rz39	RN14AB3D332J	Metal film 3.3kΩ ±5% 1W	-10
	RN14AB3D272J	Metal film 2.7kΩ ±5% 1W	-11
Rz40	PD14BY2E274J	Carbon 270kΩ ±5% 1/4W	
SEMICONDUCTOR			
Qz1,2	V03-0343-05	Transistor 2SC1419(C)	
Qz3,4	V01-0116-05	Transistor 2SA755(C)	
Qz5,6	V03-0408-05	Transistor 2SC1222(E)	
Qz7,8	V01-0146-05	Transistor 2SA640(E)	
Qz9	V01-0087-05	Transistor 2SA620WL5	
Qz10	V03-0358-05	Transistor 2SC1416(BL) or (GL)	
Qz11	V04-0068-05	Transistor 2SD415(Q) or (R)	
Dz1,2	V11-0431-05	Zener diode EQA01-06S	
Dz3,4	V11-0417-05	Zener diode EQB01-28	
Dz5~9	V11-0273-05	Diode 1S2076A	
Dz10	V11-0219-05	Diode V06B	
MISCELLANEOUS			
	J21-0744-04	L shaped holder	

The pattern of X07-1440-01 is same to the one which the pattern of X07-1440-00 is turned over.

PARTS LIST

PREAMP (X08-1470-01)

POWER AMP (X07-1440-00, 01)

Ref. No.	Parts No.	Description	Re- marks
CAPACITOR			
Ce1	CC45SL1H121K	Ceramic 120pF ±10%	
Ce2	CC45SL1H050D	Ceramic 5pF ±0.5pF	
Ce3	CC45SL1H330K	Ceramic 33pF ±10%	
Ce4	CC45SL1H101K	Ceramic 100pF ±10%	
Ce5	CE04W1H100	Electrolytic 10μF 50WV	
Ce6~8	CE04W1E100MBR	Electrolytic 10μF 25WV	
Ce9	CE02W2A221	Electrolytic 220μF 100WV	
Ce10	CQ93M1H104M	Mylar 0.1μF ±20%	
Ce11	CQ93M1H103M	Mylar 0.01μF ±20%	
Ce12	CC45SL1H050D	Ceramic 5pF ±0.5pF	
RESISTOR			
Re1	PD14BY2E562JKW	Carbon 5.6kΩ ±5% 1/4W	
Re2	PD14BY2E104JKW	Carbon 100kΩ ±5% 1/4W	
Re3,4	PD14BY2E273JKW	Carbon 27kΩ ±5% 1/4W	
Re5	PD14BY2E123JKW	Carbon 12kΩ ±5% 1/4W	
Re8	PD14BY2E102JKW	Carbon 1kΩ ±5% 1/4W	
Re9,10	PD14BY2E182JKW	Carbon 1.8kΩ ±5% 1/4W	
Re11	PD14BY2E392JKW	Carbon 3.9kΩ ±5% 1/4W	
Re12	PD14BY2E153JKW	Carbon 15kΩ ±5% 1/4W	
Re13	PD14BY2E910JBKW	Carbon 91Ω ±5% 1/4W	
Re14	PD14BY2E101JBKW	Carbon 100Ω ±5% 1/4W	
Re15	PD14BY2E333JKW	Carbon 33kΩ ±5% 1/4W	
Re16	PD14BY2E243JKW	Carbon 24kΩ ±5% 1/4W	
Re17	PD14BY2E822JBMA	Carbon 8.2kΩ ±5% 1/4W	
Re18	PD14BY2E182JKW	Carbon 1.8kΩ ±5% 1/4W	
Re19	PD14BY2E392JKW	Carbon 3.9kΩ ±5% 1/4W	
Re20	PD14BY2E202JKW	Carbon 2kΩ ±5% 1/4W	
Re21	PD14BY2E910JBKW	Carbon 91Ω ±5% 1/4W	
Re22,23	PD14BY2E331JKW	Carbon 330Ω ±5% 1/4W	
Re24,25	PD14BY2E271JKW	Carbon 270Ω ±5% 1/4W	
Re26,27	PD14BY2E133JKW	Carbon 13kΩ ±5% 1/4W	
Re28,29	PD14BY2E182JKW	Carbon 1.8kΩ ±5% 1/4W	
Re30	RN14AB3D560JB	Metal film 56Ω ±5% 2W	
Re31,32	PD14BY2E181JBMA	Carbon 180Ω ±5% 1/4W	
Re33~36	RN14AB3A100JBMA	Metal film 10Ω ±5% 1W	
Re37	RN14AB3D4R7JBMA	Metal film 4.7Ω ±5% 2W	
Re38	RN14AB3H4R7JBMA	Metal film 4.7Ω ±5% 5W	
SEMICONDUCTOR			
Qe1,2	V03-0424-05	Transistor 2SC1400(U) or (E)	
Qe3,4	V01-0147-05	Transistor 2SA810(B) or (G)	
Qe5	V03-0430-05	Transistor 2SC1746(GR)	
Qe6	V03-0366-05	Transistor 2SC1452(B) or (G)	
Qe7	V01-0073-05	Transistor 2SA673A(B) or (C)	
Qe8,9	V03-0215-05	Transistor 2SC1213A(B) or (C)	
Qe10	V01-0073-05	Transistor 2SA673A(B) or (C)	
Qe11	V04-0071-05	Transistor 2SD381(2)L	
Qe12	V02-0054-05	Transistor 2SB536(2)L	
ICel	V09-0093-05	FET 2SK58	
De1	V11-0416-05	Zener diode EQA01-24	☆
De2	V11-0254-05	Zener diode YZ-140	
De3~6	V11-0273-05	Diode 1S2076A	
POTENTIOMETER			
VRe1	R12-0050-05	470Ω(B)	
VRe2	R12-0026-05	500Ω(B)	
VRe3	R12-3035-05	47kΩ(B)	
MISCELLANEOUS			
—	F01-0210-04	Heat sink × 2	● ☆
—	F12-0034-04	Sield part A	● ☆
—	F12-0035-04	Sield part B	● ☆
Le1	L39-0080-05	Phase compensation coil	☆

Ref. No.	Parts No.	Description	Re- marks
CAPACITOR			
Cd1~6	CE04W1E100EL	Electrolytic 10μF 25WV	
Cd7,8	CC45SL1H100D	Ceramic 10pF ±0.5pF	
Cd9,10	CE04W1E101EL	Electrolytic 100μF 25WV	
Cd11~14	CQ93M1H152J	Mylar 0.0015μF ±5%	
Cd15,16	CQ93M1H122J	Mylar 0.0012μF ±5%	
Cd17,18	CQ93M1H182J	Mylar 0.0018μF ±5%	
Cd19,20	CE04W1A101EL	Electrolytic 100μF 10WV	
Cd21,22	CE04W1H010EL	Electrolytic 1μF 50WV	
Cd23	CK45D1H561M	Ceramic 560pF ±20%	
Cd24,25	CC45SL1H100D	Ceramic 10pF ±0.5pF	
Cd26~29	CK45F1H403Z	Ceramic 0.04μF ±80%—20%	
RESISTOR			
Rd1,2	PD14CY2E222JKW	Carbon 2.2kΩ ±5% 1/4W	
Rd3,4	PD14CY2E104JKW	Carbon 100kΩ ±5% 1/4W	
Rd5~8	PD14CY2E243JKW	Carbon 24kΩ ±5% 1/4W	
Rd9~12	PD14CY2E104JKW	Carbon 100kΩ ±5% 1/4W	
Rd13,14	PD14CY2E154JKW	Carbon 150kΩ ±5% 1/4W	
Rd15~18	PD14CY2E472JKW	Carbon 4.7kΩ ±5% 1/4W	
Rd19,20	PD14CY2E332FKW	Carbon 3.3kΩ ±1% 1/4W	
Rd21,22	PD14CY2E103JKW	Carbon 10kΩ ±5% 1/4W	
Rd23~26	PD14CY2E105JKW	Carbon 1MΩ ±5% 1/4W	
Rd27,28	PD14CY2E362JKW	Carbon 3.6kΩ ±5% 1/4W	
Rd29,30	PD14CY2E473JKW	Carbon 47kΩ ±5% 1/4W	
Rd31,32	PD14CY2E101JKW	Carbon 100Ω ±5% 1/4W	
Rd33,34	PD14CY2E432JKW	Carbon 4.3kΩ ±5% 1/4W	
Rd35~40	PD14BY2E824FKW	Carbon 820kΩ ±1% 1/4W	
Rd41,42	PD14BY2E684FKW	Carbon 680kΩ ±1% 1/4W	
Rd43,44	R92-0160-05	Metal film 5.6MΩ ±1% 1/4W	☆
Rd45,46	PD14BY2E164FKW	Carbon 160kΩ ±1% 1/4W	
Rd47,48	PD14CY2E683JKW	Carbon 68kΩ ±5% 1/4W	
Rd49,50	PD14CY2E123JKW	Carbon 12kΩ ±5% 1/4W	
Rd51,52	PD14CY2E112JKW	Carbon 1.1kΩ ±5% 1/4W	
Rd53,54	PD14CY2E392JKW	Carbon 3.9kΩ ±5% 1/4W	
Rd55,56	PD14CY2E101JKW	Carbon 100Ω ±5% 1/4W	
Rd57,58	PD14CY2E242JKW	Carbon 2.4kΩ ±5% 1/4W	
Rd59,60	PD14CY2E471JKW	Carbon 470Ω ±5% 1/4W	
Rd61,62	PD14CY2E564JKW	Carbon 560kΩ ±5% 1/4W	
Rd63,64	PD14CY2E222JKW	Carbon 2.2kΩ ±5% 1/4W	
Rd65,66	PD14CY2E244JKW	Carbon 240kΩ ±5% 1/4W	
SEMICONDUCTOR			
Qd1,2	V09-0095-05	FET 2SK68A(K)	
Qd3,4	V09-0096-05	FET 2SK68A(M)	
Qd5~8	V09-0098-05	FET 2SK68A(L) or (M)	
Qd9,10	V09-0094-05	FET 2SK68A(1)N	
Qd11,12	V30-0150-05	FET 2N5465	
SWITCH			
S1	S29-1080-05	Slide (INPUT SELECTOR)	☆
S2	S32-2012-05	Lever (INPUT SELECTOR)	
S3~5	S32-4007-05	Lever(DUBBING, MONITOR, ATTENUATOR) × 3	
MISCELLANEOUS			
—	J21-1440-04	PC board mounting hardware	● ☆

PARTS LIST

TONE AMP (X11-1310-00)

FILTER (X12-1130-10)

Re-
marks

☆

☆

●☆

Ref. No.	Parts No.	Description	Re- marks
CAPACITOR			
Ci1.2	CE04W1E100EL	Electrolytic 10 μ F 25WV	
Ci3.4	CC45SL1H100D	Ceramic 10pF 0.5pF	
Ci5.6	CE04W1C470EL	Electrolytic 47 μ F 16WV	
Ci7.8	CE04W1E3R3BR	Electrolytic 3.3 μ F 25WV	
Ce9.10	CE04W1H010BR	Electrolytic 1 μ F 50WV	
Ce11.12	CE04W1A470EL	Electrolytic 47 μ F 10WV	
Ce13.14	CE04W1H2R2BR	Electrolytic 2.2 μ F 50WV	
Ci15.16	CE04W1H010BR	Electrolytic 1 μ F 50WV	
Ci17.18	CE04W1A470EL	Electrolytic 47 μ F 10WV	
Ci19.20	CE04W1H2R2BR	Electrolytic 2.2 μ F 50WV	
Ci21.22	CE04W1H010EL	Electrolytic 1 μ F 50WV	
Ci23.24	CC45SL1H050D	Ceramic 5pF \pm 0.5pF	
RESISTOR			
Ri1.2	PD14CY2E222JKW	Carbon 2.2k Ω \pm 5% 1/4W	
Ri3.4	PD14CY2E105JKW	Carbon 1M Ω \pm 5% 1/4W	
Ri5.6	PD14BY2E513JKW	Carbon 51k Ω \pm 5% 1/4W	
Ri7.8	PD14CY2E472JKW	Carbon 4.7k Ω \pm 5% 1/4W	
Ri9.10	PD14CY2E102JKW	Carbon 1k Ω \pm 5% 1/4W	
Ri11.12	PD14CY2E512JKW	Carbon 5.1k Ω \pm 5% 1/4W	
Ri13.14	PD14CY2E913JKW	Carbon 91k Ω \pm 5% 1/4W	
Ri15.16	PD14CY2E333JKW	Carbon 33k Ω \pm 5% 1/4W	
Ri17.18	PD14CY2E103JKW	Carbon 10k Ω \pm 5% 1/4W	
Ri19.20	PD14CY2E273JKW	Carbon 27k Ω \pm 5% 1/4W	
Ri21.22	PD14CY2E103JKW	Carbon 10k Ω \pm 5% 1/4W	
Ri23.24	PD14CY2E303JKW	Carbon 30k Ω \pm 5% 1/4W	
Ri25	PD14BY2E224JKW	Carbon 220k Ω \pm 5% 1/4W	
Ri26	PD14CY2E224JKW	Carbon 220k Ω \pm 5% 1/4W	
Ri27.28	PD14BY2E114JKW	Carbon 110k Ω \pm 5% 1/4W	
Ri29~34	PD14CY2E105JKW	Carbon 1M Ω \pm 5% 1/4W	
Ri35	PD14BY2E224JKW	Carbon 220k Ω \pm 5% 1/4W	
Ri36	PD14CY2E224JKW	Carbon 220k Ω \pm 5% 1/4W	
Ri37.38	PD14CY2E105JKW	Carbon 1M Ω \pm 5% 1/4W	
Ri39~42	PD14CY2E221JKW	Carbon 220 Ω \pm 5% 1/4W	
Ri43~46	PD14BY2E563JKW	Carbon 56k Ω \pm 5% 1/4W	
Ri47~54	PD14CY2E105JKW	Carbon 1M Ω \pm 5% 1/4W	
Ri55~58	PD14CY2E221JKW	Carbon 220 Ω \pm 5% 1/4W	
Ri59.60	PD14CY2E563JKW	Carbon 56k Ω \pm 5% 1/4W	
Ri61.62	PD14CY2E105JKW	Carbon 1M Ω \pm 5% 1/4W	
Ri65~68	PD14CY2E104JKW	Carbon 100k Ω \pm 5% 1/4W	
Ri69.70	PD14CY2E563JKW	Carbon 56k Ω \pm 5% 1/4W	
Ri71~74	PD14CY2E334JKW	Carbon 330k Ω \pm 5% 1/4W	
SEMICONDUCTOR			
Qi1.2	V09-0095-05	FET 2SK68A(K)	
Qi3.4	V09-0094-05	FET 2SK68A(N)	
Qi5.6	V30-0149-05	FET 2N5464	
Qi7.8	V09-0098-05	FET 2SK68(L)	
Qi9~16	V09-0097-05	FET 2SK68A(N)	
Qi17.18	V09-0095-05	FET 2SK68A(K)	
POTENTIOMETER			
VR3	R21-5004-05	200k Ω (B) \times 2 TREBLE	
VR4	R21-5003-05	100k Ω (B) \times 2 BASS	
MISCELLANEOUS			
—	J21-1438-04	PC board mounting hardware	●☆
—	F10-0416-14	Shield plate	●☆

Ref. No.	Parts No.	Description	Re- marks
CAPACITOR			
Cs1.2	CE04W1V100EL	Electrolytic 10 μ F 35WV	
Cs3~6	CK45E1H103P	Ceramic 0.01 μ F \pm 100%—0%	
Cs7.8	CE04W1H010BR	Electrolytic 1 μ F 50WV	
Cs9~12	CQ93M1H563J	Mylar 0.056 μ F \pm 5%	
Cs13.14	CQ93M1H562J	Mylar 0.0056 μ F \pm 5%	
Cs15.16	CQ93M1H272J	Mylar 0.0027 μ F \pm 5%	
Cs17.18	CQ93M1H153J	Mylar 0.015 μ F \pm 5%	
Cs19.20	CQ93M1H103J	Mylar 0.01 μ F \pm 5%	
Cs21.22	CQ08S1H101J	Polystyrene 100pF \pm 5%	
Cs23.24	CQ08S1H181J	Polystyrene 180pF \pm 5%	
Cs25.26	CQ08S1H471J	Polystyrene 470pF \pm 5%	
Cs27.28	CQ93M1H222J	Mylar 0.0022 μ F \pm 5%	
Cs29.30	CQ08S1H121J	Polystyrene 120pF \pm 5%	
Cs31.32	CQ08S1H561J	Polystyrene 560pF \pm 5%	
Cs33	CK45E1H103P	Ceramic 0.01 μ F \pm 100%—0%	
RESISTOR			
Rs1.2	PD14BY2E394JKW	Carbon 390k Ω \pm 5% 1/4W	
Rs3.4	PD14BY2E914JKW	Carbon 910k Ω \pm 5% 1/4W	
Rs5.6	PD14BY2E222JKW	Carbon 2.2k Ω \pm 5% 1/4W	
Rs7.8	PD14BY2E681JKW	Carbon 680 Ω \pm 5% 1/4W	
Rs9.10	PD14BY2E563JKW	Carbon 56k Ω \pm 5% 1/4W	
Rs11.12	PD14BY2E222JKW	Carbon 2.2k Ω \pm 5% 1/4W	
Rs13.14	PD14BY2E513JKW	Carbon 51k Ω \pm 5% 1/4W	
Rs15.16	PD14BY2E154JKW	Carbon 150k Ω \pm 5% 1/4W	
Rs17~20	PD14BY2E105JKW	Carbon 1M Ω \pm 5% 1/4W	
Rs21~24	PD14BY2E562JKW	Carbon 5.6k Ω \pm 5% 1/4W	
Rs27~38	RC05GF2H106JKW	Carbon 10M Ω \pm 5% 1/4W	
Rs39~42	PD14BY2E104JKW	Carbon 100k Ω \pm 5% 1/4W	
SEMICONDUCTOR			
Qs1~4	V09-0094-05	FET 2SK68A(1)N	
SWITCH			
S8.9	S32-2012-05	Lever (LOW, HIGH) \times 2	
S10	S32-4006-06	Lever (PRESENCE)	
S11.12	S40-4020-05	Pushbutton(LOW FILTER,HIGH FILTER)	
MISCELLANEOUS			
—	J21-1443-04	Switch mounting hardware	●☆
—	J31-0140-04	Sleeve (20mm) \times 2	●☆

IMPEDANCE SELECTOR (X13-2230-10)

Ref. No.	Parts No.	Description	Re- marks
CAPACITOR			
Ch1	CK45E1H102P	Ceramic 1000pF \pm 100%—0%	
RESISTOR			
Rh1.2	PD14BY2E104JKW	Carbon 100k Ω \pm 5% 1/4W	
Rh3.4	PD14BY2E393JKW	Carbon 39k Ω \pm 5% 1/4W	
SWITCH			
S15	S32-2012-05	Lever (IMPEDANCE)	
MISCELLANEOUS			
—	J21-1441-04	Switch mounting hardware	●☆

DESTINATIONS' PARTS LIST (Model 600 & 650)

Ref. No.	U.S.A. (K)	Canada (P)	PX (U)	Australia (X)	Europe (W)	Scandinavia (L)	England (T)	South Africa (S)	Other Area (M ₁)	Model 650 (M ₂)	Description
C301	C91-0001-05	C91-0001-05	CK45E3D103 PMU	CK45E3D103 PMU	CK45E3D103 PMU	CK45E3D103 PMU	CK45E3D103 PMU	—	CK45E3D103 PMU	CK45E3D103 PMU	Capacitor 0.01μ
302	A20-0998-02	A20-0998-02	A20-0998-02	A20-0998-02	A20-0998-02	A20-0998-02	A20-1000-02	—	A20-0998-02	A20-1076-02	Panel ass'y ☆
—	A20-0999-02	A20-0999-02	A20-0999-02	A20-0999-02	A20-0999-02	A20-0999-02	A20-1001-02	—	A20-0999-02	A20-1077-02	Panel ● ☆
—	A23-0615-02	A23-0616-02	A23-0616-02	A23-0616-02	A23-0617-12	A23-0617-12	A23-0619-12	—	A23-0616-02	A23-0616-02	Rear panel ● ☆
—	B07-0131-04	B07-0131-04	B07-0131-04	B07-0131-04	B07-0131-04	B07-0131-04	B07-0131-04	—	B07-0131-04	B07-0197-04	Dress window ring ● ☆
—	B40-1315-04	B40-1315-04	B40-1320-04	B40-1316-04	B40-1317-04	B40-1318-04	B40-1319-04	—	B40-1320-04	B40-1412-04	Model name plate ● ☆
—	B42-0358-04	B42-0358-04	—	—	B42-0024-04	—	—	—	—	—	SEV sticker x 2 ●
—	B42-0439-04	B42-0439-04	—	—	—	—	—	—	—	—	Caution sticker ●
—	B46-0055-10	B46-0055-10	B46-0051-00	—	—	—	—	—	—	—	Caution sticker (Fuse) ●
—	B50-1451-00	B50-1451-00	B50-1451-00	B50-1451-00	B50-1451-00	B50-1451-00	B50-1452-00	—	B50-1451-00	B50-1543-00	Warranty card ●
—	B58-0043-00	B58-0043-00	B58-0139-00	B58-0003-00	B58-0156-00	—	—	—	B58-0003-00	B58-0003-00	Warranty card (TRIO) ☆
—	—	—	—	—	—	—	—	—	—	—	Instruction manual ●
—	—	—	—	—	—	—	—	—	—	—	Power voltage selector caution card ●
—	—	—	—	—	—	—	—	—	—	—	Carton case caution card ●
—	—	—	—	—	—	—	—	—	—	—	Power supply caution card ●
—	—	—	—	—	—	—	—	—	—	—	Spare fuse caution card ●
—	—	—	—	—	—	—	—	—	—	—	Power cord caution card ●
—	—	—	—	—	—	—	—	—	—	—	KENWOOD service stations' list ●
—	—	—	—	—	—	—	—	—	—	—	Switch stopper (power voltage selector) ☆
—	E08-0225-05	E08-0225-05	E08-0225-05	E08-0225-05	E08-0225-05	—	—	—	E08-0225-05	E08-0225-05	AC outlet x 3
—	—	—	—	—	E20-0424005 x 2	E20-0424-05	E20-0424-05	—	—	—	Terminal plate
—	E30-0181-05	E30-0181-05	E30-0515-05	E30-0185-05	E30-0580-05	E30-0292-05	—	—	E30-0515-05	E30-0515-05	Power cord
—	—	—	—	—	—	—	—	—	—	—	Fuse 4A
—	—	—	—	—	—	—	—	—	—	—	Fuse 2.5AT
—	F05-8022-05	F05-8022-05	F05-8021-05	F05-8021-05	F05-2525-05	F05-2525-05	F05-2525-05	—	F05-8021-05	F05-8021-05	Fuse 8A
—	—	—	—	—	—	—	—	—	—	—	Fuse with lead wire 8A
—	—	—	—	—	—	—	—	—	—	—	Fuse 5AT SEMKO
—	—	—	—	—	—	—	—	—	—	—	Capacitor cap
—	—	—	—	—	—	—	—	—	—	—	Carton case (inside) ☆
—	H01-1555-04	H01-1556-04	H01-1557-04	H01-1555-04	H01-1557-04	H01-1557-04	H01-1558-04	—	H01-1555-04	H01-1593-04	Carton case (outside) ☆
—	—	H03-0517-04	—	—	H03-0518-04	H03-0518-04	H03-0519-04	—	—	—	Protection cover
—	H20-0394-04	H20-0394-04	H20-0394-04	H20-0394-04	H20-0394-04	H20-0394-04	H20-0394-04	—	H20-0416-04	H20-0394-04	Polyethylene bag
—	H25-0029-04	H25-0029-04	H25-0029-04	H25-0029-04	H25-0029-04	H25-0029-04	H25-0029-04	—	H25-0029-04	H25-0029-04	Rust preventing paper
—	—	—	—	—	—	—	—	—	—	—	Leg x 4
—	J02-0073-04	J02-0049-14	J02-0049-14	J02-0049-14	J02-0049-14	J02-0049-14	J02-0049-14	—	J02-0049-14	J02-0049-14	Fuse holder
—	J13-0033-15	J13-0033-15	J13-0033-15	J13-0033-15	J13-0033-05	J13-0031-05	J13-0033-15	—	J13-0033-05	J13-0033-05	Power cord bushing
—	J41-0034-05	J41-0034-05	J41-0033-05	J41-0024-15	J41-0033-05	J41-0024-15	J41-0024-15	—	J41-0033-05	J41-0033-05	Cord band
—	—	—	—	—	—	—	—	—	—	—	Power transformer x 2
—	L01-1081-05	L01-1081-05	L01-1085-05	L01-1085-05	L01-1086-05	L01-1082-05	L01-1087-05	—	L01-1085-05	L01-1085-05	Pushbutton switch (POWER)
S14	S40-2063-05	S40-2063-05	S40-2064-05	S40-2064-05	S40-2070-05	S40-2070-05	S40-2070-05	—	S40-2064-05	S40-2064-05	Slide switch (power voltage selector) x 2
—	—	—	S31-2001-05	S31-2001-05	S31-2001-05	—	—	—	S31-2001-05	S31-2001-05	Power supply unit (A) ☆
—	X00-1700-10	X00-1700-10	X00-1700-81	X00-1700-81	X00-1700-61	X00-1700-61	X00-1700-61	—	X00-1700-81	X00-1700-81	

DESTINATIONS' PARTS LIST (Model 500)

Ref. No.	U.S.A. (K)	Canada (P)	PX (U)	Australia (X)	Europe (W)	Scandinavia (L)	England (T)	South Africa (S)	Other Area (M)	Description	
C301	C91-0001-05	C91-0001-05	CK45E3D103 PMU	CK45E3D103 PMU	CK45E3D103 PMU	CK45E3D103 PMU	CK45E3D103 PMU	—	CK45E3D103 PMU	Capacitor 0.01μF	☆
302	A20-1002-02	A20-1002-02	A20-1002-02	A20-1002-02	A20-1002-02	A20-1002-02	A20-1003-02	—	A20-1002-02	Panel ass'y	☆
—	A20-1005-02	A20-1005-02	A20-1005-02	A20-1005-02	A20-1005-02	A20-1005-02	A20-1008-02	—	A20-1005-02	Panel	● ☆
—	A23-0621-02	A23-0621-02	A23-0622-02	A23-0622-02	A23-0623-12	A23-0624-12	A23-0625-12	—	A23-0622-02	Rear panel	● ☆
—	B40-1321-04	B40-1321-04	B40-1326-04	B40-1322-04	B40-1323-04	B40-1324-04	B40-1325-04	—	B40-1326-04	Model name plate	● ☆
—	B42-0358-04	B42-0358-04	—	—	B42-0024-02	—	—	—	—	SEV sticker x 2	●
—	B42-0517-04	B42-0517-04	—	—	—	—	—	—	—	Caution sticker	●
—	B46-0056-00	B46-0055-10	B46-0051-00	—	—	—	—	—	—	Caution sticker (Fuse)	●
—	B50-1453-00	B50-1453-00	B46-0050-00	—	—	—	—	—	—	Warranty card (TRIO)	●
—	B58-0043-00	B58-0043-00	B58-0139-00	B50-1453-00	B58-0156-00	B50-1453-00	B50-1454-04	—	B50-1453-00	Instruction manual	☆
—	—	—	—	—	—	—	—	—	B58-0003-00	Power voltage selector caution card	●
—	—	—	—	—	B58-0144-00	—	—	—	B58-0101-00	Carton case caution card	●
—	—	—	—	—	B58-0146-00	—	—	—	B58-0101-00	Power supply caution card	●
—	—	—	—	—	B59-0018-00	—	B58-0214-04	—	B58-0108-00	Spare fuse caution card	●
—	—	—	—	—	—	—	—	—	—	Power cord caution card	●
—	—	—	—	—	—	—	—	—	—	KENWOOD service stations' list	●
—	—	—	—	—	—	—	—	—	D32-0077-04	Switch stopper (power voltage selector)	☆
—	E08-0225-05	E08-0225-05	E08-0225-05	E08-0225-05	E08-0225-05	—	—	—	—	AC outlet x 3	—
—	—	—	—	—	E20-0424-05	E20-0424-05	E20-0424-05	—	—	Terminal plate	—
—	E30-0181-05	E30-0181-05	E30-0515-05	E30-0185-05	E30-0580-05	E30-0292-05	—	—	E30-0515-05	Power cord	—
—	—	—	—	—	—	—	—	—	F05-4022-05	Fuse 4A	—
—	—	—	—	—	—	—	—	—	F05-2525-05	Fuse 2.5AT	—
—	F05-8022-05	F05-8022-05	F05-8021-05	F05-8021-05	—	—	—	—	F05-8021-05	Fuse 8A	—
—	—	—	—	—	—	—	—	—	—	Fuse with lead wire 8A	—
—	—	—	—	—	—	—	—	—	—	Fuse 5AT SEMKO	—
—	—	—	—	—	—	—	—	—	—	Capacitor cap	—
—	H01-1559-04	H01-1560-04	H01-1561-04	H01-1559-04	H01-1561-04	H01-1561-04	H01-1562-04	—	H01-1559-04	Carton case (inside)	☆
—	—	H03-0520-04	—	—	H03-0521-04	H03-0521-04	H03-0522-04	—	—	Carton case (outside)	☆
—	H20-0394-04	H20-0394-04	H20-0394-04	H20-0394-04	H20-0394-04	H20-0394-04	H20-0394-04	—	H20-0416-04	Protection cover	—
—	H25-0029-04	H25-0029-04	H25-0029-04	H25-0029-04	H25-0029-04	H25-0029-04	H25-0029-04	—	H25-0029-04	Polyethylene bag	—
—	x 1	x 1	x 2	x 2	x 2	x 1	x 1	—	H40-0004-04	Rust preventing paper	—
—	—	—	—	—	—	—	—	—	J20-0049-14	Leg x 4	—
—	J02-0073-04	J02-0049-14	J02-0049-14	J02-0049-14	J02-0049-14	J02-0049-14	J02-0049-14	—	J13-0033-15	Fuse holder	—
—	J13-0033-15	J13-0033-15	J13-0033-15	J13-0033-15	J13-0031-05	J13-0031-05	J13-0031-05	—	J41-0033-05	Power cord bushing	—
—	J41-0034-05	J41-0034-05	J41-0033-05	J41-0024-15	J41-0033-05	J41-0033-05	J41-0024-15	—	—	Cord band	—
—	—	—	—	—	—	—	—	—	—	Power transformer x 2	—
—	L01-1091-05	L01-1091-05	L01-1095-05	L01-1095-05	L01-1096-05	L01-1092-05	L01-1097-05	—	L01-1095-05	Power transformer x 2	—
—	S40-2063-05	S40-2063-05	S40-2064-05	S40-2064-05	S40-2070-05	S40-2070-05	S40-2070-05	—	S40-2064-05	Pushbutton switch (POWER)	—
S14	—	—	—	—	—	—	—	—	S31-2001-05	Slide switch (power voltage selector) x 2	—
—	X00-1700-11	X00-1700-11	X00-1700-82	X00-1700-82	X00-1700-62	X00-1700-62	X00-1700-62	—	X00-1700-82	Power supply unit (A)	☆

PC BOARD

▼ POWER SUPPLY (A) (X00-1700-10)

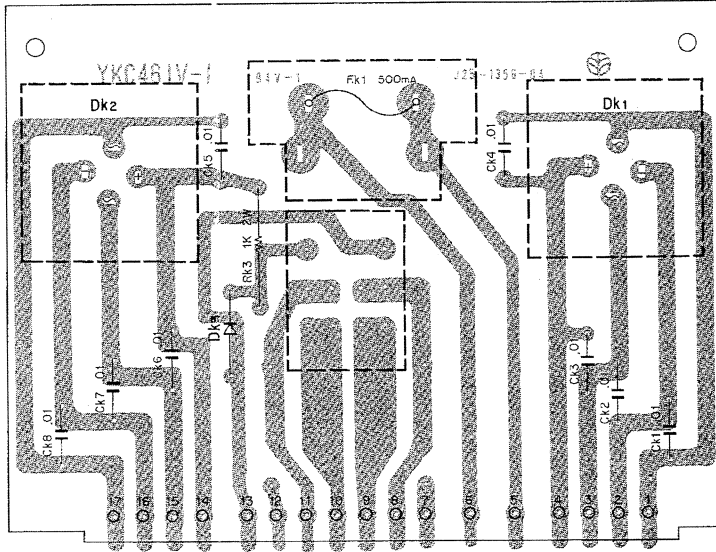

Dk1,2: M4C-5, Dk3: V06B

▼ IMPEDANCE SELECTOR (X13-2230-10)

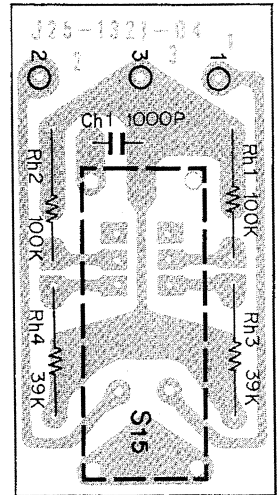

▼ POWER SUPPLY (B) (X00-1720-10)

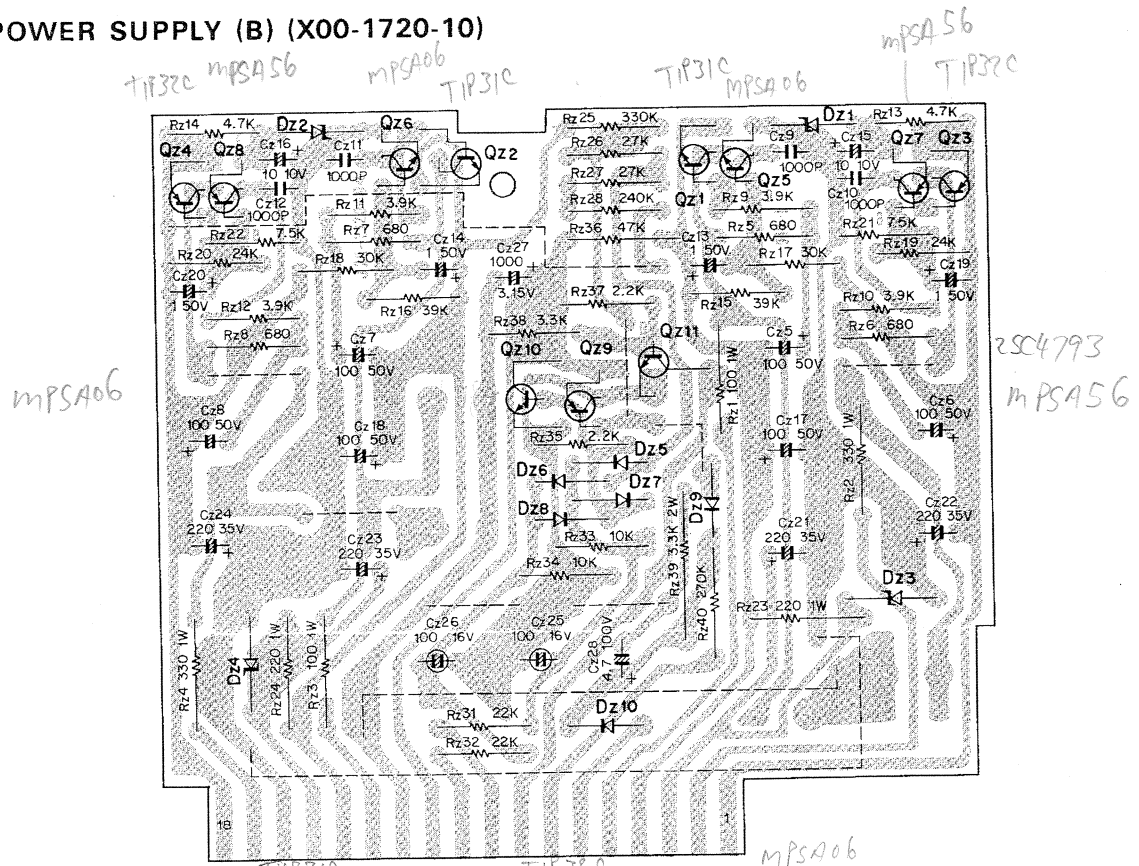

Qz1,2: 2SC1419(C), Qz3,4: 2SA755(C), Qz5,6: 2SC1222(E), Qz7,8: 2SA640(E), Qz9: 2SA620 WL5, Qz10: 2SC1416(BL) or (GR), Qz11: 2SD415(Q) or (R), Dz1,2: EQA01-06S, Dz3,4: EQB01-28, Dz5~9: 1S2076A, Dz10: V06B

PC BOARD

▼ POWER AMP (X07-1440-00)

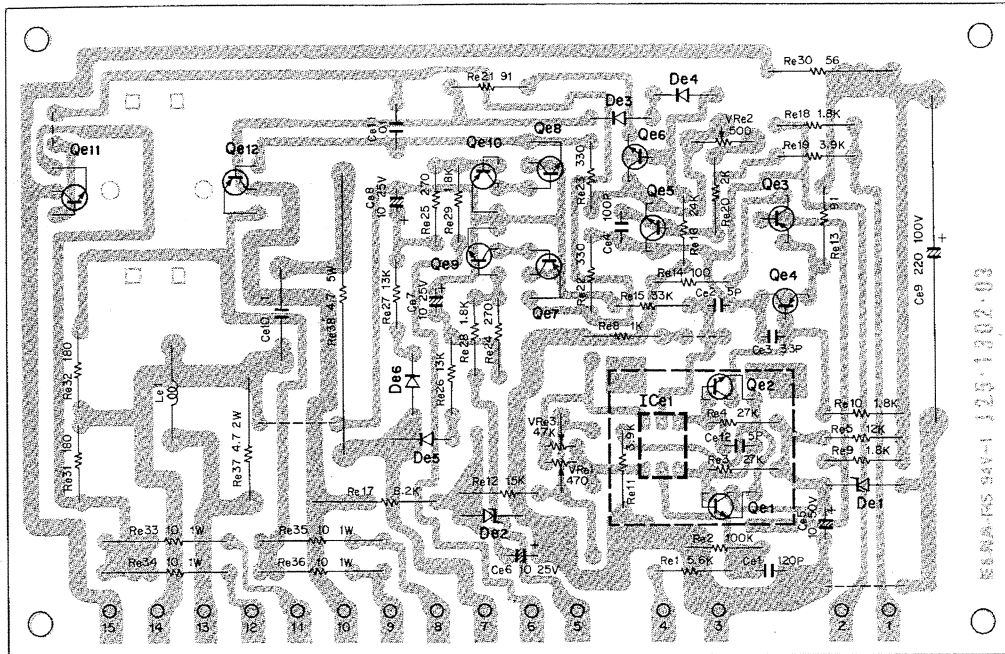

Qe1,2: 2SC140(U) or (E), Qe3,4: 2SA810(G) or (B), Qe5: 2SC1746(GR), Qe6: 2SC1452(G) or (B), Qe7,10: 2SA673A(B) or (C), Qe8,9: 2SC1213A(B) or (C), Qe11: 2SD381(2)(L), Qe12: 2SB536(2)(L), ICe1: 2SK58, De1: EOA01-24, De2: YZ140, De3~6: 1S2076A

▼ PREAMP (X08-1470-01)

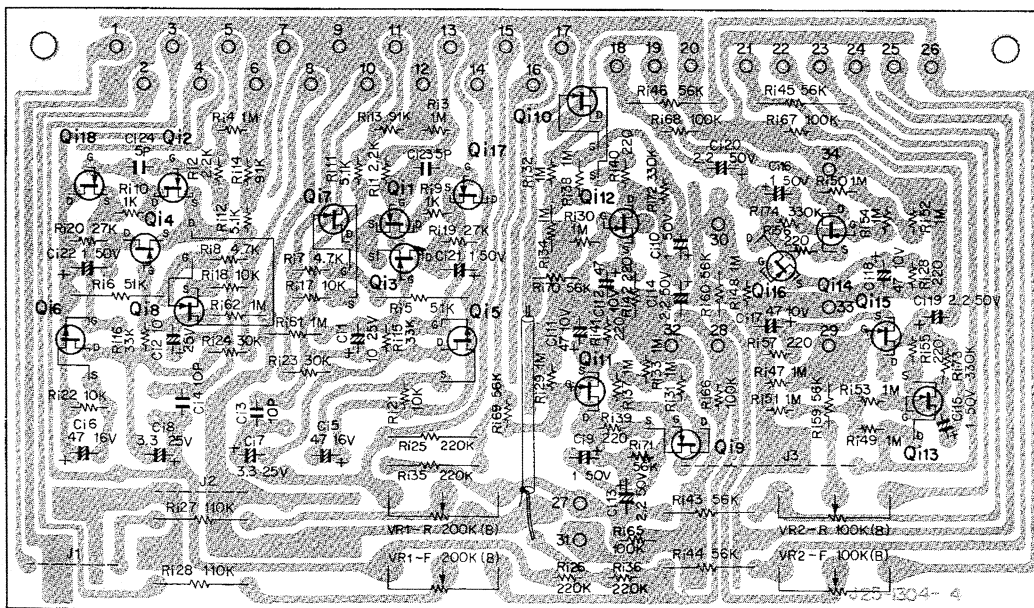

Qi1,2,17,18: 2SK68A(K), Qi3,4,9~16: 2SK68A(N), Qi5,6: 2N5464, Qi7,8: 2SK68A(L)

PC BOARD / SEMICONDUCTOR SUBSTITUTIONS & LEADS

▼ TONE AMP (X11-1310-00)

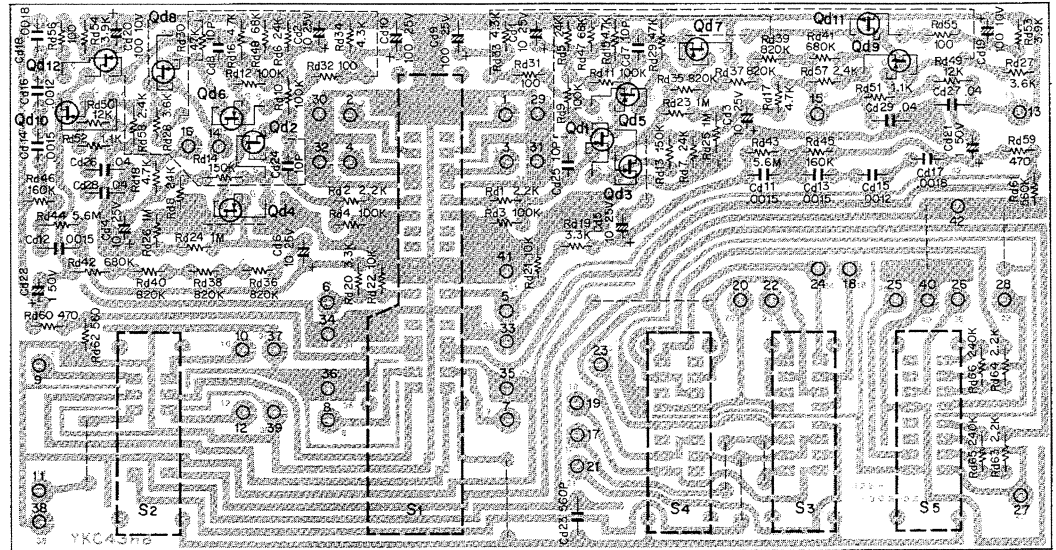

Qd1,2: 2SK68A(K), Qd3,4: 2SK68A(M), Qd5~8: 2SK68A(L) or (M), Qd9,10: 2SK68A(1)N,
Qd11,12: 2N5465

▼ FILTER (X12-1130-10)

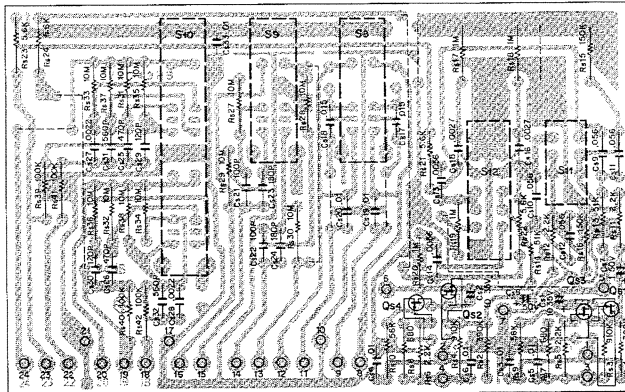

Qs1~4: 2SK68A(1)N

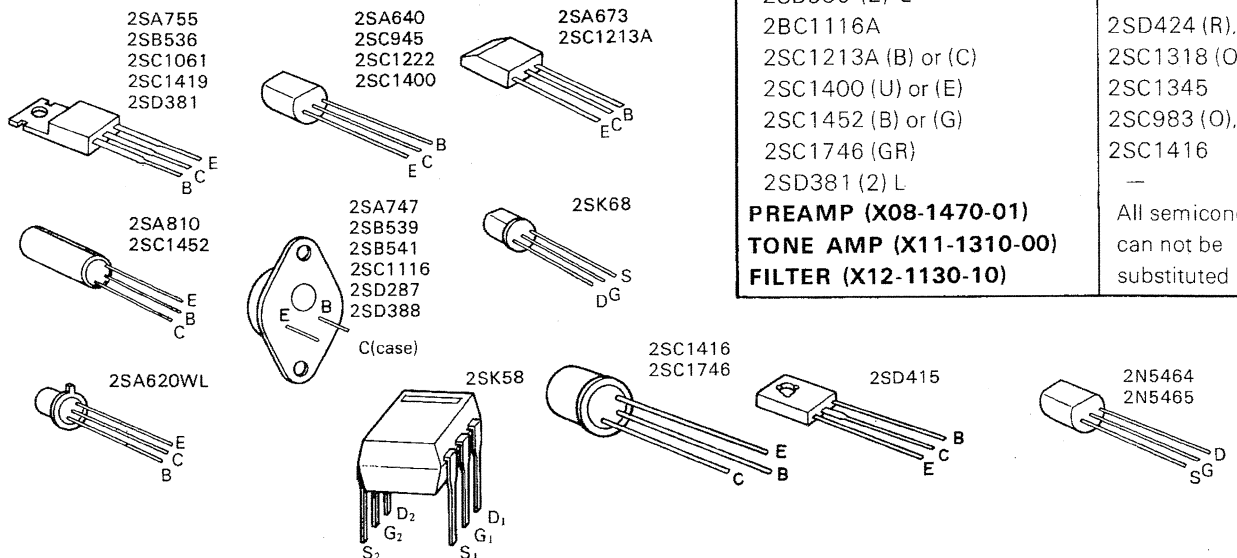

SEMICONDUCTOR NAME	SEMICONDUCTOR SUBSTITUTIONS
POWER SUPPLY (X00-1720-10)	
2SA620WL5	2SA640
2SA640 (E)	2SA763, 2SA620
2SA755 (C)	2SA489
2SC1222 (E)	2SC1345 (E)
2SC1416 (BL) or (GR)	2SC1213A (B) or (C)
2SC1419 (C)	2SC1061
2SD415 (Q) or (R)	2SC1212A (B), (C)
POWER AMP (X07-1440-00)	
2SK58	—
2SA673A (B) or (C)	2SA720 (Q), (C)
2SA747A	2SB554 (R), (O)
2SA810 (B) or (G)	2SA912 (R), (S)
2SB536 (2) L	—
2BC1116A	2SD424 (R), (O)
2SC1213A (B) or (C)	2SC1318 (O), (R)
2SC1400 (U) or (E)	2SC1345
2SC1452 (B) or (G)	2SC983 (O), (Y)
2SC1746 (GR)	2SC1416
2SD381 (2) L	—
PREAMP (X08-1470-01)	All semiconductors
TONE AMP (X11-1310-00)	can not be
FILTER (X12-1130-10)	substituted

SCHEMATIC DIAGRAM (Model 600, 650)

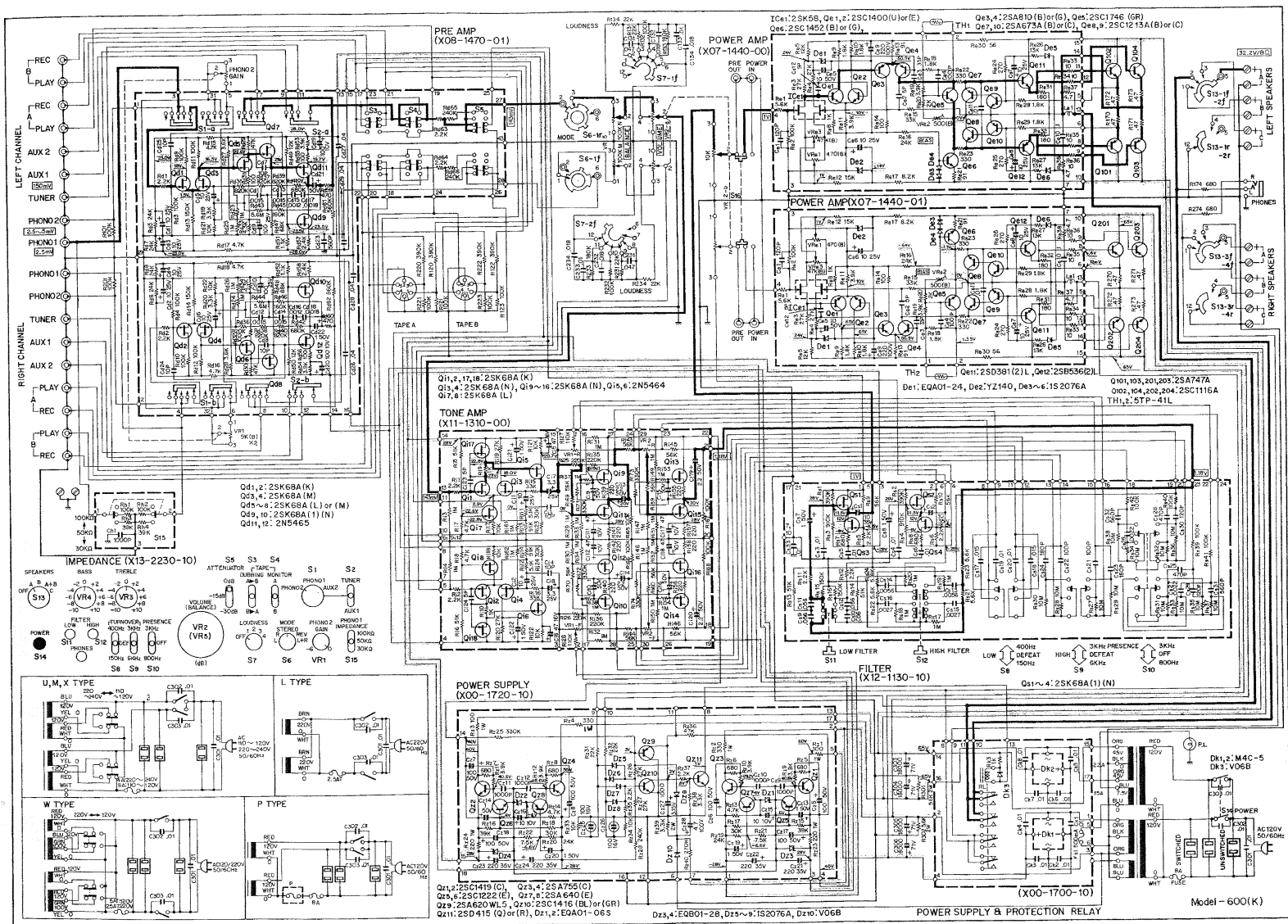

DUCTOR
PTIONS

2SA620

(E)

(A) (B) or (C)

(A) (B) (C)

(Q) (C)

(R) (O)

(R) (S)

(R) (O)

(O) (R)

(O) (Y)

ductors

e

ed

D

© 1975 by Sanyo Electric Co., Ltd.
All rights reserved by Sanyo

SCHEMATIC DIAGRAM (Model 500)

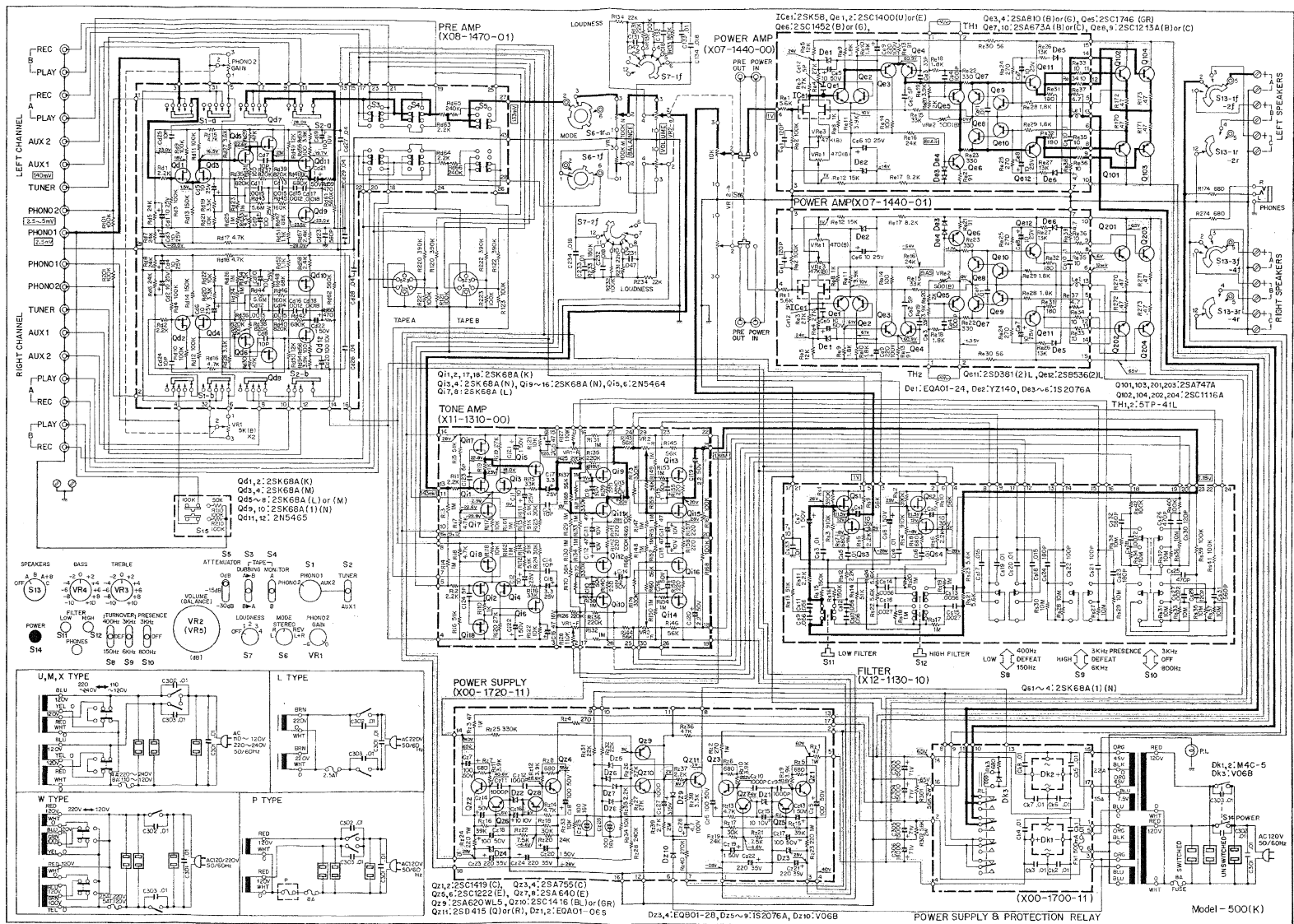

SPECIFICATIONS

Model 600, 650

POWER AMPLIFIER

Power Output:	130 watts per channel minimum, RMS at 8 ohms from 20 Hz to 20,000 Hz with no more than 0.08% total harmonic distortion
Both Channel Driven:	135 watts per channel into 8 ohms at 1,000 Hz 150 watts per channel into 4 ohms at 1,000 Hz
Dynamic Power Output:	640 watts into 4 ohms
Total Harmonic Distortion:	0.08% at rated power into 8 ohms 0.03% at 1 watt power into 8 ohms from 20 Hz to 20,000 Hz
Intermodulation Distortion:	0.08% at rated power into 8 ohms (60 Hz : 7,000 Hz 4 : 1) 0.03% at 1 watt power into 8 ohms
Power Bandwidth:	5 Hz ~ 50,000 Hz
Frequency Response:	DC to 70,000 Hz +0 dB, -1.0 dB
Damping Factor:	50 at 8 ohms
Speaker Impedance:	Accept 4 ohms to 16 ohms
Signal to Noise Ratio (IHF A):	115 dB (Short circuited)
Input Sensitivity, Impedance:	1.0V 100 kohms

PREAMPLIFIER SECTION

Input Sensitivity, Impedance & S/N (IHF A)	
Phono 1:	2.5mV 30,50, 100 kohms 76 dB (5 mV)
Phono 2:	2.5~ 5.0 mV 50 kohms 76 dB (5 mV)
Tuner:	150mV 50 kohms 90 dB
Aux:	150mV 50 kohms 90 dB
Tape Play:	150mV 50 kohms 90 dB
Maximum Input Level:	
Phono:	220mV (rms) T.H.D. 0.08% at 1,000 Hz
Output Voltage	
Tape Rec (pin):	150mV
(DIN):	30mV 80 kohms
Frequency Response	
Phono:	RIAA standard curve ± 0.2 dB
Aux, Tape Play:	5 Hz ~ 50,000 Hz ± 0 -1.0 dB
Tone Controls	
Bass	150 Hz: ± 7.5 dB at 40 Hz 400 Hz: ± 7.5 dB at 100 Hz
Treble	3 kHz: ± 7.5 dB at 10,000 Hz 6 kHz: ± 7.5 dB at 20,000 Hz
Loudness Control (-30 dB):	1: +2 dB at 100 Hz 2: +4 dB at 100 Hz 3: +6 dB at 100 Hz 4: +8 dB at 100 Hz +3 dB at 10,000 Hz
Low Filter:	40 Hz, 12 dB/oct
High Filter:	8,000 Hz, 12 dB/oct
Presence:	800 Hz: +6 dB 3 kHz: +6 dB

GENERAL

Power Requirement:	50/60 Hz 110~120V, 220~240V
Power Consumption:	790 watts at full power
AC outlet:	Switched 2, Unswitched 1
Dimensions:	W 17-5/16" (440 mm) H 6-1/16" (154 mm) D 15-9/32" (388 mm)
Weight (Net):	46.9 lbs. (21.3 kg)

Model 500

POWER AMPLIFIER

Power Output:	100 watts per channel minimum, RMS at 8 ohms from 20 Hz to 20,000 Hz with no more than 0.08% total harmonic distortion
Both Channel Driven:	110 watts per channel into 8 ohms at 1,000 Hz 135 watts per channel into 4 ohms at 1,000 Hz
Dynamic Power Output:	520 watts into 4 ohms
Total Harmonic Distortion:	0.08% at rated power into 8 ohms 0.03% at 1 watt power into 8 ohms from 20 Hz to 20,000 Hz
Intermodulation Distortion:	0.08% at rated power into 8 ohms (60 Hz : 7,000 Hz 4 : 1) 0.03% at 1 watt power into 8 ohms
Power Bandwidth:	5 Hz ~ 50,000 Hz
Frequency Response:	DC to 70,000 Hz +0 dB, -1.0 dB
Damping Factor:	50 at 8 ohms
Speaker Impedance:	Accept 4 ohms to 16 ohms
Signal to Noise Ratio (IHF A):	110 dB (Short circuited)
Input Sensitivity, Impedance:	1.0V 100 kohms

PREAMPLIFIER SECTION

Input Sensitivity, Impedance & S/N (IHF A)	
Phono 1:	2.5mV 30, 50 kohms 76 dB (5 mV)
Phono 2:	2.5~ 5.0 mV 50 kohms 76 dB (5 mV)
Tuner:	140mV 50 kohms 90 dB
Aux 1,2:	140mV 50 kohms 90 dB
Tape Play A, B:	140mV 50 kohms 90 dB
Maximum Input Level:	
Phono:	220mV (rms) T.H.D. 0.08% at 1,000 Hz
Output Voltage	
Tape Rec (pin):	140mV
(DIN):	30mV 80 kohms
Frequency Response	
Phono:	RIAA standard curve ± 0.2 dB
Aux, Tape Play:	5 Hz ~ 50,000 Hz ± 0 -1.0 dB
Tone Controls	
Bass	150 Hz: ± 7.5 dB at 40 Hz 400 Hz: ± 7.5 dB at 100 Hz
Treble	3 kHz: ± 7.5 dB at 10,000 Hz 6 kHz: ± 7.5 dB at 20,000 Hz
Loudness Control (-30 dB):	1: +2 dB at 100 Hz 2: +4 dB at 100 Hz 3: +6 dB at 100 Hz 4: +8 dB at 100 Hz +3 dB at 10,000 Hz
Low Filter:	40 Hz, 12 dB/oct
High Filter:	8,000 Hz, 12 dB/oct
Presence:	800 Hz: +6 dB 3 kHz: +6 dB

GENERAL

Power Requirement:	50/60 Hz 110~120V, 220~240V
Power Consumption:	680 watts at full power
AC outlet:	Switched 2, Unswitched 1
Dimensions:	W 17-5/16" (440 mm) H 6-1/16" (154 mm) D 15-9/32" (388 mm)
Weight (Net):	44.4 lbs. (20.2 kg)

KENWOOD ELECTRONICS, INC.

- 15777 SOUTH BROADWAY, GARDENA, CALIFORNIA 90248 U.S.A.
- 72-02 51ST AVENUE, WOODSIDE. N.Y. 11377 U.S.A.

TRIO-KENWOOD ELECTRONICS, N.V.

- HARENSESTEENWEG, 484. 1800 VILVOORDE, BELGIUM.

TRIO-KENWOOD ELECTRONICS, GmbH.

- 6056 HEUSENSTAMM, RUDOLF-BRAAS-STR. 20, WEST GERMANY.

TRIO-KENWOOD CORPORATION

- 3-6-17 AOBADAI, MEGURO-KU, TOKYO, JAPAN.