

COMPUTER CONTROLLED AM/FM STEREO SYNTHESIZER TUNER

T-7X/7LX

SERVICE MANUAL

KENWOOD

KENWOOD CORPORATION

©1986-10 PRINTED IN JAPAN
B51-3065-00(T)2090

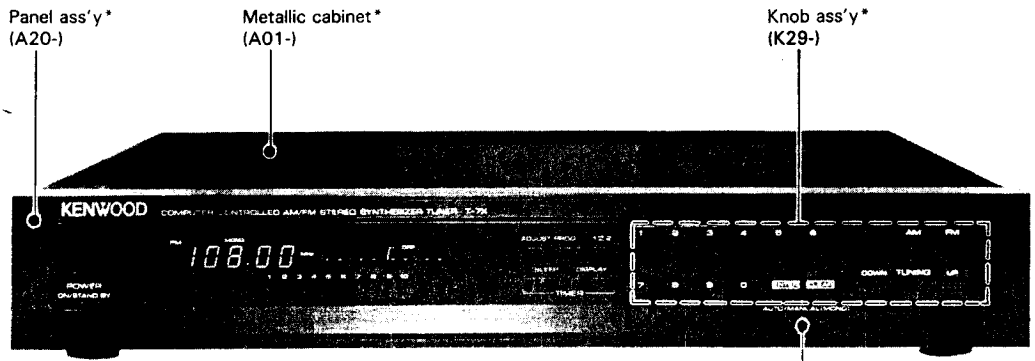

For Service Manuals Contact
MAURITRON TECHNICAL SERVICES
 8 Cherry Tree Rd, Chinnor
 Oxon OX9 4QY
 Tel: 01844-351694 Fax: 01844-352554
 Email: enquiries@mauritron.co.uk

Knob (Button)
 (K27-1338-04)

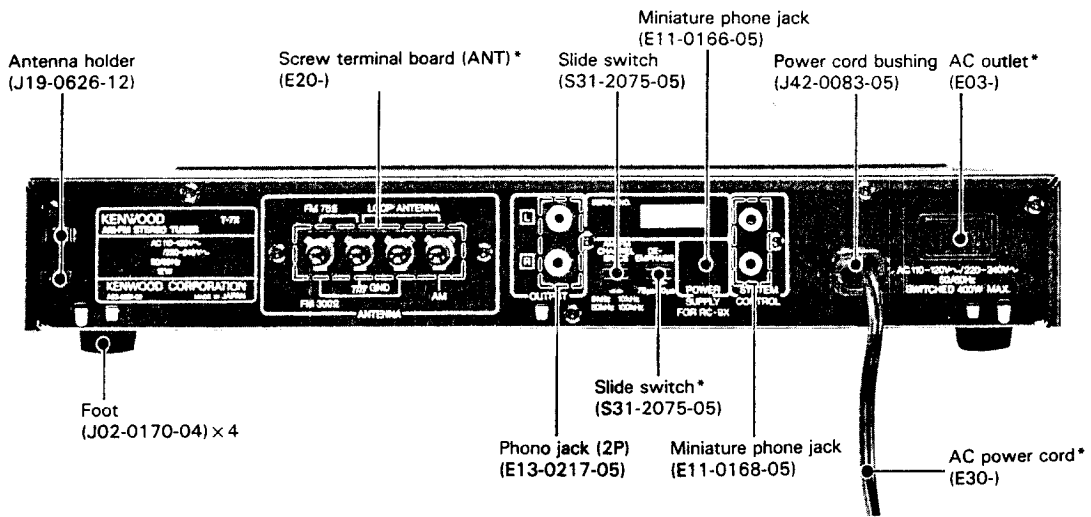

* Refer to Parts List on page 19.

Photo is T-7X.

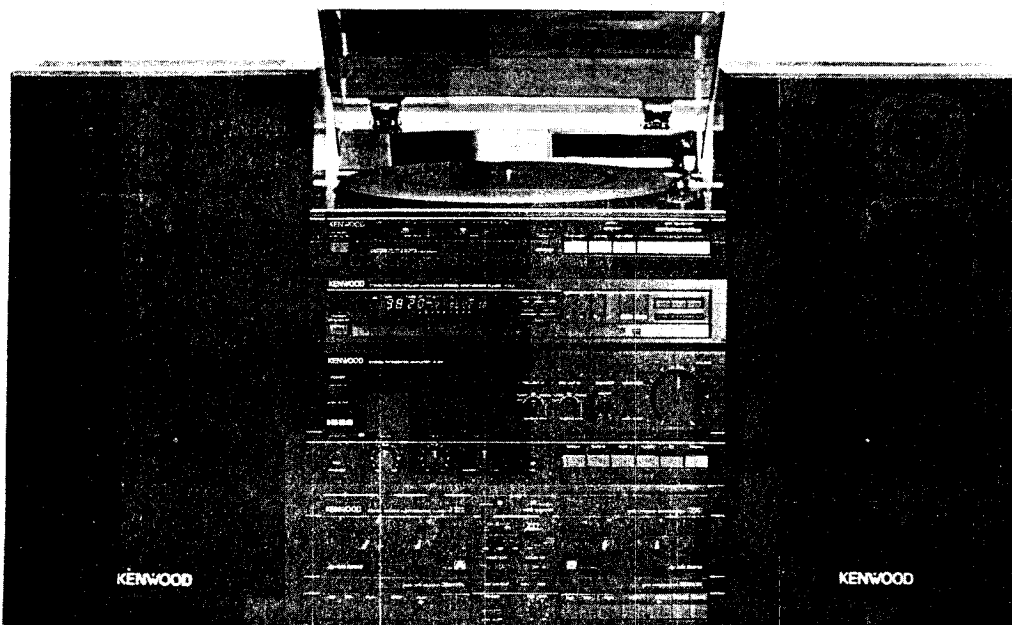

In order of top photo:
 P-5X
 T-7LX
 A-5X
 X-3WX
 S-5X (SPEAKERS)

Photo is MIDI M-50X.

System configuration and carton box (for system packing).

The system configuration and system packing carton box except speakers are as follows.

SYSTEM	AMP.	TUNER	CASSETTE DECK	TURNTABLE	SPEAKER	CARTON BOX
M-30	A-3X	T-3LX/3X	X-3WX	P-3X	S-3X	H03-0878-04
M-40	A-3X	T-7LX/7X	X-3WX	P-5X	S-3X	—
M-50	A-5X	T-7LX/7X	X-5WX	P-5X	S-5X	H03-0879-04
M-50X	A-5X	T-7LX/7X	X-3WX	P-5X	S-5X	—
M-70	A-7X	T-7LX/7X	X-7WX	P-7X	S-7VX	H03-0880-04

DISASSEMBLY FOR REPAIR

How to remove the switch unit

1. The switch unit (X13-5070-52) can be removed when its fixing pawls are removed from the front panel (1).
2. The escutcheon and the dial assembly can be removed when the escutcheon's pawls are removed from the P.C. board (2).
3. The power switch unit can be removed when its fixing pawls are removed from the front panel (3).

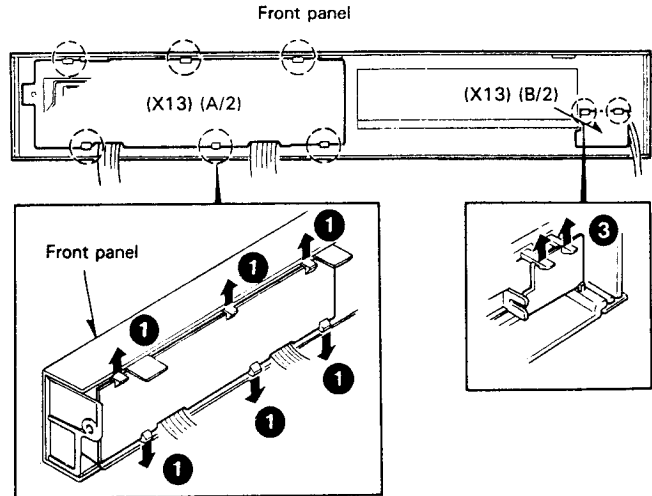

For Service Manuals Contact
MAURITRON TECHNICAL SERVICES
 8 Cherry Tree Rd, Chinnor
 Oxon OX9 4QY
 Tel:- 01844-351694 Fax:- 01844-352554
 Email:- enquiries@mauritron.co.uk

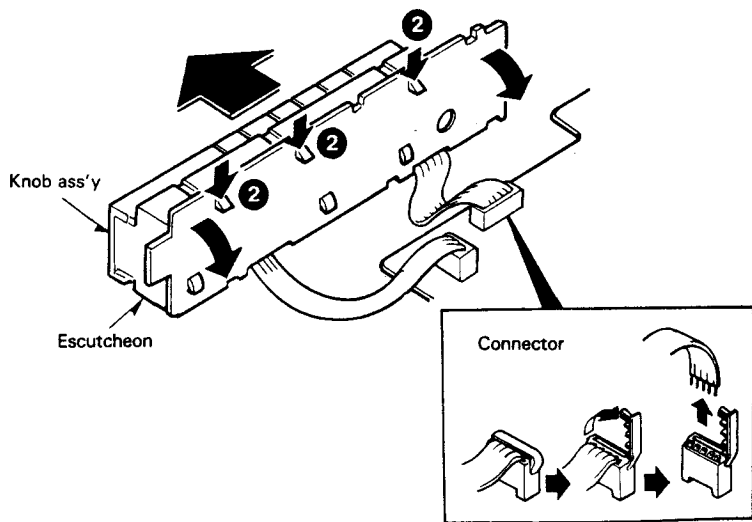

Removing the front panel

- For removing the front panel, extend the FIP retaining claws to the right and left and remove the FIP backward (4). Then remove the front panel while depressing the front panel bottom claws (5).

Fitting the ground plate

- A grounding plate is fitted from the bottom plate side in the lower middle part of the front panel as a measure against static electricity. Exercise care at the time of removal of the front panel, as the tip of the grounding plate is inserted into the gap between the aluminium portion and the molded portion of the front panel (6).

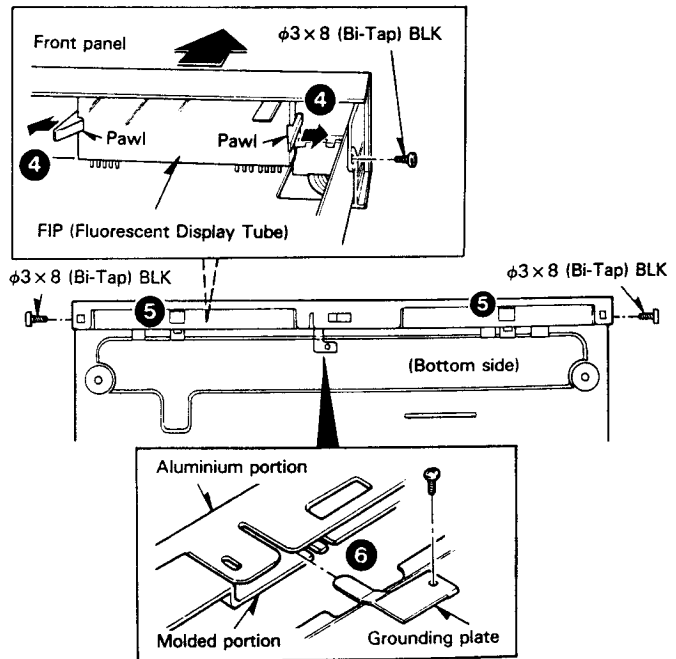

DISASSEMBLY FOR REPAIR/BLOCK DIAGRAM

How to remove the P.C. board (X05) (A/2)

1. Remove two screws on the P.C. board (1).
2. Remove one unit holder (2).
3. Remove three rear panel fixing screws (3).
4. Raise the P.C. board upward together with the rear panel (4).

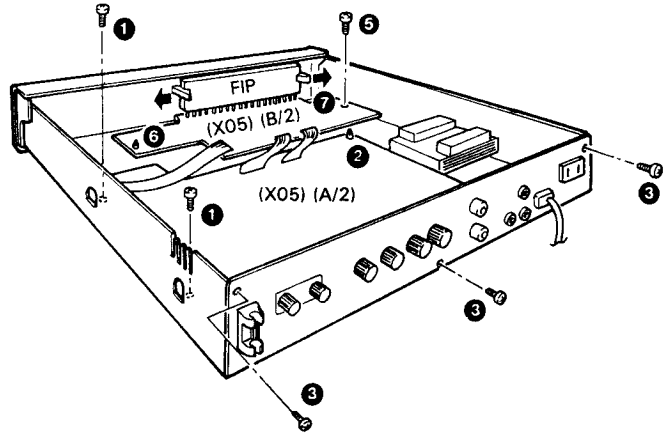

How to remove the P.C. board (X05) (B/2)

1. Remove one screw on the P.C. board (5).
2. Remove one unit holder (6).
3. Remove the FIP from the pawls of the panel (7).
4. Raise the P.C. board upward (8).

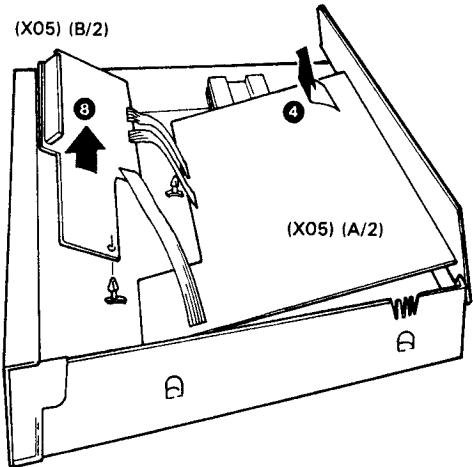

BLOCK DIAGRAM

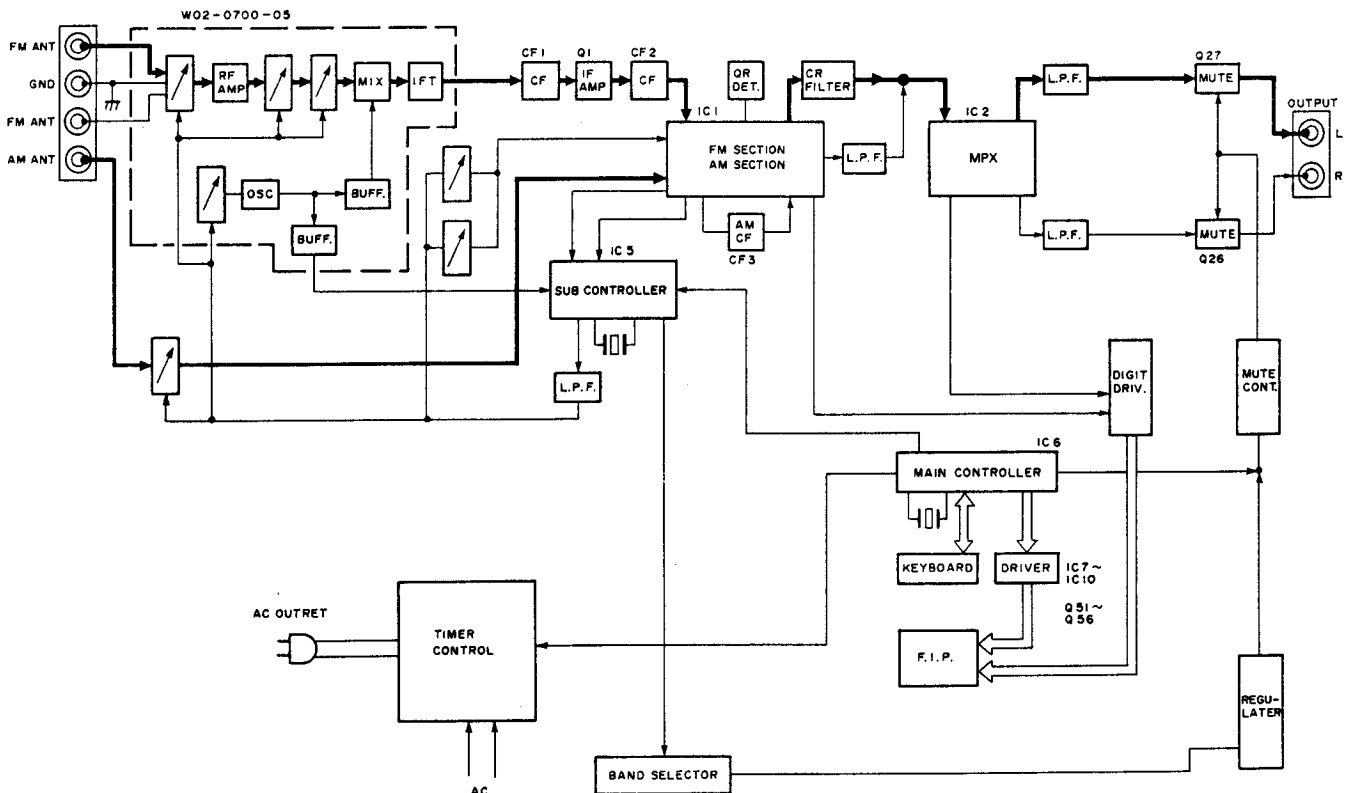

CIRCUIT DESCRIPTION

Function of components

Tuner unit (X05-3252-71)

Components	Use/Function	Operation/Condition/Interchangeability
IC1	AM/FM tuner (LA1265)	FM : IF AMP, Quadrature detection, AF pre-amp., tuning indicator, signal meter output AM : RF amp., oscillation, mixer, IF AMP. detection, AGC, OSC buffer, tuning indicator, signal meter output
IC2	MPX (AN7470)	For FM stereo
IC5	PLL frequency synthesizer (LM7001)	
IC6	Microcomputer (μ PD7516HCW-269)	
IC7 ~ 10	FIP driver (LB1294)	
Q2	FM IF amp.	10.7MHz amp.
Q4	AM-FM switch	AM at switch OFF
Q5	Buffer	Impedance converter
Q6, Q7	AM RF select	RF selection of LW, MW
Q8, Q9	AM OSC select	OSC selection of LW, MW
Q10, Q11	L.P.F. select	L.P.F. selection of LW, MW
Q12, Q13	L.P.F.	L.P.F. of PLL
Q16 ~ 18	Band + B selector	ON/OFF with the control signal from LM7001
Q25	Inversion amp.	Auto stop control
Q26, 27	Mute switch	Muting during function selection
Q28	Mute driver	
Q29, 30	Mute control	
Q36	Mute control	Muting control at power OFF
Q37	A.V.R.	+12V
Q38	Power driver	ON/OFF of the +12V line
Q39	Power control	Power ON/OFF control
Q40	A.V.R.	+5V
Q52	Display driver	ST display (FIP)
Q53		TUNE display (FIP)
Q54		1 ~ 6 display (FIP)
Q55	Display control	Controls Q54 at power ON
Q56		+5V is supplied to Q52 and Q53 at power ON
Q57, 58	Channel select	T-7X : FM/AM channel frequency step selection
Q59		T-7LX : LW channel frequency step selection

For Service Manuals Contact
MAURITRON TECHNICAL SERVICES
 8 Cherry Tree Rd, Chinnor
 Oxon OX9 4QY
 Tel: 01844-351694 Fax: 01844-352554
 Email: enquiries@mauritron.co.uk

CIRCUIT DESCRIPTION

IC6: μ PD7516HCW-269 Pin function

Terminal No.	Symbol	Name	I/O	Function												
1	P20		O	Key strobe signal, Normally "H"												
2	P21		O	Key strobe signal, Normally "H", Connected to LM7001 CL (No.4) pin												
3	P22		O	Key strobe signal, Normslly "H", Connected to LM7001 DATA (No.5) pin												
4	P23		O	Key strobe signal, Normally "L", Connected to LM7001 CE (No.3) pin												
5	RESET			Reset input pin. Pulse input when power plug is inserted into an AC outlet												
6	PPO	MUTE	O	Band select (active "H"), Muting signal during frequency scanning												
7	NC															
8	INTO	TIME BASE	I	Time base (8 Hz) input from LM7001												
9	P01		I	MIDI/Others assignment input; MIDI: "L", Others: "H"												
10	P02	SD	I	Stop signal input for auto tuning operation; When there is a station: "H", No station: "L"												
11	P03		I	With serial data: "H". Without serial data: "L", outputs the same logic signal as the POWER pin from BUSY (No.14) pin.												
12	P60		O	Key strobe signal, Normally "L"												
13	P61		I	Current assignment input of clock operation display; <input type="checkbox"/> No display: "H", <input type="checkbox"/> Display: "L"												
14	P62	BUSY	I/O	With serial data; During serial data output: "H", in normal input mode No serial data; POWER: "H", POWER OFF: "L"												
15	P63	DATA	I/O	Outputs data when serial data is output in normal input mode												
16	P50	UP	O	μ PC1362C, Normally "L", Connected to Channel UP pin												
17	P51	DOWN	O	μ PC1362C, Normally "L", Connected to Channel DOWN pin												
18	P52		O	Not used												
19	P53	POWER	O	Relay control signal output; POWER ON: "H", POWER OFF "L"												
20~23	P10~P13		I	Key return signal input port												
24	NC															
25	P40	MONO/STEREO	O	MONO/STEREO control pin; POWER OFF: "L", MONO: "H", AUTO: "L"												
26	P41	SURROUND	O	"L" and "H" are inverted by operating the Surround key. POWER OFF: "L"												
27	P42	MAIN	O	TV mode control pin, POWER OFF: "L"												
28	P43	BOTH	O													
					<table border="1"> <tr> <td></td> <td>P43</td> <td>P42</td> </tr> <tr> <td>MAIN</td> <td>L</td> <td>H</td> </tr> <tr> <td>SUB</td> <td>L</td> <td>L</td> </tr> <tr> <td>BOTH</td> <td>H</td> <td>L</td> </tr> </table>		P43	P42	MAIN	L	H	SUB	L	L	BOTH	H
	P43	P42														
MAIN	L	H														
SUB	L	L														
BOTH	H	L														
29	EVENT		I	Not used. Fixed at "H" or "L" as it is the input pin												
30	X2			System clock oscillation pin; 4.19 MHz												
31	X1															
32	V _{SS}			GND (ground) pin												
33~40	S ₀ ~S ₇		O	Flourescent display segment control pins for "a"~"h" display												
41~43	S ₁₃ ~S ₁₅			Flourescent display segment control pins for "k"~"i" display												
44~56	T ₀ ~T ₁₂		O	Flourescent display segment control pins for "G1"~"G13" display												
57	V _{LOAD}			Power supply for flourescent display drive												
58	V _{PRE}			Power supply for flourescent display pre-driver												
59~62	P30~P33		O	Key strobe signal, Normally "H"												
63	INT1	CE	I	Back up detection pin At the leading edge, the back up condition is activated by the interrupt which stops the clock.												
64	V _{DD}			Power supply pin												

OPERATION

Clock setting

The clock employs 24 hour system.

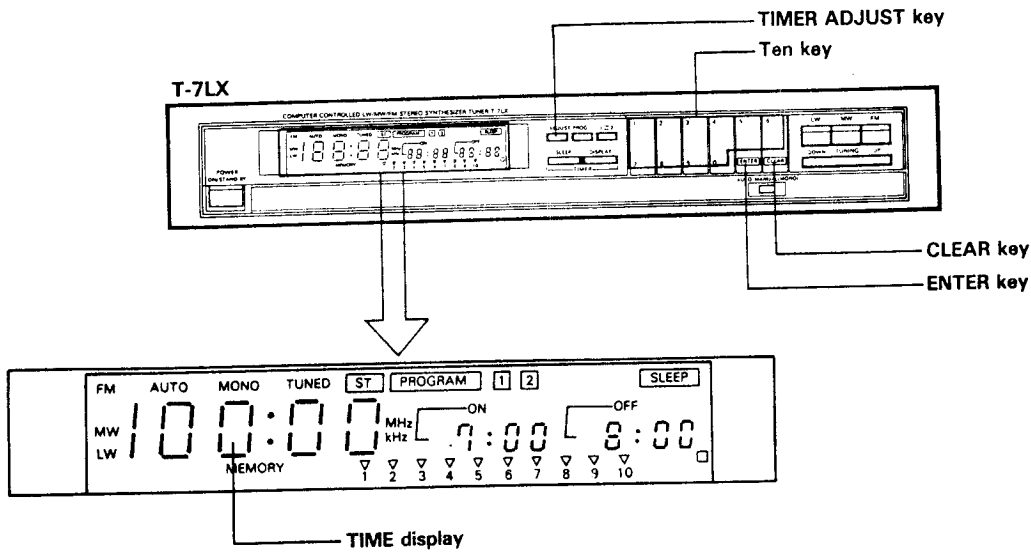

In case of power failure: _____
 When the time flashes on TIME display, this indicates a power failure occurred. Reset to the correct time.

How to Set the Time

When the display is in frequency display mode, press the DISPLAY key to change to the time display.

OPERATION	DISPLAY WINDOW	COMMENT
1. Press ADJUST		The hour display on the left starts flashing.
2. Input the hour and minute using ten key (1 to 0)		24 hour display is used. Every input advances the flashing to the right by one. This indicates where to input the next.
Example		
9:05		Input in the order of 0 → 9 → 0 → 5
16:50		Input in the order of 1 → 6 → 5 → 0
		When 4 digits are input, the entire time display flashes. If a wrong time is input, press the CLEAR key and perform operation 2 and after.
		The entire time display illuminates and seconds are counted.
3. Press ENTER key.	<p style="text-align: center;">Illuminates.</p>	Set the hour and minute according to operations 1 and 2. Use the time service from your TV, radio or telephone, then press ENTER key. This operation is practical and convenient. Pressing ADJUST key while setting the time brings the operation back to the first operation.

OPERATION

Timer function

The tuner has the function of a PROGRAM TIMER and SLEEP TIMER.

PROGRAM TIMER is for a timed playback or recording. Two sets of ON and OFF time are available within 24 hours. Set the PROGRAM TIMER key to STANDBY mode to repeat the same operation everyday.

For Service Manuals Contact
MAURITRON TECHNICAL SERVICES
 8 Cherry Tree Rd, Chinnor
 Oxon OX9 4QY
 Tel: 01844-351694 Fax: 01844-352554
 Email: enquiries@mauritron.co.uk

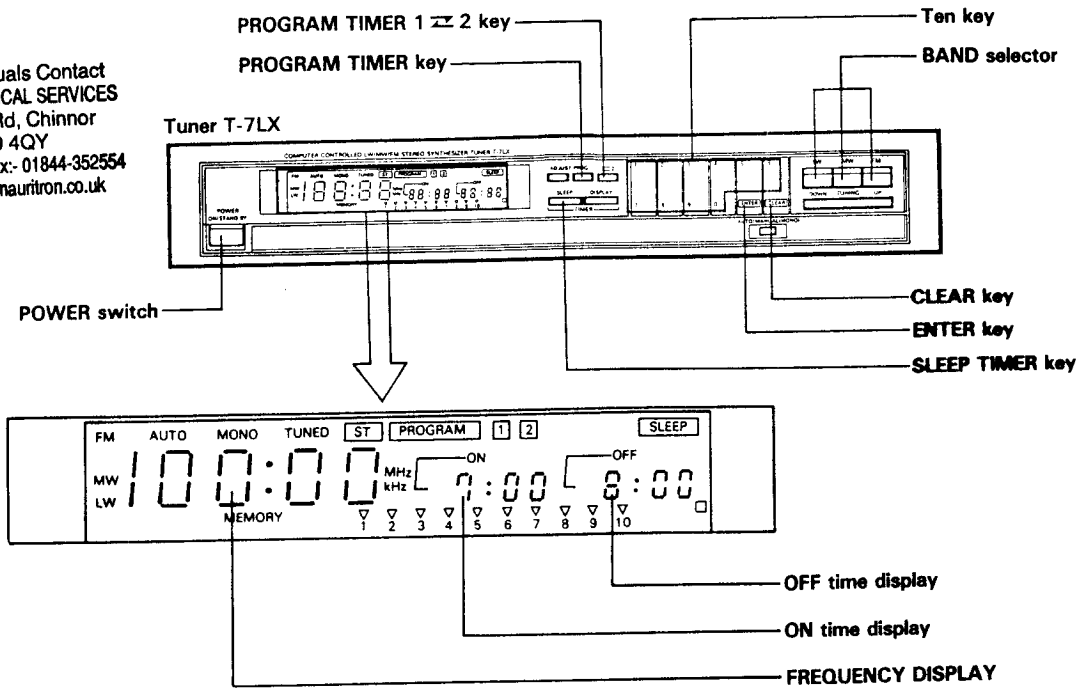



How to set PROGRAM TIMER

Adjust to the present time before operating the PROGRAM TIMER. (see page 8)

Two sets of ON and OFF time are available on the TIMER, the band and preset channels can be programmed when the TIMER turns ON. Preset the station before the PROGRAM TIMER setting. Turn the power ON to start.

OPERATION	DISPLAY WINDOW	COMMENT
PROGRAM 1 setting 1. Press PROG (program)	(Initial state) Example FM 98 MHz	⚙ indicates a flashing display PROGRAM 1 flashes. Pressing PROGRAM TIMER 1 & 2 alternately flashes keys 1 and 2. Two programs for each key can be set.
2. Press PROGRAM TIMER 1 & 2 to select PROGRAM 1.		Wait till the preset time, then the timed program turns ON.
3. Press ENTER		Pressing advances the flashing of the ON TIME DISPLAY to the right and the flashing indicates what to input. When 4 digits are input, the entire ON TIME DISPLAY flashes. When cancellation is necessary, press CLEAR to re-input.
4. Input ON time by keys 1 to 0.		Pressing advances the flashing of the ON TIME DISPLAY to the right and the flashing indicates what to input. When 4 digits are input, the entire ON TIME DISPLAY flashes. When cancellation is necessary, press CLEAR to re-input.

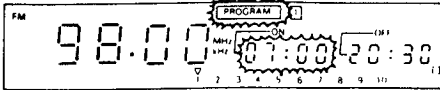
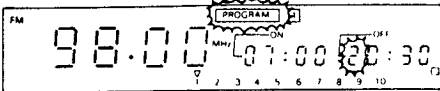
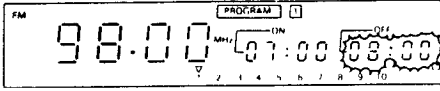
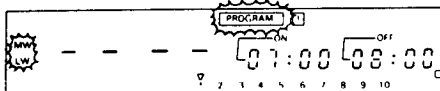
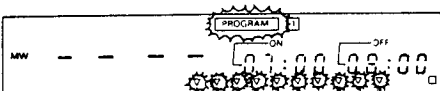
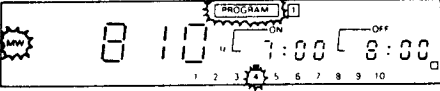
OPERATION

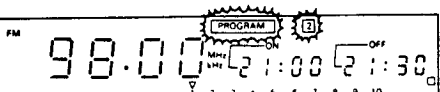
OPERATION	DISPLAY WINDOW	COMMENT
<p>5. Press ENTER key.</p> <p>6. Input OFF time by 1 to 0 keys.</p> <p>7. Press ENTER key.</p> <p>8. Press one of BAND SELECT or FM: [(AM: T-7X), (MW or LW: T-7LX)] key.</p> <p>9. Select the preset channel by 1 to 0 keys</p> <p>10. Press ENTER key.</p>	      <p style="text-align: center;">Example MW 810 kHz</p> 	<p>The entire ON TIME DISPLAY illuminates to indicate ON time is set. The left digit of the OFF TIME DISPLAY starts flashing.</p> <p>When the input is completed, the entire OFF TIME DISPLAY flashes. Press CLEAR key to cancel, start over from the beginning of the OFF time.</p> <p>The entire OFF TIME DISPLAY illuminates to indicate the OFF time is set. The display of FM, [(AM: T-7X), (MW or LW: T-7LX)] starts flashing. The frequency display becomes "-----".</p> <p>The pressed BAND key display illuminates and the PRESET CHANNEL indicator flashes.</p> <p>The selected PRESET CHANNEL indicator flashes and the preset frequency is displayed.</p> <p>BAND display and PRESET CHANNEL display illuminates to indicate the entire PROGRAM TIMER is set. The displays return to their original state in approx. 5 seconds.</p>
<p>PROGRAM 2 setting</p> <p>1. Press the PROG (program)</p> <p>2. Press PROGRAM TIMER 1 $\overline{2}$ 2 to select PROGRAM 2.</p> <p>Repeat the instructions for PROGRAM 1 setting.</p>		<p>The characters on PROGRAM 2 flash.</p>

OPERATION

TIMER standby

Operation examples to function the timer are described below. In here, the current time is 00:00 and the 100.00 MHz FM broadcast is received.

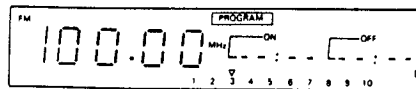

OPERATION	DISPLAY WINDOW	COMMENT
<p>To function Program 1</p> <p>In this example, 98 MHz frequency, turn-on time of 21:00 and turn-off time of 21:30 are programmed:</p> <p>Press Σ key so that 1 of the timer 1,2 indicator lights.</p>	<p>Contents of Program 1</p> <p>Approx. 5 seconds later</p>	<p>The contents of Program 1 are displayed approx. 5 seconds and only Program 1 is activated. Approx. 5 seconds later, the operation has been set and the frequency display returns to 100.00 MHz.</p> <p>By this operation, the power will be turned ON at 21:00 and turned OFF at 21:30.</p>
<p>To function Program 2</p> <p>In this example, 810 kHz frequency, turn-on time of 7:00 and turn-off time of 8:00 are programmed:</p> <p>Press Σ 2 key so that 2 of the timer 1, 2 indicator lights.</p>	<p>Contents of Program 2</p> <p>Approx. 5 seconds later</p>	<p>The contents of Program 2 are displayed approx. 5 seconds and only Program 2 is activated. Approx. 5 seconds later, the operation has been set and the frequency display returns to 100.00 MHz.</p> <p>By this operation, the power will be turned ON at 7:00 and turned OFF at 8:00.</p>
<p>To function Program 1 and 2</p> <p>Press the Σ 2 key so that 1 and 2 of the timer 1, 2 indicator light.</p>	<p>Contents of Programs</p> <p>Approx. 5 seconds later</p>	<p>The contents of the Program which will be turned on first are displayed approx. 5 seconds and both Programs (1 and 2) are activated. As the current time is 0:00, Program 2 will be turned ON first, so in this example, the contents of Program 2 are displayed approx. 5 seconds.</p> <p>Approx. 5 seconds later, the operation has been set and the frequency display in the display window returns to 100.00 MHz.</p> <p>By this operation, the power will be turned ON at 7:00 and OFF at 8:00, and also turned ON at 21:00 and OFF at 21:30.</p>

Notes:

Even though both timer 1 and 2 are programmed, when only the timer 1 is activated, the timer 2 does not function, and when only the timer 2 is activated, the timer 1 does not function.

For Service Manuals Contact
MAURITRON TECHNICAL SERVICES
 8 Cherry Tree Rd, Chinnor
 Oxon OX9 4QY
 Tel: 01844-351694 Fax: 01844-352554
 Email: enquiries@mauritron.co.uk

To deactivate the timer function

Now, 100.00 MHz FM broadcast is received.

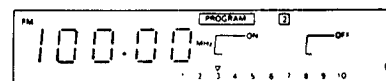

OPERATION	DISPLAY WINDOW	COMMENT
<p>Press the Σ 2 key so that both 1 and 2 of the timer 1, 2 indicator go off.</p>	<p>Approx. 5 seconds later</p>	<p>All the frequency and time indications are disappeared in the display window for approx. 5 seconds, and the timer function is deactivated.</p> <p>Then the frequency display in the display window returns to 100.00 MHz. By this, the timer will not function.</p>

OPERATION

To check the programmed contents

The contents of the timer 1 and 2 can be checked in sequence repeatedly by pressing the **1 2** key. When the timer function is not required, be sure to press the **1 2** key so that **1** and **2** of the timer 1, 2 indicator go off after checking the programmed contents.

Notes:

1. The timer operation functions only when the **1** or **2** of the timer 1, 2 indicator lights.
2. When the Program key is pressed or the POWER switch is turned ON/OFF between the ON-time and the OFF-time, the timer will not function correctly.
3. Set the program time so that Program 1 and 2 do not coincide each other. (See figure "Example".)
4. To function Program 1 and 2 continuously, be sure to leave more than 1 minute between the off-time of Program 1 and the on-time of Program 2.

Example: When receiving 98 MHz for one hour from 8:00 and 100.00 kHz for one hour from 9:00, set the ON-time of Program 1 to 8:00 and OFF-time to 8:59 and set the ON-time of Program 2 to 9:00 and OFF-time to 9:59.

5. If the timer function is left activated, the power will be supplied on the same time every day repeatedly. When the timer function is not required, deactivate the function according to "To deactivate the timer function".

6. During receiving the broadcast in the timer operable condition (with **1** or **2** of the timer 1, 2 indicator lit), when the timer-set time comes, the timer function is engaged.

At this time, the receiving broadcast station is changed to the programmed station. For this when recording the broadcast, be sure to check the programmed contents.

7. The programmed contents cannot be cancelled. If the timer function is not required, be sure to stop the function according to "To deactivate the timer function".

Example:

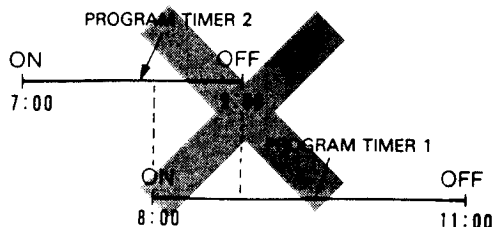

How to set SLEEP TIMER

The sleep timer can be set every 10 minutes for maximum of 1 hour and the power is turned off at preset time.

OPERATION	DISPLAY WINDOW	COMMENT
<p>1. Press SLEEP key once.</p> <p>2. Thereafter, pressing SLEEP key is as shown in the diagram on the right.</p> <p>3. To release the sleep time, press the POWER switch to turn the power off.</p>		<p>The SLEEP TIMER operates either when the power is ON or OFF. When the power is OFF, if SLEEP is pressed the power turns ON. The broadcast station last received is received again. SLEEP illuminates and 60 is displayed under it.</p>

* SLEEP TIMER has priority even when PROGRAM TIMER is set.

ADJUSTMENT

T-7X7LA

No.	ITEM	INPUT SETTINGS	OUTPUT SETTINGS	TUNER SETTINGS	ALIGNMENT POINTS	ALIGN FOR	FIG.
FM SECTION Unless otherwise specified, the individual switches should be set as following: SELECTOR: FM FM MODE/MUTING ON							
1	DISCRIMINATOR (With distortion adjustment in monaural mode)	(A) 98.0MHz 1kHz, ±75kHz dev 60dB(ANT input)	Connect a DC voltmeter between TP3 and TP4.	MONO 98.0MHz	T4	0V	(b)
2	VCO	(A) 98.0MHz 0 dev 60dB(ANT input)	Connect a 330kΩ resistor to TP9. Connect a frequency counter to the resistor via an AC voltmeter.	98.0MHz	VR1	76.00kHz	(c)
3	DISTORTION (STEREO)	(C) 98.0MHz 1kHz, ±68.25kHz dev Selector:L or R 60dB(ANT input)	(B)	98.0MHz	Front end IFT	Minimum distortion.	
4	SEPARATION (T-7LX only)	(C) 98.0MHz 1kHz, ±68.25kHz dev Selector:L or R 60dB(ANT input)	(B)	98.0MHz	VR2	Adjust so it that the crosstalk from L to R and R to L become minimum.	
5	TUNING LEVEL	(A) 98.0MHz 0 dev 16dB(ANT input)	(B)	98.0MHz	VR6	Adjust VR6 so that TUNED goes off. Then, adjust VR6 and stop at the point where TUNED goes on.	
AM-MW SECTION Keep the AM loop antenna installed. SELECTOR: AM.MW							
(1)	BAND EDGE (1)	-	Connect a DC voltmeter between VT2 and GND.	531kHz	L5	1.5V	(d)
(2)	BAND EDGE (2)	-	Connect a DC voltmeter between VT2 and GND.	1602kHz	TC4	8.0V	(d)
Repeat alignments (1) and (2) several times.							
(3)	RF ALIGNMENT (1)	(D) 603kHz 400Hz, 30% mod	(B)	603kHz	L3	Maximum amplitude and symmetry of the oscilloscope display.	
(4)	RF ALIGNMENT (2)	(D) 1404kHz 400Hz, 30% mod	(B)	1404kHz	TC2	Maximum amplitude and symmetry of the oscilloscope display.	
(5)	TUNING LEVEL	(D) 1000(999)kHz 400Hz, 30% mod 26dB(ANT input)	(B)	1000(999)kHz	VR5	Adjust VR5 so that TUNED goes off. Then, adjust VR5 and stop at the point where TUNED goes on.	
Repeat alignments (3) and (4) several times.							
AM-LW SECTION (T-7LX only) Keep the AM loop antenna installed. SELECTOR: AM.LW							
(6)	BAND EDGE (1)	-	Connect a DC voltmeter between VT2 and GND.	153kHz	L4	1.5V	(d)
(7)	BAND EDGE (2)	-	Connect a DC voltmeter between VT2 and GND.	281kHz	TC3	8.0V	(d)
Repeat alignments (6) and (7) several times.							
(8)	RF ALIGNMENT (1)	(D) 163kHz 400Hz, 30% mod	(B)	163kHz	L2	Maximum amplitude and symmetry of the oscilloscope display.	
(9)	RF ALIGNMENT (2)	(D) 270kHz 400Hz, 30% mod	(B)	270kHz	TC1	Maximum amplitude and symmetry of the oscilloscope display.	
Repeat alignments (8) and (9) several times.							

For Service Manuals Contact
MAURITRON TECHNICAL SERVICES
 8 Cherry Tree Rd, Chinnor
 Oxon OX9 4QY
 Tel: 01844-351694 Fax: 01844-352554
 Email: enquiries@mauritron.co.uk

REGLAGES

NR.	GEGENSTAND	EINGANGS-EINSTELLUNG	AUSGANGS-EINSTELLUNG	TUNER-EINSTELLUNG	ABGLEICH-PUNKTE	ABGLEICHEN FÜR	ABB.
UKW - EMPFANGSABTEILUNG Außer wenn anders angegeben, die verschiedenen Schalter wie folgt einstellen: SELECTOR: FM FM MODE/MUTING ON							
1	DISKRIMINATOR (Mit Verzerrungseinstellung in der Mono-Betriebsart)	(A) 98,0MHz 1kHz.±75kHz Hub 60dB(ANT-Eingang)	Einen Gleichspannungsmesser zwischen TP3 und TP4 anschließen.	MONO 98,0MHz	T4	0V	(b)
2	SPANNUNGS-GEREGELTER OSZILLATOR	(A) 98,0MHz 0 Hub 60dB(ANT-Eingang)	Einen 330kΩ Widerstand zu TP9 anschließen. Einen Frequenzzähler über einen Wechselspannungsmesser an den Widerstand anschließen.	98,0MHz	VR1	76,00kHz	(c)
3	KLIRRFAKTOR (STEREO)	(C) 98,0MHz 1kHz.±68,25kHz Hub Wähler:L oder R 60dB(ANT-Eingang)	(B)	98,0MHz	Frontende IPT	Minimal Klirrfaktor.	
4	STERO KANAL TRENNUNG (nur T-7LX)	(C) 98,0MHz 1kHz.±68,25kHz Hub Wähler:L oder R 60dB(ANT-Eingang)	(B)	98,0MHz	VR2	So einstellen, daß das Übersprechen von L auf R und von R auf L minimal wird.	
5	ABSTIMM PEGEL	(A) 98,0MHz 0 Hub 16dB(ANT-Eingang)	(B)	98,0MHz	VR6	Den Pegelwiderstand VR6 so einstellen, daß der TUNED anzeiger nicht leuchtet. Dann der Pegelwiderstand aufdrehen, und dem VR6 Halt geben wobei den TUNED anzeiger leuchtet wird.	
MW - EMPFANGSABTEILUNG Die MW-Rahmenantenne angebracht lassen. SELECTOR: AM, MW							
(1)	BANDKANTE (1)	-	Einen Gleichspannungsmesser zwischen VT2 und GND anschließen.	531kHz	L5	1.5V	(d)
(2)	BANDKANTE (2)	-	Einen Gleichspannungsmesser zwischen VT2 und GND anschließen.	1602kHz	TC4	8.0V	(d)
Abstimmungen (1) und (2) mehrere Male wiederholen.							
(3)	HF-ABGLEICH (1)	(D) 603kHz 400Hz. 30% mod	(B)	603kHz	L3	Maximal Amplitude und Symmetrie des Oszilloskopbildes.	
(4)	HF-ABGLEICH (2)	(D) 1404kHz 400Hz. 30% mod	(B)	1404kHz	TC2	Maximal Amplitude und Symmetrie des Oszilloskopbildes.	
(5)	ABSTIMM PEGEL	(D) 1000(999)kHz 400Hz. 30% mod 26dB(ANT-Eingang)	(B)	1000(999)kHz	VR5	Den Pegelwiderstand VR5 so einstellen, daß der TUNED anzeiger nicht leuchtet. Dann der Pegelwiderstand aufdrehen, und dem VR5 Halt geben wobei den TUNED anzeiger leuchtet wird.	
Abstimmungen (3) und (4) mehrere Male wiederholen.							
LW - EMPFANGSABTEILUNG (nur T-7LX) Die MW-Rahmenantenne angebracht lassen. SELECTOR: AM, LW							
(6)	BANDKANTE (1)	-	Einen Gleichspannungsmesser zwischen VT2 und GND anschließen.	153kHz	L4	1.5V	(d)
(7)	BANDKANTE (2)	-	Einen Gleichspannungsmesser zwischen VT2 und GND anschließen.	281kHz	TC3	8.0V	(d)
Abstimmungen (6) und (7) mehrere Male wiederholen.							
(8)	HF-ABGLEICH (1)	(D) 163kHz 400Hz. 30% mod	(B)	163kHz	L2	Maximal Amplitude und Symmetrie des Oszilloskopbildes.	
(9)	HF-ABGLEICH (2)	(D) 270kHz 400Hz. 30% mod	(B)	270kHz	TC1	Maximal Amplitude und Symmetrie des Oszilloskopbildes.	
Abstimmungen (8) und (9) mehrere Male wiederholen.							

ADJUSTMENT/REGLAGE/ABGLEICH

SYSTEM CONNECTIONS

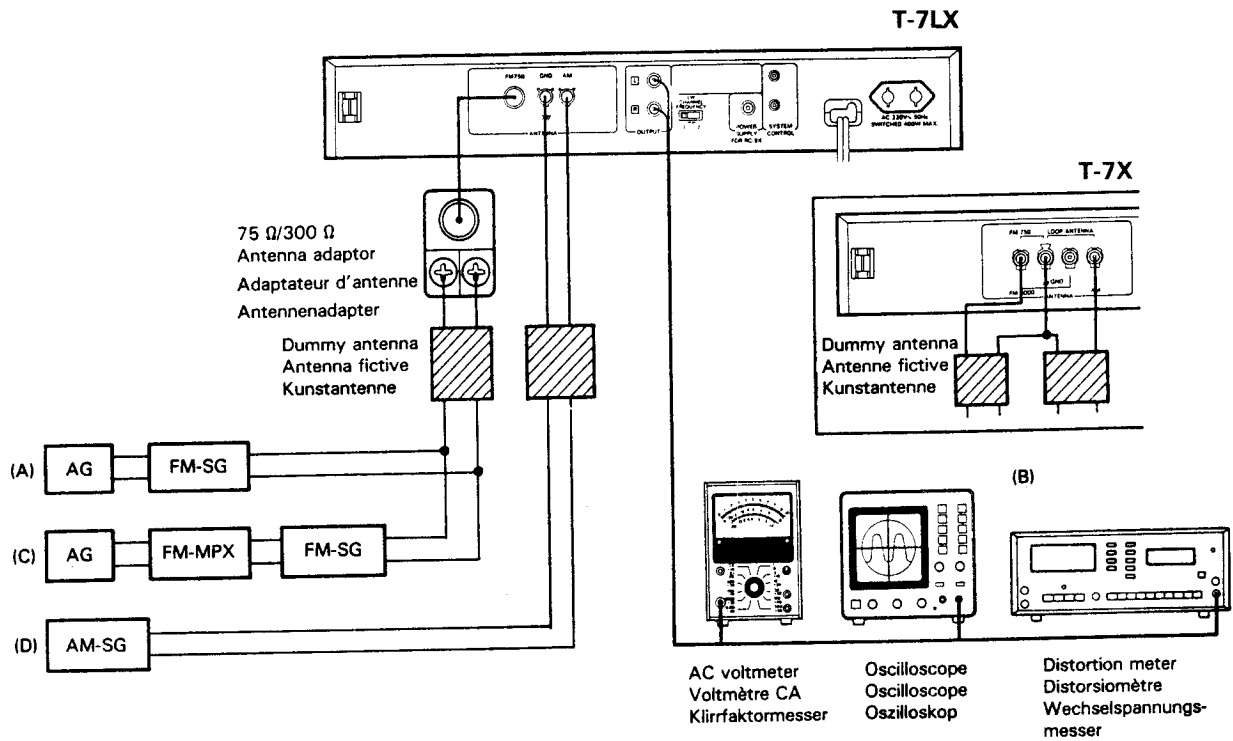

For Service Manuals Contact
MAURITRON TECHNICAL SERVICES
 8 Cherry Tree Rd, Chinnor
 Oxon OX9 4QY
 Tel: 01844-351694 Fax: 01844-352554
 Email: enquiries@mauritron.co.uk

ABGLEICH

T-7X/7LX

N°	ITEM	REGLAGE DE L'ENTREE	REGLAGE DE LA SORTIE	REGLAGE DU TUNER	POINT DE L'ALIGNEMENT	ALIGNER POUR	FIG.
SECTION MF Sauf en cas d'indications spéciales, régler chaque commutateur comme suit: SELECTEUR: FM FM MODE/MUTING ON							
1	DISCRIMINATEUR (Avec l'ajustement de distorsion en mode monaural)	(A) 98,0MHz 1kHz.±75kHz dév 60dB(Entrée ANT)	Relier un voltmètre CC entre les TP3 et TP4.	MONO 98,0MHz	T4	0V	(b)
2	OSCILLATEUR CONTROLE PAR LA TENSION	(A) 98,0MHz 0 dév 60dB(Entrée ANT)	Relier une résistance de 330kΩ à TP9. Raccorder un compteur de fréquence à une résistance par l'intermédiaire d'un voltmètre CA.	98,0MHz	VR1	76,00kHz	(c)
3	DISTORSION (STEREO)	(C) 98,0MHz 1kHz.±68,25kHz dév Selection:L ou R 60dB(Entrée ANT)	(B)	98,0MHz	Tête H.F. IPT	Distorsion minimale.	
4	SEPARASION (T-7LX seulement)	(C) 98,0MHz 1kHz.±68,25kHz dév Selection:L ou R 60dB(Entrée ANT)	(B)	98,0MHz	VR2	Le régler de manière à ce que la diaphonie de L à R et de R à L devienne minimum.	
5	NIVEAU D'ACORDER	(A) 98,0MHz 0 dév 16dB(Entrée ANT)	(B)	98,0MHz	VR6	Ajuster VR6 que TUNED est non allumé. Alors, ajuster VR6 et arrêter le mouvement de VR6 au moment où le TUNED s'allume.	
SECTION MA - P O Laisser l'antenne bouche MA installée. SELECTEUR: AM, MW							
(1)	BORD DE BANDE (1)	-	Relier un voltmètre CC entre les YT2 et GND.	531kHz	L5	1,5V	(d)
(2)	BORD DE BANDE (2)	-	Relier un voltmètre CC entre les YT2 et GND.	1602kHz	TC4	8,0V	(d)
Répéter les points (1) et (2) plusieurs fois.							
(3)	ALIGNEMENT HT (1)	(D) 603kHz 400Hz. 30% mod	(B)	603kHz	L3	Amplitude et symétrie maximale de l'affichage de l'oscilloscope.	
(4)	ALIGNEMENT HT (2)	(D) 1404kHz 400Hz. 30% mod	(B)	1404kHz	TC2	Amplitude et symétrie maximale de l'affichage de l'oscilloscope.	
(5)	NIVEAU D'ACORDER	(D) 1000(999)kHz 400Hz. 30% mod 26dB(Entrée ANT)	(B)	1000(999)kHz	VR5	Ajuster VR5 que TUNED est non allumé. Alors, ajuster VR5 et arrêter le mouvement de VR5 au moment où le TUNED s'allume.	
Répéter les points (3) et (4) plusieurs fois.							
SECTION MA - G O (T-7LX seulement) Laisser l'antenne bouche MA installée. SELECTEUR: AM, LW							
(6)	BOAD DE BANDE (1)	-	Relier un voltmètre CC entre les VT2 et GND.	153kHz	L4	1,5V	(d)
(7)	BOAD DE BANDE (2)	-	Relier un voltmètre CC entre les VT2 et GND.	281kHz	TC3	8,0V	(d)
Répéter les points (6) et (7) plusieurs fois.							
(8)	ALIGNEMENT HT (1)	(D) 163kHz 400Hz. 30% mod	(B)	163kHz	L2	Amplitude et symétrie maximale de l'affichage de l'oscilloscope.	
(9)	ALIGNEMENT HT (2)	(D) 270kHz 400Hz. 30% mod	(B)	270kHz	TC1	Amplitude et symétrie maximale de l'affichage de l'oscilloscope.	
Répéter les points (8) et (9) plusieurs fois.							

For Service Manuals Contact
MAURITRON TECHNICAL SERVICES
 8 Cherry Tree Rd, Chinnor
 Oxon OX9 4QY
 Tel: 01844-351694 Fax: 01844-352554
 Email: enquiries@mauritron.co.uk



TUNER UNIT (X05-3252-71)(B/2) COMPONENT SIDE VIEW

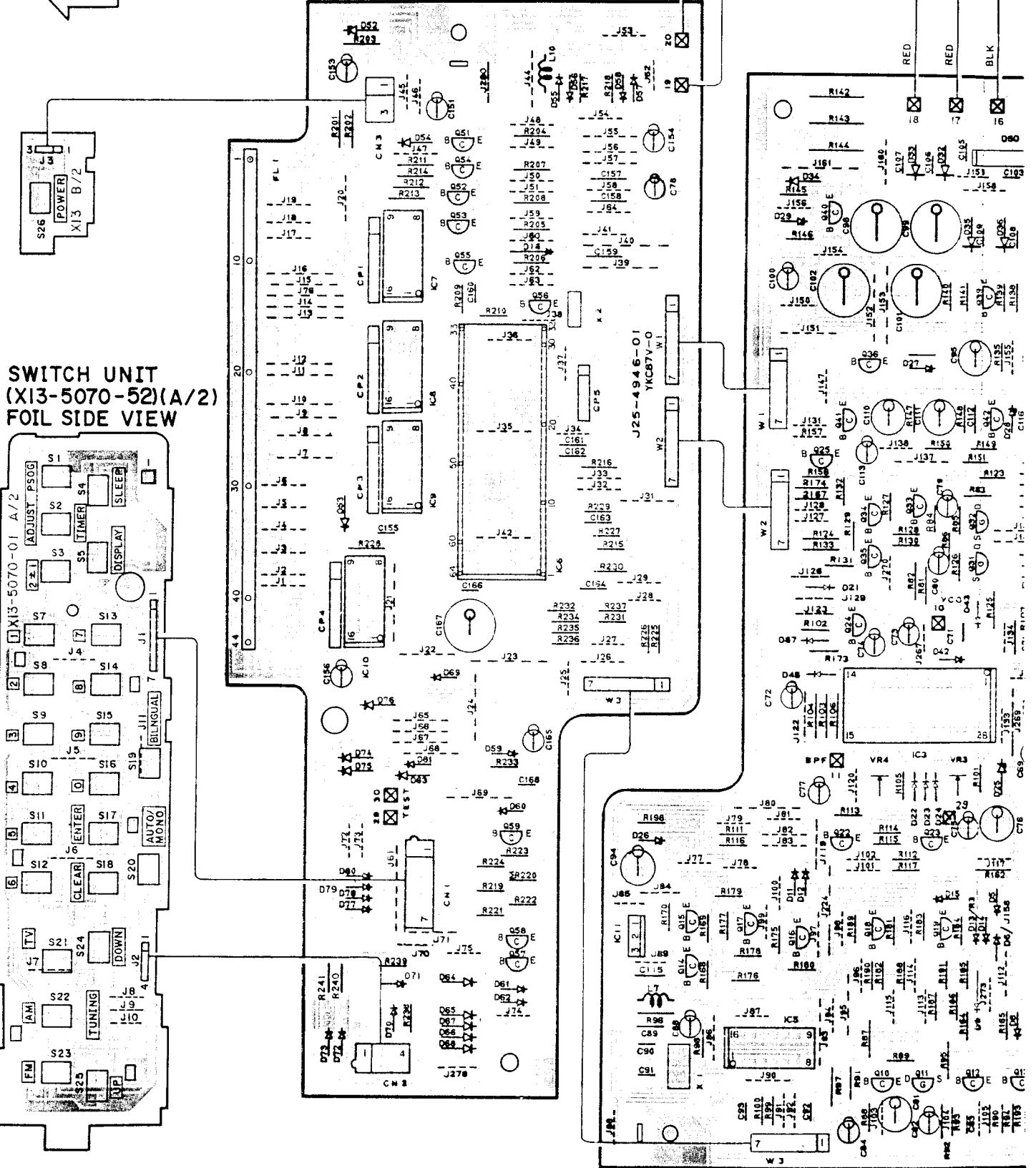

For Service Manuals Contact
MAURITRON TECHNICAL SERVICES
 8 Cherry Tree Rd, Chinnor
 Oxon OX9 4QY
 Tel: 01844-351694 Fax: 01844-352554
 Email: enquiries@mauritron.co.uk

TUNE

PC BOARD

TUNER UNIT (X05-3252-71) (B/2) COMPONENT SIDE VIEW

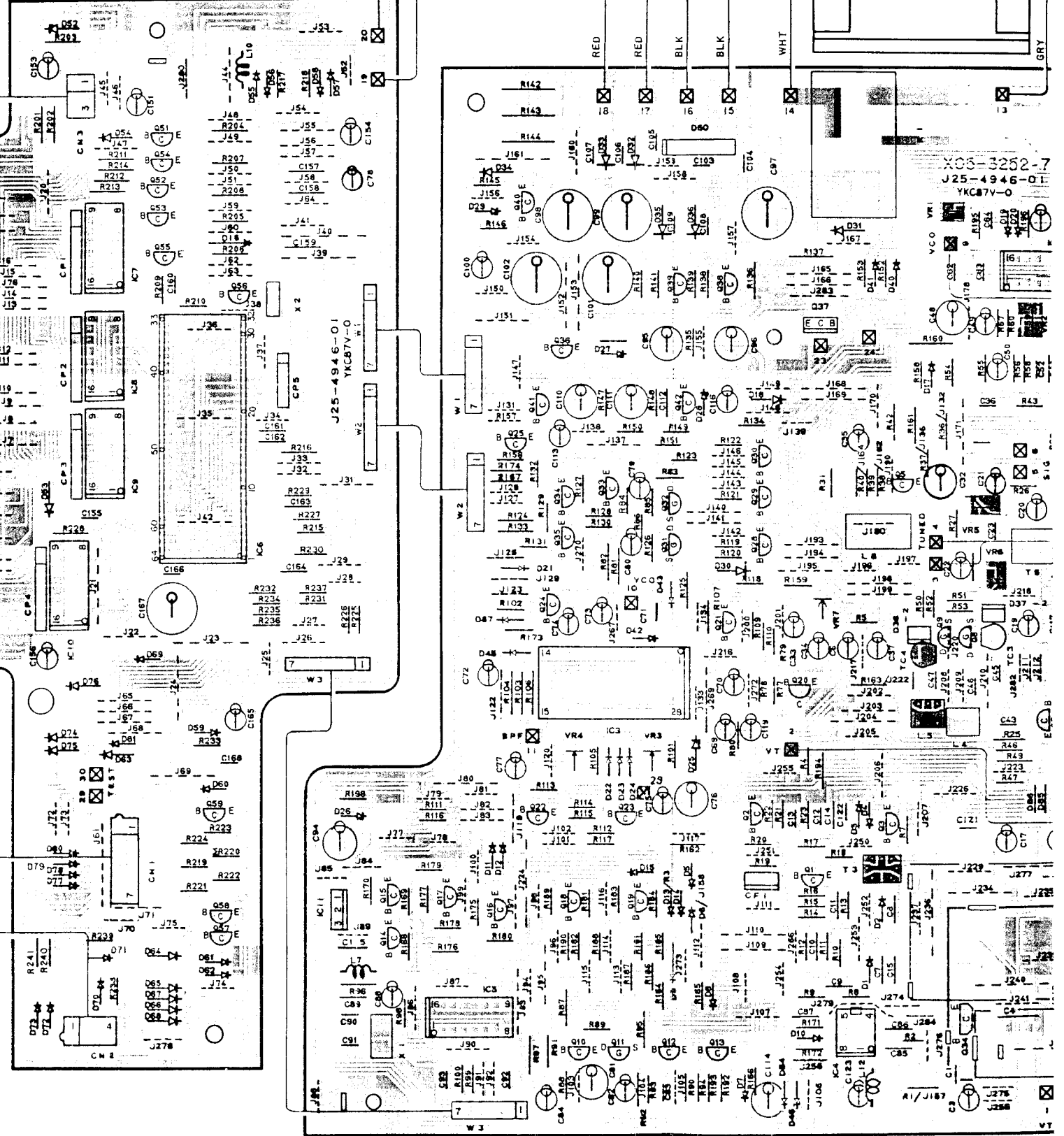

TUNER UNIT (X05-3252-71) (A/2) CO

PC BOARD

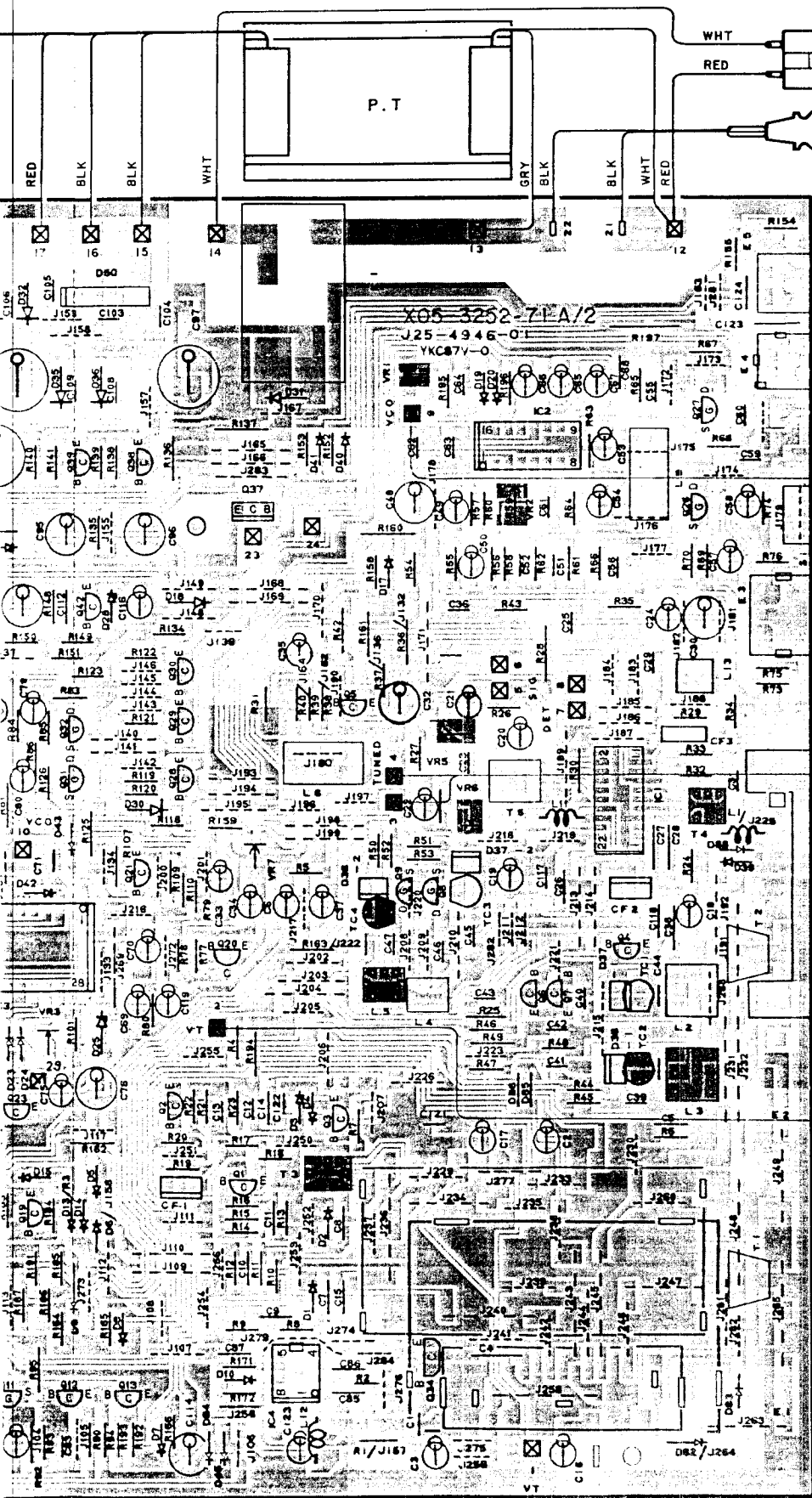

Q2	E 1.1V C 9.7V B 1.8V	Q25	E 0V C 5.5V B 0V	IC1	1-3 2.2V 4 0V 5,6 11.6V 7 11.2V 8 0V 9 3.8V 10 2.9V 11 1.5V 12 1.5V 13,14 2.4V 15 2.2V 16 1.4V 17 11.2V 18,19 0V 20,21 3.7V 22 2.7V
Q4	E 0V C 0V B 0.6V	Q26,27	G 0V S 0V D 0.57V	IC2	1 11.6V 2 2.6V 3 5.9V 4,5 9.5V 6,7 4.7V 8 0V 9 0.6V 10,11 2.5V 12-14 2.6V 15 3.2V 16 0V
Q5	E 2.3V C 9.9V B 2.9V	Q28	E 13.1V C 13.1V B 12.4V	IC5	1 1.0V 2 1.6V 3 0V 4,5 5.3V 8 0V 7 8 0V 9 12.5V 10 0V 11 2.8V 12,13 5.7V 14 12.2V 15 3.0V 16 0V
Q6	E 2.7V (2.6V) C 12.2V B 33V (0V)	Q29	E 0V C 0V B 0.6V	Q37	E - C 26.3V B -
Q7	E 2.7V (2.6V) C 12.2V B 0V (31V)	Q30	E 0V C 9.1V B 0V	Q38	E 27.5V C 26.3V B 26.8V
Q8	G 3.6V S 3.6V D 4.0V (0V)	Q36	E 0V C 0V B 0.7V	Q39	E 0V C 0V B 0.65V
Q9	G 3.6V S 3.6V D 0V (2.9V)	Q33	E 0V C 10.7V B 0V	Q40	E 6.1V C 6.1V B 5.3V
Q10	E 0V C 10.7V B 0V	Q11	G 4.6V S 4.6V D 5.1V		
Q12	E 0.6V C 5.4V B 1.2V	Q13	E 0V C 5.4V B 0.6V	IC6	9 6.1V 29,32 0V 35-56 0.3V 57,58,63 0V
Q16	E 12.3V C 12.2V B 11.6V	Q17	E 12.3V C 0V B 12.3V	Q54	E 5.3V C 5.3V B 4.7V
Q18	E 12.3V C 0V B 12.3V	Q18	E 12.3V C 0V B 12.3V	Q55	E 0V C 0V B 0.6V
		Q18	E 12.3V C 0V B 12.3V	Q56	E 4.4V C 5.3V B 0.6V
		Q18	E 12.3V C 0V B 12.3V	Q52	E 4.3V C 4.4V B 3.7V
		Q18	E 12.3V C 0V B 12.3V	Q53	E 4.4V C 4.3V B 3.7V

TUNER UNIT (X05-3252-71) (A/2) COMPONENT SIDE VIEW T-7LX

Refer to the schematic diagram for the values of resistors and capacitors.

For Service Manuals Contact
MAURITRON TECHNICAL SERVICES
 8 Cherry Tree Rd, Chinnor
 Oxon OX9 4QY
 Tel: 01844-351694 Fax: 01844-352554
 Email: enquiries@mauritron.co.uk

PARTS LIST

× New Parts

Parts without Parts No. are not supplied.

Les articles non mentionnés dans le Parts No. ne sont pas fournis.

Telle ohne Parts No. werden nicht geliefert.

Ref. No. 参照番号	Address 位置	New Parts 新	Parts No. 部品番号	Description 部品名 / 規格	Desti- nation 仕向	Re- marks 備考
T-7X/7LX						
1	1B		A01-1443-02	METALLIC CABINET	UMUEAT	
1	1B		A01-1443-02	METALLIC CABINET	E	
1	1B		A01-1480-02	METALLIC CABINET	EF	
2	2A	*	A20-5029-03	PANEL ASSY	UMUEA	
2	2A	*	A20-5030-03	PANEL ASSY	T	
2	2A	*	A20-5031-03	PANEL ASSY	EEF	
-			B46-0094-03	WARRANTY CARD	UUE	
-			B46-0095-03	WARRANTY CARD	UUE	
-			B46-0122-13	WARRANTY CARD	E	
-			B46-0123-03	WARRANTY CARD	T	
-			B46-0139-03	WARRANTY CARD	EF	
-		*	B50-6526-00	INSTRUCTION MANUAL (ENGLISH)	UMUEAE	
-		*	B50-6527-00	INSTRUCTION MANUAL (FRENCH)	MAE	
-		*	B50-6528-00	INSTRUCTION MANUAL (SPANISH)	MA	
-		*	B50-6529-00	INSTRUCTION MANUAL (ARABIC)	MA	
-		*	B50-6530-00	INSTRUCTION MANUAL (ENGLISH)	T	
-		*	B50-6531-00	INSTRUCTION MANUAL (G,D,I)	E	
-		*	B50-6543-00	INSTRUCTION MANUAL (ENGLISH)	EF	
-		*	B50-6544-00	INSTRUCTION MANUAL (FRENCH)	EF	
-		*	B50-6545-00	INSTRUCTION MANUAL (G,D,I)	EF	
-			B58-0223-04	CAUTION CARD (PRE-SET 120V)	U	
-			B58-0513-04	CAUTION CARD (PRESET220-240)	UE	
-			B58-0803-03	CAUTION CARD	EEF	
-			B59-0092-00	SERVICE DIRECTORY	UUE	
Δ	5	2A	E03-0049-05	AC PLUG	T	
Δ	6	1A	E30-0615-05	AUDIO CORD		
Δ	7	1B	E30-0459-05	AC POWER CORD	AEEF	
Δ	7	1B	E30-0812-05	AC POWER CORD	UMUE	
Δ	8	1B	E03-0036-05	AC OUTLET	UMUE	
Δ	8	1B	E03-0055-05	AC OUTLET	AEEF	
Δ	8	1B	E03-0085-05	AC OUTLET	T	
Δ	9	2A	E30-1416-05	AC POWER CORD	T	
-		*	H01-7329-04	ITEM CARTON CASE	UMUEA	
-		*	H01-7330-04	ITEM CARTON CASE	T	
-		*	H01-7331-04	ITEM CARTON CASE	E	
-		*	H01-7373-04	ITEM CARTON CASE	EF	
-			H10-3332-02	POLYSTYRENE FOAMED FIXTURE	UMUEAT	
-			H10-3332-02	POLYSTYRENE FOAMED FIXTURE	E	
-			H10-3333-02	POLYSTYRENE FOAMED FIXTURE	UMUEAT	
-			H10-3333-02	POLYSTYRENE FOAMED FIXTURE	E	
-			H10-3378-02	POLYSTYRENE FOAMED FIXTURE	EF	
-			H25-0223-04	PROTECTION BAG (750X350)		
-			H25-0232-04	PROTECTION BAG (235X350)		
10	3A, 3B		J02-0170-04	FOOT		
11	2B		J19-0514-05	UNIT HOLDER		
12	3B		J19-0586-05	UNIT HOLDER		
13	2B		J19-0626-12	ANTENNA HOLDER		
14	1A		J19-0875-03	ANTENNA HOLDER		
Δ	15	1B	J42-0083-05	POWER CORD BUSHING		
-			J61-0307-05	WIRE BAND	TEEF	

For Service Manuals Contact
MAURITRON TECHNICAL SERVICES
8 Cherry Tree Rd, Chinnor
Oxon OX9 4QY
Tel: 01844-351694 Fax: 01844-352554
Email: enquiries@mauritron.co.uk

E: Scandinavia & Europe H: Audio Club K: USA P: Canada W: Europe

T: England U: PX (Far East, Hawaii) A: Saudi Arabia EF: France made

UE: AAFES (Europe) X: Australia M: Other Areas

Δ indicates safety critical components.

PARTS LIST

* New Parts

Parts without Parts No. are not supplied.

Les articles non mentionnes dans le Parts No. ne sont pas fournis.

Telle ohne Parts No. werden nicht geliefert.

Ref. No. 参照番号	Address 位置	New Parts 新	Parts No. 部品番号	Description 部品名 / 規格	Desti- nation 仕向	Re- marks 備考
18	3A		K27-1338-04	KNØB (BUTTON)		
20	2B	*	K29-2555-03	KNØB ASSY	UMUEA	
20	2B	*	K29-2556-03	KNØB ASSY	TEEF	
Δ	22	1B	* L01-7422-05	POWER TRANSFORMER	TEEF	
Δ	22	1B	* L01-7424-05	POWER TRANSFORMER	UMUE	
Δ	22	1B	* L01-7427-05	POWER TRANSFORMER	A	
C	3B		N09-1515-05	TAPPING SCREW (Ø3X8)		
E	2B		N09-0292-05	STEPPED SCREW (Ø3X19)		
S1	2B		S31-2115-05	SLIDE SWITCH	UMUEA	
28	1A		T90-0104-25	LOOP ANTENNA	UMUEA	
28	1A		T90-0138-15	LOOP ANTENNA	TEEF	
29	1A		T90-0132-05	T TYPE ANTENNA		
30	1A		T90-0136-05	ANTENNA ADAPTOR	TEEF	
TUNER UNIT (X05-3252-71)						
C2			CE04KW1H010M	ELECTRØ	1.0UF	50WV
C5			C91-0769-05	CERAMIC	0.01UF	M
C12 ,13			CK45FF1H103Z	CERAMIC	0.010UF	Z
C12 ,13			CK45FF1H103Z	CERAMIC	0.010UF	Z
C12 ,13			CK45F1H103Z	CERAMIC	0.010UF	Z
C18			CE04KW1H2R2M	ELECTRØ	2.2UF	50WV
C19			CE04KW1C220M	ELECTRØ	22UF	16WV
C20			CE04KW1H4R7M	ELECTRØ	4.7UF	50WV
C21			CE04KW1V100M	ELECTRØ	10UF	35WV
C22			CE04KW1H3R3M	ELECTRØ	3.3UF	50WV
C23			CK45FF1H223Z	CERAMIC	0.022UF	Z
C23			CK45FF1H223Z	CERAMIC	0.022UF	Z
C23			CK45F1H223Z	CERAMIC	0.022UF	Z
C24			CE04KW1HR47M	ELECTRØ	0.47UF	50WV
C25			CF92FV1H103J	MF	0.010UF	J
C26			C91-0769-05	CERAMIC	0.01UF	M
C27 ,28			C91-0085-05	CERAMIC	0.022UF	N
C29			CC45FSL1H101J	CERAMIC	100PF	J
C29			CC45FSL1H101J	CERAMIC	100PF	J
C29			CC45SL1H101J	CERAMIC	100PF	J
C30			CE04KW1C470M	ELECTRØ	47UF	16WV
C31			CK45FF1H223Z	CERAMIC	0.022UF	Z
C31			CK45FF1H223Z	CERAMIC	0.022UF	Z
C31			CK45F1H223Z	CERAMIC	0.022UF	Z
C33			CE04KW1V100M	ELECTRØ	10UF	35WV
C35			CE04KW1V100M	ELECTRØ	10UF	35WV
C36			CF92FV1H153J	MF	0.015UF	J
C37			CE04KW1H010M	ELECTRØ	1.0UF	50WV
C38			C91-0085-05	CERAMIC	0.022UF	N
C39			CK45FF1H223Z	CERAMIC	0.022UF	Z
C39 -43			CK45FF1H223Z	CERAMIC	0.022UF	Z
C39 -43			CK45F1H223Z	CERAMIC	0.022UF	Z
C41			CK45FF1H223Z	CERAMIC	0.022UF	Z
C44			CC45FTH1H101J	CERAMIC	100PF	J
C44			CC45TH1H101J	CERAMIC	100PF	J
C45			CC45CH1H151J	CERAMIC	150PF	J
C45			CC45FCH1H151J	CERAMIC	150PF	J
C46			CQ09FS1H221JYØ	PØLYSTY	220PF	J
C47			CQ09FS1H391JYØ	PØLYSTY	390PF	J

E: Scandinavia & Europe H: Audio Club K: USA P: Canada W: Europe

T: England U: PX (Far East, Hawaii) A: Saudi Arabia EF: France made

UE: AAFES (Europe) X: Australia M: Other Areas

Δ indicates safety critical components.

PARTS LIST

× New Parts

Parts without Parts No. are not supplied.

Les articles non mentionnés dans le Parts No. ne sont pas fournis.

Telle ohne Parts No. werden nicht geliefert.

Ref. No. 参照番号	Address 位置	New Parts 新	Parts No. 部品番号	Description 部品名 / 規格	Desti- nation 仕向	Re- marks 備考
C48			CE04KW1C101M	ELECTRØ 100UF 16WV		
C49 ,50			CE04KW1C220M	ELECTRØ 22UF 16WV	TEEF	
C51 ,52			CC45FSL1H151J	CERAMIC 150PF J	UMUEA	
C51 ,52			CF92FV1H112J	MF 1100PF J	TEEF	
C53 ,54			CE04KW1HR33M	ELECTRØ 0.33UF 50WV	UMUEA	
C53 ,54			CE04KW1H2R2M	ELECTRØ 2.2UF 50WV	TEEF	
C55 ,56			CF92FV1H153J	MF 0.015UF J	UMUEA	
C55 ,56			CF92FV1H472J	MF 4700PF J	TEEF	
C57 ,58			CE04KW1H010M	ELECTRØ 1.0UF 50WV		
C59 ,60			CF92FV1H752J	MF 7500PF J	UMUEA	
C61			CC45FSL1H221J	CERAMIC 220PF J	TE	
C61			CC45SL1H221J	CERAMIC 220PF J	EF	
C62			CK45B1H561K	CERAMIC 560PF K	EF	
C62			CK45FB1H561K	CERAMIC 560PF K	UMUEAT	
C62			CK45FB1H561K	CERAMIC 560PF K	E	
C63			CF92FV1H473J	MF 0.047UF J		
C64			CO09FS1H471JYØ	POLYSTY 470PF J		
C65			CE04KW1H2R2M	ELECTRØ 2.2UF 50WV		
C66			CE04KW1H3R3M	ELECTRØ 3.3UF 50WV		
C67			CE04KW1HR47M	ELECTRØ 0.47UF 50WV		
C68			C91-0769-05	CERAMIC 0.01UF M		
C78			CE04KW1H4R7M	ELECTRØ 4.7UF 50WV		
C81			CE04KW1C470M	ELECTRØ 47UF 16WV		
C82			CE04KW1HR47M	ELECTRØ 0.47UF 50WV		
C83			CK45FF1H223Z	CERAMIC 0.022UF Z	UMUEAT	
C83			CK45FF1H223Z	CERAMIC 0.022UF Z	E	
C83			CK45F1H223Z	CERAMIC 0.022UF Z	EF	
C87			C91-0769-05	CERAMIC 0.01UF M		
C88			CE04KW1A101M	ELECTRØ 100UF 10WV		
C89			C91-0769-05	CERAMIC 0.01UF M		
C90 ,91			CC45CH1H390J	CERAMIC 39PF J	EF	
C90 ,91			CC45FCH1H390J	CERAMIC 39PF J	UMUEAT	
C90 ,91			CC45FCH1H390J	CERAMIC 39PF J	E	
C92 ,93			CK45FF1H472Z	CERAMIC 4700PF Z	UMUEAT	
C92 ,93			CK45FF1H472Z	CERAMIC 4700PF Z	E	
C92 ,93			CK45F1H472Z	CERAMIC 4700PF Z	EF	
C94 ,95			CE04KW1C471M	ELECTRØ 470UF 16WV		
C96			CE04KW1E221M	ELECTRØ 220UF 25WV		
C97			CE04KW1V102M	ELECTRØ 1000UF 35WV		
C98 ,99			CE04KW1E102M	ELECTRØ 1000UF 25WV		
C100			CE04KW0J102M	ELECTRØ 1000UF 6.3WV		
C103-107			CK45FF1H103Z	CERAMIC 0.010UF Z	UMUEAT	
C103-107			CK45FF1H103Z	CERAMIC 0.010UF Z	E	
C103-107			CK45F1H103Z	CERAMIC 0.010UF Z	EF	
C117			CK45FF1H223Z	CERAMIC 0.022UF Z	UMUEAT	
C117			CK45FF1H223Z	CERAMIC 0.022UF Z	E	
C117			CK45F1H223Z	CERAMIC 0.022UF Z	EF	
C118			C91-0769-05	CERAMIC 0.01UF M		
C123,124			C91-0749-05	CERAMIC 220PF K		
C125			CE04KW1C470M	ELECTRØ 47UF 16WV		
C126			CK45FF1H473Z	CERAMIC 0.047UF Z	UMUEAT	
C126			CK45FF1H473Z	CERAMIC 0.047UF Z	E	
C126			CK45F1H473Z	CERAMIC 0.047UF Z	EF	
C151			CE04KW1A101M	ELECTRØ 100UF 10WV		
C153			C90-1400-05	NP-ELEC 10UF 50WV		

E: Scandinavia & Europe H: Audio Club K: USA P: Canada W: Europe

T: England U: PX(Far East Hawaii) A: Saudi Arabia EF: France made

UE: AAFES(Europe) X: Australia M: Other Areas

⚠ indicates safety critical components.

PARTS LIST

× New Parts

Parts without Parts No. are not supplied.

Les articles non mentionnés dans le Parts No. ne sont pas fournis.

Telle ohne Parts No. werden nicht geliefert.

Ref. No. 参照番号	Address 位置	New Parts 新	Parts No. 部品番号	Description 部品名 / 規格	Desti- nation 仕 向	Re- marks 備考
C154			CE04KW1V100M	ELECTRØ 10UF 35WV		
C155			CK45B1H102K	CERAMIC 1000PF K	EF	
C155			CK45FB1H102K	CERAMIC 1000PF K	UMUEAT	
C155			CK45FB1H102K	CERAMIC 1000PF K	E	
C156			CE04KWOJ221M	ELECTRØ 220UF 6.3WV		
C157-159			C91-0757-05	CERAMIC 0.001UF K		
C160			CK45B1H102K	CERAMIC 1000PF K	EF	
C160			CK45FB1H102K	CERAMIC 1000PF K	UMUEAT	
C160			CK45FB1H102K	CERAMIC 1000PF K	E	
C161-164			C91-0757-05	CERAMIC 0.001UF K		
C165			CE04KW1H010M	ELECTRØ 1.0UF 50WV		
C166			CK45FF1H103Z	CERAMIC 0.010UF Z	UMUEAT	
C166			CK45FF1H103Z	CERAMIC 0.010UF Z	E	
C166			CK45F1H103Z	CERAMIC 0.010UF Z	EF	
C167			CE04KWOJ222M	ELECTRØ 2200UF 6.3WV		
TC1			C05-0097-05	CERAMIC TRIMMER CAPACITØR(30PF)	TEEF	
TC2			C05-0303-05	CERAMIC TRIMMER CAPACITØR(20PF)		
TC3			C05-0097-05	CERAMIC TRIMMER CAPACITØR(30PF)	TEEF	
TC4			C05-0303-05	CERAMIC TRIMMER CAPACITØR(20PF)		
E2	2B		E20-0318-05	SCREW TERMINAL BOARD(2P)ANT	TEEF	
E2	2B		E20-0449-05	SCREW TERMINAL BOARD(4P)ANT	UMUEA	
E3	2B		E13-0217-05	PHONE JACK (2P) OUTPUT		
E4	2B	*	E11-0166-05	MINIATURE PHONE JACK(PWR SPLY)		
E5	2B		E11-0168-05	MINIATURE PHONE JACK(SYS CØNT)		
CF1 +2			L72-0140-05	CERAMIC FILTER	UMUEA	
CF1 +2			L72-0190-05	CERAMIC FILTER	TEEF	
CF3			L72-0096-05	CERAMIC FILTER		
L1			L40-1092-14	SMALL FIXED INDUCTØR(1.0UH,M)		
L2			L31-0499-05	LW-RF CØIL	TEEF	
L3			L31-0509-05	MW-RF CØIL		
L4			L32-0288-05	LW OSCILLATING CØIL	TEEF	
L5			L32-0277-15	MW OSCILLATING CØIL		
L7			L40-1092-14	SMALL FIXED INDUCTØR(1.0UH,M)		
L8			L79-0125-05	LC FILTER	TEEF	
L9			L79-0154-05	LC FILTER	TEEF	
L10			L40-1092-14	SMALL FIXED INDUCTØR(1.0UH,M)		
L11			L40-1021-14	SMALL FIXED INDUCTØR(1.0MH,K)		
L13			L39-0128-05	PEAKING CØIL		
T4			L30-0439-05	FM IFT		
T5		*	L30-0454-05	AM IFT		
X1			L77-0578-05	CRYSTAL RESONATØR(7.2MHZ)		
X2			L78-0209-05	RESONATØR (4.194MHZ)		
CP1 -4			R90-0426-05	MULTI-COMP 100KX6 J 1/6W		
CP5			R90-0277-05	MULTI-COMP 33KX4 J 1/6W		
R3			RD14AB2E470J	FL-PROOF RD 47 J 1/4W	UMUEAT	
R3			RD14AB2E470J	FL-PROOF RD 47 J 1/4W	E	
R3			RD14GB2E470J	FL-PROOF RD 47 J 1/4W	EF	
R35			RD14AB2E101J	FL-PROOF RD 100 J 1/4W	UMUEAT	
R35			RD14AB2E101J	FL-PROOF RD 100 J 1/4W	E	
R35			RD14GB2E101J	FL-PROOF RD 100 J 1/4W	EF	
R54			RD14AB2E101J	FL-PROOF RD 100 J 1/4W	UMUEAT	
R54			RD14AB2E101J	FL-PROOF RD 100 J 1/4W	E	
R54			RD14GB2E101J	FL-PROOF RD 100 J 1/4W	EF	
R91			RD14AB2E101J	FL-PROOF RD 100 J 1/4W	UMUEAT	

E: Scandinavia & Europe H: Audio Club K: USA P: Canada W: Europe

T: England U: PX(Far East, Hawaii) A: Saudi Arabia EF: France made

UE: AAFES(Europe) X: Australia M: Other Areas

⚠ indicates safety critical components.

PARTS LIST

* New Parts

Parts without Parts No. are not supplied.

Les articles non mentionnés dans le Parts No. ne sont pas fournis.

Teile ohne Parts No. werden nicht geliefert.

Ref. No. 参照番号	Address 位置	New Parts 新	Parts No. 部品番号	Description 部品名 / 規格	Desti- nation 仕向	Re- marks 備考
R91			RD14AB2E101J	FL-PROOF RD 100 J 1/4W	E	
R91			RD14GB2E101J	FL-PROOF RD 100 J 1/4W	EF	
R96			RD14AB2E220J	FL-PROOF RD 22 J 1/4W	UMUEAT	
R96			RD14AB2E220J	FL-PROOF RD 22 J 1/4W	E	
R96			RD14GB2E220J	FL-PROOF RD 22 J 1/4W	EF	
R137			RS14DB3A680J	FL-PROOF RS 68 J 1W	UMUEAT	
R137			RS14DB3A680J	FL-PROOF RS 68 J 1W	E	
R137			RS14KB3A680J	FL-PROOF RS 68 J 1W	EF	
R142,143			RS14DB3D332J	FL-PROOF RS 3.3K J 2W	UMUEAT	
R142,143			RS14DB3D332J	FL-PROOF RS 3.3K J 2W	E	
R142,143			RS14KB3D332J	FL-PROOF RS 3.3K J 2W	EF	
R144			RS14DB3D271J	FL-PROOF RS 270 J 2W	UMUEAT	
R144			RS14DB3D271J	FL-PROOF RS 270 J 2W	E	
R144			RS14KB3D271J	FL-PROOF RS 270 J 2W	EF	
R194			RD14AB2E221J	FL-PROOF RD 220 J 1/4W	UMUEAT	
R194			RD14AB2E221J	FL-PROOF RD 220 J 1/4W	E	
R194			RD14GB2E221J	FL-PROOF RD 220 J 1/4W	EF	
R197			RS14KB3D560J	FL-PROOF RS 56 J 2W		
R198,199			RS14DB3A561J	FL-PROOF RS 560 J 1W	UMUEAT	
R198,199			RS14DB3A561J	FL-PROOF RS 560 J 1W	E	
R198,199			RS14KB3A561J	FL-PROOF RS 560 J 1W	EF	
VR1			R12-1069-05	TRIMMING PNT. (4.7K) VCO		
VR2			R12-5046-05	TRIMMING PNT. (100K) SEP	TEEF	
VR5			R12-3096-05	TRIMMING PNT. (10K) AM TUNE LVL		
VR6			R12-3098-05	TRIMMING PNT. (33K) FM TUNE LVL		
K1	2B		S51-1036-05	MAGNETIC RELAY		
S1	2B		S31-2075-05	SLIDE SWITCH (CHANNEL SPACE)	TEEF	
S1 ,2	2B		S31-2075-05	SLIDE SWITCH (CH,DE-EMPHASIS)	UMUEA	
D16 -19			1SS133	DIODE	UMUEA	
D16 -21			1SS133	DIODE	TEEF	
D20			1SS176	DIODE	TEEF	
D21			1SS133	DIODE	UMUEA	
D26 ,27			HZS13N(B2)	ZENER DIODE		
D27			RD13ES(B2)	ZENER DIODE		
D29			HZS5.1N(B2)	ZENER DIODE		
D29			RD5.1ES(B2)	ZENER DIODE		
D30 -34			DSM1A1	DIODE		
D37 ,38			KV1236(Z2)	VARIABLE CAPACITANCE DIODE	TEEF	
D38			KV1236(Z2)	VARIABLE CAPACITANCE DIODE	UMUEA	
D39 -41			1SS133	DIODE		
D50			1B4B41	DIODE		
D52			HZS5.1N(B)	ZENER DIODE		
D52			RD5.1ES(B)	ZENER DIODE		
D54 -59			1SS133	DIODE	UMUEA	
D54 -59			1SS176	DIODE		
D54 -60			1SS133	DIODE	TEEF	
D60			1SS176	DIODE	TEEF	
D61 -64			1SS133	DIODE	UMUEA	
D61 ,62			1SS176	DIODE	UMUEA	
D63 -81			1SS133	DIODE	TEEF	
D63 ,64			1SS176	DIODE		
D65 ,66			1SS176	DIODE	TEEF	
D67			1SS133	DIODE	UMUEA	
D67			1SS176	DIODE		

E: Scandinavia & Europe H: Audio Club K: USA P: Canada W: Europe

T: England U: PX(Far East, Hawaii) A: Saudi Arabia EF: France made

UE: AAFES(Europe) X: Australia M: Other Areas

 indicates safety critical components.

PARTS LIST

× New Parts

Parts without Parts No. are not supplied.

Les articles non mentionnés dans le Parts No. ne sont pas fournis.

Telle ohne Parts No. werden nicht geliefert.

Ref. No. 参照番号	Address 位置	New Parts 新	Parts No. 部品番号	Description 部品名 / 規格	Desti- nation 仕 向	Re- marks 備考
D68			1SS176	DIODE	TEEF	
D69 -80			1SS133	DIODE	UMUEA	
D69 -80			1SS176	DIODE		
D81			1SS176	DIODE	TEEF	
D88			1SS133	DIODE		
D88	2A		1SS176	DIODE		
FL1			FIP15AM14	FLUORESCENT INDICATOR TUBE		
IC1			LA1265	IC(FM/AM TUNER)		
IC2			AN747D	IC(FM MPX)		
IC5			LM7001	IC(PLL FREQUENCY SYNTHESIZER)		
IC6		*	UPD7516HCW-269	IC(MICROPROCESSOR)		
IC7 -10			LB1294	IC(6CH DARLINGTON DRIVER)		
Q2			2SC1923(Q)	TRANSISTOR		
Q4			2SC1740S(Q,R)	TRANSISTOR	UMUEA	
Q4			2SC945(A)(Q,P)	TRANSISTOR		
Q4 -7			2SC945(A)(Q,P)	TRANSISTOR	TEEF	
Q5 -7			2SC1740S(Q,R)	TRANSISTOR	TEEF	
Q8 ,9			2SK364(GR,BL)	FET	TEEF	
Q10			2SC1740S(Q,R)	TRANSISTOR	TEEF	
Q10			2SC945(A)(Q,P)	TRANSISTOR		
Q11			2SK364(GR,BL)	FET	TEEF	
Q12			2SC1845(F,E)	TRANSISTOR		
Q13			2SC1740S(Q,R)	TRANSISTOR		
Q13			2SC945(A)(Q,P)	TRANSISTOR		
Q16 ,17			2SA733(A)(Q,P)	TRANSISTOR		
Q16 ,17			2SA933S(Q,R)	TRANSISTOR	TEEF	
Q18			2SC1740S(Q,R)	TRANSISTOR	TEEF	
Q18			2SC945(A)(Q,P)	TRANSISTOR		
Q25			2SC1740S(Q,R)	TRANSISTOR		
Q25			2SC945(A)(Q,P)	TRANSISTOR		
Q26 ,27			2SK364(GR,BL)	FET		
Q28			2SA733(A)(Q,P)	TRANSISTOR		
Q28			2SA933S(Q,R)	TRANSISTOR		
Q29 ,30			2SC1740S(Q,R)	TRANSISTOR		
Q29 ,30			2SC945(A)(Q,P)	TRANSISTOR		
Q36			2SC1740S(Q,R)	TRANSISTOR		
Q36			2SC945(A)(Q,P)	TRANSISTOR		
Q37			2SC2167(Q,Y)	TRANSISTOR		
Q38			2SA999(E,F)	TRANSISTOR		
Q39			2SC1740S(Q,R)	TRANSISTOR		
Q39			2SC945(A)(Q,P)	TRANSISTOR		
Q40			2SA733(A)(Q,P)	TRANSISTOR		
Q40			2SA933S(Q,R)	TRANSISTOR		
Q52 -54			2SA733(A)(Q,P)	TRANSISTOR		
Q52 -54			2SA933S(Q,R)	TRANSISTOR		
Q55 ,56			2SC1740S(Q,R)	TRANSISTOR		
Q55 ,56			2SC945(A)(Q,P)	TRANSISTOR		
Q57 ,58			2SA733(A)(Q,P)	TRANSISTOR	UMUEA	
Q57 ,58			2SA933S(Q,R)	TRANSISTOR	UMUEA	
Q59			2SC1740S(Q,R)	TRANSISTOR	TEEF	
Q59			2SC945(A)(Q,P)	TRANSISTOR		
35	2B		W02-0699-05	FM FRONT-END ASSY	UMUEA	
35	2B		W02-0700-05	FM FRONT-END ASSY	TEEF	

For Service Manuals Contact
MAURITRON TECHNICAL SERVICES
8 Cherry Tree Rd, Chinnor
Oxon OX9 4QY
Tel: 01844-351894 Fax: 01844-352554
Email: enquiries@maurifron.co.uk

E: Scandinavia & Europe H: Audio Club K: USA P: Canada W: Europe

T: England U: PX(Far East, Hawaii) A: Saudi Arabia EF: France made

UE: AAFES(Europe) X: Australia M: Other Areas

⚠ indicates safety critical components.

PARTS LIST

× New Parts

Parts without Parts No. are not supplied.

Les articles non mentionnés dans le Parts No. ne sont pas fournis.

Telle ohne Parts No. werden nicht geliefert.

Ref. No. 参照番号	Address 位置	New Parts 新	Parts No. 部品番号	Description 部品名/規格	Desti- nation 仕向	Re- marks 備考
SWITCH UNIT (X13-5070-52)						
S1 -5	3A		S40-1064-05	PUSH SWITCH(ADJ,PROG,1/2,TIMER)		
S7 -18	3A,3B		S40-1064-05	PUSH SWITCH(CHANNEL)		
S20 -26	2A,3B		S40-1064-05	PUSH SWITCH(POWER,TUNING,ETC)		
S22 -26	2A,3B		S40-1064-05	PUSH SWITCH		
FM FRONT-END ASS'Y (U, M, UE, A) (W02-0699-05)						
D1 -3			15V110	DIODE		
TR1			2SK439	TRANSISTOR		
TR2 ,3			2SC3391	TRANSISTOR		
TR4			2SC3494	TRANSISTOR		
FM FRONT-END ASS'Y (T, E, EF) (W02-0700-05)						
D1 -4			15V110	TRANSISTOR		
TR1			3SK85	TRANSISTOR		
TR2 ,3			2SC3391	TRANSISTOR		
TR2 ,3			2SC535	TRANSISTOR		
TR4			2SC2839	TRANSISTOR		
TR5			2SK241	TRANSISTOR		
TR5			2SK439	TRANSISTOR		

E: Scandinavia & Europe H: Audio Club K: USA P: Canada W: Europe

T: England U: PX(Far East, Hawaii) A: Saudi Arabia EF: France made

UE: AAFES(Europe) X: Australia M: Other Areas

 indicates safety critical components.

SPECIFICATIONS

T-7X

EIA

FM tuner section

Tuning frequency range	87.5 MHz — 108 MHz
Antenna impedance	300 ohm balanced 75 ohm unbalanced
Sensitivity	
Usable sensitivity (IHF): MONO	0.95 μ V, 10.8 dBf
50 dB quieting sensitivity (IHF)	
MONO:	3.7 μ V, 16.3 dBf
STEREO:	49 μ V, 39.0 dBf
Total harmonic distortion	
MONO: (75 kHz Dev.) 100 Hz	0.25%
1,000 Hz	0.20%
6,000 Hz	0.25%
50 Hz — 10,000 Hz	0.40%
STEREO: (75 kHz Dev.) 100 Hz	0.40%
1,000 Hz	0.40%
6,000 Hz	0.50%
50 Hz — 10,000 Hz	0.60%
Signal-to-Noise ratio	
MONO: (75 kHz Dev.)	
65 dBf input	78 dB
85 dBf input	78 dB
STEREO: (75 kHz Dev.)	
65 dBf input	71 dB
85 dBf input	71 dB
Capture ratio	1.8 dB
Alternate channel selectivity	
IHF: \pm 400 kHz	72 dB
Stereo separation	
1,000 Hz	44 dB
50 Hz — 10,000 Hz	37 dB
15,000 Hz	30 dB
Frequency response	
30 Hz — 15,000 Hz	+0.5 dB, -2.5 dB
Image rejection ratio (98 MHz)	43 dB
IF rejection ratio (98 MHz)	87 dB
Spurious rejection ratio (98 MHz)	78 dB
AM suppression ratio	75 dB
Sub-carrier suppression ratio	34 dB
Output level/impedance	
FM: 1,000 Hz, 100% Dev.	
(fixed)	0.6 V, 3.3 kohms
AM tuner section	
Tuning Frequency Range	
9 kHz step	531 kHz ~ 1602 kHz
10 kHz step	530 kHz ~ 1610 kHz
Usable sensitivity	14 μ V, 500 μ V/m
Signal-to-Noise ratio	
(30% Mod; 1 mV input)	49 dB
Total harmonic distortion	0.5%
Image rejection ratio	40 dB
IF rejection ratio	50 dB
Selectivity (IHF)	24 dB
Output Level/Impedance	
(400 Hz, 30% Mod.)	0.18 V, 3.3 kohms
General	
Dimensions	W: 340 mm (13-3/8") H: 59 mm (2-5/16") D: 358 mm (14-1/8")
Weight (Net)	3.2 kg (7.0 lb)

T-7LX

IEC/NF

FM tuner section

Frequency range	87.5 MHz — 108 MHz
Sensitivity at 75 ohms	
MONO: S/N 26 dB,	
40 kHz Dev.	0.7 μ V
STEREO: S/N 46 dB,	
46 kHz Dev.	25 μ V
Limiting level at 75 ohms	
-3 dB point, 40 kHz dev.	0.8 μ V
Frequency response	
30 Hz — 15 kHz	+0.5 dB, -2.5 dB
Total harmonic distortion	
MONO: 1 kHz, 40 kHz dev.	0.15% (DIN)
STEREO: 1 kHz, 46 kHz dev.	0.5% (DIN)
Signal-to-Noise ratio unweighted	
MONO: 40 kHz dev.:	
1 mV input	67 dB (DIN)
STEREO: 46 kHz dev.:	
1 mV input	61 dB (DIN)
Signal-to-Noise ratio weighted	
MONO: 40 kHz dev.:	
1 mV input	74 dB (DIN)
STEREO: 46 kHz dev.:	
1 mV input	65 dB (DIN)
Capture ratio	2.0 dB (NORMAL)
Alternate channel selectivity	79 dB (DIN: \pm 300 kHz)
FM stereo separation: 1 mV input (DIN)	
250 Hz	40 dB
1 kHz	43 dB
6.3 kHz	37 dB
12.5 kHz	24 dB
Image rejection ratio (98 MHz)	76 dB
IF rejection ratio (98 MHz)	81 dB
Spurious rejection ratio	
(98 MHz)	110 dB
AM suppression ratio	68 dB
Sub-carrier suppression ratio	
do. 19 kHz, 46 kHz Dev.	65 dB
do. 38 kHz, 46 kHz Dev.	66 dB
Output level/impedance (FM)	
at 1 kHz, 100% Dev	0.6V/3.3 kohms
MW tuner section	
Tuning frequency range (9 kHz Step)	
Step)	531 kHz — 1602 kHz
Usable sensitivity	14 μ V (500 μ V/m)
Signal-to-Noise ratio	
(30% mod, 1 mV input)	49 dB
Total harmonic distortion	0.5%
Image rejection ratio	40 dB
IF rejection ratio	48 dB
Selectivity (IHF)	24 dB
Output level/impedance	
(400 Hz, 30% Mod.)	0.18V, 3.3 kohms
LW tuner section	
Tuning frequency range (1 kHz Step)	
Step)	153 kHz — 281 kHz
Usable sensitivity	14 μ V (900 μ V/m)
Signal-to-Noise ratio	
(30% mod; 1 mV input)	47 dB
Total harmonic distortion	0.5%
Image rejection ratio	37 dB
IF rejection ratio	60 dB
Selectivity (IHF)	30 dB
Output level/impedance	
(400 Hz, 30% Mod.)	0.18V, 3.3 kohms
General	
Power Consumption	
(Rated output at 8 ohms)	12 W (IEC)
AC outlet (Switched \times 1)	400 W
Dimensions	W: 340 mm H: 59 mm D: 358 mm
Weight (Net)	3.2 kg

For Service Manuals Contact
MAURITRON TECHNICAL SERVICES
 8 Cherry Tree Rd, Chinnor
 Oxon OX9 4QY
 Tel: 01844-351894 Fax: 01844-352554
 Email: enquiries@mauritron.co.uk

Note:

Component and circuitry are subject to modification to insure best operation under differing local conditions. This manual is based on, the Europe (E) standard, and provides information on regional circuit modification through use of alternate schematic diagrams, and information on regional component variations through use of parts list.

Kenwood follows a policy of continuous advancements in development. For this reason specifications may be changed without notice.

Kenwood poursuit une politique de progrès constants en ce qui concerne le développement. Pour cette raison, les spécifications sont sujettes à modifications sans préavis.

Kenwood strebt ständige Verbesserungen in der Entwicklung an. Daher bleiben Änderungen der technischen Daten jederzeit vorbehalten.

KENWOOD CORPORATION

EXPLODED VIEW

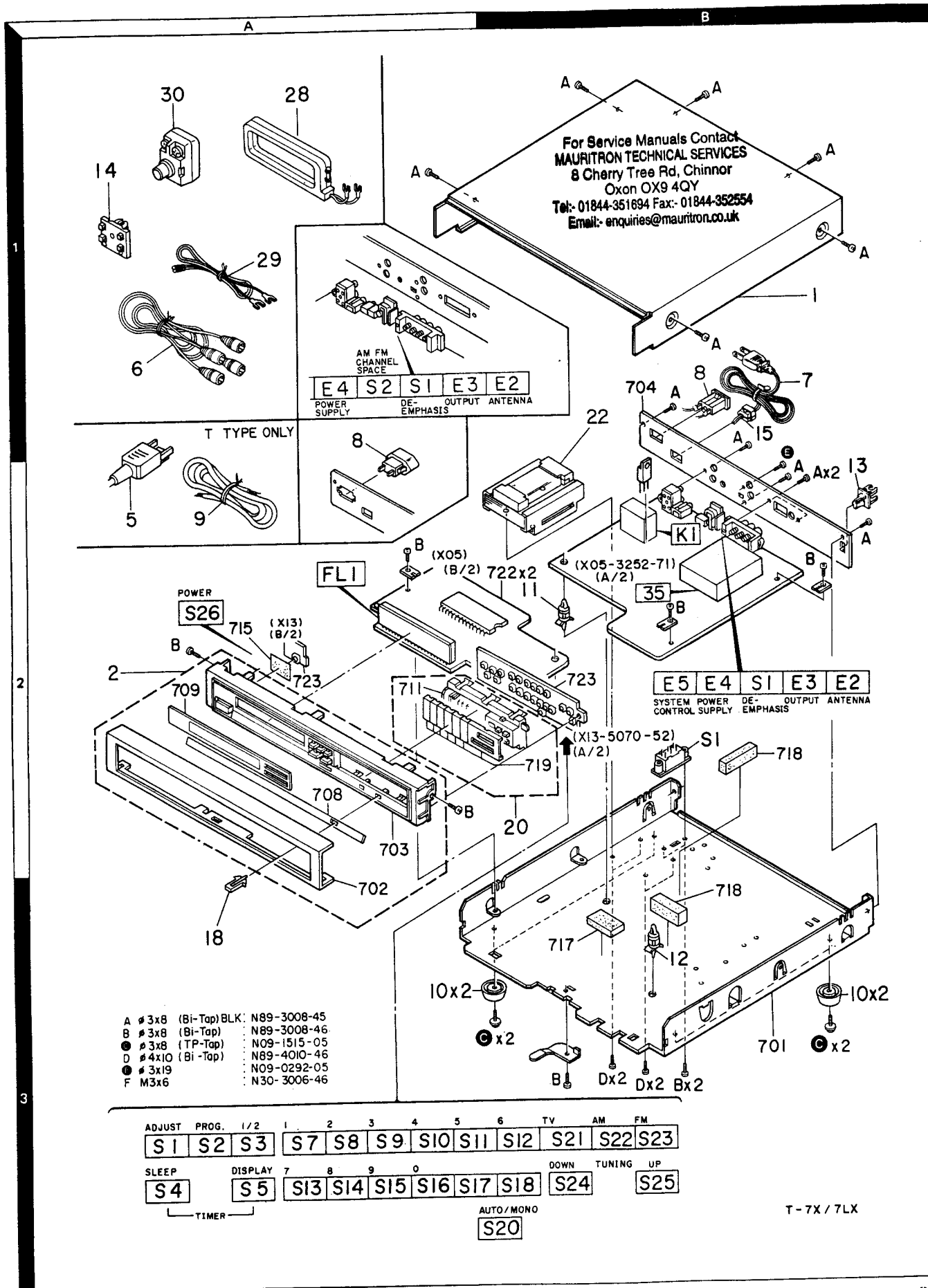

Parts with the exploded numbers larger than 700 are not supplied.

*(W02-0699-05)

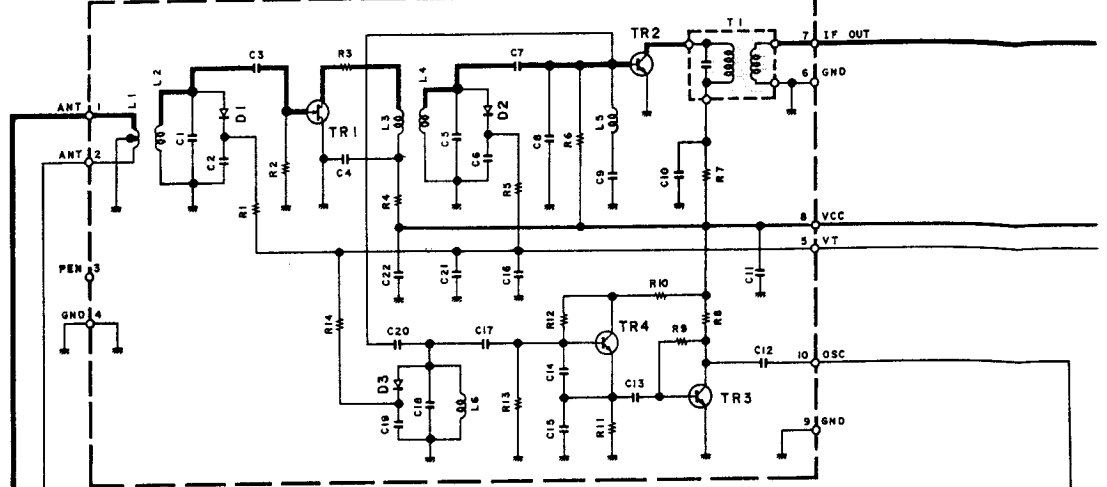

*(W02-0700-05)

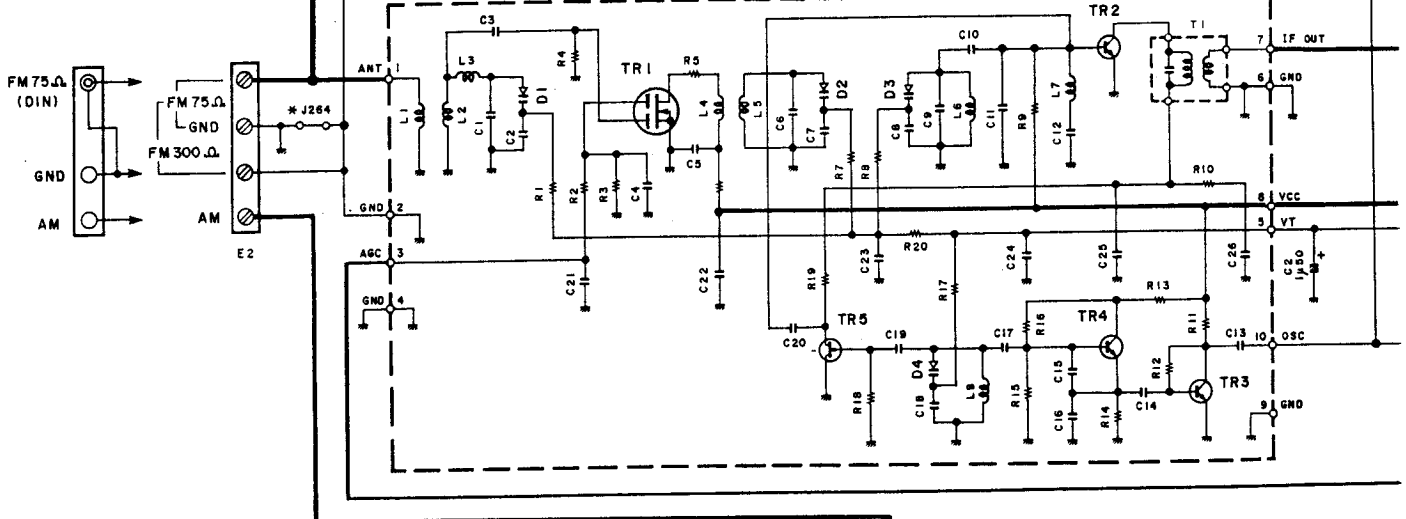

For Service Manuals Contact
MAURITRON TECHNICAL SERVICES
 8 Cherry Tree Rd, Chinnor
 Oxon OX9 4QY
 Tel: 01844-351694 Fax: 01844-352554
 Email: enquiries@mauritron.co.uk

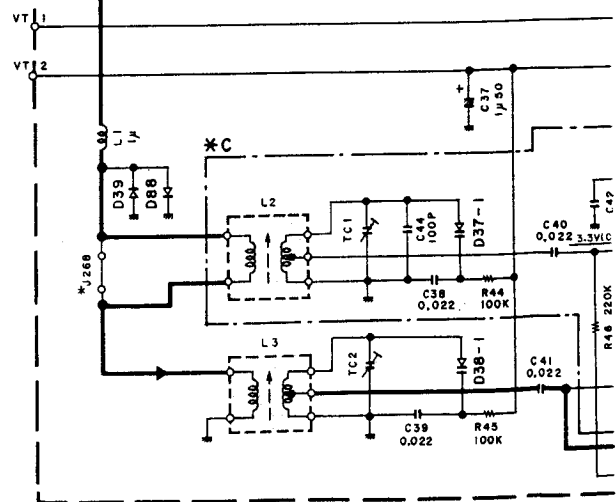

CAUTION: For continued safety, replace safety critical components only with manufacturer's recommended parts (refer to parts list).  Indicates safety critical components. To reduce the risk of electric shock, leakage-current or resistance measurements shall be carried out (exposed parts are acceptably insulated from the supply circuit) before the appliance is returned to the customer.

- 2SA733(A)
- 2SA999
- 2SC1845
- 2SC1923
- 2SC535
- 2SC945(A)

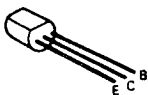

2SC2839

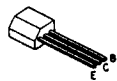

2SC2187

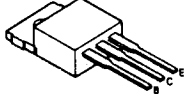

2SC3391
2SC3494

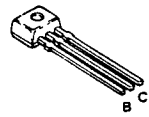

2SA933S
2SC1740S

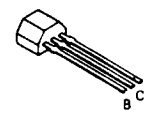

2SK364

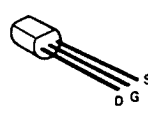

2SK241



9-05)

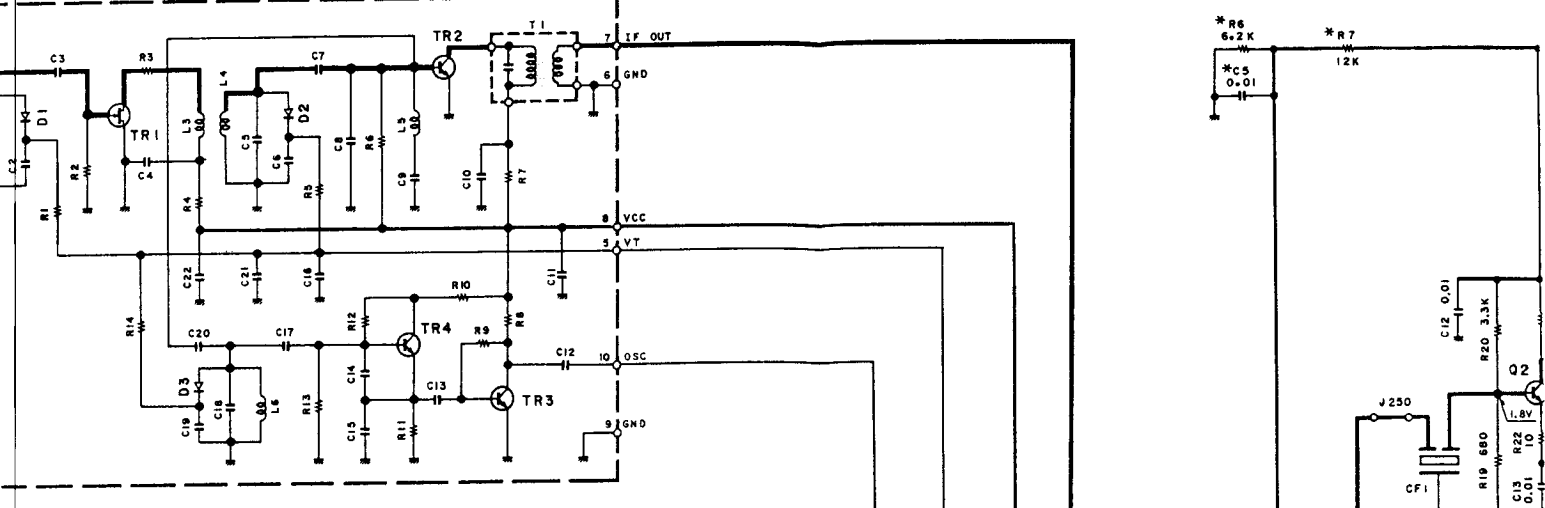

0-05)

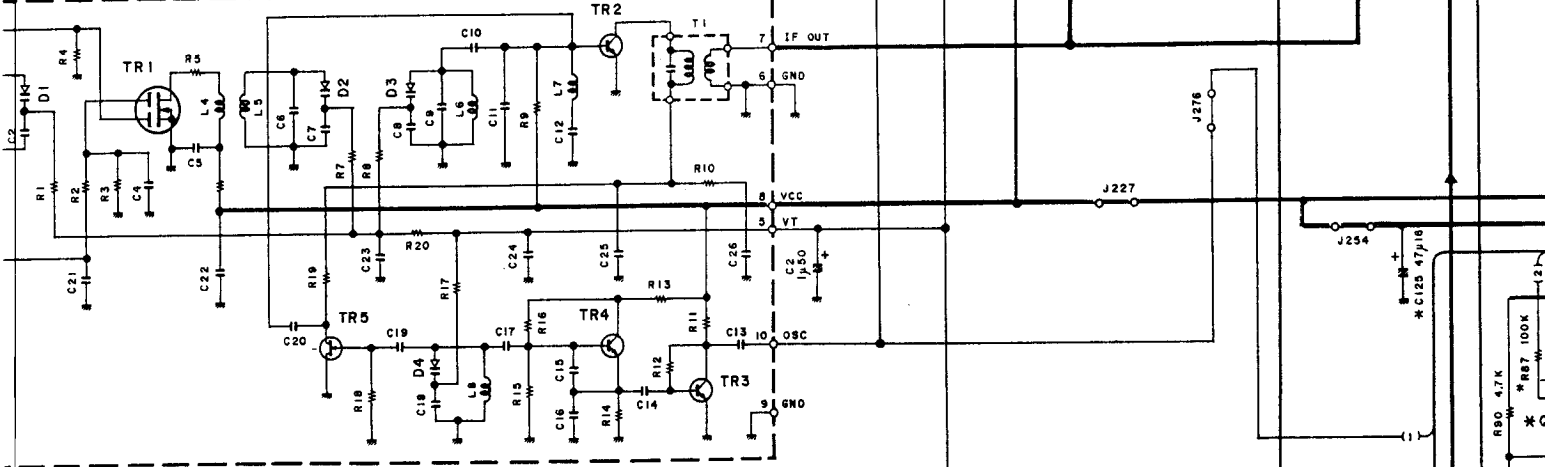

om-fer
To
ance
pta-
e is

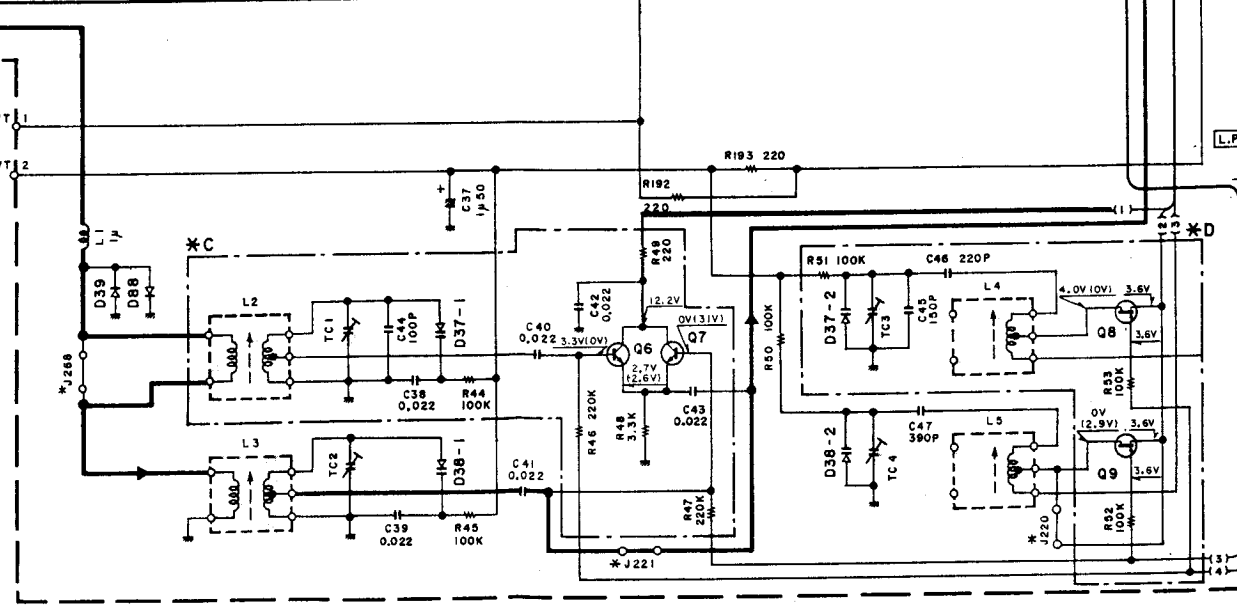

2SC3391
2SC3494

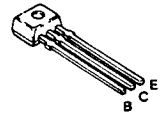

2SA933S
2SC1740S

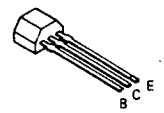

2SK364

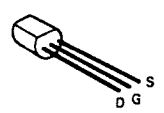

2SK241

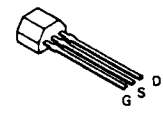

3SK85

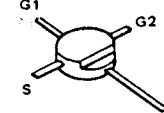

LB1294
LM7001

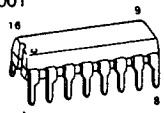

AN7470

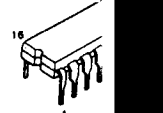

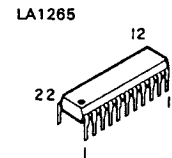
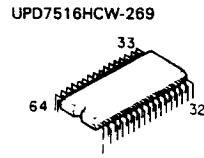
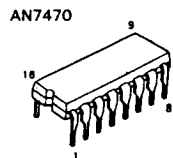
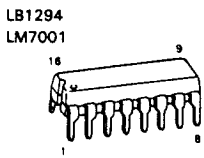
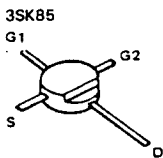
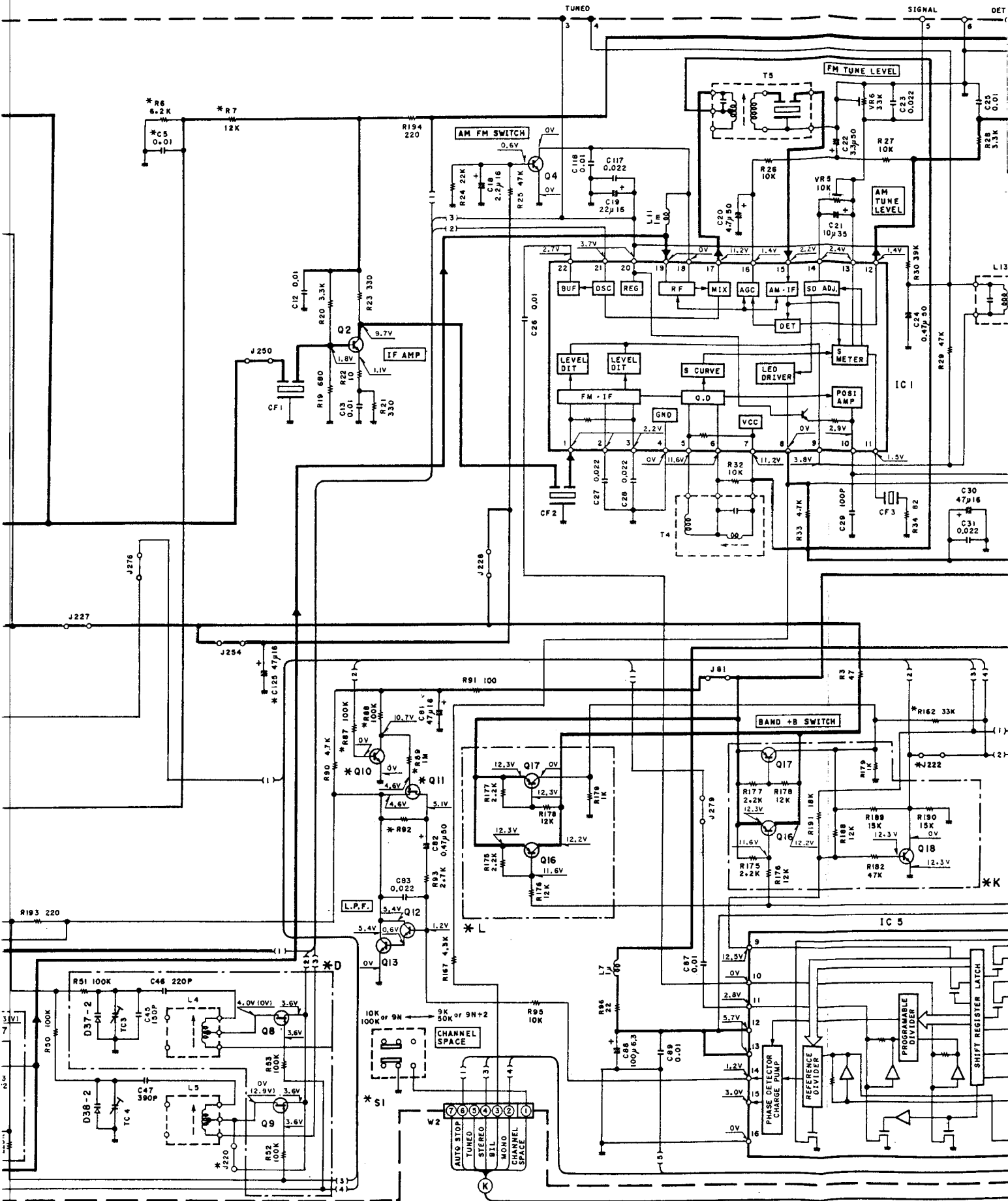

For Service Manuals Contact
MAURITRON TECHNICAL SERVICES
 8 Cherry Tree Rd, Chinnor
 Oxon OX9 4QY
 Tel: 01844-351694 Fax: 01844-352554
 Email: enquiries@mauritron.co.uk

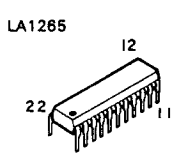
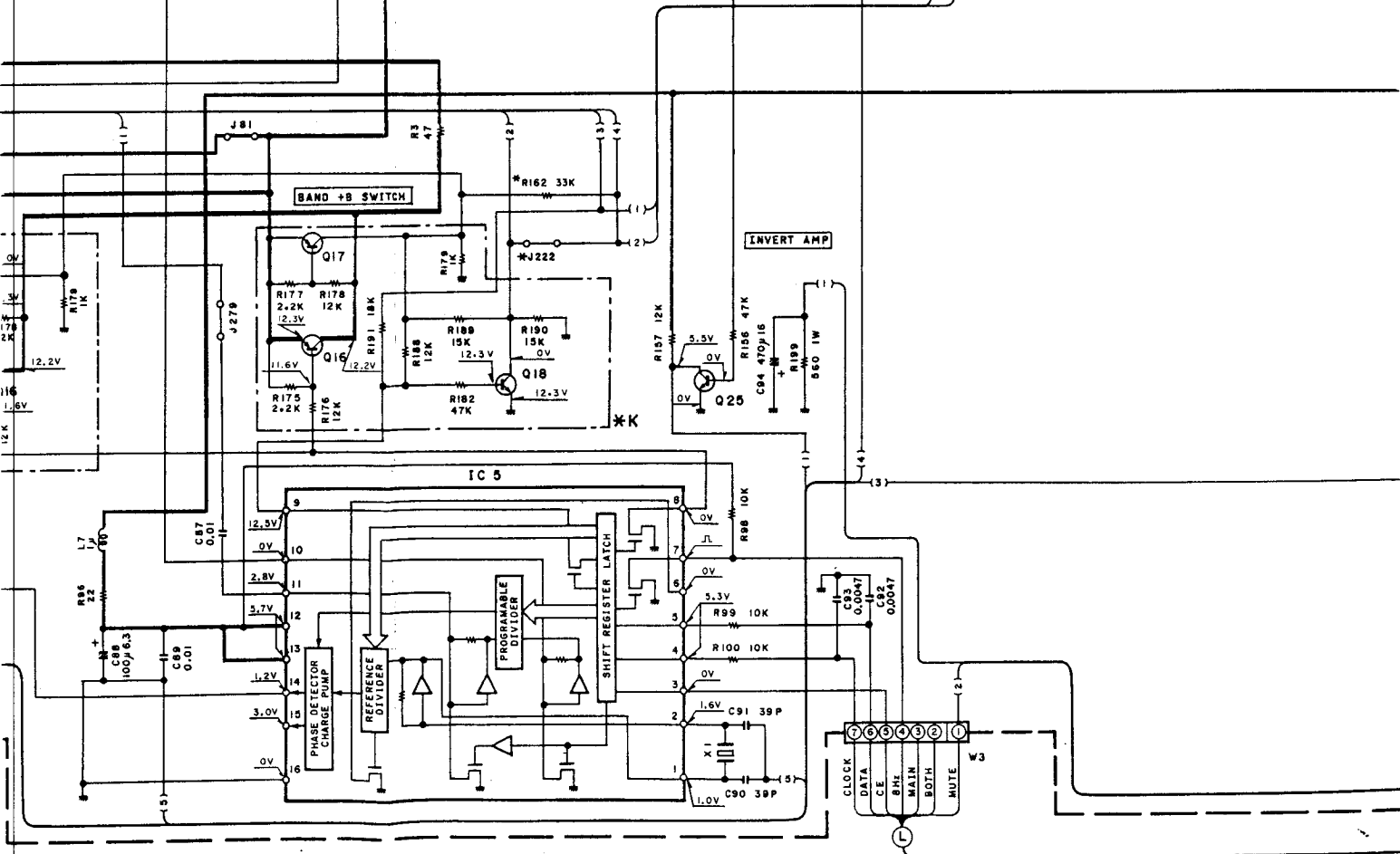
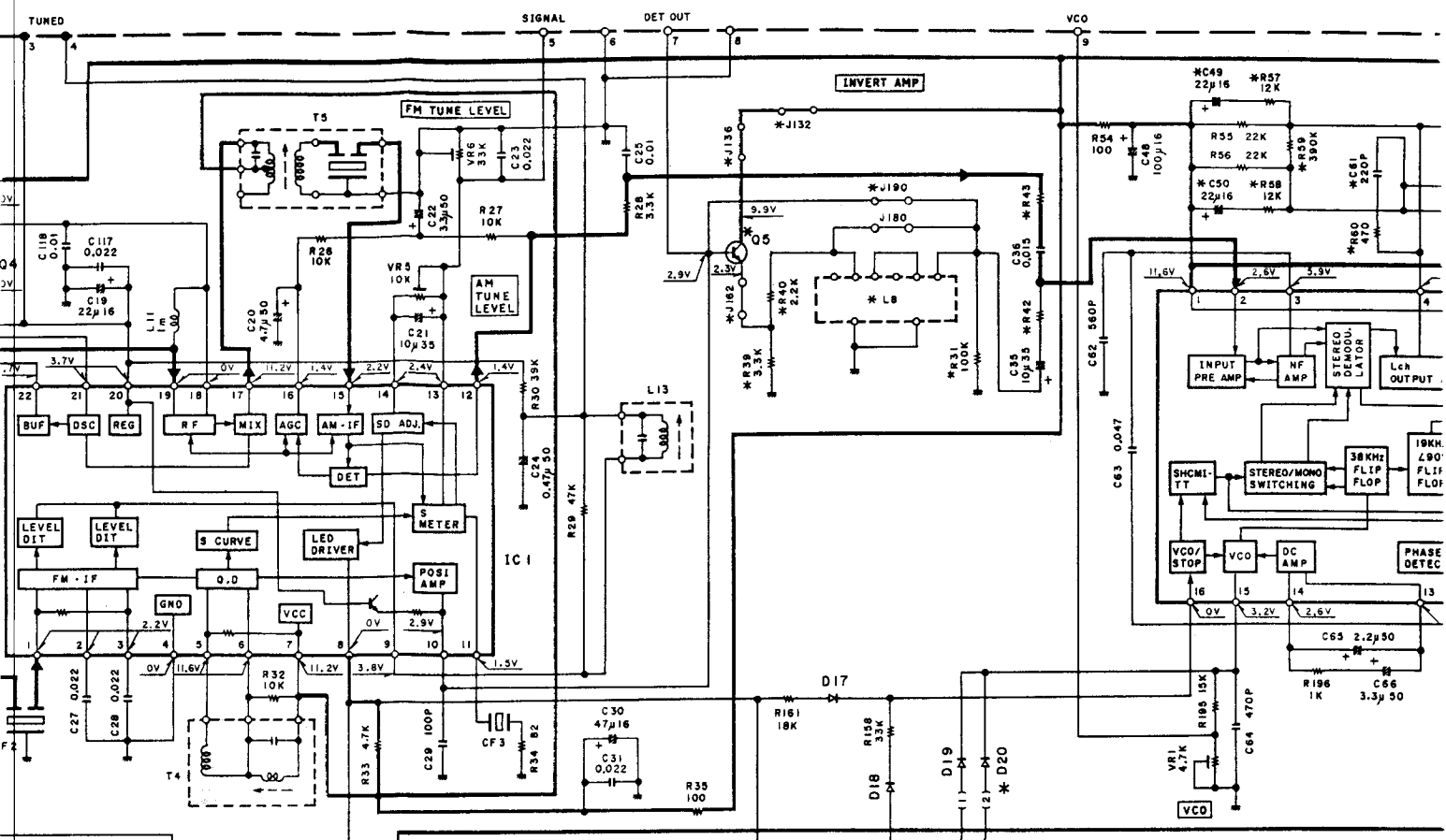

DC voltages are
voltmeter during
(with a signal st
Values may vary
dividual instrun
these are as m
broadcast signal
ANT terminal).

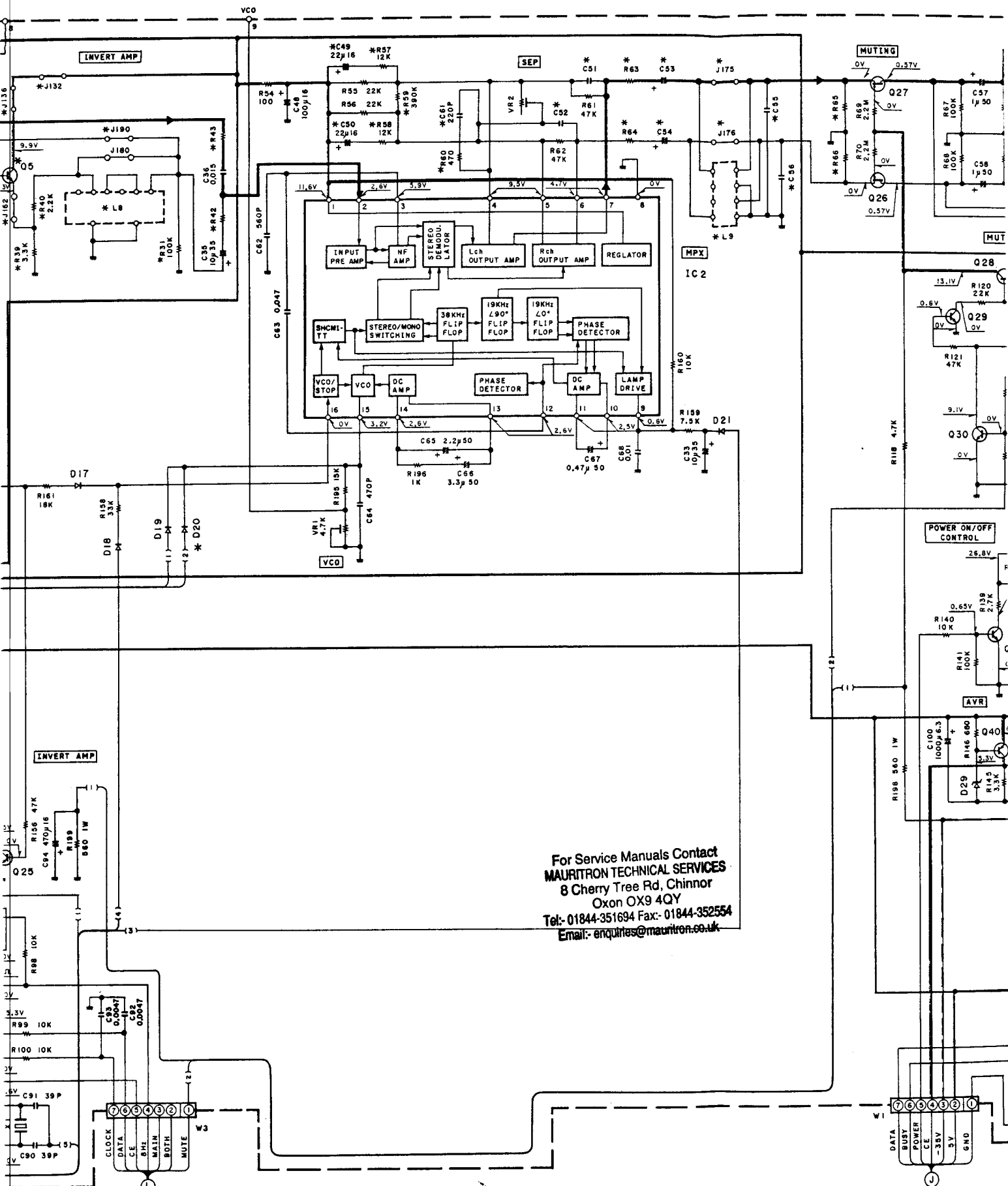

For Service Manuals Contact
MAURITRON TECHNICAL SERVICES
 8 Cherry Tree Rd, Chinnor
 Oxon OX9 4QY
 Tel: 01844-351694 Fax: 01844-352554
 Email: enquiries@mauritron.co.uk

DC voltages are as measured with a high-impedance voltmeter during reception of the FM broadcast signal (with a signal strength of 60 dB at the ANT terminal). Values may vary slightly due to variations between individual instruments or/and units. Values in parentheses are as measured during reception of the AM broadcast signal (with a signal strength of 60 dB at the ANT terminal).

Les tensions c.c. doivent être mesurées à l'aide d'un voltmètre à haute impédance pendant la réception d'un signal de programme FM (avec une force de signal de 60 dB à la borne ANT). Les valeurs peuvent varier légèrement du fait des variations inhérentes aux différents appareils et aux instruments de mesure utilisés. Les valeurs entre parenthèses doivent être mesurées pendant la réception d'un signal de programme AM (avec une force de signal de 60 dB à la borne ANT).

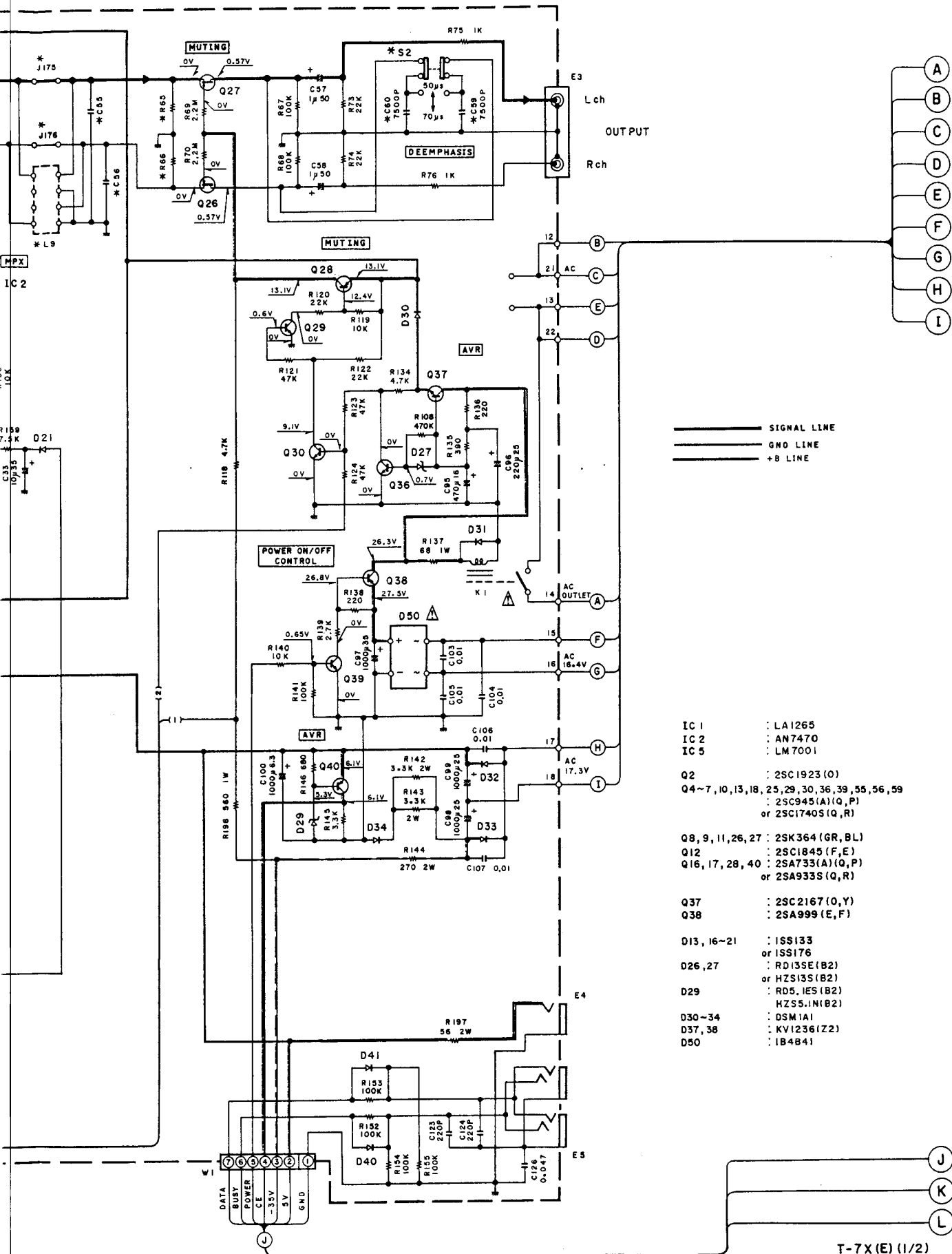

——— SIGNAL LINE
 ——— GND LINE
 ——— +B LINE

- IC 1 : LA1265
- IC 2 : AN7470
- IC 5 : LM7001

- Q2 : 2SC1923 (O)
- Q4~7, 10, 13, 18, 25, 29, 30, 36, 39, 55, 56, 59 : 2SC945 (A) (Q, P) or 2SC1740S (Q, R)

- Q8, 9, 11, 26, 27 : 2SK364 (GR, BL)
- Q12 : 2SC1845 (F, E)
- Q16, 17, 28, 40 : 2SA733 (A) (Q, P) or 2SA933S (Q, R)

- Q37 : 2SC2167 (O, Y)
- Q38 : 2SA999 (E, F)

- D13, 16~21 : 1SS133 or 1SS176
- D26, 27 : RD135E (B2) or HZS135 (B2)
- D29 : RD5, IES (B2) HZS5.1N (B2)
- D30~34 : 05M1A1
- D37, 38 : KV1236 (Z2)
- D50 : 1B4B41

T-7X (E) (1/2)

Impedance
 ast signal
 ernal).
 between in-
 parenthe-
 the AM
 B at the

Les tensions c.c. doivent être mesurées avec un volt-
 mètre à haute impédance pendant la réception d'un
 signal de programme FM (avec une force de signal
 de 60 dB à la borne ANT). Les valeurs peuvent différer
 légèrement du fait des variations inhérentes aux
 appareils et aux instruments de mesure individuels.
 Les valeurs entre parenthèses doivent être mesurées
 pendant la réception d'un signal de programme AM
 avec une force de signal de 60 dB à la borne ANT).

Die angegebenen Gleichspannungswerte wurden mit
 einem hochohmigen Spannungsmesser bei Empfang
 eines UKW-Signals (mit einer Feldstärke von 60 dB am
 Antennenanschluß) gemessen. Dabei schwanken die
 Meßwerte aufgrund von Unterschieden zwischen
 einzelnen Instrumenten oder Geräten u.U. geringfügig.
 Die eingeklammerten Gleichspannungswerte wurden
 bei Empfang eines MW-Signals (mit einer Feldstärke
 von 60 dB am Antennenanschluß) gemessen.

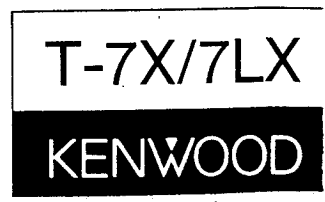

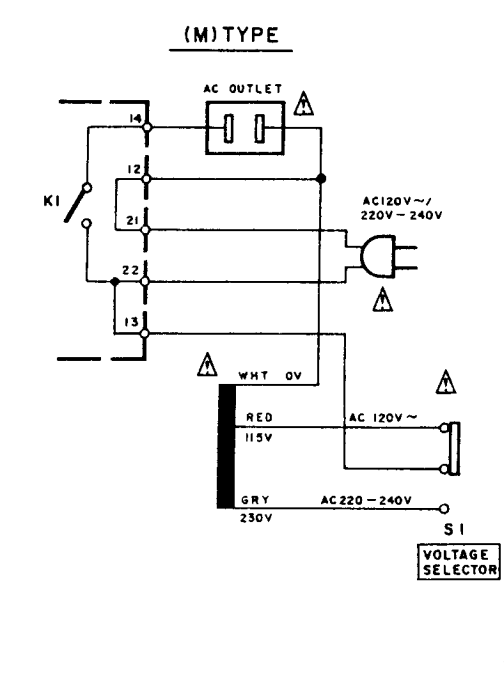
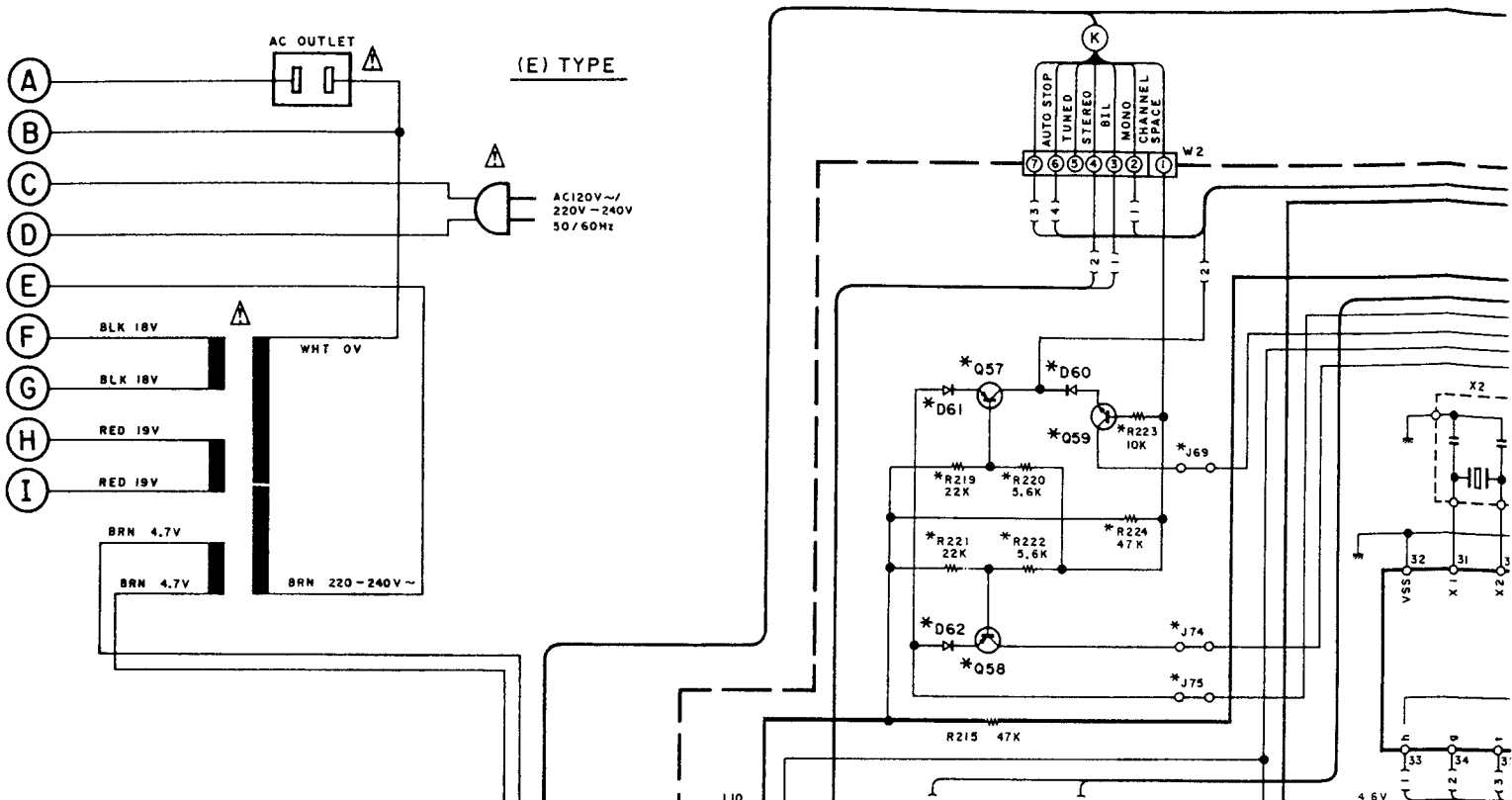

- IC 6 : μ PD7516HCW-269
- IC 7-10 : LB1294
- Q52-54, 57, 58 : 2SA733(A)(Q,P) or 2SA933S(Q,R)
- Q55, 56, 59 : 2SC945(A)(Q,P) or 2SC1740S(Q,R)
- D16, 54-81 : ISS133 or ISS176
- D52 : RD5, IES(B) or HZS5, IN(B)

Ref. NO.	R6	R7
DESTINATION		
0-21	NO	NO
2-71	YES	YES

LB, 9	S2
NO	YES
YES	NO

For Service Manuals Contact
MAURITRON TECHNICAL SERVICES
 8 Cherry Tree Rd, Chinnor
 Oxon OX9 4QY
 Tel: 01844-351694 Fax: 01844-352554
 Email: enquiries@mauritron.co.uk

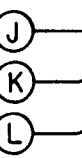

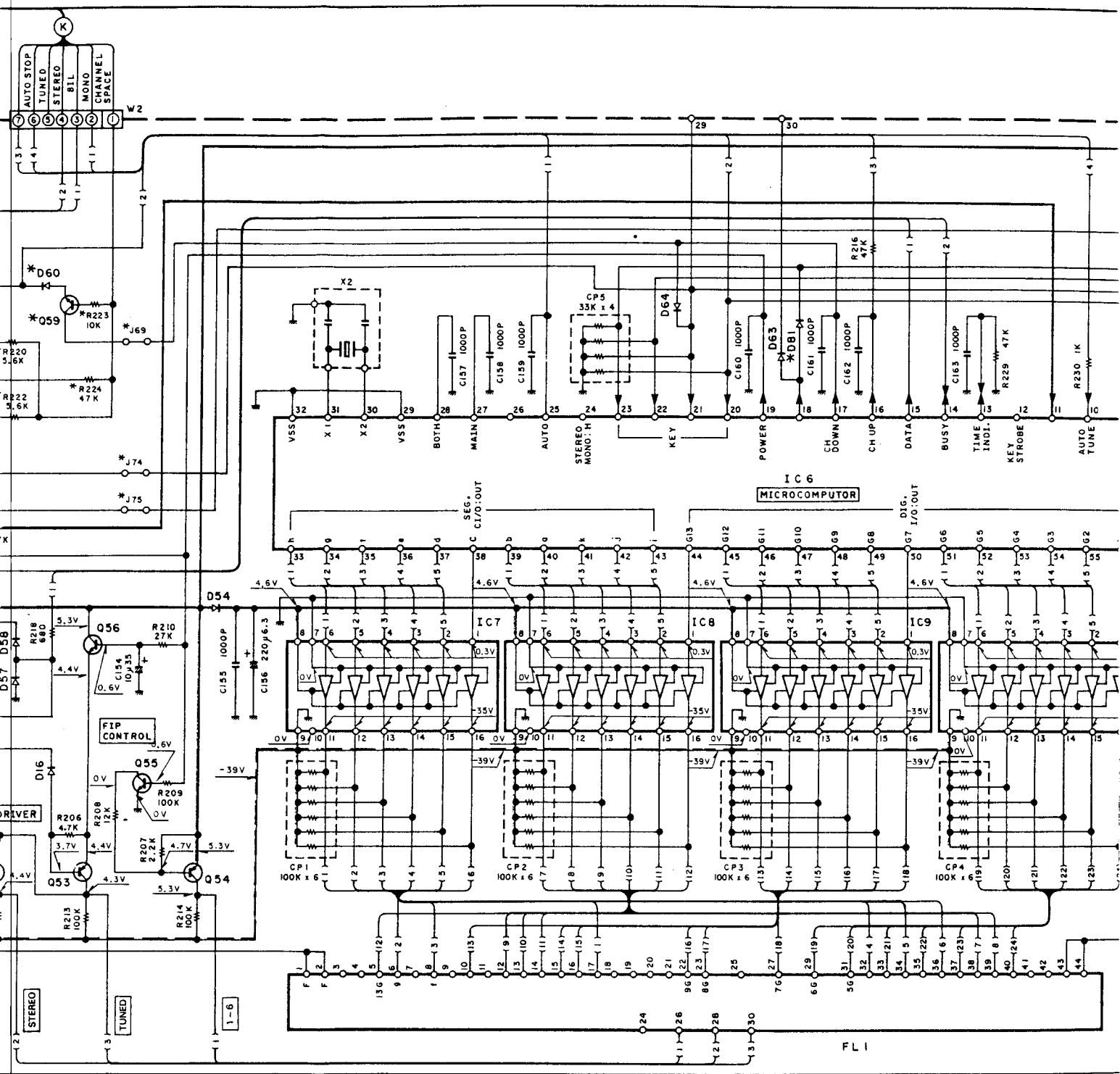

Ref. NO.	R6	R7	J132	J136	R39	R40	R42	R43	R59	R63	R64	R65	R66	R92	R162	J222	R219 ~222	R31, 44, 46~49, 51~53 57, 58, 60, 87~89 188~191, 223, 224	C59, 125
DESTINATION	0-21	NO	NO	NO	NO	NO	39K	36K	YES	3.6K	3.6K	39K	39K	J104	YES	NO	YES	NO	YES
	2-71	YES	YES	YES	YES	YES	43K	36K	NO	3.3K	3.3K	3.3K	3.3K	Ø2K	NO	YES	NO	YES	NO

L8, 9	S2	D20	D60 65, 68	D61, 62	D66	D81	J69	J74, 75	J96, 113, 114, 116, 199 205, 209, 215, 223, 261	J175, 176, 190, 268	J162	J220, 221	J264	C	D	K	L	W02-069
NO	YES	NO	NO	YES	NO	NO	NO	YES	NO	YES	NO	YES	YES	NO	NO	NO	YES	YES
YES	NO	YES	YES	NO	YES	YES	YES	NO	YES	NO	YES	NO	NO	YES	YES	YES	NO	NO

DC voltages are as measured with a high-impedance voltmeter during reception of the FM broadcast (with a signal strength of 60 dB at the ANT terminal). Values may vary slightly due to variations between individual instruments or/and units. Values in parentheses are as measured during reception of the broadcast signal (with a signal strength of 60 dB ANT terminal).

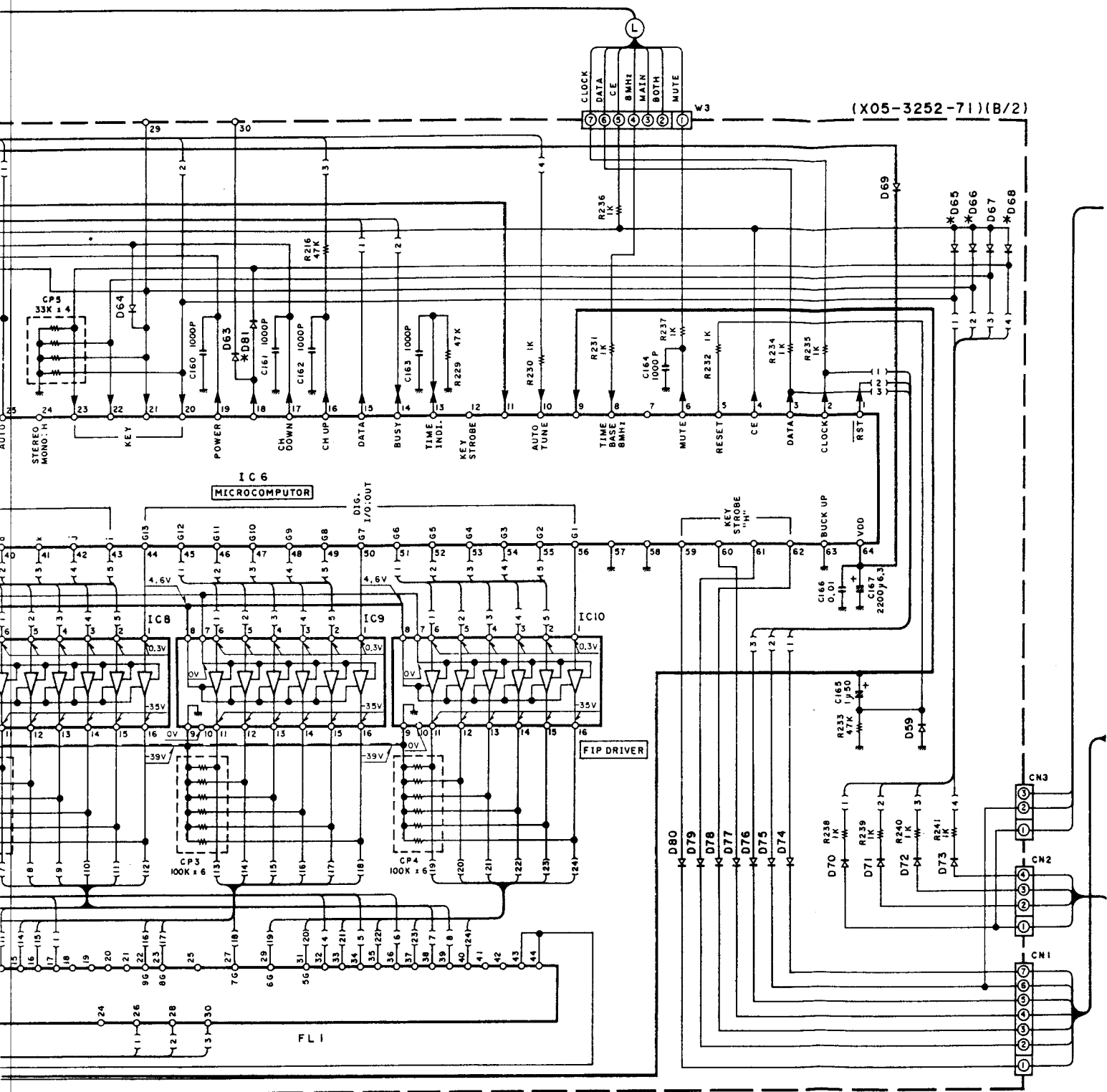

(X05-3252-71)(B/2)

R43	R59	R63	R64	R65	R66	R92	R162	J222	R219 ~222	R31,44,46~49,51~53 57,58,60,87~89 188~191,223,224	C59,60, 125	C5	C49,50,61,125	C51	C52	C53	C54	C55	C56	Q5	Q10,11 59	Q57,58
36K	YES	3.6K	3.6K	39K	39K	J104	YES	NO	YES	NO	YES	NO	NO	150P	150P	0.33µ50	0.33µ50	0.015	0.015	NO	NO	YES
36K	NO	3.3K	3.3K	3.3K	3.3K	82K	NO	YES	NO	YES	NO	YES	YES	1100P	1100P	2.2µ50	2.2µ50	0.0047	0.0047	YES	YES	NO

Q81	J69	J74, 7.5	J96,113,114,116,199, 205,209,215,223,261	J175,176, 190,268	J162	J220, 221	J264	C	D	K	L	W02-0699	W02-0700
NO	NO	YES	NO	YES	NO	YES	YES	NO	NO	NO	YES	YES	NO
YES	YES	NO	YES	NO	YES	NO	NO	YES	YES	YES	NO	NO	YES

DC voltages are as measured with a high-impedance voltmeter during reception of the FM broadcast signal (with a signal strength of 60 dB at the ANT terminal). Values may vary slightly due to variations between individual instruments or/and units. Values in parentheses are as measured during reception of the AM broadcast signal (with a signal strength of 60 dB at the ANT terminal).

Les tensions c.c. doivent être mesurées avec un voltmètre à haute impédance pendant la réception d'un signal de programme FM (avec une force de signal de 60 dB à la borne ANT). Les valeurs peuvent différer légèrement du fait des variations inhérentes aux appareils et aux instruments de mesure individuels. Les valeurs entre parenthèses doivent être mesurées pendant la réception d'un signal de programme AM avec une force de signal de 60 dB à la borne ANT).

Die angelegten Messwerte sind einzeln bei Empfang von 60 dB an

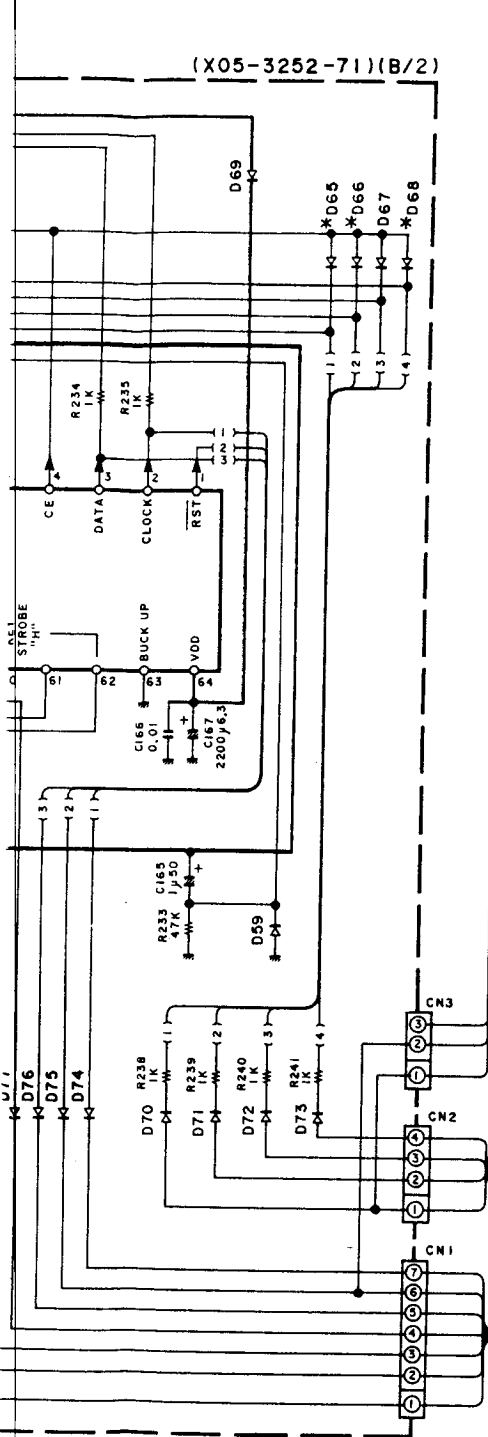

(X13-5070-52) (B/2)

(X13-5070-52) (A/2)

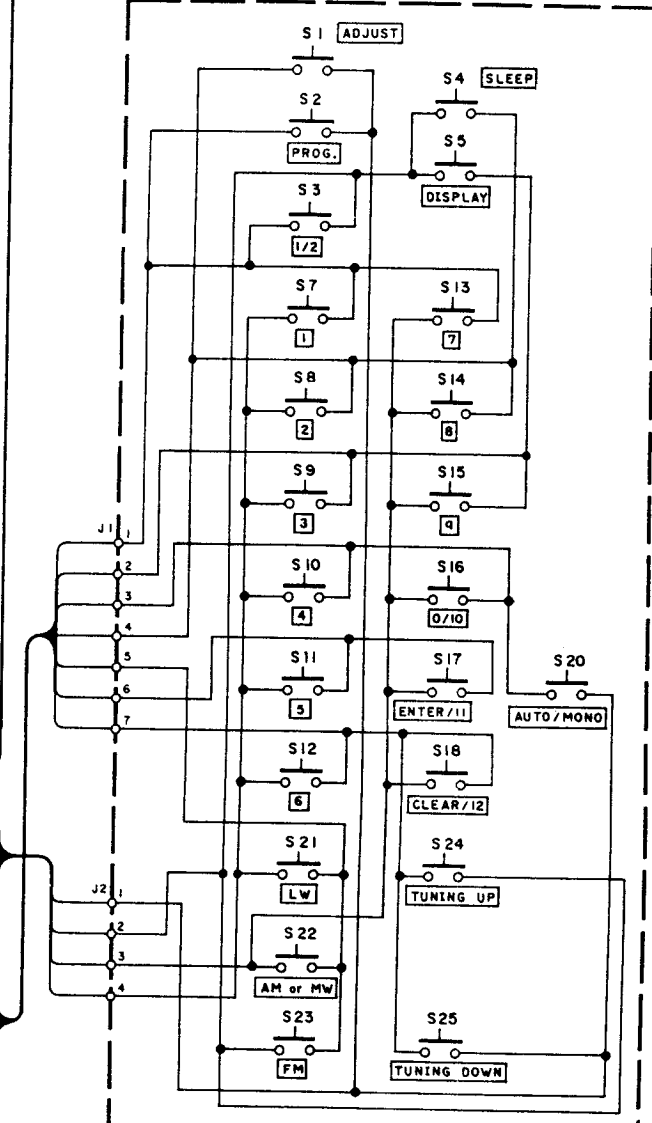

For Service Manuals Contact
MAURITRON TECHNICAL SERVICES
 8 Cherry Tree Rd, Chinnor
 Oxon OX9 4QY
 Tel: 01844-351694 Fax: 01844-352554
 Email: enquiries@mauritron.co.uk

- 2SA733(A)
- 2SA999
- 2SC1845
- 2SC1923
- 2SC535
- 2SC945(A)
- AN7470
- UPD7516HCW-269
- 2SC2839
- 2SC2167
- 2SC3391
- 2SC3494
- 2SA933S
- 2SC1740S
- 2SK364
- 2SK241
- 3SK85
- LB1294
- LM7001
- LA1265

C51	C52	C53	C54	C55	C56	Q5	Q10, 11 59	Q57, 58
50P	150P	0.33µ50	0.33µ50	0.015	0.015	NO	NO	YES
50P	1100P	2.2µ50	2.2µ50	0.0047	0.0047	YES	YES	NO

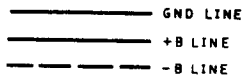

T-7X(E) (2/2)

CAUTION: For continued safety, replace safety critical components only with manufacturer's recommended parts (refer to parts list). Indicates safety critical components. To reduce the risk of electric shock, leakage-current or resistance measurements shall be carried out (exposed parts are acceptably insulated from the supply circuit) before the appliance is returned to the customer.

c.c. doivent être mesurées avec un volt-impédance pendant la réception d'un programme FM (avec une force de signal borne ANT). Les valeurs peuvent différer du fait des variations inhérentes aux instruments de mesure individuels. Les valeurs entre parenthèses doivent être mesurées à la réception d'un signal de programme AM (avec une force de signal de 60 dB à la borne ANT).

Die angegebenen Gleichspannungswerte wurden mit einem hochohmigen Spannungsmesser bei Empfang eines UKW-Signals (mit einer Feldstärke von 60 dB am Antennenanschluß) gemessen. Dabei schwanken die Meßwerte aufgrund von Unterschieden zwischen einzelnen Instrumenten oder Geräten u.U. geringfügig. Die eingeklammerten Gleichspannungswerte wurden bei Empfang eines MW-Signals (mit einer Feldstärke von 60 dB am Antennenanschluß) gemessen.

