

KENWOOD
HI/FI STEREO COMPONENTS

SERVICE MANUAL

**MODEL NINE G
(KR-9000G)**

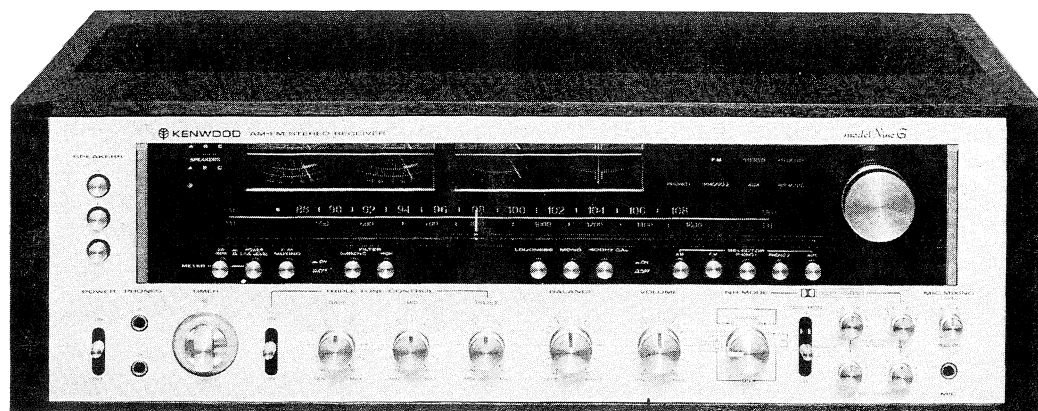

AM-FM STEREO RECEIVER

MODEL NINE G

CONTENTS

EXTERNAL VIEW	3
INTERNAL VIEW	3
DISASSEMBLY FOR REPAIR	4
DIAL CORD STRINGING	5
BLOCK DIAGRAM	6
LEVEL DIAGRAM	6
ADJUSTMENT	6
PC BOARD	8
SCHEMATIC DIAGRAM	11
SPECIFICATIONS	11
PARTS LIST	12

EXTERNAL VIEW

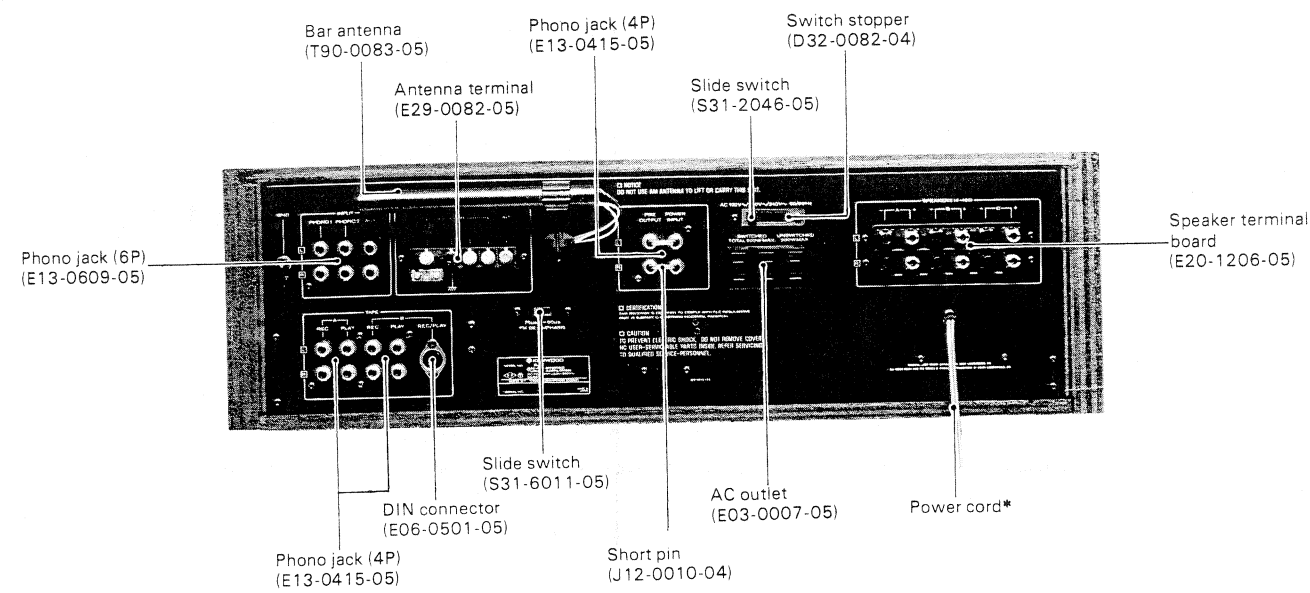
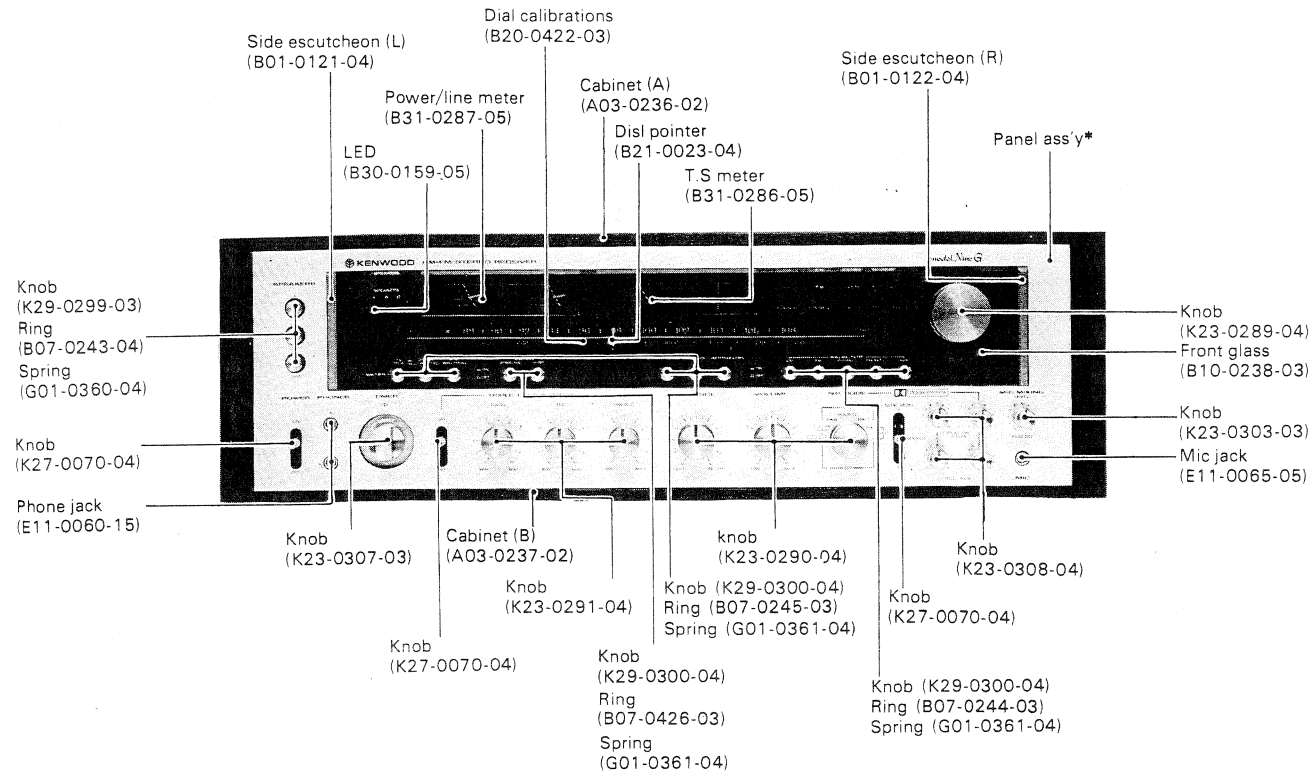

INTERNAL VIEW

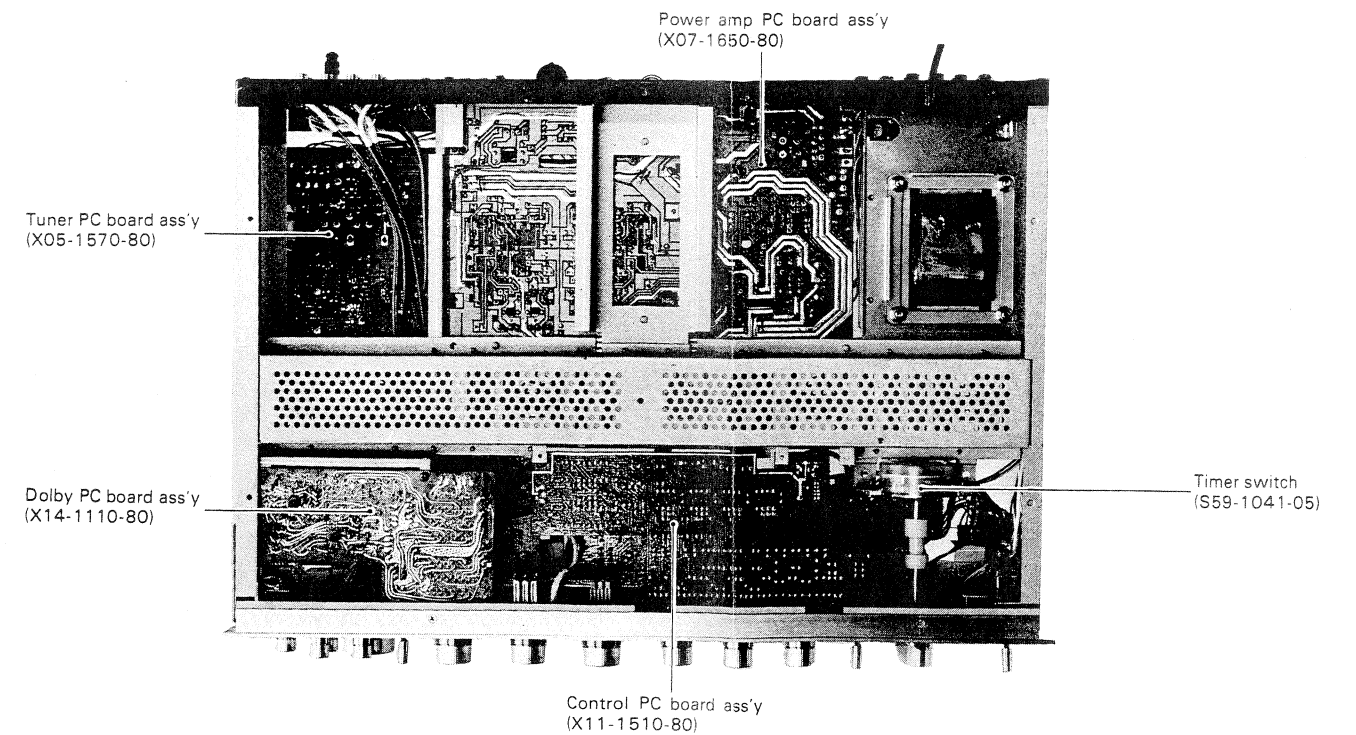
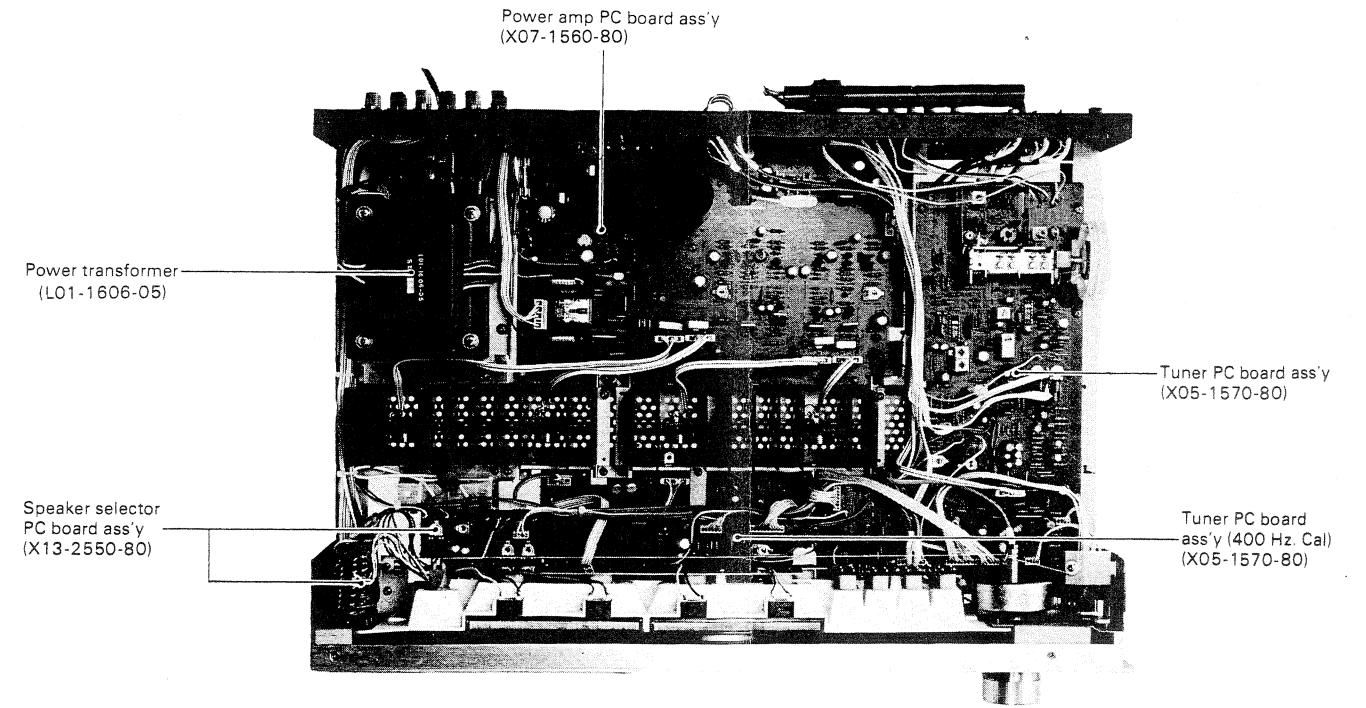

MODEL NINE G

MODEL NINE G MODEL NINE G

DISASSEMBLY FOR REPAIR

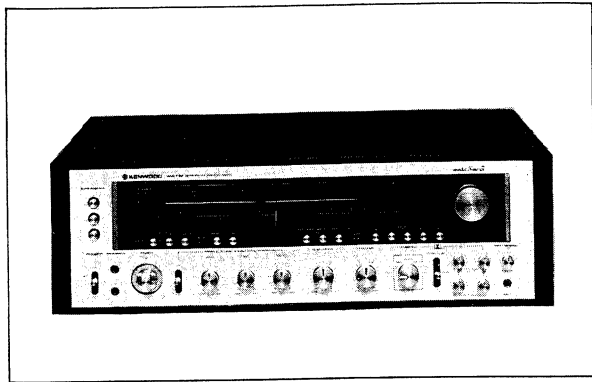

CABINET/BOTTOM BOARD/PANEL ASS'Y

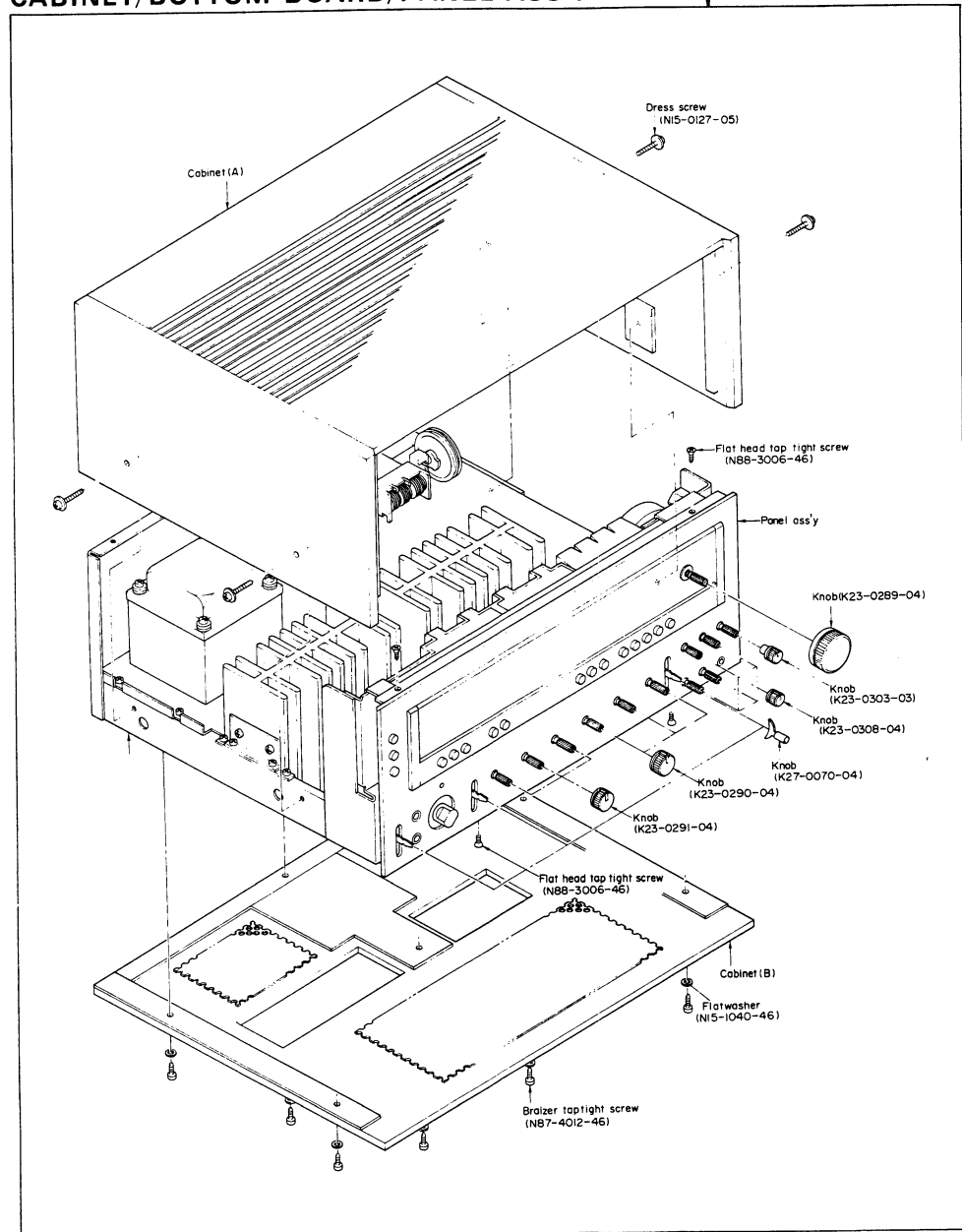

LAMP ASS'Y

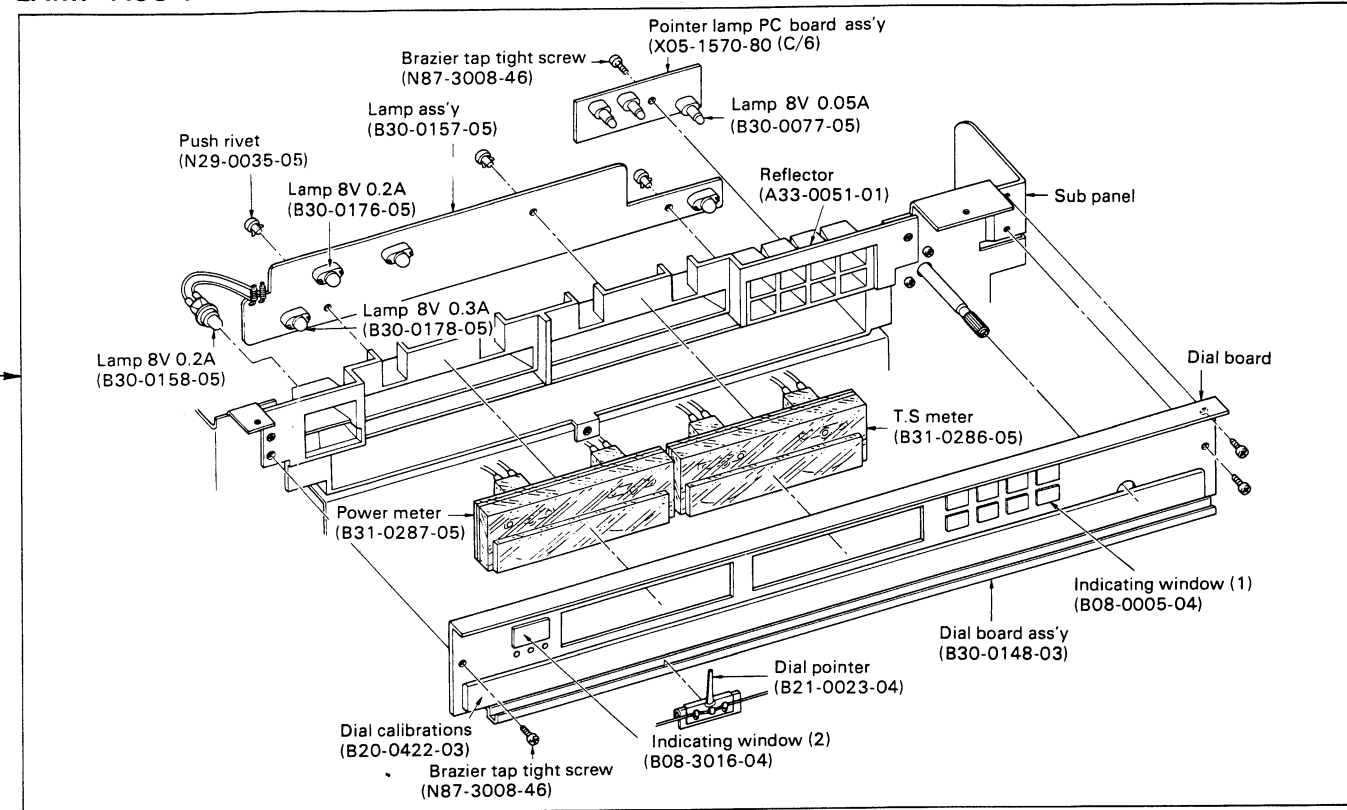

HEAT SINK

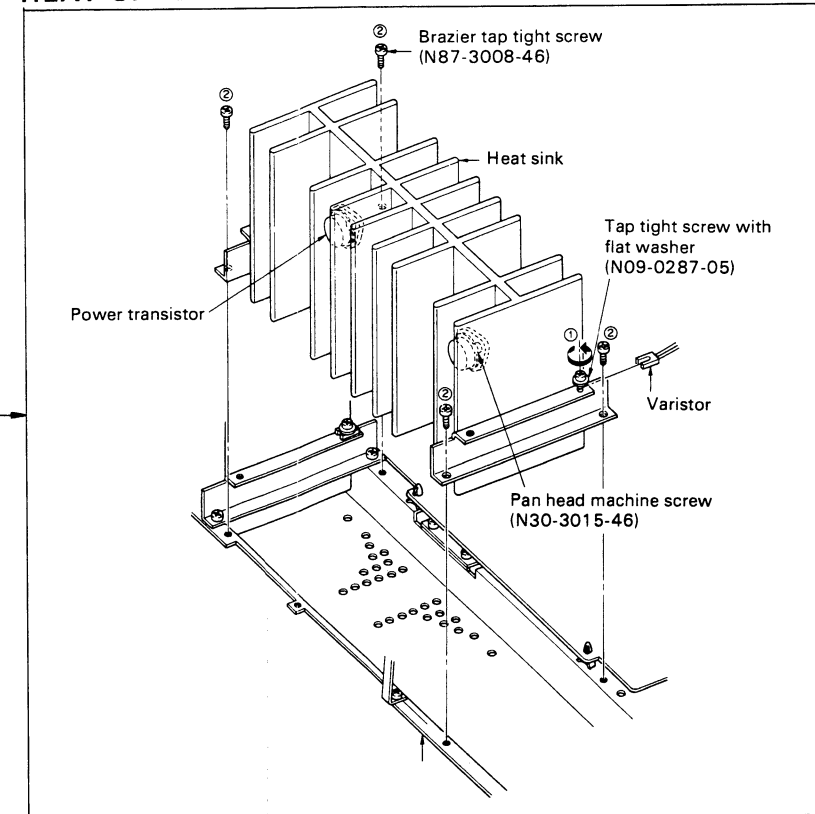

400 Hz TONE

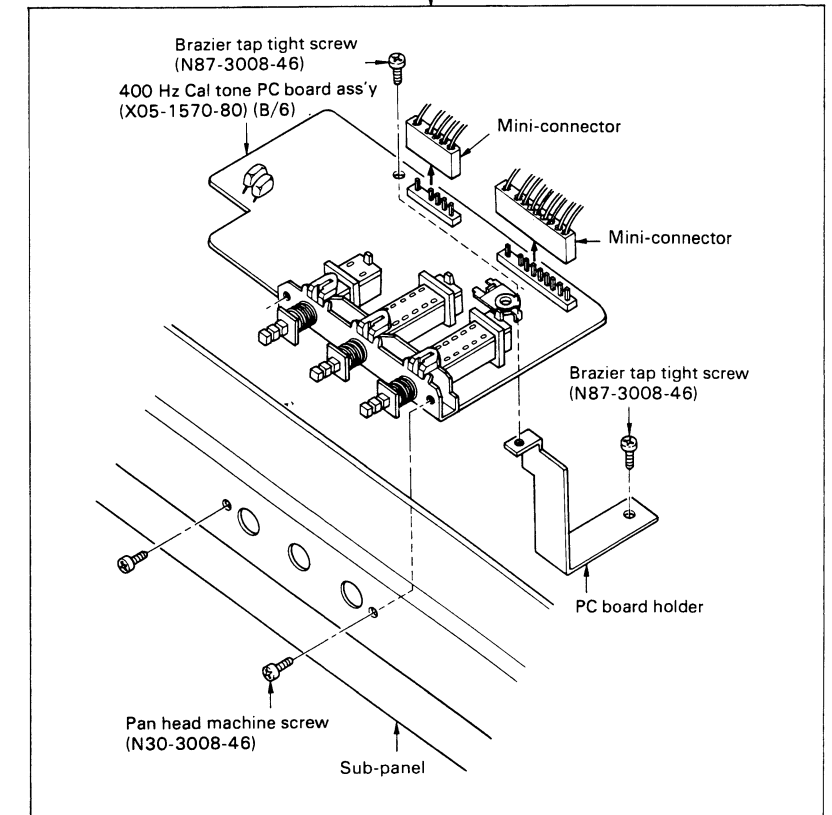

DISASSEMBLY FOR REPAIR/DIAL CORD STRINGING

TIMER

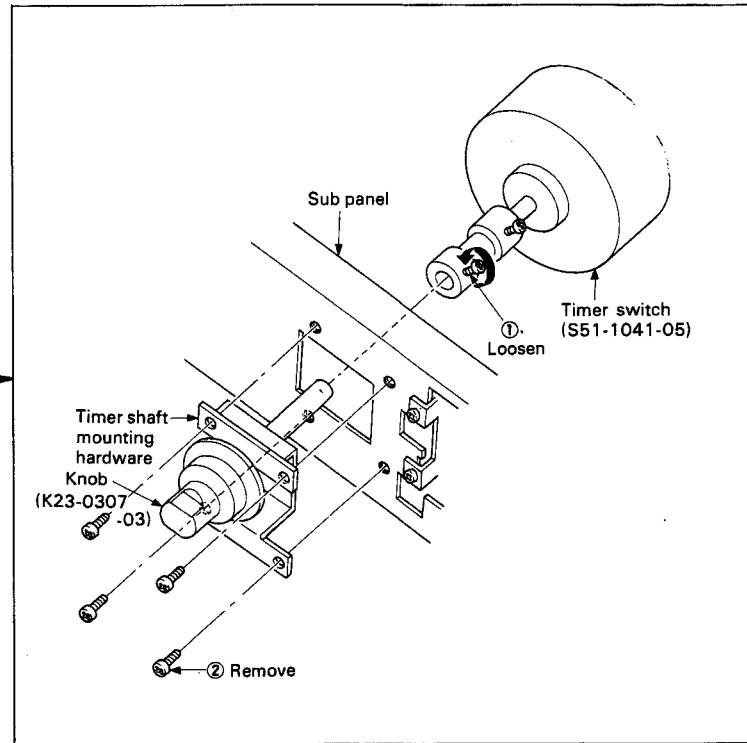

TONE AMP

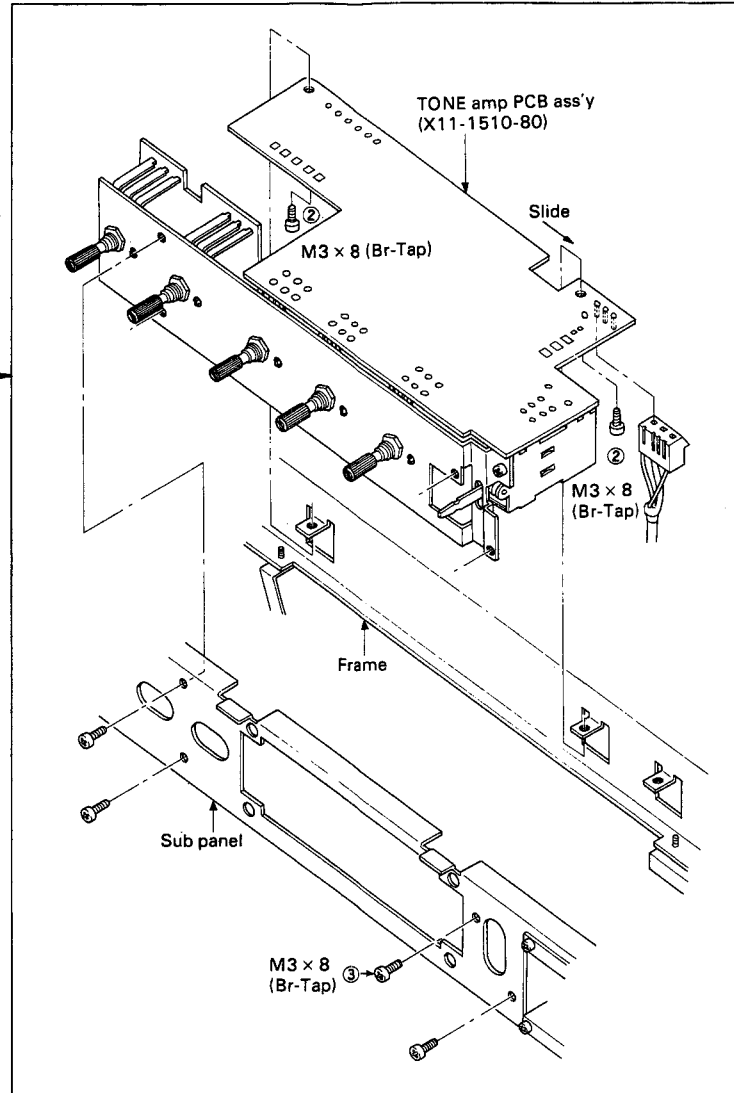

DOLBY AMP

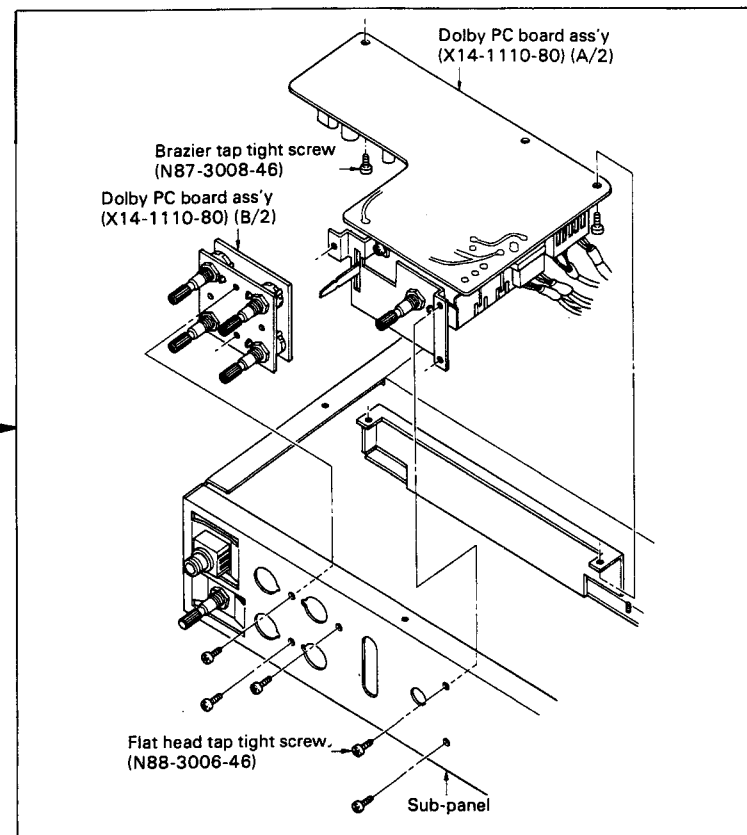

DIAL CORD STRINGING

1. Fully open the variable capacitor.
2. Set the dial pulley as illustrated, and fix it with a screw.
3. Tie the end of the dial cord and the dial spring, giving a margin of about 10 cm.
4. Hook the spring on the boss.
5. Dress the dial cord in the direction of "1" to "2", and wind it 2 turns around the dial shaft clockwise.
6. Dress the dial cord in the direction of "3" through "7", and wind it one and half turns around the dial pulley starting from its lower side.
7. Tie the dial cord rigidly with the margin cord (about 10 cm, described in 3, above) without permitting any slack.
8. Cut off the unnecessary part of the cord, and release the dial spring from the boss.
9. Fully close the variable capacitor.
10. Mount the dial pointer in position as illustrated. This setting should be checked by receiving a suitable broadcast station actually.

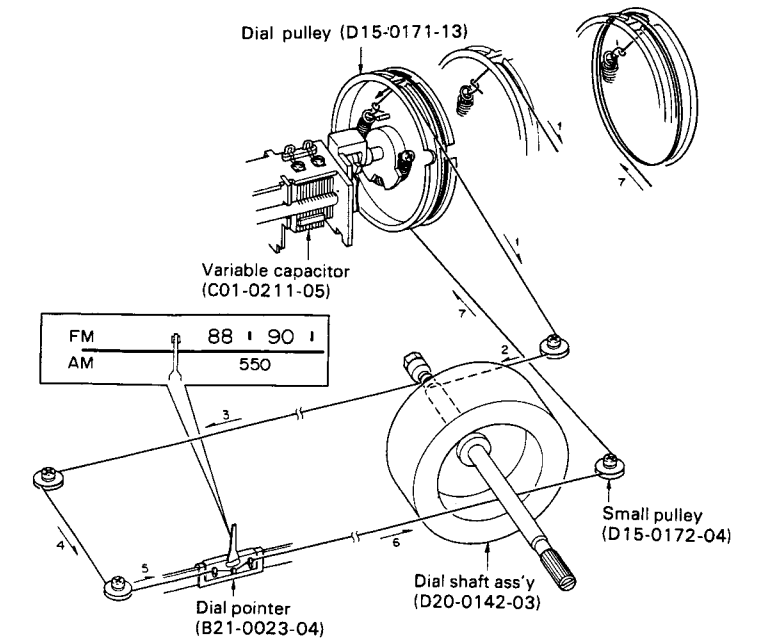

MODEL NINE G

MODEL NINE G MODEL NINE G

BLOCK DIAGRAM/LEVEL DIAGRAM

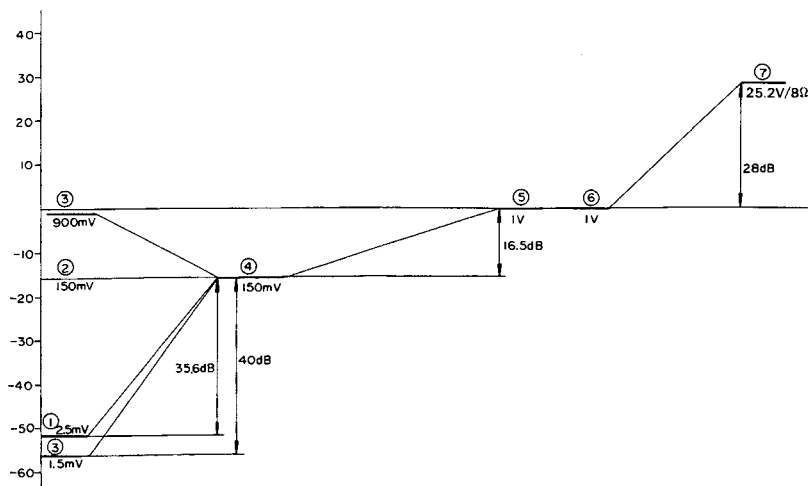
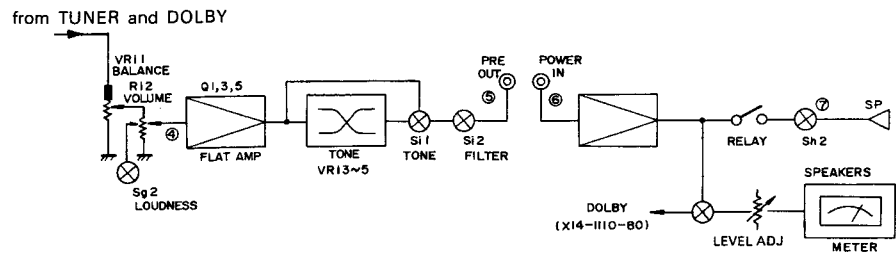
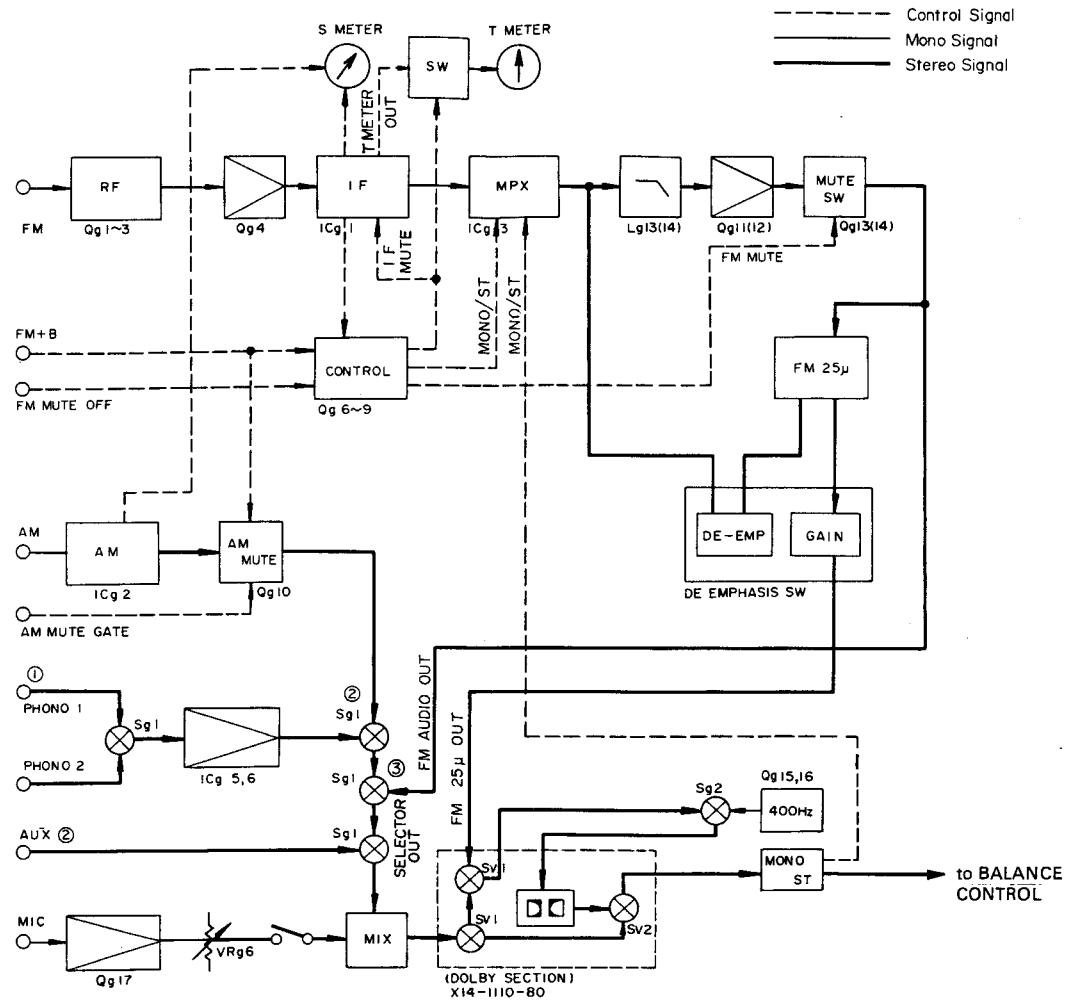

ADJUSTMENT

NO.	ALIGNMENT	TEST EQUIPMENTS		RECEIVER SETTING	OUTPUT INDICATOR	ADJUSTMENT POINTS	REMARKS
		CONNECTION	SETTING				
FM SECTION							
1	IFT	A	95 MHz 60 dB (ANT INPUT) 1 kHz (Mod) 75 kHz (Dev)	FM 95 MHz MODE: MONO	B	Lg5	Maximum output
2	DISCRI	-	-	FM MODE: MONO Interstation noise	T meter	Lg7 (primary)	Meter indication in the center
3		A	95 MHz 60 dB (ANT INPUT) 1 kHz (Mod) 75 kHz (Dev)	FM 95 MHz MODE: MONO	B	Lg7 (secondary)	Minimum distortion
4	OUTPUT	ditto	ditto	ditto	ditto	-	Confirm that output voltage is 900 mV
5	TRACKING	ditto	90 MHz 1 kHz (Mod) 75 kHz (Dev)	FM 90 MHz	ditto	Lg4, 1, 2	Maximum output
6		ditto	106 MHz 1 kHz (Mod) 75 kHz (Dev)	FM 106 MHz	ditto	CTg1, 2, 3	ditto
7	VCO	A	95 MHz 60 dB (ANT INPUT) 0 (Dev)	FM 95 MHz MODE: STEREO	C	VRg2	Frequency counter indication is 19 kHz ± 50 Hz
8	SEPARATION	D	FM-MPX: SELECTOR→L or R 1 kHz (Mod) PILOT (6.75 kHz) FM-SG: 95 MHz 60 dB (ANT INPUT) 68.25 kHz (Dev)	ditto	R output (SELECTOR→L) L output (SELECTOR→R)	VRg1	Minimum output. Adjust VRg1 so that the difference between R output and L output becomes minimum
9	DISTORTION	A	ditto	ditto	B	Lg5	Minimum distortion
10	DOLBY FM	A	95 MHz 60 dB (ANT INPUT) 1 kHz (Mod) 37.5 kHz (Dev)	FM 95 MHz Sg2 - 3: OFF Sv1: <input type="checkbox"/> FM	B	VRg3, 4	Output is 580 mV
11	400 Hz OSC LEVEL	-	-	Sg2 - 3: ON Sv1: PLAY A→B Vrv1~4: MAX	B	Vrg5	ditto
AM SECTION							
12	TRACKING	F	600 kHz 400Hz, 30% (Mod)	AM 600 kHz	B	Lg9 Bar antenna	Maximum output
13		ditto	1400 kHz 400Hz, 30% (Mod)	AM 1400 kHz	B	CTg4, 5	ditto
AUDIO SECTION							
14	BIAS CURRENT	-	-	Volume to minimum position	I	VRe1, 2	26.5 mV
METER SECTION							
15	POWER	C	1 kHz	AUX Set the volume so that output is 2.8V (RMS) Sh1 - 1: 3W Sh1 - 2: POWER	POWER/LINE meter	VRh3, 4	Meter indicates 1W
16	LINE	-	-	Sg2 - 3: ON Sv1: PLAY A→B Vrv1~4: MAX	POWER/LINE meter	VRh1, 2	Meter indicates cal.

ADJUSTMENT

TEST EQUIPMENT and its SPECIFICATIONS

STANDARD SIGNAL GENERATOR (RF-SG)

Ranges: 90 MHz ~ 108 MHz (FM)
500 kHz ~ 1600 kHz (AM)

Modulation frequency: 1 kHz, 400 Hz or external input (input level 2V or less)

Deviation: 0 ~ 7.5 kHz (FM)

Modulation: 0 ~ 30% (AM)

Output: 100 mV or more

Distortion: 0.5% or less

SOLID STATE VOLT METER (SSVM)

Ranges: 0.3 mV ~ 300V (full scale)

Frequency response: 5 Hz ~ 500 kHz

Impedance: 1MΩ or more

OSCILLOSCOPE (SCOPE)

Ranges: DC ~ 10 MHz

Sensitivity: 20 mV/cm

Impedance: 1MΩ or more

DISTORTION METER

Ranges: 0.1% (full scale)

Sensitivity: 100 mV or more

FREQUENCY COUNTER (COUNTER)

Frequency response: 10 Hz ~ 1 MHz

Sensitivity: 50 mV or more

Impedance: 1MΩ or more

AUDIO SIGNAL GENERATOR (AG)

Ranges: 5 Hz ~ 500 kHz

Waveform: Sine wave

Output: 10V r.m.s.

Distortion: 0.3% or less

NOTES FOR ADJUSTMENTS

- *Use moderate instrument outputs at all times.
- *The output level of RF-SG means ANT input level.
- *0 dB = 1 μV

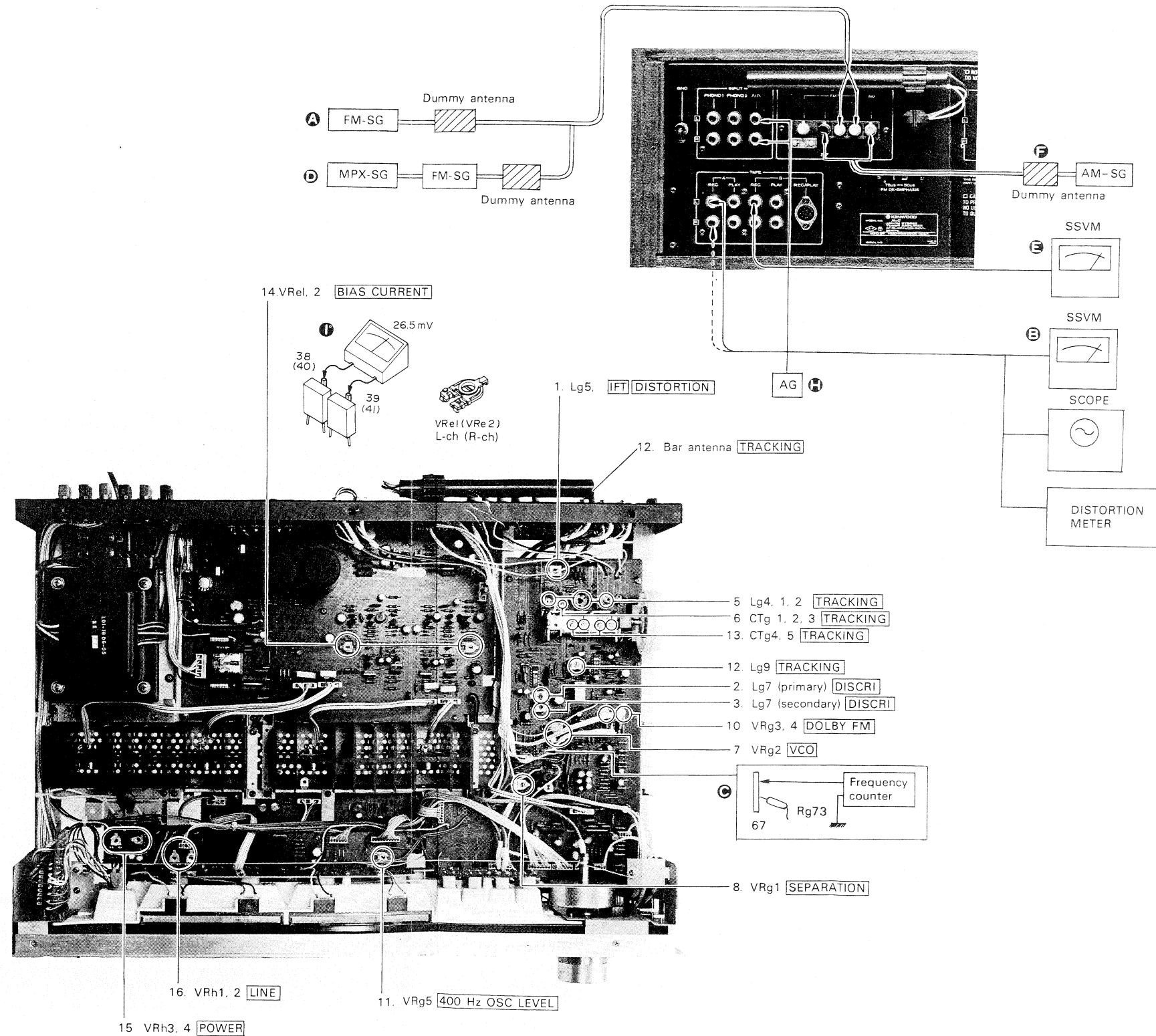

TUNER • PREAMP • SELECTOR (X05-1570-80) COMPONENT SIDE VIEW

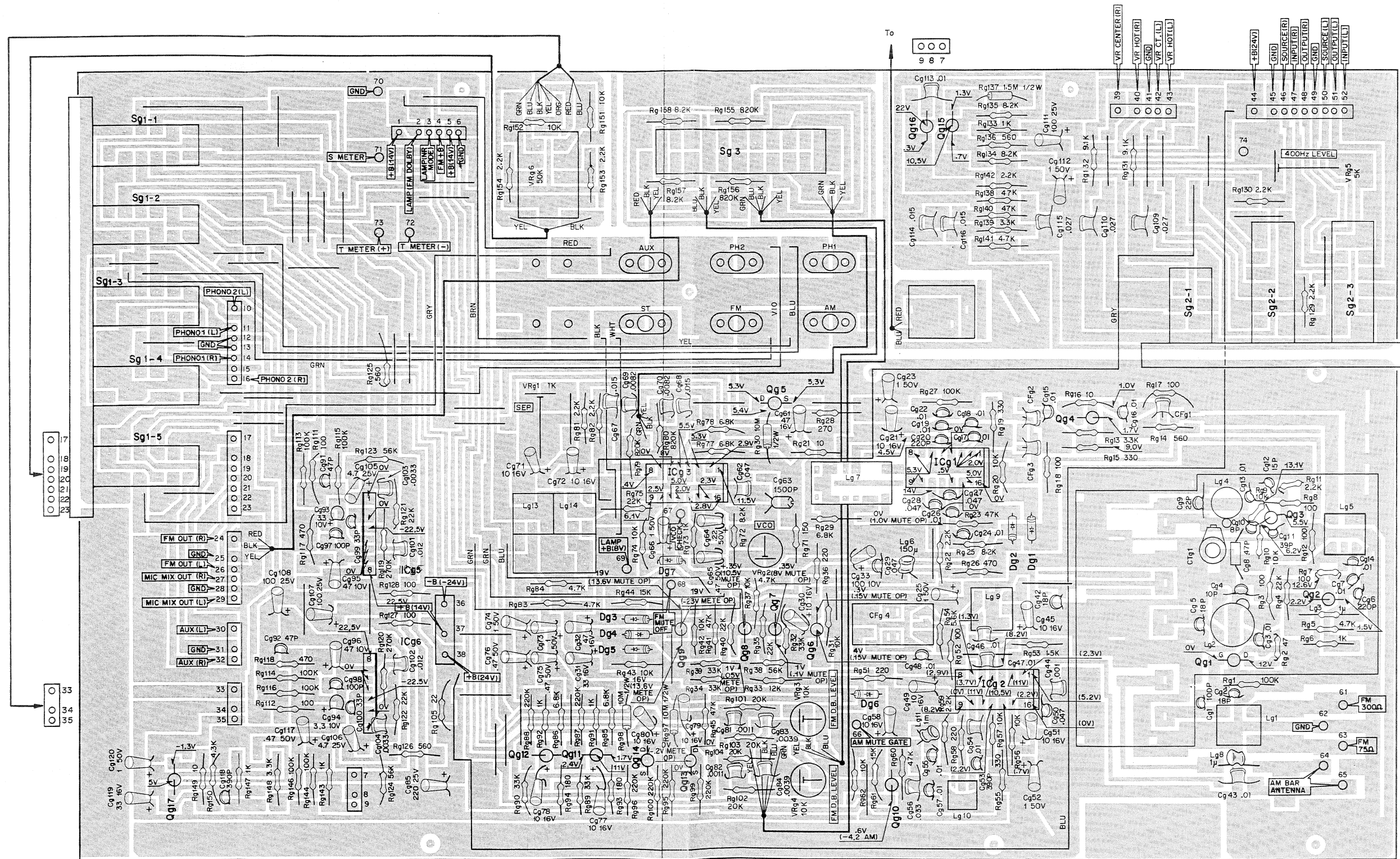

- 2SC535
- 2SC1342
- 2SC1923
- 2SC945
- 2SC828A
- 2SA733
- 2SA564A
- 2SC1845
- 2SC1222
- 2SK61
- 2SK68
- 2SK117
- 2SK105

Qg1 : 2SK61, Qg2 : 2SC535 (A, B), Qg3 : 2SC1342, Qg4 : 2SC1923, Qg5, 13, 14 : 2SK117 (Y, GR, BL) or 2SK68 (L, M, N) or 2SK105 (F, H, J), Qg6 ~ 8, 10, 15, 16 : 2SC945 (Q, P) or 2SC828A (Q, R), Qg9 : 2SA733 (Q, P) or 2SA564A (Q, R, S), Qg11, 12, 17 : 2SC1845 (F, E, U) or 2SC1222, Dg1 ~ 7 : 1S1555 or 1S2076, ICg1 : HA1137W, ICg2 : HA1197 or LA1240, ICg3 : LA3350S-L6, ICg5, 6 : HA1457

PC BOARD

POWER AMP-POWER SUPPLY (X07-1650-80)

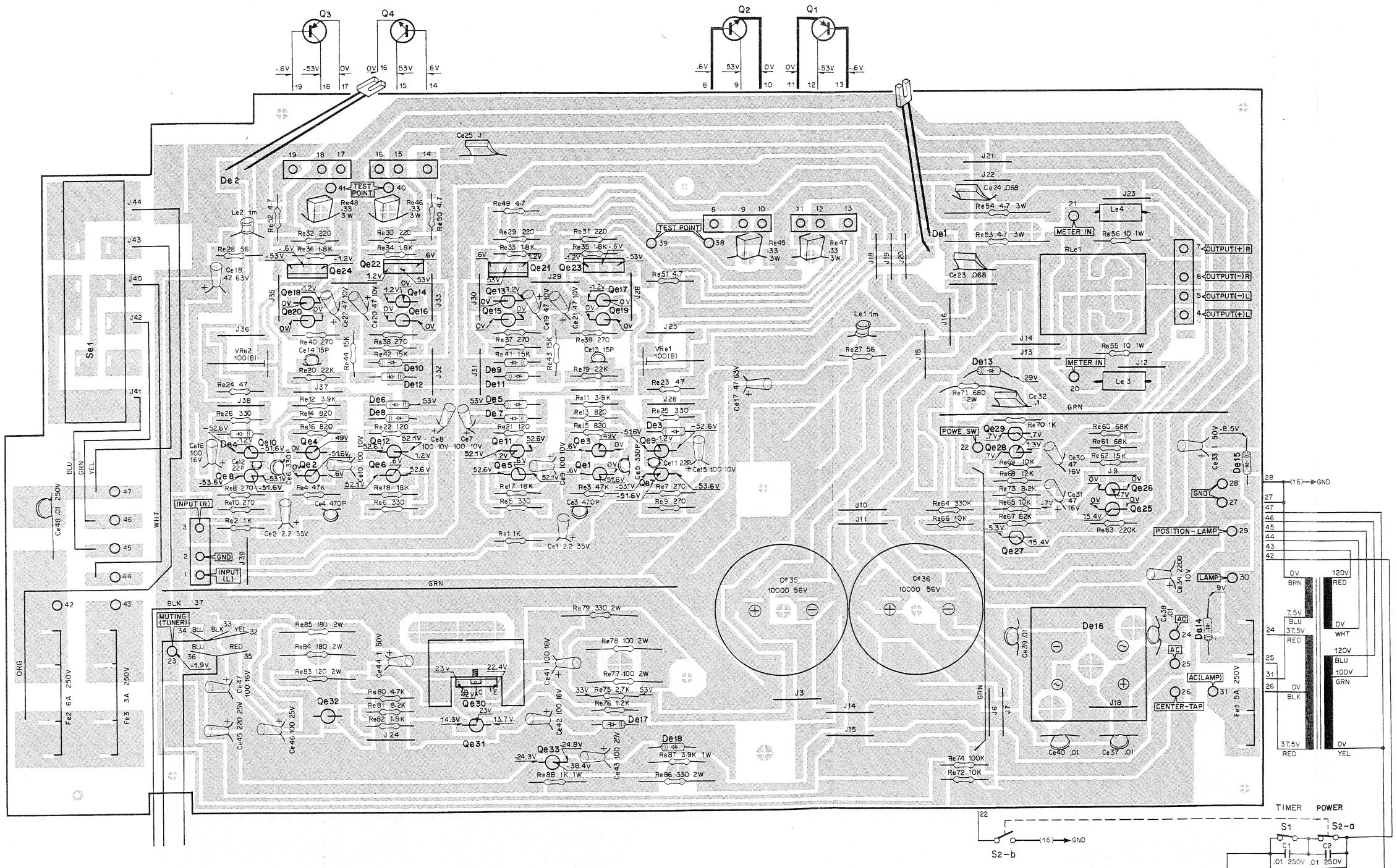

- 2SA921
- 2SA872
- 2SA872A
- 2SA912
- 2SA733
- 2SA777
- 2SB725
- 2SC1775
- 2SC1775A
- 2SC1885
- 2SC945
- 2SC2274K
- 2SC1509
- 2SD767

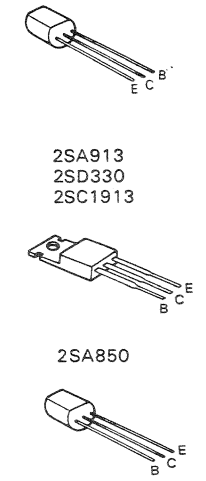

- | | | | | | |
|------------------|----------------------------------|---------------|-------------------------------------|-----------|---------------------|
| Qe1~4 | : 2SA921 (S) or 2SA872 (E) | Qe15~18,25,27 | : 2SC945 (R, Q) or 2SD767 (Q, R) | De1,2 | : STV-4H(W) |
| Qe5,6 | : 2SA872 or 2SA872A | Qe21,22 | : 2SC1913 (Q,R) | De3~8 | : 1S2076 or 1S2076A |
| Qe7,8,28,31 | : 2SC1775 or 2SC1775A | Qe23,24 | : 2SA913 (Q, R) | De9~12,15 | : 1S2076A |
| Qe9,10 | : 2SC1885 (Q, R) | Qe29 | : 2SC2274K (E, F) or 2SC1509 (Q, R) | De13,14 | : V06B |
| Qe11,12 | : 2SA912 (Q,R) | Qe30 | : 2SD330 | De16 | : M4C-51-12*1 |
| Qe13,14,19,20,26 | : 2SA733 (R, Q) or 2SB725 (Q, R) | Qe32,33 | : 2SA850 or 2SA777 (Q, R) | De17 | : XZ-132 |
| | | | | De18 | : WZ-240 |

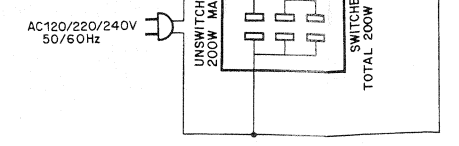

CONTROL (X11-1510-80)

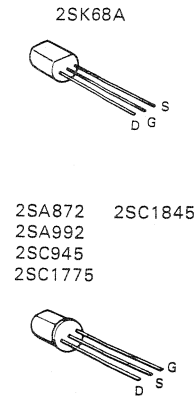
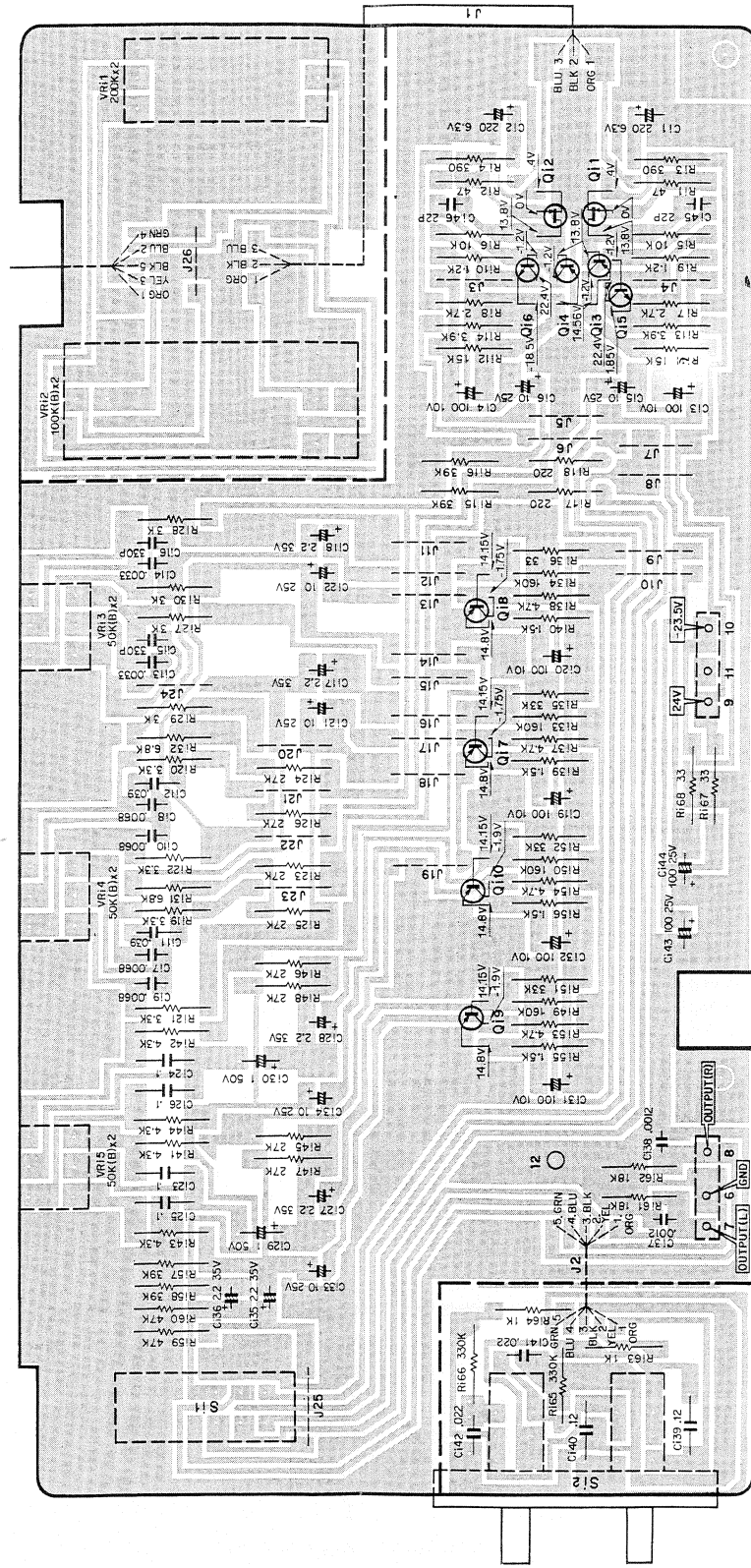

Q1,2 : 2SK68A (L, M)
Q3,4,7~10 : 2SA992 (F, E) or 2SA872
Q15,6 : 2SC1845 (F, E, U) or 2SC1775

SPEAKER SELECTOR (X13-2550-80)

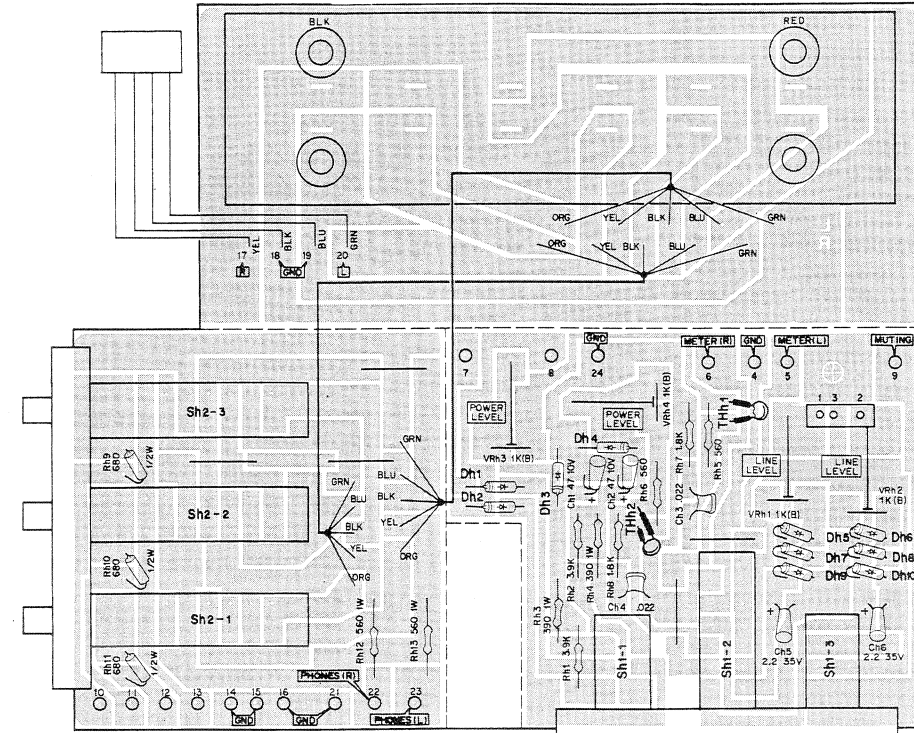

Dh1, 2 : 1N34A, Dh3, 4 : 1N60IFT, Dh5 ~ 10 : 1N60, THh1, 2 : SDT-20

DOLBY (X14-1110-80)

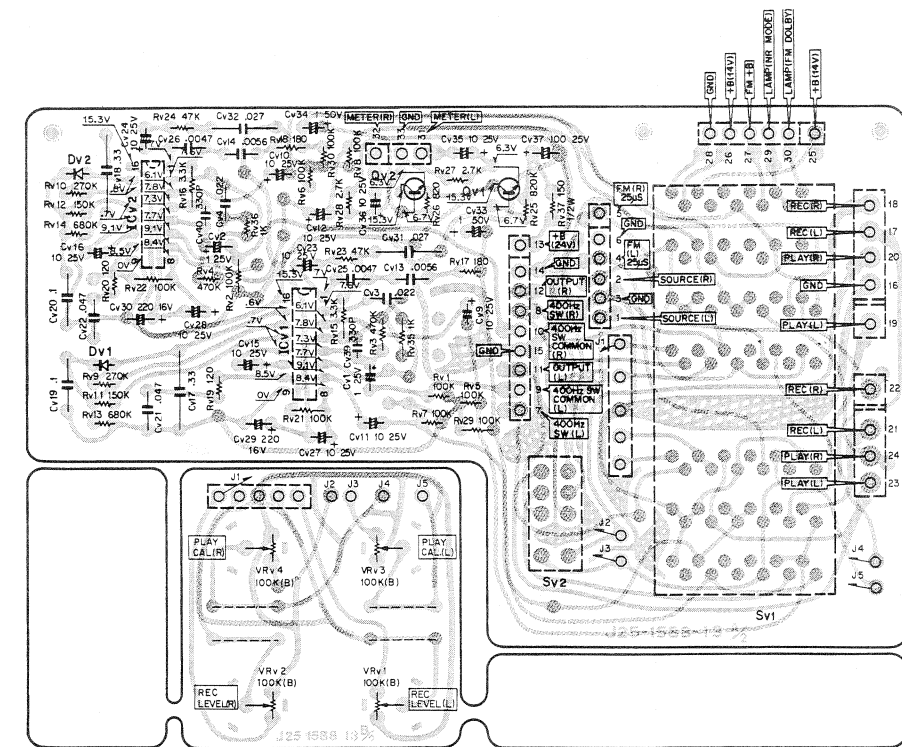

Qv1, 2 : 2SC945 (R, Q), Dv1, 2 : 1N60, ICv1, 2 : NE545B

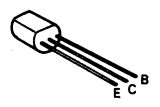
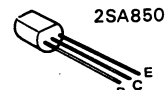
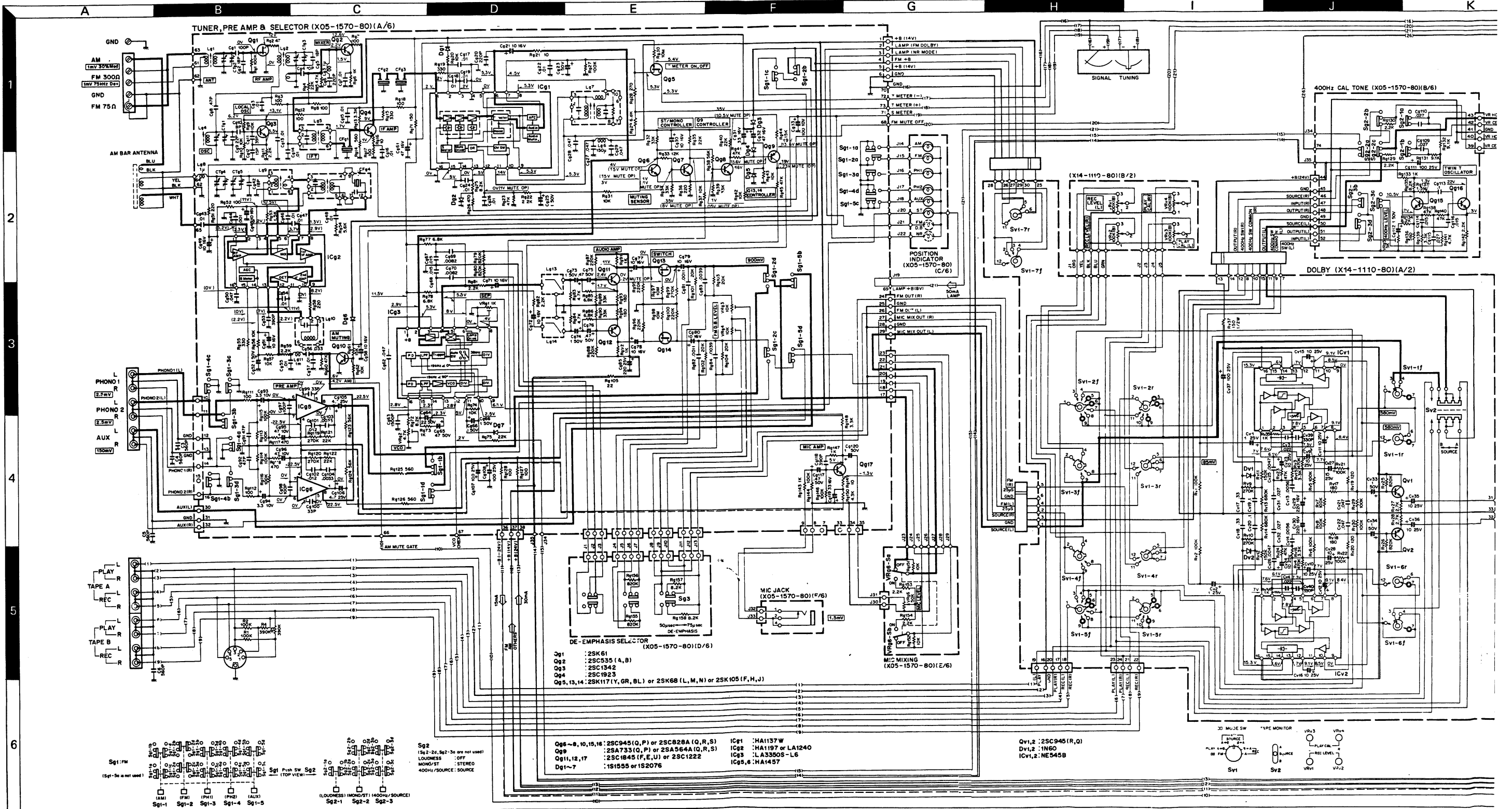

- | | | | |
|--------|---------|---------|---------|
| 2SA539 | 2SA992 | 2SC1509 | 2SC2089 |
| 2SA564 | 2SB725 | 2SC1775 | 2SC2274 |
| 2SA733 | 2SC828 | 2SC1845 | 2SD767 |
| 2SA777 | 2SC838 | 2SC1885 | |
| 2SA872 | 2SC945 | 2SC1890 | |
| 2SA912 | 2SC1222 | 2SC1923 | |
| 2SA921 | 2SC1400 | 2SC2088 | |

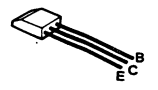
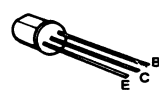

- 2SA561
 2SC381
 2SC734
 2SC785

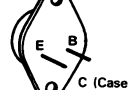

- 2SC535
 2SC1342

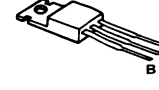

- 2SA747
 2SC1116

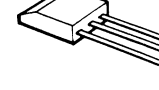

- 2SC1213A

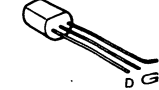

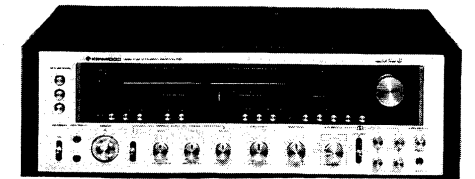
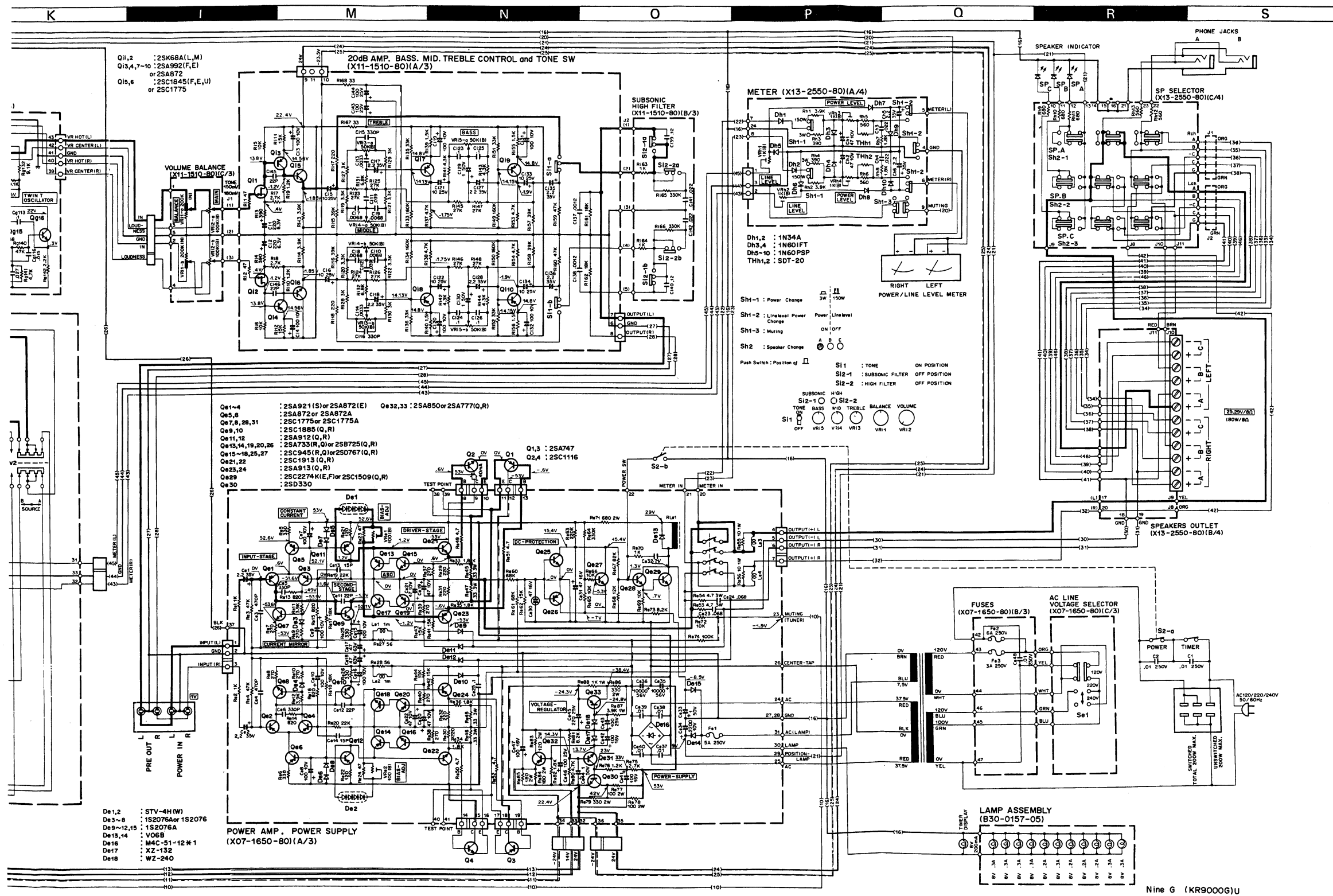

POWER AMPLIFIER SECTION

Power Output
 80 watts per channel minimum RMS, both channels driven, at 8 ohms from 20 to 20,000 Hz with no more than 0.03% total harmonic distortion.

Both Channels Driven 110 + 110W 4Ω at 1 kHz
 Dynamic Power Output 280W 4Ω
 Total Harmonic Distortion 0.03% at rated power into 8Ω
 0.01% at 1/2 rated power into 8Ω

Intermodulation Distortion 0.03% at rated power into 8Ω
 (60 Hz : 7 kHz = 4 : 1)
 0.01% at 1/2 rated power into 8Ω

Power Bandwidth 5 Hz to 100,000 Hz
 Frequency Response 5 Hz to 100,000 Hz - 1.5 dB
 Signal to Noise Ratio 115 dB (short circuited)
 Damping Factor 40 at 8 ohms
 Input Sensitivity/Impedance 1.0V/50 kΩ
 Speaker Impedance Accept 4Ω to 16Ω

PRE AMPLIFIER SECTION

Input Sensitivity/Impedance/Signal to Noise Ratio (IHF A curve)
 Phono 1 2.5 mV/50 kΩ/80 dB
 Phono 2 2.5 mV/50 kΩ/80 dB
 AUX 150 mV/50 kΩ/110 dB
 Tape A, B 150 mV/50 kΩ/110 dB
 Mic 1.5 mV/10 kΩ/70 dB
 Maximum Input Level for Phono 230 mV (RMS), T.H.D. 0.03% at 1 000 Hz

Frequency Response
 Phono RIAA standard 30 Hz to 20 kHz ± 0.3 dB
 AUX and Tape 10 Hz to 40,000 Hz - 1.0 dB

Tone Control
 Bass ±12 dB at 50 Hz
 Mid ±12 dB at 800 Hz
 Treble ±12 dB at 15 kHz
 +10 dB at 100 kHz

Loudness Control (-30 dB Vol)
 Subsonic Filter -15 dB at 18 Hz
 High Filter -6 dB at 10 kHz

Output Level/Impedance
 Tape REC (Pin) A 150 mV/100Ω
 B 150 mV/100Ω
 (DIN) A 30 mV/80 kΩ
 B 120 mV/80 kΩ
 1.0V/1 kΩ

Pre Out 1.0V/1 kΩ

FM TUNER SECTION

Usable Sensitivity 10.3 dBf (1.8 μV)
 50 dB Quieting Sensitivity
 Mono 14.7 dBf (3.0 μV)
 Stereo 37.2 dBf (40 μV)

Signal to Noise Ratio at 65 dBf
 Mono 80 dB
 Stereo 74 dB

Total Harmonic Distortion at 65 dBf
 Mono 0.1% at 1 kHz
 Stereo 0.15% at 1 kHz

Frequency Response 30 Hz to 15,000 Hz + 0.5 - 1.0 dB

Capture Ratio 1.0 dB
 Alternate Channel Selectivity 75 dB
 Spurious Response Ratio 85 dB
 Image Response Ratio 60 dB
 IF Response Ratio 75 dB
 AM Suppression Ratio at 65 dBf 65 dB
 Stereo Separation 48 dB at 1 000 Hz
 35 dB at 50 Hz to 15 000 Hz
 45 dB

Sub Carrier Product Rejection 3000 balanced and 75Ω unbalanced
 Antenna Impedance 88 MHz to 108 MHz

AM TUNER SECTION

Usable Sensitivity 20 μV
 Signal to Noise Ratio 50 dB
 Image Rejection 55 dB
 Selectivity 30 dB
 IF Rejection 30 dB
 Total Harmonic Distortion 0.5%

GENERAL

Power Requirement 50/60 Hz 110-120V/220-240V
 Power Consumption 550 watts at full power
 Switched 2 Unswitched 1
 A C Outlet 206 mm (8 1/8")
 Dimensions W 624 mm (24 9/16")
 H 206 mm (8 1/8")
 D 460 mm (18 1/8")
 Weight 19.8 kg (43.5 lb)
 24.3 kg (53.6 lb)

NOTE:
 Kenwood follows a policy of continuous advancements in development. For this reason specifications may be changed without notice.

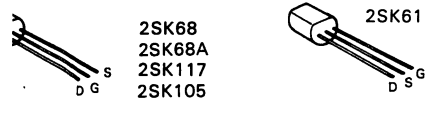

Nine G (KR900G)U

MODEL NINE G MODEL NINE G

PARTS LIST

☆: New parts
 Carbon: Carbon film resistor
 RC: Carbon composition resistor
 RW: Wire wound power resistor
 RN: Metal film resistor
 RS: Metal oxide film resistor

The parts No. of the resistor and the capacitor is changed into computer code.

U: PX, M₁: Other area, M₂: KR-9000

TOTAL

Ref. No.	Parts No.	Description	Re- marks
—	A03-0236-02	Cabinet (A)	
—	A03-0237-02	Cabinet (B)	
—	A20-1318-03	Panel ass'y	U, M ₁ ☆
—	A20-1319-03	Panel ass'y	M ₂ ☆
—	B01-0121-04	Escutcheon (L)	
—	B01-0122-04	Escutcheon (R)	
—	B01-0123-03	Escutcheon	☆
—	B07-0230-14	Escutcheon (Shaft)	
—	B07-0234-03	Lever escutcheon (TONE, TAPE)	
—	B07-0235-04	Lever escutcheon (POWER)	
—	B07-0243-04	Pushbutton switch ring (SPEAKER)	
—	B07-0244-03	Pushbutton switch ring (SELECTOR)	
—	B07-0245-03	Pushbutton switch ring (LOUDNESS/METER)	☆
—	B07-0246-03	Pushbutton switch ring (FILTER/SUBSONIC)	☆
—	B08-0005-04	Indicator (Selector)	
—	B08-2017-14	Indicator (TIMER)	
—	B08-3016-04	Indicator (Speaker)	
—	B10-0238-03	Frontglass	
—	B20-0422-03	Dial calibrations	
—	B21-0023-04	Dial pointer	
—	B30-0077-05	Pilot lamp × 2	
—	B30-0157-05	Pilot lamp ass'y	
—	B30-0158-05	Pilot lamp (8V, 200mA)	
—	B30-0159-05	LED × 3	
—	B31-0286-05	Meter (Tuning, Signal)	
—	B31-0287-05	Meter (POWER)	
—	B42-0009-04	Passed sticker	
—	B46-0062-20	Warranty card	U, M ₂
—	B46-0063-00	Warranty card	U
—	B50-1768-00	Instruction manual	U, M ₁ ☆
—	B50-1770-00	Instruction manual	M ₂ ☆
—	B59-0018-00	KENWOOD service stations' list	U
C1,2	C91-0023-05	Ceramic 0.01μF AC 250 WV	
C3~6	C52-1756-16	Ceramic 560pF ±10%	
—	D15-0171-13	Dial pulley	
—	D15-0172-04	Pulley × 4	
—	D20-0142-03	Dial shaft	
—	D21-0450-03	Timer shaft	
—	D22-0033-04	Coupler	
—	D32-0082-04	Switch stopper (Power voltage)	
—	E02-0004-05	Transistor socket × 4	
—	E03-0007-05	AC outlet	
—	E06-0501-05	DIN connector	

Ref. No.	Parts No.	Description	Re- marks
—	E11-0060-15	Phone jack × 2	
—	E13-0415-05	Phono jack (4P) × 3	
—	E13-0609-05	Phono jack (6P)	
—	E14-0107-05	Short phono plug × 2	
—	E29-0082-05	Antenna terminal board	
—	E30-0545-05	Power cord	U, M ₁
—	E30-0580-05	Power cord	M ₂
—	G01-0045-24	Dial spring	
—	G01-0360-04	Pushbutton spring × 3 (SPEAKER)	
—	G01-0361-04	Pushbutton spring × 13	
—	H01-1829-04	Carton box	U, M ₁ ☆
—	H01-1830-04	Carton box	M ₂ ☆
—	H10-1519-02	Polystyrene foamed fixture × 2	
—	H20-0443-04	Polyethylene cover	M ₁
—	H20-0449-04	Polyethylene cover	U, M ₂
—	H25-0078-04	Polyethylene bag	
—	J02-0049-14	Foot × 4	
—	J12-0010-04	Short pin × 2	
—	J19-0524-14	LED holder	
—	J41-0033-05	Cord bushing	M ₂
—	J41-0034-05	Cord bushing	U, M ₁
—	K23-0289-04	Knob (Tuning)	
—	K23-0290-04	Knob (VOL., Bal., N.R. mode) × 3	
—	K23-0291-04	Knob (TONE) × 3	
—	K23-0303-03	Knob (MIC MIXING)	
—	K23-0307-03	Knob (TIMER)	
—	K23-0308-04	Knob (DOLBY CAL.) × 4	
—	K27-0070-04	Knob (LEVER) × 3	
—	K29-0299-04	Knob (SPEAKER) × 3	
—	K29-0300-04	Knob × 11	
—	L01-1606-05	Power transformer	☆
—	N08-0127-05	Dress screw × 4	
—	N08-0128-35	GND screw	
R1,2	R43-6210-45	Carbon 100kΩ ±5% 1/4W × 2	
R3,4	R43-6239-45	Carbon 390kΩ ±5% 1/4W × 2	
S1	S33-4014-05	Lever switch (POWER)	
S2	S59-1041-05	Timer switch	
—	T90-0083-05	Bar antenna	
—	T90-0202-05	FM indoor antenna	
Q1,3	V01-0747-00	Transistor 2SA747	
Q2,4	V03-1116-00	Transistor 2SC1116	
—	X05-1570-80	Tuner PC board ass'y	
—	X07-1650-80	Power amp PC board ass'y	☆
—	X11-1510-80	Tone amp PC board ass'y	☆
—	X13-2550-80	Speaker selector PC board ass'y	
—	X14-1110-80	Dolby PC board ass'y	

TUNER (X05-1570-80)

Ref. No.	Parts No.	Description	Re- marks
—	B30-0077-05	Pilot lamp (8V, 50mA) × 6	
—	C01-0211-05	Variable capacitor	
—	C05-0055-05	Ceramic trimer (6P)	
Cg1	C71-1710-16	Ceramic 100pF ±10%	
Cg2	C71-1718-06	Ceramic 18pF ±10%	
Cg3	C55-1710-38	Ceramic 0.01μF +80%—20%	
Cg4	C71-1710-02	Ceramic 10pF ±0.5pF	
Cg5	C71-1718-06	Ceramic 18pF ±10%	
Cg6	C71-1722-16	Ceramic 220pF ±10%	
Cg7	C55-1710-38	Ceramic 0.01μF +80%—20%	
Cg8	C91-0037-05	Low capacitive 0.47pF	
Cg9	C59-1722-05	Ceramic 22pF ±5%	
Cg10	C66-1708-02	Ceramic 8pF ±5%	
Cg11	C63-1739-06	Ceramic 39pF ±10%	
Cg12	C63-1715-06	Ceramic 15pF ±10%	
Cg13~19	C55-1710-38	Ceramic 0.01μF +80%—20%	
Cg20	C71-1722-16	Ceramic 220pF ±10%	
Cg21	C24-1210-61	Electrolytic 10μF 16WV	
Cg22	C55-1710-38	Ceramic 0.01μF +80%—20%	
Cg23	C24-1710-51	Electrolytic 1μF 50WV	
Cg24	C55-1710-38	Ceramic 0.01μF +80%—20%	
Cg25	C24-1710-51	Electrolytic 1μF 50WV	
Cg26	C55-1710-38	Ceramic 0.01μF +80%—20%	
Cg27~29	C55-1747-38	Ceramic 0.047μF +80%—20%	
Cg30	C24-1210-61	Electrolytic 10μF 16WV	
Cg31	C24-1233-61	Electrolytic 33μF 16WV	
Cg32	C24-1247-61	Electrolytic 47μF 16WV	
Cg33	C24-1010-71	Electrolytic 100μF 10WV	
Cg42	C70-1718-06	Ceramic 18pF ±10%	
Cg43	C55-1710-38	Ceramic 0.01μF +80%—20%	
Cg44	C46-1710-27	Mylar 0.001μF ±20%	
Cg45	C24-1210-61	Electrolytic 10μF 16WV	
Cg46,47	C46-1710-37	Mylar 0.01μF ±20%	
Cg48	C55-1710-38	Ceramic 0.01μF +80%—20%	
Cg49	C24-1210-61	Electrolytic 10μF 16WV	
Cg50	C55-1747-38	Ceramic 0.047μF +80%—20%	
Cg51	C24-1210-61	Electrolytic 10μF 16WV	
Cg52	C24-1710-51	Electrolytic 1μF 50WV	
Cg53	C52-1739-16	Ceramic 390pF ±10%	
Cg54	C46-1710-37	Mylar 0.01μF ±20%	
Cg55	C55-1710-38	Ceramic 0.01μF +80%—20%	
Cg56	C46-1733-37	Mylar 0.033μF ±20%	
Cg57	C55-1710-38	Ceramic 0.01μF +80%—20%	
Cg58	C24-1210-61	Electrolytic 10μF 16WV	
Cg61	C24-1247-61	Electrolytic 47μF 16WV	
Cg62	C46-1747-37	Mylar 0.047μF ±20%	
Cg63	C48-1715-25	Mylar 0.0015μF ±5%	
Cg64	C25-1722-47	Electrolytic 0.22μF 50WV	
Cg65	C25-1747-47	Electrolytic 0.47μF 50WV	
Cg66	C24-1710-51	Electrolytic 1μF 50WV	
Cg67,68	C46-1715-35	Mylar 0.015μF ±5%	
Cg69,70	C46-1782-25	Mylar 0.0082μF ±5%	
Cg71,72	C24-1210-61	Electrolytic 10μF 16WV	
Cg73,74	C24-1710-51	Electrolytic 1μF 50WV	
Cg75,76	C25-1747-47	Electrolytic 0.47μF 50WV	
Cg77~80	C24-1210-61	Electrolytic 10μF 16WV	
Cg81,82	C46-1711-25	Mylar 0.0011μF ±5%	
Cg83,84	C46-1739-25	Mylar 0.0039μF ±5%	
Cg85	C24-1422-71	Electrolytic 220μF 25WV	
Cg91,92	C71-1747-06	Ceramic 47pF ±10%	
Cg93,94	C81-1033-57	Tantalum 3.3μF 10WV	
Cg95,96	C24-1047-61	Electrolytic 47μF 10WV	
Cg97,98	C71-1710-16	Ceramic 100pF ±10%	
Cg99,100	C71-1733-06	Ceramic 33pF ±10%	

PARTS LIST

Ref. No.	Parts No.	Description	Re- marks
Cg101,102	C46-1712-35	Mylar 0.012μF ±5%	
Cg103,104	C46-1733-25	Mylar 0.0033μF ±5%	
Cg105,106	C25-1447-57	Electrolytic 4.7μF 25WV	
Cg107,108	C24-1410-71	Electrolytic 100μF 25WV	
Cg109,110	C46-1727-35	Mylar 0.027μF ±5%	
Cg111	C24-1410-71	Electrolytic 100μF 25WV	
Cg112	C24-1710-51	Electrolytic 1μF 50WV	
Cg113	C46-1710-47	Mylar 0.1μF ±20%	
Cg114	C46-1715-35	Mylar 0.015μF ±5%	
Cg115	C46-1727-35	Mylar 0.027μF ±5%	
Cg116	C46-1715-35	Mylar 0.015μF ±5%	
Cg117	C25-1747-47	Electrolytic 0.47μF 50WV	
Cg118	C52-1739-16	Ceramic 390pF ±10%	
Cg119	C24-1233-61	Electrolytic 33μF 16WV	
Cg120	C24-1710-51	Electrolytic 1μF 50WV	
—	E11-0065-05	Phone jack	
Lg1	L31-0361-05	FM ANT Coil	
Lg2	L31-0410-05	FM RF Coil	
Lg3	L40-1091-41	Inductor	
Lg4	L32-0210-05	FM OSC Coil	
Lg5	L30-0282-05	FM IFT	
Lg6	L40-1511-03 or L40-1511-44 or L40-1512-03 or L40-1512-44	Inductor	
Lg7	L30-0314-05	FM IFT	☆
Lg8	L40-1092-03 or L40-1092-44	Inductor	
Lg9	L32-0217-05	AM OSC Coil	☆
Lg10	L30-0284-05	AM Detector Coil	
Lg11	L40-1021-03 or L40-1021-45	Inductor	
Lg13	L79-0029-05	Low pass filter	
Lg14	L79-0030-05	Low pass filter	
CFg1~3	L72-0052-15	FM Ceramic filter	
CFg4	L72-0030-05 or L72-0035-05	AM Ceramic filter	
VRg1	R12-1021-05	PC trimming 1 kΩ (SEPARATION)	
VRg2	R12-1040-05	PC trimming 4.7 kΩ (VCO)	
VRg3,4	R12-3045-05	PC trimming 10 kΩ	
VRg5	R12-2016-05	PC trimming 5 kΩ (400 Hz LEVEL)	
VRg6	R01-4026-05	Potentiometer 50 kΩ with switch (MIC)	☆
Rg1	R43-6210-45	Carbon 100kΩ ±5% 1/4W	
Rg2	R43-6247-05	Carbon 47Ω ±5% 1/4W	
Rg3	R43-6210-15	Carbon 100Ω ±5% 1/4W	
Rg4	R43-6222-35	Carbon 22kΩ ±5% 1/4W	
Rg5	R43-6247-25	Carbon 4.7kΩ ±5% 1/4W	
Rg6	R43-6210-25	Carbon 1kΩ ±5% 1/4W	
Rg7	R43-6210-15	Carbon 100Ω ±5% 1/4W	
Rg8	R43-6210-15	Carbon 100Ω ±5% 1/4W	
Rg9,10	R43-6210-35	Carbon 10kΩ ±5% 1/4W	
Rg11	R43-6222-25	Carbon 2.2kΩ ±5% 1/4W	
Rg12	R43-6210-15	Carbon 100Ω ±5% 1/4W	
Rg13	R43-6233-25	Carbon 3.3kΩ ±5% 1/4W	
Rg14	R43-6256-15	Carbon 560Ω ±5% 1/4W	
Rg15	R43-6233-15	Carbon 330Ω ±5% 1/4W	
Rg16	R43-6210-05	Carbon 10Ω ±5% 1/4W	
Rg17,18	R43-6210-15	Carbon 100Ω ±5% 1/4W	
Rg19	R43-6233-15	Carbon 330Ω ±5% 1/4W	
Rg20	R43-6210-35	Carbon 10kΩ ±5% 1/4W	

MODEL NINE G MODEL NINE G

PARTS LIST

Ref. No.	Parts No.	Description	Re- marks
Rg21	R43-6210-05	Carbon 10Ω ±5% 1/4W	
Rg22	R43-6222-25	Carbon 2.2kΩ ±5% 1/4W	
Rg23	R43-6247-35	Carbon 47kΩ ±5% 1/4W	
Rg25	R43-6282-25	Carbon 8.2kΩ ±5% 1/4W	
Rg26	R43-6247-15	Carbon 470Ω ±5% 1/4W	
Rg27	R43-6210-45	Carbon 100kΩ ±5% 1/4W	
Rg28	R43-6227-15	Carbon 270Ω ±5% 1/4W	
Rg29	R43-6268-25	Carbon 6.8kΩ ±5% 1/4W	
Rg30	R40-8310-68	RC 10MΩ ±20% 1/2W	
Rg31	R43-6210-35	Carbon 10kΩ ±5% 1/4W	
Rg32	R43-6233-35	Carbon 33kΩ ±5% 1/4W	
Rg33	R43-6212-35	Carbon 12kΩ ±5% 1/4W	
Rg34	R43-6233-35	Carbon 33kΩ ±5% 1/4W	
Rg35	R43-6222-35	Carbon 22kΩ ±5% 1/4W	
Rg36	R43-6222-15	Carbon 220Ω ±5% 1/4W	
Rg37	R43-6210-35	Carbon 10kΩ ±5% 1/4W	
Rg38	R43-6256-35	Carbon 56kΩ ±5% 1/4W	
Rg39	R43-6233-35	Carbon 33kΩ ±5% 1/4W	
Rg40	R43-6222-35	Carbon 22kΩ ±5% 1/4W	
Rg41	R43-6247-35	Carbon 47kΩ ±5% 1/4W	
Rg42,43	R43-6210-35	Carbon 10kΩ ±5% 1/4W	
Rg44	R43-6215-35	Carbon 15kΩ ±5% 1/4W	
Rg45	R43-6247-35	Carbon 47kΩ ±5% 1/4W	
Rg51	R43-6222-15	Carbon 220Ω ±5% 1/4W	
Rg52	R43-6210-15	Carbon 100Ω ±5% 1/4W	
Rg53	R43-6215-25	Carbon 1.5kΩ ±5% 1/4W	
Rg54	R43-6256-25	Carbon 5.6kΩ ±5% 1/4W	
Rg55	R43-6233-15	Carbon 330Ω ±5% 1/4W	
Rg56,57	R43-6210-35	Carbon 10kΩ ±5% 1/4W	
Rg58	R43-6222-15	Carbon 22kΩ ±5% 1/4W	
Rg59	R43-6222-25	Carbon 2.2kΩ ±5% 1/4W	
Rg60	R43-6247-35	Carbon 47kΩ ±5% 1/4W	
Rg61	R43-6215-35	Carbon 15kΩ ±5% 1/4W	
Rg62	R43-6210-35	Carbon 10kΩ ±5% 1/4W	
Rg71	R43-6215-15	Carbon 150Ω ±5% 1/4W	
Rg72	R43-6282-25	Carbon 8.2kΩ ±5% 1/4W	
Rg73	R43-6210-25	Carbon 1kΩ ±5% 1/4W	
Rg74	R43-6210-35	Carbon 10kΩ ±5% 1/4W	
Rg75	R43-6222-35	Carbon 22kΩ ±5% 1/4W	
Rg77,78	R43-6268-25	Carbon 6.8kΩ ±5% 1/4W	
Rg79,80	R43-6282-45	Carbon 820kΩ ±5% 1/4W	
Rg81,82	R43-6222-25	Carbon 2.2kΩ ±5% 1/4W	
Rg83,84	R43-6247-25	Carbon 4.7kΩ ±5% 1/4W	
Rg85,86	R43-6268-25	Carbon 6.8kΩ ±5% 1/4W	
Rg87,88	R43-6222-45	Carbon 220kΩ ±5% 1/4W	
Rg89,90	R43-6233-35	Carbon 33kΩ ±5% 1/4W	
Rg91,92	R43-6210-25	Carbon 1kΩ ±5% 1/4W	
Rg93,94	R43-6218-15	Carbon 180Ω ±5% 1/4W	
Rg95,96	R43-6222-45	Carbon 220kΩ ±5% 1/4W	
Rg97,98	R40-8310-68	RC 10MΩ ±20% 1/2W	
Rg99,100	R43-6222-45	Carbon 220kΩ ±5% 1/4W	
Rg101~104	R43-6220-35	Carbon 20kΩ ±5% 1/4W	
Rg105	R43-6222-05	Carbon 22Ω ±5% 1/4W	
Rg111,112	R43-6210-15	Carbon 100Ω ±5% 1/4W	
Rg113~116	R43-6210-45	Carbon 100kΩ ±5% 1/4W	
Rg117,118	R43-6247-15	Carbon 470Ω ±5% 1/4W	
Rg119,120	R43-6227-45	Carbon 270kΩ ±5% 1/4W	
Rg121,122	R43-6222-35	Carbon 22kΩ ±5% 1/4W	
Rg123,124	R43-6256-35	Carbon 56kΩ ±5% 1/4W	
Rg125,126	R43-6256-15	Carbon 560Ω ±5% 1/4W	
Rg127,128	R43-6210-15	Carbon 100Ω ±5% 1/4W	
Rg129,130	R43-6222-25	Carbon 2.2kΩ ±5% 1/4W	

Ref. No.	Parts No.	Description	Re- marks
Rg131,132	R43-6291-25	Carbon 9.1kΩ ±5% 1/4W	
Rg133	R43-6210-25	Carbon 1kΩ ±5% 1/4W	
Rg134,135	R43-6282-25	Carbon 8.2kΩ ±5% 1/4W	
Rg136	R43-6256-15	Carbon 560Ω ±5% 1/4W	
Rg137	R40-8315-58	RC 1.5MΩ ±20% 1/2W	
Rg138	R43-6247-35	Carbon 47kΩ ±5% 1/4W	
Rg139	R43-6233-25	Carbon 3.3kΩ ±5% 1/4W	
Rg140	R43-6247-35	Carbon 47kΩ ±5% 1/4W	
Rg141	R43-6247-25	Carbon 4.7kΩ ±5% 1/4W	
Rg142	R43-6222-25	Carbon 2.2kΩ ±5% 1/4W	
Rg143	R43-6210-25	Carbon 1kΩ ±5% 1/4W	
Rg144	R43-6210-45	Carbon 100kΩ ±5% 1/4W	
Rg146	R43-6210-45	Carbon 100kΩ ±5% 1/4W	
Rg147	R43-6210-25	Carbon 1kΩ ±5% 1/4W	
Rg148	R43-6233-25	Carbon 3.3kΩ ±5% 1/4W	
Rg149	R43-6210-05	Carbon 10Ω ±5% 1/4W	
Rg150	R43-6243-25	Carbon 4.3kΩ ±5% 1/4W	
Rg151,152	R43-6210-35	Carbon 10kΩ ±5% 1/4W	
Rg153,154	R43-6222-25	Carbon 2.2kΩ ±5% 1/4W	
Rg155,156	R43-6282-45	Carbon 820kΩ ±5% 1/4W	
Rg157,158	R43-6282-25	Carbon 8.2kΩ ±5% 1/4W	
Sg1	S42-3023-05	Pushbutton switch (3 key)	☆
Sg2	S42-5010-05	Pushbutton switch (5 key)	☆
Sg3	S31-6011-05	Slide switch	☆
Qg1	V09-0124-10	FET 2SK61	
Qg2	V03-0535-10	Transistor 2SC535(A,B)	
Qg3	V03-1342-00	Transistor 2SC1342	
Qg4	V03-1923-00	Transistor 2SC1923	
Qg5	V09-0122-50	FET 2SK68(L,M,N) or V09-0126-60 FET 2SK117(Y,G,R,BL) or V09-0127-30 FET 2SK105(F,H,J)	
Qg6~8	V03-0345-05	Transistor 2SC828A (Q,R) or V03-0348-05 Transistor 2SC945 (Q,P)	
Qg9	V01-0170-05	Transistor 2SA733 (Q,P) or V01-0564-50 Transistor 2SA564A (Q,R,S)	
Qg10	V03-0345-05	Transistor 2SC828A (Q,R) or V03-0348-05 Transistor 2SC945 (Q,P)	
Qg11,12	V03-0456-05	Transistor 2SC1222 or V03-1845-20 Transistor 2SC1845 (F,E,U)	
Qg13,14	V09-0122-50	FET 2SK68 (L,M,N) or V09-0126-60 FET 2SK117 (Y,G,R,BL) or V09-0127-30 FET 2SK105 (F,H,J)	
Qg15,16	V03-0345-05	Transistor 2SC828A (Q,R) or V03-0348-05 Transistor 2SC945 (Q,P)	
Qg17	V03-0456-05	Transistor 2SC1222 or V03-1845-20 Transistor 2SC1845 (F,E,U)	
Dg1~7	V11-0076-05	Diode 1S1555 or V11-0271-05 Diode 1S2076	
ICg1	V30-0133-05	IC HA1137W	
ICg2	V30-0196-05	IC HA1197 or V30-0245-10 IC LA1240	
ICg3	V30-0244-10	IC LA3350S-L6	
ICg5,6	V30-0264-10	IC HA1457	

POWER (X07-1650-80)

Ref. No.	Parts No.	Description	Re- marks
Ce1,2	C25-6522-57	Electrolytic 2.2μF 35WV	
Ce3,4	C52-1747-16	Ceramic 470pF ±10%	
Ce5,6	C52-1733-16	Ceramic 330pF ±10%	
Ce7~10	C24-1010-71	Electrolytic 100μF 10WV	
Ce11,12	C71-1722-05	Ceramic 22pF ±5%	
Ce13,14	C71-1715-05	Ceramic 15pF ±5%	
Ce15,16	C24-1010-71	Electrolytic 100μF 10WV	
Ce17,18	C24-1847-61	Electrolytic 47μF 63WV	
Ce19~22	C24-1047-61	Electrolytic 47μF 10WV	
Ce23,24	C46-1768-36	Mylar 0.068μF ±10%	
Ce25	C46-2010-47	Mylar 0.1μF ±20%	
Ce30	C26-1247-67	Electrolytic 47μF 16WV	
Ce31	C25-1247-67	Electrolytic 47μF 16WV	
Ce32	C46-1710-47	Mylar 0.1μF ±20%	
Ce33	C24-1710-51	Electrolytic 1μF 50WV	
Ce34	C24-1022-81	Electrolytic 2200μF 10WV	
Ce35,36	C90-0360-05	Electrolytic 10,000μF 56WV	
Ce37~40	C54-2710-39	Ceramic 0.01μF +100% -0%	
Ce41,42	C24-1210-71	Electrolytic 100μF 16WV	
Ce43	C24-1410-71	Electrolytic 100μF 25WV	
Ce44	C24-1710-51	Electrolytic 1μF 50WV	
Ce45	C24-1422-71	Electrolytic 220μF 25WV	
Ce46	C24-1410-71	Electrolytic 100μF 25WV	
Ce47	C24-1210-71	Electrolytic 100μF 16WV	
Ce48	C91-0023-05	Ceramic 0.01μF AC250WV	
Fe1	F05-5022-05	Fuse (5A) for Pilot lamp	
Fe2	F05-6021-05	Fuse (6A)	
Fe3	F05-3022-05	Fuse (3A)	
—	J13-0041-05	Fuse Clip × 6	
Le1,2	L40-1021-03	Inductor (1mH)	
Le3,4	L39-0080-15	Phase compensation coil	
VRe1,2	R12-0052-05	PC trimming 100Ω(B) Bias	
Re1,2	R43-6210-25	Carbon 1kΩ ±5% 1/4W	
Re3,4	R43-6247-35	Carbon 47kΩ ±5% 1/4W	
Re5,6	R43-6233-15	Carbon 330Ω ±5% 1/4W	
Re7~10	R43-6227-15	Carbon 270Ω ±5% 1/4W	
Re11,12	R43-6239-25	Carbon 3.9kΩ ±5% 1/4W	
Re13~16	R43-6282-15	Carbon 820Ω ±5% 1/4W	
Re17,18	R43-6218-35	Carbon 18kΩ ±5% 1/4W	
Re19,20	R43-6222-35	Carbon 22kΩ ±5% 1/4W	
Re21,22	R43-1212-15	Carbon 120Ω ±5% 1/4W	
Re23,24	R43-6247-05	Carbon 47Ω ±5% 1/4W	
Re25,26	R43-1233-15	Carbon 330Ω ±5% 1/4W	
Re27,28	R43-1256-05	Carbon 56Ω ±5% 1/4W	
Re29~32	R43-1222-15	Carbon 220Ω ±5% 1/4W	
Re33~36	R43-6218-25	Carbon 1.8kΩ ±5% 1/4W	
Re37~40	R43-6227-15	Carbon 270Ω ±5% 1/4W	
Re41~44	R43-6215-35	Carbon 15kΩ ±5% 1/4W	
Re45~48	R92-0113-05	Cement 0.33Ω ±5% 3W	
Re49~52	R43-1247-95	Carbon 4.7Ω ±5% 1/4W	
Re53,54	R47-5647-95	RS 4.7Ω ±5% 3W	
Re55,56	R47-5410-05	RS 10Ω ±5% 1W	
Re60,61	R43-6268-35	Carbon 68kΩ ±5% 1/4W	
Re62	R43-6215-35	Carbon 15kΩ ±5% 1/4W	
Re63	R43-6222-45	Carbon 220kΩ ±5% 1/4W	
Re64	R43-6233-45	Carbon 330kΩ ±5% 1/4W	
Re65,66	R43-6210-35	Carbon 10kΩ ±5% 1/4W	
Re67	R43-6282-35	Carbon 82kΩ ±5% 1/4W	
Re68	R43-6212-35	Carbon 12kΩ ±5% 1/4W	
Re69	R43-6210-35	Carbon 10kΩ ±5% 1/4W	

PARTS LIST

Ref. No.	Parts No.	Description	Re- marks
Re70	R43-6210-25	Carbon 1kΩ ±5% 1/4W	
Re71	R47-5568-15	RS 680Ω ±5% 2W	
Re72	R43-6210-35	Carbon 10kΩ ±5% 1/4W	
Re73	R43-6282-25	Carbon 8.2kΩ ±5% 1/4W	
Re74	R43-6210-45	Carbon 100kΩ ±5% 1/4W	
Re75	R43-6227-25	Carbon 2.7kΩ ±5% 1/4W	
Re76	R43-6212-25	Carbon 1.2kΩ ±5% 1/4W	
Re77,78	R47-5510-15	RS 100Ω ±5% 2W	
Re79	R47-5533-15	RS 330Ω ±5% 2W	
Re80	R43-6247-25	Carbon 4.7kΩ ±5% 1/4W	
Re81	R43-6282-25	Carbon 8.2kΩ ±5% 1/4W	
Re82	R43-6218-25	Carbon 1.8kΩ ±5% 1/4W	
Re83	R47-5512-15	RS 120Ω ±5% 2W	
Re84,85	R47-5518-15	RS 180Ω ±5% 2W	
Re86	R47-5533-15	RS 330Ω ±5% 2W	
Re87	R47-5439-25	RS 3.9kΩ ±5% 1W	
Re88	R47-5410-25	RS 1kΩ ±5% 1W	
Se1	S31-2046-05	Slide switch (Voltage selector)	
RLe1	S51-4034-05	Relay	
Qe1~4	V01-0189-05	Transistor 2SA872 (E) or V01-0921-10 Transistor 2SA921 (S)	
Qe5,6	V01-0198-05	Transistor 2SA872 or V01-0872-00 Transistor 2SA872A	
Qe7,8	V03-1775-00	Transistor 2SC1775 or V03-1775-30 Transistor 2SC1775A	
Qe9,10	V03-0451-05	Transistor 2SC1885 (Q,R)	
Qe11,12	V01-0912-20	Transistor 2SA912 (Q,R)	
Qe13,14	V01-0084-05	Transistor 2SA733 (R,Q) or V02-0725-20 Transistor 2SB725 (Q,R)	
Qe15~18	V03-0270-05	Transistor 2SC945 (R,Q) or V04-0767-20 Transistor 2SD767(Q,R)	
Qe19,20	V01-0084-05	Transistor 2SA733 (R,Q) or V02-0725-20 Transistor 2SB725 (Q,R)	
Qe21,22	V03-0468-05	Transistor 2SC1913 (Q,R)	
Qe23,24	V01-0188-05	Transistor 2SA913 (Q,R)	
Qe25	V03-0270-05	Transistor 2SC945 (R,Q) or V04-0767-20 Transistor 2SD767 (Q,R)	
Qe26	V01-0084-05	Transistor 2SA733 (R,Q) or V02-0725-20 Transistor 2SB725 (Q,R)	
Qe27	V03-0270-05	Transistor 2SC945(R,Q) or V04-0767-20 Transistor 2SD767 (Q,R)	
Qe28	V03-1775-00	Transistor 2SC1775 or V03-1775-30 Transistor 2SC1775A	
Qe29	V03-0494-05	Transistor 2SC1509(Q,R) or V03-2274-20 Transistor 2SC2274K(E,F)	
Qe30	V04-0330-00	Transistor 2SD330	
Qe31	V03-1775-00	Transistor 2SC1775 or V03-1775-30 Transistor 2SC1775A	
Qe32,33	V01-0173-05	Transistor 2SA850 or V01-0208-05 Transistor 2SA777 (Q,R)	
De1,2	V11-5100-10	Varistor STV-4H (W)	
De3~8	V11-0271-05	Diode 1S2076 or V11-0273-05 Diode 1S2076A	
De9~12	V11-0273-05	Diode 1S2076A	
De13,14	V11-0219-05	Diode V06B	
De15	V11-0273-05	Diode 1S2076A	
De16	V11-2101-40	Diode M4C-51-12*1	
De17	V11-4102-30	Zener Diode XZ-132	
De18	V11-0287-05	Zener Diode WZ-240	

PARTS LIST

STONE (X11-1510-80)

Ref. No.	Parts No.	Description	Re- marks
Ci1.2	C24-0822-71	Electrolytic 220 μ F 6.3WV	
Ci3.4	C24-1010-71	Electrolytic 100 μ F 10WV	
Ci5.6	C25-1410-67	Electrolytic 10 μ F 25WV	
Ci7~10	C46-1768-26	Mylar 0.0068 μ F \pm 10%	
Ci11.12	C46-1739-36	Mylar 0.039 μ F \pm 10%	
Ci13.14	C46-1733-26	Mylar 0.0033 μ F \pm 10%	
Ci15.16	C52-1733-16	Ceramic 330pF \pm 10%	
Ci17.18	C25-6522-57	Electrolytic 2.2 μ F 35WV	
Ci19.20	C24-1010-71	Electrolytic 100 μ F 10WV	
Ci21.22	C25-1410-67	Electrolytic 10 μ F 25WV	
Ci23~26	C46-1710-46	Mylar 0.1 μ F \pm 10%	
Ci27.28	C25-6522-57	Electrolytic 2.2 μ F 35WV	
Ci29.30	C25-1710-57	Electrolytic 1 μ F 50WV	
Ci31.32	C24-1010-71	Electrolytic 100 μ F 10WV	
Ci33.34	C25-1410-67	Electrolytic 10 μ F 25WV	
Ci35.36	C25-6522-57	Electrolytic 2.2 μ F 35WV	
Ci37.38	C52-1712-26	Ceramic 0.0012 μ F \pm 10%	
Ci39.40	C46-1712-46	Mylar 0.12 μ F \pm 10%	
Ci41.42	C46-1722-36	Mylar 0.022 μ F \pm 10%	
Ci43.44	C24-1410-71	Electrolytic 100 μ F 25WV	
Ci45.46	C71-1722-06	Ceramic 22pF \pm 10%	
VRi1	R06-5039-05	Potentiometer 200k Ω (MN) Dual (Balance)	
VRi2	R08-5039-05	Potentiometer 100k Ω (B) Dual(Volume)	
VRi3~5	R06-4039-05	Potentiometer 50k Ω (B) Dual(Tone)	
Ri1.2	R43-6247-05	Carbon 47 Ω \pm 5% 1/4W	
Ri3.4	R43-6239-15	Carbon 390 Ω \pm 5% 1/4W	
Ri5.6	R43-6210-35	Carbon 10k Ω \pm 5% 1/4W	
Ri7.8	R43-6227-25	Carbon 2.7k Ω \pm 5% 1/4W	
Ri9.10	R43-6212-25	Carbon 1.2k Ω \pm 5% 1/4W	
Ri11.12	R43-6215-35	Carbon 15k Ω \pm 5% 1/4W	
Ri13.14	R43-6239-25	Carbon 3.9k Ω \pm 5% 1/4W	
Ri15.16	R43-6239-35	Carbon 39k Ω \pm 5% 1/4W	
Ri17.18	R43-6222-15	Carbon 220 Ω \pm 5% 1/4W	
Ri19~22	R43-6233-25	Carbon 3.3k Ω \pm 5% 1/4W	
Ri23~26	R43-6227-35	Carbon 27k Ω \pm 5% 1/4W	
Ri27~30	R43-6230-25	Carbon 3k Ω \pm 5% 1/4W	
Ri31.32	R43-6268-25	Carbon 6.8k Ω \pm 5% 1/4W	
Ri33.34	R43-6216-45	Carbon 160k Ω \pm 5% 1/4W	
Ri35.36	R43-6233-35	Carbon 33k Ω \pm 5% 1/4W	
Ri37.38	R43-6247-25	Carbon 4.7k Ω \pm 5% 1/4W	
Ri39.40	R43-6215-25	Carbon 1.5k Ω \pm 5% 1/4W	
Ri41~44	R43-6243-25	Carbon 4.3k Ω \pm 5% 1/4W	
Ri45~48	R43-6227-35	Carbon 27k Ω \pm 5% 1/4W	
Ri49.50	R43-6216-45	Carbon 160k Ω \pm 5% 1/4W	
Ri51.52	R43-6233-35	Carbon 33k Ω \pm 5% 1/4W	
Ri53.54	R43-6247-25	Carbon 4.7k Ω \pm 5% 1/4W	
Ri55.56	R43-6215-25	Carbon 1.5k Ω \pm 5% 1/4W	
Ri57.58	R43-6239-35	Carbon 39k Ω \pm 5% 1/4W	
Ri59.60	R43-6247-35	Carbon 47k Ω \pm 5% 1/4W	
Ri61.62	R43-6218-35	Carbon 18k Ω \pm 5% 1/4W	
Ri63.64	R43-6210-25	Carbon 1k Ω \pm 5% 1/4W	
Ri65.66	R43-6233-45	Carbon 330k Ω \pm 5% 1/4W	
Ri67.68	R43-1233-05	Carbon 33 Ω \pm 5% 1/4W	
Si1	S33-2034-05	Lever switch (Tone)	
Si2	S42-2022-05	Pushbutton (Filter)	☆
Qi1.2	V09-0092-05	Transistor 2SK68A(L.M)	
Qi3.4	V01-0198-05	Transistor 2SA872 or	
	V01-0992-10	Transistor 2SA992 (F.E)	

Ref. No.	Parts No.	Description	Re- marks
Qi5.6	V03-1775-00	Transistor 2SC1775 or	
	V03-1845-20	Transistor 2SC1845 (F.E,U)	
Qi7~10	V01-0198-05	Transistor 2SA872 or	
	V01-0992-10	Transistor 2SA992 (F.E)	

SPEAKER SELECTOR (X13-2550-80)

Ref. No.	Parts No.	Description	Re- marks
Ch1.2	C24-1047-61	Electrolytic 47 μ F 10WV	
Ch3.4	C46-1722-37	Mylar 0.022 μ F \pm 20%	
Ch5.6	C25-6522-57	Electrolytic 2.2 μ F 35WV	
—	E20-1206-05	Speaker terminal	☆
VRh1~4	R12-1021-05	PC trimming potentiometer 1k Ω (B)	
Rh1.2	R43-6239-25	Carbon 3.9k Ω \pm 5% 1/4W	
Rh3.4	R47-5439-15	RS 390 Ω \pm 5% 1W	
Rh5.6	R43-6256-15	Carbon 560 Ω \pm 5% 1/4W	
Rh7.8	R43-6218-25	Carbon 1.8k Ω \pm 5% 1/4W	
Rh9~11	R40-8368-16	RC 680 Ω \pm 10% 1/2W	
Rh12.13	R47-5456-15	RS 560 Ω \pm 5% 1W	
Sh1	S42-3017-05	Pushbutton switch (Meter)	☆
Sh2	S42-3022-05	Pushbutton switch (Speaker)	
Dh1.2	V11-0400-05	Diode 1N34A	
Dh3.4	V11-0423-05	Diode 1N60IFT	
Dh5~10	V11-0051-05	Diode 1N60	
THh1.2	V22-0007-05	Thermistor SDT-20	

DOLBY (X14-1110-80)

Ref. No.	Parts No.	Description	Re- marks
Cv1.2	C81-1410-57	Tantalum 1 μ F 25WV	
Cv3.4	C46-1722-35	Mylar 0.022 μ F \pm 5%	
Cv9~12	C24-1410-61	Electrolytic 10 μ F 25WV	
Cv13.14	C49-2056-24	Film 0.0056 μ F \pm 2%	
Cv15.16	C24-1410-61	Electrolytic 10 μ F 25WV	
Cv17.18	C46-1733-45	Mylar 0.33 μ F \pm 5%	
Cv19.20	C46-1710-45	Mylar 0.1 μ F \pm 5%	
Cv21.22	C46-1747-35	Mylar 0.047 μ F \pm 5%	
Cv23.24	C24-1410-61	Electrolytic 10 μ F 25WV	
Cv25.26	C49-2047-24	Film 0.0047 μ F \pm 2%	
Cv27.28	C24-1410-61	Electrolytic 10 μ F 25WV	
Cv29.30	C24-1222-71	Electrolytic 220 μ F 16WV	
Cv31.32	C49-2027-34	Film 0.027 μ F \pm 2%	
Cv33.34	C24-1710-51	Electrolytic 1 μ F 50WV	
Cv35.36	C24-1410-61	Electrolytic 10 μ F 25WV	
Cv37	C24-1410-71	Electrolytic 100 μ F 25WV	
Cv39.40	C52-1733-16	Ceramic 330pF \pm 10%	
VRv1~4	R05-5001-05	Potentiometer 100k Ω (B) (Dolby)	☆

PARTS LIST/SEMICONDUCTOR SUBSTITUTIONS

SEMICONDUCTOR SUBSTITUTIONS

Ref. No.	Parts No.	Description	Re- marks
Rv1.2	R43-6210-45	Carbon 100kΩ ±5% 1/4W	
Rv3.4	R43-6247-45	Carbon 470kΩ ±5% 1/4W	
Rv5~8	R43-6210-45	Carbon 100kΩ ±5% 1/4W	
Rv9.10	R43-6227-45	Carbon 270kΩ ±5% 1/4W	
Rv11.12	R43-6215-45	Carbon 150kΩ ±5% 1/4W	
Rv13.14	R43-6268-45	Carbon 680kΩ ±5% 1/4W	
Rv15.16	R43-6233-25	Carbon 3.3kΩ ±5% 1/4W	
Rv17.18	R43-6218-15	Carbon 180Ω ±5% 1/4W	
Rv19.20	R43-6212-15	Carbon 120Ω ±5% 1/4W	
Rv21.22	R43-6210-45	Carbon 100kΩ ±5% 1/4W	
Rv23.24	R43-6247-35	Carbon 47kΩ ±5% 1/4W	
Rv25.26	R43-6282-45	Carbon 820kΩ ±5% 1/4W	
Rv27.28	R43-6227-25	Carbon 2.7kΩ ±5% 1/4W	
Rv29.30	R43-6210-45	Carbon 100kΩ ±5% 1/4W	
Rv35.36	R43-6210-25	Carbon 1kΩ ±5% 1/4W	
Rv37	R40-8315-16	RC 150Ω ±10% 1/2W	
Sv1	S01-7001-05	Rotary switch (DOLBY MODE)	☆
Sv2	S33-2040-05	Lever switch (TAPE MONITOR)	☆
Qv1.2	V03-0270-05	Transistor 2SC945 (R,Q)	
Dv1.2	V11-0051-05	Diode 1N60	
ICv1.2	V30-0139-05	IC NE545B	

Semiconductor Name	Substitutions
2SA747	2SA747 or $P_c \geq 100W, V_{CE0} \geq 120V, I_c \geq 10A, h_{fe} = 50 \sim 100, f_T = 15 \text{ MHz}$
2SC1116	2SC1116A or $P_c \geq 100W, V_{CE0} \geq 120V, I_c \geq 10A, h_{fe} = 50 \sim 100, f_T = 15 \text{ MHz}$
X05-1570-80	
2SA733(Q,P)	2SA564A(Q,R,S), 2SA561(Y)
2SC535(A,B)	2SC381(O,R), 2SC785(R)
2SC945(Q,P)	2SC828A(Q,R), 2SC734(Y), 2SC1213A(C,D), 2SC1890(D)
2SC1342	2SC785(R), 2SC1923
2SC1845(F,E,U)	2SC1222, 2SC1400
2SC1923	2SC785(R), 2SC381
2SK61	—
2SK117(Y,GR,BL)	2SK68(L,M,N), 2SK68A, 2SK105(F,H,J)
X07-1650-80	
2SA733(R,Q)	2SA539, 2SA561, 2SA564, 2SB725(Q,R)
2SA872	2SA872A
2SA850	2SA777(Q,R)
2SA912(Q,R)	—
2SA913(Q,R)	2SA839, 2SB536
2SA921(S)	2SA872(E)
2SC945(R,Q)	2SD767(Q,R)
2SC1775	2SC1775A
2SC1885(Q,R)	—
2SC1913(Q,R)	2SC381(R), 2SC1669
2SC2274(E,F)	2SC1509
2SD330	—
X11-1510-80	
2SA992(F,E)	2SA872, 2SA872A(E,F)
2SC1845(F,E,U)	2SC1775, 2SC1775A(E,F), 2SC1890(D,E,F), 2SC1890A(D,E,F), 2SC2088, 2SC2089
2SK68A(L,M)	—
X14-1110-80	
2SC945(P,Q)	2SC734(O,Y), 2SC1213A(B,C)

A product of

TRIO-KENWOOD CORPORATION

6-17, 3-chome, Aobadai, Meguro-ku, Tokyo 153, Japan

KENWOOD ELECTRONICS, INC.

1315 E. Watsoncenter Rd, Carson, California 90745
75 Seaview Drive, Secaucus, New Jersey 07094, U.S.A.

TRIO-KENWOOD ELECTRONICS, N.V.

Leuvensesteenweg 184 B-1930 Zaventem, Belgium

TRIO-KENWOOD ELECTRONICS GmbH

Rudolf-Braas-Str. 20, 6056 Heusenstamm, West Germany

TRIO-KENWOOD FRANCE S.A.

5, Boulevard Ney, 75018 Paris, France

TRIO-KENWOOD SVENSKA AB

Kemistvagen 10A, S-183 21 Taby, Sweden

TRIO-KENWOOD (AUSTRALIA) PTY. LTD.

30 Whiting St., Artarmon, N.S.W. 2064, Australia

KENWOOD & LEE ELECTRONICS, LTD.

Room 501, Wang Kee Building, 5th Floor, 34-37, Connaught Road, Central, Hong Kong