

A-45/65

SERVICE MANUAL

717650-51

©1991-6 PRINTED IN JAPAN
B51-4344-00(S)1991

[A-45]

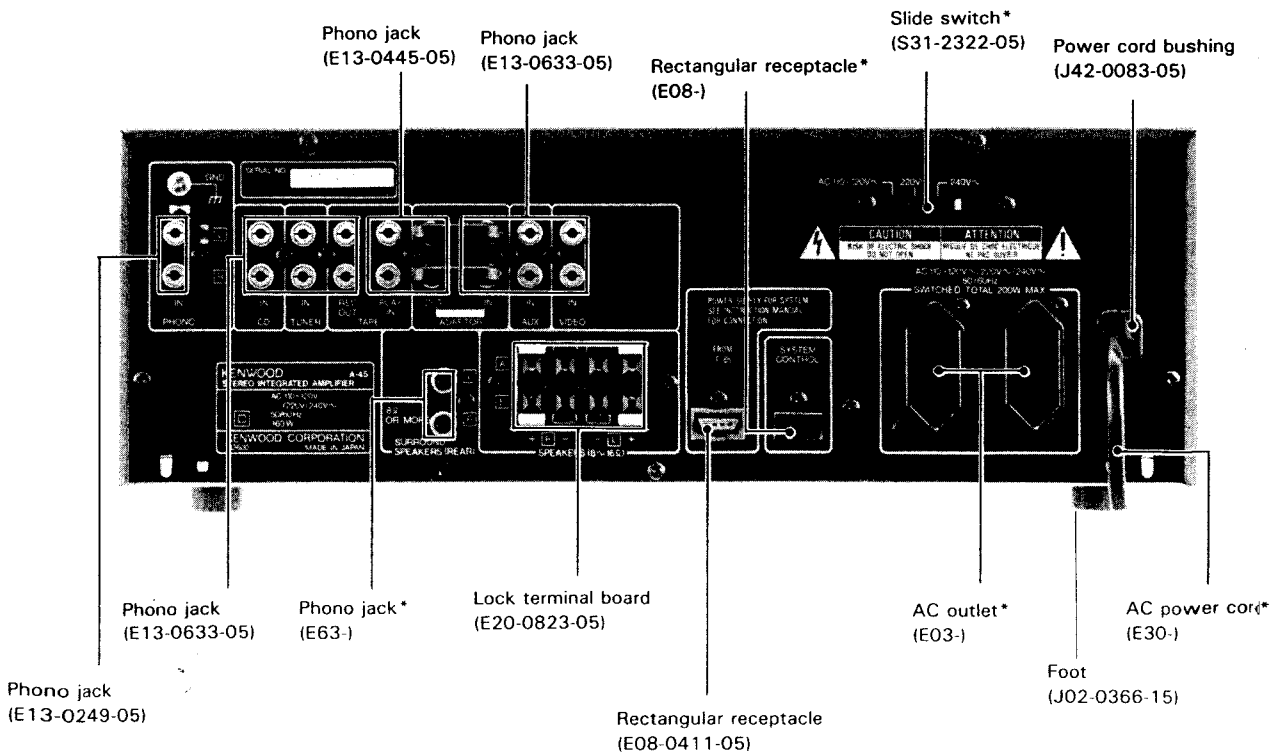
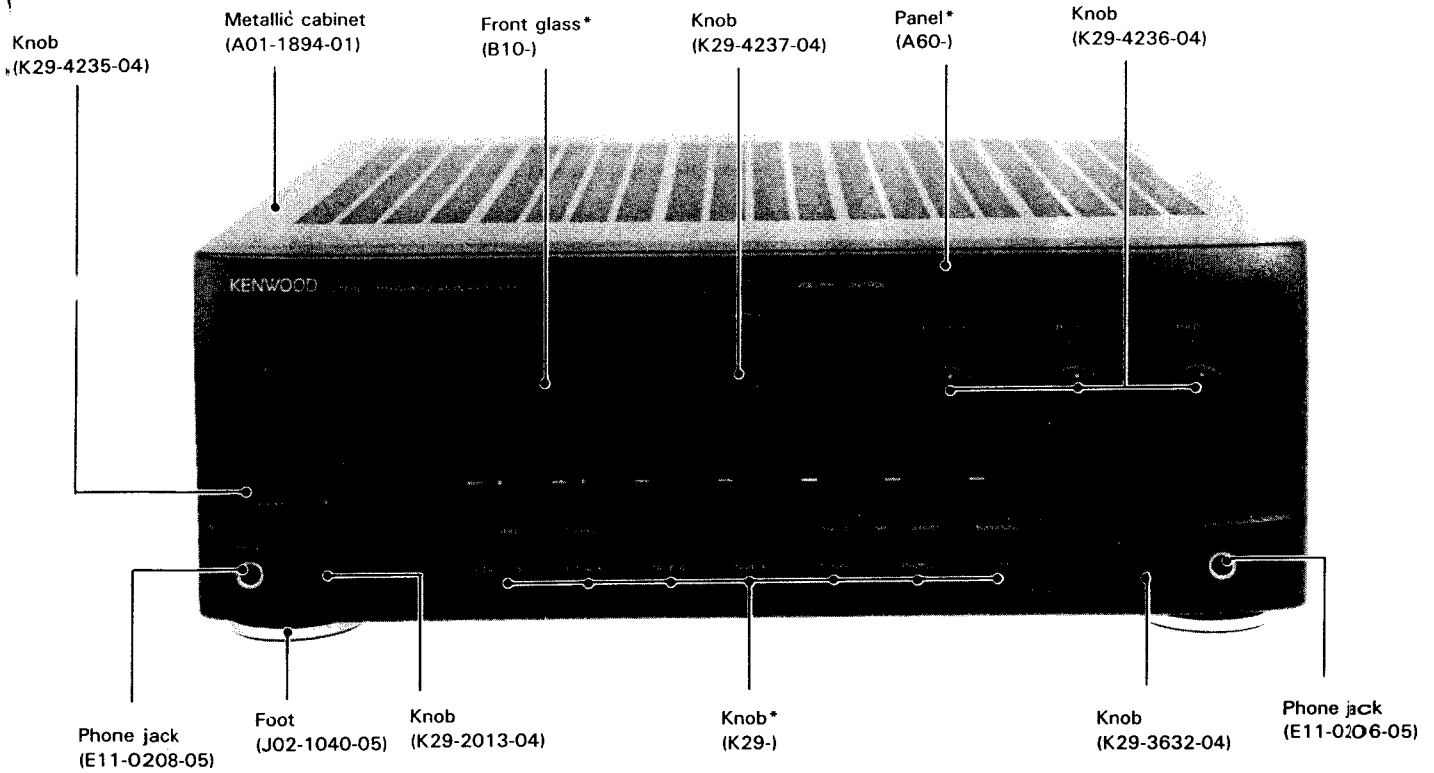

*Refer to parts list on page 19.

A-45/65

CONTENTS

CIRCUIT DESCRIPTION	3	EXPLODED VIEW	17
WIRING DIAGRAM	7	PARTS LIST	19
PC BOARD	9	SPECIFICATIONS	BACK COVER
SCHEMATIC DIAGRAM	13		

[A-65]

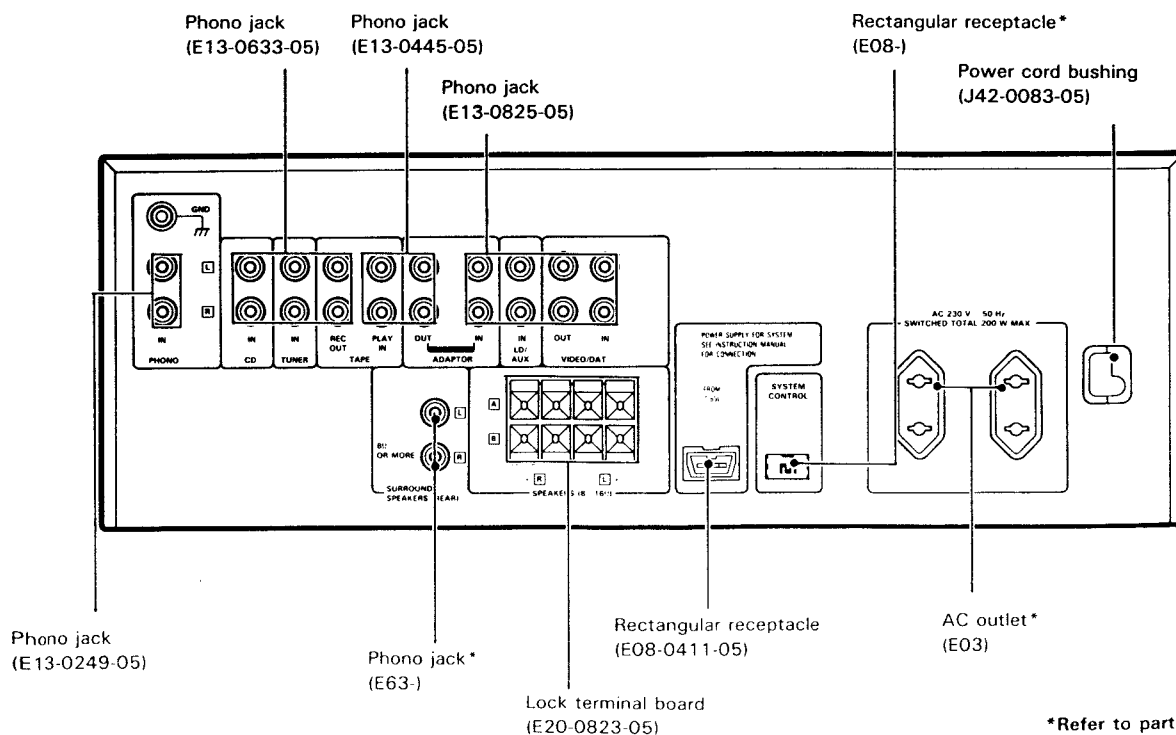
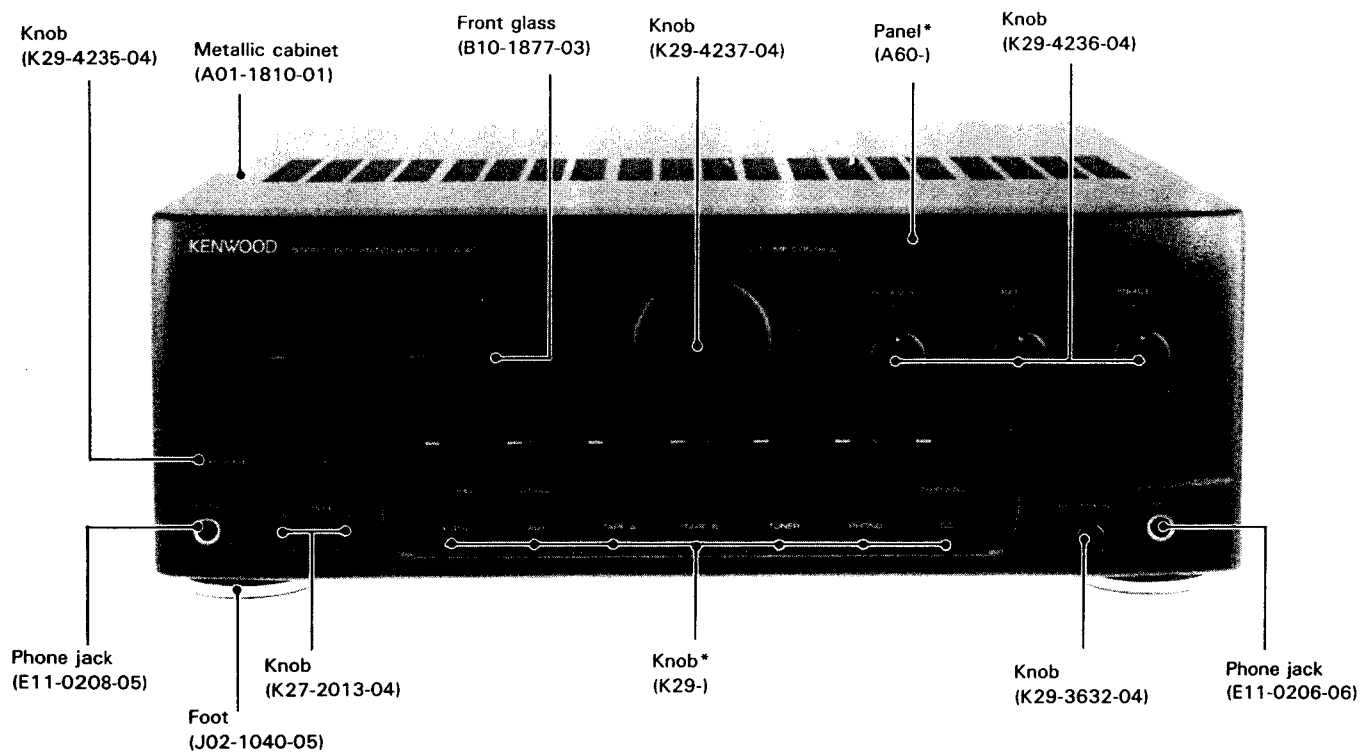

*Refer to parts list on page 19.

CIRCUIT DESCRIPTION

MICROPROCESSOR μ PD75104CW-251

1. OPERATION DESCRIPTION

1.1 Functions

(1) Features

- CD DIRECT
- SURROUND
- CD REC
- HIT MASTER
- MELODY ASSIST
- Video input: Two channels, Audio input: Seven channels
- Remote control compatible
- Serial input/output (16 bits)

(2) Control IC

TC9163N

1.2 Destination and Model

The software is common in all models and all destinations.

1.3 Key Descriptions

- **POWER**
System ON/OFF key. "0800H" is output when this key is set to ON. A sound is generated after muting for 4 seconds. "0801H" is output when this key is set to OFF. The POWER pin is set low after 800 ms. This key is ineffective for 500 ms when it is pressed.
- **TAPE A**
TAPE A select key. Sets the selector to TAPE A and mutes for 32 ms + 500 ms. Ineffective during REC.
- **VIDEO**
VIDEO select key. Sets the selector (VIDEO/AUDIO) to VIDEO and mutes for 32 ms + 500 ms. Ineffective during REC.
- **PHONO**
PHONO select key. Sets the selector to PHONO and mutes for 32 ms + 500 ms. Ineffective during REC.
- **CD**
CD select key. Sets the selector to CD and mutes for 32 ms + 500 ms. Ineffective during REC.
- **TAPE B**
TAPE B select key. Sets the selector to TAPE B and mutes for 32 ms + 500 ms. Ineffective during REC.
- **AUX**
AUX select key. Sets the selector to AUX and mutes for 32 ms + 500 ms. Ineffective during REC.
- **TUNER**
TUNER select key. Sets the selector to TUNER and mutes for 32 ms + 500 ms. Ineffective during REC.
- **SURROUND**
Surround ON/OFF key. Mutes for 32 ms + 500 ms during selection.

- **MUTE**
Mute ON/OFF key.
- **CD DIRECT**
CD DIRECT ON/OFF key. Mutes for 32 ms + 5 ms during selection.
- **CD REC**
CD REC ON/OFF key. Mutes for 32 ms + 5 ms during selection. Ineffective during REC. A selector is released when the REC mode is entered with this key set to ON.
- **MELODY ASSIST**
MELODY ASSIST ON/OFF key. Mutes for 32 ms + 500 ms during selection. Ineffective during REC.
- **HIT MASTER**
HIT MASTER ON/OFF key. Mutes for 32 ms + 500 ms during selection. Ineffective during REC.

1.4 Operation

- (1) The MELODY ASSIST and HIT MASTER keys are not set to ON at the same time.
- (2) The MELODY ASSIST and HIT MASTER keys are set to OFF when AI AUTO and AI FOCUS are started.
- (3) A selector is locked during REC when the CD REC key is set to OFF. It is released when the CD REC key is set to ON. The key is then fixed to ON.
- (4) Keys other than POWER are ineffective during protection.
- (5) The CD DIRECT and SURROUND keys are not set to ON at the same time.
- (6) The CD DIRECT key is set to OFF when set to selectors other than CD while it is on.

1.6 Initial Setting

POSITION	TUNER
CD DIRECT	OFF
SURROUND	OFF
CD REC	OFF
MELODY ASSIST	OFF
HIT MASTER	OFF
Video POSITION	VIDEO

1.7 Test Mode

- (1) Setting
Insert an AC plug while pressing the CD key.
- (2) Contents

PHONO key	Volume control increased
CD key	Volume control decreased
- (3) Initializing
Pull out the AC plug.

CIRCUIT DESCRIPTION

2.1 Pin Connection

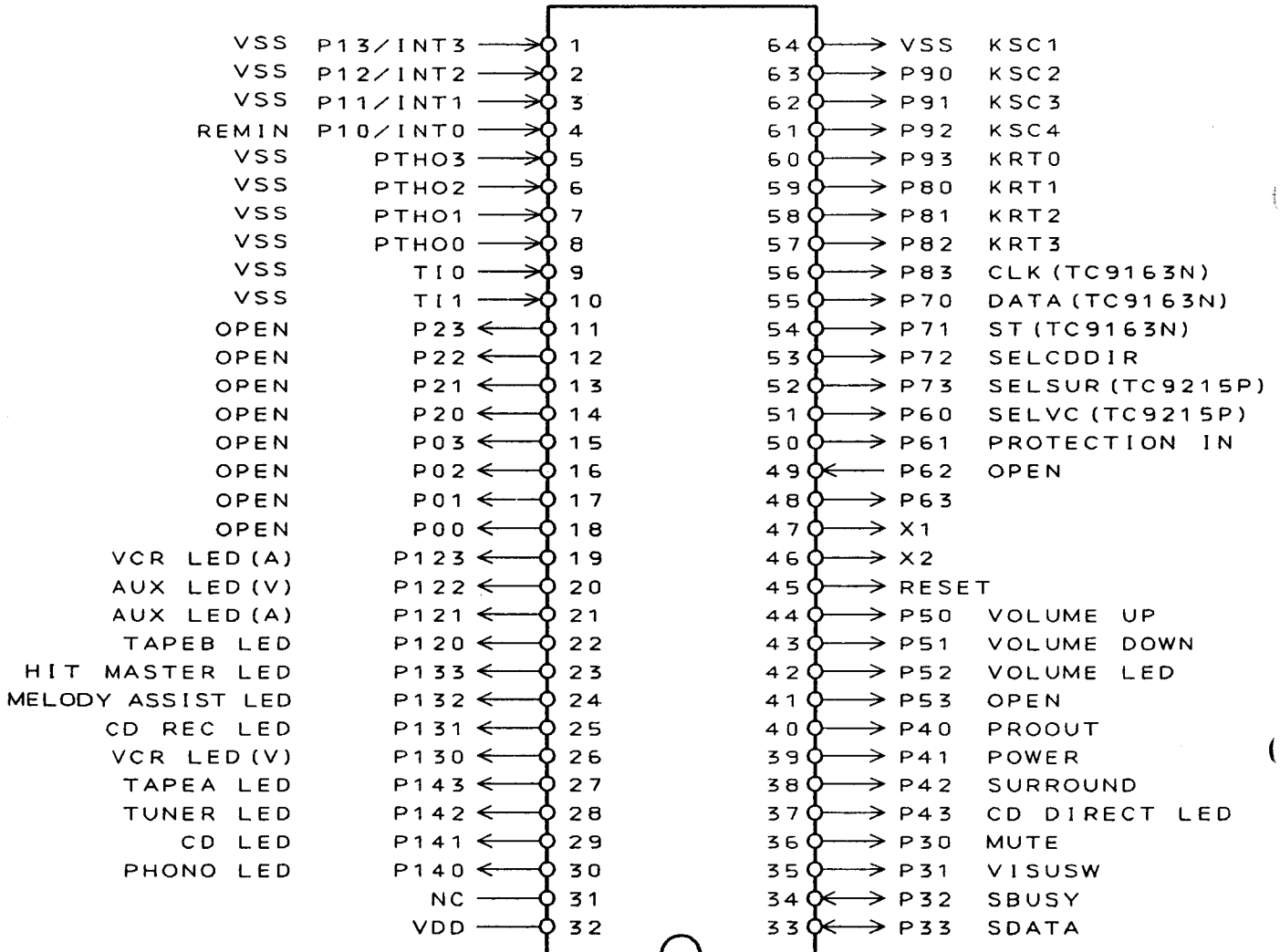

CIRCUIT DESCRIPTION

2.2 Pin Functions

Pin No.	Pin name	I/O	Name	Description
1	P13/INT3			Connected to Vss
2	P12/INT2			Connected to Vss
3	P11/INT1			Connected to Vss
4	P10/INT0	I	REMIN	Remote control input
5	PTH03			Connected to Vss or VDD
6	PTH02			Connected to Vss or VDD
7	PTH01			Connected to Vss or VDD
8	PTH00			Connected to Vss or VDD
9	T10			Connected to Vss or VDD
10	T11			Connected to Vss or VDD
11	P23	O		OPEN
12	P22	O		OPEN
13	P21	O		OPEN
14	P20	O		OPEN
15	P03	O		OPEN
16	P02	O		OPEN
17	P01	O		OPEN
18	P00	O		OPEN
19	P123	O		VCR LED (AUDIO) ON. L
20	P122	O		AUX LED (VIDEO) ON. L
21	P121	O		AUX LED (AUDIO) ON. L
22	P210	O		TAPEB LED ON. L
23	P133	O		HIT MASTER LED ON. L
24	P132	O		MELODY ASSIST LED ON. L
25	P131	O		CD REC LED ON. L
26	P130	O		VCR LED (VIDEO) ON. L
27	P143	O		TAPEA LED ON. L
28	P142	O		TUNER LED ON. L
29	P141	O		CD LED ON. L
30	P140	O		PHONO LED ON. L
31	NC			
32	VDD			
33	P33	I/O	SDATA	Serial data
34	P32	I/O	SBUSY	Serial busy
35	P31	O	VISUSW	Video selection switch ON. H

CIRCUIT DESCRIPTION

Pin No.	Pin name	I/O	Name	Description
36	P30	O	MUTE	Mute control ON. L
37	P43	O	LCDDIR	CD DIRECT LED ON. H
38	P42	O	LSUR	SURROUND LED ON. H
39	P41	O	POWER	Power port ON. H
40	P40	O	PROOUT	Speaker relay ON. H
41	P53	O		OPEN
42	P52	O	VOLLED	Volume control LED ON. H
43	P51	O	VOLDN	Volume DOWN ON. H
44	P50	O	VOLUP	Volume UP ON. H
45	RES			
46	X2			Oscillator
47	X1			
48	P63	O		OPEN
49	P62	I	PROIN1	Protection input
50	P61	O	SELVC	Voice changer selection ON. H
51	P60	O	SELSUR	Surround selection ON. H
52	P73	O	SELCDIR	CD DIRECT SW ON. H
53	P72	O	SELST	STROBE pin for TC9163N
54	P71	O	SELDT	DATA pin for TC9163N
55	P70	O	SELCLK	CLK pin for TC9163N
56	P83	I	KRT3	Key return 3
57	P82	I	KRT2	Key return 2
58	P81	I	KRT1	Key return 1
59	P80	I	KRT0	Key return 0
60	P93	O	KSC4	Key scan 4
61	P92	O	KSC3	Key scan 3
62	P91	O	KSC2	Key scan 2
63	P90	O	KSC1	Key scan 1
64	VSS			

PC BOARD (Component side view)

CONTROL UNIT

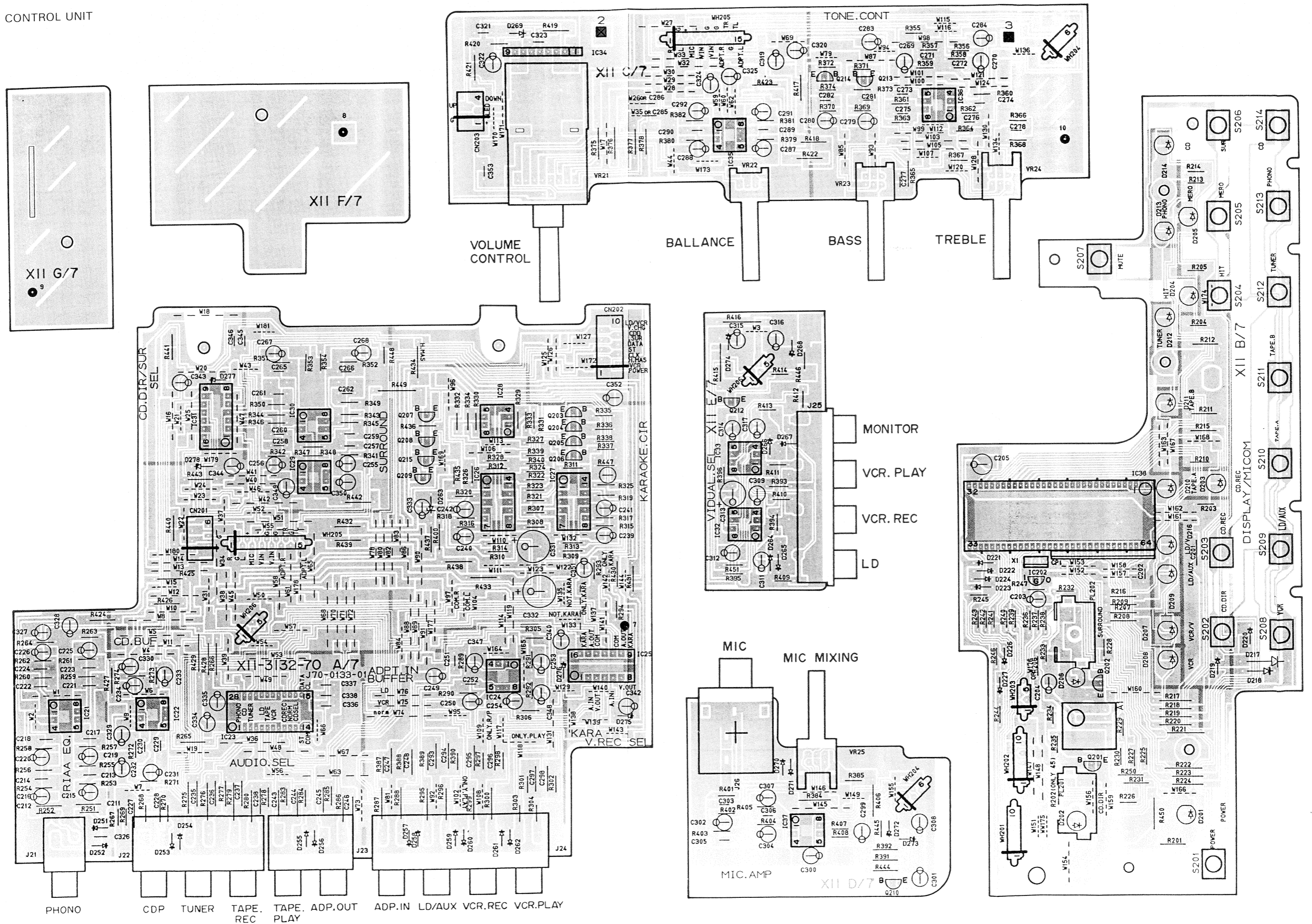

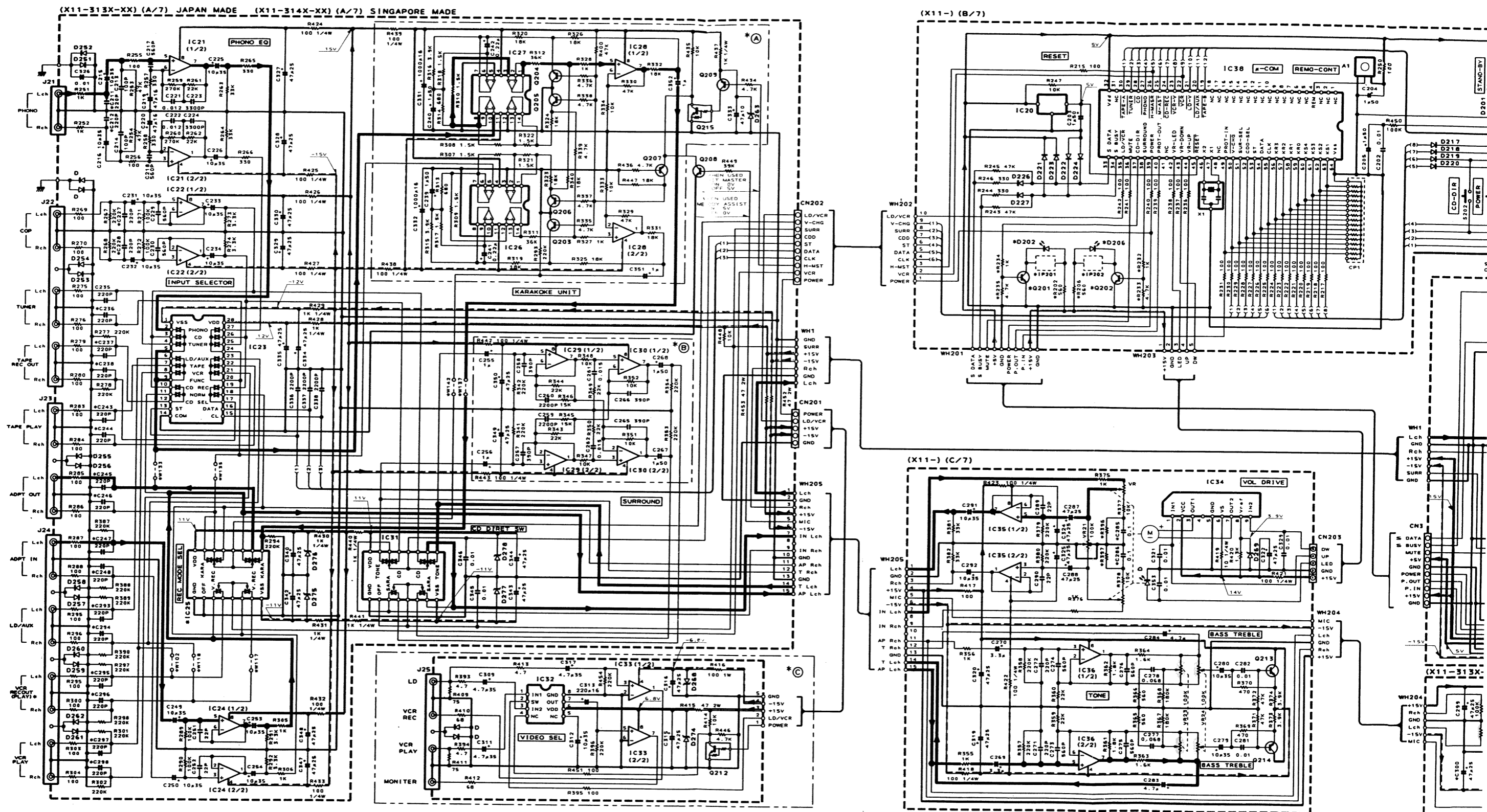

X11-313X-XX

COUNTRY	ABB	AWF. NO	A	B	C	IC28	Q202	D202	D206	D204, 205 207, 210	PL201-202	D275	C285, 286	C289, 208	R204, 205 207, 210	R206, 232	R436-408 443, 381	S204-206	W109, 116	W102, 118	W135, 135	W137, 142	W26, 35	J24	
ENGLAND	T	X11-3132-71		NO	NO	NO	NO	NO	NO	NO	NO	NO	NO	NO	NO	NO	NO	NO	NO	NO	NO	NO	NO	NO	
AUSTRALIA	X	X11-3130-22		YES	NO	YES	YES	YES	YES	NO	NO	NO	0.12µF	NO	NO	NO	NO	NO	NO	NO	NO	NO	NO	NO	6P
GENERAL MARKET	M																								
ENGLAND	T	X11-3132-70		NO	NO	NO	NO	NO	NO	NO	NO	NO	NO	NO	NO	NO	NO	NO	NO	NO	NO	NO	NO	NO	
AUSTRALIA	X	X11-3130-21		YES	YES	YES	YES	YES	YES	NO	YES	YES	0.1µF	YES	YES	YES	YES	YES	YES	NO	YES	NO	YES	YES	8P
GENERAL MARKET	M																								

X09-344X-

A-45	GEI
A-65	GEI

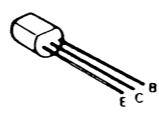

2SA992
2SC1845
2SC2003
2SC2878

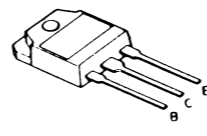

2SB1476
2SD2231

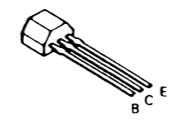

DTC124ES
2SA933S
2SC1740S



2SC4137

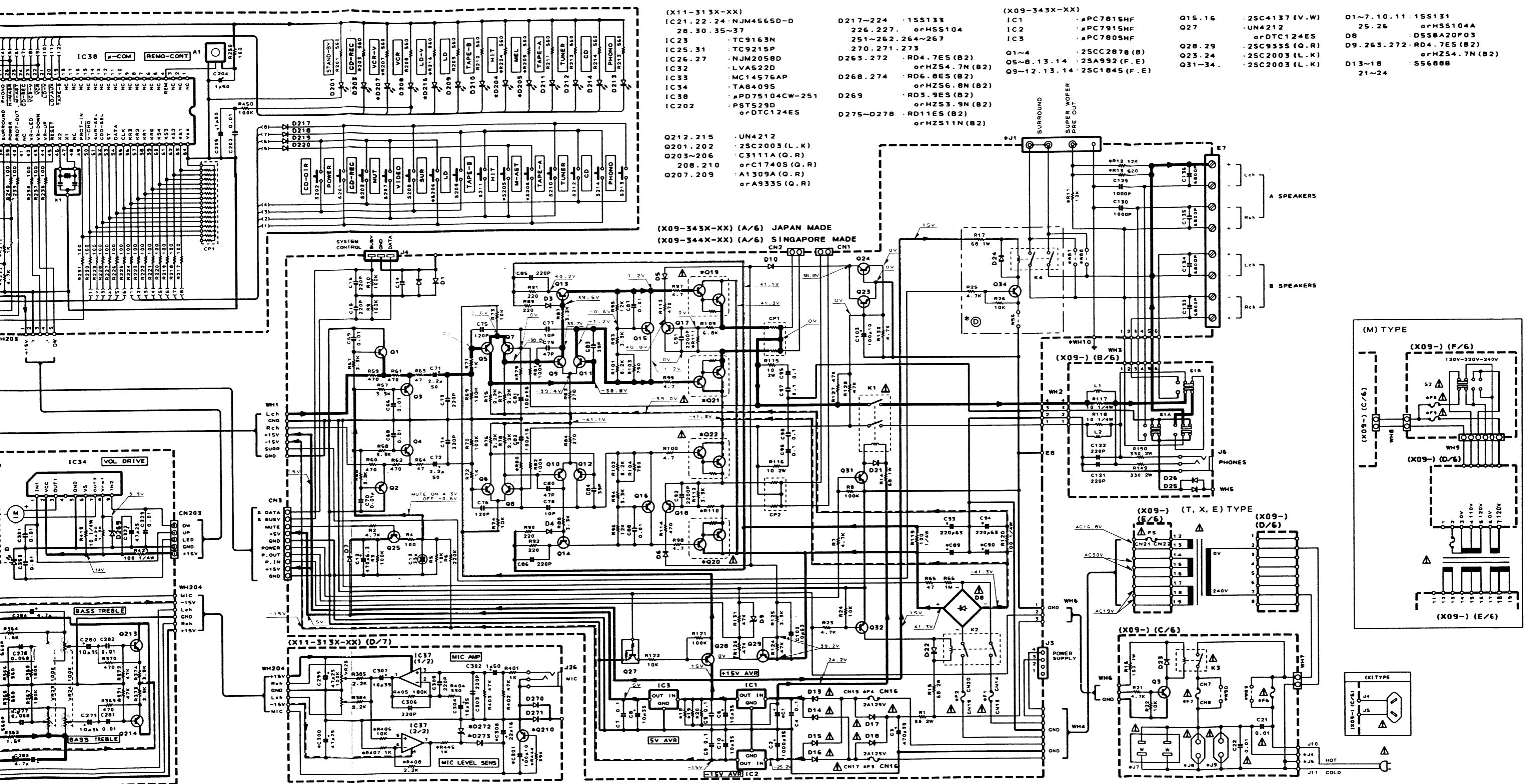

- (X11-313X-XX)
 IC21.22.24 NJM4565D-0
 28.30.35-37
 IC23 TC9163N
 IC25.31 TC9215P
 IC26.27 NJM2058D
 IC32 LVA522D
 IC33 MC14576AP
 IC34 TA8409S
 IC38 PD75104CW-251
 IC202 PST529D
 or DTC124ES
- D217-224 15S133
 226.227. or HSS104
 251-262.264-267
 270.271.273
 D263.272 RD4.7ES (B2)
 or HZ54.7N (B2)
 D268.274 RD6.8ES (B2)
 or HZ56.8N (B2)
 D269 RD3.9ES (B2)
 or HZ53.9N (B2)
 D275-D278 RD11ES (B2)
 or HZ511N (B2)
- (X09-343X-XX)
 IC1 PC7815HF
 IC2 PC7915HF
 IC3 PC7805HF
 Q1-4 2SC2078 (B)
 Q5-8.13.14 2SA992 (F.E)
 Q9-12.13.14 2SC1845 (F.E)
- Q15.16 2SC4137 (V.W)
 Q27 UN4212
 or DTC124ES
 Q28.29 2SC935 (Q.R)
 Q23.24 2SC2003 (L.K)
 Q31-34 2SC2003 (L.K)
- D1-7.10.11 15S131
 25.26 or HSS104A
 D8 D558A20F03
 D9.263.272 RD4.7ES (B2)
 or HZ54.7N (B2)
 D13-18 S56888
 21-24

(X09-343X-XX) (A/6) JAPAN MADE
 (X09-344X-XX) (A/6) SINGAPORE MADE

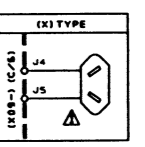
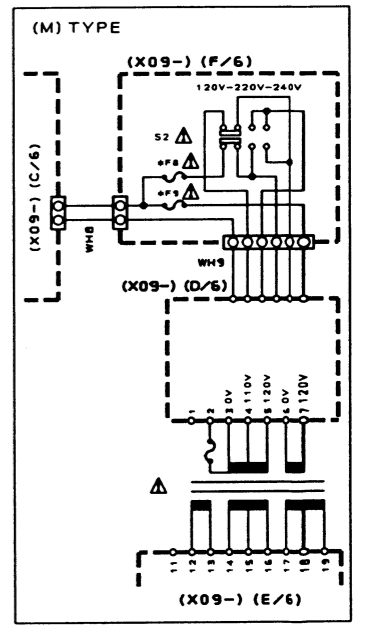

X09-344X-XX		COUNTRY	ABB.	UNIT NAME	AMP. NO.	D	F/G. MARK	W8. W9	Q21.22	Q19.20	C1	C69.90	R11-13	R18.19	R20	R79.80	R109.110	F1.2	F3.4	F6	F7	F8.9	W49.82.91	W87.88	J1	J8.9	4.5	WH10	
A-45	ENGLAND	T	X09-3440-52																										
	EUROPE	E	X09-3442-71																										
	AUSTRALIA	X	X09-3440-72																										
	GENERAL MARKET	M	X09-3440-22																										
A-65	ENGLAND	T	X09-3440-51																										
	EUROPE	E	X09-3442-70																										
	AUSTRALIA	X	X09-3440-71																										
	GENERAL MARKET	M	X09-3440-21																										

— SIGNAL LINE
 — GND LINE
 +B
 -B

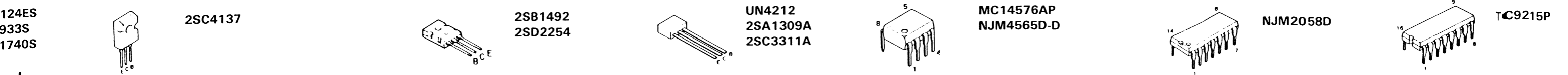

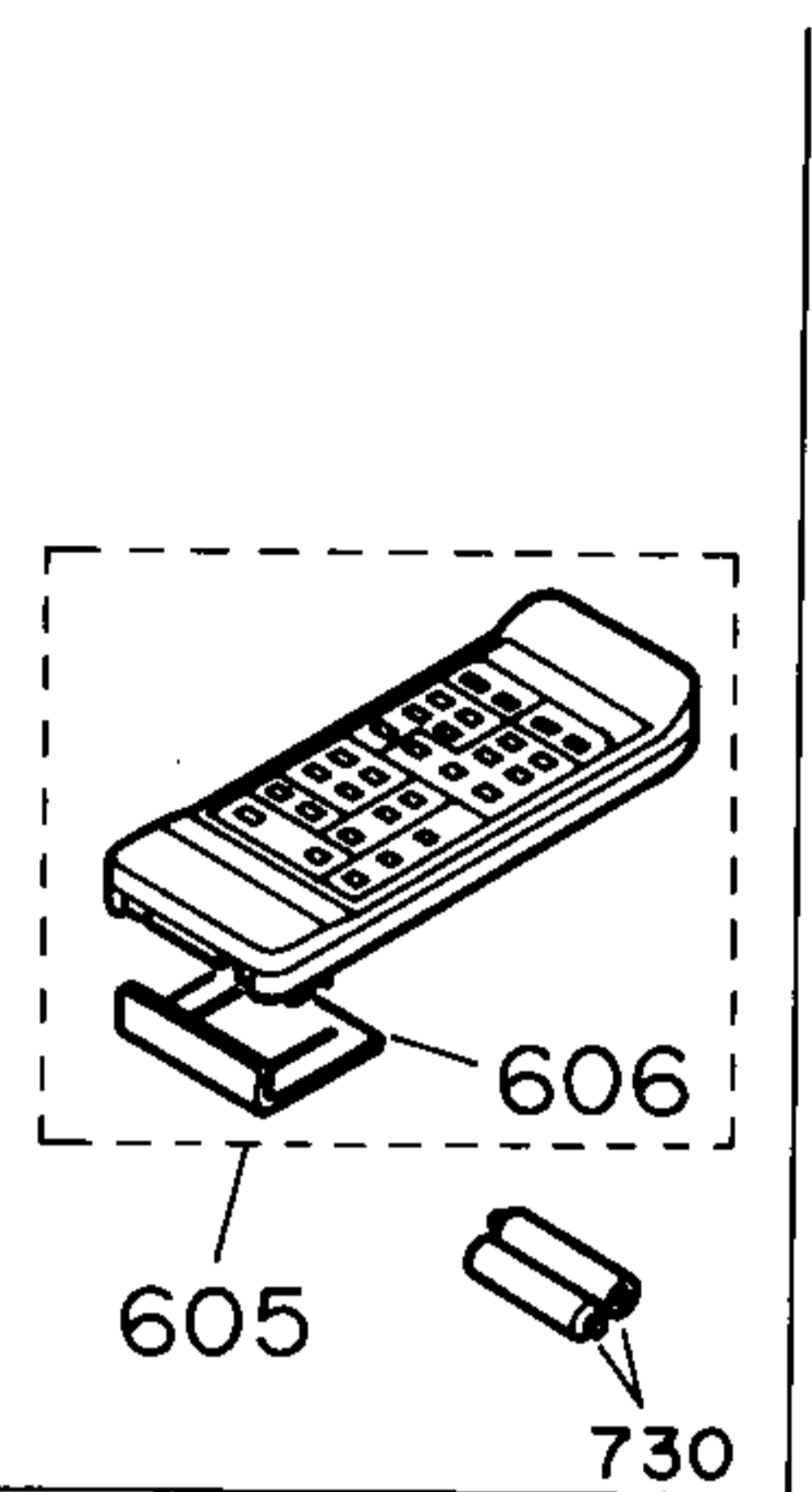
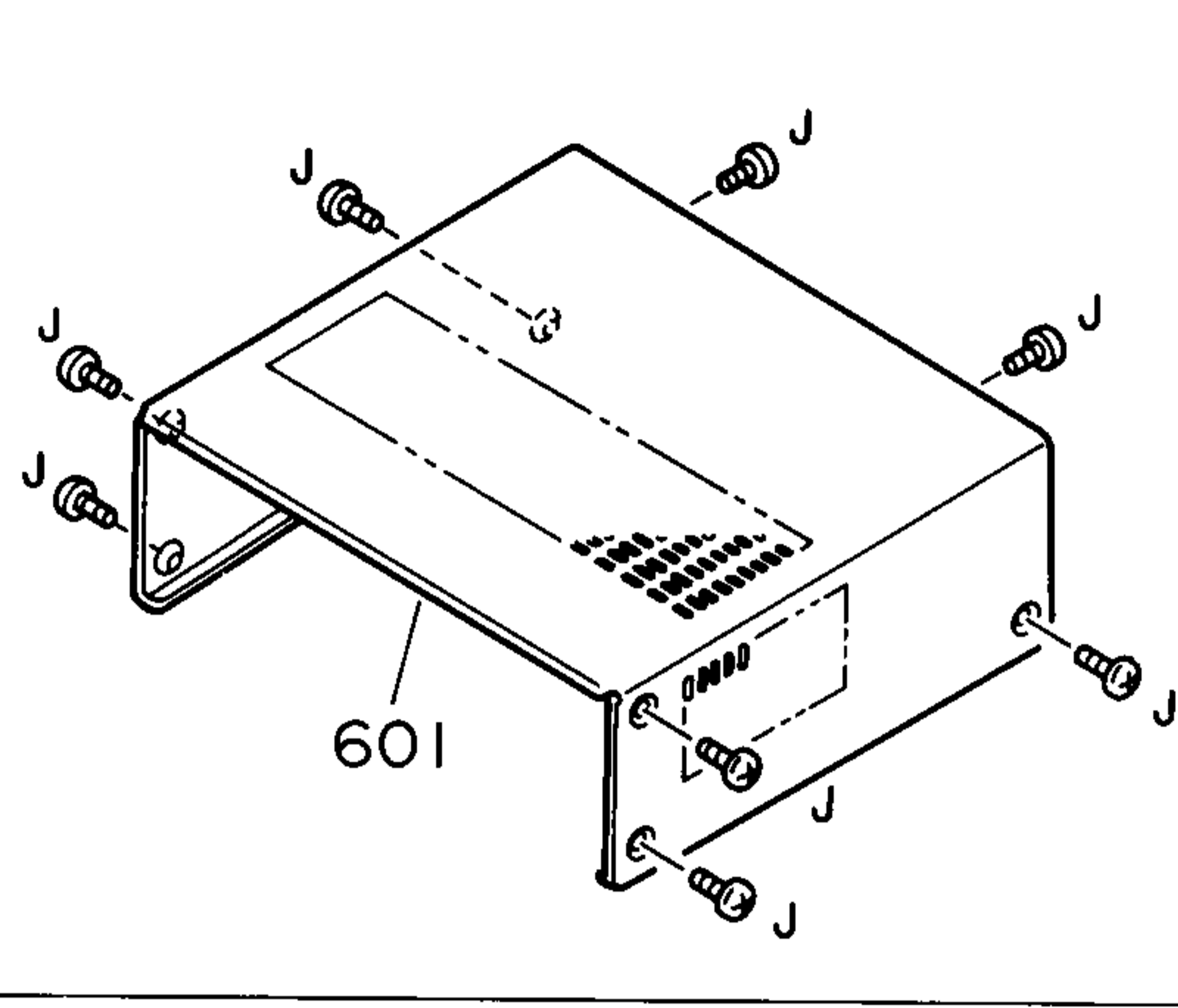

- A** M3 x 12 (Hex - Tap) : N09 - 0333 - 05
- B** M3 x 8 : N09 - 1445 - 05
- C** M3 x 8 R Tight : N09 - 1473 - 05
- D** M3 x 6 : N30 - 3006 - 46
- E** M3 x 8 : N35 - 3008 - 46
- F** M3 x 6 (Br-Tap) : N87 - 3006 - 46
- G** M2.6x8 (Bi-Tap) : N89 - 2608 - 46
- J** M3 x 8 (Bi-Tap) BLK : N89 - 3008 - 45
- K** M3 x 8 (Bi-Tap) : N89 - 3008 - 46
- L** M4 x 8 (Bi-Tap) BLK : N89 - 4008 - 45

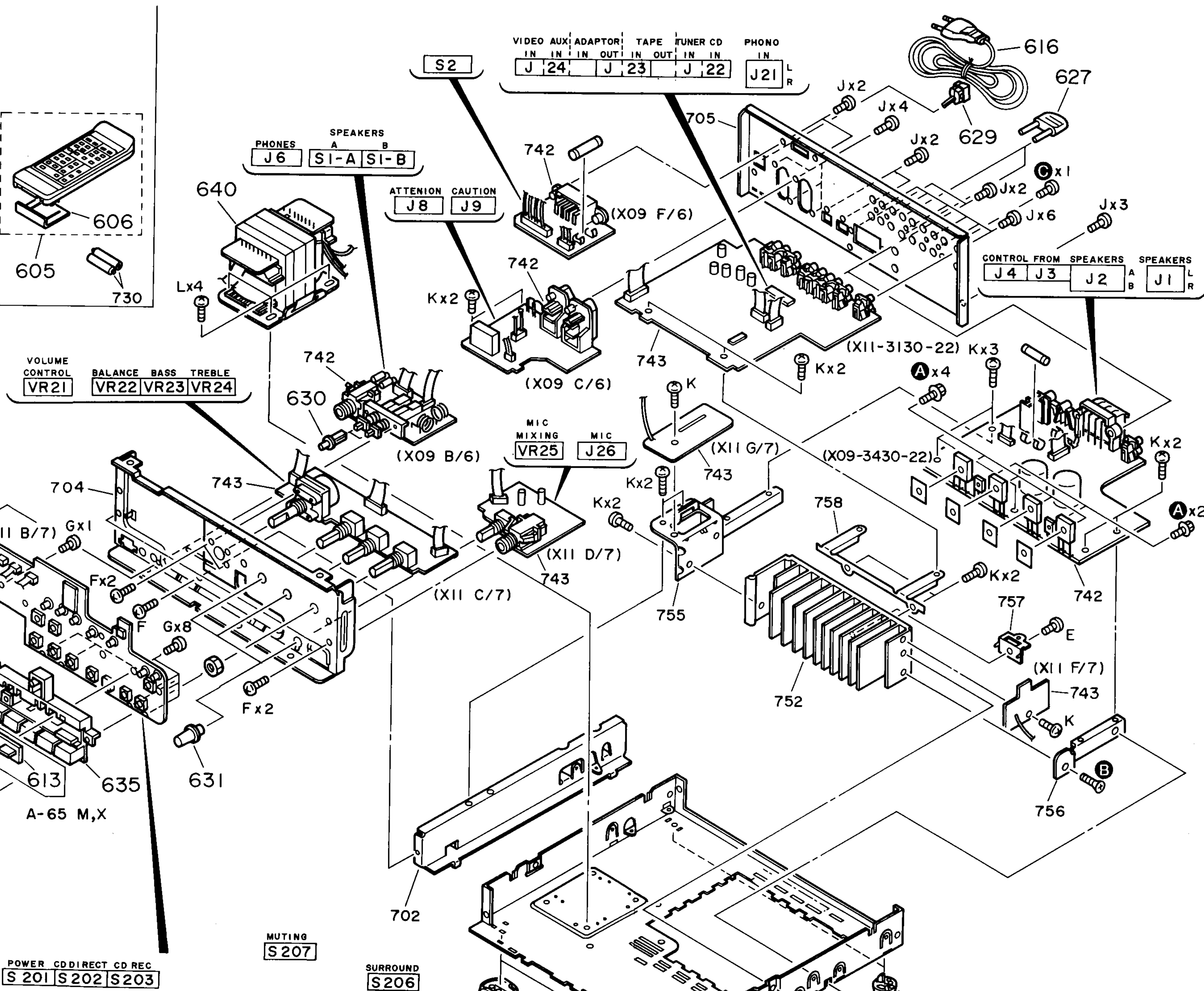
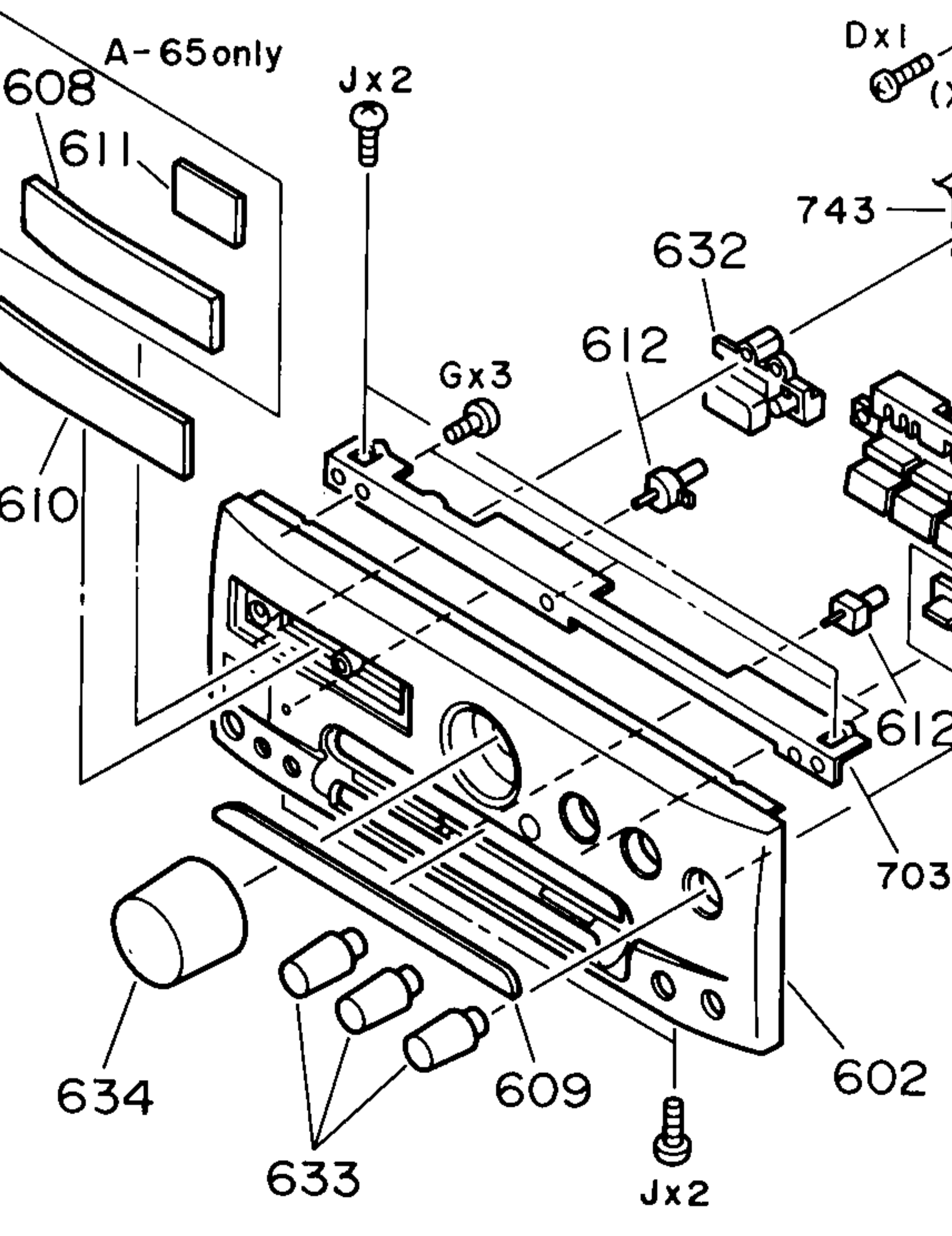

624x2