

A-58/68

SERVICE MANUAL

© 1994-8 PRINTED IN KOREA
B51-4909-00 (K) 2651

Knob (Input)
(K29-6024-04)

Metallic cabinet
(A01-3162-02)

Knob
(K29-5968-02)

Indicator
(B12-0245-03)

Panel*
(A60-)

Knob (Volume)
(K29-6024-04)

Foot (Amp)
(J02-1111-04)

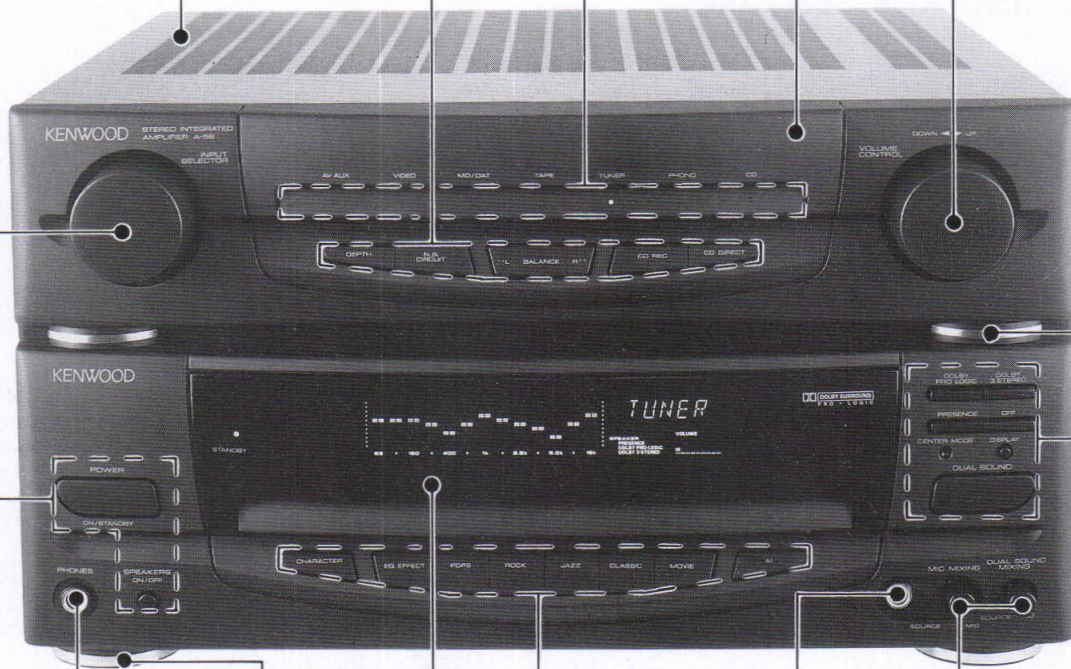

Knob (Power)
(K29-5969-13)

Phone jack (Phones)
(E11-0208-05)

Foot (Front)
(J02-1040-05)

Front glass
(B10-2050-03)

Knob
(K29-5968-02)

Phone jack (Mic)
(E11-0206-05)

Knob (Mic/Dual sound)
(K29-3886-04)

Knob (Dolby/D sound)
(K29-5969-13)

Photo is A-58.

***Refer to parts list on page 45.**

CONTENTS/EXTERNAL VIEW

CONTENTS

EXTERNAL VIEW	2
ACCESSORIES	4
CONTROL	5
REMOTE CONTROL OPERATION	7
DISASSEMBLY FOR REPAIR	8
BLOCK DIAGRAM	9
CIRCUIT DESCRIPTION	
1. Initial setting	10
2. Test mode by operating the keys of the main unit ..	11

3. μ -COM : M38197MA-090FP (X14-, IC1)	12
4. LED Driver : M66310P (X14-, IC4)	15
5. Analog IC : LC7538JM (X08-, IC8)	17
6. Analog IC : CXA1842S (X08-, IC7)	18
WIRING DIAGRAM	19
PC BOARD (COMPONENT SIDE VIEW)	21
SCHEMATIC DIAGRAM	27
EXPLODED VIEW	43
PARTS LIST	45
SPECIFICATIONS	57

EXTERNAL VIEW : A-58 (Rear panel)

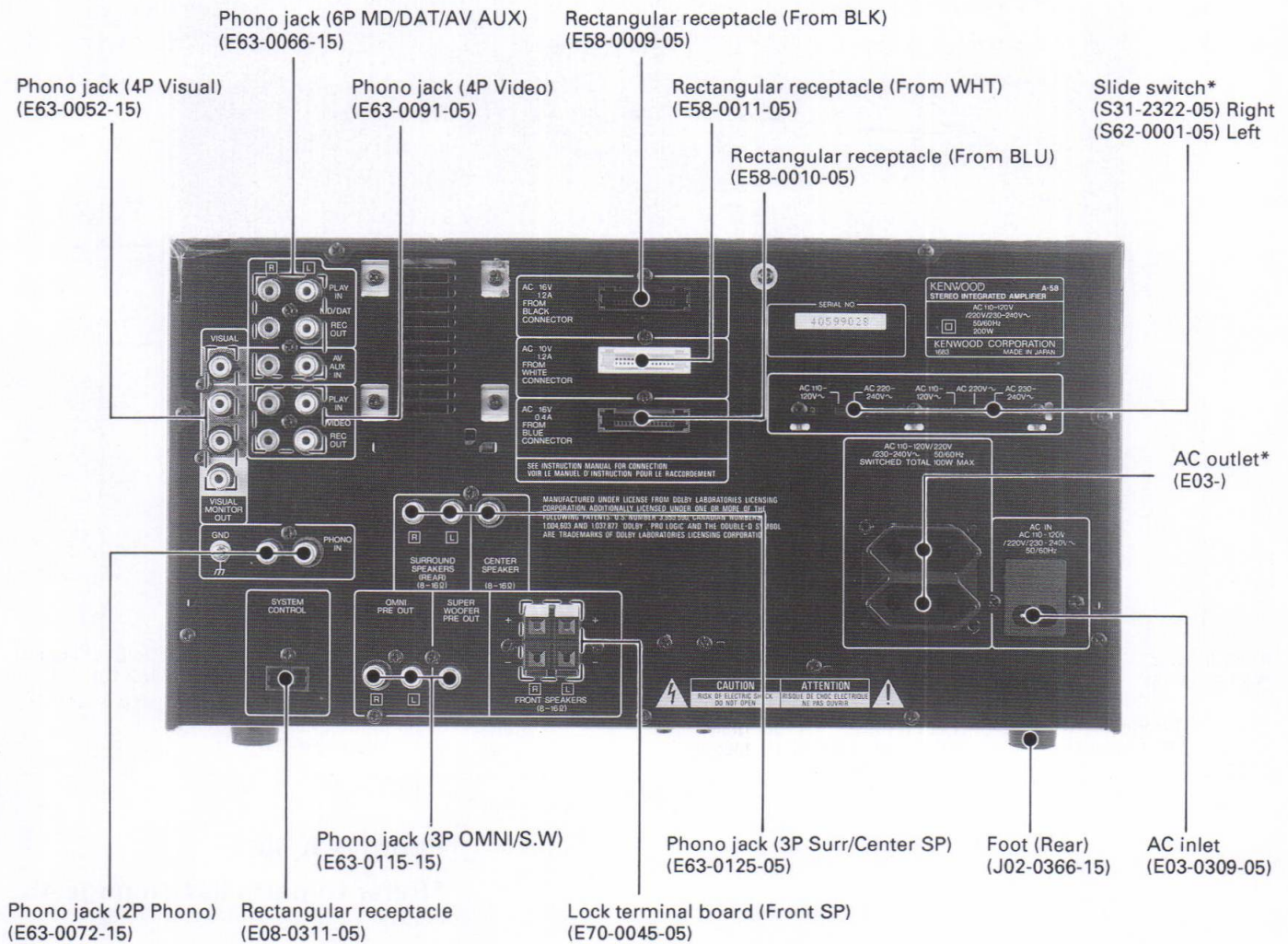

*Refer to parts list on page 45.

EXTERNAL VIEW

A-68 (Rear panel)

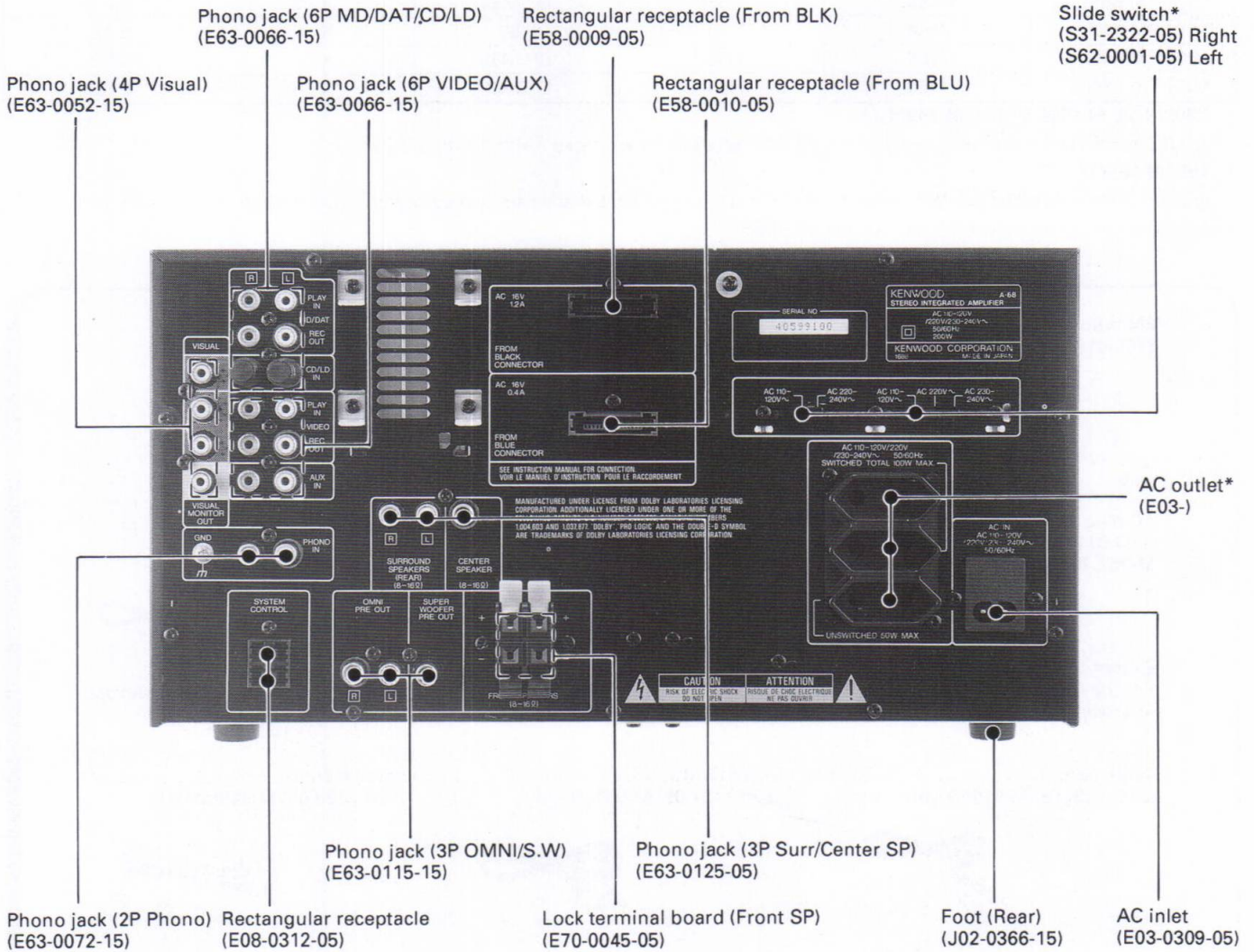

***Refer to parts list on page 45.**

ACCESSORIES

System configuration

System name	AMP / GE	TUNER	CD/LD PLAYER	CASSETTE DECK	Speakers
MIDI M-58	A-58	T-58L	DP-58	X-58	LS-58
MIDI M-58M	A-58	T-58L	DP-M58	X-58	LS-58
MIDI M-767	A-58	T-58	DP-58	X-58	S-58
MIDI M-868M	A-58	T-58	DP-M58	X-58	S-58
MIDI M-969LD	A-68	T-58	LVD-68	X-58	S-68

• **MIDI M-58, M-58M, M-767, M-868M :**

Speaker cords are packed with the Speakers. All other accessories are packed with the Amp/GE unit.

• **MIDI M-969LD**

Speaker cords are packed with the Speakers. Remote control unit and batteries are packed with the CD/LD player unit. All other accessories are packed with the Amp/GE unit.

- FM indoor antenna 1
(T90-0182-15)



- AM loop antenna ass'y 1
(T90-0195-05)



- Loop antenna stand
(J19-3645-05)



- AC plug adaptor 1
(E03-0115-05)
M-767, M-868M, M-969LD only



Except for U.K., Europe and Australia.
For the unit with a European AC plug
in areas other than Europe.

- Antenna adaptor 1
(T90-0198-05)
M-58, M-58M only

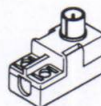

For U.K. and Europe.

- Speaker cords 2
(818. 05. 011) **LS-58**
(E31-5479-08) **S-58**
(E30-1271-08) **S-68**



For U.K. and Europe.

- Audio cord 1
(E30-0505-05) **M-969LD only**



- Video cord 1
(E30-1427-05) **M-969LD only**



- Parallel cord 1
(E30-2628-05) **M-969LD only**



- Power cord 1
(E30-2778-05) **Y**
(E30-2779-05) **M, E, G, M-969LD**
(E30-2780-05) **X**
(E30-2781-05) **T**



- Remote control unit (RC-58) 1
(A70-0986-05)
M-58, M-58M, M-767, M-868M only

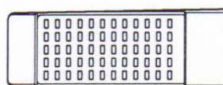

Battery cover
(A09-0106-08)

- Remote control unit (RC-68LD) 1
(X94-1050-71) **M-969LD only**



Battery cover
(F07-0721-33)

- Batteries 2



CONTROL

AMPLIFIER UNIT

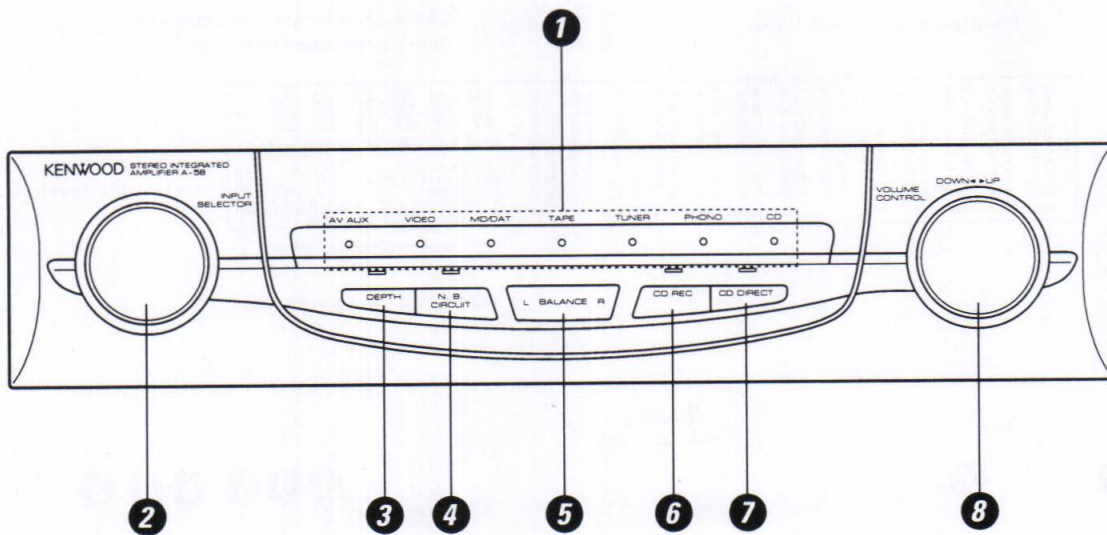

1 Input indicators

2 INPUT SELECTOR knob

Rotate to select the source component to be played.

3 DEPTH key

Press to add a depth to the sound field.

4 N.B. CIRCUIT key

Press to obtain a more natural bass sound.

5 BALANCE key

Press to adjust the volume balance between the left and right speakers

6 CD REC key

Press to play a source component while recording a CD on tape.

7 CD DIRECT key

Press to play CD with a higher sound quality.

8 VOLUME CONTROL knob

CONTROL

EQUALIZER UNIT

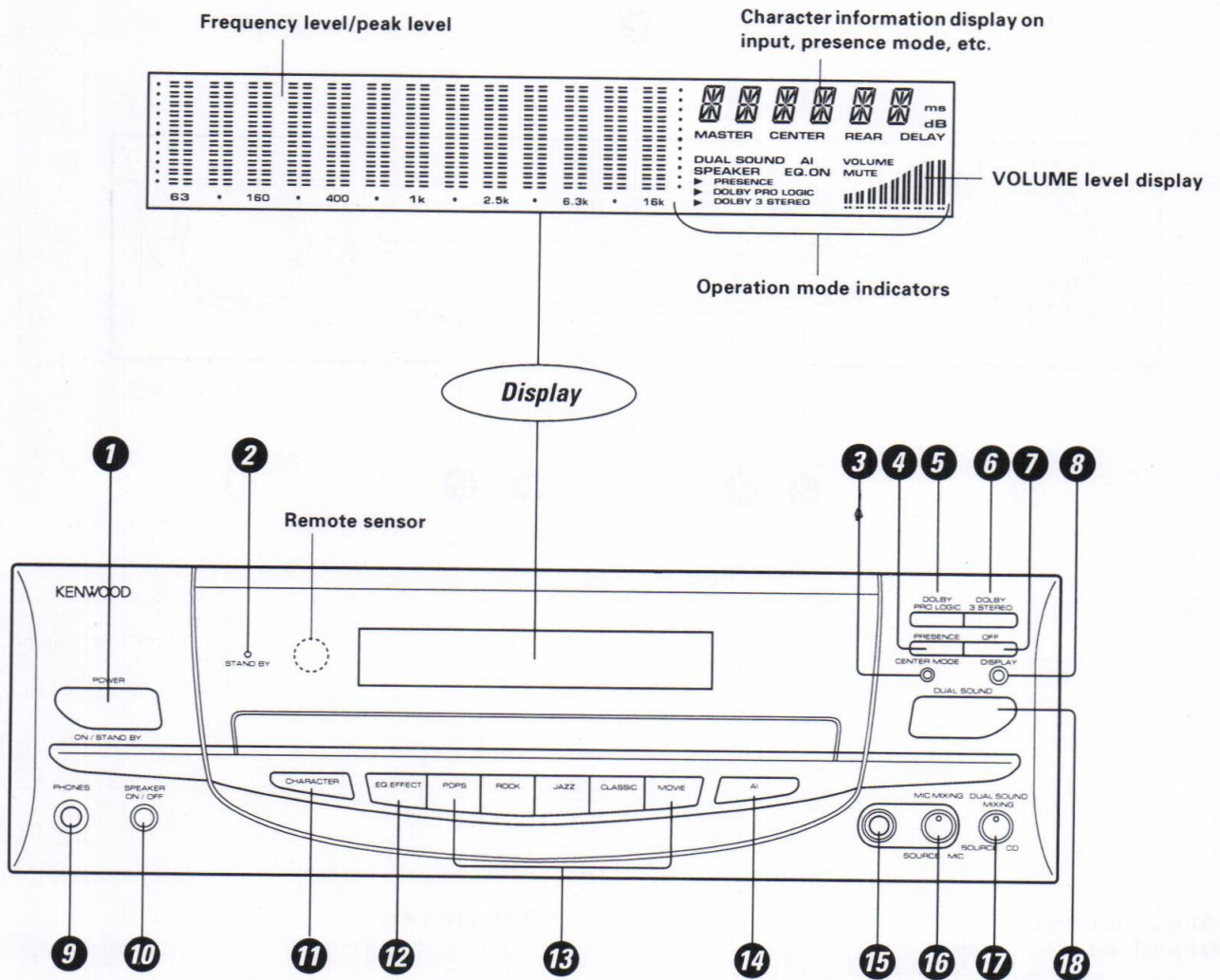

1 POWER key

2 STAND BY indicator

3 CENTER MODE key

Press when adjusting or playing the DOLBY SURROUND effect.

4 PRESENCE key

Press for presence play.

5 DOLBY PRO LOGIC key

Press when adjusting or playing the DOLBY SURROUND effect.

6 DOLBY 3 STEREO key

Press when adjusting or playing the DOLBY SURROUND effect.

7 OFF key

Press to turn the presence play or Dolby Surround play OFF.

8 DISPLAY key

Press to switch the display modes.

9 PHONES jack

Connect headphones for listening through them.

10 SPEAKER ON/OFF key

Press to defeat the speaker sound when listening through headphones.

11 CHARACTER key

Press to switch the spectrum analyzer display patterns.

12 EQ.EFFECT key

Press to turn the equalizer effect ON/OFF.

13 Equalizer preset keys

Press to recall an equalizer curve matching the music source.

14 AI key

Press to set the equalizer curve automatically in accordance with the CD played.

15 MIC jack

16 MIC MIXING knob

Adjust the volume balance between the karaoke accompaniment and microphone singing.

17 DUAL SOUND MIXING knob

Adjust the volume balance between the CD and another music source.

18 DUAL SOUND key

Press to play a CD and another music source simultaneously.

REMOTE CONTROL OPERATION

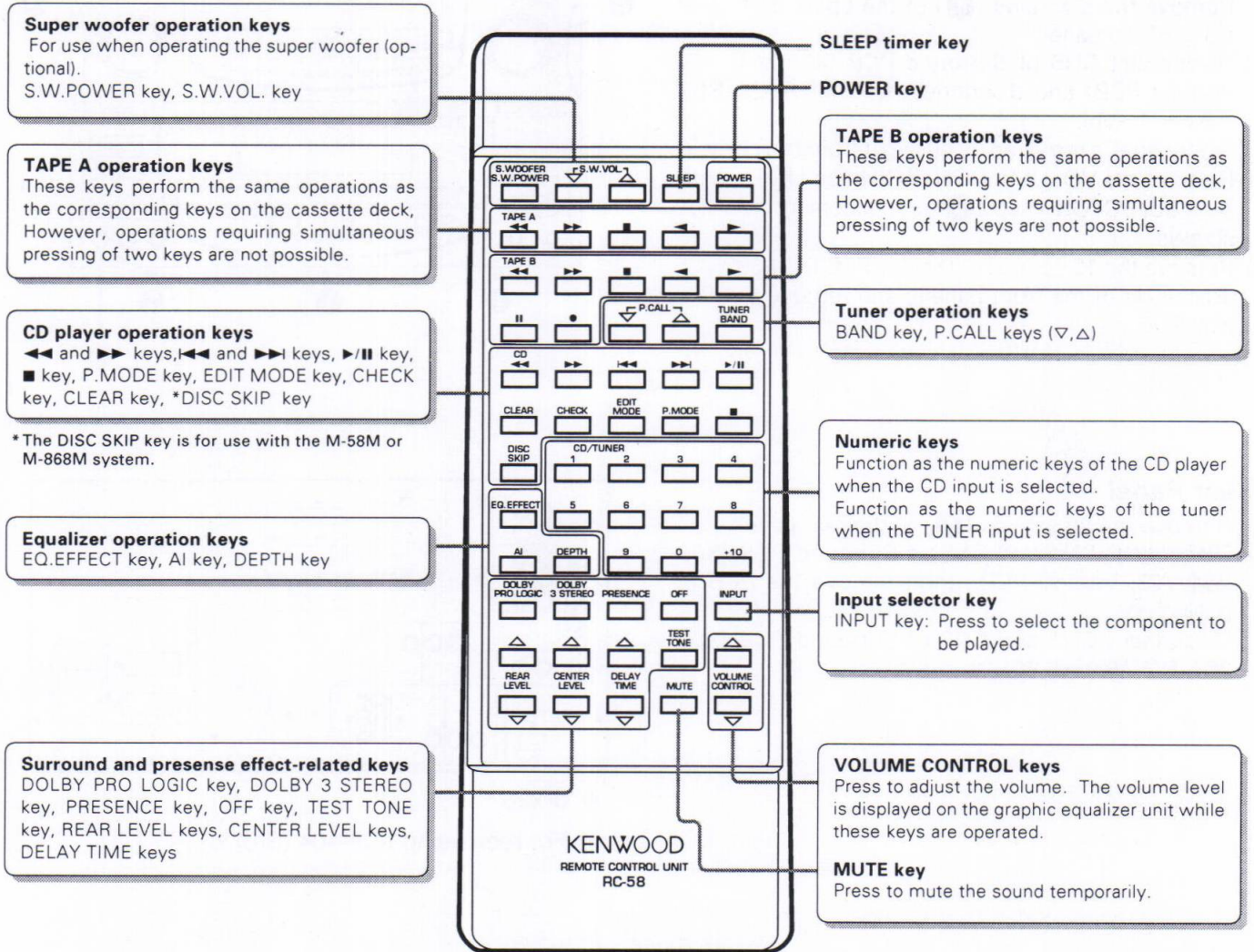

Model: RC-58
Infrared ray system

DISASSEMBLY FOR REPAIR

Front Panel

***Remove the case in advance.**

1. Remove the 6 screws (1) of the upper and lower sides of the panel.
2. Disconnect CN5 of Surround PCB (X08-264, A/3, Vertical PCB) and disconnect CN2 of Audio PCB (X09-404, A/6).
3. Front panel is removed by pulling it from the chassis.
4. Remove the VOLUME CONTROL knob (2) and INPUT SELECTOR knob (3) by loosening the Allen screws.
5. Remove the 12 screws of Display PCB (X14-392, A/5 [Back-side of the front panel]), and remove the Display PCB.

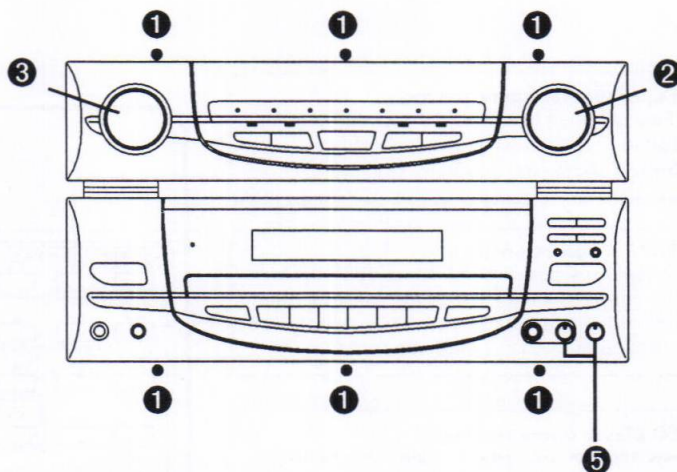

Rear Panel

1. Remove the 28 screws (4) of the rear panel.
2. Disconnect CN4 and CN6 of Surround PCB (X08-264, A/3, Vertical PCB), then remove the PCB by pulling up.
3. Disconnect CN1 and CN2 of Surround PCB (X08-264, B/3, Vertical PCB).

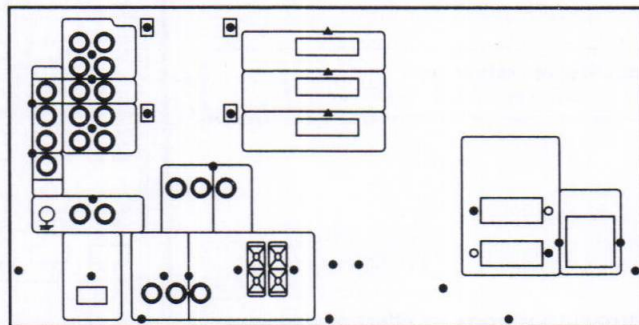

●: 4 x28

▲: For removing X09-404 (B/6) x3

Mic Mixing PCB (X09-404, E/6)

1. Remove the MIC MIXING knob and DUAL SOUND MIXING knob (5) by loosening the Allen screws.
2. While pressing the two clicks (6) of the MIC jack (with black cover), remove the PCB.

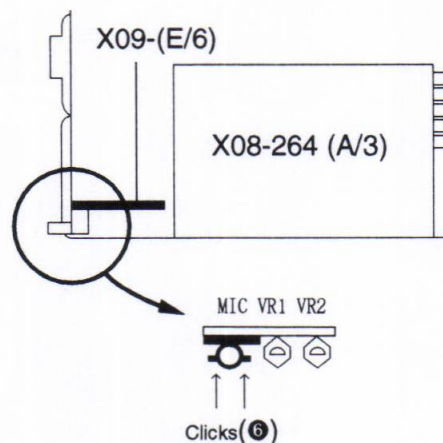

Bottom

1. Bottom part can be cut.
(Then, fix them with 2 screws.)
2. Power transistors can be changed from bottom part by removing the soldering.

BLOCK DIAGRAM

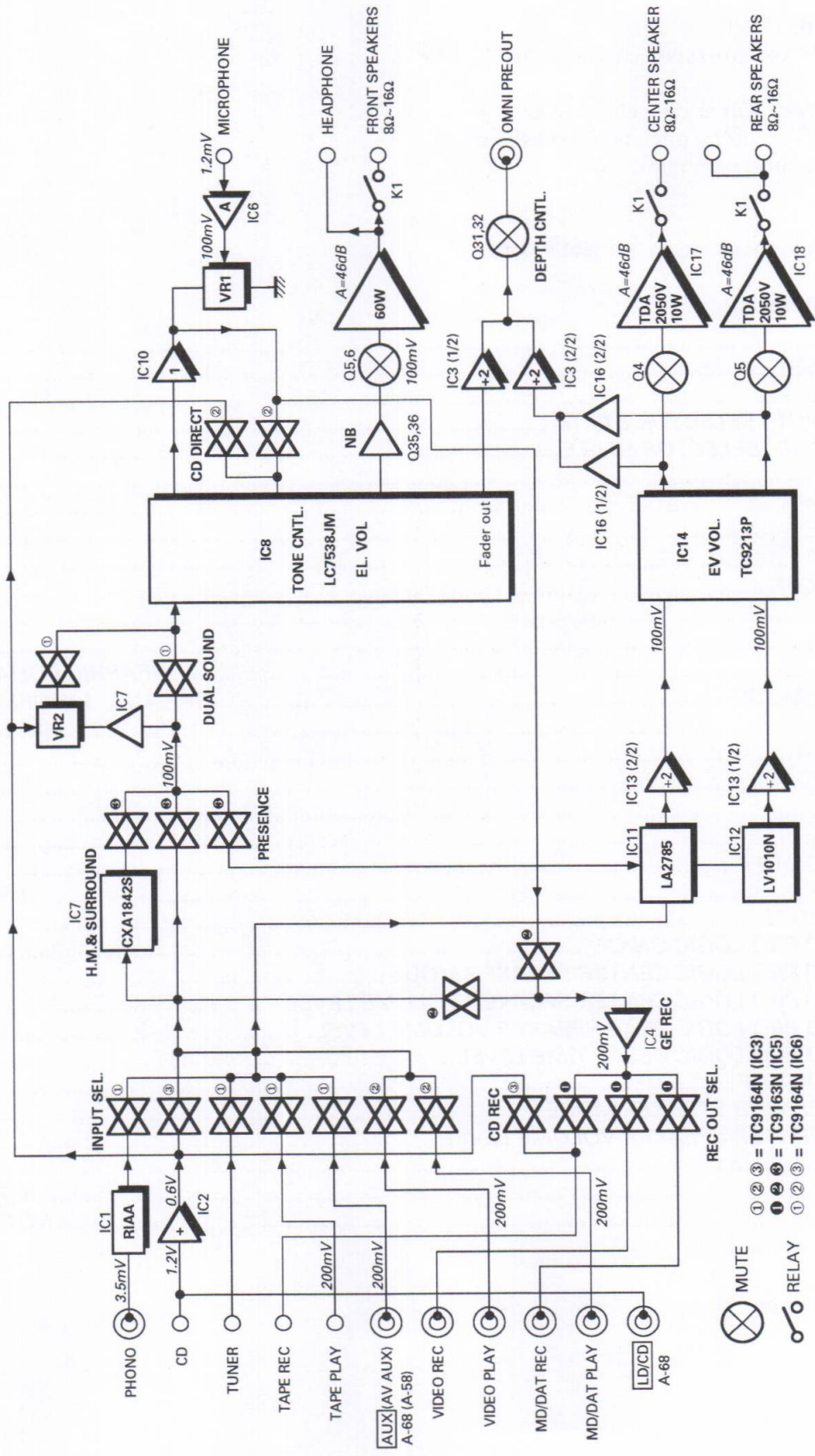

- ⊗ MUTE
 ⏏ RELAY
 ① ② ③ = TC9164N (IC3)
 ④ ⑤ ⑥ = TC9163N (IC5)
 ⑦ ⑧ ⑨ = TC9164N (IC6)

CIRCUIT DESCRIPTION

1. Initial setting

1-1. Setting method

- With the POWER key pressed, connect the AC power plug.
- When the AC power plug is connected or disconnected in the TEST mode by operating the keys of the main unit or by serial communication.

1-2. Contents

- Initialize all the functions, including the test mode.

1-3. Initial setting state

POWER ON/OFF	OFF
MAIN VOLUME LEVEL	-66dB
L/R BALANCE	CENTER
AUDIO SIGNAL INPUT · SELECTOR STATE	TUNER
VIDEO SIGNAL INPUT · SELECTOR STATE	VIDEO
SPEAKER ON/OFF	ON
N.B. CIRCUIT ON/OFF	OFF
CD REC ON/OFF	OFF
CD DIRECT ON/OFF	OFF
DUAL SOUND ON/OFF	OFF
EQ CURVE	POPS
EQ ON/OFF	OFF
DISPLAY MODE	GRAPHIC EQUALIZER MODE
SPE.ANA. DISPLAY MODE	SPE.ANA. 1 (NORMAL DISPLAY)
14seg. DISPLAY	INPUT SELECTOR
RAM DISPLAY AREA	ALL CLEAR
AI AUTO	OFF
AI FOCUS	OFF
AI LINK MODE	OFF
DEPTH CONTROL ON/OFF	OFF
PRESENCE ON/OFF	PRESENCE OFF
LAST PRESENCE MODE	ARENA
DOLBY SURROUND PRO LOGIC ON/OFF	OFF
DOLBY SURROUND PRO LOGIC CENTER SPEAKER MODE	NORMAL
DOLBY SURROUND PRO LOGIC CENTER SPEAKER VOLUME LEVEL	0dB
DOLBY SURROUND PRO LOGIC REAR SPEAKER VOLUME LEVEL	0dB
DOLBY SURROUND PRO LOGIC DELAT TIME LEVEL	20msec.
DOLBY 3 STEREO ON/OFF	OFF
DOLBY 3 STEREO CENTER SPEAKER MODE	NORMAL
DOLBY 3 STEREO CENTER SPEAKER VOLUME LEVEL	0dB
TEST MODE	OFF
DECK REC MODE	NOT REC MODE
CCRS	NOT CCRS MODE

CIRCUIT DESCRIPTION

2. Test mode by operating the keys of the main unit

2-1. Setting method

- With the PRESENCE OFF key pressed, connect the AC power plug.

2-2. Resetting method

- Disconnect the AC power plug, and the TEST MODE is reset and the system is initialized.

2-3. Contents

① Auto power on

- If the AC power plug is connected with the PRESENCE OFF key pressed, the power is turned on and all the functions are initialized.
- The operations used while the power is turned on (MUTE, IC control, etc.) are executed as in the normal operation mode. (If the power is turned on without turning on the MUTE, the protection may work and inspection may not be executed.)

② ALL LED ON mode

- If the AC power plug is connected with the PRESENCE OFF key pressed, all the FL and LED segments light up. Then, if any key of the main unit is pressed, they are set under the normal indicating condition.

③ Confirmation of effectiveness of keys of the main unit

- It can be confirmed that the keys of the main unit are accepted.
- ④ Operations of the keys and switches which operate differently in the TEST MODE from themselves in the normal condition.
The keys and switches other than the following operate normally.

• BALANCE L :

3-stage setting used to set to R → CENTER → L.

• BALANCE R :

3-stage setting used to set to L → CENTER → R.

• DISPLAY KEY

Change of bar display mode of FL tube

The bar display mode of FL tube is changed cyclically as shown below.

EQ display → Inverted SPE.ANA. display (Normal display mode)

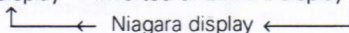

• CD REC KEY

3-stage setting of CENTER SPEAKER VOLUME LEVEL

The center speaker volume level is changed cyclically as shown below in the DOLBY SURROUND, DOLBY 3-STEREO mode.

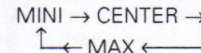

• AI KEY

3-stage setting of REAR SPEAKER VOLUME LEVEL
The rear speaker volume level is changed cyclically as shown below in the DOLBY SURROUND, DOLBY 3-STEREO mode.

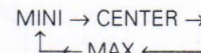

• CHARACTER KEY

3-stage setting of DELAY TIME

The delay time is changed cyclically as shown below in the DOLBY SURROUND, DOLBY 3-STEREO mode.

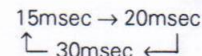

• POPS KEY

EQ LEVEL FLAT

The EQ level is set to 0 dB.

• ROCK KEY

EQ LEVEL MAX

The EQ level is set to maximum.

• JAZZ KEY

EQ LEVEL MINI

The EQ level is set to minimum.

• CLASSIC KEY

TEST TONE ON/OFF

The test tone is turned on/off only in the DOLBY SURROUND, DOLBY 3-STEREO mode.

• MOVIE KEY

ALL FL DISPLAY SEGMENTS PUTTING OUT ON/OFF

All putting out and normal putting out of the FL display segments are selected alternately.

⑤ Output of MUTE signal

- The MUTE signal operates normally.

⑥ Relay control in DOLBY mode

- The relays are controlled in the DOLBY mode as in the normal operation mode.

CIRCUIT DESCRIPTION

3. μ -COM : M38197MA-090FP (X14- [A/5], IC1)

3-1. Block diagram

Any figure in () is a Pin number.

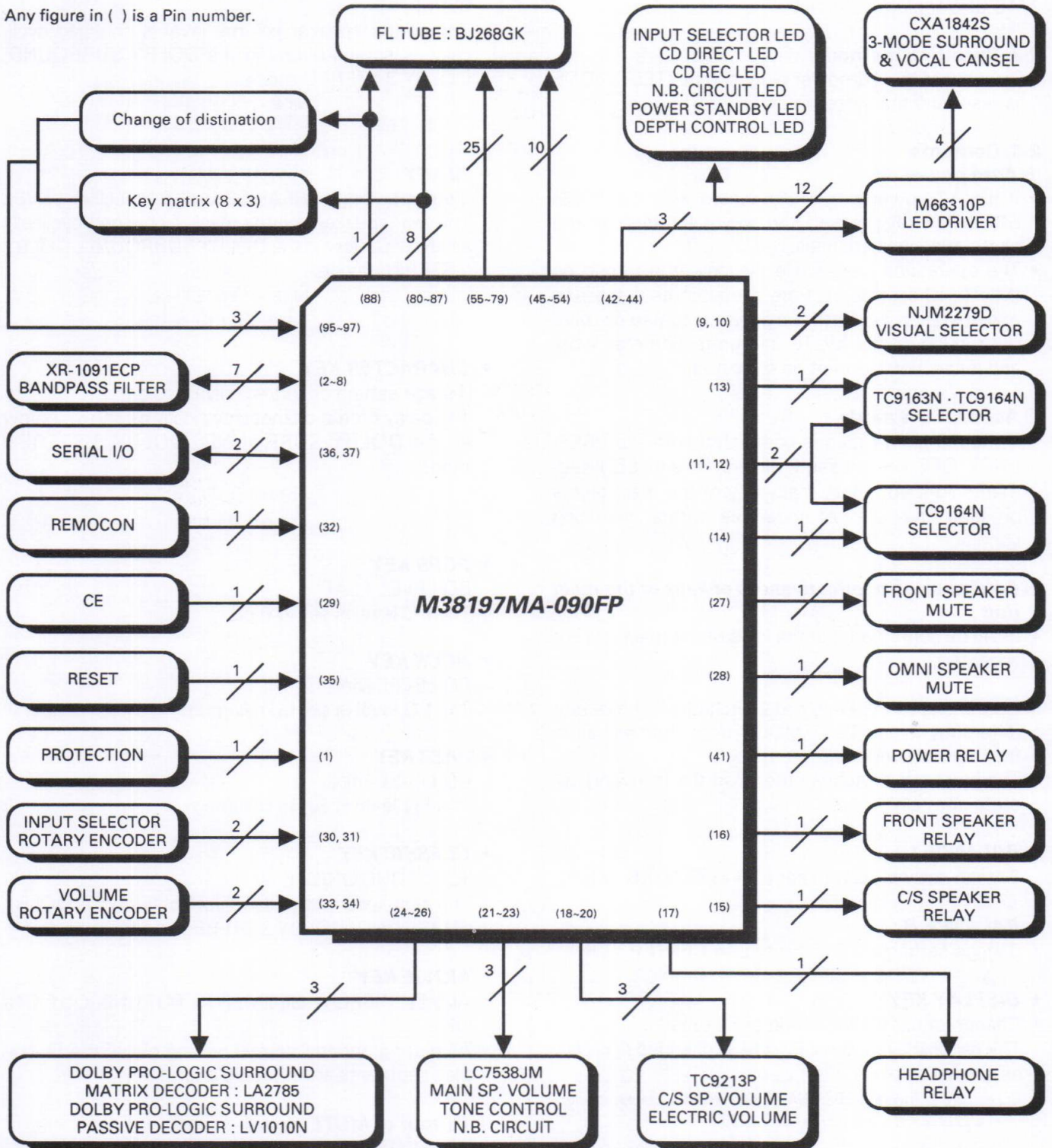

CIRCUIT DESCRIPTION

3-2. Pin connection

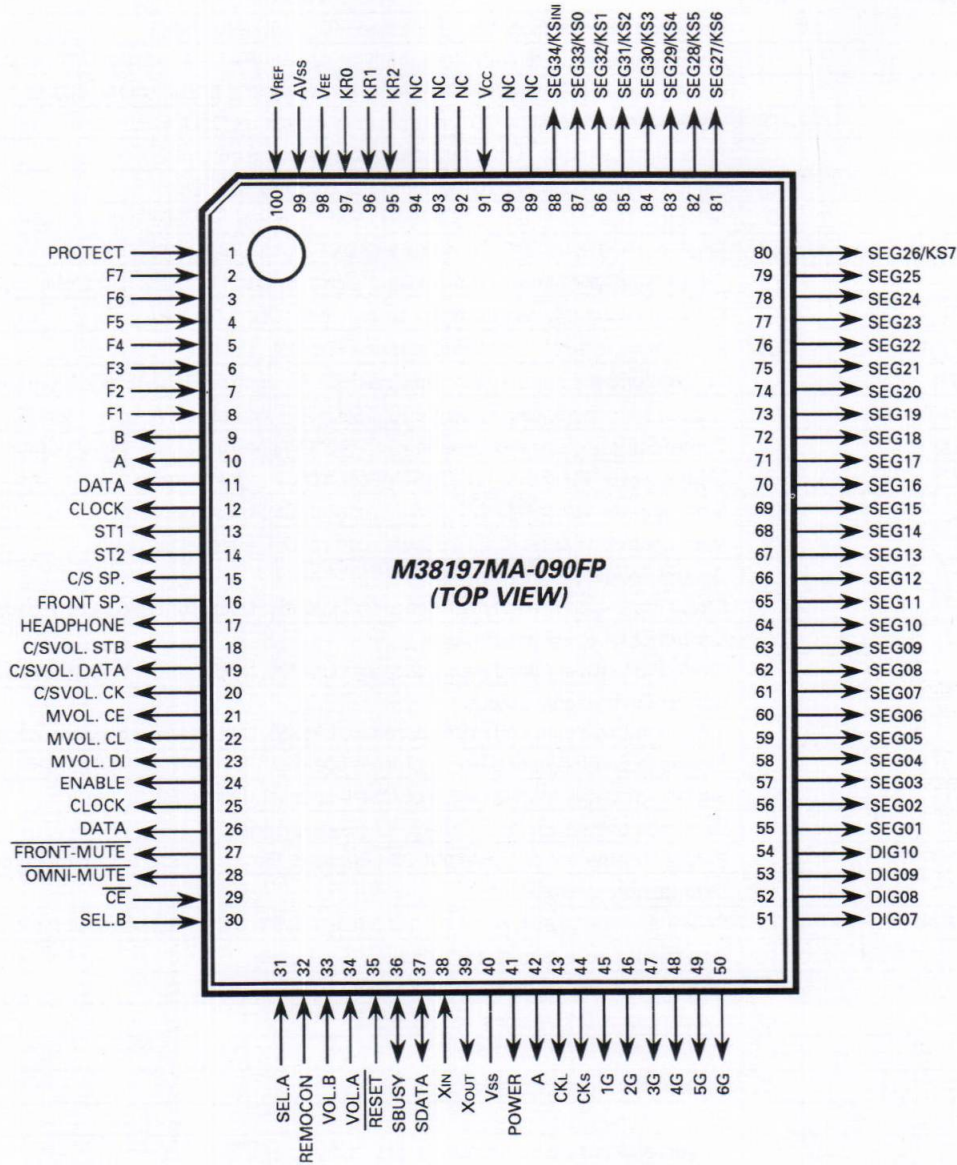

3-3. Key matrix

	KR0	KR1	KR2
KSINI	-	-	A68/A58
KS0	ROCK	DISPLAY	SPEAKER
KS1	JAZZ	CENTER MODE	POWER
KS2	AI (AUTO/FOCUS)	DUAL SOUND	CD DIRECT
KS3	MOVIE	BYPASS	CD REC
KS4	CLASSIC	DOLBY 3-STEREO	BALANCE R
KS5	POPS	DOLBY SURROUND	BALANCE L
KS6	EQ ON	PRESENCE	N.B. CIRCUIT
KS7	CHARACTER	-	DEPTH CONTROL

Change of destination

A58 type : Input selector CD · AV AUX.
A68 type : Input selector CD/LD · AUX

CIRCUIT DESCRIPTION

3-4. Pin function

No.	Name	I/O	Function
1	PROTECT	I	Detection of protection. ("H" : Detected, "L" : Not detected)
2~4	F7~F5	I	Analog signal input directly from the filter circuit. (Pin 2~4 : 16kHz, 6.3kHz, 2.5kHz)
5~8	F4~F1	I	Analog signal input directly from the filter circuit. (Pin 5~8 : 1.0kHz, 400Hz, 160Hz, 63Hz)
9, 10	B, A	O	Visual selector (NJM2279D) control signal output. ("H" : OFF, "L" : ON)
11	DATA	O	Selector (TC9163N, TC9164N) control DATA signal output.
12	CLOCK	O	Selector (TC9163N, TC9164N) control CLOCK signal output.
13	ST1	O	Selector (TC9163N : SEL2, TC9164N : SEL1) control STROBE signal output.
14	ST2	O	Selector (TC9164N : SEL3) control STROBE signal output.
15	C/S SP.	O	Center/Surround speaker relay control signal output. ("H" : ON, "L" : OFF)
16	FRONT SP.	O	Front speaker relay control signal output. ("H" : ON, "L" : OFF)
17	HEAD PHONE	O	Headphone relay control signal output. ("H" : ON, "L" : OFF)
18	C/SVOL.STB	O	Center/Surround speaker volume IC (TC9213P) control STROBE signal output.
19	C/SVOL. DATA	O	Center/Surround speaker volume IC (TC9213P) control DATA signal output.
20	C/SVOL. CK	O	Center/Surround speaker volume IC (TC9213P) control CLOCK signal output.
21	MVOL. CE	O	Main speaker volume IC (LC7538JM) control CE signal output.
22	MVOL. CL	O	Main speaker volume IC (LC7538JM) control CLOCK signal output.
23	MVOL. DI	O	Main speaker volume IC (LC7538JM) control DATA signal output.
24	ENABLE	O	Control ENABLE signal output. (Dolby Pro Logic surround matrix decoder : LA2785, Dolby surround passive decoder : LV1010N)
25	CLOCK	O	Control CLOCK signal output. (Dolby Pro Logic surround matrix decoder : LA2785, Dolby surround passive decoder : LV1010N)
26	DATA	O	Control DATA signal output. (Dolby Pro Logic surround matrix decoder : LA2785, Dolby surround passive decoder : LV1010N)
27	FRONT-MUTE	O	Signals to control muting circuit of front speaker. ("H" : OFF, "L" : ON)
28	OMNI-MUTE	O	Signals to control muting circuit of OMNI speaker. ("H" : OFF, "L" : ON)
29	\overline{CE}	I	Detection of backup. ("H" : Others, "L" : Backup mode)
30, 31	SEL.B, SEL.A	I	Rotary encoder phase signal (Pin 30 : Phase B, Pin 31 : Phase A) input for input selector.
32	REMOCON	I	Remote control signal input.
33, 34	VOL.B, VOL.A	I	Rotary encoder phase signal (Pin 33 : Phase B, Pin 34 : Phase A) input for volume.
35	\overline{RESET}	I	Detection of reset signal. ("H" : Others, "L" : Reset)
36	SBUSY	I/O	System serial BUSY signal Input/Output.
37	SDATA	I/O	System serial DATA signal Input/Output.
38	XIN	I	System clock input. (8.4MHz)
39	XOUT	O	System clock output (8.4MHz)
40	Vss	-	GND
41	POWER	O	Power relay control signal output. ("H" : ON, "L" : OFF)
42	A	O	LED driver (M66310P) control DATA signal output.
43	CKL	O	LED driver (M66310P) control LATCH CLOCK signal output.
44	CKs	O	LED driver (M66310P) control SHIFT CLOCK signal output.
45~54	1G~6G, DIG07~DIG10	O	FL tube grid 01G~10G (Pin 65~56) drive signal output. ("H" : ON, "L" : OFF)
55~79	SEG01~SEG25	O	FL tube segment P01~P25 (Pin 48~41, 39~37, 35~33, 30, 29, 26~18) drive signal output.
80~87	SEG26/KS7~SEG33/KS0	O	Key scan 7~0 signal output. ("H" : ON, "L" : OFF) FL tube segment P26~P33 (Pin 17, 16, 14~12, 9~7) drive signal output. ("H" : ON, "L" : OFF)
88	SEG34/KSINI	O	FL tube segment P34 (Pin 6) drive signal output. Key scan INI signal output. ("H" : ON, "L" : OFF)
89, 90	NC	-	Not used.
91	Vcc	I	Power input for μ -com. (+5V \pm 10%)
92~94	NC	-	Not used.
95~97	KR2~KR0	I	Key return signal input. ("H" : ON, "L" : OFF)
98	VEE	I	Pull down power input. (-30V)
99	AVss	I	A/D converter GND input. (Vss)
100	VREF	I	A/D converter reference voltage input. (+5V)

CIRCUIT DESCRIPTION

4. LED Driver : M66310P (X14- [A/5], IC4)

4-1. Pin connection

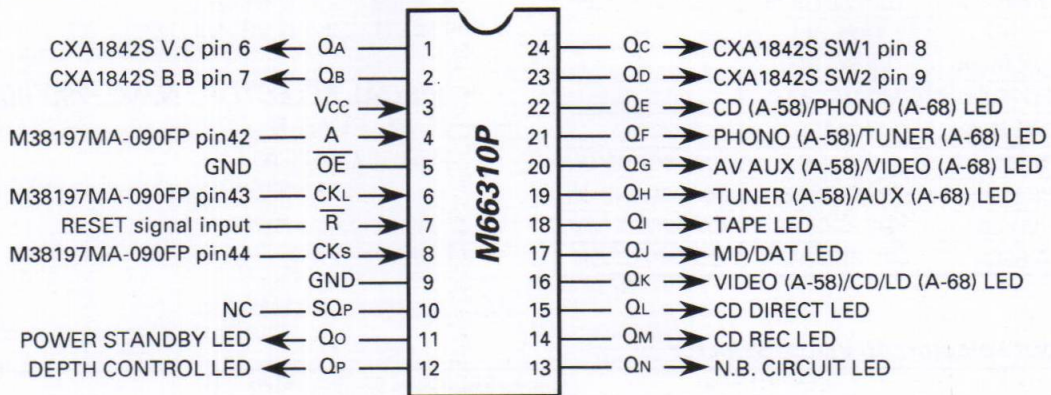

4-2. State of IC port (LED driver)

	A-58	A-68
QA	CXA1842S V.C (Pin 6)	
QB	CXA1842S B.B (Pin 7)	
Qc	CXA1842S SW1 (Pin 8)	
Qd	CXA1842S SW2 (Pin 9)	
Qe	CD	PHONO
Qf	PHONO	TUNER
Qg	AV AUX	VIDEO
Qh	TUNER	AUX
Qi	TAPE	
Qj	MD/DAT	
Qk	VIDEO	CD/LD
Ql	CD DIRECT	
Qm	CD REC	
Qn	N.B. CIRCUIT	
Qo	POWER STANDBY	
Qp	DEPTH CONTROL	

Input selector

	Qe	Qf	Qg	Qh	Qi	Qj	Qk
A-58	CD	○					
	TUNER			○			
	PHONO		○				
	TAPE				○		
	VIDEO						○
	AV AUX			○			
	MD/DAT						○
A-68	CD/LD						○
	TUNER		○				
	PHONO	○					
	TAPE				○		
	VIDEO			○			
	AUX				○		
MD/DAT						○	

○ : ON, Blank : OFF

Presence

	QA	QB	Qc	Qd
BYPASS		○	○	○
ARENA		○		○
JAZZ CLUB		○		
STADIUM		○	○	
HIT MASTER	○	○	▲	▲
DEPTH CONTROL ON		○		○

○ : ON, Blank : OFF, ▲ : Optional ON/OFF is active low

CD DIRECT/CD REC/N.B. CIRCUIT POWER STANDBY/DEPTH CONTROL

		Ql	Qm	Qn	Qo	Qp
CD DIRECT	ON	○	▲	▲	▲	
	OFF		▲	▲	▲	▲
CD REC	ON	▲	○	▲	▲	▲
	OFF	▲		▲	▲	▲
N.B. CIRCUIT	ON	▲	▲	○	▲	▲
	OFF	▲	▲		▲	▲
POWER STANDBY	ON	▲	▲	▲	○	▲
	OFF	▲	▲	▲		▲
DEPTH CONTROL	ON		▲	▲	▲	○
	OFF	▲	▲	▲	▲	

○ : ON, Blank : OFF

▲ : Optional (Conform to setting of each mode)

CIRCUIT DESCRIPTION

4-3. State of IC port (SEL. IC)

	SEL. IC1 TC9164N (IC3)	SEL. IC2 TC9163N (IC5)	SEL. IC3 TC9164N (IC6)
1	PHONO	TAPE REC	-
2	AV AUX (AUX)	VIDEO REC	-
3	VIDEO PLAY	MD/DAT REC	-
4	MD/DAT PLAY	BYPASS	-
5	TUNER	DOLBY	DUAL SOUND OFF
6	TAPE PLAY	PRESENCE	DUAL SOUND ON
7	CD (CD/LD)	GE REC ON	CD DIRECT OFF
8	CD REC	GE REC OFF	CD DIRECT ON

- **μ-com : M38197MA-090FP (IC1)**

Pin 15 : C/S S. RELAY

Pin 28 : OMNI SP. MUTE

- **VISUAL SELECTOR : NJM2279D (IC20)**

Pin 9 : CONT B

Pin10 : CONT A

Input · Output selector/AI/Visual selector

		SEL. IC1 (IC3)							SEL. IC2 (IC5)			IC20		
		8	7	6	5	4	3	2	1	3	2	1	CONTB	CONTA
CD REC OFF	CD		○							○	○	○	*	*
	CD/LD		○							○	○	○	H	H
	TUNER				○					○	○	○	*	*
	PHONO							○	○	○	○	*	*	
	TAPE			○					○	○		*	*	
	VIDEO						○		○		○	L	H	
	AV AUX							○	○	○	○	H	H	
	AUX							○	○	○	○	*	*	
CD REC ON	MD/DAT				○					○	○	*	*	
	CD	○	○						○	○		*	*	
	CD/LD	○	○						○	○		H	H	
	TUNER	○			○				○	○		*	*	
	PHONO	○						○	○	○		*	*	
	TAPE	○		○					○	○		*	*	
	VIDEO	○					○		○			L	H	
	AV AUX	○						○	○	○		H	H	
AI	AUX	○					○	○	○	○		*	*	
	MD/DAT	○			○				○			*	*	

	NJM2279D (IC20)	
	CONTB	CONTA
V.MUTE	L	L
-	L	H
VIDEO	H	L
CD/LD · AV AUX	H	H

○ : ON, Blank : OFF, * : Maintain last condition of visual selector

PRESENCE/DOLBY SURROUND/DEPTHCONTROL /CD DIRECT/DUAL SOUND

	SEL. IC2 (IC5)					IC1	
	8	7	6	5	4	OMNI SP.	C/S SP.
BYPASS		○			○	H	L
DOLBY PRO-LOGIC · 3-STEREO	○			○		L	H
PRESENCE		○	○			H	L
DEPTH CONTROL (ON)		○	○			H	L
AI (AUTO/FOCUS)	▲	▲			○	L	L

		SEL. IC3 (IC6)				IC1	
		8	7	6	5	OMNI SP.	C/S SP.
CD DIRECT	ON	○				L	L
	OFF		○			▲	▲
DUAL SOUND	ON			○			
	OFF				○		

○ : ON, Blank : OFF, ▲ : Optional (Conform to setting of each mode [DOLBY · PRESENCE])

CIRCUIT DESCRIPTION

5. Analog IC : LC7538JM (X08- [A/3], IC8)

5-1. Pin connection

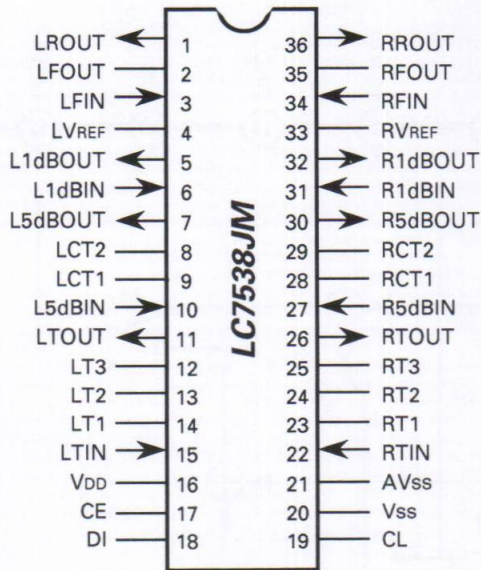

5-2. Pin function

No.	Name	I/O	Function
1	LROUT	O	Output terminal of fader.
2	LFOUT	-	NC
3	LFIN	I	Input terminal of fader.
4	LVREF		Common terminal of main volume control, fader volume control and tone control.
5	L1dBOUT	O	Output terminal of 1dB step attenuator of main volume control.
6	L1dBIN	I	Input terminal of 1dB step attenuator of main volume control.
7	L5dBOUT	O	Output terminal of 5dB step attenuator of main volume control.

No.	Name	I/O	Function
8, 9	LCT2, LCT1	O	Loudness terminal.
10	L5dBIN	I	Input terminal of 5dB step attenuator of main volume control.
11	LTOUT	O	Output terminal of tone control.
12~14	LT3~LT1		Terminal to connect BASS and TREBLE compensation capacitor for tone control circuit.
15	LTIN	I	Input terminal of tone control.
16	VDD	-	Connect power supply.
17	CE		Chip enable terminal. Data are written in the internal latch and each analog switch works when "H" changes to "L". Data transfer is set enable when at "H".
18, 19	DI, CL	I	Input terminal for serial data and clock for control.
20, 21	VSS, AVSS	-	Connect each power supply.
22	RTIN	I	Input terminal of tone control.
23~25	RT1~RT3		Terminal to connect BASS and TREBLE compensation capacitor for tone control circuit.
26	RTOUT	O	Output terminal of tone control.
27	R5dBIN	I	Input terminal of 5dB step attenuator of main volume control.
28, 29	RCT1, RCT2		Loudness terminal.
30	R5dBOUT	O	Output terminal of 5dB step attenuator of main volume control.
31	R1dBIN	I	Input terminal of 1dB step attenuator of main volume control.
32	R1dBOUT	O	Output terminal of 1dB step attenuator of main volume control.
33	RVREF		Common terminal of main volume control, fader volume control and tone control.
34	RFIN	I	Input terminal of fader.
35	RFOUT	-	NC
36	RROUT	O	Output terminal of fader.

CIRCUIT DESCRIPTION

6. Analog IC : CXA1842S (X08- [A/3], IC7)

6-1. Block diagram

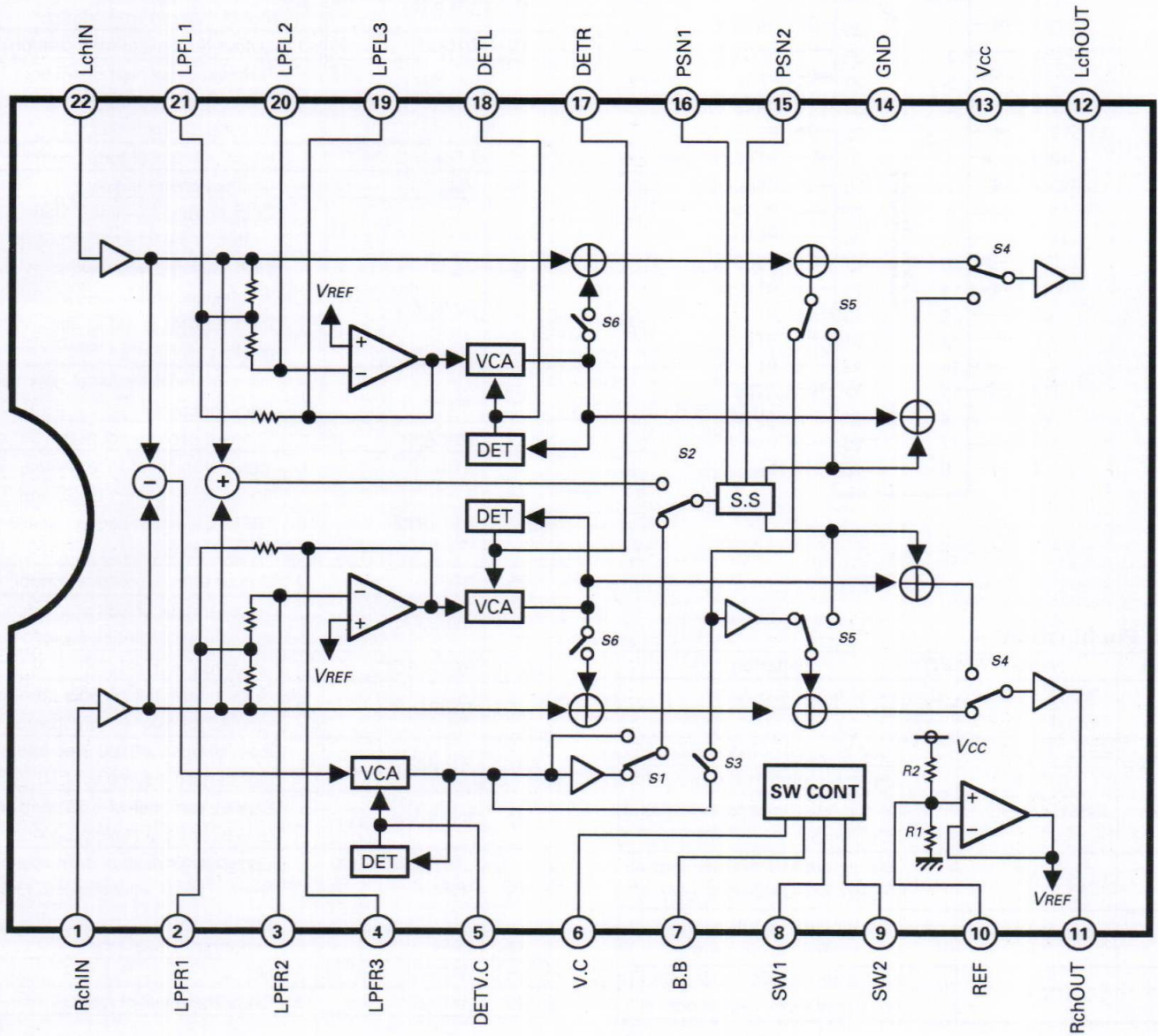

A-58/68 A-58/68

WIRING DIAGRAM

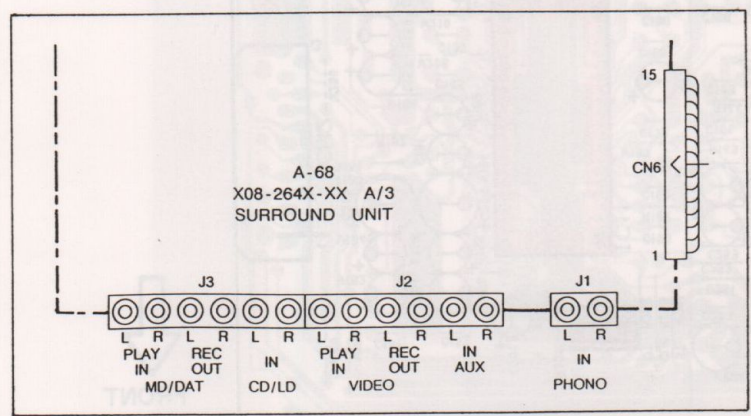
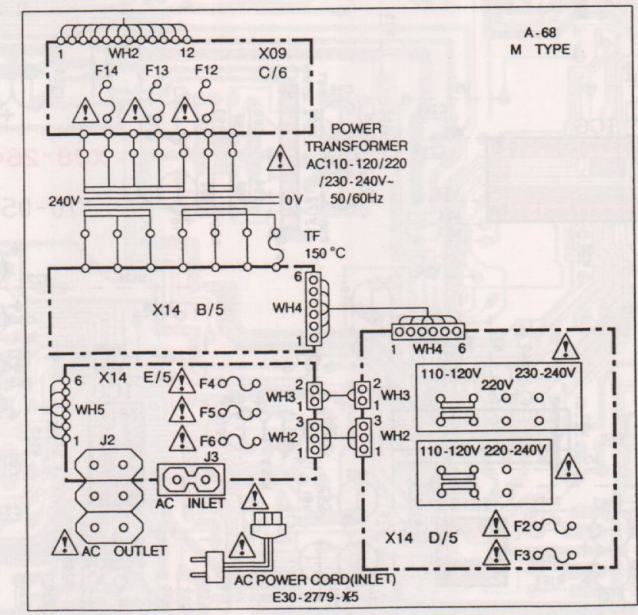
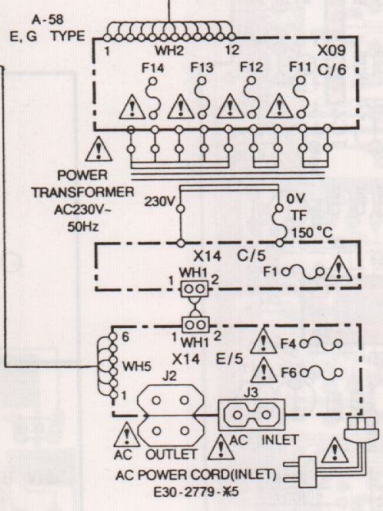
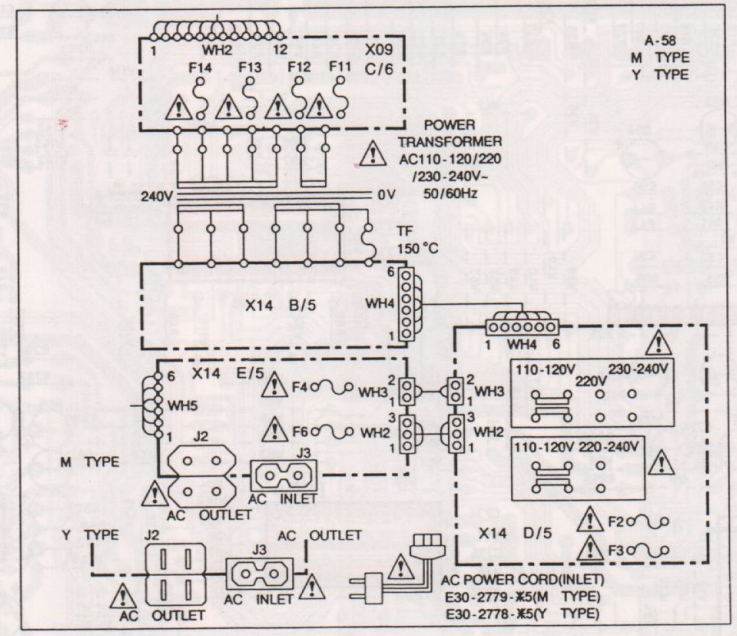
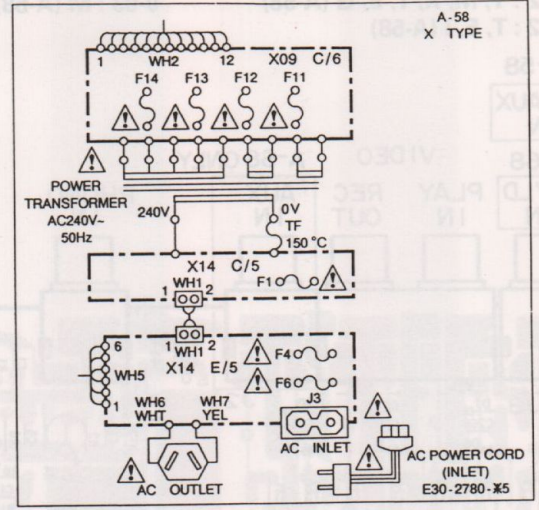
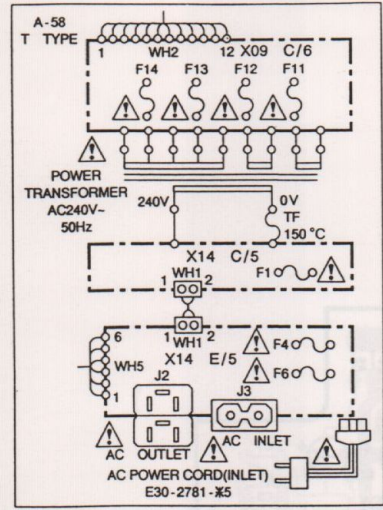
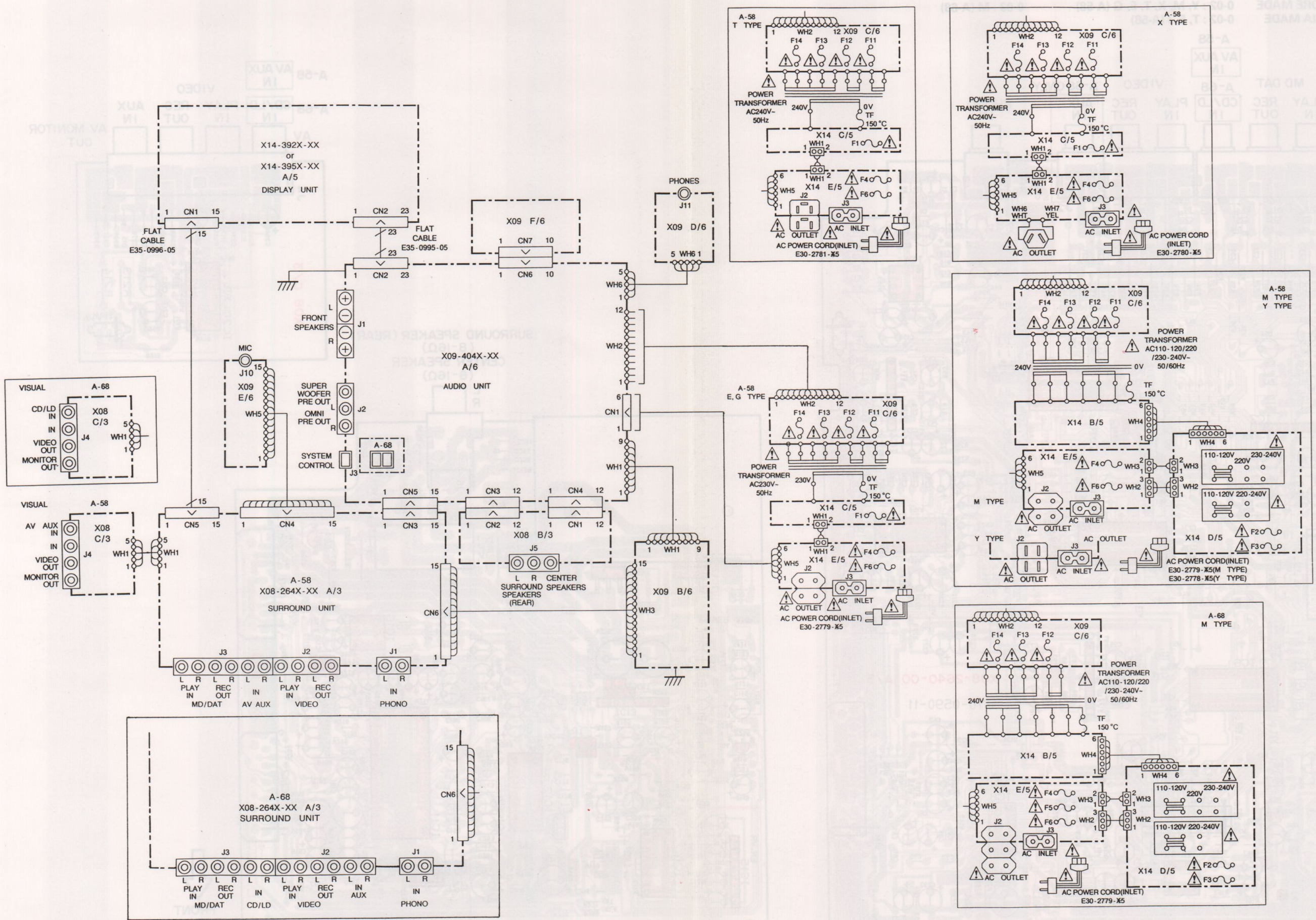

PC BOARD (COMPONENT SIDE VIEW)

SURROUND UNIT : X08-2640-XX

JAPAN MADE 0-00 : Y, M, X, T, E, G (A-58) 0-01 : M (A-68)
 SINGAPORE MADE 0-02 : Y, M, X, T, E, G (A-58) 0-03 : M (A-68)
 MALAYSIA MADE 0-02 : T, E, I (A-58)

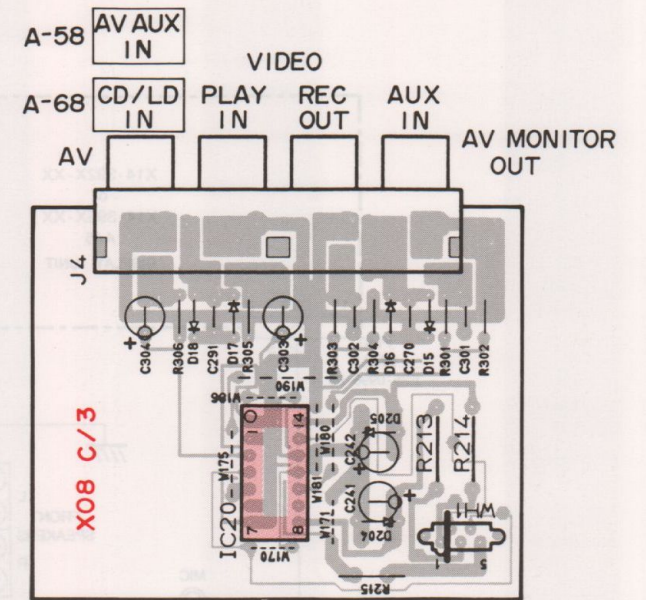
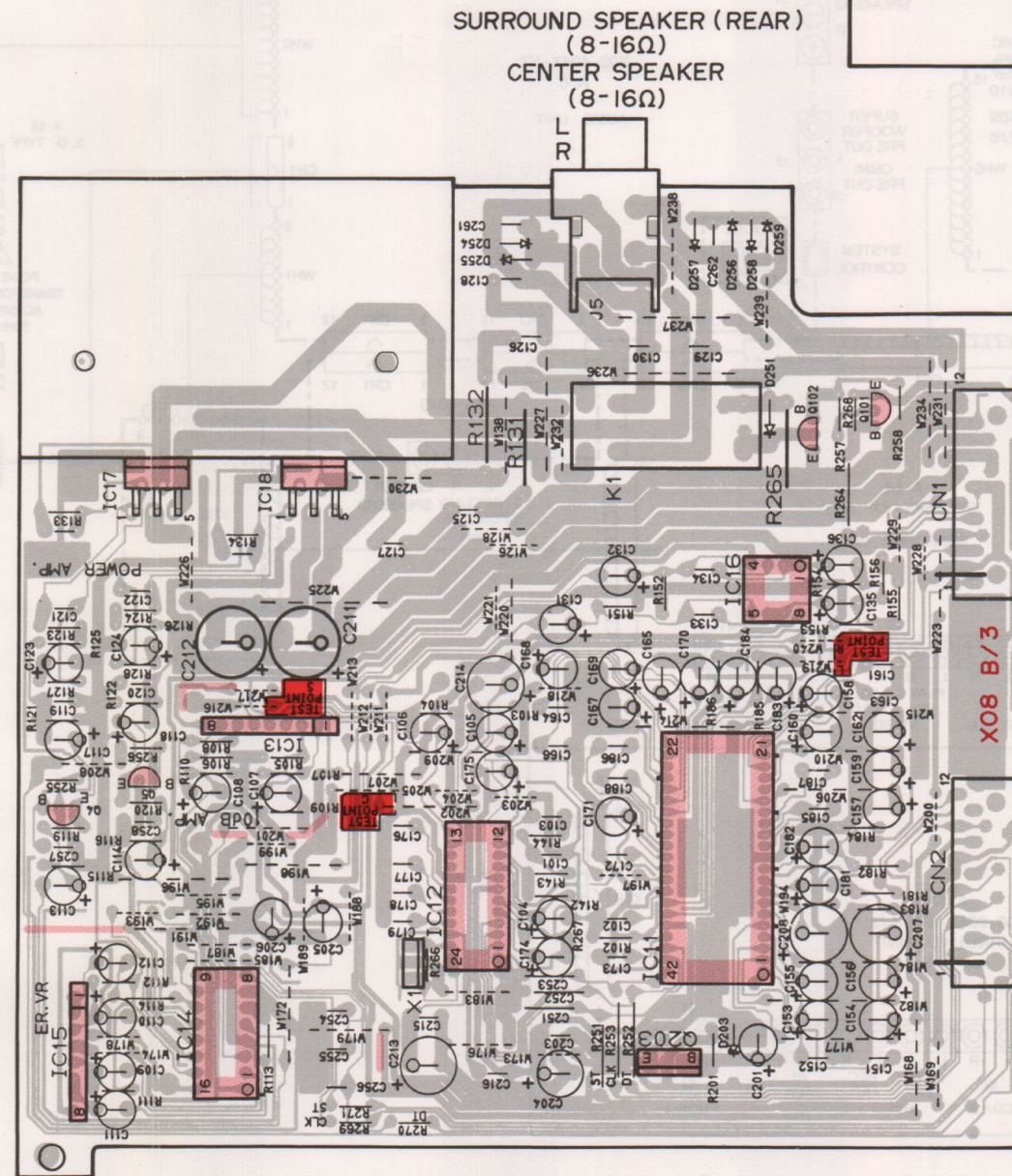
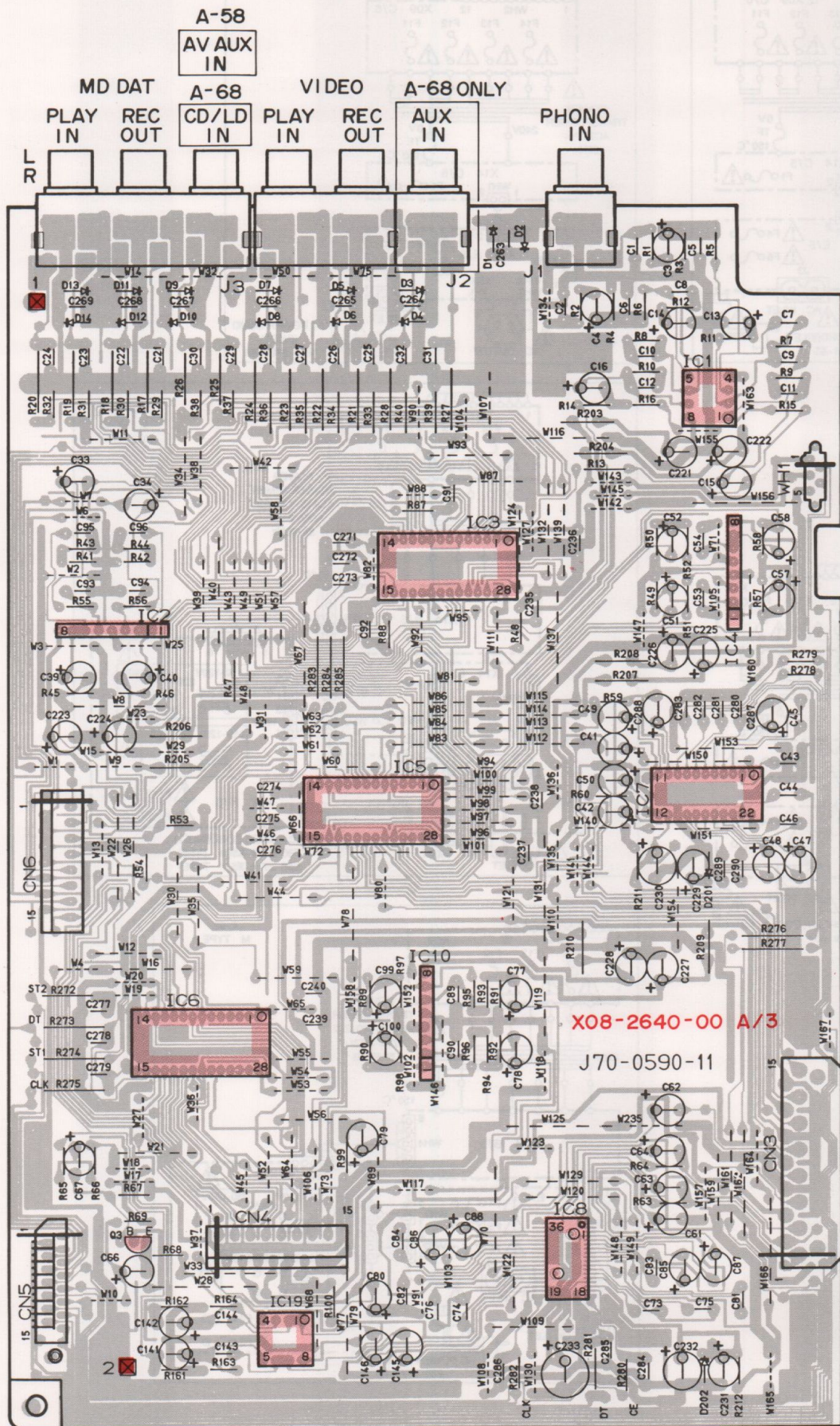

PC BOARD (COMPONENT SIDE VIEW)

AUDIO UNIT : X09-404X-XX

JAPAN MADE 0-21 : Y, M 2-71 : X, T, E, G (A-58) 0-22 : M (A-68)

SINGAPORE MADE 0-23 : Y, M 2-72 : X, T, E, G (A-58) 0-24 : M (A-68)

MALAYSIA MADE 0-23 : I 2-72 : T, E (A-58)

FRONT
←

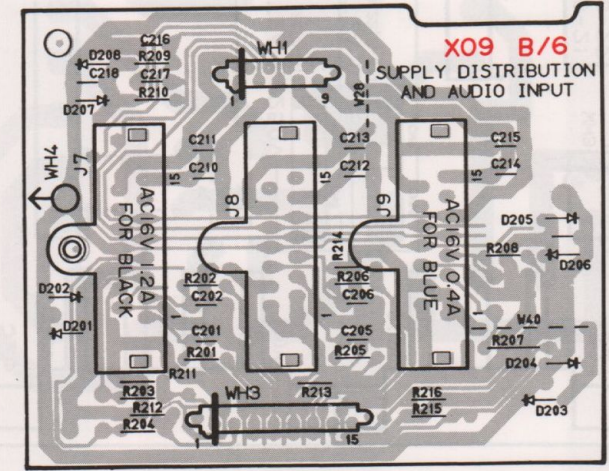
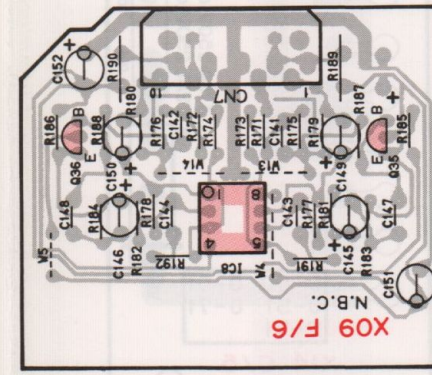
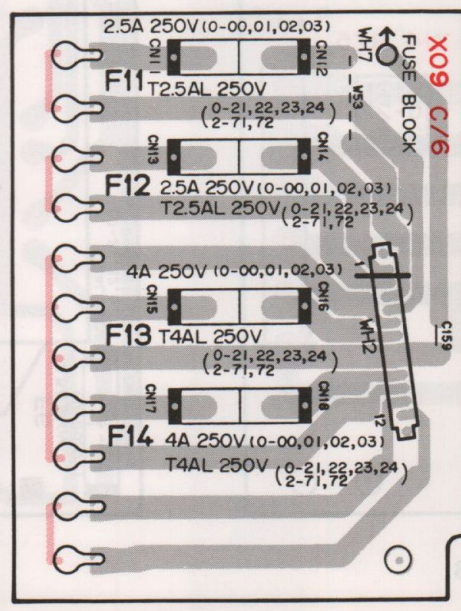
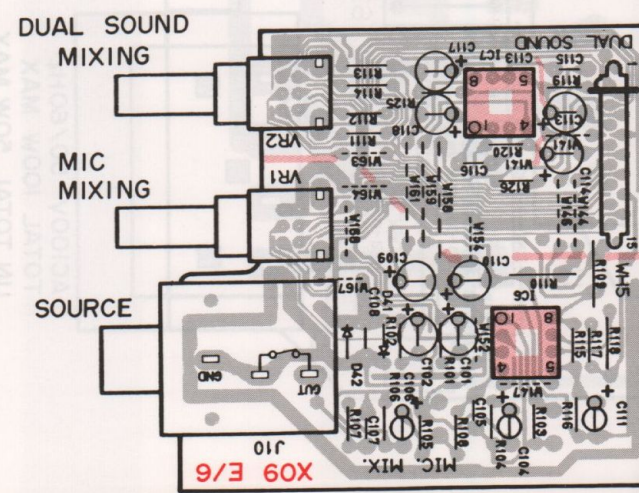
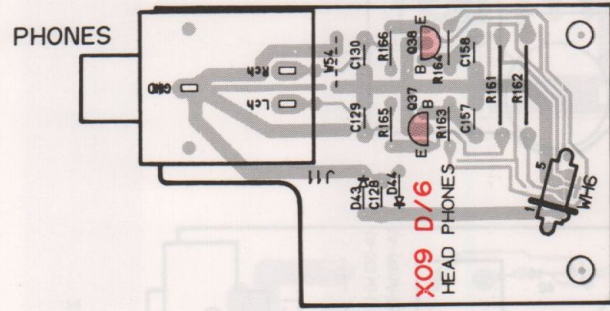
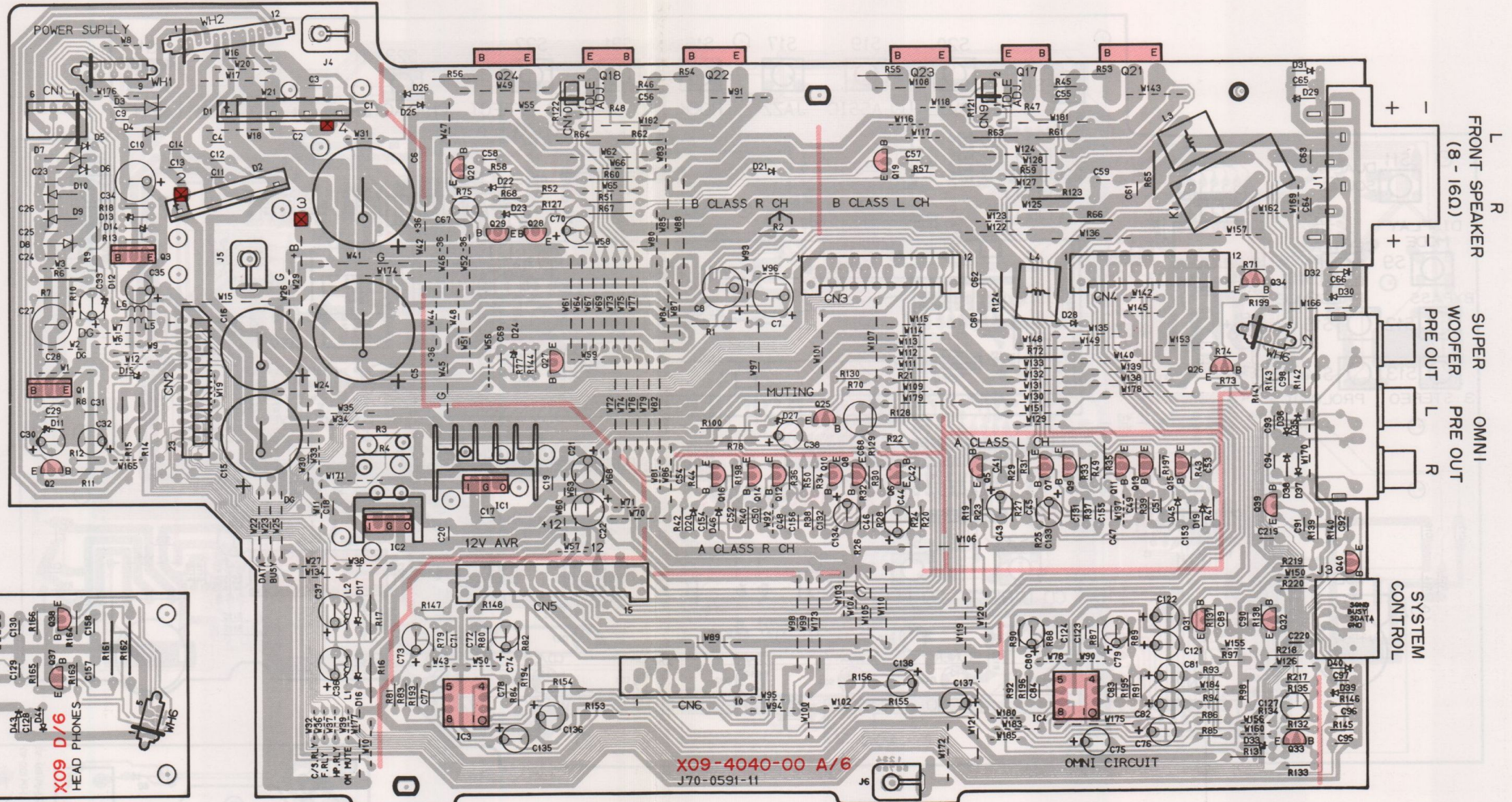

Refer to the schematic diagram for the values of resistors and capacitors.

PC BOARD (COMPONENT SIDE VIEW)

DISPLAY UNIT : X14-39XX-XX

JAPAN MADE

22-91 : Y, 20-21 : M, 20-71 : X, 20-51 : T, 22-71 : E, G (A-58)

20-22 : M (A-68)

SINGAPORE MADE

52-91 : Y, 50-21 : M, 50-71 : X, 50-51 : T, 52-71 : E, G (A-58)

50-22 : M (A-68)

MALAYSIA MADE

50-21 : I, 50-51 : T, 52-71 : E (A-58)

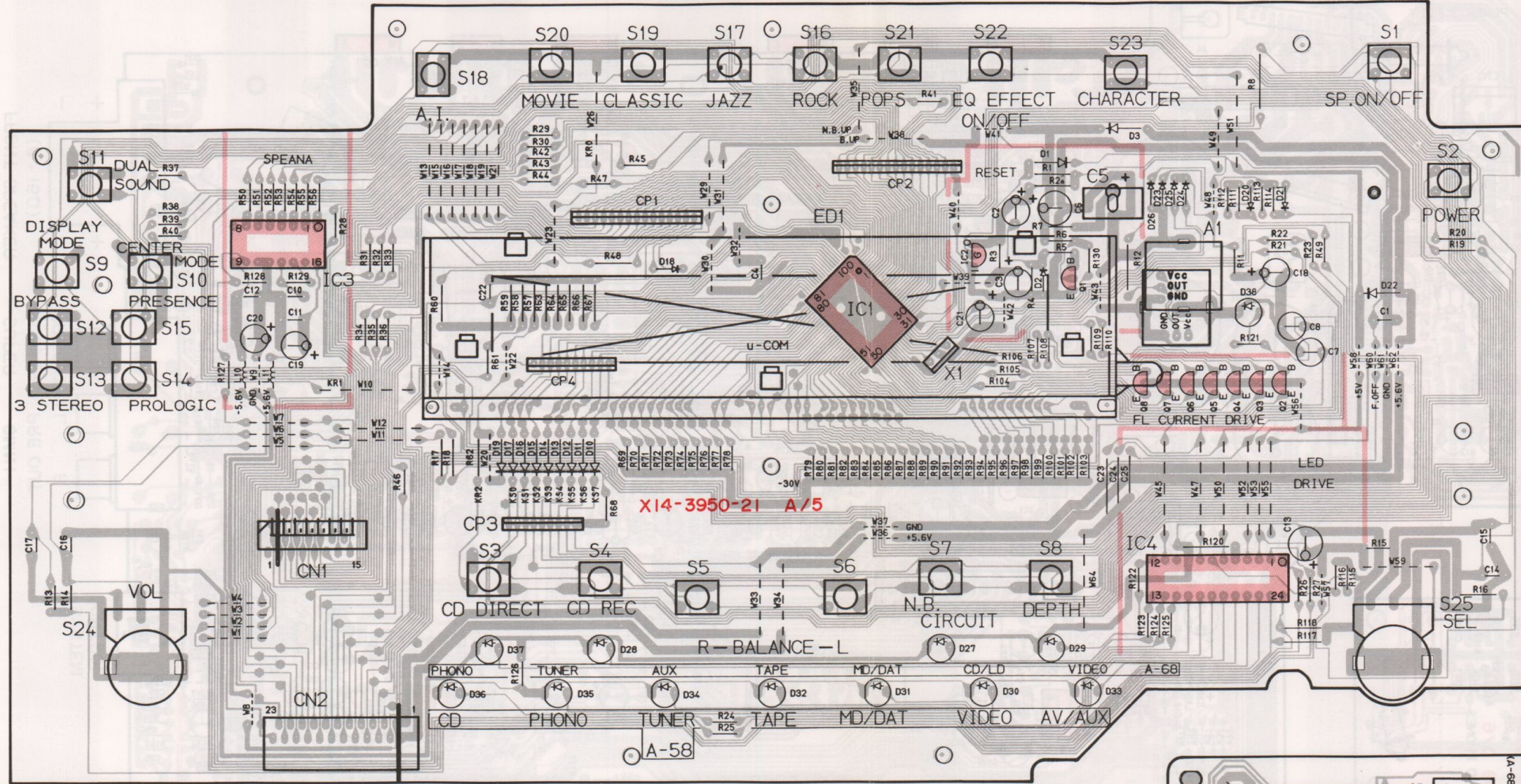

FRONT
↑

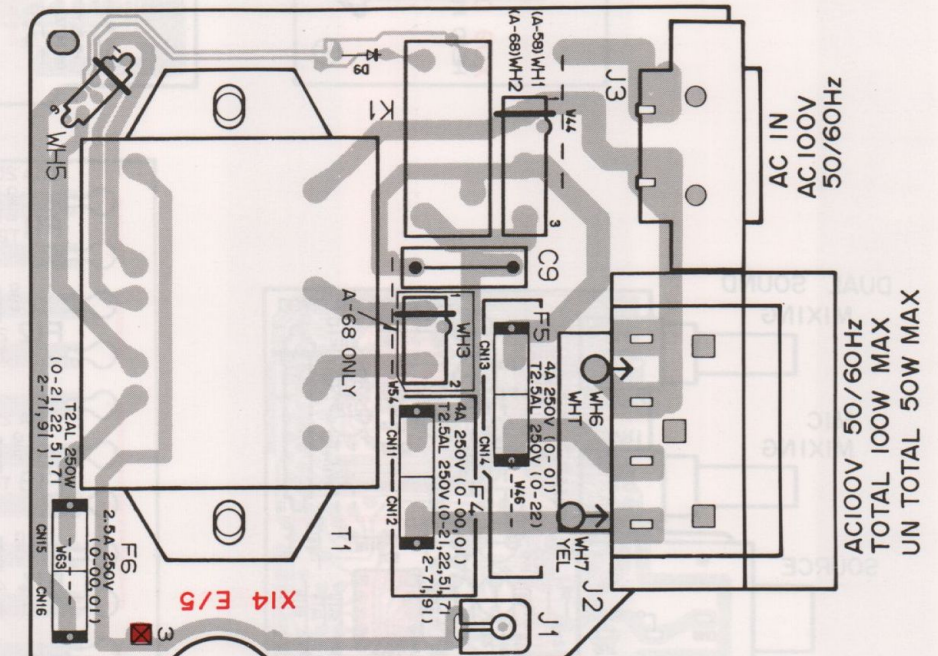
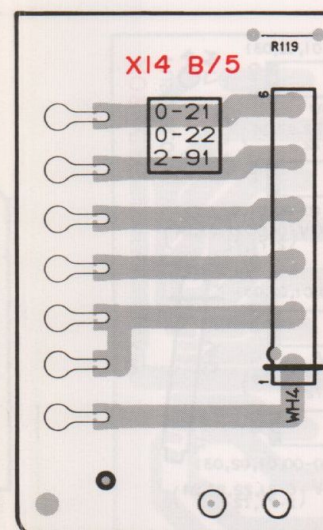
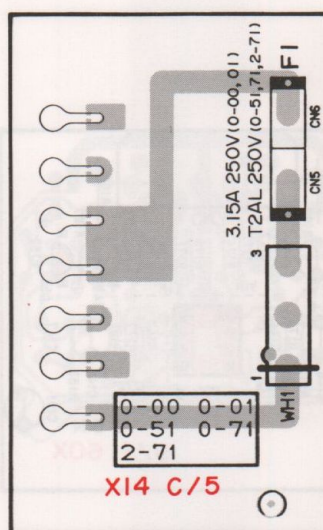
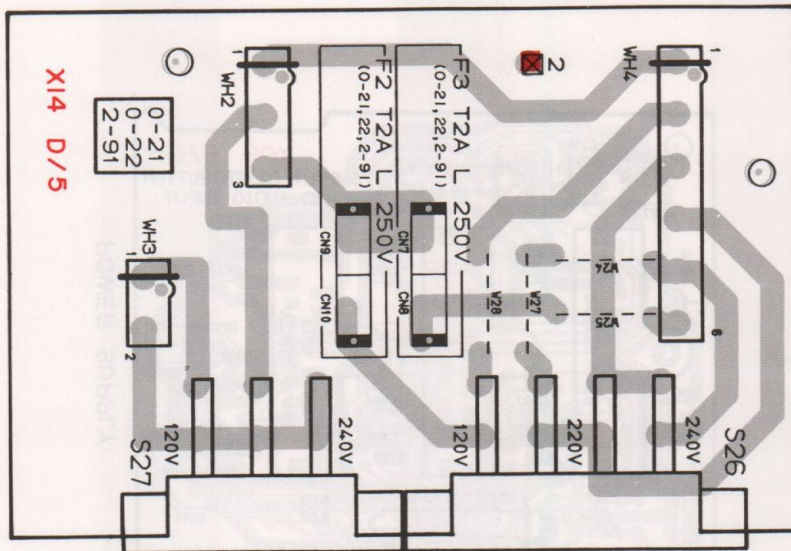

AC100V 50/60HZ
TOTAL 100W MAX
UN TOTAL 50W MAX

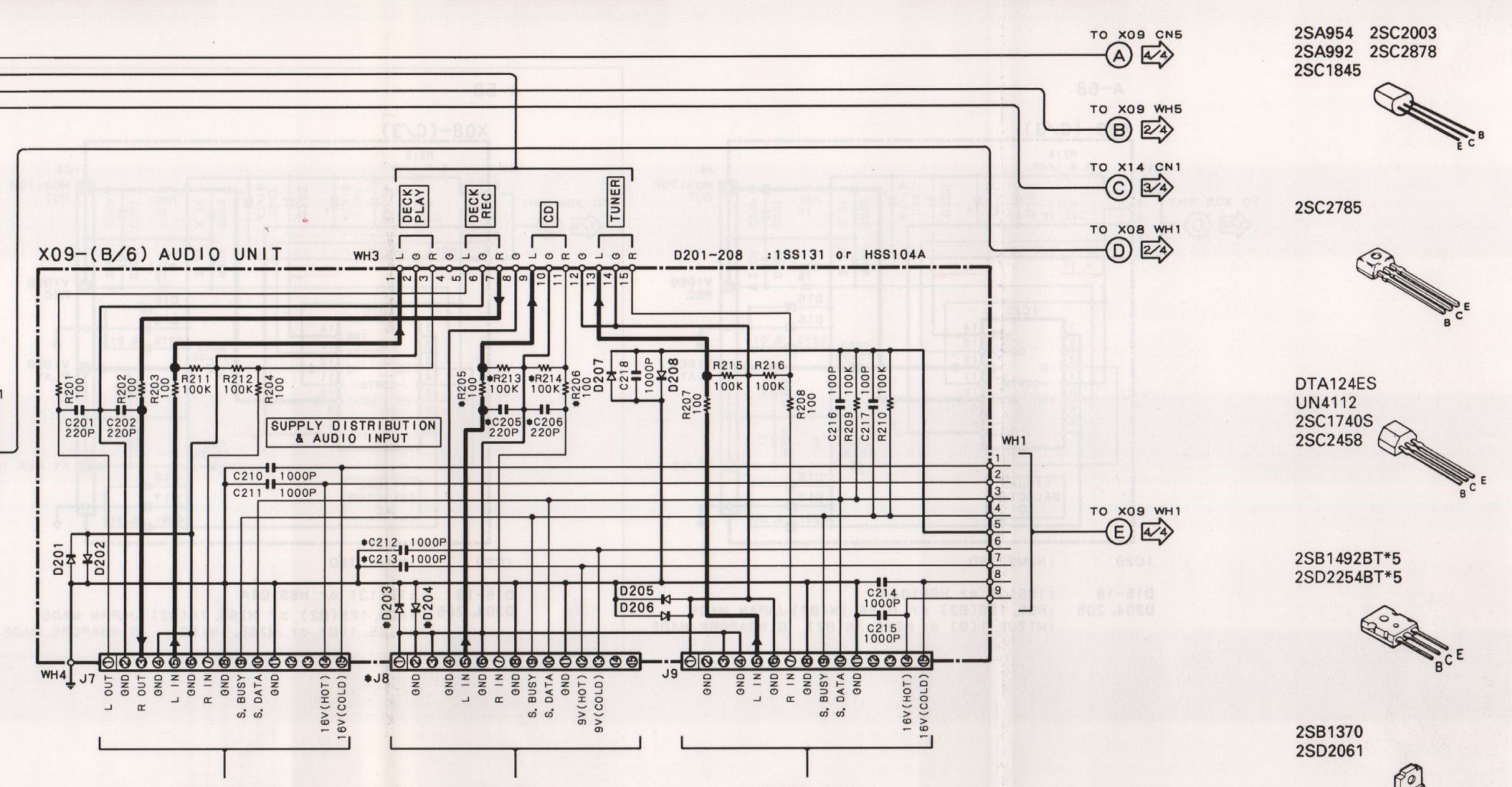
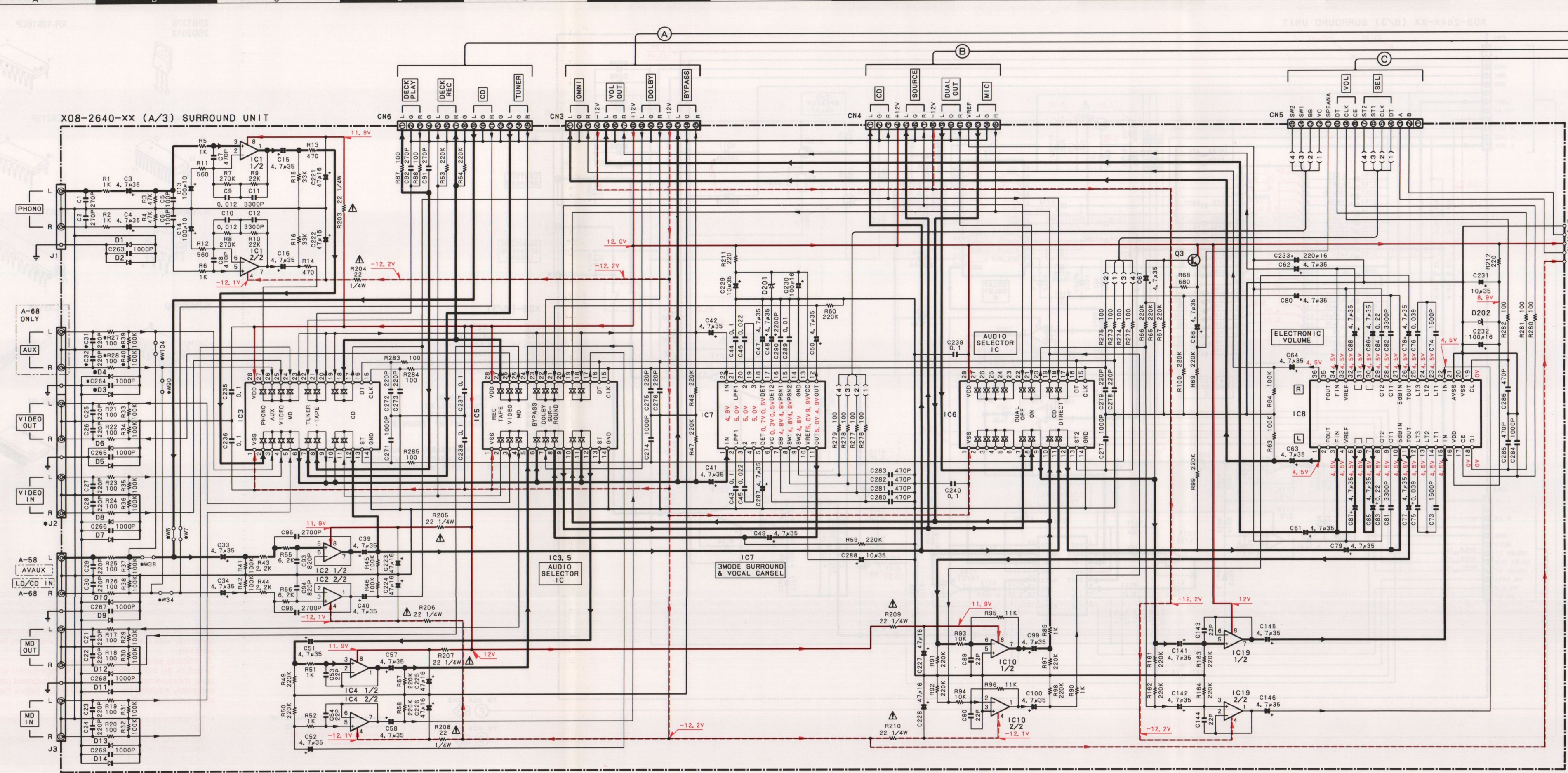

X08-(A/3)

MODEL NAME	DESTINATION	ABB.	UNIT NO.	C31, 32, 264 R27, 28, 38, 40 W34, 38, D3, 4	W6, 7 90, 104	J2
A-58 JAPAN MADE	GENERAL MARKET	M	0-00			
	AUSTRALIA	X				
	ENGLAND	T				
	EUROPE	E				
	GERMANY	G				
A-58 SINGAPORE MADE	GENERAL MARKET	M	0-02	NO	YES	E63-0091-05
	AUSTRALIA	X				
	ENGLAND	T				
	EUROPE	E				
	GERMANY	G				
A-58 MALAYSIA MADE	MALAYSIA	I	0-23			
	ENGLAND	T				
	EUROPE	E				
A-68 JAPAN MADE	GENERAL MARKET	M	0-01	YES	NO	E63-0066-15
A-68 SINGAPORE MADE	GENERAL MARKET	M	0-03			

X08-(A/3)

- IC1, 19 : XRA15218-DX or NJM4565D
- IC2, 4, 10 : NJM4565L-D
- IC3, 6 : TC9164N
- IC5 : TC9163N
- IC7 : CXA1842S
- IC8 : LC7538JM

X09-(B/6)

MODEL NAME	DESTINATION	ABB.	UNIT NO.	C205, 206, 212, 213 R205, 206, 213, 214 D203, 204, J8
A-58 JAPAN MADE	GENERAL MARKET	M	0-21	
	AUSTRALIA	X		
	ENGLAND	T		
	EUROPE	E		
	GERMANY	G		
A-58 SINGAPORE MADE	GENERAL MARKET	M	0-23	YES
	AUSTRALIA	X		
	ENGLAND	T		
	EUROPE	E		
	GERMANY	G		
A-58 MALAYSIA MADE	MALAYSIA	I	0-23	
	ENGLAND	T		
	EUROPE	E		
A-68 JAPAN MADE	GENERAL MARKET	M	0-22	NO
A-68 SINGAPORE MADE	GENERAL MARKET	M	0-24	

X09-(B/6)

- Q3 : 2SC1845(F, E)
- D1-14 : 1S131 or HSS104A
- D201, 202 : RD10ES(B2) or HZS10N(B2) JAPAN MADE
- D203 : RD10ES(B2) or MTZJ10(B) SINGAPORE MADE

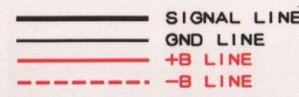

2SA954 2SC2003
2SA992 2SC2878
2SC1845

2SC28785

DTA124ES
UN4112
2SC1740S
2SC2458

2SB1492BT*5
2SD2254BT*5

2SB1370
2SD2061

CAUTION : For continued safety, replace safety critical components only with manufacturer's recommended parts (refer to parts list).
Δ Indicates safety critical components.
To reduce the risk of electric shock, leakage-current or resistance measurements shall be carried out (exposed parts are acceptably insulated from the supply circuit) before the appliance is returned to the customer.

• DC voltages are as measured with a high impedance voltmeter.
Values may vary slightly due to variations between individual instruments or units.

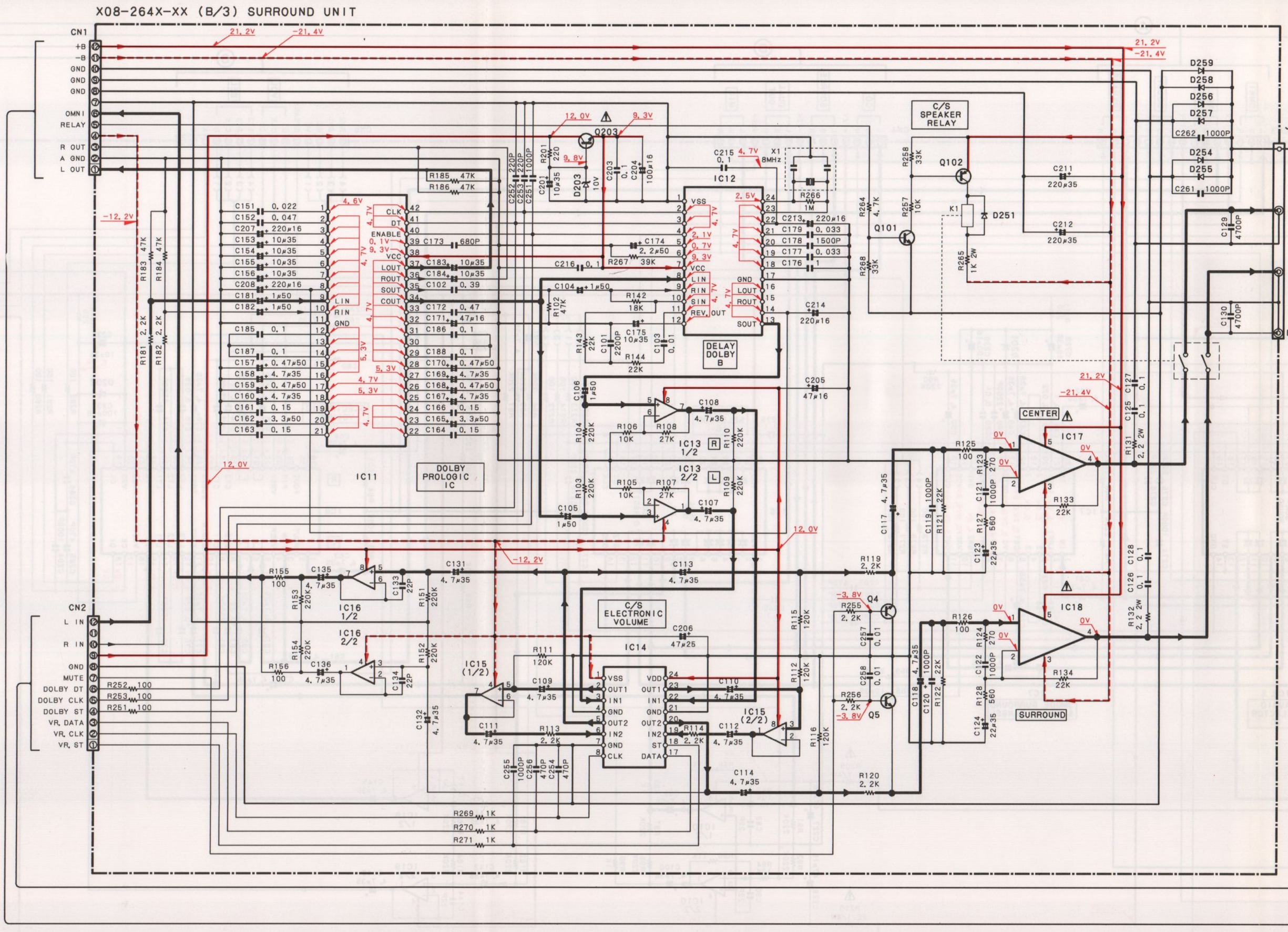
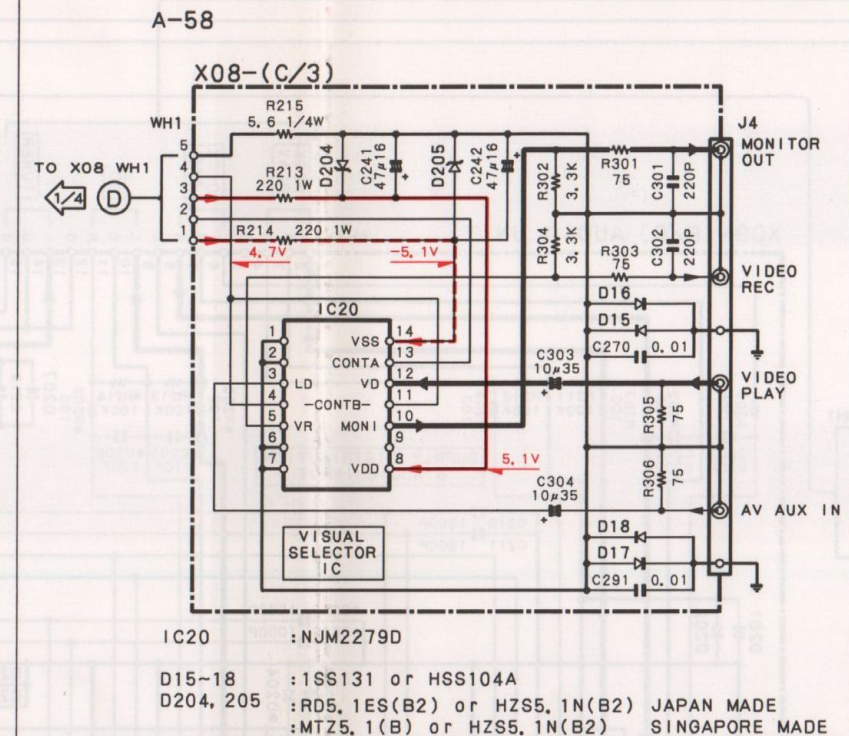
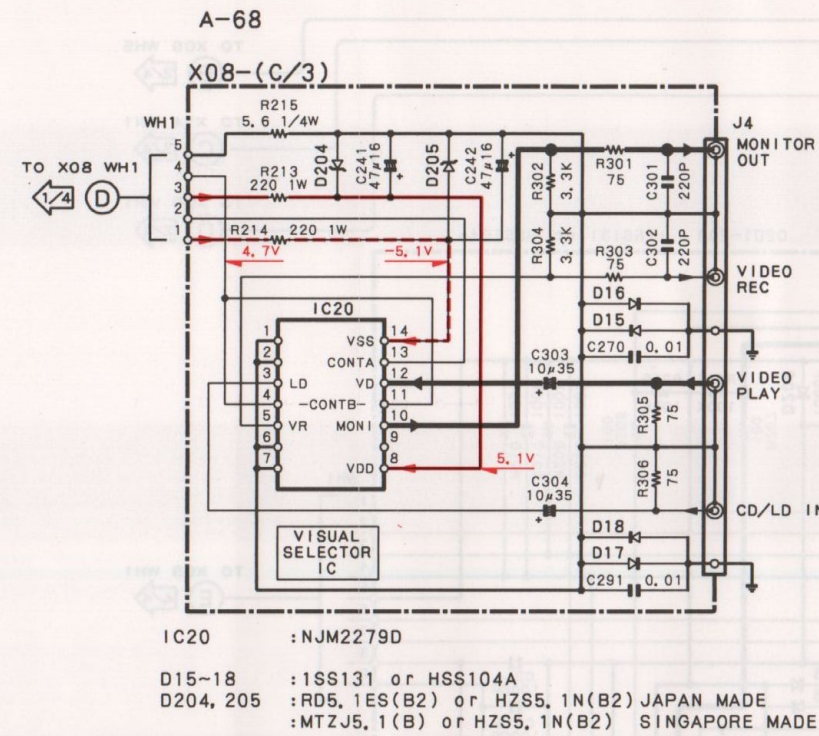

- X08-(B/3)**
- IC11 : LA2785
 IC12 : LV1010N
 IC13, 15 : NJM4565L-D
 IC14 : TC9213P
 IC16 : XRA15218-DX or NJM4565D-D
 IC17, 18 : TDA2050V
- Q4, 5 : 2SC2878(B)
 Q101 : 2SC2003(L, K)
 Q102 : 2SA954(L, K)
 Q203 : 2SD2061 or 2SD2012
- D203 : RD10ES(B2) or HZS10N(B2) JAPAN MADE
 : RD10ES(B2) or MTZ10(B) SINGAPORE MADE
 D251, 254-259 : 1S8131 or HSS104A

- 2S81375
 2SD2012
- CXA1842S
- NJM4565D-D
- NJM2279D
- XR-1091ECP
- TC9213P
- M66310P
- 2SC3311A
- LC7538JM

CAUTION: For continued safety, replace safety critical components only with manufacturer's recommended parts (refer to parts list).
 Δ Indicates safety critical components.
 To reduce the risk of electric shock, leakage-current or resistance measurements shall be carried out (exposed parts are acceptably insulated from the supply circuit) before the appliance is returned to the customer.

• DC voltages are as measured with a high impedance voltmeter. Values may vary slightly due to variations between individual instruments or/and units.

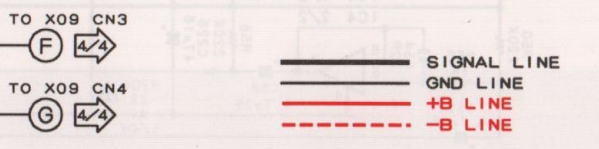

A-58/68(2/4)(K)

A-58/68
 KENWOOD

Y08-5102-91

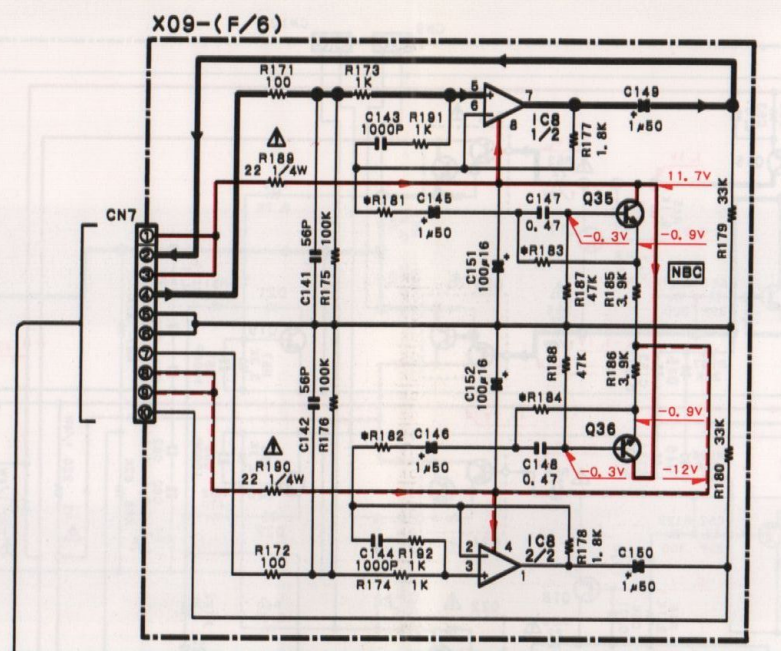
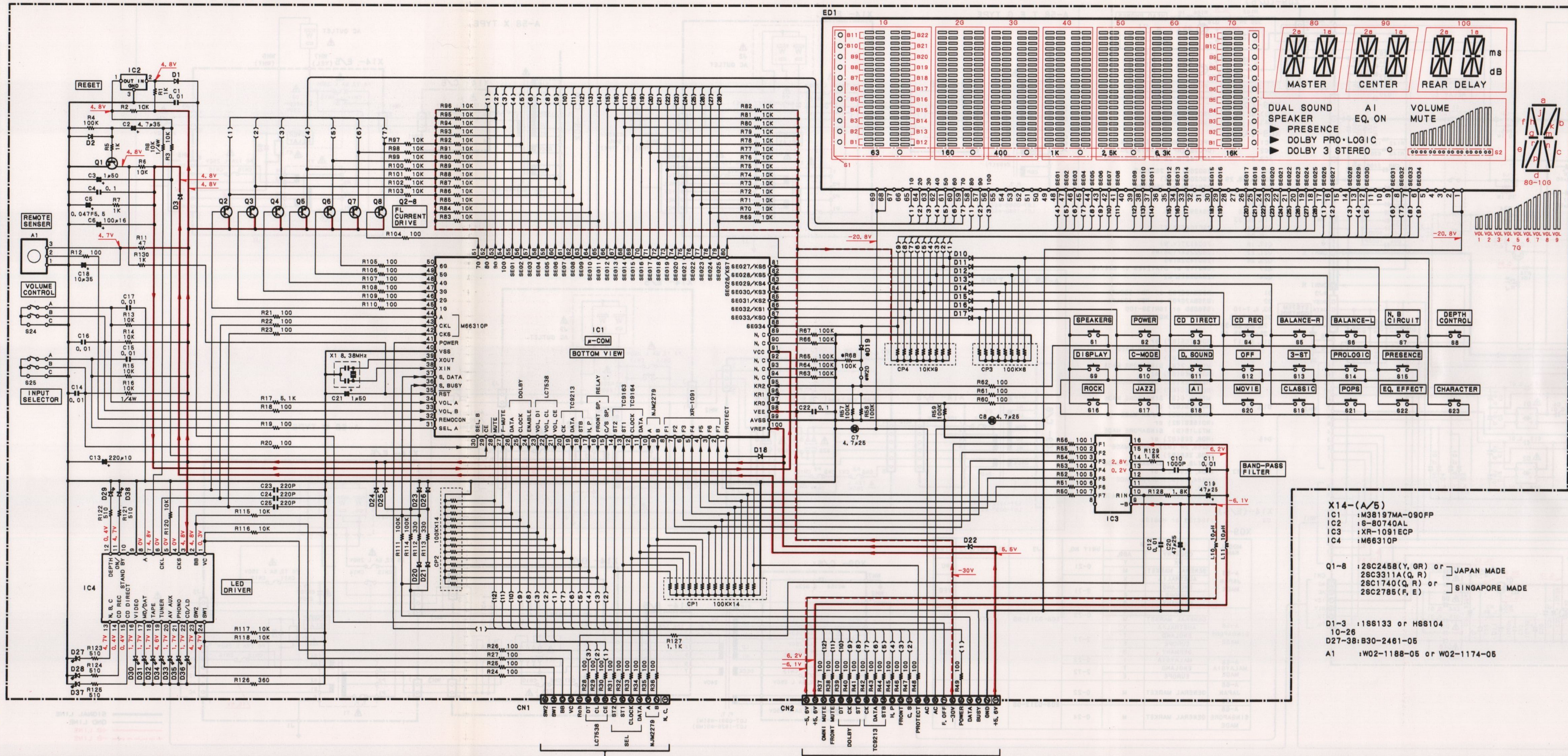

IC8 : XRA15218-DX or NJM4565D-D
Q35, 36 : 28C1845(F, E)

X09-(F/6)

MODEL NAME	DESTINATION	COUNTRY	ABB.	UNIT NO.	R181, 182	R183, 184
A-58 JAPAN MADE	GENERAL MARKET	PX	Y	0-21	680	330
	AUSTRALIA	X				
	ENGLAND	T		2-71	2.2K	330
	EUROPE	E				
	GERMANY	G				
A-58 SINGAPORE MADE	GENERAL MARKET	PX	Y	0-23	680	330
	AUSTRALIA	X				
	ENGLAND	T		2-72	2.2K	330
	EUROPE	E				
	GERMANY	G				
A-58 MALAYSIA MADE	GENERAL MARKET	PX	Y	0-23	680	330
	MALAYSIA	T				
	ENGLAND	T		2-72	2.2K	330
	EUROPE	E				
	GERMANY	G				
A-58 JAPAN MADE	GENERAL MARKET	PX	Y	0-22	1K	470
	AUSTRALIA	X				
	ENGLAND	T				
	EUROPE	E				
	GERMANY	G				
A-58 SINGAPORE MADE	GENERAL MARKET	PX	Y	0-24		
	AUSTRALIA	X				
	ENGLAND	T				
	EUROPE	E				
	GERMANY	G				

MODEL NAME	DESTINATION	COUNTRY	ABB.	UNIT NO.	D15, R68, W20
A-58 JAPAN MADE	GENERAL MARKET	PX	Y	2-81	
	AUSTRALIA	X		0-71	
	ENGLAND	T		0-81	
	EUROPE	E		2-71	
	GERMANY	G			
A-58 SINGAPORE MADE	GENERAL MARKET	PX	Y	2-81	
	AUSTRALIA	X		0-71	
	ENGLAND	T		0-81	
	EUROPE	E		2-72	
	GERMANY	G			
A-58 MALAYSIA MADE	GENERAL MARKET	PX	Y	0-21	
	MALAYSIA	T		0-81	
	ENGLAND	T		2-71	
	EUROPE	E			
	GERMANY	G			
A-58 JAPAN MADE	GENERAL MARKET	PX	Y	0-22	
	AUSTRALIA	X			
	ENGLAND	T			
	EUROPE	E			
	GERMANY	G			
A-58 SINGAPORE MADE	GENERAL MARKET	PX	Y	0-22	
	AUSTRALIA	X			
	ENGLAND	T			
	EUROPE	E			
	GERMANY	G			

X14-(A/5)
 IC1 : M38197MA-090FP
 IC2 : S-80740AL
 IC3 : XR-1091ECP
 IC4 : M66310P

Q1-8 : 28C2458(Y, GR) or JAPAN MADE
 28C3311A(Q, R)
 28C1740(Q, R) or SINGAPORE MADE
 28C2785(F, E)

D1-3 : 186133 or H8S104
 1Q-26
 D27-38, B30-2461-05

A1 : W02-1188-05 or W02-1174-05

XRA15218-DX



LA2785

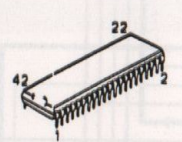

UPC7812AHF

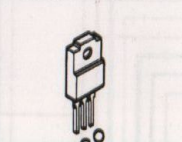

TC9163N

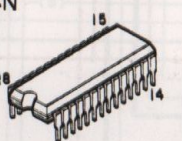

TC9164N

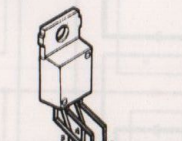

TDA2050V

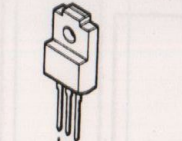

TA7812S

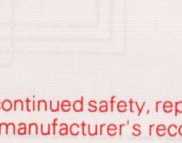

CAUTION: For continued safety, replace safety critical components only with manufacturer's recommended parts (refer to parts list).
 ⚠ Indicates safety critical components.
 To reduce the risk of electric shock, leakage-current or resistance measurements shall be carried out (exposed parts are acceptably insulated from the supply circuit) before the appliance is returned to the customer.

• DC voltages are as measured with a high impedance voltmeter. Values may vary slightly due to variations between individual instruments or/and units.

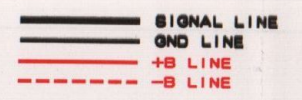

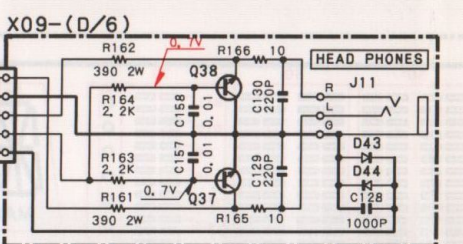
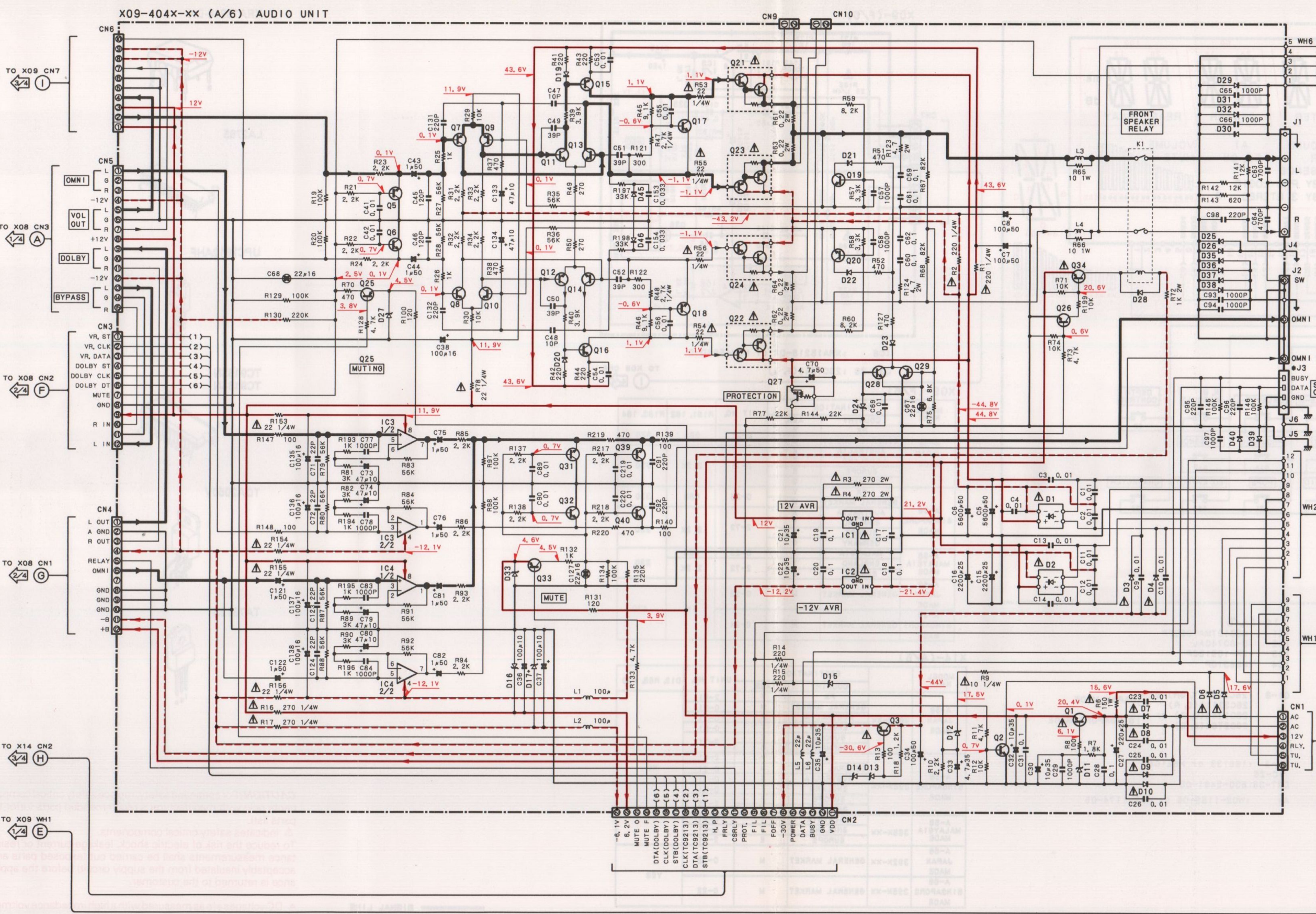

X09-(D/6)
Q37, 38 : 2SC2878(B)
Q43, 44 : 1SS131 or HSS104A
Q45 : 1SS131 or HSS104A

X09-(A/6)
IC1 : UPC7812AHF or TA7812S
IC2 : UPC7912HF or TA79012S
IC3 : XRA15218-DX or NJM4565D-D
Q1 : 2SD2061 or 2SD2012
Q2, 26, 28, 29 : 2SC2003(L, K)
Q3 : 2B81370 or 2B81375
Q5, 6, 31, 32 : 2SC2878(B)
Q9, 40 : 2SA992(F, E)
Q7-10, 15 : 16, 25, 33 : 2SC1845(F, E)
Q11-14 : 2SC4137(V, W)
Q17, 18 : 2SC4137(V, W)
Q21, 22 : 2SD2254F19BTH4S
Q23, 24 : 2SD1492BT*
Q27 : UN4112 or DTA124ES or UN4116
Q34 : 2SA954(L, K)

D1 : D558A20F03 or RBV-602LFA
D2 : D358A20F03 or RBV-402LFA
D3 : 4, 7-10 : 5S6888 or 1SR139-100
D5 : 6, 19-23 : 1SS131 or HSS104A
D11 : 16, 17 : R06, 2ES(B2) or H2S6, 2N(B2) JAPAN MADE
D12 : R06, 2ES(B2) or MTZJ6, 2(B) SINGAPORE MADE
D13 : R05, 6ES(B2) or H2S5, 6N(B2) JAPAN MADE
D14 : R05, 6ES(B2) or MTZJ5, 6(B) SINGAPORE MADE
D15 : R015ES(B2) or H2S15N(B2) JAPAN MADE
D24, 27, 33 : R015ES(B2) or MTZJ15(B) SINGAPORE MADE
D24 : R08, 2ES(B2) or H2S8, 2N(B2) JAPAN MADE
D27 : R04, 7ES(B2) or H2S4, 7N(B2) JAPAN MADE
D34 : R04, 7ES(B2) or MTZJ4, 7(B) SINGAPORE MADE

X09-(E/5)
D9 : 1SS133 or HSS104

MODEL NAME	DESTINATION	COUNTRY	ABB.	UNIT NO.	J3	F11, CN1, 12	C159	
A-58 JAPAN MADE	GENERAL MARKET	PX	Y	0-21			NO	
A-58 SINGAPORE MADE	AUSTRALIA	AU	X	0-23	E08-0311-05	YES	NO	
	ENGLAND	T	2-71					
	EUROPE	E	2-72					
	GERMANY	G						
A-58 MALAYSIA MADE	GENERAL MARKET	PX	Y	0-23	E08-0311-05	YES	NO	
	AUSTRALIA	AU	X					2-72
	ENGLAND	T	2-72					
A-58 JAPAN MADE	GENERAL MARKET	PX	Y	0-22	E08-0312-05	NO	NO	
	GENERAL MARKET	M						
A-58 SINGAPORE MADE	GENERAL MARKET	M		0-24				

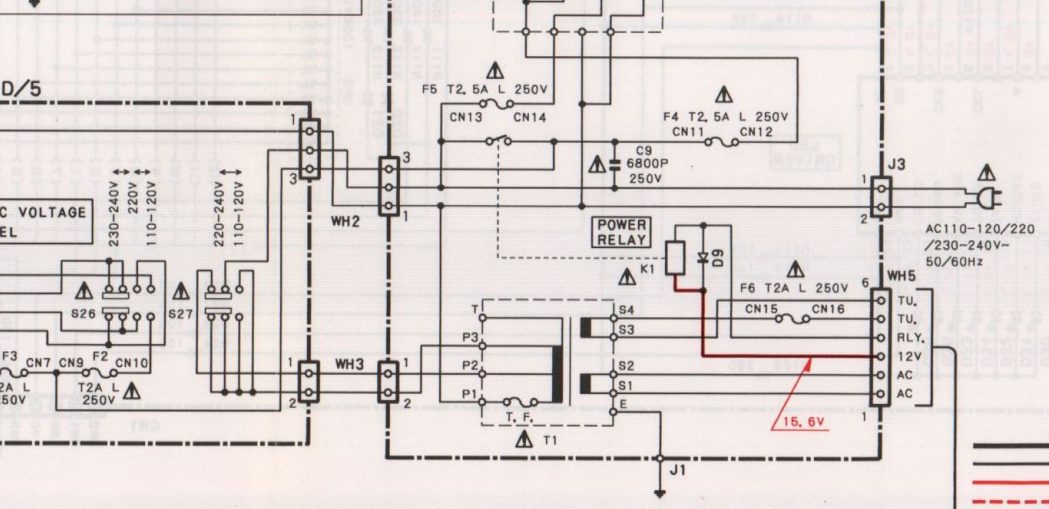
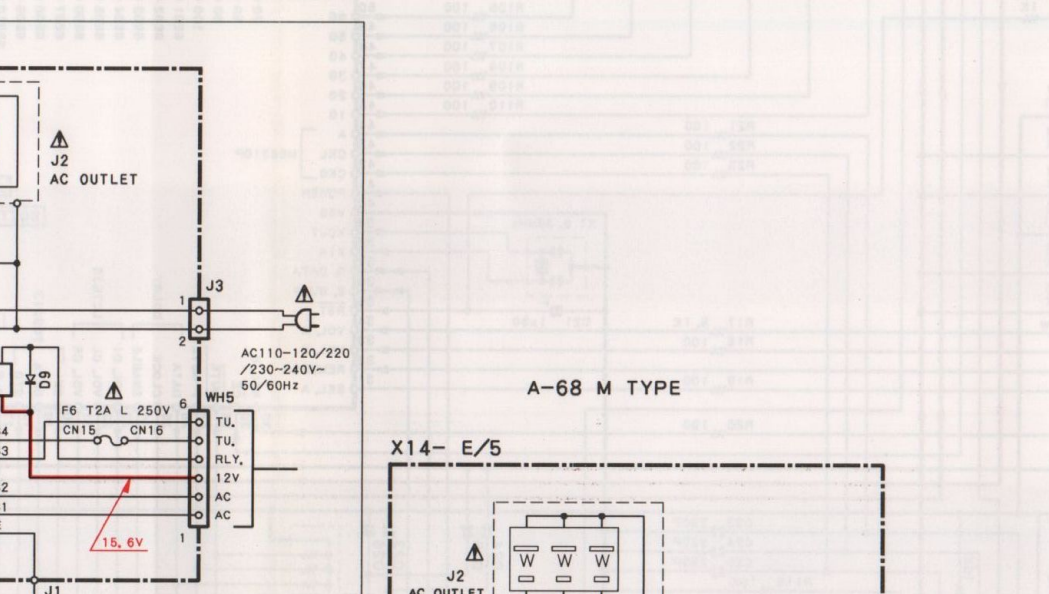
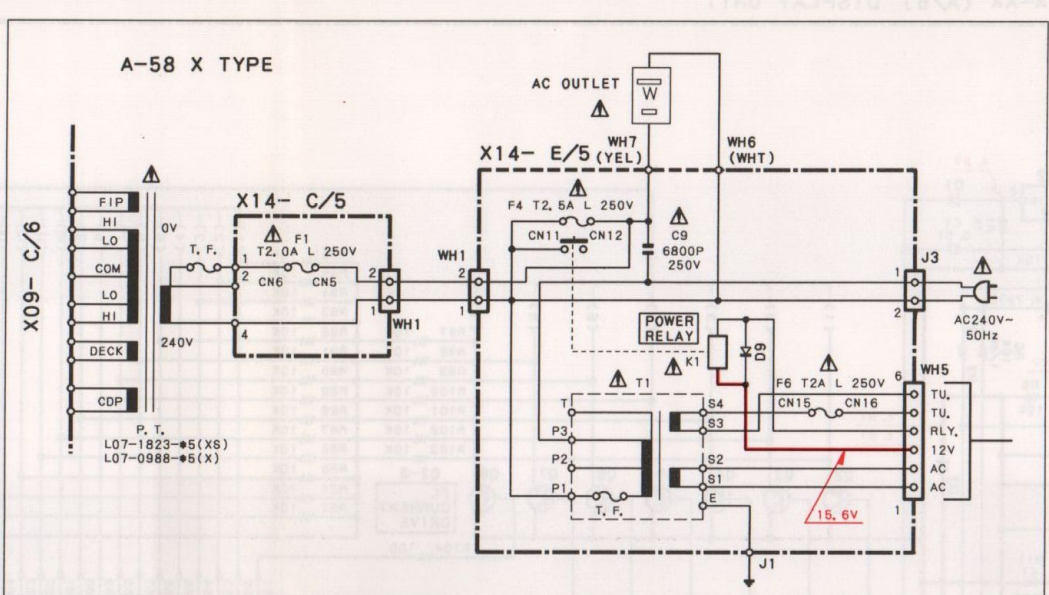
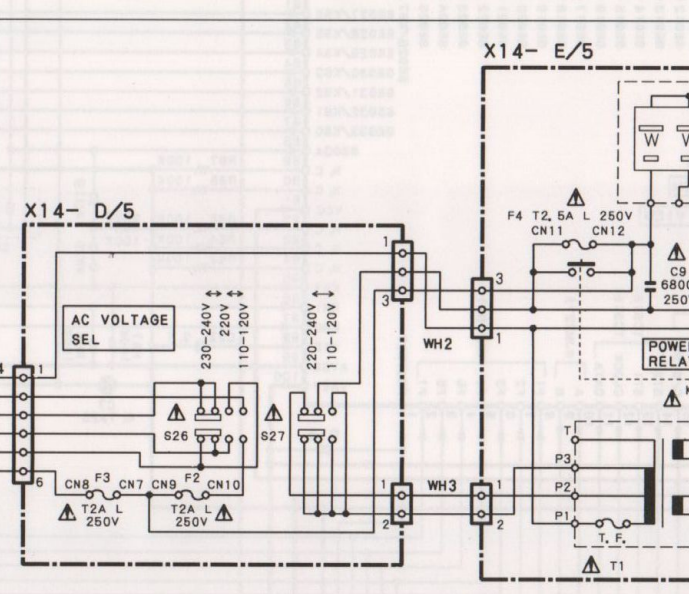
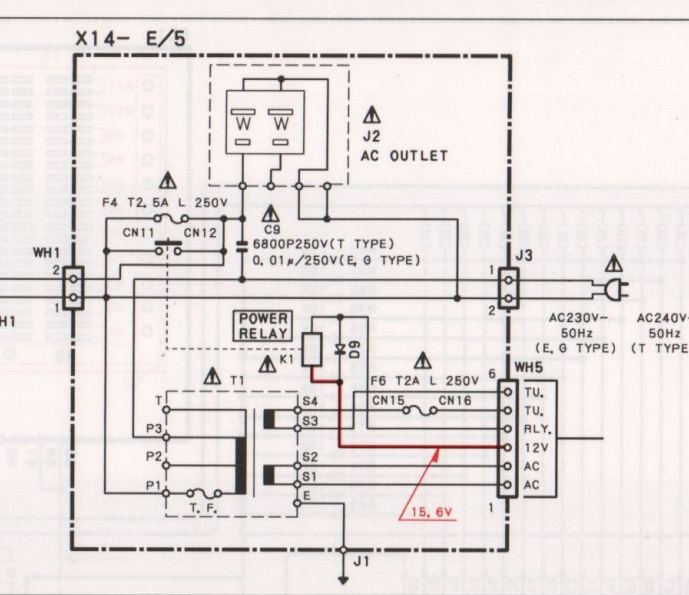
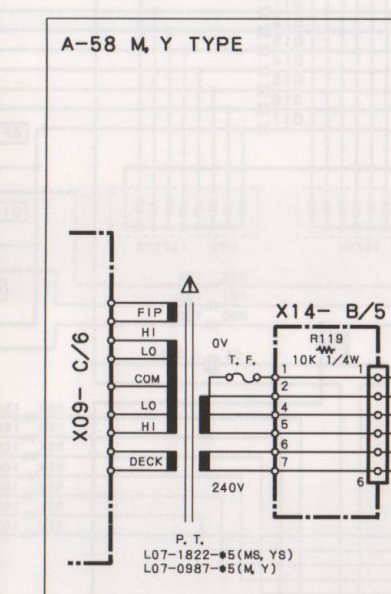
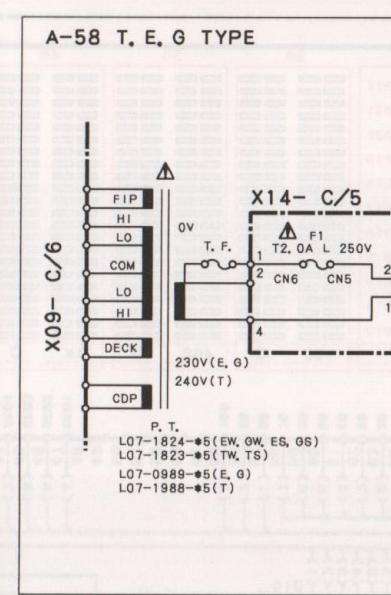

— SIGNAL LINE
— GND LINE
— +B LINE
- - - - - B LINE

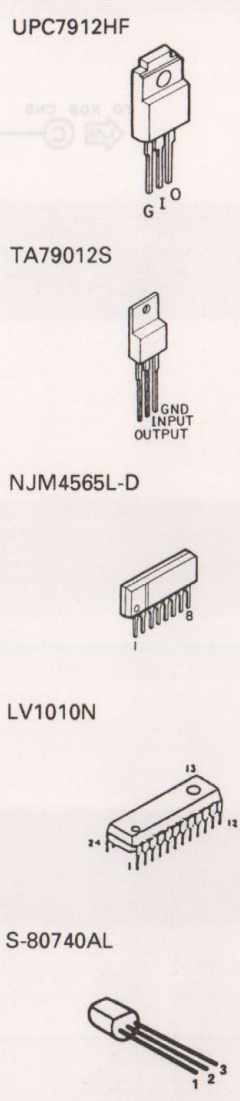

CAUTION : For continued safety, replace safety critical components only with manufacturer's recommended parts (refer to parts list).
△ Indicates safety critical components.
To reduce the risk of electric shock, leakage-current or resistance measurements shall be carried out (exposed parts are acceptably insulated from the supply circuit) before the appliance is returned to the customer.

• DC voltages are as measured with a high impedance voltmeter. Values may vary slightly due to variations between individual instruments or units.

PARTS LIST

× New Parts

Parts without Parts No. are not supplied.

Les articles non mentionnes dans le Parts No. ne sont pas fournis.

Teile ohne Parts No. werden nicht geliefert.

Ref. No.	Address	New Parts	Parts No.	Description	Destination	Remarks
参照番号	位置	新	部品番号	部品名/規格	仕向	備考
A-58						
601	1A	*	A01-3162-02	METALLIC CABINET		
605	3A	*	A60-0620-11	PANEL		
606	1B	*	A70-0986-05	REMOTE CONTROLLER ASSY		J
606	1B	*	A70-1003-05	REMOTE CONTROLLER ASSY	S/W	
607	1B	*	A09-0106-08	BATTERY COVER		
610	3A	*	B10-2050-03	FRONT GLASS		
611	3A	*	B11-0286-04	SMOKED FILTER		
612	2A	*	B12-0245-03	INDICATOR		
-			B46-0094-03	WARRANTY CARD	Y	
-			B46-0095-03	WARRANTY CARD	Y	
-			B46-0096-43	WARRANTY CARD	X	
-			B46-0310-03	WARRANTY CARD	TEG	
-		*	B58-0964-13	CAUTION CARD (UL)	Y	
-		*	B58-0965-13	CAUTION CARD (PTX TYPE PL)	XT	
-		*	B58-0966-13	CAUTION CARD (ELM TYPE PL)	ME	
-		*	B58-0968-04	CAUTION CARD	Y	
-		*	B58-0970-13	CAUTION CARD (RG TYPE PL)	G	
-		*	B60-1710-00	INSTRUCTION MANUAL (EN)	YMXTE	
-		*	B60-1711-00	INSTRUCTION MANUAL (FR)	E	
-		*	B60-1712-00	INSTRUCTION MANUAL (GE)	EG	
-		*	B60-1713-00	INSTRUCTION MANUAL (DU)	E	
-		*	B60-1714-00	INSTRUCTION MANUAL (IT)	E	
-		*	B60-1715-00	INSTRUCTION MANUAL (SP)	ME	
-		*	B60-1716-00	INSTRUCTION MANUAL (C)	M	
-		*	B60-1717-00	INSTRUCTION MANUAL (TAIWAN)	M	
△ 615	1B		E03-0115-05	AC PLUG ADAPTER	M	
△ 616	1D	*	E30-2778-05	AC POWER CORD (INLET)	Y	
△ 616	1D	*	E30-2779-05	AC POWER CORD (INLET)	MEG	
△ 616	1D	*	E30-2780-05	AC POWER CORD (INLET)	X	
△ 616	1D	*	E30-2781-05	AC POWER CORD (INLET)	T	
△ 617	2B, 2C	*	E35-0995-05	FLAT CABLE(23P)X14CN2-X09CN2		
618	1C, 3B	*	E35-0996-05	FLAT CABLE(15P)X14CN1-X08CN5		
J2	2D		E03-0141-05	AC OUTLET	X	
625	3A	*	G10-0414-04	NON-WOVEN FABRIC		
626	3C		G11-0155-14	SOFT TAPE (40X9X2)		
627	3A		G11-2186-04	CUSHION		
-		*	H50-1181-04	ITEM CARTON CASE	YMXEG	J
-		*	H50-1182-04	ITEM CARTON CASE	T	J
-		*	H50-1227-04	ITEM CARTON CASE	E	W
-		*	H50-1229-04	ITEM CARTON CASE	M	S
-		*	H50-1230-04	ITEM CARTON CASE	YXEG	S
-		*	H50-1233-04	ITEM CARTON CASE	T	S
-		*	H50-1234-04	ITEM CARTON CASE	T	W
-		*	H50-1271-04	ITEM CARTON CASE	E	S
-		*	H10-5846-12	POLYSTYRENE FOAMED FIXTURE (L)	YMXEG	J
-		*	H10-5847-02	POLYSTYRENE FOAMED FIXTURE (R)	YMXEG	J
-		*	H10-5848-12	POLYSTYRENE FOAMED FIXTURE (L)	T	J
-		*	H10-5849-02	POLYSTYRENE FOAMED FIXTURE (R)	T	J
-		*	H10-5869-02	POLYSTYRENE FOAMED FIXTURE (L)	T	W
-		*	H10-5870-02	POLYSTYRENE FOAMED FIXTURE (R)	T	W
-		*	H10-5873-02	POLYSTYRENE FOAMED FIXTURE (L)	YMXEG	S
-		*	H10-5874-02	POLYSTYRENE FOAMED FIXTURE (R)	YMXEG	S

L: Scandinavia K: USA P: Canada R: Mexico J: JAPAN MADE
 Y: PX (Far East, Hawaii) T: England E: Europe G: Germany S: SINGAPORE MADE
 Y: AAFES (Europe) X: Australia M: Other Areas W: MALAYSIA MADE

△ indicates safety critical components.

PARTS LIST

× New Parts

Parts without Parts No. are not supplied.

Les articles non mentionnes dans le Parts No. ne sont pas fournis.

Teile ohne Parts No. werden nicht geliefert.

Ref. No.	Address	New Parts	Parts No.	Description	Destination	Remarks
参照番号	位置	新	部品番号	部品名/規格	仕向	備考
-		*	H10-5875-02	POLYSTYRENE FOAMED FIXTURE (L)	T	S
-		*	H10-5876-02	POLYSTYRENE FOAMED FIXTURE (R)	T	S
-		*	H10-5877-02	POLYSTYRENE FOAMED FIXTURE (L)	E	W
-		*	H10-5878-02	POLYSTYRENE FOAMED FIXTURE (R)	E	W
-			H13-0110-04	CARTON BOARD	X	J
-			H13-0111-14	CARTON BOARD	X	S
-			H25-0232-04	PROTECTION BAG (235X350X0.03)	YMXEG	
-			H25-0382-04	PROTECTION BAG (SET)		
-			H25-0632-24	PROTECTION BAG	YMXEG	
-			H25-0644-04	PROTECTION BAG (0632 PRINTED)	T	
-			H25-0651-04	PROTECTION BAG (0232 PRINTED)	T	
-		*	H25-1540-04	PROTECTION BAG		
630	3D		J02-0366-15	FOOT REAR		
631	3C		J02-1040-05	FOOT FRONT		
632	2A, 3B	*	J02-1111-04	FOOT AMP		
647	1B		J19-3645-05	LOOP ANTENNA STAND		
-			J61-0307-05	WIRE BAND		
635	3B		K29-3886-04	KNOB MIC/DUAL SOUND		
636	3A, 3B	*	K29-5968-02	KNOB		
637	2A, 3B	*	K29-5969-13	KNOB POWER/DOLBY/D SOUND		
638	3A	*	K29-6024-04	KNOB INPUT/VOLUME		
△ 640	2C	*	L07-0987-05	POWER TRANSFORMER	YM	J
△ 640	2C	*	L07-0988-05	POWER TRANSFORMER	XT	J
△ 640	2C	*	L07-0989-05	POWER TRANSFORMER	EG	J
△ 640	2C	*	L07-1822-05	POWER TRANSFORMER	YM	S
△ 640	2C	*	L07-1823-05	POWER TRANSFORMER	T	W
△ 640	2C	*	L07-1823-05	POWER TRANSFORMER	XT	S
△ 640	2C	*	L07-1824-05	POWER TRANSFORMER	GE	W
△ 640	2C	*	L07-1824-05	POWER TRANSFORMER	EG	S
A	1D		N09-0292-05	STEPPED SCREW (3X19)		
C	1D		N09-2909-05	TAPTITE SCREW (EARTH)		
D	2C, 3C		N86-4008-45	BINDING HEAD TAPTITE SCREW		
E	1A, 1D		N89-3008-45	BINDING HEAD TAPTITE SCREW		
F	3A, 3D		N89-3006-46	BINDING HEAD TAPTITE SCREW		
G	2B, 3B		N89-3010-46	BINDING HEAD TAPTITE SCREW		
645	1B		T90-0182-15	LEAD WIRE ANTENNA		
646	1B		T90-0195-05	LOOP ANTENNA		
648	1B		T90-0198-05	ANTENNA ADAPTOR	TEG	
A-68						
601	1A	*	A01-3162-02	METALLIC CABINET		
605	3A	*	A60-0621-11	PANEL		
610	3A	*	B10-2050-03	FRONT GLASS		
611	3A	*	B11-0286-04	SMOKED FILTER		
612	2A	*	B12-0245-03	INDICATOR		
-		*	B58-0966-13	CAUTION CARD (ELM TYPE PL)		
-		*	B60-1785-00	INSTRUCTION MANUAL (EN)		
-		*	B60-1786-00	INSTRUCTION MANUAL (SP)		
-		*	B60-1787-00	INSTRUCTION MANUAL (C)		
-		*	B60-1788-00	INSTRUCTION MANUAL (TAIWAN)		
615	1B		E03-0115-05	AC PLUG ADAPTER		
△ 616	1D	*	E30-2779-05	AC POWER CORD (INLET)		
△ 617	2B, 2C	*	E35-0995-05	FLAT CABLE(23P)X14CN2-X09CN2		

L: Scandinavia K: USA P: Canada R: Mexico J: JAPAN MADE
 Y: PX (Far East, Hawaii) T: England E: Europe G: Germany S: SINGAPORE MADE
 Y: AAFES (Europe) X: Australia M: Other Areas W: MALAYSIA MADE

△ indicates safety critical components.

PARTS LIST

× New Parts

Parts without Parts No. are not supplied.

Les articles non mentionnes dans le Parts No. ne sont pas fournis.

Teile ohne Parts No. werden nicht geliefert.

Ref. No. 参照番号	Address 位置	New Parts 新	Parts No. 部品番号	Description 部品名 / 規格	Desti- nation 仕 向	Re- marks 備考
618	1C, 3B	*	E35-0996-05	FLAT CABLE(15P)X14CN1-X08CN5		
619	1B		E30-0505-05	AUDIO CORD		
620	1B		E30-1427-05	AUDIO CORD		
621	1B		E30-2628-05	CORD WITH CONNECTOR		
625	3A	*	G10-0414-04	NON-WOVEN FABRIC		
626	3C		G11-0155-14	SOFT TAPE (40X9X2)		
627	3A		G11-2186-04	CUSHION		
		*	H50-1185-04	ITEM CARTON CASE		J
		*	H50-1232-04	ITEM CARTON CASE		S
-		*	H10-5846-12	POLYSTYRENE FOAMED FIXTURE (L)		J
-		*	H10-5847-02	POLYSTYRENE FOAMED FIXTURE (R)		S
-		*	H10-5873-02	POLYSTYRENE FOAMED FIXTURE (L)		S
-		*	H10-5874-02	POLYSTYRENE FOAMED FIXTURE (R)		S
-			H25-0232-04	PROTECTION BAG (235X350X0.03)		
-			H25-0382-04	PROTECTION BAG (SET)		
-			H25-0632-24	PROTECTION BAG		
-		*	H25-1540-04	PROTECTION BAG		
630	3D		J02-0366-15	FOOT REAR		
631	3C		J02-1040-05	FOOT FRONT		
632	2A, 3B	*	J02-1111-04	FOOT AMP		
-			J61-0307-05	WIRE BAND		
635	3B		K29-3886-04	KNOB MIC/DUAL SOUND		
636	3A, 3B	*	K29-5968-02	KNOB		
637	2A, 3B	*	K29-5969-13	KNOB POWER/DOLBY/D SOUND		
638	3A	*	K29-6024-04	KNOB INPUT/VOLUME		
△ 640	2C	*	L07-0991-05	POWER TRANSFORMER		J
△ 640	2C	*	L07-1826-05	POWER TRANSFORMER		S
A	1D		N09-0292-05	STEPPED SCREW (3X19)		
C	1D		N09-2909-05	TAPTITE SCREW (EARTH)		
D	2C, 3C		N86-4008-45	BINDING HEAD TAPTITE SCREW		
E	1A, 1D		N89-3008-45	BINDING HEAD TAPTITE SCREW		
F	3A, 3D		N89-3006-46	BINDING HEAD TAPTITE SCREW		
G	2B, 3B		N89-3010-46	BINDING HEAD TAPTITE SCREW		
645	1B		T90-0182-15	LEAD WIRE ANTENNA		
646	1B		T90-0195-05	LOOP ANTENNA		
647	1B		J19-3645-05	LOOP ANTENNA STAND		
SURROUND UNIT (X08-2640-XX)						
C1 ,2			CC45FSL1H271J	CERAMIC 270PF	J	
C3 ,4			CE04KW1V4R7M	ELECTRO 4.7UF 35WV		
C5 ,6			CC45FSL1H101J	CERAMIC 100PF	J	
C7 ,8			CK45FB1H471K	CERAMIC 470PF	K	
C9 ,10		*	CQ93FMG1H123J	MYLAR 0.012UF	J	
C11 ,12		*	CQ93FMG1H332J	MYLAR 3300PF	J	
C13 ,14			CE04KW1A101M	ELECTRO 100UF 10WV		
C15 ,16			CE04KW1V4R7M	ELECTRO 4.7UF 35WV		
C21 -30			CC45FSL1H221J	CERAMIC 220PF	J	
C30 ,31			CC45FSL1H221J	CERAMIC 220PF	J	6
C33 ,34			CE04KW1V4R7M	ELECTRO 4.7UF 35WV		
C39 -42			CE04KW1V4R7M	ELECTRO 4.7UF 35WV		
C43 ,44			CF92FV1H104J	MF 0.10UF	J	
C45 ,46			CQ93FMG1H223J	MYLAR 0.022UF	J	
C47 -52			CE04KW1V4R7M	ELECTRO 4.7UF 35WV		

L: Scandinavia

K: USA

P: Canada

R: Mexico

J: JAPAN MADE

5: A-58

Y: PX (Far East, Hawaii)

T: England

E: Europe

G: Germany

S: SINGAPORE MADE

6: A-68

Y: AAFES (Europe)

X: Australia

M: Other Areas

W: MALAYSIA MADE

△ indicates safety critical components.

PARTS LIST

× New Parts

Parts without Parts No. are not supplied.

Les articles non mentionnes dans le Parts No. ne sont pas fournis.

Teile ohne Parts No. werden nicht geliefert.

Ref. No. 参照番号	Address 位置	New Parts 新	Parts No. 部品番号	Description 部品名 / 規格	Desti- nation 仕 向	Re- marks 備考
C53 ,54			CC45FSL1H220J	CERAMIC 22PF J		
C57 ,58			CE04KW1V4R7M	ELECTRO 4.7UF 35WV		
C61 -64			CE04KW1V4R7M	ELECTRO 4.7UF 35WV		
C66 ,67			CE04KW1V4R7M	ELECTRO 4.7UF 35WV		
C73 ,74		*	CQ93FMG1H152J	MYLAR 1500PF J		
C75 ,76		*	CQ93FMG1H393J	MYLAR 0.039UF J		
C77 -80			CE04KW1V4R7M	ELECTRO 4.7UF 35WV		
C81 ,82		*	CQ93FMG1H332J	MYLAR 3300PF J		
C83 ,84			CF92FV1H224J	MF 0.22UF J		
C85 -88			CE04KW1V4R7M	ELECTRO 4.7UF 35WV		
C89 ,90			CC45FSL1H220J	CERAMIC 22PF J		
C91 ,92			CC45FSL1H271J	CERAMIC 270PF J		
C93 ,94		*	CQ93FMG1H821J	MYLAR 820PF J		
C95 ,96			CQ93FMG1H272J	MYLAR 2700PF J		
C99 ,100			CE04KW1V4R7M	ELECTRO 4.7UF 35WV		
C101			CQ93FMG1H222J	MYLAR 2200PF J		
C102			CF92FV1H394J	MF 0.39UF J		
C103			CQ93FMG1H103J	MYLAR 0.010UF J		
C104-106			CE04KW1H010M	ELECTRO 1.0UF 50WV		
C107-114			CE04KW1V4R7M	ELECTRO 4.7UF 35WV		
C117,118			CE04KW1V4R7M	ELECTRO 4.7UF 35WV		
C119-122			CK45FB1H102K	CERAMIC 1000PF K		
C123,124			CE04KW1V220M	ELECTRO 22UF 35WV		
C125-128			CF92FV1H104J	MF 0.10UF J		
C129,130			CQ93FMG1H472J	MYLAR 4700PF J		
C131,132			CE04KW1V4R7M	ELECTRO 4.7UF 35WV		
C133,134			CC45FSL1H220J	CERAMIC 22PF J		
C135,136			CE04KW1V4R7M	ELECTRO 4.7UF 35WV		
C141,142			CE04KW1V4R7M	ELECTRO 4.7UF 35WV		
C143,144			CC45FSL1H220J	CERAMIC 22PF J		
C145,146			CE04KW1V4R7M	ELECTRO 4.7UF 35WV		
C151			CQ93FMG1H223J	MYLAR 0.022UF J		
C152			CQ93FMG1H473J	MYLAR 0.047UF J		
C153-156			CE04KW1V100M	ELECTRO 10UF 35WV		
C157			CE04KW1HR47M	ELECTRO 0.47UF 50WV		
C158			CE04KW1V4R7M	ELECTRO 4.7UF 35WV		
C159			CE04KW1HR47M	ELECTRO 0.47UF 50WV		
C160			CE04KW1V4R7M	ELECTRO 4.7UF 35WV		
C161			CF92FV1H154J	MF 0.15UF J		
C162			CE04KW1H3R3M	ELECTRO 3.3UF 50WV		
C163,164			CF92FV1H154J	MF 0.15UF J		
C165			CE04KW1H3R3M	ELECTRO 3.3UF 50WV		
C166			CF92FV1H154J	MF 0.15UF J		
C167			CE04KW1V4R7M	ELECTRO 4.7UF 35WV		
C168			CE04KW1HR47M	ELECTRO 0.47UF 50WV		
C169			CE04KW1V4R7M	ELECTRO 4.7UF 35WV		
C170			CE04KW1HR47M	ELECTRO 0.47UF 50WV		
C171			CE04KW1C470M	ELECTRO 47UF 16WV		
C172			CF92FV1H474J	MF 0.47UF J		
C173			CK45FB1H681K	CERAMIC 680PF K		
C174			CE04KW1H2R2M	ELECTRO 2.2UF 50WV		
C175			CE04KW1V100M	ELECTRO 10UF 35WV		
C176			CF92FV1H105J	MF 1.0UF J		
C177			CQ93FMG1H333J	MYLAR 0.033UF J		
C178		*	CQ93FMG1H152J	MYLAR 1500PF J		

L: Scandinavia K: USA P: Canada R: Mexico
 Y: PX (Far East, Hawaii) T: England E: Europe G: Germany
 Y: AAFES (Europe) X: Australia M: Other Areas

 indicates safety critical components.

PARTS LIST

× New Parts

Parts without Parts No. are not supplied.

Les articles non mentionnés dans le Parts No. ne sont pas fournis.

Teile ohne Parts No. werden nicht geliefert.

Ref. No. 参照番号	Address 位置	New Parts 新	Parts No. 部品番号	Description 部品名 / 規格	Desti- nation 仕 向	Re- marks 備考
C179			CQ93FMG1H333J	MYLAR 0.033UF J		
C181, 182			CE04KW1H010M	ELECTRØ 1.0UF 50WV		
C183, 184			CE04KW1V100M	ELECTRØ 10UF 35WV		
C185-188			CF92FV1H104J	MF 0.10UF J		
C201			CE04KW1V100M	ELECTRØ 10UF 35WV		
C203			CF92FV1H104J	MF 0.10UF J		
C204			CE04KW1C101M	ELECTRØ 100UF 16WV		
C205, 206			CE04KW1C470M	ELECTRØ 47UF 16WV		
C207, 208			CE04KW1C221M	ELECTRØ 220UF 16WV		
C211, 212			CE04KW1V221M	ELECTRØ 220UF 35WV		
C213, 214			CE04KW1C221M	ELECTRØ 220UF 16WV		
C215, 216			CF92FV1H104J	MF 0.10UF J		
C221-228			CE04KW1C470M	ELECTRØ 47UF 16WV		
C229			CE04KW1V100M	ELECTRØ 10UF 35WV		
C230			CE04KW1C101M	ELECTRØ 100UF 16WV		
C231			CE04KW1V100M	ELECTRØ 10UF 35WV		
C232			CE04KW1C101M	ELECTRØ 100UF 16WV		
C233			CE04KW1C221M	ELECTRØ 220UF 16WV		
C235-240			CF92FV1H104J	MF 0.10UF J		
C241, 242			CE04KW1C470M	ELECTRØ 47UF 16WV		
C251			C91-0757-05	CERAMIC 1000PF K		
C252, 253			C91-0749-05	CERAMIC 220PF K		
C254			CK45FB1H471K	CERAMIC 470PF K		
C255			CK45FB1H102K	CERAMIC 1000PF K		
C256			CK45FB1H471K	CERAMIC 470PF K		
C257, 258			CK45FF1H103Z	CERAMIC 0.010UF Z		
C261-263			CK45FB1H102K	CERAMIC 1000PF K		
C264			CK45FB1H102K	CERAMIC 1000PF K		
C265-269			CK45FB1H102K	CERAMIC 1000PF K		
C270			CK45FF1H103Z	CERAMIC 0.010UF Z		6
C271			CK45FB1H102K	CERAMIC 1000PF K		
C272, 273			CC45FSL1H221J	CERAMIC 220PF J		
C274			CK45FB1H102K	CERAMIC 1000PF K		
C275, 276			CC45FSL1H221J	CERAMIC 220PF J		
C277			CK45FB1H102K	CERAMIC 1000PF K		
C278, 279			CC45FSL1H221J	CERAMIC 220PF J		
C280-283			CK45FB1H471K	CERAMIC 470PF K		
C284			CK45FB1H102K	CERAMIC 1000PF K		
C285, 286			CK45FB1H471K	CERAMIC 470PF K		
C287			CE04KW1V4R7M	ELECTRØ 4.7UF 35WV		
C288			CE04KW1V100M	ELECTRØ 10UF 35WV		
C289		*	CQ93FMG1H103J	MYLAR 0.010UF J		
C290		*	CQ93FMG1H222J	MYLAR 2200PF J		
C291			CK45FF1H103Z	CERAMIC 0.010UF Z		
C301, 302			CC45FSL1H221J	CERAMIC 220PF J		
C303, 304			CE04KW1V100M	ELECTRØ 10UF 35WV		
J1			E63-0072-15	PHONØ JACK (2P)PHONØ		
J2			E63-0066-15	PHONØ JACK (6P)AUX/VIDEO		
J2			E63-0091-05	PHONØ JACK (4P)VIDEO		
J3			E63-0066-15	PHONØ JACK (6P)MD/DAT/CD/LD		
J4		*	E63-0052-15	PHONØ JACK (4P)VISUAL		5
J5		*	E63-0125-05	PHONØ JACK (3P)SURRE/CENTER SP		
661	1B, 1C		F20-1297-05	INSULATING SHEET		

L: Scandinavia

K: USA

P: Canada

R: Mexico

5: A-58

Y: PX (Far East, Hawaii)

T: England

E: Europe

G: Germany

6: A-68

Y: AAFES (Europe)

X: Australia

M: Other Areas

indicates safety critical components.

PARTS LIST

× New Parts

Parts without Parts No. are not supplied.

Les articles non mentionnes dans le Parts No. ne sont pas fournis.

Teile ohne Parts No. werden nicht geliefert.

Ref. No. 参照番号	Address 位置	New Parts 新	Parts No. 部品番号	Description 部品名/規格	Desti- nation 仕向	Re- marks 備考
X1			L78-0290-05	RESONATOR (8MHZ)		
E	1B		N89-3008-45	BINDING HEAD TAPTITE SCREW		
G	1C		N30-3008-46	PAN HEAD MACHINE SCREW		
△ R131, 132			RS14KB3D2R2J	FL-PROOF RS 2.2 J 2W		
R203-210			RD14NB2E220J	RD 22 J 1/4W		
R213, 214			RS14KB3A221J	FL-PROOF RS 220 J 1W		
R215			RD14NB2E5R6J	RD 5.6 J 1/4W		
R265			RS14KB3D102J	FL-PROOF RS 1.0K J 2W		
R267			RN14BK2C3902F	RN 39.0K F 1/6W		
K1			S76-0036-05	MAGNETIC RELAY C/SUR SPEAKER		
D1 ,2			HSS104A	DIODE		
D1 ,2			1SS131	DIODE		
D3 ,4			HSS104A	DIODE		6
D3 ,4			1SS131	DIODE		6
D5 -18			HSS104A	DIODE		
D5 -18			1SS131	DIODE		
D201-203			HZS10N(B2)	ZENER DIODE	S/W	J
D201-203			MTZJ10(B)	ZENER DIODE		
D201-203			RD10ES(B2)	ZENER DIODE		J
D204, 205			HZS5.1N(B2)	ZENER DIODE		
D204, 205			MTZJ5.1(B)	ZENER DIODE	S/W	
D204, 205			RD5.1ES(B2)	ZENER DIODE		
D251			HSS104A	DIODE		
D251			1SS131	DIODE		
D254-259			HSS104A	DIODE		
D254-259			1SS131	DIODE		
IC1			NJM4565D-D	IC(OP AMP X2)		
IC1			XRA15218-DX	IC(OP AMP X2)		
IC2			NJM4565L-D	IC(OP AMP X2)		
IC3			TC9164N	IC(16CH BILATERAL SELECTOR SW)		
IC4			NJM4565L-D	IC(OP AMP X2)		
IC5			TC9163N	IC(BILATERAL SWITCH X16)		
IC6			TC9164N	IC(16CH BILATERAL SELECTOR SW)		
IC7		*	CXA1842S	ANALOGUE IC		
IC8			LC7538JM	ANALOGUE IC		
IC10			NJM4565L-D	IC(OP AMP X2)		
IC11			LA2785	IC(DOLBY PRO LOGIC DECODER IC)		
IC12			LV1010N	DI BI-POLAR IC		
IC13			NJM4565L-D	IC(OP AMP X2)		
IC14			TC9213P	IC(2CH ELECTRONIC VOLUME)		
IC15			NJM4565L-D	IC(OP AMP X2)		
IC16			NJM4565D-D	IC(OP AMP X2)		
IC16			XRA15218-DX	IC(OP AMP X2)		
△ IC17, 18		*	TDA2050V	ANALOGUE IC		
IC19			NJM4565D-D	IC(OP AMP X2)		
IC19			XRA15218-DX	IC(OP AMP X2)		
IC20			NJM2279D	IC(VIDEO IC)		
Q3			2SC1845(F, E)	TRANSISTOR		
Q4 ,5			2SC2878(B)	TRANSISTOR		
Q101			2SC2003(L, K)	TRANSISTOR		
△ Q102			2SA954(L, K)	TRANSISTOR		
Q203			2SD2012	TRANSISTOR		

L: Scandinavia K: USA P: Canada R: Mexico J: JAPAN MADE 5: A-58
 Y: PX (Far East, Hawaii) T: England E: Europe G: Germany S: SINGAPORE MADE 6: A-68
 Y: AAFES (Europe) X: Australia M: Other Areas W: MALAYSIA MADE

△ indicates safety critical components.

PARTS LIST

× New Parts

Parts without Parts No. are not supplied.

Les articles non mentionnés dans le Parts No. ne sont pas fournis.

Teile ohne Parts No. werden nicht geliefert.

Ref. No. 参照番号	Address 位置	New Parts 新	Parts No. 部品番号	Description 部品名/規格	Desti- nation 仕向	Re- marks 備考
△ Q203			2SD2061	TRANSISTOR		
AUDIO UNIT (X09-404X-XX)						
C1	-4		CK45FF1H103Z	CERAMIC	0.010UF	Z
C5	,6	*	C90-3571-05	ELECTRO	5600UF	50WV
C7	,8		CE04KW1H101M	ELECTRO	100UF	50WV
C9	-14		CK45FF1H103Z	CERAMIC	0.010UF	Z
C15	,16		CE04KW1E222M	ELECTRO	2200UF	25WV
C17	-20		CQ93FMG1H104J	MYLAR	0.10UF	J
C21	,22		CE04KW1V100M	ELECTRO	10UF	35WV
C23	-26		CK45FF1H103Z	CERAMIC	0.010UF	Z
C27			CE04KW1E221M	ELECTRO	220UF	25WV
C28			CQ93FMG1H104J	MYLAR	0.10UF	J
C29			CK45FB1H102K	CERAMIC	1000PF	K
C30			CE04KW1V100M	ELECTRO	10UF	35WV
C31			CQ93FMG1H104J	MYLAR	0.10UF	J
C32			CE04KW1V100M	ELECTRO	10UF	35WV
C33			CE04KW1V4R7M	ELECTRO	4.7UF	35WV
C34			CE04KW1H101M	ELECTRO	100UF	50WV
C35			CE04KW1V100M	ELECTRO	10UF	35WV
C36	,37		CE04KW1A101M	ELECTRO	100UF	10WV
C38			CE04KW1C101M	ELECTRO	100UF	16WV
C41	,42		CK45FF1H103Z	CERAMIC	0.010UF	Z
C43	,44		CE04KW1H010M	ELECTRO	1.0UF	50WV
C45	,46		CC45FSL1H121J	CERAMIC	120PF	J
C47	,48		CC45FSL1H100D	CERAMIC	10PF	D
C49	-52		CC45FSL1H390J	CERAMIC	39PF	J
C53	-56		CK45FF1H103Z	CERAMIC	0.010UF	Z
C57	,58		CK45FB1H102K	CERAMIC	1000PF	K
C59	-62		CQ93FMG1H104J	MYLAR	0.10UF	J
C63	,64		CQ93FMG1H472J	MYLAR	4700PF	J
C65	,66		CK45FB1H102K	CERAMIC	1000PF	K
C67	,68		CE04HW1C220M	NP-ELEC	22UF	16WV
C69			CK45FF1H103Z	CERAMIC	0.010UF	Z
C70			CE04KW1H4R7M	ELECTRO	4.7UF	50WV
C71	,72		CC45FSL1H220J	CERAMIC	22PF	J
C73	,74		CE04KW1A470M	ELECTRO	47UF	10WV
C75	,76		CE04KW1H010M	ELECTRO	1.0UF	50WV
C77	,78		CK45FB1H102K	CERAMIC	1000PF	K
C79	,80		CE04KW1A470M	ELECTRO	47UF	10WV
C81	,82		CE04KW1H010M	ELECTRO	1.0UF	50WV
C83	,84		CK45FB1H102K	CERAMIC	1000PF	K
C89	,90		CK45FF1H103Z	CERAMIC	0.010UF	Z
C91	,92		CC45FSL1H221J	CERAMIC	220PF	J
C93	,94		CK45FB1H102K	CERAMIC	1000PF	K
C95	,96		CC45FSL1H221J	CERAMIC	220PF	J
C97			CK45FB1H102K	CERAMIC	1000PF	K
C98			CC45FSL1H221J	CERAMIC	220PF	J
C101,102			CE04KW1H010M	ELECTRO	1.0UF	50WV
C104			C90-3226-05	ELECTRO	22UF	16WV
C105			CC45FSL1H221J	CERAMIC	220PF	J
C106			C90-3253-05	ELECTRO	1UF	50WV
C107			CC45FSL1H221J	CERAMIC	220PF	J
C108			CK45FB1H102K	CERAMIC	1000PF	K
C109,110			CE04KW1C101M	ELECTRO	100UF	16WV

L: Scandinavia

K: USA

P: Canada

R: Mexico

Y: PX (Far East, Hawaii)

T: England

E: Europe

G: Germany

Y: AAFES (Europe)

X: Australia

M: Other Areas

△ indicates safety critical components.

PARTS LIST

× New Parts

Parts without Parts No. are not supplied.

Les articles non mentionnés dans le Parts No. ne sont pas fournis.

Teile ohne Parts No. werden nicht geliefert.

Ref. No. 参照番号	Address 位置	New Parts 新	Parts No. 部品番号	Description 部品名 / 規格	Desti- nation 仕 向	Re- marks 備考
C111			C90-3226-05	ELECTRO 22UF 16WV		
C113, 114			CE04KW1H010M	ELECTRO 1.0UF 50WV		
C115, 116			CC45FSL1H220J	CERAMIC 22PF J		
C117, 118			CE04KW1H010M	ELECTRO 1.0UF 50WV		
C121, 122			CE04KW1H010M	ELECTRO 1.0UF 50WV		
C123, 124			CC45FSL1H220J	CERAMIC 22PF J		
C127			CE04HW1C220M	NP-ELEC 22UF 16WV		
C128			CK45FB1H102K	CERAMIC 1000PF K		
C129-132			CC45FSL1H221J	CERAMIC 220PF J		
C133, 134			CE04KW1A470M	ELECTRO 47UF 10WV		
C135-138			CE04KW1C101M	ELECTRO 100UF 16WV		
C141, 142			CC45FSL1H560J	CERAMIC 56PF J		
C143, 144			CK45FB1H102K	CERAMIC 1000PF K		
C145, 146			CE04KW1H010M	ELECTRO 1.0UF 50WV		
C147, 148			CF92FV1H474J	MF 0.47UF J		
C149, 150			CE04KW1H010M	ELECTRO 1.0UF 50WV		
C151, 152			CE04KW1C101M	ELECTRO 100UF 16WV		
C153, 154			CQ93FMG1H333J	MYLAR 0.033UF J		
C157, 158			CK45FF1H103Z	CERAMIC 0.010UF Z		
C159			CK45FF1H223Z	CERAMIC 0.022UF Z	XTEG	5
C201, 202			CC45FSL1H221J	CERAMIC 220PF J		
C205, 206			CC45FSL1H221J	CERAMIC 220PF J		5
C210, 211			CK45FB1H102K	CERAMIC 1000PF K		
C212, 213			CK45FB1H102K	CERAMIC 1000PF K		5
C214, 215			CK45FB1H102K	CERAMIC 1000PF K		
C216, 217			CC45FSL1H101J	CERAMIC 100PF J		
C218			CK45FB1H102K	CERAMIC 1000PF K		
C219, 220			CK45FF1H103Z	CERAMIC 0.010UF Z		
J1			E70-0045-05	LOCK TERMINAL BOARD FRONT SP		
J2		*	E63-0115-15	PHONE JACK (3P)OMNI/S.W		
J3			E08-0311-05	RECTANGULAR RECEPTACLE		5
J3			E08-0312-05	RECTANGULAR RECEPTACLE		6
J7		*	E58-0009-05	RECTANGULAR RECEPTACLE FROMBLK		
J8		*	E58-0011-05	RECTANGULAR RECEPTACLE FROMWHT		5
J9		*	E58-0010-05	RECTANGULAR RECEPTACLE FROMBLU		
J10*			E11-0206-05	PHONE JACK MIC		
J11			E11-0208-05	PHONE JACK PHONES		
668	1B		F20-1284-05	INSULATING BOARD		
F11			F05-2525-05	FUSE (SEMKO) (250V T2.5AL)		5
F12			F05-2525-05	FUSE (SEMKO) (250V T2.5AL)		
F13, 14			F05-4025-05	FUSE (SEMKO) (250V T4A)		
CN11, 12			J13-0075-05	FUSE CLIP		5
CN13-18			J13-0075-05	FUSE CLIP		
L1, 2			L40-1011-17	SMALL FIXED INDUCTOR(100UH,K)		
L3, 4			L39-0085-05	PHASE COMPENSATION COIL		
L5, 6			L40-2201-17	SMALL FIXED INDUCTOR(22UH,K)		
B	2B		N09-2907-05	SEMS (TAPTITE SCREW)(3X14)		
F	2B, 2C		N89-3008-46	BINDING HEAD TAPTITE SCREW		
H	2C		N35-3008-46	BINDING HEAD MACHINE SCREW		
R1, 2			RD14NB2E221J	RD 220 J 1/4W		
R3, 4			RS14KB3D271J	FL-PROOF RS 270 J 2W		
R6			RS14KB3A151J	FL-PROOF RS 150 J 1W		
R9			RD14NB2E100J	RD 10 J 1/4W		

L: Scandinavia

K: USA

P: Canada

R: Mexico

5: A-58

Y: PX (Far East, Hawaii)

T: England

E: Europe

G: Germany

6: A-68

Y: AAFES (Europe)

X: Australia

M: Other Areas

PARTS LIST

× New Parts

Parts without Parts No. are not supplied.

Les articles non mentionnes dans le Parts No. ne sont pas fournis.

Teile ohne Parts No. werden nicht geliefert.

Ref. No. 参照番号	Address 位置	New Parts 新	Parts No. 部品番号	Description 部品名 / 規格	Desti- nation 仕 向	Re- marks 備考
△ △ △ △ △		*	R14 ,15	RD14NB2E221J	RD 220 J 1/4W	
			R16 ,17	RD14NB2E271J	RD 270 J 1/4W	
			R53 -56	RD14NB2E220J	RD 22 J 1/4W	
			R61 -64	R92-1771-05	METAL PLATE RESISTOR 0.22 2W	
			R65 ,66	RS14KB3A100J	FL-PROOF RS 10 J 1W	
△ △ △ △ △			R72	RS14KB3D102J	FL-PROOF RS 1.0K J 2W	
			R78	RD14NB2E220J	RD 22 J 1/4W	
			R109,110	RD14NB2E220J	RD 22 J 1/4W	
			R123,124	RS14KB3D4R7J	FL-PROOF RS 4.7 J 2W	
			R153-156	RD14NB2E220J	RD 22 J 1/4W	
△ △ △		*	R161,162	RS14KB3D391J	FL-PROOF RS 390 J 2W	
			R189,190	RD14NB2E220J	RD 22 J 1/4W	
			VR1 VR2	R10-5041-05 R31-0016-05	POTENTIOMETER(100KX2)MICMIXING VARIABLE RESISTOR D.SOUND	
			K1	S76-0005-05	MAGNETIC RELAY FRONT SPEAKER	
△ △ △ △ △ △ △			D1	D5SBA20F03	DIODE	
			D1	RBV-6Q2LFA	DIODE	
			D2	D3SBA20F03	DIODE	
			D2	RBV-4Q2LFA	DIODE	
			D3 ,4	S5688B	DIODE	
			D3 ,4	1SR139-100	DIODE	
			D5 ,6	HSS104A	DIODE	
△ △ △ △			D5 ,6	1SS131	DIODE	
			D7 -10	S5688B	DIODE	
			D7 -10	1SR139-100	DIODE	
			D11	HZS6.2N(B2)	ZENER DIODE	J
△ △ △ △ △ △ △ △ △ △ △ △			D11	MTZJ6.2(B)	ZENER DIODE	S/W
			D11	RD6.2ES(B2)	ZENER DIODE	
			D12	HZS5.6N(B2)	ZENER DIODE	J
			D12	MTZJ5.6(B)	ZENER DIODE	S/W
			D12	RD5.6ES(B2)	ZENER DIODE	
			D13 ,14	HZS15N(B2)	ZENER DIODE	J
			D13 ,14	MTZJ15(B)	ZENER DIODE	S/W
			D13 ,14	RD15ES(B2)	ZENER DIODE	
			D15	HZS8.2N(B2)	ZENER DIODE	J
			D15	MTZJ8.2(B)	ZENER DIODE	S/W
			D15	RD8.2ES(B2)	ZENER DIODE	
			D16 ,17	HZS6.2N(B2)	ZENER DIODE	J
△ △ △ △			D16 ,17	MTZJ6.2(B)	ZENER DIODE	S/W
			D16 ,17	RD6.2ES(B2)	ZENER DIODE	
			D19 -23	HSS104A	DIODE	
			D19 -23	1SS131	DIODE	
△ △ △ △			D24	HZS4.7N(B2)	ZENER DIODE	J
			D24	MTZJ4.7(B)	ZENER DIODE	S/W
			D24	RD4.7ES(B2)	ZENER DIODE	
			D25 ,26	HSS104A	DIODE	
△ △ △ △ △ △			D25 ,26	1SS131	DIODE	
			D27	HZS4.7N(B2)	ZENER DIODE	J
			D27	MTZJ4.7(B)	ZENER DIODE	S/W
			D27	RD4.7ES(B2)	ZENER DIODE	
			D28 -32	HSS104A	DIODE	
			D28 -32	1SS131	DIODE	
△ △			D33	HZS4.7N(B2)	ZENER DIODE	J
			D33	MTZJ4.7(B)	ZENER DIODE	S/W

L: Scandinavia

K: USA

P: Canada

R: Mexico

J: JAPAN MADE

Y: PX (Far East, Hawaii)

T: England

E: Europe

G: Germany

S: SINGAPORE MADE

Y: AAFES (Europe)

X: Australia

M: Other Areas

W: MALAYSIA MADE

△ indicates safety critical components.

PARTS LIST

× New Parts

Parts without Parts No. are not supplied.

Les articles non mentionnés dans le Parts No. ne sont pas fournis.

Teile ohne Parts No. werden nicht geliefert.

Ref. No. 参照番号	Address 位置	New Parts 新	Parts No. 部品番号	Description 部品名 / 規格	Desti- nation 仕向	Re- marks 備考
D33			RD4.7ES(B2)	ZENER DIODE		
D35 -46			HSS104A	DIODE		
D35 -46			1SS131	DIODE		
D201,202			HSS104A	DIODE		
D201,202			1SS131	DIODE		
D203,204			HSS104A	DIODE		5
D203,204			1SS131	DIODE		5
D205-208			HSS104A	DIODE		
D205-208			1SS131	DIODE		
△ IC1			TA7812S	IC(VOLTAGE REGULATOR/ +12V)		
△ IC1			UPC7812AHF	IC(VOLTAGE REGULATOR/ +12V)		
△ IC2			TA79012S	IC(VOLTAGE REGULATOR/ -12V)		
△ IC2			UPC7912HF	IC(VOLTAGE REGULATOR/ -12V)		
IC3 ,4			NJM4565D-D	IC(OP AMP X2)		
IC3 ,4			XRA15218-DX	IC(OP AMP X2)		
IC6 -8			NJM4565D-D	IC(OP AMP X2)		
△ IC6 -8			XRA15218-DX	IC(OP AMP X2)		
△ Q1			2SD2012	TRANSISTOR		
△ Q1			2SD2061	TRANSISTOR		
Q2			2SC2003(L,K)	TRANSISTOR		
△ Q3			2SB1370	TRANSISTOR		
△ Q3			2SB1375	TRANSISTOR		
Q5 ,6			2SC2878(B)	TRANSISTOR		
Q7 -10			2SA992(F,E)	TRANSISTOR		
Q11 -14			2SC1845(F,E)	TRANSISTOR		
Q15 ,16			2SA992(F,E)	TRANSISTOR		
Q17 ,18			2SC4137F19(V,W)	TRANSISTOR		
Q19 ,20			2SC1845(F,E)	TRANSISTOR		
△ Q21 ,22			2SD2254BT*5	TRANSISTOR		
△ Q23 ,24			2SB1492BT*5	TRANSISTOR		
Q25			2SA992(F,E)	TRANSISTOR		
Q26			2SC2003(L,K)	TRANSISTOR		
Q27			DTA124ES	DIGITAL TRANSISTOR		
Q27			UN4112	TRANSISTOR		
Q28 ,29			2SC2003(L,K)	TRANSISTOR		
Q31 ,32			2SC2878(B)	TRANSISTOR		
Q33			2SA992(F,E)	TRANSISTOR		
△ Q34			2SA954(L,K)	TRANSISTOR		
Q35 ,36			2SC1845(F,E)	TRANSISTOR		
Q37 -40			2SC2878(B)	TRANSISTOR		
DISPLAY UNIT (X14-39XX-XX)						
D27 -38			B30-2461-05	LED(RED) INPUT SELECTOR		
C1			CK45FF1H103Z	CERAMIC 0.010UF Z		
C2			CE04KW1V4R7M	ELECTRO 4.7UF 35WV		
C3			C90-3253-05	ELECTRO 1UF 50WV		
C4			CQ93FMG1H104J	MYLAR 0.10UF J		
C5			C90-1826-05	BACKUP 0.047F 5.5WV		
C6			CE04KW1C101M	ELECTRO 100UF 16WV		
C7 ,8			CE04HW1E4R7M	NP-ELEC 4.7UF 25WV		
△ C9			C91-0647-05	CERAMIC 0.01UF AC250V	EG	
△ C9			C91-1488-05	MF 6800PF 250VAC	YXT	
△ C9			C91-1488-05	MF 6800PF 250VAC	M	
C10			CQ93FMG1H102J	MYLAR 1000PF J		
C11 ,12			CK45FF1H103Z	CERAMIC 0.010UF Z		

L: Scandinavia

K: USA

P: Canada

R: Mexico

5: A-58

Y: PX (Far East, Hawaii)

T: England

E: Europe

G: Germany

6: A-68

Y: AAFES (Europe)

X: Australia

M: Other Areas

△ indicates safety critical components.

PARTS LIST

× New Parts

Parts without Parts No. are not supplied.

Les articles non mentionnes dans le Parts No. ne sont pas fournis.

Teile ohne Parts No. werden nicht geliefert.

Ref. No. 参照番号	Address 位置	New Parts 新	Parts No. 部品番号	Description 部品名 / 規格	Desti- nation 仕 向	Re- marks 備考
C13			CE04KW1A221M	ELECTRO 220UF 10WV		
C14 -17			CK45FF1H103Z	CERAMIC 0.010UF Z		
C18			CE04KW1V100M	ELECTRO 10UF 35WV		
C19 ,20			CE04KW1E470M	ELECTRO 47UF 25WV		
C21			C90-3253-05	ELECTRO 1UF 50WV		
C22			CQ93FMG1H104J	MYLAR 0.10UF J		
C23 -25			C91-0749-05	CERAMIC 220PF K		
△ J2			E03-0147-05	AC OUTLET		6
△ J2			E03-0148-05	AC OUTLET	Y	
△ J2			E03-0149-05	AC OUTLET	MEG	5
△ J2		*	E03-0310-05	AC OUTLET	T	
△ J3		*	E03-0309-05	AC INLET		
△ F1			F06-2021-05	FUSE (SEMKO) (250V T2AL)	XTEG	
△ F2 ,3			F06-2021-05	FUSE (SEMKO) (250V T2AL)	YM	
△ F4			F05-2525-05	FUSE (SEMKO) (250V T2.5AL)		6
△ F5			F05-2525-05	FUSE (SEMKO) (250V T2.5AL)		
△ F6			F06-2021-05	FUSE (SEMKO) (250V T2AL)		
CN5 ,6			J13-0075-05	FUSE CLIP	XTEG	
CN7 -10			J13-0075-05	FUSE CLIP	YM	
CN11,12			J13-0075-05	FUSE CLIP		6
CN13,14			J13-0075-05	FUSE CLIP		
CN15,16			J13-0075-05	FUSE CLIP		
△ L10 ,11		*	L40-1001-17	SMALL FIXED INDUCTOR(10UH,K)	YM	J
△ T1		*	L07-0979-05	POWER TRANSFORMER	EG	J
△ T1		*	L07-0980-05	POWER TRANSFORMER	XT	J
△ T1		*	L07-0981-05	POWER TRANSFORMER	YM	S
△ T1		*	L07-1828-05	POWER TRANSFORMER		
△ T1		*	L07-1829-05	POWER TRANSFORMER	EG	S
△ T1		*	L07-1830-05	POWER TRANSFORMER	XT	S
X1			L78-0605-05	RESONATOR (8.38MHZ)		
CP1 ,2			R90-0864-05	MULTI-COMP 100KX14		
CP3			R90-0492-05	MULTI-COMP 100KX8 J 1/6W		
CP4			R90-0895-05	MULTI-COMP 10KX9		
△ K1			S51-1052-05	MAGNETIC RELAY POWER		
S1 -23			S40-1064-05	PUSH SWITCH		
△ S26			S31-2322-05	SLIDE SWITCH AC VOLTAGE SEL	YM	
△ S27			S62-0001-05	SLIDE SWITCH AC VOLTAGE SEL	YM	
S24			T99-0548-05	SPEED DETECTOR VOLUME		
S25			T99-0547-05	SPEED DETECTOR INPUT SEL		
D1 -3			HSS104	DIODE		6
D1 -3			1SS133	DIODE		
D9 -18			HSS104	DIODE		
D9 -18			1SS133	DIODE		
D19			HSS104	DIODE		
D19			1SS133	DIODE		6
D20 -26			HSS104	DIODE		
D20 -26			1SS133	DIODE		
ED1		*	BJ268GK	INDICATOR TUBE		
IC1		*	M38197MA-090FP	MI-COM IC		
IC2			S-80740AL	IC(VOLTAGE DETECTOR)		
IC3			XR-1091BCP	IC(GE FILTER)		
IC4		*	M66310P	MOS-IC		
Q1 -8			2SC1740S(Q,R)	TRANSISTOR	S/W	

L: Scandinavia

K: USA

P: Canada

R: Mexico

J: JAPAN MADE

5: A-58

Y: PX (Far East, Hawaii)

T: England

E: Europe

G: Germany

S: SINGAPORE MADE

6: A-68

Y: AAFES (Europe)

X: Australia

M: Other Areas

W: MALAYSIA MADE

△ indicates safety critical components.

PARTS LIST

× New Parts

Parts without Parts No. are not supplied.

Les articles non mentionnes dans le Parts No. ne sont pas fournis.

Teile ohne Parts No. werden nicht geliefert.

Ref. No. 参照番号	Address 位置	New Parts 新	Parts No. 部品番号	Description 部品名 / 規格	Desti- nation 仕向	Re- marks 備考
Q1 -8			2SC2458(Y,GR)	TRANSISTOR	S/W	J
Q1 -8			2SC2785(F,E)	TRANSISTOR		J
Q1 -8			2SC3311A(Q,R)	TRANSISTOR		
A1			W02-1174-05	ELECTRIC CIRCUIT MODULE		
A1			W02-1188-05	ELECTRIC CIRCUIT MODULE		

L: Scandinavia **K:** USA **P:** Canada **R:** Mexico **J:** JAPAN MADE
Y: PX (Far East, Hawaii) **T:** England **E:** Europe **G:** Germany **S:** SINGAPORE MADE
Y: AAFES (Europe) **X:** Australia **M:** Other Areas **W:** MALAYSIA MADE

SPECIFICATIONS

A-58

Power amplifier section

Rated power output	
Stereo mode	
(DIN) 1kHz at 8Ω	60W+60W
Surround mode	
Center (1kHz, 0.9% T.H.D. at 8Ω)	10W
Rear (1kHz, 0.9% T.H.D. at 8Ω)	10W
Total harmonic distortion	0.06% (1kHz, 20W, 8Ω)
Frequency response	
LINE (AV AUX)	40Hz~20kHz, +0dB, -3.0dB
Signal to noise ratio	
PHONO (MM)	70dB (IHF'66)
LINE (AV AUX)	85dB (IHF'66)
Input sensitivity/Impedance	
MIC	1.5mV/10kΩ
PHONO (MM)	4mV/47kΩ
LINE (AV AUX)	200mV/47kΩ
Output level/Impedance	
TAPE REC	200mV/10kΩ
SUPER WOOFER PRE OUT	2.0V/10kΩ
OMNI PRE OUT	2.0V/10kΩ

VIDEO section

Input level/Impedance	
VIDEO (Composite)	1Vp-p/75Ω
Input (VIDEO : 1, AV AUX : 1)	
Output level/Impedance	
VIDEO (Composite)	1Vp-p/75Ω
Output (MONITOR : 1, VIDEO : 1)	

[GENERAL]

AC outlet (SWITCHED)	2 (Total 100W max.)
Power consumption	200W
Dimensions	W : 360mm (14-3/16")
	H : 196mm (7-11/16")
	D : 353mm (13-7/8")
Weight (net)	9.0kg (19.8lb)

A-68

Power amplifier section

Rated power output	
Stereo mode	
(EIAJ) 1kHz at 8Ω	75W+75W
Surround mode	
Center	12W (EIAJ)
Rear	12W (EIAJ)
Total harmonic distortion	0.06% (1kHz, 20W, 8Ω)
Frequency response	
LINE (AUX)	40Hz~20kHz, +0dB, -3.0dB
Signal to noise ratio	
PHONO (MM)	70dB (IHF'66)
LINE (AUX)	85dB (IHF'66)
Input sensitivity/Impedance	
MIC	1.5mV/10kΩ
PHONO (MM)	4mV/47kΩ
LINE (AUX)	200mV/47kΩ
Output level/Impedance	
TAPE REC	200mV/10kΩ
SUPER WOOFER PRE OUT	2.0V/10kΩ
OMNI PRE OUT	2.0V/10kΩ

VIDEO section

Input level/Impedance	
VIDEO (Composite)	1Vp-p/75Ω
Input (VIDEO : 1, AUX : 1)	
Output level/Impedance	
VIDEO (Composite)	1Vp-p/75Ω
Output (MONITOR : 1, VIDEO : 1)	

[GENERAL]

AC outlet	
SWITCHED	2 (Total 100W max.)
UNSWITCHED	1 (50W max.)
Power consumption	200W
Dimensions	W : 360mm (14-3/16")
	H : 196mm (7-11/16")
	D : 353mm (13-7/8")
Weight (net)	9.0kg (19.8lb)

KENWOOD follows a policy of continuous advancements in development. For this reason specifications may be changed without notice.

Note :

Component and circuitry are subject to modification to insure best operation under differing local conditions. This manual is based on, the General Market (M) standard, and provides information on regional circuit modification through use of alternate schematic diagrams, and information on regional component variations through use of parts list.

KENWOOD CORPORATION

14-6, Dogenzaka 1-chome, Shibuya-ku, Tokyo 150, Japan

KENWOOD SERVICE CORPORATION

P.O. BOX 22745, 2201 East Dominguez St., Long Beach, CA 90801-5745, U.S.A.

KENWOOD ELECTRONICS CANADA INC.

6070 Kestrel Road, Mississauga, Ontario, Canada L5T 1S8

KENWOOD ELECTRONICS LATIN AMERICA S.A.

P.O. BOX 55-2791, Piso 6 Plaza Chase, Cl. 47 y Aquilino de la Guardia, Panama, Republic de Panama

TRIO-KENWOOD U.K. LIMITED

KENWOOD House, Dwight Road, Watford, Herts., WD1 8EB United Kingdom

KENWOOD ELECTRONICS BENELUX N.V.

Mechelsesteenweg 418 B-1930 Zaventem, Belgium

KENWOOD ELECTRONICS DEUTSCHLAND GMBH

Rembrücker-Str. 15, 63150 Heusenstamm, Germany

TRIO-KENWOOD FRANCE S.A.

13 Boulevard Ney, 75018 Paris, France

KENWOOD ELECTRONICS ITALIA S.p.A.

Via G. Sirtori, 7/9 20129 Milano, Italy

KENWOOD ESPAÑA S.A.

Bolivia, 239-08020 Barcelona, Spain

KENWOOD ELECTRONICS AUSTRALIA PTY. LTD. (A.C.N. 001 499 074)

P.O. BOX 504, 8 Figtree Drive, Australia Centre, Homebush, N.S.W. 2140, Australia

KENWOOD & LEE ELECTRONICS, LTD.

Unit 3712-3724, Level 37 Tower one, Metroplaza, 223 Hing Fong Road, Kwai Fong, N.T. Hong Kong

KENWOOD ELECTRONICS SINGAPORE PTE LTD.

No. 1 Genting Lane #07-00, KENWOOD Building, Singapore, 1334

KENWOOD ELECTRONICS (MALAYSIA) SDN LTD.

10 th Floor, Block B, Wisma Semantan, No. 12, Jalan Gelenggang, Bukit Damansara, 50490 Kuala Lumpur, Malaysia