

2AK27

64979

©1989-8 PRINTED IN JAPAN
B51-3927-00(B)1312

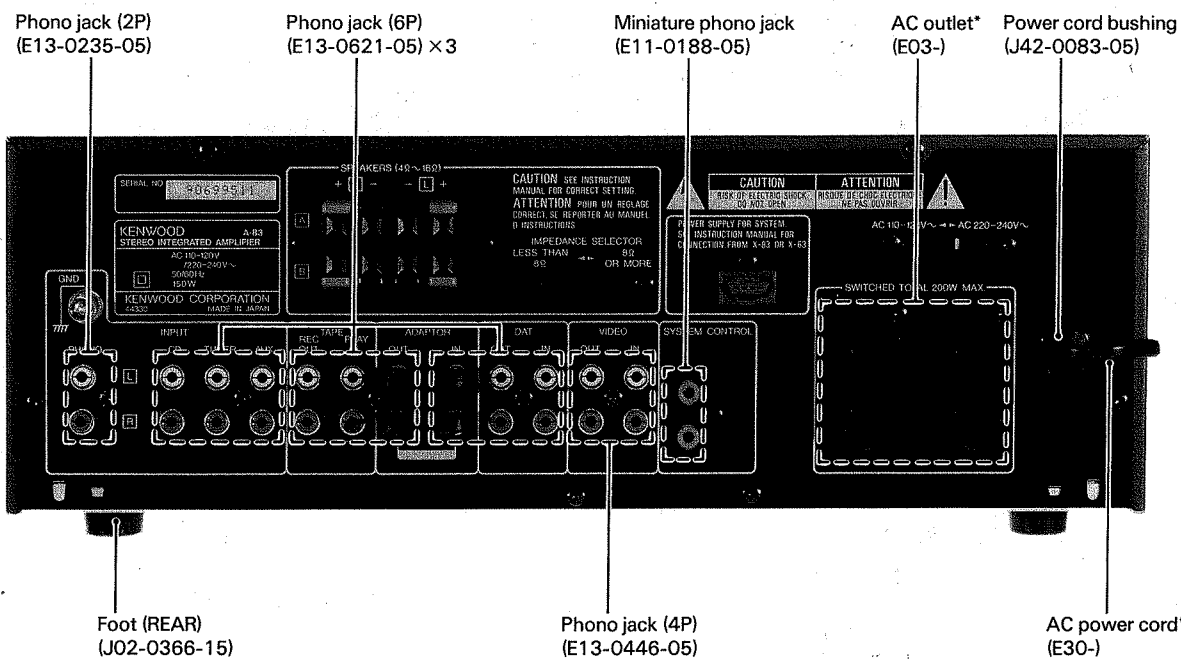
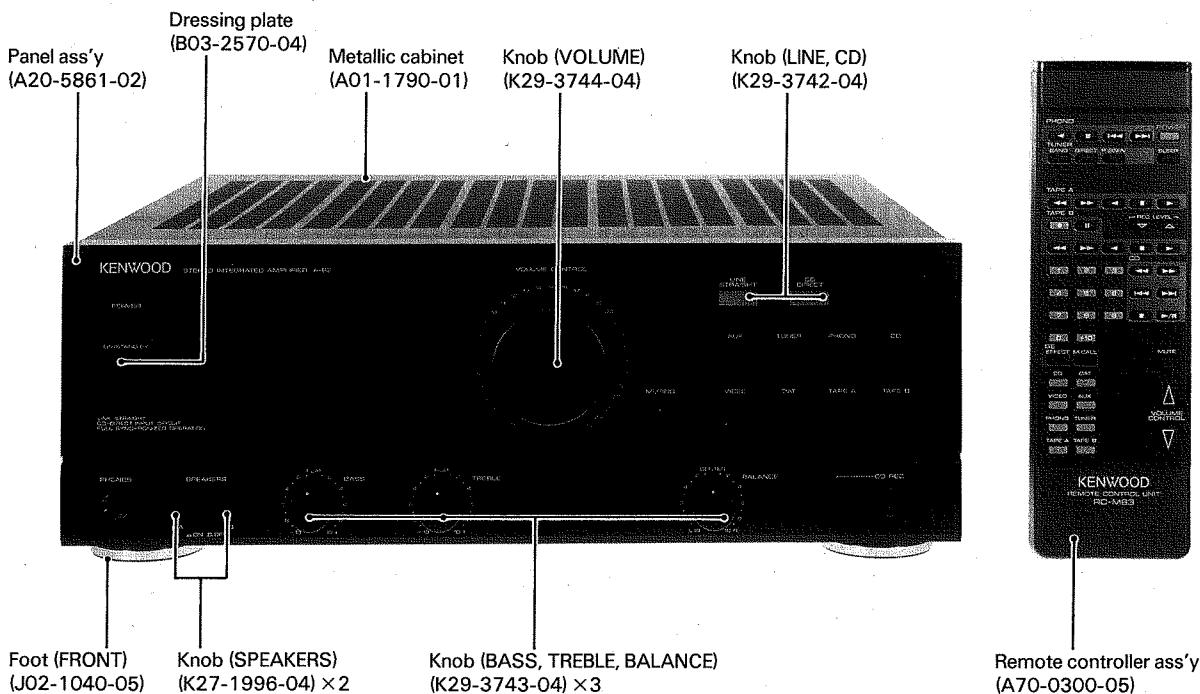

* Refer to parts list on page 26.

CONTENTS

DISASSEMBLY FOR REPAIR	2	SCHEMATIC DIAGRAM	17
BLOCK LEVEL DIAGRAM	4	EXPLODED VIEW	25
CIRCUIT DESCRIPTION	5	PARTS LIST	26
ADJUSTMENT/REGLAGE/ABGLEICH	8	SYSTEM CONNECTIONS	31
PC BOARD	9	SPECIFICATIONS	Back cover

DISASSEMBLY FOR REPAIR

Remove the case prior to the following operations.

1. Cut the five catches **1**.
2. To put the bottom board back into place after repairing, turn the bottom board 180° and hook the claws into place as shown hereunder **2**.
3. Fix down the bottom board with the two screws **3**.

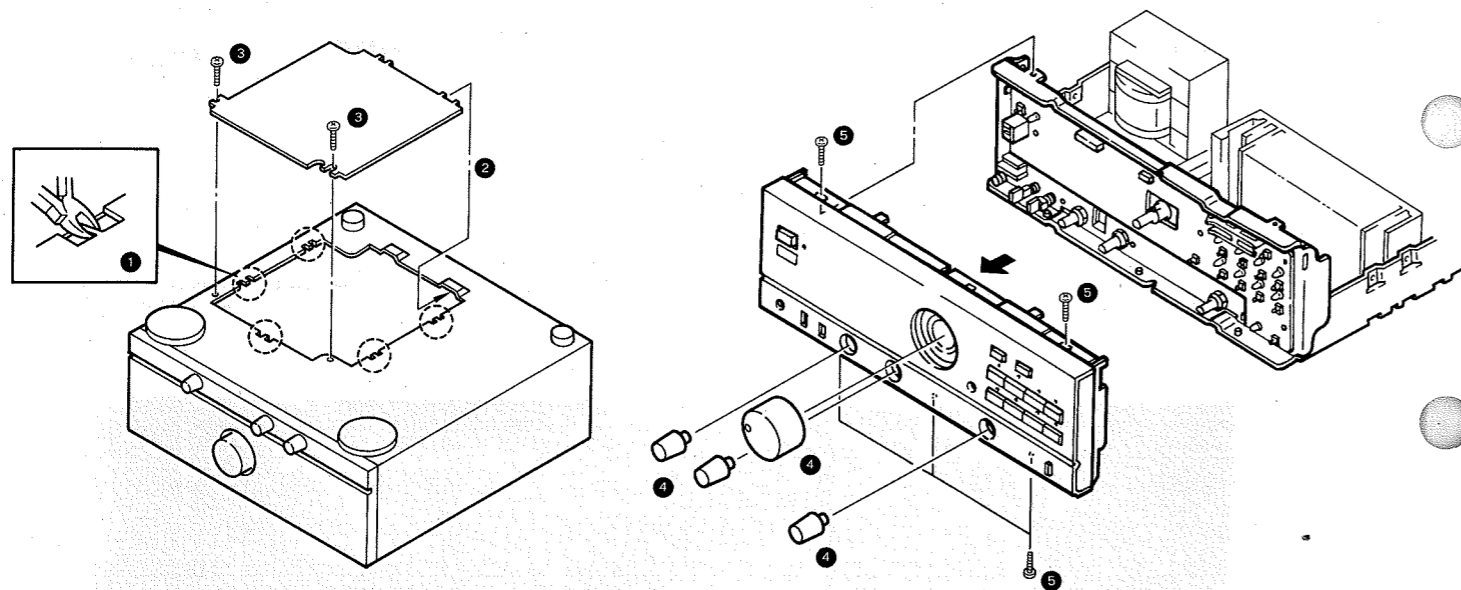

4. Draw out the four knobs **4** from their respective shafts.
5. Remove the five screws **5** of the front panel, then take out the front panel in the direction of the arrow.

6. Remove the four screws **6** fixing the PC board.

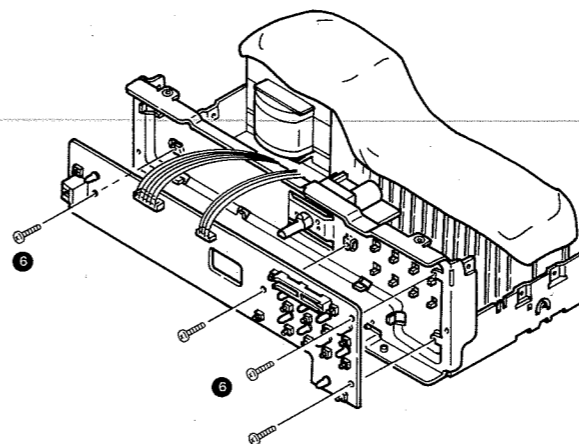

7. Remove the three screws **7** fixing the subpanel.
8. Remove the two screws **8** fixing the PC board.
9. Remove the three nuts **9** fixing the PC board.
10. Draw out the two knobs **10** from their respective shafts.
11. As shown hereunder, remove the screw and undo the catches, then detach the PC board **11**.

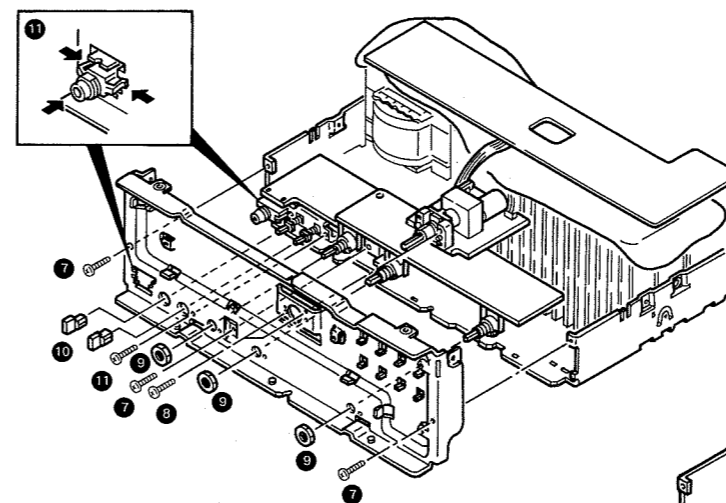

12. Remove the two screws **12** from the rear panel, then detach the PC board. (M TYPE only)
13. Remove the four screws **13** from the rear panel, then detach the PC board.

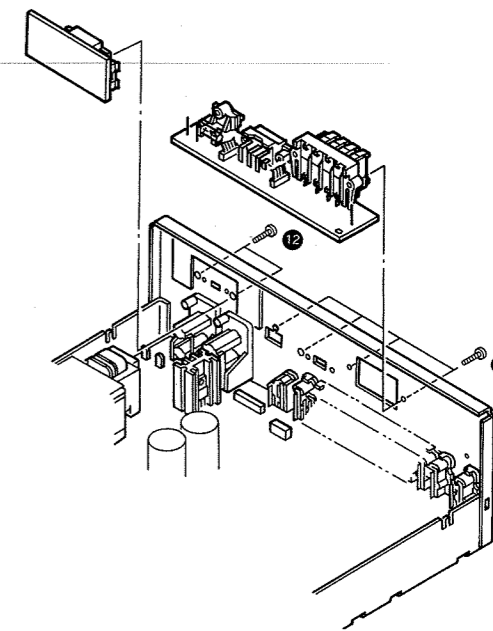

14. Remove the two screws **14** from the rear panel.
15. Remove the seven screws **15** fixing the PC board.

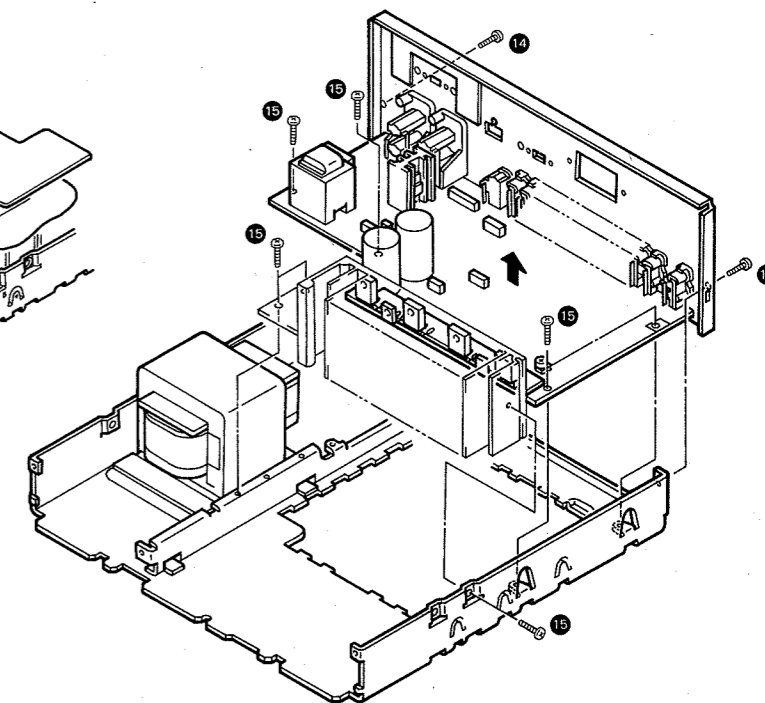

BLOCK LEVEL DIAGRAM

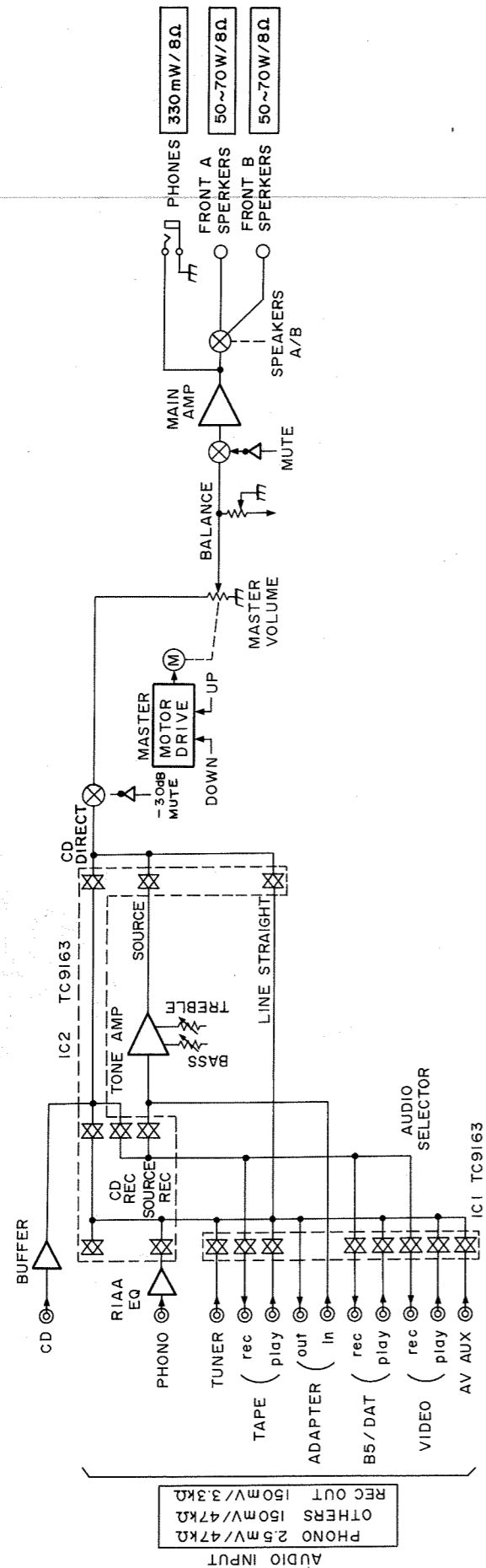

PHONO 2.5mV/47kΩ
 OTHERS 150mV/47kΩ
 REC OUT 150mV/3.3kΩ

CIRCUIT DESCRIPTION

**Component Function
 AUDIO UNIT (X09-2920-20)**

Component	Component name	Use/Function	Operation/Condition/Compatibility
IC1	μPC4570C-A	Phono equalizer	
IC2, 7	μPC4570C-A	Buffer amp	
IC3, 4	TC9163N	Input selector	
IC5	μPC7805HF	Constant-voltage power supply	+5 V (for the microcomputer)
IC6	μPC7812HF	Constant-voltage power supply	±12 V
IC201	μPC4570C-A	Op-amp	For tone amp.
IC202	μPD7538AC075	Microcomputer	
IC203	PST524D	Reset IC	High reset
IC204	BA6209N	Reversible motor driver	For driving the motor-drive volume control. When the volume is increased with the remote control, pins 2 and 5 go high. When the volume is decreased with the remote control, pins 10 and 6 go high.
Q1 ~ Q4	2SC2878(B)	Muting	
Q5 ~ Q8	2SA992(F,E)	Class-A primary stage differential amplifier	
Q9 ~ Q12	2SC1845(F,E)	Class-A secondary stage differential amplifier	
Q13, Q14	2SA992(F,E)	Class-A current mirror circuit	
Q15, Q16	2SC4137F19(V,W)	For bias current compensation	
Q17, Q18	2SC1845(F,E)		
Q19, Q20	2SC2590	Pre-driver	
Q21, Q22	2SA1110		
Q23	2SC4467LB		
Q24	2SC4467LB		
Q25	2SA1694LB	Final transistor L	
Q26	2SA1694LB	Final transistor R	
Q27		PROTECTION	
Q28	2SC945(A)(Q, P)	PROTECTION	
Q29	2SA733(A)(Q, P)	PROTECTION	
Q31	2SA992(F, E)		
Q32	2SB941		
Q33	2SC2003(L, K)	Power relay drive	Turns ON when the power is switched ON. (Q36 is only for the M-type model)
Q201, Q202	2SA733(A)(Q, P)	Muting driver	Turns Q13 and Q14 ON/OFF.
Q203, Q204	2SC2003(L, K)	Constant-voltage power supply	lamp driver

CIRCUIT DESCRIPTION

Microprocessor (μ PD7538AC-075: IC202)
Port layout

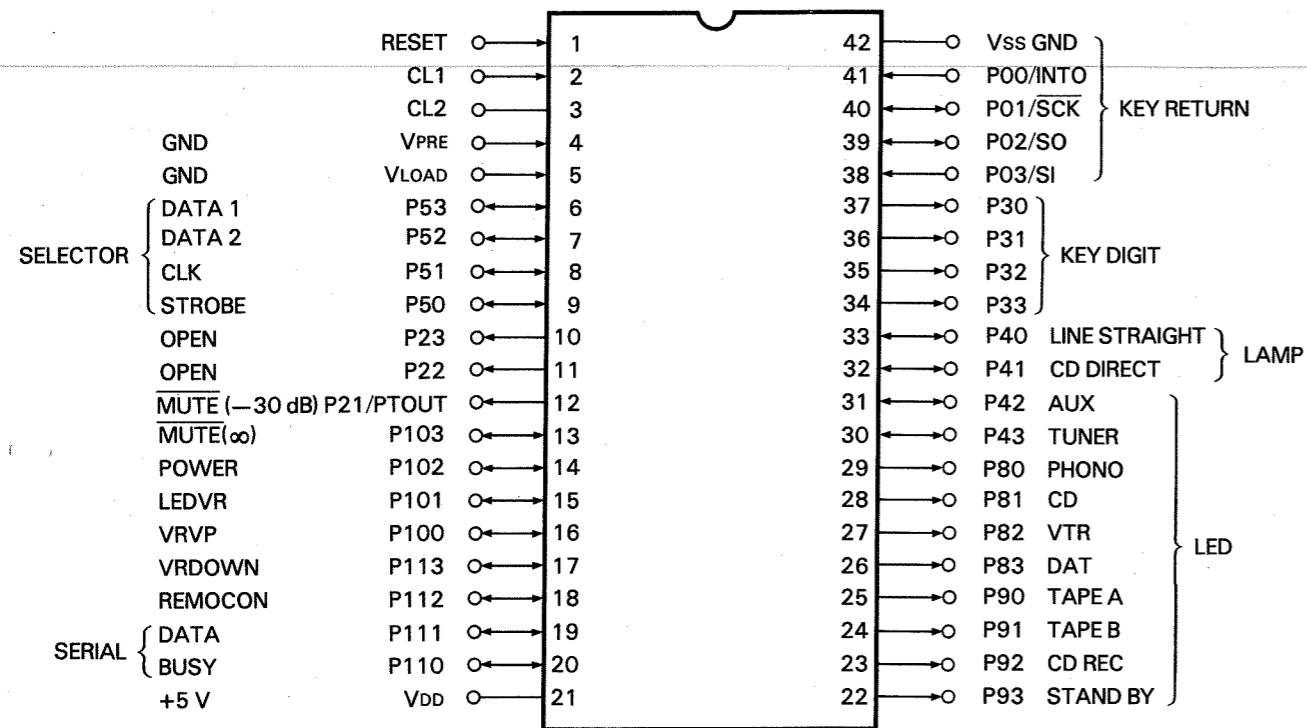

Pin Description

Pin No.	Pin Name	I/O	Function Name	Operation
1	RESET	I	RESET	System reset
2	CL1	I	CLOCK 1	System clock
3	CL2	-	CLOCK 2	System clock
4	VPRE	I	GND	GND
5	VLOAD	I	GND	GND
6	P53	O	SELECTOR DATA 1	Selector drive data signal 1
7	P52	O	SELECTOR DATA 2	Selector drive data signal 2
8	P51	O	SELECTOR CLOCK	Selector drive clock signal
9	P50	O	SELECTOR STROBE	Selector drive strobe signal
10	P23	-	NC	
11	P22	-	NC	
12	P21/PTOVT	O	MUTE (-30 dB)	Mute (-30 dB)
13	P103	O	MUTE (∞)	Mute (∞)
14	P102	O	POWER	Power relay drive
15	P101	O	LEDVR	Volume LED ON
16	P100	O	VRVP	Volume motor up
17	P113	O	VR DOWN	Volume motor down
18	P112	I	REMOCON	Remove control signal input
19	P111	I/O	SERIAL DATA	Serial signal I/O (DATA)
20	P110	I/O	SERIAL BUSY	Serial signal I/O (BUSY)
21	VDD	I	+5 V	+5 V power supply
22	P93	O	STAND-BY	LED STAND-BY
23	P92	O	CD REC	LED CD REC
24	P91	O	TAPE B	LED TAPE B

CIRCUIT DESCRIPTION

Pin No.	Pin Name	I/O	Function Name	Operation
25	P90	O	TAPE A	LED TAPE A
26	P83	O	DAT	LED DAT
27	P82	O	VTR	LED VTR
28	P81	O	CD	LED CD
29	P80	O	PHONO	LED PHONO
30	P43	O	TUNER	LED TUNER
31	P42	O	AUX	LDD AUX
32	P41	O	CD DIRECT	LAMP CD DIRECT
33	P40	O	LINE STRAIGHT	LAMP LINE STRAIGHT
34	P33	O	KEY DIGIT 3	Key scan signal bit 3
35	P32	O	KEY DIGIT 2	Key scan signal bit 2
36	P31	O	KEY DIGIT 1	Key scan signal bit 1
37	P30	O	KEY DIGIT 0	Key scan signal bit 0
38	P03/SI	I	KEY RETURN 3	Key return signal bit 3
39	P02/SO	I	KEY RETURN 2	Key return signal bit 2
40	P01/SCK	I	KEY RETURN 1	Key return signal bit 1
41	P00/INTO	I	KEY RETURN 0	Key return signal bit 0
42	Vss	I	GND	GND

Operational specification of test mode

With this unit plugged into AC, when a specific key has been pressed or when serial code "TEST ON" is input, this unit performs the operation of the test mode. When entering the test mode with this unit plugged into AC.

When the CD key has been pressed

- LEDs light in a sequence as shown below. (LED test)
* STAND-BY → LINE STRAIGHT → CD DIRECT → AUX → TUNER → PHONO → CD → VTR → DAT → TAPE A → TAPE B → CD REC → *
- Due to pressing the TUNER key, the test mode is disengaged to enter the power ON initial state. (Any other keys are disabled from operation.)

Timing chart

(1) POWER KEY ON

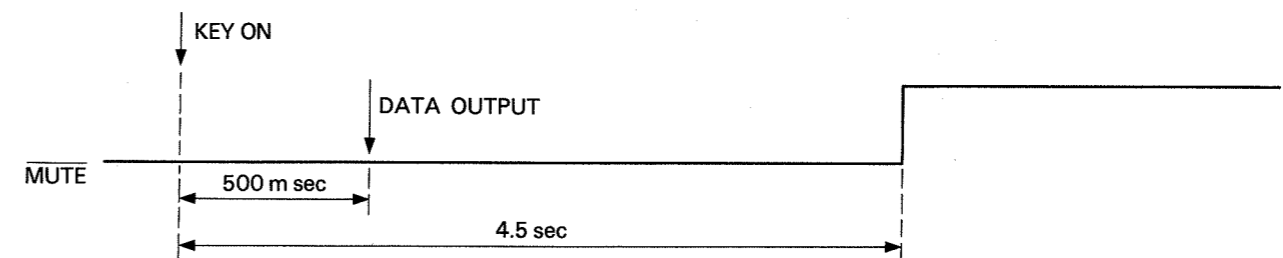

(2) SELECTOR, CD DIRECT, LINE STRAIGHT, CD REC

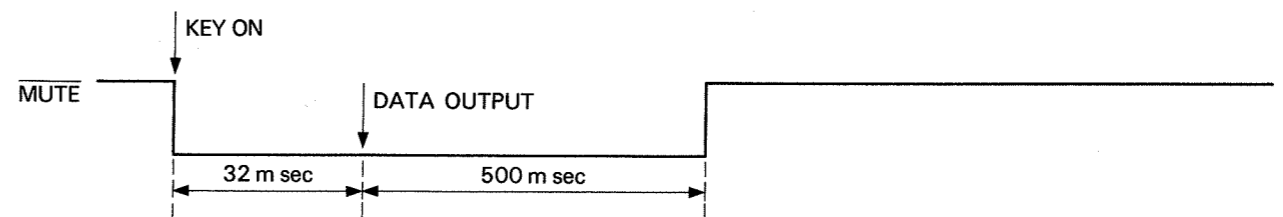

ADJUSTMENT/REGLAGE/ABGLEICH

ADJUSTMENT

No.	ITEM	INPUT SETTINGS	OUTPUT SETTINGS	AMPLIFIER SETTINGS	ALIGNMENT POINTS	ALIGN FOR	FIG.
1	IDLE CURRENT	-	Connect a DC voltmeter across CP1 (L) CP2 (R) (X09-)	VOLUME: 0	VR1 (L) VR2 (R) (X89-)	20 mV	(a)

REGLAGE

N°	ITEM	REGLAGE DE L'ENTREE	REGLAGE DE LA SORTIE	REGLAGE DE L'AMPLIFICATEUR	POINT L'ALIGNEMENT	ALIGNER POUR	
1	COURANT DE POLARISATION	-	Connecter un voltmètre de CC sur CP1 (G) CP2 (D) (X09-)	VOLUME: 0	VR1 (G) VR2 (D) (X89-)	20 mV	(a)

ABGLEICH

NR.	GEGENSTAND	EINGANGS-EINSTELLUNG	AUSGANGS-EINSTELLUNG	VERSTÄRKER EINSTELLUNG	ABGLEICH-PUNKTE	ABGLEICHEN FÜR	ABB.
1	LEERLAUFSTROM	-	Einen Gleichspannungsmesser über CP1 (L) CP2 (R) anschießen. (X09-)	VOLUME: 0	VR1 (L) VR2 (R) (X89-)	20 mV	(a)

DC voltmeter
Voltmètre de CC
Gleichspannungsmesser

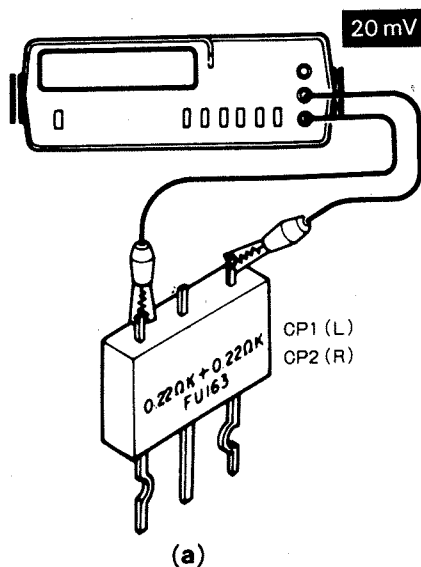

P.C. BOARD (Component side view)

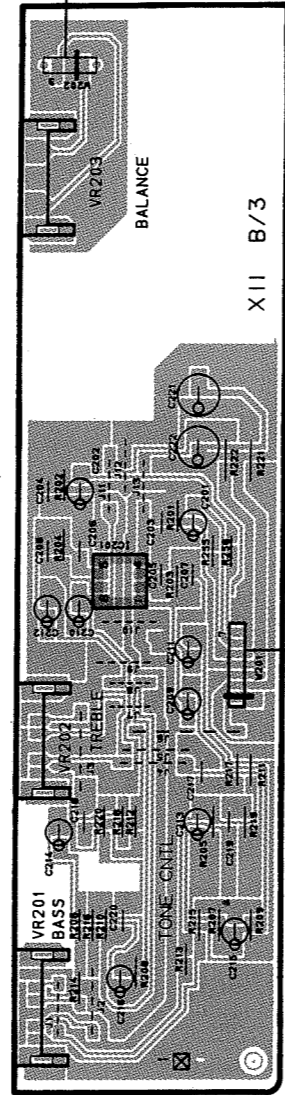
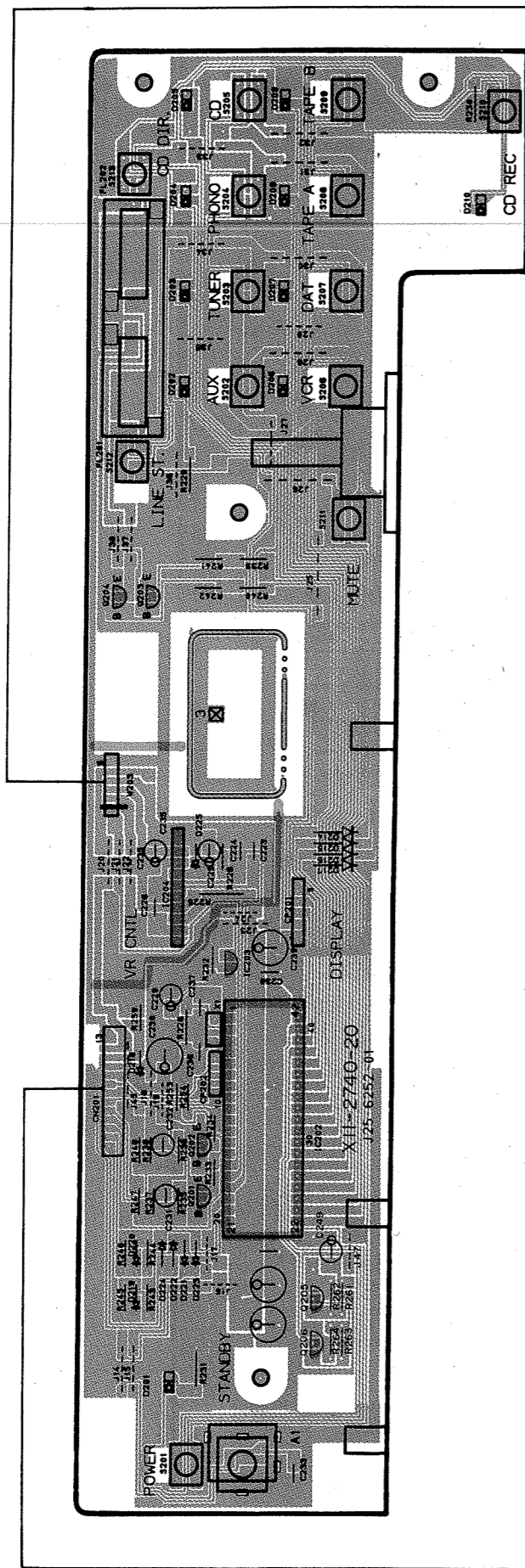

FRONT
↑

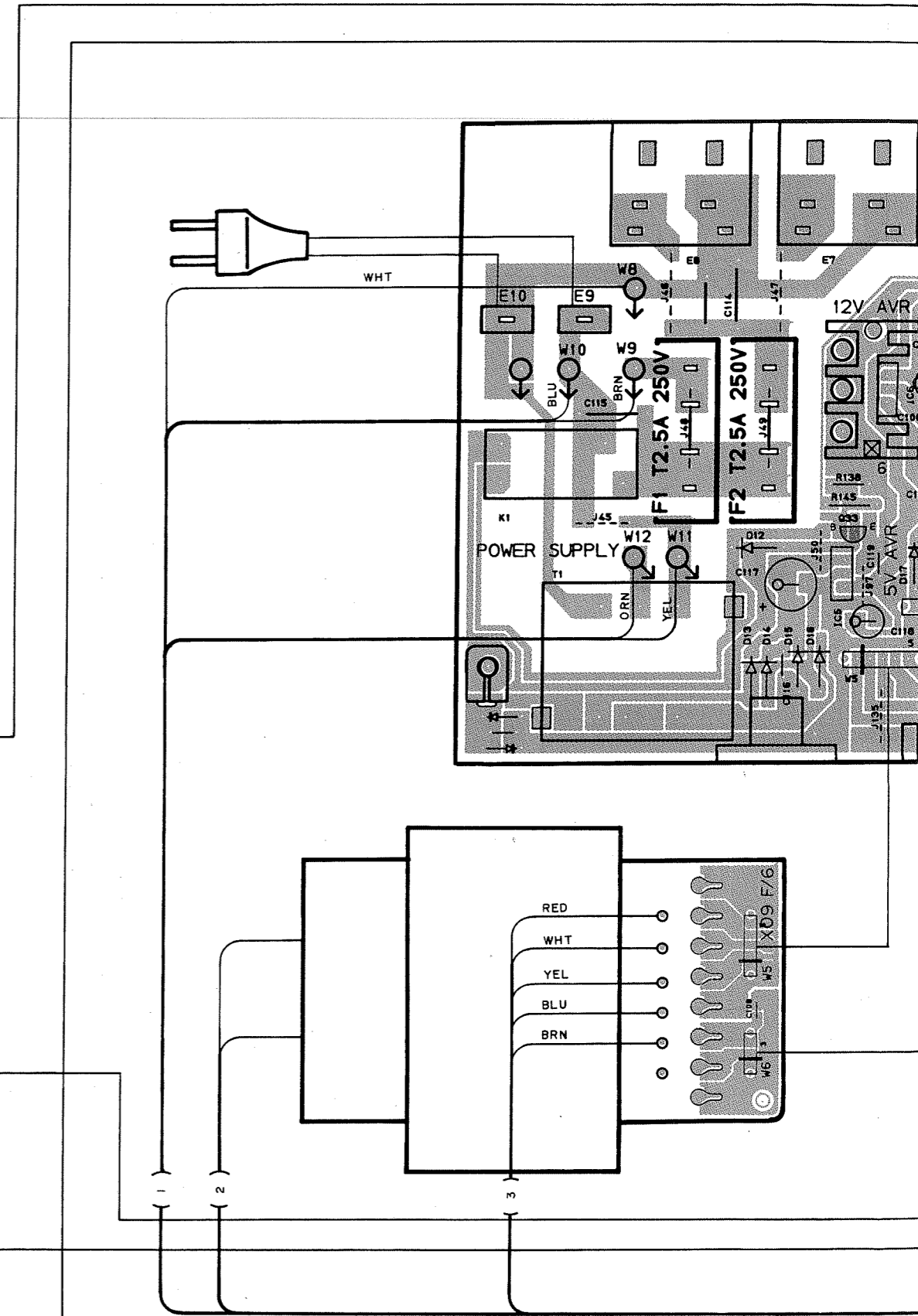
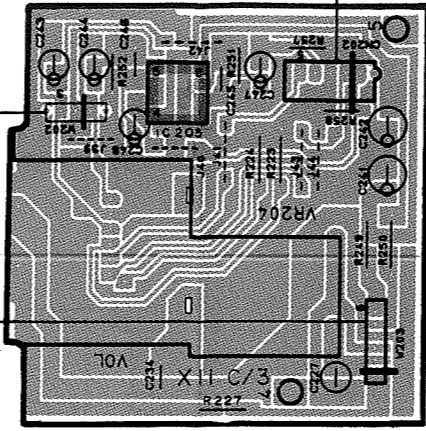
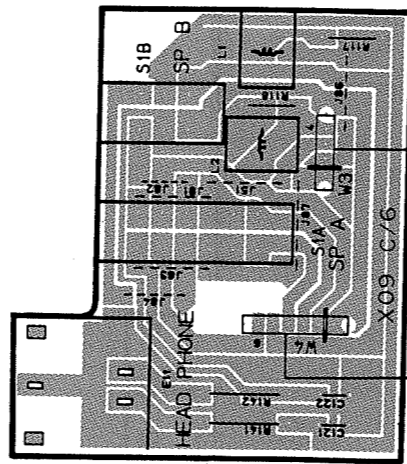

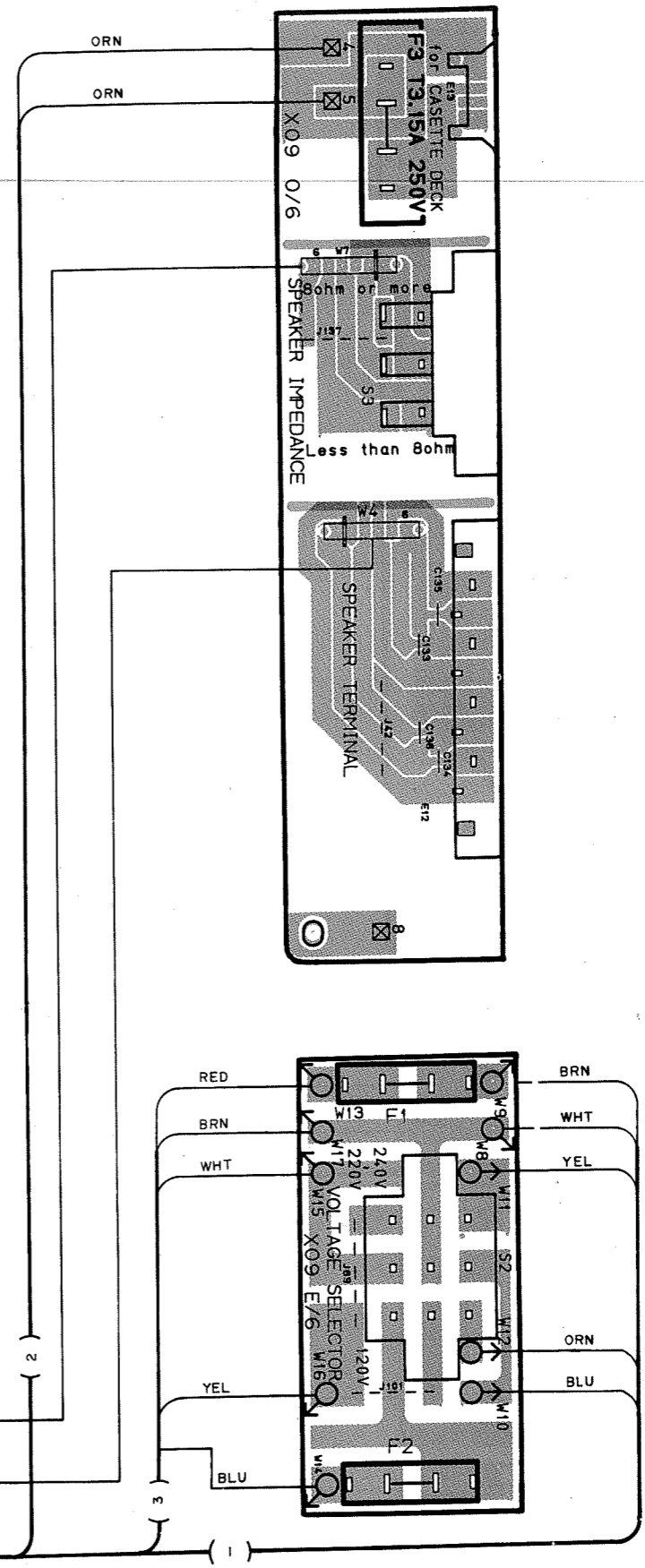
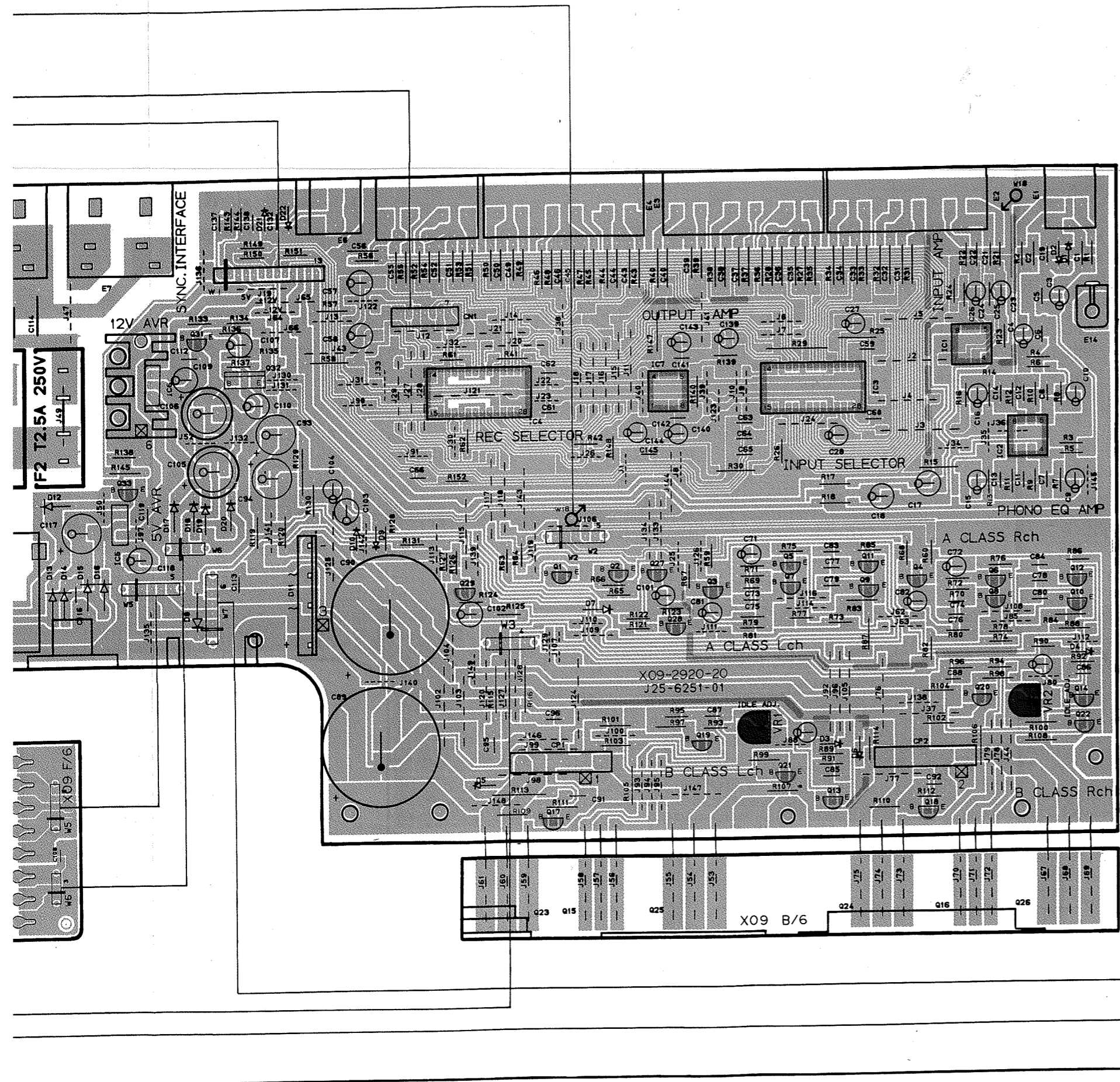

X09-2920-20

Ref. No.	Q	Address
IC		
1		4M
2		4M
3		4N
4		4O
5		4N
6		4O
7		4N
8		4O
9		4O
10		4P
11		4O
12		4P
13		5N
14		5P
17		6M
18		5O
19		5N
20		5O
21		5N
22		5P
27		4M
28		4M
29		4L
31		3K
32		3K
33		4J
1		3O
2		3O
3		3O
4		3L
5		4J
6		3K
7		3M

X11-2740-20

Ref. No.	Q	Address
IC		
201		6B
202		5B
203		3B
204		3B
201		4D
202		5C
203		
204		4B
205		1E

P.C. BOARD (Foil side view)

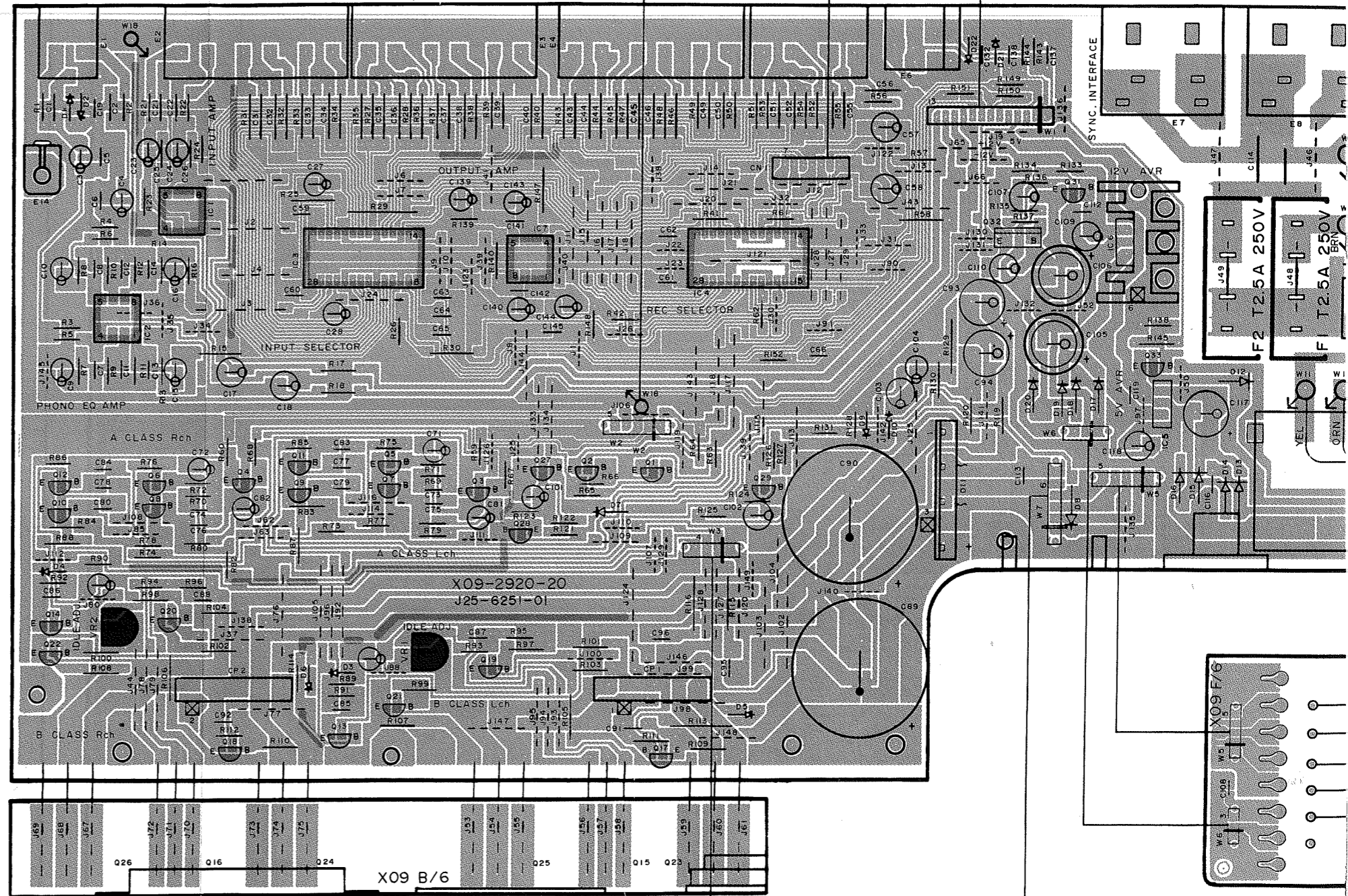
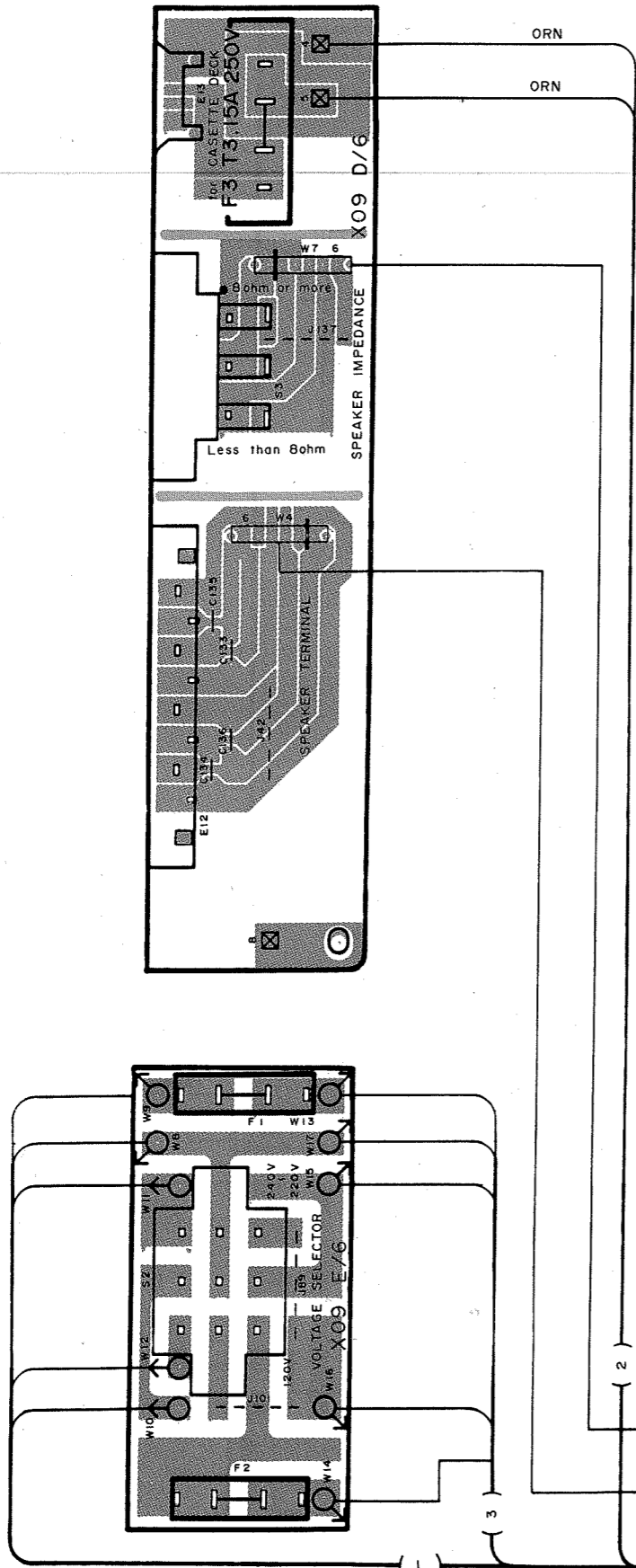

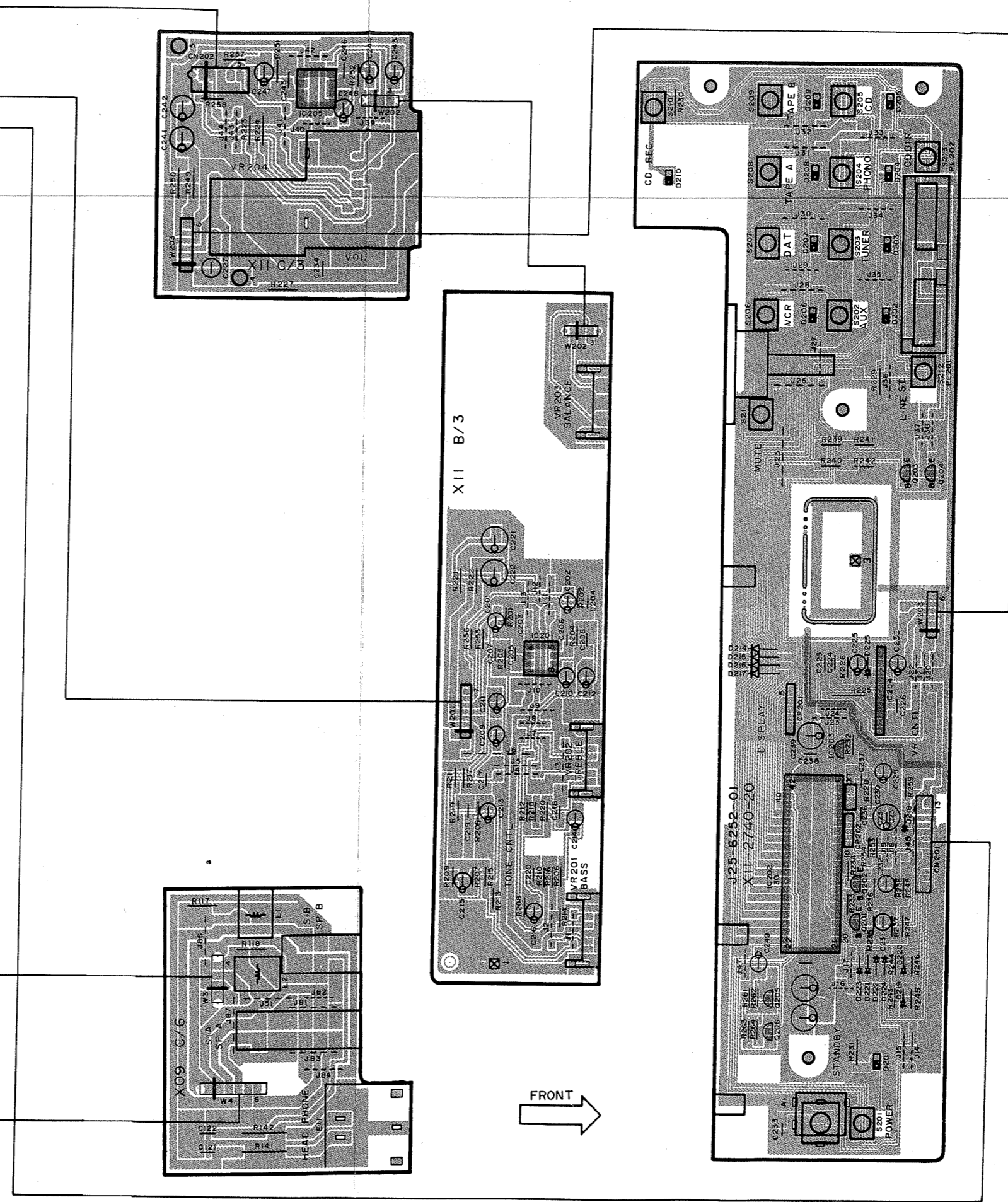
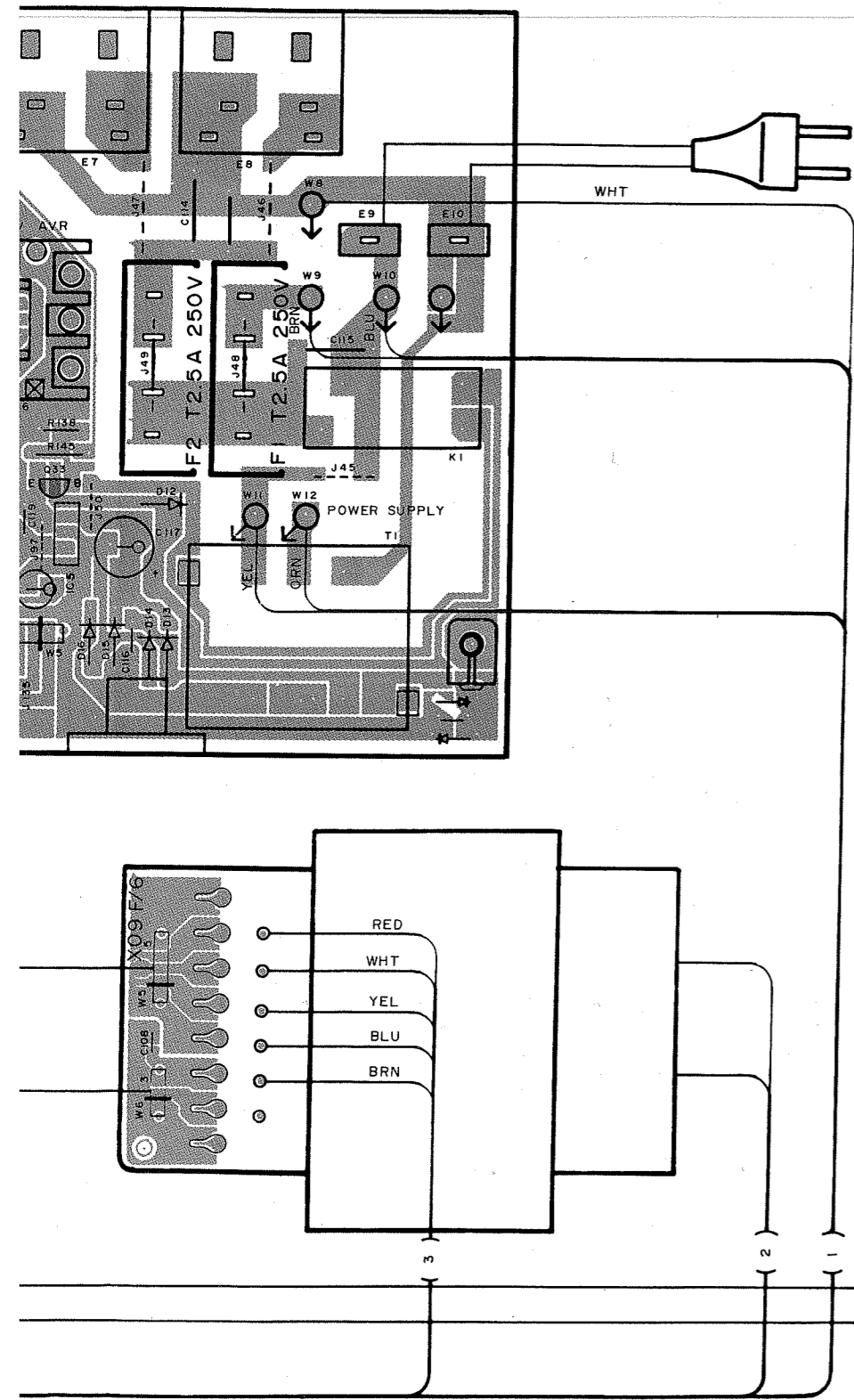

Refer to the schematic diagram for the values of resistors and capacitors.

X09-2920-20

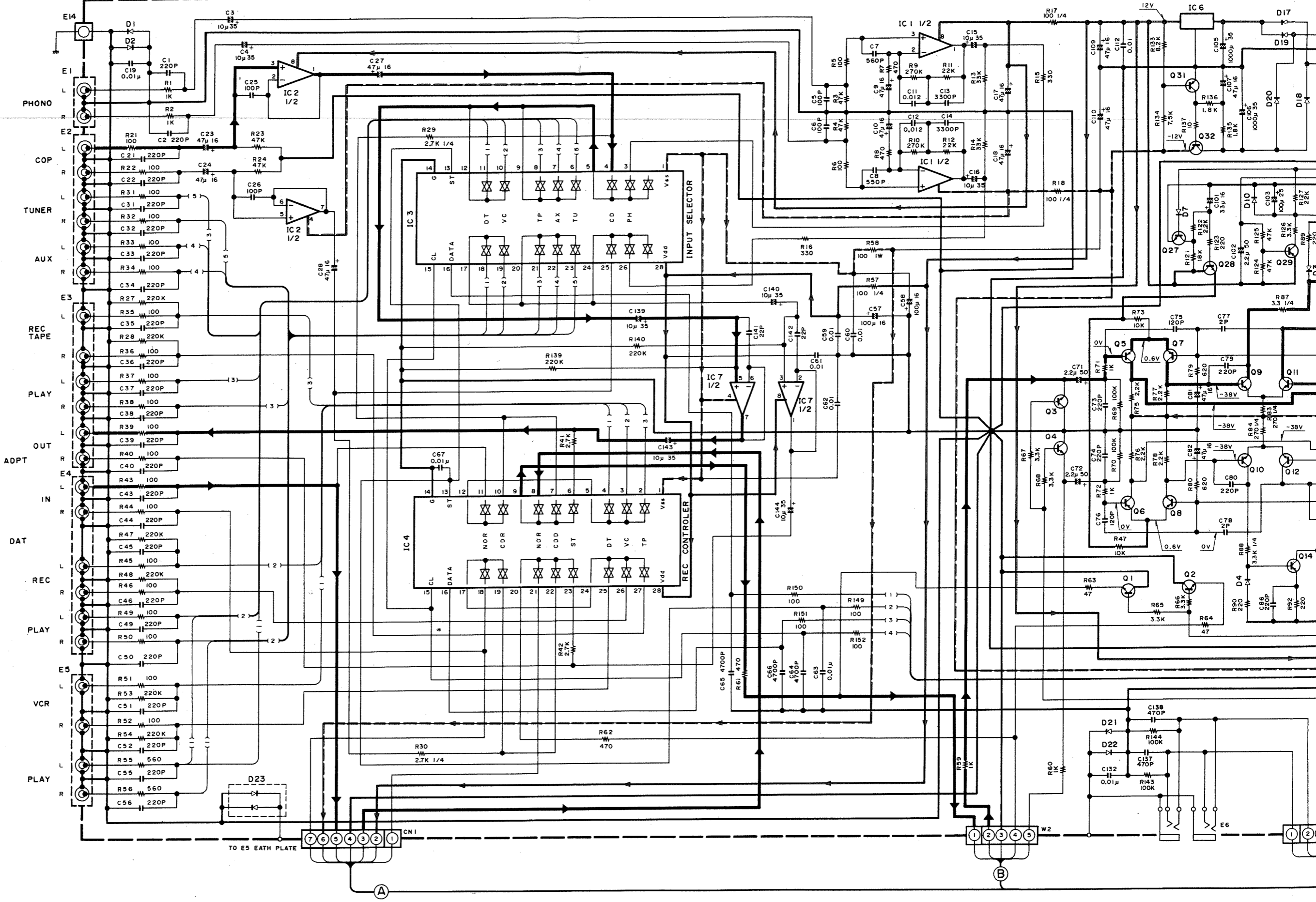

2
3
4
5
6
7

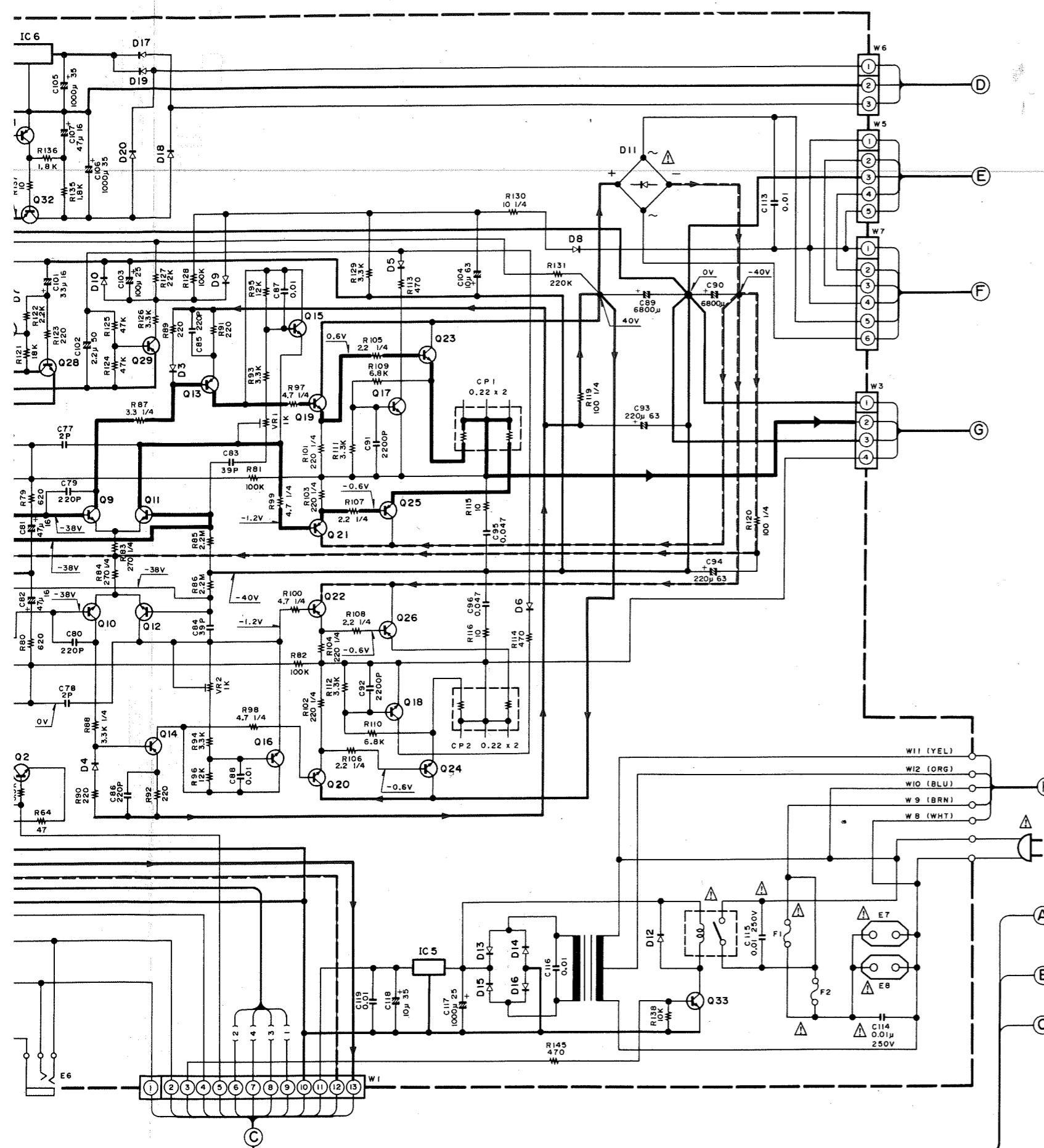

- IC 1, 2, 7 : μ PC4570C-A
- IC 3, 4 : TC9163N
- IC 5 : μ PC7805HF
- IC 6 : μ PC7812HF
- Q1 ~ 4 : 2SC2878 (B)
- Q5 ~ 8, 13, 14, 31 : 2SA992 (F.E)
- Q9 ~ 12, 17, 18 : 2SC1845 (F.E)
- Q15, 16 : 2SC4137 (V.W)
- Q19, 20 : 2SC2590
- Q21, 22 : 2SA1110
- Q23, 24 : 2SC4467
- Q25, 26 : 2SA1694
- Q29 : 2SA733 (A) (O.P)
- Q32, 33 : 2SC2003 (L.K)
- D1, 2, 21, 22 : ISS133 or HSS104
- D3 ~ 10 : ISS131 or HSS104R
- D11 : RBV-602LFA
- D12 ~ 20 : S55668
- D23 : MA156

	X09-292			
	0-20	0-71	0-51	2-71
R79, 80	620	←	←	←
S2	YES	NO	←	←
C89, 90	1785	←	←	←
C114	NO	←	YES	←
R111, 112	3.3K	←	←	←
X09 E/6	YES	NO	←	←
W10 ~ 17	YES	NO	←	←
T1 LO1-	7653	7657	←	7652
PT LO1-	8875	8872	←	8877
E7, 8	0108	NO	0109	0108
J48, 49	YES	NO	←	←
F1	NO	T2.5A	←	←
F2	NO	NO	T2.5A	←
F4	T5A	NO	←	←
F5	T2.5A	NO	←	←

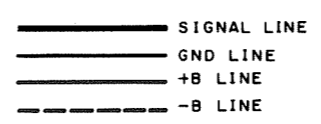

2SA733(A)
2SA992
2SC1845
2SC2003
2SC2878
2SC945(A)

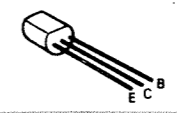

2SA1110
2SC2590

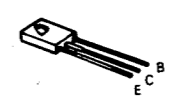

2SA1694LB
2SC4467LB

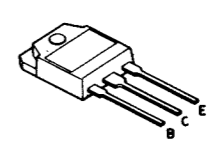

2SB941

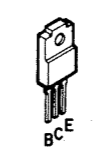

UPC4570C-A

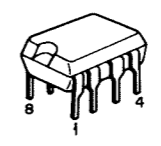

UPD7538AC-075

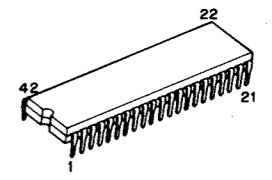

UPC7805HF
UPC7812HF

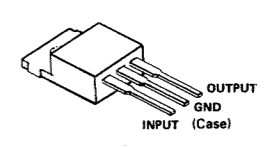

TC9163N

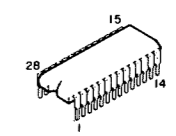

BA6209N

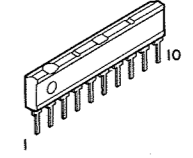

CAUTION: For continued safety, replace safety critical components only with manufacturer's recommended parts (refer to parts list). Δ Indicates safety critical components. To reduce the risk of electric shock, leakage-current or resistance measurements shall be carried out (exposed parts are acceptably insulated from the supply circuit) before the appliance is returned to the customer.

- DC voltages are measured with a high impedance voltmeter. Values may vary slightly due to variations between individual instruments or/and units.
- Les tensions c.c. doivent être mesurées avec un voltmètre à haute impédance. Les valeurs peuvent différer légèrement du fait des variations inhérentes aux appareils et aux instruments de mesure individuels.
- Die angegebenen Gleichspannungswerte wurden mit einem hochohmigen Voltmeter gemessen. Dabei schwanken die Meßwerte aufgrund von Unterschieden zwischen einzelnen Instrumenten oder Geräten u. U. geringfügig.

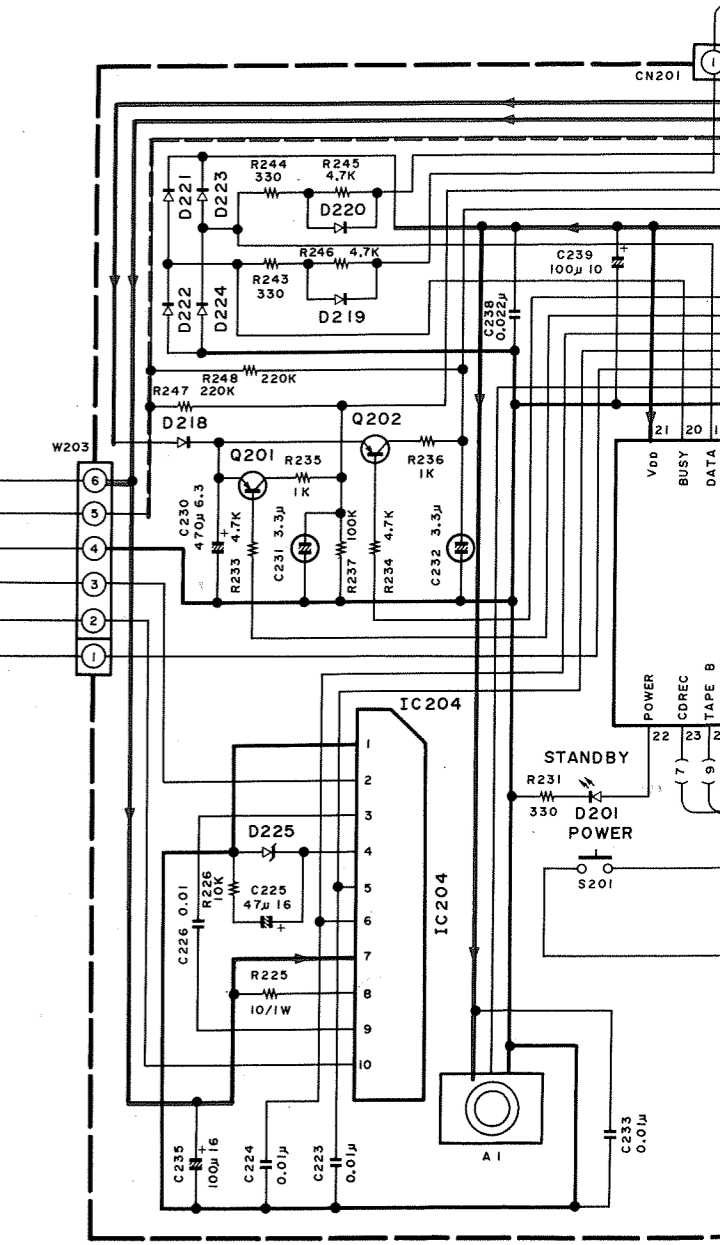
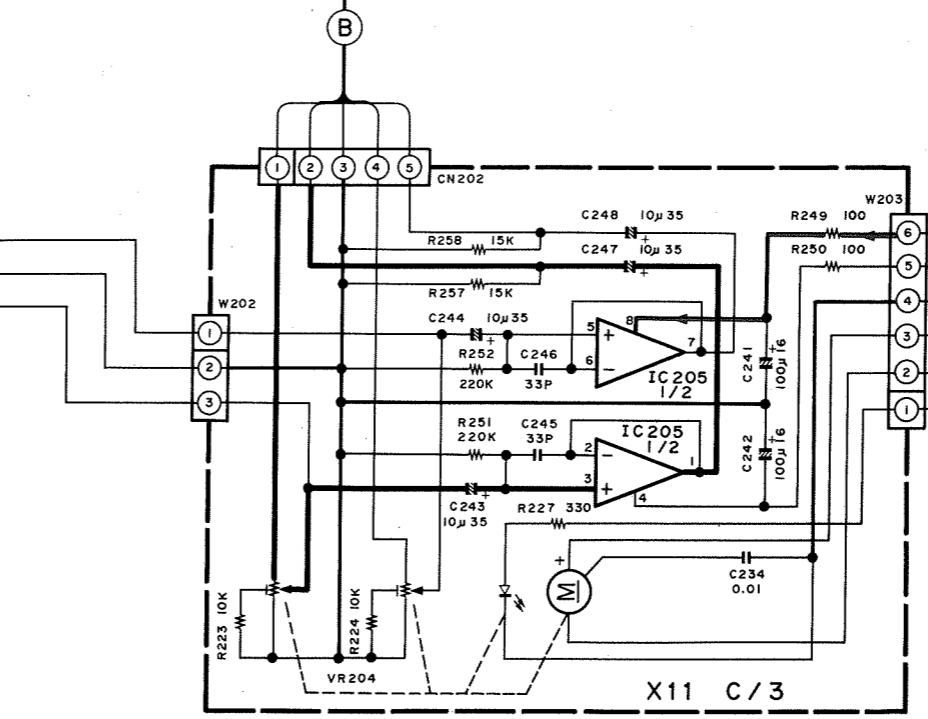
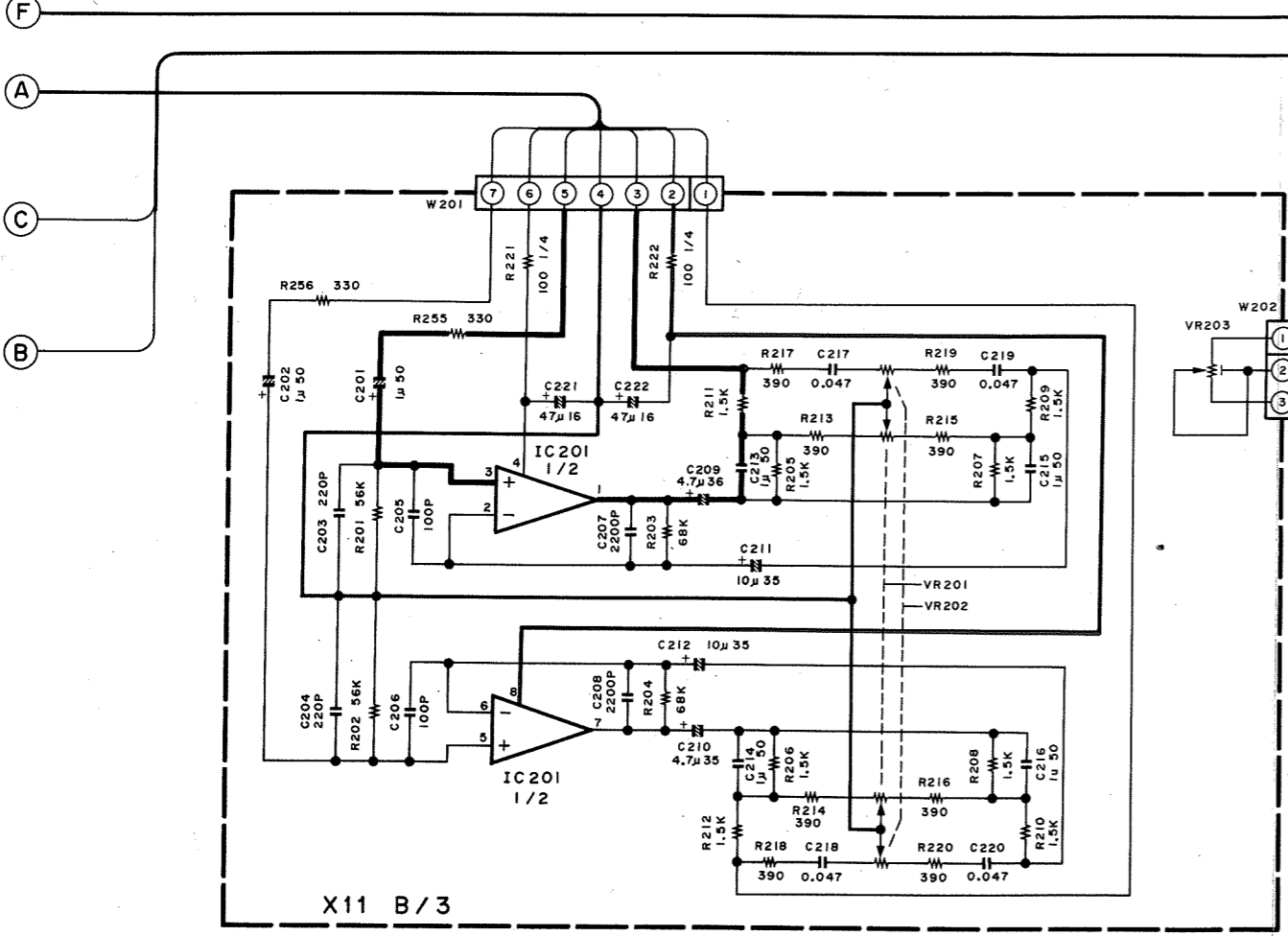
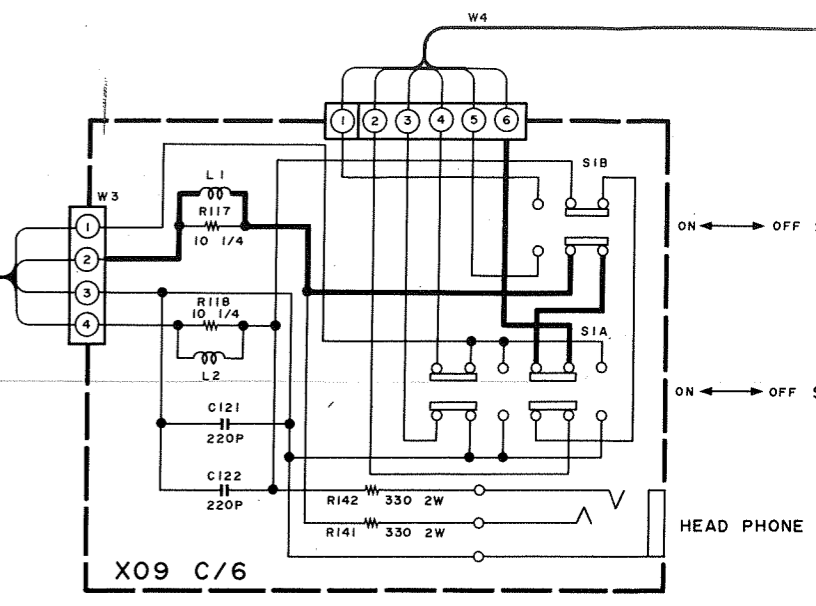
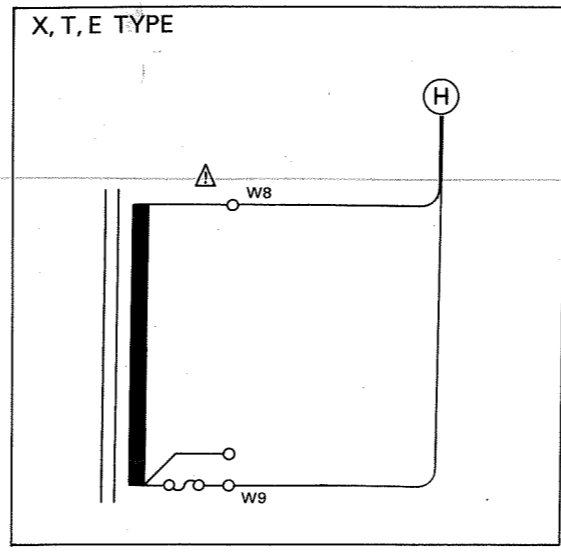
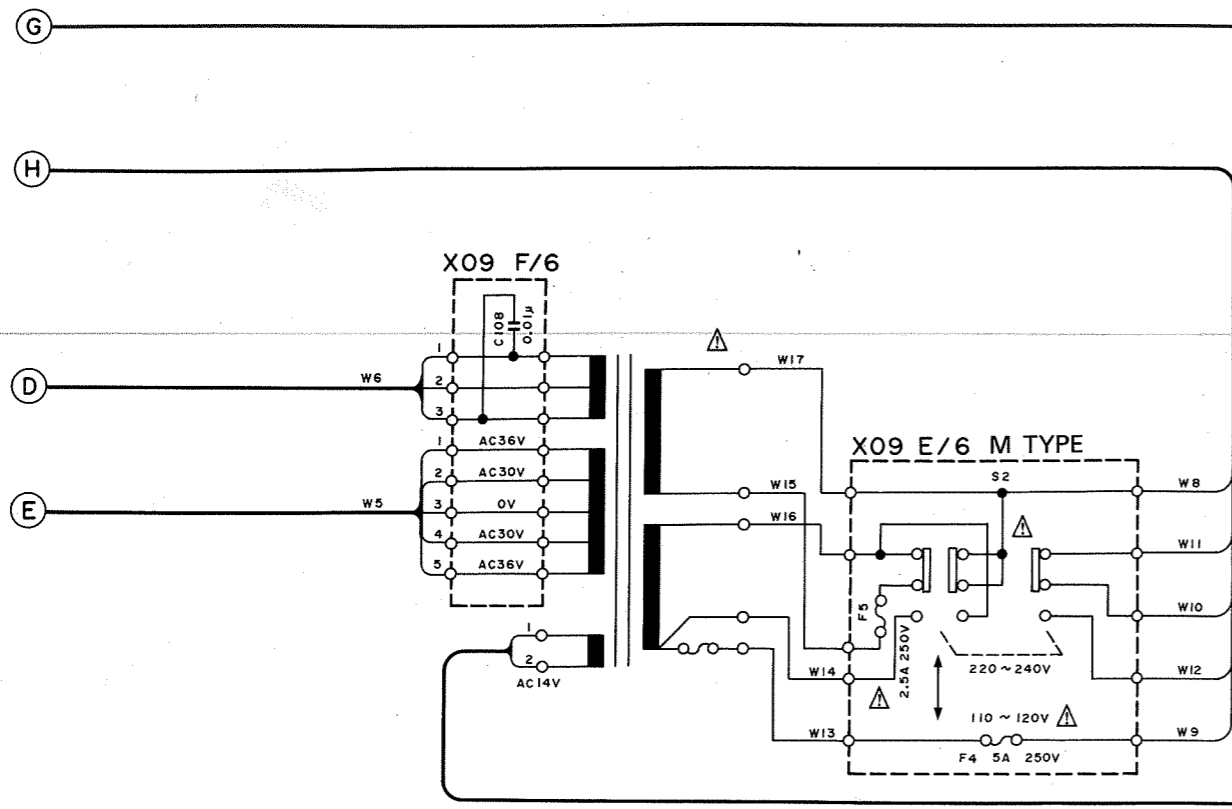

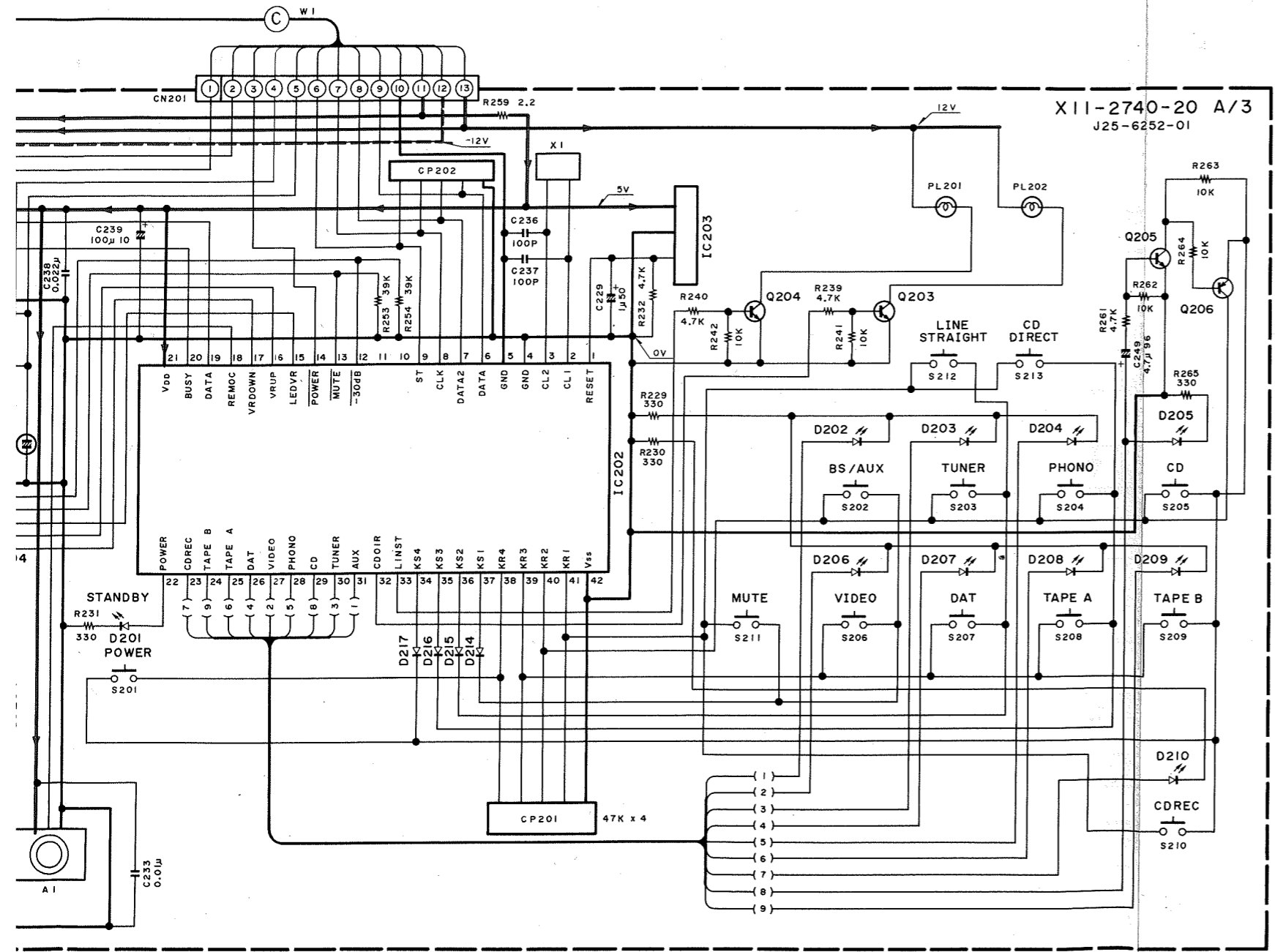
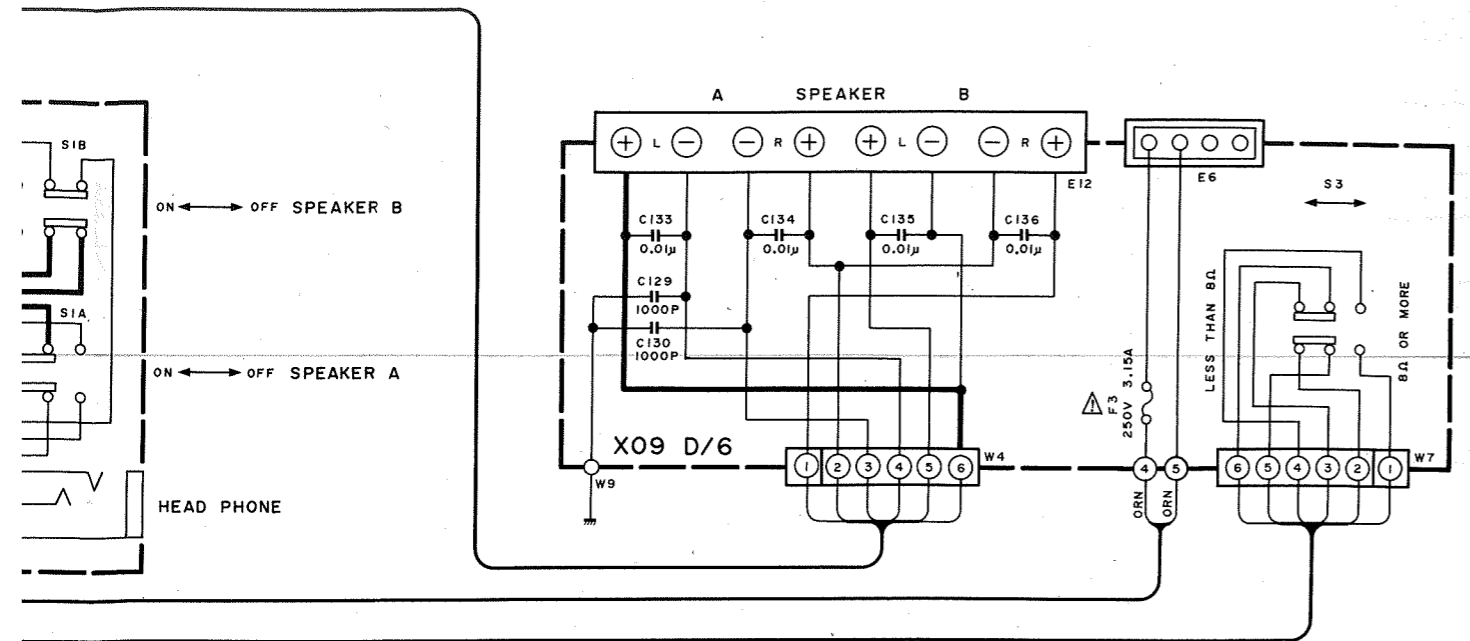

- IC201, 205 : μ PC4570C-A
- IC202 : μ PD7538AC-075
- IC203 : PST524D
- IC204 : BA6209N
- Q201, 202 : 2SA733 (A) (Q.P)
- Q203, 204 : 2SC2003 (L.K)
- D201 ~ 211 : 830-1223-05
- D204 224 : ISSI33 or HSS104A

- 2SA733(A)
- 2SA992
- 2SC1845
- 2SC2003
- 2SC2878
- 2SC945(A)

UPD7538AC-075

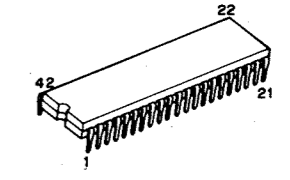

UPC7805HF
UPC7812HF

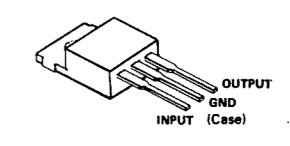

- 2SA1110
- 2SC2590



TC9163N

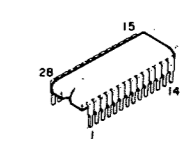

- 2SA1694LB
- 2SC4467LB

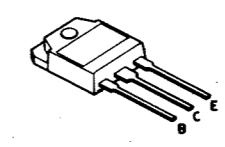

BA6209N

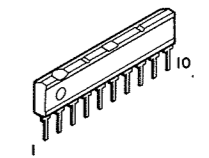

- 2SB941

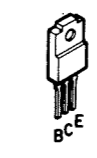

UPC4570C-A

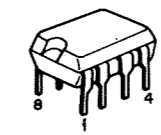

CAUTION: For continued safety, replace safety critical components only with manufacturer's recommended parts (refer to parts list). Δ Indicates safety critical components. To reduce the risk of electric shock, leakage-current or resistance measurements shall be carried out (exposed parts are acceptably insulated from the supply circuit) before the appliance is returned to the customer.

- DC voltages are measured with a high impedance voltmeter. Values may vary slightly due to variations between individual instruments or/and units.
- Les tensions c.c. doivent être mesurées avec un voltmètre à haute impédance. Les valeurs peuvent différer légèrement du fait des variations inhérentes aux appareils et aux instruments de mesure individuels.
- Die angegebenen Gleichspannungswerte wurden mit einem hochohmigen Voltmeter gemessen. Dabei schwanken die Meßwerte aufgrund von Unterschieden zwischen einzelnen Instrumenten oder Geräten u. U. geringfügig.

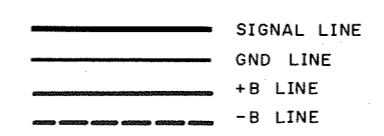

EXPLODED VIEW

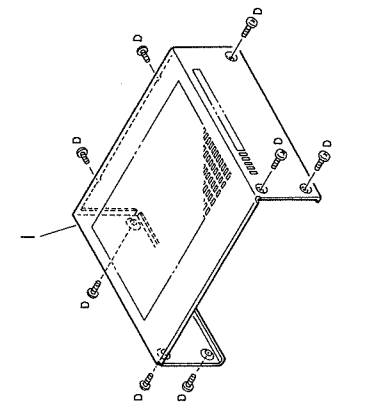
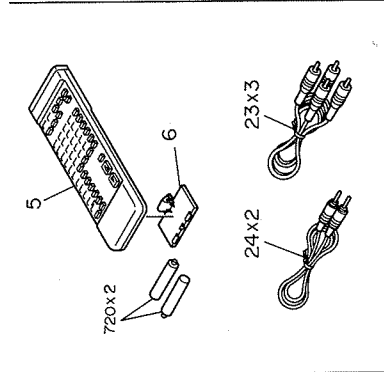
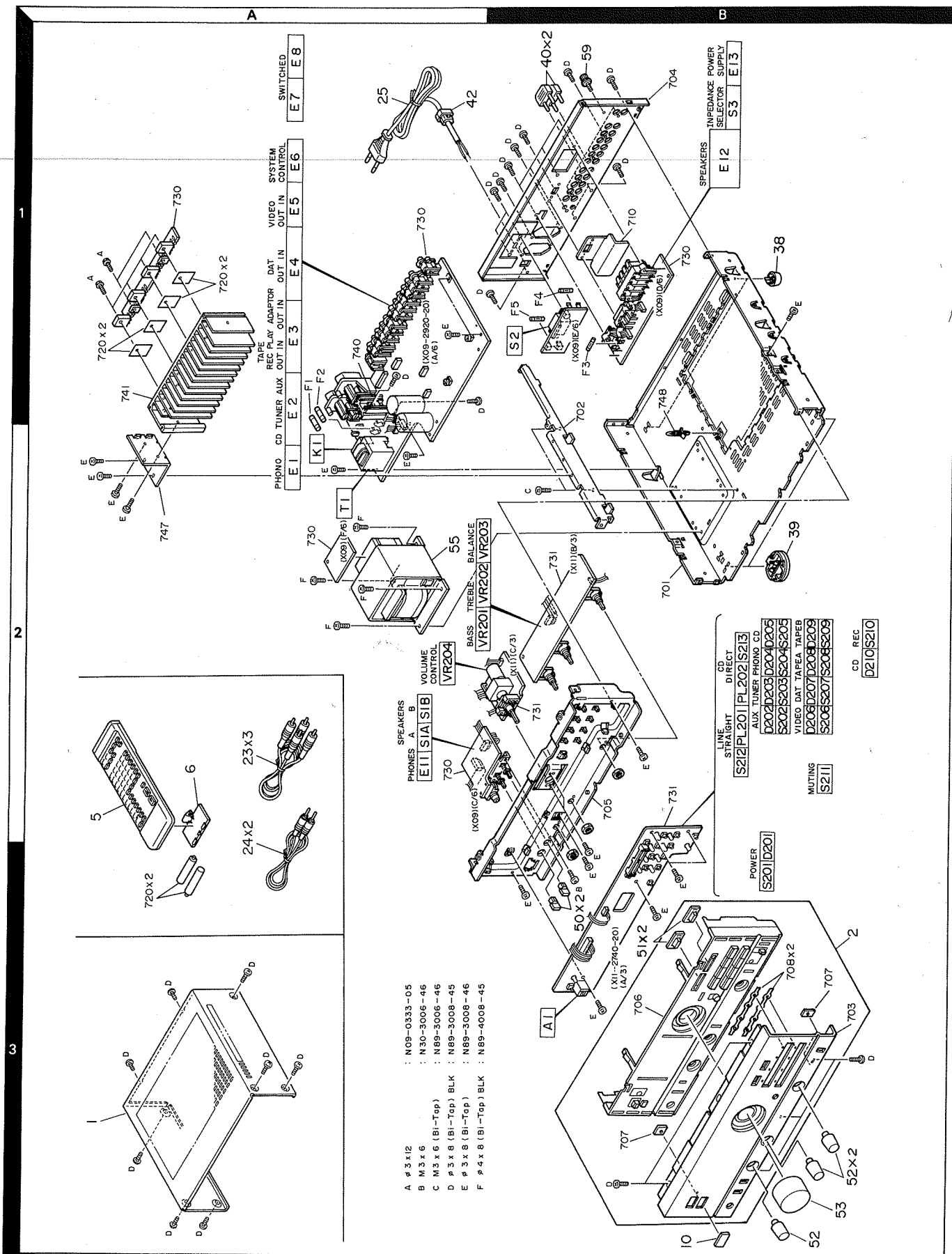

- A # 3 x 12 : N09-0333-05
- B M 3 x 6 : N30-3006-46
- C M 3 x 6 (Bi-Top) : N89-3006-46
- D # 3 x 8 (Bi-Top) BLK : N89-3008-45
- E # 3 x 8 (Bi-Top) : N89-3008-46
- F # 4 x 8 (Bi-Top) BLK : N89-4008-45

Parts with the exploded numbers larger than 700 are not supplied.

PARTS LIST

× New Parts
Parts without Parts No. are not supplied.
Les articles non mentionnés dans le Parts No. ne sont pas fournis.
Teile ohne Parts No. werden nicht geliefert.

Ref. No. 参照番号	Address 位置	New Parts 新	Parts No. 部品番号	Description 部品名/規格	Desti- nation 仕 向	Re- marks 備考
A-83						
1	1A	*	A01-1790-01	METALLIC CABINET		
2	2A	*	A20-5861-02	PANEL ASSY		
5	1B	*	A70-0300-05	REMOTE CONTROLLER ASSY		
6	1B		A09-0088-08	BATTERY CASE		
10	2A	*	B03-2570-04	DRESSING PLATE		
-			B46-0096-13	WARRANTY CARD	X	
-			B46-0122-13	WARRANTY CARD	E	
-			B46-0143-03	WARRANTY CARD	T	
-		*	B50-9827-00	INSTRUCTION MANUAL		
-		*	B50-9828-00	INSTRUCTION MANUAL	ME	
-		*	B50-9829-00	INSTRUCTION MANUAL	M	
-		*	B50-9830-00	INSTRUCTION MANUAL	E	
-		*	B50-9831-00	INSTRUCTION MANUAL		
-		*	B52-0341-00	CONNECTING DIAGRAM		
-			B58-0803-13	CAUTION CARD	E	
23	1B		E30-0615-05	AUDIO CORD		
24	1B		E30-1392-05	CORD WITH PLUG		
25	1C		E30-0459-05	AC POWER CORD	ME	
25	1C		E30-1341-05	AC POWER CORD	X	
25	1C		E30-1416-05	AC POWER CORD	T	
F1 ,2	1C		F05-2525-05	FUSE (SEMKO) (250V T2.5A)		
F3	2C		F05-3121-05	FUSE (SEMKO) (250V T3.15A)		
F4 ,5	2C		F05-5025-05	FUSE (SEMKO) (250V T5A)	M	
37	2B		G13-0439-04	CUSHION		
-		*	H01-8619-04	ITEM CARTON CASE		
-		*	H10-3884-02	POLYSTYRENE FOAMED FIXTURE		
-		*	H10-3885-02	POLYSTYRENE FOAMED FIXTURE		
-			H25-0181-04	PROTECTION BAG (150X260X0.05)		
-			H25-0224-04	PROTECTION BAG (800X400X0.03)		
-			H25-0232-04	PROTECTION BAG (235X350X0.03)		
38	2C		J02-0366-15	FOOT		
39	2B	*	J02-1040-05	FOOT		
40	2C		J12-0091-05	PIN		
42	1C		J42-0083-05	POWER CORD BUSHING		
-			J61-0307-05	WIRE BAND		
50	2A	*	K27-1996-04	KNOB (BUTTON)(SPEAKRS)		
51	2A	*	K29-3742-04	KNOB (LINE,CD)		
52	2A	*	K29-3743-04	KNOB (BASS,TREBLE,BALANCE)		
53	2A	*	K29-3744-04	KNOB (VOLUME)		
55	1B	*	L01-8872-05	POWER TRANSFORMER	XT	
55	1B	*	L01-8875-05	POWER TRANSFORMER	M	
55	1B	*	L01-8877-05	POWER TRANSFORMER	E	
59	2C		N08-0128-35	BINDING POST		
A	1C		N09-0333-05	TAPPING SCREW (3X12)		
B	1A		N30-3006-46	PAN HEAD MACHINE SCREW		
C	2B		N89-3006-46	BINDING HEAD TAPTITE SCREW		
D	1A, 2A		N89-3008-45	BINDING HEAD TAPTITE SCREW		
E	2A		N89-3008-46	BINDING HEAD TAPTITE SCREW		
F	1B		N89-4008-45	BINDING HEAD TAPTITE SCREW		

E: Scandinavia & Europe K: USA P: Canada
U: PX(Far East, Hawaii) T: England M: Other Areas
UE: AAFES(Europe) X: Australia

⚠ indicates safety critical components.

PARTS LIST

× New Parts
Parts without Parts No. are not supplied.
Les articles non mentionnés dans le Parts No. ne sont pas fournis.
Teile ohne Parts No. werden nicht geliefert.

Ref. No. 参照番号	Address 位置	New Parts 新	Parts No. 部品番号	Description 部品名/規格	Desti- nation 仕 向	Re- marks 備考
Q15 ,16		*	2SC4137F19(V,W)	TRANSISTOR		
Q23 ,24		*	2SC4467LB	TRANSISTOR		
Q25 ,26		*	2SA1694LB	TRANSISTOR		
AUDIO UNIT (X09-2920-20)						
C1 ,2			C91-0749-05	CERAMIC 220PF	K	
C3 ,4			CE04KW1V100M	ELECTRO 10UF	35WV	
C5 ,6			CC45FSL1H101J	CERAMIC 100PF	J	
C7 ,8			CK45FB1H561K	CERAMIC 560PF	K	
C9 ,10			CE04KW1C470M	ELECTRO 47UF	16WV	
C11 ,12			CF92FV1H123J	MF 0.012UF	J	
C13 ,14			CF92FV1H332J	MF 3300PF	J	
C15 ,16			CE04KW1V100M	ELECTRO 10UF	35WV	
C17 ,18			CE04KW1C470M	ELECTRO 47UF	16WV	
C19			CK45FF1H103Z	CERAMIC 0.010UF	Z	
C21 ,22			C91-0749-05	CERAMIC 220PF	K	
C23 ,24			CE04KW1C470M	ELECTRO 47UF	16WV	
C25 ,26			C91-0745-05	CERAMIC 100PF	K	
C27 ,28			CE04KW1C470M	ELECTRO 47UF	16WV	
C31 -40			C91-0749-05	CERAMIC 220PF	K	
C43 -46			C91-0749-05	CERAMIC 220PF	K	
C49 -52			C91-0749-05	CERAMIC 220PF	K	
C55 ,56			C91-0749-05	CERAMIC 220PF	K	
C57 ,58			CE04KW1C101M	ELECTRO 100UF	16WV	
C59 -67			CK45FF1H103Z	CERAMIC 0.010UF	Z	
C71 ,72			CE04KW1H2R2M	ELECTRO 2.2UF	50WV	
C73 ,74			CC45FSL1H221J	CERAMIC 220PF	J	
C75 ,76			CC45FSL1H121J	CERAMIC 120PF	J	
C77 ,78			CC45FSL1H020C	CERAMIC 2.0PF	C	
C79 ,80			CC45FSL1H221J	CERAMIC 220PF	J	
C81 ,82			CE04KW1C470M	ELECTRO 47UF	16WV	
C83 ,84			CC45FSL1H390J	CERAMIC 39PF	J	
C85 ,86			CC45FSL1H221J	CERAMIC 220PF	J	
C87 ,88			CK45FF1H103Z	CERAMIC 0.010UF	Z	
C89 ,90		*	C90-1785-05	ELECTRO 6800UF	63WV	
C91 ,92			CK45FB1H222K	CERAMIC 2200PF	K	
C93 ,94			CE04KW1J221M	ELECTRO 220UF	63WV	
C95 ,96			CF92FV1H473J	MF 0.047UF	J	
C101			CE04KW1C330M	ELECTRO 33UF	16WV	
C102			CE04KW1H2R2M	ELECTRO 2.2UF	50WV	
C103			CE04KW1E101M	ELECTRO 100UF	25WV	
C104			CE04KW1J100M	ELECTRO 10UF	63WV	
C105,106			CE04KW1V102M	ELECTRO 1000UF	35WV	
C107			CE04KW1C470M	ELECTRO 47UF	16WV	
C108			CK45FF1H103Z	CERAMIC 0.010UF	Z	
C109,110			CE04KW1C470M	ELECTRO 47UF	16WV	
C112			CF92FV1H103J	MF 0.010UF	J	
C113			CK45FF1H103Z	CERAMIC 0.010UF	Z	
C114,115			C91-0971-05	FILM 0.01UF	250WV	TE
C115			C91-0971-05	FILM 0.01UF	250WV	MX
C116			CK45FF1H103Z	CERAMIC 0.010UF	Z	
C117			CE04KW1E102M	ELECTRO 1000UF	25WV	
C118			CE04KW1V100M	ELECTRO 10UF	35WV	
C119			CF92FV1H103J	MF 0.010UF	J	
C121,122			CC45FSL1H221J	CERAMIC 220PF	J	

E: Scandinavia & Europe K: USA P: Canada W: Europe
U: PX(Far East, Hawaii) T: England M: Other Areas
UE: AAFES(Europe) X: Australia

⚠ indicates safety critical components.

印は安全部品

PARTS LIST

× New Parts
 Parts without Parts No. are not supplied.
 Les articles non mentionnés dans le Parts No. ne sont pas fournis.
 Teile ohne Parts No. werden nicht geliefert.

Ref. No. 参照番号	Address 位置	New Parts 新	Parts No. 部品番号	Description 部品名 / 規格	Desti- nation 仕 向	Re- marks 備考
C129,130 C132 C133-136 C137,138 C139,140			CK45FF1H103Z CK45FF1H103Z CF92FV1H103J CK45FB1H471K CE04KW1V100M	CERAMIC 0.010UF Z CERAMIC 0.010UF Z MF 0.010UF J CERAMIC 470PF K ELECTRO 10UF 35WV		
C141,142 C143,144			CC45FSL1H220J CE04KW1V100M	CERAMIC 22PF J ELECTRO 10UF 35WV		
E1 E2 -4 E5 E6 E7 ,8		*	E13-0235-05 E13-0621-05 E13-0446-05 E11-0188-05 E03-0108-05	PHONE JACK (2P) PHONE JACK (6P) PHONE JACK (4P) MINIATURE PHONE JACK AC OUTLET	ME	
E7 ,8 E11 E12 E13		*	E03-0109-05 E11-0162-05 E20-0823-05 E08-0411-05	AC OUTLET PHONE JACK (3P) LOCK TERMINAL BOARD(8P) RECTANGULAR RECEPTACLE	T	
73	1C,2C		J13-0054-05	FUSE CLIP		
L1 ,2 T1 T1 T1			L39-0085-05 L01-7652-05 L01-7653-05 L01-7657-05	PHASE-COMPENSATION COIL POWER TRANSFORMER POWER TRANSFORMER POWER TRANSFORMER	E M XT	
D G			N89-3008-45 N30-3008-46	BINDING HEAD TAPTITE SCREW PAN HEAD MACHINE SCREW		
CP1 ,2 R17 ,18 R57 R58 R115,116			R90-0187-05 RD14AB2E101J RD14AB2E101J RS14KB3A101J RS14KB3D100J	MULTI-COMP 0.22X2 K 5W FL-PROOF RD 100 J 1/4W FL-PROOF RD 100 J 1/4W FL-PROOF RS 100 J 1W FL-PROOF RS 10 J 2W		
R117,118 R119,120 R129 R130 R141,142			RD14AB2E100J RD14AB2E101J RS14KB3D332J RD14AB2E100J RS14KB3D331J	FL-PROOF RD 10 J 1/4W FL-PROOF RD 100 J 1/4W FL-PROOF RS 3.3K J 2W FL-PROOF RD 10 J 1/4W FL-PROOF RS 330 J 2W		
R145 VR1 ,2			RD14AB2E471J R12-1099-05	FL-PROOF RD 470 J 1/4W TRIMMING POT.(1K)		
K1 S1 S2 S3		*	S51-1052-05 S42-2173-05 S31-3010-05 S31-2136-05	MAGNETIC RELAY MULTIPLE PUSH SWITCH SLIDE SWITCH SLIDE SWITCH (POWER TYPE)	M	
D1 ,2 D1 ,2 D3 -7 D3 -7 D8			HSS104 1SS133 HSS104A 1SS131 S5566B	DIODE DIODE DIODE DIODE DIODE		
D9 ,10 D9 ,10 D11 D12 -20 D21 ,22			HSS104A 1SS131 RBV-602LFA S5566B HSS104	DIODE DIODE DIODE DIODE DIODE		
D21 ,22 IC1 ,2 IC3 ,4			1SS133 UPC4570C-A TC9163N	DIODE IC(OP AMP X2) IC(BILATERAL SWITCH X16)		

E: Scandinavia & Europe K: USA P: Canada
 U: PX(Far East, Hawaii) T: England M: Other Areas
 UE: AAFES(Europe) X: Australia

△ indicates safety critical components.

PARTS LIST

× New Parts
 Parts without Parts No. are not supplied.
 Les articles non mentionnés dans le Parts No. ne sont pas fournis.
 Teile ohne Parts No. werden nicht geliefert.

Ref. No. 参照番号	Address 位置	New Parts 新	Parts No. 部品番号	Description 部品名 / 規格	Desti- nation 仕 向	Re- marks 備考
IC5 IC6 IC7 Q1 -4 Q5 -8 Q9 -12 Q13 ,14 Q17 ,18 Q19 ,20 Q21 ,22 Q27 ,28 Q29 Q31 Q32 Q33			UPC7805HF UPC7812HF UPC4570C-A 2SC2878(B) 2SA992(F,E) 2SC1845(F,E) 2SA992(F,E) 2SC1845(F,E) 2SC2590 2SA1110 2SC945(A)(Q,P) 2SA733(A)(Q,P) 2SA992(F,E) 2SB941 2SC2003(L,K)	IC(VOLTAGE REGULATOR/ +5V) IC(VOLTAGE REGULATOR/ +12V) IC(OP AMP X2) TRANSISTOR TRANSISTOR TRANSISTOR TRANSISTOR TRANSISTOR TRANSISTOR TRANSISTOR TRANSISTOR TRANSISTOR TRANSISTOR TRANSISTOR TRANSISTOR		
CONTROL UNIT (X11-2740-20)						
D201-210 PL1 ,2 C201,202 C203,204 C205,206 C207,208 C209,210 C211,212 C213-216 C217-220 C221,222 C223,224 C225 C226 C229 C230 C231,232 C233,234 C235 C236,237 C238 C239 C241,242 C243,244 C245,246 C247,248 X1 CP201 CP202 R221,222 R225 R249,250 VR201,202 VR203 VR204 S201-213			B30-1223-05 B30-1260-05 CE04KW1H010M CC45FSL1H221J CC45FSL1H101J CK45FB1H222K CE04KW1V4R7M CE04KW1V100M CE04KW1H010M CF92FV1H473J CE04KW1C470M CK45FF1H103Z CE04KW1C470M CK45FF1H103Z CE04KW1H010M CE04KW0J471M C90-1351-05 CK45FF1H103Z CE04KW1C101M CC45FSL1H101J CK45FF1H223Z CE04KW1A101M CE04KW1C101M CE04KW1V100M CC45FSL1H330J CE04KW1V100M L78-0239-05 R90-0202-05 R90-0824-05 RD14GB2E101J RS14KB3A100J RD14GB2E101J R06-3059-05 R01-5052-05 R29-5035-05 S40-1064-05	LED(LN21CPH(V)-C) LAMP ELECTRO 1.0UF 50WV CERAMIC 220PF J CERAMIC 100PF J CERAMIC 2200PF K ELECTRO 4.7UF 35WV ELECTRO 10UF 35WV ELECTRO 1.0UF 50WV MF 0.047UF J ELECTRO 47UF 16WV CERAMIC 0.010UF Z ELECTRO 47UF 16WV CERAMIC 0.010UF Z ELECTRO 1.0UF 50WV ELECTRO 470UF 6.3WV NP-BLEC 3.3UF 50WV CERAMIC 0.010UF Z ELECTRO 100UF 16WV CERAMIC 100PF J CERAMIC 0.022UF Z ELECTRO 100UF 10WV ELECTRO 100UF 16WV ELECTRO 10UF 35WV CERAMIC 33PF J ELECTRO 10UF 35WV RESONATOR MULTI-COMP 47KX4 J 1/6W MULTIPLE RESISTOR FL-PROOF RD 100 J 1/4W FL-PROOF RS 10 J 1W FL-PROOF RD 100 J 1/4W POTENTIOMETER POTENTIOMETER(200K) POTENTIOMETER PUSH SWITCH		

E: Scandinavia & Europe K: USA P: Canada
 U: PX(Far East, Hawaii) T: England M: Other Areas
 UE: AAFES(Europe) X: Australia

△ indicates safety critical components.

PARTS LIST

× New Parts
 Parts without Parts No. are not supplied.
 Les articles non mentionnés dans le Parts No. ne sont pas fournis.
 Teile ohne Parts No. werden nicht geliefert.

Ref. No. 参照番号	Address 位置	New Parts 新	Parts No. 部品番号	Description 部品名 / 規格	Desti- nation 仕向	Re- marks 備考
D214-224			HSS104	DIODE		
D214-224			1SS133	DIODE		
D225			HZS5.1N(B2)	ZENER DIODE		
D225			RD5.1ES(B2)	ZENER DIODE		
IC201			UPC4570C-A	IC(OP AMP X2)		
IC202		*	UPD7538AC-075	IC(MICROPROCESSOR)		
IC203		*	PST524D	IC		
IC204		*	BA6209N	IC(MOTOR DRIVER)		
IC205			UPC4570C-A	IC(OP AMP X2)		
Q201, 202			2SA733(A)(Q,P)	TRANSISTOR		
Q203, 204			2SC2003(L,K)	TRANSISTOR		
A1			W02-0975-05	ELECTRIC CIRCUIT MODULE		

E: Scandinavia & Europe K: USA P: Canada
 U: PX(Far East, Hawaii) T: England M: Other Areas
 UE: AAFES(Europe) X: Australia

⚠ indicates safety critical components.

SYSTEM CONNECTIONS

Basic system connections

Make connection as shown below. When connecting the related system components, refer also to the instruction manuals of the related components.

Do not plug in the power lead until all connections are complete.

T-93L (for M-83 system)

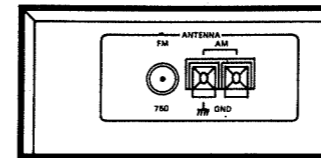

Tuner T-93 (for M-833 system)

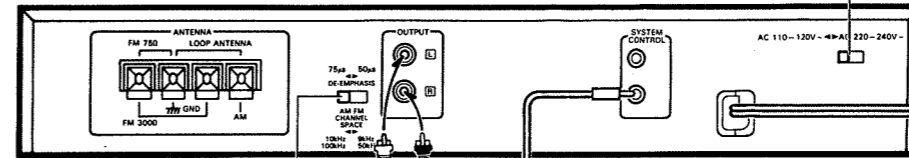

Amplifier A-83

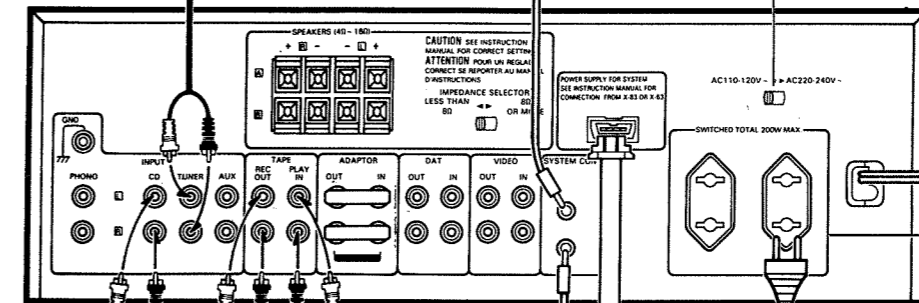

Cassette deck X-83, 63

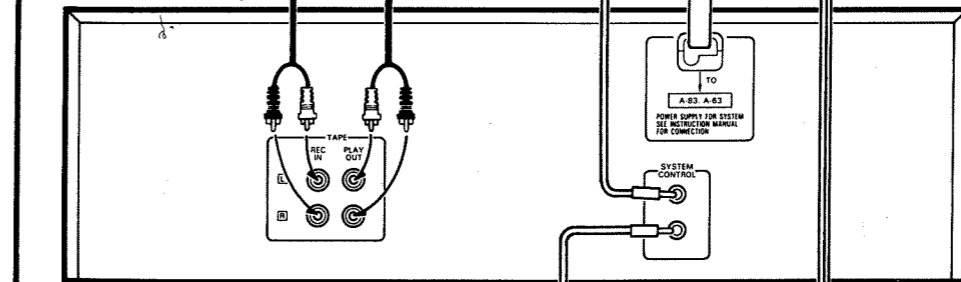

Audio cord

* CD player (DP-730, optional)

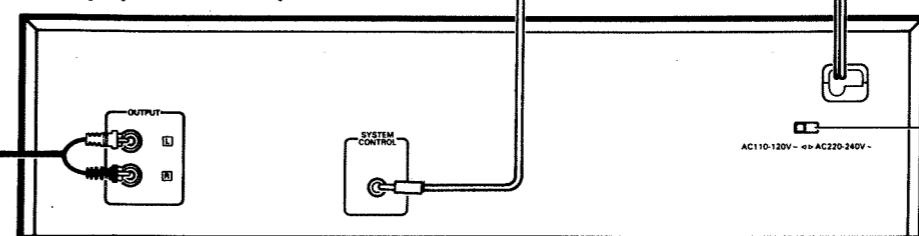

*** IMPORTANT:**
 This option may not be available in some areas. For details on options, consult your dealer.

Voltage selector (except for some areas)

To AC outlet

Voltage selector (except for some areas)

To AC outlet

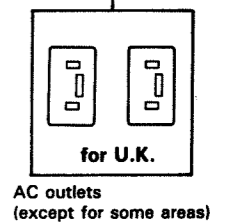

Voltage selector (except for some areas)

SPECIFICATIONS

(for Europe and U.K.)

A-83

Continuous power output	
DIN at 1 kHz 8 Ω	75 W + 75 W
IEC/NF at 8 Ω	74 W + 74 W
Total harmonic distortion	
at 1/2 rated power	0.09%
Signal to noise ratio (IHF '66)	
PHONO (MM)	77 dB
CD, TUNER, AUX, TAPE	100 dB
Signal to noise ratio (DIN at 50 mW output)	
PHONO (MM)	57 dB
CD, TUNER, AUX, TAPE	58 dB
Input sensitivity/Impedance	
PHONO (MM)	2.5 mV/47 kΩ
CD, TUNER, AUX, TAPE	150 mV/47 kΩ
Frequency response	
(10 Hz to 100,000 Hz)	+0 dB, -3 dB
Tone Controls	
BASS	± 10 dB (at 100 Hz)
TREBLE	± 10 dB (at 10 kHz)
Output level/Impedance	
TAPE REC	150 mV/3.3 kΩ
General	
Power consumption	150 W
Dimension	W: 360 mm H: 129 mm D: 371 mm
Weight (net)	7.8 kg

(Except for Europe and U.K.)

A-83

Continuous power output	
From 20 Hz to 20 kHz, 0.09% T.H.D. at 8 Ω	65 W + 65 W
Maximum useful power output	
(EIAJ at 8 Ω)	95 W + 95 W
Total harmonic distortion	
at rated power	0.09%
Signal to noise ratio (IHF '66)	
PHONO (MM)	77 dB
CD, TUNER, AUX, TAPE	100 dB
Input sensitivity/Impedance	
PHONO (MM)	2.5 mV/47 kΩ
CD, TUNER, AUX, TAPE	150 mV/47 kΩ
Frequency response	
(10 Hz to 100,000 Hz)	+0 dB, -3 dB
Tone controls	
BASS	± 10 dB (at 100 Hz)
TREBLE	± 10 dB (at 10 kHz)
Output level/Impedance	
TAPE REC	150 mV/3.3 kΩ
General	
Power consumption	150 W
Dimension	W: 360 mm H: 129 mm D: 371 mm
Weight (net)	7.8 kg

Note:

KENWOOD follows a policy of continuous advancements in development. For this reason specifications may be changed without notice.

KENWOOD CORPORATION

Shionogi Shibuya Building, 17-5, 2-chome Shibuya, Shibuya-ku, Tokyo 150, Japan

KENWOOD U.S.A. CORPORATION
2201 East Dominguez Street, Long Beach, CA 90810;
550 Clark Drive, Mount Olive, NJ 07828, U.S.A.

KENWOOD ELECTRONICS CANADA INC.
P.O. BOX 1075, 959 Gana Court, Mississauga, Ontario, Canada L4T 4C2

TRIO-KENWOOD U.K. LIMITED
KENWOOD House, Dwight Road, Watford, Herts., WD1 8EB United Kingdom

KENWOOD ELECTRONICS BENELUX N.V.
Mechelsesteenweg 418 B-1930 Zaventem, Belgium

KENWOOD ELECTRONICS DEUTSCHLAND GMBH
Rembrücker-Str. 15, 6056 Heusenstamm, West Germany

TRIO-KENWOOD FRANCE S.A.
13 Boulevard Ney, 75018 Paris, France

KENWOOD LINEAR S.p.A.
20125, MILANO-VIA ARBE, 50, ITALY

KENWOOD ELECTRONICS AUSTRALIA PTY. LTD. (INCORPORATED IN N.S.W.)
4E Woodcock Place, Lane Cove, N.S.W. 2066, Australia

KENWOOD & LEE ELECTRONICS, LTD.
Wang Kee Building, 4th Floor, 34-37, Connaught Road, Central, Hong Kong