

PC BOARD (Component side view)

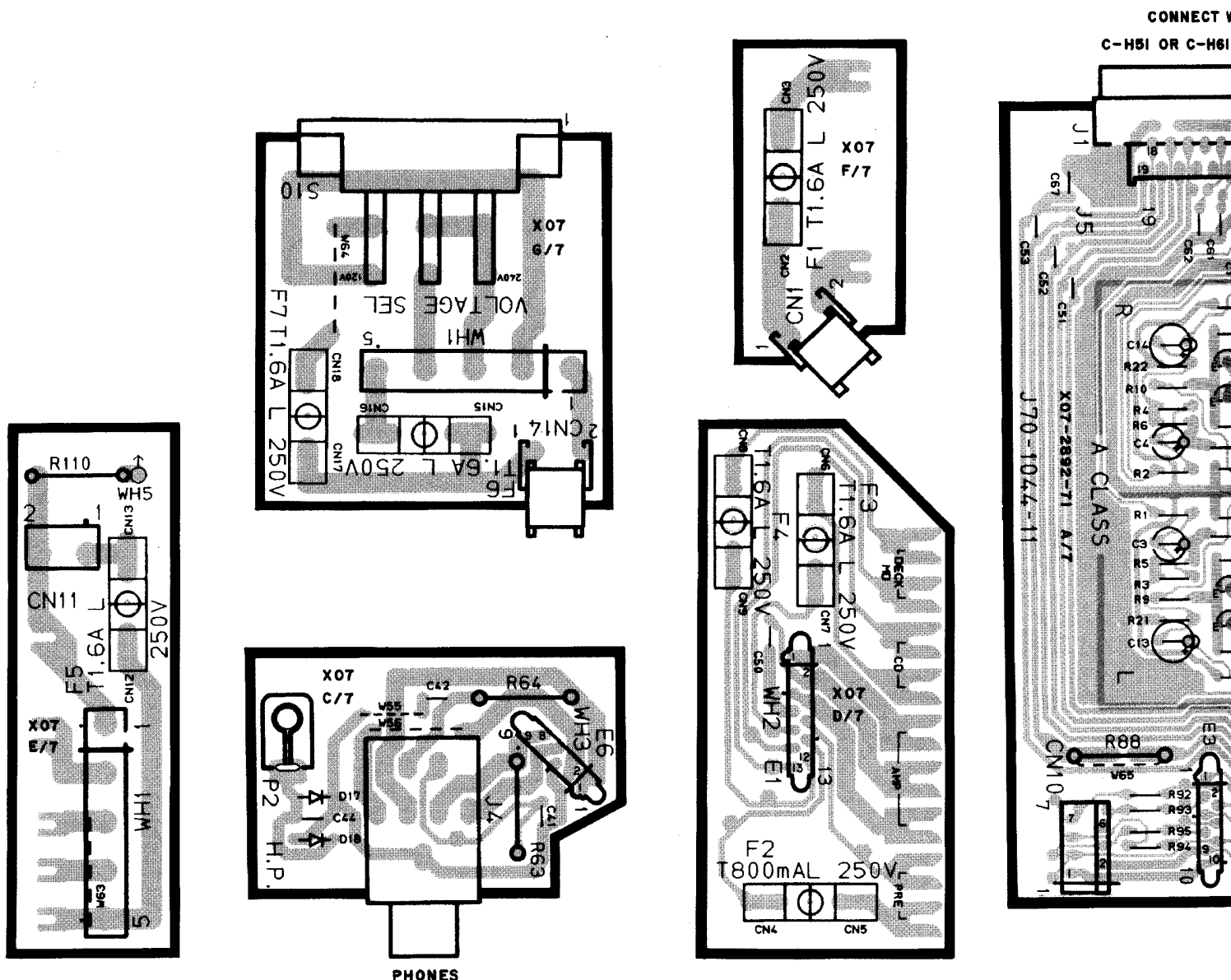

PHONES

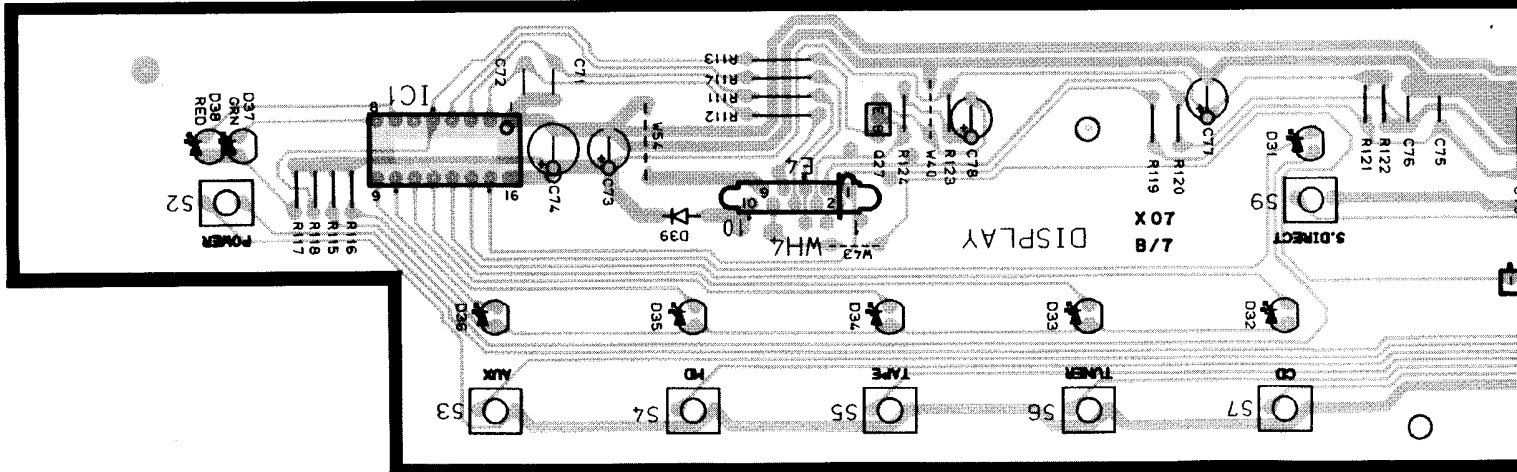

Refer to the schematic diagram for the values of resistors and capacitors.

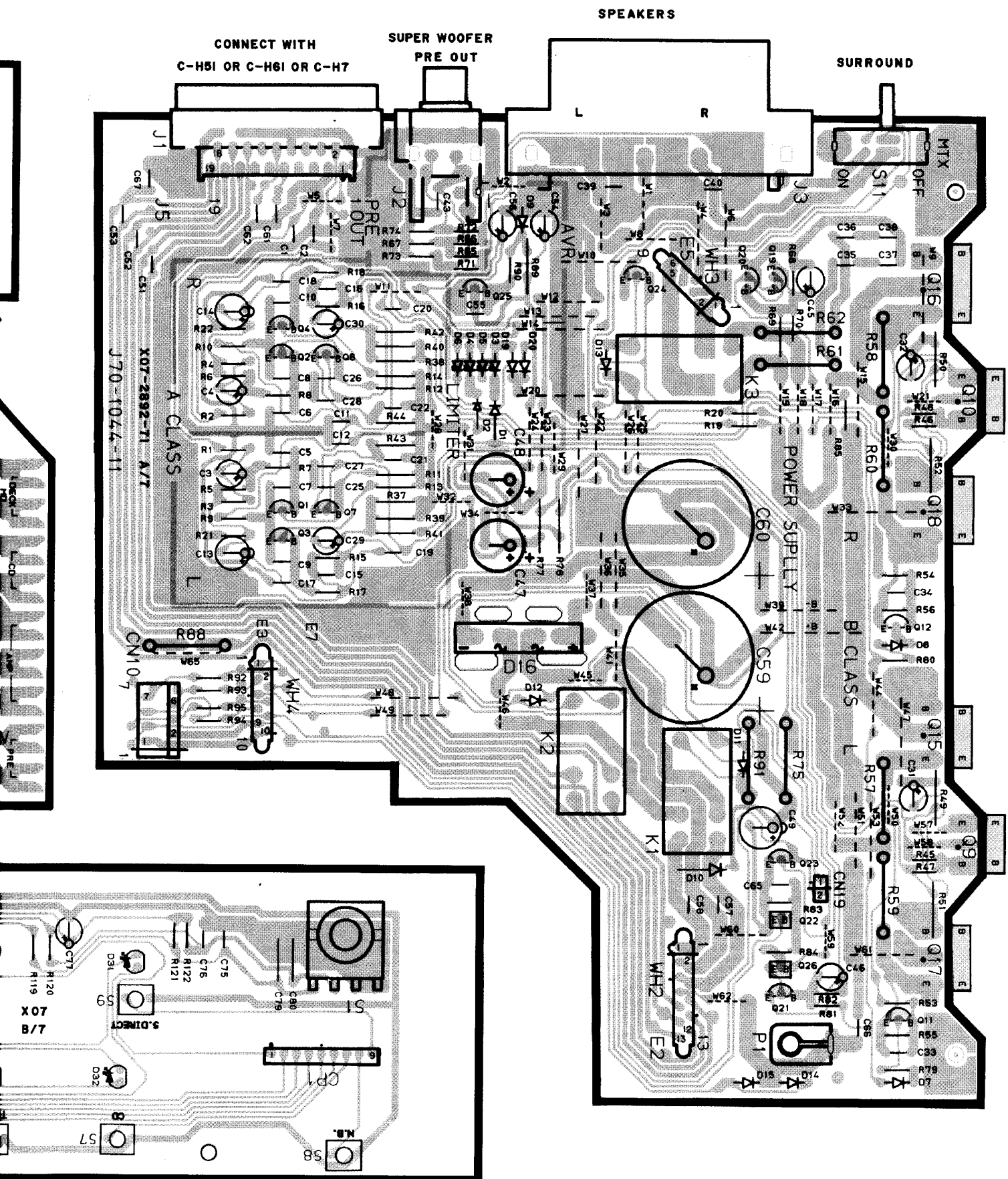

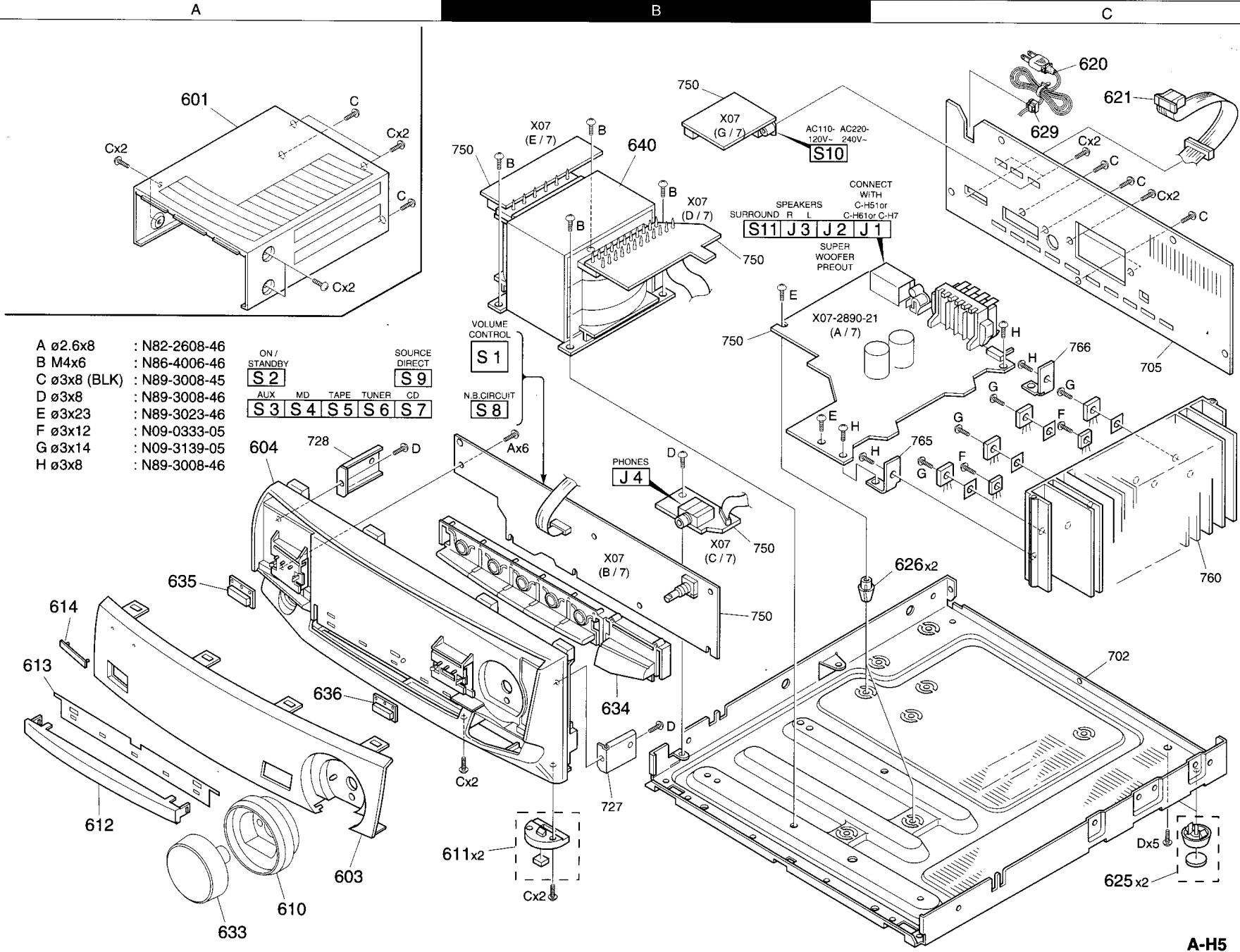

EXPLODED VIEW

A-H5

(X07-2890-11) (A/7) Note : Set input level to minimum before power on.

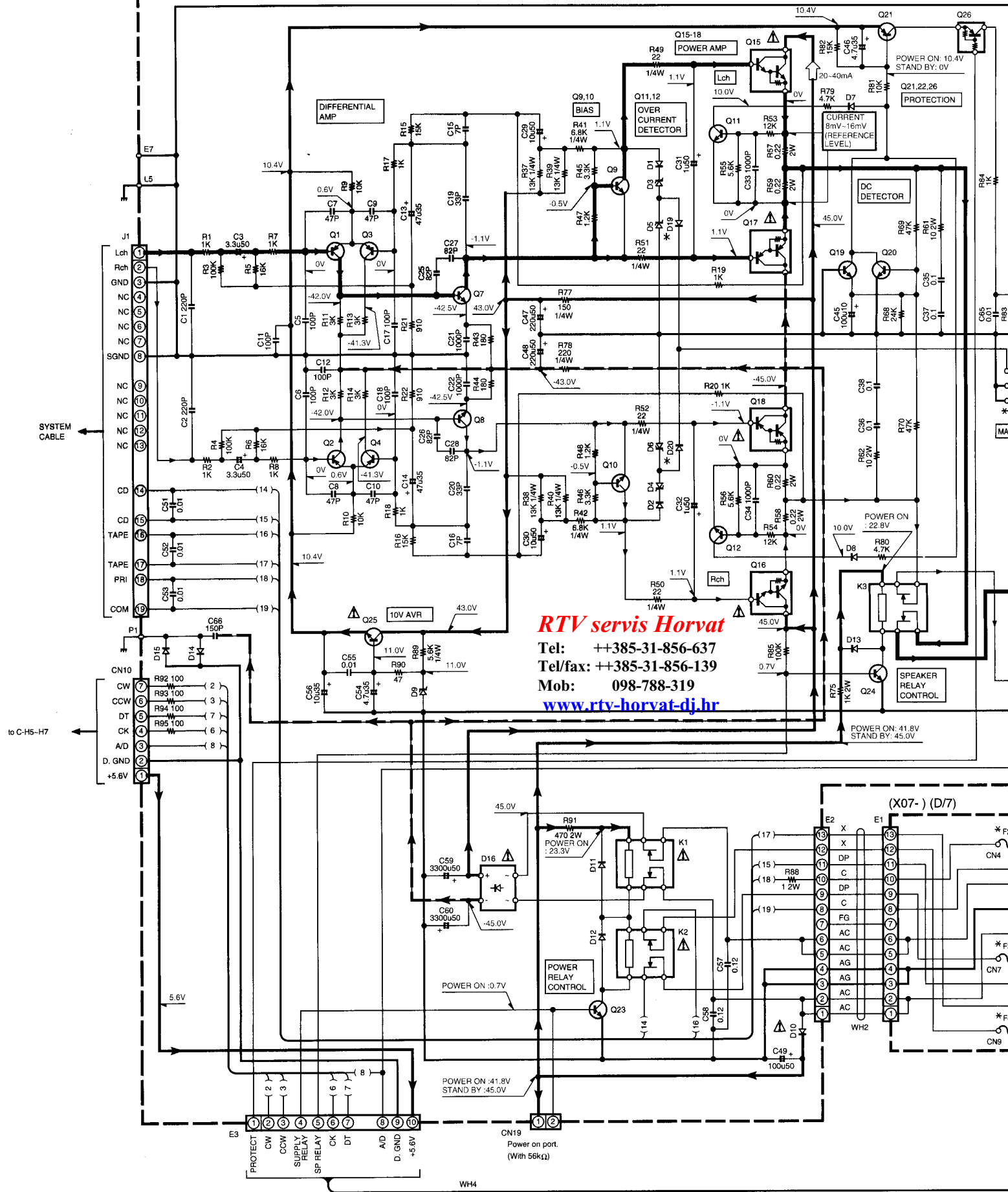

RTV servis Horvat
 Tel: ++385-31-856-637
 Tel/fax: ++385-31-856-139
 Mob: 098-788-319
www.rtv-horvat-dj.hr

DESTINATION		UNIT No.	F2	F3,4	F5
COUNTRY	ABB.				
U.S.A.	K	X07-2890-11	2A 125V	2.5A 125V	Y
PX	Y	X07-2890-21	T800mA L 250V	T1.6A L 250V	N
GENERAL MARKET	M				
MALAYSIA	I				
U.K.	T	X07-2892-71	T800mA L 250V	T1.6A L 250V	N
EUROPE	E				
RUSSIA	Q				

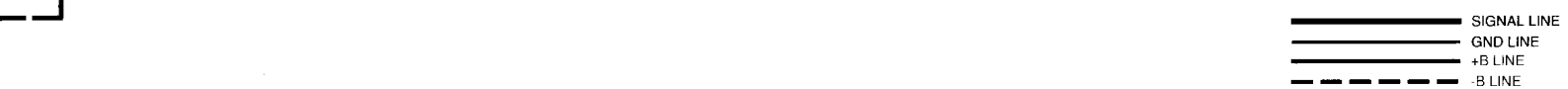
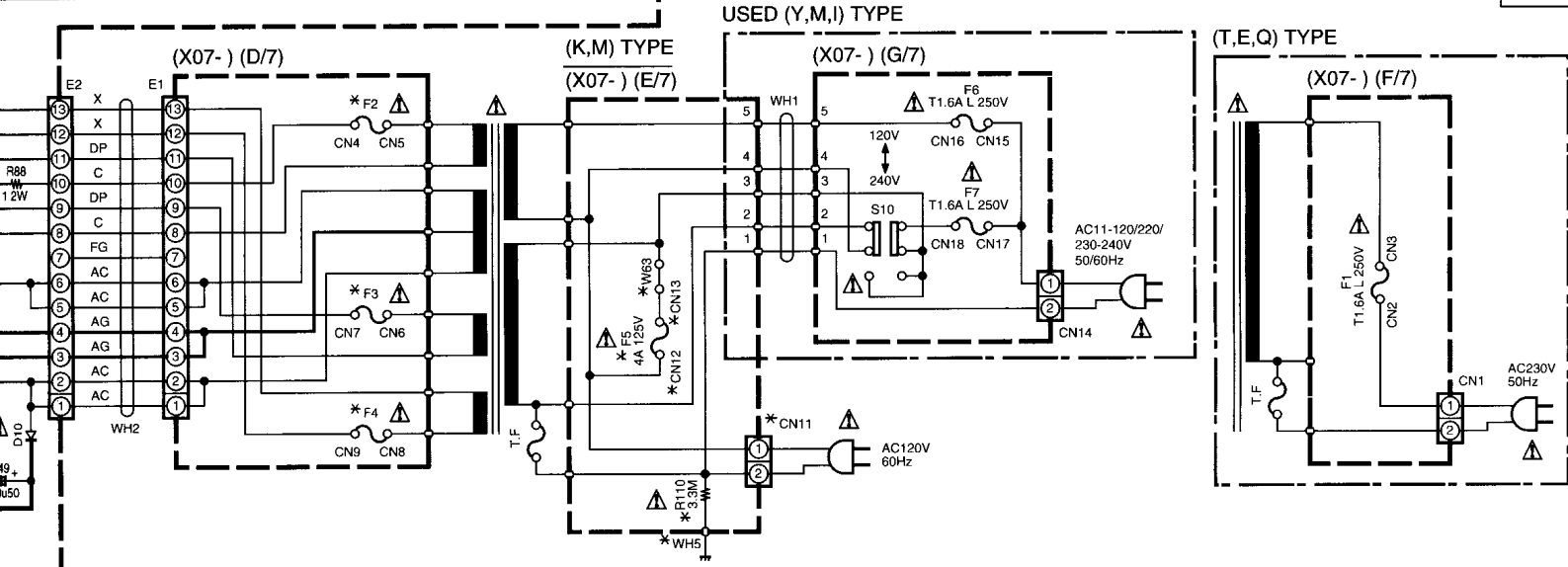
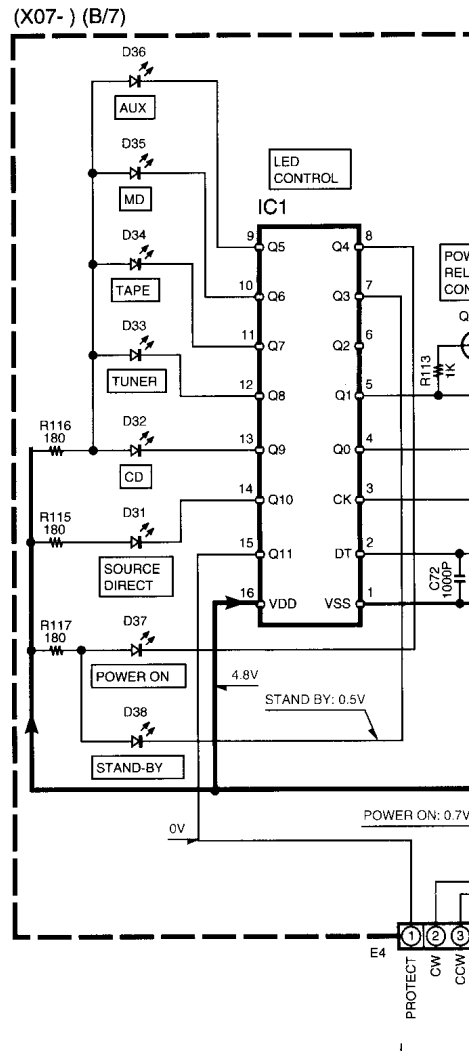
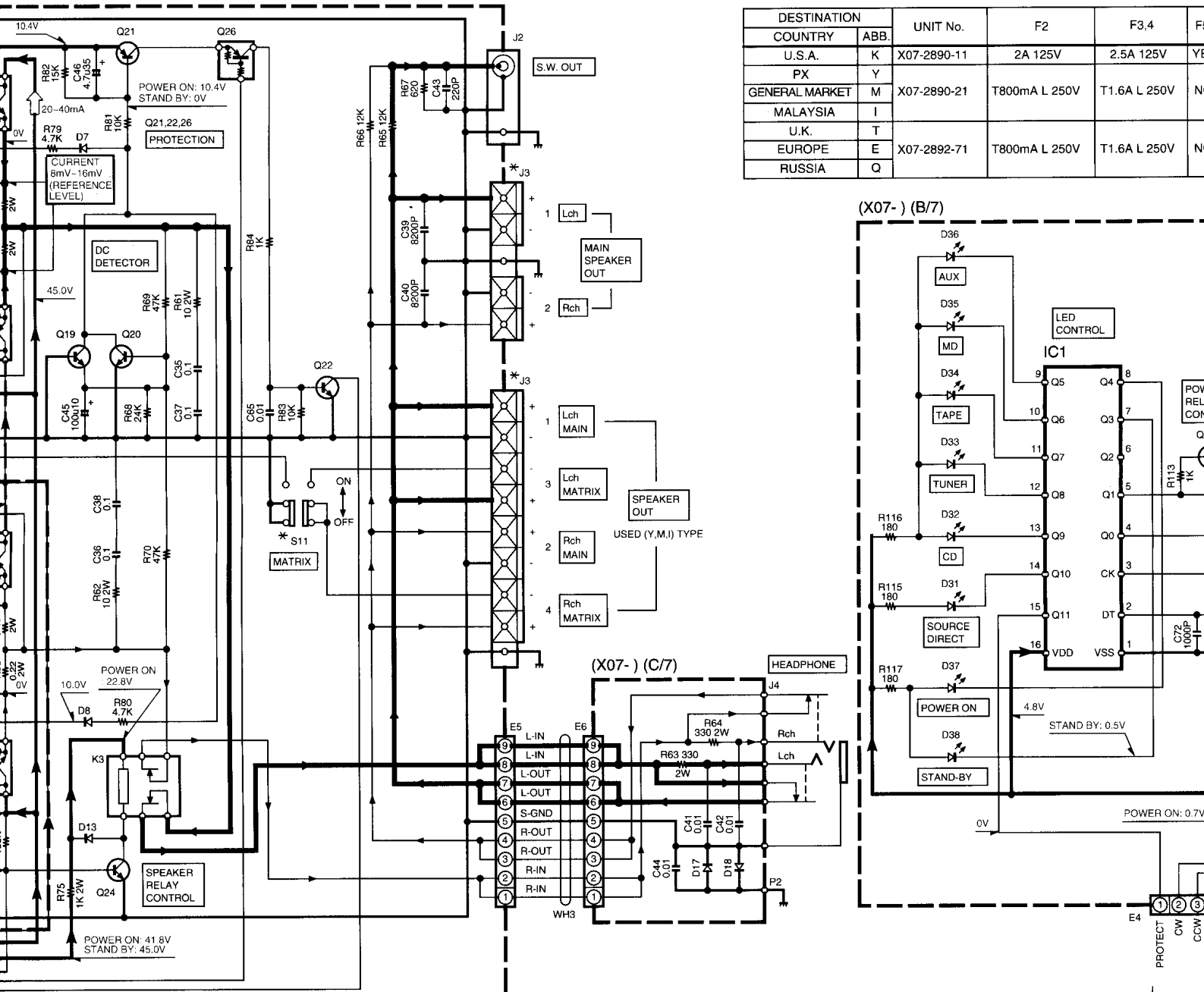

——— SIGNAL LINE
 ——— GND LINE
 ——— +B LINE
 - - - - - B LINE

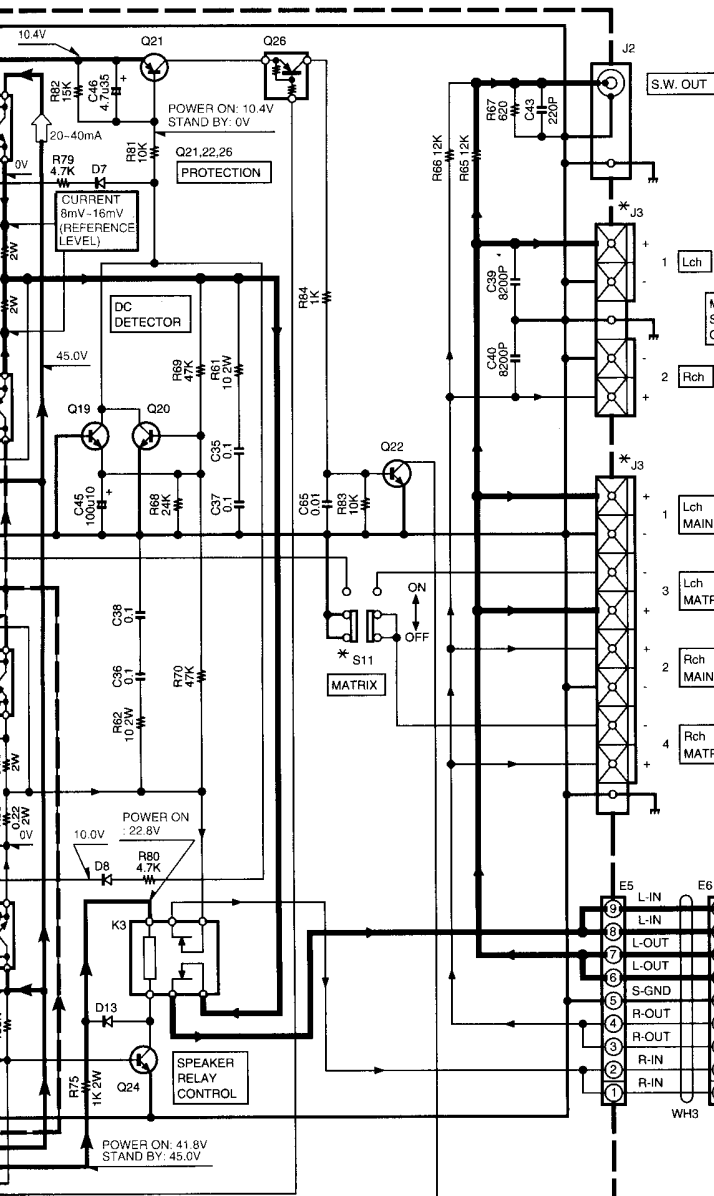

DESTINATION COUNTRY	ABB.	UNIT No.	F2	F3,4	F5	J3	D19,20	S1
U.S.A.	K	X07-2890-11	2A 125V	2.5A 125V	YES	4P	NO	NO
GENERAL MARKET	Y	X07-2890-21	T800mA L 250V	T1.6A L 250V	NO	8P	YES	YES
MALAYSIA	I							
U.K.	T	X07-2892-71	T800mA L 250V	T1.6A L 250V	NO	4P	NO	NO
EUROPE	E							
RUSSIA	Q							

RTV servis Horvat
 Tel: ++385-31-856-637
 Tel/fax: ++385-31-856-139
 Mob: 098-788-319
www.rtv-horvat-dj.hr

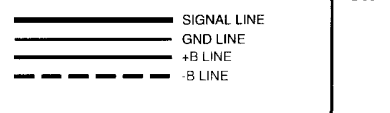
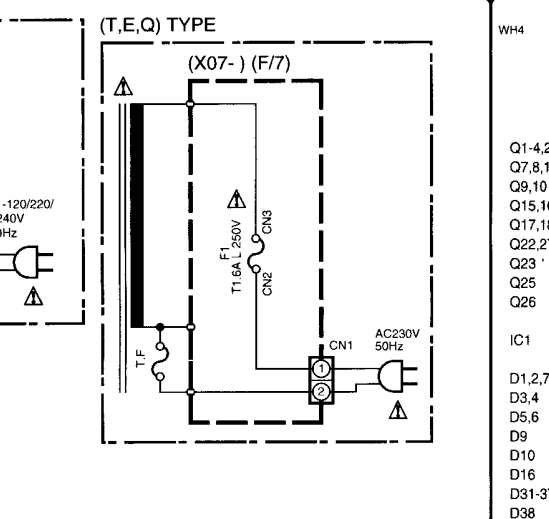
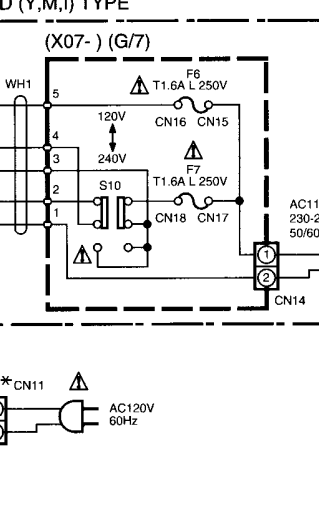
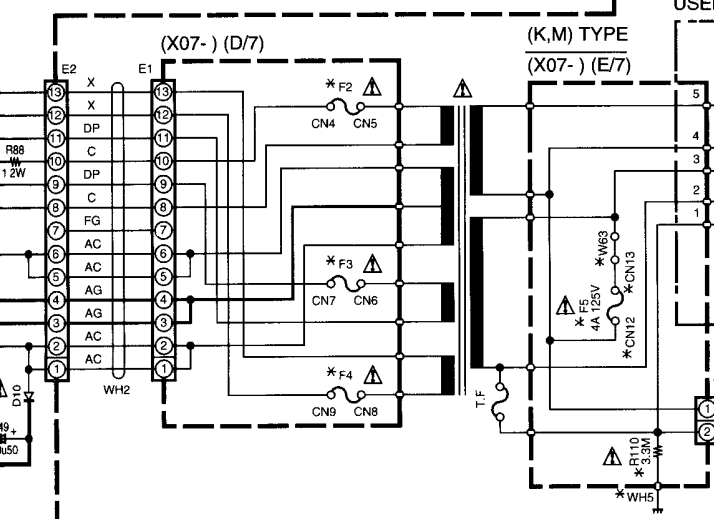
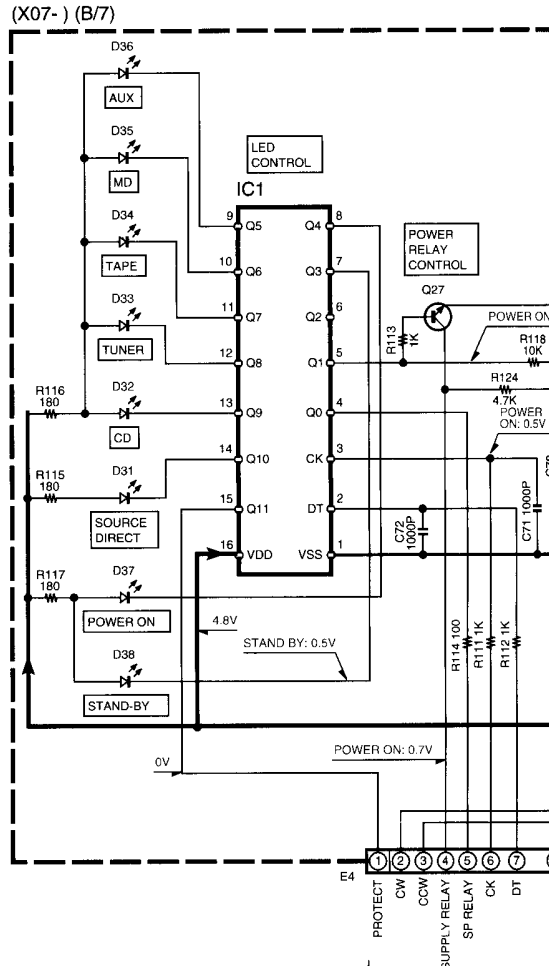

	F3,4	F5	J3	D19,20	S11	W63	WH5	CN11-13	R110
	2.5A 125V	YES	4P	NO	NO	YES	YES	YES	YES
50V	T1.6A L 250V	NO	8P	YES	YES	NO	NO	NO	NO
50V	T1.6A L 250V	NO	4P	NO	NO	NO	NO	NO	NO

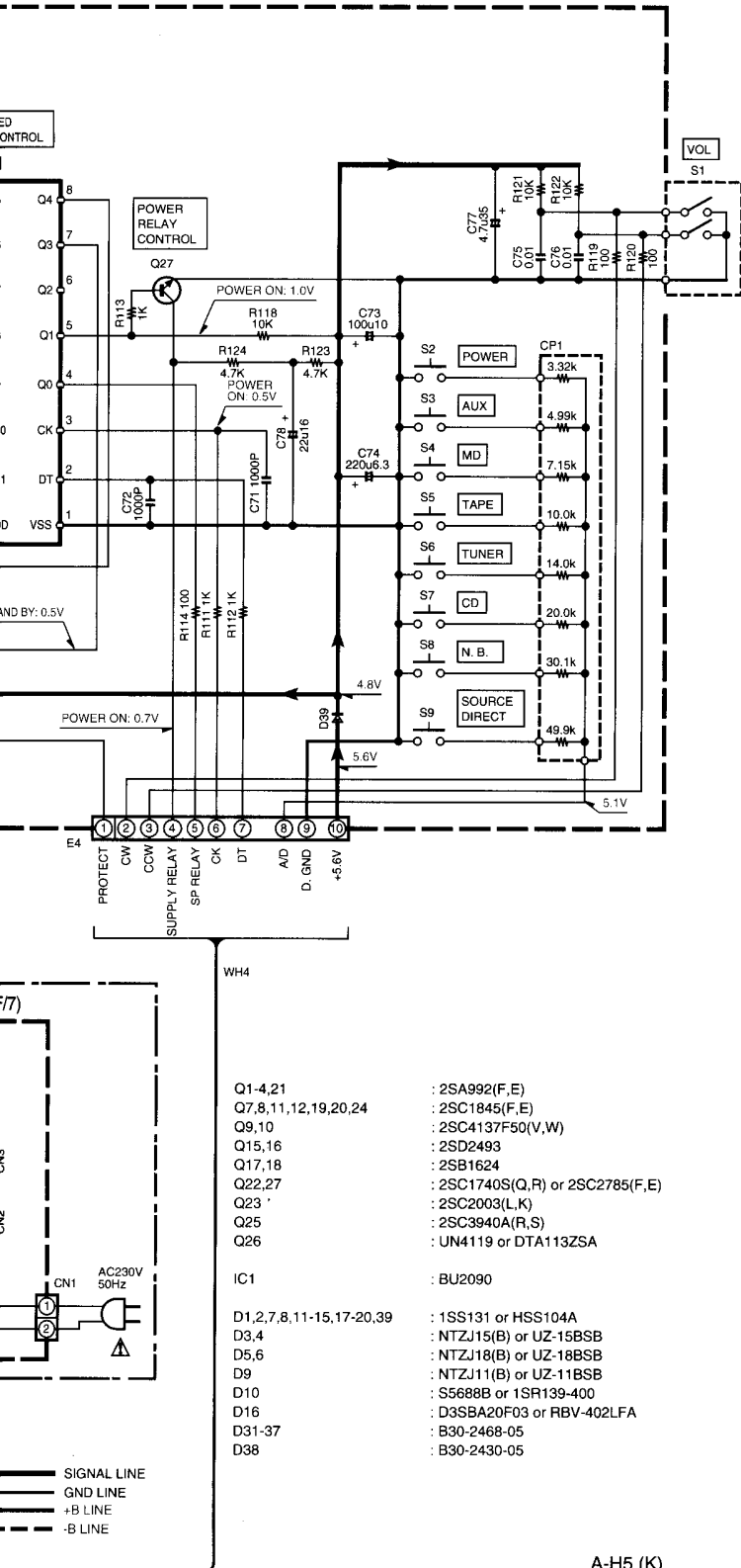

- | | |
|-------------------------|---------------------------------|
| Q1-4,21 | : 2SA992(F,E) |
| Q7,8,11,12,19,20,24 | : 2SC1845(F,E) |
| Q9,10 | : 2SC4137F50(V,W) |
| Q15,16 | : 2SD2493 |
| Q17,18 | : 2SB1624 |
| Q22,27 | : 2SC1740S(Q,R) or 2SC2785(F,E) |
| Q23 | : 2SC2003(L,K) |
| Q25 | : 2SC3940A(R,S) |
| Q26 | : UN4119 or DTA113ZSA |
| IC1 | : BU2090 |
| D1,2,7,8,11-15,17-20,39 | : 1SS131 or HSS104A |
| D3,4 | : NTZJ15(B) or UZ-15BSB |
| D5,6 | : NTZJ18(B) or UZ-18BSB |
| D9 | : NTZJ11(B) or UZ-11BSB |
| D10 | : S5688B or 1SR139-400 |
| D16 | : D3SBA20F03 or RBV-402LFA |
| D31-37 | : B30-2468-05 |
| D38 | : B30-2430-05 |

A-H5 (K)

2SA992
2SC1845
2SC2003
2SC3940A

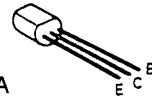

2SB1624
2SD2493

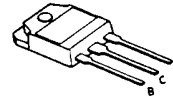

2SC2785

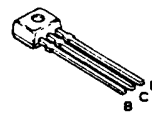

DTA113ZSA
2SC1740S

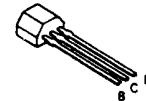

2SC4137F50

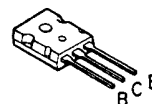

BU2090

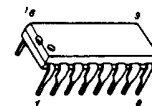

CAUTION: For continued safety, replace safety critical components only with manufacturer's recommended parts (refer to parts list). Δ indicates safety critical components. For continued protection against risk of fire, replace only with same type and rating fuse(s). To reduce the risk of electric shock, leakage-current or resistance measurements shall be carried out (exposed parts are acceptably insulated from the supply circuit) before the appliance is returned to the customer.

The DC voltage is an actual reading measured with a high impedance type voltmeter with no signal input. The measurement value may vary depending on the measuring instruments used or on the product.

* New Parts
Parts without **Parts No.** are not supplied.
Les articles non mentionnés dans le **Parts No.** ne sont pas fournis.
Teile ohne **Parts No.** werden nicht geliefert.

1

Ref. No	Add-ress	New Parts	Parts No.	Description	Desti-nation	Re-marks
A-H5						
601	1A	*	A01-3367-01	METALLIC CABINET (SLVR)		
601	1A	*	A01-3416-01	METALLIC CABINET (BLK)	TEQ	
603	2A	*	A21-1914-02	DRESSING PANEL (SLVR)		
603	2A	*	A21-1935-02	DRESSING PANEL (BLK)	TEQ	
604	1A	*	A60-1008-01	PANEL (SLVR)		
604	1A	*	A60-1037-01	PANEL (BLK)	TEQ	
610	2A	*	B07-2331-03	ESCUTCHEON (SLVR)		
610	2A	*	B07-2332-03	ESCUTCHEON (BLK)	TEQ	
611	2B	*	B07-2335-04	ESCUTCHEON		
612	2A	*	B10-2308-03	FRONT GLASS		
613	2A	*	B11-0348-04	SMOKED FILTER		
614	2A		B43-0301-04 B58-0513-04	KENWOOD BADGE CAUTION CARD (PRESET220-240)	Y	
620	1C		E30-2592-15	AC POWER CORD	MIEQ	
620	1C		E30-2605-05	AC POWER CORD	Y	
620	1C		E30-2650-05	AC POWER CORD	K	
620	1C		E30-2829-05	AC POWER CORD	T	
621	1C	*	E30-2847-05	CORD WITH CONNECTOR		
		*	H10-7242-02	POLYSTYRENE FOAMED FIXTURE	KYMIEQ	
		*	H10-7243-02	POLYSTYRENE FOAMED FIXTURE	KYMIEQ	
		*	H10-7244-02	POLYSTYRENE FOAMED FIXTURE	T	
		*	H10-7245-02	POLYSTYRENE FOAMED FIXTURE	T	
		*	H25-0681-04	PROTECTION BAG		
		*	H50-2142-04	ITEM CARTON CASE	KY	
		*	H50-2143-04	ITEM CARTON CASE	MI	
		*	H50-2144-04	ITEM CARTON CASE (BLK)	T	
		*	H50-2328-04	ITEM CARTON CASE (SLVR)	T	
		*	H50-2355-04	ITEM CARTON CASE (BLK)	EQ	
		*	H50-2356-04	ITEM CARTON CASE (SLVR)	EQ	
625	2C		J02-0366-15	FOOT		
625	2C		J19-3752-14	UNIT HOLDER		
629	1C		J42-0083-05	POWER CORD BUSHING		
629	1C		J61-0307-05	WIRE BAND		
633	2A	*	K29-6486-04	KNOB (SLVR)		
633	2A	*	K29-6600-04	KNOB (BLK)	TEQ	
634	2B	*	K29-6488-02	KNOB (SLVR)		
634	2B	*	K29-6601-02	KNOB (BLK)	TEQ	
635	2A	*	K29-6559-04	KEY TOP	K	
635	2A	*	K29-6712-04	KEY TOP	YMITEQ	
636	2A	*	K29-6602-04	KEY TOP		
640	1B	*	L07-2227-05	POWER TRANSFORMER	TE	
640	1B	*	L07-2228-05	POWER TRANSFORMER	YMI	
640	1B	*	L07-2229-05	POWER TRANSFORMER	Q	
640	1B	*	L07-2232-05	POWER TRANSFORMER	K	
POWER (X07-2890-11)						
D31 -37			B30-2468-05	LED		
D38			B30-2430-05	LED(RED)		
C1 ,2			CC45FSL1H221J	CERAMIC 220PF J		
C3 ,4			CE04KW1H3R3M	ELECTRO 3.3UF 50WV		
C5 ,6			CC45FSL1H101J	CERAMIC 100PF J		
C7 -10			CC45FSL1H470J	CERAMIC 47PF J		
C11 ,12			CC45FSL1H101J	CERAMIC 100PF J		

L : Scandinavia K : USA P : Canada R : Mexico I : Malaysia
Y : PX(Far East, Hawaii) T : Europe E : Europe G : Germany Q : Russia
Y : AAFES(Europe) X : Australia M : Other Areas

△ indicates safety critical components.

* New Parts
Parts without **Parts No.** are not supplied.
Les articles non mentionnés dans le **Parts No.** ne sont pas fournis.
Teile ohne **Parts No.** werden nicht geliefert.

2

Ref. No	Add-ress	New Parts	Parts No.	Description	Desti-nation	Re-marks
C13 ,14			CE04KW1V470M	ELECTRO 47UF 35WV		
C15 ,16			CC45FSL1H070D	CERAMIC 7.0PF D		
C17 ,18			CC45FSL1H101J	CERAMIC 100PF J		
C19 ,20			CC45FSL1H330J	CERAMIC 33PF J		
C21 ,22			CK45FB1H102K	CERAMIC 1000PF K		
C25 -28			CC45FSL1H820J	CERAMIC 82PF J		
C29 ,30			CE04KW1H100M	ELECTRO 10UF 50WV		
C31 ,32			CE04KW1H010M	ELECTRO 1.0UF 50WV		
C33 ,34			CK45FB1H102K	CERAMIC 1000PF K		
C35 -38			CF92FV1H104J	MF-C 0.10UF J		
C39 ,40			CQ93FMG1H822J	MYLAR 8200PF J		
C41 ,42			CK45FF1H103Z	CERAMIC 0.010UF Z		
C43			CC45FSL1H221J	CERAMIC 220PF J		
C44			CK45FF1H103Z	CERAMIC 0.010UF Z		
C45			CE04KW1A101M	ELECTRO 100UF 10WV		
C46			CE04KW1V4R7M	ELECTRO 4.7UF 35WV		
C47 ,48			CE04KW1H221M	ELECTRO 220UF 50WV		
C49			CE04KW1H101M	ELECTRO 100UF 50WV		
C51 -53			CK45FF1H103Z	CERAMIC 0.010UF Z		
C54			CE04KW1V4R7M	ELECTRO 4.7UF 35WV		
C55			CK45FF1H103Z	CERAMIC 0.010UF Z		
C56			CE04KW1V100M	ELECTRO 10UF 35WV		
C57 ,58			CF92FV1H124J	MF-C 0.12UF J		
C59 ,60		*	C90-3720-05	ELECTRO 3300UF 50WV		
C65			CK45FF1H103Z	CERAMIC 0.010UF Z		
C66			CC45FSL1H151J	CERAMIC 150PF J		
C71 ,72			CK45FB1H102K	CERAMIC 1000PF K		
C73			CE04KW1A101M	ELECTRO 100UF 10WV		
C74			CE04KW0J221M	ELECTRO 220UF 6.3WV		
C75 ,76			CK45FF1H103Z	CERAMIC 0.010UF Z		
C77			CE04KW1V4R7M	ELECTRO 4.7UF 35WV		
C78			CE04KW1C220M	ELECTRO 22UF 16WV		
CN1			E40-4632-05	PIN ASSY	TEQ	
CN10			E40-4297-05	FLAT CABLE CONNECTOR		
CN11			E40-4245-05	PIN ASSY	K	
CN14			E40-4632-05	PIN ASSY	YMI	
CN19			E40-4871-05	PIN ASSY		
J1			E58-0006-05	RECTANGULAR RECEPTACLE		
J2			E63-0164-05	PHONO JACK (SUPER WOOFER)		
J3			E70-0056-05	LOCK TERMINAL BOARD (SP)	YMI	
J3			E70-0057-05	LOCK TERMINAL BOARD (SP)	KTEQ	
J4			E11-0280-05	PHONE JACK (HEADPHONE)		
△ F1			F05-1623-05	FUSE (SEMKO) (250V T1.6AL)	TEQ	
△ F2			F05-8013-05	FUSE (SEMKO) (250V T800MAL)	YMITEQ	
△ F2			F50-0069-05	FUSE(5X20)	K	
△ F3 ,4			F05-1623-05	FUSE (SEMKO) (250V T1.6AL)	YMITEQ	
△ F3 ,4			F50-0070-05	FUSE(5X20)	K	
△ F5			F50-0073-05	FUSE(5X20)	K	
△ F6 ,7			F05-1623-05	FUSE (SEMKO) (250V T1.6AL)	YMI	
CN2 -9			J13-0075-05	FUSE CLIP	TEQ	
CN4 -9			J13-0075-05	FUSE CLIP	KYMI	
CN12,13			J13-0075-05	FUSE CLIP	K	
CN15-18			J13-0075-05	FUSE CLIP	YMI	
E7			J11-0808-05	WIRE CLAMPER		
CP1		*	R90-0954-05	MULTIPLE RESISTOR		
R49 -52			RD14NB2E220J	RD 22 J 1/4W		

L : Scandinavia K : USA P : Canada R : Mexico I : Malaysia
Y : PX(Far East, Hawaii) T : Europe E : Europe G : Germany Q : Russia
Y : AAFES(Europe) X : Australia M : Other Areas

△ indicates safety critical components.

PARTS LIST

A-H5

PARTS LIST

* New Parts without **Parts No.** are not supplied.
 Les articles non mentionnés dans le **Parts No.** ne sont pas fournis.
 Teile ohne **Parts No.** werden nicht geliefert.

Ref. No	Add-ress	New Parts	Parts No.	Description	Power	Desti-nation	Re-marks
R57 -60			RS14KB3DR22J	FL-PROOF RS	2W		
R61 ,62			RS14KB3D100J	FL-PROOF RS	2W		
R63 ,64			RS14KB3D331J	FL-PROOF RS	2W		
R75			RS14KB3D102J	FL-PROOF RS	2W		
R77			RD14NB2E151J	RD	1/4W		
R78			RD14NB2E221J	RD	1/4W		
R88			RS14KB3D1R0J	FL-PROOF RS	2W		
R89			RD14NB2E562J	RD	1/4W		
R91			RS14KB3D471J	FL-PROOF RS	2W		
R110			R92-1844-05	CARBON	1/2W		K
K1 ,2			S76-0060-05	MAGNETIC RELAY			
K3			S76-0061-05	MAGNETIC RELAY			
S2 -9			S70-0031-05	TACT SWITCH			
S10			S62-0001-05	SLIDE SWITCH (VOLTAGE)			YMI
S11			S62-0050-05	SLIDE SWITCH (MATRIX)			YMI
S1			T99-0559-05	ROTARY ENCODER (VOLUME)			
D1 ,2			HSS104A	DIODE			
D1 ,2			TSS131	DIODE			
D3 ,4			MTZJ15(B)	ZENER DIODE			
D3 ,4			UZ-15BSB	ZENER DIODE			
D5 ,6			MTZJ18(B)	ZENER DIODE			
D5 ,6			UZ-18BSB	ZENER DIODE			
D7 ,8			HSS104A	DIODE			
D7 ,8			TSS131	DIODE			
D9			MTZJ11(B)	ZENER DIODE			
D9			UZ-11BSB	ZENER DIODE			
D10			S5688B	DIODE			
D10			TSR139-400	DIODE			
D11 -15			HSS104A	DIODE			
D11 -15			TSS131	DIODE			
D16			D3SBA20F03	DIODE			
D16			RBV-402LFA	DIODE			
D17 -20			HSS104A	DIODE			
D17 -20			TSS131	DIODE			
D17 ,18			HSS104A	DIODE			
D17 ,18			TSS131	DIODE			
D39			HSS104A	DIODE			YMI
D39			TSS131	DIODE			YMI
IC1			BU2090	ANALOGUE IC			KTEQ
Q1 -4			2SA992(F,E)	TRANSISTOR			KTEQ
Q7 ,8			2SC1845(F,E)	TRANSISTOR			KTEQ
Q9 ,10			2SC4137F50(V,W)	TRANSISTOR			
Q11 ,12			2SC1845(F,E)	TRANSISTOR			
Q15 ,16			2SD2493	TRANSISTOR			
Q17 ,18			2SB1624	TRANSISTOR			
Q19 ,20			2SC1845(F,E)	TRANSISTOR			
Q21			2SA992(F,E)	TRANSISTOR			
Q22			2SC1740S(Q,R)	TRANSISTOR			
Q22			2SC2785(F,E)	TRANSISTOR			
Q23			2SC2003(L,K)	TRANSISTOR			
Q24			2SC1845(F,E)	TRANSISTOR			
Q25			2SC3940A(R,S)	TRANSISTOR			
Q26			DTA113ZSA	DIGITAL TRANSISTOR			
Q26			UN4119	DIGITAL TRANSISTOR			
Q27			2SC1740S(Q,R)	TRANSISTOR			
Q27			2SC2785(F,E)	TRANSISTOR			

L : Scandinavia
 I : Malaysia
 Y : PX(Far East, Hawaii)
 R : Mexico
 G : Germany
 K : USA
 P : Canada
 E : Europe
 M : Other Areas
 X : Australia
 Q : Russia
 Δ indicates safety critical components.

SPECIFICATIONS

Amplifier section

Rated power output
80 W + 80 W (1 kHz, 10 % T.H.D. at 6 Ω)
60 W + 60 W (1 kHz, 0.7 % T.H.D. at 6 Ω)
 Total harmonic distortion.....0.09 % (1 kHz, 30 W, 6 Ω)
 Signal to noise ratio
 Line (AUX, MD)
90 dB (1HF'A) (SOURCE DIRECT ON)
 Input sensitivity / Impedance
 Line (AUX, MD)200 mV / 47 kΩ
 MIC.....1.6 mV / 600 Ω
 Output level / Impedance
 SUPER WOOFER PRE OUT
2.0 V / 2.2 kΩ (SOURCE DIRECT ON)
 MD REC200 mV / 2.2 kΩ

[General]

Power consumption180 W
 Dimension.....W : 270 mm (10-5 / 8")
 H : 104 mm (4-1 / 8")
 D : 343 mm (13-1 / 2")
 Weight (net)4.6 kg (10.2 lb)

RTV servis Horvat

Tel: ++385-31-856-637
 Tel/fax: ++385-31-856-139
 Mob: 098-788-319
www.rtv-horvat-dj.hr



1. KENWOOD follows a policy of continuous advancements in development. For this reason specifications may be changed without notice.
2. The full performance may not be exhibited in an extremely cold location (under a water freezing temperature)
3. Some items are C-H5-7.

Note:

Component and circuitry are subject to modification to insure best operation under differing local conditions. This manual is based on Europe (E) standard, and provides information on regional circuit modification through use of alternate schematic diagrams, and information on regional component variations through use of parts list.

KENWOOD CORPORATION

14-6,Dogenzaka 1-chome, Shibuya-ku, Tokyo, 150 Japan

KENWOOD SERVICE CORPORATION

P.O. BOX 22745, 2201 East Dominguez St., Long Beach, CA 90801-5745, U.S.A.