

A-H5

SERVICE MANUAL

(XD-6000/8000/9580 SERIES)

© 1997-3/B51-5293-00 (K/K) 2578

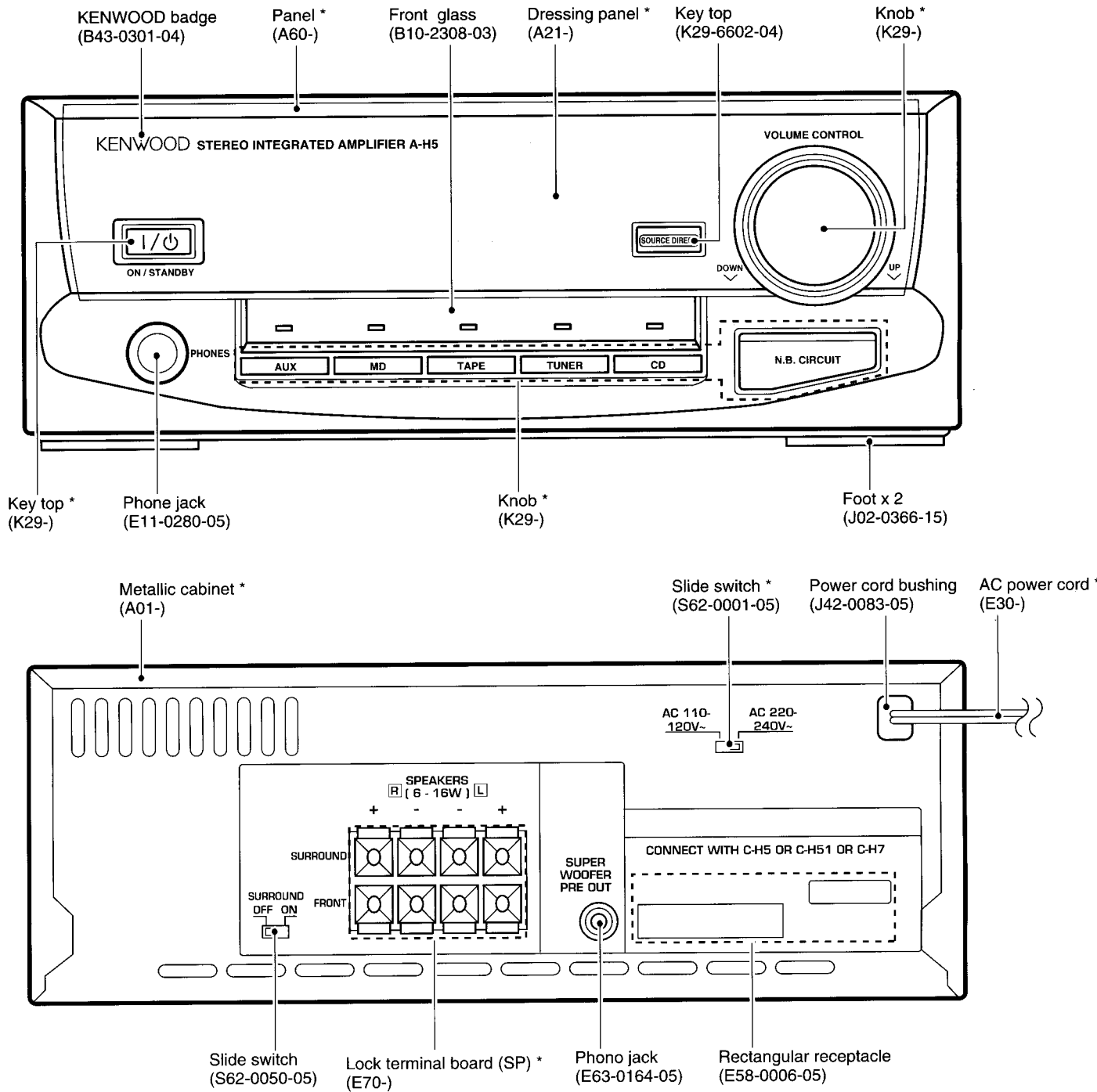

* Refer to parts list on page 11.

- Caution :**
1. Use the power supply jig PS-94UA when a repair or action confirmation are done.
 2. Set the input level to minimum before power on if supplying audio signal to A-H5.
 3. Connect 56k-ohms resistor across connector CN19 if setting A-H5 to turn on by itself.
 4. Connect C-H5, H6 or H7 to A-H5 if repairing control pcb (X07, B/7) in the A-H5.

A-H5

CONTENTS / ACCESSORIES

Contents

CONTENTS / ACCESSORIES	2	SCHEMATIC DIAGRAM	8
CONTROLS	3	PARTS LIST	11
PC BOARD	5	SPECIFICATIONS	Back cover
EXPLODED VIEW	7		

System configuration

SYSTEM	TUNER / EQUALIZER	AMPLIFIER	CASSETTE DECK	CD PLAYER	SPEAKER	MD RECORDER
XD-6060	C-H51	A-H5	X-H5	DP-H5	LS-H6	—
XD-6500	C-H5	A-H5	X-H5	DP-MH5	LS-H5	—
XD-6560	C-H51	A-H5	X-H5	DP-MH5	LS-H6	—
XD-8000	C-H6	A-H5	X-H5	DP-H5	LS-H6	—
XD-8550	C-H6	A-H5	X-H5	DP-MH5	LS-H6	—
XD-8560	C-H61	A-H5	X-H5	DP-MH5	LS-H6	—
XD-6000/W	C-H5/W	A-H5	X-H5	DP-H5	LS-H5	—
XD-6050/W	C-H5/W	A-H5	X-H5	DP-H5	LS-H5	—
XD-6550/W	C-H5/W	A-H5	X-H5	DP-MH5	LS-H5	—
XD-8050/W	C-H6/W	A-H5	X-H5	DP-H5	LS-H6	—
XD-8500/W	C-H6	A-H5	X-H5	DP-MH5	LS-H6	—
XD-9580MD	C-H7	A-H5	—	DP-MH5	LS-H6	DM-H5

Accessories

FM indoor antenna(1)
(T90-0801-05) : K,M type
(T90-0809-05) : T,E type

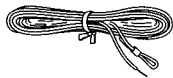

AM loop antenna(1)
(T90-0820-05)

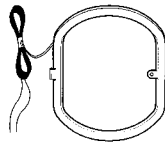

Loop antenna stand (1)
(J19-3645-05)

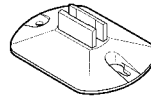

AC plug adaptor.....(2)
(E03-0115-08)

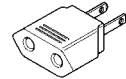

Batteries (R6/AA).....(2)



Speaker cords(2)
(E30-5156-05)

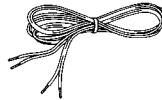

Parallel cord.....(1)
(E30-2738-05)



Remote control unit(1)
(A70-1110-05) : K,M type
(A70-1121-05) : T,E type

Battery cover (A09-0380-08)

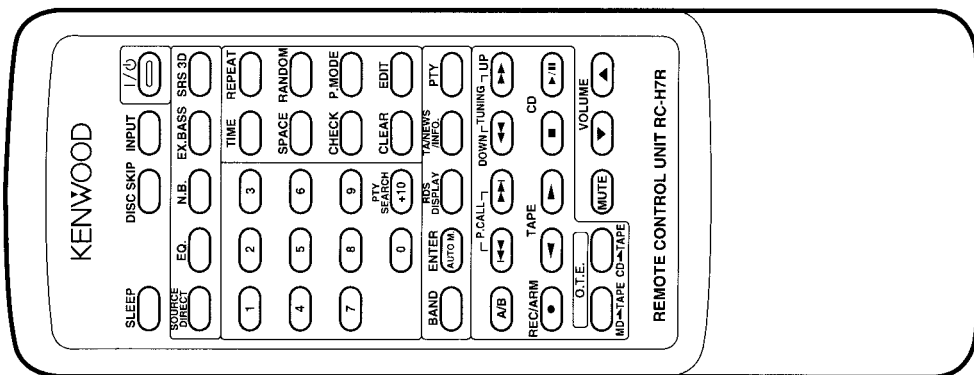

CONTROLS

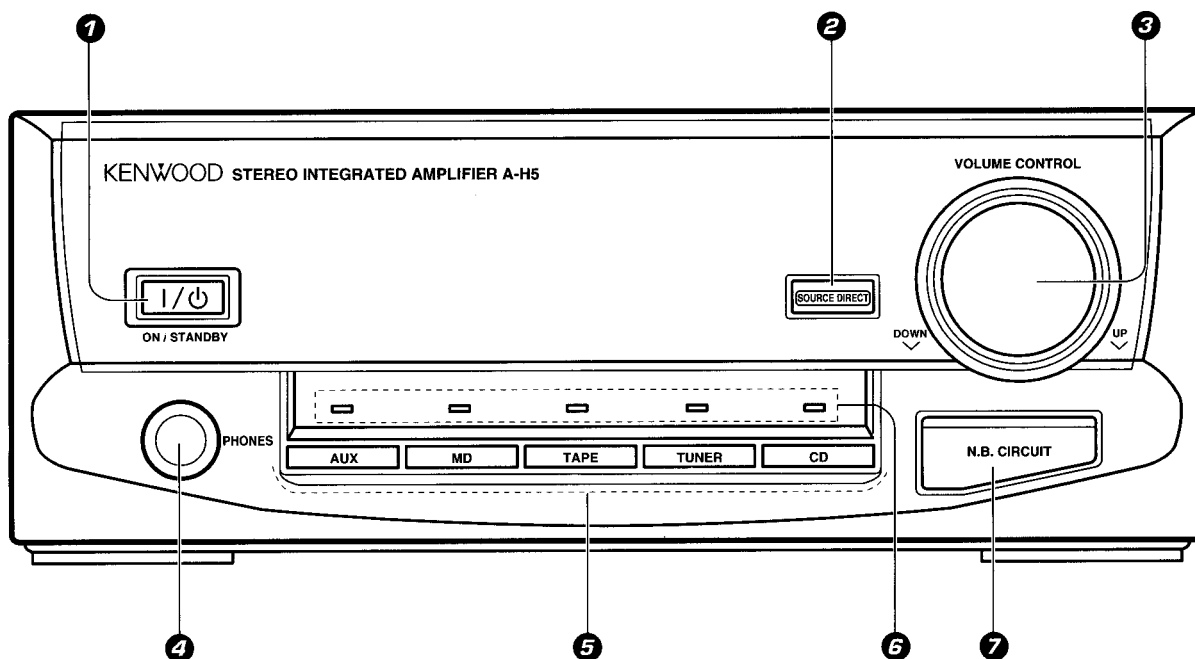
Amplifier unit**1 ON/STANDBY (I/⏻) key/Indicator**

Power ON/OFF switching is executed.

The indicator in the key lights in green when the power is ON and in red when it is off (provided that the power cord is connected to a power outlet)

2 SOURCE DIRECT key/Indicator

Press the key when you want to enjoy a purer sound.

3 VOLUME CONTROL knob

Normally this is used for volume adjustment.

This control is also used to adjust the input level when the MD recorder or other external equipment is used.

4 PHONES terminal

For connection of a headphone (optional).

5 Input key

Press to select the input source. When TAPE or CD is selected, playback starts automatically provided that a tape or disc has already been loaded.

6 Input indicators

The indicator corresponding to the currently selected input source lights up.

7 N.B. CIRCUIT key

Press to compensate for the lack of heavy bass sound which may occur during low-level listening.

CONTROLS

Remote control unit

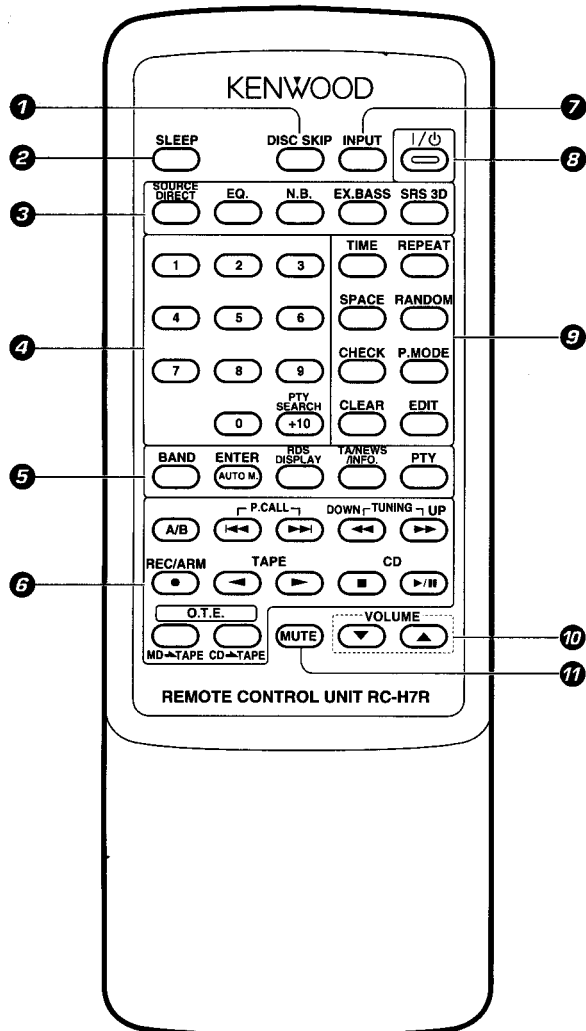

Model: RC-H7R
Infrared ray system

① DISC SKIP key (For XD-8550)

Press to select the disc to be used for playback or recording.

② SLEEP key

Press to set the sleep timer function.

③ Tone control-related keys

SOURCE DIRECT key : Press the key when you want to enjoy a purer sound.

EQ. key : Press before operating the equalizer.

N.B key : Press to compensate for the lack of heavy bass sound which may occur during low-level listening.

EX. BASS key : Press to enhance the high and low frequencies.

SRS 3D key : Switches the SRS 3D play on and off.

④ Numeric keys

Select a CD track or tuner stations.

⑤ Tuner-related keys

BAND key : Press to switch the receiving band.
ENTER/AUTO M. key : Press when entering a station in memory.

RDS DISPLAY key

TA/NEWS/INFO. key

PTY key

⑥ General operation keys

A/B key : Press to select the deck to be operated.

P.CALL (◀▶) keys :

When the TUNER input is selected, used to recall a preset station.

When the CD input is selected, used to skip tracks.

TUNING UP/DOWN (◀▶) keys :

When the TUNER input is selected, used to receive a station.

When the CD or TAPE input is selected, used to move the played position in the forward or reverse direction.

REC/ARM (●) key :

Press to start recording. Pressing the key during recording stops it after leaving a non-recorded space (blank) of about 4 seconds.

TAPE play (◀▶) keys

Stop (■) key

CD play/pause (▶/||) key

O.T.E. MD → TAPE key : Press when copying sound from a MD to a tape.

O.T.E. CD → TAPE key : Press when copying sound from a CD to a tape.

⑦ INPUT key

Press to select the input source to be played or recorded. This key has the same function as the input selector keys on the amplifier unit.

⑧ On/standby (I/⏻) key

This key has the same function as the key with the same name on the amplifier unit.

⑨ CD applied operation-related keys

TIME key : Press to switch the time information displayed on the CD player.

REPEAT key : Press to play CD track(s) repeatedly.

SPACE key : Press during CD recording etc. to create a non-recorded blank of a few seconds.

RANDOM key : Press to play tracks in a different order than the recorded order.

CHECK key : Press to check the order of tracks which have been programmed.

P.MODE key Press to switch the program mode on-off. This key is also used when entering a track in the program.

CLEAR key : Press to clear a programmed track(s)

EDIT key : Press when recording a CD.

⑩ VOLUME CONTROL (∇ Δ) keys

These keys have the same function as the VOLUME CONTROL on the amplifier unit.

⑪ MUTE key

SPEAKERS

CONNECT WITH
C-H51 OR C-H61 OR C-H7

SUPER WOOFER
PRE OUT

SURROUND

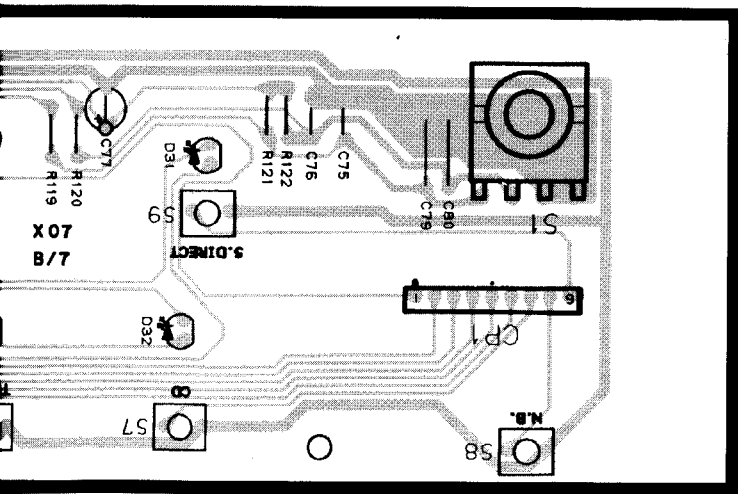
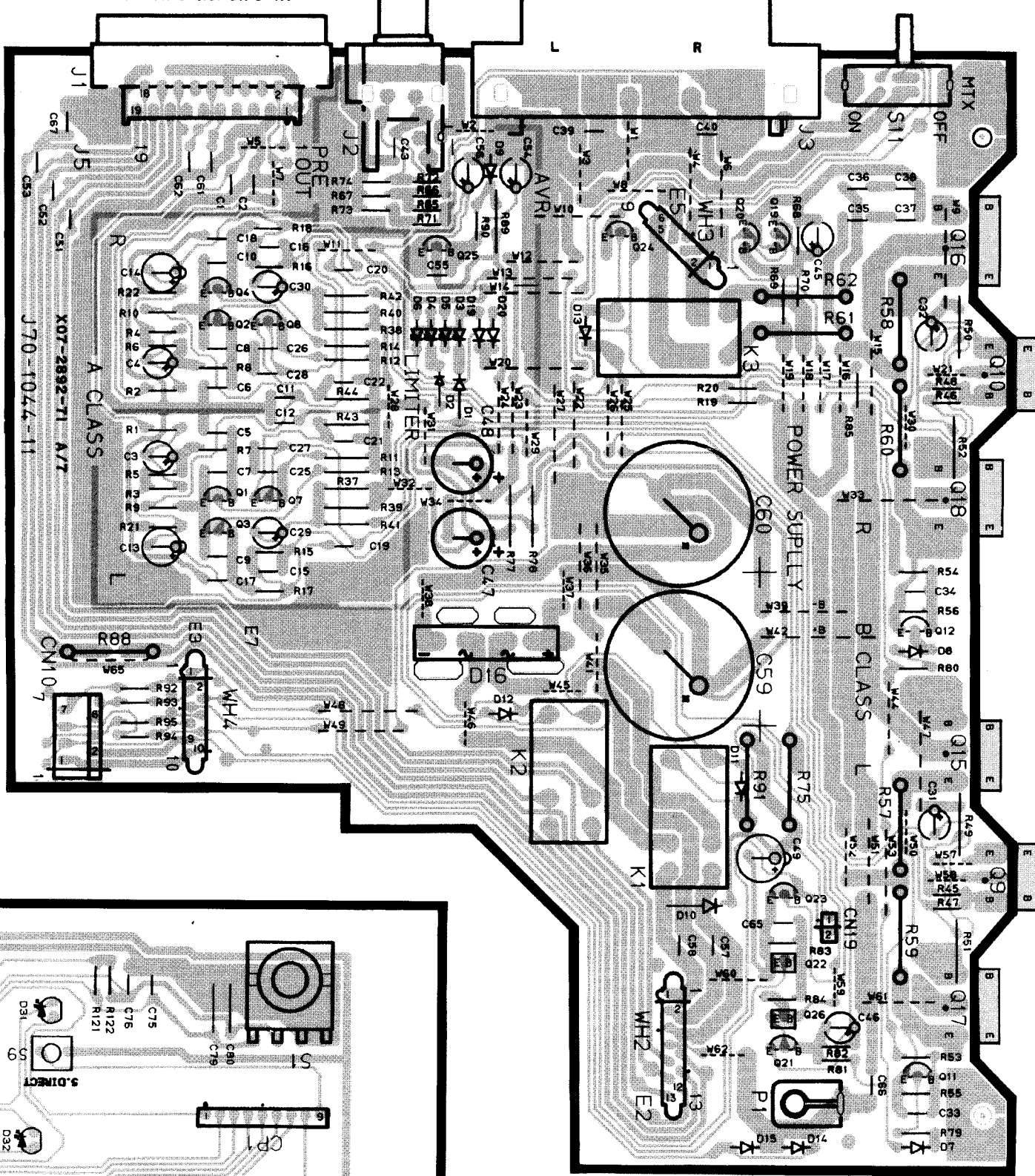

Parts with the exploded numbers larger than 700 are not supplied.

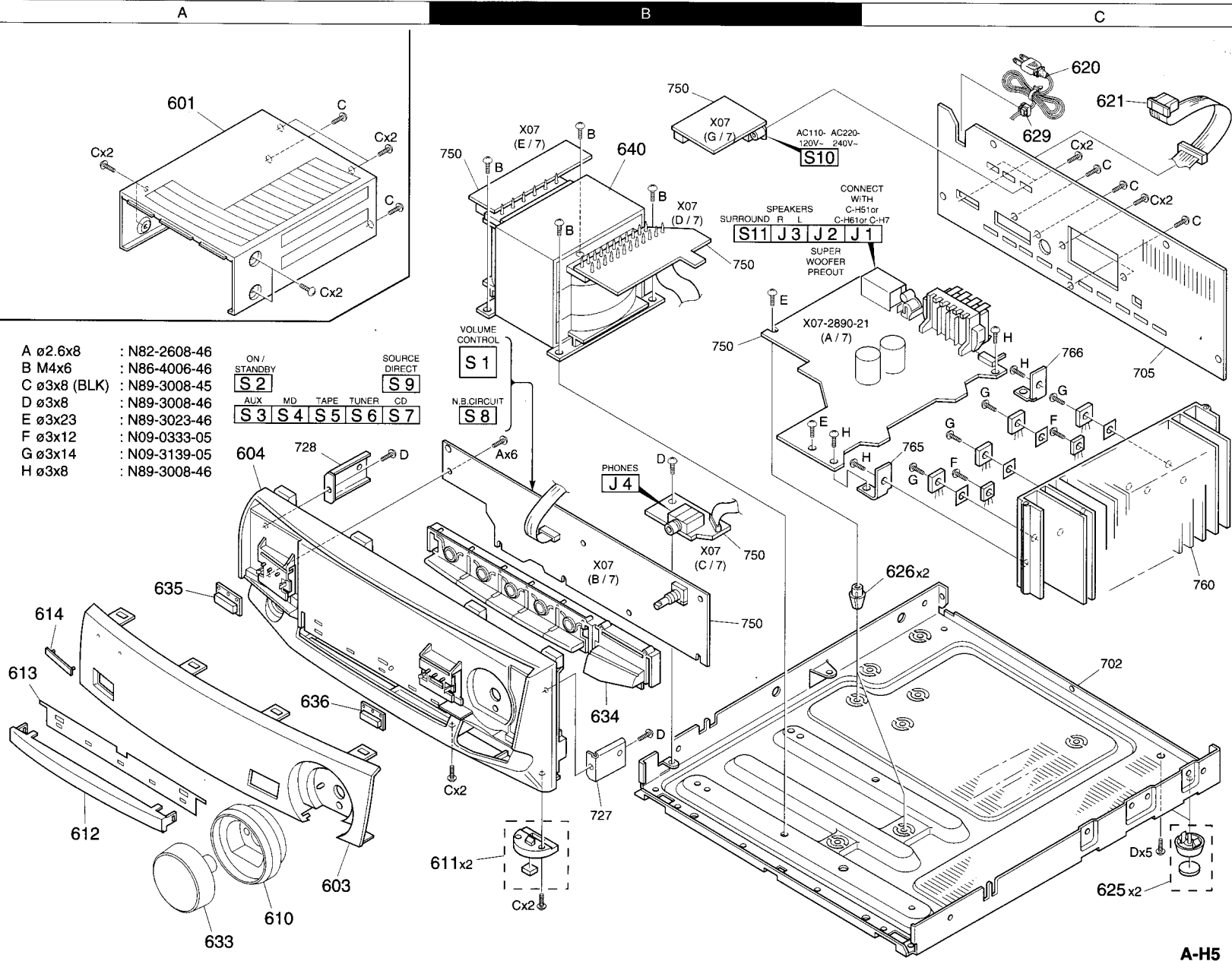

EXPLODED VIEW

A-H5

(X07-2890-11) (A/7) Note : Set input level to minimum before power on.

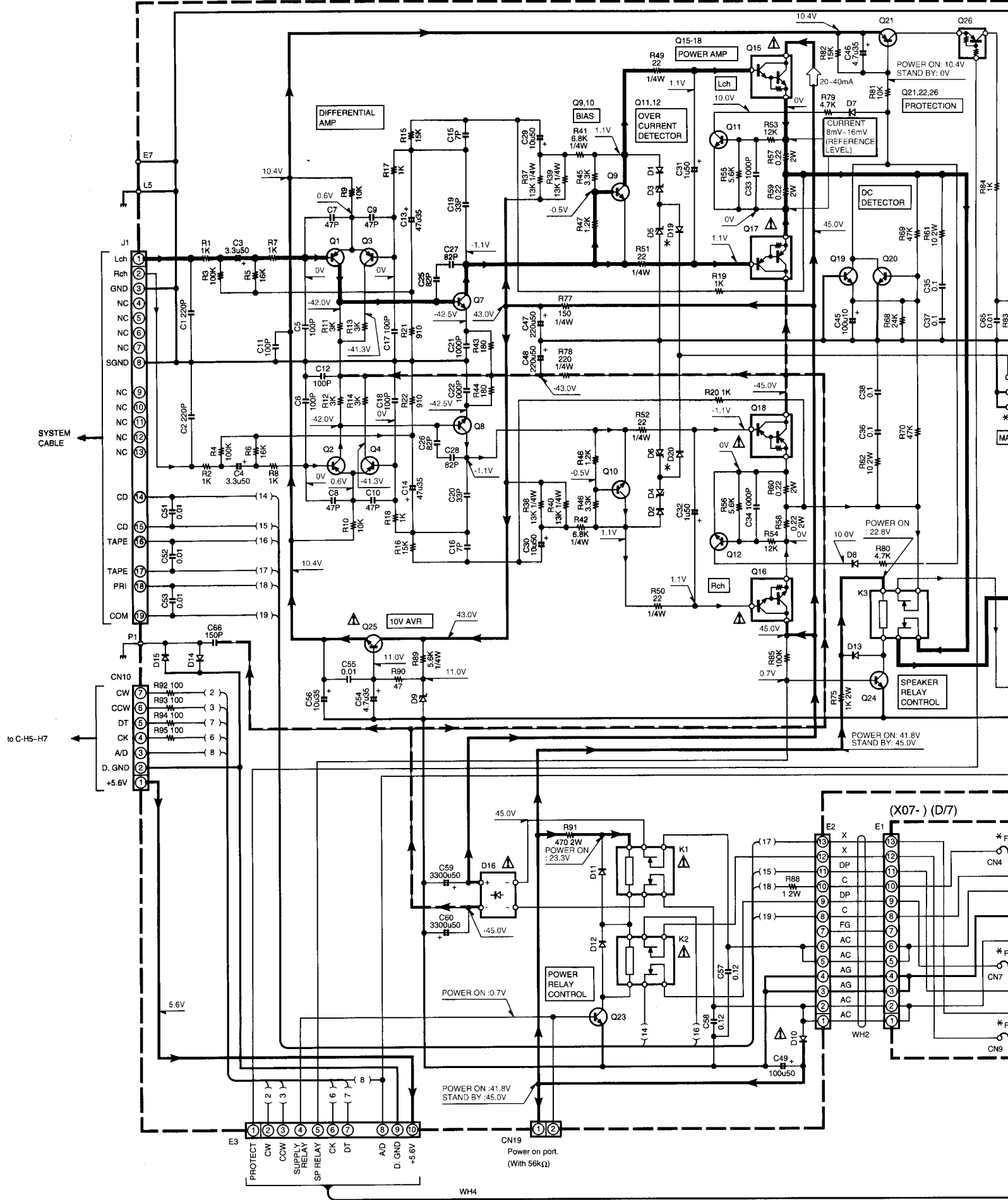

to C-H5-H7

(X07-) (D/7)

PROTECT CW COW SUPPLY RELAY SP RELAY CK DT A/D D. GND +5.6V
CN19 Power on port. (With 56k Ω)

WH4

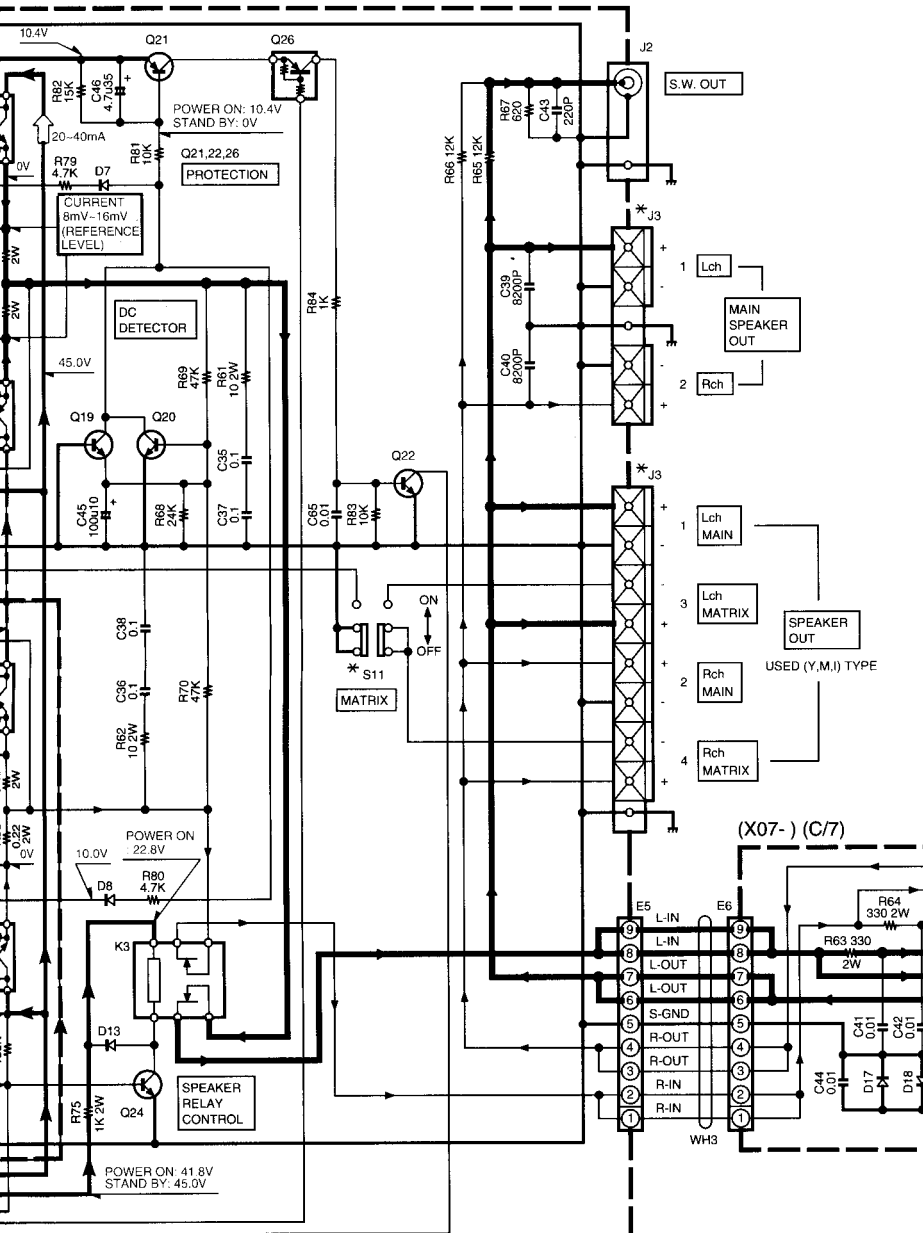

DESTINATION	ABB	UNIT No.	F2	F3,4	F
U.S.A.	K	X07-2890-11	2A 125V	2.5A 125V	Y
PX	Y				
GENERAL MARKET	M	X07-2890-21	T800mA L 250V	T1.6A L 250V	N
MALAYSIA	I				
U.K.	T				
EUROPE	E	X07-2892-71	T800mA L 250V	T1.6A L 250V	N
RUSSIA	Q				

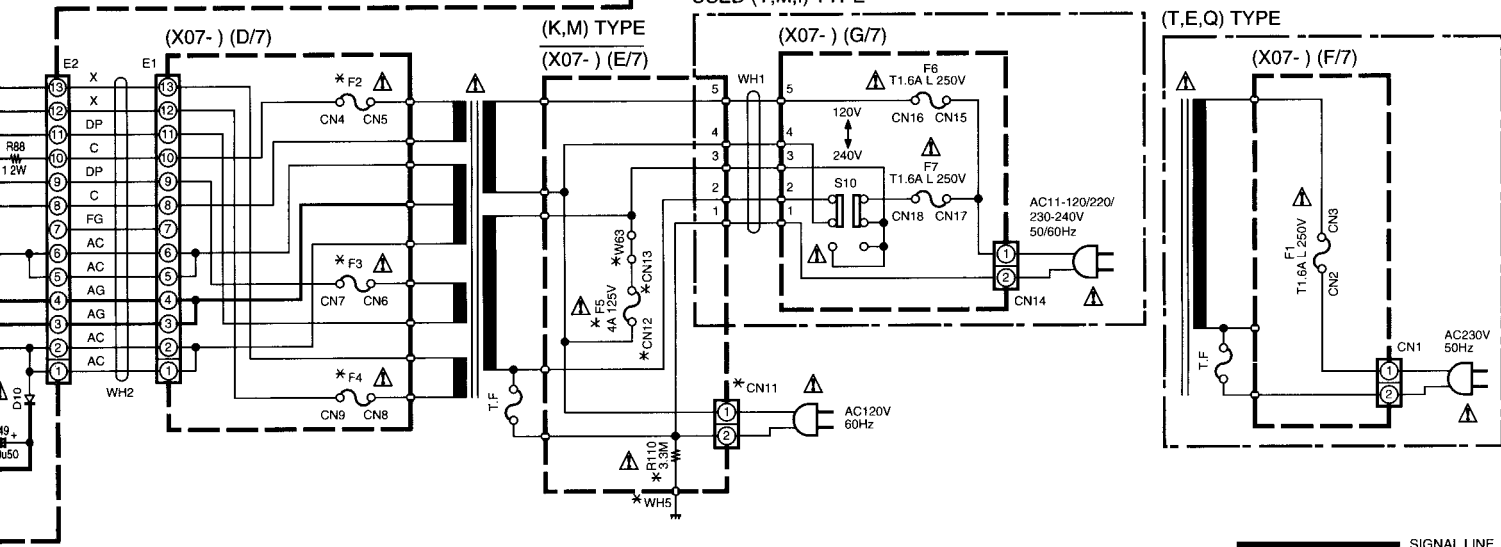
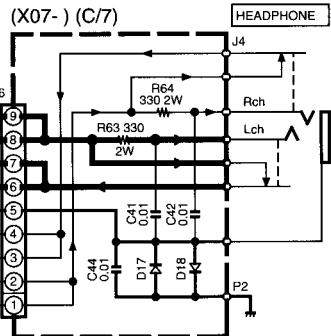
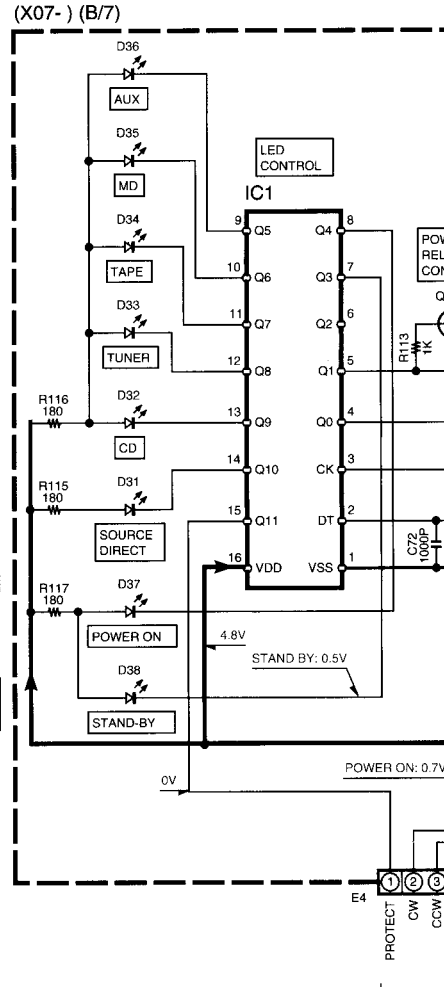

SIGNAL LINE
 GND LINE
 +B LINE
 -B LINE

DESTINATION	COUNTRY	ABB	UNIT No.	F2	F3,4	F5	J3	D19,20	S1
U.S.A.	K	X07-2890-11	2A 125V	2.5A 125V	YES	4P	NO	NO	NO
GENERAL MARKET	PX	Y	X07-2890-21	T800mA L 250V	T1.6A L 250V	NO	8P	YES	YES
MALAYSIA	I								
U.K.	T								
EUROPE	E	X07-2892-71	T800mA L 250V	T1.6A L 250V	NO	4P	NO	NO	NO
RUSSIA	Q								

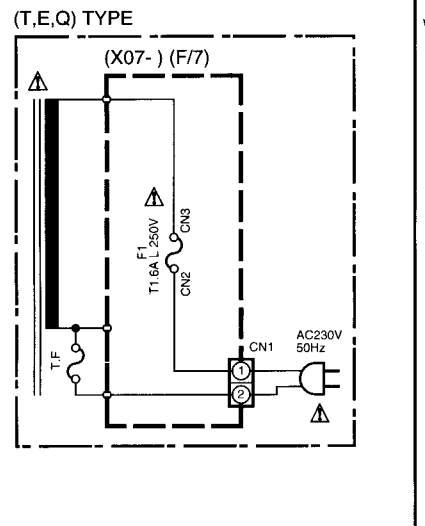
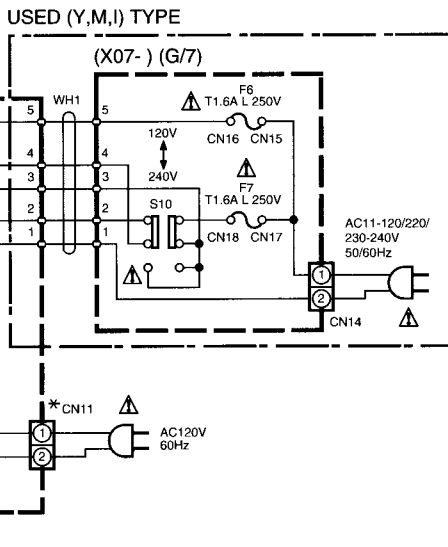
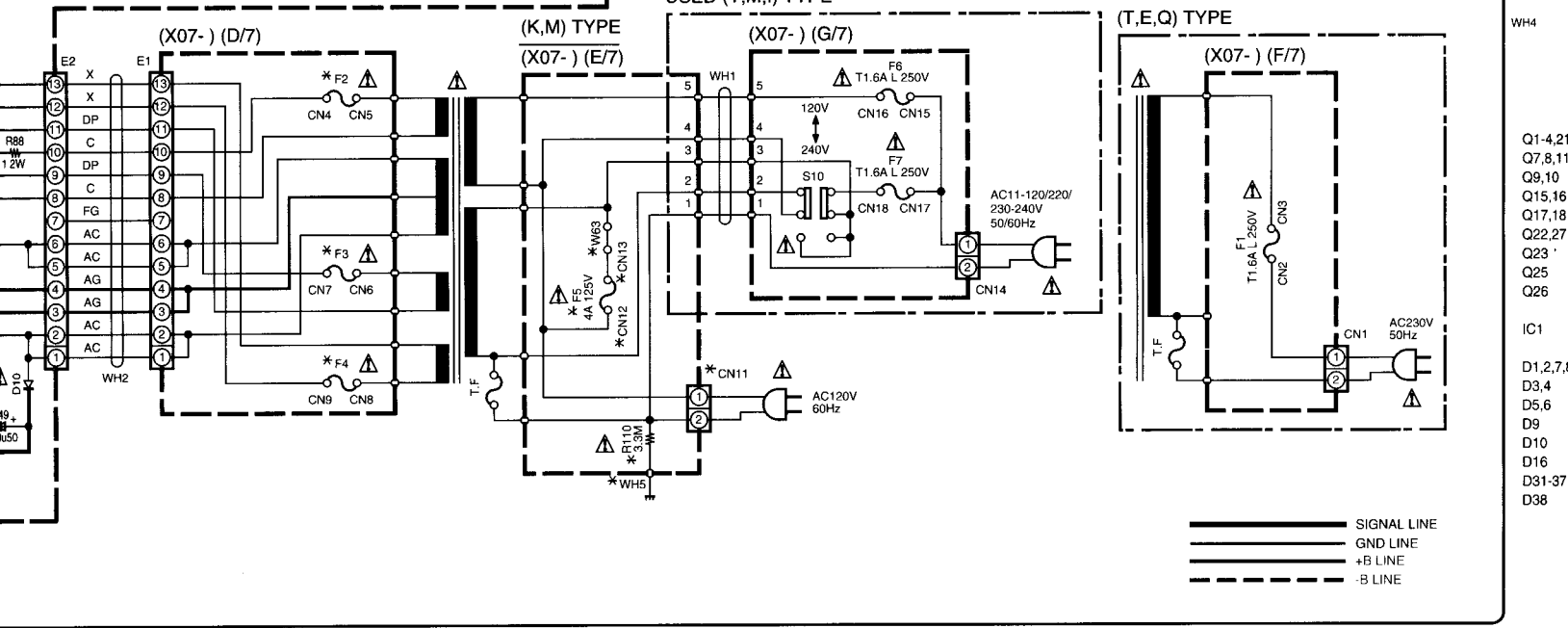
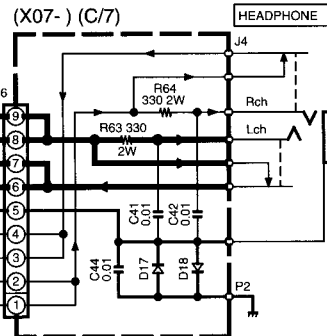
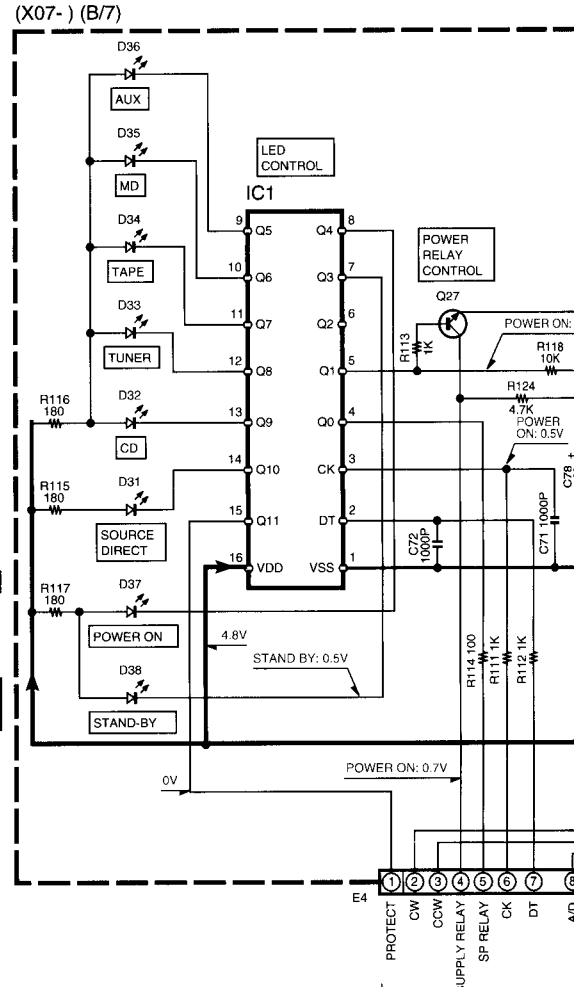
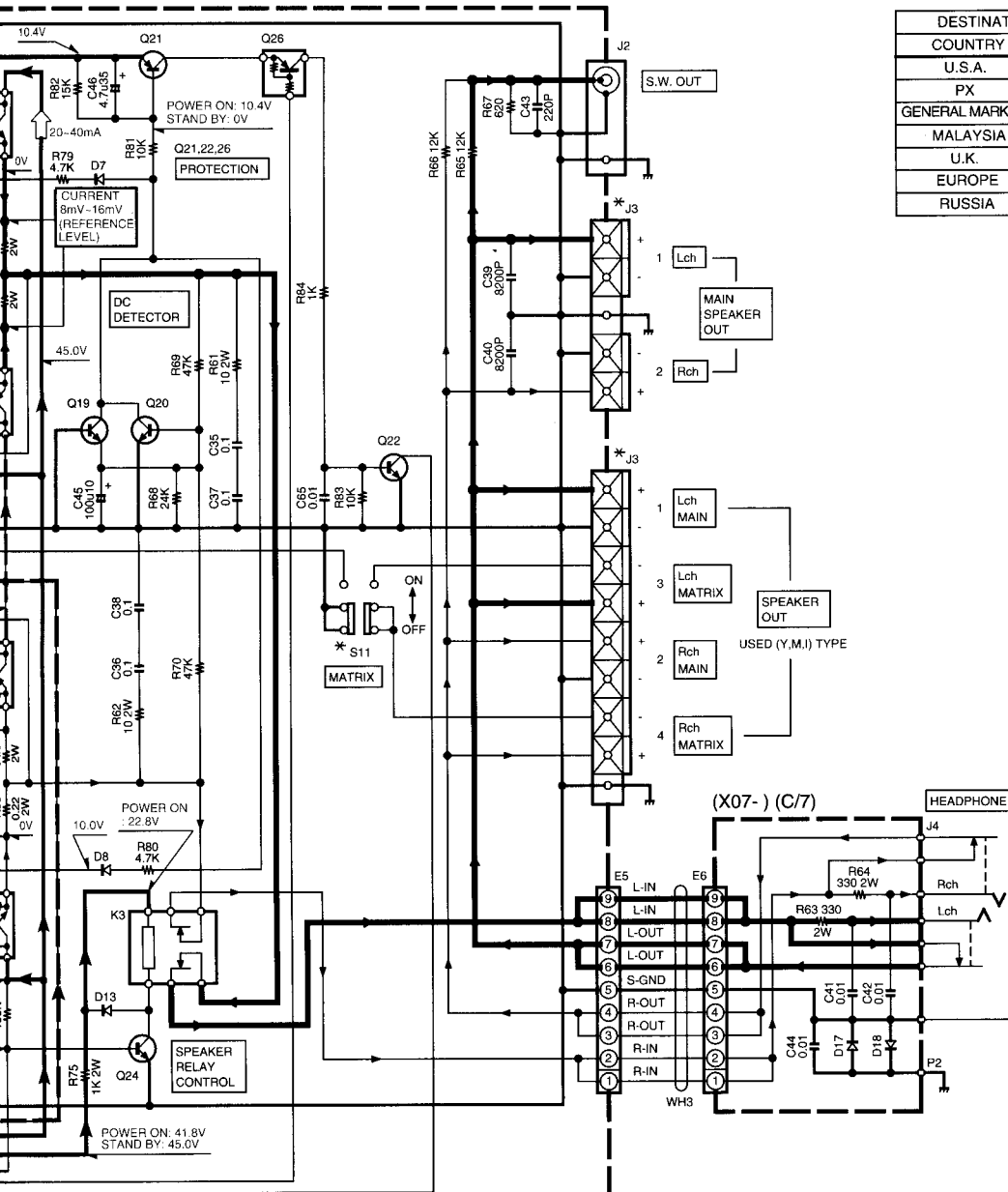

——— SIGNAL LINE
 ——— GND LINE
 ——— +B LINE
 - - - - - -B LINE

- Q1-4,21
- Q7,8,11
- Q8,10
- Q15,16
- Q17,18
- Q22,27
- Q23
- Q25
- Q26
- IC1
- D1,2,7,8
- D3,4
- D5,6
- D9
- D10
- D16
- D31-37
- D38

	F3,4	F5	J3	D19,20	S11	W63	WH5	CN11-13	R110
	2.5A 125V	YES	4P	NO	NO	YES	YES	YES	YES
50V	T1.6A L 250V	NO	8P	YES	YES	NO	NO	NO	NO
50V	T1.6A L 250V	NO	4P	NO	NO	NO	NO	NO	NO

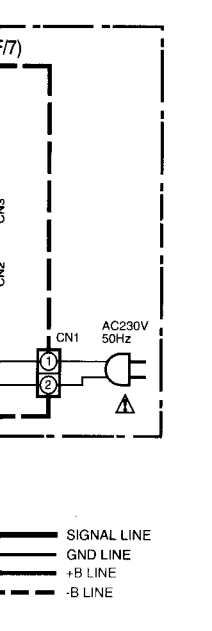
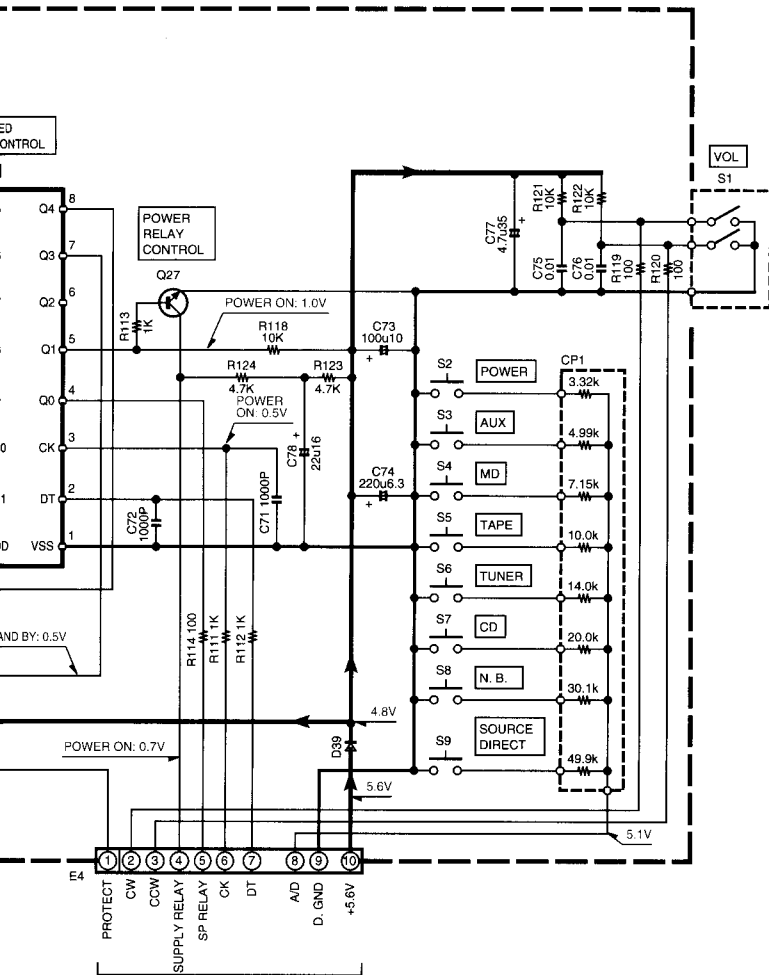

- | | |
|-------------------------|---------------------------------|
| Q1-4,21 | : 2SA992(F,E) |
| Q7,8,11,12,19,20,24 | : 2SC1845(F,E) |
| Q9,10 | : 2SC4137F50(V,W) |
| Q15,16 | : 2SD2493 |
| Q17,18 | : 2SB1624 |
| Q22,27 | : 2SC1740S(Q,R) or 2SC2785(F,E) |
| Q23 | : 2SC2003(L,K) |
| Q25 | : 2SC3940A(R,S) |
| Q26 | : UN4119 or DTA113ZSA |
| IC1 | : BU2090 |
| D1,2,7,8,11-15,17-20,39 | : 1SS131 or HSS104A |
| D3,4 | : NTZJ15(B) or UZ-15BSB |
| D5,6 | : NTZJ18(B) or UZ-18BSB |
| D9 | : NTZJ11(B) or UZ-11BSB |
| D10 | : S5688B or 1SR139-400 |
| D16 | : D3SBA20F03 or RBV-402LFA |
| D31-37 | : B30-2468-05 |
| D38 | : B30-2430-05 |

— SIGNAL LINE
 — GND LINE
 — +B LINE
 — -B LINE

A-H5 (K)

2SA992
 2SC1845
 2SC2003
 2SC3940A

2SB1624
 2SD2493

2SC2785

DTA113ZSA
 2SC1740S

2SC4137F50

BU2090

CAUTION: For continued safety, replace safety critical components only with manufacturer's recommended parts (refer to parts list). Δ indicates safety critical components. For continued protection against risk of fire, replace only with same type and rating fuse(s). To reduce the risk of electric shock, leakage-current or resistance measurements shall be carried out (exposed parts are acceptably insulated from the supply circuit) before the appliance is returned to the customer.

The DC voltage is an actual reading measured with a high impedance type voltmeter with no signal input. The measurement value may vary depending on the measuring instruments used or on the product.

Y08-5500-11

A-H5
KENWOOD

* New Parts
Parts without **Parts No.** are not supplied.
Les articles non mentionnés dans le **Parts No.** ne sont pas fournis.
Teile ohne **Parts No.** werden nicht geliefert.

①

Ref. No	Add-ress	New Parts	Parts No.	Description	Desti-nation	Re-marks
A-H5						
601	1A	*	A01-3367-01	METALLIC CABINET (SLVR)		
601	1A	*	A01-3416-01	METALLIC CABINET (BLK)	TEQ	
603	2A	*	A21-1914-02	DRESSING PANEL (SLVR)		
603	2A	*	A21-1935-02	DRESSING PANEL (BLK)	TEQ	
604	1A	*	A60-1008-01	PANEL (SLVR)		
604	1A	*	A60-1037-01	PANEL (BLK)	TEQ	
610	2A	*	B07-2331-03	ESCUTCHEON (SLVR)		
610	2A	*	B07-2332-03	ESCUTCHEON (BLK)	TEQ	
611	2B	*	B07-2335-04	ESCUTCHEON		
612	2A	*	B10-2308-03	FRONT GLASS		
613	2A	*	B11-0348-04	SMOKED FILTER		
614	2A		B43-0301-04	KENWOOD BADGE		
-			B58-0513-04	CAUTION CARD (PRESET220-240)	Y	
Δ 620	1C		E30-2592-15	AC POWER CORD	MIEQ	
Δ 620	1C		E30-2605-05	AC POWER CORD	Y	
Δ 620	1C		E30-2650-05	AC POWER CORD	K	
Δ 620	1C		E30-2829-05	AC POWER CORD	T	
621	1C	*	E30-2847-05	CORD WITH CONNECTOR		
-		*	H10-7242-02	POLYSTYRENE FOAMED FIXTURE	KYMIEQ	
-		*	H10-7243-02	POLYSTYRENE FOAMED FIXTURE	KYMIEQ	
-		*	H10-7244-02	POLYSTYRENE FOAMED FIXTURE	T	
-		*	H10-7245-02	POLYSTYRENE FOAMED FIXTURE	T	
-			H25-0681-04	PROTECTION BAG		
-		*	H50-2142-04	ITEM CARTON CASE	KY	
-		*	H50-2143-04	ITEM CARTON CASE	MI	
-		*	H50-2144-04	ITEM CARTON CASE (BLK)	T	
-		*	H50-2328-04	ITEM CARTON CASE (SLVR)	T	
-		*	H50-2355-04	ITEM CARTON CASE (BLK)	EQ	
-		*	H50-2356-04	ITEM CARTON CASE (SLVR)	EQ	
625	2C		J02-0366-15	FOOT		TEQ
626	2C		J19-3752-14	UNIT HOLDER		
Δ 629	1C		J42-0083-05	POWER CORD BUSHING		K
-			J61-0307-05	WIRE BAND		YMI
633	2A	*	K29-6486-04	KNOB (SLVR)		
633	2A	*	K29-6600-04	KNOB (BLK)	TEQ	
634	2B	*	K29-6488-02	KNOB (SLVR)		
634	2B	*	K29-6601-02	KNOB (BLK)	TEQ	
635	2A	*	K29-6559-04	KEY TOP	K	
635	2A	*	K29-6712-04	KEY TOP	YMITEQ	
636	2A	*	K29-6602-04	KEY TOP		
Δ 640	1B	*	L07-2227-05	POWER TRANSFORMER	TE	
Δ 640	1B	*	L07-2228-05	POWER TRANSFORMER	YMI	
Δ 640	1B	*	L07-2229-05	POWER TRANSFORMER	Q	
Δ 640	1B	*	L07-2232-05	POWER TRANSFORMER	K	
POWER (X07-2890-11)						
D31 -37			B30-2468-05	LED		
D38			B30-2430-05	LED(RED)		
C1 .2			CC45FSL1H221J	CERAMIC	220PF	J
C3 .4			CE04KW1H3R3M	ELECTRO	3.3UF	50WV
C5 .6			CC45FSL1H101J	CERAMIC	100PF	J
C7 -10			CC45FSL1H470J	CERAMIC	47PF	J
C11 .12			CC45FSL1H101J	CERAMIC	100PF	J

L : Scandinavia K : USA P : Canada R : Mexico I : Malaysia
Y : PXI(Far East, Hawaii) T : Europe E : Europe G : Germany Q : Russia
Y : AAFES(Europe) X : Australia M : Other Areas

Δ indicates safety critical components.

* New Parts
Parts without **Parts No.** are not supplied.
Les articles non mentionnés dans le **Parts No.** ne sont pas fournis.
Teile ohne **Parts No.** werden nicht geliefert.

②

Ref. No	Add-ress	New Parts	Parts No.	Description	Desti-nation	Re-marks
C13 .14			CE04KW1V470M	ELECTRO	47UF	35WV
C15 .16			CC45FSL1H070D	CERAMIC	7.0PF	D
C17 .18			CC45FSL1H101J	CERAMIC	100PF	J
C19 .20			CC45FSL1H330J	CERAMIC	33PF	J
C21 .22			CK45FB1H102K	CERAMIC	1000PF	K
C25 .28			CC45FSL1H820J	CERAMIC	82PF	J
C29 .30			CE04KW1H100M	ELECTRO	10UF	50WV
C31 .32			CE04KW1H010M	ELECTRO	1.0UF	50WV
C33 .34			CK45FB1H102K	CERAMIC	1000PF	K
C35 .38			CF92FV1H104J	MF-C	0.10UF	J
C39 .40			CQ93FMG1H822J	MYLAR	8200PF	J
C41 .42			CK45FF1H103Z	CERAMIC	0.010UF	Z
C43			CC45FSL1H221J	CERAMIC	220PF	J
C44			CK45FF1H103Z	CERAMIC	0.010UF	Z
C45			CE04KW1A101M	ELECTRO	100UF	10WV
C46			CE04KW1V4R7M	ELECTRO	4.7UF	35WV
C47 .48			CE04KW1H221M	ELECTRO	220UF	50WV
C49			CE04KW1H101M	ELECTRO	100UF	50WV
C51 -53			CK45FF1H103Z	CERAMIC	0.010UF	Z
C54			CE04KW1V4R7M	ELECTRO	4.7UF	35WV
C55			CK45FF1H103Z	CERAMIC	0.010UF	Z
C56			CE04KW1V100M	ELECTRO	10UF	35WV
C57 .58			CF92FV1H124J	MF-C	0.12UF	J
C59 .60		*	C90-3720-05	ELECTRO	3300UF	50WV
C65			CK45FF1H103Z	CERAMIC	0.010UF	Z
C66			CC45FSL1H151J	CERAMIC	150PF	J
C71 .72			CK45FB1H102K	CERAMIC	1000PF	K
C73			CE04KW1A101M	ELECTRO	100UF	10WV
C74			CE04KW0J221M	ELECTRO	220UF	6.3WV
C75 .76			CK45FF1H103Z	CERAMIC	0.010UF	Z
C77			CE04KW1V4R7M	ELECTRO	4.7UF	35WV
C78			CE04KW1C220M	ELECTRO	22UF	16WV
CN1			E40-4632-05	PIN ASSY		TEQ
CN10			E40-4297-05	FLAT CABLE CONNECTOR		
CN11			E40-4245-05	PIN ASSY		K
CN14			E40-4632-05	PIN ASSY		YMI
CN19			E40-4871-05	PIN ASSY		
J1			E58-0006-05	RECTANGULAR RECEPTACLE		
J2			E63-0164-05	PHONO JACK (SUPER WOOFER)		
J3			E70-0056-05	LOCK TERMINAL BOARD (SP)		YMI
J3			E70-0057-05	LOCK TERMINAL BOARD (SP)		KTEQ
J4			E11-0280-05	PHONE JACK (HEADPHONE)		
Δ F1			F05-1623-05	FUSE (SEMKO)	(250V T1.6AL)	TEQ
Δ F2			F05-8013-05	FUSE (SEMKO)	(250V T800MAL)	YMITEQ
Δ F2			F50-0069-05	FUSE(5X20)		K
Δ F3 .4			F05-1623-05	FUSE (SEMKO)	(250V T1.6AL)	YMITEQ
Δ F3 .4			F50-0070-05	FUSE(5X20)		K
Δ F5			F50-0073-05	FUSE(5X20)		K
Δ F6 .7			F05-1623-05	FUSE (SEMKO)	(250V T1.6AL)	YMI
CN2 -9			J13-0075-05	FUSE CLIP		TEQ
CN4 -9			J13-0075-05	FUSE CLIP		K/YMI
CN12,13			J13-0075-05	FUSE CLIP		K
CN15-18			J13-0075-05	FUSE CLIP		YMI
E7			J11-0808-05	WIRE CLAMPER		
CP1		*	R90-0954-05	MULTIPLE RESISTOR		
R49 -52			RD14NB2E220J	RD	22	J 1/4W

L : Scandinavia K : USA P : Canada R : Mexico I : Malaysia
Y : PXI(Far East, Hawaii) T : Europe E : Europe G : Germany Q : Russia
Y : AAFES(Europe) X : Australia M : Other Areas

Δ indicates safety critical components.

PARTS LIST

A-H5

PARTS LIST

* New Parts
Parts without **Parts No.** are not supplied.
Les articles non mentionnés dans le **Parts No.** ne sont pas fournis.
Teile ohne **Parts No.** werden nicht geliefert.

Ref. No	Add-ress	New Parts	Parts No.	Description	Desti-nation	Re-marks
R57-60			RS14KB3DP22J	FL-PROOF RS		
R61-62			RS14KB3D100J	FL-PROOF RS		
R63-64			RS14KB3D331J	FL-PROOF RS		
R75			RS14KB3D102J	FL-PROOF RS		
R77			RD14NB2E151J	RD		
R78			RD14NB2E221J	RD		
R88			RS14KB3D1R0J	FL-PROOF RS		
R89			RD14NB2E562J	RD		
R91			RS14KB3D471J	FL-PROOF RS		
R110			RS2-1844-05	CARBON		K
K1-2			S76-0060-05	MAGNETIC RELAY		
K3			S76-0061-05	MAGNETIC RELAY		
S2-9			S70-0031-05	TACT SWITCH		
S10			S62-0001-05	SLIDE SWITCH (VOLTAGE)		YMI
S11			S62-0050-05	SLIDE SWITCH (MATRIX)		YMI
S1			T99-0559-05	ROTARY ENCODER (VOLUME)		
D1-2			HSS104A	DIODE		
D1-2			1SS131	DIODE		
D3-4			MTZJ15(B)	ZENER DIODE		
D3-4			UZ-18BSB	ZENER DIODE		
D5-6			MTZJ18(B)	ZENER DIODE		
D5-6			UZ-18BSB	ZENER DIODE		
D7-8			HSS104A	DIODE		
D7-8			1SS131	DIODE		
D9			MTZJ11(B)	ZENER DIODE		
D9			UZ-11BSB	ZENER DIODE		
D10			S5688B	DIODE		
D10			1SP139-400	DIODE		
D11-15			HSS104A	DIODE		
D11-15			1SS131	DIODE		
D16			D3SBA20F03	DIODE		
D16			RBV-402LFA	DIODE		
D17-20			HSS104A	DIODE		
D17-20			1SS131	DIODE		
D17-18			HSS104A	DIODE		
D17-18			1SS131	DIODE		
D39			HSS104A	DIODE		
D39			1SS131	DIODE		
IC1			BU2090	ANALOGUE IC		
Q1-4			2SA992(F,E)	TRANSISTOR		
Q7-8			2SC1845(F,E)	TRANSISTOR		
Q9-10			2SC4137F50(V,W)	TRANSISTOR		
Q11-12			2SC1845(F,E)	TRANSISTOR		
Q15-16			2SD2493	TRANSISTOR		
Q17-18			2SB1824	TRANSISTOR		
Q19-20			2SC1845(F,E)	TRANSISTOR		
Q21			2SA992(F,E)	TRANSISTOR		
Q22			2SC1740S(Q,R)	TRANSISTOR		
Q22			2SC2785(F,E)	TRANSISTOR		
Q23			2SC2003(L,K)	TRANSISTOR		
Q24			2SC1845(F,E)	TRANSISTOR		
Q25			2SC3940A(R,S)	TRANSISTOR		
Q26			DTA113ZSA	DIGITAL TRANSISTOR		
Q26			UN4119	DIGITAL TRANSISTOR		
Q27			2SC1740S(Q,R)	TRANSISTOR		
Q27			2SC2785(F,E)	TRANSISTOR		

L : Scandinavia
Y : PX(Far East, Hawaii)
Y : AA-FE(Europe)

K : USA
T : Europe
X : Australia

P : Canada
R : Mexico
G : Germany
M : Other Areas

I : Malaysia
Q : Russia

△ indicates safety critical components.

SPECIFICATIONS

Amplifier section

Rated power output
80 W + 80 W (1 kHz, 10 % T.H.D. at 6 Ω)
60 W + 60 W (1 kHz, 0.7 % T.H.D. at 6 Ω)
 Total harmonic distortion.....0.09 % (1 kHz, 30 W, 6 Ω)
 Signal to noise ratio
 Line (AUX, MD)
90 dB (1HF'A) (SOURCE DIRECT ON)
 Input sensitivity / Impedance
 Line (AUX, MD)200 mV / 47 kΩ
 MIC.....1.6 mV / 600 Ω
 Output level / Impedance
 SUPER WOOFER PRE OUT
2.0 V / 2.2 kΩ (SOURCE DIRECT ON)
 MD REC200 mV / 2.2 kΩ

[General]

Power consumption180 W
 Dimension.....W : 270 mm (10-5 / 8")
 H : 104 mm (4-1 / 8")
 D : 343 mm (13-1 / 2")
 Weight (net)4.6 kg (10.2 lb)



1. KENWOOD follows a policy of continuous advancements in development. For this reason specifications may be changed without notice.
2. The full performance may not be exhibited in an extremely cold location (under a water freezing temperature)
3. Some items are C-H5-7.

Note:

Component and circuitry are subject to modification to insure best operation under differing local conditions. This manual is based on Europe (E) standard, and provides information on regional circuit modification through use of alternate schematic diagrams, and information on regional component variations through use of parts list.

KENWOOD CORPORATION

14-6,Dogenzaka 1-chome, Shibuya-ku, Tokyo, 150 Japan

KENWOOD SERVICE CORPORATION

P.O BOX 22745, 2201 East Dominguez St., Long Beach, CA 90801-5745, U.S.A.