

AS-3

SERVICE MANUAL

•The color of this model is divided into two types ; White (W) and Black (B).



W : White version
B : Black version



CONTENTS/ACCESSORIES

CONTROLS	3	EXPLODED VIEW	6
PC BOARD	4	PARTS LIST	7
SCHEMATIC DIAGRAM	5	SPECIFICATIONS	Back cover

Accessories

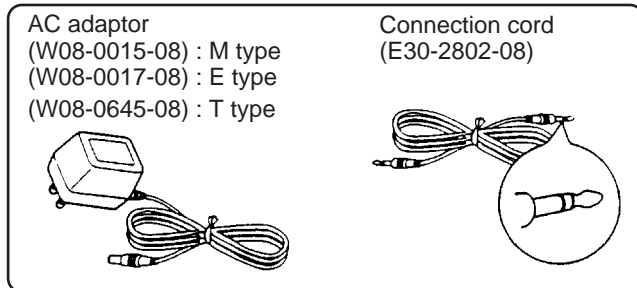

CONTROLS

Front panel

Left speaker

Right speaker

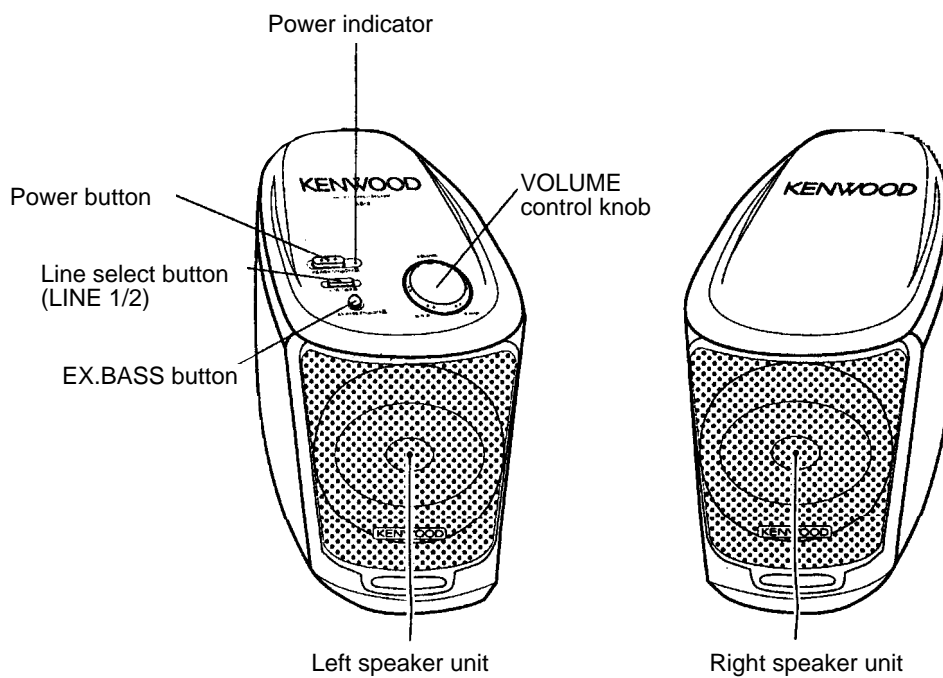

Rear panel (Left speaker)

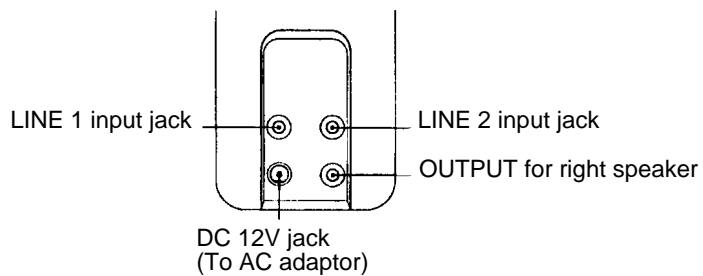

PC BOARD (Component side view)

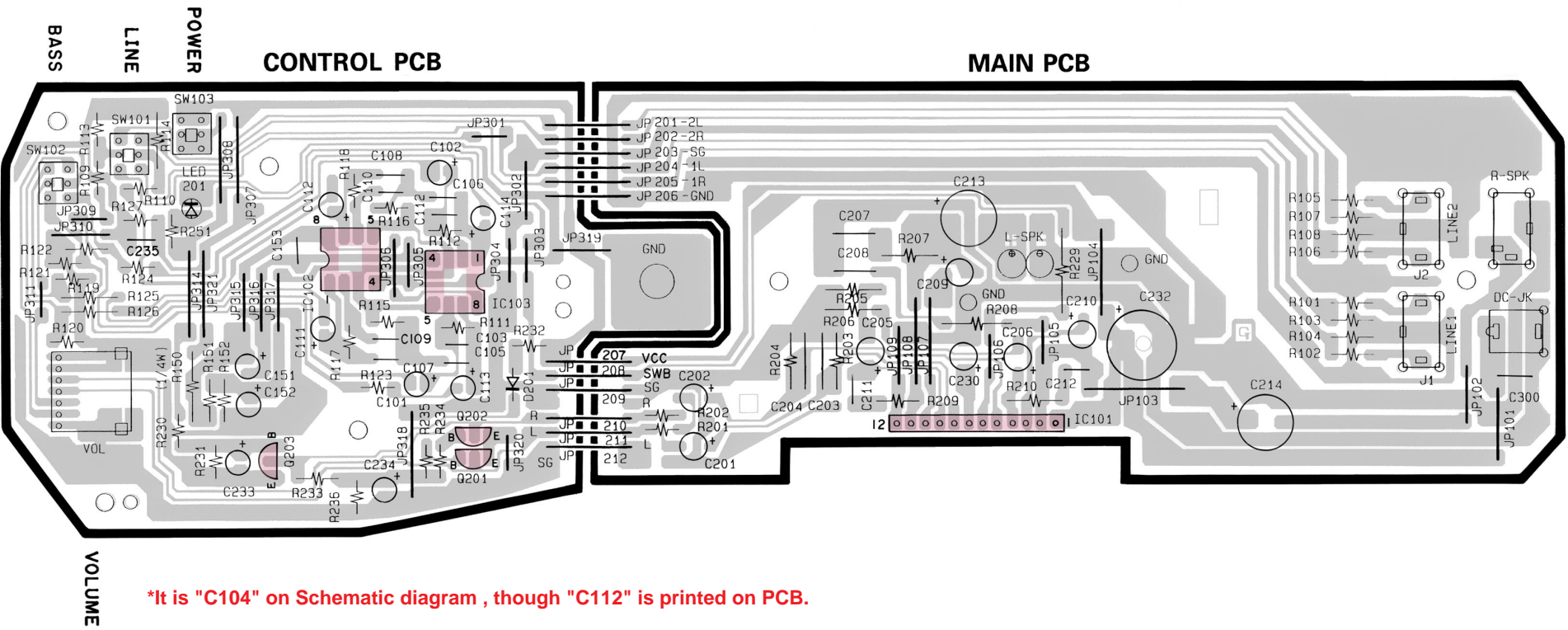

***It is "C104" on Schematic diagram , though "C112" is printed on PCB.**

Refer to the schematic diagram for the value of resistors and capacitors.

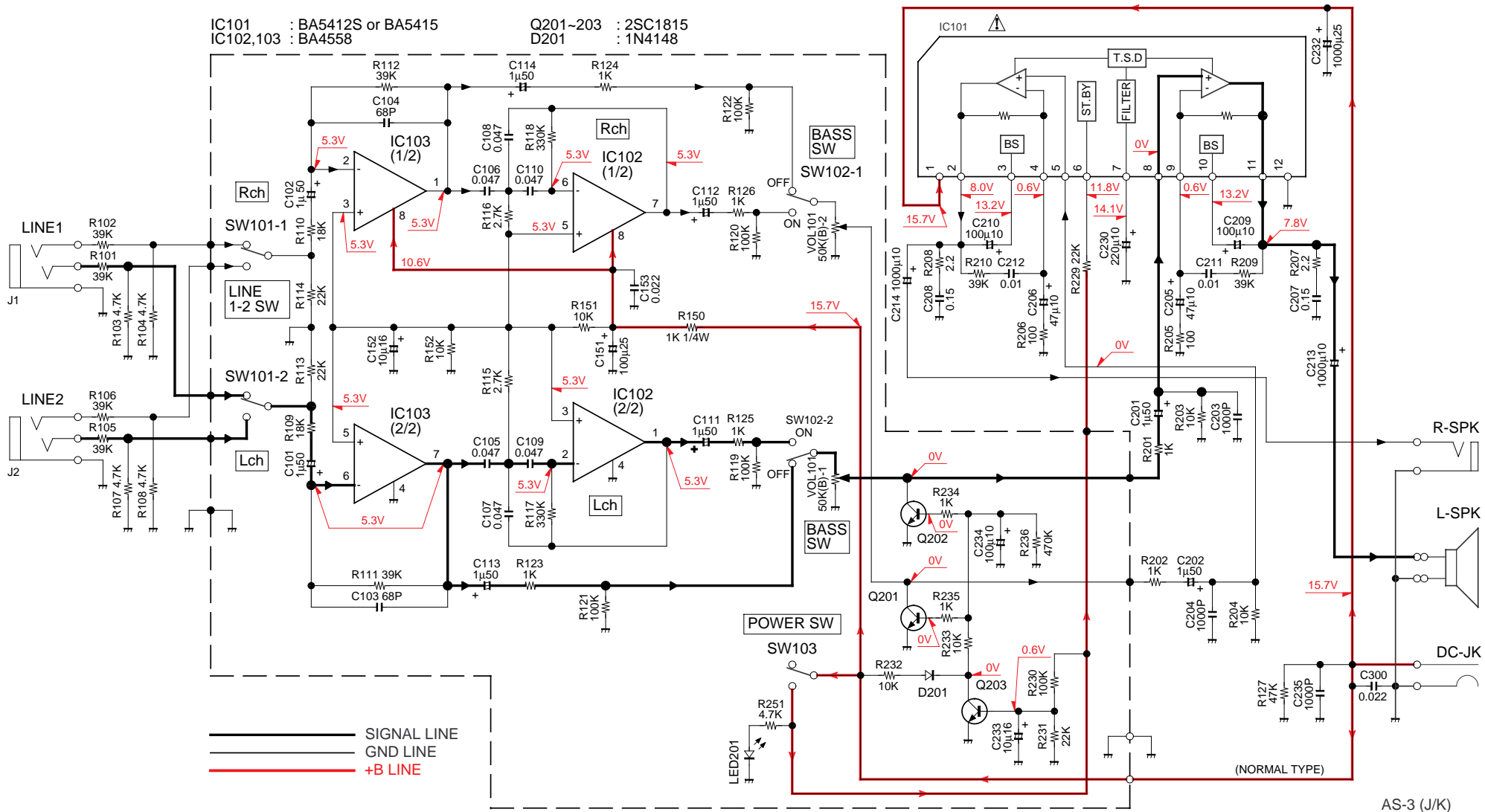

2SC1815

BA4558

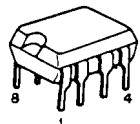
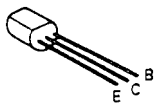

CAUTION: For continued safety, replace safety critical components only with manufacturer's recommended parts (refer to parts list). Δ indicates safety critical components. To reduce the risk of electric shock, leakage-current or resistance measurements shall be carried out (exposed parts are acceptably insulated from the supply circuit) before the appliance is returned to the customer.

- DC voltages are as measured with a high impedance voltmeter. Values may vary slightly due to variations between individual instruments or/and units.

AS-3
KENWOOD

EXPLODED VIEW(UNIT)

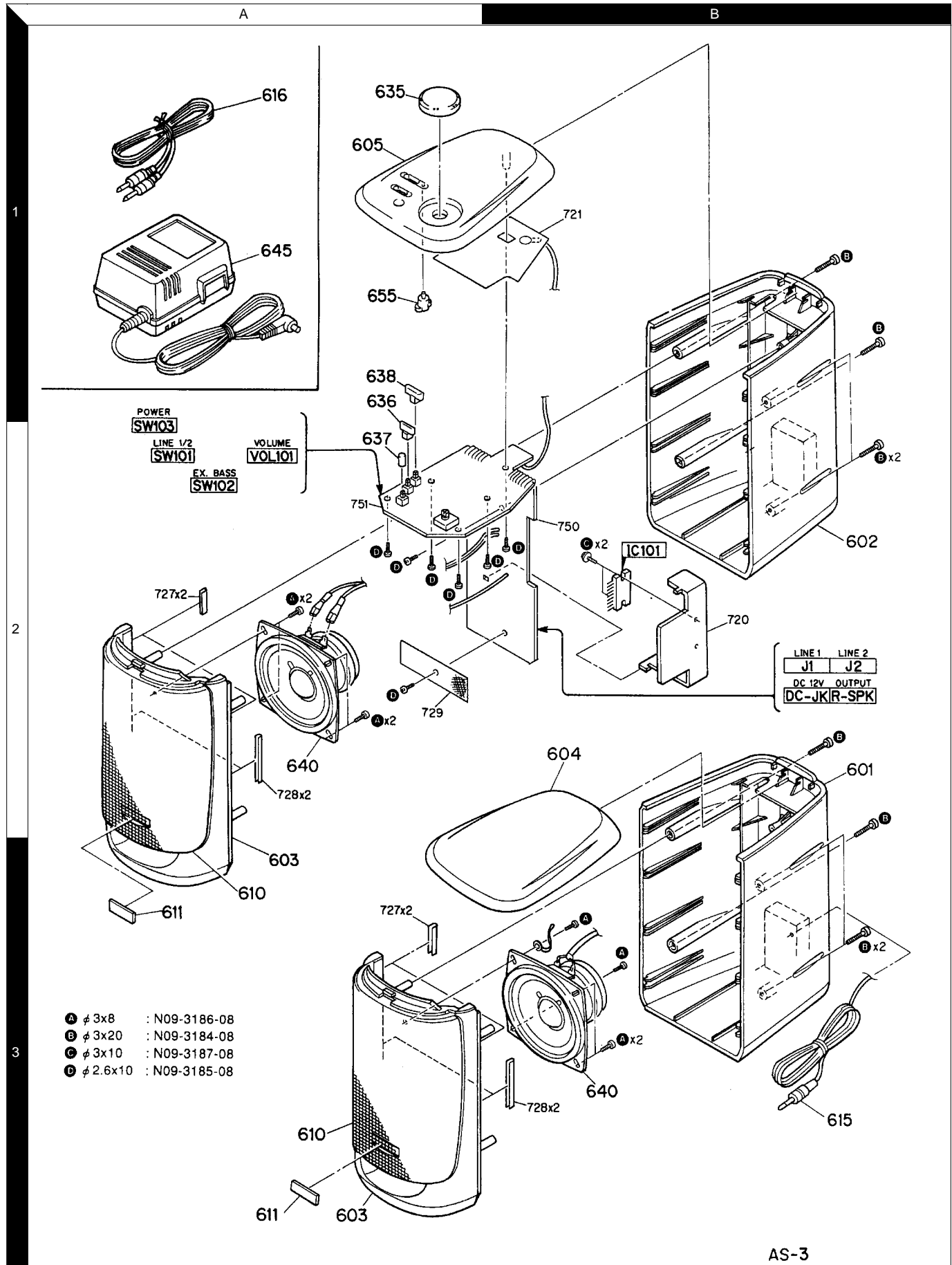

PARTS LIST

* New Parts

Parts without **Parts No.** are not supplied.

Les articles non mentionnés dans le **Parts No.** ne sont pas fournis.

Teile ohne **Parts No.** werden nicht geliefert.

NO.1

Ref. No.	Add-ress	New Parts	Parts No.	Description	Desti-nation	Re-marks
AS-3						
601	2B	*	A02-1275-08	REAR CABINET (R) (WHT)		W
601	2B	*	A02-1278-08	REAR CABINET (R) (BLK)		B
602	2B	*	A02-1276-08	REAR CABINET (L) (WHT)		W
602	2B	*	A02-1277-08	REAR CABINET (L) (BLK)		B
603	3A	*	A29-0807-08	FRONT CABINET (WHT)		W
603	3A	*	A29-0809-08	FRONT CABINET (BLK)		B
604	2B	*	A52-0181-08	TOP CABINET (R) (WHT)		W
604	2B	*	A52-0184-08	TOP CABINET (R) (BLK)		B
605	1A	*	A52-0182-08	TOP CABINET (L) (WHT)		W
605	1A	*	A52-0185-08	TOP CABINET (L) (BLK)		B
610	3A		B04-0095-08	GRILLE (BLK)		B
610	3A	*	B04-0096-08	GRILLE (WHT)		W
611	3A		B43-0287-04	KENWOOD BADGE		
-			B46-0100-30	WARRANTY CARD	TE	
-		*	B60-2291-08	INSTRUCTION MANUAL(EN)		
-		*	B60-2292-08	INSTRUCTION MANUAL(C/TAIWAN)		M
-		*	B60-2293-08	INSTRUCTION MANUAL(EN/SP)		E
-		*	B60-2294-08	INSTRUCTION MANUAL(F/G/D/I)		M
615	3B	*	E30-2817-08	SPEAKER CORD (BLK)		B
615	3B	*	E30-2818-08	SPEAKER CORD (GRY)		W
616	1A	*	E30-2802-08	CORD WITH PLUG (3P)		
-		*	H50-1622-08	ITEM CARTON CASE AS-3(B)	M	B
-		*	H50-1623-08	ITEM CARTON CASE AS-3(W)	M	W
-		*	H50-1624-08	ITEM CARTON CASE AS-3(B)	TE	B
-		*	H50-1625-08	ITEM CARTON CASE AS-3(W)	TE	W
-		*	H10-5989-08	POLYSTYRENE FOAMED FIXTURE (T)		
-			H10-5990-08	POLYSTYRENE FOAMED FIXTURE (B)		
-			H13-0189-08	CARTON BOARD (AC ADAPTOR)		
-			H20-0486-00	PROTECTION BAG (ACCESSORIES)		
-			H25-1546-08	PROTECTION BAG (SET)		
635	1A	*	K29-6237-08	KNOB VOLUME (WHT)		W
635	1A	*	K29-6241-08	KNOB VOLUME (BLK)		B
636	1A	*	K29-6238-08	KNOB LINE (WHT)		W
636	1A	*	K29-6242-08	KNOB LINE (BLK)		B
637	2A	*	K29-6239-08	KNOB EX.BASS (WHT)		W
637	2A	*	K29-6243-08	KNOB EX.BASS (BLK)		B
638	1A	*	K29-6240-08	KNOB POWER (WHT)		W
638	1A	*	K29-6244-08	KNOB POWER (BLK)		B
A	2A,3B		N09-3186-08	SCREW (M3X8)		
B	2B		N09-3184-08	SCREW (M3X20)		
C	2B		N09-3187-08	SCREW (M3X10)		
D	2A,2B		N09-3185-08	SCREW (M2.6X10)		
640	2A,3B		T07-0084-08	WOOFER (4 OHM 5W)		
△	645	1A	W08-0015-08	AC ADAPTOR	M	
△	645	1A	W08-0017-08	AC ADAPTOR	E	
△	645	1A	W08-0645-08	AC ADAPTOR	T	
CONTROL PCB						
655	1A		B12-0262-08	LED (LED201)		
C101,102			CE04KW1H010M	ELECTRO 1.0UF 50WV		
C103,104			C91-0741-05	CERAMIC 68PF J		

L:Scandinavia
Y:PX(Far East, Hawaii)
Y:AAFES(Europe)

K:USA
T:England
X:Australia
P:Canada
E:Europe
M:Other Areas

R:Mexico
G:Germany
W:White version

△ indicates safety critical components.

* New Parts

Parts without **Parts No.** are not supplied.

Les articles non mentionnés dans le **Parts No.** ne sont pas fournis.

Teile ohne **Parts No.** werden nicht geliefert.

NO.2

Ref. No.	Add-ress	New Parts	Parts No.	Description	Desti-nation	Re-marks
C105-110		*	CQ93M2A473J	MYLAR 0.047UF J		
C111-114			CE04KW1H010M	ELECTRO 1.0UF 50WV		
C151			CE04KW1E101M	ELECTRO 100UF 25WV		
C152			CE04KW1C100M	ELECTRO 10UF 16WV		
C153			CK45FF1H223K	CERAMIC 0.022UF K		
C233			CE04KW1C100M	ELECTRO 10UF 16WV		
C234			CE04KW1A101M	ELECTRO 100UF 10WV		
VOL101			R39-0006-08	VARIABLE RESISTOR 50KB X2		
SW101-103			S68-0046-08	PUSH SWITCH		
D201			1N4148	DIODE		
IC102,103			BA4558	IC(OP AMP X2)		
Q201-203			2SC1815	TRANSISTOR		
MAIN PCB						
C201,202			CE04KW1H010M	ELECTRO 1.0UF 50WV		
C203,204			C91-0757-05	CERAMIC 1000PF K		
C205,206			CE04KW1A470M	ELECTRO 47UF 10WV		
C207,208			CQ93M2A154K	MYLAR 0.15UF K		
C209,210			CE04KW1A101M	ELECTRO 100UF 10WV		
C211,212			C91-0769-05	CERAMIC 0.010UF K		
C213,214			CE04KW1A102M	ELECTRO 1000UF 10WV		
C230			CE04KW1A221M	ELECTRO 220UF 10WV		
C232			CE04KW1E102M	ELECTRO 1000UF 25WV		
C235			CQ93HP2A102J	MYLAR 1000PF J		
C300			CK45F1H223Z	CERAMIC 0.022UF Z		
DC-JK			E03-0129-08	DC JACK (DC 12V)		
J1,2			E11-0269-08	PHONO JACK (LINE 1/2)		
R-SPK			E11-0270-08	PHONO JACK (OUTPUT)		
△	IC101	*	BA5412S	IC(Power AMP)		
△	IC101	*	BA5415	IC(Power AMP)		

L:Scandinavia
Y:PX(Far East, Hawaii)
Y:AAFES(Europe)

K:USA
T:England
X:Australia
P:Canada
E:Europe
M:Other Areas

R:Mexico
G:Germany

△ indicates safety critical components.

AS-3

SPECIFICATIONS

Amplifier section

Power output (EIAJ)..... 3.5 W + 3.5 W
Frequency response 40 Hz ~ 20 kHz
Power requirement.....AC 110V ~ 120V / 220V ~ 240V
50 / 60 Hz (M type)
AC 230 V / 50 Hz (T,E type)

Speaker section

System Full-range,bass - reflex,enclosure type
Seaker unit 70 mm diameter cone type
Rated impedance..... 4 Ω

General

Dimensions 107(W) X 215(H) X 155(D) mm
Weight 800 g (Left speaker)
730 g (Right speaker)

KENWOOD follows a policy of continuous advancements in development. For this reason specifications may be changed without notice.

Note:

Component and circuitry are subject to modification to insure best operation under differing local conditions. This manual is based on the the General market (M) standard, and provides information on regional circuit modification through use of alternate schematic diagrams, and information on regional component variations through use of parts list.

KENWOOD CORPORATION

14-6,Dogenzaka 1-chome, Shibuya-ku, Tokyo, 150 Japan

KENWOOD SERVICE CORPORATION

P.O BOX 22745, 2201 East Dominguez St., Long Beach, CA 90801-5745, U.S.A.

KENWOOD ELECTRONICS CANADA INC.

6070 Kestrel Road, Mississauga, Ontario, Canada L5T 1S8

KENWOOD ELECTRONICS LATIN AMERICA S.A.

P.O BOX 55-2791, Piso 6 plaza Chase, Cl. 47 y Aquilino de la Guardia Panama, Republic de Panama

TRIO-KENWOOD U.K. LIMITED

KENWOOD House, Dwight Road, Watford, Herts., WD1 8EB., United Kingdom

KENWOOD ELECTRONICS BENELUX N.V.

Meachelsesteenweg 418, B-1930 Zaventem, Belgium

KENWOOD ELECTRONICS DEUTSCHLAND GMBH

Rembrücker Str. 15, 63150 Heusenstamm, Germany

TRIO-KENWOOD FRANCE S.A.

13 Boulevard Ney, 75018 Paris, France

KENWOOD ELECTRONICS ITALIA S.p.A.

Via G. Sirtori, 7/9 20129, Milano, Italy

KENWOOD IBERICA S.A.

Bolivia, 239-08020 Barcelona, Spain

KENWOOD ELECTRONICS AUSTRALIA PTY. LTD. (A.C.N. 001499 074)

P.O Box 504, 8 Figtree Drive, Australia Centre, Homebush, N.S.W. 2140, Australia

KENWOOD & LEE ELECTRONICS, LTD.

Unit 3712-3724, Level 37, Tower 1, Metroplaza, 223 Hing Fong Road, Kwai Fong N.T., Hong Kong

KENWOOD ELECTRONICS SINGAPORE PTE LTD.

No. 1 Genting Lane # 07-00, KENWOOD Building, Singapore, 1334

KENWOOD ELECTRONICS (MALAYSIA) SDN BHD

10th Floor, Block B, Wisma Semantan, No. 12 Janlan Gelenggang, Bukit Damansara, 50490 Kuala Lumpur, Malaysia