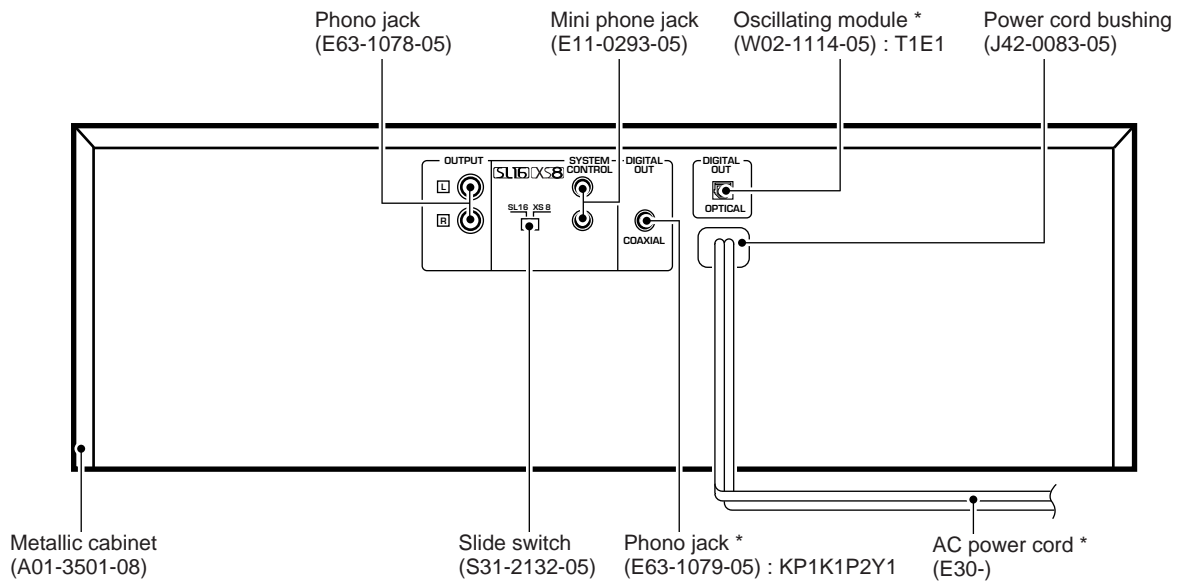

Illustration is CD-324M/DPF-J5020.



* Refer to parts list on page 17.

In compliance with Federal Regulations, following are reproductions of labels on, or inside the product relating to laser product safety.

KENWOOD-Corp. certifies this equipment conforms to DHHS Regulation No.21 CFR 1040.10, Chapter 1, Subchapter J.

DANGER : Laser radiation when open and interlock defeated.
AVOID DIRECT EXPOSURE TO BEAM.

Refer to CD-223M/DPF-J3010 service manual (B51-5409-00) if require the following items in detail.

- 1) Mechanism operation description.
- 2) Disassembly for repair.



CD-323M/324M/DPF-J5020

CONTENTS/ACCESSORIES/EXTERNAL VIEW

Contents

CONTENTS/ACCESSORIES/EXTERNAL VIEW	2	SCHEMATIC DIAGRAM	11
CIRCUIT DESCRIPTION	3	EXPLODED VIEW	15
ADJUSTMENT	8	PARTS LIST	17
PC BOARD	9	SPECIFICATIONS	Back cover

Accessories

Audio cord (1)
(E30-0505-05)

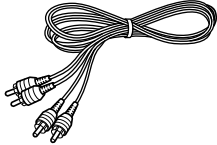

System control cord (1)
(E30-2816-05)

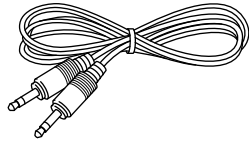

Batteries (R6/AA) (2)

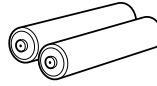

Remote control unit (1)
(A70-1257-08) : CD-324M/DPF-J5020

Battery cover : (A09-0374-08)

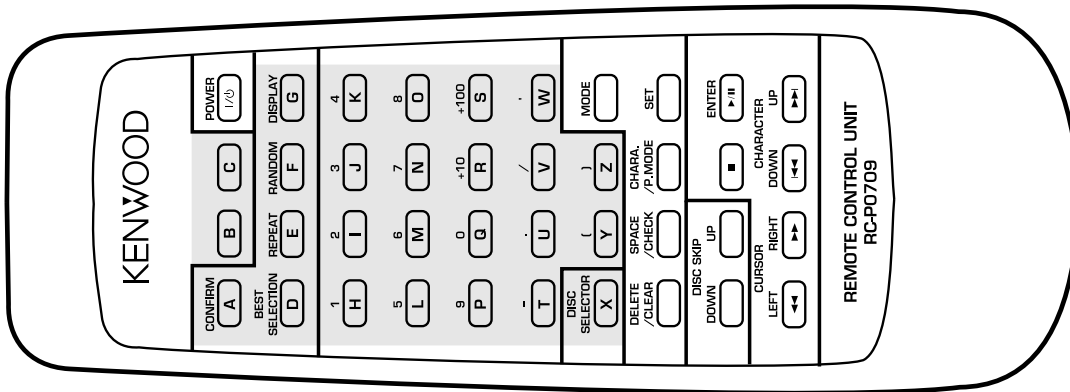

External view

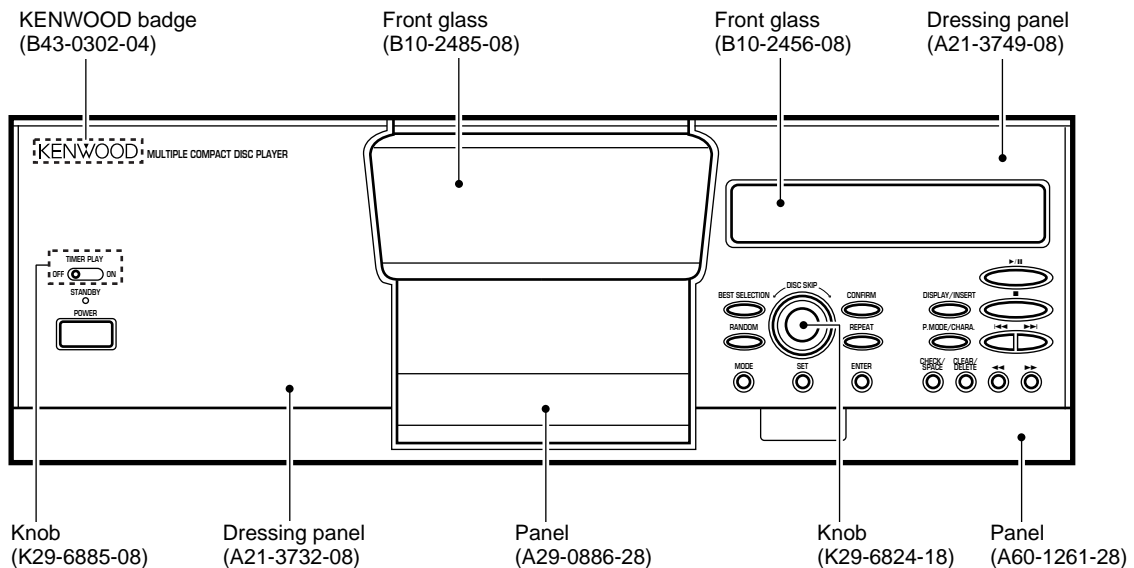

Illustration is CD-323M.

* Refer to parts list on page 17.

CD-323M/324M/DPF-J5020

CIRCUIT DESCRIPTION

1. Main microprocessor : uPD784215GF541 (IC8)

1-1 Microprocessor periphery block diagram

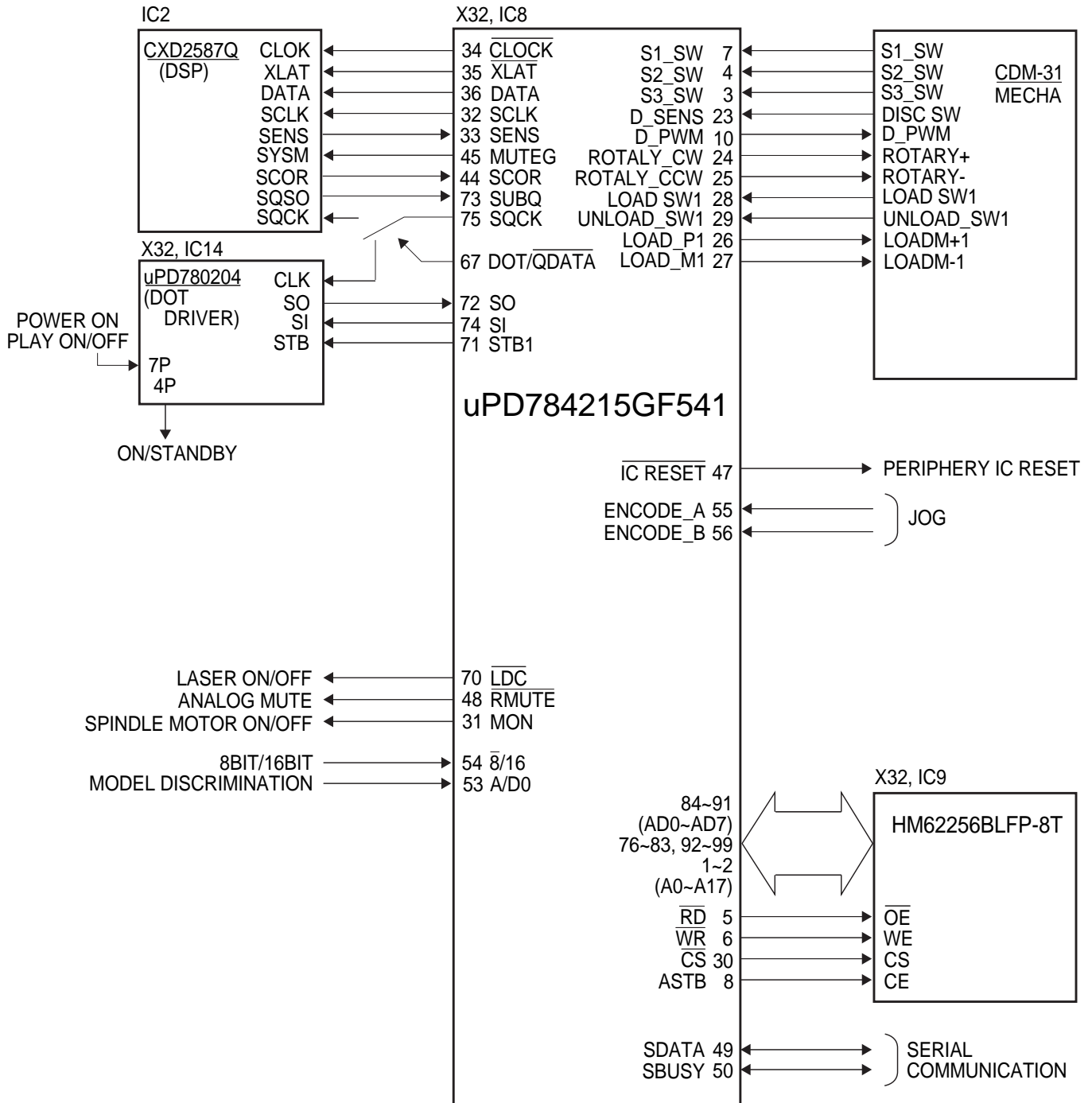

CD-323M/324M/DPF-J5020

CIRCUIT DESCRIPTION

1-2 Microprocessor pin description (X32, IC8)

Pin No.	Pin Name	I/O	Description
1	A16	O	No connection.
2	A17	O	No connection.
2	NC	-	No connection.
3	S3-SW	I	Mechanism address detector switch.
4	S2-SW	I	Mechanism address detector switch.
5	RD	O	SRAM read strobe.
6	WR	O	SRAM write strobe
7	S1-SW	I	Mechanism address detector switch.
8	ASTB(CE)	O	No connection.
9	VDD	-	Power supply (+5V).
10	+5VPUL	O	Disc sensor PWM output.
11	RTRN	O	No connection.
12	RWR	O	No connection.
13	RWRR	O	No connection.
14-21	L-D0-D7	O	No connection.
22	TEST	-	GND.
23	DISC-SW	I	Disc sensor.
24	ROTARY-CW	O	Mechanism rotary motor (+). H : CCW
25	ROTARY-CCW	O	Mechanism rotary motor (-). H : CW
26	LOADM+1	O	Loading motor (+) for main pickup.
27	LOADM-1	O	Loading motor (-) for main pickup.
28	LOAD-SW1	I	Loading switch for main pickup.
29	UNLOAD-SW1	I	Unloading switch for main pickup.
30	CS	O	SRAM CS.
31	MON	O	Control port of poor focus works.
32	SCLK	O	Sens serial data read clock.
33	SENS	I	SENS signal input.
34	CLOCK	O	Serial data clock.
35	XLAT	O	CXD2587Q latch.
36	DATA	O	Serial data output.
37	VDD	-	Power supply (+5V).
38, 39	X1, 2	-	Main system clock (12.5MHz).
40	VSS	-	GND.
41	XT2	-	No connection.
42	XT1	I	GND.
43	RESET	I	System reset signal input.
44	SCOR	I	Sub code synchro detection.
45	MUTEG	O	Muting control output. H : MUTE ON.
46	STB2	O	No connection.
47	IC RESET	O	IC reset.
48	RMUTE	O	Analog mute. L : MUTE ON.
49	SDATA	I/O	Serial data signal I/O.
50	SBUSY	I/O	Serial busy signal I/O.
51	AVDD	-	Power supply(+5V).
52	AVREF	-	A/D reference power supply.
53	A/D0	I	Model selector.
54	8/16	I	8/16 bit selector. H:16bit.
55	JOG2	I	Encoder signal A input.

CD-323M/324M/DPF-J5020

CIRCUIT DESCRIPTION

Pin No.	Pin Name	I/O	Description
56	JOG1	I	Encoder signal B input.
57	DOOR-SW	I	Door open/close detector switch.
58	LOAD-SW2	I	GND.
59	UNLOAD-SW2	I	GND.
60	DISC-SW2	I	Disc2 sensor.
61	AVSS	-	GND.
62	LOADM-2	O	No connection.
63	LOADM+2	O	No connection.
64	AVREF1	-	D/A reference power supply.
65	RXD-R	I	No connection.
66	TXD-R	O	No connection.
67	SQCK/SCK-SW	O	"SQCK,SCK(DOT/DSP clock). L: "DSP."
68	RXD SUB	I	No connection.
69	TXD SUB	O	No connection.
70	LDC	O	Laser on/off. L: Laser diode ON.
71	STB1	O	Strobe signal output to dot driver.
72	S0	I	Data input from dot driver.
73	SQS1	I	Sub code read data input.
74	S1	O	Data output to dot driver.
75	SCK/SQCK	O	Dot driver/sub code read clock.
76-83	A14~7	O	Address output to SRAM.
84-91	D0~7	I/O	SRAM data buss.
92-98	A0~6	O	Address output to SRAM.
99	A15	O	No connection.
100	VSS	-	GND.

1-3 Key matrix

(): IC14 Pin No.

VOLTAGE	KEY RETURN 0 (33)		KEY RETURN 1 (32)		KEY RETURN 2 (31)	
4.166V	323M	CHECK/SPACE	323M	MODE	323M 324M/J5020	BEST SEL. DISPLAY
3.333V	323M	CLEAR/DELETE	323M	SET	RANDOM	
2.5V	323M	FB	323M	ENTER	CONFIRM	
1.666V	323M	FF	REPEAT		323M	DISP/INS
0.833V	DOWN		323M	P.MODE/CHARA	PLAY/PAUSE	
0V	UP		POWER		STOP	

CD-323M/324M/DPF-J5020

CIRCUIT DESCRIPTION

2. FL Microprocessor : UPD780204-038 (X32, IC14)

Pin description

Pin No.	Pin Name	I/O	Description
1	VDD	–	Power supply (+5V)
2, 3	NC	–	No connection.
4	STANDBY	O	Standby LED control
5	LED-A	O	No connection.
6	LED-B	O	No connection.
7	POW-P	I/O	Timer sw on input.
8, 9	NC	–	No connection.
10	RESET	I	System reset input
11, 12	X1, 2	–	Main system clock. (5MHz).
13	VSS	–	GND.
14	XT2	–	No connection.
15	XT1	I	GND.
16	VDD	–	Power supply (+5V)
17	SCK	I	Serial clock.
18	SO	O	Data output.
19	SI	I	Data input.
20-24	NC	–	No connection.
25	AVSS	–	GND.
26~30	A/D7~A/D3	–	GND.
31~33	A/D2~A/D0	I	Key return signal input (2~0).
34	AVDD	–	A/D analog power supply.
35	AVREF	–	A/D reference power supply.
36, 37	VSS	–	GND.
38	REM	I	Remote control input. (Except for CD-323M.)
39	STB1	I	Strobe signal input.
40	VSS	–	GND.
41~45	NC	–	No connection.
46	VDD	–	Power supply (+5V)
47	NC	–	No connection.
48~52	P1~5	O	FL control output. 1G (▶■), 2G~16G (1- 1 to 5- 1).
53~57	P6~10	O	FL control output. 2G~16G (1- 2 to 5- 2).
58~62	P11~15	O	FL control output. 2G~16G (1- 3 to 5- 3).
63, 64	P16, 17	O	FL control output. 2G~16G (1- 4 to 2- 4).
65~69	P35~31	O	FL control output. 2G~16G (5- 7 to 1- 7).
70~74	P30~26	O	FL control output. 2G~16G (5- 6 to 1- 6).
75~78	P25~22	O	FL control output. 2G~16G (5-5 to 2-5).
79	VLOAD	–	Negative power supply (-37.5V).
80	P21	O	FL control output. 2G~16G (1-5).
81, 82	P20, 19	O	FL control output. 2G~16G (5-4 , 4-4).
83	NC	–	No connection.
84	P18	O	FL control output. 2G~16G (3-4).
85~92	9G~16G	O	FL control output. 9G~16G.
93~100	8G~1G	O	FL control output. 8G~1G.

CIRCUIT DESCRIPTION

3. TEST MODE

INPUT KEY	PROCEDURE	DISPLAY
Insert the AC plug to the wall outlet with pressing the SKIP-DOWN key.	INITIAL CONDITION <ul style="list-style-type: none"> • Disc No.1 moves to the center and clamp it. • Clear the memory of the SRAM. • Door opens. • Set the switch of TIMER ON PLAY to ON. • Set the switch of SYSTEM CONTROL to XS8. 	INITIAL OK!! MECH. INITIAL INITIAL NG TIMER, NG SER, NG TEST ON
Insert the AC plug to the wall outlet with pressing the REPEAT key	CIRCUIT ADJUSTMENT <ul style="list-style-type: none"> • Open the door and load the disc to the Disc No.1. • Close the door. The unit changes to test mode "05" after clamping the disc. 	
PLAY/PAUSE	Change the mode 05(tracking-on) and 03 (tracking-off) alternately by the PLAY key.	05 1 : 23 03 2 : 34
STOP	Stop the function.	00
UP	The pickup travels outwards.	MOTOR FORWARD
DOWN	The pickup travels inwards.	MOTOR REVERSE
RANDOM	Shows the result of self-adjustment. 07 EF/FB ← ↓ 08 TG/FG ↓ 09 FE/RF ↓ 10 TE/VC ——— Mode changes alternately by the RANDOM key.	07 XXX:XXX 08 XXX:XXX 09 XXX:XXX 10 XXX:XXX NG : blinking
DISPLAY	—	shows niagara mode
POWER	Check the transmission signal (Disc No.1 and Track No.99) of the remote controller. *DPF-J5020, CD-324M only.	
REPEAT	Playback PGM signal of the Track No.7,13,23,30,34 and 41 in the order. And release	
CONFIRM	Release the test mode.	
(TIMER PLAY SW)	Check the switch position.	TIMER ON, TIMER OFF
(SL16/XS8 SW)	Check the switch position.	16BIT, 8BIT
(TxD port)	Check the SL16-TEXT port. "TxD : H - RxD:L, TxD:L - RxD:H"	
Insert the AC plug to the wall outlet with pressing the UP key.	CHECK THE MECHANISM JAMMING. the order. Clamp the Disc No1,2,100,50,200 and 199 in the order.	
Insert the AC plug to the wall outlet with pressing the RANDOM key.	THE MECHANISM TEST MODE. Display shows NIAGARA until pressing any key.	
PLAY/PAUSE	Change the mode 05 (tracking-on) and 03 (tracking-off) alternately by the PLAY key.	05 1 : 23 03 2 : 34
STOP	Stop the function. Shows the result of self-adjustment. 07 EF/FB ← ↓ 08 TG/FG ↓ 09 FE/RF ↓ 10 TE/VC ——— Mode changes alternately by the STOP key.	07 XXX:XXX 08 XXX:XXX 09 XXX:XXX 10 XXX:XXX NG : blinking
UP	Arm Motor Load operation.	MOTOR LOAD
DOWN	Arm Motor Unload operation.	MOTOR UNLOAD
RANDOM	Rotary Motor Clockwise turning.	MOTOR CW
DISPLAY	Rotary Motor Counterclockwise turning.	MOTOR CCW

CD-323M/324M/DPF-J5020

CIRCUIT DESCRIPTION/ADJUSTMENT

CIRCUIT DESCRIPTION

INPUT KEY	PROCEDURE	DISPLAY
POWER	Check the transmission signal(Disc No.1 and Track No.99) of the remote controller. *DPF-J5020, CD-324M only	
REPEAT	Playback PGM signal of the Track No.7,13,23,30,34 and 41 in the order.And release he test mode.	
CONFIRM	Release the test mode.	
(TIMER PLAY SW)	Check the switch position.	TIMER ON , TIMER OFF
(SL16/XS8 SW)	Check the switch position.	16BIT, 8BIT
(TxD port)	Check the SL16-TEXT port. TxD : H → RxD : L, TxD : L → RxD : H	

4. ERROR CODE

DISPLAY	ERROR CONTENTS
MECHA ERROR 01	No input of S3. The original position error of Disc Number.
MECHA ERROR 02	No input of S2. The turning direction error to counterclockwise
MECHA ERROR 03	No input of S1. The turning direction error to clockwise
MECHA ERROR 04	No input of main load sw.
MECHA ERROR 05	No input of main unload sw.

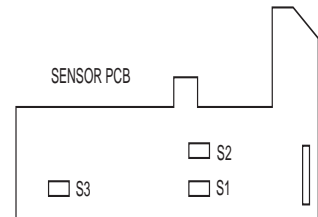

S1-3: Mechanism address detector switch.
There are load and unload switches in the main pickup.

S1 DISC 1-9
S2 DISC 10-99
S3 DISC 100-200

ADJUSTMENT

No.	ITEM	INPUT SETTING	OUTPUT SETTING	PLAYER SETTING	ALIGNMENT POINT	ALIGN FOR	FIG.
1. With pressing the RANDOM KEY, turn the power on to enter the test mode. 2. Set the Test disc to Disc NO. 1. 3. Close the door.							
1	FOCUS ERROR BIAS	Test disc Type4 /KTD-02	Connect an oscilloscope as follows. CH1:RF (CN2-1)	Press the PLAY /PAUSE key . Confirm that the display is "05".	FE BIAS VR1	Optimum eye pattern	(d)

Note:

Type 4 disc :SONY YEDS-18 Test Disc or equivalent.

LPF : Around 47kΩ + 390 pF or so.

FIG. (d)

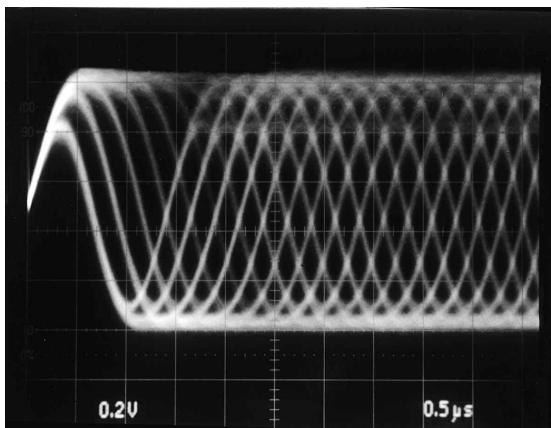

RF signal

- RF signal in test mode (PLAY).
- Perform the tangential and focusing offset are focused into one point on the display. The crossing points above and below the center shall also be looked clearly. (FE BIAS)

PC BOARD(Component side view)

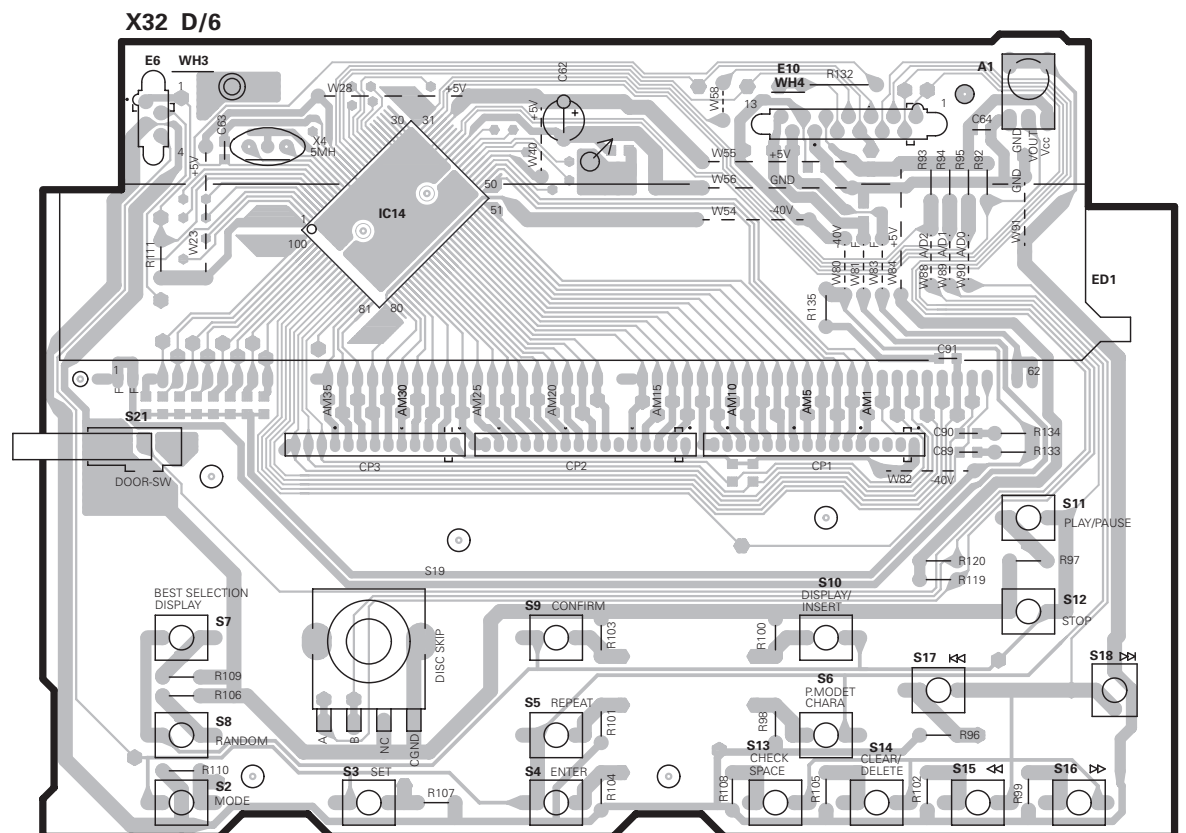
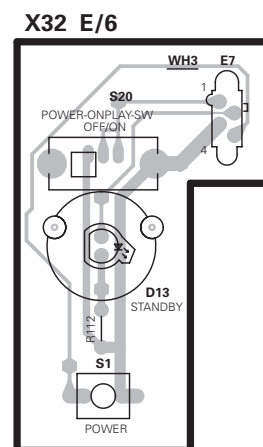
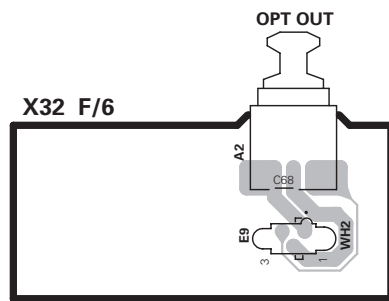
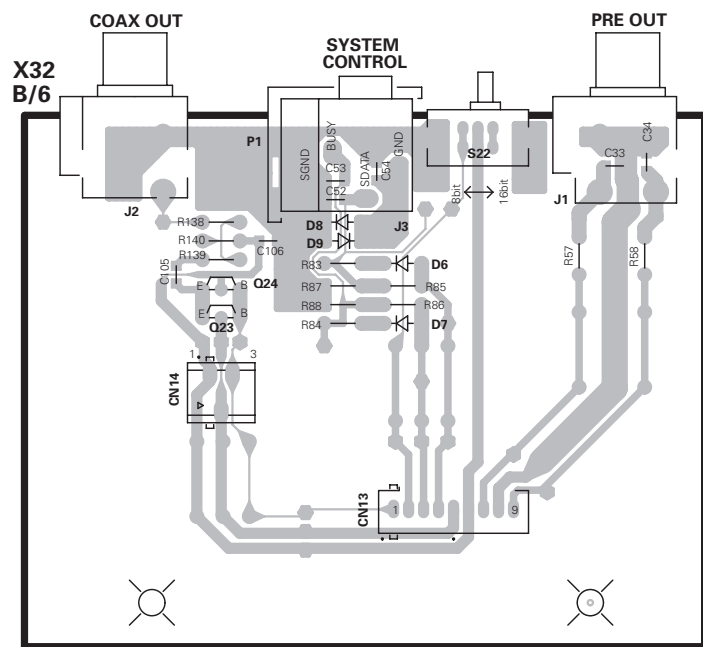
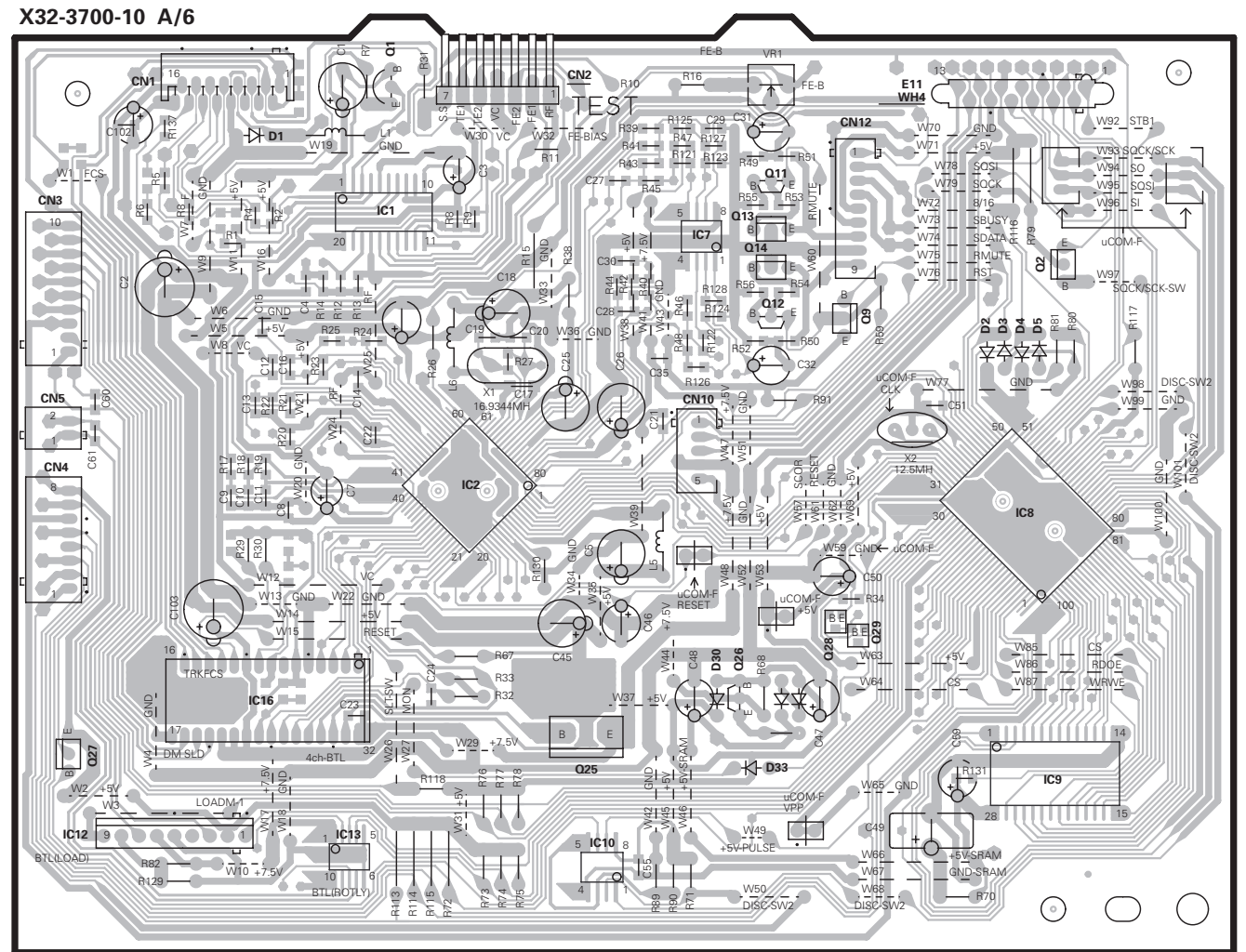
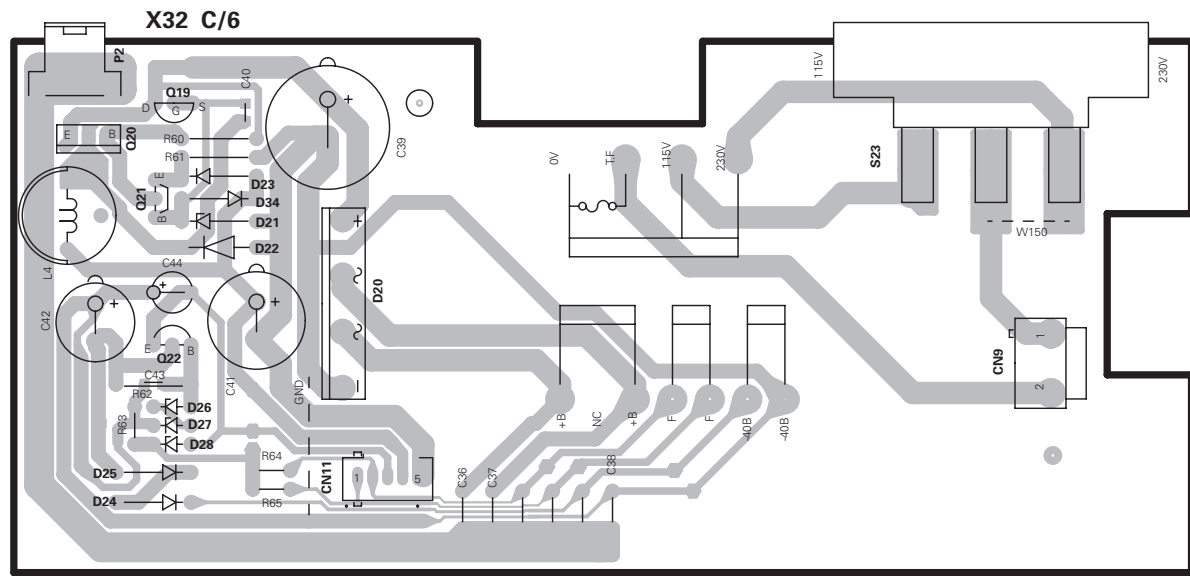

Refer to the schematic diagram for the value of resistors and capacitors.

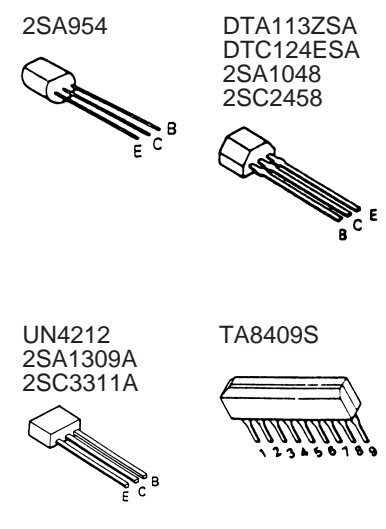
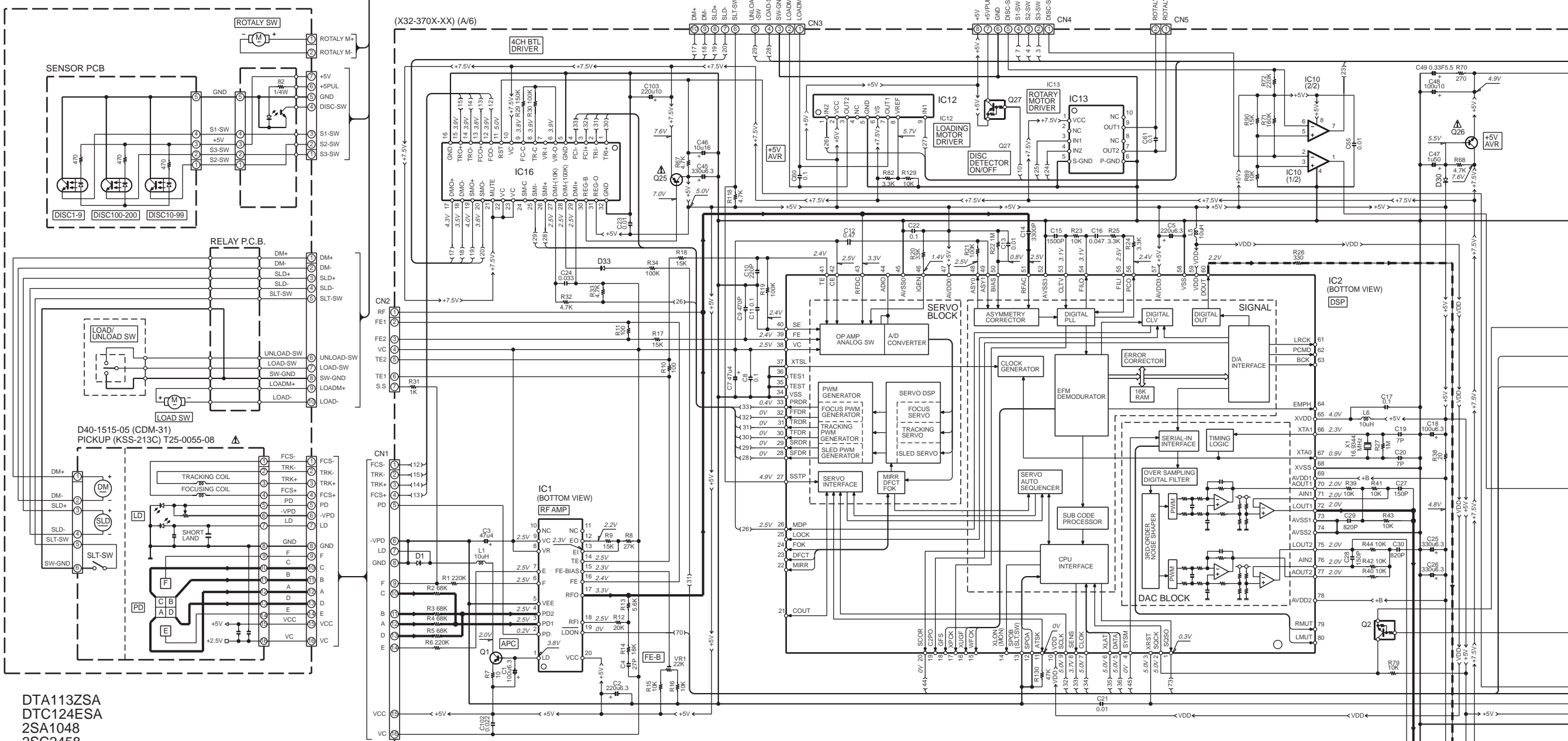

CD-323M (X32-3700-10)							
DESTINATION	COUNTRY	ABB.	UNIT No.	Ⓐ	Ⓑ	Ⓒ	Ⓓ
U.S.A.	K		0-10	NO	YES	NO	NO
CANADA	P1			NO	NO	NO	YES

CD-324M (X32-3700-11)							
DESTINATION	COUNTRY	ABB.	UNIT No.	Ⓐ	Ⓑ	Ⓒ	Ⓓ
U.S.A.	K1		0-11	YES	NO	YES	NO
CANADA	P2			NO	YES	NO	YES

DPF-J5020 (X32-3702-XX)							
DESTINATION	COUNTRY	ABB.	UNIT No.	Ⓐ	Ⓑ	Ⓒ	Ⓓ
U.K.	T1		2-91	YES	NO	YES	NO
EUROPE	E1		2-71	YES	NO	NO	YES

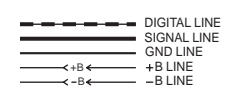

- IC1 : CXA1571M
- IC2 : CXD2587Q
- IC7 : NJM2115M
- IC8 : uPD784215GF541
- IC9 : HM62256BLFP-8T or W24258S-70LE
- IC10 : NJM2100M
- IC12 : TA8409S
- IC13 : LB1930M
- IC14 : uPD780204-038
- IC16 : BA5979S
- D1-9,23,30,33,34 : HSS104 or 1SS133
- D13 : B30-2546-05
- D20 : D3SBA20F03 or RBV-402LFA
- D21 : NJM2100M
- D22 : RD7.5JS(B) or HZS7.5S(B)
- D24,25 : S5688B or 1SR139-400
- D26 : RD16ES(B2) or HZS16N(B2)
- D27 : RD20ES(B) or HZS20N(B)
- D28 : RD11ES(B2) or HZS11N(B2)
- ED1 : 16-MT-63GK
- Q1,22 : 2SA954(L,K)
- Q2,9 : UN4212 or DTC124ESA
- Q11,12,24 : 2SA1309A(Q,R) or 2SA1048(Y,GR)
- Q19 : 2SD1450(S,T)
- Q20 : 2SK246(Y)
- Q21,23,26 : 2SC3311A(Q,R) or 2SC2458(Y,GR)
- Q25 : 2SB1640 or 2SB1417(P)
- Q27 : UN4119 or DTA113ZSA
- Q28 : UN5112 or DTA124EUA
- Q29 : UN5212 or DTC124EUA

(K,P) : AC120V 60Hz
 (Y) : AC110-120V/220-240V-50/60Hz
 (T,E) : AC230V-50Hz

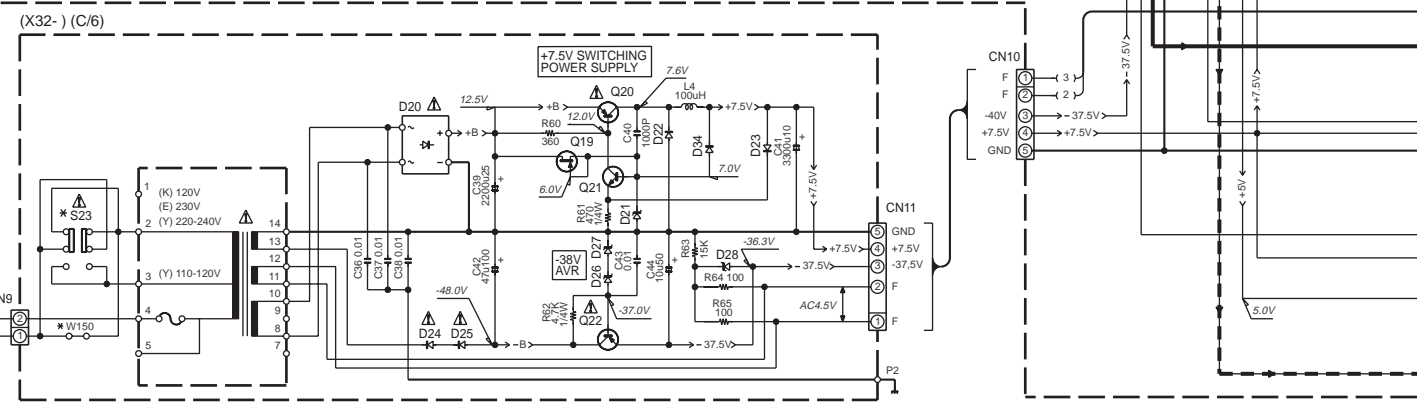

CAUTION: For continued safety, replace safety critical components only with manufacturer's recommended parts (refer to parts list). ⚠ indicates safety critical components. For continued protection against risk of fire, replace only with same type and rating fuse(s). To reduce the risk of electric shock, leakage-current or resistance measurements shall be carried out (exposed parts are acceptably insulated from the supply circuit) before the appliance is returned to the customer.

The DC voltage is an actual reading measured with a high impedance type voltmeter with no signal input. The measurement value may vary depending on the measuring instruments used or on the product.

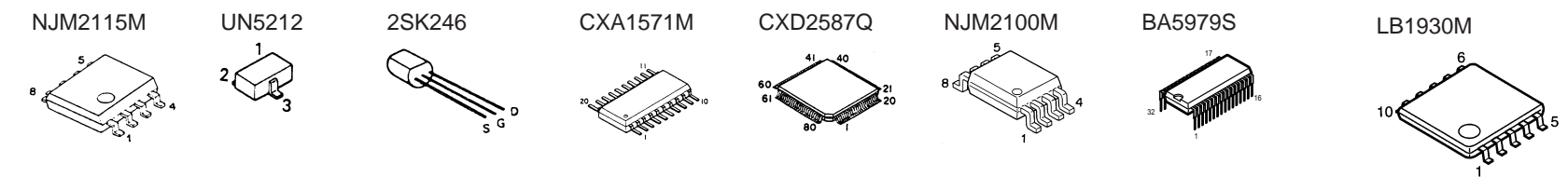

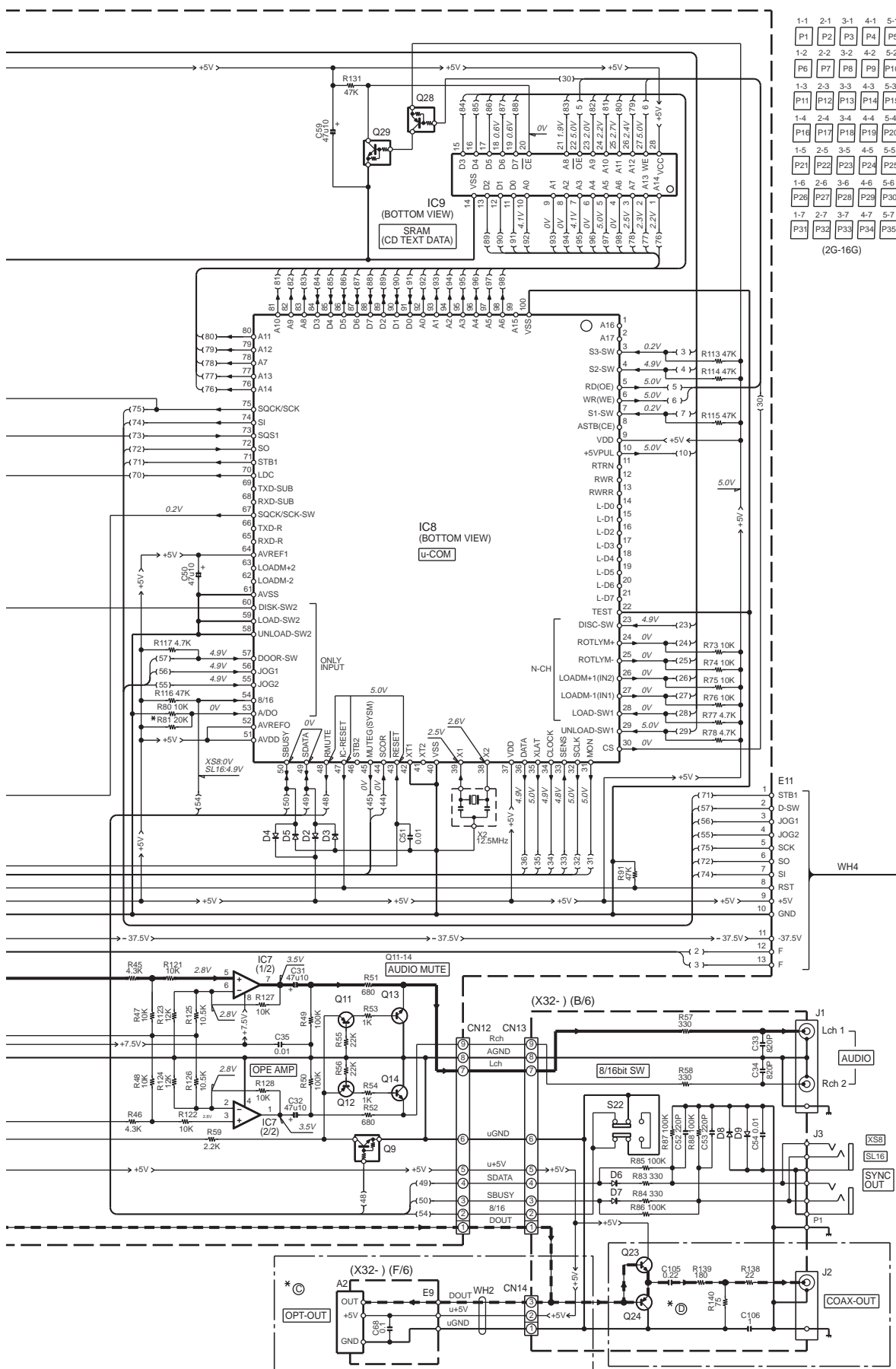

(X32-370X-XX) (D/6)

1-1	2-1	3-1	4-1	5-1
P1	P2	P3	P4	P5
1-2	2-2	3-2	4-2	5-2
P6	P7	P8	P9	P10
1-3	2-3	3-3	4-3	5-3
P11	P12	P13	P14	P15
1-4	2-4	3-4	4-4	5-4
P16	P17	P18	P19	P20
1-5	2-5	3-5	4-5	5-5
P21	P22	P23	P24	P25
1-6	2-6	3-6	4-6	5-6
P26	P27	P28	P29	P30
1-7	2-7	3-7	4-7	5-7
P31	P32	P33	P34	P35

(2G-16G)

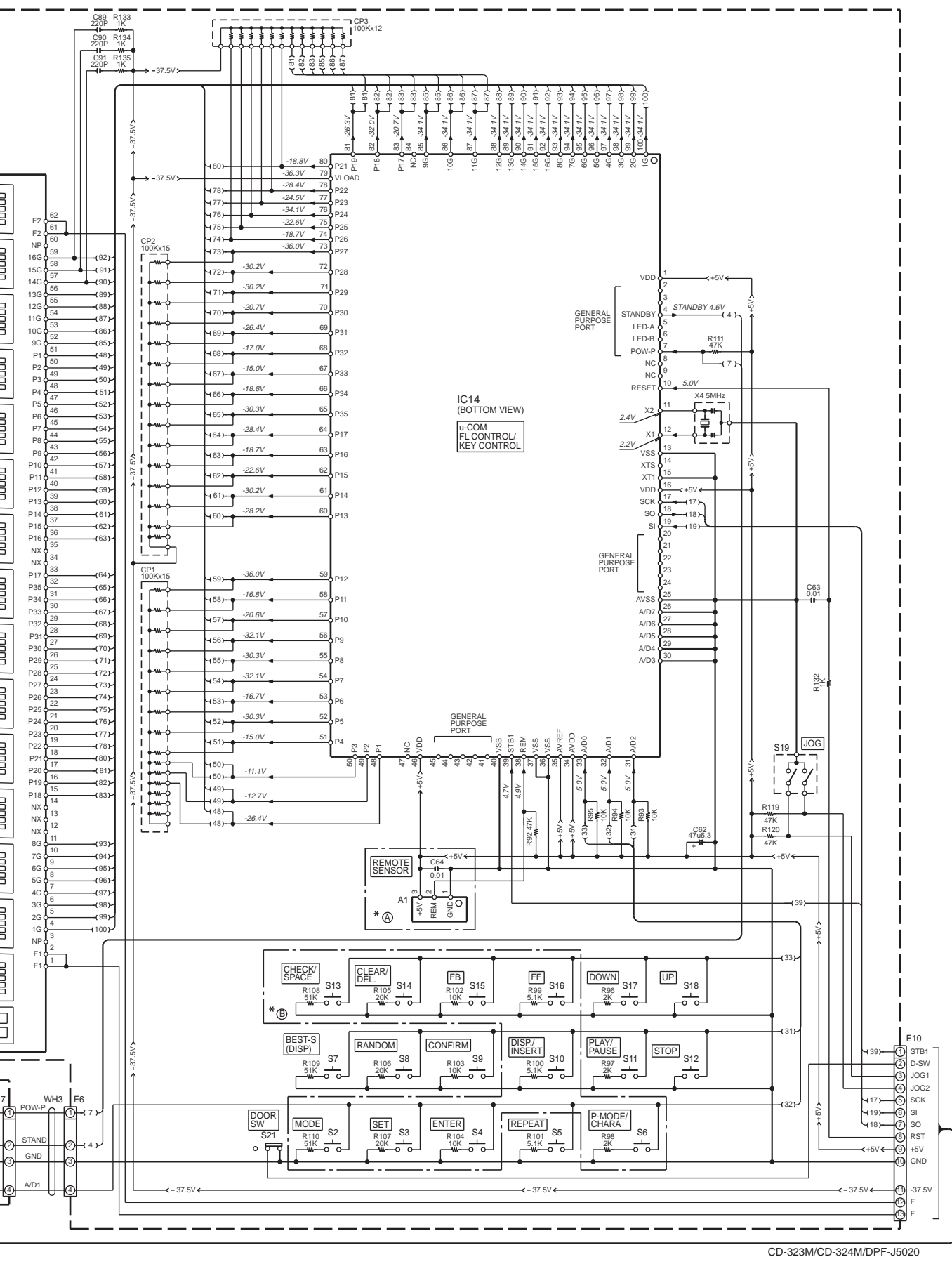
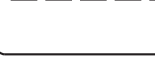
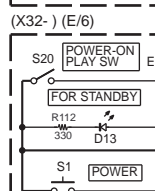
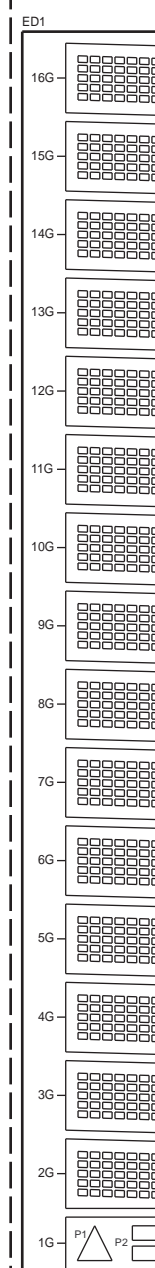

CD-323M/324M/DPF-J5020

EXPLODED VIEW(MECHANISM)

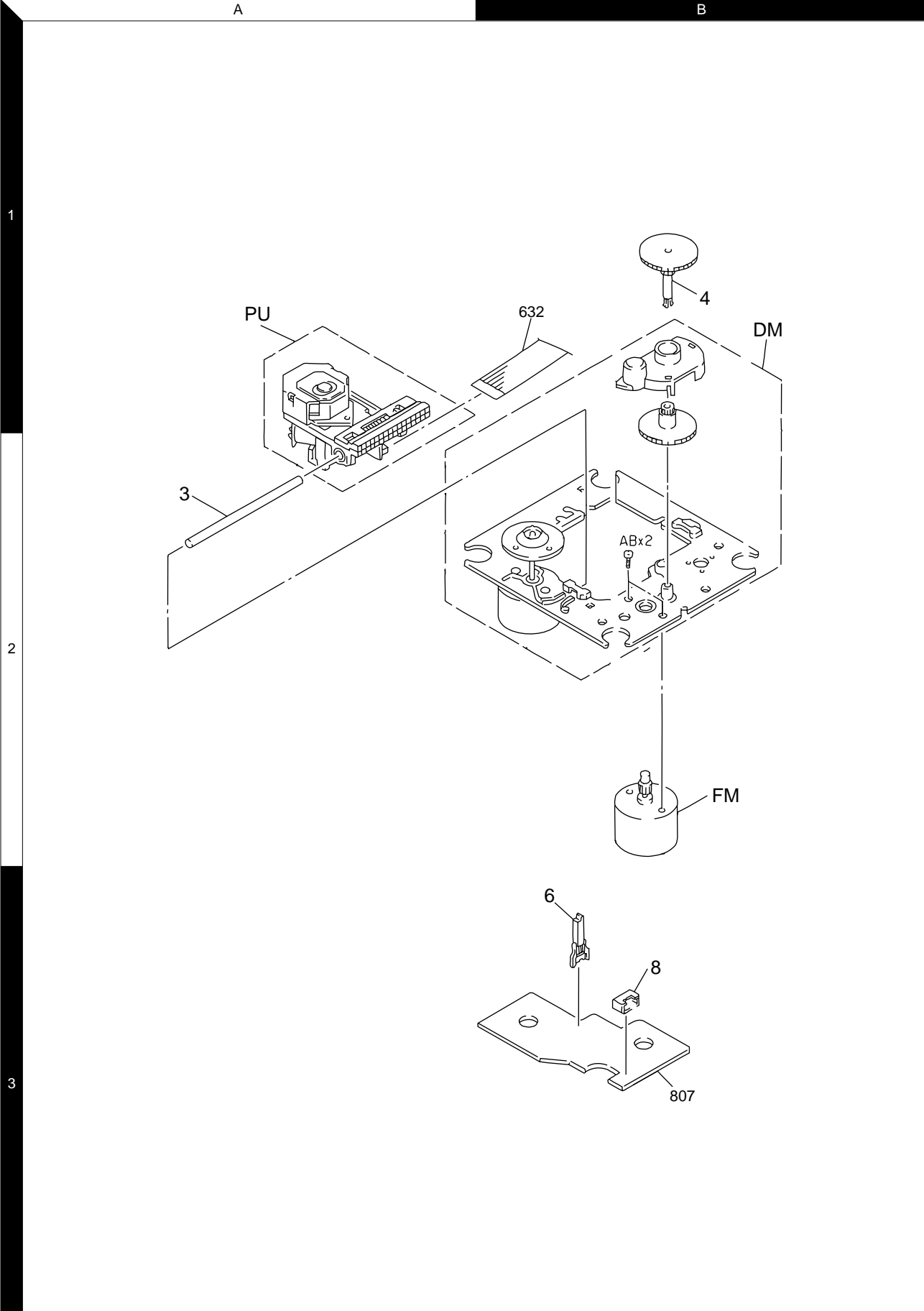

- | | | | | | |
|---|------------|---------------|---|------------|---------------|
| A | ∅ 2.6x8 | : N09-2769-05 | N | ∅ 2x4 | : N38-2040-46 |
| B | 3x6(BLK) | : N09-1445-05 | P | PUSH RIVET | : N29-0035-05 |
| C | ∅ 2.6x8 | : N82-2608-46 | Q | M2x4 | : N83-2004-45 |
| D | ∅ 3x6 | : N89-3006-46 | R | M2x2.5 | : N39-2025-46 |
| E | ∅ 3x8(BLK) | : N89-3008-45 | S | M3x3 | : N30-3003-46 |
| F | ∅ 3x8 | : N89-3008-46 | T | E-RING | : N29-0207-04 |
| G | 3x10 | : N89-3010-46 | U | E-RING | : N29-0208-04 |
| H | ∅ 3x6 | : N09-1561-05 | V | E-RING | : N29-0209-04 |
| J | M2.6x6 | : N86-2606-46 | V | WASHER | : N19-1096-04 |
| K | M2x3 | : N84-2003-46 | W | WASHER | : N19-0921-04 |
| L | M2x4 | : N86-2004-46 | X | WASHER | : N19-1171-04 |
| M | ∅ 3x6 | : N84-3006-46 | Y | WASHER | : N19-1105-04 |

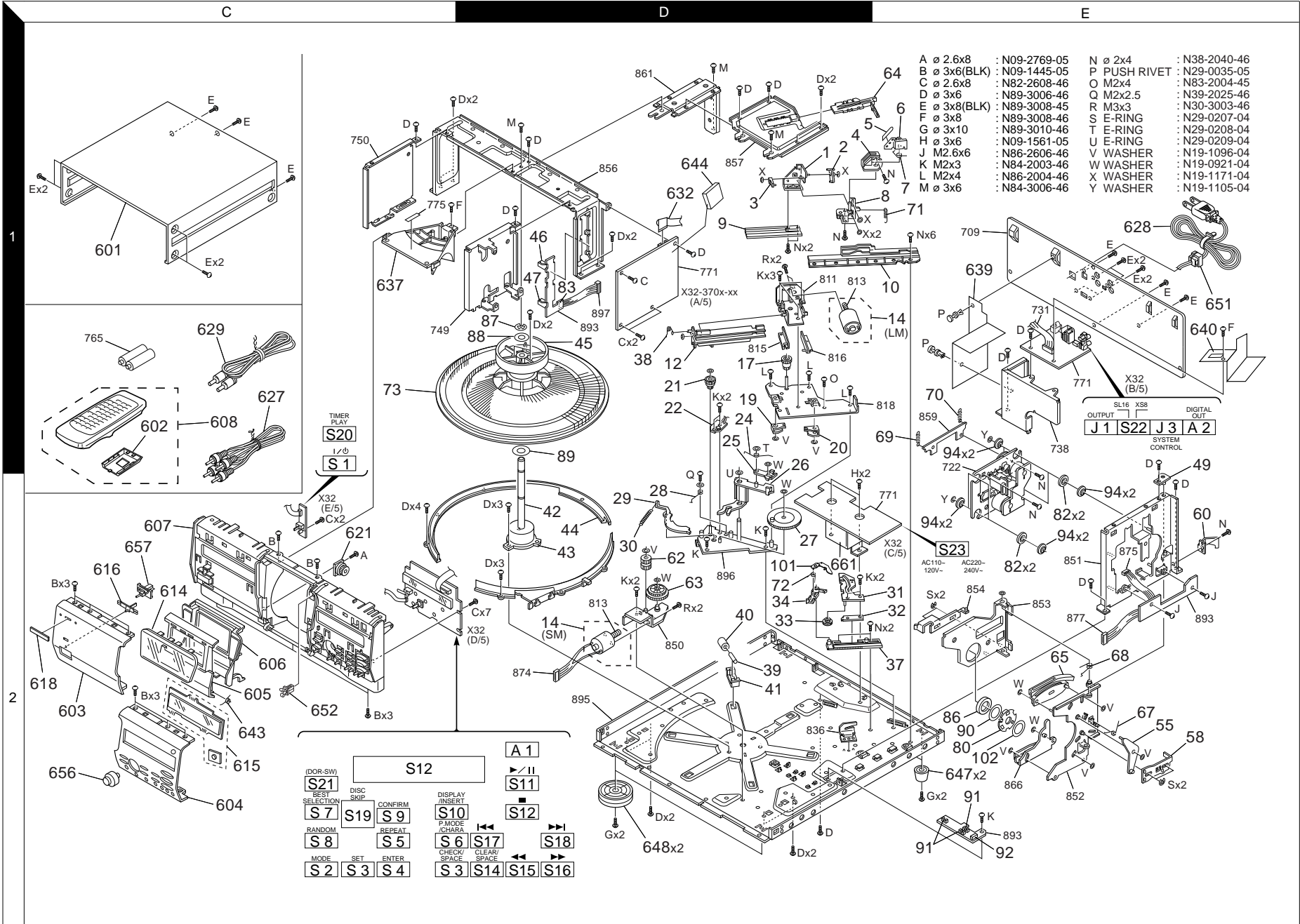

* New Parts

Parts without **Parts No.** are not supplied.
Les articles non mentionnés dans le **Parts No.** ne sont pas fournis.
Teile ohne **Parts No.** werden nicht geliefert.

①

Ref. No	Add-ress	New Parts	Parts No.	Description	Desti-nation	Re-marks
CD-323M/324M/DPF-J5020						
601	1C		A01-3501-08	METALLIC CABINET		
602	1C		A09-0374-08	CABINET	K1P2Y1	
602	1C		A09-0374-08	CABINET	T1E1	
603	2C	*	A21-3732-08	DRESSING PANEL	KP1	
603	2C	*	A21-3734-08	DRESSING PANEL	K1P2	
603	2C	*	A21-3735-08	DRESSING PANEL	T1E1	
603	2C	*	A21-3736-08	DRESSING PANEL	Y1	
604	2C		A21-3611-18	DRESSING PANEL	K1P2Y1	
604	2C	*	A21-3612-08	DRESSING PANEL	T1E1	
604	2C	*	A21-3749-08	DRESSING PANEL	KP1	
605	2C		A29-0886-28	PANEL	KP1K1	
605	2C		A29-0886-28	PANEL	P2Y1	
605	2C	*	A29-1012-18	PANEL	T1E1	
606	2C		A46-0304-18	REAR COVER	KP1K1	
606	2C		A46-0304-18	REAR COVER	P2Y1	
606	2C	*	A46-0310-08	REAR COVER	T1E1	
607	2C		A60-1260-28	PANEL	K1P2Y1	
607	2C		A60-1261-28	PANEL	KP1	
607	2C	*	A60-1457-18	PANEL	T1E1	
608	2C	*	A70-1257-08	REMOTE CONTROLLER ASSY	K1P2Y1	
608	2C	*	A70-1257-08	REMOTE CONTROLLER ASSY	T1E1	
614	2C		B10-2395-08	FRONT GLASS	K1P2Y1	
614	2C		B10-2395-08	FRONT GLASS	T1E1	
614	2C		B10-2485-08	FRONT GLASS	KP1	
615	2C		B10-2396-18	FRONT GLASS	K1P2Y1	
615	2C		B10-2396-18	FRONT GLASS	T1E1	
615	2C		B10-2456-08	FRONT GLASS	KP1	
616	2C		B12-0337-08	INDICATOR		
618	2C		B43-0302-04	KENWOOD BADGE		
-			B46-0197-00	QUESTIONNAIRE CARD	KK1	
-			B46-0310-03	WARRANTY CARD	T1E1	
-			B46-0328-03	WARRANTY CARD	KK1Y1	
-			B46-0336-03	WARRANTY CARD	P1P2	
-			B58-0513-04	CAUTION CARD (PRESET220-240)	Y1	
-			B58-0964-13	CAUTION CARD (UL)	KK1Y1	
-			B58-0965-13	CAUTION CARD (T,XtypePL)	T1	
-		*	B58-0966-13	CAUTION CARD (ELMtypePL)	E1	
-		*	B58-0967-03	CAUTION CARD (PtypePL)	P1P2	
-			B59-1104-00	SERVICE DIRECTORY	Y1	
-		*	B60-4078-08	INSTRUCTION MANUAL (EN)	KP1	
-		*	B60-4079-08	INSTRUCTION MANUAL (FR)	P1	
-		*	B60-4081-08	INSTRUCTION MANUAL (EN)	K1P2Y1	
-		*	B60-4081-08	INSTRUCTION MANUAL (EN)	T1	
-		*	B60-4082-08	INSTRUCTION MANUAL (FR)	P2E1	
-		*	B60-4083-08	INSTRUCTION MANUAL (IT/ES)	E1	
-		*	B60-4084-08	INSTRUCTION MANUAL (GE/NE)	E1	
621	2C	*	D39-0335-18	DAMPER		
627	1C		E30-0505-05	AUDIO CORD		
Δ 628	1E		E30-2788-05	AC POWER CORD	E1	
Δ 628	1E		E30-2789-05	AC POWER CORD	Y1	
Δ 628	1E		E30-2791-05	AC POWER CORD	T1	
Δ 628	1E	*	E30-2883-05	AC POWER CORD	KP1K1	

L : Scandinavia K : USA P : Canada R : Mexico C : China I : Malaysia
Y : PX(Far East, Hawaii) T : Europe E : Europe G : Germany V : China(Shanghai)
Y : AAFES(Europe) X : Australia Q : Russia H : Korea M : Other Areas Δ indicates safety critical components.

* New Parts

Parts without **Parts No.** are not supplied.
Les articles non mentionnés dans le **Parts No.** ne sont pas fournis.
Teile ohne **Parts No.** werden nicht geliefert.

②

Ref. No	Add-ress	New Parts	Parts No.	Description	Desti-nation	Re-marks
Δ 628	1E	*	E30-2883-05	AC POWER CORD	P2	
629	1C		E30-2816-05	CORD WITH PLUG		
632	1D	*	E35-2325-08	FLAT CABLE		
637	1C		F07-1613-08	COVER		
639	1E		F20-3515-08	INSULATING BOARD		
640	1E	*	F20-3525-08	INSULATING BOARD		
643	2C		G01-4026-18	TORSION COIL SPRING		
644	1D	*	G13-0595-08	CUSHION		
-		*	H10-7397-18	POLYSTYRENE FOAMED FIXTURE		
-		*	H10-7398-18	POLYSTYRENE FOAMED FIXTURE		
-		*	H12-2401-08	PACKING FIXTURE		
-		*	H21-0353-18	PROTECTION SHEET		
-		*	H25-0232-04	PROTECTION BAG (235X350X0.03)	KP1K1	
-			H25-0232-04	PROTECTION BAG (235X350X0.03)	P2Y1E1	
-			H25-0651-04	PROTECTION BAG (0232 PRINT)	T1	
-			H25-0692-04	PROTECTION BAG		
-		*	H50-3179-08	ITEM CARTON CASE	KP1	
-		*	H50-3181-08	ITEM CARTON CASE	K1P2	
-		*	H50-3182-08	ITEM CARTON CASE	Y1T1E1	
647	2E	*	J02-1416-08	FOOT (1-8200-2103-0)		
648	2D	*	J02-1414-08	FOOT (1-8200-2101-0)	KP1K1	
648	2D	*	J02-1414-08	FOOT (1-8200-2101-0)	P2Y1	
648	2D	*	J02-1415-08	FOOT (1-8200-2102-0)	T1E1	
Δ 651	1E		J42-0083-05	POWER CORD BUSHING		
652	2C		J52-0039-05	PUSH LATCH		
-			J61-0098-05	WIRE BAND		
656	2C		K29-6824-18	KNOB		
657	2C	*	K29-6885-38	KNOB		
Δ 661	2D		L07-2449-08	POWER TRANSFORMER	KP1K1	
Δ 661	2D		L07-2449-08	POWER TRANSFORMER	P2	
Δ 661	2D		L07-2450-08	POWER TRANSFORMER	Y1	
Δ 661	2D		L07-2451-08	POWER TRANSFORMER	T1E1	
CD PLAYER UNIT (X32-370X-XX)						
D13		*	B30-2546-05	LED(RED3(80))		
C1			C90-3214-05	ELECTRO	100UF	6.3WV
C2			C90-3215-05	ELECTRO	220UF	6.3WV
C3			C90-3203-05	ELECTRO	47UF	4WV
C4			CC73FSL1H270J	CHIP C	27PF	J
C5			CE04KW0J221M	ELECTRO	220UF	6.3WV
C7			C90-3203-05	ELECTRO	47UF	4WV
C8			CK73FB1E104K	CHIP C	0.10UF	K
C9			CC73FSL1H471J	CHIP C	470PF	J
C10			CC73FSL1H221J	CHIP C	220PF	J
C11			CK73FB1E104K	CHIP C	0.10UF	K
C12			CK73FB1C474K	CHIP C	0.47UF	K
C13			CK73FB1H103K	CHIP C	0.010UF	K
C14			CK73FB1H332K	CHIP C	3300PF	K
C15			CK73FB1H152K	CHIP C	1500PF	K
C16			CK73FB1H473K	CHIP C	0.047UF	K
C17			CK73EB1H104K	CHIP C	0.10UF	K
C18			C90-3214-05	ELECTRO	100UF	6.3WV

L : Scandinavia K : USA P : Canada R : Mexico C : China I : Malaysia
Y : PX(Far East, Hawaii) T : Europe E : Europe G : Germany V : China(Shanghai)
Y : AAFES(Europe) X : Australia Q : Russia H : Korea M : Other Areas Δ indicates safety critical components.

PARTS LIST

CD-323M/324M/DPF-J5020

* New Parts
Parts without **Parts No.** are not supplied.
Les articles non mentionnés dans le **Parts No.** ne sont pas fournis.
Teile ohne **Parts No.** werden nicht geliefert.

3

Ref. No	Add- ress	New Parts	Parts No.	Description	Desti- nation	Re- marks
C19, 20			CC73FCH1H070D	CHIP C 7.0PF D		
C21			CK73FB1H103K	CHIP C 0.010UF K		
C22			CK73FB1E104K	CHIP C 0.10UF K		
C23			CK73FB1H103K	CHIP C 0.010UF K		
C24			CK73FB1H333K	CHIP C 0.033UF K		
C25, 26			CE04KW0J331M	ELECTRO 330UF 6.3WV		
C27, 28			CC73FSL1H151J	CHIP C 150PF J		
C29, 30			CC73FSL1H821J	CHIP C 820PF J		
C31, 32			CE04KW1A470M	ELECTRO 47UF 10WV		
C33, 34			CC73FSL1H821J	CHIP C 820PF J		
C35			CK73FB1H103K	CHIP C 0.010UF K		
C36-38			CK45FF1H103Z	CERAMIC 0.010UF Z		
C39			CE04KW1E222M	ELECTRO 2200UF 25WV		
C40			CK73FB1H102K	CHIP C 1000PF K		
C41			CE04KW1A332M	ELECTRO 3300UF 10WV		
C42			CE04KW2A470M	ELECTRO 47UF 100WV		
C43			CK73FB1H103K	CHIP C 0.010UF K		
C44			CE04KW1H100M	ELECTRO 10UF 50WV		
C45			CE04KW0J331M	ELECTRO 330UF 6.3WV		
C46			CE04KW1C100M	ELECTRO 10UF 16WV		
C47			CE04KW1H010M	ELECTRO 1.0UF 50WV		
C48			CE04KW1A101M	ELECTRO 100UF 10WV		
C49			C90-3623-05	BACK UP 0.33F 5.5V		
C50			CE04KW1A470M	ELECTRO 47UF 10WV		
C51			CK73FB1H103K	CHIP C 0.010UF K		
C52, 53			CC73FSL1H221J	CHIP C 220PF J		
C54, 55			CK73FB1H103K	CHIP C 0.010UF K		
C59			CE04KW1A470M	ELECTRO 47UF 10WV		
C60, 61			CK73FB1E104K	CHIP C 0.10UF K		
C62			C90-3212-05	ELECTRO 47UF 6.3WV		
C63			CK73FB1H103K	CHIP C 0.010UF K		
C64			CK73FB1H103K	CHIP C 0.010UF K	K1P2Y1	
C64			CK73FB1H103K	CHIP C 0.010UF K	T1E1	
C68			CK73FB1E104K	CHIP C 0.10UF K	T1E1	
C89-91			CC73FSL1H221J	CHIP C 220PF J		
C102			CK73FB1H223K	CHIP C 0.022UF K		
C103			C90-3223-05	ELECTRO 220UF 10WV		
C105			CK73FB1C224K	CHIP C 0.22UF K	KP1K1	
C105			CK73FB1C224K	CHIP C 0.22UF K	P2Y1	
C106			CK73FF1C105Z	CHIP C 1.0UF Z	KP1K1	
C106			CK73FF1C105Z	CHIP C 1.0UF Z	P2Y1	
CN1			E40-4997-05	FLAT CABLE CONNECTOR		
CN2			E40-4979-05	PIN ASSY		
CN3			E40-3268-05	PIN ASSY		
CN4			E40-3266-05	PIN ASSY		
CN5			E40-3260-05	PIN ASSY		
CN9			E40-4245-05	PIN ASSY		
CN10, 11			E40-3249-05	PIN ASSY		
CN12, 13			E40-3253-05	PIN ASSY		
CN14			E40-4293-05	FLAT CABLE CONNECTOR	T1E1	
J1		*	E63-1078-05	PHONO JACK		
J2		*	E63-1079-05	PHONO JACK	KP1K1	
J2		*	E63-1079-05	PHONO JACK	P2Y1	
J3			E11-0293-05	MINIATURE PHONE JACK(2P)		

L : Scandinavia K : USA P : Canada R : Mexico C : China I : Malaysia
Y : PX(Far East, Hawaii) T : Europe G : Germany V : China(Shanghai)
Y : AAFES(Europe) X : Australia Q : Russia H : Korea M : Other Areas ▲ indicates safety critical components.

* New Parts
Parts without **Parts No.** are not supplied.
Les articles non mentionnés dans le **Parts No.** ne sont pas fournis.
Teile ohne **Parts No.** werden nicht geliefert.

4

Ref. No	Add- ress	New Parts	Parts No.	Description	Desti- nation	Re- marks
P1			F10-0816-04	SHIELDING PLATE		
-			J19-5789-04	HOLDER		
L1			L40-1001-17	SMALL FIXED INDUCTOR(10UH,K)		
L4			L33-0558-05	CHOKE COIL		
L5, 6			L40-1001-17	SMALL FIXED INDUCTOR(10UH,K)		
X1			L77-2226-05	CRYSTAL RESONATOR(16.9344MHZ)		
X2		*	L78-0615-05	RESONATOR (12.5MHZ)		
X4			L78-0284-05	RESONATOR (5MHZ)		
CP1, 2			R90-0875-05	MULTI-COMP 100KX15		
CP3			R90-0479-05	MULTI-COMP 100KX12		
R1			RK73FB2A224J	CHIP R 220K J 1/10W		
R2-5			RK73FB2A683J	CHIP R 68K J 1/10W		
R6			RK73FB2A224J	CHIP R 220K J 1/10W		
R8			RK73FB2A273J	CHIP R 27K J 1/10W		
R9			RK73FB2A153J	CHIP R 15K J 1/10W		
R12			RK73FB2A203J	CHIP R 20K J 1/10W		
R13			RK73FB2A562J	CHIP R 5.6K J 1/10W		
R14			RK73FB2A183J	CHIP R 18K J 1/10W		
R17, 18			RK73FB2A153J	CHIP R 15K J 1/10W		
R19			RK73FB2A104J	CHIP R 100K J 1/10W		
R20			RK73FB2A333J	CHIP R 33K J 1/10W		
R21			RK73FB2A104J	CHIP R 100K J 1/10W		
R22			RK73FB2A105J	CHIP R 1.0M J 1/10W		
R23			RK73FB2A103J	CHIP R 10K J 1/10W		
R24, 25			RK73FB2A332J	CHIP R 3.3K J 1/10W		
R27			RK73FB2A105J	CHIP R 1.0M J 1/10W		
R34			RK73FB2A104J	CHIP R 100K J 1/10W		
R39-44			RK73FB2A103J	CHIP R 10K J 1/10W		
R45, 46			RK73FB2A432J	CHIP R 4.3K J 1/10W		
R47, 48			RK73FB2A103J	CHIP R 10K J 1/10W		
R49, 50			RK73FB2A104J	CHIP R 100K J 1/10W		
R51, 52			RK73FB2A681J	CHIP R 680 J 1/10W		
R53, 54			RK73FB2A102J	CHIP R 1.0K J 1/10W		
R55, 56			RK73FB2A223J	CHIP R 22K J 1/10W		
R121, 122			RK73FB2A103J	CHIP R 10K J 1/10W		
R123, 124			R92-1867-05	METAL 12K F 1/10W		
R125, 126			R92-1876-05	METAL 10.5K F 1/10W		
R127, 128			RK73FB2A103J	CHIP R 10K J 1/10W		
R131			RK73FB2A473J	CHIP R 47K J 1/10W		
VR1			R12-3101-05	TRIMMING POT.		
S1			S70-0031-05	TACT SWITCH	K1P2Y1	
S2-4			S70-0031-05	TACT SWITCH	KP1	
S5			S70-0031-05	TACT SWITCH		
S6			S70-0031-05	TACT SWITCH	KP1	
S7-9			S70-0031-05	TACT SWITCH		
S10			S70-0031-05	TACT SWITCH	KP1	
S11, 12			S70-0031-05	TACT SWITCH		
S13-16			S70-0031-05	TACT SWITCH	KP1	
S17, 18			S70-0031-05	TACT SWITCH		
S20			S62-0070-05	SLIDE SWITCH		
S21			S64-0034-05	LEVER SWITCH		
S22			S31-2132-05	SLIDE SWITCH		

L : Scandinavia K : USA P : Canada R : Mexico C : China I : Malaysia
Y : PX(Far East, Hawaii) T : Europe G : Germany V : China(Shanghai)
Y : AAFES(Europe) X : Australia Q : Russia H : Korea M : Other Areas ▲ indicates safety critical components.

* New Parts

Parts without **Parts No.** are not supplied.

Les articles non mentionnés dans le **Parts No.** ne sont pas fournis.

Teile ohne **Parts No.** werden nicht geliefert.

5

Ref. No	Add-ress	New Parts	Parts No.	Description	Desti-nation	Re-marks
Δ S23			S31-2131-05	SLIDE SWITCH (POWER TYPE)	Y1	
S19			T99-0596-05	ROTARY ENCODER		
D1~9			HSS104	DIODE		
D1~9			1SS133	DIODE		
Δ D20			D3SBA20F03	DIODE		
Δ D20			RBV-402LFA	DIODE		
D21			HZS7.5S(B)	ZENER DIODE		
D21			RD7.5JS(B)	ZENER DIODE		
D22			DLM10C	DIODE		
D23			HSS104	DIODE		
D23			1SS133	DIODE		
Δ D24, 25			S5688B	DIODE		
Δ D24, 25			1SR139-400	DIODE		
D26			HZS16N(B2)	ZENER DIODE		
D26			RD16ES(B2)	ZENER DIODE		
D27			HZS20N(B)	ZENER DIODE		
D27			RD20ES(B)	ZENER DIODE		
D28			HZS11N(B2)	ZENER DIODE		
D28			RD11ES(B2)	ZENER DIODE		
D30			HSS104	DIODE		
D30			1SS133	DIODE		
D33, 34			HSS104	DIODE		
D33, 34			1SS133	DIODE		
ED1			16-MT-63GK	INDICATOR TUBE		
IC1			CXA1571M	IC(CD RF AMP)		
IC2			CXD2587Q	MOS-IC		
IC7			NJM2115M	ANALOGUE IC		
IC8			UPD784215GF541	MI-COM IC		
IC9			HM62256BLFP-8T	MEMORY IC		
IC9			W24258S-70LE	MEMORY IC		
IC10			NJM2100M	IC(OP AMPLIFIER)		
IC12			TA8409S	MOS-IC		
IC13			LB1930M	ANALOGUE IC		
IC14			UPD780204-038	MI-COM IC		
IC16			BA5979S	ANALOGUE IC		
Q1			2SA954(L,K)	TRANSISTOR		
Q2			DTC124ESA	DIGITAL TRANSISTOR		
Q2			UN4212	DIGITAL TRANSISTOR		
Q9			DTC124ESA	DIGITAL TRANSISTOR		
Q9			UN4212	DIGITAL TRANSISTOR		
Q11, 12			2SA1048(Y,GR)	TRANSISTOR		
Q11, 12			2SA1309A(Q,R)	TRANSISTOR		
Q13, 14			2SD1450(S,T)	TRANSISTOR		
Q19			2SK246(Y)	FET		
Δ Q20			2SB1165(R,S)	TRANSISTOR		
Q21			2SC2458(Y,GR)	TRANSISTOR		
Q21			2SC3311A(Q,R)	TRANSISTOR		
Δ Q22			2SA954(L,K)	TRANSISTOR		
Q23			2SC2458(Y,GR)	TRANSISTOR		
Q23			2SC2458(Y,GR)	TRANSISTOR		
Q23			2SC3311A(Q,R)	TRANSISTOR	KP1K1	
Q23			2SC3311A(Q,R)	TRANSISTOR	P2Y1	
Q23			2SC3311A(Q,R)	TRANSISTOR	KP1K1	
Q23			2SC3311A(Q,R)	TRANSISTOR	P2Y1	
Q24			2SA1048(Y,GR)	TRANSISTOR	KP1K1	

L : Scandinavia K : USA P : Canada R : Mexico C : China I : Malaysia

Y : PX(Far East, Hawaii) T : Europe E : Europe G : Germany V : China(Shanghai)

Y : AAFES(Europe) X : Australia Q : Russia H : Korea M : Other Areas Δ indicates safety critical components.

* New Parts

Parts without **Parts No.** are not supplied.

Les articles non mentionnés dans le **Parts No.** ne sont pas fournis.

Teile ohne **Parts No.** werden nicht geliefert.

6

Ref. No	Add-ress	New Parts	Parts No.	Description	Desti-nation	Re-marks
Q24			2SA1048(Y,GR)	TRANSISTOR		
Q24			2SA1309A(Q,R)	TRANSISTOR		
Q24			2SA1309A(Q,R)	TRANSISTOR		
Δ Q25			2SB1417(P)	TRANSISTOR		P2Y1
Δ Q25			2SB1640	TRANSISTOR		KP1K1
						P2Y1
Δ Q26			2SC2458(Y,GR)	TRANSISTOR		
Δ Q26			2SC3311A(Q,R)	TRANSISTOR		
Q27			DTA113ZSA	DIGITAL TRANSISTOR		
Q27			UN4119	DIGITAL TRANSISTOR		
Q28			DTA124EUA	DIGITAL TRANSISTOR		
Q28			UN5112	DIGITAL TRANSISTOR		
Q29			DTC124EUA	DIGITAL TRANSISTOR		
Q29			UN5212	DIGITAL TRANSISTOR		
A1			W02-2561-05	ELECTRIC CIRCUIT MODULE		K1P2Y1
A1			W02-2561-05	ELECTRIC CIRCUIT MODULE		T1E1
A2			W02-1114-05	OSCILLATING MODULE		T1E1
MECHANISM CHANGER (MG-CH1)						
1	1D		A11-1134-08	BASE ARM		
2	1D		D10-3788-08	LEVER R		
3	1D		D12-0158-08	CAM CHANGE		
4	1E		J19-5892-08	HOLDER ARM		
5	1E		G16-0912-08	RUBBER		
6	1E		D10-3778-08	ARM DISC		
7	1E		G01-4060-08	SPG DISC H		
8	1E		J21-6576-08	PLATE ARM		
9	1D		D10-3785-08	SLIDER RACK		
10	1E		J19-5891-08	HOLDER RACK		
12	1D		D10-3787-08	LEVER CHANGE		
14	1E, 2D		T42-0920-08	MOTOR		
17	1D		D13-1856-08	GEAR D		
19	1D		D10-3781-08	LEVER HOOK A		
20	1E		D10-3782-08	LEVER HOOK B		
21	1D		D13-1857-08	GEAR E		
22	1D		S64-0038-08	LEVER SW		
24	1D		G01-4066-08	SPG LIMITER		
25	1D		J21-6579-08	PLATE LIMITER		
26	1D	*	D10-3779-18	ARM SWING		
27	2D		D13-1855-08	GEAR CAM		
28	2D		G01-4067-08	SPG CHASSIS SUB		
29	2D		J21-6573-08	PLATE LOCK		
30	2D		G01-4061-08	SPG LOCK LEVER		
31	2D	*	D10-3780-18	SLIDER CAM		
32	2D		J21-6574-08	PLATE SLIDE		
33	2D		D13-1854-08	GEAR SLIDER		
34	2D	*	D10-3786-18	LEVER STOPPER		
37	2D		J90-0854-08	GUIDE RACK		
38	1D		G01-4064-08	SPG CHANGE		
39	2D		D21-1899-08	PIN ROLLER		
40	2D		D14-0393-08	HOLDER ROLLER		
41	2D		J19-5888-08	ROLLER GUIDE		
42	2D		D21-1900-08	SHAFT MAIN		
43	2D		J19-5890-08	HOLDER SHAFT		
44	2D		J90-0856-08	GUIDE DISC		
45	1D		D32-0354-08	STOPPER DISC		

L : Scandinavia K : USA P : Canada R : Mexico C : China I : Malaysia

Y : PX(Far East, Hawaii) T : Europe E : Europe G : Germany V : China(Shanghai)

Y : AAFES(Europe) X : Australia Q : Russia H : Korea M : Other Areas Δ indicates safety critical components.

PARTS LIST

CD-323M/324M/DPF-J5020

CD-323M/324M/DPF-J5020

PARTS LIST/SPECIFICATIONS

PARTS LIST

* New Parts
Parts without **Parts No.** are not supplied.
Les articles non mentionnés dans le **Parts No.** ne sont pas fournis.
Teile ohne **Parts No.** werden nicht geliefert.

Ref. No	Add-ress	New Parts	Parts No.	Description	Desti-nation	Re-marks
46	1D		J19-5893-08	HOLDER SENSOR		
47	1D		J19-5927-08	HOLDER SENSOR		
49	1E		J21-6570-08	PLATE HOLD T		
55	2E		J21-6580-08	PLATE LINK		
58	2E		J21-6571-08	PLATE SLIDER A		
60	2E		J21-6575-08	PLATE SUPPORT B		
62	2D		D13-1852-08	GEAR B		
63	2D		D13-1853-08	GEAR C		
64	1E		J90-0885-08	GUIDE DISC U		
65	2E		J19-5894-08	HOLDER DISC U		
67	2E		G01-4057-08	SPG SLIDER		
68	2E		G01-4058-08	SPG HOLD MAGNET		
69	1E		G01-4062-08	SPG DAMPER A		
70	1E		G01-4063-08	SPG DAMPER B		
71	1E		G01-4059-08	SPG PLATE ARM		
72	2D		G01-4065-08	SPG STOPPER		
73	1C		J19-5889-08	STOCKER ROTARY		
80	2E	*	J11-0840-08	CLAMP		
82	2E		J02-1412-08	INSULATOR		
83	1D		E40-8285-08	CONNECTOR 5P		
86	2E		T99-0565-05	MAGNET		
87	1D		N29-0287-08	E-RING 6.0		
88	1D		N19-1458-08	PSW 8.5X16X0.5		
89	1D		N19-1460-08	PSW 8.5X30X0.5		
90	2E		J69-0083-04	DOUBLE COATED TAPE		
91	2E		T95-0160-08	PHOTO INTERRUPTER		
92	2E		E40-8284-08	CONNECTOR 5P		
94	1E, 2E		N19-1461-08	FLAT WASHER		
101	2D	*	D32-0360-08	PLATE STOPPER		
102	2E	*	G16-0936-08	SHEET		
LED			SIM-20ST	LED TRANSISTOR		
TR			RPM-20PB	CHIP R	470 J 1/10W	
R			RK73FB2A471J			
MECHANISM ASSY (D40-1515-05)						
3	2A		D10-3606-08	ROD		
4	1B		D13-1720-08	GEAR		
6	3B		S74-0038-08	LEAF SWITCH		
8	3B		E40-3264-05	PIN ASSY		
DM	1B		A11-1082-18	SUB CHASSIS ASSY		
FM	2B		T42-0817-08	MOTOR ASSY		
PU	1A	*	T25-0055-08	OPTICAL PICKUP HEAD		

L: Scandinavia
Y: PX(Far East, Hawaii)
Y: AA(FE)(Europe)
K: USA
T: Europe
X: Australia
P: Canada
E: Europe
O: Russia
R: Mexico
G: Germany
H: Korea
C: China
V: China(Shanghai)
I: Malaysia
M: Other Areas
A indicates safety critical components.

HOW TO READ THE PARTS LIST ABBREVIATION OF MODEL AND MASS PRODUCTION'S DESTINATIONS

MODEL	ABB.	Australia	Canada	China	England	Germany	Korea	Malaysia
CD-323M			P1					
CD-324M			P2					
DPF-J5020				T1	E1			
MODEL	ABB.	Mexico	PX(AAFES)	Russia	Scandinavia	Shanghai	USA	Other area
CD-323M							K	
CD-324M							K1	
DPF-J5020			Y1					

SPECIFICATIONS

CD-323M

[Format]

System Compact disc digital audio system
Laser Semiconductor laser

[D/A Convertors]

D/A Conversion 1 Bit
Oversampling 8 fs (352.8 kHz)

[Audio]

Frequency response 4 Hz ~ 20 kHz, ± 0.5 dB
Signal to noise ratio More than 98 dB
Dynamic range More than 96 dB
Total harmonic distortion + noise

..... Less than 0.004% (at 1 kHz)
Channel separation More than 92 dB (at 1 kHz)

Wow & flutter Unmeasurable Limit

Output level/impedance

Fixed 2.0 V/1 kΩ

Digital output

Coaxial 0.5 Vp-p/75Ω

[General]

Power consumption 10 W

Dimensions
W : 440 mm (17-5/16")
H : 173 mm (6-13/16")
D : 479 mm (18-7/8")

Weight (Net) 7.3 kg (16.1 lb)

CD-324M/DPF-J5020

[Format]

System Compact disc digital audio system
Laser Semiconductor laser

[D/A Convertors]

D/A Conversion 1 Bit
Oversampling 8 fs (352.8 kHz)

[Audio]

Frequency response 4 Hz ~ 20 kHz, ± 0.5 dB
Signal to noise ratio More than 98 dB
Dynamic range More than 96 dB
Total harmonic distortion + noise

..... Less than 0.004% (at 1 kHz)
Channel separation More than 92 dB (at 1 kHz)

Wow & flutter Unmeasurable Limit

Output level/impedance

Fixed 2.0 V/1 kΩ

Digital output

Coaxial (For U.S.A., U.S. Military and Canada) 0.5 Vp-p/75Ω

Optical (Except for U.S.A., U.S. Military and Canada)
..... -15 dBm ~ -21 dBm (Wave length 660 nm)

[General]

Power consumption 10 W

Dimensions
W : 440 mm (17-5/16")
H : 173 mm (6-13/16")
D : 479 mm (18-7/8")

Weight (Net) 7.3 kg (16.1 lb)



1. KENWOOD follows a policy of continuous advancements in development. For this reason specifications may be changed without notice.
2. The full performance may not be exhibited in an extremely cold location (under a water-freezing temperature).

Note:

Component and circuit are subject to modification to insure best operation under differing local conditions. This manual is based on Europe (E) standard, and provides information on regional circuit modification through use of alternate schematic diagrams, and information on regional component variations through use of parts list.

KENWOOD CORPORATION

14-6, Dogenzaka 1-chome, Shibuya-ku, Tokyo, 150-8501 Japan

KENWOOD SERVICE CORPORATION

P.O. BOX 22745, 2201 East Dominguez St., Long Beach, CA 90801-5745, U.S.A.