

CD-425M/4260M/4700M

DPF-J6030

SERVICE MANUAL

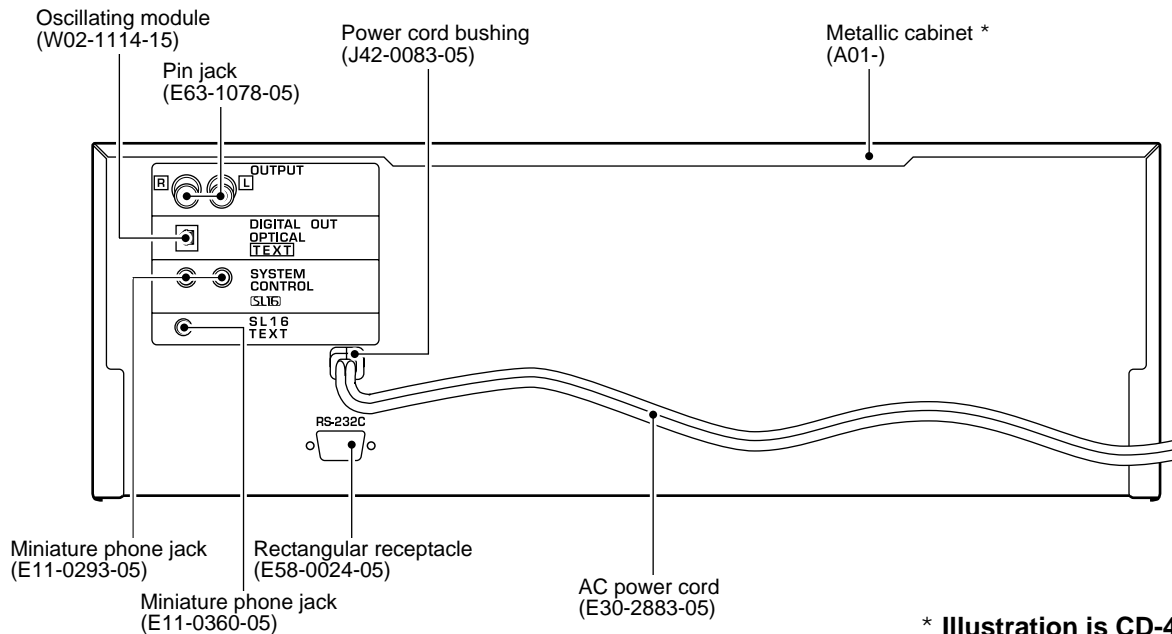
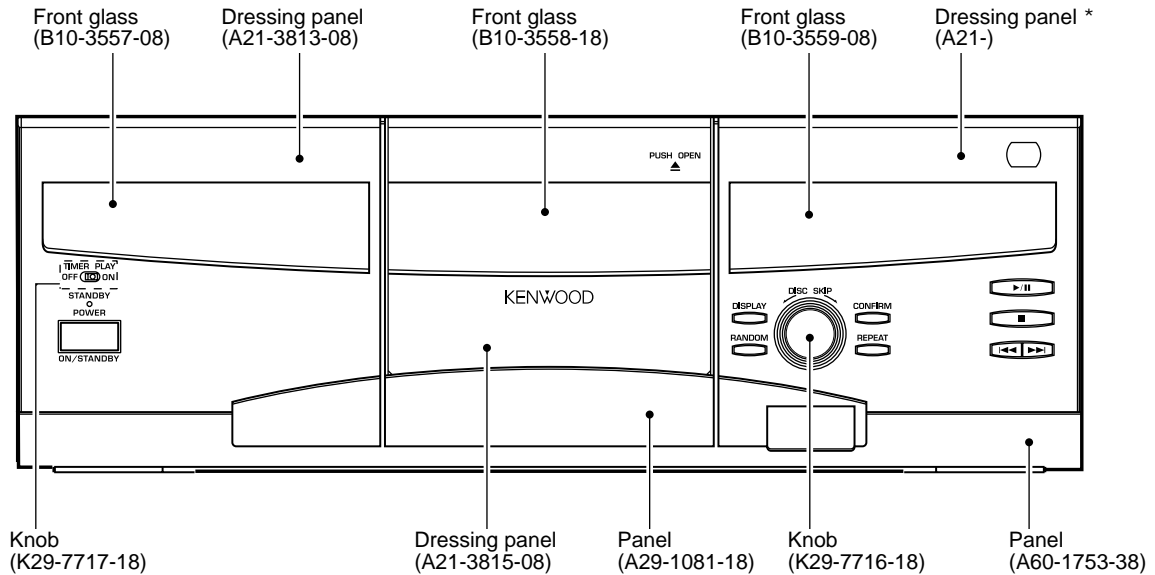

* Illustration is CD-4260M/4700M.

* Refer to parts list on page 18.

In compliance with Federal Regulations, following are reproduction of labels on, or inside the product relating to laser product safety.

KENWOOD-Crop. certifies this equipment conforms to DHHS Regulations No.21 CFR 1040. 10, Chapter 1, Subchapter J.

DANGER : Laser radiation when open and interlock defeated.
AVOID DIRECT EXPOSURE TO BEAM.

Refer to CD-223M/DPF-J3010 service manual (B51-5409-00) if require the following items in detail.

- 1) Mechanism operation description.
- 2) Disassembly for repair.



CONTENTS / ACCESSORIES / CAUTIONS

Contents

CONTENTS / ACCESSORIES / CAUTIONS.....	2	SCHEMATIC DIAGRAM	11
EXTERNAL VIEW	2	EXPLODED VIEW	15
CIRCUIT DESCRIPTION	3	PARTS LIST	17
ADJUSTMENT	8	SPECIFICATIONS	Back cover
PC BOARD	9		

Accessories

Audio cord (2) (E30-0505-05)	System control cord (1) (E30-2816-05)	Communication cord (1) (E30-2861-05)	Batteries (R6/AA) (4)
---------------------------------------	--	---	-----------------------------

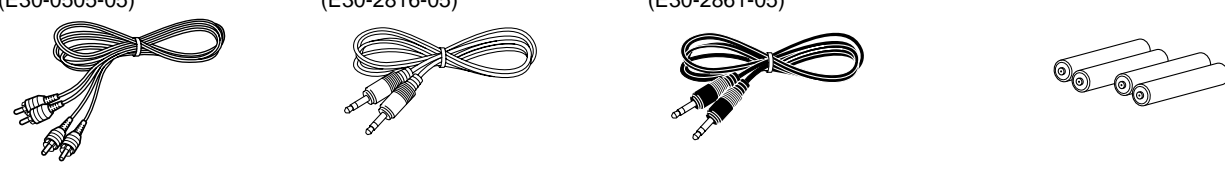

Remote control units (2) (A70-1326-05): RC-KB2	(A70-1336-18): RC-P0714
---	-------------------------



Battery cover (A09-1176-08)

Battery cover (A09-0374-08)

Cautions

Operation to reset

The microcomputer may malfunction (impossibility to operate, erroneous display, etc.) when the connection cords are unplugged while power is ON or due to an external factor. In this case, execute the following method to reset the microcomputer and return it to normal condition.

Unplug the power cord from the power socket and plug the power cord into the socket again.

To reset the registered contents

The registered contents for title, music type, user file, best selection and DTS disc can be reset by the following procedure.

Unplug the power cord from the power socket, and while holding the ■ key depressed, plug the power cord into the socket again.

EXTERNAL VIEW

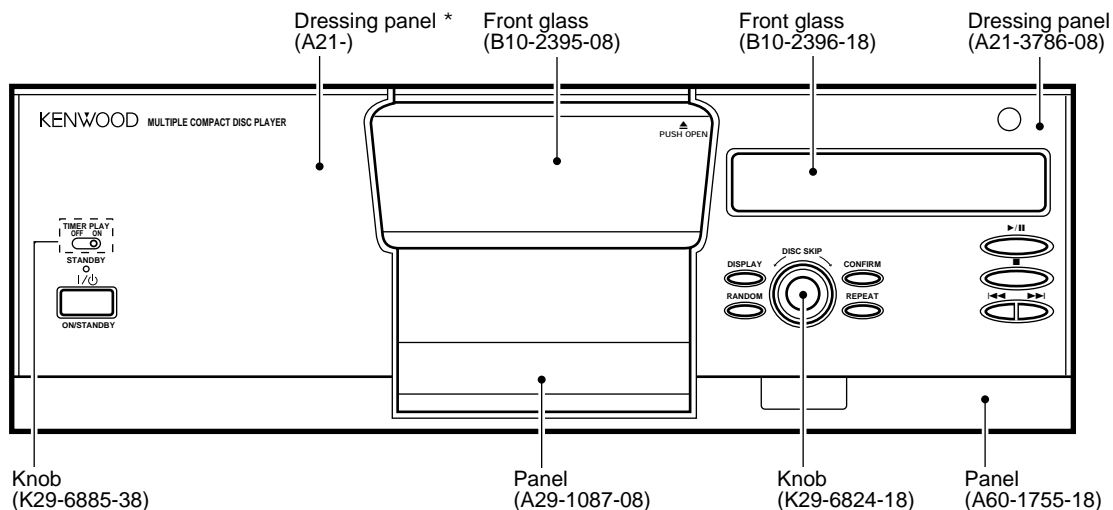

* Illustration is CD-425M/DPF-J6030.

* Refer to parts list on page 17.

CIRCUIT DESCRIPTION

1. Main Microprocessor : uPD784217GF501

Microprocessor periphery block diagram

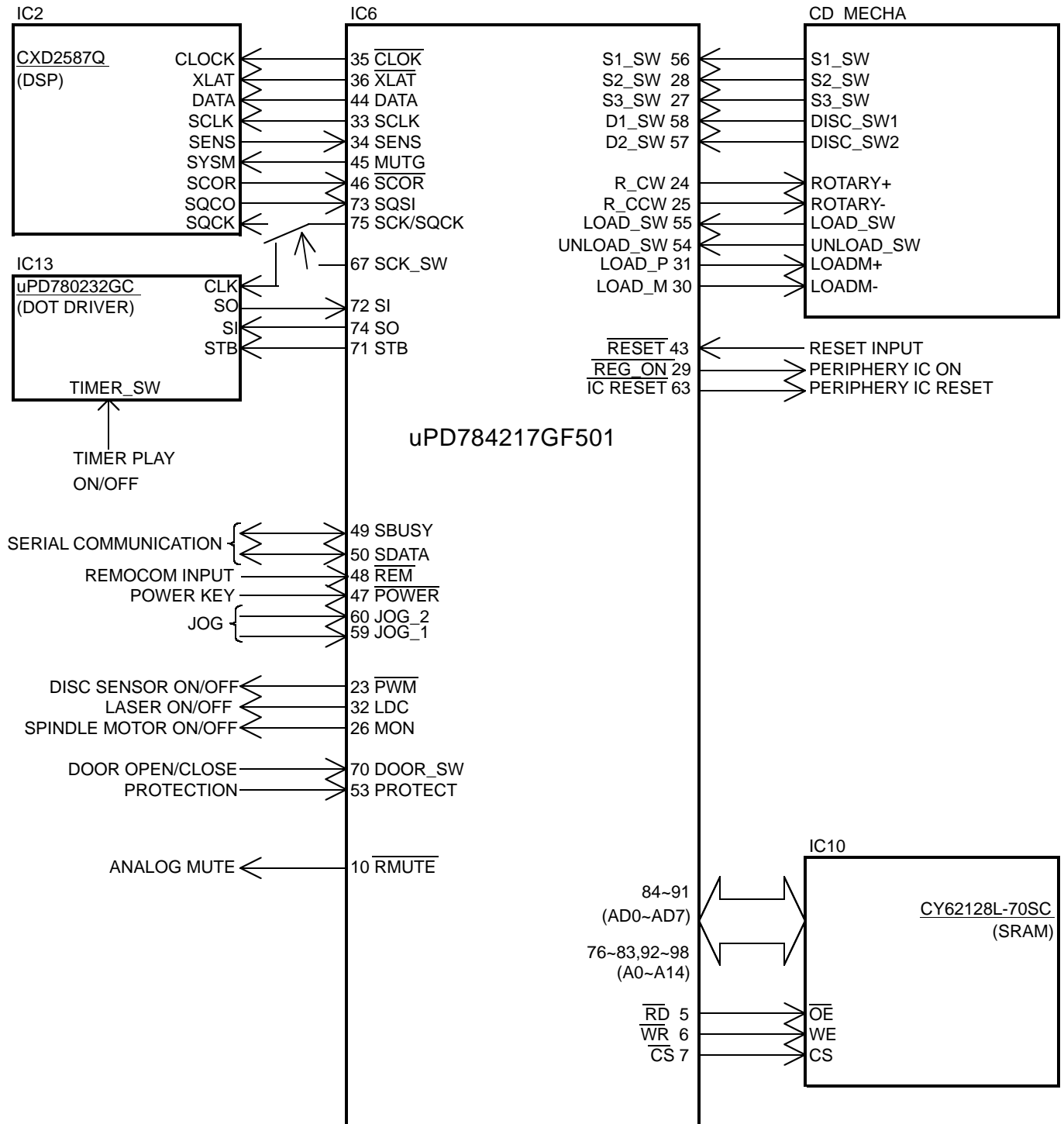

2. Key matrix

PORT		A/D 0(IC13,22pin)	A/D 1(IC13,21pin)
VOLTAGE	RESISTER		
2.9V	5.1K	RANDOM	REPEAT
2.0V	3K	DISPLAY	CONFIRM
1.2V	2K	STOP	DOWN
0.4V	SHORT	PLAY	UP

CIRCUIT DESCRIPTION

3. Microprocessor pin description (X32, IC6) :UPD784217GF501

Pin No.	Pin Name	I/O	Description
1	A16(1M)	O	No used.
2	A17	O	No connection.
3	SCL	O	No connection.
4	SDA	I/O	No connection.
5	RD	O	SRAM read strobe.
6	WR	O	SRAM write strobe
7	CE	O	Chip selector
8	ASTB(CE)	O	No connection.
9	VDD	-	Power supply(+5V).
10	RMUTE	O	Analog muting signal output.
11	RWRR	O	No connection.
12	RWR	I	No connection.
13	RTRN	I	No connection.
14-21	L-D7-D0	O	No connection.
22	VPP	-	GND.
23	+5VPWM	O	Disc sensor ON/OFF. L:on
24	R-M-CW	O	Mechanism rotary motor(+). H:CCW
25	R-M-CCW	O	Mechanism rotary motor(-). H:CW
26	MON	O	Control port of poor focus works.
27	S3-SW	I	Mechanism address detector switch.
28	S2-SW	I	Mechanism address detector switch.
29	REG-ON	O	Power ON/OFF control.
30	LOADM- (IN2)	O	Loading motor(-) for main pickup.
31	LOADM+ (IN1)	O	Loading motor(+) for main pickup.
32	LDC	O	Laser on/off. L: Laser diode on.
33	SCLK	O	Sens serial data read clock.
34	SENS	I	SENS signal input.
35	CLK	O	Serial data clock.
36	XLAT	O	CXD2587Q latch. H → L:latch
37	VDD	-	Power supply(+5V).
38,39	X1,2	-	Main system clock(12.5MHz).
40	VSS	-	GND.
41	XT2	-	No connection.
42	XT1	I	GND.
43	RESET	I	System reset signal input.
44	DATA	O	Serial data output.
45	MUTEG(SYSTEM)	O	System muting control output.
46	SCOR	I	Sub code synchro detection.
47	POWER	I	Power key input terminal.
48	REM	I	Remote control signal input.
49	SBUSY	I/O	Serial busy signal I/O.
50	SDATA	I/O	Serial data signal I/O.
51	AVDD	-	Power supply(+5V).
52	AVREF	-	A/D reference power supply.
53	PROTECT	I	Detection signal input of protection.
54	UNLOAD-SW1	I	Unloading switch for main pickup.
55	LOAD-SW1	I	Loading switch for main pickup.
56	S1-SW	I	Mechanism address detector switch.
57	DISC-SW2	I	Disc2 sensor input..
58	DISC-SW	I	Disc sensor.
59	JOG2	I	Encoder signal input.
60	JOG1	I	Encoder signal input.

CIRCUIT DESCRIPTION

Pin No.	Pin Name	I/O	Description
61	AVSS	-	GND.
62	LED	O	STANDBY LED control terminal.
63	ICRESET	O	IC reset.
64	AVREF1	-	D/A reference power supply.
65	RXD-232C	I	No connection.
66	TXD-232C	O	No connection.
67	SQCK/SCK-SW	O	SQCK,SCK(DOT/DSP clock) selector. L:DSP.
68	RXD-R	I	No connection.
69	TXD-R	O	No connection.
70	DOOR-SW	I	Door open/close detector switch.
71	STB1	O	Strobe signal output to dot driver.
72	S1	O	Data output to dot driver.
73	SQS1	I	Sub code read data input.
74	S0	I	Data input from dot driver.
75	SCK/SQCK	O	Dot driver/sub code read clock.
76-83	A0~A7	O	Address output to SRAM.
84-91	D0-7	I/O	SRAM data bus.
92-98	A8~A14	O	Address output to SRAM.
99	A15(1M)	O	No used.
100	VSS	-	GND.

4. FL Microprocessor : UPD 780232GC-012 (X32-IC13)

Pin description

Pin No.	Pin Name	I/O	Description
1	VDD	-	Power supply(+5V)
2	VSS	-	GND.
3,4	X1,2	-	Main system clock.(5MHz).
5	VPP	-	GND.
6	RESET	I	System reset input.
7	SCK	I	Serial clock.
8	SI	I	Data input.
9	SO	O	Data output.
10	POW-P	I/O	Timer sw on input.
11	LED-A	O	No used.
12	LED-B	O	No used.
13	STANDBY	O	No used.
14	NC	-	No used.
15	STB	I	Strobe signal input.
16	REM	I	No used.
17	NC	-	No used.
18	AVSS	-	GND.
19,20	A/D3,A/D2	-	GND.
21,22	A/D1,A/D0	I	Key return signal input(1,0).
23	VSS	-	GND.
24,25	AVDD/VDD	-	Power supply(+5V)
26	NC	-	No connection.
27-43	P1-P17	O	FL control output. 1G(▶■),2G-16G(P1to P17).
44-58	P21-35	O	FL control output. 2G-16G(P21to P35).
59	VDD	-	Power supply(+5V)
60	VLOAD	-	Negative power supply(-37.5V)
61-63	P18-P20	O	FL control output. 2G-16G(P18 to P20).
64	NC	-	No connection.
65-72	1G-8G	O	FL control output.1G-8G.
73-80	9G-16G	O	FL control output.9G-16G.

CD-425M/4260M/4700M/DPF-J6030

CIRCUIT DESCRIPTION

5. Test mode

INPUT KEY	PROCEDURE	DISPLAY
Insert the AC plug to the wall outlet with pressing the SKIP-DOWN key.	INITIAL CONDITION <ul style="list-style-type: none"> • Disc No.1 moves to the center. • Clear the memory of the SRAM. • Door opens. • Set the switch of TIMER ON PLAY to ON. • Set the switch of SYSTEM CONTROL to XS8. 	MECHA. INITIAL INITIAL OK!! INITIAL NG TIMER, NG SER, NG
Insert the AC plug to the wall outlet with pressing the REPEAT key	CIRCUIT ADJUSTMENT <ul style="list-style-type: none"> • Open the door and load the disc to the Disc No.1. • Close the door. The unit changes to test mode 05 . after clamping the disc 	TEST ON
PLAY/PAUSE	Change the mode 05(tracking-on) and 03(tracking-off) alternately . by the PLAY key	05 XX:XX 03 XX:XX
STOP UP DOWN RANDOM	Stop the function. The pickup travels outwards. The pickup travels inwards. Shows the result of self-adjustment. 07 EF/FB 08 TG/FG 09 FE/RF 10 TE/VC Mode changes alternately by the RANDOM key.	00 MOTOR FORWARD MOTOR REVERSE 07 XXX:XXX 08 XXX:XXX 09 XXX:XXX 10 XXX:XXX NG: blinking
REPEAT	Playback PGM signal of the Track No.7,13,23,30,34 and 41 in the order. And release the test mode.	
CONFIRM (TIMER PLAY SW)	Release the test mode. Check the switch position.	TIMER ON , TIMER OFF
Insert the AC plug to the wall outlet with pressing the UP key.	CHECK THE MECHANISM JAMMING. Clamp the Disc No1,2,100,50,200 and 199 in the order.	
Insert the AC plug to the wall outlet with pressing the RANDOM key.	THE MECHANISM TEST MODE. Display shows Niagara until pressing any keys.	
PLAY/PAUSE	Change the mode 05(tracking-on) and 03(tracking-off) alternately by the PLAY key.	05 XX:XX 03X:XX
STOP	Stop the function. Shows the result of self-adjustment. 07 EF/FB 08 TG/FG 09 FE/RF 10 TE/VC Mode changes alternately by the STOP key.	07 XXX:XXX 08 XXX:XXX 09 XXX:XXX 10 XXX:XXX NG: blinking
UP	Arm Motor Load operation.	MOTOR LOAD
DOWN	Arm Motor Unload operation.	MOTOR UNLOAD
RANDOM	Rotary Motor Clockwise turning.	MOTOR CW
DISPLAY	Rotary Motor Counterclockwise turning.	MOTOR CCW
REPEAT	Playback PGM signal of the Track No.1,23 and 41 in the order.And release the test mode.	
CONFIRM (TIMER PLAY SW)	Release the test mode. Check the switch position.	TIMER ON , TIMER OFF

CIRCUIT DESCRIPTION

6. Error code

DISPLAY	ERROR CONTENTS
MECHA ERROR 01	No input of S3. The original position error of Disc Number.
MECHA ERROR 02	No input of S2. The turning direction error to counterclockwise
MECHA ERROR 03	No input of S1. The turning direction error to clockwise
MECHA ERROR 04	No input of main load sw.
MECHA ERROR 05	No input of main unload sw.
MECHA ERROR 08	No backed up(AC power cord has disconnected).

S1-3: Mechanism address detector switch.

There are load and unload switches in the main pickup.

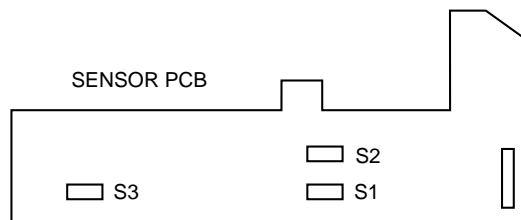

S1 DISC 1~9
 S2 DISC 10~99
 S3 DISC 100~200

ADJUSTMENT

No.	ITEM	INPUT SETTING	OUTPUT SETTING	PLAYER SETTING	ALIGNMENT POINT	ALIGN FOR	FIG.
1. With pressing the REPEAT KEY, turn the power on to enter the test mode. 2. Set the Test disc to Disc NO. 1. 3. Close the door.							
1	FOCUS ERROR BIAS	Test disc Type4 /KTD-02	Connect an oscilloscope as follows. CH1:RF (CN2-1)	Press the PLAY /PAUSE key . Confirm that the display is "05".	FE BIAS VR1	Optimum eye pattern	(d)
2	LASER CURRENT CHECK	Test disc Type4	Connect the DC voltmeter to LASER CURRENT CHECK LAND on X32.	Press the PLAY /PAUSE key to check that the display is 03 or 05.	-	0.5±0.2V	

Note:

Type 4 disc :SONY YEDS-18 Test Disc or equivalent.

LPF : Around 47kΩ + 390 pF or so.

FIG. (d)

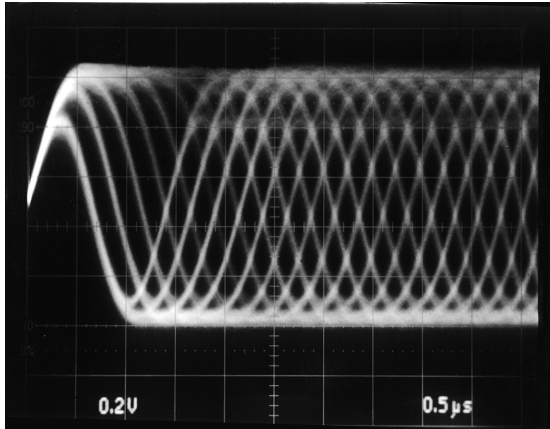

- RF signal in test mode (PLAY).
- Perform the tangential and focusing offset are focused into one point on the display. The crossing points above and below the center shall also be looked clearly. (FE BIAS)

PC BOARD(Component side view)

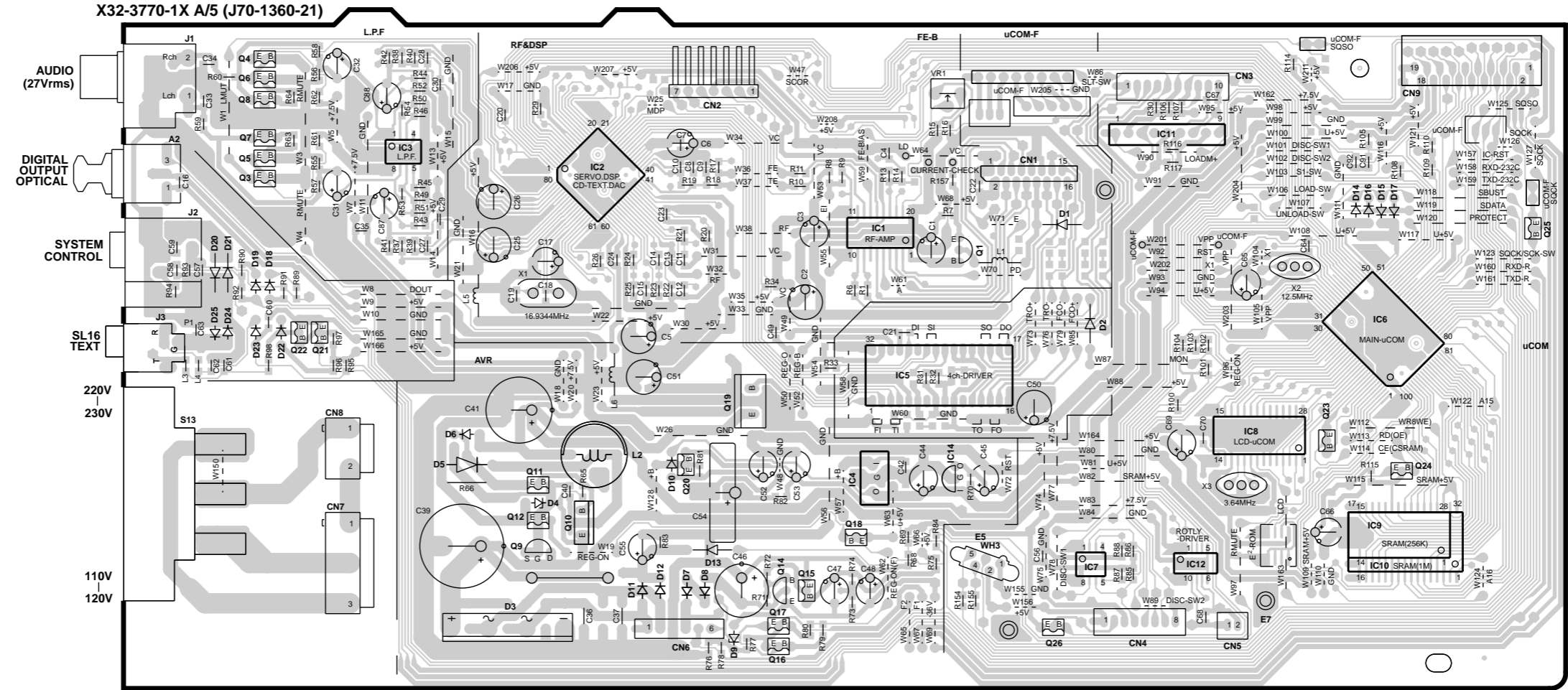
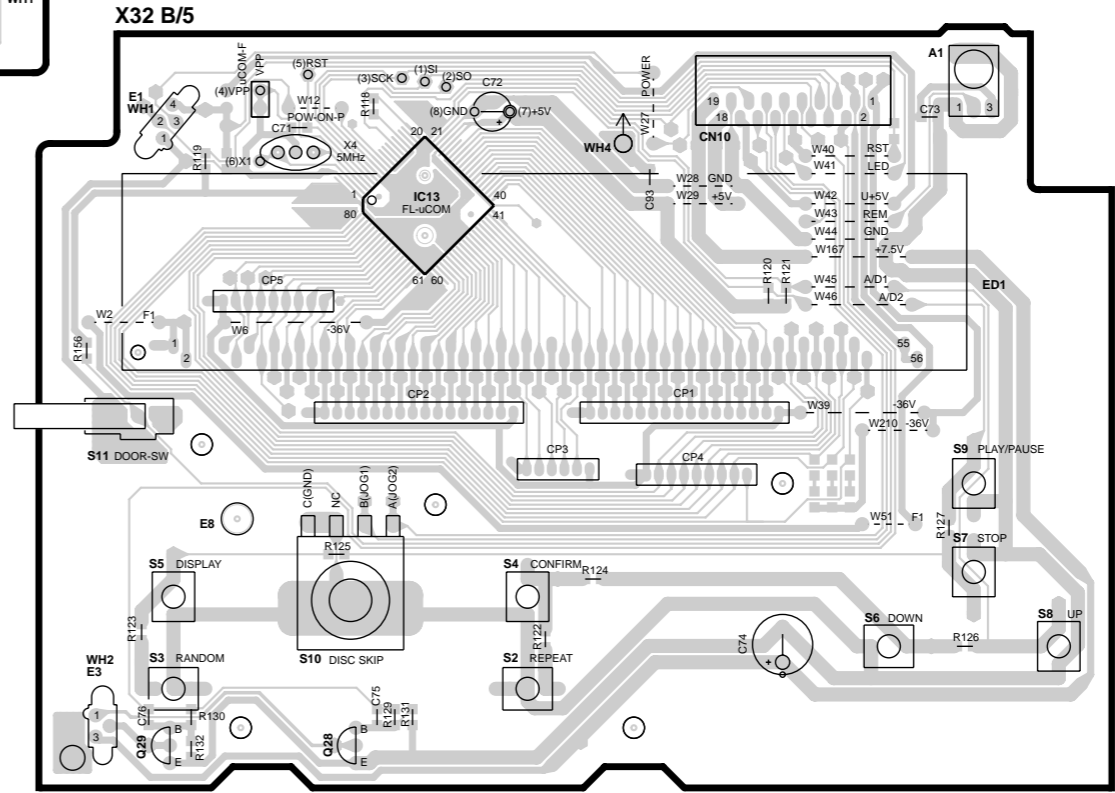
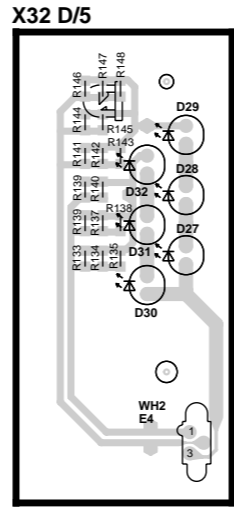
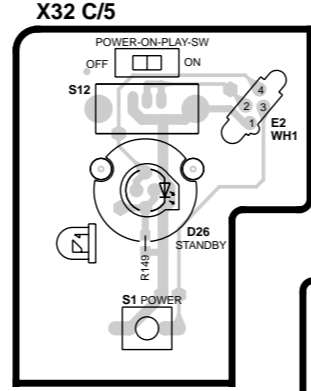
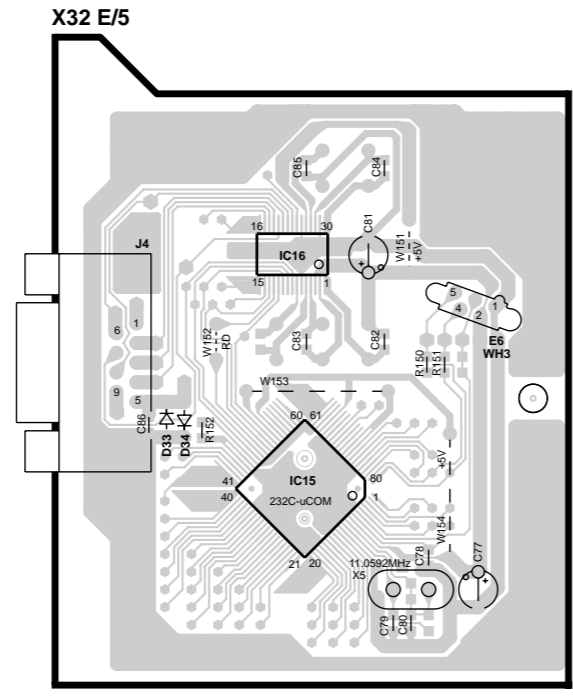

Refer to the schematic diagram for the value of resistors and capacitors.

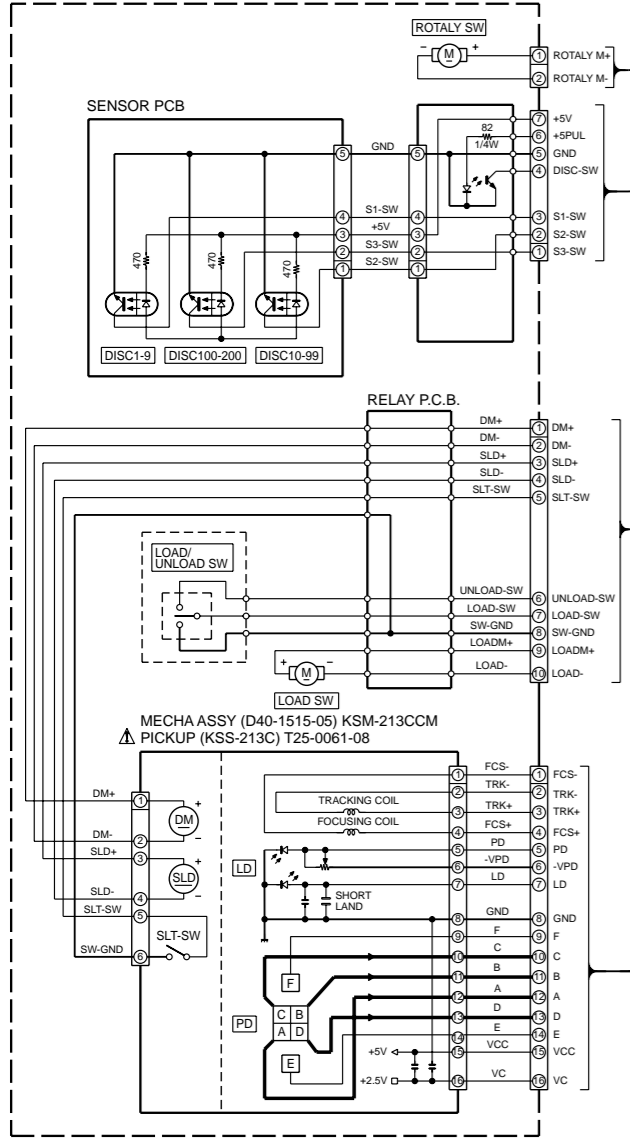

- IC1 : CXA1821M
 - IC2 : CXD2587Q *
 - IC3 : NJM2115M
 - IC4 : UPC7805AHF or BA17805T
 - IC5 : BA5979S
 - IC6 : UPD784217GF501
 - IC7 : NJM2100M
 - IC8 : UPD17215GT-737
 - IC10 : SM51008BF70LL or CY62128L-70SC or M5M51008CFP70H
 - IC11 : TA8409S
 - IC12 : LB1930M
 - IC13 : UPD78023GCO12
 - IC14 : PST1993D-T
 - IC15 : UPD784035GC868
 - IC16 : UPD4723
- Q1,14 : 2SA954(L,K)
 - Q3,4,12,21,24,25 : 1S133 or HSS104
 - Q5,6 : DTA143TSA or UN4116
 - Q7,8,16,17 : 2SD1450(S,T)
 - Q9 : 2SK246(Y)
 - Q10 : 2SB1165(R,S)
 - Q11,20 : 2SC2785(F,E) or 2SC2458(Y,GR)
 - Q15 : 2SA1175(F,E) or 2SA1048(Y,GR)
 - Q18,26 : DTA1132SA or UN4119
 - Q19 : 2SB1640 or 2SB1417(Q,P)
 - Q22 : DTC113ZSA or UN4219
 - Q23 : DTA124ESA or UN4112
 - Q28,29 : 2SC3246(J,K)
- D1,2,6,10,13-25,33,34 : 1S133 or HSS104
 - D3 : D3SBA20F03 or RBV-402LFA
 - D4 : MTZJ7.5(B) or RD7.5J5(B2)
 - D5 : DLM10C
 - D7,8,11,12 : S5688B(TPB5)
 - D9 : MTZJ11(B) or RD11E5(B2)
 - D26 : B30-2493-05 or B30-2532-05
 - D27-32 : B30-2532-05
 - D27-32 : B30-2532-05
 - ED1 : 16-MT-66GNK
 - A1 : W02-2561-05
 - A2 : W02-1114-15

CD-4260M (X32-3770-12)			
DESTINATION	COUNTRY	ABB.	S10
U.S.A.	K	0-12	T99-0639
CANADA	P		

CD-425M (X32-3770-11)			
DESTINATION	COUNTRY	ABB.	S10
U.S.A.	K	0-11	T99-0596
CANADA	P		

CD-4700M (X32-3770-12)			
DESTINATION	COUNTRY	ABB.	S10
U.S.A.	K1	0-12	T99-0639

DPF-J6030 (X32-3700-11)			
DESTINATION	COUNTRY	ABB.	S10
U.K.	T	0-11	T99-0596
EUROPE	E		

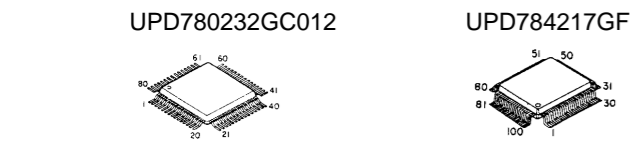
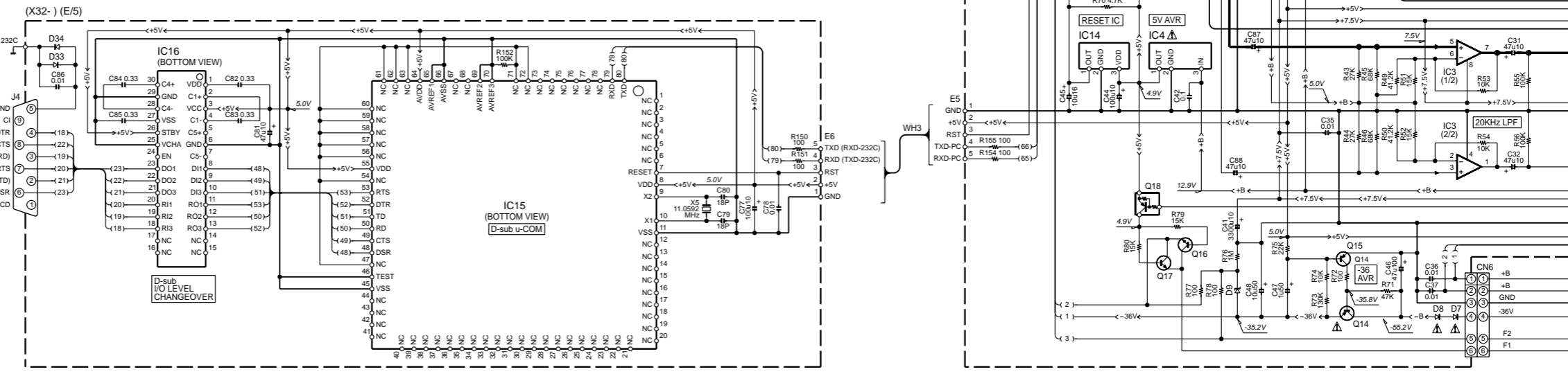
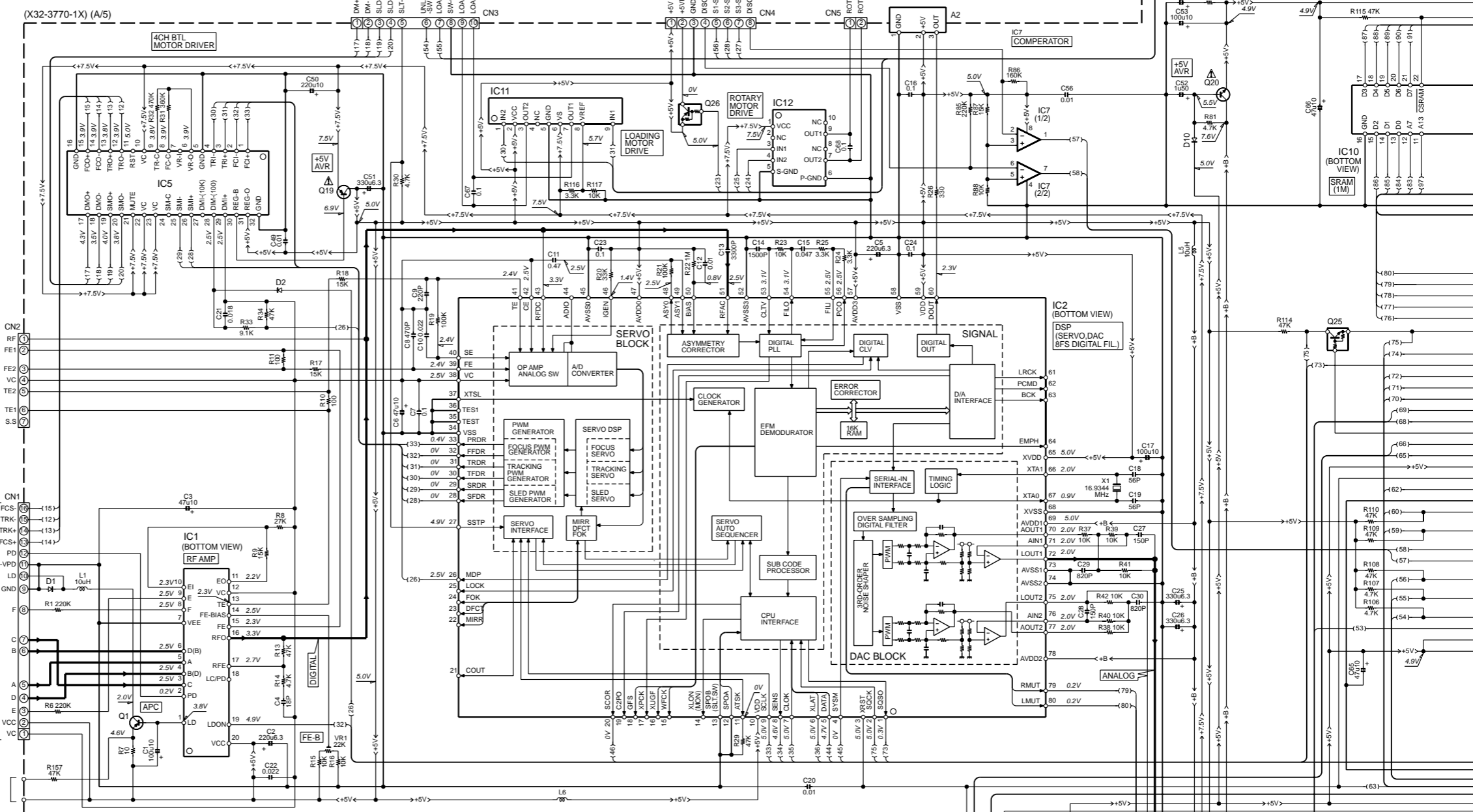

CAUTION: For continued safety, replace safety critical components only with manufacturer's recommended parts (refer to parts list). Δ indicates safety critical components. For continued protection against risk of fire, replace only with same type and rating fuse(s). To reduce the risk of electric shock, leakage-current or resistance measurements shall be carried out (exposed parts are acceptably insulated from the supply circuit) before the appliance is returned to the customer.

The DC voltage is an actual reading measured with a high impedance type voltmeter. The measurement value may vary depending on the measuring instruments used or on the product. Refer to the voltage during PLAY unless otherwise specified; The value shown in () is the voltage measured at the moment of STOP.

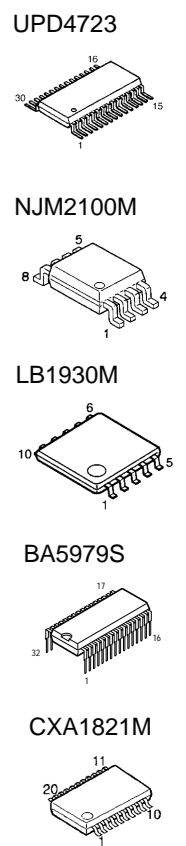
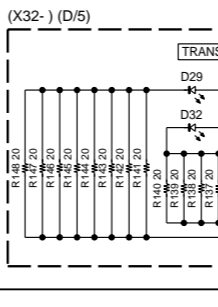
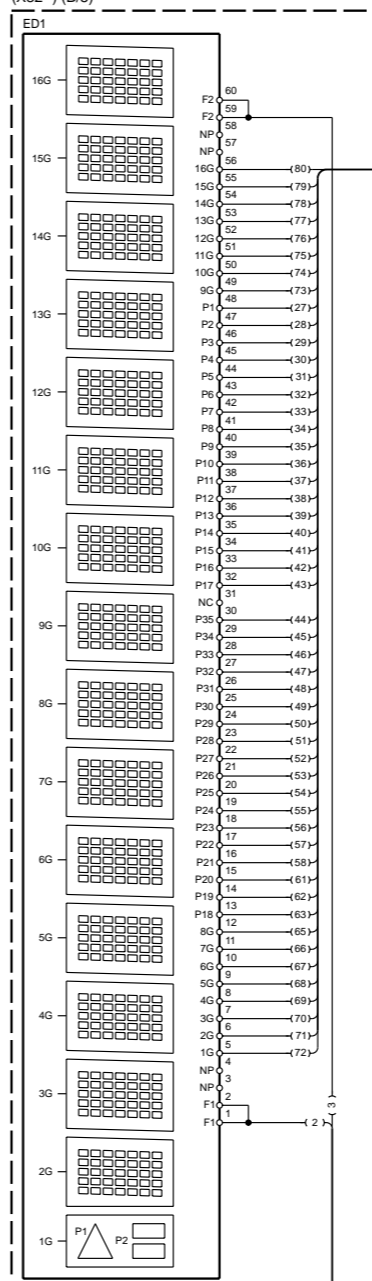
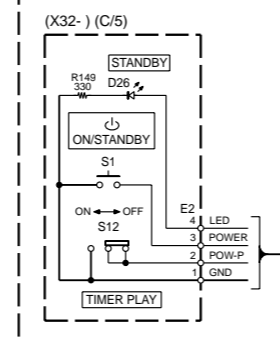
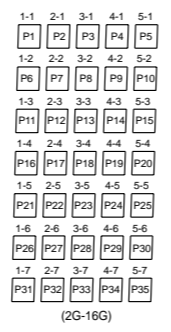
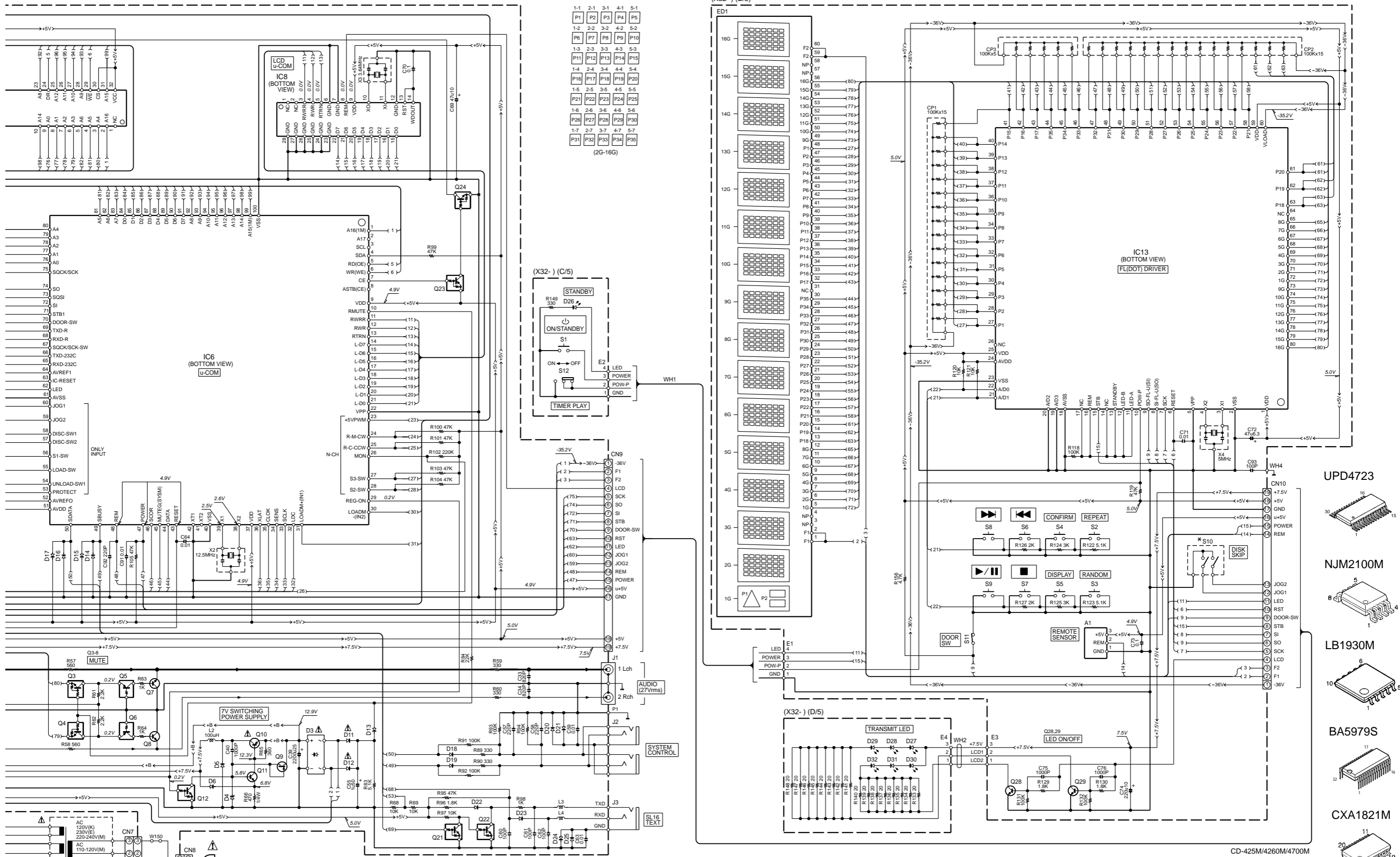

- TA8409S
- NJM2115M
- 2SK246
- 2SA954
- 2SC3246
- 2SA1175
- 2SC2785
- UN4212
- UN4219
- BA17805T
- UPC7805AHF
- DTA113ZSA
- 2SA1048
- DTA124ESA
- 2SC2458
- DTA143TSA
- DTC124ESA
- UN4112
- UN4116
- 5M51008BFP70LL
- Y22-8240-10

CD-425M/4260M/4700M/DPF-J6030

KENWOOD

EXPLODED VIEW(MECHANISM)

AB $\varnothing 2 \times 25$: N39-2025-46

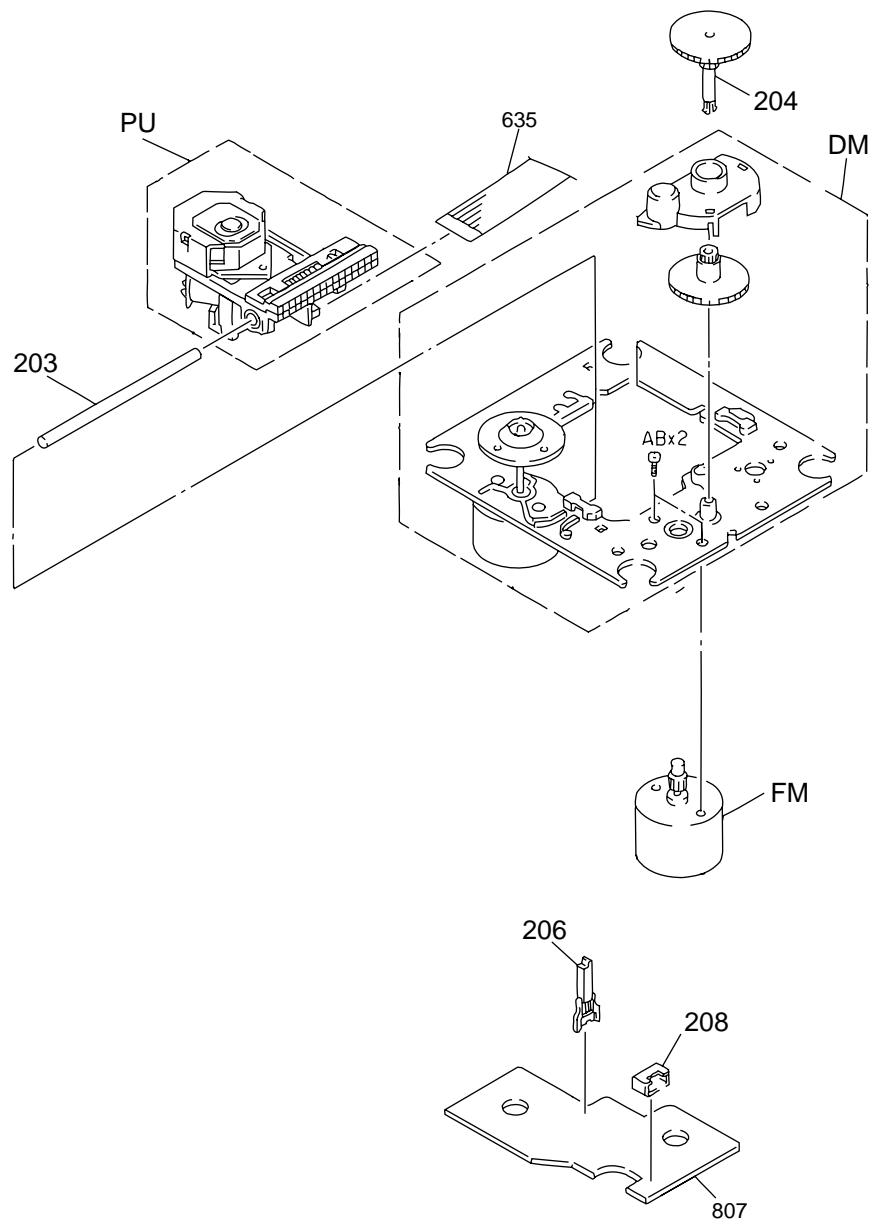

EXPLODED VIEW(UNIT)

Parts with exploded view numbers larger than 700 are not supplied.

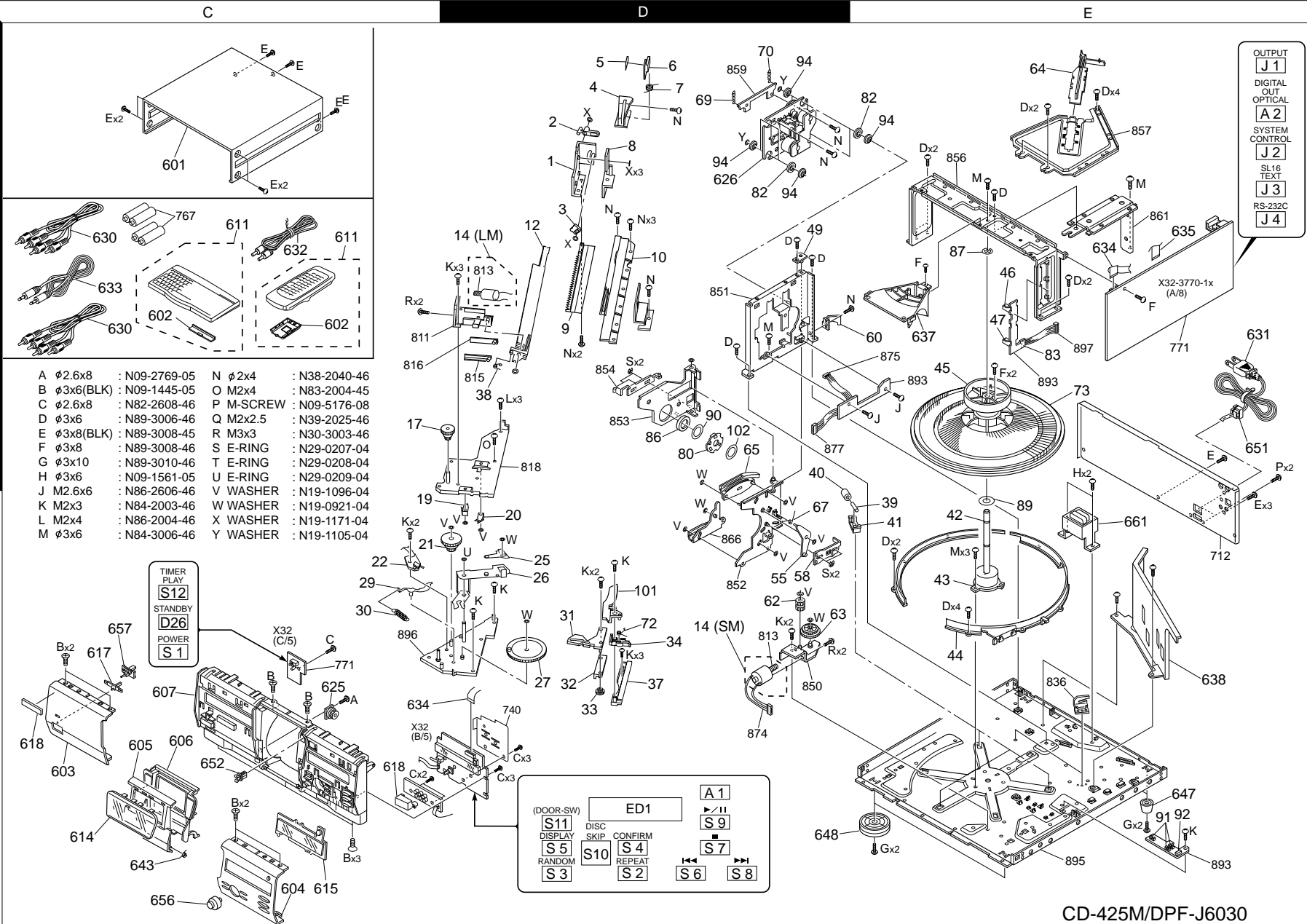

CD-425M/DPF-J6030

Parts with exploded view numbers larger than 700 are not supplied.

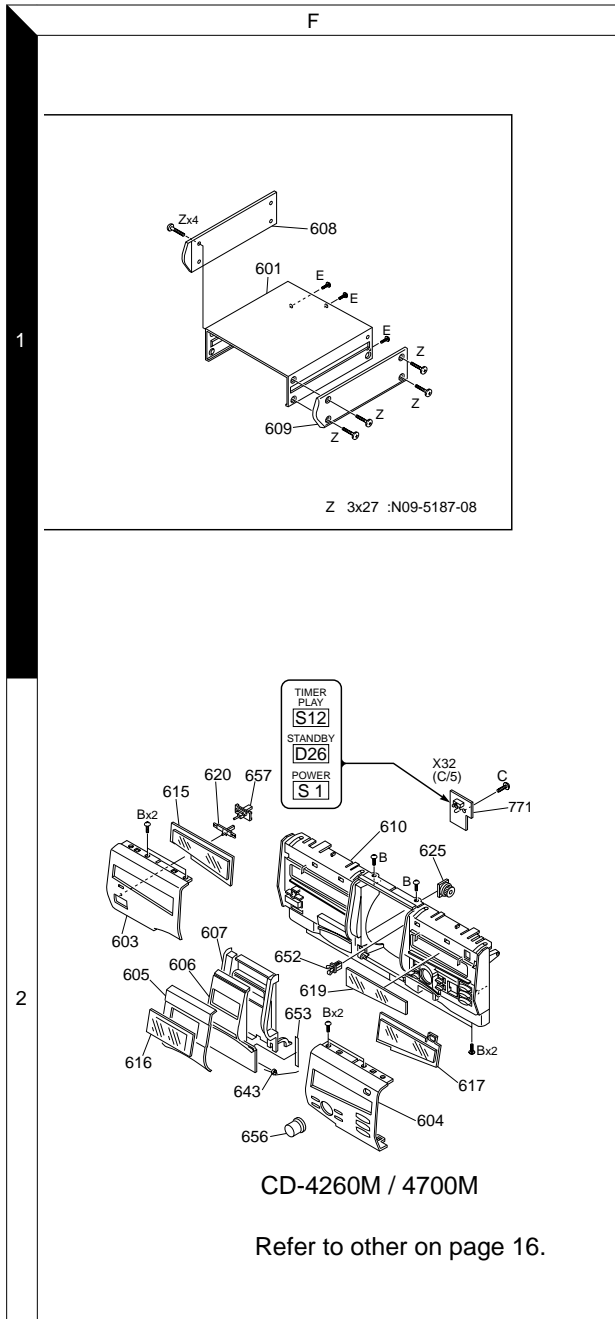

* New Parts
 Parts without **Parts No.** are not supplied.
 Les articles non mentionnés dans le **Parts No.** ne sont pas fournis.
 Teile ohne **Parts No.** werden nicht geliefert.

1

Ref. No	Add-ress	New Parts	Parts No.	Description	Desti-nation	Re-marks
CD-425M/DPF-J6030						
601	1C	*	A01-3723-18	METALLIC CABINET		
602	1C		A09-0374-08	BATTERY COVER		
602	1C		A09-1176-08	BATTERY COVER (KEYBOARD)		
603	2C	*	A21-3794-08	DRESSING PANEL	KP	
603	2C	*	A21-3796-08	DRESSING PANEL	TE	
604	2C		A21-3786-08	DRESSING PANEL		
605	2C		A29-1087-08	PANEL		
606	2C	*	A46-0310-18	REAR COVER		
607	2C	*	A60-1755-18	PANEL		
611	1C		A70-1326-05	REMOTE CONTROLLER ASSY(RC-KB2)		
611	1C		A70-1336-18	REMOTE CONTROLLER ASSY(RC-P0714)		
614	2C		B10-2395-08	FRONT GLASS (DOOR)		
615	2C		B10-2396-18	FRONT GLASS (FL)		
616	2C		B10-2405-28	FRONT GLASS (IR)		
617	2C		B12-0337-08	INDICATOR		
618	2C		B43-0314-04	KENWOOD BADGE		
-	-	-	B20-0623-18	SCALE		
-	-	-	B46-0310-03	WARRANTY CARD	TE	
-	-	-	B46-0328-03	WARRANTY CARD	K	
-	-	-	B46-0347-03	WARRANTY CARD	P	
-	-	-	B58-0964-13	CAUTION CARD (UL)	K	
-	-	-	B58-0965-13	CAUTION CARD (T,XtypePL)	T	
-	-	-	B58-0966-13	CAUTION CARD (ELMtypePL)	E	
-	-	-	B58-0967-03	CAUTION CARD (PtypePL)	P	
-	-	*	B58-1674-03	CAUTION CARD (P1,PRA,A4,1)	K	
-	-	*	B60-4454-08	INSTRUCTION MANUAL (EN)	KPT	
-	-	*	B60-4455-08	INSTRUCTION MANUAL (FR)	PE	
-	-	*	B60-4456-08	INSTRUCTION MANUAL (IT/ES)	E	
-	-	*	B60-4457-08	INSTRUCTION MANUAL (GE/NE)	E	
625	2C		D39-0335-18	DAMPER		
626	1D		D40-1515-05	MECHANISM ASSY		
630	1C		E30-0505-05	AUDIO CORD		
631	1E		E30-2788-05	AC POWER CORD	E	
631	1E		E30-2791-05	AC POWER CORD	T	
631	1E		E30-2883-05	AC POWER CORD	KP	
632	1C		E30-2816-05	SYSTEM CONTROL CORD		
633	1C		E30-2861-05	COMMUNICATION CORD		
634	2D		E35-2446-08	FLAT CABLE (19P)		
635	1E		E35-2459-08	FLAT CABLE (16P)		
637	1E		F07-1613-08	COVER		
638	2E		F07-1691-18	COVER		
643	2C		G01-4026-18	TORSION COIL SPRING		
-	-	*	H10-7397-28	POLYSTYRENE FOAMED FIXTURE		
-	-	*	H10-7398-28	POLYSTYRENE FOAMED FIXTURE		
-	-		H12-3410-08	PACKING FIXTURE		
-	-		H21-0353-18	PROTECTION SHEET		
-	-		H25-0232-04	PROTECTION BAG (235X350X0.03)	KPE	
-	-		H25-0651-04	PROTECTION BAG (0232 PRINT)	T	
-	-		H25-1668-08	PROTECTION BAG		

L : Scandinavia K : USA P : Canada R : Mexico C : China I : Malaysia
 Y : PX(Far East,Hawaii) T : England E : Europe G : Germany V : China(Shanghai)
 Y : AAFES(Europe) X : Australia Q : Russia H : Korea M : Other Areas Δ indicates safety critical components.

EXPLODED VIEW (UNIT) / PARTS LIST

CD-425M/4260M/4700M/DPF-J6030

* New Parts
Parts without **Parts No.** are not supplied.
Les articles non mentionnés dans le **Parts No.** ne sont pas fournis.
Teile ohne **Parts No.** werden nicht geliefert.

②

Ref. No	Add-ress	New Parts	Parts No.	Description	Desti-nation	Re-marks
-		*	H50-3539-08	ITEM CARTON CASE	KP	
-		*	H50-3553-08	ITEM CARTON CASE	TE	
647	2E		J02-1461-18	FOOT		
648	2E		J02-1474-08	FOOT		
651	1E		J42-0083-05	POWER CORD BUSHING		
652	2C		J52-0039-05	PUSH LATCH		
656	2C		K29-6824-18	KNOB		
657	2C		K29-6885-38	KNOB		
661	2E		L07-2844-18	POWER TRANSFORMER	KP	
661	2E		L07-2846-18	POWER TRANSFORMER	TE	
P		*	N09-5176-08	MACHINE SCREW		
CD-4260M/4700M						
601	1F	*	A01-3536-18	METALLIC CABINET	KP	
601	1F	*	A01-3738-18	METALLIC CABINET	K1	
602	1C		A09-0374-08	BATTERY COVER		
602	1C		A09-1176-08	BATTERY COVER(KEYBOARD)		
603	2F	*	A21-3813-08	DRESSING PANEL		
604	2F	*	A21-3826-18	DRESSING PANEL	KP	
604	2F	*	A21-3827-18	DRESSING PANEL	K1	
605	2F	*	A21-3815-08	DRESSING PANEL		
606	2F	*	A29-1081-18	PANEL		
607	2F	*	A46-0331-38	REAR COVER		
608	1F	*	A50-1342-18	SIDE PLATE	K1	
609	1F	*	A50-1343-18	SIDE PLATE	K1	
610	2F	*	A60-1753-38	PANEL		
611	1C		A70-1326-05	REMOTE CONTROLLER ASSY(RC-KB2)		
611	1C		A70-1336-18	REMOTE CONTROLLER ASSY(RC-P0714)		
615	2F		B10-3557-08	FRONT GLASS (L)SMOKE		
616	2F		B10-3558-18	FRONT GLASS (DOOR)		
617	2F		B10-3559-08	FRONT GLASS (R)SMOKE		
618	2F		B10-3560-08	FRONT GLASS (IR)		
619	2F		B11-0400-08	COLOR FILTER		
620	2F		B12-0326-04	INDICATOR		
-			B20-0623-18	SCALE		
-			B46-0328-03	WARRANTY CARD	KK1	
-			B46-0347-03	WARRANTY CARD	P	
-			B58-0964-13	CAUTION CARD (UL)	KK1	
-			B58-0967-03	CAUTION CARD (PtypePL)	P	
-		*	B58-1674-03	CAUTION CARD (P1,PRA,A4,1)	KK1	
-		*	B60-4454-08	INSTRUCTION MANUAL (EN)		
-		*	B60-4455-08	INSTRUCTION MANUAL (FR)	P	
625	2F		D39-0322-05	DAMPER		
626	1D		D40-1515-05	MECHANISM ASSY		
630	1C		E30-0505-05	AUDIO CORD		
631	1E		E30-2883-05	AC POWER CORD		
632	1C		E30-2816-05	SYSTEM CONTROL CORD		
633	1C		E30-2861-05	COMMUNICATION CORD		
634	2D,1E		E35-2446-08	FLAT CABLE(19P)		
635	1E		E35-2459-08	FLAT CABLE(16P)		
637	1E		F07-1613-08	COVER		

L : Scandinavia K : USA P : Canada R : Mexico C : China I : Malaysia
Y : PX(Far East,Hawaii) T : England E : Europe G : Germany V : China(Shanghai)
Y : AAFES(Europe) X : Australia Q : Russia H : Korea M : Other Areas

⚠ indicates safety critical components.

* New Parts
Parts without **Parts No.** are not supplied.
Les articles non mentionnés dans le **Parts No.** ne sont pas fournis.
Teile ohne **Parts No.** werden nicht geliefert.

③

Ref. No	Add-ress	New Parts	Parts No.	Description	Desti-nation	Re-marks
638	2E		F07-1691-18	COVER		
643	2F		G01-4199-08	TORSION COIL SPRING		
-			H10-7632-08	POLYSTYRENE FOAMED FIXTURE		
-			H10-7633-08	POLYSTYRENE FOAMED FIXTURE		
-			H12-3410-08	PACKING FIXTURE		
-			H25-0232-04	PROTECTION BAG (235X350X0.03)		
-			H25-1668-08	PROTECTION BAG		
-		*	H50-3551-08	ITEM CARTON CASE	KP	
-		*	H50-3554-08	ITEM CARTON CASE	K1	
647	2E		J02-1461-18	FOOT		
648	2E		J02-1466-08	FOOT		
651	1E		J42-0083-05	POWER CORD BUSHING		
652	2F		J52-0039-05	PUSH LATCH		
653	2F		J69-0216-08	ADHESIVE TAPE		
656	2F		K29-7716-18	KNOB		
657	2F		K29-7717-18	KNOB		
661	2E		L07-2844-18	POWER TRANSFORMER		
P		*	N09-5176-08	MACHINE SCREW		
Z			N09-5187-08	SET SCREW	K1	
CD PLAYER UNIT (X32-3770-1X)						
D26			B30-2493-05	LED(RED,P=5MM)		
D27 -32			B30-2532-05	LED(INFRARED)		
C1			CE04KW1A101M	ELECTRO 100UF		10WV
C2			CE04KW0J221M	ELECTRO 220UF		6.3WV
C3			CE04KW1A470M	ELECTRO 47UF		10WV
C4			CC73FCH1H180J	CHIP C 18PF		J
C5			CE04KW0J221M	ELECTRO 220UF		6.3WV
C6			CE04KW1A470M	ELECTRO 47UF		10WV
C7			CK73FB1E104K	CHIP C 0.10UF		K
C8			CC73FSL1H471J	CHIP C 470PF		J
C9			CC73FSL1H221J	CHIP C 220PF		J
C10			CK73FB1H223K	CHIP C 0.022UF		K
C11			CK73FB1C474K	CHIP C 0.47UF		K
C12			CK73FB1H103K	CHIP C 0.010UF		K
C13			CK73FB1H332K	CHIP C 3300PF		K
C14			CK73FB1H152K	CHIP C 1500PF		K
C15			CK73FB1H473K	CHIP C 0.047UF		K
C16			CK73FB1E104K	CHIP C 0.10UF		K
C17			CE04KW1A101M	ELECTRO 100UF		10WV
C18 ,19			CC73FCH1H560J	CHIP C 56PF		J
C20			CK73FB1H103K	CHIP C 0.010UF		K
C21			CK73FB1H183K	CHIP C 0.018UF		K
C22			CK73FB1H223K	CHIP C 0.022UF		K
C23 ,24			CK73FB1E104K	CHIP C 0.10UF		K
C25 ,26			CE04KW0J331M	ELECTRO 330UF		6.3WV
C27 ,28			CC73FSL1H151J	CHIP C 150PF		J
C29 ,30			CC73FSL1H821J	CHIP C 820PF		J
C31 ,32			CE04KW1A470M	ELECTRO 47UF		10WV
C33 ,34			CC73FSL1H821J	CHIP C 820PF		J
C35			CK73FB1H103K	CHIP C 0.010UF		K
C36 ,37			CK45FF1H103Z	CERAMIC 0.010UF		Z

L : Scandinavia K : USA P : Canada R : Mexico C : China I : Malaysia
Y : PX(Far East,Hawaii) T : England E : Europe G : Germany V : China(Shanghai)
Y : AAFES(Europe) X : Australia Q : Russia H : Korea M : Other Areas

⚠ indicates safety critical components.

* New Parts
 Parts without **Parts No.** are not supplied.
 Les articles non mentionnés dans le **Parts No.** ne sont pas fournis.
 Teile ohne **Parts No.** werden nicht geliefert.

4

Ref. No	Add-ress	New Parts	Parts No.	Description	Desti-nation	Re-marks
C39			CE04KW1E222M	ELECTRO	2200UF	25WV
C40			CK73FB1H102K	CHIP C	1000PF	K
C41			CE04KW1A332M	ELECTRO	3300UF	10WV
C42			CK73FB1E104K	CHIP C	0.10UF	K
C44			CE04KW1A101M	ELECTRO	100UF	10WV
C45			CE04KW1C100M	ELECTRO	10UF	16WV
C46			CE04KW2A470M	ELECTRO	47UF	100WV
C47			CE04KW1H010M	ELECTRO	1.0UF	50WV
C48			CE04KW1H100M	ELECTRO	10UF	50WV
C49			CK73FB1H103K	CHIP C	0.010UF	K
C50			CE04KW1A221M	ELECTRO	220UF	10WV
C51			CE04KW0J331M	ELECTRO	330UF	6.3WV
C52			CE04KW1H010M	ELECTRO	1.0UF	50WV
C53			CE04KW1A101M	ELECTRO	100UF	10WV
C54			C90-3542-05	BACKUP	1.0F	5.5WV
C55			CE04KW1H010M	ELECTRO	1.0UF	50WV
C56			CK73FB1H103K	CHIP C	0.010UF	K
C57 ,58			CC73FSL1H221J	CHIP C	220PF	J
C59			CK73FB1H103K	CHIP C	0.010UF	K
C60 -62			CC73FSL1H101J	CHIP C	100PF	J
C63 ,64			CK73FB1H103K	CHIP C	0.010UF	K
C65 ,66			CE04KW1A470M	ELECTRO	47UF	10WV
C67 ,68			CK73FB1E104K	CHIP C	0.10UF	K
C69			CE04KW1A470M	ELECTRO	47UF	10WV
C70			CK73FB1E104K	CHIP C	0.10UF	K
C71			CK73FB1H103K	CHIP C	0.010UF	K
C72			CE04RW0J470M	ELECTRO	47UF	6.3WV
C73			CK73FB1E104K	CHIP C	0.10UF	K
C74		*	CE04RW1A221M	ELECTRO	220UF	10WV
C75 ,76			CK73FB1H102K	CHIP C	1000PF	K
C77			CE04KW1A101M	ELECTRO	100UF	10WV
C78			CK73FB1H103K	CHIP C	0.010UF	K
C79 ,80			CC73FCH1H180J	CHIP C	18PF	J
C81			CE04KW1A470M	ELECTRO	47UF	10WV
C82 -85			CK73FB1C334K	CHIP C	0.33UF	K
C86			CK73FB1H103K	CHIP C	0.010UF	K
C87 ,88			CE04KW1A470M	ELECTRO	47UF	10WV
C91			CK73FB1H103K	CHIP C	0.010UF	K
C92			CC73FSL1H221J	CHIP C	220PF	J
C93			CC73FSL1H101J	CHIP C	100PF	J
CN1			E40-4856-05	FLAT CABLE CONNECTOR		
CN2			E40-4979-05	PIN ASSY		
CN3			E40-3254-05	PIN ASSY		
CN4			E40-3252-05	PIN ASSY		
CN5			E40-3246-05	PIN ASSY		
CN6			E40-3241-05	PIN ASSY		
CN7			E40-4428-05	PIN ASSY		
CN8			E40-4245-05	PIN ASSY		
CN9 ,10			E40-4944-05	FLAT CABLE CONNECTOR		
J1			E63-1078-05	PIN JACK		
J2			E11-0293-05	MINIATURE PHONE JACK(2P)		
J3			E11-0360-05	MINIATURE PHONE JACK(BLK,2.5 S		
J4		*	E58-0024-05	RECTANGULAR RECEPTACLE		
-			J19-5878-05	UNIT HOLDER		

L : Scandinavia K : USA P : Canada R : Mexico C : China I : Malaysia
 Y : PX(Far East,Hawaii) T : England E : Europe G : Germany V : China(Shanghai)
 Y : AAFES(Europe) X : Australia Q : Russia H : Korea M : Other Areas Δ indicates safety critical components .

* New Parts
 Parts without **Parts No.** are not supplied.
 Les articles non mentionnés dans le **Parts No.** ne sont pas fournis.
 Teile ohne **Parts No.** werden nicht geliefert.

5

Ref. No	Add-ress	New Parts	Parts No.	Description	Desti-nation	Re-marks
-		*	J19-6037-03	HOLDER		
E7			J11-0808-05	WIRE CLAMPER		
L1			L40-1001-17	SMALL FIXED INDUCTOR(10UH,K)		
L2			L33-0558-05	CHOKE COIL		
L3 ,4			L79-1216-05	LINE FILTER		
L5 ,6			L40-1001-17	SMALL FIXED INDUCTOR(10UH,K)		
X1			L77-2288-05	CRYSTAL RESONATOR(16.9344MHZ)		
X2			L78-0615-05	RESONATOR (12.5MHZ)		
X3			L78-0674-05	RESONATOR (3.64MHZ)		
X4			L78-0284-05	RESONATOR (5MHZ)		
X5		*	L77-2289-05	CRYSTAL RESONATOR(11.0592MHZ)		
CP1 ,2			R90-0875-05	MULTI-COMP 100KX15		
CP3			R90-0855-05	MULTI-COMP 100KX5	J	
R1			RK73FB2A224J	CHIP R	220K	J 1/10W
R6			RK73FB2A224J	CHIP R	220K	J 1/10W
R7			RK73FB2A100J	CHIP R	10	J 1/10W
R8			RK73FB2A273J	CHIP R	27K	J 1/10W
R9			RK73FB2A153J	CHIP R	15K	J 1/10W
R10 ,11			RK73FB2A101J	CHIP R	100	J 1/10W
R13			RK73FB2A473J	CHIP R	47K	J 1/10W
R14			RK73FB2A472J	CHIP R	4.7K	J 1/10W
R15 ,16			RK73FB2A103J	CHIP R	10K	J 1/10W
R17 ,18			RK73FB2A153J	CHIP R	15K	J 1/10W
R19			RK73FB2A104J	CHIP R	100K	J 1/10W
R20			RK73FB2A333J	CHIP R	33K	J 1/10W
R21			RK73FB2A104J	CHIP R	100K	J 1/10W
R22			RK73FB2A105J	CHIP R	1.0M	J 1/10W
R23			RK73FB2A103J	CHIP R	10K	J 1/10W
R24 ,25			RK73FB2A332J	CHIP R	3.3K	J 1/10W
R26			RK73FB2A331J	CHIP R	330	J 1/10W
R29			RK73FB2A473J	CHIP R	47K	J 1/10W
R30			RK73FB2A472J	CHIP R	4.7K	J 1/10W
R31			RK73FB2A364J	CHIP R	360K	J 1/10W
R32			RK73FB2A474J	CHIP R	470K	J 1/10W
R33			RK73FB2A912J	CHIP R	9.1K	J 1/10W
R34			RK73FB2A473J	CHIP R	47K	J 1/10W
R37 -42			RK73FB2A103J	CHIP R	10K	J 1/10W
R43 ,44			RK73FB2A273J	CHIP R	27K	J 1/10W
R45 ,46			RK73FB2A683J	CHIP R	68K	J 1/10W
R49 ,50			R92-1937-05	CHIP R	41.2K	F
R51 ,52			R92-1938-05	METAL GLAZE RESISTOR		
R53 ,54			RK73FB2A103J	CHIP R	10K	J 1/10W
R55 ,56			RK73FB2A104J	CHIP R	100K	J 1/10W
R57 ,58			RK73FB2A561J	CHIP R	560	J 1/10W
R59 ,60			RK73FB2A331J	CHIP R	330	J 1/10W
R61 ,62			RK73FB2A222J	CHIP R	2.2K	J 1/10W
R63 ,64			RK73FB2A102J	CHIP R	1.0K	J 1/10W
R65			RK73FB2A361J	CHIP R	360	J 1/10W
R68 ,69			RK73FB2A103J	CHIP R	10K	J 1/10W
R70			RK73FB2A472J	CHIP R	4.7K	J 1/10W
R71			RK73FB2A473J	CHIP R	47K	J 1/10W
R72			RK73FB2A101J	CHIP R	100	J 1/10W
R73			RK73FB2A134J	CHIP R	130K	J 1/10W
R74			RK73FB2A103J	CHIP R	10K	J 1/10W

L : Scandinavia K : USA P : Canada R : Mexico C : China I : Malaysia
 Y : PX(Far East,Hawaii) T : England E : Europe G : Germany V : China(Shanghai)
 Y : AAFES(Europe) X : Australia Q : Russia H : Korea M : Other Areas Δ indicates safety critical components .

PARTS LIST

CD-425M/4260M/4700M/DPF-J6030

* New Parts
Parts without **Parts No.** are not supplied.
Les articles non mentionnés dans le **Parts No.** ne sont pas fournis.
Teile ohne **Parts No.** werden nicht geliefert.

6

Ref. No	Add-ress	New Parts	Parts No.	Description	Desti-nation	Re-marks
R75			RK73FB2A223J	CHIP R 22K J 1/10W		
R76			RK73FB2A105J	CHIP R 1.0M J 1/10W		
R77 ,78			RK73FB2A101J	CHIP R 100 J 1/10W		
R79 ,80			RK73FB2A153J	CHIP R 15K J 1/10W		
R81			RK73FB2A472J	CHIP R 4.7K J 1/10W		
R82			RK73FB2A271J	CHIP R 270 J 1/10W		
R83			RK73FB2A512J	CHIP R 5.1K J 1/10W		
R84			RK73FB2A223J	CHIP R 22K J 1/10W		
R85			RK73FB2A224J	CHIP R 220K J 1/10W		
R86			RK73FB2A164J	CHIP R 160K J 1/10W		
R87			RK73FB2A153J	CHIP R 15K J 1/10W		
R88			RK73FB2A103J	CHIP R 10K J 1/10W		
R89 ,90			RK73FB2A331J	CHIP R 330 J 1/10W		
R91 -94			RK73FB2A104J	CHIP R 100K J 1/10W		
R95			RK73FB2A473J	CHIP R 47K J 1/10W		
R96			RK73FB2A182J	CHIP R 1.8K J 1/10W		
R97			RK73FB2A103J	CHIP R 10K J 1/10W		
R98			RK73FB2A102J	CHIP R 1.0K J 1/10W		
R99 -101			RK73FB2A473J	CHIP R 47K J 1/10W		
R102			RK73FB2A224J	CHIP R 220K J 1/10W		
R103-105			RK73FB2A473J	CHIP R 47K J 1/10W		
R106,107			RK73FB2A472J	CHIP R 4.7K J 1/10W		
R108-110			RK73FB2A473J	CHIP R 47K J 1/10W		
R114,115			RK73FB2A473J	CHIP R 47K J 1/10W		
R116			RK73FB2A332J	CHIP R 3.3K J 1/10W		
R117			RK73FB2A103J	CHIP R 10K J 1/10W		
R118			RK73FB2A104J	CHIP R 100K J 1/10W		
R119			RK73FB2A473J	CHIP R 47K J 1/10W		
R120,121			RK73FB2A103J	CHIP R 10K J 1/10W		
R122,123			RK73FB2A512J	CHIP R 5.1K J 1/10W		
R124,125			RK73FB2A302J	CHIP R 3.0K J 1/10W		
R126,127			RK73FB2A202J	CHIP R 2.0K J 1/10W		
R129,130			RK73FB2A182J	CHIP R 1.8K J 1/10W		
R131,132			RK73FB2A104J	CHIP R 100K J 1/10W		
R133-148			RK73FB2A200J	CHIP R 20 J 1/10W		
R149			RK73FB2A331J	CHIP R 330 J 1/10W		
R150,151			RK73FB2A101J	CHIP R 100 J 1/10W		
R152			RK73FB2A104J	CHIP R 100K J 1/10W		
R154,155			RK73FB2A101J	CHIP R 100 J 1/10W		
R156			RK73FB2A472J	CHIP R 4.7K J 1/10W		
R157			RK73FB2A473J	CHIP R 47K J 1/10W		
VR1			R12-3101-05	TRIMMING POT.(22K)		
S1 -9			S70-0031-05	TACT SWITCH		
S11			S64-0034-05	LEVER SWITCH		
S12			S62-0070-05	SLIDE SWITCH		
S10			T99-0596-05	ROTARY ENCODER(CD-425M/DPF-J6030)		
S10			T99-0639-05	ROTARY ENCODER(CD-4260M/4700M)		
D1 ,2			HSS104	DIODE		
D1 ,2			1SS133	DIODE		
D3			D3SBA20F03	DIODE		
D3			RBV-402LFA	DIODE		
D4			MTZJ7.5(B)	ZENER DIODE		
D4			RD7.5JS(B2)	ZENER DIODE		

L : Scandinavia K : USA P : Canada R : Mexico C : China I : Malaysia
Y : PX(Far East,Hawaii) T : England E : Europe G : Germany V : China(Shanghai)
Y : AAFES(Europe) X : Australia Q : Russia H : Korea M : Other Areas Δ indicates safety critical components.

* New Parts
Parts without **Parts No.** are not supplied.
Les articles non mentionnés dans le **Parts No.** ne sont pas fournis.
Teile ohne **Parts No.** werden nicht geliefert.

7

Ref. No	Add-ress	New Parts	Parts No.	Description	Desti-nation	Re-marks
D5			DLM10C	DIODE		
D6			HSS104	DIODE		
D6			1SS133	DIODE		
D7 ,8			S5688B(TPB5)	DIODE		
D9			MTZJ11(B)	ZENER DIODE		
D9			RD11ES(B2)	ZENER DIODE		
D10			HSS104	DIODE		
D10			1SS133	DIODE		
D11 ,12			S5688B(TPB5)	DIODE		
D13 -25			HSS104	DIODE		
D13 -25			1SS133	DIODE		
D33 ,34			HSS104	DIODE		
D33 ,34			1SS133	DIODE		
ED1			16-MT-66GNK	FLUORESCENT INDICATOR TUBE		
IC1			CXA1821M	ANALOGUE IC		
IC2			CXD2587Q*	MOS-IC		
IC3			NJM2115M	ANALOGUE IC		
IC4			BA17805T	ANALOGUE IC		
IC4			UPC7805AHF	ANALOGUE IC		
IC5			BA5979S	ANALOGUE IC		
IC6		*	UPD784217GF501	MI-COM IC		
IC7			NJM2100M	IC(OP AMPLIFIER)		
IC8			UPD17215GT-737	MI-COM IC		
IC10			CY62128L-70SC	MEMORY IC		
IC10			M5M51008CFP70H	MEMORY IC		
IC10			5M51008BFP70LL	MEMORY IC		
IC11			TA8409S	MOS-IC		
IC12			LB1930M	ANALOGUE IC		
IC13			UPD780232GC012	MI-COM IC		
IC14			PST993D-T	ANALOGUE IC		
IC15		*	UPD784035GC868	MI-COM IC		
IC16		*	UPD4723	ANALOGUE IC		
Q1			2SA954(L,K)	TRANSISTOR		
Q3 ,4			DTC124ESA	DIGITAL TRANSISTOR		
Q3 ,4			UN4212	DIGITAL TRANSISTOR		
Q5 ,6			DTA143TSA	DIGITAL TRANSISTOR		
Q5 ,6			UN4116	DIGITAL TRANSISTOR		
Q7 ,8			2SD1450(S,T)	TRANSISTOR		
Q9			2SK246(Y)	FET		
Q10			2SB1165(R,S)	TRANSISTOR		
Q11			2SC2458(Y,GR)	TRANSISTOR		
Q11			2SC2785(F,E)	TRANSISTOR		
Q12			DTC124ESA	DIGITAL TRANSISTOR		
Q12			UN4212	DIGITAL TRANSISTOR		
Q14			2SA954(L,K)	TRANSISTOR		
Q15			2SA1048(Y,GR)	TRANSISTOR		
Q15			2SA1175(F,E)	TRANSISTOR		
Q16 ,17			2SD1450(S,T)	TRANSISTOR		
Q18			DTA113ZSA	DIGITAL TRANSISTOR		
Q18			UN4119	DIGITAL TRANSISTOR		
Q19			2SB1417(Q,P)	TRANSISTOR		
Q19			2SB1640	TRANSISTOR		
Q20			2SC2458(Y,GR)	TRANSISTOR		
Q20			2SC2785(F,E)	TRANSISTOR		
Q21			DTC124ESA	DIGITAL TRANSISTOR		

L : Scandinavia K : USA P : Canada R : Mexico C : China I : Malaysia
Y : PX(Far East,Hawaii) T : England E : Europe G : Germany V : China(Shanghai)
Y : AAFES(Europe) X : Australia Q : Russia H : Korea M : Other Areas Δ indicates safety critical components.

* New Parts
 Parts without **Parts No.** are not supplied.
 Les articles non mentionnés dans le **Parts No.** ne sont pas fournis.
 Teile ohne **Parts No.** werden nicht geliefert.

9

Ref. No	Add-ress	New Parts	Parts No.	Description	Desti-nation	Re-marks
Q21			UN4212	DIGITAL TRANSISTOR		
Q22			DTC113ZSA	DIGITAL TRANSISTOR		
Q22			UN4219	DIGITAL TRANSISTOR		
Q23			DTA124ESA	DIGITAL TRANSISTOR		
Q23			UN4112	DIGITAL TRANSISTOR		
Q24 ,25			DTC124ESA	DIGITAL TRANSISTOR		
Q24 ,25			UN4212	DIGITAL TRANSISTOR		
Q26			DTA113ZSA	DIGITAL TRANSISTOR		
Q26			UN4119	DIGITAL TRANSISTOR		
Q28 ,29			2SC3246(J,K)	TRANSISTOR		
A1			W02-2561-05	ELECTRIC CIRCUIT MODULE		
A2			W02-1114-15	OSCILLATING MODULE		
MECHANISM CHANGER (MG-CH1)						
1	1D		A11-1134-08	BASE ARM		
2	1D		D10-3788-08	LEVER R		
3	1D		D12-0158-08	CAM CHANGE		
4	1D		J19-5892-08	HOLDER ARM		
5	1D		G16-0912-08	RUBBER		
6	1D		D10-3778-08	ARM DISC		
7	1D		G01-4060-08	SPG DISC H		
8	1D		J21-6576-08	PLATE ARM		
9	1D		D10-3785-08	SLIDER RACK		
10	1D		J19-5891-08	HOLDER RACK		
12	1D		D10-3787-08	LEVER CHANGE		
14	1D,2D		T42-0920-08	MOTOR		
17	1C		D13-1856-08	GEAR D		
19	2C		D10-3781-08	LEVER HOOK A		
20	2D		D10-3782-08	LEVER HOOK B		
21	2C		D13-1857-08	GEAR E		
22	2C		S64-0038-08	LEVER SW		
25	2D		J21-6579-08	PLATE LIMITER		
26	2D		D10-3779-18	ARM SWING		
27	2D		D13-1855-18	GEAR CAM		
29	2C		J21-6573-08	PLATE LOCK		
30	2C		G01-4061-08	SPG LOCK LEVER		
31	2D		D10-3780-18	SLIDER CAM		
32	2D		J21-6574-08	PLATE SLIDE		
33	2D		D13-1854-08	GEAR SLIDER		
34	2D		D10-3786-18	LEVER STOPPER		
37	2D		J90-0854-08	GUIDE RACK		
38	1D		G01-4064-08	SPG CHANGE		
39	2E		D21-1899-08	PIN ROLLER		
40	1D		D14-0393-08	HOLDER ROLLER		
41	2E		J19-5888-08	ROLLER GUIDE		
42	2E		D21-1900-18	SHAFT MAIN		
43	2E		J19-5890-08	HOLDER SHAFT		
44	2E		J90-0856-08	GUIDE DISC		
45	1E		D32-0354-08	STOPPER DISC		
46	1E		J19-5893-08	HOLDER SENSOR		
47	1E		J19-5927-08	HOLDER SENSOR		
49	1D		J21-6570-08	PLATE HOLD T		
55	2D		J21-6580-18	PLATE LINK		

L : Scandinavia K : USA P : Canada R : Mexico C : China I : Malaysia
 Y : PX(Far East,Hawaii) T : England E : Europe G : Germany V : China(Shanghai)
 Y : AAFES(Europe) X : Australia Q : Russia H : Korea M : Other Areas Δ indicates safety critical components.

* New Parts
 Parts without **Parts No.** are not supplied.
 Les articles non mentionnés dans le **Parts No.** ne sont pas fournis.
 Teile ohne **Parts No.** werden nicht geliefert.

9

Ref. No	Add-ress	New Parts	Parts No.	Description	Desti-nation	Re-marks
58	2D		J21-6571-08	PLATE SLIDER A		
60	1E		J21-6575-08	PLATE SUPPORT B		
62	2D		D13-1852-08	GEAR B		
63	2D		D13-1853-08	GEAR C		
64	1E		J90-0855-08	GUIDE DISC U		
65	1D		J19-5894-08	HOLDER DISC U		
67	2D		G01-4057-08	SPG SLIDER		
69	1D		G01-4062-08	SPG DAMPER A		
70	1D		G01-4063-08	SPG DAMPER B		
72	2D		G01-4065-08	SPG STOPPER		
73	1E		J19-5889-08	STOCKER ROTARY		
80	1D		J11-0840-08	CLAMPER		
82	1D,1E		J02-1412-08	INSULATOR		
83	1E		E40-8285-08	CONNECTOR 5P		
86	1D		T99-0565-05	MAGNET		
87	1E		N29-0287-08	E-RING 6.0		
89	2E		N19-1460-08	PSW 8.5X30X0.5		
90	1D		J69-0083-04	DOUBLE COATED TAPE		
91	2E		T95-0160-08	PHOTO INTERRUPTER		
92	2E		E40-8284-08	CONNECTOR 5P		
94	1D,1E		N19-1461-08	FLAT WASHER		
101	2D		D32-0360-08	PLATE STOPPER		
102	1D		G16-0936-08	SHEET		
LED			SIM-20ST	LED		
TR			RPM-20PB	TRANSISTOR		
R			RK73FB2A471J	CHIP R	470	J 1/10W
MECHANISM ASSY (D40-1515-05)						
203	2A		D10-3606-08	ROD		
204	1B		D13-1720-08	GEAR		
206	3B		S74-0038-08	LEAF SWITCH		
208	3B		E40-3264-05	PIN ASSY		
DM	1B		A11-1082-18	SUB CHASSIS ASSY		
FM	2B		T42-0817-08	MOTOR ASSY		
PU	1A		T25-0061-08	OPTICAL PICKUP HEAD		

L : Scandinavia K : USA P : Canada R : Mexico C : China I : Malaysia
 Y : PX(Far East,Hawaii) T : England E : Europe G : Germany V : China(Shanghai)
 Y : AAFES(Europe) X : Australia Q : Russia H : Korea M : Other Areas Δ indicates safety critical components.

HOW TO READ THE PARTS LIST
ABBREVIATION OF MODEL AND MASS PRODUCTION'S DESTINATIONS

MODEL	ABB.	Australia	Canada	China	England	Europe	Germany	Korea	Malaysia
CD-425M	-	-	P	-	-	-	-	-	-
CD-4260M	-	-	P	-	-	-	-	-	-
CD-4700M	-	-	-	-	-	-	-	-	-
DPF-J6030	-	-	-	-	T	E	-	-	-
MODEL	ABB.	Mexico	PX/AAFES	Russia	Scandinavia	Shanghai	USA	Other area	
CD-425M	-	-	-	-	-	-	K	-	-
CD-4260M	-	-	-	-	-	-	K	-	-
CD-4700M	-	-	-	-	-	-	K1	-	-
DPF-J6030	-	-	-	-	-	-	-	-	-

PARTS LIST

CD-425M/4260M/4700M/DPF-J6030

CD-425M/4260M/4700M/DPF-J6030

SPECIFICATIONS

[Format]

System Compact disc digital audio system
Laser Semiconductor laser

[D/A Convertors]

D/A Conversion 1 Bit
Oversampling 8 fs (352.8 kHz)

[Audio]

Frequency response 4 Hz ~ 20 kHz, \pm 0.5 dB
Signal to noise ratio More than 105 dB
Dynamic range More than 95 dB
Total harmonic distortion + noise
..... Less than 0.005% (at 1 kHz)
Channel separation More than 95 dB (at 1 kHz)
Wow & flutter Unmeasurable Limit
Output level/impedance
Fixed 2.0 V/1 k Ω
Digital output
Optical -15 dBm ~ -21 dBm (Wave length 660 nm)

[Laser]

Wave length 760 ~ 800 nm
Laser power class Class 1 (IEC)

[General]

CD-4700M
Power consumption 10 W
Dimensions
W : 481 mm (18-15/16")
H : 163 mm (6-7/16")
D : 484 mm (19-1/16")
Weight (Net) 9.0 kg (19.8 lb)

CD-4260M
Power consumption 10 W
Dimensions
W : 440 mm (17-5/16")
H : 163 mm (6-7/16")
D : 484 mm (19-1/16")
Weight (Net) 7.2 kg (15.9 lb)

CD-425M/DPF-J6030
Power consumption 10 W
Dimensions
W : 440 mm (17-5/16")
H : 163 mm (6-7/16")
D : 479 mm (18-7/8")
Weight (Net) 7 kg (15.4 lb)

1. KENWOOD follows a policy of continuous advancements in development. For this reason specifications may be changed without notice.
2. The full performance may not be exhibited in an extremely cold location (under a water-freezing temperature).

Note:

Component and circuit are subject to modification to insure best operation under differing local conditions. This manual is based on Europe (E) standard, and provides information on regional circuit modification through use of alternate schematic diagrams, and information on regional component variations through use of parts list.

KENWOOD CORPORATION

14-6, Dogenzaka 1-chome, Shibuya-ku, Tokyo, 150-8501 Japan

KENWOOD SERVICE CORPORATION

P.O. BOX 22745, 2201 East Dominguez St., Long Beach, CA 90801-5745, U.S.A.

KENWOOD ELECTRONICS CANADA INC.

6070 Kestrel Road, Mississauga, Ontario, Canada L5T 1S8

KENWOOD ELECTRONICS LATIN AMERICA S.A.

P.O. BOX 55-2791, Piso 6 plaza Chase, Cl. 47 y Aquilino de la Guardia Panama, Republic de Panama

KENWOOD ELECTRONICS BRASIL LTDA.

Av. Moema, 170-17", Andar-Cobertura "B", Ed. Maximum Service Center, 04077-020 Moema, São Paulo-SP-Brasil

KENWOOD ELECTRONICS U.K. LIMITED

KENWOOD House, Dwight Road, Watford, Herts., WD1 8EB., United Kingdom

KENWOOD ELECTRONICS BELGUM N.V.

Meachelsesteenweg 418, B-1930 Zaventem, Belgium

KENWOOD ELECTRONICS DEUTSCHLAND GMBH

Rembrücker Str. 15, 63150 Heusenstamm, Germany

KENWOOD ELECTRONICS FRANCE S.A.

13 Boulevard Ney, 75018 Paris, France

KENWOOD ELECTRONICS ITALIA S.p.A.

Via G. Sirtori, 7/9 20129, Milano, Italy

KENWOOD IBÉRICA S.A.

Bolivia, 239-08020 Barcelona, Spain

KENWOOD ELECTRONICS AUSTRALIA PTY. LTD.

(A.C.N. 001 499 074)
16 Giffnock Avenue, North Ryde, N.S.W. 2113, Australia

KENWOOD ELECTRONICS (HONG KONG) LTD.

Unit 3712-3724, Level 37, Tower 1, Metroplaza, 223 Hing Fong Road, Kwai Fong N.T., Hong Kong

KENWOOD ELECTRONICS GULF FZE

P.O. Box 61318, Jebel Ali, Dubai, U.A.E.

KENWOOD ELECTRONICS SINGAPORE PTE LTD.

No. 1 Genting Lane #02-02, KENWOOD Building, Singapore, 349544

KENWOOD ELECTRONICS (MALAYSIA) SDN BHD.

#4.01 Level 4, Wisma Academy Lot 4A, Jalan 19/1 46300 Petaling Jaya Selangor Darul Ehsan Malaysia

KENWOOD ELECTRONICS (THAILAND) CO., LTD.

2019 New Pechburi Road, Bangkapi, Huaykwang, Bangkok, 10320 Thailand