

STEREO INTEGRATED AMPLIFIER/TUNER C-V100/V150/V300/V350 SERVICE MANUAL

KENWOOD

© 1997-6/B51-5323--00 (K/K) 3676

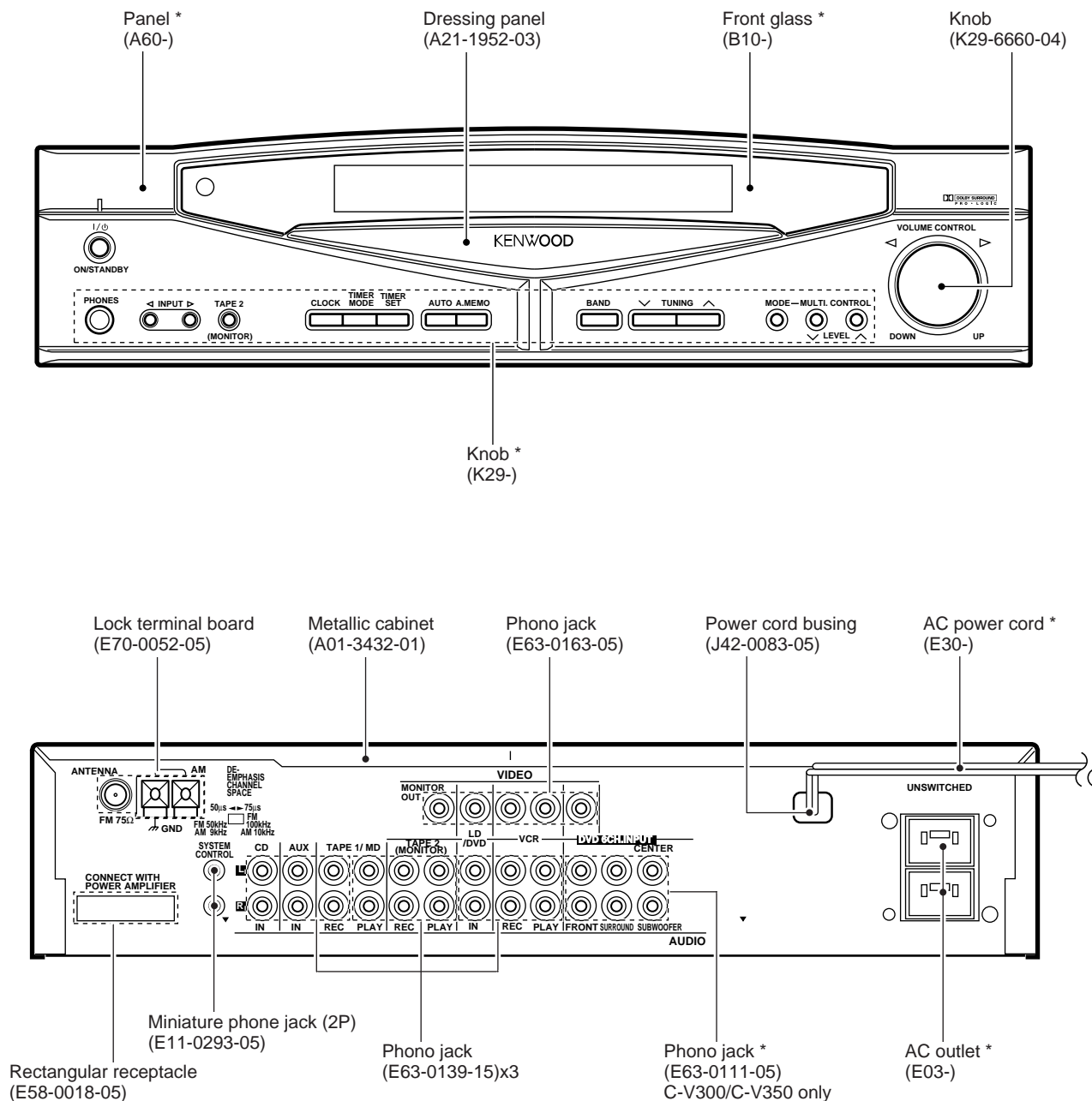

Illustration is C-V100.

* Refer to parts list on page 33.

Caution : No connection of ground line if disassemble the unit.
Please connect the ground line on rear panel, PCBs, Chassis and some others.

C-V100/V150/V300/V350

CONTENTS / ACCESSORIES

Contents

CONTENTS / ACCESSORIES	2	PC BOARD	15
CONTROLS	3	SCHEMATIC DIAGRAM	23
DISASSEMBLY FOR REPAIR	7	EXPLODED VIEW	41
BLOCK DIAGRAM	8	PARTS LIST	43
CIRCUIT DESCRIPTION	9	SPECIFICATIONS	54
ADJUSTMENT	14		

How to reset the microcomputer

The microcomputer may malfunction (impossibility operation, erroneous display, etc.) when the power cord is unplugged and plugged in again while the unit is in ON mode with the Key pressed or due to other external causes. In this case, execute the procedure on the right to reset the microcomputer and return the unit to the normal condition.

- ① Unplug the power cord from the wall outlet.
- ② While pressing and holding the POWER or (ON/STANDBY) key, plug the AC cord into the wall outlet again

• Resetting the microcomputer clears the memory you entered and returns in to the initial condition when the unit left the factory.

Accessories (C-V100/300)

FM indoor antenna(1)
(T90-0809-05): MICX type
(T90-0810-05): KPY type

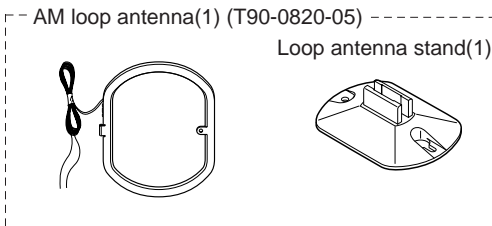
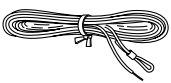

Remote control unit(1) *
(C-V100)
(Except U.S.A. and Canada)

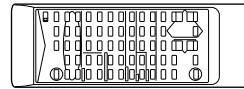

Cable tidy(2)
(F07-0102-04)



Graphical Remote Control unit(1) *
(C-V300)
(C-V100, only U.S.A. and Canada) *

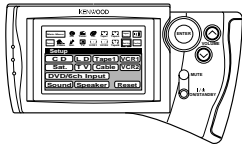

Batteries(R03/AAA) (4)
(C-V300)
(C-V100, only U.S.A. and Canada) *

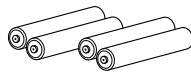

*AC plug adapter (1)
(E03-0115-05)

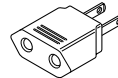

* Use to adapt the plug on the power cord to the shape of the wall outlet. (Accessory only for regions where use is necessary)

Batteries(R6/AA) (2)
(C-V100)
(Except U.S.A. and Canada)

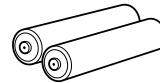

(C-V150/350)

FM indoor antenna(1)
(T90-0809-05): MICX type
(T90-0810-05): ET type

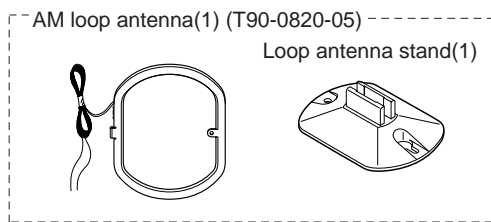

Graphical Remote Control unit(1) *
(C-V350)

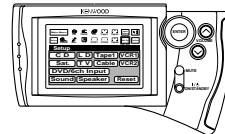

(Optional with the C-V150)

Cable tidy(2)
(F07-0102-04)



Remote control unit(1) *
(C-V150)

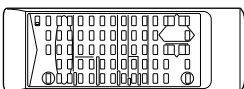

Batteries(R03/AAA) (4)
(C-V350)

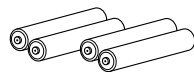

Microphone(1)
(W01-0935-05)

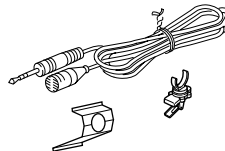

Batteries(R6/AA) (2)
(C-V150)

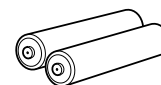

* Refer to parts list on page 33.

C-V100/V150/V300/V350

CONTROLS

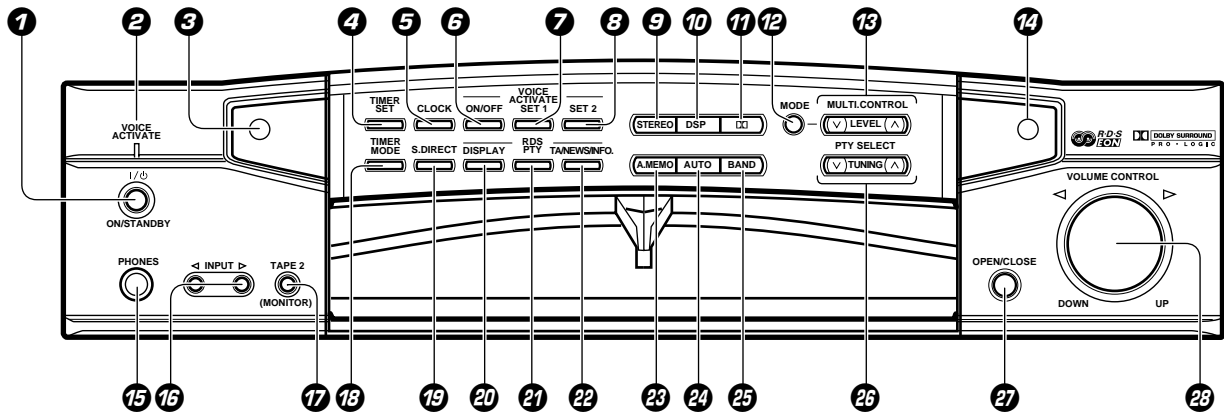
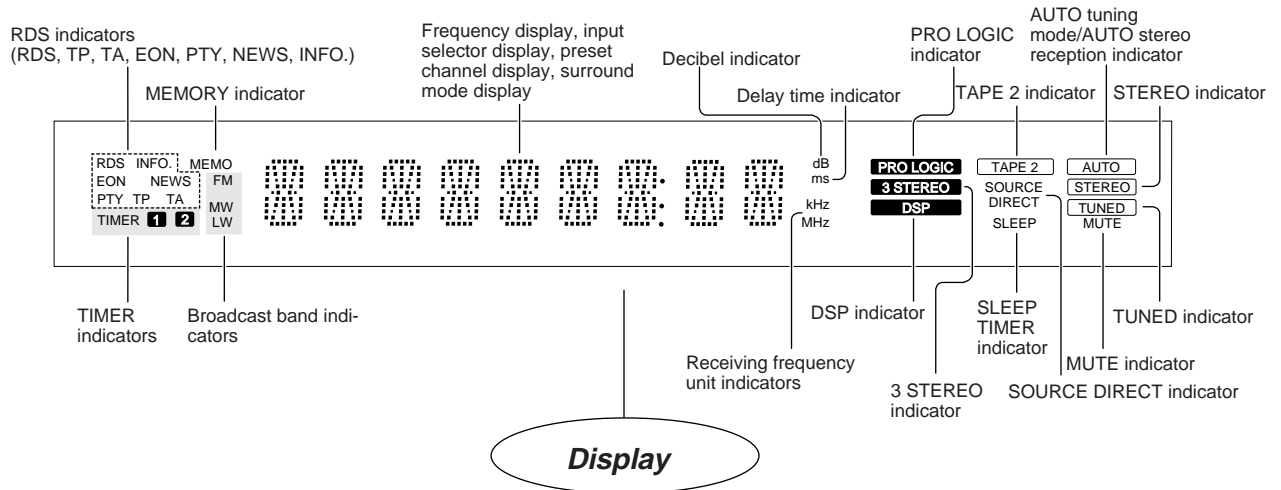

The keys which have the same names as the controls on the remote control unit provide the same functions as them.

- 1 I/⏻ (ON/STANDBY) key**
Press to switch between ON and STANDBY.
- 2 VOICE ACTIVATE indicator**
Lights to indicate an occurrence of voice activation.
- 3 Remote sensor**
- 4 TIMER SET key**
Press to set the timer function.
- 5 CLOCK key**
Press to set the clock.
- 6 VOICE ACTIVATE ON/OFF key**
Press to switch the voice-activation operation ON and OFF.
- 7 VOICE ACTIVATE SET 1 key**
Press to record words for use in voice activation.
- 8 VOICE ACTIVATE SET 2 key**
Press to record words for use in voice activation.
- 9 STEREO key**
- 10 DSP key**
- 11 DOLBY key**
- 12 MODE key**
Press to switch various setting modes.
- 13 MULTI.CONTROL key**
Press to select various setting modes.
- 14 GRC transmitter**
Outputs the signals transmitted to the Graphical Remote Control.
- 15 PHONES jack**
For use in headphones listening.
- 16 INPUT SELECTOR key**
Press to select the input.
- 17 TAPE 2 (MONITOR) key**
For use in monitoring of recording, etc.
- 18 TIMER MODE key**
Press to switch the timer modes.
- 19 S.DIRECT key**
Press to switch the Source Direct function which allows to reproduce the source with a better quality.
- 20 RDS DISPLAY key**
Press to switch the RDS display.
- 21 RDS PTY key**
For use during reception of RDS broadcasting.
- 22 RDS TA/NEWS/INFO. key**
For use during reception of RDS broadcasting.
- 23 A.MEMO key**
Press when using the auto memory function.
- 24 AUTO key**
Press to select the tuning mode. The auto tuning or manual tuning mode can be selected. The input selection display of a source can be switched to another by pressing and holding the **AUTO** key for more than 2 seconds.
- 25 BAND key**
Press to switch the broadcasting band.
- 26 TUNING keys (▲, ▼)**
Press to select the radio station to be received. These keys are also used in the clock adjustment and timer operations.
- 27 OPEN/CLOSE key**
- 28 VOLUME CONTROL knob**

STANDBY mode indication

While standby mode is indicated, a small amount of power is supplied to the system to back up the memory. In this mode, the system can be turned ON by remote control.

With this unit, standby mode is indicated by means of the display panel. The system is in standby mode while the clock display is shown.

C-V100/V150/V300/V350

CONTROLS

For C-V100

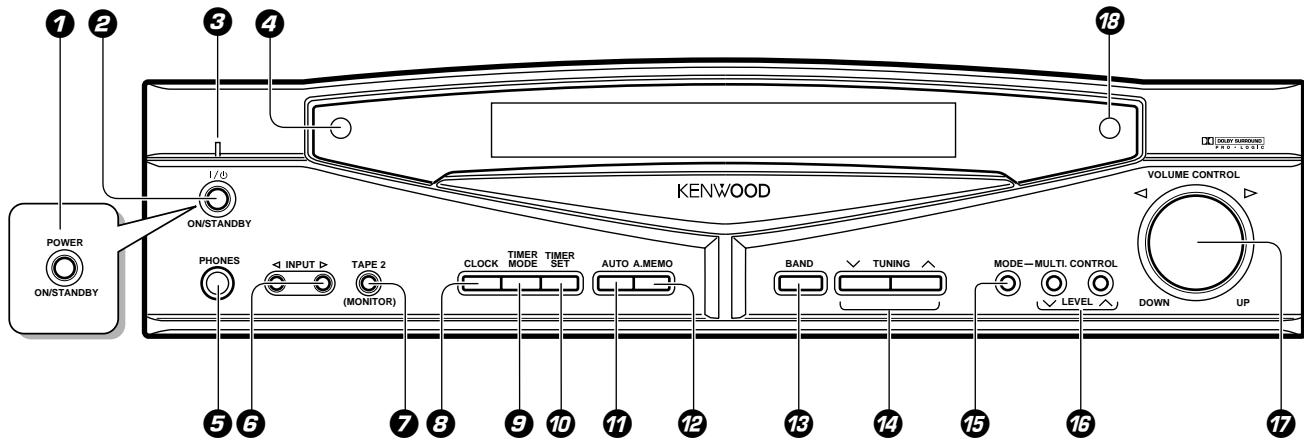
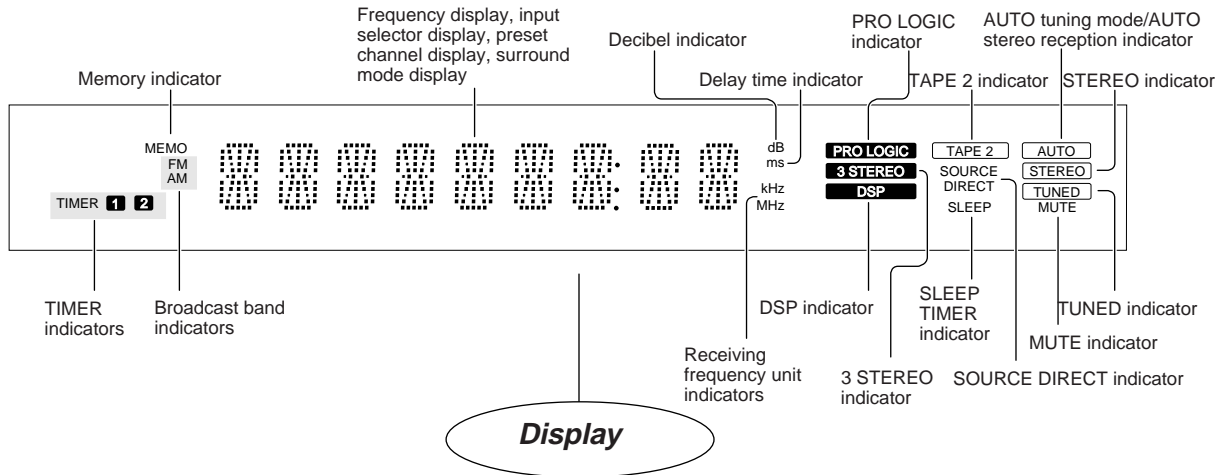

The keys which have the same names as the controls on the remote control unit provide the same functions as them.

- 1 POWER (ON/STANDBY) key (U.S.A. and Canada)**
Press to switch between ON and STANDBY.
- 2 I/ψ (ON/STANDBY) key**
Press to switch between ON and STANDBY.
- 3 STANDBY indicator**
- 4 Remote sensor**
- 5 PHONES jack**
For use in headphones listening.
- 6 INPUT SELECTOR key**
Press to select the input.
- 7 TAPE 2 (MONITOR) key**
For use in monitoring of recording, etc.
- 8 CLOCK key**
Press to set the clock.
- 9 TIMER MODE key**
Press to switch the timer modes.
- 10 TIMER SET key**
Press to set the timer function.
- 11 AUTO key**
Press to select the tuning mode. The auto tuning or manual tuning mode can be selected.
- 12 A.MEMO key**
Press when using the auto memory function.
- 13 BAND key**
Press to switch the broadcasting band.
- 14 TUNING keys (∧, ∨)**
Press to select the radio station to be received. These keys are also used in the clock adjustment and timer operations.
- 15 MODE key**
Press to switch various setting modes.
- 16 MULTI CONTROL key**
Press to select various setting modes.
- 17 VOLUME CONTROL knob**
- 18 GRC transmitter**
Outputs the signals transmitted to the Graphical Remote Control.

STANDBY mode indication

While standby mode is indicated, a small amount of power is supplied to the system to back up the memory. In this mode, the system can be turned ON by remote control.

CONTROLS

Controls and indicators

The Graphical Remote Control (GRC) unit provided with the AV CONTROL CENTER can also control KENWOOD cassette decks, CD player and LD player which are connected to it through system control cords. For details of the controllable functions, refer to the instruction manuals of these components.

Model: GRC-100/150
Infrared system

 Perform "Model Type Setup" of the GRC before using it.

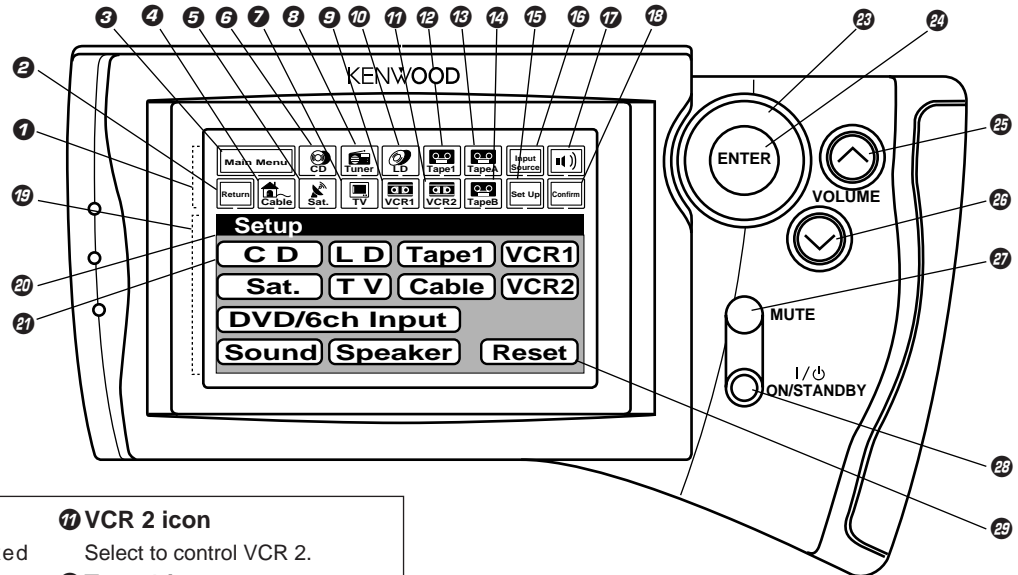

Segment screen

- | | |
|---|--|
| <p>1 Segment screen
This area displays the fixed icons.</p> <p>2 Return icon
Select to return to the previous display.</p> <p>3 Main Menu icon
Select to change the input source or select Main Menu 2.</p> <p>4 Cable TV icon
Select to control the cable TV.</p> <p>5 Satellite Tuner icon
Select to control the satellite tuner.</p> <p>6 CD icon
Select to control the CD player.</p> <p>7 TV icon
Select to control the TV.</p> <p>8 Tuner icon
Select to control the tuner.</p> <p>9 VCR 1 icon
Select to control VCR 1.</p> <p>10 LD icon
Select to control the LD player.</p> | <p>11 VCR 2 icon
Select to control VCR 2.</p> <p>12 Tape 1 icon
Select to control cassette deck 1.</p> <p>13 Tape A icon
Select to control cassette deck A.</p> <p>14 Tape B icon
Select to control cassette deck B.</p> <p>15 Set Up icon
Select to make setup operations.</p> <p>16 Input Source icon
Select to switch the input source.</p> <p>17 Sound icon
Select to control the sound-related functions.</p> <p>18 Confirm icon
Select to confirm a setting, etc.</p> <ul style="list-style-type: none"> • The input source can be selected using icon 3 or 16. • Icons 4 to 14 are used to select the component to be controlled. |
|---|--|

Menu screen

- 19 Menu screen**
This area displays the control key icons and level information.
- 20 Mode display**
The above illustration indicates the Setup mode.
- 21 CD icon**
Select to set up the CD player.
- 22 Reset icon**
Select to return to the "Model Type Setup" menu screen.

Operation keys

- 23 Joystick key**
For use in selecting icons. The joystick moves in 8 directions.
- 24 ENTER key**
Press to enter a selection.
- 25 VOLUME (UP) control key**
Press to increase the volume level.
- 26 VOLUME (DOWN) control key**
Press to decrease the volume level.
- 27 MUTE key**
Press to mute sound temporarily.
- 28 I / ⏻ (ON/STANDBY) key**
Press to switch the AV CONTROL CENTER and the components connected to it through system control cords between ON and STANDBY.

Approximate operating range

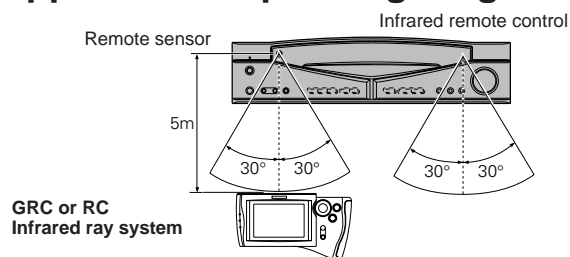

- The supplied batteries are intended for use in operation check. Therefore, their lives may be shorter than ordinary batteries.
- When the remote-controllable distance gets shorter than before, replace all four batteries with new ones.
- Malfunction may occur if direct sunlight or the light of a high-frequency fluorescent lamp enters the remote sensor. In such a case, change the system installation position to prevent the malfunction.
- The GRC display may show erroneous information when the GRC unit is operated from outside the specified range.

CONTROLS

Names and functions of the keys

The "RC" remote control unit provided with the AV CONTROL CENTER can also control KENWOOD cassette decks, CD player and LD player connected to the AV CONTROL CENTER through system control cords. For details of the controllable functions, refer to the instruction manuals of these components.

The RC keys with the same names as the corresponding keys on the main unit have the same function as the main unit keys.

1 I/ψ (POWER) key

Press to switch the AV CONTROL CENTER and the components connected to it through system control cords between ON and STANDBY.

2 A ↔ B switch

Some of the RC keys function in two ways. The key functions indicated inside () are usable when this switch is set to B.

Usually set this switch to A. In this manual, the description of a function which requires this switch to be set to B is accompanied with the illustration of .

3 Numeric keys

Use these keys as the numeric key of the currently selected input source component.

4 TUNER operation keys

- BAND key**
(RDS DISPLAY key)
- MEMO key**
(AUTO MEMORY key)
- P.CALL ▽:down key**
(PTY key)
- P.CALL ▲:up key**
(TA/NEWS/INFO. key)

5 LD player operation key

Read the instruction manual of the LD player.

: CX key

AUTO DIGITAL key

6 AV CONTROL CENTER operation keys

- PRO LOGIC key
- 3 STEREO key
- DSP key
- STEREO key
- SOURCE DIRECT key
- TEST TONE key
- MODE key

Use this key to select the setting modes.

MULTI CONTROL LEVEL

▲: up key, ▼: down key

Use these keys to adjust the tone or set the surround play.

TAPE 2 (MONITOR) key

INPUT key

Use this key as the input selector key.

MUTE key

Use this key to mute the sound temporarily.

VOLUME ▲: up key, ▼: down key

Use these keys to adjust the volume.

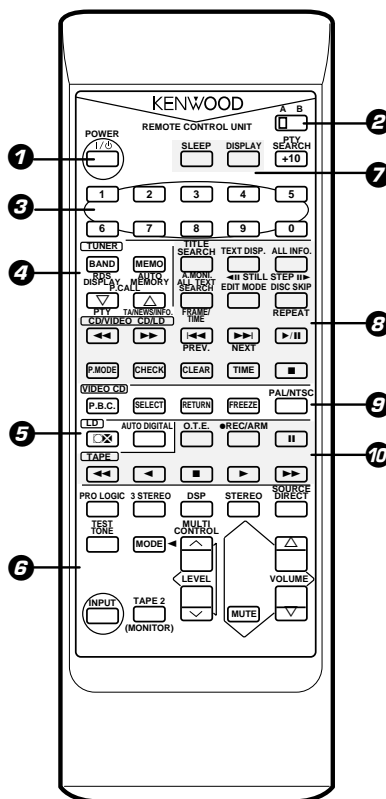

Model: RC-S503/RC-S505
Infrared system

10 Cassette deck operation keys

Read the instruction manual of the cassette deck.

● REC/ARM key

|| key

◀◀ key

◀ key

■ key

▶ key

▶▶ key

(O.T.E. key)

7 Key

SLEEP key

Press when setting the sleep timer.

DISPLAY key

Press to switch the displayed information.

8 CD/VIDEO CD/LD player operation keys

Read the instruction manuals of the CD player, VIDEO CD player and/or LD player.

TITLE SEARCH key

(A.MONI key)

TEXT DISP. key

(STILL STEP ◀◀ key)

ALL INFO. key

(STILL STEP ▶▶ key)

ALL TEXT SEARCH key

(FRAME/TIME key)

EDIT MODE key

DISC SKIP key

(REPEAT key)

◀◀ key

▶▶ key

◀◀ key (PREV.)

▶▶ key (NEXT)

▶/|| key

P.MODE key

CHECK key

CLEAR key

TIME key

■ key

9 VIDEO CD player-specific operation keys

Read the instruction manual of the VIDEO CD player.

P.B.C. key

SELECT key

RETURN key

FREEZE key

PAL / NTSC key

Loading batteries

1 Slide open the cover.

2 Insert batteries.

3 Close the cover.

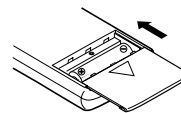
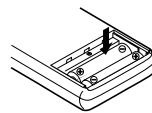
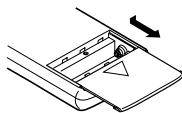

• Insert two AA-size (R6/SUM-3) batteries as indicated by the polarity marking.

C-V100/V150/V300/V350

DISASSEMBLY FOR REPAIR

1. Remove the 1 screw (①), Then pull the slider (②) till last
2. While raise the slider of left side, remove the slider from the bosses (③,④)

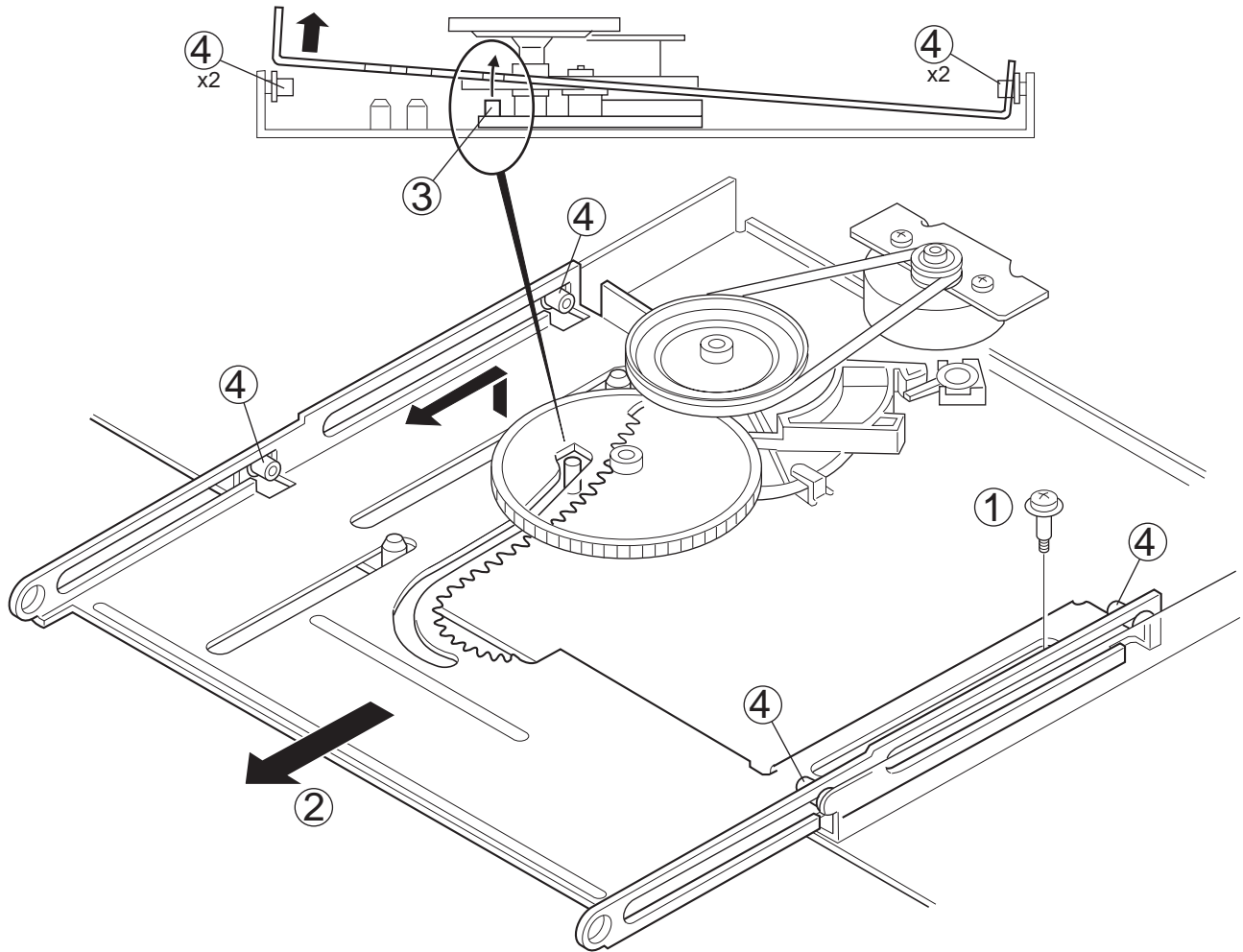

CIRCUIT DESCRIPTION

1. New Functions

1-1 Amp section

- (a) LCD Remote Control with System Control Code
Display on remote control shows the present condition of others units; CD player, cassette deck and so.
- (b) One Touch Operation
- In power off mode, system will turn on and start to play-back if play key on every unit; CD, DECK, DVD, and MD will be pressed .
 - In power off mode, system will turn on and start to open if open/close key on every unit; CD, DECK (single), DVD, and MD will be pressed
- (c) Voice Activation (C-V150/V350)
In voice activation mode, when system has "KENWOOD" word it will turn on and start to playback CD or LD player even if power switch is turn off.
Key word will be available of changing any other word.
- (d) Automatic Power-off
The system will be turned off if it is turned on by voice activation and selector keeps position at CD or LD position and system does to stop condition for 30 mints in CD or LD mode.

1-2 Tuner section

EON(Enhanced Other Network) (C-V150/V350)

- Automatic memory (broadcasting station name with sort mode), FM station will be morized after RDS station are done.
- In the case of broadcasting TA(Traffic information), NEWS(PTY), and INFO(PTY) in same network station, system will receive TA, NEWS, INFO or normal board-castings automatically.

2. Backup and Initial Data

Power	:off
Main volume	:-65dB
Audio selector	:tuner
Video selector	:vcr
Tape 1/md	:tape 1
Ld/dvd(C-V300/V350)	:ld
Tape 2/monitor	:off
FI display mode	:selector
Source direct	:off
Surround mode	:stereo
Dolby mode	:pro logic
Dsp mode	:Arena
Speaker level	:0dB
Balance	:Center
Input level	:0dB
Delay time	:20ms
Effect level	:3
Tone bass	:0dB
Tone treble	:0db
Tuning mode	:Auto
Preset memory	:Test frequency
Last band	:FM
Fm last frequency	:87.5MHz
Am (mw) last frequency	:531kHz
	(channel space 9kHz)
	:530kHz
	(channel space 10kHz)
Lw last frequency	:153kHz
Last P.ch	:-ch
PTY select mode(C-V150/V350)	:off
RDS display mode	:frequency
TA/NEWS/INFO	:off
Clock	:A.M.12:00
Timer	:off
Sleep timer	:off
Voice activation key word	:KENWOOD
Voice activation	:on

*Initial setting : While pressing the CD key, plug the power cord into the ac power outlet.

C-V100/V150/V300/V350

CIRCUIT DESCRIPTION

3. Main microprocessor uPD 780205GF031 (X11 : IC6) : C-V100/V300
 uPD 780206GF019 (X11 : IC6) : C-V150/V350

3-1 Microprocessor periphery block diagram

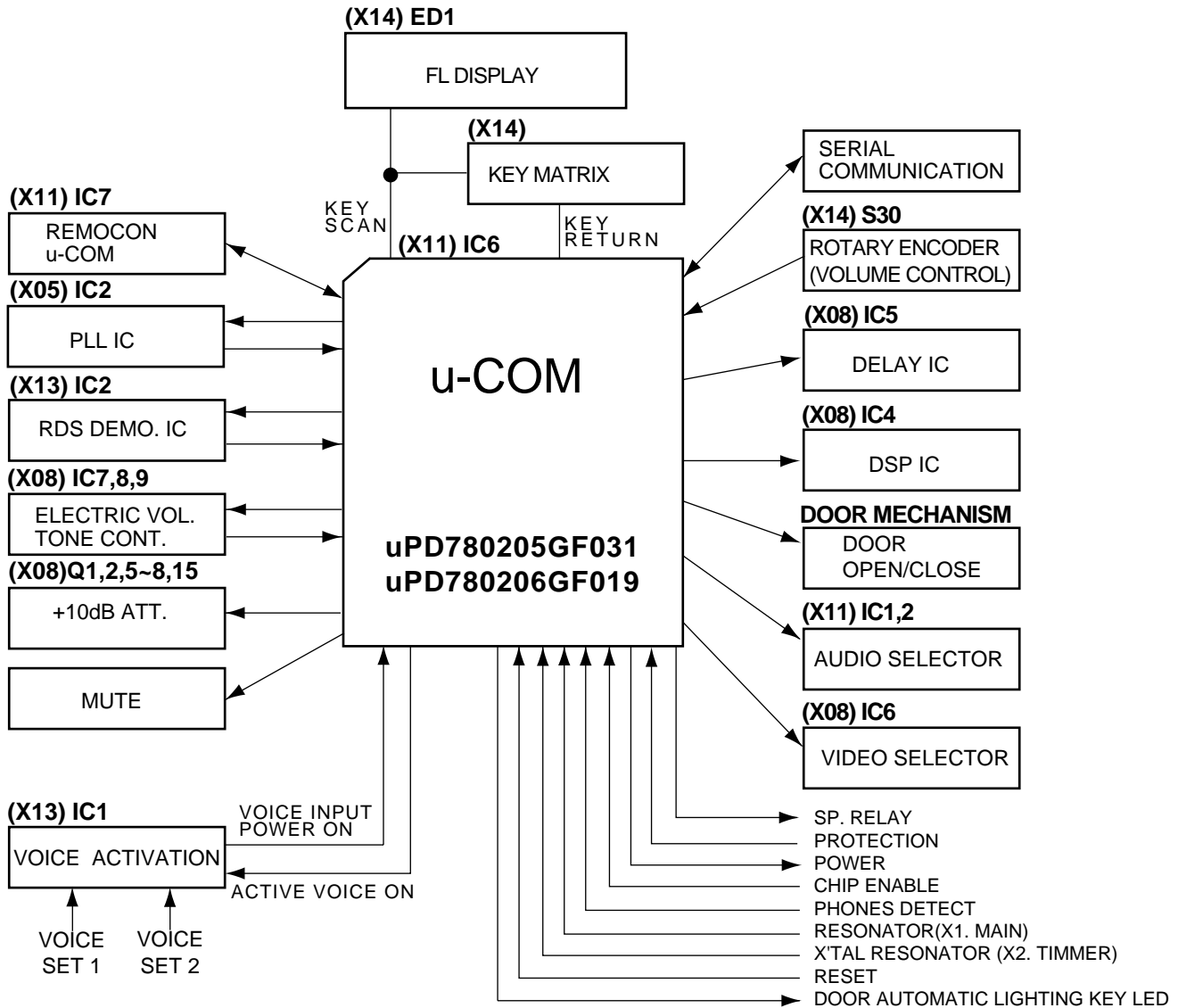

3-2 Key matrix

No. into ○: Pin No. of main u-COM

	② KR3	③ KR2	④ KR1	⑤ KR0
⑦③ KS0	(S.DIRECT)	(STEREO)	(DSP)	(DOLBY)
⑦④ KS1	VOICE ON / OFF	DISPLAY (RDS)	PTY	TA / NEWS / INFO.
⑦⑤ KS2	MODE	MULTI LEVEL ◁	MULTI LEVEL ▷	(OPEN / CLOSE)
⑦⑥ KS3	CLOCK SET	AUTO MEMORY	BAND	AUTO
⑦⑦ KS4	TUNING △	TIMER SET	INPUT ◁	INPUT ▷
⑦⑧ KS5	TUNING ▽	TIMER MODE	ON / STANDBY	TAPE 2 (MONITOR)
KS6				
⑧① KS7	DSW0 / D15	DSW1 / D14	DSW2 / D13	DSW3
⑧② KS8	DSW4 / D16			

- () : C-V300/V350 function
- DSW1 ~ DSW4 : Tuner distinction
- DSW5 : C-V100/V150 or C-V300/V350 Model distinction
- PTY, TA / NEWS / INFO, DISPLAY (RDS) : RDS function model (C-V150/V350)

CIRCUIT DESCRIPTION

3-3 Pin description

Pin No.	Port Name	I/O	Description
1	Vdd	I	Power supply (+5V)
2~5	KR3-0	I	key return 3 ~ 0
6,7	ENC_VOL1,2	I	Encoder pulse detect1, 2
8	/HP_DET	I	Headphone detect L : Yes
9	/CE	I	Chip enable L : Enable
10	/RESET	I	Microprocessor reset L : Reset
11,12	X1,2	I	Clock generator
13	IC(vpp)	-	Connect to Vss
14,15	XT1,2	-	Sub clock generator
16	Vdd	-	Power supply (+5V)
17	/HP_MUTE	O	Mute of headphones
18	PROTECTION	I	Protection detection
19	SBUSY	I/O	Serial data busy
20	SDATA	I/O	Serial data
21	DSP_CLK	O	Clock for DSP
22	DSP_DATA	O	Data for DSP
23	DSP_ST	O	Strobe for DSP
24	/MUTE	O	Mute control L : Mute on
25	Avss	-	GND of a/d converter
26	PLL_DO	O	PLL do
27	PLL_CE	O	Chip enable for pll
28	PLL_DATA	O	Data detection for pll
29	PLL_CLK	O	Clock for pll
30	/T_MUTE	O	Mute for tuner L : Mute on
31	/STEREO	I	Stereo signal detection L : Stereo
32	/SD	I	Synchro signal detection L : SD detection
33	RDS_SLEVEL	I	Signal level of rds
34	Avdd	-	Analog power supply for a/d converter
35	Avref	-	Reference voltage for a/d converter
36	RDS_CLK	I	Clock for rds
37	RDS_DATA	I	Data for rds
38	DOOR_LED	O	Door led automatic light key
39	REMOCON_IN	I	Input port of remote control signal
40	Vss	-	GND
41	+10dB_ATT	O	+10dB attenuator L : Att on
42	VOL_DATA	I/O	Electric volume control data
43	INPUT_LEVEL	O	0/-6dB switch of input level
44	DOOR_DET1	I	Door open detection switch
45	DOOR_DET2	I	Door close detection switch
46	Vdd	-	Power supply (+5V)
47	M_OPEN	O	Motor open function
48	M_CLOSE	O	Motor close function
49	CS_RELAY	O	Center and surround speaker relay control L : C, Sch off
50	F_RELAY	O	Front and sub-woofer speaker relay control L : L, R, Switch off
51	TC9215	O	2/6ch switch of input L : 2ch
52	REM_RWRREQ	O	Rewrite request signal of left-right remote control data L : Request
53	REM_PWR	I	Rewrite in signal of left-right remote control data L : rewrite-in

C-V100/V150/V300/V350

CIRCUIT DESCRIPTION

Pin No.	Port Name	I/O	Description
54	REM_REREN	I	Transmit signal of left-right remote control dat L : Transmission
55~62	INP0-7	O	Remote control data bits 0-7
63	VOICE_CTRL	O	Voice activation/standby led
64	SEL_STB1	O	Strobe signal for selector ic
65	SEL_DATA	O	Data signal for selector ic
66	SEL_CLK	O	Clock signal for selector ic
67	VOICE_CTRL	I	Input port of voice activation
68	VOL_CLK	O	Clock signal for electric volume
69~71	VSEL1-3	O	Video selector 1-3
72	POWER	O	Power relay control
73~78	SEG 11-16	O	Display segment control 11-16/key scan 0-5
79	Vload	-	Connect to pull down resistor
80	SEG10	O	Display segment control 10
81	SEG9	O	Display segment control 9/key scan 7(tuner selection)
82	SEG8	O	Display segment control 8/key scan8(model selection)
83~89	SEG1-7	O	Display segment control 1-7
90~100	GRID1-11	O	Display grid control 1-11

3-4 DESTINATION LIST OF TUNER

Destination	Band	Frequency Range	Channel space	IF	PLL Frequency	Diode SW (X11)			
						DSW3	DSW2 (D13)	DSW1 (D14)	DSW0 (D15)
K1 (1700)	FM	87.5MHz ~ 108.0MHz	100kHz	-10.7MHz	50kHz	0	0	0	0
	AM	530kHz ~ 1700kHz	10kHz	+450kHz	10kHz				
K2 (1610)	FM	87.5MHz ~ 108.0MHz	100kHz	+10.7MHz	25kHz	0	0	0	1
	AM	530kHz ~ 1610kHz	10kHz	+450kHz	10kHz				
E1	FM	87.5MHz ~ 108.0MHz	50kHz	+10.7MHz	25kHz	0	0	1	1
	AM	531kHz ~ 1602kHz	9kHz	+450kHz	9kHz				
E3 (RDS)	FM	87.5MHz ~ 108.0MHz	50kHz	+10.7MHz	25kHz	0	1	0	1
	AM	531kHz ~ 1602kHz	9kHz	+450kHz	9kHz				
E4 (LW) (RDS)	FM	87.5MHz ~ 108.0MHz	50kHz	+10.7MHz	25kHz	0	1	1	0
	MW	531kHz ~ 1602kHz	9kHz	+450kHz	9kHz				
	LW	153kHz ~ 279kHz	9kHz	+450kHz	9kHz				
M	K2/E1 change only setting "DSW1" (DSW1 = 0 : K2, 1 : E1)					0	0	(Q3, D11) X	1

☆ Diode SW (DSWx) :

0 = no diode (static mode, LOW)

1 = diode (static mode, HIGH)

X = Transistor SW (0 = OFF/1 = ON)

3-5 MODEL DISTINCTION

- C-V350, 300/C-V150, 100

MODEL	DIODE SW (X11) D16
C-V150, 100	0
C-V350, 300	1

C-V100/V150/V300/V350

CIRCUIT DESCRIPTION

[TEST MODE]

1. SETTING

SETTING	While depressing the <input type="checkbox"/> INPUT key, then plug the power cord into AC outlet. The display becomes the all lighting, then push a key. The display becomes normal.
CANCEL	POWER OFF (Remove the AC plug from the AC outlet)

2. DESCRIPTION

	OPERATION KEY	TUNER	EXCEPT TUNER	REMARKS																																												
1	<input type="checkbox"/> INPUT	00 87.50 ↔ CD ↔ LD ↔ 6ch INPUT(C-V300/V350 only) ↔ TAPE 1 ↔ AUX ↔ VCR																																														
2	TIMER SET	PRESET ch UP	PROLOGIC ↔ 3 STEREO																																													
3	TIMER MODE	PRESET ch DOWN	ARENA → JAZZ CLUB STADIUM ←																																													
4	CLOCK	FL lighting ON ↔ OFF	STEREO MUTE ON ↔ OFF																																													
5	DISPLAY	TIMER NO PS ↔ 01 87.50		C-V150/V350																																												
6	PTY	INPUT SELECTOR → OFF, S-LEVEL → ON, S-LEVEL		C-V150/V350																																												
7	TA/NEWS/INFO	TA → NEWS → INFO		C-V150/V350																																												
8	STEREO	STEREO MUTE ON ↔ OFF		EXCEPT C-V100																																												
9	<input type="checkbox"/>	PRO LOGIC ON ↔ OFF	PRO LOGIC ↔ 3 STEREO (TEST TONE ON / OFF by AUTO key)	EXCEPT C-V100																																												
10	A, MEMO	FREQUENCY UP																																														
11	AUTO	AUTO ON ↔ OFF	SOURCE DIRECT ON ↔ OFF	STEREO																																												
12	MODE	<table border="1"> <thead> <tr> <th>Key</th> <th>LEVEL</th> </tr> </thead> <tbody> <tr> <td>BASS</td> <td>DOWN ↔ UP</td> </tr> <tr> <td>TREBLE</td> <td></td> </tr> <tr> <td>LR BALANCE</td> <td></td> </tr> <tr> <td>SW ch</td> <td></td> </tr> <tr> <td>INPUT</td> <td>-6dB ↔ 0dB</td> </tr> </tbody> </table>	Key	LEVEL	BASS	DOWN ↔ UP	TREBLE		LR BALANCE		SW ch		INPUT	-6dB ↔ 0dB	<table border="1"> <thead> <tr> <th>key</th> <th>LEVEL</th> <th>TUNING</th> <th>BAND</th> </tr> </thead> <tbody> <tr> <td>VOLUME</td> <td></td> <td>-89dB ↔ 0dB</td> <td>-40dB</td> </tr> <tr> <td>SP. SW</td> <td></td> <td>MIN ↔ MAX</td> <td>0dB</td> </tr> <tr> <td>DELAY</td> <td></td> <td>15 ↔ 30</td> <td>20</td> </tr> <tr> <td>INPUT</td> <td>-6dB ↔ 0dB</td> <td>-6dB ↔ 0dB</td> <td>0</td> </tr> <tr> <td>EFFECT</td> <td></td> <td>1 ↔ 5</td> <td>3</td> </tr> <tr> <td>L. R BALANCE</td> <td>DOWN ↔ UP</td> <td>Lmax ↔ Rmax</td> <td>CENTER</td> </tr> <tr> <td>TONE</td> <td></td> <td>MIN ↔ MAX</td> <td>FLAT</td> </tr> </tbody> </table>	key	LEVEL	TUNING	BAND	VOLUME		-89dB ↔ 0dB	-40dB	SP. SW		MIN ↔ MAX	0dB	DELAY		15 ↔ 30	20	INPUT	-6dB ↔ 0dB	-6dB ↔ 0dB	0	EFFECT		1 ↔ 5	3	L. R BALANCE	DOWN ↔ UP	Lmax ↔ Rmax	CENTER	TONE		MIN ↔ MAX	FLAT	
Key	LEVEL																																															
BASS	DOWN ↔ UP																																															
TREBLE																																																
LR BALANCE																																																
SW ch																																																
INPUT	-6dB ↔ 0dB																																															
key	LEVEL	TUNING	BAND																																													
VOLUME		-89dB ↔ 0dB	-40dB																																													
SP. SW		MIN ↔ MAX	0dB																																													
DELAY		15 ↔ 30	20																																													
INPUT	-6dB ↔ 0dB	-6dB ↔ 0dB	0																																													
EFFECT		1 ↔ 5	3																																													
L. R BALANCE	DOWN ↔ UP	Lmax ↔ Rmax	CENTER																																													
TONE		MIN ↔ MAX	FLAT																																													

C-V100/V150/V300/V350

ADJUSTMENT

No.	ITEM	INPUT SETTING	OUTPUT SELECTOR	TUNER / AMP SETTING	ALIGNMENT POINTS	ALIGN FOR	FIG.
SELECTOR : FM							
1	DISCRIMINATOR L31↔L32 (E, T only)	(A) 98.0MHz 1kHz, ±40kHz dev (E, T type) 60dBu (ANT INPUT)	Connect a DC voltmeter between port of CN2	AUTO 98.0MHz	L31 (X05-)	0V	(a)
			(B)		L32 (X05-)	Minimum distortion	
2	DISTORTION (STEREO)	(C) 98.0MHz 1kHz, ±40kHz dev pilot: ±6kHz dev 60dBu (ANT INPUT)	(B)	AUTO (98.0MHz)	IFT (W02-)	Minimum distortion	(a)

(a)

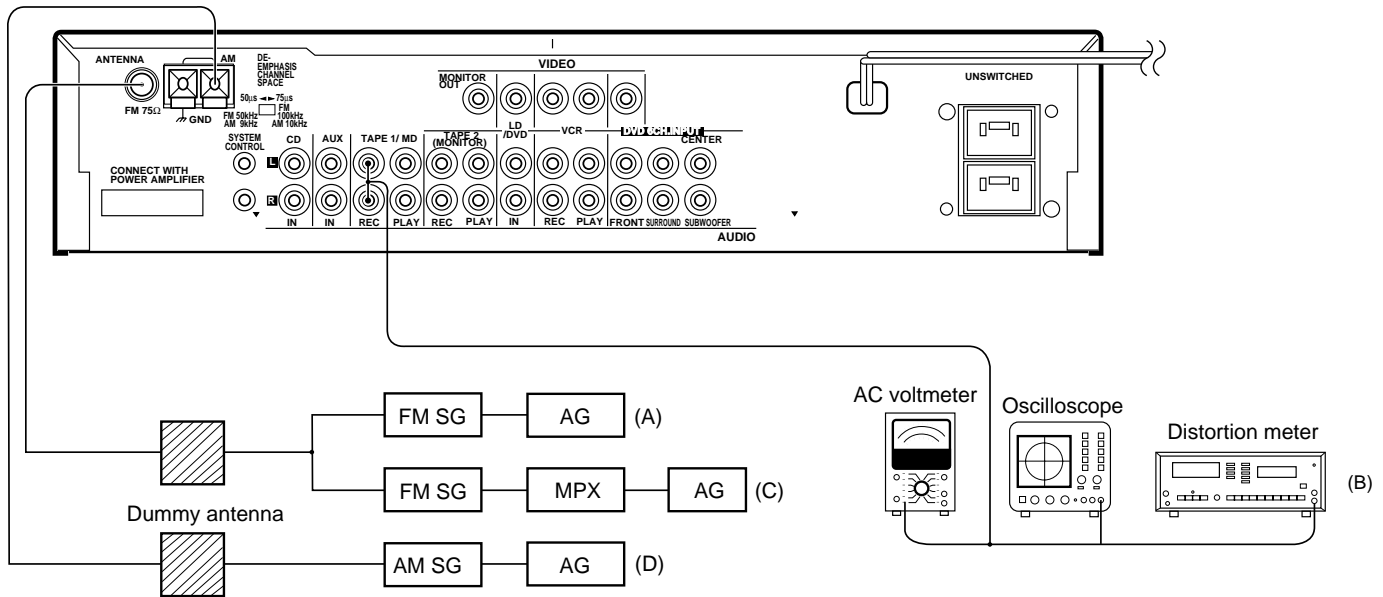

ERROR MESSAGE

DISPLAY	DESCRIPTION
ERR 1	Main u-com sub clock no output
ERR 2	Main u-com sub clock frequency NG

PC BOARD (Component side view)

(X05-4670-20) J70-0959-11

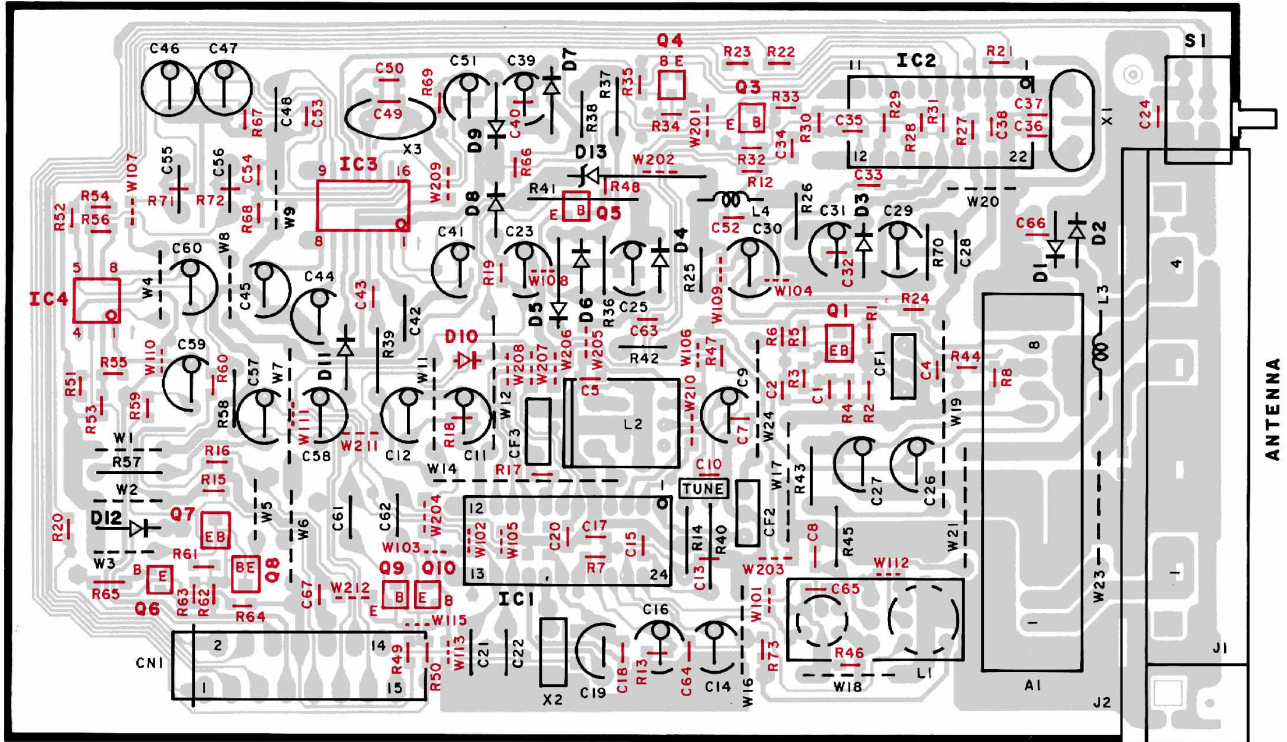

(X05-468X-XX) J70-0960-21

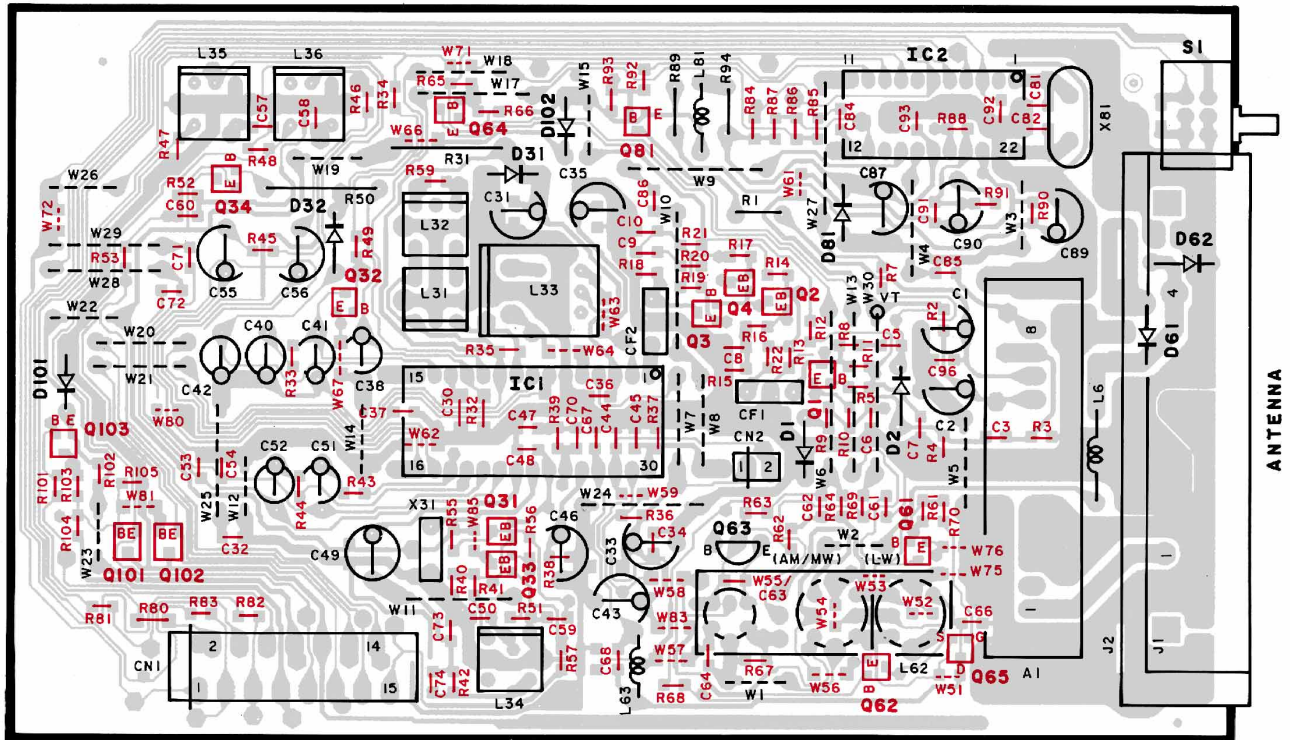

Refer to the schematic diagram for the value of resistors and capacitors.

PC BOARD (Component side view)

(X14-4360-10) (A/3)

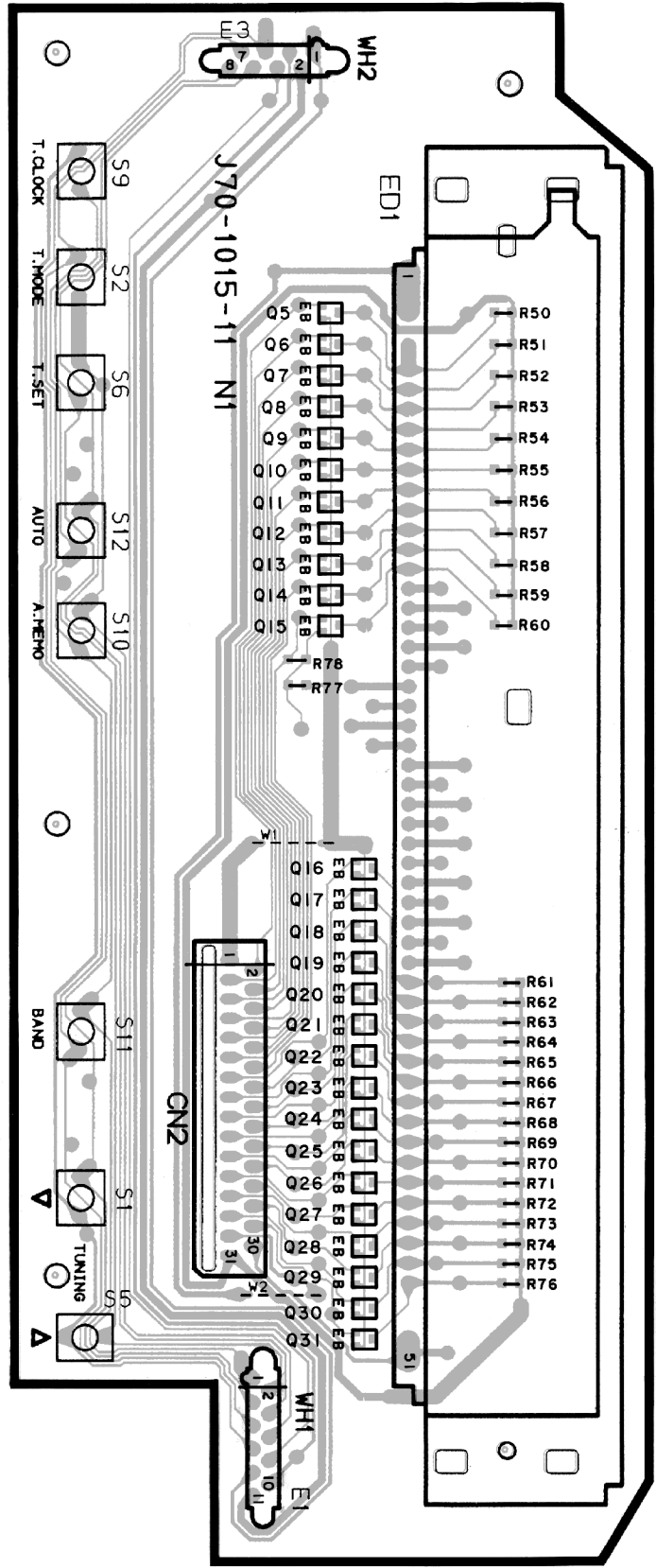
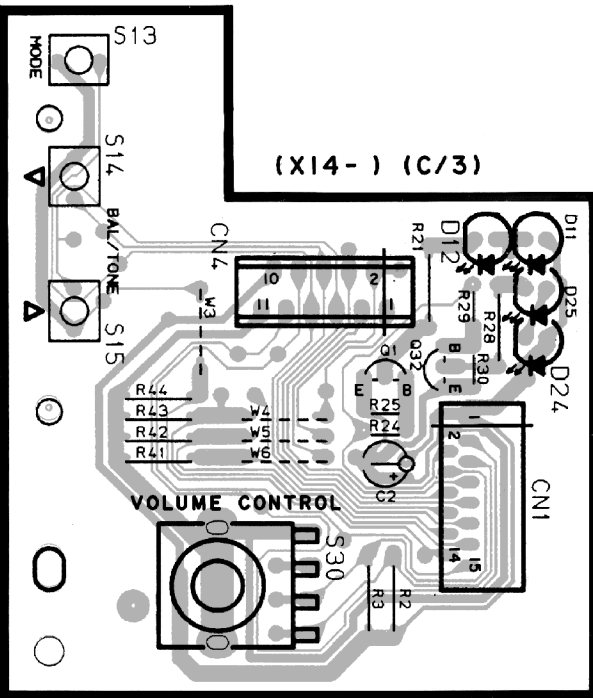
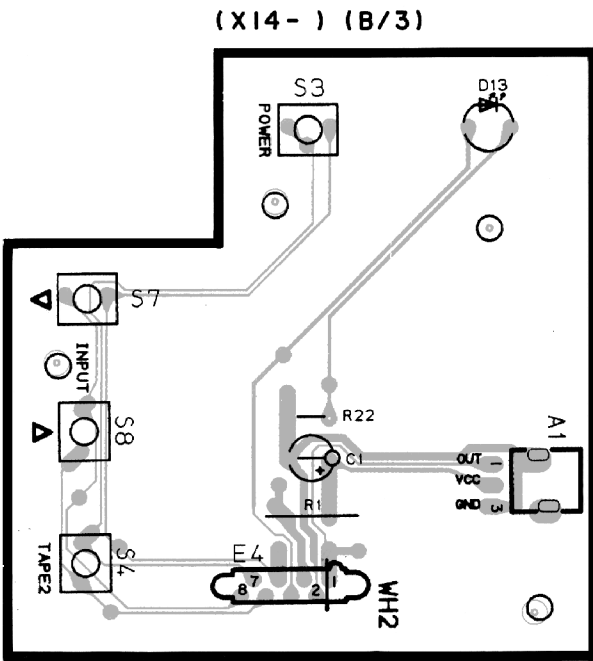

PC BOARD(Component side view)

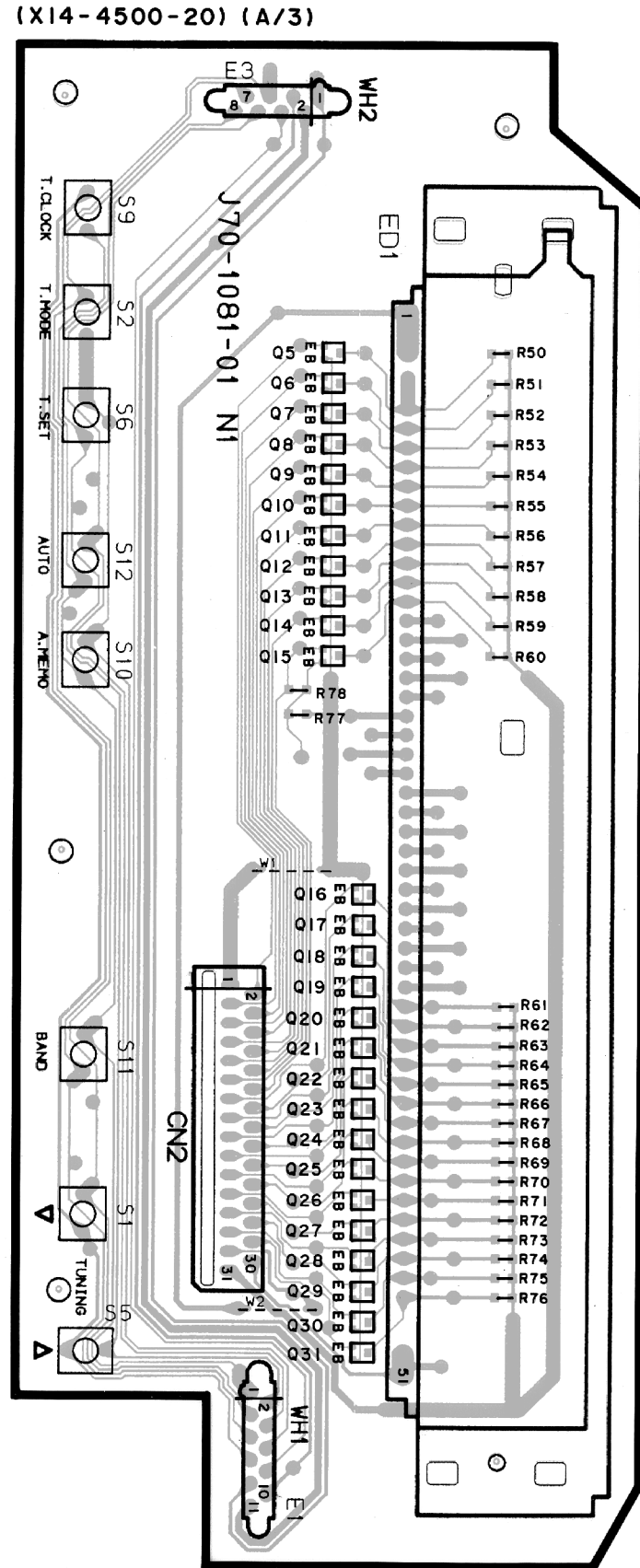
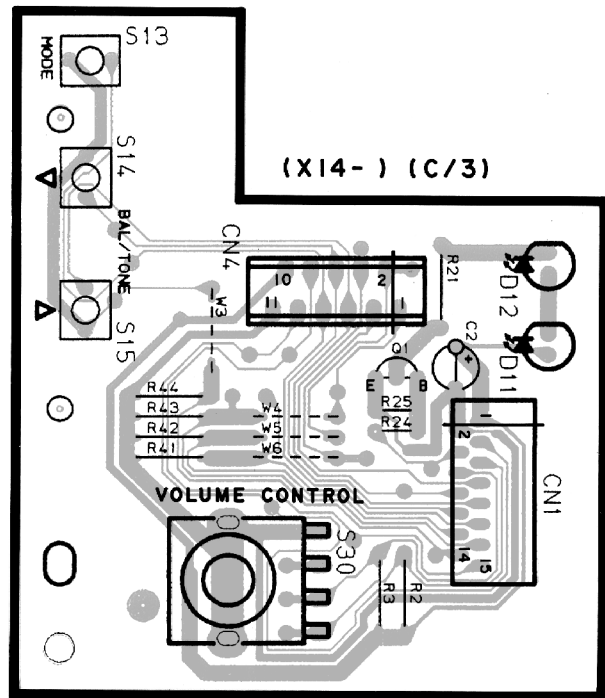
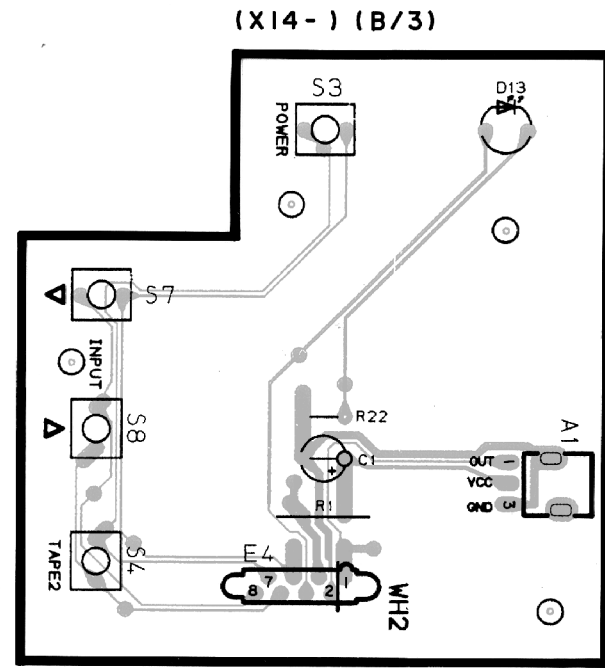

(X14-4372-70) (A/4)
(X14-4510-20) (A/4)

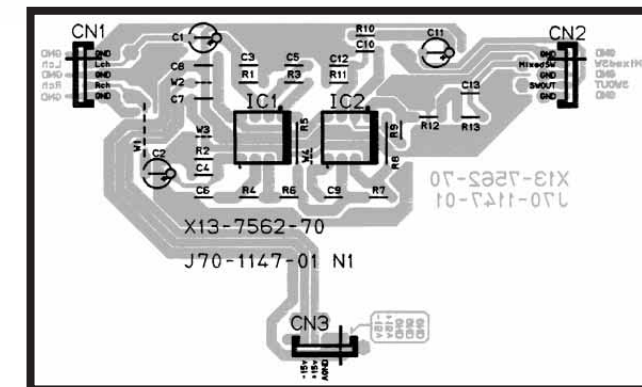
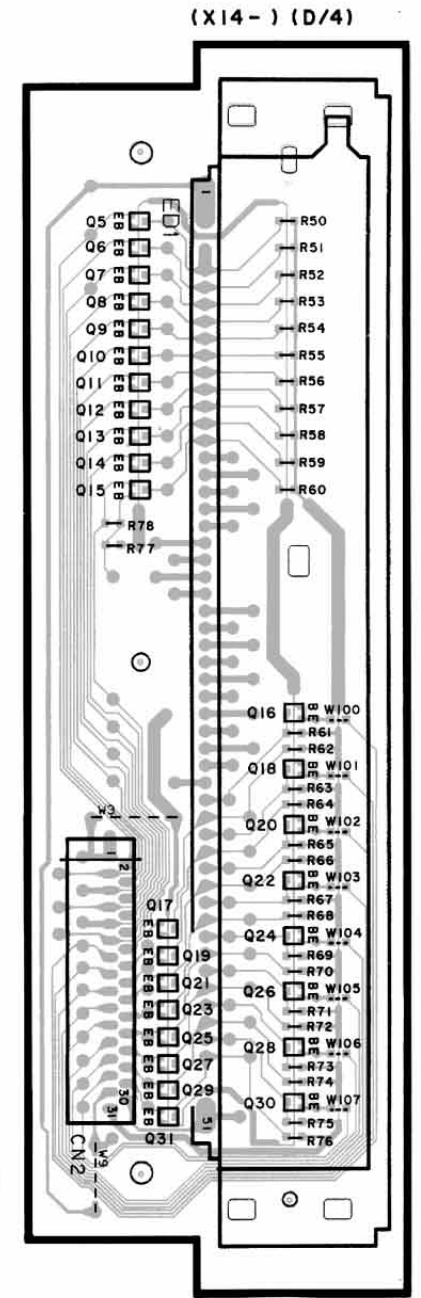
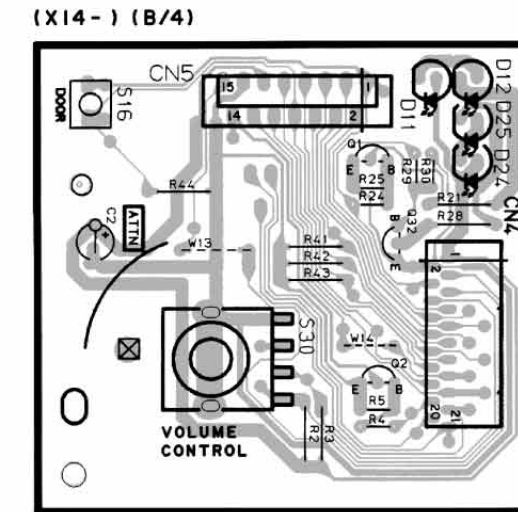
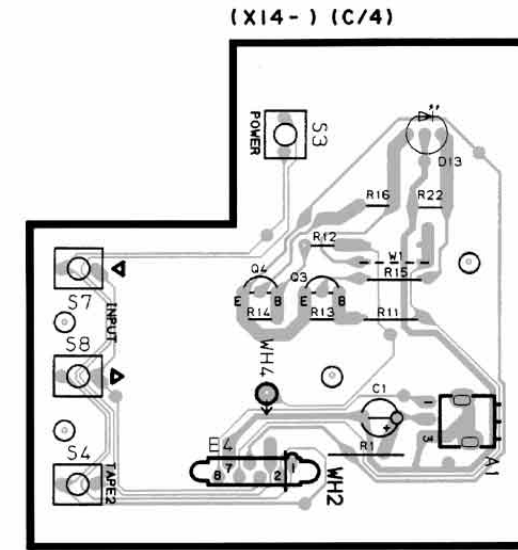
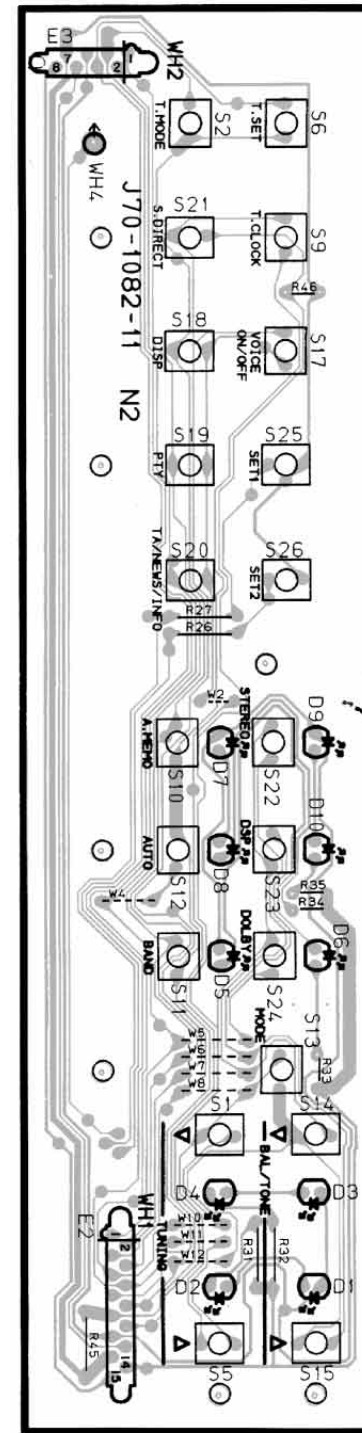

PC BOARD(Component side view)

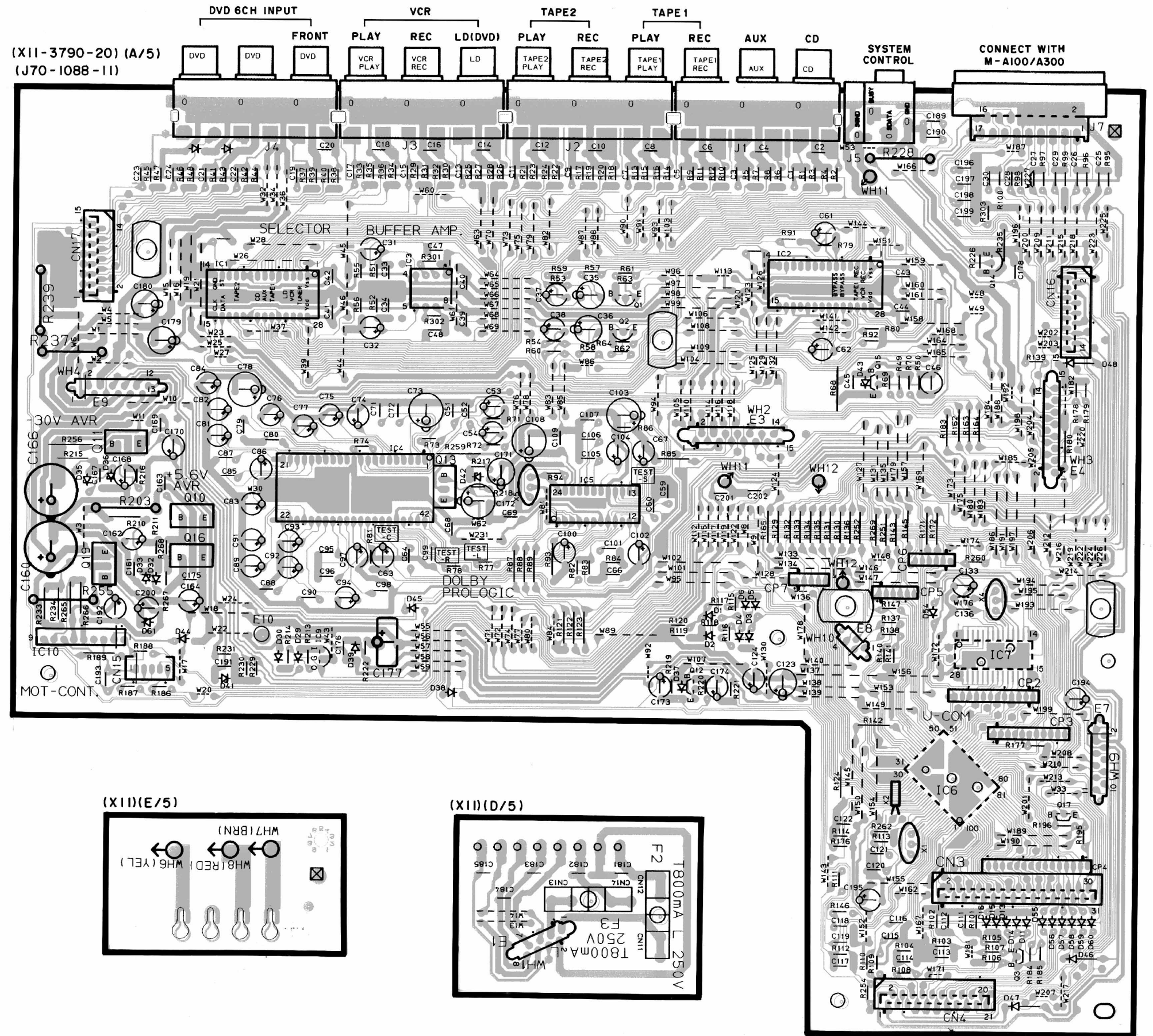
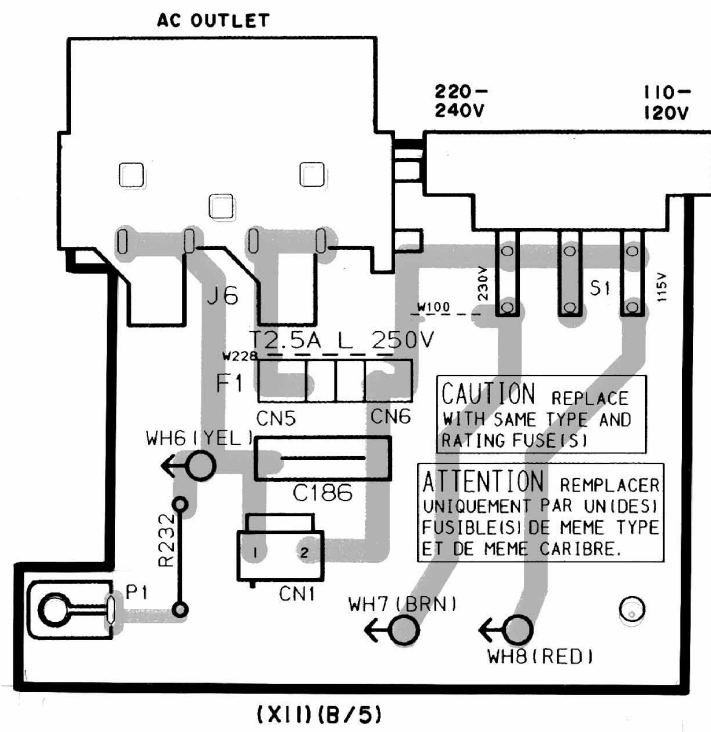

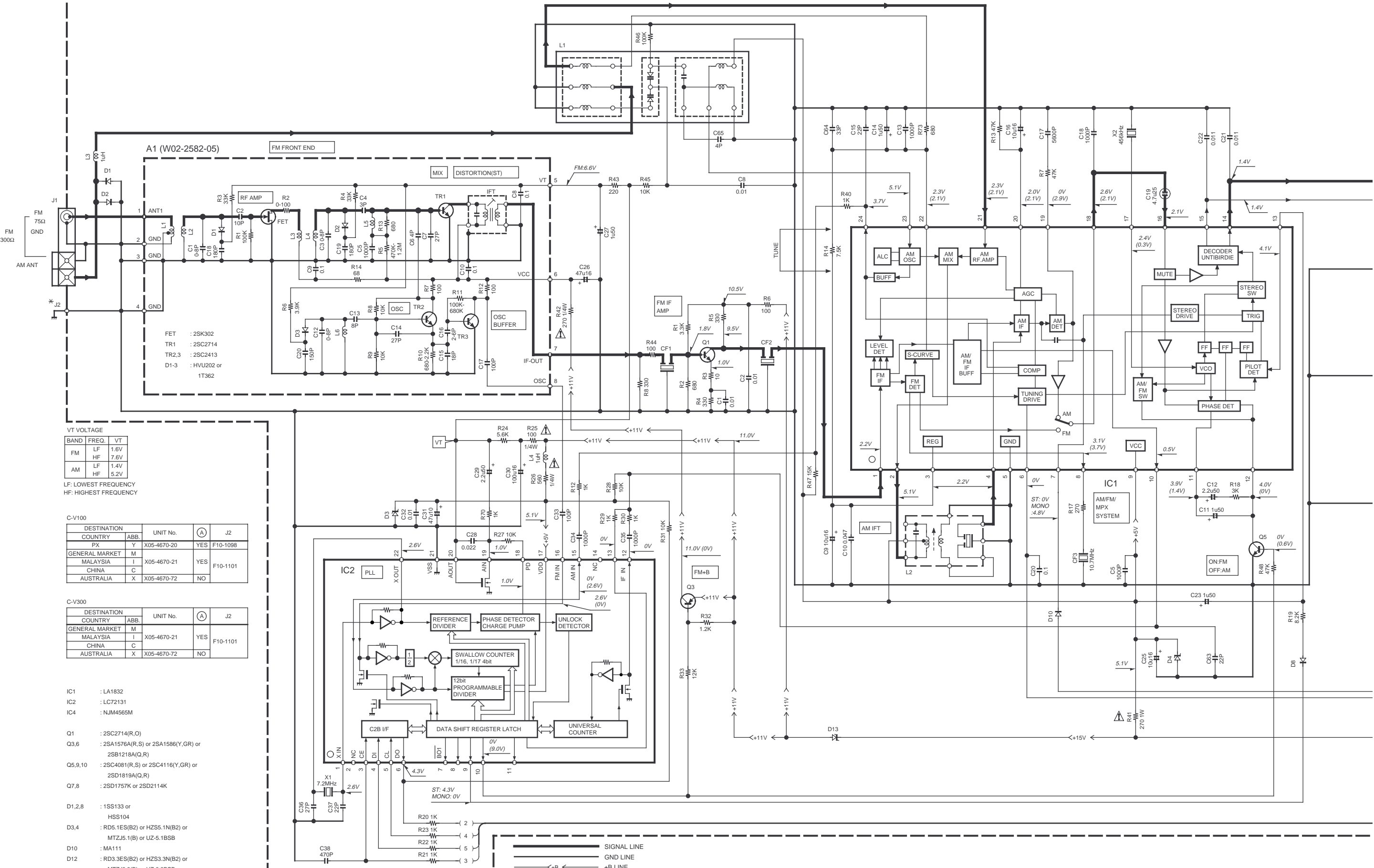

- FET : 2SK302
 TR1 : 2SC2714
 TR2,3 : 2SC2413
 D1-3 : HVU202 or 1T362

VT VOLTAGE

BAND	FREQ.	VT
FM	LF	1.6V
	HF	7.6V
AM	LF	1.4V
	HF	5.2V

LF: LOWEST FREQUENCY
 HF: HIGHEST FREQUENCY

C-V100

DESTINATION	COUNTRY	ABB.	UNIT No.	(A)	J2
GENERAL MARKET	PX	Y	X05-4670-20	YES	F10-1098
MALAYSIA	M	I	X05-4670-21	YES	F10-1101
CHINA	C	C	X05-4670-21	NO	
AUSTRALIA	X	X	X05-4670-72	NO	

C-V300

DESTINATION	COUNTRY	ABB.	UNIT No.	(A)	J2
GENERAL MARKET	M	I	X05-4670-21	YES	F10-1101
MALAYSIA	C	C	X05-4670-21	NO	
CHINA	X	X	X05-4670-72	NO	

- IC1 : LA1832
 IC2 : LC72131
 IC4 : NJM4565M
- Q1 : 2SC2714(R,O)
 Q3,6 : 2SA1576A(R,S) or 2SA1586(Y,GR) or 2SB1218A(Q,R)
 Q5,9,10 : 2SC4081(R,S) or 2SC4116(Y,GR) or 2SD1819A(Q,R)
 Q7,8 : 2SD1757K or 2SD2114K
- D1,2,8 : 1SS133 or HSS104
 D3,4 : RD5.1ES(B2) or HZS5.1N(B2) or MTZJ5.1(B) or UZ-5.1BSB
 D10 : MA111
 D12 : RD3.3ES(B2) or HZS3.3N(B2) or MTZJ3.3(B) or UZ-3.3BSB
 D13 : RD2.7ES(B2) or HZS2.7N(B2) or MTZJ2.7(B) or UZ-2.7BSB

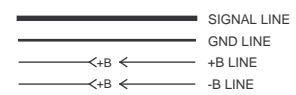

CAUTION: For continued safety, replace safety critical components only with manufacturer's recommended parts (refer to parts list). Δ indicates safety critical components. For continued protection against risk of fire, replace only with same type and rating fuse(s). To reduce the risk of electric shock, leakage-current or resistance measurements shall be carried out (exposed parts are acceptably insulated from the supply circuit) before the appliance is returned to the customer.

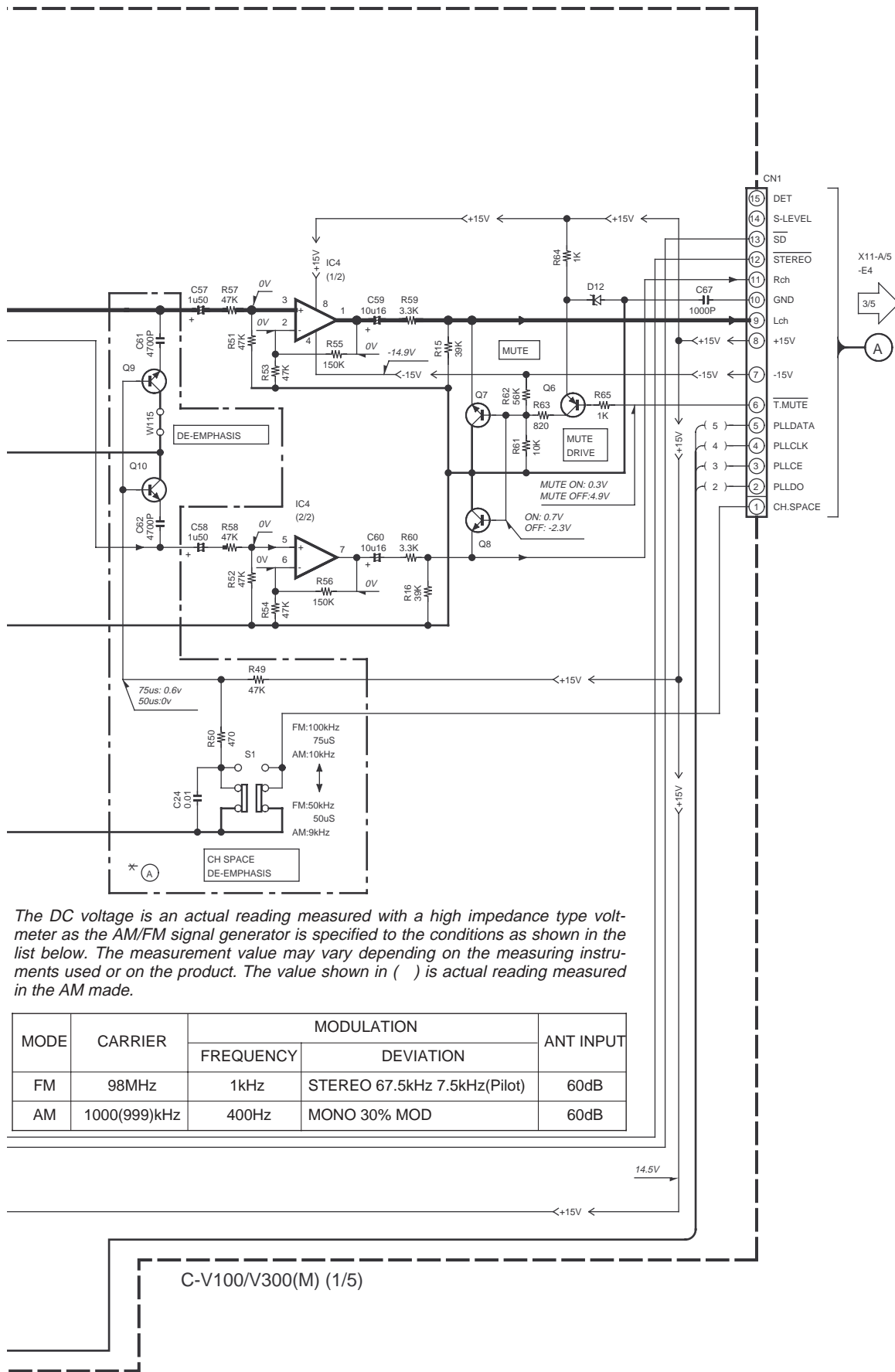

The DC voltage is an actual reading measured with a high impedance type voltmeter as the AM/FM signal generator is specified to the conditions as shown in the list below. The measurement value may vary depending on the measuring instruments used or on the product. The value shown in () is actual reading measured in the AM made.

MODE	CARRIER	MODULATION		ANT INPUT
		FREQUENCY	DEVIATION	
FM	98MHz	1kHz	STEREO 67.5kHz 7.5kHz(Pilot)	60dB
AM	1000(999)kHz	400Hz	MONO 30% MOD	60dB

C-V100/V300(M) (1/5)

C-V100/V150/V300/V350

Y05-3370-10

KENWOOD

C-V150/V350 (X05-468X-XX)

DESTINATION COUNTRY ABB.	UNIT No.	(A) - (C)	R3	R16, 20	R61-66, 68,70	C53, 54	C62, 63	C73	Q61-65	CF1,2	L62	W11	W6,13, 56,76	W51,52, 54,55
EUROPE	E	2-71	YES	1.8K	10	NO	NO	NO	NO	L72-0536 (MS3)	L39-1351	NO	NO	YES
U.K.	T	0-51	YES	1.8K	10	YES	YES	NO	NO	YES	L39-1352	NO	YES	NO

C-V100 (X05-4680-10)

DESTINATION COUNTRY ABB.	UNIT No.	(A) - (C)	R3	R16, 20	R61-66, 68,70	C53, 54	C62, 63	C73	Q61-65	CF1,2	L62	W11	W6,13, 56,76	W51,52, 54,55
U.S.A.	K	0-10	NO	560	15	NO	NO	YES	NO	L72-0596 (MS2)	L39-1351	YES	NO	YES
CANADA	P	0-10	NO	560	15	NO	NO	YES	NO	YES	L39-1351	YES	NO	YES

(X05-468X-XX) C-V100/V150/V350 (K,P,T,E) TYPE

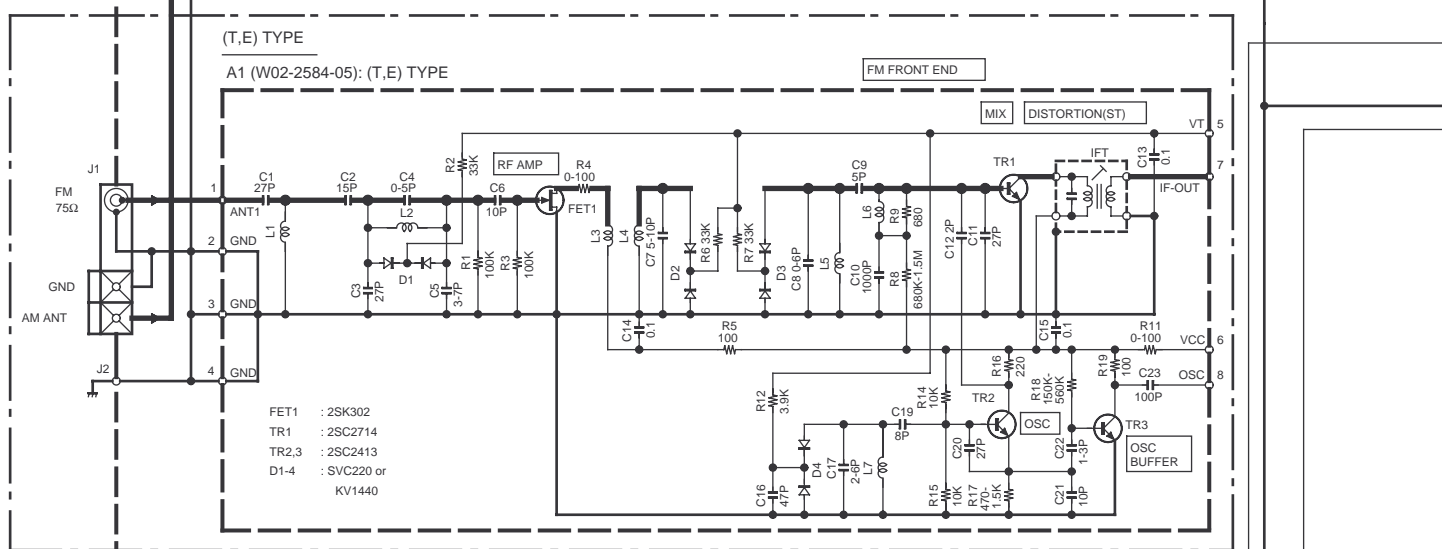
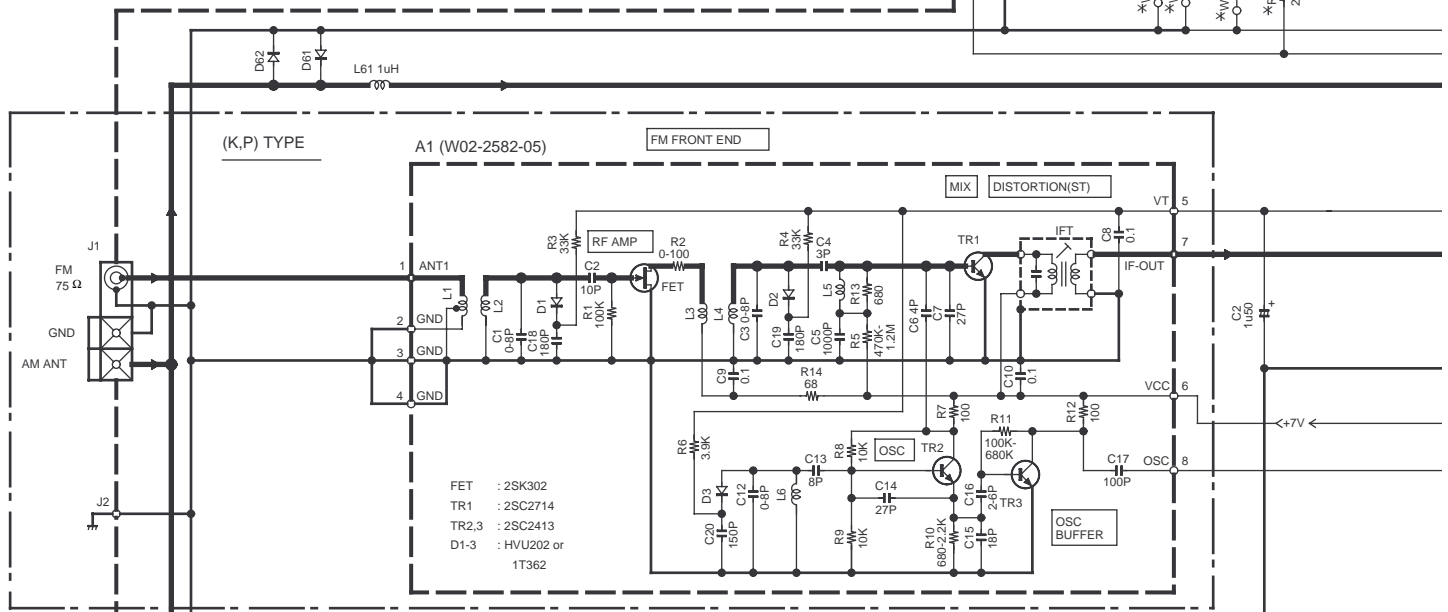
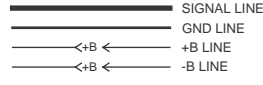
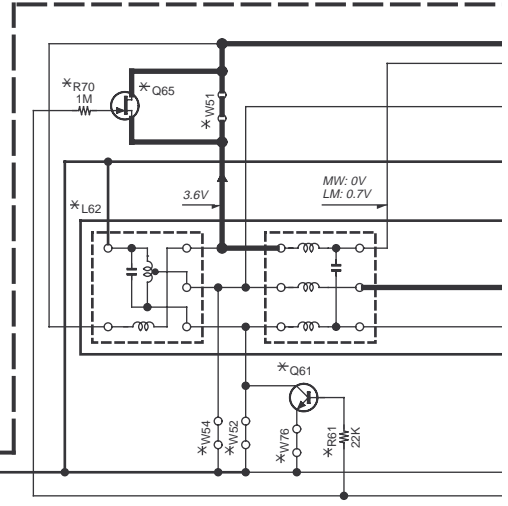

IC1	: LA1836	D1,2,32,61,62	: 1SS133 or HSS104
IC2	: LC72131	D31	: RD8.2ES(B2) or HZS8.2N(B2)
Q1,2,4,31-34,61,62	: 2SC4081(R,S) or 2SC4116(Y,GR)	D81	: RD5.1ES(B2) or HZS5.1(B2)
Q3,64,81,103	: 2SA1576A(R,S) or 2SA1586(Y,GR)	D101	: RD3.3ES(B2) or HZS3.3N(B2)
Q63	: 2SC2878(B)	D102	: RD2.7ES(B2) or HZS2.7N(B2)
Q65	: 2SK302(Y,GR)		
Q101,102	: 2SD1757K		

BAND	FREQ.	VT
FM	LF	1.6V
	HF	7.8V
AM	LF	1.3V
	HF	5.0V

LF: LOWEST FREQUENCY
HF: HIGHEST FREQUENCY

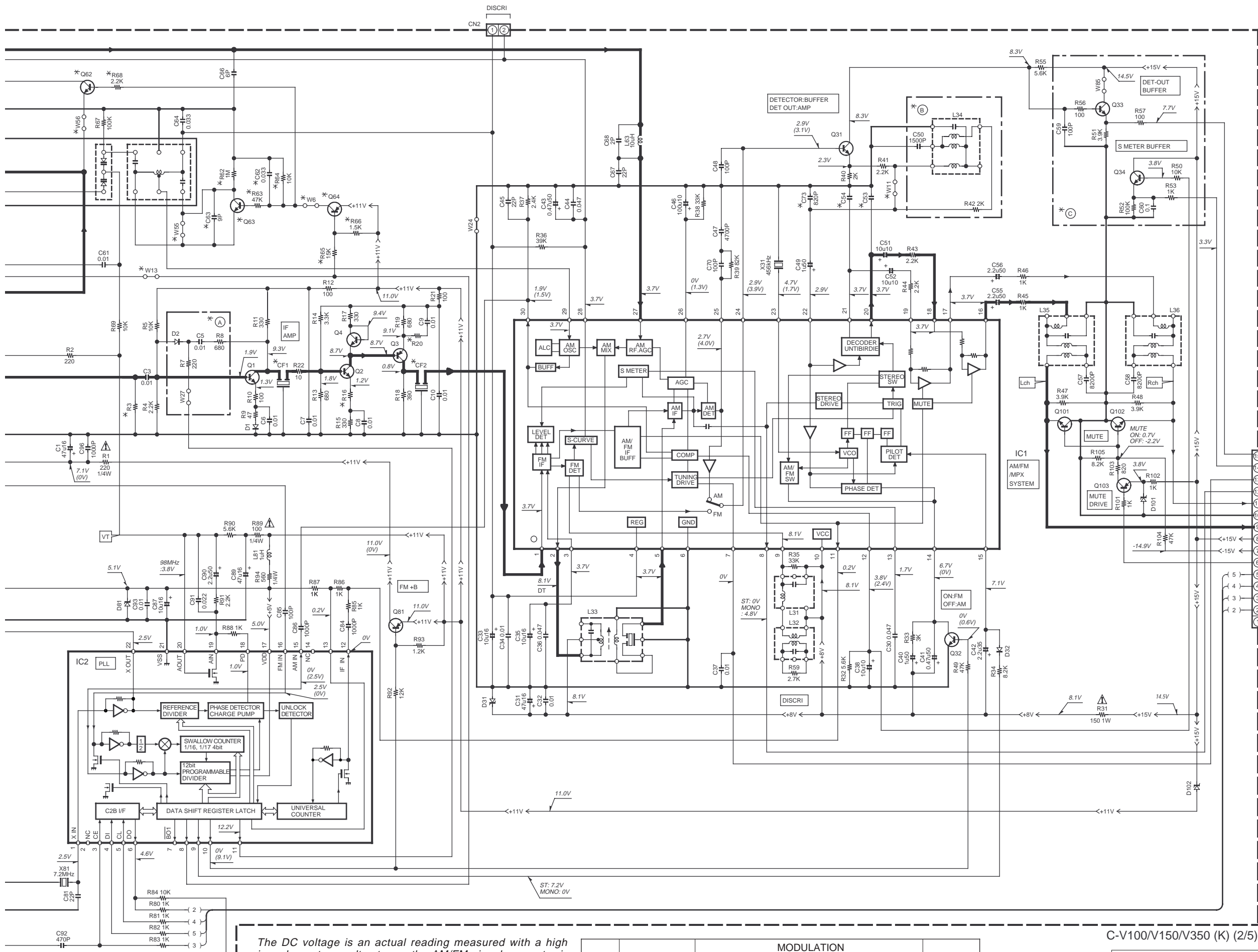

CAUTION: For continued safety, replace safety critical components only with manufacturer's recommended parts (refer to parts list). Δ indicates safety critical components. For continued protection against risk of fire, replace only with same type and rating fuse(s). To reduce the risk of electric shock, leakage-current or resistance measurements shall be carried out (exposed parts are acceptably insulated from the supply circuit) before the appliance is returned to the customer.

The DC voltage is an actual reading measured with a high impedance type voltmeter with no signal input. The measurement value may vary depending on the measuring instruments used or on the product.

- 2SC2003
- 2SC2878
- 2SC3246
- 2SD1894
- 2SA1175
- 2SC2785
- DTC124ESA
- 2SA1048
- 2SC1740
- S2SC2458
- UN5119
- 2SA15862
- SB1218A2
- SC2714
- 2SC4081
- 2SC4116
- 2SD1819A
- 2SD2114K
- 2SB1370
- 2SD2061
- UN4212
- 2SA1309A
- 2SC3311A

The DC voltage is an actual reading measured with a high impedance type voltmeter as the AM/FM signal generator is specified to the conditions as shown in the list below. The measurement value may vary depending on the measuring instruments used or on the product. The value shown in () is actual reading measured in the AM mode.

MODE	CARRIER	MODULATION		ANT INPUT
		FREQUENCY	DEVIATION	
FM	98MHz	1kHz	STEREO 67.5kHz 7.5kHz(Pilot)	60dB
AM	1000(999)kHz	400Hz	MONO 30% MOD	60dB

C-V100/V150/V350 (K) (2/5)

C-V100/V150/V300/V350

Y05-3370-10

KENWOOD

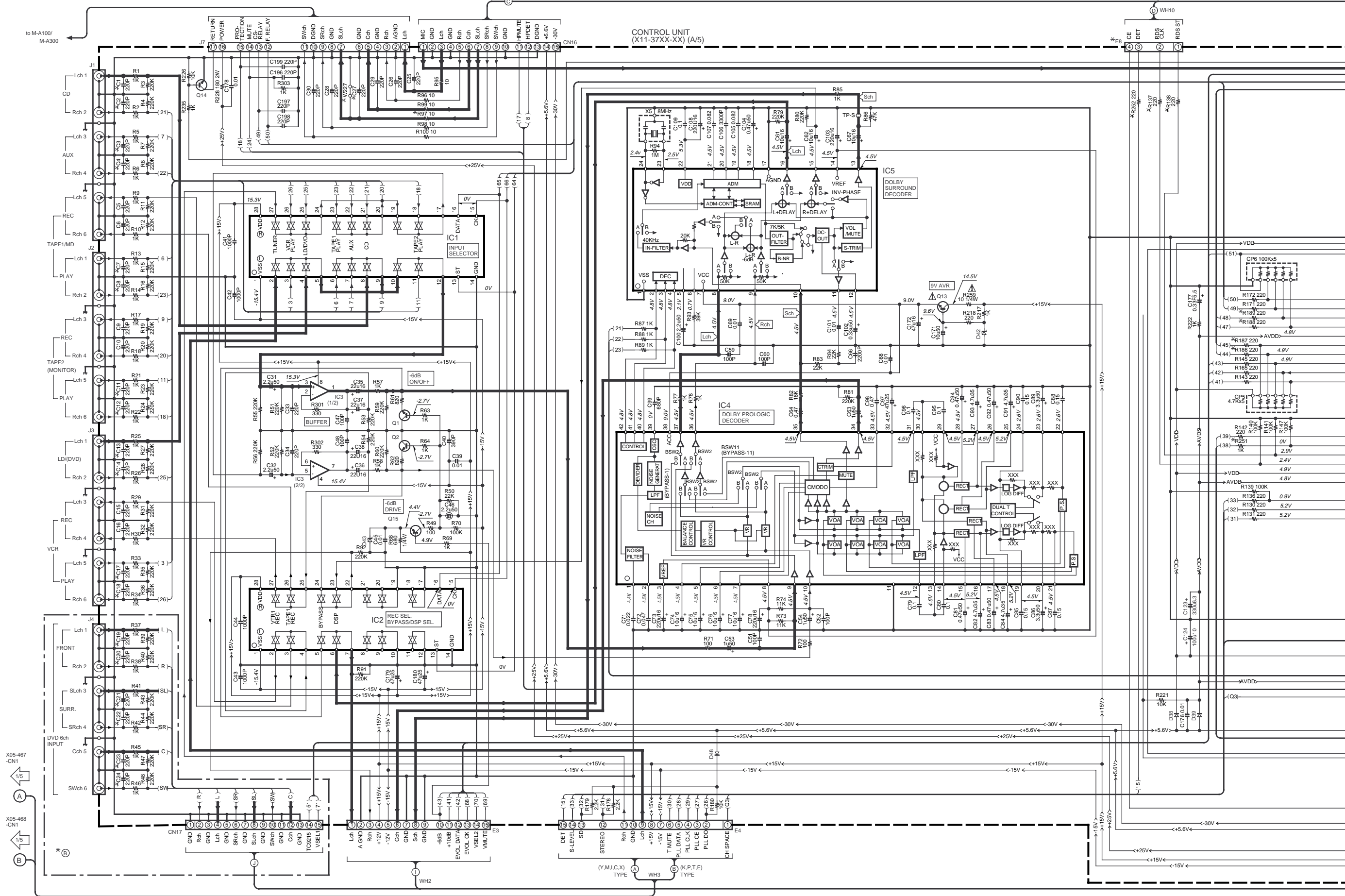

CAUTION: For continued safety, replace safety critical components only with manufacturer's recommended parts (refer to parts list). Δ indicates safety critical components. For continued protection against risk of fire, replace only with same type and rating fuse(s). To reduce the risk of electric shock, leakage-current or resistance measurements shall be carried out (exposed parts are acceptably insulated from the supply circuit) before the appliance is returned to the customer.

DOLBY and the double-D symbol are trademarks of Dolby Laboratories Licensing Corporation. Noise reduction circuit made under license from Dolby Laboratories Licensing Corporation.

The DC voltage is an actual reading measured with a high impedance type voltmeter with no signal input. The measurement value may vary depending on the measuring instruments used or on the product.

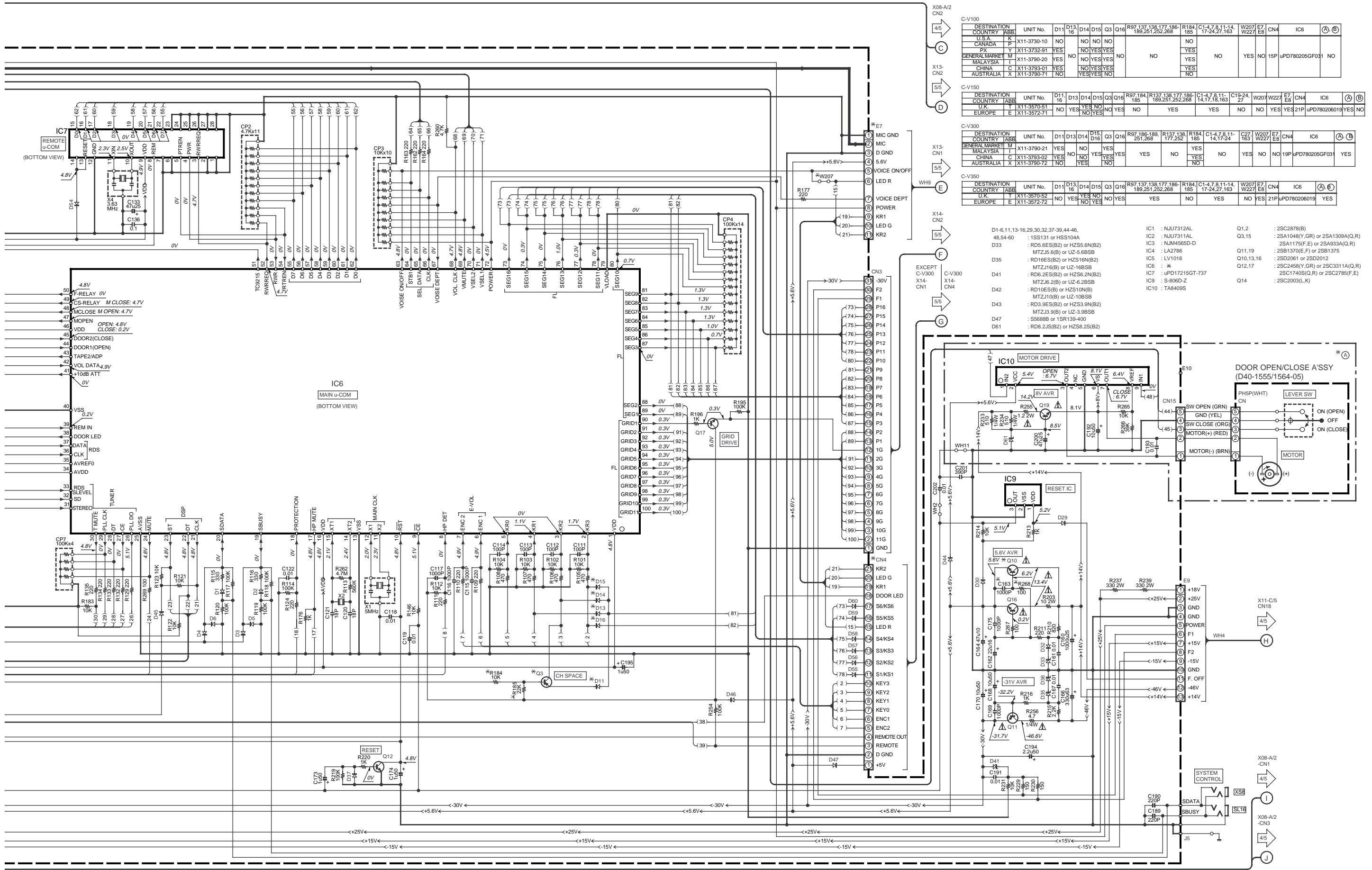

DESTINATION COUNTRY	UNIT No.	D11	D13	D14	D15	Q3	Q16	R97,137,138,177,186-185	R184,185	C1-4,7,8,11-14,17-24,27,163	W207, E7, W227, E8	CN4	IC6	(A)	(B)
USA	K X11-3730-10	NO	NO	NO	NO	NO	NO	NO	NO	NO	NO	NO	NO		
CANADA	P X11-3732-91	YES	NO	NO	YES	YES	NO	NO	NO	NO	NO	NO	NO		
GENERAL MARKET	M X11-3790-20	YES	NO	NO	YES	YES	NO	NO	NO	NO	NO	NO	NO		
CHINA	C X11-3793-01	YES	NO	NO	YES	YES	NO	NO	NO	NO	NO	NO	NO		
AUSTRALIA	X X11-3790-71	NO	NO	NO	YES	YES	NO	NO	NO	NO	NO	NO	NO		

DESTINATION COUNTRY	UNIT No.	D11	D13	D14	D15	Q3	Q16	R97,137,138,177,186-185	R184,185	C1-4,7,8,11-14,17,18,163	C19-24,27	W207, W227, E7, E8	CN4	IC6	(A)	(B)
UK	X11-3570-51	NO	YES	NO	NO	NO	NO	NO	NO	NO	NO	NO	NO	NO		
EUROPE	E X11-3572-71	NO	YES	NO	YES	NO	NO	NO	NO	NO	NO	NO	NO	NO		

DESTINATION COUNTRY	UNIT No.	D11	D13	D14	D15	Q3	Q16	R97,137,138,177,186-185	R184,185	C1-4,7,8,11-14,17-24,27,163	C27,183	W207, W227, E7, E8	CN4	IC6	(A)	(B)
GENERAL MARKET	M X11-3790-21	YES	NO	NO	YES	YES	NO	NO	NO	NO	NO	NO	NO	NO		
CHINA	C X11-3793-02	YES	NO	NO	YES	YES	NO	NO	NO	NO	NO	NO	NO	NO		
AUSTRALIA	X X11-3790-72	NO	NO	NO	YES	YES	NO	NO	NO	NO	NO	NO	NO	NO		

DESTINATION COUNTRY	UNIT No.	D11	D13	D14	D15	Q3	Q16	R97,137,138,177,186-185	R184,185	C1-4,7,8,11-14,17-24,27,163	W207, E7, W227, E8	CN4	IC6	(A)	(B)	
U.K.	X11-3570-52	NO	YES	NO	YES	NO	NO	NO	NO	NO	NO	NO	NO	NO		
EUROPE	E X11-3572-72	NO	YES	NO	YES	NO	NO	NO	NO	NO	NO	NO	NO	NO		

- D1-6,11,13-16,29,30,32,37-39,44-46, 48,54-60 : 1S5131 or HSS104A
- D33 : RD5.6E(S)(B2) or HZS5.6N(B2) MTZJ5.6(B) or UZ-5.6BSB
- D35 : RD16E(S)(B2) or HZS16N(B2) MTZJ16(B) or UZ-16BSB
- D41 : RD6.2E(S)(B2) or HZS6.2N(B2) MTZJ6.2(B) or UZ-6.2BSB
- D42 : RD10E(S)(B) or HZS10N(B) MTZJ10(B) or UZ-10BSB
- D43 : RD3.9E(S)(B2) or HZS3.9N(B2) MTZJ3.9(B) or UZ-3.9BSB
- D47 : S5688B or 1SR139-400
- D61 : RD8.2J(S)(B2) or HZS8.2S(B2)
- IC1 : NUJ7312AL
- IC2 : NUJ7311AL
- IC3 : NJM4565D-D
- IC4 : LA2786
- IC5 : LV1016
- IC6 : *
- IC7 : uPD17215GT-737
- IC9 : S-806D-Z
- IC10 : TA8409S
- Q1.2 : 2SC2878(B)
- Q3.15 : 2SA1048(Y,GR) or 2SA1309A(Q,R)
- Q3.15 : 2SA1175(F,E) or 2SA933A(Q,R)
- Q11,19 : 2SB1370(E,F) or 2SB1375
- Q10,13,16 : 2SD2061 or 2SD2012
- Q12,17 : 2SC1458(Y,GR) or 2SC311A(Q,R)
- Q12,17 : 2SC1740S(Q,R) or 2SC2785(F,E)
- Q14 : 2SC2003(L,K)

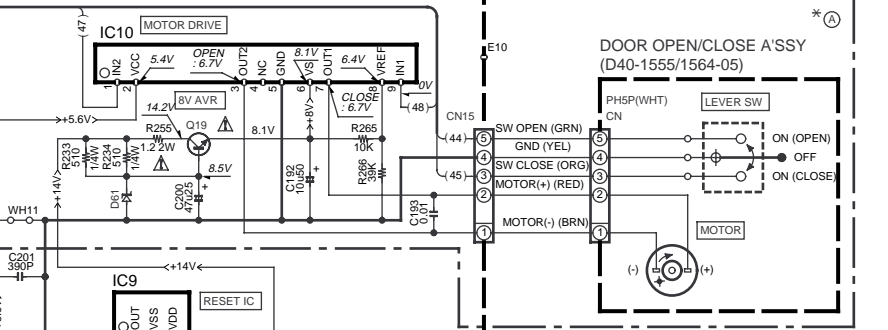

C-V100/V150/V300/V350 (K) (3/5)

C-V100/V150/V300/V350

Y05-3370-10

KENWOOD

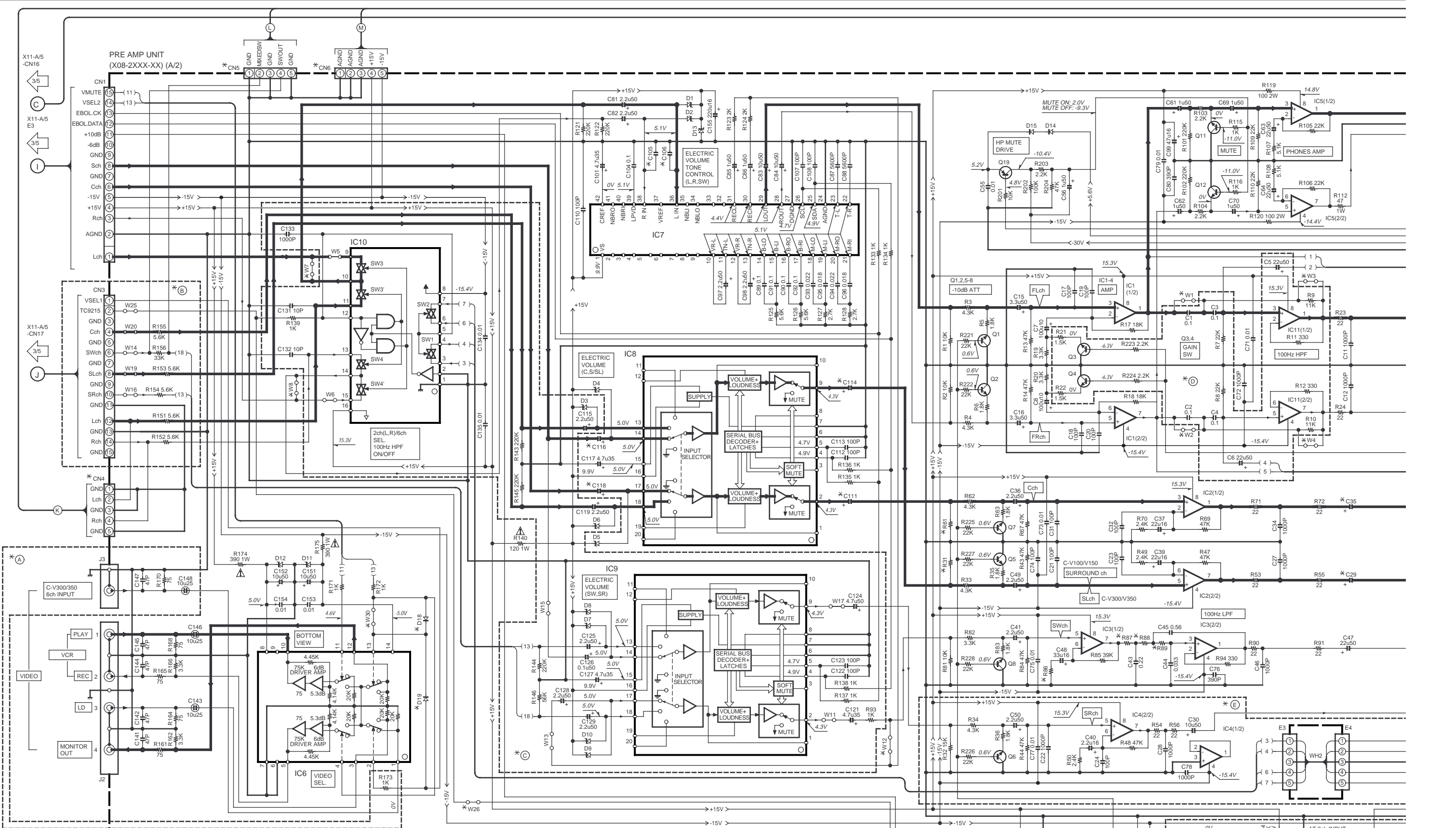

X11-A/5 -E9	(X08-2760-10)	Q1-8,11,12	: 2SC2878(B)	(X08-2810-20)	Q1-8,11,12	: 2SC2878(B)
	IC1,5,11	: NJM4580D-D		IC1,5,11	: NJM4580D-D	
	IC2-4	: NJM4565D-D		IC2-4	: NJM4565D-D	
	IC6	: NJM2279D		IC6	: NJM2279D	
	IC7	: TDA7466		IC7	: TDA7466	
	IC8,9	: TDA7309		IC8,9	: TDA7309	
	IC10	: TC9215AP		IC10	: TC9215AP	
	D1-10	: RD8.2ES(B2) or HZS8.2N(B2)		D1-10	: MTZJ8.2(B) or UZ-8.2BSB	
	D11,12	: RD5.1ES(B2) or HZS5.1N(B2)		D11,12	: MTZJ5.1(B) or UZ-5.1BSB	
	D13	: RD10ES(B2) or HZS10N(B2)		D13	: MTZJ10(B) or UZ-10BSB	
	D14,15,18,19	: 1SS131 or HSS104A		D14,15,18,19	: 1SS131 or HSS104A	
	D16	: RD3.9ES(B2) or HZS3.9N(B2)		D16	: MTZJ3.9(B) or UZ-3.9BSB	

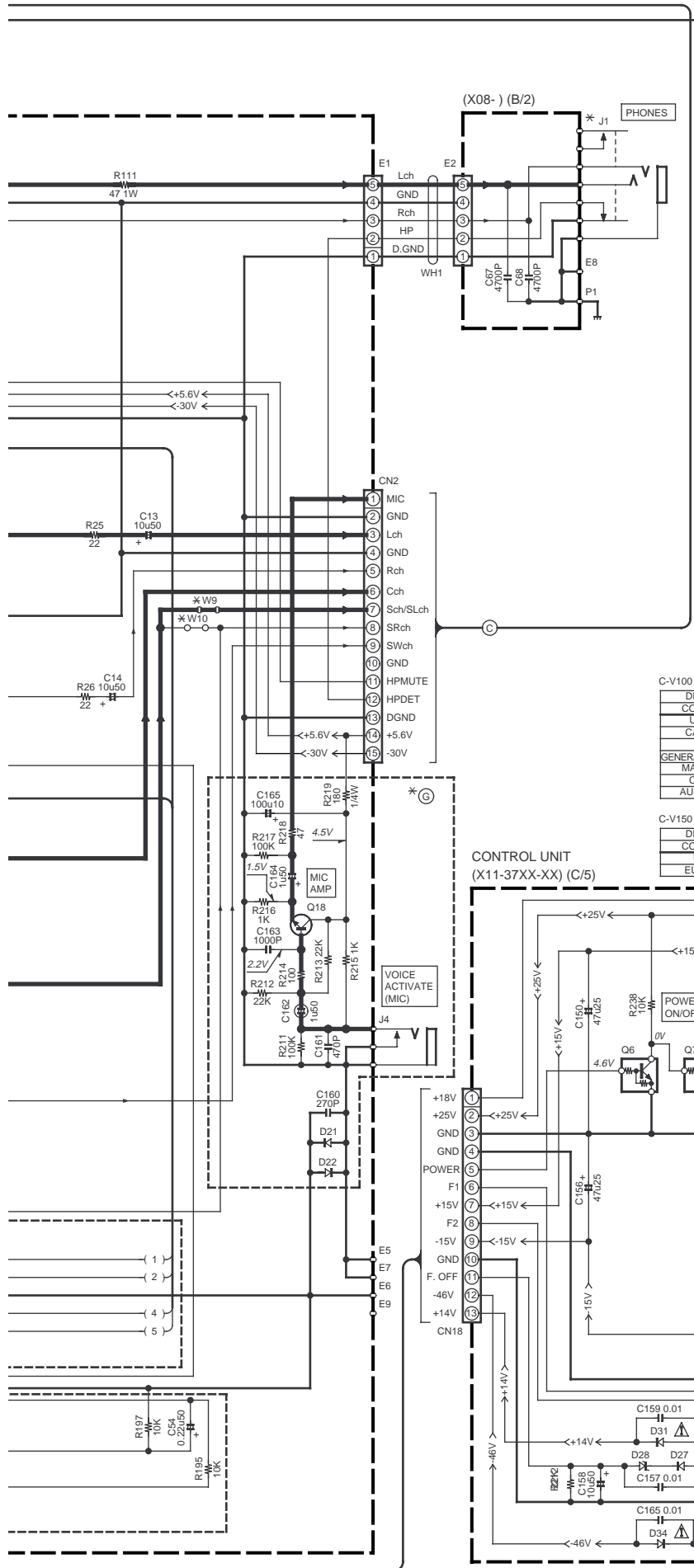

C-V100

DESTINATION	COUNTRY	ABB	UNIT No.	A - G	D18, 19	W1-4,7,8, 10,12,29,30	W5,6,9,11,13-17,19-28,31-36,39,41-43	C29, 35	C48	C105, 106	C111, 114	C116, 118	C160	J1	R31,61, 87-89	R86	CN4-6
GENERAL MARKET	AUSTRALIA	M	X08-2810-20		NO	NO	YES							E11-0282-05	10K	470	NO
	CHINA	X															
	MALAYSIA	C															
	U.S.A.	K															
	CANADA	P															
	MALAYSIA	I	X08-2760-10											E11-0280-05			

C-V150 (X08-2762-71)

DESTINATION	COUNTRY	ABB	UNIT No.	A - F	G	D18, 19	W1-4,7,8, 10,12,29,30	W5,6,9,11,13-17,19-28,31-36,39,41-43	C29, 35	C48	C105, 106	C111, 114	C116, 118	C160	J1	R31,61, 87-89	R86	CN4-6
EUROPE	U.K.	E	T	NO	YES	NO	YES							YES	E11-0280-05	10K	470	NO

C-V300 (X08-2810-21)

DESTINATION	COUNTRY	ABB	UNIT No.	A - F	G	D18, 19	W1-4,7,8, 10,12,29,30	W5,6,9,11,13-17,19-28,31-36,39,41-43	C29, 35	C48	C105, 106	C111, 114	C116, 118	C160	J1	R31, 61	R86	R87-89	CN4-6	
GENERAL MARKET	AUSTRALIA	M	X	YES	NO	YES	NO	YES								E11-0282-05	15K	820	11K	YES
	CHINA	X																		
	MALAYSIA	I																		

C-V350 (X08-2762-72)

DESTINATION	COUNTRY	ABB	UNIT No.	A - G	D18, 19	W1-4,7,8, 10,12,29,30	W5,6,9,11,13-17,19-28,31-36,39,41-43	C29, 35	C48	C105, 106	C111, 114	C116, 118	C160	J1	R31, 61	R86	R87-89	CN4-6	
EUROPE	U.K.	E	T	YES	YES	NO	YES							YES	E11-0280-05	15K	820	11K	YES

C-V100

DESTINATION	COUNTRY	ABB	UNIT No.	F1	F2,3	CN1	CN5,6	S1	R232	P1	W100	W228	J6	WH8
U.S.A.	K	X11-3730-10		1.25A	250V	E40-8126-05		NO	YES	YES	YES		E03-0148-05	NO
CANADA	P	X11-3732-91						NO	YES	NO	NO	YES	E03-0149-05	YES
GENERAL MARKET	M	X11-3790-20		NO			NO	YES	NO	NO	YES		E03-0330-05	NO
	MALAYSIA	I						NO	NO	NO			E03-0325-05	NO
	CHINA	C	X11-3793-01											
	AUSTRALIA	X	X11-3790-71								YES			

C-V150

DESTINATION	COUNTRY	ABB	UNIT No.	F1	F2,3	CN1	CN5,6	S1	R232	P1	W100	W228	J6	WH8
U.K.	T	X11-3530-51		YES	T800mA L 250V	E40-8126-05	YES	NO	NO	NO	YES	NO	E03-0310-05	NO
EUROPE	E	X11-3532-71											E03-0149-05	NO

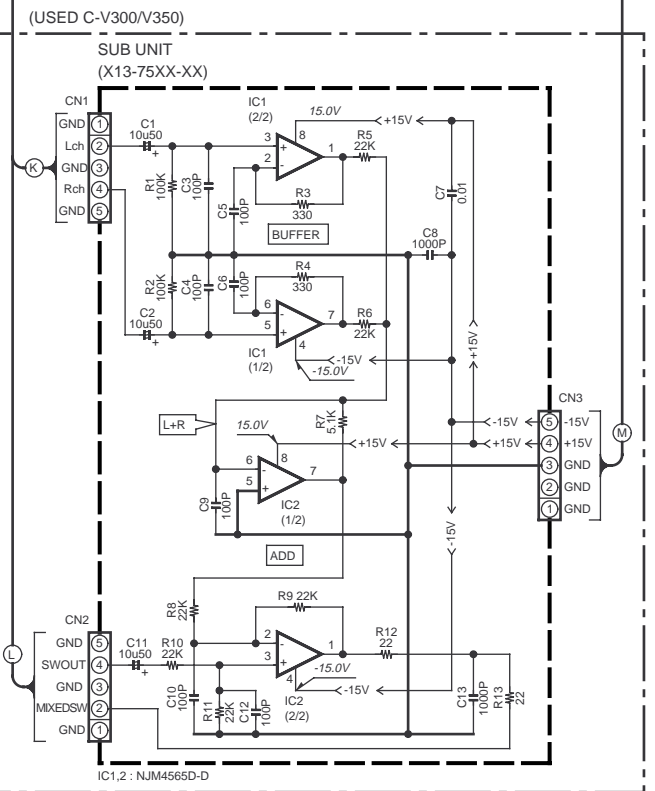
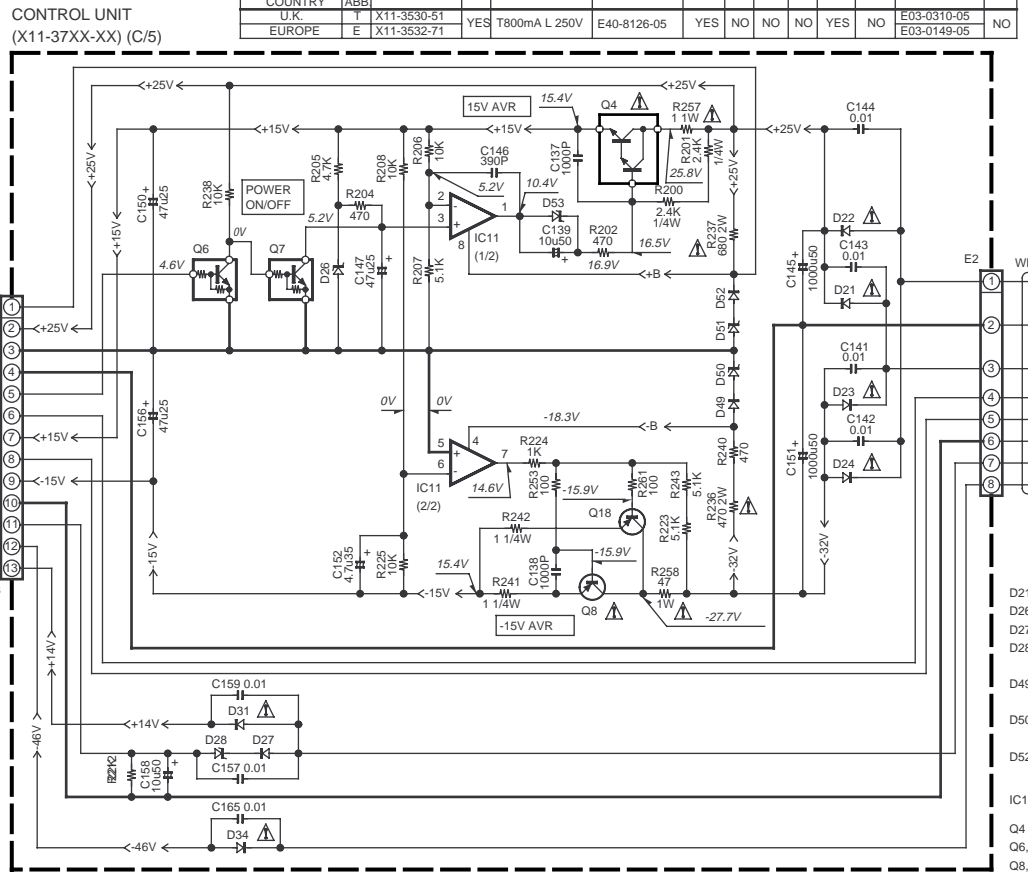

C-V300

DESTINATION	COUNTRY	ABB	UNIT No.	F1	F2,3	CN1	CN5,6	S1	R232	P1	W100	W228	J6	WH8
GENERAL MARKET	M	X11-3790-21		NO	T800mA L 250V	E40-4245-05	NO	YES	NO	NO	NO	YES	E03-0149-05	YES
	CHINA	C	X11-3793-02					NO	NO	NO			E03-0330-05	NO
	AUSTRALIA	X	X11-3790-72										E03-0325-05	NO

C-V350

DESTINATION	COUNTRY	ABB	UNIT No.	F1	F2,3	CN1	CN5,6	S1	R232	P1	W100	W228	J6	WH8
U.K.	T	X11-3530-52		YES	T800mA L 250V	E40-8126-05	YES	NO	NO	NO	YES	NO	E03-0310-05	NO
EUROPE	E	X11-3532-72											E03-0149-05	NO

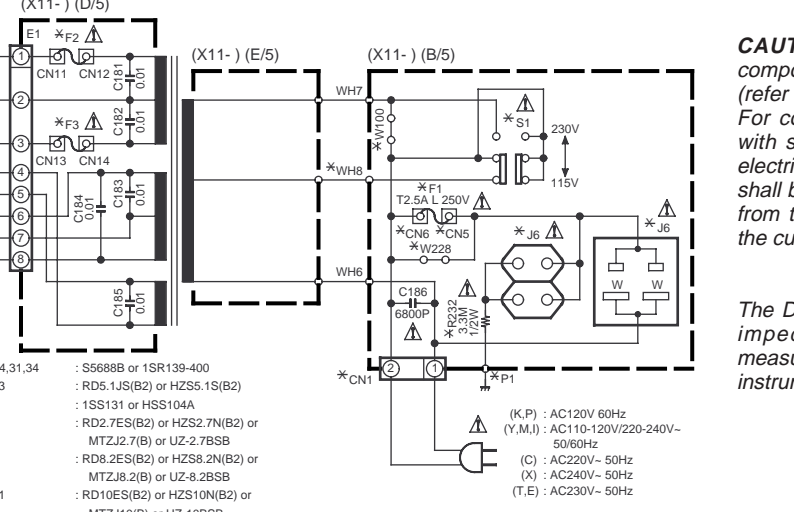

- D21-24,31,34 : S5688B or 1SR139-400
- D26,53 : RD5.1JS(B2) or HZS5.1S(B2)
- D27 : 1SS131 or HSS104A
- D28 : RD2.7ES(B2) or HZS2.7N(B2) or MTZJ2.7(B) or UZ-2.7BSB
- D49 : RD8.2ES(B2) or HZS8.2N(B2) or MTZJ8.2(B) or UZ-8.2BSB
- D50,51 : RD10ES(B2) or HZS10N(B2) or MTZJ10(B) or UZ-10BSB
- D52 : RD6.2ES(B2) or HZS6.2N(B2) or MTZJ6.2(B) or UZ-6.2BSB
- IC11 : NJM4558D
- Q4 : 2SD1894
- Q6,7 : UN4212 or DTC124ESA
- Q8,18 : 2SB1370(E,F) or 2SB1375

C-V100/V150/V300/V350 (K) (4/5)

CAUTION: For continued safety, replace safety critical components only with manufacturer's recommended parts (refer to parts list). Δ indicates safety critical components. For continued protection against risk of fire, replace only with same type and rating fuse(s). To reduce the risk of electric shock, leakage-current or resistance measurements shall be carried out (exposed parts are acceptably insulated from the supply circuit) before the appliance is returned to the customer.

The DC voltage is an actual reading measured with a high impedance type voltmeter with no signal input. The measurement value may vary depending on the measuring instruments used or on the product.

C-V100/V150/V300/V350

DISPLAY UNIT
(X14-4XXX-XX) (A/3) : V-C100

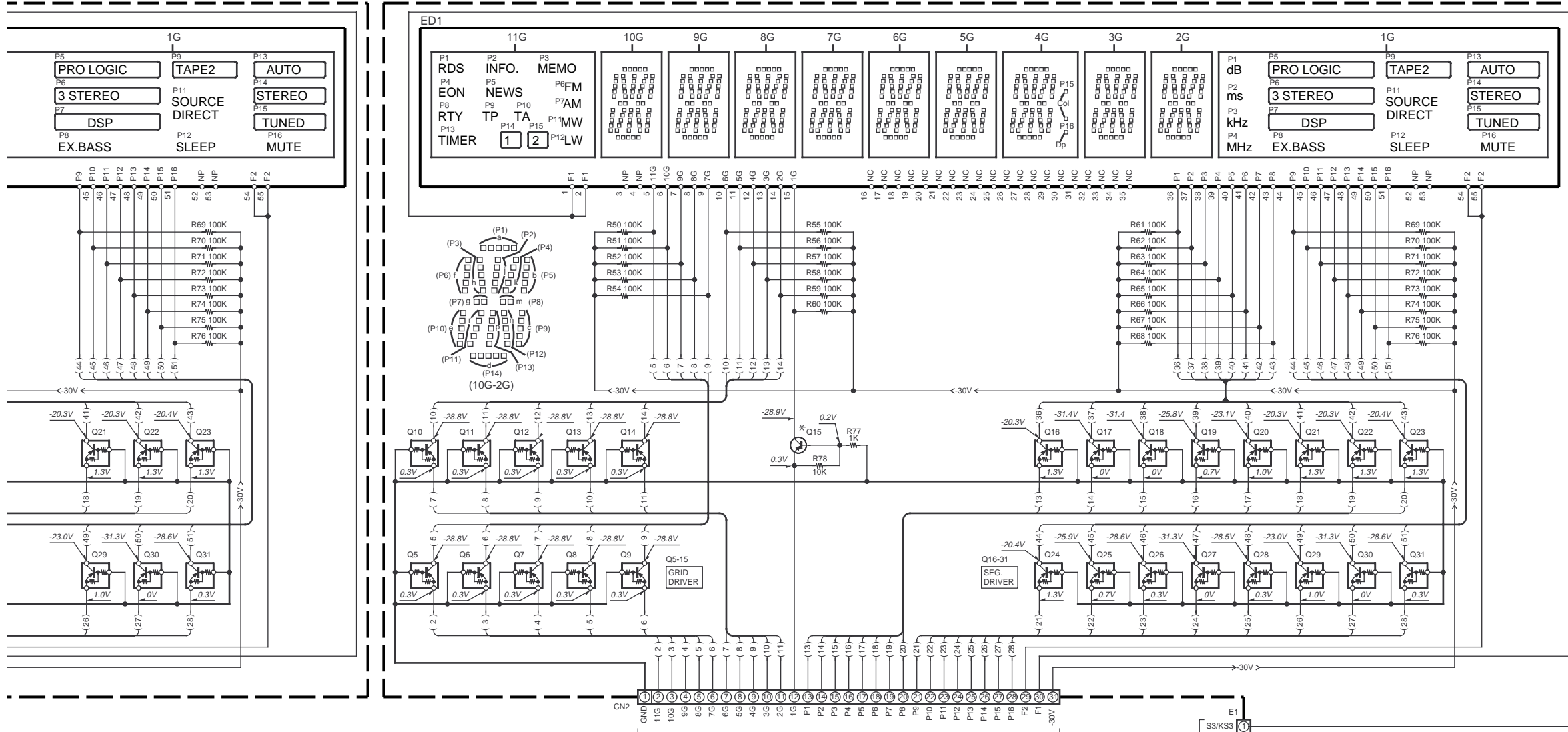

CAUTION: For continued safety, replace safety critical components only with manufacturer's recommended parts (refer to parts list). Δ indicates safety critical components. For continued protection against risk of fire, replace only with same type and rating fuse(s). To reduce the risk of electric shock, leakage-current or resistance measurements shall be carried out (exposed parts are acceptably insulated from the supply circuit) before the appliance is returned to the customer.

The DC voltage is an actual reading measured with a high impedance type voltmeter with no signal input. The measurement value may vary depending on the measuring instruments used or on the product.

S17-20, 25, 26	Q3,4	Q15
NO	NO	2SB1218A(Q,R) or 2SA1576A(R,S)
S17-20, 25, 26	Q3,4	Q15
YES	YES	2SA1576A(R,S) or 2SA1586(Y,GR)

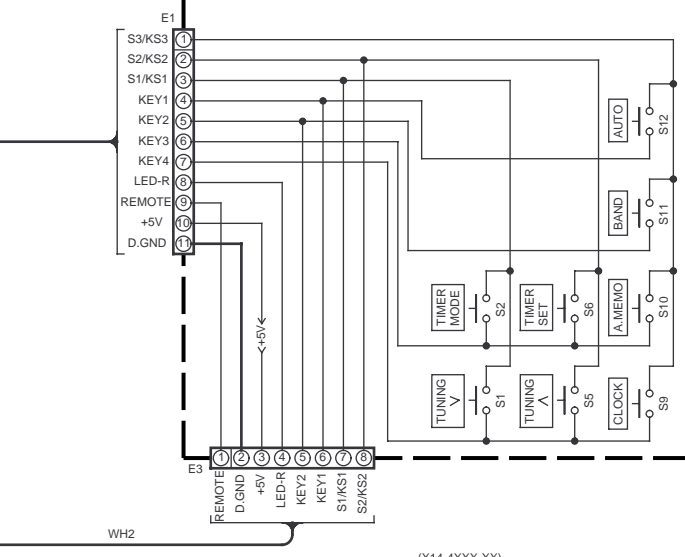
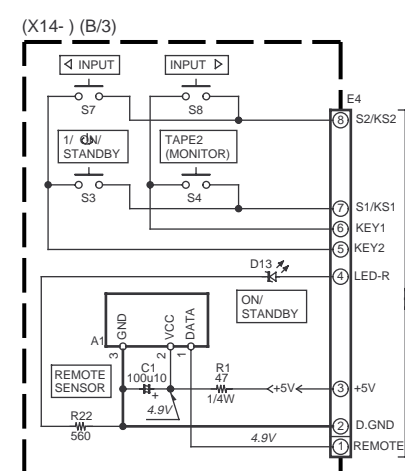
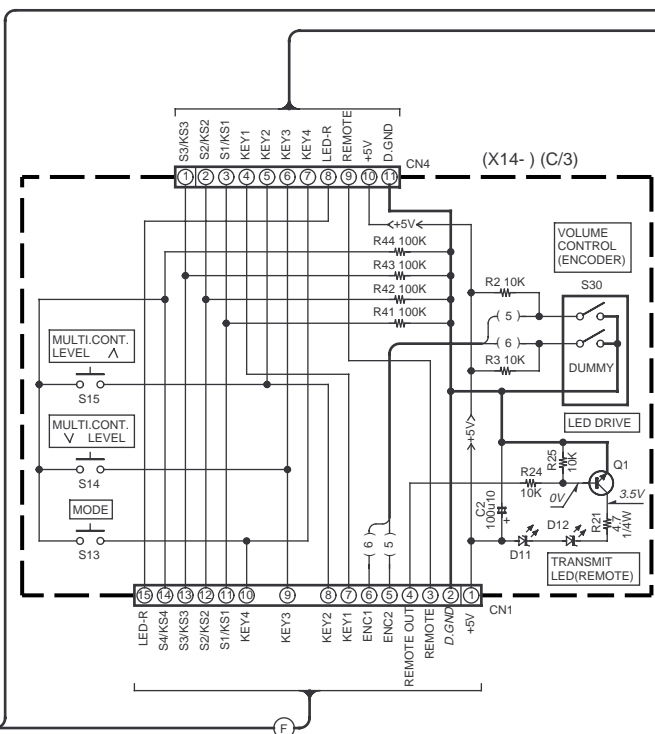

DESTINATION	COUNTRY	ABB	UNIT No.	Q15
U.S.A.	K		X14-4360-10	2SA1576A(R,S) or 2SA1586(Y,GR)
CANADA	P			
FX				
GENERAL MARKET	M		X14-4500-20	2SB1218A(Q,R) or 2SA1576A(R,S)
MALAYSIA	I			
CHINA	C			
AUSTRALIA	X			

- (X14-4XXX-XX)
 Q1 : 2SC3246
 Q5-14,16-31 : UN5119 or DTA113ZUA
 Q15 : *
 D11,12 : B30-2519-05
 D13 : B30-2493-05
 ED1 : 20U64100SA
 A1 : W02-2598-05

C-V100/V150/V300/V350(M) (5/5)

- 2SB1375
- 2SD1757K
- NJM2279D
- TC9215AP
- TDA7309
- SAA6579
- TDA7466
- NJM4565M
- LA1836
- LC72131
- LA1832 LV1016
- NJU7311AL NJU7312AL
- NJM4558D NJM4565D-D
- TA8409S
- NJM4580D-D
- 2SK302
- LA2786

C-V100/V150/V300/V350

Y05-3370-10

KENWOOD

C-V100/V150/V300/V350

EXPLODED VIEW(UNIT)

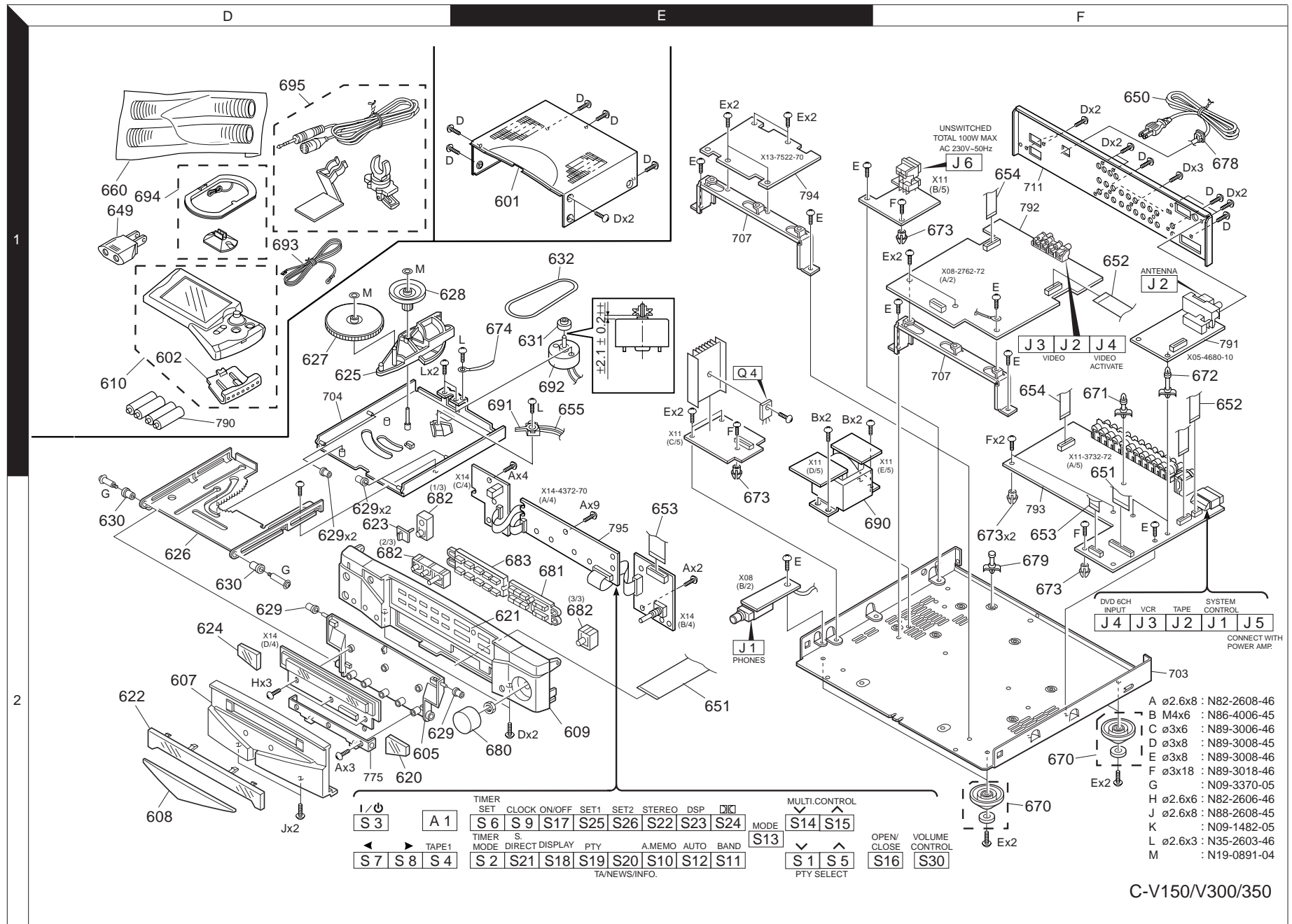

C-V150/V300/350

Parts with the exploded numbers larger than 700 are not supplied.

C-V100/V150/V300/V350

PARTS LIST

* New Parts

Parts without **Parts No.** are not supplied.

Les articles non mentionnés dans le **Parts No.** ne sont pas fournis.

Teile ohne **Parts No.** werden nicht geliefert.

①

Ref. No	Add-ress	New Parts	Parts No.	Description	Desti-nation	Re-marks
C-V100						
601	1A	*	A01-3432-01	METALLIC CABINET		
602	1A	*	A09-0378-08	BATTERY COVER	YMICX	
602	1A	*	A09-0379-08	BATTERY COVER	KP	
608	2A	*	A21-1952-03	DRESSING PANEL		
609	2A	*	A60-1142-01	PANEL	KPY	
609	2A	*	A60-1168-01	PANEL	MICX	
610	1A	*	A70-1150-05	REMOTE CONTROL ASSY(RC-S503)	YMICX	
610	1A	*	A70-1159-05	REMOTE CONTROL ASSY(RGC-100)	KP	
622	2A	*	B10-2347-02	FRONT GLASS	KPY	
622	2A	*	B10-2385-02	FRONT GLASS	MICX	
623	2A	*	B12-0311-04	INDICATOR		
-			B46-0096-53	WARRANTY CARD	X	
-			B46-0326-03	WARRANTY CARD	C	
-			B46-0328-03	WARRANTY CARD	KY	
-			B46-0336-03	WARRANTY CARD	P	
-			B58-0513-04	CAUTION CARD (PRESET220-240)	Y	
-			B58-0964-13	CAUTION CARD (UL)	KY	
-			B58-0965-13	CAUTION CARD	X	
-			B58-0966-13	CAUTION CARD	MI	
-			B58-0967-03	CAUTION CARD (PL)	P	
-			B58-1546-03	CAUTION CARD	C	
-			B59-1104-00	SERVICE DIRECTORY	Y	
-		*	B59-1121-03	SUB-INSTRUCTION MANUAL		
-		*	B59-1122-03	SUB-INSTRUCTION MANUAL	P	
-		*	B59-1123-03	SUB-INSTRUCTION MANUAL	C	
-		*	B59-1129-03	SUB-INSTRUCTION MANUAL	MI	
-		*	B59-1130-03	SUB-INSTRUCTION MANUAL	M	
-		*	B59-1131-03	SUB-INSTRUCTION MANUAL		
-		*	B60-3198-00	INSTRUCTION MANUAL(ENG)	P	
-		*	B60-3199-00	INSTRUCTION MANUAL(FRN)	M	
-		*	B60-3200-00	INSTRUCTION MANUAL(SPN)	MI	
-		*	B60-3201-00	INSTRUCTION MANUAL(TWN)	C	
-		*	B60-3202-00	INSTRUCTION MANUAL(CHN)		
△ 649	1A		E03-0115-05	AC PLUG ADAPTER	MI	
△ 650	1C		E30-2592-15	AC POWER CORD	MI	
△ 650	1C		E30-2717-05	AC POWER CORD	X	
△ 650	1C		E30-2787-05	AC POWER CORD	KPY	
△ 650	1C		E30-2789-05	AC POWER CORD	Y	
△ 650	1C		E30-2830-05	AC POWER CORD	C	
651	2B	*	E35-1772-05	FLAT CABLE (31P)		
652	1C	*	E35-1774-05	FLAT CABLE (15P)		
660	1A	*	F07-1602-04	COVER		
-		*	H10-7286-02	POLYSTYRENE FOAMED FIXTURE	KPY	
-		*	H10-7287-02	POLYSTYRENE FOAMED FIXTURE	JPY	
-		*	H10-7371-02	POLYSTYRENE FOAMED FIXTURE	MICX	
-		*	H10-7372-02	POLYSTYRENE FOAMED FIXTURE	MICX	
-		*	H13-0281-04	CARTON BOARD	X	
-			H25-0232-04	PROTECTION BAG (235X350X0.03)		
-			H25-1516-04	PROTECTION BAG		
-		*	H30-0100-04	ADHESIVE DOUBLE-COATED TAPE	KPY	
-		*	H30-0602-04	ADHESIVE DOUBLE-COATED TAPE	MICX	
-		*	H50-2334-04	ITEM CARTON CASE	KPY	

L : Scandinavia
Y : PX(Far East, Hawaii)
Y : AAFES(Europe)

K : USA
T : Europe
X : Australia

P : Canada
E : Europe
M : Other Areas

R : Mexico
G : Germany
Q : Russia

△ indicates safety critical components.

* New Parts

Parts without **Parts No.** are not supplied.

Les articles non mentionnés dans le **Parts No.** ne sont pas fournis.

Teile ohne **Parts No.** werden nicht geliefert.

②

Ref. No	Add-ress	New Parts	Parts No.	Description	Desti-nation	Re-marks
-		*	H50-2483-04	ITEM CARTON CASE	MI	
-		*	H50-2484-04	ITEM CARTON CASE	C	
-		*	H50-2519-04	ITEM CARTON CASE	X	
670	2C	*	J02-1188-03	FOOT	KPY	
670	2C	*	J02-1189-03	FOOT	MICX	
671	1C	*	J19-3331-05	UNIT HOLDER		
672	1C	*	J19-3642-05	UNIT HOLDER		
673	2B,1C	*	J19-3732-04	UNIT HOLDER	KPY	
△ 673	2B,1C	*	J19-3751-04	UNIT HOLDER	MICX	
△ 678	1C	*	J42-0083-05	POWER CORD BUSHING		
△ 679	2C	*	J19-2598-05	UNIT HOLDER		
-		*	J61-0098-05	WIRE BAND	KPY	
-		*	J61-0307-05	WIRE BAND	MICX	
680	2A	*	K29-6660-04	KNOB		
681	2A	*	K29-6661-02	KNOB	KPY	
681	2A	*	K29-6779-02	KNOB	MICX	
682	2A	*	K29-6662-02	KNOB	KPY	
682	2A	*	K29-6780-02	KNOB	MICX	
△ 690	1B	*	L07-2327-05	POWER TRANSFORMER	KP	
△ 690	1B	*	L07-2328-05	POWER TRANSFORMER	Y	
△ 690	1B	*	L07-2331-05	POWER TRANSFORMER	CX	
△ 690	1B	*	L07-2332-05	POWER TRANSFORMER	MI	
693	1A		T90-0809-05	LEAD WIRE ANTENNA	MICX	
693	1A		T90-0810-05	LEAD WIRE ANTENNA	KPY	
694	1A		T90-0820-05	LOOP ANTENNA		
C-V150/V300/V350						
601	1B		A01-3432-01	METALLIC CABINET		
602	1A		A09-0378-08	BATTERY COVER (V150)	ET	
602	1A		A09-0379-08	BATTERY COVER (V300/350)	ETMICX	
605	2A		A46-0303-01	REAR COVER		
607	2A		A29-0861-01	PANEL	ET	
607	2A		A29-0881-01	PANEL	MICX	
608	2A	*	A21-1953-03	DRESSING PANEL (V150)	ET	
608	2A	*	A21-1954-03	DRESSING PANEL	MICX	
608	2A	*	A21-1955-03	DRESSING PANEL (V350)	ET	
609	2B	*	A60-1144-01	PANEL	ET	
609	2B	*	A60-1145-01	PANEL	MICX	
610	1A	*	A70-1136-05	REMOTE CONTROLLER ASSY(V150)	ET	
610	1A	*	A70-1137-05	REMOTE CONTROLLER ASSY(V350)	ET	
610	1A	*	A70-1159-05	REMOTE CONTROLLER ASSY(V300)	MICX	
620	2A	*	B10-2384-04	FRONT GLASS	MICX	
621	2B	*	B03-3802-13	DRESSING PLATE	MICX	
621	2B	*	B03-3803-03	DRESSING PLATE	ET	
622	2A	*	B10-2349-02	FRONT GLASS	ET	
622	2A	*	B10-2382-02	FRONT GLASS	MICX	
623	2A		B12-0311-04	INDICATOR		
624	2A		B10-2350-04	FRONT GLASS	ET	
624	2A	*	B10-2383-04	FRONT GLASS	MICX	
625			B10-2351-04	FRONT GLASS	ET	
-			B46-0096-53	WARRANTY CARD	X	
-			B46-0310-03	WARRANTY CARD	ET	
-			B46-0326-03	WARRANTY CARD	C	
-			B58-0945-03	CAUTION CARD	T	
-			B58-0965-13	CAUTION CARD (PL)	T	

L : Scandinavia
Y : PX(Far East, Hawaii)
Y : AAFES(Europe)

K : USA
T : Europe
X : Australia

P : Canada
E : Europe
M : Other Areas

R : Mexico
G : Germany
Q : Russia

△ indicates safety critical components.

PARTS LIST

* New Parts
Parts without **Parts No.** are not supplied.
Les articles non mentionnés dans le **Parts No.** ne sont pas fournis.
Teile ohne **Parts No.** werden nicht geliefert.

③

Ref. No	Add-ress	New Parts	Parts No.	Description	Desti-nation	Re-marks
-			B58-0966-13	CAUTION CARD (PL)	E	
-			B58-1546-03	CAUTION CARD	C	
-			B59-1121-03	SUB-INSTRUCTION MANUAL		
-			B59-1122-03	SUB-INSTRUCTION MANUAL(ENG)	MICX	
-			B59-1124-03	SUB-INSTRUCTION MANUAL(FRN)	E	
-			B59-1125-03	SUB-INSTRUCTION MANUAL(GRN)	E	
-			B59-1126-03	SUB-INSTRUCTION MANUAL(NTH)	E	
-			B59-1127-03	SUB-INSTRUCTION MANUAL(ITL)	E	
-			B59-1128-03	SUB-INSTRUCTION MANUAL (V150)	E	
-			B59-1129-03	SUB-INSTRUCTION MANUAL(CHN)	C	
-			B59-1130-03	SUB-INSTRUCTION MANUAL(TLN)	MI	
-			B59-1131-03	SUB-INSTRUCTION MANUAL(SPN)	M	
-			B59-1133-03	SUB-INSTRUCTION MANUAL(ENG)	T	
-		*	B60-3198-00	INSTRUCTION MANUAL(ENG)		
-		*	B60-3200-00	INSTRUCTION MANUAL(SPN)	M	
-		*	B60-3201-00	INSTRUCTION MANUAL(TWN)	MI	
-		*	B60-3202-00	INSTRUCTION MANUAL(CHN)	C	
-		*	B60-3203-00	INSTRUCTION MANUAL(ENG)	T	
-		*	B60-3204-00	INSTRUCTION MANUAL(FRN)	E	
-		*	B60-3205-00	INSTRUCTION MANUAL(NTH)	E	
-		*	B60-3206-00	INSTRUCTION MANUAL(ITL)	E	
-		*	B60-3207-00	INSTRUCTION MANUAL(V150)(SPN)	E	
-		*	B60-3208-00	INSTRUCTION MANUAL(GRN)	E	
625	1A		D10-3715-04	ARM ASSY		
626	2A		D10-3716-01	SLIDER		
627	1A		D13-1807-04	GEAR		
628	1A		D13-1808-03	GEAR		
629	2A		D14-0385-04	ROLLER		
630	2A		D14-0386-04	ROLLER		
631	1B		D15-0407-04	MOTOR PULLEY		
632	1B		D16-0715-03	BELT		
△ 649	1A		E03-0115-05	AC PLUG ADAPTER	MI	
△ 650	1C		E30-2592-15	AC POWER CORD	MI	
△ 650	1C		E30-2717-05	AC POWER CORD	X	
△ 650	1C		E30-2788-05	AC POWER CORD	E	
△ 650	1C		E30-2791-05	AC POWER CORD	T	
△ 650	1C		E30-2830-05	AC POWER CORD	C	
651	2B	*	E35-1773-05	FLAT CABLE		
652	1C		E35-1774-05	FLAT CABLE (15P)		
653	2B,2C	*	E35-1775-05	FLAT CABLE	MICX	
653	2B,2C	*	E35-1861-05	FLAT CABLE	ET	
654	1C	*	E35-1781-05	FLAT CABLE		
655	1B	*	E35-1810-05	WIRING HARNESS		
660	1A		F07-1602-04	COVER		
-			G11-0153-04	SOFT TAPE (80X12X3)		
-			H10-7286-02	POLYSTYRENE FOAMED FIXTURE	E	
-			H10-7287-02	POLYSTYRENE FOAMED FIXTURE	E	
-			H10-7288-02	POLYSTYRENE FOAMED FIXTURE	T	
-			H10-7289-02	POLYSTYRENE FOAMED FIXTURE	T	
-		*	H10-7371-02	POLYSTYRENE FOAMED FIXTURE	MICX	
-		*	H10-7372-02	POLYSTYRENE FOAMED FIXTURE	MICX	
-		*	H13-0281-04	CARTON BOARD	X	

L : Scandinavia K : USA P : Canada R : Mexico
Y : PX(Far East, Hawaii) T : Europe E : Europe G : Germany
Y : AAFES(Europe) X : Australia M : Other Areas Q : Russia

△ indicates safety critical components.

* New Parts
Parts without **Parts No.** are not supplied.
Les articles non mentionnés dans le **Parts No.** ne sont pas fournis.
Teile ohne **Parts No.** werden nicht geliefert.

④

Ref. No	Add-ress	New Parts	Parts No.	Description	Desti-nation	Re-marks
-			H20-0568-04	PROTECTION COVER	MIC	
-			H25-0232-04	PROTECTION BAG (235X350X0.03)	E	
-			H25-0651-04	PROTECTION BAG (0232)	T	
-			H25-1516-04	PROTECTION BAG	E	
-			H30-0100-04	ADHESIVE DOUBLE-COATED TAPE	ET	
-		*	H30-0602-04	ADHESIVE DOUBLE-COATED TAPE	MICX	
-		*	H50-2386-04	ITEM CARTON CASE(V350)	E	
-		*	H50-2387-04	ITEM CARTON CASE(V350)	T	
-		*	H50-2439-04	ITEM CARTON CASE(V150)	E	
-		*	H50-2482-04	ITEM CARTON CASE(V150)	E	
-		*	H50-2486-04	ITEM CARTON CASE	MI	
-		*	H50-2487-04	ITEM CARTON CASE	C	
-		*	H50-2520-04	ITEM CARTON CASE	X	
670	2C		J02-1188-03	FOOT	ET	
670	2C	*	J02-1189-03	FOOT	MICX	
671	1C		J19-3331-05	UNIT HOLDER		
672	1C		J19-3642-05	UNIT HOLDER	ET	
673	2B,1C		J19-3732-04	UNIT HOLDER		
673	2B,1C		J19-3751-04	UNIT HOLDER	MICX	
674	1B		J19-5833-05	LEAD HOLDER		
△ 678	1C		J42-0083-05	POWER CORD BUSHING		
679	2C		J19-2598-05	UNIT HOLDER		
-			J61-0098-05	WIRE BAND	ET	
-			J61-0307-05	WIRE BAND	MICX	
680	2B		K29-6660-04	KNOB		
681	2B		K29-6664-02	KNOB	ET	
681	2B	*	K29-6775-02	KNOB	MICX	
682	2A,2B		K29-6665-02	KNOB	ET	
682	2A,2B	*	K29-6776-02	KNOB	MICX	
683	2B		K29-6666-02	KNOB	ET	
683	2B	*	K29-6668-02	KNOB	MICX	
△ 690	2C	*	L07-2329-05	POWER TRANSFORMER	MI	
△ 690	2C	*	L07-2330-05	POWER TRANSFORMER	ET	
△ 690	2C	*	L07-2333-05	POWER TRANSFORMER	CX	
691	1B		S64-0026-05	LEVER SWITCH		
692	1B		T42-0882-05	DC MOTOR		
693	1A		T90-0809-05	LEAD WIRE ANTENNA	MICX	
693	1A		T90-0810-05	LEAD WIRE ANTENNA	ET	
694	1A		T90-0820-05	LOOP ANTENNA		
695	1A		W01-0935-05	MICROPHONE	ET	
TUNER(X05-4670-20)						
C1	.2		CK73FB1H103K	CHIP C	0.01UF	K
C5			CK73FB1H102K	CHIP C	1000PF	K
C8			CK73FB1H103K	CHIP C	0.01UF	K
C9			CE04LW1C100M	ELECTRO	10UF	16WV
C10			CK73FB1H473K	CHIP C	0.047UF	K
C11			CE04LW1H010M	ELECTRO	1.0UF	50WV
C12			CE04LW1H2R2M	ELECTRO	2.2UF	50WV
C13			CK73FB1H102K	CHIP C	1000PF	K
C14			CE04LW1H010M	ELECTRO	1.0UF	50WV
C15			CC73FCH1H220J	CHIP C	22PF	J

L : Scandinavia K : USA P : Canada R : Mexico
Y : PX(Far East, Hawaii) T : Europe E : Europe G : Germany
Y : AAFES(Europe) X : Australia M : Other Areas Q : Russia

△ indicates safety critical components.

C-V100/V150/V300/V350

PARTS LIST

* New Parts

Parts without **Parts No.** are not supplied.

Les articles non mentionnés dans le **Parts No.** ne sont pas fournis.

Teile ohne **Parts No.** werden nicht geliefert.

5

Ref. No	Add-ress	New Parts	Parts No.	Description	Desti-nation	Re-marks
C16			CE04LW1C100M	ELECTRO 10UF 16WV		
C17			CK73FB1H562K	CHIP C 5600PF K		
C18			CK73FB1H102K	CHIP C 1000PF K		
C19			CE04HW1E4R7M	NP-ELEC 4.7UF 25WV		
C20			CK73FB1E104K	CHIP C 0.10UF K		
C21 ,22			CQ93FMG1H113J	MYLAR 0.011UF J		
C23			CE04LW1H010M	ELECTRO 1.0UF 50WV	YMIC	
C24			CK73FB1H103K	CHIP C 0.010UF K		
C25			CE04LW1C100M	ELECTRO 10UF 16WV		
C26			CE04LW1C470M	ELECTRO 47UF 16WV		
C27			CE04LW1H010M	ELECTRO 1.0UF 50WV		
C28			CQ93FMG1H223J	MYLAR 0.022UF J		
C29			CE04LW1H2R2M	ELECTRO 2.2UF 50WV		
C30			CE04LW1C101M	ELECTRO 100UF 16WV		
C31			CE04LW1A470M	ELECTRO 47UF 10WV		
C32			CK73FB1H103K	CHIP C 0.010UF K		
C33			CC73FSL1H101J	CHIP C 100PF J		
C34 ,35			CK73FB1H102K	CHIP C 1000PF K		
C36			CC73FCH1H270J	CHIP C 27PF J		
C37			CC73FCH1H220J	CHIP C 22PF J		
C38			CK73FB1H471K	CHIP C 470PF K		
C57 ,58			CE04LW1H010M	ELECTRO 1.0UF 50WV		
C59 ,60			CE04LW1C100M	ELECTRO 10UF 16WV		
C61 ,62			CQ93FMG1H472J	MYLAR 4700PF J	YMIC	
C63			CC73FCH1H220J	CHIP C 22PF J		
C64			CC73FCH1H330J	CHIP C 33PF J		
C65			CC73FCH1H040C	CHIP C 4.0PF C		
C67			CK73FB1H102K	CHIP C 1000PF K		
CN1			E40-4609-05	PIN ASSY		
J1			E70-0052-05	LOCK TERMINAL BOARD		
CF1 ,2			L72-0531-05	CERAMIC FILTER		
CF3			L72-0593-05	CERAMIC FILTER		
L1			L39-1348-05	COMBINATION COIL		
L2			L30-0911-05	AM IFT		
L3 ,4			L40-1091-17	SMALL FIXED INDUCTOR(1UH)		
X1			L77-1122-05	CRYSTAL RESONATOR(7.2MHZ)	MICX	
X1			L77-2159-05	CRYSTAL RESONATOR(7.2MHZ)	Y	
X2			L78-0637-05	RESONATOR (456KHZ)		
R1			RK73FB2A332J	CHIP R 3.3K J 1/10W		
R2			RK73FB2A681J	CHIP R 680 J 1/10W		
R3			RK73FB2A100J	CHIP R 10 J 1/10W		
R4 ,5			RK73FB2A331J	CHIP R 330 J 1/10W		
R6			RK73FB2A101J	CHIP R 100 J 1/10W		
R7			RK73FB2A473J	CHIP R 47K J 1/10W		
R8			RK73FB2A331J	CHIP R 330 J 1/10W		
R12			RK73FB2A102J	CHIP R 1.0K J 1/10W		
R13			RK73FB2A473J	CHIP R 47K J 1/10W		
R15 ,16			RK73FB2A393J	CHIP R 39K J 1/10W		
R17			RK73FB2A271J	CHIP R 270 J 1/10W		
R18			RK73FB2A302J	CHIP R 3.0K J 1/10W		
R19			RK73FB2A822J	CHIP R 8.2K J 1/10W		
R20 -23			RK73FB2A102J	CHIP R 1.0K J 1/10W		
R24			RK73FB2A562J	CHIP R 5.6K J 1/10W		

L : Scandinavia
Y : PX(Far East, Hawaii)
Y : AAFES(Europe)

K : USA
T : Europe
X : Australia

P : Canada
E : Europe
M : Other Areas

R : Mexico
G : Germany
Q : Russia

Δ indicates safety critical components.

* New Parts

Parts without **Parts No.** are not supplied.

Les articles non mentionnés dans le **Parts No.** ne sont pas fournis.

Teile ohne **Parts No.** werden nicht geliefert.

5

Ref. No	Add-ress	New Parts	Parts No.	Description	Desti-nation	Re-marks
Δ R25			RD14NB2E101J	RD 100 J 1/4W		
Δ R26			RD14NB2E561J	RD 560 J 1/4W		
R27 ,28			RK73FB2A103J	CHIP R 10K J 1/10W		
R29 ,30			RK73FB2A102J	CHIP R 1.0K J 1/10W		
R31			RK73FB2A103J	CHIP R 10K J 1/10W		
R32			RK73FB2A122J	CHIP R 1.2K J 1/10W		
R33			RK73FB2A123J	CHIP R 12K J 1/10W		
Δ R41			RS14KB3A271J	FL-PROOF RS 270 J 1W		
R42			RD14NB2E271J	RD 270 J 1/4W		
R44			RK73FB2A101J	CHIP R 100 J 1/10W		
R46			RK73FB2A104J	CHIP R 100K J 1/10W		
R47			RK73FB2A153J	CHIP R 15K J 1/10W		
R48			RK73FB2A473J	CHIP R 47K J 1/10W		
R49			RK73FB2A473J	CHIP R 47K J 1/10W	YMIC	
R50			RK73FB2A471J	CHIP R 470 J 1/10W	YMIC	
R51 -54			RK73FB2A473J	CHIP R 47K J 1/10W		
R55 ,56			RK73FB2A154J	CHIP R 150K J 1/10W		
R59 ,60			RK73FB2A332J	CHIP R 3.3K J 1/10W		
R61			RK73FB2A103J	CHIP R 10K J 1/10W		
R62			RK73FB2A563J	CHIP R 56K J 1/10W		
R63			RK73FB2A821J	CHIP R 820 J 1/10W		
R64			RK73FB2A102J	CHIP R 1.0K J 1/10W		
R65			RK73EB2B102J	CHIP R 1.0K J 1/8W		
R73			RK73FB2A681J	CHIP R 680 J 1/10W		
W101-106			R92-0670-05	CHIP R 0 OHM		
W108-113			R92-0670-05	CHIP R 0 OHM		
W115			R92-0670-05	CHIP R 0 OHM		
W201-212			R92-0679-05	CHIP R 0 OHM		
S1			S62-0034-05	SLIDE SWITCH	YMIC	
D1 ,2			HSS104	DIODE		
D1 ,2			1SS133	DIODE		
D3 ,4			HZS5.1N(B2)	ZENER DIODE		
D3 ,4			MTZJ5.1(B)	ZENER DIODE		
D3 ,4			RD5.1ES(B2)	ZENER DIODE		
D3 ,4			UZ-5.1BSB	ZENER DIODE		
D8			HSS104	DIODE		
D8			1SS133	DIODE		
D10			MA111	DIODE		
D12			HZS3.3N(B2)	ZENER DIODE		
D12			MTZJ3.3(B)	ZENER DIODE		
D12			RD3.3ES(B2)	ZENER DIODE		
D12			UZ-3.3BSB	ZENER DIODE		
D13			HZS2.7N(B2)	ZENER DIODE		
D13			MTZJ2.7(B)	ZENER DIODE		
D13			RD2.7ES(B2)	ZENER DIODE		
D13			UZ-2.7BSB	ZENER DIODE		
IC1			LA1832	ANALOGUE IC		
IC2			LC72131	MOS-IC		
IC4			NJM4565M	IC(OP AMP X2)		
Q1			2SC2714(R,O)	TRANSISTOR		
Q3			2SA1576A(R,S)	TRANSISTOR		
Q3			2SA1586(Y,GR)	TRANSISTOR		
Q3			2SB1218A(Q,R)	TRANSISTOR		
Q5			2SC4081(R,S)	TRANSISTOR		

L : Scandinavia
Y : PX(Far East, Hawaii)
Y : AAFES(Europe)

K : USA
T : Europe
X : Australia

P : Canada
E : Europe
M : Other Areas

R : Mexico
G : Germany
Q : Russia

Δ indicates safety critical components.

PARTS LIST

* New Parts

Parts without **Parts No.** are not supplied.

Les articles non mentionnés dans le **Parts No.** ne sont pas fournis.

Teile ohne **Parts No.** werden nicht geliefert.

7

Ref. No	Add-ress	New Parts	Parts No.	Description	Desti-nation	Re-marks
Q5			2SC4116(Y,GR)	TRANSISTOR		
Q5			2SD1819A(Q,R)	TRANSISTOR		
Q6			2SA1576A(R,S)	TRANSISTOR		
Q6			2SA1586(Y,GR)	TRANSISTOR		
Q6			2SB1218A(Q,R)	TRANSISTOR		
Q7 ,8			2SD1757K	TRANSISTOR		
Q7 ,8			2SD2114K	TRANSISTOR		
Q9 ,10			2SC4081(R,S)	TRANSISTOR	YMIC	
Q9 ,10			2SC4116(Y,GR)	TRANSISTOR		
Q9 ,10			2SD1819A(Q,R)	TRANSISTOR	YMIC	
A1			W02-2582-05	FM FRONT-END ASSY		
TUNER(X05-4680-10)						
C1			CE04LW1C470M	ELECTRO	47UF	16WV
C2			CE04LW1H010M	ELECTRO	1.0UF	50WV
C3			CK73FB1H103K	CHIP C	0.010UF	K
C5			CK73FB1H103K	CHIP C	0.010UF	K
C6 -10			CK73FB1H103K	CHIP C	0.010UF	K
C30			CK73EB1E473K	CHIP C	0.047UF	K
C31			CE04LW1C470M	ELECTRO	47UF	16WV
C32			CK73FB1H103K	CHIP C	0.010UF	K
C33			CE04LW1C100M	ELECTRO	10UF	16WV
C34			CK73FB1H103K	CHIP C	0.010UF	K
C35			CE04LW1C100M	ELECTRO	10UF	16WV
C36			CK73FB1E473K	CHIP C	0.047UF	K
C37			CK73FB1H103K	CHIP C	0.010UF	K
C38			C90-3217-05	ELECTRO	10UF	10WV
C40			C90-3253-05	ELECTRO	1.0UF	50WV
C41			C90-3251-05	ELECTRO	0.47UF	50WV
C42			C90-3240-05	ELECTRO	2.2UF	35WV
C43			CE04LW1HR47M	ELECTRO	0.47UF	50WV
C44			CK73FB1E473K	CHIP C	0.047UF	K
C45			CC73FCH1H220J	CHIP C	22PF	J
C46			CE04LW1A101M	ELECTRO	100UF	10WV
C47			CK73FB1H472K	CHIP C	4700PF	K
C48			CC73FSL1H101J	CHIP C	100PF	J
C49			CE04LW1H010M	ELECTRO	1.0UF	50WV
C50			CK73FB1H152K	CHIP C	1500PF	K
C51 ,52			C90-3217-05	ELECTRO	10UF	10WV
C53 ,54			CK73FB1H223K	CHIP C	0.022UF	K
C53 ,54			CK73FB1H333K	CHIP C	0.033UF	K
C55 ,56			CE04LW1H2R2M	ELECTRO	2.2UF	50WV
C57 ,58			CK73FB1H822K	CHIP C	8200PF	K
C59			CC73FSL1H101J	CHIP C	100PF	J
C60			CK73FB1E104K	CHIP C	0.10UF	K
C61			CK73FB1H103K	CHIP C	0.010UF	K
C62			CK73FB1H333K	CHIP C	0.033UF	K
C63			CC73FCH1H090D	CHIP C	9.0PF	D
C64			CK73FB1H333K	CHIP C	0.033UF	K
C66			CC73FCH1H060D	CHIP C	6.0PF	D
C67			CC73FCH1H220J	CHIP C	22PF	J
C68			CC73FSL1H020C	CHIP C	2.0PF	C
C70			CC73FSL1H101J	CHIP C	100PF	J
C73			CK73FB1H821K	CHIP C	820PF	K
C81			CC73FCH1H220J	CHIP C	22PF	J

L : Scandinavia
Y : PX(Far East, Hawaii)
Y : AAFES(Europe)

K : USA
T : Europe
X : Australia
M : Other Areas

P : Canada
E : Europe
G : Germany
Q : Russia

△ indicates safety critical components.

* New Parts

Parts without **Parts No.** are not supplied.

Les articles non mentionnés dans le **Parts No.** ne sont pas fournis.

Teile ohne **Parts No.** werden nicht geliefert.

8

Ref. No	Add-ress	New Parts	Parts No.	Description	Desti-nation	Re-marks
C82			CC73FCH1H270J	CHIP C	27PF	J
C84			CK73FB1H102K	CHIP C	1000PF	K
C85			CC73FSL1H101J	CHIP C	100PF	J
C86			CK73FB1H102K	CHIP C	1000PF	K
C87			CE04LW1C100M	ELECTRO	10UF	16WV
C89			CE04LW1C470M	ELECTRO	47UF	16WV
C90			CE04LW1H2R2M	ELECTRO	2.2UF	50WV
C91			CK73FB1H223K	CHIP C	0.022UF	K
C92			CC73FSL1H471J	CHIP C	470PF	J
C93			CK73FB1H103K	CHIP C	0.010UF	K
C96			CK73FB1H102K	CHIP C	1000PF	K
CN1			E40-4609-05	PIN ASSY		
CN2			E40-4871-05	PIN ASSY		
J1			E70-0052-05	LOCK TERMINAL BOARD		
CF1 ,2			L72-0536-05	CERAMIC FILTER		ET
CF1 ,2			L72-0596-05	CERAMIC FILTER		KP
L31			L30-0943-05	FM IFT		
L32			L30-0944-05	FM IFT		
L33			L30-0911-05	AM IFT		
L34			L79-1240-05	LC FILTER		ET
L35 ,36			L79-1239-05	LC FILTER		
L61			L40-1091-17	SMALL FIXED INDUCTOR(1UH)		
L62			L39-1351-05	COMBINATION COIL		KPE
L62			L39-1352-05	COMBINATION COIL		T
L63			L40-1001-17	SMALL FIXED INDUCTOR(10UH,K)		
L81			L40-1091-17	SMALL FIXED INDUCTOR(1UH)		
X31			L78-0637-05	RESONATOR (456KHZ)		
X81			L77-2159-05	CRYSTAL RESONATOR(7.2MHZ)		
R1			RD14NB2E221J	RD	220	J 1/4W
R2			RK73FB2A221J	CHIP R	220	J 1/10W
R3			RK73FB2A182J	CHIP R	1.8K	J 1/10W
R3			RK73FB2A561J	CHIP R	560	J 1/10W
R4			RK73FB2A222J	CHIP R	2.2K	J 1/10W
R5			RK73FB2A103J	CHIP R	10K	J 1/10W
R7			RK73FB2A221J	CHIP R	220	J 1/10W
R8			RK73FB2A681J	CHIP R	680	J 1/10W
R9			RK73FB2A470J	CHIP R	47	J 1/10W
R10			RK73FB2A101J	CHIP R	100	J 1/10W
R11			RK73FB2A331J	CHIP R	330	J 1/10W
R12			RK73FB2A101J	CHIP R	100	J 1/10W
R13			RK73FB2A681J	CHIP R	680	J 1/10W
R14			RK73FB2A332J	CHIP R	3.3K	J 1/10W
R15			RK73FB2A331J	CHIP R	330	J 1/10W
R16			RK73FB2A100J	CHIP R	10	J 1/10W
R16			RK73FB2A150J	CHIP R	15	J 1/10W
R17			RK73FB2A331J	CHIP R	330	J 1/10W
R18			RK73FB2A391J	CHIP R	390	J 1/10W
R19			RK73FB2A681J	CHIP R	680	J 1/10W
R20			RK73FB2A100J	CHIP R	10	J 1/10W
R20			RK73FB2A150J	CHIP R	15	J 1/10W
R21			RK73FB2A101J	CHIP R	100	J 1/10W
R22			RK73FB2A100J	CHIP R	10	J 1/10W
R31			RS14KB3A151JFR	FL-PROOF RS	150	J 1W

L : Scandinavia
Y : PX(Far East, Hawaii)
Y : AAFES(Europe)

K : USA
T : Europe
X : Australia
M : Other Areas

P : Canada
E : Europe
G : Germany
Q : Russia

△ indicates safety critical components.

C-V100/V150/V300/V350

PARTS LIST

* New Parts

Parts without **Parts No.** are not supplied.

Les articles non mentionnés dans le **Parts No.** ne sont pas fournis.

Teile ohne **Parts No.** werden nicht geliefert.

9

Ref. No	Add-ress	New Parts	Parts No.	Description	Desti-nation	Re-marks
R32			RK73EB2B562J	CHIP R 5.6K J 1/8W		
R33			RK73FB2A302J	CHIP R 3.0K J 1/10W		
R34			RK73FB2A822J	CHIP R 8.2K J 1/10W		
R35			RK73FB2A333J	CHIP R 33K J 1/10W		
R36			RK73FB2A393J	CHIP R 39K J 1/10W		
R37			RK73FB2A242J	CHIP R 2.4K J 1/10W		
R38			RK73FB2A333J	CHIP R 33K J 1/10W		
R39			RK73FB2A823J	CHIP R 82K J 1/10W		
R40			RK73FB2A202J	CHIP R 2.0K J 1/10W		
R41			RK73FB2A222J	CHIP R 2.2K J 1/10W		
R42			RK73FB2A202J	CHIP R 2.0K J 1/10W	ET	
R43 ,44			RK73FB2A222J	CHIP R 2.2K J 1/10W		
R45 ,46			RK73FB2A102J	CHIP R 1.0K J 1/10W		
R47 ,48			RK73FB2A392J	CHIP R 3.9K J 1/10W		
R49			RK73FB2A473J	CHIP R 47K J 1/10W		
R51			RK73FB2A392J	CHIP R 3.9K J 1/10W		
R52			RK73FB2A104J	CHIP R 100K J 1/10W		
R53			RK73FB2A102J	CHIP R 1.0K J 1/10W		
R55			RK73FB2A562J	CHIP R 5.6K J 1/10W		
R56 ,57			RK73FB2A101J	CHIP R 100 J 1/10W		
R59			RK73FB2A272J	CHIP R 2.7K J 1/10W		
R61			RK73FB2A223J	CHIP R 22K J 1/10W	T	
R62			RK73FB2A105J	CHIP R 1.0M J 1/10W	T	
R63			RK73FB2A473J	CHIP R 47K J 1/10W	T	
R64			RK73FB2A103J	CHIP R 10K J 1/10W	T	
R65			RK73FB2A153J	CHIP R 15K J 1/10W	T	
R66			RK73FB2A152J	CHIP R 1.5K J 1/10W	T	
R67			RK73FB2A104J	CHIP R 100K J 1/10W		
R68			RK73FB2A222J	CHIP R 2.2K J 1/10W	T	
R69			RK73FB2A103J	CHIP R 10K J 1/10W		
R70			RK73FB2A105J	CHIP R 1.0M J 1/10W	T	
R80			RK73EB2B102J	CHIP R 1.0K J 1/8W		
R81 -83			RK73FB2A102J	CHIP R 1.0K J 1/10W		
R84			RK73FB2A103J	CHIP R 10K J 1/10W		
R85 -88			RK73FB2A102J	CHIP R 1.0K J 1/10W		
Δ R89			RD14NB2E101J	RD 100 J 1/4W		
R90			RK73FB2A562J	CHIP R 5.6K J 1/10W		
R91			RK73FB2A222J	CHIP R 2.2K J 1/10W		
R92			RK73FB2A123J	CHIP R 12K J 1/10W		
R93			RK73FB2A122J	CHIP R 1.2K J 1/10W		
R94			RD14NB2E561J	RD 560 J 1/4W		
R101,102			RK73FB2A102J	CHIP R 1.0K J 1/10W		
R103			RK73FB2A821J	CHIP R 820 J 1/10W		
R104			RK73FB2A473J	CHIP R 47K J 1/10W		
R105			RK73FB2A822J	CHIP R 8.2K J 1/10W		
W51 ,52			R92-0670-05	CHIP R 0 OHM	KPE	
W53			R92-0670-05	CHIP R 0 OHM		
W54 ,55			R92-0670-05	CHIP R 0 OHM	KPE	
W56			R92-0679-05	CHIP R 0 OHM	T	
W57 ,58			R92-0679-05	CHIP R 0 OHM		
W59			R92-0670-05	CHIP R 0 OHM		
W61			R92-0670-05	CHIP R 0 OHM		
W62 -64			R92-0679-05	CHIP R 0 OHM		
W66 ,67			R92-0679-05	CHIP R 0 OHM		
W71			R92-0670-05	CHIP R 0 OHM		

L : Scandinavia
Y : PX(Far East, Hawaii)
Y : AAFES(Europe)

K : USA
T : Europe
X : Australia
M : Other Areas

P : Canada
E : Europe
M : Other Areas

R : Mexico
G : Germany
Q : Russia

Δ indicates safety critical components.

* New Parts

Parts without **Parts No.** are not supplied.

Les articles non mentionnés dans le **Parts No.** ne sont pas fournis.

Teile ohne **Parts No.** werden nicht geliefert.

10

Ref. No	Add-ress	New Parts	Parts No.	Description	Desti-nation	Re-marks
W75			R92-0670-05	CHIP R 0 OHM		
W76			R92-0670-05	CHIP R 0 OHM	T	
W81			R92-0679-05	CHIP R 0 OHM		
W83			R92-0679-05	CHIP R 0 OHM		
W85			R92-0670-05	CHIP R 0 OHM	ET	
D1			HSS104	DIODE		
D1			1SS133	DIODE		
D2			HSS104	DIODE	ET	
D2			1SS133	DIODE	ET	
D31			HZS8.2N(B2)	ZENER DIODE		
D31			RD8.2ES(B2)	ZENER DIODE		
D32			HSS104	DIODE		
D32			1SS133	DIODE		
D61 ,62			HSS104	DIODE		
D61 ,62			1SS133	DIODE		
D81			HZS5.1N(B2)	ZENER DIODE		
D81			RD5.1ES(B2)	ZENER DIODE		
D101			HZS3.3N(B2)	ZENER DIODE		
D101			RD3.3ES(B2)	ZENER DIODE		
D102			HZS2.7N(B2)	ZENER DIODE		
D102			RD2.7ES(B2)	ZENER DIODE		
IC1			LA1836	ANALOGUE IC		
IC2			LC72131	MOS-IC		
Q1 ,2			2SC4081(R,S)	TRANSISTOR		
Q1 ,2			2SC4116(Y,GR)	TRANSISTOR		
Q3			2SA1576A(R,S)	TRANSISTOR		
Q3			2SA1586(Y,GR)	TRANSISTOR		
Q4			2SC4081(R,S)	TRANSISTOR		
Q4			2SC4116(Y,GR)	TRANSISTOR		
Q31 ,32			2SC4081(R,S)	TRANSISTOR		
Q31 ,32			2SC4116(Y,GR)	TRANSISTOR		
Q33 ,34			2SC4081(R,S)	TRANSISTOR	ET	
Q33 ,34			2SC4116(Y,GR)	TRANSISTOR	ET	
Q61 ,62			2SC4081(R,S)	TRANSISTOR	T	
Q61 ,62			2SC4116(Y,GR)	TRANSISTOR	T	
Q63			2SC2878(B)	TRANSISTOR	T	
Q64			2SA1576A(R,S)	TRANSISTOR	T	
Q64			2SA1586(Y,GR)	TRANSISTOR	T	
Q65			2SK302(Y,GR)	FET	T	
Q81			2SA1576A(R,S)	TRANSISTOR		
Q81			2SA1586(Y,GR)	TRANSISTOR		
Q101,102			2SD1757K	TRANSISTOR		
Q103			2SA1576A(R,S)	TRANSISTOR		
Q103			2SA1586(Y,GR)	TRANSISTOR		
A1			W02-2582-05	FM FRONT-END ASSY	KP	
A1			W02-2584-05	FM FRONT-END ASSY	ET	
PRE(X08-2760-10 / X08-2810-20)						
C1 -4	35		CF92FV1H104J	MF-O 0.10UF J		
C5 ,6	35		CE04KW1H220M	ELECTRO 22UF 50WV		
C7 ,8			CE04KW1A101M	ELECTRO 100UF 10WV		
C11 ,12			CK45FB1H102K	CERAMIC 1000PF K		
C13 ,14			CE04KW1H100M	ELECTRO 10UF 50WV		
C15 ,16			CE04KW1H3R3M	ELECTRO 3.3UF 50WV		
C17 -21			CC45FSL1H101J	CERAMIC 100PF J		

L : Scandinavia
Y : PX(Far East, Hawaii)
Y : AAFES(Europe)

K : USA
T : Europe
X : Australia
M : Other Areas

P : Canada
E : Europe
M : Other Areas

R : Mexico
G : Germany
Q : Russia
3 : C-V300
10 : C-V100
15 : C-V100/V150
35 : C-V300/V350
350 : C-V350

Δ indicates safety critical components.

PARTS LIST

* New Parts

Parts without **Parts No.** are not supplied.

Les articles non mentionnés dans le **Parts No.** ne sont pas fournis.

Teile ohne **Parts No.** werden nicht geliefert.

11

Ref. No	Add-ress	New Parts	Parts No.	Description	Desti-nation	Re-marks
C22	35		CC45FSL1H101J	CERAMIC 100PF J		
C23			CC45FSL1H101J	CERAMIC 100PF J		
C24	35		CC45FSL1H101J	CERAMIC 100PF J		
C27			CK45FB1H102K	CERAMIC 1000PF K		
C28	35		CK45FB1H102K	CERAMIC 1000PF K		
C29	15		CE04KW1H0R1M	ELECTRO 0.1UF 50WV		
C29	35		CE04KW1H100M	ELECTRO 10UF 50WV		
C30	35		CE04KW1H100M	ELECTRO 10UF 50WV		
C31 ,32			CC45FSL1H101J	CERAMIC 100PF J		
C34			CK45FB1H102K	CERAMIC 1000PF K		
C35	15		CE04KW1H0R1M	ELECTRO 0.1UF 50WV		
C35	35		CE04KW1H100M	ELECTRO 10UF 50WV		
C36			CE04KW1H2R2M	ELECTRO 2.2UF 50WV		
C37			CE04KW1C220M	ELECTRO 22UF 16WV		
C39			CE04KW1C220M	ELECTRO 22UF 16WV		
C40	350		CE04KW1C220M	ELECTRO 22UF 16WV	ET	
C41			CE04KW1H2R2M	ELECTRO 2.2UF 50WV		
C43			CF92FV1H224J	MF-C 0.22UF J		
C44			CQ93FMG1H333J	MYLAR 0.033UF J		
C45			CF92FV1H564J	MF-C 0.56UF J		
C46			CK45FB1H102K	CERAMIC 1000PF K		
C47			CE04KW1H220M	ELECTRO 22UF 50WV		
C48			CE04KW1C330M	ELECTRO 33UF 16WV		
C49			CE04KW1H2R2M	ELECTRO 2.2UF 50WV		
C50	35		CE04KW1H2R2M	ELECTRO 2.2UF 50WV		
C51			CK45FF1H103Z	CERAMIC 0.010UF Z		
C52			CE04HW1E100M	NP-ELEC 10UF 25WV	MICX	
C52			CE04HW1H010M	NP-ELEC 1.0UF 50WV	KPYET	
C55			CK45FF1H103Z	CERAMIC 0.010UF Z		
C56			CE04KW1H010M	ELECTRO 1.0UF 50WV		
C61 ,62			CE04KW1H010M	ELECTRO 1.0UF 50WV		
C63 ,64			CE04KW1H220M	ELECTRO 22UF 50WV		
C67 ,68			CK45FF1H472Z	CERAMIC 4700PF Z		
C69 ,70			CE04KW1H010M	ELECTRO 1.0UF 50WV		
C71			CQ93FMG1H103J	MYLAR 0.010UF J		
C72			CQ93FMG1H102J	MYLAR 1000PF J		
C73			CQ93FMG1H103J	MYLAR 0.010UF J		
C74			CQ93FMG1H102J	MYLAR 1000PF J		
C75			CQ93FMG1H103J	MYLAR 0.010UF J		
C76			CQ93FMG1H102J	MYLAR 1000PF J		
C77	35		CQ93FMG1H103J	MYLAR 0.010UF J		
C78	35		CQ93FMG1H102J	MYLAR 1000PF J		
C79			CQ93FMG1H103J	MYLAR 0.010UF J		
C80			CQ93FMG1H391K	MYLAR 390PF K		
C81 ,82			CE04KW1H2R2M	ELECTRO 2.2UF 50WV		
C83 ,84			CE04KW1H100M	ELECTRO 10UF 50WV		
C85 ,86			CE04KW1H010M	ELECTRO 1.0UF 50WV		
C87 ,88			CQ93FMG1H562J	MYLAR 5600PF J		
C89 -92			CF92FV1H104J	MF-C 0.10UF J		
C93 ,94			CQ93FMG1H223J	MYLAR 0.022UF J		
C95 ,96			CQ93FMG1H183J	MYLAR 0.018UF J		
C97 ,98			CE04KW1H2R2M	ELECTRO 2.2UF 50WV		
C99			CE04KW1C470M	ELECTRO 47UF 16WV		
C101			CE04KW1V4R7M	ELECTRO 4.7UF 35WV		
C104			CF92FV1H104J	MF-C 0.10UF J		

L : Scandinavia K : USA P : Canada R : Mexico 3 : C-V300 35 : C-V300/V350
 Y : PX(Far East, Hawaii) T : Europe E : Europe G : Germany 10 : C-V100 350 : C-V350
 Y : AAFES(Europe) X : Australia M : Other Areas Q : Russia 15 : C-V100/V150

⚠ indicates safety critical components.

* New Parts

Parts without **Parts No.** are not supplied.

Les articles non mentionnés dans le **Parts No.** ne sont pas fournis.

Teile ohne **Parts No.** werden nicht geliefert.

12

Ref. No	Add-ress	New Parts	Parts No.	Description	Desti-nation	Re-marks
C105,106	35		CC45FSL1H100D	CERAMIC 10PF D		
C105,106	15		CC45FSL1H101J	CERAMIC 100PF J		
C107,108			CC45FSL1H101J	CERAMIC 100PF J		
C110			CC45FSL1H101J	CERAMIC 100PF J		
C111	15		CE04KW1H010M	ELECTRO 1.0UF 50WV		
C111	35		CE04KW1H4R7M	ELECTRO 4.7UF 50WV		
C112,113			CC45FSL1H101J	CERAMIC 100PF J		
C114	15		CE04KW1H010M	ELECTRO 1.0UF 50WV		
C114	35		CE04KW1H4R7M	ELECTRO 4.7UF 50WV		
C115	35		CE04KW1H2R2M	ELECTRO 2.2UF 50WV		
C116	35		CE04KW1H0R1M	ELECTRO 0.1UF 50WV		
C116	15		CE04KW1H2R2M	ELECTRO 2.2UF 50WV		
C117			CE04KW1V4R7M	ELECTRO 4.7UF 35WV		
C118	35		CE04KW1H0R1M	ELECTRO 0.1UF 50WV		
C118	15		CE04KW1H2R2M	ELECTRO 2.2UF 50WV		
C119	35		CE04KW1H2R2M	ELECTRO 2.2UF 50WV		
C121	35		CE04KW1V4R7M	ELECTRO 4.7UF 35WV		
C122,123	35		CC45FSL1H101J	CERAMIC 100PF J		
C124	35		CE04KW1H4R7M	ELECTRO 4.7UF 50WV		
C125	35		CE04KW1H2R2M	ELECTRO 2.2UF 50WV		
C126	35		CE04KW1H0R1M	ELECTRO 0.1UF 50WV		
C127	35		CE04KW1V4R7M	ELECTRO 4.7UF 35WV		
C128,129	35		CE04KW1H2R2M	ELECTRO 2.2UF 50WV		
C131,132	35		CC45FSL1H100D	CERAMIC 10PF D		
C133	35		CK45FB1H102K	CERAMIC 1000PF K		
C134,135	35		CK45FF1H103Z	CERAMIC 0.010UF Z		
C141,142			CC45FSL1H470J	CERAMIC 47PF J		
C143			CE04HW1E100M	NP-ELEC 10UF 25WV		
C144,145			CC45FSL1H470J	CERAMIC 47PF J		
C146			CE04HW1E100M	NP-ELEC 10UF 25WV		
C147	35		CC45FSL1H470J	CERAMIC 47PF J		
C148	35		CE04HW1E100M	NP-ELEC 10UF 25WV		
C151,152	15		CE04KW1H100M	ELECTRO 10UF 50WV		
C153,154			CK45FF1H103Z	CERAMIC 0.010UF Z		
C155			CE04KW1C221M	ELECTRO 220UF 16WV		
C160			CC45FSL1H271J	CERAMIC 270PF J		ET
C161			CK45FB1H471K	CERAMIC 470PF K		ET
C162			CE04KW1H010M	ELECTRO 1.0UF 50WV		ET
C163			CK45FB1H102K	CERAMIC 1000PF K		ET
C164			CE04KW1H010M	ELECTRO 1.0UF 50WV		ET
C165			CE04KW1A101M	ELECTRO 100UF 10WV		ET
CN1			E40-4609-05	PIN ASSY		
CN2			E40-4902-05	FLAT CABLE CONNECTOR		
CN3	35		E40-4902-05	FLAT CABLE CONNECTOR		
J1			E11-0280-05	PHONE JACK		KPYET
J1			E11-0282-05	PHONE JACK		MICX
J2			E63-0163-05	PHONO JACK		
J3	35		E63-1005-05	PHONO JACK		
J4			E11-0283-05	MINIATURE PHONE JACK(3P)		ET
W5 ,6	35		E31-0001-00	JUMPER WIRE		
W9	35		E31-0001-00	JUMPER WIRE		
W11	35		E31-0001-00	JUMPER WIRE		
W13 -17	35		E31-0001-00	JUMPER WIRE		
W19 -28	35		E31-0001-00	JUMPER WIRE		

L : Scandinavia K : USA P : Canada R : Mexico 3 : C-V300 35 : C-V300/V350
 Y : PX(Far East, Hawaii) T : Europe E : Europe G : Germany 10 : C-V100 350 : C-V350
 Y : AAFES(Europe) X : Australia M : Other Areas Q : Russia 15 : C-V100/V150

⚠ indicates safety critical components.

C-V100/V150/V300/V350

PARTS LIST

* New Parts

Parts without **Parts No.** are not supplied.
Les articles non mentionnés dans le **Parts No.** ne sont pas fournis.
Teile ohne **Parts No.** werden nicht geliefert.

13

Ref. No	Add-ress	New Parts	Parts No.	Description	Desti-nation	Re-marks
W31 -36	35		E31-0001-00	JUMPER WIRE		
W39	35		E31-0001-00	JUMPER WIRE		
W43	35		E31-0001-00	JUMPER WIRE		
E1 ,2	15		J19-3290-05	LEAD HOLDER		
E5 -9			J11-0809-05	WIRE CLAMPER		
R7 ,8	35		RD14BB2C223J	RD 22K J 1/6W		
R9 ,10	35		RD14BB2C113J	RD 11K J 1/6W		
R11 ,12	35		RD14BB2C331J	RD 330 J 1/6W		
R31	15		RD14BB2C103J	RD 10K J 1/6W		
R31 ,32	35		RD14BB2C153J	RD 15K J 1/6W		
R34	35		RD14BB2C432J	RD 4.3K J 1/6W		
R36	35		RD14BB2C182J	RD 1.8K J 1/6W		
R44	35		RD14BB2C473J	RD 47K J 1/6W		
R48	35		RD14BB2C473J	RD 47K J 1/6W		
R50	35		RD14BB2C242J	RD 2.4K J 1/6W		
R54	35		RD14BB2C220J	RD 22 J 1/6W		
R56	35		RD14BB2C220J	RD 22 J 1/6W		
R61	15		RD14BB2C103J	RD 10K J 1/6W		
R61	35		RD14BB2C153J	RD 15K J 1/6W		
R86	15		RD14BB2C471J	RD 470 J 1/6W		
R86	35		RD14BB2C821J	RD 820 J 1/6W		
R87 -89	15		RD14BB2C103J	RD 10K J 1/6W		
R87 -89	35		RD14BB2C113J	RD 11K J 1/6W		
R93	35		RD14BB2C102J	RD 1.0K J 1/6W		
R111,112			RS14KB3A470J	FL-PROOF RS 47 J 1W		
R119,120			RS14KB3D101J	FL-PROOF RS 100 J 2W		
R137-139	35		RD14BB2C102J	RD 1.0K J 1/6W		
R140	35		RS14KB3A121J	FL-PROOF RS 120 J 1W		
R143-145	35		RD14BB2C224J	RD 220K J 1/6W		
R146	35		RD14BB2C563J	RD 56K J 1/6W		
R151-155	35		RD14BB2C562J	RD 5.6K J 1/6W		
R156	35		RD14BB2C333J	RD 33K J 1/6W		
R170	35		RD14BB2C750J	RD 75 J 1/6W		
R173	35		RD14BB2C102J	RD 1.0K J 1/6W		
R174,175			RS14KB3A391J	FL-PROOF RS 390 J 1W		
R181			RD14NB2E152J	RD 1.5K J 1/4W		
R219			RD14NB2E181J	RD 180 J 1/4W	ET	
R226	35		RD14BB2C223J	RD 22K J 1/6W		
D1 ,2			HZS8.2N(B2)	ZENER DIODE		
D1 ,2			MTZJ8.2(B)	ZENER DIODE		
D1 ,2			RD8.2ES(B2)	ZENER DIODE		
D1 ,2			UZ-8.2BSB	ZENER DIODE		
D3	35		HZS8.2N(B2)	ZENER DIODE		
D3	35		MTZJ8.2(B)	ZENER DIODE		
D3	35		RD8.2ES(B2)	ZENER DIODE		
D4 ,5			UZ-8.2BSB	ZENER DIODE		
D4 ,5			HZS8.2N(B2)	ZENER DIODE		
D4 ,5			MTZJ8.2(B)	ZENER DIODE		
D4 ,5			RD8.2ES(B2)	ZENER DIODE		
D4 ,5			UZ-8.2BSB	ZENER DIODE		
D6 -10	35		HZS8.2N(B2)	ZENER DIODE		
D6 -10	35		MTZJ8.2(B)	ZENER DIODE		
D6 -10	35		RD8.2ES(B2)	ZENER DIODE		

L : Scandinavia K : USA P : Canada R : Mexico 3 : C-V300 35 : C-V300/V350
Y : PX(Far East, Hawaii) T : Europe E : Europe G : Germany 10 : C-V100 350 : C-V350
Y : AAFES(Europe) X : Australia M : Other Areas Q : Russia 15 : C-V100/V150

⚠ indicates safety critical components.

* New Parts

Parts without **Parts No.** are not supplied.
Les articles non mentionnés dans le **Parts No.** ne sont pas fournis.
Teile ohne **Parts No.** werden nicht geliefert.

14

Ref. No	Add-ress	New Parts	Parts No.	Description	Desti-nation	Re-marks
D6 -10	35		UZ-8.2BSB	ZENER DIODE		
D11 ,12			HZS5.1N(B2)	ZENER DIODE		
D11 ,12			MTZJ5.1(B)	ZENER DIODE		
D11 ,12			RD5.1ES(B2)	ZENER DIODE		
D11 ,12			UZ-5.1BSB	ZENER DIODE		
D13			HZS10N(B2)	ZENER DIODE		
D13			MTZJ10(B)	ZENER DIODE		
D13			RD10ES(B2)	ZENER DIODE		
D13			UZ-10BSB	ZENER DIODE		
D14 ,15			HSS104A	DIODE		
D14 ,15			1SS131	DIODE		
D16			HZS3.9N(B2)	ZENER DIODE		
D16			MTZJ3.9(B)	ZENER DIODE		
D16			RD3.9ES(B2)	ZENER DIODE		
D16			UZ-3.9BSB	ZENER DIODE		
D18 ,19	35		HSS104A	DIODE		
D18 ,19	35		1SS131	DIODE		
D20 ,21			HSS104A	DIODE		ET
D20 ,21			1SS131	DIODE		ET
IC1			NJM4580D-D	IC(OP AMP X2)		
IC2 ,3			NJM4565D-D	IC(OP AMP X2)		
IC4	35		NJM4565D-D	IC(OP AMP X2)		
IC5			NJM4580D-D	IC(OP AMP X2)		
IC6			NJM2279D	IC(VIDEO IC)		
IC7			TDA7466	ANALOGUE IC		
IC8			TDA7309	ANALOGUE IC		
IC9	35		TDA7309	ANALOGUE IC		
IC10	35		TC9215AP	ANALOGUE IC		
IC11	35		NJM4580D-D	IC(OP AMP X2)		
Q1 ,2			2SC2878(B)	TRANSISTOR		
Q3 ,4	35		2SC2878(B)	TRANSISTOR		
Q5			2SC2878(B)	TRANSISTOR		
Q6	35		2SC2878(B)	TRANSISTOR		
Q7 ,8			2SC2878(B)	TRANSISTOR		
Q11 ,12			2SC2878(B)	TRANSISTOR		
Q15			2SA1048(Y,GR)	TRANSISTOR		
Q15			2SA1175(F,E)	TRANSISTOR		
Q15			2SA1309A(Q,R)	TRANSISTOR		
Q15			2SA933AS(Q,R)	TRANSISTOR		
Q16			2SC1740S(Q,R)	TRANSISTOR		
Q16	35		2SC2458(Y,GR)	TRANSISTOR		
Q16			2SC2785(F,E)	TRANSISTOR		
Q16			2SC3311A(Q,R)	TRANSISTOR		
Q17	35		2SA1048(Y,GR)	TRANSISTOR		
Q17	35		2SA1175(F,E)	TRANSISTOR		
Q17	35		2SA1309A(Q,R)	TRANSISTOR		
Q17	35		2SA933AS(Q,R)	TRANSISTOR		
Q18			2SC1740S(Q,R)	TRANSISTOR		
Q18			2SC2458(Y,GR)	TRANSISTOR		ET
Q18			2SC2785(F,E)	TRANSISTOR		ET
Q18			2SC3311A(Q,R)	TRANSISTOR		ET
Q19			2SA1048(Y,GR)	TRANSISTOR		
Q19			2SA1175(F,E)	TRANSISTOR		
Q19			2SA1309A(Q,R)	TRANSISTOR		
Q19			2SA933AS(Q,R)	TRANSISTOR		

L : Scandinavia K : USA P : Canada R : Mexico 3 : C-V300 35 : C-V300/V350
Y : PX(Far East, Hawaii) T : Europe E : Europe G : Germany 10 : C-V100 350 : C-V350
Y : AAFES(Europe) X : Australia M : Other Areas Q : Russia 15 : C-V100/V150

⚠ indicates safety critical components.

PARTS LIST

* New Parts

Parts without **Parts No.** are not supplied.

Les articles non mentionnés dans le **Parts No.** ne sont pas fournis.

Teile ohne **Parts No.** werden nicht geliefert.

15

Ref. No	Add-ress	New Parts	Parts No.	Description	Desti-nation	Re-marks
CONTROL(X11-3730-10 / X11-3790-20)						
C1 -4			CC45FSL1H221J	CERAMIC 220PF J	ET	
C5 ,6			CC45FSL1H221J	CERAMIC 220PF J		
C7 ,8			CC45FSL1H221J	CERAMIC 220PF J	ET	
C9 ,10			CC45FSL1H221J	CERAMIC 220PF J		
C11 -14			CC45FSL1H221J	CERAMIC 220PF J	ET	
C15 ,16			CC45FSL1H221J	CERAMIC 220PF J		
C17 ,18			CC45FSL1H221J	CERAMIC 220PF J	ET	
C19 -24	350		CC45FSL1H221J	CERAMIC 220PF J	ET	
C25 ,26			CC45FSL1H221J	CERAMIC 220PF J		
C27		3	CC45FSL1H221J	CERAMIC 220PF J	MICXET	
C28 -30			CC45FSL1H221J	CERAMIC 220PF J		
C31 ,32			CE04KW1H2R2M	ELECTRO 2.2UF 50WV		
C33 ,34			CC45FSL1H221J	CERAMIC 220PF J		
C35 ,36			C90-3748-05	ELECTRO 22UF 16WV		
C37 ,38			CE04KW1C220M	ELECTRO 22UF 16WV		
C39			CK45FF1H103Z	CERAMIC 0.010UF Z		
C40			CK45FB1H391K	CERAMIC 390PF K		
C41 -44			CQ93FMG1H102J	MYLAR 1000PF J		
C45			CK45FF1H103Z	CERAMIC 0.010UF Z		
C46			CE04HW1H2R2M	NP-ELEC 2.2UF 50WV		
C47 ,48			CC45FSL1H101J	CERAMIC 100PF J		
C51 ,52			CC45FSL1H101J	CERAMIC 100PF J		
C53 ,54			CE04KW1H010M	ELECTRO 1.0UF 50WV		
C59 ,60			CC45FSL1H101J	CERAMIC 100PF J		
C61 ,62			CE04KW1C100M	ELECTRO 10UF 16WV		
C63			CE04KW1H010M	ELECTRO 1.0UF 50WV		
C64			CF92FV1H474J	MF-C 0.47UF J		
C66			CQ93FMG1H222J	MYLAR 2200PF J		
C67			CE04KW1C100M	ELECTRO 10UF 16WV		
C68 ,69			CK45FF1H103Z	CERAMIC 0.010UF Z		
C71			CQ93FMG1H223J	MYLAR 0.022UF J		
C72			CQ93FMG1H473J	MYLAR 0.047UF J		
C73			CE04KW1C221M	ELECTRO 220UF 16WV		
C74 -77			CE04KW1C100M	ELECTRO 10UF 16WV		
C78			CE04KW1C221M	ELECTRO 220UF 16WV		
C79 ,80			CQ93FMG1H104J	MYLAR 0.10UF J		
C81			CE04KW1HR47M	ELECTRO 0.47UF 50WV		
C82			CE04KW1V4R7M	ELECTRO 4.7UF 35WV		
C83			CE04KW1HR47M	ELECTRO 0.47UF 50WV		
C84			CE04KW1V4R7M	ELECTRO 4.7UF 35WV		
C85			CF92FV1H154J	MF-C 0.15UF J		
C86			CE04KW1H3R3M	ELECTRO 3.3UF 50WV		
C87 ,88			CF92FV1H154J	MF-C 0.15UF J		
C89			CE04KW1H3R3M	ELECTRO 3.3UF 50WV		
C90			CF92FV1H154J	MF-C 0.15UF J		
C91			CE04KW1V4R7M	ELECTRO 4.7UF 35WV		
C92			CE04KW1HR47M	ELECTRO 0.47UF 50WV		
C93			CE04KW1V4R7M	ELECTRO 4.7UF 35WV		
C94			CE04KW1HR47M	ELECTRO 0.47UF 50WV		
C95 ,96			CQ93FMG1H104J	MYLAR 0.10UF J		
C97			CE04KW1E470M	ELECTRO 47UF 25WV		
C98			CF92FV1H474J	MF-C 0.47UF J		
C99			CQ93FMG1H681J	MYLAR 680PF J		

L : Scandinavia K : USA P : Canada R : Mexico 3 : C-V300 35 : C-V300/V350
 Y : PX(Far East, Hawaii) T : Europe E : Europe G : Germany 10 : C-V100 350 : C-V350
 Y : AAFES(Europe) X : Australia M : Other Areas Q : Russia 15 : C-V100/V150

Δ indicates safety critical components.

* New Parts

Parts without **Parts No.** are not supplied.

Les articles non mentionnés dans le **Parts No.** ne sont pas fournis.

Teile ohne **Parts No.** werden nicht geliefert.

15

Ref. No	Add-ress	New Parts	Parts No.	Description	Desti-nation	Re-marks
C100			CE04KW1H2R2M	ELECTRO 2.2UF 50WV		
C101			CQ93FMG1H103J	MYLAR 0.010UF J		
C102			CE04KW1HR33M	ELECTRO 0.33UF 50WV		
C103			CE04KW1C221M	ELECTRO 220UF 16WV		
C104			CE04KW1HR47M	ELECTRO 0.47UF 50WV		
C105			CQ93FMG1H823J	MYLAR 0.082UF J		
C106			CQ93FMG1H332J	MYLAR 3300PF J		
C107			CQ93FMG1H823J	MYLAR 0.082UF J		
C108			CE04KW1C221M	ELECTRO 220UF 16WV		
C109			CQ93FMG1H104J	MYLAR 0.10UF J		
C111-114			CC45FSL1H101J	CERAMIC 100PF J		
C115-117			CK45FB1H102K	CERAMIC 1000PF K		
C118,119			CK45FF1H103Z	CERAMIC 0.010UF Z		
C120,121			CC45FCH1H180J	CERAMIC 18PF J		
C122			CK45FF1H103Z	CERAMIC 0.010UF Z		
C123			CE04KW0J331M	ELECTRO 330UF 6.3WV		
C124			CE04KW1A101M	ELECTRO 100UF 10WV		
C133			CE04KW1E470M	ELECTRO 47UF 25WV		
C136			CQ93FMG1H104J	MYLAR 0.10UF J		
C137,138			CK45FB1H102K	CERAMIC 1000PF K		
C139			CE04KW1H100M	ELECTRO 10UF 50WV		
C141-144			CK45FF1H103Z	CERAMIC 0.010UF Z		
C145			CE04KW1H102M	ELECTRO 1000UF 50WV		
C146			CK45FB1H391K	CERAMIC 390PF K		
C147			CE04KW1E470M	ELECTRO 47UF 25WV		
C150			CE04KW1E470M	ELECTRO 47UF 25WV		
C151			CE04KW1H102M	ELECTRO 1000UF 50WV		
C152			CE04KW1V4R7M	ELECTRO 4.7UF 35WV		
C156			CE04KW1E470M	ELECTRO 47UF 25WV		
C157			CK45FF1H103Z	CERAMIC 0.010UF Z		
C158			CE04KW1H100M	ELECTRO 10UF 50WV		
C159			CK45FF1H103Z	CERAMIC 0.010UF Z		
C160			CE04KW1E102M	ELECTRO 1000UF 25WV		
C161			CK45FF1H103Z	CERAMIC 0.010UF Z		
C162			CE04KW1C220M	ELECTRO 22UF 16WV		
C163			CK45FB1H102K	CERAMIC 1000PF K	ET	
C163		3	CK45FB1H102K	CERAMIC 1000PF K	MICX	
C164			CE04KW1A470M	ELECTRO 47UF 10WV		
C165			CK45FF1H103Z	CERAMIC 0.010UF Z		
C166			CE04KW1J331M	ELECTRO 330UF 63WV		
C167			CK45FF1H103Z	CERAMIC 0.010UF Z		
C168			CE04KW1H100M	ELECTRO 10UF 50WV		
C169			CK45FB1H102K	CERAMIC 1000PF K		
C170			CE04KW1H100M	ELECTRO 10UF 50WV		
C171		*	C90-3747-05	ELECTRO 4.7UF 50WV		
C172		*	C90-3749-05	ELECTRO 47UF 16WV		
C173,174			CE04KW1H010M	ELECTRO 1.0UF 50WV		
C175			CK45FB1H102K	CERAMIC 1000PF K		
C176			CK45FF1H103Z	CERAMIC 0.010UF Z		
C177			C90-3623-05	BACK UP 0.33F 5.5V		
C178			CK45FF1H103Z	CERAMIC 0.010UF Z		
C179,180			CE04KW1E470M	ELECTRO 47UF 25WV		
C181-185			CK45FF1H103Z	CERAMIC 0.010UF Z		
C186			C91-1488-05	MF 6800PF 250VAC		
C189,190			CC45FSL1H221J	CERAMIC 220PF J		

Δ

L : Scandinavia K : USA P : Canada R : Mexico 3 : C-V300 35 : C-V300/V350
 Y : PX(Far East, Hawaii) T : Europe E : Europe G : Germany 10 : C-V100 350 : C-V350
 Y : AAFES(Europe) X : Australia M : Other Areas Q : Russia 15 : C-V100/V150

Δ indicates safety critical components.

C-V100/V150/V300/V350

PARTS LIST

* New Parts

Parts without **Parts No.** are not supplied.

Les articles non mentionnés dans le **Parts No.** ne sont pas fournis.

Teile ohne **Parts No.** werden nicht geliefert.

17

Ref. No	Add-ress	New Parts	Parts No.	Description	Desti-nation	Re-marks
C191			CK45FF1H103Z	CERAMIC 0.010UF Z		
C192	3		CE04KW1H100M	ELECTRO 10UF 50WV	ET	
C192			CE04KW1H100M	ELECTRO 10UF 50WV	MICX	
C193			CK45FF1H103Z	CERAMIC 0.010UF Z		
C194			CE04HW1H2R2M	NP-ELEC 2.2UF 50WV		
C195			CE04KW1H010M	ELECTRO 1.0UF 50WV		
C196-199			CC45FSL1H221J	CERAMIC 220PF J		
C200			CE04KW1E470M	ELECTRO 47UF 25WV		
C201			CK45FB1H391K	CERAMIC 390PF K		
C202			CK45FB1H103Z	CERAMIC 0.010UF Z		
CN1		*	E40-4245-05	PIN ASSY	MICX	
CN1			E40-8126-05	PIN ASSY	KPYET	
CN3			E40-4918-05	FLAT CABLE CONNECTOR		
CN4	10		E40-4902-05	FLAT CABLE CONNECTOR		
CN4	3		E40-4906-05	FLAT CABLE CONNECTOR	MICX	
CN4			E40-4908-05	FLAT CABLE CONNECTOR	ET	
CN15			E40-3249-05	PIN ASSY	MICXET	
CN16			E40-4902-05	FLAT CABLE CONNECTOR		
CN17	35		E40-4902-05	FLAT CABLE CONNECTOR		
CN18			E40-4607-05	FLAT CABLE CONNECTOR		
J1 -3			E63-0139-15	PHONO JACK		
J4	35		E63-0111-05	PHONO JACK		
J5			E11-0293-05	MINIATURE PHONE JACK(2P)		
Δ J6			E03-0148-05	AC OUTLET	KPY	
Δ J6			E03-0149-05	AC OUTLET	EMI	
Δ J6			E03-0310-05	AC OUTLET	T	
Δ J6			E03-0325-05	AC OUTLET	X	
Δ J6			E03-0330-05	AC OUTLET	C	
J7			E58-0018-05	RECTANGULAR RECEPTACLE		
W207	10		E31-0001-00	JUMPER WIRE		
W228	10		E31-0001-00	JUMPER WIRE		
Δ F1			F05-2525-05	FUSE (SEMKO) (250V T2.5AL)	ET	
Δ F2 ,3			F05-8013-05	FUSE (SEMKO) (250V T800MAL)	MICX	
Δ F2 ,3			F05-8013-05	FUSE (SEMKO) (250V T800MAL)	YTE	
Δ F2 ,3			F50-0067-05	FUSE (5X20)	KP	
CN5 ,6			J13-0075-05	FUSE CLIP	ET	
CN11-14			J13-0075-05	FUSE CLIP		
E10			J11-0808-05	WIRE CLAMPER		
X1			L78-0284-05	RESONATOR (5MHZ)		
X2			L77-2173-05	CRYSTAL RESONATOR(32.768KHZ)		
X4		*	L78-0674-05	RESONATOR		
X5			L78-0290-05	RESONATOR (8MHZ)		
CP2			R90-0860-05	MULTI-COMP 4.7K X1 1		
CP3			R90-0812-05	MULTI-COMP 10KX10 J 1/6W		
CP4			R90-0864-05	MULTI-COMP 100KX14		
CP5			R90-0892-05	MULTI-COMP 4.7KX5		
CP6			R90-0855-05	MULTI-COMP 100KX5 J		
CP7			R90-0482-05	MULTI-COMP 100KX4 J 1/6W		
R37 ,38	35		RD14BB2C102J	RD 1.0K J 1/6W		
R39 ,40	35		RD14BB2C224J	RD 220K J 1/6W		
R41 ,42	35		RD14BB2C102J	RD 1.0K J 1/6W		
R43 ,44	35		RD14BB2C224J	RD 220K J 1/6W		
R45 ,46	35		RD14BB2C102J	RD 1.0K J 1/6W		

L : Scandinavia K : USA P : Canada R : Mexico 3 : C-V300 35 : C-V300/V350
 Y : PX(Far East, Hawaii) T : Europe E : Europe G : Germany 10 : C-V100 350 : C-V350
 Y : AAFES(Europe) X : Australia M : Other Areas Q : Russia 15 : C-V100/V150

Δ indicates safety critical components.

* New Parts

Parts without **Parts No.** are not supplied.

Les articles non mentionnés dans le **Parts No.** ne sont pas fournis.

Teile ohne **Parts No.** werden nicht geliefert.

18

Ref. No	Add-ress	New Parts	Parts No.	Description	Desti-nation	Re-marks
R47 ,48	35		RD14BB2C224J	RD 220K J 1/6W		
R68			RD14NB2E681J	RD 680 J 1/4W		
R97	35		RD14BB2C100J	RD 10 J 1/6W		
R186-189	3		RD14BB2C221J	RD 220 J 1/6W	MICX	
Δ R203			RS14KB3D100J	FL-PROOF RS 10 J 2W		
R228			RS14KB3D181J	FL-PROOF RS 180 J 2W		
Δ R232			R92-1769-05	CARBON 3.3M J 1/2W	KP	
R233,234	3		RD14BB2E511J	RD 510 J 1/4W	MICX	
Δ R236			RS14KB3D471J	FL-PROOF RS 470 J 2W		
Δ R237			RS14KB3D331J	FL-PROOF RS 330 J 2W		
R239			RS14KB3D331J	FL-PROOF RS 330 J 2W		
R240			RS14KB3D471J	FL-PROOF RS 470 J 2W		
R241,242			RD14NB2E1R0J	RD 1 J 1/4W		
R251	3		RD14BB2C102J	RD 1.0K J 1/6W	MICX	
Δ R255			RS14KB3D1R2J	FL-PROOF RS 1.2 J 2W	ET	
Δ R255	3		RS14KB3D1R2J	FL-PROOF RS 1.2 J 2W	MICX	
Δ R256			RD14NB2E4R7J	RD 4.7 J 1/4W		
Δ R257			RS14KB3A1R0J	FL-PROOF RS 1 J 1W		
Δ R258			RS14KB3A470J	FL-PROOF RS 47 J 1W		
Δ R259			RD14NB2E100J	RD 10 J 1/4W		
R265	3		RD14BB2C103J	RD 10K J 1/6W	MICX	
Δ R268	3		RD14BB2C101J	RD 100 J 1/6W	MICX	
Δ S1			S62-0001-05	SLIDE SWITCH	YMI	
D1 -6			HSS104A	DIODE		
D1 -6			1SS131	DIODE		
D11			HSS104A	DIODE	YMIC	
D11			1SS131	DIODE	YMIC	
D13			HSS104A	DIODE	ET	
D13			1SS131	DIODE	TX	
D14			HSS104A	DIODE	TX	
D14			1SS131	DIODE	YEMICX	
D15			HSS104A	DIODE	YEMICX	
D15			1SS131	DIODE		
D16	35		HSS104A	DIODE	ETMICX	
D16	35		1SS131	DIODE	ETMICX	
Δ D21 -24			S5688B	DIODE		
Δ D21 -24			1SR139-400	DIODE		
D26			HZS5.1S(B2)	ZENER DIODE		
D26			RD5.1JS(B2)	ZENER DIODE		
D27			HSS104A	DIODE		
D27			1SS131	DIODE		
D28			HZS2.7N(B2)	ZENER DIODE		
D28			MTZJ2.7(B)	ZENER DIODE		
D28			RD2.7ES(B2)	ZENER DIODE		
D28			UZ-2.7BSB	ZENER DIODE		
D29 ,30			HSS104A	DIODE		
D29 ,30			1SS131	DIODE		
Δ D31			S5688B	DIODE		
Δ D31			1SR139-400	DIODE		
D32			HSS104A	DIODE		
D32			1SS131	DIODE		
D33			HZS5.6N(B2)	ZENER DIODE		
D33			MTZJ5.6(B)	ZENER DIODE		

L : Scandinavia K : USA P : Canada R : Mexico 3 : C-V300 35 : C-V300/V350
 Y : PX(Far East, Hawaii) T : Europe E : Europe G : Germany 10 : C-V100 350 : C-V350
 Y : AAFES(Europe) X : Australia M : Other Areas Q : Russia 15 : C-V100/V150

Δ indicates safety critical components.

PARTS LIST

* New Parts

Parts without **Parts No.** are not supplied.

Les articles non mentionnés dans le **Parts No.** ne sont pas fournis.

Teile ohne **Parts No.** werden nicht geliefert.

19

Ref. No	Add-ress	New Parts	Parts No.	Description	Desti-nation	Re-marks
D33			RD5.6ES(B2)	ZENER DIODE		
D33			UZ-5.6BSB	ZENER DIODE		
D34			S5688B	DIODE		
D34			1SR139-400	DIODE		
D35			HZS16N(B2)	ZENER DIODE		
D35			MTZJ16(B)	ZENER DIODE		
D35			RD16ES(B2)	ZENER DIODE		
D35			UZ-16BSB	ZENER DIODE		
D36			HZS18N(B2)	ZENER DIODE		
D36			MTZJ18(B)	ZENER DIODE		
D36			RD18ES(B2)	ZENER DIODE		
D36			UZ-18BSB	ZENER DIODE		
D37 -39			HSS104A	DIODE		
D37 -39			1SS131	DIODE		
D41			HZS6.2N(B2)	ZENER DIODE		
D41			MTZJ6.2(B)	ZENER DIODE		
D41			RD6.2ES(B2)	ZENER DIODE		
D41			UZ-6.2BSB	ZENER DIODE		
D42			HZS10N(B)	ZENER DIODE		
D42			MTZJ10(B)	ZENER DIODE		
D42			RD10ES(B)	ZENER DIODE		
D42			UZ-10BSB	ZENER DIODE		
D43			HZS3.9N(B2)	ZENER DIODE		
D43			MTZJ3.9(B)	ZENER DIODE		
D43			RD3.9ES(B2)	ZENER DIODE		
D43			UZ-3.9BSB	ZENER DIODE		
D44 -46			HSS104A	DIODE		
D44 -46			1SS131	DIODE		
D47			S5688B	DIODE		
D47			1SR139-400	DIODE		
D48			HSS104A	DIODE		
D48			1SS131	DIODE		
D49			HZS8.2N(B2)	ZENER DIODE		
D49			MTZJ8.2(B)	ZENER DIODE		
D49			RD8.2ES(B2)	ZENER DIODE		
D49			UZ-8.2BSB	ZENER DIODE		
D50 ,51			HZS10N(B2)	ZENER DIODE		
D50 ,51			MTZJ10(B)	ZENER DIODE		
D50 ,51			RD10ES(B2)	ZENER DIODE		
D50 ,51			UZ-10BSB	ZENER DIODE		
D52			HZS6.2N(B2)	ZENER DIODE		
D52			MTZJ6.2(B)	ZENER DIODE		
D52			RD6.2ES(B2)	ZENER DIODE		
D52			UZ-6.2BSB	ZENER DIODE		
D53			HZS5.1S(B2)	ZENER DIODE		
D53			RD5.1JS(B2)	ZENER DIODE		
D54 -60			HSS104A	DIODE		
D54 -60			1SS131	DIODE		
D61		3	HZS8.2S(B2)	ZENER DIODE	ET MICX	
D61		3	HZS8.2S(B2)	ZENER DIODE	ET MICX	
D61		3	RD8.2JS(B2)	ZENER DIODE	ET MICX	
D61		3	RD8.2JS(B2)	ZENER DIODE	ET MICX	
IC1			NJU7312AL	ANALOGUE IC		
IC2			NJU7311AL	ANALOGUE IC		
IC3			NJM4565D-D	IC(OP AMP X2)		

L : Scandinavia K : USA P : Canada R : Mexico 3 : C-V300 35 : C-V300/V350
 Y : PX(Far East, Hawaii) T : Europe E : Europe G : Germany 10 : C-V100 350 : C-V350
 Y : AAFES(Europe) X : Australia M : Other Areas Q : Russia 15 : C-V100/V150

⚠ indicates safety critical components.

* New Parts

Parts without **Parts No.** are not supplied.

Les articles non mentionnés dans le **Parts No.** ne sont pas fournis.

Teile ohne **Parts No.** werden nicht geliefert.

20

Ref. No	Add-ress	New Parts	Parts No.	Description	Desti-nation	Re-marks
IC4			LA2786	ANALOGUE IC		
IC5			LV1016	DI BI-POLAR IC		
IC6		*	UPD780205GF031	MI-COM IC	KPY MICX ET	
IC6		*	UPD780205GF031	MI-COM IC		
IC6		*	UPD780206GF019	MI-COM IC		
IC7		*	UPD17215GT-737	MI-COM IC		
IC9			S-806D-Z	ANALOGUE IC		
IC10			TA8409S	MOS-IC	ET MICX	
IC10	3		TA8409S	MOS-IC		
IC11			NJM4558D	ANALOGUE IC		
Q1 ,2			2SC2878(B)	TRANSISTOR		
Q3			2SA1048(Y,GR)	TRANSISTOR	YMIC	
Q3			2SA1175(F,E)	TRANSISTOR	YMIC	
Q3			2SA1309A(Q,R)	TRANSISTOR	YMIC	
Q3			2SA933AS(Q,R)	TRANSISTOR		
⚠ Q4			2SD1894	TRANSISTOR		
Q6 ,7			DTC124ESA	DIGITAL TRANSISTOR	YMIC	
Q6 ,7			UN4212	DIGITAL TRANSISTOR	YMIC	
⚠ Q8			2SB1370(E,F)	TRANSISTOR		
⚠ Q8			2SB1375	TRANSISTOR		
⚠ Q10			2SD2061	TRANSISTOR	ET MICX	
⚠ Q10		3	2SD2061	TRANSISTOR		
⚠ Q11			2SB1370(E,F)	TRANSISTOR		
⚠ Q11			2SB1375	TRANSISTOR		
⚠ Q12			2SC1740S(Q,R)	TRANSISTOR		
Q12			2SC2458(Y,GR)	TRANSISTOR		
Q12			2SC2785(F,E)	TRANSISTOR		
Q12			2SC3311A(Q,R)	TRANSISTOR		
⚠ Q13			2SD2061	TRANSISTOR		
Q14			2SC2003(L,K)	TRANSISTOR		
Q15			2SA1048(Y,GR)	TRANSISTOR		
Q15			2SA1175(F,E)	TRANSISTOR		
Q15			2SA1309A(Q,R)	TRANSISTOR		
Q15			2SA933AS(Q,R)	TRANSISTOR		
⚠ Q16			2SD2061	TRANSISTOR		
Q17			2SC1740S(Q,R)	TRANSISTOR		
Q17			2SC2458(Y,GR)	TRANSISTOR		
Q17			2SC2785(F,E)	TRANSISTOR		
Q17			2SC3311A(Q,R)	TRANSISTOR		
Q18			2SB1370(E,F)	TRANSISTOR		
Q18			2SB1375	TRANSISTOR		
⚠ Q19			2SD2061	TRANSISTOR	ET MICX	
⚠ Q19	3		2SD2061	TRANSISTOR		
SUB(X13-7522-70)						
C1			CE04KW1V100M	ELECTRO	10UF	35WV
C2			CE04KW1A101M	ELECTRO	100UF	10WV
C3 ,4			CE04KW1C220M	ELECTRO	22UF	16WV
C5			CQ93FMG1H102J	MYLAR	1000PF	J
C6			CQ93FMG1H182J	MYLAR	1800PF	J
C7			CQ93FMG1H103J	MYLAR	0.010UF	J
C8			CE04KW1A101M	ELECTRO	100UF	10WV
C9 ,10			CC45FCH1H270J	CERAMIC	27PF	J
C11			CK45FF1H103Z	CERAMIC	0.010UF	Z
C12			CE04KW1H010M	ELECTRO	1.0UF	50WV

L : Scandinavia K : USA P : Canada R : Mexico 3 : C-V300 35 : C-V300/V350
 Y : PX(Far East, Hawaii) T : Europe E : Europe G : Germany 10 : C-V100 350 : C-V350
 Y : AAFES(Europe) X : Australia M : Other Areas Q : Russia 15 : C-V100/V150

⚠ indicates safety critical components.

C-V100/V150/V300/V350

PARTS LIST

* New Parts

Parts without **Parts No.** are not supplied.

Les articles non mentionnés dans le **Parts No.** ne sont pas fournis.

Teile ohne **Parts No.** werden nicht geliefert.

21

Ref. No	Add-ress	New Parts	Parts No.	Description	Desti-nation	Re-marks
C21			CE04KW1H2R2M	ELECTRO 2.2UF 50WV		
C22			CC45FSL1H331J	CERAMIC 330PF J		
C23			CK45FB1H561K	CERAMIC 560PF K		
C24			CK45FF1H103Z	CERAMIC 0.010UF Z		
C25			CC45FCH1H330J	CERAMIC 33PF J		
C26			CC45FCH1H390J	CERAMIC 39PF J		
C27			CK45FF1H103Z	CERAMIC 0.010UF Z		
C28			CE04KW1A101M	ELECTRO 100UF 10WV		
CN1			E40-4808-05	PIN ASSY		
CN2			E40-4294-05	FLAT CABLE CONNECTOR		
L1			L40-1001-17	SMALL FIXED INDUCTOR(10UH,K)		
L2			L40-1091-17	SMALL FIXED INDUCTOR		
X1			L78-0626-05	RESONATOR (16M)		
X2			L77-2200-05	CRYSTAL RESONATOR(4.332MHZ)		
R33			RD14NB2E101J	RD 100 J 1/4W		
D1 -8			HSS104A	DIODE		
D1 -8			1SS131	DIODE		
IC1		*	RF5S830-0021	MOS-IC		
IC2			SAA6579	ANALOGUE IC		
Q1			2SC2458(Y,GR)	TRANSISTOR		
Q1			2SC3311A(Q,R)	TRANSISTOR		
Q2			2SA1048(Y,GR)	TRANSISTOR		
Q2			2SA1309A(Q,R)	TRANSISTOR		
Q3			2SC2878(B)	TRANSISTOR		
SUB(X13-7562-70 / X13-7570-20)						
C1 ,2			CE04KW1H100M	ELECTRO 10UF 50WV		
C3 -6			CC45FSL1H101J	CERAMIC 100PF J		
C7			CQ93FMG1H103J	MYLAR 0.010UF J		
C8			CQ93FMG1H102J	MYLAR 1000PF J		
C9 ,10			CC45FSL1H101J	CERAMIC 100PF J		
C11			CE04KW1H100M	ELECTRO 10UF 50WV		
C12			CC45FSL1H101J	CERAMIC 100PF J		
C13			CK45FB1H102K	CERAMIC 1000PF K		
C14			CQ93FMG1H103J	MYLAR 0.010UF J		
C15			CQ93FMG1H102J	MYLAR 1000PF J		
CN1 -3			E40-8180-05	PIN ASSY		
IC1 ,2			NJM4565D-D	IC(OP AMP X2)		
DISPLAY(X14-4360-10 / X14-4500-20)						
C1 ,2			CE04KW1A101M	ELECTRO 100UF 10WV		
CN1		*	E40-4940-05	FLAT CABLE CONNECTOR		
CN2		*	E40-8086-05	FLAT CABLE CONNECTOR		
CN4		*	E40-4808-05	PIN ASSY		
-		*	J19-5793-03	HOLDER		
R1			RD14NB2E470J	RD 47 J 1/4W		
R50 -76			RK73FB2A104J	CHIP R 100K J 1/10W		
R77			RK73FB2A102J	CHIP R 1.0K J 1/10W		
R78			RK73FB2A103J	CHIP R 10K J 1/10W		
S1 -15			S70-0031-05	TACT SWITCH		
S30			T99-0559-05	ROTARY ENCODER		

L : Scandinavia K : USA P : Canada R : Mexico 3 : C-V300 35 : C-V300/V350
 Y : PX(Far East, Hawaii) T : Europe E : Europe G : Germany 10 : C-V100 350 : C-V350
 Y : AAFES(Europe) X : Australia M : Other Areas Q : Russia 15 : C-V100/V150

⚠ indicates safety critical components.

* New Parts

Parts without **Parts No.** are not supplied.

Les articles non mentionnés dans le **Parts No.** ne sont pas fournis.

Teile ohne **Parts No.** werden nicht geliefert.

22

Ref. No	Add-ress	New Parts	Parts No.	Description	Desti-nation	Re-marks
ED1		*	20U64100SA	INDICATOR TUBE		
Q1			2SC3246	TRANSISTOR		
Q5 -14			DTA113ZUA	DIGITAL TRANSISTOR		
Q5 -14			UN5119	DIGITAL TRANSISTOR		KPY
Q15			2SA1576A(R,S)	TRANSISTOR		
Q15			2SA1586(Y,GR)	TRANSISTOR		MICX
Q15			2SB1218A(Q,R)	TRANSISTOR		
Q16 -31			DTA113ZUA	DIGITAL TRANSISTOR		
Q16 -31			UN5119	DIGITAL TRANSISTOR		
A1		*	W02-2598-05	OPTIC RECEIVING MODULE		
DISPLAY(X14-4372-70 / X14-4510-20)						
D1 -10			B30-2508-05	LED(AMBER,D=3,P=2)		
D11 ,12		*	B30-2519-05	LED(INFRARED,D=5,)		
D13	3	*	B30-2493-05	LED(RED)		
D14	15	*	B30-2507-05	LED(RED/GRN,D=5)		
C1 ,2			CE04KW1A101M	ELECTRO 100UF 10WV		
CN1	15		E40-4946-05	FLAT CABLE CONNECTOR		
CN2			E40-4956-05	FLAT CABLE CONNECTOR		
CN4	3		E40-4944-05	FLAT CABLE CONNECTOR		
CN5			E40-4609-05	PIN ASSY		
CN6	15		E40-4293-05	FLAT CABLE CONNECTOR		
W1	3		E31-0001-00	JUMPER WIRE		
W2	15		E31-0001-00	JUMPER WIRE		
-		*	J19-5793-03	HOLDER		
E6	15	*	J19-3288-05	LEAD HOLDER		
R1			RD14NB2E470J	RD 47 J 1/4W		
R11 ,12	15		RD14BB2C103J	RD 10K J 1/6W		
R13 ,14	15		RD14BB2C222J	RD 2.2K J 1/6W		
R15 ,16	15		RD14BB2C221J	RD 220 J 1/6W		
R22	3		RD14BB2C561J	RD 560 J 1/6W		
R26 ,27	15		RD14BB2C101J	RD 100 J 1/6W		
R50 -76			RK73FB2A104J	CHIP R 100K J 1/10W		
R77			RK73FB2A102J	CHIP R 1.0K J 1/10W		
R78			RK73FB2A103J	CHIP R 10K J 1/10W		
S1 -16			S70-0031-05	TACT SWITCH		
S17 -20	15		S70-0031-05	TACT SWITCH		
S21 -24			S70-0031-05	TACT SWITCH		
S25 ,26	15		S70-0031-05	TACT SWITCH		
S30			T99-0559-05	ROTARY ENCODER		
ED1		*	20U64100SA	INDICATOR TUBE		
Q1			2SC3246	TRANSISTOR		
Q2			2SC2003(L,K)	TRANSISTOR		
Q3 ,4	15		2SA1175(F,E)	TRANSISTOR		
Q3 ,4	15		2SA933AS(Q,R)	TRANSISTOR		
Q5 -14			DTA113ZUA	DIGITAL TRANSISTOR		
Q5 -14			UN5119	DIGITAL TRANSISTOR		
Q15	15		2SA1576A(R,S)	TRANSISTOR		
Q15			2SA1586(Y,GR)	TRANSISTOR		
Q15	3		2SB1218A(Q,R)	TRANSISTOR		
Q16 -31			DTA113ZUA	DIGITAL TRANSISTOR		
Q16 -31			UN5119	DIGITAL TRANSISTOR		
A1		*	W02-2598-05	OPTIC RECEIVING MODULE		

L : Scandinavia K : USA P : Canada R : Mexico 3 : C-V300 35 : C-V300/V350
 Y : PX(Far East, Hawaii) T : Europe E : Europe G : Germany 10 : C-V100 350 : C-V350
 Y : AAFES(Europe) X : Australia M : Other Areas Q : Russia 15 : C-V100/V150

⚠ indicates safety critical components.

SPECIFICATIONS

For C-V350

Audio section

Total harmonic distortion (1 kHz, 1V)	0.01 %
Signal to noise ratio (IHF'66)	
CD	93 dB
Input sensitivity / impedance	
CD	200 mV / 47k Ω
Tone controls	
BASS	± 8 dB (at 100 Hz)
TREBLE	± 8 dB (at 10 kHz)
Output level / impedance	
TAPE REC	200 mV / 1 k Ω

Video section

VIDEO inputs / outputs (composite)	1 Vp-p/75 Ω
---------------------------------------	--------------------

FM Tuner section

Tuning frequency range	87.5 MHz~108 MHz
Usable sensitivity (DIN)	
MONO	1.2 μ V (at 75 Ω) / 13.2 dBf (40 kHz dev., S/N 26 dB)
STEREO	35 μ V (at 75 Ω) / 42 dBf (46 kHz dev., S/N 46 dB)
Signal to noise ratio (DIN weighted at 1 kHz, 40 kHz dev.)	
MONO	65 dB (65.2 dBf input)
STEREO	60 dB (65.2 dBf input)
Selectivity (DIN ± 300 kHz)	64 dB
Stereo separation (DIN, 1 kHz)	36 dB
Frequency response	30 Hz~15 kHz, + 0.5 dB, - 3.0 dB

MW Tuner section

Tuning frequency range	531 kHz ~ 1,602 kHz
Usable sensitivity (30% mod., S/N 20 dB)	20 μ V / (700 μ V / m)
Signal to noise ratio (at 30% mod. 1mV input)	48 dB

LW Tuner section

Tuning frequency range	153 kHz ~ 279 kHz
Usable sensitivity (30% mod., S/N 20 dB)	35 μ V
Signal to noise ratio (at 30% mod. 1mV input)	45 dB

General

Power consumption	25 W
AC outlet	
UN SWITCHED	2 : (Total 100 W max)
Dimensions	W : 400 mm H : 105 mm D : 382 mm
Weight (net)	5.2 kg

For C-V150

Audio section

Total harmonic distortion (1 kHz, 1V)	0.01 %
Signal to noise ratio (IHF'66)	
CD	93 dB
Input sensitivity / impedance	
CD	200 mV / 47k Ω
Tone controls	
BASS	± 8 dB (at 100 Hz)
TREBLE	± 8 dB (at 10 kHz)
Output level / impedance	
TAPE REC	200 mV / 1 k Ω

Video section

VIDEO inputs / outputs (composite)	1 Vp-p/75 Ω
---------------------------------------	--------------------

FM Tuner section

Tuning frequency range	87.5 MHz~108 MHz
Usable sensitivity (DIN)	
MONO	1.2 μ V (at 75 Ω) / 13.2 dBf (40 kHz dev., S/N 26 dB)
STEREO	35 μ V (at 75 Ω) / 42 dBf (46 kHz dev., S/N 46 dB)
Signal to noise ratio (DIN weighted at 1 kHz, 40 kHz dev.)	
MONO	65 dB (65.2 dBf input)
STEREO	60 dB (65.2 dBf input)
Selectivity (DIN ± 300 kHz)	64 dB
Stereo separation (DIN, 1 kHz)	36 dB
Frequency response	30 Hz~15 kHz, + 0.5 dB, - 3.0 dB

MW Tuner section

Tuning frequency range	531 kHz ~ 1,602 kHz
Usable sensitivity (30% mod., S/N 20 dB)	20 μ V / (700 μ V / m)
Signal to noise ratio (at 30% mod. 1mV input)	48 dB

LW Tuner section

Tuning frequency range	153 kHz ~ 279 kHz
Usable sensitivity (30% mod., S/N 20 dB)	35 μ V
Signal to noise ratio (at 30% mod. 1mV input)	45 dB

General

Power consumption	25 W
AC outlet	
UN SWITCHED	2 : (Total 100 W max)
Dimensions	W : 400 mm H : 105 mm D : 382 mm
Weight (net)	5.2 kg



1. KENWOOD follows a policy of continuous advancements in development. For this reason specifications may be changed without notice.
2. Full performance may not be exhibited in extremely cold locations (below 0 deg.C).

SPECIFICATIONS

For C-V300

Audio section

Total harmonic distortion (1 kHz, 1V)	0.01 %
Signal to noise ratio (IHF'66)	
CD	93 dB
Input sensitivity / impedance	
CD	200 mV / 47k Ω
Tone controls	
BASS	± 8 dB (at 100 Hz)
TREBLE	± 8 dB (at 10 kHz)
Output level / impedance	
TAPE REC	200 mV / 1 k Ω

Video section

VIDEO inputs / outputs (composite)	1 Vp-p/75 Ω
---------------------------------------	--------------------

FM Tuner section

Tuning frequency range	87.5 MHz~108 MHz
Usable sensitivity	
MONO	1.6 V (at 75 Ω) / 15.2 dBf (75 kHz dev., SINAD. 30 dB)
50dB quieting sensitivity	
STEREO	31.6 μ V (at 75 Ω) / 41.2 dBf (75 kHz dev.)
Signal to noise ratio (1 kHz, 75 kHz dev.)	
MONO	75 dB (65.2 dBf input)
STEREO	68 dB (65.2 dBf input)
Selectivity (IHF \pm 400 kHz)	50 dB
Stereo separation (1 kHz)	40 dB
Frequency response	30 Hz~15 kHz, + 0.5 dB, - 3.0 dB

AM Tuner section

Tuning frequency range	(9 kHz) 531 kHz ~ 1,602 kHz (10 kHz) 530 kHz ~ 1,610 kHz
Usable sensitivity (30% mod., S/N 20 dB)	16 \pm V / (600 μ / m)
Signal to noise ratio (at 30% mod. 1mV input)	48 dB

General

Power consumption	25 W
AC outlet	2: (Total 100 W max) (Australia 1 : (100 W max))
Dimensions	W : 400 mm H : 105 mm D : 382 mm
Weight (net)	5.2 kg

For C-V100

(Except U.S.A. and Canada)

Audio section

Total harmonic distortion (1 kHz, 1V)	0.01 %
Signal to noise ratio (IHF'66)	
CD	93 dB
Input sensitivity / impedance	
CD	200 mV / 47k Ω
Tone controls	
BASS	± 8 dB (at 100 Hz)
TREBLE	± 8 dB (at 10 kHz)
Output level / impedance	
TAPE REC	200 mV / 1 k Ω

Video section

VIDEO inputs / outputs (composite)	1 Vp-p/75 Ω
---------------------------------------	--------------------

FM Tuner section

Tuning frequency range	87.5 MHz~108 MHz
Usable sensitivity	
MONO	1.6 μ V (at 75 Ω) / 15.2 dBf (75 kHz dev., SINAD. 30 dB)
50dB quieting sensitivity	
STEREO	31.6 μ V (at 75 Ω) / 41.2 dBf (75 kHz dev.)
Signal to noise ratio (1 kHz, 75 kHz dev.)	
MONO	75 dB (65.2 dBf input)
STEREO	68 dB (65.2 dBf input)
Selectivity (IHF \pm 400 kHz)	50 dB
Stereo separation (1 kHz)	40 dB
Frequency response	30 Hz~15 kHz, + 0.5 dB, - 3.0 dB

AM Tuner section

Tuning frequency range	(9 kHz) 531 kHz ~ 1,602 kHz (10 kHz) 530 kHz ~ 1,610 kHz
Usable sensitivity (30% mod., S/N 20 dB)	16 μ V / (600 μ V / m)
Signal to noise ratio (at 30% mod. 1mV input)	48 dB

General

Power consumption	25 W
AC outlet	2: (Total 100 W max) (Australia 1:(100 W max))
Dimensions	W : 400 mm H : 105 mm D : 382 mm
Weight (net)	3.9 kg



1. KENWOOD follows a policy of continuous advancements in development. For this reason specifications may be changed without notice.
2. Full performance may not be exhibited in extremely cold locations (below 0 deg.C).

SPECIFICATIONS

For C-V100

(U.S.A. and Canada)

Audio section

Total harmonic distortion (1 kHz, 1V)0.01 %
Signal to noise ratio (IHF' 66)
CD93 dB
Input sensitivity / impedance
CD 200 mV / 47k Ω
Tone controls
BASS ± 8 dB (at 100 Hz)
TREBLE ± 8 dB (at 10 kHz)
Output level / impedance
TAPE REC 200 mV / 1 k Ω

Video section

VIDEO inputs / outputs
(composite)1 Vp-p/75 Ω

FM Tuner section

Tuning frequency range 87.5 MHz~108 MHz
Usable sensitivity
MONO 1.6 μ V (at 75 Ω) / 15.2 dBf
(75 kHz dev., SINAD. 30 dB)
50dB quieting sensitivity
STEREO 31.6 μ V (at 75 Ω) / 41.2 dBf
(75 kHz dev.)

Signal to noise ratio (1 kHz, 75 kHz dev.)

MONO 75 dB (65.2 dBf input)
STEREO 68 dB (65.2 dBf input)
Selectivity (IHF \pm 400 kHz) 70 dB
Stereo separation (1 kHz) 40 dB
Frequency response30 Hz~15 kHz, + 0.5 dB, - 3.0 dB

AM Tuner section

Tuning frequency range 530 kHz ~ 1,700 kHz
Usable sensitivity
(30% mod., S/N 20 dB) 16 μ V / (600 μ V / m)
Signal to noise ratio
(at 30% mod. 1mV input) 48 dB

General

Power consumption 25 W
AC outlet
UN SWITCHED 2 : (Total 100 W max)
Dimensions W : 400 mm (15-3/4")
H : 105 mm (4-1/8")
D : 382 mm (15-1/16")
Weight (net) 3.9 kg (8.6 lb)



1. KENWOOD follows a policy of continuous advancements in development. For this reason specifications may be changed without notice.
2. Full performance may not be exhibited in extremely cold locations (below 0 deg.C).

Note:

Component and circuit are subject to modification to insure best operation under differing local conditions. This manual is based on Europe (E) standard, and provides information on regional circuit modification through use of alternate schematic diagrams, and information on regional component variations through use of parts list.

KENWOOD CORPORATION

14-6,Dogenzaka 1-chome, Shibuya-ku, Tokyo, 150 Japan

KENWOOD SERVICE CORPORATION

P.O BOX 22745, 2201 East Dominguez St., Long Beach, CA 90801-5745, U.S.A.

KENWOOD ELECTRONICS CANADA INC.

6070 Kestrel Road, Mississauga, Ontario, Canada L5T 1S8

KENWOOD ELECTRONICS LATIN AMERICA S.A.

P.O BOX 55-2791, Piso 6 plaza Chase, Cl. 47 y Aquilino de la Guardia Panama, Republic de Panama

KENWOOD ELECTRONICS U.K. LIMITED

KENWOOD House, Dwight Road, Watford, Herts., WD1 8EB., United Kingdom

KENWOOD ELECTRONICS BENELUX N.V.

Meachelsesteenweg 418, B-1930 Zaventem, Belgium

KENWOOD ELECTRONICS DEUTSCHLAND GMBH

Rembrücker Str. 15, 63150 Heusenstamm, Germany

KENWOOD ELECTRONICS FRANCE S.A.

13 Boulevard Ney, 75018 Paris, France

KENWOOD ELECTRONICS ITALIA S.p.A.

Via G. Sirtori, 7/9 20129, Milano, Italy

KENWOOD IBÉRICA S.A.

Bolivia, 239-08020 Barcelona, Spain

KENWOOD ELECTRONICS AUSTRALIA PTY. LTD.

(A.C.N. 001499 074)

P.O Box 504, 8 Figtree Drive, Australia Centre, Homebush, N.S.W. 2140, Australia

KENWOOD & LEE ELECTRONICS, LTD.

Unit 3712-3724, Level 37, Tower 1, Metroplaza, 223 Hing Fong Road, Kwai Fong N.T., Hong Kong

KENWOOD ELECTRONICS GULF FZE

P.O.Box 61318, Jebel Ali, Dubai, U.A.E.

KENWOOD ELECTRONICS SINGAPORE PTE LTD.

No. 1 Genting Lane #02-02, KENWOOD Building, Singapore, 349544

KENWOOD ELECTRONICS (MALAYSIA) SDN BHD.

#4.01 Level 4, Wisma Academy Lot 4A, Jalan 19/1 46300 Petaling Jaya Selangor Darul Ehsan Malaysia